

Transistor Circuits for the Constructor

No. 2

E. N. BRADLEY

The instruments described include A RADIO MICROPHONE OR RECORD PLAYER; A WIEN BRIDGE OSCILLATOR; A TWO STAGE MATCH-BOX RECEIVER; A NOVEL SIGNAL TRACER; and A WIDE RANGE COMMUNICATOR.

A feature of all the circuits is the economy and simplicity of their layouts, calling for few proprietary items and enabling the constructor to use (and make) inexpensive components.

LONDON: NORMAN PRICE (PUBLISHERS) LTD.

Three shillings and sixpence net

ELECTRICAL ENGINEERING FOR ORDINARY NATIONAL CERTIFICATE

G. N. Patchett, B.Sc.(Eng.), Ph.D., M.I.E.E., M.Brit.I.R.E., M.I.R.E.
 Vol. 1—*Current Electricity* 7/6 Vol. 4—*Direct Current Machines* 8/6
 Vol. 2—*Magnetism and Electrostatics* 6/- Vol. 5—*Basic Electronics* 5/-
 Vol. 3—*Alternating Current Theory* 10/6

RADIO SERVICING

Vol. 1—*Basic Electrotechnology* 5/- Vol. 4—*Fault-Finding* 5/-
 Vol. 2—*Intermediate Radio Theory* 8/6 Vol. 5—*Specimen Answers 1955/1959 (Inter)* 8/6
 Vol. 3—*Final Radio Theory* 6/- Vol. 6—*Specimen Answers 1955/1959 (Final)* 8/6

TELEVISION SERVICING

G. N. Patchett, B.Sc.(Eng.), Ph.D., M.I.E.E., M.Brit.I.R.E., M.I.R.E.
 Vol. 1 5/- Vol. 2 6/- Vol. 3 5/- Vol. 4 7/6

AUDIO HANDBOOK SERIES

N. H. Crowhurst, A.M.I.E.E., M.I.R.E.
 No. 1 **AMPLIFIERS** 3/6 No. 4 **PUBLIC ADDRESS** 4/6
 No. 2 **FEEDBACK** 3/6 No. 5 **THE QUEST FOR QUALITY** 6/-

AN F.M. TUNER: THEORY AND CONSTRUCTION 5/-

E. Adler, B.Sc. (Eng.), A.M.I.E.E.

RADIO SERVICING INSTRUMENTS 4/6

E. N. Bradley

ELECTRONIC NOVELTIES FOR THE CONSTRUCTOR 5/-

E. N. Bradley

RADIO CONTROL OF MODELS 5/-

G. Sommerhoff, M.A.

TELEVISION SYNCHRONIZING SEPARATORS 5/-

G. N. Patchett, B.Sc.(Eng.), Ph.D., M.I.E.E., M.Brit.I.R.E., M.I.R.E.

TRANSISTOR CIRCUITS FOR THE CONSTRUCTOR Nos. 1, 2 & 3

E. N. Bradley each 3/6

TELEVISION TEST EQUIPMENT 5/-

E. N. Bradley

TELEVISION CIRCUIT REFINEMENTS 5/-

C. H. Banthorpe

THE OSCILLOSCOPE BOOK 5/- **TELEVISION FAULTS** 5/-

E. N. Bradley

N. Stevens

MAGNETIC RECORDING 4/6

M. L. Quartermaine

TV PREAMPLIFIERS FOR BANDS I AND III 5/-

B. L. Morley

TELEVISION TIMEBASE CIRCUITS 5/-

C. H. Banthorpe

ELECTRONIC GADGETS FOR THE CONSTRUCTOR 3/6

E. N. Bradley

PRACTICAL TV AERIAL MANUAL FOR BANDS I AND III 5/-

R. Laidlaw

OSCILLOSCOPE EQUIPMENT 5/-

D. W. Easterling

HOW TO GET THE BEST OUT OF YOUR TAPE RECORDER 8/6

Percival J. Guy

BRITISH TRANSISTOR MANUAL 12/6

E. N. Bradley

SERVICING TRANSISTOR RECEIVERS 6/-

F. R. Pettit

USING AN OSCILLOSCOPE 6/6

D. W. Easterling

EXTRA EQUIPMENT FOR YOUR TAPE RECORDER 6/-

A. H. Rasheed

RECORDS AND GRAMOPHONE EQUIPMENT 8/6

E. N. Bradley

TRANSISTOR
CIRCUITS
FOR THE
CONSTRUCTOR

No. 2

E. N. Bradley

LONDON
NORMAN PRICE (PUBLISHERS) LTD.

NORMAN PRICE (PUBLISHERS) LTD.
150 OSSULSTON STREET, LONDON, N.W.1

First published 1957
Sixth impression 1961

Printed in Great Britain by
A. BROWN & SONS, LTD., Hull.

CONTENTS

	PAGE
1. USING TRANSISTORS	7
2. A RADIO MICROPHONE OR RECORD PLAYER	10
3. A WIEN BRIDGE OSCILLATOR	15
4. A MATCH-BOX RECEIVER	20
5. A SIGNAL TRACER	25
6. A WIDE RANGE COMMUNICATOR	29

ILLUSTRATIONS

FIGURE		PAGE
1.	A Method of Mounting Transistors	8
2.	The Radio Microphone/Record Player	11
3.	Tagboard Layout	13
4.	The Wien Bridge Oscillator	16
5.	Ganging the Controls	17
6.	Tagboard Layout	18
7.	The Match-Box Receiver	20
8.	The Tuning Coils	21
9.	Layout for the Match-Box Receiver	22
10.	The Component Board	23
11.	The On-Off Switch	23
12.	The Signal Tracer	25
13.	The Component Board	25
14.	Internal Layout of the Signal Tracer	27
15.	The Probe and Earth Clip	27
16.	The Wide Range Communicator	29
17.	Tagboard Layout	30

ACKNOWLEDGEMENTS

The author wishes to thank Mullard Ltd. and Repanco Ltd. for their kind and generous assistance.

I

USING TRANSISTORS

THIS second collection of transistor circuits in the present series is also intended for constructors who have some practice in the building of conventional valve equipment but who are new to transistor techniques.

This book does not deal with transistor theory; the circuits here described can be built first and the finer points of transistor operation considered later, if the reader so desires. Those requiring information on transistor theory and practice are referred to *Transistors and Crystal Diodes: What they are and How they work*, by B. R. Bettridge (from the same publishers).

The constructor handling transistors for the first time must observe certain precautions to avoid damaging the components. Perhaps of greatest importance is the need to check battery polarity very carefully before connecting up a unit after construction and, subsequently, when connecting new batteries. Reversing the battery polarity will almost certainly ruin a transistor. All the types currently available on the British market are *p-n-p* transistors in which the emitter is positive, the collector negative and the base biased between the two. It is advisable to wire all the negative leads in black and the positive leads in red so that polarity checks are automatic.

Polarity reversals and voltage overloads can come from unexpected sources, e.g. when checking with an ohmmeter which has an internal battery. Whenever possible a circuit which requires testing should have the transistors removed and tested separately. Electrolytic capacitors of low working voltage ratings are often used in transistor equipment and the same precautions apply respecting polarity reversals and overloads. It is worth remembering that a test meter switched to the OHMS range usually has its internal battery negative pole connected to the positive meter socket.

Circuit changes and additions must never be made with the circuit switched on. Connecting even an $0.01\mu\text{Fd}$ capacitor into circuit might lead to a charging surge sufficient to damage a transistor junction.

Transistors are very robust but nevertheless they must be handled with reasonable care. Their connecting leads should never be bent at the seal where they emerge; any necessary bend should be at least $\frac{1}{4}$ " down the wire. Some leads are gold plated, which should not be mistaken for tarnish and must not be cleaned off.

If transistors are soldered into circuit it is essential to protect the internal junctions from excessive heating. The leads should be left as long as possible and each lead, as it is soldered, must be

gripped by a pair of broad-nosed pliers whose mass will act as a heat sink, preventing too much heat being conducted up the lead and into the transistor body. The joint should be made as quickly as possible and the pliers held in place until the joint is cool.

The writer prefers not to solder transistors into circuit, but to mount them by means of 6 B.A. bolts. The majority of the circuits described were built, in their original form, on miniature tagboards $1\frac{7}{8}$ " wide and up to $4\frac{5}{8}$ " long, containing 18 tags on each side. It was found possible to tap the central holes of these tags with a 6 B.A. thread, the tags selected for transistor connections being so treated and a bolt run into the tapped hole to keep it clear of stray solder. Each tag, as it was wired, was coded *e*, *b* or *c* to denote the transistor lead, this coding being repeated on the rear of the tag-board.

With the circuit wiring completed the transistors were prepared for mounting, their leads being shaped with light tweezers into twisted loops, the length of lead between the component body and the loop being left sufficiently long to bring the transistor into the centre of the board. Excess wire was then cut away.

The bolts were run out of the tagboard and slipped through the loops on the transistor leads, a plain brass washer protecting the loop on either side. The bolts were then run back into their appropriate holes, each transistor lead being gripped by the tweezers as its bolt was tightened down to prevent its twisting. Checks were made on the lead spacing and the separation of the washers (the tags being rather close together) and the units were then ready for testing. This system allows the transistors to be changed to other equipment at any time without the attendant dangers of unsoldering and resoldering.

The method is shown in Fig. 1. In the upper section of the diagram is shown an edgewise view of the component board,

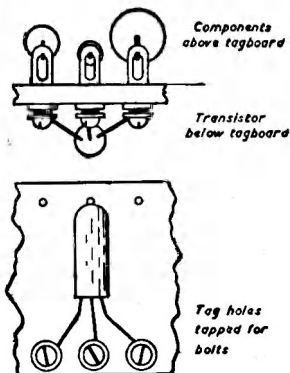

FIG. 1. A METHOD OF MOUNTING TRANSISTORS

carrying resistors and capacitors above and transistors below. The lower view shows the positioning of the transistor on the rear of the board.

If the majority of the components in a circuit are mounted in this way it is usually a simple matter to arrange the controls, the tagboard and the battery in a small case; plastic food boxes have been found ideal for this purpose.

During the first tests of any transistor circuit it is as well to include a milliammeter in the negative battery lead so that unexpectedly high currents can be seen immediately and the circuit switched off for checking. In some cases the impedance of the milliammeter coil may lead to instability, howling or motor-boating. This is generally cured by switching up to the next higher range where the moving coil is shunted by a low resistance, but a capacitance of about $2\mu\text{Fd}$ can be connected across the meter terminals instead, using a low voltage paper capacitor.

Checking can also start on a single cell giving 1.5V. Some circuits will not operate correctly on such a low voltage but in the event of any wrong connections or accidental short circuits the test current will still show high whilst the voltage will probably be low enough to prevent any serious damage.

The battery voltages shown in the circuit diagrams should be regarded as maximum permissible voltages: the experienced experimenter will know where he can try the effect of a higher voltage supply.

A RADIO MICROPHONE OR RECORD PLAYER

THE circuit shown in Fig. 2 is basically that of a midget radio transmitter which can be modulated by a microphone or gramophone pick-up and coupled into any radio receiver without actual electrical connections. A number of applications are apparent, ranging from dance music on a midget home receiver without pick-up sockets to "mystery announcements" and party playlets from an adjoining room.

It is obvious that to comply with regulations the r.f. power transmitted from such a unit must be very small—comparable with the output from a signal generator—and must be undetectable outside the premises where it is in use. Similar circuits using valves commonly give undesirably large outputs whereas the transistor oscillator is practically incapable of delivering too much power. Other features are that the unit can be made very small and robust and is very cheap to run.

The oscillator is modulated by a two stage audio amplifier, using OC71s, whose input circuit is shown in the diagram as suitable for magnetic pick-ups. A crystal pick-up should have its "live" lead taken to the slider of R_1 through a resistance of about 330k Ω . Crystal microphones could be connected directly into the input terminals but it is worth testing the effect of a step-down transformer, the microphone being connected across the larger winding. The smaller winding, which should have a step-down ratio of 3 : 1 or 5 : 1 is then connected across the input terminals. A moving coil loudspeaker makes a satisfactory microphone when coupled in through its output transformer, the correct primary tapping where available being chosen by trial.

The audio amplifier, which has a conventional stabilized circuit, modulates the oscillator through transformer T_1 which in the original unit was a Repanco push-pull transistor driver transformer. Other transformers could of course be tried. The oscillator transistor, shown in the diagram as a Mullard OC44, has its emitter tapped on to the main tuned winding, feedback being inductively coupled from the collector.

The oscillator coil is wound on an Aladdin polystyrene former $\frac{1}{4}$ " in diameter with a 1" winding length. L_1 , consisting of 25 turns closewound of 30 s.w.g., d.c.c. copper wire is wound on first, making a single layer along the former. This coil is covered with a turn of adhesive tape and L_2 wound on in the same direction, consisting of 80 turns of 36 s.w.g., d.c.c. copper wire, tapped at the

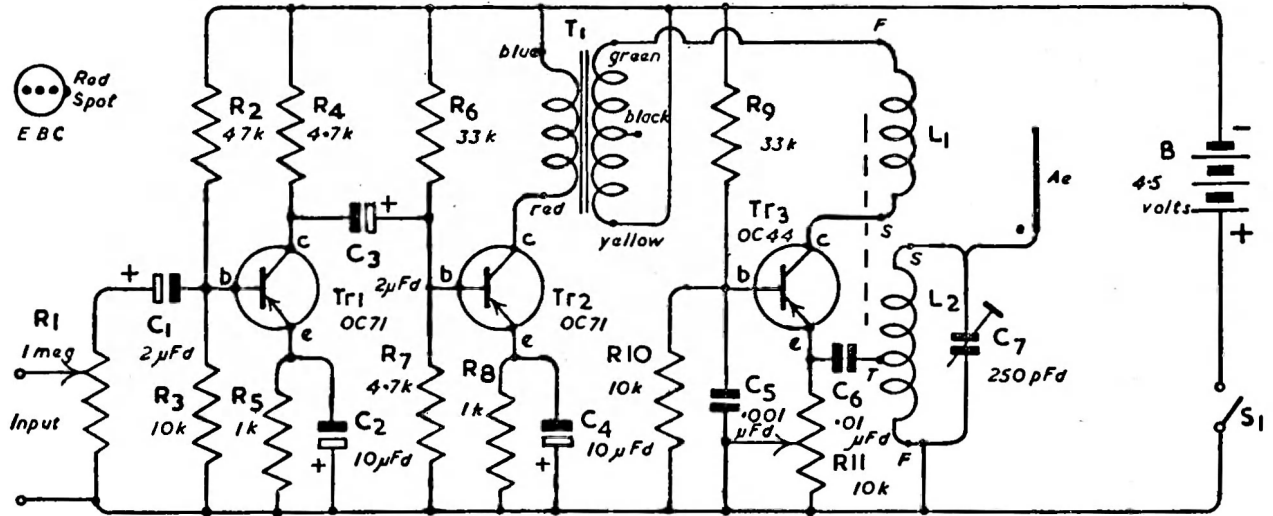

FIG. 2. THE RADIO MICROPHONE/RECORD PLAYER



70th turn. The tapping is simply made by twisting a few inches of the wire back on itself to form a pigtail, then wind on a further 10 turns and cover the whole coil with a turn of adhesive tape. Note that the finish of the main winding is earthed to the positive side of the circuit, the emitter tap thus being only 10 turns up from earth.

The coil is tuned by C_7 , a semi-variable compression capacitor, and by an iron dust core run fully into the windings.

Probably any transistor with a cut-off frequency of 2Mc/s or so will work well in this arrangement. Besides the OC44 an OC45 was tested with equally good results. The values of R_9 and R_{10} may need alteration for other transistor types.

If the unit is used close to a radio receiver which has a ferrite rod or other internal aerial, no aerial will be needed on the player itself. For better coupling, or where it is required to use the player a few feet away from the receiver, a short rod or plate aerial can be connected to L_2 as shown in Fig. 2.

The unit can be built into any case or box, and could easily be fitted into a small gramophone cabinet if desired. Tagboard construction is recommended and the layout of the prototype is shown in Fig. 3. Note that in this case even the controls were tagboard mounted, giving a very compact assembly.

COMPONENTS LIST FOR THE RADIO MICROPHONE OR
RECORD PLAYER, FIG. 2

L_1, L_2	25 turns 30 s.w.g., d.c.c. closewound, overwound with 80 turns 36 s.w.g., d.c.c. tapped at 70 turns, on $\frac{1}{4}$ " diameter former.
C_1, C_3	$2\mu\text{Fd}$ 6 v.w. miniature electrolytic.
C_2, C_4	$10\mu\text{Fd}$ 6 v.w. miniature electrolytic.
C_5	$0\cdot001\mu\text{Fd}$ midget mica.
C_6	$0\cdot01\mu\text{Fd}$ tubular ceramic.
C_7	250pFd compression capacitor, semi-variable.
R_1	1meg midget volume control, with s.p. switch.
R_2	$47\text{k}\Omega$ $\frac{1}{4}$ watt.
R_3, R_{10}	$10\text{k}\Omega$ $\frac{1}{4}$ watt.
R_4, R_7	$4\cdot7\text{k}\Omega$ $\frac{1}{4}$ watt.
R_5, R_8	$1\text{k}\Omega$ $\frac{1}{4}$ watt.
R_6, R_9	$33\text{k}\Omega$ $\frac{1}{4}$ watt.
R_{11}	$10\text{k}\Omega$ wirewound midget potentiometer.
Tr_1, Tr_2	Mullard OC71.
Tr_3	Mullard OC44.
T_1	Repanco Push-Pull Driver Transformer, TT 4.
S_1	S.P. on-off switch, ganged with R_1 .
	Miniature tagboard.
B	4.5V battery.

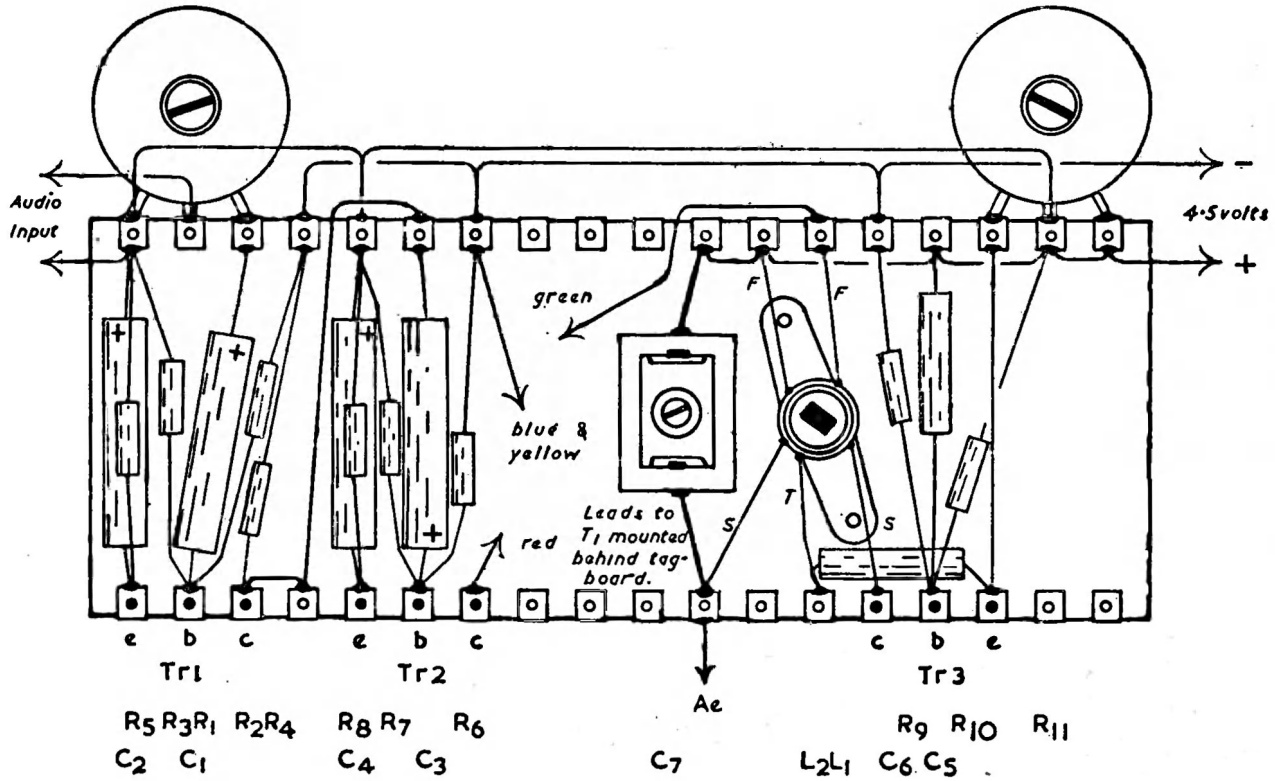

FIG. 3. TAGBOARD LAYOUT

The working voltages quoted for C_1 to C_4 are the **minimum** permissible voltages. Depending on the make of components used it may be necessary to accept higher working voltage ratings which, of course, is no disadvantage. Resistors of 1/10th or 1/20th watt ratings would be satisfactory, but as these are not always obtainable $\frac{1}{4}$ watt ratings are specified.

Fig. 3 is an indication of layout and is not to scale.

When the circuit has been carefully checked the audio section should first be tested with the pick-up or microphone it is intended to use; Tr_3 may therefore be omitted from the circuit. Connect high impedance headphones across the green and yellow leads of T_1 and, with the input coupled, switch on. Pick-ups should be tested on a known record, and microphones can be tested by connecting them in on a long lead and placing them in front of a radio receiver in another room. Good quality, good strength signals should be heard in the headphones. If a little more output is thought desirable try increasing R_4 to $10k\Omega$. If the output seems poor try different matchings into the amplifier (varying transformer ratios, etc.). There should be adequate gain from any normal pick-up or sensitive microphone.

With the audio section tested disconnect the headphones and battery and connect in Tr_3 . Reconnect the battery, place the unit beside a radio receiver (preferably one with an internal aerial) and switch on. Tune the receiver to a quiet spot between 200 and 250 metres. Turn R_{11} on the unit to a value of about $2.5k\Omega$.

With an input to the player tune C_7 until a signal is heard in the receiver. Fine adjustments can be made with an insulated trimming tool on the iron dust core in the oscillator coil.

Check the signals for volume and try the effect of using a short rod or small plate aerial on the player unit. Obtain the correct modulation depth by varying both R_1 and R_{11} ; it will be found that R_{11} has quite an effect on the signal and the best setting of this control should be found by trial.

Current consumption measured in the negative battery lead will be about 2 to 3mA.

A WIEN BRIDGE OSCILLATOR

IT is sometimes said that a transistorized Wien Bridge oscillator is not really practicable owing to the low input and output impedances of transistors, and that good waveforms, with level outputs, are difficult to obtain. In the circuit of Fig. 4 steps have been taken to remedy these drawbacks and, whilst the instrument is not of laboratory standards, it is a very useful oscillator, giving a good sine wave output at practically constant level (with some fall off at the higher frequencies) from approximately 100 to 12,500 c.p.s.

The oscillatory circuit is arranged round Tr_1 and Tr_2 , feedback being supplied from the second collector into the resistance-capacitance network round S_{1a} and S_{1b} . The frequency of oscillation is controlled by R_2 , R_3 , two 20k potentiometers ganged together, and the capacitances selected by S_{1a} and S_{1b} . The amplitude of oscillation is controlled by the emitter resistance selected by S_{1c} , the bias controls R_6 , R_7 and R_8 being set on their respective ranges for good waveform. R_5 , R_9 and R_{10} are kept at relatively high values to assist the operation of the circuit. This results in reduced temperature stability but it is, of course, impossible for the transistors to "run away" with the values of collector loads employed.

Negative feedback to improve the waveform is supplied to the base of Tr_1 by taking R_5 direct to the collector. The negative feedback through R_{13} from the collector of Tr_2 to the emitter of Tr_1 assists materially in keeping the output amplitude constant over the three ranges.

For some applications of the oscillator the amplifier-output stage round Tr_3 is unnecessary. It is included, however, to isolate the oscillator from the output load and to provide an output amplitude control, R_{16} . Variation of transistor characteristics may lead, in some cases, to overloading of the output stage, with consequent flattening of the waveform. This can be remedied by reducing the value of R_{11} by trial.

The experimenter with transistor experience may find it of interest to vary the frequency ranges by the inclusion of greater and smaller capacitances, and to change the values of the feedback resistors, etc., taking the normal precautions against overloading the transistors when so doing.

Twin or ganged potentiometers as used for the fine frequency control, R_2 , R_3 can often be obtained from advertisers in the technical periodicals, but two separate components can be ganged by the method shown in Fig. 5. A "U" shaped bracket of 16 or 18 gauge aluminium supports the controls, which have their spindles

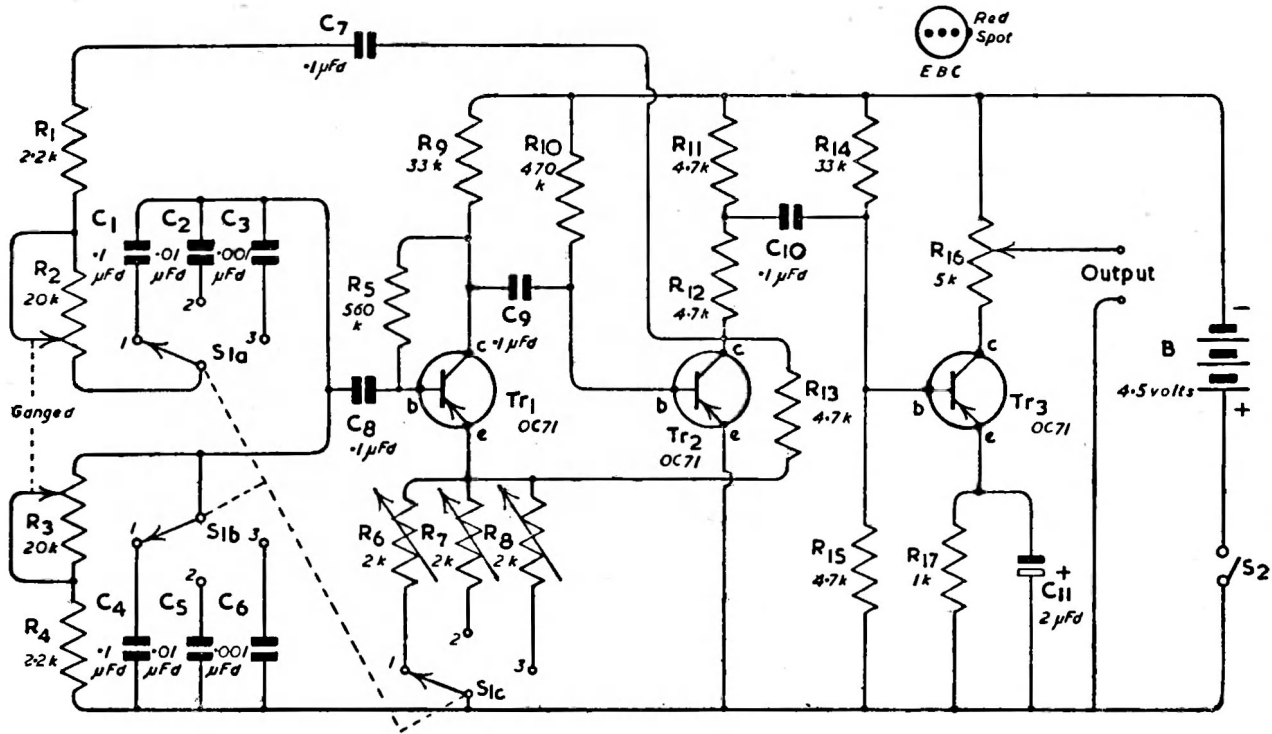

FIG. 4. THE WIEN BRIDGE OSCILLATOR

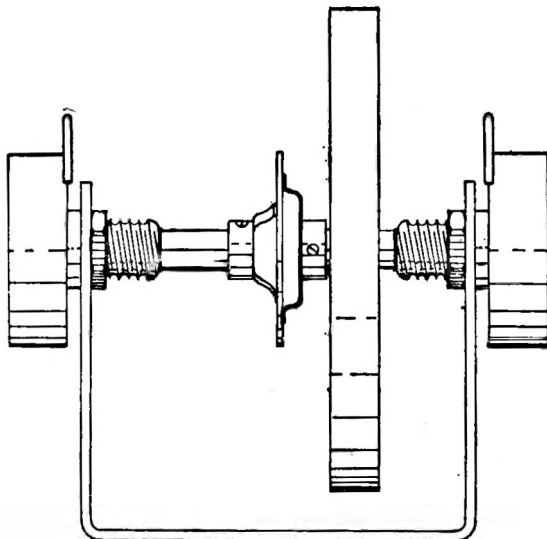

FIG. 5. GANGING THE CONTROLS.

joined by means of a flexible drive coupling. One spindle carries a tuning drum which should protrude through the front panel of the instrument case so that it can be driven round by finger pressure. The rim of the drum can be covered by a layer of thin card on which frequency calibrations can be drawn, the card then being coated with transparent varnish. A more elaborate system would employ two drums, one calibrated and showing through a small window in the instrument case, and the other driven from a knob and spindle by a cord drive.

Either a plastic or metal case may be used to house the oscillator, with R_2 , R_3 , S_1 , R_{15} and S_2 mounted as front panel controls. R_1 and R_4 , and C_1 to C_6 inclusive can be supported in the wiring to these controls. R_6 , R_7 and R_8 , whilst not front panel controls, should be accessible, and may therefore be mounted either on one side or on the back of the case. The remaining components, with the transistors, may then be mounted on a small tagboard as shown in Fig. 6.

When wiring the oscillator ensure that R_2 and R_3 are correctly ganged, *i.e.* that both put maximum resistance into circuit at the same time. If the leads to either control are crossed the oscillator will not work. Particular care is needed on this point where separate components are ganged as in Fig. 5.

With the wiring completed, the circuit may be tested and

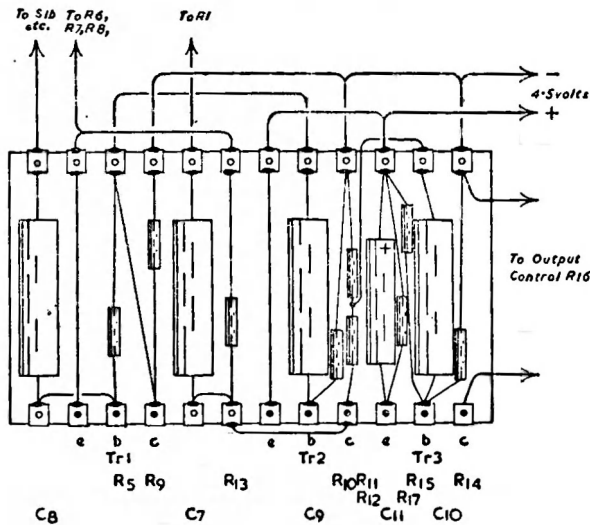

FIG. 6. TAGBOARD LAYOUT

COMPONENTS LIST FOR THE WIEN BRIDGE OSCILLATOR,
FIG. 4

$C_1, C_4, C_7, C_8, C_9, C_{10}$. 0.1 μ Fd midget tubular.
C_2, C_5	. 0.01 μ Fd midget tubular.
C_3, C_6	. 0.001 μ Fd midget mica.
C_{11}	. 2 μ Fd 3 v.w. miniature electrolytic.
R_1, R_4	. 2.2k Ω $\frac{1}{4}$ watt.
R_2, R_3	. Twin ganged 20k Ω potentiometers. <i>See text.</i>
R_5	. 560k Ω $\frac{1}{4}$ watt.
R_6, R_7, R_8	. 2k Ω miniature preset potentiometers.
R_9, R_{14}	. 33k Ω $\frac{1}{4}$ watt.
R_{10}	. 470k Ω $\frac{1}{4}$ watt.
$R_{11}, R_{12}, R_{13}, R_{15}$. 4.7k Ω $\frac{1}{4}$ watt.
R_{16}	. 5k Ω miniature potentiometer.
R_{17}	. 1k Ω $\frac{1}{4}$ watt.
Tr_1, Tr_2, Tr_3	. Mullard OC71.
S_{1a}, b, c	. 3-pole 3-way rotary switch.
S_2	. S.P. on-off switch.
Miniature tagboard.	
B	. 4.5V battery.

adjusted. Set R_2, R_3 to maximum resistance, R_6, R_7 and R_8 all to maximum resistance, turn S_1 to range 1 and switch on. Connect an oscilloscope to the output sockets and turn R_{16} for full output.

Watching the oscilloscope screen, turn R_6 down until oscillation suddenly commences. At this point the waveform should be good; turning R_6 to a lower resistance will give a distorted waveform and, finally, a fair approximation to a square wave. Turn R_2, R_3 through their complete travel—if the output falls in amplitude or oscillation ceases at any point, turn R_6 to a slightly lower resistance. The final setting of R_6 must be made so that steady oscillation is obtained all round the travel of R_2, R_3 with the best waveform possible.

The second and third ranges can be set in the same manner.

The ranges on the original were:

1. 100—500 c.p.s.
2. 500—2,500 c.p.s.
3. 2,500—12,500 c.p.s.

If an oscilloscope is not available the oscillator can be set up by connecting headphones to the output sockets *via* an $0.1\mu\text{Fd}$ capacitor. R_6 is then adjusted on range 1 so that oscillation is just maintained over the travel of R_2, R_3 . The second and third ranges are set in the same manner, R_7 and R_8 being turned down just sufficiently to maintain oscillation over each range.

The simplest method of calibrating the oscillator is to compare it, by means of an oscilloscope, with a standard audio generator. Failing this it can be calibrated, again using an oscilloscope, by comparison with the 50 c.p.s. mains supply, Lissajou figures being set up at 50 cycles intervals, and at fractions such as $\frac{1}{5}, \frac{2}{5}, \frac{3}{5}$, etc. If C_1 to C_6 have low tolerances it is sufficient to calibrate only the lowest range, the other two ranges being multiples of 10 and 100 on the lowest. If necessary C_2 and C_5 on the second range, and C_3 and C_6 on the third, can be padded with small extra capacitances in parallel, or large extra capacitances in series, to give accurate range multiplication. Again, an oscilloscope is needed as well as a second variable oscillator to act as a reference.

If, as is recommended in Chapter 1, a milliammeter is connected in the negative battery lead for the first trials, it will indicate that approximately 1mA only is drawn from the 4.5V battery by the unit, though this current varies with temperature.

It will be noted that the values of coupling capacitors C_7 to C_{10} inclusive are comparatively low for a transistor circuit. Higher values were tested but were found unnecessary. Frequencies much below 100 c.p.s. are not obtained satisfactorily from this circuit; capacitances larger than the $0.1\mu\text{Fd}$ of C_1 and C_4 in the lowest range give a pulsing rather than a sine wave oscillation.

A MATCH-BOX RECEIVER

TRANSISTORS readily lend themselves to miniaturized novelty construction and such a design is shown in Fig. 7, which is the circuit of a very simple 2-stage receiver for headphone listening, contained in a *Swan Vestas* match-box.

The receiver has a permeability tuned reacting detector using a Mullard OC44, coupled into an OC71 amplifier. Other transistors could be used, though Tr_1 must be a good r.f. junction type. High impedance headphones are recommended for use with the receiver though if it is to be carried about in the pocket a midget or deaf-aid earpiece will be almost an essential. A 250 ohms earpiece, if obtainable, will connect directly into Tr_2 as a collector load with satisfactory results, but lower impedance earpieces must be matched in by means of a step-down transformer. Room can be found in the case for a midget transformer by using a smaller 1.5V cell than that shown in Fig. 9.

The small size of the case makes a full tuning sweep over the whole medium wave range impossible and it is intended that the trimmer, C_1 , should be chosen for the local station in the constructor's area. Alternatively, a different L_1 and C_1 will allow the long wave Light Programme to be tuned.

The sensitivity is such that the receiver is suited mainly to good reception areas where the small ferrite rod will give sufficient pick up for full headphone volume. The long wave programme has been heard at a distance of 250 miles, however, using an extra aerial of 2 feet of wire or, alternatively, an earth connection.

The aerial and reaction coils on the ferrite rod are shown in

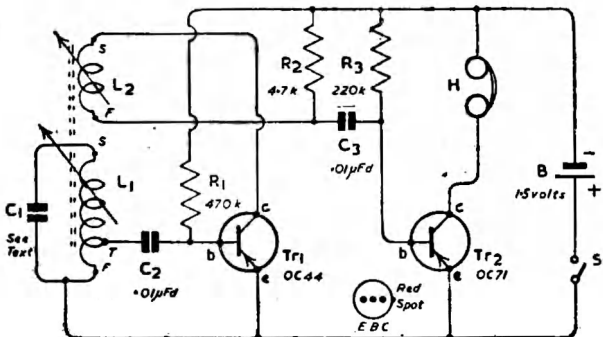

FIG. 7. THE MATCH-BOX RECEIVER

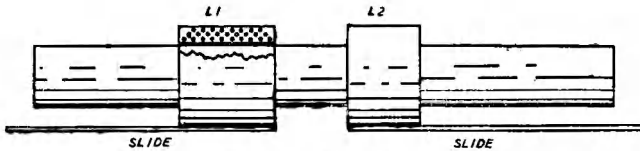

FIG. 8. THE TUNING COILS

Fig. 8. The rod is cut from a standard length of $\frac{5}{16}$ " diameter material, and should be $2\frac{15}{16}$ " long to fit snugly into the match-box tray. Ferrite rod is cut by filing two deep nicks at opposite points, then snapping off the required portion by a firm, decisive bend at the nicks. The coils are wound on formers of thin card. First put a turn of thin metal foil round the ferrite rod—*Mirap* aluminium foil is ideal—then glue or cement a turn of card over the foil. The former for the tuning coil should be $\frac{1}{2}$ " wide and that for the reaction coil $\frac{3}{8}$ " wide. Leave the formers on the rod whilst the coils are wound over them.

For the tuning coil put on 70 turns of 36 s.w.g., d.c.c. copper wire in three smooth closewound layers, bringing out a tap at the 60th turn. To make the tap simply twist a few inches of wire back on itself to make a pigtail, then continue with the final 10 turns. The wire gauge is not important though much larger wire cannot be used as it will require too much space. Wind the reaction coil with 25 turns of 36 s.w.g., d.c.c. copper wire.

With the coils still on the rod, smear them with a cement such as *Durafix* and cover them with another turn of the thin card or thick paper. The cement should be applied fairly generously and the outer layer of card bound into place with a few turns of bare wire. The whole assembly should then be left to dry.

If long wave tuning is required the tuning coil former should be $\frac{3}{4}$ " wide and the winding must be of 160 turns of wire tapped at 140 turns. The coil should be finished in the same way, with a coating of cement and an outer covering of card or paper.

When the coils are dry strip off the wire binding on the outer card and stick to each coil a celluloid "slide", about 3" long and $\frac{1}{4}$ " wide. These slides form the tuning and reaction controls and are to move the coils along the ferrite rod, so they must be firmly fixed. As shown in Fig. 8, the long axes of the slides are in line with the ferrite rod. When the cement securing the slides is dry the coils can be removed from the rod, the metal foil stripped off and the coils replaced. The foil should have given the coils just sufficient spacing to enable them to move freely along the rod.

The whole aerial assembly can now be mounted in the match-box tray, as shown in Fig. 9. The slides rest on the bottom of the tray and protrude through small slits cut between the bottom and ends

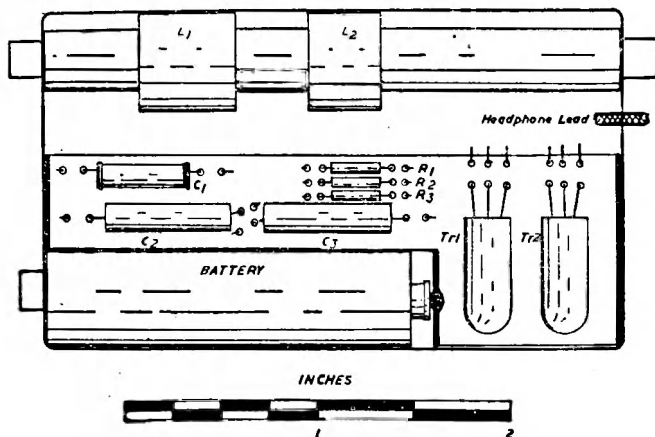

FIG. 9. LAYOUT FOR THE MATCH-BOX RECEIVER

of the tray. Each end of the ferrite rod is now cemented into place against the end of the tray.

The small components and transistors are mounted on a component board which can be cut from sheet celluloid. The board is shaped to fit round the 1.5V cell and has a bent-up lip carrying the positive battery contact as shown in Fig. 10. Other lips are bent up to clamp the cell in position and, at the ends, to fit the match-box tray. Celluloid is bent to shape by immersing it in hot water.

The components are mounted on the board by having their leads passed through pairs of holes as shown in Fig. 9. The wiring can then be carried out using thin insulated flex. The soldered connections to the transistors must be made with great care, their leads being gripped with broad-nosed pliers in the manner described in Chapter 1. Small transistor holders are now appearing on the market and are advertised in some technical periodicals, which may be used for transistor mountings thus obviating soldering leads.

The metal contact on the lip of the board can be made from a small copper rivet or brass eyelet, with the positive lead secured under it. If the lead is soldered on, heat must be conducted away from the metal very quickly if the celluloid is not to melt, and a damp rag held to the face of the eyelet or rivet will help. The contact is positioned to meet the positive pole of the battery. The celluloid lips must have sufficient spring and be so shaped that they hold the battery in position in the tray.

The on-off switch and negative battery connector is shown in Fig. 11. It consists of a celluloid slide carrying a well-rounded small copper rivet to which is secured the insulated, flexible negative lead. A small hole is cut in the card covering the cell and the circuit is

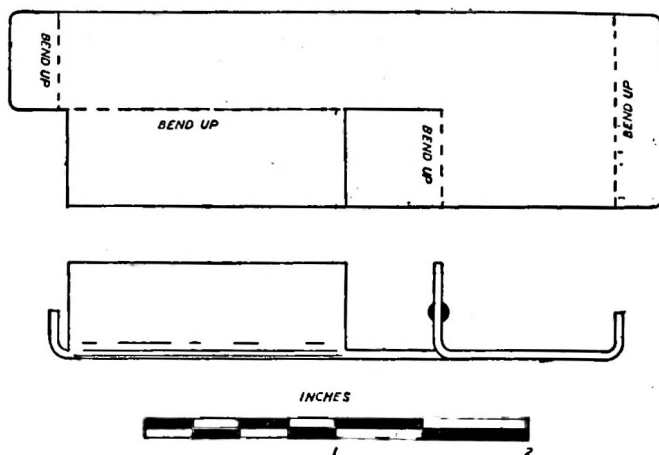
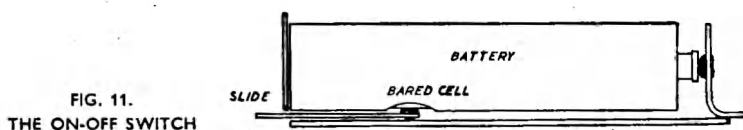

FIG. 10. THE COMPONENT BOARD (Proportions shown are for a "Fountain Pen" cell)

FIG. 11.
THE ON-OFF SWITCH

switched on by sliding the copper rivet into contact with the zinc. To switch off, the slide is pushed or pulled so that the rivet rides up on the card covering of the battery. Sufficient tension and pressure is given to the assembly by pressure from the match-box cover when the tray is closed.

Two types of cell are suitable for the receiver. The proportions shown in Fig. 9 are for a single "Fountain Pen" cell which will cause a slight bulging of the match box but which will fit satisfactorily. If extra space is needed an *Ever Ready* D21 Hearing Aid cell should be used. This cell is less than an inch long and will allow plenty of room for a small transformer, if a low impedance deaf-aid earpiece is to be matched in. This small cell may need packing to put sufficient tension on the slide switch.

The tuning ranges obtained with the .70 turn medium wave coil were:

C_1 ,	27pFd	.	.	1,400—1,100kc/s
C_1 ,	47pFd	.	.	1,200—1,000kc/s
C_1 ,	75pFd	.	.	1,000—850kc/s
C_1 ,	100pFd	.	.	900—750kc/s
C_1 ,	150pFd	.	.	750—600kc/s

For long wave tuning with the 160 turns coil the value of C_1 should be 400pFd.

COMPONENTS LIST FOR THE MATCH-BOX RECEIVER,
FIG. 7

L_1, L_2	. . .	See text.
C_1	. . .	See text.
C_2, C_3	. . .	0.01 μ Fd midget tubular.
R_1	. . .	470k Ω 1/10th watt.
R_2	. . .	4.7k Ω 1/10th watt.
R_3	. . .	220k Ω 1/10th watt.
Tr_1	. . .	Mullard OC44.
Tr_2	. . .	Mullard OC71.
H	. . .	High impedance headphones or high impedance earpiece or low impedance deaf-aid earpiece with matching transformer.
B	. . .	1.5V "Fountain Pen" cell or <i>Ever Ready</i> D21

With the circuit wired and checked set the two coils at the extreme ends of the ferrite rod and switch on. A current check in the negative battery lead will show a consumption of about 0.5mA.

Slide L_2 slowly along the rod to approach L_1 . When the coils are still well separated the circuit should go gently into oscillation with a quiet hiss; moving L_2 nearer to L_1 will result in a loud howl. If oscillation does not commence reverse the connections to L_2 . If there is still no oscillation check the connections to both coils and make sure that the finish of L_1 is connected to the positive side of the circuit so that the tap is only 10 turns up from earth. If connections are reversed on this coil the receiver will not operate.

It is possible that reaction will be too fierce. In this case increase the value of R_1 to 560k Ω , 820k Ω or 1M, choosing the correct value by trial. (Switch off and remove the battery during any changes to the circuit.)

Now move L_1 from the end of the rod towards the centre (the point of lowest frequency), moving L_2 back at the same time so that the circuit is kept on the edge of oscillation. The local station should be found without difficulty—remember that the aerial is directional, and turn the receiver if signals seem weak. If nothing is heard check that C_1 is the right value for the locality, and try the effect of connecting one or two feet of insulated wire to the top end of C_1 . At the author's West Country location French stations can be received during the day with 18" of wire added to the coil.

If the local station only is required the slides can now be trimmed so that just sufficient of the celluloid strip is left outside the match-box tray for fine tuning adjustments.

A SIGNAL TRACER

THE circuit of the signal tracer shown in Fig. 12, suitable for r.f. i.f. and audio operation, is so similar to many others that, by itself, it would hardly be worth a description. What is novel about this circuit is the manner in which the signal tracer is housed and switched, and the way in which the components are mounted in the instrument.

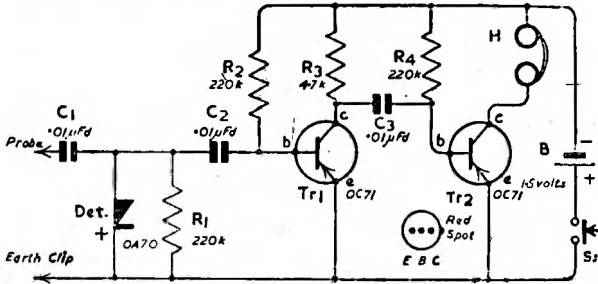

FIG. 12. THE SIGNAL TRACER

The whole tracer comprises a two stage amplifier following a detector, is suitable for high impedance headphones, and is fitted into an aluminium cigar-tube to make a probe-shaped unit. A prod and earth clip make contact with the circuit under test, and the tracer is switched on by resting the tip of the prod on a contact point, then lightly pressing on the tracer housing. This brings a contact down on the positive pole of the battery, so completing the circuit and powering the tracer. Releasing the pressure switches off the tracer.

The tracer is built on a small component board cut from sheet

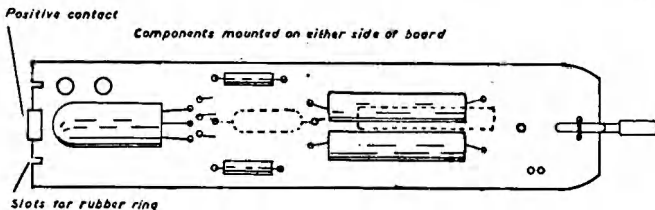

FIG. 13. THE COMPONENT BOARD

paxolin and shaped, see Fig. 13, to be a sliding fit into the cigar-tube. The complete assembly inside the tube is shown in Fig. 14. The prod itself is a length of 16 s.w.g. tinned copper wire covered with insulating sleeving and protruding from a hole drilled at the nose of the tube. The earth clip is brought out on an insulated flexible wire from a side hole. The far end of the component board carries the positive contact and a rubber ring which bears on the positive end of the 1.5V cell. The length of the ring is just sufficient to keep the contact clear of the positive pole of the cell, the can of which rests on a light spring retained by the screw-on base of the tube.

Pressure on the prod tip moves the whole component board down the tube, buckling the rubber ring and allowing the positive contact to meet the positive pole of the cell.

The size of the component board will depend on the cigar-tube chosen. Average cigar-tubes are about 5" long and $\frac{5}{8}$ " or $\frac{3}{4}$ " in diameter. A suitable cell is a "Fountain Pen" or similar sized torch cell. The dimensions of the board should be worked out by measuring the space left inside the tube with the cell fitted.

Fig. 15 shows how the prod is anchored through a pair of holes drilled at the front end of the board. A turn of wire through small holes drilled on either side of the prod gives added strength. Both sides of the board carry components which have their leads passed through pairs of small holes, as shown in Fig. 13. Connections are then made by insulated flexible wire. The soldered connections to the transistors must be made with great care, as described in Chapter 1.

The positive contact on the end of the component board can be made from a scrap of sheet brass secured in a slit drilled and filed in the paxolin or, alternatively, bolted on by an 8 B.A. bolt. The negative connection to the battery is made by taking an insulated flexible lead to the spring at the rear of the case or by soldering this lead directly to the can of the cell.

The cell is held centrally within the tube by a packing made of thin card, rubber sheet or other suitable material. The packing is not a continuous ring but is cut along its length to provide a space for the headphone lead which is anchored on the component board by a pair of holes and which passes down by the battery, through the spring and out *via* a hole in the centre of the end cap.

When using the signal tracer care must be taken not to overload the detector and first transistor by feeding in high power signals. Care must also be taken to avoid electrical shock when tracing signals through an a.c./d.c. receiver. The whole tracer circuit may be isolated from the metal tube by separating the battery spring from the bottom cap by an insulating washer and lining the inside of the tube with bakelized linen; but since the tracer is intended to

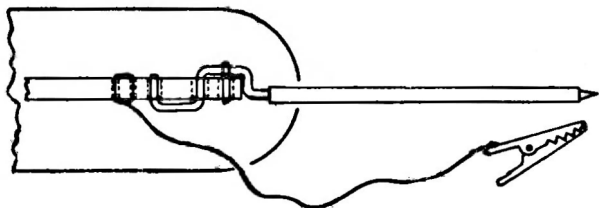
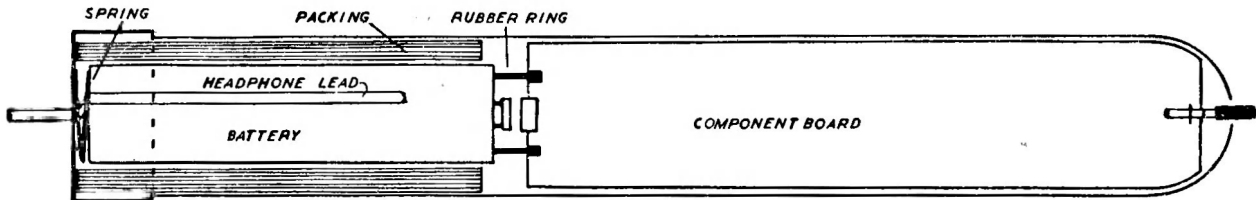

FIG. 14. (TOP) INTERNAL LAYOUT OF THE SIGNAL TRACER

FIG. 15. THE PROBE AND EARTH CLIP

work with headphones there is always a need for caution. Universal receivers are best isolated from the mains by a 1 : 1 power transformer; failing this always ensure that the chassis is connected to the neutral line before making tests.

COMPONENTS LIST FOR THE SIGNAL TRACER,

FIG. 12

C_1, C_2, C_3	.	.	0.01 μ Fd midget tubular (C_1 , 500 v.w.).
R_1, R_2, R_4	.	.	220k Ω 1/10th watt.
R_3	.	.	4.7k Ω 1/10th watt.
<i>Det.</i>	.	.	Mullard OA70.
Tr_1, Tr_2	.	.	Mullard OC71.
<i>H</i>	.	.	High impedance headphones.
<i>B</i>	.	.	1.5V cell, "Fountain Pen".

A WIDE RANGE COMMUNICATOR

THE circuit shown in Fig. 16 is the receiving end in a communications system of which the transmitter may be either an amplifier or radio receiver giving an output of between 1 and 4 watts. The system works by magnetic coupling. Round the whole area to be covered is run a single wire to form a large one turn loop, the ends of which are connected in place of a loudspeaker to the secondary of the amplifier or radio output transformer. The transistor receiver, which is no more than a very high gain amplifier connected to an induction coil, will then give strong headphone reception anywhere within the loop. The receiver can be made sufficiently small to be carried in a breast pocket and a deaf-aid earpiece makes a light and unobtrusive listening device.

The prototype was tested by running a plastic covered flex wire round the boundaries of a large garden, the wire resting on the ground. This loop was fed from a radio receiver with about $1\frac{1}{2}$ watts. Reception at all points within the loop was excellent with practically no variation in volume from point to point. For this reason no volume control is fitted to the receiver, since volume can be controlled by adjustment of the input to the transmitting loop.

There are obvious and various applications. A garden loop similar to that described will allow a favourite radio programme to be enjoyed while the garden work goes on, without annoyance to the neighbours. A microphone connected to the pick-up terminals on the receiver will transmit the ringing of a telephone or front door bell. A loop round a large garage or small factory, connected to a microphone and amplifier system, would keep key workers in contact with the office. (In steel framed buildings careful checks

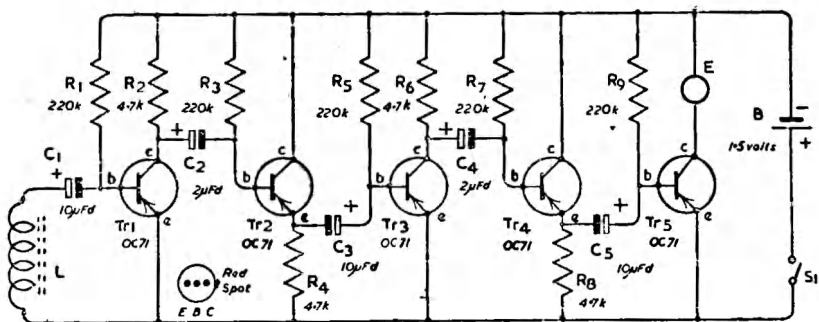

FIG. 16. THE WIDE RANGE COMMUNICATOR

during the running of the loop should be made to avoid areas of poor signal.)

The amplifier, shown in Fig. 16, consists of three common emitter stages, round Tr_1 , Tr_3 and Tr_5 , coupled by two common collector stages round Tr_2 and Tr_4 . The common collector stages, which are rather similar to valve cathode-follower stages, have high input and low output impedances, thus forming excellent matching stages between the common emitter stages which have low input and high output impedances. The values of the coupling capacitors depend on whether a high to high or low to low impedance coupling is required; the polarity of the capacitors should be observed.

The whole amplifier is supplied from a 1.5V cell and draws about 1.5mA.

Best results are obtained if a high impedance earpiece is used. A deaf-aid earpiece with a 250 ohms impedance can be connected directly to the collector of Tr_5 as shown, but a low impedance earpiece (30 ohms or so) must be matched in through a step-down transformer. A third common collector stage could of course follow Tr_5 to feed a low impedance earpiece from its emitter, but transformer coupling to the collector of Tr_5 seemed preferable on trial. If high impedance headphones can be worn they give excellent results.

Fig. 17 shows the layout of the original unit which was built on a miniature 18-way tagboard. If an output transformer is used with the earpiece, a midjet component should be obtained and mounted

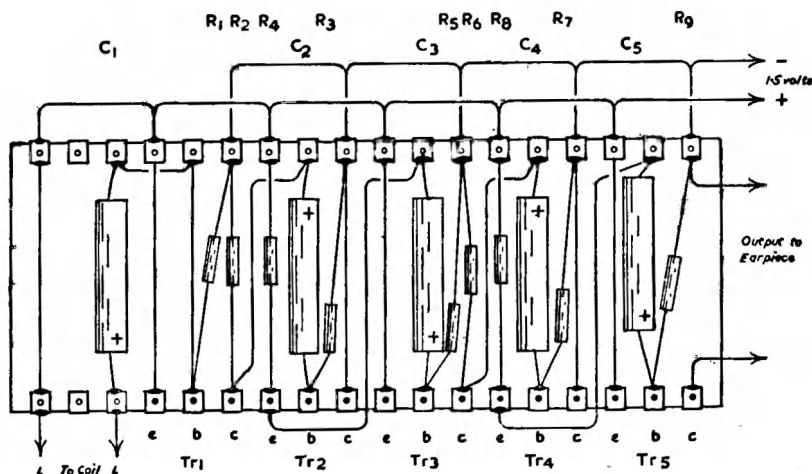

FIG. 17. TAGBOARD LAYOUT

on the front, or component, side of the board between the output tags.

The pick-up coil from which the amplifier derives its input signal may be an air cored coil wound on a former about 6" in diameter and consisting of 250 turns. Such a coil, however, is not conveniently housed, particularly as it must be held horizontally within the loop for correct coupling, so a ferrite rod cored coil was tested, and found especially suitable. A ferrite rod 4" long should be wound with 100 or 150 turns of 36 s.w.g., d.c.c. copper wire (the gauge is not important), the turns being closewound in a single layer. (A larger number of turns, though giving greater sensitivity, leads to instability.) Since the directivity of ferrite rod is in a plane perpendicular to the rod itself, this coil can be mounted vertically for maximum pick-up. If the coil is mounted along one edge of the tag-board, with the 1.5V cell supported on the rear of the board, the whole unit can then be fitted into a slim case no more than 5" tall, 2" wide and slightly over an inch deep. The case must not be metal and can be made of balsa wood, perspex or other light material.

COMPONENTS LIST FOR THE WIDE RANGE COMMUNICATOR,

FIG. 16

L	150 turns 36 s.w.g., d.c.c. on 4" ferrite rod, closewound.
C_1, C_3, C_5	10 μ Fd 3 v.w. miniature electrolytic.
C_2, C_4	2 μ Fd 3 v.w. miniature electrolytic.
R_1, R_3, R_5, R_7, R_9	220k Ω $\frac{1}{4}$ watt.
R_2, R_4, R_6, R_8	4.7k Ω $\frac{1}{4}$ watt.
$Tr_1, Tr_2, Tr_3, Tr_4, Tr_5$	Mullard OC71.
E	High impedance earpiece or low impedance earpiece with matching transformer.
S_1	S.P. on-off switch.
B	1.5V cell, "Fountain Pen" or <i>Ever Ready</i> D21.

Electrolytic capacitors with higher working voltages may be used, the values quoted being the lowest permissible. One-tenth or one-twentieth watt resistors may be used if available.

First trials of the communicator can be carried out with a temporary loop round the workshop or a room, fed from the extension speaker sockets of a radio receiver. If the output transformer has a tapped secondary the correct tappings should be found by trial—the loop impedance is low and in the tests of the prototype

a large loop was found to give best results from a typical beam power output stage with a matching ratio of 100 : 1. Where it is required to drive both a loudspeaker and a loop from a single output transformer secondary, it may be found desirable to connect a small resistance of 1 or 2 ohms in series with the loop. Much depends on the loop itself, which must be arranged to suit local conditions; practical tests will quickly reveal the matching and input power requirements.

