

RADIO
Handbook
TENTH EDITION

THE RADIO HANDBOOK

TENTH EDITION

by

Editors and Engineers

Compiled and revised from material
originally prepared by

W. W. SMITH

R. L. DAWLEY

F. C. JONES

LEIGH NORTON

FAUST GONSETT

E. H. CONKLIN

K. H. ROTHMAN

JAY BOYD

K. V. R. LANSINGH

W. E. McNATT

R. M. GILBERT

J. E. BEARDSLEY

ALICE McMULLEN

B. A. ONTIVEROS

AND OTHERS

THIS EDITION, CLOTHBOUND, \$2.00 IN CONTINENTAL U.S.A.; ELSEWHERE, \$2.25
(This book is revised and brought up to date at frequent intervals)

PUBLISHED AND DISTRIBUTED BY

EDITORS AND ENGINEERS, Ltd.

1300 KENWOOD ROAD, SANTA BARBARA, CALIFORNIA

TENTH EDITION

COPYRIGHT, 1946, BY

EDITORS AND ENGINEERS, Ltd.

1300 KENWOOD ROAD, SANTA BARBARA, CALIFORNIA

COPYRIGHT SECURED UNDER PAN-AMERICAN CONVENTION
ALL TRANSLATION RIGHTS RESERVED

PRINTED IN U. S. A. BY THE KABLE BROTHERS COMPANY

THE RADIO HANDBOOK

Table of Contents

| | |
|---|-----|
| Frontispiece..... | 4 |
| CHAPTER | |
| 1. Introduction to Radio..... | 5 |
| 2. Fundamental Electrical and Radio Theory..... | 17 |
| 3. Vacuum Tube Theory..... | 50 |
| 4. Radio Receiver Theory..... | 68 |
| 5. Radio Receiving Tube Characteristics..... | 96 |
| 6. Radio Receiver Construction..... | 138 |
| 7. Transmitter Theory..... | 158 |
| 8. Radiotelephony Theory..... | 188 |
| 9. Frequency Modulation..... | 215 |
| 10. Transmitting Tubes..... | 231 |
| 11. Transmitter Design..... | 266 |
| 12. Exciters and Low Powered Transmitters..... | 275 |
| 13. Medium and High Power R.F. Amplifiers..... | 291 |
| 14. Speech and Modulation Equipment..... | 302 |
| 15. Power Supplies..... | 321 |
| 16. Transmitter Construction..... | 346 |
| 17. U.H.F. Communication..... | 374 |
| 18. U.H.F. Receivers and Transceivers..... | 395 |
| 19. U.H.F. Transmitters..... | 410 |
| 20. Antenna Theory and Operation..... | 428 |
| 21. Directive Antenna Arrays..... | 458 |
| 22. U.H.F. Antennas..... | 472 |
| 23. Transmitter Adjustment..... | 477 |
| 24. Test and Measuring Equipment..... | 484 |
| 25. The Cathode Ray Oscilloscope..... | 516 |
| 26. Workshop Practice..... | 527 |
| 27. Broadcast Interference..... | 537 |
| 28. Radio Mathematics and Calculations..... | 544 |

Appendix—Buyer's Guide—Index

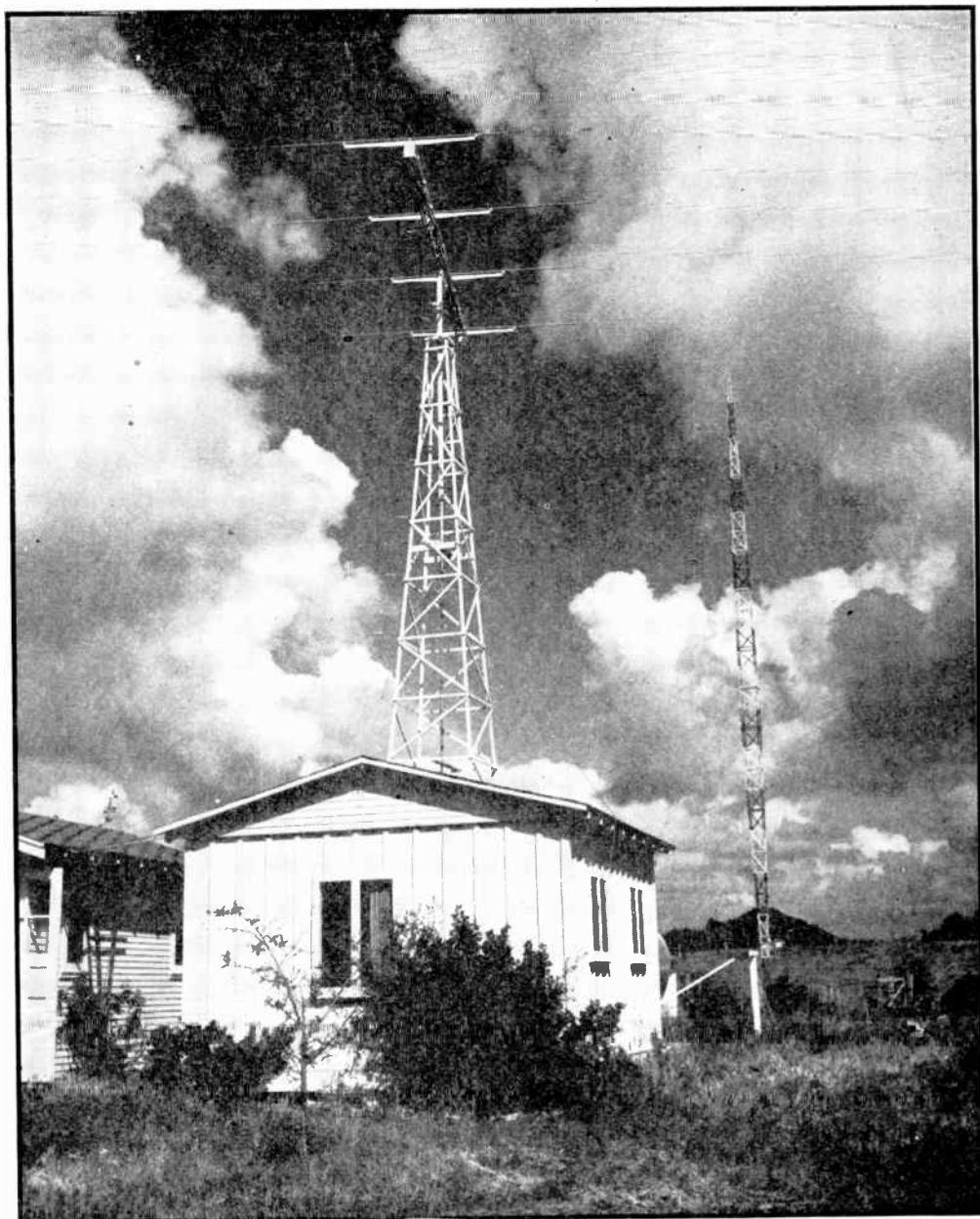

The amateur "shack" has become a familiar part of the American landscape. That of W6JRM is typical of many hundreds throughout the country.

Introduction to Radio

RADIO is so large a field that it is subdivided into a number of classes of which only shortwave or high frequency radio is covered in this book. These frequencies, although not so well known to the general public as commercial broadcasting frequencies, are by far the most widely used in present day radio.

The largest group of persons interested in high frequency radio at the start of World War II were the more than 50,000 radio amateurs; strictly speaking a radio amateur is anyone interested in radio non-commercially, but the term is ordinarily applied only to those hobbyists possessing a government license and transmitting equipment.

It was for the radio amateur, and particularly for the serious amateur, that most of the material in this book was originally developed, particularly the equipment shown; however, in each equipment group simple items are also shown for the student and beginner. The principles of high frequency radio are of course identical whether the equipment is used for commercial or non-commercial purposes; and the equipment differs little for either purpose, the principal difference being that commercial equipment is usually made to be as reliable as possible with less regard to cost while amateur equipment must often be constructed for as little cost as possible.

Amateur Radio Amateur Radio was suspended for the duration of the war, but as this book goes to press is being restored gradually. It is a fascinating hobby with several phases. So strong is the fascination offered by this hobby that many executives, engineers, and operators enjoy amateur radio as an avocation even though they are also engaged in the radio field commercially. It captures and holds the interest of many people in all walks of life, and in all countries of the world where amateur activities are permitted by law.

Although amateur radio is considered "only a hobby" by the general public, its history contains countless incidents of technical achieve-

ment, particularly in the now widely used high frequencies which were developed by amateurs while engineers still considered them generally useless. The old adage that necessity is the mother of invention has been more than true in amateur radio, for the average amateur has very limited funds which he can afford to devote to his hobby, and many an attempt to do something more cheaply has also resulted in doing it better.

Amateurs are a fraternal lot; their common interest makes them "brothers under the skin." When visiting strange towns an amateur often looks up friends with whom he has become acquainted over the air; even if he knows no amateurs in a given vicinity his amateur call usually makes him more than welcome. Amateur radio clubs have been formed all over the country; meetings feature both elementary and advanced technical talks, study sessions and code classes, social contacts, and "eats." Veteran amateurs met at such meetings will "give a hand" to the newcomer; among those met at club meetings will usually be found some other newcomers, one of whom should be selected if possible as a study companion; such a companion is particularly useful when it comes to learning the radio code.

Amateurs have rendered much public service through furnishing communications to and from the outside world in cases where disaster has isolated an area by severing all wire communications. Amateurs have a proud record of heroism and service in such occasions. Many expeditions to remote places have been kept in touch with home by communication with amateur stations on the high frequencies. The amateur's fine record of performance with the "wireless" equipment of World War I has been surpassed by his outstanding service in World War II. By the time peace came in the Pacific in the summer of 1945, many thousand former amateur operators were serving in the allied armed forces. They had supplied the army, navy, marines, coast guard, merchant marine, civil service, war plants, and civilian defense organizations with *trained* personnel for radio,

radar, wire, and visual communications and for teaching.

Some amateurs revel in contacts with far-distant countries; these are called "dx" men. Others specialize in relaying messages. Some are tireless experimenters, getting as much pleasure from building, improving, and tearing down equipment as from actual operation on the air. Others prefer not to specialize, but simply to "chew the rag" with any other amateur whom they may happen to contact on the air.

Amateurs often refer to themselves as "hams"; the origin of this slang term is obscure, but its use is well-established; it does not imply poor ability or worse as in the phrase "ham actor"; in fact many hams are also prominent radio engineers in their working hours.

License Every radio transmitting station in the United States no matter how low its power must have a license from the federal government before being operated; some classes of stations must have a permit from the government before even being constructed. And every operator of a transmitting station must have an operator's license before operating a transmitter. There are no exceptions. Similar laws apply in practically every important country.

Before the U.S.A. entered World War II, it was comparatively simple to obtain both amateur operator and station licenses, and it is expected that similar rules will prevail again after the war's end. To secure an amateur operator's license from the Federal Communications Commission, you must be a citizen of the U.S.A., master the radio code, know how amateur transmitters and receivers work and how they must be adjusted, and be familiar

with the laws and regulations pertaining to amateur operators and stations. Examinations usually consist of a written theoretical examination and a code test; the required code speed is 13 words per minute, both sending and receiving.

Starting Your Study When you start to prepare yourself for the amateur or other examination you will find that the circuit diagrams, tube characteristic curves, and formulas appear confusing and difficult of understanding. But after a few study sessions one becomes sufficiently familiar with the notation of the diagrams and the basic concepts of theory and operation so that the acquisition of further knowledge becomes easier and even fascinating.

As it takes considerable time to become proficient in sending and receiving code, it is a good idea to interperse technical study sessions with periods of code practice. Many short code practice sessions benefit one more than a fewer number of longer sessions. Alternating between one study and the other keeps the student from getting "stale" since each type of study serves as a sort of respite from the other.

When you have practiced the code long enough you will be able to follow the gist of the slower sending stations. Many stations send very slowly when working other stations at great distances. Stations repeat their calls many times when calling other stations before contact is established, and one need not have achieved much code proficiency to make out their calls and thus determine their location.

Granted that it is advisable to start in with learning the code, you will want to know how to go about mastering it in the shortest amount of time with the least amount of effort.



Figure 1.

Amateur station W9RIL, typical of hundreds of medium-power "ham" outfits throughout the U.S.A. and some foreign countries. As is usually the case, the receiving equipment is of commercial manufacture, while the transmitting equipment is home-made.

Figure 2.
The receiving position of the preprocessing and elaborate installation of W6PMB shows that equipment may be made to blend harmoniously with home furnishings.



The Code The applicant for an amateur license must be able to send and receive the Continental Code (sometimes called the International Morse Code) at a speed of 13 words per minute, with an average of five characters to the word. Thus 65 characters must be copied consecutively without error in one minute. Similarly 65 consecutive characters must be sent without error in the same time. Code tests usually last about five minutes; if 65 consecutive characters at the required rate are copied correctly anywhere during the five-minute period, the applicant is usually considered to have passed the test successfully.

A code speed of 16 words per minute is required for the lowest class of commercial radio operator's license. Higher classes require greater speeds.

If the code test is failed, the applicant must wait at least two months before he may again appear for another test. Approximately 30% of amateur applicants fail to pass the test. It should be expected that nervousness and excitement will at least to some degree temporarily lower the applicant's code ability. The best prevention against this is to master the code at a little greater than the required speed under ordinary conditions. Then if you slow down a little due to nervousness during a test the result will not prove "fatal."

Memorizing the Code There is no shortcut to code proficiency. To memorize the alphabet entails but a few evenings of diligent application, but considerable time is required to build up speed. The exact time required depends upon the individual's ability and the regularity of practice.

While the speed of learning will naturally

vary greatly with different individuals, about 70 hours of practice (no practice period to be over 30 minutes) will usually suffice to bring a speed of about 13 w.p.m.; 16 w.p.m. requires about 120 hours; 20 w.p.m., 175 hours.

Since code reading requires that individual letters be recognized instantly, any memorizing scheme which depends upon orderly sequence, such as learning all "dab" letters and all "dit" letters in separate groups, is to be discouraged. Before beginning with a code practice set it is necessary to memorize the whole alphabet perfectly. A good plan is to study only two or three letters a day and to drill with those letters until they become part of your consciousness. Mentally translate each day's letters into their sound equivalent wherever they are seen, on signs, in papers, indoors and outdoors. Tackle two additional letters in the code chart each day, at the same time reviewing the characters already learned.

Avoid memorizing by routine. Be able to sound out any letter immediately without so much as hesitating to think about the letters preceding or following the one in question. Know C, for example, apart from the sequence ABC. Skip about among all the characters learned, and before very long sufficient letters will have been acquired to enable you to spell out simple words to yourself in "dit dabs." This is interesting exercise, and for that reason it is good to memorize all the vowels first and the most common consonants next.

Actual code practice should start only when the entire alphabet, the numerals, period, comma, and interrogation point have been memorized so thoroughly that any one can be sounded without the slightest hesitation. Do not bother with other punctuation or miscellaneous signals until later.

THE RADIOTELEGRAPH CODE

| | | | |
|---|---------|---|---------|
| A | •— | N | —•• |
| B | —••• | O | —•—•— |
| C | —•••• | P | •—•—• |
| D | —••• | Q | —•—••— |
| E | • | R | •—•• |
| F | ••—•• | S | •••• |
| G | —•—•• | T | —•— |
| H | ••••• | U | ••—•— |
| I | ••• | V | ••••— |
| J | ••—•—•— | W | •—•—•— |
| K | —••—• | X | •••••— |
| L | •••••— | Y | —••—•—• |
| M | —•—•— | Z | —•—••• |

NUMERALS, PUNCTUATION MARKS, ETC.

| | | | |
|---|----------|---|-----------|
| 1 | •—•—•—•— | 6 | —••••• |
| 2 | ••—•—•— | 7 | —•—•••• |
| 3 | ••••—•— | 8 | —•—•—••• |
| 4 | •••••—• | 9 | —•—•—•—• |
| 5 | •••••• | Ø | —•—•—•—•— |

INTERNATIONAL DISTRESS SIGNAL ••••••••••

| | |
|---------------------|-------------|
| PERIOD | •—•••••— |
| COMMA | —•—•—•—•— |
| INTERROGATION | ••—•—•—• |
| QUOTATION MARK | •—••••—• |
| COLON | —•—•—•—•— |
| SEMICOLON | —•—•—•—•—• |
| PARENTHESIS | —•—•—•—•—•— |
| FRACTION BAR | —•—•—•—• |
| WAIT SIGN | •—•••• |
| DOUBLE DASH (BREAK) | —•—•—•— |
| ERROR (ERASE) SIGN | •••••••• |
| END OF MESSAGE | •—••••• |
| END OF TRANSMISSION | •••••••— |

Figure 3.

The Continental (or International Morse) Code is used for all radio communications. DO NOT memorize from the printed page; code is a language of SOUND, and must not be learned visually; learn by listening as explained in the text. Ø means zero, being sometimes so written to distinguish it from letter "O"; it is often sent as one long dash (equivalent to 5 dots).

| | |
|----|----------|
| ä | ••••• |
| á | ••••• |
| ch | •—•—•—•— |
| é | ••••• |
| ñ | —•—•—•—• |
| ö | —•—•—•—• |
| ü | ••••• |

Figure 4.

The above foreign characters may occasionally be encountered, so it is well to know them.

Sound not Sight Each letter and figure *must* be memorized by its *sound* rather than its appearance. Code is a system of sound communication, the same as is the spoken word. The letter *A*, for example, is one short and one long sound in combination sounding like *dit dab*, and it must be remembered as such, and not as "dot dash."

As you listen to the sound of a letter transmitted slowly by an experienced operator, you will notice how closely the dots resemble the sound *dit* and the dashes *dab*.

You must learn the individual sounds of each code signal so that you associate these *instantly* with the various specific characters for which they stand. If you attempt to learn by visualizing the dots and dashes, you will never be able to translate them into the characters for which they stand with any degree of speed, so avoid any visualization right from the start.

Practice Time, patience, and regularity are required to learn the code right. Do not expect to accomplish it within a few days.

Don't practice too long at one stretch; it does more harm than good. Thirty minutes at a time should be the limit.

Lack of regularity in practice is the most common cause of lack of progress. Irregular practice is very little better than no practice at all. Write down what you have heard; then forget it; *do not look back*. If your mind dwells even for an instant on a signal about which you have doubt, you will miss the next few characters while your attention is diverted.

Take it easy; do not become confused or nervous. Try to ignore the presence of other persons. If you find that they make you nervous, it is a good idea to ask some friends to stand near you and talk with each other while you are practicing. After a few sessions you will become used to external sounds and they will bother you no more.

Each person can learn only so fast; do not try to exceed your natural rate or you will become overanxious and actually slow down your progress.

While various automatic code machines, phonograph records, etc., will give you practice, by far the best practice is to obtain a study companion who is also interested in learning the code. When you have both memorized the alphabet you can start sending to each other. Practice with a key and oscillator or key and buzzer generally proves superior to all automatic equipment. Two such sets operated between two rooms are fine—or between your house and his will be just that much better. Avoid talking to your partner while practicing. If you must ask him a question, do it in code. It makes more interesting practice than confining yourself to random practice material.

When two co-learners have memorized the code and are ready to start sending to each other for practice, it is a good idea to enlist the aid of an experienced operator for the first practice session or two so that they will get an idea of how properly formed characters sound.

When you are practicing with another beginner don't gloat if you seem to be learning to receive faster than he. It may be that his *sending* is better than yours. Remember that the quality of sending affects the maximum copying speed of a beginner to a very large degree. If the sending is bad enough, the newcomer won't be able to read it at all and even an old-timer may have trouble getting the general drift of what you are trying to say.

During the first practice period the speed should be such that substantially solid copy can be made without strain. Never mind if this is only two or three words per minute. In the next period the speed should be increased slightly to a point where nearly all of the characters can be caught only through conscious effort. When the student becomes proficient at this new speed, another slight increase may be made, progressing in this manner until a speed of about 16 words per minute is attained if the object is to pass the amateur 13-word per minute code test. The margin of 3 w.p.m. is recommended to overcome a possible excitement factor at examination time. Then when you take the test you don't have to worry about the "jitters" or an "off day."

Speed should not be increased to a new level until the student finally makes solid copy with ease for at least a five-minute period at the old level. How frequently increases of speed can be made depends upon individual ability and the amount of practice. Each increase is apt to prove disconcerting, but remember "you are never learning when you are comfortable."

With the restoration of amateur radio, a number of amateurs will again send code practice on the air on schedule once or twice each week; excellent practice can be obtained after you have bought or constructed your receiver by taking advantage of these sessions. A

stamped, self-addressed envelope accompanying an inquiry to the American Radio Relay League, West Hartford, Connecticut, will bring a list of the stations transmitting code practice in your vicinity.

If you live in a medium or large city, the chances are that there is an amateur radio club in your vicinity which will resume free code practice classes when amateur radio transmission is again permitted.

Practice At the start use plain English, sending from a book, newspaper, or anything handy. Also practice disconnected words from the list on page 11, which is said to contain about half the words commonly spoken in English.

More detailed instructions on code learning and practice may be obtained from several textbooks which are written to cover this subject exclusively.*

Skill When you listen to someone speaking you do not consciously think how his words are spelled. This is also true when you read. In code you must train your ears to read code just as your eyes were trained in school to read printed matter. With enough practice you acquire skill, and from skill, speed. In other words, it becomes a *habit*, something which can be done without conscious effort. Conscious effort is fatal to speed; we can't think rapidly enough; a speed of 25 words a minutes, which is a common one in commercial operations, means 125 characters per minute or more than two per second, which leaves no time for conscious thinking.

Speed comes only through practice, and lots of it; however, as stated above, this does not mean long practice sessions, which are actually harmful.

Perfect Formation of Characters When transmitting on the code practice set to your partner, concentrate on the *quality* of your sending, *not* on your speed. Your partner will appreciate it and he could not copy you if you speeded up anyhow.

If you want to get a reputation as having an excellent "fist" on the air, just remember that speed alone won't do the trick. Proper execution of your letters and spacing will make much more of an impression. Fortunately, as you get so that you can send evenly and accurately, your sending speed will automatically increase. Remember to try to see how *evenly* you can *send*, and how *fast* you can *receive*. Concentrate on making signals properly with

*THE RADIO CODE MANUAL, 174 pages, containing general instructions, 20 code lessons with practice material, how to build code practice equipment, and how to operate a code class, may be obtained from our book department for \$2.50 plus seven cents postage (add tax in Calif.).

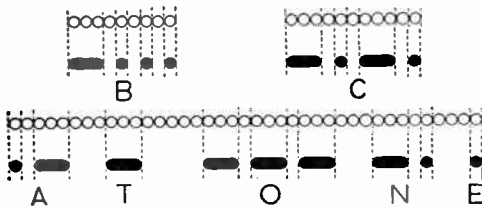

Figure 5.

Diagram illustrating relative lengths of dashes and spaces compared to the dot. A dash is exactly equal in length to three dots; spaces between parts of a letter equal one dot; those between letters, three dots; space between words, five dots. Note that a slight increase in the space between two parts of a letter will make it sound like two different letters.

your key. Perfect formation of characters is paramount to everything else. Make every signal right no matter if you have to practice it hundreds or thousands of times. Never allow yourself to vary the slightest from perfect formation once you have learned it. Never mind how slowly you must send in order to be accurate. In the long run you will gain speed much more quickly if you have learned right, and you will never get much speed if you learn wrong. Everything else is secondary to perfection at this point.

If possible, get a good operator to listen to your sending for a short time, asking him to criticize even the slightest imperfections.

Timing It is of the utmost importance to maintain uniform spacing in characters and combinations of characters. Lack of uniformity at this point probably causes beginners more trouble than any other single factor. Every dot, every dash, and every space must be correctly timed. In other words, accurate timing is absolutely essential to intelligibility, and timing of the spaces between the dots and dashes is just as important as the lengths of the dots and dashes themselves.

The characters are timed with the dot as a "yardstick." A standard dash is three times as long as a dot. The spacing between parts of the same letter is equal to one dot; the space between letters is equal to three dots, and that between words equal to five dots. There is *no such thing* as long, medium, or short dashes; a dash must always equal the length of three dots, neither more nor less.

The rule for spacing between letters and words is not strictly observed when sending slower than about 10 words per minute for the benefit of someone learning the code and desiring receiving practice. When sending at, say, 5 w.p.m., the individual letters should be made the same as if the sending rate were

about 10 w.p.m., except that the spacing between letters and words is greatly exaggerated. The reason for this is obvious. The letter *L*, for instance, will then sound exactly the same at 10 w.p.m. as at 5 w.p.m., and when the speed is increased above 5 w.p.m. the student will not have to become familiar with what may seem to him like a new sound, although it is in reality only a faster combination of dots and dashes. At the greater speed he will merely have to learn the identification of the *same* sound without taking as long to do so.

Experience has shown that it does not aid a student in identifying a letter by sending the individual components of the letter at a speed corresponding to less than 10 w.p.m. By sending the letter moderately fast a longer space can be left between letters for a given code speed, thus giving the student more time to identify the letter.

There are no degrees of readability in signals. They are either right or wrong, and if they are wrong, it is usually irregular spacing or irregular dash lengths which make them so. If you find that you have a tendency towards irregularity, practice those characters which give you trouble no matter how long you must do so. Until they can be formed perfectly you are not ready for speed.

Be particularly careful of letters like *B* in which many beginners seem to have a tendency to leave a longer space after the dash than that which they place between succeeding dots, thus making it sound like *TS*. Similarly, make sure that you do not leave a longer space after the first dot in the letter *C* than you do between other parts of the same letter; otherwise it will sound like *NN*.

Sending vs. Receiving Once you have memorized the code thoroughly you should concentrate on increasing your receiving speed. True, if you have to practice with another newcomer who is learning the code with you, you will both have to do some sending. But don't attempt to practice *sending* just for the sake of increasing your sending speed.

When transmitting on the code practice set to your partner so that he can get receiving practice, concentrate on the *quality* of your sending, not on your speed.

Because it is comparatively easy to learn to send rapidly, especially when no particular care is given to the quality of sending, many operators who have just received their licenses get on the air and send mediocre or worse code at 20 w.p.m. when they can barely receive good code at 13. Most oldtimers remember their own period of initiation and are only too glad to be patient and considerate if you tell them that you are a newcomer. But the surest way

| | | | | |
|-----|------|---------|------------|------------|
| MY | OFF | SAID | DOWN | AWAY |
| AN | PAY | ONLY | OTHER | GIVE |
| OF | END | WOULD | LIKE | HIGH |
| DO | AND | THEN | UNDER | INTEREST |
| IT | KEY | LONG | HEAR | HIMSELF |
| UP | NOT | MANY | DONT | FACT |
| AM | PER | BECAUSE | ALSO | WITHOUT |
| NO | HIS | YOUR | DOES | ANOTHER |
| HE | OWN | KNOW | YOURS | PURPOSE |
| OR | PUT | OVER | HALF | POWER |
| IN | HER | WHEN | EACH | DONE |
| TO | ARE | FROM | WHERE | NAME |
| AS | OWE | SOME | TODAY | SMALL |
| ME | ALL | WERE | LAST | BELIEVE |
| GO | DIE | THERE | ONCE | STAND |
| WE | NEW | WELL | SAYS | THINK |
| BE | BUY | THEY | SAME | ADVISE |
| AT | HOT | AFTER | THING | NEXT |
| US | ADD | BEEN | BUSINESS | WENT |
| SO | LIE | YEAR | AGAIN | UNTIL |
| ON | NOR | THEIR | CAME | POSSIBLE |
| IF | FOR | ABOUT | BACK | ALWAYS |
| BY | SAT | THAN | AGAINST | MATTER |
| GOT | NOW | COULD | NOTHING | GOING |
| DID | SEA | SUCH | THREE | FOUND |
| BIG | HAS | THOSE | PART | BEST |
| LOT | ASK | VERY | RIGHT | WATER |
| HAM | DUE | MORE | JUST | LESS |
| LET | OUT | BEFORE | BETWEEN | USED |
| SHE | SEE | WHAT | GOVERNMENT | HOUSE |
| TWO | WAY | SHALL | PRESENT | GENERAL |
| THE | TRY | GOOD | HOME | TAKEN |
| LOW | TEN | EVEN | CENT | FOUR |
| HAD | ITS | INTO | WHILE | SOON |
| BUT | OIL | WITH | BOTH | WHOSE |
| SAW | LAW | MUST | LEFT | SEVERAL |
| OUR | DAY | COME | TELL | HEREWITH |
| TOO | CAN | THEM | MORNING | SITUATION |
| HOW | BID | HAVE | THOUGHT | CONDITIONS |
| EAT | YES | THIS | CALL | LOVE |
| FEW | WAS | HERE | ALMOST | FRONT |
| WAR | YOU | WILL | ASKED | LARGE |
| HIM | CAR | FIRST | HAND | THOUGH |
| MAY | YET | WHICH | SERVICE | MIND |
| WHO | AIR | MADE | FIVE | KEEP |
| SAY | BAD | WORLD | MIGHT | MYSELF |
| FAR | OLD | MUCH | AMONG | NECESSARY |
| NET | USE | UPON | DEAR | WRONG |
| WHY | ANY | TIME | WHOLE | FULL |
| GET | MAN | SHOULD | CITY | BETTER |
| BIT | THAT | MAKE | WANT | ADVICE |

Figure 6.

This list of words makes excellent practice material; vary the order in which you use them so that they will not be unconsciously memorized. These words, with their variations and repetitions, are said to include more than half the words used in every-day English. Practice them until you recognize most of them by their complete sounds, instead of as a series of letters, especially if you want to receive with ease at high speeds.

to incur their scorn is to try to impress them with your "lightning speed," and then to request them to send more slowly when they come back at you at the same speed.

Stress your copying ability; never stress your sending ability. It should be obvious that if you try to send faster than you can receive, your ear will not recognize any mistakes which your hand may make.

Using the Key

Figure 7 shows the proper position of the hand, fingers and wrist when manipulating a telegraph or radio key. The forearm should rest naturally on the desk. It is preferable that the key be placed far enough back from the edge of the table (about 18 inches) that the elbow can rest on the table. Otherwise, pressure of the table edge on the arm will tend to hinder the circulation of the blood and weaken the ulnar nerve at a point where it is close to the surface, which in turn will tend to increase fatigue considerably.

The knob of the key is grasped lightly with the thumb along the edge; the index and third fingers rest on the top towards the front or far edge. The hand moves with a free up and down motion, the wrist acting as a fulcrum. The power must come entirely from the arm muscles. The third and index fingers will bend slightly during the sending but not because of deliberate effort to manipulate the finger muscles. Keep your finger muscles just tight enough to act as a "cushion" for the arm motion and let the slight movement of the fingers take care of itself. The key's spring is adjusted

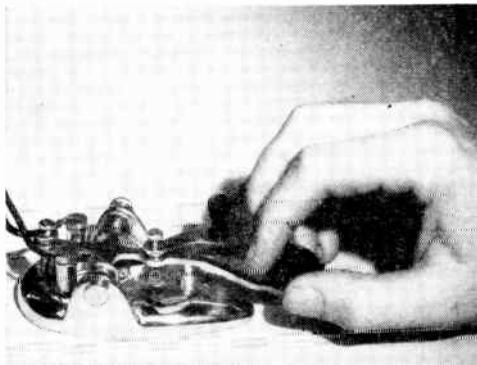

Figure 7.

PROPER POSITION OF FINGERS FOR OPERATING A TELEGRAPH KEY.

The fingers hold the knob and act as a cushion. The hand rests lightly on the key. The muscles of the forearm provide the power, the wrist acting as a fulcrum. The power should not come from the wrist, but rather from the forearm muscles.

to the individual wrist and should be neither too stiff nor too loose. Use a moderately stiff tension at first and gradually lighten it as you get more proficient. The separation between the contacts must be the proper amount for the desired speed, being somewhat under 1/16 inch for slow speeds and slightly closer together (about 1/32 inch) for faster speeds. Avoid extremes in either direction.

Do not allow the muscles of arm, wrist, or fingers to become tense. Send with a full, free arm movement. Avoid like the plague any finger motion other than the slight cushioning effect mentioned above.

Remember that you are using different muscles from those which you have used previously. Give them time to become used to the new demands which you put upon them.

Stick to the regular hand key for learning code. No other key is satisfactory for this purpose. Not until you have thoroughly mastered both sending and receiving at the maximum speed in which you are interested should you tackle any form of automatic or semi-automatic key such as the Vibroplex ("bug") or the "sideswiper."

Difficulties

Should you experience difficulty in increasing your code speed after you have once memorized the characters, there is no reason to become discouraged. It is more difficult for some people to learn code than for others, but there is no justification for the contention sometimes made that "some people just can't learn the code." It is not a matter of intelligence; so don't feel ashamed if you seem to experience a little more than the usual difficulty in learning code. Your reaction time may be a little slower or your coordination not so good. If this is the case, remember *you can still learn the code*. You may never learn to send and receive at 40 w.p.m., but you can learn sufficient speed for all non-commercial purposes and even for most commercial purposes if you have patience, and refuse to be discouraged by the fact that others seem to pick it up more rapidly.

Never write down dots and dashes to be translated later. If the alphabet has actually been mastered before hand, there will be no hesitation from failure to recognize most of the characters unless the sending speed is too great.

When the sending operator is sending just a bit too fast for you (the best speed for practice), you will occasionally miss a signal or a small group of them. When you do, leave a blank space; do not spend time futilely trying to recall it; dismiss it, and center attention on the next letter; otherwise you'll miss more. Do not ask the sender any questions until the transmission is finished.

Two or three w.p.m. over your comfortable speed is sufficient; do not let the sender go faster, or you will miss so much as to become discouraged. "Pushing" yourself moderately develops speed just as pushing your muscles develops physical strength.

To prevent guessing and get equal practice on the less common letters, depart occasionally from plain language material and use a jumble of letters in which the usually less commonly used letters predominate.

As mentioned before, many students put a greater space after the dash in the letter B than between other parts of the same letter so that it sounds like TS. C. F. Q. V. X. Y and Z often give similar trouble. Make a list of words or arbitrary combinations in which these letters predominate and practice them, both sending and receiving until they no longer give you trouble. Stop everything else and stick at them. So long as they give you trouble you are not ready for anything else.

Follow the same procedure with letters which you may tend to confuse such as F and L, which are often confused by beginners. Keep at it until you *always* get them right without having to stop *even an instant* to think about it.

Watch particularly the length of your dashes. They must be equivalent to three dots, neither more nor less. Avoid dragging them out or clipping them off. Non-uniform dashes are a sure sign of a poor operator.

If you do not instantly recognize the sound of any character, you have not learned it; go back and practice your alphabet further. You should never have to omit writing down every signal you hear except when the transmission is too fast for you.

Write down what you hear, not what you think it should be. It is surprising how often the word which you guess will be wrong.

While a slow learner can ultimately get his "13 per" by following the same learning method if he has perseverance, the following system of auxiliary practice oftentimes proves of great aid in increasing one's speed when progress by the usual method seems to have reached a temporary standstill. All that is required is the usual practice outfit plus an extra operator. This last item should be of good quality, guaranteed to pay proper attention to spacing.

Suppose we call the fellow at the key the teacher and the other fellow the student. Assume the usual positions but for the moment lay aside paper and pencil. Instead the student will read from a duplicate newspaper the same text that the operator is sending.

The teacher is to start sending at a rate just slower than the student's top speed judged by his last test. This will allow the student to follow accurately each letter as it is transmitted.

After a warming-up period of about one minute the sending speed is to be increased gradually but steadily and continued for a period of five minutes. An equal rest period is beneficial before the second session. Speed for the second period ought to be started at half-way between the original starting speed and the speed used at the end of the first period. Follow the same procedure for the second and third practice periods.

At the start of the third *reading* practice period the student should start copying immediately, using the *same text as before* at a speed just above his previous copying ability. It will be found that one session of the *reading* practice will for the time being increase the student's copying ability from 10 to 20%. The teacher should watch the student and not increase the sending speed too much above his copying ability as this brings about a condition of confusion and is more injurious than beneficial.

Copying Behind All good operators copy several words behind, that is, while one word is being received, they are writing down or typing, say, the fourth or fifth previous word. At first this is very difficult, but after sufficient practice it will be found actually to be *easier* than copying close up. It also results in more accurate copy and enables the receiving operator to capitalize and punctuate copy as he goes along. It is not recommended that the beginner attempt to do this until he can send and receive accurately and with ease at a speed of at least 12 words a minute.

It requires a considerable amount of training to dissociate the action of the subconscious mind from the direction of the conscious mind. It may help some in obtaining this training to write down two columns of short words. Spell

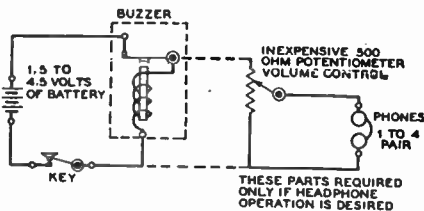

Figure 8.

THE SIMPLEST CODE PRACTICE SET CONSISTS OF A KEY AND BUZZER.

The buzzer is adjusted to give a steady, high pitched "whinc." If desired, the phones may be omitted, in which case the buzzer should be mounted firmly on a sounding board. Either crystal or magnetic carphones may be used. Phones should be connected in parallel, not series.

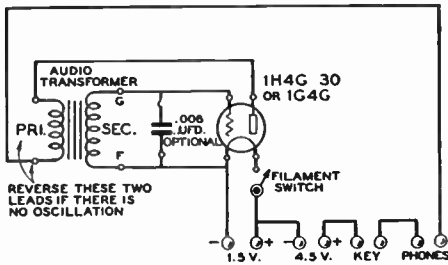

Figure 9.

SIMPLEST TYPE V.T. CODE PRACTICE OSCILLATOR.

Power is furnished by a dry cell and a $4\frac{1}{2}$ volt "G" battery. If the .006- μ fd. capacitor is omitted, a higher pitched note will result. The note may have too low a pitch even with the capacitor omitted, unless the smallest, cheapest audio transformer available is used. The earphones should be of the magnetic type, as plate current must flow through the earphones.

the first word in the first column out loud while writing down the first word in the second column. At first this will be a bit awkward, but you will rapidly gain facility with practice. Do the same with all the words, and then reverse columns.

Next try speaking aloud the words in the one column while writing those in the other column; then reverse columns.

After the foregoing can be done easily, try sending with your key the words in one column while spelling those in the other. It won't be easy at first, but it is well worth keeping after if you intend to develop any real code proficiency. Do *not* attempt to catch up. There is a natural tendency to close up the gap, and you must train yourself to overcome this.

Next have your code companion send you a word either from a list or from straight text; do not write it down yet. Now have him send the next word; *after* receiving this second word, write the first word. After receiving the third word, write the second word; and so on. Never mind how slowly you must go, even if it is only two or three words per minute. *Stay behind.*

It will probably take quite a number of practice sessions before you can do this with any facility. After it is relatively easy, then try staying two words behind; keep this up until it is easy. Then try three words, four words, and five words. The more you practice keeping received material in mind, the easier it will be to stay behind. It will be found easier at first to copy material with which one is fairly familiar, then gradually switch to less familiar material.

Automatic Code Machines

The two practice sets which are described in this chapter are of most value

when you have someone with whom to practice. Automatic code machines are not recommended to anyone who can possibly obtain a companion with whom to practice, someone who is also interested in learning the code. If you are unable to enlist a code partner and have to practice by yourself, the best way to get receiving practice is by the use of a tape machine (automatic code sending machine) with several practice tapes. Or you can use a set of phonograph code practice records. The records are of use only if you have a phonograph whose turntable speed is readily adjustable. The tape machine can be rented by the month for a reasonable fee.

Once you can copy about 10 w.p.m. you can also get receiving practice by listening to slow sending stations on your receiver. Many amateur stations send slowly particularly when working far distant stations. When receiving conditions are particularly poor many commercial stations also send slowly, sometimes repeating every word. Until you can copy around 10 w.p.m. your receiver isn't of much use, and either another operator or a machine or records is necessary for getting receiving practice after you have once memorized the code.

Code Practice Sets

If you don't feel too foolish doing it, you can secure a measure of code practice with the help of a partner by sending "dit-dah" messages to each other while riding to work, eating lunch, etc. It is better, however, to use a buzzer or code practice oscillator in conjunction with a regular telegraph key.

As a good key may be considered an investment, it is wise to make a well-made key your first purchase. Regardless of what type code practice set you use, you will need a key, and later on you will need one to key your transmitter. If you get a good key to begin with, you won't have to buy another one later.

The key should be rugged and have fairly heavy contacts. Not only will the key stand up better, but such a key will contribute to the "heavy" type of sending so desirable for radio work. Morse (telegraph) operators use a "light" style of sending and can send somewhat faster when using this light touch. But, in radio work static and interference are often present, and a slightly heavier dot is desirable. If you use a husky key, you will find yourself automatically sending in this manner.

Special types of keys, especially the semi-automatic "bug" type, should be left alone by the beginner. Mastery of the standard type key should come first. The correct manner of using such a key was discussed above.

To generate a tone simulating a code signal as heard on a receiver, either a mechanical buzzer or an audio oscillator (howler) may be used. The buzzer may be mounted on a sounding board in order to increase the fullness and volume of the tone; or it may be mounted in a cardboard box stuffed with cotton in order to silence it, and the signal fed into a pair of earphones. The latter method makes it possible to practice without annoying other people as much, though the clicking of the key will no doubt still bother someone in the same room.

A buzzer-type code practice circuit is shown in Figure 8. The buzzer should be of good quality or it will change tone during keying; also the contacts on a cheap buzzer will soon wear out. The volume control, however (used only for headphone operation), may be of the least expensive type available, as it will not be subjected to constant adjustment as in a radio receiver. For maximum buzzer and battery life, use the least amount of voltage that will provide stable operation of the buzzer and sufficient volume. Some buzzers operate stably on $1\frac{1}{2}$ volts, while others require more.

A vacuum tube audio oscillator makes the best code practice oscillator, as there is no sound except that generated in the earphones, and the note more closely resembles that of a radio signal. Such a code practice oscillator is diagrammed schematically in Figure 9. The parts are all screwed to a wood board, and connections made to the phones and batteries by means of Fahnestock clips, as illustrated in Figure 10. A single dry cell supplies filament power, and a $4\frac{1}{2}$ -volt C battery supplies plate voltage. Both filament and plate current are very low, and long battery life can be expected. The vacuum tube is the biggest item from the

standpoint of cost, but it can later be used in a field-strength meter with the same batteries supplying power. Such a device is very handy to have around a station, as it can be used for neutralizing, checking the radiation characteristics of your antenna, etc.

A 1H4G, 30, or 1G4G may be used with the same results. The first two are 2-volt tubes, but will work satisfactorily on a 1.5-volt filament battery because of the very small amount of emission required for the low value of plate current drawn. Be sure to get a socket that will accommodate the particular tube you buy.

Oddly, it is important that the audio transformer used *not* be of good quality; if it is, it may have so much inductance that it will be impossible to get a sufficiently high pitched note. If you buy a new transformer, get the smallest, cheapest one you can buy. The old transformers used in moderately priced sets of 12 years ago are fine for the purpose, and can oftentimes be picked up for a small fraction of a dollar at the "junk parts" stores. The turns ratio is not important; it may be anything between 1.5/1 and 6/1.

The tone may be varied by substituting a larger (.025 μ fd.) or smaller (.001 μ fd.) capacitor for the .006 μ fd. capacitor shown in the diagram. A lower capacitance capacitor will raise the pitch of the note somewhat and vice versa. The highest pitch that can be obtained with a given transformer will result when the capacitor is left out of the circuit altogether. Lowering the plate voltage to 3 volts will also have a noticeable effect upon the pitch of the note. If the particular transformer you use does not provide a note of a pitch that suits you, the pitch can be altered in this manner.

Figure 10.
THE CIRCUIT OF FIGURE 9
IS USED IN THIS BATTERY
OPERATED CODE OSCILLA-
TOR.

A tube and audio transformer essentially comprise the oscillator. Fahnestock clips screwed to the base-board are used to make connections to batteries, key, and phones.

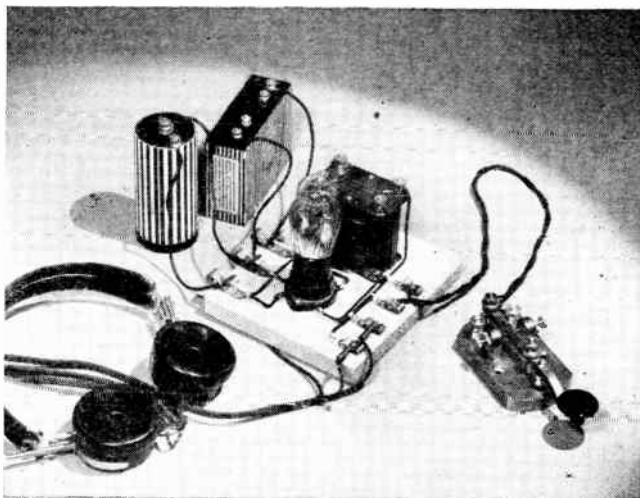



Figure 11.
De luxe high power amateur stations such as that of W9TJ are not so numerous as are less pretentious installations, but nevertheless there are several hundred throughout the U.S.A.

Using a 1H4G, a standard no. 6 dry cell for filament power, and a 4½-volt C battery for plate power, the oscillator may be constructed for about \$2.00, exclusive of key and ear-phones. The filament battery life will be about 700 hours, the plate battery life considerably more. This set has an advantage over an a.c. operated practice set in that it can be used where there is no 110-volt power available; you can take it on a Sunday picnic if you wish. Also, there is no danger of electrical shock.

The carrier-operated keying monitor described in Chapter 24 also may be used for

code practice, and is recommended where loud speaker operation is desired, such as for group practice.

A regenerative or other oscillating receiver never should be used for code practice by keying its "howl." We advise against this because such a receiver may radiate the keyed signals and constitute an illegal transmission.

For the same reason, no unlicensed transmitter, however low its output power, should ever be used to generate code practice oscillations. Nor should code practice signals be transmitted by radio except by licensed stations.

| | | | | | |
|-------|-------|-------|-------|-------|-------|
| KYKXQ | FVTGB | 35476 | 3V3V4 | QMWNE | SGRT |
| LUDHW | YHNUJ | 00572 | B6B67 | RBTVY | SDHG |
| HSUSK | MUKIL | 72649 | 4V3B7 | UXIZO | SWYF |
| WKSOD | PLOKM | 99736 | 5HSOφ | ALSKD | ACVHR |
| WOSMF | IJNUH | 26294 | W2ATF | JFHGT | WGTX |
| KJHGF | BYVGT | 93856 | K6BZQ | PZOXI | FQST |
| ZQZYX | FCRDX | 22557 | FA8G6 | CUVYB | WNE |
| OPGJU | ESZWA | 37495 | 1φPM4 | TNRME | WGFF |
| ASDFG | ?.,,? | 55100 | 45XVG | WQLAK | SUEH1 |
| QWERT | .,.,. | 10000 | 86QHK | PGOFI | SGYOS |
| ZXCVB | ??.,, | 00009 | 86QHC | ISUAT | WGCEM |
| POIUY | .,,? | 26483 | LKJ55 | QBWNE | GAHEU |
| LKJHG | 12345 | 27385 | WMS7G | RNTBY | AOEHT |
| MNBVC | 67890 | 28465 | 36Y94 | OFUXY | WGKFQ |
| QAZWS | 05647 | 37495 | 117GT | YATSR | HSGEY |
| XEDCR | 28596 | 92220 | 6SQ7G | EVRNY | SYSGE |

The above list of jumbled characters (similar to many cipher codes) will be found handy for accuracy practice; no characters can be guessed as when working from straight text. φ is used to indicate zero in the groups containing both letters and figures.

Fundamental Radio and Electrical Theory

Constitution of Matter All matter is made up of approximately 92 fundamental constituents commonly called *elements*. These elements can exist either in the free state such as iron, oxygen, carbon, copper, tungsten, and aluminum, or in chemical unions commonly called *compounds*. The smallest unit which still retains all the original characteristics of an element is the *atom*.

Combinations of atoms, or subdivisions of compounds, result in another fundamental unit, the *molecule*. The molecule is the smallest unit of any compound. All reactive elements when in the gaseous state also exist in the molecular form, made up of two or more atoms. The nonreactive or noble gaseous elements helium, neon, argon, krypton, xenon, and radon are the only gaseous elements that ever exist in a truly atomic state.

The Atom An atom is an extremely small unit of matter—there are literally billions of them making up so small a piece of material as a speck of dust. But to understand the basic theory of electricity and hence of radio, we must go further and divide the atom into its main components, a positively charged nucleus and a cloud of negatively charged particles that surround the nucleus. These particles, swirling around the nucleus in elliptical orbits at an incredible rate of speed, are called orbital electrons.

It is upon the behavior of these electrons that depends the study of electricity and radio, as well as allied sciences. Actually it is possible to subdivide the nucleus of the atom into other particles: the proton, nuclear electron, negatron, positron, and neutron; but this further subdivision can be left to quantum mechanics and atomic physics. As far as radio theory is concerned it is only necessary for the

reader to think of the normal atom as being composed of a nucleus having a net positive charge that is exactly neutralized by the one or more orbital electrons surrounding it.

The atoms of different elements differ in respect to the charge on the positive nucleus and in the number of electrons revolving around this charge. They range all the way from hydrogen, having a net charge of one on the nucleus and one orbital electron, to uranium with a net charge of 92, and 92 orbital electrons. The number of orbital electrons is called the *atomic number* of the element.

From the above it must not be thought that the electrons revolve in a haphazard manner around the nucleus. Rather, the electrons in an element having a large atomic number are grouped into "shells" having a definite number of electrons. In the first shell there is room for only 2 electrons; in the next, 2; the next, 6; then 2, 6, 10, 2, 6, 10, etc., until a total of 92 electrons can be accommodated in the heaviest atom, that of uranium. The only atoms in which these shells are completely filled are those of the inert or noble gases mentioned before; all other elements have one or more uncompleted shells of electrons. If the uncompleted shell is nearly empty, the element is *metallic* in character, being most metallic when there is only one electron in the outer shell. If the incomplete shell lacks only one or two electrons, the element is usually *non-metallic*. Elements with a shell about half completed will exhibit both non-metallic and metallic character; carbon, silicon, and arsenic are examples of this type of element.

In metallic elements these outer-shell electrons are rather loosely held. Consequently, there is a continuous helter-skelter movement of these electrons and a continual shifting from one atom to another. The electrons which move about in a substance are called *free*

electrons, and it is the ability of these electrons to drift from atom to atom which makes possible the *electric current*.

If the free electrons are numerous and loosely held, the element is a good conductor. On the other hand, if there are few free electrons, as is the case when the electrons in an outer shell are tightly held, the element is a poor conductor. If there are virtually no free electrons, as a result of the outer shell electrons being tightly held, the element is a good insulator.

Electromotive Force: The free electrons in a conductor move constantly about and change their position in a haphazard manner. To produce a drift of electrons or *electric current*, along a wire it is necessary that there be a difference in pressure or *potential* between the two ends of the wire. This *potential difference* can be produced by connecting a battery to the ends of the wire.

As will be explained later, there is an excess of electrons at the negative terminal of a battery and a deficiency of electrons at the positive terminal, due to chemical action. When the battery is connected to the wire, the deficient atoms at the positive terminal attract free electrons from the wire in order to become neutral. The attracting of electrons continues through the wire, and finally the excess electrons at the negative terminal of the battery are attracted by the positively charged atoms at the end of the wire. The same result would be obtained if the wire were connected between the terminals of a generator.

Thus it is seen that a potential difference is the result of a difference in the number of electrons between the two (or more) points in question. The force or pressure due to a potential difference is termed the *electromotive force*, usually abbreviated *e.m.f.* or *E.M.F.* It is expressed in units called *volts*.

It should be noted that for there to be a potential difference between two bodies or points it is not necessary that one have a positive charge and the other a negative charge. If two bodies each have a negative charge, but one more negative than the other, the one with the lesser negative charge will act as though it were positively charged *with respect to the other body*. It is the *algebraic* potential difference that determines the force with which electrons are attracted or repulsed, the potential of the earth being taken as the zero reference point.

The Electric Current The flow of electrons along a conductor due to the application of an electromotive force constitutes an electric current. This drift

is in addition to the irregular movement of the electrons. However, it must not be thought that each free electron travels from one end of the circuit to the other. On the contrary, each free electron travels only a short distance before colliding with an atom; this collision generally knocking off one or more electrons from the atom, which in turn move a short distance and collide with other atoms, knocking off other electrons. Thus, in the general drift of electrons along a wire carrying an electric current, each electron travels only a short distance and the excess of electrons at one end and the deficiency at the other are balanced by the source of the e.m.f. When this source is removed the state of normalcy returns; there is still the rapid interchange of free electrons between atoms, but there is no general trend or "net movement" in either one direction or the other.

There are two units of measurement associated with current, and they are often confused. The *rate of flow* of electricity is stated in *amperes*. The unit of *quantity* is the *coulomb*. A coulomb is equal to 6.28×10^{18} electrons, and when this quantity of electrons flows by a given point in every second, a current of one ampere is said to be flowing. An ampere is equal to one coulomb per second; a coulomb is, conversely, equal to one ampere-second. Thus we see that *coulomb* indicates *amount*, and *ampere* indicates *rate of flow*.

Many textbooks speak of current flow as being from the positive terminal of the e.m.f. source through the conductor to the negative terminal. Nevertheless, it has long been an established fact that the current flow in a metallic conductor is the *electronic* flow from the negative terminal of the source of voltage through the conductor to the positive terminal. This is easily seen from a study of the foregoing explanation of the subject. The only exceptions to the electronic direction of flow occur in gaseous and electrolytic conductors where the flow of positive ions toward the cathode or negative electrode constitutes a positive flow in the opposite direction to the electronic flow. (An ion is an atom, molecule, or particle which either lacks one or more electrons, or else has an excess of one or more electrons.)

In radio work the terms "electron flow" and "current" are becoming accepted as being synonymous, but the older terminology is still accepted in the electrical (industrial) field. Because of the confusion this sometimes causes, it is safest to refer to the direction of electron flow rather than to the direction of the "current."

Throughout this book electron flow and current flow will be considered as one and the same thing.

Resistance The flow of current in a material depends upon the ease with which electrons can be detached from the atoms of the material and upon its molecular structure. In other words, the easier it is to detach electrons from the atoms the more free electrons there will be to contribute to the flow of current, and the fewer collisions that occur between free electrons and atoms the greater will be the total electron flow.

The opposition to a steady electron flow is called the *resistance* of a material, and is one of its physical properties. The resistance of a uniform length of a given substance is directly proportional to its length and specific resistance, and inversely proportional to its cross-sectional area. A wire with a certain resistance for a given length will have twice as much resistance if the length of the wire is doubled. For a given length, doubling the cross-sectional area of the wire will halve the resistance.

The resistance also depends upon temperature, increasing with increases in temperature for most substances (including most metals), due to increased electron acceleration and hence a greater number of impacts between electrons and atoms. However, in the case of some substances such as carbon and glass the temperature coefficient is negative, which means that the resistance decreases as the temperature increases. This is also true of electrolytes. The temperature may be raised by the external application of heat, or by the flow of the current itself. In the latter case, this is due to the fact that heat is generated when the electrons and atoms collide. (See *Heating Effect*.)

The unit of resistance is the *ohm*. Every substance has a *specific resistance*, usually expressed as *ohms per mil-foot*, which is determined by the material's molecular structure and temperature. A mil-foot is a piece of material one circular mil in area and one foot long.

Conductors and Insulators In the molecular structure of many materials such as glass, porcelain, and mica all electrons are tightly held within their orbits and there are comparatively few free electrons. This type of substance will conduct an electric current only with great difficulty and is known as an *insulator*. An insulator is said to have a high electrical *resistance*.

On the other hand, materials that have a large number of free electrons are known as *conductors*. Most metals, those elements which have only one or two electrons in their outer shell, are good conductors. Silver, copper, and aluminum, in that order, are the best of the common conductors and are said to have the greatest *conductivity*, or lowest resistance to the flow of an electric current.

Fundamental Electrical Units These units are the *volt*, the *ampere*, and the *ohm*.

They were mentioned in the preceding paragraphs, but were not completely defined.

The fundamental unit of *current*, or *rate of flow* of electricity is the ampere. A current of one ampere will deposit silver from a specified solution of silver nitrate at a rate of 1.118 milligrams per second.

The international standard for the ohm is the resistance offered by a column of mercury at 0° C., 14.4521 grams in mass, of constant cross-sectional area and 106.300 centimeters in length. The expression *megohm* (1,000,000 ohms) is also sometimes used when speaking of very large values of resistance.

A volt is the e.m.f. that will produce a current of one ampere through a resistance of one ohm. The standard of electromotive force is the Weston cell which at 20° C. has a potential of 1.0183 volts across its terminals. This cell is used only for reference purposes, since only an infinitesimal amount of current may be drawn from it without disturbing its characteristics.

Ohm's Law The relationship between the electromotive force (voltage), the flow of current (amperes), and the resistance which impedes the flow of current (ohms), is very clearly expressed in a simple but highly valuable law known as *Ohm's law*.



Figure 1.
SIMPLE SERIES CIRCUITS.

At "A" the battery is in series with a single resistance. At "B" the battery is in series with two resistors, the resistors themselves being in series. The arrows indicate the direction of electron flow.

Figure 2.
SIMPLE PARALLEL CIRCUIT.

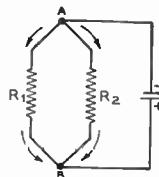

The two resistors, R_1 and R_2 are said to be in parallel, because the current divides between them. An electron leaving point A goes through either R_1 or R_2 , but not both, to get to the positive terminal of the battery.

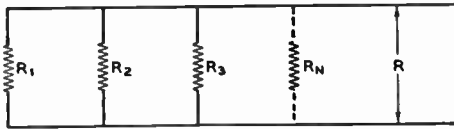

Figure 3. SEVERAL RESISTORS IN PARALLEL.

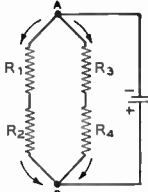

Figure 4. SERIES PARALLEL CIRCUIT.

In this arrangement, both series and parallel connections are employed.

This law states that the current in amperes is equal to the voltage in volts divided by the resistance in ohms. Expressed as an equation:

$$I = \frac{E}{R}$$

If the voltage (E) and resistance (R) are known, the current (I) can be readily found. If the voltage and current are known, and the resistance is unknown, the resistance (R) is equal to $\frac{E}{I}$. When the voltage is the unknown

quantity, it can be found by multiplying $I \times R$. These three equations are all secured from the original by simple transposition. The expressions are here repeated for quick reference:

$$I = \frac{E}{R} \quad R = \frac{E}{I} \quad E = IR$$

where I is the current in amperes,
R is the resistance in ohms,
E is the electromotive force in volts.

Applications of Ohm's Law All electrical circuits fall into one of three classes: series circuits, parallel circuits, and series-parallel circuits. A series circuit is one in which the current flows in a single continuous path and is of the same value at every point in the circuit. In a parallel circuit there are two or more current paths between two points in the circuit, as shown in Figure 2. Here the current divides at A, part going through R_1 and part through R_2 , and combines at B to return to the battery. Figure 4 shows a series-parallel circuit. There are two paths between points A and B as in the parallel circuit, and in addition there are two resist-

ances in series in each branch of the parallel combination. Two other examples of series-parallel arrangements appear in Figure 5. The way in which the current splits to flow through the parallel branches is shown by the arrows.

In every circuit, each of the parts has some resistance: the batteries or generator, the connecting conductors, and the apparatus itself. Thus, if each part has some resistance, no matter how little, and a current is flowing through it, there will be a voltage drop across it. In other words, there will be a potential difference between the two ends of the circuit element in question. This drop in voltage is equal to the product of the current and the resistance, hence it is called the IR drop.

The source of voltage has an internal resistance, and when connected into a circuit so that current flows, there will be an IR drop in the source just as in every other part of the circuit. Thus, if the terminal voltage of the source could be measured in a way that would cause no current to flow, it would be found to be more than the voltage measured when a current flows by the amount of the IR drop in the source. The voltage measured with no current flowing is termed the *no load* voltage; that measured with current flowing is the *load* voltage. It is apparent that a voltage source having a low internal resistance is most desirable, in order that the internal IR drop will be as small as possible, thereby making the load voltage more nearly equal to the no load voltage.

Resistances in Series The current flowing in a series circuit is equal to the voltage impressed divided by the total resistance across which the voltage is impressed. Since the same current flows through every part of the circuit, it is merely necessary to add all the individual resistances to obtain

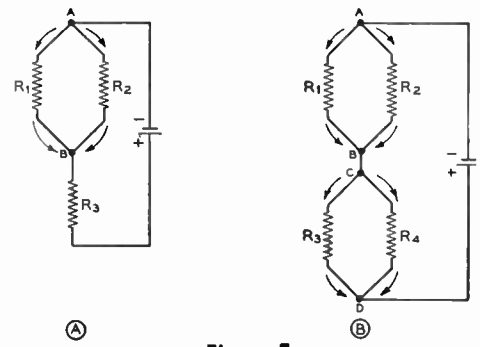

Figure 5. OTHER COMMON SERIES-PARALLEL CIRCUITS.

the total resistance. Expressed as a formula:

$$R_{\text{total}} = R_1 + R_2 + R_3 + \dots + R_N$$

Of course, if the resistances happened to be all of the same value, the total resistance would be the resistance of one multiplied by the number in the circuit.

Resistances in Parallel Consider two resistors, one of 100 ohms and one of 10 ohms, connected in parallel as in

Figure 2, with a voltage of 10 volts applied across the combination. The same voltage is across each resistor, so the current through each can be easily calculated.

$$I = \frac{E}{R}$$

$$E = 10 \text{ volts}$$

$$R = 100 \text{ ohms}$$

$$I = \frac{10}{100} = 0.1 \text{ ampere}$$

$$E = 10 \text{ volts}$$

$$R = 10 \text{ ohms}$$

$$I = \frac{10}{10} = 1.0 \text{ ampere}$$

Until it divides at A, the entire current of 1.1 amperes is flowing through the conductor from the battery, and again from B through the conductor to the battery. Since this is more current than flows through the smaller resistor it is evident that the resistance of the parallel combination must be less than 10 ohms, the resistance of the smaller resistor. We can find this value by applying Ohm's law.

$$R = \frac{E}{I}$$

$$E = 10 \text{ volts}$$

$$I = 1.1 \text{ amperes}$$

$$R = \frac{10}{1.1} = 9.09 \text{ ohms}$$

The resistance of the parallel combination is 9.09 ohms.

Mathematically, we can derive a simple formula for finding the effective resistance of two resistors connected in parallel. This formula is:

$$R = \frac{R_1 \times R_2}{R_1 + R_2}$$

where R is the unknown resistance,
 R_1 is the resistance of the first resistor,
 R_2 is the resistance of the second resistor.

If the effective value required is known, and it is desired to connect one unknown resistor in parallel with one of known value, to obtain this unknown value the following transposition of the above formula will simplify the problem:

$$R_2 = \frac{R_1 \times R}{R_1 - R}$$

where R is the effective value required,
 R_1 is the known resistor,
 R_2 is the value of the unknown resistance necessary to give R when in parallel with R_1 .

The resultant value of placing a number of unlike resistors in parallel is equal to the reciprocal of the sum of the reciprocals of the various resistors. This can be expressed as:

$$R = \frac{1}{\frac{1}{R_1} + \frac{1}{R_2} + \frac{1}{R_3} + \dots + \frac{1}{R_n}}$$

The effective value of placing any number of unlike resistors in parallel can be determined from the above formula. However, it is commonly used only when there are three or more resistors under consideration, since the simplified formula given at the top of this column is more convenient when only two resistors are being used.

When two or more resistances of the same value are placed in parallel, the effective resistance of the paralleled resistors is equal to the value of one of the resistors divided by the number of resistors in parallel.

The effective value of resistance of two or more resistors connected in parallel is *always* less than the value of the lowest resistance in the combination. It is well to bear this simple rule in mind, as it will assist greatly in approximating the value of paralleled resistors.

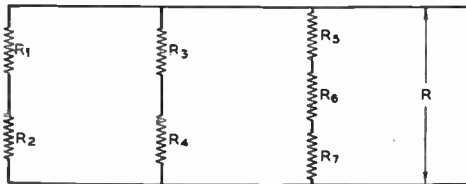

Figure 6.
RESISTORS IN SERIES-PARALLEL.

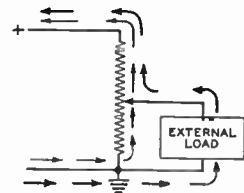

Figure 7.
Indicating flow of electrons through a tapped voltage divider to an external load.

Shunts When a voltage is applied to a circuit consisting of two or more resistances in parallel the resulting current divides itself among the paths in inverse proportion to the resistance of each path. With respect to one of the elements those connected in parallel with it are said to *shunt* it.

An example of a shunt which is of particular interest is the use of a resistance to shunt an ammeter or milliammeter (a device for measuring current) so that part of the current in the circuit will be bypassed around the meter. By this means the range of a meter may be greatly extended. Multiplying the range by powers of 10 makes it possible to use the original calibration scale without having to perform calculations in taking readings.

To calculate the amount of resistance required in a given case, the basic form of Ohm's law can be used. However, the following formula (derived from Ohm's law) simplifies the calculations:

$$R = \frac{R_m \times I_m}{I - I_m}$$

where R = resistance of shunt in ohms,
 R_m = resistance of meter in ohms,
 I_m = full scale current for meter,
 I = full scale current for new calibration.

Resistances in Series-Parallel To find the total resistance of several resistors connected in series-parallel, it is usually easiest to apply either the formula for series resistors or the parallel resistor formula first, in order to reduce the original arrangement to a simpler one. For instance, in Figure 4 the series resistors should be added in each branch, then there will be but two resistors in parallel to be calculated. Similarly in Figure 6, although here there will be three parallel resistors after adding the series resistors in each branch. In Figure 5 the paralleled resistors should be reduced to the equivalent series value, and then the series resistance values can be added.

Resistances in series-parallel can be solved by combining the series and parallel formulas into one similar to the following (refer to Figure 6):

$$R = \frac{1}{\frac{1}{R_1 + R_2} + \frac{1}{R_3 + R_4} + \frac{1}{R_5 + R_6 + R_7}}$$

Voltage Dividers A voltage divider is exactly what its name implies: a resistor or a series of resistors connected across a source of voltage from which various lesser values of voltage may be obtained by connection to various points along the resistor.

A voltage divider serves a most useful purpose in a radio receiver, transmitter or amplifier, because it offers a simple means of obtaining plate, screen, and bias voltages of different values from a common power supply source. It may also be used to obtain very low voltages of the order of .01 to .001 volt with a high degree of accuracy, even though a means of measuring such voltages is lacking. The procedure for making these measurements can best be given in the following example:

Assume that an accurately calibrated voltmeter reading from 0 to 150 volts is available, and that the source of voltage is exactly 100 volts. This 100 volts is then impressed through a resistance of exactly 1,000 ohms. It will, then, be found that the voltage along various points on the resistor, with respect to the grounded end, is exactly proportional to the resistance at that point. From Ohm's law, the current would be 0.1 ampere; this current remains unchanged since the original value of resistance (1,000 ohms) and the voltage source (100 volts) are unchanged. Thus, at a 500-ohm point on the resistor (half its entire resistance), the voltage will likewise be halved or reduced to 50 volts.

The equation (E = I × R) gives the proof: E = 500 × 0.1 = 50. At the point of 250 ohms on the resistor, the voltage will be one-fourth the total value, or 25 volts (E = 250 × 0.1 = 25). Continuing with this process, a point can be found where the resistance measures exactly 1 ohm and where the voltage equals 0.1 volt. It is, therefore, obvious that if the original source of voltage and the resistance can be measured, it is a simple matter to predetermine the voltage at any point along the resistor, provided that the current remains constant, and provided that no current is taken

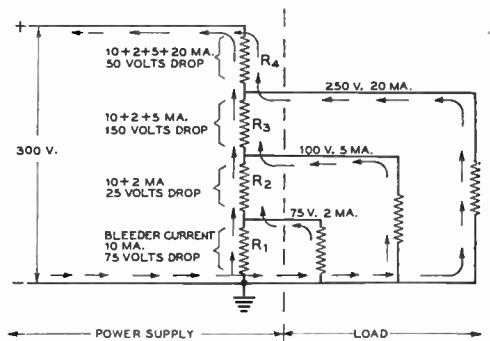

Figure 8.
COMBINED BLEEDER RESISTOR AND VOLTAGE DIVIDER.
 The method of calculating the values of the resistors (or resistance between taps) is covered in the text.

from the tap-on point unless this current is taken into consideration.

Design of Voltage Dividers Proper design of a voltage divider for any type of radio equipment is a relatively simple matter. The first consideration is the amount of "bleeder current" to be drawn. In addition, it is also necessary that the desired voltage and the exact current at each tap on the voltage divider be known.

Figure 7 illustrates the flow of current in a simple voltage divider and load circuit. The light arrows indicate the flow of bleeder current, while the heavy arrows indicate the flow of the load current. The design of a combined bleeder resistor and voltage divider, such as is commonly used in radio equipment, is illustrated in the following example.

A power supply delivers 300 volts and is conservatively rated to supply all needed current for the receiver and still allow a bleeder current of 10 milliamperes. The following voltages are wanted: 75 volts at 2 milliamperes for the detector tube, 100 volts at 5 milliamperes for the screens of the tubes, and 250 volts at 20 milliamperes for the plates of the tubes. The required voltage drop across R_1 is 75 volts, across R_2 25 volts, across R_3 150 volts, and across R_4 it is 50 volts. These values are shown in the diagram of Figure 8. The respective current values are also indicated. Applying Ohm's law:

$$R_1 = \frac{E}{I} = \frac{75}{.01} = 7,500 \text{ ohms.}$$

$$R_2 = \frac{E}{I} = \frac{25}{.012} = 2,083 \text{ ohms.}$$

$$R_3 = \frac{E}{I} = \frac{150}{.017} = 8,823 \text{ ohms.}$$

$$R_4 = \frac{E}{I} = \frac{50}{.037} = 1,351 \text{ ohms.}$$

$$R_{\text{Total}} = 7,500 + 2,083 + 8,823 + 1,351 = 19,757 \text{ ohms.}$$

A 20,000-ohm resistor with three sliding taps will be of the approximately correct size, and would ordinarily be used because of the difficulty in securing four separate resistors of the exact odd values indicated, and because no adjustment would be possible to compensate for any slight error in estimating the probable currents through the various taps.

When the sliders on the resistor once are set to the proper point, as in the above example, the voltages will remain constant at the values shown as long as the current remains a constant value.

Disadvantages of Voltage Dividers One of the serious disadvantages of the voltage divider becomes evident when the current drawn from one of the

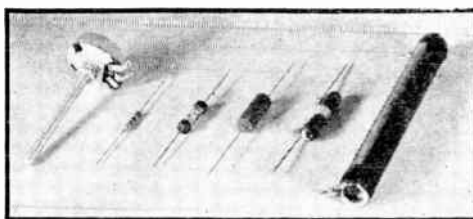

Figure 9.
**COMMON TYPES OF RESISTORS
USED IN RADIO CONSTRUCTION.**

To the left is a variable resistor (potentiometer). The next two are insulated type carbon resistors, the larger being rated to dissipate more power safely. The next two are small wire-wound resistors, while the resistor to the right is a large (75 watt) resistor of the voltage divider variety. The turns of the latter are exposed so as to enable contact to any portion of the resistance element by means of one or more "slider" type connector clamps.

taps changes. It is obvious that the voltage drops are interdependent and, in turn, the individual drops are in proportion to the current which flows through the respective sections of the divider resistor. The only remedy lies in providing a heavy steady bleeder current in order to make the individual currents so small a part of the total current that any change in current will result in only a slight change in voltage. This can seldom be realized in practice because of the excessive values of bleeder current which would be required.

Kirchhoff's Laws Ohm's law is all that is necessary to calculate the values in simple circuits, such as the preceding examples; but in more complex problems, involving more than one voltage in the same closed circuit, the use of *Kirchhoff's laws* will greatly simplify the calculations. These laws are merely rules for applying Ohm's law.

The first law states that at any point in a circuit the current flowing toward the point is equal to the current flowing from it. In other words, if currents flowing to the point are considered positive, and those flowing from the point are considered negative, their sum—taking signs into account—is zero. Such a sum is known as an *algebraic sum*.

Figure 10 illustrates this first law. It is readily seen that 4 amperes flow toward point A, and 2 amperes flow away through the two 5-ohm resistors in series, while the remaining 2 amperes flow away through the 10-ohm resistor. Thus, there are 4 amperes flowing to point A and 4 amperes flowing away from the point. If R is the effective resistance of the network, $R_1 = 10$ ohms, $R_2 = 5$ ohms, $R_3 =$

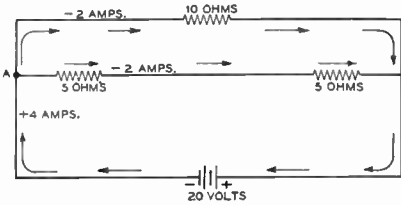

Figure 10.
ILLUSTRATING KIRCHHOFF'S FIRST LAW.
The current flowing towards point "A" is equal to the current flowing away from point "A."

5 ohms, and $E = 20$ volts, we can set up the following equation:

$$\frac{E}{R} - \frac{E}{R_1} - \frac{E}{R_2 + R_3} = 0$$

$$\frac{20}{5} - \frac{20}{10} - \frac{20}{5 + 5} = 0$$

$$4 - 2 - 2 = 0$$

Kirchhoff's second law states that in any closed path in a network the sum of the IR drops must equal the sum of the applied e.m.f.s, or, the algebraic sum of the IR drops and the applied e.m.f.s in any closed path in a network is zero. The applied e.m.f.s are considered positive, while IR drops taken in the direction of current flow (including the internal drop of the source) are considered negative.

Power in Resistive Circuits

In order to cause electrons to flow through a conductor, constituting a current flow, it is necessary to apply an electromotive force (voltage) across the circuit. Less power is expended in creating a small current flow through a given resistance than in creating a large one; so it is necessary to have a unit of power as a reference.

The unit of electrical power is the *watt*, which is the amount of power used when an e.m.f. of 1 volt forces a current of 1 ampere through a circuit. The power in a resistive circuit is equal to the product of the voltage applied across, and the current flowing in, a given circuit. Hence: P (watts) = E (volts) \times I (amperes).

Since it is often convenient to express power in terms of the resistance of the circuit and the current flowing through it, a substitution of IR for E ($E = IR$) in the above formula gives: $P = IR \times I$ or $P = I^2R$. In terms of voltage and resistance, $P = E^2/R$. Here, $I = E/R$ and when this is substituted for I the original formula becomes $P = E \times E/R$, or $P = E^2/R$. To repeat these three expressions:

$$P = EI, \quad P = I^2R, \quad \text{and} \quad P = E^2/R,$$

Figure 11.

To dissipate the greatest amount of power in the load, R_L (the load resistance) should be equal to R_I (the internal resistance of the battery).



where P is the power in watts,
 E is the electromotive force in volts,
 and
 I is the current in amperes.

To apply the above equations to a typical problem: The voltage drop across a cathode resistor in a power amplifier stage is 50 volts; the plate current flowing through the resistor is 150 milliamperes. The number of watts the resistor will be required to dissipate is found from the formula: $P = EI$, or $50 \times .150 = 7.5$ watts (.150 amperes is equal to 150 milliamperes). From the foregoing it is seen that a 7.5-watt resistor will safely carry the required current, yet a 10- or 20-watt resistor would ordinarily be used to provide a safety factor.

In another problem, the conditions being similar to those above, but with the resistance and current being the *known* factors, the solution is obtained as follows: $P = I^2R = .0225 \times 333.33 = 7.5$. If only the voltage and resistance are known, $P = E^2/R = 2500/333.33 = 7.5$ watts. It is seen that all three equations give the same result; the selection of the particular equation depends only upon the known factors.

Heating Effect

Heat is generated when a source of voltage causes a current to flow through a resistor (or, for that matter, through any conductor). As explained earlier, this is due to the fact that heat is given off when free electrons collide with the atoms of the material. More heat is generated in high resistance materials than in those of low resistance, since the free electrons must strike the atoms harder to knock off other electrons. As the heating effect is a function of the current flowing and the resistance of the circuit, the power expended in heat is given by the second formula: $P = I^2R$.

Load Matching

To develop the maximum power in the load upon a source of e.m.f., it is necessary to make the resistance (or impedance) of the load equal to the internal resistance (or impedance) of the source. This can best be illustrated by Figure 11. Assume R_I is the internal resistance of the source and has a value of 1 ohm, while the source E has a no-load voltage of 2 volts. If the load resistance R_L is also 1 ohm, the current is:

$$I = \frac{E}{R_I + R_L} = \frac{2}{1 + 1} = 1 \text{ ampere.}$$

The total power dissipated is:

$$P = EI = 2 \times 1 = 2 \text{ watts,}$$

which is divided equally between the source and the load.

If R_L is 2 ohms the current is:

$$I = \frac{2}{1 + 2} = 0.67 \text{ ampere,}$$

and the total power dissipated is:

$$P = 2 \times 0.67 = 1.34 \text{ watts.}$$

The portion dissipated in the load is:

$$P = 0.67^2 \times 2 = 0.9 \text{ watt,}$$

and the remainder, 0.44 watt, is dissipated in the source. If R_L is 0.5 ohm, the current in the circuit is:

$$I = \frac{2}{1 + 0.5} = 1.33 \text{ amperes.}$$

The total power is:

$$P = 2 \times 1.33 = 2.66 \text{ watts.}$$

The load dissipation is:

$$P = 1.33^2 \times 0.5 = 0.88 \text{ watt,}$$

while 1.78 watts are dissipated in the source. Thus, it is seen that, while the total dissipated power may be greater under other conditions, the dissipation in the load is greatest when its resistance equals that of the source.

Electromagnetism

The common bar or horseshoe magnet is familiar to most people. The magnetic field which surrounds it causes the magnet to attract other magnetic materials, such as iron nails or tacks. Exactly the same kind of magnetic field is set up around any conductor carrying a current, but the field exists only while the current is flowing.

Magnetic Fields Before a potential, or voltage, is applied to a conductor there is no external field, because there is no general movement of the electrons in one direction. However, the electrons do progressively move along the conductor when an e.m.f. is applied, the direction of motion depending upon the polarity of the e.m.f. Since each electron has an electric field about it, the flow of electrons causes these fields to build up into a resultant external field which acts in a plane at right angles to the direction in which the current is flowing. This field is known as the *magnetic field*.

The magnetic field around a current-carrying conductor is illustrated in Figure 12. The direction of this magnetic field depends entirely upon the direction of electron drift or current flow in the conductor. When the flow is toward

the observer, the field about the conductor is clockwise; when the flow is away from the observer, the field is counter-clockwise. This is easily remembered if the left hand is clenched, with the thumb outstretched and pointing in the direction of electron flow. The fingers then indicate the direction of the magnetic field around the conductor.

Each electron adds its field to the total external magnetic field, so that the greater the number of electrons moving along the conductor, the stronger will be the resulting field.

One of the fundamental laws of magnetism is that *like poles repel one another and unlike poles attract one another*. This is true of current-carrying conductors as well as of permanent magnets. Thus, if two conductors are placed side by side and the current in each is flowing in the same direction, the magnetic fields will also be in the same direction and will combine to form a larger and stronger field. If the current flow in adjacent conductors is in opposite directions, the magnetic fields oppose each other and tend to cancel.

The magnetic field around a conductor may be considerably increased in strength by winding the wire into a coil. The field around each wire then combines with those of the adjacent turns to form a total field through the coil which is concentrated along the axis of the coil and behaves externally in a way similar to the field of a bar magnet.

If the left hand is held so that the thumb is outstretched and parallel to the axis of a coil, with the fingers curled to indicate the direction of current flow around the turns of the coil, the thumb then points in the direction of the north pole of the magnetic field.

The Magnetic Circuit In the magnetic circuit, the units which correspond to current, voltage, and resistance in the electrical circuit are flux, magnetomotive force, and reluctance.

Flux; Flux Density As a current is made up of a drift of electrons, so is a magnetic field made up of lines of force, and the total number of lines of force in a given magnetic circuit is termed the *flux*. The flux depends upon the material, cross sec-

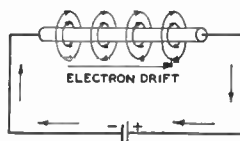

Figure 12.

Magnetic lines of force produced around a conductor carrying an electric current.

tion, and length of the magnetic circuit, and it varies directly as the current flowing in the circuit. The unit of flux is the *maxwell*, and the symbol is the Greek letter ϕ (phi).

Flux density is the number of lines of force per unit area. It is expressed in *gauss* if the unit of area is the square centimeter (1 gauss = 1 line of force per square centimeter), or in *lines per square inch*. The symbol for flux density is B if it is expressed in gaussess, or B if expressed in lines per square inch.

Magnetomotive Force The force which produces a flux in a magnetic circuit is called *magnetomotive force*. It is abbreviated m.m.f. and is designated by the letter F . The unit of magnetomotive force is the *gilbert*, which is equivalent to $1.26 \times NI$, where N is the number of turns and I is the current flowing in the circuit in amperes.

The m.m.f. necessary to produce a given flux density is stated in gilberts per centimeter (H), or in ampere-turns per inch (H).

Reluctance Magnetic reluctance corresponds to electrical resistance, and is the property of a material that opposes the creation of a magnetic flux in the material. It is expressed in *oersteds* or in *rels*, and the symbol is the letter R . An oersted is the reluctance of 1 cubic centimeter of vacuum. A material has a reluctance of 1 rel when an m.m.f. of 1 ampere-turn (NI) generates a flux of 1 line of force in it. Combinations of reluctances are treated the same as resistances in finding the total effective reluctance. The *specific reluctance* of any substance is its reluctance per unit volume.

Except for iron and its alloys, most common materials have a specific reluctance very nearly the same as that of a vacuum, which, for all practical purposes, may be considered the same as the specific reluctance of air.

Ohm's Law for Magnetic Circuits The relations between flux, magnetomotive force, and reluctance are exactly the same as the relations between current, voltage, and resistance in the electrical circuit. These can be stated as follows:

$$\phi = \frac{F}{R} \quad R = \frac{F}{\phi} \quad F = \phi R$$

where ϕ = flux, F = m.m.f., and R = reluctance. If F is in gilberts, R will be expressed in oersteds, but if F is in ampere-turns, then R will be in rels.

Permeability Permeability expresses the ease with which a magnetic field may be set up in a material as compared

with the effort required in the case of air. Iron, for example, has a permeability of around 2000 times that of air, which means that a given amount of magnetizing effect produced in an iron core by a current flowing through a coil of wire will produce 2000 times the *flux density* that the same magnetizing effect would produce in air. It may be expressed by the ratio B/H or B/H . In other words,

$$\mu = \frac{B}{H} \text{ or } \mu = \frac{B}{H}$$

where μ is the permeability, B is the flux density in gaussess, B is the flux density in lines per square inch, H is the m.m.f. in gilberts per centimeter, and H is the m.m.f. in ampere-turns per inch. These relations may also be stated as follows:

$$H = \frac{B}{\mu} \text{ or } H = \frac{B}{\mu}, \text{ and } B = H\mu \text{ or } B = H\mu$$

It can be seen from the foregoing that permeability is inversely proportional to the specific reluctance of a material.

Saturation Permeability is similar to *electric conductivity*. There is, however, one important difference: the permeability of magnetic materials is not independent of the magnetic current (flux) flowing through it, although electrical conductivity is substantially independent of the electric current in a wire. When the flux density of a magnetic conductor has been increased to the *saturation point*, a further increase in the magnetizing force will not produce a corresponding increase in flux density.

Calculations To simplify magnetic circuit calculations, a magnetization curve may be drawn for a given unit of material. Such a curve is termed a $B-H$ curve, and is arrived at by experiment. $B-H$ curves for most common magnetic materials are available in many reference books, so none will be given here.

Residual Magnetism; Retentivity The magnetism remaining in a material after the magnetizing force is removed is called *residual magnetism*. *Retentivity* is the property which causes a magnetic material to have residual magnetism after having been magnetized.

Hysteresis; Coercive Force *Hysteresis* is the characteristic of a magnetic system which causes a loss of power due to the fact that a negative magnetizing force must be applied to reduce the residual magnetism to zero. This negative

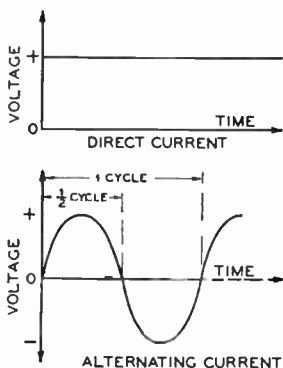

Figure 13.

Graphical comparison of unidirectional (direct) current and alternating current.

force is termed *coercive force*. By "negative" magnetizing force is meant one which is of the opposite polarity with respect to the original magnetizing force. Hysteresis loss is apparent in transformers and chokes by the heating of the core.

Alternating Current

To this point in the text, consideration has been given primarily to a current consisting of a steady flow of electrons in one direction. This type of current flow is known as *unidirectional* or *direct current*, abbreviated *d.c.* Equally as important in radio work and more important in power practice is another and altogether different type of current, known as *alternating current* and abbreviated *a.c.* Power distribution from one point to another and into homes and factories is almost universally *a.c.* On the other hand, the plate supply to vacuum tubes is almost universally *d.c.*

Generation of Alternating Current

Faraday discovered that if a conductor which forms part of a closed

circuit is moved through a magnetic field so as to cut across the lines of force, a current will flow in the conductor. He also discovered that, if a conductor in a second closed circuit is brought near the first conductor and the current in the first one is varied, a current will flow in the second conductor. This effect is known as *induction*, and the currents so generated are *induced currents*. In the latter case it is the lines of force which are moving and cutting the second conductor, due to the varying current strength in the first conductor.

A current is induced in a conductor if there is a relative motion between the conductor and a magnetic field, its direction of flow depending upon the direction of the relative motion between the conductor and the field, and its strength depends upon the intensity of the field, the rate of cutting lines of force, and the number of turns in the conductor.

An alternating current is one which periodically rises from zero to a maximum in one direction, decreases to zero and changes its direction, rises to a maximum in the opposite direction, and decreases to zero again. (Refer to Figure 13.) This complete process is called a *cycle*, and from zero through a maximum and back to zero is an *alternation* or *half-cycle*. The number of times per second that the current goes through a complete cycle is called the *frequency*.

A machine that generates alternating current is termed an *alternator* or *a.c. generator*. Such a machine in its basic form is shown in Figure 14. It consists of two permanent magnets, *M*, the opposite poles of which face each other and are machined so that they have a common radius. Between these two poles, *north* (*N*) and *south* (*S*), a magnetic field exists. If a conductor in the form of *C* is so suspended that it can be freely rotated between the two poles, and if the opposite ends of conductor *C* are brought to collector rings, *R*, which are contacted by brushes (*B*), there will be a flow of alternating current when conductor *C* is

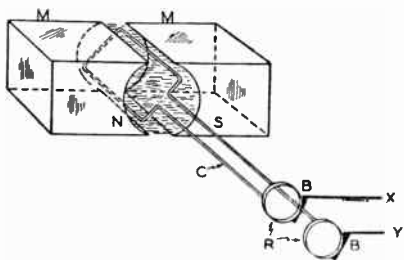

Figure 14.

Schematic representation of the simplest form of the alternator.

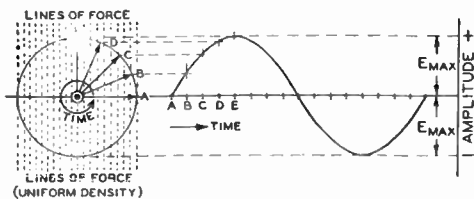

Figure 15.

Graph showing the output voltage of the alternator of figure 14. The output is called a "sine wave" for reasons explained in the text.

rotated. This current will flow out through the collector rings R and brushes B to the external circuit, X-Y.

The field intensity between the two pole pieces is substantially constant over the entire area of the pole face. However, when the conductor is moving parallel to the lines of force at the top or bottom of the pole faces, no lines are being cut. As the conductor moves on across the pole face it cuts more and more lines of force for each unit distance of travel, until it is cutting the maximum number of lines when opposite the center of the pole. Therefore, zero current is induced in the conductor at the instant it is midway between the two poles, and maximum current is induced when it is opposite the center of the pole face. After the conductor has rotated through 180° it can be seen that its position with respect to the pole pieces will be exactly opposite to that when it started. Hence, the second 180° of rotation will produce an alternation of current in the opposite direction to that of the first alternation.

The current does *not* increase directly as the angle of rotation, but rather as the *sine* of the angle; hence, such a current has the mathematical form of a *sine wave*. Although most electrical machinery does not produce a strictly pure sine curve, the departures are usually so slight that the assumption can be regarded as fact for most practical purposes. All that has been said in the foregoing paragraphs concerning alternating current also is applicable to alternating voltage.

Why the voltage output of a conductor revolving in a magnetic field is a sine wave is made clear by reference to figure 15.

The rotating arrow to the left represents a conductor rotating in a constant magnetic field of uniform density. The arrow also can be taken as a *vector* representing the strength of the magnetic field. This means that the length of the arrow is determined by the strength of the field (number of lines of force), which is constant. Now if the arrow is rotating at a constant rate (that is, with constant *angular velocity*), then the voltage developed across the conductor will be proportional to the rate at which it is cutting lines of force, which rate is proportional to the vertical distance between the tip of the arrow and the horizontal base line.

If EO is taken as unity or a voltage of 1, then the voltage (vertical distance from tip of arrow to the horizontal base line) at point C for instance may be determined simply by referring to a table of sines and looking up the sine of the angle which the arrow makes with the horizontal, because in a right triangle the "side opposite is equal to the sine of the included angle times the hypotenuse."

When the arrow has traveled from A to point E, it has traveled 90 degrees or one quarter cycle. The other three quadrants are not shown because their complementary or mirror relationship to the first quadrant is obvious.

It is important to note that time units are represented by *degrees* or quadrants. The fact that AB, BC, CD, and DE are equal chords (forming equal quadrants) simply means that the arrow (conductor or vector) is traveling at a constant speed, because these points on the radius represent the passage of equal units of time.

The whole picture can be represented in another way, and its derivation from the foregoing is shown in figure 15. The time base is represented by a straight line rather than by angular rotation. Points A, B, C, etc., represent the same units of time as before. When the voltage corresponding to each point is projected to the corresponding time unit, the familiar *sine curve* is the result.

The instantaneous value of voltage at any given instant can be calculated as follows:

$$e = E_{\max} \sin 2\pi ft,$$

where e = the instantaneous voltage,

E = maximum crest value of voltage,

f = frequency in cycles per second, and

t = time in seconds.

The instantaneous current can be found from the same formula by substituting i for e and I_{\max} for E_{\max} . The formula then becomes:

$$i = I_{\max} \sin 2\pi ft,$$

where i = the instantaneous current,

I = maximum crest value of current,

f = frequency in cycles per second, and

t = time in seconds.

Radians The term $2\pi f$ in the preceding equation should be thoroughly understood because it is of basic importance. Returning again to the rotating point of Figure 15, it can be seen that when this point leaves its horizontal position and begins its rotation in a counter-clockwise direction, through a complete revolution back to its initial starting point, it will have traveled through 360 electrical degrees. In electrical work, instead of referring to this movement in terms of degrees, it is customary to express the movement in terms of *radians*. Mathematically, a radian is an arc of the circle equal in length to the radius of the circle. There are 2π radians in 360 degrees, so that one radian is equivalent to 57.32 degrees. (See Figure 17.)

When the conductor in the simple alternator has moved through 2π radians it has generated one cycle. $2\pi f$ then represents one cycle, multiplied by the number of cycles per second (the frequency) of the alternating voltage or current, and is, therefore, the *angular velocity*.

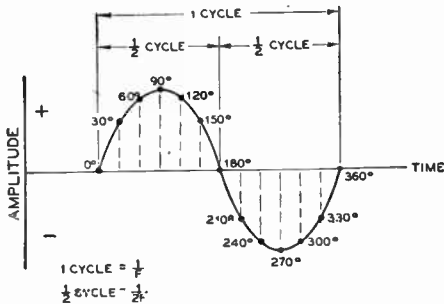

Figure 16.

Illustrating one cycle of sine wave alternation. For an understanding of the "degrees" of time along the linear time base, refer to the left hand (rotating) representation of figure 15. As one cycle represents one revolution of the alternator, one cycle is said to constitute 360 electrical degrees.

In technical literature $2\pi f$ is often replaced by ω , the Greek letter omega. Velocity multiplied by time gives the distance traveled, so $2\pi ft$ represents the angular distance through which the conductor has traveled, and since the instantaneous voltage or current is proportional to the sine of this angle, it is possible to calculate these quantities at any instant of time, provided that the wave very closely approximates a sine curve.

Frequency The frequency of an alternating current or voltage may be any value greater than zero up to millions of cycles per second. Up to about 20,000 cycles per second are considered audio frequencies, since all except those from zero to about 16 c.p.s. are audible to the human ear. The a.c. power which is supplied to homes and factories is generally 25, 50, or 60 c.p.s. Frequencies above 20,000 c.p.s. are known as radio frequencies. But they are usually spoken of in terms of kilocycles, rather than cycles, because the numbers become too large. When the frequency gets above a few thousand kilocycles, the term megacycle is used. A kilocycle is equal to 1000 cycles, and a megacycle equals 1,000,000 cycles. A conversion table for simplifying this terminology is given here:

- 1,000 cycles = 1 kilocycle. The abbreviation for kilocycle is kc.
- 1 cycle = 1/1,000 of a kilocycle. .001 kc. or 10^{-3} kc.
- 1 megacycle = 1,000 kilocycles. or 1,000,000 cycles, 10^3 kc. or 10^6 cycles.
- 1 kilocycle = 1/1000 megacycle. .001 megacycle. or 10^{-3} Mc. The abbreviation for megacycles is Mc.

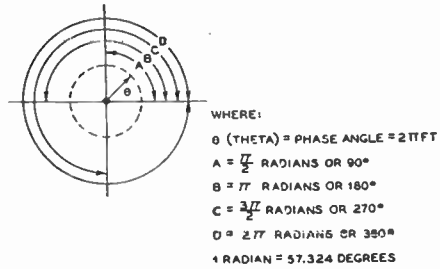

Figure 17.

Illustrating system of notation employed in alternating current or voltage calculations.

Effective Value of Voltage and Current

The instantaneous value of an alternating current or voltage varies throughout the cycle, so that the effective value of this current or voltage must be determined by comparing the a.c. heating effect with that of d.c. Thus, an alternating current will have an effective value of 1 ampere when it produces the same heat in a conductor as does 1 ampere of direct current.

This effective value is derived by taking the instantaneous values of current over a cycle of alternating current, squaring these values, taking an average of the squares, and then taking the square root of the average. By this procedure, the effective value becomes known as the root mean square or r.m.s. value. This is the value that is read on a.c. voltmeters and a.c. ammeters. The r.m.s. value is 70.7 (for sine waves only) per cent of the peak or maximum instantaneous value and is expressed as follows:

$$E_{eff} \text{ or } E_{r.m.s.} = 0.707 \times E_{max}, \text{ or}$$

$$I_{eff} \text{ or } I_{r.m.s.} = 0.707 \times I_{max}.$$

The following relations are extremely useful in radio and power work:

$$E_{r.m.s.} = 0.707 \times E_{max}, \text{ and}$$

$$E_{max} = 1.414 \times E_{r.m.s.}$$

Rectified Alternating Current or Pulsating Direct Current

If an alternating current is passed through a full-wave rectifier, it emerges in the form of a current of varying amplitude which flows in one direction only. Such a current is known as rectified a.c. or pulsating d.c. A typical wave form of a pulsating direct current as would be obtained from the output of a full-wave rectifier is shown in Figure 18.

Measuring Instruments designed for d.c. operation will not read the peak or instantaneous maximum value of the pulsating d.c. output from the rectifier; it will read only the average value. This can be explained by assuming that it could be possible to cut off some of the

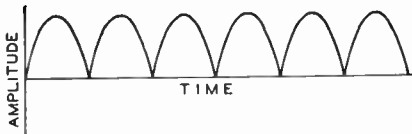

Figure 18.
Waveform obtained at output of a full wave rectifier having 100 per cent rectification efficiency. Each pulse has the same shape as one half-cycle of a sine wave. This kind of current is known as pulsating d.c.

peaks of the waves, using the cut-off portions to fill in the spaces that are open, thereby obtaining an average d.c. value. A milliammeter and voltmeter connected to the adjoining circuit, or across the output of the rectifier, will read this average value. It is related to peak value by the following expression:

$$E_{avg} = 0.636 \times E_{max}$$

It is thus seen that the average value is 63.6 per cent of the peak value.

Relationship Between Peak, R.M.S. or Effective, and Average Values

To summarize the three most significant values of an a.c. wave: the peak value is equal to 1.41 times the r.m.s. or effective, and the r.m.s. value is equal to 0.707 times the peak value; the average value of a full-wave rectified a.c. wave is 0.636 times the peak value, and the average value of a rectified wave is equal to 0.9 times the r.m.s. value. This latter factor is of value in determining the voltage output from a power supply which operates with a choke-input filter system. If the input choke is of ample inductance, the d.c. voltage output of a full wave power supply will be 0.9 times the r.m.s. a.c. output of the used secondary of the transformer (one-half secondary voltage in the case of a full-wave rectifier and the full secondary voltage in the case of bridge rectification) less the drop in the rectifier tubes and the resistance drop in the filter inductances.

Inductance

In the section titled "Generation of Alternating Current" a brief explanation of induction was given, and it would be well for the reader to review it at this point.

If a switch is inserted in the circuit shown in Figure 11, a pulsating direct current can be produced by closing and opening the switch. When it is first closed, the current does not instantaneously rise to its maximum value, but builds up to it. While it is building up, the magnetic field is expanding around the conductor. Of course, this happens in a small

fraction of a second. If the switch is then opened, the current dies down and the magnetic field contracts. This expanding and contracting field will induce a current in any other conductor that is part of a continuous circuit which it cuts. Such a field can be obtained in the way just mentioned by means of a vibrator interruptor, or by applying a.c. to the circuit in place of the battery. Varying the resistance of the circuit will also produce the same effect. This inducing of a current in a conductor due to a varying current in another conductor not in actual contact is called *electromagnetic induction*.

Self-induction

If an alternating current flows through a coil the varying magnetic field around each turn cuts itself and the adjacent turn and induces a voltage in the coil of opposite polarity to the applied e.m.f. The amount of induced voltage depends upon the number of turns in the coil, the current flowing in the coil, and the number of lines of force threading the coil. The voltage so induced is known as a *counter-e.m.f.* or *back-e.m.f.*, and the effect is termed *self-induction*. When the applied voltage is building up, the counter-e.m.f. opposes the rise; when the applied voltage is decreasing, the counter-e.m.f. is of the same polarity and tends to maintain the current. Thus, it can be seen that self-induction tends to prevent any change in the current in the circuit.

The storage of energy in a magnetic field is expressed in *joules* and is equal to $(LI^2)/2$. (A joule is equal to 1 watt-second. L is defined immediately following.)

The Unit of Inductance; The Henry

Inductance is usually denoted by the letter L, and is expressed in *henrys*. A coil has an inductance of 1 henry when a voltage of 1 volt is induced by a current change of 1 ampere per second. The henry, while commonly used in audio frequency circuits, is too large for reference to inductance coils such as those used in radio frequency circuits; *millihenry* or *microhenry* are more commonly used, in the following manner:

- 1 *henry* = 1,000 *millihenrys*, or 10^3 *millihenrys*.
- 1 *millihenry* = 1/1,000 of a *henry*, .001 *henry*, or 10^{-3} *henry*.
- 1 *microhenry* = 1/1,000,000 of a *henry*, or .000001 *henry*, or 10^{-6} *henry*.
- 1 *microhenry* = 1/1,000, of a *millihenry*, .001 or 10^{-3} *millihenrys*.
- 1,000 *microhenrys* = 1 *millihenry*.

Mutual Induction

When one coil is near another, a varying cur-

rent in one will produce a varying magnetic field which cuts the turns of the other coil, inducing a current in it. This induced current is also varying, and will therefore induce another current in the first coil. This reaction between two coupled circuits is called *mutual induction*, and can be calculated and expressed in henrys. The symbol for mutual inductance is *M*. Two circuits thus joined are said to be *inductively coupled*.

The magnitude of the mutual inductance depends upon the shape and size of the two circuits, their positions and distances apart, and the permeability of the medium. The extent to which two inductances are coupled is expressed by a relation known as *coefficient of coupling*. This is the ratio of the mutual inductance actually present to the maximum possible value.

The formula for mutual inductance is $L = L_1 + L_2 + 2M$ when the coils are poled so that their fields add. When they are poled so that their fields buck, then $L = L_1 + L_2 - 2M$.

If a 3 henry coil and a 4 henry coil are placed so that there is no coupling between them, then the combined inductance of the two in series will be 7 henrys. But if the coils are placed in inductive relation to each other, the inductance of the two in series will be either greater or less than 7 henrys, depending upon whether the polarity is such that the mutual inductance aids the self-inductance or bucks the self-inductance. If the total inductance of the two coils when coupled measured either 6 or 8 henrys, then the mutual inductance would be (from the formula) $\frac{1}{2}$ henry.

Inductances in Parallel Inductances in parallel are combined exactly as are resistors in parallel, provided that they are far enough apart so that the mutual inductance is entirely negligible.

Inductances in Series Inductances in series are additive, just as are resistors in series, again provided that no mutual inductance exists. In this case, the total inductance *L* is:

$$L = L_1 + L_2 + \dots \text{etc.}$$

Where mutual inductance does exist:

$$L = L_1 + L_2 + 2M,$$

where *M* is the mutual inductance.

This latter expression assumes that the coils are connected in such a way that all flux linkages are in the same direction, i.e., additive. If this is not the case and the mutual linkages *subtract* from the self-linkages, the following formula holds:

$$L = L_1 + L_2 - 2M,$$

where *M* is the mutual inductance.

Core Material Ordinary magnetic cores cannot be used for radio frequencies because the *eddy current losses* in the core material become enormous as the frequency is increased. The principal use for magnetic cores is in the audio-frequency range below approximately 15,000 cycles, whereas at very low frequencies (50 to 60 cycles) their use is mandatory if an appreciable value of inductance is desired.

An air core inductor of only 1 henry inductance would be quite large in size, yet values as high as 500 henrys are commonly available in small iron core chokes. The inductance of a coil with a magnetic core will vary with the amount of current (both a.c. and d.c.) which passes through the coil. For this reason, iron core chokes that are used in power supplies have a certain inductance rating at a *predetermined value of d.c.*

The permeability of air does not change with flux density; so the inductance of iron core coils often is made less dependent upon flux density by making part of the magnetic path air, instead of utilizing a closed loop of iron. This incorporation of an *air gap* is necessary in many applications of iron core coils, particularly where the coil carries a considerable d.c. component. Because the permeability of air is so much lower than that of iron, the air gap need comprise only a small fraction of the magnetic circuit in order to provide a substantial proportion of the total reluctance.

One exception to the statement that metal core inductances are highly inefficient at radio frequencies is in the use of *powdered* iron cores in some types of intermediate frequency transformers. These cores are made of very *fine particles* of powdered iron, which are first treated with an insulating compound so that each particle is insulated from the other. These particles are then moulded into a solid core around which the wire is wound. Eddy current losses are greatly reduced, with the result that

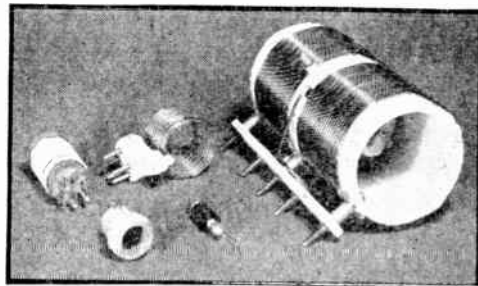

Figure 19.

Common types of inductors employed in radio equipment. The smallest is a radio frequency choke coil; the largest is a power amplifier tank coil.

these special iron cores are entirely practical in circuits which operate up to 1500 kc. in frequency.

Inductive Reactance As was previously stated, when an alternating current flows through an inductance, a back- or counter-electromotive force is developed; this force opposes any change in the initial e.m.f. This property of an inductance causes it to offer opposition or *impedance* to a change in current. The measure of impedance offered by an inductance to an alternating current of a given frequency is known as its *inductive reactance*. This is expressed as X_L :

$$X_L = 2\pi fL,$$

where X_L = inductive reactance expressed in ohms.

$$\pi = 3.1416 \quad (2\pi = 6.283),$$

f = frequency in cycles,

L = inductance in henrys.

Inductive Reactance at R.F. It is very often necessary to compute inductive reactance at radio frequencies. The same formula may be used, but to make it less cumbersome the inductance is expressed in *millihenrys* and the frequency in *kilocycles*. For higher frequencies and smaller values of inductance, frequency is expressed in *megacycles* and inductance in *microhenrys*. The basic equation need not be changed, since the multiplying factors for inductance and frequency appear in numerator and denominator, and hence are cancelled out. However, it is not possible in the same equation to express L in millihenrys and f in cycles without conversion factors.

Should it become desirable to know the value of inductance necessary to give a certain reactance at some definite frequency, a transposition of the original formula gives the following:

$$L = X_L \div (2\pi f),$$

or when X_L and L are known,

$$f = \frac{X_L}{2\pi L}.$$

Electrostatic Storage of Energy

So far we have dealt only with the storage of energy in an electromagnetic field in the form of an inductance.

Electrical energy can also be stored in an electrostatic field. A device capable of storing energy in such a field is called a *condenser* and is said to have a certain *capacitance*. The energy stored in an electrostatic field is expressed in *joules* and is equal to $CE^2/2$, where C is the capacity in *farads* (a unit of capacity to be discussed) and E is the potential in volts. The

charge is equal to CE, the charge being expressed in coulombs.

Capacitance and Condensers Two metallic plates separated from each other by a thin layer of insulating material (called a *dielectric*, in this case), become a *condenser*. When a source of d.c. potential is momentarily applied across these plates, they may be said to become charged. If the same two plates are then joined together momentarily by means of a wire, the condenser will *discharge*.

When the potential was first applied, electrons immediately flowed from one plate to the other through the battery or such source of d.c. potential as was applied to the condenser plates. However, the circuit from plate to plate in the condenser was *incomplete* (the two plates being separated by an insulator) and thus the electron flow ceased, meanwhile establishing a shortage of electrons on one plate and a surplus of electrons on the other.

Remember that when a deficiency of electrons exists at one end of a conductor, there is always a tendency for the electrons to move about in such a manner as to re-establish a state of balance. In the case of the condenser herein discussed, the surplus quantity of electrons on one of the condenser plates cannot move to the other plate because the circuit has been broken; that is, the battery or d.c. potential was removed. This leaves the condenser in a *charged* condition; the condenser plate with the electron *deficiency* is *positively* charged, the other plate being *negative*.

In this condition, a considerable stress exists in the insulating material (dielectric) which separates the two condenser plates, due to the mutual attraction of two unlike potentials on the plates. This stress is known as *electrostatic* energy, as contrasted with *electromagnetic* energy in the case of an inductance. This charge can also be called *potential energy* because it

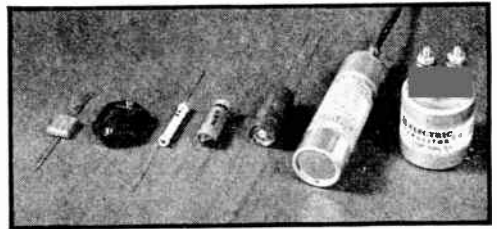

Figure 20.

Common types of fixed capacitors employed in radio equipment. The two to the left are of the mica dielectric type, the next is a ceramic dielectric "zero coefficient" type, the next a tubular paper type, the next a midget electrolytic, the next a large electrolytic (wet), and the last an oil-filled paper-dielectric filter condenser.

is capable of performing work when the charge is released through an external circuit.

In case it is difficult for the reader to understand why the charge is proportional to the voltage but the energy is proportional to the voltage squared, the following analogy may make things clear.

The charge represents a definite amount of electricity, a given number of electrons. The potential energy possessed by these electrons depends not only upon their number, but also upon their potential or voltage.

Compare the electrons to water, and two condensers to standpipes, a 1 μ fd. condenser to a standpipe having a cross section of 1 square foot and a 2 μ fd. condenser to a standpipe having a cross section of 2 square feet. The charge will represent a given volume of water, as the "charge" simply indicates a certain number of electrons. Suppose the water is equal to 5 gallons.

Now the potential energy, or capacity for doing work, of the 5 gallons of water will be twice as great when confined to the 1 sq. ft. standpipe as when confined to the 2 sq. ft. standpipe. Yet the volume of water, or "charge" is the same in either case.

Likewise a 1 μ fd. condenser charged to 1000 volts possesses twice as much potential energy as does a 2 μ fd. condenser charged to 500 volts, though the charge is the same in either case.

The Unit of Capacitance: The Farad If the external circuit of the two condenser plates is completed by joining the terminals together with a piece of wire, the electrons will rush immediately from one plate to the other through the external circuit and establish a state of equilibrium. This latter phenomenon explains the discharge of a condenser. The amount of stored energy in a charged condenser is dependent upon the charging potential, as well as a factor which takes into account the size of the plates, dielectric thickness, nature of the dielectric, and the number of plates. This factor, which is determined by the foregoing, is called the capacity of a condenser and is expressed in farads.

The farad is such a large unit of capacity that it is rarely used in radio calculations, and the following more practical units have, therefore, been chosen:

1 microfarad = 1/1,000,000 of a farad, or .000001 farad, or 10^{-6} farads.

1 micro-microfarad = 1/1,000,000 of a microfarad, or .000001 microfarad, or 10^{-6} microfarads.

1 milli-microfarad = one-millionth of one-millionth of a farad, or 10^{-12} farads.

If the capacity is to be expressed in microfarads in the equation given under energy stor-

age, the factor C would then have to be divided by 1,000,000, thus:

$$\text{Stored energy in joules} = \frac{C \times E^2}{2 \times 1,000,000}$$

This storage of energy in a condenser is one of its very important properties, particularly in those condensers which are used in power supply filter circuits.

Dielectric Constant The capacity of a condenser is greatly affected by the thickness and nature of the dielectric separation between plates. Certain materials offer a greater capacity than others, depending upon their physical makeup and chemical constitution. This property is expressed by a constant K, called the dielectric constant. A table for some of the commonly used dielectrics is given here:

| <i>Material</i> | <i>Dielectric Constant</i> |
|-------------------------------------|----------------------------|
| Air | 1.00 |
| Mica | 5.75 |
| Hard rubber | 2.50 to 3.00 |
| Glass | 4.90 to 9.00 |
| Bakelite derivatives | 3.50 to 6.00 |
| Celluloid | 4.10 |
| Fiber | 4 to 6 |
| Wood (without special preparation): | |
| Oak | 3.3 |
| Maple | 4.4 |
| Birch | 5.2 |
| Transformer oil | 2.5 |
| Castor oil | 5.0 |
| Porcelain, steatite | 6.5 |
| Lucite | 2.5 to 3.0 |
| Quartz | 4.75 |
| Victron, Trolitul | 2.6 |

Dielectric Breakdown If the charge becomes too great for a given thickness of a certain dielectric, the condenser will break down, i.e., the dielectric will puncture. It is for this reason that condensers are rated in the manner of the amount of voltage they will safely withstand as well as the capacity in microfarads. This rating is commonly expressed as the d.c. working voltage.

Calculation of Capacity The capacity of two parallel plates is given with good accuracy by the following formula:

$$C = 0.2248 \times K \times \frac{A}{t}$$

where C = capacity in micro-microfarads,
 K = dielectric constant of spacing material,
 A = area of dielectric in square inches,
 t = thickness of dielectric in inches.

This formula indicates that the capacity is

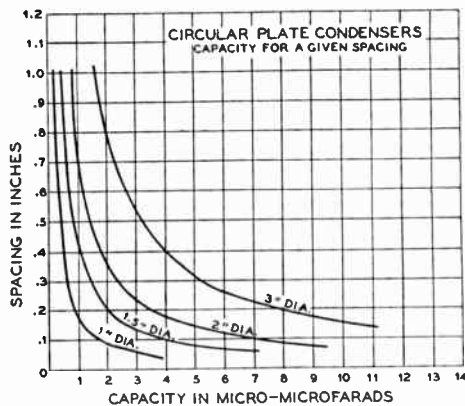

Figure 21.
 Illustrating the effect of plate area and spacing upon the capacity of a condenser having two flat, circular electrodes. The capacity given is for a dielectric of air.

directly proportional to the area of the plates and inversely proportional to the thickness of the dielectric (spacing between the plates). This simply means that when the area of the plate is doubled, the spacing between plates remaining constant, the capacity will be doubled. Also, if the area of the plates remains constant, and the plate spacing is doubled, the capacity will be reduced to half.

The above equation also shows that capacity is directly proportional to the dielectric constant of the spacing material. A condenser that has a capacity of 100 $\mu\text{mfd.}$ in air would have a capacity of 500 $\mu\text{mfd.}$ when immersed in castor oil, because the dielectric constant of castor oil is 5.0, or five times as great as the dielectric constant of air.

Where the area of the plates is definitely set, and when it is desired to know the spacing needed to secure a required capacity,

$$t = \frac{A \times 0.2248 \times K}{C}$$

where all units are expressed just as in the preceding formula. This formula is not confined to condensers having only square or rectangular plates, but also applies when the plates are circular in shape. The only change will be the calculation of the *area* of such circular plates; this area can be computed by squaring the *radius* of the plate, then multiplying by 3.1416, or "pi." Expressed as an equation:

$$A = 3.1416 \times r^2,$$

where r = radius in inches.

The capacity of a multi-plate condenser can be calculated by taking the capacity of one section and multiplying this by the number of dielectric spaces. In such cases, however, the formula gives no consideration to the effects of

edge capacity; so the capacity as calculated will not be entirely accurate. These additional capacities will be but a small part of the effective total capacity, particularly when the plates are reasonably large and thin, and the final result will, therefore, be within practical limits of accuracy.

Equations for calculating capacities of condensers in *parallel* connections are the same as those for resistors in *series*:

$$C = C_1 + C_2, \text{ etc.}$$

Condensers in *series* connection are calculated in the same manner as are resistors in *parallel* connection.

The formulas are repeated: (1) For two or more condensers of *unequal* capacity in series:

$$C = \frac{1}{\frac{1}{C_1} + \frac{1}{C_2} + \frac{1}{C_3}}$$

or $\frac{1}{C} = \frac{1}{C_1} + \frac{1}{C_2} + \frac{1}{C_3}$

(2) Two condensers of *unequal* capacity in series:

$$C = \frac{C_1 \times C_2}{C_1 + C_2}$$

(3) Three condensers of *equal* capacity in series:

$$C = \frac{C_1}{3}, \text{ where } C_1 \text{ is the common capacity.}$$

(4) Three or more condensers of *equal* capacity in series:

$$C = \frac{\text{Value of common capacity}}{\text{Number of condensers in series}}$$

(5) Six condensers in series parallel:

$$C = \frac{1}{\frac{1}{C_1} + \frac{1}{C_2} + \frac{1}{C_3} + \frac{1}{C_4} + \frac{1}{C_5} + \frac{1}{C_6}}$$

Capacitive Reactance It has been explained that inductive reactance is the measure of the ability of an inductance to offer impedance to the flow of an alternating current. Condensers have a similar property although in this case the opposition is to the *voltage* which acts to charge the condenser. This property is called *capacitive reactance* and is expressed as follows:

$$X_c = \frac{1}{2\pi fC},$$

where X_c = capacitive reactance in ohms,
 π = 3.1416,
 f = frequency in cycles,
 C = capacity in farads.

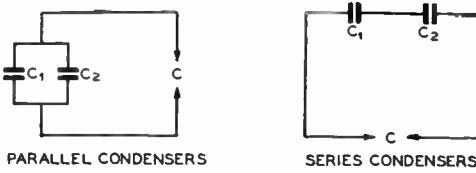

Figure 22.

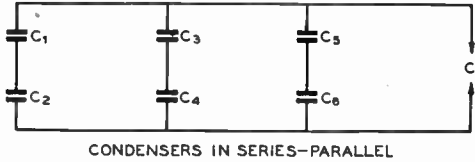

Figure 23.

Capcitive Re- Here again, as in the case
actance of R. F. of inductive reactance,
 the units of capacity and
 frequency can be converted into smaller units
 for practical problems encountered in radio
 work. The equation may be written:

$$X_c = \frac{1,000,000}{2 \pi f C}$$

where f = frequency in megacycles,
 C = capacity in micro-microfarads.

In the design of filter circuits, it is often convenient to express frequency (f) in *cycles* and capacity (C) in *microfarads*, in which event the same formula applies.

Condensers in A. C. and D. C. Circuits When a condenser is connected into a direct current circuit, it will block the d.c., or stop the flow of current. Beyond the initial movement of electrons during the period when the condenser is being charged, there will be no flow of current because the circuit is effectively broken by the dielectric of the condenser.

Strictly speaking, a very small current may actually flow because the dielectric of the condenser may not be a perfect insulator. This minute current flow is the leakage current previously referred to and is dependent upon the internal d.c. resistance of the condenser. This leakage current is usually quite noticeable in most types of electrolytic condensers.

When an alternating current is applied to a condenser, the condenser will charge and discharge a certain number of times per second in accordance with the frequency of the alternating voltage. The electron flow in the charge and discharge of a condenser when an a.c. potential is applied constitutes an alternating current, in effect. It is for this reason that a condenser will pass an alternating current yet offer practically infinite opposition to a direct current. These two properties are repeatedly in evidence in a radio circuit.

Voltage Rating of Condensers in Series Any good paper dielectric filter condenser has such a high internal resistance (indicating a good dielectric) that the exact resistance

will vary considerably from condenser to condenser even though they are made by the same manufacturer and are of the same rating. Thus, when 1000 volts, d.c. is connected across two 1- μ fd. 500-volt condensers in series, the chances are that the voltage will divide unevenly and one condenser will receive more than 500 volts and the other less than 500 volts.

Voltage Equalizing Resistors By connecting a half-megohm 1-watt carbon resistor across each condenser, the voltage will be equalized because the resistors act as a voltage divider, and the internal resistances of the condensers are so much higher (many megohms) that they have but little effect in disturbing the voltage divider balance.

Carbon resistors of the inexpensive type are not particularly accurate (not being designed for precision service); therefore it is advisable to check several on an accurate ohmmeter to find two that are as close as possible in resistance. The exact resistance is unimportant, just so it is the same for the two resistors used.

Condensers in Series on A.C. When two condensers are connected in series, *alternating* voltage pays no heed to the relatively high internal resistance of each condenser, but divides across the condensers in inverse proportion to the *capacity*. Because, in addition to the d.c. across a capacitor in a filter or audio amplifier circuit there is usually an a.c. or a.f. voltage component, it is inadvisable to series-connect condensers of unequal capacitance even if dividers are provided to keep the d.c. within the ratings of the individual capacitors.

For instance, if a 500-volt 1- μ fd. condenser is used in series with a 4- μ fd. 500-volt condenser across a 250-volt a.c. supply, the 1- μ fd. condenser will have 200 volts a.c. across it and the 4- μ fd. condenser only 50 volts. An equalizing divider to do any good in this case would have to be of very low resistance because of the comparatively low impedance of the condensers *to a.c.* Such a divider would draw excessive current and be impracticable.

The safest rule to follow is to use only con-

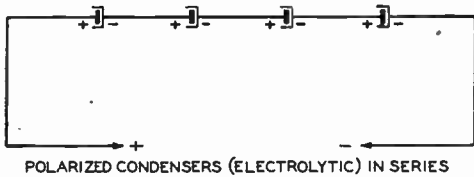

Figure 24.

condensers of the same capacity and voltage rating and to install matched high resistance proportioning resistors across the various condensers to equalize the d.c. voltage drop across each condenser. This holds regardless of how many capacitors are series-connected.

Electrolytic Condensers Electrolytic condensers use a very thin film of oxide as the dielectric, and are polarized; that is, they have a positive and a negative terminal which must be properly connected in a circuit; otherwise, the oxide will boil, and the condenser will no longer be of service. When electrolytic condensers are connected in series, the positive terminal is always connected to the positive lead of the power supply; the negative terminal of the condenser connects to the positive terminal of the next condenser in the series combination. The method of connection for condensers in series is shown in Figure 24.

Similar electrolytic capacitors, of the same capacity and made by the same manufacturer, have more nearly uniform (and much lower) internal resistance, though it still will vary considerably. However, the variation is not nearly as great as encountered in paper condensers, and the lowest d.c. voltage is across the weakest (leakiest) electrolytic condenser of a series group.

As an electrolytic capacitor begins to show signs of breaking down from excessive voltage, the leakage current goes up, which tends to heat the condenser and aggravate the condition. However, when used in series with one or more others, the lower resistance (higher leakage current) tends to put less d.c. voltage on the weakening condenser and more on the remaining ones. Thus, the capacitor with the lowest leakage current, usually the best capacitor, has the highest voltage across it. For this reason, dividing resistors are not essential across series-connected electrolytic capacitors.

Phase When an alternating current flows through a purely resistive circuit, it will be found that the current will go through maximum and minimum in perfect step with the voltage. In this case the current is said to be in step or *in phase* with the voltage. For this reason, Ohm's law will apply equally well

for a.c. or d.c. where pure resistances are concerned, provided that the *effective* values of a.c. are used in the calculations.

If a circuit has capacity or inductance or both, in addition to resistance, the current does not reach a maximum at the same instant as the voltage; therefore Ohm's law will *not* apply. It has been stated that inductance tends to resist any change in current; when an inductance is present in a circuit through which an alternating current is flowing, it will be found that the current will reach its maximum *behind* or later than the voltage. In electrical terms, the current will *lag* behind the voltage, or, conversely, the voltage will *lead* the current.

If the circuit is *purely* inductive, i.e., if it contains neither resistance nor capacitance, the current *lags* the voltage by 90 degrees as in Figure 25. The angle will be less than 90 degrees if resistance is in the circuit.

When pure *capacity* alone is present in an a.c. circuit (no inductance or resistance of any kind), the opposite effect will be encountered; the current will *lead* the voltage by 90 degrees. The presence of resistance in the circuit will tend to decrease this angle.

Comparison of Inductive to Capacitive Reactance with Changing Frequency

From the equation for *inductive* reactance, it is seen that as the

frequency becomes greater the reactance increases in a corresponding manner. The reactance is doubled when the frequency is doubled. If the reactance is to be very large when the frequency is low, the value of inductance must be very large.

The equation for capacitive reactance shows that the reactance varies *inversely* with frequency and capacity. With a fixed value of capacity, the reactance will become less as the

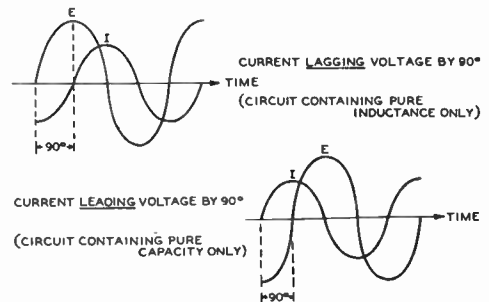

Figure 25.

The above two illustrations show the manner in which a pure inductance or a pure capacitance (no resistance component in either) will cause the current in the circuit either to lead or to lag the voltage by 90 degrees.

frequency increases. When the frequency is fixed, the reactance will be greater as the capacity is lowered.

A comparison of the two types of reactance, inductive and capacitive, shows that in one case (inductive) the reactance *increases* with frequency, whereas in the other (capacitive) the reactance *decreases* with frequency.

Reactance and Resistance in Combination

When a circuit includes a capacity or an inductance or

both, in addition to a resistance, the simple calculations of Ohm's law will *not* apply when the total impedance to alternating current is to be determined. Reference is here made to the passage of an *alternating current* through the circuit; the reactance must be considered in addition to the d.c. resistance because reactance offers an opposition to the flow of alternating current.

When alternating current passes through a circuit which contains only a condenser, the voltage and current relations are as follows:

$$E = IX_c, \text{ and } I = \frac{E}{X_c}$$

where E = voltage,

I = current in amperes,

$X_c = \text{capacitive reactance or } \frac{1}{2\pi fC}$
(expressed in ohms).

Power Factor

It should now be apparent to the reader that in such

circuits that have reactance as well as resistance, it will not be possible to calculate the power as in a d.c. circuit or as in an a.c. circuit in which current and voltage are in-phase. The reactive components cause the voltage and current to reach their maximums at different times, as was explained under *Phase*, and to calculate the power in such a circuit we must use a value called the *power factor* in our computations.

The *power factor* in a resistive-reactive a.c. circuit may be expressed as the *actual* watts (as measured by a watt-meter) divided by the product of voltage and current or:

$$\frac{W}{E \times I}$$

where W = watts as measured,

E = voltage (r.m.s.)

I = current in amperes (r.m.s.)

Stated in another manner:

$$\frac{W}{E \times I} = \cos\theta$$

The character θ is the angle of phase difference between current and voltage. The product of volts times amperes gives the *apparent* power of the circuit, and this must

be multiplied by the $\cos\theta$ to give the *actual* power. This factor $\cos\theta$ is called the *power factor* of the circuit.

When the current and voltage are in-phase, this factor is equal to 1. Resonant or purely resistive circuits are then said to have unity power factor, in which case:

$$W = E \times I, W = I^2R, W = \frac{E^2}{R}$$

Applying Ohm's Law to Alternating Current

Ohm's law applies equally to direct or alternating current, *provided* the circuits

under consideration are purely resistive, that is, circuits which have neither inductance (coils) nor capacitance (condensers). Problems which involve tube filaments, drop resistors, electric lamps, heaters or similar resistive devices can be solved from Ohm's law, regardless of whether the current is direct or alternating. When a condenser or coil is made a part of the circuit, a property common to either, called *reactance*, must be taken into consideration.

When the circuit contains inductance only, yet with the same conditions as above, the formula is as follows:

$$E = IX_l, \text{ and } I = \frac{E}{X_l}$$

where E = voltage,

I = current in amperes,

$X_l = \text{inductive reactance or } 2\pi fL$
(expressed in ohms).

When a circuit has resistance, capacitive reactance, and inductive reactance in *series*, the effective total opposition to the alternating current flow is known as the *impedance* of the circuit. Stated otherwise, impedance of a circuit is the vector sum of the resistance and the difference between the two reactances,

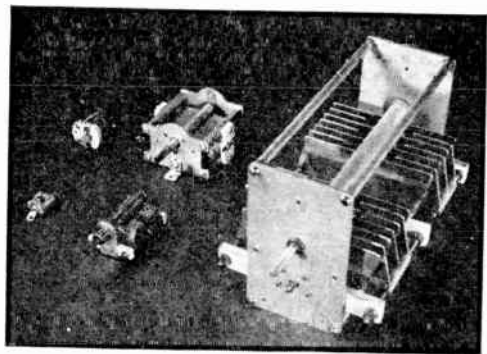

Figure 26.

Variable condensers commonly employed in radio equipment. The smallest is a mica dielectric "compression trimmer," the largest an air dielectric, split stator tank condenser for a radio frequency power amplifier.

the latter being designated as the *net reactance*.

$$Z = \sqrt{r^2 + (X_L - X_C)^2} \text{ or}$$

$$Z = \sqrt{r^2 + \left(2\pi fL - \frac{1}{2\pi fC}\right)^2}$$

where Z = impedance in ohms,
 r = resistance in ohms,
 X_L = inductive reactance
 $(2\pi fL)$ in ohms,

X_C = capacitive reactance $\left(\frac{1}{2\pi fC}\right)$
 in ohms.

An example will serve to clarify the relationship of resistance and reactance to the total impedance. If a 10-henry choke, a 2- μ f.d. condenser, and a resistance of 10 ohms (which is represented by the d.c. resistance of the choke) are all connected in *series* across a 60-cycle source of voltage:

for reactance $X_L = 6.28 \times 60 \times 10 = 3,750$
 ohms (approx.),

$$X_C = \frac{1,000,000}{6.28 \times 60 \times 2} = 1,300 \text{ ohms (approx.)}$$

$$r = 10 \text{ ohms}$$

Substituting these values in the impedance equation:

$$Z = \sqrt{10^2 + (3750 - 1300)^2} = 2450 \text{ ohms.}$$

This is nearly 250 times the value of the d.c. resistance of 10 ohms. The subject of impedance is more fully covered under *Resonant Circuits*.

In actual practice the iron core choke would act as though the *resistance* were somewhat more than 10 ohms (the value as read on an ohmmeter) because on a.c. there would also be core losses, which show up (produce the same effect as) additional d.c. resistance in the winding. However, to simplify the foregoing problem the effect of core losses was ignored.

Resonant Circuits

The reader is advised to review at this point the subject matter on inductance, capacity, and alternating current, in order that he may

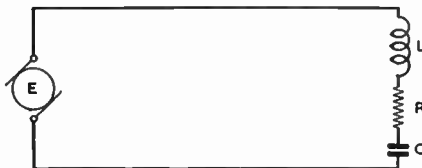

Figure 27.
 Schematic circuit of a series resonant circuit containing resistance.

be able to gain a complete understanding of the action of resonant circuits. Once the basic conception of the foregoing has been mastered, the more complex circuits in which they appear in combination will present no great problem.

Figure 27 shows an inductance, a capacitance, and a resistance arranged in series, with a variable frequency source, E , of a.c. applied across the combination.

Some resistance is always present in a circuit because it is possessed in some degree by both the inductor and the capacitor. If the frequency of the alternator E is varied from nearly zero to some high frequency, there will be one particular frequency at which the inductive reactance and capacitive reactance will be equal. This is known as the *resonant frequency*, and in a series circuit it is the frequency at which the circuit current will be a maximum. Such series resonant circuits are chiefly used when it is desirable to allow a certain frequency to pass through the circuit (low impedance to this frequency), while at the same time the circuit is made to offer considerable opposition to currents of other frequencies.

If the values of inductance and capacity both are fixed, there will be only one resonant frequency.

For mechanical reasons, it is more common to change the capacitance rather than the inductance when a circuit is tuned, yet the inductance can be made variable if desired.

In the following table there are five radically different ratios of L to C (inductance to capacitance) each of which satisfies the resonant condition, $X_L = X_C$. When the frequency is constant, L must increase and C must decrease in order to give equal reactance. Figure 28 shows how the two reactances change with frequency; this illustration will greatly aid in clarifying this discussion.

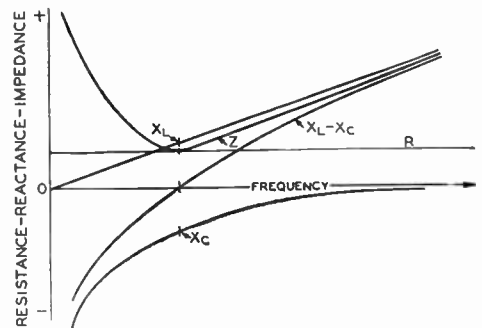

Figure 28.
 Variation in reactance and impedance of a series resonant circuit with changing frequency.

If both the inductance and capacitance are made variable, the circuit may then be changed or *tuned*, so that a number of combinations of inductance and capacitance can resonate at the same frequency. This can be more easily understood when one considers that inductive reactance and capacitive reactance travel in opposite directions as the frequency is changed. For example, if the frequency were to remain constant and the values of inductance and capacitance were then changed, the following combinations would have equal reactance:

Frequency is constant at 60 cycles.

L is expressed in henrys.

C is expressed in microfarads (.000001 farad.)

| L | X _L | C | X _C |
|----------|----------------|--------|----------------|
| .265 | 100 | 26.5 | 100 |
| 2.65 | 1,000 | 2.65 | 1,000 |
| 26.5 | 10,000 | .265 | 10,000 |
| 265.00 | 100,000 | .0265 | 100,000 |
| 2,650.00 | 1,000,000 | .00265 | 1,000,000 |

Frequency of Resonance From the formula for resonance,

$$2\pi fL = \frac{1}{2\pi fC}, \text{ the resonant frequency}$$

can readily be solved. In order to isolate f on one side of the equation, merely multiply both sides by 2πf, thus giving:

$$4\pi^2 f^2 L = \frac{1}{C}.$$

Divided by the quantity 4π²L, the result is:

$$f^2 = \frac{1}{4\pi^2 LC}.$$

Then, by taking the square root of both sides:

$$f = \frac{1}{2\pi \sqrt{LC}},$$

where f = frequency in cycles,
L = inductance in henrys,
C = capacity in farads.

It is more convenient to express L and C in smaller units, especially in making radio-frequency calculations; f can also be expressed in megacycles or kilocycles. A very useful group of such formulas is:

$$f^2 = \frac{25,330}{LC} \text{ or } L = \frac{25,330}{f^2 C} \text{ or } C = \frac{25,330}{f^2 L}$$

where f = frequency in megacycles,
L = inductance in microhenrys,
C = capacity in micromicrofarads.

Impedance of Series Resonant Circuits The impedance across the terminals of a series resonant circuit (Figure 27) is:

$$Z = \sqrt{r^2 + (X_L - X_C)^2},$$

where Z = impedance in ohms,
r = resistance in ohms,
X_C = capacitive reactance in ohms,
X_L = inductive reactance in ohms.

From this equation, it can be seen that the impedance is equal to the vector sum of the circuit resistance and the *difference* between the two reactances. Since at the resonant frequency X_L equals X_C, the difference between them (Figure 28) is obviously zero, so that at resonance the impedance is simply equal to the resistance of the circuit; therefore, because the resistance of most normal radio-frequency circuits is of a very low order, the impedance is also low.

At frequencies higher and lower than the resonant frequency, the difference between the reactances will be a definite quantity and will add with the resistance to make the impedance higher and higher as the circuit is tuned off the resonant frequency.

If X_C should be greater than X_L, then the term (X_L - X_C) will give a negative number. However, this is nothing to worry about because when the difference is squared the product is always positive. This means that the smaller reactance is subtracted from the larger, regardless of whether it be capacitive or inductive, and the difference squared.

Current and Voltage in Series Resonant Circuits Formulas for calculating currents and voltages in a series resonant circuit are similar to those of Ohm's law.

$$I = \frac{E}{Z} \quad E = IZ$$

The complete equations:

$$I = \frac{E}{\sqrt{r^2 + (X_L - X_C)^2}}$$

$$E = I \sqrt{r^2 + (X_L - X_C)^2}$$

Inspection of the above formulas will show the following to apply to series resonant circuits: When the impedance is low, the current will be high; conversely, when the impedance is high, the current will be low.

Since it is known that the impedance will be very low at the resonant frequency, it follows that the current will be a maximum at this point. If a graph is plotted of the current against the frequency either side of resonance, the resultant curve becomes what is known as a *resonance curve*. Such a curve is shown in Figure 29, the frequency being plotted against *current* in the series resonant circuit.

Several factors will have an effect on the shape of this resonance curve, of which resistance and L-to-C ratio are the important con-

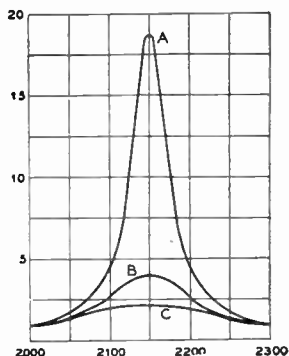

Figure 29.
Resonance curve showing the effect of resistance upon the selectivity of a tuned circuit. The curves apply to voltage in a parallel resonant circuit or to current in a series resonant circuit.

siderations. The curves B and C in Figure 29 show the effect of adding increasing values of resistance to the circuit. It will be seen that the peaks become less and less prominent as the resistance is increased; thus, it can be said that the *selectivity* of the circuit is thereby *decreased*. Selectivity in this case can be defined as the ability of a circuit to discriminate against frequencies adjacent to the resonant frequency.

Voltage Across Coil and Condenser in Series Circuit

Because the a.c. or r.f. voltage across a coil and condenser is proportional to the reactance (for a given current), the actual voltages across the coil and across the condenser may be many times greater than the *terminal* voltage of the circuit. Furthermore, since the individual reactances can be very high, the voltage across the condenser, for example, may be high enough to cause flashover, even though the applied voltage is of a value considerably below that at which the condenser is rated.

Circuit Q—Sharpness of Resonance

An extremely important property of a capacitance or an inductance is its factor-of-merit, more generally called its *Q*. It is this factor, *Q*, which primarily determines the sharpness of resonance of a tuned circuit. This factor can be expressed as the ratio of the reactance to the resistance, as follows:

$$Q = \frac{2\pi fL}{R}$$

where *R* = total resistance.

The actual resistance in a wire or inductance can be far greater than the d.c. value when

the coil is used in a radio-frequency circuit; this is because the current does not travel through the entire cross-section of the conductor, but has a tendency to travel closer and closer to the surface of the wire as the frequency is increased. This is known as the *skin effect*.

The actual current-carrying portion of the wire is decreased, therefore, and the resistance is increased. This effect becomes even more pronounced in square or rectangular conductors because the principal path of current flow tends to work outwardly toward the four edges of the wire.

Examination of the equation for *Q* may give rise to the thought that even though the resistance becomes greater with frequency, the inductive reactance does likewise, and that the *Q* might be a constant. In actual practice, however, this is true only at very low frequencies; the resistance usually increases more rapidly with frequency than does the reactance, with the result that *Q* normally decreases with increasing frequency.

The *Q* of a condenser ordinarily is much higher than that of the best coil. Therefore, it usually is the merit of the coil that limits the overall *Q* of the circuit.

At audio frequencies the core losses in an iron core inductance greatly reduce the *Q* from the value that would be obtained simply by dividing the reactance by the resistance. Obviously the core losses also represent circuit resistance, just as much so as though the loss occurred in the wire itself.

Parallel Resonance

In radio circuits, parallel resonance (more correctly termed *antiresonance*) is more frequently encountered than series resonance; in fact, it is the basic foundation of receiver and transmitter circuit operation. A circuit is shown in Figure 30.

The "Tank" Circuit

In this circuit, as contrasted with a circuit for series resonance, *L* (inductance) and *C* (capacitance) are connected in *parallel*, yet the *combination* can be considered to be in series with the remainder of the circuit. This combination of *L* and *C*, in conjunction with *R*, the resistance which is principally included in *L*, is sometimes called a *tank* circuit because it effectively functions as a storage tank when incorporated in vacuum tube circuits.

Contrasted with series resonance, there are two kinds of current which must be considered in a parallel resonant circuit: (1) the line current, as read on the indicating meter *M*₁, (2) the circulating current which flows within the parallel *L-C-R* portion of the circuit. See Figure 30.

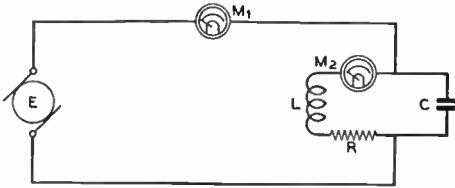

Figure 30.

THE PARALLEL RESONANT (ANTI-RESONANT) TANK CIRCUIT.

L and C comprise the reactive elements of the tank and R indicates the r.f. resistance of the coil. (A good condenser has such low r.f. resistance that it is small in proportion to that of a coil, and therefore can be ignored.)

M₁ indicates what is called the "line current" or the current that keeps the tank in a state of oscillation.

M₂ indicates the "tank current," which is many times greater than the line current if the circuit Q is high (resistance low).

At the resonant frequency, the line current (as read on the meter M₁) will drop to a very low value, although the circulating current in the L-C circuit may be quite large. It is interesting to note that the parallel resonant circuit acts in a distinctly opposite manner to that of a series resonant circuit, in which the current is at a maximum and the impedance is minimum at resonance. It is for this reason that in a parallel resonant circuit the principal consideration is one of impedance rather than current. It is also significant that the impedance curve for parallel circuits is very nearly identical to that of the current curve for series resonance. The impedance at resonance is expressed as:

$$Z = \frac{(2\pi fL)^2}{R}$$

- where Z = impedance in ohms,
- L = inductance in henrys,
- f = frequency in cycles,
- R = resistance in ohms.

Or, impedance can be expressed as a function of Q as:

$$Z = 2\pi fLQ$$

showing that the impedance of a circuit is directly proportional to its Q at resonance.

The curves illustrated in Figure 29 can be applied to parallel resonance. Reference to the curve will show that the effect of adding resistance to the circuit will result in both a broadening out and a lowering of the peak of the curve. Since the voltage of the circuit is directly proportional to the impedance, and since it is this voltage that is applied to the grid of the vacuum tube in a detector or amplifier circuit, the impedance curve must have a sharp peak in order for the circuit to be selective. If the curve is broad-topped in shape,

both the desired signal and the interfering signals at close proximity to resonance will give nearly equal voltages on the grid of the tube, and the circuit will then be non-selective; i.e., it will tune broadly.

Effect of L/C Ratio in Parallel Circuits

In order that the highest possible voltage can be developed across

a parallel resonant circuit, the impedance of this circuit must be very high. The impedance will be greater when the ratio of inductance-to-capacitance is great, that is, when L is large as compared with C. When the resistance of the circuit is very low, X_L will equal X_C at maximum impedance. There are innumerable ratios of L and C that will have equal reactance, at a given resonant frequency, exactly as is the case in a series resonant circuit.

In practice, where a certain value of inductance is tuned by a variable capacitance over a fairly wide range in frequency, the L/C ratio will be small at the lowest frequency and large at the high-frequency end. The circuit, therefore, will have unequal gain and selectivity at the two ends of the band of frequencies which is being tuned. Increasing the Q of the circuit (lowering the resistance) will obviously increase both the selectivity and gain.

Circulating Tank Current of Resonance

The Q of a circuit has a definite bearing on the circulating

tank current at resonance. This tank current is very nearly the value of the line current multiplied by the circuit Q. For example: an r.f. line current of 0.050 amperes, with a circuit Q of 100, will give a circulating tank current of approximately 5 amperes. From this it can be seen that the inductance and connecting wires in a circuit with a high Q must be of very low resistance, particularly in the case of high power transmitters, if heat losses are to be held to a minimum.

Because the voltage across the tank at resonance is determined by the Q, it is possible to develop very high peak voltages across a high Q tank with but little line current.

Effect of Coupling on Impedance

If a parallel resonant circuit is coupled to another circuit, such

as an antenna output circuit, the impedance of the parallel circuit is decreased as the coupling becomes closer. The effect of closer (tighter) coupling is the same as though an actual resistance were added to the parallel circuit. The resistance thus coupled into the tank circuit can be considered as being reflected from the output or load circuit to the driver circuit.

**Tank Circuit
Flywheel Effect**

When the plate circuit of a class B or class C operated tube (defined in the following chapter) is connected to a parallel resonant circuit, the plate current serves to maintain this L/C circuit in a state of oscillation.

The plate current is supplied in short pulses which do not begin to resemble a sine wave, even though the grid may be excited by a sine-wave voltage. These spurts of plate current are converted into a sine wave in the plate tank circuit by virtue of the "Q" or "flywheel effect" of the tank.

If a tank did not have some resistance losses, it would, when given a "kick" with a single pulse, continue to oscillate indefinitely. With a moderate amount of resistance or "friction" in the circuit the tank will still have inertia, and continue to oscillate with decreasing amplitude for a time after being given a "kick." With such a circuit, almost pure sine-wave voltage will be developed across the tank circuit even though power is supplied to the tank in short kicks or spurts, so long as the spurts are evenly spaced with respect to time and have a frequency that is the same as the resonant frequency of the tank.

Another way to visualize the action of the tank is to recall that a resonant tank with moderate Q will discriminate strongly against harmonics of the resonant frequency. The distorted plate current pulse in a class C amplifier contains not only the fundamental frequency (that of the grid excitation voltage) but also higher harmonics. As the tank offers low impedance to the harmonics and high impedance to the fundamental (being resonant to the latter), only the fundamental—or sine-wave voltage—appears across the tank circuit in substantial magnitude.

Transformers

When two coils are placed in such inductive relation to each other that the lines of force from one cut across the turns of the other and induce a voltage in so doing, the combination can be called a *transformer*. The name is derived from the fact that energy is transformed from one voltage into another. The inductance in which the original flux is produced is called the *primary*; the inductance which *receives* the induced voltage is called the *secondary*. In a radio receiver power transformer, for example, the coil through which the 110-volt a.c. passes is the *primary*, and the coil from which a higher or lower voltage than the a.c. line potential is obtained is the *secondary*.

Transformers can have either air or magnetic cores, depending upon whether they are to be operated at radio or audio frequencies. The reader should thoroughly impress upon

his mind the fact that current can be transferred from one circuit to another *only* if the primary current is changing or alternating. From this it can be seen that a power transformer cannot possibly function as such when the primary is supplied with non-pulsating d.c.

A power transformer usually has a magnetic core which consists of laminations of iron, built up into a square or rectangular form, with a center opening or window. The secondary windings may be several in number, each perhaps delivering a different voltage. The secondary voltages will be proportional to the number of turns and to the primary voltage.

If a primary winding has an a.c. potential of 110 volts applied to 220 turns of wire on the primary, it is evident that this winding will have 2 turns per volt. A secondary winding of 10 turns, wound on the transformer core, would have a potential of 5 volts. If the secondary winding has 500 turns, the potential would be 250 volts, etc. Thus, a transformer can be designed to have either a step-up or step-down ratio, or both simultaneously. The same applies to air core transformers for radio-frequency circuits.

**Transformer
Action**

Transformers are used in alternating current circuits to transfer power at one voltage and impedance to another circuit at another voltage and impedance. There are three main classifications of transformers: those made for use in power-frequency circuits (25, 50, and 60 cycles), those made for use at radio frequencies, and those made for audio-frequency applications. Power transformers will be discussed in the section devoted to *Power Supplies*, and r.f. transformers are analyzed later on in this chapter; a few of the pertinent facts concerning audio transformers will be covered in the following paragraphs.

**Impedance Matching
in Audio Circuits**

In most audio applications it will be the function of the audio transformer to match the impedance of the plate circuit of a vacuum-tube amplifier to a load circuit of a different impedance.

In all audio-frequency circuit applications, it is only necessary to refer to the *tube tables* in this book in order to find the recommended load impedance for a given tube and a given set of operating conditions. For example, the tables show that a type 42 pentode tube requires a load impedance of 7000 ohms. Audio transformers are always rated for both their primary and secondary impedance, which means that the primary impedance will be of the rated value *only* when the secondary is terminated in its rated impedance.

If a 7000-ohm plate load is to work into a

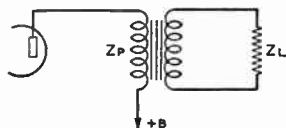

Figure 31.

The reflected impedance Z_p varies directly in proportion to Z_L and in proportion to the square of the turns ratio.

7-ohm loudspeaker voice coil, the impedance ratio of the transformer would be $\frac{7000}{7} =$

1000-to-1. Hence, the turns-ratio will be the square root of 1000, or 31.6. This does not mean that the primary will have only 31.6 turns of wire and only 1 turn on the secondary. The primary must have a certain *inductance* in order to offer a high impedance to the lower audio frequencies. Consequently, it must have a large number of turns of wire in the primary winding.

To summarize, a certain transformer will have a certain impedance ratio (determined by the square of the turns ratio) which will remain constant. If the transformer is terminated with an impedance or resistance *lower* than the original rated value, the reflected impedance on the primary will also be lower than the rated value. If the transformer is terminated in an impedance *higher* than rated, the reflected primary impedance will be higher.

For push-pull amplifiers the recommended primary impedance is stated as some certain value, *plate to plate*; this refers to the impedance of the total winding without consideration of the center tap. The reflected impedance across the total primary will follow the same rules as previously given for single-ended stages.

The voltage relationship in primary and secondary is the same as the turns ratio. For a step-down turns ratio of 10-to-1, the corresponding *voltage* step-down ratio would be 10-to-1 though the *impedance* ratio would be 100-to-1. This information is useful when it is desired to convert the turns ratios given on certain types of driver transformers into impedance ratios.

The same type of reasoning and subsequent calculation would be used in determining the turns ratio for a modulation transformer to couple a certain pair of class B modulators to a class C final amplifier. The recommended plate-to-plate load impedance for the modulator tubes can be obtained from the tube tables given later on. The final amplifier load resistance is then determined by dividing its plate voltage by the plate current at which it is to operate. The turns ratio of the modulation

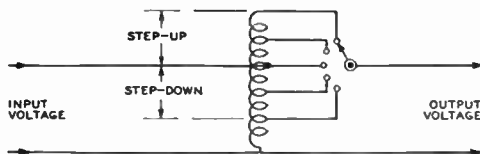

Figure 32.

Schematic diagram of an auto-transformer showing the method of connecting it to the line and to the load. When only a small amount of step up or step down is to be employed, the auto transformer may be much smaller physically for a given power than would be a transformer with isolated primary and secondary.

transformer is then equal to the square root of the ratio between the modulator load impedance and the amplifier load resistance; the transformer may be either step-up or step-down, as the case may be.

The Auto Transformer

The type of transformer in Figure 32, when wound with heavy wire over an iron core, is a common device in primary power circuits for the purpose of increasing or decreasing the line voltage. In effect, it is merely a continuous winding with taps taken at various points along the winding, the input voltage being applied to the bottom and also to one tap on the winding. If the output is taken from this same tap, the voltage ratio will be 1-to-1; i.e., the input voltage will be the same as the output voltage. On the other hand, if the output tap is moved down toward the common terminal, there will be a step-down in the turns ratio with a consequent step-down in voltage.

The opposite holds true if the output terminal is moved upward from the middle input terminal; there will be a voltage step-up in this case. The initial setting of the middle input tap is chosen so that the number of turns will have sufficient reactance to keep the no-load primary current at a reasonably low value.

In the same manner as voltage is stepped up and down by changing the number of turns in a winding, so can impedance be stepped up or down. Figure 33A shows an application of this principle as applied to a vacuum tube circuit which couples one circuit to another.

Assuming that the grid impedance may be of a lower value than the desired load impedance on the preceding stage, a step-down ratio will be necessary in order to give maximum transfer of energy. In B of Figure 33 the grid impedance is very high as compared with the tank impedance of the driver stage, and thus there is required a step-up ratio to the grid. The driver plate is tapped down on its plate tank coil in order to make this impedance step-up possible. A driver tube with very low plate impedance

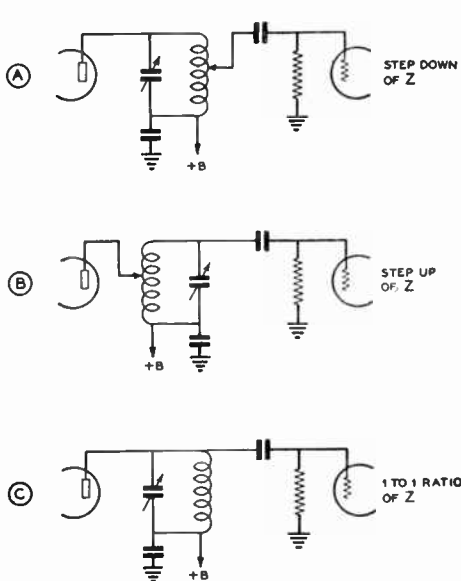

Figure 33.

Impedance step up and step down may be obtained by utilizing the plate tank circuit of a vacuum tube as an auto-transformer. In this manner the dynamic plate load on the tube can be made any desired value.

must be used if a good order of plate efficiency is to be realized.

In C of Figure 33, the grid impedance very closely approximates the desired plate load impedance, and this connection is used when no transformation is required.

**Inductive Coupling—
The Radio-Frequency
Transformer**

Inductive coupling is often used when two circuits are to be coupled. This method of coupling is shown in Figures 34A and 34B.

The two inductances are placed in such inductive relation to each other that the lines of force from the primary coil cut across the turns of the secondary coil, thereby inducing a voltage in the secondary. As in the case of capacitive coupling, impedance transformation here again becomes of importance. If two parallel tuned circuits are coupled very closely together, the circuits can in reality be over-coupled. This is illustrated by the curve in Figure 35.

The dotted line, curve A, is the original curve or that of the primary coil alone. Curve B shows what takes place when two circuits are overcoupled; the resonance curve will have a definite dip on the peak, or a double hump. This principle of overcoupling is advantageously utilized in bandpass circuits where, as

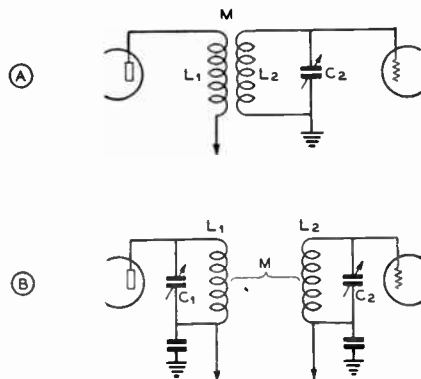

Figure 34.

Two commonly used types of inductive coupling between radio frequency circuits. With the arrangement at "A," the coupling between L_1 and L_2 is made quite close.

shown in C, the coupling is adjusted to such a value as to reduce the peak of the curve to a virtual flat top, with no dip in the center as in B.

Some undesirable capacitive coupling may result when circuits are closely or tightly coupled; if this capacitive coupling is appreciable, the tuning of the circuits will be affected. The amount of capacitive coupling can be reduced by so arranging the physical shape of the inductances as to enable only a minimum surface of one to be presented to the other.

Another method of accomplishing the same purpose is by electrical means. A curtain of closely-spaced parallel wires or bars, connected together only at one end, and with this end connected to ground, will allow electromagnetic coupling but not electrostatic coupling. Such a device is called a *Faraday screen*.

Link Coupling

Still another method of decreasing capacitive coupling is by means of a *coupling link* circuit between two parallel resonant circuits. The capacity of the coupling link, which has but few turns, is so small as to be negligible. Also, one side of the link is often grounded to reduce further any capacitive coupling that may exist.

Link coupling is widely used in transmitter circuits because it adapts itself so universally and eliminates the need of a radio-frequency choke. Link coupling is very simple; it is diagrammed in A and B of Figure 36.

In A of Figure 36, there is an impedance step-down from the primary coil to the link circuit. This means that the line which connects the two links or loops will have a low impedance and therefore can be carried over

a considerable distance without introduction of appreciable loss. A similar link or loop is at the output end of the line; this loop is coupled to the grid tank of the driven stage.

Still another link coupling method is shown in B of Figure 36. It is similar to that of A, with the exception that the primary line is tapped on the coil, rather than being terminated in a link or loop.

Unity Coupling Another commonly used type of coupling is that known as *unity coupling*, by reason of the fact that the turns ratio between primary and secondary is 1-to-1 and the coupling is the closest possible. This method of coupling is illustrated in C of Figure 36. Only one of the windings is tuned, although the interwinding of the two coils gives an effect in the untuned winding as though it were actually tuned with a condenser.

Coefficient of Coupling The term *coefficient of coupling* is used to indicate the degree of coupling between two circuits, and in the case of inductively coupled circuits is the ratio of the mutual inductance actually present to the maximum mutual inductance theoretically obtainable with the two coils. It can be seen that the coefficient of coupling, often designated as K, cannot have a value greater than 1. The coefficient is the ratio of the mutual inductance to the geometric mean of the two inductances, as follows:

$$K = \frac{M}{\sqrt{L_1 L_2}}$$

where M is the mutual inductance and L₁ and L₂ are the individual inductances

A coefficient of coupling of, say, 0.23 sometimes is expressed as a coefficient of 23 per cent.

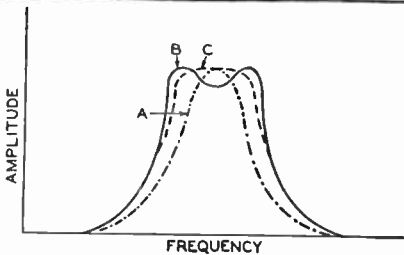

Figure 35.

EFFECT OF COUPLING BETWEEN CIRCUITS UPON THE RESONANCE CURVE.

Curve A indicates the curve when the circuits are under coupled, B is the curve resulting from over coupling, and C is the curve resulting from a critical value of intermediate coupling, called "critical coupling."

Critical Coupling As the coupling between two resonant tank circuits is increased, a point is reached where closer coupling will not increase the current flowing in the secondary or "load tank." As the coupling coefficient is increased appreciably beyond this value, which is called *critical coupling*, two resonance peaks appear, as illustrated by curve B in Figure 35.

The coupling coefficient which gives critical coupling is dependent upon the Q of each tank circuit. As either tank is more heavily loaded, a higher value of coupling coefficient is required to reach critical coupling.

$$\text{Critical coupling} = \frac{1}{\sqrt{Q_p Q_s}}$$

In using this formula it should be borne in mind that the effective Q of a tank is determined not just by the losses in the coil and condenser, but also by the order of resistance coupled into the tank by an antenna, the plate resistance of a tube, or any other resistance that is either in series with the tank or in shunt with any part of it.

It is interesting and important to note that maximum power may be delivered to the secondary of a tuned transformer with *very loose coupling between the two coils* if both circuits have a high Q.

Resonant circuits also can be coupled by means of mutual resistance or capacitance, as

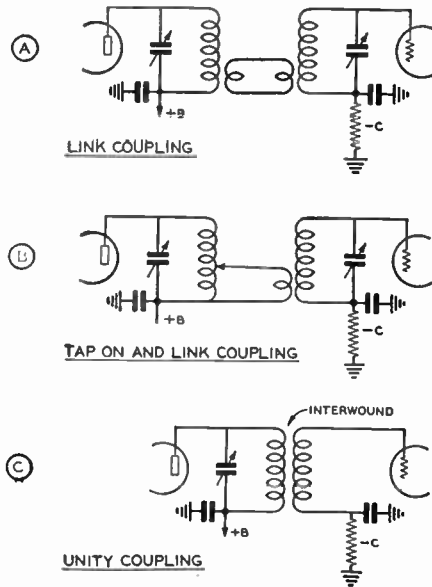

Figure 36.

Two types of link (inductive) coupling and (C) unity coupling.

well as by mutual inductance. The only requirement is that there be mutual *impedance*, which means an impedance common to both tanks. Most of the remarks that have been made pertaining to inductive coupling also apply (at least substantially so) to other forms of impedance coupling between resonant circuits. However, as inductive coupling is by far the most common method of coupling two tuned circuits, the others will not be given special treatment.

Electric Filters Broadly speaking, any combination of inductance and capacity in a circuit, or a combination of resistance with either inductance or capacitance, is termed a *filter*, as it will favor certain frequencies and discriminate against certain frequencies.

There are many applications where it is desirable to pass a d.c. component without passing a superimposed a.c. component, or to pass all frequencies above or below a certain frequency while rejecting or attenuating all others, or to pass only a certain band or bands of frequencies while attenuating all others.

All of these things can be done by suitable combinations of inductance, capacity, and resistance. However, as whole books have been devoted to nothing but electric filters, it can be appreciated that it is possible only to touch upon them superficially in a book which covers general radio theory in a single chapter.

A filter acts by virtue of its property of offering very high impedance to the undesired frequencies, while offering but little impedance to the desired frequencies. This will also apply

to d.c. with a superimposed a.c. component, as d.c. can be considered as an alternating current of zero frequency so far as filter discussion goes.

When it is desired to reject or pass only a single frequency or else a very narrow band of frequencies, a resonant circuit often is used as a filter. To reject a certain frequency a series resonant circuit may be placed across the load or a parallel resonant (anti-resonant) circuit placed in series with the load. To pass a certain frequency while rejecting others, the series circuit is placed in series with the load or the parallel circuit across the load. The attenuation will be determined by the effective Q of the L-C resonant circuit. When greater attenuation than is obtained with one high Q circuit is required, two or more such resonant circuits are employed, each circuit contributing additional attenuation.

When it is desired to pass or reject a slightly wider band of frequencies, overcoupled tank circuits often are employed. (Refer to Figure 35.) This increases the bandwidth somewhat, at the same time maintaining good attenuation of the unwanted frequencies.

If the band of frequencies to be passed exceeds one octave (2/1), or if it is desired to pass all frequencies above or below a certain *cut off frequency*, then it is more common practice to use L, T, or π section filters. Such filters are shown in Figure 37. Sometimes the filter is comprised of several sections, and is best analyzed by breaking it down into its individual component sections. A properly designed filter is designed to work into a load of a certain impedance, usually a pure resistance. For a given cut off frequency, the higher the load resistance the higher will be the proper value of inductance and the lower the correct value of capacity.

Even the best filter that can be built will not pass frequencies immediately adjacent to the cut off frequency on one side while completely rejecting frequencies immediately adjacent on the other side of the cut off frequency. Instead there is an *attenuation* of the unwanted frequencies, which in the simpler filters increases steadily as the frequency is removed from cut-off.

The rapidity of attenuation (usually expressed in *decibels*) also is expressed as *sharpness of cut off*. A filter which exhibits high attenuation to frequencies only slightly removed from the cut off frequency is said to have *sharp cut off*.

Band-pass filters designed to pass a wide band of frequencies most often are made up of cascaded high-pass sections and low-pass sections.

Where great attenuation is not required, and where some attenuation within the pass

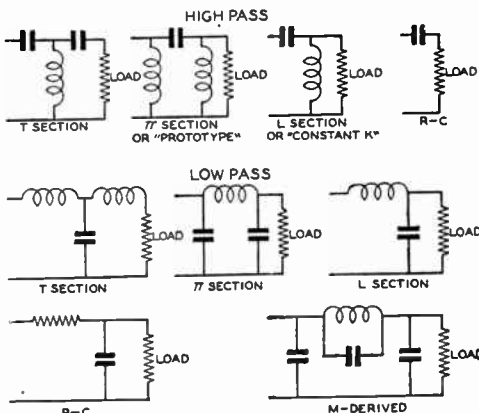

Figure 37.

Several types of filter circuits commonly employed in radio equipment. A high-pass filter and a low-pass filter may be used in combination to form a "band pass" filter.

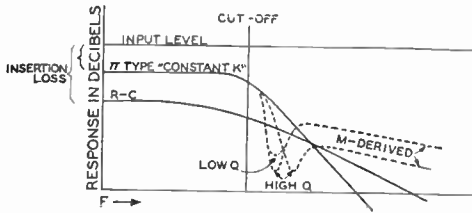

Figure 38.
TYPICAL RESPONSE CURVES OF COMMON LOW-PASS FILTER CIRCUITS.

band is not objectionable, then either the inductive components or the capacitive components sometimes are replaced by resistors of suitable rating. The most common filter of this type is the low pass "R-C filter" consisting of series resistance and shunt capacitance, widely used for decoupling between circuits and for filtering power supply ripple out of direct current voltages. Such filters are practicable only where the direct current is comparatively low, or where considerable d.c. voltage drop can be tolerated or is desired.

Sometimes a shunt or series element of an L-C filter is resonated with a reactance of opposite sign. When this is done, the section is known as an *M-derived* section. If the complementary reactance is added to a series arm, the section is said to be *shunt derived*; if added to the shunt arm, *series derived*.

A derived filter has sharper cut off than a regular constant K filter, but has less attenuation than the constant K section at frequencies far removed from cut off. The effect of resonating the series inductance of a π section filter to form an M-derived filter is shown in Figure 38. The "notch" frequency is determined by the resonant frequency of the filter element which is tuned. The closer the resonant frequency is made to cut off, the sharper will be the cut off attenuation, but the less will be the attenuation at several times the cut off frequency.

The amount of attenuation obtained at the "notch" when a derived section is used is determined by the effective Q of the resonant arm.

Oftentimes a K section and a derived section are cascaded to obtain the combined characteristic of sharp cut off and good remote-frequency attenuation. Such a filter is known as a *composite filter*.

All filters have some *insertion loss*. This is the attenuation (substantially uniform) provided to frequencies within the pass band. The insertion loss varies with the kind of filter, the Q of capacitors and inductors used, and the type termination employed.

A properly terminated filter section acts, at

frequencies within the pass band, very much like a section of transmission line (described in Chapter 20). However, the phase shift through the filter is not proportional to frequency, while with a terminated transmission line it very nearly is so. Because a filter can be made to simulate a section of transmission line, filters sometimes are termed *artificial lines*.

A section of transmission line, on the other hand, when either *shorted* or *open circuited* at the ends will act very much like a resonant tank circuit. A detailed discussion is given in Chapter 17.

Conduction of an Electric Current

So far this chapter has dealt only with the conduction of current by a stream of electrons through a conductor or by electrostatic coupling through a capacitor. While this is the most common method of transmission, there are other types of conduction which are equally important in their respective branches of the field. An electric current may also be transmitted by the motion of minute particles of matter, by the motion of charged atoms called *ions*, and by a stream of electrons in a vacuum.

The carrying of current by charged particles, such as bits of dust, is only of academic interest in radio. However, there is a commercial process (called the Cottrell process) which uses this type of conduction in industrial dust precipitation. A highly charged wire inside a grounded metal chamber is placed so that the dust-laden flue gases from certain industrial processes (usually metallurgic refining) must pass through the chamber. The dust particles are first attracted to the wire; there they attain a high electric charge which causes them to be attracted to the sides of the chamber where they are precipitated and subsequently collected. A small electric current between the center electrode and the chamber is the result of the carrying of the charges by the dust particles.

Conduction by Ions When a high enough voltage is placed between two terminals in air or any other gas,

that gas will break down suddenly, the resistance between the two points will drop from an extremely high value to a very low value, and a comparatively large electric current will flow to the accompaniment of an amount of visible light either as a flash, an arc, a spark, or a colored discharge such as is found in the "neon" sign. This type of conduction is due to gas ions which are generated when the electric stress between the two points becomes so great that electrons are torn from the molecules of the gas with the production of a quantity of

positively charged gas ions and negative electrons. The breakdown voltage for a particular gas is dependent upon the pressure, the spacing of the electrodes, and the type of electrodes.

Lightning, tank condenser flashovers, and ignition sparks in an automobile are such discharges that occur at atmospheric pressure or above. However, the pressure of the gas is usually reduced to facilitate the ease of breakdown of the gas, as in the "neon" sign, mercury-vapor lamp, or voltage regulator tubes such as the VR-150-30. If a heated filament is used as one electrode in the discharge chamber, the breakdown voltage is further reduced to a value called the *ionization potential* of the gas. This principle is used in the 866, the 83, and other mercury-vapor rectifiers. Through the use of the heated cathode, the break-down potential is reduced from about 10,000 volts to approximately 15 volts and the conduction of electric current is made unidirectional, enabling the discharge chamber to be used as a rectifier. The applications of the principle of ionic conduction in vacuum tubes (along with discussion of electronic conduction) will be covered in more detail in the chapter devoted to *Vacuum Tube Theory*.

The emission of colored light which accompanies an electric discharge through a gas is due to the re-combination of the ionized gas molecules and the free electrons to form neutral gas molecules. There is a definite color spectrum which is characteristic of every gas—and for that matter for every element when it is in the gaseous state. For neon this color is orange-red, for mercury it is blue-violet, for sodium, almost pure yellow—and so on through the list of the elements. This principle is used in the spectroscopic identification of elements by their characteristic lines in the spectrum (called Fraunhofer lines).

Electrolytic Conduction

Nearly all inorganic chemical compounds (and a few organic ones of certain molecular structure) when dissolved in water undergo a chemical-electrical change known as *electrolytic disassociation* which results in the production of ions similar in certain properties to those formed as a result of the electric breakdown of a gas. For example, when sodium chloride or table salt is dissolved in water a certain percentage of it ionizes or breaks down into positively charged sodium ions, or sodium atoms with a deficiency of one electron, and negatively charged chloride ions, or chlorine atoms with one excess electron. Similarly, sodium hydroxide disassociates into positive sodium ions and negative hydroxyl ions—sulfuric acid into positive hydrogen ions and negative sulfate ions.

This solution of an ionized compound and

water renders the aqueous solution a conductor of electricity. (Water in the pure form is a good insulator.) The conductivity of the solution is proportional to the mobility of the ions and to the quantity of them available in the solution. Maximum conductivity is had not when there is a maximum of the compound in solution but rather when there is a maximum of ions in solution; this condition is ordinarily obtained when neither concentrated nor dilute but about midway between. Maximum conductivity in a sulfuric acid solution as used in storage batteries is obtained when there is about 30 per cent by weight of the acid in solution in the water. It is for this reason that acid of about 30 per cent concentration is used as an electrolyte in storage batteries.

Conduction of electricity through an *electrolyte*, as a conducting solution is called, is made possible by the mobility of the charged ions in solution. When a positively and a negatively charged wire are placed in an electrolyte the negative ions are attracted to the positive wire and the positive ions are attracted to the negative wire. As the ions reach the wire carrying the charge opposite to their own, their excess or their deficiency of electrons is neutralized by the respective deficiency or excess of electrons on the wire, and the ion changes from the ionic to the atomic or molecular state. If the ion happened to be that of a metal such as copper, copper will be *plated* upon the negative electrode that had been placed into the solution; if the negative ion was that of chlorine (the chloride ion), then chlorine in the gaseous form will appear at the positive electrode. The conduction of an electric current through an electrolyte always results in a chemical change in the electrolyte. This fact is employed commercially in electroplating and electrolytic refining processes.

The Primary Cell

If two dissimilar metals are placed in an electrolyte a potential difference will appear between the two materials. This postulate is employed commercially in the primary cell, or "dry cell" as it is somewhat incorrectly called.

The operation of the primary cell depends upon the differences in the two electro-chemical constants for the materials used as the electrodes. With the zinc and carbon used in the dry cell (with a paste containing ammonium chloride as the electrolyte) the potential is 1.53 volts. With other electrolytes and electrodes the potential output of the cell varies from 0.7 to 2.5 volts.

When current is taken from a primary cell, the negative electrode (usually the zinc container) dissolves in the electrolyte with the

production of hydrogen gas. If only the positive and the negative electrodes and the electrolyte were contained in the cell, this hydrogen gas would collect as a film on the surface of the negative electrode. When this film does form, the internal resistance of the cell increases due to the insulating properties of the film of gas. A cell is said to have become "polarized" when this has taken place. To reduce this effect, an oxidizing agent called a "depolarizer" (manganese dioxide, in the case of the dry cell) is incorporated into the electrolyte. If current is taken from the cell at a reasonable rate the depolarizer oxidizes the hydrogen into water as fast as it is formed. This formation of water as a result of the normal operation of the cell is one of the reasons that a dry cell "sweats" when it is approaching the end of its useful life.

Dry cells and batteries of them are very commonly employed in portable radio equipment as both filament and plate supply, and frequently as plate supply at locations where there is no source of alternating current.

**The Secondary Cell—
Storage Batteries**

The primary cell, as described in the preceding paragraphs, produces its voltage as a result of chemical action of the electrolyte on one of the elements. When the material comprising the ac-

tive element is used up, the cell is no longer useful and must be discarded. The secondary cell, on the other hand, is capable of being recharged to its original energy content when it has been depleted.

There are two common types of secondary cells: the *Edison cell*, which uses iron as the negative pole and nickel oxide as the positive in a 20 per cent solution of potassium hydroxide as the electrolyte; and the *lead cell*, which uses lead as the negative pole and lead dioxide as the positive pole in an electrolyte of 30 per cent sulfuric acid.

The Edison cell battery has longer life, and generally will stand more abuse than a lead-acid type battery. However, the lower cost of the latter type battery makes it much more widely used. The common automobile battery is a lead-acid type battery. The lead-acid type battery has a much lower internal resistance, which makes it much more suitable where heavy current must be delivered for a short time.

When a storage battery is being discharged, chemical energy is being converted into electrical energy. When the battery is being charged, by causing a reverse current to flow between electrodes, electrical energy is being converted to chemical energy. Actually, a battery cannot "store" electricity; only a condenser can do that.

Vacuum-Tube Theory

THE science of radio is based upon one of the most versatile developments of the twentieth century—the electron tube, or as it is more commonly named, the vacuum tube. It is the utilization of the unique characteristics of the vacuum tube in various circuit arrangements which makes possible modern radio communication; for that matter, long distance wire communication also owes its efficiency to the versatility of the vacuum tube.

This chapter is divided into two main sections. The first is devoted to the basic theory of the vacuum tube and to a discussion of the various types which have been developed up to the present time. The second part discusses the application of the vacuum tube to the various circuit arrangements which have been developed to utilize its characteristics.

Brief History of the Vacuum Tube

Thomas Edison is credited with the discovery that an additional wire or plate placed inside a lighted incandescent lamp would acquire a negative charge of electricity. J. A. Fleming undertook the study of his findings in 1895, and as a result of his findings in 1904 he patented the two-electrode tube or *diode* which became known as the Fleming valve. Then, in 1906, Lee de Forest discovered that a third element could be placed between the cathode and plate to control the flow of electrons from one to the other. This third element was called a *grid* from its physical resemblance to the grid or grate of a stove. The insertion of the grid into the space between the cathode and plate in the diode resulted in the most versatile of vacuum tubes, the triode.

In recent times other elements or grids have been added to the original triode to augment the electron flow in a particular manner, or to give a particular characteristic to the vacuum tube. These later types have been called *multi-element* tubes. The names for these multi-element tubes are obtained by adding the Greek prefix for the number of elements to the root

-ode: diode, triode, tetrode, pentode, hexode, and heptode respectively for tubes having two, three, four, five, six, and seven elements.

MECHANICS OF THE VACUUM TUBE

The original Edison discovery was that a heated filament would give off electrons to a cold plate in the same evacuated chamber. It was later discovered that if the plate were charged positively with respect to the filament, a much larger proportion of the emitted electrons would be attracted to the plate. But, if the plate were charged negatively with respect to the filament, the electron flow would stop. This valve action meant that the vacuum tube could be used as a rectifier since it would pass current only in one direction. It is this rectifying action of the diode which is used for the production of direct current from alternating current as supplied by the a.c. mains.

The discovery that additional elements could be placed between the cathode and plate to control the electron flow in any desired manner resulted in the simultaneous development of the vacuum tube and improvement of the radio art to make use of the greater capabilities of the improved tubes. In recent years, however, the improvement of the art has commonly come first, with improved types of tubes being developed as the need for them arose.

Thermionic Emission

The free electrons in any metal are continually in motion at all temperatures. But at ordinary atmospheric temperatures, these electrons do not have sufficient energy to penetrate the surface of the material. It is necessary that some form of external energy be supplied to the surface for emission to take place. When this energy supply is in the form of heat, the result is called thermionic emission; when the energy is in the form of light it is called photo-emission. The phenomena of photo-emission is applied in the photo-electric tube, while thermi-

onic emission supplies the electrons for the operation of the vacuum tube.

In order that thermionic emission may take place, it is necessary that the cathode or filament of the vacuum tube be heated to the point where the free electrons in the emitter have sufficient velocity to penetrate the surface. The degree of temperature to which the emitter must be heated varies greatly with the type of emitter. Since there are several types of emitters commonly found in present day transmitting and receiving tubes, these will be described separately.

Types of Emitters

Emitters as used in present-day vacuum tubes may be classed into two groups: the directly heated or filament type, and the indirectly heated or heater-cathode type.

Directly heated emitters may be further subdivided into three important groups, all of which are important and commonly used in modern tubes. These classifications are: the pure tungsten filament, the thoriated-tungsten filament, and the oxide-coated filament.

The Pure Tungsten Filament

Pure tungsten wire was used as the filament in nearly all the earlier transmitting and receiving tubes. However, the thermionic efficiency of tungsten wire as an emitter (the number of milliamperes emission per watt of filament heating power) is quite low, the filaments become fragile after use, their life is rather short, and they are susceptible to burnout at any time. Pure tungsten filaments must be run at bright white heat (about 2500° Kelvin). For these reasons, tungsten filaments have been replaced in all applications where another type of filament could be used. They are, however, still universally employed in most water-cooled tubes and in certain large, high-power air-cooled triodes where another filament type would be unsuitable. Tungsten filaments are the most satisfactory for high-power, high-voltage tubes where the emitter is subjected to positive ion bombardment due to the residual gas content of the tubes. Tungsten is not adversely affected by such bombardment.

The Thoriated-Tungsten Filament

In the course of experiments made upon tungsten emitters, it was found that filaments made from tungsten having a small amount of thoria (thorium oxide) as an impurity had much greater emission than those made from the pure metal. Subsequent improvements have resulted in the highly efficient carburized thoriated-tungsten fila-

ment as used in virtually all medium-power transmitting tubes today.

Thoriated-tungsten emitters consist of a tungsten wire containing about 1% thoria. The new filament is first carburized by heating it to a high temperature in an atmosphere containing a hydrocarbon at reduced pressure. Then the envelope is highly evacuated and the filament is flashed for a minute or two at about 2600° K before being burned at 2200° K for a longer period of time. The flashing causes some of the thoria to be reduced by the carbon to metallic thorium. The activating at a lower temperature allows the thorium to diffuse to the surface of the wire to form a layer of the metal one molecule thick. It is this single-molecule layer of thorium which reduces the work function of the tungsten filament to such a value that the electrons will be emitted from a thoriated filament thousands of times more rapidly than from a pure tungsten filament *operated at the same temperature.*

The carburization of the tungsten surface seems to form a layer of tungsten carbide which holds the thorium layer much more firmly than the plain tungsten surface. This allows the filament to be operated at a higher temperature, with consequent greater emission, for the same amount of thorium evaporation. Thorium evaporation from the surface is a natural consequence of the operation of the thoriated-tungsten filament. The carburized layer on the tungsten wire plays another role in acting as a reducing agent to produce new thorium from the thoria to replace that lost by evaporation. This new thorium continually diffuses to the surface during the normal operation of the filament.

One thing to remember about any type of filament, particularly the thoriated type, is that the emitter deteriorates practically as fast when "standing by" (no plate current) as it does with any normal amount of emission load. Also, a thoriated filament may be either temporarily or permanently damaged by a heavy overload which may strip the surface layer of thorium from the filament.

Reactivating Thoriated-Tungsten Filaments

Thoriated-tungsten filaments (and *only* thoriated-tungsten filaments) which have gone "flat" as a result of insufficient filament voltage, a severe temporary overload, a less severe extended overload, or even normal operation may quite frequently be reactivated to their original characteristics by a process similar to that of the original activation. However, only filaments which have been made by a reputable manufacturer and which have not approached too close to the end of their useful life may be successfully reactivated. The fila-

ment found in certain makes of tubes may be reactivated three or four times before it will cease to operate as a thoriated emitter.

The actual process of reactivation is simple enough and only requires a filament transformer with taps allowing voltage up to about 25 volts or so. The tube which has gone flat is placed in a socket to which only the two filament wires have been connected. The filament is then "flashed" for about 20 to 40 seconds at from $1\frac{1}{2}$ to 2 times normal rated voltage. The filament will become extremely bright during this time and, if there is still some thoria left in the tungsten and if the tube didn't originally fail as a result of an air leak, some of this thoria will be reduced to metallic thorium. The filament is then burned at 15 to 25 per cent overvoltage for from 30 minutes to 3 to 4 hours to bring this new thorium to the surface.

The tube should then be tested to see if it shows signs of renewed life. If it does, but is still weak, the burning process should be continued at about 10 to 15 per cent overvoltage for a few more hours. This should bring it back almost to normal. If the tube checks still very low after the first attempt at reactivation, the complete process can be repeated as a last effort.

Thoriated-tungsten filaments are operated at about 1900° K or at a bright yellow heat. A burnout at normal filament voltage is almost an unheard of occurrence. The ratings placed upon tubes by the manufacturers are figured for a life expectancy of 1000 hours. Certain types may give much longer life than this but the average transmitting tube will give from 1000 to 5000 hours of useful life.

The Oxide-Coated Filament The most *efficient* of all modern filaments is the oxide-coated type which consists of a mixture of barium and strontium oxides coated upon a wire or strip usually consisting of a nickel alloy. This type of filament operates at a dull-red to orange-red temperature (1050° to 1170° K) at which temperature it will emit large quantities of electrons. The oxide-coated filament is somewhat more efficient than the thoriated-tungsten type in small sizes and it is considerably less expensive to manufacture. For this reason all receiving tubes and quite a number of the low-powered transmitting tubes use the oxide-coated filament. Another advantage of the oxide-coated emitter is its extremely long life—the average tube can be expected to run from 3000 to 5000 hours, and when loaded very lightly, tubes of this type have been known to give 50,000 hours of life before their characteristics changed to any great extent.

The oxide-coated filament does have the dis-

advantage, however, that it is unsuitable for use in tubes which must withstand more than about 600 volts of plate potential. Some years back, transmitting tubes for operation up to 2000 volts were made with oxide-coated filaments but they have been discontinued. More satisfactory operation is obtainable at medium plate potentials with thoriated filaments.

Oxide filaments are unsatisfactory for use at high plate voltages because: (1) their activity is seriously impaired by the high temperature necessary to de-gas the high-voltage tubes and, (2) the positive ion bombardment which takes place even in the best evacuated high-voltage tube causes destruction of the oxide layer on the surface of the filament.

Oxide-coated filaments operate by virtue of a mono-molecular layer of alkaline-earth metal (barium and strontium) which forms on the surface of the oxide coating. Such filaments do not require reactivation since there is always more than sufficient reduction of the oxides and diffusion of the metals to the surface of the filament to meet the emission needs of the cathode.

Indirectly Heated Filaments The Heater Cathode

The heater type cathode was developed as a result of the requirement for a type of emitter which could be operated from alternating current and yet would not introduce a.c. ripple modulation even when used in low-level stages. It consists essentially of a small nickel-alloy cylinder with a coating of strontium and barium oxides on its surface similar to that used on the oxide-coated filament. Inside the cylinder is an insulated heater element consisting usually of a double spiral of tungsten wire. The heater may operate on any voltage from 2 to 117 volts, although 6.3 is by far the most common value. The heater is operated at quite a high temperature so that the cathode itself may be brought to operating temperature in a matter of 15 to 30 seconds. Heat coupling between the heater and the cathode is mainly by radiation, although there is some thermal conduction through the insulating coating on the heater wire, as this coating is also in contact with the cathode thimble.

Indirectly heated cathodes are employed in all a.c. operated tubes which are designed to operate at a low level either for r.f. or a.f. use. However, some receiver power tubes use heater cathodes (6L6, 6V6, 6F6, and 6B4G) as do some of the low-power transmitter tubes (802, 807, T21, and RK39). Heater cathodes are employed exclusively when a number of tubes are to be operated in series as in an a.c.-d.c. receiver. A heater cathode is often called a uni-potential cathode because there is no

voltage drop along its length as there is in the filament-type cathode.

Types of Vacuum Tubes

If a cathode capable of being heated either indirectly or directly is placed in an evacuated envelope along with a plate, such a two-element vacuum tube is called a diode. The diode is the simplest of all vacuum tubes and is the fundamental type from which all the others are derived; hence, the diode and its characteristics will be discussed first.

Characteristics of the Diode

When the cathode within a diode is heated, it will be found that a few of the electrons leaving the cathode will leave with sufficient velocity to reach the plate. If the plate is electrically connected back to the cathode, the electrons which have had sufficient velocity to arrive at the plate will flow back to the cathode through the external circuit. This small amount of initial plate current is an effect found in all two-element vacuum tubes.

If a battery or other source of d.c. voltage is placed in the external circuit between the plate and cathode so that it places a positive potential on the plate, the flow of current from the cathode to plate will be increased. This is due to the strong attraction offered by the positively charged plate for any negatively charged particles. If the positive potential on the plate is increased, the flow of electrons between the cathode and plate will also increase up to the

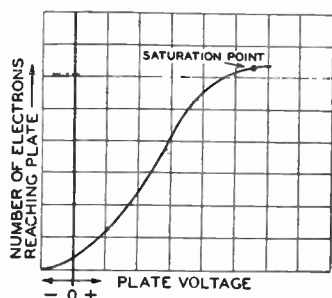

Figure 1.

CURVE SHOWING NUMBER OF ELECTRONS REACHING THE PLATE OF A DIODE PLOTTED AS A FUNCTION OF THE PLATE VOLTAGE.

It will be noticed that there is a small flow of plate current even with zero voltage. This initial flow can be stopped by a small negative plate potential. As the plate voltage is increased in a positive direction, the plate current increases approximately as the $3/2$ power of the plate voltage until the saturation point is reached. At this point all the electrons being emitted from the cathode are being attracted to the anode.

point of *saturation*. Saturation current flows when all of the electrons leaving the cathode are attracted to the plate, and no increase in plate voltage can increase the number of electrons being attracted.

The Space Charge Effect

As a cathode is heated so that it begins to emit, those electrons which have been discharged into the surrounding space form in the immediate vicinity of the cathode a negative charge which acts to repel those electrons which normally would be emitted were the charge not present. This cloud of electrons around the cathode is called the *space charge*. The electrons comprising the charge are continuously changing, since those electrons making up the original charge fall back into the cathode and are replaced by others emitted by it.

The effect of the space charge is to make the current through the tube variable with respect to the plate-to-cathode drop across it. As the plate voltage is increased, the positive charge of the plate tends to neutralize the negative space charge in the vicinity of the cathode. This neutralizing action upon the space charge by the increased plate voltage allows a greater number of electrons to be emitted from the cathode which, obviously, causes a greater plate current to flow. When the point is reached at which the space charge around the cathode is neutralized completely, all the electrons that the cathode is capable of emitting are being attracted to the plate and the tube is said to have reached *saturation* plate current as mentioned above.

Insertion of Grid—The Triode

If an element consisting of a mesh or spiral of wire is inserted concentric with the plate and between the plate and the cathode, such an element will be able to control by electrostatic action the cathode-to-plate current of the tube. The new element is called a grid, and a vacuum tube containing a cathode, grid, and plate is commonly called a triode.

If this new element through which the electrons must pass in their course from cathode to plate is made negative with respect to the cathode, the negative charge on this grid will effectively repel the negatively charged electrons (like charges repel; unlike charges attract) back into the space charge surrounding the cathode. Hence, the number of electrons which are able to pass through the grid mesh and reach the plate will be reduced, and the plate current will be reduced accordingly. As a matter of fact, if the charge on the grid is made sufficiently negative, all the electrons leaving the cathode will be repelled back to it

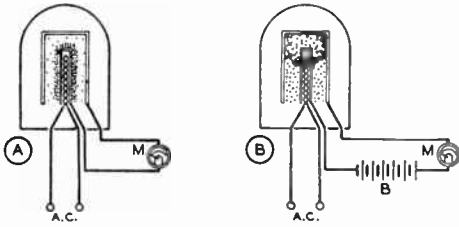

Figure 2.

ILLUSTRATING THE SPACE CHARGE EFFECT IN A DIODE.

(A) shows the space charge existing in the vicinity of the cathode with zero or a small amount of plate voltage. A few high-velocity electrons will reach the plate to give a small plate current even with no plate voltage. (B) shows how the space charge is neutralized and all the electrons emitted by the cathode are attracted to the plate with a battery sufficient to cause saturation plate current.

and the plate current will be reduced to zero. Any d.c. voltage placed upon a grid is called a *bias* (especially so when speaking of a control grid). The smallest negative voltage which will cause cutoff of plate current at a particular plate voltage is called the value of *cutoff bias*.

Figure 3 illustrates an analogy of the method in which the number of electrons flowing to the plate is controlled by the grid bias. Figure 4 graphically shows essentially the same information as shown in Figure 3; i.e., the manner in which the plate current of a typical triode will vary with different values of grid bias. Figure 4 also shows graphically the cut-off point, the approximately linear relation between grid bias and plate current over the operating range of the tube, and the point of plate current saturation. However, the point of plate current saturation comes at a different

position with a triode as compared to a diode. Plate current non-linearity or saturation may begin either at the point where the full emission capabilities of the filament have been reached, or at the point where the positive grid voltage approaches the positive plate voltage.

This latter point is commonly referred to as the *diode bend* and is caused by the positive voltage of the grid allowing it to rob from the current stream electrons that would normally go to the plate. When the plate voltage is low with respect to that required for full current from the cathode, the diode bend is reached before plate current saturation. When the plate voltage is high, saturation is reached first.

From the above it can be seen that the grid acts as a valve in controlling the electron flow from the cathode to the plate. As long as the grid is kept negative with respect to the cathode, only an extremely small amount of grid energy is required to control a comparatively large amount of plate power. Even if the grid is operated in the positive region a portion of the time, so that it will draw current, the grid energy requirements are still very much less than the energy controlled in the plate circuit. It is for this reason that a vacuum tube is commonly called a valve in British countries.

Interelectrode Capacitance

In the preceding chapter it was mentioned that two conductors separated by a dielectric form a *condenser*, or that there is *capacitance* between them. Since the electrodes in a vacuum tube are conductors and they are separated by a dielectric, vacuum, there is capacitance between them. Although the interelectrode capacitances are so small as to be of little consequence in audio-frequency work, they are large enough to be of considerable importance when the tubes are operated at radio frequencies.

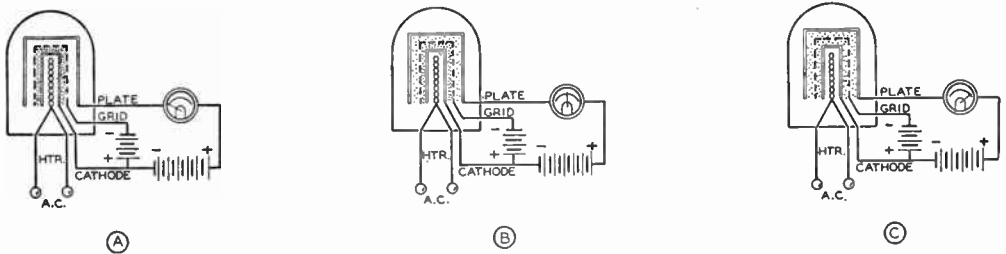

Figure 3.

ANALOGY OF THE ACTION OF THE GRID IN A TRIODE.

(A) shows the tube with cutoff bias on the grid. Note that all the electrons emitted by the cathode remain inside the grid mesh. (B) shows the same tube with an intermediate value of bias on the grid. Note the medium plate current and the fact that there is a reserve of electrons remaining within the grid mesh. (C) shows the tube with a value of grid bias (positive or negative) which allows virtually all the electrons emitted by the cathode to be attracted to the plate. Saturation plate current is attained in this case.

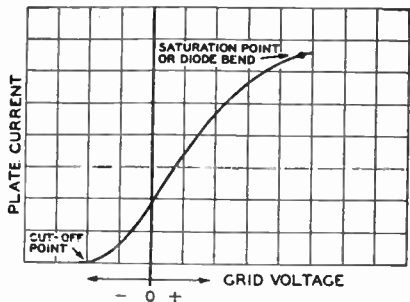

Figure 4.

PLATE CURRENT PLOTTED AGAINST GRID VOLTAGE, WITH CONSTANT PLATE VOLTAGE.

For values of grid bias between those which give plate current cutoff and plate current saturation, the value of plate current varies more or less linearly with respect to changes in grid voltage.

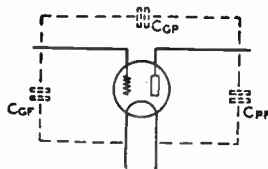

Figure 5.

STATIC INTERELECTRODE CAPACITANCES WITHIN A TRIODE.

Figure 5 shows the interelectrode capacitances of a triode as they appear to a circuit in which the tube is operating. The static capacitances are simply as shown in the drawing, but when a vacuum tube is actually operating as an amplifier there is another consideration known as the *Miller effect* which causes the dynamic input capacitance to be different from the static value. The output capacitance of an amplifier is essentially the same as the static value such as is given in the tube tables. The grid-to-plate capacity is also the same as the static value, but since the C_{gp} acts as a small condenser, coupling energy back from the plate to the grid circuit, the dynamic input capacitance is equal to the static value plus an amount determined by the gain of the stage and the grid-to-plate feedback capacity. Expressed as an equation:

$$C_{gf}(\text{dynamic}) = C_{gf}(\text{static}) + (M + 1) C_{gp}$$

where C_{gf} is the grid-to-filament capacitance, C_{gp} is the grid-to-plate capacitance, and M is the stage gain.

In addition to the undesirable Miller effect, whereby the input capacity of an amplifier is increased by the grid-to-plate capacity, this C_{gp} can also cause uncontrollable regeneration or oscillation in radio frequency amplifiers. However, all the undesirable effects of the grid-to-plate capacity can be balanced out by means of a neutralizing circuit. These circuits are discussed under *Neutralization* in the chapter devoted to *Transmitter Theory*.

Tetrode or Screen-Grid Tube

The quest for a simpler and more easily usable method of eliminating the grid-to-plate capacity of the triode led to the development of the

effects of the triode led to

screen-grid tube or *tetrode*. When another grid is added between the grid and plate of a vacuum tube the tube is called a tetrode, and because the new grid is called a *screen*, as a result of its screening or shielding action, the tube is often called a screen-grid tube. The interposed screen grid acts as an electrostatic shield between the grid and plate, with the consequence that the grid-to-plate capacity is reduced. Although the screen grid is maintained at a positive voltage with respect to the cathode of the tube, it is maintained at ground potential with respect to r.f. by means of a by-pass condenser of very low reactance at the frequency of operation.

In addition to the shielding effect, the screen grid serves another very useful purpose. Since the screen is maintained at a positive potential, it serves to increase or accelerate the flow of electrons to the plate. There being large openings in the screen mesh, most of the electrons pass through it and on to the plate. Due also to the screen, the plate current is largely independent of plate voltage, thus making for high amplification. When the screen voltage is held at a constant value, it is possible to make large changes in plate voltage without appreciably affecting the plate current.

Secondary Emission; Pentodes

When the electrons from the cathode approach the plate with sufficient velocity, they dislodge electrons upon striking the plate. This effect of *bombarding* the plate with high velocity electrons, with the consequent dislodgement of other electrons from the plate, is known as *secondary emission*. This effect can cause no particular difficulty in a triode because the secondary electrons so emitted are eventually attracted back to the plate. In the screen-grid tube, however, the screen is close to the plate and is maintained at a positive potential. Thus, the screen will attract these electrons which have been knocked from the plate, particularly when the plate voltage falls to a lower value than the screen voltage, with the result that the plate current is lowered and the amplification is decreased.

This effect is eliminated when still another

element is added between the screen and plate. This additional element is called a *suppressor*, and tubes in which it is used are called *pentodes*. The suppressor grid is sometimes connected to cathode within the tube, sometimes it is brought out to a connecting pin on the tube base, but in any case it is established negative with respect to the minimum plate voltage. The secondary electrons that would travel to the screen if there were no suppressor are diverted back to the plate. The plate current is, therefore, not reduced and the amplification possibilities are increased.

Pentodes for radio applications are designed so that the suppressor increases the limits to which the plate voltage may swing; therefore the consequent power output and gain can be very great. Pentodes for radio-frequency service function in such a manner that the suppressor allows high voltage gain, at the same time permitting fairly high gain at low plate voltage. This holds true even if the plate voltage is the same or slightly lower than the screen voltage.

Beam Power Tubes A beam power tube makes use of a new method for suppressing secondary emission. In this tube there are four electrodes: a cathode, a grid, a screen, and a plate, so spaced and placed that secondary emission from the plate is suppressed without actual power. Because of the manner in which the electrodes are spaced, the electrons which travel to the plate are slowed down when the plate voltage is low, almost to zero velocity in a certain region between screen and plate. For this reason the electrons form a stationary cloud, a *space charge*. The effect of this space charge is to repel secondary electrons emitted from the plate and thus cause them to return to the plate. In this way, secondary emission is suppressed.

Another feature of the beam power tube is the low current drawn by the screen. The screen and the grid are spiral wires wound so that each turn in the screen is shaded from the cathode by a grid turn. This alignment of the screen and the grid causes the electrons to travel in sheets between the turns of the screen so that very few of them strike the screen itself. Because of the effective suppressor action provided by the space charge, and because of the low current drawn by the screen, the beam power tube has the advantages of high power output, high power sensitivity, and high efficiency. The 6L6 is such a beam power tube, designed for use in the power amplifier stages of receivers and speech amplifiers or modulators. Larger tubes employing the beam-power principle are being made by various manufacturers for use in the radio-frequency stages of

transmitters. These tubes feature extremely high power sensitivity (a very small amount of driving power is required for a large output), good plate efficiency, and freedom from the requirement for neutralization. Among these transmitting beam power tubes are the T21 of Taylor, the 807, 814, and 813 of RCA and G.E., and the HY-65, HY-67, and HY-69 of Hytron.

Television Amplifier Pentodes There was a need in television work, where extremely wide bands of frequencies must be passed by an amplifier, for vacuum tubes which would give extremely high amplification and still have comparatively low plate impedance and shunt capacitances. This need led to the development of the 1851, 6AB7, 6AC7, 1231, etc.—all of which answer this requirement with slight individual variations. Through the use of a large cathode and a very fine mesh grid spaced very close to the cathode, it has been possible to obtain in these pentodes amplification factors of 6000 and above with transconductances of 5000 to 12,000. The true significance of these figures can be grasped after the material in the latter part of this chapter has been studied.

Pentagrid Converters A pentagrid converter is a multiple grid tube so designed that the functions of superheterodyne oscillator and mixer are combined in one tube. One of the principal advantages of this type of tube in superheterodyne circuits is that the coupling between oscillator and mixer is automatically accomplished; the oscillator elements effectively modulate the electron stream and, in so doing, the conversion conductance is high. The principal disadvantage of these tubes lies in the fact that they are not particularly suited for operation at frequencies much above 20 Mc.

Special Purpose Mixer Tubes Notable among the special purpose multiple grid tubes is the 6L7 heptode, used principally as a mixer in superheterodyne circuits. This tube has *five* grids: control grid, screens, suppressor and special injection grid for oscillator input. Oscillator coupling to control grid and screen grid circuits of ordinary pentodes is effective as far as mixing is concerned, but has the disadvantage of considerable interaction between oscillator and mixer.

The 6L7 has a special *injection grid* so placed that it has reasonable effect on the electron stream without the disadvantage of interaction between the screen and control grid. The principal disadvantage is that it requires fairly high oscillator input in order to realize

its high conversion transconductance. It may also be used as an r.f. pentode amplifier.

The 6J8G and 6K8 are two tubes specifically designed for converter service. They consist of a heptode mixer unit and a triode unit in the same envelope, internally connected to provide the proper injection for conversion work. While both tubes function as a triode oscillator feeding a heptode mixer, the method of injection is different. In the 6J8G, the control grid of the oscillator is connected internally to a special shielded injector grid in the heptode section. In the 6K8, the number one grid of the heptode is connected internally to the control grid of the oscillator triode.

Single-Ended Tubes From the introduction of the screen-grid tube until about 1940, it has been standard practice to bring the control grid (or the no. 1 grid as it is called) of all pentodes and tetrodes designed for radio frequency amplifier use in receivers through the top of the envelope. This practice was started because it was much easier to shield the input from the output circuit when one was at the top and the other at the bottom of the envelope. This was true both of the elements and of their associated circuits. Complete isolation was difficult, if not impossible, with the older single-end tubes.

With the introduction of the octal-based metal tube it became feasible to design and manufacture high-gain r.f. amplifier and mixer tubes with all the terminals brought out the base. The metal envelope gives excellent shielding of the elements from external fields, and through the use of a small additional shield inside the locating pin of the octal socket, the diametrically opposite grid and plate pins of the tubes are well shielded from each other. A more or less complete line of tubes for ordinary receiving service has been made available in the single-ended type. The type numbers of these tubes contain an S between the filament voltage and the rating classification letter as: 6SA7, 6SQ7, 12SK7, etc.

Another type of single-ended tube which has come into prominent usage is the *locktall* group. These locktall tubes are all glass with a metal base and metal locating pin; the tube prongs extend through the bottom of the glass envelope and make direct connection to the elements of the tube. Due to the shortness and directness of the leads to the elements, locktall tubes are generally conceded to be the most satisfactory type for high-frequency work. A quite complete line for all ordinary receiving purposes is now being manufactured in the locktall type. The distinguishing feature of the locktall tube numbers is the fact that these numbers start out with a 7 or a 14 instead of the 6 or 12 used in conventional receiving types,

as: 7A7, 7C5, 14A7, etc. The heater voltage ratings, however, are 6.3 or 12.6 volts as in the other conventional types. Locktall tubes are also made in the 1.4-volt series; these have a characteristic number beginning with 1L such as: 1LA4, 1LA6, etc.

Dual Tubes Some of the commonly known vacuum tubes are in reality two tubes in one, i.e., in a single glass or metal envelope. Twin triodes, such as the types 53, 6A6, 6SC7, and 6N7, are examples. A disadvantage of these twin-triode tubes for certain applications is the fact that the cathodes of both tubes are brought out to the same base pin.

Of a different nature are the 6H6 and 7A6 twin diodes and the 6F8G, 6SN7-GT, 7F7, and 6C8G twin triodes. The cathodes of each of these tubes are brought to a separate base pin on the socket, thus making them true twin tubes. Other types combine the functions of a double diode and either low or high μ triode in the same envelope, as well as a similar combination with a pentode instead of a triode. Still other types combine a pentode and a triode, a pentode and a power supply rectifier, and electron-ray indicating tubes (magic eyes) with their self-contained triode d.c. voltage amplifier.

Special U. H. F. Tubes Conventional tubes become less efficient at the ultra-high and very-high frequencies. At frequencies between several hundred and several thousand megacycles, tube inter-electrode capacitances assume new importance, since only small amounts of capacitance can be tolerated in microwave circuits. Also, electron transit time (that is, the time in millionths of a second required for an electron leaving the cathode to reach the control grid) in conventional tubes is too slow for the fast-moving cycle of grid-signal voltage. Length of leads between actual tube elements and base pins is important, too, since these wires have inductance and only a small amount of inductance can be tolerated in microwave circuits.

Special ultra-high-frequency tubes have been developed to overcome these difficulties. Interelectrode spacing is cut down to reduce electron transit time, and electrode areas have been decreased to prevent the increase in capacitance that ordinarily would result from such close spacing. Tube envelopes are shortened or the electrode assembly is mounted nearer the base, and short terminal leads are brought directly through the glass envelope in order to reduce lead inductance and impedance. Such special tubes include the button-base, acorn and lighthouse types. Still other types of tubes, operating on relatively new principles,

have been developed for the *super-high* frequencies.

Manufacturer's Tube Manuals The larger tube manufacturers offer at a nominal cost tube manuals which are very complete and give much valuable data which, because of space limitations, cannot be included in this* handbook. Those especially interested in vacuum tubes are urged to purchase one of these books as a supplementary reference.

APPLICATION AND OPERATION OF THE VACUUM TUBE

The preceding section of this chapter has been devoted to the general theory of vacuum tubes and to the various forms in which they commonly appear. The succeeding section will be devoted to the application of the characteristics and abilities of the vacuum tube to the problems of amplification, oscillation, rectification, detection, frequency conversion, and electrical measurements.

The Vacuum Tube as an Amplifier

The ability of a grid of a vacuum tube to control large amounts of plate power with a small amount of input energy allows the vacuum tube to be used as an amplifier. It is the ability of the vacuum tube to amplify an extremely small amount of energy up to almost any amount without change in anything except amplitude which makes the vacuum tube such an extremely useful adjunct to modern industry and communication.

The most important considerations of a vacuum tube, aside from its power handling ability (which will be treated later on), are amplification factor, plate resistance, and mutual conductance or *transconductance*.

Amplification Factor or μ The amplification factor or μ (μ) of a vacuum tube is the ratio of a change in plate voltage to a change in grid voltage, either of which will cause the same change in plate current. Expressed as a differential equation:

$$\mu = - \frac{dE_p}{dE_g} \quad I_p = \text{constant}$$

The μ can be determined experimentally by making a slight change in the plate voltage, thus slightly changing the plate current. The plate current is then returned to its original value by a change in grid voltage. The ratio of the increment in plate voltage to the increment in grid voltage is the μ of the tube. The foregoing assumes that the experiment is conducted on the basis of rated voltages as shown in the manufacturer's tube tables.

Plate Resistance The plate resistance of a vacuum tube is the ratio of a change in plate voltage to the change in plate current which the voltage change produces. To be accurate, the changes should be very small with respect to the operating values. Expressed as an equation:

$$R_p = \frac{dE_p}{dI_p}$$

The plate resistance can also be determined by the experiment mentioned above. By noting the change in plate current as it occurs when the plate voltage is changed (grid voltage held constant), and by dividing the latter by the former, the plate resistance can then be determined. Plate resistance is expressed in ohms.

Transconductance The mutual conductance, also referred to as *transconductance*, is the ratio of the amplification factor (μ) to the plate resistance:

$$G_M = \frac{\mu}{R_p} = \frac{\frac{dE_p}{dE_g}}{\frac{dE_p}{dI_p}} = \frac{dI_p}{dE_g}$$

Transconductance is most commonly expressed in micro-reciprocal-ohms or *micromhos*. However, since transconductance expresses change in plate current as a function of a change in grid voltage, a tube is often said to have a transconductance of so many milliamperes-per-volt. If the transconductance in milliamperes-per-volt is multiplied by 1000 it will then be expressed in micromhos. Thus the transconductance of a 6A3 could be called either 5.25ma./volt or 5250 micromhos.

The transconductance is probably the most important single characteristic of a vacuum tube. It is often called the figure of merit because the G_M is an excellent indication of the effectiveness of a tube as an amplifier and of its power sensitivity—the greater the transconductance, the greater will be the gain of an r.f. amplifier, and the greater will be the power output with a given grid voltage of a power audio amplifier.

Gain per Stage When a vacuum tube is used as a resistance-coupled audio amplifier, it is important to know in advance just how much gain will be obtained from a particular stage. The stage gain of a large number of common vacuum tubes under various circuit conditions is given in the *RCA Receiving Tube Manual* (25c from RCA) and in other vacuum-tube manuals. However, when it is desired to know what a specific tube will do under certain specified op-

erating conditions, the following two formulas will be of assistance—in either case they will indicate the gain in voltage to be expected from a stage at a medium audio frequency in the vicinity of 1000 cycles. The stage gain at extremely high and low frequencies will be governed by the values of resistance and capacitance making up the circuit.

$$\text{Gain, triode amplifier} = \frac{\mu R_L}{R_p + R_L}$$

where: μ is the amplification factor of the tube
 R_L is the plate load resistance of the stage
 R_p is the plate resistance of the tube.

$$\text{Gain, pentode amplifier} = G_M R_L$$

where: G_M is the tube transconductance in *mbos* (micromhos/10⁶)
 R_L is the load resistance of the stage and where the plate resistance of the tube is large compared to the load resistance.

As a practical example of the method of determining the gain of a triode amplifier, suppose we take the case of a 6F5 tube with a plate resistance of 66,000 ohms and an amplification factor of 100 operating into a load resistance of 50,000 ohms. The voltage amplification of the stage as calculated from the above equation would be:

$$\frac{100 \times 50,000}{66,000 + 50,000} = 43$$

From the foregoing it is seen that an input of 1 volt to the grid of the tube will give an output of 43 volts (a.c.).

The calculation of the approximate gain of a resistance-coupled pentode audio stage is even more simple. Suppose the amplifier tube is a 6SJ7 with a transconductance of 1600 micromhos (from the tube tables). This tube's transconductance in *mbos* would be (taking off 6 decimal places) 0.0016 *mbos*. If the load resistance of the tube is 100,000 ohms, the gain would be (pointing ahead 5 places to multiply 0.0016 by 100,000) 160.

AUDIO-FREQUENCY AMPLIFIERS

Amplifiers designed to operate at a low level at radio, intermediate, and audio frequencies are almost invariably of the class A type. Higher level audio amplifiers can be of the class A, class AB, or class B type; these classifications and their considerations will be considered first. The class B and class C amplifiers as used for medium and high-level radio-frequency work will be considered under *Radio-Frequency Amplifiers*.

The Class A Amplifier A class A amplifier is, by definition, *an amplifier in which the grid bias and alternating grid voltages are such that plate current in a specific tube flows at all times.* The output waveform from a class A amplifier is a faithful reproduction of the exciting a.c. voltage upon the grid. For the above conditions to be the case it is necessary that the grid bias, or the operating point, of the amplifier be chosen with care to allow maximum output with minimum distortion.

Figure 6 shows the operating characteristic of a typical triode. It will be noticed that the curve of plate current with varying grid voltage is quite linear within certain limits—outside these limits it is no longer a straight line. For an amplifier to be able to put out a voltage waveform which is a faithful reproduction of the input waveform, it is necessary that the range over which the grid voltage will be varied shall give a linear variation in plate current. Also, a class A amplifier must not draw grid current; so the operating point must be midway between the point of zero grid bias and the point on the operating characteristic where the curvature becomes noticeable. Such a point has been chosen graphically in Figure 6.

When the grid bias is varied around this operating point, the fluctuation in grid potential results in a corresponding fluctuation in plate current. When this current flows through a suitable load device, it produces a varying voltage drop which is a replica of the original input voltage, although greater in amplitude.

Should the signal voltage on the grid be per-

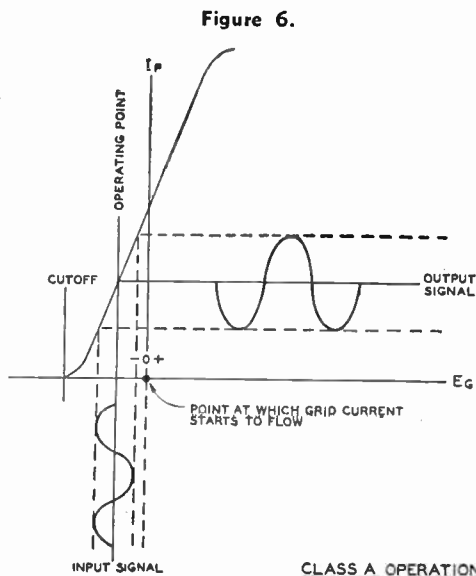

Figure 6.

mitted to go too far negative, the negative half cycle in the plate output will not be the same as the positive half cycle. In other words, the output wave shape will not be a duplicate of the input, and *distortion* in the output will therefore result. The fundamental property of class A amplification is that the bias voltage and input signal level must not advance beyond the point of zero grid potential; otherwise, the grid itself will become positive. Electrons will then flow into the grid and through its external circuit in much the same manner as if the grid were actually the plate. The result of such a flow of grid current is a lowering of the input impedance of the tube so that power is required to drive it.

Since class A amplifiers are never designed to draw grid current, they do not realize the optimum capabilities of any individual tube.

Inspection of the operating characteristic of Figure 6 reveals that there is a long stretch of linear characteristic far into the positive grid region. As only the small portion of the operating characteristic below the zero grid bias line can be used, the plate circuit efficiency of a class A amplifier is low. However, they are used because they have very little distortion and, since only an infinitesimal amount of power is required on the grid, a large amount of power amplification may be obtained. Low-level audio and radio frequency amplifying stages in receivers and audio amplifiers are invariably operated class A. The correct values of bias for the operation of tubes as class A amplifiers are given in the *Tube Tables*.

The Class AB Amplifier

A class AB amplifier is one in which the grid bias and alternating grid voltages are such that plate current in a specific tube flows for appreciably more than half but less than the entire electrical cycle when delivering maximum output.

In a class AB amplifier, the fixed grid bias is made higher than would be the case for a push-pull class A amplifier. The resting plate current is thereby reduced and higher values of plate voltage can be used without exceeding the rated plate dissipation of the tube. The result is an increase in power output.

Class AB amplifiers can be subdivided into class AB₁ and class AB₂. There is no flow of grid current in a class AB₁ amplifier; that is, the peak signal voltage applied to each grid does not exceed the negative grid bias voltage. In a class AB₂ amplifier, the grid signal is greater than the bias voltage on the peaks, and grid current flows.

The class AB amplifier should be operated in push-pull if distortion is to be held to a minimum. Class AB₂ will furnish more power output for a given pair of tubes than will class

AB₁. The grids of a class AB₂ amplifier draw current, which calls for a power driver stage.

The Class B Amplifier

A class B amplifier is one in which the grid bias is approximately equal to the cutoff value so that the plate current is very low (almost zero) when no exciting grid voltage is applied and so that plate current in a specific tube flows for approximately one-half of each cycle when an alternating grid voltage is applied.

A class B audio amplifier always operates with two tubes in push-pull. The bias voltage is increased to the point where but very little plate current flows. This point is called the *cutoff point*. When the grids are fed with voltage 180 degrees out of phase, that is, one grid swinging in a positive direction and the other in a negative direction, the two tubes will alternately supply current to the load.

When the grid of tube no. 1 swings in a positive direction, plate current flows in this tube. During this process, grid no. 2 swings negatively beyond the point of cutoff; hence, no current flows in tube no. 2. On the other half-cycle, tube no. 1 is idle, and tube no. 2 furnishes current. Each tube operates on one-half cycle of the input voltage so that the complete input wave is reproduced in the plate circuit. Since the plate current rests at a very low value when no signal is applied, the plate efficiency is much higher than in a class A amplifier.

There is a much higher, steady value of plate current flow in a class A amplifier, regardless of whether or not a signal is present. The average plate dissipation or plate loss is much greater than in a class B amplifier of the same power output capability.

Figure 7.

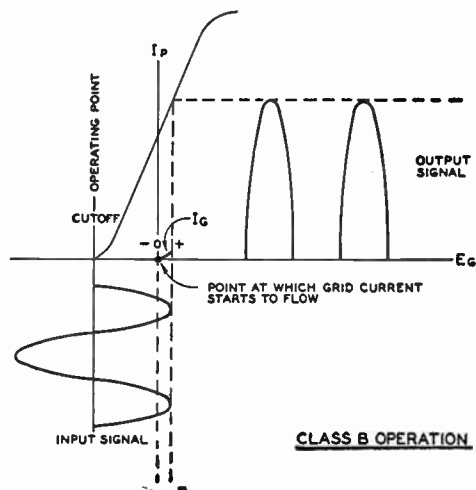

Because the plate current rises from a very low to a very high peak value on input swings in a class B audio amplifier, the demands upon the power supply are quite severe; a power supply for class B amplifier service must have good *regulation*. A high-capacitance output capacitor must be used in the filter circuit to give sufficient storage to supply power for the stronger audio peaks, and a choke-input filter system is required for good regulation.

Load Impedance for Amplifiers The plate current in an amplifier increases and decreases in proportion to

the value of applied input signal. If useful power is to be realized from such an amplifier, the plate circuit must be terminated in a suitable resistance or impedance across which the power can be developed. When increasing and decreasing plate current flows through a resistor or impedance, the voltage drop across this load will constantly change because the plate current is constantly changing. The actual value of voltage on the plate will vary in accordance with the IZ drop across the load, even though a steady value of direct current may be applied to the load impedance; hence, for an alternating voltage on the grid of the tube, there will be a constant change in the voltage at the plate.

The static characteristic curves give an indication of the performance of the tube for only one value of plate voltage. If the plate voltage is changed, the characteristic curve will shift. This sequence of change can be plotted in a form that permits a determination of tube performance; it is customary to plot the plate current for a series of permissible values of plate voltage at some fixed value of grid voltage.

The process is repeated for a sufficient number of grid voltage values in order that adequate data will be available. A group or family of plate voltage—plate current curves, each for a different grid potential, makes possible the calculation of the correct load impedance for the tube. Dynamic characteristics include curves for variations in amplification factor, plate resistance, transconductance and detector characteristics.

The correct value of load impedance for a rated power output is always specified by the tube manufacturer. The plate coupling device generally reflects this impedance to the tube.

Tubes in Parallel and Push-Pull Two or more tubes can be connected in parallel in order to secure greater power output; two tubes in parallel will give

approximately twice the output of a single tube. Since their plate resistances are in parallel, the required load impedance will be half that for a single tube.

When power is to be increased by the use of two tubes, it is generally advisable to connect them in push-pull; in this connection the power output is doubled and the *harmonic content*, or *distortion*, is reduced. The input voltage applied to the grids of two tubes is 180 degrees out of phase, the voltage usually being secured from a center-tapped secondary winding with the center tap connected to the source of bias and the outer ends of the winding connected to each grid. The plates are similarly fed into a center-tapped winding and plate voltage is introduced at the center tap. The signal voltage supplied to one grid must always swing in a positive direction when the other grid swings negatively. The result is an increase in plate current in one tube with a decrease in plate current in the other at any given instant; one tube *pushes* as the other *pulls*.

Distortion in Audio Amplifiers Distortion exists when the output wave shape of an amplifier differs from the

shape of the input voltage wave. There are three main types of distortion which can exist in an audio amplifier. These are: frequency distortion, where the gain of the amplifier is not the same for all frequencies which are to be passed; non-linear distortion, which results in cross modulation of the various audio frequencies fed into the amplifier and which also results in the production of harmonics of these tones; and phase distortion, which is the result of the amplifier's having different delay characteristics for various audio frequencies.

Frequency distortion can be kept to a minimum through the use of high-quality audio transformers wherever transformers are needed and through the use of the proper values of coupling and by-pass capacitors and feed resistors in the resistance coupled stages. Careful choice of components can result in an audio amplifier which is "flat within 1 db from 25 to 15,000 cycles"; such an amplifier would give high quality reproduction, provided non-linear and phase distortion were also at a minimum.

Non-linear distortion is usually caused by the overloading of some vacuum tube within the amplifier—usually the output stage. The presence of non-linear distortion is usually expressed by the rating of the amplifier at a certain percentage of r.m.s. harmonic distortion at a certain amount of output power. The amount of non-linear distortion almost invariably increases with increasing power output from the amplifier. Non-linear distortion is peculiar in that it always results in the production of frequencies in the output wave-shape of the amplifier which were not present in the input. Since these spurious frequencies resulting from non-linear distortion are mainly in the form of *harmonics* of the input fre-

quency (integral multiples: second harmonic, twice frequency; third harmonic, three times frequency, etc.), non-linear distortion is usually called *harmonic distortion*.

The presence of strong harmonics in an audio frequency amplifier gives rise to speech and music distortion which is plainly apparent to the human ear. Triode amplifiers give rise to distortion which is mainly second harmonic, pentodes and tetrodes give rise to more third harmonic distortion than second, while a balanced push-pull amplifier produces only odd harmonic distortion (third, fifth, seventh, etc.). Third harmonic distortion is much more apparent to the ear than second harmonic. Since the harmonic distortion naturally falls in the higher frequency region of reproduction (harmonics are multiples of their generating wave frequencies), the upper frequency limit of the reproducing system determines the maximum amount of harmonic distortion which can be permitted. In a conventional reproducing system such as is found in the average good quality receiver, the value of 5 per cent is generally accepted as the maximum permissible total harmonic distortion; of this total value not more than 2 per cent should be attributable to third and higher order harmonics for good reproduced quality.

Phase distortion is not generally considered to be of great importance in a single audio or speech amplifier. However, when a large number of audio amplifiers are cascaded, as in long wire line repeater amplifiers, the cumulative phase distortion can become serious; properly designed delay circuits and other measures are taken to correct the normal delay under these conditions. Phase distortion must also be kept to a minimum for proper operation of television video amplifiers and of audio amplifiers with degenerative feedback.

Voltage and Power Amplification

Practically all amplifiers can be divided into two classifications: *voltage amplifiers* and *power amplifiers*. In a voltage amplifier, it is desirable to increase the voltage to a maximum possible value, consistent with allowable distortion. The tube is not required to furnish *power* because the succeeding tube is always biased to the point where no grid current flows. The selection of a tube for voltage amplifier service depends upon the voltage amplification it must provide, upon the load that is to be used and upon the available value of plate voltage. The varying signal current in the plate circuit of a voltage amplifier is employed in the plate load solely in the production of *voltage* to be applied to the grid of the following stage. The plate voltage is always relatively high, the plate current small.

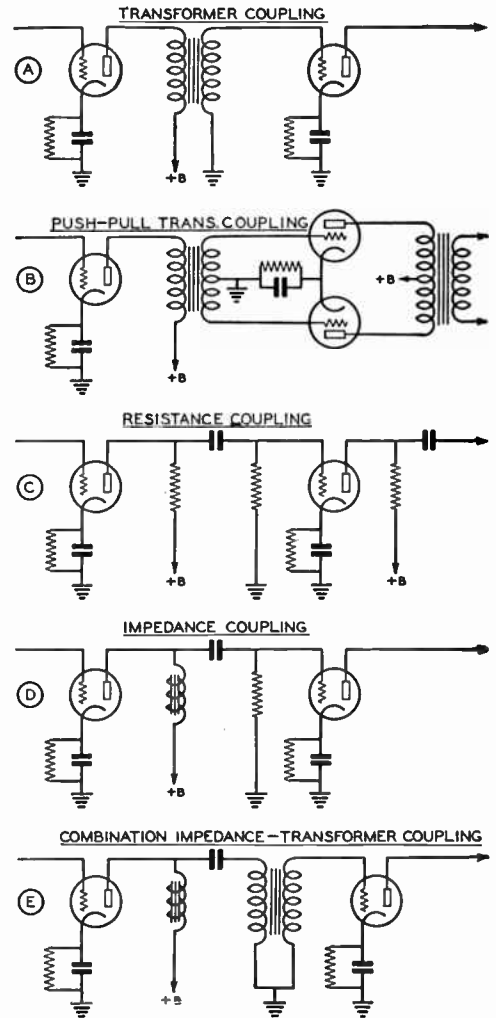

Figure 8.
FIVE COMMON METHODS OF AUDIO-FREQUENCY INTERSTAGE COUPLING.

A *power amplifier*, in contrast, must be capable of supplying a heavy current into a load impedance that usually lies between 2000 and 20,000 ohms. Power amplifiers normally furnish excitation to power-consuming devices such as loud-speakers and modulated class C amplifiers. They also serve as drivers for other larger amplifier stages whose grids require power from the preceding stage. Power amplifiers are common in transmitters.

The difference between the plate power input and output is dissipated in the tubes in the form of heat, and is known as the *plate dissipation*.

patron. Tubes for power amplifier service have larger plates and heavier filaments than those for a voltage amplifier. High-power audio circuits for commercial broadcast transmitters call for tubes of such proportions that it becomes necessary to cool their plates by means of water, fans, or blowers.

Interstage Coupling Common methods of coupling one stage to another in an audio amplifier are shown in Figure 8.

Transformer coupling for a single-ended stage is shown in A; coupling to a *push-pull* stage in B; *resistance coupling* in C; *impedance coupling* in D. A combination *impedance-transformer* coupling system is shown in E; this arrangement is generally chosen for high permeability audio transformers of small size and where it is necessary to prevent the plate current from flowing through the transformer primary. The plate circuit in the latter is *shunt-fed*. A resistor of appropriate value is often substituted for the impedance in the circuit shown in E.

Radio-Frequency Amplifiers

Radio-frequency amplifiers, as used in transmitters, invariably fall into the "power" classification. Also, since they operate into sharply tuned tank circuits which tend to take out irregularities in the plate current waveform and give a comparatively pure sine-wave output, more efficient conditions of operation may be used than for an audio amplifier in which the output waveform must be the same as the input over a wide band of frequencies. Class B and Class C r.f. amplifiers come in this group.

The Class B R.F. Amplifier The definition of a Class B r.f. amplifier is the same as that of a class B amplifier for audio use. However, the r.f. amplifier operates into a tuned circuit and covers only a very small range of frequencies, while the audio type works into an untuned load and may cover a range of 500 or 1000 to 1 in frequency.

Class B radio-frequency amplifiers are used primarily as *linear amplifiers* whose function is to increase the output from a modulated class C stage. The bias is adjusted to the cutoff value. In a single-ended stage, the r.f. plate current flows on alternate half cycles. The power output in class B r.f. amplifiers is proportional to the square of the grid excitation voltage. The grid voltage excitation is doubled in a linear amplifier at 100 per cent modulation, the grid excitation voltage being supplied by the modulated stage; hence, the power output on modulation peaks in a linear stage is in-

creased four times in value. In spite of the fact that power is supplied to the tank circuit only on alternate half cycles by a single-ended class B r.f. amplifier, the flywheel effect of the tuned tank circuit supplies the missing half cycle of radio frequency, and the complete waveform is reproduced in the output to the antenna.

The Class C R.F. Amplifier A class C amplifier is defined as an amplifier in which the grid bias is appreciably greater than the cutoff value so that the plate current in each tube is zero when no alternating grid voltage is applied, and so that plate current in a specific tube flows for appreciably less than one half of each cycle when an alternating grid voltage is applied.

Angle of Plate Current Flow The class C amplifier differs from others in that the bias voltage is increased to a point well beyond cutoff. When a tube is biased to cutoff, as in a class B amplifier, it draws plate current for a half cycle or 180°. As this point of operation is carried beyond cutoff, that is, when the grid bias becomes more negative, the angle of plate current flow decreases. Under normal conditions, the optimum value for class C amplifier operation is approximately 120°. The plate current is at zero value during the first 30° because the grid voltage is still approaching cutoff. From 30° to 90°, the grid voltage has advanced beyond cutoff and swings to a maximum in a region which allows plate current to flow. From 90° to 150°, the grid voltage returns to cutoff, and the plate current decreases to zero. From 150° to 180°, no plate current flows, since the grid voltage is beyond cutoff.

The plate current in a class C amplifier flows in pulses of high amplitude, but of short duration. Efficiencies up to 75 per cent are realized under these conditions. It is possible to convert nearly all of the plate input power into r.f. output power (approximately 90 per cent efficiency) by increasing the excitation, plate voltage, and bias to extreme values.

Linearity of Class C Amplifiers The r.f. plate current is proportional to the plate voltage; hence the power output is proportional to the square of the plate voltage. Class C amplifiers are invariably used for plate modulation because of their high efficiency and because they reflect a pure resistance load into the modulator. The plate voltage of the class C stage is doubled on the peaks at 100 per cent modulation; since the plate current is also doubled, the power output at this point is consequently increased four times.

Figure 9 illustrates graphically the operation

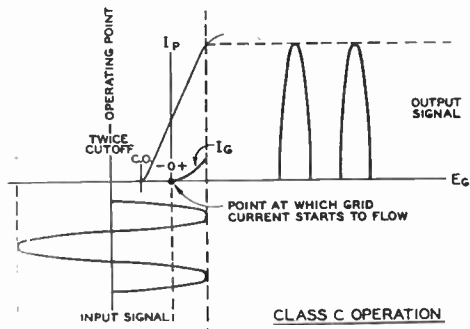

Figure 9.

of a class C amplifier with twice cut-off bias and with the peak grid swing of such a value as just to approach the diode bend in the plate characteristic. When the excitation voltage is increased beyond this point, the plate current waveform will have a dip at the crest due to the taking of electrons from the plate current stream by the grid on its highly positive peaks.

The Vacuum Tube as an Oscillator

The ability of an amplifier tube to control power enables it to function as an oscillator or a generator of alternating current in a suitable circuit. When part of the amplified output is coupled back into the input circuit, sustained oscillation will be generated provided the input voltage to the grid is of the proper magnitude and phase with respect to the plate.

The voltage that is fed back and applied to the grid must be 180° out of phase with the voltage across the load impedance in the plate circuit. The voltage swings are of a frequency depending upon circuit constants.

If a parallel resonant circuit consisting of an inductance and capacitance is inserted in series with the plate circuit of an amplifier tube and a connection is made so that part of the potential drop is impressed 180° out of phase on the grid of the same tube, amplification of the potential across the L/C circuit will result. The potential would increase to an unrestricted value were it not for the limited plate voltage and the limited range of linearity of the tube characteristic, which causes a reversal of the process beyond a certain point. The rate of reversal is determined by the time constant or resonant frequency of the tank circuit.

The frequency range of an oscillator can be made very great; thus, by varying the circuit constants, oscillations from a few cycles per second up to many millions can be generated. A number of different types of oscillators are treated in detail under the section devoted to *Transmitter Theory*.

The Vacuum Tube as a Rectifier

It was stated at the first of this chapter that when the potential of the plate of a two-element vacuum tube or diode is made positive with respect to the cathode, electrons emitted by the cathode will be attracted to the plate and a current will flow in the external circuit that returns the electrons to the cathode. If, on the other hand, the plate is made negative with respect to the cathode the electron flow in the external circuit will cease, due to the repulsion of the electronic stream within the tube back to the cathode. From this is derived a valuable property, namely, the ability of a vacuum tube to pass current in one direction only and hence to function as a *rectifier* or a device to convert alternating current into pulsating d.c.

The Half-Wave Rectifier

Figure 10A shows a half-wave rectifier circuit. For convenience of explanation, a conventional power rectifier has been chosen, although the same diagram and explanation would apply to diode rectification as employed in the detector circuits of many receivers.

When a sine-wave voltage is induced in the secondary of the transformer, the rectifier plate is made alternately positive and negative as the polarity of the alternating current changes. Electrons are attracted to the plate from the cathode when the plate is positive, and current then flows in the external circuit. On the succeeding half cycle, the plate becomes negative with respect to the cathode, and no current flows. Thus, there will be an interval before the succeeding half cycle occurs when the plate again becomes positive. Under these conditions, plate current once more begins to flow, and there is another pulsation in the output circuit.

Because one half of the complete wave is

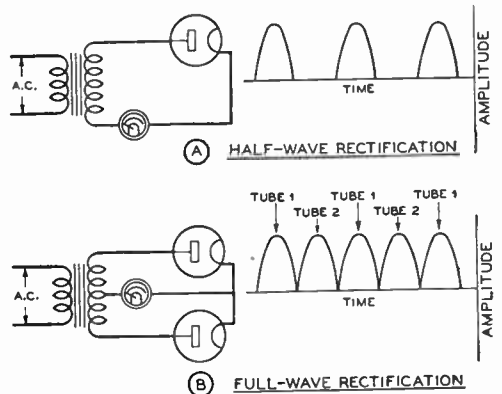

Figure 10.

absent in the output, the result is what is known as *half-wave rectification*. The output power is the average value of these pulsations; it will, therefore, be of a low value because of the interval between pulsations.

Full-Wave Rectification In a *full-wave circuit* (Figure 10B), the plate of one tube is positive when the other plate is negative; although the current changes its polarity, one of the plates is always positive. One tube, therefore, operates effectively on each half cycle, but the output current is in the same direction. In this type of circuit the rectification is complete and there is no gap between plate current pulsations. This output is known as *rectified a.c.* or *pulsating d.c.*

Mercury Vapor Rectifiers If a two-element electron tube is evacuated and then filled with a gas such as mercury vapor, its characteristics and performance will differ radically from those of an ordinary high-vacuum diode tube.

The principle upon which the operation of a gas-filled rectifier depends is known as the phenomenon of gaseous ionization, which was discussed under *Fundamental Theory*. Investigation has shown that the electrons emitted by a hot cathode in a mercury-vapor tube are accelerated toward the anode (plate) with great velocity. These electrons move in the electrical field between the hot cathode and the anode. In this space they collide with the mercury-vapor molecules which are present.

If the moving electrons attain sufficient velocity to enable them to break through a potential difference of more than 10.4 volts (for mercury), they literally knock the electrons out of the atoms with which they collide.

As more and more atoms are broken up by collision with electrons, the mercury vapor within the tube becomes *ionized* and transmits a considerable amount of current. The ions are repelled from the anode when it is positive; they are then attracted to the cathode, thus tending to neutralize the negative space charge as long as saturation current is not drawn. This effect neutralizes the negative space charge to such a degree that the voltage drop across the tube is reduced to a very low and constant value. Furthermore, a considerable reduction in heating of the diode plate, as well as an improvement in the voltage regulation of the load current, is achieved. The efficiency of rectification is thereby increased because the voltage drop across any rectifier tube represents a waste of power.

Detection or Demodulation

Detection is the process by which the audio component is separated from the modulated

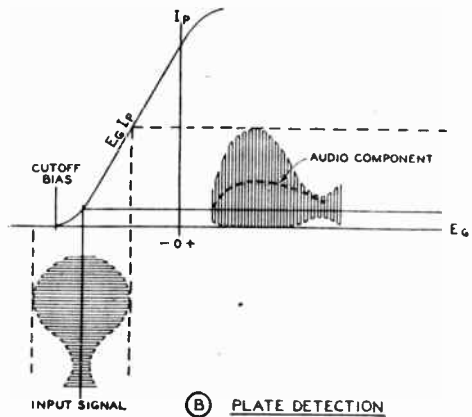
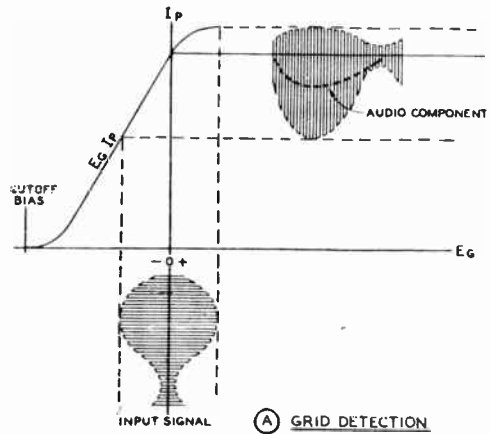

Figure 11. ILLUSTRATING DETECTOR OPERATION IN UPPER AND LOWER-BEND PORTION OF THE CHARACTERISTIC CURVE.

radio-frequency signal carrier at the receiver. Detection always involves either rectification or nonlinear amplification of an alternating current.

Two general types of amplifying detectors are used in radio circuits.

Plate Detector The plate detector or *bias detector* (sometimes called a *power detector*) amplifies the radio-frequency wave and then rectifies it, and passes the resultant audio signal component to the succeeding audio amplifier. The detector operates on the lower bend in the plate current characteristic, because it is biased close to the cutoff point and therefore could be called a single-ended class B amplifier. The plate current is low in the absence of a signal, and the

audio component is evidenced by an increase in the average unmodulated plate current. See Figure 11.

Grid Detector The grid detector differs from the plate detector in that it rectifies in the grid circuit and then amplifies the resultant audio signal. The only source of grid bias is the grid leak so that the plate current is maximum when no signal is present. This form of detector operates on the upper or saturated bend of its characteristic curve and the demodulated signal appears as an audio-frequency decrease in the average plate current. However, at low plate voltage, most of the rectification takes place as the result of the curvature in the grid characteristic. By proper choice of grid leak and plate voltage, distortion can be held to a reasonably small value. In extreme cases the distortion can reach a very high value, particularly when the carrier signal is modulated to a high percentage. In such cases the distortion can reach 25 per cent.

The grid detector will absorb some power from the preceding stage because it draws grid current. It is significant to relate that the higher gain through the grid detector does not necessarily indicate that it is more sensitive. Detector sensitivity is a matter of *rectification efficiency* and amplification, not of amplification alone. Grid leak detectors are often used in regenerative detector circuits because smoother

control of *regeneration* is possible than in other forms of plate and bias detectors.

Non-Amplifying Detectors In addition to the two previous types of amplifying detectors, both of which have a certain inherent amount of harmonic distortion, there are two main types of non-amplifying detectors which have, of late, been more widely used because of their lowered harmonic distortion and other advantages.

Diode Detector In this type of detector the input r.f. signal (almost invariably at the intermediate frequency of the receiver) is simply rectified by the diode and the modulation component appears as an alternating voltage, in addition to the d.c. component, across the diode load resistor. This type of detection, although it gives no gain and has a loading effect on the circuit that feeds it, is frequently used in high-quality receivers because of the relatively distortionless detection or demodulation that is obtained. Figure 12A shows a combined detector-a.v.c. rectifier circuit commonly used in high-quality receivers. It will be noticed that a separate diode and rectifier circuit is used to obtain the a.v.c. voltage. This is done to eliminate the *a.c. shunt loading* of the a.v.c. bus upon the detector circuit. If the a.v.c. voltage is taken from the detector diode load resistor, the effect of the a.c. shunt loading of the a.v.c. circuit can be serious enough to cause as high as 25 per cent harmonic distortion of a 100 per cent modulated input signal. However, inexpensive midget receivers in which the high-frequency response is limited, frequently take the a.v.c. voltage from the detector load resistor and rely upon the limited high-frequency response to make the distortion unnoticeable.

Certain circuits are available for compensating for the a.c. shunt loading effect of the a.v.c. circuit upon the detector load resistor, but the most satisfactory arrangement is that shown in 12A in which a separate rectifier taking its r.f. voltage from the plate of the last i.f. amplifier is used to supply the a.v.c. voltage. It is also best that the lead marked "to audio" in Figure 12A connect directly to the first audio grid, and thus that diode biasing be used upon this grid. If an additional capacitor and potentiometer is used between the diode load resistor and the first audio stage, the shunt loading effect of the additional volume control resistor can be as serious as the a.c. loading of the a.v.c. circuit.

Infinite Impedance Detector Figure 12B illustrates this comparatively recently popularized type of detector circuit which has advantages over

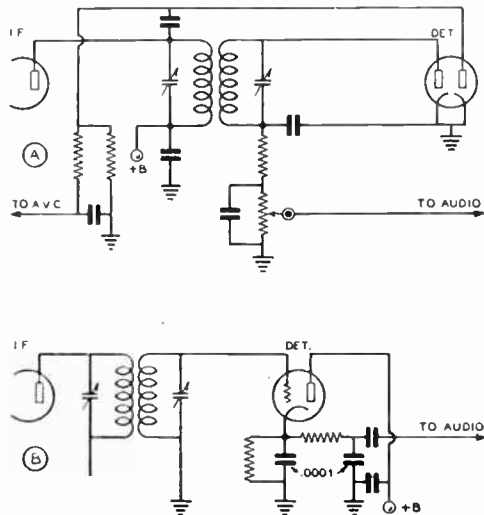

Figure 12.
(A) DIODE DETECTOR WITH SEPARATE A.V.C. RECTIFIER. (B) INFINITE IMPEDANCE DETECTOR.

previous types where distortion-free detection is required. The circuit is essentially the same as that for plate or power-detection, except that the output voltage is taken from the cathode circuit instead of from the plate. This gives the advantage that practically 100 per cent degenerative feedback is incorporated into the circuit with a consequent great reduction in harmonic distortion as compared to the simple plate detector. The circuit gives no loading to the circuit from which it obtains its voltage—hence the name, infinite-impedance detection. Also, due to the 100 per cent degenerative feedback, the circuit has a gain of one. Essentially the same output voltage will be obtained from this detector as will be obtained from a diode detector.

When automatic volume control is to be used in a receiver which employs an infinite impedance detector, the a.v.c. rectifier circuit shown using the right hand diode of Figure 12A can be used. It is common practice to use a combination tube such as the 6B8 as a combined last i.f. amplifier and a.v.c. rectifier, with a separate tube such as a 6J5 as the infinite impedance detector.

Frequency Converters or Mixers Another common usage of the vacuum tube is as a frequency changer or mixer tube. This is the operation performed by the first detector or mixer in a super-heterodyne, and consists of changing (most frequently) a particular high-frequency signal (bearing the desired modulation) to a fixed intermediate frequency. In this service, the high-frequency signal and another signal from a local oscillator, whose frequency is either lower or higher than the h.f. signal by an amount equal to the intermediate frequency (the frequency to which it is desired to convert), are fed to appropriate grids of the converter tube. The resultant intermodulation of the two signals in the converter tube produces one frequency which is the sum of the two, and another frequency which is equal to the difference between their frequencies. It is this latter frequency which is selected by the output circuit of the mixer tube, and which is subsequently fed to the intermediate frequency amplifier.

Conversion Conductance The relative efficiency of a converter tube in changing one frequency to another is called its conversion conductance or conversion trans-conductance. Recent improvements in mixer tubes have allowed sizeable improvements to be made in the efficiency of mixer stages. With

the latest types of mixer tubes it is possible to obtain nearly as much gain from a frequency changing stage as from an amplifier stage with its input and output circuits on the same frequency. Discussion of mixer characteristics will be found in the chapter, *Receiver Theory*, and under the section *Special Purpose Mixer Tubes* earlier in this chapter.

The Vacuum Tube as a Measuring Device The characteristics of the vacuum tube make it very well suited for use as a measuring device in electrical circuits, especially when no power may be taken from the circuit under measurement. Vacuum tube voltmeters are the most common application of this principle. V.t. voltmeters of the peak-indicating and r.m.s. types will be found in the chapter *Test and Measurement Equipment*.

Particular types of vacuum tube voltmeters utilizing the action of an electron stream upon a fluorescent material to give a visual indication are the electron-ray or "magic-eye" tubes, and the cathode-ray oscilloscope. In the electron-ray tube a small knife whose charge varies with the voltage under measurement (usually the amplified d.c. voltage of an a.v.c. circuit) deflects the electron stream to produce a varying angle of fluorescence on the visible screen at the end of the tube.

In the cathode-ray tube an electron gun consisting of cathode, grid, and accelerating anode or plate (the "electron gun") shoots a fine beam of electrons between two sets of deflecting plates separated by 90° to a fluorescent viewing screen at the end of the tube. One set of deflecting plates is most commonly set up so that it will deflect the stream of electrons back and forth in the horizontal plane. The other set of deflecting plates is oriented so that it will deflect the same stream up and down in the vertical plane. The practical design, construction, and application of the cathode-ray oscilloscope to the problems of the amateur station is covered in Chapter 25.

The cathode ray oscilloscope tube is the basis of the viewing systems in television and radar receivers. In these applications, however, the tube construction, especially the selection and placing of electrodes, is more complex than that of the simple oscilloscope tube. The viewing system of the absolute altimeter, whereby airplanes determine their height above the earth, likewise employ cathode ray tubes.

Highly specialized electron tube circuits make it possible to measure frequency, phase angle, power factor, speed, etc., with d.c. milliammeters and microammeters.

Radio Receiver Theory

RADIO receivers vary widely in their complexity and basic design, depending upon the intended application and upon economic factors. A simple radio receiver for reception of radiotelephony signals consists of an earphone, a galena or carborundum rectifier, and a length of wire for an antenna. However, such a receiver is highly insensitive, and offers no significant discrimination between two signals in the same portion of the spectrum.

On the other hand, a dual-diversity receiver designed for single sideband reception and employing double detection would occupy the better portion of a relay rack and probably cost more than a good automobile.

Detection

Radiotelephony Demodulation

Figure 1 illustrates an elementary form of radiotelephony receiver employing a diode detector. Energy from a passing radio wave will induce a voltage in the antenna and cause a radio-frequency current to flow from antenna to ground through coil L_1 . The alternating magnetic field set up around L_1 links with the turns of L_2 and causes an r.f. current to flow through the parallel-tuned circuit, L_2 - C . When variable condenser C is adjusted so that the tuned circuit is resonant at the frequency of the applied signal, the r.f. voltage is maximum, as explained in Chapter 2. This r.f. voltage is applied to the diode detector where it is rectified into a pulsating direct current and passed through the earphones. The pulsations in this voltage correspond to the voice modulation placed on the signal at the transmitter. As the earphone diaphragms vibrate back and forth following the pulsating current they audibly reproduce the original modulation.

The operation of the detector circuit is shown graphically above the detector circuit in Figure 1. The modulated carrier is shown at A, as it is applied to the antenna. B represents the same carrier, increased in amplitude, as it appears across the tuned circuit. In C the pulsating d.c. output from the detector is seen.

By adding an audio amplifier, as shown in Figure 2A, the output of the receiver may be increased greatly. In 2A, the earphones of Figure 1 have been replaced by a resistor, R , and an r.f. by-pass condenser, C_1 . The audio voltage across R and C_1 is coupled to the grid of a class A audio amplifier by means of a coupling condenser C_2 , and the headphones are placed in the plate circuit of the amplifier stage. Grid bias is supplied by a C battery, which is connected to the amplifier grid through a high resistance, R_1 .

To simplify the circuit shown at 2A, the load resistor, R , and its by-pass condenser may be moved around the circuit until they are in series with the diode plate, instead of its cathode. The voltage across R and C_1 is still pulsating d.c., with the pulsation corresponding to the modulation on the signal, but the d.c. voltage at the diode plate is now always negative with respect to ground. Having a negative voltage at the diode plate allows the amplifier stage grid to be directly connected to this point, thus dispensing with the bias battery, the grid return resistor R_1 , and coupling condenser C_1 .

Still further simplification of the circuit is shown at 2C, where the triode grid has entirely replaced the diode plate, thus eliminating one tube from the circuit. An r.f. by-pass condenser C_3 has been added to 2C to remove any r.f. which finds its way into the plate circuit. The circuit shown at 2C is known as a *grid leak detector*, and as the above discussion has shown, it is simply a diode detector plus an electron coupled audio amplifier, both combined in a single tube. The grid-leak detector is not limited to triodes; tetrodes or pentodes may also be used, these generally having greater sensitivity than the triodes.

There are many types of detectors, but they all consist of a non-linear device which serves as a *rectifier*, to convert the envelope of the inaudible radio frequency oscillations into audio frequency voltages.

Radiotelegraphy Reception

Since a c.w. telegraphy signal consists of an unmodulated carrier which

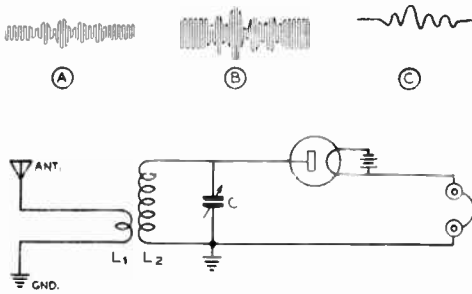

Figure 1.
ELEMENTARY FORM OF RECEIVER.
This diode detector with a single tuned circuit would make a very poor receiver, and is shown merely for purposes of illustration. (See text.)

is interrupted to form dots and dashes, it is apparent that such a signal would not be made audible by detection alone. While the keying is a form of modulation, it is composed of such low frequency components that the keying envelope itself is below the audible range for hand keying speeds. Some means must be provided whereby an audible tone is heard while the unmodulated carrier is being received, the tone stopping immediately when the carrier is interrupted.

The most simple means of accomplishing this is to feed a locally generated carrier of a slightly different frequency into the same detector, so that the incoming signal will *mix* with it to form an audible *beat note*. The difference frequency, or *heterodyne* as the beat note is known, will of course stop and start in accordance with the incoming c.w. radiotelegraph signal, because the audible heterodyne can exist only when both the incoming and the locally generated carriers are present.

The Autodyne Detector The local signal which is used to beat with the desired c.w. signal in the detector may be supplied by a separate low-power oscillator in the receiver itself, or the detector may be made to self-oscillate, and thus serve the dual purpose of detector and oscillator. A detector which self-oscillates to provide a beat note is known as an *autodyne* detector, and the process of obtaining feedback between the detector plate and grid is called *regeneration*. A typical autodyne or regenerative detector is shown in Figure 3.

An autodyne detector is most sensitive when it is barely oscillating, and for this reason a regeneration control is always included in the circuit to adjust the feedback to the proper amount. Condenser C_1 in Figure 3 is the re-

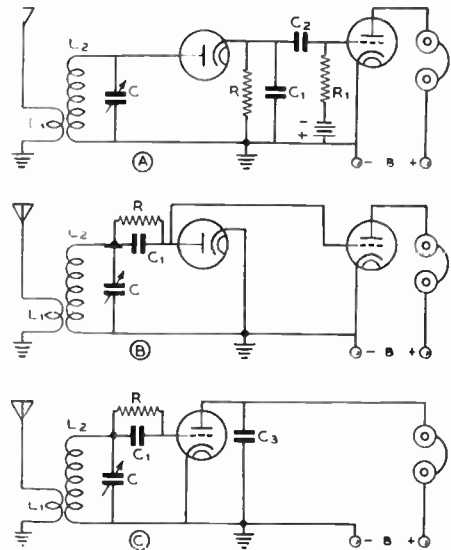

Figure 2.
EVOLUTION OF THE GRID LEAK DETECTOR.

Illustrating how a diode detector and triode audio amplifier may have their functions incorporated in a single triode, comprising a grid leak detector.

generation control. This condenser serves as a variable plate by-pass condenser, and is commonly called a "throttle condenser."

With the detector regenerative but not oscillating, it is also extremely sensitive. When the circuit is adjusted to operate in this manner, modulated signals may be received with considerably greater strength than with a non-regenerative detector.

The circuit shown in Figure 3 is but one of many regenerative detectors. There are several methods by which regeneration may be obtained, and also several alternative methods of controlling the regeneration. In tubes with an indirectly-heated cathode, regeneration may be obtained by tapping the cathode onto the grid coil a few turns up from the ground end, or by returning the cathode to ground through a coil coupled to the grid winding. With tetrode or pentode tubes, feedback is sometimes provided by connecting the screen, rather than the plate, to the tickler coil.

Other methods of controlling regeneration vary the voltage on one of the tube elements, usually the plate or screen. Examples of some of the possible variations in regeneration and control methods are shown in Figure 4.

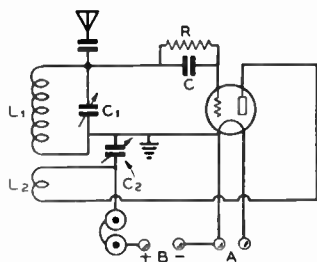

Figure 3.
REGENERATIVE DETECTOR EMPLOYING TRIODE.
The regenerative detector makes the simplest practicable high frequency receiver.

Superregenerative Receivers

At ultra-high frequencies, when it is desired to keep weight and cost at a minimum, a special form of the regenerative receiver known as the *superregenerator* is often used for radio-telephony reception. The superregenerator is essentially a regenerative receiver with a means provided to throw the detector rapidly in and out of oscillation. The frequency at which the detector is made to go in and out of oscillation varies in different receivers, but is usually between 20,000 and 200,000 times a second. This considerably increases the sensitivity of the oscillating detector so that the usual "background hiss" is greatly amplified when no signal is being received. This hiss diminishes in proportion to the strength of the received signal, loud signals eliminating the hiss entirely.

Quench Methods There are two systems in common use for causing the detector to break in and out of oscillation rapidly. In one, a separate *interruption-frequency oscillator* is arranged so as to vary the voltage rapidly on one of the detector tube elements (usually the plate, sometimes the screen) at the high rate necessary. The interruption-frequency oscillator commonly uses a conventional tickler-feedback circuit with coils appropriate for its operating frequency.

The second, and simplest, type of super-regenerative detector circuit is arranged so as to produce its own interruption frequency oscillation, without the aid of a separate tube. The detector tube damps (or "quenches") itself out of signal-frequency oscillation at a high rate by virtue of the use of a high value of grid leak and proper size plate-blocking and grid condensers, in conjunction with an excess of feedback. In this type of "self-quenched" detector, the grid leak is quite often returned to the positive side of the power sup-

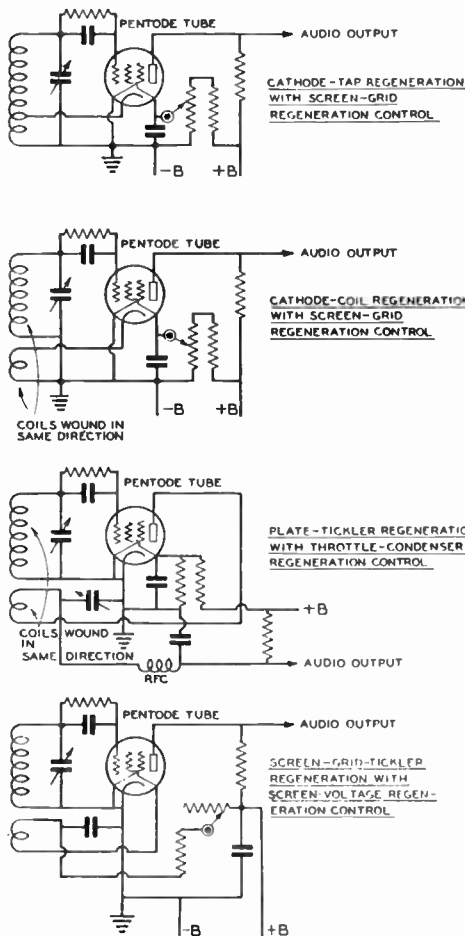

Figure 4.
REGENERATIVE DETECTOR CIRCUITS.

These circuits illustrate some of the more popular regenerative detectors. Values of 1 to 3 megohms for grid leaks are common. The grid condenser usually has a capacity of .0001 μ f., while the screen by-pass is 0.1 μ f. Pentode detectors operate best when the feedback is adjusted so that they start to oscillate with from 30 to 50 volts on the screen grid.

ply (through the coil) rather than to the cathode. A representative self-quenched super-regenerative detector circuit is shown in Figure 5.

Except where it is impossible to secure sufficient regenerative feedback to permit super-regeneration, the self-quenching circuit is to be preferred; it is simpler, is self-adjusting as regards quenching amplitude, and has ideal quenching wave form. To obtain as good re-

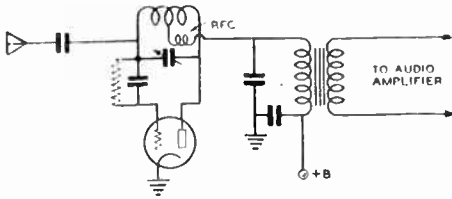

Figure 5.

SUPERREGENERATIVE DETECTOR.

A self-quenched superregenerative detector such as that illustrated here is about as sensitive as any ultra high frequency receiver that can be built. It has the further advantage of inherent a.v.c. action, but the disadvantage that it will radiate a strong, rough signal unless a well shielded r.f. stage is used ahead of it.

sults with a separately quenched superregenerator, very careful design and critical circuit operation are required. However, such circuits are useful when it is possible to make a certain tube oscillate on a very high frequency but impossible to obtain enough regeneration for self-quenching action.

The optimum quenching frequency is a function of the signal frequency. As the operating frequency goes up, so does the optimum quenching frequency. When the quench frequency is too low, maximum sensitivity is not obtained. When it is too high, both sensitivity and selectivity suffer. In fact, the optimum quench frequency for an operating frequency below 15 Mc. is in the audible range. This makes the superregenerator a mediocre performer on low frequencies, because it is not feasible to have the quench in the audible range.

The high background noise or hiss which is heard on a properly designed superregenerator when no signal is being received is not the quench frequency component "leaking through"; it is tube and tuned circuit fluctuation noise, indicating that the receiver is extremely sensitive.

A moderately strong signal will cause the background noise to disappear completely, because the superregenerator has an inherent and instantaneous automatic volume control characteristic. This same a.v.c. characteristic makes the receiver comparatively insensitive to impulse noise such as ignition pulses, a highly desirable feature. This characteristic also results in appreciable distortion of the received radiotelephony signal, but not enough to affect the intelligibility seriously.

The selectivity of a superregenerator is rather poor as compared to a superheterodyne,

but is excellent for so simple a receiver when figured on a percentage basis rather than absolute kc. bandwidth.

F.M. Reception A superregenerative receiver will receive frequency modulated signals with results comparing favorably with amplitude modulation if the frequency swing of the f.m. transmitter is sufficiently high. For such reception, the receiver is detuned slightly from either side of resonance.

Superregenerative receivers radiate a strong, broad, and rough signal. For this reason it is necessary in most applications to employ a radio frequency amplifier stage ahead of the detector, with thorough shielding and bypassing throughout the receiver.

Practical superregenerative receiver circuits, along with a further discussion of their operation, will be found under U.H.F. Receivers.

Superheterodyne Receivers

Because of its superiority and nearly universal use in all fields of radio reception, the theory of operation of the superheterodyne should be familiar to every radio student and experimenter. The following discussion concerns superheterodynes for amplitude-modulation reception. It is, however, applicable in part to receivers for frequency modulation. The points of difference between the two types of receivers, together with circuits required for f.m. reception, will be found in Chapter 9.

Principle of Operation In the superheterodyne, the incoming signal is applied to a mixer consisting of a non-linear impedance such as an overbiased vacuum tube. The signal is mixed with a steady signal generated locally in an oscillator stage, with the result that a signal bearing all the modulation applied to the original *but of a frequency equal to the difference between the local oscillator and incoming signal frequencies* appears in the mixer output circuit. The output from the mixer stage is fed into a fixed-tune *intermediate-frequency amplifier*, where it is amplified and detected in the usual manner, and passed on to the audio amplifier. Figure 6 shows a block diagram of the fundamental superheterodyne arrangement. The basic components are shown in heavy lines, the simplest superheterodyne consisting simply of these three units. However, a good communications receiver will comprise all of the elements shown, both heavy and dotted boxes.

Superheterodyne Advantages The advantages of superheterodyne reception are directly attributable to the use of the fixed-tune intermediate-frequency

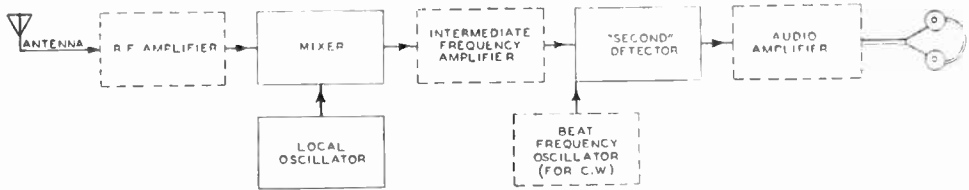

Figure 6.

ESSENTIAL UNITS OF A SUPERHETERODYNE.

The basic portions of the circuit are shown solid. Practicable receivers employ one or more of the dotted units in addition to the basic units, and a really good communications receiver employs them all.

(i.f.) amplifier. Since all signals are converted to the intermediate frequency, this section of the receiver may be designed for optimum selectivity and amplification. High amplification is easily obtained in the intermediate-frequency amplifier, since it operates at a relatively low frequency, where conventional pentode-type tubes give a great deal of voltage gain. A typical i.f. amplifier stage is shown in Figure 7.

From the diagram it may be seen that both the grid and plate circuits are tuned. Tuning both circuits in this way is advantageous in two ways; it increases the selectivity, and it allows the tubes to work into a high-impedance resonant plate load, a very desirable condition where high gain is desired. The tuned circuits used for coupling between i.f. stages are known as *i.f. transformers*. These will be more fully discussed later in this chapter.

Choice of Intermediate Frequency The choice of a frequency for the i.f. amplifier involves several considerations. One of these considerations is in the matter of selectivity; the lower the intermediate frequency the greater the obtainable selectivity. On the other hand, a rather high intermediate frequency is desirable from the standpoint of *image* elimination, and also for the reception of signals from television and f.m. transmitters and modulated self-controlled oscillators, all of which occupy a rather wide band of frequencies, making a broad selectivity characteristic desirable. Images are a peculiarity common to all superheterodyne receivers, and for this reason they are given a detailed discussion later in this chapter.

While intermediate frequencies as low as 30 kc. were common at one time, and frequencies as high as 60 Mc. are used in some specialized forms of receivers, most present-day communications superheterodynes nearly always use intermediate frequencies around either 455 kc. or 1600 kc. Frequencies some-

times encountered in the older broadcast-band receivers are 175 kc. and 262 kc. Modern broadcast receivers usually employ an i.f. around 455 kc.

Generally speaking, it may be said that for maximum selectivity consistent with a reasonable amount of image rejection for signal frequencies up to 30 Mc., intermediate frequencies in the 450-470 kc. range are used, while for a good compromise between image rejection and selectivity, 1600 kc. is used. For the reception of both amplitude and frequency modulated signals above 30 Mc., intermediate frequencies near 2100, 4300 and 5000 kc. are often used.

Arithmetical Selectivity Aside from allowing the use of fixed-tune band pass amplifier stages, the superheterodyne has an overwhelming advantage over the t.r.f. type of receiver because of what is commonly known as *arithmetical selectivity*.

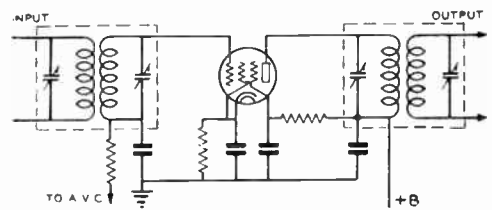

Figure 7.

TYPICAL I.F. AMPLIFIER STAGE.

Variable- μ pentodes are ordinarily used as i.f. amplifier tubes. Most of the ordinary tubes require a cathode resistor of around 300 ohms and a 100,000-ohm screen dropping resistor. The high-transconductance "television" type pentodes usually need less cathode resistance, and values as low as 100 ohms are common. The screen resistor for the "television" types may have a value between 50,000 and 75,000 ohms. By-pass condensers are usually .05 or 0.1- μ f.

This can best be illustrated by considering two receivers, one of the t.r.f. type and one of the superheterodyne type, both attempting to receive a desired signal at 10,000 kc. and eliminate a strong interfering signal at 10,010 kc. In the t.r.f. receiver, separating these two signals in the tuning circuits is practically impossible, since they differ in frequency by only 0.1 per cent. However, in a superheterodyne with an intermediate frequency of, for example, 1000 kc., the desired signal will be converted to a frequency of 1000 kc. and the interfering signal will be converted to a frequency of 1010 kc., both signals appearing at the input of the i.f. amplifier. In this case, the two signals may be separated much more readily, since they differ by 1 per cent, or 10 times as much as in the first case.

Mixer Circuits The most important single section of the superheterodyne is the *mixer*. No matter how much signal is applied to the mixer, if the signal is not converted to the intermediate frequency and passed on to the i.f. amplifier with a strength greater than the noise level at the i.f. input, it is lost. The tube manufacturers have released a variety of special tubes for mixer applications, each having specific advantages.

Figure 8 shows several representative mixer-oscillator circuits. At "A" is illustrated control-grid injection from an electron-coupled oscillator to the mixer. The mixer tube for this type of circuit is usually a sharp-cut-off pentode of the 6SJ7 or similar type. The coupling condenser, C, between the oscillator and mixer is quite small, usually 1 or 2 μfd .

This same circuit may be used with the oscillator output being taken from a triode oscillator grid or cathode. The only disadvantage to this method is that interlocking, or "pulling," between the mixer and oscillator tuning controls is likely to take place. A rather high value of cathode resistor (10,000 to 50,000 ohms) is usually used with this circuit.

Injection of oscillator voltage into mixer elements other than the control grid, is illustrated by B, C, D and E. The circuit of B shows injection into the suppressor grid of the mixer tube. The suppressor is biased negatively by connecting it directly to the grid of the oscillator.

An alternative method of obtaining bias for the suppressor, and one which is less prone to cause interlocking between the oscillator and mixer, is shown in C. In this circuit, the suppressor bias is obtained by allowing the rectified suppressor-grid current to flow through a 100,000-ohm resistor to ground. The coupling condenser between oscillator and mixer may be 50 or 100 μfd . with this circuit. Output from the oscillator may be taken from the cathode

instead of the grid end of the coil, as shown, if sufficient oscillator output is available. Mixer cathode resistors having values between 500 and 5000 ohms are ordinarily used with the circuits of B and C.

The mixer circuit shown in D is similar in appearance to that of B. The difference in the two lies in the type of tube used as a mixer. The 6L7 shown in D is especially designed for mixer service. It has a separate, shielded *injector grid*, by means of which voltage from the oscillator may be injected. This circuit permits the same variations as the suppressor-injection system in regard to the method of connection into the oscillator circuit. The 6L7 requires rather high screen voltage and draws considerable screen current, and, for these reasons, the screen-dropping resistor is usually made around 15,000 ohms.

Screen grid injection is shown at E. This circuit is likely to cause rather bad pulling at high frequencies, as there is no electrostatic shielding within the mixer tube between the screen grid and the control grid. A variation of this circuit, in which the pulling effect is reduced considerably, consists of using an electron-coupled oscillator circuit similar to that shown in A and connecting the plate of the oscillator and the screen of the mixer directly together. A voltage of about 100 volts is then applied to both the oscillator plate and the mixer screen.

E.C.O. Harmonics One disadvantage to the use of an electron-coupled type oscillator with the output taken from the plate is that the untuned plate circuit of the e.c. oscillator contains a large amount of harmonic output. Therefore, considerable selectivity must be used ahead of the mixer to prevent the harmonics of the oscillator from beating with undesired signals at higher frequencies and bringing them in along with the desired signal. If it is desired to use an e.c. type oscillator to secure receiver stabilization in regard to voltage changes, it will usually be found best to take the oscillator output from the tuned grid circuit, where the harmonic content is low. The plate of the oscillator tube may be bypassed directly to ground with this arrangement.

Improved Control-Grid Injection In F, an improved control grid injection type mixer circuit is shown. This circuit allows peak mixer conversion transconductance under wide variations in oscillator output. The bias on the mixer is automatically maintained at the correct value through the use of grid-leak bias, rather than by cathode bias. The mixer grid leak should have a value of from 3 to 5 megohms. As in the circuit

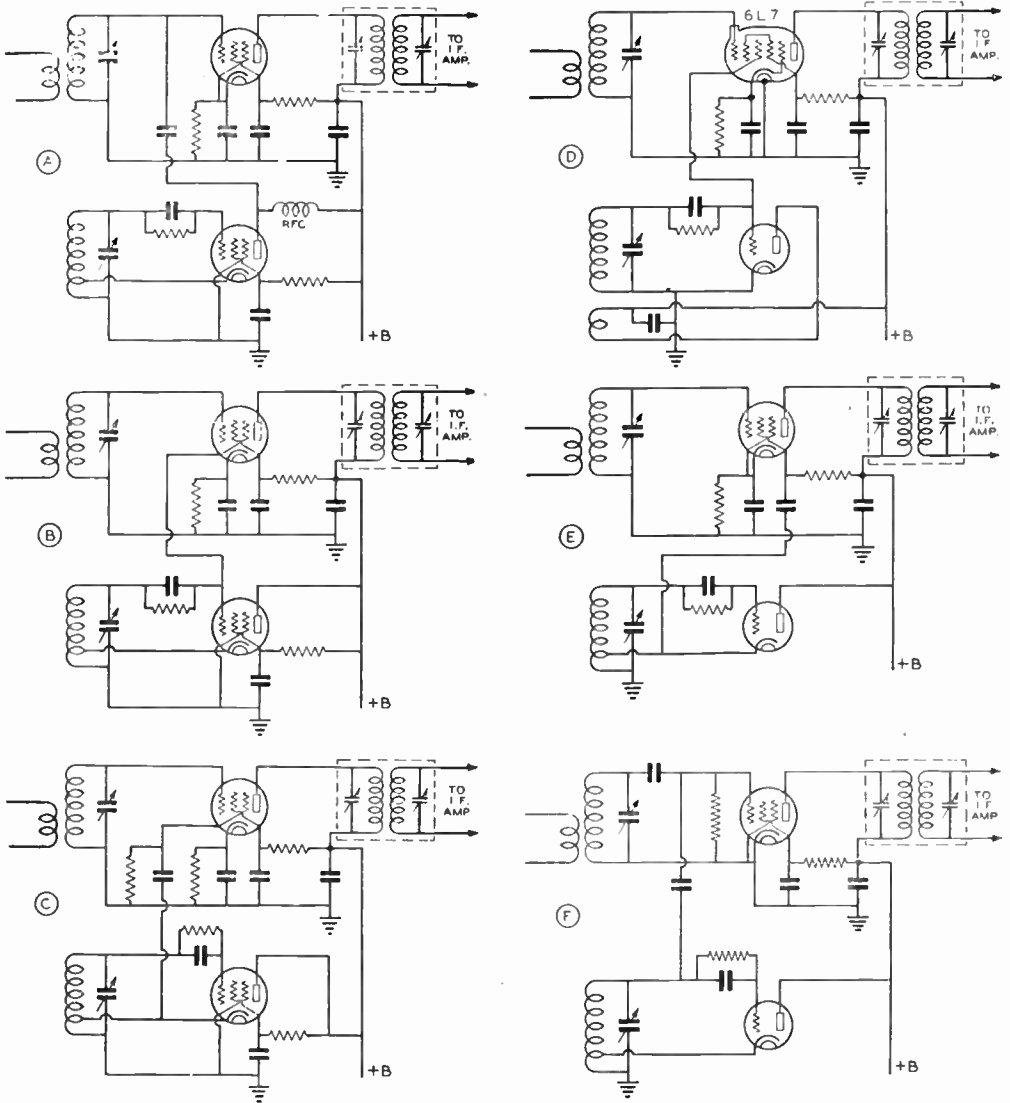
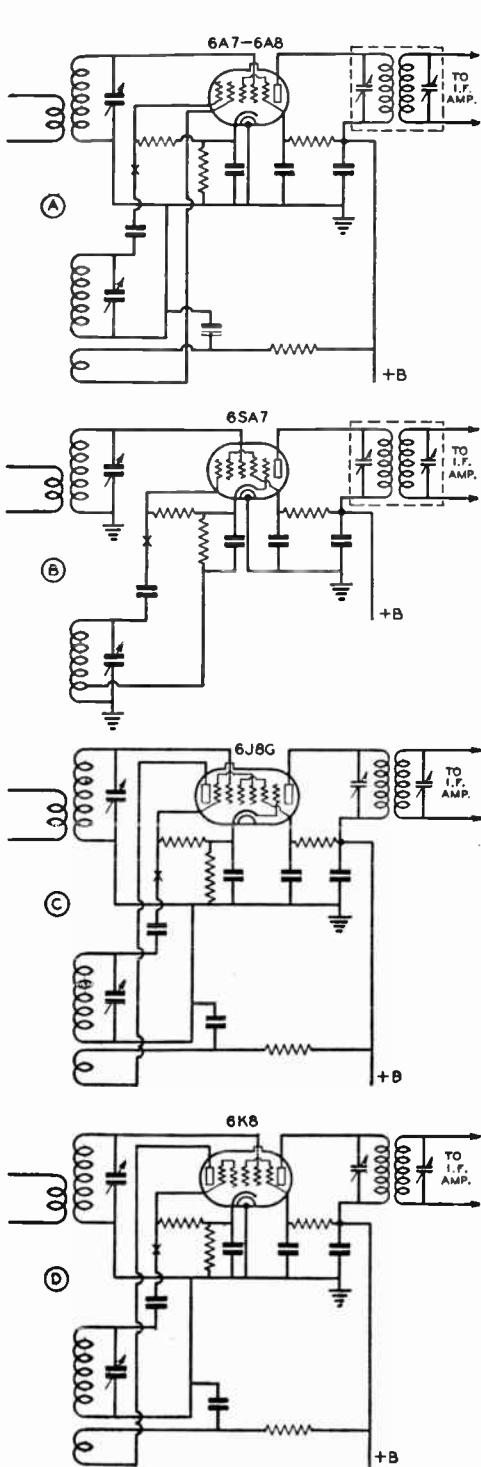

Figure 8.
MIXER-OSCILLATOR COMBINATIONS.

The various oscillators do not have to be used with the mixers with which they happen to be shown. The triode oscillator shown at E could replace the pentode circuit shown at B, for instance.

shown at A, the coupling condenser should be quite small—on the order of 1 or 2 μfd . It is absolutely essential that a rather high value of series screen dropping resistor be used with this circuit to limit the current drawn by the mixer tube in case the oscillator injection voltage (and consequently the mixer bias) is inadvertently removed. The value of the screen

resistor will probably lie around 100,000 ohms or above, depending upon the type of mixer tube and the available plate voltage. The resistor value should be determined experimentally by using a value which limits the mixer cathode current when the oscillator is not operating to the maximum permissible current specified by the tube manufacturer.



The different oscillator circuits shown in Figure 8 are not necessarily limited to use with the mixers with which they happen to be shown. Almost any oscillator arrangement may be used with a particular mixer circuit. Examples of some of the possible combinations will be found in Chapter 6.

Triode Mixers A triode having a high transconductance and high amplification factor is the *quietest* mixer tube, exhibiting somewhat less gain but a better signal-to-noise ratio than a comparable multi-grid mixer tube. However, below 30 Mc. it is possible to construct a receiver that will get down to the atmospheric noise level without resorting to a triode mixer, and the additional difficulties experienced in avoiding "pulling", undesirable feedback, etc., a triode with control-grid injection to make multi-grid tubes the popular choice for this application on the lower frequencies.

On very high frequencies, where set noise rather than atmospheric noise limits the weak signal response, and r.f. amplifiers contribute little if anything towards improving the signal to noise ratio, triode mixers are more widely used. A 6J6 miniature twin triode with grids in push-pull and plates in parallel makes an excellent mixer up to about 600 Mc.

Injection Voltage The amplitude of the injection voltage will affect the conversion transconductance of the mixer, and therefore should be made optimum if maximum gain is desired. If fixed bias is employed on the injection grid, the optimum injection voltage is quite critical. If cathode bias is used, the optimum voltage is not so critical; and if grid leak bias is employed, the optimum injection voltage is not at all critical just so it is adequate. Typical optimum injection voltages will run from 1 to 10 volts for control grid injection, and 45 volts or so for screen or suppressor grid injection.

"Converter" Tubes There is a series of *converter* tubes available in which the functions of the oscillator and mixer are combined in a single tube. Typical of these tubes are the 6A7, 6A8, and 6SA7. The term *pentagrid* has been applied to these tubes because they have 5 grids, one of the extra grids

Figure 9.
CONVERTER CIRCUITS.
 A and B are for "pentagrid" tubes, and C and D are for "triode-heptode" and "triode-hexode" tubes. The points marked "X" show where injection from a separate oscillator may be introduced.

being used as grid and the other as the anode for the oscillator section of the circuit. Suitable circuits for use with these tubes are shown in Figures 9A and 9B. Generally speaking, the use of such tubes is not recommended in high performance, high frequency communications receivers.

Another set of combination tubes known as *triode-heptodes* and *triode-hexodes* is also available for use as combination mixers and oscillators. These tubes are exemplified by the 6J8G and the 6K8; they get their name from the fact that they contain two separate sets of elements—a triode and a heptode in one case, and a triode and a hexode in the other. Representative circuits for both types are shown at 9C and 9D.

Certain of the combination mixer-oscillator tubes make good high frequency mixers when their oscillator section is left unused and the oscillator section grid is connected to a separate oscillator capable of high output. The 6K8, 6J8G and 6SA7 perform particularly well when used in this manner. A circuit of this type for use with a 6K8 is shown in Figure 10. The points marked "X" in Figure 9 show the proper place to inject r.f. from a separate oscillator with the other combination type converter tubes. When the 6A7 and 6A8 types are used with a separate oscillator, the unused oscillator anode-grid is connected directly to the screen.

Mixer Noise and Images

The effects of *mixer noise* and *images* are troubles common to all superheterodynes. Since both these effects can largely be obviated by the same remedy, they will be considered together.

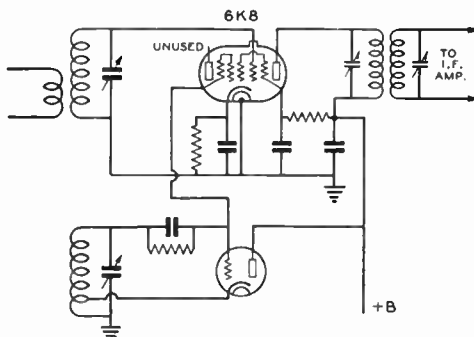

Figure 10.

DUAL PURPOSE CONVERTER TUBE WITH SEPARATE OSCILLATOR.

The performance of certain "combination" converter tubes can be improved, especially at high frequencies, by employing a separate oscillator for injection. The points "X" in figure 9 show where a separate oscillator may be connected with each of the tubes shown.

Mixer Noise Mixer noise of the shot-effect type, which is evidenced by a hiss in the audio output of the receiver, is caused by exceedingly small irregularities in the plate current in the mixer stage and will mask weak signals. Noise of an identical nature is generated in an amplifier stage, but due to the fact that the gain in the mixer stage is considerably lower than in an amplifier stage using the same tube, the proportion of inherent noise present in a mixer usually is considerably greater than in an amplifier stage using a comparable tube.

Although this noise cannot be eliminated, its effects can be greatly minimized by placing sufficient signal-frequency amplification having a high signal-to-noise ratio ahead of the mixer. This remedy causes the signal output from the mixer to be large in proportion to the noise generated in the mixer stage. Increasing the gain after the mixer will be of no advantage in eliminating mixer noise difficulties; greater selectivity after the mixer will help to a certain extent, but cannot be carried too far, since this type of selectivity decreases the i.f. bandpass and if carried too far will not pass the sidebands that are an essential part of a voice modulated signal.

Images There always are *two* signal frequencies which will combine with a given frequency to produce the same difference frequency. For example: assume a superheterodyne with its oscillator operating on a higher frequency than the signal, which is common practice in present superheterodynes, tuned to receive a signal at 14,100 kc. Assuming an i.f.-amplifier frequency of 450 kc., the mixer input circuit will be tuned to 14,100 kc., and the oscillator to 14,100 plus 450, or 14,550 kc. Now, a *strong* signal at the oscillator frequency plus the intermediate frequency (14,550 plus 450, or 15,000 kc.) will also give a difference frequency of 450 kc. in the mixer output and will be heard also. Note that the image is always *twice* the intermediate frequency away from the desired signal. Images cause "repeat points" on the tuning dial.

The only way that the image could be eliminated in this particular case would be to make the selectivity of the mixer input circuit, and any circuits preceding it, great enough so that the 15,000-kc. signal never reaches the mixer grid in sufficient amplitude to produce interference.

For any particular intermediate frequency, image interference troubles become increasingly greater as the frequency to which the signal-frequency portion of the receiver is tuned is increased. This is due to the fact that the percentage difference between the desired frequency and the image frequency decreases

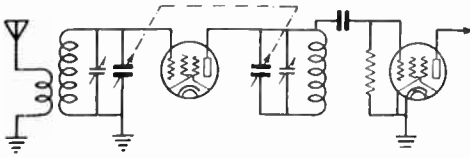

Figure 11.
TYPICAL RADIO FREQUENCY
AMPLIFIER.

as the receiver is tuned to a higher frequency. The ratio of strength between a signal at the image frequency and a signal at the frequency to which the receiver is tuned producing equal output is known as the *image ratio*. The higher this ratio, the better the receiver in regard to image-interference troubles.

With but a single tuned circuit between the mixer grid and the antenna, and with 400-500 kc. i.f. amplifiers, image ratios of one hundred (40 db) and over are easily obtainable up to frequencies around 5000 kc. Above this frequency, greater selectivity in the mixer grid circuit through the use of additional tuned circuits between the mixer and the antenna is necessary if a good image ratio is to be maintained.

R.F. Stages Since the necessary tuned circuits between the mixer and the antenna can be combined with tubes to form r.f. amplifier stages, the reduction of the effects of mixer noise and the increasing of the image ratio can be accomplished in a single section of the receiver. When incorporated in the receiver, this section is known simply as an *r.f. amplifier*; when it is a separate unit with a separate tuning control it is often known as a *preselector*. Either one or two stages are commonly used in the preselector or r.f. amplifier. Some preselectors use regeneration to obtain still greater amplification and selectivity. An r.f. amplifier or preselector embodying more than two stages rarely ever is employed, because of the instability usually experienced.

The amplification obtained in an r.f. stage depends upon the type of circuit which is used; if the plate load impedance can be made very high, the gain may be as much as 200 or 300 times. Normal values of gain in the broadcast band are in the vicinity of 50 times. A gain of 30 per r.f. stage is considered excellent for shortwave receivers in the range 3 to 10 Mc. Radio-frequency amplifiers for the range 10 to 50 Mc. seldom provide a gain of more than 10 times, because of the difficulty in obtaining high load impedances (due largely to the shunt effect of most tubes). A typical r.f. amplifier is illustrated in Figure 11.

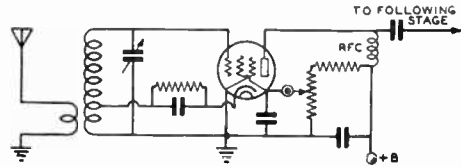

Figure 12.
REGENERATIVE R.F. AMPLIFIER.

The use of regeneration in the r.f. amplifier allows greater amplification to be obtained, particularly at the higher frequencies where tubes and tuned circuits begin to show poor performance in conventional circuits.

Regenerative R.F. Stages In low cost receivers, and in those where maximum performance with a minimum number of stages is desired, controlled regeneration in an r.f. stage is often used. The regenerative r.f. amplifier increases amplification and selectivity in a manner similar to that of the regenerative detector. The regenerative r.f. amplifier is never allowed to oscillate, however; the greatest amplification is obtained with the circuit operating just below the point of oscillation. Figure 12 shows a regenerative r.f. stage of the type generally used on the higher frequencies. This is a special adaptation of the familiar electron-coupled oscillator circuit.

One minor disadvantage of the regenerative r.f. stage is the need for an additional control for regeneration. A more important disadvantage is that, due to the high degree of selectivity obtainable with the regenerative stage, it is usually impossible to secure accurate enough tracking between its tuning circuit and the other tuning circuits in the receiver to make single-dial control feasible. Where single-dial control is desired, a small "trimmer" condenser is usually provided across the main r.f.-stage tuning condenser. By making this condenser controllable from the front panel, it is possible to compensate manually for slight inaccuracies in the tracking. A further discussion of regenerative r.f. stages will be found in the section on superheterodyne receivers, in which they are most often used.

Double Conversion As previously mentioned, the use of a higher intermediate frequency will also improve the image ratio, at the expense of i.f. selectivity, by placing the desired signal and the image farther apart. To give both good image ratio at the higher frequencies and good selectivity in the i.f. amplifier, a system known as *double conversion* is sometimes employed. In this system, the incoming signal is first converted

to a rather high intermediate frequency, and then amplified and again converted, this time to a much lower frequency. The first i.f. frequency supplies the necessary wide separation between the image and the desired signal, while the second one supplies the bulk of the i.f. selectivity.

When properly designed, a receiver of this type is capable of excellent performance, but such an equipment is quite complex and subject to various "birdies" and spurious responses unless especial care is taken in the design to avoid such difficulties.

Regenerative Preselectors R.f. amplifiers for frequencies below 20 Mc. can be made to operate efficiently in a non-regenerative condition. The amplification and selectivity are ample over this range. For higher frequencies, on the other hand, *controlled regeneration* in the r.f. amplifier is often desirable for the purpose of increasing the gain and selectivity.

A disadvantage of the regenerative r.f. amplifier is the need for an additional (regeneration) control, and the difficulty of maintaining alignment between this circuit and the following tuned circuits. Resonant effects of antenna systems usually must be taken into account; a variable antenna coupling device can sometimes be used to compensate for this effect, however.

The reason for using regeneration at the higher frequencies and not at the medium and low frequencies can be explained as follows: The signal-to-noise ratio (output signal) of the average r.f. amplifier (one not specifically designed for u.h.f.) is not made higher by the incorporation of regeneration. But the signal-to-noise ratio of the *receiver as a whole* is improved at the very high frequencies because of the extra gain provided ahead of the mixer, this extra gain tending to make the signal output a larger portion of the total signal-plus-noise output of the receiver. At low frequencies an r.f. stage has sufficient gain to do this without resorting to regeneration.

Signal-Frequency Tuned Circuits

The signal-frequency tuned circuits in superheterodynes and tuned radio frequency types of receivers consist of coils of either the solenoid, or universal-wound types shunted by variable condensers. It is in these tuned circuits that the causes of success or failure of a receiver often lie. The universal-wound type coils usually are used at frequencies below 2000 kc.; above this frequency the single-layer solenoid type of coil is more satisfactory.

Impedance and Q The two factors most affecting the tuned circuits are impedance and Q. As explained in Chap-

ter 2, Q is the ratio of reactance to resistance in the circuit. Since the resistance of modern condensers is low at ordinary frequencies, the resistance usually can be considered to be concentrated in the coil. The resistance to be considered in making Q determinations is the r.f. resistance, not the d.c. resistance of the wire in the coil. The latter ordinarily is low enough that it may be neglected. This r.f. resistance is influenced by such factors as wire size and type, and the proximity of metallic objects or poor insulators, such as coil forms with high losses.

It may be seen from the curves shown in Chapter 2 that higher values of Q lead to better selectivity and increased r.f. voltage across the tuned circuit. The increase in voltage is due to an increase in the circuit impedance with the higher values of Q.

Frequently it is possible to secure an increase in impedance in a resonant circuit, and consequently an increase in gain from an amplifier stage, by increasing the reactance through the use of larger coils and smaller tuning condensers (higher L/C ratio).

Input Resistance Another factor which influences the operation of tuned circuits is the input resistance of the tubes placed across these circuits. At broadcast frequencies, the input resistance of most conventional r.f. amplifier tubes is high enough so that it is not bothersome. But as the frequency is increased, the input resistance becomes lower and lower, until it ultimately reaches a value so low that no amplification can be obtained from the r.f. stage.

The two contributing factors to the decrease in input resistance with increasing frequency are the transit time required by an electron traveling between the cathode and grid, and the inductance of the cathode lead common to both the plate and grid circuits. As the frequency becomes higher, the transit time can become an appreciable portion of the time required by an r.f. cycle of the signal voltage, and current will actually flow into the grid even though it is biased negatively. The result of this effect is similar to that which would be obtained by placing a resistance between the tube's grid and cathode.

Since the input resistance of conventional broadcast receiver tubes can reach rather low values at frequencies above 20 Mc. or thereabouts, there is often no practical advantage to be realized by going to great pains to design a very high impedance tuned circuit for these frequencies, and then shunting it with the tube's input resistance. At any given frequency the tube input resistance remains constant, regardless of what is done to the tuned circuit, and increasing the tuned circuit im-

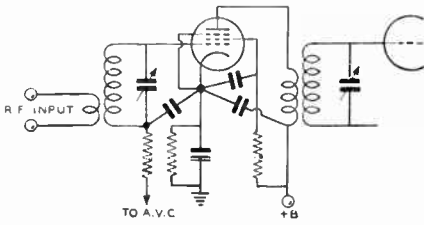

Figure 13.

BY-PASSING IN HIGH FREQUENCY STAGES.

To reduce the effects of common cathode lead inductance, which is detrimental at the higher frequencies, all by-pass condensers should be returned directly to the cathode terminal of the socket. Tubes with two cathode leads give improved performance; the grid return is made to one lead and the screen and plate returns to the other.

pedance beyond twice the input resistance will have but little effect on the net grid-to-ground impedance of the amplifier stage.

The limiting factor in r.f. stage gain is the ratio of input conductance to the tube transconductance. When the input conductance becomes so great that it equals the transconductance, the tube no longer can act as an amplifier. One of the ways of increasing the ratio of transconductance to input conductance is exemplified by the "acorn" and "miniature" type tubes, such as the 956, 6AK5, etc., in which the input conductance is reduced through the use of a smaller element structure while the transconductance remains nearly as high as that of tubes ordinarily used at lower frequencies. Another method of accomplishing an increase in transconductance to input conductance ratio is by greatly increasing the transconductance at the expense of a proportionately small increase in input conductance. The latter method is exemplified by the so-called "television pentodes" such as the 6AC7, which have extremely high transconductance and an input conductance several times that of the acorn tubes.

An increase in transconductance-input conductance ratio is obtained in certain u.h.f. tubes by the use of separate cathode leads for the grid and plate returns. By this means, the inductance common to both circuits may be held to a minimum, and the input conductance thus decreased.

With conventional tubes having a single cathode terminal, the only control the constructor has over the input resistance is through eliminating, so far as possible, the cathode lead inductance common to the input and output circuits. This means that all by-

pass condensers associated with a tube should be connected separately and directly to the socket cathode terminal. The ground connection for the stage may be made by a single condenser from the cathode to chassis. A typical circuit is shown in Figure 13.

Some of the difficulties presented by input-resistance effects may be obviated by tapping the grid down on the coil, as shown in Figure 14. Although this circuit does not actually cause any reduction in the tube's input conductance, it does remove some of the loading from the tuned circuit, and thus will improve the selectivity. With a tuned circuit which has a high impedance, there will be no loss in r.f. voltage applied to the grid, and the net result of tapping the grid down on the coil will be an improvement in selectivity (and image rejection) without significant loss in stage gain. This circuit is commonly employed with high-transconductance "video" tubes above about 20 Mc.

Superheterodyne Tracking

Because the oscillator in a superheterodyne operates "offset" from the other front end circuits, in some cases it is necessary to make special provisions to allow the oscillator to track when similar tuning condenser sections are ganged. The usual method of obtaining good tracking is to operate the oscillator on the high-frequency side of the mixer and use a series "tracking condenser" to slow down the tuning rate of the oscillator. The oscillator tuning rate must be slower because it covers a smaller range than does the mixer when both are expressed as a percentage of frequency. At frequencies above 7000 kc. and with ordinary intermediate frequencies, the difference in percentage between the two tuning ranges is so small that it may be disregarded in receivers designed to cover only a small range, such as an amateur band.

A mixer and oscillator tuning arrangement in which a series tracking condenser is provided is shown in Figure 15. The value of the

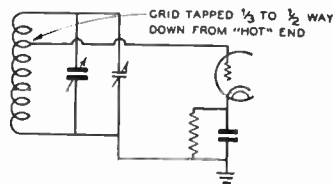

Figure 14.

REDUCING GRID-LOADING EFFECTS.

By tapping the grid down on the coil, as shown, the selectivity may be increased when high-transconductance tubes are used at high frequencies.

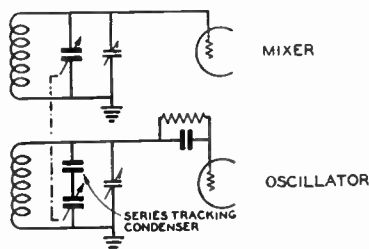

Figure 15.
SERIES TRACKING EMPLOYED IN H.F. OSCILLATOR OF A SUPERHETERODYNE.

The series padder permits use of a gang condenser with identical gangs, as the padder slows down the rate of capacity change in the oscillator. This assumes "high side" injection.

tracking condenser varies considerably with different intermediate frequencies and tuning ranges, capacities as low as $.0001 \mu\text{fd.}$ being used at the lower tuning-range frequencies, and values up to $.01 \mu\text{fd.}$ being used at the higher frequencies.

Bandspread Tuning The frequency to which a receiver responds may be varied by changing the size of either the coils or the condensers in the tuning circuits, or both. In short-wave receivers a combination of both methods is usually employed, the coils being changed from one band to another, and variable condensers being used to tune the receiver across each band. In practical receivers, coils may be changed by one of two methods: a switch, controllable from the panel, may be used to switch coils of different sizes into the tuning circuits or, alternatively, coils of different sizes may be plugged manually into the receiver, the connection into the tuning circuits being made by suitable plugs on the coils. Where there are several "plug-in" coils for each band, they are sometimes arranged to a single mounting strip, allowing them all to be plugged in simultaneously.

In receivers using large tuning condensers to cover the short-wave spectrum with a minimum of coils, tuning is likely to be quite difficult, owing to the large frequency range covered by a small rotation of the variable condensers. To alleviate this condition, some method of slowing down the tuning rate, or *bandspreading*, must be used.

Quantitatively, bandspread is usually designated as being inversely proportional to the range covered. Thus, a *large* amount of bandspread indicates that a *small* frequency range is covered by the bandspread control. Conversely, a *small* amount of bandspread is taken

to mean that a *large* frequency range is covered by the bandspread dial.

Types of Bandspread Bandspreading systems are of two general types: electrical and mechanical. Mechanical systems are exemplified by high-ratio dials in which the tuning condensers rotate much more slowly than the dial knob. In this system there is often a separate scale or pointer either connected or geared to the dial knob to facilitate accurate dial readings. However, there is a limit to the amount of mechanical bandspread which can be obtained in an inexpensive dial and condenser before the speed-reduction unit and condenser bearings develop backlash and wobble, which make tuning difficult. To overcome this, most receivers employ a combination of electrical and mechanical bandspread. In this system, a moderate reduction in the tuning rate is obtained in the dial, and the rest of the reduction obtained by *electrical bandspreading*.

Parallel Bandspread In one form of electrical bandspread, two tuning condensers are used in parallel across each coil, one of rather high capacity to cover a large tuning range, and another of small capacity to cover a small range around the frequency to which the large condenser is set. These condensers are usually controlled by separate dials or knobs, the large condenser being known as the *bandsetting* condenser, and the smaller one being the bandspread condenser. Where there is more than one tuned circuit in the receiver, a bandsetting and a bandspread condenser are used across *each* coil, and all the condensers serving in each capacity are mechanically connected together, or *ganged*, thus allowing a single dial to be used for each purpose, even though there may be several tuned circuits.

Since the tuning range of a tuned circuit is proportional to the ratio of minimum to maximum capacity across it, a wide variation in the amount of bandspreading is made possible by a proper choice of the two capacities. The greater the capacity of the bandsetting condenser in proportion to the bandspread condenser, the greater will be the bandspread.

The bandspreading method described above is usually known as the *parallel* system. This system, as applied to a single tuned circuit, is diagrammed in Figure 16A. The large tuning, or bandsetting, Condenser, C_F , usually has a maximum capacity of from 100 to $370 \mu\text{fd.}$ The bandspread condenser, C_B , usually has a value of from 10 to $50 \mu\text{fd.}$, depending upon the design of the receiver. In typical amateur receivers, a bandspread trimmer is built into each plug-in coil.

Dual-Ratio Bandspread In some manufactured tuning assemblies, a single set of stationary plates (stator) in the tuning condenser is acted upon by two separate rotors, one of large capacity for bandsetting and the other of small capacity for bandspread. Each rotor is operated by a separate dial. This system allows the bandsetting and bandspread functions to be combined in a single tuning-condenser unit, minimizing stray shunt and feedback capacities.

Sometimes the same dial is used for both bandsetting and bandspreading purposes, the change from one function to the other being accomplished by a "gear-shifting" mechanism built into the dial. The schematic of this bandspread system is shown in Figure 16B.

The parallel system of bandspreading has one major disadvantage, especially for amateur-band usage. This disadvantage lies in the fact that if the bandspreading condenser is made large enough to cover the lower-frequency amateur bands with optimum capacity being used across the coil in the bandsetting condenser, an extremely large bandsetting-condenser is needed to give an equal amount of bandspread on the high-frequency bands. The high capacity across the coils reduces the impedance of the tuned circuits on the high-frequency bands.

Parallel Bandspread Calculations The following formulas will be found useful in designing parallel-bandspread circuits:

$$C_F = \frac{C_B F_L^2}{F_H^2 - F_L^2} \text{ where}$$

C_F = Capacity of "bandsetting" condenser ($\mu\text{fd.}$ or $\mu\mu\text{fd.}$)

C_B = Capacity range of bandspread condenser (same units as C_F)

F_L = Low-frequency end of tuning range (kc. or Mc.)

F_H = High-frequency end of tuning range (same units as F_L .)

Where it is desired to know the number of turns to wind on a coil:

$$N = \sqrt{\frac{380,000 (D + 3L) (F_H^2 - F_L^2)}{D^2 C_B F_H^2 F_L^2}}, \text{ where}$$

N = Number of turns

D = Diameter of coil, in inches

L = Length of coil, in inches

F_H = High-frequency end of tuning range, in megacycles

F_L = Low-frequency end of tuning range, in megacycles

C_B = Capacity range of bandspread condenser, in $\mu\mu\text{fd.}$

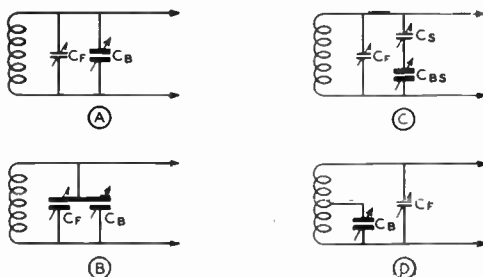

Figure 16.
BANDSPREAD CIRCUITS.

Parallel bandspread is illustrated at A and B, series bandspread at C, and tapped-coil bandspread at D.

In both the above formulas C_B represents the amount of capacity variation supplied by the bandspread condenser. In well-designed midget condensers, the variation will approach the rated maximum capacity, and the maximum capacity may be used for C_B without serious error. In the first formula, the result C_F will include all fixed capacities across the circuit, including the input capacity of the tube, stray capacity to ground, and the minimum capacity of the bandspread condenser.

Tapped-Coil System To allow equal bandspread on the amateur bands and still not use extremely high bandsetting capacities on the higher frequencies, the variation of the parallel system shown in Figure 16D is often employed. As the bandspread condenser, C_B , is connected across part of the coil, this method is known as the *tapped coil* system.

The effectiveness of the bandspread condenser in tuning the coil depends upon the portion of the coil included across the bandspread condenser terminals. As the number of turns between the condenser terminals is decreased, the amount of bandspread increases.

In most amateur-band receivers employing the tapped-coil system of bandspreading, a separate bandsetting condenser is permanently connected across each coil. These condensers are either mounted within the coils, in the plug-in-coil system, or alongside the coils in the bandswitching system.

Tapped-coil bandspread is quite widely used in modern amateur-band receivers, especially in home constructed sets. Its principal advantage is that it allows equal bandspread, to any degree desired, over several amateur bands. Another advantage is that it facilitates accurate tracking in ganged tuning circuits; the coil taps are adjusted until the circuits track identically.

Best results with the tapped-coil system will be obtained when C_B is made just large enough to tune the widest band when connected completely across a suitable coil, and then tapping C_B down the required amount on the narrower bands. (By "widest band" is meant the widest in terms of percentage, not kilocycles.)

Calculating the correct point for the location of the tap in the tapped-coil system is rather complicated, and for this reason, the recommended procedure is to wind a test coil with bare wire (for space wound coils) or a tap every few turns (for close wound coils) and determine the optimum turn experimentally.

Stray Circuit Capacity In this book and in other radio literature, mention is sometimes made of "stray" or circuit capacity. This capacity is in the usual sense defined as the capacity remaining across a coil when all the tuning, bandspread, and padding condensers across the circuit are at their minimum capacity setting.

Circuit capacity can be attributed to two general sources. One source is that due to the input capacitance of the tube when its cathode is heated. The input capacitance varies somewhat from the static or "cold" value when the tube is in actual operation. Such factors as plate load impedance, grid bias, and frequency will cause a change in input capacitance. However, in all except the extremely high-transconductance tubes, the published measured input capacitance is quite close to the effective value when the tube is used within its recommended frequency range. But in the high-transconductance types the effective capacitance varies considerably from the published figures under different operating conditions.

The second source of circuit capacity, and that which is more easily controllable, is that contributed by the minimum capacity of the variable condensers across the circuit and that due to capacity between the wiring and ground. In well-designed high-frequency receivers, every effort is made to keep this portion of the circuit capacity at a minimum, since a large capacity reduces the tuning range available with a given coil and prevents a good L/C ratio, and consequently a high-impedance tuned circuit, from being obtained.

A good percentage of stray circuit capacity is due also to distributed capacity of the coil and capacity between wiring points and chassis.

Typical values of circuit capacity may run from 10 to 75 $\mu\text{fd.}$ in high-frequency receivers, the first figure representing concentric-line receivers with acorn or miniature tubes and extremely small tuning condensers, and the latter representing all-wave sets with band-switching, large tuning condensers, and conventional tubes.

I.F. Tuned Circuits

I.f. amplifiers usually employ bandpass circuits of some sort. A bandpass circuit is exactly what the name implies—a circuit for passing a band of frequencies. Bandpass arrangements can be designed for almost any degree of selectivity, the type used in any particular application depending upon the use to which the i.f. amplifier is to be put.

I.F. Transformers Intermediate frequency transformers ordinarily consist of two or more tuned circuits and some method of coupling the tuned circuits together. Some representative arrangements are shown in Figure 17. The circuit shown at A is the conventional i.f. transformer, with the coupling, M, between the tuned circuits being provided by inductive coupling from one coil to the other. As the coupling is increased, the selectivity curve becomes less peaked, and when a condition known as "critical coupling" is reached, the top of the curve begins to flatten out. When the coupling is increased still more, a dip occurs in the top of the curve.

The windings for this type of i.f. transformer, as well as most others, nearly always consist of small, flat universal-wound pies mounted either on a piece of dowel to provide an air core or on powdered-iron impregnated bakelite for "iron core" i.f. transformers. The iron-core transformers generally have somewhat more gain and better selectivity than equivalent air-core units between 175 and 2000 kc.

The circuits shown at B and C are quite similar. Their only difference is the type of mutual coupling used, an inductance being used at B and a capacitance at C. The operation of both circuits is similar. Three resonant circuits are formed by the components. In B, for example, one resonant circuit is formed by L_1 , C_1 , C_2 and L_2 all in series. The frequency of this resonant circuit is just the same as that of a single one of the coils and condensers, since the coils and condensers are similar in both sides of the circuit, and the resonant frequency of the two condensers and the two coils all in series is the same as that of a single coil and condenser. The second resonant frequency of the complete circuit is determined by the characteristics of each half of the circuit containing the mutual coupling device. In B, this second frequency will be lower than the first, since the resonant frequency of L_1 , C_1 and the inductance, M, or L_2 , C_2 and M is lower than that of a single coil and condenser, due to the inductance of M being added to the circuit.

The opposite effect takes place at C, where the common coupling impedance is a condenser. Thus, at C the second resonant fre-

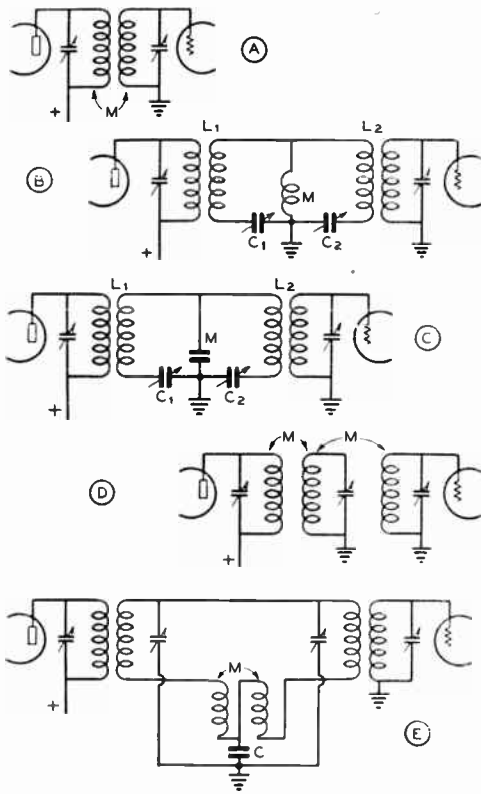

Figure 17.
I.F. AMPLIFIER COUPLING ARRANGEMENTS.

All of these arrangements give a better shape factor (more straight sided selectivity curve) than would the same number of resonant circuits coupled by means of tubes.

quency is higher than the first. In either case, however, the circuit has two resonant frequencies, resulting in a flat-topped selectivity curve. The width of the top of the curve is controlled by the reactance of the mutual coupling component. As this reactance is increased (inductance made greater, capacity made smaller), the two resonant frequencies become farther apart and the curve is broadened.

In the circuit of Figure 17D, there is inductive coupling between the center coil and each of the outer coils. The result of this arrangement is that the center coil acts as a sharply tuned coupler between the other two. A signal somewhat off the resonant frequency of the transformer will not induce as much voltage in the center coil as will a signal of the correct frequency. When a smaller voltage is induced in the center coil, it in turn transfers

a still smaller voltage to the output coil. The effective coupling between the outer coils increases as the resonant frequency is approached, and remains nearly constant over a small range and then decreases again as the resonant band is passed.

Another very satisfactory bandpass arrangement, which gives a very straight-sided, flat-topped curve, is the negative-mutual arrangement shown at E. Energy is transferred between the input and output circuits in this arrangement by both the negative-mutual coils, M, and the common capacitive reactance, C. The negative-mutual coils are interwound on the same form, and connected "backward."

Transformers usually are made tunable over a small range to permit accurate alignment in the circuit in which they are employed. This is accomplished either by means of a variable capacitor across a fixed inductance, or by means of a fixed capacitor across a variable inductance. The former usually employ either a mica compression condenser (designated "mica tuned"), or a small, air dielectric variable condenser (designated "air tuned"). Those which use a fixed capacitor usually employ a powdered iron core on a threaded rod to vary the inductance, and are known as "permeability tuned".

Shape Factor It is obvious that to pass modulation sidebands and to allow for slight drifting of the transmitter carrier frequency and the receiver local oscillator, the i.f. amplifier must pass not a single frequency but a band of frequencies. The width of this pass band, usually 6 to 12 kc. in a good communications receiver, is known as the "pass band", and is arbitrarily taken as the width between the two frequencies at which the response is attenuated 6 db, or is "6 db down". However, it is apparent that to discriminate against an interfering signal which is stronger than the desired signal, much more than 6 db attenuation is required. The attenuation arbitrarily taken to indicate adequate discrimination against an interfering signal is 60 db.

It is apparent that it is desirable to have the band width at 60 db down as narrow as possible, but it must be done without making the pass band (6 db down points) too narrow for satisfactory reception of the desired signal. The figure of merit used to show the ratio of bandwidth at 6 db down to that at 60 db down is designated *shape factor*. The ideal i.f. curve, a rectangle, would have a shape factor of 1.0. The i.f. shape factor in typical communications receivers runs from 3.0 to 5.5.

The most practicable method of obtaining a low shape factor for a given number of tuned circuits is to employ them in pairs, as in Figure 17A, adjusted to *critical coupling*

(the value at which two resonance points just begin to become apparent). If this gives too sharp a "nose" or pass band, then coils of lower Q should be employed, with the coupling maintained at the critical value. As the Q is lowered, closer coupling will be required for critical coupling.

Conversely if the pass band is too broad, coils of higher Q should be employed, the coupling being maintained at critical. If the pass band is made more narrow by using looser coupling instead of raising the Q and maintaining critical coupling, the shape factor will not be as good.

The pass band will not be much narrower for several pairs of identical, critically coupled tuned circuits than for a single pair. However, the shape factor will be greatly improved as each additional pair is added, up to about 5 pairs, beyond which the improvement for each additional pair is not significant. Commercially available communications receivers of good quality normally employ 3 or 4 double tuned transformers with coupling adjusted to critical or slightly less.

"Miller Effect" As mentioned previously, the dynamic input capacitance of a tube varies slightly with bias. As a.v.c. voltage normally is applied to i.f. tubes for radiotelephony reception, the effective grid-cathode capacitance varies as the signal strength varies, which produces the same effect as slight detuning of the i.f. transformer. This effect is known as "Miller effect", and can be minimized to the extent that it is not troublesome either by using a fairly low L/C ratio in the transformers or by incorporating a small amount of degenerative feedback, the latter being most easily accomplished by leaving part of the cathode resistor unbypassed for r.f.

Crystal Filters The pass band of an intermediate frequency amplifier may be made very narrow through the use of a piezoelectric filter crystal employed as a series resonant circuit in a bridge arrangement known as a crystal filter. The shape factor is quite poor, as would be expected when the selectivity is obtained from the equivalent of a single tuned circuit, but the very narrow pass band obtainable as a result of the extremely high Q of the crystal makes the crystal filter useful for c.w. telegraphy reception. The pass band of a 455 kc. crystal filter may be made as narrow as 50 cycles, while 5 kilocycles represent about the narrowest pass band that can be obtained with a 455 kc. tuned circuit of practicable dimensions.

The electrical equivalent of a filter crystal is

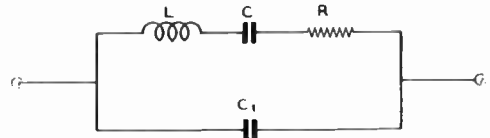

Figure 18.
ELECTRICAL EQUIVALENT OF QUARTZ FILTER CRYSTAL.

The crystal is equivalent to a very large inductance in series with a very small condenser and resistor, with a larger though still small condenser across the whole circuit (representing stray capacity).

shown in Figure 18. For a given frequency, L is very high, C very low, and R (assuming a good crystal of high Q) is very low. Capacity C_1 represents the shunt capacity of the electrodes, plus the crystal holder and wiring, and is many times the capacity of C. This makes a parallel resonant circuit with a frequency only slightly higher than that of the series resonant circuit L, C. For crystal filter use it is the series resonant characteristic that we are primarily interested in.

The electrical equivalent of the basic crystal filter circuit is shown in Figure 19. If the impedance of Z plus Z_1 is low compared to the impedance of the crystal X at resonance, then the current flowing through Z_1 , and the voltage developed across it, will be almost in inverse proportion to the impedance of X, which has a very sharp resonance curve.

If the impedance of Z plus Z_1 is made high compared to the resonant impedance of X, then there will be no appreciable drop in voltage across Z_1 as the frequency departs from the resonant frequency of X until the point is reached where the impedance of X approaches that of Z plus Z_1 . This has the effect of broad-

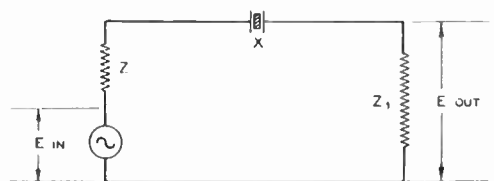

Figure 19.
EQUIVALENT OF CRYSTAL FILTER CIRCUIT.

For a given voltage out of the generator, the voltage developed across Z_1 depends upon the ratio of the impedance of X to the sum of the impedances Z and Z_1 . Because of the high Q of X, its impedance changes rapidly with frequency.

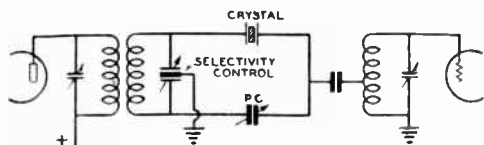

Figure 20.

TYPICAL CRYSTAL FILTER CIRCUIT.

This circuit incorporates a selectivity control and a phasing control to permit maximum exploitation of the filter crystal.

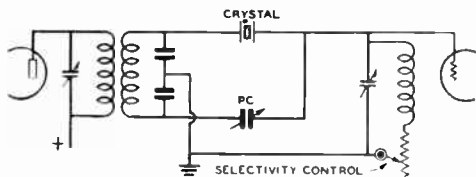

Figure 21.

WIDE RANGE, VARIABLE SELECTIVITY CRYSTAL FILTER.

This circuit permits better selectivity control than the circuit of figure 20, and does not require a split stator variable condenser.

ening out the curve of frequency versus voltage developed across Z_1 , which is another way of saying that the selectivity of the crystal filter (but not the crystal proper) has been reduced.

In practicable filter circuits the impedances Z and Z_1 usually are represented by some form of tuned circuit, but the basic principle of operation is the same.

Practical Filters It is necessary to balance out the capacity across the crystal holder (C_1 in Figure 18) to prevent by-passing around the crystal of undesired signals off the crystal resonant frequency. The balancing is done by a *phasing* circuit which takes out-of-phase voltage from a balanced input circuit and passes it to the output side of the crystal in proper phase to neutralize that passed through the holder capacity. A representative practical filter arrangement is shown in Figure 20. The phasing condenser is indicated in the diagram by PC. The balanced input circuit may be obtained either through the use of a split-stator condenser as shown, or by the use of a center-tapped input coil.

Variable-Selectivity Filters In the circuit of Figure 20, the selectivity is *minimum* with the crystal input circuit tuned to resonance, since at resonance the impedance of the tuned circuit is maximum. As the input circuit is detuned from resonance, however, the impedance decreases, and the selectivity becomes greater. In this circuit, the output from the crystal filter is tapped down on the i.f. stage grid winding to provide a low value of series impedance in the output circuit. It will be recalled that for maximum selectivity, the total impedance in series with the crystal (both input and output circuits) must be low. If one is made low and the other is made variable, then the selectivity may be varied at will from sharp to broad.

The circuit shown in Figure 21 also achieves variable selectivity by adding a variable im-

pedance in series with the crystal circuit. In this case, the variable impedance is in series with the crystal output circuit. The impedance of the output tuned circuit is varied by varying the Q. As the Q is reduced (by adding resistance in series with the coil), the impedance decreases and the selectivity becomes greater. The input circuit impedance is made low by using a non-resonant secondary on the input transformer.

A variation of the circuit shown at Figure 21 consists of placing the variable resistance across the coil and condenser, rather than in series with them. The result of adding the resistor is a reduction of the output impedance, and an increase in selectivity. The circuit behaves oppositely to that of Figure 21, however; as the resistance is lowered the selectivity becomes greater. Still another variation of Figure 21 is to use the tuning condenser across the output coil to vary the output impedance. As the output circuit is detuned from resonance, its impedance is lowered, and the selectivity increases. Sometimes a set of fixed condensers and a multipoint switch are used to give step-by-step variation of the output circuit tuning, and thus of the crystal filter selectivity.

Rejection Notch As previously discussed, a filter crystal has both a resonant (series resonant) and an anti-resonant (parallel resonant) frequency, the impedance of the crystal being quite low at the former frequency, and quite high at the latter frequency. The anti-resonant frequency is just slightly higher than the resonant frequency, the difference depending upon the effective shunt capacity of the filter crystal and holder. As adjustment of the phasing condenser controls the effective shunt capacity of the crystal, it is possible to vary the anti-resonant frequency of the crystal slightly without unbalancing the circuit sufficiently to let undesired signals "leak through" the shunt capacity in appreciable amplitude. At the exact anti-resonant fre-

quency of the crystal the attenuation is exceedingly high, because of the high impedance of the crystal at this frequency. This is called the "rejection notch", and can be utilized to virtually eliminate the heterodyne image or "repeat tuning" of c.w. signals. The beat frequency oscillator can be so adjusted and the phasing condenser so adjusted that the desired beat note is of such a pitch that the image (the same audio note on the other side of zero beat) falls in the rejection notch and is inaudible. The receiver then is said to be adjusted for "single signal" operation.

The rejection notch sometimes can be employed to reduce interference from an undesired *phone* signal which is very close in frequency to a desired phone signal. The filter is adjusted to "broad" so as to permit telephony reception, and the receiver tuned so that the carrier frequency of the undesired signal falls in the rejection notch. The modulation sidebands of the undesired signal still will come through, but the carrier heterodyne will be effectively eliminated and interference greatly reduced.

Crystal Filter Considerations

A crystal filter, especially when adjusted for "single signal" reception, greatly reduces interference and background noise, the latter feature permitting signals to be copied that would ordinarily be too weak to be heard above the background hiss. However, when the filter is adjusted for maximum selectivity, the pass band is so narrow that the received signal must have a high order of stability in order to stay within the pass band. Likewise, the local oscillator in the receiver must be highly stable, or constant retuning will be required. Another effect that will be noticed with the filter adjusted to "sharp" is a tendency for code characters to produce a ringing sound, and have a hangover or "tails." This limits the code speed that can be copied satisfactorily when the filter is adjusted for extreme selectivity.

Beat-Frequency Oscillators

The beat-frequency oscillator, usually called the *b.f.o.*, is a necessary adjunct for reception of c.w. telegraph signals on superheterodynes which do not use regenerative second detectors. The oscillator is coupled into or just ahead of second detector circuit and supplies a signal of nearly the same frequency as that of the desired signal from the i.f. amplifier. If the i.f. amplifier is tuned to 455 kc., for example, the b.f.o. is tuned to approximately 454 or 456 kc. to produce an audible (1000 cycle) beat note in the output of the second detector of the receiver. The carrier signal itself is, of course, inaudible. The b.f.o. is not used

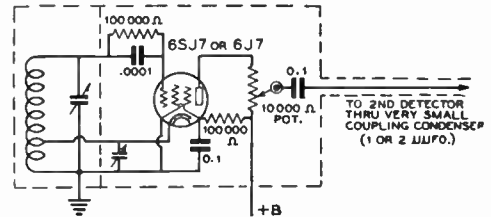

Figure 22.

VARIABLE-OUTPUT B.F.O. CIRCUIT.

Being able to vary the output of the b.f.o. is sometimes helpful when receiving weak signals.

for voice reception, except as an aid in searching for weak stations.

The b.f.o. input to the second detector need only be sufficient to give a good beat note on an average signal. Too much coupling into the second detector will give an excessively high hiss level, masking weak signals by the high noise background.

Figure 22 shows a method of manually adjusting the b.f.o. output to correspond with the strength of received signals. This type of variable b.f.o. output control is a useful adjunct to any superheterodyne, since it allows sufficient b.f.o. output to be obtained to give a "beat" with strong signals and at the same time permits the b.f.o. output, and consequently the hiss, to be reduced when attempting to receive weak signals. The circuit shown is somewhat better than those in which one of the electrode voltages on the b.f.o. tube is changed, as the latter usually change the frequency of the b.f.o. at the same time they change the strength, making it necessary to reset the trimmer each time the output is adjusted.

The b.f.o. usually is provided with a small trimmer which is adjustable from the front panel to permit adjustment over a range of 5 or 10 kc. For single signal reception the b.f.o. always is adjusted to the high frequency side, in order to permit placing the heterodyne image in the rejection notch.

In order to reduce the b.f.o. signal output voltage to a reasonable level which will prevent blocking the second detector, the signal voltage is delivered through a low-capacitance (high-reactance) condenser having a value of 1 to 2 $\mu\mu\text{fd}$. and connected after the 0.1- μfd . unit in Figure 22.

Care must be taken with the b.f.o. to prevent harmonics of the oscillator from being picked up at multiples of the b.f.o. frequency. The complete b.f.o. together with the coupling circuits to the second detector, should be thoroughly shielded to prevent pickup of the harmonics by the input end of the receiver.

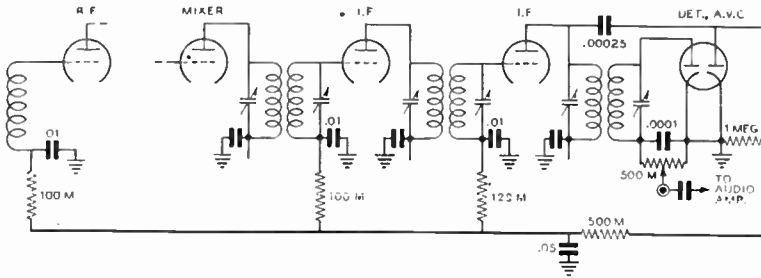

Figure 23.

DOUBLE-DIODE DETECTOR-A. V. C. CIRCUIT.

Any of the ordinary small dual-diode tubes may be used in this circuit. The left-hand diode serves as the detector, while the right-hand section operates as an a.v.c. rectifier. Using separate diodes for the detector and a.v.c. functions help to improve the audio fidelity.

Detector, Audio, and Control Circuits

Detectors Second detectors for use in superheterodynes are usually of the diode, plate, or infinite impedance types, which were described in detail in Chapter 3. Occasionally, grid-leak detectors are used in receivers using one i.f. stage or none at all, in which case the second detector usually is made regenerative.

Diodes are the most popular second detectors because they allow a simple method of obtaining automatic volume control to be used. Diodes load the tuned circuit to which they are connected, however, and thus reduce the selectivity slightly. Special i.f. transformers are used for the purpose of providing a low-impedance input circuit to the diode detector.

Automatic Volume Control The elements of an automatic volume control (a.v.c.) system are shown in Figure 23. A dual diode tube is used as a combination diode detector and a.v.c. rectifier. The left-hand diode operates as a simple rectifier in the manner described earlier in this chapter. Audio voltage, superimposed on a d.c. voltage, appears across the 500,000-ohm potentiometer (the volume control) and the .0001-μfd. condenser, and is passed on to the audio amplifier. The right-hand diode receives signal voltage directly from the primary of the last i.f. amplifier, and acts as the a.v.c. rectifier. The pulsating d.c. voltage across the 1-megohm a.v.c.-diode load resistor is filtered by a 500,000-ohm resistor and a .05-μfd. condenser, and applied as bias to the grids of the r.f. and i.f. amplifier tubes; an increase or decrease in signal strength will cause a corresponding increase or decrease in a.v.c. bias voltage, and thus the gain of the receiver is automatically adjusted to compensate for changes in signal strength.

By disassociating the a.v.c. and detecting

functions through using separate diodes, as shown, most of the ill effects of a.c. shunt loading on the detector diode are avoided. This type of loading causes serious distortion, and the additional components required to eliminate it are well worth their cost. Even with the circuit shown, a.c. loading can occur unless a very high (5 megohms, or more) value of grid resistor is used in the following audio amplifier stage.

An a.v.c. circuit which may be added to a receiver not so equipped is shown in Figure 24. In this circuit, the pentode section of a duplex-diode-pentode is used as a resistance coupled i.f. amplifier which receives its excitation from the detector grid circuit. The output from the pentode is applied to the two diodes in parallel, through a coupling condenser, and the rectified voltage across the diode load resistor is used as a.v.c. bias.

A.V.C. in B.F.O.-Equipped Receivers

In receivers having a beat-frequency oscillator for the reception of radiotelegraph signals, the use of a.v.c. can result in a great loss in sensitivity when the b.f.o. is switched on. This is because the beat oscillator output acts exactly like a strong received signal, and causes the a.v.c. circuit to put high bias on the r.f. and i.f. stages, thus greatly reducing the receiver's sensitivity. Due to the above effect, it is necessary to provide a method of making the a.v.c. circuit inoperative when the b.f.o. is being used. The simplest method of eliminating the a.v.c. action is to short the a.v.c. line to ground when the b.f.o. is turned on. A two-circuit switch may be used for the dual purpose of turning on the beat oscillator and shorting out the a.v.c. if desired.

Signal Strength Indicators Visual means for determining whether or not the receiver is properly tuned, as well as an indication of the relative signal

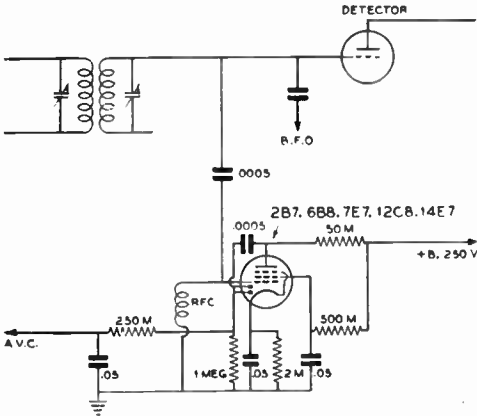

Figure 24.
A.V.C. CIRCUIT SUITABLE FOR ANY SUPERHETERODYNE.

This circuit may be added to a receiver not equipped with a.v.c. The duo-diode-pentode acts as an a.v.c. amplifier, giving improved a.v.c. action.

strength, are both provided by means of *tuning indicators* of the meter or vacuum-tube types. Direct current milliammeters can be connected in the plate-supply circuit of an r.f. amplifier, as shown in Figure 25, so that the change in plate current, due to the a.v.c. voltage which is supplied to that tube, will indicate proper tuning. Sometimes these d.c. meters are built in such a manner as to produce a shadow of varying width. Vacuum-tube tuning indicators are designed so that an electron-ray "eye" pattern changes its size when the input circuit of the tube is connected across all or part of the a.v.c. voltage. The basic circuit for this type of indicator is illustrated in Figure 26.

When an ordinary meter is used in the plate circuit of a stage, for the purpose of indicating signal strength, the meter reads backwards with respect to strength. This is because increased a.v.c. bias on stronger signals causes lower plate current through the meter. For this reason, special meters which indicate zero at the right-hand end of the scale are often used for signal strength indicators in this type of circuit. Alternatively, the meter may be mounted upside down, so that the needle moves toward the right with increased signal strength.

Audio Amplifiers Audio amplifiers are employed in nearly all radio receivers. The audio amplifier stage or stages are usually of the class A type, although class AB push-pull stages are used in some receivers.

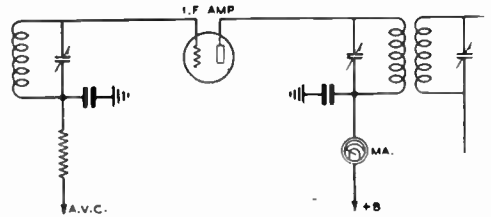

Figure 25.
LOW-RANGE MILLIAMMETER AS A TUNING OR SIGNAL STRENGTH INDICATOR.

The plate current to an i.f. stage varies as the a.v.c. bias changes. A 0-10 d.c. milliammeter will serve in most cases. The meter reads "backwards" in this circuit, strong signals causing the current to decrease more than weak ones.

The operation of both of these types of amplifiers was described in Chapter 3. The purpose of the audio amplifier is to bring the relatively weak signal from the detector up to a strength sufficient to operate a pair of headphones or a loud speaker. Either triodes, pentodes, or beam tetrodes may be used, the pentodes and beam tetrodes usually giving greater output. In some receivers, particularly those employing grid leak detection, it is possible to operate the headphones directly from the detector, without audio amplification. In such receivers, a single audio stage with a beam tetrode or pentode tube is ordinarily used to drive the loud speaker. Representative audio amplifier arrangements will be found in Chapter 3.

Noise Suppression

The problem of noise suppression confronts the listener who is located in places where interference from power lines, electrical appliances, and automobile ignition systems is troublesome. This noise is often of such intensity as to swamp out signals from desired stations.

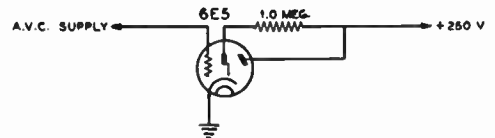

Figure 26.
ELECTRON-RAY TUNING INDICATOR.
Other "eye" tubes such as the 6U5 and 6AB5 may also be used in this circuit.

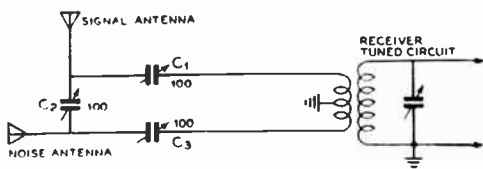

Figure 27.

NOISE-BALANCING CIRCUIT.

This circuit, when properly adjusted, reduces the intensity of power-leak and similar interference.

There are three principal methods for reducing this noise:

- (1) A.c. line filters at the source of interference, if the noise is created by an electrical appliance.
- (2) Noise-balancing circuits for the reduction of power-leak interference.
- (3) Noise-limiting circuits for the reduction, in the receiver itself, of interference of the type caused by automobile ignition systems.

Power Line Filters Many household appliances, such as electric mixers, heating pads, vacuum sweepers, refrigerators, oil burners, sewing machines, doorbells, etc., create an interference of an intermittent nature. The insertion of a line filter near the source of interference often will effect a complete cure. Filters for small appliances can consist of a 0.1- μ fd. condenser connected across the 110-volt a.c. line. Two condensers in series across the line, with the midpoint connected to ground, can be used in conjunction with ultra-violet ray machines, refrigerators, oil burner furnaces, and other more stubborn offenders. In severe cases of interference, additional filters in the form of heavy-duty r.f. choke coils must be connected in series with the 110-volt a.c. line on both sides of the line right at the interfering appliance.

Noise Balancing Most power line noise interference can be greatly reduced by the installation of a *noise-balancing* circuit ahead of the receiver, as shown in Figure 27. The noise-balancing circuit adds the noise components from a separate noise antenna in such a manner that this noise antenna will buck the noise picked up by the regular receiving antenna. The noise antenna can consist of a connection through a .002 μ fd. mica capacitor to one side of the a.c. line, in some cases, while at other times an additional wire, 20 to 50 feet in length, can be run parallel to

the a.c. house supply line. The noise antenna should pick up as much noise as possible in comparison with the amount of signal pickup. The regular receiving antenna should be a good-sized outdoor antenna, high and in the clear, so that the signal-to-noise ratio will be as high as possible. When the noise components are balanced out in the circuit ahead of the receiver, the signals will not be attenuated to as great a degree.

This type of noise balancing is not a simple process; it requires a bit of experimentation in order to obtain good results. However, when proper adjustments have been made, it is possible to reduce the power leak noise from 3 to 5 "S" points without reducing the signal strength more than one S point, and in some cases there will be no reduction in signal strength whatsoever. This permits reception of weak signals through bad power leak interference. Hash type interference from electrical appliances can be reduced to a very low value by means of the same circuits.

The coil should be center-tapped and connected to the receiver ground connection in most cases. The pickup coil consists of 4 turns of hookup wire 2 inches in diameter, which can be slipped over the first r.f. tuned coil in most radio receivers. A 2-turn coil is more appropriate for 10- and 20-meter operation, though the 4-turn coil is suitable if care is taken in adjusting the condensers to avoid 10-meter resonance (unless very loose inductive coupling is used).

When properly balanced, the usual power line buzz can be reduced nearly to zero without attenuating the desired signal more than 50 per cent. Sometimes an incorrect adjustment will result in balancing out the signal as well as the noise. A good high antenna for signal reception will ordinarily overcome this effect.

With this circuit, some readjustment is necessary from band to band in the shortwave spectrum. Noise-balancing systems require a good deal of patience and experimenting at each particular receiving location.

Peak Noise Limiters Numerous noise-limiting circuits which are beneficial in overcoming key clicks, automobile ignition interference, and similar noise impulses have become popular. They operate on the principle that each individual noise pulse is of very short duration, yet of very high amplitude. The popping or clicking type of noise from electrical ignition systems may produce a signal having a peak value ten to twenty times as great as the incoming radio signal, but an average power much less than the signal.

As the duration of this type of noise peak is short, the receiver can be made inoperative during the noise pulse without the human ear

detecting the total loss of signal. Some noise limiters actually *punch a hole* in the signal, while others merely *limit* the maximum peak signal which reaches the headphones or loud-speaker.

The noise peak is of such short duration that it would not be objectionable except for the fact that it produces an overloading and integrating effect on the receiver, which increases its time constant. A sharp voltage peak will give a kick to the diaphragm of the headphones or speaker, and the momentum or inertia keeps the diaphragm in motion until the dampening of the diaphragm stops it. This movement produces a popping sound which may completely obliterate the desired signal. If the noise pulse can be limited to a peak amplitude equal to that of the desired signal, the resulting interference is practically negligible for moderately low repetition rates, such as ignition noise.

Virtually all of the practicable peak limiters for radiotelephony employ one or two diodes either as "clippers" or "gates" in the a.f. system, the former being known as the *shunt* type and the latter the *series* type. When a noise pulse exceeds a certain predetermined threshold value, the limiter diode acts either as a dead short or open circuit, depending upon whether it is used in a shunt or series circuit. The threshold is made to occur at a level high enough that it will not clip modulation peaks enough to impair voice intelligibility, but low enough to limit the noise peaks effectively.

Because the action of the peak limiter is needed most on very weak signals, and these usually are not strong enough to produce proper a.v.c. action, a threshold setting that is correct for a strong phone signal is not correct for optimum limiting on very weak signals. For this reason the threshold control often is tied in with the a.v.c. system so as to make the optimum threshold adjustment automatic instead of manual.

Suppression of impulse noise by means of an audio peak limiter is best accomplished at the very front end of the audio system, and for this reason the function of superheterodyne second detector and limiter often are combined in a composite circuit.

The amount of limiting that can be obtained is a function of the audio distortion than can be tolerated. Because excessive distortion will reduce the intelligibility as much as will background noise, the degree of limiting for which the circuit is designed has to be a compromise.

Peak noise limiters working at the second detector are much more effective when the i.f. bandwidth of the receiver is broad, because a sharp i.f. amplifier will produce an integrating effect which lengthens the pulses by the time they reach the second detector, making the limiter less effective. U.h.f. superheterodynes have

an i.f. bandwidth considerably wider than the minimum necessary for voice sidebands (to take care of drift and instability). Therefore, they are capable of better peak noise suppression than a standard communications receiver having an i.f. bandwidth of perhaps 8 kc. Likewise, when a crystal filter is used on the "sharp" position an a.f. peak limiter is of little benefit.

Practical Peak Noise Limiter Noise limiters range all the way from an audio stage running at very low screen or plate voltage, to elaborate affairs employing 5 or more tubes. Rather than attempt to show the numerous types, many of which are quite complex considering the mediocre results obtained, only one will be described. It is just about as effective as the most elaborate limiter that can be constructed, yet requires the addition of but a single diode and a few resistors and capacitors over what would be employed in a good superheterodyne without a limiter. This circuit, with but minor modifications in resistance and capacitance values, is incorporated in one form or another in several of the better factory built communications receivers.

Referring to Figure 28, the circuit shows a conventional superheterodyne second detector, a.v.c., and first audio stage with the addition of one tube element, D_2 , which may be either a separate diode or part of a twin-diode as illustrated. Diode D_2 acts as a series gate, allowing audio to get to the grid of the a.f. tube only so long as the diode is conducting. The diode is biased by a d.c. voltage obtained in the same manner as a.v.c. control voltage, the bias being such that pulses of short duration no longer conduct when the pulse voltage exceeds the carrier by approximately 60 per cent. This also clips voice modulation peaks, but not enough to impair intelligibility.

It is apparent that the series diode clips only *positive* modulation peaks, by limiting upward modulation to about 60 per cent. Negative or downward peaks are limited automatically to 100 per cent in the detector, because obviously the rectified voltage out of the diode detector cannot be less than zero. Limiting the downward peaks to 60 per cent or so instead of 100 per cent would result in but little improvement in noise reduction, and the results do not justify the additional components required.

It is important that the exact resistance values shown be used, for best results, and that 10 per cent tolerance resistors be used for R_2 and R_1 . Also, the rectified carrier voltage developed across C_2 should be at least 5 volts for good limiting.

The limiter will work well on c.w. telegraphy if the amplitude of beat frequency oscillator in-

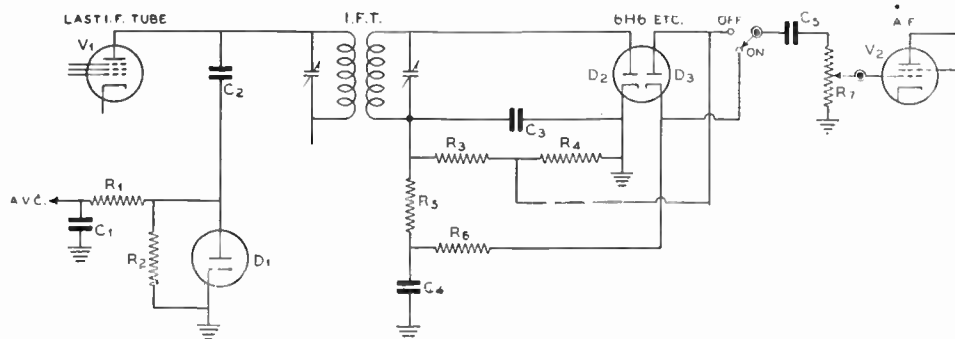

Figure 28.

PEAK NOISE LIMITER AND ASSOCIATED CIRCUITS.

This limiter is of the series type, and is self adjusting to the carrier strength for phone reception. For proper operation, at least 5 volts should be developed across the secondary of I.F.T. under carrier conditions.

R₁, R₂—1 meg., ½ watt

R₃, R₄—250,000 ohms, ½ watt (10% tolerance)

R₅, R₆—1 meg., ½ watt

R₇—2 meg. potentiometer, a.f. taper

C₁—0.1 μfd., 200 v.

C₂—50 μfd. mica

C₃—100 μfd. mica

C₄, C₅—0.01 μfd.

jection is not too high. Variable injection is to be preferred, adjustable from the front panel. If this feature is not provided, the b.f.o. injection should be reduced to the lowest value that will give a satisfactory beat. When this is done, effective limiting and a good beat can be obtained by proper adjustment of the r.f. and a.f. gain controls. It is assumed, of course, that the a.v.c. is cut out of the circuit for c.w. telegraphy reception.

Receiver Characteristics

A good communications receiver should have certain features and meet certain performance characteristics. While some things must of necessity be a compromise in an inexpensive receiver, it is desirable that a communications receiver conform to the following requirements.

Sensitivity The sensitivity of a receiver is not a function of gain or overall amplification, but of signal-to-noise ratio. The receiver should have sufficient sensitivity over the whole range of frequencies covered so that with an average antenna the hiss or background noise is *atmospheric* noise, and not noise emanating in the set itself. This is quite easy to obtain below about 10 Mc., but increasingly difficult on higher frequencies.

The only way to measure the sensitivity of a receiver accurately is with a good signal generator. However, one way to tell whether the sensitivity is good or bad is to disable the a.v.c., turn up the gain until background noise is heard, and then remove the antenna. The

background noise should drop at least several decibels in a quiet location under quiet atmospheric conditions, on all frequencies within the range. If it doesn't, the receiver is not all that could be desired.

Sensitivity is measured in absolute units by determining the number of microvolts of carrier input required in order to obtain a 10 db difference in audio output under modulation and modulation-off conditions, assuming 30 per cent modulation at 400 or 1000 cycles. Even this measurement does not serve as a true yardstick, as the input impedance of the receiver must be taken into consideration. For instance, if the input impedance of a certain receiver is changed from 70 ohms to 600 ohms, the sensitivity (based on signal to noise ratio) will not be affected. It is apparent, however, that when measured as indicated above, the receiver will show less sensitivity when 600 ohm input is incorporated.

Selectivity The selectivity should be as great as will permit intelligible reception of radiophone signals, assuming the receiver is stable and does not drift seriously with changes in temperature and line voltage. It should be remembered that true selectivity is not just a measure of the i.f. pass band at 6 db down, but of the band width at 60 db down, because this order of attenuation is required in order to reject strong signals.

Spurious Response A poorly designed super-heterodyne will respond (in addition to the desired frequency) to the

regular image, to frequencies the i.f. away from harmonics of the high frequency oscillator, and to the intermediate frequency. On a good superheterodyne the regular image will be at least 60 db down on the lower frequencies, and at least 50 db down on the higher frequencies. Other spurious responses should be at least 80 db down. Harmonics of the b.f.o. will be virtually inaudible.

Stability A good receiver should be highly stable with regard to vibration and jars, to line voltage variations, tube warm up, and changes in ambient temperature and humidity.

Cross Modulation A good receiver will receive a weak signal without interference from a very strong, modulated signal which is well outside the pass band of the i.f. but within the pass band of the pre-selector stages. Unless a receiver is highly invulnerable to cross modulation it cannot be employed in close proximity to a transmitter working within about 5 per cent in frequency.

Gain Gain is easy to get, in a.f. stages and i.f. stages. The only requirement is that it be sufficient to permit reception, at full audio output, of a signal which is just barely above the noise level.

Distortion Frequency response and harmonic distortion are not so important in a communications receiver. So long as the distortion does not exceed 15 per cent, it is not serious. The frequency response should be reasonably flat between 250 and 3500 cycles, and preferably should cut off sharply outside these limits. If the same receiver is to be used for entertainment purposes, a wider frequency response and less distortion are desirable.

A.V.C. The a.v.c. should hold the output within a few decibels, regardless of whether a signal is just above the noise level or almost strong enough to overload the receiver. The a.v.c. should not detune the i.f. stages or the high frequency oscillator when handling a fading signal. The time constant should be as short as practicable or about 0.1 second, so as to permit following a rapidly fading signal.

Controls It is highly desirable that the receiver have both r.f. and a.f. gain controls. The b.f.o. frequency and the injection amplitude should preferably be adjustable from the front panel. The tuning dial or dials should work smoothly without backlash, and provide sufficient bandspread for easy tuning.

Receiver Adjustment

A simple regenerative receiver requires little adjustment other than those necessary to insure correct tuning and smooth regeneration over some desired range. Receivers of the tuned radio-frequency type and superheterodynes require precise alignment to obtain the highest possible degree of selectivity and sensitivity.

Good results can be obtained from a receiver only when it is properly aligned and adjusted. The most practical technique for making these adjustments is given below.

Instruments A very small number of instruments will suffice to check and align any multitube receiver, the most important of these testing units being a modulated oscillator and a d.c. and a.c. voltmeter. The meters are essential in checking the voltage applied at each circuit point from the power supply. If the a.c. voltmeter is of the oxide-rectifier type, it can be used, in addition, as an output meter when connected across the receiver output when tuning to a modulated signal. If the signal is a steady tone, such as from a test oscillator, the output meter will indicate the value of the detected signal. In this manner, lineup adjustments may be visually noted on the meter rather than by increases or decreases of sound intensity as detected by ear.

T.R.F. Receiver Alignment Alignment procedure in a multistage t.r.f. receiver is exactly the same as aligning a single stage. If the detector is regenerative, each preceding stage is successively aligned while keeping the detector circuit tuned to the test signal, the latter being a station signal or one locally generated by a test oscillator loosely coupled to the antenna lead. During these adjustments, the r.f. amplifier gain control is adjusted for maximum sensitivity, assuming that the r.f. amplifier is stable and does not oscillate. Oscillation is indicative of improper by-passing or shielding. Often a sensitive receiver can be roughly aligned by tuning for maximum noise pickup.

Superheterodyne Alignment Aligning a superhet is a detailed task requiring a great amount of care and patience. It should never be undertaken without a thorough understanding of the involved job to be done and then only when there is abundant time to devote to the operation. There are no short cuts; every circuit must be adjusted individually and accurately if the receiver is to give peak performance. The precision of each adjustment is dependent upon the accuracy with which the preceding one was made.

Superhet alignment requires (1) a good sig-

nal generator (modulated oscillator) covering the radio and intermediate frequencies and equipped with an attenuator and B-plus switch; (2) the necessary socket wrenches, screwdrivers, or "neutralizing tools" to adjust the various i.f. and r.f. trimmer condensers; and (3) some convenient type of tuning indicator, such as a copper-oxide or electronic voltmeter.

Throughout the alignment process, unless specifically stated otherwise, the r.f. gain control must be set for maximum output, the beat oscillator switched off, and the a.v.c. turned off or shorted out. When the signal output of the receiver is excessive, either the attenuator or the a.f. gain control may be turned down, but never the r.f. gain control.

I.F. Alignment After the receiver has been given a rigid electrical and mechanical inspection, and any faults which may have been found in wiring or the selection and assembly of parts corrected, the i.f. amplifier may be aligned as the first step in the checking operations.

The coils for the r.f. (if any), mixer, and high-frequency oscillator stages must be in place. It is immaterial which coils are inserted.

With the signal generator set to give a modulated signal on the frequency at which the i.f. amplifier is to operate, clip the "hot" output lead from the generator to the last i.f. stage through a small fixed condenser to the control grid. Adjust both trimmer condensers in the last i.f. transformer (the one between the last i.f. amplifier and the second detector) to resonance as indicated by maximum deflection of the output meter.

Each i.f. stage is adjusted in the same manner, moving the hot lead, stage by stage, back toward the front end of the receiver and backing off the attenuator as the signal strength increases in each new position. The last adjustment will be made to the first i.f. transformer, with the hot signal generator lead connected to the control grid of the mixer. Occasionally it is necessary to disconnect the mixer grid lead from the coil, grounding it through a 1,000- or 5,000-ohm resistor, and coupling the signal generator through a small capacitance to the grid.

When the last i.f. adjustment has been completed, it is good practice to go back through the i.f. channel, re-peaking all of the transformers. It is imperative that this recheck be made in sets which do not include a crystal filter, and where the simple alignment of the i.f. amplifier to the generator is final.

I.F. with Crystal Filter

There are several ways of aligning an i.f. channel which contains a crystal-filter circuit.

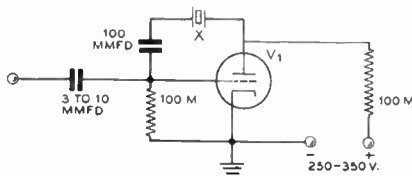

Figure 29.

CRYSTAL TEST OSCILLATOR.

A filter crystal may be placed in an oscillator such as this to make preliminary alignment adjustments. Final touching up should be done with the filter crystal in the receiver and operable.

However, the following method is one which has been found to give satisfactory results in every case: If the i.f. channel is known to be far out of alignment, or if the initial alignment of a new receiver is being attempted, the crystal itself should first be used to control the frequency of a test oscillator. The circuit shown in Figure 29 can be used. The crystal will oscillate at its anti-resonant frequency in this circuit, while as a filter it functions at its resonant frequency. However, the two are sufficiently close together for preliminary adjustments.

Any high transconductance triode such as a 6J5, or a triode connected, high transconductance pentode or beam tube such as a 6SG7 or 6V6 may be used for V_1 . The a.c. plate voltage, which is used to give the necessary modulated note, may be obtained by hooking to one plate of the rectifier tube in the receiver power pack.

For the final alignment of a new receiver, or touching up of a receiver that has already been aligned and is suspected of having drifted slightly out, the crystal should be placed in the receiver and an unmodulated carrier from a signal generator fed into the grid of the mixer at the i.f. With the b.f.o. off and the crystal filter switched in, the signal generator is tuned slowly to find where the crystal peaks. The "S" meter of the receiver or a microammeter in series with the second detector load resistor can be used as an indicator. When the crystal peak is found, all i.f. transformers are touched up to peak at that frequency.

If a signal generator is not available for this procedure, the coupling from the receiver b.f.o. may be temporarily broken and the output of the b.f.o. coupled loosely to the mixer. In this manner the b.f.o. is made to serve as a signal generator.

Because the crystal filter is so sharp, it is preferable to make this final adjustment with no modulation on the signal generator. Hence

the need for a different method of output indication.

B.F.O. Adjustment Adjusting the beat oscillator on a receiver that has no front panel adjustment is relatively simple. It is only necessary to tune the receiver to resonance with any signal, as indicated by the tuning indicator, and then turn on the b.f.o. and set its trimmer (or trimmers) to produce the desired beat note. Setting the beat oscillator in this way will result in the beat note being stronger on one "side" of the signal than on the other, which is what is desired for c.w. reception. The b.f.o. should *not* be set to "zero beat" when the receiver is tuned to resonance with the signal, as this will cause an equally strong beat to be obtained on both sides of resonance.

Front-End Alignment Alignment of the "front end" of a manufactured receiver is a somewhat involved process, varies considerably from one receiver to another, and for that reason will not be discussed here. Those interested in the alignment of such receivers usually will find full instructions in the operating manual or instruction book supplied with the receiver. Likewise, full alignment data are always given when an "all wave" tuning assembly for incorporation in home-built receivers is purchased.

In aligning the front end of a home-constructed superheterodyne which covers only the amateur bands, the principal problems are those of securing proper bandspread in the oscillator, and then tracking the signal-frequency circuits with the oscillator. The simplest method of adjusting the oscillator for proper bandspread is to tune in the oscillator on an "all wave" receiver, and adjust its bandspread so that it covers a frequency range equal to that of the tuning range desired in the receiver but over a range of frequencies equal to the desired signal range plus the intermediate frequency. For example: if the receiver is to tune from 13,950 to 14,450 kc. to cover the 14-Mc. amateur band with a 50-kc. leeway at each end, and the intermediate frequency is 455 kc., the oscillator should tune from $13,950 + 455$ kc. to $14,450 + 455$ kc., or from 14,405 to 14,905 kc.

(Note: The foregoing assumes that the oscillator will be operated on the high-frequency side of the signal, which is the usual condition. It is quite possible, however, to have the oscillator on the low-frequency side of the signal, and if this is desired, the intermediate frequency is simply *subtracted* from the signal frequency, rather than added, to give the required oscillator frequency.)

If no calibrated auxiliary receiver is avail-

able, the following procedure should be used to adjust the oscillator to its proper tuning range: A modulated signal from the signal generator is fed into the mixer grid, with mixer grid coil for the band being used in place, and with the signal generator set for the highest frequency in the desired tuning range and the bandspread condenser in the receiver set at minimum capacity. Next, the oscillator bandsetting condenser is slowly decreased from maximum capacity until a strong signal from the signal generator is picked up. The first strong signal picked up will be when the oscillator is on the low-frequency side of the signal. If it is desired to use this beat, the oscillator bandsetting condenser need not be adjusted further. However, if it is intended to operate the oscillator on the high-frequency side of the signal, in accordance with usual practice, the bandsetting condenser should be decreased in capacity until the second strong signal is heard. When the signal is properly located, the mixer grid should be next tuned to resonance by adjusting its padder condenser for maximum signal strength.

After the high-frequency end of the band has thus been located, the receiver bandspread condenser should be set at maximum capacity, and the signal generator slowly tuned toward the low-frequency end of its range until its signal is again picked up. If the bandspread adjustment happens to be correctly made, the signal generator calibration will show that it is at the low-frequency end of the desired tuning range. If calibration shows that the low-frequency end of the tuning range falls either higher or lower than what is desired, it will be necessary to make the required changes in the bandspread circuit described in the preceding section on *Bandspread*, and repeat the checking process until the tuning range is correct.

Tracking After the oscillator has been set so that it covers the correct range, the tracking of the mixer tuning may be tackled. With the signal generator set to the high-frequency end of the tuning range and *loosely* coupled to the mixer grid, the signal from the generator should be tuned in on the receiver, and the mixer padding condenser adjusted for maximum output. Next, tune both the receiver and the signal generator to the low-frequency end of the receiver's range, and check to see if it is necessary to reset the mixer padder to secure maximum output. If the tracking is correct, it will be found that no change in the padder capacity will be necessary. If, however, it is found that the output may be increased by retuning the padder, it will be necessary to readjust the mixer bandspread.

An increase in signal strength with an in-

crease in padding capacity indicates that the bandwidth is too great, and it will be necessary to increase the tuning range of the mixer. An increase in signal strength with a decrease in padding capacity shows that the mixer tuning range is too great, and the bandwidth will have to be increased.

When the mixer bandwidth has been adjusted so that the tracking is correct at both ends of a range as narrow as an amateur band, it may be assumed that the tracking is nearly correct over the whole band. The signal generator should then be transferred to the r.f. stage, if the receiver has one, and the procedure described for tracking the mixer carried out in the r.f. stage. This adjustment preferably should be made with the antenna connected, as the loading of the antenna affects the tuning of the r.f. stage slightly.

Series Tracking Condensers

The above discussion applies solely to receivers in which a small tuning range is covered with each set of coils, and where the ranges covered by the oscillator and mixer circuits represent nearly equal percentages of their operating frequencies, i.e., where the intermediate frequency is low. When these conditions are not satisfied, such as in continuous-coverage receivers and in receivers in which the intermediate frequency is a large proportion of the signal frequency, it becomes

necessary to make special provisions for oscillator tracking. These provisions usually consist of ganged tuning condensers in which the oscillator section plates are shaped differently and have a different capacity range than those used across the other tuned circuits, or the addition of a "tracking condenser" in series with the oscillator tuning condenser in conjunction with a smaller coil.

While series tracking condensers are seldom used in home-constructed receivers, it may sometimes be necessary to employ one, as in, for example, a receiver using a 1600-kc. i.f. channel and covering the 3500-4000 kc. amateur band. The purpose of the series tracking condenser is to slow down the oscillator's tuning rate when it operates on the high-frequency side of the signal. This method allows perfect tracking at three points throughout the tuning range. The three points usually chosen for the perfect tracking are at the two ends and center of the tuning range; between these points the tracking will be close enough for practical purposes.

In home-constructed sets, the adjustment of the tracking condenser and oscillator coil inductance is largely a matter of cut-and-try, requiring a large amount of patience and an understanding of the results to be expected when the series capacity and the oscillator inductance are changed. After each adjustment, low- and high-end tuning must be checked.

Radio Receiving Tube Characteristics

FOOTNOTE references for both standard and special receiving tubes will be found immediately following the socket connection diagrams for these tubes. Footnote references for various cathode-ray tubes will be found immediately following the separate group of socket connections for cathode-ray tubes.

A suffix (G) in parentheses after a standard octal base tube indicates that the tube also is manufactured with glass envelope, a suffix (GT) indicating that the tube also is manufactured with small tubular glass envelope. Thus 6J5 (G) (GT) indicates that this tube is available with metal, glass, or small tubular glass envelope; 6AG7 indicates that this tube is available only in metal; and 5Y3-G indicates that this tube is available only in glass.

The "Bantam" line of GT type tubes by one manufacturer have a metal shell base which is connected to the pin which would ground the shell of an equivalent metal tube. A sleeve shield slipped over the tube thus is automatically grounded.

Several manufacturers supply certain of their tubes with ceramic base at a slight increase in the price. The ceramic base ordinarily is indicated by the presence of the letter "X" at the end of the regular type number.

Certain of the "7" series of tubes have a nominal heater rating of 7 volts instead of the usual 6.3-volt rating. The heater is the same, however, and either the "6" series or the "7" series may be used on either 6.3 or 7 volts. To simplify the tables, all such tubes are shown with a rating of 6.3 volts. The same applies to certain of the "14" series of tubes, these tubes having the same heater as corresponding tubes of the "12" series but a nominal heater rating of 14 volts instead of 12.6 volts.

Socket terminals shown as unused in the table of socket connections should not be used

as tie-points for other wiring unless the tube has no corresponding pin, because "dead" pins are sometimes used as element supports.

When a "G" or "GT" octal base tube is used, the shell grounding terminal (usually pin no. 1) for the corresponding metal counterpart should be connected to ground the same as for a metal tube, as many "G" and "GT" types contain an internal shield.

Tube Base Connections

There are from 4 to 8 pins on tube bases, with the exception of the 5- and 8-prong types of bases the filament or heater pins are those which are heavier than the others.

With the exception of the octal (8-pin) base, the numbering system for the pins is as follows (viewing the tube or socket from the bottom, and with the two heavier heater [or filament] pins horizontal): the no. 1 pin is the left-hand heater or filament pin. Pins no. 2, 3, and so forth follow around in a clockwise direction, the highest number being the right-hand cathode pin. Octal (8-pin) numbers start with no. 1 which is the first pin to the left of the key.

The letters F-F or H-H designate filament or heater, C or K for the cathode, P for the plate, etc., in socket connection or wiring diagrams. The grids of multigrid tubes are numbered with respect to the position they occupy: no. 1 grid is closest to the cathode, no. 2 next closest, etc. When it is desirable that certain elements have a very low capacity with respect to other elements within the tube, they are sometimes terminated in a lead brought out to a cap on top of the tube.

This chapter includes data on receiving tube characteristics, tube socket connections, special purpose and cathode-ray tubes, and cathode-ray socket connections.

| TYPE | DESIGN | BASE CONN'S | CATHODE TYPE & RATING | | USED AS | PLATE SUPPLY | GRID BIAS ② | SCREEN SUPPLY | SCREEN CURRENT | PLATE CURRENT | R _p A.C. PLATE RESISTANCE | G _M TRANSCONDUCTANCE (GRID-PLATE) | J _J AMPLIFICATION FACTOR | LOAD FOR STATED POWER OUTPUT | POWER OUTPUT |
|---|--------------------------------------|-------------|------------------------|---------------------|--|---|-----------------------------|--|----------------|---------------|--------------------------------------|--|-------------------------------------|------------------------------|--------------|
| | | | F=FILAMENT H=HEATER | TYPE | | | | | | | | | | | |
| AD | HALF-WAVE RECTIFIER | 4G | H | 6.3 0.3 | RECTIFIER | FOR OTHER CHARACTERISTICS, REFER TO TYPE 1V | | | | | | | | | |
| AF | FULL-WAVE RECTIFIER | 4C | F | 2.5 3.0 | RECTIFIER | FOR OTHER CHARACTERISTICS, REFER TO TYPE 82 | | | | | | | | | |
| AG | FULL-WAVE RECTIFIER | 4C | F | 5.0 3.0 | RECTIFIER | FOR OTHER CHARACTERISTICS, REFER TO TYPE 83 | | | | | | | | | |
| BA | FULL-WAVE RECTIFIER | 4J | COLD | — — | RECTIFIER | FOR OTHER CHARACTERISTICS, REFER TO TYPE CK1009/BA | | | | | | | | | |
| BH | FULL-WAVE RECTIFIER | 4J | COLD | — — | RECTIFIER | MAX. A.C. VOLTAGE PER PLATE (RMS) 350. TUBE DROP 90 V. MAX. D.C. OUTPUT CURRENT, 125 MA. | | | | | | | | | |
| BR | FULL-WAVE RECTIFIER | 4J | COLD | — — | RECTIFIER | MAX. A.C. VOLTAGE PER PLATE (RMS) 300. TUBE DROP 60 V. MAX. D.C. OUTPUT CURRENT, 50 MA. | | | | | | | | | |
| LA | POWER AMPLIFIER PENTODE | 5B | F | 6.3 0.3 | CLASS A AMPLIFIER | FOR OTHER CHARACTERISTICS, REFER TO TYPE 6A4/LA | | | | | | | | | |
| PZ | POWER AMPLIFIER PENTODE | 5B | F | 2.5 1.75 | CLASS A AMPLIFIER | FOR OTHER CHARACTERISTICS, REFER TO TYPE 47 | | | | | | | | | |
| PZH | POWER AMPLIFIER PENTODE | 6B | H | 2.5 1.75 | AMPLIFIER | FOR OTHER CHARACTERISTICS, REFER TO TYPE 6F6 | | | | | | | | | |
| XXB | TWIN-TRIODE FREQUENCY CONVERTER | | F | 1.4 0.1 2.8 0.05 | RATINGS FOR EACH SECTION | 90 | 0 -3 | — | — | 4.5 1.4 | 11200 1900 | 1300 760 | 14.5 | — | — |
| XXD | TWIN-TRIODE | 8AC | H | 12.6 0.15 | EACH UNIT AS CLASS A AMPLIFIER | FOR OTHER CHARACTERISTICS, REFER TO TYPE 14AF7 | | | | | | | | | |
| XXFM | TWIN-DIODE TRIODE | | H | 6.3 0.3 | TRIODE UNIT AS CLASS A AMPLIFIER DIODE SECTIONS | 100 | 0 | — | — | 1.2 | 85000 | 1000 | 85 | — | — |
| | | | | | | 250 | -1 | — | — | 1.9 | 8700 | 1500 | 100 | — | — |
| MAX. A.C. VOLTAGE PER PLATE (RMS), 100. MAX. D.C. OUTPUT CURRENT, 4 MA. | | | | | | | | | | | | | | | |
| XXL | TRIODE | 5AC | H | 6.3 0.3 | CLASS A AMPLIFIER | 100 | 0 | — | — | 10 | 7000 | 3600 | 25 | — | — |
| | | | | | | 250 | -8 | — | — | 8 | 8700 | 2300 | 20 | — | — |
| 00-A | DETECTOR TRIODE | 4D | D.C. F | 5.0 0.25 | GRID-LEAK DETECT. | 45 | GRID RETURN TO (-) FILAMENT | | — | 1.5 | 30000 | 666 | 20 | — | — |
| 01-A | DETECTOR-AMPLIFIER TRIODE | 4D | D.C. F | 5.0 0.25 | CLASS A AMPLIFIER | 90 | -4.5 | — | — | 2.5 | 11000 | 725 | 8.0 | — | — |
| | | | | | | 135 | -9.0 | — | — | 3.0 | 10000 | 800 | 8.0 | — | — |
| OZ3 | FULL-WAVE GAS RECTIFIER | 5N | COLD | — — | RECTIFIER | FOR OTHER CHARACTERISTICS, REFER TO TYPE OZ4 | | | | | | | | | |
| OZ4(G) | FULL-WAVE GAS RECTIFIER | 4R | COLD | — — | RECTIFIER | STARTING SUPPLY VOLTAGE PER PLATE, 300 MIN. PEAK VOLTS. 200 MAX. MA. D.C. OUTPUT CURRENT, 75 MAX., 30 MIN. MA., D.C. VOLTS. AVERAGE DYNAMIC TUBE VOLTAGE DROP 24 VOLTS. PEAK PLATE CURRENT, OUTPUT VOLTAGE, 300 MAX. | | | | | | | | | |
| OZ4A/1003 | FULL-WAVE GAS RECTIFIER | 4R | COLD | — — | RECTIFIER | STARTING SUPPLY VOLTAGE PER PLATE, 300 MIN. PEAK VOLTS. 360 MAX. MA. D.C. OUTPUT CURRENT, 120 MAX., 30 MIN. MA., D.C. VOLTS. AVERAGE DYNAMIC TUBE VOLTAGE DROP 24 VOLTS. PEAK PLATE CURRENT, OUTPUT VOLTAGE, 265 MAX. | | | | | | | | | |
| 1A3 | H.F. DIODE | 5AP | H | 1.4 0.15 | DETECTOR RECTIFIER | MAX. PEAK INVERSE VOLTS, 330 | | MAX. D.C. OUTPUT MA., 0.5 | | | | | | | |
| | | | | | | MAX. PEAK PLATE MA. 5.0 | | MAX. D.C. HEATER-CATHODE POTENTIAL, 140 VOLTS. | | | | | | | |
| 1A4P | SUPER-CONTROL R.F. AMPLIFIER PENTODE | 4M | D.C. F | 2.0 0.06 | AMPLIFIER | FOR OTHER CHARACTERISTICS, REFER TO TYPE 1D5GP | | | | | | | | | |
| 1A4T | SUPER-CONTROL R.F. AMPLIFIER TETRODE | 4K | D.C. F | 2.0 0.06 | AMPLIFIER | FOR OTHER CHARACTERISTICS, REFER TO TYPE 1D5-GT | | | | | | | | | |
| 1A5-GT/G | POWER AMPLIFIER PENTODE | 6X | D.C. F | 1.4 0.05 | CLASS A AMPLIFIER | 85 | -4.5 | 85 | 0.7 | 3.5 | 300000 | 800 | 240 | 25000 | 0.100 |
| | | | | | | 90 | -4.5 | 90 | 0.8 | 4.0 | 300000 | 850 | 255 | 25000 | 0.115 |
| 1A6 | PENTAGRID CONVERTER ⑥ | 6L | D.C. F | 2.0 0.06 | CONVERTER | FOR OTHER CHARACTERISTICS, REFER TO TYPE 1D7-G | | | | | | | | | |
| 1A7-GT/G | PENTAGRID CONVERTER ⑥ | 7Z | D.C. F | 1.4 0.05 | CONVERTER | 90 | 0 | 45 | 0.6 | 0.55 | 600000 | ANODE GRID NO 2: 90 MAX. VOLTS, 1.2 MA. OSCILLATOR GRID (NO 1) RESISTOR, 0.2 MEG. CONVERSION TRANSCOND., 250 MICROMHOS | | | |
| 1AB5 | PENTODE R.F. AMPLIFIER | 5BF | D.C. F | 1.2 0.05 | R.F. AMPLIFIER | 90 | 0 | 90 | 0.8 | 3.5 | 275000 | 1100 | — | — | — |
| | | | | | | 150 | -1.5 | 150 | 2.0 | 6.8 | 125000 | 1350 | — | — | — |
| 1B4-P/951 | PENTODE R.F. AMPLIFIER | 4M | D.C. F | 2.0 0.06 | AMPLIFIER | FOR OTHER CHARACTERISTICS, REFER TO TYPE 1E5-GP | | | | | | | | | |

Types AD to 1B4 97

| | | | | | | | | | | | | | | | | |
|-----------|--------------------------------------|-----|--------|-----|------|-----------------------------------|---|---|--|---------|-------------|----------------------|---|------------------------------|---------------|-------------|
| 1B5/25S | DUPLEX-DIODE TRIODE | 6M | D.C. F | 2.0 | 0.06 | TRIODE UNIT AS AMPLIFIER | FOR OTHER CHARACTERISTICS, REFER TO TYPE 1H6-G | | | | | | | | | |
| 1B7-GT/G | PENTAGRID CONVERTER | 7Z | D.C. F | 1.4 | 0.10 | OSCILLATOR-AMPLIFIER CONVERTER | 90 | GRID RETURNS THRU 200 000 Ω RESISTOR TO (L-F) | 45 | 1.3 | 1.5 | 350 000 | 350 | GRID N° 2, 90 VOLTS, 1.6 MA. | | |
| 1B8-GT | MULTI-PURPOSE | 8AW | D.C. F | 1.4 | 0.10 | DIODE-TRIODE BEAM AMPLIFIER | 90 | TRIODE 0 BEAM AMP-6 | 90 | 1.4 | 0.15 6.3 | 240 000 | 275 1150 | 66 | 14 000 | 0.210 |
| 1C4 | SUPER CONTROL R.F. AMPLIFIER PENTODE | 4M | D.C. F | 2.0 | 0.12 | AMPLIFIER | 180 | 0 | 67.5 | 0.9 | 2.5 | 1 000 000 | 1 000 | 1 000 | — | — |
| 1C5-GT/G | POWER AMPLIFIER PENTODE | 6X | D.C. F | 1.4 | 0.10 | CLASS A AMPLIFIER | 83 90 | -7.0 -7.5 | 83 90 | 1.6 1.6 | 7.0 7.5 | 110 000 115 000 | 1500 1550 | 165 178 | 9000 8000 | 0.200 0.240 |
| 1C6 | PENTAGRID CONVERTER ⑧ | 6L | D.C. F | 2.0 | 0.12 | CONVERTER | FOR OTHER CHARACTERISTICS, REFER TO TYPE 1C7-G | | | | | | | | | |
| 1C7-G | PENTAGRID CONVERTER ⑧ | 7Z | D.C. F | 2.0 | 0.12 | CONVERTER | 135 180 | -3.0 -3.0 | 67.5 67.5 | 2.5 2.0 | 1.3 1.5 | 600 000 700 000 | ANODE GRID (N°2) 180 ③ MAX. VOLTS 4.0 MA., OSCILLATOR GRID (N°1) RESISTOR CONVERSION TRANSCOND, 325 MICROMHOS ⑨ | | | |
| 1D4(GXGT) | POWER AMPLIFIER PENTODE | 5B | D.C. F | 2.0 | 0.24 | CLASS A AMPLIFIER | 180 | -6.0 | 180 | 2.3 | 9.5 | 137 000 | 2400 | 330 | 15 000 | 0.750 |
| 1D5-GP | SUPER CONTROL R.F. AMPLIFIER PENTODE | 5Y | D.C. F | 2.0 | 0.06 | CLASS A AMPLIFIER | 90 180 | -3.0 -3.0 | 67.5 67.5 | 0.9 0.8 | 2.2 2.3 | 600 000 1 000 000 | 720 750 | 425 750 | — | — |
| 1D5-GT | SUPER CONTROL R.F. AMPLIFIER PENTODE | 5R | D.C. F | 2.0 | 0.06 | AMPLIFIER | 135 180 | -3.0 -3.0 | 67.5 67.5 | 0.7 0.7 | 2.2 2.2 | 350 000 600 000 | 625 650 | 219 390 | — | — |
| 1D7-G | PENTAGRID CONVERTER ⑧ | 7Z | D.C. F | 2.0 | 0.06 | CONVERTER | 135 180 | -3.0 -3.0 | 67.5 67.5 | 2.5 2.4 | 1.2 1.3 | 400 000 500 000 | ANODE GRID (N°2) 180 MAX. VOLTS, 2.3 MA. OSCILLATOR GRID (N°1) RESISTOR CONVERSION TRANSCOND, 300 MICROMHOS ⑨ | | | |
| 1D8-GT | DIODE-TRIODE POWER AMPLIFIER PENTODE | 8AJ | D.C. F | 1.4 | 0.10 | PENTODE UNIT AS CLASS A AMPLIFIER | 45 90 | -4.5 -9.0 | 45 90 | 0.3 1.0 | 1.6 5.0 | 300 000 200 000 | 650 925 | 195 195 | 20 000 12 000 | 0.035 0.200 |
| 1E4-G | GENERAL PURPOSE TRIODE | 5S | D.C. F | 1.4 | 0.05 | AMPLIFIER | 90 | -3.0 | — | — | 1.5 | 17 000 | 825 | 14 | — | — |
| 1E5-GP | R.F. AMPLIFIER PENTODE | 5Y | D.C. F | 2.0 | 0.06 | CLASS A AMPLIFIER | 90 180 | -3.0 -3.0 | 67.5 67.5 | 0.7 0.6 | 1.6 1.6 | 1 000 000 1 500 000 | 600 650 | 550 1000 | — | — |
| 1E7-G | TWIN-PENTODE POWER AMPLIFIER | 8C | D.C. F | 2.0 | 0.24 | PUSH-PULL CLASS A AMPLIFIER | 135 | -7.5 | 135 | 2.0 | 7.0 | 260 000 | 1425 | 370 | 24 000 | 0.575 ⑩ |
| 1F4 | POWER AMPLIFIER PENTODE | 5K | D.C. F | 2.0 | 0.12 | AMPLIFIER | FOR OTHER CHARACTERISTICS, REFER TO TYPE 1F5-G | | | | | | | | | |
| 1F5-G | POWER AMPLIFIER PENTODE | 6X | D.C. F | 2.0 | 0.12 | CLASS A AMPLIFIER | 90 135 | -3.0 -4.5 | 90 135 | 1.1 2.4 | 4.0 8.0 | 240 000 200 000 | 1400 1700 | 336 340 | 20 000 16 000 | 0.110 0.310 |
| 1F6 | DUPLEX-DIODE PENTODE | 6W | D.C. F | 2.0 | 0.06 | PENTODE UNIT AS CLASS A AMPLIFIER | FOR OTHER CHARACTERISTICS, REFER TO TYPE 1F7-GV | | | | | | | | | |
| 1F7-G(GV) | DUPLEX-DIODE PENTODE | 7AD | D.C. F | 2.0 | 0.06 | PENTODE UNIT AS R.F. AMPLIFIER | 180 | -1.5 | 67.5 | 0.7 | 2.2 | 1 000 000 | 650 | 650 | — | — |
| | | | | | | PENTODE UNIT AS A.F. AMPLIFIER | 135 ⑪ | -2.0 | SCREEN SUPPLY, 135 VOLTS APPLIED THROUGH 0.8 MEGOHM RESISTOR GRID RESISTOR ⑩ 1.0 MEGOHM, VOLTAGE GAIN 46 | | | | | | | |
| 1G4-GT/G | DETECTOR AMPLIFIER TRIODE | 5S | D.C. F | 1.4 | 0.05 | CLASS A AMPLIFIER | 90 | -6.0 | — | — | 2.3 | 10 700 | 825 | 8.8 | — | — |
| 1G5-G | POWER AMPLIFIER PENTODE | 6X | D.C. F | 2.0 | 0.12 | CLASS A AMPLIFIER | 90 135 | -6.0 -13.5 | 90 135 | 2.5 2.5 | 8.5 8.7 | 133 000 160 000 | 1500 1550 | 200 250 | 8500 9000 | 0.25 0.55 |
| 1G6-GT/G | TWIN-TRIODE AMPLIFIER | 7AB | D.C. F | 1.4 | 0.10 | CLASS B AMPLIFIER | 90 | 0 | — | — | 2.0 | — | — | — | 12 000 | 0.675 ⑫ |
| 1H4-G | DETECTOR AMPLIFIER TRIODE ① | 5S | D.C. F | 2.0 | 0.06 | CLASS A AMPLIFIER | 90 135 180 | -4.5 -9.0 -13.5 | — | — | 2.5 3.0 3.1 | 11 000 10 300 10 300 | 850 900 900 | 9.3 9.3 9.3 | — | — |
| | | | | | | CLASS B AMPLIFIER | 157.5 | -15.0 | — | — | 1.0 ⑬ | — | — | — | 8000 | 2.1 ⑭ |
| 1H5-GT/G | DIODE HIGH-MU TRIODE | 5Z | D.C. F | 1.4 | 0.05 | TRIODE UNIT AS CLASS A AMPLIFIER | 90 | 0 | — | — | 0.15 | 240 000 | 275 | 65 | — | — |
| 1H6-G | DUPLEX-DIODE TRIODE | 7AA | D.C. F | 2.0 | 0.06 | TRIODE UNIT AS CLASS A AMPLIFIER | 135 | -3.0 | — | — | 0.8 | 35 000 | 575 | 20 | — | — |
| 1J5-G | POWER AMPLIFIER PENTODE | 6X | D.C. F | 2.0 | 0.12 | CLASS A AMPLIFIER | 135 | -16.5 | 135 | 1.8 | 7.0 | 125 000 | 1000 | 125 | 13 500 | 0.450 |

| TYPE | DESIGN | BASE CONNS | CATHODE TYPE & RATING | | USED AS | PLATE SUPPLY VOLTS | GRID BIAS ⁽²⁾ VOLTS | SCREEN SUPPLY VOLTS | SCREEN CURRENT MILLIAMPS | PLATE CURRENT MILLIAMPS | R _p A.C. PLATE RESISTANCE OHMS | G _m TRANSDUC TANCE (GRID-PLATE) μMHOS | μ AMPLIFI- CATION FACTOR | LOAD FOR STATED POWER OUTPUT OHMS | POWER OUTPUT WATTS |
|-----------|--------------------------------------|------------|-----------------------|-----------|-----------------------------------|---|--------------------------------|---------------------|--------------------------|-------------------------|---|--|--|-----------------------------------|--------------------|
| | | | F= FILAMENT HEATER | H= HEATER | | | | | | | | | | | |
| | | | TYPE | VOLTS/AMP | | | | | | | | | | | |
| 1J6-G | TWIN-TRIODE AMPLIFIER | 7AB | D.C. F | 2.0 0.24 | CLASS B AMPLIFIER | 135 135 | 0 -3.0 | — | — | 5 0 1.7 37 | — | — | — | 10000 10000 | 2.1 1.9 36 |
| 1L4 | R.F. AMPLIFIER PENTODE | 6AR | D.C. F | 1.4 0.05 | CLASS A AMPLIFIER | 90 90 | 0 0 | 67.5 90 | 1.2 2.0 | 2 9 4.5 | 600 000 350 000 | 925 1025 | 555 360 | — | — |
| 1LA4 | POWER AMPLIFIER PENTODE | 5AD | D.C. F | 1.4 0.05 | CLASS A AMPLIFIER | FOR OTHER CHARACTERISTICS, REFER TO TYPE 1A5-GT/G | | | | | | | | | |
| 1LA6 | PENTAGRID CONVERTER | 7AK | D.C. F | 1.4 0.05 | CONVERTER | 90 | 0 | 45 | 0 6 | 0 55 | 750 000 | ANODE GRID (No 2) 90 MAX. VOLTS, 1.2 MA. OSCILLATOR GRID (No 1) RESISTOR, 0.2 MEG. CONVERSION TRANSCOND., 250 MICROMHOS | | | |
| 1LB4(G) | POWER AMPLIFIER PENTODE | 5AD | D.C. F | 1.4 0.05 | CLASS A AMPLIFIER | 90 | -9.0 | 90 | 1.0 | 5 0 | 200 000 | 925 | 185 | 12 000 | 0.200 |
| 1LB6(GL) | PENTAGRID CONVERTER | 8AX | D.C. F | 1.4 0.05 | CONVERTER | 90 | 0 | 67.5 | 2 2 | 0 4 | 2 000 000 | 100 | ANODE GRID 67.5 V., 1.2 MA. | | |
| 1LC5 | R.F. AMPLIFIER PENTODE | 7AO | D.C. F | 1.4 0.05 | CLASS A AMPLIFIER | 45 90 | 0 0 | 45 45 | 0.25 0.20 | 1.1 1.5 | 700 000 1 500 000 | 750 775 | 525 1160 | — | — |
| 1LC6 | PENTAGRID CONVERTER ⑥ | 7AK | D.C. F | 1.4 0.05 | CONVERTER | 45 90 | 0 0 | 35 35 | 0.75 0.7 | 0.7 0.75 | 300 000 650 000 | ANODE GRID (No 2) 45 MAX. VOLTS, 1.4 MA. OSCILLATOR GRID (No 1) RESISTOR, 0.2 MEG. CONVERSION TRANSCOND., 250 μMHOS FOR 45 V. OPERATION, 275 μMHOS FOR 90 V. OPER. | | | |
| 1LD5 | DIODE-PENTODE | 6AX | D.C. F | 1.4 0.05 | PENTODE UNIT AS AMPLIFIER | 45 90 | 0 0 | 45 45 | 0.12 0.10 | 0.55 0.60 | 900 000 750 000 | 550 575 | 495 430 | — | — |
| 1LE3-(GL) | GENERAL PURPOSE TRIODE | 4AA | D.C. F | 1.4 0.05 | AMPLIFIER | FOR OTHER CHARACTERISTICS, REFER TO TYPE 1E4-G | | | | | | | | | |
| 1LH4 | DIODE-HIGH-MU TRIODE | 5AG | D.C. F | 1.4 0.05 | TRIODE UNIT AS CLASS A AMPLIFIER | 90 | 0 | — | — | 0.15 | 240 000 | 275 | 65 | — | — |
| 1LN5 | R.F. AMPLIFIER PENTODE | 7AO | D.C. F | 1.4 0.05 | CLASS A AMPLIFIER | FOR OTHER CHARACTERISTICS, REFER TO TYPE 1N5-GT/G | | | | | | | | | |
| 1N5-GT/G | R.F. AMPLIFIER PENTODE | 5Y | D.C. F | 1.4 0.05 | CLASS A AMPLIFIER | 90 | 0 | 90 | 0.3 | 1.2 | 1 500 000 | 750 | 1125 | — | — |
| 1N6-GT/G | DIODE-POWER AMPLIFIER PENTODE | 7AM | D.C. F | 1.4 0.05 | PENTODE UNIT AS CLASS A AMPLIFIER | 90 | -4.5 | 90 | 0.7 | 3.4 | 300 000 | 800 | 240 | 25 000 | 0.100 |
| 1P5-GT/G | R.F. AMPLIFIER PENTODE | 5Y | D.C. F | 1.4 0.05 | CLASS A AMPLIFIER | 90 | 0 | 90 | 0.7 | 2.3 | 800 000 | 750 | 640 | — | — |
| 1Q5-GT/G | BEAM POWER AMPLIFIER | 6AF | D.C. F | 1.4 0.10 | CLASS A AMPLIFIER | 90 | -4.5 | 90 | 1.3 | 9.5 | 75 000 | 2 200 | 165 | 8 000 | 0.270 |
| 1R4/1294 | U.H.F. DIODE | 4AH | H | 1.4 0.15 | U.H.F. DETECTOR | 10 V. R.M.S. | — | — | — | 5.0 | — | RESONANT FREQUENCY 685 MEGACYCLES | | | |
| 1R5 | PENTAGRID CONVERTER | 7AT | D.C. F | 1.4 0.05 | CONVERTER | 45 90 | 0 0 | 45 67.5 | 1.9 3.2 | 0.7 1.6 | 600 000 600 000 | GRID (No 1) RESISTOR, 100 000 OHMS CONVERSION TRANSCOND., 300 MICROMHOS | | | |
| 1S4 | POWER AMPLIFIER PENTODE | 7AV | D.C. F | 1.4 0.10 | CLASS A AMPLIFIER | 45 90 | -4.5 -7.0 | 45 67.5 | 0.8 1.4 | 3.8 7.4 | 100 000 100 000 | 1250 1575 | 125 158 | 8 000 8 000 | 0.065 0.270 |
| 1S5 | DIODE-PENTODE | 6AU | D.C. F | 1.4 0.05 | PENTODE UNIT AS CLASS A AMPLIFIER | 67.5 | 0 | 67.5 | 0.4 | 1.6 | 600 000 | 625 | LOAD RESISTANCE, 1 MEGOHM SCREEN RESISTANCE, 3 MEGOHM GRID RESIST., 10 MEG., VOLT. GAIN 40 | | |
| 1SA6-GT | R.F. AMPLIFIER PENTODE | 6BD | D.C. F | 1.4 0.05 | AMPLIFIER | 90 | 0 | 67.5 | 0.68 | 2.45 | 800 000 | 970 | 775 | — | — |
| 1SB6-GT | DIODE-PENTODE | 6BE | D.C. F | 1.4 0.05 | PENTODE UNIT AS AMPLIFIER | 90 | 0 | 67.5 | 0.38 | 1.45 | 700 000 | 665 | 465 | — | — |
| 1T4 | SUPER-CONTROL R.F. AMPLIFIER PENTODE | 6AR | D.C. F | 1.4 0.05 | CLASS A AMPLIFIER | 45 90 | 0 0 | 45 67.5 | 0.7 1.4 | 1.7 3.5 | 350 000 500 000 | 700 900 | 245 450 | — | — |

| | | | | | | | | | | | | | | | | | |
|-------------|-------------------------------------|-----|------|-----|------|---|---|-------------------------|------------|---|---|---|---|------|--------------|---------------------|--|
| 1T5-GT | BEAM POWER AMPLIFIER | 6X | D.C. | 1.4 | 0.05 | CLASS A AMPLIFIER | 90 | -6.0 | 90 | 1.4 | 6.5 | — | 1150 | — | 14000 | 0.170 | |
| 1-V | HALF-WAVE RECTIFIER | 4G | H | 6.3 | 0.3 | WITH CONDENSER INPUT FILTER | MAX. A.C. PLATE VOLTS (RMS) 325 MAX. D.C. OUTPUT MA., 45 | | | | MINIMUM TOTAL EFFECTIVE PLATE SUPPLY IMPEDANCE: UP TO 117 VOLTS, 0 OHMS. AT 150 VOLTS, 30 OHMS; AT 325 VOLTS, 75 OHMS | | | | | | |
| 2A3 | POWER AMPLIFIER TRIODE | 4D | F | 2.5 | 2.5 | CLASS A AMPLIFIER PUSH-PULL CLASS AB AMPLIFIER | 250 300 | -45.0 | — | — | 60.0 80.0 | 800 | 5250 | 4.2 | 2500 3000 | 3.5 10.0 15.0 | |
| 2A5 | POWER AMPLIFIER PENTODE | 6B | H | 2.5 | 1.75 | AMPLIFIER | FOR OTHER CHARACTERISTICS, REFER TO TYPE 6F6 | | | | | | | | | | |
| 2A6 | DUPLEX-DIODE HIGH-MU TRIODE | 6G | H | 2.5 | 0.8 | TRIODE UNIT AS AMPLIFIER | FOR OTHER CHARACTERISTICS, REFER TO TYPE 6SQ7 | | | | | | | | | | |
| 2A7(S) (42) | PENTAGRID CONVERTER (8) | 7C | H | 2.5 | 0.8 | CONVERTER | FOR OTHER CHARACTERISTICS, REFER TO TYPE 6A8 | | | | | | | | | | |
| 2B6 | DIRECT-COUPLED AMPLIFIER | 7J | H | 2.5 | 2.25 | AMPLIFIER | 250 | -24.0 | — | — | 40.0 | 5150 | 3500 | 18 | 5000 | 4.0 | |
| 2B7(S) (43) | DUPLEX-DIODE PENTODE | 7D | H | 2.5 | 0.8 | PENTODE UNIT AS AMPLIFIER | FOR OTHER CHARACTERISTICS, REFER TO TYPE 6B8-G | | | | | | | | | | |
| 2C21/1642 | TWIN-TRIODE AMPLIFIER | 7BH | H | 6.3 | 0.6 | CLASS A AMPLIFIER | 250 | -16.5 | — | — | 8.3 | 7600 | 1375 | 10.4 | — | — | |
| 2C22 | TRIODE AMPLIFIER | 4AM | H | 6.3 | 0.3 | CLASS A AMPLIFIER | 300 | -10.5 | — | — | 11.0 | 6600 | 3000 | 20 | — | — | |
| 2E5 | ELECTRON-RAY TUBE | 6R | H | 2.5 | 0.8 | TUNING INDICATOR | FOR OTHER CHARACTERISTICS, REFER TO TYPE 6E5 | | | | | | | | | | |
| 2G5 | ELECTRON-RAY TUBE | 6R | H | 2.5 | 0.8 | VISUAL INDICATOR | 250 | -22 FOR 0° SHADOW ANGLE | TARGET 250 | PLATE VOLTAGE SUPPLIED THROUGH 1 MEGOHM RESISTOR | | | | | | | |
| 2S/4S | DUPLEX-DIODE | 5D | H | 2.5 | 1.35 | DETECTOR | THE TWO DIODE PLATES EACH RATED APPROX. 40 MA. WITH 50 VOLTS D.C. ON THE PLATES | | | | | | | | | | |
| 2W3 (GT) | HALF-WAVE RECTIFIER | 4X | F | 2.5 | 1.5 | RECTIFIER | MAXIMUM A.C. VOLTAGE 350 VOLTS (RMS) MAXIMUM D.C. OUTPUT CURRENT 55 MILLIAMPERES | | | | | | | | | | |
| 2X3 (G) | HALF-WAVE RECTIFIER (41) | 4X | F | 2.5 | 2.0 | WITH CONDENSER INPUT FILTER WITH CHOKE-INPUT FILTER | MAX. A.C. PLATE VOLTS (RMS) 350 MAX. PEAK INVERSE VOLTS, 1400 | | | MAX. D.C. OUTPUT MA., 125 MAX. PEAK PLATE MA., 375 | | | MINIMUM TOTAL EFFECTIVE SUPPLY IMPEDANCE, 10 OHMS | | | | |
| 2Z2/G84 | HALF-WAVE RECTIFIER | 4B | F | 2.5 | 1.5 | RECTIFIER | MAXIMUM A.C. PLATE VOLTS RMS, 350. | | | | MAXIMUM D.C. OUTPUT CURRENT, 50 MA. | | | | | | |
| 3A4 | POWER AMPLIFIER PENTODE | 7BB | D.C. | 1.4 | 0.2 | CLASS A AMPLIFIER PARALLEL FILS. | 135 | -7.5 | 90 | 2.6 | 14.8 | 90000 | 1900 | — | 8000 | 0.6 | |
| | | | | | | | 150 | -8.4 | 90 | 2.2 | 13.3 | 100000 | 1900 | — | 8000 | 0.7 | |
| 3A5 | H.F. TWIN-TRIODE | 7BC | D.C. | 1.4 | 0.22 | R.F. POWER AMP. PARALLEL FILS. EACH UNIT AS CLASS A AMPLIFIER | 150 | — | 135 | 6.5 | 18.3 | GRID RESISTOR, 0.2 MEGOHM GRID CURRENT, 0.13 MA. | | | — | 1.2 AT 10 MC. | |
| | | | | | | | 90 | -2.5 | — | — | 3.7 | 8300 | 1800 | 15 | — | — | |
| 3A8-GT | DIODE-TRIODE R.F. AMPLIFIER PENTODE | 8AS | D.C. | 1.2 | 0.1 | TRIODE UNIT AS CLASS C AMPLIFIER PENTODE UNIT AS CLASS A AMPLIFIER | 90 | 0 | — | — | 0.2 | 200000 | 325 | 65 | — | — | |
| | | | | | | | 90 | 0 | 90 | 0.5 | 1.5 | 800000 | 750 | — | — | — | |
| 3B5-GT | BEAM POWER AMPLIFIER | 7AP | D.C. | 1.4 | 0.1 | CLASS A AMPLIFIER | 67.5 | -7.0 | 67.5 | 0.6 | 8.0 | 100000 | 1650 | — | 5000 | 0.2 | |
| | | | F | 2.8 | 0.05 | | 67.5 | -7.0 | 67.5 | 0.5 | 6.7 | 100000 | 1500 | — | 5000 | 0.18 | |
| 3B7/1291 | UHF TWIN-TRIODE | 7BE | D.C. | 1.4 | 0.22 | CLASS B AMPLIFIER | 135 | 0 | — | — | 19 | — | 1900 | 20 | 18000 | 1.5 | |
| | | | | | | | 90 | 0 | — | — | 10.4 | — | 1850 | 20 | 8000 | 1.0 | |
| 3C5-GT | POWER AMPLIFIER PENTODE | 7AD | D.C. | 1.4 | 0.10 | CLASS A AMPLIFIER | 90 | -9.0 | 90 | 1.4 | 6.0 | — | 1550 | — | 8000 | 0.24 | |
| | | | | | | | 90 | -9.0 | 90 | 1.4 | 6.0 | — | 1950 | — | 10000 | 0.26 | |
| 3D6/1299 | BEAM POWER AMPLIFIER | 6BB | D.C. | 1.4 | 0.22 | CLASS A AMPLIFIER | 150 | -4.5 | 90 | 1.0 | 9.8 | — | 2400 | — | 14000 | 0.6 | |
| | | | | | | | 135 | -4.5 | 90 | 1.2 | 9.8 | — | 2400 | — | 12000 | 0.5 | |
| 3LE4 | POWER AMPLIFIER PENTODE | 6BA | D.C. | 1.4 | 0.1 | CLASS A AMPLIFIER | 90 | -9.0 | 90 | 2.0 | 10.0 | 100000 | 1700 | — | 6000 | 0.325 | |
| | | | | | | | 90 | -9.0 | 90 | 1.8 | 8.8 | 110000 | 1600 | — | 6000 | 0.300 | |

| TYPE | DESIGN | BASE CONNS | CATHODE TYPE & RATING | | | USED AS | PLATE SUPPLY VOLTS | GRID BIAS ② VOLTS | SCREEN SUPPLY VOLTS | SCREEN CURRENT MILLIAMPS. | PLATE CURRENT MILLIAMPS. | R _p A.C. PLATE RESISTANCE OHMS | G _m TRANSCONDUCTANCE (GRID-PLATE) μMHOS | μI AMPLIFICATION FACTOR | LOAD FOR STATED POWER OUTPUT OHMS | POWER OUTPUT WATTS |
|----------|-------------------------|------------|-------------------------|-------|------|-------------------------------------|--|-------------------|---------------------|---------------------------|--------------------------|---|--|-------------------------|-----------------------------------|--------------------|
| | | | F = FILAMENT H = HEATER | VOLTS | AMP. | | | | | | | | | | | |
| | | | TYPE | | | | | | | | | | | | | |
| 3LF4 | POWER AMPLIFIER PENTODE | 6BB | D.C. | 1.4 | 0.1 | CLASS A AMPLIFIER | 90 | -4.5 | 90 | 1.3 | 9.5 | 750 000 | 2200 | — | 8000 | 0.27 |
| | | | F | 2.8 | 0.05 | | 90 | -4.5 | 90 | 1.0 | 8.0 | 800 000 | 2000 | | 8000 | 0.23 |
| 3Q4 | POWER AMPLIFIER PENTODE | 7BA | D.C. | 1.4 | 0.1 | CLASS A AMPLIFIER | 90 | -4.5 | 90 | 2.1 | 9.5 | 100 000 | 2150 | — | 10000 | 0.27 |
| | | | F | 2.8 | 0.05 | | 90 | -4.5 | 90 | 1.7 | 7.7 | 120 000 | 2000 | | 10000 | 0.24 |
| 3Q5-GT/G | BEAM POWER AMPLIFIER | 7AQ | D.C. | 1.4 | 0.1 | CLASS A AMPLIFIER | 90 | -4.5 | 90 | 1.3 | 9.5 | 100 000 | 2100 | — | 8000 | 0.27 |
| | | | F | 2.8 | 0.05 | | 90 | -4.5 | 90 | 1.0 | 8.0 | 110 000 | 1800 | | 8000 | 0.23 |
| 3S4 | POWER AMPLIFIER PENTODE | 7BA | D.C. | 1.4 | 0.1 | CLASS A AMPLIFIER | 90 | -7.0 | 67.5 | 1.4 | 7.4 | 100 000 | 1575 | — | 8000 | 0.27 |
| | | | F | 2.8 | 0.05 | | 90 | -7.0 | 67.5 | 1.1 | 6.1 | 100 000 | 1425 | | 8000 | 0.235 |
| 4A6-G | TWIN TRIODE AMPLIFIER | 8L | D.C. | 4.0 | 0.06 | CLASS A AMPLIFIER CLASS B AMPLIFIER | 90 | -1.5 | — | — | 2.2 | — | 13300 | — | — | — |
| | | | F | 2.0 | 0.12 | | 90 | 0 | — | — | 4.6 | — | — | — | — | 8000 |
| 4S | DUPEX DIODE | 5D | H | 2.5 | 1.35 | DETECTOR | FOR OTHER CHARACTERISTICS, REFER TO TYPE 2S/4S | | | | | | | | | |
| 5R4-GY | FULL-WAVE RECTIFIER | 5T | F | 5.0 | 2.0 | WITH CONDENSER INPUT FILTER | MAX. A.C. VOLTS PER PLATE (RMS), 900 | | | MAX. D.C. OUTPUT MA, 150 | | | MIN. TOTAL EFFECTIVE SUPPLY IMPED. PER PLATE, 575 OHMS | | | |
| | | | | | | WITH CHOKE INPUT FILTER | MAX. PEAK INVERSE VOLTS, 2800 | | | MAX. PEAK PLATE MA, 650 | | | | | | |
| 5T4 | FULL-WAVE RECTIFIER | 5T | F | 5.0 | 2.0 | WITH CONDENSER INPUT FILTER | MAX. A.C. VOLTS PER PLATE (RMS), 950 | | | MAX. D.C. OUTPUT MA, 175 | | | MIN. VALUE OF INPUT CHOKE, 10 HENRIES | | | |
| | | | | | | WITH CHOKE INPUT FILTER | MAX. PEAK INVERSE VOLTS, 2800 | | | MAX. PEAK PLATE MA, 650 | | | | | | |
| 5J4-G | FULL-WAVE RECTIFIER | 5T | F | 5.0 | 2.0 | WITH CONDENSER INPUT FILTER | MAX. A.C. VOLTS PER PLATE (RMS), 450 | | | MAX. D.C. OUTPUT MA, 225 | | | MIN. TOTAL EFFECTIVE SUPPLY IMPED. PER PLATE, 150 OHMS | | | |
| | | | | | | WITH CHOKE INPUT FILTER | MAX. PEAK INVERSE VOLTS, 1550 | | | MAX. PEAK PLATE MA, 675 | | | | | | |
| 5V4-G | FULL-WAVE RECTIFIER | 5L | H | 5.0 | 2.0 | WITH CONDENSER INPUT FILTER | MAX. A.C. VOLTS PER PLATE (RMS), 550 | | | MAX. D.C. OUTPUT MA, 225 | | | MIN. TOTAL EFFECTIVE SUPPLY IMPED. PER PLATE, 75 OHMS | | | |
| | | | | | | WITH CHOKE INPUT FILTER | MAX. PEAK INVERSE VOLTS, 1550 | | | MAX. PEAK PLATE MA, 675 | | | | | | |
| 5V4-G | FULL-WAVE RECTIFIER | 5L | H | 5.0 | 2.0 | WITH CONDENSER INPUT FILTER | MAX. A.C. VOLTS PER PLATE (RMS), 375 | | | MAX. D.C. OUTPUT MA, 175 | | | MIN. TOTAL EFFECTIVE SUPPLY IMPED. PER PLATE, 100 OHMS | | | |
| | | | | | | WITH CHOKE INPUT FILTER | MAX. PEAK INVERSE VOLTS, 1400 | | | MAX. PEAK PLATE MA, 525 | | | | | | |
| 5W4-GTG | FULL-WAVE RECTIFIER | 5T | F | 5.0 | 1.5 | WITH CONDENSER INPUT FILTER | MAX. A.C. VOLTS PER PLATE (RMS), 500 | | | MAX. D.C. OUTPUT MA, 175 | | | MIN. TOTAL EFFECTIVE SUPPLY IMPED. PER PLATE, 50 OHMS | | | |
| | | | | | | WITH CHOKE INPUT FILTER | MAX. PEAK INVERSE VOLTS, 1400 | | | MAX. PEAK PLATE MA, 525 | | | | | | |
| 5X3 | FULL-WAVE RECTIFIER | 4C | F | 5.0 | 2.0 | WITH CONDENSER INPUT FILTER | MAX. A.C. VOLTS PER PLATE (RMS), 400 | | | MAX. D.C. OUTPUT MA, 110 | | | — | | | |
| | | | | | | WITH CHOKE INPUT FILTER | MAX. PEAK INVERSE VOLTS, 1700 | | | MAX. | | | | | | |
| 5X4-G | FULL-WAVE RECTIFIER | 5Q | F | 5.0 | 3.0 | RECTIFIER | FOR OTHER CHARACTERISTICS, REFER TO TYPE 5U4-G | | | | | | | | | |
| 5Y3-GT/G | FULL-WAVE RECTIFIER | 5T | F | 5.0 | 2.0 | WITH CONDENSER INPUT FILTER | MAX. A.C. VOLTS PER PLATE (RMS), 350 | | | MAX. D.C. OUTPUT MA, 125 | | | MIN. TOTAL EFFECTIVE SUPPLY IMPED. PER PLATE, 50 OHMS | | | |
| | | | | | | WITH CHOKE INPUT FILTER | MAX. PEAK INVERSE VOLTS, 1400 | | | MAX. PEAK PLATE MA, 375 | | | | | | |
| 5Y4-G | FULL-WAVE RECTIFIER | 5Q | F | 5.0 | 2.0 | RECTIFIER | MAX. A.C. VOLTS PER PLATE (RMS), 500 | | | MAX. D.C. OUTPUT MA, 125 | | | MIN. TOTAL EFFECTIVE SUPPLY IMPED. PER PLATE, 50 OHMS | | | |
| | | | | | | WITH CHOKE INPUT FILTER | MAX. PEAK INVERSE VOLTS, 1400 | | | MAX. PEAK PLATE MA, 375 | | | | | | |
| 5Z3 | FULL-WAVE RECTIFIER | 4C | F | 5.0 | 3.0 | RECTIFIER | FOR OTHER CHARACTERISTICS, REFER TO TYPE 5U4-G | | | | | | | | | |
| 5Z4-GTG | FULL-WAVE RECTIFIER | 5L | H | 5.0 | 2.0 | WITH CONDENSER INPUT FILTER | MAX. A.C. VOLTS PER PLATE (RMS), 350 | | | MAX. D.C. OUTPUT MA, 125 | | | MIN. TOTAL EFFECTIVE SUPPLY IMPED. PER PLATE, 50 OHMS | | | |
| | | | | | | WITH CHOKE INPUT FILTER | MAX. PEAK INVERSE VOLTS, 1400 | | | MAX. PEAK PLATE MA, 375 | | | | | | |
| 6A3 | POWER AMPLIFIER PENTODE | 4D | F | 8.3 | 1.0 | CLASS A AMPLIFIER | FOR OTHER CHARACTERISTICS, REFER TO TYPE 8B4-G | | | | | | | | | |

| | | | | | | | | | | | | | | | | | |
|-------------|--------------------------------------|-----|---|-----|------|---|---|-----------------------|-------------------------------|------------|----------------------------|------------------|---|--|---|---|--|
| 6A4/LA | POWER AMPLIFIER PENTODE | 5B | F | 6.3 | 0.3 | CLASS A AMPLIFIER | 100 80 | -6.5 -12.0 | 100 180 | 1.6 3.9 | 9.0 22.0 | 83250 45500 | 1200 2200 | — | 110000 8000 | 0.31 1.40 | |
| 6A5-G | POWER AMPLIFIER TRIODE | 6T | H | 6.3 | 1.0 | CLASS A AMPLIFIER PUSH-PULL CLASS AB PUSH-PULL CLASS AB | 250 325 325 | -45.0 -68.0 | — | — | 60 40 40 | 800 — | 5250 — | 4.2 — | 2500 3000 5000 | 3.75 15.0 10.0 | |
| 6A6 | TWIN-TRIODE AMPLIFIER | 7B | H | 6.3 | 0.8 | CLASS B AMPLIFIER | FOR OTHER CHARACTERISTICS, REFER TO 6N7-G | | | | | | | | | | |
| 6A7 6A7S | PENTAGRID CONVERTER | 7C | H | 6.3 | 0.3 | CONVERTER | FOR OTHER CHARACTERISTICS, REFER TO 6A8 | | | | | | | | | | |
| 6A8(G)GT | PENTAGRID CONVERTER | 8A | H | 6.3 | 0.3 | CONVERTER | 100 250 | -1.5 -3.0 | 50 100 | 1.3 2.7 | 1.1 3.5 | 600000 360000 | ANODE GRID (N° 2) 250 Ω MAX. VOLTS, 4 MA OSCILLATOR-GRID (N° 1) RESISTOR 100 Ω CONVERSION TRANSCOND., 550 μMHOS | | | | |
| 6AB5/6N5 | ELECTRON-RAY TUBE | 6R | H | 6.3 | 0.15 | VISUAL INDICATOR | PLATE AND TARGET SUPPLY = 135 VOLTS. TRIODE PLATE RESISTOR = 0.25 MEG. TARGET CURRENT = 2 MA. GRID BIAS, -10.0 VOLTS; SHADOW ANGLE, 0°; BIAS, 0 VOLTS; ANGLE 90°; PLATE CURRENT, 0.5 MA. | | | | | | | | | | |
| 6AB6-G | DIRECT-COUPLED POWER AMPLIFIER | 7AU | H | 6.3 | 0.5 | CLASS A AMPLIFIER | 250 250 | 0 — | INPUT TRIODE OUTPUT TRIODE | | 5.0 34.0 | 40000 | 1800 | 72 | 8000 | 3.5 | |
| 6AB7/1853 | TELEVISION-AMP. PENTODE | 8N | H | 6.3 | 0.45 | CLASS A AMPLIFIER | 300 | -3.0 | 200 | 3.2 | 12.5 | 700000 | 5000 | — | — | — | |
| 6AC5-GT/G | HIGH-MU POWER AMPLIFIER TRIODE | 6Q | H | 6.3 | 0.4 | CLASS B AMPLIFIER DYNAMIC COUPLED AMPLIFIER WITH TYPE 6P5-G DRIVER | 250 | 0 | — | — | 5.0 | — | — | — | 10000 | 8.0 | |
| 6AC6-G(GT) | DIRECT-COUPLED POWER AMPLIFIER | 7W | H | 6.3 | 1.1 | CLASS A AMPLIFIER | 180 180 | 0 — | INPUT TRIODE OUTPUT TRIODE | | 7.0 45.0 | 18000 | 3000 | 54 | 4000 | 3.8 | |
| 6AC7/1852 | TELEVISION AMP. PENTODE | 8N | H | 6.3 | 0.45 | CLASS A AMPLIFIER | 300 | CATHODE BIAS | 150 | 2.5 | 10.0 | 750000 | 9000 | CATHODE-BIAS RESISTOR 160 OHMS | | | |
| 6AD5-G | HIGH-MU TRIODE | 6Q | H | 6.3 | 0.3 | CLASS A AMPLIFIER | 250 | -2.0 | — | — | 0.9 | 66000 | 1500 | 100 | — | — | |
| 6AD6-G | TWIN ELECTRON- RAY TUBE | 7AG | H | 6.3 | 0.15 | VISUAL INDICATOR | TARGET 150 V., CONTROL ELECTRODE 75 V. AT 0°, 8 V. AT 90°, -50 V. AT 135° TARGET 100 V., CONTROL ELECTRODE 45 V. AT 0°, 0 V. AT 90°, -23 V. AT 135° | | | | | | | | | | |
| 6AD7-G | TRIODE-POWER PENTODE | 8AY | H | 6.3 | 0.85 | TRIODE CLASS A PENTODE CLASS A | 250 250 | -25.0 -18.5 | — | — | 4.0 34.0 | 19000 80000 | 325 2500 | 6.0 — | 7000 | 3.2 | |
| 6AE5-GT/G | AMPLIFIER TRIODE | 6Q | H | 6.3 | 0.3 | CLASS A AMPLIFIER | 95 | -15.0 | — | — | 7.0 | 3500 | 1200 | 4.2 | — | — | |
| 6AE6-G | TWIN PLATE TRIODE | 7AH | H | 6.3 | 0.15 | SHARP-CUTOFF TRIODE REMOTE-CUTOFF TRIODE | 250 250 250 | -1.5 -9.5 -35.0 | — | — | 4.5 0.01 6.5 0.01 | 35000 25000 | 950 1000 | 33.0 25.0 | CONTROL TUBE FOR TWIN-ELECTRON RAY INDICATOR TUBES, SUCH AS 6AF6-G | | |
| 6AE7-GT | TWIN-INPUT TRIODE | 7AX | H | 6.3 | 0.5 | DRIVER | 250 | -13.5 | 38 | — | 5.0 | 9300 | 1500 | 14 | — | — | |
| 6AF5-G | TRIODE AMPLIFIER | 6Q | H | 6.3 | 0.3 | CLASS A AMPLIFIER | 180 | -18.0 | — | — | 7.0 | 4900 | 1500 | 7.4 | — | — | |
| 6AF6-G | TWIN ELECTRON- RAY TUBE | 7AG | H | 6.3 | 0.15 | VISUAL INDICATOR | TARGET VOLTAGE 135 VOLTS. CONTROL ELECTRODE VOLTAGE 0 VOLTS; SHADOW ANGLE, 100°; TARGET CURRENT, 0.9 MA. CONTROL ELECTRODE VOLTAGE 81 VOLTS; ANGLE 0° TARGET VOLTAGE 250 VOLTS. CONTROL ELECTRODE VOLTAGE 0 VOLTS; SHADOW ANGLE, 100°; TARGET CURRENT, 2.4 MA. CONTROL ELECTRODE VOLTAGE 153 VOLTS; ANGLE 0° | | | | | | | | | | |
| 6AF7-G | TWIN ELECTRON- RAY TUBE | 8AG | H | 6.3 | 0.3 | VISUAL INDICATOR | | | | | | | | | | | |
| 6AG5 | R.F. AMPLIFIER PENTODE | 7BD | H | 6.3 | 0.3 | CLASS A AMPLIFIER | 100 250 | CATHODE BIAS | 100 150 | 1.6 2.0 | 5.5 7.0 | 300000 800000 | 4750 5000 | CATHODE BIAS RESISTOR, 100 Ω CATHODE BIAS RESISTOR, 200 Ω | | | |
| 6AG6(G) | POWER AMPLIFIER PENTODE | 7S | H | 6.3 | 1.25 | CLASS A AMPLIFIER | 250 | -6.0 | 250 | 6.0 | 32 | — | 10000 | — | 8500 | 3.75 | |
| 6AG7 | VIDEO POWER AMPLIFIER PENTODE | 8Y | H | 6.3 | 0.65 | CLASS A AMPLIFIER | 300 | -2.0 | 125 | 7.0 | 28.0 | 100000 | 7700 | — | 3500 | PEAK-TO-PEAK VOLTS OUTPUT 140 APPROX. | |
| 6AH5(G) | BEAM POWER AMPLIFIER | 6AP | H | 8.3 | 0.9 | CLASS A AMPLIFIER | 350 | -18 | 250 | — | — | 33000 | 5200 | — | 4200 | 10.8 | |

| TYPE | DESIGN | BASE CONN'S | CATHODE TYPE & RATING | | | USED AS | PLATE SUPPLY | GRID BIAS ② | SCREEN SUPPLY | SCREEN CURRENT | PLATE CURRENT | R _p A.C. PLATE RESISTANCE | G _m TRANSCON- DUCTANCE (GRID-PLATE) | μ AMPLIFI- CATION FACTOR | LOAD FOR STATED POWER OUTPUT | POWER OUTPUT | | | | | | | | | | |
|---------------|---|----------------|--------------------------|------|-------|-------------------------------------|--|--|--|-------------------|------------------|--|--|-----------------------------------|---------------------------------------|-----------------|------|-------|-------|-------|------------|------------|------|-------|------|-------|
| | | | F=FILAMENT H=HEATER | TYPE | VOLTS | | | | | | | | | | | | AMP. | VOLTS | VOLTS | VOLTS | MILLIAMPS. | MILLIAMPS. | OHMS | μMHOS | OHMS | WATTS |
| | | | | | | | | | | | | | | | | | | | | | | | | | | |
| 6AH7-GT | TWIN-TRIODE AMPLIFIER | 8BE | H | 6.3 | 0.3 | CLASS A AMPLIFIER | 250 | -9.0 | — | — | 12 | 6600 | 2400 | 16 | — | — | | | | | | | | | | |
| 6AJ5 | R.F. PENTODE | 7BD | H | 6.3 | 0.175 | CLASS A AMPLIFIER | 28 | 200 OHMS CATH. RES. | 28 | 1.05 | 2.9 | — | 2750 | — | — | — | | | | | | | | | | |
| 6AK5 | R.F. PENTODE | 7BD | H | 6.3 | 0.175 | CLASS A AMPLIFIER | 180 | -2.0 | 120 | 2.4 | 7.7 | 690 000 | 5100 | 3500 | — | — | | | | | | | | | | |
| 6AK6 | POWER AMPLIFIER PENTODE | 7BK | H | 6.3 | 0.15 | CLASS A AMPLIFIER | 180 | -9.0 | 180 | 2.5 | 15.0 | 200 000 | 2300 | — | 10 000 | 1.1 | | | | | | | | | | |
| 6AL5 | UHF TWIN- DIODE | 6BT | H | 6.3 | 0.3 | DETECTOR | RESONANT FREQUENCY 700 MC. MAXIMUM RMS VOLTAGE: 150 VOLTS PER PLATE MAX. D.C. OUTPUT CURRENT: 9 MA. PER PLATE | | | | | | | | | | | | | | | | | | | |
| 6AL6(G) | BEAM POWER AMPLIFIER | 6AM | H | 6.3 | 0.9 | CLASS A AMPLIFIER | 250 | -14.0 | 250 | 5.0 | 72.0 | 22500 | 6000 | — | 2500 | 6.5 | | | | | | | | | | |
| 6AN6 | QUADRUPLE DIODES | FIG. 12 | H | 6.3 | 0.2 | RATINGS FOR EACH DIODE | MAX. A.C. VOLTS PER PLATE (RMS), 117 MAX. PEAK INVERSE VOLTS, 210 MAX. D.C. OUTPUT MA., 3.3 MAX. PEAK PLATE MA., 10.0 | | | | | | | | | | | | | | | | | | | |
| 6AQ6 | DUO-DIODE HIGH-μ TRIODE | 7BT | H | 6.3 | 0.15 | TRIODE UNIT AS CLASS A AMPLIFIER | 100 250 | -1.0 -3.0 | — | — | 0.8 1.0 | 61000 58000 | 1150 1200 | 70 70 | — | — | | | | | | | | | | |
| 6AR6 | BEAM POWER AMPLIFIER | FIG. 13 | H | 6.3 | 1.2 | CLASS A AMPLIFIER | 250 | -22.5 | 250 | 4.0 | 82.5 | — | 5400 | — | 2000 | 10.0 | | | | | | | | | | |
| 6AS6 | R.F. PENTODE | FIG. 14 | H | 6.3 | 0.175 | CLASS A AMPLIFIER | FOR OTHER CHARACTERISTICS, REFER TO TYPE 6AK5 | | | | | | | | | | | | | | | | | | | |
| 6B4-G | POWER AMPLIFIER TRIODE | 5S | F | 6.3 | 1.0 | CLASS A AMPLIFIER | 325 | CATHODE BIAS, 850 OHMS -68 VOLTS, FIXED BIAS | — | 80.0 80.0 | — | — | — | — | 5000 5000 | 10.0 15.0 | | | | | | | | | | |
| 6B5 | DIRECT-COUPLED POWER AMPLIFIER | 6AS | H | 6.3 | 0.8 | CLASS A AMPLIFIER | FOR OTHER CHARACTERISTICS, REFER TO TYPE 6N6-G | | | | | | | | | | | | | | | | | | | |
| 6B6-G | DUPLEX-DIODE HIGH-μ TRIODE | 7V | H | 6.3 | 0.3 | TRIODE UNIT AS AMPLIFIER | FOR OTHER CHARACTERISTICS, REFER TO TYPE 6SQT | | | | | | | | | | | | | | | | | | | |
| 6B7 6B7S ④ | DUPLEX-DIODE PENTODE | 7D | H | 6.3 | 0.3 | PENTODE UNIT AS AMPLIFIER | FOR OTHER CHARACTERISTICS, REFER TO TYPE 6B8 | | | | | | | | | | | | | | | | | | | |
| 6B8(G/GT) | DUPLEX-DIODE PENTODE | 8E | H | 6.3 | 0.3 | PENTODE UNIT AS R.F. AMPLIFIER | 100 250 | -3.0 -3.0 | 100 125 | 1.7 2.3 | 5.8 9.0 | 300 000 600 000 | 950 1125 | — | — | — | | | | | | | | | | |
| | | | | | | PENTODE UNIT AS R.F. AMPLIFIER | 90 300 ⑩ | CATHODE BIAS, 3500 OHMS, CATHODE BIAS, 1600 OHMS, | SCREEN RESISTOR, 1.1 MEG. SCREEN RESISTOR, 1.2 MEG. | — | — | 7700 | 2200 | 17 | — | — | | | | | | | | | | |
| 6C4 | H.F. TRIODE | 6BG | H | 6.3 | 0.15 | CLASS A AMPLIFIER | 250 | -8.5 | — | — | 10.5 | — | 1250 | 20 | — | — | | | | | | | | | | |
| 6C5GT/G | DETECTOR AMPLIFIER TRIODE ① | 6Q | H | 6.3 | 0.3 | CLASS A AMPLIFIER BIAS DETECTOR | 250 | -8.0 | — | — | 8.0 | 10000 | 2000 | 20 | — | — | | | | | | | | | | |
| 6C6 | TRIPLE-GRID DETECTOR AMPLIFIER | 6F | H | 6.3 | 0.3 | AMPLIFIER DETECTOR | APPROXIMATE PLATE CURRENT TO BE ADJUSTED TO 0.2 MA. WITH NO SIGNAL | | | | | | | | | | | | | | | | | | | |
| 6C7 | DUPLEX-DIODE TRIODE | 7G | H | 6.3 | 0.3 | TRIODE UNIT AS AMPLIFIER | 250 | -9.0 | — | — | 5.5 | — | 1250 | 20 | — | — | | | | | | | | | | |
| 6C8-G | TWIN-TRIODE AMPLIFIER | 8G | H | 6.3 | 0.3 | EACH UNIT AS AMPLIFIER | 250 | -4.5 | — | — | 3.2 | 22500 | 1600 | 36 | — | — | | | | | | | | | | |
| 6D6 | TRIPLE-GRID SUPER-CONTROL AMPLIFIER | 6F | H | 6.3 | 0.3 | AMPLIFIER MIXER | FOR OTHER CHARACTERISTICS, REFER TO TYPE 6U7-G | | | | | | | | | | | | | | | | | | | |
| 6D7 | TRIPLE-GRID DETECTOR AMPLIFIER | 7H | H | 6.3 | 0.3 | DETECTOR AMPLIFIER | FOR OTHER CHARACTERISTICS, REFER TO TYPE 6J7 | | | | | | | | | | | | | | | | | | | |
| 6D8-G | PENTAGRID CONVERTER ⑧ | 8A | H | 6.3 | 0.15 | CONVERTER | 135 250 | -3.0 -3.0 | 67.5 100 | — | — | 600 000 400 000 | ANODE GRID (N°2): 250 ③ MAX. VOLTS 4.3 MA. OSCILLATOR-GRID (N°1) RESISTOR ⑨ CONVERSION TRANSCONDUCTANCE, 550 μMH | | | | | | | | | | | | | |

| | | | | | | | | | | | | | | | | | | |
|-------------|-------------------------------------|-----|---|-----|-------|---|--|---|--|--------------|--------------|--|---|------------------------------|----------------|-------------|----------------|--------------|
| 6E5 | ELECTRON-RAY TUBE | 6R | H | 6.3 | 0.3 | VISUAL INDICATOR | PLATE AND TARGET SUPPLY = 100 VOLTS, TRIODE PLATE RESISTOR = 0.5 MEGOHM. TARGET CURRENT = 1.0 MA. GRID BIAS, 3.3 VOLTS; SHADOW ANGLE, 0° BIAS, 0 VOLTS; ANGLE, 90°; PLATE CURRENT, 0.19 MA. PLATE AND TARGET SUPPLY = 250 VOLTS, TRIODE PLATE RESISTOR = 1.0 MEGOHM. TARGET CURRENT = 4.0 MA. GRID BIAS, -8.0 VOLTS; SHADOW ANGLE, 0°; BIAS, 0 VOLTS; ANGLE, 90°; PLATE CURRENT, 0.24 MA. | | | | | | | | | | | |
| 6E6 | TWIN TRIODE | 7B | H | 6.3 | 0.6 | PUSH-PULL CLASS A AMPLIFIER | 180 250 | -20.0 -27.5 | — | — | 11.5 18.0 | 4300 3500 | 1400 1700 | 6 6 | 15000 14000 | 0.75 1.6 | 56 | |
| 6E7 | TRIPLE-GRID SUPER-CONTROL AMPLIFIER | 7H | H | 6.3 | 0.3 | AMPLIFIER MIXER | FOR OTHER CHARACTERISTICS, REFER TO TYPE 6U7-G | | | | | | | | | | | |
| 6E8(G) | TRIODE-HEXODE CONVERTER | 8O | H | 6.3 | 0.3 | OSCILLATOR MIXER | 150 250 | 0 -2.0 | VALUES FOR TRIODE UNIT VALUES FOR HEXODE UNIT | | | 2600 | CONVERSION TRANSCONDUCTANCE 2800 MICROMHOS | | | | | |
| 6F4 | TRIODE (ACORN TYPE) | 7BR | H | 6.3 | 0.225 | CLASS A AMPLIFIER | 80 | CATHODE BIAS RESISTOR, 150 Ω | | | 13.0 | GRID CURRENT, 7.5 MA. | | | — | 1.8 | | |
| | | | | | | CLASS C AMPLIFIER | 150 | -15.0 | — | — | 20.0 | DRIVING POWER, 0.2 WATT | | | | | | |
| 6F5GT/G | HIGH-MU TRIODE | 5M | H | 6.3 | 0.3 | CLASS A AMPLIFIER | FOR OTHER CHARACTERISTICS, REFER TO TYPE 6SF5 | | | | | | | | | | | |
| 6F6GT/G | POWER AMPLIFIER PENTODE | 7S | H | 6.3 | 0.7 | PENTODE CLASS A AMPLIFIER | 250 285 | -16.5 -20.0 | 250 285 | 6.5 7.0 | 34.0 38.0 | 80000 78000 | 2500 2550 | — | 7000 7000 | 3.2 4.8 | | |
| | | | | | | TRIODE CLASS A AMPLIFIER | 250 | -20.0 | — | — | 31.0 | 2600 | 2600 | 6.8 | 4000 | 0.85 | | |
| | | | | | | PENTODE PUSH-PULL CLASS A AMPLIFIER | 315 315 | CATH BIAS -24.0 | 285 285 | 12.0 12.0 | 13 | 62.0 62.0 | 13 | CATHODE BIAS RESISTOR, 320 Ω | | | 10000 10000 | 10.5 11.0 |
| | | | | | | PENTODE PUSH-PULL CLASS AB ₂ AMP | 375 375 | CATH BIAS -26.0 | 250 250 | 8.0 5.0 | 13 | 54.0 34.0 | 13 | CATHODE BIAS RESISTOR, 340 Ω | | | 10000 10000 | 19.0 18.5 |
| | | | | | | TRIODE PUSH-PULL CLASS AB ₂ AMP | 350 350 | CATH BIAS -38.0 | — | — | — | 50.0 48.0 | 13 | CATHODE BIAS RESISTOR, 730 Ω | | | 10000 6000 | 9.0 13.0 |
| | | | | | | TRIODE UNIT AS CLASS A AMPLIFIER | 100 | -3.0 MIN | — | — | — | 3.5 | 16000 | 500 | 8.0 | — | — | |
| 6F7 6F7S | TRIODE PENTODE | 7E | H | 6.3 | 0.7 | PENTODE UNIT AS CLASS A AMPLIFIER | 100 250 | -3.0 MIN | 100 100 | 1.6 1.5 | 6.3 6.5 | 290000 850000 | 1050 1100 | — | — | — | | |
| | | | | | | PENTODE UNIT AS MIXER | 250 | -10.0 | 100 | 0.6 | 2.8 | OSCILLATOR PEAK VOLTS = 7.0 CONVERSION TRANSCONDUCTANCE = 300 MICROMHOS | | | | | | |
| | | | | | | EACH UNIT AS AMPLIFIER | 90 250 | 0 -8.0 | — | — | 10.0 9.0 | 6700 7700 | 3000 2600 | 20 20 | — | — | | |
| 6F8-G | TWIN-TRIODE AMPLIFIER | 8G | H | 6.3 | 0.6 | EACH UNIT AS AMPLIFIER | 90 250 | 0 -8.0 | — | — | 10.0 9.0 | 6700 7700 | 3000 2600 | 20 20 | — | — | | |
| 6G5 | ELECTRON-RAY TUBE | 6R | H | 6.3 | 0.3 | VISUAL INDICATOR | FOR OTHER CHARACTERISTICS, REFER TO TYPE 6U5/6G5 | | | | | | | | | | | |
| 6G6-G | POWER AMPLIFIER PENTODE | 7S | H | 6.3 | 0.15 | PENTODE CLASS A AMPLIFIER | 135 180 | -6.0 -9.0 | 135 180 | 2.0 2.5 | 11.5 15.0 | 170000 175000 | 2100 2300 | — | 12000 10000 | 0.6 1.1 | | |
| | | | | | | TRIODE CLASS A AMPLIFIER | 180 | -12.0 | — | — | 11.0 | 4750 | 2000 | 9.5 | 12000 | 0.25 | | |
| 6H4-GT | DIODE | 5AF | H | 6.3 | 0.15 | DETECTOR RECTIFIER | 100 MAX. | — | — | — | 4.0 MAX. | — | — | — | — | — | | |
| 6H5 | ELECTRON-RAY TUBE | 6R | H | 6.3 | 0.3 | VISUAL INDICATOR | FOR OTHER CHARACTERISTICS, REFER TO TYPE 6U5/6G5 | | | | | | | | | | | |
| 6H6GT/G | TWIN DIODE | 7Q | H | 6.3 | 0.3 | DETECTOR RECTIFIER | MAXIMUM A.C. VOLTAGE PER PLATE, 150 RMS MAXIMUM D.C. OUTPUT CURRENT, 4 MA. | | | | | | | | | | | |
| 6H8-G | DUPLEX-DIODE PENTODE | 8E | H | 6.3 | 0.3 | PENTODE UNIT AS AMPLIFIER | 250 | -2.0 | — | — | 8.5 | 650000 | 2400 | — | — | — | | |
| 6J4 | UHF AMPLIFIER TRIODE | 7BQ | H | 6.3 | 0.4 | GROUNDING-GRID CLASS A AMPLIFIER | 100 150 | CATHODE BIAS RESISTOR, 100 Ω | | | 10.0 15.0 | 5000 4500 | 11000 12000 | 55 55 | — | — | | |
| 6J5GT/G | DETECTOR-AMPLIFIER-TRIODE | 6Q | H | 6.3 | 0.3 | CLASS A AMPLIFIER | 90 250 | 0 -8.0 | — | — | 10.0 9.0 | 6700 7700 | 3000 2600 | 20 20 | — | — | | |
| | | | | | | EACH UNIT AS CLASS A AMPLIFIER | 100 | CATHODE BIAS RESISTOR FOR BOTH UNITS, 50 OHMS | | | 8.5 | 7100 | 5300 | 38 | — | — | | |
| 6J6 | TWIN TRIODE | 7BF | H | 6.3 | 0.45 | PUSH-PULL CLASS C AMPLIFIER | 150 | -10.0 | CATHODE RESISTOR 220 Ω, BOTH UNITS | | 30.0 | GRID CURRENT, 16 MA. DRIVING POWER, 0.35 WATT | | | — | 3.5 | | |

| TYPE | DESIGN | BASE CONNS | CATHODE TYPE & RATING | | | USED AS | PLATE SUPPLY | GRID BIAS ② | SCREEN SUPPLY | SCREEN CURRENT | PLATE CURRENT | R _p A.C. PLATE RESISTANCE | G _m TRANSCONDUCTANCE (GRID-PLATE) | μ AMPLIFICATION FACTOR | LOAD FOR STATED POWER OUTPUT | POWER OUTPUT | | | |
|------------|-------------------------------------|------------|-----------------------|------------|------|---|---|---------------------|---------------|----------------|----------------|--------------------------------------|--|------------------------|------------------------------|--------------|-------|-----|-------|
| | | | F = FILAMENT | H = HEATER | TYPE | | | | | | | | | | | | VOLTS | AMP | VOLTS |
| 6J7(G)(GT) | TRIPLE-GRID DETECTOR AMPLIFIER | 7R | H | 6.3 | 0.3 | PENTODE CLASS A R.F. AMPLIFIER | 100 250 | -3.0 -3.0 | 100 100 | 0.5 0.5 | 2.0 2.0 | 1000 000 1500 000 | 1165 1225 | — | — | — | | | |
| | | | | | | PENTODE CLASS A A.F. AMPLIFIER | 90 300 | — | — | — | — | — | — | — | — | — | — | — | |
| | | | | | | PENTODE BIAS DETECTOR | 250 | -4.3 | 100 | — | — | — | — | — | — | — | — | — | — |
| | | | | | | TRIODE (15) CLASS A AMPLIFIER | 180 250 | -5.3 -8.0 | — | — | 5.3 6.5 | 11000 10500 | 1600 1900 | 20 20 | — | — | — | — | |
| 6J8-G | TRIODE-HEPTODE CONVERTER | 8H | H | 6.3 | 0.3 | TRIODE UNIT AS AMPLIFIER | 100 250 | — | — | — | — | — | — | — | — | | | | |
| | | | | | | HEPTODE UNIT AS AMPLIFIER | 100 250 | -3.0 -3.0 | 100 100 | 3.2 3.5 | 1.3 1.3 | 800 000 2500 000 | — | — | — | — | — | | |
| 6K5GT/G | HIGH-μ TRIODE | 5U | H | 6.3 | 0.3 | CLASS A AMPLIFIER | 100 250 | -1.5 -3.0 | — | — | 0.35 1.1 | 78000 50000 | 900 1400 | 70 70 | — | — | | | |
| 6K6GT/G | POWER AMPLIFIER PENTODE | 7S | H | 6.3 | 0.4 | CLASS A AMPLIFIER | 250 | -18.0 | 250 | 5.5 | 32.0 | 68 000 | 2300 | — | 7600 | 3.40 | | | |
| 6K7(G)(GT) | TRIPLE-GRID SUPER-CONTROL AMPLIFIER | 7R | H | 6.3 | 0.3 | CLASS A AMPLIFIER | 90 250 | -3.0 -3.0 | 90 125 | 1.3 2.6 | 5.4 10.5 | 300 000 600 000 | 1275 1650 | — | — | — | | | |
| | | | | | | MIXER IN SUPERHETERODYNE | 250 | -10.0 | 100 | — | — | — | — | — | — | — | — | — | |
| 6K8(G)(GT) | TRIODE-HEXODE CONVERTER | 8K | H | 6.3 | 0.3 | TRIODE UNIT AS OSCILLATOR | 100 | — | — | — | — | — | — | — | — | | | | |
| | | | | | | HEXODE UNIT AS MIXER | 100 250 | -3.0 -3.0 | 100 100 | 6.2 6.0 | 2.3 2.5 | 400 000 600 000 | — | — | — | — | — | | |
| 6L5-G | DETECTOR AMPLIFIER-TRIODE | 6Q | H | 6.3 | 0.15 | CLASS A AMPLIFIER | 135 250 | -5.0 -9.0 | — | — | 3.5 8.0 | 11300 9000 | 1500 1900 | 17 17 | — | — | | | |
| 6L6(G) | BEAM-POWER AMPLIFIER | 7AC | H | 6.3 | 0.9 | SINGLE TUBE CLASS A AMPLIFIER | 250 250 | -14.0 CATH. BIAS | 250 250 | 5.0 5.4 | 72.0 75.0 | — | — | — | — | — | | | |
| | | | | | | PUSH-PULL CLASS A AMPLIFIER | 270 270 | -17.5 CATH. BIAS | 270 270 | 11.0 11.0 | 134.0 134.0 | 13 13 | 22500 23500 | 6000 5700 | — | — | — | — | |
| | | | | | | PUSH-PULL CLASS AB ₁ AMPLIFIER | 360 360 | -22.5 CATH. BIAS | 270 270 | 5.0 5.0 | 88.0 88.0 | 13 13 | — | — | — | — | — | — | |
| | | | | | | PUSH-PULL CLASS AB ₂ AMPLIFIER | 360 360 | -18.0 -22.5 | 225 270 | 3.5 5.0 | 78.0 88.0 | 13 13 | — | — | — | — | — | — | |
| | | | | | | SINGLE TRIODE (21) CLASS A AMPLIFIER | 250 250 | -20.0 CATH. BIAS | — | — | — | — | — | — | — | — | — | — | — |
| | | | | | | MIXER IN SUPERHETERODYNE | 250 | -3.0 | 100 | 7.1 | 2.4 | — | — | — | — | — | — | — | — |
| 6L7(G) | PENTAGRID MIXER AMPLIFIER ⑨ | 7T | H | 6.3 | 0.3 | CLASS A AMPLIFIER | 250 | -3.0 ②④ | 100 | 8.5 | 5.3 | 600 000 | 1100 | — | — | — | | | |
| 6M6-G | POWER AMPLIFIER PENTODE | 7S | H | 6.3 | 1.2 | CLASS A AMPLIFIER | 250 | -6.0 | 250 | 4.0 | 36.0 | — | 9500 | — | 7000 | 4.4 | | | |
| 6M7-G | R.F. AMPLIFIER PENTODE | 7R | H | 6.3 | 0.3 | R.F. AMPLIFIER | 250 | -2.5 | 125 | 2.8 | 10.5 | 900 000 | 3400 | — | — | — | | | |
| 6M8-G(GT) | DIODE-TRIODE PENTODE | 8AU | H | 6.3 | 0.6 | TRIODE UNIT AS A.F. AMPLIFIER | 100 | -1.0 | — | — | 0.5 | 91 000 | 1100 | — | — | — | | | |
| | | | | | | PENTODE UNIT AS R.F. AMPLIFIER | 100 | -3.0 | — | — | 8.5 | 200 000 | 1900 | — | — | — | — | | |
| 6N4 | H.F. TRIODE | FIG. 15 | H | 6.3 | 0.2 | CLASS A AMPLIFIER | 180 | -3.5 | — | — | 12.0 | — | 6000 | 32.5 | — | — | | | |
| 6N5(G) | ELECTRON-RAY TUBE | 6R | H | 6.3 | 0.15 | VISUAL INDICATOR | FOR OTHER CHARACTERISTICS, REFER TO TYPE 6AB5/6N5 | | | | | | | | | — | — | | |

| | | | | | | | | | | | | | | | | |
|-----------|--------------------------------|-----|---|-----|------|------------------------------------|---|--------------------------------------|---------|-----|--------------------------------|--|---|---------------------|--------------------------------------|-------------|
| 6N6-G | DIRECT-COUPLED POWER AMPLIFIER | 7AU | H | 6.3 | 0.8 | CLASS A AMPLIFIER | OUTPUT TRIODE: PLATE VOLTS, 300; PLATE MA., 42; LOAD, 7000 OHMS INPUT TRIODE: PLATE VOLTS, 300; PLATE MA., 9; GRID VOLTS, 0. A.F. SIGNAL VOLTS (RMS), 15 | | | | | | 4.0 | | | |
| 6N7-GT/G | TWIN-TRIODE AMPLIFIER | 8B | H | 6.3 | 0.8 | CLASS A AMPLIFIER (AS DRIVER) (11) | 250 | -5.0 | — | — | 6.0 | 11300 | 3100 | 35 | 20000 OR MORE | EXCEEDS 0.4 |
| | | | | | | CLASS B AMPLIFIER | 294 | -6.0 | — | — | 7.0 | 11000 | 3200 | 35 | — | — |
| 6P5-GT/G | DETECTOR AMPLIFIER TRIODE | 6Q | H | 6.3 | 0.3 | CLASS A AMPLIFIER | 300 | 0 | — | — | 35.0 | POWER OUTPUT IS FOR ONE TUBE AT STATED PLATE-TO-PLATE LOAD | | | | |
| | | | | | | BIAS DETECTOR | 300 | 0 | — | — | 35.0 | 8000 | 8000 | 10.0 | 10.0 | |
| 6P7-G | TRIODE PENTODE | 7U | H | 6.3 | 0.3 | TRIODE UNIT AS OSCILLATOR | 100 | -3.0 | — | — | 2.4 | 16200 | 525 | 8.5 | D.C. GRID CURRENT = 0.15 MILLIAMPERE | |
| | | | | | | PENTODE UNIT AS MIXER | 250 | -10.0 | 100 | 0.6 | 2.8 | 2000000 | CONVERSION TRANSCOND.; 300 μ MHOS OSCILLATOR PEAK VOLTS = 7.0 | | | |
| 6P8-G | TRIODE HEXODE | 8K | H | 6.3 | 0.8 | TRIODE UNIT AS OSCILLATOR | 100 | TRIODE GRID RESISTOR, 50000 Ω | | | 2.2 | — | — | — | — | — |
| | | | | | | HEXODE UNIT AS MIXER | 250 | -2.4 | 75 (25) | 1.4 | 1.5 | — | 650 | — | — | — |
| 6Q6-G | DIODE-TRIODE | 6Y | H | 6.3 | 0.15 | TRIODE UNIT AS CLASS A AMPLIFIER | 250 | -3.0 | — | — | 1.2 | — | 1050 | 65 | — | |
| 6Q7(G)GT | DUPLEX-DIODE HIGH-MU TRIODE | 7V | H | 6.3 | 0.3 | TRIODE UNIT AS CLASS A AMPLIFIER | 100 | -1.5 | — | — | 0.35 | 87500 | 800 | 70 | — | |
| | | | | | | BIAS DETECTOR | 250 | -3.0 | — | — | 1.1 | 58000 | 1200 | 70 | — | — |
| 6R6-G | REMOTE CUTOFF R.F. PENTODE | 6AW | H | 6.3 | 0.3 | CLASS A AMPLIFIER | 90 | CATHODE BIAS, 7600 OHMS | | | GRID RESISTOR (10) 0.5 MEGOHM | | | GAIN PER STAGE = 32 | | |
| | | | | | | BIAS DETECTOR | 300 (18) | CATHODE BIAS, 3000 OHMS | | | — | | | GAIN PER STAGE = 45 | | |
| 6R7-GT/G | DUPLEX-DIODE TRIODE | 7V | H | 6.3 | 0.3 | CLASS A AMPLIFIER | 250 | -3.0 | 100 | 1.7 | 7.0 | 800000 | 1450 | — | — | |
| | | | | | | BIAS DETECTOR | 250 | -9.0 | — | — | 9.5 | 8500 | 1900 | 16 | — | — |
| 6S5 | ELECTRON-RAY TUBE | 6R | H | 6.3 | 0.3 | VISUAL INDICATOR | FOR OTHER CHARACTERISTICS, REFER TO TYPE 6X6(G) | | | | | | | | | |
| 6S6-GT | REMOTE CUTOFF PENTODE | 5AK | H | 6.3 | 0.45 | R.F. AMPLIFIER | 250 | -2.0 | 100 | 3.0 | 13 | 350000 | 4000 | — | — | |
| 6S7(G) | TRIPLE-GRID AMPLIFIER | 7R | H | 6.3 | 0.15 | CLASS A AMPLIFIER | 135 | -3.0 | 67.5 | 0.9 | 3.7 | 1000000 | 1250 | — | — | |
| | | | | | | BIAS DETECTOR | 250 | -3.0 | 100 | 2.0 | 8.5 | 1000000 | 1750 | — | — | |
| 6SA7-GT/G | PENTAGRID CONVERTER (29) | 8R | H | 6.3 | 0.3 | CONVERTER | 100 | — | 100 | 8.5 | 3.3 | 500000 | GRID N°1 RESISTOR, 20000 OHMS | | | |
| 6SC7(GT) | TWIN-TRIODE AMPLIFIER | 8S | H | 6.3 | 0.3 | EACH UNIT AS AMPLIFIER | 250 | -2.0 | — | — | 2.0 | 53000 | 1325 | 70 | — | |
| 6SD7-GT | R.F. AMPLIFIER PENTODE | 8N | H | 6.3 | 0.3 | CLASS A AMPLIFIER | 250 | -2.0 | 100 | 1.9 | 6.0 | 1000000 | 3600 | — | — | |
| 6SE7-GT | R.F. AMPLIFIER PENTODE | 8N | H | 6.3 | 0.3 | CLASS A AMPLIFIER | 250 | -1.5 | 100 | 1.5 | 4.5 | 1100000 | 3400 | — | — | |
| | | | | | | BIAS DETECTOR | 100 | -1.0 | — | — | 0.4 | 85000 | 1150 | 100 | — | — |
| 6SF5(GT) | HIGH-MU TRIODE | 6AB | H | 6.3 | 0.3 | CLASS A AMPLIFIER | 250 | -2.0 | — | — | 0.9 | 66000 | 1500 | 100 | — | |
| | | | | | | BIAS DETECTOR | 90 | CATHODE BIAS, 8800 OHMS | | | GRID RESISTOR, (10) 0.5 MEGOHM | | | GAIN PER STAGE = 43 | | |
| 6SF7 | DIODE SUPER-CONTROL PENTODE | 7AZ | H | 6.3 | 0.3 | PENTODE UNIT AS CLASS A AMPLIFIER | 100 | -1.0 | 100 | 3.4 | 12.0 | 200000 | 1975 | — | — | |
| | | | | | | BIAS DETECTOR | 250 | -1.0 | 100 | 3.3 | 12.4 | 700000 | 2050 | — | — | |
| 6SG7(GT) | H.F. AMPLIFIER PENTODE | 8BK | H | 6.3 | 0.3 | CLASS A AMPLIFIER | 100 | -1.0 | 100 | 3.2 | 8.2 | 250000 | 4100 | — | — | |
| | | | | | | BIAS DETECTOR | 250 | -2.5 | 150 | 3.4 | 9.2 | 1000000+ | 4000 | — | — | |
| 6SH7(GT) | H.F. AMPLIFIER PENTODE | 8BK | H | 6.3 | 0.3 | CLASS A AMPLIFIER | 100 | -1.0 | 100 | 2.1 | 5.3 | 350000 | 4000 | — | — | |
| | | | | | | BIAS DETECTOR | 250 | -1.0 | 150 | 4.1 | 10.8 | 900000 | 4900 | — | — | |

| TYPE | DESIGN | BASE CONNS | CATHODE TYPE & RATING | | | USED AS | PLATE SUPPLY | GRID BIAS (2) | SCREEN SUPPLY | SCREEN CURRENT | PLATE CURRENT | R _p A.C. PLATE RESISTANCE | G _m TRANS-CONDUCTANCE (GRID-PLATE) | μ AMPLIFICATION FACTOR | LOAD FOR STATED POWER OUTPUT | POWER OUTPUT |
|-----------|-------------------------------------|------------|----------------------------|------|---------|----------------------------------|--|---|-------------------------------|-----------------------------|---|--------------------------------------|---|------------------------|------------------------------|--------------|
| | | | F = FILAMENT H = HEATER | TYPE | VOLTS | | AMP. | VOLTS | VOLTS | VOLTS | MA | MA | OHMS | μMHOS | | OHMS |
| 6SJ7(GT) | TRIPLE-GRID DETECTOR AMPLIFIER | 8N | H | 6.3 | 0.3 | CLASS A AMPLIFIER | 100 | -3.0 | 100 | 0.9 | 2.9 | 700 000 | 1575 | — | — | — |
| | | | | | | | 250 | -3.0 | 100 | 0.8 | 3.0 | 1500 000 | 1650 | | | |
| 6SK7-GT/G | TRIPLE-GRID AMPLIFIER | 8N | H | 6.3 | 0.3 | CLASS A AMPLIFIER | 100 | -1.0 | 100 | 4.0 | 13.0 | 120 000 | 2350 | — | — | — |
| 250 | -3.0 | 100 | 2.6 | 9.2 | 800 000 | 2000 | | | | | | | | | | |
| 6SL7-GT | TWIN-TRIODE AMPLIFIER | 8BD | H | 6.3 | 0.3 | CLASS A AMP. (49) | 250 | -2.0 | — | — | 2.3 | 44 000 | 1600 | 70 | — | — |
| 6SN7-GT | TWIN-TRIODE AMPLIFIER | 8BD | H | 6.3 | 0.6 | CLASS A AMP. (39) | 90 | 0 | — | — | 10.0 | 6700 | 3000 | 20 | — | — |
| | | | | | | | 250 | -8.0 (40) | — | — | 9.0 | 7700 | 2600 | 20 | — | — |
| 6SQ7-GT/G | DUPLEX-DIODE HIGH-MU TRIODE | 8Q | H | 6.3 | 0.3 | TRIODE UNIT AS CLASS A AMPLIFIER | 250 | -2.0 | — | — | 0.9 | 91 000 | 1100 | 100 | — | — |
| | | | | | | | 90 | — | — | — | — | — | — | — | — | — |
| | | | | | | | 300 (18) | CATHODE BIAS, 11000 OHMS CATHODE BIAS, 3900 OHMS | GRID RESISTOR (10) 0.5 MEGOHM | | { GAIN PER STAGE = 40 GAIN PER STAGE = 53 | | | | | |
| 6SR7(GT) | DUPLEX-DIODE TRIODE | 8Q | H | 6.3 | 0.3 | TRIODE UNIT AS CLASS A AMPLIFIER | 250 | -9.0 | — | — | 9.5 | 8500 | 1900 | 16 | 10000 | 0.3 |
| 6SS7 | TRIPLE-GRID SUPER-CONTROL AMPLIFIER | 8N | H | 6.3 | 0.15 | CLASS A AMPLIFIER | 100 | -1.0 | 100 | 3.1 | 12.2 | 120 000 | 1930 | — | — | — |
| | | | | | | | 250 | -3.0 | 100 | 2.0 | 9.0 | 1000 000 | 1850 | — | — | — |
| 6ST7 | DUPLEX-DIODE TRIODE | 8Q | H | 6.3 | 0.15 | TRIODE UNIT AS CLASS A AMPLIFIER | FOR OTHER CHARACTERISTICS, REFER TO TYPE 6SR7 | | | | | | | | | |
| 6T5 | ELECTRON-RAY TUBE | 6R | H | 6.3 | 0.3 | VISUAL INDICATOR | 250 | CUT-OFF BIAS = 12 V. | | | 0.24 | TARGET CURRENT 4 MA. | | — | — | — |
| 6T6GM | R.F. AMPLIFIER PENTODE | 6Z | H | 6.3 | 0.45 | CLASS A AMPLIFIER | 250 | -1.0 | 100 | 2.0 | 10.0 | 1000 000 | 5500 | — | — | — |
| 6T7-G | DUPLEX-DIODE HIGH-MU TRIODE | 7V | H | 6.3 | 0.15 | TRIODE UNIT AS CLASS A AMPLIFIER | 250 | -3.0 | — | — | 1.2 | 62 000 | 1050 | 65 | — | — |
| | | | | | | | 90 | — | — | — | — | — | — | — | — | — |
| | | | | | | | 300 (19) | CATHODE BIAS, 8300 OHMS CATHODE BIAS, 4580 OHMS | GRID RESISTOR (10) 0.5 MEGOHM | | { GAIN PER STAGE = 30 GAIN PER STAGE = 40 | | | | | |
| 6U5/6G5 | ELECTRON-RAY TUBE | 6R | H | 6.3 | 0.3 | VISUAL INDICATOR | PLATE & TARGET SUPPLY = 100 VOLTS. TRIODE PLATE RESISTOR = 1 MEG. TARGET CURRENT = 1.0 MA. GRID BIAS, -8 VOLTS; SHADOW ANGLE, 0°; BIAS, 0 VOLTS; ANGLE, 90°; PLATE CURRENT, 0.19 MA. | | | | | | | | | |
| | | | | | | | PLATE & TARGET SUPPLY = 250 VOLTS. TRIODE PLATE RESISTOR = 1 MEG. TARGET CURRENT = 4.0 MA. GRID BIAS, -22 VOLTS; SHADOW ANGLE, 0°; BIAS, 0 VOLTS; ANGLE, 90°; PLATE CURRENT = 0.24 MA. | | | | | | | | | |
| 6U6-GT | BEAM POWER AMPLIFIER | 7AC | H | 6.3 | 0.75 | CLASS A AMPLIFIER | 200 | -14.0 | 135 | 3.0 | 56.0 | 20000 | 6200 | — | 3000 | 5.5 |
| 6U7-G | TRIPLE-GRID SUPER-CONTROL AMPLIFIER | 7R | H | 6.3 | 0.3 | CLASS A AMPLIFIER | 100 | -3.0 | 100 | 2.2 | 8.0 | 250 000 | 1500 | — | — | — |
| | | | | | | | 250 | -3.0 | 100 | 2.0 | 8.2 | 800 000 | 1600 | | | |
| | | | | | | | 100 | -10.0 | 100 | — | — | OSCILLATOR PEAK VOLTS = 7.0 | | | | |
| | | | | | | | 250 | -10.0 | 100 | — | — | OSCILLATOR PEAK VOLTS = 7.0 | | | | |
| 6V6-GT/G | BEAM POWER AMPLIFIER | 7AC | H | 6.3 | 0.45 | CLASS A AMPLIFIER | 180 | -8.5 | 180 | 3.0 | 29.0 | 58 000 | 3700 | — | 5500 | 2.0 |
| | | | | | | | 315 | -13.5 | 225 | 2.2 | 34.0 | 77 000 | 3750 | | 8500 | 5.5 |
| | | | | | | | 250 | -15.0 | 250 | 5.0 (13) | 70.0 (13) | — | — | 10000 | 8.5 (12) | |
| | | | | | | | 300 | -20.0 | 300 | 5.0 | 78.0 | — | — | 8000 | 13.0 | |
| 6V7-G | DUPLEX-DIODE TRIODE | 7V | H | 6.3 | 0.3 | TRIODE UNIT AS CLASS A AMPLIFIER | FOR OTHER CHARACTERISTICS, REFER TO TYPE 85 | | | | | | | | | |
| 6W5(G) | FULL-WAVE RECTIFIER | 6S | H | 6.3 | 0.9 | WITH CONDENSER INPUT FILTER | MAXIMUM A.C. VOLTS PER PLATE (RMS), 325. | | | MAXIMUM D.C. OUTPUT MA., 90 | | | | | | |
| | | | | | | | WITH CHOKE INPUT FILTER | MAXIMUM A.C. VOLTS PER PLATE (RMS), 450. | | | MAX. D.C. OUTPUT MA., 90. VOLT DROP AT 90 MA., 24 VOLTS | | | | | |

| | | | | | | | | | | | | | | | | | |
|-----------|-------------------------------------|--------|---|-------------|------------|-----------------------------|--|----------------|---------------|--|--|---|---|-----|---------------|------------|--|
| 6W6-GT | BEAM POWER AMPLIFIER | 7AC | H | 6.3 | 1.25 | CLASS A AMPLIFIER | 125 | -9.5 | 135 | 2.5 | 58.0 | — | 9000 | 150 | 2000 | 3.5 | |
| 6W7-G | TRIPLE-GRID DETECTOR AMPLIFIER | 7R | H | 6.3 | 0.15 | CLASS A AMPLIFIER | 250 | -3.0 | 100 | 0.5 | 2.0 | 1500 000 | 1225 | — | — | — | |
| 6X5-GT/G | FULL-WAVE RECTIFIER | 6S | H | 6.3 | 0.6 | WITH CONDENSER INPUT FILTER | MAX. A.C. VOLTS PER PLATE (RMS), 325 MAX. PEAK INVERSE VOLTS, 1250 | | | MAX. D.C. OUTPUT MA., 70 MAX. PEAK PLATE MA., 210 | | MIN. TOTAL EFFECTIVE SUPPLY IMPEDANCE PER PLATE, 150 OHMS | | | | | |
| | | | | | | WITH CHOKE INPUT FILTER | MAX. A.C. VOLTS PER PLATE (RMS), 450 MAX. PEAK INVERSE VOLTS, 1250 | | | MAX. D.C. OUTPUT MA., 70 MAX. PEAK PLATE MA., 210 | | MINIMUM VALUE OF INPUT CHOKE, 8 HENRIES | | | | | |
| 6X6-G | ELECTRON-RAY TUBE | 7AL | H | 6.3 | 0.3 | VISUAL INDICATOR | TARGET 250 | -8.0 0 | VANE GRID 135 | TARGET CURRENT, 0 MA. TARGET CURRENT, 2 MA. | VALUES FOR 0° ANGLE VALUES FOR 300° ANGLE | | | | | | |
| 6Y5(G) | FULL-WAVE RECTIFIER ④ | 6J | H | 8.3 | 0.8 | RECTIFIER | MAX. A.C. VOLTS PER PLATE (RMS), 350 MAX. PEAK INVERSE VOLTS, 1500 | | | MAX. D.C. OUTPUT MA., 50 MAX. PEAK PLATE MA., 200 | | | | | | | |
| 6Y6-G(GT) | BEAM POWER AMPLIFIER | 7AC | H | 8.3 | 1.25 | CLASS A AMPLIFIER | 135 200 | -13.5 -14.0 | 135 135 | 3.5 2.2 | 58.0 61.0 | 9300 18300 | 7000 7100 | — | 2000 2600 | 3.6 6.0 | |
| 6Y7-G | TWIN-TRIODE AMPLIFIER | 8B | H | 6.3 | 0.6 | CLASS B AMPLIFIER | 180 250 | 0 | — | — | 7.6 10.6 | — | — | — | 7000 14000 | 5.5 8.0 | |
| 6Z3 | HALF-WAVE RECTIFIER | 4G | H | 8.3 | 0.3 | RECTIFIER | FOR OTHER CHARACTERISTICS, REFER TO TYPE 1V | | | | | | | | | | |
| 6Z4/84 | FULL-WAVE RECTIFIER | 5D | H | 6.3 | 0.5 | RECTIFIER | FOR OTHER CHARACTERISTICS, REFER TO TYPE 84/8Z4 | | | | | | | | | | |
| 6Z5 | FULL-WAVE RECTIFIER | 6K | H | 6.3 12.6 | 0.8 0.4 | RECTIFIER | FOR OTHER CHARACTERISTICS, REFER TO TYPE 84/8Z4 | | | | | | | | | | |
| 6Z7-G | TWIN-TRIODE AMPLIFIER | 8B | H | 6.3 | 0.3 | CLASS B AMPLIFIER | 135 180 | 0 | — | — | 6.0 8.4 | — | — | — | 9000 12000 | 2.5 4.2 | |
| 6ZY5-G | FULL-WAVE RECTIFIER | 6S | H | 6.3 | 0.3 | WITH CONDENSER INPUT FILTER | MAX. A.C. VOLTS PER PLATE (RMS), 325 MAX. PEAK INVERSE VOLTS, 1250 | | | MAX. D.C. OUTPUT MA., 40 MAX. PEAK PLATE MA., 120 | | MIN. TOTAL EFFECTIVE SUPPLY IMPEDANCE PER PLATE, 225 OHMS | | | | | |
| | | | | | | WITH CHOKE INPUT FILTER | MAX. A.C. VOLTS PER PLATE (RMS), 450 MAX. PEAK INVERSE VOLTS, 1250 | | | MAX. D.C. OUTPUT MA., 40 MAX. PEAK PLATE MA., 120 | | MINIMUM VALUE OF INPUT CHOKE, 13.5 HENRIES | | | | | |
| 7A4 | DETECTOR AMPLIFIER TRIODE | 5AC | H | 8.3 | 0.3 | CLASS A AMPLIFIER | FOR OTHER CHARACTERISTICS, REFER TO TYPE 6J5-GT/G | | | | | | | | | | |
| 7A5 | POWER AMPLIFIER PENTODE | 6AA | H | 6.3 | 0.75 | CLASS A AMPLIFIER | 110 125 | -7.5 -9.0 | 110 125 | 3.0 3.3 | 40.0 44.0 | 14000 17000 | 5800 6000 | — | 2500 2700 | 1.5 2.2 | |
| 7A6 | TWIN DIODE | 7AJ | H | 8.3 | 0.15 | DETECTOR RECTIFIER | MAXIMUM A.C. VOLTAGE PER PLATE (RMS), 150 MAXIMUM D.C. OUTPUT CURRENT, 10 MA. | | | | | | | | | | |
| 7A7(LM) | TRIPLE-GRID SUPER-CONTROL AMPLIFIER | 8V | H | 6.3 | 0.3 | CLASS A AMPLIFIER | FOR OTHER CHARACTERISTICS, REFER TO TYPE 6SK7-GT/G | | | | | | | | | | |
| 7A8 | OCTODE CONVERTER | 8U | H | 6.3 | 0.15 | CONVERTER | 250 | -3.0 MIN. | 100 | 3.2 | 3.0 | 700 000 | ANODE-GRID (N° 2): 200 ③ MAX. VOLTS, 4.2 MA. OSCILLATOR-GRID (N° 1) RESISTOR, 50 000 Ω. CONVERSION TRANSCON., 550 μMHOS | | | | |
| 7AB7/1204 | UHF PENTODE | FIG. 4 | H | 6.3 | 0.15 | CLASS A AMPLIFIER | 250 | -2 | 100 | 0.8 | 1.75 | 80D000 | 1200 | — | — | — | |
| 7B4 | HIGH-MU TRIODE | 6AE | H | 6.3 | 0.4 | CLASS A AMPLIFIER | FOR OTHER CHARACTERISTICS, REFER TO TYPE 6SF5 | | | | | | | | | | |
| 7B5(LT) | POWER AMPLIFIER PENTODE | 6AE | H | 6.3 | 0.4 | CLASS A AMPLIFIER | FOR OTHER CHARACTERISTICS, REFER TO TYPE 6K6-GT/G | | | | | | | | | | |
| 7B6(LM) | DUPLEX-DIODE HIGH-MU TRIODE | 8W | H | 6.3 | 0.3 | TRIODE UNIT AS AMPLIFIER | FOR OTHER CHARACTERISTICS, REFER TO TYPE 6SQ7-GT/G | | | | | | | | | | |
| 7B7 | TRIPLE-GRID SUPER-CONTROL AMPLIFIER | 8V | H | 6.3 | 0.15 | CLASS A AMPLIFIER | 100 250 | -3.0 -3.0 | 100 100 | 1.8 1.7 | 8.2 8.5 | 30D000 75D000 | 1675 1750 | — | — | — | |
| 7B8(LM) | PENTAGRID CONVERTER | 8X | H | 8.3 | 0.3 | CONVERTER | FOR OTHER CHARACTERISTICS, REFER TO TYPE 6A8 | | | | | | | | | | |
| 7C4/203A | UHF DIODE | 4AH | H | 8.3 | 0.15 | UHF DIODE DETECTOR | 10V, RMS | | | | | 9.0 | RESONANT FREQUENCY 613 MEGACYCLES | | | | |

| TYPE | DESIGN | BASE CONNS | CATHODE TYPE & RATING | | USED AS | PLATE SUPPLY | GRID BIAS ② | SCREEN SUPPLY | SCREEN CURRENT | PLATE CURRENT | R _p AC. PLATE RESISTANCE | G _m TRANSCON- DUCTANCE (GRID-PLATE) | μ AMPLIFI- FACTOR | LOAD FOR STATED POWER OUTPUT | POWER OUTPUT WATTS |
|----------|---|---------------|----------------------------|-------|---------|--------------------------------------|----------------|------------------|--|------------------|---|---|--|---------------------------------------|--------------------------------------|
| | | | F = FILAMENT H = HEATER | | | | | | | | | | | | |
| | | | TYPE | VOLTS | | | | | | | | | | | |
| 7C5(LT) | BEAM POWER AMPLIFIER | 6AA | H | 6.3 | 0.45 | | | | | | | | | | |
| | | | | | | | | | | | | | | | |
| 7C6 | DUPLEX-DIODE HIGH-MU TRIODE | 8W | H | 6.3 | 0.15 | CLASS A AMPLIFIER | 250 | -1.0 | — | — | 1.3 | 100 000 | 1000 | 100 | — |
| 7C7 | TRIPLE-GRID DETECTOR AMPLIFIER | 8V | H | 6.3 | 0.15 | CLASS A AMPLIFIER | 100 250 | -3.0 -3.0 | 100 100 | 0.4 0.5 | 1.8 2.0 | 1200 000 2000 000 | 1225 1300 | — | — |
| 7D7 | TRIODE-HEXODE CONVERTER | 8AR | H | 6.3 | 0.43 | OSCILLATOR MIXER | 150 250 | -3.0 -3.0 | VALUES FOR TRIODE UNIT VALUES FOR HEXODE UNIT | | 3.5 | 18800 | 1900 | 32 | CONVERS. TRANSCOND. 275 MICROMHOS |
| 7E5/1201 | UHF TRIODE | 8BN | H | 6.3 | 0.15 | CLASS A AMPLIFIER | 180 | -3.0 | — | — | 5.5 | 12000 | — | 36 | — |
| 7E6 | DUPLEX-DIODE TRIODE | 8W | H | 6.3 | 0.3 | TRIODE UNIT AS CLASS A AMPLIFIER | | | | | | | | | |
| | | | | | | | | | | | | | | | |
| 7E7 | DUPLEX-DIODE PENTODE | 8AE | H | 6.3 | 0.3 | PENTODE UNIT AS CLASS A AMPLIFIER | 100 250 | -1.0 -3.0 | 100 100 | 2.7 1.6 | 10.0 7.5 | 150 000 700 000 | 1600 1300 | — | — |
| 7F7 | TWIN TRIODE AMPLIFIER | 8AC | H | 6.3 | 0.3 | EACH UNIT AS AMPLIFIER | | | | | | | | | |
| | | | | | | | | | | | | | | | |
| 7F8 | TWIN TRIODE AMPLIFIER | 8BW | H | 6.3 | 0.3 | R.F. AMPLIFIER | 180 250 | -1.0 -2.5 | — | — | 12.0 10.0 | 8500 10400 | 7000 5000 | — | — |
| 7G7/1232 | TRIPLE-GRID AMPLIFIER | 8V | H | 6.3 | 0.45 | CLASS A AMPLIFIER | 250 | -2.0 | 100 | 2.0 | 6.0 | 800 000 | 4500 | — | — |
| 7G8/1206 | DUAL TETRODE | 8BV | H | 6.3 | 0.3 | EACH UNIT AS CLASS A AMPLIFIER | 250 | -2.5 | 100 | 0.8 | 4.5 | 225 000 | 2100 | — | — |
| 7H7 | TRIPLE-GRID SUPER-CONTROL AMPLIFIER | 8V | H | 6.3 | 0.3 | CLASS A AMPLIFIER | 100 250 | -1.0 -2.5 | 100 150 | 3.3 3.5 | 8.2 9.5 | 250 000 800 000 | 3800 3800 | — | — |
| 7J7 | TRIODE-HEPTODE CONVERTER | 8AR | H | 6.3 | 0.3 | TRIODE UNIT AS OSCILLATOR | 100 250 | -3.0 -3.0 | 100 100 | 3.1 2.9 | 1.1 1.3 | 300 000 1500 000 | CONVERSION TRANSCOND., 260 MICROMHOS CONVERSION TRANSCOND., 300 MICROMHOS | | |
| | | | | | | | | | | | | | | | |
| 7K7 | DUPLEX-DIODE HIGH-MU TRIODE | 8BF | H | 6.3 | 0.3 | TRIODE UNIT AS CLASS A AMPLIFIER | 250 | -2.0 | — | — | 2.3 | 44 000 | 1600 | 70 | — |
| 7L7 | TRIPLE-GRID AMPLIFIER | 8V | H | 6.3 | 0.3 | CLASS A AMPLIFIER | 100 250 | -1.0 -1.5 | 100 100 | 2.4 1.5 | 5.5 4.5 | 100 000 1000 000 | 3000 3100 | — | — |
| 7N7 | TWIN TRIODE AMPLIFIER | 8AC | H | 6.3 | 0.6 | EACH UNIT AS AMPLIFIER | 250 | -3.0 | — | — | 9.0 | 7700 | 2600 | 20 | — |
| 7Q7 | PENTAGRID CONVERTER | 8AL | H | 6.3 | 0.3 | CONVERTER | | | | | | | | | |
| | | | | | | | | | | | | | | | |
| 7R7 | DUPLEX-DIODE PENTODE | 8AE | H | 6.3 | 0.3 | PENTODE UNIT AS AMPLIFIER | 250 | -1.0 | 100 | 2.1 | 5.7 | 1 000 000 | 3200 | — | — |
| 7S7 | TRIODE-HEXODE CONVERTER | 8AR | H | 6.3 | 0.3 | OSCILLATOR MIXER | 250 250 | — | — | — | 5.0 1.7 | — | TRIODE GRID CURRENT, 0.4 MA.; RESISTOR 50000 CONVER. TRANSCON., 60C μMHOS (E _{C3} = -2V) | | |
| 7T7(GL) | TRIPLE-GRID AMPLIFIER | 8V | H | 6.3 | 0.3 | CLASS A AMPLIFIER | 250 | -1.0 | 150 | 4.1 | 10.8 | 900 000 | 4900 | — | — |
| 7V7 | R.F. AMPLIFIER PENTODE | 8V | H | 6.3 | 0.45 | CLASS A AMPLIFIER | 300 | -2.0 | 150 | 3.9 | 9.6 | 300 000 | 5800 | — | — |
| 7W7 | H.F. AMPLIFIER PENTODE | 8BJ | H | 6.3 | 0.45 | EXTENDED CUTOFF CLASS A AMPLIFIER | 300 | -2.0 | 150 | 3.9 | 10.0 | 300 000 | 5800 | — | — |

| | | | | | | | | | | | | | | | | |
|------------------|-------------------------------------|----------|-----------|-------------|------------|-----------------------------------|--|----------------|------------|------------|--|------------------|--------------|--|-----------------|------------|
| 7Y4 | FULL-WAVE RECTIFIER | 5AB | H | 8.3 | 0.5 | WITH CONDENSER INPUT FILTER | MAX. A.C. VOLTS PER PLATE (RMS), 325 MAX. PEAK INVERSE VOLTS, 1250 | | | | MAX. D.C. OUTPUT MA., 60 MAX. PEAK PLATE MA., 180 | | | MIN. TOTAL EFFECTIVE SUPPLY IMPEDANCE PER PLATE, 150 Ω | | |
| | | | | | | WITH CHOKE INPUT FILTER | MAX. A.C. VOLTS PER PLATE (RMS), 450 MAX. PEAK INVERSE VOLTS, 1250 | | | | MAX. D.C. OUTPUT MA., 80 MAX. PEAK PLATE MA., 180 | | | MINIMUM VALUE OF INPUT CHOKE, 10 HENRIES | | |
| 7Z4 | FULL-WAVE RECTIFIER | 5AB | H | 8.3 | 0.85 | WITH CONDENSER INPUT FILTER | MAX. A.C. VOLTS PER PLATE (RMS), 325 MAX. PEAK INVERSE VOLTS, 1250 | | | | MAX. D.C. OUTPUT MA., 100 MAX. PEAK PLATE MA., 300 | | | MIN. TOTAL EFFECTIVE SUPPLY IMPEDANCE PER PLATE, 75 Ω | | |
| | | | | | | WITH CHOKE INPUT FILTER | MAX. A.C. VOLTS PER PLATE (RMS), 450 MAX. PEAK INVERSE VOLTS, 1250 | | | | MAX. D.C. OUTPUT MA., 100 MAX. PEAK PLATE MA., 300 | | | MINIMUM VALUE OF INPUT CHOKE, 6 HENRIES | | |
| 10 | POWER AMPLIFIER TRIODE | 4D | F | 7.5 | 1.25 | CLASS A AMPLIFIER | 350 425 | -32.0 -40.0 | — | — | 16.0 18.0 | 5150 5000 | 1550 1600 | 8.0 8.0 | 11000 102000 | 0.9 1.6 |
| 11 12 | DETECTOR AMPLIFIER TRIODE ① | 4F 4D | D.C. F | 1.1 | 0.25 | CLASS A AMPLIFIER | 90 135 | -4.5 -10.5 | — | — | 2.5 3.0 | 15500 15000 | 425 440 | 6.6 6.6 | — | — |
| 12A5 | POWER AMPLIFIER PENTODE | 7F | H | 6.3 12.6 | 0.6 0.3 | CLASS A AMPLIFIER | 100 180 | -15.0 -25.0 | 100 180 | 3.0 8.0 | 6.5 14.0 | 50000 35000 | 1700 2400 | — | 4500 3300 | 0.8 3.4 |
| 12A6(GT) | BEAM POWER AMPLIFIER | 7AC | H | 12.6 | 0.15 | CLASS A AMPLIFIER | 250 | -12.5 | 250 | 3.5 | 30.0 | 70000 | 3000 | — | 7500 | 2.6 |
| 12A7 | RECTIFIER PENTODE | 7K | H | 12.6 | 0.3 | PENTODE UNIT AS CLASS A AMPLIFIER | 135 | -13.5 | 135 | 2.5 | 9.0 | 102000 | 975 | — | 13500 | 0.55 |
| | | | | | | HALF-WAVE RECTIFIER | MAXIMUM A.C. PLATE VOLTAGE, 125 VOLTS RMS MAXIMUM D.C. OUTPUT CURRENT, 30 MILLIAMPERES | | | | | | | | | |
| 12A8-GT/G | PENTAGRID CONVERTER ② | 8A | H | 12.6 | 0.15 | CONVERTER | FOR OTHER CHARACTERISTICS, REFER TO TYPE 6A8 | | | | | | | | | |
| 12AH7-GT | TWIN TRIODE AMPLIFIER | 8BE | H | 12.6 | 0.15 | EACH UNIT AS CLASS A AMPLIFIER | 250 | -9.0 | — | — | 12.0 | 8600 | 2400 | 16 | — | — |
| 12B6M ③ | DIODE TRIODE | 6Y | H | 12.6 | 0.15 | CLASS A AMPLIFIER | 250 | -2.0 | — | — | 0.9 | 91000 | 1100 | 100 | — | — |
| 12B7 ④ 12B7ML | TRIPLE-GRID SUPER-CONTROL AMPLIFIER | 8V | H | 12.6 | 0.15 | CLASS A AMPLIFIER | FOR OTHER CHARACTERISTICS, REFER TO TYPE 14A7/12B7 | | | | | | | | | |
| 12B8-GT | TRIODE PENTODE | 8T | H | 12.6 | 0.3 | TRIODE UNIT AS CLASS A AMPLIFIER | 90 100 | 0 -1.0 | — | — | 2.8 0.6 | 37000 73000 | 2400 1500 | 90 110 | — | — |
| | | | | | | PENTODE UNIT AS CLASS A AMPLIFIER | 90 100 | -3.0 -3.0 | 90 100 | 2.0 2.0 | 7.0 8.0 | 170000 200000 | 1600 2100 | 360 360 | — | — |
| | | | | | | PENTODE UNIT AS R.F. AMPLIFIER | 250 | -3.0 | 125 | 2.3 | 10.0 | 60000 | 1325 | — | — | — |
| 12C8 | DUPLEX-DIODE PENTODE | 8E | H | 12.6 | 0.15 | PENTODE UNIT AS A.F. AMPLIFIER | CATHODE BIAS, 3500 OHMS. SCREEN RESISTOR, 1.1 MEG. } CATHODE BIAS, 1600 OHMS. SCREEN RESISTOR, 1.2 MEG. } | | | | GRID RESISTOR 0.5 MEG. ⑩ { GAIN PER STAGE, 55 GAIN PER STAGE, 79 | | | | | |
| 12E5-GT/G | AMPLIFIER TRIODE | 6Q | H | 12.6 | 0.15 | CLASS A AMPLIFIER | 250 | -13.5 | — | — | 5.0 | 9500 | 1450 | 13.6 | — | — |
| 12F5-GT | HIGH-MU TRIODE | 5M | H | 12.6 | 0.15 | CLASS A AMPLIFIER | FOR OTHER CHARACTERISTICS, REFER TO TYPE 6SF5 | | | | | | | | | |
| 12G7-G | DUPLEX-DIODE HIGH-MU TRIODE | 7V | H | 12.6 | 0.15 | TRIODE UNIT AS CLASS A AMPLIFIER | 250 | -3.0 | — | — | — | 58000 | 1200 | 70 | — | — |
| 12H6 | TWIN DIODE | 7Q | H | 12.6 | 0.15 | DETECTOR RECTIFIER | FOR OTHER CHARACTERISTICS, REFER TO TYPE 6H6 | | | | | | | | | |
| 12J5(GT) | DETECTOR AMPLIFIER TRIODE | 6Q | H | 12.6 | 0.15 | AMPLIFIER | FOR OTHER CHARACTERISTICS, REFER TO TYPE 6J5 | | | | | | | | | |
| 12J7GT/G | TRIPLE-GRID DETECTOR AMPLIFIER | 7R | H | 12.6 | 0.15 | AMPLIFIER | FOR OTHER CHARACTERISTICS, REFER TO TYPE 6J7 | | | | | | | | | |
| 12K7GT/G | TRIPLE-GRID SUPER-CONTROL AMPLIFIER | 7R | H | 12.6 | 0.15 | AMPLIFIER | FOR OTHER CHARACTERISTICS, REFER TO TYPE 6K7 | | | | | | | | | |
| 12K8(GT) | TRIODE-HEXODE CONVERTER | 8K | H | 12.6 | 0.15 | OSCILLATOR MIXER | FOR OTHER CHARACTERISTICS, REFER TO TYPE 6K6 | | | | | | | | | |

| TYPE | DESIGN | BASE CONNS | CATHODE TYPE & RATING | | | USED AS | PLATE SUPPLY | GRID BIAS ② | SCREEN SUPPLY | SCREEN CURRENT | PLATE CURRENT | R _p A.C. PLATE RESISTANCE | G _m TRANSCONDUCTANCE (GRID-PLATE) | J _i AMPLIFICATION FACTOR | LOAD FOR STATED POWER OUTPUT | POWER OUTPUT | | |
|------------------------------|-------------------------------------|------------|-----------------------|-------------|------------|-----------------------------------|--|--------------|---------------|----------------|---------------|---|--|--|------------------------------|--------------|-------|-----|
| | | | F = FILAMENT | H = HEATER | TYPE | | | | | | | | | | | | VOLTS | AMP |
| | | | | | | | | | | | | | | | | | | |
| | | | | | | VOLTS | VOLTS | VOLTS | MILLIAMPS. | MILLIAMPS. | OHMS | UMHOS | OHMS | WATTS | | | | |
| 12L8-GT | TWIN PENTODE | 8BU | H | 12.6 | 0.15 | EACH UNIT AS CLASS A AMPLIFIER | 180 | 9.0 | 180 | 2.8 | 13.0 | 160 000 | — | — | 10000 | 1.0 | | |
| 12Q7-GT/T | DUPLEX-DIODE HIGH-MU TRIODE | 7V | H | 12.6 | 0.15 | TRIODE UNIT AS AMPLIFIER | FOR OTHER CHARACTERISTICS, REFER TO TYPE 6Q7 | | | | | | | | | | | |
| 12SA7-GT/T | PENTAGRID CONVERTER ② | 8R 8AD | H | 12.6 | 0.15 | MIXER | FOR OTHER CHARACTERISTICS, REFER TO TYPE 6SA7 | | | | | | | | | | | |
| 12SC7 | TWIN-TRIODE AMPLIFIER | 8S | H | 12.6 | 0.15 | AMPLIFIER | FOR OTHER CHARACTERISTICS, REFER TO TYPE 6SC7 | | | | | | | | | | | |
| 12SF5(GT) | HIGH-MU TRIODE | 6AB | H | 12.6 | 0.15 | AMPLIFIER | FOR OTHER CHARACTERISTICS, REFER TO TYPE 6SF5 | | | | | | | | | | | |
| 12SF7 | DIODE SUPER-CONTROL AMP. | 7AZ | H | 12.6 | 0.15 | PENTODE UNIT AS CLASS A AMPLIFIER | FOR OTHER CHARACTERISTICS, REFER TO TYPE 6SF7 | | | | | | | | | | | |
| 12SG7(GT) | H.F. AMPLIFIER PENTODE | 8BK | H | 12.6 | 0.15 | CLASS A AMPLIFIER | FOR OTHER CHARACTERISTICS, REFER TO TYPE 6SG7 | | | | | | | | | | | |
| 12SH7(GT) | H.F. AMPLIFIER PENTODE | 8BK | H | 12.6 | 0.15 | CLASS A AMPLIFIER | FOR OTHER CHARACTERISTICS, REFER TO TYPE 6SH7 | | | | | | | | | | | |
| 12SJ7(GT) | TRIPLE-GRID DETECTOR AMPLIFIER | 8N | H | 12.6 | 0.15 | CLASS A AMPLIFIER | FOR OTHER CHARACTERISTICS, REFER TO TYPE 6SJ7 | | | | | | | | | | | |
| 12SK7-GT/T | TRIPLE-GRID SUPER-CONTROL AMPLIFIER | 8N | H | 12.6 | 0.15 | CLASS A AMPLIFIER | FOR OTHER CHARACTERISTICS, REFER TO TYPE 6SK7 | | | | | | | | | | | |
| 12SL7-GT | TWIN-TRIODE AMPLIFIER | 8BD | H | 12.6 | 0.15 | EACH UNIT AS CLASS A AMPLIFIER | FOR OTHER CHARACTERISTICS, REFER TO TYPE 6SL7 | | | | | | | | | | | |
| 12SN7-GT | TWIN-TRIODE AMPLIFIER | 8BD | H | 12.6 | 0.3 | EACH UNIT AS CLASS A AMPLIFIER | FOR OTHER CHARACTERISTICS, REFER TO TYPE 6SN7 | | | | | | | | | | | |
| 12SQ7-GT/T | DUPLEX-DIODE HIGH-MU TRIODE | 8Q | H | 12.6 | 0.15 | TRIODE UNIT AS CLASS A AMPLIFIER | FOR OTHER CHARACTERISTICS, REFER TO TYPE 6SQ7 | | | | | | | | | | | |
| 12SR7(GT) | DUPLEX-DIODE TRIODE | 8Q | H | 12.6 | 0.15 | TRIODE UNIT AS CLASS A AMPLIFIER | FOR OTHER CHARACTERISTICS, REFER TO TYPE 6SR7 | | | | | | | | | | | |
| 12SW7-GT | DUPLEX-DIODE TRIODE | 8Q | H | 12.6 | 0.15 | TRIODE UNIT AS CLASS A AMPLIFIER | 250 | -9.0 | — | — | 9.5 | — | 1900 | 16 | — | — | | |
| 12SX7-GT | TWIN-TRIODE AMPLIFIER | 8BD | H | 12.6 | 0.3 | EACH UNIT AS CLASS A AMPLIFIER | 250 | -8.0 | — | — | 9.0 | — | 2600 | 20.5 | — | — | | |
| 12SY7(GT) | PENTAGRID CONVERTER | 8AD | H | 12.6 | 0.15 | CONVERTER | 250 | -2.0 | 100 | 9.0 | 3.5 | — | OSCILLATOR-GRID (N° 1) RESISTOR, 20000 Ω CONVERSION TRANSCOND., 450 MICROMHOS | | | | | |
| 12Z3 | HALF-WAVE RECTIFIER | 4G | H | 12.6 | 0.3 | WITH CONDENSER INPUT FILTER | MAX. A.C. PLATE VOLTS (RMS), 235 MAX. D.C. OUTPUT MA., 55 MIN. TOTAL EFFECTIVE PLATE SUPPLY IMPEDANCE: UP TO 117 VOLTS, 0 OHMS; AT 150 VOLTS, 30 OHMS; AT 235 VOLTS, 75 OHMS | | | | | | | | | | | |
| 12Z5 | RECTIFIER-DOUBLER | 7L | H | 6.3 12.6 | 0.6 0.3 | RECTIFIER | MAXIMUM A.C. VOLTAGE PER PLATE (RMS), 225 MAXIMUM D.C. OUTPUT CURRENT PER PLATE, 60 MA. | | | | | | | | | | | |
| 14A4 | DETECTOR AMPLIFIER TRIODE | 5AC | H | 12.6 | 0.15 | CLASS A AMPLIFIER | FOR OTHER CHARACTERISTICS, REFER TO TYPE 6J5 | | | | | | | | | | | |
| 14A5 | BEAM POWER AMPLIFIER | 6AA | H | 12.6 | 0.15 | CLASS A AMPLIFIER | 250 | -12.5 | 250 | 3.5 | 30.0 | 50 000 | 3 000 | — | 7 500 | 2.5 | | |
| 14A7/12B7 14A7ML/12B7ML ② | TRIPLE-GRID SUPER-CONTROL AMPLIFIER | 8V | H | 12.6 | 0.15 | CLASS A AMPLIFIER | 100 250 | -1.0 -3.0 | 100 100 | 4.0 2.8 | 13.0 9.2 | 120 000 800 000 | 2350 2000 | — | — | — | | |
| 14AF7 | TWIN TRIODE | 8AC | H | 12.6 | 0.15 | EACH UNIT AS CLASS A AMPLIFIER | 250 | -10.0 | — | — | 9.0 | 7 600 | 2100 | 16 | — | — | | |
| 14B6 | DUPLEX-DIODE HIGH-MU TRIODE | 8W | H | 12.6 | 0.15 | TRIODE UNIT AS CLASS A AMPLIFIER | FOR OTHER CHARACTERISTICS, REFER TO TYPE 6SQ7 | | | | | | | | | | | |

| | | | | | | | | | | | | | | | | |
|-----------|-------------------------------------|-----------------------------|--------|------|-------|-----------------------------------|---|----------------|--|--------------------------|--------------|------------------|---|---|--------------|----------------|
| 14B8 | PENTAGRID CONVERTER | 8X | H | 12.8 | 0.15 | CONVERTER | FOR OTHER CHARACTERISTICS, REFER TO TYPE 6A6 | | | | | | | | | |
| 14C5 | BEAM POWER AMPLIFIER | 6AA | H | 12.6 | 0.225 | CLASS A AMPLIFIER | FOR OTHER CHARACTERISTICS, REFER TO TYPE 6V6 | | | | | | | | | |
| 14C7 | R.F. AMPLIFIER PENTODE | 8V | H | 12.6 | 0.15 | AMPLIFIER | 250 | -3.0 | 100 | 0.7 | 2.2 | 1000000 | 1575 | — | — | — |
| 14E6 | DUPLEX-DIODE TRIODE | 8W | H | 12.6 | 0.15 | TRIODE UNIT AS CLASS A AMPLIFIER | FOR OTHER CHARACTERISTICS, REFER TO TYPE 6R7 | | | | | | | | | |
| 14E7 | DUPLEX-DIODE PENTODE | 8AE | H | 12.6 | 0.15 | PENTODE UNIT AS CLASS A AMPLIFIER | FOR OTHER CHARACTERISTICS, REFER TO TYPE 7E7 | | | | | | | | | |
| 14F7 | TWIN-TRIODE AMPLIFIER | 8AC | H | 12.6 | 0.15 | EACH UNIT AS CLASS A AMPLIFIER | FOR OTHER CHARACTERISTICS, REFER TO TYPE 6SL7-GT | | | | | | | | | |
| 14H7 | TRIPLE-GRID SUPER-CONTROL AMPLIFIER | 8V | H | 12.6 | 0.15 | CLASS A AMPLIFIER | FOR OTHER CHARACTERISTICS, REFER TO TYPE 7H7 | | | | | | | | | |
| 14J7 | TRIODE-HEXODE CONVERTER | 8AR | H | 12.6 | 0.15 | CONVERTER | FOR OTHER CHARACTERISTICS, REFER TO TYPE 7J7 | | | | | | | | | |
| 14N7 | TWIN-TRIODE AMPLIFIER | 8AC | H | 12.6 | 0.3 | EACH UNIT AS AMPLIFIER | FOR OTHER CHARACTERISTICS, REFER TO TYPE 7N7 | | | | | | | | | |
| 14Q7 | PENTAGRID CONVERTER | 8AL | H | 12.6 | 0.15 | CONVERTER | FOR OTHER CHARACTERISTICS, REFER TO TYPE 6SA7 | | | | | | | | | |
| 14R7 | DUPLEX-DIODE PENTODE | 8AE | H | 12.6 | 0.15 | PENTODE UNIT AS AMPLIFIER | FOR OTHER CHARACTERISTICS, REFER TO TYPE 7R7 | | | | | | | | | |
| 14S7 | TRIODE-HEPTODE CONVERTER | 8BL | H | 12.6 | 0.15 | OSCILLATOR MIXER | FOR OTHER CHARACTERISTICS, REFER TO TYPE 7S7 | | | | | | | | | |
| 14V7 | R.F. AMPLIFIER PENTODE | 8V | H | 12.6 | 0.225 | CLASS A AMPLIFIER | FOR OTHER CHARACTERISTICS, REFER TO TYPE 7V7 | | | | | | | | | |
| 14W7 | H.F. AMPLIFIER PENTODE | 8BJ | H | 12.6 | 0.225 | EXTENDED CUTOFF CLASS A AMPLIFIER | FOR OTHER CHARACTERISTICS, REFER TO TYPE 7W7 | | | | | | | | | |
| 14Y4 | FULL-WAVE RECTIFIER | 5AB | H | 12.6 | 0.3 | WITH CONDENSER INPUT FILTER | MAX. A.C. VOLTS PER PLATE (RMS), 325 | | | MAX. D.C. OUTPUT MA., 70 | | | MIN. TOTAL EFFECTIVE SUPPLY IMPEDANCE, 150 OHMS | | | |
| | | | | | | WITH CHOKE INPUT FILTER | MAX. A.C. VOLTS PER PLATE (RMS), 450 | | | MAX. D.C. OUTPUT MA., 70 | | | MINIMUM VALUE OF INPUT CHOKE, 10 HENRIES | | | |
| 14Z3 | HALF-WAVE RECTIFIER | 4G | H | 12.6 | 0.3 | RECTIFIER | FOR OTHER CHARACTERISTICS, REFER TO TYPE 12Z3 | | | | | | | | | |
| RK-15 | TRIODE POWER AMPLIFIER | 4D WITH N° 3 BLANK GRID CAP | F | 2.5 | 1.75 | AMPLIFIER | CHARACTERISTICS SAME AS TYPE 46 WITH CLASS B CONNECTIONS | | | | | | | | | |
| 15 | R.F. AMPLIFIER PENTODE | 5F | D.C. F | 2.0 | 0.22 | CLASS A AMPLIFIER | 67.5 135 | -1.5 -1.5 | 67.5 67.5 | 0.3 0.3 | 1.85 1.85 | 600000 800000 | 710 750 | 450 600 | — | — |
| RK-16 | TRIODE-POWER AMPLIFIER | 5A | H | 2.5 | 2.0 | AMPLIFIER | CHARACTERISTICS SAME AS TYPE 59 WITH CLASS A TRIODE CONNECTIONS | | | | | | | | | |
| RK-17 | PENTODE POWER AMPLIFIER | 5F | H | 2.5 | 2.0 | AMPLIFIER | FOR OTHER CHARACTERISTICS, REFER TO TYPE 2A6 | | | | | | | | | |
| 18 | POWER AMPLIFIER PENTODE | 6B | H | 14.0 | 0.3 | CLASS A AMPLIFIER | FOR OTHER CHARACTERISTICS, REFER TO TYPE 6F6 | | | | | | | | | |
| 19 | TWIN-TRIODE AMPLIFIER | 6C | D.C. F | 2.0 | 0.26 | AMPLIFIER | FOR OTHER CHARACTERISTICS, REFER TO TYPE 1J6-G | | | | | | | | | |
| 20 | POWER AMPLIFIER TRIODE | 4D | D.C. F | 3.3 | 0.132 | CLASS A AMPLIFIER | 90 135 | -16.5 -22.5 | — | — | 3.0 6.5 | 8000 6300 | 415 525 | 3.3 3.3 | 9600 6500 | 0.045 0.110 |
| 20J8 (GM) | TRIODE-HEPTODE CONVERTER | 8H | H | 20.0 | 0.15 | CONVERTER | FOR OTHER CHARACTERISTICS, REFER TO TYPE 6J8-G | | | | | | | | | |
| 21A7 | TRIODE-HEXODE CONVERTER | 8AR | H | 21.0 | 0.16 | OSCILLATOR MIXER | 150 250 | -3.0 -3.0 | VALUES FOR TRIODE VALUES FOR HEXODE | | 3.5 — | 16800 1500000 | 1900 — | CONVERSION TRANSCOND., 275 MICROMHOS | | |
| 22 | R.F. AMPLIFIER TETRODE | 4K | D.C. F | 3.3 | 0.132 | SCREEN-GRID R.F. AMPLIFIER | 135 135 | -1.5 -1.5 | 45 67.5 | 0.6 1.3 | 1.7 3.7 | | | | | |
| RK-24 | TRIODE AMPLIFIER OSCILLATOR | 4D | D.C. F | 2.0 | 0.12 | CLASS A AMPLIFIER | 160 | -13.5 | — | — | 6.0 | 5000 | 1600 | 6.0 | 12000 | 0.25 |

| TYPE | DESIGN | BASE CONN'S | CATHODE TYPE & RATING | | | USED AS | PLATE SUPPLY | GRID BIAS ② | SCREEN SUPPLY | SCREEN CURRENT | PLATE CURRENT | R _p A.C. PLATE RESISTANCE | G _m TRANSCONDUCTANCE (GRID-PLATE) | μ AMPLIFICATION FACTOR | LOAD FOR STATED POWER OUTPUT | POWER OUTPUT | |
|--------------|-------------------------------|-------------|-----------------------|-----------|-------|--|--|--|----------------|--|--|--------------------------------------|--|------------------------|------------------------------|--------------|------|
| | | | F= FILAMENT | H= HEATER | VOLTS | | | | | | | | | | | | AMP. |
| | | | TYPE | | | | | | | | | | | | | | |
| 24-A 24-S | R.F. AMPLIFIER TETRODE | 5E | H | 2.5 | 1.75 | SCREEN-GRID R.F. AMPLIFIER | 180 250 | -3.0 -3.0 | 90 90 | 1.7 1.7 | ② 4.0 4.0 | 400 000 600 000 | 1000 1050 | 400 630 | — | — | |
| | | | | | | BIAS DETECTOR | 250 ⑬ | -5.0 APPROX. | 20 TO 45 | PLATE CURRENT ADJUSTED TO 0.1 MA. WITH NO SIGNAL | | | | | | | |
| 25A6-GT/G | POWER AMPLIFIER PENTODE | 7S | H | 25.0 | 0.3 | CLASS A AMPLIFIER | 95 160 | -15.0 -18.0 | 95 120 | 4.0 6.5 | 20.0 33.0 | 45000 42000 | 2000 2375 | — | 4500 5000 | 0.9 2.2 | |
| 25A7-GT/G | RECTIFIER PENTODE | 8F | H | 25.0 | 0.3 | PENTODE UNIT AS CLASS A AMPLIFIER | 100 | -15.0 | 100 | 4.0 | 20.5 | 50000 | 1800 | — | 4500 | 0.77 | |
| 25AC5-GT/G | HIGH-μ POWER AMPLIFIER TRIODE | 6Q | H | 25.0 | 0.3 | CLASS B AMPLIFIER | 180 | 0 | — | — | 4.0 13 | — | — | — | 4800 | 6.0 | |
| | | | | | | DYNAMIC-COUPLED AMP. WITH TYPE 6A E5-GT DRIVER | 110 | BIAS FOR BOTH 25AC5-GT AND 6A E5-GT DEVELOPED IN CIRCUIT. AVERAGE PLATE CURRENT OF DRIVER, 7 MA. AVERAGE PLATE CURRENT OF 25AC5-GT, 45 MA. | | | | | | | | | |
| 25B5 | DIRECT-COUPLED TRIODES | 6D | H | 25.0 | 0.3 | CLASS A AMPLIFIER | IN. PLATE 100 | 0 | OUT. PLATE 180 | OUT. PLATE 46 | IN. PLATE 5.8 | — | — | — | 4000 | 3.8 | |
| 25B6-G | POWER AMPLIFIER PENTODE | 7S | H | 25.0 | 0.3 | CLASS A AMPLIFIER | 105 200 | -16.0 -23.0 | 105 135 | 2.0 1.8 | 48.0 62.0 | 15500 18000 | 4800 5000 | — | 1700 2500 | 2.4 7.1 | |
| 25B8-GT | TRIODE PENTODE | 8T | H | 25.0 | 0.15 | | FOR OTHER CHARACTERISTICS, REFER TO TYPE 12B8-GT | | | | | | | | | | |
| 25C6-G | BEAM POWER AMPLIFIER | 7AC | H | 25.0 | 0.3 | AMPLIFIER | FOR OTHER CHARACTERISTICS, REFER TO TYPE 6V6G | | | | | | | | | | |
| 25D8-GT | DIODE-TRIODE PENTODE | 8AF | H | 25.0 | 0.15 | TRIODE AMPLIFIER PENTODE AMPLIFIER | 100 100 | -1.0 -3.0 | — 100 | — 2.7 | 0.5 8.5 | 91000 200000 | 1100 1900 | 100 — | — — | — — | |
| 25L6-GT/G | BEAM POWER AMPLIFIER | 7AC | H | 25.0 | 0.3 | AMPLIFIER | FOR OTHER CHARACTERISTICS, REFER TO TYPE 50L6GT | | | | | | | | | | |
| 25N6(G) | DIRECT-COUPLED TRIODES | 7W | H | 25.0 | 0.3 | AMPLIFIER | FOR OTHER CHARACTERISTICS, REFER TO TYPE 25B5 | | | | | | | | | | |
| 25S/1B5 | DUPLEX-DIODE TRIODE | 6M | D.C. F | 2.0 | 0.06 | TRIODE UNIT AS AMPLIFIER | FOR OTHER CHARACTERISTICS, REFER TO TYPE 1B5/25S | | | | | | | | | | |
| 25X6-GT | FULL-WAVE RECTIFIER | 7Q | H | 25.0 | 0.15 | RECTIFIER | MAXIMUM A.C. VOLTS PER PLATE (RMS), 125 MAXIMUM D.C. OUTPUT CURRENT, 75 MA | | | | | | | | | | |
| 25Y4(GT) | HALF-WAVE RECTIFIER | 5AA | H | 25.0 | 0.15 | RECTIFIER | MAXIMUM A.C. VOLTS PER PLATE (RMS), 125 MAXIMUM D.C. OUTPUT CURRENT, 75 MA. | | | | | | | | | | |
| 25Y5 | RECTIFIER DOUBLER | 6E | H | 25.0 | 0.3 | RECTIFIER | MAXIMUM A.C. VOLTS PER PLATE (RMS), 235 MAXIMUM D.C. OUTPUT CURRENT, 75 MA. } HALF-WAVE OPERATION | | | | | | | | | | |
| 25Z3 | HALF-WAVE RECTIFIER | 4G | H | 25.0 | 0.3 | RECTIFIER | MAXIMUM A.C. VOLTS PER PLATE (RMS), 250 MAXIMUM D.C. OUTPUT CURRENT, 50 MA. | | | | | | | | | | |
| 25Z4(GT) | HALF-WAVE RECTIFIER | 5AA | H | 25.0 | 0.3 | RECTIFIER | MAXIMUM A.C. VOLTS PER PLATE (RMS), 125 MAXIMUM D.C. OUTPUT CURRENT, 126 MA. | | | | | | | | | | |
| 25Z5 | RECTIFIER DOUBLER | 6E | H | 25.0 | 0.3 | RECTIFIER DOUBLER | FOR OTHER CHARACTERISTICS, REFER TO TYPE 25Z6 | | | | | | | | | | |
| 25Z6-GT/G | RECTIFIER DOUBLER | 7Q | H | 25.0 | 0.3 | VOLTAGE DOUBLER | MAX. A.C. VOLTS PER PLATE RMS, 117 MAX. D.C. OUTPUT MA., 175 | | | | MINIMUM TOTAL EFFECTIVE PLATE SUPPLY IMPEDANCE: HALF-WAVE, 30 OHMS; FULL-WAVE, 0 OHMS | | | | | | |
| | | | | | | HALF-WAVE RECTIFIER | MAX. PLATE VOLTAGE (RMS), 235 MAX. D.C. OUTPUT MA. PER PLATE, 75 | | | | MINIMUM TOTAL EFFECTIVE SUPPLY IMPEDANCE PER PLATE: UP TO 117 V., 0 OHMS; AT 150 V., 40 OHMS; AT 235 V., 100 OHMS. | | | | | | |
| 26 | AMPLIFIER TRIODE | 4D | F | 1.5 | 1.05 | CLASS A AMPLIFIER | 90 180 | -7.0 -14.5 | — | — | 2.9 6.2 | 8900 7300 | 935 1150 | 8.3 8.3 | — | — | |

| | | | | | | | | | | | | | | | | |
|----------------------|--|-----------------------|--------|------|------|--------------------------------|--|----------------|--------------|---------------|--|-------------------|--------------|------------|----------------|----------------|
| 26A7-GT | TWIN PENTODE AMPLIFIER | 8BU EXCEPT BEAM POWER | H | 26.5 | 0.6 | EACH UNIT AS CLASS A AMPLIFIER | 26.5 | -4.5 | 26.5 | 4.0 | 20.0 | — | 5000 | — | 1500 | 0.15 |
| 27 27S (42) | DETECTOR AMPLIFIER TRIODE (1) | 5A | H | 2.5 | 1.75 | CLASS A AMPLIFIER | 135 250 | -9.0 -21.0 | — | — | 4.5 5.2 | 9000 9250 | 1000 975 | 9.0 9.0 | — | — |
| | | | | | | BIAS DETECTOR | 250 | -30.0 APPROX. | — | — | PLATE CURRENT ADJUSTED TO 0.2 MA. WITH NO SIGNAL | | | | | |
| 28D7 | TWIN BEAM POWER AMPLIFIER | 8BS | H | 28.0 | 0.4 | EACH UNIT AS CLASS A AMPLIFIER | 28 | -3.5 | 28 | 1.0 | 12.5 | 3000 | 3000 | — | 4000 | 0.1 |
| 28Z5 | FULL-WAVE RECTIFIER | 5AB | H | 28 | 0.24 | FULL-WAVE RECTIFIER | 325 VOLTS RMS MAX. PER PLATE, CONDENSER INPUT. 450 VOLTS RMS MAX. PER PLATE, CHOKE INPUT. MAXIMUM D.C. OUTPUT, 100 MA. MAXIMUM D.C. OUTPUT, 100 MA. | | | | | | | | | |
| 30 | DETECTOR AMPLIFIER TRIODE (1) | 4D | D.C. F | 2.0 | 0.06 | AMPLIFIER | FOR OTHER CHARACTERISTICS, REFER TO TYPE 1H4G | | | | | | | | | |
| 31 | POWER AMPLIFIER TRIODE | 4D | D.C. F | 2.0 | 0.13 | CLASS A AMPLIFIER | 135 180 | -22.5 -30.0 | — | — | 8.0 12.3 | 4100 3600 | 925 1050 | 3.8 3.8 | 7000 5700 | 0.185 0.375 |
| | | | | | | SCREEN-GRID R.F. AMPLIFIER | 135 180 | -3.0 -3.0 | 67.5 67.5 | | | | | | | |
| 32 | R.F. AMPLIFIER TETRODE | 4K | D.C. F | 2.0 | 0.06 | BIAS DETECTOR | 180 (17) | -6.0 APPROX. | 67.5 | — | PLATE CURRENT ADJUSTED TO 0.2 MA. WITH NO SIGNAL | | | | | |
| | | | | | | H.W. RECTIFIER | MAXIMUM A.C. PLATE VOLTS (RMS), 125. MAXIMUM D.C. OUTPUT CURRENT, 60 MA. | | | | | | | | | |
| 32L7-GT | RECTIFIER-BEAM POWER AMPLIFIER | 8Z | H | 32.5 | 0.3 | CLASS A AMPLIFIER | 110 | -7.5 | 110 | 3.0 | 40.0 | 15000 | 6000 | — | 2500 | 1.5 |
| 33 | POWER AMPLIFIER PENTODE | 5K | D.C. F | 2.0 | 0.26 | CLASS A AMPLIFIER | 180 | -18.0 | 180 | 5.0 | 22.0 | 55000 | 700 | — | 6000 | 1.4 |
| 34 | SUPER-CONTROL R.F. AMPLIFIER PENTODE | 4M | D.C. F | 2.0 | 0.06 | R.F. AMPLIFIER | 135 180 | -3.0 MIN. | 67.5 67.5 | 1.0 1.0 | 2.8 2.8 | 600000 1000000 | 360 620 | — | — | — |
| | | | | | | SCREEN-GRID R.F. AMPLIFIER | 180 250 | -3.0 MIN. | 90.0 90.0 | 2.5 2.5 | 6.3 6.3 | 300000 400000 | 1020 1050 | 305 420 | — | — |
| 35/51 (2) 35S/51S | SUPER-CONTROL R.F. AMPLIFIER TETRODE | 5E | H | 2.5 | 1.75 | SCREEN-GRID R.F. AMPLIFIER | 180 250 | -3.0 MIN. | 90.0 90.0 | 2.5 2.5 | 6.3 6.3 | 300000 400000 | 1020 1050 | 305 420 | — | — |
| 35A5(LT) | BEAM POWER AMPLIFIER | 6AT | H | 35.0 | 0.15 | CLASS A AMPLIFIER | 110 | -7.5 | 110 | 3.0 | 40.0 | 14000 | 5800 | — | 2500 | 1.5 |
| 35L6-GT/G | BEAM POWER AMPLIFIER | 7AC | H | 35.0 | 0.15 | CLASS A AMPLIFIER | FOR OTHER CHARACTERISTICS, REFER TO TYPE 35A5 | | | | | | | | | |
| 35Y4 | HALF-WAVE RECTIFIER (HEATER TAP FOR PILOT) | 5AL | H | 35.0 | 0.15 | RECTIFIER | 235 MAXIMUM A.C. VOLTS, (RMS) 60 MA. OUTPUT CURRENT WITH PANEL LAMP 235 MAXIMUM A.C. VOLTS, (RMS) 100 MA. OUTPUT CURRENT WITHOUT PANEL LAMP | | | | | | | | | |
| 35Z3(LT) | HALF-WAVE RECTIFIER | 4Z | H | 35.0 | 0.15 | WITH CONDENSER INPUT FILTER | MAX. A.C. PLATE VOLTS, (RMS) 235 MAX. D.C. OUTPUT MA., 100 | | | | MIN. TOTAL EFFECTIVE PLATE SUPPLY IMPEDANCE: UP TO 117 VOLTS, 15 OHMS; AT 150 VOLTS, 40 OHMS; AT 235 VOLTS, 100 OHMS | | | | | |
| 35Z4-GT | HALF-WAVE RECTIFIER | 5AA | H | 35.0 | 0.15 | WITH CONDENSER INPUT FILTER | MAX. A.C. PLATE VOLTS, (RMS) 250 MAX. PEAK INVERSE VOLTS, 720 (22) | | | | MAXIMUM D.C. OUTPUT MA., 100 MAXIMUM PEAK PLATE MA., 600 | | | | | |
| 35Z5-GT/G | HALF-WAVE RECTIFIER (HEATER TAP FOR PILOT) | 6AD | H | 35.0 | 0.15 | WITH CONDENSER INPUT FILTER | MAX. A.C. PLATE VOLTS, (RMS) 235. MINIMUM TOTAL EFFECTIVE PLATE SUPPLY IMPEDANCE: UP TO 117 VOLTS, 15 OHMS; AT 235 VOLTS, 100 OHMS. MAX. D.C. OUTPUT MA. WITH PILOT AND NO SHUNT RESISTOR, 60; WITH PILOT AND SHUNT RESISTOR, 90; WITHOUT PILOT, 100 | | | | | | | | | |
| 35Z6-G(GT) | RECTIFIER DOUBLER | 7Q | H | 35.0 | 0.3 | RECTIFIER DOUBLER | MAXIMUM A.C. VOLTS PER PLATE (RMS), 235 MAXIMUM D.C. OUTPUT MA., 110 | | | | | | | | | |
| 36 | R.F. AMPLIFIER PENTODE | 5E | H | 6.3 | 0.3 | SCREEN-GRID R.F. AMPLIFIER | 100 250 | -1.5 -3.0 | 55 90 | — 1.7 (27) | 1.8 3.2 | 550000 550000 | 850 1080 | 470 595 | — | — |
| | | | | | | BIAS DETECTOR | 100 250 (16) | -5.0 -8.0 | 55 90 | — | GRID BIAS VALUES ARE APPROXIMATE. PLATE CURRENT ADJUSTED TO 0.2 MA. WITH NO SIGNAL | | | | | |
| 37 | DETECTOR AMPLIFIER TRIODE (1) | 5A | H | 6.3 | 0.3 | CLASS A AMPLIFIER | 90 250 | -6.0 -18.0 | — | — | 2.5 7.5 | 11500 8400 | 800 1100 | 9.2 9.2 | — | — |
| | | | | | | BIAS DETECTOR | 90 250 | -10.0 -28.0 | — | — | GRID BIAS VALUES ARE APPROXIMATE. PLATE CURRENT ADJUSTED TO 0.2 MA. WITH NO SIGNAL | | | | | |
| 38 | POWER AMPLIFIER PENTODE | 5F | H | 6.3 | 0.3 | CLASS A AMPLIFIER | 100 250 | -9.0 -25.0 | 100 250 | 1.2 3.8 | 7.0 22.0 | 140000 100000 | 875 1200 | — | 15000 10000 | 0.27 2.50 |

| TYPE | DESIGN | BASE CONNS | CATHODE TYPE & RATING | | | USED AS | PLATE SUPPLY | GRID BIAS ② | SCREEN SUPPLY | SCREEN CURRENT | PLATE CURRENT | R _p A.C. PLATE RESISTANCE | G _m TRANSCONDUCTANCE (GRID-PLATE) | μ AMPLIFICATION FACTOR | LOAD FOR STATED POWER OUTPUT | POWER OUTPUT | |
|-----------------|--|------------|-----------------------|----------|-------|---|---|---|--------------------------|----------------|--|--|--|--|--|-------------------|----------------|
| | | | F=FILAMENT | H=HEATER | VOLTS | | | | | | | | | | | | AMP. |
| | | | TYPE | | | | | | | | | | | | | | |
| | | | | | | VOLTS | VOLTS | VOLTS | MILLIAMPS. | MILLIAMPS. | OHMS | μMHQS | | OHMS | WATTS | | |
| 39/44 | SUPER-CONTROL R.F. AMPLIFIER PENTODE | 5F | H | 6.3 | 0.3 | CLASS A AMPLIFIER | 90 250 | -3.0 MIN. | 90 90 | 1.6 1.4 | 5.6 5.8 | 375000 1000000 | 960 1050 | 360 1050 | — | — | |
| 40 | VOLTAGE AMPLIFIER TRIODE | 4D | D.C. F | 5.0 | 0.25 | CLASS A AMPLIFIER | 135 180 ⑩ | -1.5 -3.0 | — | — | 0.2 0.2 | 150000 150000 | 200 200 | 30 30 | — | — | |
| 40Z5/ 40Z5GT | HALF-WAVE RECTIFIER (HEATER TAP FOR PILOT) | 6AD | H | 45.0 | 0.15 | RECTIFIER | FOR OTHER CHARACTERISTICS, REFER TO TYPE 45Z5GT | | | | | | | | | | |
| 41 | POWER AMPLIFIER PENTODE | 6B | H | 6.3 | 0.4 | AMPLIFIER | FOR OTHER CHARACTERISTICS, REFER TO TYPE 6K6-G | | | | | | | | | | |
| RK42 | TRIODE AMPLIFIER PENTODE | 4D | D.C. F | 1.5 | 0.06 | AMPLIFIER | FOR OTHER CHARACTERISTICS, REFER TO TYPE 1H4-G | | | | | | | | | | |
| 42 | POWER AMPLIFIER PENTODE | 6B | H | 6.3 | 0.7 | AMPLIFIER | FOR OTHER CHARACTERISTICS, REFER TO TYPE 6F6 | | | | | | | | | | |
| RK43 | TWIN-TRIODE POWER AMPLIFIER OSCILLATOR | 6C | D.C. F | 1.5 | 0.12 | CLASS A AMPLIFIER | 135 | -4.5 | — | — | 3.0 | 14500 | 90D | 13 | VALUES FOR ONE TRIODE | | |
| | | | | | | CLASS B AMPLIFIER | 135 | -6.0 | — | — | 4.0 | — | — | — | 24000 | 0.95 | ③ |
| | | | | | | R.F. AMPLIFIER | 135 | -20.0 | D.C. GRID CURRENT, 3 MA. | 14.0 | — | — | — | — | — | — | — |
| 43 | POWER AMPLIFIER PENTODE | 6B | H | 25.0 | 0.3 | AMPLIFIER | FOR OTHER CHARACTERISTICS, REFER TO TYPE 25A6 | | | | | | | | | | |
| 44 | SUPER-CONTROL R.F. AMPLIFIER PENTODE | 5F | H | 6.3 | 0.3 | CLASS A AMPLIFIER | FOR OTHER CHARACTERISTICS, REFER TO TYPE 39/44 | | | | | | | | | | |
| 45 | POWER AMPLIFIER TRIODE | 4D | F | 2.5 | 1.5 | CLASS A AMPLIFIER | 180 275 | -31.5 -56.0 | — | — | 31.0 36.0 | 1650 1700 | 2125 2050 | 3.5 3.5 | 2700 4600 | 0.82 2.0 | |
| | | | | | | PUSH-PULL CLASS AB ₂ AMPLIFIER | 275 275 | CATHODE BIAS, 775 OHMS -68.0 VOLTS, FIXED BIAS ⑬ | | | 36.0 28.0 ⑬ | — | — | — | — | 5060 3200 | 12.0 18.0 ⑭ |
| | | | | | | | | | | | | MAX. A.C. PLATE VOLTAGE (RMS), 117 VOLTS MAX. PEAK INVERSE VOLTAGE, 350 VOLTS | | | MAX. D.C. OUTPUT MA, 65 MAX. PEAK PLATE MA, 390 | | |
| 45Z3 | HALF-WAVE RECTIFIER | 5AM | H | 45.0 | 0.075 | WITH-CONDENSER INPUT FILTER | | | | | MAX. D.C. OUTPUT MA, 65 MAX. PEAK PLATE MA, 390 | | | MIN. TOTAL EFFECTIVE SUPPLY IMPEDANCE, 15 OHMS | | | |
| 45Z5-GT | HALF-WAVE RECTIFIER (HEATER TAP FOR PILOT) | 6AD | H | 45.0 | 0.15 | WITHOUT PILOT | MAX. A.C. PLATE VOLTS (RMS), 250 ② | | | | MAX. PEAK PLATE MA, 600 | | | MAX. D.C. OUTPUT MA., 100 | | | |
| | | | | | | WITH PILOT | MAX. A.C. PLATE VOLTS (RMS), 250 ② | | | | MAX. D.C. OUTPUT MA., 60 | | | | | | |
| 46 | DUAL-GRID POWER AMPLIFIER | 5C | F | 2.5 | 1.75 | CLASS A AMPLIFIER ⑰ | 250 | -33.0 | — | — | 22.0 | 2380 | 2350 | 5.6 | 6400 | 1.25 | |
| | | | | | | CLASS B AMPLIFIER ⑱ | 300 400 | 0 0 | — | — | 8.0 12.0 ⑬ | — | — | — | 5200 5800 | 16.0 20.0 ⑭ | |
| 47 | POWER AMPLIFIER PENTODE | 5B | F | 2.5 | 1.75 | CLASS A AMPLIFIER | 250 | -16.5 | 250 | 6.0 | 31.0 | 60000 | 2500 | 150 | 7000 | 2.7 | |
| 48 | POWER AMPLIFIER PENTODE | 6A | D.C. H | 30.0 | 0.4 | TETRODE CLASS A AMPLIFIER | 96 125 | -19.0 -20.0 | 96 100 | 9.0 9.5 | 52.0 56.0 | — | 3890 3900 | — | 1500 1500 | 2.0 2.5 | |
| | | | | | | TETRODE PUSH-PULL CLASS A AMPLIFIER | 125 | -20.0 | 100 | — | 100 ⑬ | — | — | — | 3000 | 5.0 ⑭ | |
| 49 | DUAL-GRID POWER AMPLIFIER | 5C | D.C. F | 2.0 | 0.12 | CLASS A AMPLIFIER ⑰ | 135 | -20.0 | — | — | 6.0 | 4175 | 1125 | 4.7 | 11000 | 0.17 | |
| | | | | | | CLASS B AMPLIFIER ⑱ | 180 | 0 | — | — | 4.0 ⑬ | — | — | — | 12000 | 3.5 ⑭ | |
| EF-50 | HIGH FREQUENCY PENTODE AMPLIF. | FIG. 8 | H | 6.3 | 0.3 | R.F. AMPLIFIER | 250 | 150 OHMS | 250 | 3.1 | 10.0 | 600000 | 6300 | — | — | — | |
| 50 | POWER AMPLIFIER TRIODE | 4D | F | 7.5 | 1.25 | CLASS A AMPLIFIER | 300 400 450 | -54.0 -70.0 -84.0 | — | — | 35.0 55.0 55.0 | 2000 1800 1800 | 1900 2100 2100 | 3.8 3.8 3.8 | 4600 3670 4350 | 1.6 3.4 4.6 | |

| | | | | | | | | | | | | | | | | |
|-----------|---|--------------|--------|-------|------|----------------------------------|--|--------------|------------|------------|--|----------------|--------------|-----|--------------|-------------------|
| 50A5 | BEAM POWER AMPLIFIER | 6AA | H | 50.0 | 0.15 | CLASS A AMPLIFIER | 200 | -8.0 | 110 | 1.5 | 50.0 | 35000 | 8250 | — | 3000 | 4.7 |
| 50C6-G | BEAM POWER AMPLIFIER | 7AC | H | 50.0 | 0.15 | AMPLIFIER | FOR OTHER CHARACTERISTICS, REFER TO TYPE 6Y6-G | | | | | | | | | |
| 50L6(GT) | BEAM POWER AMPLIFIER | 7AC | H | 50.0 | 0.15 | CLASS A AMPLIFIER | 110 110 | -7.5 -7.5 | 110 110 | 4.0 4.0 | 49.0 49.0 | 10000 10000 | 8200 8200 | — | 1500 2000 | 2.1 2.2 |
| 50Y6-GT/G | RECTIFIER DOUBLER | 7Q | H | 50.0 | 0.3 | VOLTAGE DOUBLER | MAX. A.C. VOLTS PER PLATE (RMS), 117 MAX. D.C. OUTPUT MA., 75 | | | | MIN. TOTAL EFFECTIVE PLATE SUPPLY IMPEDANCE: HALF-WAVE, 30 OHMS; FULL WAVE, 15 OHMS | | | | | |
| | | | | | | HALF-WAVE RECTIFIER | MAX. PLATE VOLTAGE (RMS), 235 MAX. D.C. OUTPUT MA. PER PLATE, 75 | | | | MIN. TOTAL EFFECTIVE SUPPLY IMPEDANCE PER PLATE: UP TO 117 V, 15 OHMS; AT 150 V, 40 OHMS; AT 235 V, 100 OHMS | | | | | |
| 50Z6-G | FULL-WAVE RECTIFIER | 7Q | H | 50.0 | 0.3 | RECTIFIER | MAXIMUM A.C. PLATE VOLTS (RMS), 250 MAXIMUM D.C. OUTPUT MA., 250 | | | | | | | | | |
| 50Z7-G | RECTIFIER DOUBLER | 8AN | H | 50.0 | 0.15 | RECTIFIER DOUBLER | MAXIMUM A.C. PLATE VOLTS (RMS), 117. MAXIMUM D.C. OUTPUT CURRENT WHEN USED WITH 2.9 VOLTS 0.17 AMP. PANEL LAMP, 65 MA. | | | | | | | | | |
| 51 51S | SUPER-CONTROL R.F. AMPLIFIER TETRODE | 5E | H | 2.5 | 1.75 | SCREEN-GRID R.F. AMPLIFIER | FOR OTHER CHARACTERISTICS, REFER TO TYPES 35/51, 35S/51S | | | | | | | | | |
| 52 | DUAL-GRID POWER AMPLIFIER | 5C | F | 6.3 | 0.3 | CLASS A AMP. (21) | 110 | 0 | — | — | 43.0 | 1750 | 3000 | 5.2 | 2000 | 1.5 |
| | | | | | | CLASS B AMP. (23) | 180 | 0 | — | — | 3.0 (13) | — | — | — | 10000 | 5.0 (12) |
| 53 | TWIN-TRIODE AMPLIFIER | 7B | H | 2.5 | 2.0 | AMPLIFIER | FOR OTHER CHARACTERISTICS, REFER TO TYPE 6N7 | | | | | | | | | |
| M-54 | TETRODE POWER AMPLIFIER | TINNED LEADS | D.C. F | 0.825 | 0.04 | AMPLIFIER | 45 | -4.0 | 45 | 0.1 | 0.8 | 13000 | — | — | 35000 | 0.005 |
| 55 55S | DUPLEX-DIODE TRIODE | 6G | H | 2.5 | 1.0 | TRIODE UNIT AS AMPLIFIER | FOR OTHER CHARACTERISTICS, REFER TO TYPE 85 | | | | | | | | | |
| 56 56S | DETECTOR AMPLIFIER TRIODE (1) | 5A | H | 2.5 | 1.0 | DETECTOR AMPLIFIER | FOR OTHER CHARACTERISTICS, REFER TO TYPE 6P5-G | | | | | | | | | |
| 56AS | DETECTOR AMPLIFIER TRIODE | 5A | H | 6.3 | 0.3 | DETECTOR AMPLIFIER | FOR OTHER CHARACTERISTICS, REFER TO TYPE 6P5-G | | | | | | | | | |
| 57 57S | TRIPLE-GRID DETECTOR AMPLIFIER | 6F | H | 2.5 | 1.0 | DETECTOR AMPLIFIER | FOR OTHER CHARACTERISTICS, REFER TO TYPE 6J7 | | | | | | | | | |
| 57AS | TRIPLE-GRID DETECTOR AMPLIFIER | 6F | H | 6.3 | 0.4 | DETECTOR AMPLIFIER | FOR OTHER CHARACTERISTICS, REFER TO TYPE 6J7 | | | | | | | | | |
| 58 58S | TRIPLE-GRID SUPER-CONTROL AMPLIFIER | 6F | H | 2.5 | 1.0 | AMPLIFIER MIXER | FOR OTHER CHARACTERISTICS, REFER TO TYPE 6U7-G | | | | | | | | | |
| 58AS | TRIPLE-GRID SUPER-CONTROL AMPLIFIER | 6F | H | 6.3 | 0.4 | AMPLIFIER MIXER | FOR OTHER CHARACTERISTICS, REFER TO TYPE 6U7-G | | | | | | | | | |
| 59 | TRIPLE-GRID POWER AMPLIFIER | 7A | H | 2.5 | 2.0 | TRIODE (6) CLASS A AMPLIFIER | 250 | -28.0 | — | — | 28.0 | 2300 | 2800 | 6.0 | 5000 | 1.25 |
| | | | | | | PENTODE (5) CLASS A AMPLIFIER | 250 | -18.0 | 250 | 9.0 | 35.0 | 40000 | 2500 | — | 6000 | 3.0 |
| | | | | | | TRIODE (7) CLASS B AMPLIFIER | 300 400 | 0 0 | — | — | 20.0 26.0 (13) | — | — | — | 4600 6000 | 15.0 20.0 (12) |
| M-64 | TETRODE VOLTAGE AMP. | TINNED LEADS | F | 0.825 | 0.02 | CLASS A AMPLIFIER | 30 | 0 | — | — | 0.03 | 200000 | 110 | 25 | — | — |
| 70A7-GT | RECTIFIER-BEAM POWER AMPLIFIER (HEATER TAP FOR PILOT) | 8AB | H | 70.0 | 0.15 | HALF-WAVE RECT. | MAXIMUM A.C. PLATE VOLTS (RMS), 125. MAX. D.C. OUTPUT CURRENT, 60 MA. | | | | | | | | | |
| | | | | | | CLASS A AMPLIFIER | 110 | -7.5 | 110 | 3.0 | 40.0 | — | 5800 | 80 | 2500 | 1.5 |
| 70L7-GT | RECTIFIER-BEAM POWER AMPLIFIER | 8AA | H | 70.0 | 0.15 | HALF-WAVE RECT. | MAXIMUM A.C. PLATE VOLTS (RMS), 125. MAX. D.C. OUTPUT CURRENT, 70 MA. | | | | | | | | | |
| | | | | | | CLASS A AMPLIFIER | 110 | -7.5 | 110 | 3.0 | 43.0 | 15000 | 7500 | — | 2000 | 1.8 |

| TYPE | DESIGN | BASE CONN'S | CATHODE TYPE & RATING | | | USED AS | PLATE SUPPLY | GRID BIAS ② | SCREEN SUPPLY | SCREEN CURRENT | PLATE CURRENT | R _p A.C. PLATE RESISTANCE | G _m TRANSCONDUCTANCE (GRID-PLATE) | J _J AMPLIFICATION FACTOR | LOAD FOR STATED POWER OUTPUT | POWER OUTPUT |
|-------------|-------------------------------------|--------------|-----------------------|-------|-------|-----------------------------------|---|----------------|---------------|--------------------------|--|--|--|-------------------------------------|------------------------------|----------------|
| | | | F=FILAMENT H=HEATER | TYPE | VOLTS | | | | | | | | | | | |
| 71-A | POWER AMPLIFIER TRIODE | 4D | F | 5.0 | 0.25 | CLASS A AMPLIFIER | 90 180 | -16.5 -40.0 | — | — | 10.0 20.0 | 2170 1750 | 1400 1700 | 3.0 3.0 | 3000 4800 | 0.125 0.790 |
| M-74 | TETRODE VOLTAGE AMPLIFIER | TINNED LEADS | F | 0.625 | 0.02 | CLASS A AMPLIFIER | 30 | 0 | 7.0 | 0.01 | 0.02 | 500 000 | 125 | 70.0 | — | — |
| 75 75S ④ | DUPLEX-DIODE HIGH-MU TRIODE | 6G | H | 6.3 | 0.3 | AMPLIFIER | FOR OTHER CHARACTERISTICS, REFER TO TYPE 65Q7 | | | | | | | | | |
| 76 | DETECTOR AMPLIFIER TRIODE ① | 5A | H | 6.3 | 0.3 | AMPLIFIER DETECTOR | FOR OTHER CHARACTERISTICS, REFER TO TYPE 6P5-G | | | | | | | | | |
| 77 | TRIPLE-GRID DETECTOR AMPLIFIER | 6F | H | 6.3 | 0.3 | CLASS A AMPLIFIER | 100 250 | -1.5 -3.0 | 60 100 | 0.4 0.5 | 1.7 2.3 | 800 000 1 000 000+ | 1100 1250 | — | — | — |
| | | | | | | BIAS DETECTOR | 250 | -1.95 | 50 | CATHODE CURRENT 0.65 MA. | | — | PLATE RESISTOR, 250 000 OHMS GRID RESISTOR, ⑩, 250 000 OHMS | | | |
| 78 | TRIPLE-GRID SUPER-CONTROL AMPLIFIER | 6F | H | 6.3 | 0.3 | AMPLIFIER MIXER | FOR OTHER CHARACTERISTICS, REFER TO TYPE 6K7 | | | | | | | | | |
| 79 | TWIN-TRIODE AMPLIFIER | 6H | H | 6.3 | 0.6 | CLASS B AMPLIFIER | 180 250 | 0 0 | — | — | 7.6 10.6 | POWER OUTPUT IS FOR ONE TUBE AT STATED PLATE-TO-PLATE LOAD | | | 7000 14 000 | 5.5 8.0 |
| 80 | FULL-WAVE RECTIFIER | 4C | F | 5.0 | 2.0 | RECTIFIER | FOR OTHER CHARACTERISTICS, REFER TO TYPE 5Y3-GT/G | | | | | | | | | |
| 81 | HALF-WAVE RECTIFIER | 4B | F | 7.5 | 1.25 | WITH CONDENSER INPUT FILTER | MAX. A.C. PLATE VOLTS (RMS), 700 MAX. PEAK INVERSE VOLTS, 2000 | | | | MAXIMUM D.C. OUTPUT MA., 85 MAXIMUM PEAK PLATE MA., 500 | | | | | |
| 82 | FULL-WAVE RECTIFIER ④ | 4C | F | 2.5 | 3.0 | WITH CONDENSER INPUT FILTER | MAX. A.C. VOLTS PER PLATE (RMS), 450 MAX. PEAK INVERSE VOLTS, 1550 | | | | MAX. D.C. OUTPUT MA., 115 MAX. PEAK PLATE MA., 345 | | MIN. TOTAL EFFECTIVE SUPPLY IMPEDANCE PER PLATE, 50 OHMS | | | |
| | | | | | | WITH CHOKE INPUT FILTER | MAX. A.C. VOLTS PER PLATE (RMS), 550 MAX. PEAK INVERSE VOLTS, 1550 | | | | MAX. D.C. OUTPUT MA., 115 MAX. PEAK PLATE MA., 345 | | MIN. VALUE OF INPUT CHOKE, 6 HENRIES | | | |
| 83 | FULL-WAVE RECTIFIER ④ | 4C | F | 5.0 | 3.0 | WITH CONDENSER INPUT FILTER | MAX. A.C. VOLTS PER PLATE (RMS), 450 MAX. PEAK INVERSE VOLTS, 1550 | | | | MAX. D.C. OUTPUT MA., 225 MAX. PEAK PLATE MA., 675 | | MIN. TOTAL EFFECTIVE SUPPLY IMPEDANCE PER PLATE, 50 OHMS | | | |
| | | | | | | WITH CHOKE INPUT FILTER | MAX. A.C. VOLTS PER PLATE (RMS), 550 MAX. PEAK INVERSE VOLTS, 1550 | | | | MAX. D.C. OUTPUT MA., 225 MAX. PEAK PLATE MA., 675 | | MIN. VALUE OF INPUT CHOKE, 3 HENRIES | | | |
| 83-V | FULL-WAVE RECTIFIER | 4L | H | 5.0 | 2.0 | RECTIFIER | FOR OTHER CHARACTERISTICS, REFER TO TYPE 5V4-G | | | | | | | | | |
| G-84 | HALF-WAVE RECTIFIER | 4B | F | 2.5 | 1.5 | RECTIFIER | FOR OTHER CHARACTERISTICS, REFER TO TYPE 2Z2/G84 | | | | | | | | | |
| 84/6Z4 | FULL-WAVE RECTIFIER | 5D | H | 6.3 | 0.5 | WITH CONDENSER INPUT FILTER | MAX. A.C. VOLTS PER PLATE (RMS), 325 MAX. PEAK INVERSE VOLTS, 1250 | | | | MAX. D.C. OUTPUT MA., 60 MAX. PEAK PLATE MA., 180 | | MIN. TOTAL EFFECTIVE SUPPLY IMPEDANCE PER PLATE, 65 OHMS | | | |
| | | | | | | WITH CHOKE INPUT FILTER | MAX. A.C. VOLTS PER PLATE (RMS), 450 MAX. PEAK INVERSE VOLTS, 1250 | | | | MAX. D.C. OUTPUT MA., 60 MAX. PEAK PLATE MA., 180 | | MIN. VALUE OF INPUT CHOKE, 10 HENRIES | | | |
| 85 85S ④ | DUPLEX-DIODE TRIODE | 6G | H | 6.3 | 0.3 | TRIODE UNIT AS CLASS A AMPLIFIER | 135 250 | -10.5 -20.0 | — | — | 3.7 8.0 | 11 000 7 500 | 750 1 100 | 8.3 8.3 | 25 000 20 000 | 0.075 0.350 |
| 85AS ④ | DUPLEX-DIODE TRIODE | 6G | H | 6.3 | 0.3 | TRIODE UNIT AS CLASS A AMPLIFIER | 250 | -9.0 | — | — | 5.5 | — | 1250 | 20.0 | — | — |
| 89 | TRIPLE-GRID POWER AMPLIFIER | 6F | H | 6.3 | 0.4 | AS TRIODE ⑥ CLASS A AMPLIFIER | 160 250 | -20.0 -31.0 | — | — | 17.0 32.0 | 3300 2600 | 1425 1800 | 4.7 4.7 | 7000 5500 | 0.30 0.90 |
| | | | | | | AS PENTODE ④ CLASS A AMPLIFIER | 100 250 | -1.0 -25.0 | 100 250 | 1.6 5.5 | 9.5 32.0 | 104 000 70 000 | 1200 1800 | — | 10700 6750 | 0.33 3.40 |
| | | | | | | AS TRIODE ⑦ CLASS B AMPLIFIER | 180 | 0 | — | — | 6.0 ⑬ | — | — | — | 13600 9400 | 2.5 3.5 ⑭ |

| | | | | | | | | | | | | | | | | | | | | |
|----------------------|-----------------------------------|----------------------|-----------|-------|-------|--|---|--------------------------------|----------|------------|---|------------------|---|------------|----------------|-----------------|--|--|--|--|
| V-99 99, X-99 | DETECTOR AMPLIFIER TRIODE ① | 4E 4D | D.C. F | 3.3 | 0.063 | CLASS A AMPLIFIER | 90 | -4.5 | — | — | 2.5 | 15500 | 425 | 6.6 | — | — | | | | |
| 101 D | DETECTOR AMPLIFIER TRIODE | FIG. 7 | D.C. F | 4.2 | 1.0 | CLASS A AMPLIFIER | 135 | -9.0 | — | — | 9.0 | — | 1070 | 6.0 | — | — | | | | |
| 101 F | DETECTOR AMPLIFIER TRIODE | FIG. 7 | D.C. F | 4.0 | 0.505 | CLASS A AMPLIFIER | 130 | -8.0 | — | — | 7.0 | 6010 | 1095 | 6.5 | — | — | | | | |
| 112-A | DETECTOR AMPLIFIER TRIODE ① | 4D | D.C. F | 5.0 | 0.25 | CLASS A AMPLIFIER | 90 180 | -4.5 -13.5 | — | — | 5.0 7.7 | 5400 4700 | 1575 1800 | 8.5 8.5 | 5000 10650 | 0.035 0.265 | | | | |
| HY-113/ HY-123 | MINIATURE TRIODE | 5K WITH NO SCREEN | D.C. F | 1.4 | 0.07 | OSCILLATOR DETECTOR | 45 | -4.5 | — | — | 0.4 | 25000 | 250 | 6.3 | — | — | | | | |
| HY-114 | TRIODE | SPECIAL | D.C. F | 1.4 | 0.12 | UHF OSCILLATOR DETECTOR AMPLIFIER | 180 | OSCILLATOR GRID CURRENT, 3 MA. | | | 15.0 | 20000 | 1000 | 20 | — | — | | | | |
| HY-115 HY-145 | MINIATURE PENTODE | 5K | D.C. F | 1.4 | 0.07 | VOLTAGE AMP. | 45 | -1.5 | 22.5 | 0.008 | 0.03 | 5200000 | 58 | 300 | — | — | | | | |
| 117L7-GT 117M7-GT | RECTIFIER-BEAM POWER AMPLIFIER | 8A0 | H | 117.0 | 0.09 | HALF-WAVE RECT. CLASS A AMPLIFIER | MAX. A.C. PLATE VOLTS (RMS), 117 | | | | MAX. D.C. OUTPUT CURRENT, 75 MA. | | | | | | | | | |
| | | | | | | | 105 | -5.2 | 105 | 4.0 | 43.0 | 17000 | 5300 | — | 4000 | 0.85 | | | | |
| 117N7-GT | RECTIFIER-BEAM POWER AMPLIFIER | 8AV | H | 117.0 | 0.09 | HALF-WAVE RECT. CLASS A AMPLIFIER | MAX. A.C. PLATE VOLTS (RMS), 117 | | | | MAX. D.C. OUTPUT CURRENT, 75 MA. | | | | | | | | | |
| | | | | | | | 100 | -6.0 | 100 | 5.0 | 51.0 | 16000 | 7000 | — | 3000 | 1.2 | | | | |
| 117P7-GT | RECTIFIER-BEAM POWER AMPLIFIER | 8AV | H | 117.0 | 0.09 | HALF-WAVE RECT. CLASS A AMPLIFIER | FOR OTHER CHARACTERISTICS, REFER TO TYPE 117L7-GT/117M7-GT | | | | | | | | | | | | | |
| 117Z4-GT | HALF-WAVE RECTIFIER | 5AA | H | 117.0 | 0.04 | RECTIFIER | MAX. A.C. PLATE VOLTS (RMS), 117 MAX. D.C. OUTPUT MA., 350 | | | | MAX. D.C. OUTPUT MA., 90 MAX. PEAK PLATE MA., 450 | | MIN. TOTAL EFFECTIVE SUPPLY IMPEDANCE, 30 OHMS | | | | | | | |
| 117Z6-GT/G | RECTIFIER DOUBLER | 7Q | H | 117.0 | 0.075 | VOLTAGE DOUBLER HALF-WAVE RECTIFIER | MAX. A.C. PLATE VOLTS (RMS), 117 MAX. D.C. OUTPUT MA., 60 | | | | MIN. TOTAL EFFECTIVE POWER SUPPLY IMPEDANCE: HALF- WAVE, 30 OHMS; FULL-WAVE, 15 OHMS | | | | | | | | | |
| | | | | | | | MAX. A.C. PLATE VOLTS (RMS), 235 MAX. D.C. OUTPUT MA., PER PLATE, 60 | | | | | | | | | | MIN. TOTAL EFFECTIVE POWER SUPPLY IMPEDANCE PER PLATE: UP TO 117V, 15 OHMS; AT 150V, 40 OHMS; AT 235V, 100 OHMS | | | |
| HY-123 | MINIATURE TRIODE | 5K WITH NO SCREEN | D.C. F | 1.4 | 0.07 | OSCILLATOR DETECTOR | FOR OTHER CHARACTERISTICS, REFER TO TYPE HY-113/HY-123 | | | | | | | | | | | | | |
| HY-125/ HY-155 | PENTODE POWER AMPLIFIER ③ | 5K | D.C. F | 1.4 | 0.07 | CLASS A AMPLIFIER | 45 90 | -3.0 -7.5 | 45 90 | 0.2 0.5 | 0.9 2.6 | 825000 420000 | 310 450 | 255 190 | 50000 28000 | 0.0115 0.090 | | | | |
| HY-145 | MINIATURE PENTODE ③ | 5K | D.C. F | 1.4 | 0.07 | VOLTAGE AMP. | FOR OTHER CHARACTERISTICS, REFER TO TYPE HY-115/HY-145 | | | | | | | | | | | | | |
| HY-155 | PENTODE POWER AMPLIFIER ③ | 5K | D.C. F | 1.4 | 0.07 | CLASS A AMPLIFIER | FOR OTHER CHARACTERISTICS, REFER TO TYPE HY-125/HY-155 | | | | | | | | | | | | | |
| 182-B/ 482-B | TRIODE AMPLIFIER | 4D | D.C. F | 5.0 | 1.25 | CLASS A AMPLIFIER | 250 | -35.0 | — | — | 18.0 | — | 1500 | 5.0 | — | — | | | | |
| 183/ 483 | POWER TRIODE | 4D | D.C. F | 5.0 | 1.25 | CLASS A AMPLIFIER | 250 | -60.0 | — | — | 25.0 | 18000 | 1800 | 3.2 | 4500 | 2.0 | | | | |
| HY-245 | PENTODE ③ VOLTAGE AMP. | HY-245 HY-255 | D.C. F | 1.25 | 0.028 | CLASS A AMPLIFIER | 45 | 0 | 45 | 0.2 | 0.4 | 1000000 | 375 | — | — | — | | | | |
| HY-255 | PENTODE ③ POWER AMPLIFIER | HY-245 HY-255 | D.C. F | 1.25 | 0.028 | CLASS A AMPLIFIER | 45 | -1.5 | 45 | 0.35 | 1.1 | — | 450 | — | — | — | | | | |
| 446 A 446 B | "LIGHTHOUSE" UHF TRIODE | FIG. 11 | H | 6.3 | 0.75 | OSCILLATOR AMPLIFIER CONVERTER | 250 | 200 Ω | — | — | 15.0 | — | 4500 | 45.0 | — | — | | | | |
| 464 A | "LIGHTHOUSE" UHF TRIODE | FIG. 9 | H | 6.3 | 0.75 | CLASS A AMPLIFIER | 250 | 100 Ω | — | — | 25.0 | — | 7000 | — | — | — | | | | |
| 482 B | TRIODE AMPLIFIER | 4D | D.C. | 5.0 | 1.25 | CLASS A AMPLIFIER | FOR OTHER CHARACTERISTICS, REFER TO TYPE 182 B/482 B | | | | | | | | | | | | | |

| TYPE | DESIGN | BASE CONNS | CATHODE TYPE & RATING | | | USED AS | PLATE SUPPLY VOLTS | GRID BIAS ② VOLTS | SCREEN SUPPLY VOLTS | SCREEN CURRENT MILLIAMPS | PLATE CURRENT MILLIAMPS | R _p A.C. PLATE RESISTANCE OHMS | G _m TRANSCONDUCTANCE UMHOS | μ AMPLIFICATION FACTOR | LOAD FOR STATED POWER OUTPUT OHMS | POWER OUTPUT WATTS | |
|--------------------|----------------------------------|------------|-----------------------|--------|-------------------|-----------------------------------|---|--------------------------------|---------------------|--------------------------|-------------------------|---|---------------------------------------|------------------------|-----------------------------------|--------------------|-----------------|
| | | | FILAMENT HEATER | | CLASS A AMPLIFIER | | | | | | | | | | | | |
| | | | TYPE | VOLTS | | | | | | | | | | | | | AMP. |
| 483 | POWER TRIODE | 4D | D.C. F | 5.0 | 1.25 | CLASS A AMPLIFIER | FOR OTHER CHARACTERISTICS, REFER TO TYPE 183/483 | | | | | | | | | | |
| 485 | TRIODE | 5A | H | 3.0 | 1.3 | CLASS A AMPLIFIER | 180 | -9.0 | — | — | 6.0 | 9300 | 1350 | 12.5 | — | — | |
| CK-501 CK-501-X | MINIATURE PENTODE | ⑤1 | TINNED LEADS | D.C. F | 1.25 | 0.033 | CLASS A AMPLIFIER | 30 45 | 0 -1.25 | 30 45 | 0.06 0.055 | 0.3 0.28 | 1000 000 1500 000 | 325 300 | — | — | |
| CK-502-AX | MINIATURE PENTODE | ⑤1 | TINNED LEADS | D.C. F | 1.25 | 0.030 | POWER OUTPUT | 45 | -1.5 | 45 | 0.11 | 0.45 | 250 000 | 500 | — | 100 000 | 0.006 |
| CK-502 CK-502-X | MINIATURE PENTODE | ⑤1 | TINNED LEADS | D.C. F | 1.25 | 0.033 | A.F. OUTPUT AMPLIFIER ③ | 30 45 | 0 -1.25 | 30 45 | 0.06 0.06 | 0.55 0.6 | 500 000 700 000 | 400 500 | — | 60 000 80 000 | 0.0035 0.011 |
| CK-503-AX | MINIATURE PENTODE | ⑤1 | TINNED LEADS | D.C. F | 1.25 | 0.03 | POWER OUTPUT | 45 | -2.5 | 45 | 0.18 | 0.5 | 400 000 | 475 | — | 50 000 | 0.010 |
| CK-503 CK-503-X | MINIATURE PENTODE | ⑤1 | TINNED LEADS | D.C. F | 1.25 | 0.033 | A.F. OUTPUT AMPLIFIER ③ | 30 | 0 | 30 | 0.35 | 1.5 | 150 000 | 600 | — | 20 000 | 0.007 |
| CK-504 CK-504-X | MINIATURE PENTODE | ⑤1 | TINNED LEADS | D.C. F | 1.25 | 0.033 | A.F. OUTPUT AMPLIFIER ③ | 30 | 0 | 30 | 0.09 | 0.4 | 500 000 | 350 | — | 60 000 | 0.0045 |
| CK-505-AX | MINIATURE PENTODE | ⑤1 | TINNED LEADS | D.C. F | 0.625 | 0.03 | VOLTAGE AMPLIFIER | 30 | 0 | 30 | 0.07 | 0.2 | 500 000 | 180 | VOLT. GAIN 35 | 1 000 000 | — |
| CK-505 CK-505-X | MINIATURE PENTODE | ⑤1 | TINNED LEADS | D.C. F | 0.625 | 0.03 | IMPED. COUPLED VOLTAGE AMP. RESIST. COUPLED VOLTAGE AMP. | 30 45 | 0 -1.25 | 30 40 | 0.07 0.08 | 0.17 0.2 | 1 100 000 2 000 000 | 140 150 | — | — | — |
| | | | | | | | | 30 | 0 | 30 | 0.007 | 0.02 | GAIN PER STAGE = 15 | | | | |
| CK-506-AX | MINIATURE PENTODE | ⑤1 | TINNED LEADS | D.C. F | 1.25 | 0.050 | POWER OUTPUT | 45 | -4.5 | 45 | 0.4 | 1.25 | 120 000 | 500 | — | 30 000 | 0.025 |
| CK-507-AX | MINIATURE PENTODE | ⑤1 | TINNED LEADS | D.C. F | 1.25 | 0.05 | POWER OUTPUT | 45 | -2.5 | 45 | 0.21 | 0.6 | 300 000 | 500 | — | 50 000 | 0.012 |
| CK-509-AX | MINIATURE TRIODE | ⑤1 | TINNED LEADS | D.C. F | 0.625 | 0.030 | VOLTAGE AMPLIFIER | 45 | 0 | — | — | 0.15 | 150 000 | 160 | VOLT. GAIN 16 | 1 000 000 | — |
| CK-510-AX | TWIN SPACE CHARGE TETRODE | ⑤1 | TINNED LEADS | D.C. F | 0.625 | 0.50 | EACH UNIT AS CLASS A AMPLIFIER | 45 | 0 | 45 THRU 0.2 MEG. | 0.2 | 0.060 | 500 000 | 65 | 32.5 | — | — |
| (GL)559 | "LIGHTHOUSE" UHF DIODE | FIG. 10 | H | 6.3 | 0.75 | DETECTOR | 5.0 | — | — | — | 24.0 | — | — | — | — | — | |
| (HY)615 | TRIODE | SPECIAL | H | 6.3 | 0.15 | UHF OSCILLATOR DETECTOR AMPLIFIER | 300. | OSCILLATOR GRID CURRENT, 3 MA. | | | 20 | 20 000 | 2200 | 22.0 | — | 4.0 | |
| (WE)717A | PENTODE | 8BK | H | 6.3 | 0.175 | CLASS A AMPLIFIER | 120 | -2.0 | 120 | 2.5 | 7.5 | 390 000 | 4000 | — | — | — | |
| (GL)840 | R.F. PENTODE | 5J | D.C. F | 2.0 | 0.13 | CLASS A AMPLIFIER | 180 | -3.0 | 67.5 | 0.7 | 1.0 | 1000 000 | 410 | 400 | — | — | |
| (GL)864 | TRIODE AMPLIFIER | 4D | D.C. F | 1.1 | 0.25 | CLASS A AMPLIFIER | 90 | -4.5 | — | — | 2.9 | 13500 | 610 | 8.2 | — | — | |
| 950 | POWER AMPLIFIER PENTODE | 5B | D.C. F | 2.0 | 0.12 | CLASS A AMPLIFIER | FOR OTHER CHARACTERISTICS, REFER TO TYPE 1J5-G | | | | | | | | | | |
| 951 | R.F. AMPLIFIER PENTODE | 4M | D.C. F | 2.0 | 0.06 | AMPLIFIER | FOR OTHER CHARACTERISTICS, REFER TO TYPE 1B4P/951 | | | | | | | | | | |
| 954 | ACORN PENTODE DETECTOR AMPLIFIER | 1 | H | 6.3 | 0.15 | CLASS A AMPLIFIER | 90 250 | -3.0 -3.0 | 90 100 | 0.5 0.7 | 1.2 2.0 | 1000 000 1500 000+ | 1100 1400 | 1100 2000+ | — | — | |

| | | | | | | | | | | | | | | | | |
|---------------|--|-----------|-----------|------------|--------------|-----------------------------------|---|---------------|------------|----------|------------|----------------|--------------|----------|---|---|
| 955 | ACORN TRIODE DETECTOR AMPLIFIER OSCILLATOR | 2 | H | 6.3 | 0.15 | CLASS A AMPLIFIER | 90 250 | -2.5 -7.0 | — | — | 2.5 6.3 | 14700 11400 | 1700 2200 | 25 25 | — | — |
| 956 | ACORN SUPER-CONTROL PENTODE | 1 | H | 6.3 | 0.15 | R.F. AMPLIFIER MIXER | 250 250 | -3.0 -10.0 | 100 100 | 2.7 — | 6.7 — | 700000 | 1800 | 1400 | — | — |
| 957 | ACORN TRIODE DETECTOR AMPLIFIER OSCILLATOR | 3 | D.C. F | 1.25 | 0.05 | CLASS A AMPLIFIER | 135 | -5.0 | — | — | 2.0 | 24600 | 650 | 16 | — | — |
| 958 958-A | ACORN TRIODE A.F. AMPLIFIER OSCILLATOR | 3 | D.C. F | 1.25 | 0.10 | CLASS A AMPLIFIER | 135 | -7.5 | — | — | 3.0 | 10000 | 1200 | 12 | — | — |
| 959 | ACORN PENTODE DETECTOR AMPLIFIER | 4 | D.C. F | 1.25 | 0.05 | CLASS A AMPLIFIER | 135 | -3.0 | 67.5 | 0.4 | 1.7 | 800000 | 600 | 480 | — | — |
| 1003/OZ4A | FULL-WAVE GAS RECTIFIER | 4R | COLD | — | — | RECTIFIER | FOR OTHER CHARACTERISTICS, REFER TO TYPE OZ4A/1003 | | | | | | | | | |
| CK-1009/BA | FULL-WAVE RECTIFIER | 4J | COLD | — | — | RECTIFIER | MAX. A.C. VOLTAGE PER PLATE (RMS), 350 MAX. D.C. OUTPUT CURRENT, 350 MA. TUBE DROP 80 V. | | | | | | | | | |
| 1201 1201A | UHF TRIODE | 8BN | H | 6.3 | 0.15 | CLASS A AMPLIFIER | FOR OTHER CHARACTERISTICS, REFER TO TYPE 7E5/1201 | | | | | | | | | |
| 1203 1203A | UHF DIODE | 4AH | H | 6.3 | 0.15 | UHF DIODE DETECTOR | FOR OTHER CHARACTERISTICS, REFER TO TYPE 7C4/1203A | | | | | | | | | |
| 1204 | UHF PENTODE | FIG. 4 | H | 6.3 | 0.15 | CLASS A AMPLIFIER | FOR OTHER CHARACTERISTICS, REFER TO TYPE 7AB7/1204 | | | | | | | | | |
| 1206 | DUAL TETRODE | 8BV | H | 6.3 | 0.3 | EACH UNIT AS CLASS A AMPLIFIER | FOR OTHER CHARACTERISTICS, REFER TO TYPE 7G6/1206 | | | | | | | | | |
| 1221 1223 | PENTODE | 6F 7R | H | 6.3 | 0.3 | CLASS A AMPLIFIER | FOR OTHER CHARACTERISTICS, REFER TO TYPE 6J7 | | | | | | | | | |
| 1231 | PENTODE AMPLIFIER | 8V | H | 6.3 | 0.45 | CLASS A AMPLIFIER | 300 | -2.5 | 150 | 2.5 | 10 | 700000 | 5500 | 3850 | — | — |
| 1232 | TRIPLE-GRID AMPLIFIER | 8V | H | 6.3 | 0.45 | CLASS A AMPLIFIER | FOR OTHER CHARACTERISTICS, REFER TO TYPE 7G7/1232 | | | | | | | | | |
| 1284 | UHF PENTODE | FIG. 3 | H | 12.6 | 0.15 | CLASS A AMPLIFIER | 250 | -3.0 | 100 | 2.5 | 9.0 | 800000 | 2000 | — | — | — |
| 1291 | UHF TWIN TRIODE | 7BE | D.C. F | 1.4 2.8 | 0.22 0.11 | CLASS B AMPLIFIER | FOR OTHER CHARACTERISTICS, REFER TO TYPE 3B7/1291 | | | | | | | | | |
| 1293 | UHF TRIODE | FIG. 2 | D.C. F | 1.4 | 0.11 | CLASS A AMPLIFIER | 90 | 0 | — | — | 4.7 | 10750 | 1300 | 14 | — | — |
| 1294 | UHF DIODE | 4AH | H | 1.4 | 0.15 | UHF DETECTOR | FOR OTHER CHARACTERISTICS, REFER TO TYPE 1R4/1294 | | | | | | | | | |
| 1299 | BEAM POWER AMPLIFIER | 6BB | D.C. F | 1.4 2.8 | 0.22 0.11 | CLASS A AMPLIFIER | FOR OTHER CHARACTERISTICS, REFER TO TYPE 3D6/1299 | | | | | | | | | |
| (GL)1603 | NON-MICROPHONIC TRIPLE-GRID AMPLIFIER | 6F | H | 6.3 | 0.3 | DETECTOR AMPLIFIER | FOR OTHER CHARACTERISTICS, REFER TO TYPE 6J7 | | | | | | | | | |
| (GL)1609 | PENTODE AMPLIFIER | 5K | D.C. F | 1.1 | 0.25 | CLASS A AMPLIFIER | 135 | -1.5 | 67.5 | 0.65 | 2.5 | 400000 | 725 | 300 | — | — |
| 1611 | POWER AMPLIFIER PENTODE | 7S | H | 6.3 | 0.7 | RELAY TUBE | SELECTED 6F6. FOR OTHER CHARACTERISTICS, REFER TO TYPE 6F6 | | | | | | | | | |
| (GL)1612 | PENTAGRID MIXER AMPLIFIER | 7T | H | 6.3 | 0.3 | MIXER OR CLASS A AMPLIFIER | SELECTED 6L7. FOR OTHER CHARACTERISTICS, REFER TO TYPE 6L7 | | | | | | | | | |
| (GL)1620 | TRIPLE-GRID DETECTOR AMPLIFIER | 7R | H | 6.3 | 0.3 | AMPLIFIER | SELECTED 6J7. FOR OTHER CHARACTERISTICS, REFER TO TYPE 6J7 | | | | | | | | | |

| TYPE | DESIGN | BASE CONNS | CATHODE TYPE & RATING | | | USED AS | PLATE SUPPLY | GRID BIAS ② | SCREEN SUPPLY | SCREEN CURRENT | PLATE CURRENT | R _p A.C. PLATE RESISTANCE | G _m TRANSCON- DUCTANCE | μ AMPLIFI- CATION FACTOR | LOAD FOR STATED POWER OUTPUT | POWER OUTPUT | |
|----------|---|---------------|--------------------------|------|-------|---------------------------|--|----------------|----------------------------|---------------------------------|------------------|--|---|-----------------------------------|---------------------------------------|-----------------|------|
| | | | F= FILAMENT H= HEATER | TYPE | VOLTS | | | | | | | | | | | | AMP. |
| | | | | | | | | | | | | | | | | | |
| (GL)1621 | POWER AMPLIFIER PENTODE | 7S | H | 6.3 | 0.7 | AMPLIFIER | SELECTED 6F6. FOR OTHER CHARACTERISTICS, REFER TO TYPE 6F6 | | | | | | | | | | |
| (GL)1622 | BEAM POWER AMPLIFIER | 7AC | H | 6.3 | 0.9 | AMPLIFIER | SELECTED 6L6. FOR OTHER CHARACTERISTICS, REFER TO TYPE 6L6 | | | | | | | | | | |
| (GL)1629 | ELECTRON-RAY TUBE | 7AL | H | 12.6 | 0.15 | VISUAL INDICATOR | FOR OTHER CHARACTERISTICS, REFER TO TYPE 6E5 | | | | | | | | | | |
| (GL)1631 | BEAM POWER AMPLIFIER | 7AC | H | 12.6 | 0.45 | CLASS A AMPLIFIER | FOR OTHER CHARACTERISTICS, REFER TO TYPE 8L6 | | | | | | | | | | |
| (GL)1632 | BEAM POWER AMPLIFIER | 7AC | H | 12.6 | 0.6 | CLASS A AMPLIFIER | FOR OTHER CHARACTERISTICS, REFER TO TYPE 25L6 | | | | | | | | | | |
| (GL)1633 | TWIN TRIODE | 8BD | H | 25.0 | 0.15 | CLASS A AMPLIFIER | FOR OTHER CHARACTERISTICS, REFER TO TYPE 6SN7-GT | | | | | | | | | | |
| (GL)1634 | TWIN TRIODE AMPLIFIER | 8S | H | 12.6 | 0.15 | AMPLIFIER | SELECTED 12SC7, FOR OTHER CHARACTERISTICS, REFER TO TYPE 12SC7 | | | | | | | | | | |
| 1635 | TWIN TRIODE AMPLIFIER | 8B | H | 6.3 | 0.6 | CLASS B AMPLIFIER | 400 | 0 | — | — | 10 ⑬ | — | — | — | 14 000 | 17 ⑭ | |
| 1644 | TWIN PENTODE POWER AMPLIFIER | 8BU | H | 12.6 | 0.15 | EACH UNIT AS AMPLIFIER | SELECTED 12L6-GT. FOR OTHER CHARACTERISTICS, REFER TO TYPE 12L6-GT | | | | | | | | | | |
| (GL)1851 | TELEVISION AMPLIFIER PENTODE | 7R | H | 6.3 | 0.45 | CLASS A AMPLIFIER | FOR OTHER CHARACTERISTICS, REFER TO TYPE 6AC7/1852 | | | | | | | | | | |
| 1852 | TELEVISION AMPLIFIER PENTODE | 8N | H | 6.3 | 0.45 | CLASS A AMPLIFIER | FOR OTHER CHARACTERISTICS, REFER TO TYPE 6AC7/1852 | | | | | | | | | | |
| 1853 | TELEVISION AMPLIFIER PENTODE | 8N | H | 6.3 | 0.45 | CLASS A AMPLIFIER | FOR OTHER CHARACTERISTICS, REFER TO TYPE 6AB7/1853 | | | | | | | | | | |
| 7000 | LOW NOISE AMPLIFIER | 7R | H | 6.3 | 0.3 | CLASS A AMPLIFIER | FOR OTHER CHARACTERISTICS, REFER TO TYPE 6J7 | | | | | | | | | | |
| 7193 | TRIODE AMPLIFIER | 4AM | H | 6.3 | 0.3 | CLASS A AMPLIFIER | SELECTED 2C22. FOR OTHER CHARACTERISTICS, REFER TO TYPE 2C22 | | | | | | | | | | |
| 7700 | NON-MICROPHONIC TRIPLE-GRID AMPLIFIER | 6F | H | 6.3 | 0.3 | CLASS A AMPLIFIER | FOR OTHER CHARACTERISTICS, REFER TO TYPE 6J7 | | | | | | | | | | |
| (GL)9001 | TRIPLE-GRID DETECTOR AMPLIFIER | 7BD | H | 6.3 | 0.15 | CLASS A AMPLIFIER | 250 | -3.0 | 100 | 0.7 | 2.0 | 1000000+ | 1400 | — | — | — | |
| | MIXER | | | | | 250 | -5.0 | 100 | OSC. PEAK VOLTAGE, 4 VOLTS | | | 550 | — | — | — | | |
| (GL)9002 | TRIODE DETECTOR AMPLIFIER OSCILLATOR | 7BS | H | 6.3 | 0.15 | CLASS A AMPLIFIER | 90 | -2.5 | — | — | 2.5 | 14700 | 1700 | 25 | — | — | |
| | MIXER | | | | | 250 | -7.0 | — | — | 6.3 | 11400 | 2200 | 25 | — | — | | |
| 9003 | TRIPLE-GRID SUPER-CONTROL AMPLIFIER | 7BD | H | 6.3 | 0.15 | CLASS A AMPLIFIER | 250 | -3.0 | 100 | 2.7 | 6.7 | 700000 | 1600 | — | — | — | |
| | MIXER | | | | | 250 | -10.0 | 100 | OSC. PEAK VOLTAGE, 9 VOLTS | | | 600 | — | — | — | | |
| 9004 | UHF DIODE | 9004 | H | 6.3 | 0.15 | DETECTOR | MAX. A.C. VOLTAGE, 117 | | | MAX. D.C. OUTPUT CURRENT, 5 MA. | | | | | | | |
| (GL)9005 | UHF DIODE | 9005- 58G | H | 3.6 | 0.165 | DETECTOR | MAX. A.C. VOLTAGE, 117 | | | MAX. D.C. OUTPUT CURRENT, 1 MA. | | | | | | | |
| 9006 | UHF DIODE | 6BH | H | 6.3 | 0.15 | DETECTOR | MAX. A.C. VOLTAGE, 270 | | | MAX. D.C. OUTPUT CURRENT, 5 MA. | | | | | | | |

| CONTROL, REGULATOR, AND SPECIAL RECTIFIER TUBES | | | | | | | | | | | | | | |
|---|---------------------------------|------------|-------------------------|-------|------|---------------------------|---------------------------------|---------------------------------|-------------------------|-------------------------|------------------------------|-------------------|------------------|---|
| TYPE | DESIGN | BASE CONNS | CATHODE TYPE AND RATING | | | PURPOSE | MAX. PEAK FORWARD ANODE VOLTAGE | MAX. PEAK INVERSE ANODE VOLTAGE | MAX. PEAK ANODE CURRENT | OPERATING ANODE VOLTAGE | MAX. OPERATING ANODE CURRENT | TUBE VOLTAGE DROP | PRE-HEATING TIME | MISCELLANEOUS DATA |
| | | | TYPE | VOLTS | AMP. | | | | | | | | | |
| OA2 | MINIATURE GAS VOLTAGE REGULATOR | FIG. 16 | COLD | — | — | VOLTAGE REGULATOR | — | — | — | 150 D.C. | 5 MIN. 30 MAX. | — | — | MINIMUM D.C. STARTING VOLTAGE, 155 |
| OA3/VR75 | GAS VOLTAGE REGULATOR | 4W | COLD | — | — | VOLTAGE REGULATOR | — | — | — | 75 D.C. | 5 MIN. 40 MAX. | — | — | MINIMUM D.C. STARTING VOLTAGE, 100. REGULATION (5 TO 40 MA.), 5 VOLTS |
| OA4-G | GAS TRIODE STARTER-ANODE TYPE | 4V | COLD | — | — | RELAY SERVICE | 225 STARTER TIED TO ANODE | — | 100 | 105 TO 130 RMS | 25 | — | — | STARTER-ANODE BIAS, 70 MAXIMUM PEAK VOLTS. SUM OF BIAS AND SIGNAL VOLTAGES, 110 MIN. PEAK VOLTS |
| OB3/VR90 | GAS VOLTAGE REGULATOR | 4W | COLD | — | — | VOLTAGE REGULATOR | — | — | — | 90 D.C. | 5 MIN. 40 MAX. | — | — | MINIMUM D.C. STARTING VOLTAGE, 125. REGULATION (5 TO 40 MA.), 8 VOLTS |
| OC3/VR105 | GAS VOLTAGE REGULATOR | 4W | COLD | — | — | VOLTAGE REGULATOR | — | — | — | 105 D.C. | 5 MIN. 40 MAX. | — | — | MINIMUM D.C. STARTING VOLTAGE, 133. REGULATION (5 TO 40 MA.), 2 VOLTS |
| OD3/VR150 | GAS VOLTAGE REGULATOR | 4W | COLD | — | — | VOLTAGE REGULATOR | — | — | — | 150 D.C. | 5 MIN. 40 MAX. | — | — | MINIMUM D.C. STARTING VOLTAGE, 185. REGULATION (5 TO 40 MA.), 4 VOLTS |
| 1C21 | GAS TRIODE | 4V | COLD | — | — | RELAY SERVICE | 180 GRID TIED TO CATHODE | — | 100 | 125 TO 145 D.C. | 25 | — | — | GRID BIAS, 66 MAX. PEAK VOLTS. SUM OF BIAS & SIGNAL VOLTAGES, 100 MIN. PEAK VOLTS |
| 2A4-G | THYRATRON, GAS TRIODE | 5S | F | 2.5 | 2.5 | GRID-CONTROLLED RECTIFIER | 200 | 200 | 1250 | — | 100 | 15 | 2 | PEAK VOLTS BETWEEN ANY TWO ELECTRODES, 250 MAX. CONTROL POLARITY, NEGATIVE |
| 2C4 | THYRATRON, MINIATURE GAS TRIODE | FIG. 17 | H | 2.5 | 0.6 | GRID-CONTROLLED RECTIFIER | 350 | 350 | 22 | — | 5 | 17 | 30 | CONTROL POLARITY, NEGATIVE |
| 2D21 | THYRATRON MINIATURE GAS TRIODE | 7BN | H | 6.3 | 0.6 | GRID-CONTROLLED RECTIFIER | 650 | 1300 | 500 | — | 100 | 8 | 10 | GRID N° 1: CIRCUIT RESISTANCE 10 MAX. MEGOHM., -100 VOLTS MAX. GRID N° 2, -100 V. MAX. |
| | | | | | | RELAY SERVICE | — | — | — | 400 RMS | — | — | 10 | SIGNAL VOLTAGE, 5 VOLTS PEAK GRID N° 1: CIRCUIT RESIST. 1 MEG. 5 V. RMS BIAS. ANODE CIRCUIT RESISTANCE, 2000 OHMS |
| 2V3-G | HALF-WAVE RECTIFIER | 4Y | F | 2.5 | 5.0 | RECTIFIER | — | 16 500 | 12 | — | 2 | — | — | — |
| 2X2/879 | HALF-WAVE RECTIFIER | 4AB | H | 2.5 | 1.75 | RECTIFIER | — | 12 500 | 100 | 4500 MAX. RMS | 7.5 | — | — | — |
| 2Y2 | HALF-WAVE RECTIFIER | 4AB | H | 2.5 | 1.75 | RECTIFIER | — | — | — | 4500 MAX. RMS | 5.0 | — | — | — |
| 3B26 | HIGH VACUUM DIODE | 4Y | H | 2.5 | 4.6 | CLIPPER TUBE | — | 15 000 | 8000 | — | 20 | — | — | — |
| 3C23 | THYRATRON GAS MERCURY TRIODE | 3G | F | 2.5 | 7.0 | GRID-CONTROLLED RECTIFIER | 1250 | 1250 | 6000 | — | 1500 | 15 | 15 | CONTROL POLARITY, NEGATIVE |

| | | | | | | | | | | | | | | |
|---------------|---|------------------|------|-----|------|---|---|-------|-------|-------------------|------|----|-----|---|
| 3C31/C1B | THYRATRON, GAS TRIODE | 3G | F | 2.5 | 6.0 | GRID-CONTROLLED RECTIFIER | 450 | 700 | 7700 | — | 640 | 14 | 40 | MAX. GRID CURRENT, 25 MA. CONTROL POLARITY, NEGATIVE |
| 4B22 | FULL-WAVE GAS RECTIFIER | MOGUL SCREW | F | 2.5 | 12.0 | RECTIFIER | — | 340 | 15000 | — | 5000 | — | 20 | MAX. FREQUENCY, 150 CPS |
| 4B23 | FULL-WAVE GAS RECTIFIER | MOGUL SCREW | F | 2.5 | 17.0 | RECTIFIER | — | 425 | 15000 | — | 5000 | — | 120 | MAX. FREQUENCY, 150 CPS |
| 4B24 | FULL-WAVE GAS RECTIFIER | SPECIAL 4-PIN | F | 2.5 | 11.0 | RECTIFIER | — | 725 | 10000 | — | 2500 | 13 | 30 | MAX. FREQUENCY, 150 CPS |
| 4B25 | FULL-WAVE GAS RECTIFIER | SPECIAL 4-PIN | F | 2.5 | 17.0 | RECTIFIER | — | 700 | 9400 | — | 6000 | 15 | 40 | MAX. FREQUENCY, 150 CPS |
| 4B26/ 2000 | HALF-WAVE GAS RECTIFIER | MOGUL SCREW | F | 2.2 | 18.0 | RECTIFIER | — | 375 | 36000 | — | 6000 | 8 | — | MINIMUM STARTING VOLTAGE 20 VOLTS RMS MAX. FREQUENCY, 60 CPS |
| 4B27 | FULL-WAVE MERCURY-VAPOR RECTIFIER | SPECIAL 4-PIN | F | 2.5 | 10.0 | RECTIFIER | — | 1000 | 3100 | — | 2000 | 13 | 60 | MAX. FREQUENCY, 150 CPS |
| 4B28 | HALF-WAVE GAS RECTIFIER | MOGUL SCREW | F | 2.2 | 18.0 | RECTIFIER | — | 300 | 36000 | — | 6000 | — | — | MAX. FREQUENCY, 60 CPS |
| C5B | THYRATRON, GAS TRIODE | MOGUL SCREW | F | 2.5 | 23.0 | GRID-CONTROLLED RECTIFIER | 750 | 1250 | 30000 | — | 5000 | 12 | 60 | CONTROL POLARITY, NEGATIVE |
| C6J | THYRATRON, GAS TRIODE | SPECIAL 4-PIN | F | 2.5 | 20.0 | GRID-CONTROLLED RECTIFIER | 750 | 1250 | 77000 | — | 6400 | 14 | 60 | CONTROL POLARITY, NEGATIVE |
| 6D4 | THYRATRON MINIATURE GAS TRIODE | FIG 18 | H | 8.3 | 0.25 | GRID-CONTROLLED RECTIFIER | 350 | 350 | 110 | — | 25 | 18 | 30 | CONTROL POLARITY, NEGATIVE |
| 6Q5-G | THYRATRON GAS TRIODE | 6Q | H | 6.3 | 0.6 | SWEEP OSC. OR GRID-CONTROLLED RECTIFIER | FOR OTHER CHARACTERISTICS, REFER TO TYPE 884 | | | | | | | |
| 6Y3 | HALF-WAVE RECTIFIER | 4Y | F | 8.3 | 0.7 | RECTIFIER | — | 14000 | 100 | 5000 RMS, MAX. | 7.5 | — | — | — |
| FG17 | THYRATRON MERCURY TRIODE | 3G | F | 2.5 | 5.0 | RELAY OR GRID-CONTROLLED RECTIFIER | 2500 | 5000 | 2000 | — | 500 | — | 5 | MAX. GRID CURRENT, 250 MA. MERCURY TEMP. 40 TO 80° C. CONTROL POLARITY, NEGATIVE |
| FG27A | THYRATRON MERCURY TRIODE | FIG. 19 | F | 5.0 | 4.7 | RELAY OR GRID-CONTROLLED RECTIFIER | 1000 | 1000 | 10000 | — | 2500 | — | 60 | MAX. GRID CURRENT, 1.0 AMP. MERCURY TEMP. 40 TO 80° C. CONTROL POLARITY, NEGATIVE |
| FG32 | HALF-WAVE MERCURY RECTIFIER | FIG. 20 | H | 5.0 | 4.6 | RECTIFIER | 1000 | 1000 | 15000 | — | 2500 | — | 300 | MERCUR [®] TEMP. 40 TO 80° C. MAX. FREQUENCY, 150 CPS |
| FG57 | THYRATRON MERCURY TRIODE | FIG. 21 | H | 5.0 | 4.6 | RELAY OR GRID-CONTROLLED RECTIFIER | 1000 | 1000 | 15000 | — | 2500 | — | 300 | MAX. GRID CURRENT, 1.0 AMP. MERCURY TEMP. 40 TO 80° C. CONTROL POLARITY, NEGATIVE |
| RK-62 | GAS TRIODE | 4D | F | 1.4 | 0.05 | SUPER-REGEN. DETECTOR CONTROL TUBE | — | — | — | 45 D.C. | 1.5 | 30 | — | RELAY RESISTANCE, 5000 TO 10000 OHMS |
| FG67 | THYRATRON MERCURY TRIODE | FIG. 21 | H | 5.0 | 4.6 | INVERTER OR GRID-CONTROLLED RECTIFIER | 1000 | 1000 | 15000 | — | 2500 | — | 300 | MAX. GRID CURRENT, 1.0 AMP. MERCURY TEMP. 40 TO 80° C. CONTROL POLARITY, POSITIVE |
| 72 | HALF-WAVE RECTIFIER | 4P | F | 2.5 | 3.0 | RECTIFIER | — | 20000 | 100 | — | 20.0 | — | — | — |
| 73 | HIGH-VACUUM DIODE | 4Y | F | 2.5 | 4.25 | CLIPPER TUBE | — | 13000 | 3000 | — | 30.0 | — | — | — |
| VR75-30 | GAS VOLTAGE RECTIFIER | 4W | COLD | — | — | VOLT. REGULATOR | FOR OTHER CHARACTERISTICS, REFER TO TYPE 0A3/VR75 | | | | | | | |
| FG81A | THYRATRON, GAS TRIODE | 3G | F | 2.5 | 5.0 | RELAY OR GRID-CONTROLLED RECTIFIER | 500 | 500 | 2000 | — | 500 | — | 5 | MAX. GRID CURRENT, 250 MA. CONTROL POLARITY, NEGATIVE |

| TYPE | DESIGN | BASE CONN'S | CATHODE TYPE AND RATING | | | PURPOSE | MAX. PEAK FORWARD ANODE VOLTAGE | MAX. PEAK INVERSE ANODE VOLTAGE | MAX. PEAK ANODE CURRENT MILLIAMPS. | OPERATING ANODE VOLTAGE | MAX. OPERATING ANODE CURRENT MILLIAMPS. | TUBE VOLTAGE DROP | PRE-HEATING TIME SECONDS | MISCELLANEOUS DATA |
|----------------|------------------------------|------------------------------|-------------------------|-------|------|---|--|---------------------------------|------------------------------------|-------------------------|---|-------------------|--------------------------|--|
| | | | TYPE | VOLTS | AMP. | | | | | | | | | |
| VR90-30 | GAS VOLTAGE REGULATOR | 4W | COLD | — | — | VOLTAGE REGULATOR | FOR OTHER CHARACTERISTICS, REFER TO TYPE OB3/VR90 | | | | | | | |
| FG 105 | THYRATRON MERCURY TRIODE | SPECIAL MOGUL 4-PIN, BAYONET | H | 5.0 | 10.0 | GRID-CONTROLLED RECTIFIER | 10000 | 10000 | 16000 | — | 4000 | — | 300 | MAX. GRID # 1 CURRENT, 1 AMP. MAX. GRID # 2 CURRENT, 2 AMP. MERCURY TEMP. 25 TO 50°C. CONTROL POLARITY, NEGATIVE |
| VR105-30 | GAS VOLTAGE REGULATOR | 4W | COLD | — | — | VOLTAGE REGULATOR | FOR OTHER CHARACTERISTICS, REFER TO TYPE OC3/VR105 | | | | | | | |
| VU-111 | HALF-WAVE RECTIFIER | BRITISH STANDARD 4-PIN | F | 4.0 | 1.05 | RECTIFIER | — | 14000 | 350 | 5000 RMS, MAX. | 50 | — | — | — |
| VR150-30 | GAS VOLTAGE REGULATOR | 4W | COLD | — | — | VOLTAGE REGULATOR | FOR OTHER CHARACTERISTICS, REFER TO TYPE OD3/VR150 | | | | | | | |
| CE220 | HALF-WAVE RECTIFIER | 4P | F | 2.5 | 3.0 | RECTIFIER | FOR OTHER CHARACTERISTICS, REFER TO TYPE 72 | | | | | | | |
| (WE)274A | FULL-WAVE REGULATOR | 4C | F | 5.0 | 2.0 | RECTIFIER | — | 1650 | 525 | — | 175 | — | — | — |
| (WE)274B | FULL-WAVE RECTIFIER | 5T | F | 5.0 | 2.0 | RECTIFIER | FOR OTHER CHARACTERISTICS, REFER TO TYPE (WE) 274A | | | | | | | |
| (WE)346B | COLD CATHODE GAS TRIODE | SPECIAL 4-PIN | COLD | — | — | RECTIFIER, RELAY OR REGULATOR | 200 | 200 | — | — | — | 80 | — | MAX. PEAK CATHODE CUR. 100 MA. MAX. AVERAGE CATH. CUR. 35 MA. CONTROL POLARITY, POSITIVE |
| (WE)359A | COLD CATHODE GAS TRIODE | TINNED LEADS | COLD | — | — | RECTIFIER RELAY OR REGULATOR | 165 | 165 | — | — | — | 85 | — | MAX. PEAK CATHODE CUR. 50 MA. MAX. AVERAGE CATH. CUR. 18 MA. CONTROL POLARITY, POSITIVE |
| (WE) 393A (GL) | THYRATRON GAS MERCURY TRIODE | FIG. 24 | F | 2.5 | 7.0 | GRID-CONTROLLED RECTIFIER | 1250 | 12 | 6000 | — | 1500 | — | 15 | MAX. GRID CURRENT, 50 MA. MERCURY TEMP. -40 TO +80°C. MAX. FREQ. 150 CPS. NEG. CONT. |
| (WE)394A | THYRATRON GAS MERCURY TRIODE | FIG. 22 | F | 2.5 | 3.2 | GRID-CONTROLLED RECTIFIER | 1250 | 1250 | 2500 | — | 640 | — | 15 | MAX. GRID CURRENT, 50 MA. MERCURY TEMP. -40 TO +80°C. MAX. FREQ. 150 CPS. NEG. CONT. |
| (WE)395A | COLD CATHODE GAS TRIODE | TINNED LEADS | COLD | — | — | RECTIFIER RELAY OR REGULATOR | 140 | 140 | — | — | — | 80 | — | MAX. PEAK CATHODE CUR. 36 MA. MAX. AVERAGE CATH. CUR. 13 MA. CONTROL POLARITY, POSITIVE |
| (WE)727A | COLD CATHODE GAS TRIODE | TINNED LEADS | GOLD | — | — | RECTIFIER RELAY OR REGULATOR | | | | | | | | |
| (GL)874 | GAS VOLTAGE REGULATOR | 4S | COLD | — | — | VOLTAGE REGULATOR | — | — | — | 90 D.C. | 10 MIN. 50 MAX. | — | — | MINIMUM D.C. STARTING VOLTAGE, 130. REGULATION (10 TO 50 MA.) 7 V. |
| (GL)878 | HALF-WAVE RECTIFIER | FIG. 23 | F | 2.5 | 5.0 | RECTIFIER | — | 20000 | 20 | — | 5.0 | — | — | — |
| 879 | HALF-WAVE RECTIFIER | 4AB | H | 2.5 | 1.75 | RECTIFIER | FOR OTHER CHARACTERISTICS, REFER TO TYPE 2X2/879 | | | | | | | |
| 884 | THYRATRON GAS TRIODE | 6Q | H | 6.3 | 0.6 | SWEEP OSCILL. GRID-CONTROLLED RECTIFIER | 300 | 300 | 300 | — | 2 | — | 30 | GRID RESISTOR NOT LESS THAN 1000 OHMS PER MAX. INSTANT. VOLTS ON GRID. CONTROL POLARITY, NEGATIVE |
| 885 | THYRATRON GAS TRIODE | 5A | H | 2.5 | 1.5 | SWEEP OSCILL. GRID-CONTROLLED RECTIFIER | 300 | 300 | 300 | — | 75 | — | 30 | GRID RESISTOR NOT LESS THAN 1000 OHMS PER MAX. INSTANT. VOLTS ON GRID. CONTROL POLARITY, NEGATIVE |

| | | | | | | | | | | | | | | |
|-------------------|--------------------------------|--------------------|------|-----|------|--|--|-----|-----|--------------------|----------------------|----|----|--|
| 967 | THYRATRON MERCURY TRIODE | 3G | F | 2.5 | 5.0 | RELAY OR GRID-CONTROLLED RECTIFIER | FOR OTHER CHARACTERISTICS, REFER TO TYPE FG17 | | | | | | | |
| (GL)991 | NEON VOLTAGE REGULATOR | BAYONET CANDELA | COLO | - | - | VOLTAGE REGULATOR | - | - | 3 | 43 MIN. 67 MAX. | 0.4 MIN. 2.0 MAX. | - | - | MINIMUM D.C. STARTING VOLTAGE, 87 |
| 2000 | HALF-WAVE GAS RECTIFIER | MOGUL SCREW | F | 2.2 | 18.0 | RECTIFIER | FOR OTHER CHARACTERISTICS, REFER TO TYPE 4626/2000 | | | | | | | |
| (GL) (WL) 2050 | THYRATRON GAS TRIODE | 8BA | H | 6.3 | 0.6 | RELAY OR GRID-CONTROLLED RECTIFIER | FOR OTHER CHARACTERISTICS, REFER TO TYPE 2021 | | | | | | | |
| (GL)2051 | THYRATRON GAS TETRODE | 8BA | H | 6.3 | 0.6 | RELAY OR GRID-CONTROLLED RECTIFIER | 350 | 700 | 375 | - | 75 | 14 | 10 | MAX. GRID #1 AND #2 VOLTAGE, -100 VOLTS. MAX. GRID RESISTOR, 10 MEG. |

FOOTNOTE REFERENCES FOR STANDARD AND SPECIAL RECEIVING TUBES

- ¹For grid leak detection, plate volts 45, grid return to plus filament.
²Either a.c. or d.c. may be used on the filament or heater, except as specifically noted. For use of d.c. on filament types, decrease stated grid volts by $\frac{1}{2}$ of filament voltage.
³Supply voltage applied through 20,000-ohm dropping resistor.
⁴Mercury vapor type.
⁵Grid no. 1 is control grid; grid no. 2 is screen; grid no. 3 is tied to cathode.
⁶Grid no. 1 is control grid. Grids nos. 2 and 3 tied to plate.
⁷Grids nos. 1 and 2 connected together; grid no. 3 connected to plate.
⁸Grids nos. 3 and 5 are screen. Grid no. 4 is control grid (input).
⁹Grids nos. 2 and 4 are screen. Grid no. 1 is control grid (input).
¹⁰For grid of following tube.
¹¹Both grids connected together; likewise both plates.
¹²Power output is for 2 tubes at stated plate-to-plate load.
¹³For 2 tubes.
¹⁴Preferably obtained by using 70,000-ohm dropping resistor in series with 90-volt supply.
¹⁵Grids nos. 2 and 3 tied to plate.
¹⁶Applied through plate resistor of 250,000 ohms or 500-hy. choke shunted by 250,000-ohm resistor.
¹⁷Applied through plate resistor of 100,000 ohms.
¹⁸Applied through plate resistor of 250,000 ohms.
¹⁹50,000 ohms.
²⁰Requires different socket from small 7 pin.
²¹Grid no. 3 tied to plate.
²²Plate voltages greater than 125 volts r.m.s. require 100-ohm (min.) series plate resistor.
²³Applied through plate resistor of 150,000 ohms.
²⁴For signal input control grid. Grid no. 3 bias, minus 3 volts.
²⁵Applied through 200,000-ohm plate resistor.
²⁶Grids nos. 2 and 4 are screen. Grid no. 3 is control grid.
²⁷Maximum.
²⁸Megohms.
²⁹Grids nos. 1 and 2 tied together.
³⁰Grids nos. 2 and 3 tied together.
³¹Designed especially for hearing aid use.
³²"X" types have removable octal base. Types without "X" have peanut-type bases.
³³Operates into crystal earphone.
³⁴Operates into magnetic reproducer.
³⁵Unless otherwise specified, values are for the two units.
³⁶Power output is for one tube at stated plate-to-plate load.
³⁷Per plate.
³⁸Two sections have common plate; value is for each triode.
³⁹Values are for each unit.
⁴⁰D.c. resistance in grid circuit should not exceed 1.0 megohm under maximum rated conditions per unit.
⁴¹Values are for two tubes with filaments in series; equivalent to one type 5Y3-GT/5Y3-G.
⁴²Types with suffixes "M", "ML", and "S" have external shield connected to cathode pin.

Subscript 1 on class of amplifier service indicates that grid current does not flow on any part of input cycle.

Subscript 2 on class of amplifier service indicates that grid current flows on some part of input cycle.



3G

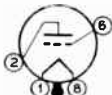

4AA



4AB

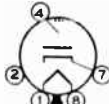

4AH



4AM



4B



4BJ



4C



4D



4F



4F



4G

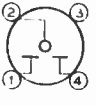

4J

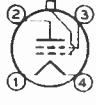

4K



4L



4M

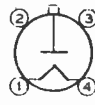

4P

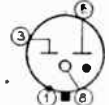

4R

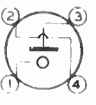

4S

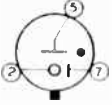

4V

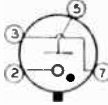

4W

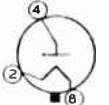

4X

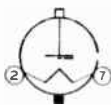

4Y

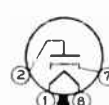

4Z

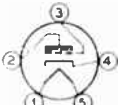

5A

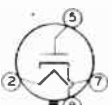

5AA



5AB



5AC

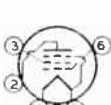

5AD

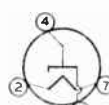

5AF



5AG

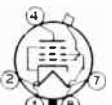

5AK

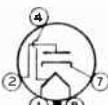

5AL



5AM



5AP

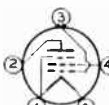

5B

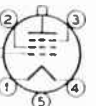

5BB

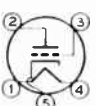

5BC

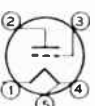

5BD

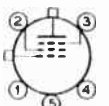

5BE

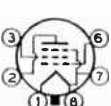

5BF

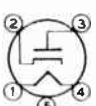

5BG

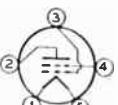

5C

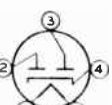

5D

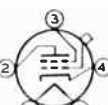

5E



5F

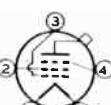

5J

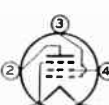

5K

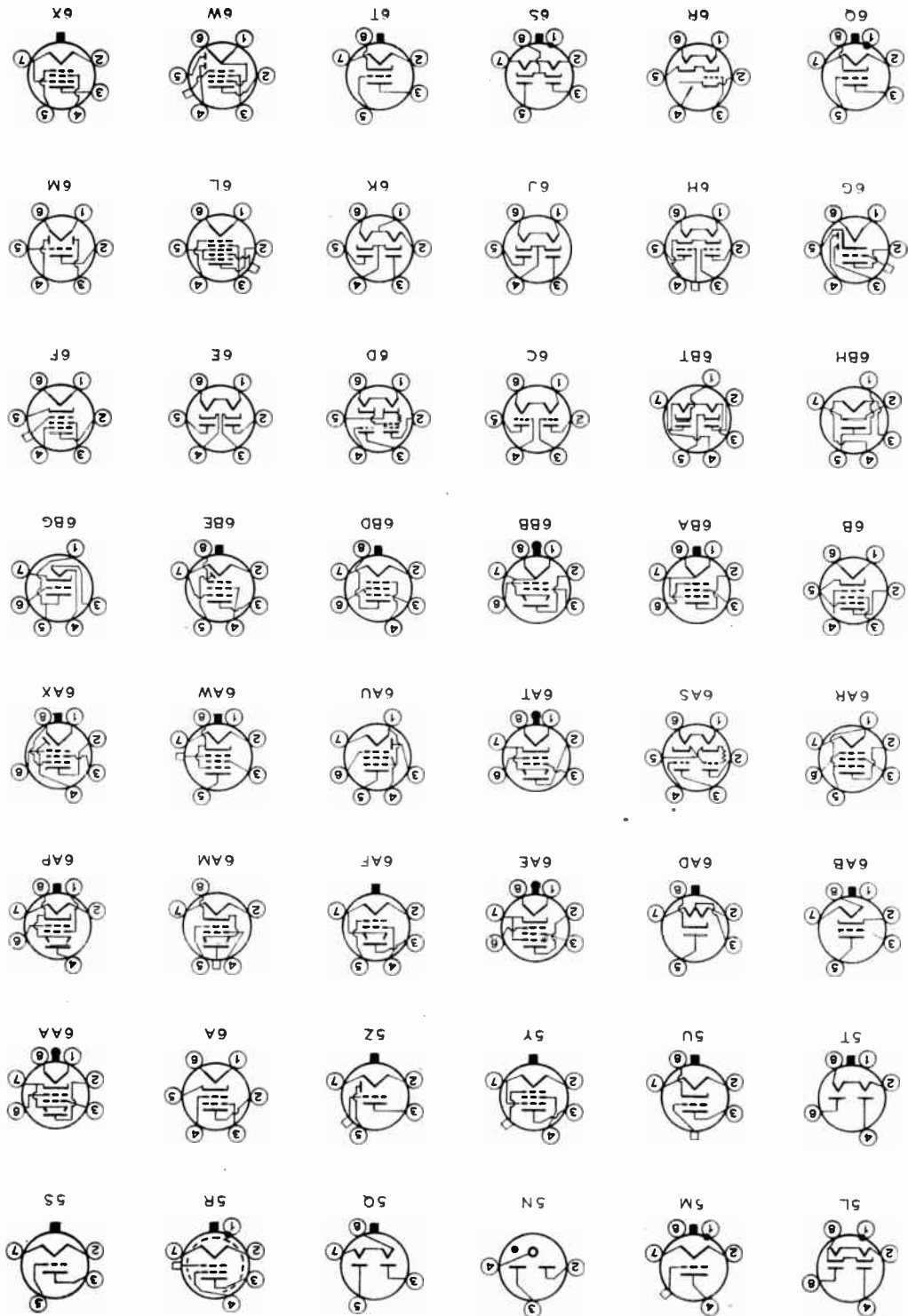

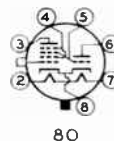
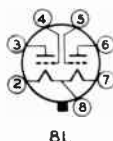
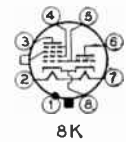
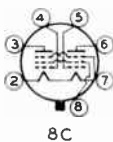
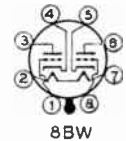
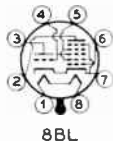
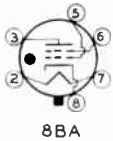
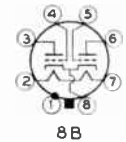
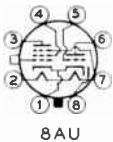
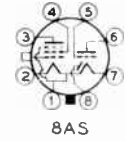
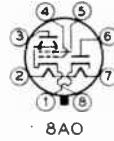
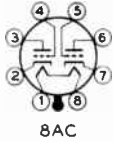
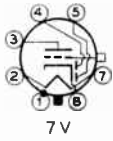
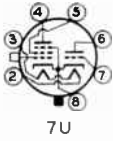

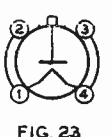
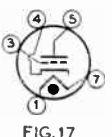
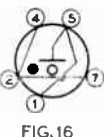
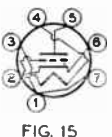
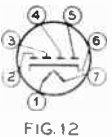
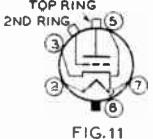
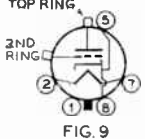
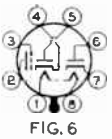
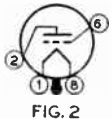
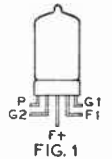
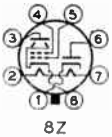
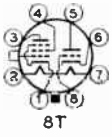

CATHODE-RAY TRANSMITTING TYPES

| TYPE | USED AS | BASE CONN'S | HEATER | | ANODE N° 1 | ANODE N° 2 | GRID #1 CUT-OFF VOLTS | GRID #2 VOLTS | COLLECTOR | | AVERAGE D.C. DEF. PLATE VOLTS | ROTATOR ELECTRODE VOLTS | MASK ELECTRODE VOLTS | DEFLECTING FLUX DENSITY GAUSSES | FOCUSING DENSITY GAUSSES | PEAK-TO-PEAK DEFLECTING VOLTAGE | | TYPE OF PICKUP |
|------|------------|----------------|--------|------|---|---------------------|-----------------------------|---|--------------|--------------------|---|-------------------------------|----------------------------|--|------------------------------------|---------------------------------------|--------|-------------------|
| | | | VOLTS | AMP. | | | | | VOLTS | μAMPS | | | | | | HORIZ. | VERTI. | |
| 1840 | ORTHICON | 11 | 6.3 | 0.6 | 250 | — | -40 APPR. | 225 | — | — | 225 | 100 APPROX. | -3 | 25 APPROX. | 70 APPROX. | 160 | — | DIRECT OR FILM |
| 1847 | ICONOSCOPE | 12 | 6.3 | 0.6 | 150 | 600 (3) | -120 APP. | 600 (3) | 600 (3) | — | — | — | — | — | — | 200 | 225 | DIRECT |
| 1848 | ICONOSCOPE | 13 | 6.3 | 0.6 | 300 APPR. | 1000 (4) | -50 APPR. | 1000 | 1000 (4) | 0.1 | — | — | — | — | — | — | — | DIRECT |
| 1849 | ICONOSCOPE | 14 | 6.3 | 0.6 | 360 | 1000 | -30 APPR. | — | 1000 | 0.05 TO 0.10 | — | — | — | — | — | — | — | FILM |
| 1850 | ICONOSCOPE | 14 | 6.3 | 0.6 | FOR OTHER CHARACTERISTICS, REFER TO TYPE 1849 | | | | | | | | | | | | | DIRECT |
| 1898 | MONOSCOPE | 15 | 2.5 | 2.1 | 240 300 360 | 800 1000 1200 | -50 APPR. -80 " -70 " | PATTERN ELECTRODE VOLTAGE { 750 950 BEAM CURRENT 1150 μAMP. { 1 APPROX. 2 " 3 " | | | | 135 170 200 | 125 155 185 | TEST PATTERN | | | | |
| 1899 | MONOSCOPE | 16 | 2.5 | 2.1 | 260 390 | 1000 1500 | — -60 | — | 1050 1700 | — | PATTERN ELECTRODE VOLTAGE { 1000 1500 BEAM CURRENT, μAMP. { 2 4 | | | | TEST PATTERN | | | |

CATHODE RAY TUBES

OSCILLOSCOPE AND TELEVISION RECEIVING TYPES

| TYPE | BASE CONN'S | HEATER | | DEFLEC- TION | SCREEN DIA. INCHES | USED AS | FOCUS- ING | | GRID N°1 CUTOFF VOLTS | GRID N°2 | MAX. PEAK VOLTS BET- WEEN ANODE N°2 & ANY DEFLECTION PLATE | MAXIMUM FLUORESCENT SCREEN INPUT POWER PER SQ. CENTIMETER (MILLIWATTS MOVING PATTERN) | DEFLECTION SENSITIVITY MM/VOLTS D.C. | | | PEAK TO PEAK SIGNAL SWING VOLTS | ① SCREEN MATERIAL |
|--------------|----------------|--------|------|----------------------|------------------------------|--------------|---|--|------------------------------------|-------------|---|---|--|--|----------|--|-------------------------|
| | | VOLTS | AMP. | | | | ANODE N°1 VOLTS | ANODE N°2 VOLTS | | | | | D1 & D2 | D3 & D4 | | | |
| | | | | | | | | | | | | | | | | | |
| 2AP1/1814-P1 | 17 | 6.3 | 0.6 | ELECTRO- STATIC | 2 | OSCILLOSCOPE | 125 250 | 500 1000 | -30 -60 | — | 660 | — | 0.22 0.11 | 0.26 0.13 | — | P1 | |
| 3AP1/906-P1 | 1 | 2.5 | 2.1 | ELECTRO- STATIC | 3 | OSCILLOSCOPE | 128 170 230 285 345 475 | 400 600 800 1000 1200 1500 | — -20 — -34 — -50 | — | 900 | 10 | 0.81 0.55 0.41 0.33 0.27 0.22 | 0.67 0.56 0.44 0.35 0.29 0.23 | — | P1 | |
| 3AP4/906-P4 | 1 | 2.5 | 2.1 | ELECTRO- STATIC | 3 | PICTURE TUBE | FOR OTHER CHARACTERISTICS, REFER TO TYPE 3AP1/906-P1 | | | | | | | | | P4 | |
| 3AP5/906-P5 | 1 | 2.5 | 2.1 | ELECTRO- STATIC | 3 | OSCILLOSCOPE | FOR OTHER CHARACTERISTICS, REFER TO TYPE 3AP1/906-P1 | | | | | | | | | P5 | |
| 3BP1 | 18 | 6.3 | 0.6 | ELECTRO- STATIC | 3 | OSCILLOSCOPE | 430 575 | 1500 2000 | -45 -60 | — | 550 | — | 0.153 0.115 | 0.207 0.155 | — | P1 | |
| 3DP1 | 18 | 6.3 | 0.6 | ELECTRO- STATIC | 3 | OSCILLOSCOPE | 431 | 1500 | -45 | — | 550 | — | 0.17 | — | — | P1 | |
| 3EP1/1806-P1 | 2 | 6.3 | 0.6 | ELECTRO- STATIC | 3 | OSCILLOSCOPE | 431 | 1500 | -45 | — | 550 | — | 0.153 | 0.205 | — | P1 | |
| 3FP7 | 20 | 6.3 | 0.6 | ELECTRO- STATIC | 3 | OSCILLOSCOPE | 575 | ANODE # 2 2000 ANODE # 3 4000 (5) | -60 | — | 550 | — | 0.101 | 0.141 | — | P7 | |
| 3GP1 | 19 | 6.3 | 0.6 | ELECTRO- STATIC | 3 | OSCILLOSCOPE | 234 350 | 1000 1500 | -33 -50 | — | 500 | — | 0.32 0.211 | 0.36 0.241 | — | P1 | |
| 3GP4 | 19 | 6.3 | 0.6 | ELECTRO- STATIC | 3 | OSCILLOSCOPE | FOR OTHER CHARACTERISTICS, REFER TO TYPE 3GP1 | | | | | | | | | P4 | |
| 3GP5 | 19 | 6.3 | 0.6 | ELECTRO- STATIC | 3 | OSCILLOSCOPE | FOR OTHER CHARACTERISTICS, REFER TO TYPE 3GP1 | | | | | | | | | P5 | |
| 3HP7 | 21 | 6.3 | 0.6 | ELECTRO- MAGNETIC | 3 | OSCILLOSCOPE | — | 4000 | -27 | 150 | FOCUSING, 398 AMPERE TURNS | | | — | P7 | | |
| 5AP1/1805-P1 | 2 | 6.3 | 0.6 | ELECTRO- STATIC | 5 | OSCILLOSCOPE | 432 575 | 1500 2000 | -27 -35 | — | 500 | 10 | 0.23 0.17 | 0.26 0.21 | 15 20 | P1 | |
| 5AP4/1800-P1 | 2 | 6.3 | 0.6 | ELECTRO- STATIC | 5 | PICTURE TUBE | FOR OTHER CHARACTERISTICS, REFER TO TYPE 5AP1/1805-P1 | | | | | | | | | P4 | |
| 5BP1/1802-P1 | 2 | 6.3 | 0.6 | ELECTRO- STATIC | 5 | OSCILLOSCOPE | 250 310 425 | 1200 1500 2000 | — -21 -35 | — | 500 | 10 | 0.50 0.40 0.30 | 0.55 0.44 0.33 | — | P1 | |
| 5BP2 | 2 | 6.3 | 0.6 | ELECTRO- STATIC | 5 | OSCILLOSCOPE | FOR OTHER CHARACTERISTICS, REFER TO TYPE 5BP1/1802-P1 | | | | | | | | | P2 | |
| 5BP4/1802-P4 | 2 | 6.3 | 0.6 | ELECTRO- STATIC | 5 | PICTURE TUBE | FOR OTHER CHARACTERISTICS, REFER TO TYPE 5BP1/1802-P1 | | | | | | | | | P4 | |
| 5BP5 | 2 | 6.3 | 0.6 | ELECTRO- STATIC | 5 | OSCILLOSCOPE | FOR OTHER CHARACTERISTICS, REFER TO TYPE 5BP1/1802-P1 | | | | | | | | | P5 | |
| 5CP1 | 20 | 6.3 | 0.6 | ELECTRO- STATIC | 5 | PICTURE TUBE | 430 | ANODE # 2 1500 ANODE # 3 3000 (5) | -45 | — | 550 | — | 0.37 | 0.45 | — | P1 | |

| | | | | | | | | | | | | | | | | |
|--------------|----|-----|-----|------------------|---|--------------|---|--|------------|------------|----------------------------|----|----------------|--------------|----|----|
| 5CP4 | 20 | 6.3 | 0.6 | ELECTRO-STATIC | 5 | PICTURE TUBE | FOR OTHER CHARACTERISTICS, REFER TO TYPE 5CP1 | | | | | | | | P4 | |
| 5CP5 | 20 | 6.3 | 0.6 | ELECTRO-STATIC | 5 | OSCILLOSCOPE | FOR OTHER CHARACTERISTICS, REFER TO TYPE 5CP1 | | | | | | | | P5 | |
| 5CP7 | 20 | 6.3 | 0.6 | ELECTRO-STATIC | 5 | OSCILLOSCOPE | 575 | ANODE # 2 2000 ANODE # 3 4000 (5) | -60 | - | 550 | - | 0.276 | 0.326 | - | P7 |
| 5FP7 | 22 | 6.3 | 0.6 | ELECTRO-MAGNETIC | 5 | OSCILLOSCOPE | - | 4000 | -45 | 250 | FOCUSING, 398 AMPERE TURNS | | | | - | P7 |
| 5GP1 | 2 | 6.3 | 0.6 | ELECTRO-STATIC | 5 | OSCILLOSCOPE | 337 | 1500 | -30 | - | 550 | - | 0.94 | 0.47 | - | P1 |
| 5HP1 | 2 | 6.3 | 0.6 | ELECTRO-STATIC | 5 | OSCILLOSCOPE | 337 425 | 1500 2000 | -30 -40 | - | 500 | - | 0.40 0.30 | 0.45 0.33 | - | P1 |
| 5HP4 | 2 | 6.3 | 0.6 | ELECTRO-STATIC | 5 | PICTURE TUBE | FOR OTHER CHARACTERISTICS, REFER TO TYPE 5HP1 | | | | | | | | P4 | |
| 5JP1 | 23 | 6.3 | 0.6 | ELECTRO-STATIC | 5 | OSCILLOSCOPE | 390 | ANODE # 2 1500 ANODE # 3 3000 (5) | -56 | - | 500 | - | 0.33 | 0.374 | - | P1 |
| 5JP2 | 23 | 6.3 | 0.6 | ELECTRO-STATIC | 5 | OSCILLOSCOPE | FOR OTHER CHARACTERISTICS, REFER TO TYPE 5JP1 | | | | | | | | P2 | |
| 5JP4 | 23 | 6.3 | 0.6 | ELECTRO-STATIC | 5 | PICTURE TUBE | FOR OTHER CHARACTERISTICS, REFER TO TYPE 5JP1 | | | | | | | | P4 | |
| 5JP5 | 23 | 6.3 | 0.6 | ELECTRO-STATIC | 5 | OSCILLOSCOPE | FOR OTHER CHARACTERISTICS, REFER TO TYPE 5JP1 | | | | | | | | P5 | |
| 5LP1 | 24 | 6.3 | 0.6 | ELECTRO-STATIC | 5 | OSCILLOSCOPE | 375 | ANODE # 2 1500 ANODE # 3 3000 (5) | -45 | - | 550 | - | 0.33 | 0.374 | - | P1 |
| 5LP2 | 24 | 6.3 | 0.6 | ELECTRO-STATIC | 5 | OSCILLOSCOPE | FOR OTHER CHARACTERISTICS, REFER TO TYPE 5LP1 | | | | | | | | P2 | |
| 5LP4 | 24 | 6.3 | 0.6 | ELECTRO-STATIC | 5 | PICTURE TUBE | FOR OTHER CHARACTERISTICS, REFER TO TYPE 5LP1 | | | | | | | | P4 | |
| 5LP5 | 24 | 6.3 | 0.6 | ELECTRO-STATIC | 5 | OSCILLOSCOPE | FOR OTHER CHARACTERISTICS, REFER TO TYPE 5LP1 | | | | | | | | P5 | |
| 5MP1 | 1 | 2.5 | 2.1 | ELECTRO-STATIC | 5 | OSCILLOSCOPE | 250 375 | 1500 1500 | -33 -50 | - | 660 | - | 0.365 | 0.423 | - | P1 |
| 5MP4 | 1 | 2.5 | 2.1 | ELECTRO-STATIC | 5 | PICTURE TUBE | FOR OTHER CHARACTERISTICS, REFER TO TYPE 5MP1 | | | | | | | | P4 | |
| 5MP5 | 1 | 2.5 | 2.1 | ELECTRO-STATIC | 5 | OSCILLOSCOPE | FOR OTHER CHARACTERISTICS, REFER TO TYPE 5MP1 | | | | | | | | P5 | |
| 5NP1 | 2 | 6.3 | 0.6 | ELECTRO-STATIC | 5 | OSCILLOSCOPE | 337 | 1500 | -30 | - | 500 | - | 0.4 | 0.445 | - | P1 |
| 7AP4 | 3 | 2.5 | 2.1 | ELECTRO-MAGNETIC | 7 | PICTURE TUBE | 675 | 3500 | -67.5 | - | - | 5 | - | - | 15 | P4 |
| 7BP7/1813-P7 | 22 | 6.3 | 0.6 | ELECTRO-MAGNETIC | 7 | OSCILLOSCOPE | - | 4000 | 45 | 250 | FOCUSING, 398 AMPERE TURNS | | | | P7 | |
| 7CP1/1811-P1 | 25 | 6.3 | 0.6 | ELECTRO-MAGNETIC | 7 | OSCILLOSCOPE | 780 1365 | 4000 7000 | -45 -45 | 250 250 | - | - | - | - | - | P1 |
| 9AP4/1804-P4 | 4 | 2.5 | 2.1 | ELECTRO-MAGNETIC | 9 | PICTURE TUBE | 1225 1425 | 6000 7000 | -38 -40 | 250 250 | - | 5 | - | - | 25 | P4 |
| 9CP4 | 26 | 2.5 | 2.1 | ELECTRO-MAGNETIC | 9 | PICTURE TUBE | - | 7000 | -110 | - | - | 10 | - | - | 25 | P4 |
| 9GP7 | 22 | 6.3 | 0.6 | ELECTRO-MAGNETIC | 9 | OSCILLOSCOPE | - | 4000 | -45 | 250 | FOCUSING, 398 AMPERE TURNS | | | | P7 | |
| 9JP1/1809-P1 | 27 | 2.5 | 2.5 | ELECTRO-STATIC | 9 | OSCILLOSCOPE | 785 1570 | 2500 5000 | -45 -90 | - | 3000 | - | 0.272 0.136 | - | - | P1 |

| TYPE | BASE CONN'S | HEATER | | DEFLEC-TION | SCREEN DIA. INCHES | USED AS | FOCUS-ING ANODE | | GRID N°1 CUTOFF VOLTS | GRID N°2 | MAX. PEAK VOLTS BETWEEN ANODE N°2 & ANY DEFLECTION PLATE | MAXIMUM FLUORESCENT SCREEN INPUT POWER PER SQ. CENTIMETER (MILLIWATTS MOVING PATTERN) | DEFLECTION SENSITIVITY MM/VOLTS D.C. | | | PEAK TO PEAK SIGNAL SWING VOLTS | ① SCREEN MATERIAL |
|---------------|-------------|--------|------|-------------------------|-----------------------|--------------|--|--|--------------------------|------------|--|---|--------------------------------------|---------------------------------|----------|---------------------------------|-------------------|
| | | VOLTS | AMP. | | | | -VOLTS | VOLTS | | | | | D ₁ & D ₂ | D ₃ & D ₄ | | | |
| 9LP7 | 22 | 6.3 | 0.6 | ELECTRO-MAGNETIC | 9 | OSCILLOSCOPE | — | 4000 | -80 | 250 | FOCUSING, 398 AMPERE TURNS | | | | P7 | | |
| 12AP4/1803-P4 | 4 | 2.5 | 2.1 | ELECTRO-MAGNETIC | 12 | PICTURE TUBE | 12 40 14 60 | 6000 7000 | -75 -75 | 25C 250 | — | 5 | — | — | 25 25 | P4 | |
| 12CP4 | 26 | 2.5 | 2.1 | ELECTRO-MAGNETIC | 12 | PICTURE TUBE | — | 7000 | -110 | — | — | 10 | — | — | 25 | P4 | |
| 12DP7 | 21 | 6.3 | 0.6 | ELECTRO-MAGNETIC | 12 | OSCILLOSCOPE | — | 4000 | -45 | 250 | FOCUSING, 396 AMPERE TURNS | | | | P7 | | |
| 12GP7 | 28 | 6.3 | 0.6 | ELECTRO-STATIC | 12 | OSCILLOSCOPE | 12 30 | ANODE # 2 4300 ANODE # 3 5500 (S) | -140 | — | — | — | 0.35 | 0.37 | — | P7 | |
| 24-XH | 5 | 6.3 | 0.6 | ELECTRO-STATIC | 2 | OSCILLOSCOPE | 120 | 600 | -60 | — | — | 10 | 0.14 | 0.16 | — | P5 | |
| 902-(P1) | 5 | 6.3 | 0.6 | ELECTRO-STATIC | 2 | OSCILLOSCOPE | 100 150 | 400 600 | -80 -80 | — | 350 | 5 | 0.28 0.19 | 0.33 0.22 | — | P1 | |
| 903 | 4 | 2.5 | 2.1 | ELECTRO-MAGNETIC | 9 | OSCILLOSCOPE | 1360 | 7000 | -120 | 25C | — | 10 | — | — | — | P1 | |
| 904 | 6 | 2.5 | 2.1 | ELECTRO-STATIC-MAGNETIC | 5 | OSCILLOSCOPE | 970 | 4600 | -140 | 250 | 4300 | 10 | 0.09 | — | — | P1 | |
| 905 | 7 | 2.5 | 2.1 | ELECTRO-STATIC | 5 | OSCILLOSCOPE | 450 | 2000 | -60 | — | 1000 | 10 | 0.19 | 0.23 | — | P1 | |
| 906-P1 | 1 | 2.5 | 2.1 | ELECTRO-STATIC | 3 | OSCILLOSCOPE | SAME AS TYPE 3AP1/906-P1 | | | | | | | | | | |
| 906-P4 | 1 | 2.5 | 2.1 | ELECTRO-STATIC | 3 | PICTURE TUBE | SAME AS TYPE 3AP4/906-P4 | | | | | | | | | | |
| 906-P5 | 1 | 2.5 | 2.1 | ELECTRO-STATIC | 3 | OSCILLOSCOPE | SAME AS TYPE 3AP5/906-P5 | | | | | | | | | | |
| 907 | 7 | 2.5 | 2.1 | ELECTRO-STATIC | 3 | OSCILLOSCOPE | FOR OTHER CHARACTERISTICS, REFER TO TYPE 905 | | | | | | | | | | P5 |
| 908 | 1 | 2.5 | 2.1 | ELECTRO-STATIC | 3 | OSCILLOSCOPE | FOR OTHER CHARACTERISTICS, REFER TO TYPE 3AP1/906-P1 | | | | | | | | | | P5 |
| 909 | 7 | 2.5 | 2.1 | ELECTRO-STATIC | 5 | OSCILLOSCOPE | FOR OTHER CHARACTERISTICS, REFER TO TYPE 905 | | | | | | | | | | P2 |
| 910 | 1 | 2.5 | 2.1 | ELECTRO-STATIC | 3 | OSCILLOSCOPE | FOR OTHER CHARACTERISTICS, REFER TO TYPE 3AP1/906-P1 | | | | | | | | | | P2 |
| 911 | 1 | 2.5 | 2.1 | ELECTRO-STATIC | 3 | OSCILLOSCOPE | FOR OTHER CHARACTERISTICS, REFER TO TYPE 3AP1/906-P1 ② | | | | | | | | | | P1 |
| 912 | 8 | 2.5 | 2.1 | ELECTRO-STATIC | 5 | OSCILLOSCOPE | 3000 | 15000 | -125 | 250 | 7000 | 10 | 0.028 | 0.034 | — | P1 | |
| 913 | 5 | 6.3 | 0.6 | ELECTRO-STATIC | 1 | OSCILLOSCOPE | 100 | 500 | -65 | — | 250 | 5 | 0.07 | 0.10 | — | P1 | |
| 914 | 9 | 2.5 | 2.1 | ELECTRO-STATIC | 9 | OSCILLOSCOPE | 1450 | 7000 | -50 | 250 | 3000 | 10 | 0.073 | 0.093 | — | P1 | |
| 1800 | 4 | 2.5 | 2.1 | ELECTRO-MAGNETIC | 9 | PICTURE TUBE | 1250 | 6000 | -75 | 250 | — | 10 | — | — | 25 | P3 | |
| 1801 | 10 | 2.5 | 2.1 | ELECTRO-MAGNETIC | 5 | PICTURE TUBE | 450 | 3000 | -35 | — | — | 10 | — | — | 20 | P3 | |
| 1802-P1 | 2 | 6.3 | 0.6 | ELECTRO-STATIC | 5 | OSCILLOSCOPE | SAME AS TYPE 5BP1/1802-P1 | | | | | | | | | | |

| | | | | | | | | | | | | | | | | |
|---------|----|-----|-----|----------------------|----|--------------|----------------------------|-----|---|---|---|---|------|------|---|----|
| 1802-P4 | 2 | 6.3 | 0.6 | ELECTRO- STATIC | 5 | PICTURE TUBE | SAME AS TYPE 5BP4/1802-P4 | | | | | | | | | |
| 1803-P4 | 4 | 2.5 | 2.1 | ELECTRO- MAGNETIC | 12 | PICTURE TUBE | SAME AS TYPE 12AP4/1803-P4 | | | | | | | | | |
| 1804-P4 | 4 | 2.5 | 2.1 | ELECTRO- MAGNETIC | 9 | PICTURE TUBE | SAME AS TYPE 9AP4/1804-P4 | | | | | | | | | |
| 1805-P1 | 2 | 6.3 | 0.6 | ELECTRO- STATIC | 5 | OSCILLOSCOPE | SAME AS TYPE 5AP1/1805-P1 | | | | | | | | | |
| 1805-P4 | 2 | 6.3 | 0.6 | ELECTRO- STATIC | 5 | PICTURE TUBE | SAME AS TYPE 5AP4/1805-P4 | | | | | | | | | |
| 1806-P1 | 2 | 6.3 | 0.6 | ELECTRO- STATIC | 3 | OSCILLOSCOPE | SAME AS TYPE 3EP1/1806-P1 | | | | | | | | | |
| 1809-P1 | 27 | 2.5 | 2.1 | ELECTRO- STATIC | 9 | OSCILLOSCOPE | SAME AS TYPE 9JP1/1809-P1 | | | | | | | | | |
| 1811-P1 | 25 | 6.3 | 0.6 | ELECTRO- MAGNETIC | 7 | OSCILLOSCOPE | SAME AS TYPE 7CP1/1811-P1 | | | | | | | | | |
| 1813-P7 | 22 | 6.3 | 0.6 | ELECTRO- MAGNETIC | 7 | OSCILLOSCOPE | SAME AS TYPE 7BP7/1813-P7 | | | | | | | | | |
| 1814-P1 | 17 | 6.3 | 0.6 | ELECTRO- STATIC | 2 | OSCILLOSCOPE | SAME AS TYPE 2AP1/1814-P1 | | | | | | | | | |
| 2002 | 5 | 6.3 | 0.6 | ELECTRO- STATIC | 2 | OSCILLOSCOPE | 120 | 600 | - | - | - | - | 0.16 | 0.17 | - | P1 |

REFERENCES

¹Screen materials are classified as follows: Phosphor no. 1 is of medium persistence and produces green fluorescence. Phosphor no. 2 is of long persistence and produces bluish-white fluorescence. Phosphor no. 3 is of medium persistence and produces yellow fluorescence. Phosphor no. 4 is of medium persistence and produces white fluorescence. Phosphor no. 5 is of short persistence and produces bluish fluorescence.

Phosphor no. 7 is of long persistence and produces bluish fluorescence.

²Type 911 is identical with type 906 except that the gun material is designed to be unusually free from magnetization effects.

³Collector, grid no. 2, and anode no. 2 are connected together within the tube.

⁴Collector and anode no. 2 are connected together within the tube.

⁵Anode no. 3 is an intensifier electrode.

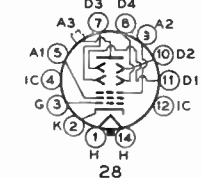
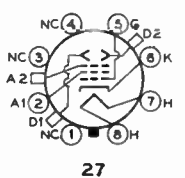
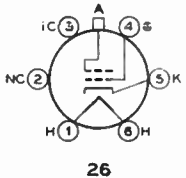
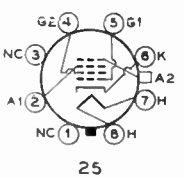
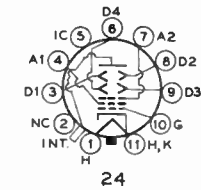
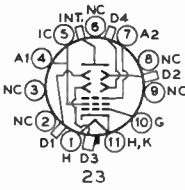
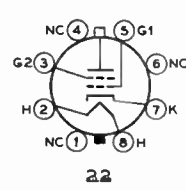
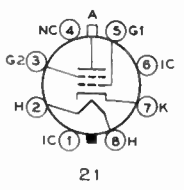
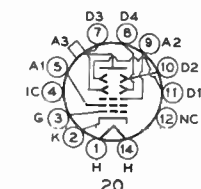
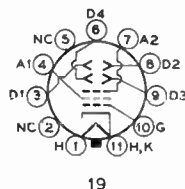
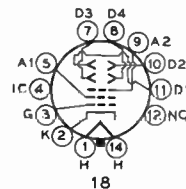
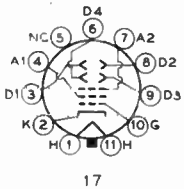
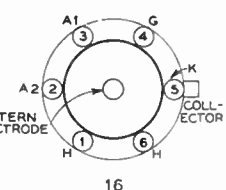
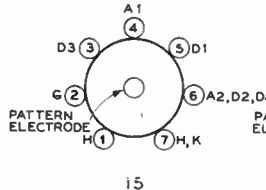
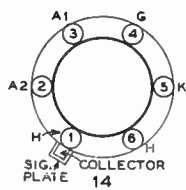
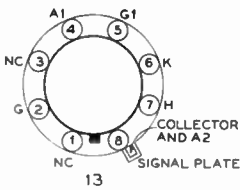
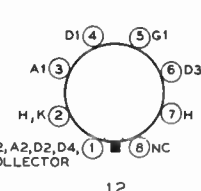
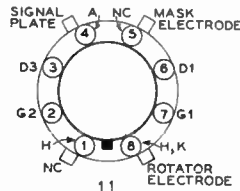
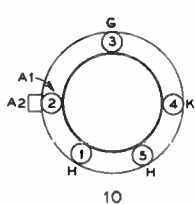
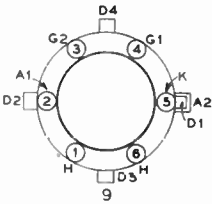
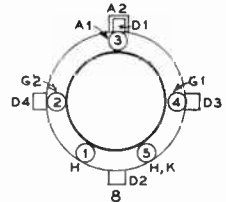
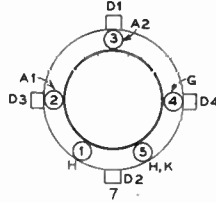
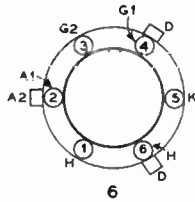
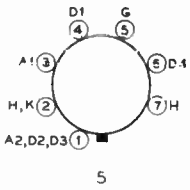
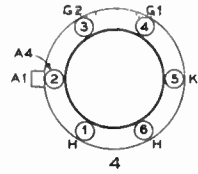
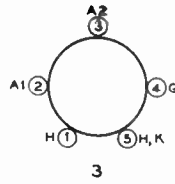
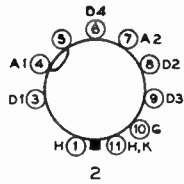
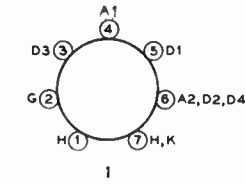

Radio Receiver Construction

THE receivers to be described in this chapter can, for the most part, be constructed with a few inexpensive hand tools. Whether one saves anything over purchasing a factory built receiver depends upon several factors (see Chapter 26). In any event, there is the satisfaction of constructing one's own equipment, and the practical experience that can be gained only by actually building apparatus.

After finishing the wiring of these receivers it is suggested that one go over the wiring very carefully to check for errors before applying plate voltage to the receiver. If possible, have someone else check the wiring after you have gone over it yourself. Some tubes can be damaged permanently by having screen voltage applied when there is no voltage on the plate. Electrolytic condensers can be damaged permanently by hooking them up backwards (wrong polarity). Transformer, choke, and coil windings can be burned out by incorrect wiring of the high voltage leads. Almost any tube can be damaged by incorrect connections; no tube can last long with plate voltage applied to the control grid.

Before starting construction, be sure to read the Chapter on *Workshop Practice*.

SIMPLE 2-TUBE AUTODYNE

A simple yet versatile receiver of modest cost is illustrated in Figures 1, 2, and 4. The receiver uses an autodyne detector and one stage of impedance coupled a.f. to give good earphone volume on all signals. The circuit is simple, as inspection of Figure 3 will disclose.

The receiver uses 6.3-volt tubes, which may be supplied heater power from either a small 6.3-volt filament transformer or a regular 6-volt auto battery. For regular home use a transformer is recommended, but the provision for use with a battery permits semiportable operation. This makes the receiver a good one for a beginner, as it can later be used for a portable or emergency receiver, if one decides

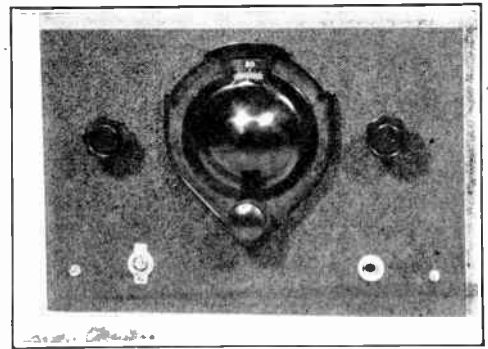

Figure 1.
SIMPLE 2-TUBE AUTODYNE RECEIVER.

This receiver is inexpensive to build and has excellent weak signal response. While not as selective as more elaborate receivers, it makes a good set for the newcomer's first receiver.

to build or buy a more elaborate receiver.

Plate voltage is supplied from a standard medium-duty 45-volt B battery. Such a battery, costing only a little over a dollar, will last over a year with normal use, as the B current drain of the receiver is only a few milliamperes. This voltage is sufficient for good performance of the receiver, because the full plate voltage is supplied to the detector as a result of the use of a choke (CH₁) instead of the usual plate resistor in the plate circuit of the detector. Also, the *amplification* of the 6C5 is practically as great at 45 volts as at the full maximum rated voltage of 250 volts. The maximum undistorted power output of the a.f. stage is considerably less at 45 volts, but as it is more than sufficient to drive a pair of phones, there is no point in using higher plate voltage. For these reasons, a single B battery was decided upon in preference to an a.c. pow-

er pack, because the battery is not only much less expensive but also permits portable operation.

When wired as shown in the diagram, the receiver should not be used with higher plate voltage, because the screen potentiometer is across the full plate voltage, and also because the 1¼-volt bias on the 6C5 is not sufficient for higher plate voltage.

If inexpensive components are chosen, the receiver can be built for about \$12, including B battery and midjet filament transformer.

While the receiver will operate on 30 megacycles and a 30-Mc. coil is included in the coil table, the receiver is designed primarily for 14-, 7.0-, and 3.5-Mc. operation. No matter how well constructed, an autodyne receiver is not particularly effective on 30 Mc., especially for phone reception.

For 14-, 7.0-, and 3.5-Mc. operation the receiver compares favorably with the most expensive when it comes to picking up weak, distant stations, especially on c.w. However, in common with all autodyne receivers, loud local signals have a tendency to block, and therefore more trouble will be experienced with QRM than with a superheterodyne.

The chassis consists of a 6 x 9-inch Masonite "Presdwood" top and a 1¾-inch back of the same material. These are fastened to two pieces of wood which form the sides of the chassis. The wooden sides are 1¾ inches high, ¾ inch thick, and are 6 inches long, including the Masonite back. The whole thing is held together with wood screws, as may be seen in

COIL TABLE

For 2-Tube Autodyne

All coils wound with no. 22 d.c.c. on standard 1½-inch forms

3.5-4.0 MC.

29 turns closewound; cathode tap 1½ turns from ground

7.0-7.3 MC.

16 turns spaced 1¾ inches; cathode tap 1½ turns from ground

14.0-14.4 MC.

7 turns spaced 1¼ inches; cathode tap 1½ turns from ground

21.0-21.5 MC.

5 turns spaced 1¼ inches; cathode tap 1 turn from ground

28-30 MC.

4 turns spaced 1¼ inches; cathode tap 1 turn from ground

Figures 2 and 4. A 7 x 11-inch metal front panel is attached by means of wood screws sunk in the wooden end pieces of the chassis.

Inexpensive wafer sockets are used. Because the thickness of the chassis would make it necessary to drill holes large enough to take the whole tube base if the sockets were mounted below the chassis, as is customary with metal chassis, the sockets are mounted

Figure 2.
BACK VIEW OF THE
2-TUBE AUTODYNE.

The chassis is made of wood and Masonite wall board. The "shield hat" for the grid leak and capacitor hides most of the main tuning capacitor.



- C₁—15- μ fd. midget variable
- C₂—100- μ fd. midget variable
- C₃—0.001- μ fd. smallest size mica capacitor
- C₄—0.25- μ fd. tubular, 400 volts
- C₅—0.005- μ fd. midget mica
- C₆—0.1- μ fd. tubular, 400 volts
- R₁—3 meg., 1/2 watt
- R₂—50,000-ohm potentiometer
- R₃—250,000 ohms, 1/2 watt
- R₄—500,000 ohms, 1/2 watt
- CH₁—300 or more hy., 5 ma.
- BC—1 1/4-volt bias cell
- L₁—See coil table

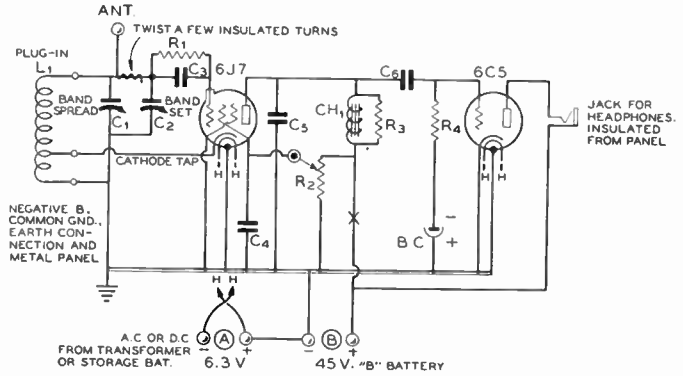

Figure 3.
WIRING DIAGRAM OF 2-TUBE AUTODYNE.
 By substituting a 6S7 for the 6J7 and a 6L5-G for the 6C5, the receiver can be run economically from dry cells for heater power. Only 4 1/2 volts is required, and three no. 6 dry cells will give over 150 hours life.

on top of the chassis. This is clearly illustrated in the photographs.

Correct connection of the socket terminals can be assured by referring to the socket connections for the 6J7 and 6C5 in Chapter 5. Bear in mind that these are bottom views of the sockets, with the socket facing you the same as when soldering to the terminals from the underside of the chassis.

Connections for filament and plate power are made by means of a terminal strip which is mounted over a hole cut in the back of the chassis. If the proper tools for cutting out a long, rectangular hole are not available, four separate holes about 3/8 inch in diameter will take the terminal screws and lugs. If desired, the terminal strip can be replaced by four Fahnestock clips screwed directly to the back of the chassis.

The phone jack is shown mounted on the front panel, along with a toggle switch in the B plus lead. If mounted on the metal front panel, the phone jack must be insulated from the panel by means of fiber washers to prevent shorting the plate voltage. The jack can be mounted on the back of the chassis, in which case it will not require insulating washers.

The screen potentiometer is across the B battery and draws a small amount of current even with the filaments turned off; hence, it is necessary either to unhook the B battery when the set is not in use, or else incorporate a switch to accomplish the same thing. If desired, a potentiometer with an "off switch" can be used, in which case the B battery may be disconnected simply by turning the potentiometer knob all the way to the left. The

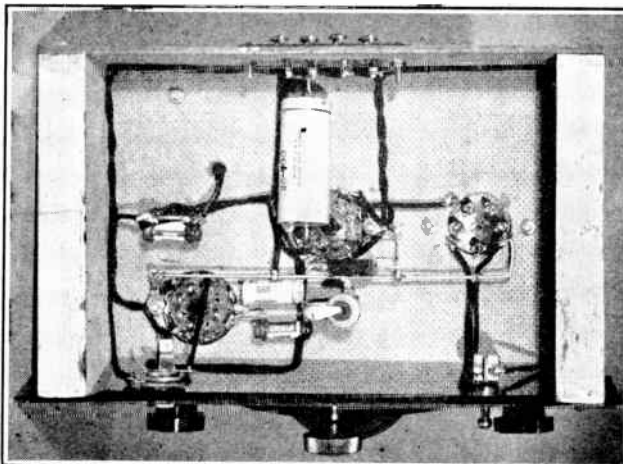

Figure 4.
UNDER-CHASSIS VIEW OF 2-TUBE AUTODYNE.
 The construction of the chassis and placement of components is clearly illustrated. If desired the phone jack may be mounted on the back of the chassis.

heaters are turned off by turning off the 110-volt supply to the filament transformer.

As is true with any grid leak type detector, the grid lead (including the grid leak and condenser) must be shielded thoroughly in order to avoid bad hum pickup, commonly known as "grid hum." This is accomplished effectively by soldering the grid leak and grid capacitor (both of the smallest physical size procurable) directly to the grid clip, and shielding the whole business by means of a "hat" consisting of a regular metal tube grid shield cap to which is soldered a rectangular piece of tin can or galvanized iron as shown in the illustration. The latter measures about $1\frac{1}{2} \times 3$ inches and is bent in the form of a "U," then soldered to the grid clip shield. Care must be taken that the shield does not short out against any of the connecting leads.

The antenna may consist of a 50 to 100 foot length of wire as high and in the clear as possible. It is capacitance coupled to the receiver by means of a few turns of insulated wire around the grid lead. A small 3-30 μfd . compression type mica trimmer may be substituted for the twisted wire as a variable coupling capacitor, if desired.

After the correct position of the bandset capacitor (C_s) is determined for a given band, a scratch or mark is made on the back rotor plate to enable one to adjust the bandset capacitor for any band simply by observing the marks on the bandset capacitor.

The wiring diagram assumes that the receiver will be used with magnetic type ear-

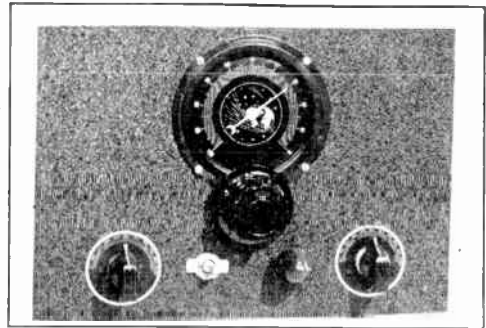

Figure 5.
SIMPLE 3-TUBE
SUPERHETERODYNE

The bandset capacitor is to the left, the detector "resonating" capacitor to the right. The latter makes an effective volume control. The small knob operates the regeneration potentiometer.

phones. If crystal earphones are used, a small 30-hy. choke should be connected across the headphone jack.

SIMPLE 3-TUBE SUPERHETERODYNE

The small superheterodyne shown in the accompanying illustrations has many of the advantages of sets having many more tubes. It has good image rejection, selectivity and

Figure 6.
REAR VIEW OF THE
SIMPLE SUPER.

The detector coil is to the left, directly above the detector tuning capacitor, and the oscillator coil is to the right. Antenna terminals, power socket, speaker plug socket, and earphone jack may be seen on the back-drop of the chassis.



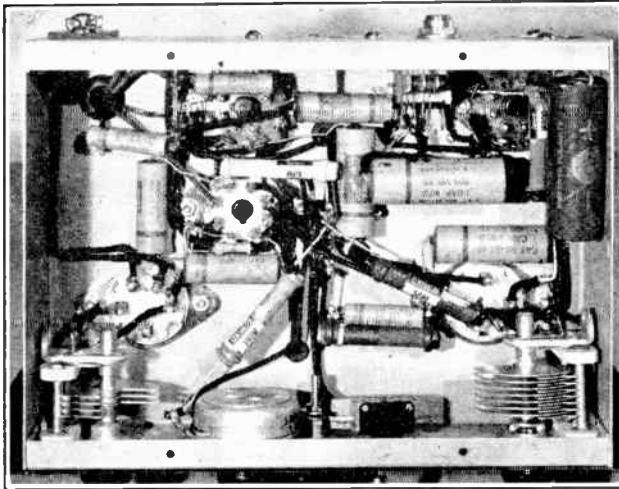

Figure 7.
UNDER-CHASSIS VIEW
OF SIMPLE SUPER.

Not much room to spare, but all components fit without crowding. The phone jack is mounted directly on the rear drop of the metal chassis; because of the method of connection, no insulating washers are required.

sensitivity, and drives either phones or a dynamic loudspeaker to good volume.

A 6K8 converter directly feeds a regenerative second detector operating at a frequency just above 1500 kc. The latter is impedance coupled to a beam tetrode audio tube. The

plate current and audio power output are too great for a pair of phones; so the phones are connected in the screen circuit.

Excellent selectivity and sensitivity are obtained on 'phone by running up the regeneration on the second detector right to the edge

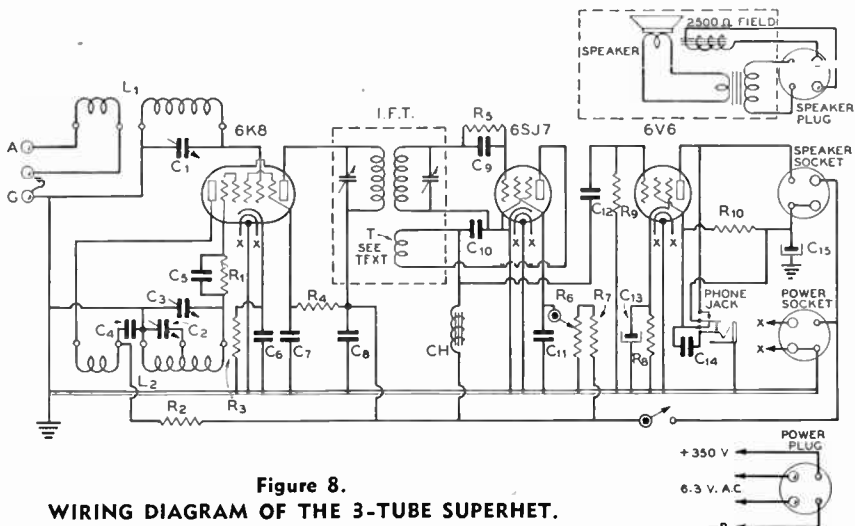
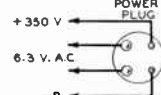

Figure 8.
WIRING DIAGRAM OF THE 3-TUBE SUPERHET.

- C₁, C₂—50- μ fd. midget variable
- C₃—140- μ fd. midget variable
- C₄, C₈, C₁₁, C₁₄—0.1- μ fd. tubular, 400 volts
- C₅, C₉—0.001- μ fd. tubular, 600 volts
- C₆, C₇, C₁₂—0.1- μ fd. tubular, 600 volts
- C₁₀—0.001- μ fd. tubular, 600 volts
- C₁₃—25- μ fd. 25 volt electrolytic
- C₁₅—4- μ fd. 450 volt midget tubular electrolytic

- R₁, R₂—50,000 ohms, 1 1/2 watts
- R₃—300 ohms, 1 watt
- R₄—40,000 ohms, 1 1/2 watts
- R₅—5 meg. insulated 1/2 watt resistor
- R₆—100,000-ohm potentiometer
- R₇—100,000 ohms, 1 1/2 watts
- R₈—400 ohms, 10 watts
- R₉—500,000 ohms, 1 1/2 watts
- R₁₀—10,000 ohms, 10 watts

- R₁₀—10,000 ohms, 10 watts
- IFT—1500 kc. replacement type i.f. trans. (see text for tickler data)
- CH—High impedance audio choke, 500 or more hy.
- Phone Jack—Two-circuit "filament lighting" type



of oscillation. By advancing the regeneration control still farther, the second detector will oscillate, thus providing autodyne reception of code signals. The regeneration also acts as a sensitivity control to prevent blocking by very loud local signals. To keep loud phone signals from blocking, the regeneration is decreased way below the edge of oscillation. To keep loud c.w. signals from blocking, the regeneration control is advanced full on.

COIL TABLE For Simple Super

1750-2050-KC. MIXER

58 turns no. 24 enam. closewound on $1\frac{1}{2}$ " form, padded with 50- μ fd. midget mica fixed capacitor placed inside form; ant. coil 14 turns closewound at ground end spaced $\frac{1}{4}$ in. from grid winding

1750-2050-KC. OSC.—3.5-4.0-MC. MIXER

42 turns no. 22 d.c.c. closewound on $1\frac{1}{2}$ " form; bandsread tap 20 turns from ground end; tickler 9 turns closewound, spaced $1/16$ " from main winding

3.5-4.0-MC. OSC.—7.0-7.3-MC. MIXER

20 turns no. 22 d.c.c. spaced to $1\frac{1}{2}$ " on $1\frac{1}{2}$ " form; bandsread tap 12 turns from ground end; tickler 8 turns closewound, spaced $\frac{1}{8}$ " from main winding

7.0-7.3-MC. OSC.—14-14.4-MC. MIXER

11 turns no. 22 d.c.c. spaced to $1\frac{1}{4}$ " on $1\frac{1}{2}$ " form; bandsread tap 5 turns from ground end; tickler 6 turns closewound, spaced $\frac{1}{8}$ " from main winding

14 14.4-MC. OSC.—28-30-MC. MIXER

$5\frac{1}{2}$ turns no. 22 d.c.c. spaced to 1 in. on $1\frac{1}{4}$ " form; bandsread tap 3 turns from ground end; tickler 4 turns closewound, spaced $1/16$ " from main winding

21.0-21.5-MC. OSC.

$4\frac{1}{4}$ turns no. 22 d.c.c. spaced to 1 inch on $1\frac{1}{4}$ " form; bandsread tap 1 turn from ground. Tickler 2 turns closewound, spaced $1/16$ " from main winding.

21.0-21.5-MC. MIXER

6 turns no. 22 d.c.c. spaced to 1 inch on $1\frac{1}{4}$ " form. Antenna coil 3 turns closewound, spaced $1/16$ " from main winding.

28-30-MC. OSC.

3 turns no. 22 d.c.c. spaced to 1" on $1\frac{1}{4}$ " form; bandsread tap $1\frac{1}{2}$ turns from ground end; tickler 2 turns closewound, spaced $1/16$ " from main winding

Tickler is always at ground end of main coil. Note that two highest frequency coils are on $1\frac{1}{4}$ " forms, rest $1\frac{1}{2}$ ". Tickler polarity must be as shown in diagram to secure oscillation.

The 6K8 converter is conventional, and no special precautions need be taken with this stage except to keep the mixer-section leads as short as possible in order to obtain maximum performance on 10 meters. A minimum number of coils is required for all-band operation (10 to 160 meters) because the oscillator coil for each band serves as the detector coil for the next higher frequency band, the tickler serving as the antenna winding. Thus all coils except the 160-meter mixer and 10-meter oscillator coils do double duty.

The set is built on a metal chassis measuring $2\frac{1}{2} \times 6 \times 8$ inches. This supports a 7×10 -inch front panel. The correct placement of components may be seen in the illustrations.

To obtain regeneration in the grid-leak type second detector, a tickler coil is added to the i.f. transformer. Inspection of Figure 8 will show that the second detector then resembles the common "autodyne" grid-leak detector with regeneration control.

For maximum performance, the detector should go into oscillation when the screen voltage is about 35 volts. This is accomplished by using as a tickler 3 turns of no. 22 d.c.c. wire wound around the dowel of the i.f. transformer, right against the grid winding. Few tickler turns are required, as there is no antenna to load the detector, and therefore it goes into oscillation with but little feedback.

To wind the tickler, simply remove the shield from the i.f. transformer, and, using a 1-foot piece of the same d.c.c. wire used to wind the plug-in coils, wrap 3 turns around the dowel as closely as possible to the grid winding. Then twist the two leads together to keep the turns in place and replace the shield. The polarity of the tickler must be correct for regeneration; if oscillation is not obtained, reverse the two tickler leads.

Care must be taken with the grid leak, grid capacitor, and grid lead of the 6SJ7; otherwise there will be "grid hum." The outside foil of the tubular grid capacitor should go to the i.f. grid coil and *not* to the grid of the tube. The connection to the grid pin of the 6SJ7 socket should be kept as short as possible—not over $\frac{1}{2}$ inch, and both grid leak and grid capacitor should be kept at least $\frac{1}{2}$ inch from other wiring. In some cases it may be necessary to shield the grid leak and capacitor with a small piece of grounded tin in order to eliminate grid hum completely.

The phone jack is a special type, commonly called a 2-circuit "filament lighting" jack. It is connected so that when the phones are inserted they not only are connected in the screen circuit in such a way that no d.c. flows through the phones, but the speaker transformer is shorted out in order to silence the speaker. Switching the plate of the 6V6 di-

rectly to B plus also improves the quality in the phones slightly.

Any well-filtered power supply delivering between 300 and 375 volts at 50 ma. can be used to supply the receiver. If the speaker is of the p.m. type, requiring no field supply, a 200 to 250 volt power pack will suffice.

Either a 2-wire feeder or single-wire antenna worked against ground can be used. For doublet input, connect to the two antenna coil terminals. For Marconi input, ground one terminal and connect the antenna to the other.

Adjusting the mica trimmer on the grid side of the i.f. transformer changes the intermediate frequency. The trimmer on the plate coil should always be resonated for maximum signal strength. It need not be touched after the initial adjustment unless the grid trimmer is changed. The intermediate frequency should be adjusted to about 1550 kc. and then a check made to make sure it is not right on some nearby broadcast station.

The only band on which images may be bothersome is the 28-30-Mc. band. Usually objectionable images can be eliminated without serious loss in signal strength by shifting the h.f. oscillator to the other side by means of the bandset capacitor. The receiver will work with the oscillator either *higher or lower* by the intermediate frequency than the received signal. On the higher frequency bands, the bandset capacitor tunes over a wide enough

band of frequencies so that it hits both sides.

On certain bands the gain and sensitivity are better with the h.f. oscillator on one side of the detector than on the other. Some experimenting with the bandset capacitor should be made on those bands where it is possible to hit both the high and low side with the bandset capacitor.

Economical 5-Tube Superheterodyne

The sensitivity of the simple superheterodyne just described can be increased by the addition of a tuned r.f. stage ahead of the mixer. The gain and selectivity can be increased by the addition of an i.f. stage. These additions do not add greatly to the cost, and the improvement in performance makes their use highly desirable. The construction, however, is somewhat more difficult, and should not be attempted as the builder's first effort.

Electrically the receiver is essentially the same as the 3-tube superheterodyne, except for the addition of a 6K7 radio frequency stage and a 6SK7 intermediate frequency amplifier. To minimize the number of tuning controls, the tuning capacitors for the r.f. and mixer stages are ganged together.

Mechanical Layout The r.f. stage is located on the left front corner of the 7 x 11 x 2-inch chassis. The mixer stage

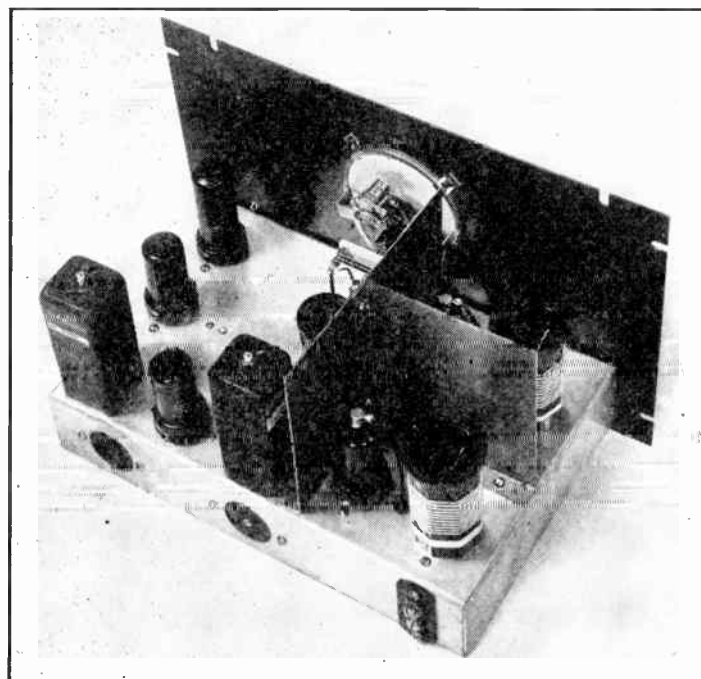
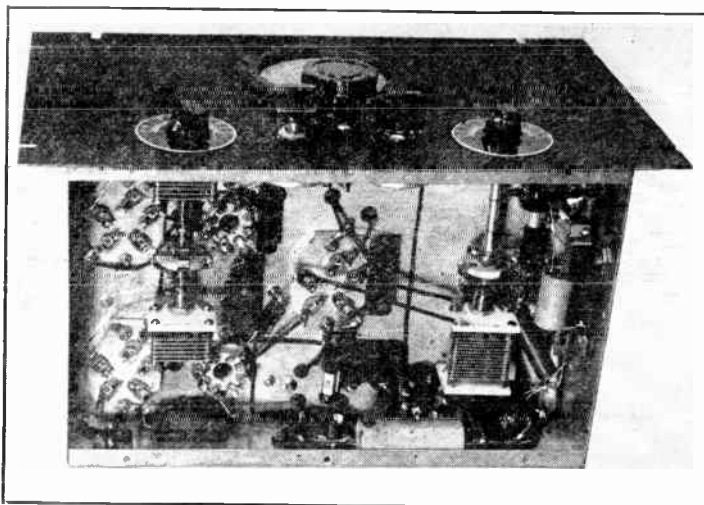

Figure 9.
TOP VIEW OF 5-TUBE
SUPERHET.

R.f. stage at the front, mixer at the rear, and the i.f. and audio strung out along the rear and far edge of the chassis. A corner of the oscillator coil may be seen peeking around the front-to-rear shield.

Figure 10.
SHOWING FRONT
PANEL AND UNDER-
SIDE OF CHASSIS.

Most of the "works" are under the chassis. The two ganged r.f. and mixer tuning capacitors are visible in this photograph, as is the oscillator band-setting capacitor.



is placed at the rear left corner of the chassis, with the shield partition visible in Figure 9 separating it from the r.f. stage. Placing the r.f. and mixer coils toward the edge of the chassis removes them from the proximity of the front-to-back shield, which otherwise might lower the gain obtained in the tuned circuits.

The under-chassis view, Figure 10, shows the location of the two 50- μ fd. ganged capacitors used to tune the r.f. and mixer stages. By reversing the usual mounting procedure on these capacitors and hanging them stator side down from the chassis, the shafts are brought out at the center of the front drop.

A small Isolantite coupling is used to gang the two capacitors.

For data on how to wind the tickler turns on the second i.f. transformer, refer to the description given for the 3-tube superheterodyne previously described. The procedure is the same for either receiver. The remarks pertaining to grid hum in the second detector also apply to the 5-tube model.

The receiver is designed for enclosure in a metal cabinet. The cabinet completes the shielding between the r.f. and mixer stages, and prevents oscillation. If a metal cabinet is not used, more elaborate shielding partitions than those shown in Figure 9 may be required.

COIL DATA For 5-Tube Super

All coils are wound with no. 22 d.c.c. wire

3.5-4.0 MC.

L₁—42 turns on 1½" dia. form; antenna 7 turns closewound

L₂—42 turns closewound on 1½" dia. form; primary 9 turns closewound

L₃—20 turns spaced to occupy 1½" on 1½" dia. form, tapped 15 turns from ground; tickler 8 turns closewound

7.0-7.3 MC.

L₁—21 turns spaced to occupy 1½" on 1½" dia. form; antenna 6 turns closewound

L₂—21 turns spaced to occupy 1½" on 1½" dia. form—primary 7 turns closewound

L₃—10 turns spaced to occupy 1¼" on 1½" dia. form, tapped 6½ turns from ground; tickler 6 turns closewound

14-14.4 MC.

L₁—11 turns spaced to occupy 1¼" on 1½" dia. form; antenna 4 turns closewound

L₂—11 turns spaced to occupy 1¼" on 1½" dia. form; primary 6 turns closewound

L₃—6 turns spaced to occupy 1" on 1¼" dia. form, tapped 4 turns from ground; tickler 4 turns closewound

21.0-21.5 MC.

L₁—Use 28-Mc. L₁ coil

L₂—Use 28-Mc. L₂ coil

L₃—5 turns spaced to occupy 1" on 1¼" dia. form, tapped 2 turns from ground end; tickler 3 turns closewound.

28-30 MC.

L₁—6 turns spaced to occupy 1" on 1¼" dia. form; antenna 4 turns closewound.

L₂—7 turns spaced to occupy 1" on 1¼" dia. form; primary 4 turns closewound

L₃—3 turns spaced to occupy 1" on 1¼" dia. form, tapped 2 turns from ground end; tickler 3 turns closewound

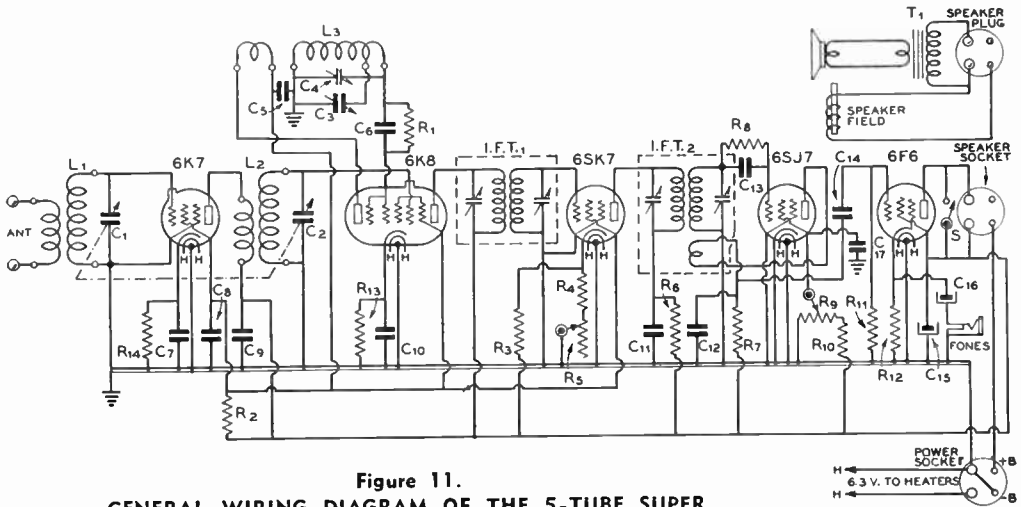

Figure 11.
GENERAL WIRING DIAGRAM OF THE 5-TUBE SUPER.

- C₁, C₂—50- μ fd. midget variable
- C₃—25- μ fd. midget variable
- C₄—140- μ fd. midget variable
- C₅—0.1- μ fd. 400-volt tubular
- C₆—0.001- μ fd. mica
- C₇—0.01- μ fd. 400-volt tubular
- C₈, C₉, C₁₀, C₁₁—0.1- μ fd. 400-volt tubular
- C₁₂—0.0005- μ fd. mica
- C₁₃—0.001- μ fd. mica

- C₁₄—0.01- μ fd. 400-volt tubular
 - C₁₅—8- μ fd. 450-volt electrolytic
 - C₁₆—10- μ fd. 25-volt electrolytic
 - C₁₇—0.1- μ fd. 400-volt tubular
- Note: Omitted from the diagram was a capacitor from the 6SK7 i.f. stage cathode to ground. This capacitor should be a .01- μ fd. 400-volt unit.

- R₁—75,000 ohms, 1/2 watt
- R₂—25,000 ohms, 2 watts
- R₃—60,000 ohms, 1 watt
- R₄—300 ohms from stop on R₅
- R₅—10,000-ohm potentiometer
- R₆—2000 ohms, 1/2 watt
- R₇—250,000 ohms, 1/2 watt
- R₈—1 megohm, 1/2 watt
- R₉—10,000-ohm potentiometer
- R₁₀—100,000 ohms, 1 watt

- R₁₁—250,000 ohms, 1/2 watt
 - R₁₂—600 ohms, 10 watts
 - R₁₃, R₁₄—300 ohms, 1/2 watt
- I.F.T.₁—1500-kc. input i.f. transformer
 I.F.T.₂—1500-kc. input i.f. transformer (see text for alterations)
 S—S.p.s.t. toggle switch
 L₁, L₂, L₃—See coil table
 T₁—Pentode output transformer (on speaker chassis)

Coils If the data given in the coil table are followed closely, no trouble should be experienced in getting the r.f. and mixer stages to track accurately. It will be noted that the r.f. and mixer coil secondaries are identical on all bands except 28-30 megacycles, where the r.f. stage has one less turn. It is a simple matter to check the tracking. All that is necessary is to loosen the set screws on the coupling between the r.f. and mixer capacitors and resonate each capacitor separately. By observing the amount of capacitance used to resonate each stage near the center of the band in question, it may be determined whether an increase or decrease in the inductance of either coil is necessary.

The oscillator bandspread tap location given in the coil table will give nearly full-dial coverage of each band. Individual constructors who may have different ideas as to the proper amount of bandspread to use may move the taps along the coils to obtain any desired amount. The 14- or 3.5- Mc. 'phone bands may be spread across the whole dial, for instance, by moving the taps on the coils for

these bands nearer the grounded end. Conversely, any one of the bands may be packed into a few dial divisions by moving the coil tap on that band to the grid end of the coil.

Initial Operation After the receiver has been connected to a power supply delivering from 250 to 300 volts and a speaker having a field resistance of 1500 to 2500 ohms, the i.f. stage and second detector input circuit should be aligned. This is best accomplished with the aid of a signal generator, operating in the 1500-to-1600 kc. range, coupled loosely to the grid of the mixer. The detector should go into oscillation very smoothly when the regeneration control, R₈, is advanced. If oscillation does not take place it is probable that the tickler is improperly phased, and the tickler connections should be reversed.

After the i.f. amplifier has been aligned, a set of coils should be plugged in and the oscillator bandsetting capacitor set to the proper capacitance for the coils in use. With a 0-100 scale, with zero at the low capacitance end, this setting will be as follows: 21 and 28 Mc., 35;

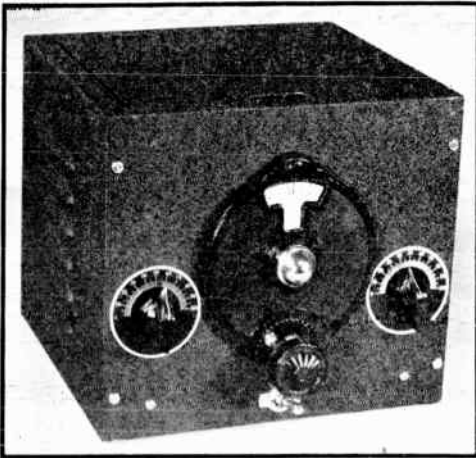

Figure 12.

THE 6K8-6J5 CONVERTER IN ITS CABINET.

This converter may be used ahead of nearly any broadcast receiver to give good high-frequency reception of both 'phone and c.w. signals. The left-hand knob controls the oscillator bandset capacitor, while the right-hand knob operates the mixer-section trimmer. The large dial is for bandspread tuning. The switch below the dial controls the b.f.o.

bandsetting control has been adjusted to center the hand on the dial, the receiver is ready for use.

CONVERTERS

Quite often it is desired to adapt a broad cast-band receiver to short-wave reception, or to improve the short-wave reception of an inexpensive "all-wave" receiver. For this purpose, one of the converters described on the following pages may be used. There is no object, of course, in adding a single-tube converter of the type shown in Figures 12 and 14 to a well-designed communications receiver which already has a high-performance converter section plus one or more r.f. stages. On the other hand, a high-gain converter of the type shown in Figures 15 and 16 often can give exceptional results when used with a good communications receiver.

6K8 Converter with B.F.O.

The unit shown in Figures 12 and 14 and diagrammed in Figure 13 is intended for use ahead of "broadcast" or "all-wave broadcast" receivers. Since receivers of this type are not usually equipped with a beat-frequency oscillator for c.w. telegraphy reception, a b.f.o. is included on the converter chassis.

Plug-in coils are used in the converter to cover the amateur bands from 3.5 to 30 Mc. with full bandspread on each band. The high-frequency broadcast and commercial code stations between the amateur bands may also be received with the coils shown, by simply ad-

14 Mc., 80; 7.0 Mc., 60; 3.5 Mc., 60. Next, the r.f. and mixer tuning control should be brought into resonance, and, after the oscillator

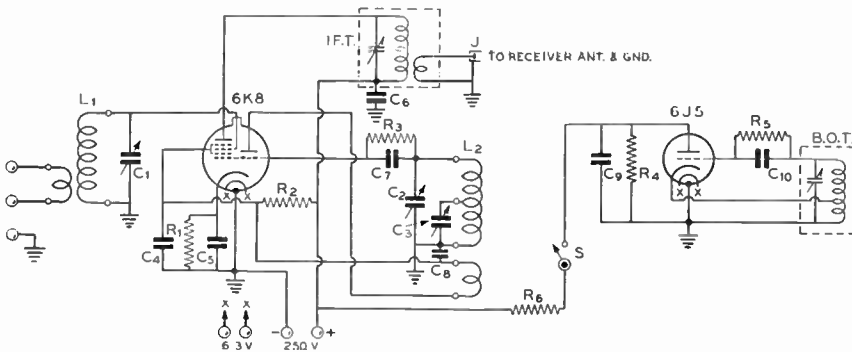



Figure 14.
TOP-REAR VIEW OF
THE CONVERTER
CHASSIS.

The mixer section is at the left front and the oscillator section at the right front in this view, with the 6K8 between the coils. The b.f.o. and output transformers are at the rear, with the 6J5 between them.

COIL DATA For 6K8-6J5 Converter

All coils are wound on 1¼" diameter forms with no. 22 d.c.c. wire

3.5-4.0 MC.

Oscillator—22 turns 1¼" long, tapped 15 turns from ground; tickler 6 turns closewound

Mixer—45 turns closewound; antenna coil 7 turns closewound

7.0-7.3 MC.

Oscillator—15 turns 1¼" long, tapped 7 turns from ground; tickler 4 turns closewound

Mixer—30 turns closewound; antenna coil 6 turns closewound

14.0-14.4 MC.

Oscillator—7 turns 1" long, tapped 3 turns from ground; tickler 3 turns inter-wound with grid winding

Mixer—14 turns 1½" long; antenna coil 5 turns closewound

21.0-21.5 MC.

Oscillator—Use 28-Mc. oscillator coil

Mixer—Use 28-Mc. mixer coil

28-30 MC.

Oscillator—3 turns 1¼" long, tapped 1 turn from ground; tickler 2 turns interwound with grid coil

Mixer—7 turns 1¼" long; antenna coil 4 turns closewound

justing the panel bandsetting capacitors to the desired frequency. The use of bandspread also allows easy tuning in these other ranges.

The unit consists essentially of a 6K8 triode-hexode converter tube functioning as a mixer and oscillator with its output on about 1600 kc., and a 6J5 b.f.o. also on 1600 kc.

Mechanical Construction The complete converter is built into a small 7 x 8 x 7½-inch cabinet of standard manufacture. The chassis is also a standard unit and is designed to be used with this particular cabinet.

Three controls and the b.f.o. switch are mounted upon the front panel. The left control is the knob on the bandset control, which consists of a 100- μ fd. variable capacitor connected across the oscillator-section coil. The center capacitor is the 35- μ fd. midget bandspread capacitor, which is operated by the main tuning dial. The right-hand control is the mixer-section tuning condenser, and consists of a 50- μ fd. midget connected directly across the grid coil.

The photograph of the chassis shows the location of most of the components. The oscillator- and mixer-section coil sockets are mounted directly behind their respective bandsetting capacitors. Steatite sockets are used for these coils, and also for the 6K8 tube, which is located in the center of the chassis

directly behind the bandspread capacitor. The output transformer, I.F.T., is located near the left rear corner of the chassis, with the 6J5 and the b.f.o. transformer to its right. The output transformer is made from a standard 1600-kc. iron-core i.f. transformer by simply removing one of the windings and winding about 20 turns of the wire from the discarded coil back around the dowel as close to the remaining winding as possible. One of the leads from the 20-turn winding is grounded, and the other is brought to an auto-type connector at the rear of the chassis. A shielded single-conductor lead should be used to connect the converter to the receiver antenna and ground terminals, the shield acting as the ground connection between the converter and receiver.

Tuning Up Tuning up the converter is a comparatively simple process, provided the coil table has been followed exactly, and provided a high gain broadcast receiver is available for the first test. The b.c. set is first tuned to 1600 kc. (or a point close to that frequency where no b.c. or police stations are audible) and the gain turned up until background noise can be heard. The 7.0-Mc. coils should be plugged into the converter, as this band is most likely to have plenty of signals day or night.

With the bandset capacitor on the oscillator at about half scale, tune the primary on the 1600-kc. output i.f. transformer in the converter at the same time that the mixer-section tuning capacitor is being rotated back and forth. A point will be found where the hiss

(or perhaps a signal) comes in loudest. The output transformer trimmer should now be adjusted for maximum hiss, after which it should not be touched. Now the oscillator bandsetting capacitor should be slowly varied, following with the mixer capacitor to keep the background noise at maximum, until the desired signals are found. The mixer trimmer should next be carefully set for maximum signal strength, and the tuning done with the bandspread dial. A single setting of the mixer bandsetting capacitor will serve for about half the bandspread capacitor tuning range, after which the mixer tuning should again be peaked for maximum signal strength.

To receive c.w. telegraph signals, the b.f.o. is turned on by means of switch S and the trimmer on the beat-oscillator transformer adjusted for a beat note of suitable pitch. If the beat-oscillator output is too great, the receiver may be blocked, or weak signals may be masked by hiss. Too little beat-oscillator output will not give a "beat" with loud signals. The b.f.o. output may be adjusted by changing the size of R_4 ; increasing the resistance will increase the output, decreasing it will decrease the output.

High Performance Converter

The converter seen in the photos of Figures 15 and 16 and the diagram of Figure 17 is intended to allow superlative performance on the 14-, 21- and 28-Mc. amateur bands when used in conjunction with a first-class communication receiver. When used with a high-performance communication receiver on the

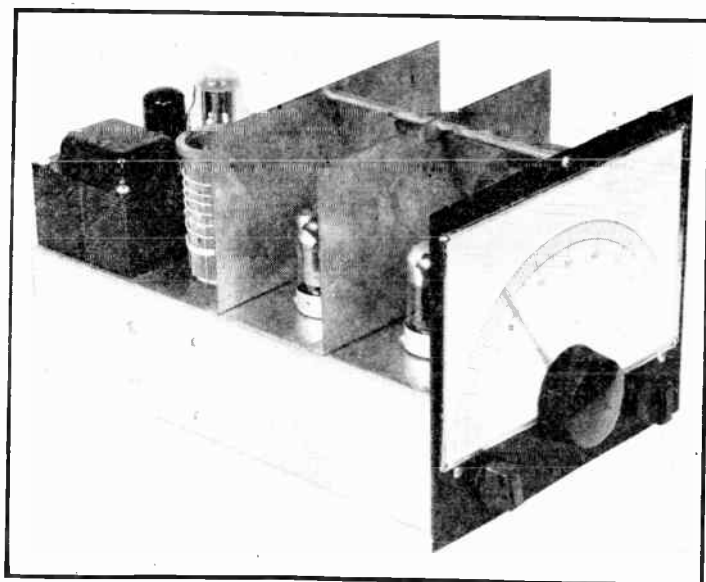

Figure 15.
THE HIGH PER-
FORMANCE CON-
VERTER.

The oscillator section is between the panel and first shield, the mixer between the two shields, and the r.f. stage behind the rear shield. The 1232 r.f. stage tube can not be seen in this view; it occupies the same position behind the rear shield as the coils take in the mixer and oscillator sections. A manufactured dial similar to the home-built one shown is now available.

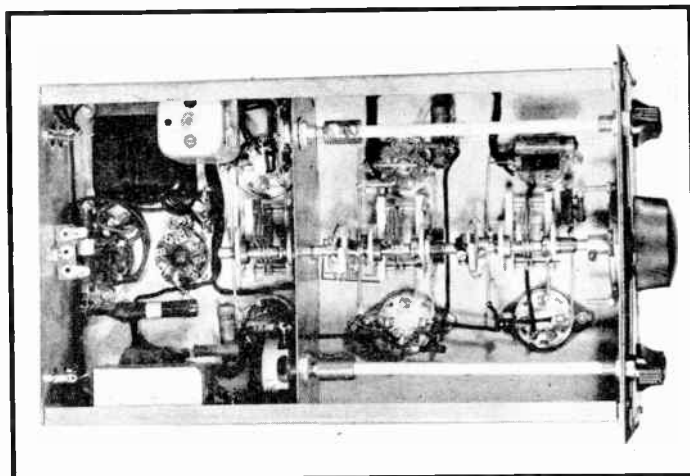

Figure 16.
UNDER-CHASSIS
VIEW OF THE
CONVERTER.

Note the shield partition between the r.f. and mixer-oscillator sections. The gain control and antenna switch are mounted on this shield.

3.5- and 7.0-Mc. bands, the converter probably will not give any great improvement in sensitivity, since such receivers by themselves are very sensitive in these bands. However, due principally to the limitations of coil switching systems, an improvement in the performance can often be made in the 14.0- and 28-Mc. ranges through the use of the converter. With modest receivers in the lower priced brackets (especially those not having an r.f. stage) the converter will also provide improved performance on 3.5 and 7.0 Mc. For this reason, data on 3.5- and 7.0-Mc. coils are included in the coil table; the converter might just as well be used on every band where its use results in improved performance.

While the heater and plate current requirements are not great, they are somewhat more than can be taken safely from the plate supply of many commercial receivers. Hence, a small power pack has been made an integral part of the unit. To prevent drift as a result of heating of the oscillator components, the oscillator is placed to the front of the chassis and the power pack to the extreme rear. This also gives a positive drive on the oscillator tuning capacitor, as there is no flexible coupling between dial and oscillator tuning capacitor to permit backlash. To stabilize the oscillator against frequency changes due to plate voltage changes (as a result of line voltage changes), a voltage regulator tube is used.

To provide maximum conversion gain in the mixer, grid leak bias and control grid injection are employed. This, in conjunction with the high gain tubes used both in the r.f. and mixer stages, gives a high potential overall gain. The full potential gain is closely approached as a result of fairly low-C low-loss tank circuits, difficult to obtain on high frequency bands with all-band bandswitching but easily ob-

tained with plug-in coils when proper mechanical layout is employed. The oscillator is made high-C for the sake of stability, as it provides more than sufficient excitation when control grid injection is employed.

For maximum signal-to-noise ratio, the r.f. stage is run "wide open" on weak signals. However, the converter has so much gain that the receiver with which it is used may be blocked on loud local signals. Hence, an r.f. gain control (R_1) is provided. This is normally left full on, and backed off only when a signal is so loud that there is blocking.

Construction The converter is constructed on a 7 x 12 x 3-inch chassis, with a front panel 7 inches high by 8 inches wide. The two stage shields are standard $5\frac{1}{2}$ x 7-inch manufactured items, cut down to a height of 4 inches.

Under the chassis, a partition is placed $5\frac{1}{4}$ inches from the rear drop. It is cut from a piece of 20 gauge sheet metal. This partition is $2\frac{3}{4}$ inches high and serves both as a shield between the r.f. and mixer stages, and as a mounting support for the antenna switch and the gain control, both of which are operated from the front panel by means of shaft extensions. No shielding is employed between the oscillator and mixer capacitors, as it is unnecessary.

All three tuning capacitors are bolted directly to the underside of the main chassis, and are connected by means of flexible shaft couplings. The arrangement of the balance of the components should be clear from inspection of the illustrations.

Output Transformer The output transformer, I.F.T., is a modified 1500-kc. i.f. transformer. The secondary wind-

ing is removed, and in its place are wound 15 turns of no. 22, d.c.c. wire as close to the primary coil as possible. To permit mounting of the transformer under the chassis, its shield can is cut off to a height of about 2 inches.

The Dial The dial seen in the photographs is constructed around a planetary reduction unit supplied as part of a manufactured vernier dial. Since the dial was built, however, the manufacturers of the reduction unit have themselves introduced a similar dial, which can be used in place of the home-made one shown. It will be necessary to cut a small slot in the top front of the chassis to take the top portion of the dial reduction unit.

Injection The control-grid injection employed provides high conversion gain, and is not especially critical as to coupling. However, if too little coupling is used,

there will be a reduction in conversion gain, and if too much coupling is used, there will likewise be a reduction in gain together with "pulling" between the mixer and h.f. oscillator when aligning the coils. Two pieces of push-back hookup wire, twisted together for about 1/2 inch, will be found to provide about the right amount of coupling if the exact mechanical layout illustrated is followed. Because of the stray capacitance coupling present, very little additional coupling capacitance will be required.

The type of control-grid injection used in this converter has two advantages: it allows the mixer cathode to be grounded directly without an intervening resistor and by-pass capacitor, and it allows the mixer bias to automatically adjust itself to the proper amount for correct operation, even though the oscillator output varies widely. Since the mixer bias is provided by a grid leak (R_5) the cir-

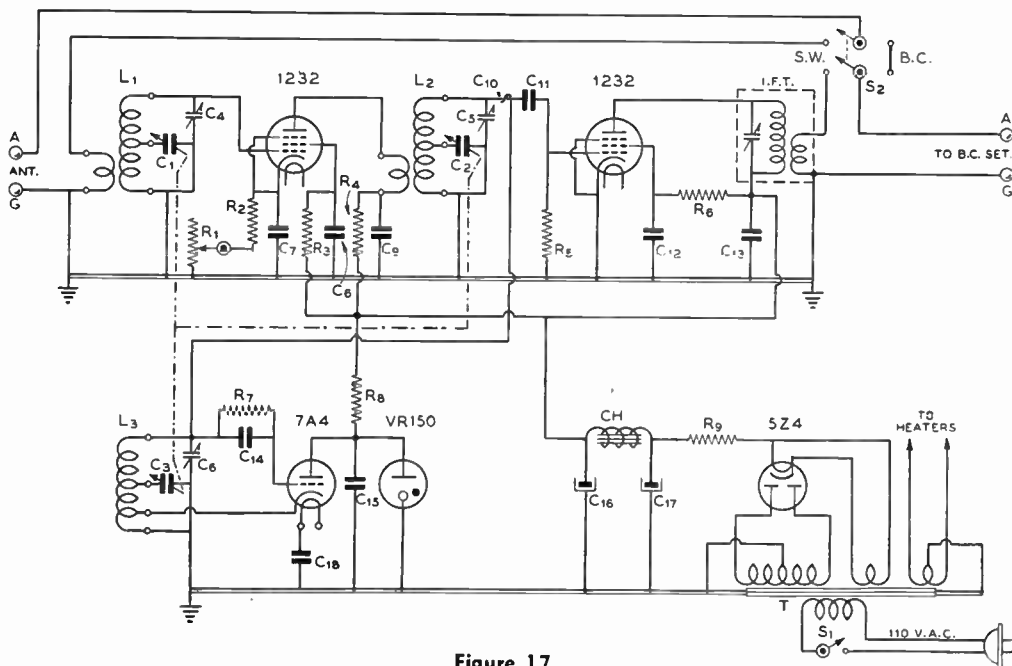

Figure 17.

WIRING DIAGRAM OF THE CONVERTER.

- C1, C2, C3 — 35- μ fd. midget variable, straight line capacity (semi-circular)
- C4, C5, C6 — Mounted inside coils, see coil table
- C7, C8, C9 — .01- μ fd. 400-volt tubular
- C10 — Injection coupling; see text
- C11 — .001- μ fd. mica

- C12, C13 — .01- μ fd. 400-volt tubular
- C14 — .001- μ fd. mica
- C15 — .01- μ fd. 400-volt tubular
- C16, C17 — 8 μ fd. 450-volt electrolytic
- C18 — .01- μ fd. 400-volt tubular
- R1 — 10,000-ohm potentiometer

- R2 — 250 ohms, 1/2 watt
- R3 — 75,000 ohms, 1/2 watt
- R4 — 2000 ohms, 1/2 watt
- R5 — 5 megohms, 1/2 watt
- R6 — 75,000 ohms, 1/2 watt
- R7 — 50,000 ohms, 1/2 watt
- R8 — 5000 ohms, 10 watts

- R9 — 2000 ohms, 10 watts
- S1 — 5-p.s.t. (on R1)
- S2 — D.p.d.f. tap switch
- I.F.T. — Modified 1500-kc. i.f. transformer; see text
- T — 700 v. c.t., 70 ma.; 5 v., 3 a.; 6.3 v. c.t., 2.5 a.
- CH — 10 hy., 40 ma.
- L1, L2, L3 — See coil table

COIL DATA

High-Performance Converter

All coils are wound with no. 22 d.c.c. wire

28 MC.

Oscillator—3 turns spaced to occupy 1¼" on 1½" dia. form; bandsread tap 1¼ turns from ground; cathode tap 1 turn from ground. C₆ is 50-μfd. air trimmer

Mixer—6 turns spaced to occupy 1½" on 1½" dia. form, tapped 1⅞ turns from ground; primary 3 turns closewound; C₅ is 12-μfd. ceramic-based mica trimmer

R.F. Stage—Same as mixer

21 MC.

Same coils as used for 28 Mc. except trimmers set to different values.

14 MC.

Oscillator—9 turns spaced to occupy 1¼" on 1½" dia. form; bandsread tap 3 turns from ground; cathode tap 2½ turns from ground. C₆ is 75-μfd. air trimmer

Mixer—12 turns spaced to occupy 1½" on 1½" dia. form, tapped 3 turns from ground; primary 6 turns closewound; C₅ is 12-μfd. ceramic-based mica.

R.F.—Stage—Same as mixer except primary

has 5 turns closewound

7 MC.

Oscillator—18 turns spaced to occupy 1½" on 1½" dia. form; bandsread tap 6 turns from ground, cathode tap 5½ turns from ground. C₆ is 75-μfd. air trimmer

Mixer—23 turns spaced to occupy 1½" on 1½" dia. form, tapped 8 turns from ground; primary 12 turns closewound; C₅ is 35-μfd. ceramic-based mica trimmer

R.F. Stage—Same as mixer except primary has 8 turns closewound

3.5 MC.

Oscillator—21 turns closewound on 1½" dia. form; bandsread tap 13 turns from ground, cathode tap 7 turns from ground. C₆ is 75-μfd. mica trimmer

Mixer—40 turns closewound on 1½" dia. form, tapped 26 turns from ground; primary 14 turns closewound. C₅ is 35-μfd. mica trimmer

R.F. Stage—Same as mixer except primary 10 turns closewound

All primary windings are placed at ground end of grid windings, and spaced approximately ¼" therefrom

cuit does have the disadvantage, however, that when the mixer is not receiving excitation from the oscillator there is no bias on the mixer, and it may draw excessive plate and screen current. For this reason, the oscillator coil should never be changed without first turning off the plate supply.

The Coils All coils are wound on standard 1½-inch 5-prong forms with no. 22 d.c.c. wire. The padding capacitors are mounted inside the coil forms, ceramic compression type being used for the r.f. and detector, and air tuned type for the oscillator coils. If the coil specifications are followed ex-

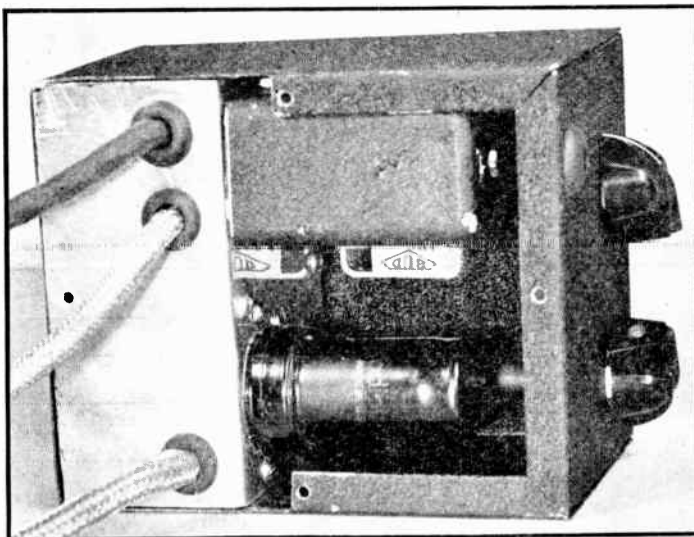

Figure 18.
ACCESSORY CRYSTAL FILTER.

Looking into the crystal with the left side plate removed. The tube and the input transformer are in the foreground in this view. The shafts to the phasing (top) and selectivity-control (bottom) capacitors are hidden from view, as is the crystal, which is behind the input transformer. The input transformer primary is trimmed to resonance through the grommet-filled hole at the upper left of the panel. Note the large shielded leads for input and output connections.

actly, no difficulty should be experienced in getting the coils to track.

The oscillator is operated on the "high side" (that is, its frequency is equal to the signal frequency *plus* the intermediate frequency) on all bands. Getting the coils to track is a simple procedure if the coil data is followed closely.

To align the coils, simply insert the proper coils for a band, adjust the oscillator padder (bandset capacitor) to center the band on the dial (making sure the oscillator is on the proper side of the signal frequency), and then, after tuning in a signal near the center of the dial, peak up the mixer and r.f. trimmers for maximum signal.

VARIABLE-SELECTIVITY CRYSTAL FILTER

The variable-selectivity crystal filter unit pictured in Figures 18 and 20 and diagrammed in Figure 19 may be built for about \$12, including the crystal and the output coupling tube. When used with a small, inexpensive communications receiver, the unit gives the owner selectivity comparable with that of the most expensive sets.

The theory of the crystal filter operation is discussed in Chapter 4, so the following description will concern only the mechanical details and operation of the unit.

Construction The complete filter, including the 6SK7 output coupling tube, is contained in a 3 x 4 x 5-inch metal box. As the photos show, the unit is constructed on an aluminum chassis which mounts vertically to one of the 4-inch sides of the box. The chassis is 2 $\frac{7}{8}$ inches wide, 1 $\frac{3}{4}$ inches high, and 3 $\frac{7}{8}$ inches long. A shield partition divides the underside of the chassis into two separate sections. On one side of the shield is the wiring associated with the input circuit up as far as the crystal and phasing capacitor, while on the other side is the output circuit and the remainder of the components. It is absolutely essential that this shield be employed, since coupling around the crystal between the input and output circuits in any manner whatsoever will completely ruin the selectivity characteristic of the unit.

A single standard i.f. transformer, which may be of either the "input" or "interstage" type, serves to provide parts for both T₁ and T₂. The transformer should be removed from its shield can and, after disconnecting the leads from the bottom coil to its trimmer, saw through the dowel about 3/16 inch below the cardboard disc under the top winding. The sawed-off bottom section of the transformer becomes the coil for T₂ when mounted to the shield partition by means of a short brass wood screw.

The secondary of T₁ is made by winding about 100 turns (the exact number is not critical) of small wire in a slot formed between the cardboard disc originally on the transformer and another circular piece of cardboard which is glued across the bottom of the dowel. If the dowel was cut off 3/16 inch below the original disc, this will make a winding slot 3/16 inch wide and about 1/2 inch deep in which to put the secondary winding. In the unit shown, this winding was made with some wire from an old i.f. winding, which happened to be handy at the moment. Any small silk- or cotton-covered wire—no. 30 or thereabouts—will do, however. The ends of the winding may be secured to the unused trimmer terminals, after which the trimmer plates may be nipped off with a pair of diagonals. Enough of the trimmer plates should be left to keep the terminal tabs from pulling through the holes in the ceramic mounting plate.

Before the input transformer is reassembled, its shield can should be cut down to a height of 2 $\frac{1}{2}$ inches, and a pair of spade bolts secured to the bottom edge by screws or rivets to allow it to be firmly mounted to the chassis.

On the output side of the under-chassis shield are mounted the output winding, T₂, the selectivity control, C₆, the fixed capacitor across T₂, and the output coupling tube with its associated resistors and by-pass capacitors.

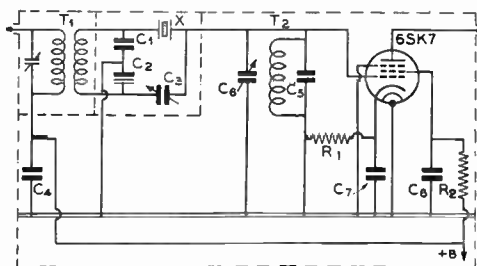

Figure 19.
CRYSTAL FILTER DIAGRAM.

C₁, C₃—0.001- μ fd. mica
C₂—25- μ fd. midget variable, one rotor and two stator plates removed. A corner of one of the rotor plates should be bent over to short out the capacitor at the maximum capacitance setting.
C₄—0.01- μ fd. 400-volt tubular
C₅—100- μ fd. zero-temperature-co-efficient fixed padder
C₆—25- μ fd. midget variable

C₇, C₈—0.1- μ fd. 400-volt tubular

R₁—500 ohms, 1/2 watt

R₂—100,000 ohms, 1/2 watt. This resistor may be eliminated and the screen run directly to positive lead if the receiver has a 100-volt plate supply.

T₁, T₂—See text

X—Filter crystal, 450-500 kc. (To match receiver intermediate frequency)

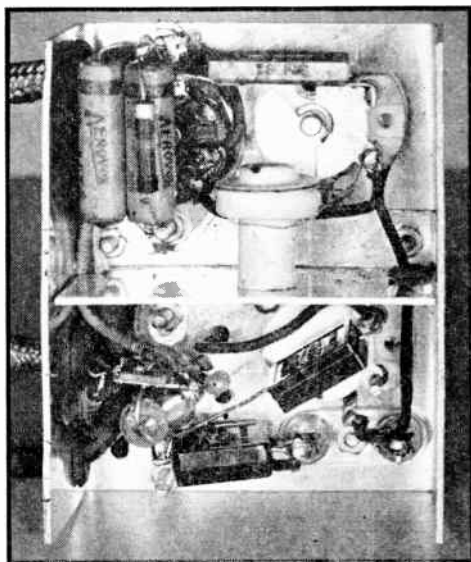

Figure 20.
UNDER THE CRYSTAL FILTER
CHASSIS.

Note the shield between the input and output sections of the filter. The input section is at the bottom, the output circuits at the top, in this view. The bypass capacitors for the 6SK7 are placed across the tube socket to help prevent oscillation from capacity coupling between the grid and plate.

A zero-temperature-coefficient padding capacitor (C_5) is used across the output winding for padding purposes.

A small 25- μ fd. variable capacitor is used for C_6 , the selectivity control. When the output circuit is tuned to resonance by means of this capacitor, the selectivity is at a minimum. As the circuit is detuned from resonance the selectivity increases.

Wiring No particular precautions need be observed in the wiring of the unit except the very important one of keeping the input and output circuits well separated and shielded from each other at all points. The only other trouble which might occur would be oscillation in the output stage. Any possibility of oscillation may be obviated by locating the screen and cathode by-pass capacitors for the 6SK7 so that they lie across the socket between the grid and plate terminals.

The shaft couplings to C_3 and C_4 are made from a piece of an inexpensive bakelite trimming tool. The hexagonal hole in the tool is small enough so that it makes a tight fit when placed over the nut on the end of the capacitor shaft. A standard $\frac{1}{4}$ -inch bakelite shaft

is run into the other end of the coupling and held in place by means of a 4-40 machine screw in a hole tapped through the coupling.

Leads to and from the filter are made from low-capacity shielded wire. The leads should not be any longer than absolutely necessary, since the additional capacity accompanying the superfluous length may be enough to prevent obtaining resonance in the input and output tuned circuits. A 3-wire cable is used to supply filament and positive B power to the unit, the negative connection being made through the shield on the input and output leads.

In order to fit the chassis into the cabinet, it is necessary to do some tailoring on the cabinet. The lip along one side of what is to be the back of the cabinet should be removed by means of tin snips or a hack saw and enough of the lips on the same side of the top and bottom removed to allow the chassis to be slid into the cabinet. The chassis is held in the cabinet by means of a 2-inch-long 6-32 machine screw through the rear of the box and the chassis.

Operation The filter is intended to be used with receivers having one stage of 450- to 500-kc. i.f. amplification. With receivers having more than one stage, trouble may be encountered with overall oscillation of the i.f. amplifier when the filter unit is added, since the filter contributes some gain. A test will determine whether the filter can be used ahead of two i.f. stages in any particular receiver. If the gain is excessive and the receiver oscillates, R_1 can be raised to about 5000 to 10,000 ohms.

To place the filter in use the input lead is connected to the plate of the receiver mixer tube, and the output lead connected to the "plate" lead from the first i.f. transformer in the receiver. The latter lead is, of course, disconnected from the mixer plate. Filament power for the filter unit may be obtained from any convenient point in the receiver, while B power should be taken from the common B positive lead in the receiver.

Before trying to tune up the filter, it is wise to check to see if there is any coupling in the receiver itself which might by-pass signals around the filter. This test may be made by connecting the filter into the receiver in the manner described above, and then removing the 6SK7 output coupling tube from the filter. With the tube removed, there should be no signals passing around the filter, and the receiver should be dead. Any external coupling which allows signals to pass around the filter should be eliminated, as it will reduce the maximum selectivity which may be obtained.

After checking for coupling around the filter and eliminating any that may be found, the

tube in the filter may be replaced and the tuning process started. As the receiver intermediate frequency should not be greatly different than that of the crystal, the preliminary tuning may be done by listening to the background noise. Simply adjust the primary trimmer on T_1 , capacitor C_6 , and the trimmer across the receiver i.f. transformer following the filter for maximum noise. The proper setting of the phasing capacitor C_3 , will be with the plates about one-third meshed, if the components shown in the original version are used.

Next, a steady signal should be picked up on the receiver and, with C_6 detuned somewhat from the "maximum noise" position, the i.f. amplifier in the receiver is peaked to the crystal. The primary trimmer on T_1 should now be checked again to make sure it is accurately tuned to resonance.

With the above adjustments made, the selectivity control, C_6 , should be detuned from resonance as far as possible (maximum selectivity), which should result in a pronounced ringing sound in the phones or speaker, and final trimming adjustments made with the signal accurately tuned in. A check on the operation of the filter may be made by setting the selectivity at maximum, switching on the receiver's beat oscillator, and accurately tuning in a c.w. signal—the correct way to tune is so that the pitch of the beat note is identical with that of the background noise. If the filter is working properly, the c.w. signal will remain at approximately constant strength as the selectivity control is turned toward the broad position, while the background noise and interfering signals will increase greatly in strength.

'Phone Operation For 'phone reception the filter may be adjusted for as little or as much selectivity as the situation requires. When QRM is not had, the filter may be cut out entirely by running the phasing capacitor to maximum capacitance, so that the bent corner of the rotor plate shorts it out. With slight QRM, the filter may be cut in and the selectivity control set at the broadest position, which results in a great reduction in heterodynes, while not greatly reducing the high-frequency speech components. Signals covered by QRM may be made readable by advancing the selectivity control toward maximum. Naturally, the sidebands of the desired signal are clipped by increasing the selectivity, thus reducing the highs, but signals may often be fully understood which would be completely lost without the filter.

One important use of the crystal filter is to eliminate 'phone heterodynes. This is done by first accurately tuning in the desired signal and then carefully adjusting the phasing capacitor to drop the heterodyning signal into the crystal

rejection notch. The ability of the crystal to eliminate heterodynes in this way depends upon the setting of the selectivity control. The closer the desired and interfering signals are together (the lower the heterodyne pitch) the more the selectivity must be increased to allow the rejection to be effective. At maximum setting the filter will allow heterodynes down to a few hundred cycles to be eliminated.

Some distortion of voice signals must be expected during heterodyne elimination, since the high selectivity of the crystal filter results in side-band clipping.

HIGH GAIN 5-BAND PRESELECTOR

If a superheterodyne has less than two stages of preselection, its performance often can be greatly improved by the addition of this high gain preselector. The improvement in image ratio and signal-to-noise ratio will be most noticeable on the higher frequency bands, and will be especially noticeable if the receiver itself has no r.f. stage at all.

The preselector uses a type 1851 pentode. This tube has a low noise level and extremely high transconductance. In fact, it is necessary to tap the plate of the tube down from the "hot" end of the tuned plate coil in order to avoid oscillation.

The tuned plate circuit is link-coupled to the input terminals of the receiver to which the preselector is to be attached. The coupling link is of the coaxial type, made of flexible shielded conductor. The use of a tuned output circuit and an efficient coupling system



Figure 21.

5-BAND HIGH GAIN PRESELECTOR.

This high gain preselector uses an 1851 tube, tuned output circuit, and moderate regeneration. It makes a worthwhile addition to any receiver having less than 2 r.f. stages.

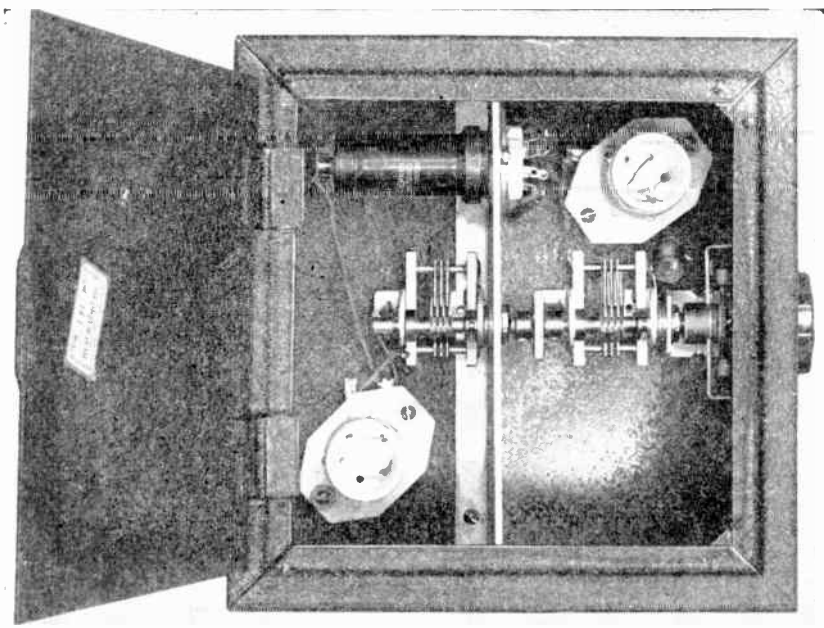

Figure 22.
LOOKING DOWN INTO THE 1851 HIGH GAIN PRESELECTOR.
An aluminum partition shields the input from the output circuit, and serves as a support for the tube and rear tuning capacitor.

makes this preselector greatly superior in performance to the simpler, more common type of 1-stage preselector in which the plate of the preselector tube is capacitively coupled to the antenna post of the receiver.

The preselector is moderately regenerative; in fact, it tends to oscillate unless the input circuit is rather tightly coupled to an antenna.

The 1851 has a very low input resistance, especially on 30 megacycles. For this reason the grid is tapped down on the input coil, being connected approximately to the center of the coil. This reduces the grid loading to one-quarter without reducing the input voltage, due to the higher impedance obtained with the tapped arrangement.

Tapping the grid and plate leads down on their respective coils effectively reduces the minimum shunt capacities, thus allowing a greater tuning range with a given tuning capacitor. With the 50- μfd . tuning capacitors illustrated, approximately a 2-1 range in frequency is possible with each set of coils. This gives practically continuous coverage of the short-wave spectrum with the coils listed in the coil table. The coils cover the following ranges: 1.7 to 3.5 Mc., 3 to 6 Mc., 6.5 to 11 Mc., 10 to 19 Mc., and 18 to 33 Mc. Thus, the preselector can be used effectively with

communication receivers of the continuous coverage all-wave type.

If oscillation is troublesome even when tight antenna coupling is used, the plate coil can be tapped a little farther down towards the ground (B plus) end.

If desired, a 6J7 or 6K7 can be used in place of the 1851. If one of these tubes is used, both grid and plate should be connected directly to the "hot" ends of their respective coils, instead of to the center. R_g should be increased to 100,000 ohms. The gain will not be quite as high as with an 1851, and the tuning range will be reduced slightly. The latter can be offset by using 75- μfd . tuning capacitors instead of 50- μfd . capacitors.

Tracking can be checked by rotating the rear tuning capacitor separately while listening to a station and watching the R meter.

Construction The unit is built in a 7 x 7 x 7-inch cabinet and chassis. A 6 $\frac{1}{4}$ x 5 $\frac{1}{4}$ -inch aluminum partition with a $\frac{1}{2}$ -inch lip to permit fastening to the chassis, as illustrated in Figure 22, shields the input from the output circuits. The rear tuning capacitor is mounted on this partition and driven from the front capacitor by means of an insulated coupling.

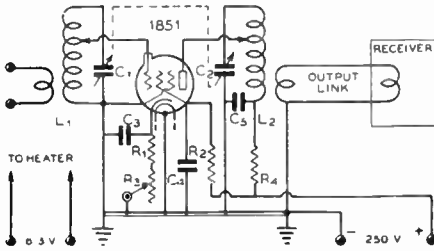

Figure 23.
SCHEMATIC CIRCUIT OF THE 1851 PRESELECTOR.

- | | |
|---|---|
| C_1, C_2 —50- μ fd. mid- -et variable | R_2 —50,000 ohms, $\frac{1}{2}$ watt |
| C_3 —0.1- μ fd. 400-volt tubular | R_3 —10,000-ohm poten- -tiometer |
| C_4, C_5 —0.1- μ fd. 400- volt tubular | R_4 —5000 ohms, 1 watt |
| R_1 —200 ohms, 1 watt | Coils—See coil table |

For maximum gain on the higher frequency range, tuning capacitors, sockets, and coil forms should have ceramic insulation.

Most receivers will stand a slight additional drain on the plate and filament supplies without overheating. For this reason, the preselector voltages may be robbed from the receiver with which the preselector is to be used. If the receiver power supply already runs quite hot, indicating that it is being overloaded, a separate power supply for the preselector is to be preferred.

Care should be taken to wind the coils in close conformity to the data given in the coil table if it is desired to "hit" the bands with-

COIL DATA
1851 Preselector

1.715-2.05 MC.

Grid—80 turns of no. 26 enam. closewound on $1\frac{1}{2}$ " dia. form; tapped 20 turns from ground; primary 12 turns
Plate—Same as grid; secondary 3 turns

3.5-4.0 MC.

Grid—44 turns no. 22 d.c.c. closewound on $1\frac{1}{2}$ " dia. form; tapped 15 turns from ground; primary 8 turns
Plate—Same as grid; secondary 3 turns

7.0-7.3 MC.

Grid—24 turns of no. 22 d.c.c. spaced to occupy $1\frac{1}{2}$ " on $1\frac{1}{2}$ " dia. form; tapped 10 turns from ground; primary 5 turns
Plate—Same as grid; except tap 12 turns from ground; secondary 3 turns

14-14.4 MC.

Grid—15 turns of no. 20 d.c.c. spaced to occupy 1" on $1\frac{1}{8}$ " dia. form; tapped at center; primary 3 turns
Plate—Same as grid; secondary 2 turns

21.0-21.5 MC.

Use same coils as for 28-30 Mc.

28-30 MC.

Grid—8 turns of no. 20 d.c.c. spaced to occupy 1" on $1\frac{1}{8}$ " dia. form; tapped at center; primary 2 turns
Plate—Same as grid; secondary 2 turns

out much cut-and-trying. The coil forms should be made of high quality dielectric; do not use cheap "mud" composition forms.

Transmitter Theory

General

A radio communication or broadcast transmitter consists of a source of radio frequency power, or *carrier*; a system for *modulating* the carrier whereby either voice or telegraph keying is superimposed upon it; and an antenna system, including feed line, for *radiating* the intelligence-carrying radio frequency power. The power supply employed to convert primary power to the various voltages required by the r.f. and modulator portions of the transmitter may also be considered part of the transmitter. Power supplies are treated separately in a later chapter.

Voice modulation usually is accomplished by varying either the amplitude or the frequency of the radio frequency carrier in accordance with the audio frequency components of intelligence to be transmitted. The process of modulation is covered in detail in chapter 8.

Radiotelegraph modulation (keying) normally is accomplished either by interrupting, shifting the frequency of, or superimposing an audio tone on the radio frequency carrier in accordance with the dots and dashes to be transmitted.

The complexity of the radio frequency generating portion of the transmitter is dependent upon the power, order of stability, and frequency desired. An oscillator feeding an antenna directly is the simplest form of radio frequency generator. A complex generator would be represented by a highly stable, high power, high frequency generator where a crystal controlled oscillator is employed for stability, several amplifier stages are utilized for isolation of the oscillator and to multiply the frequency of and amplify the magnitude of the oscillator output, and a final power amplifier is employed to build up the power to that desired for feeding the antenna.

Oscillators

In Chapter 3, it was explained that the amplifying properties of a tube having three or more elements give it the ability to generate an

alternating current of a frequency determined by the components associated with it. A vacuum tube operated in such a circuit is called an oscillator, and its function is essentially to convert a source of direct current into radio frequency alternating current of a predetermined frequency.

Oscillators for controlling the frequency of conventional radio transmitters can be divided into two general classes: self-controlled and crystal-controlled.

There are a great many types of self-controlled oscillators, each of which is best suited to a particular application. They can further be subdivided into the classifications of: negative-grid oscillators, electron-orbit oscillators, negative-resistance oscillators, and velocity modulation oscillators.

Negative-Grid Oscillators A negative-grid oscillator is essentially a vacuum-tube amplifier with a sufficient portion of the output energy coupled back into the input circuit to sustain oscillation. The control grid is biased a considerable amount negative with respect to the cathode. This oscillator finds most common application in low- and medium-frequency transmitter control circuits. Common types of negative-grid oscillators are diagrammed in Figure 1.

The Hartley Illustrated in Figure 1(A) is the oscillator circuit which finds the most general application at the present time; this circuit is commonly called the Hartley. The operation of this oscillator will be described as an index to the operation of all negative-grid oscillators; the only real difference between the various circuits is the manner in which energy for excitation is coupled from the plate to the grid circuit.

When plate voltage is applied to the Hartley oscillator shown at (A), the sudden flow of plate current accompanying the application of plate voltage will cause an electro-magnetic field to be set up in the vicinity of the coil. The building-up of this field will cause an instantaneous potential drop to appear from turn-to-

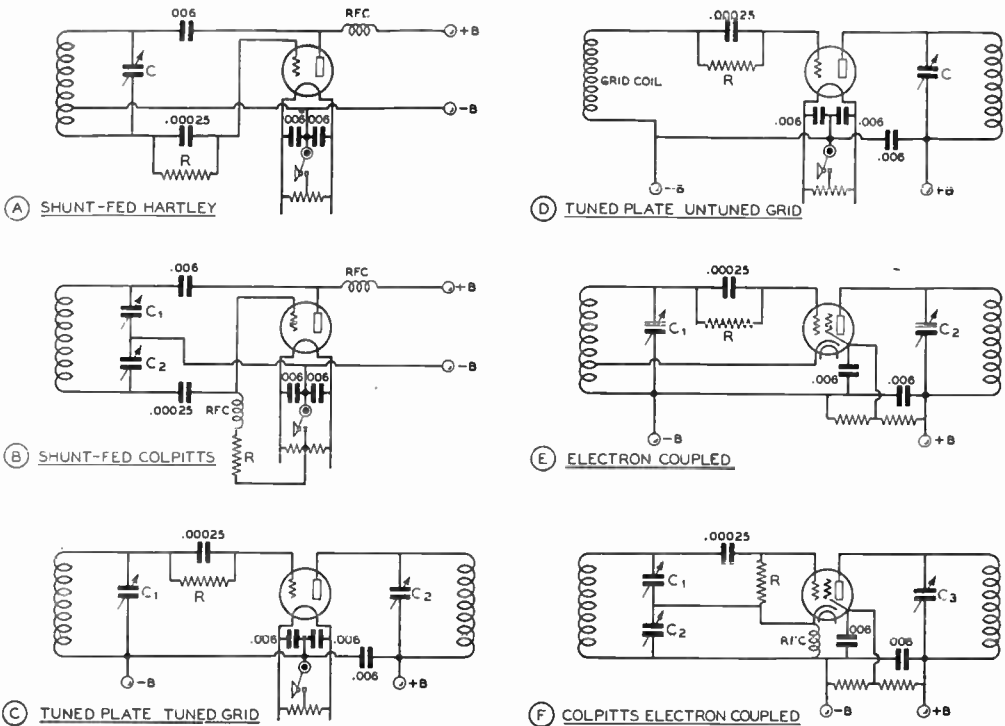

Figure 1.

COMMON TYPES OF SELF-EXCITED OSCILLATORS.

Fixed capacitor values shown are typical, but do not necessarily represent optimum values for every application. Though triodes are shown in A, B, C and D, screen grid tubes may be used, the screen being grounded to r.f. by means of a bypass capacitor.

turn along the coil. Due to the inductive coupling between the portion of the coil in which the plate current is flowing and the grid portion, a potential will be induced in the grid portion.

Since the cathode tap is between the grid and plate ends of the coil, the induced grid voltage acts in such manner as to increase further the plate current to the tube. This action will continue for a short period of time determined by the inductance and capacity of the tuned circuit, until the "flywheel" effect of the tuned circuit causes this action to come to a maximum and then to reverse itself. The plate current then decreases, the magnetic field around the coil also decreasing, until a minimum is reached, when the action starts again in the original direction and at a greater amplitude than before. The amplitude of these oscillations, the frequency of which is determined by the coil-condenser circuit, will increase in a very short period of time to a limit determined by the plate voltage or the cathode emission of the oscillator tube.

The Colpitts Figure 1 (B) shows a version of the Colpitts oscillator. It can be seen that this is essentially the same circuit as the Hartley except that the ratio of a pair of capacitances in series determine the effective cathode tap, instead of actually using a tap on the tank coil. Also, the net capacity of these two condensers comprises the tank capacity of the tuned circuit. It is somewhat less susceptible to parasitic (spurious) oscillations than the Hartley.

The T.P.T.G. The tuned-plate tuned-grid oscillator illustrated at (C) has a tank circuit in both the plate and grid circuits. The feedback of energy from the plate to the grid circuits is accomplished by the plate-to-grid interelectrode capacity within the tube. The necessary phase reversal in feedback voltage is provided by tuning the grid tank condenser to the low side of the desired frequency and the plate condenser to the high side.

For best operation of the Hartley and Colpitts oscillators, the voltage from grid to cathode

ode, determined by the tap on the coil or the setting of the two condensers, normally should be from $\frac{1}{3}$ to $\frac{1}{2}$ that appearing between plate and cathode. A broadly resonant coil may be substituted for the grid tank to form the T.N.T. oscillator shown at (D).

Electron-Coupled Oscillators

In any of the oscillator circuits just described it is possible to take energy from the oscillator circuit by coupling an external load to the tank circuit. Since the tank circuit determines the frequency of oscillation of the tube, any variations in the conditions of the external circuit will be coupled back into the frequency determining portion of the oscillator. These variations will result in frequency instability.

The frequency determining portion of an oscillator may be coupled to the load circuit only by an electron stream, as illustrated in (E) and (F) of Figure 1. When it is considered that the screen of the tube acts as the plate to the oscillator circuit, the plate merely acting as a coupler to the load, then the similarity between the cathode-grid-screen circuit of these oscillators and the cathode-grid-plate circuits of the corresponding prototype can be seen.

The electron-coupled oscillator has great stability with respect to load and voltage variation. Load variations have very little effect on the frequency, since the only coupling between the oscillating circuit and the load is through the electron stream flowing through the other elements to the plate. The plate is electrostatically shielded from the oscillating portion by the bypassed screen.

The stability of the e.c.o. with respect to variations in supply voltages is explained as follows: The frequency will shift in one direction with an increase in screen voltage, while an increase in plate voltage will cause it to shift in the other direction. By a proper proportioning of the resistors that comprise the voltage divider supplying screen voltage, it is possible to make the frequency of the oscillator substantially independent of supply voltage variations.

V.F.O. Transmitter controls

When used to control the frequency of a transmitter in which there are stringent limitations on frequency tolerance, several precautions are taken to ensure that a variable frequency oscillator will stay on frequency. The oscillator is fed from a voltage regulated power supply, is of rugged mechanical construction to avoid the effects of shock and vibration, is compensated for or protected against changes in ambient room temperature, and isolated from feedback or stray coupling from

other portions of the transmitter by shielding, filtering of voltage supply leads, and incorporation of one or more "buffer" amplifier stages. In a high power transmitter a small amount of stray coupling from the final amplifier to the oscillator can produce appreciable degradation of the oscillator stability if both are on the same frequency. Therefore, the oscillator usually is operated on a subharmonic of the transmitter output frequency, with one or more frequency multipliers between the oscillator and final amplifier.

Special UHF Oscillators

Electron-orbit and velocity modulation oscillators are used for extremely high-frequency work (above 300 Mc.) and depend for their operation upon the fact that an electron takes a finite time to pass from one element to another inside a vacuum tube. The *Klystron* and *Magnetron*, two widely used u.h.f. and microwave oscillators in the transit time and velocity modulation categories, are later described in the *u.b.f.* chapter.

Negative Resistance Oscillators

Negative-resistance oscillators often are used when unusually high frequency stability is desired, as in a frequency meter. The *dynatron* of a few years ago and the newer *transitron* are examples of oscillator circuits which make use of the negative resistance characteristic between different elements in some multi-grid tubes.

In the *dynatron*, the negative resistance is a consequence of secondary emission of electrons from the plate of a tetrode tube. By a proper proportioning of the electrode voltage, an increase in screen voltage will cause a decrease in screen current, since the increased screen voltage will cause the screen to attract a larger number of the secondary electrons emitted by the plate. Since the net screen current flowing from the screen supply will be decreased by an increase in screen voltage, it is said that the screen circuit presents a negative resistance.

If any type of tuned circuit, or even a resistance-capacitance circuit, is connected in series with the screen, the arrangement will oscillate—provided, of course, that the external circuit impedance is greater than the negative resistance. A negative resistance effect similar to the *dynatron* is obtained in the *transitron* circuit, which uses a pentode with the suppressor coupled to the screen. The negative resistance in this case is obtained from a combination of secondary emission and inter-electrode coupling, and is considerably more stable than that obtained from uncontrolled secondary emission alone in the *dynatron*.

The chief distinction between a conventional "negative grid" oscillator and a "negative re-

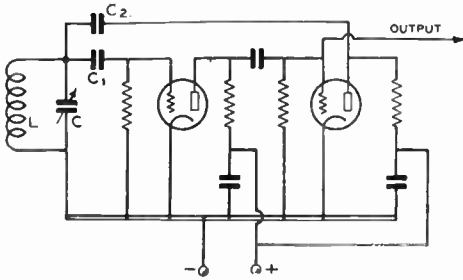

Figure 2.

THE FRANKLIN OSCILLATOR CIRCUIT.

In this oscillator, a separate phase-inverter tube is used to feed a portion of the output back into the input circuit in the proper phase to sustain oscillation.

sistance" oscillator is that in the former the tank circuit must act as a phase inverter in order to permit the amplification of the tube to act as a negative resistance, while in the latter the tube acts as its own phase inverter. Thus a negative resistance oscillator requires only an untapped coil and a single capacitor as the frequency determining tank circuit, and is classed as a "two terminal" oscillator. In fact, the time constant of an R/C circuit may be used as the frequency determining element and such an oscillator is rather widely used as a tunable audio frequency oscillator.

The Franklin Oscillator

The Franklin oscillator makes use of two cascaded tubes to obtain the negative-resistance

effect (Figure 2). The tubes may be either a pair of triodes, tetrodes, or pentodes, a dual triode, or a combination of a triode and a multi-grid tube. The chief advantages of this oscillator circuit is that the frequency determining tank only has two terminals, and one side of the circuit is grounded.

The second tube acts as a phase inverter to give an effect similar to that obtained with the dynatron or transitron, except that the effective transconductance is much higher. If the tuned circuit is replaced by an R/C circuit, the oscillator then becomes a *multivibrator*.

Quartz Crystal Oscillators

Quartz and tourmaline are naturally occurring crystals having a structure such that when plates are cut in certain definite relationships to the crystallographic axes, these plates will show the *piezo-electric* effect—the plates will be deformed in the influence of an electric field, and, conversely, when such a plate is com-

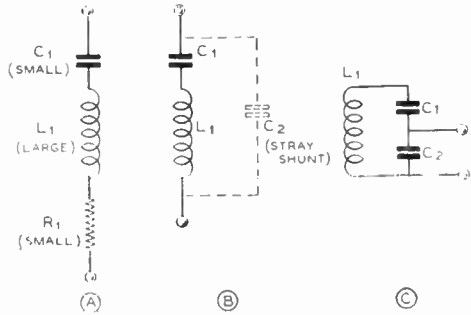

Figure 3.

EQUIVALENT ELECTRICAL CIRCUIT OF QUARTZ PLATE IN A HOLDER.

At (A) is shown the equivalent series resonant circuit of the crystal itself, at (B) is shown how the shunt capacity of the holder electrodes and associated wiring affects the circuit to produce the combination circuit of (C) which exhibits both series resonance and parallel resonance (anti-resonance), the separation in frequency being very close and determined by the ratio of C_1 to C_2 .

pressed or deformed in any way a potential difference will appear upon its opposite sides.

The crystal has mechanical resonance, and will vibrate at a very high frequency because of its stiffness, the natural period of vibration depending upon the dimensions and crystallographic orientation. Because of the piezo-electric properties, it is possible to cut a quartz plate which, when provided with suitable electrodes, will have the characteristics of a series resonant circuit with a very high L/C ratio and very high Q. The Q is several times as high as can be obtained with an inductor-capacitor combination in conventional physical sizes. The equivalent electrical circuit is shown in Figure 3A, the resistance component simply being an acknowledgment of the fact that the Q, while high, does not have an infinite value.

The shunt capacity of the electrodes and associated wiring (crystal holder and socket, plus circuit wiring) is represented by the dotted portion of Figure 3B. In a high frequency crystal this will be considerably greater than the capacity component of an equivalent series L/C circuit, and unless the shunt capacity is balanced out in a bridge circuit, the crystal will exhibit both resonant (series resonant) and anti-resonant (parallel resonant) frequencies, the latter being slightly higher than the series resonant frequency and approaching it as C_2 is increased.

The parallel resonant characteristic permits the crystal to be used in place of an L/C tank in an oscillator, with greatly increased stability as a result of the much higher Q.

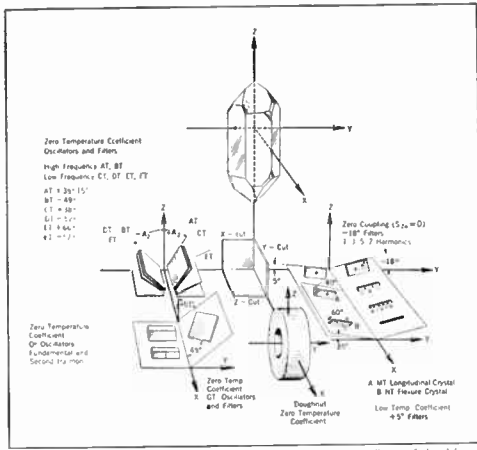

Figure 4.

ILLUSTRATING THE ORIENTATION OF QUARTZ CRYSTAL PLATES WITH RESPECT TO NATURAL CRYSTAL.

The series resonance characteristic is employed in crystal filter circuits in receivers, as covered in chapter 4, and also in certain oscillator circuits wherein the crystal is used as a selective feedback element in such a manner that the phase of the feedback is correct and the amplitude adequate only at or very close to the series resonant frequency of the crystal.

While quartz, tourmaline, and Rochelle salts crystals all exhibit the piezo-electric effect, quartz is the material widely employed for frequency control, as their characteristics make tourmaline less desirable and Rochelle salts unsuitable.

As the cutting and grinding of quartz plates has progressed to a high state of development and these plates may be purchased at prices which discourage the cutting and grinding by simple hand methods for one's own use, the procedure will be only lightly touched upon here.

The crystal "blank" is cut from the raw quartz at a predetermined orientation with respect to the optical and electrical axes, the orientation determining the activity, temperature coefficient, thickness coefficient, and other characteristics. Various orientations or "cuts" having useful characteristics are illustrated in Figure 4.

The crystal blank is then rough-ground down almost to frequency, the frequency increasing in inverse ratio to the oscillating dimension (usually the thickness). It is then finished to exact frequency either by careful

lapping, by etching, or plating. The latter process consists of finishing it to a frequency slightly higher than that desired and then silver plating the electrodes right on the crystal, the frequency decreasing as the deposit of silver is increased. If the crystal is not etched, it must be carefully scrubbed and "baked" several times to stabilize it, or otherwise the frequency and activity of the crystal will change with time. Irradiation by X-rays recently has been used in crystal finishing.

Unplated crystals usually are mounted in "pressure" or "clamped" holders, in which two electrodes are held against the crystal faces under slight pressure. Unplated crystals also are sometimes mounted in an "air gap" holder, in which there is a very small gap between the crystal and one or both electrodes. By making this gap variable, the frequency of the crystal may be altered over narrow limits (about 0.3% for certain types).

The temperature coefficient of frequency for various crystal cuts of the "-T" rotated family is indicated in Figure 4. These angles are typical, but crystals of a certain cut will vary slightly. By controlling the orientation and dimensioning, the "turning point" (point of zero temperature coefficient) for a BT cut plate may be made either lower or higher than the 75 degrees shown. Also, by careful control of axes and dimensions, it is possible to get AT cut crystals with a much flatter characteristic than is common to that type.

The first quartz plates used are either Y cut or X cut. The former had a very high temperature coefficient which was discontinuous, causing the frequency to jump at certain critical temperatures. The X cut had a moderately bad coefficient, but it was more continuous, and by keeping the crystal in a temperature controlled oven, a high order of stability could be obtained. However, the X cut crystal was considerably less active than the Y cut, especially in the case of poorly ground plates.

For frequencies between 500 kc. and about 6 Mc., the AT cut crystal now is the most widely used. It is active, can be made free from spurious responses, and has an excellent temperature characteristic. However, above about 6 Mc. it becomes quite thin, and a difficult production job. Between 6 Mc. and about 12 Mc., the BT cut plate is widely used. It also works well between 500 Kc. and 6 Mc., but the AT cut is more desirable when a high order of stability is desired and no crystal oven is employed.

For low frequency operation on the order of 100 kc., such as is required in a frequency standard, the GT cut crystal is recommended, though CT and DT cuts also are widely used for applications between 50 and 500 kc. The

CT, DT, and GT cut plates are known as *con-tour* cuts, as these plates oscillate along the long dimension of the plate or "bar", and are much smaller physically than would be the case for a regular AT or BT cut crystal for the same frequency.

Crystal Holders Crystals normally are purchased ready mounted. The best type mount is determined by the type crystal and its application, and usually an optimum mounting is furnished with the crystal. However, certain features are desirable in all holders. One of these is exclusion of moisture and prevention of electrode oxidation. The best means of accomplishing this is a metal holder, hermetically sealed, with glass insulation and a metal-to-glass bond. However, such holders are more expensive, and a ceramic or phenolic holder with rubber gasket will serve where requirements are not too exacting.

Temperature Control; Crystal Ovens Where the frequency tolerance requirements are not too stringent and the ambient temperature does not include extremes, an AT cut plate, or a BT cut plate with optimum (mean temperature) turning point, will often provide adequate stability without resorting to a temperature controlled oven. However, for broadcast stations and other applications where very close tolerances must be maintained, a thermostatically controlled oven, adjusted for a temperature slightly higher than the highest ambient likely to be encountered, must of necessity be employed.

Harmonic Cut Crystals Just as a vibrating string can be made to vibrate on its harmonics, a quartz crystal will exhibit mechanical resonance (and therefore electrical resonance) at harmonics of its fundamental frequency. When employed in the usual holder, it is possible to excite the crystal only on its odd harmonics.

By grinding the crystal especially for harmonic operation, it is possible to enhance its operation as a harmonic resonator, and BT and AT cut crystals designed for optimum operation on the 3d, 5th, and even the 7th harmonic are available. The 5th and 7th harmonic types, especially the latter, require special holder and oscillator circuit precautions for satisfactory operation, but the 3d harmonic type needs little more consideration than a regular fundamental type. A crystal ground for optimum operation on a particular harmonic may or may not be a good oscillator on a different harmonic or on the fundamental. One interesting characteristic of a harmonic cut crystal is that its harmonic frequency is not quite an exact multiple

of its fundamental, though the disparity is very small.

The harmonic frequency for which the crystal was designed is the "working frequency". It is not the "fundamental", but the crystal itself actually oscillates on this "working frequency" when it is functioning in the proper manner.

When a harmonic cut crystal is employed, a selective tuned circuit must be employed somewhere in the oscillator in order to discriminate against the fundamental frequency or undesired harmonics. Otherwise the crystal might not always oscillate on the intended frequency. For this reason the Pierce oscillator, later described in this chapter, is not suitable for use with harmonic cut crystals, because the only tuned element in this oscillator circuit is the crystal itself.

Crystal Current; Heating and Fracture For a given crystal operating as an anti-resonant tank in a given oscillator at fixed load impedance and plate and screen voltages, the r.f. current through the crystal will increase as the shunt capacity C_2 of Figure 3 is increased, because this effectively increases the "step up ratio" of C_1 to C_2 . For a given shunt capacity, C_2 , the crystal current for a given crystal is directly proportional to the r.f. voltage across C_2 . This voltage may be measured by means of a vacuum tube voltmeter having a low input capacitance, and such a measurement is a more pertinent one than a reading of r.f. current by means of a thermogalvanometer inserted in series with one of the leads to the crystal holder.

The function of a crystal is to provide accurate frequency control, and unless it is used in such a manner as to take advantage of its inherent high stability, there is no point in using a crystal oscillator. For this reason a crystal oscillator should not be run at high plate input in an attempt to obtain considerable power directly out of the oscillator, as such operation will cause the crystal to heat, with resultant frequency drift and possible fracture.

Crystal Oscillator Circuits

Considerable confusion exists as to nomenclature of crystal oscillator circuits, due to a tendency to name a circuit after its discoverer. Nearly all the basic crystal oscillator circuits were either first used or else developed independently by G. W. Pierce, but he has not been so credited in all the literature.

Use of the crystal oscillator in master oscillator circuits in radio transmitters dates back to about 1924 when the first application articles appeared.

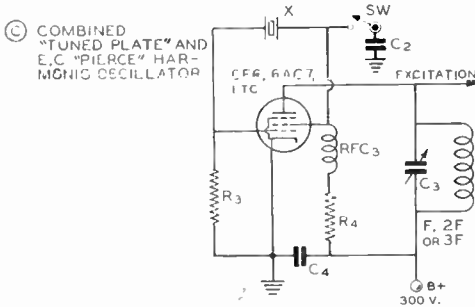
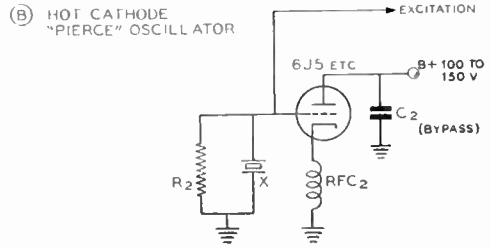
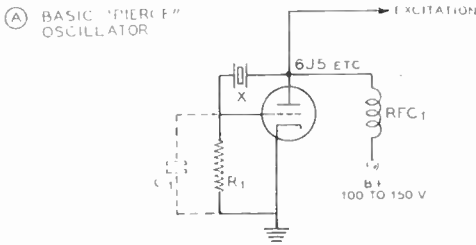

Figure 5.
BASIC PIERCE OSCILLATOR CIRCUIT AND VARIATIONS.

(A) shows the basic Pierce oscillator circuit. Unless the shunt capacity contributed by the following stage is low, C_1 usually will be required for optimum operation. Its value normally is from 25 to 75 μfd . The choke RFC_1 may be replaced by a non inductive resistor of 50,000 ohms. A much higher plate supply voltage then will be required.

(B) shows the circuit of (A) with the r.f. ground moved to the plate, the cathode floating. This permits grounding one side of the crystal, and makes available the full r.f. voltage across the crystal for excitation to the next stage.

(C) shows a modified Pierce which is electron coupled to a tank delivering high harmonic output. Closing switch Sw grounds the screen to r.f. and the oscillator then may be used as a "tuned plate" oscillator of the type illustrated in Figure 6-B for output on the fundamental crystal frequency. Some beam tetrodes do not work well with Sw open in this circuit. A pentode having high transconductance is recommended.

The Pierce Oscillator The Circuit of 5(A) is the simplest crystal oscillator circuit. It is one of those developed by Pierce, and is generally known among amateurs as the "Pierce oscillator". The crystal simply replaces the tank circuit in a Colpitts or ultra-audio oscillator. The r.f. excitation available to the next stage is low, being somewhat less than that developed across the crystal. Condenser C_1 will make more of the voltage across the crystal available for excitation, and sometimes will be found necessary to ensure oscillation. Its value is small, usually approximately equal to or slightly greater than the stray capacity from the plate circuit to ground (including the grid of the stage being driven).

If the r.f. choke has adequate inductance, a crystal (even a harmonic cut crystal) will almost invariably oscillate on its fundamental. The Pierce oscillator therefore cannot be used with harmonic cut crystals.

The circuit at B is the same as that of A except that the plate instead of the cathode is operated at ground r.f. potential. All of the r.f. voltage developed across the crystal is available for excitation to the next stage, but

still is low for reasonable values of crystal current. For best operation a tube with low heater-cathode capacity is required.

The circuit at C is an electron coupled Pierce oscillator which delivers higher excitation voltage at two or three times the fundamental crystal frequency than the r.f. voltage developed across the crystal. For "straight through" operation on the crystal frequency, Sw should be closed, converting the circuit to that of Figure 6B. A pentode tube with very high transconductance and a screen configuration which permits a fair amount of screen current will give optimum operation on harmonics. The screen acts as the anode of a triode oscillator when Sw is open, and some of the "beam" tetrodes draw too little screen current to do the job. A type 6AG7 tube will work nicely even with crystals having rather poor activity. A 6F6 will work with crystals having normal activity.

Tuned-Plate Crystal Oscillator The circuit shown in Figure 6A is also one used by Pierce, but is more widely referred to as the "Miller" oscillator. To avoid confusion, we shall refer to it as the

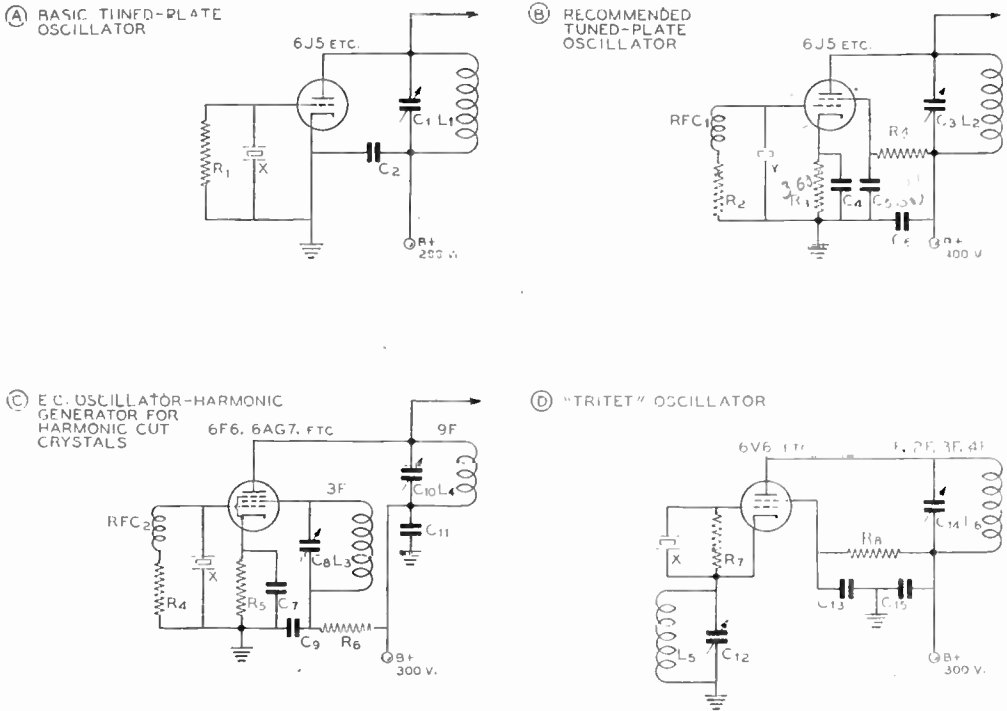

Figure 6.

BASIC TUNED-PLATE CRYSTAL OSCILLATOR AND VARIATIONS.

(A) shows the basic "Tuned-Plate" oscillator. The plate tank must be tuned to a frequency somewhat higher than that of the crystal, in order to obtain the necessary phase shift in the feedback voltage.

(B) shows the tuned plate oscillator as most widely employed. A video or a.f. power type pentode or beam tetrode permits high output with low crystal current. R_1 prevents the tube from drawing excessive plate current when the stage is not oscillating.

(C) shows an electron coupled oscillator of the tuned plate type for use with harmonic cut crystals when it is desired to obtain a high order of frequency multiplication directly out of the oscillator stage. A 3rd harmonic cut crystal is assumed. 3F represents the "working frequency" of the crystal, the fundamental F being of no real concern in this type circuit.

(D) shows another variation of the "tuned plate" oscillator. The screen acts as the anode of a triode crystal oscillator, coupling to the plate tank being via the electron stream. Tank L₁-C₁₁ still is in the oscillator "plate" circuit, even though it is connected between cathode and ground. The cathode of an oscillator is the reference point; the ground connection is arbitrary in so far as the oscillator is concerned.

"tuned plate" crystal oscillator. It is essentially an Armstrong or "tuned plate-tuned grid" oscillator with the crystal replacing the usual L-C grid tank. The plate tank C₁-L₁ must be tuned to a frequency slightly higher than the anti-resonant (parallel resonant) frequency of the crystal. Whereas the Pierce circuits of Figure 5 will oscillate at (or very close to) the anti-resonant frequency of the crystal, the circuits of Figure 6 will oscillate at a frequency a little above the anti-resonant frequency of the crystal.

The diagram shown in Figure 6A is the basic circuit. The most popular version of the tuned plate oscillator employs a pentode or beam tetrode with cathode bias to prevent excessive plate dissipation when the circuit is not oscillating. The resistor R₁ is optional. Its omission will reduce both crystal current and oscillator efficiency, resulting in somewhat more output for a given crystal current. The tube usually is an audio or video type beam pentode or tetrode, the plate-grid capacity of such tubes being sufficient to ensure stable

oscillation but not so high as to offer excessive feedback with resulting high crystal current. The 6V6 makes an excellent all-around tube for this type circuit.

When a harmonic cut crystal is employed and it is desired to obtain operating frequency excitation with the minimum number of tubes, a 6AG7 in the circuit of Figure 6C is suitable. However, as tubes are relatively cheap, and no saving in tank circuits is realized, it usually is preferable to use a tuned plate oscillator such as that shown at B together with the required number of frequency multiplier stages. The 9F output of a circuit such as that shown at C is quite low.

Special Harmonic Oscillators Appreciable harmonic output may be obtained from a number of crystal oscillators which are simply variations of either Figure 5C or Figure 6C. The most common ones simply have the screen of the tube bypassed to ground for r.f., with the r.f. choke or tuned tank moved from the screen to the cathode circuit. In the latter class is the "Tritet" circuit widely employed by amateurs for a number of years (Figure 6D). The only advantage of grounded screen operation is that "straight through" operation on the fundamental crystal frequency is improved; in fact, the "hot" screen circuit of Figure 6C should be employed only where harmonic output is desired.

Whereas a 6AG7 pentode is recommended for Figure 6C, a beam tetrode is preferable for Figure 6D unless the pentode has the suppressor brought out separately so that it may be connected to ground instead of to the cathode. If the suppressor is connected to the cathode inside the tube, undesirable feedback will result, as the screen then no longer shields the control grid from the plate.

Crystal Oscillator Tuning The tunable circuits of all oscillators illustrated should be tuned for maximum output as indicated by maximum excitation to the following stage, except that the oscillator plate tank of tuned plate oscillators (C_1 of Figure 6A, C_2 of Figure 6B, etc.) should be backed off slightly towards the low capacity side from maximum output, as the oscillator then is in a more stable condition and sure to "take off" immediately when power is applied. This is especially important when the oscillator is keyed, as for break-in c.w. operation.

Crystal Switching It is desirable to keep stray shunt capacities in the crystal circuit as low as possible, regardless of the oscillator circuit. If a selector switch is

used, this means that both switch and crystal sockets must be placed close to the oscillator tube socket. This is especially true of harmonic cut crystals operating on a comparatively high frequency. In fact, on the highest frequency crystals it is preferable to use a turret arrangement for switching, as the stray capacities can be kept lower.

Crystal Oscillator Keying When the crystal oscillator is keyed, it is necessary that crystal activity and oscillator tube transconductance be moderately high, and that oscillator loading and crystal shunt capacity be low. Below 2500 kc. and above 6 Mc. these considerations become especially important. Sometimes a low frequency crystal showing good activity will not follow rapid keying, the reasons for which are not fully understood. A similar crystal of the same order of Q and activity often will key satisfactorily in the same circuit.

Radio Frequency Amplifiers

The output of the oscillator stage in a transmitter (whether it be self-controlled or crystal controlled) must be kept down to a fairly low level to maintain stability and to maintain a factor of safety from fracture of the crystal when one is used. The low power output of the oscillator is brought up to the desired power level by means of radio-frequency amplifiers. The two classes of r.f. amplifiers that find widest application in radio transmitters are the class B and class C types.

The Class B Amplifier Class B amplifiers are used in a radio-telegraph transmitter when maximum power gain is desired in a particular stage. A class B amplifier operates with cut-off bias and a comparatively small amount of excitation. Power gains of 20 to 200 or so are obtainable in a well-designed class B amplifier. The plate efficiency of a Class B c.w. amplifier will run around 65 per cent.

The Class B Linear Amplifier Another type of class B amplifier is the class B linear stage as employed in radio-phone work. This type of amplifier is used to increase the level of a modulated carrier wave, and depends for its operation upon the linear relation between excitation voltage and output voltage. Or, to state the fact in another manner, the power output of a class B linear stage varies linearly with the square of the excitation voltage.

The class B linear amplifier is operated with cutoff bias and a small value of excitation, the actual value of exciting power being such

that the power output under carrier conditions is one-fourth of the peak power capabilities of the stage. Class B linears are very widely employed in broadcast and commercial installations, but are comparatively uncommon in amateur application, since tubes with high plate dissipation are required for moderate output. The carrier efficiency of such an amplifier is approximately 33 per cent.

The Class C Amplifier Class C amplifiers are very widely used in all types of transmitters. Good power gain may be obtained (values of gain from 3 to 20 are common) and the plate circuit efficiency may be, under certain conditions, as high as 85 per cent. Class C amplifiers operate with considerably more than cutoff bias and ordinarily with a large amount of excitation as compared to a class B amplifier. The bias for a normal class C amplifier is such that plate current on the stage flows for approximately 120° of the 360° excitation cycle. Class C amplifiers are used in transmitters where a fairly large amount of excitation power is available and good plate circuit efficiency is desired.

Plate Modulated Class C The characteristic of a class C amplifier which makes it linear with respect to changes in plate voltage is that which allows such an amplifier to be *plate modulated* for radiotelephony. Through the use of higher bias than is required for a c.w. class C amplifier and greater excitation, the linearity of such an amplifier may be extended from zero plate voltage to twice the normal value. The output power of a class C amplifier, adjusted for plate modulation, varies with the square of the plate voltage. This is the same condition that would take place if a resistor equal to the voltage on the amplifier, divided by its plate current, were substituted for the amplifier. Therefore, the stage presents a resistive load to the modulator.

Grid Modulated Class C If the grid current to a class C amplifier is reduced to a low value, and the plate loading is increased to the point where the plate dissipation approaches the rated value, such an amplifier may be grid modulated for radiotelephony. If the plate voltage is raised to quite a high value and the stage is adjusted carefully, efficiencies as high as 42 to 45 per cent with good modulation capability and comparatively low distortion may be obtained. Fixed bias is required. This type of operation is termed class C grid modulation and is coming into increasing favor among amateur radiotelephone operators.

Grid Excitation Adequate grid excitation must be available for class B or class C service. The excitation for a plate-modulated class C stage must be sufficient to drive a normal value of d.c. grid current through a grid bias supply of about 2½ times cutoff. The bias voltage preferably should be obtained from a combination of grid leak and fixed C-bias supply.

Cutoff bias can be calculated by dividing the amplification factor of the tube into the d.c. plate voltage. This is the value normally used for class B amplifiers (fixed bias, no grid leak). Class C amplifiers use from 1½ to 5 times this value, depending upon the available grid drive, or excitation, and the desired plate efficiency. Less grid excitation is needed for c.w. operation, and the values of fixed bias (if greater than cutoff) may be reduced, or the value of the grid leak resistor can be lowered until normal rated d.c. grid current flows.

The values of grid excitation listed for each type of tube may be reduced by as much as 50 per cent if only moderate power output and plate efficiency are desired. When consulting the tube tables, it is well to remember that the power lost in the tuned circuits must be taken into consideration when calculating the available grid drive. At very high frequencies, the r.f. circuit losses may even exceed the power required for grid drive unless low loss tank circuits are used.

Readjustments in the tuning of the oscillator, buffer, or doubler circuits, will often result in greater grid drive to the final amplifier.

Link coupling between stages, particularly to the final amplifier grid circuit, normally will provide more grid drive than can be obtained from other coupling systems. The number of turns in the coupling link, and the location of the turns on the coil, can be varied with respect to the tuned circuits to obtain the greatest grid drive for allowable values of buffer or doubler plate current. Slight readjustments sometimes can be made after plate voltage has been applied to the driver tube.

Excessive grid current damages tubes by overheating the grid structure; beyond a certain point of grid drive, no increase in power output can be obtained for a given plate voltage.

Neutralization of R. F. Amplifiers

The plate-to-grid feedback capacity of triodes makes it necessary that they be neutralized for operation as r.f. amplifiers at frequencies above about 500 kc. Those screen-grid tubes, pentodes, and beam tetrodes which have a plate-to-grid capacity of .02 $\mu\text{mfd.}$ or less may ordinarily be operated as an amplifier without neutralization in a well-designed amplifier up to 30 Mc.

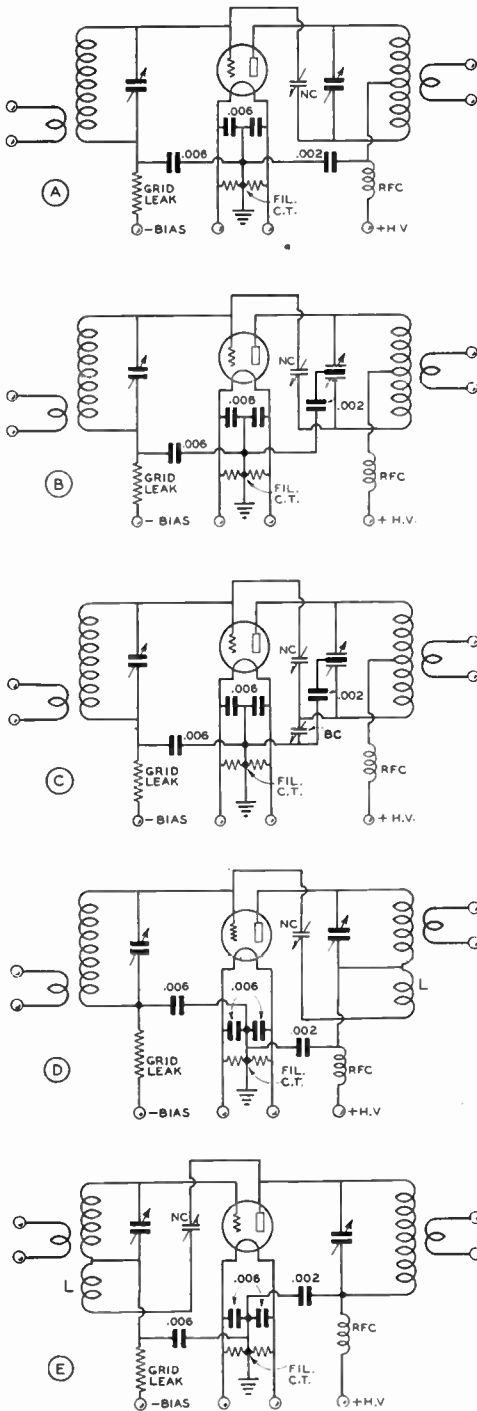

Neutralizing Circuits The object of neutralization is to cancel or "neutralize" the capacitive feedback of energy from plate to grid. There are two general methods by which this energy feedback may be eliminated: the first, and the most common method, is through the use of a capacity bridge, and the second method is through the use of a parallel reactance of equal and opposite polarity to the grid-to-plate capacity, to nullify the effect of this capacity.

The capacity-bridge method of neutralization is divided into two systems: grid neutralization and plate neutralization. The use of grid neutralization causes an amplifier to be either regenerative or degenerative. Hence, only plate neutralization (the capacity bridge system), coil neutralization (the opposite reactance system), and Hazeltine neutralization are recommended for neutralizing a single-ended r.f. amplifier stage.

Tapped-Coil Plate Neutralization Figure 7A shows a circuit for the neutralization of a single-ended triode r.f. amplifier by means of a tapped coil in the plate circuit. This circuit is satisfactory for frequencies below about 7 Mc. with ordinary tubes, but a considerable amount of regeneration will be found when this circuit is used on frequencies above 7 Mc. Some regeneration can be tolerated in an amplifier for c.w. use, but for phone operation, either of the split-stator circuits described in the next two paragraphs should be used.

Split-Stator Plate Neutralization Figure 7B shows the neutralization circuit which is most widely used in single-ended r.f. stages. The use of a split-stator plate condenser makes the electrical balance of the circuit substantially independent of the mutual coupling within the coil and also makes the balance independent of the place where the coil is tapped. With conventional tubes this circuit will allow one neutralization adjustment to be made on, say, 14 Mc., and this adjustment usually will hold sufficiently close for all lower frequency bands.

Figure 7C shows an alternative circuit for split-stator neutralization of a single-ended amplifier stage which, with low-capacity tubes, can be made to remain in adjustment on all bands from 56 Mc. on down in frequency. The additional balancing condenser BC serves merely as an adjustment to keep the capacity-to-

Figure 7.
COMMON NEUTRALIZATION CIRCUITS FOR SINGLE ENDED AMPLIFIERS.

ground exactly the same from each side of the balanced plate tank circuit.

This condenser can be either a small adjustable one of the type commonly used for neutralization, or the relative capacity to ground of the two sides of the circuit can be proportioned so that there is a balance. In determining the balance of the circuit, it must be remembered that the plate-to-filament capacity of the power amplifier tube is the main item to cause the unbalance.

If the other capacities of the circuit are perfectly balanced with respect to ground, the capacity of the condenser BC should be approximately equal to the plate-to-ground capacity of the tube being neutralized. However, it is often just as convenient to unbalance the circuit wiring capacities to ground until the additional capacity on the neutralizing side of the circuit is about equal to that on the plate side. At the point where the plate-to-ground capacity is exactly balanced, the amplifier will neutralize perfectly (at least as nearly perfect as a push-pull amplifier) and will stay neutralized on all bands for which the amplifier tubes are satisfactory.

Hazeltine Neutralization An alternative system of neutralization, wherein the neutralizing circuit is inductively coupled to one of the tank coils, is shown in Figures 7D and 7E. Figure 7D shows the plate neutralized Hazeltine circuit, while 7E shows the grid neutralized arrangement. In either case, it will be noticed that there is no tank current flowing through the neutralizing coil L.

In this circuit arrangement, the size of the neutralizing condenser NC is determined by the coefficient of coupling between the tank coil and L, and upon their relative inductances. It is possible, by proper proportioning of the neutralizing coil L on each band, to make one setting of NC correct for all bands.

Push-Pull Neutralization Two tubes of the same type can be connected for *push-pull* operation so as to obtain twice as much output as that of a single tube. A push-pull amplifier, such as that shown in Figure 8A, also has an advantage in that the circuit can more easily be balanced than a single-tube r.f. amplifier. The various inter-electrode capacities and the neutralizing condensers are connected in such a manner that those on one side of the tuned circuits are exactly equal to those on the opposite side. For this reason, push-pull r.f. amplifiers can be more easily neutralized in very-high-frequency transmitters; also, they usually remain in perfect neutralization when tuning the amplifier to different bands.

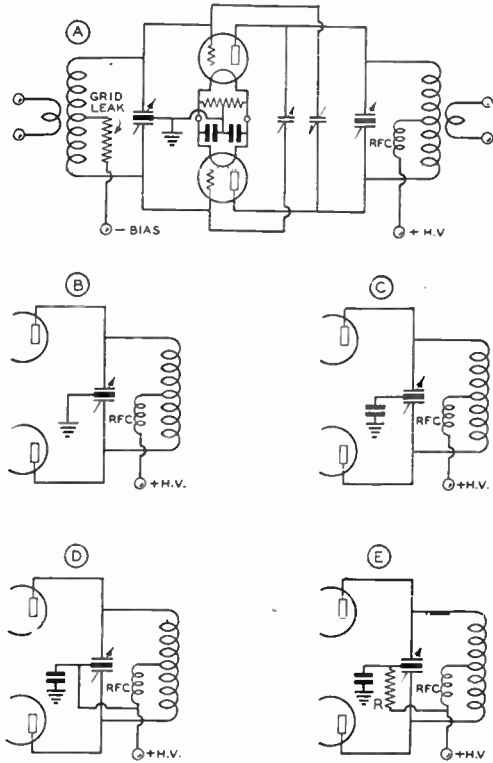

Figure 8.
CROSS NEUTRALIZED PUSH-PULL AMPLIFIER AND COMMON PLATE TANK ARRANGEMENTS.

The circuit shown in Figure 8A is perhaps the most commonly used arrangement for a push-pull r.f. amplifier stage. The rotor of the grid condenser is grounded, and the rotor of the plate tank condenser is allowed to float. Under certain conditions, the circuit of 8B may be used (when the plate tank condenser has a much larger voltage rating than the maximum possible peak output of the power tubes) with the rotor of the grid condenser grounded or not, as desired. It is also possible to use a single-section grid condenser with a tapped coil (un-bypassed) for low-frequency operation with this circuit arrangement.

Figure 8C shows an alternative arrangement for the return of the rotor of the plate tank condenser. The by-pass condenser from the rotor to ground can be any capacity from .01 $\mu\text{f.}$ down to .0005 $\mu\text{f.}$ and even down to .0001 $\mu\text{f.}$ for an u.h.f. amplifier. For phone use, it is best to have some sort of a coupling arrangement to make the rotor of the tuning

condenser follow plate voltage fluctuations. As long as the rotor of the tuning condenser is at the same d.c. potential as the stators, there will be a much reduced chance of breakdown on modulation peaks.

Figures 8D and 8E show two arrangements which tend to keep the rotor of the condenser as nearly as possible at the same d.c. potential as the stators. In Figure 8D the rotor of the condenser, and the ungrounded side of the by-pass condenser, is merely connected to the plate supply side of the r.f. choke. This is an excellent arrangement for use with moderate plate voltages but has the disadvantage that considerable stress is placed on the mica by-pass condenser; should this condenser break down, the plate supply will be shorted. Figure 8E shows an alternative arrangement which has the advantage that, should the mica by-pass condenser short out, only the resistor R will be destroyed. For a mica by-pass capacity of $.001 \mu\text{fd.}$ and a maximum 100 per cent modulation frequency of 3000 cycles, a 25,000-ohm resistor will be satisfactory for R.

Shunt

Neutralization

The feedback of energy from grid to plate in an unneutralized r.f. amplifier is a result of the grid-to-plate capacity of the amplifier tube. A neutralization circuit is merely an electrical arrangement for nullifying the effect of this capacity. All the previous neutralization circuits have made use of a bridge circuit for balancing out the grid-to-plate energy feedback by feeding back an equal amount of energy of opposite phase.

Another method of eliminating the feedback effect of this capacity, and hence of neutralizing the amplifier stage, is shown in Figure 9. The grid-to-plate capacity in the triode amplifier tube acts as a capacitive reactance, coupling energy back from the plate to the grid circuit. If we parallel this capacity with an inductance having the same value of reactance of opposite sign the reactance of one will cancel the reactance of the other and we will have a high-impedance tuned circuit from grid to plate.

This neutralization circuit can be used on ultra-high frequencies where other neutralization circuits are unsatisfactory. This is true because the lead length in the neutralization circuit is practically negligible. The circuit can also be used with push-pull r.f. amplifiers. In this case, each tube will have its own neutralizing reactor connected from grid to plate.

The big advantage of this arrangement is that it allows the use of single-ended tank circuits with a single-ended amplifier.

The chief disadvantage of the shunt neutralized arrangement is that the stage must be reneutralized each time the stage is retuned to

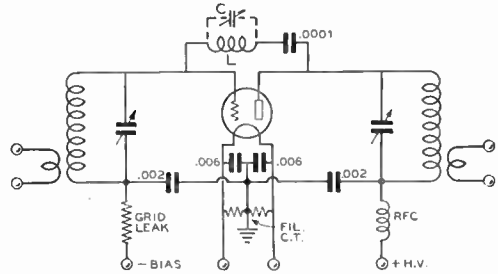

Figure 9.

SHUNT NEUTRALIZED AMPLIFIER.

This type of neutralization is very effective at the higher frequencies, but must be re-adjusted for an appreciable change in frequency.

a new frequency sufficiently removed that the grid and plate tank circuits must be retuned to resonance. However, by the use of plug-in coils and the trimmer condenser C in parallel with the grid-to-plate capacity, it is possible to shift the band of operation and to trim to any frequency within the band. This trimmer condenser, if used, must be insulated for somewhat more voltage than the tank condenser. The $.0001\text{-}\mu\text{fd.}$ condenser in series with the neutralizing circuit is merely a blocking condenser to isolate the plate voltage from the grid circuit. The coil L will have to have a very large number of turns for the band of operation in order to be resonant with the comparatively small grid-to-plate capacity. But since, in all ordinary cases with tubes operating on frequencies for which they were designed, the L/C ratio of the tuned circuit will be very high, the coil can use comparatively small wire, although it must be wound on air or very low-loss dielectric, and must be insulated for the sum of the plate r.f. voltage and the grid r.f. voltage.

Neutralizing Procedure

An r.f. amplifier is neutralized to prevent self-oscillation or regeneration. A neon bulb, a flashlight lamp and loop of wire, or an r.f. galvanometer can be used as a *null indicator* for neutralizing low-power stages. *The plate voltage lead is disconnected from the r.f. amplifier stage while it is being neutralized.* Normal grid drive then is applied to the r.f. stage, the neutralizing indicator is coupled to the plate coil, and the plate tuning condenser is tuned to resonance. The neutralizing condenser (or condensers) then can be adjusted until *minimum* r.f. is indicated for resonant settings of both grid and plate tuning condensers. Both neutralizing condensers are adjusted simul-

taneously and to approximately the same value of capacity when a physically symmetrical push-pull stage is being neutralized.

A final check for neutralization should be made with a d.c. milliammeter connected in the grid leak or grid-bias circuit. There will be no movement of the meter reading as the plate circuit is tuned through resonance (without plate voltage being applied) when the stage is completely neutralized. The milliammeter check is more accurate than any other means for indicating complete neutralization and it also is suitable for neutralizing the stages of a high-power transmitter.

Plate voltage should be *completely* removed by actually opening the d.c. plate circuit. (Turning off the *filaments* of the rectifier tubes will do the trick.) If there is a d.c. return through the plate supply, a small amount of plate current will flow when grid excitation is applied, even though no primary a.c. voltage is being fed to the plate transformer.

Push-pull circuits usually can be more completely neutralized than single-ended circuits at very high frequencies. In the intermediate range of from 3 to 15 Mc., single-ended circuits will give satisfactory results.

Neutralizing Problems When a stage cannot be completely neutralized, the difficulty can be traced to one or more of the following causes: (1) Filament leads not by-passed to the common ground bus connection of that particular stage. (2) Ground lead from the rotor connection of the split-stator tuning condenser to filament open or too long. (3) Neutralizing condensers in a field of excessive r.f. from one of the tuning coils. (4) Electromagnetic coupling between grid and plate coils, or between plate and preceding buffer or oscillator circuits. (5) Insufficient shielding or spacing between stages, or between grid and plate circuits in compact transmitters. (6) Shielding placed too close to plate circuit coils, causing induced currents in the shields. (7) Parasitic oscillations when plate voltage is applied. The cure for the latter is mainly a matter of cut and try—rearrange the parts, change the length of grid or plate or neutralizing leads, insert an ultra-high-frequency r.f. choke in the grid lead or leads, or eliminate the grid r.f. chokes which may be the cause of a low-frequency parasitic (in conjunction with plate r.f. chokes). See *Parasitic Oscillation in R.F. Amplifiers* later in this chapter.

Grounded Grid Amplifiers

Certain triodes, some by accident and some by design, have a grid configuration and lead arrangement which results in very low plate

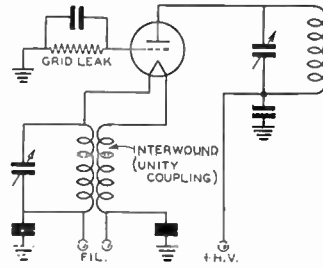

Figure 10.
GROUNDING GRID AMPLIFIER.

This type amplifier requires no neutralization, but can be used successfully only with certain type tubes. For heater-cathode type tubes, the cathode is connected to one side of the filament.

to filament capacity when the control grid is grounded, the grid acting as an effective shield much in the manner of the screen in a screen grid tube.

By connecting such a triode in the circuit of Figure 10, taking the usual precautions against stray capacitive and inductive coupling between input and output leads and components, a stable power amplifier is realized which requires no neutralization.

At ultra high frequencies, where it is difficult to obtain satisfactory neutralization with conventional triode circuits (particularly when a wide band of frequencies is to be covered), the grounded grid arrangement is about the only practicable means of employing a triode amplifier. However, it is seldom used otherwise, because it exhibits various unusual characteristics some of which are undesirable.

Because of the large amount of degeneration inherent in the circuit, considerably more excitation is required than if the same tube were employed in a conventional grounded-cathode circuit. The degeneration can be minimized by utilizing a tube with a high amplification factor (on the order of 50), and tubes designed for grounded grid operation usually will be found to have a high amplification factor.

The additional power required to drive a triode in a grounded grid amplifier is not lost, as it shows up in the output circuit and adds to the power delivered to the load. But nevertheless it means that a larger driver stage is required for an amplifier of given output, because the small amount of power delivered to the amplifier load by the driver stage of a grounded grid amplifier is not sufficient to increase the effective power gain appreciably.

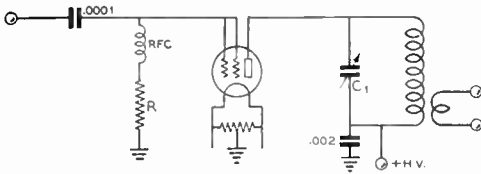

Figure 11.
CONVENTIONAL FREQUENCY DOUBLER.

A high- μ dual grid triode makes an excellent frequency doubler. The plate tank is tuned to twice the excitation frequency. High bias and excitation are required for good efficiency.

Screen Grid Amplifiers

Screen grid tubes (tetrodes and pentodes) intended for use as radio frequency power amplifiers have very low capacity between plate and control grid (assuming both cathode and screen are run at ground r.f. potential). The resulting coupling between output and input circuits is not sufficient to cause significant regeneration when the tube is employed at frequencies for which it was designed.

To prevent feedback from capacitive coupling *external* to the tube, the input and output circuits must be well screened from each other. Also, to prevent feedback via inductive coupling, the coils must be either shielded from each other or well separated or so oriented that no mutual coupling exists. Capacitive feedback external to the tube(s) will be less in a push-pull circuit, because of the appreciable "cross neutralizing" capacity that is inherent in the wiring of a push-pull stage.

Amplifier Adjustment

Plate Circuit Tuning After an amplifier is completely neutralized, reduced plate voltage should be applied before any load is coupled to the amplifier. This reduction in plate voltage should be at least 50 per cent of normal value, because the plate current will rise to excessive values when the plate tuning condenser is not adjusted to the point of resonance as indicated by the greatest dip in reading of the d.c. plate current milliammeter. The r.f. voltage across the plate circuit is greatest at this point.

With no load, the r.f. voltage may be several times as high as when operating under conditions of full load; this may result in condenser flashover if normal d.c. voltage is applied. The no-load plate current at resonance should dip to roughly 15 per cent of normal value. If the plate circuit losses are excessive, or if *parasitic oscillations* are taking place, the no-load plate current will be higher.

Loading The load (antenna or succeeding r.f. stage) then can be coupled to the amplifier under test. The coupling can be increased until the plate current at resonance (greatest dip in plate current meter reading) approaches the normal values for which the tube is rated. The value at reduced plate voltage should be proportionately less in order to prevent excessive plate current load when normal plate voltage is applied. Full plate voltage should not be applied to an amplifier unless the r.f. load also is connected; otherwise the condensers may arc or flash over, thereby causing an abnormally high plate current which may damage the tube. The tuned circuit impedance is lowered when the amplifier is loaded, as are the r.f. voltages across the plate and neutralizing condensers.

Grid Excitation Excessive grid excitation is just as injurious to a vacuum tube as abnormal plate current or low filament voltage. Too much grid driving power will overheat the grid wires in the tube, and will cause a release of gas in certain types of tubes. An excess of grid drive will not appreciably increase the power output and can increase the efficiency only slightly. The grid current in the tube should not exceed the values listed in the *Tube Tables*, and care also should be exercised to have the bias voltage low enough to prevent flashover in the stem of the vacuum tube.

Grid excitation usually refers to the actual r.f. power input to the grid circuit of the vacuum tube, part of which is used to drive the tube, and part of which is lost in the C-bias supply. There is no way to avoid wasting a portion of the excitation power in the bias supply. The loss is the same with battery bias as with grid leak bias.

Frequency Multipliers

Quartz crystals are not ordinarily used for direct control of the output of high-frequency transmitters. *Frequency multipliers* are usually employed to multiply the frequency to the desired value. These multipliers operate on exact multiples of the crystal frequency; a 3.6-Mc. crystal oscillator can be made to control the output of a transmitter on 7.2 or 14.4 Mc., or even on 28.8 Mc., by means of one or more frequency multipliers. When used at twice frequency, they are often termed *frequency doublers*. A simple doubler circuit is shown in Figure 11. It consists of a vacuum tube with its plate circuit tuned to *twice* the frequency of the grid driving circuit. This doubler can be excited from a crystal oscillator or another multiplier amplifier stage.

Doubling is best accomplished by operating

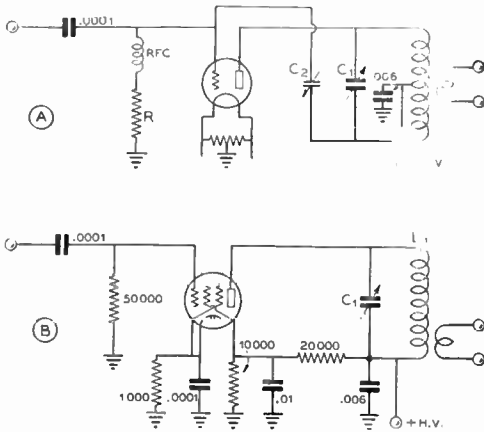

Figure 12.

COMMON FREQUENCY MULTIPLIER CIRCUITS.

(A) shows a circuit which may be used either as a neutralized straight amplifier or a regenerative frequency multiplier. (B) shows a pentode multiplier with cathode regeneration, a result of the undersized cathode bypass capacitor and large cathode resistor.

the tube with extremely high grid bias. The grid circuit is driven approximately to the normal value of d.c. grid current through the r.f. choke and grid leak resistor, shown in Figure 11. The resistance value generally is from two to five times as high as that used with the same tube for straight amplification. Consequently, the grid bias is several times as high for the same value of grid current.

Neutralization is seldom necessary in a doubler circuit, since the plate is tuned to twice the frequency of the grid circuit. The impedance of the grid driving circuit is very low at the doubling frequency, and thus there is little tendency for self-excited oscillation.

A doubler can either be neutralized or made more regenerative by adjusting C_2 in the circuit shown in Figure 12.

When condenser C_2 is of the proper value to neutralize the plate-to-grid capacity of the tube, the plate circuit can be tuned to twice the frequency (or to the same frequency) as that of the source of grid drive; the tube can be operated either as a neutralized amplifier or doubler. The capacity of C_2 can be increased so that the doubler will become regenerative, if the r.f. impedance of the external grid driving circuit is high enough at the output frequency of the stage.

Frequency doublers require bias of several times cutoff; high- μ tubes therefore are desirable for this type of service. Tubes which

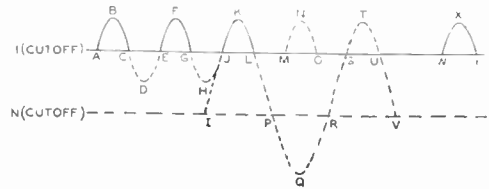

Figure 13.

ILLUSTRATING FREQUENCY DOUBLER ACTION (SEE TEXT)

have amplification factors from 20 to 200 are suitable for doubler circuits. Tetrodes and pentodes make excellent doublers. Low- μ triodes, having amplification constants of from 3 to 10, are not applicable for doubler service. In extreme cases the grid voltage must be as high as the plate voltage for efficient doubling action,

Angle of Flow in Frequency Multipliers

The angle of plate current flow in a frequency multiplier is a very important factor in determining the efficiency. As

the angle of flow is decreased for a given value of grid current, the efficiency increases. To reduce the angle of flow, higher grid bias is required so that the grid excitation voltage will exceed the cutoff value for a shorter portion of the exciting-voltage cycle. For a high order of efficiency, frequency doublers should have an angle of flow of 90 degrees or less, triplers 60 degrees or less, and quadruplers 45 degrees or less. Under these conditions the efficiency will be on the same order as that of a straight amplifier stage running class B, or about 65 per cent. As the angle of flow is made greater than these limiting values, the efficiency falls off rapidly. The reason is apparent from a study of Figure 13.

The pulses ABC, EFG, JKL illustrate 180 degree excitation pulses under class B operation, the solid straight line indicating cut-off bias. If the bias is increased by N times, to the value indicated by the dotted straight line, and the excitation increased until the peak r.f. voltage with respect to ground is the same as before, then the excitation frequency can be cut in half and the effective excitation pulses will have almost the same shape as before. The only difference is that every other pulse is missing; MNO simply shows where the missing pulse would go. However, if the Q of the plate tank circuit is high, it will have sufficient "flywheel" effect to carry over through the missing pulse, and the only effect will be that the plate input and r.f. output at optimum loading drop to approximately half. As the

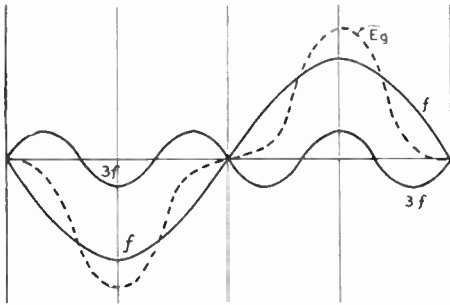

Figure 14.

PEAKED WAVEFORM OBTAINED BY ADDITION OF FUNDAMENTAL AND THIRD-HARMONIC ENERGY IN PROPER PHASE.

When fundamental frequency (f) energy and third-harmonic ($3f$) energy are added in the proper phase the result is a peaked waveform as shown by E_g . This peaked waveform, when used as excitation for a frequency multiplier stage, gives considerably higher plate efficiency than when sine-wave excitation voltage is applied to the grid of the tube.

input frequency is half the output frequency, an efficient frequency doubler is the result.

By the same token, a tripler or quadrupler can be analyzed, the tripler skipping two excitation pulses and the quadrupler three. In each case the excitation pulse ideally should be short enough that it does not exceed 90 degrees at the output frequency; otherwise the excitation actually is *bucking* the output over a portion of the cycle.

In actual practice, it is found uneconomical to provide sufficient excitation to run a tripler or quadrupler in this fashion. Usually the excitation pulses will be at least 90 degrees, with correspondingly low efficiency, but it is more practicable to accept the low efficiency and build up the output in succeeding amplifier stages. The efficiency can become quite low before the power again becomes less than unity.

Distorted Drive Multiplier By altering the shape of the exciting voltage from its usual sine wave form at the exciting frequency, it is possible to decrease the angle of flow and thus increase the efficiency without resorting to increases in the excitation voltage and bias.

The angle of flow may be decreased by adding some properly phased third harmonic voltage to the excitation. The result of adding the third harmonic voltage to the fundamental is shown graphically in Figure 14. As shown by the dotted curve, E_g , when the fundamental

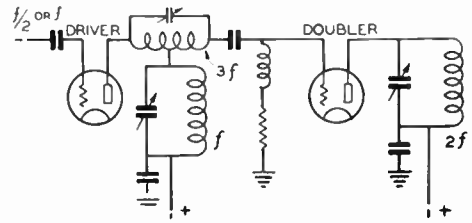

Figure 15.

CIRCUIT FOR COMBINING FUNDAMENTAL AND THIRD - HARMONIC ENERGY IN PROPER PHASE FOR PEAKED WAVEFORM.

The small third-harmonic tank circuit connected as shown adds the fundamental and third harmonic in the proper phase relation for producing a peaked excitation waveform on the grid of the doubler.

and third harmonic voltages are added in the proper phase, the result is a grid excitation voltage having a peaked wave form, exactly what is required for high-efficiency frequency multiplying. The method by which the third harmonic is added is shown in Figure 15. A small, center-tapped tank circuit tuned to three times the driver frequency is placed between the driver plate and the coupling condenser to the frequency-multiplier stage. The center tap of this coil is connected to the "hot" end of the driver plate tank, which remains tuned to the fundamental frequency. The third-harmonic tank circuit can be tuned accurately to frequency by coupling to it a small, low-current dial lamp in a loop of wire and tuning for maximum brilliancy. An absorption wavemeter may be coupled to the third-harmonic tank after it has been tuned, to make sure that it is on the correct harmonic. The tuning of this circuit is not critical.

When tripling or quadrupling the addition of the peaking circuit will result in a tendency of the multiplier to self-oscillate at certain dial settings unless a well screened r.f. tetrode or pentode is used in place of the triode illustrated.

Push-Push Multipliers Two tubes can be connected in parallel to give twice the output of a single tube doubler. If the grids are driven *out* of phase instead of *in* phase, the tubes then no longer work simultaneously, but rather one at a time. The effect is to fill in the missing pulses (Figure 13). Not only is the output doubled, but several advantages accrue which cannot be obtained by straight parallel operation.

Chief among these is the effective neutraliza-

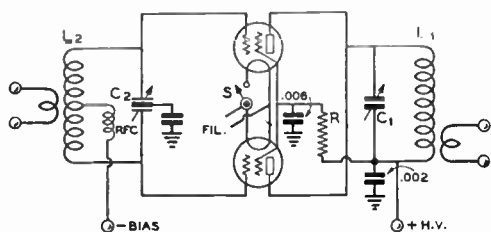

Figure 16.

PUSH-PUSH MULTIPLIER CIRCUIT.

in this type of doubler or quadrupler the grids are connected in push-pull and the plates are connected in parallel. A pair of triodes, a dual triode, or a pair of pentodes or tetrodes may be used. In the diagram shown, the heater of one of the tubes may be opened and the other tube operated as a neutralized amplifier, the other tube acting as the neutralizing capacitor.

tion of the fundamental and all *odd* harmonics, an advantage when spurious emissions must be minimized. Another advantage is that when the available excitation is low and excitation pulses exceed 90 degrees, the output and efficiency will be greater than for the same tubes connected in parallel.

The same arrangement may be used as a quadrupler, with considerably better efficiency than for straight parallel operation, because seldom is it practicable to supply sufficient excitation to permit 45 degree excitation pulses. As pointed out above, the push-push arrangement exhibits better efficiency than a single ended multiplier when excitation is inadequate for ideal multiplier operation.

A typical push-push doubler is illustrated in Figure 16. When high transconductance tubes are employed, it is necessary to employ a split-stator grid tank condenser to prevent self oscillation; with well screened tetrodes or pentodes having medium values of transconductance, a split coil arrangement with a single section condenser may be employed (the center tap of the grid coil being bypassed to ground).

Tank Circuit Capacities

Optimum tuning capacity values for class C amplifier tank circuits for a particular application can be determined easily by charts or formulas. The best ratio of C to L, capacitance to inductance, depends upon the operating plate voltage and current, and upon the type of circuit. Proper choice of capacity-to-inductance ratio for resonance at any given frequency is important in obtaining low harmonic output, and also low distortion in the case of a modulated class C amplifier.

A class C amplifier produces a very dis-

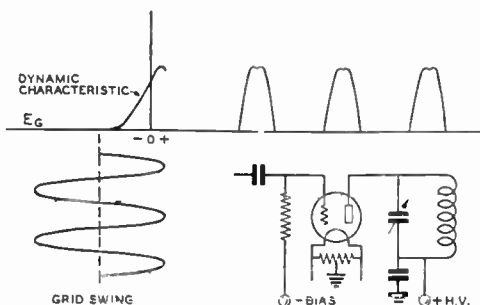

CLASS C AMPLIFIER PLATE CURRENT WAVEFORM

Figure 17.

torted plate current wave form in the form of pulses as shown in Figure 17. The LC circuit is tuned to resonance, and its purpose is to smooth out these pulses, by its storage or "tank" action, into a sine wave of radio-frequency output. Any wave-form distortion of the carrier frequency results in harmonic interference in higher-frequency channels.

A class A radio-frequency amplifier would produce a sine wave output if the exciting voltage were a sine wave. However, the a.c. plate current would be flowing during the full 360° of each r.f. cycle, resulting in excessive plate loss in the tube for any reasonable value of output. The class A amplifier tube converts d.c. input to r.f. a.c. by acting like a variable resistance, and therefore heats considerably. A class C amplifier when driven hard with short, nearly rectangular pulses acts like an electronic switch, and therefore can convert considerable d.c. input to r.f. with very little heating. A tube in a class C amplifier will deliver several times as much power for a given plate loss as when used in a class A amplifier.

The tuned circuit must have a good flywheel effect in order to furnish a sine-wave output to the antenna when it is receiving energy in the form of very distorted pulses such as shown in Figure 17. The LC circuit fills in power over the complete r.f. cycle, providing the LC ratio is sufficiently low. The flywheel effect is generally defined as the ratio of radio-frequency volt-amperes to actual power output, or VA/W. This is equivalent to Q and should not be much less than 4π, or 12.5, for a single ended class-C amplifier. At this value of VA/W or Q, one-half of the stored energy in the LC circuit is absorbed by the antenna. If a lower value of Q is used, the storage power is insufficient to produce a sine (undistorted) wave output to the antenna and power will be wasted in radiation of harmonics.

Too high a value of VA/W or Q will result in excessive circulating r.f. current loss in

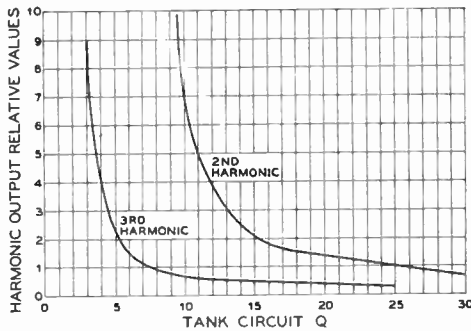

Figure 18.
HARMONIC OUTPUT PLOTTED
AGAINST TANK CIRCUIT Q.

the LC circuit and lowered output to the antenna.

Harmonic Radiation vs. Q Opinions vary as to the optimum value of Q, but a careful analysis of the whole problem seems to indicate that a value of 12 is suitable for most amateur, police, or commercial phone or c.w. transmitters. A value of 15 to 20 will result in less harmonic radiation at the expense of a little additional heat power loss in the tank or LC circuit. The charts shown have been calculated for an operating value of Q=12. For push-pull operation only half the Q is required to give the same flywheel effect.

The curves shown in Figure 18 indicate the sharp increase in harmonic output into the antenna circuit for low values of Q. The curve for the second harmonic rises nearly vertically for Q values of less than 10. The third harmonic is not seriously large for values of Q over 4 or 5. These curves show that push-pull amplifiers may be operated at lower values of Q, since the second harmonic is cancelled to a large extent if there is no capacitive or unbalanced coupling between the tank circuit and the antenna feeder system.

Effect of Loading on Q The Q of a circuit depends upon the resistance in series with the capacitance and inductance. This series resistance is very low for a low-loss coil not loaded by an antenna circuit. The value of Q may be from 100 to 300 under these conditions. Coupling an antenna circuit has the effect of increasing the series resistance, though in this case the power is consumed as useful radiation by the antenna. Mathematically, the antenna increases the value of R in the expression $Q = \omega L/R$

where L is the coil inductance and ω is the term $2\pi f$, f being in cycles per second.

The antenna coupling can be varied to obtain any value of Q from 3 to values as high as 100 or 200. However, the value of Q=12 or Q=20 if desired) will not be obtained at normal values of d.c. plate current in the class C amplifier tube unless the C-to-L ratio in the tank circuit is correct for that frequency of operation.

Condenser values of C_1 , C_2 and C_3 shown in Figures 19, 20 and 21 are for the total capacity across the inductance. This includes the tube inter-electrode capacities, distributed coil capacity, wiring capacities and tuning condenser capacity. If a split-stator condenser is used, the effective capacity is equal to half of the value of each section, since the two sections are in series across the tuned circuit. The total stray capacities range from approximately 2 up to 30 $\mu\text{mfd.}$ and largely depend upon the type of tube or tubes used in the class C amplifier.

The tubes in the push-pull circuit of Figure 21 work on a portion of each half cycle, so less storage or flywheel effect is needed and a value of Q=6 may be used instead of Q=12.

The values of R_p are easily calculated by dividing the d.c. plate supply voltage by the total d.c. plate current (expressed in amperes). Correct values of total tuning capacity are shown in the charts for the different amateur bands. The shunt stray capacity can be estimated closely enough for all practical purposes. The coil inductance should then be chosen which will produce resonance at the desired frequency with the total calculated tuning capacity.

The capacities shown are the minimum recommended values and they should be increased 50 per cent to 100 per cent for modulated class C amplifiers where economically feasible. The values shown in the charts are sufficient for c.w. operation of class C amplifiers. It is again emphasized that these values are *total capacities* across the tank circuit, and should not be considered as the capacity *per section* for a split-stator condenser. If a split-stator condenser is to be used, the *per section* capacity should be *twice* that indicated by the charts shown on the opposite page.

Tuning Condenser Air Gap

Plate-Spacing Requirements for Various Circuits and Plate Voltages In determining condenser air gaps, the peak r.f. voltage impressed across the condenser is the important item, since the experimental and practical curves of air gap versus peak volts as published by the Allen D. Cardwell Mfg. Corp. may be applied to any

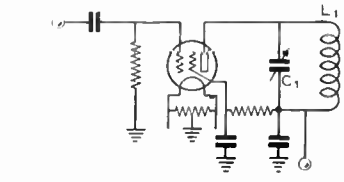
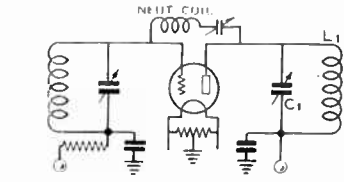
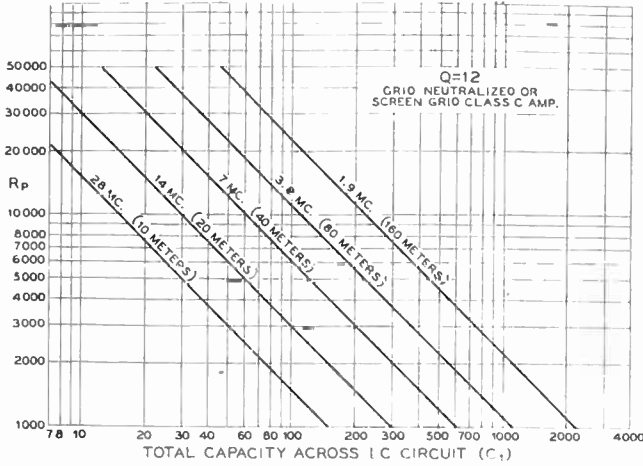

Figure 19.

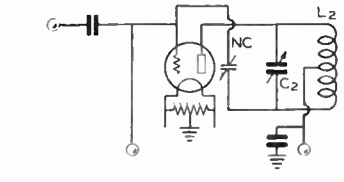
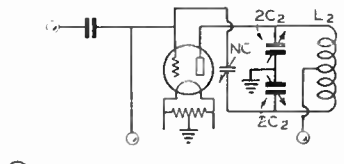
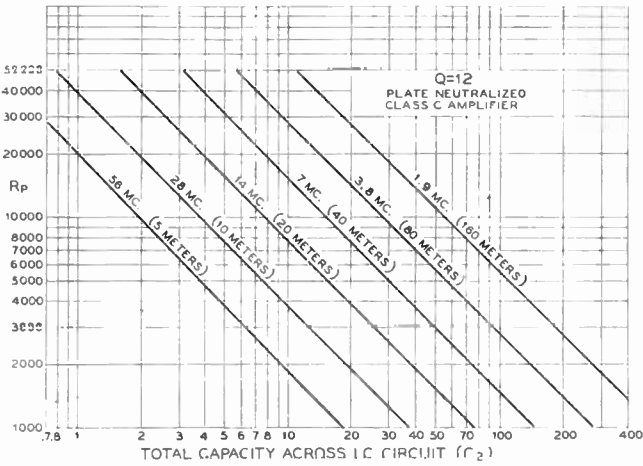

Figure 20.

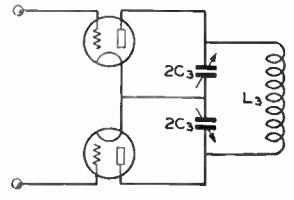
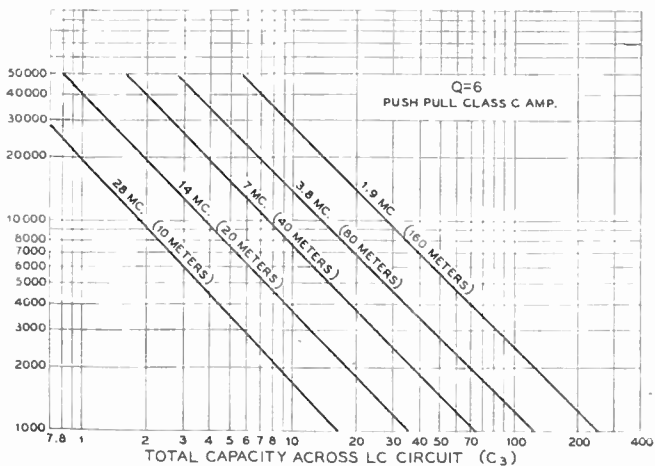

Figure 21.

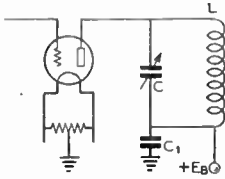

Figure 22.

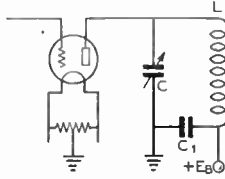

Figure 23.

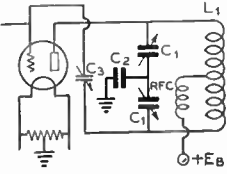

Figure 24.

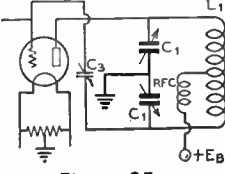

Figure 25.

| BREAKDOWN RATINGS OF COMMON PLATE SPACINGS | |
|--|------------------------|
| AIR-GAP IN INCHES | PEAK VOLTAGE BREAKDOWN |
| .030 | 1000 |
| .050 | 1500 |
| .070 | 3000 |
| .078 | 3500 |
| .084 | 3800 |
| .100 | 4150 |
| .144 | 5000 |
| .175 | 5700 |
| .200 | 6200 |
| .250 | 7200 |
| .300 | 8200 |
| .350 | 9250 |
| .375 | 10,000 |
| .500 | 12,000 |

condenser with polished plates having rounded edges. Typical peak breakdown voltages for corresponding air gaps are listed in the table. These values can be used in any circuit. The problem is to find the peak r.f. voltage in each case; this can be done quite easily.

The r.f. voltage in the plate circuit of a class C amplifier tube varies from nearly zero to nearly twice the d.c. plate voltage. If the d.c. voltage is being 100 per cent modulated by an audio voltage, the r.f. peaks will reach nearly four times the d.c. voltage. The circuits shown in Figures 23 and 25 require a tuning condenser with plate spacing which will have an r.f. peak breakdown rating at least equal to 2 times or 4 times the d.c. plate voltage for c.w. and plate-modulated amplifiers respectively.

It is possible to reduce the air gap to one-half by connecting the amplifier so that the d.c. plate voltage does not appear across the tuning condenser. This is done in Figures 22 and 24. These circuits should always be used in preference to those of Figures 23 and 25,

since the tuning condenser is only about one-fourth as large physically for the same capacity, and is less expensive.

For a class B linear, class C grid-modulated, or c.w. amplifier, the r.f. voltage across the tube varies from nearly zero up to twice E_b . The r.f. voltage is an a.c. voltage varying from zero to a positive and then to a negative maximum over each cycle. The fixed (mica) condenser C_1 in Figure 22 and C_2 in Figure 24 insulates the rotor from d.c. and allows us to subtract the d.c. voltage value from the tube peak r.f. voltage value in calculating the breakdown voltage to be expected.

These rules apply to a loaded amplifier or buffer stage. If either is operated without an r.f. load, the peak voltages may be greater. For this reason no amplifier should be operated without load when anywhere near normal d.c. plate voltage is applied.

A factor of safety in the air-gap rating should be applied to insure freedom from r.f. flashover. This is especially true when using the circuits of Figures 23 and 25; in these circuits the plate supply is shorted when a flashover occurs. Knowing the peak r.f. voltage, an air gap should be chosen which will be about 100 per cent greater than the breakdown rating. The air gaps listed will break down at the approximate peak voltages in the table. If the circuits are of the form shown in Figures 23 and 25, the peak voltages across the condensers will be nearly twice as high, and twice as large an air gap is needed. The fixed condensers, usually of the mica type, shown in Figures 22 and 24 must be rated to withstand the d.c. plate voltage plus any audio voltage. This condenser should be rated at a d.c. working voltage of at least *twice the d.c. plate supply in a plate modulated amplifier*, and at least *equal to the d.c. supply* in any other type of r.f. amplifier. See also Figure 8D and accompanying

| Recommended Air gap (approx. 100% factor of safety) for the circuits of figures 22 and 24. Spacings should be multiplied by 1.5 for same factor of safety with circuits of Figures 23 and 25. | | |
|---|-------|------------|
| D.C. PLATE VOLTAGE | C. W. | PLATE MOD. |
| 400 | .030 | .050 |
| 600 | .050 | .070 |
| 750 | .050 | .084 |
| 1000 | .070 | .100 |
| 1250 | .070 | .144 |
| 1500 | .078 | .200 |
| 2000 | .100 | .250 |
| 2500 | .175 | .375 |
| 3000 | .200 | .500 |
| 3500 | .250 | .600 |

text for further data on how to get the rotor to follow the modulated plate voltage.

Push-Pull Stages The circuits of Figures 24 and 25 apply without any change in calculations to push-pull amplifiers. Only one tube is supplying power to the tuned circuit at any given instant, each one driving a part of each half cycle. The different value of Q and increased power output increase the peak voltages slightly, but, for all practical purposes, the same calculation rules may be employed.

These rules apply to any form of r.f. amplifier, with a recommended factor of safety of 100 per cent to prevent flashover in the condenser. This is sufficient for operation into normal loads at all times, providing there are no freak parasitic oscillations present. The latter sometimes cause flashover across air gaps which should ordinarily stand several times the normal peak r.f. voltages. This is especially true of low-frequency parasitics.

The actual peak voltage values of a stable, loaded r.f. amplifier actually are a little less than the calculations indicate, which gives an additional factor of safety in the design.

Parasitic Oscillation in R.F. Amplifiers

Parasitics are undesirable oscillations either of very high or very low frequencies which may occur in radio-frequency amplifiers.

They may cause spurious signals (which are often rough in tone) other than normal harmonics, hash on each side of a modulated carrier, key clicks, voltage breakdown or flashover, instability or inefficiency, and shortened life or failure of the tubes. They may be damped and stop by themselves after keying or on modulation cycles, or they may be undamped and built up during ordinary unmodulated transmission, continuing if the excitation is removed. They may result from series or parallel resonant circuits of all types. Due to the neutralizing lead length or the nature of most parasitic circuits, the amplifier usually is not neutralized for the parasitic frequency.

Sometimes the fact that the plate supply is keyed obscures parasitic oscillations that might be very severe if the plate voltage were left on and only the excitation removed.

In some cases, an all-wave receiver will prove helpful in finding out if the amplifier is without spurious oscillations, but it may be necessary to check from one meter on up, to be perfectly sure. A normal harmonic is weaker than the fundamental but of good tone; a strong harmonic or a rough note at any frequency generally indicates a parasitic.

Low-Frequency Parasitics

One type of unwanted oscillation often occurs in shunt-fed circuits in which the grid and plate chokes resonate, coupled through the tube's inter-electrode capacity. It also can happen with series feed. This oscillation is generally at a much lower frequency than the desired one and causes additional carriers to appear, spaced from perhaps twenty to a few hundred kilocycles on either side of the main wave. One cure is to change the type of feed in either the grid or plate circuit or to eliminate one choke. Another is to use much less inductance in the grid choke than in the plate choke, or to replace the grid choke by a wire-wound resistor if the grid is series fed. In a class C stage with grid-leak bias, no r.f. choke is required if the bias is series fed.

This type of parasitic may take place in push-pull circuit, in which case the tubes are effectively in parallel for the parasitic and hence, the neutralization is not effective. The grids or plates can be connected together without affecting the undesired oscillation; this is a simple test for this type of parasitic.

Parallel Tubes A very high frequency inter-tube oscillation often occurs when tubes are operated in parallel. Non-inductive damping resistors or manufactured parasitic suppressors in the grid circuit, or short inter-connecting grid leads, together with small plate choke coils, will prove helpful.

Tapped Inductances When capacity coupling is used between stages, particularly when one of the stages is tapped down from the end of the coil, additional parasitic circuits are formed because of the multiple resonant effects of this complex circuit. Inductive or link coupling permits making adjustments without forming these undesired circuits. A condenser tapped across only part of an inductance, for bandspread tuning or capacity loading, also can give rise to parasitics.

Multi-Element Tubes

Screen-grid, pentode, and beam tetrode tubes may help to minimize parasitic circuits by requiring no neutralization, but their high gain occasionally aggravates other parasitic oscillations. Furthermore, the bypass circuit from the additional elements to the filament must be short and effective, particularly at the higher frequencies, to prevent undesired internal coupling. At very high frequencies, a certain critical value of screen bypass condenser may improve the internal shielding without causing a new parasitic oscillation. The capacity should be such as to series resonate the tube and circuit leads. A blocking

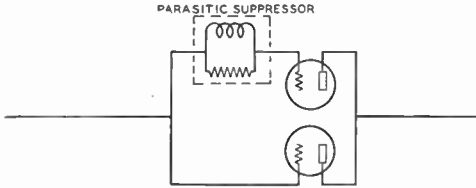

Figure 26.
PARASITIC SUPPRESSOR.

Showing the use of a parasitic suppressor in series with one grid of a pair of paralleled tubes. In a push-pull amplifier which develops parasitics, the parasitic suppressor can be connected in series with the lead from the grid tank circuit to the grid of one of the tubes.

(relaxation) effect may occur if the screen is fed through a series resistor. Also, the screen circuit can act as the plate in a tuned-grid tuned-plate oscillation that can be detuned or damped at the control grid terminal.

Crystal Stages Crystal oscillators are seldom suspected of parasitic oscillation troubles, but are often guilty. The same remedial measures as recommended for amplifiers should be employed.

Parasitic Suppressors The most common type of parasitic is of the u.h.f. type, which fortunately can usually be dampened by inserting a parasitic suppressor of the type illustrated in Figure 26 in the grid lead, or in one grid lead of either a push-pull or parallel tube amplifier.

Grid Bias

Radio-frequency amplifiers require some form of *grid bias* for proper operation. Practically all r.f. amplifiers operate in such a manner that plate current flows in the form of short, peaked impulses which have a duration of only a fraction of an r.f. cycle. To accomplish this, the grid bias is at least sufficient to cut off the plate current, and in very high efficiency class C amplifiers this bias may be several times the cutoff value. Cutoff bias, it will be recalled, is that value of grid voltage which will reduce the plate current to zero at the plate voltage employed. The method for calculating it has been indicated previously. This theoretical value of cut-off will not reduce the plate current completely to zero, due to the variable- μ tendency or "knee" which is characteristic of all tubes as the cutoff point is approached. This factor, however, is of no importance in practical applications.

Class C Bias Radiophone class C amplifiers should be operated with the grid bias adjusted to values between two and

three times cutoff at normal values of d.c. grid current, to permit linear operation (necessary when the stage is plate-modulated). C.w. telegraph transmitters can be operated with bias as low as cutoff, if only limited excitation is available and moderate plate efficiency is satisfactory. In a c.w. transmitter, the bias supply or resistor should be adjusted to the point which will allow normal grid current to flow for the particular amount of grid driving r.f. power available. This form of adjustment will allow more output from the under-excited r.f. amplifier than when higher bias is used with corresponding lower values of grid current.

Grid-Leak Bias A resistor can be connected in the grid circuit of an r.f. amplifier to provide grid-leak bias. This resistor, R_1 in Figure 27, is part of the d.c. path in the grid circuit.

The r.f. excitation applied to the grid circuit of the tube causes a pulsating direct current to flow through the bias supply lead, due to the rectifying action of the grid, and any current flowing through R_1 produces a voltage drop across that resistance. The grid of the tube is positive for a short duration of each r.f. cycle, and draws electrons from the filament or cathode of the tube during that time. These electrons complete the circuit through the d.c. grid return.

The voltage drop across the resistance in the grid return provides a *negative bias* for the grid. The r.f. chokes in Figures 27, 28, 29 and 30 prevent the r.f. excitation from flowing through the bias supply, or from being short-circuited to ground. The by-pass condenser across the bias source proper is for the purpose of providing a low impedance path for the small amount of stray r.f. energy which passes through the r.f. choke.

Grid-leak bias automatically adjusts itself over fairly wide variations of r.f. excitation. The value of grid-leak resistance should be such that normal values of grid current will flow at the maximum available amount of

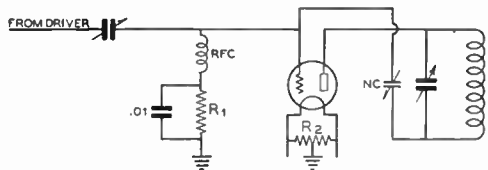

Figure 27.
GRID LEAK BIASED STAGE.

Showing how a resistor may be connected in series with the grid return lead to obtain bias due to the flow of rectified grid current through the resistor.

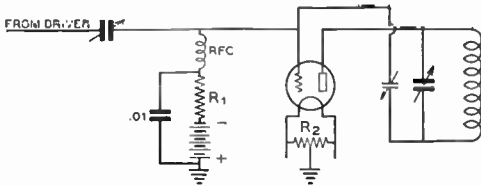

Figure 28.
COMBINATION GRID LEAK AND BATTERY BIAS.

A battery may be added to the arrangement of Figure 27 to provide protection in case of excitation failure.

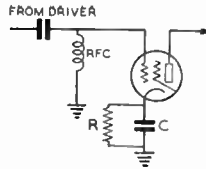

Figure 29.
CATHODE OR "AUTOMATIC" BIAS.

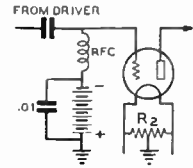

Figure 30.
BATTERY BIAS.

r.f. excitation. Grid-leak bias cannot be used for grid-modulated or linear amplifiers in which the average d.c. grid current is constantly varying with modulation.

Safety Bias Grid-leak bias alone provides no protection against excessive plate current in case of failure of the source of r.f. grid excitation. A C-battery or C-bias supply can be connected in series with the grid leak, as shown in Figure 28. This fixed "protective" bias will protect the tube in the event of failure of grid excitation. "Zero-bias" tubes do not require this bias source in addition to the grid leak, since their plate current will drop to a safe value when the excitation is removed.

Cathode Bias A resistor can be connected in series with the cathode or center-tapped filament lead of an amplifier to secure *automatic bias*. The plate current flows through this resistor, then back to the cathode or filament, and the voltage drop across the resistor can be applied to the grid circuit by connecting the grid bias lead to the grounded, or power supply end of the resistance R, as shown in Figure 29.

The grounded (B-minus) end of the cathode resistor is negative relative to the filament by an amount equal to the voltage drop across the resistor. The value of resistance must be so chosen that the sum of the desired grid and plate current flowing through the resistor will bias the tube for proper operation.

This type of bias is used more extensively in audio-frequency than in radio-frequency amplifiers. The voltage drop across the resistor must be subtracted from the total plate supply voltage when calculating the power input to the amplifier, and this loss of plate voltage in an r.f. amplifier may be excessive. A class A audio amplifier is biased only to approximately one-half cutoff, whereas an r.f. amplifier may be biased to twice cutoff, or more, and thus the plate supply voltage loss may be a large percentage of the total avail-

able voltage when using low- or medium- μ tubes.

Oftentimes just enough cathode bias is employed in an r.f. amplifier to act as safety bias to protect the tubes in case of excitation failure, with the rest of the bias coming from a grid leak.

Separate Bias Supply A "C" battery or an external C-bias supply, sometimes is used for grid bias, as shown in Figure 30.

Battery bias gives very good voltage regulation and is satisfactory for grid-modulated or linear amplifiers, which operate at low grid current. In the case of class C amplifiers which operate with high grid current, battery bias is not very satisfactory. This direct current has a charging effect on the dry batteries; after a few months of service the cells will become unstable, bloated, and noisy.

A separate a.c. operated power supply can be used as a substitute for dry batteries. The bleeder resistance across the output of the filter can be made sufficiently low in value that the grid current of the amplifier will not appreciably change the amount of negative grid-bias voltage. This type of bias supply is used in class B audio and class B r.f. linear amplifier service where the voltage regulation in the C-bias supply is important. For a class C amplifier, regulation is not so important, and an economical design of components in the power supply, therefore, can be utilized. In this case, the bias voltage must be adjusted with normal grid current flowing, as the grid current will raise the bias considerably when it is flowing through the bias-supply bleeder resistance.

Interstage Coupling

Energy is usually coupled from one circuit of a transmitter into another either by *capacitive coupling*, *inductive coupling*, or *link coupling*. The latter is a special form of inductive coupling. The choice of a coupling method depends upon the purpose for which it is used.

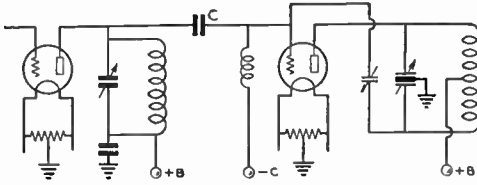

Figure 31.
CAPACITIVE INTERSTAGE COUPLING.
This is the simplest form of interstage coupling.

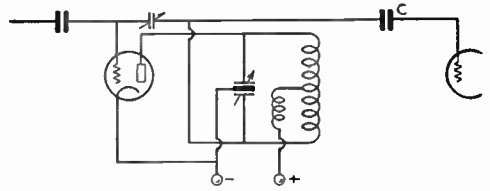

Figure 32.
BALANCED CAPACITIVE COUPLING.
This type of capacitive interstage coupling helps to equalize the capacities across the two sides of the driver tank circuit.

Capacitive Coupling Capacitive coupling between an amplifier or doubler circuit and a preceding driver stage is shown in Figure 31.

The coupling condenser, C, isolates the d.c. plate supply from the next grid and provides a low impedance path for the r.f. energy between the tube being driven and the driver tube. This method of coupling is simple and economical for low-power amplifier or exciter stages, but has certain disadvantages, particularly for high frequency stages. The grid leads in an amplifier should be as short as possible, but this is difficult to attain in the physical arrangement of a high-power amplifier with respect to a capacitively-coupled driver stage.

Disadvantages of Capacity Coupling The r.f. choke in series with the C-bias supply lead must offer an extremely high impedance to the r.f. circuit, and this is difficult to obtain when the transmitter is operated on several harmonically related bands. Another disadvantage of capacitive coupling is the difficulty of adjusting the load on the driver stage. Impedance adjustment can be accomplished by tapping the coupling lead a part of the way down on the plate coil of the tuned stage of the driver circuit, but often when this is done a parasitic oscillation tendency becomes very troublesome and is difficult to eliminate.

Capacitive coupling places the grid-to-filament capacity of the driven tube directly across

the driver tuned circuit, which sometimes makes the r.f. amplifier difficult to neutralize because the additional driver stage circuit capacities are connected into the grid circuit. Difficulties from this source can be partially eliminated by using a center-tapped or split-stator tank circuit in the plate of the driver stage, and capacity coupling to the opposite end from the plate. This method places the plate-to-filament capacity of the driver across one-half of the tank and the grid-to-filament capacity of the following stage across the other half. This type of coupling is shown in Figure 32.

Capacitive coupling can be used to advantage in reducing the total number of tuned circuits in a transmitter so as to conserve space and cost. It also can be used to advantage between stages for driving beam tetrode or pentode amplifier or doubler stages. These tubes require relatively small amounts of grid excitation, and a reduction in driving efficiency is not so important.

Inductive Coupling *Inductive coupling* (Figure 33) consists of two coils electromagnetically coupled to each other. The degree of coupling is controlled by varying the mutual inductance of the two coils, which is accomplished by changing the spacing between the coils.

Inductive coupling is used extensively for coupling r.f. amplifiers in radio receivers. However, the mechanical problems involved in adjusting the degree of coupling as is usually required in a transmitter limit its usefulness in transmitters.

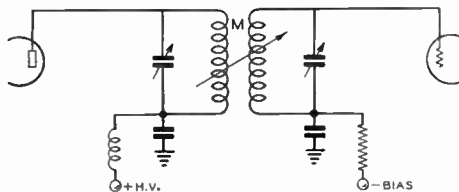

Figure 33.
INDUCTIVE INTERSTAGE COUPLING.

Unity Coupling If the grid tuning condenser of Figure 33 is removed and the coupling increased to the maximum practicable value by interwinding the turns of the two coils, the circuit in so far as r.f. is concerned acts like that of Figure 31, in which one tank serves both as plate tank for the driver and grid tank for the driven stage. The interwound grid winding serves simply to isolate the d.c. plate voltage of the driver from

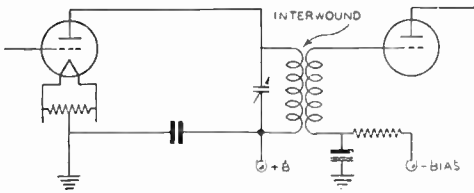

Figure 34.
"UNITY" INDUCTIVE COUPLING.

Because of the high mutual inductance, the one tuning capacitor resonates both circuits.

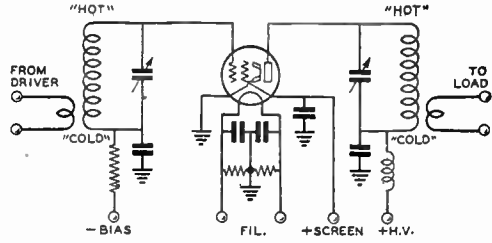

Figure 35.
LINK COUPLED CIRCUIT.

Showing link coupling into and out of a single-ended beam-tetrode amplifier stage. The coupling links should be placed at the "cold" or low-potential ends of the grid and plate coils.

the grid of the driven stage, and to provide a return for d.c. grid current. This type of coupling, illustrated in Figure 34, is commonly known as "unity coupling".

Because of the high mutual inductance, both primary and secondary are resonated by the one condenser.

Link Coupling A special form of inductive coupling which is widely employed in radio transmitter circuits is known as *link coupling*. A low impedance r.f. transmission line couples the two tuned circuits together. Each end of the line is terminated in one or more turns of wire, or *loops*, wound around the coils which are being coupled together. These loops should be coupled to each tuned circuit at the point of zero r.f. potential, or *nodal point*. A ground connection to one side of the link is used in special cases where harmonic elimination is important, or where capacitive coupling between two circuits must be minimized.

Typical link coupled circuits are shown in Figures 35 and 36. Some of the advantages of link coupling are the following:

- (1) It eliminates coupling taps on tuned circuits.
- (2) It permits the use of series power supply connections in both tuned grid and tuned plate circuits, and thereby eliminates the need of r.f. chokes.
- (3) It allows separation between transmitter stages without appreciable r.f. losses or stray chassis currents.
- (4) It reduces capacitive coupling and thereby makes neutralization more easily attainable in r.f. amplifiers.
- (5) It provides semi-automatic impedance matching between plate and grid tuned circuits, with the result that greater grid drive can be obtained in comparison to capacitive coupling.
- (6) It effectively reduces spurious radiations.

The link coupling line and loops can be made of No. 18 gauge push-back wire for coupling low-power stages. High-power circuits can be link-coupled by means of No. 8 to No. 12 rubber-covered wire, twisted low-impedance antenna-feeder wire, concentric lines, or open-wire lines of No. 12 or No. 14 wire spaced 1/2 inch.

Radio-Frequency Chokes

Radio-frequency chokes are connected in circuits for the purpose of preventing r.f. energy from being short-circuited, or escaping into power supply circuits. They consist of inductances wound with a large number of turns, either in the form of a solenoid or universal pie-winding. These inductances are designed to have as much inductance and as little distributed or shunt capacity as possible. The unavoidable small amount of distributed capacity resonates the inductance, and this frequency normally should be much lower than the frequency at which the transmitter or receiver circuit is operating. R.f. chokes for operation on several bands must be designed carefully so

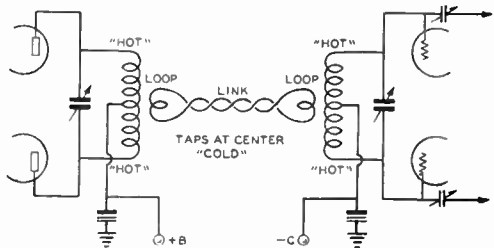

Figure 36.
PUSH-PULL LINK COUPLING.

When link coupling is used between push-pull stages or between "split" tank circuits, the coupling loops are placed at the center of the coils.

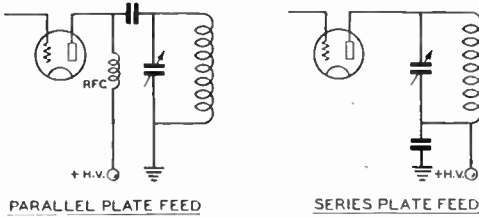

Figure 37.
ILLUSTRATING PARALLEL AND SERIES PLATE FEED.

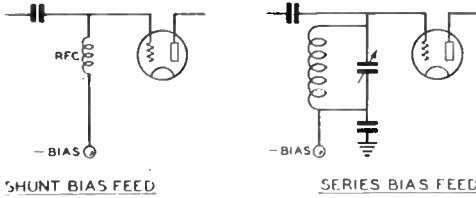

Figure 38.
ILLUSTRATING SHUNT AND SERIES BIAS FEED.

that the impedance of the choke will be extremely high (several hundred thousand ohms) in each of the bands.

The direct current which flows through the r.f. choke largely determines the size of wire to be used in the winding. The inductance of r.f. chokes for very short wave-lengths is much less than for chokes designed for broadcast and ordinary short-wave operation. A very high inductance r.f. choke has more distributed capacity than a smaller one, with the result that it will actually offer *less* impedance at very high frequencies.

Another consideration, just as important as the amount of d.c. the winding will carry, is the r.f. voltage which may be placed across the choke without its breaking down. This is a function of insulation, turn spacing, frequency, and other factors.

Some chokes which are designed to have a high impedance over a very wide range of frequency are, in effect, really two chokes; a u.h.f. choke in series with a high frequency choke. A choke of this type is polarized; that is, it is important that the correct end of the combination choke be connected to the "hot" side of the circuit.

Shunt and Series Feed Direct-current grid and plate connections are made either by *series* or *parallel feed* systems.

Simplified forms of each are shown in Figures 37 and 38.

Series feed can be defined as that in which

the d.c. connection is made to the grid or plate circuits at a point of very low r.f. potential. Shunt feed always is made to a point of high r.f. voltage and always requires a high impedance r.f. choke or resistance to prevent waste of r.f. power.

Parallel and Push-Pull Tube Circuits

The comparative r.f. power output from parallel or push-pull operated amplifiers is the same if proper impedance matching is accomplished, if sufficient grid excitation is available in both cases, and if the frequency of measurement is considerably lower than the frequency limit of the tubes.

Parallel Operation Operating tubes in parallel has some advantages in transmitter's designed for operation below 10 Mc. Only one neutralizing condenser is required for parallel operation, as against two for push-pull. Above about 10 Mc., depending upon the tube type, parallel tube operation is not advisable. Low-C vacuum tubes can be connected in parallel with less difficulty than the high-C types, in which the combined inter-electrode capacities may be quite high in the parallel connection.

Push-Pull Operation The push-pull connection provides a well-balanced circuit insofar as miscellaneous capacities are concerned; in addition, the circuit can be neutralized more completely, especially in high-frequency amplifiers. The L/C ratio in a push-pull amplifier can be made higher than in a plate-neutralized parallel-tube operated amplifier. Push-pull amplifiers, when perfectly balanced, have less second-harmonic output than parallel or single-tube amplifiers, but in practice undesired capacitive coupling and circuit unbalance partly offset the theoretical harmonic-reducing advantages of push-pull r.f. circuits.

Transmitter Keying

The carrier from a c.w. transmitter must be broken into dots and dashes for the transmission of code characters. The carrier signal is of a constant amplitude while the key is closed, and is entirely removed when the key is open. When code characters are being transmitted, the carrier may be considered as being modulated by the keying. If the change from the no-output condition to full-output, or vice versa, occurs too rapidly, the rectangular pulses which form the keying characters contain high order harmonics which take up a wide frequency band as sidebands and are heard as clicks.

The two general methods of keying a c.w. transmitter are those which control the excita-

tion, and those which control the plate voltage which is applied to the final amplifier. *Excitation keying* can be of several forms, such as crystal oscillator keying, buffer stage keying, or blocked-grid keying. In this arrangement, plate voltage is applied to the final amplifier at all times.

Key Click Elimination Key click elimination is accomplished by preventing a too-rapid make-and-break of power to the antenna circuit, rounding off the keying characters so as to limit the harmonics and thereby the sidebands to a value which does not cause interference to adjacent channels. Too much lag will prevent fast keying, but fortunately key clicks can be practically eliminated without limiting the speed of manual (hand) keying. Some circuits which eliminate key clicks introduce too much time-lag and thereby add *tails* to the dots. These tails may cause the signals to be difficult to copy at high speeds.

Click Filters Eliminating key clicks by some of the key-click filter circuits illustrated in the following text is not certain with every individual transmitter. The constants in the time-lag and spark-producing circuits depend upon the individual characteristics of the transmitter, such as the type of filter, power input, and various circuit impedances. All keying systems have one or more disadvantages, so that no particular method can be recommended as an ideal one. An intelligent choice can be made by the reader for his particular transmitter requirements by carefully analyzing the various keying circuits.

Sparkling Contacts Just as any electrical circuit producing sparks will cause interference to *nearby* receivers unless precautions are taken to prevent it, so will a sparking key or relay cause interference unless measures are taken to prevent it. The interference produced will have no correlation with the frequency upon which the transmitter is operating; the clicks produced are not keying sidebands, but rather are due to the sparking contacts and their associated wiring acting as a crude form of a periodic spark transmitter.

Clicks due to key sparks can be minimized by limiting the amount of power handled by the key, and then putting an r.f. bypass condenser right across the key terminals (on the key, not at the transmitter), and in stubborn cases a couple of r.f. chokes in series with the key leads right at the key terminals.

A sparking relay, which usually will be called upon to handle considerably more power, can be prevented from causing trouble by housing it in a grounded metal can and by-

passing to the can all leads to the relay at the point they enter the can. If this does not suffice, inserting r.f. chokes in series with the leads, right at the relay, should prove satisfactory.

Clicks due to sparking contacts should not be confused with those due to keying sidebands. The former may be heard over most of the radio spectrum if not suppressed, but only for a short distance. Clicks due to keying sidebands are actually radiated by the transmitting antenna, and may be heard for a great distance, but under the worst conditions only over a band of frequencies a few per cent either side of the carrier frequency.

Primary Keying One simple form of clickless keying which is satisfactory for certain applications under some conditions is *primary keying*. The key or keying relay is placed in the primary winding of the a.c. plate transformer feeding the final amplifier (and in some cases one or more of the preceding stages).

The inherent lag in the plate supply filter will "round off" the keying to the point where keying sidebands are insignificant. In fact, if a heavily filtered 60 cycle single phase supply is used, there may be too much lag for anything but slow hand keying, and code characters will have objectionable "tails". However, if the plate supply filter is engineered as a multiple section low-pass filter working into its characteristic impedance and designed for about 40 cycle cut-off, it is possible to obtain nearly pure direct current and yet key through the filter cleanly at high speed.

When precautions are taken against spark radiation, this type of keying is an almost sure cure for clicks. The disadvantages are (1) a heavy relay is required, in order to avoid sticking contacts, and (2) the special filter requirements, or else acceptance of a modulated note, in order to avoid keying tails.

Grid-Controlled Rectifiers The relay troubles encountered with primary keying when high power is used may be avoided by the use of grid controlled rectifiers. The arrangement is somewhat more expensive, as the grid controlled rectifier tubes cost considerably more than straight rectifiers of the same power and voltage rating. Also, auxiliary equipment is required for providing an isolated source of grid bias for the rectifiers.

The filter considerations are the same as for primary keying, as in each case the supply voltage is interrupted *ahead* of the power supply filter.

A typical circuit, applicable to a 1 kilowatt transmitter, is illustrated in Figure 39. The

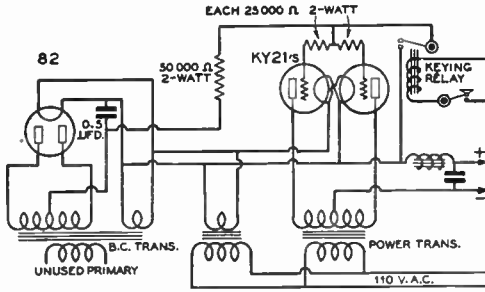

Figure 39.

TYPICAL GRID-CONTROLLED RECTIFIER KEYING.

A small receiver-type power transformer is used for the bias supply. It must be insulated from ground by mounting away from the grounded chassis of the power supply. The keying relay should have the contacts well isolated from the key circuit, in order to afford protection to the operator.

bias transformer must have a filament winding of the same filament voltage used on the rectifiers. The whole transformer is at the power supply voltage above ground, and must be well insulated from the metal chassis and other grounded portions of the circuit.

The keying relay must likewise be insulated for the plate voltage; that is, there must be adequate spacing between the relay solenoid and the contacts, because the former should be at ground potential in order to provide protection to the operator from the high voltage.

Blocked Grid Keying The negative grid bias in a medium- or low-power r.f. amplifier can easily be increased in magnitude sufficiently to reduce the amplifier output to zero. The circuits shown in Figures 40 and 41 represent two methods of such blocked grid keying.

In Figure 40, R_1 is the usual grid leak. Additional fixed bias is applied through a 100,000-ohm resistor R_2 to block the grid current and reduce the output to zero. As a general rule, a small 300- to 400-volt power supply with the positive side connected to ground can be used for the additional C-bias supply.

The circuit of Figure 41 can be applied by connecting the key across a portion of the plate supply bleeder resistance. When the key is open, the high negative bias is applied to the grid of the tube, since the filament center tap is connected to a positive point on the bleeder resistor. Resistor R_2 is the normal bleeder; an additional resistor of from one-fourth to one-half the value of R_2 is connected in the circuit for R_1 . A disadvantage of this circuit is that one side of the key may be placed at a positive

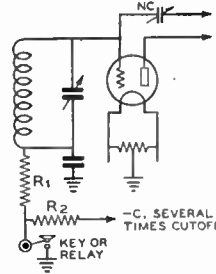
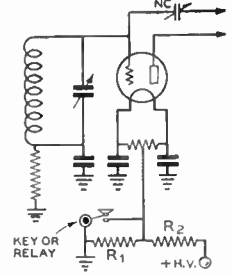

Figure 40. **COMMON BLOCKED-GRID KEYING CIRCUITS.**



potential of several hundred volts above ground, with the attendant danger of shock to the operator. Blocked grid keying is not particularly effective for eliminating key clicks, though lag circuits can be incorporated which will reduce the clicks to an acceptable value.

Oscillator Keying; Break-in A stable and quick-acting crystal oscillator may be keyed in the plate, cathode or screen-grid circuit for break-in operation.

Considerations pertaining to keying of crystal oscillators are covered earlier in this chapter under crystals and crystal oscillators.

Assuming that the crystal oscillator itself is capable of being keyed without clicks, it is still possible to transmit serious keying side-band clicks if the oscillator is followed by several heavily driven amplifier stages. A heavily excited class C amplifier or multiplier acts like a "clipper" stage, tending to square up a rounded excitation impulse, and the cumulative effect of several such stages cascaded is sufficient to square up the "softened" characters out of the oscillator to the point where bad clicks result. The cure is to start at the stage driving the final amplifier, and, working back towards the oscillator, reduce the excitation to each stage to the point where a barely perceptible decrease in antenna power is observed.

Parasitics with Oscillator Keying When keying in the crystal stage, or, for that matter, any stage ahead of the final amplifier, the stages following the keyed one must be absolutely stable so that parasitic or output frequency oscillation will not occur when the excitation is rising on the beginning of each keying impulse. This type of oscillation gives rise to extremely offensive clicks which cannot be eliminated by any type of filter; in fact, a filter designed to slow up the rate at which signal comes to full strength may only make them worse.

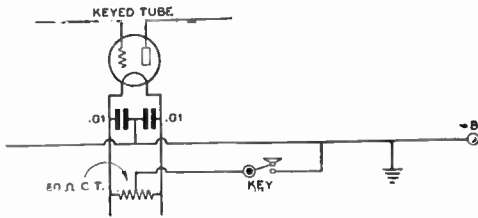

Figure 42.
CENTER TAP KEYING.

The center tap of the filament transformer must not be grounded, and must feed only the stage or stages to be keyed. The grid bias should be returned to ground rather than to center tap.

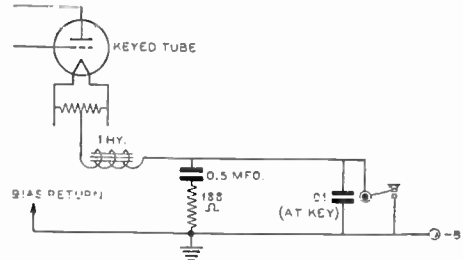

Figure 43.
CENTER TAP KEYING WITH FILTER.

The constants shown are optimum for typical values of plate voltage and plate current, under average conditions. However, some alteration of these values may be required in some instances to give complete suppression of clicks. When high plate voltage is used, a relay should be substituted for the key.

Center-Tap Keying The lead from the center-tap connection to the filament of an r.f. amplifier or oscillator tube can be opened and closed for keying a circuit (Figure 42). This opens the B-minus circuit, and at the same time opens the grid-bias return lead. For this reason, the grid circuit is blocked at the same time that the plate circuit is opened, so that excessive sparking does not occur at the key contacts. Unfortunately, this method of keying applies the power too suddenly to the tube, producing a serious key click. This click often can be eliminated with the key click eliminator shown in Figure 43.

Vacuum Tube C.T. Keying A variation on the center tap keying circuit of Figure 42 producing virtually no clicks is one in which the key or relay is replaced by one or more low resistance triodes in parallel, as in Figure 44. These tubes act as an infinite resistance when sufficient blocking bias is applied to them, and as a very low resistor when the bias is removed. The desired amount of lag or "cushioning effect" can be obtained by employing suitable resistor and condenser values in the grid of the keyer tube(s). Because very little spark is produced at the key, due to the small amount of power in the key circuit, sparking clicks are easily suppressed. The cost of keyer tubes makes this type of keying rather expensive for high power transmitters, but it is not excessive when the power is low enough that receiver tubes can be employed as keyer tubes. The circuit of Figure 44

will handle a keyed stage operating up to 1000 volts. One type 45 tube should be used for every 50 ma of plate current.

Because of the series resistance of the keyer tubes, the plate voltage at the keyed tube will be about 100 volts less than the power supply voltage. This voltage appears as bias on the keyed tube, assuming the bias return is made to ground, and should be taken into consideration when providing bias. In some cases this voltage alone will provide adequate bias.

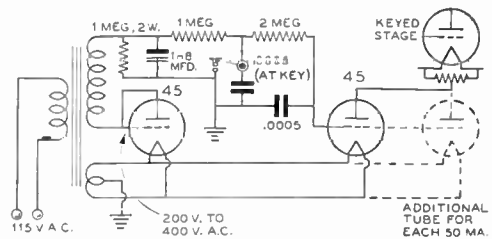

Figure 44.
CENTER TAP KEYING WITH VACUUM TUBE RELAY.

Click suppression is more effectively accomplished when vacuum tubes are used to key the center tap circuit. One type 45 tube should be used for every 50 ma. drawn by the keyed stage. The system becomes uneconomical for high power stages, because of the cost of suitable keyer tubes.

Radiotelephony Theory*

(Amplitude Modulation)

IF THE output of a good radiotelegraph transmitter is by some means varied in amplitude at an audio frequency rate instead of interrupted in accordance with code characters, a tone will be heard on a receiver tuned to the signal. If the audio tone is replaced with a band of audio frequencies comprising voice or music intelligence, then the voice or music which is superimposed on the radio frequency carrier will be heard on the receiver.

When voice, music, video, or other intelligence is superimposed on a radio frequency carrier by means of a corresponding variation in the *amplitude* of the radio frequency output of a transmitter, *amplitude modulation* is the result. C.w. keying of a telegraph transmitter is the simplest form of amplitude modulation, while video modulation in a television transmitter represents a highly complex form. Systems for modulating the amplitude of a carrier envelope in accordance with voice, music, or similar types of complicated waveforms are many and varied, and will be discussed later on in this chapter.

Sidebands Modulation is essentially a form of *mixing*, already covered in a previous chapter. To transmit voice at radio frequencies by means of amplitude modulation, the voice frequencies are mixed with a radio frequency carrier so that the voice frequencies are converted to radio frequency *sidebands*. Though it may be difficult to visualize, *the amplitude of the radio frequency carrier does not vary during modulation.*

Even though the amplitude of radio frequency voltage representing the composite signal (resultant of the carrier and sidebands,

called the "envelope") will vary from zero to twice the unmodulated signal value during full modulation, the amplitude of the *carrier* component does not vary. Also, so long as the amplitude of the modulating voltage does not vary, the amplitude of the sidebands will remain constant. For this to be apparent, however, it is necessary to measure the amplitude of each component with a highly selective filter. Otherwise, the measured power or voltage will be a *resultant* of two or more of the components, and the amplitude of the resultant will vary at an audio rate.

If a carrier frequency of 5000 kc. is modulated by a pure tone of 1000 cycles, or 1 kc., two sidebands are formed: one at 5001 kc. (the sum frequency) and one at 4999 kc. (the difference frequency). The frequency of each sideband is independent of the amplitude of the modulating tone, or *modulation percentage*; the frequency of each sideband is determined only by the frequency of the modulating tone. This assumes, of course, that the transmitter is not modulated in excess of its capability.

When the modulating signal consists of multiple frequencies, as is the case with voice or music modulation, two sidebands will be formed by each modulating frequency (one on each side of the carrier), and the radiated signal will consist of a *band* of frequencies. The *band width*, or space taken up in the frequency spectrum by an amplitude modulated signal, is equal to twice the highest modulating frequency. For example, if the highest modulating frequency is 5000 cycles, then the signal (assuming modulation of complex and varying waveform) will occupy a band extending from 5000 cycles below the carrier to 5000 cycles above the carrier.

Frequencies up to at least 2500 cycles, and preferably 3500 cycles, are necessary for good speech intelligibility. If a filter is incorporated in the audio system to cut out all frequencies above approximately 3000 cycles, the band width of a radiotelephone signal can be lim-

*Because of its increasing use and importance, a separate chapter has been devoted to frequency modulation. It is felt, however, that a thorough understanding of amplitude modulation is a prerequisite; therefore this chapter should be studied before proceeding to f.m.

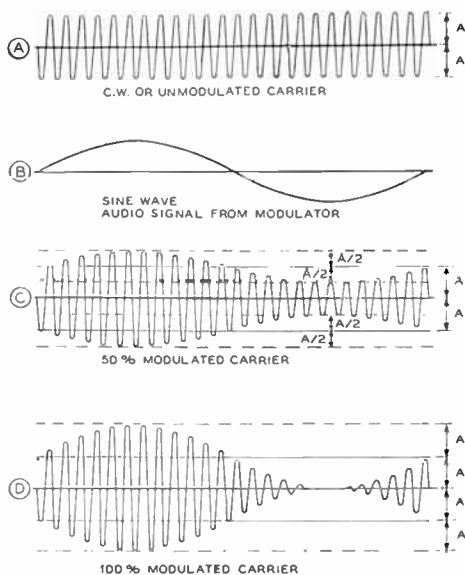

Figure 1.

MODULATION OF A CARRIER WAVE.

The top drawing (A) represents a continuous carrier wave; (B) shows the audio signal output from the modulator. (C) shows the audio signal impressed upon the carrier to the extent of 50 per cent modulation, and (D) shows the carrier with 100 per cent modulation. These drawings illustrate the mechanics of amplitude modulation.

ited to 6 kc. without a significant loss in intelligibility. However, if harmonic distortion is introduced subsequent to the filter, as would happen in the case of an overloaded modulator or overmodulation of the carrier, new frequencies will be generated and the signal will occupy a band wider than 6 kc.

Mechanics of Modulation

A c.w. or unmodulated r.f. carrier wave is represented in Figure 1-A. An audio frequency sine wave is represented by the curve of Figure 1-B. When the two are combined or "mixed," the carrier is said to be amplitude modulated, and a resultant similar to 1-C or 1-D is obtained. It should be noted that under modulation, each half cycle of r.f. voltage differs slightly from the preceding one and the following one; therefore at no time during modulation is the r.f. wave form a pure sine wave. This is simply another way of saying that during modulation the transmitted r.f. energy no longer is confined to a single radio frequency.

It will be noted that the *average* amplitude

of the peak r.f. voltage, or modulation envelope, is the same with or without modulation. This simply means that the modulation is symmetrical, assuming a symmetrical (sine) modulating wave, and that for distortionless modulation the upward modulation is limited to a value of twice the unmodulated carrier wave amplitude because the amplitude cannot go below zero on downward portions of the modulation cycle. Figure 1-D illustrates the maximum obtainable distortionless modulation with a sine modulating wave, the r.f. voltage at the peak of the r.f. cycle varying from zero to twice the unmodulated value, and the r.f. power varying from zero to four times the unmodulated value (because the power varies as the square of the voltage).

While the average r.f. *voltage* of the modulated wave over a modulation cycle is the same as for the unmodulated carrier, the average *power* increases with modulation. If the radio frequency power is integrated over the audio cycle, it will be found that with 100 per cent sine wave modulation the average r.f. power has increased 50 per cent. This additional power is represented by the sidebands, because as previously mentioned, the carrier power does not vary under modulation. Thus, when a 100 watt carrier is modulated 100 per cent by a sine wave, the total r.f. power is 150 watts; 100 watts in the carrier and 25 watts in each of the two sidebands.

Modulation Percentage

So long as the *relative proportion* of the various sidebands making up voice modulation is maintained, the signal may be received and detected without distortion. However, the higher the average amplitude of the sidebands, the greater the audio signal produced at the receiver. For this reason it is desirable to increase the *modulation percentage*, or degree of modulation, to the point where maximum peaks just hit 100 per cent. If the modulation percentage is increased so that the peaks exceed this value, distortion is introduced, and if carried very far, bad interference to signals on nearby channels will result.

Percentage of Modulation

The amount by which a carrier is being modulated may be expressed either as a modulation factor, varying from zero to 1.0 at maximum modulation, or as a percentage. The percentage of modulation is equal to 100 times the modulation factor. Figure 2A shows a carrier wave modulated by a sine-wave audio tone. A picture such as this might be seen on the screen of a cathode-ray oscilloscope with saw-tooth sweep on the horizontal plates and the modulated carrier impressed on the vertical plates. The same carrier without modulation

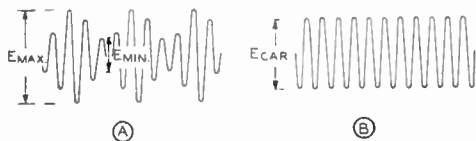

Figure 2.
GRAPHICAL REPRESENTATION OF MODULATED AND UNMODULATED CARRIER.

The method of determining the percentage modulation from the voltage points indicated is described in the text.

would appear on the oscilloscope screen as Figure 2B.

The percentage of modulation of the positive peaks and the percentage of modulation of the negative peaks can be determined from two oscilloscope pictures such as shown.

The modulation factor of the positive peaks may be determined by the formula:

$$M = \frac{E_{max} - E_{car}}{E_{car}}$$

The factor for negative peaks may be determined from this formula:

$$M = - \frac{E_{min} - E_{car}}{E_{car}}$$

In the two above formulas E_{max} is the maximum carrier amplitude with modulation and E_{min} is the minimum amplitude; E_{car} is the steady-state amplitude of the carrier without modulation. Since the deflection of the spot on a cathode-ray tube is linear with respect to voltage, the relative voltages of these various amplitudes may be determined by measuring the deflections, as viewed on the screen, with a rule calibrated in inches or centimeters. The percentage of modulation of the carrier may be had by multiplying the modulation factor thus obtained by 100.

If the modulating voltage is symmetrical, such as a sine wave, and modulation is accomplished without the introduction of distortion, then the percentage modulation will be the same for both negative and positive peaks. However, the distribution and phase relationships of harmonics in voice and music waveforms are such that the percentage modulation of the negative modulation peaks may exceed the percentage modulation of the positive peaks, and vice versa. The percentage modulation when referred to without regard to polarity is an indication of the average of the negative and positive peaks.

Modulation Capability The modulation capability of a transmitter is the maximum percentage to which that transmitter may be modulated before spurious sidebands are generated in the output or before the distortion of the modulating waveform becomes objectionable. The highest modulation capability which any transmitter may have modulation on the negative peaks is 100 per cent. The maximum permissible modulation of many transmitters is less than 100 per cent, especially on positive peaks. The modulation capability of a transmitter may be limited by flat tubes or by tubes with insufficient filament emission, by insufficient excitation or grid bias to a plate modulated stage, too light loading of any type of amplifier carrying modulated r.f., insufficient power output capability in the modulator, or too much excitation to a grid-modulated stage or a class B linear amplifier. In any case, the FCC regulations specify that no transmitter be modulated in excess of its modulation capability. Hence, it is desirable to make the modulation capability of a transmitter as near as possible to 100 per cent so that the carrier power may be used most efficiently.

Speech Waveform Dissymmetry The manner in which the human voice is produced by the vocal cords gives rise to a certain dissymmetry in the waveform of voice sounds when they are picked up by a good-quality microphone. This is especially pronounced in the male voice, and more so on certain voiced sounds than on others. The result of this dissymmetry in the waveform is that the voltage peaks on one side of the average value of the wave will be considerably greater, often two or three times as great, as the voltage excursions on the other side of the zero axis. The average value of energy on both sides of the wave is, of course, the same.

The net result of this dissymmetry in the male voice waveform is an optimum polarity of the modulating voltage that must be observed if maximum sideband energy is to be obtained without distortion or generation of "splatter" on adjacent channels.

A double-pole double throw "phase reversing" switch in the input or output leads of any transformer in the speech amplifier system will permit poling the extended peaks in the direction of maximum modulation capability. The optimum polarity may be determined easily by listening on a selective receiver tuned to a frequency 30 to 50 kc. removed from the desired signal and adjusting the phase reversing switch to the position which gives the least "splatter" when the transmitter is modulated rather heavily. If desired, the switch then may be replaced with wiring.

Single Sideband Transmission Because all of the intelligibility is contained in the sidebands on one side of the carrier, it is not necessary to transmit sidebands on both sides of the carrier. Also, because the carrier is simply a single radio frequency wave of unvarying amplitude, it is not necessary to transmit the carrier if some means is provided for inserting a locally generated carrier at the receiver.

When the carrier is suppressed but both upper and lower sidebands are transmitted, it is necessary to insert a locally generated carrier at the receiver of *exactly* the same frequency as the carrier which was suppressed. For this reason, suppressed-carrier double-sideband systems have no practical application.

When the carrier is suppressed and only the upper or lower sidebands are transmitted, a highly intelligible signal may be obtained at the receiver even though the locally generated carrier differs a few cycles from the frequency of the carrier which was suppressed at the transmitter. A communications system utilizing but one group of sidebands with carrier suppressed is known as a "single sideband" system, and such systems are sometimes used for commercial point to point work, where rather elaborate equipment can be tolerated. The two chief advantages of the system are: (1) the effective power gain which results from putting all the radiated power in intelligence carrying sideband frequencies instead of mostly into radiated carrier, and (2) elimination of the selective fading and distortion that normally occurs in a conventional double sideband system when the carrier fades and the sidebands do not, consequently overmodulating the carrier, when there is interference due to multiple path transmission.

Because single sideband equipment is complex and in limited use, the method whereby the carrier and one sideband are filtered out and a virtual carrier reinserted at the receiver will not be treated in detail.

Systems of Amplitude Modulation

There are many different systems and methods for amplitude modulating a carrier, but most may be grouped under two general classifications: *variable efficiency* systems in which the average input to the stage remains constant with and without modulation and the variations in the efficiency of the stage in accordance with the modulating voltage accomplish the modulation; and *constant efficiency* systems in which the input to the stage is varied by one means or another to accomplish the modulation. The various systems under each classification have individual characteristics which make certain ones best suited to particular applications.

Variable Efficiency Modulation Since the average input remains constant in a stage employing variable efficiency modulation, and since the average power output of the stage increases with modulation, the limiting factor in such an amplifier is the plate dissipation of the tubes in the stage when they are in the unmodulated condition. Hence, for the best relation between tube cost and power output the tubes employed should have as high a plate dissipation rating per dollar as possible.

The plate efficiency in such an amplifier is doubled when going from the unmodulated condition to the peak of the modulation cycle. Hence, the unmodulated efficiency of such an amplifier must always be less than 45 per cent, since the maximum peak efficiency obtainable in a conventional amplifier is in the vicinity of 90 per cent. Since the peak efficiency in certain types of amplifiers will be as low as 60 per cent, the unmodulated efficiency in such amplifiers will be in the vicinity of 30 per cent.

Assuming a typical amplifier having a peak efficiency of 70 per cent, the following figures give an idea of the operation of an idealized efficiency-modulated stage adjusted for 100 per cent sine wave modulation. It should be kept in mind that the plate voltage is constant at all times, even over the audio cycles.

| | |
|---|------------|
| Plate input without modulation..... | 100 watts |
| Output without modulation..... | 35 watts |
| Efficiency without modulation..... | 35% |
| Input on 100% positive modulation peak (plate current doubles)..... | 200 watts |
| Efficiency on 100% positive peak..... | 70% |
| Output on 100% positive modulation peak | 140 watts |
| Input on 100% negative peak..... | 0 watts |
| Efficiency on 100% negative peak..... | 0% |
| Output on 100% negative peak..... | 0 watts |
| Average input with 100% modulation | 100 watts |
| Average output with 100% modulation (35 watts carrier plus 17.5 watts sidebands)..... | 52.5 watts |
| Average efficiency with 100% modulation | 52.5% |

The classic example of efficiency modulation is the class B linear r.f. amplifier. Other common systems of efficiency modulation are control grid modulation, screen grid modulation, and suppressor grid modulation. Cathode modulation is a combination of variable efficiency modulation and variable input modulation.

Class C Grid Modulation The most widely used system of efficiency modulation for communications work is class C control grid bias modulation.

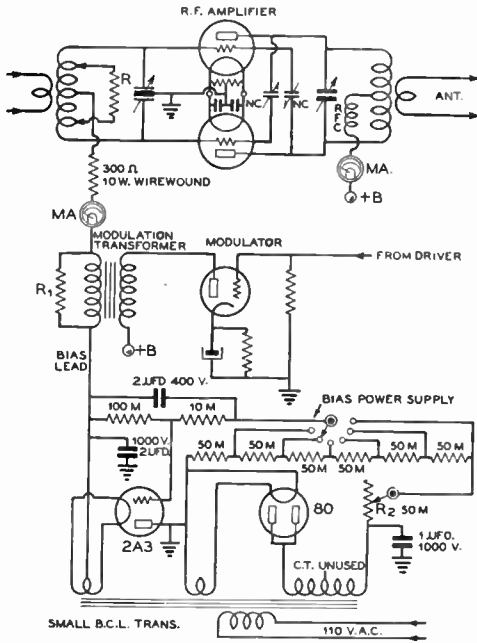

Figure 3.
TYPICAL GRID BIAS-MODULATED AMPLIFIER.

Note especially the r.f. and a.f. swamping resistors, R and R₁, and the voltage regulated bias pack. The 300-ohm grid resistor is for the purpose of parasitic suppression, not bias.

The distortion is slightly higher than for a properly operated class B linear amplifier, but the efficiency is also higher, and the distortion can be kept within tolerable limits for communications work.

Class C grid modulation requires high plate voltage on the modulated stage, if maximum output is desired. The plate voltage is normally run about 50 per cent higher than for maximum output with plate modulation.

The driving power required for operation of a grid-modulated amplifier under these conditions is somewhat more than is required for operation at lower bias and plate voltage, but the increased power output obtainable overbalances the additional excitation requirement. Actually, almost half as much excitation is required as would be needed if the same stage were to be operated as a class C plate-modulated amplifier. The resistor R across the grid tank of the stage serves as "swamping" to stabilize the r.f. driving voltage. At least 50 per cent of the output of the driving stage should be dissipated in this swamping resistor under carrier conditions. If a reasonable amount of reserve excitation power is avail-

able and if a high-C grid tank is used on the grid-modulated stage, no swamping resistor will be required when the bias is at least 6 times cutoff, because the high tank losses under these conditions produce the same result as the swamping resistor.

A comparatively small amount of audio power will be required to modulate the amplifier stage 100 per cent. An audio amplifier having 20 watts output will be sufficient to modulate an amplifier with one kilowatt input. Proportionately smaller amounts of audio will be required for lower powered stages. However, the audio amplifier that is being used as the grid modulator should, in any case, either employ low plate resistance tubes such as 2A3's, employ degenerative feedback from the output stage to one of the preceding stages of the speech amplifier, or be resistance loaded with a resistor across the secondary of the modulation transformer. This provision of low driving impedance in the grid modulator is to insure good regulation in the audio driver for the grid modulated stage. Good regulation of both the audio and the r.f. drivers of a grid modulated stage is quite important if distortion-free modulation approaching 100 per cent is desired, because the grid impedance of the modulated stage varies widely over the audio cycle.

With the normal amount of comparatively tight antenna coupling to the modulated stage, a non-modulated carrier efficiency of 40 per cent can be obtained with substantially distortion-free modulation up to practically 100 per cent. If the antenna coupling is decreased slightly from the condition just described, and the excitation is increased to the point where the amplifier draws the same input, carrier efficiency of 50 per cent is obtainable with tolerable distortion at 90 per cent modulation.

Tuning the Grid-Bias Modulated Stage

It will be noticed, by reference to Figure 3, that a special type of bias supply for the grid-modulated stage has been incorporated as a part of the schematic of the stage. This was done purposely to make it clear that a special type of high-voltage bias supply is required for best operation of such an amplifier. The arrangement shown has the advantage that the supply has very good regulation up to about 75 ma. of grid current (the maximum capability of a single 2A3) and that the voltage may be varied from nearly zero to about 700 volts; also, this particular supply may be constructed quite inexpensively.

The most satisfactory procedure for tuning a stage for grid-bias modulation of the class C type is as follows. The amplifier should first be neutralized, and any possible tendency to-

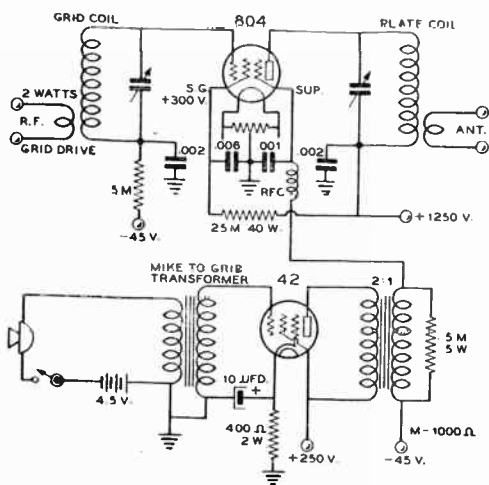

Figure 4.

TYPICAL SUPPRESSOR GRID-MODULATED AMPLIFIER.

The simplest form of speech equipment is shown, but a better microphone and a speech amplifier could just as well be used.

about half the maximum obtainable from the particular amplifier, or usually to about 35 per cent. The peak efficiency at the time of complete modulation must reach twice this value. It is difficult to obtain 100 per cent modulation without distortion, though 90 per cent to 95 per cent can easily be obtained and with good linearity.

The same modulator design problems apply to the suppressor-modulated transmitter as do to a grid-modulated amplifier, because the suppressor normally will be driven positive over the peak of the audio cycle at high modulation percentage. The control grid in the suppressor-modulated stage is driven to about the same degree as for c.w. or plate modulation. The r.f. excitation adjustment is not critical, but the excitation should be ample if good efficiency is to be obtained.

A medium powered suppressor-modulated amplifier is shown in Figure 4. An 804 as the amplifier will supply about 20 watts of carrier. An 803 may be substituted to increase the carrier output to about 50 or 60 watts. Either tube may be excited to full output by a 6L6 operating either as a frequency multiplier or as a crystal oscillator. A type 6F6 or 42 will serve as modulator for either tube.

It is possible to operate a suppressor-modulated amplifier stage as a doubler. The efficiency suffers somewhat but the voice quality will be found to be satisfactory.

The Class B Linear Amplifier

The operation of the class B linear amplifier has been discussed in the chapter devoted to vacuum-tube theory, and hence will only be covered quite generally here. The linear amplifier is well suited for broadcast use, because by careful design and adjustment distortion can be kept at a negligible value, even at high modulation percentages. However, the efficiency is less than can be obtained with class C grid bias modulation.

The grid circuit of linear amplifier is fed modulated r.f. energy and the stage amplifies carrier and sidebands linearly. The stage is biased to "extended" cutoff with no excitation, so that when excitation is applied the plate current flows in 180° pulses. This long period of plate current flow limits the theoretical peak efficiency to 78.5 per cent, the practical peak efficiency to about 65 per cent, and the average carrier efficiency to about 30 to 33 per cent.

The power output from a correctly operating linear amplifier will be about one half the maximum plate dissipation of the stage, under the carrier conditions. The schematic of a linear amplifier is exactly the same as that of a conventional amplifier, whether single ended or push-pull, except that a swamping resistor is usually placed across the grid circuit of the stage. The excitation requirements for a class B linear amplifier are somewhat less than for a class C grid modulated stage running at the same power input.

input Modulation Systems

Constant efficiency variable-input modulation systems operate by virtue of the addition of external power to the modulated stage to effect the modulation. There are two general classifications that come under this heading; those systems in which the additional power is supplied as audio frequency energy from a modulator, usually called plate modulation systems, and those systems in which the additional power to effect modulation is supplied as direct current from the plate supply.

Under the former classification comes Heising modulation (probably the oldest type of modulation to be applied to a continuous carrier), class B plate modulation, and series modulation. These types of plate modulation are by far the easiest to get into operation, and they give a very good ratio of power input to the modulated stage to power output; 65 to 80 per cent efficiency is the general rule. It is for these two important reasons that these modulation systems, particularly class B plate modulation, are at present the most popular for communications work.

Modulation systems coming under the second classification are of comparatively recent

ward parasitics under any condition of operation should be eliminated. Then the antenna should be coupled to the plate circuit, the grid bias should be run up to the maximum available value, and the plate voltage and excitation should be applied. The grid bias voltage should then be reduced until the amplifier draws the approximate amount of plate current it is desired to run, and modulation corresponding to about 80 per cent is then applied. If the plate current kicks up when modulation is applied, the grid bias should be reduced; if the plate meter kicks down, increase the grid bias.

When the amount of bias voltage has been found (by adjusting the fine control, R_2 , on the bias supply) where the plate meter remains constant with modulation, it is more than probable that the stage will be drawing either too much or too little input. The antenna coupling should then be either increased or decreased (depending on whether the input was too little or too much, respectively) until the input is more nearly the correct value. The bias should then be readjusted until the plate meter remains constant with modulation as before. By slight jockeying back and forth of antenna coupling and grid bias, a point can be reached where the tubes are running at rated plate dissipation, and where the plate milliammeter on the modulated stage remains substantially constant with modulation.

The linearity of the stage should then be checked by any of the conventional methods; the trapezoidal pattern method employing a cathode-ray oscilloscope is probably the most satisfactory. The check with the trapezoidal pattern will allow the determination of the proper amount of gain to employ on the speech amplifier. Incidentally, too much audio power on the grid of the modulated stage should not be used in the tuning-up process, as the plate meter will kick quite erratically and it will be impossible to make a satisfactory adjustment.

Tubes for Grid Bias Modulation If a grid bias modulated tube is run at or near maximum permissible rated plate voltage, the amount of carrier power that may be obtained is limited by the plate dissipation, rather than peak filament emission. Therefore, for good economy a tube should be chosen for the modulated stage which has a high plate dissipation rating in proportion to its cost.

Pentodes or beam tetrodes, especially the latter, may be control grid modulated under class C conditions with good efficiency, and less excitation is required than for a triode giving the same carrier power. However, their use is justified only in transmitters where neutralization is a problem, as in multi-band quick-

change transmitters, because such considerably more than a triode of plate dissipation.

High transconductance and a high μ are desirable in a triode to be grid modulated.

Coupling Transformers for Grid Modulation The secondary should be delivered in

secondary of the modulation transformer distortionless output of at least 2 per cent, preferably 5 per cent of the d.c. modulated stage. If low plate resistances such as 2A3's are employed, the transformer need not be resistive. If pentodes or beam tetrode modulators are employed, the secondary of the transformer should be shunted with a resistor having a resistance slightly higher than the value which gives maximum undistorted power from the modulators.

The turns ratio of the transformer should be such that the peak audio voltage across the secondary under normal conditions and full undistorted modulation the modulator is equal to approximately the cut off bias for the particular r.f. stage and plate voltage used, regardless of the amount of bias actually employed.

Screen-Grid Modulation can be accomplished by varying the screen grid voltage in a

grid tube. The screen grid voltage is reduced to between one-half and two-thirds the value used for c.w. operation. The modulator is correspondingly reduced and operates as an efficiency-modulator somewhat similar to ordinary grid modulation.

Distortionless modulation is possible to about 80 per cent. The r.f. excitation is regulated, as in a control grid modulator stage. Likewise, the control grid modulation is provided from a low resistance source passed for a.f. The excitation is regulated as in control grid modulation.

As screen-grid modulation is favored with class C grid modulation, it is seldom employed.

Suppressor Modulation Still another method of modulation can be accomplished by applying audio to the suppressor grid of a pentode tetrode or class C. A change in bias of the suppressor grid will change the operating point of a pentode tube; the application of audio thus provides a simple means of grid modulation.

The suppressor grid is biased at a point which reduces the p

development but have been widely applied to broadcast work. There are quite a few systems in this class. Two of the more widely used are the Doherty linear amplifier, and the Terman-Woodyard high-efficiency grid modulated amplifier. Both systems operate by virtue of a carrier amplifier and a peak amplifier connected together by electrical quarter-wave lines. They will be described later in this section.

Plate Modulation Plate modulation is the application of the audio power to the *plate circuit* of an r.f. amplifier. The r.f. amplifier must be operated class C for this type of modulation in order to obtain a radio-frequency output which changes in exact accordance with the variation in plate voltage. *The r.f. amplifier is 100 per cent modulated when the peak a.c. voltage from the modulator is equal to the d.c. voltage applied to the r.f. tube.* The positive peaks of audio voltage increase the instantaneous plate voltage on the r.f. tube to *twice* the d.c. value, and the negative peaks reduce the voltage to zero.

The instantaneous plate *current* to the r.f. stage also varies in accordance with the modulating voltage. The peak alternating current in the output of a modulator must be equal to the d.c. plate current of the class C r.f. stage at the point of 100 per cent modulation. This combination of change in audio voltage and current can be most easily referred to in terms of *audio power in watts*.

In a sinusoidally modulated wave, the antenna current increases approximately 22 per cent for 100 per cent modulation with a pure tone input; an r.f. meter in the antenna circuit indicates this increase in antenna current. The *average power* of the r.f. wave increases 50 per cent for 100 per cent modulation, the efficiency remaining constant.

This indicates that in a plate-modulated radiotelephone transmitter, the audio-frequency channel must supply this additional 50 per cent increase in average power. If the power input to the modulated stage is 100 watts, for example, the *average power* will increase to 150 watts at 100 per cent modulation, and this additional 50 watts of power must be supplied by the *modulator* when plate modulation is used. The actual antenna power is a constant percentage of the total value of input power.

One of the advantages of plate (or power) modulation is the ease with which proper adjustments can be made in the transmitter. Also, there is less plate loss in the r.f. amplifier for a given value of carrier power than with other forms of modulation, because the plate efficiency is higher.

By properly matching the plate impedance of the r.f. tube to the output of the modulator, the ratio of voltage and current swing to d.c.

voltage and current is automatically obtained. The modulator should have a peak voltage output equal to the average d.c. plate voltage on the modulated stage. The modulator should also have a *peak power* output equal to the d.c. plate input power to the modulated stage. The *average* power output of the modulator will depend upon the type of waveform. If the amplifier is being Heising modulated by a class A stage, the modulator must have an average power output capability of one-half the input to the class C stage. If the modulator is a class B audio amplifier, the average power required of it may vary from one-quarter to one-half the class C input depending upon the waveform. However, the *peak* power output of any modulator must be equal to the class C input to be modulated. This subject is completely covered in the section *Speech Waveforms*.

Heising Modulation Heising modulation is the oldest system of plate modulation, and usually consists of a class A audio amplifier coupled to the r.f. amplifier by means of a modulation choke coil, as shown in Figure 5.

The d.c. plate voltage and plate current in the r.f. amplifier must be adjusted to a value which will cause the plate impedance to match the output of the modulator, since the modulation choke gives a 1-to-1 coupling ratio. A series resistor, by-passed for audio frequencies by means of a capacitor, must be connected in series with the plate of the r.f. amplifier to obtain modulation up to 100 per cent. The a.c. or audio output voltage of a class A amplifier does not reach a value equal to the d.c. voltage applied to the amplifier and, consequently, the d.c. plate voltage impressed across the r.f. tube must be reduced to a value equal to the maximum available a.c. peak voltage if 100% modulation is to be obtained without distortion.

A higher degree of distortion can be tolerated in low-power emergency phone transmitters which use a pentode modulator tube, and the series resistor and by-pass capacitor are usually omitted in such transmitters.

Class B Plate Modulation High-level class B plate modulation is the least expensive method of plate modulation. Figure 6 shows a conventional class B plate-modulated class C amplifier.

The statement that the modulator output power must be one-half the class C input for 100 per cent modulation is correct only if the waveform of the modulating power is a *sine wave*. Where the modulator waveform is speech, the average modulator power for 100 per cent modulation is considerably less than one-half the class C input. If a modulator is

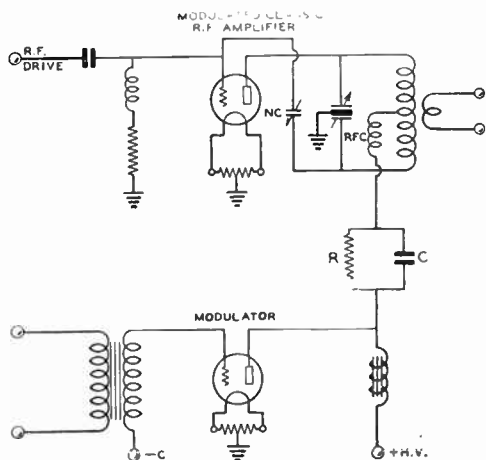

Figure 5.

HEISING PLATE MODULATION.

This type of modulation was the first form of plate modulation. It is sometimes known as "constant current" modulation. Because of the effective 1:1 ratio of the coupling choke, it is impossible to obtain 100 per cent modulation unless the plate voltage to the modulated stage is dropped slightly by resistor R. The capacitor C merely bypasses the audio around R, so that the full a.f. output voltage of the modulator is impressed on the Class C stage.

to be used *only with speech*, it seems logical that its design be based upon the peculiarities of speech rather than on the characteristics of the sine wave. The difference between speech and the sine wave is so pronounced that a 100-watt class B modulator, if properly designed for speech, may be used to modulate fully an input of from 300 to 400 watts. The idea cannot be applied to Heising modulators (class A single ended) for reasons that will be apparent when it is recalled that such modulators run hottest when resting and that the plate operating voltage limits the peak output as well as the average output.

Power Relations in Speech Waveforms

It has been determined experimentally that the ratio of peak to average power in a speech waveform is approximately 4 to 1 as contrasted to a ratio of 2 to 1 in a sine wave. This is due to the high harmonic content of such a waveform, and to the fact that this high harmonic content manifests itself by making the wave unsymmetrical and causing sharp peaks or "fingers" of high energy content to appear. Thus for speech, the average modulator plate current, plate dissipation, and power output are approximately one-half the sine wave values for a given peak output power. In other words, a 100-watt class

B modulator, if used to modulate 100 per cent with speech an input of 200 watts, delivers an average power of only about 50 watts and the average plate current and plate dissipation are only one-half the permissible values. In order to take full advantage of the tube ratings, the design should be altered so that the peak power output is increased until the average plate current or plate dissipation becomes the limiting factor.

Both peak power and average power are necessarily associated with waveform. Peak power is just what the name implies: the power at the peak of a wave. Peak power, although of the utmost importance in modulation, is of no great significance in a.c. power work, except insofar as the average power may be determined from the peak value of a known waveform.

There is no time element implied in the definition of peak power; peak power may be instantaneous—and for this reason average power, which is definitely associated with time, is the important factor in plate dissipation. It is possible that the peak power of a given waveform be several times the average value; for a sine wave, the peak power is twice the average value, and for speech the peak power is approximately four times the average value. For 100 per cent modulation, the peak (instantaneous) audio power must equal the class C input, although the average power for this value of peak varies widely depending upon the modulator waveform, being 50 per cent for a sine wave and about 25 per cent for typical speech tones. The problem then of obtaining more speech power consists in obtaining as

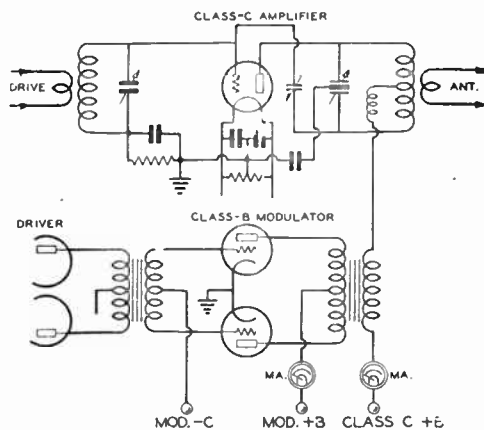

Figure 6.

CLASS B PLATE MODULATION.

This type modulation is the most practicable form of high level modulation for communications work.

Figure 7.

CLASS C INPUT THAT CAN BE FULLY SPEECH-MODULATED BY TYPICAL CLASS B TUBES

| Class B Tubes | Class C Power Input | Class B P-P Load | Plate Voltage | Average Speech Plate Current | Class B Bias | Driver Tubes | Average Driving Power | Driver Transformer Ratio Pri. to 1/2 Sec. |
|---------------|---------------------|------------------|---------------|------------------------------|--------------|--------------|-----------------------|---|
| TZ-20 | 250 | 4850 | 750 | 145 | 0 | 2-2A3 | 7 | 2.6:1 |
| 809 | 300 | 4800 | 750 | 165 | -1 1/2 | 2-2A3 | 5 | 4.5:1 |
| 809 | 400 | 7200 | 1000 | 150 | -8 | 2-2A3 | 5 | 4.5:1 |
| YZ-40 | 300 | 5100 | 1000 | 200 | -5 | 2-2A3 | 8 | 2.6:1 |
| TZ-40 | 600 | 7400 | 1250 | 182 | -9 | 2-2A3 | 7 | 2.8:1 |
| 203Z | 800 | 5500 | 1250 | 250 | 0 | 4-2A3 | 15 | 2.75:1 |
| 810 | 2000 | 8000 | 2250 | 375 | -60 | 4-2A3 | 15 | 2.0:1 |

high a peak power as possible without exceeding the average plate dissipation or current rating of the tubes.

Since the power output varies as the square of the peak current, the most logical thing to do to obtain high peak power is to increase the peak current. This may be done by decreasing the class B modulator plate-to-plate load.

At this point it might be assumed that this increase in peak current is nothing more or less than a gross overload without regard for the manufacturer's ratings. However, a little reflection will show that the manufacturer's rating is given as average current and that the actual peak current (this cannot be read by a meter) varies widely with the mode of operation. An average plate current of 100 ma. in class C operation may call for a dynamic peak plate current of nearly 1 ampere, whereas in class B service this same 100 ma. represents a peak of perhaps 300 ma. No ill effects will result if the peak plate current is increased to such a point that the average plate current with speech, as read on the plate meter, is equal to the sine-wave value as specified by the manufacturer. With this in mind, the peak plate current may be safely doubled, assuming that the plate dissipation does not become the limiting factor.

Modulation Transformer Calculations

The modulation transformer is a device for matching the load impedance of the class C amplifier to the recommended load impedance of the class B modulator tubes. Modulation transformers intended for communications work are usually designed to carry the class C plate current through their secondary windings, as shown in Figure 6. The manufacturer's ratings should be consulted to insure that the d.c. plate current being pulled through the secondary winding does not exceed the maximum rating.

The load resistance presented by the class C r.f. amplifier to the modulation transformer is calculated by dividing the d.c. plate-to-filament voltage by the plate current of the stage. For example, a pair of 75T tubes in a push-pull amplifier operating at 1200 volts and 250 milli-

amperes present a load impedance of 1200 divided by 0.25 amperes, or 4800 ohms.

$$Z = \frac{E}{I} = \frac{1200}{0.25} = 4800 \text{ ohms,}$$

where Z is the load impedance of the class C r.f. amplifier.

The power input is 1200 × 0.25 or 300 watts.

By reference to Figure 7 we see that a pair of 809's operating at 750 volts will fully modulate an input of 300 watts to a class C amplifier with voice-waveform audio power. In other words, the peak audio output of the class B 809's when operated into a load impedance of 4800 ohms and at a plate voltage of 750, is 300 watts. It just so happens that the recommended plate-to-plate load resistance of the 809's under these operating conditions is the same as the load presented by the class C amplifier. Hence, the modulation transformer should have a primary-to-secondary ratio of 1-to-1. The other operating conditions for the 809 modulator will be found in Figure 7. A modulation transformer rated to handle 125 watts of audio will be ample for the purpose.

Suppose we take as another example, to illustrate the method of calculation, the case of a pair of 54 Gammatrons operating at 2000 volts at 250 ma. This amplifier would present a load resistance of 2000 divided by 0.25 amperes or 8000 ohms. The plate power input would be 2000 times 0.25 amperes or 500 watts. By reference to Figure 7 we see that a pair of TZ40's at 1000 volts will put out 500 peak audio watts and hence will modulate 500 watts input with speech waveform. The plate-to-plate load for these tubes is given as 5100 ohms; hence, our problem is to match a load of 8000 ohms to the proper load resistance of the TZ40's of 5100 ohms.

A 200-to-300 watt audio transformer will be required for the job. If the taps on the transformer are given in terms of impedances it will only be necessary to connect the secondary for 8000 ohms and the primary to 5100 ohms. If it is necessary to determine the turns ratio of the transformer it can be determined in the

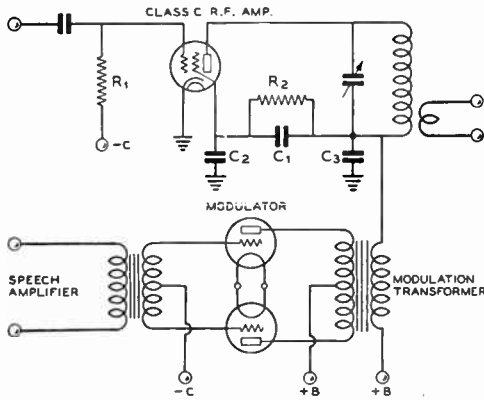

Figure 8.
PLATE MODULATION OF A SCREEN GRID TUBE.

Distortionless, high percentage plate modulation of a screen grid tube requires that the screen be modulated in phase with the plate. Capacitor C₁ prevents capacitor C₂ from contributing excessive phase shift and attenuation at the higher audio frequencies.

following manner. The square root of the impedance ratio is equal to the turns ratio, hence:

$$\sqrt{\frac{8000}{5100}} = \sqrt{1.57} = 1.25$$

The transformer must have a turns ratio of 1.25 to 1, step up. The transformer must be step-up since the higher impedance is on the secondary. When the primary impedance is the higher of the two impedances, the transformer must be connected step-down.

Plate-and-Screen Modulation

When *only* the plate of a screen-grid tube is modulated, it is impossible to obtain high percentage linear modulation, except in the case of certain beam tubes. A dynatronic action usually takes place when the instantaneous plate voltage falls below the d.c. screen voltage, and this prevents linear modulation. However, if the screen is modulated simultaneously with the plate, the instantaneous screen voltage drops in proportion to the drop in the plate voltage, and linear modulation can then be obtained. A circuit for such a system is shown in Figure 8.

The screen r.f. by-pass capacitor, C₃, should not have a value greater than .01 μfd., preferably not larger than .005 μfd. It should be large enough to bypass effectively all r.f. voltage without short-circuiting high-frequency audio voltages. The plate by-pass capacitor can be of any value from .002 μfd. to .005 μfd. The screen-dropping resistor, R₂, should reduce

the applied high voltage to the value specified for operating the particular tube in the circuit. Capacitor C₁ is seldom required, yet some tubes may require this capacitor in order to keep C₂ from attenuating the high audio frequencies. Different values between .002 and .0002 μfd should be tried for best results.

Another method is to have a third winding on the modulation transformer, through which the screen-grid is connected to a low-voltage power supply. The ratio of turns between the two output windings depends upon the type of screen-grid tube which is being modulated. The latter arrangement is more economical insofar as modulator power is concerned, because there is no waste of audio power across a screen-grid voltage-dropping resistor. However, this loss is relatively small anyway with most tubes. The special transformer is not justified except perhaps for high power.

If the screen voltage is derived from a dropping resistor (*not* a divider) that is by-passed for r.f. but not a f., it is possible to secure quite good modulation up to about 90 per cent by applying modulation only to the plate, provided that the screen voltage and excitation are first run up as high as the tube will stand safely. Under these conditions, the screen tends to modulate itself to an extent, the screen voltage varying over the audio cycle as a result of the screen impedance increasing with plate voltage, and decreasing with a decrease in plate voltage.

The modulation transformer for plate-and-screen-modulation, when utilizing a dropping resistor, is similar to the type of transformer used for any plate-modulated phone. In Figure 8, the combined screen and plate current is divided into the plate voltage in order to obtain the class C amplifier load impedance. The audio power required to obtain 100 per cent sine-wave modulation is one-half the d.c. power input to the screen, screen resistor, and plate of the modulated r.f. stage.

Cathode Modulation Cathode modulation offers a workable compromise between the good plate efficiency but expensive modulator of high-level plate modulation, and the poor plate efficiency but inexpensive modulator of grid modulation. Cathode modulation consists essentially of an admixture of the two.

The efficiency of the average well-designed plate-modulated transmitter is in the vicinity of 75 to 80 per cent, with a compromise perhaps at 77.5 per cent. On the other hand, the efficiency of a good grid-modulated transmitter may run from 28 to maybe 40 per cent, with the average falling at about 34 per cent. Now since cathode modulation consists of simultaneous grid and plate modulation, in phase with

OPERATION CURVES FOR CATHODE-MODULATED R-F AMPLIFIERS

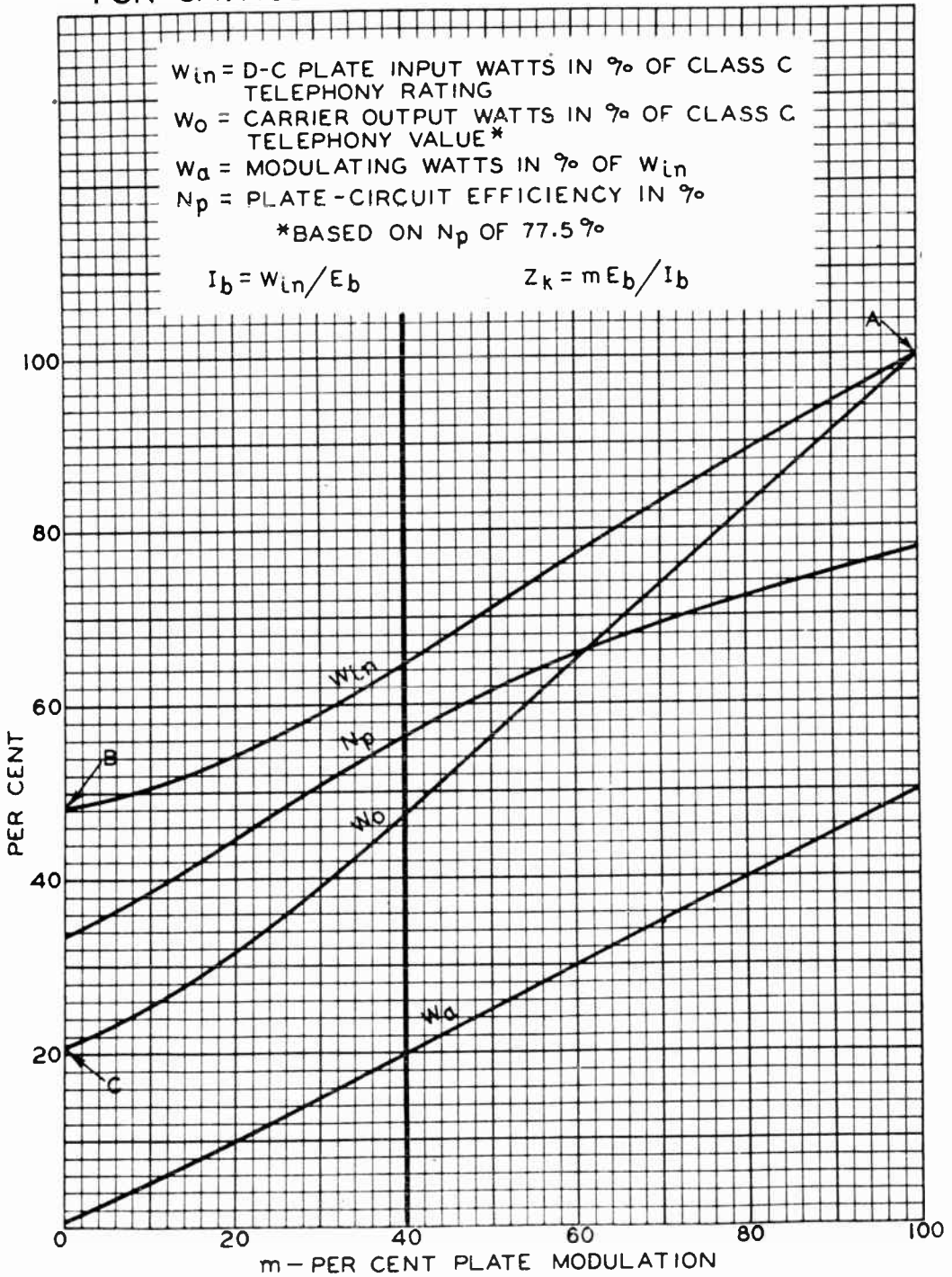

Figure 9.

Courtesy RCA Mfg. Co., Inc.

each other, we can theoretically obtain any efficiency from about 34 to 77.5 per cent from our cathode-modulated stage, depending upon the relative percentages of grid and plate modulation.

Since the system is a compromise between the two fundamental modulation arrangements, a value of efficiency approximately half way between the two would seem to be the best compromise. Experience has proven this to be the case. A compromise efficiency of about 56.5 per cent, roughly half way between the two limits, has proven to be optimum. Calculation has shown that this value of efficiency can be obtained from a cathode-modulated amplifier when the audio frequency modulating power is approximately 20 per cent of the d.c. input to the cathode-modulated stage.

Cathode-Modulation Operating Curves

Figure 9 shows a set of operating curves for cathode-modulated r.f. amplifier stages. The chart is a plot of the percentage of plate modulation (*m*) against plate circuit efficiency, audio power required, plate input wattage in per cent of the plate-modulated class C rating, and output power in percentage of the class C phone output rating. These last two curves are not of as great importance in designing new transmitters as are the curves showing the relationship between per cent plate modulation and plate circuit efficiency.

Optimum Operating Conditions

As was mentioned before, the optimum operating condition for a normal cathode modulated amplifier is that at which the audio power output of the cathode modulator is about 20 per cent of the d.c. input to the modulated stage. Under these conditions the plate efficiency will be in the vicinity of 56.5 per cent (between 54 and 58 per cent in a practical transmitter). The limiting factor in an efficiency modulated amplifier of this type is, to a large extent, plate dissipation. If, under the conditions given above, the plate dissipation of the tube under carrier conditions is less than the rated value, the plate input can be increased until rated plate dissipation is reached. The plate dissipation for any condition of operation can easily be determined by reference to Figure 9 and a little calculation. Determine the input, and from the efficiency value given, figure the power output from the stage. Subtract this from the plate input, and the result is the amount that the tube will be required to dissipate.

Cathode Impedance The impedance of the cathode circuit of an amplifier which is being cathode modulated is

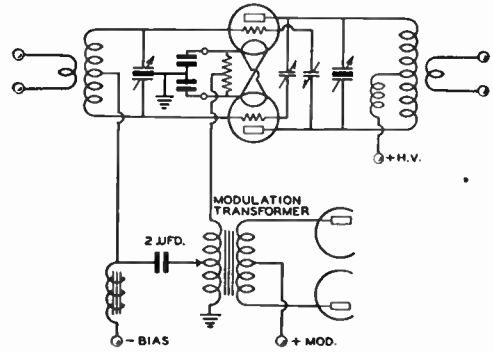

Figure 10. CONVENTIONAL CATHODE MODULATION.

The modulation transformer in series with the cathode return of the modulated stage must match the cathode impedance of this stage. The choke in series with the grid return of the stage should have from 15 to 40 henrys inductance and should be capable of carrying the full grid current of the stage. The grid tap on the modulation transformer is varied, after the stage has been placed into operation, to give the best modulation pattern.

an important consideration in the selection of the transformer which is to be used to couple the modulator. The cathode impedance of an amplifier is equal to the peak modulating voltage divided by the peak a.f. component of the plate current of the stage. The peak modulating voltage is equal to the plate voltage times *m* (the per cent plate modulation).

$$\text{Hence: } Z_k = m \frac{E_p}{I_p}$$

Or, simply, the cathode impedance is equal to the per cent plate modulation (expressed as a decimal; e.g., 0.4 for 40%) times the plate voltage, divided by the plate current.

Cathode Modulator A typical cathode-modulated r.f. amplifier is shown in Figure 10. The modulator which is used to feed the audio into the cathode circuit of the modulated stage should preferably have a power output of 20 per cent of the d.c. input to the stage, for 40 per cent plate modulation. Although this is the recommended percentage of plate modulation, satisfactory operation may be had with other percentage values than this provided the proper operating values are taken from Figure 9. The modulator tubes may be operated class A, class AB, or class B, but it is recommended that some form of degenerative feedback be employed around the modulator tubes when they are to be operated in any manner other than class A. This is particularly true of beam tetrodes when used

as modulators; if some form of feedback is not used around them the harmonic distortion can easily be serious enough to be objectionable, since the cathode modulated stage does not present a strictly linear impedance.

The transformer which couples the modulator to the cathode circuit of the modulated amplifier should match the cathode impedance, as calculated by the formula above, and in addition should have a number of taps so that the proper amount of audio voltage will be impressed upon the grid of the stage. In most cases one of the conventional multi-match output transformers will be satisfactory for the job, the cathode lead and the ground terminal of the stage being connected to the proper taps to give the desired value of impedance. The stage is then coupled to a cathode-ray oscilloscope so that the modulated waveform is shown on the screen. As the stage is being modulated, the grid is tapped varying amounts up and down on the modulation transformer until the best waveform is obtained on the screen of the oscilloscope. The more closely the grid is tapped to the cathode, the less will be the amount of audio voltage upon the grid. On the other hand, if the grid return is grounded, the full cathode swing will be placed upon the grid. It will be found that low- μ tubes will require a larger percentage of the total cathode swing upon them than will tubes with a higher μ factors. Hence, high- μ tubes will be tapped closer to cathode; low- μ tubes will be tapped more closely to ground.

Excitation The r.f. driver for a cathode-modulated stage should have about the same power output capabilities as would be required to drive a c.w. amplifier to the same input as it is desired to drive the cathode-modulated stage. However, some form of excitation control should be available since the amount of excitation power has a direct bearing on the linearity of a cathode-modulated amplifier stage. If link coupling is used between the driver and the modulated stage, variation in the amount of link coupling will afford ample excitation variation. If much less than 40% plate modulation is employed, the stage begins to resemble a grid bias modulated stage, and the necessity for good r.f. regulation will apply.

Biasing Systems Any of the conventional biasing arrangements which are suitable for use on a class C amplifier are also suitable for use with a cathode-modulated stage. Battery bias, grid leak bias, and power supply bias all are usable in their conventional fashion; cathode bias may be used if the bias resistor is by-passed with a high capacitance electrolytic capacitor. In any case the bias volt-

age should be variable or adjustable so that the optimum value for distortionless modulation can be found. If grid leak or cathode bias is used, the value of the grid leak or cathode resistor should be adjustable. Grid leak bias is not recommended if the per cent plate modulation is less than 30%, as the stage then is then essentially a grid modulated amplifier, requiring a well-regulated bias source.

The Doherty and the Terman-Woodyard Modulated Amplifiers

These two amplifiers will be described collectively since they operate upon a

very similar principle. Figure 11 shows a greatly simplified schematic diagram of the operation of both types. Both systems operate by virtue of a carrier tube (V_1 in both Figures 11a and 11b) which supplies the unmodulated carrier, and whose output is reduced to supply negative peaks, and a peak tube (V_2) whose function is to supply approximately half the positive peak of the modulation cycle and whose additional function is to lower the load impedance on the carrier tube so that it will be able to supply the other half of the positive peak of the modulation cycle.

The peak tube is enabled to increase the output of the carrier tube by virtue of an impedance inverting line between the plate circuits of the two tubes. This line is designed to have a characteristic impedance of one-half the value of load into which the carrier tube operates under the carrier conditions. Then a load of one-half the characteristic impedance of the quarter-wave line is coupled into the output. By experience with quarter-wave lines in antenna-matching circuits we know that such a line will vary the impedance at one end of the line in such a manner that the geometric mean between the two terminal impedances will be equal to the characteristic impedance of the line. Thus, if we have a value of load of *one-half* the characteristic impedance of the line at one end, the other end of the line will present a value of *twice* the characteristic impedance of the line to the carrier tube V_1 .

This is the situation that exists under the carrier conditions when the peak tube merely floats across the load end of the line and contributes no power. Then as a positive peak of modulation comes along, the peak tube starts to contribute power to the load until at the peak of the modulation cycle it is contributing enough power so that the impedance at the load end of the line is equal to R , instead of the $R/2$ that is presented under the carrier conditions. This is true because at a positive modulation peak (since it is delivering full power) the peak tube subtracts a negative resistance of $R/2$ from the load end of the line.

Now, since under the peak condition of

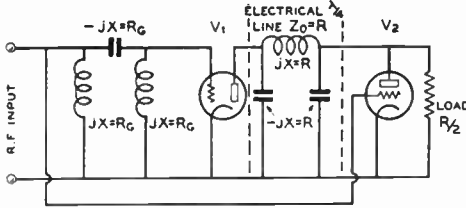

Figure 11-A.

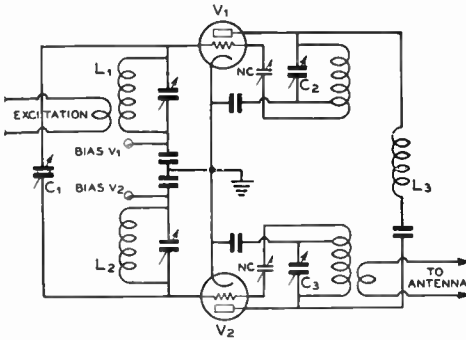

Figure 11-B.

SIMPLIFIED SCHEMATICS OF "HIGH EFFICIENCY" LOW LEVEL MODULATION STAGE.

The basic system, comprising a "carrier tube" and a "kicker tube", is the same for either bias modulation or excitation modulation. The operation is described in the accompanying text.

modulation the load end of the line is terminated in R ohms instead of $R/2$, the impedance at the carrier-tube will be reduced from $2R$ ohms to R ohms. This again is due to the impedance inverting action of the line. Since the load resistance on the carrier tube has been reduced to half the carrier value, its output at the peak of the modulation cycle will be doubled. Thus we have the necessary condition for a 100 per cent positive modulation peak; the amplifier will deliver four times as much power as it does under the carrier conditions.

On negative modulation peaks the peak tube does not contribute; the output of the carrier tube is reduced until on a 100 per cent negative peak its output is zero.

The Electrical Quarter-Wave Line

While an electrical quarter-wave line (consisting of a pi network with the inductance and capacitance legs having a reactance equal to the characteristic impedance of the line) does have the desired impedance-inverting effect, it also has the undesirable effect of introducing a 90° phase shift across such a line. If the shunt elements are

capacitances, the phase shift across the line leads by 90° ; if they are inductances, the phase shift lags by 90° . Since there is an undesirable phase shift of 90° between the plate circuits of the carrier and peak tubes, an equal and opposite phase shift must be introduced in the exciting voltage to the grid circuits of the two tubes so that the resultant output in the plate circuit will be in phase. This additional phase shift has been indicated in Figure 11a and a method of obtaining it has been shown in Figure 11b.

Comparison Between Linear and Grid Modulator

The difference between the Doherty linear amplifier and the Terman-Woodward grid-modulated amplifier is the same as the difference between any linear and grid-modulated stages. Modulated r.f. is applied to the grid circuit of the Doherty linear amplifier with the carrier tube biased to cutoff and the peak tube biased to the point where it draws substantially zero plate current at the carrier condition. In the Terman-Woodward grid-modulated amplifier the carrier tube runs class C with comparatively high bias and high plate efficiency, while the peak tube again is biased so that it draws almost no plate current. Unmodulated r.f. is applied to the grid circuits of the two tubes and the modulating voltage is inserted in series with the fixed bias voltages. From one-half to two-thirds as much audio voltage is required at the grid of the peak tube as is required at the grid of the carrier tube.

Operating Efficiencies

The resting carrier efficiency of the grid-modulated amplifier may run as high as is obtainable in any class C stage, 80 per cent or better. The resting carrier efficiency of the linear will be about as good as is obtainable in any class B amplifier, 60 to 65 per cent. The overall efficiency of the bias-modulated amplifier at 100 per cent modulation will run about 75 per cent; of the linear, about 60 per cent.

In Figure 11b the circuits are detuned enough to give an effect equivalent to the shunt elements of the quarter-wave "line" of Figure 11a. At resonance, the coils L_1 and L_2 in the grid circuits of the two tubes have each an inductive reactance equal to the capacitive reactance of the capacitor C_1 . Thus we have the effect of a pi network consisting of shunt inductances and series capacitance. In the plate circuit we want a phase shift of the same magnitude but in the opposite direction; so our series element is the inductance L_3 whose reactance is equal to the characteristic impedance desired of the network. Then the plate tank capacitors of the two tubes C_2 and C_4 are in-

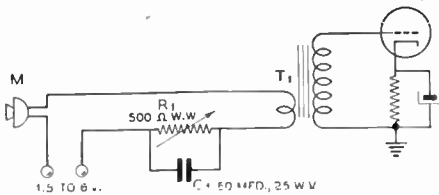

Figure 12.
SINGLE BUTTON MICROPHONE
INPUT CIRCUIT.

The variable resistance R_1 serves as a gain control and at the same time permits running minimum button current. The transformer T_1 usually has a primary of about 100 ohms and a secondary of between 100,000 and 500,000 ohms, thus providing high gain.

creased an amount past resonance, so that they have a capacitive reactance equal to the inductive reactance of the coil L_2 . It is quite important that there be no coupling between the inductors.

Although both these types of amplifiers are highly efficient and require no high-level audio equipment, they are difficult to adjust—particularly so on the higher frequencies—and it would be an extremely difficult problem to design a multi-band rig employing the circuit. However, the grid-bias modulation system has advantages for the high-power transmitter that may make some amateurs interested more than academically in the circuit.

Speech Equipment

Microphones A microphone is a *transducer*, a converter of mechanical to electrical energy. It usually, but not necessarily, consists of a diaphragm which moves in accordance with the compressions and rarefactions of the air called *sound waves*. The diaphragm then actuates some device which changes its electrical properties in accordance with the amount of physical movement.

If the diaphragm is very tightly stretched, the natural period of its vibration can be placed at a frequency which will be out of range of the human voice. This obviously reduces the sensitivity of the microphone, yet it greatly improves the uniformity of response to the wide range encountered for voice or musical tones. If the natural mechanically resonant period of the diaphragm falls within the voice range, the sensitivity is greatly increased near the resonant frequency. This results in distorted output if the diaphragm is not heavily damped, a familiar example being found in the old-type land-line telephone microphone.

A good microphone must respond equally to all voice frequencies; it must not introduce noise, such as hiss; it must have sufficient sen-

sitivity to eliminate the need of excessive audio amplification; its characteristics should not vary with changes in temperature, humidity, or position, and its characteristics should remain constant over a useful period of life.

Carbon Microphone Carbon microphones can be divided into two classes: (1) *single-button*, (2) *double-button*. The single-button microphone consists of a diaphragm which exerts a mechanical pressure on a group of carbon granules. These granules are placed behind the diaphragm between two electrodes, one of which is secured directly to the diaphragm and moves in accordance with the vibration of the diaphragm. This vibration changes the pressure on the carbon granules, resulting in a change of electrical resistance to current flowing between the electrodes, the direct current being supplied from an external source. The variation in resistance causes a change in the current which flows through the primary winding of a coupling transformer, thereby inducing a voltage in the secondary winding of this transformer. This voltage is then amplified as may be required. (See Figure 12.)

Single-button microphones are useful for operation in portable transmitters because their sensitivity is greater than that of other types of microphones, thereby requiring less audio amplification to supply audio modulating power to the transmitter. They can be made quite rugged, another desirable feature for portable or mobile use.

The earlier type single button microphones had a high hiss level and a bad resonance peak in the middle of the voice range. However, the latest types have been improved to the extent that they have fair fidelity and excellent intelligibility. The hiss level is sufficiently low that it is not noticed when the microphone is used close to the lips at normal voice level. When the microphone is used close to the lips, second harmonic distortion generated by the microphone reaches a significant magnitude, but is not excessively high for communications work.

Most of the newer single-button microphones are not positional, which means that they can be shaken during use or operated in any position without noticeable change in characteristics.

Single-button carbon microphones usually have a d.c. resistance of from 30 to 100 ohms. The effective impedance is the same as the d.c. resistance. The maximum permissible button current will vary with the particular make of microphone, but usually is from 50 to 75 ma. Excessive button current will cause the microphone to become noisy if allowed to persist.

When only a comparatively narrow band of voice frequencies need be considered, as in communications work, it is possible to design a microphone input transformer with a very high step-up ratio. When such a transformer is used and maximum permissible button current is applied to the microphone, as much as 25 volts peak will be obtained across the secondary when speaking directly into the microphone at normal voice level.

In order to conserve battery drain and prolong the useful life of the microphone button, it is recommended that for a volume control a rheostat be employed in series with the microphone, rather than the more conventional potentiometer volume control across a transformer secondary. By choosing a supply voltage suitable for the particular microphone and amplifier employed, sufficient volume range adjustment can be obtained in this manner. The rheostat (R_1 in Figure 12) preferably should be wirewound, and should be bypassed with a high-capacity low voltage electrolytic capacitor.

When the microphone voltage is taken from a 6-volt storage battery which also supplies a vibrator pack or dynamotor, a "hash filter" usually will be required in order to prevent undesirable hum modulation via the microphone circuit. A very low resistance, iron core choke, bypassed at the input with a 0.5 μ f. paper and at the output by a 50 μ f. electrolytic, make a satisfactory filter.

Double-Button Microphones The double-button microphone has two groups of carbon granules arranged in small containers on either side of the diaphragm. This push-pull effect minimizes the even-harmonic distortion. The diaphragm is normally stretched to such an extent that its natural period is between 6,000 and 8,000 cycles per second. This reduces the sensitivity of the microphone, and greater audio amplification is needed to secure the same output as from a single-button carbon microphone. On the other hand, the tone quality from the double-button microphone is better. The hiss is aggravated by the fact that the output of the microphone is much lower (20 to 45 db) than that of a single-button microphone for a given button current.

The double-button microphone was very popular a decade or two ago, but now is seldom used.

Condenser Microphones A condenser microphone has a better frequency response than a carbon microphone, and it does not produce a hiss. This type of microphone consists of a highly damped or stretched diaphragm mounted very close to a metal plate but insulated from the plate. The move-

ment of the diaphragm changes the spacing between the two electrodes, resulting in a change in electrical capacitance. When a d.c. polarizing voltage is applied across the plates an a.c. voltage will be generated when the diaphragm is actuated, by reason of the change in capacitance between the plates. This voltage can then be amplified by means of vacuum tubes.

The diaphragm of a typical condenser microphone is made of duralumin sheet, approximately 1/1000 inch thick, with approximately the same spacing between the diaphragm and the rear heavy plate electrode. The output is approximately 75 db below an ordinary single-button carbon microphone with unstretched diaphragm.

The low output of a condenser microphone necessitates considerable preamplification, the first stage being located, of necessity, very close to the microphone. The output impedance is extremely high and the unit must, therefore, be well shielded in order to prevent r.f. and 60-cycle a.c. hum pickup. It is sensitive to changes in barometric pressure and humidity. More modern types of microphones are replacing the condenser type. A typical condenser microphone preamplifier is illustrated in Figure 13.

Crystal Microphones The crystal microphone operates on the principle that a change in dimensions of a piezoelectric material, such as a Rochelle salt crystal, generates a small a.c. voltage which can be amplified by means of vacuum tubes. No d.c. polarizing voltage or current or coupling transformer is required for the crystal microphone; thus, it is a very simple device to connect into an audio amplifier.

Crystal microphones can be divided into two classifications: (1) the diaphragm type, (2) the grille type.

The diaphragm type is relatively inexpensive, and consists of a semifloating diaphragm which subjects the crystal to deformation in accordance with the applied sound pressure. The fidelity is equal to that of most two-button carbon microphones, and there is no background noise or hiss generated in the microphone itself.

The grille type consists of a group of crystals connected in series or series-parallel, for the purpose of obtaining adequate electrical output without aid of a diaphragm.

The output level varies between—55 db and 80 db for various types of crystal microphones. The grille type is less directional to sound pickup than most other types, and is capable of almost perfect fidelity. However, they have from 10 to 25 db less output than the grille type.

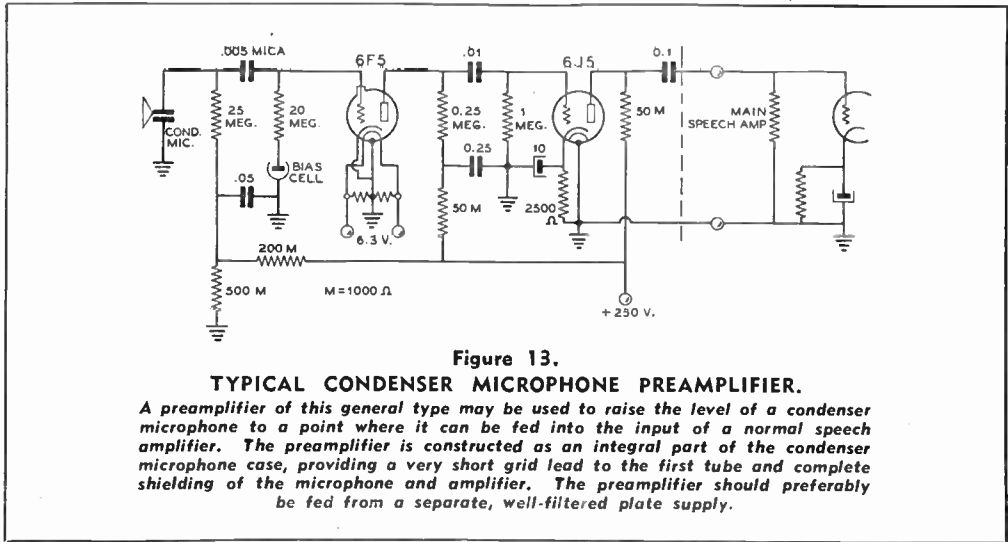

Figure 13.
TYPICAL CONDENSER MICROPHONE PREAMPLIFIER.
A preamplifier of this general type may be used to raise the level of a condenser microphone to a point where it can be fed into the input of a normal speech amplifier. The preamplifier is constructed as an integral part of the condenser microphone case, providing a very short grid lead to the first tube and complete shielding of the microphone and amplifier. The preamplifier should preferably be fed from a separate, well-filtered plate supply.

The crystal element used in both types is damaged permanently by high ambient temperatures. This limits the usefulness for certain applications, but nevertheless the crystal microphone is the most widely used high quality microphone for communications and public address use.

Velocity or Ribbon Microphones

The velocity or ribbon type microphone has a thin, corrugated, metal strip diaphragm which is loosely supported between the poles of a horseshoe magnet. A minute current is induced in this strip when it moves in a magnetic field, and this current can be fed to the primary of a step-up-ratio transformer of high ratio because of the very low impedance of the ribbon.

The microphone output must be amplified by means of a very high gain preamplifier, because the output level is around -85 db. This type of microphone is rugged and simple in construction. It cannot be used for close talking without overemphasizing the lower frequencies, and should therefore be placed at least 2 feet from the source of sound. It is very sensitive to a.c. hum pickup, which is one of the principal reasons why it is not more widely used outside of broadcast applications.

The impedance of the ribbon is so low that it is difficult to design a ribbon-to-grid transformer with good fidelity. For best quality, two transformers are usually used in cascade: ribbon-to-200 ohms and 200 ohms-to-grid.

The ribbon microphone has excellent fidelity. The loosely supported ribbon has a natural period of vibration of but a few cycles as second, which serves the same purpose as stretching the diaphragm of a diaphragm type

microphone to resonate above the useful range. However, the ribbon is vulnerable to wind currents, and is easily damaged by a strong current of air unless protected by a suitable wind screen.

The ribbon microphone is bi-directional, having a figure of eight pattern with two complete nulls displaced 180 degrees.

The "boominess" which results from talking very close to a ribbon velocity microphone is caused by the fact that the diaphragm does not work on the sound pressure of the wave, as in most microphones, because both sides of the ribbon are exposed. Instead, the ribbon follows the *particle velocity* of the sound wave. The ratio of particle velocity to sound pressure increases rapidly when the distance from the sound source to the microphone is made much less than a wavelength. Because the distance measured in wavelength is much shorter for the lower frequencies, low frequencies are accentuated when the sound source is close, but normal when the distance is a considerable fraction of a wavelength at the lowest frequency present.

Dynamic Microphone

The dynamic (moving coil) type of microphone operates on the same general principle as the ribbon microphone except that it is a pressure-operated device (only one side of the diaphragm exposed to the sound wave). A small coil of wire, actuated by a diaphragm, is suspended in a magnetic field, and the movement of the coil in this field generates an alternating current. The output impedance is approximately 30 ohms as against approximately 1 ohm for the ribbon type of microphone. The output level of the high fidelity types is about -85

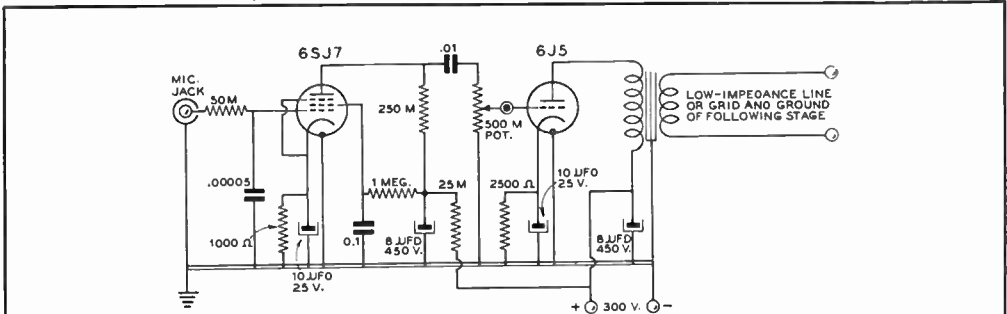

Figure 14.
RECOMMENDED SPEECH AMPLIFIER INPUT CIRCUIT.

This is a simple and conventional speech amplifier circuit for operating out of a crystal, high-impedance dynamic, or other low-level microphone. The voltage gain will be in the vicinity of 2300, which means that the amplifier will have a gain of about 67 db. With a crystal mike with output of -50 db the output of the 6J5 will be about plus 17 db; this is ample to drive a pair of 2A3's as a driver for a class B modulator. In this case a push-pull input transformer would be used in the plate circuit of the 6J5. If it is desired to feed a low-impedance line, a plate-to-line transformer should be used in the 6J5 plate circuit.

db, the level varying with different makes. The output level of the p.a. types is somewhat higher, and the fidelity is almost as good. This type of microphone is quite rugged, but has the disadvantage of picking up hum when used close to any power transformers.

An inexpensive and very satisfactory dynamic microphone for amateur transmitters can be made from a small, permanent-magnet type, dynamic loudspeaker. One of the newer 5-inch types with alloy magnet will give surprising fidelity at relatively high output level.

A shielded cable and plug are essential to prevent hum pickup. The unit can be mounted in any suitable type of container. The circuit diagram is shown in Figure 16.

Directional Effects Crystal microphones, as well as those of some other types, can be mounted in a spherical housing with the diaphragm oriented horizontally in order to secure a non-directional effect. De-

cidely unidirectional effects may sometimes be required and microphones for this purpose are commercially available.

Noise Cancelling Microphones By exposing both sides of the diaphragm of a single-button microphone to the sound waves, it will operate as a velocity or pressure gradient device. The increase in the ratio of particle velocity to sound pressure at very close distances (covered under the velocity microphone) then can be exploited to advantage to obtain a microphone which actually discriminates against sounds emanating at a distance from the microphone. A close-talking carbon microphone giving a reduction in ambient background noise level of from 15 to 20 db over conventional close-talking micro-

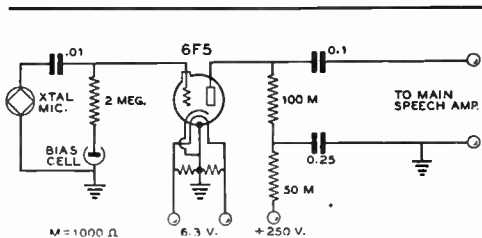

Figure 15.
SIMPLE PRE-AMPLIFIER OR SPEECH AMPLIFIER INPUT STAGE.

This amplifier stage makes a good input stage, providing about 35 db gain with very low hum and tube noise.

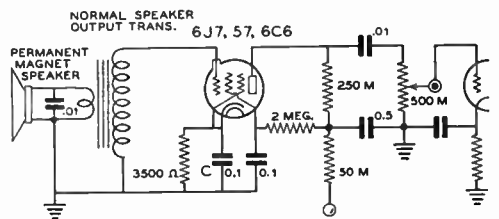

Figure 16.
HIGH-GAIN INPUT STAGE USING PENTODE.

This circuit will contribute slightly more tube noise than the circuit of Figure 15, but is satisfactory for all except the lowest level microphones. The small P.M. type speaker used as a microphone provides adequate fidelity for communications work, at low cost. A regular dynamic microphone may be substituted. The voltage gain of the stage is over 40 db.

phones utilizes this principle. The microphone is corrected acoustically to compensate for the "boominess" that ordinarily would result from talking directly into a velocity microphone. Because of the compensation, the bass response is poor for distant sounds, but because of the specific close-talking application of the microphone this is of academic interest.

Microphones of this type can be used successfully in locations of ambient noise so high that it is difficult or impossible to hear one's own voice.

Speech Amplifiers

That portion of the audio channel between the microphone or its preamplifier and the power amplifier or modulator stage can be defined as the *speech amplifier*. It consists of from one to three stages of *voltage amplification* with resistance, impedance, or transformer coupling between stages. The input level is generally about -50 db in the case of a speech amplifier designed for a double-button carbon microphone or preamplifier input. The input level is approximately -70 db when the speech amplifier is designed for operation from a diaphragm-type crystal microphone. Some conventional speech amplifier circuits are shown in the preceding pages. Other speech amplifier circuits are shown in the chapter on *Speech and Modulation Equipment*.

It is possible to dispense with the preamplifier with certain types of low-level microphones by designing the speech amplifier input to work at -100 db or so, but it is better practice and entails less constructional care if a speech amplifier with less gain is used, in conjunction with a preamplifier to make up the required overall amplification. Less trouble with hum and feedback will be encountered with the latter method.

Designing a speech amplifier to work at -70 db is comparatively easy, as there is little trouble from power supply hum getting into the input of the amplifier by stray capacitive or inductive coupling.

Amplifier Gain Calculations The power gain in amplifiers, or the power loss in attenuators, can be conveniently expressed in terms of db *units*, which are an expression of ratio between two power levels. The calculation of db gain or loss is given in the chapter, "Radio Mathematics and Calculations."

Phase Inverters Quite frequently in the design of a speech amplifier it is desirable to go from a single-ended stage into a push-pull power output stage, or a push-pull driver for class B grids. A push-

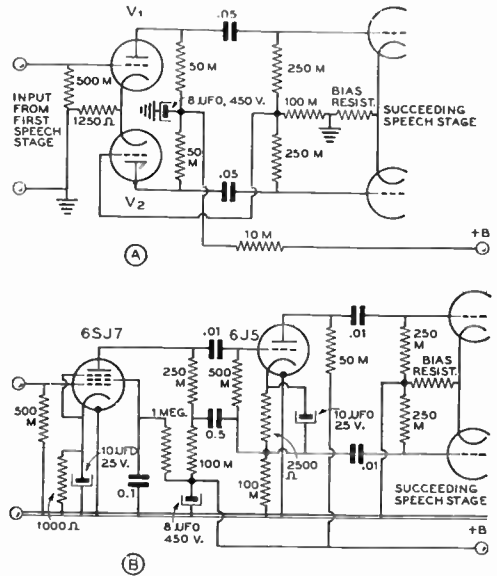

Figure 17.
RECOMMENDED PHASE-INVERTER CIRCUITS.

(A) shows the "floating paraphrase" circuit which is the best for all ordinary applications. (B) shows an excellent complete front end for a speech amplifier which will deliver ample voltage output to drive any of the conventional power audio tubes when a conventional crystal or high-impedance dynamic microphone is used on the input. The circuit shown at (A) is quite flexible and is capable of considerable change to suit different circuit conditions. That shown at (B) should be used as is without change if its excellent operating characteristics are to be retained. Both circuits are fully described in the accompanying text.

pull input transformer can be used to obtain the 180°-out-of-phase voltages necessary for the grids of the output tubes. But good quality push-pull input transformers are expensive and have a tendency to pick up inductive hum

Figure 17 shows two *electronic* phase-inverter circuits which have proved to give excellent results in all normal types of applications. Both make use of degenerative feedback to stabilize and equalize the voltages developed across the two halves of the output circuit. The circuit shown at (A) can be used with any two tubes of the low-power types usually employed in low-level audio work. One of the most satisfactory arrangements is to use a dual tube for both V₁ and V₂. The 6N7, 6F8-G, 6SC7, 6SN7, 7F7, and 6Z7-G twin triodes all are suitable for this application. The voltage gain of this phase inverter from the grid of V₁ to the two grids of the succeeding speech stage is slightly less than *twice* the actual gain of V₁.

V_1 and V_2 need not be biased from the same cathode resistor; they may each have a separate cathode resistor (by-passed or not by-passed, as desired) and degenerative feedback from the output of the amplifier may be fed back into the cathode of V_1 (but *not* into V_2).

The voltage which appears on the grid of V_2 arises from the unbalance in the output voltages delivered by the two phase-inverter tubes. Hence, the higher the gain of the tube at V_2 the less will be the difference between the voltages fed to the two output stage grids. In any case, if the gain of V_2 is above 15, the voltage appearing on the grid fed by V_2 will be at least 94 per cent of that appearing at the other grid.

The circuit shown at (B) of Figure 17 has a total voltage gain from the input grid of the 6SJ7 to the two grids of the push-pull speech stage of about 2300. This is ample gain to operate from a source such as a crystal microphone or pickup into the grids of a pair of 6A3's, 6V6's, or 6L6's. The 6SJ7 stage gives a gain of about 150, while the 6J5 gives a total gain of about 14, or about 7 for each output tube grid. This circuit is unique among cathode-follower phase-inverter circuits in that the full gain of the cathode follower tube (6J5) is obtained, although this gain is split, of course, between the two grid circuits of the following stage. Slight adjustments in the value of the 100,000-ohm resistor in the cathode circuit of the 6J5 will allow exactly equal and opposite voltages to be obtained on the grids of the succeeding stage.

Tube Considerations, Voltage Amplifiers The gain of a resistance-coupled triode is primarily a function of the amplification factor, because the plate load resistance can be made much higher than the plate resistance of the tube where voltage amplification rather than power output is desired. If the plate load resistance were infinite, and the tube were somehow supplied with plate voltage, the voltage gain would be equal to the amplification factor of the tube. If the plate load resistance were made equal to the plate resistance of the tube, the gain would be equal to the amplification factor divided by two. Usually the plate load resistor is made several times the plate resistance, and the voltage gain runs about 0.75 of the μ of the tube.

As it is difficult to build a triode with μ of more than 100, the voltage gain of a single triode in a resistance coupled amplifier is limited to approximately 75, and for many tubes is much less.

Resistance coupled pentode amplifiers usually employ tubes designed for pentode amplification (as contrasted to power pentodes) and the plate resistance of such tubes is very high,

often over a megohm. The voltage gain of such a tube is equal to the plate load resistance in thousands of ohms times the transconductance in thousands of micromhos. However, it should be kept in mind that if the plate coupling resistor is made very high the plate voltage and current on the tube are thus limited to a very low value, and the transconductance under such conditions is much lower than the value listed in the tube tables for normal plate and screen voltages. However, by using optimum values of plate resistor, it is possible to obtain gains on the order of 300, which is considerably greater than can be obtained from an ordinary high μ triode.

Tube Considerations, Power Amplifiers The plate load resistance giving maximum power output (without regard to voltage gain) from a given triode depends upon the amount of distortion which can be tolerated. If the maximum tolerable distortion limit is set anywhere between 3 and 10 per cent, it will be found that maximum output is obtained when the plate load resistance (assuming a resistive load) is equal to 2 or 3 times the dynamic plate resistance of the tube.

Optimum grid bias under these conditions will be found to be approximately $\frac{2}{3}$ the value of cut off bias, the latter being determined by dividing the plate voltage by the μ of the tube. If the plate dissipation of the tube under these conditions does not equal or approach the maximum rated dissipation for the tube, then the output capabilities of the tube are not being fully realized. The plate voltage can be raised until the plate dissipation at $\frac{2}{3}$ cut off bias equals the maximum recommended value for the tube, assuming that the maximum rated plate voltage is not exceeded first. The latter condition may easily occur when the amplification factor of the tube is high. For this reason the amplification factor and plate resistance of power output triodes are made low. There is no point in running high plate voltage on a power amplifier when it is possible to design the tube to give full output at moderate plate voltage.

The maximum power output of a triode operated as recommended above is approximately 20 per cent of the plate input for sine wave modulation. If higher distortion can be tolerated, as in communications work, the efficiency at maximum output is approximately 25 per cent.

The plate load resistance which gives maximum power output from a pentode or beam power amplifier cannot be determined from a simple "rule of thumb." Whereas the load resistance must be considerably *higher* than the

dynamic plate resistance of a triode for low distortion, the load resistance for a pentode or beam tetrode must be considerably *lower* than the plate resistance of the tube. The exact value of optimum load, however, must be evolved either by cut and try or by rather involved calculations. The same pertains to the bias, though in general the optimum class A bias will be about the same or slightly lower than for a triode, expressed in terms of percentage of cut off bias. The optimum values of bias and load resistance for a pentode or tetrode power audio stage are best taken from the manufacturer's data, the more pertinent of which is given in the tube data tables in this book.

The efficiency of a pentode or beam tetrode at maximum undistorted sine wave output is slightly higher than for a triode if only the plate input is considered, running about 30 per cent. However, if the tube draws much screen current, the overall efficiency will not be appreciably greater than that of a triode.

Push-pull beam tetrodes running class AB will give high output with moderate distortion, and are widely used in public address and communications work where audio powers on the order of 10 to 200 watts are required.

Inverse Feedback Inverse feedback, also called *negative feedback* or *degenerative feedback*, is a method of lowering the distortion, hum and noise generated in an audio stage at the expense of voltage gain. It also reduces the *effective* plate resistance of the stage and improves the frequency response. The reduction in distortion, noise, and effective plate resistance is proportional to the amount of feedback.

Basically, the application of inverse feedback to an audio system consists of taking a portion of the voltage developed at the output of a stage and feeding it back to the input of that or a preceding stage, 180 degrees out of phase with the input voltage. The loss in gain resulting from the incorporation of inverse feedback can be made up by adding an additional stage of voltage amplification at the front end of the amplifier, where distortion is very low anyhow because of the comparatively low magnitude of the signal at that point in the amplifier.

Inverse feedback systems are of two kinds, inverse *voltage* feedback, and inverse *current* feedback. In the former, the circuit is arranged so that the voltage fed back is proportional to the *voltage* developed across the load. This type of inverse feedback reduces the effective internal or "dynamic" plate resistance of the amplifier, and is the most commonly used type.

Negative *current* feedback also feeds an out-of-phase voltage back to the input, but the voltage is taken across a resistance in series with the output load, so that the voltage fed back is proportional to the *current* developed in the output load. An unbypassed cathode resistor in a single ended stage provides this type of feedback, which is satisfactory where the load impedance is constant regardless of amplitude or frequency. Because the latter condition obtains only in a few special applications, this type feedback is not so widely used as inverse voltage feedback.

As will be explained later, there is a limit to the amount of inverse feedback which can be employed without encountering a tendency towards oscillation. The reduction in distortion and gain resulting from inverse feedback can be approximated quite closely by the following rule:

Determine the gain without feedback, and note the percentage of the output voltage which will be fed back, the latter being designated the *feedback factor*. Divide the *gain without feedback* by the *original gain times the feedback factor, plus 1*. Thus, if the original gain (without feedback) was 20 and the feedback factor is 0.20 (meaning that 20% of the output voltage is fed back), then the gain with feedback is

$$\frac{20}{20(0.2) + 1} \text{ or } 4.$$

Phase Shift It is apparent that unless the feedback voltage is between 90 and 270 degrees out of phase with the input voltage, the feedback will cause *regeneration* rather than degeneration. When employing a degenerative feedback circuit, care must be taken to see that the feedback is not regenerative rather than degenerative at very low and very high frequencies outside the desired frequency range, causing oscillation. For instance, a feedback amplifier may be designed to have very nearly 180 degrees phase shift (optimum) over the range 100 to 5,000 cycles, yet have less than 90 or more than 270 degrees phase shift at say 10 cycles or 50,000 cycles. The problem is to keep the gain sufficiently low at the frequencies where the feedback is regenerative that the amplifier does not oscillate.

In a single resistance-coupled stage, it is impossible to obtain phase shift in excess of 90 degrees, regardless of frequency or circuit constants.

In a two stage amplifier it is comparatively easy to keep the phase shift sufficiently low to permit a high degree of feedback without oscillation, but when three resistance-coupled

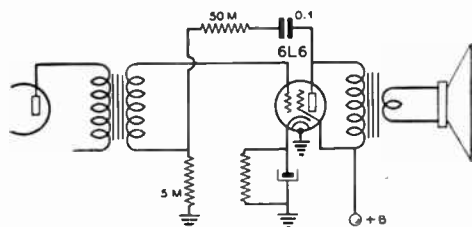

Figure 18.
INVERSE VOLTAGE FEEDBACK INCORPORATED IN A SINGLE STAGE BEAM POWER AMPLIFIER.

stages are included in the feedback "loop," considerable care must be taken to avoid instability. In a multi-stage amplifier the tendency towards oscillation can be reduced by designing one stage with a pass band just sufficient for the intended application, and the remaining stage or stages to have as little attenuation as possible outside the pass band. This arrangement keeps the gain well down at all frequencies having appreciable phase shift.

When transformer coupling is employed within the feedback loop, the tendency towards oscillation is aggravated. The leakage reactance in a transformer, especially in a cheap one, causes considerable phase shift at the higher audio frequencies. Also, unless the transformer is designed for good bass response, there will be appreciable phase shift at the lower end of the audio range. For this reason it is difficult to employ a worthwhile amount of feedback around a loop containing more than two good or one mediocre transformer. Transformers having a turns ratio near unity will give the least trouble; those with a high step-up or step-down ratio will produce so much phase shift that the incorporation of negative feedback around even the one transformer is not always feasible.

Negative Feedback Circuits In Figure 18, a simple method of applying inverse feedback to an audio amplifier is shown. With the values of resistance as indicated, the negative feedback is approximately 10 per cent. This reduces the gain of the audio amplifier; however, it still has approximately twice the sensitivity of a typical triode amplifier with similar plate circuit characteristics. The plate circuit impedance of the 6L6 is greatly reduced, an advantage when working into a loudspeaker (because a loudspeaker is not a constant impedance device).

Inverse feedback can be applied in a some-

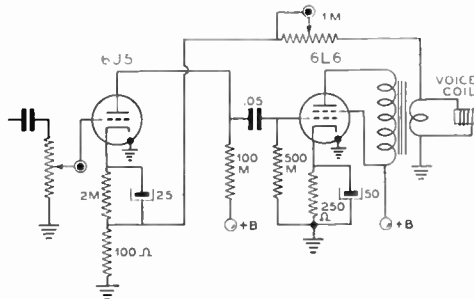

Figure 19.
INVERSE VOLTAGE FEEDBACK AROUND A TWO STAGE AMPLIFIER, WITH ADJUSTABLE FEEDBACK.

what different manner, as shown in Figure 19, for a two-stage amplifier. This method is particularly desirable, in that the tube driving the output stage does not have to deliver a high output voltage to offset the "bucking" effect of the feedback, as is the case where the feedback voltage is merely fed back from the plate to the grid circuit of the same stage.

The polarity of the secondary winding of the output transformer, in all cases where the feedback connection is made to the secondary, should be that which will produce degeneration and reduction in amplifier gain, rather than regeneration and howl or increase of gain.

The circuit of Figure 20 shows inverse feedback applied over three stages of amplification. These two systems are suitable for operation as speech amplifiers and modulators for grid-modulated radio-telephones, or low-power plate-modulated transmitters. The 100-ohm cathode resistor should be located as near as possible to the 6C5 tube cathode terminal in order to prevent undesirable pickup and feedback at frequencies other than those desired.

Because three stages, including two transformers, are included within the loop, some juggling of coupling and bypass capacitor values to suit the transformers and circuit layout employed probably will be required in order to permit a worthwhile amount of feedback to be obtained without oscillation. The transformers must be of good quality, having low leakage reactance.

Parallel Inverse Feedback Circuit Figure 21 shows a particularly simple and effective means of obtaining degenerative feedback around a pentode or beam tetrode output stage. The distortion at all output levels of the 6L6 amplifier stage is greatly reduced, and the permissible power output, before serious distortion starts to occur, is increased from about 5 watts without

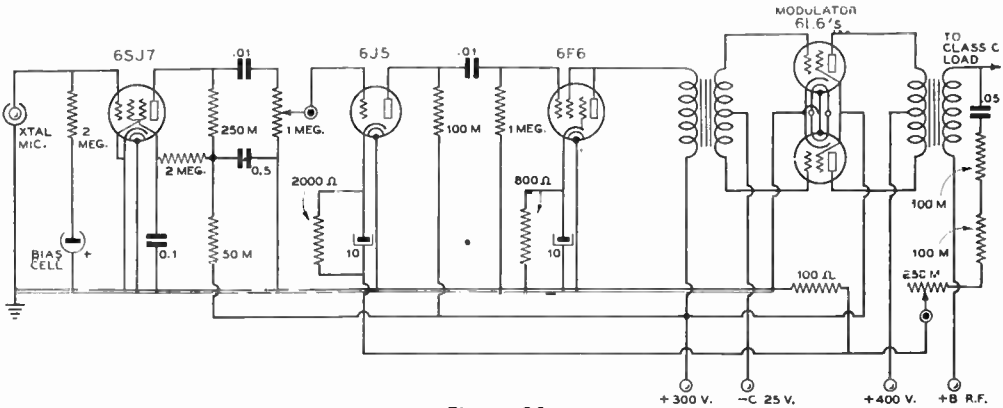

Figure 20.

40-WATT BEAM POWER AMPLIFIER WITH INVERSE FEEDBACK.

Unless high quality transformers are employed, excessive phase shift will prevent using more than a small amount of feedback without encountering oscillation.

feedback to about 6.5 watts with the feedback circuit shown. The circuit consists simply of a high-gain audio stage, using a tube with high plate impedance, coupled to a beam-tube or pentode output stage. Degenerative feedback is accomplished by the inclusion of the 500,000 ohm resistor from the plate of the output tube to the plate of the 6SJ7.

The correct value of plate load impedance is 2500 ohms. The gain of the combined two-tube circuit is intermediate between the value required for excitation of the 6L6 alone and the value required with a 6SJ7 amplifier without feedback in front of it; about 1 volt peak is required at the grid of the 6SJ7 for full output from the 6L6. The circuit is satisfactory for use as a low-power grid or plate modulator, as a driver for a class B stage, or to operate a speaker. A speech amplifier using this circuit is given in chapter 14.

within the feedback loop are small values of interstage coupling capacitors, any sort of shunting capacitors such as a plate by-pass on a modulated stage, and large values of series resistance anywhere within the feedback loop. If there should arise in case of oscillation caused by too large a value of series resistor in the feedback circuit proper, this trouble can often be cured by shunting the series resistor with a very small value of mica capacitor—0.00004 μfd. or so. However, in a case where it is impossible to eliminate oscillation in a circuit employing degenerative feedback, it is always possible to eliminate the difficulty by reducing the amount of feedback. In a circuit with a large amount of phase change with frequency, it may be necessary to

Rectified Carrier Inverse Feedback It is possible to include a modulated r.f. power amplifier stage within the feedback loop if certain precautions are taken, thus reducing the hum, noise, and modulation distortion generated by or within the modulated r.f. stage itself. This type of feedback is employed in most broadcast transmitters, and also can be used to advantage in communications transmitters.

The method consists of rectifying a small amount of carrier signal in order to recover the audio envelope, and feeding this audio voltage back into an appropriate part of the speech amplifier in the proper phase. Two inverse feedback rectifier circuits are shown in Figures 22 and 23.

Things which must be carefully avoided

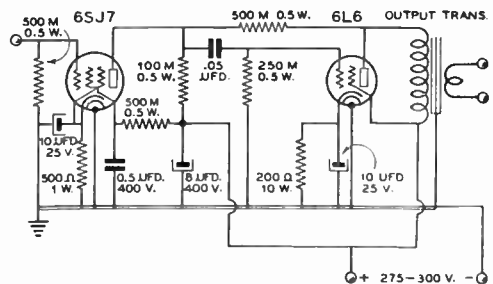

Figure 21.

"SHUNT" OR "PARALLEL" TYPE OF INVERSE VOLTAGE FEEDBACK IN A SINGLE-ENDED BEAM POWER OUTPUT STAGE.

This simple feedback circuit keeps the distortion at a very low value up to the full output capability of the 6L6.

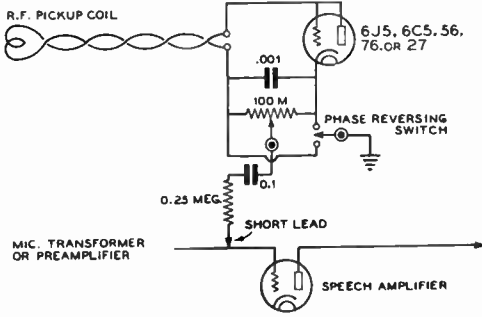

Figure 22.

DIODE CARRIER RECTIFIER PROVIDING INVERSE FEEDBACK OF AUDIO ENVELOPE VOLTAGE.

This method of inverse feedback reduces distortion and noise in both modulator and modulated stage. It is widely used in broadcast practice, but cannot be employed to full advantage in a transmitter using class B plate modulation with an inexpensive modulation transformer. The leakage reactance of the latter encourages undesirable oscillations, unless the feedback factor is low.

reduce the feedback to an amount so small that it may as well be eliminated. This is the condition which usually arises when it is attempted to place degenerative feedback around a plate modulated transmitter using class B modulators. Degenerative feedback may be used satisfactorily from the rectified carrier back to the audio system in transmitters using Heising plate modulation, and suppressor or control-grid modulation. The system is especially suited to application in transmitters using grid-bias modulation, as it is easy to apply and reduces to a negligible value the appreciable distortion inherent in a class C grid bias modulated stage.

Cathode Followers It was stated in the discussion of negative feedback that negative current feedback could be obtained by omitting the cathode bypass capacitor of a cathode-biased audio amplifier stage. If the plate load resistance is reduced to zero, the feedback factor is unity. There is then no plate load resistance across which audio voltage can be developed, but an audio voltage approaching the magnitude of the grid input voltage will appear across the cathode resistor.

The gain will be less than 1, usually running between 0.7 and 0.9 for typical tubes and circuits. However, the effective internal impedance of the *cathode follower*, as such a circuit is called, is much lower than the dynamic plate impedance of the tube. Because of this characteristic, the cathode follower is widely

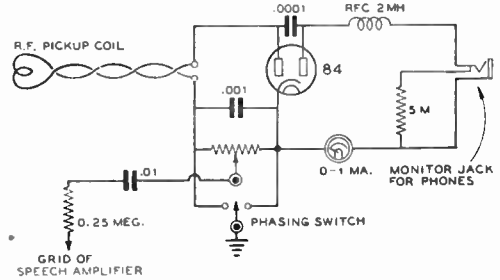

Fig. 23.

CARRIER RECTIFIER CIRCUIT PROVIDING BOTH INVERSE FEEDBACK VOLTAGE AND MONITORING SIGNAL.

used in audio work to transfer an a.f. voltage at a high impedance to a voltage at low impedance without benefit of a transformer, and with but small loss in voltage amplification.

A cathode follower stage for audio work is illustrated in Figure 24. For straight audio applications, the cathode resistor R_2 should be the same value that would normally be employed with the tube as a class A amplifier which has full B supply voltage on the plate (no plate load resistor). This value of cathode resistor will give maximum undistorted output.

The effective internal impedance of the cathode follower circuit illustrated is approximately 1,000,000 divided by the transconductance of the tube in micromhos. Thus, a tube with a transconductance of 5000 would have an effective internal impedance of 200 ohms. This internal impedance is in shunt with the cathode resistor which has the effect of lowering the net impedance of the cathode circuit still further. Thus, if the cathode resistance is 400 ohms in the foregoing example, the net impedance is 200 ohms in parallel with 400 ohms, or 133 ohms.

While the effective internal impedance is a function of transconductance, and the ratio of μ to plate resistance has little bearing on the effective internal impedance when a tube is used as a cathode follower, a tube with a comparatively low μ is preferable when maximum undistorted output is required. This is explained by the fact that a high μ tube requires but little bias for class A operation, and obviously the permissible input voltage is limited by cut off bias when undistorted output is desired. Because of the high degree of inherent negative feedback in a cathode follower stage, the distortion is very low within the operating limits of the tube. The maximum power output of a cathode follower stage is roughly 10 per cent of the power that can be obtained from the same tube used in conjunction with a

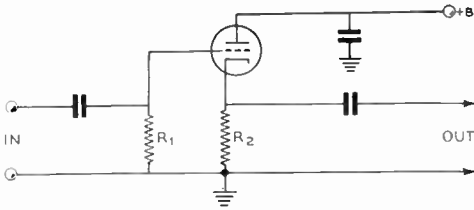

Figure 24.

TYPICAL CATHODE FOLLOWER CIRCUIT FOR A.F. CIRCUITS.

This is the simplest form of cathode follower. The effective internal impedance of the tube is reduced to a very low value, as explained in the text.

step down output transformer, assuming the same operating potentials. Power pentodes and beam tetrodes make good cathode followers when triode connected (screen tied to plate).

Cathode followers have certain characteristics which are of importance in video, pulse, and vacuum tube voltmeter work, and for these applications they often comprise circuits more complex than that of Figure 24. Because of their many variations and limited application, these circuits and a discussion of their characteristics are not within the scope of this book.

Bass Suppression Most of the power represented by ordinary speech (particularly the male voice) lies below 1000 cycles. If all frequencies below 400 or 500 cycles are eliminated or substantially attenuated, there is a considerable reduction in power with but insignificant reduction in intelligibility. This means that the speech level may be increased considerably without overmodulation or overload of the audio system, which is equivalent to a corresponding increase in transmitter power. Furthermore, audio transformers and modulation transformers may be much smaller for a given audio power in watts, because the size of a transformer for a given power depends primarily upon the lowest frequency to be transmitted.

When a moderate amount of bass suppression is employed, the speech will not only be highly intelligible, but will appear to be of "good quality". However, careful observation and comparison with the speaker's actual voice will reveal that the transmitted speech is not "full" and "natural", two important considerations in broadcast work which are relatively unimportant in communications work.

As pointed out above, bass suppression permits a higher percentage modulation at the voice frequencies providing intelligibility, which is equivalent to a substantial increase in power. It is not necessary to suppress the bass

frequencies completely, but only to attenuate them until, as the audio gain is increased, overmodulation first occurs at the voice frequencies that afford intelligibility, rather than at the power-consuming bass frequencies.

The simplest and probably the most practicable methods of bass suppression are simply to skimp on the size of the interstage coupling capacitors or cathode bypass capacitors in a resistance coupled amplifier, choosing values which cause the response to start to droop at about 600 cycles.

Predetermining the frequency characteristic by calculation of the cathode bypass capacitor is a rather complicated procedure, as the tube and other circuit parameters enter the picture. However, it is a simple matter to determine what value of interstage coupling capacitor is required to start a bass "droop" at any particular desired frequency. It is done as follows:

Make the grid coupling resistor at least twice the value of the associated plate coupling resistor. Then choose a value of coupling capacitor which has a reactance at 600 cycles which is equal to the resistance of the grid coupling resistor. (Refer to the reactance-frequency chart in the chapter *Radio Mathematics and Calculations*.) If this procedure is applied to two cascaded resistance-coupled stages, an attenuation curve will be obtained which is about optimum, the response being down approximately 10 db at 400 cycles, and 20 db at 250 cycles. If desired, the knee of the response curve may be moved up or down in frequency by proper choice of coupling capacitor, and the sharpness of the cut off may be controlled by choice of the number of "bass suppressed" stages.

Inverse feedback should not be used around a bass suppressed stage, as the feedback will tend to "iron out" the frequency response by partially restoring the bass.

Speech Clipping A characteristic of speech waveforms is the presence of frequently recurring high-intensity peaks of very short duration. These peaks will cause overmodulation if the "average" level of modulation on loud syllables exceeds approximately 30 per cent. These sharp peaks do not add appreciably to the intelligibility, and a highly understandable signal will still be obtained if they are removed by "clipping".

Such clipping can be accomplished simply by increasing the gain of the speech amplifier until the average level of modulation on loud syllables approaches 90 per cent. This is equivalent to increasing the power by about 10 times, a very worthwhile gain. However, the clipping when accomplished in this manner will produce higher order sidebands known as "splatter", causing the transmitted signal to

occupy a considerable slice of spectrum. Interference from such a signal will be found to be particularly bad on nearby receivers, sometimes effectively blanketing out 200 kc. or more even on a selective receiver.

The splatter can be reduced to the point of virtual elimination by clipping the speech waveforms in the speech amplifier, ahead of the modulator, and then filtering out the objectionable distortion components by means of a sharp low-pass filter having a cut off frequency of approximately 3500 cycles. However, such a clipper circuit must be carefully adjusted, and even then does not work to full advantage unless phase shift can be avoided in transformers following the low pass filter. This can be done in a grid modulated transmitter merely by the use of a good modulation transformer and proper circuit design. The clipper should be full wave (push pull) so as to clip both negative and positive peaks in a grid modulated transmitter, because a grid modulated transmitter has a modulation capability not exceeding 100 per cent in both negative and positive directions.

Clipping of negative peaks by excessive modulation of a plate modulated transmitter produces a particularly vicious form of splatter, because the clipping is more abrupt than in a grid modulated transmitter in which clipping occurs in the modulated stage itself. However, deliberate clipping without splatter is more easily accomplished in a plate modulated transmitter, because the clipper can be made effectively self adjusting. It is a simple matter to design and adjust a plate modulated transmitter to have considerable more than 100 per cent modulation capability in the positive (upward) direction. This means that only the *negative* peaks need be clipped before filtering. This is accomplished by means of the simple circuit illustrated in Figure 25, which requires no adjustment. The 5R4-GY is an inexpensive high-vacuum rectifier which is satisfactory for class C plate inputs up to 3000 volts at 500 ma. d.c. The filament transformer should be insulated for at least 3 and preferably 4 times the d.c. plate voltage, and the rectifier socket should be well insulated from the chassis.

The low pass filter comprising C_1 , L_1 and C_2 should be proportioned to give 3500-cycle cut off into an impedance equal to the d.c. plate voltage divided by the d.c. plate current, the constants being calculated quite easily from the classical formula for pi filters.

The capacitor C_2 may consist of the r.f. plate bypass capacitor in the plate modulated class C stage, if desired. Otherwise, the value of the plate bypass should be subtracted when determining C_2 , as the two capacitors will be effectively in parallel.

The splatter choke normally will run be-

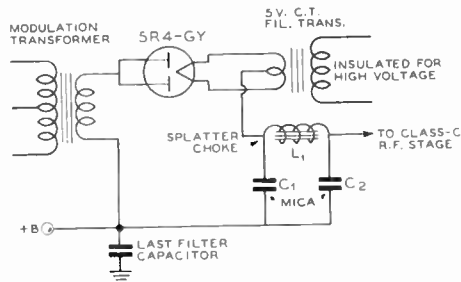

Figure 25.
SMITH "SPLATTER SUPPRESSOR" FOR PLATE - MODULATED TRANSMITTER.
This circuit permits a high percentage of modulation without "splatter," requires few additional components and no adjustment.

tween 0.5 and 1.5 henry. Suitable chokes, with taps to permit choice of exact inductance value, are commercially available.

Automatic Modulation Control

Unless the speaker's head is held in the same position with respect to the microphone and the voice level is kept even, the maximum amount of modulation that can be obtained without overmodulation will exist only part of the time, the remainder of the time there being either overmodulation or something less than full modulation. To facilitate keeping the modulation level near optimum without resorting to careful visual monitoring and "riding the gain", automatic modulation control circuits often are employed. Such circuits are especially useful in communications transmitters operated by unskilled personnel, as the gain setting for optimum modulation no longer is critical when a.m.c. is employed.

An a.m.c. circuit is essentially a "delayed a.v.c." system designed for audio stages instead of r.f. stages. Or, it may be considered as a compressor with an abrupt threshold at about 90 per cent modulation. It is designed to have a very fast "take hold", and moderately slow "let go", so that there will be no appreciable "swish, swish" in background noise between words.

An a.m.c. system usually comprises a rectifier with delay bias, an R/C filter with rapid rise and rather slow decay time, and a variable mu tube at the input of the speech amplifier. When the peak voltage exceeds the predetermined level, it is rectified, filtered, and fed back as bias to the controlled tube to reduce the gain.

Practical application of a.m.c. systems will be found in the chapter *Speech and Modulation Equipment*.

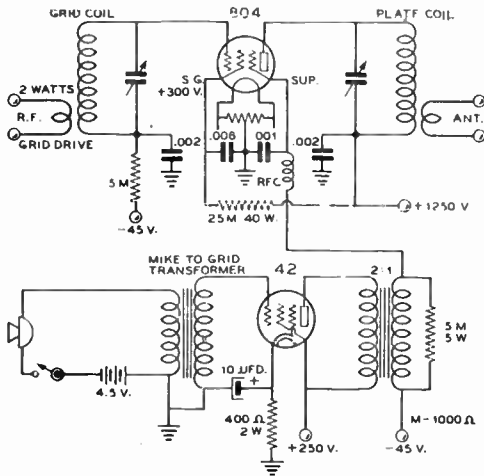

Figure 4.
TYPICAL SUPPRESSOR GRID-MODULATED AMPLIFIER.
The simplest form of speech equipment is shown, but a better microphone and a speech amplifier could just as well be used.

about half the maximum obtainable from the particular amplifier, or usually to about 35 per cent. The peak efficiency at the time of complete modulation must reach twice this value. It is difficult to obtain 100 per cent modulation without distortion, though 90 per cent to 95 per cent can easily be obtained and with good linearity.

The same modulator design problems apply to the suppressor-modulated transmitter as do to a grid-modulated amplifier, because the suppressor normally will be driven positive over the peak of the audio cycle at high modulation percentage. The control grid in the suppressor-modulated stage is driven to about the same degree as for c.w. or plate modulation. The r.f. excitation adjustment is not critical, but the excitation should be ample if good efficiency is to be obtained.

A medium powered suppressor-modulated amplifier is shown in Figure 4. An 804 as the amplifier will supply about 20 watts of carrier. An 803 may be substituted to increase the carrier output to about 50 or 60 watts. Either tube may be excited to full output by a 6L6 operating either as a frequency multiplier or as a crystal oscillator. A type 6F6 or 42 will serve as modulator for either tube.

It is possible to operate a suppressor-modulated amplifier stage as a doubler. The efficiency suffers somewhat but the voice quality will be found to be satisfactory.

The Class B Linear Amplifier

The operation of the class B linear amplifier has been discussed in the chapter devoted to vacuum-tube theory, and hence will only be covered quite generally here. The linear amplifier is well suited for broadcast use, because by careful design and adjustment distortion can be kept at a negligible value, even at high modulation percentages. However, the efficiency is less than can be obtained with class C grid bias modulation.

The grid circuit of linear amplifier is fed modulated r.f. energy and the stage amplifies carrier and sidebands linearly. The stage is biased to "extended" cutoff with no excitation, so that when excitation is applied the plate current flows in 180° pulses. This long period of plate current flow limits the theoretical peak efficiency to 78.5 per cent, the practical peak efficiency to about 65 per cent, and the average carrier efficiency to about 30 to 33 per cent.

The power output from a correctly operating linear amplifier will be about one half the maximum plate dissipation of the stage, under the carrier conditions. The schematic of a linear amplifier is exactly the same as that of a conventional amplifier, whether single ended or push-pull, except that a swamping resistor is usually placed across the grid circuit of the stage. The excitation requirements for a class B linear amplifier are somewhat less than for a class C grid modulated stage running at the same power input.

Input Modulation Systems

Constant efficiency variable-input modulation systems operate

by virtue of the addition of external power to the modulated stage to effect the modulation. There are two general classifications that come under this heading; those systems in which the additional power is supplied as audio frequency energy from a modulator, usually called plate modulation systems, and those systems in which the additional power to effect modulation is supplied as direct current from the plate supply.

Under the former classification comes Heising modulation (probably the oldest type of modulation to be applied to a continuous carrier), class B plate modulation, and series modulation. These types of plate modulation are by far the easiest to get into operation, and they give a very good ratio of power input to the modulated stage to power output; 65 to 80 per cent efficiency is the general rule. It is for these two important reasons that these modulation systems, particularly class B plate modulation, are at present the most popular for communications work.

Modulation systems coming under the second classification are of comparatively recent

ward parasitics under any condition of operation should be eliminated. Then the antenna should be coupled to the plate circuit, the grid bias should be run up to the maximum available value, and the plate voltage and excitation should be applied. The grid bias voltage should then be reduced until the amplifier draws the approximate amount of plate current it is desired to run, and modulation corresponding to about 80 per cent is then applied. If the plate current kicks up when modulation is applied, the grid bias should be reduced; if the plate meter kicks down, increase the grid bias.

When the amount of bias voltage has been found (by adjusting the fine control, R_2 , on the bias supply) where the plate meter remains constant with modulation, it is more than probable that the stage will be drawing either too much or too little input. The antenna coupling should then be either increased or decreased (depending on whether the input was too little or too much, respectively) until the input is more nearly the correct value. The bias should then be readjusted until the plate meter remains constant with modulation as before. By slight jockeying back and forth of antenna coupling and grid bias, a point can be reached where the tubes are running at rated plate dissipation, and where the plate milliammeter on the modulated stage remains substantially constant with modulation.

The linearity of the stage should then be checked by any of the conventional methods; the trapezoidal pattern method employing a cathode-ray oscilloscope is probably the most satisfactory. The check with the trapezoidal pattern will allow the determination of the proper amount of gain to employ on the speech amplifier. Incidentally, too much audio power on the grid of the modulated stage should not be used in the tuning-up process, as the plate meter will kick quite erratically and it will be impossible to make a satisfactory adjustment.

Tubes for Grid Bias Modulation If a grid bias modulated tube is run at or near maximum permissible rated plate voltage, the amount of carrier power that may be obtained is limited by the plate dissipation, rather than peak filament emission. Therefore, for good economy a tube should be chosen for the modulated stage which has a high plate dissipation rating in proportion to its cost.

Pentodes or beam tetrodes, especially the latter, may be control grid modulated under class C conditions with good efficiency, and less excitation is required than for a triode giving the same carrier power. However, their use is justified only in transmitters where neutralization is a problem, as in multi-band quick-

change transmitters, because such tubes cost considerably more than a triode of equivalent plate dissipation.

High transconductance and a medium or high μ are desirable in a triode which is to be grid modulated.

Coupling Transformers for Grid Modulation The modulator should be capable of delivering at the secondary of the modulation transformer a distortionless output of at least 2 per cent and preferably 5 per cent of the d.c. input to the modulated stage. If low plate resistance triodes such as 2A3's are employed, the secondary of the transformer need not be resistance loaded. If pentodes or beam tetrode modulators are employed, the secondary of the modulation transformer should be shunted with a resistor having a resistance slightly higher than the value which gives maximum undistorted output power from the modulators.

The turns ratio of the transformer should be such that the *peak* audio voltage developed across the secondary under normal operating conditions and full undistorted output from the modulator is equal to approximately twice cut off bias for the particular r.f. tube or tubes and plate voltage used, regardless of the amount of bias actually employed.

Screen-Grid Modulation Modulation can be accomplished by varying the screen grid voltage in an r.f. screen-grid tube. The screen grid voltage must be reduced to between one-half and one-third the value used for c.w. operation. The r.f. output is correspondingly reduced and the tube then operates as an efficiency-modulated device, somewhat similar to ordinary grid modulation.

Distortionless modulation is limited to about 80 per cent. The r.f. excitation must have good regulation, as in a control grid bias modulated stage. Likewise, the control grid bias must be provided from a low resistance source, by-passed for a.f. The excitation must be low, and as in control grid modulation, is critical.

As screen-grid modulation does not compare favorably with class C grid bias modulation, it is seldom employed.

Suppressor Modulation Still another form of efficiency modulation can be obtained by applying audio voltage to the suppressor grid of a pentode tube which is operated class C. A change in bias voltage on the suppressor grid will change the r.f. output of a pentode tube; the application of audio voltage thus provides a simple method of obtaining modulation.

The suppressor grid is biased negatively to a point which reduces the plate efficiency to

Frequency Modulation

TO experimentally inclined amateurs, building and operating frequency modulation (f.m.) equipment offers much in the way of enjoyment and instruction. In this chapter various points of difference between f.m. and amplitude modulation transmission and reception will be discussed and the advantages of f.m. for certain types of communication pointed out. Since the distinguishing features of the two types of transmission lie entirely in the modulating circuits at the transmitter and in the detector and limiter circuits in the receiver, these parts of the communication system will receive the major portion of attention.

Modulation As previously described in this book, *modulation* is the process of altering a radio wave in accordance with the intelligence to be transmitted. The nature of the intelligence is of little importance as far as the process of modulation is concerned; it is the *method* by which this intelligence is made to give a distinguishing characteristic to the radio wave which will enable the receiver to convert it back into intelligence that determines the type of modulation being used.

Figure 1 is an oscillogram of an r.f. carrier amplitude modulated by a sine-wave audio voltage. After modulation the resultant modulated r.f. wave is seen still to vary about the zero axis at a constant rate, but the strength of the individual r.f. cycles is proportional to the amplitude of the modulation voltage.

In Figure 2, the carrier of Figure 1 is shown frequency modulated by the same modulating voltage. Here it may be seen that modulation voltage of one polarity causes the carrier frequency to decrease, as shown by the fact that the individual r.f. cycles of the carrier are spaced farther apart. A modulating voltage of the opposite polarity causes the frequency to increase, and this is shown by the r.f. cycles being squeezed together to allow more of them to be completed in a given time interval.

Figures 1 and 2 reveal two very important characteristics about amplitude- and frequency-

modulated waves. First, it is seen that while the amplitude (power) of the signal is varied in a.m. transmission, no such variation takes place in f.m. In many cases this advantage of f.m. is probably of equal or greater importance than the widely publicized noise reduction capabilities of the system. When 100 per cent amplitude modulation is obtained, the average power output of the transmitter must be increased by 50 per cent. This additional output must be supplied either by the modulator itself, in the high-level system, or by operating one or more of the transmitter stages at such a low output level that they are capable of producing the additional output without distortion, in the low-level system. On the other hand, a frequency modulated transmitter requires an insignificant amount of power from the modulator and needs no provision for increased power output on modulation peaks. All of the stages between the oscillator and the antenna may be operated as high-efficiency class B or class C amplifiers or frequency multipliers.

The second characteristic of f.m. and a.m. waves revealed by Figures 1 and 2 is that both types of modulation result in distortion of the r.f. carrier. That is, after modulation, the r.f. cycles are no longer sine waves, as they would be if no frequencies other than the fundamental carrier frequency were present. It may be shown in the amplitude modulation case illustrated, that there are only two additional frequencies present, and these are the familiar "side frequencies," one located on each side of the carrier, and each spaced from the carrier by a frequency interval equal to the modulation frequency. In regard to frequency and amplitude, the situation is as shown in Figure 3. The strength of the carrier itself does not vary during modulation, but the strength of the side frequencies depends upon the percentage of modulation. At 100 per cent modulation the power in the side frequencies is equal to half that of the carrier.

Under frequency modulation, the carrier wave again becomes distorted, as shown in

Figure 2. But, in this case, many more than two additional frequencies are formed. The first two of these frequencies are spaced from the carrier by the modulation frequency, and the additional side frequencies are located out on each side of the carrier and are also spaced from each other by an amount equal to the modulation frequency. Theoretically, there are an infinite number of side frequencies formed, but, fortunately, the strength of those beyond the frequency "swing" of the transmitter under modulation is relatively low.

One set of side frequencies that might be formed by frequency modulation is shown in Figure 4. Unlike amplitude modulation, the strength of the component at the carrier frequency varies widely in f.m., and it may even

disappear entirely under certain conditions. The variation of strength of the carrier component is useful in measuring the amount of frequency modulation, and will be discussed in detail later in this chapter.

One of the great advantages of f.m. over a.m. is the reduction in noise at the receiver which the system allows. If the receiver is made responsive only to changes in frequency, a considerable increase in signal-to-noise ratio is made possible through the use of f.m., when the signal is of greater strength than the noise. The noise reducing capabilities of f.m. arise from the inability of noise to cause appreciable frequency modulation of the noise-plus-signal voltage which is applied to the detector in the receiver.

F.M. Terms Unlike amplitude modulation, the term "percentage modulation" means little in f.m. practice, unless

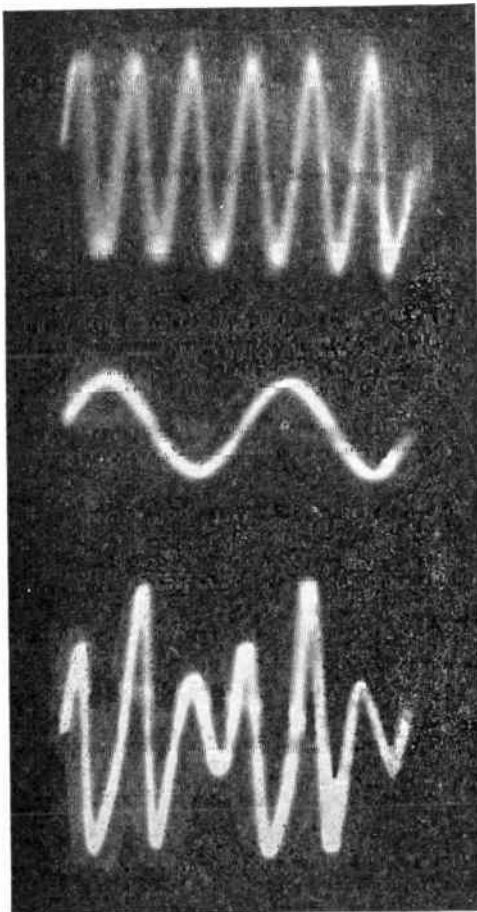
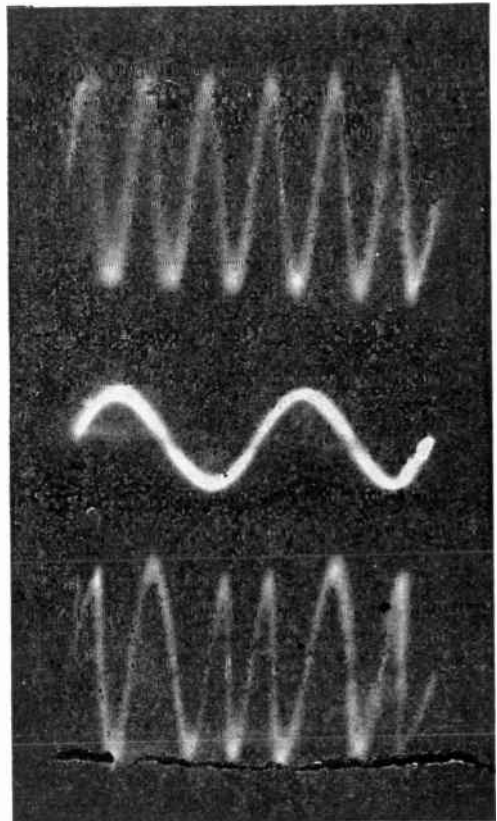

Figure 1.
AMPLITUDE MODULATION.

Oscilloscope pattern of an amplitude-modulated wave. The unmodulated carrier is shown at the top, modulating wave at the center, and the resultant modulated wave at the bottom.

Figure 2.
FREQUENCY MODULATION.
The unmodulated carrier wave (top) and the modulating wave (center) are the same as those shown in Figure 1. Note the difference in the wave form of the resultant modulated wave (bottom).



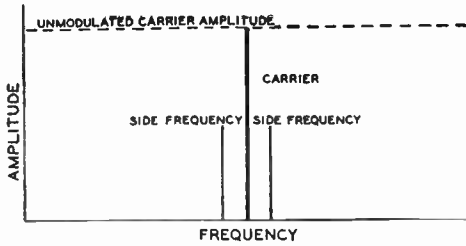

Figure 3.

A. M. SIDE FREQUENCIES.

For each a.m. modulating frequency, a pair of side frequencies is produced. The side frequencies are spaced away from the carrier by an amount equal to the modulation frequency, and their amplitude is directly proportional to the amplitude of the modulation. The amplitude of the carrier does not change under modulation.

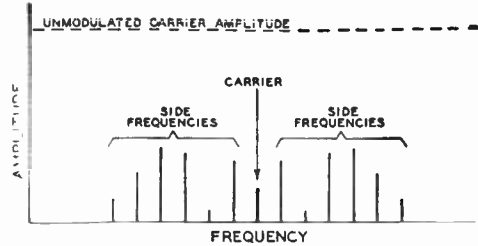

Figure 4.

F. M. SIDE FREQUENCIES.

With f.m. each modulation frequency component causes a large number of side frequencies to be produced. The side frequencies are separated from each other and the carrier by an amount equal to the modulation frequency, but their amplitude varies greatly as the amount of modulation is changed. The carrier strength also varies greatly with frequency modulation. The side frequencies shown represent a case where the deviation each side of the "carrier" frequency is equal to five times the modulating frequency. Other amounts of deviation with the same modulation frequency would cause the relative strengths of the various sidebands to change widely.

the receiver characteristics are specified. There are, however, three terms, *deviation*, *modulation index*, and *deviation ratio*, which convey considerable information concerning the character of the f.m. wave.

Deviation is the amount of frequency shift each side of the unmodulated or "resting" carrier frequency which occurs when the transmitter is modulated. Deviation is ordinarily measured in kilocycles, and in a properly operating f.m. transmitter it will be directly proportional to the amplitude of the modulating signal. When a symmetrical modulating signal is applied to the transmitter, equal deviation each side of the resting frequency is obtained during each cycle of the modulating signal, and the total frequency range covered by the f.m. transmitter is sometimes known as the "swing." If, for instance, a transmitter operating on 1000 kc. has its frequency shifted from 1000 kc. to 1010 kc., back to 1000 kc., then to 990 kc., and again back to 1000 kc. during one cycle of the modulating wave, the *deviation* would be 10 kc. and the *swing* 20 kc.

The *modulation index* of an f.m. signal is the ratio of the deviation to the audio modulating frequency, when both are expressed in the same units. Thus, in the example above, if the signal is varied from 1000 kc. to 1010 kc. to 990 kc. and back to 1000 kc. at a rate (frequency) of 2000 times a second, the modulation index would be 5, since the deviation (10 kc.) is 5 times the modulating frequency (2000 cycles, or 2 kc.).

The relative strengths of the f.m. carrier and the various side frequencies depend directly upon the modulation index, these relative strengths varying widely as the modulation index is varied. In the preceding example, for instance, side frequencies occur on the high

side of 1000 kc. at 1002, 1004, 1006, 1008, 1010, 1012, etc., and on the low frequency side at 998, 996, 994, 992, 990, 988, etc. In proportion to the unmodulated carrier strength (100 per cent), these side frequencies have the following strengths, as indicated by a modulation index of 5: 1002 and 998—33 per cent, 1004 and 996—5 per cent, 1006 and 994—36 per cent, 1008 and 992—39 per cent, 1010 and 990—26 per cent, 1012 and 988—13 per cent. The carrier strength (1000 kc.) will be 18 per cent of its unmodulated value. Changing the amplitude of the modulating signal will change the deviation, and thus the modulation index will be changed, with the result that the side frequencies, while still located in the same places, will have widely different strength values from those given above.

The *deviation ratio* is similar to the modulation index in that it involves the ratio between a modulating frequency and deviation. In this case, however, the deviation in question is the peak frequency shift obtained under full modulation, and the audio frequency to be considered is the maximum audio frequency to be transmitted. When the maximum audio frequency to be transmitted is 5000 cycles, for example, a deviation ratio of 3 would call for a peak deviation of 3 x 5000, or 15 kc. at full modulation. The noise-suppression capabilities of f.m. are directly related to the deviation ratio. As the deviation ratio is increased, the noise suppression becomes better *if* the signal is somewhat stronger than the noise. Where the noise approaches the signal in strength,

however, low deviation ratios allow communication to be maintained in many cases where high-deviation-ratio f.m. and conventional a.m. are incapable of giving service. For each value of signal-to-noise ratio at the receiver, there is a maximum deviation ratio which may be used, beyond which the signal becomes smothered in the noise. Up to this critical deviation ratio, however, the noise suppression becomes progressively better as the deviation ratio is increased.

For high-fidelity f.m. broadcasting purposes, a deviation ratio of 5 is ordinarily used, the maximum audio frequency being 15,000 cycles, and the peak deviation at full modulation being 75 kc. Since a swing of 150 kc. is covered by the transmitter, it is obvious that wide-band f.m. transmission must necessarily be confined to the ultra-high frequencies, where room for the signals is available.

For strictly communication work, where the noise-suppression advantages of f.m. must be realized under adverse signal-to-noise ratios, and where maximum coverage for a given amount of power is of prime importance, deviation ratios of 1 to 3 will be found most satisfactory.

Bandwidth Required by F.M.

As the above discussion has indicated, many side frequencies are set up when a radio-frequency carrier is frequency modulated; theoretically, in fact, an infinite number of side frequencies is formed. Fortunately, however, the amplitudes of those side frequencies falling outside the frequency range over which the transmitter is "swung" are so small that most of them may be ignored. In f.m. transmission, when a complex modulating wave (speech or music) is used, still additional side frequencies resulting from a beating together of the various frequency components in the modulating wave are formed. This is a situation, that does not occur in amplitude modulation and it might be thought that the large number of side frequencies thus formed might make the frequency spectrum produced by an f.m. transmitter prohibitively

wide. Analysis shows, however, that the additional side frequencies are of very small amplitude, and, instead of increasing the bandwidth, modulation by a complex wave actually reduces the effective bandwidth of the f.m. wave. This is especially true where speech modulation is used, since most of the power in voiced sounds is concentrated at low frequencies around 400 cycles.

When all factors are considered, it is found that an f.m. signal will occupy an effective bandwidth of about $2\frac{1}{2}$ times the maximum swing at peak modulation.

Modulating Circuits

A successful frequency modulated transmitter must meet two requirements: (1) The frequency deviation must be symmetrical about a fixed frequency, for symmetrical modulation voltage. (2) The deviation must be directly proportional to the amplitude of the modulation, and independent of the modulation frequency. There are several methods of frequency modulation which will fulfill these requirements. Some of these methods will be described in the following paragraphs.

Mechanical Modulators

The arrangement shown in Figure 5 is undoubtedly the simplest of all frequency modulators. A condenser microphone is connected across the oscillator tank circuit, and the variations in capacity produced by the microphone cause the oscillator frequency to vary at the frequency of the impressed sound. Since condenser microphones are difficult to obtain, and the amount of r.f. voltage which may be safely impressed across them is small, the circuit is of little practical use, however. Figure 6 shows a modification of Figure 5 which is more suited to practical application. Here the variable capacity device which varies the frequency consists of a condenser, one plate of which is moved by being mechanically coupled to an electro-mechanical driving unit

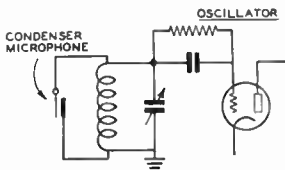

Figure 5.

SIMPLE FREQUENCY MODULATOR.

The variations in capacity of a condenser microphone as sound strikes the diaphragm will cause a corresponding variation in the oscillator frequency.

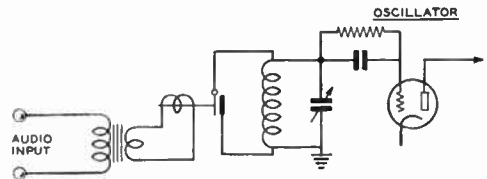

Figure 6.

ELECTRICALLY DRIVEN CONDENSER MODULATOR.

Certain types of audio reproducers, such as earphones and recorders, may be mechanically connected to one plate of a small variable condenser to give frequency modulation. It is important that the driving unit be of the "constant amplitude" type.

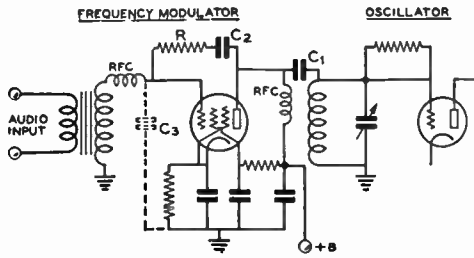

Figure 7.

REACTANCE-TUBE MODULATOR.

This is a popular form of frequency modulator. The operation of the circuit is described in the text. Typical values for the components will be found in similar circuits shown in Chapter 19.

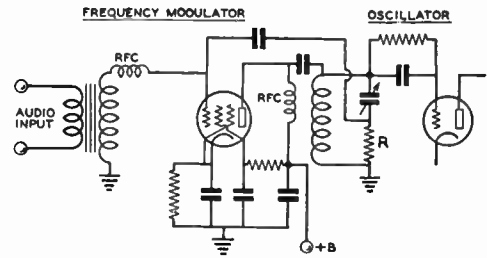

Figure 8.

REACTANCE-TUBE MODULATOR.

This circuit operates similarly to the one shown in Figure 7. The difference between the two lies in the method in which the r.f. grid voltage is shifted 90 degrees in phase from the r.f. plate voltage.

such as a loud speaker or phonograph recording head. This circuit, while practical, is seldom used, because most driving units do not give frequency modulation which complies with requirement (2). The requirement is met by piezo-electric (crystal) reproducers such as earphones and recorders, however, and this type of "constant amplitude" driving unit may be used successfully.

Reactance-Tube Modulators

One of the most practical ways of obtaining frequency modulation is through the use of a *reactance-tube modulator*. In this arrangement the modulator plate-cathode circuit is connected across the oscillator tank circuit, and made to appear as either a capacitive or inductive reactance by exciting the modulator grid with a voltage which either leads or lags the oscillator tank voltage by 90 degrees. The leading or lagging grid voltage causes a corresponding leading or lagging plate current, and the plate-cathode circuit appears as a capacitive or inductive reactance across the oscillator tank circuit. When the transconductance of the modulator tube is varied, by varying one of the element voltages, the magnitude of the reactance across the oscillator tank is varied. By applying audio modulating voltage to one of the elements, the transconductance, and hence the frequency, may be varied at an audio rate. When properly designed and operated, the reactance-tube modulator gives linear frequency modulation, and is capable of producing large amounts of deviation.

There are numerous possible configurations of the reactance-tube modulator circuit. The difference in the various arrangements lies principally in the type of phase-shifting circuit used to give a grid voltage which is in phase quadrature with the r.f. voltage at the modulator plate.

Figure 7 is a diagram of one of the most popular forms of reactance-tube modulators.

The modulator tube, which is usually a sharp cutoff pentode such as a 6J7 or 6SJ7, has its plate coupled through a blocking condenser, C_1 , to the "hot" side of the oscillator grid circuit. Another blocking condenser, C_2 , feeds r.f. to the phase shifting network $R-C_3$ in the modulator grid circuit. If the resistance of R is made large in comparison with the reactance of C_3 at the oscillator frequency, the current through the $R-C_3$ combination will be nearly in phase with the voltage across the tank circuit, and the voltage across C_3 will lag the oscillator tank voltage by almost 90 degrees. The result of the 90-degree lagging voltage on the modulator grid is that its plate current lags the tank voltage by 90 degrees, and the reactance tube appears as an inductance in shunt with the oscillator inductance, thus raising the oscillator frequency.

The phase-shifting condenser C_3 is usually provided by the input capacitance of the modulator tube and stray capacity between grid and ground, and it will not ordinarily be found necessary to employ an actual condenser for this purpose at frequencies above 2 or 3 Mc. Resistance R will usually have a value of between 25,000 and 100,000 ohms. Either resistance or transformer coupling, as shown, may be used to feed audio voltage to the modulator grid. When a resistance coupling is used, it is necessary to shield the grid circuit adequately, since the high impedance grid circuit is prone to pick up stray r.f. and low frequency a.c. voltage, and cause undesired frequency modulation. Another disadvantage to the use of a resistance in the grid circuit is that small amounts of grid current may bias the grid of the reactance tube to the point where its effectiveness as a modulator is reduced considerably.

Another of the numerous practical reactance-tube circuits is shown in Figure 8. In this circuit, the 90-degree phase shift in grid excitation to the modulator is obtained by plac-

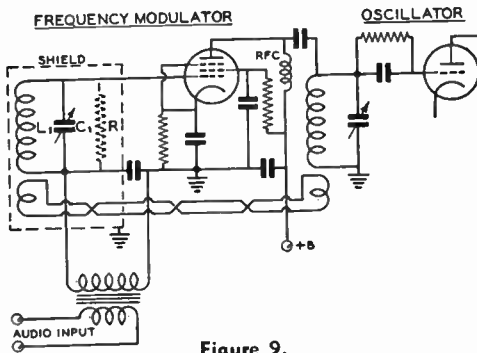

Figure 9.

TUNED PHASE-SHIFT CIRCUIT.

By using a tuned circuit, L_1-C_1 , to shift the phase of the reactance-tube grid excitation, the phase shift may be adjusted to reduce the loading on the oscillator under modulation.

ing a resistor in series with the oscillator tank condenser. Since the current through the tank condenser leads the voltage across the tank circuit by 90 degrees, the r.f. voltage applied to the modulator grid will also lead this voltage by the same amount; the modulator plate current will lead the tank voltage, and the modulator tube will appear as a condenser.

The resistor, R , may be placed in series with the tank coil, rather than the condenser, in which case the phase relationships are such that the reactance tube appears as an inductance. Too much resistance in either leg of the oscillator tank will result in such a low Q circuit that it will be impossible to maintain oscillation. Carbon resistors of around 25 ohms will provide sufficient excitation to the modulator for good sensitivity.

There are several possible variations of the basic reactance-tube modulator circuits shown in Figures 7 and 8. The audio input may be applied to the suppressor grid, rather than the control grid, if desired. This method requires that the control grid be returned to ground through a rather high resistance (250,000 ohms to 1 megohm) or through an r.f. choke. Another modification is to apply the audio to a grid other than the control grid in a mixer or pentagrid converter tube which is used as the modulator. Generally, it will be found that the transconductance variation per volt of control-element voltage variation will be greatest when the control (audio) voltage is applied to the control grid. In cases where it is desirable to separate completely the audio and r.f. circuits, however, applying audio voltage to one of the other elements will often be found advantageous in spite of the somewhat lower sensitivity.

In spite of the fact that high-plate resistance pentodes are usually used as reactance tubes, it will often be found that amplitude modula-

tion due to loading of the oscillator by the reactance tube takes place when a large amount of frequency modulation is attempted. The cure for this type of amplitude modulation will usually be found in adjusting the phase of the r.f. voltage applied to the reactance tube grid until it differs somewhat from the recommended 90-degree relation with the r.f. at the plate. One such method consists of using the reactance-tube circuit shown in Figure 7 in conjunction with a Hartley or Colpitts oscillator, in which the center of the oscillator tank circuit is grounded for r.f. In this case, both ends of the oscillator coil will be equally "hot," and the C_2-R combination may be connected to the opposite end of the tank circuit from which the reactance-tube plate is connected. Then, by adjustment of C_2 or R , the phase shift between grid and plate may be made more than 90 degrees, and amplitude modulation balanced out.

A circuit which allows the phase shift to be set exactly at 90 degrees, or to be varied either way, is shown in Figure 9. This circuit uses a separate tuned circuit in the reactance-tube grid. The additional circuit may be coupled to the oscillator either by a link, as shown, or simply by placing the two coils close to each other. When the L_1-C_1 circuit is tuned to resonance, the voltage developed across it will be 90° out of phase, with the voltage across the oscillator tank. Detuning the L_1-C_1 circuit in one direction or the other will cause the phase shift to become greater or less than 90°.

To reduce the excitation applied to the grid of the reactance tube and to make the tuning of the phase-shifting network less critical, a resistance, R , may be placed across the circuit. The resistor may have a value as low as a few hundred ohms, and it will be found that large changes in the value of resistance will make it necessary to change the setting of C_1 to maintain the correct amount of phase shift.

Adjusting the Phase Shift One of the simplest methods of adjusting the phase shift to the correct amount is to place a pair of earphones in series with the oscillator cathode-to-ground circuit and adjust the phase-shift network until minimum sound is heard in the 'phones when frequency modulation is taking place. If an electron-coupled or Hartley oscillator is used, this method requires that the cathode circuit of the oscillator be inductively or capacitively coupled to the grid circuit, rather than tapped on the grid coil. The 'phones should be adequately by-passed for r.f. of course.

Stabilization Due to the presence of the frequency modulator, the stabilization of an f.m. oscillator in regard to

voltage changes is considerably more involved than in the case of a simple self-controlled oscillator for transmitter frequency control. If desired, the oscillator itself may be made perfectly stable under voltage changes, but the presence of the frequency modulator destroys the beneficial effect of any such stabilization. It thus becomes desirable to apply the stabilizing arrangement to the modulator as well as the oscillator. If the oscillator itself is stable under voltage changes, or, in other words, self-compensated by some means such as the use of an electron-coupled circuit, it is only necessary to apply voltage-frequency compensation to the modulator. Stabilized power supply arrangements suitable for use on the modulator or both modulator and oscillator are described fully in Chapter 15.

A circuit in which automatic stabilization of the effects of voltage variations on the modulator is obtained, is shown in Figure 10. In this circuit, the reactance-tube grids are connected in push-pull across the phase-shifting circuit L-C, while the plates are connected in parallel and tied to the oscillator tank in the usual manner. Any variation in the plate-supply voltage to the reactance tubes causes equal and opposite effects in their reactance, and there is no net reactance variation.

Another method of oscillator stabilization makes use of a discriminator circuit. This arrangement stabilizes the frequency against changes arising from any cause (except the desired modulation) by comparing the oscillator frequency with a crystal controlled standard and applying the proper compensating

voltages. A block diagram of this method is shown in Figure 11. Output from one of the stages of the transmitter is mixed with the output of a crystal oscillator to give an "intermediate frequency" output which is applied to a conventional discriminator. The discriminator, which will be more completely described later in this chapter, is a circuit arrangement to produce an output voltage which depends on the frequency of the r.f. applied to it.

The d.c. voltage produced by the discriminator is applied to a reactance tube tied across the oscillator tank circuit. As the average or "center" frequency varies one way or the other from the correct value, a positive or negative voltage appears across the discriminator load resistors. When this voltage is placed on the control element of the reactance tube, it attempts to restore the center (mid-modulation or unmodulated) radio frequency to a value which gives zero voltage output from the discriminator. The oscillator can never be fully restored to its correct frequency, however, since the discriminator output voltage would then be zero, and no frequency correction would be taking place. The frequency is actually shifted back to a value somewhere between what it should be and what it would have been without stabilization. The reactance tube which takes care of the frequency correction may also be used as the modulator, and the frequency stabilizing voltage may be applied in series with the audio voltage or, alternatively, it may be applied to another of the tube elements. The audio output of the

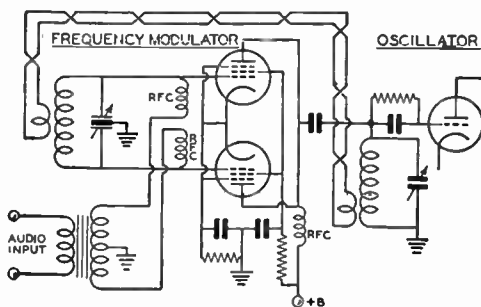

Figure 10.

STABILIZED REACTANCE-TUBE MODULATOR.

Frequency shift due to voltage changes on the modulator may be greatly reduced by the use of this circuit. Changes in element voltages cause equal and opposite changes in reactance in the two modulators, thus minimizing the frequency shift. The reactance-tubes' grids receive excitation from a balanced tuned circuit so that one tube receives voltage lagging the oscillator tank voltage by 90°, while the other tube is excited with a voltage that leads the tank voltage by 90°.

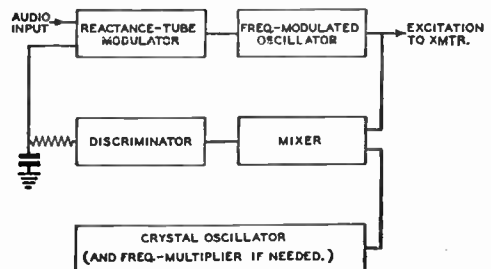
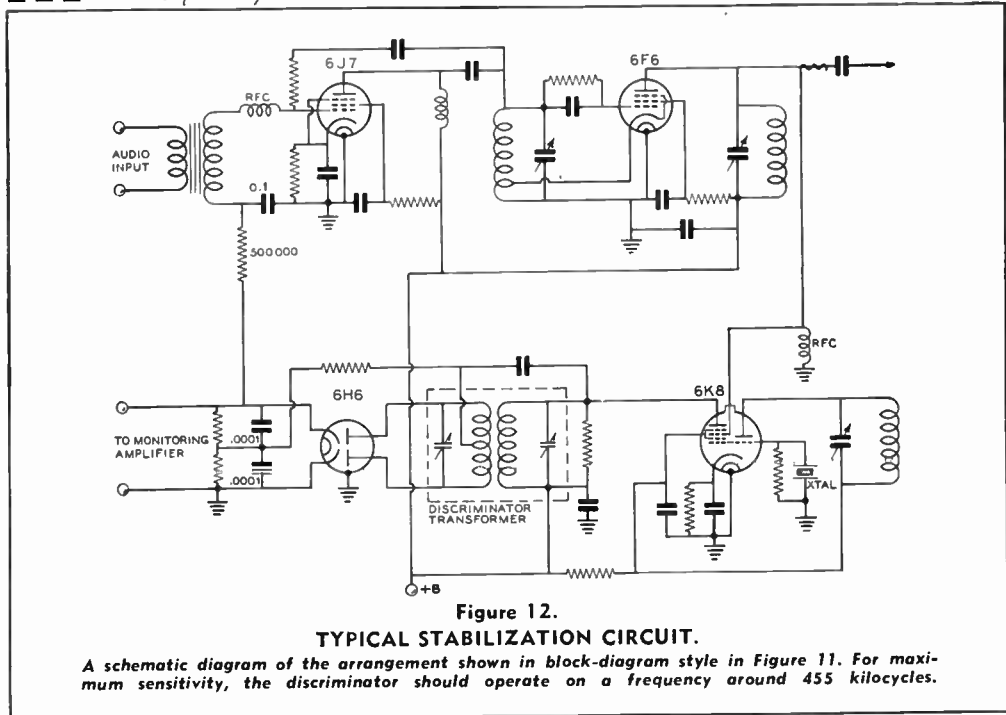

Figure 11.

DISCRIMINATOR STABILIZING ARRANGEMENT.

A frequency-modulated oscillator may be stabilized against undesired frequency shift by comparing the transmitter frequency with that of a crystal oscillator. The difference between the two frequencies is applied to a discriminator circuit, and any change from a predetermined difference will cause the discriminator to restore the transmitter to its correct frequency. An R-C filter is used to remove the audio modulation from the discriminator output.



discriminator must be removed by a simple R-C filter so that the compensating voltage is direct current without superimposed audio. The audio output of the discriminator may be used for monitoring purposes, if desired. Obviously the stability of the complete arrangement is dependent upon the stability of the discriminator components under temperature and humidity changes, and upon the stability of the crystal oscillator. Ordinarily the stability of the crystal oscillator will be sufficiently great that the discriminator will be the limiting factor in the amount of stabilization obtainable, making it necessary to use discriminator components (especially the tuned input transformer) of good quality. A typical stabilizing circuit, with provision for monitoring, is shown in Figure 12.

The frequency of the crystal used in the stabilizing circuit will depend upon the frequency at which the discriminator operates, and the frequency of the stage in the transmitter from which the stabilizer signal is taken. If a b.c. replacement type discriminator transformer designed for a frequency in the 400-500 kc. range is used, the r.f. input for the stabilizer may be obtained from the transmitter oscillator stage, or, if more sensitivity is desired, from the plate circuit of the frequency multiplier following the oscillator. The crystal oscillator must operate on a frequency such that its fundamental, or one of its harmonics, falls at a frequency which differs from

that of the transmitter stage applied to the stabilizer by an amount equal to the discriminator frequency. If the required crystal frequency falls higher than is easily obtainable with a crystal, it may be necessary to use a frequency multiplier after the crystal stage.

Linearity Test It is almost a necessity to run a static test on the reactance-tube frequency modulator to determine its linearity and effectiveness, since small changes in the values of components, and in stray capacities will almost certainly alter the modulator characteristics. A frequency-versus-control-voltage curve should be plotted to ascertain that equal increments in control voltage, both in a positive and a negative direction, cause equal changes in frequency. If the curve shows that the modulator has an appreciable amount of non-linearity, changes in bias, electrode voltages, and resistance values may be made to obtain a straight-line characteristic.

Figure 13 shows a method of connecting two $4\frac{1}{2}$ -volt C batteries and a potentiometer to plot the characteristic of the modulator. It will be necessary to use a zero-center voltmeter to measure the grid voltage, or else reverse the voltmeter leads when changing from positive to negative grid voltage. When a straight-line characteristic for the modulator is obtained by the static test method, the capacities of the various by-pass condensers in the circuit must be kept small to retain this characteristic when

an audio voltage is used to vary the frequency in place of the d.c. voltage with which the characteristic was plotted.

Phase Modulation— the Armstrong System

By means of phase modulation (p.m.) it is possible to dispense with self-controlled oscillators, and obtain directly crystal-controlled f.m. In the final analysis, p.m. is simply frequency modulation in which the deviation is directly proportional to the modulation frequency. If an audio modulating signal of 1000 cycles causes a deviation of $\frac{1}{2}$ kc., for example, a 2000-cycle modulating signal of the same amplitude will give a deviation of 1 kc., and so on. To produce an f.m. signal, it is necessary to make the deviation independent of the modulation frequency, and proportional only to the amplitude of the modulating signal. With p.m., this is done by including a frequency correcting network in the audio system of the transmitter. The audio correction network must have an attenuation that varies directly with frequency, and this requirement is easily met by a very simple resistance-capacity network.

While the equipment required for a p.m. type of f.m. transmitter is rather complex, its operation and adjustment are quite simple. In fact, it is a question whether the p.m. method will not ultimately prove more satisfactory for low-deviation communication-type f.m. than the reactance-tube method, when the necessary frequency-controlling apparatus required by the latter system is considered. Actually, the circuits for obtaining p.m. are no more complicated than the reactance-tube f.m. circuits. The complications with p.m. arise from the fact that very little actual frequency modulation is produced by the phase-modulating method, and a great deal of frequency multiplication is necessary to obtain a reasonable amount of deviation. The frequency multiplication may be carried out at very low power levels, however, with low-cost, small receiving parts.

Odd-harmonic distortion is produced when f.m. is obtained by the phase-modulation method, and the amount of this distortion that can be tolerated is the limiting factor in determining the amount of p.m. that can be used. Since the aforementioned frequency-correcting network causes the lowest modulating frequency to have the greatest amplitude, maximum phase modulation takes place at the lowest modulating frequency, and the amount of distortion that can be tolerated at this frequency determines the maximum deviation that can be obtained by the p.m. method. For high-fidelity broadcasting, the deviation produced by p.m. is limited to an amount equal to about one-third of the lowest modulating

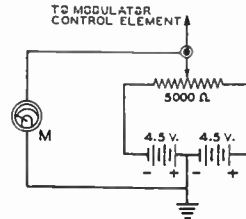

Figure 13.

This circuit allows the control characteristic of the frequency modulator to be easily checked. As the potentiometer arm is moved one way or the other from the center position, a positive or negative voltage is placed on the modulator control element.

frequency. When the lowest modulating frequency is 30 cycles, the deviation is thus limited to about 10 cycles, and it may be seen that an enormous amount of frequency multiplication is necessary to get a deviation of, say, 75 kc. on the output frequency.

In voice modulation, the peak intensity occurs at around 400 cycles and, with a slight increase in distortion, it is possible to increase the deviation until it equals one-half this frequency. The deviation would thus be 200 cycles, and the necessary amount of frequency multiplication can be greatly reduced. With a constant deviation of 200 cycles, the distortion produced at a modulation frequency of 400 cycles is about 7 per cent, with higher distortion at lower frequencies and negligible distortion at higher frequencies. Fortunately, the distortion at frequencies lower than 400 cycles is not of great importance, since the amplitude of these components is low enough so that the amount of modulation deviation is reduced, with a corresponding decrease in the actual distortion.

P.M. Circuits

To obtain phase modulation it is only necessary to shift the phase of the sidebands produced in amplitude modulation by 90 degrees. When the phase-shifted sidebands are re-combined with the carrier, the result is a phase-modulated signal. A block diagram of the basic p.m. arrangement is shown in Figure 14. Output from a crystal or other high-stability oscillator is supplied to two circuit branches. In one of the branches is a balanced modulator, which produces sidebands, minus the carrier, when modulation is applied. The other branch, which contains a mixer, is fed through a phase-shifting circuit. The output of the two branches is combined in the plate circuit of the mixer, and the result is a phase-modulated carrier. By feeding the audio to the modulator through the R-C attenuator network shown, the phase modulation is made inversely proportional to

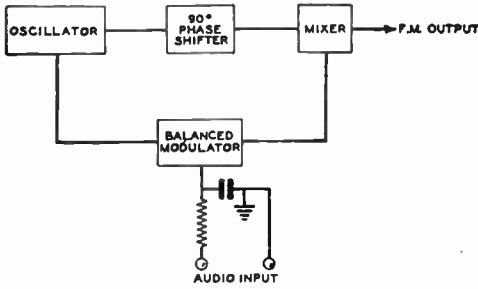

Figure 14.

PHASE MODULATOR BLOCK DIAGRAM.

The R-C network in the audio input leads makes the amount of phase modulation inversely proportional to the audio frequency, thus giving frequency modulated output.

frequency, and the final result is a frequency-modulated signal. Although the diagram shows the phase-shifting network between the oscillator and mixer tubes, it does not necessarily have to be in this position; quite often it will be found in either the input or output circuits of the balanced-modulator stage. The only requirement is that there be a 90-degree phase difference between the two components supplied to the mixer, and the location of the phase-shift network is largely a matter of convenience.

To increase the small amount of deviation produced by the p.m. method to a usable amount, a considerable amount of frequency multiplication is needed between the exciter and the transmitter output stage. The necessary frequency multiplication may be obtained in either one of two ways: The oscillator frequency may be made low enough so that the frequency multiplication necessary to reach the desired output frequency will be sufficient to give the desired deviation, or a moderately high frequency oscillator may be followed by a small amount of frequency multiplication, and the signal then "beaten back" by means of a heterodyne oscillator and a mixer to another moderately high-frequency, whence it

may be multiplied in the usual manner to the output frequency. As an example of the first method, a crystal oscillator using a 460- to 465-kc. filter type crystal may have its frequency increased 128 times by a string of doublers or quadruplers to reach the 58.5- to 60-Mc. amateur f.m. band. If the original maximum deviation was 200 cycles, the deviation on the output frequency would thus be 25.6 kc.

An example of the second method is the use of a crystal oscillator, followed by the phase modulator, on 1800 kc. The p.m. output is tripled to 5400 kc., where the deviation is then 3 times what it originally was. Beating the 5400-kc. output with another crystal oscillator on 7250 kc. gives a difference of frequency of 1850 kc., with the deviation still tripled from its original value. By a series of doublers or quadruplers the 1850-kc. signal may be multiplied 32 times to reach a frequency of 59.2 Mc., which is also in the 58.5- to 60-Mc. amateur band. The increase in deviation will be equal to the product of the two frequency multiplications (3 x 32) or 96 times. A block diagram of the basic method is shown in Figure 15.

Measurement of Deviation

When a single-frequency modulating voltage is used with an f.m. transmitter, the relative amplitudes of the various sidebands and the carrier vary widely as the deviation is varied by increasing or decreasing the amount of modulation. Since the relationship between the amplitudes of the various sidebands and carrier to the audio modulating frequency and the deviation is known, a simple method of measuring the deviation of a frequency modulated transmitter is possible. In making the measurement, the result is given in the form of the modulation index for a certain amount of audio input. As previously described, the modulation index is the ratio of the peak frequency deviation to the frequency of the audio modulation.

The measurement is made by applying a sine-wave audio voltage of known frequency

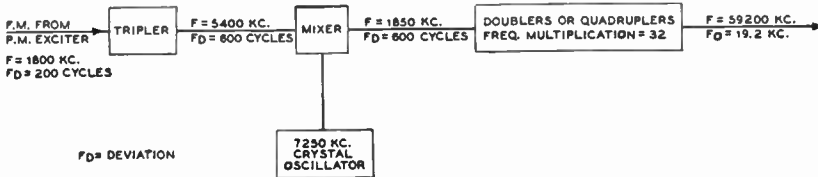

Figure 15.

P.M. DEVIATION-INCREASING SCHEME

The small amount of f.m. deviation caused by phase modulation may be increased to useful amounts by multiplying the frequency somewhat, heterodyning it down to a low frequency, and again multiplying to the output frequency. The increase in deviation is equal to the product of the separate frequency multiplications, or, in the case shown above 3 x 32, or 96 times.

to the transmitter, and increasing the modulation until the amplitude of the carrier component of the frequency modulated wave reaches zero. The modulation index for zero carrier may then be determined from the table below. As may be seen from the table, the first point of zero carrier is obtained when the modulation index has a value of 2.405,—in other words, when the deviation is 2.405 times the modulation frequency. For example, if a modulation frequency of 1000 cycles is used, and the modulation is increased until the first carrier null is obtained, the deviation will then be 2.405 times the modulation frequency, or 2,405 kc. If the modulating frequency happened to be 2000 cycles, the deviation at the first null would be 4.810 kc. Other carrier nulls will be obtained when the index is 5.52, 8.654, and at increasing values separated approximately by π . The following is a listing of the modulation index at successive carrier nulls up to the tenth:

| Zero carrier point no. | Modulation index |
|------------------------|------------------|
| 1 | 2.405 |
| 2 | 5.520 |
| 3 | 8.654 |
| 4 | 11.792 |
| 5 | 14.931 |
| 6 | 18.071 |
| 7 | 21.212 |
| 8 | 24.353 |
| 9 | 27.494 |
| 10 | 30.635 |

The only equipment required for making the measurements is a calibrated audio oscillator of good wave form, and a communication receiver equipped with a beat oscillator and crystal filter. The receiver should be used with its crystal filter set for a bandwidth of approximately twice the modulation frequency, to exclude sidebands spaced from the carrier by the modulation frequency. The unmodulated carrier is accurately tuned in on the receiver with the beat oscillator operating, and modulation from the audio oscillator is then applied to the transmitter, and the modulation increased until the first carrier null is obtained. This first carrier null will correspond to a modulation index of 2.405, as previously mentioned. Successive null points will correspond to the indices listed in the table. A volume indicator in the transmitter audio system may be used to measure the audio level required for different amounts of deviation, and the indicator thus calibrated in terms of frequency deviation. If the measurements are made at the fundamental frequency of the oscillator, it will be necessary to multiply the frequency deviation by the harmonic upon which the transmitter is operating, of course. It will probably be most convenient to make the determi-

nation at some frequency intermediate between that of the oscillator and that at which the transmitter is operating, and then multiply the result by the frequency multiplication between that point and the transmitter output frequency.

Frequency-Modulation Reception

In contrast with the transmitter, where the use of f.m. greatly simplifies the modulation problem, for serious work the use of f.m. necessitates a receiver somewhat more complicated than would be necessary for amplitude modulation. While ordinary superheterodyne, t.r.f., and superregenerative receivers will receive f.m. after a fashion, serious work requires a receiver especially designed for f.m. reception.

The f.m. receiver must have, first of all, a bandwidth sufficient to pass the range of frequencies generated by the f.m. transmitter. And since the receiver must be a superheterodyne if it is to have good sensitivity at the frequencies to which f.m. is restricted, i.f. bandwidth is an important factor in its design.

The second requirement of the f.m. receiver is that it incorporate some sort of device for converting frequency changes into amplitude changes, in other words, a detector operating on frequency variations rather than amplitude variations. The third requirement, and one which is necessary if the full noise reducing capabilities of the f.m. system of transmission are desired, is a limiting device to eliminate amplitude variations before they reach the detector. A block diagram of the essential parts of an f.m. receiver is shown in Figure 16.

The Frequency Detector

The simplest device for converting frequency variations to amplitude variations is an "off-tune" resonant circuit, as illustrated in Figure 17. With the carrier tuned in at point "A," a certain amount of r.f. voltage will be developed across the tuned circuit,

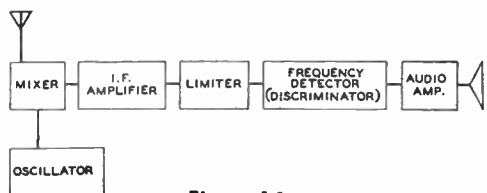

Figure 16. RECEIVER BLOCK DIAGRAM.

Up to the amplitude limiter stage, the f.m. receiver is similar to an a.m. receiver, except for a somewhat wider i.f. bandwidth. The limiter removes any amplitude modulation, and the frequency detector following the limiter converts frequency variations into amplitude variations.

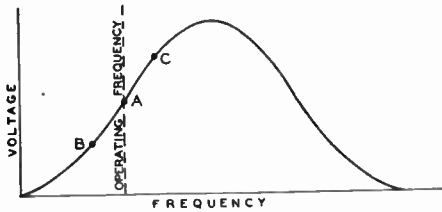

Figure 17.

"OFF TUNE" FREQUENCY DETECTOR.
A portion of the resonance characteristic of a tuned circuit may be used as shown to convert frequency variations into amplitude variations.

and, as the frequency is varied either side of this frequency by the modulation, the r.f. voltage will increase and decrease to points "C" and "B" in accordance with the modulation. If the voltage across the tuned circuit is applied to an ordinary detector, the detector output will vary in accordance with the modulation, the amplitude of the variation being proportional to the deviation of the signal, and the rate being equal to the modulation frequency. It is obvious from Figure 17 that only a small portion of the resonance curve is usable for linear conversion of frequency variations into amplitude variations, since the linear portion of the curve is rather short. Any frequency variation which exceeds the linear portion will cause distortion of the recovered audio.

Trovis Discriminator

Another form of frequency detector

or *discriminator*, is shown in Figure 18. In this arrangement two tuned circuits are used, one tuned on each side of the i.f. amplifier frequency, and with their resonant frequencies spaced slightly more than the expected transmitter "swing" apart. Their outputs are combined in a differential rectifier so that the voltage across the series load resistors, R_1 and R_2 , is equal to the algebraic sum of the individual output voltages of each rectifier. When a signal at the i.f. mid-frequency is received, the voltages across the load resistors are equal and opposite, and the sum voltage is zero. As the r.f. signal varies from the mid-frequency, however, these individual voltages become unequal, and a voltage having the polarity of the larger voltage and equal to the difference between the two voltages appears across the series resistors, and is applied to the audio amplifier. The relationship between frequency and discriminator output voltage is shown in Figure 19. The separation of the discriminator peaks and the linearity of the output voltage vs. frequency curve depend upon the discriminator frequency, the Q of the tuned circuits, and the value of the diode load resistors. As the in-

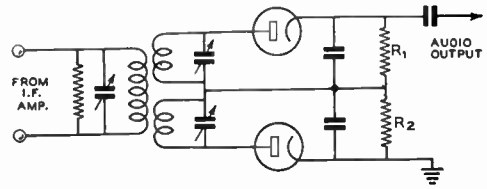

Figure 18.
TRAVIS DISCRIMINATOR.

intermediate (and discriminator) frequency is increased, the peaks must be separated farther to secure good linearity and output. Within limits, as the diode load resistors or the Q are reduced, the linearity improves, and the separation between the peaks must be greater.

Foster-Seeley Discriminator

The most widely used form of discriminator is that shown in Figure 20. This type of discriminator yields an output-voltage-versus-frequency characteristic similar to that shown in Figure 19. Here, again, the output voltage is equal to the algebraic sum of the voltages developed across the load resistors of the two diodes, the resistors being connected in series to ground. However, this *Foster-Seeley* discriminator requires only two tuned circuits instead of the three used in the previous discriminator. The operation of the circuit results from the phase relationships existing in a transformer having a tuned secondary. In effect, as a close examination of the circuit will reveal, the primary circuit is in series, for r.f., with each half of the secondary to ground. When the received signal is at the resonant frequency of the secondary, the r.f. voltage across the secondary is 90 degrees out of phase with that across the primary. Since each diode is connected across one half of the secondary winding and the primary winding in series, the resultant r.f. voltages applied to each are equal, and the voltages developed across each

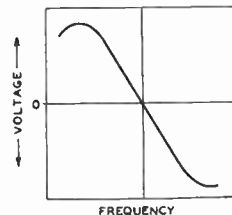

Figure 19.

DISCRIMINATOR VOLTAGE-FREQUENCY CURVE.

At its "center" frequency the discriminator produces zero output voltage. On either side of this frequency it gives a voltage of a polarity and magnitude which depend on the direction and amount of frequency shift.

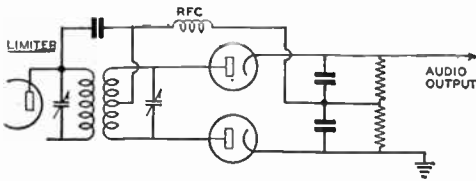

Figure 20.
FOSTER-SEELEY DISCRIMINATOR.

This discriminator depends on the phase relationships between a primary and a tuned secondary for its operation.

diode load resistor are equal and of opposite polarity. Hence, the net voltage between the top of the load resistors and ground is zero. This is shown vectorially in Figure 21A, where the resultant voltages R and R' which are applied to the two diodes are shown to be equal when the phase angle between primary and secondary voltages is 90 degrees. If, however, the signal varies from the resonant frequency, the 90-degree phase relationship no longer exists between primary and secondary. The result of this effect is shown in Figure 21B, where the secondary r.f. voltage is no longer 90 degrees out of phase with respect to the primary voltage. The resultant voltages applied to the two diodes are now no longer equal, and a d.c. voltage proportional to the difference between the r.f. voltages applied to the two diodes will exist across the series load resistors. As the signal frequency varies back and forth across the resonant frequency of the discriminator, an a.c. voltage of the same frequency as the original modulation, and proportional to the deviation, is developed and passed on to the audio amplifier.

Limiters The limiter in an f.m. receiver serves to remove amplitude modulation and pass on to the discriminator a frequency modulated signal of constant amplitude; a typical circuit is shown in Figure 22. The limiter tube is operated as an i.f. stage with very low plate voltage and with grid leak bias, so that it overloads quite easily. Up to a certain point the output of the limiter will increase with an increase in signal. Above this point, however, the limiter becomes overloaded, and further large increases in signal will not give any increase in output. To operate successfully, the limiter must be supplied with a large amount of signal, so that the amplitude of its output will not change for rather wide variations in amplitude of the signal. Noise, which causes little frequency modulation but much amplitude modulation of the received signal is virtually wiped out in the limiter.

The voltage across the grid resistor, R_1 , va-

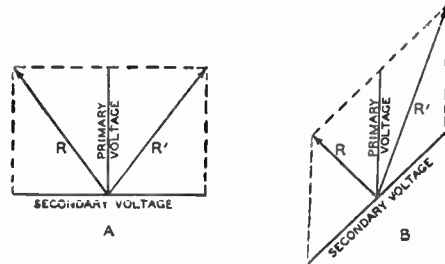

Figure 21.

DISCRIMINATOR VECTOR DIAGRAM.

A signal at the resonant frequency of the secondary will cause the secondary voltage to be 90 degrees out of phase with the primary voltage, as shown at A, and the resultant voltages R and R' are equal. If the signal frequency changes, the phase relationship also changes, and the resultant voltages are no longer equal, as shown at B. A differential rectifier is used to give an output voltage proportional to the difference between R and R' .

ries with the amplitude of the received signal, and for this reason, conventional amplitude modulated signals may be received on the f.m. receiver by connecting the input of the audio amplifier to the top of this resistor, rather than to the discriminator output. When properly filtered by a simple R-C circuit, the voltage across R_1 may also be used as a.v.c. voltage for the receiver. When the limiter is operating properly, a.v.c. is neither necessary nor desirable, however.

Receiver Design Considerations One of the most important factors in the design of an

f.m. receiver is the frequency swing which it is intended to handle. It will be apparent from Figure 19 that if the straight portion of the discriminator circuit covers a wider range of frequencies than those generated by the transmitter, the audio output will be reduced from the maximum value of which the receiver is capable.

In this respect, the term "modulation percentage" is more applicable to the f.m. receiver than it is to the transmitter, since the "modulation capability" of the communication system is limited by the receiver bandwidth and the discriminator characteristic; full utilization of the linear portion of the characteristic amounts, in effect, to "100 per cent" modulation. This means that some sort of standard should be agreed upon, for any particular type of communication, to make it unnecessary to vary the transmitter swing to accommodate different receivers.

Two considerations influence the receiver bandwidth necessary for any particular type of communication. These are the maximum audio frequency which the system will handle, and

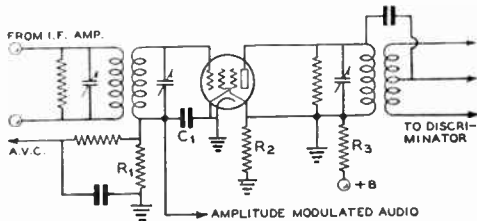

Figure 22.

LIMITER CIRCUIT.

The limiter stage overloads easily, and when overloaded will not reproduce amplitude variations. R_1 may have a value of from 250,000 ohms to 1 megohm. Capacitor C_1 should be rather small, about .0001 ufd. Resistors R_2 and R_3 should be proportioned so that the plate and screen voltage is from 10 to 30 volts.

the deviation ratio which will be employed. For voice communication, the maximum audio frequency is more or less fixed at 3000 to 4000 cycles. In the matter of deviation ratio, however, the amount of noise suppression which the f.m. system will provide is influenced by the ratio chosen, since the improvement in signal-to-noise ratio which the f.m. system shows over amplitude modulation is equivalent to a constant multiplied by the deviation ratio. This assumes that the signal is somewhat stronger than the noise at the receiver, however, as the advantages of wide-band f.m. in regard to noise suppression disappear when the signal-to-noise ratio approaches unity.

On the other hand, a low deviation ratio is likely to be more satisfactory for strictly communication work, where readability at low signal-to-noise ratios is more important than additional noise suppression when the signal is already appreciably stronger than the noise.

As mentioned previously, broadcast f.m. practice is to use a deviation ratio of 5. When this ratio is applied to a voice-communication system, the total "swing" becomes 30 to 40 kc. With lower deviation ratios, such as are sometimes used for voice work, the swing becomes proportionately less, until at a deviation ratio of 1 the swing is equal to twice the highest audio frequency. Actually, however, the receiver bandwidth must be slightly greater than the expected transmitter swing, since for distortionless reception the receiver must pass the complete band of energy generated by the transmitter, and this band will always cover a range somewhat wider than the transmitter swing.

No definite recommendations can be given for the proper reception bandwidth to be used in a receiver designed for voice f.m. work, since there is as yet no standardization in regard to deviation ratio and maximum audio

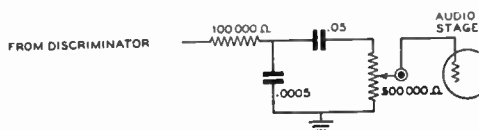

Figure 23.

LOW-PASS FILTER.

A low-pass filter is necessary in the f.m. receiver to remove high frequency noise components.

frequency. For best results, however, it should be remembered that the receiver must have a bandwidth sufficiently wide to pass all of the side frequencies of appreciable strength produced by the transmitter. At the same time, the selectivity of the i.f. channel should be such that the pass band is no wider than is absolutely necessary, since the additional bandwidth in the receiver only serves to decrease the signal-to-noise ratio.

Audio Bandwidth To realize the full noise reducing capabilities of f.m., it is essential that the pass band of the audio section of the receiver be limited to that necessary for communication. The noise output of the discriminator is proportional to the audio frequency of the noise, and the improvement in signal-to-noise ratio depends almost entirely on receiver deviation ratio, or the ratio between one-half the r.f. bandwidth and the audio bandwidth.

A suitable filter for removing frequencies higher than those necessary for communication is shown in Figure 23. The 100,000-ohm resistor and the .0005-ufd. capacitor reduce the high frequency audio which is passed to the audio amplifier.

PULSE-TIME MODULATION

Instead of frequency modulating a carrier directly as is done in a conventional f.m. system, it is possible to make use of a sub carrier. Thus, if a 1000-Mc. carrier is amplitude modulated at 100 kc. to provide a "sub carrier" and the latter is frequency modulated, an indirect method of frequency modulation results.

Instead of a sine wave sub carrier as a vehicle for the f.m. intelligence, square wave modulation may be substituted with but little difference in results except for increased bandwidth.

Certain u. h. f. and microwave tubes such as the magnetron are not easily frequency modulated directly, and amplitude modulation of such tubes is limited to a very low percentage if distortion is to be held within tolerable limits. However, such tubes can be amplitude modulated fully with square waves, as such

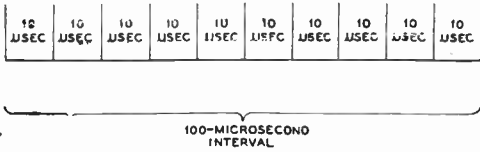

Figure 24.
TYPICAL PULSE-TIME MODULATION CHANNEL ARRANGEMENT.

operation is essentially the same as "on-off" keying and linearity is not a consideration. Frequency modulating the comparatively low-frequency square wave generator is accomplished easily, and a simple, stable system capable of low distortion is the result. The system exhibits the same advantages as regards noise reduction as does conventional f.m.

The train of square waves may be considered as a series of rectangular pulses in which the pulse length (mark) is equal to the time between pulses (space). Now if the pulses are shortened and the repetition rate maintained, the ratio of "mark" to "space" will no longer be 50-50, but much less. If the peak power is maintained and the pulse length is only 1/10 as long as a space, the *average* power goes way down. If the receiver can be made to respond only to energy (both signal and noise) above a certain threshold amplitude, an increase in signal to noise ratio is obtained with the shorter pulses, if the power is considered from the standpoint of average value. Such a system is called *pulse-time modulation*. It provides all the advantages of sub carrier f.m. and at the same time provides an effective power gain when tubes are employed which are capable of very high peak power but not much average power. Most magnetrons fall into the latter category, because of the limited amount of power that may be dissipated safely at the anode.

Pulse-time modulation offers other advantages for certain applications such as relay operation. By providing a fixed time delay in the output of the receiver and a suitable "blocking" or muting arrangement to kill the receiver for the duration of the transmitted pulse, it is possible to operate the transmitter and receiver of a repeater on the same r.f. channel without the usual feedback difficulties.

Pulse-time modulation also is uniquely well suited to multi-channel operation, this being accomplished by means of a "time division" or "commutation" in conjunction with a marker or synchronizing pulse. This system is described below.

The pulse receiver may be arranged to discriminate between pulses of predetermined amplitude, width, repetition rate, shape, time

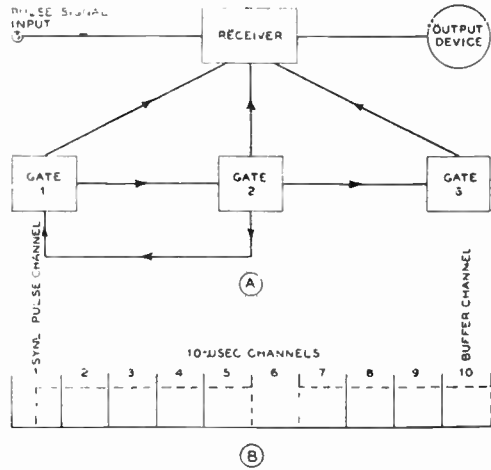

Figure 25.
PULSE-TIME MODULATION SYSTEM.

of arrival, etc. In common communication systems, channeling is accomplished by means of frequency discrimination. In a representative pulse-time modulation system, channeling is accomplished in an entirely different manner, by a division of time along a basic time interval. To understand how this is done, refer to Figure 24.

Here, the basic time interval (width of the block) is 100 microseconds. Short pulses may be transmitted to a receiving system completely at any part of this interval. For instance, a complete pulse may be exchanged in the first tenth of the interval (i.e., in the first 10 microseconds). The 100-microsecond interval accordingly may be divided into a number of shorter intervals, say of 10 microseconds each. Now, if a pulse be visualized as occurring completely in one 10-microsecond interval, it is readily seen that the receiving system would be idle during the other 90 microseconds. However, other pulses might easily be delivered during any of the other 10-microsecond intervals. It remains to make each of several receiving systems responsive to a particular one of these intervals (which now may be visualized as channels), but not to the others. In this way a channeling system will be obtained—one which is based upon *time division*. Thus, a receiver might be made responsive to pulses arriving in the third channel (30-microsecond sub-interval), while rejecting pulses in every other channel. The 100-microsecond interval would be repeated in its entirety in a *frequency-modulation* pulse-time modulation scheme.

In practical pulse-time modulation systems, one channel is reserved for synchronizing

pulses and another as a "buffer" channel in which no transmission is made. These usually are at extreme ends of the basic time interval. Thus, in a 100-microsecond interval, the first 10-microsecond sub-interval might be the synchronizing pulse channel, while the last sub-interval would be left vacant as the buffer channel. This would allow 8 channels for pulse communication (See Figure 25).

A receiver circuit would be arranged to receive pulses in channel 6, for example, by making it responsive only to pulses in the 60-microsecond sub-interval, as well as to the special synchronizing pulses arriving in the first sub-interval. This might be accomplished by maintaining the a.f. channel normally at cutoff and having it respond only during the 60-microsecond sub-interval (6th channel).

This ingenious action may be secured by means of vacuum-tube "gating" circuits, of the biased multivibrator type, which keep the receiver cut off except during the desired reception sub-interval. In a receiver of the type just mentioned, three such gates would be employed. This arrangement is illustrated by the block diagram in Figure 25.

In this scheme, communication pulses are assumed to be transmitted in sub-intervals 2 to 9, while a synchronizing pulse is transmitted in sub-interval 1. No pulse whatever is transmitted in sub-interval 10. Reception is desired only in one sub-interval, say, number 6. Action takes place in this manner: When the receiver first is switched on, any pulses received, in whatever sub-interval, operate the a.v.c. circuit to cut off the receiver. But when the empty sub-interval No. 10 arrives, this a.v.c. voltage leaks off and the receiver once more is in a responsive condition. The synchronizing pulse then arrives in the center of sub-interval 1 (at 5 microseconds) and

triggers gate 1 which, in turn, blocks the receiver for $4\frac{1}{2}$ microseconds (as shown by the first dotted rectangle in Figure 25-B). At the end of the 5th microsecond, however, this gating action, which has prevented reception of any pulses in the first five channels, ceases. A differentiated pulse on the end of the first gating voltage triggers gate 2 at this time. Gate 2 then delivers a voltage which is of such polarity as to open the receiver for response to channel 6 pulses. This is accomplished by bucking out the a.v.c. voltage. At the same time, gate 2 blocks gate 1 so that the latter will not be re-triggered by gate 2 output voltage and accidentally cut off the receiver. Gate 2 is timed to keep the receiver open only during the 10-microsecond duration of channel 6. At the close of that sub-interval, a differentiated pulse at the end of the gate 2 voltage triggers gate 3 which then builds up and maintains a blocking voltage (shown by the second dotted rectangle in Figure 25-B) to cut the receiver off from the end of the 6th sub-interval to the end of the 10th. At the end of the 10th channel (last sub-interval), gate 3 voltage disappears and the receiver again is in condition to receive a synchronizing pulse from the center of channel 1. The cycle of events then is repeated. In this same manner, other receiving systems may be operated only from pulses in other channels, while rejecting all other pulses except the synchronizing pulse in channel 1.

One practical form of gating circuit is the biased multivibrator. Being biased, this circuit establishes the "gate" (by biasing a receiver stage with multivibrator output voltage of the proper polarity) but does not oscillate like a conventional multivibrator. Consequently, the gate is maintained uninterruptedly for a predetermined time interval.

Transmitting Tubes

TRANSMITTING TUBES

(Plate Dissipation)

- | | |
|--|---|
| 2 Watts—HY24, HY114B | 75 Watts—HF75, TW75, HF100, TF100, 111-H, ZB120, HK257, (Amp.) 845, (United) 945, 8001 |
| 2.5 Watts—RK33 | 80 Watts—828* |
| 3 Watts—HY63 | 85 Watts—(Taylor) 211, (Amperex) 242A, WE242A, GL-242C, (United) 342B, (United) 384D |
| 3.5 Watts—HY6J5GTX, HY615 | 100 Watts—RK36, RK38, RK48, 100TH, 100TL, HF120, HF125, HF140, AB150, 203A, (RCA) 211, WL-211, 211C, 211D, HK254, 261A, 276A, (United) 303A, (United) 311, (United) 361A, (United) 376A, 813, WL-813, GL-835, 838, WL-838, 845, WL-845, 850, 852, 860, WL-860, (United) 938, 8003 |
| 5 Watts—1626 | 125 Watts—T125, HF130, GL-146, HF150, GL-152, HF175, (Amperex) 211C, (Amperex) 211H, (Amperex) 261A, (Amperex) 276A, 803, WL-803, 805, WL-805, (United) 905, (Amperex) 805 |
| 6 Watts—RK24, 1610 | 150 Watts—TW150, HF200, HF250, HD203A, HK354, HK354C, D, E, F, 810*, WL-810*, 1627, 8000* |
| 10 Watts—RK23, RK25, RK25B, RK34, RK45, HY65, 802, WL-802, 1613 | 160 Watts—HF200 |
| 12 Watts—RK44, 837, WL-837, (Amperex) 842 | 200 Watts—T200, HF300, (Taylor) T814, T822, HV12, HV18, HV27 |
| 14 Watts—(United) 305-D | 225 Watts—806*, WL-806* |
| 15 Watts—RK10, HK14, HY60, HY75, RK100, WE307A, 832, (RCA) 841, (Amperex) 841, 843, 844, 865, WL-865, (United) 942, HY6V6GTX, 1619 | 250 Watts—GL-159, GL-169, 204A, WL-204A, 250TH, 250TL, (United) 304A, (Amperex) 308B |
| 20 Watts—T20, TZ20, (United) 310, 801, 801A, (United) 941, 1608 | 275 Watts—212E, 241B |
| 21 Watts—T21, HY6L6GX, RK49, 1614 | 300 Watts—HK654, WL-833A, (Amperex) 833, (Amperex) 849 |
| 25 Watts—RK11, RK12, HK24, HY25, RK28, RK30, RK39, RK41, HY61, WE254B, WL-815*, 1624 | 350 Watts—WE270A, (Amperex) 270A, (United) 312E |
| 30 Watts—HY30Z, HY31Z, WE316A, 807*, WL-807*, 809*, WL-809*, HY1231Z, 1623*, 1625* | 400 Watts—831, 849, WL-849, 861, WL-861, (United) 949 |
| 35 Watts—800, WL-800 | 450 Watts—450TH, 450TL, 833A*, HK854H, HK854L |
| 40 Watts—RK18, RK20A, RK31, HY40, HY40Z, T40, TZ40, RK46, HY69, WE300A, 804, 829, (Amperex) 830, (United) 930, HY1269, 1628 | |
| 50 Watts—(United) BW11, RK32, RK35, RK37, RK47, HK54, WE304B, (Amperex) 304B, 808, 834, (Taylor) 8415W | |
| 55 Watts—T55, 811*, WL-811*, 812*, WL-812* | |
| 60 Watts—RK51, HF60, WE305A, 830B, 826, (United) 930B | |
| 62.5 Watts—RK52 | |
| 65 Watts—HY51A, HY51B, HY51Z, HY67, 203Z, (RCA, GE) 814*, WL-814* | |
| 70 Watts—35T, WE282A, WL-828 | |

*Intermittent-service rating. Continuous-service ratings run from 10 to 35 percent lower than these figures.

Prefixes used by tube manufacturers: Amperex—A, HF, ZB. Continental Electric—CE. Eitel-McCullough (Elmac)—UH, RF (also suffixes T, TH & TL). Federal—F. General Electric—GL. Hytran—HY. RCA Manufacturing Co.—none. Raytheon—RK, CK, RX. Sylvania—none. Taylor—T, TT, TZ. United Electronics—BW, CV, CW, HV, UX, VE. Western Electric—D, WE. Westinghouse—WL.

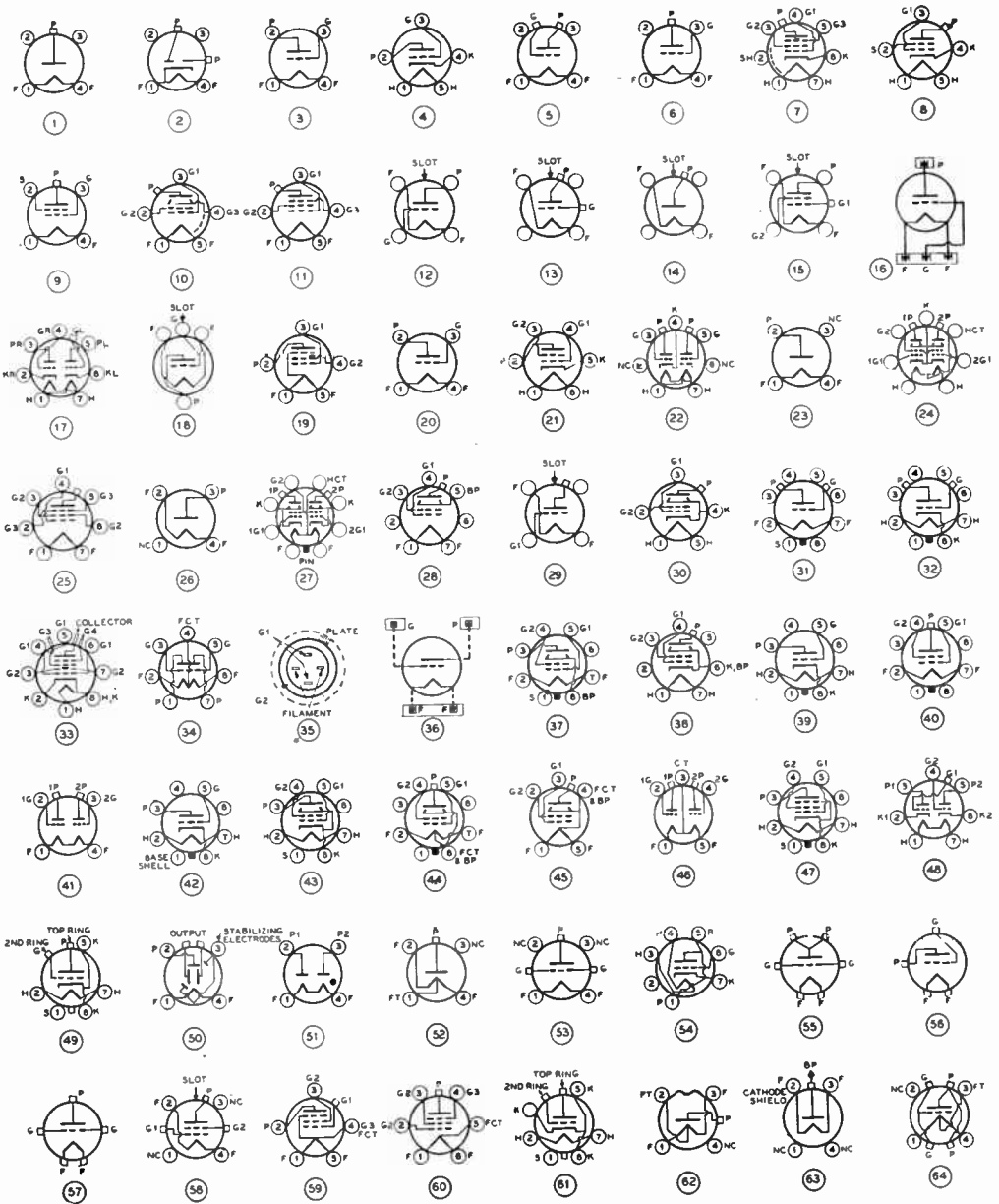

TRANSMITTING TUBE SOCKET CONNECTIONS—BOTTOM VIEWS

| Mfr. No. | Type | Cathode | | Base ³ and Connections | Max. Plate Voltage | Max. Plate Current (ma.) | Triode Mu or Max. Screen Voltage | Max. D.C. Control Grid Current (ma.) | Max. Plate Dissipation (Watts) | Max. Screen Dissipation (Watts) | Interelectrode Capacitances μ fds. | | | Typical ¹⁾ Operation | Plate Volts | Control Grid Bias | Screen Volts | Suppressor Volts | Plate ⁷ Current (ma.) | D.C. ⁸ Control Grid Current (ma.) | Screen Current (ma.) | Grid ⁴ Driving Power (Approx. Watts) | Load Imped. P to P (Ohms) | Power Output (Watts) typical | Mfr. ⁵ | |
|---------------|-------------------------------|------------|-------------|-----------------------------------|--------------------|--------------------------|----------------------------------|--------------------------------------|--------------------------------|---------------------------------|--|------------|------------|---------------------------------|--|----------------------|---------------------|------------------|----------------------------------|--|----------------------|---|---|------------------------------|-------------------|---------------|
| | | G-F In-put | P-F Out-put | | | | | | | | G-P Feed-back | | | | | | | | | | | | | | | |
| 2C21 | Twin Triode | 6.3 | 0.6 | 7-pin S. 48 | 250 | | 10.4 | | | | | 2.6 2.6 | 1.4 2.0 | 2.4 1.8 | Class A Amplifier | 250 | -16.5 | | | 11.3 | | | | | | Kenrad |
| 2C22 | U.H.F. Triode | 6.3 | 0.3 | 8-pin O. 32 | 300 | | 20 | | 3.5 | | | 2.2 | 0.7 | 3.6 | Class A Amplifier | 300 | -10.5 | | | 11 | | | | | | Kenrad |
| 2C25 | Triode | 7.0 | 1.18 | 4-pin M. 3 | 450 | 60 | 8 | 15 | 15 | | | 4.1 | 3.0 | 7.0 | Class C Amp. Osc. | 450 | -100 | | | 65 | 15 | | 3.2 | | 19 | |
| | | | | | | | | | | | | | | | Class C Amp. Plate-Mod. | 350 | -100 | | | 50 | 12 | | 2.2 | | 12 | |
| 2C26 2C26A | U.H.F. Triode | 6.3 | 1.15 | 8-pin O. 32 | 350 | | 18.3 | | 10 | | | 2.6 | 1.1 | 2.8 | Special Oscillator | 350 | -15 | | | 16 | | | | | | |
| 2C34 | Twin Triode | 6.3 | 0.8 | 7-pin M. 22 | | | | | | | | | | | For other characteristics refer to type | | | | | | | | | | | |
| 2C43 2C44 | U.H.F. Triode | 6.3 | 0.75 | 5-pin O. 49 | 500 | 40 | | | 5.0 | | | 2.7 | 0.1 | 2.0 | Class C Amp. Oscillator | 250 | | | | | | | | | | G.E. |
| 2C45 | Triode | 7.0 | 1.18 | 4-pin M. 3 | 250 | 40 | 3.6 | | 10.0 | | | 5.0 | 3.0 | 7.7 | Class A Modulator | 250 | -40 | | | 29 | 0 | | 0 | | 1.0 | |
| 2E22 | Pentode | 6.3 | 1.5 | 5-pin M. 11 | 750 | 100 | 250 | | 30 | 10 | 13 | 8.0 | 0.2 | | Class C Amp. (Telegraphy) | 750 | | 250 | 22.5 | 100 | 6 | 16 | 0.55 | | 53 | Kenrad |
| 2J35 | Split-Plate Magnetron | 1.8 | 2.0 | 4-pin M. 50 | 1000 | 5 | | | 4 | | | | | | Magnetron Oscillator | 1000 | | | | 4 | | | Magnetic Field Intensity 1300 Gauss, Wavelength, 10 cm. approx. | 1.0 | | RCA |
| 3B21 | Full-Wave Gas Rectifier | 2.5 | 5.5 | 4-pin M. 51 | | | | | | | | | | | Max. inverse voltage 340 volts peak. Max. peak current, 3 amp. Max. rated current 1 amp. Max. frequency 150 C.P.S. Minimum preheating time 15 seconds. | | | | | | | | | | | |
| 3B22 | Full-Wave Gas Rectifier | 2.5 | 6.25 | 4-pin M. 51 | | | | | | | | | | | Max. inverse voltage, 725 volts peak. Max. peak current 4 amp. Max. rated current 1 amp. Minimum preheating time, 20 seconds. | | | | | | | | | | | C. E. |
| 3B23 | Full-Wave Hi-Vacuum Rectifier | 2.5H | 8.0 | 4-pin M. 2 | | | | | | | | | | | For other characteristics, refer to type RK-22 | | | | | | | | | | | |
| 3B24 | Half-Wave Hi-Vacuum Rectifier | 2.5 5.0 | 0.15 0.3 | 4-pin M. 52 | | | | | | | | | | | Max. peak inverse voltage, 20,000 volts. With 2.5 volts on Filament, Max. peak current 150 MA. Max. rated current, 30 MA. With 5.0 volts on filament, Max. peak current 300 MA. Max. rated current, 60 MA. | | | | | | | | | | | W. E. C. E. |
| 3B25 | Half-Wave Gas Rectifier | 2.5 | 5.0 | 4-pin M. 1 | | | | | | | | | | | Max. peak inverse voltage, 4,000 volts. Max. peak current 2 amp. Max. rated current, 0.5 amp. Max. frequency 500 C.P.S. Tube voltage drop, 10 volts approx. Preheating time 30 seconds. | | | | | | | | | | | Kenrad RCA |
| 3C24 | H.F. Triode | 6.3 | 3.0 | 4-pin S. 5 | 2000 | 75 | 23 | 25 | 25 | | | 1.7 | 0.3 | 1.5 | Class C, amp. osc. | 1000 1500 2000 | -80 -110 -170 | | | 7.2 6.7 6.5 | 15 15 17 | | 2.6 3.1 4.5 | | 47 75 100 | |

| | | | | | | | | | | | | | | | | | | | | | | | | | | | | | | | | | |
|---------------|---|-------------|--------------|---------------------------------|-------|------|-----|------|-------|---|------|-----|--------------------|-------------------------------|-------|-------|-----|------|------|-----|------|-------|--------|-------|----------------------|-------------|--|--|--|--|--|--|--|
| 3C28 | H.F. Triode | 6.3 | 3.0 | 4-pin S. 53 | 2000 | 75 | 25 | 25 | 25 | 1.8 | 0.2 | 1.8 | Class C Amp. Osc. | 1000 | | | | 75 | 25 | | | | | 35 | | | | | | | | | |
| 3E29 | P. P. Beam Power Pentode ^{1,2} | 6.3 12.6 | 2.25 1.12 | Special 24 ^{1,5} | | | | | | For other characteristics, refer to type 829B | | | | | | | | | | | | | | | | | | | | | | | |
| 4C22 | Triode | 10 | 2.0 | 4-pin M. 5 | | | | | | For other characteristics, refer to type HF100, TF100 | | | | | | | | | | | | | | | | | | | | | | | |
| 4E27 | Beam Power Pentode | 5.0 | 7.5 | 7-pin Giant Bayonet 25 | | | | | | Identical to type 8001 except 3/4" shorter in height. | | | | | | | | | | | | | | | | | | | | | | | |
| 6C4 | H. F. Triode | 6.3 | 0.15 | 7-pin B. 54 | 300 | 25 | 17 | 8 | 5 | 1.8 | 1.3 | 1.6 | Class C Amp. Osc. | 300 | -27 | | | 25 | 7 | | | 0.35 | | 5.5 | RCA Kenrad RAY | | | | | | | | |
| HY-6J5 GTX | Triode | 6.3H | 0.3 | Cer. Octal 42 | 250 | 20 | 20 | 4.0 | 3.5 | 3.8 | 3.0 | 2.7 | Class-C Telegraphy | 250 | -30 | | | 20 | 2.0 | | | 0.2 | | 3 | Hy- tron | | | | | | | | |
| | | | | | | | | | | | | | Class-C Telephony | 250 | -30 | | | 20 | 2.5 | | | 0.4 | | 3 | | | | | | | | | |
| | | | | | | | | | | | | | Class-C Telegraphy | 500 | -50 | 250 | | 90 | 2.0 | 9 | | 0.5 | | 30 | | | | | | | | | |
| HY-6L8 GX | Beam Tetrode | 6.3H | 0.9 | Cer. Octal 43 | 500 | 90 | 300 | 3.5 | 21 | 3.0 | 11.0 | 8.0 | 0.5 | Class-C Telephony | 400 | -45 | 225 | | 80 | 3.0 | 9 | | 0.8 | | 70 | Hy- tron | | | | | | | |
| | | | | | | | | | | | | | | Class-AB ₂ Audio | 500 | -25 | 300 | | 230 | | 20 | 0.6 | 4660 | | 25 | | | | | | | | |
| | | | | | | | | | | | | | | Class-C Telegraphy | 300 | -45 | 200 | | 60 | 2.5 | 7.5 | | 0.25 | | 12 | | | | | | | | |
| HY-6V8 GTX | Beam Tetrode | 6.3H | 0.5 | Cer. Octal 43 | 300 | 60 | 225 | 3.5 | 15 | 2.5 | 10.0 | 8.5 | 0.4 | Class-C Telephony | 250 | -45 | 200 | | 60 | 2.0 | 6 | | 0.4 | | 10 | Hy- tron | | | | | | | |
| | | | | | | | | | | | | | | Class-AB ₂ Audio | 300 | -22.5 | 300 | | 120 | | 18 | 0.4 | 5000 | | 22 | | | | | | | | |
| | | | | | | | | | | | | | | Class-C Telegraphy | 300 | -45 | 200 | | 60 | 2.0 | 6 | | 0.4 | | 10 | | | | | | | | |
| 9C21 | Water Forced- Air Cooled Triode | 19.5 | 415 | Special Water Cooled | 15000 | 6000 | | | 40000 | | | | | A.F. Amp. and Mod. Class B | 14000 | -300 | | | 7100 | | | 150 | | 61000 | RCA | | | | | | | | |
| | | | | | 12500 | 4000 | 38 | 1000 | 28000 | 95 | 1.8 | 48 | Class-C Telephony | 12500 | -1670 | | | 3500 | 790 | | 1570 | | 38000 | | | | | | | | | | |
| | | | | | 17000 | 9000 | | 1000 | 40000 | | | | Class-C Telephony | 17000 | -1600 | | | 7900 | 900 | | 1800 | | 100000 | | | | | | | | | | |
| 9C22 | Forced Air Cooled Triode | 19.5 | 415 | Special Water Cooled | 15000 | 6000 | | | 20000 | | | | | A.F. Amp. and Mod. Class B | 14000 | -300 | | | 7100 | | | 150 | | 61000 | RCA | | | | | | | | |
| | | | | | 12500 | 4000 | 38 | 1000 | 14000 | 95 | 1.8 | 48 | Class-C Telephony | 12500 | -1670 | | | 3500 | 790 | | 1570 | | 38000 | | | | | | | | | | |
| | | | | | 17000 | 8000 | | 1000 | 20000 | | | | Class-C Telephony | 17000 | -1600 | | | 5000 | 800 | | 1450 | | 65000 | | | | | | | | | | |
| RK-10 | Triode | 7.5 | 1.25 | 4-pin M. 3 | 450 | 65 | 8 | 15 | 15 | 3 | 4 | 8 | Class-C Telephony | 450 | -130 | | | 65 | 15 | | | 3.2 | | 19 | Ray. | | | | | | | | |
| | | | | | | | | | | | | | Class-C Telephony | 350 | -100 | | | 50 | 12 | | | 2.2 | | 12 | | | | | | | | | |
| RK-11 | Triode | 6.3 | 3.0 | 4-pin M. 6 | 750 | 105 | 20 | 35 | 25 | 7 | 0.9 | 7 | Class-C Telephony | 750 | -120 | | | 105 | 21 | | | 3.2 | | 55 | Ray. | | | | | | | | |
| | | | | | | | | | | | | | Class-C Telephony | 600 | -120 | | | 85 | 24 | | | 3.7 | | 38 | | | | | | | | | |
| HV-12 | Triode | 10 | 4.0 | Giant 4-pin 29 | 2500 | 210 | 12 | 60 | 200 | 8.5 | 4 | 8.5 | Class-C Telephony | 2000 | -300 | | | 200 | 9 | | | 8 | | 300 | United | | | | | | | | |
| | | | | | | | | | | | | | Class-B Audio | 2000 | -160 | | | 275 | | | 7 | 14400 | 400 | | | | | | | | | | |

| Mfr. No. | Type | Cathode | | Base ² and Connections | Max. Plate Voltage | Max. Plate Current (ma.) | Triode Mu or Max. Screen Voltage | Max. D.C. Control Grid Current (ma.) | Max. Plate Dissipation (Watts) | Max. Screen Dissipation (Watts) | Interelectrode Capacitances μ fd.s. | | | Typical ¹ Operation | Plate Volts | Control Grid Bias | Screen Volts | Suppressor Volts | Plate ² Current (ma.) | D.C. ³ Control Grid Current (ma.) | Screen Current (ma.) | Grid ⁴ Driving Power (Approx. Watts) | Load Imped. P to P (Ohms) | Power Output (Watts) typical | Mfr. ⁵ |
|----------------------|-------------|------------|-------------|-----------------------------------|--------------------|--------------------------|----------------------------------|--------------------------------------|--------------------------------|---------------------------------|---|------|------------|--------------------------------|-------------|-------------------|--------------|------------------|----------------------------------|--|----------------------|---|---------------------------|------------------------------|-------------------|
| | | G-F In-put | P-F Out-put | | | | | | | | G-P Feed-back | | | | | | | | | | | | | | |
| HV-27 | Triode | 10 | 4 | Giant 4-pin 29 | 2500 | 210 | 26 | 60 | 200 | | 8.5 | 3.5 | 14.5 | Class-C Telegraphy | 2000 | -300 | | | 200 | 12 | | 9 | | 300 | United |
| | | | | | | | | | | | | | | Class-B Audio | 2000 | -60 | | | 325 | | | 9 | 12400 | 400 | |
| RK-28 | Pentode | 10 | 5.0 | Giant 5-pin 11 | 2000 | 150 | 400 | 25 | 100 | 35 | 15 | 15 | 0.02 | Class-C Telegraphy | 2000 | -100 | 400 | +45 | 150 | 13 | 55 | 2.0 | | 210 | Ray. |
| | | | | | | | | | | | | | | Class-C Telephony | 1500 | -100 | 400 | +45 | 135 | 13 | 52 | 2.0 | | 155 | |
| | | | | | | | | | | | | | | Sup.-Mod. Telephony | 2000 | -100 | 400 | -45 | 85 | 13 | 65 | 1.8 | | 60 | |
| RK-28-A | Pentode | 10 | 5.0 | Giant 5-pin 11 | 2000 | 400 | | | 125 | 35 | 15 | 15 | 0.02 | Class C Amp. Telegraphy | 2000 | -100 | 400 | 45 | 170 | 10 | 60 | 1.6 | | 250 | Ray. |
| | | | | | | | | | | | | | | Class C Amp. Plate Mod. | 1500 | -100 | 400 | 45 | 135 | 10 | 54 | 1.6 | | 150 | |
| | | | | | | | | | | | | | | Class C Amp. Grid Mod. | 2000 | -55 | 400 | 45 | 80 | 2 | 18 | 0.5 | | 60 | |
| HV-30-Z | Triode | 6.3 | 2.25 | 4-pin M. 617 | 850 | 90 | 87 | 25 | 30 | | 6.0 | 1.0 | 4.8 | Class-C Telegraphy | 850 | -75 | | | 90 | 25 | | 2.5 | | 58 | Hytron |
| | | | | | | | | | | | | | | Class-C Telephony | 700 | -75 | | | 90 | 25 | | 3.5 | | 47 | |
| | | | | | | | | | | | | | | Class-B Audio | 850 | 0 | | | 180 | | | 2 | 10000 | 110 | |
| RK-30 | Triode | 7.5 | 3.25 | 4-pin M. 5 | 1250 | 80 | 15 | 25 | 35 | | 2.75 | 2.75 | 2.5 | Class-C Telegraphy | 1250 | -180 | | | 90 | 18 | | 5.2 | | 85 | Ray. |
| | | | | | | | | | | | | | | Class-C Telephony | 1000 | -200 | | | 80 | 15 | | 4.5 | | 60 | |
| | | | | | | | | | | | | | | Class-B Audio | 1250 | -70 | | | 130 | 26 | | 3.4 | 21000 | 106 | |
| Twin 30 ² | Dual Triode | 6 | 4 | 4-pin M. | 1500 | 85 ea. Sect. | 32 | 30 ea. Sect. | 30 ea. Sect. | | 1.9 | 0.2 | 2 | Class-C Telegraphy | 1500 | -100 | | | 150 | 40 | | 15 | | 175 | Elmac |
| | | | | | | | | | | | | | | Class C. Telephony | 1250 | -100 | | | 135 | 40 | | 15 | | 125 | |
| HV-31Z ¹⁶ | Twin Triode | 6.3 | 2.5 | 4-pin M. 31 | 500 | 150 | 45 | 30 | 30 | | 5 per section | 1.9 | 5.5 | Class-C Telegraphy | 500 | -45 | | | 150 | 25 | | 2.5 | | 56 | Hytron |
| | | | | | | | | | | | | | | Class-C Telephony | 400 | -45 | | | 150 | 30 | | 3.5 | | 45 | |
| | | | | | | | | | | | | | | Class-B Audio | 500 | 0 | | | 150 | | | 1.8 | 7000 | 51 | |
| RK-31 | Triode | 7.5 | 3.0 | 4-pin M. 6 | 1250 | 115 | 75 | 76 | 40 | | 7 | 2.0 | 10 | Class-C Telegraphy | 1250 | -80 | | | 100 | 30 | | 3.9 | | 90 | Ray. |
| | | | | | | | | | | | | | | Class-C Telephony | 1000 | -80 | | | 100 | 28 | | 3.5 | | 70 | |
| | | | | | | | | | | | | | | Class-B Audio | 1250 | 0 | | | 220 | 76 | | 4.4 | 18000 | 190 | |
| RK-32 | Triode | 7.5 | 3.25 | 4-pin M. 5 | 1250 | 100 | 11 | 25 | 50 | | 2.5 | 0.7 | 3.4 | Class-C Telegraphy | 1250 | -225 | | | 100 | 14 | | 4.8 | | 90 | Ray. |
| | | | | | | | | | | | | | | Class-C Telephony | 1000 | -310 | | | 100 | 21 | | 8.7 | | 70 | |
| RK-33 | Twin Triode | 6.3 | 0.6 | 7-pin S. 17 | 250 | 20 ea. Sect. | 10 | 6.0 | 2.5 | | Left Triode 3.0 Right Triode 2.0 | 2.5 | 3.0 2.0 | Class-C Amp.-Osc. | 250 | -60 | | | 20 | 6.0 | 0.54 | | 3.5 | Ray. | |

| Mfr. No. | Type | Cathode | | Base ³ and Connections | Max. Plate Voltage | Max. Plate Current (ma.) | Triode Mu or Max. Screen Voltage | Max. D.C. Control Grid Current (ma.) | Max. Plate Dissipation (Watts) | Max. Screen Dissipation (Watts) | Inter-electrode Capacitances $\mu\text{fd.}$ | | | Typical ⁹ Operation | Plate Volts | Control Grid Bias | Screen Volts | Suppressor Volts | Plate ⁷ Current (ma.) | D.C. ⁸ Control Grid Current (ma.) | Screen Current (ma.) | Grid ⁴ Driving Power (Approx. Watts) | Load Imped. P to P (Ohms) | Power Output (Watts) typical | Mfr. ⁵ |
|----------|--------------------|--------------------|-------|-----------------------------------|--------------------|--------------------------|----------------------------------|--------------------------------------|--------------------------------|---------------------------------|--|-------------|---------------|--------------------------------|-------------|-------------------|--------------|------------------|----------------------------------|--|----------------------|---|---------------------------|------------------------------|-------------------|
| | | Volts ² | Amps. | | | | | | | | G-F In-put | P-F Out-put | G-P Feed-back | | | | | | | | | | | | |
| TZ-40 | Triode | 7.5 | 2.5 | 4-pin M. 6 | 1500 | 150 | 62 | 45 | 40 | | 4.8 | 0.8 | 5.0 | Class-C Telegraphy | 1500 | - 90 | | | 150 | 38 | | 10 | | 165 | Taylor |
| | | | | | | | | | | | | | | Class-C Telephony | 1250 | -100 | | | 125 | 30 | | 7.5 | | 116 | |
| | | | | | | | | | | | | | | Class-B Audio | 1500 | - 9.0 | | | 250 | | 6.0 | 12000 | 250 | | |
| RK-41 | Beam Power Tetrode | 2.5H | 2.4 | 5-pin M. 30 | 600 | 100 | 300 | 5.0 | 25 | 3.5 | 13 | 10 | 0.2 | Class-C Telegraphy | 600 | - 90 | 300 | | 93 | 3.0 | 10 | 0.38 | | 36 | Ray. |
| | | | | | | | | | | | | | | Class-C Telephony | 475 | - 50 | 250 | | 85 | 2.5 | 3.0 | 0.2 | 26 | | |
| RK-42 | Triode | 1.5 | 0.06 | 4-pin S. 3 | 180 | 7.5 | 8 | | | | 3 | 2.1 | 6.0 | Class-A Audio | 180 | -13.5 | | | 3.9 | | | | | | Ray. |
| RK-43 | Twin Triode | 1.5 | 0.12 | 6-pin S. | 135 | 15 (both triodes) | 13 | 3.0 | | | 1.9 | 2.1 | 4.2 | Class-C Amp.-Osc. | 100 | - 20 | | | 14 | 3.0 | | 0.2 | | 1.25 | Ray. |
| | | | | | | | | | | | | | | Class-B Audio | 135 | - 5 | | | 12.5 | 1.0 | | 0.027 | 24000 | 0.95 | |
| RK-44 | Pentode | 12.6H | 0.7 | 7-pin M. 7 | 500 | 80 | 200 | 8.0 | 12 | 8.0 | 10 | 10 | 0.2 | Class-C Telegraphy | 500 | - 75 | 200 | +40 | | 3.0 | 15 | 0.4 | | 22 | Ray. |
| | | | | | | | | | | | | | | Class-C Telephony | 400 | - 40 | 140 | +40 | 45 | | | 11 | | | |
| RK-45 | Pentode | 12.6H | 0.45 | 7-pin M. 7 | 500 | 60 | 250 | 10 | 10 | 8.0 | 10 | 10 | 0.02 | Class-C Telegraphy | 500 | - 90 | 200 | +45 | 50 | 4.0 | 30 | 0.5 | | 22 | Ray. |
| | | | | | | | | | | | | | | Class-C Telephony | 400 | - 90 | 150 | 0 | 40 | 5.0 | 30 | | 13.5 | | |
| RK-46 | Pentode | 12.6 | 2.5 | 5-pin M. 11 | 1250 | 92 | 300 | 15 | 40 | 15 | 14 | 12 | 0.1 | Class-C Telegraphy | 1250 | -100 | 300 | +45 | 92 | 11.6 | | 1.6 | | | Ray. |
| | | | | | | | | | | | | | | Class-C Telephony | 1000 | -100 | 300 | 0 | 75 | 10 | 30 | 1.3 | 52 | | |
| RK-47 | Beam Power Tetrode | 10 | 3.25 | 5-pin M. 10 | 1250 | 150 | 300 | 10 | 50 | 10 | 13 | 10 | 0.12 | Class-C Telegraphy | 1250 | - 70 | 300 | | 138 | 7.0 | 14 | 1.0 | | 120 | Ray. |
| | | | | | | | | | | | | | | Class-C Telephony | 900 | -120 | 250 | | 90 | 7.5 | 23 | 1.2 | 55 | | |
| RK-48 | Beam Power Tetrode | 10 | 5.0 | Giant 5-pin 10 | 2000 | 180 | 400 | 20 | 100 | 22 | 17 | 13 | 0.13 | Class-C Telegraphy | 2000 | -100 | 400 | | 180 | 6.5 | 40 | 1.0 | | 250 | Ray. |
| | | | | | | | | | | | | | | Class-C Telephony | 1500 | -100 | 400 | | 148 | 6.5 | 50 | 1.0 | 165 | | |
| RK-49 | Beam Power Tetrode | 6.3H | 0.9 | 6-pin M. 21 | 400 | 100 | 300 | 6.0 | 21 | 3.5 | 11.5 | 10.6 | 1.4 | Class-C Telegraphy | 400 | - 50 | 250 | | 95 | 3.0 | 8.0 | 0.2 | | 25 | Ray. |
| | | | | | | | | | | | | | | Class-C Telephony | 300 | - 45 | 200 | | 60 | 5.0 | 15 | 0.3 | 13 | | |
| UH-50 | Triode | 7.5 | 3.25 | 4-pin M. 5 | 1250 | 125 | 10.6 | 25 | 50 | | 2.2 | 0.3 | 2.6 | Class-C Telegraphy | 1250 | -225 | | | 125 | 20 | | 7.5 | | 115 | Eimac |
| | | | | | | | | | | | | | | Class C Plate Mod. | 1250 | -325 | | | 125 | 20 | | 10 | 115 | | |
| | | | | | | | | | | | | | | Grid. Mod. Amp. | 1250 | -200 | | | 60 | 2 | | 3 | 25 | | |
| 50-T | Triode | 5.0 | 6.0 | 4-pin M. 5 | 3000 | 100 | 12 | 30 | 75 | | 2.0 | 0.4 | 2.0 | Class-C Amplifier | 3000 | -600 | | | 100 | 25 | | | 250 | Eimac | |

| | | | | | | | | | | | | | | | | | | | | | | | | |
|--------|---------|------|------|-----------------------------|-------|-----|------|----|------|---|------|------|------------------------|------|--------|-----|--|-----|-----|----|------|-------|-------|---------|
| UH-51 | Triode | 5.0 | 6.5 | 4-pin M. 5 | 2000 | 175 | 10.6 | 25 | 50 | 2.2 | 0.3 | 2.3 | Class-C Telegraphy | 2000 | — 500 | | | 150 | 20 | | 15 | | 225 | Eimac |
| | | | | | | | | | | | | | Class-C Plate Mod. | 1500 | — 400 | | | 165 | 20 | | 15 | | 200 | |
| | | | | | | | | | | | | | Grid. Mod. Amp. | 1500 | — 400 | | | 85 | 2 | | 8 | | 65 | |
| HY-51A | Triodes | 7.5 | 3.5 | 4-pin M. 6 | 1000 | 175 | 25 | 25 | 65 | 7.1 | 1.1 | 7.0 | Class-C Telegraphy | 1000 | — 75 | | | 175 | 20 | | 7.5 | | 131 | Hy-tron |
| | | | | | | | | | | | | | Class-C Telephony | 800 | — 67.5 | | | 150 | 15 | | 7.5 | | 104 | |
| HY-51B | | 10.0 | 2.25 | | | | | | | | | | Class-B Audio | 1000 | — 45 | | | 300 | | | 5.0 | 9000 | 285 | |
| HY-51Z | Triode | 7.5 | 3.5 | 4-pin M. 6 ¹⁷ | 1000 | 175 | 85 | 35 | 65 | 7.1 | 1.1 | 7.0 | Class-C Telegraphy | 1000 | — 22.5 | | | 175 | 35 | | 10 | | 131 | Hy-tron |
| | | | | | | | | | | | | | Class-C Telephony | 1000 | — 30 | | | 150 | 35 | | 10 | | 104 | |
| | | | | | | | | | | | | | Class-B Audio | 1250 | 0 | | | 300 | | | 4.0 | 2500 | 285 | |
| RK-51 | Triode | 7.5 | 3.75 | 4-pin M. 6 | 1500 | 150 | 20 | 40 | 60 | 6.0 | 2.5 | 6.0 | Class-C Telegraphy | 1500 | — 250 | | | 150 | 31 | | 10 | | 170 | Ray. |
| | | | | | | | | | | | | | Class-C Telephony | 1250 | — 200 | | | 105 | 17 | | 4.5 | | 96 | |
| RK-52 | Triode | 7.5 | 3.75 | 4-pin M. 6 | 1500 | 130 | 150 | 50 | 62.5 | 6.6 | 2.2 | 12 | Class-C Telegraphy | 1500 | — 120 | | | 130 | 40 | | 7.0 | | 135 | Ray. |
| | | | | | | | | | | | | | Class-C Telephony | 1250 | — 120 | | | 115 | 47 | | 8.5 | | 105 | |
| | | | | | | | | | | | | | Class-B Audio | 1250 | 0 | | | 300 | 100 | | 7.5 | 10000 | 250 | |
| 53-A | Triode | 5.0 | 12.5 | 55 | 15000 | | | | | 3.6 | 0.4 | 1.9 | Oscillator at 300 M.C. | | | | | | | | | | 50 | |
| HK-54 | Triode | 5.0 | 5.0 | 4-pin M. 5 | 3000 | 135 | 27 | 20 | 50 | 1.9 | 0.2 | 1.9 | Class-C Telegraphy | 2000 | — 269 | | | 130 | 20 | | | | 210 | H&K |
| | | | | | | | | | | | | | Class-C Telephony | 2000 | — 269 | | | 130 | 20 | | 9.0 | | 210 | |
| | | | | | | | | | | | | | Class-B Audio | 1500 | — 45 | | | 198 | | | 8.0 | | 200 | |
| T-55 | Triode | 7.5 | 3.0 | 4-pin M. 6 | 1500 | 165 | 20 | 40 | | 4.95 | 1.15 | 3.85 | Class-C Telegraphy | 1500 | — 140 | | | 165 | 20 | | 5.6 | | 183.5 | Taylor |
| | | | | | | | | | | | | | Class-C Telephony | 1500 | — 200 | | | 135 | 20 | | 6.75 | | 158 | |
| RK-56 | Tetrode | 6.3 | 0.55 | 5-pin M. 8 | 300 | | 300 | | 8.0 | 4.5 | 10 | 9.00 | Class-C Telegraphy | 400 | — 40 | 300 | | 62 | 1.6 | 12 | 0.1 | | 12.5 | Ray. |
| | | | | | | | | | | | | | Class-C Plate Mod. | 250 | — 40 | 200 | | 50 | 1.6 | 10 | 0.28 | | 8.5 | |
| HY-57 | Triode | 6.3 | 2.25 | 4-pin M. 6 | 850 | 110 | 50 | 25 | 40 | 4.9 | 1.7 | 5.1 | Class-C Telegraphy | 850 | — 48 | | | 110 | 15 | | 2.5 | | 70 | Hy-tron |
| | | | | | | | | | | | | | Class-C Plate Mod. | 700 | — 45 | | | 90 | 17 | | 5.0 | | 47 | |
| | | | | | | | | | | | | | Grid Mod. Amp. | 850 | | | | 70 | | | | | 20 | |
| RK-57 | Triode | 10 | 3.25 | 4-pin Giant 29 | | | | | | For other characteristics, refer to Type 805. | | | | | | | | | | | | Ray. | | |
| RK-58 | Triode | 10 | 3.25 | 4-pin Giant 29 | 1250 | 175 | | 70 | 100 | 8.5 | 10.5 | 6.5 | Class-C Telegraphy | 1250 | — 90 | | | 150 | 30 | | 6 | | 130 | Ray. |
| | | | | | | | | | | | | | Class-C Plate Mod. | 1000 | — 135 | | | 150 | 50 | | 16 | | 100 | |
| | | | | | | | | | | | | | Class-B Telephony | 1250 | | | | 106 | 15 | | 6 | | 42.5 | |

| Mfr. No. | Type | Cathode | | Base ³ and Connections | Max. Plate Voltage | Max. Plate Current (ma.) | Triode Mu or Max. Screen Voltage | Max. D.C. Control Grid Current (ma.) | Max. Plate Dissipation (Watts) | Max. Screen Dissipation (Watts) | Interelectrode Capacitances $\mu\text{fds.}$ | | | Typical ⁹ Operation | Plate Volts | Control Grid Bias | Screen Volts | Suppressor Volts | Plate Current (ma.) | D.C. ⁸ Control Grid Current (ma.) | Screen Current (ma.) | Grid ⁴ Driving Power (Approx. Watts) | Load Imped. P to P (Ohms) | Power Output (Watts) typical | Mfr. ⁵ |
|-----------------|-------------------------------|--------------------|---------------|-----------------------------------|--------------------|--------------------------|----------------------------------|--------------------------------------|--------------------------------|---------------------------------|--|-------------|---------------|----------------------------------|-------------|-------------------|--------------|------------------|---------------------|--|----------------------|---|---------------------------|------------------------------|-------------------|
| | | Volts ³ | Amps. | | | | | | | | G-F In-put | P-F Out-put | G-P Feed-back | | | | | | | | | | | | |
| RK-59 | Triode | 6.3 | 1.0 | 4-pin M. 57 | 500 | 90 | 25 | 25 | 15 | | 5 | 1 | 9 | Class-C Amp. Oscillator | 500 | - 60 | | | 90 | 14 | | 1.3 | | 32 | Ray. |
| HF-60 | Triode | 10 | 2.5 | 4-pin M. 5 | 1600 | 150 | 20 | | 60 | | | | 5.2 | Class-C Amp. Oscillator | 1600 | -150 | | | | | | | | 100 | Amp. |
| RK-60 | Full-Wave Hi-Vacuum Rectifier | 5 | 3 | 4-pin M. 2 | 212C Peak Inverse | 250 | | | | | | | | Full-Wave Rectifier | 750 | | | | 250 average | | | | | | Ray. |
| HY-60 | Beam Power Tetrode | 6.3H | 0.5 | 5-pin M. 30 | 425 | 60 | 225 | 5.0 | 15 | 2.5 | 10 | 8.5 | 0.1 | Class-C Telephony | 425 | - 45 | 225 | | 60 | 2.5 | 7.0 | 0.25 | | 16 | Hytron |
| | | | | | | | | | | | | | | Class-C Telephony | 325 | - 45 | 225 | | 60 | 2.0 | 8.5 | 0.2 | | 10 | |
| HY-61 807 | Beam Power Tetrode | 6.3H | 0.9 | 5-pin M. 30 | 600 | 100 | 300 | 5.0 | 25 | 3.5 | 11 | 7.0 | 0.2 | Class-C Telephony | 600 | - 50 | 250 | | 100 | 3.0 | 9.0 | 0.22 | | 40 | Hytron |
| | | | | | | | | | | | | | | Class-AB ₂ P.P. Audio | 600 | - 30 | 300 | | 200 | | 20 | 0.4 | 6660 | 80 | |
| HY-63 | Beam Tetrode | 2.5 1.25 | .1125 .225 | Cer. Octal 44 | 250 | 25 | 180 | 2 | 3 | 0.6 | 9.5 | 7.4 | 0.15 | Class-C Telephony | 250 | -22.5 | 135 | | 25 | 2.0 | 4 | 0.2 | | 4.3 | Hytron |
| | | | | | | | | | | | | | | Class-C Telephony | 250 | - 35 | 135 | | 20 | 2.0 | 3 | 0.2 | | 3.5 | |
| | | | | | | | | | | | | | | Class-AB ₂ Audio | 250 | | 180 | | 50 | | 6 | 0.2 | | 7 | |
| RK-63 RK-63A | Triode | 5.0 | 10 | 4-pin Giant 13 | 3000 | 250 | 37 | 60 | 200 | | 2.7 | 1.1 | 3.3 | Class-C Telephony | 3000 | -200 | | | 233 | 45 | | 17 | 525 | Ray. | |
| | | | | | | | | | | | | | | Class-C Plate Mod. | 2500 | -200 | | | 205 | 50 | | 19 | 405 | | |
| | | | | | | | | | | | | | | Class-B Telephony | 3000 | -150 | | | 100 | 1.0 | | 12 | 100 | | |
| | | | | | | | | | | | | | | Grid. Mod. Amp. | 3000 | -250 | | | 100 | 7.0 | | 12.5 | 100 | | |
| RK-64 | Pentode | 6.3 | 0.5 | 5-pin M. 8 | 400 | | 100 | | 6 | 3 | 10 | 9 | 0.4 | Class-C Telephony | 400 | - 30 | 100 | 30 | 35 | 3 | 10 | 0.18 | | 10 | Ray. |
| | | | | | | | | | | | | | | Class-C Plate Mod. | 300 | - 30 | | 30 | 26 | 4 | 8 | 0.2 | | 8 | |
| HY-65 | Beam Tetrode | 6.3 | 0.8 | Cer. Octal 40 | 450 | 63 | 250 | 6 | 10 | 2.5 | 9.5 | 7.4 | 0.12 | Class-C Telephony | 450 | - 45 | 200 | | 63 | 3 | 7 | 0.5 | | 19 | Hytron |
| | | | | | | | | | | | | | | Class-C Telephony | 350 | - 45 | 200 | | 63 | 3 | 7 | 0.5 | | 14 | |
| RK-65 | Tetrode | 5.0 | 14 | 4-pin Giant 58 | 3000 | | 500 | | 215 | 35 | 10.5 | 4.75 | 0.24 | Class-C Telephony | 3000 | -100 | 400 | | 240 | 24 | 70 | 6 | | 510 | Ray. |
| | | | | | | | | | | | | | | Class-C Plate & Screen Mod. | 2500 | -150 | | | 200 | 22 | 70 | 6.3 | | 380 | |
| RK-66 | Tetrode | 6.3 | 1.5 | 5-pin M. 11 | 600 | | 300 | | 30 | 3.5 | 12 | 10.5 | 0.25 | Class-C Amp. Osc. | 600 | - 60 | 300 | | 90 | 5 | 11 | 0.5 | | 40 | Ray. |
| | | | | | | | | | | | | | | Class-C Plate Mod. | 500 | - 50 | | | 75 | 3.2 | 8 | 0.23 | | 25 | |

| | | | | | | | | | | | | | | | | | | | | | | | | | | |
|--------------------|-------------------------------|-------------|------------|-------------------------|------|-----|------|-------|----|-----|------|------|------|---|---|------|------|-----|-----|-------------------|-----|------|------|-------|-----------------|----------------|
| HY-67 | Beam Tetrode | 6.3 12.6 | 4.0 2.0 | 5-pin M. 45 | 1250 | 175 | 300 | 15 | 65 | 10 | | | | | Class-C Telegraphy | 1250 | - 80 | 300 | | 175 | 10 | 22.5 | 1.5 | | 152 | Hy- tron |
| | | | | | | | | | | | | | | | Class-C Telephony | 1000 | -150 | 300 | | 145 | 14 | 17.5 | 2 | | 101 | |
| HY-69 | Beam Power Tetrode | 6.3 | 1.5 | 5-pin M. 10 | 600 | 100 | 300 | 7.5 | 40 | 5.0 | 15.3 | 7.3 | 0.19 | | Class-C Telegraphy | 600 | - 60 | 250 | | 100 | 4.0 | 12.5 | 0.25 | | 42 | Hy- tron |
| | | | | | | | | | | | | | | | Class-C Telephony | 600 | - 60 | 250 | | 100 | 4.0 | 10 | 0.25 | | 42 | |
| | | | | | | | | | | | | | | | Class-AB ₂ P. P. Audio | 600 | - 35 | 300 | | 240 | | 29 | 0.7 | 4500 | 97 | |
| V-70 V-70B | Triode | 10 | 2.5 | 4-pin Giant 29 | 1500 | 140 | 14 | 25 | 70 | | 5 | 2.3 | 9 | | Class-C Amp. Telegraphy | 1500 | -215 | | | 130 | 6 | | 3 | | 140 | United |
| | | | | Class-C Amp. Plate Mod. | | | | | | | | | | | 1250 | -250 | | | 130 | 6 | | 3 | | 120 | | |
| V-70A V-70C | Triode | 10 | 2.5 | 4-pin Giant 29 | 1500 | 140 | 25 | 20 | 70 | | 5 | 2 | 9.5 | | Class-C Amp. Telegraphy | 1000 | -110 | | | 140 | 30 | | 7 | | 90 | United |
| | | | | Class C Amp. Plate Mod. | | | | | | | | | | | 80 | -150 | | | 95 | 20 | | 5 | | 50 | | |
| HF-75 | Triode | 10 | 3.25 | 4-pin M. 5 | 2000 | 120 | 12.5 | | 75 | | | | | 2 | Class C Amp. Oscillator | 2000 | | | | 120 | | | | | 150 | Amp. |
| HY-75 ¹ | Triode | 6.3 | 2.5 | Octal 31 | 450 | 100 | 10 | 20 | 15 | | 1.8 | 0.95 | 3.8 | | Class-C Telegraphy | 450 | - 60 | | | 82 | 15 | | 1.5 | | 21 ¹ | Hy- tron |
| | | | | | | | | | | | | | | | Class-C Telephony | 450 | - 60 | | | 62 | 20 | | 2.5 | | 16 ¹ | |
| RK-75 | Pentode | 5.5 | 1.0 | 5-pin M. 10 | | | | | | | | | | | For other characteristics, refer to Type WE-307A. | | | | | | | | | | | Ray. |
| TW-75 | Triode | 7.5 | 4.15 | 4-pin M. Fig. 5 | 2000 | 175 | 29 | 60 | 75 | | 3.35 | 0.7 | 1.5 | | Class-C Telegraphy | 2000 | -175 | | | 150 | 37 | | 12.7 | | 225 | Taylor |
| | | | | | | | | | | | | | | | Class-C Telephony | 2000 | -260 | | | 125 | 32 | | 13.2 | | 198 | |
| 75-T | Triode | 5 | 6.5 | 4-pin M. Fig. 5 | 3000 | 250 | 10 | 30 | 75 | | 2.2 | 0.3 | 2.3 | | Class-C Telegraphy | 2000 | -400 | | | 225 | 30 | | | | 375 | Eimac |
| | | | | | | | | | | | | | | | Class-C Telephony | 2000 | -400 | | | 200 | 30 | | | 300 | | |
| 75-TH | Triode | 5 | 6.2 | 4-pin M. 5 | 2000 | 225 | 22 | 35 | 75 | | 2.7 | 0.25 | 2.3 | | Class-C Amp. Oscillator | 1500 | | | | 115 | 30 | | | | 100 | Eimac |
| 75-TL | Triode | 5 | 6.2 | 4-pin M. 5 | | | | | | | | | | | For other characteristics, refer to Type 75-T. | | | | | | | | | | | Eimac |
| HF-100 TF-100 | Triode | 10 | 2.0 | 4-pin M. 5 | 1750 | 150 | 23 | 30 | 75 | | 3.5 | 1.4 | 4.5 | | Class-C Telegraphy | 1500 | -290 | | | 150 | 18 | | 6.0 | | 170 | Amp. Taylor |
| | | | | | | | | | | | | | | | Class-C Telephony | 1250 | -250 | | | 110 | 21 | | 8.0 | | 105 | |
| | | | | | | | | | | | | | | | Class-B Audio | 1750 | - 62 | | | 270 | | | 9.0 | 16000 | 350 | |
| RK-100 | Gas Triode | 6.3H | 0.9 | 6-pin M. 21 | 150 | 250 | 40 | 100.0 | 15 | | 23 | 3.0 | 19 | | Class-C R.F. Amp. | 110 | | | | 185 | 40 | | 2.1 | | 12 | Ray. |
| | | | | | | | | | | | | | | | Class-A Audio | 110 | -1.6 | | | 65 ¹¹ | 8.5 | | | 4.2 | | |
| | | | | | | | | | | | | | | | Class-A P. P. Audio | 110 | -1.6 | | | 130 ¹¹ | 17 | | 2000 | 9 | | |
| 100R | Hi-Vacuum Half-Wave Rectifier | 5.0 | 6.2 | 4-pin M. 1 | | | | | | | | | | | For other characteristics, refer to Type 8020. | | | | | | | | | | | |

| Mfr. No. | Type | Cathode | | Base ³ and Connections | Max. Plate Voltage | Max. Plate Current (ma.) | Triode Mu or Max. Screer Voltage | Max. D.C. Control Grid Current (ma.) | Max. Plate Dissipation (Watts) | Max. Screen Dissipation (Watts) | Interelectrode Capacitances $\mu\text{mfd.}$ | | | Typical [†] Operation | Plate Volts | Control Grid Bias | Screen Volts | Suppressor Volts | Plate ⁷ Current (ma.) | D.C. ⁶ Control Grid Current (ma.) | Screen Current (ma.) | Grid ⁴ Driving Power (Approx. Watts) | Load Imped. P to P (Ohms) | Power Output (Watts) typical | Mfr. ⁵ |
|---------------------|--------------|------------|-------------|-----------------------------------|--------------------|--------------------------|----------------------------------|--------------------------------------|--------------------------------|---------------------------------|--|------|------|--------------------------------|-------------|-------------------|--------------|------------------|----------------------------------|--|----------------------|---|---------------------------|------------------------------|-------------------|
| | | G-F In-put | P-F Out-put | | | | | | | | G-P Feed-back | | | | | | | | | | | | | | |
| 100-TH | Triode | 5.0 | 6.5 | 4-pin M. 5 | 3000 | 225 | 30 | 50 | 100 | | 2.2 | 0.3 | 2.0 | Class-C Telegraphy | 3000 | -210 | | | 125 | 50 | 30 | | 300 | Eimac | |
| | | | | | | | | | | | | | | Class-C Telephony | 3000 | -210 | | | 125 | 50 | 30 | | 300 | | |
| | | | | | | | | | | | | | | Class-B Audio ¹⁰ | 3000 | | | | | | 30000 | 500 | | | |
| 100-TL | Triode | 5.0 | 6.5 | 4-pin M. 5 | 3000 | 225 | 12 | 35 | 100 | | 2.0 | 4.0 | 2.3 | Class-C Telegraphy | 3000 | -600 | | | 135 | 30 | 40 | | 300 | Eimac | |
| | | | | | | | | | | | | | | Class-C Telephony | 3000 | -600 | | | 135 | 30 | 40 | | 300 | | |
| | | | | | | | | | | | | | | Class-B Audio ¹⁰ | 3000 | | | | | | 30000 | 465 | | | |
| 111-H | Triode | 10 | 2.25 | 4-pin M. 5 | 1500 | 160 | 23 | | 75 | | | | 4.6 | Class-C Amp. Oscillator | 1500 | | | | 160 | | | | 175 | | |
| HY-114 ¹ | Triode | 1.4 | 0.12 | Octal 31 | 180 | 15 | 20 | 3 | | | 1.2 | 0.6 | 1.7 | Class-C Telephony | 180 | | | | 15 | 3 | | | 2 | Hytron | |
| HY-114B | Triode | 1.25 | 0.145 | Octal 31 | 180 | 15 | 12 | 3 | 2 | | 1.4 | 1.45 | 1.85 | Class-C Telephony | 180 | -30 | | | 15 | 1.5 | 0.15 | | 2 ¹¹ | Hytron | |
| | | | | | | | | | | | | | | Class-C Telephony | 180 | -30 | | | 15 | 1.5 | 0.25 | | 2 ¹¹ | | |
| HF-120 | Triode | 10 | 3.25 | 4-pin Giant | 1250 | 175 | 12 | | 100 | | | | 10.5 | Class-C Amp. Oscillator | 1250 | | | | 175 | | | | 150 | Amp. | |
| ZB-120 | Triode | 10 | 2.0 | 4-pin Giant 12 | 1500 | 160 | 90 | 40 | 75 | | 5.3 | 3.2 | 5.2 | Class-C Telephony | 1250 | -135 | | | 160 | 23 | 5.5 | | 145 | Amp. | |
| | | | | | | | | | | | | | | Class-C Telephony | 1000 | -150 | | | 120 | 21 | 5.0 | | 95 | | |
| | | | | | | | | | | | | | | Class-B Audio | 1250 | 0 | | | 300 | | 4.0 | 9000 | 245 | | |
| HF-125 | Triode | 10 | 3.25 | 4-pin Giant | 1500 | 175 | 25 | | 100 | | | | 11.5 | Class-C Amp. Oscillator | 1500 | | | | 175 | | | 200 | Amp. | | |
| T-125 | Triode | 10 | 4.5 | 4-pin Giant 13 | 2500 | 250 | 25 | 70 | 125 | | 6.3 | 1.3 | 6.0 | Class-C Telephony | 2500 | -200 | | | 250 | 35 | 12.5 | | 500 | Taylor | |
| | | | | | | | | | | | | | | Class-C Telephony | 2000 | -165 | | | 250 | 35 | 12 | | 375 | | |
| 125-M | Beam Tetrode | 5 | 6.5 | 5-pin Giant | 3000 | 225 | | 30 | 125 | | 13 | 3.7 | 0.1 | | | | | | | | | | 375 | Eimac | |
| VT-127A | Triode | 5 | 10.5 | 55 | 16000 | | 15 | | 100 | | | | | Oscillator at 200 Mc. | | | | | | | | | 75 | | |
| HF-130 | Triode | 10 | 3.25 | 4-pin Giant | 1250 | 210 | 12.5 | | 125 | | | | 9 | Class-C Amp. Oscillator | 1250 | -210 | | | | | | | | 170 | Amp. |
| | | | | | | | | | | | | | | Class-C Amp. Oscillator | 1250 | | | | 175 | | | | 150 | Amp. | |

| | | | | | | | | | | | | | | | | | | | | | | | | |
|--------|--------|---------|-----------|-----------------------|------|-----|------|-----|-----|--|------|------|------|---|------|------|--|-----|-----|----|------|-------|--------|------|
| GL-146 | Triode | 10 | 3.25 | Special Large 4-pin 6 | 1500 | 175 | 78 | 80 | 125 | | 7.2 | 3.9 | 9.2 | Class-C Telephony | 1250 | -150 | | | 180 | 30 | | | 150 | G.E. |
| | | | | | | | | | | | | | | Class-C Telephony | 1000 | -200 | | | 160 | 40 | | | 100 | |
| | | | | | | | | | | | | | | Class-B Audio | 1250 | 0 | | | 320 | | | 8400 | 250 | |
| HF-150 | Triode | 10 | 3.25 | 4-pin Giant | 1500 | 210 | 12.5 | | 125 | | | | 7.2 | Class-C Amp. Oscillator | 1500 | | | 210 | | | | 200 | Amp. | |
| TW-150 | Triode | 10 | 4.1 | 4-pin 50-Watt 13 | 3000 | 200 | 35 | 60 | 150 | | 3.9 | 0.8 | 2.0 | Class-C Telephony | 3000 | -170 | | 200 | 45 | | 17 | 470 | Taylor | |
| | | | | | | | | | | | | | | Class-C Telephony | 3000 | -260 | | 165 | 40 | | 17 | 400 | | |
| 150-T | Triode | 5 | 10 | 4-pin Giant 13 | 3000 | 200 | 13 | 50 | 150 | | 3 | 0.5 | 3.5 | Class-C Amp. Telegraphy | 3000 | -600 | | 200 | 35 | | | 450 | Eimac | |
| GL-152 | Triode | 10 | 3.25 | Special Large 4-pin 6 | 1500 | 175 | 25 | 60 | 125 | | 7 | 4 | 8.8 | Class-C Telephony | 1250 | -150 | | 180 | 30 | | | 150 | G.E. | |
| | | | | | | | | | | | | | | Class-C Telephony | 1000 | -150 | | 160 | 30 | | | 100 | | |
| | | | | | | | | | | | | | | Class-B Audio | 1250 | -40 | | 320 | | | 8400 | 250 | | |
| 152-TL | Triode | 5 or 10 | 13 or 6.5 | Special | 3000 | 500 | 10 | 75 | 150 | | 5 | 0.75 | 5 | Two parallel connected 7-5-T's in one envelope. | | | | | | | | Eimac | | |
| HK-154 | Triode | 5 | 6.5 | 4-pin M. 5 | 1500 | 175 | 6.7 | 30 | 50 | | 4.3 | 1.1 | 5.9 | Class-C Amp. Telegraphy | 1500 | -590 | | 167 | 20 | | 15 | 200 | H & K | |
| | | | | | | | | | | | | | | Class-C Amp. Plate Mod. | 1250 | -460 | | 170 | 20 | | 12 | 162 | | |
| | | | | | | | | | | | | | | Grid Modulated Amp. | 1500 | -450 | | 52 | | | 5 | 28 | | |
| HK-158 | Triode | 12.6 | 2.5 | 4-pin M. 5 | 2000 | 200 | 25 | 40 | 50 | | 4.7 | 1.0 | 4.6 | Class-C Amp. Oscillator | 2000 | -150 | | 125 | 25 | | 6 | 200 | H.&K | |
| | | | | | | | | | | | | | | Class-C Amp. Plate Mod. | 2000 | -140 | | 105 | 25 | | 5 | 170 | | |
| | | | | | | | | | | | | | | Class-C Telephony | 2000 | -200 | | 400 | 17 | | 6 | 620 | | |
| GL-159 | Triode | 10 | 9.6 | Special Large 4-pin 6 | 2000 | 400 | 20 | 100 | 250 | | 11 | 5 | 17.6 | Class-C Telephony | 1500 | -240 | | 400 | 23 | | 9 | 450 | G.E. | |
| | | | | | | | | | | | | | | Class-B Audio | 2000 | -100 | | 660 | | | 6880 | 900 | | |
| | | | | | | | | | | | | | | Class-C Telephony | 2000 | -130 | | 400 | 42 | | 10 | 620 | | |
| GL-169 | Triode | 10 | 9.6 | Special Large 4-pin 6 | 2000 | 400 | 85 | 100 | 250 | | 11.5 | 4.7 | 19 | Class-C Telephony | 1500 | -130 | | 400 | 45 | | 10 | 450 | G.E. | |
| | | | | | | | | | | | | | | Class-B Audio | 2000 | -18 | | 660 | | | 6 | 7000 | | 900 |
| | | | | | | | | | | | | | | Class-C Amp. Oscillator | 2000 | | | 250 | | | | 300 | | |
| HF-175 | Triode | 10 | 4.0 | 4-pin Giant | 2000 | 250 | 18 | | 125 | | | | 6.3 | Class-C Telephony | 2500 | -300 | | 200 | 18 | | 8.0 | 380 | Amp. | |
| HF-200 | Triode | 10 | 3.4 | 4-pin Giant 13 | 2500 | 200 | 18 | 50 | 150 | | 5.2 | 1.2 | 5.8 | Class-C Telephony | 2000 | -350 | | 160 | 20 | | 9.0 | 250 | Amp. | |
| | | | | | | | | | | | | | | Class-B Audio | 2500 | -130 | | 360 | | | 8.0 | 16000 | | 600 |

| WL-207 | Water Cooled Triode | 22 | 52 | Special Water Cooled | | | | | | | | | | | | | | | | | West-Ing-house |
|------------------|-------------------------------|----|------|----------------------|-------------------|----------|----------------|-----|-------|------|-----|------|--|--|--|--|--|--|--|--|----------------|
| 207 | Water Cooled Triode | 22 | 52 | Special Water Cooled | 15000 | 2000 | 20 | 200 | 10000 | 18 | 2.0 | 27 | | | | | | | | | G.E. RCA |
| T-211 | Triode | 10 | 3.25 | 4-pin Giant 12 | 1250 | 175 | 12 | 50 | 100 | 7.0 | 6.0 | 14 | | | | | | | | | Taylor |
| WL-211 | Triode | 10 | 3.25 | 4-pin Giant 12 | | | | | | | | | | | | | | | | | West-Ing-house |
| 211 | Triode | 10 | 3.25 | 4-pin Giant 12 | 1250 | 175 | 12 | 50 | 100 | 6.0 | 5.5 | 14.5 | | | | | | | | | RCA G.E. W.E. |
| T-211-C | Triode | 10 | 3.25 | 4-pin Giant 12 | 1250 | 175 | 12.5 | 60 | 100 | 6.0 | 6.5 | 9.0 | | | | | | | | | Taylor |
| 211-C | Triode | 10 | 3.25 | 4-pin Giant 12 | 1250 | 210 | 12 | 50 | 125 | 5.5 | 3.5 | 9.0 | | | | | | | | | Amp. United |
| T-211-D 211-D | Triode | 10 | 3.25 | 4-pin Giant 12 | 1250 | 175 | 12 | 50 | 100 | 7.0 | 6.0 | 14 | | | | | | | | | Taylor Amp. |
| 211-H HD-211C | Triode | 10 | 3.25 | 4-pin Giant 29 | 1500 | 210 | 12.5 | 50 | 125 | 5.5 | 1.9 | 7.2 | | | | | | | | | Amp. Taylor |
| 212E | Triode | 14 | 6.0 | 4-pin W.E. 18 | 3000 | 350 | $\frac{9}{16}$ | 75 | 275 | 14.9 | 8.6 | 18.8 | | | | | | | | | W.E. United |
| 217-A | Half-Wave Hi-Vacuum Rectifier | 10 | 3.25 | 4-pin Giant 26 | 3500 Inverse Peak | 600 Peak | | | | | | | | | | | | | | | RCA |
| 217-C | Half-Wave Hi-Vacuum Rectifier | 10 | 3.25 | 4-pin Giant 14 | 7500 Inverse Peak | 600 Peak | | | | | | | | | | | | | | | RCA G.E. |

| Mfr. No. | Type | Cathode | | Base ³ and Connections | Max. Plate Voltage | Max. Plate Current (ma.) | Triode Mu or Max. Screen Voltage | Max. D.C. Control Grid Current (ma.) | Max. Plate Dissipation (Watts) | Max. Screen Dissipation (Watts) | Interelectrode Capacitances μ fd. | | | Typical ⁹ Operation | Plate Volts | Control Grid Bias | Screen Volts | Suppressor Volts | Plate Current (ma.) | D.C. ⁸ Control Grid Current (ma.) | Screen Current (ma.) | Grid ⁴ Driving Power (Approx. Watts) | Load Imped. P to P (Ohms) | Power Output (Watts) typical | Mfr. ⁵ | |
|----------|-----------------------------------|-----------|------------|-----------------------------------|--------------------|--------------------------|----------------------------------|--------------------------------------|--------------------------------|---------------------------------|---------------------------------------|------|-----|---|-----------------------------|-------------------|--------------|------------------|---------------------|--|----------------------|---|---------------------------|------------------------------|-------------------|-------|
| | | G-F Input | P-F Output | | | | | | | | G-P Feedback | | | | | | | | | | | | | | | |
| Z-225 | Half-Wave Mercury Vapor Rectifier | 2.5 | 5 | 4-pin M. 1 | 10000 Inverse Peak | 1000 Peak | | | | | | | | Half-Wave Rectifier | | | | | 250 average | | | | | | United | |
| 227-A | Triode | 10.5 | 10.6 | 55 | 15000 | | 30 | | 100 | | | 3.25 | 0.3 | 2.45 | Oscillator at 200 Mc. | | | | | | | | | 75 | | |
| WE-242A | Triode | 10 | 3.25 | 4-pin Giant 12 | 1250 | 150 | 12.5 | 50 | 85 | | | 6.5 | 4.0 | 13 | Class-C Telegraphy | 1250 | -200 | | | 150 | 30 | | 11 | | 125 | W.E. |
| | | | | | | | | | | | | | | | Class-C Telephony | 1000 | -175 | | | 150 | 30 | | 10 | | 100 | |
| | | | | | | | | | | | | | | | Class-B Audio | 1250 | -80 | | | 300 | | | 25 | 8000 | 200 | |
| 242-B | Triode | 10 | 3.25 | 4-pin Giant 12 | 1250 | 150 | 12.5 | 50 | 100 | | | 7 | 6 | 13.6 | Class-C Amp. Telegraphy | 1250 | -175 | | | 150 | | | | | 130 | |
| | | | | | | | | | | | | | | | Class-C Amp. Plate Mod. | 1000 | -160 | | | 150 | 50 | | | | 100 | |
| | | | | | | | | | | | | | | | Class-B Amp. Telephony | 1250 | -80 | | | 120 | | | | | 50 | |
| GL-242-C | Triode | 10 | 3.25 | 4-pin Giant 12 | 1250 | 150 | 12.5 | 50 | 85 | | | 6.1 | 4.7 | 13 | Class-C Telegraphy | 1250 | -225 | | | 150 | 20 | | 7 | | 130 | G.E. |
| | | | | | | | | | | | | | | | Class-C Telephony | 1000 | -260 | | | 150 | 35 | | 14 | | 100 | |
| | | | | | | | | | | | | | | | Class-B Audio | 1250 | -95 | | | 300 | | | 8 | 7600 | 200 | |
| T-249-B | Half-Wave Mercury Vapor Rectifier | 2.5 | 7.5 | 4-pin M. 1 | 10000 Peak Inverse | 1500 Peak | | | | | | | | In Single-Phase Full-Wave Rectifier | 3530 R.M. S. Input | | | | | | | | | | Taylor | |
| HF-250 | Triode | 10.5 | 4 | 4-pin Giant 13 | 2500 | 200 | 18 | | 150 | | | | | 5.8 | Class-C Amp. Oscillator | 2500 | | | | | | | | 375 | Amp. | |
| 250-TH | Triode | 5.0 | 10.5 | 4-pin Giant 13 | 3000 | 350 | 32 | 100 | 250 | | | 3.5 | 0.3 | 3.3 | Class-C Telegraphy | 3000 | -210 | | | 330 | 75 | | 99 | | 750 | Eimac |
| | | | | | | | | | | | | | | | Class-C Telephony | 3000 | -210 | | | 330 | 75 | | 99 | | 750 | |
| | | | | | | | | | | | | | | | Class-B Audio ¹⁰ | 1250 | | | | | | | | | 3280 | |
| 250-TL | Triode | 5.0 | 10.5 | 4-pin Giant 13 | 3000 | 350 | 13 | 50 | 250 | | | 3.8 | 0.5 | 3.5 | Class-C Telegraphy | 3000 | -600 | | | 330 | 45 | | 99 | | 750 | Eimac |
| | | | | | | | | | | | | | | | Class-C Telephony | 3000 | -600 | | | 330 | 45 | | 99 | | 750 | |
| | | | | | | | | | | | | | | | Class-B Audio ¹⁰ | 1250 | | | | | | | | | 3280 | |
| HK-252-L | Triode | 5 or 10 | 13 or 6.5 | Special | | | | | | | | | | For other characteristics refer to Type 152-TL. | | | | | | | | | | | H&K | |

| Model | Type | 5 | 10 | 4-pin Giant | | | | | | | | | | | | | | | | | | | | | | | | | | | | | | | | | | | | | | | | | | | | | |
|----------------|---------------------|-----|------|------------------------|------|-----|------|-----|-----|------|------|------|----------------------------|--------------------|---------|------|--------|-----|-----|-----|-----|------|-----|--|--|--|--|--|--|--|--|--|--|--|--|--|-----|--|--|--|--|--|--|--|--|--|--|--|--|
| HK-253 | Half-Wave Rectifier | | | 4-pin Giant 14 | | | | | | | | | | | | | | | | | | | | | | | | | | | | | | | | | H&K | | | | | | | | | | | | |
| HK-254 | Triode | 5.0 | 7.5 | 4-pin Giant 13 | 4000 | 200 | 25 | 40 | 100 | 3.3 | 1.1 | 3.4 | Max. D.C. output current | 350 | MA. | | | | | | | | | | | | | | | | | | | | | | | | | | | | | | | | | | |
| | | | | | | | | | | | | | Max. peak plate current | 1500 | | | | | | | | | | | | | | | | | | | | | | | | | | | | | | | | | | | |
| | | | | | | | | | | | | | Class-C R.F. Amp. | 3000 | -251 | | | | | | | | | | | | | | | | | | | | | | | | | | | | | | | | | | |
| WE-254A | Tetrode | 5 | 3.25 | 4-pin M. 9 | 750 | | 175 | 20 | 5 | 4.6 | 9.4 | 0.1 | Class-C R.F. Amp. | 750 | -90 | 175 | | | | | | | | | | | | | | | | | | | | | | | | | | | | | | | | | |
| | | | | | | | | | | | | | Class-C Amplifier | 750 | -90 | 175 | | | | | | | | | | | | | | | | | | | | | | | | | | | | | | | | | |
| WE-254B | Tetrode | 7.5 | 3.25 | 4-pin M. 9 | 750 | 75 | 150 | 25 | 25 | 4.0 | 11.2 | 5.4 | 0.85 | Class-C R.F. Amp. | 750 | -125 | 150 | | | | | | | | | | | | | | | | | | | | | | | | | | | | | | | | |
| | | | | | | | | | | | | | | Class-C Telegraphy | 2000 | -200 | 500 | +60 | 150 | 6.0 | 11 | 1.4 | | | | | | | | | | | | | | | | | | | | | | | | | | | |
| HK-257 | Beam Power Pentode | 5.0 | 7.5 | 7-pin Giant Bayonet 25 | 3000 | 150 | 500 | 25 | 75 | 13.8 | 6.7 | 0.04 | Class-C Telephony | 1800 | -130 | 400 | +60 | 135 | 8.0 | 11 | 1.7 | | | | | | | | | | | | | | | | | | | | | | | | | | | | |
| | | | | | | | | | | | | | Class-C Telephony | 1800 | -130 | 400 | +60 | 135 | 8.0 | 11 | 1.7 | | | | | | | | | | | | | | | | | | | | | | | | | | | | |
| | | | | | | | | | | | | | Sup. Mod. Telephony | 2000 | -130 | 500 | -300 | 55 | 3.0 | 27 | 0.4 | | | | | | | | | | | | | | | | | | | | | | | | | | | | |
| HK-257B | Beam Power Pentode | 5 | 7.5 | 7-pin Giant Bayonet 25 | | | | | | | | | Identical to HK-257 except | 34" | shorter | in | height | | | | | | | | | | | | | | | | | | | | | | | | | | | | | | | | |
| 261-A 276-A | Triode | 10 | 3.25 | 4-pin Giant 12 | 1250 | 210 | 12.5 | 50 | 125 | 5.5 | 3.5 | 9 | Class-C Telegraphy | 1250 | -250 | | | 200 | 10 | | 3.5 | | | | | | | | | | | | | | | | | | | | | | | | | | | | |
| | | | | | | | | | | | | | Class-C Telephony | 1250 | -300 | | | 166 | 8 | | 3.5 | | | | | | | | | | | | | | | | | | | | | | | | | | | | |
| | | | | | | | | | | | | | Class-B Audio | 1250 | -99 | | | 400 | | | 4.5 | 6700 | 320 | | | | | | | | | | | | | | | | | | | | | | | | | | |
| WE-270A | Triode | 10 | 9.75 | Special 16 | 3000 | 375 | 16 | 75 | 350 | 18 | 2.0 | 21 | Class-C Telegraphy | 3000 | -375 | | | 350 | 70 | | 37 | | | | | | | | | | | | | | | | | | | | | | | | | | | | |
| | | | | | | | | | | | | | Class-C Telephony | 2250 | -300 | | | 300 | 70 | | 32 | | | | | | | | | | | | | | | | | | | | | | | | | | | | |
| | | | | | | | | | | | | | Class-B Audio | 2000 | -105 | | | 750 | | | 75 | 6000 | 850 | | | | | | | | | | | | | | | | | | | | | | | | | | |
| GL-276-A | Triode | 10 | 3 | 4-pin Giant 12 | 1250 | 125 | 12 | 50 | 100 | 6 | 4 | 9 | Class-C Telegraphy | 1250 | -225 | | | 125 | 20 | | 7 | | | | | | | | | | | | | | | | | | | | | | | | | | | | |
| | | | | | | | | | | | | | Class-C Telephony | 1000 | -260 | | | 125 | 35 | | 14 | | | | | | | | | | | | | | | | | | | | | | | | | | | | |
| | | | | | | | | | | | | | Class-B Audio | 1250 | -95 | | | 250 | | | 7.5 | 9000 | 175 | | | | | | | | | | | | | | | | | | | | | | | | | | |
| WE-282A | Tetrode | 10 | 3.0 | 4-pin Giant 9 | 1000 | 100 | 15D | 50 | 70 | 5.0 | 12.2 | 6.8 | 0.2 | Class-C R.F. Amp. | 1000 | -150 | 150 | | | | | | | | | | | | | | | | | | | | | | | | | | | | | | | | |
| WE-284-B | Triode | 10 | 3.25 | 4-pin Giant 29 | 1250 | 150 | 5 | 100 | 100 | 4.2 | 5.3 | 7.4 | Class-C Amp. Telegraphy | 1250 | -500 | | | 150 | | | | | | | | | | | | | | | | | | | | | | | | | | | | | | | |
| | | | | | | | | | | | | | Class-C Amp. Plate Mod. | 1000 | -430 | | | 150 | 50 | | | | | | | | | | | | | | | | | | | | | | | | | | | | | | |
| | | | | | | | | | | | | | Class-B Amp. Telephony | 1250 | -270 | | | 120 | | | | | | | | | | | | | | | | | | | | | | | | | | | | | | | |
| WE-284D | Triode | 10 | 3.25 | 4-pin Giant 12 | 1250 | 150 | 4.8 | 100 | 85 | 6 | 5.6 | 8.3 | Class-C Amp. Telegraphy | 1250 | -530 | | | 150 | | | | | | | | | | | | | | | | | | | | | | | | | | | | | | | |
| | | | | | | | | | | | | | Class-C Amp. Plate Mod. | 1000 | -450 | | | 150 | 50 | | | | | | | | | | | | | | | | | | | | | | | | | | | | | | |

| Mfr. No. | Type | Cathode | | Base ³ and Connections | Max. Plate Voltage | Max. Plate Current (ma.) | Triode Mu or Max. Screen Voltage | Max. D.C. Control Grid Current (ma.) | Max. Plate Dissipation (Watts) | Max. Screen Dissipation (Watts) | Interelectrode Capacitances $\mu\text{mfd.}$ | | | Typical ⁹ Operation | Plate Volts | Control Grid Bias | Screen Volts | Suppressor Volts | Plate ⁷ Current (ma.) | D.C. ⁵ Control Grid Current (ma.) | Screen Current (ma.) | Grid ⁴ Driving Power (Approx. Watts) | Load Imped. P to P (Ohms) | Power Output (Watts) typical | Mfr. ⁵ |
|---------------------|---------|------------|-------------|-----------------------------------|--------------------|--------------------------|----------------------------------|--------------------------------------|--------------------------------|---------------------------------|--|-----|------|------------------------------------|-------------|-------------------|--------------|------------------|----------------------------------|--|----------------------|---|---------------------------|------------------------------|-------------------|
| | | G-F In-put | P-F Out-put | | | | | | | | G-P Feed-back | | | | | | | | | | | | | | |
| WE-295-A | Triode | 10 | 3.25 | 4-pin Giant 12 | 1250 | 175 | 25 | 50 | 100 | | 6.5 | 5.5 | 14.5 | Class-C Amp. Telegraphy | 1250 | -125 | | | 150 | | | | | 125 | W.E. |
| | | | | | | | | | | | | | | Class-C Amp. Plane Mod. | 1000 | -125 | | | 150 | 50 | | | | 100 | |
| | | | | | | | | | | | | | | Class-B Amp. Telephony | 1250 | -75 | | | 105 | | | | | 42.5 | |
| HF-300 | Triode | 11 | 4.0 | 4-pin Giant 13 | 3000 | 275 | 23 | 60 | 200 | | 6.0 | 1.4 | 6.5 | Class-C Telegraphy | 2000 | -200 | | | 275 | 36 | | 13 | | 410 | Amp. |
| | | | | | | | | | | | | | | Class-C Telephony | 2000 | -300 | | | 250 | 36 | | | 17 | 385 | |
| | | | | | | | | | | | | | | Class-B Audio | 2000 | -72 | | | 430 | | | 14 | 9600 | 650 | |
| WE-300A | Triode | 5.0 | 1.2 | 4-pin M. 3 | 450 | 100 | 3.8 | | 40 | | 9.0 | 4.3 | 15 | Class-A Audio | 450 | -97 | | | 30 | | | | 14.6 | W.E. | |
| | | | | | | | | | | | | | | Class-A P.P. Audio | 450 | | | | 140 | | | | 25 | | |
| 300-T | Triode | 8 | 11.5 | 4-pin Giant 13 | 3500 | 350 | 16 | 75 | 300 | | 4 | 0.6 | 4 | Class-C Amplifier | 3500 | -600 | | | 300 | 60 | | | 800 | Elmac | |
| 303-A | Triode | 10 | 3.25 | 4-pin Giant 12 | | | | | | | | | | For other characteristics refer to | | | Type | 203-A | | | | | | | |
| 304-A | Triode | 11 | 3.85 | Special 16 | | | | | | | | | | For other characteristics refer to | | | Type | 204-A | | | | | | | |
| HK-304L | Triode | 5 or 10 | 26 or 13 | Special | | | | | | | | | | For other characteristics refer to | | | Type | 304-TL | | | | | | | H&K |
| WE-304B | Triode | 7.5 | 3.25 | 4-pin M. 5 | 1250 | 100 | 11 | 25 | 50 | | 2.0 | 0.7 | 2.5 | Class-C R.F. Amp. | 1250 | -225 | | | 100 | | | | | 85 | W.E. |
| | | | | | | | | | | | | | | Class-B Audio | 1250 | -110 | | | 100 | | 10 | 14000 | 140 | | |
| 304-TL | Triode | 5 or 10 | 26 or 13 | Special | 3000 | 1000 | | 150 | 300 | | 10 | 1.5 | 10 | Four parallel connected | 757's | in one envelope | | | | | | | | | Elmac |
| WE305A ¹ | Tetrode | 10 | 3.1 | 4-pin M. | 1000 | 125 | 200 | 40 | 60 | 6.0 | 10.5 | 5.4 | 0.14 | Class-C R.F. Amp. | 1000 | -270 | 200 | | 125 | | | | | 85 | W.E. |
| WE-306A | Pentode | 2.75 | 2.0 | 5-pin M. 59 | 300 | | 300 | | 15 | 6 | 13 | 13 | 0.35 | Class-C Amp. Telephony | 300 | -50 | 180 | | 36 | 3 | 15 | | | 7 | W.E. |
| WE-307A | Pentode | 5.5 | 1.0 | 5-pin M. 10 | 500 | 60 | 250 | 7.0 | 15 | 6.0 | 15 | 12 | 0.55 | Class-C Telegraphy | 500 | -35 | 250 | 0 | 60 | 1.4 | 13 | | | 20 | W.E. |
| | | | | | | | | | | | | | | Sup.-Mod. Telephony | 500 | -35 | 200 | -50 | 40 | 1.5 | 20 | | | 6.0 | |

| | | | | | | | | | | | | | | | | | | | | | | | | | |
|---------------------|---------|------|------|------------------|-------|-----|-----|----|-----|------|------|------|-------------------------------------|-------------------------|-------|--------------------|-------|-----|-----|-----|-------|----------------|--------|------|----|
| WE-308B | Triode | 14 | 4 | Special 4-pin 18 | 2250 | 325 | 8 | 75 | 250 | 13.6 | 9.3 | 17.4 | Class-C Amp. Telegraphy | 1750 | -400 | | | 300 | | | | 350 | W.E. | | |
| | | | | | | | | | | | | | Class-C Amp. Plate Mod. | 1250 | -320 | | | 300 | 75 | | | 250 | | | |
| | | | | | | | | | | | | | Class-B Amp. Telephony | 1750 | -230 | | | 215 | | | | 125 | | | |
| 310 | Triode | 7.5 | 1.25 | 4-pin M. 3 | 600 | 70 | 8 | 15 | 20 | 4 | 2.2 | 7 | Class-C Telegraphy | 600 | -150 | | | 65 | 15 | | 4 | 25 | United | | |
| | | | | | | | | | | | | | Class-C Telephony | 500 | -190 | | | 55 | 15 | | 4.5 | 18 | | | |
| | | | | | | | | | | | | | Class-B Audio | 600 | -75 | | | 130 | | | 10000 | 45 | | | |
| WE-312A | Pentode | 10 | 2.8 | 6-pin M. 60 | 1250 | | 500 | | 50 | 20 | 15.5 | 12.3 | 0.15 | Class-C Amp. Telegraphy | 1250 | -55 | 300 | 20 | 100 | 5.5 | 36 | 0.7 | 90 | W.E. | |
| | | | | | | | | | | | | | | Class-C Amp. Plate Mod. | 1000 | -40 | | | 40 | 95 | 7.0 | 35 | 1.0 | | 65 |
| | | | | | | | | | | | | | | Suppressor Mod. Amp. | 1250 | -50 | | | -85 | 50 | 5.0 | 42 | 0.55 | | 23 |
| WE316A ¹ | Triode | 2.0 | 3.65 | No base | 450 | 80 | | 12 | 30 | 1.2 | 0.8 | 1.6 | Class-C Telegraphy | 450 | | Ad-justed for Tube | | | | | | 7.5 at 500 Mc. | W.E. | | |
| 327-A | Triode | 10.5 | 10.6 | 57 | 15000 | | | 30 | 100 | 3.4 | 0.3 | 2.25 | Oscillator at 200 Mc. | | | | | | | | | 75 | | | |
| 327-B | Triode | 10.5 | 10.6 | 57 | 15000 | | | 30 | 75 | 3.4 | 0.3 | 2.45 | | | | | | | | | | | | | |
| 342-B | Triode | 10 | 3.25 | 4-pin Giant 12 | | | | | | | | | For other characteristics, refer to | | | Type | 242-B | | | | | | | | |
| HK-354 | Triode | 5.0 | 10 | 4-pin Giant 29 | 4000 | 300 | 14 | 50 | 150 | 9.0 | 0.4 | 4.0 | Class-C Telegraphy | 4000 | -690 | | | 245 | 50 | | 48 | 830 | H.&K. | | |
| | | | | | | | | | | | | | Class-C Telephony | 3000 | -550 | | | 210 | 50 | | 35 | 525 | | | |
| | | | | | | | | | | | | | Class-B Audio | 2500 | -165 | | | 350 | | | 20 | 15000 | | 577 | |
| HK354C ¹ | Triode | 5.0 | 10 | 4-pin Giant 13 | 4000 | 300 | 14 | 50 | 150 | 4.5 | 1.1 | 3.8 | Class-C Telegraphy | 4000 | -69C | | | 245 | 50 | | 48 | 830 | H.&K. | | |
| | | | | | | | | | | | | | Class-C Telephony | 3000 | -550 | | | 210 | 50 | | 35 | 525 | | | |
| | | | | | | | | | | | | | Class-B Audio | 2500 | -165 | | | 350 | | | 20 | 15000 | | 577 | |
| HK-354D | Triode | 5.0 | 10 | 4-pin Giant 13 | 3500 | 300 | 22 | 55 | 150 | 4.5 | 1.1 | 3.8 | Class-C R.F. Amp. | 3500 | -490 | | | 240 | 50 | | 38 | 690 | H.&K. | | |
| | | | | | | | | | | | | | Class-B Audio | 2500 | -112 | | | 290 | | | 20 | 20000 | | 519 | |
| HK-354E | Triode | 5.0 | 10 | 4-pin Giant 13 | 3500 | 300 | 35 | 60 | 150 | 4.5 | 1.1 | 3.8 | Class-C R.F. Amp. | 3500 | -448 | | | 240 | 60 | | 45 | 690 | H.&K. | | |
| | | | | | | | | | | | | | Class-B Audio | 2000 | -37.5 | | | 372 | | | 20 | 11000 | | 472 | |
| HK-354F | Triode | 5.0 | 10 | 4-pin Giant 13 | 3500 | 390 | 50 | 75 | 150 | 4.5 | 1.1 | 3.8 | Class-C R.F. Amp. | 3500 | -36B | | | 250 | 75 | | 50 | 720 | H.&K. | | |
| | | | | | | | | | | | | | Class-B Audio | 2500 | -35 | | | 300 | | | 20 | 20000 | | 550 | |
| 356-A ¹ | Triode | 5.0 | 5.0 | 4-pin Giant 29 | 1500 | 120 | 50 | 35 | 50 | 2.25 | 1.0 | 2.75 | Class-C Telegraphy | 1500 | -60 | | | 100 | 35 | | 9.5 | 140 | W.E. | | |

| Mfr. No. | Type | Cathode | | Base ³ and Connections | Max. Plate Voltage | Max. Plate Current (ma.) | Triode Mu or Max. Screen Voltage | Max. D.C. Control Grid Current (ma.) | Max. Plate Dissipation (Watts) | Max. Screen Dissipation (Watts) | Interelectrode Capacitances μ fds. | | | Typical ¹ Operation | Plate Volts | Control Grid Bias | Screen Volts | Suppressor Volts | Plate ⁷ Current (ma.) | D.C. ⁸ Control Grid Current (ma.) | Screen Current (ma.) | Grid ⁴ Driving Power (Approx. Watts) | Load Imped. P to P (Ohms) | Power Output (Watts) typical | Mfr. ⁵ |
|---------------------|--------------------------|------------|-------------|-----------------------------------|--------------------|--------------------------|----------------------------------|--------------------------------------|--------------------------------|---------------------------------|--|------|------|-------------------------------------|-------------------------|-------------------|--------------------------------|------------------|----------------------------------|--|----------------------|---|---------------------------|------------------------------|-------------------|
| | | G-F In-put | P-F Out-put | | | | | | | | G-P Feed-back | | | | | | | | | | | | | | |
| WE-361A | Triode | 10 | 3.25 | 4-pin Giant 12 | | | | | | | | | | For other characteristics, refer to | | Type | 261-A | | | | | | | | W.E. |
| WE-376A | Triode | 10 | 3 | 4-pin Giant 12 | | | | | | | | | | For other characteristics, refer to | | Type | GL-27 | 6A | | | | | | | W.E. |
| GL-448A GL-446B | U.H.F. Triode | 6.3 | 0.75 | 6-pin O. 61 | 400 | 20 | 45 | | 3.75 | | | 2.2 | 0.02 | 1.6 | Class-C Amp. Oscillator | 250 | Grid Leak Resistor 20,000 ohms | | 25 | | | | | | G.E. |
| 450-TH | Triode | 7.5 | 12 | 4-pin Giant 13 | 6000 | 500 | 32 | 125 | 450 | | 4.0 | 0.6 | 4.0 | Class-C Telephony | 4000 | -400 | | | 500 | 70 | | 100 | | 1550 | Eimac |
| | | | | | | | | | | | | | | Class-C Telephony | 4000 | -400 | | | 400 | 70 | | 100 | | 1250 | |
| 450-TL | Triode | 7.5 | 12 | 4-pin Giant 13 | 6000 | 500 | 16 | 75 | 450 | | 4.0 | 0.6 | 4.0 | Class-C Telephony | 4000 | -700 | | | 500 | 70 | | 100 | | 1550 | Eimac |
| | | | | | | | | | | | | | | Class-C Telephony | 4000 | -700 | | | 400 | 70 | | 100 | | 1250 | |
| HK-454H | Triode | 5 | 11 | 4-pin Giant 13 | 5000 | 375 | 30 | 85 | 250 | | 4.6 | 1.4 | 3.4 | Class-C Amp. | 3500 | -275 | | | 270 | 60 | | 28 | | 760 | H.&K. |
| HK-454L | Triode | 5 | 11 | 4-pin Giant 13 | 5000 | 375 | 12 | 60 | 250 | | 4.6 | 1.4 | 3.4 | Class-C Amp. | 3500 | -450 | | | 270 | 45 | | 30 | | 760 | H.&K. |
| GL-464 GL-464A | U.H.F. Triode | 6.3 | 0.75 | 5-pin O. 49 | | | | | | | | | | For other characteristics, refer to | | Type | 2C43 | | | | | | | | G.E. |
| WL-473 | Forced Air Cooled Triode | 6 | 60 | Special | 3000 | 1400 | 22 | | 2500 | | 77 | 0.6 | 15 | Class-C Amp. Telephony | 3000 | -600 | | | 1400 | 330 | | 330 | | 3250 | West-ing-house |
| | | | | | | | | | | | | | | Class-C Amp. Plate Mod. | 2500 | -500 | | | 1400 | 380 | | 340 | | 2700 | |
| | | | | | | | | | | | | | | Class-B Amp. Telephony | 3000 | -160 | | | 1100 | 50 | | 15 | | 800 | |
| 527 | Triode | 5.5 | 13.5 | 55 | 20000 | | 38 | | 300 | | 19 | 1.4 | 12 | Oscillator at 200 Mc. | | | | | | | | | | 250 | |
| HY-615 ¹ | Triode | 6.3H | 0.15 | Octal 32 | 300 | 20 | 22 | 4 | 3.5 | | 1.4 | 1.45 | 1.85 | Class-C Telephony | 300 | -35 | | | 20 | 1.4 | | 0.2 | | 4.5 ¹⁹ | Hy-tron |
| | | | | | | | | | | | | | | Class-C Telephony | 300 | -35 | | | 20 | 2.0 | | 0.4 | | 4.5 ¹⁹ | |
| HK-654 | Triode | 7.5 | 15 | 4-pin Giant 13 | 4000 | 600 | 25 | 100 | 300 | | 6.2 | 1.5 | 5.5 | Class-C Telephony | 2500 | -406 | | | 500 | 75 | | 59 | | 950 | H.&K. |
| | | | | | | | | | | | | | | Class-C Telephony | 3000 | -390 | | | 400 | 95 | | 60 | | 945 | |
| | | | | | | | | | | | | | | Class-B Audio | 1500 | -45 | | | 643 | | | 50 | | 675 | |

| 705A RK-705A WE-705A | Half Wave Rectifier | 2.5 5.0 | 10 5.0 | Special 4-pin 62 | Parallel connection of Fil. | | | | | | | Series connection of Fil. | | | | | | | Ray. W.E. | | | | | |
|----------------------------|---------------------------|------------|-----------|------------------------|---|-----|-----|-----|------|------|------|--|------------------------------|------|-------|-----|------|-----|--------------|-----|-------|-------|----------------------|-----------------------|
| | | | | | Max. D.C. output current 50 Ma. Max. inverse Peak voltage 35000. Max. peak plate current 375 Ma. | | | | | | | Max. D.C. output current 100 Ma. Max. inverse Peak voltage 35000. Max. peak plate current 750 Ma. | | | | | | | | | | | | |
| 800 | Triode | 7.5 | 3.25 | 4-pin M. 5 | 1250 | 80 | 15 | 35 | 2.75 | 2.75 | 2.5 | Class-C Telephony | 1250 | -175 | | | 70 | 15 | | 4.0 | | 65 | RCA G.E. West. | |
| | | | | | | | | | | | | Class-C Telephony | 1000 | -200 | | | 70 | 15 | | 4.0 | | 50 | | |
| | | | | | | | | | | | | Class-B Audio | 1250 | -70 | | | 130 | | | 3.4 | | 106 | | |
| 801 801-A | Triode | 7.5 | 1.25 | 4-pin M. 3 | 600 | 70 | 8 | 15 | 4.5 | 1.5 | 6.0 | Class-C Telephony | 600 | -150 | | | 65 | 15 | | 4.0 | | 25 | RCA G.E. | |
| | | | | | | | | | | | | Class-C Telephony | 500 | -190 | | | 55 | 15 | | 4.5 | | 18 | | |
| | | | | | | | | | | | | Class-B Audio | 600 | -75 | | | 130 | | | 3.0 | | 45 | | |
| HY 801-A 801 | Triode | 7.5 | 1.25 | 4-pin M. 3 | 600 | 70 | 8 | 15 | 4.5 | 1.5 | 6.0 | Class-C Telephony | 600 | -200 | | | 70 | 15 | | 4 | | 30 | Hy- tron | |
| | | | | | | | | | | | | Class-C Telephony | 500 | -200 | | | 60 | 15 | | 4.5 | | 22 | | |
| | | | | | | | | | | | | Class-B Audio | 600 | -75 | | | 130 | 8 | | 3 | 10000 | 22.5 | | |
| WL-802 | Pentode | 6.3H | 0.9 | 7-pin M. 7 | | | | | | | | For other characteristics, refer to | Type | 802 | | | | | | | | West. | | |
| 802 ^a | Pentode | 6.3H | 0.9 | 7-pin M. 7 | 600 | 60 | 250 | 7.5 | 13 | 12 | 8.5 | 0.15 | Class-C Amp. Telephony | 600 | -120 | 250 | +40 | 55 | 2.4 | 16 | 0.3 | | 23 | RCA G.E. Kenrad |
| | | | | | | | | | | | | | Class-C Amp. Plate Mod. | 500 | -40 | 245 | +40 | 40 | 1.5 | 15 | 0.1 | | 12 | |
| | | | | | | | | | | | | | Class-C Amp. Suppressor Mod. | 600 | -100 | 250 | -45 | 30 | 5 | 24 | 0.6 | | 6.3 | |
| WL-803 | Pentode | 10 | 5 | 5-pin Giant 11 | | | | | | | | For other characteristics, refer to | Type | 803 | | | | | | | | West. | | |
| 803 | Pentode | 10 | 5.0 | 5-pin Giant 11 | 2000 | 175 | 600 | 50 | 125 | 17.5 | 29 | 0.15 | Class-C Telephony | 2000 | -90 | 500 | +40 | 160 | 12 | 45 | 2.0 | | 210 | RCA G.E. |
| | | | | | | | | | | | | | Class-C Telephony | 1600 | -80 | 500 | +100 | 150 | 20 | 55 | 4.0 | | 155 | |
| | | | | | | | | | | | | | Sup.-Mod. Telephony | 1500 | -100 | 310 | -90 | 100 | 20 | 70 | 3.5 | | 50 | |
| 804 ^a | Pentode | 7.5 | 3.0 | 5-pin M. 11 | 1500 | 100 | 300 | 15 | 50 | 16 | 14.5 | 0.01 | Class-C Amp. Telephony | 1500 | -100 | 300 | 45 | 100 | 7 | 35 | 1.95 | | 110 | G.E. RCA Ken. |
| | | | | | | | | | | | | | Class-C Amp. Plate Mod. | 1250 | -90 | 250 | 50 | 75 | 6 | 20 | 0.75 | | 65 | |
| | | | | | | | | | | | | | Class-C Amp. Suppressor Mod. | 1500 | -115 | 300 | -50 | 50 | 7 | 32 | 0.95 | | 28 | |
| T-805 | Triode | 10 | 3.2 | 4-pin Giant 29 | 1750 | 210 | 45 | 70 | 125 | 8.4 | 1.3 | 7.7 | Class-C Telephony | 1750 | -90 | | | 200 | 44 | | 9.2 | | 270 | Taylor |
| | | | | | | | | | | | | | Class-C Telephony | 1500 | -140 | | | 175 | 40 | | 10.5 | | 208 | |
| | | | | | | | | | | | | | Class-B Audio | 1750 | -22.5 | | | 420 | | | 10 | 9350 | 320 | |
| WL-805 | Triode | 10 | 3.25 | 4-pin Giant 29 | | | | | | | | For other characteristics, refer to | Type | 805 | | | | | | | | West. | | |

| Mfr. No. | Type | Cathode | | Base ² and Connections | Max. Plate Voltage | Max. Plate Current (ma.) | Triode Mu or Max. Screen Voltage | Max. D.C. Control Grid Current (ma.) | Max. Plate Dissipation (Watts) | Max. Screen Dissipation (Watts) | Interelectrode Capacitances $\mu\text{fds.}$ | | | Typical ¹ Operation | Plate Volts | Control Grid Bias | Screen Volts | Suppressor Volts | Plate ⁷ Current (ma.) | D.C. ⁵ Control Grid Current (ma.) | Screen Current (ma.) | Grid ⁴ Driving Power (Approx. Watts) | Load Imped. P to P (Ohms) | Power Output (Watts) typical | Mfr. ³ |
|------------------|--------------------|--------------------|-------|-----------------------------------|--------------------|--------------------------|----------------------------------|--------------------------------------|--------------------------------|---------------------------------|--|------------|--------------|--|-------------|-------------------|--------------|------------------|----------------------------------|--|----------------------|---|---------------------------|------------------------------|-------------------|
| | | Volts ² | Amps. | | | | | | | | G-F Input | P-F Output | G-P Feedback | | | | | | | | | | | | |
| 805 | Triode | 10 | 3.25 | 4-pin Giant 29 | 1500 | 210 | 45 | 60 | 125 | | 8.5 | 10.5 | 6.5 | Class-G Telegraphy | 1500 | -105 | | | 200 | 40 | | 8.5 | | 215 | RCA G.E. |
| | | | | | | | | | | | | | | Class-K Telephony | 1250 | -160 | | | 160 | 60 | | 16 | | 140 | |
| | | | | | | | | | | | | | | Class-B Audio | 1500 | -16 | | | 400 | | | 7.0 | 8200 | 370 | |
| WL-806 | Triode | 5 | 10 | 4-pin Giant 29 | | | | | | | | | | For other characteristics, refer to Type 806 | | | | | | | | | | West. | |
| 806 ^a | Triode | 5 | 10 | 4-pin Giant 29 | 3300 | 300 | 12.6 | 50 | 225 | | 5.5 | 0.4 | 4.0 | Class-C Amp. Telegraphy | 3300 | -600 | | | 300 | 40 | | 34 | | 780 | RCA G.E. Ken. |
| | | | | | | | | | | | | | | Class-C Amp. Plate Mod. | 3000 | -670 | | | 195 | 27 | | 24 | | 460 | |
| | | | | | | | | | | | | | | Class-B Audio | 3300 | -240 | | | 475 | | | 35 | 16000 | 1120 | |
| WL-807 | Beam Power Tetrode | 6.3H | 0.9 | 5-pin M. 30 | | | | | | | | | | For other characteristics, refer to Type 807 | | | | | | | | | | West. | |
| 807 ^a | Beam Power Tetrode | 6.3H | 0.9 | 5-pin M. 30 | 750 | 100 | 300 | 5 | 30 | 3.5 | 11 | 7 | 0.2 | Class-C Amp. Telegraphy | 750 | -45 | 250 | | 100 | 3.5 | 6 | 0.2 | | 50 | RCA G.E. Ken. |
| | | | | | | | | | | | | | | Class-C Amp. Plate Mod. | 600 | -90 | 275 | | 100 | 4 | 6.5 | 0.4 | | 42.5 | |
| | | | | | | | | | | | | | | Class-AB ₂ Audio | 750 | -32 | 300 | | 240 | | 10 | 0.2 | 6950 | 120 | |
| 808 | Triode | 7.5 | 4.0 | 4-pin M. 5 | 1500 | 150 | 47 | 35 | 50 | | 5.3 | 0.15 | 2.8 | Class-C Telegraphy | 1500 | -200 | | | 125 | 30 | | 9.5 | | 140 | RCA |
| | | | | | | | | | | | | | | Class-C Telephony | 1250 | -225 | | | 100 | 32 | | 10.5 | | 105 | |
| | | | | | | | | | | | | | | Class-B Audio | 1500 | -25 | | | 190 | | | 4.8 | 18300 | 185 | |
| WL-809 | Triode | 6.3 | 2.5 | 4-pin M. 6 | | | | | | | | | | For other characteristics, refer to Type 809 | | | | | | | | | West. | | |
| 809 ^a | Triode | 6.3 | 2.5 | 4-pin M. 6 | 1000 | 100 | 50 | 35 | 30 | | 5.7 | 0.9 | 6.7 | Class-C Amp. Telegraphy | 1000 | -75 | | | 100 | 25 | | 3.8 | | 75 | RCA G.E. Ken. |
| | | | | | | | | | | | | | | Class-C Amp. Plate Mod. | 750 | -60 | | | 100 | 32 | | 4.3 | | 55 | |
| | | | | | | | | | | | | | | Class-B Audio | 1000 | -10 | | | 200 | | | 3.4 | 11600 | 145 | |
| WL-810 | Triode | 10 | 4.5 | 4-pin Giant 29 | | | | | | | | | | For other characteristics, refer to Type 810 | | | | | | | | | West. | | |

| | | | | | | | | | | | | | | | | | | | | | | | | | |
|---------------------|-----------------------------------|-------------|--------------|----------------|-------------------|----------|-----|----|-----|--|------|------|------|--|------|-------|-----|--|-------------|-----|----|------|-------|-------|---------------|
| 810 ^a | Triode | 10 | 4.5 | 4-pin Giant 29 | 2250 | 275 | 36 | 70 | 150 | | 8.7 | 12 | 4.8 | Class-C Telephony | 2250 | — 160 | | | 275 | 40 | | 12 | | 475 | RCA G.E. |
| | | | | | | | | | | | | | | Class-C Telephony | 1800 | — 200 | | | 250 | 50 | | 17 | | 335 | |
| | | | | | | | | | | | | | | Class-B Audio | 2250 | — 60 | | | 450 | | | 13 | 11600 | 725 | |
| WL-811 | Triode | 6.3 | 4.0 | 4-pin M. 6 | | | | | | | | | | For other characteristics, refer to Type 811 | | | | | | | | | | West. | |
| 811 ^a | Triode | 6.3 | 4.0 | 4-pin M. 6 | 1500 | 150 | 160 | 50 | 55 | | 5.5 | 0.6 | 5.5 | Class-C Telephony | 1500 | — 113 | | | 150 | 35 | | 8.0 | | 170 | RCA G.E. |
| | | | | | | | | | | | | | | Class-C Telephony | 1250 | — 125 | | | 125 | 50 | | 11 | | 120 | |
| | | | | | | | | | | | | | | Class-B Audio | 1500 | — 9.0 | | | 200 | | | 4.2 | 18000 | 225 | |
| WL-812 | Triode | 6.3 | 4.0 | 4-pin M. 6 | | | | | | | | | | For other characteristics, refer to Type 812 | | | | | | | | | | West. | |
| 812 ^a | Triode | 6.3 | 4.0 | 4-pin M. 6 | 1500 | 150 | 29 | 35 | 55 | | 5.3 | 0.8 | 5.3 | Class-C Telephony | 1500 | — 175 | | | 150 | 25 | | 6.5 | | 170 | RCA G.E. |
| | | | | | | | | | | | | | | Class-C Telephony | 1250 | — 125 | | | 125 | 25 | | 6.0 | | 120 | |
| | | | | | | | | | | | | | | Class-B Audio | 1500 | — 46 | | | 200 | | | 4.7 | | 225 | |
| WL-813 | Beam Power Tetrode | 10 | 5 | 7-pin L. 28 | | | | | | | | | | For other characteristics, refer to Type 813 | | | | | | | | | | West. | |
| 813 | Beam Power Tetrode | 10 | 5.0 | 7-pin L. 28 | 2000 | 180 | 40G | 25 | 100 | | 16.3 | 14 | 0.2 | Class-C Telephony | 2000 | — 9C | 400 | | 180 | 3.0 | 15 | 0.5 | | 260 | RCA G.E. |
| | | | | | | | | | | | | | | Class-C Telephony | 1600 | — 130 | 400 | | 150 | 6.0 | 20 | 1.2 | | 175 | |
| | | | | | | | | | | | | | | Class-C Telephony | 2500 | — 190 | | | 300 | 51 | | 17 | | 600 | |
| T-814 | Triode | 10 | 4.0 | 4-pin Giant 29 | 3000 | 300 | 1½ | 60 | 200 | | 8.5 | 2.1 | 13.5 | Class-C Telephony | 2000 | — 7½ | | | 250 | 43 | | 13.7 | | 405 | Taylor |
| | | | | | | | | | | | | | | Class-B Audio | 1500 | — 35 | | | 500 | | | 7.0 | 6800 | 525 | |
| | | | | | | | | | | | | | | For other characteristics, refer to Type 814 | | | | | | | | | | | |
| WL-814 | Beam Power Tetrode | 10 | 3.25 | 5-pin M. 10 | | | | | | | | | | For other characteristics, refer to Type 814 | | | | | | | | | | West. | |
| 814 ^a | Beam Power Tetrode | 10 | 3.25 | 5-pin M. 10 | 1500 | 150 | 300 | 15 | 65 | | 13.5 | 13.5 | 0.1 | Class-C Telephony | 1500 | — 90 | 300 | | 150 | 10 | 24 | 1.5 | | 160 | RCA G.E. |
| | | | | | | | | | | | | | | Class-C Telephony | 1250 | — 150 | 300 | | 144 | 10 | 20 | 3.2 | | 130 | |
| | | | | | | | | | | | | | | For other characteristics, refer to Type 815 | | | | | | | | | | | |
| WL-815 | P.P. Beam Power Tetrode | 6.3 or 12.6 | 0.8 per Unit | Octal 27 | | | | | | | | | | For other characteristics, refer to Type 815 | | | | | | | | | | West. | |
| 815 ^{b, c} | P.P. Beam Power Tetrode | 6.3 or 12.6 | 0.8 per Unit | Octal 27 | 500 | 150 | 200 | 10 | 25 | | 14 | 8.5 | 0.2 | Class-C Amp. Telephony | 500 | — 45 | 200 | | 150 | 3.5 | 17 | 0.18 | | 56 | RCA G.E. Ken. |
| | | | | | | | | | | | | | | Class-C Amp. Plate Mod. | 400 | — 45 | 175 | | 150 | 3 | 15 | 0.16 | | 45 | |
| 816 | Half-Wave Mercury-Vapor Rectifier | 2.5 | 2 | 4-pin M. 1 | 5000 Inverse Peak | 500 Peak | | | | | 3.2 | | | Half-Wave Rectifier | | | | | 125 Average | | | | | RCA | |

| Mfr. No. | Type | Cathode | | Base ³ and Connections | Max. Plate Voltage | Max. Plate Current (ma.) | Triode Mu or Max. Screen Voltage | Max. D.C. Control Grid Current (ma.) | Max. Plate Dissipation (Watts) | Max. Screen Dissipation (Watts) | Inter-electrode Capacitances $\mu\mu\text{fds.}$ | | | Typical ⁹ Operation | Plate Volts | Control Grid Bias | Screen Volts | Suppressor Volts | Plate ⁷ Current (ma.) | D.C. ⁸ Control Grid Current (ma.) | Screen Current (ma.) | Grid ⁴ Driving Power (Approx. Watts) | Load Imped. P to P Ohms | Power Output (Watts) typical | Mfr. ⁵ | | | | | | | | | | |
|--------------------|---------------------------------------|--------------------|----------------|-----------------------------------|--------------------|--------------------------|----------------------------------|--------------------------------------|--------------------------------|---------------------------------|--|------------|--------------|--------------------------------|-------------|-------------------|--------------|------------------|----------------------------------|--|----------------------|---|-------------------------|------------------------------|-------------------|-----------------------------|-------|------|-----|-----|-----|-----|------|-------|-----|
| | | Volts ³ | Amps. | | | | | | | | G-F Input | P-F Output | G-P Feedback | | | | | | | | | | | | | | | | | | | | | | |
| T-822 | Triode | 10 | 4.0 | 4-pin Giant 29 | 3000 | 300 | 30 | 60 | 200 | | | 8.5 | 2.1 | 13.5 | | | | | 300 | 51 | | 17 | | 600 | Taylor | | | | | | | | | | |
| | | | | | | | | | | | | | | | | | | | | | | | | | | Class-C Telephony | 2000 | - 75 | | 250 | 43 | | 13.7 | | 405 |
| | | | | | | | | | | | | | | | | | | | | | | | | | | Class-B Audio | 1500 | - 35 | | 500 | | | 7.0 | 6800 | 525 |
| 825 ¹ | Inductive-Output Amplifier | 6.3 | 0.75 | Special Octal 33 | 2000 (Collector) | 50 (Collector) | | 2.5 | 50 (Collector) | | | | | | | | | | | | | | | | | | RCA | | | | | | | | |
| 826 ¹ | Triode | 7.5 | 4 | Special 34 | 1000 | 125 | 31 | 35 | 60 | | | 3.7 | 1.4 | 2.9 | | | | | 125 | 35 | | 5.8 | | 86 | RCA | | | | | | | | | | |
| | | | | | | | | | | | | | | | | | | | | | | | | | | Class-C Telephony | 800 | - 98 | | 94 | 35 | | 6.2 | 53 | |
| 827-R ¹ | Beam Tetrode | 7.5 | 25 | Special 35 | 3500 | 500 | 1000 | 150 | 800 | | | 21 | 13 | 0.18 | | | | | 428 | 110 | 185 | 50 | | 1050 | RCA | | | | | | | | | | |
| | | | | | | | | | | | | | | | | | | | | | | | | | | Class-C Telephony | 3000 | -325 | 750 | 400 | 125 | 125 | 68 | 825 | |
| WL-828 | Beam Power Pentode | 10 | 3.25 | 5-pin M 10 | | | | | | | | | | | | | | | | | | | | | | | West. | | | | | | | | |
| 828 ⁶ | Beam Power Pentode | 10 | 3.25 | 5-pin M. 10 | 2000 | 180 | 750 | 15 | 80 | | | 13.5 | 14.5 | 0.05 | | | | | 180 | 12 | 28 | 2.2 | | 200 | RCA Ken. | | | | | | | | | | |
| | | | | | | | | | | | | | | | | | | | | | | | | | | Class-C Amp. Telephony | 1500 | -100 | 400 | +75 | 160 | 12 | 28 | 2.7 | 150 |
| | | | | | | | | | | | | | | | | | | | | | | | | | | Class-AB ₁ Audio | 2000 | -120 | 750 | +60 | 270 | 60 | 0 | 18500 | 385 |
| 829 ¹ | P.P. Beam Power Tetrode ¹² | 6.3 or 12.6 | 1.125 per Unit | Special 24 ¹⁵ | 500 | 240 | 225 | 15 | 40 | | | 15.2 | 6.5 | 0.1 | | | | | 240 | 12 | 32 | 0.7 | | 83 | RCA G.E. | | | | | | | | | | |
| | | | | | | | | | | | | | | | | | | | | | | | | | | Class-C Telephony | 425 | - 60 | 200 | 212 | 11 | 35 | 0.8 | 63 | |
| 829-A | P.P. Beam Power Tetrode | 6.3 | 2.25 | Special 24 ¹⁵ | | | | | | | | | | | | | | | | | | | | | | | | | | | | | | | |
| 829-B | P.P. Beam Power Tetrode ¹² | 6.2 | 2.25 | Special 24 ¹⁵ | 750 | 240 | 225 | 15 | 40 | 6 | | 14.5 | 7 | 0.1 | | | | | 160 | 12 | 30 | 0.8 | | 87 | RCA Ken. | | | | | | | | | | |
| | | | | | | | | | | | | | | | | | | | | | | | | | | Class-C Amp. Plate Mod. | 600 | - 70 | 200 | 150 | 12 | 30 | 0.9 | 70 | |
| | | | | | | | | | | | | | | | | | | | | | | | | | | Class-C Amp. Grid Mod. | 750 | - 55 | 200 | 80 | 0 | 5 | 0.7 | 24 | |
| 830-B | Triode | 10 | 2.0 | 4-pin M. 6 | 1000 | 150 | 25 | 30 | 60 | | | 5.0 | 1.8 | 11 | | | | | 140 | 30 | | 7.0 | | 90 | RCA | | | | | | | | | | |
| | | | | | | | | | | | | | | | | | | | | | | | | | | Class-C Telephony | 800 | -150 | | 95 | 20 | | 5.0 | 50 | |
| | | | | | | | | | | | | | | | | | | | | | | | | | | Class-B Audio | 1000 | - 35 | | 280 | | | 6.0 | 7600 | 175 |

| | | | | | | | | | | | | | | | | | | | | | | | | | |
|--------------------|--|-------------|--------------|---------------------------|-------------------|-----------|------|-----|-----|-----|------|-----|------|---|------|------|-----|-----|-------------|------|----|------|-------|-------|-----------------|
| 831 ¹ | Triode | 11 | 10 | Special Baseless | 3500 | 350 | 14.5 | 75 | 400 | | 3.8 | 1.4 | 4 | Class-C Telephony | 3500 | -400 | | | 275 | 40 | | 30 | | 590 | RCA |
| | | | | | | | | | | | | | | Class-C Telephony | 3000 | -500 | | | 200 | 60 | | 50 | | 360 | |
| 832 ¹ | P.P. Beam Power Tetrode ^{1,2} | 6.3 or 12.6 | 0.8 per Unit | Special 24 ^{1,2} | 400 | 90 | | 6.0 | 15 | | 7.5 | 3.8 | 0.05 | Class-C Telephony | 400 | -60 | 250 | | 90 | 3.0 | 18 | 0.18 | | 22 | RCA |
| | | | | | | | | | | | | | | Class-C Telephony | 325 | -50 | 210 | | 68 | 1.2 | 15 | 0.06 | | 12 | |
| | | | | | 750 | 55 | 250 | | 15 | 3.4 | | | | Class-C Amp. Grid Mod. | 750 | -60 | 210 | | 29 | 0 | 2 | 0.1 | | 8.5 | |
| 832-A ¹ | P.P. Beam Power Tetrode ^{1,2} | 6.3 or 12.6 | 1.6 or 0.8 | Special 24 ^{1,2} | 600 | 68 | 250 | 6 | 10 | 3.4 | 7.5 | 3.8 | .05 | Class-C Amp. Plate Mod. | 600 | -65 | 200 | | 36 | 2.6 | 16 | 0.16 | | 17 | RCA Ken. |
| | | | | | 750 | 90 | 250 | 6 | 15 | 5 | | | | Class-C Amp. Telephony | 750 | -65 | 200 | | 48 | 2.8 | 15 | 0.19 | | 26 | |
| WL-833A | Triode | 10 | 10 | Special 36 | | | | | | | | | | For other characteristics, refer to Type 833A | | | | | | | | | | West. | |
| | | | | | | | | | | | | | | Class-C Telephony | 4000 | -225 | | | 500 | 95 | | 35 | | 1600 | |
| 833-A ⁴ | Triode | 10 | 10 | Special 36 | 4000 | 500 | 35 | 100 | 450 | | 12.3 | 8.5 | 6.3 | Class-C Telephony | 4000 | -325 | | | 450 | 90 | | 42 | | 1500 | RCA G.E. |
| | | | | | | | | | | | | | | Class-B Audio | 4000 | -100 | | | 900 | | | 38 | 11000 | 2700 | |
| | | | | | | | | | | | | | | Class-C Telephony | 1250 | -225 | | | 90 | 15 | | 4.5 | | 75 | RCA G.E. |
| 834 ¹ | Triode | 7.5 | 3.25 | 4-pin M. 5 | 1250 | 100 | 10.5 | 20 | 50 | | 2.2 | 0.6 | 2.6 | Class-C Telephony | 1000 | -310 | | | 90 | 17.5 | | 6.5 | | 58 | RCA G.E. |
| | | | | | | | | | | | | | | Class-C Telephony | 1250 | -225 | | | 150 | 18 | | 7 | | 130 | |
| | | | | | | | | | | | | | | Class-C Telephony | 1000 | -260 | | | 150 | 35 | | 14 | | 100 | G.E. |
| GL-835 | Triode | 10 | 3.25 | Giant 4-pin 12 | 1250 | 175 | 12 | 50 | 100 | | 6 | 5 | 9.25 | Class-B Audio | 1250 | -95 | | | 320 | | | 8 | 9000 | 260 | |
| 836 | Half-Wave HI-Vacuum Rectifier | 2.5H | 5.0 | 4-pin M. 1 | 5000 Inverse Peak | 1000 Peak | | | | | | | | Half-Wave Rectifier | | | | | 250 average | | | | | | RCA G.E. |
| WL-837 | Pentode | 12.6H | 0.7 | 7-pin M. 7 | | | | | | | | | | For other characteristics, refer to Type 837 | | | | | | | | | | | West. |
| | | | | | | | | | | | | | | Class-C Amp. Telephony | 500 | -75 | 200 | +40 | 60 | 4.0 | 15 | 0.4 | | 22 | Ken. G.E. RCA |
| 837 | Pentode | 12.6H | 0.7 | 7-pin M. 7 | 500 | 50 | 200 | 8 | 12 | | 16 | 10 | 0.2 | Class-C Amp. Plate Mod. | 400 | -40 | 140 | +40 | 45 | 5.0 | 20 | 0.3 | | 11 | |
| | | | | | | | | | | | | | | For other characteristics, refer to Type 838 | | | | | | | | | | | West. |
| | | | | | | | | | | | | | | Class-C Telephony | 1250 | -90 | | | 150 | 30 | | 6.0 | | 130 | |
| 838 | Triode | 10 | 3.25 | 4-pin Giant 12 | 1250 | 175 | High | 70 | 100 | | 6.5 | 5.0 | 8.0 | Class-C Telephony | 1000 | -135 | | | 150 | 60 | | 16 | | 100 | RCA Taylor G.E. |
| | | | | | | | | | | | | | | Class-B Audio | 1250 | 0 | | | 320 | | | 7.5 | 9000 | 260 | |
| | | | | | | | | | | | | | | Class-C Telephony | 450 | -34 | | | 50 | 15 | | 1.8 | | 15 | |
| 841 | Triode | 7.5 | 1.25 | 4-pin M. 3 | 450 | 60 | 30 | 20 | | | 4.0 | 3.0 | 7.0 | Class-C Telephony | 350 | -47 | | | 50 | 15 | | 2.0 | | 11 | RCA Ray. |
| | | | | | | | | | | | | | | Class-B Audio | 425 | -5.0 | | | 114 | | | 3.6 | 7000 | 28 | |

| Mfr. No. | Type | Cathode | | Base ³ and Connections | Max. Plate Voltage | Max. Plate Current (ma.) | Triode Mu or Max. Screen Voltage | Max. D.C. Control Grid Current (ma.) | Max. Plate Dissipation (Watts) | Max. Screen Dissipation (Watts) | Interelectrode Capacitances $\mu\text{fd.}$ | | | Typical ¹ Operation | Plate Volts | Control Grid Bias | Screen Volts | Suppressor Volts | Plate ² Current (ma.) | D.C. ³ Control Grid Current (ma.) | Screen Current (ma.) | Grid ⁴ Driving Power (Approx. Watts) | Load Imped. P to P (Ohms) | Power Output (Watts) typical | Mfr. ⁵ | |
|------------------|------------------------------|------------|-------------|-----------------------------------|--------------------|--------------------------|----------------------------------|--------------------------------------|--------------------------------|---------------------------------|---|-----|------|---|-------------|-------------------|--------------|------------------|----------------------------------|--|----------------------|---|---------------------------|------------------------------|-------------------|-------|
| | | G-F In-put | P-F Out-put | | | | | | | | G-P Feed-back | | | | | | | | | | | | | | | |
| 841-A | Triode | 10 | 2 | 4-pin M. 6 | 1250 | 150 | 14.6 | 30 | 50 | | 3.5 | 2.5 | 9.0 | Class-C Amp. | | | | | | | | | | 85 | | |
| 841-SW | Triode | 10 | 2 | 4-pin M. 6 | 1000 | 150 | 14.6 | 30 | 50 | | | | 9 | Class-C Amp. | | | | | | | | | | | | |
| 842 | Triode | 7.5 | 1.25 | 4-pin Giant 12 | 425 | | 3 | | 12 | | 4 | 3 | 7 | Class-A Audio | 425 | -100 | | | 28 | | | | 8000 | 3 | RCA | |
| 843 | Triode | 2.5H | 2.5 | 5-pin M. 4 | 450 | 40 | 7.7 | 7.5 | 15 | | 4.0 | 4.0 | 4.5 | Class-C Telegraphy | 450 | -140 | | | 30 | 5.0 | | 1.0 | | 7.5 | G.E. | |
| | | | | | | | | | | | | | | Class-C Telephony | 350 | -150 | | | 30 | 7.0 | | 1.6 | | 5.0 | RCA | |
| 844 | Tetrode | 2.5H | 2.5 | 5-pin M. 8 | 500 | 30 | 18.0 | 5.0 | 15 | | 9.5 | 7.5 | 0.15 | Class-C Telegraphy | 500 | -125 | 175 | | 25 | 5.0 | | | | 9.0 | RCA | |
| | | | | | | | | | | | | | | Class-C Telephony | 500 | -100 | 150 | | 20 | | | | | 4.0 | | |
| WL-845 | Triode | 10 | 3.25 | 4-pin Giant 12 | | | | | | | | | | For other characteristics, refer to Type #45 | | | | | | | | | | | West. | |
| 845 | Triode | 10 | 3.25 | 4-pin Giant 12 | 1250 | 120 | 5.3 | | 100 | | 6 | 6.5 | 13.5 | Class-A Audio | 1250 | -195 | | | 80 | | | | | 30 | G.E. | |
| | | | | | | | | | | | | | | Class-AB Audio | 1250 | -225 | | | 240 | | | | 6600 | 115 | RCA Taylor | |
| 846 ¹ | Water Cooled U. H. F. Triode | 11 | 51 | Special Water Cooled | 7500 | 1000 | 4.0 | 150 | 2500 | | 6.5 | 1.5 | 9 | Class-B Telephony | 7000 | -100 | | | 450 | | | 175 | | 1000 | G.E. | |
| | | | | | | | | | | | | | | Class-C Telegraphy | 7000 | -900 | | | 900 | 140 | | 300 | | 4.25kw | RCA | |
| WL-849 | Triode | 11 | 5 | Special | | | | | | | | | | For other characteristics, refer to Type #49 by R.C.A. and G.E. | | | | | | | | | | | | West. |
| 849 | Triode | 11 | 5.0 | Special | 3000 | 350 | 19 | 35 | 400 | | 17 | 3.0 | 33.5 | Class-C Telegraphy | 2500 | -250 | | | 300 | 20 | | 8.0 | | 560 | | |
| | | | | | | | | | | | | | | Class-C Telephony | 2000 | -300 | | | 300 | 30 | | 14 | | 425 | G.E. | |
| | | | | | | | | | | | | | | Class-B Audio | 2000 | -105 | | | 650 | | | 16 | 6400 | 900 | | |
| 849 | Triode | 11 | 5.0 | Special | 3000 | 350 | 19 | 125 | 400 | | 11 | 2.0 | 33 | Class-C Telegraphy | 2500 | -250 | | | 350 | 9.0 | | 3.0 | | 330 | | |
| | | | | | | | | | | | | | | Class-C Telephony | 2000 | -300 | | | 300 | 10 | | 4.0 | | 425 | Amp. | |
| | | | | | | | | | | | | | | Class-B Audio | 2000 | -90 | | | 680 | | | 8.0 | 6400 | 850 | | |
| 850 | Tetrode | 10 | 3.25 | 4-pin Giant 15 | 1250 | 175 | 175 | 40 | 100 | 10 | 17 | 25 | 0.25 | Class-C Telegraphy | 1250 | -150 | 175 | | 160 | 35 | 10 | | 130 | RCA | | |
| WL-851 | Triode | 11 | 15.5 | Special 16 | | | | | | | | | | For other characteristics, refer to Type #51 | | | | | | | | | | | West. | |

| | | | | | | | | | | | | | | | | | | | | | | | | |
|---------|------------------------------------|-----|------|------------------------------|--------------------|------------|------|------|--------|------|------|------|--|-------|-------|-----|--|-------|------|----|------|-------|--------|----------|
| 851 | Triode | 11 | 15.5 | Special 16 | 3000 | 1000 | 20.5 | 200 | 750 | 25.5 | 4.5 | 47 | Class-A Audio | 2500 | - 92 | | | 240 | | | 0 | 5000 | 160 | G.E. |
| | | | | | | | | | | | | | Class-B Audio | 3000 | - 135 | | | 1200 | | | 6 | 5600 | 2.4kw | RCA |
| | | | | | | | | | | | | | Class-C Telephony | 2500 | -250 | | | 900 | 100 | | 45 | | 1.7kw | |
| 852 | Triode | 10 | 3.25 | 4-pin M. top grid side plate | 3000 | 150 | 12 | 40 | 100 | 1.9 | 1.0 | 2.6 | Class-C Telephony | 3000 | -600 | | | 85 | 15 | | 12 | | 165 | RCA |
| | | | | | | | | | | | | | Class-C Telephony | 2000 | -500 | | | 67 | 30 | | 23 | | 75 | |
| | | | | | | | | | | | | | Class-C Telephony | 5000 | -310 | | | 450 | 75 | | 40 | | 1820 | |
| HK-854H | Triode | 7.5 | 12 | Giant 4-pin 13 | 6000 | 600 | 30 | 110 | 450 | 8 | 0.5 | 4 | Class-C Telephony | 4000 | -285 | | | 475 | 100 | | 50 | | 1520 | H & K |
| | | | | | | | | | | | | | Class-B Audio | 4000 | -140 | | | 670 | | | 45 | 14500 | 1970 | |
| | | | | | | | | | | | | | Class-C Telephony | 5000 | -575 | | | 450 | 45 | | 40 | | 1800 | |
| HK-854L | Triode | 7.5 | 12 | Giant 4-pin 13 | 6000 | 600 | 14 | 80 | 450 | 6 | 0.5 | 5 | Class-C Telephony | 4000 | -625 | | | 475 | 65 | | 58 | | 1520 | H & K |
| | | | | | | | | | | | | | Class-B Audio | 4000 | -315 | | | 660 | | | 45 | 14500 | 1880 | |
| | | | | | | | | | | | | | | | | | | | | | | | | |
| 857-B | Half-Wave Mercury-Vapor Rectifier | 5 | 30 | Special | 22000 Inverse Peak | 40 Amperes | | | | | | | Half-Wave Rectifier | | | | | | | | | | | RCA G.E. |
| 858 | Water Cooled Triode | 22 | 52 | Special Water Cooled | 20000 | 2000 | 42 | 250 | 20000 | 16 | 2.0 | 18 | Class-B Telephony | 18000 | -300 | | | 900 | | | 85 | | 5.6kw | G.E. |
| | | | | | | | | | | | | | Class-C Telephony | 18000 | -1200 | | | 1800 | | | 250 | | 22.4kw | RCA |
| WL-860 | Tetrode | 10 | 3.25 | 4-pin M. Top Grid Side Plate | | | | | | | | | For other characteristics, refer to Type 860 | | | | | | | | | | | West. |
| 860 | Tetrode | 10 | 3.25 | 4-pin M. top grid side plate | 3000 | 150 | 300 | 40 | 100 | 7.75 | 7.5 | 0.08 | Class-C Telephony | 3000 | -150 | 300 | | 85 | 15 | | 7.0 | | 165 | RCA G.E. |
| | | | | | | | | | | | | | Class-C Telephony | 2000 | -200 | 220 | | 85 | 38 | 25 | 17 | | 105 | |
| WL-861 | Tetrode | 11 | 10 | Special | | | | | | | | | For other characteristics, refer to Type 861 | | | | | | | | | | | West. |
| 861 | Tetrode | 11 | 10 | Special | 3500 | 350 | 500 | 75 | 400 | 14.5 | 10.5 | 0.1 | Class-C Telephony | 3500 | -250 | 500 | | 300 | 40 | 40 | 90 | | 700 | RCA G.E. |
| | | | | | | | | | | | | | Class-C Telephony | 3000 | -200 | 375 | | 200 | 55 | | 35 | | 400 | |
| | | | | | | | | | | | | | Class-B Audio | 12000 | 0 | | | 13000 | | | 450 | 1800 | 90kw | |
| 862 | Water and Forced-Air Cooled Triode | 33 | 207 | Special Water Cooled | 20000 | 10000 | 48 | 1000 | 100000 | 52 | 2.0 | 75 | Class-B Telephony | 18000 | -200 | | | 4200 | | | 1100 | | 25kw | RCA G.E. |
| | | | | | | | | | | | | | Class-C Telephony | 12000 | -800 | | | 5000 | 1000 | | 2000 | | 45kw | |
| | | | | | | | | | | | | | | | | | | | | | | | | |
| 865 | Tetrode | 7.5 | 2.0 | 4-pin M. 9 | 750 | 60 | | 15 | 15 | 8.5 | 8 | 0.1 | Class-C Telephony | 750 | - 80 | 125 | | 40 | 5.5 | | 1.0 | | 16 | RCA G.E. |
| | | | | | | | | | | | | | Class-C Telephony | 500 | -120 | 125 | | 40 | 9.0 | | 2.5 | | 10 | |

| Mfr. No. | Type | Cathode | | Base ³ and Connections | Max. Plate Voltage | Max. Plate Current (ma.) | Triode Mu or Max. Screen Voltage | Max. D.C. Control Grid Current (ma.) | Max. Plate Dissipation (Watts) | Max. Screen Dissipation (Watts) | Interelectrode Capacitances μ fds. | | | Typical ⁹ Operation | Plate Volts | Control Grid Bias | Screen Volts | Suppressor Volts | Plate ⁷ Current (ma.) | D.C. ⁸ Control Grid Current (ma.) | Screen Current (ma.) | Grid ⁴ Driving Power (Approx. Watts) | Load Imped. P to P (Ohms) | Power Output (Watts) typical | Mfr. ⁵ | |
|--------------|-----------------------------------|------------|-------------|-----------------------------------|---------------------------------|--------------------------|----------------------------------|--------------------------------------|--------------------------------|---------------------------------|--|--|--|---|-------------|-------------------|--------------|------------------|----------------------------------|--|----------------------|---|---------------------------|------------------------------|----------------------------------|-----|
| | | G-F In-put | P-F Out-put | | | | | | | | G-P Feed-back | | | | | | | | | | | | | | | |
| 866 866-A | Half-Wave Mercury Vapor Rectifier | 2.5 | 5.0 | 4-pin M. 1 | 10000 Inverse Peak | 1000 Peak | | | | | | | | Half-Wave Rectifier | | | | | 250 average | | | | | | Amp. Ray. RCA G.E. Hytron United | |
| 866B | Half-Wave Mercury Vapor Rectifier | 5 | 5 | 4-pin M. 1 | | | | | | | | | | Max. Peak Inverse Voltage | e, 8500 | | Ma. | | | | | | | | | |
| HY-866 Jr. | Half-Wave Mercury-Vapor Rectifier | 2.5H | 3.0 | 4-pin M. 23 ¹⁴ | 5000 ¹¹ Inverse Peak | 500 Peak | | | | | | | | Half-Wave Rectifier | | | | | 125 average. | | | | | | Hytron | |
| 866 Jr. | Half-Wave Mercury Vapor Rectifier | 2.5 | 3.0 | 4-pin M. 23 | 3500 Inverse Peak | 250 Peak | | | | | | | | Half-Wave Rectifier | | | | | 125 average | | | | | | Taylor | |
| 869-B | Half-Wave Mercury-Vapor Rectifier | 5 | 18 | Special 16 (no grid) | 20000 Inverse Peak | 10 Am-peres Peak | | | | | | | | Half-Wave Rectifier | | | | | 2.5 Am-peres Average | | | | | | RCA G.E. | |
| 870 | Half-Wave Mercury-Vapor Rectifier | 5H | 70 | Special | 16000 Inverse Peak | 450 Am-peres Peak | | | | | | | | Half-Wave Rectifier | | | | | 75 Am-peres Average | | | | | | G.E. RCA | |
| 870A | Half-Wave Mercury-Vapor Rectifier | 5H | 65 | Special | | | | | | | | | | Max. Peak Inverse Plate Voltage for supply frequency up to 150 cycles Cond. Mercury Temp. 35° to 40°C, 16000 max. volts. Peak Plate Current for supply frequency above 25 cycles 450 max. amp. Average Plate Current 75 max. amp. Tube drop 10 volts Peak. 30 min. starting time. | | | | | | | | | | | | RCA |
| 871 | Half-Wave Mercury Vapor Rectifier | 2.5 | 2 | 4-pin M. 1 | | | | | | | | | | Max. A.C. Voltage 1750. Max. D.C. output current 250 MA. Max. inverse Peak Voltage 5000. Max. Peak Plate Current 500MA. | | | | | | | | | | | | RCA |
| 872 | Half-Wave Mercury Vapor Rectifier | 5.0 | 10 | 4-pin Giant 14 | 7500 Inverse Peak | 5000 Peak | | | | | | | | Half-Wave Rectifier | | | | | 1250 av. | | | | | | RCA G.E. | |

| Model | Description | Frequency (MHz) | Power (W) | Grids | Inverse Peak (W) | 5000 Peak (W) | Other Characteristics | Ref. Type | Modulation (Type) | Dist. (Type) | Class | Power (W) | Dist. (Type) | Dist. (Type) | Dist. (Type) | Dist. (Type) | Dist. (Type) | Dist. (Type) | Dist. (Type) | Dist. (Type) | Manufacturer | | |
|--------------------|--------------------------------------|-----------------|-----------|------------------------------|--------------------|---------------|---------------------------|-------------------|-------------------|-------------------|---------------------|-----------|--|--------------|--------------|--------------|--------------|--------------|--------------|--------------|--------------|---------------------------|-------|
| 872-A | Half-Wave Mercury Vapor Rectifier | 5.0 | 6.75 | 4-pin Giant 14 | 10000 Inverse Peak | 5000 Peak | | | | | Half-Wave Rectifier | | 1250 av. | | | | | | | | | Amp. Ray. RCA Taylor G.E. | |
| WL-880 | Water Cooled UHF Triode | 12.6 | 320 | Special Water Cooled | | | For Other Characteristics | refer to Type 880 | | | | | | | | | | | | | | Westing House | |
| 880 ¹ | Water Cooled U. H. F. Triode | 12.6 | 320 | Special Water Cooled | 10500 | 6000 | 20 | 600 | 20000 | 29 | 2.6 | 26 | Class-B Telephony | 10000 | -430 | | 3000 | | 500 | | 10kw | G.E. RCA | |
| | | | | | | | | | | | | | Class-C Telephony | 10000 | -1200 | | 3600 | 500 | | 880 | | 28kw | |
| 887 ¹ | Water and Air Cooled U. H. F. Triode | 11 | 24 | Water Cooled Integral Jacket | 3000 | 400 | 18 | 75 | 1000 | 2.5 | 2.7 | 6.9 | Class-B Telephony | 3000 | -300 | | 200 | 1.0 | 50 | | 200 | RCA | |
| | | | | | | | | | | | | | Class-C Telephony | 2000 | -500 | | 200 | 50 | | 40 | | 300 | |
| 888 ¹ | Water and Air Cooled U. H. F. Triode | 11 | 24 | Water Cooled Integral Jacket | 3000 | 400 | 30 | 100 | 1000 | 2.5 | 2.8 | 7.8 | Class-C Telephony | 2000 | -350 | | 200 | 80 | 40 | | 300 | RCA | |
| | | | | | | | | | | | | | Class-C Telegraphy | 3000 | -300 | | 400 | 80 | | 45 | | 800 | |
| WL-889 | Water and Air Cooled U. H. F. Triode | 11 | 125 | Special | | | | | | | | | For other characteristics, refer to Type 889 | | | | | | | | | West. | |
| WL-889R | Forced-Air Cooled U. H. F. Triode | 11 | 125 | Special | | | | | | | | | For other characteristics, refer to Type 889-R | | | | | | | | | West. | |
| 889 ¹ | Water and Air Cooled U. H. F. Triode | 11 | 125 | Special Water Cooled | 7500 | | | | | 18.8 | 2.2 | 17.8 | Class-B Telephony | 7500 | -300 | | 900 | | 80 | | 2000 | G.E. RCA | |
| 889-R ¹ | Forced-Air Cooled U. H. F. Triode | | | Special Forced-Air Cooled | 8500 | 2000 | 21 | 250 | 5000 | Class-C Telephony | 6000 | -900 | | 1000 | 100 | | 140 | | 4000 | | | | |
| WL-891 | Water Cooled Triode | Two Unit | Unit 60 | Special Water Cooled | | | | | | | | | For other characteristics, refer to Type 891 | | | | | | | | | West. | |
| | | Each 11 | | | | | | | | | | | | | | | | | | | | | |
| 891 | Water Cooled Triode | Two Unit | Unit 60 | Special Water Cooled | 15000 | 2000 | 8 | 150 | 7500 | 18 | 2.0 | 27 | Class-A Audio | 8000 | -630 | | 900 | | 0 | 5200 | 2000 | RCA G.E. | |
| | | Each 11 | | | | | | | | | | | Class-B Telephony | 14000 | -1500 | | 560 | | 0 | | 2275 | | |
| WL-891R | Forced Air Cooled Triode | Two Unit | Unit 60 | Special Forced Air Cooled | | | | | | | | | For other characteristics, refer to Type 891R | | | | | | | | | | West. |
| | | Each 11 | | | | | | | | | | | | | | | | | | | | | |

| Mfr. No. | Type | Cathode | | Base ³ and Connections | Max. Plate Voltage | Max. Plate Current (ma.) | Triode or Max. Screen Voltage | Max. O.C. Control Grid Current (ma.) | Max. Plate Dissipation (Watts) | Max. Screen Dissipation (Watts) | Interelectrode Capacitances $\mu\text{mfd.}$ | | | Typical ¹ Operation | Plate Volts | Control Grid Bias | Screen Volts | Suppressor Volts | Plate ⁷ Current (ma.) | D.C. ⁸ Control Grid Current (ma.) | Screen Current (ma.) | Grid ⁴ Driving Power (Approx. Watts) | Load Imped. P to P (Ohms) | Power Output (Watts) typical | Mfr. ⁵ |
|----------|------------------------------------|---|---------------------------|-----------------------------------|--------------------|--------------------------|-------------------------------|--------------------------------------|--------------------------------|---------------------------------|--|------------|---|--------------------------------|-------------|-------------------|--------------|------------------|----------------------------------|--|----------------------|---|---------------------------|------------------------------|-------------------|
| | | Volts ² | Amps. | | | | | | | | G-F Input | P-F Output | G-P Feed-back | | | | | | | | | | | | |
| 891-R | Forced Air Cooled Triode | Two Unit | Special Forced Air Cooled | 10000 | 2000 | 8 | 150 | 4000 | | 18 | 2 | 30 | Class-C Telephony | 6000 | -2000 | | | | 750 | 100 | | 260 | | 3500 | RCA G.E. |
| | | Each Unit 11 60 | | | | | | | | | | | Class-C Telegraphy | 10000 | -2000 | | | | 1400 | 110 | | 310 | | 10kw | |
| WL-892 | Water Cooled Triode | Two Unit | Special Water Cooled | | | | | | | | | | For other characteristics refer to Type | 892 | | | | | | | | | | West. | |
| | | Each Unit 11 60 | | | | | | | | | | | | | | | | | | | | | | | |
| 892 | Water Cooled Triode | Two Unit | Special Water Cooled | 15000 | 2000 | 50 | 250 | 10000 | | 18 | 2.0 | 27 | Class-B Audio | 12500 | -170 | | | | 2800 | | | 420 | 10000 | 22kw | G.E. RCA |
| | | Each Unit 11 60 | | | | | | | | | | | Class-C Telephony | 10000 | -1600 | | | 720 | 115 | | 260 | | 6000 | | |
| WL-892R | Forced Air Cooled Triode | Two Unit | Special Forced Air Cooled | | | | | | | | | | For other characteristics refer to Type | 892-R | | | | | | | | | | West. | |
| | | Each Unit 11 60 | | | | | | | | | | | | | | | | | | | | | | | |
| 892-R | Forced-Air Cooled Triode | Two Unit | Special Forced-Air Cooled | 12500 | 2000 | 50 | 250 | 4000 | | 18 | 2.0 | 0 | Class-C Telephony | 8000 | -1300 | | | | 750 | 175 | | 350 | | 5000 | G.E. RCA |
| | | Each Unit 11 60 | | | | | | | | | | | Class-C Telegraphy | 10000 | -1300 | | | 1400 | 180 | | 400 | | 10kw | | |
| WL-893 | Water and Forced-Air Cooled Triode | | Special | | | | | | | | | | For other characteristics refer to Type | 893 | | | | | | | | | | | West. |
| WL-893R | Forced-Air Cooled Triode | | Special | | | | | | | | | | For other characteristics refer to Type | 893R | | | | | | | | | | | West. |
| 893 | Water and Forced-Air Cooled Triode | Multi-Strand Filament for 1, 3 or 6 phase A.C. or D.C. For D.C. heating | Special Water Cooled | 20000 | 4000 | 36 | 400 | 20000 | | 48 | 3.2 | 33 | Class-B Audio | 18000 | -450 | | | | 5500 | | | 140 | 8000 | 70kw | RCA G.E. |
| | | | | | | | | | | | | | Class-B Telegraphy | 15000 | -340 | | | 2000 | | 200 | | 10kw | | | |
| 893-R | Forced-Air Cooled Triode | 20 | 183 | Special Forced-Air Cooled | | | | | | | | | Class-C Telephony | 12000 | -1000 | | | 2000 | 140 | | 210 | | 18kw | RCA G.E. | |
| | | | | | | | | | | | | | Class-C Telegraphy | 18000 | -1000 | | | 3600 | 210 | | 340 | | 50kw | | |
| WL-895 | Water Cooled Triode | 19 | 138 | Special Water Cooled | 17000 | 9000 | 37 | | 40000 | | | | | Class-B Audio | 12500 | -250 | | | 10400 | | | 700 | 2700 | 95000 | West. |
| | | | | | 12500 | 9000 | 37 | 1500 | 40000 | | 80 | 8 | 40 | Class-C Amp. Plate Mod. | 12500 | -1500 | | | 4400 | | | 1700 | | 45000 | |
| | | | | | 17000 | 9000 | 37 | 1500 | 40000 | | | | | Class-C Amp. Telegraphy | 17000 | -1000 | | | 7500 | 1000 | | 1700 | | 100000 | |

| | | | | | | | | | | | | | | | | | | | | | | | | | | | | |
|------------------------|------------------------------------|---|-------|-------------------------------------|--------------------|-----------|-----|------|--------|---|---------|-------------|------|----|----------------------|-----------------------------|-------------------------|-------|--------------|-------|------|------|-------|------|--------|----------|-------|-------|
| WL-895R | Forced-Air Cooled Triode | 19 | 138 | Special Forced Air Cooled | 17000 | 9000 | 37 | | 20000 | | | | | | Class-B Audio | 10000 | -200 | | | 11500 | | | 600 | 2100 | 70000 | West. | | |
| | | | | | 12500 | 9000 | 37 | 1500 | 20000 | | | 80 | 8 | 40 | | | Class-C Amp. Plate Mod. | 12500 | -1500 | | | 4400 | | | 1700 | | | 45000 |
| | | | | | 17000 | 9000 | 37 | 1500 | 20000 | | | | | | | | Class-C Amp. Telegraphy | 17000 | -1800 | | | 6000 | 900 | | 2200 | | | 84000 |
| 898 | Water and Forced-Air Cooled Triode | Multi-Strand Filament for 1, 3 or 6 phase A.C., or D.C. | | Special Water and Forced-Air Cooled | 20000 | 10000 | 44 | 1000 | 100000 | | 52 | 2.0 | 75 | | | Class-B Audio | 12000 | -100 | | 13000 | | | 6000 | 2000 | 90kw | RCA G.E. | | |
| | | Class-B Telephony | 18000 | | | | | | | | | | | | | -250 | | 4200 | | | 1100 | | 25kw | | | | | |
| | | Class-C Telephony | 12000 | | | | | | | | | | | | | -800 | | 5000 | 1000 | | 2000 | | 45kw | | | | | |
| | | Class-C Telegraphy | 18000 | | | | | | | | | | | | | -600 | | 8330 | 900 | | 2400 | | 100kw | | | | | |
| WL-899-A | Water Cooled Triode | 14.5 | 180 | Special Water Cooled | 18000 | 2500 | 27 | | 20000 | | | | | | Class-B Telephony | 15000 | -400 | | 1700 | 70 | | 660 | | 8000 | West. | | | |
| | | | | | 10000 | 2500 | 27 | 500 | 15000 | | | 10 | 5 | 23 | | | Class-C Plate Mod. | 10000 | -1600 | | 1250 | 330 | | 850 | | | 10000 | |
| | | | | | 18000 | 5000 | 27 | 600 | 30000 | | | | | | | | Class-C Telegraphy | 18000 | -2000 | | 2800 | 150 | | 480 | | | 35000 | |
| 975-A | Half-Wave Mercury-Vapor Rectifier | 5 | 10 | Giant 4-pin 14 | 15000 Inverse Peak | 6000 Peak | | | | | | | | | Half-Wave Rectifier | | | | 1500 Average | | | | | | United | | | |
| HY-1231Z ¹⁶ | Twin Triode | 12.6 | 1.5 | 5-pin M. 46 | 500 | 150 | 45 | 30 | 30 | | 5.0 Per | 1.9 Section | 5.5 | | | Class-C Telegraphy | 500 | -150 | | 150 | 30 | | 2.5 | | 56 | Hy-tron | | |
| | | | | | | | | | | | | | | | | Class-C Telegraphy | 400 | -100 | | 150 | 30 | | 3.5 | | 45 | | | |
| | | | | | | | | | | | | | | | | Class-B Audio | 500 | 0 | | 150 | 30 | | 1.8 | 7000 | 51 | | | |
| HY-1269 | Beam Tetrode | 12.6 | 1.5 | 5-pin M. 10 | 750 | 120 | 300 | 7.5 | 40 | 5 | 15.3 | 3.0 | 0.19 | | | Class-C Telegraphy | 750 | -70 | 300 | 120 | 4 | 12.5 | 0.25 | | 63 | Hy-tron | | |
| | | | | | | | | | | | | | | | | Class-C Telegraphy | 600 | -70 | 250 | 100 | 4 | 10.0 | 0.35 | | 42 | | | |
| | | | | | | | | | | | | | | | | Class-AB ₂ Audio | 600 | -35 | 300 | 240 | 6 | 29 | 0.7 | 4500 | 97 | | | |
| 1602 | Triode | 7.5 | 1.25 | 4-pin M. 3 | 450 | 60 | 8 | 15 | 15 | | 4 | 3 | 7 | | | Class-C Amp. Telegraphy | 450 | -115 | | 55 | 15 | | 3.3 | | 13 | G.E. | | |
| | | | | | | | | | | | | | | | | Class-C Amp. Telegraphy | 350 | -135 | | 45 | 15 | | 3.5 | | 8 | | | |
| 1608 | Triode | 2.5 | 2.5 | 4-pin M. 3 | 425 | 95 | 20 | 25 | 20 | | 8.5 | 3.0 | 9.0 | | | Class-C Telegraphy | 425 | -200 | | 95 | 25 | | | | 20 | RCA | | |
| | | | | | | | | | | | | | | | | Class-C Telegraphy | 350 | -200 | | 85 | 25 | | | | 16 | | | |
| 1610 | Crystal-Oscillator Pentode | 2.5 | 1.75 | 5-pin M. 19 | 400 | 30 | 200 | 3 | 6 | 2 | 8.6 | 13 | 1.2 | | Oscillator-Amplifier | 400 | -50 | 150 | | 22.5 | 1.5 | 7 | 0.1 | | 5 | RCA | | |

| Mfr. No. | Type | Cathode | | Base ³ and Connections | Max. Plate Voltage | Max. Plate Current (ma.) | Triode or Max. Screen Voltage | Max. D.C. Control Grid Current (ma.) | Max. Plate Dissipation (Watts) | Max. Screen Dissipation (Watts) | Interelectrode Capacitances μ fds. | | | Typical ¹ Operation | Plate Volts | Control Grid Bias | Screen Volts | Suppressor Volts | Plate Current (ma.) | D.C. ² Control Grid Current (ma.) | Screen Current (ma.) | Grid ⁴ Driving Power (Approx. Watts) | Load Imped. P to P (Ohms) | Power Output (Watts) typical | Mfr. ⁵ |
|-------------------|---------------------------------|-----------|------------|-----------------------------------|--------------------|--------------------------|-------------------------------|--------------------------------------|--------------------------------|---------------------------------|--|--------------------|-------|---------------------------------|--------------|-------------------|--------------|------------------|---------------------|--|----------------------|---|---------------------------|------------------------------|-------------------|
| | | G-F Input | P-F Output | | | | | | | | G-P Feedback | Volts ² | Amps. | | | | | | | | | | | | |
| 1613 | Pentode (Metal) | 6.3H | 0.7 | Octal 47 | 350 | 50 | 275 | 5 | 10 | 2.5 | 8.5 | 11.5 | 0.5 | Class-C Telegraphy | 350 | -35 | 200 | | 50 | 3.5 | 10 | 0.22 | | 9 | RCA G.E. |
| | | | | | | | | | | | | | | Class-C Telephony | 275 | -35 | 200 | | 42 | 2.8 | 10 | 0.16 | | 6 | |
| 1614 | Beam Tetrode (Metal) | 6.3H | 0.9 | Octal 43 | 375 | 110 | 300 | 5 | 21 | 315 | | | | Class-C Telegraphy | 375 | -35 | 200 | | 88 | 3.5 | 9 | 0.18 | | 17 | RCA G.E. |
| | | | | | | | | | | | | | | Class-C Telephony ¹⁸ | 325 | -70 | | | 65 | 9 | 0.8 | | 11 | | |
| 1616 | Half-Wave High-Vacuum Rectifier | 2.5 | 5 | 4-pin M. 1 | 5500 Inverse Peak | 800 Peak | | | | | | | | Half-Wave Rectifier | | | | | 130 Average | | | | | | RCA G.E. |
| 1619 | Beam Tetrode (Metal) | 2.5 | 2 | Octal 37 | 400 | 75 | 300 | 5 | 15 | 3.5 | 10.5 | 12.5 | 0.35 | Class-C Telegraphy | 400 | -55 | 300 | | 75 | 5 | 10.5 | 0.36 | | 19.5 | RCA |
| | | | | | | | | | | | | | | Class-C Telephony | 325 | -50 | 285 | | 62 | 2.8 | 7.5 | 0.18 | | 13 | |
| | | | | | | | | | | | | | | Class-AB ₂ Audio | 400 | -16.5 | 300 | | 150 | | 11.5 | | 6000 | 36 | |
| 1623 | Triode | 6.3 | 2.5 | 4-pin M. 6 | 1000 | 100 | 20 | 25 | 30 | | | | | Class-C Telegraphy | 750 | -85 | | | 100 | 17 | | 2.5 | | 55 | RCA G.E. |
| | | | | | | | | | | | | | | Class-C Telephony | 600 | -125 | | | 83 | 25 | | 5 | | 38 | |
| | | | | | | | | | | | | | | Class-B Audio | 750 | -25 | | | 200 | | | 4.0 | 8400 | 100 | |
| 1624 | Beam Power Tetrode | 2.5 | 2.0 | 5-pin M. 10 | 600 | 30 | 300 | 5.0 | 25 | | | | | Class-C Telegraphy | 600 | -60 | 300 | | 90 | 5.0 | 10 | 0.43 | | 35 | RCA |
| | | | | | | | | | | | | | | Class-C Telephony | 500 | -50 | 275 | | 75 | 3.3 | 9.0 | 0.25 | | 24 | |
| | | | | | | | | | | | | | | Class-AB ₂ Audio | 600 | -25 | 300 | | 42 | | 15 | 1.2 | 7500 | 72 | |
| 1625 | Beam Tetrode | 12.6 | 0.45 | 7-pin M. 38 | | | | | | | | | | For other characteristics, | See 807 Data | | | | | | | | | RCA | |
| 1626 | Triode | 12.6 | 0.25 | Octal 39 | 250 | 25 | 5 | 8 | 5 | | | | | Oscillator | 250 | 14000 ohms | | | 25 | 5 | | | 4 | RCA | |
| 1627 | Triode | 5 | 9 | Giant 4-pin 29 | | | | | | | | | | For other characteristics, | See 810 Data | | | | | | | | | | RCA |
| 1628 ¹ | Triode | 3.5 | 3.25 | Special Base-less | 1000 | 60 | 23 | 15 | 40 | | | | | Class-C Telegraphy | 1000 | -65 | | | 50 | 15 | | 1.7 | | 35 | RCA |
| | | | | | | | | | | | | | | Class-C Telephony | 800 | -100 | | | 40 | 11 | | 1.6 | | 22 | |
| 8000 ⁶ | Triode | 10 | 4.5 | Giant 4-pin 29 | 2250 | 275 | 16.5 | 40 | 150 | | | | | Class-C Telegraphy | 2250 | -210 | | | 275 | 25 | | 9 | | 475 | RCA |
| | | | | | | | | | | | | | | Class-C Telephony | 1800 | -320 | | | 250 | 20 | | 8.8 | | 335 | |
| | | | | | | | | | | | | | | Self-Rectifying Osc. | 2500 a.c. | 5000 ohms | (Two Tubes) | 320 | 40 | | | | | 650 | |
| | | | | | | | | | | | | | | Class-B Audio | 2250 | -130 | | | 450 | | | 7.9 | 12000 | 725 | |

| | | | | | | | | | | | | | | | | | | | | | | | | | | | | | | | | |
|---------------------|-----------------------------------|-----|------|-------------------|--|------|------|----|------|-----|------|------|---|-----------|-----------|-------------|------|-----|------|----|------|-------|----------|------|--|--|--|--|--|--|--|-----|
| 8001 | Beam Pentode | 5 | 7.5 | Giant 7-pin 25 | 2000 | 150 | 500 | 25 | 75 | 11 | 5.5 | 0.1 | Class-C Telegraphy | 2000 | -200 | 500 | +60 | 150 | 6 | 11 | 1.4 | 230 | RCA | | | | | | | | | |
| | | | | | | | | | | | | | Class-C Telephony | 1800 | -130 | 400 | +60 | 135 | 8 | 11 | 1.7 | 178 | | | | | | | | | | |
| | | | | | | | | | | | | | Sup. Mod. Telephony | 2000 | -130 | 500 | -300 | 55 | 3 | 27 | 0.4 | 35 | | | | | | | | | | |
| 8002 ¹ | Water Cooled Triode | 16 | 39 | Special | 3500 | 1000 | 20.5 | | 1200 | | | | | | | | | | | | | | G.E. | | | | | | | | | |
| 8002-R ¹ | Forced-Air Cooled Triode | | | | | | | | | | | | | | | | | | | | | | | | | | | | | | | |
| 8003 | Triode | 10 | 3.25 | Giant 4-pin 29 | 1350 | 250 | 12 | 50 | 100 | 5.8 | 3.4 | 11.7 | Class-C Telegraphy | 1350 | -180 | | | 245 | 35 | | 11 | 250 | RCA | | | | | | | | | |
| | | | | | | | | | | | | | Class-C Telephony | 1100 | -250 | | | 200 | 40 | | 15 | 167 | | | | | | | | | | |
| | | | | | | | | | | | | | Self-Rectifying Osc. | 1500 a.c. | 5000 ohms | (Two Tubes) | 400 | 40 | | | | | | 500 | | | | | | | | |
| | | | | | | | | | | | | | Class-B Audio | 1350 | -100 | | | 490 | | | 10.5 | 6000 | | 460 | | | | | | | | |
| 8005 ⁶ | Triode | 10 | 3.25 | 4-pin M. 6 | 1500 | 200 | 20 | 45 | 85 | 6.4 | 1.0 | 5 | Class-B Audio | 1500 | -70 | | | 310 | | | 4 | 10000 | 300 | RCA | | | | | | | | |
| | | | | | | | | | | | | | Class-C Telegraphy | 1500 | -140 | | | 200 | 32 | | 7.5 | 220 | | | | | | | | | | |
| | | | | | | | | | | | | | Max. D.C. Output Current 1250 M.A. Max. Inverse Peak Voltage 10000. Max. Peak Plate Current 5000 M.A. Same as 872A / 872 except for heavy duty base and filament connected to pins 2 and 3. Plate to top cap. | | | | | | | | | | | | | | | | | | | |
| 8008 | Half-Wave Mercury Vapor Rectifier | 5 | 7.5 | 4-pin 63 | | | | | | | | | Max. D.C. Output Current 1250 M.A. Max. Inverse Peak Voltage 10000. Max. Peak Plate Current 5000 M.A. Same as 872A / 872 except for heavy duty base and filament connected to pins 2 and 3. Plate to top cap. | | | | | | | | | | | | | | | | | | | RCA |
| 8010-R | U. H. F. Triode | 6.3 | 2.4 | Special | 1350 | 150 | 30 | 20 | 50 | 2.3 | 0.07 | 1.5 | Class-C Amplifier | | | | | | | | | | | G.E. | | | | | | | | |
| 8012 | U. H. F. Triode | 6.3 | 2.0 | Special Base-less | 1000 | 80 | 18 | 20 | 40 | 2.7 | 0.35 | 2.8 | Class-C Amp. Telegraphy | 1000 | -90 | | | 50 | 14 | | 1.6 | 35 | RCA G.E. | | | | | | | | | |
| | | | | | | | | | | | | | Class-C Amp. Plate Mod. | 800 | -105 | | | 40 | 10.5 | | 1.4 | 22 | | | | | | | | | | |
| | | | | | | | | | | | | | Class-C Amp. Grid Mod. | 1000 | -135 | | | 50 | 4 | | 3.5 | 20 | | | | | | | | | | |
| 8013-A | Half Wave Rectifier | 2.5 | 5 | 4-pin M. 1 | | | | | | | | | Output Current 20 M.A. Max. Inverse Peak Voltage 40000. Max. Peak Plate Current 150 M.A. | | | | | | | | | | | | | | | | | | | RCA |
| 8020 | Half Wave Rectifier | 5.0 | 5.5 | 4-pin M. 1 | Max. A.C. Plate Voltage 10000. Max. D.C. Output Current 100 M.A. Max. Inverse Peak Voltage 40000. Max. Peak Plate Current 750 M.A. | | | | | | | | | | | | | | | | | | | G.E. | | | | | | | | |
| | | 5.8 | 6.5 | | Max. A.C. Plate Voltage 12500. Max. D.C. Output Current 100 M.A. Max. Inverse Peak Voltage 40000. Max. Peak Plate Current 750 M.A. | | | | | | | | | | | | | | | | | | | | | | | | | | | |
| 8025 | U. H. F. Triode | 6.3 | 1.92 | 4-pin M. 64 | 1000 | 65 | 18 | | 30 | | | | Class-C Amp. Grid Mod. | 1000 | -135 | | | 50 | 4 | | 3.5 | 20 | RCA | | | | | | | | | |
| | | | | | 1000 | 65 | 18 | 20 | 20 | 2.7 | 0.35 | 2.8 | Class-C Amp. Plate Mod. | 800 | -105 | | | 40 | 10.5 | | 1.4 | 22 | | | | | | | | | | |
| | | | | | 1000 | 80 | 18 | 20 | 30 | | | | Class-C Amp. Telegraphy | 1000 | -90 | | | 50 | 14 | | 1.6 | 35 | | | | | | | | | | |

REFERENCES INDICATED IN TUBE TABLES

- ¹Designed specifically for u.h.f. application.
- ²The suffix "H" indicates indirectly-heated cathode.
- ³S—small; M—medium; L—large. The final numbers refer to above socket connection diagrams.
- ⁴Grid driving requirements for r.f. service are subject to wide variation depending upon impedance of plate circuit. Values given are for typical plate impedances. A reserve of excitation power should always be available, and allowance should be made for appreciable circuit losses at ultra high frequencies when choosing a driver tube.
- ⁵Manufactured by the following: Amperex (Amp.), Eimac, General Electric Co. (G.E.), Heintz & Kaufman Ltd. (H & K), Hytron, Raytheon, (Ray.), RCA Manufacturing Co. (RCA), Taylor, United Electronics Co. (United), and Westinghouse Electric Corp. (West.).
- ⁶Intermittent commercial and amateur service ratings. For use where long tube life and reliability of operation are more important than tube cost, refer to more conservative ratings as given in manufacturer's data sheets.
- ⁷Plate current is the maximum signal value for Class B and Class AB audio applications.
- ⁸Grid current is the maximum signal value for Class B audio application.
- ⁹Plate-screen modulation is assumed in the Class C telephony application of tetrodes and pentodes.
- ¹⁰Bias must be adjusted at no signal for maximum rated dissipation.
- ¹¹No-signal value for RK-100.
- ¹²Characteristics are per-section unless otherwise noted.
- ¹³Characteristics are for two tubes unless otherwise noted.
- ¹⁴Cathode connected to pin 4.
- ¹⁵Socket is provided with built-in by-pass capacitors.
- ¹⁶Characteristics are for both sections unless otherwise noted.
- ¹⁷Grid connected to pins 2 and 3.
- ¹⁸Triode connected, screen tied to plate.
- ¹⁹At 112 Mc.

Transmitter Design

RECEIVERS are designed pretty much as an integral unit, but there are infinite combinations of tubes, exciter circuits, amplifier circuits, and power supply arrangements which one may incorporate in a "200-watt" transmitter. For this reason, few complete transmitter circuit diagrams are shown in this book.

If a tube requires 25 watts r.f. driving power for a certain application, it is obvious that it makes little difference just what exciter circuit is used so long as it puts out 25 watts on the desired bands. Because of its characteristics one exciter may be preferred by one amateur, another exciter by another amateur.

It is fortunate that there is this flexibility with regard to transmitter design, because it makes it easy for an amateur to start out with a low power transmitter and then add to it from time to time, perhaps later going on phone. It also permits one a certain degree of "custom tailoring" of his transmitter to suit his particular requirements.

In several following chapters of this book are described inexpensive yet versatile and efficient exciters, power amplifiers, speech amplifiers, modulators, and power supplies. It is the purpose of this chapter to give the reader sufficient general design information to be able to work out various combinations of these independent yet complementary units, and to evolve one which is well suited to his particular needs and pocketbook. However, before proceeding further, one should be thoroughly familiar with the chapter on fundamental transmitter theory, Chapter 7.

Exciters and Transmitters A 5-watt crystal oscillator may be accurately referred to as a transmitter *when it is used to feed an antenna*. On the other hand a multi-tube r.f. unit winding up in a 150-watt power amplifier may be properly termed an exciter *when it is used to drive a higher power amplifier*. Thus we see that any r.f. unit, even a simple oscillator, may be either an exciter or a transmitter depending upon how it is used.

The requirements for a low power (15 to 75

watt) transmitter are practically the same as for an exciter of the same output: The overall efficiency should be good, the unit should cover all the desired bands with a minimum of coil changing and retuning, and both initial cost and upkeep should be low in proportion to the power output.

Virtually all medium- and high-power amplifiers (200-800 watts output) are very much the same except for the particular make and power rating of components used. Perhaps half the amateurs making use of high power use cross-neutralized push-pull final amplifiers which differ only in the method of obtaining bias and method of antenna coupling.

For this reason, several low power r.f. units and several medium- and high-power amplifiers are described, and the reader is permitted to use his own ingenuity in working out the combination which appears to fit his requirements. If one is designing a complete transmitter, to which no additions are to be made, it is probably best to decide first upon the final amplifier and then work backwards from there, the driving requirements of the particular tubes used determining the exciter. On the other hand, many amateurs do not have the wherewithal to start right off with high power, and are therefore very likely to decide upon the highest powered r.f. unit they can afford and let it go at that. In the latter event, the unit may have slightly more output than is required to drive an amplifier whose addition is contemplated at a later date. However, a reserve of excitation power is not a liability and does not represent poor economy unless carried to extremes. Hence, one who cannot afford to start off with high power can pick out the highest powered exciter he can afford and use it as a transmitter, without worrying too much about its adaptability for use with a particular power amplifier later on. A 75-watt r.f. unit is slightly larger than necessary for driving a pair of 35T's, HK54's, 808's, T40's, HY51's, etc., but there is no reason why one should not use such a combination. *Not enough* excitation is a much more serious condition than an over-

abundance of excitation, there being no objection to the latter except from an economic standpoint.

Choosing Tubes Low-power exciters invariably use receiving tubes or "modified" receiving tubes for the sake of economy. Large scale production brings the cost of 42's, 6L6's, etc., down to a price that would be impossible were they designed for and purchased only by amateurs. Some tubes, like the T21 and 807, resemble standard receiving tubes in one or more respects, and while costing more than a standard receiving tube equivalent (6L6G in this case), are still obtainable at a price below that which would be necessary were they not outgrowths of receiving tubes.

The tubes in the high power amplifier and in the class B modulator (if used) should be chosen with care. While in general there is little to choose between tubes by reliable manufacturers, some are better adapted than others for certain applications. Also, the more recently released tubes of a particular manufacturer are usually better and less expensive than older tubes of the same general type.

Some of the older type tubes, such as the venerable 203-A, have been improved upon and their price periodically lowered until they compare favorably with recently released tubes; for certain applications they are a good buy and are highly recommended. Other tubes of this vintage, such as the 865, have been superseded by less expensive tubes giving better performance, and are manufactured primarily for replacement purposes.

Tubes for modulator service should have good emission and plate dissipation. Interelectrode capacities are relatively unimportant (within reason). For triode class B modulator service, the usual practice is to use high μ tubes so that little or no bias is required.

For oscillator service, tubes with medium μ are most satisfactory.

For doubler service, either pentodes, tetrodes, or high μ triodes are satisfactory.

For class C or class B r.f. service, the amplification factor is not important, though tubes with a medium high μ (20 to 30) are most popular.

In class A audio service, low μ triodes are to be preferred, though pentodes or beam tubes may be used when the load is constant or if inverse feedback is used.

Driving Power It is always advisable to have a slight reserve of driving power in order to be on the safe side. Therefore, the potential output of an exciter on the band upon which its output is least (usually the highest frequency band) should be

slightly greater than the excitation requirements of the following stage as determined from the manufacturer's tube data.

Plate modulated class C amplifiers require the most excitation, the tube requiring full maximum rated grid current, and at least $2\frac{1}{2}$ times cutoff bias if full plate input is run.

C.w. and buffer amplifiers should preferably be run at full rated grid current (though they may run with as much as 50 per cent less) and at $1\frac{1}{2}$ times cutoff or greater bias. Thus an unmodulated final amplifier or buffer can be used with considerably less excitation than a plate modulated stage of the same power.

Cathode modulated amplifiers require about the same amount of excitation power as c.w. amplifiers, the bias being greater but the grid current much less. Cathode modulated stages are commonly run at from $2\frac{1}{2}$ to 4 times cutoff bias at approximately an eighth the grid current recommended for plate modulation.

High efficiency grid modulation requires still less excitation. The bias is from 2 to 4 times cutoff but the grid current is very low, seldom greater than a few ma. even for high power stages. The power dissipated in the grid swamping resistor, a necessary adjunct to a correctly operated grid modulated stage, keeps the excitation requirements from being even less than they are.

The excitation required for a typical 200-watt output amplifier will run about as follows: plate modulated, 35 watts; c.w. or buffer, 20 watts; cathode modulated, 15 watts; grid modulated, 8 watts. The whole problem of excitation requirements depends so much upon operating conditions that one had best refer to the manufacturer's data sheets or to Chapter 10 of this Handbook.

The question of calculating excitation requirements for a doubler stage was not covered in the foregoing discussion, because the excitation power required depends to such a great degree upon the doubler efficiency desired. For high efficiency doublers, the bias should be at least 5 times cutoff and the grid current about half the maximum rated value for the tube. Thus it is seen that for good doubler efficiency a tube requires as much excitation power as does a plate modulated stage of the same power output rating.

Also to be taken into consideration, when tentatively planning a transmitter, are such things as the limiting factor in tube design. For instance, in a grid modulated transmitter, the output is always limited by the plate dissipation, while for plate modulated phone work either the plate voltage or plate current rating is exceeded first. Thus we see that for grid modulation, a tube with high plate dissipation is of prime importance, while for plate modulated operation the matter of filament

emission and insulation are of greatest importance.

Another thing to be taken into consideration, especially when designing a phone transmitter, is the item of filament voltage. Obviously a saving can be effected if both r.f. amplifier tubes and modulator tubes can be run from the same filament winding.

Care should be taken to make sure that the tubes chosen are capable of efficient and safe operation on the highest frequency used.

Design Considerations

Transmitter Wiring At the higher frequencies, solid enamelled copper wire is most efficient for r.f. leads. Tinned or stranded wire will show greater losses at these frequencies. Tank coil and tank condenser leads should be of heavier wire than other r.f. leads, though there is little point in using wire heavier than is used for the tank coil itself.

All grounds and by-passes in an r.f. stage should be made to a common point, and the grounding points for several stages bonded together with heavy wire.

The best type of flexible lead from the envelope of a tube to a terminal is thin copper strip, cut from thin sheet copper. Heavy, rigid leads to these terminals may crack the envelope glass when a tube heats or cools.

Wires carrying only a.f. or d.c. should be chosen with the voltage and current in mind. Some of the low-voltage-filament type transmitting tubes draw heavy current, and heavy wire must be used to avoid voltage drop. The voltage is low, and, hence, not much insulation is required. Filament and heater leads are usually twisted together. An initial check should be made on the filament voltage of all tubes of 25 watts or more plate dissipation rating. This voltage should be measured right at the tube sockets. If it is low, the filament transformer voltage should be raised. If this is impossible, heavier or paralleled wires should be used for filament leads, cutting down their length if possible.

Spark plug type high tension ignition cable makes the best wire for high voltage leads. This cable will safely withstand the highest voltages encountered in an amateur transmitter. If this cable is used, the high voltage leads may be cabled right in with filament and other low voltage leads. For high voltage leads in low-power excitors, where the plate voltage is not over 450 volts, ordinary radio hookup wire of good quality will serve the purpose. Twisted lamp cord, in good condition with insulation intact, can be used for power supply leads between low-power exciter units and power supplies where the voltage does not exceed 400 volts.

No r.f. leads should be cabled; in fact it is better to use enamelled or bare copper wire for r.f. leads and rely upon spacing for insulation. All r.f. joints should be soldered, and the joint should be a good mechanical junction before solder is applied. Soldering technique is covered in Chapter 26.

Coil Placement While metal shield baffles are effective in suppressing stray capacity coupling between circuits, they are not always effective in suppressing inductive coupling. To eliminate all inductive coupling between two coils in inductive relation to each other, each coil should be completely enclosed in an individual shield can. This is not always convenient; so more often the inductive coupling is minimized by orienting the coils for maximum suppression of coupling, and shield baffles are used only to prevent stray capacity coupling between stages.

For best Q a coil should be in the form of a solenoid approximately as long as its diameter. For minimum interstage coupling, coils should be made as small physically as is practicable. The coils should then be placed so that adjoining coils are oriented for minimum mutual coupling. To determine if this condition exists, apply the following test: the axis of one of the two coils must lie in the plane formed by the center turn of the other coil. If this condition is not met, there is bound to be appreciable coupling unless the unshielded coils are very small in diameter or are spaced a considerable distance from each other.

Variable Condensers The question of optimum C/L ratio and condenser plate spacing is covered in the chapter on transmitter theory. For all-band operation of a high power stage, it is recommended that a condenser just large enough for 40-meter c.w. operation be chosen. (This will have sufficient capacity for 'phone operation on all higher frequency bands.) Then use fixed padding condensers for operation on 80 and 160 meters. Such padding condensers are available in air, gas-filled, and vacuum types.

Specially designed variable condensers are recommended for u.h.f. work; ordinary condensers often have "loops" in the metal frame which resonate near the operating frequency.

Insulation On frequencies above 7 Mc., ceramic, polystyrene, or Mycalex insulation is to be recommended, though hard rubber will do almost as well. Cold flow must be considered when using polystyrene (Victron, Amphenol 912, etc.) or hard rubber. Bakelite has low losses on the lower frequencies but should never be used in the field of high-frequency tank circuits.

Lucite, which is available in rods, sheets, or tubing, is excellent for use at all radio frequencies where the r.f. voltages are not especially high. It is very easy to work with ordinary tools and is not expensive. The loss factor depends to a considerable extent upon the amount and kind of plasticizer used.

The most important thing to keep in mind regarding insulation is that the best insulation is none at all. If it is necessary to reinforce air-wound coils to keep turns from vibrating or touching, use strips of Lucite or polystyrene cemented in place with Amphénoi 912 coil dope. This will result in lower losses than the commonly used celluloid ribs and Duco cement.

Metering The ideal transmitter would have an individual meter in every circuit requiring measurement. However, for the sake of economy, many of us are forced to measure filament and plate voltages by means of a test set or universal meter during the initial tryout of the transmitter, and then assume that these voltages will be maintained. Further economies can be effected by doubling up on meters when measuring current in various circuits in which the current is variable, and is an index of transmitter tuning.

By a system of plugs and jacks, or a selector switch, one or two milliammeters can be used to make all the measurements necessary to tune up a transmitter properly. However, it often is of considerable advantage to be able to observe the current of several circuits or stages simultaneously. Thus the problem boils down to: buy as many meters as you can afford, or as many as the total transmitter investment justifies, purchasing the most necessary meters first. Obviously one would not be justified in buying \$100 worth of meters for a transmitter containing other parts totaling \$75. On the other hand, the purchase of a filament voltmeter to keep careful tab on the filament voltage of a pair of 250 watt tubes is a good investment.

Probably the most popular arrangement calls for meter switching or meter jacks in the low power stages and individual meters in the last stage. Ordinarily, r.f. meters are not used except in certain antenna coupling circuits. Where line voltage does not fluctuate appreciably, one can get by very nicely with just d.c. milliammeters, plate current meters in the low power stages, and a grid and a plate meter in the final stage.

Where it is impossible to keep meter or meter leads well away from high r.f. voltage or heavy r.f. current, d.c. meters should be bypassed with small .004 or larger condensers directly at the meter terminals. The condenser is placed across the terminals, not from one

terminal to ground. Such condensers are a wise precaution in all cases, because even though meter and meter leads are kept away from r.f. components, the meter may be subjected to considerable r.f. because of an r.f. choke not doing a 100 per cent job of blocking r.f. from the meter.

Most meters now come with bakelite cases. If the "zero adjuster" screw is well insulated, such meters can be placed in positive high voltage leads where the voltage does not exceed 1000 volts. When the voltage is higher than 1000 volts, the meter should preferably be placed behind a protective glass. The meter should not be mounted directly on a grounded metal panel when the plate voltage exceeds 2000 volts, as the metal portions of the meter may arc through the bakelite case to the grounded metal panel, particularly when plate modulation is used.

One highly recommended method of arranging meters in a high-powered rack and panel transmitter is to group all meters on a Masonite meter panel at the top of the rack, near eye level of the operator and not close to any of the tuning dials. With the Masonite meter panel, there is no danger of meters arcing to ground, and because of the position of the meters there is little likelihood of an operator accidentally coming in contact with the meters.

An alternate system is to place all meters in low voltage circuits directly on the metal panels (assuming meters are of the bakelite case type) and to place the plate milliammeters in all stages having a plate voltage of more than 1000 behind the panel, where they are observed through small windows.

Meter Switching This method can be used to advantage where the voltages on the leads which carry the current to be measured are not greater than about 500 volts to ground. Fifty-ohm resistors are inserted in the leads, and because the resistance of the meter is so low compared to the 50-ohm resistors, the meter can be considered as being inserted in series with the circuit when it is tapped across the resistor. Thus, with a double pole selector switch having sufficient positions, one can use a single meter to measure the current in several circuits.

The resistor should be made 25 ohms where the current to be measured runs over 200 ma., and the resistor increased to 200 ohms when the current to be measured is less than 15 ma. It is necessary to minimize the resistance where heavy current is present, in order to avoid excessive voltage drop when the meter is not shunting the resistor. It is necessary to increase the value of resistance when the current is so low that a low range meter must be used to measure the current. Low range milliammeters

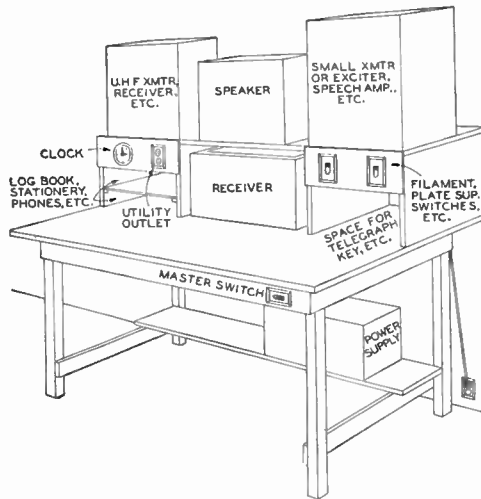

Figure 1.

UTILITY TYPE OPERATING TABLE.

Any amateur handy with a hammer and saw can construct a table of this type with little difficulty and at small cost. If a power supply is placed under the table as shown, it should be housed on the front and top in order to protect the operator from accidental contact with any of the components with his foot. If the equipment supported by the table is especially heavy, the two back legs of the table should be cross braced.

begin to show appreciable resistance themselves, and their calibration will be thrown off when shunted by too low a value of resistor.

Meter switching is not practicable in high voltage circuits (over 1200 volts). For measuring plate current in high power stages, the resistor should be placed either in the B minus lead or in the filament return (center tap). Placing the meter resistor in the B minus is not practical except when a power supply is used to feed but a single stage, or when heater-type tubes or separate filament transformers are used, as otherwise the meter would indicate total current to all the stages.

Placing the meter in the filament return gives a reading of the total *space current*, which includes both grid current and plate current (and in the case of tetrodes and pentodes, screen current). This point is covered later under *Meter Jacks*.

It is possible, by means of various systems of shunts, to use a single low-range meter for measuring widely different values of current in different circuits, much in the manner of the single-meter test set so popular with servicemen. For instance, a 0-25 ma. meter could be used for measuring grid current in several stages, and then used as a 0-250 ma. instrument when switched into the plate circuit of

the final stage by the incorporation of a shunt in the latter circuit to extend the range to 250 ma. Ordinarily, however, a meter is used as a single-scale instrument with this type of switching, a 0-25 ma. meter being used only to read current in circuits carrying up to 25 ma.

Meter Jacks A popular method of using one meter to measure the current in several circuits is to incorporate jacks in the various circuits to be measured. Instead of using low values of resistors across the packs to provide a current path when the meter is not plugged in a circuit, shorting type jacks are used so that when a meter is removed from a jack the circuit is automatically closed.

As with meter switching, meter shunts may be placed across certain of the jacks to extend the range of a milliammeter; however, it is more common practice to have a low range meter and a high range meter, and plug the appropriate meter in each circuit.

Meter jacks should not be used except where one side of the circuit can be grounded. This permits one to measure grid current, and, indirectly, plate current. The plate current is ascertained by measuring the current flowing in the filament return and subtracting the grid current (including screen current if the tube has a screen).

In connecting up meter jacks it is important that they be wired so that the meters read in the correct direction. This can be determined by figuring just which way the current is flowing in each circuit. If this were not done, the leads to the meter would have to be reversed when reading grid current after cathode current.

It necessitates insulating the frame of either the grid current jack or the cathode current jack from a grounded metal panel if such a panel is used. It is common practice to ground the frame of the cathode circuit jack and insulate the frame of the grid current jack, as this affords maximum protection to the operator.

A piece of heavily-insulated rubber covered 2-wire cable can be used to connect the meter to the meter plug. If the meter is permanently mounted on the panel, the meter cord should be long enough to reach all meter jacks into which it is to be plugged. To protect low range meters, cathode current jacks in stages drawing heavy current are usually placed in such a position that it is impossible to reach the jack with the cord attached to the low-range meter.

Meter jacks should never be placed in high-voltage leads, and it is inadvisable to use them in any circuit where one side of the jack is not at ground potential. When used for measur-

ing cathode current, the *frame* of the jack should always be grounded, as a defective contact in the jack or a blown meter might otherwise endanger the operator by putting high potential on the meter cord and plug.

A 50-ohm carbon resistor across the terminals of all cathode current meter jacks will not affect the calibration of the meter, yet will protect the operator from possible shock in the event that the meter should blow or the cord open up or come loose on the ground side. In this case, the resistor is more of a protective device than a substitute path for the current when the meter is being used in some other circuit, and little current will flow through the resistor unless the jack, cord, or meter becomes defective.

The Audio System In constructing audio equipment, the low level stages should always be mounted on a metal chassis and the bottom of the chassis shielded. For amateur work, "high fidelity" is neither necessary nor desirable, as the sideband width is increased without an increase in intelligibility. This means that high-output microphones of the "p.a." type designed particularly for speech transmission (such as the high output, diaphragm crystal) can be used, and the speech amplifier need have but moderate gain. This greatly simplifies the problem of construction, as the difficulties and chances for trouble go up rapidly as the maximum overall gain of an amplifier is increased much beyond this point. Elaborate precautions against r.f. and a.f. feedback and hum pickup must be taken when low-level high-fidelity microphones of the broadcast type are used, but with the type recommended only a few simple precautions need be taken.

If a microphone which requires an input transformer is used, such as the dynamic type, care must be taken in the orientation of the input transformer in order to avoid hum pickup, especially if it is within a few feet of power transformers. Heavily-shielded input transformers of the "hum bucking" type are recommended for input transformers.

It is a good idea to design the amplifier for about 150 or 200 cycle cutoff, as this not only increases the effective modulation power (as explained in Chapter 14) but also minimizes hum troubles. This means that one can use inexpensive audio components, and also that one need not isolate the d.c. from the primary of a.f. transformers, because such isolation is required only for very low frequencies (below about 150 cycles). *Low harmonic distortion* is of more importance in getting a good sounding amateur signal than is wide-range frequency response.

The foregoing is more appropriately and ex-

tensively covered in the chapter on radio-telephony theory, but is mentioned here because it is so much tied in with transmitter design: how we lay out or plan the speech system of a transmitter depends upon just what features are to be incorporated and what requirements must be met. Before planning a speech amplifier or modulator one should read both the chapter on *Radiotelephony Theory* and the chapter on *Workshop Practice*.

Mains Supply The problem of supplying the transmitter with alternating current power from the supply mains and turning the transmitter on and off, and "stand-by" while listening, is a problem that can be attacked in many ways, the "best" method being a matter of individual preference.

To make sure that an outlet will stand the full load of the entire transmitter, plug in an electric heater rated at about 50 per cent greater wattage than the power you expect to draw from the line. If the line-voltage does not drop more than 5 volts (assuming a 117 volt line) under load and the wiring does not overheat, the wiring is adequate to supply the transmitter. About 750 watts total drain is the maximum that should be drawn from a 117 volt "lighting" outlet or circuit. For greater power, a separate pair of heavy conductors should be run right from the meter box. For a 1 kw. phone transmitter the total drain is so great that a 220 volt "split" system ordinarily will be required. Most of the newer homes are wired with this system, as are homes utilizing electricity for cooking and heating.

With a 3-wire system, be sure there is no fuse in the neutral wire at the fuse box. A neutral fuse is not required if both "hot" legs are fused, and, should a neutral fuse blow, there is a chance that damage to the radio transmitter will result.

If you have a high power transmitter and do a lot of operating, it is a good idea to check on your local power rates if you are on a straight "lighting" rate. In some cities a lower rate can be obtained (but with a higher "minimum") if electrical equipment such as an electric heater drawing a specified amount of current is permanently wired in. It is not required that you use this equipment, and many an amateur who runs his kilowatt phone rig far into the night has made a worthwhile saving on his electric bill by scaring up an old 3 kw. air heater at the secondhand store and permanently installing it in the operating room. Naturally, however, there would be no saving unless you expect to occupy the same dwelling for a considerable length of time.

Probably the most popular transmitter switching system is the one shown in Figure 2. All transmitter tube filaments and possibly the

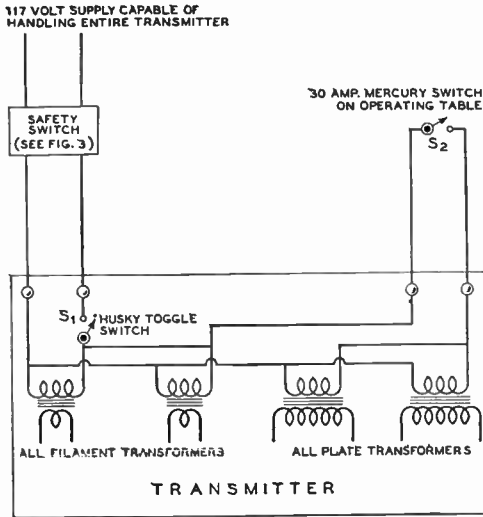

Figure 2.
**POPULAR METHOD OF SUPPLYING
AND SWITCHING MEDIUM POWER
TRANSMITTER.**

This arrangement is the one most widely used when the transmitter cannot be reached easily from the operating position. S₂ should never be turned on until S₁ has first been on for 15 seconds, preferably 30 seconds. S₁ should never be turned on except when S₂ is off; thus S₁ should always be turned off before S₂ is turned off.

speech amplifier plate voltage are turned on by means of one primary switch. With this switch on, the transmitter is in "standby" position (as soon as any mercury vapor rectifiers have once reached operating temperature).

Another switch, the "send-receive" switch S₂, is connected so as to control all plate transformers except possibly that used for the speech amplifier (which usually is a combined plate-filament transformer). This is perhaps the simplest method, but requires that the modulator and all r.f. tubes be supplied from filament windings that are not combined with plate windings on the same core. As this is common transformer practice anyway, except for low voltage supplies, no special requirements need be considered when purchasing transformers.

The send-receive switch in this system should be capable of handling the required power with considerable to spare, because of the inductive nature of the load. Thirty ampere mercury switches may be purchased for less than a dollar, and besides having a smooth and positive action, they will last almost indefinitely. They resemble an ordinary house lighting toggle switch in appearance. The latter, costing less than the mercury type, will be

found satisfactory in low-powered transmitters.

Another popular arrangement is to use fixed safety bias on the entire transmitter, so that the excitation may be removed at the "front end" of the transmitter without any of the succeeding tubes becoming overheated or going into parasitic oscillation. The transmitter then is turned on and off (or keyed, for that matter) simply by opening and closing the cathode or screen of the oscillator.

To minimize the external wiring, the most common practice is to turn the filaments on right at the transmitter, only the send-receive switch being placed on the operating desk, as in Figure 2. When the transmitter is small and is placed right on or beside the operating desk, both filament and send-receive switches may be placed on the transmitter.

In Figure 3 is shown an arrangement which protects mercury vapor rectifiers against premature application of plate voltage without resorting to a time delay relay. No matter which switch is thrown first, the filaments will be turned on first and off last. However, double pole switches are required in place of the usual single pole switches.

Safety Precautions

The best way for an operator to avoid serious accidents from the high voltage supplies of a transmitter is for him to use his head, act only with deliberation, and not take unnecessary chances. However, no one is infallible, and chances of an accident are greatly lessened if certain factors are taken into consideration in the design of a transmitter, in order to protect the operator in the event of a lapse of caution. If there are too many things one must "watch out for" or keep in mind there is a good chance that sooner or later there will be a mishap; and it only takes *one*. When designing or constructing a transmitter, the following safety considerations should be given attention.

Grounds For the utmost in protection, everything of metal on the front panel of a transmitter capable of being touched by the operator should be at ground potential. This includes dial set screws, meter "zero adjuster" screws, meter cases if of metal, meter jacks, *everything* of metal protruding through the front panel or capable of being touched or *nearly* touched by the operator. This applies whether or not the panel itself is of metal. Do not rely upon the insulation of meter cases or tuning knobs for protection.

The B negative or chassis of all plate power supplies should be connected together, and to an external ground such as a waterpipe. In the

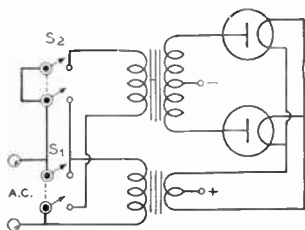

Figure 3.

FOOLPROOF RECTIFIER PROTECTION.

No matter which switch is thrown first, the filaments always will be turned on first and off last. The primaries of other filament transformers are connected in parallel with the primary of the rectifier filament transformer.

case of a bias supply, the B positive should be connected to the common ground.

Exposed Wires and Components

It is not necessary to resort to rack and panel construction in order to provide complete enclosure of all components and wiring of the transmitter. Even with bread-board construction it is possible to arrange things so as to incorporate a protective housing which will not interfere with ventilation yet will prevent contact with all wires and components carrying high voltage d.c. or a.c.

If everything on the front panel is at ground potential (with respect to external ground) and all units are effectively housed with protective covers, then there is no danger except when the operator must reach into the interior part of the transmitter, as when changing coils, neutralizing, adjusting coupling, or shooting trouble. The latter procedure can be made safe by making it possible for the operator to be *absolutely certain* that all voltages have been turned off and that they cannot be turned on either by short circuit or accident. This can be done by incorporation of the following system of main primary switch and safety signal light.

Combined Safety Signal and Switch

The common method of using red pilot lights to show when a circuit is "on" is useless except from an ornamental standpoint. When the red pilot is not lit it *usually* means that the circuit is turned off, but it *can* mean that the circuit is on but the lamp is burned out or not making contact.

To enable you to grab the tank coils in your transmitter with absolute assurance that it is impossible for you to obtain a shock except from possible undischarged filter condensers (see following topic for elimination of this hazard), it is only necessary to incorporate a device similar to that of Figure 4. It is placed near the point where the main 110-volt leads

enter the room (preferably near the door) and in such a position as to be inaccessible to small children. Notice that this switch breaks *both* leads; switches that open just one lead do not afford complete protection, as it is sometimes possible to complete a primary circuit through a short or accidental ground. Breaking just one side of the line may be all right for turning the transmitter on and off, but when you are going to stick an arm inside the transmitter, *both* 110-volt leads should be broken.

When you are all through working your transmitter for the time being, simply throw the main switch to neutral. Then you can leave the transmitter and even go on a vacation with absolute peace of mind.

When you find it necessary to work on the transmitter or change coils, throw the switch so that the green pilots light up. These can be ordinary 15-watt green bulbs. One should be placed on the front panel of the transmitter; others should be placed so as to be easily visible when changing coils or making adjustments requiring the operator to reach inside the transmitter. These lamps are inexpensive, and as several will draw less than 100 watts from the line, a half dozen may be scattered around the transmitter.

For 100 per cent protection, just obey the following rule: *never work on the transmitter or reach inside any protective cover except when the green pilots are glowing.* To avoid confusion, no other green pilots should be used on the transmitter; if you want an indicator jewel to show when the filaments are lit, use amber instead of green.

If the main switch is out of reach of small children, a conspicuous sign, such as "DO

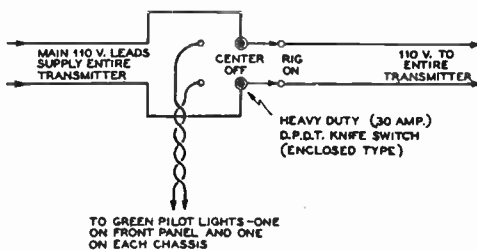

Figure 4.

COMBINED MAIN SWITCH AND SAFETY SIGNAL.

After shutting down the transmitter for the day, throw the main switch to neutral. If you are going to work on the transmitter, throw the switch all the way to "pilot," thus turning on the green pilot lights and making it impossible for there to be primary voltage on any transformer in the transmitter even by virtue of a short or accidental ground. To live to a ripe old age, simply obey the rule of "never work on the transmitter unless green lights are on."

NOT TOUCH UNDER ANY CIRCUMSTANCES," placed on the switch cover will guard against the off chance that someone else would throw the switch unexpectedly. An alternative is to place the switch on the under side of the operating table out of sight. The latter is not so desirable when small children have access to the room.

Safety Bleeders High capacity filter condensers of good quality hold their charge for some time, and when the voltage is more than 1000 volts it is just about as dangerous to get across an undischarged 4- μ fd. filter condenser as it is to get across a high voltage supply that is turned on. Most power supplies incorporate bleeders to improve regulation, but as these are generally wire-wound resistors, and as wire-wound resistors occasionally open up without apparent cause, it is desirable to incorporate an auxiliary safety bleeder across each heavy-duty bleeder. Carbon resistors will not stand much dissipation and sometimes change in value slightly with age. However, the chance of their opening up when run well within their dissipation rating is almost unheard of.

To make *sure* that all condensers are bled, it is best to short each one with an insulated screwdriver. However, this is sometimes awkward and always inconvenient. One can be virtually sure by connecting auxiliary carbon bleeders across all wire-wound bleeders used on supplies of 1000 volts or more. For every 500 volts, connect in series a 500,000-ohm 1-watt carbon resistor. The drain will be negligible (1 ma.) and each resistor will have to dissipate only 0.5 watt. Under these conditions the resistors will last indefinitely with no chance of opening up. For a 1500-volt supply,

connect three 500,000-ohm resistors in series. If the voltage exceeds an integral number of 500 volt divisions, assume it is the next higher integral value; for instance, assume 1800 volts as 2000 volts and use four resistors.

Do *not* attempt to use fewer resistors by using a higher value for the resistors; not over 500 volts should appear across any single 1-watt resistor.

In the event that the regular bleeder blows, it will take several seconds for the auxiliary bleeder to drain the condensers down to a safe voltage, because of the very high resistance. Hence, it is best to allow 10 or 15 seconds after turning off the plate supply before attempting to work on the transmitter.

"Hot" Adjustments Some amateurs contend that it is almost impossible to make certain adjustments, such as coupling and neutralizing, unless the transmitter is running. The best thing to do is to make all neutralizing and coupling devices adjustable from the front panel by means of flexible control shafts which are broken with insulated couplings to permit grounding of the panel bearing.

If your particular transmitter layout is such that this is impracticable and you refuse to throw the main switch to make an adjustment—throw the main switch—take a reading—throw the main switch—make an adjustment—and so on, then protect yourself by making use of long adjusting rods made from $\frac{1}{2}$ -inch dowel sticks which have been wiped with oil when perfectly free from moisture.

If you are addicted to the use of pickup loop and flashlight bulb as a resonance and neutralizing indicator, then fasten it to the end of a long dowel stick and use it in that manner.

Exciters and Low Powered Transmitters

As we go to press, the F. C. C. has assigned no post-war low-frequency amateur bands. The Government proposes to withhold the 160-meter band from amateurs and to assign a new 21-21.5-Mc. band. Other likely allocations are 3.5-4, 7-7.3, 14-14.4, and 28-29.7 Mc. The equipment shown in this chapter covers pre-war 10-, 20-, 40-, 80-, and 160-meter bands. Coils to accommodate new bands may be designed from data appearing under TRANSMITTER THEORY and in CHAPTER 28.

SIMPLE 15-WATT TWO BAND EXCITER OR TRANSMITTER

Illustrated in Figures 1 and 2 is the simplest practical exciter or transmitter for fixed-station use. It uses only one tube and one crystal, and with four easily wound coils provides about 15 watts output on 80 meters and approximately 12 watts on 40. With few exceptions, the parts are all inexpensive standard receiver items. With the particular antenna-coupling circuit illustrated, the unit may be used with a wide variety of antennas, although the simple antenna to be described is strongly recommended. It gives good performance on both bands.

The unit operates as a regenerative crystal oscillator of the harmonic type on 40 meters and as a straight tetrode crystal oscillator on 80 meters. The change from one form of oscillator to the other is taken care of automatically when the coils are changed, as a result of the jumper in the 80-meter coil.

If the unit is used as an exciter, the antenna coupling tank L_2 and C_2 may be omitted, the output of the oscillator being link coupled to the following stage instead. The antenna tank circuit illustrated was included in the model shown because it can be used in conjunction with an end-fed wire for 2-band operation. If the unit is first used as a transmitter and then later used as an exciter when another stage is added, the antenna tank circuit can be removed from the oscillator unit and used as the grid tank of the amplifier.

Construction The whole transmitter is built on a $9\frac{1}{2} \times 6\frac{1}{2} \times 1$ inch thick wooden baseboard to which is mounted a $10\frac{1}{2} \times 6\frac{1}{2}$ inch "Presdwood" front panel.

Baseboard-mounting type bakelite sockets are used for both the tube and the coils. Five-prong sockets are used for the coils and a 6-prong one for the tube. Another 5-prong

socket of the same type is placed directly behind the tube and used to mount the crystal.

The panel supports the two midget "tank" condensers, C_1 and C_2 , and the 0-100 ma. meter. A small through-type insulator directly above the antenna-tuning condenser is used for an antenna terminal.

The two Fahnestock clips at the right rear of the baseboard are used for key connections. A small 4-terminal strip at the left rear of the baseboard provides a convenient method of making heater and plate voltage connections to the power supply. The only other components mounted on either the panel or base are two 2-terminal tie points. These are screwed to the baseboard, one between each coil and condenser. They are used to support the coupling links, to be described later.

Wiring With the exception of the coupling link, the heater leads, and one of the meter leads, all wiring is done with no. 14 bus-bar. This heavy wire allows the various fixed condensers and resistors to be supported directly from the wiring.

A single piece of bus-bar running along the back of the baseboard between the tube and the crystal, and connected to one of the power supply terminals at one end, and to one of the key terminals at the other is used for a *common ground* lead. All of the ground connections shown on the diagram are made to this lead, which in turn should be connected to a waterpipe or other good external ground.

As may be seen from the diagram, there is a link around each coil. These links couple the plate coil to the simple antenna-matching circuit. The link around the plate coil is 3 turns of push-back wire, while the one around the antenna coil is 4 turns of the same type of wire. The links are each $1\frac{3}{4}$ inches in diameter and are permanently connected in the transmitter. They are supported by the tie-points

previously mentioned. Two small pieces of tape wrapped around each link coil serve to hold the turns together. The link around the plate coil should be placed at such a height above the socket that when the plate coil is plugged in, the link is around the bottom portion of the coil. The bottom of the plate coil should be the end which is connected through C_3 to ground on 40 meters and, by means of the jumper, directly to ground on 80 meters.

The link coil around the antenna coil should be positioned so that it falls at the center of the antenna coil. About 6 inches of twisted push-back wire is used as a coupling line between the two coils. The twisted line is connected to tie-points at each end of the line.

Coils The jumper on the 80-meter coil allows the transmitter to work as a conventional tetrode oscillator on 80 meters and as a regenerative oscillator on 40 meters.

The antenna coil connections are the same for both bands. If socket connections are made as the diagram shows, the two ends of the coils are connected to the cathode and plate prongs, and the center tap to the grid prong.

The leads to the key may be any reasonable length (up to 10 feet, if necessary). A 0.02- μ f.d. condenser, C_1 , is connected directly across the key. This condenser is used to minimize key clicks and is most effective when placed right at the key rather than in the transmitter. Be sure the frame of the key connects to the grounded key terminal and not the terminal that goes to the meter.

Power Supply The power supply recommended is a standard brute-force filtered affair using receiver compon-

COIL TABLE

| Band | Plate Coil | Antenna Coil |
|------|--|---|
| 80 | 41 turns, close-wound | 50 turns center-tapped, close-wound |
| 40 | 21 turns, spaced to a length of two inches | 26 turns, center-tapped, spaced to a length of two inches |

All coils wound with no. 20 double-cotton-covered wire on 1½" dia. forms.

ents throughout. The parts are mounted on a small baseboard in a convenient manner, and the heater and plate voltage connections brought out to a 4-post terminal strip similar to that on the transmitter. The power transformer should not deliver more than 350 volts r.m.s. each side of the c.t. or else the peak voltage on the filter condensers will be too high when the key is up.

Antenna The best type of antenna for use with this transmitter is the end-fed half-wave 80-meter type. Such an antenna, if erected reasonably in the clear, will give good results on both 80 and 40 meters. On both bands the antenna is not particularly directional, although a slight increase in signal strength will be noticed in certain directions. On 40 meters the antenna produces low-angle radiation, an advantage in working dx.

The antenna should measure 135 feet from the far end to the antenna terminal on the transmitter, and be erected in the clear and as high and as much in a straight line as possible.

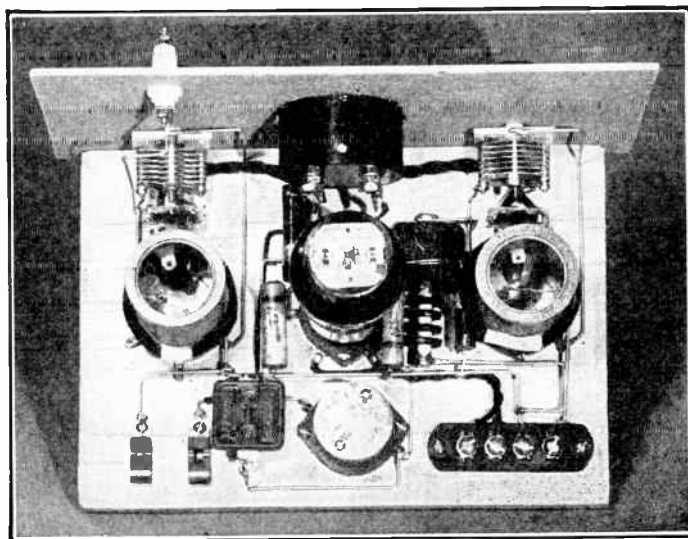

Figure 1.
SIMPLEST PRACTICAL EXCITER OR TRANSMITTER.

This unit delivers 12 to 15 watts on 40 or 80 meters with an 80-meter crystal. The antenna coupling tank (to the left) can be omitted if this unit is to be used only as an exciter.

Tuning Up If all the wiring has been done properly, no difficulty should be experienced in placing the transmitter in operation. Leads to the power supply and key should be connected (ordinary lamp cord of good quality will do), and a 6.3-volt 150-ma. dial light placed in series with the antenna at the transmitter. A crystal with a frequency between 3502 and 3648 kc. should be placed in the crystal socket. One in this range will allow operation on both the 80- and 40-meter bands.

When the transmitter is properly adjusted for 80-meter operation, it should be possible to tune the antenna coupling circuit through resonance without pulling the oscillator out of oscillation. The dial light should increase in brilliance as the antenna circuit is tuned up to resonance and then decrease as it is detuned from resonance on the other side.

When this condition is obtained, remove the dial lamp from the antenna and make the antenna connection directly to the antenna post. Then, without touching the antenna-tuning condenser, turn the plate condenser toward maximum capacity until the point of maximum capacity at which the circuit will still oscillate is found. The final adjustment of the plate condenser should be made while listening to the signal from the transmitter in a monitor or receiver. The condenser should be set at the

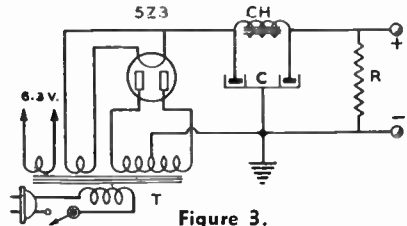

Figure 3.

RECOMMENDED POWER SUPPLY.

- T—700 v.c.t., 90 ma.; 5 C—Dual 8- μ fd. electro-lytic, 450 v.
- CH—30 hy., 110 ma. R—40,000 ohms, 20 watts

furthest point toward maximum capacity at which the keying is clean and distinct without chirps or lag.

The farther down the plate coil the coupling link is placed, the looser the coupling to the antenna circuit. If the coupling is too tight, the oscillator won't oscillate or the note will be chirpy. If the coupling is too loose, full power will not be delivered to the antenna.

The coupling should be adjusted by varying the position of the *plate coil coupling link*. never by detuning the antenna condenser, which should always be tuned to resonance. If it cannot be tuned to resonance without the transmitter's going out of oscillation or developing keying chirps, the coupling is too tight.

If the dial lamp in the antenna lead does not give sufficient indication to be observed handily, a 2-volt 60-ma. bulb may be substituted. Do not use a 60-ma. lamp unless you are unable to get a satisfactory indication on a 150-ma. bulb. The maximum antenna current will be low at this point (a current "node") and will vary somewhat in different antenna installations.

On 40 meters the tuning is simpler, because the transmitter acts as a regenerative harmonic oscillator and will oscillate and key cleanly regardless of how heavily the plate circuit is loaded. Therefore, it is necessary only to tune for greatest output, without regard to keying chirps or non-oscillation.

When the unit is used as an exciter the tuning is the same except that instead of tuning for greatest brilliancy of the lamp in the antenna lead, adjustments should be made for maximum grid current to the following stage. Coupling is adjusted as described for operation with an antenna; the position of the link around L_1 is varied until the desired coupling is obtained. *Be sure to turn off the power supply before making coupling adjustments.*

5-WATT 160 METER V.F.O.

Illustrated in Figures 4, 5, 6, and 7 is a variable frequency exciter which is very stable,

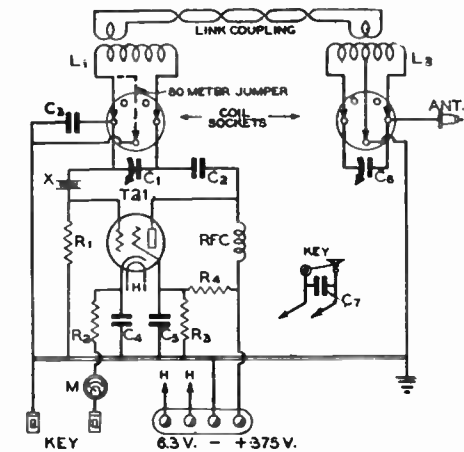

Figure 2.

THE R.F. PORTION OF THE TRANSMITTER

- C₁—50- μ fd. midget variable
- C₂—0.01- μ fd. mica
- C₃—0.0005- μ fd. mica
- C₄, C₅—0.01- μ fd. 600-volt tubular
- C₆—50- μ fd. midget variable
- C₇—0.02- μ fd. 600-volt tubular
- R₁—100,000 ohms, 1 watt
- R₂—400 ohms, 10 watts
- R₃—20,000 ohms, 10 watts
- R₄—5000 ohms, 10 watts
- RFC—2.5-mh., 125-ma. choke
- X—20-meter X or AT crystal
- L₁, L₂—See coil table
- M—0-100 milliamperes

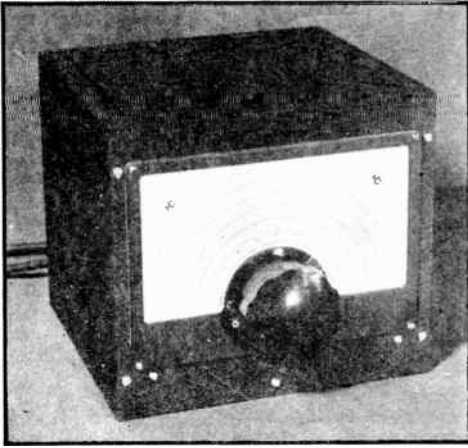

Figure 4.
5-WATT 160 METER V.F.O. OF HIGH STABILITY.

Delivering its output in the 160 meter band, this unit can be used for all band operation. It takes up very little room on the operating table, the frequency doublers being made part of the transmitter proper instead of being incorporated in the frequency control unit.

is free from drift, and uses relatively few parts. The output is on 160 meters, which permits operation on all bands. To minimize the size of the unit on the operating table, frequency doublers are incorporated in the transmitter proper instead of being made an integral part of the v.f.o. unit. The output is approximately 5 watts.

To minimize frequency drift from heating, the two amplifier stages are allowed to run continuously, the oscillator being switched on and off with the main transmitter. Thus, the amplifier stages dissipate approximately the same amount of heat regardless of whether or

not the oscillator is running. These two stages derive plate supply from a small 275-volt pack which is turned on with the transmitter filaments; it feeds no other stages.

To reduce drift further, this power pack and the voltage regulator tube for the oscillator are made external to the tube, and all tubes in the v.f.o. unit are mounted so as to project from the cabinet as shown in the photographs. The greatest portion of the heat radiated by the tubes is kept outside the cabinet, and the remainder is kept from affecting the oscillator components by proper ventilation of the cabinet. Except for a few minutes when the device is first turned on, the drift is negligible even when doubling to 10 meters.

A standard high-C Hartley oscillator feeds an untuned class A buffer, which in turn feeds a fixed-tuned class A amplifier. This arrangement provides excellent isolation of the oscillator, yet requires only one tuning condenser.

The output circuit is designed for use with a 70-ohm coaxial line to the transmitter proper. This may be of the inexpensive, flexible type having rubber dielectric. If the following tube requires 25 peak volts or less of r.f. voltage, no tuned circuit is required at the far end of the line. The line simply is terminated at the far end in a resistor consisting of two 150-ohm 2-watt carbon resistors in parallel, giving a terminating resistance of 75 ohms. The grid of the tube to be excited is coupled through a blocking condenser from the "hot" end of the terminating resistor. A 6L6, 6V6, 807, etc. driven in this manner will receive sufficient excitation for efficient operation either as a doubler or straight amplifier, and the coupling line may be made any length without detrimental effects.

Where greater drive is required, such as might be the case where a tube such as an 813, 809, etc. is to be excited, the coaxial line is link-coupled to a tuned circuit at the trans-

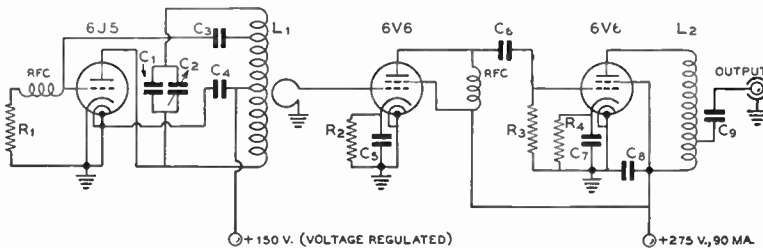

Figure 5.
SCHEMATIC DIAGRAM OF 160 METER V.F.O.

- | | | | | | | | | | | | | | | |
|--|------------------------------------|---|---------------------------------------|---------------------------------------|---|---------------------------------------|--|---------------------------------------|----------------------------------|-----------------------------------|----------------------------------|-----------------------------------|-------------------|--|
| C ₁ —335- μ fd. midget condenser (used as fixed padder) | bearing type, semi-circular plates | C ₂ —100- μ fd. zero temperature co-efficient mica condenser | C ₃ —0.006- μ fd. mica | C ₄ —0.006- μ fd. mica | C ₅ —0.05- μ fd. tubular | C ₆ —0.006- μ fd. mica | C ₇ , C ₈ —0.05- μ fd. tubular | C ₉ —0.006- μ fd. mica | R ₁ —300 ohms, 1 watt | R ₂ —1000 ohms, 1 watt | R ₃ —300 ohms, 1 watt | R ₄ —1000 ohms, 1 watt | RFC—2.5 mh. choke | L ₁ , L ₂ —Refer to text |
|--|------------------------------------|---|---------------------------------------|---------------------------------------|---|---------------------------------------|--|---------------------------------------|----------------------------------|-----------------------------------|----------------------------------|-----------------------------------|-------------------|--|

mitter end in the conventional manner. Using this arrangement, the full output of the exciter will be available as excitation to the transmitter. Thus, much greater driving voltage is obtained, but at the expense of an additional tuned circuit.

All parts of the oscillatory circuit are made as solid mechanically as is possible. The stability of a v.f.o. depends as much as anything upon mechanical construction. While a cast type chassis and cabinet is preferable, the standard type shown is satisfactory because of its small size. A larger cabinet and chassis of this type would lack sufficient rigidity.

The cabinet measures 7 inches high by 8 inches wide by 8 inches deep. The chassis measures 7 inches by 7 inches by 1½ inches deep. For the sake of rigidity, a "closed end" type chassis should be chosen in preference to an open ended type. Holes are drilled in the rear of the cabinet to accommodate not only the power and output cables, but also the three tubes, as shown in Figure 7. Several ⅜-inch holes are drilled along the top rear of the cabinet, as shown in this illustration, to encourage what heat is generated or transferred inside the cabinet to be carried out as quickly as possible by convection.

All oscillator components are placed above chassis, all amplifier components below. This minimizes capacity coupling feedback, as the only r.f. connection between the upper and lower decks is via the single turn coupling link around the cold portion of the oscillator coil.

The socket for the oscillator tube is mounted by means of heavy brackets so that the tube

may be allowed to protrude out the rear of the cabinet in the same manner as the amplifier tubes. The tuning condenser is supported by means of 1½-inch ceramic pillars and small brackets. The padding condenser is supported on the tuning condenser by means of small strips of aluminum cut and drilled to accommodate the condenser bolts and studs so that the two condensers are mounted back to back about ½-inch apart. The tuning condenser is mounted upside down, as shown in the illustration. The assembly is further strengthened by an aluminum cross brace between the stator lug of the top condenser and one end of the coil form. This brace also serves as an electrical connection between the condenser and coil. The ceramic coil form is raised off the chassis by means of ¾-inch ceramic pillar insulators.

As the rotor of the tuning condenser is "hot," it must be insulated from the metal parts of the dial (which are grounded). This automatically is taken care of in the particular dial used in the unit illustrated, as an insulated coupling is an integral part of the dial mechanism. A smooth working dial with no backlash is a virtual necessity.

Because of the comparatively large amount of lumped padding capacity across the tank, a tuning condenser with semi-circular plates will provide a more uniform distribution of kilocycles than will a modified plate shape. The frequency coverage is from 1750 to 2050 kc., with a few kilocycles overlap at each end.

Coils The temperature coefficient of the oscillator coil is minimized by using

Figure 6.
INTERIOR CONSTRUCTION
OF 160 METER V.F.O.

All parts of the oscillator circuit are made very rigid. The connector at the far end of the chassis back-drop is for the coaxial output cable, the near one for power connections.

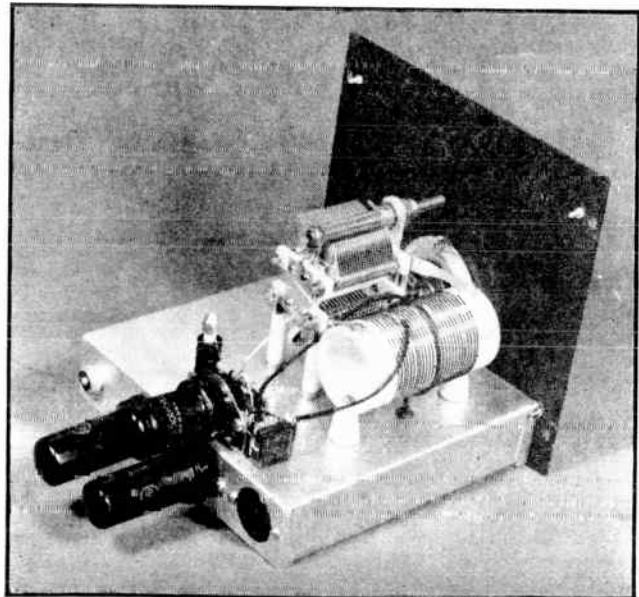

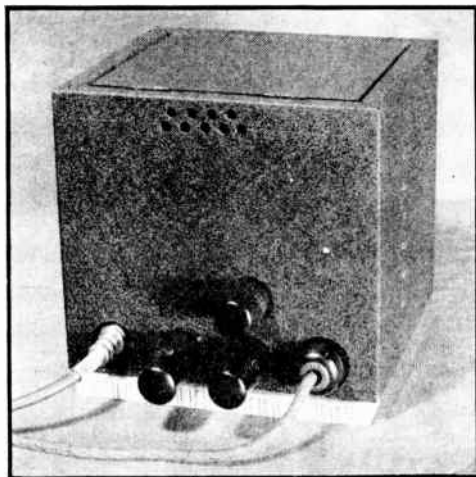

Figure 7.
REAR VIEW OF 160 METER V.F.O.
CABINET.

Holes are punched in the rear of the cabinet just large enough to take the tubes. Air entering the lower side louvres and leaving by the holes in the top rear of the cabinet keeps what little heat is generated inside the cabinet from affecting the oscillator components.

a ceramic form and winding on the wire in such a manner that it is under tension. The wire first is stretched until it is near the breaking point. Then, with both wire and form maintained at a temperature as high as will permit handling, the wire is wound tightly on the form. When the wire and form cool to room temperature, the wire will be under considerable tension, and the linear expansion of the wire with changes in room temperature will be greatly reduced. The temperature coefficient of the ceramic form is only about $\frac{1}{8}$ that of the copper wire, while the coefficient of a bakelite form (commonly used for the purpose) is about twice that of the copper wire. Another advantage of the ceramic form is that its white color reflects any small amount of radiant heat that may reach it, whereas black bakelite would not. Because of these various precautions, no temperature compensating capacitors are required in order to avoid frequency drift.

The ceramic form measures $1\frac{3}{4}$ inches in diameter by $3\frac{1}{2}$ inches long. The coil contains 26 turns of no. 20 enamelled, spaced to cover $2\frac{3}{8}$ inches on the form. The wire first is stretched as previously described and wound on the form while warm. The coil is tapped at the exact center and at 6 turns from the center. In making the tapped connections, care must be taken not to heat the wire on the form any more than is necessary to make a good

soldered joint, or it will lose its tension on the form. If this happens, the coil should be heated and the wire pulled tight again.

The untuned output coil consists of 82 turns of no. 26 d.c.c. scramble-wound over a space of about $\frac{1}{2}$ inch on a 1-inch diameter bakelite form. It is tapped 8 turns from the ground end for the output connection. The turns are held in place by coil dope or Duco cement.

The coupling link from the oscillator to the buffer consists of a single turn of hookup wire around the center of the coil.

Operation The unit should be set on a piece of sponge rubber to protect it from jars or vibration. A piece of typewriter pad or "kneeling pad" will be satisfactory. When possible, the exciter should be allowed to warm up for 5 or 10 minutes before operating the v.f.o. unit on the air.

The cascaded frequency multiplier unit described later in this chapter is particularly well suited for use with this v.f.o. unit, providing output on 160, 80, 40, or 20 meters at the flip of a switch.

25-WATT V.F.O. FOR 80, 40, AND 20 METERS

Illustrated in Figures 8-11 is a v.f.o. unit which delivers 20-25 watts on either 80, 40, or 20 meters simply by changing one coil. The power supply is self-contained, drift as a result of heat being minimized by proper compensation. The unit is patterned after a design developed by G. W. Shuart.

The 6SJ7 electron-coupled oscillator operates on 160 meters, covering the range from 1750 to 2000 kc. The frequency control components are procurable as a standard manufactured unit which has been designed for mechanical stability and low temperature co-

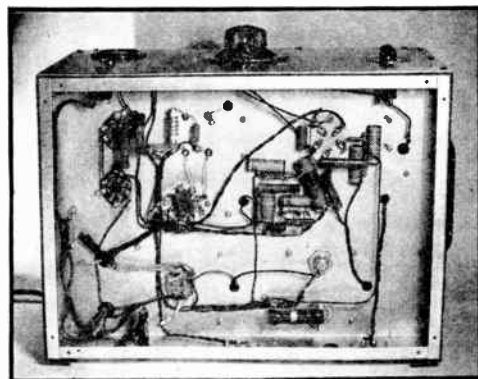

Figure 8.
UNDER-CHASSIS VIEW OF
25-Watt V.F.O.

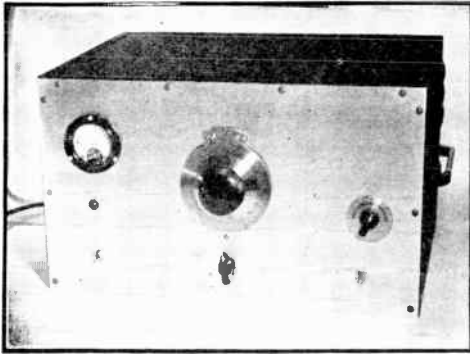

Figure 9.
20-25 WATT V.F.O. FOR 20, 40, AND 80 METERS.

Incorporating an 807 output tube and integral 500-volt power supply, this v.f.o. is capable of considerably more output than most. Because of the high power output and multi-band operation, it is more properly termed a "v.f.o.-exciter."

efficient of frequency. The unit is comprised of a shield can which houses L_1 , C_a , C_b , C_c , C_s and R_1 .

The output of the 6SJ7 oscillator is tuned to 80 meters by a broadly tuned tank, also available as a standard unit. The characteristics of this unit are such that most of the 3500-4000 kc. band can be covered without the necessity for retuning the trimmer condenser. When operating on higher frequency bands, the trimmer is set for about 3600 kc. and left alone.

The 80 meter tank excites a 6SK7 whose output is fixed-tuned to a frequency near the center of the 7 Mc. band. The permeability

tuned 40-meter coil is a stock item. The following stage, the 807, is tuned either to 20 meters (on which frequency it operates as a doubler), to 40 meters, or to 80 meters. Enough 80-meter excitation is developed across the low-C 40-meter tank L_3 to permit the 807 to operate on 80 meters with about the same efficiency as is obtained when doubling. Thus, to obtain output on any of the three bands, it is necessary only to change the output coil L_4 .

On the higher frequency bands it will be unnecessary to retune L_1 when moving from one portion of the band to another, but to cover the extreme limits of the 80-meter band it will be necessary to readjust C_s for maximum output.

Compound voltage regulation is used on the oscillator screen, and standard regulation on the plate. This makes the oscillator absolutely immune to changes in line voltage.

By means of S_3 , it is possible to change from oscillator keying to amplifier keying simply by throwing a switch. Fixed battery bias on the 807 reduces the plate and screen current to this stage to a very low value when the key is up during oscillator keying. By adjusting the switch S_3 for amplifier keying, it is possible to set the frequency with the aid of a receiver without putting a signal on the air simply by shutting the standby switch S_1 while the key is open. This assumes that the balance of the transmitter uses safety bias or else that the plate voltage is removed for the moment.

Coils As mentioned previously, all coils except L_1 are available as standard items. However, for those who might wish to construct their own, the specifications are given.

Figure 10.
INTERIOR CONSTRUCTION OF V.F.O.-EXCITER.

Because the required characteristic of the temperature compensating condenser is determined largely by the physical construction of the unit, it is recommended that the layout shown here be followed closely.

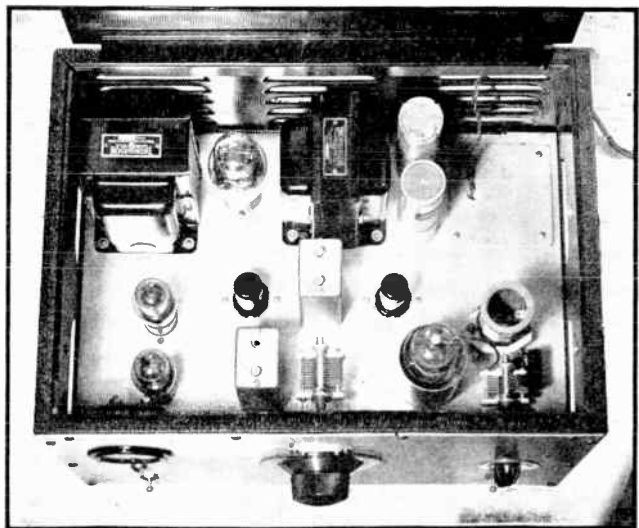

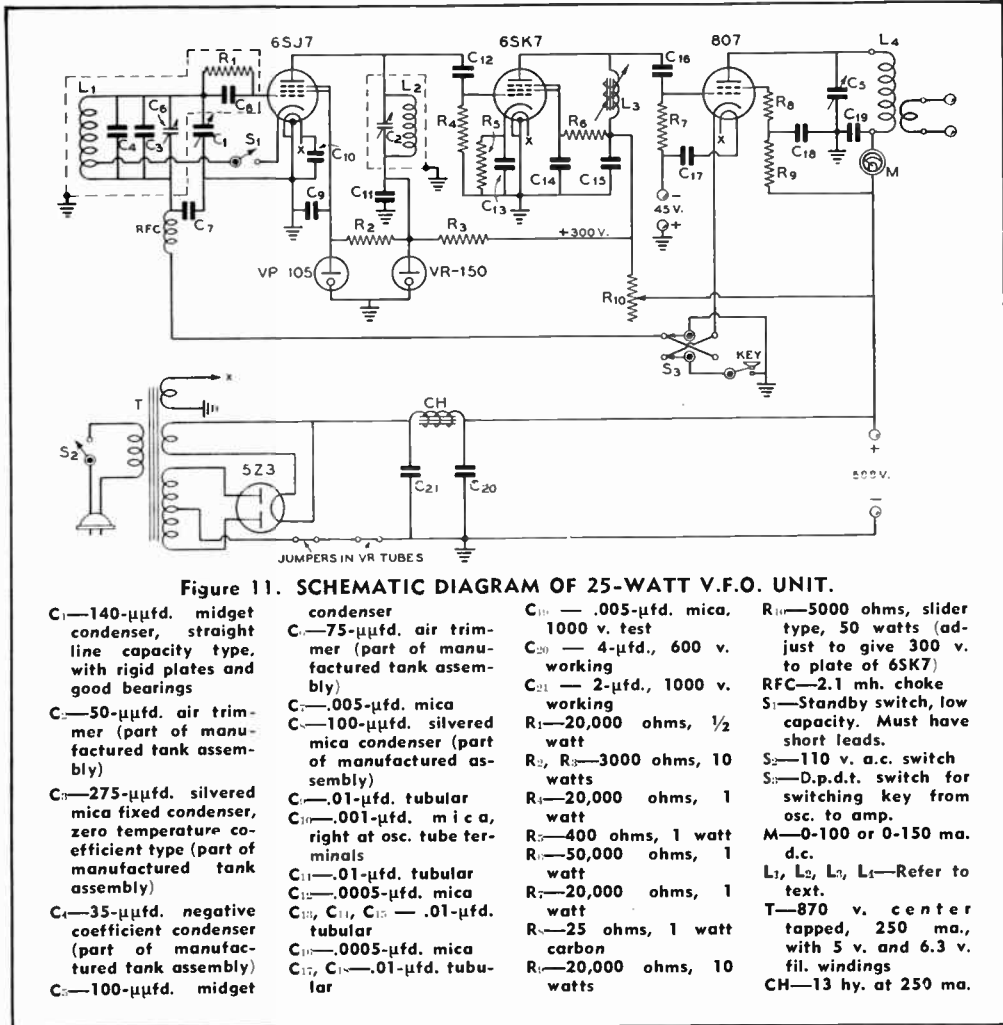

Figure 11. SCHEMATIC DIAGRAM OF 25-WATT V.F.O. UNIT.

- | | | | |
|---|--|--|--|
| <p>C₁—140-μfd. midget condenser, straight line capacity type, with rigid plates and good bearings</p> <p>C₂—50-μfd. air trimmer (part of manufactured tank assembly)</p> <p>C₃—275-μfd. silvered mica fixed condenser, zero temperature coefficient type (part of manufactured tank assembly)</p> <p>C₄—35-μfd. negative coefficient condenser (part of manufactured tank assembly)</p> <p>C₅—100-μfd. midget</p> | <p>condenser</p> <p>C₆—75-μfd. air trimmer (part of manufactured tank assembly)</p> <p>C₇—0.005-μfd. mica</p> <p>C₈—100-μfd. silvered mica condenser (part of manufactured assembly)</p> <p>C₉—0.01-μfd. tubular</p> <p>C₁₀—0.001-μfd. mica, right at osc. tube terminals</p> <p>C₁₁—0.01-μfd. tubular</p> <p>C₁₂—0.0005-μfd. mica</p> <p>C₁₃, C₁₄, C₁₅—0.01-μfd. tubular</p> <p>C₁₆—0.0005-μfd. mica</p> <p>C₁₇, C₁₈—0.01-μfd. tubular</p> | <p>C₁₉—0.005-μfd. mica, 1000 v. test</p> <p>C₂₀—4-μfd., 600 v. working</p> <p>C₂₁—2-μfd., 1000 v. working</p> <p>R₁—20,000 ohms, 1/2 watt</p> <p>R₂, R₃—3000 ohms, 10 watts</p> <p>R₄—20,000 ohms, 1 watt</p> <p>R₅—400 ohms, 1 watt</p> <p>R₆—50,000 ohms, 1 watt</p> <p>R₇—20,000 ohms, 1 watt</p> <p>R₈—25 ohms, 1 watt carbon</p> <p>R₉—20,000 ohms, 10 watts</p> | <p>R₁₀—50 ohms, slider type, 50 watts (adjust to give 300 v. to plate of 6SK7)</p> <p>RFC—2.1 mh. choke</p> <p>S₁—Standby switch, low capacity. Must have short leads.</p> <p>S₂—110 v. a.c. switch</p> <p>S₃—D.p.d.t. switch for switching key from osc. to amp.</p> <p>M—0-100 or 0-150 ma. d.c.</p> <p>L₁, L₂, L₃, L₄—Refer to text.</p> <p>T—870 v. center tapped, 250 ma., with 5 v. and 6.3 v. fil. windings</p> <p>CH—13 hy. at 250 ma.</p> |
|---|--|--|--|

Coil L₁ consists of 30 turns of no. 24 enamelled, close-wound on a 7/8-inch diameter ceramic form, with cathode tap 10 turns from the ground end, mounted in coil shield.

Coil L₂ consists of 60 turns of no. 24 enamelled wire, close-wound on 7/8" diameter form.

Coil L₃ consists of 36 turns of no. 28, close-wound on 5/8-inch diameter form with adjustable "tuning plug."

Coils for L₁ all are wound on standard 1 1/2-inch diameter 5-prong forms. The 80-meter coil consists of 38 turns of no. 24 spaced to 1 5/8 inches with a 10-turn link at the cold end.

The 40-meter coil consists of 18 turns of no. 20, spaced to 1 1/2 inches, with a 5-turn link at the cold end. The 20-meter coil consists of 9 turns of no. 16, spaced to 1 1/4 inches, with a 3-turn link at the cold end.

Because the requirements of the temperature compensating condenser are determined largely

by the physical construction of the v.f.o. unit, it is important that the layout shown in the illustration be adhered to closely in order to keep the drift to a negligible value.

Data on the manufactured tank circuits will be found in the Buyer's Guide.

MULTI-BAND FREQUENCY MULTIPLIER

The cascaded doubler unit illustrated in Figures 12-15 permits output on any 4 consecutive amateur bands between 5 and 160 meters at the throw of a switch. The only difference is in the coil specifications given later on.

Output on the lowest frequency band will be determined by the power of the unit employed to excite the frequency multiplier, as on this band the excitation merely is "shunted around" the unit by the selector switch. Out-

Figure 12.
MULTI-BAND FREQUENCY MULTIPLIER.

This unit delivers approximately 15 watts on 10, 20, or 40 meters when supplied with 80-meter excitation. No coils need be changed when changing from band to band.

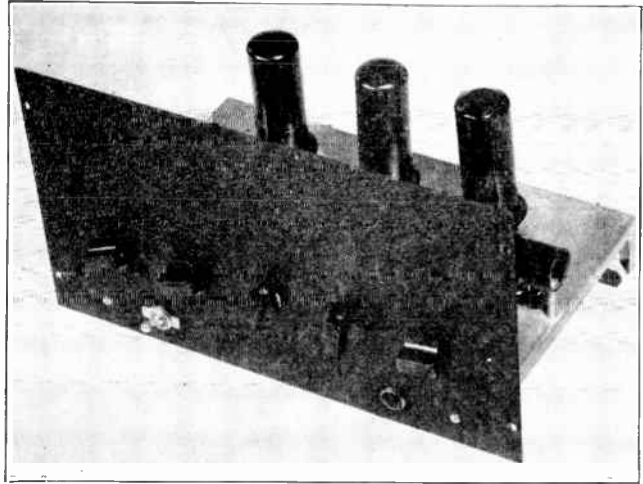

put of the doubler stages will be about 15 watts except on 5 meters, where the output will be close to 10 watts.

The unit consists of three 6L6 doubler stages, with provision for coupling out of any of them by means of a switch in the link circuit. This same switch also applies full screen voltage to the particular 6L6 which happens to be serving as the output tube, the others running at reduced screen voltage.

Except for the switching arrangement, the circuit is perfectly straightforward, excepting possibly for the incorporation of fixed battery bias. A standard duty 45-volt bias battery costs no more than cathode resistors and by-pass

condensers for the three stages, will last for at least 2 years, and permits better oscillator keying.

Construction The construction is shown clearly in the illustrations. A 7 x 11 inch chassis supports a 7 x 12 inch front panel. As the tank coils are all tuned to different bands, there is no need for taking special precautions to avoid coupling between coils. All four coils are wound on a single 10½-inch length of 1 inch dia. bakelite tubing. If desired, the coils can just as well be wound on four separate forms. Tuning condensers are supported from the chassis (not the panel) by

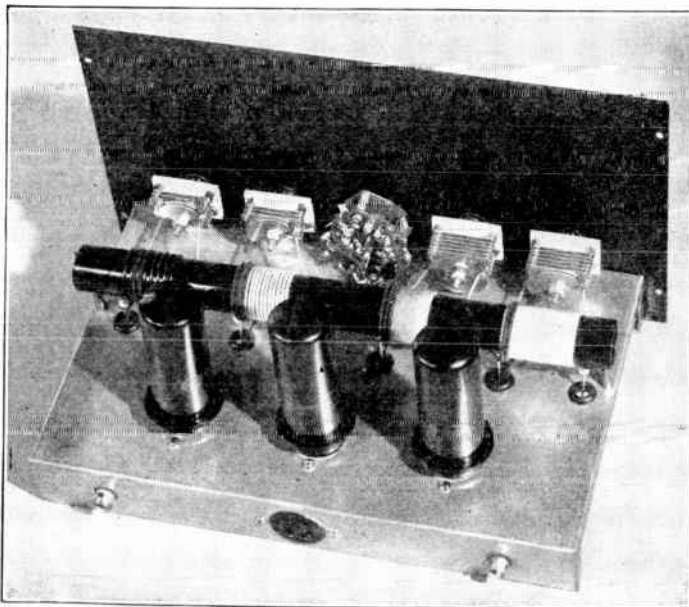

Figure 13.
SHOWING CONSTRUCTION OF MULTI-BAND FREQUENCY MULTIPLIER.

Because the coils all are tuned to a different band, there is little coupling between them even though mounted on a single winding form. Those shown here are for 80, 40, 20, and 10 meters.

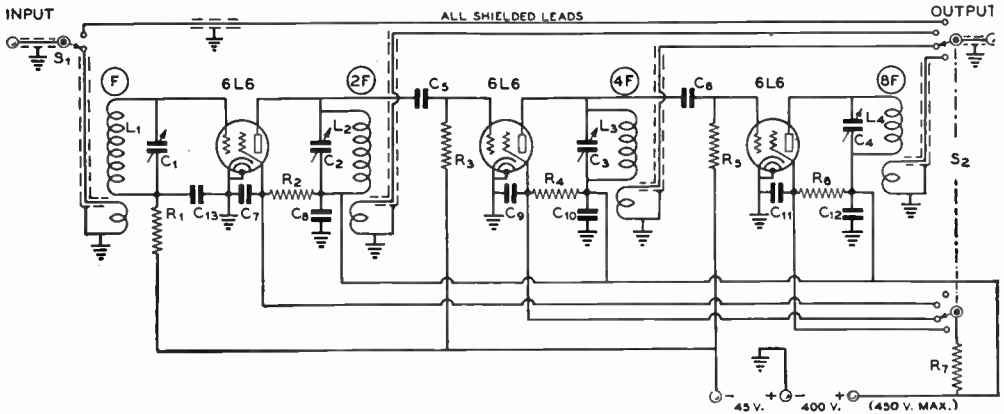

Figure 14.

SCHEMATIC DIAGRAM OF MULTI-BAND FREQUENCY MULTIPLIER.

- | | | | |
|--|--|---------------------------------------|--|
| C ₁ , C ₂ —35- μ fd. midget variable | C ₇ to C ₁₀ —0.003- μ fd. mica | R ₁ —50,000 ohms, 2 watts | S ₁ —Single-pole double-throw toggle switch |
| C ₃ , C ₄ —25- μ fd. midget variable | R ₁ —100,000 ohms, 2 watts | R ₂ —100,000 ohms, 2 watts | S ₂ —2-pole 4-throw rotary switch |
| C ₅ , C ₆ —25- μ fd. midget mica fixed | R ₂ —50,000 ohms, 2 watts | R ₃ —50,000 ohms, 2 watts | Coils—See text |
| | R ₃ —100,000 ohms, 2 watts | R ₄ —15,000 ohms, 10 watts | |

means of brackets furnished by the manufacturer.

Coils The 160-meter coil consists of 120 turns of no. 28 enamelled wire, close-wound, with a 4-turn link at the ground end.

The 80-meter coil consists of 48 turns of no. 24 d.c.c. close-wound, with a 3-turn link at the ground end.

The 40-meter coil consists of 23 turns of no. 20 d.c.c., close-wound, with a 3-turn link at the ground end.

The 20-meter coil consists of 13 turns of no. 18 d.c.c., spaced to 1 inch, with a 3-turn link at the ground end.

The 10-meter coil consists of 8 turns of no. 16 enamelled, spaced to 1 inch, with a 2-turn link at the ground end.

The 5-meter coil consists of 3 turns of no. 14 enamelled, spaced to 1 inch, with a 1-turn link at the ground end.

All coupling links are wound with no. 18 pushback hookup wire. Link connections are made as shown in Figures 13 and 15.

Operation When the three stages are properly resonated, only slight readjustment of the tuning knobs will be required to peak up the output when changing bands or moving from one end of the band to the other.

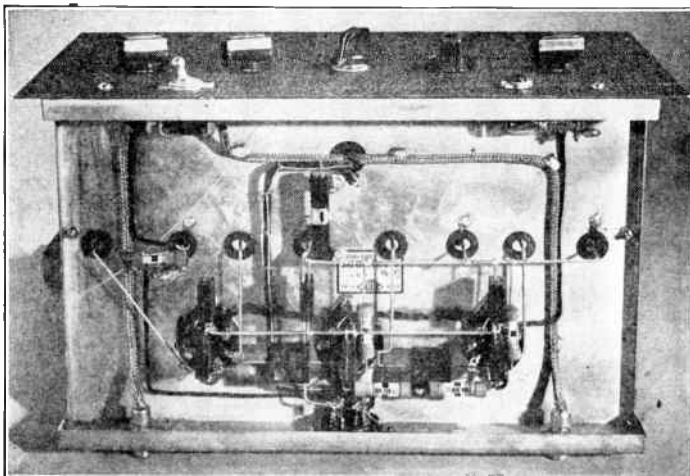

Figure 15. UNDER-CHASSIS VIEW OF MULTI-BAND FREQUENCY MULTIPLIER.

Auto radio antenna couplers are used for making link connections in and out of the unit. Either shielded solid conductor or twisted hookup wire may be used for the link coupling line.

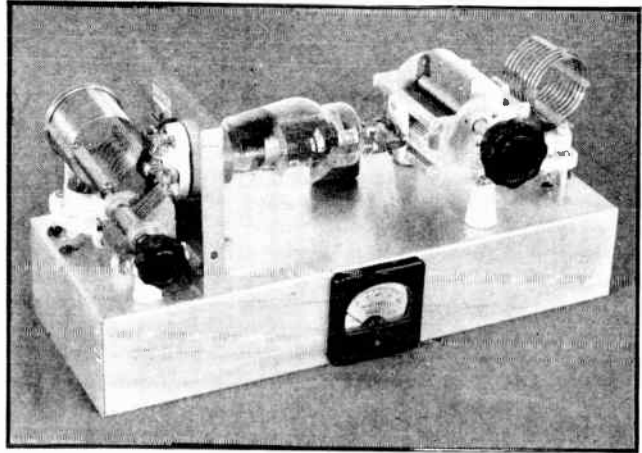

Figure 16.
25-WATT UTILITY UNIT,
USABLE EITHER AS AN R.F.
AMPLIFIER OR OSCILLATOR.
This unit may be used as a crystal oscillator on 160, 80, or 40 meters, or it may be used as an r.f. amplifier (either doubling or straight through) on any band from 10 to 160 meters.

When the unit is tuned up initially, care should be taken to make sure the various doublers are working on their second harmonic and not their third harmonic.

807 UTILITY UNIT

The unit illustrated in Figures 16-18 can be used as a 20-watt crystal oscillator on 160, 80, or 40 meters, or it can be used as a 25-watt straight amplifier on any amateur band from 10 to 160 meters, or it may be used as a 20-watt frequency doubler on any band from 10 to 80 meters.

When used as an amplifier, it may be either link-coupled or capacity-coupled to the exciter tank. When used as a crystal oscillator, the crystal is plugged into the two socket holes indicated in Figure 17. When capacity coupling is used to the unit, the same two connections are used. The coils are provided with a jumper so that when one is plugged into the grid socket the tuning condenser C₁ is cut into the circuit.

Manufactured type 50-watt end-linked coils are used, the jumper being added. Duplicate coils are not required for grid and plate, as the plate tank makes use of the coil designated by the manufacturer for use on the next higher frequency band (except on 10 meters). This provides a better value of Q in the single ended plate tank circuit, and minimizes the number of coils required to hit several bands. For instance, the "80-meter" coil is used as an 80-meter coil in the grid circuit, but is used as a 160-meter coil when used in the plate circuit. On 10 meters, however, a "10-meter" coil is used in the plate circuit, as the "5-meter" coil requires an excessive amount of capacity to hit 10 meters. Thus, for operation on all bands from 10 to 160 meters, two 10-meter coils would be required, but only one coil for each of the lower frequency bands.

Construction The unit is built on a chassis measuring 5 inches by 13½ inches by 2½ inches deep. However, a chassis of slightly different dimensions could be used just as well.

Because of the small diameter of the coils, coupling between them is kept to a satisfactory minimum simply by spacing them sufficiently. Electrostatic coupling between grid and plate circuits is prevented by the shield baffle which supports the 807 socket.

The design is such as to accommodate a front panel, the type being left to the preference of the individual constructor. If the con-

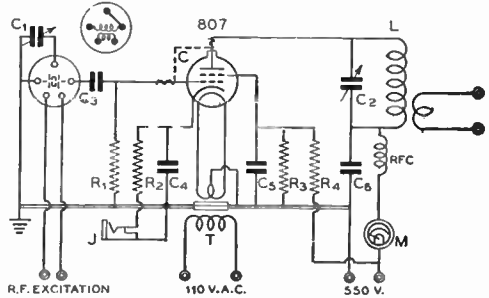

Figure 17.
SCHEMATIC DIAGRAM OF 25-WATT
UTILITY UNIT.

- C₁—100-μfd. midget condenser
- C₂—350-μfd. condenser, .03" air gap
- C₃—.001-μfd. midget mica
- C₄—.01-μfd. tubular paper
- C₅—.002-μfd. mica
- C₆—.005-μfd. mica, 1000 v.
- R₁—100,000 ohms, 1 watt
- R₂—500 ohms, 10 watts
- R₃—25,000 ohms, 10 watts
- R₄—10,000 ohms, 10 watts
- L—Manufactured type 50-watt plug-in coils
- M—0-100 or 0-150 ma. d.c.
- T—6.3 volt, 2 amp. fil. trans.
- RFC—2.5 mh. choke
- J—Closed circuit jack (for key)

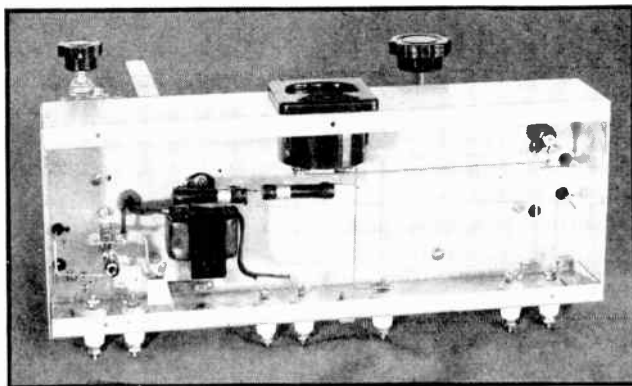

Figure 18.
UNDER-CHASSIS VIEW OF
UTILITY UNIT.

As will be observed in this illustration, the condensers are mounted so that the shafts project beyond the edge of the chassis, to permit use of a Masonite or metal front panel.

structor is concerned with symmetry of the panel layout, the grid condenser can be raised on higher standoffs so that the shaft height is the same as that of the plate condenser.

When the unit is used as a crystal oscillator, there is not sufficient feedback to support oscillation except possibly on 40 meters. Hence, when the unit is to be employed as an oscillator, a small piece of insulated wire must be tied to the grid prong of the 807 and run over the shield partition for about 3 inches towards the top of the 807. No more feedback coupling should be used on any band than is required to support stable oscillations, as excessive feedback capacity will result in a high value of r.f. crystal current.

Sufficient cathode bias is provided to limit the plate current to a safe value when no excitation is applied. This permits the unit to be used as an r.f. amplifier after a keyed oscillator or v.f.o.

The unit may be plate-screen modulated with excellent results. The only requirement is that there be sufficient excitation, and that the 807 not be too heavily loaded. The latter ap-

plies particularly when modulating the unit as a frequency doubler.

100-WATT BANDSWITCHING EXCITER OR TRANSMITTER

In Figures 19-23 is shown a unit delivering approximately 100 watts output on all bands from 10 to 160 meters without need for changing coils. Coil switching is incorporated in all three stages of the unit. Using an 814 beam tetrode in the last stage, the output approaches 100 watts on 10 meters and is well in excess of 100 watts on all lower frequency bands.

The oscillator is a conventional 6L6 tetrode type with a tank coil circuit that hits both 80 and 160 meters simply by rotating the condenser plates. To accommodate 40-meter crystals, a shorting switch is connected to a tap on the coil to permit shorting out of sufficient turns to hit 40 meters. The oscillator is run at moderate plate voltage and very low screen voltage to keep the r.f. crystal current low, as not much output is required to drive the 807 stage.

The 807 buffer utilizes a manufactured type midget coil turret to permit output on all bands simply by throwing the coil switch. However, the 10-meter section is not used, inasmuch as the output of the 807 is not sufficient when quadrupling from 40 meters to drive the 814; the latter requires more excitation on 10 meters than on the other bands, due to relatively high input capacity and resulting tank circuit losses with capacity coupling.

The 814 stage thus may be driven either on 1 or 2 times crystal frequency, and the 814 stage may be run either straight through or as a doubler, the efficiency being nearly as good when doubling as when working straight through as a result of high bias and adequate excitation. Thus, output from the 814 is available on 1, 2, or 4 times crystal frequency.

As the oscillator tank is mounted below the chassis, and the buffer and 814 amplifier tanks

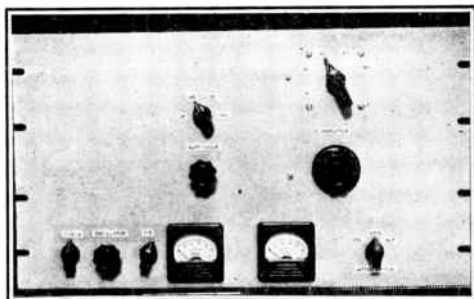
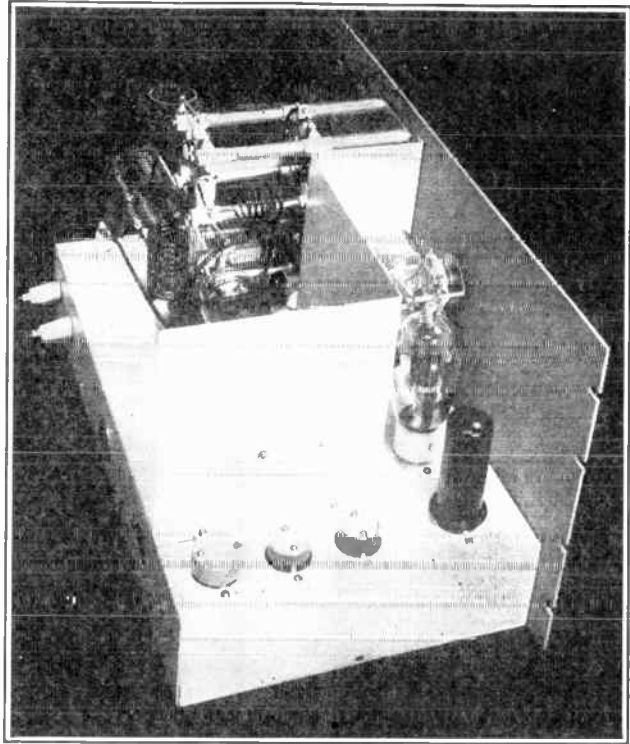

Figure 19.
100-WATT 10-160 METER BAND-
SWITCHING EXCITER.

This exciter delivers about 90 watts on 10 meters and well over 100 watts on lower frequency bands.

**Figure 20 (right).
REAR VIEW OF EXCITER
SHOWING OSCILLATOR
AND BUFFER.**

The 814 plate tank and bandswitch may be seen behind the shield baffle separating the oscillator and buffer from the final stage.



**Figure 21 (below).
UNDER-CHASSIS OF THE 100-
WATT 814 BANDSWITCHING
EXCITER.**

The tapped oscillator coil may be seen to the lower right. Most of the resistors are mounted on a terminal strip for the sake of neatness. The meter switch may be seen to the left of the two meters.

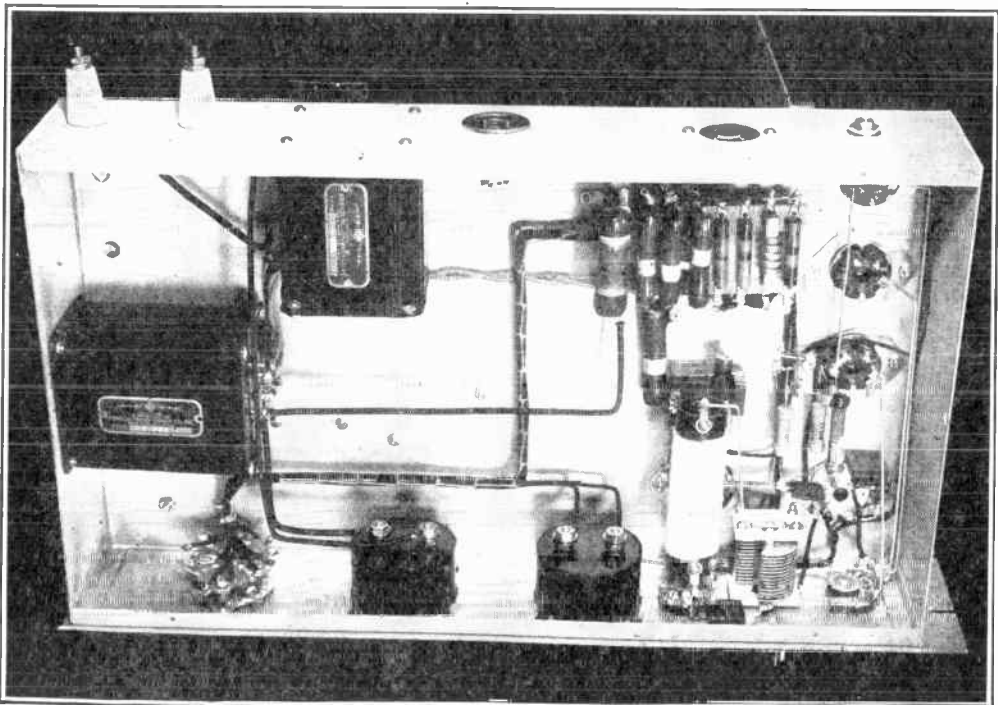

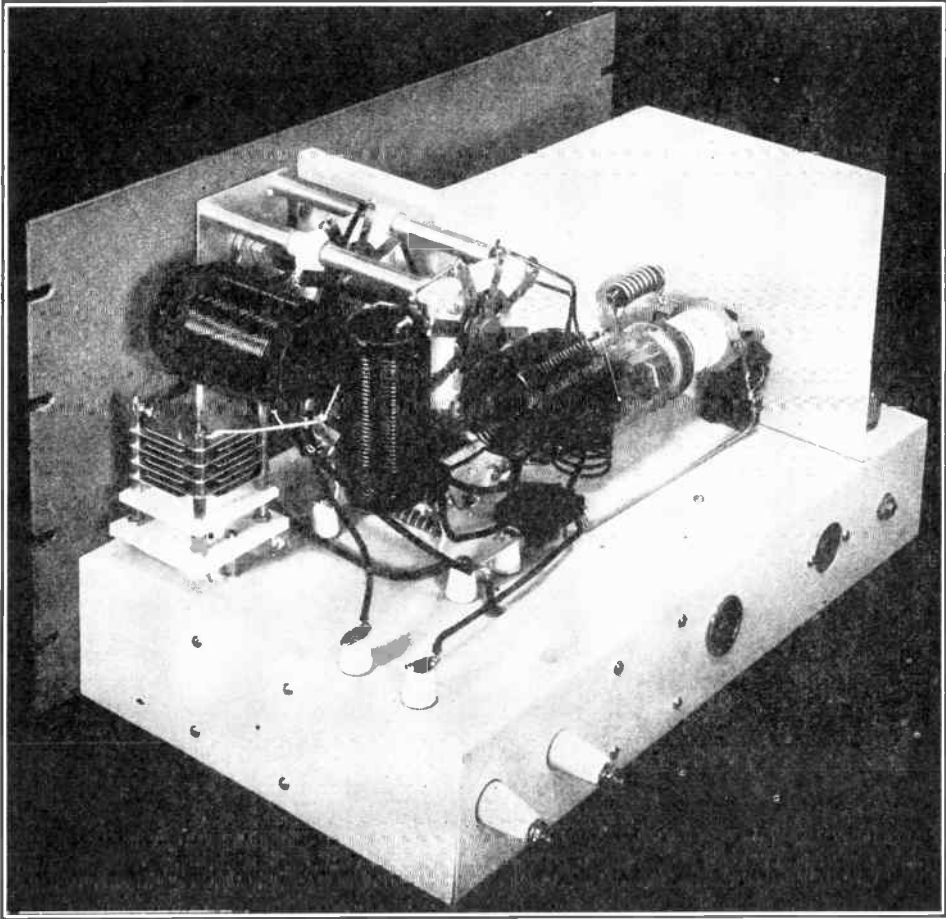

Figure 22.

814 OUTPUT AMPLIFIER OF 100-WATT BANDSWITCHING EXCITER.

Four of the 5 coils are visible in this photo. The 10-meter coil is hidden by the bandswitch and tank condenser. The fixed air padding condenser, permanently connected across the 160-meter coil, may be seen in the left foreground.

are separated by a shield baffle above the chassis, all three stages are effectively shielded from each other. This results in stable operation when working "straight through."

Three crystal sockets and a crystal switch permit selection of 3 crystals from the front panel. The leads from the crystal sockets to the 6L6 grid via the crystal switch should be made as short and direct as possible. In fact, when a 40-meter crystal is used, it is advisable to place it in the front crystal socket.

The particular method of connecting the low-voltage power supply permits both screen voltage and fixed bias to be obtained for the 814, at the same time providing a desirable compensating action which keeps the 814 grid current from rising to dangerously high values

when the load is removed. This compensating effect is obtained with grid leak bias and screen voltage from a series dropping resistor, but is not obtained with ordinary fixed bias and fixed screen voltage. With the system shown, it is important that the B-500 and B-1250 volt leads are *not* connected together as is common practice.

The 814 plate tank consists of a husky, 2-gang band switch and 5 coils; data for winding the latter are given in the coil table. To provide a low minimum tuning capacity for good 10-meter efficiency yet sufficient capacity to give a good "Q" on 160 meters, a 100- μfd . variable condenser is used for tuning, and the 160-meter coil is permanently shunted by a 50- μfd . air padder.

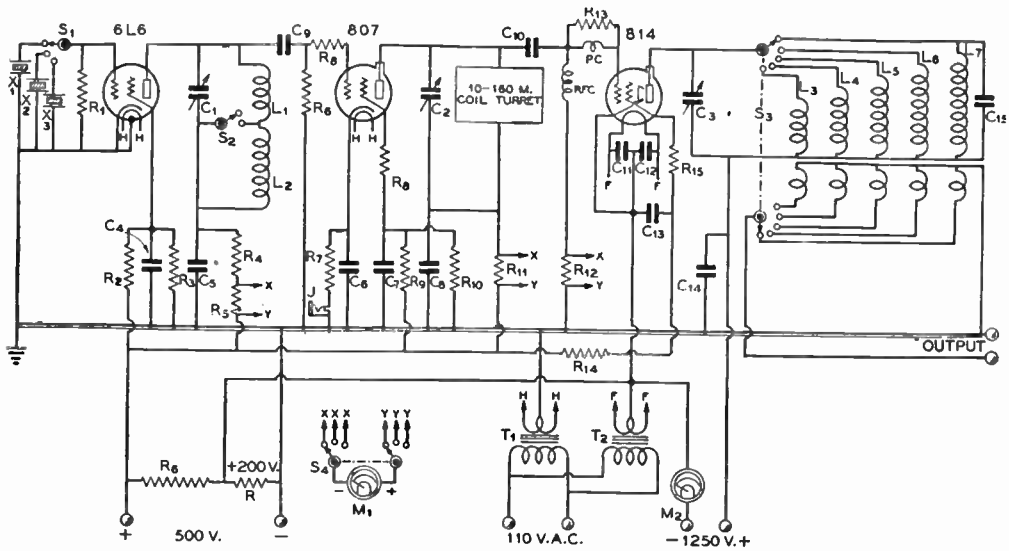

Figure 23.

WIRING DIAGRAM OF BANDSWITCHING 814 EXCITER.

- | | | | |
|---------------------------------------|--|---|---|
| R—4000 ohms, 25 watts | R ₁₁ —50,000 ohms, 2 watts | C ₁ , C ₂ , C ₁₁ , C ₇ , C—003-μfd. midget mica, 1000 v. test | C ₁₅ —50-μfd. air padder, 4000 v. spacing |
| R ₁ —50,000 ohms, 1 watt | R ₁₁ , R ₁₂ —50 ohms, 1 watt | C ₁₂ , C ₁₃ , C ₁₄ —25-μfd. midget mica, 1000 v. test | M ₁ —0 100 ma. d.c. |
| R ₂ —50,000 ohms, 1 watt | R ₁₃ , PC—Parasitic suppressor | C ₁₀ —100-μfd. mica, 1000 v. test | M ₂ —0-250 ma. d.c. |
| R ₃ —60,000 ohms, 2 watts | R ₁₄ —5000 ohms, 10 watts | C ₉ —100-μfd. mica, 1000 v. test | T ₁ —6.3 v. 2 amp. |
| R ₄ —2500 ohms, 10 watts | R ₁₅ —50 ohms, 1 watt | C ₈ —100-μfd. mica, 1000 v. test | T ₂ —10 v. 4 amp. |
| R ₅ —50 ohms, 1 watt | C ₁ —140-μfd. midget variable | C ₁₁ , C ₁₂ , C ₁₃ —003-μfd., midget mica, 1000 v. test | S ₁ —Single-pole 3-throw "tone control" switch |
| R ₆ —100,000 ohms, 2 watts | C ₂ —100-μfd. midget variable | C ₁₄ —002-μfd., 5000 v. test | S ₂ —Single-pole 2-throw "tone control" switch |
| R ₇ —750 ohms, 10 watts | C ₃ —100-μfd. variable 3000 v. spacing | | S ₃ —High power two-gang 5-position bandswitch |
| R ₈ —50 ohms, 1 watt | | | S ₄ —Double-pole rotary meter switch |
| R ₉ —100,000 ohms, 1 watt | | | |

Both to permit shortest possible leads and as a safety precaution, the 814 tuning condenser is set back from the front panel and driven by means of an extension shaft and insulated coupling. The rotor of this condenser is 1250 volts above ground, and the insulated coupling makes it unnecessary to rely upon the insulation of the tuning knob, a bad practice when the voltage is as high as this. The rotors of C₁ and C₂ are also above ground, but as the voltage is not particularly high it is only necessary to use knobs with well protected set screws. These two condensers are insulated from the chassis by means of fiber washers.

A 250-ma. meter is permanently connected in the B negative of the 814. Because screen voltage is derived from the low-voltage power supply, the meter reads plate current only; it is not necessary to allow for the screen current when reading this meter. A 100-ma. meter is used to measure current in the various oscillator and buffer circuits by means of a meter switch.

U.h.f. parasitic suppressors are used both

in the 807 and 814 stages. These consist of 50-ohm resistors in the 807 control grid and screen grid leads, a 50-ohm resistor in the 814 screen, and a regular parasitic suppressor in the 814 control grid. These suppressors also eliminate all tendency toward instability when working "straight through" on crystal frequency.

The 10- and 20-meter coils must be mounted with very short leads to the 814 coil switch. The leads to the other three coils are not so important. There is bound to be some coupling (both capacitive through the switch and inductive as a result of the unshielded coils) between the high-frequency coils when being used and the low-frequency coils which are left "floating." This is because the 40-meter coil hits fairly close to 10 meters with nothing in shunt, and the 80-meter coil self-resonates near 20 meters. The coils were so designed and placed that the effect is not particularly serious, but small sparks can be drawn from the unused tanks. Fortunately this results in but little loss in efficiency when the 814 stage is loaded,

COIL DATA**FOR 100-WATT BANDSWITCHING EXCITER****OSCILLATOR COIL**

74 turns of no. 22 d.c.c. close-wound on 3½ in. length of 1 in. dia. bakelite tubing, tapped at 24th turn. L₁ is 40-meter section (24 turns).

BUFFER COIL

Manufactured 10-160 meter midget coil turret. 10-meter tap not used.

814 PLATE COILS**10 Meters**

6 turns no. 12 enamelled 1⅛ in. dia. spaced to 1⅛ in. (Wound on 1 in. form and form removed.) Link 1 turn at cold end.

20 Meters

11 turns no. 12 enamelled 1⅛ in. dia. spaced to 2 in. (Wound on 1 in. form and form removed.) Link 1 turn at cold end.

40 Meters

18 turns no. 12 enamelled 1¾ in. dia. spaced to 2¼ in. and turns held in place with two celluloid strips cemented to coil with Duco cement. Link 2 turns at cold end.

80 Meters

32 turns no. 12 enamelled close-wound on 3½ in. length of 1½ in. dia. bakelite tubing. Link 3 turns at cold end.

160 Meters

44 turns no. 14 enamelled close-wound on 3¾ in. length of 2 in. dia. bakelite tubing. Link 4 turns at cold end.

All links wound with solid no. 16 having high voltage insulation.

but it does keep the unloaded minimum plate current from being as low as would be the case were plug-in coils used.

On 10 meters the plate current should not be allowed to run over 100 ma. or the plate dissipation will be exceeded. On other bands the plate current should be kept below 110 ma. when doubling, and below 130 ma. when working "straight through." The grid current should be adjusted to about 10 ma. when working straight through, and about 15 or 20 ma. when doubling. Under no conditions should the grid current be allowed to run over 20 ma. when the 814 is loaded.

The grid current to the 814 can be adjusted by detuning the 807, as the 807 is run at such low screen voltage that it will not draw too much plate current or overheat when detuned.

The particular bandswitch used for the 814

plate tank has 6 positions, which leaves one extra. Instead of being left blank, this position is jumpered to the 160 meter switch point. This makes it impossible to remove plate voltage from the 814 by throwing the switch to the unused position. Tubes such as the 814 can be permanently damaged by running them with full screen voltage and no plate voltage.

When mounting the 814 socket, be sure to orient it so that the position of the 814 will correspond to that recommended for horizontal mounting in the manufacturer's application notes. In wiring the 814 socket, be sure to connect the beam forming plates to the *filament return* instead of to ground, as is the more common practice. Connecting the beam forming plates to ground in this case will put 200 volts negative bias on them, greatly reducing the output of the stage.

CHAPTER THIRTEEN

Medium and High Power R. F. Amplifiers

As we go to press, the F. C. C. has assigned no post-war low-frequency amateur bands. The Government proposes to withhold the 160-meter band from amateurs and to assign a new 21-21.5-Mc. band. Other likely allocations are 3.5-4, 7-7.3, 14-14.4, and 28-29.7 Mc. The equipment shown in this chapter covers pre-war 10-, 20-, 40-, 80-, and 160-meter bands. Coils to accommodate new bands may be designed from data appearing under TRANSMITTER THEORY and in CHAPTER 28.

THE amplifiers to be shown in the following pages are typical of those, which, through popular use, have become more or less standard for frequencies up to 30 Mc. and for power outputs of 200 to 800 watts. On frequencies above 30 Mc. special problems arise, and for this reason amplifiers for the higher frequencies are treated separately in Chapters 17 and 19.

Most of the amplifiers illustrated are of the push-pull type, because of the unquestioned superiority of the balanced circuit at high frequencies. The single-ended arrangement finds its widest application in low-power stages, and many such circuits will be found elsewhere in this book. A representative high-power single-ended amplifier is shown later in this chapter, however. It will be noticed that this amplifier is essentially the same as a push-pull amplifier except that one tube and one neutralizing condenser are removed.

Standard Push-Pull Amplifier

Figure 1 shows a standard push-pull amplifier circuit. While certain variations in the method of applying plate and filament voltage and in obtaining bias are sometimes found, the basic circuit remains the same in all amplifiers. All of the push-pull amplifiers illustrated in this chapter use this basic circuit, with such minor variations as are indicated in the descriptions of the individual amplifiers.

Filament Supply The amplifier filament transformer may be placed right on the amplifier chassis, or it may be located in the power supply, if allowance is made for the voltage drop in the connecting leads. This voltage drop can reach serious proportions where amplifier tubes having low-voltage, high-current filaments are used. In any case, the filament voltage should be the correct value specified by the tube manufacturer when measured *at the tube sockets*. A filament transformer having a tapped primary often will be found useful in adjusting the filament voltage. Where there is a choice be-

tween having the filament voltage slightly high or slightly low, the higher voltage is preferable. If the amplifier is to be greatly overloaded, a filament voltage slightly higher than the rated value will give greater tube life.

Plate Feed The series plate-voltage feed shown in Figure 1 is the most satisfactory method for push-pull stages. This method of feed puts high voltage on the plate tank coil, of course, but since the r.f. voltage on the coil is in itself sufficient reason for protecting the coil from accidental bodily contact, no additional protective arrangements are made necessary by the use of series feed. On the low frequency bands a plate r.f. choke is not always required with this type of amplifier. However, one is usually desirable on the higher frequency bands, and as the choke does no harm in any case its incorporation is advisable.

The insulation in the plate-supply circuit should be adequate for the voltages encountered. In c.w. and grid-modulated stages, the insulation of the r.f. choke and wiring should be capable of withstanding voltages at least as high as the plate voltage. Where plate modulation is used, the insulation should be able to withstand at least twice the d.c. plate voltage. If the plate-current meter is placed in the positive lead, it, too, must have adequate insulation between the movement and case.

Grid Bias The recommended method of obtaining bias for c.w. or plate modulated telephony is to use just sufficient fixed bias to protect the tubes in the event of excitation failure and obtain the rest from a grid leak. However, the grid leak may be returned directly to the filament circuit if an overload relay is incorporated in the plate circuit, the relay being adjusted to trip immediately when excitation is removed. For grid modulation it is necessary that all the bias be obtained from a fixed source; this makes a grid leak impracticable for this class of service.

The grid leak R₁ serves effectively as an r.f. choke in the grid circuit because the r.f. volt-

age impressed upon it is very low, and no grid r.f. choke is required when a grid leak is used. However, if no grid leak is incorporated, as would be the case for fixed bias for grid modulation, an r.f. choke should be substituted for R_1 . This choke should have a different value of inductance than the choke in the plate circuit, since equal values of inductance will often cause a low-frequency parasitic oscillation. Should low-frequency parasitics persist with different sized chokes, a 200-ohm, 10-watt wire-wound resistor may be placed in series with the grid choke. The resistor will suppress the oscillation without otherwise affecting the operation of the amplifier.

Metering It will be noticed in Figure 1 that M_2 is placed in the negative-to-filament return rather than in positive high-voltage lead. This is a safety precaution. When connected as shown in the diagram, M_2 will read plate current only, as M_1 is returned to the "hot" side of M_2 instead of to the negative plate lead. This will require an extra external lead if fixed bias is used, as the positive of the bias supply cannot be connected to the negative plate voltage under these conditions without resulting in a short across M_2 .

When measuring current in the filament return of filament type tubes, it is necessary that the stage have *either* an individual power supply or else a filament supply which is not used to supply any other *filament type* tubes (heater tubes may be operated from the same filament supply). If this requirement is not met, a meter jack will read the current being drawn by more than one stage at the same time. If desired, meter jacks or a switch may be substituted for the individual meters in Figure 1.

Plate Circuit In the circuit shown in Figure 1, the rotor of the plate tank condenser is left "floating" (ungrounded). This permits a tank condenser of less spacing to be used, as there is no d.c. impressed across it. When the rotor is "floating" it is imperative that the amplifier be symmetrical from a physical standpoint, and that the coupling to the external load be symmetrical. Because the rotor will be at high d.c. potential if the condenser *should* arc over, it is advisable to use an insulated coupling between the rotor shaft and the tuning dial or knob.

In cases where it is impossible to obtain equal loading of the two tubes in the push-pull amplifier, it may become necessary to ground the rotor of the plate condenser through a by-pass condenser. If the stage is plate modulated, it may then be necessary to connect the rotor of the condenser to the modulated plate voltage lead directly or through

a 25,000- to 100,000-ohm resistor to allow the rotor to follow the modulation voltage. The resistor may be a 1-watt carbon unit. When the resistor is used, the by-pass condenser between rotor and ground should not have a capacity of greater than .001 μ fd. A larger condenser causes excessive phase shift between the modulated voltage and the voltage on the rotor at the higher audio frequencies, and thus increases the instantaneous voltage between rotor and stator. There is no restriction on the size of by-pass condenser when a direct connection is used between the rotor and modulated voltage, except that the condenser must not be so large that it by-passes an appreciable portion of the modulation.

Because of the high minimum capacity of tuning condensers having sufficient maximum capacity for proper 160-meter operation, it is good practice to use a split stator plate tuning condenser just sufficiently large for 40-meter c.w. operation (about 75 μ fd. per section for commonly used ratios of plate voltage to plate current) and then use external plug-in fixed padding condensers for 80- and 160-meter operation. The cost is about the same as for a split stator condenser having sufficient capacity for 160-meter phone operation, and the efficiency on 10 and 20 meters is higher because of the lesser bulk and minimum capacity of the tuning condenser. In the low and medium power range, fixed air pad-ders are the least expensive; for high power operation, fixed vacuum condensers are about as economical as the regular air types. Recommended values of tank circuit capacity for different bands and applications are given in Chapter 7.

For high-power operation on 10 and 20 meters, a fixed capacitance is sometimes used in conjunction with a variable inductance to replace the more common type of plate tank consisting of a fixed inductance and variable capacitance. This is permissible in the circuit of Figure 1 so long as the fixed tank condenser is symmetrically constructed. It is not advisable to substitute a single-section variable condenser of twice the spacing and half the per-section capacity for C_2 because it would upset the symmetry of the circuit; the rotor (frame) consists of so much more metal than the stator that there would be considerable unbalance with this type of condenser.

Plate tank coils for medium- and high-power amplifiers may be wound of bare or enameled copper wire (no. 14 or larger) or of the smaller sizes of copper tubing. Coils for 28 Mc. and sometimes for 14 Mc., may be made self supporting when wound with the larger sizes of wire or with copper tubing. For lower frequencies, high-grade ceramic forms may be used, or the coils may be made mechanically

rigid by cementing the turns to celluloid strips.

Grid Circuit As the power in the grid circuit is so much lower than in the plate circuit, it is customary to use a split stator grid condenser with sufficient capacity for operation on the lowest frequency band, and also to ground the rotor. A physically small condenser has a greater ratio of maximum to minimum capacity, and it is possible to get a grid condenser that will be satisfactory on all bands from 10 to 160 meters without need for external auxiliary capacitors. As both r.f. and d.c. voltages are relatively low in the grid circuit, the rotor of the condenser can be grounded without increasing the cost appreciably, as very little more spacing will be required and the condenser is relatively small anyhow (in comparison with the plate tank condenser). Grounding of the rotor simplifies mounting of the condenser, and also provides circuit balance and insures electrical symmetry. It also retards u.h.f. parasitics by by-passing them to the ground in the grid circuit.

Coils for the grid circuit may in most cases be mounted on small jack-bar or tube-base type supports. Wire sizes up to no. 14 will be suitable for driving powers up to 100 watts. To restrict the field and thus aid in neutralizing, the grid coils should be physically no larger than absolutely necessary.

Layout The most important consideration in constructing a push-pull amplifier is to maintain electrical symmetry on both sides of the circuit. Of utmost importance in

maintaining electrical balance is the stray capacity between each side of the circuit and ground.

Large masses of metal placed near one side of the grid or plate circuits can cause serious unbalance, especially at the higher frequencies, where the tank capacity between one side of the tuned circuit and ground is often quite small in itself. Capacity unbalance most often occurs when a large plate or grid coil is located with one of its ends close to a metal panel. The solution to this difficulty is to mount the coil parallel to the panel to make the capacities equal from each end to ground, or to place a large piece of metal opposite the "free" end of the coil to accomplish the same purpose.

Wherever possible, the grid and plate coils should be mounted at right angles to each other. If this is not practical, the coils should be separated as far as possible. A small amount of coupling between the two coils is not in itself greatly detrimental, since it can usually be balanced out by the neutralizing circuit, but the coupling will vary when coils are changed and it will be necessary to readjust the neutralization when changing bands.

All r.f. leads should be made as short and direct as possible, of course. The leads from the tube grids and plates should be connected directly to their respective tank condensers, rather than to the coils. The connections between the coils and condensers should be of wire or tubing at least as large as that used in the coils themselves. Plate and grid leads to the coils need not be as heavy as the tank circuit leads, but the use of flexible tinned "braid"

Figure 1.
STANDARD PUSH-PULL
R.F. AMPLIFIER CIRCUIT.

The mechanical design must be symmetrical and the output coupling must be evenly balanced. Individual meters may be substituted for the two meter jacks. If a grid r.f. choke is substituted for R_1 for fixed bias operation, a 200-ohm wire-wound resistor should be placed in series if a low frequency parasitic oscillation occurs.

C_1 —Approx. 1 $\mu\text{fd.}$ per section per meter of wavelength. 1000 volt spacing for HK-54, 35T, 755, 812, 808, etc. 2000-volt spacing for 100TH, HK-254, HF-200, T200, etc.

C_2 —Refer to tank condenser data and Q charts in Chapter 7 for capacity and spacing.

C_3, C_4 —Suitable neutralizing condensers, 50% greater air gap than C_2 . Maximum usable capacity should be slightly greater than grid-plate capacity of tubes.

C_5, C_6 —0.02 $\mu\text{fd.}$ or larger.

C_7 —Not over .004 $\mu\text{fd.}$

R_1 —Of such value that normal grid current for tubes will produce enough voltage drop to make a total of twice cut-off bias including any fixed bias. Higher resistance can be used with slight increase in efficiency if reserve of excitation is available. Wattage rating equal to I²R. The resistor may be omitted entirely and fixed bias equal to twice cut-off or

more may be used, if desired. RFC — 2.5-mh. r.f. choke designed for all-band operation, of suitable d.c. rating. Not always found necessary.

T_1 — Filament transformer of suitable voltage and current rating. Tapped primary desirable, especially if transformer is located some distance from the amplifier.

M_1, M_2 — Suitable grid- and plate-current meters.

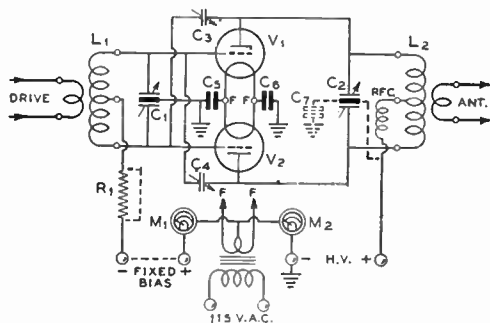

is to be avoided wherever possible, since the braid has rather high r.f. resistance. Where braid must be used to provide flexibility when connecting to grid or plate caps on the tube envelopes, a short piece of the braid should be soldered to the end of a solid-wire lead and the wire used for the major portion of the connection. A still better method is to use thin, flexible copper strip for leads to the tube caps.

Many of the troubles so often associated with neutralizing can be obviated by running the neutralizing leads directly to the tube grids and plates entirely separately from the grid and plate leads to the tank circuits. Having a portion of the plate or grid connections to their tank circuits serve as part of a neutralizing lead, or vice versa, can often result in apparently mysterious neutralizing troubles. The importance of eliminating the common leads is shown by the fact that certain tubes designed for u.h.f. work have entirely separate leads brought out from the elements for tank-circuit and neutralizing connections.

Excitation The excitation requirements for high- and medium-power amplifiers vary so widely that it is difficult to make definite general statements of the driving power which should be provided. However, a good average figure for the excitation power to modern triodes in a class C amplifier is that it should approximate 10 per cent of the expected power output of the stage. Where extremely high efficiency in the amplifier is desired, the excitation may have to be as high as 20 or 30 per cent of the power output, and where the amplifier can be operated class B for c.w. purposes, the excitation power may sometimes be as low as 5 per cent of the power output. Pentodes and tetrodes generally require less excitation than triodes of equivalent plate dissipation, but their high input capacities make them more difficult to excite, and the required driver power output, while usually considerably less than that required for an equivalent triode, is not always as low as is sometimes thought. Excessive excitation to pentodes or tetrodes will often result in reduced power output and efficiency, however. Except in the case of pentodes and tetrodes, it is best to err on the side of excessive excitation, since the surplus will do no harm and a scarcity of excitation will cause a loss in output and efficiency.

The best rule to follow in adjusting the excitation is to use all the excitation available, and then adjust the bias until the grid current is at the rated operating figure given by the tube manufacturer. In push-pull or parallel stages, the current should be twice the value given for one tube, of course. If a fixed bias supply is used, and the grid current is excessive

with the bias voltage set at its maximum value, additional grid-leak bias should be introduced to reduce the current to its rated value. The actual bias will then be equal to the fixed supply voltage plus the voltage contributed by the IR drop in the bias resistor. Where grid-leak bias alone is used, the bias will simply be equal to the IR drop in the resistor (grid current in amperes times grid-leak resistance in ohms). A combination of grid-leak or fixed bias and cathode-resistor bias will give a total bias equal to the sum of the voltage contributed by the IR drop in the cathode resistor and the voltage supplied by the grid-leak or bias supply. When computing the drop across a cathode resistor it must be remembered that not only the plate current, but also the grid current and the screen current, if any, flow through the cathode resistor.

The above general rule for adjusting the bias to conform with the excitation will sometimes lead to a value of bias that is too low for class C phone operation, when the excitation is low. In such cases it is not possible to get more bias by raising the value of the grid leak, since the grid current drops as the resistance is increased, and little increase in bias occurs.

Single-Ended Stages Most of the preceding discussion, except the section on circuit balance, applies equally well to single-ended as well as push-pull stages. Even in single-ended stages, however, it is desirable to maintain capacity balance to ground from both sides of the plate circuit when a split-stator plate condenser is used to obtain neutralizing voltage. In the single-ended stage, capacity balance is obtained by adding a capacity from the "free" end of the plate tank to ground, to make up for the tube's plate-filament capacity across the other side of the circuit. The balancing capacity may be obtained by placing an actual condenser equal to the plate-filament capacity between the free end of the tank circuit and ground, or in the case of tubes having a low plate-filament capacity, by locating the plate coil so that its free end is close to the chassis or panel. An example of the latter system is shown later.

Because the single-ended circuit is not inherently balanced to ground, the necessity of obtaining proper ground connections is all-important. The filament, grid, and plate by-pass condensers should all be returned by the shortest possible *separate* leads to a common point on the chassis. Grounding these condensers to widely separated points on the chassis, or to a common ground bus, is quite likely to lead to difficulties with feedback or instability due to coupling between the various circuits in the chassis or common lead. The connection between the filament by-pass condensers and



Figure 2.

PUSH-PULL 8005 AMPLIFIER.

This amplifier will deliver an output of 440 watts on c.w., or 340 watts when plate modulated. The amplifier is designed for mounting in a standard rack, and its layout is perfectly straightforward. Note that the grid and plate coils are mounted at right angles to each other to reduce coupling between the input and output circuits.

chassis should be as short as possible, with the other by-pass condensers grounded where the filament by-passes are connected to the chassis. At the higher frequencies, it may even be advisable, in some cases, to connect the grid and plate by-pass condensers right to one of the filament terminals on the tube socket, and then by-pass that side of the filament to the chassis with the shortest possible leads and also by-pass the two sides of the filament together at the socket.

The pictorial illustrations in this chapter will be found useful for the purpose of furnishing ideas for possible mechanical layouts. All of the arrangements shown permit very short r.f. leads, but it is not necessary to use the particular tubes specified in each case for the particular physical layout illustrated. For instance, with very slight modifications in the amplifier, 35T's, HK54's, HY-51's, 812's, or T55's could be used in the amplifier pictured in Figures 2 and 3 by providing the proper grid leak and filament transformer. Much of the enjoyment to be obtained from amateur radio comes from experimenting with the design of amplifiers such as these, and the units

in this chapter are shown simply as samples of arrangements which have given good results. The individual constructor will often find it advisable and instructive to alter the designs to suit components which he has on hand, or to incorporate different tubes than those shown.

Push-Pull 8005 Amplifier

An amplifier using push-pull 8005 tubes is shown in Figures 2 and 3. This amplifier is capable of giving a power output of 440 watts for c.w. service, or 340 watts when plate modulated (ICAS ratings).

The amplifier is constructed on a 17 x 10 x 2-inch chassis, which is surmounted by a standard relay-rack panel 8¾ inches high. From left to right across the chassis are located the grid coil, grid condenser, neutralizing condensers, tubes, plate condenser, and the plate coil. To shorten the length of the grid and plate leads, the two tank condensers are raised above the chassis on 1¾-inch standoff insulators. The grid coil jack bar is raised above the chassis a small amount by mounting it on the insulators supplied by its manufacturer. The grid coils are "50-watt" manufactured units. In the plate

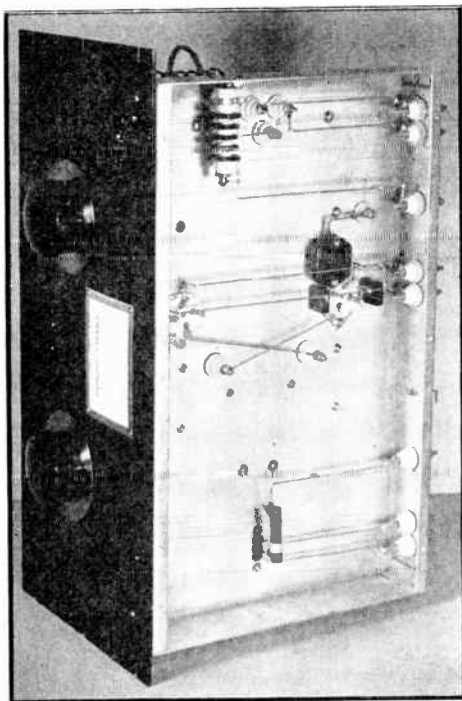

Figure 3.
UNDER-CHASSIS VIEW OF THE 8005
AMPLIFIER.

The filament and plate by-pass condensers, plate r.f. choke, and the grid resistor are mounted under the chassis. The crossed grid leads from the above-chassis neutralizing and grid circuit may be seen in this photo.

circuit, a standard manufactured jack-bar assembly is used, with home-wound coils mounted on a matching plug assembly. The jack bar is supplied with mounting feet, and these are supported 1 inch above the chassis by means of standoff insulators. Ten- and 20-meter coils for the plate circuit may be wound "on air" and supported from the plug-in base. The 40-m. coil is wound on the 2½" diameter ceramic form manufactured for use with the plug bar.

Terminals at the rear of the chassis are provided for connection of the various supply voltages, the link from the exciter, and connections to the antenna. The d.c. portion of the plate circuit is wired as shown by the dotted lines in Figure 1.

For c.w. use, the plate voltage may be as high as 1500 volts, and the plate current as high as 400 ma. The grid current should be 65 ma. for the two tubes, while bias may be obtained from a fixed supply of 130 volts or from a resistor of 2000 ohms.

When plate modulated, the plate voltage

should be 1250 volts for maximum output, while the plate current may be as high as 380 ma. A fixed supply of 195 volts or a 3500-ohm resistor may be used for grid bias. The grid current should be 60 ma. An exciter having an output of 30 to 40 watts will be adequate for exciting the amplifier on either 'phone or c.w.

35-TG Amplifier

The amplifier shown in Figure 4 follows the general diagram of Figure 1, as do all the push-pull amplifiers in this chapter. Since the grid terminals on the 35-TG's are on the side of the glass envelope, it is convenient in an amplifier using these tubes to place all the r.f. components and r.f. wiring above the chassis. To help keep the length of the plate leads to a minimum, the tube sockets are mounted about ½ inch below the chassis. Half-inch sleeves over the socket mounting screws serve to hold the sockets firmly in position. The plate connections to the tank condenser and neutralizing condensers are made by means of thin, flat copper strip, to provide the necessary flexibility. Radiator-type connectors are used on the tube plate terminals.

The neutralizing condensers are a type ordinarily intended to mount with the plate of their plates vertical. However, for use in this amplifier, it is more convenient from a wiring standpoint to have them mount at right angles to their usual position. This is done by screwing what should be the bottoms of the two condensers together, with a strip of scrap chassis metal placed between the two bottoms. The strip of metal extends past the bottom on one side, and the extension bent to form a mounting foot for both condensers.

Spacing sleeves 1 inch long are used to support the grid-coil socket, which is an ordinary 5-prong Isolantite socket. The grid coils are "50-watt" manufactured units. The plate coils are also of the manufactured type; they have a power rating of 500 watts. A swinging antenna-coupling coil, which is part of the plate coil jack-bar assembly, allows the antenna loading to be adjusted to the proper value.

Standoff insulators are provided at the rear of the chassis for connections to the plate, filament, and bias supplies, and for link leads from the exciter. For c.w. use, the plate voltage may be as high as 2000 volts, and the plate current run up to 250 ma. without difficulty. The plates of the 35-TG's will run red at normal plate dissipation. When the amplifier is plate modulated, the plate voltage may be as high as 1500 volts, and the plate circuit loaded to 250 ma. When plate modulation is used, the rotor of the plate tank condenser should be connected to the modulated high voltage and by-passed to ground, as shown by the dotted lines in Figure 1.

The grid current for the two tubes should be 60 ma. under normal operating conditions. Bias may be supplied by either a resistor or a fixed supply, or a combination of each. For c.w. operation at 2000 plate volts, the fixed bias should be at least 175 volts, or a 3000-ohm resistor may be used with 60 ma. of grid current flowing. In plate-modulated service, bias may be provided by a fixed supply of at least 120 volts, or by a resistor of at least 2000 ohms, with 60 ma. grid current. The exciter should have an output of 40 to 50 watts.

HK-254 Amplifier

An amplifier capable of handling the full legal amateur input of 1 kw. in c.w. use is shown in Figure 5. High-efficiency operation of the HK-254 tubes is necessary if they are to be kept within their plate dissipation rating at 1 kw. input, and the amplifier has been constructed with this requirement in mind. The arrangement of parts shown in the photo allows the average length of the r.f. leads to be kept down to about 1 inch. None of the r.f. leads is over 2½ inches long.

The amplifier is constructed on a 17 x 12 x 3-inch chassis, most of the wiring being above the chassis. The arrangement of parts proceeds in an ordinary manner from left to right along the chassis. Near the left end of the chassis is a 5-prong socket for the plug-in grid coils, which are wound on standard 1½-inch receiving-type forms. To the right of the coil socket is the split-stator grid condenser, which is surmounted by the neutralizing condensers. Next in line are the tubes, which are mounted near the front and back of the chassis, with their sockets below the chassis. The plate tank condenser is located directly to the right of the tubes, and it is mounted upside down to bring its stator terminals near the tube plate connections. Large jack-top standoff insulators (4½ inches) are used to support the plate coil, and these bring the coil terminals up next to the condenser stator terminals. Through-panel standoff insulators in the rear drop of the chassis provide terminals for the connection of plate, grid, and filament voltage, and the link from the exciter.

For c.w. use, the plate voltage should be

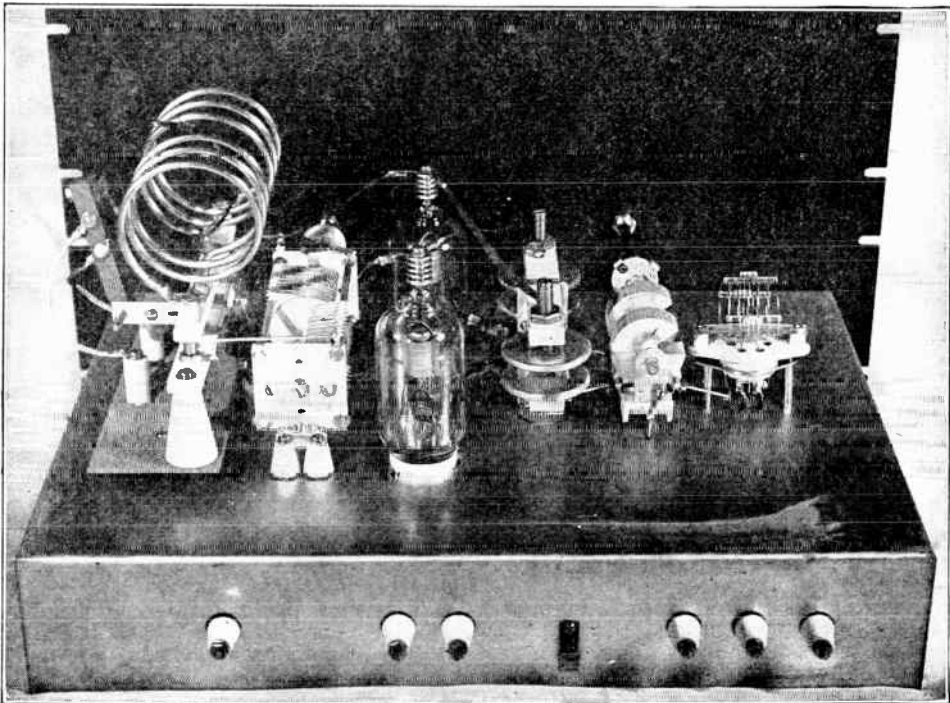

Figure 4.

400-WATT 35-TG AMPLIFIER.

This amplifier is capable of supplying a 400-watt signal on c.w., and nearly that much on 'phone. Any exciter having an output of 40 to 50 watts will serve to drive it. The terminals at the rear of the chassis are for plate, bias, and filament voltage connections. The antenna or antenna coupler is connected to the variable link terminals on the plate coil assembly.

2500 volts, and the plate current may be as high as 400 ma. The grid current should be 80 ma. for both tubes. Bias may be from a fixed source of 250 volts or more, or from a resistor of at least 3000 ohms, with 80 ma. of grid current flowing. In plate-modulated service, the plate voltage, grid bias, and grid current requirements remain as above, but the plate current should be held below a maximum of 350 ma. An exciter power output of 75 watts will be adequate for 'phone or c.w. service.

TW-150 Amplifier

The amplifier pictured in Figure 6 is suitable for operation on 5-, 10-, or 20-meter 'phone or c.w., and 40-meter c.w., with an input of 1 kw. The amplifier is intended to mount behind a standard relay-rack panel, as are all the other amplifiers shown in this chapter. However, the amplifier is shown in Figure 6 with the panel removed, to help in showing the method of construction. The panel goes across the right side of the amplifier in the photo, with the shafts from the two tank condensers projecting through the panel. To avoid confusion in the following discussion, the location of the parts will be described as though the side facing the observer were the front; actually, however, it is the left side of the amplifier.

An 8 x 17 x 3-inch chassis is used for the amplifier, and the tubes are located toward the front, protruding through 3-inch diameter

holes. The sockets are mounted on the chassis bottom plate. Immediately behind the TW-150's, and elevated so that stator tie rods are about an inch below the tube plate terminals, is the plate tuning condenser. Between the tubes, and forward from the condenser, are the neutralizing condensers, positioned so that short, direct leads are featured between lower plate connecting lugs and tube grid terminals.

A length of Mycalex strip between and above the neutralizing condensers and fastened to them supports the plate circuit r.f. choke, and two shorter lengths similarly fastened and protruding to right and left over the tube grid caps support the 3-inch ceramic pillars which in turn support the plate tank mounting assembly. The grid tuning condenser mounts on the chassis front drop, while the grid coil and the grid leak mount below chassis on the bottom plate.

Connections from the plate coil and the tube plate cap terminals to the tank condenser run directly to the stator tie rod. The tie at the frame is made with clips which come with adjustable resistors of the 50-watt type. Cross-over neutralizer connections are made to the inside ends of these tie rods. Grid connections from neutralizers to tubes, tubes to tuning condenser, and condenser to coil assembly are all unusually short for kilowatt construction.

The high-voltage plate supply should provide a maximum of 3000 volts at 330 ma. for

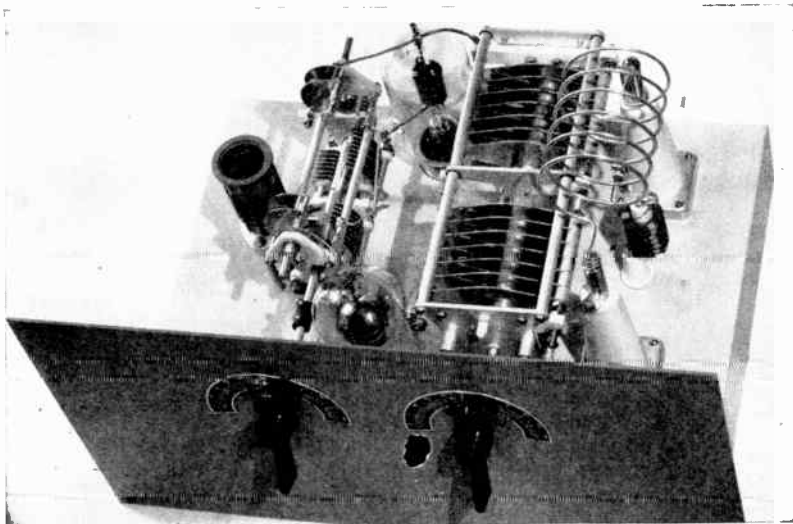

Figure 5.

800-WATT AMPLIFIER WITH HK-254's

This high powered amplifier will take a full kilowatt input on c.w. if 75 watts of excitation is available. High efficiency operation is required, as otherwise the plate dissipation rating of the tubes will be exceeded at 1 kw. input. The HK-254's are fed 2500 volts and loaded to 400 ma. The physical layout illustrated permits an average r.f. lead length of slightly over 1 inch; no lead is over 2½ inches.

990 watts input, 'phone or c.w. The grid current should be 80 ma. under operating conditions, and bias may be supplied by a fixed source of 260 volts, or from a resistor of approximately 3500 ohms. About 75 watts of excitation will be needed by the amplifier at the higher frequencies.

Single-Ended 152-T Amplifier

Although it is usually preferable, both from a standpoint of efficiency and tube cost, to use a push-pull amplifier for medium and high power transmitters, circumstances, such as the availability of a large tube or desire to couple

an extremely unbalanced load to the amplifier, sometimes make it advisable to use a single-ended output stage.

The 152-T amplifier illustrated in Figures 7 and 9 and diagrammed in Figure 8 is typical of single-ended amplifier circuits. The circuit shown is also applicable to other tubes having a relatively low output capacity. Where the tube's output capacity is high, however, special circuit arrangements are necessary to assure correct neutralization, as explained in Chapter 7.

For a single-ended amplifier, it is necessary that the rotor of the plate tank condenser

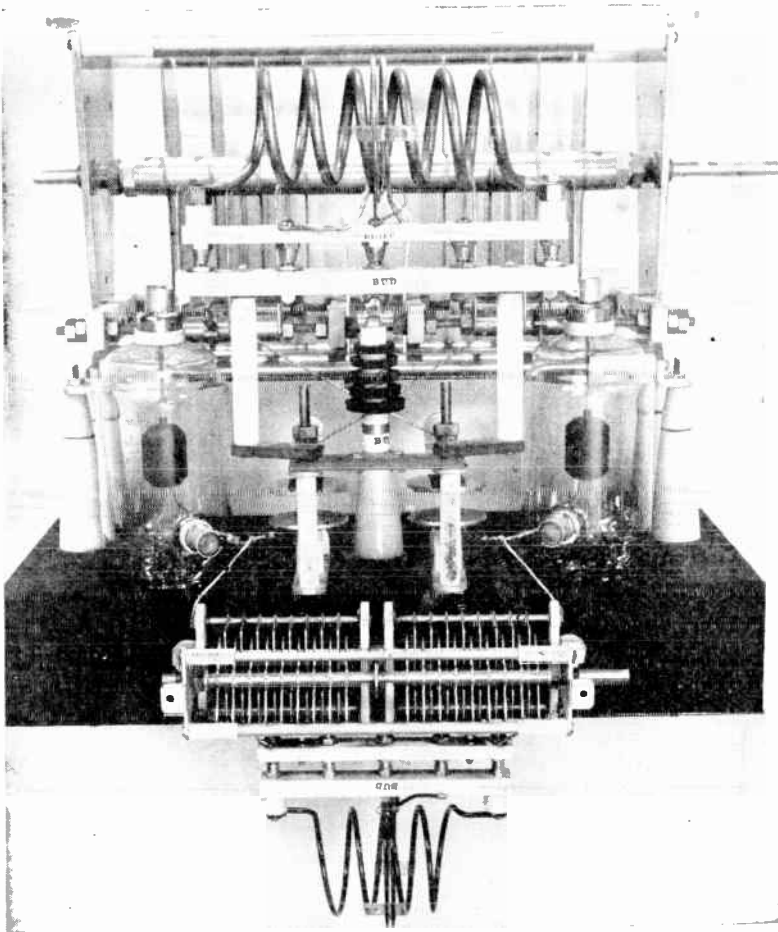

Figure 6.

800-WATT AMPLIFIER OF UNUSUAL DESIGN.

This "skeletonized" push-pull TW-150 amplifier is capable of handling an input of 1 kilowatt, with a plate efficiency of between 75 and 80 per cent. The amplifier is intended to be mounted behind a 19-inch rack panel with the tuning controls being connected to the grid and plate condensers by means of insulated couplings. Note how the r.f. leads are kept to extremely short lengths, for an amplifier of this size, through the use of the unconventional chassis arrangement.

have an r.f. return to ground. This may be done either by grounding the rotor of the condenser directly, or grounding it through a by-pass condenser. If it is grounded directly, the tank condenser must have somewhat more spacing because both d.c. and r.f. are impressed across it. If it is by-passed to ground through a high-voltage mica condenser of .002- μ fd. to .004- μ fd. capacity, as shown in the diagram, there will no longer be impressed, under steady carrier conditions, anything between the condenser plates except r.f. voltage. However, transient peaks will be impressed across the variable condenser during plate modulation or primary keying of the stage. Hence, to remove all voltage from the variable

condenser except the r.f. voltage across the coil, the rotor of the condenser should be connected directly or through a resistance to the positive high voltage lead, as previously described in this chapter. There can then be no a.f. or d.c. transient voltage impressed across the condenser sections, because both the rotor and the stator sections are at the same potential except with respect to r.f. voltage across the coil. If the stage is *grid* modulated or if the transmitter is keyed in a low level stage so that plate voltage appears on the tank at all times, then there is no point in connecting the rotor of the condenser to positive high voltage; simply by-passing it to ground with a high-voltage condenser will be sufficient.

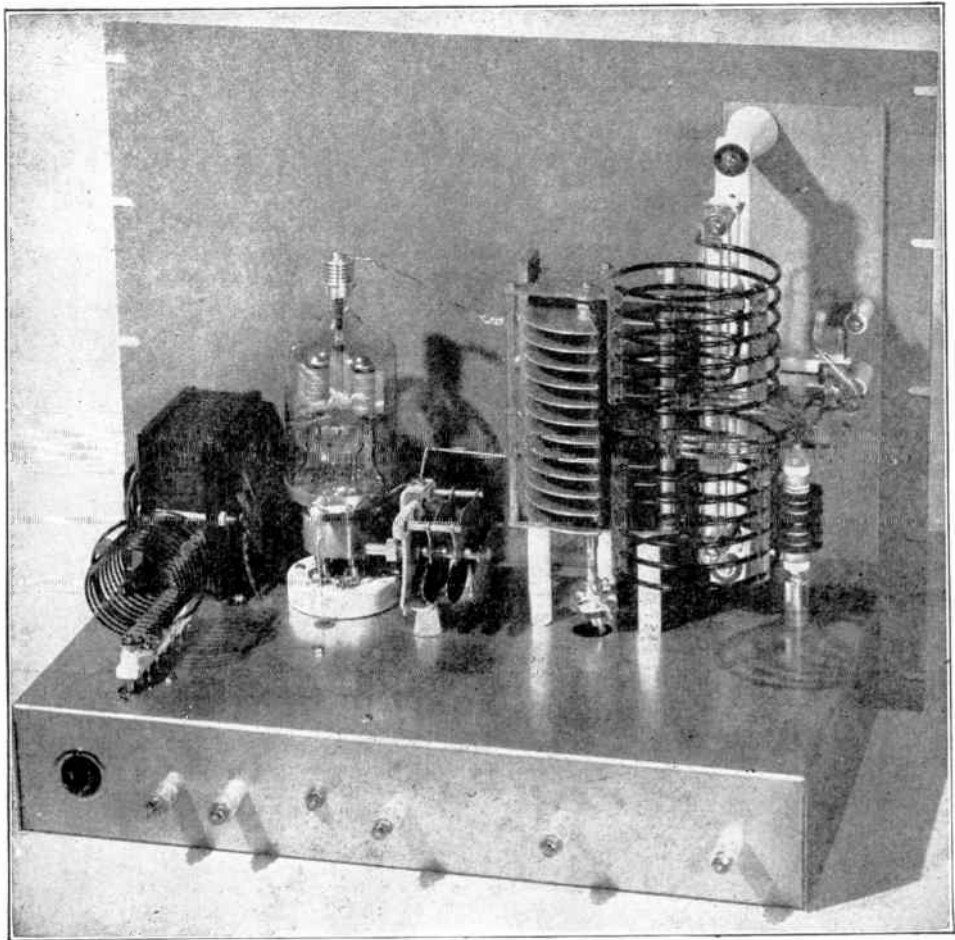

Figure 7.

750-WATT SINGLE-ENDED 152-T AMPLIFIER.

This amplifier will give an output of 750 watts on c.w. when run at an input of 900 watts. Mounting the plate tank circuit vertically, with the neutralizing condenser between the tube and tank circuit, aids in preserving circuit balance in the single-ended plate neutralized stage. The filament transformer is located on the chassis.

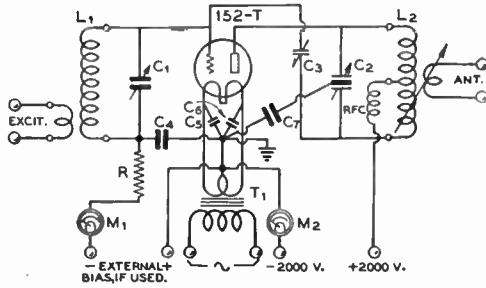

Figure 8.

If a tube has a plate-filament capacity of more than approximately $2 \mu\text{fd.}$, it is desirable to connect across the section of the tuning condenser, to which the neutralizing condenser is connected, a capacitance exactly equal to the plate-filament capacity of the tube. The circuit will then be balanced regardless of the setting of the plate tank condenser, and neutralization will hold for all bands when once set for one of the higher frequency bands. In the 152-T amplifier, a small amount of capacity between the neutralizing end of the tank circuit and ground is obtained by mounting the tank condenser and coil vertically, the capacity between

WIRING DIAGRAM OF TYPICAL SINGLE-ENDED AMPLIFIER.

This diagram is for the amplifier illustrated in Figures 7 and 9. The tank condenser illustrated is for 10, 20, and 40 meter operation only. The 152-T has two separate sets of filament connections brought out to the socket. These may be connected in series and operated from a 10-volt transformer, as shown in the diagram, or they may be connected in parallel and supplied from a 5-volt transformer.

- C₁ — 100- $\mu\text{fd.}$, .070" spacing
- C₂ — 50- $\mu\text{fd.}$ per section, .171" spacing
- C₃ — 9- $\mu\text{fd.}$, .238" spacing
- C₄, C₅, C₆ — .002- $\mu\text{fd.}$ 1000-volt mica
- C₇ — .002- $\mu\text{fd.}$ 5000-volt mica
- R — 7000 ohms, 50 watts. If fixed cut-off bias is used (250 v.) this resistor may be reduced to 3000 ohms, 20 watts
- L₁ — "100-Watt" manufactured coil
- L₂ — "1 Kw." manufactured coil with swinging link mounting
- RFC — 2.5 mhy., 500 ma.
- T₁ — 10 volts, 7 amp. (if filaments are connected in parallel T₁ may be 5 volts, 14 amp.)
- M₁ — 0-100 ma.
- M₂ — 0-500 ma.

the bottom end of the tank circuit and the grounded chassis being approximately equal to the tube's plate-to-filament capacity. Besides providing this additional capacity, the vertically-mounted tank circuit helps keep both the plate and neutralizing leads to a minimum length.

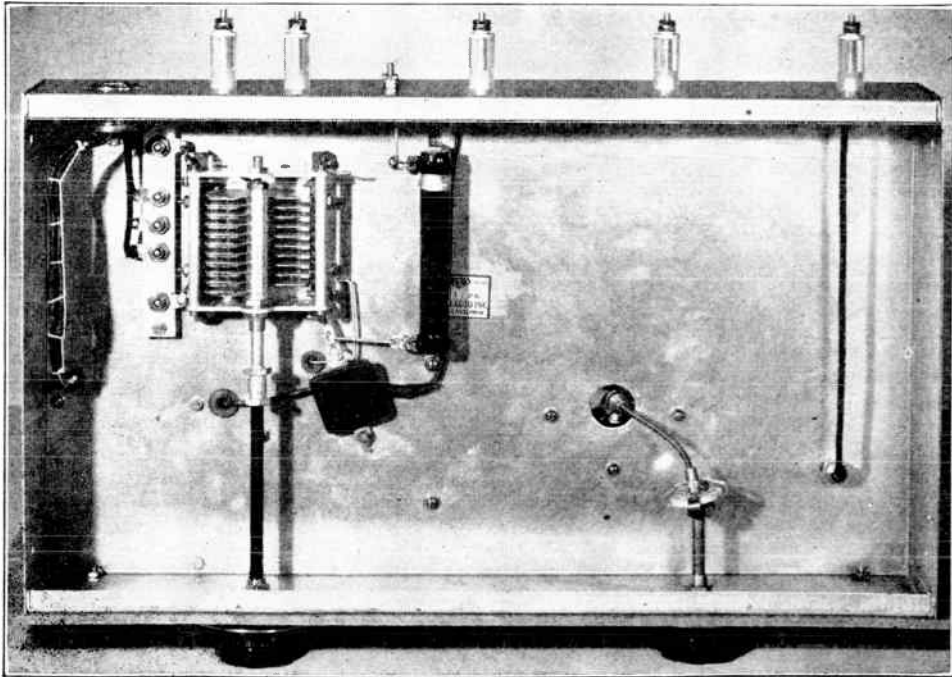

Figure 9.

UNDER-CHASSIS VIEW OF THE SINGLE-ENDED AMPLIFIER.

The grid condenser and bias resistor are located under the amplifier chassis. Note the flexible shaft which allows the vertically mounted plate condenser to be controlled from the panel.

Speech and Modulation Equipment

THIS chapter covers the design, construction, and operation of speech amplifiers and modulators, and arrangements such as automatic modulation control circuits, which are normally a portion of the modulation equipment.

The audio equipment required in a 'phone transmitter will vary widely with different types of microphones, different modulation systems, and different amounts of power to be modulated. Since it would be virtually impossible to show designs that would be suited to any type of application, a number of good designs of conventional type will be shown to indicate the method of approach to the problem. These particular designs should more or less completely solve the speech amplifier problem in 75 per cent of the usual amateur transmitter installations. For those special cases where the designs shown are not completely suitable, small variations in the necessary respects will almost surely adapt the designs to individual needs.

The amplifiers and modulators shown have been thoroughly proven in actual use in amateur stations. Consequently, if these designs are followed exactly, no trouble should be experienced, either in getting them to work, or in their subsequent application to the job at hand. However, when making alterations in the designs to adapt the equipment to slightly different applications, due caution and forethought should be used in making the changes.

Hum Difficulties It is more than likely that inductive hum pickup will be the problem most frequently encountered, both in making alterations in amplifier design, and in installing the speech equipment in the operating room or in the transmitter. The proximity of power supply equipment to the audio transformers or to the low-level grid leads should always be considered.

Any chokes or transformers in the low-level audio stages should be mounted as far as possible from power transformers and input filter chokes which have relatively large surround-

ing a.c. fields. The audio transformers and coupling chokes can be properly oriented on the chassis before the holes are drilled for their mounting. A pair of headphones should be connected across the winding of each audio transformer or choke; 110-volts a.c. is then supplied to the primaries of all power transformers, and the audio transformer, or choke, is then rotated to determine the center of the hum "null." It should be bolted to the chassis in this position, even if it detracts from the neatness of the amplifier.

Some manufacturers offer special hum-bucking transformers for use in low-level audio stages; the transformers are so wound that they need not be specially oriented for minimum hum pickup.

Especial care need not be taken with high-level audio transformers, such as class B input and output transformers, if they are well-shielded and are not mounted too close to any power transformers.

The use of resistance coupling in the low-level audio stages of a speech amplifier makes it unnecessary to take precautions against inductive hum pickup. But grid and plate leads should be well isolated from power supply and high-level audio circuits, to prevent electrostatic pickup. However, it is usually much easier to shield the low-level section of a speech amplifier from electrostatic pickup than it is from inductive hum pickup such as can arise when transformer coupling is used.

A separate ground lead from the speech amplifier to an external ground is strongly advisable when the amplifier is not integral with the rest of the transmitter. With relay rack construction, in which the rack frame constitutes a common ground for both r.f. and audio units, a heavy copper bus run as direct as possible to a good external ground will suffice.

Amplifier Input Circuits Various types of input circuits for speech amplifiers have been shown in the chapter *Radiotelephony Theory*. The majority

Figure 1.

25-WATT AUDIO CHANNEL.

This speech amplifier or modulator unit will modulate any class C stage running from 35 to 50 watts input. Or it can be used to cathode modulate an amplifier stage running from 100 to 200 watts input. It comprises a high-gain speech amplifier working into a pair of pentode connected 42's or 6F6-G's in class AB with semi-fixed bias.

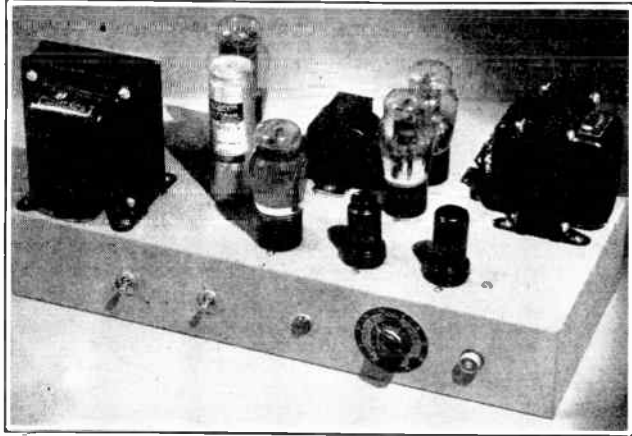

of the speech amplifiers and modulators shown later on in this chapter have input circuits designed for the use of the diaphragm-type crystal microphone. This type of input circuit has been shown, since that is the type of microphone most suited to amateur usage, and since the majority of amateurs now operating phone transmitters are using this type of microphone, or are contemplating the purchase of one. For those amateurs who prefer another type, such as the dynamic or the condenser, or for those who have another type microphone in good condition and who do not desire to purchase another, the special input circuits to

the first speech stage shown in Chapter 8 can be adapted to the speech amplifiers to be described.

25-Watt General Purpose Modulator

For plate modulation, or combined plate and screen modulation of a low-powered transmitter, a modulator with an output in the vicinity of 25 watts is usually required. Such a unit is pictured in Figures 1 and 2, the schematic wiring diagram appearing in Figure 3. This modulator is simple and inexpensive to construct, and will plate modulate inputs of 40 to 60 watts on voice with excellent quality; the

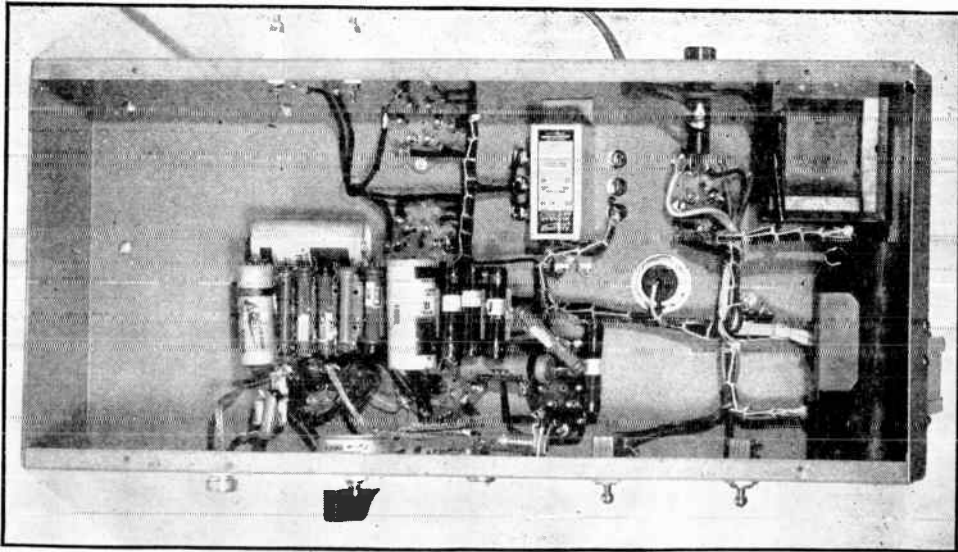

Figure 2.

UNDER-CHASSIS VIEW OF THE 25-WATT MODULATOR.

The filter choke and all resistors and condensers except C₁₀ are mounted below the chassis. The use of a resistor strip adds to the appearance and facilitates checking and replacement of these units.

maximum output of the modulator, with voice frequency input and tolerable harmonic distortion, is about 25 watts.

While the unit can be used to drive a class B modulator, or to grid modulate a high powered grid modulated transmitter simply by tying a 15,000-ohm 10-watt resistor between the plates of the push-pull 42's, the unit is not recommended for such work, as it does not work as well into a variable load as do some of the other units to be described. In other words, the unit works best when the output feeds into a constant load, such as when it is used to plate modulate a low-powered transmitter.

Tube Lineup The first stage of the amplifier, a pentode-connected 6SJ7, is designed to operate from a crystal or other high impedance microphone. The input plug is of the shielded type, allowing a firm screw-on connection to the grounded side of the microphone cable.

A 6C5 in a conventional resistance-coupled circuit amplifies the output of the 6SJ7 sufficiently to drive the triode-connected 42 which has more than sufficient output to swing the

grids of the push-pull modulators with low distortion.

The values of the coupling condensers C_1 and C_6 were chosen with respect to R_3 and R_4 so that the gain will be attenuated in the extreme bass register (below 150 cycles). The advantages of bass suppression for voice transmission were covered in Chapter 8.

42's were chosen for use in the last two stages because they are inexpensive considering their power capabilities; also, they will give service under a moderate overload.

The output tubes are operated with semi-stabilized cathode bias. The resistor R_{11} stabilizes the screen voltage and the grid bias, and at the same time acts as a bleeder for the power supply.

Operation The variable ratio output transformer makes the modulator adaptable to almost any transmitter. The taps should be connected so that a load of approximately 10,000 ohms, plate to plate, is placed on the 42's when the modulated stage is drawing normal plate current. The correct method of connecting the transformer taps for any particular installation can be determined quite

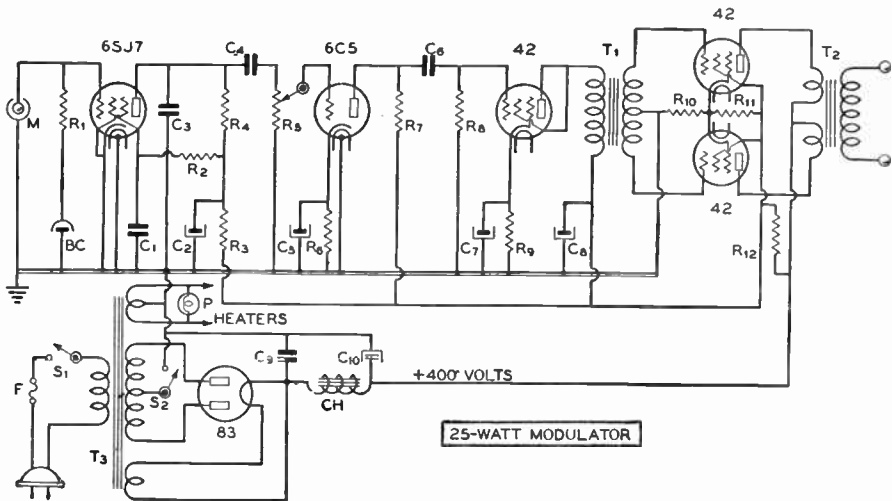

Figure 3.

WIRING DIAGRAM OF THE 25-WATT MODULATOR.

- | | | | |
|--|--|--|--|
| C_1 —0.25- μ fd. 400-volt tubular | C_3 —12- μ fd. 450-volt electrolytic | R_7 —2500 ohms, 1 watt | T_2 —Variable ratio 30-watt output transformer |
| C_2 —12- μ fd. 450-volt electrolytic | C_6 —4- μ fd. 600-volt paper | R_8 —50,000 ohms, 1 watt | T_3 —720 v., c.t., 125 ma. |
| C_3 —0.001- μ fd. mica | C_{10} —8- μ fd. 450-volt electrolytic | R_9 —200,000 ohms, 1 watt | T_4 —6.3 v., 4 a.; 5 v., 3 a. |
| C_4 —0.1- μ fd. 400-volt tubular | R_1 —1 megohm, 1/2 watt | R_{10} —750 ohms, 10 watts | CH—30-hy. 110-ma. choke (not over 200 ohms) |
| C_5 —10- μ fd. 25-volt electrolytic | R_2 —1 megohm, 1 watt | R_{11} —250 ohms, 10 watts | P—Pilot lamp |
| C_6 —0.1- μ fd. 400-volt tubular | R_3 —50,000 ohms, 1 watt | R_{12} —10,000 ohms, 10 watts | F—2-ampere fuse |
| C_7 —10- μ fd. 50-volt electrolytic | R_4 —250,000 ohms, 1 watt | T_1 —2000 ohms, 10 watts | BC—Bias cell |
| | R_5 —250,000-ohm potentiometer | T_2 —3/1 pri.-to-1/2 sec. driver trans. (42 to 42's class A-B) | M—Shielded microphone connector |

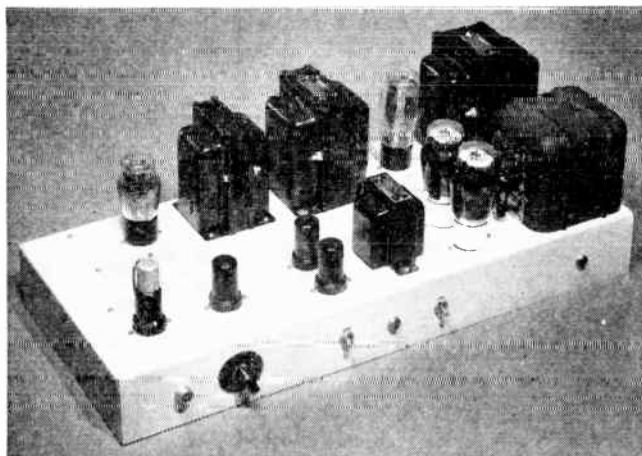

Figure 4.
TOP VIEW OF THE 60-WATT
T-21 MODULATOR.

The power supply components are lined up along the rear half of the chassis, starting with the bias rectifier and ending with the oversize power transformer on the right rear. The audio frequency stages progress from left to right along the front of the chassis ending up with the multiple-match output transformer on the right end.

easily by referring to the impedance ratio chart supplied with the particular make of transformer used.

As an example, if the modulated stage draws 100 ma. at 500 volts (such as a single 809), the load on the secondary of the modulation transformer will be 5000 ohms. Look up on the transformer chart the closest combination which reflects a 10,000-ohm plate-to-plate load on the primary when a 5000-ohm load is placed across the secondary of the transformer.

A 60-Watt T-21 Modulator Incorporating A.M.C.

The modulator illustrated in Figure 4 is designed primarily for use as a complete speech amplifier and modulator, to operate from a diaphragm-type crystal microphone, and to plate modulate about 150 watts input to a class C amplifier. It could, of course, also be used as a cathode modulator for 400 to 500 watts input to the stage; or, with about 20 db of feedback to the grids of the 6J5 drivers, it could be used as a high-level driver for a high-power class B stage.

A. M. C. Provision Automatic modulation control has been incorporated into the design of the first stage of the amplifier. If it is desired to use the a.m.c. provision, and it is highly recommended that it be used, the a.m.c. rectifier may be coupled into the terminal marked "a.m.c. input." If it is not desired to use a.m.c., the terminal may be left open or grounded, as desired. Incidentally, there must be a biasing system incorporated into the a.m.c. rectifier, as shown in the one at the end of this chapter; some of the earlier a.m.c. systems had the biasing system incorporated into the speech amplifier, and, hence, did not need any bias on the a.m.c.

rectifier. If an unbiased rectifier is used with this arrangement, the a.m.c. action will not come into effect until 100 per cent modulation is reached.

A New Phase-Inverter Circuit The 6J5 phase inverter operates in a new-type circuit which is quite simple and yet which gives a reasonable amount of gain. On first glance it might appear that the 6J5 operates in the conventional "hot cathode" circuit, which has been used for some years with reasonable success. But, while the old circuit gave practically no voltage gain in the phase inverter, by changing a few values and adding one resistor and condenser, the voltage gain of the circuit has been increased to approximately 7 per side, or a total gain of about 14—quite a worthwhile improvement from the addition of just one resistor and condenser.

The operation of the circuit is simple as will be apparent from inspection of the diagram. In the conventional arrangement, with C_7 and R_6 not in the circuit, when a voltage is impressed upon the grid of the 6J5 half the voltage output of the tube appears across the cathode return resistor R_{10} . This voltage is fed back 180° out of phase with the incoming voltage, and in series with it. The resulting 50 per cent degenerative feedback reduces the gain of the stage to slightly more than 1. But, by isolating the cathode feedback voltage from the exciting voltage which appears across R_7 , the plate circuit of the 6L7, the degenerative feedback is greatly reduced, and the stage attains almost normal gain—in addition to its function as a phase inverter.

One consideration in the design is the shunt resistance of R_{10} and R_6 , as compared to the resistance of R_{11} ; (R_{10} and R_6 are effectively shunted as far as audio frequencies are concerned by the effects of condensers C_7 and C_6).

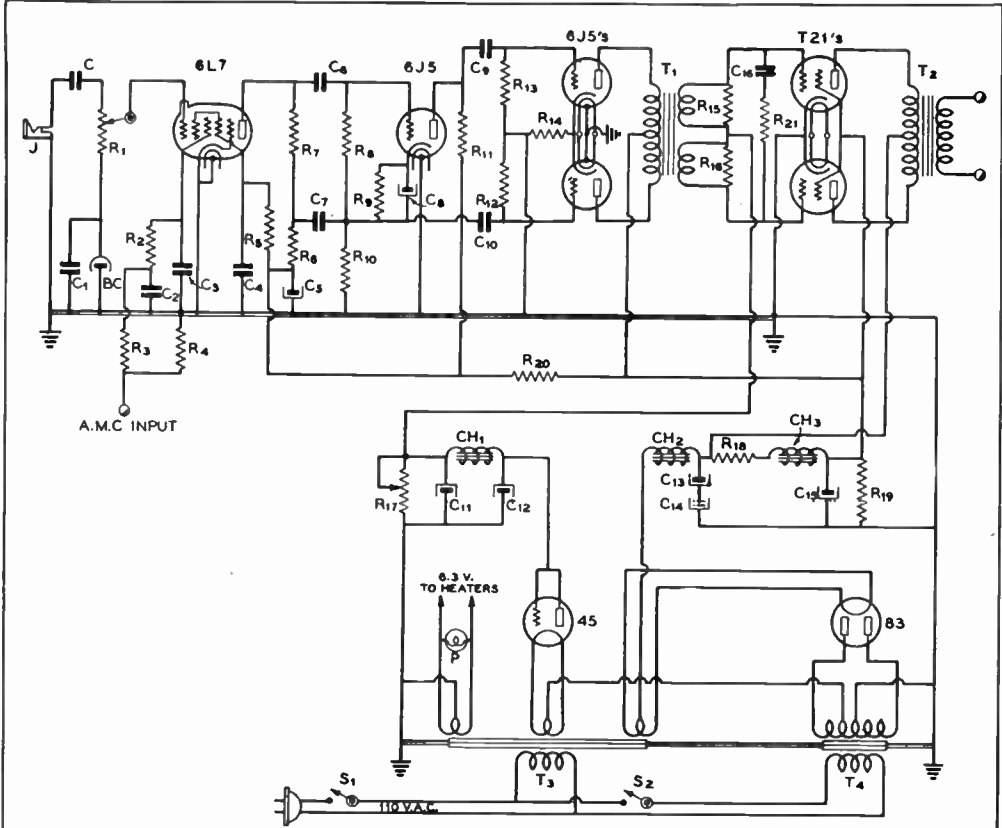

Figure 5.

WIRING DIAGRAM OF THE 60-WATT T-21 MODULATOR.

- | | | | |
|--|---|--|--|
| C, C ₁ —0.1- μ fd. 400-volt tubular | C ₁₀ , C ₁₁ , C ₁₂ —8- μ fd. 450-volt electrolytic | R ₁₁ —50,000 ohms, 1/2 watt | BC—Bias cell |
| C ₂ —0.005- μ fd. 400-volt tubular | C ₁₃ —0.005- μ fd. mica | R ₁₂ , R ₁₃ —250,000 ohms, 1/2 watt | T ₁ —5:1 driver - to - 6L6 trans. |
| C ₃ —0.5- μ fd. 400-volt tubular | R ₁ —1.0 megohm potentiometer | R ₁₄ —600 ohms, 1 watt | T ₂ —Multi-match output trans. |
| C ₄ —0.1- μ fd. 400-volt tubular | R ₂ —1.0 megohm, 1/2 watt | R ₁₅ , R ₁₆ —10,000 ohms, 1 1/2 watts | T ₃ —2.5 v., 3.5 a.; 5 v., 3 a.; 6.3 v., 3 a. filament trans. |
| C ₅ —8- μ fd. 450-volt electrolytic | R ₃ —100,000 ohms, 1/2 watt | R ₁₇ —1500-ohm 10-watt slider or 1000-ohm 10-watt fixed | T ₄ —1030 v. c. t., 250 ma.; bias tap at 30 volts |
| C ₆ —0.1- μ fd. 400-volt tubular | R ₄ —500,000 ohms, 1/2 watt | R ₁₈ —2000 ohms, 10 watts | CH ₁ —7.2-hy., 120-ma. choke |
| C ₇ —0.5- μ fd. 400-volt tubular | R ₅ —1.0 megohm, 1/2 watt | R ₁₉ —25,000 ohms, 20 watts | CH ₂ —13-hy., 250-ma. choke |
| C ₈ —10- μ fd. 25-volt electrolytic | R ₆ —100,000 ohms, 1/2 watt | R ₂₀ —5000 ohms, 10 watts | CH ₃ —15-hy., 85 m a. choke |
| C ₉ , C ₁₀ —0.1- μ fd. 400-volt tubular | R ₇ , R ₈ —250,000 ohms, 1/2 watt | R ₂₁ —5000 ohms, 1 1/2 watts | S ₁ —A.c. line switch |
| C ₁₁ , C ₁₂ —16- μ fd. 100-volt electrolytic | R ₉ —2500 ohms, 1/2 watt | J—Microphone jack | S ₂ —Plate on-off switch |

The shunt effect of the first two should be equal to R₁₁. The most satisfactory way of obtaining this is to make R₁₀ and R₆ each twice the value of R₁₁. This allows an equal audio voltage division between the plate and cathode circuits of the inverter tube. The plate impedance of the 6L7 is so high (approximately 0.8 megohm) as not to disturb the balance of the circuit materially.

P. P. 6J5 Drivers The driver stage for the T-21's is perfectly conventional, and consists of a pair of 6J5's operating into a 5:1 driver-to-6L6 class AB₂ transformer. The swamping resistors, R₁₅ and R₁₆, across the secondary of the driver transformer serve to improve the audio regulation. T-21's are used as final modulator tubes, with 400 volts on their plates and operating with fixed bias.

Separate Bias Supply The bias supply uses a 45 with the grid and plate strapped together, operating from the 30-volt tap on the power transformer. With the particular components that were used in the laboratory model of this modulator, when R_{17} was made a 1000-ohm 10-watt resistor, the bias voltage was the proper value on the T-21's. But to allow for variations in tubes and equipment, it is better to use a 1500-ohm adjustable resistor in this position. In any case, the shorting tap on the resistor will be very near to 1000 ohms.

The resistor-capacity network from grid to grid on the T-21's, C_{16} and R_{21} , was placed in the circuit to improve the waveform of the output at speech frequencies. Through the use of comparatively low value of coupling condensers from stage to stage within the amplifier, the frequency response of the amplifier

drops quite sharply below 150 cycles. This reduces the difficulties resulting from hum pickup, and allows a higher relative modulation percentage to be obtained on the voice frequencies above 150 cycles, those that contribute most to the intelligibility.

The primary and secondary of the multi-match output transformer should be "strapped" in such a manner as to present a plate-to-plate load impedance of 4000 ohms to the T-21 tubes, with the value of secondary load impedance into which the tubes are working. Maximum output and maximum modulating ability, with minimum harmonic distortion, will be obtained from the amplifier under these operating conditions.

Note that a cover should be placed on the bottom of the chassis to minimize electrostatic pickup.

5-Watt Speech Amplifier or Grid Modulator with Degenerative Feedback

Figure 7 illustrates a simple 5-watt amplifier specifically designed to operate from a crystal microphone, and to be used as a grid modulator for a medium- to high-powered amplifier. A single-ended 6L6 is used as the output tube, with degenerative feedback from its plate back to its grid circuit. The use of degenerative feedback greatly lowers the plate impedance of the 6L6, and considerably reduces any harmonic distortion that might be introduced as a result of the operation of a single-ended beam tetrode stage. The reduction in the plate impedance of the 6L6 by feedback improves the regulation of the output voltage with respect to such changes in loading as are had when grid modulating an amplifier.

The Feedback Circuit The addition of the single resistor R_{11} from the plate of the 6L6 back to the plate of the 6SJ7 amplifier stage, reduces the harmonic distortion, measured from the input of the 6SJ7 to the output of the amplifier, from approximately 11 per cent to less than 3 per cent at 5 watts output. The addition of the

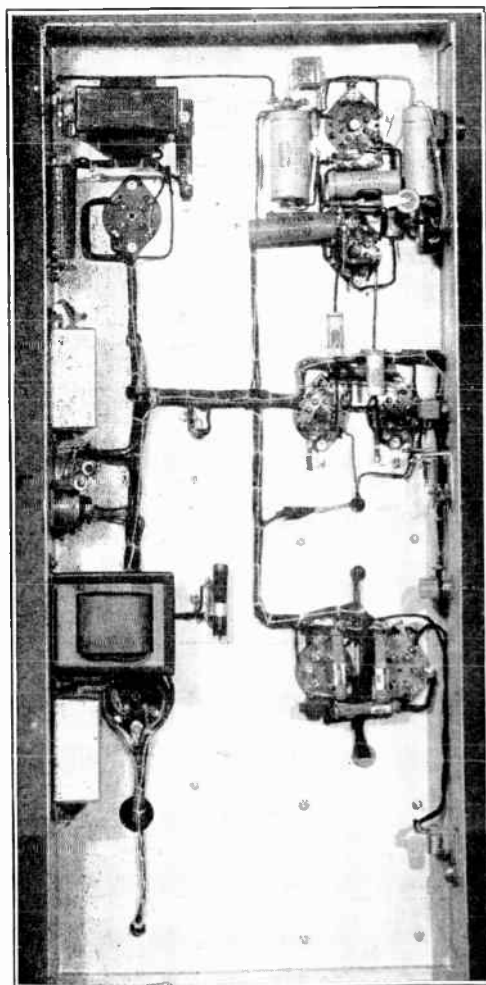

Figure 6.
UNDER-CHASSIS VIEW OF THE T-21 MODULATOR

All power supply components are arranged along the rear side of the chassis and all audio components along the front. The single interconnecting cable between the two halves of the amplifier tends to minimize electrostatic coupling between them and hence to reduce hum pickup. However, to minimize electrostatic pickup from external sources it has been found desirable to place a metal cover on the bottom of the chassis. The chassis should be connected to external ground by an independent connection.

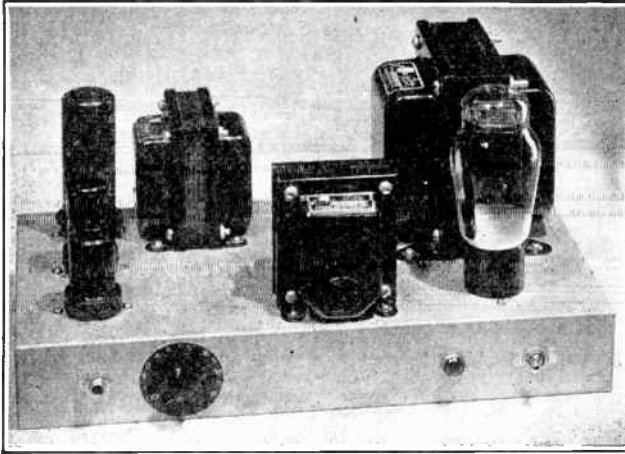

Figure 7.
FRONT VIEW OF THE
5-WATT AMPLIFIER.

The three audio tubes, the 6J5 first stage, the 6SJ7 second, and the 6L6 power amplifier are lined up along the left end of the chassis. The output transformer is alongside the 6L6; the other components are those associated with the power supply. The jack for the crystal microphone and the volume control are on the front drop of the chassis.

resistor for the shunt feedback circuit reduces the gain of the amplifier only a small percentage; there is ample gain to give full output when using a diaphragm-type crystal microphone on the input.

The power supply uses an input resistor instead of the more common input condenser or choke. The resistor serves to limit the voltage of the power supply to the proper value, both because of its action as a resistance, and because it acts as an input impedance ahead of the first condenser. It also contributes to the filtering action.

The Output Circuit

The shunt resistor, R_{13} , serves a triple purpose. In the first place, it acts as a load upon the output of the 6L6 to stabilize its output with respect to variations in load. Second, it acts as a bleeder upon the power supply to reduce the possibility of blowing the filter condensers in the interval between the heating up of the filament of the 5Z3 and the coming to operating temperature of, the cathode of the 6L6. Third, its drain through the secondary of the output transformer opposes that of the 6L6, and tends to cancel the saturating action

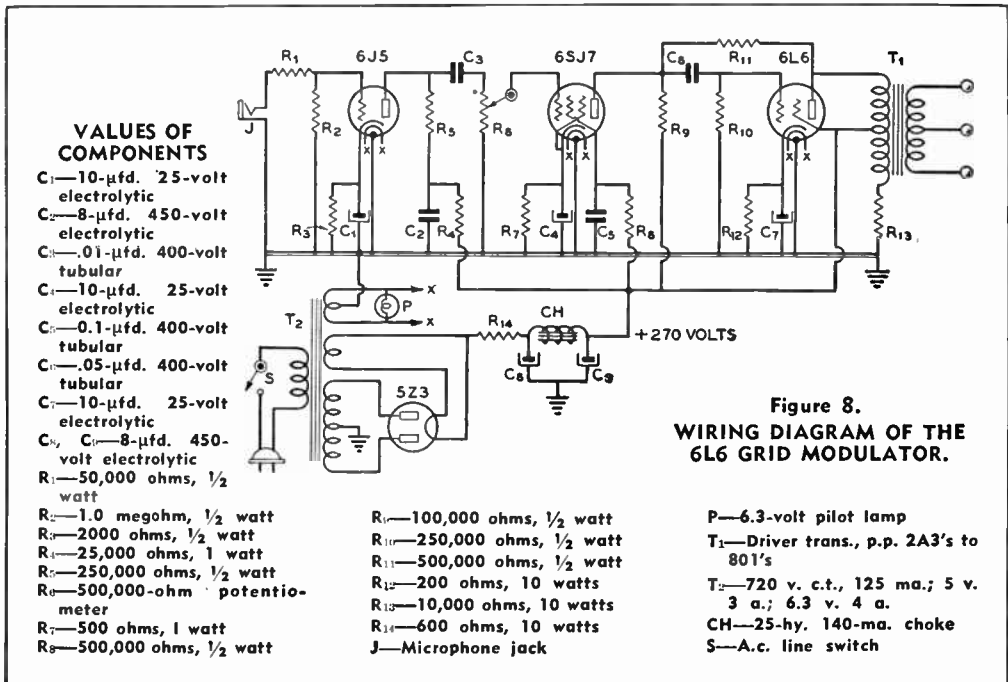

Figure 8.
WIRING DIAGRAM OF THE
6L6 GRID MODULATOR.

of the plate current of the 6L6 upon the core.

The output transformer T_1 is a unit designed to be used as a driver transformer between push-pull 2A3's and the grids of a pair of 801's in class B. However, by using it in the amplifier as shown, it is possible to obtain a selection of four different impedance ratios from the plate of the 6L6 to the grid of the tube being modulated. If the 6L6 is fed into the side of the transformer originally meant for the 2A3's, the use of the full secondary will give a ratio of 2.35 to 1 step up; the use of half of the secondary will give about 1.2 to 1 step up. Then, if the 6L6 is operated into the side designed for the 801's, the use of the total secondary will give a ratio of 1.7 to 1 step up, and the use of half of the secondary will give a ratio of 1 to 0.85 step down. This latter ratio is the one most likely to be used when modulating medium- μ tubes at normal plate voltages. The step-up ratios would be used with medium- μ or low- μ tubes at comparatively high plate voltages and plate inputs up to 1 kilowatt.

If the output transformer is connected to the plate of the 6L6 in the manner for which it was designed (the 6L6 feeding into the 2A3 side), the secondary may be connected to the

grids of a pair of medium-power class B tubes. Tests have shown that the amplifier thus connected has ample gain and power output to drive a pair of 809's, HY-25's, HY-40Z's, or a pair of 811's, HY-51Z's, TZ-40's at 1250 volts.

Push-Pull 2A3 Amplifier-Driver

A speech amplifier-driver for a medium-powered class B modulator is shown in Figures 10 and 11. The amplifier is designed to work out of a diaphragm-type crystal microphone, although any other type of input circuit could be used with equally good results. Alternative input circuits have been shown in Chapter 8.

The first stage utilizes one of the new single-ended metal pentodes: a 6SJ7. The gain control is between its plate circuit and the grid of the 6C5 second stage. The output tubes are a pair of 2A3's, operating with a self-bias resistor in their common filament return. Operating in this manner, the 2A3's have an undistorted output of approximately 10 watts.

As a Driver A pair of 2A3's operating in this manner will have ample output to drive almost any class B modulator whose output is 300 watts or less. The driver transformer for coupling the plates of the

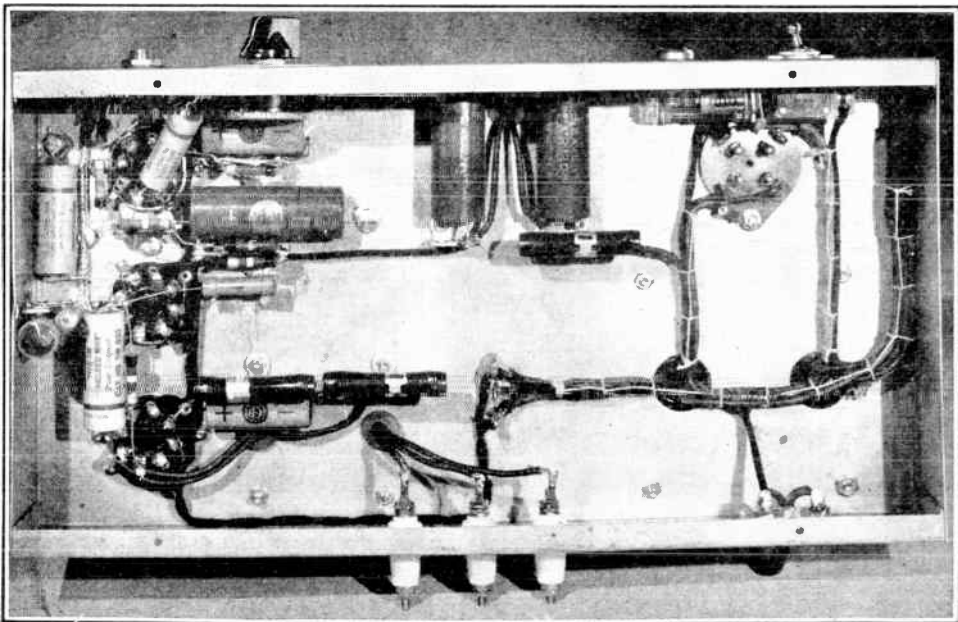
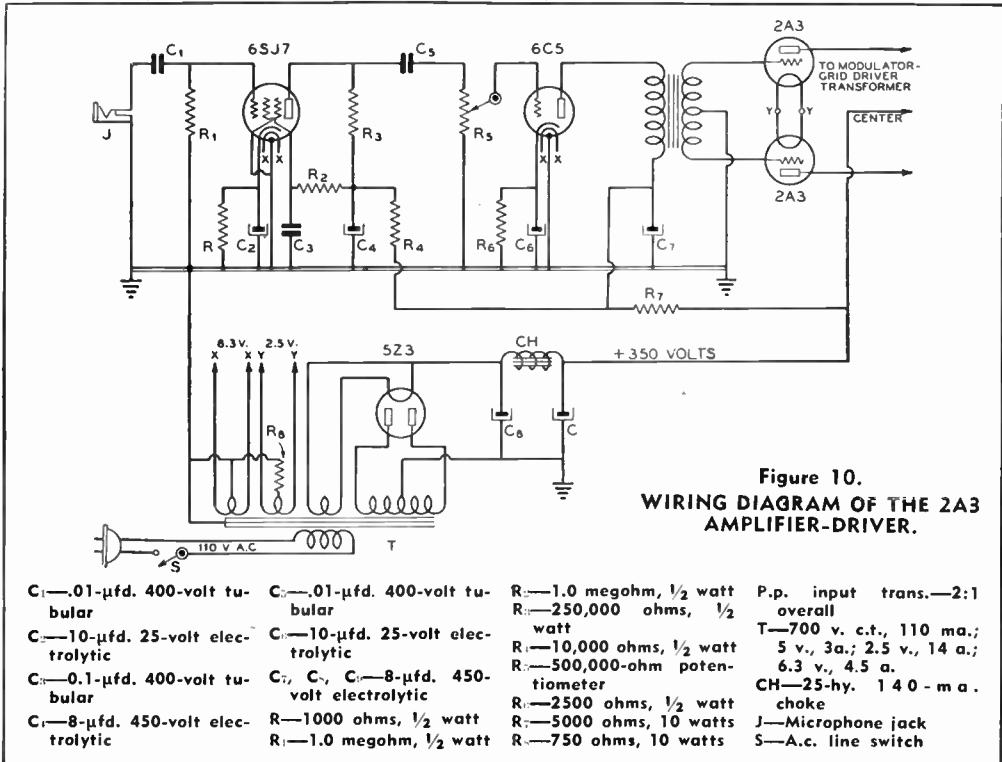

Figure 9.

UNDER-CHASSIS VIEW OF THE 6L6 AMPLIFIER OR GRID MODULATOR.

Under-chassis layout is comparatively simple and is made to present a neat appearance by cabling all the power supply leads. The three feedthrough insulators on the back-drop of the chassis are the three leads from the secondary of the modulation transformer; they can be used either to feed the grid return of the grid modulated stage, they may be used to plate modulate 10 to 15 watts input to a class C stage, or they may be fed to the grids of a medium power class B modulator.



2A3's to the grids of the class B stage is not shown, since it has been found best to have this transformer at the grids of the driven tubes, rather than at the plates of the drivers. The correct transformer step-down ratios for driving almost any class B tube have been set down in tabular form by the various transformer manufacturers. When the driver transformer is purchased, one should be obtained which has the proper ratio for the tubes to be used. Some manufacturers make multiple-ratio

transformers which allow a proper match to be obtained for a large number of tubes.

A 3-wire shielded cable should be run from the output of the 2A3 tubes to the driver transformer at the grids of the class B tubes. This cable may be made any reasonable length up to as much as thirty feet. Make sure that the insulation from the 3 wires to ground is ample to withstand at least twice the d.c. voltage on the plates of the 2A3 tubes.

For driving a class B modulator of less than

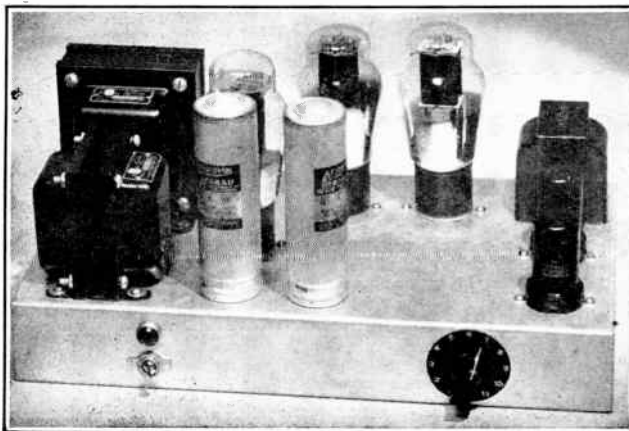

Figure 11.
THE 2A3 SPEECH AMPLIFIER-DRIVER.

The jack for the crystal microphone is mounted on the right drop of the chassis directly alongside the grid lead of the 6SJ7 first speech stage. The low plate impedance of the 2A3's makes this amplifier an ideal driver for any medium power class B modulator.

75 watts output, type 45's may be substituted for the 2A3's with no changes in circuit constants. The 45's are less expensive.

Class B 809 Modulator

Figures 12 and 13 illustrate and show the schematic of a class B modulator using a pair of 809's. This modulator is designed to be driven by the push-pull 2A3 speech amplifier-driver shown on the preceding pages. A pair of 45's also could be used as drivers, but the 2A3's will have a reserve of driving power that will make for better quality from the modulator.

Voice Modulation Operation With the 809's operating at 750 volts plate and 4.5 volts of bias, the plate-to-plate load should be 4800 ohms for maximum speech-waveform peak audio output. Under these conditions, the instantaneous peak output from the tubes will be about 300 watts, which will allow the 809's to modulate an input of 300 watts to the class C amplifier. With 900 volts on the 809's, the proper plate-to-plate load resistance is 6200 ohms, and the peak output will be about 350 watts. If the plate voltage is raised to 1000 and the bias to 8 or 9 volts, the proper plate-to-plate load value is 7200 ohms, and the tubes will deliver a peak output of 400 watts, allowing them to voice modulate an input of 400 watts to the final stage.

Under all the above conditions of operation, full output from the 809's will be obtained when they are driven to an average plate current of approximately 160 ma. as indicated by the milliammeter M in the plate circuit. Testing of the modulator, with sine-wave

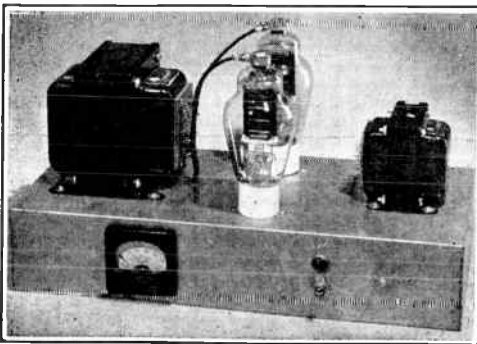

Figure 12.

CLASS B 809 MODULATOR.

Multiple ratio transformers have been used both in the grid and plate circuits of the modulator to increase its flexibility in matching various driver combinations and in coupling to various values of load impedance.

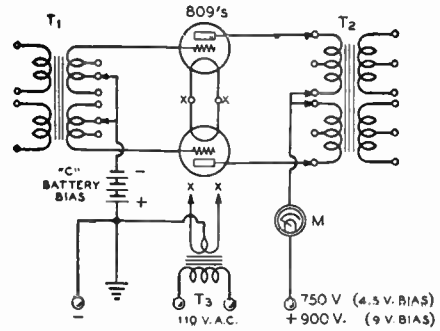

Figure 13.

SCHEMATIC DIAGRAM OF THE 809 MODULATOR.

- T₁—Multiple-ratio input transformers; 4.5:1 step-down ratio usually used
- T₂—Multiple-impedance output transformer
- T₃—6.3-volt 5-ampere filament transformer
- M—0-250 d.c. milliammeter

audio as generated by an audio oscillator, is not to be recommended, except for a very short period of time, just long enough to make the measurement. If continuous modulation with a sine-wave tone is attempted, the maximum plate dissipation ratings of the 809's will be exceeded.

The input transformer ratio of total primary to half secondary should be approximately 4.5 to 1 for all conditions of operation.

Sine-Wave Operation If it is desired to operate the 809's under the sine-wave audio conditions for modulating a smaller input to the class C stage, the following conditions will apply: plate voltage, 500; grid bias, 0; plate-to-plate load impedance, 5200 ohms; power output, 60 watts (which will modulate an input of 120 watts to the class C stage); maximum signal plate current, 200 ma. Another set of conditions, recommended for somewhat greater power output with sine-wave audio, are: plate voltage, 750; grid bias, 4½; plate-to-plate load, 8400 ohms; power output, 100 watts (which will sine-wave modulate 200 watts input to the class C stage); maximum signal plate current, 200 ma. The correct driver transformer stepdown ratio for these operating conditions is also 4.5:1.

Alternative conditions for sine-wave operation of the 809 modulator are given under the ICAS ratings for the tube. With 1000 plate volts, 10 volts of grid bias, and a plate-to-plate load resistance of 11,600 ohms, the pair of 809's have a class B sine-wave rating of 145 watts. The tubes will, under these conditions, be able to plate modulate 290 watts into the

class C amplifier, neglecting insertion losses in the modulation transformer.

150-Watt Class B 811 Speech System Incorporating Splatter Suppressor

Figure 14 shows a rear view of a complete speech amplifier and modulator, utilizing a pair of 811's in the class B output stage. The speech amplifier uses a 6SJ7, 6N7, and ends up in a pair of 6L6's, with degenerative feedback, as the driver for the class B tubes. Ample gain is afforded by the speech circuit for operation from a crystal microphone, or one of the new high-impedance dynamic types. The output circuit of the modulator incorporates a combination splatter suppressor and low-pass filter circuit. The rectifier tube, in series with the plate lead to the final amplifier, eliminates the negative plate current swings which can be caused by large negative modulation peaks, while the 3500-cycle cutoff low-pass filter prevents the transmission of high-frequency splatter components generated in the rectifier tube, and attenuates speech components or distortion falling above 3500 cycles.

Since this modulator is a portion of the 250-watt bandswitching 813 transmitter described in Chapter 16, the circuit diagram is not also shown here. The reader is referred to the

chapter *Transmitter Construction* for the circuit diagram and further information on this complete speech and modulator system. The unit is capable of sine-wave modulating up to 300 watts input to the class C stage, with a 1250-volt plate supply for the 811's.

Speech-Modulator Unit with TZ-40's for 600 Watts Input

Illustrated in Figures 15 and 16, and diagrammed in Figure 17, is a complete speech channel capable of plate-modulating an input of between 500 and 600 watts on voice. It incorporates a.m.c., inverse feedback, and other desirable modern features.

The combined speech amplifier and class B modulator, with the associated power supply for the speech amplifier, is built upon one 24 x 10 x 3 inch metal chassis. The underside of the chassis is not painted; the plated cadmium finish on this side facilitates the grounding of the various components.

The power supply for the speech stages is mounted along the left hand side of the chassis. Then there are mounted, in a row, the 6J7 first audio stage, the 6L7 a.m.c. amplifier, and the 6F6 last audio. Then, in the next row, in front, is the multitap driver transformer for the class B stage, then the two 6V6 drivers

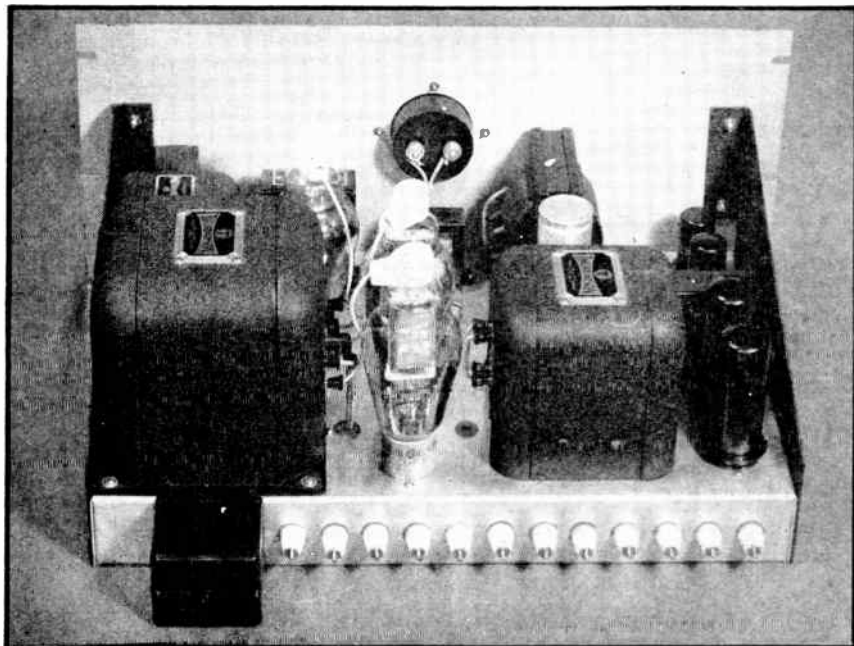

Figure 14.
REAR VIEW OF THE CLASS B 811 MODULATOR
INCORPORATING SPLATTER SUPPRESSOR.

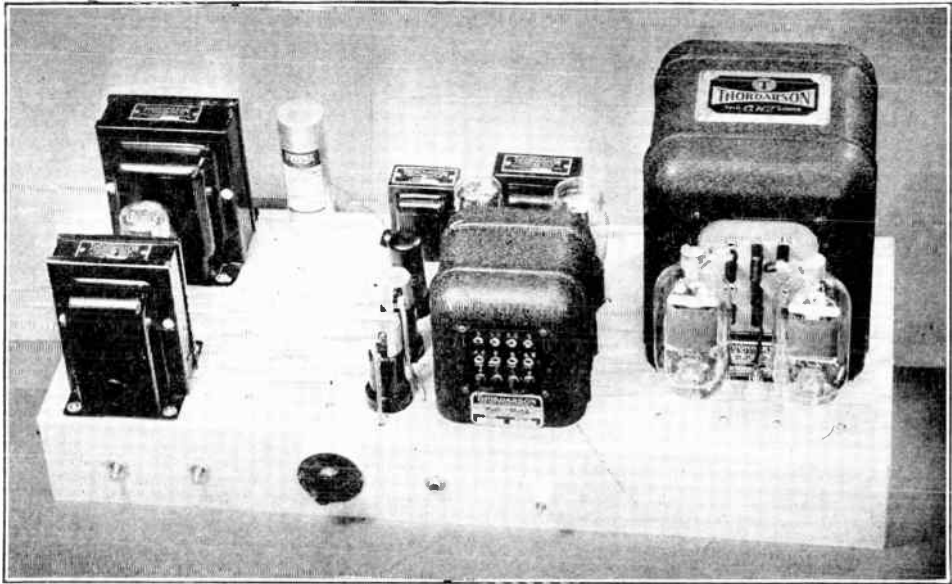

Figure 15.

FRONT VIEW OF THE TZ-40 SPEECH AMPLIFIER-MODULATOR.

This combined speech amplifier and modulator will fully modulate up to 600 watts on voice. It incorporates inverse feedback, a.m.c., and other features.

and, in back, the coupling transformer between the 6F6 and the two 6V6G's.

On the right hand end of the chassis are mounted the two TZ-40 modulators and their associated class B output transformer.

Looking at the front of the chassis, at the extreme left, the on-off switch for all filaments and for the plate supply for the speech amplifier can be seen. The plate supply for the TZ-40's is controlled at the transmitter proper. The next switch is the on-off switch for the a.m.c. circuit. Then comes the gain control, the microphone input jack, and the binding post for connection to the a.m.c. peak rectifier.

The under-chassis view is practically self-explanatory. At the extreme right end of the chassis is the 7.5-volt filament transformer for the TZ-40's, and to the left of the center of the chassis are mounted the resistor plates. Only the upper one can be seen, as the two are mounted one above the other.

The speech amplifier uses a 6J7 metal tube connected as a high-gain pentode in the input. The circuit is conventional, and the tube is designed to operate from a diaphragm-type crystal microphone. The closed circuit jack on the input of the amplifier is shielded by a small metal can to eliminate any possibility of coupling between the output of the amplifier and the input circuit. Since the large metal spring of the jack is at grid potential, it is desirable to shield it from the output circuit

of the 6V6G's, and from the a.m.c. lead which runs very close to the jack.

Automatic Modulation Control

The second stage of the amplifier—the a.m.c. stage—utilizes a 6L7 tube. The 500,000-ohm volume control is placed between the plate circuit of the 6J7 and the control grid of the 6L7. This potentiometer must be of the insulated-shaft type, since the entire 6L7 circuit operates considerably above ground potential.

The 879 reverse peak rectifier should be connected as follows: the plate of the tube should be connected directly to the a.m.c. binding post on the amplifier, and the filament of the tube should be connected to the lead that goes to the plates of the modulated class C amplifier. The filament should be lighted from a 2.5-volt filament transformer that is adequately insulated for twice the average plate voltage of the modulated amplifier, plus 1000 volts. Also, it is often a good idea to remove the negative peak rectifier as far as conveniently possible from both the speech amplifier and the class C final.

Since the injection grid of the 6L7 a.m.c. amplifier is 70 to 90 volts above ground potential (the whole a.m.c. stage is, as mentioned before, at this potential above ground), the 879 peak rectifier will begin to operate when the plate voltage on the class C amplifier

becomes less than 70 or 90 volts, as the case may be. Then, as the modulator tends to drive the plate voltage lower than this, the gain on the speech amplifier will be reduced as the injector-grid bias on the 6L7 becomes negative. As this negative bias is increased, the signal output of the modulator is reduced. The final result: the output voltage of the modulator is reduced to an amount that will not cut the negative-peak plate voltage on the class C stage to zero; consequently, there is no overmodulation.

The gain on the speech amplifier may be run up to an amount which will permit a higher average voice level from the transmitter without any chance of overmodulation in any case. When the resulting signal is heard

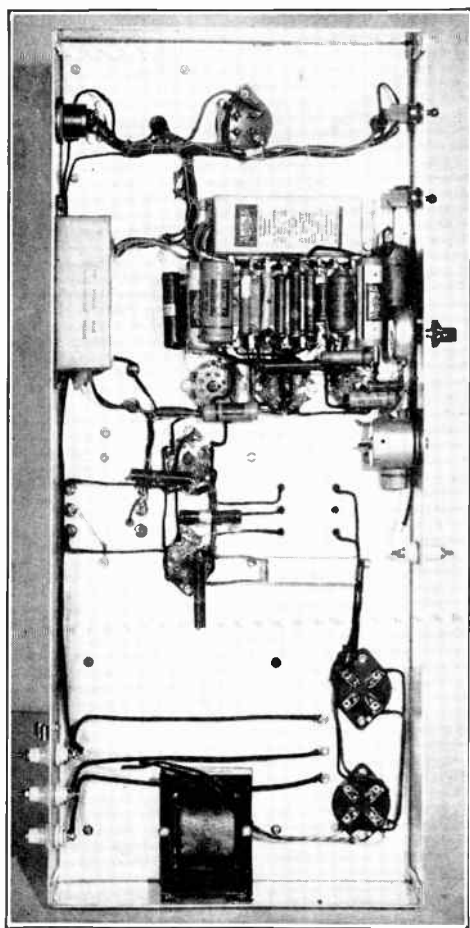

Figure 16.
UNDER-CHASSIS VIEW OF THE TZ-40 MODULATOR.

The use of a resistor terminal plate, under-chassis wiring, and placement of components can be seen.

over the air, the transmitter seems to be modulated at a much higher percentage, although there is no tendency toward overmodulation splatter or hash.

The 6V6G Drivers A pair of 6V6's or 6V6G's are used as drivers for the TZ40's.

By using degenerative feedback from the secondary of the driver transformer to the screens of the 6V6's, the plate impedance of these tubes is lowered, thus making them well suited for use as drivers.

Beam tetrodes, when connected in the conventional manner, are not particularly well-suited as drivers for a class B stage unless a considerable amount of swamping is used. The high plate resistance of the tubes in the conventional method of connection causes a large drop in output voltage when any increase in load is placed upon them.

When first placing the amplifier in operation, it is very important that the screens be connected to the proper side of the class B modulation transformer secondary. The only way of finding out which side is the proper one is to connect up the amplifier and try it out. It is best not to have plate voltage on the TZ40's when this test is made; something may flash over. If the 6V6G's oscillate, reverse the connections between the screen grid coupling condensers and the class B grids, and the correct phase relation between the screen and plate voltages will be obtained.

TZ-40 Operating Conditions The TZ40's operate with zero bias under the conditions recommended by the manufacturers. The standing plate current on the two tubes is approximately 45 ma. with an applied plate voltage of 1000 volts. It will be somewhat higher, in the vicinity of 60 ma., if the full rated plate voltage of 1250 volts is used. Since this value of standing plate current results in an appreciable amount of plate dissipation, a small amount of grid bias is desirable, in order to lower the plate current under no-signal conditions. A pair of 1½-volt batteries in series to give 9 volts is suitable as bias for 1250-volt operation.

For maximum peak power output from the TZ40's (for the adjustment which will modulate the greatest class C input with voice), the plate-to-plate load impedance for the 1000-volt conditions would be 5100 ohms. Under these conditions of operation, the modulator would be capable of 100 per cent voice-modulation at an input of 500 watts to the class C stage; the plate current on the TZ40's should kick up to 200 to 250 ma. under normal modulation.

For maximum peak modulating capabilities at 1250 volts, the plate-to-plate load value should be 7400 ohms; the unit would be capa-

Figure 17.
SCHEMATIC DIAGRAM OF THE TZ-40 MODULATOR AND ASSOCIATED
A.M.C. SPEECH AMPLIFIER.

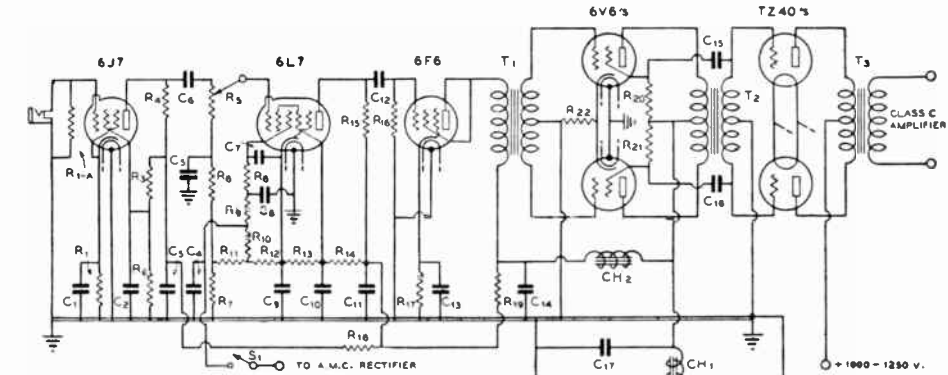

- C₁—10- μ fd. 25-volt electrolytic
- C₂—25- μ fd. 400-volt tubular
- C₃—4- μ fd. 450-volt electrolytic
- C₄, C₅—0.5- μ fd. 400-volt tubular
- C₆—0.2- μ fd. 400-volt tubular
- C₇—0.1- μ fd. 400-volt tubular
- C₈—0.02- μ fd. 400-volt tubular
- C₉—8- μ fd. 450-volt electrolytic
- C₁₀—0.5- μ fd. 400-volt tubular
- C₁₁—8- μ fd. 450-volt electrolytic
- C₁₂—8- μ fd. 450-volt electrolytic
- C₁₃—8- μ fd. 450-volt electrolytic
- C₁₄—0.3- μ fd. 400-volt tubular
- C₁₅—10- μ fd. 25-volt electrolytic
- C₁₆—8- μ fd. 450-volt electrolytic
- C₁₇—8- μ fd. 450-volt electrolytic
- R₁—1000 ohms, 1 watt
- R₂—5 megohms, 1 1/2 watts
- R₃—50,000 ohms, 1 watt
- R₄—500,000 ohms, 1 watt
- R₅—250,000 ohms, 1 watt
- R₆—500,000-ohm potentiometer
- R₇—500,000 ohms, 1 watt
- R₈—4500 ohms, 5 watts
- R₉—1 megohm, 1 watt
- R₁₀—100,000 ohms, 1 watt
- R₁₁—500,000 ohms, 1 watt
- R₁₂—350 ohms, 1 watt
- R₁₃—150 ohms, 1 watt
- R₁₄—5000 ohms, 5 watts
- R₁₅—7500 ohms, 5 watts
- R₁₆—100,000 ohms, 1 watt
- R₁₇—100,000 ohms, 1 watt
- R₁₈—750 ohms, 10 watts
- R₁₉—10,000 ohms, 5 watts
- R₂₀, R₂₁—2000 ohms, 5 watts
- R₂₂, R₂₃—5000 ohms, 3 watts
- R₂₄—300 ohms, 10 watts

- T₁—Triode power tube to p.p. power tube driver transformer
- T₂—Multi-match class B input transformer
- T₃—Multi-match class B output (300 watt)
- T₄—745 v. c.t., 145 ma.; 5 v. 3 a.; 6.3 v., 4.5 a.
- T₅—7.5 volts, 4 amperes
- CH₁—10-hy., 150-ma. filter choke
- CH₂—10-hy., 65-ma. filter choke
- S₁—A.m.c. on-off switch
- S₂—110-v. a.c. switch

ble of fully modulating 600-watts input, and the plate current would kick up to 175 to 225 ma. under full modulation.

If it is desired to operate the class B stage under conventional conditions for maximum *sine-wave* audio output, the plate-to-plate load resistance would be 6800 ohms under the 1000-volt conditions; the power output would be 175 rated watts, and the plate current would kick up to 250 to 275 ma. on peaks.

Complete 203Z Modulator and Speech Amplifier for Inputs Up to 800 Watts

Figures 18 and 19 show a speech amplifier and class B modulator suitable for modulating from 400 to 800 watts input to the class C final stage. The speech amplifier portion of the modulator is more or less conventional, except

for the inclusion of automatic peak compression to allow a higher average percentage of modulation without the danger of overmodulation on occasional loud voice peaks. The delay action in the compressor (the percentage of modulation at which compression starts) can be controlled by means of the potentiometer R₁₁. All components in the 6J7 first speech stage should be thoroughly shielded to prevent grid hum, and to reduce the possibility of either r.f. or audio feedback.

Operation of the Class B 203Z's The class B operating conditions recommended by the manufacturer for sine-wave audio output are 7900 ohms plate to plate at 1250 volts on the plate and 4 1/2 volts of grid bias. Under these conditions the tubes will deliver 300 watts of sine-wave audio. For maximum speech audio output the



Figure 18.
203-Z SPEECH-MODULATOR
FOR INPUTS TO 800 WATTS.
The complete speech amplifier and class B output stage are built upon a single relay-rack panel and its associated chassis. The speech amplifier incorporates automatic peak limiting and uses a pair of 2A3's as drivers for the 203-Z's.

plate-to-plate load resistance should be reduced to 5500 ohms. Under these conditions, the tubes will modulate an input of 800 watts, as compared to the 600 watts they will modulate under sine-wave audio operating conditions.

Power supplies, both for the speech amplifier portion and for the class B stage, are external. 1250 volts will be required for the 203Z's, and about 350 volts for the speech amplifier portion. The 1250-volt supply should have good regulation up to a maximum drain of 350 ma., and the 350-volt supply should be capable of handling 125 ma. continuously.

Simplified Automatic Modulation Control

Figure 20 shows the circuit of a simplified method of obtaining the necessary bias required for an automatic-modulation-control system. This rectifier circuit must be used with the 60-watt T-21 modulator shown earlier in this chapter, if satisfactory a.m.c. action is desired. Through the use of the circuit illustrated, the bias required for all a.m.c. systems is placed on the rectifier tube itself, instead of being placed on the cathode of the a.m.c. tube in the speech amplifier. This greatly simplifies the design of the a.m.c. stage in the speech system.

"Advance" Bias System In the circuit diagram, this "advance" bias is obtained by means of a voltage divider, consisting of a 50,000-ohm and a 500,000-ohm resistor, which reduces the

d.c. plate voltage applied to the diode cathode about 9 per cent. This acts as the "advance" bias. The resistor R_1 can be of the 1-watt size for plate supplies up to 1000 volts, and a 2-watt for up to 2000 volts. The 500,000-ohm resistor can be made of ten similar carbon resistors, wired in series and well insulated from the chassis. C_1 , R_1 , and R_2 can be mounted on bakelite resistor mounting strips or panels about 1 inch away from the chassis, with the strip mounted on stand off insulators. The diode filament transformer must be well insulated between windings in order to withstand the peaks in the positive direction.

The Rectifier Diode The diode itself must have sufficient inverse peak rating, which means that an 866 Jr. is suitable for use in sets with plate supplies up to 1000 volts, an 866 up to 2500 volts, and an 879 for higher plate supplies. Mercury vapor in the rectifiers seems to make no difference in operation at the low currents used in a.m.c. circuits.

The purpose of C_1 in the circuit diagram is to by-pass the audio peak overload voltage into the diode cathode. The diode then has the full amount of a.c. peak across it, and a little over 90 per cent of the d.c. plate voltage. C_1 can be a 0.5- or 1- μ fd. 400- or 600-volt paper condenser, as long as it is mounted well in the clear of nearby grounds.

The control bias is developed across R_2 , which can be of any value between 100,000 and 250,000 ohms. No condenser should be connected across this resistor unless there is

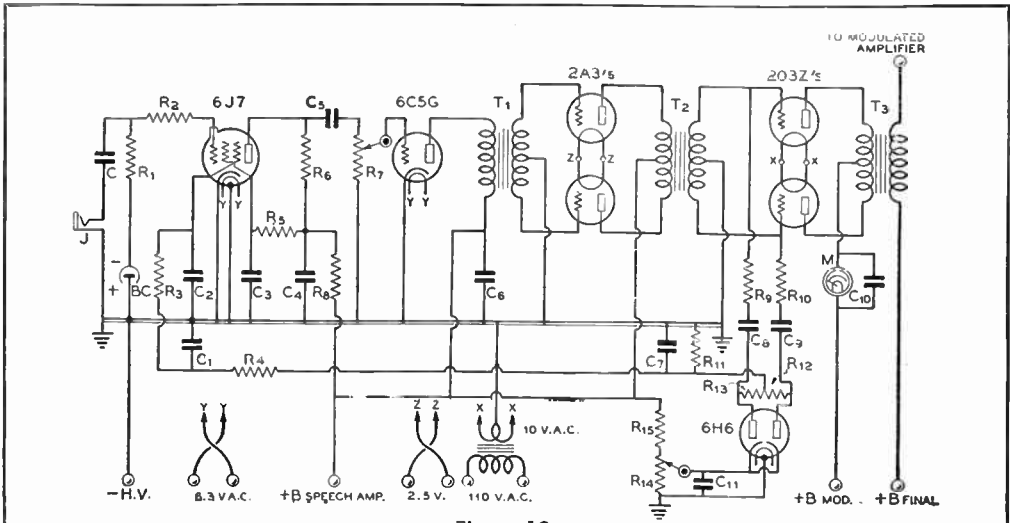

Figure 19.

WIRING DIAGRAM OF THE CLASS B 203-Z MODULATOR.

- | | | | |
|------------------------------------|--|---|---|
| C—0.01- μ fd. 400-volt tubular | C—0.25- μ fd. 400-volt tubular | R—1.0 megohm, 1/2 watt | R ₁₁ —100,000 ohms, 1 watt |
| C—0.1- μ fd. 400-volt tubular | C ₅ , C ₆ —0.1- μ fd. 400-volt tubular | R—250,000 ohms, 1/2 watt | J—Microphone jack |
| C—0.1- μ fd. 400-volt tubular | C ₁₀ —0.002- μ fd. mica | R—1.0 megohm potentiometer | BC—Bias cell |
| C—0.25- μ fd. 400-volt tubular | C ₁₁ —1.0- μ fd. paper, 400 volts | R—50,000 ohms, 1/2 watt | T ₁ —Push pull input trans. |
| C—0.5- μ fd. 400-volt tubular | R ₁ —1.0 megohm, 1/2 watt | R ₁₀ , R ₁₁ —2.0 megohms, 1/2 watt | T ₂ —Class B Input for 203Z's |
| C—0.01- μ fd. 400-volt tubular | R—50,000 ohms, 1/2 watt | R ₁₂ , R ₁₃ , R ₁₄ —100,000 ohms, 1 watt | T ₃ —300-watt variable-ratio modulation trans. |
| C—0.5- μ fd. 400-volt tubular | R—300,000 ohms, 1/2 watt | R ₁₄ —50,000 ohm potentiometer | M—0-500 d.c. milliammeter |

some stray r.f. present. If there should be any, it must be by-passed with a small .002- μ fd. condenser. The time delay circuit should be confined mainly to C₅ and R₅, which can have values of 0.5 μ fd. and 1 megohm in most speech transmitters. Additional audio filter in the form of C₂, 0.1 μ fd., and R₁, 0.5 megohm, is generally necessary to prevent audio feedback and a "blurring" effect on high levels of speech input. These resistors can be of 0.5- or 1-watt size.

A.M.C. Tubes It is possible to supply a.c.c. voltage to the control grid of an amplifier, such as to a 6K7 or even a 6N7. The suppressor grid of a 6C6, 6J7, or 6K7 requires about twice as much negative bias for the same reduction in gain as does the injector grid of a 6L7. It is advisable to use a 6L7 whenever possible. However, this a.m.c. circuit can be applied to nearly any existing phone transmitter, with hardly any changes in the speech amplifier.

A.M.C. Advantages A.m.c. practically eliminates sideband splatter in all cases, and prevents modulation in ex-

cess of 100 per cent. In addition, it allows an average higher level of modulation, which results in better signal at the receiver. The two phone transmitters of the same carrier output, one with a.m.c. and one without, both not overmodulated, will have about 2 to 3 db difference in level. The 3 db increase available from the use of a.m.c. is equivalent to doubling the carrier signal.

One other point should be mentioned: a.m.c. will handle only from 15 to 20 db excessive level peaks without considerable audio distortion. So don't try to push the average modulation level up to 99 per cent at all times. Use the manual gain control, too, and keep the level of modulation down to a point where it sounds right in a monitor. An oscilloscope will usually indicate 100 per cent modulation many times a minute on an average speech, when the gain adjustment is correct for good monitor quality.

The a.m.c. circuit shown in Figure 20, however, is *not* suitable for use with the TZ40 speech amplifier-modulator shown in Figure 15. All this speech amplifier requires is a half-wave rectifier. The same voltage ratings apply for this rectifier as for the one just described,

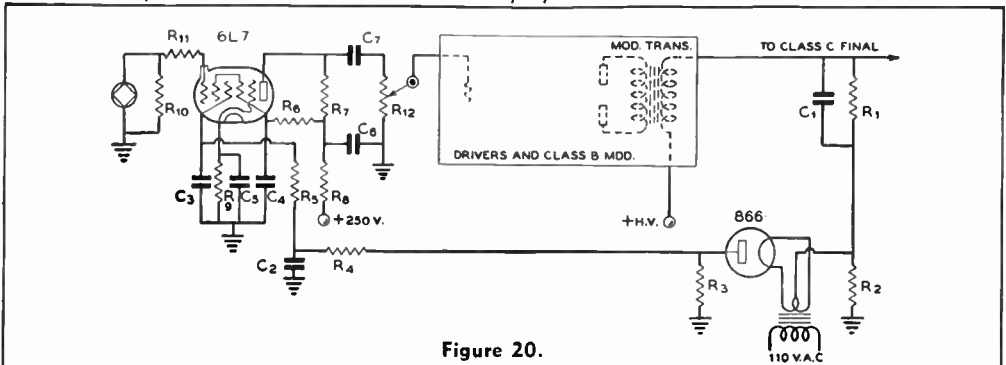

Figure 20.

A.M.C. ARRANGEMENT WITH SIMPLIFIED BIAS SYSTEM.

- | | | | |
|---|---|--|--|
| C ₁ —0.5- μ fd. 600-volt tubular | C ₂ —0.5- μ fd. 400-volt tubular | R ₃ —100,000 ohms, 1 watt | R ₄ —30,000 ohms, 1 watt |
| C ₃ —0.1- μ fd. 400-volt tubular | C ₄ —0.02- μ fd. 400-volt tubular | R ₅ —500,000 ohms, 1/2 watt | R ₆ —1000 ohms, 1/2 watt |
| C ₅ , C ₆ —0.5- μ fd. 400-volt tubular | R ₇ —50,000 ohms, 2 to 20 watts (see text) | R ₈ —1.0 megohm, 1/2 watt | R ₉ —1.0 megohm, 1/2 watt |
| C ₇ —10- μ fd. 25-volt electrolytic shunted by .01- μ fd. 400-volt tubular | R ₈ —500,000 ohms, 10 watts | R ₉ —250,000 ohms, 1 watt | R ₁₀ —25,000 ohms, 1/2 watt |
| | | R ₁₁ —200,000 ohms, 1 watt | R ₁₂ —500,000-ohm potentiometer |

with the c.t. of its filament connected directly to the plate voltage lead to the plate modulated stage, and the plate connected to the input terminal on the amplifier.

Efficient Splatter Suppressor

Phone splatter (adjacent channel interference) can be greatly reduced in a *plate modulated* transmitter by the incorporation of the circuit shown in Figure 21.

Simply inserting a low pass filter of suitable cut off frequency between the modulator and class C modulated amplifier will minimize splatter from high order harmonics generated in the modulator itself, but will do nothing towards eliminating splatter generated in the class C stage as a result of the negative peak clipping which occurs each time the plate voltage swings below zero.

By inserting a high vacuum rectifier between the modulator and low pass filter, negative peak clipping is virtually eliminated. A 5Z3 will be suitable for a d.c. plate voltage up to 2000 volts and d.c. plate current up to 300 ma. For greater plate current, two 5Z3's may be paralleled.

The 5Z3 filament transformer secondary must be insulated for at least twice the plate voltage, and should have reasonably low capacity to the primary and core.

For voice work, the cut off frequency of the low pass filter should be about 3000 cycles.

Trouble Shooting in the Speech Amplifier

Great care is necessary in the design of speech amplifiers in order to prevent hum,

distortion, and feedback at radio- or audio-frequencies. Certain precautions can be taken in building the speech amplifier, as related here: (1) Shield all low-level grid and plate leads. (2) Avoid overheating the shielded wires (rubber insulation) when soldering ground connections to the shield. (3) Shield all input and microphone connections. (4) Wire the filaments with twisted conductors. (5) Mount resistors and condensers as near as possible to socket terminals. (6) Orient the input and low-level audio transformers in a position of minimum hum when a.c. power is applied to the primaries of the power supply transformers. (7) Shield the input and low-level stage tubes. (8) Use a good ground connection to the metal chassis (waterpipe or ground rod connection). (9) Ground all transformer and choke coil cores. (10) Use metal cabinets and chassis, rather than breadboard construction. (11) By-pass low-level audio stage cathode by-pass electrolytic condensers with a .002- μ fd. mica condenser, for the purpose of preventing rectification of stray r.f. energy which will sometimes produce hum.

The power supply for a speech amplifier should be exceptionally well filtered. This may require 3 sections of filter, consisting of 3 high-capacity condensers and 2 or 3 filter chokes. When space permits, the power supply should be placed several feet from the speech amplifier.

Shielding The speech amplifier and microphone leads should be completely shielded for the elimination of r.f. feedback. A concentric or a *balanced* 2-wire r.f. transmission line to a remotely located antenna is

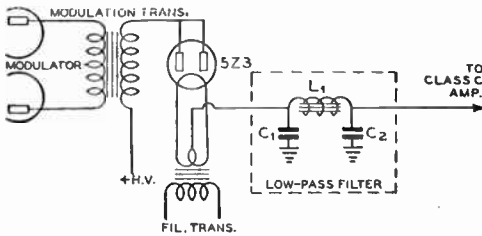

Figure 21.

SPLATLER SUPPRESSOR CIRCUIT.

C₁, C₂, L₁—Components of low-pass filter; characteristic impedance is the same as the class C load impedance; cutoff frequency is 3000 cycles.

the most effective method of preventing r.f. feedback into the microphone or speech amplifier circuits in the range of from 5 to 20 meters.

The impedance of ground leads at such short wavelengths makes it impossible completely to eliminate stray r.f. currents. End-fed antennas and single-wire fed systems are particularly troublesome with respect to r.f. feedback.

Audio feedback may cause motor-boating, whistling, or howling noises in the audio amplifiers. Insufficient by-pass capacity across the plate supply of a multistage speech amplifier is an additional cause of motor-boating. The first stage of a speech amplifier should have a resistance filter in its plate supply lead, which may consist of a 10,000- to 50,000-ohm 1-watt resistor in series with the positive B lead, with a 0.5- μ fd. condenser connected to ground from the amplifier side of the series resistor. (See Figure 22.)

A defective tube will introduce hum or distortion, as well as affect the overall gain or power output of an audio amplifier. Incorrect bias on any amplifier stage will produce harmonic distortion, which changes the quality of speech. This bias voltage should be of the correct value for the actual plate-to-cathode voltage, rather than the plate supply output voltage; (these may be widely different in a resistance-coupled stage). Excessive audio input to any amplifier stage will produce amplitude distortion. Incorrect plate coupling impedances or resistances will cause distortion. A damaged or poor microphone is another source of distortion. Cathode resistors should be by-passed with ample capacity to provide a low impedance path for the lowest frequencies. Push-pull, and especially class B amplifiers, require balanced tubes.

Power Supplies for Radiotelephony

A power supply for a radiotelephone transmitter should furnish nonpulsating d.c. volt-

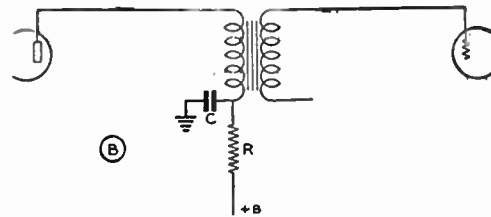
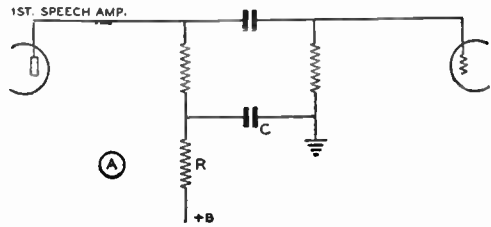

Figure 22.

RC FILTER CIRCUITS FOR USE IN DECOUPLING AUDIO STAGES.

The value of resistor R can be from 2000 to 50,000 ohms; C can be from 1 to 8 microfarads.

age to the crystal oscillator or other source of frequency control. The amount of pulsation, or ripple voltage, should be less than 1 per cent of the d.c. voltage, especially for radio transmitters operating on very high frequencies. Hum or ripple voltage in the plate supply to the oscillator will frequency-modulate the r.f. output slightly. Each frequency multiplier stage increases the frequency modulation, until the carrier hum becomes objectionable in high-frequency transmitters. Many amateurs 10-meter phones suffer from this difficulty, which is noticed especially with selective receivers.

The power supply for the front end of the speech channel must be thoroughly filtered, in order to avoid amplification of the ripple in the succeeding audio or speech amplifier stages. The plate supply for the final audio amplifier stage does not require as much filter as the preceding stages, and, in the case of a push-pull audio or driver stage, a single-section filter will suffice.

Buffer stages of a control-grid modulated transmitter must have very well-filtered plate supplies (more than the buffers in a plate-modulated transmitter), in order to prevent hum modulation in the grid circuit on which the speech audio frequencies are impressed. On the other hand, the plate supply for the grid-modulated stage itself does not require quite as much filter as does a comparable plate-modulated stage. This indicates that a single-section filter will suffice for a grid-mod-

ulated stage, whereas a 2-section filter is desirable for plate modulation. In the event that only a single-section filter is used for a grid-modulated stage, condenser input is desirable. A single-section choke input filter does not furnish sufficient ripple suppression, except for a c.w. amplifier or a *push-pull* modulator stage.

Class B Modulator Voltage Regulation Power supply voltage regulation of class B modulators is of great importance, because the plate current varies appreciably with the amount of speech input. Choke input, utilizing preferably a *swinging-choke* with high no-current inductance rating

(25 hy. or more) and low d.c. resistance, in conjunction with mercury vapor rectifiers and a husky filter condenser (at least 4 μ fd.), will make a good power supply. If the resting plate current of the modulator tubes is high, as is the case with some of the zero bias class B tubes, a swinging type choke is not essential; however, even so, the choke should have high inductance (10 or 20 hy.).

A comparatively high degree of ripple, as compared to a modulated amplifier power supply, can be tolerated in a power supply feeding a push-pull audio or modulator stage, because a good percentage of the hum is cancelled out in the coupling transformer, if the modulator tubes are well matched.

Power Supplies

ANY device which incorporates vacuum tubes requires a power supply for the filament and plate circuits of the tube or tubes. The filaments of the tubes must be heated in order to produce a source of electrons within the vacuum tubes; direct-current voltages are needed for the other electrodes in order to obtain detection, amplification, and oscillation.

Rectification

Either a.c. or d.c. voltage may be used for filament power supply in most applications; however, the a.c. power supply is the more economical and can be used with most tubes without introduction of hum in the output of the vacuum tube device. The plate potential must be secured from a d.c. source, such as from batteries or a rectified and filtered a.c. power supply.

First the a.c. must be converted into a unidirectional current; this is accomplished by means of vacuum tube *rectifiers*, of either the *full-* or *half-wave* type.

Half-Wave Rectifiers A half-wave rectifier passes one half of the wave of each cycle of the alternating current and blocks the other half. The output current is of a *pulsating* nature, which can be smoothed into pure, direct current by means of *filter* circuits. Half-wave rectifiers produce a pulsating current which has zero output during one half of each a.c. cycle; this makes it difficult to filter the output properly into d.c. and also to secure good voltage regulation for varying loads.

Full-Wave Rectifiers A full-wave rectifier consists of a pair of half-wave rectifiers working on opposite halves of the cycle, connected in such a manner that each half of the rectified a.c. wave is combined in the output as shown in Figure 1. This pulsating unidirectional current can be filtered to any desired degree, depending upon

the particular application for which the power supply is designed.

A full-wave rectifier consists of two plates and a filament, either in a single glass or metal envelope for low-voltage rectification or in the form of two separate tubes, each having a single plate and filament for high-voltage rectification. The plates are connected across the high-voltage a.c. power transformer winding, as shown in Figure 2. The power transformer is for the purpose of transforming the 110-volt a.c. line supply to the desired secondary a.c. voltages for filament and plate supplies. The transformer delivers alternating current to the two plates of the rectifier tube; one of these plates is positive at any instant during which the other is negative. The center point of the high-voltage transformer winding is usually grounded and is, therefore, at zero voltage, thereby constituting the *negative B connection*.

While one plate of the rectifier tube is conducting, the other is inoperative, and vice versa. The output voltages from the rectifier tubes are connected together through a common rectifier filament circuit, and thus the plates alternately supply pulsating current to the output (load) circuit. The rectifier tube filaments are always positive in polarity with respect to the output in this type circuit.

The output current pulsates 120 times per second for a full-wave rectifier connected to a 60-cycle a.c. line supply, and the output from the rectifier must connect to a *filter*, which will smooth the pulsations into direct current. Filters are designed to select or reject alternating currents; those most commonly used in a.c. power supplies are of the *low-pass* type. This means that pulsating currents which have a frequency below the cutoff frequency of the filter will pass through the filter to the load. Direct current can be considered as alternating current of zero frequency; this passes through the low-pass filter. The 120-cycle pulsations are similar to alternating current in characteristic, so that the filter must be designed to have a *cutoff* at a frequency *lower than 120 cycles* (for a 60 cycle a.c. supply).

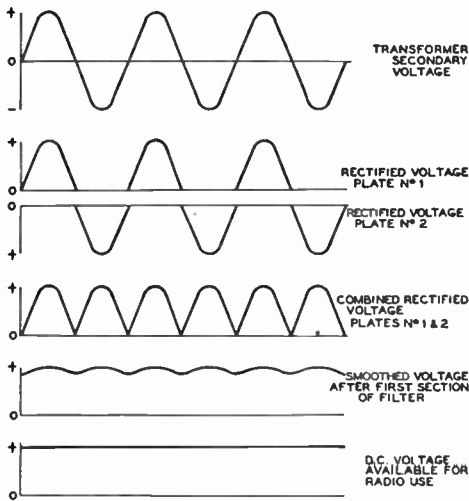

Figure 1.
FULL-WAVE RECTIFICATION.

Showing effects of rectification and filtering of an alternating current. A full-wave rectifier is shown in Figure 2.

Filter Circuits

A low-pass filter consists of combinations of inductance and capacitance. An inductance or *choke coil* offers an impedance to any change in the current that flows through it. A high-inductance choke coil offers a relatively high impedance to the flow of pulsating current, with the result that the *a.c. component* or *ripple* passes from the rectifier tube through the load only with the greatest of difficulty. A capacitance has exactly the opposite action to that of an inductance. It offers a low impedance path to the flow of alternating or pulsating current, but presents practically infinite resistance to the flow of direct current. Inductance coils are usually connected in series with the rectifier outputs, while condensers are connected across the positive and negative leads of the circuit. A simple filter circuit is shown in Figure 3.

Electricity always follows the path of least resistance or impedance. The direct current will travel through the choke and back to the ground (negative B) connection through the *external load*, which normally consists of the plate circuits of vacuum tubes. The *a.c. component*, or *ripple*, tends to be impeded by the choke and short-circuited by the condensers across the filter, which offer a lower reactance to the pulsating voltage than that offered by the load. The *load impedance* across the output of most filter systems is generally high, usually from 5,000 to 10,000 ohms. This load

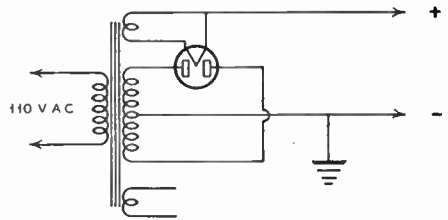

Figure 2.
STANDARD FULL-WAVE SINGLE-PHASE RECTIFIER CIRCUIT.

resistance can be calculated by dividing the output voltage by the total load current; this value is necessary in making calculations for low-pass resonant types of filter circuits.

Resonant Type Filters

In Figure 4 condenser C_1 tunes the choke coil inductance to series resonance at the ripple frequency. Series resonance provides a very low impedance to the resonant frequency limited only by the actual resistance of the choke coil (since the reactance of both the condenser C_1 and the choke coil cancel each other).

The filter circuit in Figure 4 accomplishes the same purpose as a large shunt condenser at the ripple frequency, but is not effective in short-circuiting the higher harmonics in the output of the rectifier system. Additional low-pass filter circuits are needed to remove these harmonic components, which are of great enough magnitude to produce objectionable high-pitched hum in the vacuum tube amplifier circuits.

A typical *low-pass* filter is diagrammed in Figure 5. The combination of C_1 , C_2 , and L should give a cutoff frequency below that of the rectified output pulsation frequency.

This type of filter is very effective, yet un-critical because the circuit can be designed with *any* cutoff frequency, as long as the attenuation or rejection at the 120-cycle-and-higher harmonic frequencies is great. This type of filter is sometimes called a "*brute force*" filter, because large values of inductance and capacitance are normally used without much attention being paid to the actual cutoff frequency. Inductance values of 10 to 30 henrys are used for filter chokes, and shunt capacities of from 2 to 16 microfarads commonly are used for C_1 and C_2 in Figure 5.

A *resonant trap circuit*, such as shown in Figure 6, is sometimes used to increase the impedance of the choke L at some particular frequency, such as 120 cycles per second.

Parallel resonance of C_2 and L provides a very high impedance at the resonant frequency. The condenser C_2 tends to by-pass the higher

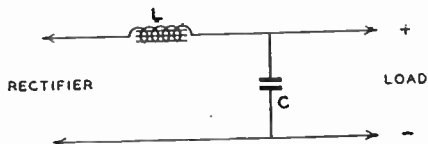

Figure 3.

SIMPLE SINGLE-SECTION CHOKE-INPUT FILTER.

With commonly used values of L and C , the percentage ripple will be between 3 and 10 per cent, depending upon the load resistance. This type of filter is often used to feed a push-pull modulator stage (in which much of the plate voltage ripple cancels out) and telegraphy amplifiers in which slight modulation of the carrier can be tolerated.

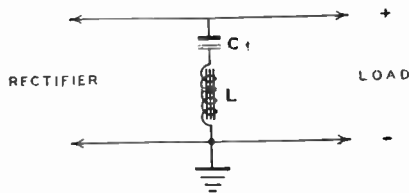

Figure 4.

SERIES RESONANT FILTER CIRCUIT.

If the ripple voltage is high, a high a.c. component will appear across each reactance. With high values of L and correspondingly low values of C , the a.c. voltage across each of these components may exceed the d.c. supply voltage.

ripple harmonics that get through the trap circuit. This type of filter is often used in conjunction with an additional section of filter of the type shown in Figure 3.

The single-section, low-pass filter in Figure 5 is often combined with an additional choke coil as shown in Figure 7. The additional choke coil L , is an aid in filtering and also provides better voltage regulation for varying d.c. loads, such as presented by a class B audio amplifier.

A two-section, low-pass filter with condenser input is shown in Figure 8. In some cases, additional sections of choke coils and condensers are added for the purpose of obtaining very pure direct current.

Resistors may be used in place of inductances in circuits where the load current is of low value, or where the applied d.c. voltage must be reduced to some desired value.

The ripple in the output of a filter circuit can be measured with an oscilloscope or by means of the simple circuit in Figure 9. A high-voltage condenser C_n , having a capacity of from $\frac{1}{4}$ to $1 \mu\text{fd.}$, and a high-resistance copper-oxide a.c. voltmeter provides a method of measuring the actual ripple voltage.

The voltmeter should be plugged into the measuring jack after the power supply and external load circuit are in normal operating condition, and the meter should be removed from the shorting type jack before turning off the power supply or removing the load. The charging current through condenser C_n would soon burn out the meter if it were left in the circuit at all times.

Rectifier and Filter Circuit Considerations

The shunt condensers in a filter system serve a dual purpose. They provide: (1) a low impedance path for ripple, (2) an energy-storing system for maintaining constant voltage output from the power supply. The condensers

are charged when the peak voltage is applied across them from the output of the rectifier; during the time in which the rectifier output decreases to zero, the filter condensers supply output current to the load. This action provides a constant output voltage.

R.M.S. and Peak Values In an a.c. circuit, the maximum peak voltage or current is $\sqrt{2}$ or 1.41 times that indicated by the a.c. meters in the circuit. The meters read the root-mean-square (r.m.s.) values, which are the peak values divided by 1.41 for a sine wave.

If a potential of 1,000 r.m.s. volts is obtained from a high-voltage secondary winding of a transformer, there will be 1,410-volts peak potential from the rectifier plate to ground. The rectifier tube has this voltage impressed on it, either positively when the current flows or "inverse" when the current is blocked on the other half-cycle. The inverse peak voltage which the tube will stand safely is used as a rating for rectifier tubes. At higher voltages the tube is liable to arc back, thereby destroying it. The relations between peak inverse voltage, total transformer voltage and filter output voltage depend upon the characteristics of the filter and rectifier circuits (whether full- or half-wave, bridge, etc.).

Rectifier tubes are also rated in terms of peak plate current. The actual direct load cur-

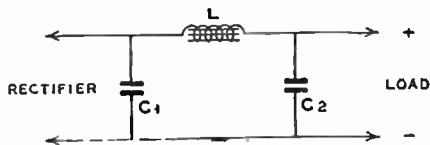

Figure 5.

SINGLE-SECTION CONDENSER INPUT OR π -TYPE FILTER.

This filter is also known as a low-pass or "brute force" filter.

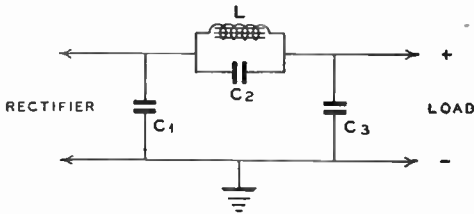

Figure 6.
TUNED FILTER CIRCUIT.

The condensers C_1 and C_3 are the usual values which would be used with a "brute force" filter circuit. The value of C_2 is adjusted to resonate the choke L to the main ripple frequency. This type of filter has very great attenuation to the main ripple frequency, but its attenuation to the ripple frequency harmonics is less than a filter of the "brute force" type. Hence it is advisable to follow a filter of this type with a section of "brute force" filter; very excellent filtering is thus attained.

rent which can be drawn from a given rectifier tube or tubes depends upon the type of filter circuit. A full-wave rectifier with condenser input may be called upon to deliver a peak current several times the direct load current.

In a filter with choke input, the peak current is not much greater than the load current if the inductance of the choke is fairly high (assuming full wave rectification).

A full-wave rectifier with two rectifier elements requires a transformer which delivers twice as much a.c. voltage as would be the case with a half-wave rectifier or bridge rectifier.

Bridge Rectification The bridge rectifier is a type of full-wave circuit in which four rectifier elements or tubes are operated from a single high-voltage winding on the power transformer.

While twice as much output voltage can be obtained from a bridge rectifier as from a center-tapped circuit, the permissible output current is only one-half as great for a given power transformer. In the bridge circuit, four rectifiers and three filament heating trans-

former windings are needed, as against two rectifiers and one filament winding in the center-tapped full-wave circuit. In a bridge rectifier circuit, the inverse peak voltage impressed on any one rectifier tube is halved, which means that tubes of lower peak voltage rating can be used for a given voltage output.

The output voltage across the filter circuit depends upon the design of the filter, resistance of rectifier power transformer, and load resistance. A low-resistance rectifier, such as the mercury-vapor type 83 or 866, has very low voltage drop in comparison with most high-vacuum (not mercury-filled) rectifiers. The filter circuit with condenser input, i.e., a condenser across the rectifier output, will deliver a higher d.c. voltage than one with choke input, but at a sacrifice both in voltage regulation and the amount of available load current.

The d.c. voltage across the load circuit of a condenser-input filter may be as high as 1.4 times the a.c. input voltage (r.m.s.) across one of the rectifier tubes if the input condenser capacity is large and the current drain small. Low values of load resistance (heavy current drain) will cause this type of power supply to have a d.c. voltage output as low or even lower than the a.c. input to the rectifier. The maximum permissible load current in this same circuit is less for a given transformer-secondary wire size and rectifier tube peak current rating than would be the case for a choke-input filter.

A choke-input filter will reduce the d.c. voltage to a value of 0.9 the a.c. r.m.s. value, but the output voltage with choke input is fairly constant over a wide range of load resistances, and the allowable load current is greater than with condenser input for a given rectifier and power transformer.

Filter Choke Coils Filter inductors often consist of a coil of wire wound on a laminated iron and steel core. The size of wire is determined by the amount of direct current which is to flow through the choke coil. This direct current mag-

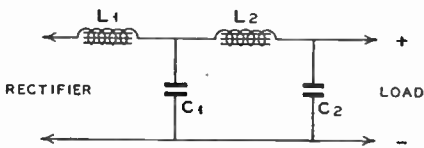

Figure 7.
LOW-PASS "BRUTE FORCE" FILTER WITH INPUT CHOKE.

Adding an input choke to the "brute force" filter improves both regulation and filtering at a sacrifice in output voltage.

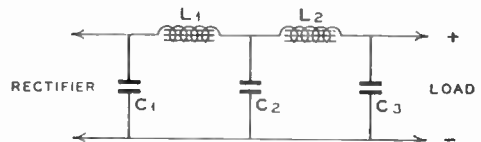

Figure 8.
2-SECTION LOW-PASS FILTER FOR USE WHERE VERY PURE D.C. IS REQUIRED.

This type of power supply filter is widely used in conjunction with low level speech amplifier stages.

netizes the core and reduces the inductance of the choke coil; therefore, filter choke coils of the "smoothing" type are built with an air gap, a small fraction of an inch in the iron core, for the purpose of preventing saturation when maximum d.c. flows through the coil winding.

This "air gap" is usually in the form of a piece of fiber inserted between the ends of the laminations. The air gap reduces the initial inductance of the choke coil, but keeps it at a higher value under maximum load conditions. The coil must have a great many more turns for the same initial inductance when an air gap is used.

As mentioned previously, choke input tends to keep the output voltage of the filter at approximately 0.9 of the r.m.s. voltage impressed upon the filter from the rectifiers. However, this effect does not take place until the load current exceeds a certain minimum value. In other words, as the load current is decreased, at a certain critical point the output voltage begins to soar. This point is determined by the inductance of the input choke. If it has high inductance, the current can be reduced to a very low value before the output voltage begins to rise. Under these conditions, a low-drain bleeder resistor will keep the current in excess of the critical point, and the voltage will not soar even if the external load is removed.

For this purpose, chokes are made with little or no air gap in order to give them more inductance at low values of current. Their filtering effectiveness at maximum current is impaired somewhat, because they saturate easily, but their high inductance at low values of current permits use of a smaller bleeder to keep the current in excess of the critical value. Such chokes are called *smoothing chokes* because while they have high initial inductance, the inductance rapidly falls to a comparatively low value as the current through the choke is increased.

The d.c. resistance of any filter choke should be as low as possible in conjunction with the desired value of inductance. Small filter chokes, such as those used in radio receivers, usually have an inductance of from 6 to 15 henrys, and a d.c. resistance of from 200 to 400 ohms. A high d.c. resistance will reduce the output voltage, due to the voltage drop across each choke coil. Large filter choke coils for radio transmitters and class B amplifiers usually have less than 100 ohms d.c. resistance.

Filter Condensers There are two types of filter condensers: (1) paper dielectric type, (2) electrolytic type.

Paper condensers consist of two strips of metal foil separated by several layers of waxed

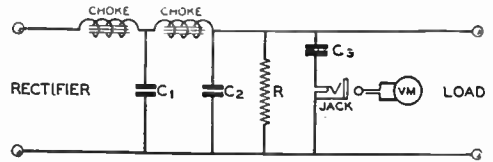

Figure 9.
CIRCUIT FOR MEASURING A.C.
RIPPLE.

The meter should not be inserted in the circuit until after the voltage is turned on; otherwise the charging current surge may blow the meter. The jack must be of the closed-circuit type. C₃ must be rated at considerably more than the plate voltage to provide a safety factor.

paper. Some types of paper condensers are wax-impregnated; others, especially the high-voltage types, are oil-impregnated. High-voltage filter condensers which are oil-impregnated will withstand a greater peak voltage than those impregnated with wax, but they are more expensive to manufacture. Condensers are rated both for *flash* test and normal operating voltages; the latter is the important rating and is the maximum voltage which the condenser should be required to withstand in service.

The condenser across the rectifier circuit in a condenser-input filter should have a working voltage rating equal to at least 1.41 times the r.m.s. voltage output of the rectifier. The remaining condensers may be rated more nearly in accordance with the d.c. voltage.

Electrolytic condensers are of two types: (1) wet, (2) dry. The wet electrolytic condenser consists of two aluminum electrodes immersed in a solution called an *electrolyte*. A very thin film of oxide is formed on the surface of one electrode, called the *anode*. This acts as the dielectric. The electrolytic condenser must be correctly connected in the circuit so that the anode always is at positive potential with respect to the electrolyte, the latter actually serving as the other electrode (plate) of the condenser. A reversal of the polarity for any length of time will ruin the condenser.

The dry type of electrolytic condenser uses an electrolyte in the form of paste. The dielectric in both kinds of electrolytic condensers is not perfect; these condensers have a much higher direct current leakage than the paper type. The leakage current is greater in the wet electrolytic than in the dry types, but the former are self-healing and are not permanently damaged by moderate voltage overloads.

The high capacitance of electrolytic condensers results from the thinness of the film which is formed on the plates. The maximum voltage that can be safely impressed across the

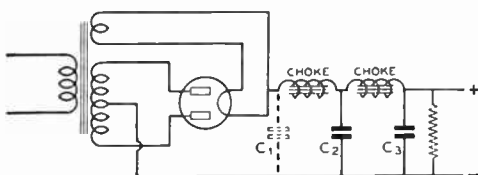

Figure 10.

STANDARD 2-SECTION FILTER.

When C_1 is connected in the circuit, the filter is termed "condenser input." If C_1 is omitted, the filter is called "choke input."

average electrolytic filter condenser is between 450 and 600 volts; the working voltage is usually rated at 450. When electrolytic condensers are used in filter circuits of high-voltage supplies, the condensers should be connected in series. The positive terminal of one condenser must connect to the negative terminal of the other, in the same manner as dry batteries are connected in series.

It is not necessary to connect shunt resistors across each electrolytic condenser section as it is with paper capacitors connected in series, because electrolytic capacitors have fairly low internal d.c. resistance as compared to paper condensers. Also, if there is any variation in resistance, it is that electrolytic unit in the poorest condition which will have the highest leakage current, and therefore the voltage across this condenser will be lower than that across one of the series connected units in better condition and having higher internal resistance. Thus we see that equalizing resistors are not only unnecessary across series connected electrolytic condensers but are actually undesirable. This assumes, of course, similar capacitors by the same manufacturer and of the same capacity and voltage rating. It is *not advisable* to connect in series electrolytic condensers of different make or ratings.

There is very little economy in using electrolytic condensers in series in circuits where more than two of these condensers would be required to prevent voltage breakdown.

Wet electrolytic capacitors housed in an aluminum can ordinarily use the can as the negative electrode, or contact to the electrolyte (the electrolyte being the true electrode). Wet electrolytic condensers should always be mounted in a vertical position. To allow escape of gas generated as a result of electrolysis, a small vent is provided.

Electrolytic condensers can be greatly reduced in size by use of etched aluminum foil for the anode. This greatly increases the surface area, and the dielectric film covering it, but raises the power factor slightly. For this reason, ultra-midget electrolytic condensers should not be used at full rated d.c. voltage

when a high a.c. component is present, such as would be the case for the input condenser in a condenser-input filter.

When a dry (paste electrolyte) electrolytic condenser is subjected to over voltage and the leakage current is increased substantially, the condenser may be considered as no longer fit for service, as heating caused by the rupture will aggravate the condition. As previously mentioned, mildly ruptured wet electrolytic condensers will heal if normal voltage is applied to them for a time.

Bleeder Resistors A heavy-duty resistor should be connected across the output of a filter in order to draw some load current at all times. This resistor avoids soaring of the voltage at no load when swinging choke input is used, and also provides a means for discharging the filter condensers when no external vacuum-tube circuit load is connected to the filter. This *bleeder* resistor should normally draw approximately 10 per cent of the full load current.

The power dissipated in the bleeder resistor can be calculated by dividing the square of the d.c. voltage by the resistance. This power is dissipated in the form of heat, and, if the resistor is not in a well-ventilated position, the wattage rating should be higher than the actual wattage being dissipated. High voltage, high capacity filter condensers can hold a dangerous charge if not bled off, and wire-wound resistors occasionally open up without warning. Hence it is wise to place carbon resistors in series across the regular wire-wound bleeder as explained in Chapter 11 under *Safety Precautions*.

When purchasing a bleeder resistor, be sure that the resistor will stand not only the required wattage, but also the *voltage*. Some resistors have a voltage limitation which makes it impossible to force sufficient current through them to result in rated wattage dissipation. This type of resistor usually is provided with

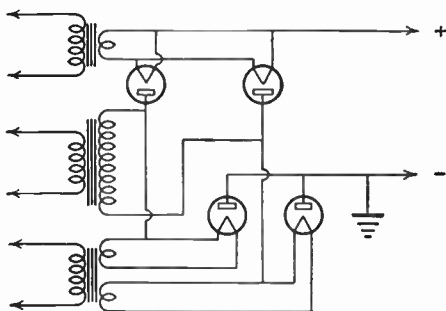

Figure 11.

BRIDGE RECTIFIER CIRCUIT.

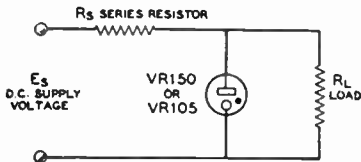

Figure 12.

STANDARD CIRCUIT FOR GLOW-DISCHARGE REGULATOR.

The regulator tube will maintain the voltage across its terminals constant to within 1 or 2 volts for moderate variations in R_L or E_S .

slider taps, and is designed for voltage divider service. An untapped, non-adjustable resistor is preferable as a high voltage bleeder, and is less expensive. Several small resistors may be used in series, if desired, in order to obtain the required wattage and voltage rating.

Glow-Discharge Voltage Regulators

Three very useful tubes for stabilizing the voltage on receivers, electron coupled oscillators in exciters, frequency meters, and other devices requiring a constant source of voltage of between 100 and 300 volts are the VR-75-30, VR-105-30, and VR-150-30 glow-discharge type voltage-regulator tubes. These tubes are similar except for their voltage ratings. The remarks following apply generally to all, though the examples apply specifically to the VR-150. All three tubes have the same current rating.

The VR-105 and VR-75 are useful for stabilizing the voltage on the oscillator section of 6J8, 6K8 and similar mixer tubes, for use in the cathode of the feedback tube in a 2A3 type voltage regulated power supply, and many other applications. The VR-150 is suited where higher voltage is desirable.

Two VR type tubes may be connected in series to provide exactly 210, 255, or 300 volts when more than 150 volts is required.

A VR type tube may be used to stabilize the voltage across a variable load or the voltage across a constant load fed from a varying source of voltage. Thus can be seen their many possible applications and wide range of usefulness.

A device requiring, say, only 50 volts can be stabilized against *supply voltage* variations by means of a VR-105 simply by putting a suitable resistor in series with the regulated voltage and the load, dropping the voltage from 105 to 50 volts. However, it should be borne in mind that under these conditions the device will *not* be regulated for *varying load*: in other words, if the *load resistance* varies, the voltage across the load will vary, even though the regulated voltage remains at 105 volts.

To maintain constant voltage across a *vary-*

ing load resistance there must be *no* series resistance between the regulator tube and the load. This means that the device must be operated exactly at one of the voltages obtainable by seriesing two or more similar or different VR tubes.

A VR-150 may be considered as a stubborn variable resistor having a range of from 30,000 to 5000 ohms and so intent upon maintaining a fixed voltage of 150 volts across its terminals that when connected across a voltage source having *very poor regulation* it will instantly vary its own resistance within the limits of 5000 and 30,000 ohms in an attempt to maintain the same 150 volt drop across its terminals when the supply voltage is varied. The theory upon which a VR tube operates is covered under the subject of gaseous conduction in the chapter on *Vacuum Tube Theory*, and will not be discussed here.

It is paradoxical that in order to do a good job of regulating, the regulator tube must be fed from a voltage source having poor regulation (high series resistance). The reason for this presently will become apparent.

If a high resistance is connected across the VR tube, it will not impair its ability to maintain a fixed voltage drop. However, if the load is made too low, a variable 5000 to 30,000 ohm shunt resistance (the VR-150) will not exert sufficient effect upon the resulting resistance to provide constant voltage except over a *very limited* change in supply voltage or load resistance. The tube will supply maximum regulation, or regulate the largest load, when the source of supply voltage has high internal or high series resistance, because a variation in the effective internal resistance of the VR tube will then have more controlling effect upon the load shunted across it.

In order to provide greatest range of regulation, a VR tube (or two in series) should be used with a series resistor (to effect a poorly regulated voltage source) of such a value that it will permit the VR tube to draw from 15 to 20 ma. under normal or average conditions of supply voltage and load impedance. For maximum control range, the series resistance should be not less than approximately 20,000 ohms, which will necessitate a source of voltage considerably in excess of 150 volts. However, where the supply voltage is limited, good control over a *limited range* can be obtained with as little as 3000 ohms series resistance. If it takes less than 3000 ohms series resistance to make the VR tube draw 15 to 20 ma. when the VR tube is connected to the load, then the supply voltage is not high enough for proper operation.

Should the current through a VR-150, VR-105, or VR-75 be allowed to exceed 30 ma., the life of the tube will be shortened. If the



Figure 13.
VOLTAGE REGULATED POWER SUPPLY.

This power pack is capable of putting out from 175 to 300 volts at an average current of 60 ma. with very good stability with respect to both load and supply voltage variations.

current falls below 5 ma., operation will become unstable. Therefore, the tube must operate within this range, and within the two extremes will maintain the voltage within 1.5 per cent. It takes a voltage excess of at least 10 or 15 per cent to "start" a VR type regulator; and to insure positive starting each time the voltage supply should preferably exceed the regulated output voltage rating by about 20 per cent or more. This usually is automatically taken care of by the fact that if sufficient series resistance for good regulation is employed, the voltage impressed across the VR tube before the VR tube ionizes and starts passing current is quite a bit higher than the starting voltage of the tube.

When a VR tube is to be used to regulate

the voltage applied to a circuit drawing less than 15 ma. normal or average current, the simplest method of adjusting the series resistance is to remove the load and vary the series resistor until the VR tube draws exactly 30 ma. Then connect the load, and that is all there is to it. This method is particularly recommended when the load is a heater type vacuum tube, which may not draw current for several seconds after the power supply is turned on. Under these conditions, the current through the VR tube will never greatly exceed 30 ma. even when it is running unloaded (while the heater tube is warming up and the power supply rectifier has already reached operating temperature).

Figure 12 illustrates the standard glow discharge regulator tube circuit. The tube will maintain the voltage across R_L constant to within 1 or 2 volts for moderate variations in R_L or E_s .

Voltage Regulated Power Supplies

When it is desired to stabilize the potential across a circuit drawing more than a few milliamperes, it is advisable to use a voltage regulated power supply of the type shown in Figures 13 and 14 rather than glow discharge type tubes. The power pack illustrated will deliver up to 300 volts of well-regulated voltage, the output voltage holding within 1 volt for variations in line voltage or load resistance of 25 per cent.

The maximum current that may be drawn from the supply without detrimentally affecting the regulation is determined by the desired output voltage, the latter being adjustable by variation of R_3 . At 200 volts the output voltage is constant up to 100 ma., the maximum current which the 6B4-G and power transformer will stand. At 300 volts, the maximum usable output voltage, the useful range is from

Figure 14.
SCHEMATIC OF THE VOLTAGE REGULATED SUPPLY.

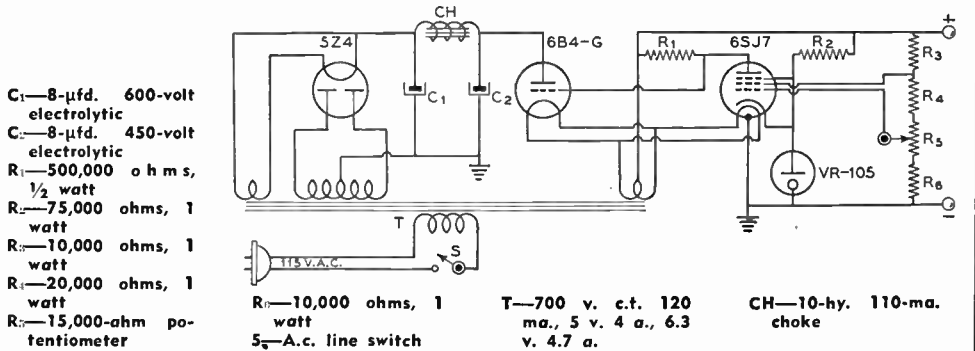

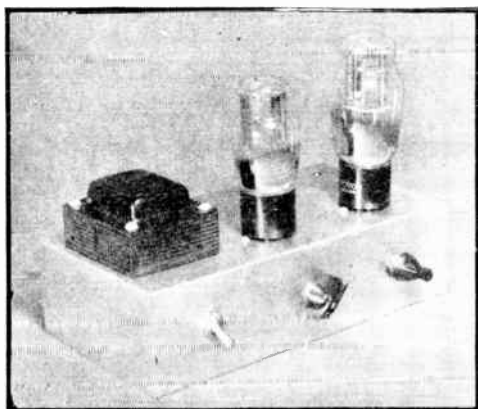

Figure 15.
VOLTAGE REGULATED GRID BIAS SUPPLY.

0 to 50 ma. At the latter voltage the regulator begins to lose control when more than 50 ma. is drawn from the supply.

The system works by virtue of the fact that the 6B4-G acts as a variable series resistance or loss, and is controlled by a regulator tube much in the manner of a.v.c. circuits or inverse feedback as used in radio receivers and a.f. amplifiers. The 6SJ7 amplifier controls the bias on the 6B4-G, which in turn controls the resistance of the 6B4-G, which in turn controls the output voltage, which in turn controls the plate current of the 6SJ7, thus completing the cycle of regulation. It is readily apparent that under these conditions any change in the output voltage will tend to "resist itself," much as the a.v.c. system of a receiver resists any change in signal strength delivered to the detector.

Because it is necessary that there always be a moderate voltage drop through the 6B4-G in order for it to have proper control, the rest of the power supply is designed to deliver as much output voltage as possible considering the r.m.s. voltage of the b.c.l. type power transformer. This calls for a low resistance full-wave rectifier, a high capacity input condenser, and a low d.c. resistance filter choke. A 5Z4 rectifier is used in place of an 83 or other mercury vapor tube to avoid possible "hash" in any nearby receiver. This tube has lower resistance than an 80 or 5Z3 and in addition, since it is a heater type, plate voltage will not be applied to the regulator tubes until they are up to operating temperature.

Voltage-Regulated Bias Pack The type of voltage-regulated power supply discussed in the previous paragraphs is not suited for use as a bias pack.

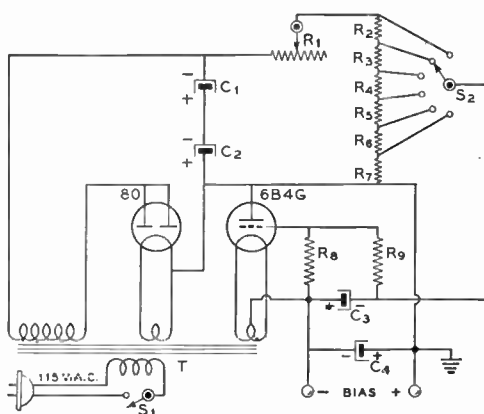

Figure 16.
SCHEMATIC OF THE REGULATED BIAS PACK.

- C_1, C_2, C_3, C_4 —4- μ fd. 450-volt electrolytics
- R_1 —50,000-ohm potentiometer
- $R_2, R_3, R_4, R_5, R_6, R_7$ —50,000 ohms, $\frac{1}{2}$ watt
- R_8 —100,000 ohms, $\frac{1}{2}$ watt
- R_9 —10,000 ohms, $\frac{1}{2}$ watt
- S_1 —A.c. line switch
- S_2 —Voltage selector switch, s.p. 6-position
- T —480 v. c.t. 40 ma., 5 v. 2 a., 6.3 v. 2 a.

Since the direction of current flow in a bias power supply is opposite from that of a regular power supply, a special type of pack must be used for bias service. A suitable pack for use in a regulated bias circuit is shown in Figures 15 and 16. In this type of power supply, the regulator tube (6B4-G, 2A3, or 6A3) acts as a variable bleeder resistor which automatically adjusts its resistance to a value such that the grid current flowing through it will develop a constant value of voltage across the output terminals of the pack.

Inspection of the circuit diagram, Figure 16, will show that the circuit consists of a half-wave power supply (to obtain greater voltage from the b.c.l.-type power transformer), a pair of electrolytic condensers in series as the filter, and a tapped voltage divider feeding the grid of the 6B4-G regulator tube. The tap switch, S_2 , provides a rough voltage adjustment from about 100 to 600 volts, while the rheostat, R_1 , allows a fine voltage adjustment to be made. The maximum grid current which may be run through the pack is determined by the plate dissipation of the 6B4-G. The permissible grid current varies from about 100 ma. in the vicinity of 100 volts of bias down to about 25 ma. in the 600-volt region.

Rectifier Circuits

The three types of rectifier circuits for sin-

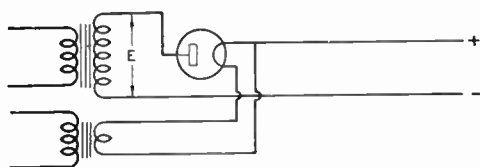

Figure 17.
SINGLE-PHASE HALF-WAVE RECTIFIER.

The output from this type rectifier is not easily filtered except where very little current is drawn (assuming 25 to 60 cycle supply).

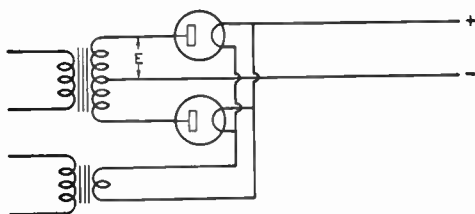

Figure 18.
SINGLE-PHASE FULL-WAVE RECTIFIER.

gle-phase a.c. line supply consist of a half-wave rectifier, as shown in Figure 17, a full-wave rectifier, as shown in Figure 18, and a bridge rectifier circuit as shown in Figure 19.

Three-phase circuits can be connected for half-wave rectification, as shown in Figure 20, or for full-wave rectification as shown in Figure 21.

The most popular circuits are those shown in Figures 18 and 19. The maximum transformer voltage of the high-voltage secondary, d.c. output voltage for choke-input filter, and maximum direct load current are shown in the accompanying table in terms of rectifier tube peak ratings. These peak ratings are listed in a separate table for a few commonly used rectifier tubes.

As an example, suppose type 866-A rectifier tubes are used as in Figure 18: The maximum transformer voltage E across each side of the center tap is 0.35 times 10,000 or 3,500 volts. The d.c. voltage at the input to the filter (choke input) is 3.500 times 0.9 or 3.150 volts. The maximum advisable d.c. output current is 0.66 times the peak plate current of 1.0 ampere or 660 milliamperes.

These are the maximum voltages and currents which can be used without exceeding the ratings of the rectifier tubes. The actual d.c. voltage at the output of the filter will depend upon the d.c. resistance of the filter, and can be found by subtracting the IR drop across

the filter chokes from the value of 0.9 times the transformer voltage E. This does not take into consideration the voltage drop in the power transformer and rectifier tubes. The voltage drop across a mercury vapor rectifier tube is always between 10 and 15 volts. However, the voltage drop across high-vacuum rectifier tubes can be many times greater.

The power supply circuits illustrated in Figures 22 to 25 represent commonly-used connections for power transformers. The values of d.c. output voltage are indicated in each case for a load current of 100 ma. The transformer secondary potential is 1,100 volts. The interesting figures in connection with each circuit are those of the primary current.

The circuit in Figure 25 should never be used unless the load current is very low. Manufacturers generally rate their transformers in terms of secondary r.m.s. voltage and the maximum d.c. load current which can be taken from a choke input filter circuit such as shown in Figure 22. In order to prevent overload of the power transformer in Figure 25, the load current must be reduced to less than one third of the value which can be drawn from the circuit in Figure 22. The load which can be drawn from the circuit in Figure 24 without overload to the power transformer is approxi-

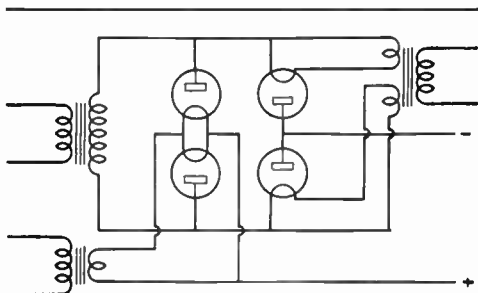

Figure 19.
BRIDGE CIRCUIT.

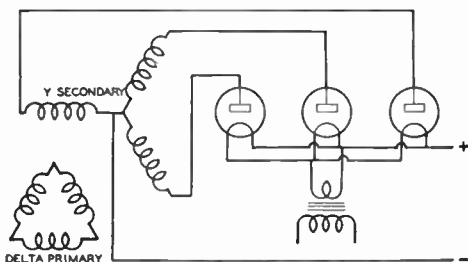

Figure 20.
HALF-WAVE 3-PHASE RECTIFIER.
The output of this rectifier has a d.c. component and a higher ripple frequency (3 times supply frequency), and therefore is easier to filter than a single-phase full-wave rectifier.

| TUBE TYPE | PEAK INV. VOLTAGE | PEAK PLATE CURRENT |
|------------|-------------------|--------------------|
| 82 | 1550 | .345 |
| 83 | 1550 | .675 |
| 866 Jr. | 5000 | .500 |
| 816 | 5000 | .500 |
| 866A / 866 | 10000 | 1.000 |
| 249-B | 10000 | 1.500 |
| KY-21 | 11000 | 3.000 (grid) |
| RX-21 | 11000 | 3.000 |
| 872 | 7500 | 5.000 |
| 872-A | 10000 | 5.000 |
| 869 | 20000 | 5.000 |

mately 50 per cent of that for the circuit in Figure 22. The permissible direct load current in Figure 23 would only be two-thirds as much as for Figure 22, for a given transformer size.

Mercury Vapor Rectifier Tubes When new or long-unused high-voltage rectifier tubes of the mercury vapor type are first placed in service, the filaments should be operated at normal temperature for approximately 20 minutes before plate voltage is applied, in order to remove all traces of mercury from the cathode. After this preliminary operation, plate voltage can be applied within 20 to 30 seconds of the time the filaments are turned on each time the power supply is used. If plate voltage is applied before the filament is brought to full temperature, active material may be knocked off the oxide-coated filament, and the life of the tube will be greatly shortened.

Small r.f. chokes must sometimes be connected in series with the plate leads of mercury vapor rectifier tubes in order to prevent the generation of radio-frequency hash. These r.f. chokes must have sufficiently heavy wire to carry the load current, and enough inductance to attenuate the r.f. parasitic noise current from flowing into the filter supply leads and radiating into nearby receivers.

Small resistors or small iron-core choke coils should be connected in series with each plate lead of a mercury-vapor rectifier tube when used in circuits such as those shown in Figure 26.

These resistors tend to prevent one plate

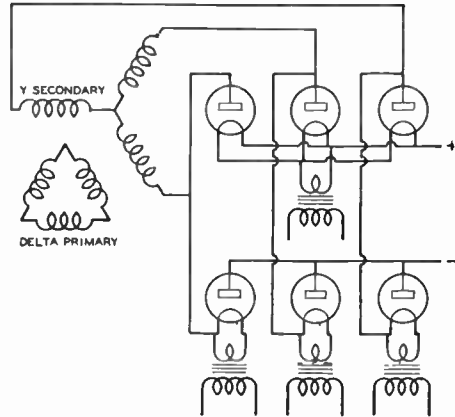

Figure 21.

FULL-WAVE 3-PHASE RECTIFIER.

Even with no filter the output of this rectifier will have a high percentage of d.c. A simple filter will suppress the small amount of ripple, because of the high ripple frequency (6 times supply frequency).

from carrying the major portion of the current. *High-vacuum* type rectifiers which are connected in parallel do not require these resistors or chokes.

Bias Voltage Power Supplies Power packs to supply negative grid voltage for radio or audio amplifiers differ from plate supplies mainly in that the positive and negative connections are reversed; the positive terminal of a C-bias supply is connected to ground. The filter chokes are usually connected in series with the hot (ungrounded) lead, which in this case is the *negative lead*.

The bias voltage supply for a linear r.f. amplifier or class B audio amplifier must have a very low resistance bleeder. The bleeder should be chosen so that the normal bleeder current is at least 8 times the *peak* grid current of the class B modulator or linear r.f. amplifier. If this condition is not met, the bias pack will act somewhat as a grid leak and the bias on the tubes will rise excessively under modulation.

| FIGURE NO. | TRANSFORMER VOLTS MAX. "E" | D.C. OUTPUT VOLTS AT INPUT TO FILTER | D.C. OUTPUT CURRENT IN AMPERES |
|------------|----------------------------|--------------------------------------|--------------------------------|
| 18 | .35 x Inv. Pk. Vtg. | .9 x E | .66 x Pk. Plate |
| 19 | .7 x Inv. Pk. Vtg. | .9 x E | .66 x Pk. Plate |
| 20 | .43 x Inv. Pk. Vtg. | 1.12 x E | .83 x Pk. Plate |
| 21 | .43 x Inv. Pk. Vtg. | 2.25 x E | 1.0 x Pk. Plate |

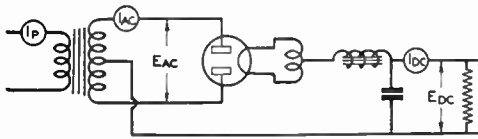

Figure 22.
FULL-WAVE RECTIFIER—CHOKES INPUT.

$E_{DC} — 435 \text{ v.}$ $E_{AC} — 1100 \text{ v.}$
 $I_{DC} — 100 \text{ ma.}$ $I_{AC} — 71 \text{ ma.}$
 $I_{PRI} — 0.6 \text{ a.}$

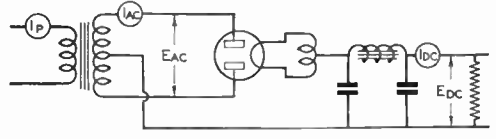

Figure 23.
FULL-WAVE RECTIFIER—CONDENSER INPUT.

$E_{DC} — 675 \text{ v.}$ $E_{AC} — 1100 \text{ v.}$
 $I_{DC} — 100 \text{ ma.}$ $I_{AC} — 103 \text{ ma.}$
 $I_{PRI} — 0.9 \text{ a.}$

High μ tubes require so little bias and draw so much grid current for class B operation (either r.f. or a.f.) that battery bias is ordinarily employed. It is inadvisable to use a bias pack for this purpose unless the required bias voltage is more than 90 volts.

When a pack having a tapped bleeder is used for this type of service, the tap on the bleeder should be by-passed for voice frequencies, even though the pack already has a large filter condenser across the outside terminals of the bleeder.

High efficiency grid modulation also requires a low resistance source of bias, though the bias voltage required is usually several times as great as for a class B stage using tubes of similar power. For this reason, bias for this type of amplifier is more commonly obtained from a regulated bias pack rather than from a conventional pack utilizing a very low resistance bleeder in order to comply with the requirement of low resistance in the bias supply. Such a regulated bias pack is described earlier in this chapter. Another is described in Chapter 8 under *Class C Grid Modulation*.

Bias Pack Considerations

It should be borne in mind that when a power supply is used "inverted" in order to provide bias to a stage drawing grid current, the grid current flows in the *same direction*

as the bleeder current. This means that the grid current does not flow through the power pack as when a pack is used to supply plate voltage, but rather through the bleeder. The transformer and chokes in the bias pack actually have less work to do when the biased stage is drawing grid current, because the greater the grid current flowing through the bleeder the greater the voltage drop across it and the less current the bias pack supplies to the bleeder. In fact, if the grid current is great enough and the bleeder resistor high enough, the voltage developed across the bleeder will be greater than the maximum voltage which the power pack can deliver, and hence the power pack will be delivering no current to the bleeder. Under these conditions, it is quite possible for the voltage to exceed the voltage rating of the bias pack filter condensers.

Bear in mind that the bleeder always acts as a grid leak when grid current is flowing, and while the effect can be minimized by making the resistance quite low, all grid current *must flow through the bleeder*, as it cannot flow back through the bias pack.

Class C amplifiers, both c.w. and plate modulated, require high grid current and considerably more than cutoff bias, the bias sometimes being as high as 4 or 5 times cutoff. To protect the tubes against excitation failure, it is desirable that fixed bias sufficient to limit the plate current to a safe value be used. This

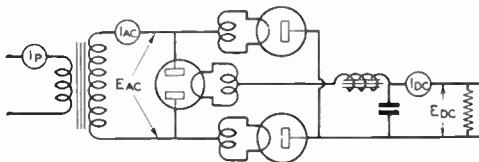

Figure 24.
BRIDGE RECTIFIER—CHOKES INPUT.

$E_{DC} — 860 \text{ v.}$ $E_{AC} — 1100 \text{ v.}$
 $I_{DC} — 100 \text{ ma.}$ $I_{AC} — 96 \text{ ma.}$
 $I_{PRI} — 1.1 \text{ a.}$

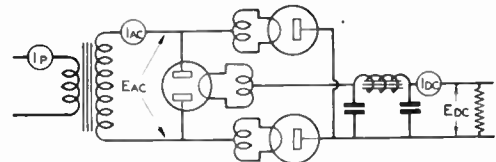

Figure 25.
BRIDGE RECTIFIER—CONDENSER INPUT.

$E_{DC} — 1200 \text{ v.}$ $E_{AC} — 1100 \text{ v.}$
 $I_{DC} — 100 \text{ ma.}$ $I_{AC} — 148 \text{ ma.}$
 $I_{PRI} — 1.65 \text{ a.}$

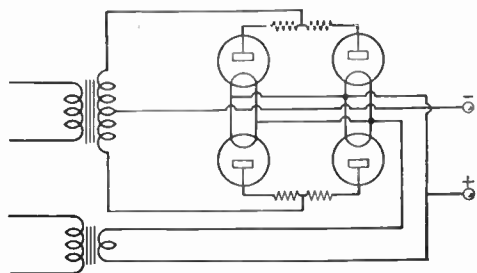

Figure 26.

PARALLEL OPERATION OF MERCURY-VAPOR RECTIFIERS.

Small, center-tapped resistors or iron core chokes are used to make the current divide evenly. If not used, one rectifier of each parallel pair tends to take the whole load. 100 ohms or 1 hy., center tapped, is satisfactory for each equalizer.

is normally the amount of bias that would be used on the same tubes at the same plate voltage in a class B modulator. It is best practice to obtain only this amount of bias from a bias pack, the additional required amount being obtained from a variable grid leak which is adjusted for correct bias and grid current while the stage is running under normal conditions.

This condition is such that the voltage divider tap on the bias pack will be delivering only a portion of the full bias pack voltage when the biased stage is inoperative. Then, when grid current flows to the biased stage, there is no danger of the voltage rising to dangerously high values across the filter condensers in the bias pack.

A bias power supply for providing "protective bias" to the r.f. stages of a medium-power radio transmitter is shown in Figure 27.

Two bleeder resistors with slider adjustments provide any desired value of negative grid bias for the r.f. amplifiers. The location of the slider on the resistors should be determined experimentally with the amplifier in operation, since the direct grid current of the r.f. amplifier itself will affect the voltage across the bias supply taps. The circuit illustrated is practically free from reaction between buffer and final amplifier bias.

Transmitter Power Input Control

In the interests of interference reduction, one should run only sufficient power input to a radio transmitter to maintain satisfactory communication. The power input to the final r.f. amplifier of a c.w. transmitter can be controlled over a very wide range by means of an autotransformer connected as in Figure 29. The a.c. voltage can be varied from a few

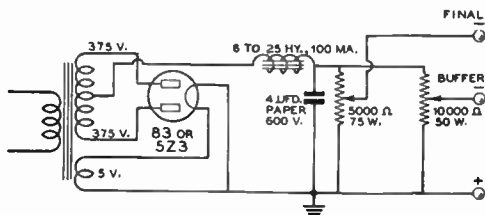

Figure 27.

BIAS PACK FOR C.W. OR PLATE MODULATED TRANSMITTER.

This pack will deliver up to 250 volts of protective bias to the various stages of a high-power 'phone or c.w. transmitter. A large safety factor in the filter condenser is provided to permit using the full output of the pack for bias as would be the case with crystal keying of high power using medium- μ tubes and running heavy grid current. The power transformer should be of about 75 ma. rating. This type of bias pack does not have good regulation, and should not be used with class B linear or class B audio stages; such applications require a very low resistance bleeder. To bias a grid modulated amplifier, another section of filter should be added.

volts up to 130 volts, by means of a relatively small autotransformer. This a.c. voltage should be applied only to the high-voltage power transformer which supplies plate power to the final r.f. amplifier.

Convenient adjustment of input to a phone transmitter other than of the plate modulated type is a more difficult problem. Input to a plate-modulated transmitter can be varied the same as for a c.w. transmitter without danger of overmodulating the reduced input, if the primary voltage for the plate transformer that feeds the modulators is fed from the same tap on the autotransformer as the plate transformer for the final amplifier. This assumes the modulators are of the "zero bias" type. If one power supply is used for both, the problem is further simplified.

Reducing the power of a grid-modulated final amplifier is more of a problem. The best method for reducing power is to reduce the r.f. excitation and audio gain together, without disturbing the bias or plate voltage or antenna coupling adjustment.

Those using linear r.f. amplifiers can either incorporate a switching arrangement for throwing the antenna over to the low-level modulated stage and thus reduce power about 10 db, or else merely reduce excitation to the linear amplifier without disturbing the a.f. gain control.

Overload Protection

To protect the tubes in a medium or high power final amplifier in the event of excita-

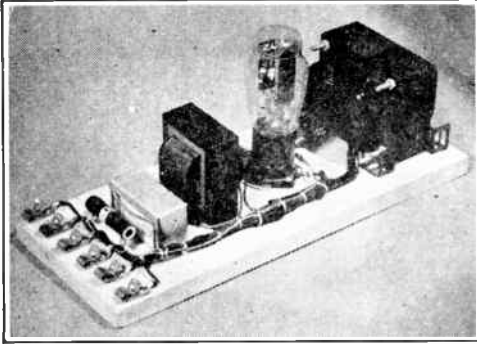

Figure 28.
TYPICAL 300-350 VOLT POWER SUPPLY.

This type of power pack ordinarily utilizes a power transformer having from 325 to 350 volts each side of c.t. with integral filament windings, and a brute force or pi-type filter consisting of a single choke and dual 8- μ fd. electrolytic condenser. The rectifier is usually an 80 or 5Z3. Such packs commonly deliver from 50 to 150 ma., depending upon the ratings of the transformer and choke, and are most commonly used with receivers, a.f. amplifiers and drivers, and low power exciter stages. They are also used as bias packs, in which case a very low resistance bleeder is used, adjustable taps being provided so that the bleeder can be used as a voltage divider.

tion failure, any one of several courses is satisfactory. If very high μ tubes of the "zero bias" type commonly used as modulators are used in the class C amplifier, no protection is necessary if the tubes are run within their voltage rating. However, such tubes ordinarily require somewhat more excitation than an equivalent medium high μ tube. Thus, an 811 requires more excitation than an 812, nearly twice as much when plate modulated.

Safety bias from a bias pack or batteries invariably is used on the various stages in a c.w. transmitter which is oscillator keyed. However, when the final amplifier is keyed, or for telephony, such bias is not required from the standpoint of keying, but simply to protect the tubes from excessive dissipation in the event of accidental excitation failure. Other means of protecting the tubes against such possibility are as follows:

Overload relays, which can be adjusted to trip and stay open at any desired amount of plate current, can be used to open the primary of the plate transformer. However, such relays are rather expensive as compared to simple relays of the s.p.s.t. type, and usually cost as much as a bias pack.

A small instrument fuse (*Littel fuse*) of appropriate current rating can be placed in the center tap lead to the amplifier stage (the grid

leak going to ground or B minus side of the fuse). These fuses cost but 10 cents, and while rated at only 250 volts, will work satisfactorily at high plate voltage when placed in the center tap lead and not in the B plus or B minus lead. The current rating should be such that the fuse does not blow immediately when the plate current is excessive, but does blow before the tubes become hot enough to be damaged. The correct value to use can be determined by blowing one or two fuses experimentally by detuning the amplifier or otherwise making it draw a momentarily large plate current.

These methods of protection (overload relay or fuse) are satisfactory only when the amplifier tube draws *considerably more current at zero bias than it does under normal operating conditions*. This generally will apply with tubes having a μ of 30 or less. It is obvious that if the tube draws about the same plate current at zero bias and no excitation as it does under normal conditions, the dissipation can be excessive without the fuse or overload relay being actuated. By looking up the characteristic curves on a tube it is possible to ascertain if it draws appreciably more plate current at zero bias and no excitation than it does under normal operating conditions.

Perhaps the best type of protection is obtained by means of an inexpensive s.p.s.t. relay which is actuated by the grid current to the final stage. The relay winding should be such that the contacts close at about half normal grid current, and the winding should be capable of handling somewhat more than normal grid current without damage. Suitable relays are those sold by several manufacturers for less than \$1.75, and a suitable winding can be had for almost any grid current from 25 to 200 ma. by the choice of 6, 12, and 24 volt d.c. windings available.

The relay contacts may be used to short out a cathode bias resistor. In this way, the amplifier has cathode bias until excitation is applied, then the relay closes and shorts out the cathode bias. Used in this manner, the relay contacts have little work to do. Just sufficient cathode bias should be used to keep the plate dissipation from exceeding the rated maximum when

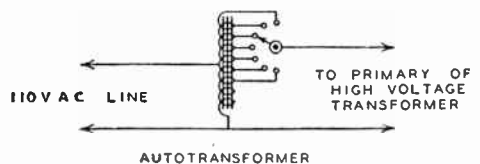

Figure 29.
AUTOTRANSFORMER VOLTAGE CONTROL.

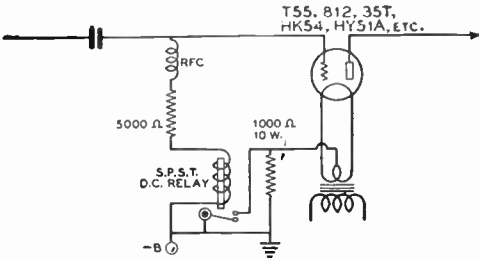

Figure 30.

IMPROVED CATHODE BIAS SYSTEM.

At the cost of a small inexpensive relay, the protection of cathode bias may be obtained with none of the disadvantages of the latter. When excitation is applied, the cathode bias resistor is shorted out. This circuit shows a typical application. The relay should close at about half normal grid current and be capable of standing the maximum grid current.

excitation fails. Normally about 750 ohms will be about right for one tube and 400 ohms for two tubes.

If the relay contacts are sufficiently heavy, they may be used to break the primary of the high voltage plate transformer feeding the final amplifier. Because of the inductive "kick", rather heavy contacts will be required in this service when running high power.

Because the cathode bias resistor is shorted out when normal plate current is being drawn, the resistor need not have a high dissipation rating. A 10-watt resistor will be large enough for a 250 watt rig. A typical circuit using this arrangement is shown in Figure 30.

Typical Power Supplies

Several photographs and diagrams of power supplies are shown throughout this chapter to illustrate the more common methods of construction. Figures 13 and 14 show a voltage regulated power supply of the vacuum tube regulated type with a 6B4-G as the regulator tube. Figures 15 and 16, respectively, show a bias pack of the stabilized type, also using a 6B4-G as the regulator tube. Figure 28 illustrates a simple 300-350 volt supply of the type commonly used to supply filament and plate voltages to a receiver, v.f.o., or to the low-level stages in a transmitter. Figures 31, 32, 33, and 34 illustrate methods of construction of medium power plate supplies for 600, 1500 and 600, and 1500 volts of the types usually built for supplying plate voltage to the intermediate and final amplifiers of amateur transmitters.

Transformer Design

A common problem in radio and allied work is to determine how a transformer can be built to supply certain power requirements for a

particular application, or how to calculate the windings needed to fit a certain transformer core which is already on hand. These problems can be solved by a small amount of calculation.

The most important factor in determining the size of any transformer is the amount of core material available. The electrical rating, as well as the physical size, is determined almost entirely by the size of the core. The core material is also important. The present practice is to use high-grade silicon-steel sheet. It will be assumed that this type of material is to be employed in all construction herein described. Soft sheet-iron or stovepipe iron is sometimes substituted, but transformers made from such materials will have about 50 to 60 per cent of the power rating, pound for pound of core, as those made from silicon-steel.

The Core

The core size determines the performance of a transformer because the entire energy circulating in the transformer (except small amounts of energy dissipated in resistance losses in the primary) must be transformed from electrical energy in the primary winding to magnetic energy in the core, and reconverted into electrical energy in the secondary. The amount of core material determines quite definitely the power that any transformer will handle.

Transformer cores are often designed so that if the losses per cubic inch of core material are determined, these losses can be used as a

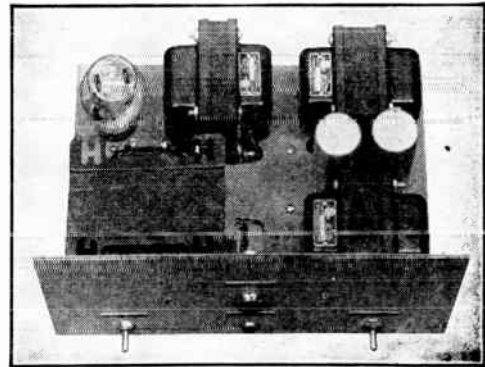

Figure 31.

TYPICAL 500-600 VOLT POWER SUPPLY.

Power supplies such as this are commonly used to feed low power r.f. stages, modulators, etc. The power transformer is generally rated at from 600 to 750 volts each side of c.t. at from 150 to 250 ma. and has no filament windings. An 83 or 5Z3 and swinging choke input filter having 600-volt all-filled paper condensers are ordinarily used. Round can condensers of this type are usually less expensive than equivalent ones in square cans.

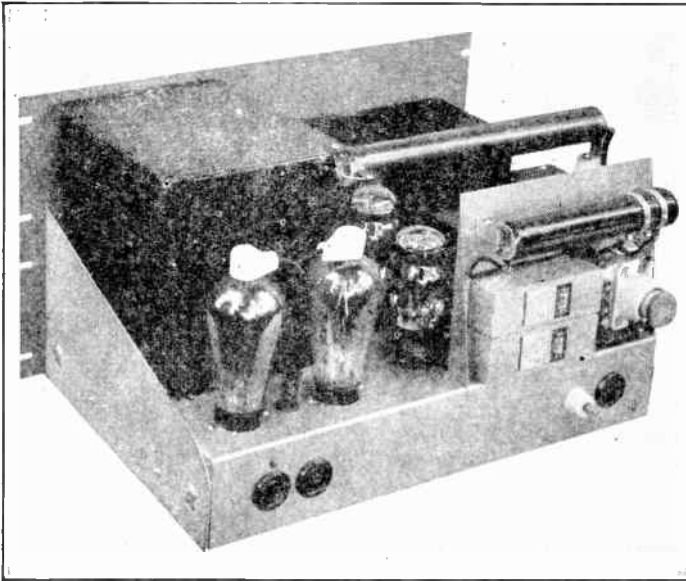
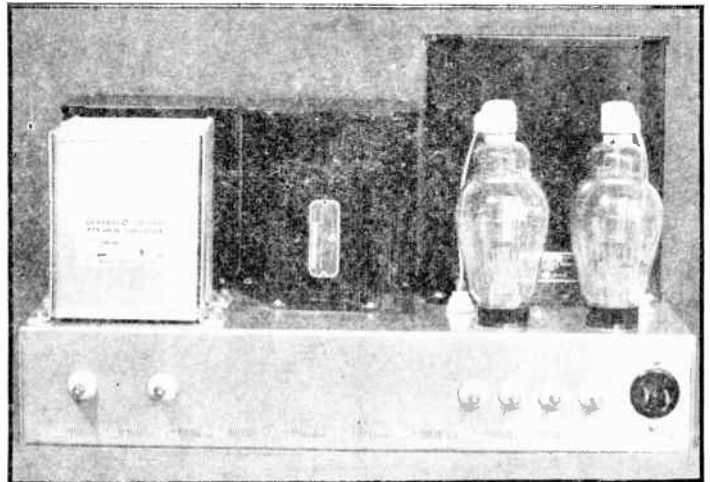

Figure 32.
**POWER SUPPLY FOR
RELAY RACK
MOUNTING.**

Illustrating well - designed dual power pack for relay rack mounting. Observe the fuse, bleeders, and the feed-through terminal for the high voltage connection. This unit delivers 1500 and 600 volts. Note that the heaviest components are mounted towards the front panel to minimize the strain on panel and chassis.

Figure 33.
**GENERAL PURPOSE
1500-VOLT POWER
SUPPLY.**

Taps are provided on the secondary of the power transformer so that the output voltage of the power supply may be reduced to 1250 or 1000 volts should this be desirable. The permissible current drain from the supply at either of the three voltages is 300 ma.



basis for calculating the rating of the transformer. These losses exist in watts, and are divided between the eddy current loss and the hysteresis loss. The eddy current loss is the loss due to the lines of force moving across the core, just as if it were a conductor, and setting up currents in it.

• Induced currents of this type are very undesirable and they are merely wasted in heating the core, which then tends to heat the windings, increase the resistance of the coils, and reduce the overall power handling ability of the transformer. To reduce such losses, transformer cores are made of thin sheets, usually about no. 29 gauge. These sheets are insulated from each other by a coat of thin varnish,

shellac or japan, or by the iron-oxide scale which forms on the sheets during the manufacturing process and which forms a good insulator between sheets.

Hysteresis The magnetic flux in the core lags behind the magnetizing force that produces it, which is, of course, the primary supply. Because all transformers operate on alternating current, the core is subjected to continuous magnetizing and demagnetizing force, due to the alternating effect of the a.c. field. This *hysteresis* (meaning "to lag") heats the iron, due to molecular friction caused by the iron molecules re-orienting themselves as the direction of the magnetizing flux changes.

Saturation The higher the field strength, the greater the heat produced. A condition can be reached where a further increase in magnetizing flux does not produce a corresponding increase in the flux density. This is called "saturation," and is a condition which would cause considerable heat in a core. In practice, it has been found that all core material must be operated with the magnetic flux well below the limit of saturation.

Core Losses All core losses manifest themselves as heat, and these losses are the determining factor in transformer rating. They are spoken of as "total core loss," generally used as a single figure, and for common use a core loss of from 0.75 watt to 2.5 watts per pound of core material can be assumed for 60 cycles. The lower figure is for the better grades of thin sheet, while the higher loss is for heavier grades.

About 1 watt per pound is a very satisfactory rating for common grades of material. This rating is also dependent on the manner in which the transformer is built and mounted, and on the ease with which the heat is radiated from the core. Transformers with higher losses may be used for intermittent service.

The transformer core loss can be assumed to be from 5 to 10 per cent of the total rating for small transformers. Thus, if the core loss is known, the rating of the transformer can be easily determined. If the figure of 1 watt per pound is assumed, the problem is further simplified. To determine the rating of the transformer, weigh the core. If, for example, the core weighs 10 pounds, the transformer will handle from 100 to 200 watts. Such a transformer core can be assumed to have about 150 watts nominal rating.

If the weighing of the core is inconvenient, the weight can be calculated from the cubic content or volume. Sheet-steel core laminations

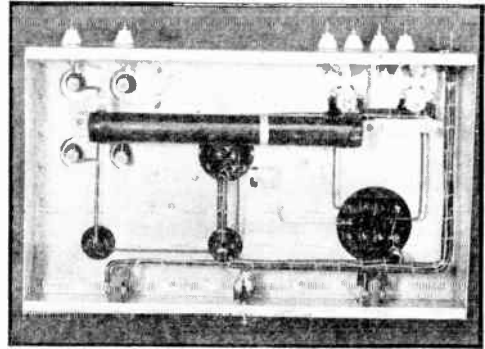

Figure 34.
UNDER-CHASSIS VIEW OF THE 1500-VOLT SUPPLY.

weigh approximately one-fourth pound per cubic inch.

Transformer cores are generally made in two types: shell, and core. The shell-type has a center leg which accommodates the windings, and this is twice the cross-sectional areas of the side legs. The core-type is made from strips built up into a hollow-like affair of uniform cross section. For the shell-type core, the area is taken as the square section of the center leg, in this case $2\frac{1}{4} \times 4\frac{1}{2}$ inches and in the core-type, this area is taken as the section of one leg, and is also $2\frac{1}{4} \times 4\frac{1}{2}$ inches, or an actual core area in both cases of 10.1 square inches, which is large enough for a comparatively large transformer.

Turns Per Volt To determine the number of turns for a given voltage, apply the following formula:

$$E = \frac{4.44 N B A T}{10^8}$$

Where E equals the volts of the circuit; N, the

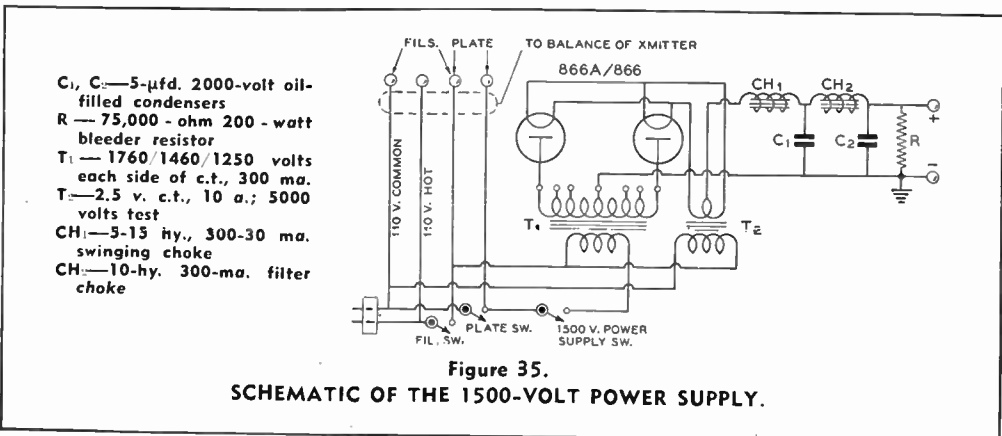

Figure 35.
SCHEMATIC OF THE 1500-VOLT POWER SUPPLY.

Copper Wire Table

| Gauge No. B. & S. | Diam. in Mils ¹ | Circular Mil Area | Turns per Linear Inch ² | | | | Turns per Square Inch ² | | | | Feet per Lb. | | Ohms per 1000 ft. 25° C. | Correct Capacity at 1500 C.M. per Amp. ³ | Diam. in mm. |
|-------------------|----------------------------|-------------------|------------------------------------|--------|------------------|--------|------------------------------------|--------|--------|------|--------------|-------|--------------------------|---|--------------|
| | | | Enamel | S.S.C. | D.S.C. or S.C.C. | D.C.C. | S.C.C. | Enamel | D.C.C. | Bare | D.C.C. | | | | |
| 1 | 289.3 | 82690 | — | — | — | — | — | — | — | — | 3.947 | — | .1264 | 55.7 | 7.348 |
| 2 | 257.6 | 66370 | — | — | — | — | — | — | — | — | 4.977 | — | .1593 | 44.1 | 6.544 |
| 3 | 229.4 | 52640 | — | — | — | — | — | — | — | — | 6.276 | — | .2009 | 35.0 | 5.827 |
| 4 | 204.3 | 41740 | — | — | — | — | — | — | — | — | 7.914 | — | .2533 | 27.7 | 5.189 |
| 5 | 181.9 | 33100 | — | — | — | — | — | — | — | — | 9.980 | — | .3195 | 22.0 | 4.621 |
| 6 | 162.0 | 26250 | — | — | — | — | — | — | — | — | 12.58 | — | .4028 | 17.5 | 4.115 |
| 7 | 144.3 | 20820 | — | — | — | — | — | — | — | — | 15.87 | — | .5080 | 13.8 | 3.665 |
| 8 | 128.5 | 16510 | 7.6 | — | 7.4 | 7.1 | — | — | — | — | 20.01 | 19.6 | .6405 | 11.0 | 3.264 |
| 9 | 114.4 | 13090 | 8.6 | — | 8.2 | 7.8 | — | — | — | — | 25.23 | 24.6 | .8077 | 8.7 | 2.906 |
| 10 | 101.9 | 10380 | 9.6 | — | 9.3 | 8.9 | 87.5 | 84.8 | 80.0 | — | 31.82 | 30.9 | 1.018 | 6.9 | 2.588 |
| 11 | 90.74 | 8234 | 10.7 | — | 10.3 | 9.8 | 110 | 105 | 97.5 | — | 40.12 | 38.8 | 1.284 | 5.5 | 2.305 |
| 12 | 80.81 | 6530 | 12.0 | — | 11.5 | 10.9 | 136 | 131 | 121 | — | 50.59 | 48.9 | 1.619 | 4.4 | 2.053 |
| 13 | 71.96 | 5178 | 13.5 | — | 12.8 | 12.0 | 170 | 162 | 150 | — | 63.80 | 61.5 | 2.042 | 3.5 | 1.828 |
| 14 | 64.08 | 4107 | 15.0 | — | 14.2 | 13.8 | 211 | 198 | 183 | — | 80.44 | 77.3 | 2.575 | 2.7 | 1.628 |
| 15 | 57.07 | 3257 | 16.8 | — | 15.8 | 14.7 | 262 | 250 | 223 | — | 101.4 | 97.3 | 3.247 | 2.2 | 1.450 |
| 16 | 50.82 | 2583 | 18.9 | 18.9 | 17.9 | 16.4 | 321 | 306 | 271 | — | 127.9 | 119 | 4.094 | 1.7 | 1.291 |
| 17 | 45.26 | 2048 | 21.2 | 21.2 | 19.9 | 18.1 | 397 | 372 | 329 | — | 161.3 | 150 | 5.163 | 1.3 | 1.150 |
| 18 | 40.30 | 1624 | 23.6 | 23.6 | 22.0 | 19.8 | 493 | 454 | 399 | — | 203.4 | 188 | 6.510 | 1.1 | 1.024 |
| 19 | 35.89 | 1288 | 26.4 | 26.4 | 24.4 | 21.8 | 592 | 553 | 479 | — | 256.5 | 237 | 8.210 | .86 | .9116 |
| 20 | 31.96 | 1022 | 29.4 | 29.4 | 27.0 | 23.8 | 745 | 725 | 625 | — | 323.4 | 298 | 10.35 | .68 | .8118 |
| 21 | 28.46 | 810.1 | 33.1 | 32.7 | 29.8 | 26.0 | 970 | 895 | 754 | — | 407.8 | 370 | 13.05 | .54 | .7230 |
| 22 | 25.35 | 642.4 | 37.0 | 36.5 | 34.1 | 30.0 | 1150 | 1070 | 910 | — | 514.2 | 461 | 16.46 | .43 | .6438 |
| 23 | 22.57 | 509.5 | 41.3 | 40.6 | 37.6 | 31.6 | 1400 | 1300 | 1080 | — | 648.4 | 584 | 20.76 | .34 | .5733 |
| 24 | 20.10 | 404.0 | 46.3 | 45.3 | 41.5 | 35.6 | 1700 | 1570 | 1260 | — | 817.7 | 745 | 26.17 | .27 | .5106 |
| 25 | 17.90 | 320.4 | 51.7 | 50.4 | 45.6 | 38.6 | 2060 | 1910 | 1510 | — | 1031 | 903 | 33.00 | .21 | .4547 |
| 26 | 15.94 | 254.1 | 58.0 | 55.6 | 50.2 | 41.8 | 2500 | 2300 | 1750 | — | 1300 | 1118 | 41.62 | .17 | .4049 |
| 27 | 14.20 | 201.5 | 64.9 | 61.5 | 55.0 | 45.0 | 3030 | 2780 | 2020 | — | 1639 | 1422 | 52.48 | .13 | .3606 |
| 28 | 12.64 | 159.8 | 72.7 | 68.6 | 60.2 | 48.5 | 3670 | 3350 | 2310 | — | 2067 | 1759 | 66.17 | .11 | .3211 |
| 29 | 11.26 | 126.7 | 81.6 | 74.8 | 65.4 | 51.8 | 4300 | 3900 | 2700 | — | 2607 | 2207 | 83.44 | .084 | .2859 |
| 30 | 10.03 | 100.5 | 90.5 | 83.3 | 71.5 | 55.5 | 5040 | 4660 | 3020 | — | 3287 | 2534 | 105.2 | .067 | .2546 |
| 31 | 8.928 | 79.70 | 101. | 92.0 | 77.5 | 59.2 | 5920 | 5280 | — | — | 4145 | 2768 | 132.7 | .053 | .2268 |
| 32 | 7.950 | 63.21 | 113. | 101. | 83.6 | 62.6 | 7060 | 6250 | — | — | 5227 | 3137 | 167.3 | .042 | .2019 |
| 33 | 7.080 | 50.13 | 127. | 110. | 90.3 | 66.3 | 8120 | 7360 | — | — | 6591 | 4697 | 211.0 | .033 | .1798 |
| 34 | 6.305 | 39.75 | 143. | 120. | 97.0 | 70.0 | 9600 | 8310 | — | — | 8310 | 6168 | 266.0 | .026 | .1601 |
| 35 | 5.615 | 31.52 | 158. | 132. | 104. | 73.5 | 10900 | 8700 | — | — | 10480 | 6737 | 335.0 | .021 | .1426 |
| 36 | 5.000 | 25.00 | 175. | 143. | 111. | 77.0 | 12200 | 10700 | — | — | 13210 | 7877 | 423.0 | .017 | .1270 |
| 37 | 4.453 | 19.83 | 198. | 154. | 118. | 80.3 | — | — | — | — | 16660 | 9309 | 533.4 | .013 | .1131 |
| 38 | 3.965 | 15.72 | 224. | 166. | 126. | 83.6 | — | — | — | — | 21010 | 10666 | 672.6 | .010 | .1007 |
| 39 | 3.531 | 12.47 | 248. | 181. | 133. | 86.6 | — | — | — | — | 26500 | 11907 | 848.1 | .008 | .0897 |
| 40 | 3.145 | 9.88 | 282. | 194. | 140. | 89.7 | — | — | — | — | 33410 | 14222 | 1069 | .006 | .0799 |

¹A mil is 1/1000 (one thousandth) of an inch.

²The figures given are approximate only, since the thickness of the insulation varies with different manufacturers.

³The current-carrying capacity at 1000 C.M. per ampere is equal to the circular-mil area (Column 3) divided by 1000.

Table courtesy P. R. Mallory & Co.

cycles of the circuit; B, the number of magnetic lines per square inch of the magnetic circuit; A, the number of square inches of the magnetic circuit; and T, the number of turns.

The proper value for B, for small transformers and for ordinary grades of sheet-iron, such as are now being considered, is 75,000 for 25 cycles and 50,000 for 50 or 60 cycles.

Rewriting the above formula

$$T = \frac{E \times 10^8}{4.44 N B A}$$

and since N and B are known

$$T = \frac{10^8}{4.44 \times 60 \times 50,000} \times \frac{E}{A}$$

from which

$$T = 7.5 \times \frac{E}{A}$$

That is, for a transformer to be used on a 60-cycle circuit, the proper number of turns for the primary coil is obtained by multiplying the line voltage by 7.5 and dividing this product by the number of square inches cross section of the magnetic circuit

On a 25-cycle circuit, the 7.5 becomes 12, and on 50 cycles it becomes 9.

Design Example Assume a transformer core that is to be used on a 115-volt, 60-cycle circuit for supplying power to two rectifier tubes, each of which takes 1,000 volts on the plate. The rectifier is of the full-wave type. The core measures $2\frac{1}{2} \times 4\frac{1}{2}$

inches; hence,

$$T = \frac{7.5 \times 115}{2.25 \times 4.5} = 85 \text{ (to the nearest}$$

turn), and the volts per turn equals

$$\frac{115}{85} = 1.353 \text{ which is the same for all coils.}$$

Now, the secondary coil must have two windings in series, each to give 1,000 volts, and with a middle tap. The secondary turns

$$\text{will be } \frac{2000}{1.353} = 1478 \text{ with a tap taken out at the 739th turn.}$$

Allowing 1,500 circular mils per ampere, the primary wire should be no. 12. The size of the wire on the plate coils may be no. 22 or 24 for a 400 to 300 ma. rating.

To determine the quantity of iron to pile up for a core, it is well to consider 1 to 1.5 volts per turn as a conservative range. For trial, assume 1.25 volts. Then by transforming the first equation

$$A = 7.5 \times \frac{E}{T} \text{ or, the area required is } 7.5$$

times the volts per turn; in this case, $7.5 \times 1.25 = 9.38$ square inches.

The magnetic cross section must be measured at right angles to the laminations that are enclosed by the coil, the center leg when the core is built up around the coil, and either leg where the core is built up inside the coil,

Figure 36.

COMBINED MODULATOR AND POWER SUPPLY.

While ordinarily it is preferable to design a power supply as an integral independent unit, it sometimes is desirable for reasons of limited space to construct a modulator or r.f. unit with its power supply on the same chassis. In this example a modulator and its power supply are mounted on a single chassis, thus making use of every bit of space. Also, external connecting cables are avoided, but special care must be taken to prevent hum being picked up from the power supply by the input stage of the speech amplifier.



Transformer Design Chart

SECONDARY WINDINGS (Turns for Voltages Given)
HIGH-VOLTAGE WINDING

| WATTS | Section of Core (inches) | Area of Core (Square inches) | Primary Turns | Primary Wire Size | Turns per Volt | 2.5 volts | 5.0 volts | 6.3 volts | 7.5 volts | 10 volts | 250 volts | 300 volts | 350 volts | 400 volts | 450 volts | 500 volts | 600 volts | 700 volts | 800 volts | 900 volts | 1000 volts | 1250 volts | 1500 volts |
|-------|--------------------------|------------------------------|---------------|-------------------|----------------|-----------|-----------|-----------|-----------|----------|-----------|-----------|-----------|-----------|-----------|-----------|-----------|-----------|-----------|-----------|------------|------------|------------|
| 10 | 1/2 x 1/2 | .25 | 3500 | 31 32 | | 80 | 160 | 205 | 240 | 320 | | | | | | | | | | | | | |
| 10 | 1/2 x 3/4 | .31 | 2800 | 31 24.2 | | 61 | 122 | 147 | 182 | 242 | | | | | | | | | | | | | |
| 12 | 1/2 x 3/4 | .37 | 2300 | 30 20.0 | | 50 | 100 | 126 | 150 | 200 | | | | | | | | | | | | | |
| 12 | 3/4 x 3/4 | .38 | 2280 | 30 19.6 | | 48 | 96 | 124 | 147 | 196 | | | | | | | | | | | | | |
| 15 | 3/4 x 3/4 | .46 | 1875 | 29 16.1 | | 42 | 84 | 105 | 124 | 161 | | | | | | | | | | | | | |
| 22 | 5/8 x 1 | .62 | 1400 | 26 12.2 | | 31 | 61 | 77 | 92 | 122 | | | | | | | | | | | | | |
| 20 | 3/4 x 3/4 | .55 | 1570 | 28 13.6 | | 34 | 68 | 86 | 102 | 136 | | | | | | | | | | | | | |
| 25 | 3/4 x 1 | .75 | 1150 | 27 16.0 | | 25 | 50 | 63 | 75 | 100 | 2620 | 3150 | 3700 | 4200 | 4750 | 5250 | | | | | | | |
| 30 | 3/4 x 1 1/4 | .83 | 930 | 26 8.1 | | 21 | 42 | 52 | 62 | 81 | 2100 | 1500 | 3140 | 3400 | 3800 | 4200 | | | | | | | |
| 30 | 1/2 x 1 1/2 | 1.12 | 770 | 24 6.7 | | 17 | 34 | 43 | 50 | 67 | 1860 | 2100 | 2500 | 2840 | 3150 | 3500 | 4200 | 5000 | | | | | |
| 50 | 1 x 1 | 1.0 | 860 | 24 7.5 | | 19 | 38 | 48 | 57 | 75 | 1950 | 2400 | 2700 | 3150 | 3600 | 3900 | 4700 | 5500 | | | | | |
| 60 | 1 x 1 1/4 | 1.25 | 690 | 23 6.0 | | 15 | 30 | 38 | 45 | 60 | 1600 | 1900 | 2200 | 2500 | 2800 | 3150 | 3800 | 4400 | | | | | |
| 65 | 1 x 1 1/2 | 1.50 | 575 | 23 5.0 | | 13 | 25 | 32 | 38 | 50 | 1300 | 1575 | 1850 | 2100 | 2400 | 2650 | 3150 | 3700 | | | | | |
| 75 | 1 x 1 3/4 | 1.75 | 490 | 22 4.2 | | 11 | 21 | 27 | 31 | 42 | 1100 | 1320 | 1550 | 1750 | 2000 | 2200 | 2650 | 3150 | 3800 | 4000 | 4100 | | |
| 110 | 1 x 2 | 2.0 | 430 | 21 3.7 | | 9 | 18 | 23 | 28 | 37 | 980 | 1170 | 1370 | 1550 | 1750 | 1960 | 2300 | 2750 | 3100 | 3500 | 3900 | | |
| 105 | 1 1/4 x 1 1/4 | 1.56 | 550 | 21 4.8 | | 12 | 24 | 31 | 36 | 48 | 1260 | 1510 | 1770 | 2050 | 2240 | 2510 | 3050 | 3500 | 4100 | 4500 | 5020 | | |
| 100 | 1 1/4 x 1 1/2 | 1.87 | 460 | 21 3.8 | | 9 | 19 | 25 | 29 | 38 | 1000 | 1200 | 1400 | 1600 | 1800 | 2000 | 2400 | 2720 | 3200 | 3560 | 4000 | | |
| 120 | 1 1/4 x 1 3/4 | 2.18 | 400 | 20 3.5 | | 9 | 18 | 21 | 26 | 35 | 920 | 1100 | 1315 | 1470 | 1650 | 1840 | 2200 | 2560 | 2940 | 3300 | 3700 | 4620 | 5500 |
| 140 | 1 1/4 x 2 | 2.5 | 330 | 19 3.2 | | 8 | 16 | 20 | 24 | 32 | 810 | 1020 | 1180 | 1340 | 1510 | 1680 | 2050 | 2350 | 2680 | 3000 | 3380 | 4200 | 5050 |
| 125 | 1 1/2 x 1 1/2 | 2.25 | 380 | 20 3.3 | | 8 | 16 | 21 | 25 | 33 | 870 | 1040 | 1210 | 1400 | 1560 | 1730 | 2100 | 2420 | 2800 | 3120 | 3500 | 4400 | 5250 |
| 150 | 1 1/2 x 1 3/4 | 2.61 | 330 | 18 2.9 | | 7 | 14 | 19 | 22 | 29 | 760 | 910 | 1130 | 1220 | 1360 | 1530 | 1840 | 2100 | 2450 | 2750 | 3050 | 3800 | 4650 |
| 200 | 1 1/2 x 2 | 3.0 | 290 | 17 2.12 | | 6 | 12 | 15 | 18 | 24 | 630 | 765 | 890 | 1020 | 1150 | 1265 | 1522 | 1780 | 2050 | 2380 | 2350 | 3200 | 3840 |
| 300 | 2 x 2 | 4.0 | 215 | 15 1.87 | | 5 | 9 | 12 | 14 | 19 | 490 | 590 | 690 | 780 | 880 | 980 | 1180 | 1360 | 1570 | 1760 | 1950 | 2350 | 2940 |
| 100 | 2 x 2 1/2 | 5.0 | 175 | 14 1.52 | | 4 | 8 | 10 | 12 | 15 | 395 | 470 | 550 | 640 | 710 | 790 | 950 | 1110 | 1265 | 1420 | 1590 | 1980 | 2400 |
| 500 | 2 x 3 | 6.0 | 115 | 13 1.26 | | 3 | 6 | 8 | 9 | 12 | 330 | 395 | 455 | 530 | 595 | 660 | 790 | 920 | 1060 | 1200 | 1330 | 1650 | 2000 |

that is, between the arrows in the sketches shown on page 328.

It should be kept in mind that there is a copper or resistance loss in all transformers. This is caused by the passage of the current through the windings, and is commonly spoken of as the "IR" loss. It manifests itself directly as heat and varies as the load is varied; the heavier the load, the more heat is developed.

This heat, as well as other heat losses, must be removed, or the transformer will burn up. Most transformers are so arranged that both the core and windings can radiate heat into the surrounding air and thus cool themselves. Large transformers are mounted in oil for cooling, and also for the purpose of increasing the insulation factor.

In any transformer, the voltage ratio is directly proportional to the turns ratio. This means that if the transformer is to have 110-volts input and 250 turns for the primary, and if the output is to be 1,100 volts, 2,500 turns will be needed. This may be expressed:

$$\frac{E_p}{E_s} = \frac{T_p}{T_s}$$

It is often more convenient to take the figure obtained for the primary winding and, by dividing by the supply voltage, the number of turns per volt is calculated. This accomplished, the number of turns for any given voltage can be calculated by simple multiplication.

Radio transformers are generally of small size. The matter of power factor can therefore be disregarded, more especially because they work into an almost purely resistive load. In the design of radio transformers, the power

factor can be safely assumed as unity, in which case the apparent watts and the actual watts are the same. Admittedly, this is not always a correct assumption, but it will suffice for common applications.

The size of the wire to be used in any transformer depends upon the amperage to be carried. For a continuous load, at least 1,000 circular mils per ampere must be allowed. For transformers which have poor ventilation, or continuous heavy load service, or where price is not the first consideration, 1,500 circular mils per ampere is a preferable figure. If, for example, a transformer is rated at 100-watts primary load on 110 volts, the current is

$$I = \frac{W}{V} = \frac{100}{110} = 0.90 \text{ amperes}$$

and if the assumption is 1,000 circular mils per ampere, it will be found that this will require $1,000 \times .90$, or 900 circular mils. The wire table on page 324 shows that no. 20 wire for 1,200 mils is entirely satisfactory. If it is desired to use 1,500 circular mils, instead of 1,000, this will require $1,500 \times .90$ or 1,350 mils, which corresponds to approximately no. 19 wire. The difference seems to be small, yet it is large enough to reduce heating and to improve overall performance. Assume, for tentative design, a 600-volt, 100-ma. high-voltage secondary; a 3-ampere 5-volt secondary; and 2.5-volt 7.5-ampere secondary. Simple calculation will show a 60-watt load on the high-voltage secondary, 15 watts on the 5-volt winding, and 16 watts on the 2.5-volt winding; a total of 91 watts. The core and copper loss is 10 watts. The wire sizes for the secondaries will be for 100-ma. current, no. 30 wire; 3

Figure 37.

DUAL POWER SUPPLY.

In a rack-mounted power supply, which is supported from the front panel, it is advisable to place the heavy components close to the front panel to minimize the strain on the panel and chassis. Note the position of the heavy plate transformer. The chassis contains a 350-volt power supply and a 1250-volt power supply. Low voltage power supply components are to the right.

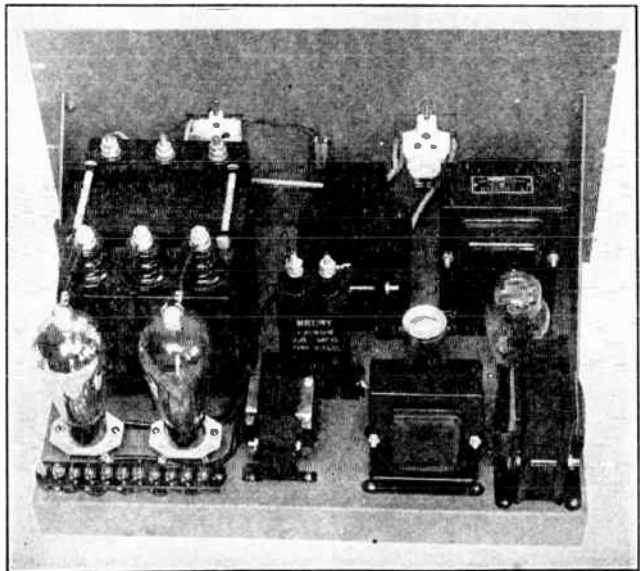

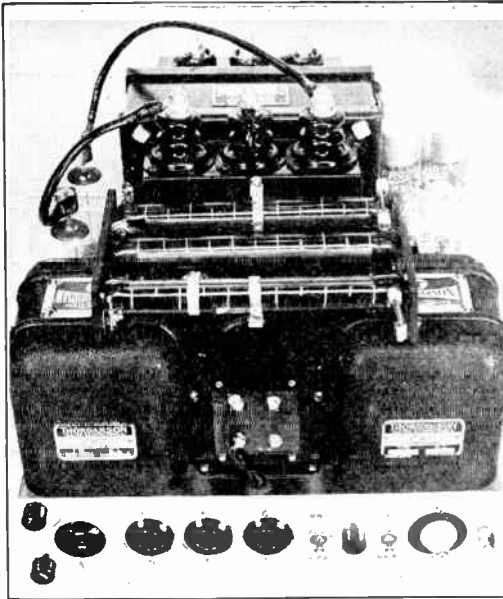

Figure 38.
ILLUSTRATING COMPACT POWER SUPPLY CONSTRUCTION.

This dual power supply illustrates what can be crowded on a chassis when space is at a premium. Note how the heavy bleeders, which also act as voltage dividers, are mounted so as to provide free circulation of air. A pair of 86's serve as rectifier in a conventional circuit for a high voltage supply; an 83 rectifier is used in the low voltage supply.

amperes at 5 volts, no. 15 wire; no. 11 wire for the 7.5-ampere secondary.

For high-voltage secondary windings, a small percentage of turns should be added to overcome the resistance of the small wire used, so that the output voltage will be as high as anticipated. The figures given in the table include this percentage which is added to the theoretical ratio and, consequently, the number of turns shown in the table can be accepted as the actual number to be wound on the core of any given transformer.

Insulation Allowance should always be made for the insulation and size of the windings. Good insulation should be provided between the core and the windings and also between each winding and between turns. Numerous materials are satisfactory for this purpose; varnished paper or cloth, called empire, is satisfactory, although costly. Good bond paper will serve well as an insulating medium for small transformer windings.

Insulation between primary and secondary and to the core must be exceptionally good, as

well as the insulation between windings. Thin mica or micanite sheet is very good. Thin fibre, commonly called fish paper, is also a good insulator; bristol board, or strong, thin cardboard may also be used. In all cases, the completed coil should be impregnated with insulating varnish, and either dried in air or baked in an oven. Common varnishes or shellac are unsatisfactory on account of the moisture content of these materials. Air-drying insulating varnish is practical for all-around purposes; baking varnish may be substituted, but the fumes given off are inflammable and often explosive. Care must be exercised in the handling of this type of material. Collodion and banana oil lacquer are positively dangerous, and in the event of a short circuit or transformer burn-out, a serious fire may result.

If it is desired to wind a transformer on a given core, it is much better to calculate the actual space required for the windings, then determine whether there is enough available space on the core. If this precaution is not observed, the designer may find that only about half the turns are actually wound on the core, when the space is about three-fourths filled. From 15 to 40 per cent more space than calculated must be allowed. The winding of transformers by hand is a laborious process. Unless the builder is an experienced coil-winder, there is every chance that a sizable portion of the space will be used up by insulation, etc., not sufficient space remaining for the winding. Calculate the cubical space needed for the total number of turns, and allow from 15 to 40 per cent additional space in the core window. This saves much time and labor.

Filter Choke Considerations

A choke is a coil of high inductance. It offers an extremely high impedance to alter-

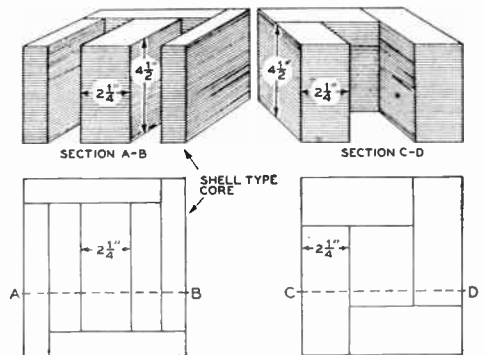

Figure 39.
TYPES OF TRANSFORMER CORES.

nating current, or to current which is substantially alternating, such as pulsating d.c. delivered at the output of a rectifier.

Choke coils are used in power supplies as part of the complete filter system in order to produce an effectively-pure direct current from the pulsating current source, that is, from the rectifier. The wire size of the choke must be such that the current flowing through it does not cause an appreciable voltage drop due to the ohmic resistance of the choke; at the same time, sufficient inductance must be maintained to provide ample smoothing of the rectified current.

Smoothing Chokes The function of a smoothing choke is to discriminate as much as possible between the a.c. ripple which is present and the desired d.c. that is to be delivered to the output. Its air gap should be large enough so that the inductance of the choke does not vary materially over the normal range of load current drawn from the power supply, but no larger than necessary to give maximum inductance at full current rating.

Swinging Chokes In certain radio circuits the power drawn by a vacuum tube amplifier can vary widely. Class B audio amplifiers are good examples of this type of amplifier. The plate current drawn by a class B audio amplifier can vary 1000 per cent or more. It is desirable to keep the d.c. output voltage applied to the plate of the amplifier as constant as possible, and the voltage should be independent of the current drawn from the power supply. The output voltage from a given power supply is always higher with a condenser input filter than with a choke-type input filter. When the input choke is of the *swinging* variety, it means that the induc-

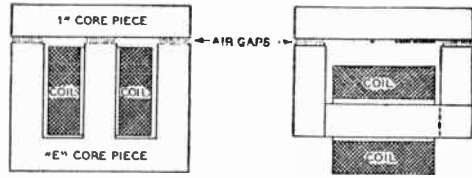

Figure 40.
Two types of choke coil construction. The air gap is approximately 1/32 inch. The gap may be filled with non-magnetic material, such as brass, bakelite, etc.

tance of the choke varies widely with the load current drawn from the power supply, due to the fact that high initial inductance is obtained by utilizing a "butt" gap, or none at all as in a transformer core.

A choke is made up from a silicon-steel core which consists of a number of thin sheets of steel, similar to a transformer core, but wound with only a single winding. The size of the core and the number of turns of wire, together with the air gap which must be provided to prevent the core from saturating, are factors which determine the inductance of a choke. The relative sizes of the core and coil determine the amount of d.c. which can flow through the choke without reducing the inductance to an undesirable low value due to magnetization.

The same core material which is used in ordinary radio power transformers, or from those which are burned out, is satisfactory for all general purposes.

In construction, the choke winding must be insulated from the core with a sufficient quantity of insulating material so that the highest peak voltages which are to be experienced in service will not rupture the insulation.

CHOKE TABLE FOR TRANSMITTER POWER SUPPLY UNITS

| CURRENT M.A. | WIRE SIZE | NO. TURNS | LBS. WIRE | APPROX. CORE (Area) | AIR GAP | WT. CORE |
|--------------|-----------|-----------|-----------|---------------------|---------|----------|
| 200 | No. 27 | 2000 | 1.5 | 1 1/2" x 1 1/2" | 3/32" | 4 lbs. |
| 250 | No. 26 | 2000 | 1.75 | 1 1/2" x 2" | 3/32" | 5 lbs. |
| 300 | No. 25 | 2250 | 2 | 2" x 2" | 1/8" | 6 lbs. |
| 400 | No. 24 | 2250 | 3 | 2" x 2 1/2" | 1/8" | 7 lbs. |
| 500 | No. 23 | 2500 | 4 | 2 1/2" x 2 1/2" | 1/8" | 10 lbs. |
| 750 | No. 21 | 3000 | 6 | 2 1/2" x 3" | 1/8" | 14 lbs. |
| 1000 | No. 20 | 3000 | 7.5 | 3" x 3" | 1/8" | 18 lbs. |

NOTES: These are approximately based on high-grade silicon steel cores with total air gaps as given. Air gaps indicated are total of all gaps.

The use of standard "E" and "I" laminations is recommended. If strips are used, and if an ordinary square core is used, the number of turns should be increased about 25%. Choke coils built as per the above table will have an approximate inductance of 10 to 15 henrys. Because considerable differences occur due to winding variations, allowable flux densities of cores, etc., the exact inductance cannot be stated; these chokes will, however, give satisfactory service in radio transmitter power supply systems.

The wire used is based on 1000 circular mils per ampere; this will cause some heating on long runs, and if the chokes are to be used continuously, as in a radiotelephone station in continuous service, it is good practice to use the next size larger choke shown for such loads.

TRANSFORMERLESS POWER SUPPLIES

Line Rectifier Figure 41 shows a simple transformerless power supply which may be operated directly from the power line. This circuit usually is found in a.c.-d.c. receivers but may be used in low-powered excitors and transmitters, bias packs and test instruments. When operated from an a.c. line, the circuit acts as a simple half-wave rectifier and delivers d.c. load currents up to about 75 milliamperes at a d.c. voltage slightly less than the r.m.s. line voltage, depending upon the type of rectifier tube (V) employed. When the circuit is operated from a d.c. line, tube V passes current only when its plates are connected to the positive side of the line and acts as a low resistance in the circuit.

The heater of the rectifier tube is operated from the power line through a series resistor, R, which often takes the form of a flexible winding on an asbestos string within the regular line cord. In order to keep the resistance and size of R low, only tubes having high-voltage, low-current heaters are employed in circuits of the transformerless type. Such tubes include types 12Z3, 25Y5, 25Z5, 25Z6, 35Z3, 35Z4, 35Z5, 45Z5, 50Y6 and 50Z7. The 117Z6 requires no dropping resistor, since this tube has a 117-volt heater.

Filter capacitors C₁ and C₂ are high-capacitance components, their common rating being between 16 and 40 microfarads.

The d.c. output voltage of the line rectifier may be stabilized by means of a glow-discharge voltage regulator tube, such as described earlier in this chapter. The voltage may be stabilized at 105 volts by means of a type VR-105 tube, at 90 v. by means of a VR-90, or at 75 v. by means of a VR-75.

Voltage Doubler Figure 42 shows a transformerless power supply circuit which will deliver d.c. output voltage, at low current levels, equal approximately to twice the r.m.s. value of the power line voltage. The no-load d.c. output voltage is equal

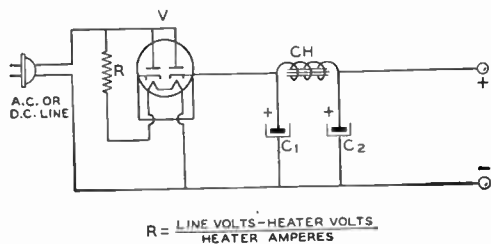

$$R = \frac{\text{LINE VOLTS} - \text{HEATER VOLTS}}{\text{HEATER AMPERES}}$$

Figure 41.
LINE RECTIFIER.

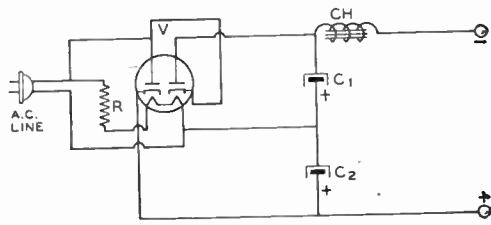

Figure 42.
VOLTAGE DOUBLER.

to 2.82 times the r.m.s. line voltage value. Because of its action, this circuit is known as a *voltage doubler*. At higher current levels, the output voltage is slightly under twice the line voltage.

As in the line rectifier circuit just described, V in the doubler circuit is a high-voltage, low-current-heater tube, R is a heater dropping resistor (the value of which is calculated as shown in Figure 41), and C₁ and C₂ are electrolytic capacitors rated at not less than 16 microfarads each.

D.c. output voltage of the doubler may be stabilized by means of glow discharge tubes in any of the following combinations: 150 v.—one VR-150; 165 v.—VR-75 and VR-90 in series; 180 v.—VR-105 and VR-75 in series; 195 v.—VR-105 and VR-90 in series; 210 v.—two VR-105's in series.

Voltage Quadrupler The transformerless power supply circuit in Figure 43 uses two identical high-voltage-heater rectifier tubes, V₁ and V₂, and four electrolytic "filter" capacitors, C₁ to C₄, rated at 16 to 40 microfarads each. But since this circuit is in effect two doublers in combination, it delivers a d.c. output voltage equal under light load to approximately four times the r.m.s. value of the line voltage. For this reason, the circuit is known as a *voltage quadrupler*. The output voltage decreases as the load current is increased. The no-load d.c. output voltage

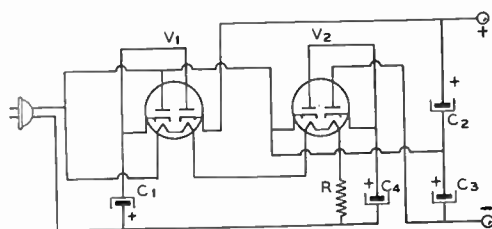

Figure 43.
VOLTAGE QUADRUPLER.

delivered by the quadrupler circuit is equal to 5.66 times the r.m.s. line voltage value.

The d.c. output voltage of the quadrupler may be stabilized by means of series-connected glow-discharge voltage regulator tubes. For example, stabilized 300-volt output may be obtained by means of two type VR-150 tubes connected in series.

BATTERY-OPERATED PORTABLE POWER SUPPLIES

Vibrapacks The vibrator-type power supply has as its heart a step-up transformer operated from a storage battery by means of a vibrating reed interrupter connected in series with the battery and primary. The job of the interrupter is to chop up the direct current from the battery at a regular rate so as to produce rising and falling magnetic flux in the transformer and consequently a high alternating voltage across the secondary winding. Standard automobile radios employ vibrator-type power supplies.

Vibrator-type power supplies and replacement vibrators may be purchased so reasonably that home building of these units is not feasible. The vibrapack generally employed in portable amateur transmitters and receivers is driven by a 6-volt storage battery.

One type vibrator power supply utilizes a standard tube, such as type 6X5, to rectify the secondary voltage. In this respect, it does not differ from the well-known power line-operated

power supply. Another type, however, employs an extra pair of vibrator contacts to rectify the high-voltage output by mechanical action.

The vibrator transformer-rectifier combination requires the usual capacitor-choke filter to smooth out the rectified current pulsations. In addition, r.f. filters must be included in the circuit to minimize transmission of damped wave r.f. voltages generated by the-sparking contacts of the vibrator.

Vibrator-type power supplies are commercially available with d.c. output ratings as high as 400 volts at 200 milliamperes.

Genemotors The genemotor is an improved type of dynamotor designed specifically to supply d.c. plate, screen and grid voltages for portable radio transmitters and receivers. The dynamotor type of construction differs from the conventional motor generator in that both motor and generator coils are wound on the same armature core. Small-sized portable radio genemotors are designed to run on low d.c. voltages, from 6 to 24, delivered by storage batteries. The 6-volt type is in common amateur use.

Genemotors may be supplied with built-in filters so that the machine need only be connected to the battery and radio equipment. 6-volt genemotors are available with d.c. output ratings as high as 500 volts at 200 milliamperes.

Transmitter Construction

As we go to press, the F. C. C. has assigned no post-war low-frequency amateur bands. The Government proposes to withhold the 160-meter band from amateurs and to assign a new 21-21.5-Mc. band. Other likely allocations are 3.5-4, 7-7.3, 14-14.4, and 28-29.7 Mc. The equipment shown in this chapter covers pre-war 10-, 20-, 40-, 80-, and 160-meter bands. Coils to accommodate new bands may be designed from data appearing under TRANSMITTER THEORY and in CHAPTER 28.

THE units shown in this chapter are complete transmitters, including modulator and power supply. The complete transmitters are shown for the benefit of those who prefer to construct a whole transmitter from a tried and proven circuit which has been engineered from the standpoint of an integral unit rather than attempt to work out an individual design from the exciter, amplifier, power supply, and modulator units shown elsewhere in this book.

All but one of the complete transmitters shown in this chapter are equipped for radiophone work, because it is a simple matter to omit the modulation equipment if 'phone operation is not desired.

40-WATT TRANSMITTER-EXCITER

The unit illustrated in Figures 1, 2, 4, and 5 is intended to serve as a complete 'phone-c.w. transmitter, or as an r.f. and audio driver for a higher power final amplifier and modulator. The transmitter is designed to provide utmost

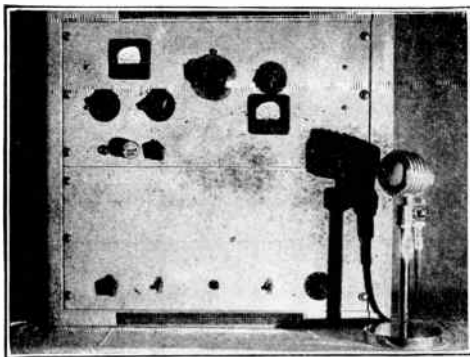

Figure 1.

40-WATT EXCITER-TRANSMITTER.

By itself, this unit forms a complete 40-watt 'phone-c.w. transmitter. With the r.f. amplifier and modulator unit shown later in this chapter it forms a 200-watt transmitter for 'phone or c.w. operation on bands from 10 to 160 meters.

flexibility, including bandswitching and provision for crystal control from its own crystal oscillator or excitation from a separate variable-frequency oscillator.

R.F. Section

The r.f. section, which is placed at the top of the 17½-inch rack-cabinet, employs a 6L6 as a crystal oscillator followed by another 6L6 as a doubler-quadrupler and an HY-69 amplifier-doubler output stage. All bands from 160 to 10 meters are covered through the use of both stage switching and coil switching.

Bandswitching For 160-meter operation, a crystal in that band is placed in the crystal socket on the panel and switch S_1 (Figure 3) is thrown to the upper position. With S_1 in this position, the HY-69 is excited directly from the crystal oscillator plate circuit, the doubler-quadrupler stage being cut out of the circuit. Either 160- or 80-meter crystals may be used when 80-meter output is desired, with the HY-69 being operated either as a straight amplifier or doubler.

To reach 40 meters, S_1 is thrown to the lower position, cutting in the second 6L6. An 80-meter crystal is used for this band. The doubler-quadrupler plate circuit is tuned to 20 meters for 20- or 10-meter output and the HY-69 used as a straight amplifier on 20 meters or doubler to 10 meters.

The high capacity plate tank condensers in the two 6L6 stages allow plenty of leeway in winding coils for these stages which will hit two adjacent bands. Although the condensers are somewhat larger than they need to be to cover two bands, their cost is but little greater than that of condensers which will "just cover" the required frequency range. The small additional cost is easily offset by the reduction of coil-winding difficulties. Battery bias is used on the doubler-quadrupler and output stages to permit the use of crystal keying and to allow the doubler-quadrupler to be operated without

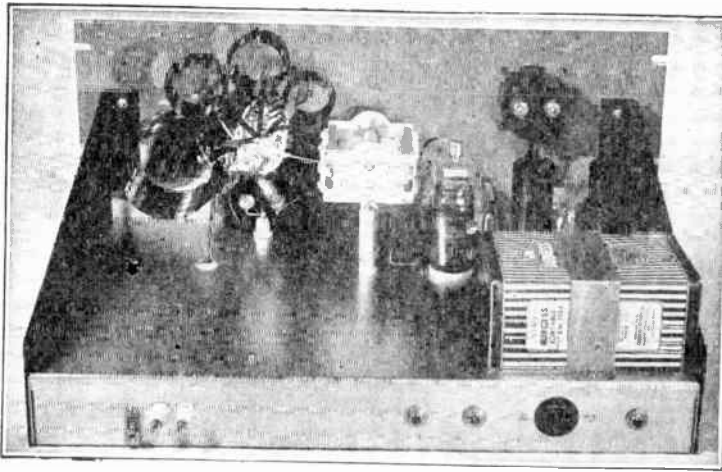

Figure 2.
R.F. SECTION CHASSIS.

The r.f. components of the exciter-transmitter are located on this chassis, which is located at the top of the cabinet shown in figure 1. The battery at the rear of the chassis supplies fixed bias to the exciter stage, to allow crystal keying.

excitation on the 80- and 160-meter bands. The battery is mounted on the r.f. chassis, and since the current through the battery is small, it may be expected to give long life.

Coil Turret A manufactured coil-turret assembly is used in the plate circuit of the HY-69 stage. The turret is composed of four coils, separate coils being used for the 10-, 20- and 40-meter bands, while a single tapped coil is used to cover the 80- and 160-meter bands. One change is required in the coil assembly, as supplied by the manufacturer, to adapt it to use in this transmitter. This change

simply involves removing 1 turn from the 2-turn coupling loop on the 10-meter coil, since tests show that the maximum efficiency of transfer to the antenna or following stage is obtained when the coupling coil is reduced to 1 turn. When used as a low power transmitter, the r.f. unit should be coupled to the antenna by means of a universal coupler, as shown in Chapter 20.

Metering The two meters visible on the panel read the plate and grid currents in the output stage. The grid meter serves to show when the doubler-quadrupler

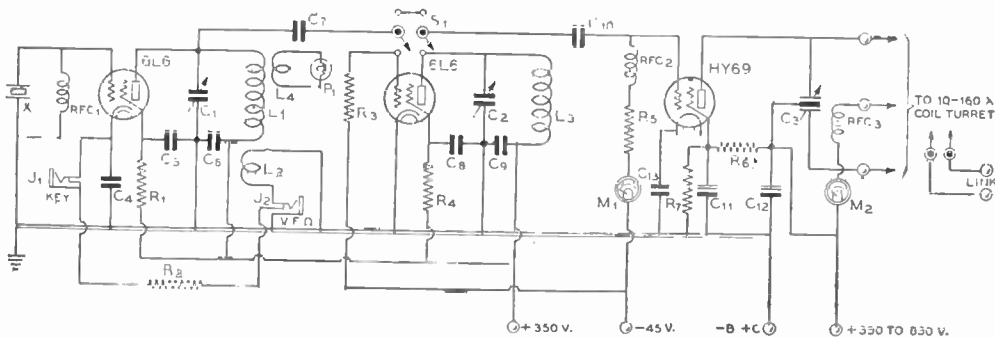

Figure 3.

R.F. SECTION DIAGRAM.

- C₁, C₂ — 320- μ fd. midget variable
- C₃ — 265- μ fd. per section, .070" spacing
- C₄, C₅, C₆ — .01- μ fd. 600-volt tubular
- C₇ — .001- μ fd. mica
- C₈, C₉ — .004- μ fd. mica
- C₁₀ — .0005- μ fd. mica
- C₁₁ — .002- μ fd. mica

- C₁₂, C₁₃ — .004- μ fd. mica
- R₁ — 15,000 ohms, 10 watts
- R₂ — 600 ohms, 10 watts
- R₃ — 250,000 ohms, 2 watts
- R₄ — 13,000 ohms, 10 watts
- R₅ — 40,000 ohms, 2 watts

- R₆ — 23,000 ohms, 10 watts
- R₇ — 50,000 ohms, 2 watts
- RFC₁, RFC₂, RFC₃ — 2.5 mhy., 125 ma.
- J₁, J₂ — Closed-circuit jack
- S₁ — D.p.d.t selector switch, laminated bakelite insulation
- M₁ — 0-15 ma.

- M₂ — 0-150 ma
- L₁ — 1 1/2 inch long, close-wound with no. 22 d.c.c. on 1" dia. form
- L₂ — 2 turn link at cold end of L₁
- L₃ — 12 turns no. 18 d.c.c. 1" dia. and wound to a length of 1 1/2"
- X — 160- or 80-meter crystal

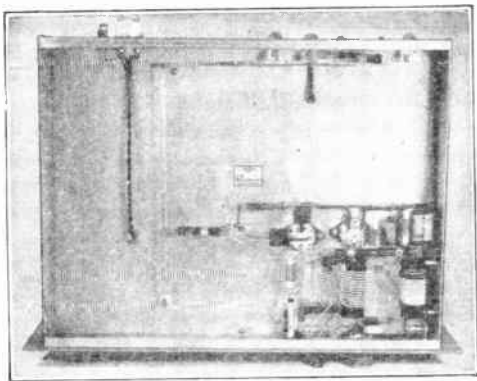

Figure 4.

BOTTOM VIEW OF R.F. CHASSIS.

The location of the plate coils for the two 6L6 stages is clearly shown in this photograph. It is important that the twisted leads connecting to the r.f. output terminals at the rear of the chassis be kept well separated from the HY 69 grid circuit.

stage is tuned to resonance, no other meter being needed for this purpose. When the output stage is operated on the 20- and 10-meter bands, where the excitation is from the doubler-quadrupler, it is helpful to have some indication of the operation of the crystal oscillator stage, however, and the pilot light at the lower left corner of the panel makes a convenient, inexpensive indicator. The 150-ma., 6.3-volt pilot lamp (brown bead) is coupled to the crystal stage plate coil through a 1-turn loop, L_4 .

V.F.O. Operation Means for exciting the transmitter-exciter from a variable frequency oscillator is provided by a 2-turn coil, L_2 , around the ground end of the crystal stage plate coil. When an ordinary

phone plug is used to terminate the link from the v.f.o., placing the plug in J_2 couples the v.f.o. to L_1 and, at the same time, opens the cathode circuit of the crystal oscillator circuit by breaking the circuit between R_2 and ground. The crystal stage plate tank circuit acts as a tuned grid circuit for the second 6L6 or the HY-69 when a v.f.o. is used.

Power Supply and Audio Chassis

The lower chassis in the rack, which, like the r.f. chassis, measures 13 x 17 inches, mounts the audio and power supply section of the transmitter-exciter.

Audio Section The audio section of the transmitter is intended to serve as a modulator for the HY-69, to form a complete 'phone transmitter, or as a driver for a class B modulator, when the r.f. section is used as an exciter for a medium-power final amplifier. Although the normal output rating for 6A3's is only 10 watts, it is possible to obtain nearly three times this output by driving the grids somewhat and using a low value of plate load. This amount of output is sufficient to fully modulate a plate input of 60 watts to the HY-69. The modulation transformer secondary is merely connected in series with the plate supply to the HY-69, to use the unit as a complete 'phone transmitter.

As the wiring diagram shows, the circuit of the speech amplifier is strictly conventional. The amplifier is designed to give full output with diaphragm-type crystal microphones (-45 to -50 db output level). High level moving-coil (dynamic) microphones will also supply sufficient input to the speech amplifier, if this type is preferred. The 6SJ7 grid resistor, R_1 , should be replaced by a line-to-grid transformer if a moving-coil microphone is used. Since the speech amplifier and the power sup-

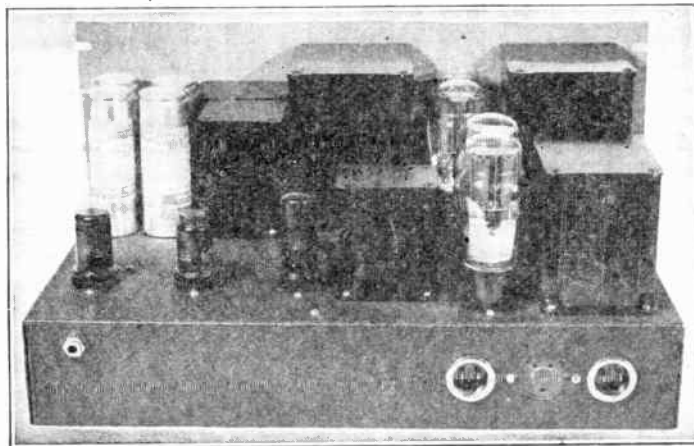

Figure 5.
**THE AUDIO AND
POWER SUPPLY
SECTION.**

All of the audio and power supply components are located on this, the lower chassis in the rack. Outlets at the rear of this chassis are provided for the microphone, line voltage, cable to r.f. section and external switch.

ply are on the same chassis, it will probably be necessary to revolve the input transformer while listening to the output of the amplifier to determine the mounting position which results in minimum hum pickup.

Power Supply A single transformer rated at 460 volts a.c. each side of the center tap at 325 milliamperes is used in the dual-voltage power supply. To handle the 300 milliamperes of current drawn by the complete transmitter-exciter, two type 83 rectifiers are used. One of the rectifiers operates into a condenser-input filter and delivers 600 volts at 100 milliamperes to the HY-69 stage. The other 83 rectifier delivers voltage to a two-section, choke-input filter and thence to the 6L6 r.f. stages and to the speech amplifier-modulator. Plate voltage for the 6A3 audio output is taken from the junction of the two filter chokes following the latter rectifier.

Filament transformer T_2 supplies all of the filament requirements of the unit. This transformer has two 5-volt and two 6.3-volt windings. Each of the 5-volt windings supplies one rectifier tube, while one of the 6.3-volt windings supplies heater power to the entire transmitter with the exception of the push-pull 6A3 stage, which must have a separate winding to allow the use of cathode bias.

Operation

To place the unit into operation it is necessary merely to place the proper crystal in the oscillator stage, throw S_1 to the correct position, depending upon the output frequency desired, switch to the proper plate coil in the HY-69 stage, and tune each stage to resonance as indicated by the meters and the pilot light r.f. indicator. The only trouble which is likely to be experienced is oscillation in the HY-69 stage on 20 meters, the highest frequency at which this stage runs as a straight amplifier. If oscillation occurs, it will probably be traceable to capacity coupling between the antenna coupling leads below the chassis and the HY-69 grid circuit, and these leads should be kept well separated. Should oscillation persist, with the antenna leads well separated from the grid circuit wiring and with the transmitter loaded by the antenna, it will be necessary to shield the antenna leads by placing a shield braid over them and grounding the braid to the chassis.

Normal grid current on the HY-69 is 5 milliamperes. The tank circuit may be loaded by the antenna or following stage until the plate current reaches 100 milliamperes.

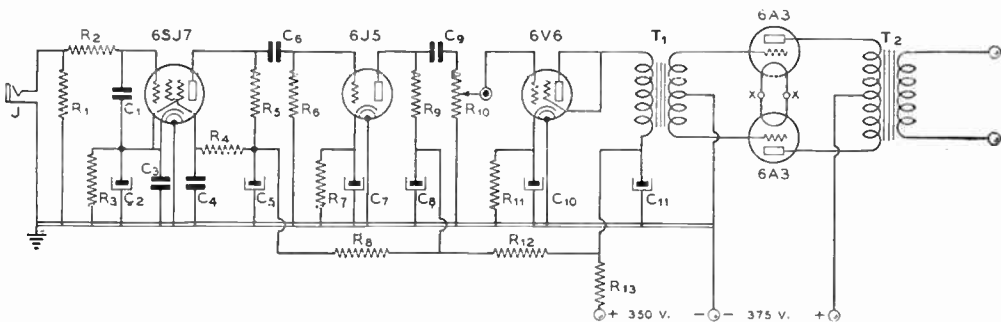

Figure 6.

SPEECH AND MODULATOR CIRCUIT.

- C₁—0.001- μ fd. mica
- C₂—10- μ fd. 25-volt electrolytic
- C₃—0.01- μ fd. 600-volt tubular
- C₄—25- μ fd. 600-volt tubular
- C₅—8- μ fd. 450-volt electrolytic
- C₆—0.03- μ fd. 600-volt tubular
- C₇—10- μ fd. 25-volt electrolytic
- C₈—8- μ fd. 450-volt tubular
- C₉—0.05- μ fd. 600-volt tubular

- C₁₀—10- μ fd. 50-volt electrolytic
- C₁₁—8- μ fd. 450-volt electrolytic
- R₁—1 megohm, 1/2 watt
- R₂—25,000 ohms, 1/2 watt
- R₃—500 ohms, 1/2 watt
- R₄—1 megohm, 1/2 watt
- R₅—100,000 ohms, 1/2 watt
- R₆—500,000 ohms, 1/2 watt
- R₇—1000 ohms, 1 watt

- R₈—25,000 ohms, 1 watt
- R₉—50,000 ohms, 1 watt
- R₁₀—250,000-ohm potentiometer
- R₁₁—600 ohms, 2 watts
- R₁₂—15,000 ohms, 20 watts
- R₁₃—2500 ohms, 10 watts
- T₁—Driver transformer for triode-connected 6F6 to class B grids. 3:1 ratio, pri. to 1/2 sec.

- T₂—40-watt variable-ratio modulation transformer. Connected to give 3000-ohm modulator plate-to-plate load with 6000-ohm r.f. load. (For driver service substitute driver transformer with 3:1 pri. to 1/2 sec. ratio.)

J—Single-circuit jack

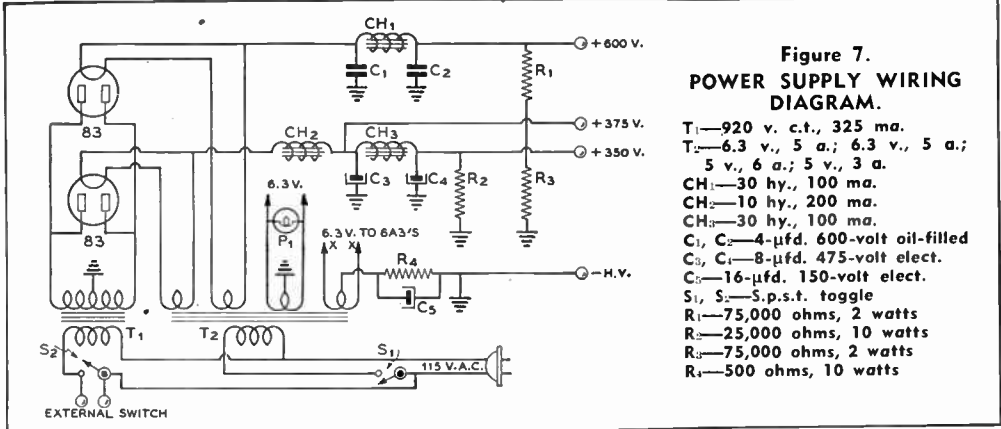

200-WATT R.F. AMPLIFIER AND MODULATOR

The unit shown in Figure 8 and diagrammed in Figure 9 has been designed specifically to operate in conjunction with the 40-watt r.f. and audio driver unit previously described. Together the two units form a complete 'phone-c.w. transmitter with an output of 200 watts. The r.f. output stage together with its associated modulator and power supply is housed in a 26 1/4-inch rack cabinet which matches that used for the exciter stages.

The R. F. Amplifier

To provide the best balance between cost and a reasonable amount of power output, the tubes used in the r.f. amplifier are 812's. These tubes are moderate in cost, yet they are capable of producing a 200-watt carrier with a small amount of excitation and a medium-voltage power supply. The input necessary for 200 watts of output is approximately 250 watts (1300 volts at 200 ma.). The photograph of Figure 10 shows clearly the mechanical layout of the stage. The chassis, which measures 17 x 13 x 3 inches, is surmounted by a 14-inch rack-notched panel. The grid coil plugs into a socket near the left edge of the chassis. Between the grid coil and the tubes is located the split stator grid condenser, which is held 1 3/8 inches above the chassis by spacers to allow its dial to line up with the plate condenser dial. The leads from the grid condenser stators are carried through the chassis to the socket grid terminals by small feedthrough insulators.

To aid in keeping the neutralizing leads short, the neutralizing condensers are placed side by side between the 812's. These condensers are supported from their rear mounting feet by small feedthrough insulators, which also serve to carry the rotor connection to the grid terminals at the sockets. Connecting the

neutralizing condensers directly to the grid terminals, rather than to the grid condenser above the chassis, reduces the length of lead which is common to both the neutralizing and tank circuits, thus aiding in securing complete neutralization on all bands. When once set, the neutralizing adjustment need not be changed when changing bands.

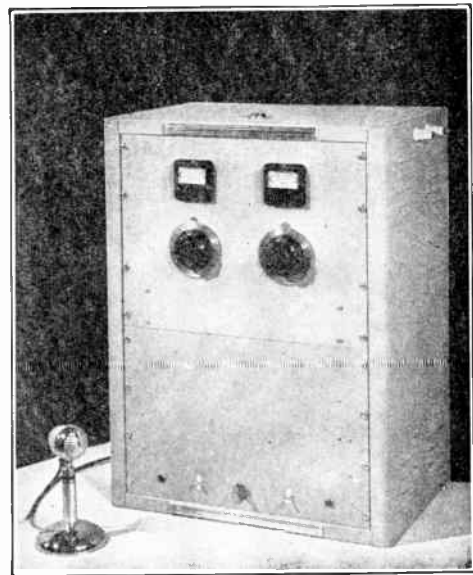

Figure 8. 200-WATT R.F. AMPLIFIER AND MODULATOR.

Inside this cabinet are two chassis, one consisting of a push-pull 812 r.f. amplifier and the other a 1250-volt power supply and a class B 811 modulator. The switches on the lower panel control the filament and plate voltages and disconnect the modulator for c.w. operation. Antenna connections are made to the two stand-off insulators near the top of the right side of the cabinet.

Coils Standard manufactured coil assemblies are used in both the grid and plate circuits of the 200-watt amplifier. The plate coil jack-bar assembly has a swinging pickup loop permanently connected to it. This loop is a flat-wound coil designed specifically to permit a good energy transfer to the antenna regardless of the diameter of the plate coil. The grid coupling loops are an integral part of each grid coil, being mounted in the coil plug in such a way that the coupling may be varied by pushing them in or out of the coil. The coupling should be adjusted so that the grid current measures 50 milliamperes with the amplifier loaded.

The manufactured coils available for use in the amplifier grid circuit require more capacity on the 160-meter band than is provided by the 140- μ fd. per section grid condenser, making it necessary to connect a padder condenser permanently across these coils. The padder consists of a small, ceramic zero-temperature-coefficient 25- μ fd. unit which is permanently connected across the 160-meter coil. It is essential that this condenser be of the type indicated, since the ordinary "postage stamp" type of mica condenser will not stand the circulating tank r.f. current without overheating.

Protective Bias Relay RY is placed in the grid return circuit to allow protective cathode bias to be applied to the 812's when the excitation is removed. This arrangement allows the exciter to be keyed in the crystal oscillator stage without danger of

damaging the final amplifier tubes. It also obviates the necessity for lowering the final amplifier plate voltage when the transmitter is being tuned, since there will always be sufficient bias on the 812's regardless of whether they are receiving grid excitation or not.

The relay is designed to close at a current of 30 milliamperes. When the grid current is less than this amount, the relay contacts are opened and resistor R_2 is cut into the filament center tap circuit, placing sufficient cathode bias on the 812's so that the plate current is held to a safe value.

Modulator and Power Supply

The class B 811 modulator and the 1300-watt power supply for the modulator and r.f. amplifier are mounted on the lower chassis in the rack. Top and bottom views of this section are shown in Figures 12 and 13.

The Modulator The modulator section of the transmitter needs little comment, since it consists merely of the two

Figure 9.
WIRING DIAGRAM FOR THE 812
AMPLIFIER AND MODULATOR.

C₁—140- μ fd. per section midget variable
C₂—200- μ fd. per section, .100" spacing
C₃—.002- μ fd. mica
C₄, C₅—.004- μ fd. mica
C₆, C₇—6- μ fd. midget variable, .200" spacing
C₈—.002- μ fd. 5000-volt mica
C₉, C₁₀—4- μ fd. 1500-volt oil-filled
R₁—3000 ohms, 20 watts
R₂—500 ohms, 20 watts
R₃, R₄, R₅—100,000 ohms, 1 watt
RFC—5-mhy., 500-ma. choke
L₁—Manufactured variable-link "50-watt" coils. See text for padder on 160-meter coil.
L₂—"500-watt" manufactured coils with variable-link mounting

T₁—123-watt variable-impedance modulation transformer
T₂—6.3 v., 20 a.
T₃—2.5 v., 10 a., 10,000-volt insulation
T₄—2850 v., c.t., 300 ma.
CH₁—8-25 hy. 300-ma. swinging choke
CH₂—15 hy. 200-ma. choke
M₁—0-100 ma.
M₂—0-300 ma.
RY—30-ma. relay
S₁—Single-pole, four-position tap switch (only two positions used). Should have wide spacing between contacts.
S₂—S.p.s.t. toggle
S₃—S.p.s.t. door switch
S₄—S.p.d.t. toggle
P₁, P₂—6.3-volt pilot lamp
PC—Parasitic choke

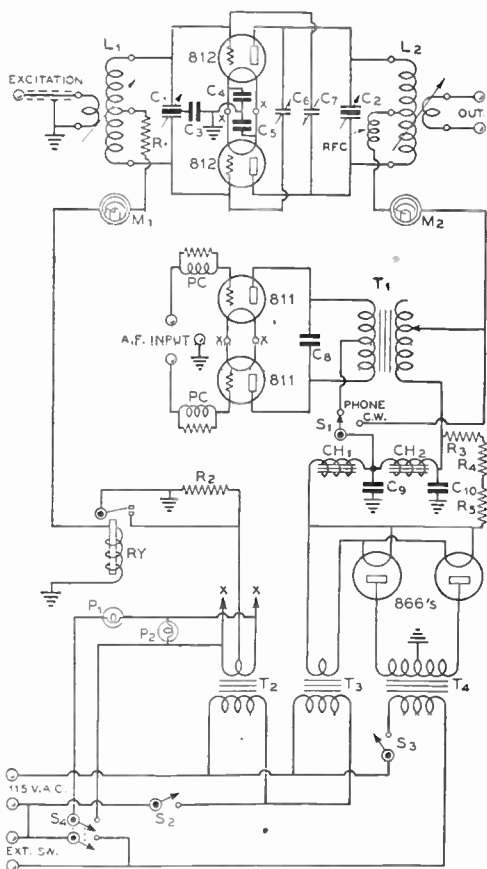

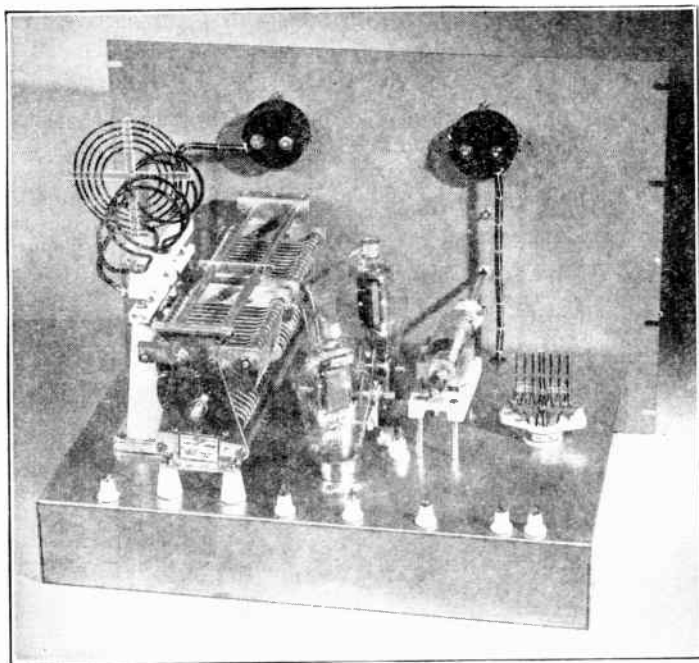

Figure 10.
P.P. 812 R.F.
AMPLIFIER.

As with all push-pull amplifiers, symmetry is an important factor in the design of this stage. The plate and tank circuit leads are kept short by sinking the tube sockets below the chassis and mounting the plate coil assembly on tall stand-off insulators.

811's and their associated output transformer. The two modulator tubes are located near the left edge of the chassis with the output transformer between them and the panel. The wiring diagram shows parasitic suppressors in the modulator grid leads. These, however, may not be necessary—they are included in the diagram to show where they should be placed in case modulator parasitics should develop. C_s between the modulator plates reduces high frequency harmonics from the modulator, which cause the signal to "splatter," and this condenser should not be omitted in any case.

The modulator driver transformer is located on the exciter chassis, the correct unit being indicated in the caption under Figure 6. A tapped 125-watt modulation transformer couples the modulators to the r.f. load. The taps on the transformer are adjusted to reflect a 15,000-ohm load on the modulators when working into a 6500-ohm secondary load. Switch S_1 , which shorts out the modulation transformer secondary and removes the plate voltage from the modulator for c.w. work, is a ceramic single-pole 4-position tap switch. Only two of the taps on the switch are actually in use—it was chosen because of the wide spacing between contacts.

Power Supply The power supply section of the final amplifier and modulator unit occupies the center and right-hand portion of the lower chassis. The locations of

the various components are plainly visible in Figures 12 and 13.

Of the three switches shown in the power supply wiring diagram, two are on the panel. These are S_2 and S_3 . S_2 is placed in series with the primaries of the two filament transformers and controls all of the amplifier filaments. S_3 controls the plate voltage to the final amplifier and modulator. S_3 is a safety "door switch" in

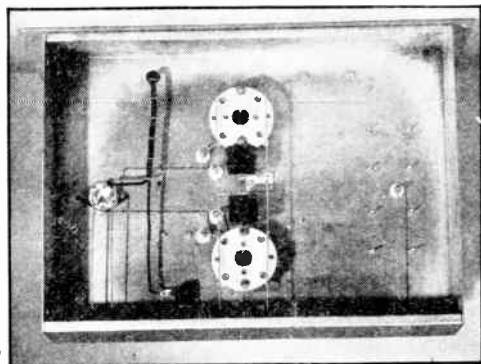

Figure 11.
BOTTOM VIEW OF THE R.F.
AMPLIFIER.

The filament leads and most of the grid circuit r.f. wiring are under the chassis. Note that separate feedthrough insulators are used to carry the leads from the socket grid terminals to the grid and neutralizing condensers, thus eliminating common grid and neutralizing leads.

Figure 12.

POWER SUPPLY AND 811 MODULATOR.

The major portion of this chassis is given over to the power supply components. The power transformer is located near the panel to reduce its "leverage" on the panel mounting screws. The modulators are located near the right edge of the chassis with the modulation transformer between the tubes and the panel. Note the safety door switch on the rear drop of the chassis above the right-hand 110-volt connector.

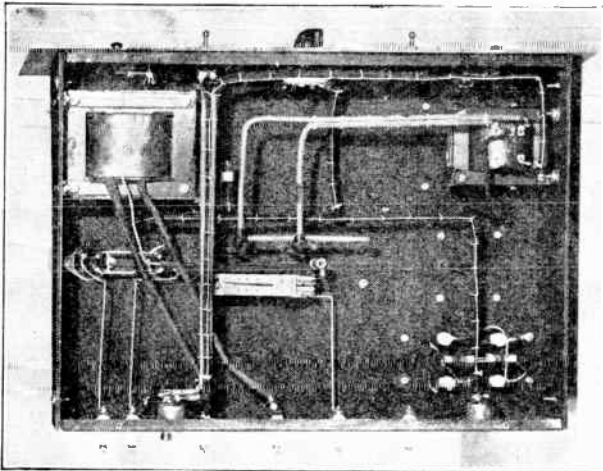

Figure 13.

UNDER THE POWER SUPPLY-MODULATOR CHASSIS.

The 2.5-volt and 6.3-volt filament transformers are located under this chassis. Near the center of the chassis the grid-current-operated safety bias relay may be seen.

series with the primary of the plate transformer. This switch is located on the rear drop of the chassis and closes only when the rear door of the rack is closed. It is operated by the long machine screw visible on the inside of the rear door in Figure 14.

The leads marked "external switch" are connected in parallel with the similarly marked leads in the exciter power supply. Closing the plate switch in either the exciter-amplifier section of the transmitter or closing a separate external switch across the leads will turn on the plate power in both sections. Care should be taken to make sure that the side of the external switch line which is connected to the 115-volt supply at the r.f. amplifier-modulator

end is connected to the corresponding external switch lead at the exciter end. Since one side of the a.c. supply voltage is connected to the common external switch lead at each unit, care must also be taken in connecting the line voltage to the two units to ascertain that the 115-volt a.c. line will not be shorted. A close inspection of the two diagrams will show the need for observing this precaution.

Three 100,000-ohm, 1-watt resistors, R_3 , R_4 , and R_5 , are used to bleed off the charge in the filter condensers should the power supply be turned off when there is no load being drawn from it. These resistors are included as a safety precaution; they do not serve as a "bleeder" to improve the power supply regu-



Figure 14.
REAR VIEW OF R.F.
AMPLIFIER AND
MODULATOR.

Neatly cabled leads between the two chassis aid in giving the unit a finished appearance. The two stand-off insulators near the right edge of the upper chassis are for link connections from the r.f. exciter, while the similar insulators on the lower chassis connect to the audio driver.

lation, since in normal operation no bleeder will be needed because there will always be sufficient load on the power supply, even when the transmitter is being keyed for c.w. operation.

150-WATT C.W. TRANSMITTER

The 150-watt-output c.w. transmitter shown in Figures 15 through 21 has its own self-contained 1400-volt power supply. It may be operated either with its own crystals or excited from an external v.f.o.

The Circuit The transmitter consists essentially of an 812 amplifier stage excited by an 807 triode crystal oscillator. For use with an external v.f.o. the 807 is made to serve as a buffer or doubler requiring very little excitation.

The 807 triode stage is conventional in every way. A combination of cathode and grid-leak bias is used, to help keep the crystal current at a minimum. Fortunately, the available power supply voltage is high enough so that the loss of a few volts in the cathode resistor does not reduce the output capabilities of the

crystal stage. With the key down the voltage between the 807 cathode and plate is exactly 500 volts.

A double-pole, 3-position tap switch, S_2 , takes care of changing the inductance in the cathode circuit when changing to 80- or 40-meter crystals, and also acts to rearrange the circuit slightly for v.f.o. excitation. It will be seen from the diagram that when the switch is in the bottom position, the tuning condenser, C_3 , is connected across the whole cathode coil, the connection to the top of the coil being made directly, while the connection to the bottom is completed through ground by means of C_{12} and C_{13} . With the switch in this position an 80-meter crystal may be plugged into XS and the 807 plate circuit tuned to 80, 40, or 20 meters. For 40- or 20-meter operation with a 40-meter crystal, S_2 is thrown to the center position. In this position the top half of L_1 is connected across C_3 , while the bottom half is by-passed to ground on each end, thus effectively shorting it for r.f.

To use a v.f.o. to excite the 807, S_2 is thrown to the top position. This by-passes both ends of L_1 (and the 807 cathode) to ground, and

also connects the stator of C_5 to the "grid" side of the crystal socket, thereby allowing a coil to be placed in place of the crystal and to be tuned by C_6 .

Amplifier Stage The final-amplifier stage is unusual in respect to most present-day transmitters in its neutralizing circuit. The use of this circuit eliminates some of the troubles so often encountered with single-ended stages at the higher frequencies with the more common split-stator, or "built-out" grid and plate types of neutralizing. Although the neutralizing condenser control is brought out to the panel, the control need not be touched when changing bands, once the coupling between L_2 and L_3 is adjusted to the proper value for each band.

Power Supply In order to realize the full capabilities of the 812 it must be supplied with 1000 to 1500 plate volts. This amount of voltage is conveniently and economically supplied by a small power transformer and a bridge rectifier using three 5Z3's. With a bridge rectifier, the power transformer center tap may be used to supply a voltage equal to half that obtained from the full supply, and this low voltage is used on the crystal oscillator stage. The main filter choke is placed in the negative lead, where it is common to both the high- and low-voltage sections of the power supply. Additional filter for the low-voltage is provided by an additional choke in the low-voltage positive lead and a pair of 8- μ fd. electrolytic condensers in series between the low-voltage positive and ground. The single 2- μ fd. 2000-volt condenser across the high-voltage section is adequate filter for the 812 for c.w. work. The high voltage available from the power supply is near 1450 volts under load, the exact amount depending on the line voltage.

Keying Break-in operation with the transmitter is made possible by keying both stages by the blocked-grid method. The manner in which the keying arrangement works is quite simple, although it is not too evident from the diagram. The blocking bias is obtained by raising the cathode circuits of both tubes up above ground by about 150 volts. It will be seen that the cathode of the 807 and the filament of the 812 are connected together and both leads are run to a tap on the voltage divider, R_{12} . When the key is closed, the section of the voltage divider between the tap and ground is shorted out, thus bringing the cathodes of both tubes back directly to ground in the usual manner. By proper adjustment of the tap on R_{12} the cathode-to-plate voltage on the oscillator may be made to remain constant

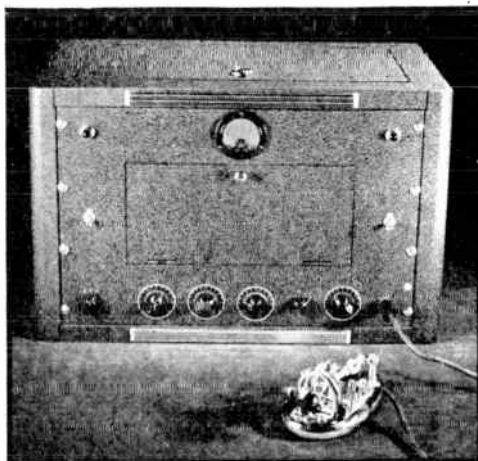

Figure 15.
150-WATT C.W. TRANSMITTER.
This completely self-contained c.w. transmitter delivers 150 watts on 20, 40, or 80 meters.

with the key up or down. This is due to the fact that when the key is up only a portion of the power supply voltage is actually applied to the oscillator tube, and when the key is down the total power supply voltage drops somewhat because of the increased load. By properly adjusting the tap on the voltage divider, it is easily possible to make the key-up and key-down voltage between the 807 cathode and plate have the same value.

The constant-voltage condition on the oscillator may be secured by adjusting the voltage-divider tap so that the voltage between the tap and ground is close to 150 volts. The correct location of the tap will vary with the loading of the 812 stage, and it is probably best set by actually connecting a voltmeter between the 807 cathode and plate-supply lead and making the adjustment under actual operating conditions. The voltage between the filament and plate of the 812 will also be found to be very constant with this method of keying. When the tap is adjusted for zero change on the oscillator, the 812 plate-filament voltage varies only 50 volts under keying.

Construction A standard rack-width cabinet is used to house the transmitter. Easy access to the plug-in coils and the crystal is provided by using a panel having a large door in its center. The coils are located so that they may easily be reached through this door. A double-pole "door" switch disconnects both sides of the line from the transmitter when the door is opened, thus eliminating any danger from contact with the a.c. supply or the high

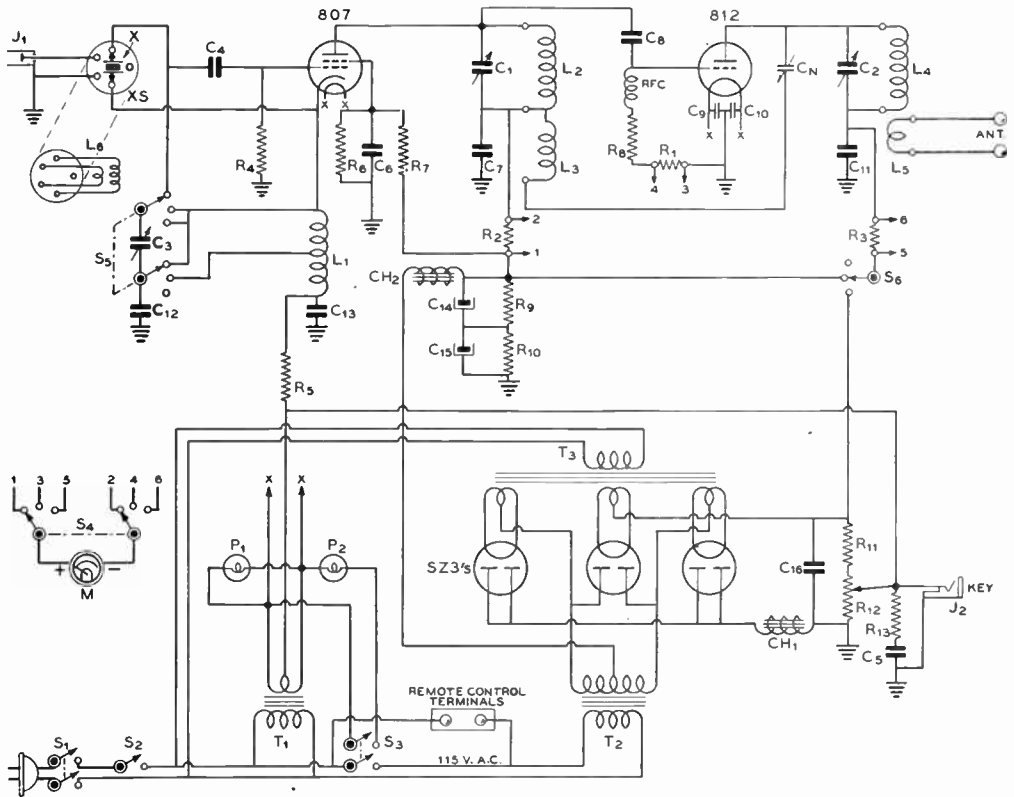

Figure 16.
SCHEMATIC DIAGRAM OF 150-WATT C.W. TRANSMITTER.

- | | | | |
|--|--|---|--|
| C ₁ — 100-μfd. -midget variable | C ₁₁ , C ₁₂ — 8-μfd. 450-volt electrolytic | R ₁₁ — 25,000 ohms, 50 watts | CH ₁ — Swinging choke 8-40 hy., 250 ma., max. |
| C ₂ — 110-μfd., .078" spacing | C ₁₃ — 2-μfd. 2000-volt, oil-filled | R ₁₂ — 25,000 ohms, 50 watts, with slider | CH ₂ — 12 hy., 125 ma. |
| C ₃ — 150-μfd. midget variable | C ₁₄ — 6-μfd. midget variable, .200" spacing | R ₁₃ — 100 ohms, 1 watt | L ₁ , L ₂ , L ₃ , L ₄ , L ₅ , L ₆ — See coil table |
| C ₄ — .003-μfd. mica | C ₁₅ — 2-μfd. 2000-volt, oil-filled | T ₁ — 6.3 v., c.t., 7.5 a. | RFC — 2½ mhy., 125 ma. |
| C ₅ — 1.0-μfd. 400-volt tubular | C ₁₆ — 3-μfd. 2000-volt, oil-filled | T ₂ — 1575 v., c.t., 300 ma. | M — 0-150 ma. |
| C ₆ — .003-μfd. mica | C ₁₇ — 2-μfd. 2000-volt, oil-filled | T ₃ — 3 5-volt windings, each 3 amps., high-voltage insulation | P ₁ — 6.3-v. pilot, green |
| C ₇ — .002-μfd. 1000-volt mica | C ₁₈ — 2-μfd. 2000-volt, oil-filled | S ₁ — D.p.s.t. "door" switch | P ₂ — 6.3-v. pilot, red |
| C ₈ — .0001-μfd. 1000-volt mica | C ₁₉ — 2-μfd. 2000-volt, oil-filled | S ₂ — S.p.s.t. toggle | J ₁ — Automobile-type connector (for link input from v.f.o.) |
| C ₉ , C ₁₀ — .003-μfd. mica | C ₂₀ — 2-μfd. 2000-volt, oil-filled | S ₃ — D.p.s.t. toggle | J ₂ — Closed-circuit jack |
| C ₁₁ — .002-μfd. 2500-volt mica | C ₂₁ — 2-μfd. 2000-volt, oil-filled | S ₄ — Meter-type tap switch, see text for alterations | XS — Crystal or grid-coil socket |
| C ₁₂ , C ₁₃ — .003-μfd. mica | C ₂₂ — 2-μfd. 2000-volt, oil-filled | S ₅ — 3-position, double-pole tap switch | X — 80- or 40-meter crystal |

voltage. It was deemed advisable to remove the line voltage from the whole transmitter, rather than just from the high-voltage supply, since the 110-volt terminals on the rectifier filament transformer are located where they might possibly be touched when reaching in to change crystals.

To enable the coils to be easily reached through the panel door the rather unorthodox r.f. section construction seen in the photographs is employed. A sheet-metal partition

with two 90° bends serves to support both r.f. tubes, and at the same time shields the stages from each other. The partition is 4 inches high. It measures 2½ inches along the side which supports the 807, 5 inches along the long side between stages, and 3 inches along the 812 side. The long side of the partition is located 8 inches from the left edge of the 17 x 12 x 13-inch chassis. Several spade bolts along the bottom edge of the partition serve to hold it firmly to the chassis. The 807 socket is located

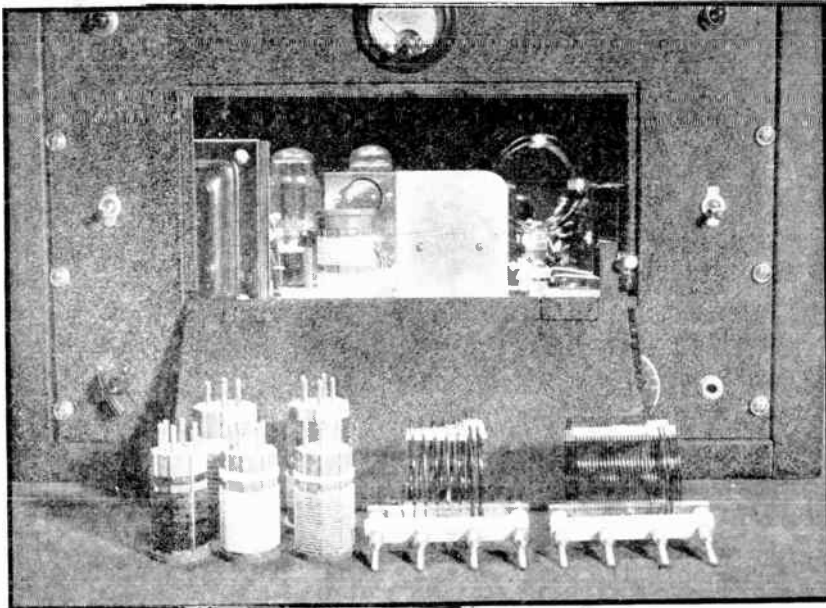

Figure 17.

ILLUSTRATING METHOD OF CHANGING COILS.

Coils are changed through a door in the front panel. A safety switch automatically disconnects the primary a.c. voltage when the door is opened.

near the bottom of its side of the shield partition, to allow space for the crystal socket above the tube. The crystal is thus easily reached through the panel door.

When mounting the 812 socket, it must be remembered that when the tube lies horizontally it must be turned so that the plane of the filament is vertical. Failure to observe this precaution is likely to lead to the untimely demise of the 812 should the filament lean down against the grid. But with the filament plane vertical, no trouble will be experienced with the horizontal type of tube mounting.

The shaft from S_5 , the oscillator cathode-coil bandswitch, extends up through the chassis so that the knob occupies a position alongside

the base of the 807. As this switch is used only when changing crystals or when changing from crystal to v.f.o., it is no inconvenience to have the switch behind the panel door, rather than on the panel itself.

The plug-in coils are located so as to be reached easily through the panel door. The oscillator plate coil is located directly in front of the 807, while the amplifier coil is placed alongside the 812. Rounding off the top corner of the shield partition in front of the 812 prevents scratches when the amplifier coil is being changed. However, there is plenty of room between the shield and the edge of the door to get the coil in and out through the hole in the panel without difficulty.

Most of the power-supply components are mounted above the chassis along the left side and across the rear. The power transformer occupies the left front corner of the chassis; placing it near the front reduces the turning moment on the panel if the transmitter is later to be panel-supported in a large rack. Directly behind the power transformer is the three-winding filament transformer which supplies the 5Z3's. The three rectifiers are placed in a line along the rear of the chassis, followed by the swinging choke, CH_1 , and the 6.3-volt filament transformer for the 807 and 812. The high voltage filter condenser, C_{10} , the bleeder

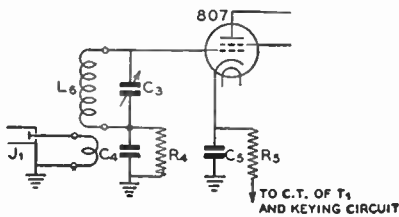

Figure 18.

ALTERNATE CIRCUIT WHICH CAN BE USED WHEN V.F.O. OPERATION IS NOT CONTEMPLATED.

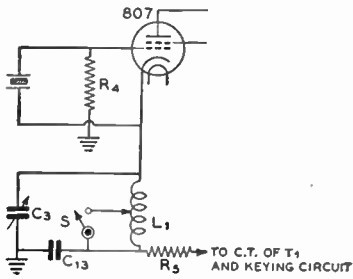

Figure 19.

ALTERNATE CIRCUIT WHICH CAN BE USED WHEN TRANSMITTER IS TO BE USED EXCLUSIVELY WITH AN EXTERNAL V.F.O.

resistors, and the low-voltage filter, C_{11} - C_{15} - CH_2 , are in convenient position below the chassis.

A glance at the under-chassis photograph will reveal the location of most of the parts placed in this section of the transmitter. However, due to the angle from which the picture

was taken, the shield between the 807- and 812-stage under-chassis components does not show up particularly well. This shield is 9 inches long by 3 inches high and is located directly below the long side of the above-chassis partition. One end of the shield is placed against the front drop of the chassis, the space at the rear being used to allow the power supply wiring to pass back and forth between the ends of the chassis.

A small feed-through insulator is used to carry the lead from L_3 to the neutralizing condenser through the shield. The lead from the neutralizing condenser to the 812 plate runs directly to the bottom of the feed-through insulator which serves to carry the lead from the plate to the tank condenser, C_2 . Connecting the neutralizing lead to the insulator, rather than to the tank condenser, keeps the inductance common to the tank and neutralizing circuits to a minimum, thus aiding in securing proper neutralization on all bands.

It is necessary to cut down the length of the meter switch to allow it to fit in front of C_2 . As supplied by the manufacturer, the switch



Figure 20.

INTERIOR CONSTRUCTION OF 150-WATT TRANSMITTER.
The location and function of the various parts are covered in the text.

has enough spacing between sections so that standard-size 2-watt resistors may be mounted across it, but it may easily be cut down to a length just sufficient to meet the leads from the compact 1-watt resistors seen in the photograph. The cutting down process is quite simple: The back switch wafer is removed, the spacers are pulled off the supporting screws and cut down to a length of $\frac{7}{8}$ inch, and the switch is reassembled. The excess screw length may be removed by cutting with a hack saw, or by bending the screws until they break.

The Coils Data on winding the 807 plate and cathode coils and the grid coils used for v.f.o. operation is given in the coil table. The plate coils used on the 812 stage are manufactured 150-watt articles. As the manufacturer supplies these coils only with the links at the center, it is necessary to move the links to one end for use with the single-ended tank circuit if the capacity coupling to the antenna is to be kept to a minimum. The links are moved by unsoldering their ends from the plugs and cutting under the celluloid link-spacing blocks with a knife. When the link is loose from the coil it is simply slid to one end of the coil and cemented in place with Duco cement. The two ends are then reconnected to the plugs. As the center plug is not used in the single-ended circuit, it and the center-tap lead to the coil may be removed, if desired.

To obtain the proper single-ended L/C ratios with the 812 plate coils it is necessary to cut down on the inductance of the manufactured units. Three turns should be removed from the 20-meter coil, 5 turns from the 40-meter coil, and 7 turns from the 80-meter coil.

Tuning Up The initial tuning of the transmitter is best done on 40 meters, using an 80-meter crystal. The crystal is placed in its socket, and the 40-meter coils are placed in the 807 and 812 plate circuits. Switch S_6 should be set so as to remove the plate voltage from the final amplifier (top position in the diagram), a key is plugged into the keying jack, and S_5 is set to the bottom (80 meter) position. After allowing the filaments to reach operating temperature, S_5 may be closed. If the keying circuit is working properly, there will be no indication of current in any of the three meter switch positions until the key is closed. Closing the key will now give a plate current reading on the 807 stage. This current should be between 60 and 80 ma., depending upon whether the crystal is oscillating or not, and whether the plate circuit is resonated. Placing the cathode tuning condenser, C_3 , near maximum capacity should cause the crystal to oscillate, and the meter may be

COIL SPECIFICATIONS

L_1

The section from the tap to cathode has 7 turns spaced to occupy $\frac{1}{2}$ inch. Section from bottom end to tap has 10 turns close-wound. Form is 1" in diameter. Wound with no. 22 d.c.c. wire.

L_2

80 Meters—19 turns of no. 22 d.c.c. close-wound on $\frac{1}{2}$ " dia. form.
40 Meters—13 turns of no. 22 d.c.c. spaced to occupy $\frac{7}{8}$ " on $\frac{1}{2}$ " dia. form.
20 Meters—7 $\frac{1}{2}$ turns of no. 22 d.c.c. spaced to occupy $\frac{7}{8}$ " on $\frac{1}{2}$ " dia. form.

L_3

80 Meters—42 turns of no. 22 enam., close-wound. Spaced $\frac{3}{16}$ " from L_2 .
40 Meters—21 turns of no. 22 d.c.c., close-wound. Spaced $\frac{3}{16}$ " from L_2 .
20 Meters—9 turns of no. 22 d.c.c., close-wound. Spaced $\frac{1}{4}$ " from L_2 .

L_1 and L_2 must be wound in the same direction and L_3 located at the ground end of L_2 . The spacing between L_2 and L_3 should be adjusted for proper neutralization as described in the text.

L_4

160 Meters—55 turns of no. 24 enam., close-wound on 1" dia. form. Link—8 turns.
80 Meters—35 turns of no. 22 d.c.c. close-wound on 1" dia. form. Link—5 turns.
40 Meters—19 turns of no. 22 d.c.c. spaced to occupy $\frac{1}{4}$ " on 1" dia. form. Link—4 turns.

switched to the 812 grid circuit and C_1 tuned for maximum grid current. If all goes well the grid current will be slightly above 30 ma. when C_1 and C_2 are both adjusted for maximum output.

Neutralization may be accomplished by tuning the 812 plate circuit through resonance and observing the drop in grid current. Unless the stage should happen to be neutralized on the first try—which is not likely—there will be a very pronounced drop in grid current when the plate tank is resonated. Rocking the 812 plate condenser back and forth through resonance with one hand, the neutralizing condenser should be adjusted with the other hand until the variation in grid current is eliminated. If the data in the coil table for L_2 and L_3 has been followed accurately and the stray capacities are about the same as in the original model, neutralization will be obtained when the neutralizing condenser knob is set at 50 on the scale. If more capacity than this is needed for neutralization, L_2 and L_3 should be pushed closer together; if less capacity, they should be separated farther. When the correct spacing between coils is found, they should be cemented in place with low-loss coil dope.

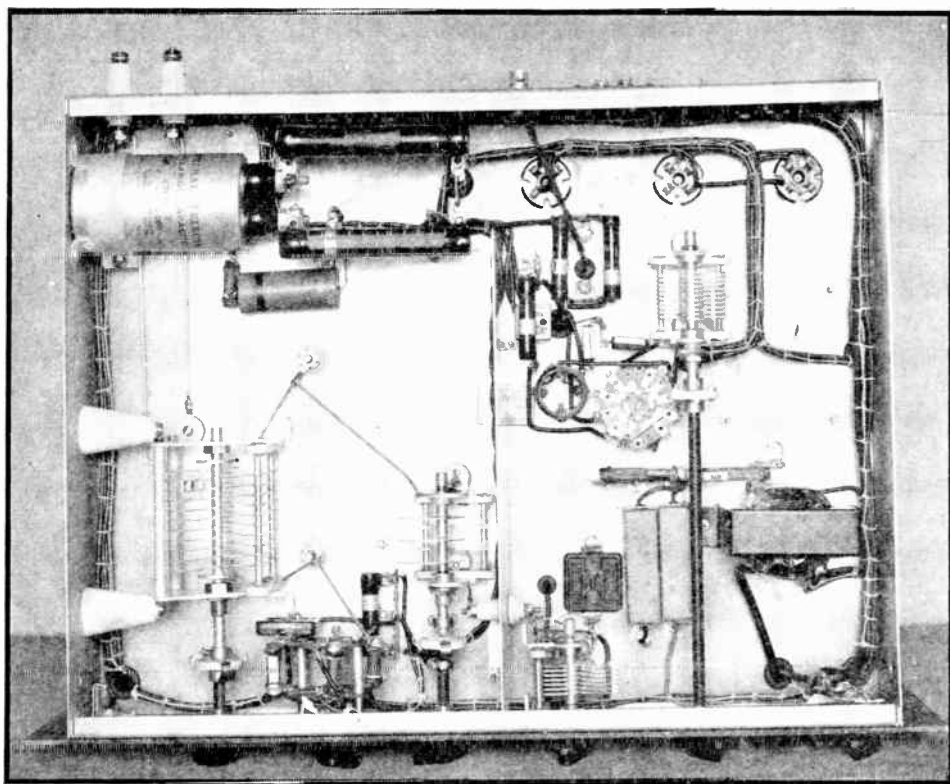

Figure 21.

UNDER-CHASSIS VIEW OF 150-WATT C.W. TRANSMITTER.

At the rear left may be seen the high voltage filter condenser and voltage divider. The variable condenser toward the right rear is used for tuning the 807 cathode coil, which may be seen alongside the wafer type cathode bandswitch. The low voltage filter choke and condensers may be seen near the right front corner of the chassis.

With neutralization completed, the plate supply may be turned off, S_6 set to the low-voltage (center) position, the meter switch set to read the 812 plate current, and the high voltage again turned on. With the key closed, the 812 plate circuit may then be tuned to resonance, as indicated by the usual minimum plate current point. The minimum plate current should be about 4 milliamperes with the low plate voltage. Opening S_5 , switching S_6 to the high-voltage position, and closing S_5 , will now put the full power supply voltage on the 812. The minimum plate current should now be approximately 10 milliamperes. The antenna loading should be adjusted so that the plate current under load is approximately 135 milliamperes, which represents an input of nearly 200 watts, and an output of somewhat over 150 watts.

To use a 40-meter crystal "straight through" on 40 meters, S_5 is thrown to the center position and the 807 cathode and plate circuits are again tuned for maximum grid current to the

812. It will be found that when the plate circuit of the 807 is operating on the crystal frequency the plate tuning will be somewhat similar to that obtained with a conventional triode, tetrode, or pentode oscillator. That is, the crystal will pop into oscillation when the plate circuit is tuned to a frequency slightly higher than that of the crystal. The correct setting is the same as with a conventional oscillator—slightly less capacity than the point where the crystal breaks into oscillation.

To operate on 80 meters, an 80-meter crystal is used with the cathode switch set in the 80-meter position. The adjustment of the coupling between L_2 and L_3 should be carried out as described above to secure neutralization at a reading of 50 on the neutralizing condenser scale.

For 20-meter operation either an 80- or 40-meter crystal may be used. The 40-meter crystal is to be preferred, however, since the excitation to the 812 will be rather low with the crystal plate circuit tuned to the fourth

harmonic of the 80-meter crystal. The cathode switch must be set at the proper position for the crystal being used, of course. As on the 80- and 40-meter 807 plate coils, the coupling between L_2 and L_3 on the 20-meter coil should be adjusted so that neutralization is obtained at mid-scale on the neutralizing condenser. Once the coupling between these coils is properly adjusted on each band, the neutralizing condenser need not be touched when changing bands. In fact, changing between any two bands can easily be done in less than two minutes, including the time necessary to allow the tubes to warm up after the panel door is closed.

V.F.O. Excitation To use the transmitter with excitation from a separate v.f.o., the crystal should be replaced with the L_6 coil which matches the output frequency of the v.f.o., and S_5 thrown to the

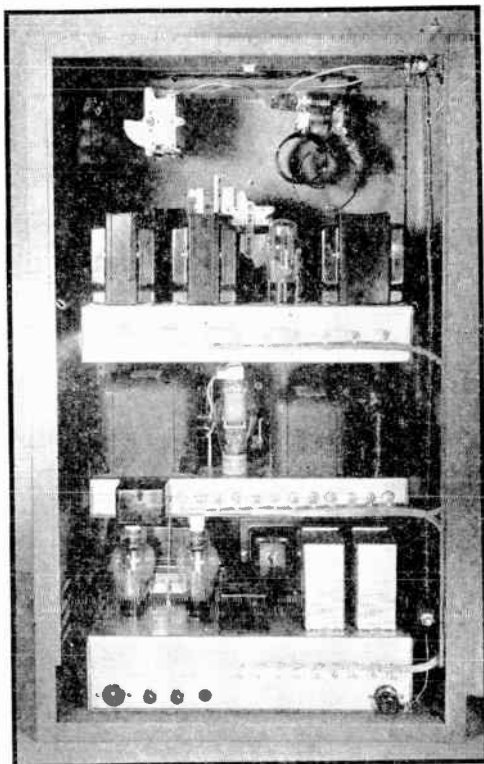

Figure 23.
250-WATT TRANSMITTER—
REAR VIEW.

The rear cabinet door is open to show the method of assembly. Interlock switches are provided to disconnect the high voltage when either the top or rear doors are opened. Note how the interconnecting leads between decks are cabled up the side of the chassis.

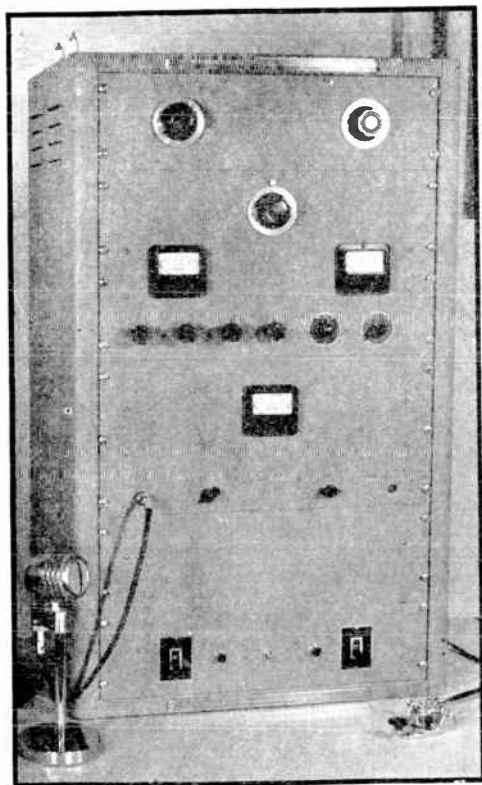

Figure 22.
250-WATT 'PHONE-C.W.
TRANSMITTER.

The transmitter is housed in a rack-style cabinet, and it presents a neat and finished appearance. The antenna tuner is at the top, followed toward the bottom by the r.f. section, the speech-modulator, and the power supply.

v.f.o. (bottom) position, where C_3 is used to tune L_6 . It is preferable to have the v.f.o. output on half the transmitter output frequency, thus doubling in the 807. Although no trouble with oscillation in the 807 stage when running "straight through" on the v.f.o. frequency was experienced in the original transmitter model, perfect shielding between grid and plate circuits is difficult to attain, and doubling is to be recommended. Data for 160-, 80-, or 40-meter grid coils is given in the coil table, so that v.f.o. output on any of these bands may be used.

Antenna Coupling Since the type of antenna coupling arrangement will depend upon the individual's choice of antenna, no coupling unit is shown. With antennas using an untuned feed line, the feeders may be connected directly to the terminals at the rear of

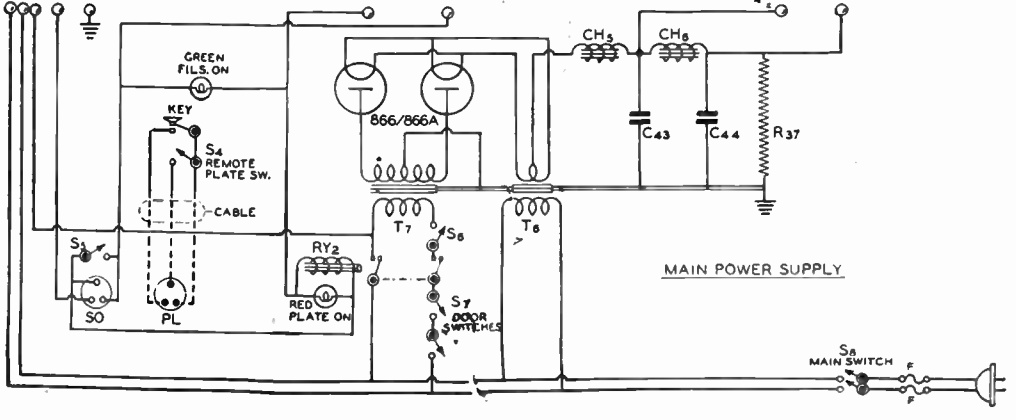
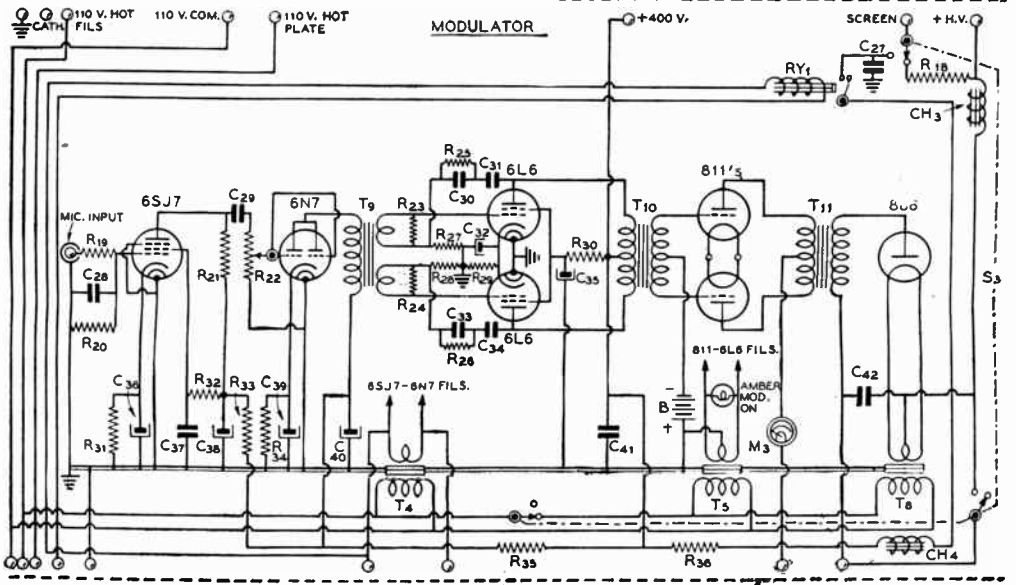
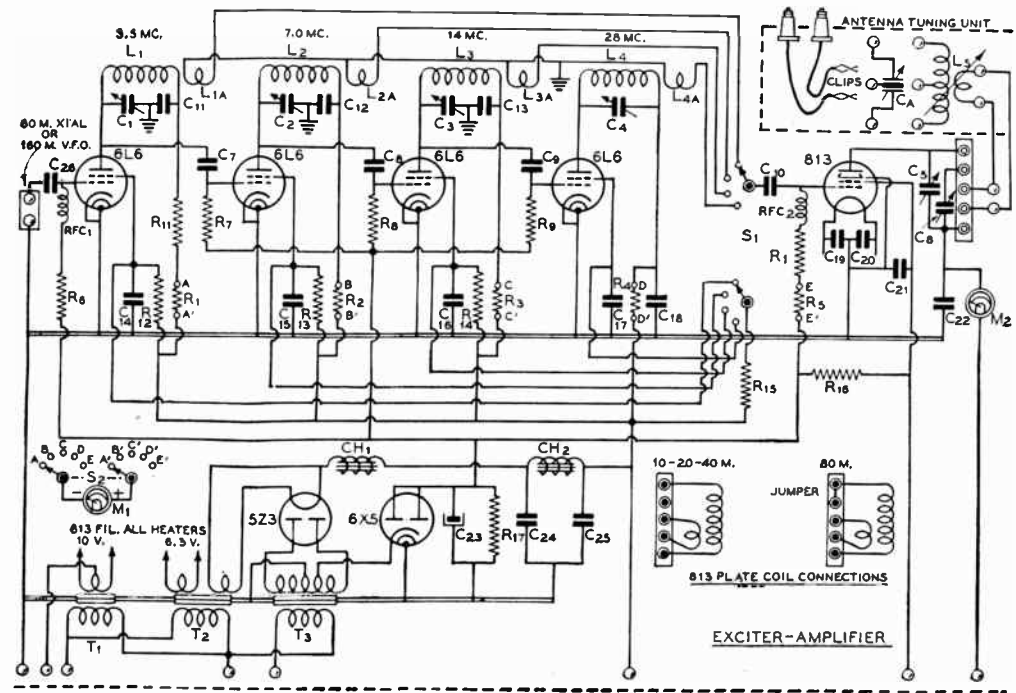

Figure 24.

250-WATT 'PHONE-C.W. TRANSMITTER COMPONENT VALUES.

| | | | |
|---|---|--|--|
| C ₁ —50- μ fd. per section, .171" spacing | C ₁₁ —2- μ fd. 600 - volt oil-filled | R ₁₀ —50,000 ohms, 1/2 watt | S ₃ —3-pole, 2-position Isolantite selector switch |
| C ₂ , C ₃ —50- μ fd. mid-gate variable | C ₁₂ —0.02- μ fd. 5000-volt mica | R ₁₁ —1500 ohms, 1/2 watt | S ₄ , S ₅ —S.p.s.t. toggle |
| C ₄ —35- μ fd. mid-gate variable | C ₁₃ , C ₁₄ —5- μ fd., 2000-volt oil-filled | R ₁₂ —10,000 ohms, 2 watts | S ₆ —S.p.s.t. mercury toggle switch |
| C ₅ —15- μ fd. mid-gate variable | R ₁ , R ₂ , R ₃ , R ₄ , R ₅ —50 ohms, 1/2 watt | R ₁₃ —5000 ohms, 10 watts | S ₇ —S.p.s.t. interlock switches |
| C ₆ , C ₇ —70 - μ fd., .070" spacing | R ₆ —25,000 ohms, 1 watt | R ₁₄ —100,000 ohms, 100 watts | S ₈ —D.p.s.t. mercury toggle switch |
| C ₈ , C ₉ , C ₁₀ —.00005- μ fd. mica | R ₇ , R ₈ , R ₉ —100,000 ohms, 2 watts | T ₁ —10 v., 8 a. | M ₁ —0-100 ma. |
| C ₁₁ —.005- μ fd. mica | R ₁₅ —5000 ohms, 2 watts | T ₂ —5 v., 3 a.; 6.3 v., 6 a. | M ₂ —0-250 ma. |
| C ₁₂ , C ₁₃ , C ₁₄ —.005- μ fd. 1000-volt mica | R ₁₆ —2000 ohms, 2 watts | T ₃ —1030 v., c.t., bias tap at 30 v. | M ₃ —0-200 ma. |
| C ₁₅ to C ₂₁ —.003- μ fd. mica | R ₁₇ , R ₁₈ , R ₁₉ —100,000 [*] ohms, 2 watts | T ₄ —6.3 v., c.t., 2 a. | L ₁ —30 turns no. 20 d.c.c., close-wound on 1 1/2" dia. form |
| C ₂₂ —.001- μ fd. 5000-volt mica | R ₂₀ —15,000 ohms, 10 watts | T ₅ —6.3 v., c.t., 10 a. | L _{2A} —9 turns pushback wire over ground end of L ₁ |
| C ₂₃ —25- μ fd. 50-volt electrolytic | R ₂₁ —150,000 ohms, 2 watts | T ₆ —2.5 v., c.t., 10 a.; 7500-v. insulation | L ₂ —25 turns no. 18 d.c.c. close-wound on 1" dia. form |
| C ₂₄ , C ₂₅ —4- μ fd. 600-volt oil-filled | R ₂₂ —2000 ohms, 10 watts | T ₇ —3750 v., c.t., 300 ma. | L _{2A} —9 turns hookup wire over ground end of L ₂ |
| C ₂₆ —.0001- μ fd. mica | R ₂₃ —5000 ohms, 10 watts | T ₈ —2.5 v., c.t., 7500-volt insulation | L ₃ —11 turns no. 20 d.c.c. spaced to occupy 1 1/2" on 1" form |
| C ₂₇ —25- μ fd. 400-volt tubular | R ₂₄ —50,000 ohms, 1/2 watt | T ₉ —Interstage trans. 1:3 ratio, split secondary | L _{3A} —5 turns hookup wire over cold end of L ₃ |
| C ₂₈ —.00005- μ fd. mica | R ₂₅ —1 megohm, 1/2 watt | T ₁₀ —Driver trans. 2.8:1 ratio pri. to 1/2 sec. | L ₄ —8 turns no. 12 enam. 1" dia. and spaced to a length of 1 1/2". Self-supporting |
| C ₂₉ —.00005- μ fd. mica | R ₂₆ —1 megohm potentiometer | T ₁₁ —Variable - ratio modulation trans., 125-watt rating | L _{4A} —3 turns hookup wire over ground end of L ₄ |
| C ₃₀ —50- μ fd. 25-volt electrolytic | R ₂₇ , R ₂₈ —250,000 ohms, 1/2 watt | CH ₁ , CH ₂ —13 hy., 250 ma. | L ₅ —"500-watt" plug-in coils with swinging link |
| C ₃₁ —.00005- μ fd. mica | R ₂₉ , R ₃₀ —100,000 ohms, 1/2 watt | CH ₃ —0.8 hy., 300 ma. "splatter choke" | B—4 1/2-volt battery |
| C ₃₂ —0.1- μ fd. 400-volt tubular | R ₃₁ , R ₃₂ —100,000 ohms, 1/2 watt | CH ₄ —15 hy., 85 ma. | RY ₁ —S.p.s.t. 6-volt a. c. coil |
| C ₃₃ —8- μ fd. 450-volt electrolytic | R ₃₃ , R ₃₄ —25,000 ohms, 1/2 watt | CH ₅ —20.5 hy., swinging, 300 ma. | RY ₂ —D.p.s.t. 6-volt a. c. coil |
| C ₃₄ —10- μ fd. 25-volt electrolytic | R ₃₅ —200 ohms, 1/2 watt | CH ₆ —12 hy., 300 ma. | |
| C ₃₅ —0.25- μ fd. 400-volt tubular | R ₃₆ —7500 ohms, 10 watts | RFC ₁ , RFC ₂ —2 1/2 mhy., 125 ma. | |
| C ₃₆ , C ₃₇ —Dual 8- μ fd. 450-volt electrolytic | R ₃₇ —1500 ohms, 1/2 watt | S ₁ —2-pole, 4-position Isolantite selector switch | |
| C ₃₈ —10- μ fd. 25-volt electrolytic | R ₃₈ —2 megohms, 1/2 watt | S ₂ —2-pole, 5-position selector switch | |

the transmitter, varying the number of turns on the coupling links to secure proper loading. Where an antenna tuner of some type is to be used (see Chapter 20), the link terminals from the coupler may be connected to the transmitter terminals and the coupling adjusted at the antenna end for correct loading.

250-WATT 'PHONE-C.W. TRANSMITTER

The accompanying photographs and diagram illustrate a bandswitching 'phone-c.w. transmitter which is capable of 250 watts input on either 'phone or c.w. on all bands from 80 through 10 meters. The transmitter is complete in every respect in that it includes the entire speech channel and modulator, the antenna tuning network, a click-filtered keying circuit, 'phone-c.w. switch, and, in addition, can be controlled and keyed at a distance.

R.F. Section Essentially, the r.f. section of the transmitter consists of a 6L6 crystal oscillator stage operating in the 80-meter band followed by three 6L6 doubler stages, and an 813 beam tetrode output stage. If desired, the transmitter may be used with a variable frequency exciter by connecting the v.f.o. output leads across the crystal socket. The v.f.o. output should be at 160 meters, the crystal stage acting as a doubler to 80 meters.

Bandswitching Excitation to the 813 stage on any band from 80 to 10 meters is obtained by use of non-resonant pickup coils wound around the plate coils of each of the doubler stages. Referring to the circuit diagram (Figure 24) it may be seen that the upper section of S₁ connects the grid condenser of the 813 to the desired doubler. The lower section of S₁ serves to place full

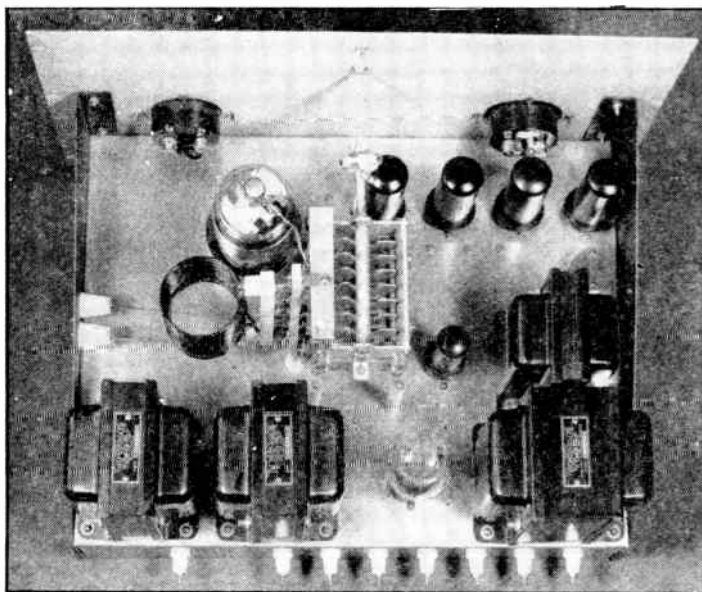

Figure 25.
LOOKING DOWN ON
THE 250-WATT R.F.
SECTION.

All of the above-chassis components are visible in this view. The four exciter tubes are located in line near the front of the chassis. The 813 and its plate tank circuit occupy the center portion of the chassis, while the power supply components are placed along the rear edge. The bias rectifier tube is alongside the final amplifier plate tank condenser.

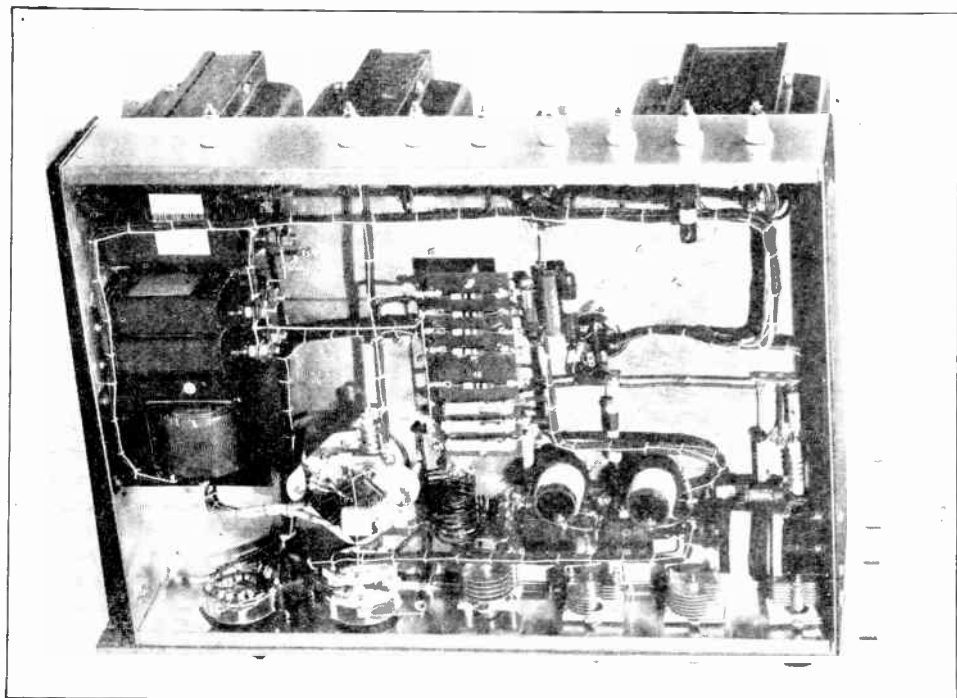

Figure 26.

UNDER-CHASSIS VIEW OF THE 813 TRANSMITTER R.F. CHASSIS.

Most of the wiring is under the chassis. Note that the 813 socket is sunk below the chassis and held in position with the aid of long 6-32 screws and 1-inch hollow spacers. To aid in wiring, the meter resistors and the doubler bias resistors are mounted on a strip at the center of the chassis. Cabling the d.c. leads together aids in giving a neat appearance to the transmitter.

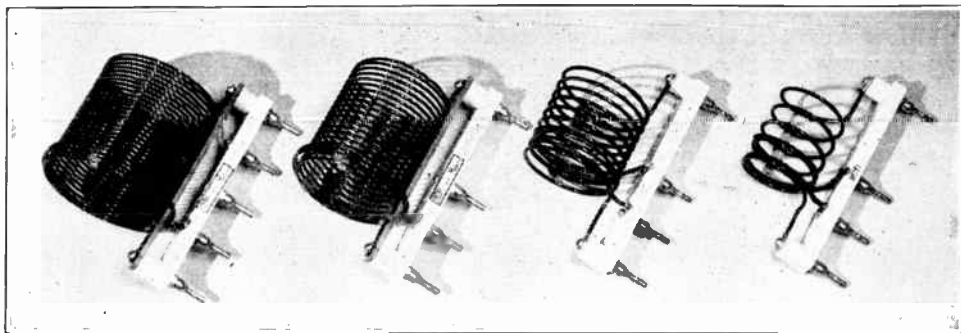

Figure 27.

THE 813 PLATE COILS.

The 80- and 40-meter coils at the left are manufactured units. The 20-meter coil has 9 turns of number 10 enameled wire and is 2½ inches in diameter and 3 inches long. The 10-meter coil is also wound with number 10 enameled wire; it has 5 turns 2 inches in diameter and is 3 inches long. Note the additional plug on the 80-meter coil which serves to connect the extra tank condenser. On each of the higher frequency coils the antenna coupling coil consists of 2 turns of well insulated wire pushed between the turns at the ground end of the plate winding.

screen voltage on the stage being used to excite the final amplifier. Since each of the doubler stages supplies much more output than needed to drive a following 6L6 doubler, there is no need to run these stages at full screen voltage except when they are used to excite the final stage. The last 6L6 (10-meter doubler) is used only to excite the 813 on 10 meters, and for this reason the screen voltage to this stage is removed entirely except when the excitation switch is thrown to the 10-meter position.

It will be noted from the circuit diagram that in the first three exciter stages of the transmitter the tank condenser rotors are grounded and the r.f. circuit between the coils and tank condenser completed through mica condensers. On the 10-meter exciter stage, however, the condenser rotor is insulated from ground and condenser and coil by-passed to ground together. This circuit change in the 10-meter stage is made necessary because of the inadvisability of attempting to include a small mica condenser in the tank circuit at such a high frequency.

In the interest of maximum efficiency and compactness, plug-in coils are used in the 813 plate circuit. The four coils are shown in Figure 27. Standard end-linked coils are used on the 80- and 40-meter bands, but since the manufactured coils available for use on the 20- and 10-meter bands had too much inductance for use with the high-output-capacity 813, these coils were inexpensively wound to the proper inductance and mounted on the same type jack bar as supplied with the manufactured coils. Data on the winding of the coils for the two high-frequency bands are given under the photograph.

On all bands except 80 meters the tank capacity across the coils is provided by con-

denser C_5 alone. On 80 meters, however, an extra plug and a jumper on the coil plug bar place the additional 35- μ fd. condenser, C_6 , across the coil. The addition of the other 35- μ fd. condenser is necessary to allow a good plate circuit Q to be realized at the lower frequency. Although C_6 is actually a variable condenser, as shown in the diagram, it is permanently set at full capacity and used as a fixed air condenser. The compactness and exact similarity of dimensions of C_6 with C_5 makes it better suited to use in regard to mounting and space requirements than would be a conventional fixed air condenser.

Bias and Power Supply

The exciter power supply utilizes a power transformer which is rated at 515 volts a.c. each side of center tap at 250 milliamperes. This transformer is also provided with a bias tap which delivers 30 volts a.c. for bias purposes. When rectified by a 5Z3 and filtered by a two-section, choke-input filter, the power supply output voltage is 400 volts under load. This voltage is used as plate and screen supply to the exciter stages, as screen supply for the 813 output stage, and as plate voltage to the speech amplifier and driver in the next deck below.

Through the use of a 6X5 as a half-wave bias rectifier, 40 volts of fixed protective bias is made available for all of the transmitter stages. The bias voltage is developed across the load resistor, R_{15} , and is filtered by a single 25- μ fd. electrolytic condenser, C_{23} . Because the current drawn from the bias supply is small, and since the class C operated stages in the transmitter are incapable of operating as grid modulated amplifiers, any small amount of ripple voltage remaining in the bias supply

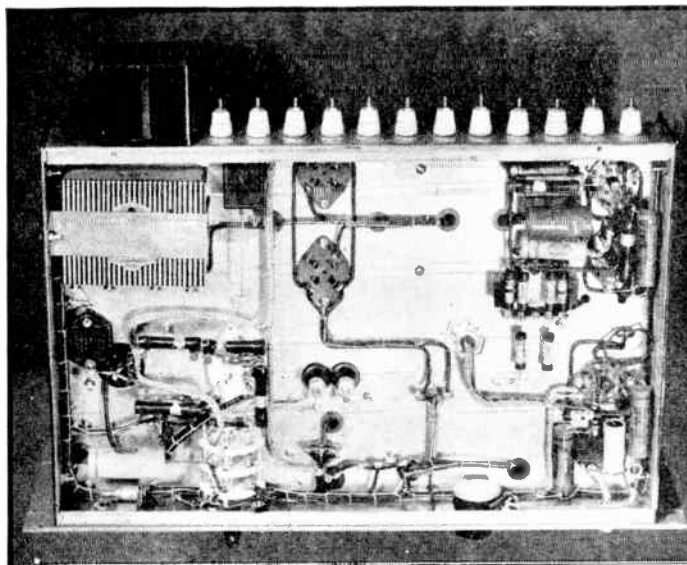

Figure 28.
BOTTOM VIEW OF
SPEECH AMPLIFIER
AND MODULATOR
CHASSIS.

In this photo the speech amplifier section is seen at the right, progressing from bottom (front) to top (rear). The modulator section is at the left. Note the modulator bias battery, the keying relay on the chassis rear drop, and the 'phone-c.w. switch on the front drop.

after the small filter is not reproduced in the form of hum modulation on the carrier.

Keying The transmitter is keyed by means of a built-in keying relay. The leads in series with the 6.3-volt coil of the relay are brought out to the remote-control plug on the back of the transmitter. The keying circuit itself is somewhat unique in that negative bias is applied to the screen of the 813 when the keying relay is open. Inspection of the circuit

diagram will show that when the key circuit is open the screen of the 813 is connected to the -40-volt bias supply through the 150,000-ohm resistor R_{16} . But when the keying circuit is closed, the screen is fed from the -400-volt supply through the 5000-ohm resistor R_{36} and the choke CH_4 . Condenser C_{27} , which is across the screen circuit when the rig is being operated on c.w., serves to delay the rise and fall of screen voltage as the rig is keyed, and thus gives clean keying without clicks or tails.

Figure 29.
POWER SUPPLY FOR
THE 250-WATT
TRANSMITTER.

To keep the height of this deck to a minimum, the power transformer is mounted with the primary side through a large hole in the chassis. The core-clamping bolts are used to hold the transformer to the chassis, and the regular mounting feet are cut off. The two filter chokes, filter condensers, rectifiers, and the keying relay are above the chassis. The rectifier filament transformer and the bleeder resistor are under the chassis.

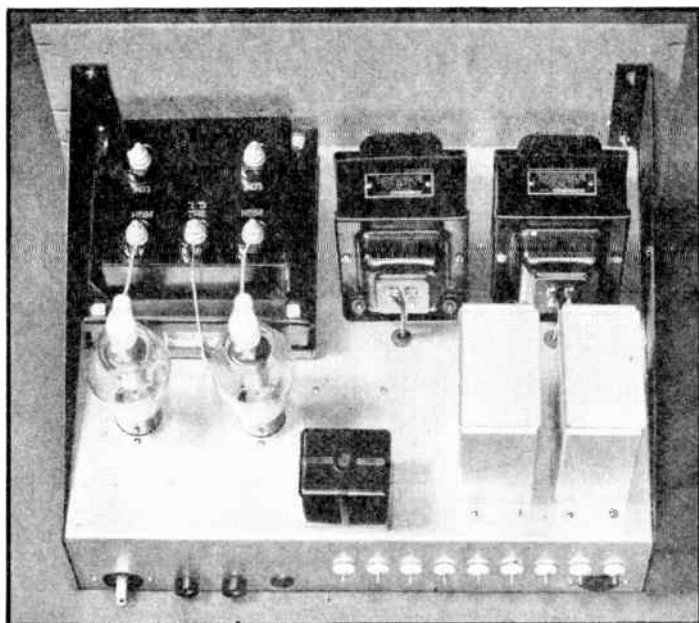

Since R_{16} has many times the resistance of the bias load resistor R_{15} , no change in bias voltage results when the screen voltage is applied to the 813. The circuit gives exceptionally clean keying at all speeds, since the current through the key is small, and the negative bias when the key is up effectively prevents emission of a "back wave."

Modulator Channel The second deck of the transmitter is devoted to the speech amplifier, modulator, and the splatter suppressor circuit. The speech amplifier proper is designed to operate from a conventional diaphragm-type crystal microphone. It starts out with a 6SJ7 high-gain input stage. This is followed by a 6N7, and the driver for the class B stage consists of a pair of 6L6's with degenerative feedback. The speech amplifier has ample gain to operate from any of the common types of high-impedance dynamic and crystal microphones.

The modulator stage itself consists of a pair of 811's in class B operating with 1500 volts on their plates and with 4.5 volts of grid bias. Under these conditions of operation, the 811's are easily capable of putting out the 150 to 175 watts of audio power (including the loss in the output transformer and splatter filter and the energy required to modulate the screen of the 813) needed to plate modulate the 813 with 250 watts input. The screen of the 813 is fed modulated plate voltage by means of a drop resistor from the modulated 1500 volts feeding the 813 plate.

The splatter suppressor consists of an 866A/866 rectifier tube in series with the plate lead to the final amplifier, with a 1000-cycle low-pass filter between the rectifier circuit and the modulated amplifier. A short discussion of the operation of splatter-suppressor circuits has been given in Chapter 8, *Radiotelephony Theory*. Suffice to say here that the rectifier in series with the plate voltage lead eliminates negative-peak clipping, while the low-pass filter attenuates all components of modulation and all components which may be generated by the splatter tube above 4000 cycles.

When the phone-c.w. switch on the modulator deck is changed to c.w., the modulation transformer and the splatter suppressor are shorted out, the filament voltage is removed from the 6L6's and the 811's, and the screen circuit of the 813 is removed from the drop resistor going to the final plate supply and connected to the keying relay circuit.

Construction The transmitter is built into a standard cabinet rack 37 inches high and 14¾ inches deep. The rack has 35 inches of panel space which is apportioned among the various decks as follows:

power supply, 10½ inches; modulator 8¾ inches; r.f. section, 10½ inches; antenna tuner, 5¼ inches. The power supply is built upon a 13 x 17 x 1-inch chassis, the modulator upon a 11 x 17 x 2-inch chassis having a bottom plate. The r.f. section and 400-volt power supply are built upon a 13 x 17 x 3-inch chassis, and the antenna tuning network is entirely supported from the panel.

Every effort has been made to keep the 813 plate circuit lead length to a minimum through grouping the tube, coil, and condenser near the center of the chassis. The use of a shield made from a 3-inch coil shield around the base of

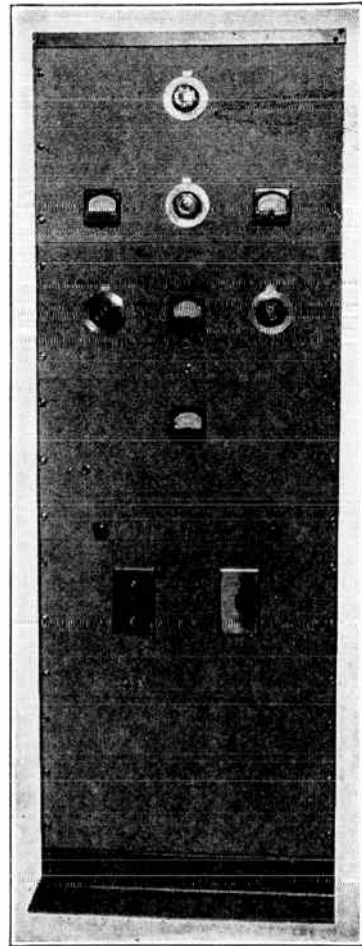

Figure 30.

400-WATT TRANSMITTER.

This 5-foot relay rack contains the complete 400-watt (carrier) radio-telephone transmitter. A pair of class B 203Z's plate modulate a pair of push-pull HK254's.

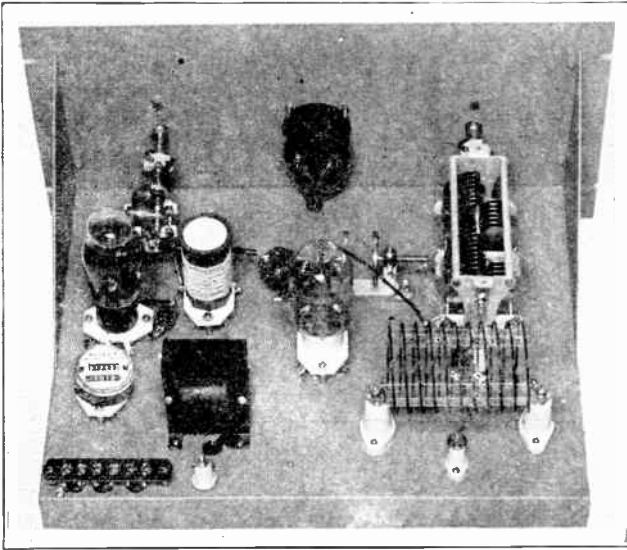

Figure 31.

EXCITER CHASSIS.

The 6L6-G harmonic oscillator and the HK-54 buffer-doubler stages are located on this deck.

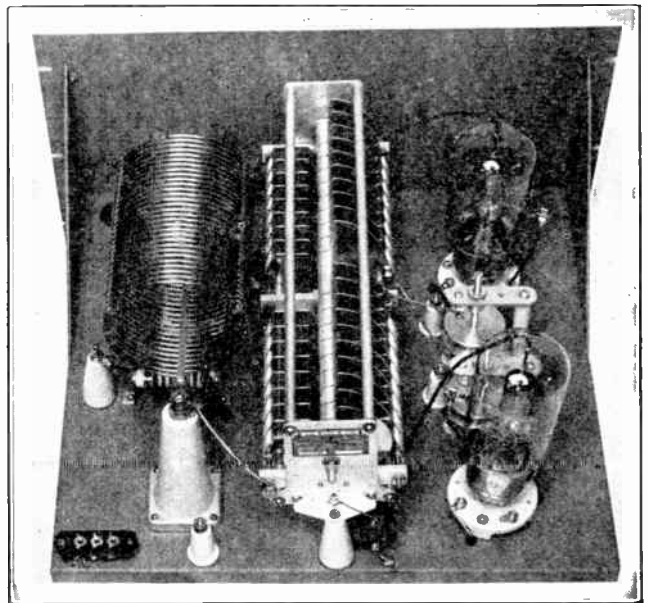

Figure 32.

THE FINAL AMPLIFIER DECK.

A shelf having a narrow lip around it is used to support the final amplifier components. The grid circuit is under the shelf.

the 813 above the chassis effectively eliminates any tendency toward oscillation or instability in the final amplifier which might result from capacity coupling between the grid lead within the tube and the plate tank circuit.

Operation In operating the transmitter it is only necessary to place the proper coil for the desired band in the plate circuit of the output stage, throw the excitation switch to excite the 813 stage from the proper exciter stage, and tune the exciter and

final stages to resonance as indicated by minimum plate current. The normal currents on the various stages should be about as follows: oscillator—35 ma.; 40-meter doubler—20 ma.; 20-meter doubler—30 ma.; 10-meter doubler—40 ma.; 813 grid—6-10 ma., depending on band; 813 plate—180 ma., loaded. When the transmitter is tuned up for the first time, the excitation to the 813 on each band should be adjusted to give the required amount of grid current by sliding the coupling coils along the plate coils of each doubler stage.

Figure 33.
BOTTOM VIEW OF THE
FINAL AMPLIFIER.

The grid coil is shielded from the plate circuit by the metal supporting shelf.

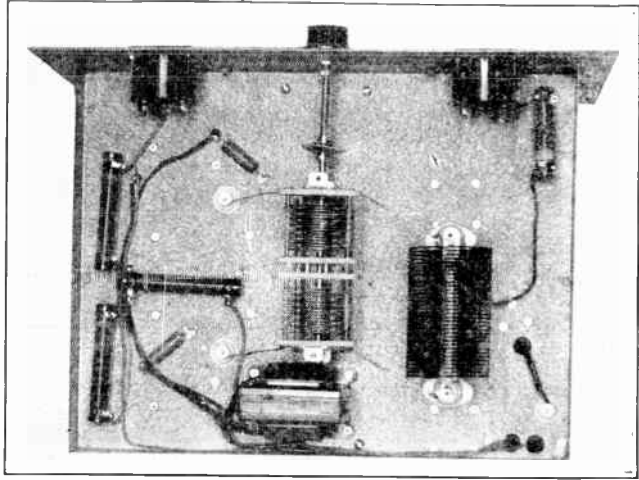

Figure 34.
SPEECH AND MODULATOR
DECK.

The entire audio channel is contained in one rack unit. The shield on the back of the panel encloses the input jack, bias cell, grid resistor, etc., and prevents hum pick-up.

The antenna tuning network is very flexible in that it is only necessary to change a couple of clips to obtain almost any type of antenna coupling or matching arrangement.

When operating on 'phone, the resting modulator current should be about 45 ma. This current will kick up to about 150 to 175 ma. for normal voice modulation.

400-WATT 10-160 METER PLATE-MODULATED 'PHONE

While the amateur to whom price is no item will naturally want to run a full kilowatt input plate-modulated 'phone when interested in high power, the amateur who is interested in economy will do better to content himself with

a 'phone transmitter running in the neighborhood of 600-watts input to the plate-modulated stage. Tubes and modulation transformers for this power are widely available and quite reasonably priced, but when one goes to a full kilowatt the price of these components goes up distressingly. As there is less than 3 db difference (just barely discernible) between a kilowatt and 600 watts input, the cost of the additional power will not be justified in the case of the majority of amateurs.

Hence, for a high-power 'phone transmitter, one delivering about 400 watts of carrier is shown—a very economical size. If one insists upon running a full kilowatt input, it is possible to do so with substantially the same cir-

Figure 35.
WIRING DIAGRAM OF THE 400-WATT 'PHONE TRANSMITTER.

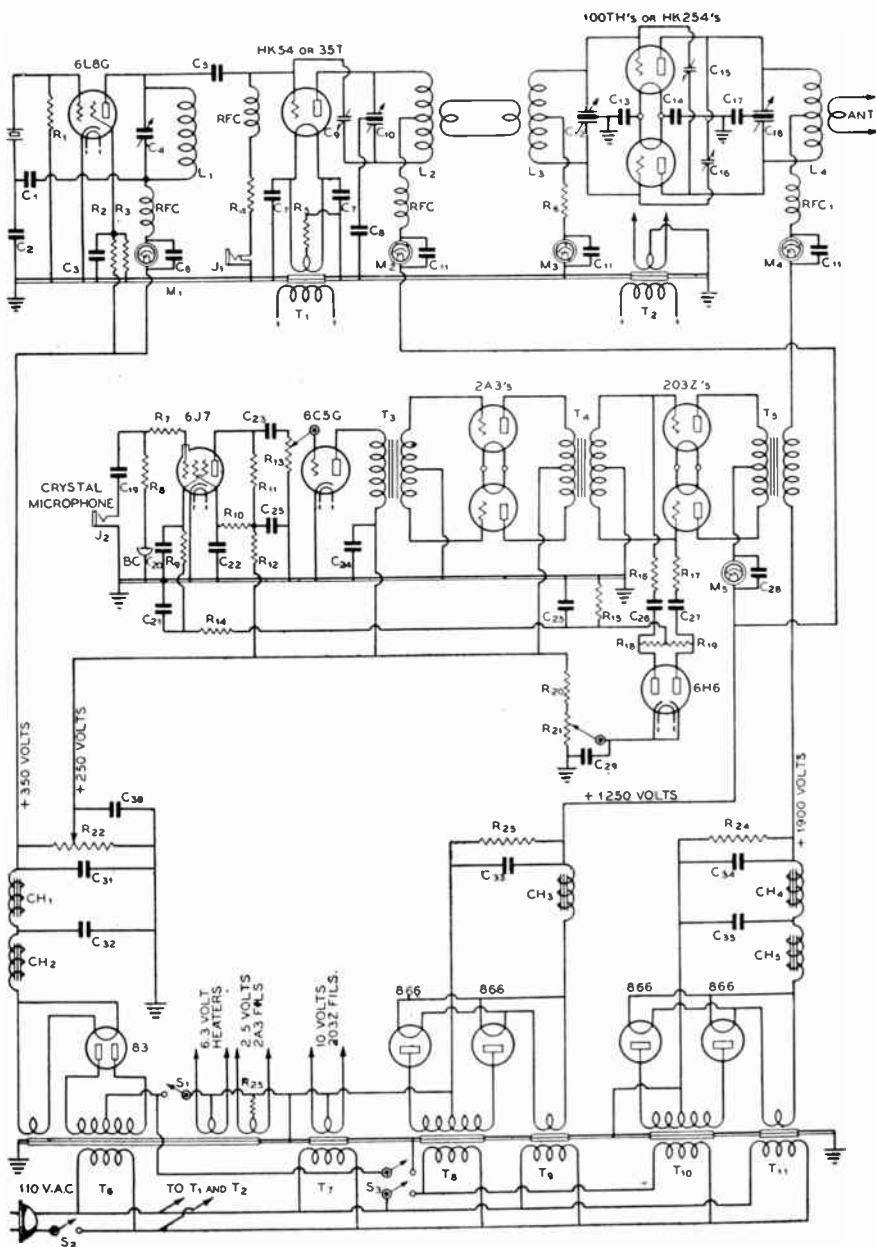

CONSTANTS USED IN FIGURE 35.

- C₁—0.004- μ fd. mica
- C₂—0.02- μ fd. mica
- C₃—0.01- μ fd. tubular
- C₄—50- μ fd. midget
- C₅—0.005- μ fd. mica
- C₆—0.002- μ fd. mica
- C₇—0.01- μ fd. tubular
- C₈—0.002- μ fd. mica, 2500 volts
- C₉—Disc type neutralizing condenser
- C₁₀—80- μ fd. per section, 3000-v. spacing
- C₁₁—0.02- μ fd. mica
- C₁₂—80- μ fd. per section, 3000-v. spacing
- C₁₃, C₁₄—0.01- μ fd. tubular
- C₁₅, C₁₆—Disc type neutralizing condensers
- C₁₇—0.001- μ fd. mica, 5000 v.
- C₁₈—75- μ fd. per section, 1/4" air gap
- C₁₉—0.01- μ fd. tubular
- C₂₀, C₂₁, C₂₂—0.1- μ fd. tubular
- C₂₃—0.1- μ fd. tubular
- C₂₄—0.1- μ fd. tubular
- C₂₅—0.5- μ fd. tubular
- C₂₆, C₂₇—0.1- μ fd. tubular
- C₂₈—0.02- μ fd. mica
- C₂₉—1- μ fd. paper, 400 volts
- C₃₀, C₃₁, C₃₂—8- μ fd. electrolytics, 450 volts
- C₃₃—2- μ fd., 1500 v.
- C₃₄, C₃₅—2- μ fd. 2000 v.
- R₁—100,000 ohms, 1 watt
- R₂—10,000 ohms, 10 watts
- R₃—50,000 ohms, 2 watts
- R₄—15,000 ohms, 10 watts
- R₅—300 ohms, 10 watts
- R₆—2000 ohms, 50 watts
- R₇—50,000 ohms, 1/2 watt
- R₈—1 meg., 1/2 watt
- R₉—250,000 ohms, 1/2 watt
- R₁₀—1 meg., 1/2 watt
- R₁₁—250,000 ohms, 1 watt
- R₁₂—50,000 ohms, 1/2 watt
- R₁₃—1 meg. tapered pot.
- R₁₄—250,000 ohms, 1/2 watt
- R₁₅—100,000 ohms, 1 watt
- R₁₆, R₁₇—2 meg., 1/2 watt
- R₁₈, R₁₉, R₂₀—100,000 ohms, 1 watt
- R₂₁—50,000-ohm pot.
- R₂₂—25,000 ohms, 50 watts
- R₂₃—75,000 ohms, 100 watts
- R₂₄—100,000 ohms, 100 watts
- R₂₅—750 ohms, 10 watts
- RFC—2.5 mh., 125 ma.
- RFC—2.5 mh., 500 ma.
- M₁—0-100 ma. d.c. or meter jack
- M₂—0-200 ma. d.c.
- M₃—0-100 ma. d.c. or meter jack
- M₄—0-500 ma. d.c.
- T₁—5 v. 6 amp.
- T₂—5 v. 15 amp.
- T₃—Push-pull input trans.
- T₄—Class B input for 203Z
- T₅—300-watt variable ratio modulation transformer
- T₆—440 v. each side c.t., 250 ma., and indicated fil. windings
- T₇—10 v. 7.5 amp.
- T₈—1500 v. each side c.t., 300 ma.
- T₉—2.5 v. 10 amp., h.v. insulation
- T₁₀—2200 v. each side c.t., 300 ma.
- T₁₁—2.5 v. 10 amp., h.v. insulation
- CH₁, CH₂—12 hy., 200 ma.
- CH₃—5-20 hy. 300 ma.
- CH₄—12 hy. 300 ma.
- CH₅—5-20 hy., 300 ma.

cuit by replacing the 1250-volt power supply with a 1500-volt 400-ma. supply, and the 1900-volt supply with a 2500-volt 400-ma. supply. This will permit the use of an HK254 or 100TH buffer and 250TH's or HK354D's in the modulated amplifier. Slightly greater spacing will be required for the plate tank condenser C₁₈. The 203Z's can be replaced with 822's to deliver sufficient audio power at 1500 volts to modulate fully a kilowatt input on speech waveforms.

Construction of the 400-watt transmitter illustrated obviously is not for the newcomer. And the amateur who has had sufficient construction experience to warrant an attempt at the building of the transmitter will find the

illustrations and wiring diagram largely self-explanatory.

R.F. Exciter A 6L6G harmonic oscillator driving a 35-T or HK54 neutralized amplifier or doubler forms the exciter portion of the transmitter. The HK54 stage is link-coupled to the grid circuit of the modulated amplifier. The HK54 is first neutralized when working as a straight amplifier on 20 meters. The neutralization will then hold close enough and be sufficiently accurate for operation on all bands. The neutralizing condenser is not disturbed when the stage is used as a doubler. The small disk-type neutralizing condenser is visible in Figure 31.

400-WATT 'PHONE TRANSMITTER COIL DATA

| BAND | 160 | 80 | 40 | 20 | 10 |
|----------------------|--|---|---|---|--|
| 6L6G PLATE | 66 turns no. 22 d.c.c. 1 1/2" diam. close-wound | 30 turns no. 20 d.c.c. 1 1/2" diam. 1 1/2" long | 15 1/2 turns no. 18 d.c.c. 1 1/2" diam. 1 1/2" long | 7 1/2 turns no. 16 enam. 1 1/2" diam. 1 1/4" long | |
| BUFFER & FINAL GRIDS | 80 turns no. 18 d.c.c. 2 5/8" diam. close-wound center tap | 36 turns no. 14 enam. 2 3/4" diam. 8 turns/in. center tap | 20 turns no. 14 enam. 2 5/8" diam. 5 turns/in. center tap | 10 turns no. 14 enam. 2 1/2" diam. 2 1/2 turns per in. center tap | 6 turns no. 12 enam. 1 3/4" diam. 1 1/2 turns per in. center tap |
| FINAL PLATE | Use 80 λ coil shunted by fixed tank condenser (see text) | 28 turns no. 10 enam. 4 1/2" diam. 4 1/2 turns per in. center tap | 20 turns no. 10 enam. 3 1/2" diam. 3 turns/in. center tap | 10 turns no. 10 enam. 3 1/4" diam. 1 1/2 turns per in. center tap | 6 turns no. 10 enam. 2 1/4" diam. 1 turn/in. center tap |

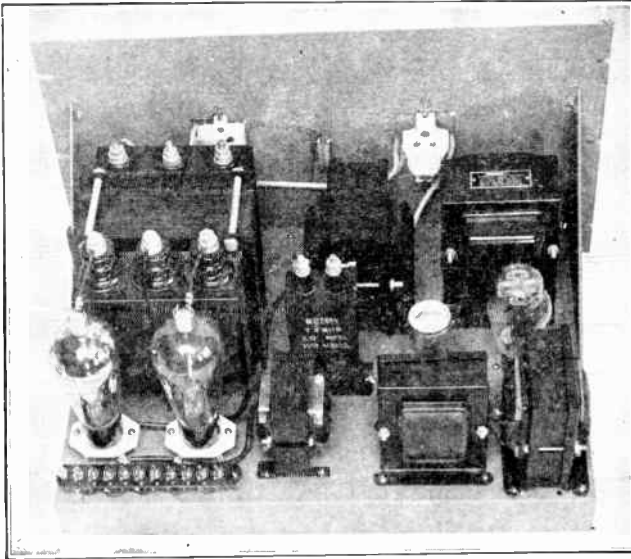

Figure 36.

**350- AND 1250-VOLT
POWER SUPPLIES.**

The low voltage power supply components are located toward the right edge in this rear view.

Figure 37.
**THE 1900-VOLT POWER
SUPPLY.**

This power supply feeds the modulated amplifier stage. It has a 2-section filter in order to remove all carrier hum.

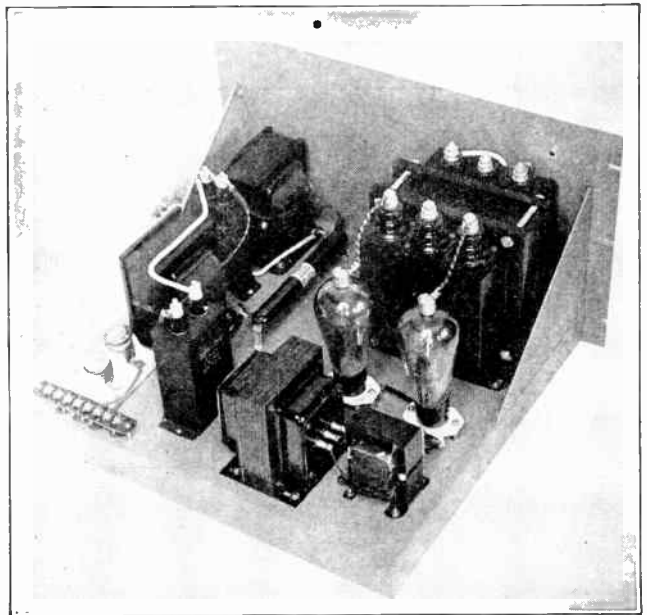

Modulated Amplifier The tubes in the final amplifier "loaf" at between 550- and 600-watts input. While a pair of HK54's or 35-T's could be run at a half-kilo-watt input at the plate voltage specified, such input with plate modulation is rather severe and larger tubes will give longer life. HK254's or 100TH's can be run considerably under their rated maximum plate current rating, and very long life can be expected.

Sufficient coupling between the buffer and modulated amplifier usually can be obtained

with a single turn link around the center of buffer plate and final grid coils. If the grid current to the modulated amplifier runs over 80 ma., the grid tank condenser can be detuned slightly. If it is impossible to obtain 80-ma. grid current on the lower-frequency bands, 2-turn links will be required for those coils.

To eliminate the need for a more bulky, higher capacity plate tank condenser for 160-meter operation, which would not be advisable for 10-meter operation due to the high minimum capacity, the following expedient is re-

sorted to: the 75-meter amplifier plate coil is made slightly lower Q than optimum. The same coil is then used on 160 meters by shunting a fixed vacuum padding condenser of 50- μ fd. capacity across the tank tuning condenser. This results in a Q slightly higher than optimum for 160-meter operation, but the compromise design of the coil results in operation substantially as satisfactory as would be obtained with separate 75-meter and 160-meter coils.

The Speech System

The speech amplifier-driver and 300-watt modulator are conventional except for the incorporation of automatic peak compression to allow a higher average percentage of modulation without the danger of overmodulation on occasional loud voice peaks. The delay action (percentage modulation at which compression starts) can be adjusted by means of the potentiometer R_2 . The modulators are fed from the same 1250-volt supply that furnishes plate voltage to the buffer amplifier.

All leads and components in the 6J7 first speech stage should be shielded to prevent grid hum and possible feedback. TZ40's can be substituted for the 203Z's by utilizing 9 volts of fixed battery bias. The tubes will supply sufficient output for complete modulation of 600 watts input when voice is used, though they will not last as long as 203Z's.

The Power Supplies

The 350-volt and the 1250-volt power supplies are built on one chassis; the 1900-volt supply has a chassis of its own. To keep the carrier hum at a very low level, a 2-section filter is used in the 1900-volt supply feeding the modulated amplifier. As the push-pull modulators and the r.f. driver stage are relatively insensitive to a moderate amount of plate supply ripple, a

single-section filter suffices for the 1250-volt supply.

While it is desirable to have six meters to facilitate reading of all important grid and plate current values simultaneously, it is possible to get by with fewer meters by incorporating metering jacks. Such jacks should be placed in filament return leads rather than in plate leads when the plate potential is over 500 volts. Meters in filament return jacks read combined grid and plate current, and the grid current should be subtracted from the meter reading to determine the actual value of plate current.

Construction

The mechanical construction and lay-out of components can be observed in the various illustrations. All chassis measure 13 x 17 x 1½ inches and have end brackets to strengthen them. All panels are of standard 19-inch width, with heights as follows: final amplifier, 12¼ inches; exciter 8¾ inches; all others, 10½ inches.

Operation

Initial tuning of as elaborate and expensive a transmitter as this should preferably be done by an experienced operator who is familiar with tuning and adjustment of high-power 'phone transmitters. General considerations regarding transmitter tuning and adjustments are covered in the transmitter theory chapter. The following meter readings are typical of normal operation:

6L6G cathode current: 35 to 60 ma.

Buffer grid current: 10 to 15 ma.

Buffer plate current: 50 to 75 ma. as buffer; 80 to 100 ma. as doubler.

Final plate current: 300 to 325 ma.

203Z plate current: 75 to 100 ma. resting, swinging up to approximately 200 ma. on voice peaks.

U. H. F. Communication

AN OLD and reasonable definition of *ultra-high frequencies* is: *those frequencies which are not regularly returned to the earth at great distances.* Under this definition, the limit between *high* and *ultra-high* frequencies shifts with the sunspot cycle. The official F. C. C. definition designates as *very high* (V.H.F.) those frequencies between 30 and 300 Mc., as *ultra high* (U.H.F.) those between 300 and 3000 Mc., and as *super high* (S.H.F.) those between 3000 and 30,000 Mc. In scientific circles, the term *microwave* has been accepted to describe wavelengths between 1 centimeter and 1 meter (corresponding in the reverse order to frequencies between 300 and 30,000 megacycles).

Post-war higher-frequency U. S. amateur assignments are 50-54 Mc. (5.6 to 6 meters); 144-148 Mc. (2.02 to 2.08 meters); 220-225 Mc. (1.33 to 1.36 meters); 420-450 Mc. (66.7 to 71.5 centimeters); 1145-1245 Mc. (24.1 to 26.2 centimeters); 2300-2450 Mc. (12.25 to 13.05 centimeters); 5250-5650 Mc. (5.32 to 5.72 centimeters); 10,000-10,500 Mc. (2.86 to 3 centimeters); and 21,000-22,000 Mc. (1.362 to 1.429 centimeters). As we go to press, the F. C. C. has not stated which types of emission will be authorized in each of these bands, nor has the official date for the inauguration of amateur communication within these bands been announced.

Propagation

Direct Communication *Horizon.* local, or direct point-to-point reception refers to two points between which there is no obstruction to the waves. This might be one mile or two hundred, depending on the altitude of the antennas and the nature of the intervening land.

The distance to the horizon is given by the approximate equation $d=1.22 \sqrt{H}$ where the distance d is in miles and the antenna height H is in feet. This must be applied separately to the transmitting and receiving antennas and

the results added. However, refraction and diffraction of the signal around the spherical earth cause a smaller reduction in field strength than would occur in the absence of such bending, so that the average radio horizon is somewhat beyond the optical horizon.

There is, however, no sharp discontinuity of the signal at the horizon; that is, an airplane taking off beyond and below the horizon will begin to encounter some signal before reaching an altitude from which the transmitting antenna is actually in sight.

Ground Wave Because the signal is heard consistently beyond the horizon, the term *ground wave* is usually applied out to 30 or more miles—and much longer when one or both antennas are high. The waves are propagated, presumably, by *diffraction* or dispersion around the curve in the earth's surface in the same way as light is diffracted around a sharp corner. Out to this distance, the transmitting and receiving antennas give best results when both are either vertical or horizontal.

Low Atmosphere Bending *Pi-skip,* extended ground wave, refracted-diffracted, or low atmosphere bending dx mean essentially the same thing. All refer to distances out to perhaps 200 or 300 miles, in the absence of unusual aurora or magnetic activity. Beams are pointed close to the direct line between the stations. The first two terms refer to the distance but not to the method by which the transmission is accomplished, and presumably differ from the local or ground wave type only because the greater distance is covered as a result of more power, better antennas, or more sensitive receivers.

Low atmosphere bending, on the other hand, in the narrow sense refers to pushing the signal over at the same distance with the aid of a temperature discontinuity or inversion in the lower atmosphere that bends the waves slight-

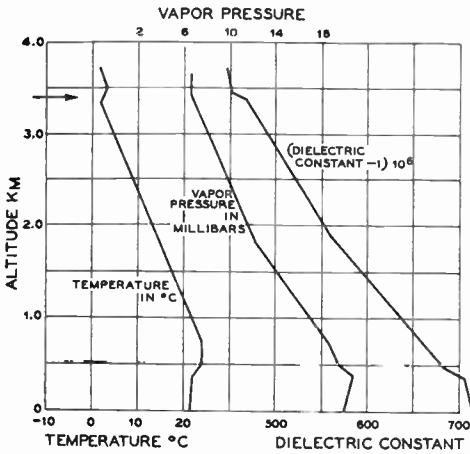

Figure 1.
ILLUSTRATING TYPICAL TEMPERATURE INVERSION AT 3.4 KM.

Air mass boundary heights shown by U. S. Weather Bureau free air data, compared to measured heights from frequency sweep patterns on ultra high frequencies.

enough to be considered normal. Signal strength decreases with distance and, if the favorable condition in the lower atmosphere covers sufficient area, the range is limited only by the transmitter power, antenna gain, receiver sensitivity, and signal-to-noise ratio. There is no skip distance. Usually, transmission due to this condition is accompanied by slow fading, although fading can be violent at a point where direct waves of about the same strength are also received.

Bending in the troposphere, which refers to the region from the earth's surface up to about 10 kilometers, is more likely to occur on days when there are stratus clouds than on clear, cool days with a deep blue sky. The temperature or humidity discontinuities may be broken up by vertical convection currents over land in the daytime but are more likely to continue during the day over water. This condition is in some degree predictable from weather information several days in advance. It does not depend on the sunspot cycle. Like direct communication, best results require similar antenna polarization or orientation at both the transmitting and receiving ends, whereas in transmission via a reflection in the ionosphere (that part of the atmosphere between about 50 and 500 kilometers high) it makes little difference whether antennas are similarly oriented.

Figure 1 illustrates an air mass boundary at 3.4 kilometers, taken from United States Weather Bureau free air data in the vicinity of New York City, at a time when the same height was indicated by ultra-high frequency measurements being made by Bell Laboratories. The arrow points to the inversion or discontinuity in temperature and vapor pressure,

ly downward, rather than just simple brute force methods implied by the other terms.

When the temperature, pressure, or water-vapor content of the atmosphere does not change smoothly with rising altitude, the discontinuity causes a slight bend in the waves and thus, if the bend is downward, extends the range. Ordinarily this condition is more prevalent at night and in the summer. In certain areas, such as along the west coast of North America, it is believed to be frequent

Figure 2.
TYPICAL U.H.F. PROPAGATION CHARACTERISTICS.

Calculated curves for air boundary reflected and earth refracted-diffracted radiation components, in both vertical and horizontal polarization. Short doublet antennas, 1 kw. power radiated, wavelength 4.7 meters, ground conductivity 5×10^{-11} E.M.U., and dielectric constant 80 for sea water. Height of transmitting antenna 42 meters, of receiving antenna 5 meters, air boundary height 1500 meters, effective radius of earth 8500 kilometers.

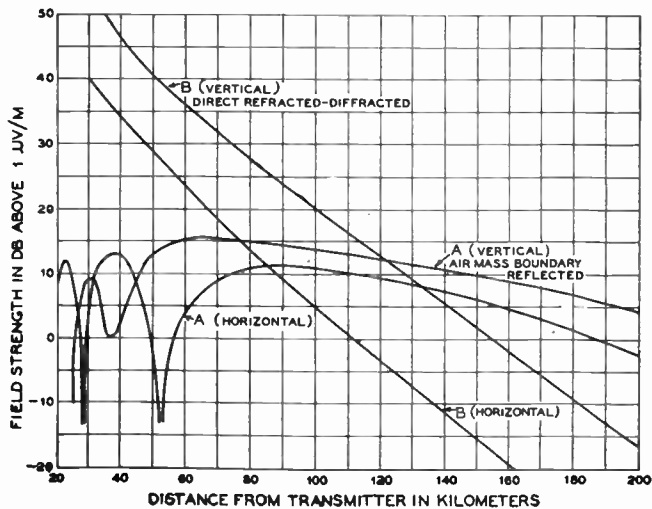

and the resulting change in the dielectric constant of the air.

Figure 2 shows typical ultra-high frequency propagation characteristics for a sea water path in the vicinity of New York City, calculated for an air mass boundary at 1500 meters (curve A) and for the earth refracted-diffracted radiation component for ground conductivity 5×10^{-11} E. M. U., and dielectric constant 80 for sea water (curve B) for horizontal and vertical antennas, wave length 4.7 meters (64 megacycles), short doublet antennas, 1 kilowatt power radiated. Most severe fading is generally encountered at such a distance that curves A and B cross, with slow fading at greater distances.

Aurora-Type DX The same and longer distances can be reached below 60 Mc. during periods of visible displays of the aurora borealis, and during magnetic disturbances. This has been termed *aurora-type dx*. These conditions reach a maximum somewhat after the sunspot cycle peak, possibly because the spots on the sun are nearer to its equator (and more directly in line with the earth) in the latter part of the cycle. Ionospheric storms generally accompany magnetic storms. The normal layers of the ionosphere may be churned or broken up, making radio transmission over long distances difficult or impossible on high frequencies. Unusual conditions in the ionosphere sometimes modulate ultra-high frequency radio waves so that a definite tone or noise modulation is noticed even on transmitters located only a few miles away.

Information is not available as to how high a frequency will be returned by the ionosphere under these conditions, but it is estimated that frequencies from 25 to 100 Mc. may be affected. A peculiarity of this type of propagation of ultra-high frequency signals in the northern hemisphere is that directional antennas usually must be pointed in a northerly direction for best results for transmission or reception, regardless of the direction of the other station being contacted. Distances out to 700 or 800 miles have been covered during magnetic storms, using 30 and 60 Mc. transmitters, with little evidence of any silent zone between the stations communicating with each other. Generally, voice-modulated transmissions are difficult or impossible due to the tone or noise modulation on the signal. Most of the communication of this type has taken place by c.w. or by tone modulated waves with a keyed carrier, and using receivers having an *i.f.* selectivity comparable to that of ordinary commercial high frequency receivers. Because of the association of this type of transmission with magnetic storms, it is assumed that the neces-

sary condition is more likely to occur during or following the sunspot cycle peak.

Short Skip The lower of the two more important ionosphere layers is the E region. This accounts for 160-meter and broadcast dx at night. Sometimes a *sporadic* condition exists in this layer, the height of which is usually about 110 kilometers (68 miles) above sea level, which will reflect the highest frequency waves that return to the earth. A single hop can be as long as 1,200 miles, or moderately longer at favorable locations or with antennas producing effective low angle radiation (below 3°). Occasionally 1,300 or 1,400 miles can be covered in a single hop, possibly with the help of low atmosphere bending at each end. Sporadic-E layer reception may occur at any time, but is much more prevalent from late April to early September in the northern temperate zone, and slightly more likely to occur in the late morning and early evening. The sporadic-E layer is spotty, accounting for reception in definite areas completely surrounded by a silent zone, and permitting only a few days of double hop reception during a period of several years. Sporadic-E reflections support communication at frequencies up to at least 60 Mc., reception at as short a distance as 310 statute miles on 56 Mc., in one instance, indicates that the ionization was sufficiently intense so that, theoretically, frequencies as high as $2\frac{1}{2}$ meters (112 Mc.) might have been received erratically at 1,200 miles on that day. At increasing frequencies the silent zone is larger and the reception zone smaller, indicating that the practical limit of sporadic reflections by this layer may be in the vicinity of 80 to 100 Mc.

Since the maximum sunspot activity in 1937-38, the number of hours of reception by reflections from this layer has decreased, at least for frequencies above 50 megacycles and, in general, the skip zone has become larger. However, the "life cycle" is now starting.

When an ionosphere reflection takes place, the polarization of the receiving antenna can be independent of that of the transmitting antenna with equally good results. However, because of the fact that ultra-high frequency antennas are generally placed a number of wave lengths above ground, their vertical plane patterns may contain several angles at which transmission or reception is impossible; a null for a horizontal may be at the same angle as a maximum for a vertical antenna located at the same height, and the reverse, thus accounting for widely varying comparisons between the two antenna types, should the waves come in at one of these critical angles.

Beam antennas show some directivity on re-

ception via sporadic-*E* layer reflections, but are not generally as effective as in the low atmosphere bending type of propagation. This has been attributed to the fact that the signal intensity of sporadic-*E* layer transmissions is very high, being comparable to that received within the visible horizon.

Long Skip The higher of the two major reflecting layers of the ionosphere is the *F* region. This accounts for long-skip signals coming down as far away as 2,200 miles in a single hop, with multiple hops common. The silent or skip zone may be around 600 miles at 30 Mc., and longer at increasing frequencies, when ionization is most intense. On winter days this region accounted for 30 Mc. transmission during the favorable part of the sunspot cycle just passed, except when sporadic-*E* reflections were present. Observations and ionosphere measurements show that long-distance communication at frequencies as high as 50 Mc. was possible on a few favorable days in 1937 and 1938. Trans-Atlantic 56 Mc. reception for intervals of a few minutes during the favorable part of the sunspot cycle has been reported, but has not been entirely confirmed. Ionosphere and sunspot records suggest that it may be 1947 or so before there is another favorable time for this kind of work.

Trans-Atlantic communication at 30 Mc. was noticeably poorer in early 1941 than in the previous 5 years. Transmission southward from the continental United States is possible at higher frequencies than across the Atlantic.

The silent zone mentioned above has not always been entirely reliable. On days when 30 Mc. transmissions became possible during the past several years, stations have been contacted within the normal skip zone in the morning and afternoon, during which periods it was determined that signals in the northern temperate zone left the transmitter and arrived at the receiver from a southeasterly direction in the morning, and a southwesterly direction in the afternoon, regardless of the location of the stations. This phenomenon has been attributed to reflection from scattered clouds of electrons forming or dispersing in the *F* region nearer the Equator.

Summary Ultra-high frequency signals may be heard at distances up to 200 miles or more with fair consistency when antennas are in the clear, and when the receiver has a favorable signal-to-noise ratio. The signal strength within this range depends upon air mass boundary conditions in the troposphere. This type of propagation is effective for frequencies as high as 200-400 Mc.

Scattered reflections during ionospheric or magnetic storms produce an extension of trans-

mission range to at least 500-600 miles, particularly when continuous waves are used at the transmitter and when the receiver passes a narrow band of frequencies. This type of propagation may be limited roughly to frequencies below 100 Mc.

Sporadic-*E* layer reflections produce extremely loud signals at distances roughly up to 1,200 miles, with a silent zone that is likely to be at least 500 miles at 60 Mc. and 300 miles at 30 Mc., but generally 200 or 300 miles longer. This sporadic condition is unlikely to affect frequencies above 80 to 100 Mc., and is less likely to occur in the winter or during the sunspot minimum which we are now approaching.

For frequencies of 30 to 45 Mc., *F* layer transmissions in the northern hemisphere are almost entirely confined to the months of August to April over the daylight path. It is unlikely that 60 Mc. signals will be returned by this layer.

Equipment Considerations

Years ago, tube bases were removed to get down to 100 meters, but experimentation is making 0.7 meter as easy as 10 meters was a few years ago. Limits in the use of triode or pentode tubes are being approached, however, and this has forced further tube and circuit development. Beam tetrode tubes are now available to provide a kilowatt on 2½ meters, and good output on 1¼ meters. Triodes are now available to turn out considerable power on ¾ meters (400 Mc.). The tuned circuit—the basis of radio—is undergoing changes and has been replaced by *cavity resonance* at microwaves.

Even a perfect circuit must be coupled to something to be useful. A vacuum tube grid presents an apparent low resistance to the tuned circuit at short wavelengths. At 60 Mc., this is about 2300 and 2500 ohms for the 6L7 and 1852, compared with 54,000 for the acorn 954 and 956 and the newer low-priced button tubes, the 9001 and 9003. Normal receiving pentodes such as the type 57 have a relatively low input resistance even at 14 Mc., reducing the effectiveness of the best circuit. With increasing frequency, there is a point for each tube where the output is no larger than the input, and the shot-effect noise is added to the signal arriving in its plate circuit. This makes necessary the use of acorn or button type tubes above a certain frequency.

In a properly designed receiver, thermal agitation in the first tuned circuit is amplified by subsequent tubes and predominates in the output. For good signal-to-set-noise ratio, therefore, one must strive for a high-gain r.f. stage exclusive of regeneration. Hiss can be held down by giving careful attention to this point. A mixer has one-third of the gain of

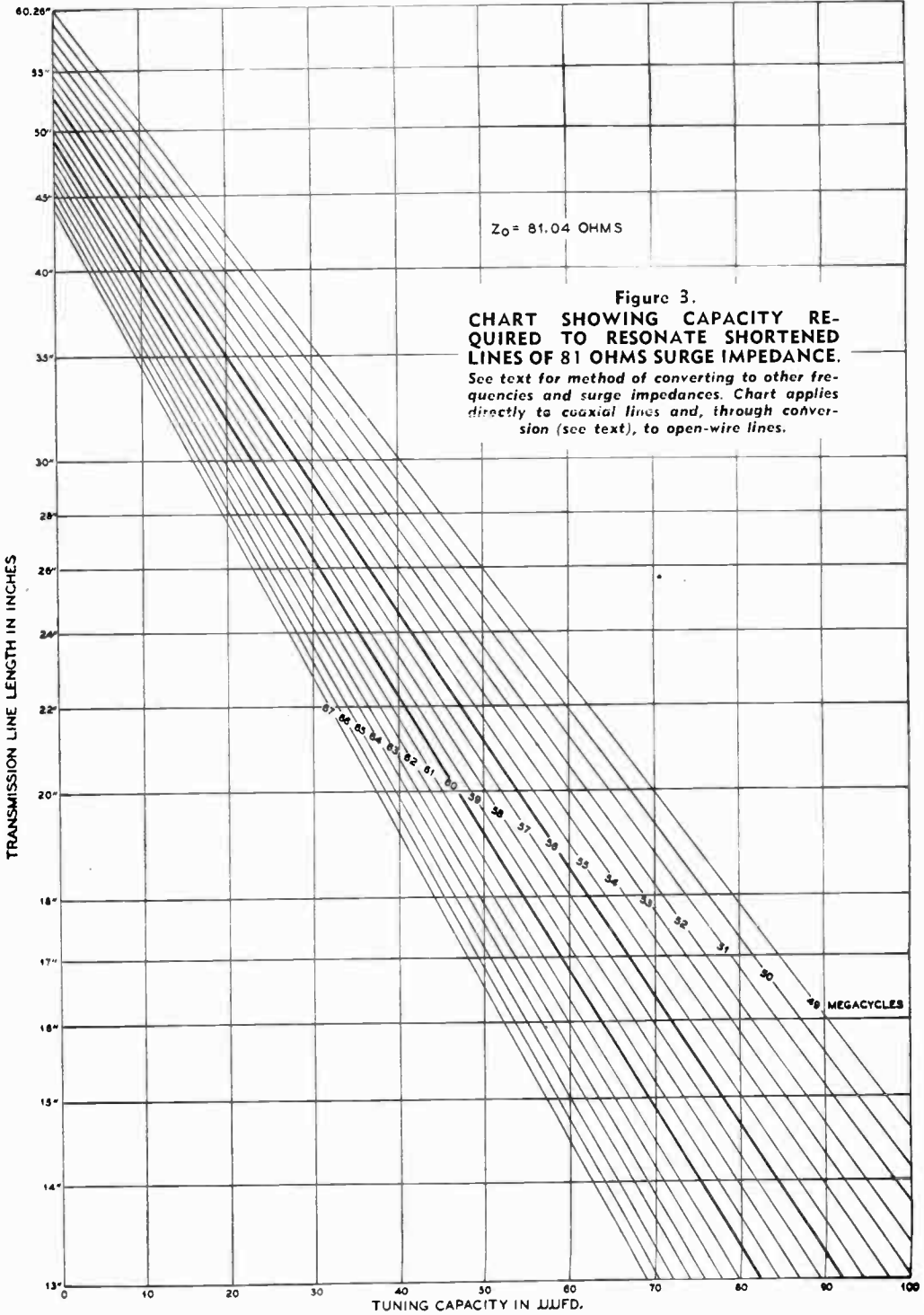

in r.f. tube of the same type; so it is advisable to precede a mixer by an efficient r.f. stage. It is also of some value to have good r.f. selectivity before the first detector in order to reduce noises produced by beating noise at one frequency against noise at another, to produce noise at the intermediate frequency in a superheterodyne or at audio frequencies in a superregenerator.

The frequency limit of a transmitting tube is reached when the shortest possible external connections are used as the tuned circuit, except for abnormal types of oscillation. Generally, amplifiers will operate at higher frequencies than will oscillators. For satisfactory efficiency in an amplifier, it is important to place all tuning capacitors so that leads and capacitor frame have very little inductance. Otherwise, such leads should be increased to an electrical half wavelength. Wires or parts are often best considered as sections of transmission lines rather than as simple resistances, capacitances, or inductances.

Transmission Line Circuits At increasingly higher frequencies, it becomes progressively more difficult to obtain a satisfactory amount of selectivity and impedance from an ordinary coil and capacitor used as a resonant circuit. On the other hand, quarter wavelength sections of parallel conductors or concentric transmission line are not only better but also become of practical dimensions.

Full quarter wavelength lines resonate regardless of the ratio of diameter to conductor spacing—with due allowance for the length of the shorting disc or bar. Substantial open-end impedance, Z_s , and selectivity, Q , can be built up with lines less than a quarter wavelength, loaded with capacitance at the open end, provided that the capacitor is an excellent one—preferably copper plates attached to the conductors with no dielectric losses. This is more important, of course, in lines used for frequency control that are lightly loaded. Lines also can be tuned (if not loaded with capacitance) by substituting a variable capacitor for the shorting bar or disc.

Any unintentional radiation from a coupling link, or resistance coupled into the line, will reduce its effectiveness. Lines that are much shorter than a quarter wave may require considerable capacitance to restore resonance; the amount of required capacitance can be reduced by using a line with a higher surge impedance—that is, wider spacing for 2-wire lines, or a smaller inner conductor for a given outer conductor of a coaxial line. For greatest selectivity, or oscillator frequency control, the conductor radius should be about a quarter of the center-to-center line spacing or, in a coaxial,

the inner conductor should be a quarter of the diameter of the outer pipe. For high impedance, ordinarily desired anywhere except for oscillator frequency control, the ratio can be 8-to-1 or higher, thus reducing the necessary loading capacitance on short lines.

Very large spacing is undesirable on open wire lines where the shorting bar may radiate so much that the tuned circuit has radiation resistance coupled into it and the impedance is reduced. Preferably, the active surfaces of lines should be copper or silver. A thin chrome plate over copper is also fairly satisfactory, as is an aluminum surface. The conductivity of the center conductor in a coaxial tank is much more important than that of the outer conductor, due to its smaller diameter.

Tuning Short Lines Tubes hooked on to the open end of a transmission line provide a capacitance that makes the resonant length less than a quarter wavelength. The same holds true for a loading capacitor. How much the line is shortened depends on its surge impedance. It is given by the equation $\frac{1}{2}\pi fc = Z_0 \tan l$, in which $\pi = 3.1416$, f is the frequency, c the capacitance, Z_0 the surge impedance of the line, and $\tan l$ is the tangent of the electrical length in degrees.

The surge or characteristic impedance of such lines can be calculated from the equations $Z_0 = 276.3 \log_{10} (D/r)$ ohms for 2-wire lines and $Z_0 = 138.15 \log_{10} (b/a)$ ohms for coaxial lines, where Z_0 is the surge impedance, \log_{10} refers to the common logarithm, D and r refer to center-to-center spacing and conductor radius of two wire lines, b and a are outer conductor inner diameter and inner conductor outer diameter for coaxial lines. Charts showing characteristic surge impedance for parallel conductors and for coaxial lines may be found in Chapter 20, Figures 12 and 13.

The capacitive reactance of the capacitance across the end is $\frac{1}{2}\pi fc$ ohms. For resonance, this must equal the surge impedance of the line times the tangent of its electrical length (in degrees, where 90° equals a quarter wave). It will be seen that twice the capacitance will resonate a line if its surge impedance is halved; also that a given capacitance has twice the loading effect when the frequency is doubled.

The accompanying chart (Figure 3) can be used to determine the necessary line length of tuning capacitance. For 112 Mc., use the 56 Mc. curve but divide the capacitance and line length scales by two. That is, if an 81.04-ohm line 30 inches long will tune to 56 Mc. with 28.20 μfd capacitance, and 81.04-ohm line 15 inches long will tune to 112 Mc. with a 14.10- μfd capacitor. Likewise, a 60-inch line of the same impedance will tune to 28 Mc. with

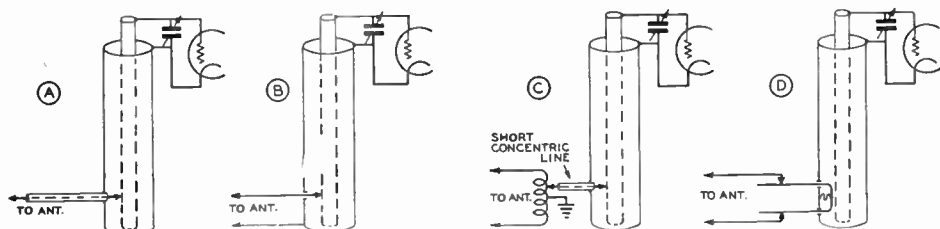

Figure 4.

METHODS OF COUPLING ANTENNA TO COAXIAL RESONANT CIRCUIT.

(A) Coupling a concentric line feeder to a concentric line resonant circuit. (B) Unbalanced method of coupling 2-wire line into a concentric line circuit. (C) Balanced-to-unbalanced method of coupling a 2-wire line to a concentric line resonant circuit. (D) Balanced loop method of obtaining good coupling from 2-wire line to a concentric line circuit.

56.40 μmfd . This sounds like a lot of capacitor, and can be reduced to 28.20 μmfd . by doubling the line impedance to 162.08 ohms. But, in any event, this circuit will outperform a coil both as to gain and selectivity. The capacitances mentioned include circuit capacitance; in the case of a mixer preceded by an r.f. stage, this will amount to about 10 μmfd . with acorn tubes, allowing 3 μmfd . for capacitor minimum.

Coupling Into Lines

It is possible to couple into a parallel rod line by tapping directly on one or both rods, preferably through blocking capacitors if any d.c. is present. More commonly, however, a "hairpin" is inductively coupled at the shorting bar end, either to the bar or to the two rods, or both. Thus usually results in a balanced load. Should a loop unbalanced to ground be coupled in, any resulting unbalance reflected into the rods can be reduced with a simple Faraday screen, made of a few parallel

wires placed between the hairpin loop and the rods. These should be soldered at only one end and grounded.

An unbalanced tap on a coaxial resonant circuit can be made directly on the inner conductor at the point where it is properly matched. For low impedances, such as a concentric line feeder, a small one-half turn loop can be inserted through a hole in the outer conductor of the coaxial circuit, being in effect a half of the hairpin type recommended for coupling balanced feeders to coaxial resonant lines. The size of the loop and closeness to the inner conductor determines the impedance matching and loading. Such loops coupled in near the shorting disc do not alter the tuning appreciably, if not overcoupled. Various coupling circuits are shown in Figure 4.

Frequency Measurements

At ultra-high frequencies, Lecher wires or frames can be used to determine the approximate frequency of an oscillator; a crystal harmonic or receiver oscillator harmonic can then be used for closer measurement. A 10-meter receiver with 1.6 Mc. i.f. will pick up an image 3.2 Mc. from a 10-meter signal. If a 5-meter signal is picked up while the receiver is still tuned to 10 meters, signal and image will be only 1.6 Mc. apart, and the dial setting will be incorrect by one-half of the i.f. This applies in the same manner to other situations where the unknown signal is twice the frequency to which the receiver is set.

To explain, a 29-Mc. signal would be heard with the receiver oscillator higher in frequency by the amount of the i.f., or 30.6 Mc., with the dial reading 29 Mc. The image would come in when the oscillator is tuned to 27 Mc., at which time the dial would read 25 Mc. On the second harmonic, however, the dial set at 29 Mc. will place the 30.6-Mc. oscillator harmonic at 61.2 Mc., and bring signals 1.6 Mc. lower, or on 59.6 Mc. The su

| Frequency (Mc.) | 1/4 Wave (inches) | 1/2 Wave (inches) |
|-----------------|-------------------|-------------------|
| 50 | 59.1 | 118.2 |
| 51 | 57.9 | 115.9 |
| 52 | 56.8 | 113.5 |
| 53 | 55.7 | 111.5 |
| 54 | 54.7 | 109.5 |
| 144 | 20.5 | 41.0 |
| 145 | 20.4 | 40.8 |
| 164 | 20.2 | 40.4 |
| 147 | 20.0 | 40.0 |
| 148 | 19.9 | 39.8 |
| 220 | 13.41 | 26.82 |
| 221 | 13.35 | 26.70 |
| 222 | 13.30 | 26.60 |
| 223 | 13.22 | 26.44 |
| 224 | 13.18 | 26.36 |
| 225 | 13.12 | 26.24 |

FREQUENCY VS. WAVELENGTH

harmonic of this is 29.8 Mc., or one-half of the i.f. higher than the dial setting of 29.0 Mc.

A 59.6-Mc. signal would also come in as an image when the receiver dial reads 27.4 Mc., or only times the i.f. rather than twice as on the fundamental. At this setting, the oscillator is on 29 Mc., and its second harmonic is on 58 Mc., producing a 1.6-Mc. i.f. by beating against the 59.6-Mc. signal. The above is based on the assumption that the oscillator frequency is higher than the received signal, as is customary in commercial receivers. With a little care, this method can be used to spot bands as well as to place a transmitter in a band with fair accuracy.

Measurements may be made of signals in the 50-54-Mc. band by employing a receiver which will tune from 25 to 27 megacycles.

Lecher Wire Systems

A Lecher wire measuring system consists of a pair of parallel wires one or more wave-

lengths long, short circuited at one end to provide a pick-up loop which can be coupled to the tuned circuit of a transmitter or receiver. The wires can be No. 12, approximately 1 inch apart. The shorter wavelength units can be stretched on a long wooden framework if no supports or insulators are used in the measuring range.

Energy induced in the parallel wires establishes standing waves of voltage and current along the wire when resonance is established with a shorting bar. The sliding bar (see Figure 5) is moved along the wires until two successive points are located which cause the oscillator under test to draw more plate current or go out of oscillation. The distance between these two points is a half wavelength.

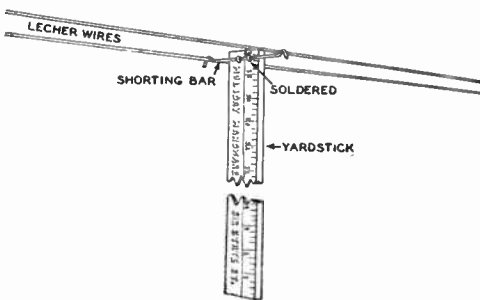

Figure 5.
LECHER WIRE MEASURING EQUIPMENT.

The wires are spaced about 1 1/2 inches and pulled taut. "Bumps" will appear exactly 1/2 wavelength apart on the wires as the jumper is slid along. The wires may be coupled to the oscillator under measurement by means of twisted line.

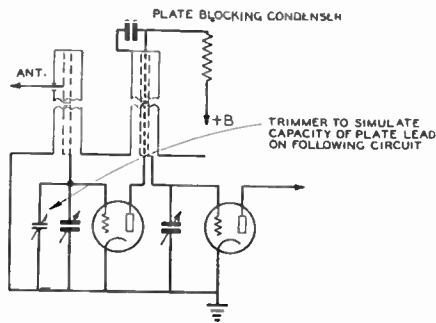

Figure 6.
CONCENTRIC TANK CIRCUITS AS USED IN ULTRA HIGH FREQUENCY RECEIVERS.

Concentric tanks are best at very high frequencies as they have a much higher impedance at these frequencies.

This can be converted into meters by multiplying the length in feet by 0.61 (actually 0.6096), or the length in inches by 0.0508. For microwaves, the length in inches is usually converted to wavelength in centimeters by multiplying by 5.08. These factors convert to the metric system and take care of the fact that the points are one-half rather than one wavelength apart. An accuracy of only 1 per cent or so can be expected; receiver or oscillator harmonics should supplement these measurements for greater accuracy.

Lecher Frames

For a quick check of wavelength, any two parallel wires or rods can be used as a quarter wave Lecher frame. The open ends can be held near the oscillator while a screw driver or other shorting bar is run down the rods. The oscillator frequency will change and the output will dip when the Lecher frame crosses resonance. This point will give a close approximation of the frequency if half the shorting bar length plus one conductor from the shorting bar to the end near the oscillator is taken as 0.95 of a quarter wavelength. Accuracy to better than 3 per cent can be expected with this system.

Limitations of Lecher Systems

Lecher wires and frames become less practical at the extremely high frequencies. This is because the corresponding wavelengths become so very short. Consider a point near the middle of the super-high-frequency region, say 13,000 Mc. The corresponding wavelength is 2.3 centimeters and the distance of travel of the shorting bar between half-wave points is only 0.454 inch. The distance of

travel of the bar between the limits of the highest amateur band (21,000 to 22,000 Mc.) would be *one hundredth of an inch*.

It is likely that most of the direct higher-frequency measurements will be made by means of amateur cavity resonators with and without crystal detectors, and that indirect measurements will be made with heterodyne frequency meters employing butterfly circuits or cavity tuners. Detailed descriptions of these devices will appear in our *Ultra-High-Frequency Handbook*.

Receiver Theory

So long as small triodes and pentodes will operate normally, they are generally preferred as u.h.f. tubes over other receiving methods that have been devised. However, the input capacitance of these tubes limits the frequency to which they can be tuned. The input resistance, which drops to a low value at very short wave-lengths, limits the stage gain and broadens the tuning. The effect of these fac-

tors can be reduced by tapping the grid down on the input circuit, if a reasonably good tuned circuit is used.

A mixer or detector can have a gain only of about one-third of that for the same tube used as an r.f. amplifier, so that for gain and principally for satisfactory signal-to-noise ratio, a good r.f. stage is advisable. The first tube in a u.h.f. receiver is most important in raising the signal above the thermal agitation noise of the input circuit, for which reason small u.h.f. types are definitely preferred. Regeneration increases over-all gain without improving the signal-to-noise ratio, provided that increased selectivity in the regenerative stage does not determine the receiver's over-all selectivity.

Superregenerative Receivers

A very effective simple receiver for use at ultra-high frequencies, if properly adjusted, is the superregenerative receiver. The theory of this type is covered in Chapter 4 and is illustrated in Chapter 18.

Superheterodyne Receivers

Although they involve the use of more tubes, superheterodyne receivers are somewhat less critical to adjust properly than the superregenerative type. They have the advantages of not causing broad interference locally, and have greater selectivity. The main problem in them is to obtain adequate oscillator voltage injection so that the conversion gain is satisfactory. Screen or suppressor injection requires a strong oscillator if the mixer tube's grid circuit is properly shielded; if it is not, leakage to the control grid will provide grid injection. The latter (often recommended by tube manufacturers for best gain on ultra-high frequencies) results in greatest "pulling" but this can be eliminated by use of a high intermediate frequency and proper construction.

Cathode injection is not recommended by manufacturers because a long cathode lead increases the *transit time effect* and decreases the apparent input resistance of the tube; however, at very high frequencies, several good receivers have used this variation of grid injection by having the mixer cathode clip tap directly on the oscillator tank with very little inductance from the tap to ground and to the grid and plate r.f. return leads.

A stable hum-free oscillator is necessary in a u.h.f. superheterodyne. Small tubes like the 9002 are satisfactory for this purpose. Heater chokes may reduce hum in cathode-above-ground circuits. Double-oscillator circuits or a very high i.f. can be used to reduce the oscillator frequency. Crystal controlled oscillators can be used when the i.f. channel is a tunable receiver.

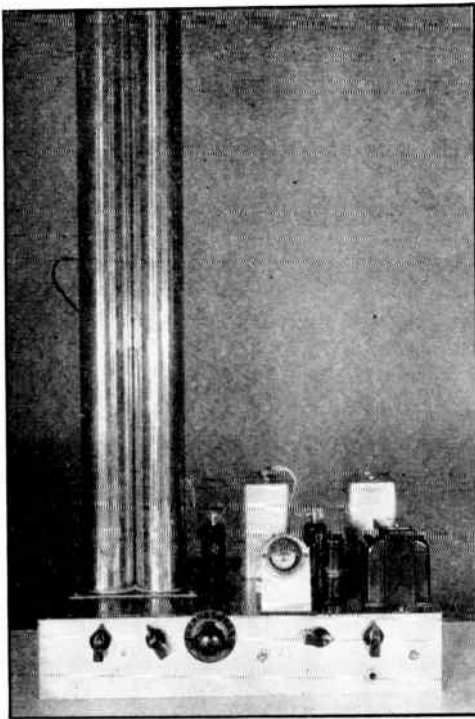

Figure 7.
SUPERHETERODYNE FOR 56 MC.
USING CONCENTRIC TANK
CIRCUITS.

The acorn tubes used in the high frequency stages are located under the chassis. With a slight change in the tank dimensions, this receiver may be used for the 50-54-Mc. band.

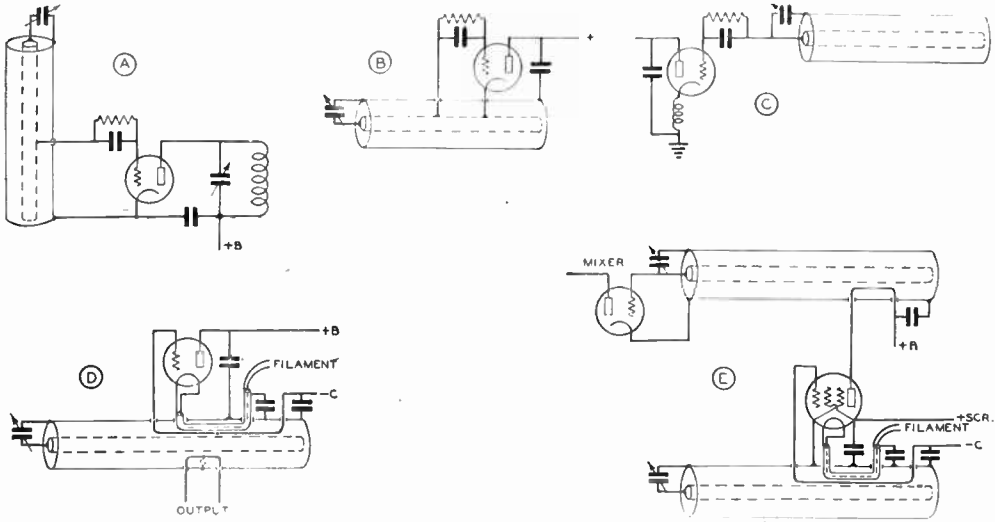

Figure 8.

TYPICAL COAXIAL LINE CONTROLLED OSCILLATOR CIRCUITS.

(A) Concentric-line-tuned grid, coil-tuned-plate oscillator, (B) Cathode-above-ground type oscillator circuit with concentric line. (C) Single control oscillator circuit without tap on a line, although stability can be increased by tapping the grid down. (D) RCA's oscillator circuit used in a broad band transmitter having good stability, requiring only one tuned circuit. (E) Similar to (D) but showing pentode tube and balanced loop coupling to mixer stage. All coaxial tanks are shorted at the end opposite the tuning capacitor.

Here again, an r.f. stage is advantageous to prevent the oscillator from radiating, and to obtain the best signal-to-set-noise ratio, the gain of the r.f. stage being higher than for the mixer, with its output riding over subsequent noise in the receiver. The use of sections of transmission lines instead of coils can improve gain and simplify adjustment and ganging.

High signal input resulting from the use of a carefully designed antenna and feed line, and properly adjusted coupling to the input circuit of the receiver, are essential in obtaining maximum performance. Balanced or shielded feed lines, to reduce pick-up of undesired outside noise, are helpful. The best antenna systems are generally those that are most effective at angles close to the horizontal.

Special Reception Devices

War-time electronic research has produced numerous components and devices which overcome the detrimental effects of high interelectrode capacitances, common impedances, high electron transit time, etc. in higher-frequency receivers and test instruments. These include wave guides, resonant cavities, crystal detectors, special-purpose tubes, etc., which are described later in this chapter.

Transmitter Theory

At ultra-high frequencies, simple but well constructed stabilized oscillators coupled di-

rectly to the antenna are satisfactory for c.w. at 28 and 50 Mc., and for modulated waves above 60 Mc. Master oscillators can be built to drive modulated amplifiers with adequate frequency stability. Where highly stable transmission is desired, however, the tendency among amateurs is to use a crystal or electron-coupled oscillator at a lower frequency, followed by frequency multipliers. This arrangement provides good stability under modulation, but may drift in frequency more with heating than will a well designed transmission-line-controlled u.h.f. oscillator.

Single-ended oscillator and amplifier stages are often used, but there is reason to prefer push-pull circuits in order to reduce tube capacitance across resonant circuits, to obtain bal-

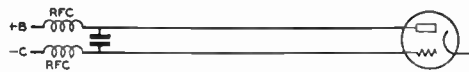

Figure 9.

SIMPLIFIED SCHEMATIC OF SINGLE TUBE OSCILLATOR USING RESONANT LINE WITH PARALLEL CONDUCTORS.

Tubes with an amplification factor of more than 10 are not well suited for use in this circuit. The blocking capacitor serves as a shorting bar when frequency adjustment is required. The amount of feedback can be controlled over certain limits by varying the bias resistor or bias voltage.

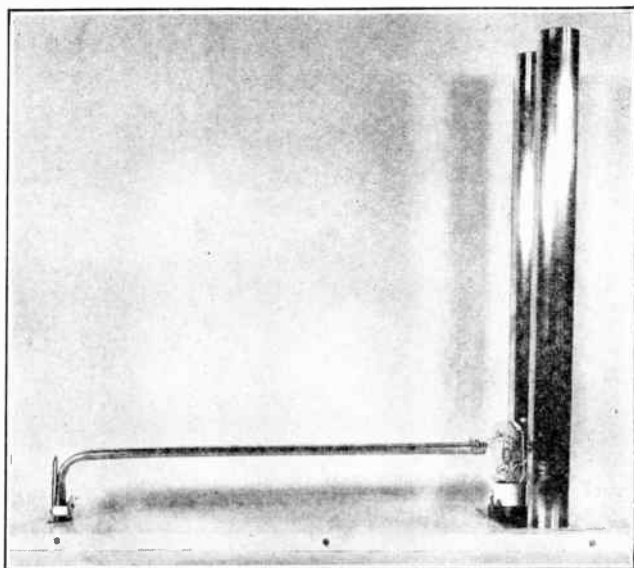

Figure 10.
TYPICAL U.H.F. PUSH-PULL OSCILLATOR USING CLOSE-SPACED RESONANT PIPES FOR FREQUENCY CONTROL.

A "Twin-30" special u.h.f. dual triode is used and permits high efficiency at 224 megacycles. This oscillator is satisfactory for the new 144-148-Mc. and 220-225-Mc. amateur bands, requiring only an alteration in pipe lengths.

anced arrangements, and to reduce the importance of the cathode leads.

In oscillators, it is highly important to have a lightly loaded, high Q circuit to control the frequency. Such circuits can substantially reduce hum, drift, and frequency modulation. Partial neutralization is a help. A concentric line (when not used with a poor loading capacitor) with loose coupling to the grid of the oscillator tube will turn out a good job in a single-ended or push-pull circuit. More commonly, parallel rods are used in push-pull circuits, particularly in plate circuits; if they have a large diameter, remarkably good stability can be obtained.

Due to the appreciable length of cathode leads in terms of wavelength at ultra-high frequencies, push-pull transmitters sometimes become inoperative or unusually inefficient as the frequency is raised. A section of small-size transmission line electrically a half wavelength long can be used to interconnect filaments and place them at ground potential, as indicated by Figure 13. The shorting bar can be moved to the plate where output is greatest or, in some cases, to the only place where oscillation will occur. This application of resonant lines should not be confused with the tuned-plate tuned-grid circuit in which the grid line is moved around to the filament and adjusted to provide the reactance common to grid and plate circuits necessary to maintain oscillation.

Neutralizing capacitors are often used on u.h.f. oscillators, being adjusted on either side of true neutralization, in order to control the amount of feedback and to reduce the effect of tube and plate circuit variations upon the frequency-controlling grid circuit.

Two band operation in oscillators using parallel rods can be arranged conveniently by shorting the open end of the grid control line with a second shorting bar, and readjusting the plate circuit. The resulting half wavelength grid line is loaded by the tube input capacitance, making it desirable to slide the grid taps down farther, and requiring a very much shortened line. For instance, a quarter wavelength grid line on 112 Mc. may be 19 or more inches long, whereas a loaded half wavelength line on 224 Mc. may turn out to be only $9\frac{1}{2}$ inches, making it necessary to slide the upper or second shorting bar down from the former open end of the line.

As in the case of receivers, good antennas

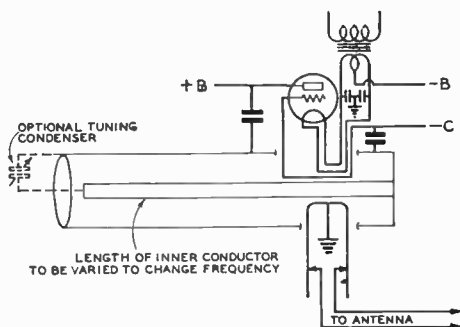

Figure 11.
COAXIAL PIPE OSCILLATOR USING SINGLE TANK CIRCUIT.

The frequency can be varied either by the optional tuning capacitor shown or by varying the length of the inner conductor of the concentric line.

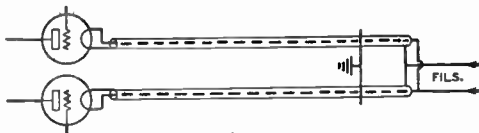

Figure 12.
Arrangement for using shortened $\frac{1}{2}$ -wave line in filament circuit to put both filaments at exact ground potential.

are helpful, and low angle power is most useful. Less trouble is reported with the proper adjustment of antennas for transmitting than for receiving, however, probably because there is power available with which to work.

Amplifier Hints

The driving power required by an amplifier tube can be high if there are leads of any appreciable length from the grid or plate to any tuning capacitor other than one used as a shorting bar on a pair of rods, or if the capacitor has a long inductive path through its frame. The returns from these circuits to the cathode are important, especially in single-ended stages. Lead inductance can be reduced by using copper ribbon or tubing for connections, instead of smaller wire.

Frequency doublers have been used to 224 Mc. Push-pull triplers, especially when some regeneration is permitted by using a dual frequency grid circuit or a tuned cathode circuit, are highly satisfactorily even above 224 Mc. when suitable tubes are used.

Oscillation difficulties often arise in beam tetrodes due to the resonant frequency of the screen circuit. Where this occurs and cannot be corrected by changing the screen by-pass capacitor or its position, a small choke can be inserted in the screen lead before the by-pass capacitor.

Both in receivers and transmitters, regeneration or oscillation often results from the use of cathode bias, not adequately by-passed for u.h.f. Ordinary by-pass capacitors have considerable inductance in them which combined with their capacitance may place a sizable reactance in common with the grid and plate returns. Small silvered mica capacitors have sometimes proved better than units of average size and higher capacitance. Special u.h.f. sockets with built-in by-pass capacitors can be used to advantage above 200 Mc.

SPECIAL HIGHER-FREQUENCY DEVICES

Wave Guides A wave guide is a hollow rectangular or cylindrical metal pipe or tube through which v.h.f., u.h.f., or s.h.f. energy may be transmitted lengthwise.

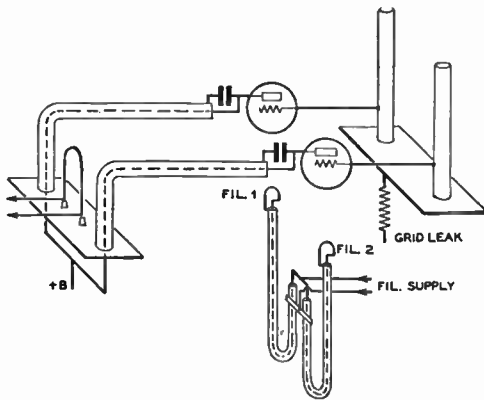

Figure 13.
Practical physical layout for push-pull oscillator using resonant lines in filament, grid, and plate circuits.

The energy passes from one end of the tube, where it is introduced through coupling (capacitive or inductive) or by radiation, to the other end by means of multiple reflections between the inner walls. The reflections resemble those that take place between the earth and ionosphere in sky-wave transmission. And in this respect, one inner wall of the wave guide is analogous to the earth's surface; the other to the ionosphere. All reflections are from the clean, smooth inner walls of the guide. The energy does not penetrate deeply into the wall; hence, the small losses of the wave guide are due mainly to skin effect. Because there is no penetration of energy through the walls, the outer wall of the tube may be grounded at any point.

Output may be taken from a wave guide by means of coupling (electrostatic or electromagnetic) or by radiation. Generally, the same means is employed to extract energy as to excite the wave guide.

Evolution of the wave guide is illustrated by Figure 14. From these sketches, it is seen that the height of the tube must be at least a half-wavelength. Actually, the height usually is made about 0.7 wavelength. If the distance exceeds a half-wavelength, then the parallel open line must be considered as two parallel flat strips rather than wires. The tube width a serves only to establish the voltage breakdown and impedance.

Unlike the transmission line from which it is evolved, the wave guide confines within its walls the energy which it transmits. No radiation and leakage occur. When designed properly for a given set of operating conditions, the wave guide will transmit energy with low loss from one point in a communication system to another.

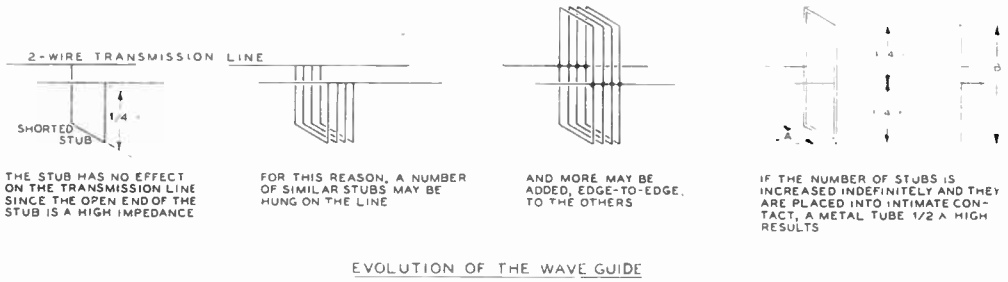

Figure 14.

Propagation velocity through a wave guide is slower than in air, because the wave travels through the guide zig-zagging by reflections instead of directly from input to output end. Figure 15 illustrates propagation of magnetic waves of two different lengths through a guide. The shorter wavelength at (A) undergoes fewer reflections than the longer wavelength at (B), hence is transmitted through the guide more rapidly.

Any wave guide has a definite *cutoff frequency* below which energy will not be transmitted. In this respect, the guide acts as a high-pass filter. This frequency is determined by the cross section of the tube. This may better be understood by considering that waves are reflected successively *across* the tube and are not transmitted at all unless the dimension *b* in Figure 14 exceeds a half-wavelength.

The relationship between the electromagnetic and electrostatic fields and their separate propagation within the wave guide determine the *mode* of propagation. There are several modes, but two general classifications under which they may be grouped—TM (transverse-magnetic) when there is no magnetic or *H* field in the direction of propagation but only an electrostatic or *E* component; and TE (transverse-electrostatic) when there is a magnetic component in the direction of propagation but no electric component. These two classifications are made possible by the fact that if one field has a component in the direction of propagation, the other does not. More

specific designations (such as TE_{0-1}) refer to modes resulting from more complicated reflections and not entirely described by the two general classifications.

Wave guides are extremely useful in transmitting microwave energy, without radiation or interference and with low losses, from one point to another. In one application, the end of the guide is flared out in the shape of a horn, for radiation in one direction.

Energy may be injected into and transferred out of a wave guide by means of small antenna *probes* or loops inserted into each end of the guide. The same sort of device is used at both excitation and pickup ends. The wave guide cross section configuration and the type and placement of the probe should be such as to provide a favorable mode of propagation at the frequency involved. This will insure low loss transmission with a minimum of wave guide area.

Resonant Cavities A *cavity* is a closed resonant chamber made of metal. It is known also as a *rhumbatron*. The cavity, having both inductance and capacitance, supersedes the coil-capacitor tuned circuit at extremely high frequencies where common L and C components, of even the most refined design, prove impractical because of the tiny electrical and physical dimensions they must have. Microwave cavities have high Q factors and are superior to conventional tuned circuits. They may be employed in the manner of an absorption wavemeter or as the tuned circuit in other r.f. test instruments and in microwave transmitters and receivers.

Resonant cavities usually are closed on all sides and all of their walls are made of electrical conductor. However, in some forms, small openings are present for the purpose of excitation. Cavities have been produced in several shapes including the plain sphere, dimpled sphere, sphere with reentrant cones of various sorts, cylinder, prism (including cube), ellipsoid, ellipsoid-hyperboloid, doughnut-shape, and various reentrant types. In appearance,

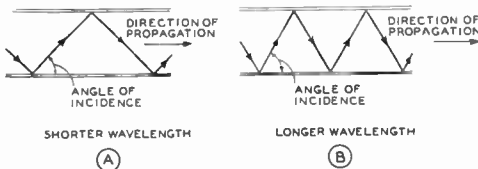

Figure 15. PROPAGATION THROUGH WAVE GUIDE.

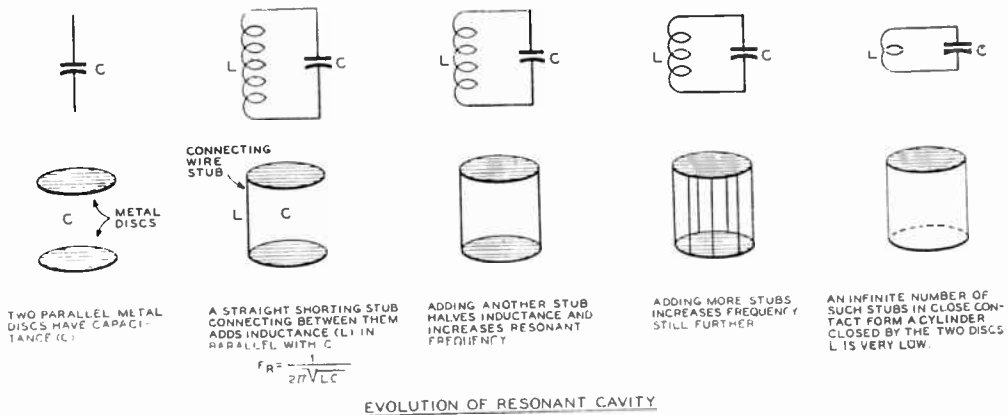

Figure 16.

they resemble in their simpler forms metal boxes or cans.

The cavity actually is a linear circuit, but one which is superior to the *transmission line*. The cavity resonates in much the same manner as does a barrel or a closed room with reflecting walls into which sound is introduced. It is a common experience to have heard the reinforcement of sound of a critical frequency in a room or barrel.

Because electromagnetic energy, and the associated electrostatic energy, oscillates to and fro inside them in one mode or another, resonant cavities resemble wave guides. The mode of operation in a cavity is affected by the manner in which microwave energy is injected. Harmonics of a fundamental frequency may be present.

Figure 16 depicts the evolution of the simple cylindrical cavity. Other shapes may be analyzed in much the same fashion. After such a unit is derived, it remains to inject microwave energy into the cavity to have it resonate at the same frequency as an equivalent L-C tank. Energy may be injected into a cavity by means of a concentric-line probe (Figure 18-A); loop (18-B); hole (18-C); grid-filled holes, as

when the cavity is mounted inside an electron tube (18-D); or by means of an attached wave guide.

The resonant frequency of a cavity may be varied, if desired, by means of a metal sphere, as shown in Figure 17-A, or a movable metal disc (See Figure 17-B). When the disc or slug is at the center of the cavity, the resonant frequency is lowest, because the slug shortens the electrostatic (E) lines and increases the effective capacitance. When the slug is at the top or bottom of the cavity, however, the resonant frequency is highest because the slug shortens the magnetic (H) lines and decreases the effective inductance. A cavity that is too small for a given wavelength will not oscillate.

The resonant frequencies of simple spherical, cylindrical, and cubical cavities may be calculated simply for one particular mode. Wavelength (in centimeters) is indicated by the following simple resonance formulae:

- For Cylinder $\lambda_r = 2.6 \times \text{radius}$
- " Cube $\lambda_r = 2.83 \times \text{half of one side}$
- " Sphere $\lambda_r = 2.28 \times \text{radius}$

Butterfly Circuit

Unlike the cavity resonator which in its conventional form is a fixed-frequency device, the butterfly circuit is a tunable v.h.f. device which permits coverage of a microwave band. The butterfly circuit is very similar to a conventional coil-variable capacitor combination, except that both inductance and capacitance are provided by what appears to be a variable capacitor alone. The Q of this device is somewhat less than that of a concentric-line tuned circuit but is entirely adequate for numerous applications.

Figure 19-A shows construction of a single butterfly section. The butterfly-shaped rotor, from which the device derives its name, turns

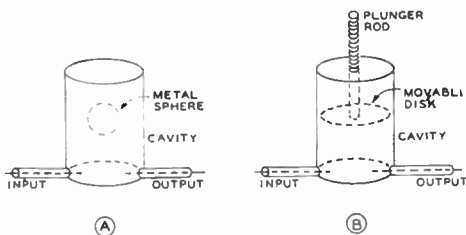

Figure 17. TUNED RESONANT CAVITIES.

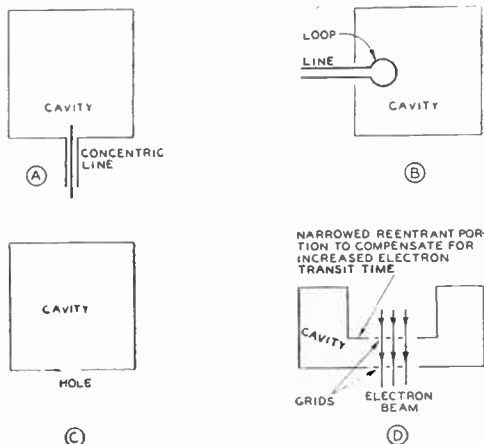

Figure 18.
METHODS OF EXCITING RESONANT CAVITIES.

in relation to the unconventional stator. The two stator "fins" or sectors are in effect joined together by a semi-circular metal band, integral with the sectors, which provides the circuit inductance. When the rotor is set to fill the loop opening (the position in which it is shown in Figure 19-A), the circuit inductance is reduced to minimum. When the rotor occupies the position indicated by the dotted lines, the inductance is maximum. Inductance variation in practical butterfly circuits is in the ratio of 1.5:1 to 3.5:1.

Direct circuit connections may be made to points A and B. If balanced operation is desired, either point C or D will provide the "center-tap" (electrical mid-point). Coupling may be effected by means of a small single-turn loop placed near point E or F. The butterfly thus permits continuous variation of both capacitance and inductance, as indicated by the equivalent circuit in Figure 19-B, while at the same time eliminating all pigtailed and wiping contacts.

Several butterfly sections may be stacked in parallel in the same way that variable capaci-

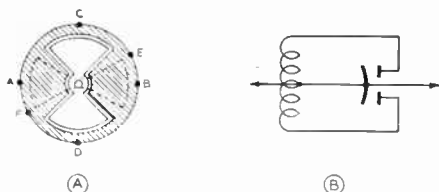

Figure 19.
BUTTERFLY CIRCUIT.

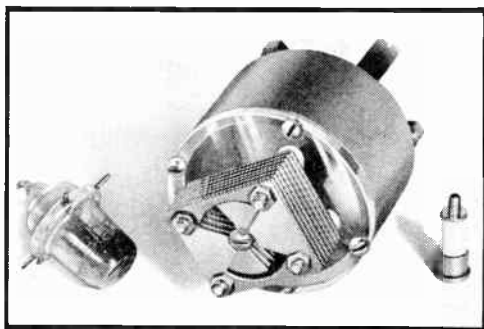

Figure 20.
900-3000-Mc. Butterfly Circuit. Acorn tube and 1N22 crystal detector are shown for size.
Courtesy General Radio Co.

tors are built up. In stacking these sections, the effect of adding inductances in parallel is to lower the total circuit inductance, while the addition of stators and rotors raises the total capacitance, as well as the ratio of maximum to minimum capacitance. Figure 20 is a photograph of a stacked butterfly unit designed to tune from 900 to 3000 Mc.

Butterfly circuits have been applied specifically, at this time, to test oscillators and heterodyne frequency meters in the 100-1000-Mc. group. One recently announced heterodyne frequency meter includes a 100-200-Mc. butterfly oscillator to provide a frequency measuring range of 10 to 3000 Mc.

Special Grid-Controlled and Diode Tubes Tubes employing the conventional grid-controlled and diode rectifier principles have been modernized, through various expedients, for operation at frequencies as high, in some new types, as 1000 Mc. Beyond that frequency, electron transit time becomes important and new principles must be enlisted. In general, the improvements have consisted of (1) reducing electrode spacing to cut down electron transit time, (2) reducing electrode areas to decrease interelectrode capacitances, and (3) shortening of electrode leads either by mounting the electrode assembly close to the tube base or by bringing the leads out directly through the glass envelope at nearby points. Through reduction of lead inductance and interelectrode capacitances, input and output resonant frequencies due to tube construction have been increased substantially.

Tubes embracing one or more of the adaptive features just outlined include the later locktall types (particularly the 1.4-volt series), high-frequency acorns, button-base types, and the new lighthouse types. Type 6J4 button-base triode will reach 500 Mc. Type 6F4 acorn

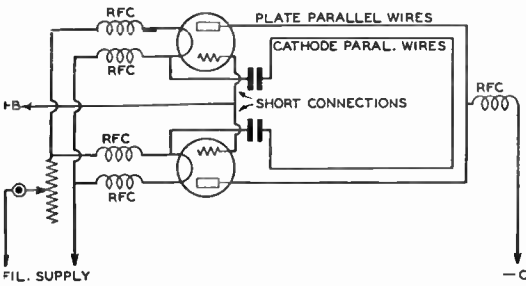

Figure 21.
KOZANOWSKI OSCILLATOR.

This type of u.h.f. oscillator requires the use of tubes having cylindrical elements, such as the HK-24 and 54, 35TG and 75T, 1628 and 852, and HY-75. Certain receiving tubes such as the 7A4, 955, etc., may also be used for lower power outputs. The grid dissipation of the tubes is the most important limiting factor on their power output.

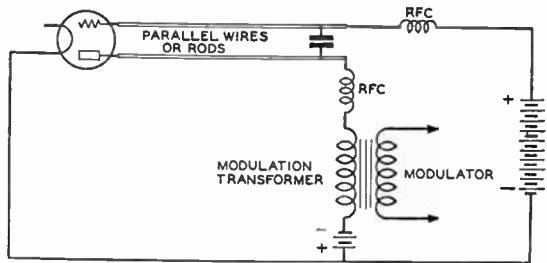

Figure 22.
BARKHAUSEN-KURTZ OR GILL-MORRELL OSCILLATOR.

As with all oscillators of the electron-orbit type, the grid dissipation will be very high and the oscillator tube should have cylindrical elements. This circuit may also be used as a detector for micro wave signals, with the transformer feeding into an audio amplifier instead of being fed audio energy for modulation.

triode is recommended for use up to 1200 Mc. Type 1A3 button-base diode has a resonant frequency of 1000 Mc., while type 9005 acorn diode resonates at 1500 Mc. The 829-B and 832-A push-pull transmitting beam power types will give full rated c.w. output at 200 Mc. Type 826 transmitting triode will give 80% of normal rated output at 300 Mc., while type 8012 u.h.f. transmitting triode will give full output at 500 Mc.

Electron-Orbit Oscillator

The range of oscillation in ordinary circuits is limited by the time required for electrons to travel from cathode to anode. This transit time is negligible at low frequencies, but becomes an important factor below 5 meters. With ordinary tubes, oscillation cannot be secured below 1 meter, but by means of *electron-orbit oscillators*, in which the grid is made positive and the plate is kept at zero or slightly negative potential, oscillation can be obtained on wavelengths very much below 1 meter.

Parallel-wire tuning circuits can be connected to these tube oscillators in order to increase the power output and efficiency. The tubes most suitable for this type of operation have cylindrical plates and grids, and their output is limited by the amount of power which can be dissipated by the grids. For transmitting, tubes such as the 35T, HK-54, 852, etc., can be used in the circuit shown in Figure 21, which is a modification of the circuit of Figure 22. More output is obtained by using a tuned-cathode circuit instead of tuned-grid circuit. Modulation can be applied to either the plate or grid. The frequency stability is very poor. Use is limited to unmodulated service.

Regenerative Oscillators

The introduction of RCA "acorn" tubes made low power 1/2-meter regenerative oscillators practical. These tubes are more efficient than ordinary types for ultra-high-frequency work, and are available in several types in both 6.3 v. and 1.4 v. series. They are satisfactory for low-power transmitters and super-regenerative receivers. The regenerative circuits are quite similar to those for longer wavelengths, except for the physical size of capacitors and coils. The tube element spacing in these acorn tubes is made so small that electron transit time becomes a negligible factor for wavelengths above 0.6 meter.

Acorn tubes are also made in r.f. pentode amplifier types, both sharp cutoff and remote cutoff. However, these require concentric tank circuits below 2 1/2 meters, because at such high frequencies it is impossible, due to high losses, to obtain appreciable gain (high Q) with conventional tanks.

For higher power oscillators, special transmitting tubes designed for microwave work are offered by several manufacturers, notably Western Electric, Hytron, RCA and Eimac. The HK-24 also makes an excellent microwave tube when two are used in push-pull.

For maximum output at 2 1/2 meters and shorter wavelengths, filament chokes are sometimes required. One way to avoid the necessity for filament chokes and at the same time increase the efficiency is to substitute a tuned filament circuit for the usual tuned grid circuit, by-passing the grids to ground.

Microwave regenerative oscillators are most efficient when linear tank circuits are used in place of coils, and when two tubes are used

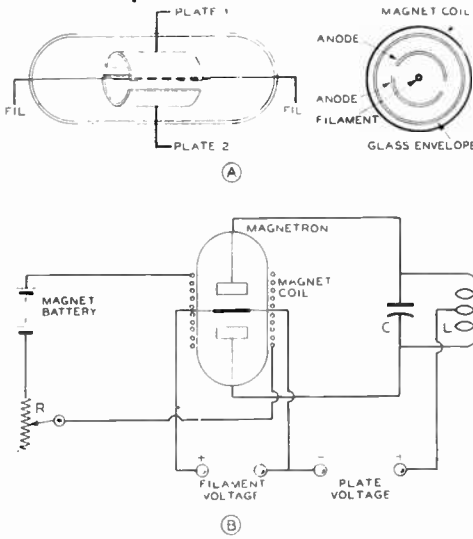

Figure 23.
DETAILS OF SIMPLE MAGNETRON AND CIRCUIT.

in push-pull. Maximum output and efficiency cannot be obtained with single-ended circuits.

Magnetron Oscillators

In its simplest form, the magnetron tube is a filament-type diode with two half-cylindrical plates or anodes situated coaxially with respect to the filament. This construction is illustrated by Figure 23-A. The magnetron is connected to a resonant circuit, as shown in Figures 23-B and 24. The tube is surrounded by an electromagnet coil which, in turn, is connected to a d.c. energizing source through a rheostat, R, for controlling the strength of the magnetic field. The coil is so arranged with respect to the tube that the lines of force it sets up are parallel to the axis of the electrodes.

Under the influence of the strong magnetic field, electrons leaving the filament are deflected from their normal paths and move in circular orbits within the anode cylinder. This effect results in a negative resistance which sustains oscillations. The oscillation frequency is very nearly the value determined by L and C, in Figure 23-B. In other magnetron circuits, the frequency may be governed by the electron rotation, no external tuned circuits being employed. Wavelengths of less than 1 centimeter have been produced with such circuits.

Figure 24 shows a split-anode magnetron connected to a parallel-line tank circuit.

More complex magnetron tubes employ no external tuned circuit, but utilize instead one or more resonant cavities which are integral

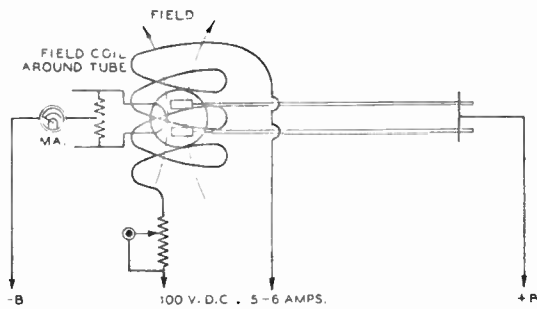

Figure 24.
SPLIT-ANODE MAGNETRON MICRO WAVE OSCILLATOR

Special magnetron tubes delivering several watts output at extremely high frequencies are available for certain experimental purposes. Their main disadvantage for amateur work is that they are rather difficult to obtain. Also, a source of d.c. of large magnitude is required for the field electromagnet.

with the anode structure. Figure 25 shows a cross-sectional view of a magnetron of this type having four anodes. The filament (cathode) runs through the center of a smaller common chamber, and the latter is connected to the four resonant cavities by means of accurately dimensioned slots. The entire structure is derived from a solid copper block. Relatively high efficiencies and fractional centimeter operation characterize this type of magnetron oscillator. Power outputs as high as 300 watts have been obtained with the multi-segment magnetron.

The Klystron

The Klystron is a specialized microwave tube which depends upon velocity modulation of an electron stream for its operation. In various sizes, this tube is employed as a voltage amplifier, power amplifier, superheterodyne oscillator or mixer, detector, and frequency multiplier. The Klystron removes the necessity (so important in

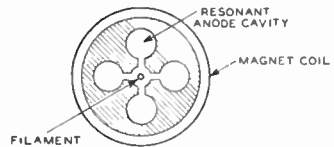

Figure 25.
CONSTRUCTION OF THE MULTI-SEGMENT MAGNETRON.

This tube has its anode split to form four units and four internal chambers which act as resonant cavities.

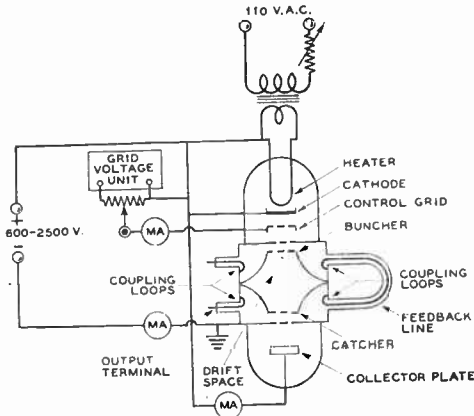

Figure 26.
KLYSTRON OSCILLATOR.

conventional grid-controlled tubes) of limiting electron transit time to a fraction of the time required for one microwave cycle. Extremely high frequencies are reached with the Klystron.

In addition to heater, cathode, and control grid (which, together, form an electron gun), and a collector plate, two cavity resonators of reentrant shape are included in the Klystron tube. One of these, known as the *buncher*, immediately follows the control grid. The electron beam from the gun section enters the buncher through a grid in the aperture in one of its reentrant walls and leaves through a similar grid aperture in the other parallel reentrant wall. The second cavity, known as the *catcher*, follows the buncher and has a similar pair of grids in its own parallel reentrant walls. Buncher and catcher are mounted "back-to-back" to provide a *drift space* for the electron beam passing from one cavity to the other. This tube construction is shown in Figure 26.

The electron beam from the gun comes under the influence of the electrostatic field between the two buncher grids as the beam passes through the buncher apertures. The grid field is oscillating if the buncher cavity is being excited by oscillating energy, and this field is parallel to the electron beam which it acts alternately to accelerate and retard. The beam thus becomes velocity-modulated. If the Klystron is being used as an amplifier, the input signal is applied as excitation to the buncher cavity.

When the electron beam reaches the drift space, where there is no field, those electrons which have been sped up on one-half-cycle overtake those immediately ahead which were slowed down on the other half-cycle. In this way, the beam electrons become bunched to-

gether. As the bunched groups pass through the two grids of the catcher cavity, they impart some of their energy to these grids. The catcher grid-space is charged to different voltage levels by the passing electron bunches, and a corresponding oscillating field is set up in the catcher cavity. The catcher is designed to resonate at the frequency of the velocity-modulated beam.

In the Klystron amplifier, energy delivered by the bunches to the catcher grids is greater than that applied to the buncher cavity by the input signal. In the Klystron oscillator (Figure 26), a feedback loop connects the two cavities. Coupling to either buncher or catcher is provided by small loops which enter the cavities by way of concentric lines, as shown in Figure 26.

The Klystron is an electron-coupled device. When used as an oscillator, its output voltage is rich in harmonics. Klystron oscillators of various types afford power outputs ranging from less than 1 watt to several hundred watts. Beam efficiencies vary between 50 and 75 percent. Frequency may be shifted to some extent by varying the beam voltage. One type of Klystron has exhibited a frequency change of 19.6 kc. per volt at beam voltages around 950 v. Tuning is carried on mechanically in some Klystrons by altering (by means of knob settings) the shape of the resonant cavity.

Microwave Amplifiers It is extremely difficult to get into operation any type of amplifier circuit of the conventional type at a frequency greater than about 250 Mc. The main reasons for this difficulty have been the extremely high amounts of loading of the inter-electrode capacitances, the high inductances of leads to elements, and the practical impossibility of obtaining a satisfactory neutralizing arrangement. However, the Klystron was described in the preceding section as a tube which may be employed as a microwave amplifier. In addition to the Klystron, there is available another ingenious electron tube which makes use of a resonant cavity in the output circuit. This tube, the RCA 825, is recommended as an amplifier at microwaves. At 500 Mc., its power output is 35 watts. Figure 27 shows the circuit arrangement of the 825 amplifier.

Crystal Rectifier More than two decades have passed since the crystal (mineral) rectifier enjoyed widespread use in radio receivers. Low-priced tubes completely supplanted the fragile and relatively insensitive crystal detector, although it did continue for a few years as a simple meter rectifier in absorption wavemeters after its demise as a receiver component.

Today, the crystal detector is of new im-

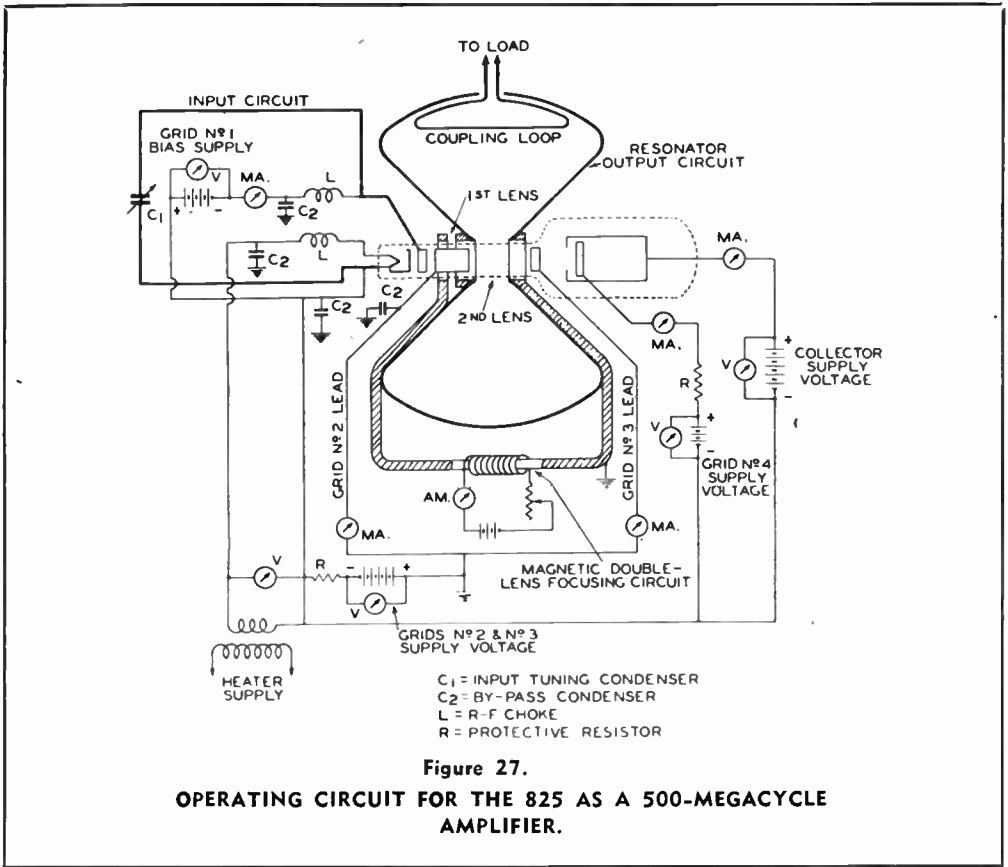

portance in microwave communication. It is being employed as a detector and as a mixer in receivers and test instruments used at extremely high radio frequencies. At some of the frequencies employed in microwave operations, the crystal rectifier is the only satisfactory detector or mixer. The chief advantages of the crystal rectifier are very low capacitance, freedom from transit-time difficulties, and its two-terminal nature. No batteries or a.c. power supply are required for its operation.

The crystal detector consists essentially of a small piece of some satisfactory mineral, such as galena (natural lead sulphide), or metal, such as silicon, mounted in a base of low-melting-point alloy and contacted by means of a thin, springy feeler wire known as the *cat whisker*. This arrangement is shown in Figure 28-A.

The complex physics of crystal rectification is beyond the scope of this discussion. It is sufficient to state that current flows from several hundred to several thousand times more readily in one direction through the contact of cat whisker and crystal than in the opposite direction. Consequently, an alternating cur-

rent (including one of microwave frequency) will be rectified by the crystal detector. The load, through which the rectified currents flow, may be connected in series or shunt with the crystal, although the former connection is most generally employed. Certain spots on the crystal surface afford more intense output currents than others and these accordingly are searched for with the cat whisker.

If the cat whisker is by some means permanently secured in contact with a very sensitive spot, a *fixed crystal detector* is obtained which

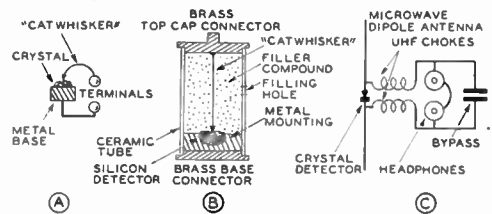

Figure 28.
MICROWAVE CRYSTAL DETECTOR.

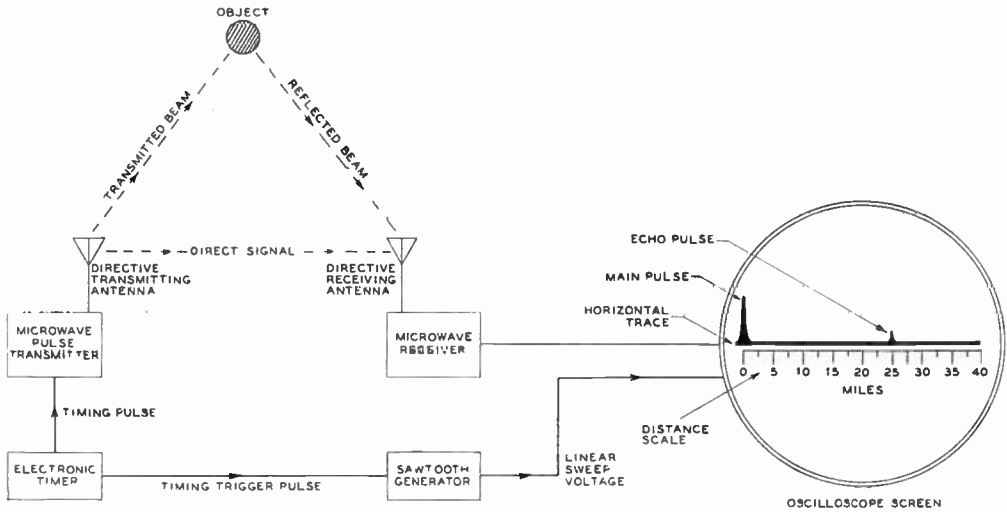

Figure 29.
RADAR SYSTEM.

requires no further adjustment. The basic arrangement of a modern fixed crystal detector developed during World War II for microwave work, particularly radar, is shown in Figure 28-B. Once the cat whisker of this unit is set at the factory to the most sensitive spot on the surface of the silicon crystal and its pressure is adjusted, a filler compound is injected through the filling hole to hold the cat whisker permanently in position. This filler probably is a cold flowing and hardening material, since most hot substances destroy sensitive spots of crystals. This same crystal detector unit appears beside the butterfly circuit in the photograph, Figure 20.

Crystal detectors have lower output than vacuum tubes used in the same circuit positions, and are damaged easily by strong local signals which destroy their sensitive spots. However, when these units follow radio-frequency amplifiers or heterodyne oscillators, the impressed signal may be limited to a safe value by means of careful circuit design and adjustment. Sufficient audio amplification following a crystal detector, or i.f. amplification following a crystal mixer will compensate for the reduced output.

Figure 28-C shows the simplest microwave receiver employing a crystal detector. If the headphones are replaced with a d.c. microammeter, the arrangement may be used as a simple field strength meter.

Radar

Some of the principles which have made war-time radar possible undoubtedly will be

applied to certain phases of civilian electronics. Radar itself probably will be employed on air lanes, ship lanes, and railroads. For these reasons, no microwave discussion would be complete without some description of the radar process. The present edition of this Handbook will not attempt to give specific circuit and antenna data for radar equipment, because of the limited amount of technical data cleared for civilian consumption up to the time of this writing, and also because the editors are unable yet to estimate the extent of amateur interest in this subject. Nor can it be expected that all phases of radar can be covered in this limited space.

In one radar system, which has been selected for explanation, distant objects may be detected and their distances and directions from the search point determined. The block diagram of Figure 29 illustrates the basic arrangement of this type of radar. Transmitter, receiver, timer, and viewing apparatus comprise a single unit.

In this arrangement, a microwave transmitter sends short pulses in a straight line out from a directive antenna pointed toward the distant object or target. The transmitted pulses are high powered and of short duration. Each is only one to several microseconds long. The transmitter "keying" is controlled by an electronic timer which sets the rate at which pulses are transmitted. The repetition rate may be such that several thousand pulses of r.f. energy are transmitted each second. Between pulses, the transmitter is quiescent.

The pulse-modulated beam from the trans-

mitting antenna strikes the object and is reflected by the latter. A portion of the reflected energy reaches the receiving antenna. Meanwhile, the receiving antenna also picked up an earlier signal when the pulse first left the transmitting antenna. Two separated signals thus are received—one direct; the other reflected.

Output voltages from the receiver are presented to the vertical deflection plates of a cathode ray oscilloscope, and accordingly tend to trace vertical lines on the oscilloscope screen. The horizontal plates of the oscilloscope receive linear sweep voltage from a sawtooth-wave generator. The latter is synchronized by the same electronic timer that originates the transmitter keying pulse.

When the timed pulse first leaves the transmitting antenna, it actuates the receiver and oscilloscope. At this same instant, the electronic timer triggers the sawtooth generator and starts the horizontal trace on its way across the oscilloscope screen. The net result is that the transmitted pulse appears on the screen. In the ensuing interval, while the pulse-modulated beam is traveling to the object and back again, both transmitter and receiver are quiescent. But upon arrival of the reflected beam, the *echo* pulse is reproduced on the screen a short distance to the right of the direct pulse. Unless the beam strikes an object, there will be no echo pulse on the screen. The elapsed time interval between transmitted pulse and received echo can be determined easily from their spacing on the screen, since the linear sweep frequency is known and from this may be found the number of microseconds per inch of horizontal trace. The horizontal trace thus is the electronic stop-watch of this system.

The velocity of all radio waves is approximately 186,000 miles per second. The distance of the object accordingly may be determined by multiplying 1.86 by one-half the elapsed time between the pulses (one-half the time because the beam must make a round trip). For a direct-reading scale, the horizontal axis of the oscilloscope screen may be graduated in miles, as shown in Figure 29. With this arrangement, adjustments are made to set the initial pulse to

zero. The distance of the object then may be determined by noting the position of the echo pulse on the mileage scale.

The transmitter beam is interrupted thousands of times each second. However, each pulse is so short that the quiet period between pulses is long by comparison. The transmitted pulses are spaced so as to allow sufficient time for the echo to be received before another pulse is transmitted. Otherwise, the second transmitted pulse might obliterate the echo from the first one. The transmission of a large number of pulses accomplishes two purposes—it maintains images on the screen by persistence of vision, and it enables the viewing operator to detect objects that move from front to back in the search beam.

Since the transmitting antenna array must be pointed directly at the object, both the horizontal and vertical angles of the antenna may be measured, and thus the azimuth and elevation of the object. An object moving to or from the transmitter shows up as an echo pulse that moves across the viewing screen at the same speed. A narrow search beam is transmitted. No object, conducting or non-conducting, can escape detection, although some targets return a stronger reflected signal than others. Nor are darkness or fog of any moment. As in shooting, the larger target is the more vulnerable.

There are several methods of pulsing a microwave transmitter. The nearest equivalent to simple keying would be the use of a mechanical interrupter to turn the transmitter on and off repetitively. However, electronic timing and keying circuits offer the advantages of accuracy of adjustment, simple maintenance, and no moving parts. The timer portion of these circuits usually is based upon the multi-vibrator or blocked oscillator principle.

Large amounts of peak power are transmitted in the pulse-modulated beam. *Peak* power in the pulses may attain several hundred kilowatts, although the *average* and *r.m.s.* power (with which we usually are concerned) may be rated only in watts. This is one of the interesting and useful characteristics of steep pulses. Steep, narrow pulses are especially suited to sounding and radar.

U. H. F. Receivers and Transceivers

50-54-MC. CONVERTER

For receiving stabilized amplitude modulated signals in the 50-54-Mc. band, an ordinary communications receiver can be used in conjunction with a suitable converter. The converter illustrated in Figures 1 and 2 will be found highly sensitive and ideal for the job.

A high gain mixer using either an 1852 or 1231 receives injection voltage from a 6C5, 6J5, or 7A1 "hot cathode" oscillator.

Construction

The photograph illustrates the layout. A small stock cabinet and the chassis designed for it form the basis for the unit. Mounted in

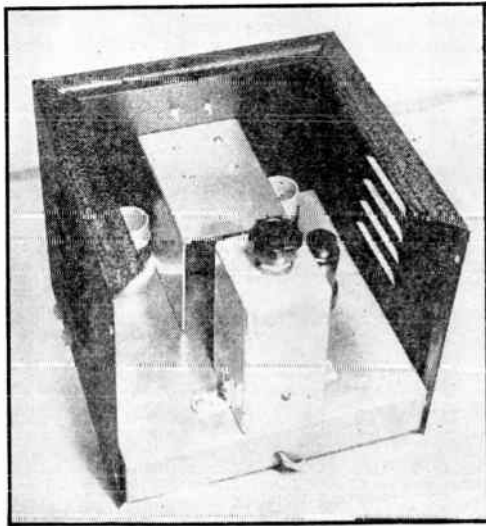

Figure 1.
INSIDE THE 1852 U.H.F. CONVERTER CABINET.

The two-gang tuning capacitor is under the U-shaped shield between the two coils. The can in the foreground houses the output coil, L_1 , and its trimmer, C_1 . Directly behind this can and hidden from view is the 1852; the 6C5 may be seen to the right.

the center of the panel is a small 25- μ fd. per section dual-stator variable. The section nearer the panel, tuning the mixer input, has only one remaining stator plate; the rear portion, for the oscillator, has all but two stator plates removed. This capacitor is mounted with the four tapped holes in the frame pointing upward. These holes are then used to support a shield which in addition to covering the capacitor also acts as a baffle between the two coils.

Directly back of the tuning gang is the 1852 mixer; to the left is the oscillator coil, and to the right, the mixer coil. The can behind the 1852 contains a tuned output coil and link coupling to the receiver used as an i.f. channel. Below the tuning gang is a 15- μ fd. trimmer on the mixer to eliminate tracking problems on separate bands.

All oscillator leads should be made rigid to avoid shock detuning of the circuit. The ground leads are all brought to one point, which is even more advisable in the mixer circuit where an extra fraction of an inch in the cathode lead, common to both the grid and plate returns, is undesirable in that it affects the gain.

The converter is designed to work into a receiver tuned to a spot between 3000 and 3500 kc. The output coil L_1 is simply a midget b.c.l. antenna coil of the type having a low impedance primary. The coil is tuned by the mica trimmer C_1 and used backwards, the "primary" acting in this case as the secondary.

In some cases, operation will be improved by connecting a .0005- μ fd. midget mica capacitor directly from the plate of the 6C5 to ground.

Adjustment

The first step in lining up the converter is to adjust the output circuit to resonance with the receiver used as an i.f. amplifier. This is easily done, inasmuch as the receiver noise, due both to shot effect in the mixer tube and signal or background racket at the i.f. increases when the circuit is brought in tune. The oscillator can be tuned around to locate a signal, but an easier way to set the oscillator is to

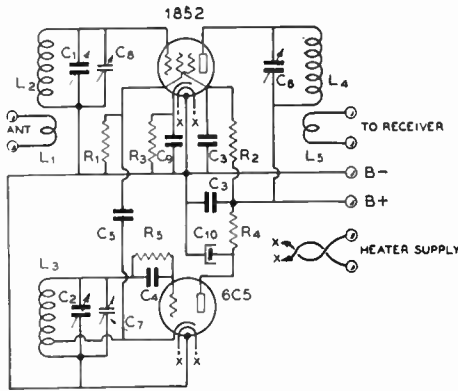

Figure 2.
GENERAL WIRING DIAGRAM OF THE 1852 CONVERTER.

- C₁, C₈—Dual 25- μ fd. midget, altered as described in text
- C₂—0.01 μ fd. mica
- C₃, C₄—0.00005- μ fd. mica
- C₅—100 μ fd. mica trimmer
- C₆—25- μ fd. air trimmer
- C₇—17.5- μ fd. midget
- C₈—0.01- μ fd. mica
- C₁₀—8- μ fd. 450-volt electrolytic
- R₁—25,000 ohms, 1/2 watt
- R₂—40,000 ohms, 1 watt
- R₃—1500 ohms, 1 watt
- R₄—5000 ohms, 1 watt
- R₅—50,000 ohms, 1/2 watt
- L₁—3 turns at cold end of L₃
- L₂—3 turns on 1" form spaced dia. of wire
- L₃—3 3/4 turns on 1" form spaced dia. of wire. Cathode tapped 3/4 turn from cold end
- L₄, L₅—Solenoid type midget b.c.i. antenna coil, half of turns removed from both windings

listen for it in an all-wave receiver and set it at 28 Mc. plus the i.f.

When this adjustment has been made, there remains only to line up the mixer input circuit on outside noise or on a signal, using the trimmer on the panel (which also acts as a gain control). Ordinarily it will be necessary to obtain proper antenna coupling, inasmuch as high antenna pick-up and transfer to the mixer input will be important in determining weak-signal sensitivity and signal-to-noise ratio.

Voltage Regulation If plate voltage fluctuations are sufficient to cause an objectionable shift in the oscillator frequency, as might be the case with an ac. power pack running from a line to which several large intermittent loads are connected, the oscillator plate voltage can be stabilized simply by hooking a VR-150-30 type voltage regulator tube between the low side of R₁ and ground. The VR tube should be shunted by a .05- μ fd. tubular capacitor. The plate supply should have at least 225 volts for the VR tube to function properly.

112-350-MC. SUPERREGENERATIVE RECEIVER

The superregenerative receiver illustrated in Figures 3-6 can be used between 112 and 350 Mc. by means of plug-in inductances. With the shortest possible jumper of no. 8 wire plugged into the coil socket, the frequency is about 350 Mc.

The oscillator utilizes a 9002 or 6C4 midget triode. The important feature of the oscillator is the use of the smallest possible components and shortest possible leads, with nothing but Isolantite or polystyrene insulation comprising or touching the r.f. components.

To obtain the shortest possible leads, the tube is mounted on its side as illustrated in Figure 5. An Amphenol polystyrene crystal

holder socket is used as a coil jack. The tuning capacitor is the smallest size air trimmer with all but one stator and one rotor plate removed, the two plates being double spaced. The shaft is driven through a ceramic insulated coupling.

No regeneration control is provided, the antenna coupling being increased to the greatest value which will permit superregeneration.

Considerable feeder loss will be present at 224 Mc. and higher, even with the best transmission line. Therefore, the transmission line should be as short as possible, besides being of good quality.

The 112-Mc. coil consists of 6 turns of no. 14 enamelled wire on a 1/2-inch inside diameter, spaced to 3/8 inch. The ends are sweated into "phone tip" plugs or pins from the base of a discarded tube having less than 8 prongs.

The 220-Mc. coil consists of a 4 1/2-inch length of no. 8 bare copper wire bent into the shape of a "U." For higher frequencies, up to

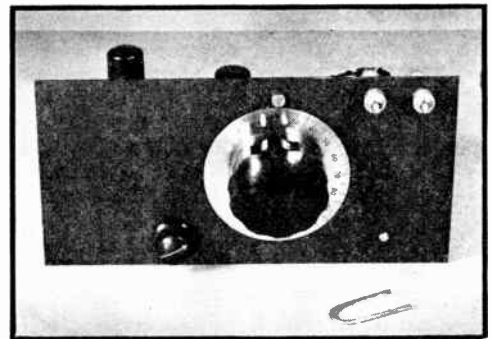

Figure 3.
SIMPLE RECEIVER FOR USE BETWEEN 112 and 350 MC.

The set is a superregenerative with a 9002 oscillator and plug-in inductances. The "coil" in the foreground is for 224 Mc.

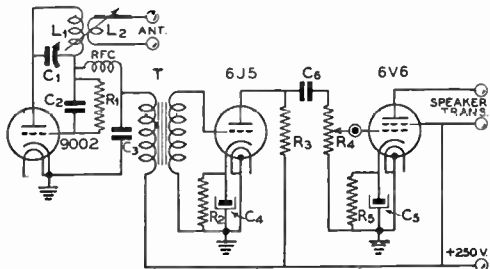

Figure 4.

WIRING DIAGRAM OF U.H.F. SUPERREGENERATOR.

- C₁—Small "trimmer" type 5-plate midget variable air capacitor with all but one rotor and one stator plate removed, the two remaining plates being double spaced
- C₂—Smallest size 50- μ fd. mica fixed capacitor
- C₃—.006- μ fd. mica
- C₄, C₆—10- μ fd. 25 v. electrolytics
- C₅—.05- μ fd. tubular paper
- R₁—500,000 ohms, $\frac{1}{2}$ watt
- R₂—2000 ohms, $\frac{1}{2}$ watt
- R₃—50,000 ohms, $\frac{1}{2}$ watt
- R₄—100,000-ohm pot., a.f. taper
- R₅—400 ohms, $\frac{1}{2}$ watts
- L₁—Refer to text
- L₂—1 or 2 turns hookup wire coupled to L₁, using fewest no. of turns which will permit sufficient coupling
- T—Midget 1-3 ratio interstage transformer

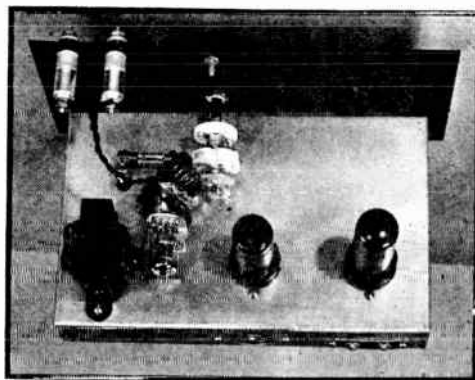

Figure 5.

CONSTRUCTION DETAILS OF U.H.F. SUPERREGENERATOR.

All r.f. components are placed as close together as possible. All insulation is either polystyrene or Isalantite.

approximately 350 Mc., a correspondingly shorter "U" is required.

The frequency of the 112-Mc. coil may be adjusted to hit a desired band by spreading or compressing the turns. The higher frequency "coils" can be similarly adjusted (but over narrower limits) by shoving them in or out of the coil socket a short distance.

The last filter capacitor in the power pack feeding the receiver should have a capacity of at least 8 μ fd. or else there may be a tendency for the receiver to "motorboat."

By carefully adjusting the number of turns

in the coils, and their spacing by cut and try, this receiver may be made to cover the 144-148 and 220-225-Mc. amateur bands.

It is inadvisable to permit the plate voltage to be applied to the detector tube for more than a few seconds when it is not oscillating, as the high value of plate current drawn by the tube in a non-oscillating condition is sufficient to damage the tube if allowed to persist.

The two feed-through type antenna terminal insulators are satisfactory for a close-spaced, 2-wire open line. Such a line is less expensive than a good low loss coaxial line, but will radiate considerably on 220 Mc. meters. If a coaxial line is to be used, a coaxial type terminal connector should be substituted.

112-MC. SUPERHET FOR EITHER AMPLITUDE OR FREQUENCY MODULATION

The 112-Mc. superheterodyne illustrated in Figures 7-10 provides excellent performance on either amplitude modulated (a.m.) or frequency modulated (f.m.) signals. The i.f. channel is broad enough that amplitude modulated oscillators can be received satisfactorily if the oscillator is reasonably stable.

High sensitivity is provided by the use of an acorn pentode and a coaxial pipe tank circuit in the mixer, in conjunction with control grid injection of the oscillator voltage.

Although the circuit constants shown are for 112-Mc. operation, this receiver may easily be adapted to the new 144-148-Mc. amateur band by experimental reduction of the length of the coaxial tank and by removing a few turns from the "hot" end of coil L₁.

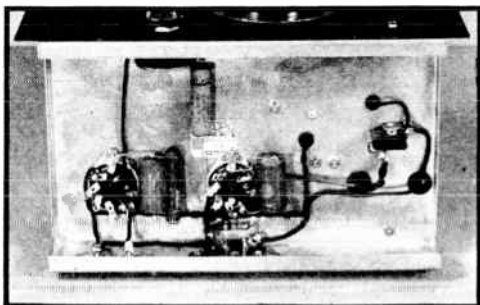

Figure 6.

UNDER-CHASSIS VIEW OF U.H.F. SUPERREGENERATOR.

Placement and wiring of the a.f. and d.c. components is not particularly critical.

For reception of amplitude modulated signals, the limiter is "opened up" by means of switch S_1 (which is operated by turning R_1 full off) and the 6H6 discriminator is changed to a diode demodulator by means of switch S_2 .

Construction

The chassis, which is surmounted by an 8 x 17-inch panel, measures 7 x 15 x 3 inches. The 956 is located near the left rear corner of the chassis, with its concentric grid tank running along the rear of the chassis, as is apparent from the photographs. The concentric tank is held to the chassis by two copper straps, one near each end. The mixer grid capacitor is placed between the 956 and the left edge of the chassis, making it convenient to secure short leads to both the mixer and the inner conductor of the tank circuit.

To help in obtaining short leads, the oscillator socket has been mounted with its base above the chassis, making it necessary that the 6J5GT be located under the chassis. The oscillator grid coil is supported from the tuning capacitor on one end and the no. 1 socket terminal on the other. The plate by-pass, C_{21} , is located right at the socket and connected in the shortest possible manner between the plate and no. 1 terminal. A dial having a built-in planetary reduction unit is used on the oscillator to allow accurate tuning.

To aid in isolating the oscillator and mixer

from each other so that the injection may be controlled by pushing the lead from the mixer grid in and out of the outside conductor of the mixer tank circuit, a 3 x 4-inch copper shield is placed between the two stages. The shielding is supported by small angle brackets.

The first i.f. transformer, T_1 , is located directly in front of the mixer, with the first 1852 between this transformer and the panel. The second i.f. stage with its associated transformers, T_2 and T_3 , runs along the front of the chassis from left to right. Behind T_3 is the 6SJ7 limiter, which feeds through the discriminator transformer at its right to the 6H6 discriminator between the transformer and the panel. The audio follows along the right edge of the chassis, while the VR-150 regulator is located behind T_4 .

The only wiring precaution that needs to be observed is keeping the grid and plate leads short. This holds for the i.f. section as well as for the high frequency circuit. No regeneration trouble in the i.f. section should be experienced if the grid and plate leads run directly from small holes below the i.f. transformer to their proper terminating point on the sockets.

The mica by-pass and coupling capacitors in the mixer and oscillator sections should be of the smallest physical size available, since a physically small .00005- μ fd. capacitor will often prove to be a better by-pass or coupling



Figure 7.

LOOKING DOWN FROM THE FRONT OF THE 112-MC. F.M.-A.M. RECEIVER.

The adjustable coupling lead from the oscillator grid through the concentric mixer grid tank is visible in this photograph. The controls are, from left to right, mixer tuning, oscillator tuning, limiter "threshold" and limiter cut out, audio gain, and f.m.-a.m. switch.

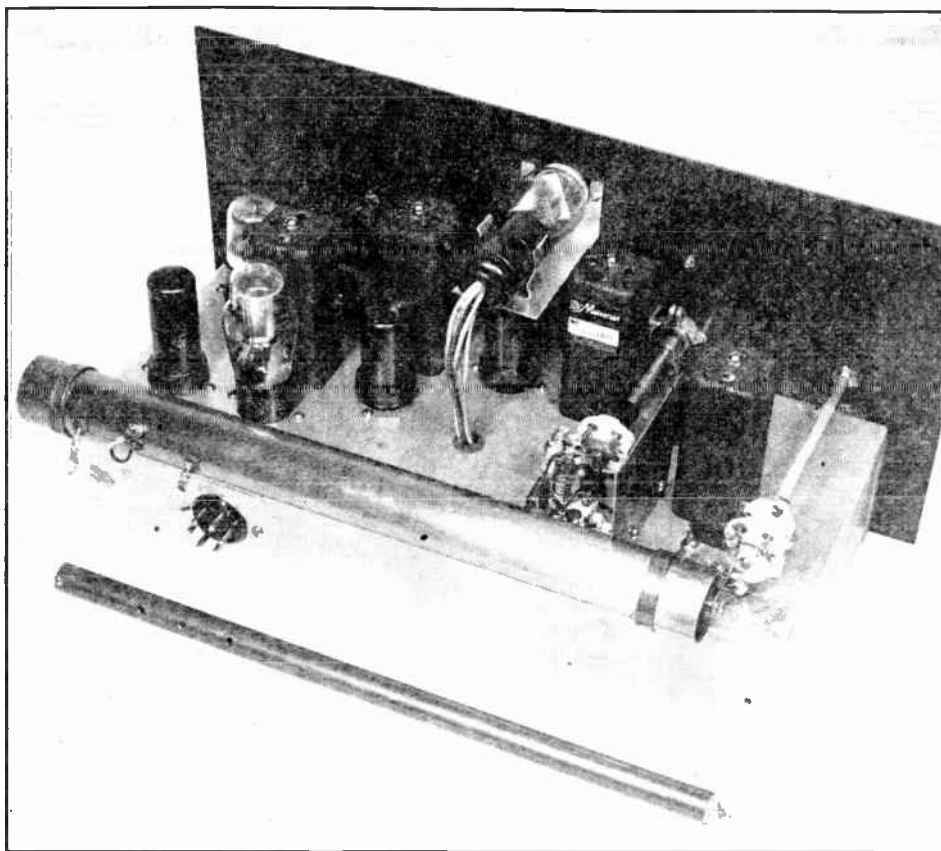

Figure 8.

CONSTRUCTION DETAILS OF THE 112-MC. F.M.-A.M. RECEIVER.

The outer conductor of the concentric pipe tank is held firmly and grounded electrically to the chassis by means of a narrow copper strap at each end of the tank. The shield partition between the oscillator and mixer circuits is necessary for good stability. The smaller diameter tank shown in the foreground works almost as well as the large one, and may be substituted if desired. The inner conductor of the smaller tank is held in position at the unshorted end by means of a polystyrene spacer.

device at 112 Mc. than a .002- μ fd. or larger mica capacitor having proportionately larger dimensions.

The Coaxial Tank The mixer tank consists of a 14-inch length of $1\frac{3}{8}$ -inch copper pipe as the outer conductor and a $\frac{3}{16}$ -inch copper tubing inner conductor. These conductors give a radius ratio of approximately 7-1, which seems to be a good compromise between impedance, Q, and overall tank size.

No actual "shorting disc" is used with the line shown in the receiver. The inner conductor is merely flattened at the "closed" end of the tank and two short right-angle bends

made to allow it to be held to the outer conductor with a screw. This method is perfectly permissible where extremely high Q in the line is not necessary.

The antenna coupling "loop" is a piece of no. 10 wire covered with "spaghetti" where it is inside the tank, and supported within the tank by being run through tight fitting grommets in the outer conductor. A lead soldered to the center of the loop inside the tank is brought out and provided with a lug to enable the center of the loop to be grounded when a balanced, 2-wire feeder is used. The end of the loop nearest the shorted end of the tank is grounded when a single-feeder type antenna is used. The loop is $2\frac{1}{2}$ inches wide, but

Figure 9.
WIRING DIAGRAM
OF THE
F.M.-A.M.
RECEIVER.

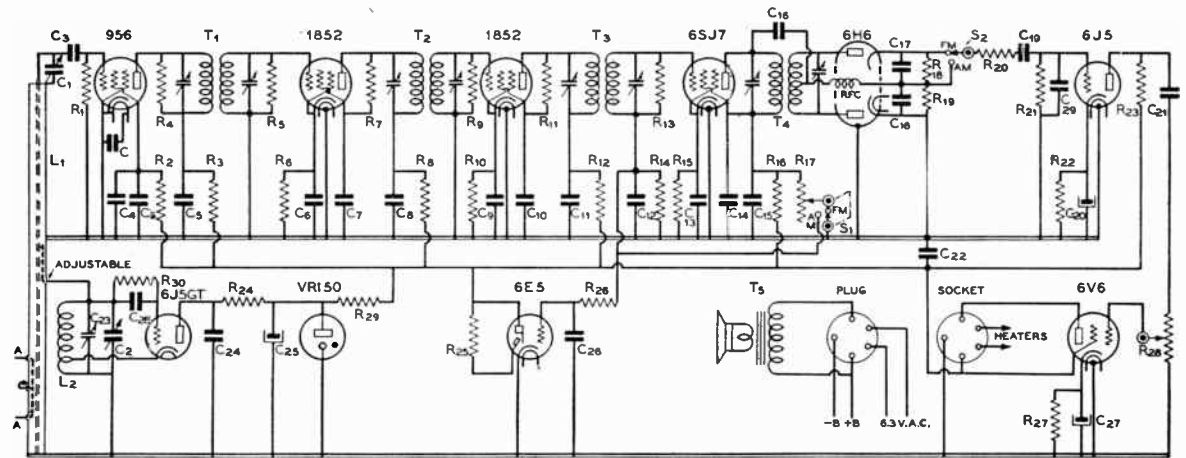

VALUES OF COMPONENTS

- C₁—0.001- μ fd. mica
- C₂—7- μ fd. midget with one stator plate removed
- C₃—15- μ fd. midget variable
- C₄, C₅—0.001- μ fd. mica
- C₆, C₇, C₈, C₉, C₁₀, C₁₁—0.1- μ fd. 600-volt tubular
- C₁₂—0.001- μ fd. mica
- C₁₃, C₁₄, C₁₅—0.1- μ fd. 600-volt tubular
- C₁₆—0.0005- μ fd. mica
- C₁₇, C₁₈—0.001- μ fd. mica
- C₁₉—0.1- μ fd. 600-volt tubular
- C₂₀—10- μ fd. 25-volt electrolytic
- C₂₁—0.1- μ fd. 600-volt tubular
- C₂₂—0.1- μ fd. 600-volt tubular
- C₂₃—2-35- μ fd. mica trimmer
- C₂₄—0.005- μ fd. mica
- C₂₅—8- μ fd. 450-volt electrolytic
- C₂₆—0.1- μ fd. 600-volt tubular
- C₂₇—10- μ fd. 25-volt electrolytic
- C₂₈—0.001- μ fd. mica
- C₂₉—0.005- μ fd. mica
- C₃₀—5 megohms, 1/2 watt
- C₃₁—100,000 ohms, 1 watt
- R₁—2000 ohms, 1/2 watt
- R₂—50,000 ohms, 1/2 watt
- R₃—150 ohms, 1/2 watt
- R₄—30,000 ohms, 1 watt
- R₅—2000 ohms, 1/2 watt
- R₆—50,000 ohms, 1/2 watt
- R₇—150 ohms, 1/2 watt
- R₈—30,000 ohms, 1 watt
- R₉—2000 ohms, 1/2 watt
- R₁₀—2000 ohms, 1/2 watt
- R₁₁—30,000 ohms, 1 watt
- R₁₂—2000 ohms, 1/2 watt
- R₁₃—50,000 ohms, 1/2 watt
- R₁₄—250,000 ohms, 1/2 watt
- R₁₅—100 ohms, 1/2 watt
- R₁₆—75,000 ohms, 1 watt
- R₁₇—10,000-ohm wire-wound potentiometer
- R₁₈—100,000 ohms, 1/2 watt
- R₁₉—100,000 ohms, 1/2 watt
- R₂₀—50,000 ohms, 1/2 watt
- R₂₁—500,000 ohms, 1/2 watt
- R₂₂—2000 ohms, 1/2 watt
- R₂₃—50,000 ohms, 1 watt
- R₂₄—3000 ohms, 1 watt
- R₂₅—1 megohm, 1/2 watt (supplied with 6E5 socket assembly)
- R₂₆—1 megohm, 1/2 watt
- R₂₇—500 ohms, 10 watts
- R₂₈—500,000-ohm potentiometer
- R₂₉—3000 ohms, 10 watts
- R₃₀—100,000 ohms, 1/2 watt
- T₁, T₂, T₃, T₄—3000 kc. output i.f. transformer. See text for alterations to T₄
- T₅—Pentode-plate-to-voice coil transformer (on speaker)
- S₁—5-p.d.t. switch (on R₁₇)
- S₂—S.p.d.t. toggle switch
- RFC—2 1/2 mhy.
- L₁—14" copper concentric line. Outer conductor 1 3/8" o.d., inner conductor 3/16" o.d. See text
- L₂—5 turns of no. 16 bare copper, 1/4" inside diameter and wound to a length of 1/2". Cathode tap 1 1/2 turns from ground end

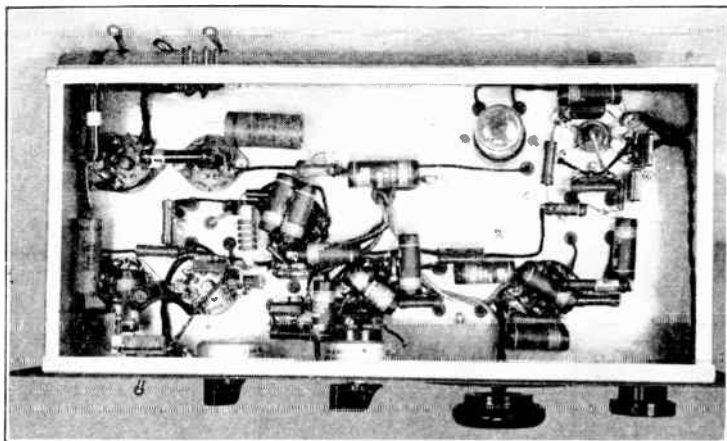

Figure 10.
UNDER-CHASSIS
VIEW.

The 956 mixer and the 6J5GT oscillator may be seen under the chassis of the receiver. The two lugs protruding from the concentric tank at the upper left of the photograph are for antenna connections.

experiment will probably be necessary to obtain optimum coupling with lines of different impedance than the 400-ohm feeder used with the original receiver. Coupling adjustments are made by pushing the loop toward or away from the inner conductor.

If desired, a smaller diameter tank may be used, so long as the outer conductor is at least $\frac{1}{2}$ inch in diameter and the conductor ratio is kept between 6 and 10. Unless the ratio is exactly 7, the length of the tank will have to be altered slightly. The performance will be practically as good as with the $1\frac{3}{8}$ inch diameter tank.

The Discriminator Transformer As received from the manufacturer the transformer, T_4 (located between the 6SJ7 and the 6H6 in the wiring diagram, Figure 9 on page) has no center tap on its secondary; neither does it have sufficient coupling to serve well as a discriminator transformer. Consequently, the transformer must be altered as follows: After removing the transformer from its shield can, the lower winding, which is to become the secondary, is completely unwound from the dowel. If the unwinding is done carefully a narrow ridge of the compound, with which the windings are impregnated will be left on each side of the space the winding occupied. These ridges will form a sort of "slot" in which to rewind the wire which has been removed. It will be found that about 65 turns of wire were on the winding, but it will be impossible to get more than 55 to 58 turns back in the slot by hand scramble-winding methods. In the receiver shown, a trial re-winding of the wire indicated that 56 turns could be replaced, necessitating that the center tap be brought out at the 28th turn.

After the secondary has been rewound on

the dowel, it should be thoroughly covered with Duco cement or a similar coil compound, and allowed to dry for an hour or more. When the cement has dried thoroughly, it will be found that a firm pressure against the winding will allow it to be slid along the dowel toward the primary to increase the coupling between the windings. The proper location for the secondary is a position where the distance between the adjacent edges of primary and secondary is about $\frac{1}{8}$ inch. Another coating of Duco cement or coil dope will hold the winding in place, and the transformer may be re-assembled in its original shield can and installed in the receiver.

Adjustment

Aligning the I.F. Channel There is no really simple way of accurately aligning the i.f. and discriminator in an f.m. receiver. The inclusion of a 6E5 "magic eye" tube operating from the voltage developed across the limiter bias does help considerably, however, aside from its intended use as an accurate tuning indicator for placing f.m. signals "on the nose." Probably the easiest method of aligning the receiver is first to couple loosely an ordinary tone-modulated signal generator to the plate of the mixer stage. With both switches set for "a.m." make a rough alignment for maximum audio output. This assumes that the i.f. transformers are somewhere in the vicinity of alignment so that some sort of signal may be forced through the i.f. channel to get a start on the trimming process. If no signal is heard at the output when the signal generator is applied at the mixer plate and tuned around over a narrow range around 3000 kc., it must be assumed that the i.f. transformers are considerably out of alignment and the usual procedure of first coupling the signal generator to the primary of the last i.f. transformer (T_4)

and then working back toward the mixer stage must be followed.

After a rough setting of the trimmers has been made the alignment may take on a more exact nature. With the signal generator still applied to the primary of T_1 , but with switch S_1 changed to the "f.m." position by cutting in all of R_{11} , each trimmer on the first three i.f. transformers should be adjusted for maximum voltage across R_{11} , as indicated by the closing of the "eye." Next, the setting of the trimmer across the secondary of T_1 should be tackled—and here is where the trimming becomes critical. Since the trimmer adjusting screw is "hot" for r.f., the tool used for this adjustment should be of the low-capacitance type having a long composition or wood handle.

The discriminator output switch, S_2 , should be thrown to the "f.m." position and—assuming that the primary of T_1 has been set up somewhere near resonance in the previous rough alignment—tuning the secondary winding through resonance should give a very sharp and definite drop in the audio output, the audio-tone volume increasing on either side of resonance but dropping to a very low value or disappearing entirely at exact resonance. The signal from the signal generator should be kept at i.f. resonance, as indicated by the 6E5, during the alignment.

The last adjustment to be made should be that on the primary of T_1 . There are two ways of getting this circuit properly tuned. Probably the simplest method is to keep the signal generator tuned right in the "notch" of the secondary winding but increase the amount of signal applied to the i.f. channel until a small amount of audio comes through at this frequency and then tune the primary winding for maximum decrease or "dip" in the remaining audio.

The other method of trimming the primary involves rocking the signal generator back and forth across the resonant frequency previously obtained, observing the strength of the peaks in audio output which are heard on each side of the "notch." When the primary is properly tuned, these peaks will be symmetrically located, one on each side of the "notch" frequency, and of equal strength. If the i.f. loading resistors are of the values indicated under the diagram, and the coupling between the primary and secondary of T_1 has been properly adjusted, the peaks will be approximately 130 kc. apart.

Those who find it more convenient to use an unmodulated signal at the i.f. frequency and a vacuum-tube voltmeter on zero-center high-resistance voltmeter to align the i.f. and discriminator may do so by connecting the indicating instrument between the top of R_{11} and

ground and, after aligning the i.f. transformers up to T_2 by the 6E5, adjusting T_1 so that zero voltage is obtained at the center of the i.f. band, and equal and oppositely-polarized voltages are obtained for equal and opposite shifts in signal-generator frequency from center frequency. When a vacuum-tube voltmeter is used for this adjustment it will be necessary to place a battery in series with the instrument to bring it somewhere near half scale.

R. F. Alignment There is little that need be said about tuning up the front end of the receiver, since the only problem is to find the band. The simplest way to do this is to hunt for a 112-Mc. signal with the oscillator padding capacitor, C_{21} , keeping the mixer grid aligned by following with C_{11} . In the absence of signals, the best procedure would be to set the oscillator tuning capacitor at mid-scale and adjust the padding capacitor so that the oscillator is on a frequency 3000 kc. lower than the center of the band, or 111 Mc. The frequency should be measured by Lecher wires, the proper distance between points being very close to 53 inches. A detailed discussion of the use of Lecher wires is given in Chapter 17. The glow in the VR-150 makes a fairly good resonance indicator for this purpose.

Lining up the mixer grid involves only tuning the mixer grid capacitor and adjusting the antenna and oscillator coupling for maximum background or signal. The two coupling adjustments will be found to be somewhat interdependent, and should be adjusted simultaneously. The mixer coupling is not extremely critical, however, and optimum results should be obtained over a wide range of injection voltage. Two inches of wire available for pushing through the grommet and into the mixer grid tank will provide sufficiently wide range of coupling from the oscillator. Too little coupling will result in a loss of sensitivity, while too much coupling will cause bad pulling of the oscillator by the mixer tuning. Fortunately, maximum sensitivity is realized with quite a bit less coupling than is required to cause serious pulling.

50-54-Mc. Operation This receiver makes an excellent 50-54-Mc. f.m. superheterodyne if a suitable coil is substituted for the coaxial mixer tank and a larger coil is substituted for the high frequency oscillator tank. No other changes need be made.

400-MC. SUPERREGENERATOR OR TRANSCEIVER

Illustrated in Figures 11-17 is a highly effective 400-Mc. superregenerative receiver of a design by J. C. Reed. Amateur transmission on

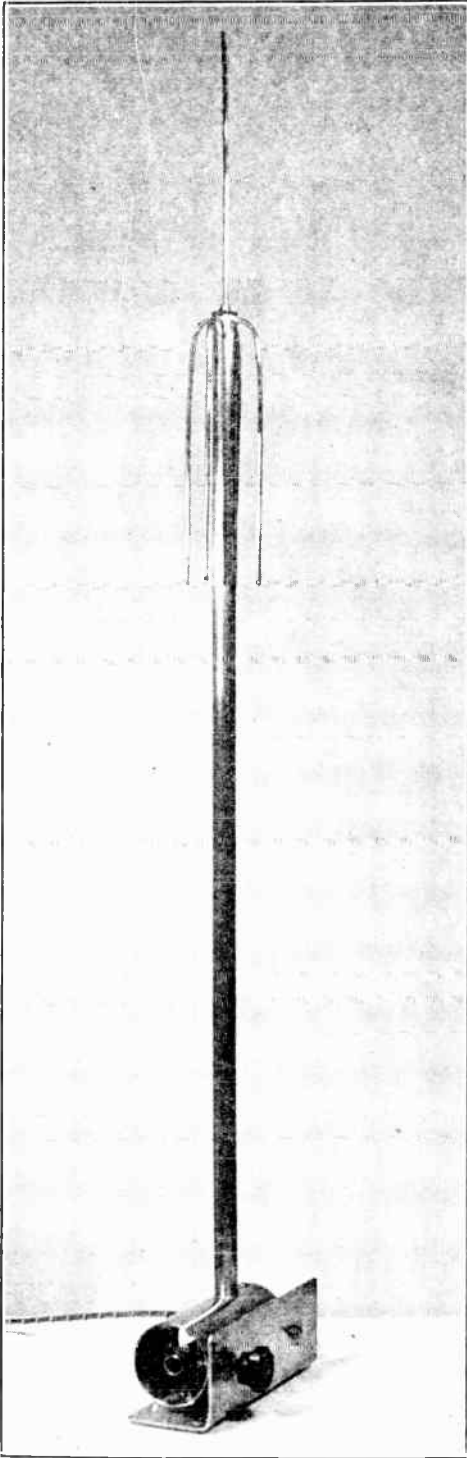

400 Mc. is no longer permissible. However, this circuit is wide-range in tuning and will cover the new 420-450-Mc band.

Losses in the transmission line are minimized by making it as efficient as possible and limiting its length. The antenna, coaxial feeder, and oscillator are constructed as an integral unit. The a.f. section is conventional, and is housed in a separate unit. It may be patterned after that of Figure 4, for use only as a receiver, or after Figure 24 if it is to be used as a transceiver.

For fixed station use, the unit may be mounted outdoors with the oscillator proper in a weatherproof "dog house" and tuned remotely either by means of a small, reversible "tuning motor" such as that employed on some broadcast sets, or else by means of cord and pulleys. If such an arrangement is impractical, the oscillator may be placed in the operating room and the outdoor antenna fed by means of "u.h.f. type" coaxial cable of about 30 ohms. However, the latter arrangement will not be as efficient because of the losses on even the best line at this very high frequency.

For mobile use in an auto, the oscillator may be mounted on a small projecting shelf fastened by means of removable clamps to the car window sill. This will put the radiating portion of the antenna above the top of the car on most of the later models.

The oscillator is of the cathode-above ground type using a concentric line. This concentric line is made of a 2-inch copper pipe $4\frac{1}{2}$ inches long for the outside conductor, and a $\frac{1}{2}$ -inch copper pipe of the same length for the inside conductor.

The diameter of the inner conductor is not critical. For maximum Q the ratio of conductors should be about 3.6, although a much higher value can be used without a noticeable effect.

The cathode connection and one filament connection are tied together by a copper bar soldered directly to the inner conductor 1 inch from the end. Grooves are filed in the bar for the cathode and filament leads in such a way that the tube is held in place by a plate held over the two leads, and thereby acting as a support for the tube. A copper strip is connected to the other filament lead and run down alongside the inner conductor to the cold end of the pipe. This filament lead is insulated from the inner conductor by a thin sheet of

Figure 11.

400-MEGACYCLE OSCILLATOR.

This oscillator may be used either as a super-regenerative receiver or as a transceiver. An acorn type 955 triode is used.

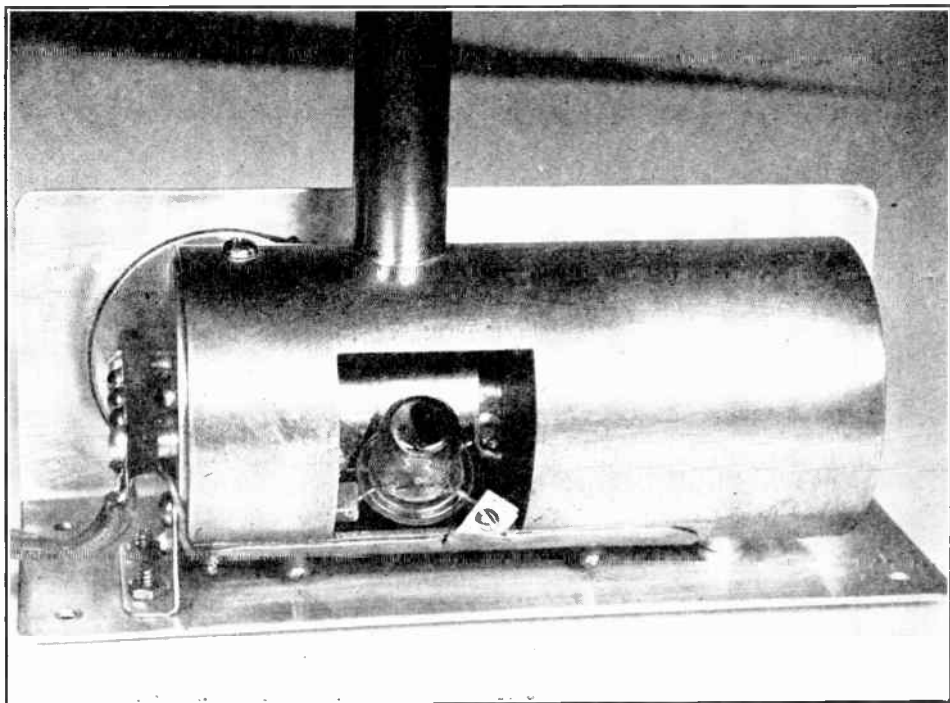

Figure 12.
CONSTRUCTION OF MICROWAVE "PIPE" OSCILLATOR.
 A portion of the outside pipe is cut away to permit installation of the tube.
 Observe the "built in" by-pass capacitors.

mica. Equal results can be obtained with the filament lead down through the inside of the inner conductor by drilling a hole in the $\frac{1}{2}$ -inch pipe near the cathode connection. If this type of connection is used, the filament wire will have to be by-passed to ground at the cold end of the pipe.

The grid is connected approximately half way up the pipe through a mica capacitor consisting of a copper band $\frac{3}{32}$ inch wide, insulated by a thin sheet of mica. The band is a tight fit over the mica and the pipe. A 2-megohm grid resistor is connected from the grid capacitor to the inner pipe.

The plate by-pass to ground is a copper plate $3 \times 1\frac{1}{4}$ inches, and is insulated from the outer conductor by mica.

Tuning is accomplished by varying the distance of a copper sheet $1\frac{1}{2}$ inches wide alongside the end section of the inner conductor. This sheet is of hard-drawn copper so that it will spring back on its own accord, thereby simplifying tuning arrangements. A string belt is run around the tuning shaft to a pulley $1\frac{3}{4}$ inches in diameter to act as a tuning indicator. With this size tuning capacitor the re-

ceiver will tune from approximately 325 to 476 Mc.

In mounting the attached concentric feed line for the antenna, a $\frac{1}{2}$ -inch hole is cut in

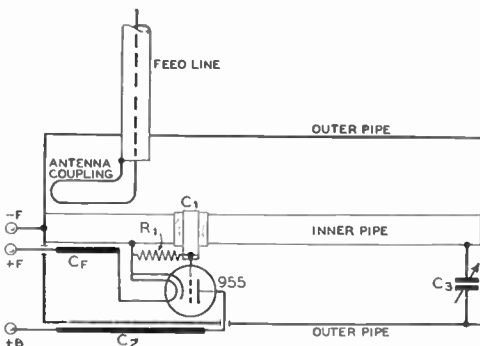

Figure 13.
SCHEMATIC DIAGRAM OF MICRO-WAVE RECEIVER.

R_1 has a value of 2 megohms. Capacitors C_1 , C_2 , and C_3 are described in the text. Tuning capacitor C_3 is shown in detail in Figure 15.

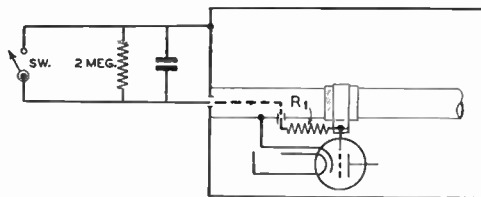

Figure 14.
BASIC MODIFICATION FOR TRANSMITTER USE.

Resistor R_1 is chosen so as to make the tube draw normal plate current as a transmitter. It normally will be between 5000 and 20,000 ohms, $\frac{1}{2}$ watt. Plate voltage when transmitting should not exceed about 150 volts.

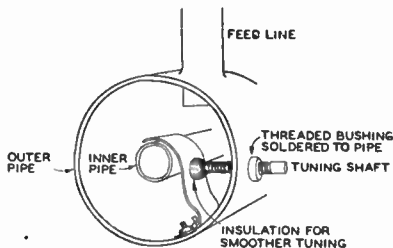

Figure 15.
TUNING ARRANGEMENT.

The tuning shaft is turned by means of a small knob, and a cable around the shaft drives an indicator which is provided with a large pulley as described in the text.

the 2-inch pipe near the closed end so that the $\frac{1}{2}$ -inch pipe can be soldered directly to the oscillator. An alcohol torch or very heavy soldering copper will be required. The inner conductor of the concentric feed line is connected to a $\frac{1}{4} \times 1\frac{1}{2}$ -inch copper strip. The other end of this strip is connected to the 2-inch pipe in such a manner that the antenna coupling can be varied by sliding the feed line closer to or farther from the inner conductor of the oscillator.

If a conventional type coaxial line is to be used, a regular terminal connector can be mounted on the outside pipe conductor about $1\frac{1}{2}$ inches up from the bottom, and the hair-pin coupling loop arranged the same as for the integral feed line.

If the oscillator is placed some distance from the rest of the receiver, the by-pass capacitor for the quench frequency component (usually .002 to .006 μ fd.) should be placed

directly across the terminals of the oscillator marked "B plus" and "F minus." If this is not done, radiation from the wire carrying the quench component may cause bad hash in neighboring broadcast receivers.

In Figure 14 is shown the basic modification for using the oscillator in a transceiver arrangement. The resistor R_1 ordinarily will be

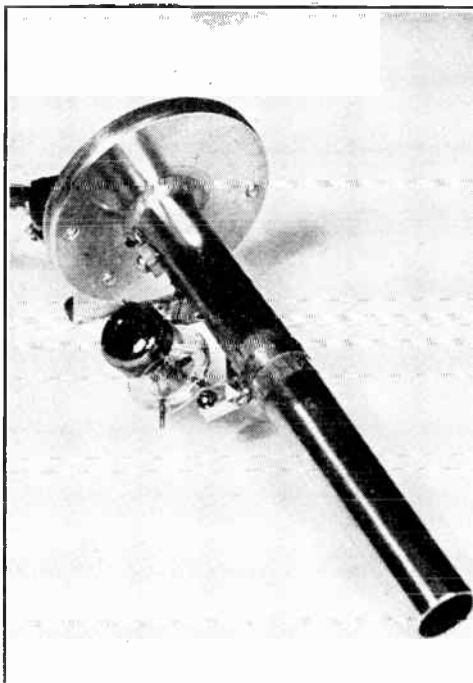

Figure 17.
CONSTRUCTION DETAIL OF OSCILLATOR.

The assembly shown below can be slid out intact after the plate connection to the 955 is disconnected.

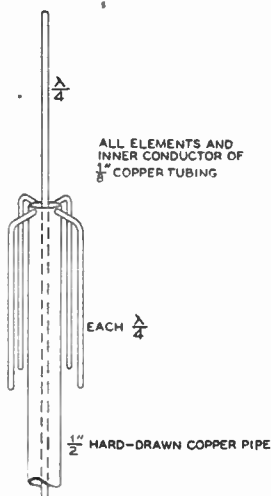

Figure 16.
DETAIL OF RADIATOR AND FEED LINE.

The inner conductor is kept in place by means of three or four polystyrene centering washers cemented in place with liquid polystyrene.

from 5000 to 20,000 ohms, $\frac{1}{2}$ watt. SW is one section of the transceiver send-receive switch. (See Figure 24.) The midget mica by-pass capacitor across the 2-megohm resistor may be from about 10 to 50 $\mu\text{f.d.}$, the exact value having some effect upon the quenching action of the receiver. It should be connected to the bias wire and to the outer conductor end plate with the shortest possible leads right at the point where the wire leaves the end plate.

COMPACT 144-148-MC. SUPER-REGENERATIVE RECEIVER

Illustrated in Figures 18 and 19 is a compact and inexpensive 144-148-Mc. superregenerative receiver that will give excellent results on amplitude modulated signals either for mobile or fixed station use. It will also work fairly well on frequency modulated signals, especially if the deviation (frequency swing) is comparatively large, but should be considered primarily as an amplitude modulation receiver.

Figure 18 illustrates the arrangement of components. If desired, the receiver need not be made quite so compact; this will simplify the wiring job somewhat.

It is important that a polystyrene, ceramic, or low loss (mica filled) bakelite locktall socket be used for the 7A4 or 6C4 for best results. Also, care should be taken to see that the rotor of the tuning capacitor goes to the grid and the stator to the plate. A bakelite or hard rubber shaft extension must be used with the tuning capacitor in order to prevent body capacitance detuning effects. As an alternative, an insulated coupler may be used in conjunction with a short piece of metal shafting and a panel

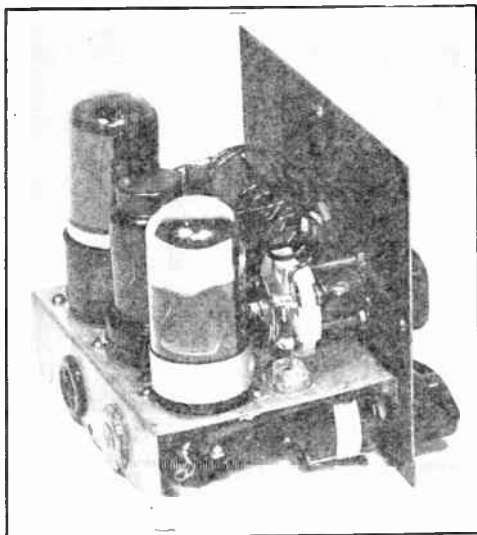
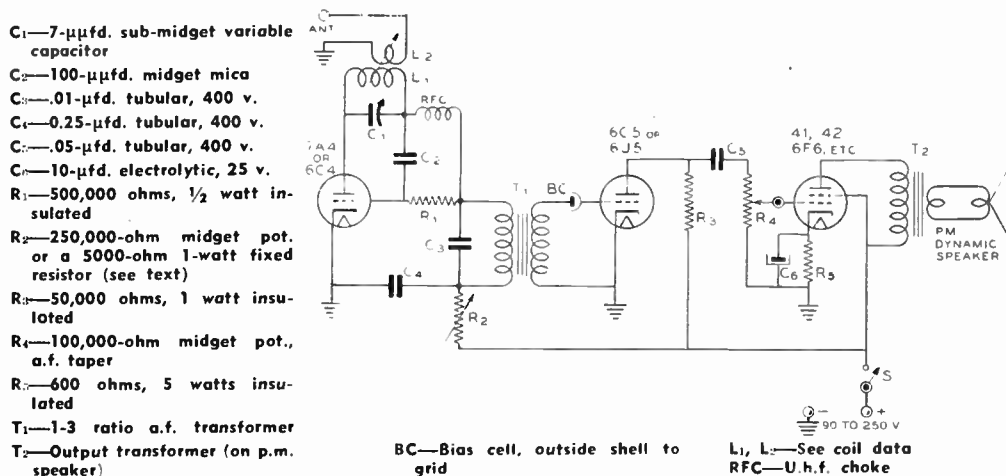

Figure 18.
INTERIOR VIEW OF THE RECEIVER.
The tuning capacitor is supported from the front panel by means of two long bolts. The variable antenna coupling coil may be seen in back of the tank coil.

bearing. Both r.f. choke and grid leak should be connected with the shortest possible leads to the r.f. circuit.

The tank coil, which is soldered directly to the tuning capacitor terminals, consists of 4 turns of no. 14 enameled wire, $\frac{1}{2}$ inch in diameter, spaced and trimmed as necessary to hit

Figure 19.
CIRCUIT FOR THE SUPERREGENERATIVE 3-TUBE RECEIVER.



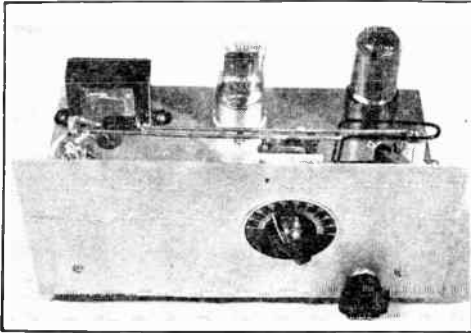

Figure 20.

224-MC. SUPERREGENERATIVE RECEIVER.

An HY-615 triode oscillator and linear tank circuit provide high sensitivity.

the band (as determined by Lecher wires).

One of the features of the receiver that results in vastly increased performance and easier tuning is variable antenna coupling. This control has been found of greater importance than the regeneration control, as the latter may be set and left alone if variable antenna coupling is provided. In fact, the regeneration control may be omitted, if desired, in which case a 5000-ohm 1-watt resistor is substituted for R₂.

The antenna coil consists of 2 turns of wire 1 inch in diameter, supported at the grid end of the tank coil. These are cemented with Amphenol 912 to a piece of Lucite or polystyrene ¼-inch shafting, which is supported from the front panel by a pinch-fit shaft bearing. The bearing is placed slightly below the level of the bottom edge of the tank coil in order to permit sufficient variation in coupling.

Flexible, insulated wire is used for making connection to the 2-turn antenna coil.

When tuning the receiver, the tightest antenna coupling which will permit superregeneration should be used.

220-MC. SUPERREGENERATIVE RECEIVER

Except for the substitution of a linear tank circuit and an oscillator tube better adapted for use at the higher frequency, the 220-Mc. receiver of Figures 20-23 is substantially the same from an electrical standpoint as the 144-Mc. superregenerative receiver of Figures 18 and 19. The mechanical construction is somewhat different, however, as may be seen from Figures 20, 21, and 23.

The receiver is constructed on a 5½ x 11-inch chassis, 1½ inches high, which supports a 5 x 9-inch front panel. The HY-615 oscillator tube is placed at one end of the chassis, as illustrated, in order to permit horizontal mounting of the linear tank circuit. This tank circuit consists of a length of no. 10 bare copper wire, bent back on itself so that the spacing of the two wires is approximately equal to the wire diameter. The grid wire is cut off shorter than the plate wire, in order to allow the insertion of the small grid capacitor and grid leak. The overall length of the tank, from the center of the tube caps to the center of the bolt in the standoff insulator which supports the closed end of the "U" and acts as the plate voltage connection is 7¾ inches. This pillar type standoff insulator is 2 inches high.

Tuning is by means of an improvised split-stator type capacitor, the rotor of which is left "floating." A Cardwell ZR-35-AS "Trim Air" is operated upon as follows. Disassemble the capacitor so that all rotor and stator plates

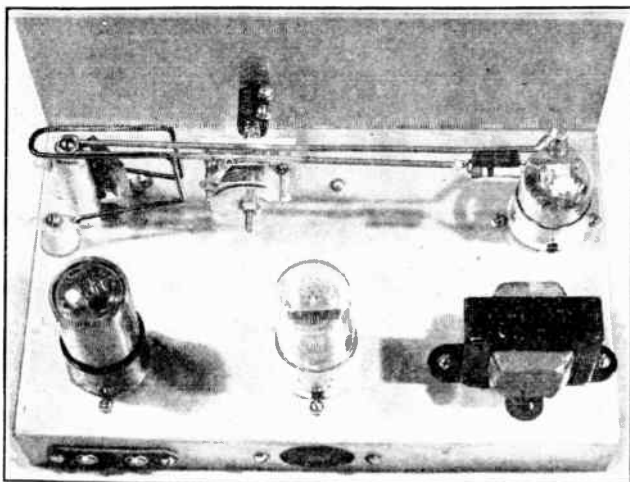
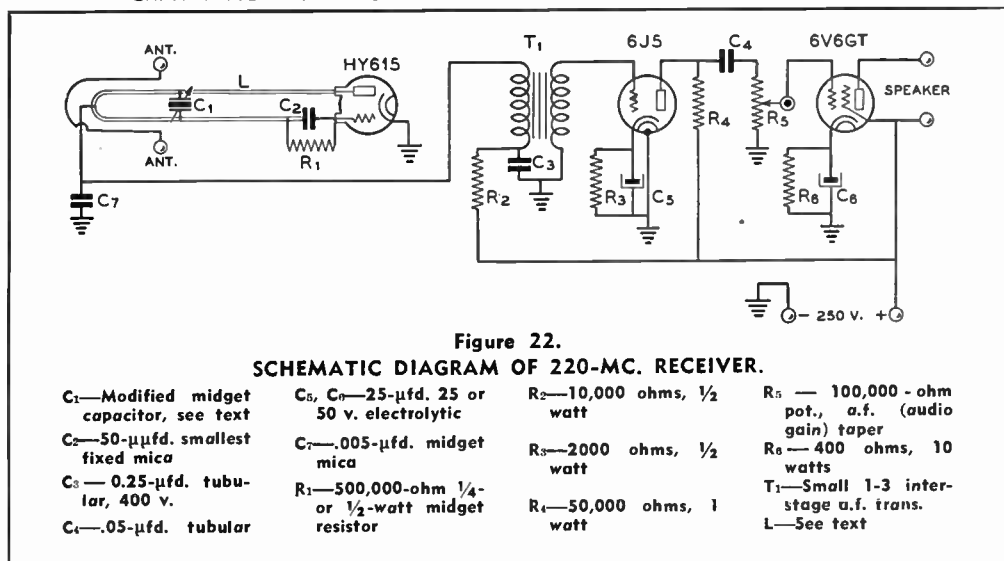

Figure 21.

ILLUSTRATING MECHANICAL CONSTRUCTION OF 224-MC. RECEIVER.

Note particularly the modified tuning capacitor and the arrangement of the linear tank and the antenna coupling "hair-pin loop"



are removed. Discard all except four rotor and two stator plates. The four remaining rotor plates are not altered, but the two stator plates are trimmed with a pair of heavy shears so that each plate is supported by only *one* of the two stud bolts which originally supported all stator plates. The capacitor then is assembled, making use of the original spacing washers, so that the two stator plates are 5/16 inch apart, one plate being supported by one stud bolt and the other plate being supported by the other stud bolt. The four rotor plates are then attached, spaced so that each stator plate is enveloped by two rotor plates with the original spacing of .03 inch between adjacent rotor and stator plates. Inspection of Figure 21 shows how the capacitor looks when reassembled.

Connection from each stator to the parallel wires is made by means of two 7/8-inch solder lugs, the lugs being bent in towards each other as illustrated in order to permit connection at approximately the same point on each tank wire with respect to the closed end of the tank. The tuning capacitor is mounted inverted by means of a "Trim Air" bracket so that the lugs attach to the tank wires 2 3/4 inches up from the bolt through the bottom of the "U." The capacitor is driven by means of an insulated shaft extension.

The antenna coupling loop is made of no. 12 enameled wire, bent as shown in Figures 20 and 21, and varied with respect to the tank wires in order to vary the coupling.

Capacitor C₇ should be grounded directly to the chassis with the shortest possible lead.

The receiver runs at full plate voltage at all times, the antenna coupling being adjusted to the closest value which will still permit super-regeneration.

When the receiver is initially put into operation, the frequency range should be checked by means of Lecher wires. If slightly off, the frequency range can be altered sufficiently by varying the spacing between the two tank wires: spreading the wires slightly *lowers* the frequency. If the frequency is very far off, it will be necessary to alter the length of the tank wires slightly as required to enable the tuning capacitor to cover the band.

144-MC. MOBILE TRANSCEIVER

With a few minor circuit changes and additional components, the 144-Mc. superregenerative receiver illustrated in Figures 18 and 19 makes an excellent transceiver for mobile work. An output of between 2 and 3 watts, enough to deliver a strong signal over considerable distance, is obtainable at the maximum recommended plate voltage.

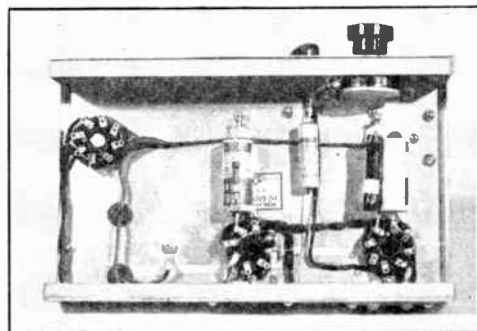

Figure 23.
UNDER-CHASSIS VIEW OF 220-MC. RECEIVER.

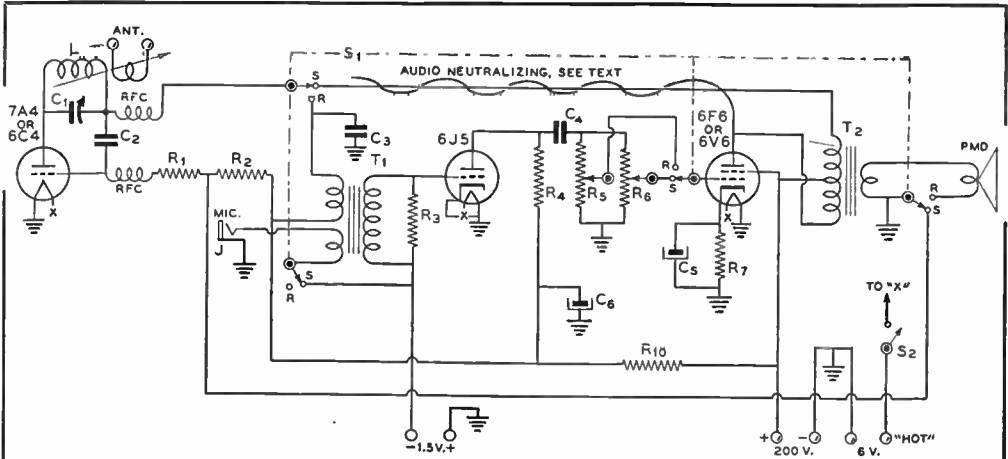

Figure 24.

144-MC. MOBILE TRANSCEIVER SCHEMATIC DIAGRAM.

- | | | | |
|--|---|--|---|
| <p>C₁ — 5-μfd. double-spaced midget capacitor (with mounting bracket and ceramic shaft coupling) C₂ — 100 μfd. smallest mica capacitor C₃ — .01-μfd. tubular capacitor, 400 v. C₄ — .05-μfd. tubular capacitor, 400 v. C₅ — 10-μfd. 25 v. electrolytic</p> | <p>C₆ — 8-μfd. midget tubular electrolytic, 450 v. R₁ — 2500 ohms, 2 watts R₂ — 1 meg., 1 watt R₃ — 100,000 ohms, 1/2 watt R₄ — 100,000 ohms, 1 watt R₅, R₆ — 100,000-ohm potentiometer, a.f. gain taper</p> | <p>R₇ — 500 ohms, 5 watts R₈ — 7500 ohms, 1 watt RFC — Midget u. h. f. chokes J — Open circuit jack (a closed circuit jack will short the microphone battery) S₁ — 4-pole 2-throw rotary switch S₂ — 5.p.s.t. toggle switch</p> | <p>T₁ — Transceiver transformer: plate and s.b. mike to single grid T₂ — Universal output transformer: 14,000-ohm c.f. pri., adjustable voice coil winding PMD — Small p.m. dynamic speaker</p> |
|--|---|--|---|

The layout is substantially the same as that for the receiver, illustrated in Figure 18, and therefore is not shown here: Also, the remarks pertaining to the r.f. portion of the circuit, including tank coil, tuning capacitor, and adjustable antenna coil, apply to the transceiver. This unit may be made in midget size.

Dual volume controls are provided to permit independent adjustment of gain when receiving and when transmitting. Microphone voltage is obtained from a standard 1 1/2-volt dry cell, in order to avoid the possibility of vibrator or generator hash getting into the speech system through the 6-volt supply lead. The battery also provides C bias for the 6J5 speech or audio amplifier. Because the drain on the battery is so low, many hundreds of hours of transmission are possible before replacement is required.

To prevent a.f. feedback it may be found necessary to neutralize the capacitance which exists between contacts on the send-receive switch. Should the a.f. system go into oscillation when the gain control is advanced, simply run a length of insulated wire from the plate of the output tube to the switch, this wire being twisted around the wire running from the opposite end of the transformer to the switch. At the switch, the end of the free

wire is adjusted with respect to the wire from T₁ (thus varying the capacitance between them) until it is possible to run the gain full on, both on transmit and on receive, without a.f. feedback.

Occasionally such feedback can be eliminated simply by transposing the two secondary wires on T₁, in which case the neutralizing lead will not be required.

The two r.f. chokes should have their leads clipped off short on the "hot" end to minimize the length of connecting wire between r.f. chokes and the tank circuit.

The adjustable antenna coupling serves as regeneration control, the detector running at high plate voltage at all times. The coupling always is adjusted to the closest value which will still permit superregeneration. This provides maximum sensitivity when receiving and maximum output when transmitting.

The plate supply voltage should not greatly exceed 200 volts on transmission, as excessive plate voltage will cause the oscillator tube to overheat and the plate current to "run away."

An antenna system suited for mobile use with this transceiver is described in Chapter 22. The distance which can be worked depends upon the antenna and the location; 50 miles is common from an elevated location.

U.H.F. Transmitters

IN THE higher-frequency spectrum allocated for post-war use, there are nine amateur bands above 30 Mc. These are 50-54, 144-148, 220-225, 420-450 (temporarily shared with an air navigation aid), 1145-1245, 2300-2450, 5250-5650, 10,000-10,500, and 21,000-22,000 Mc. It will be observed that the ends of these bands are not in harmonic relation as were the pre-war u.h.f. bands. Equipment designed for use in these ranges usually is quite different from apparatus designed for use at frequencies lower than 30 Mc. Hence, this chapter will deal with the practical design of transmitters for use above 30 Mc. Equipment will be described for use in the 50-54-, 144-148-, and 220-225-Mc. bands. At the time of this writing, national security regulations do not permit publication of precise data on special transmitting gear for frequencies above 1000 Mc.

It is desirable to use m.o.p.a. or crystal-controlled operation wherever possible. However, great simplicity is obtainable in u.h.f. transmitters by directly modulating the r. f. power oscillator in any band where this type of operation is allowed. But even in modulated oscillators some attempt usually is made to stabilize the oscillator. Stabilization most often is accomplished through the use of high-Q systems, particularly in the grid circuit. High Q is obtained through the use of linear tanks (parallel rods or pipes) or by means of concentric tanks. The grid circuit Q often is increased still further by tapping the tube grid connection down on the quarter-wave grid line.

Portable and mobile operation on authorized frequencies above 144 Mc. can be accomplished with a minimum equipment by the use of transceivers, or combined transmitter-receivers such as were described in the last chapter.

Chapter Subdivisions In order to classify the types of equipment used on the ultra-high frequencies and the microwaves, this chapter will be subdivided into the following divisions: *Oscillators and M.O.P.A. Transmitters*, *Crystal Controlled Transmitters*

and U.H.F. Amplifiers, Frequency Modulation Transmitters, and Microwave Transmitters.

OSCILLATORS AND M.O.P.A. TRANSMITTERS

The majority of the equipment to be shown under this heading will be of the simple oscillator type, since this type of equipment is quite adequate for experimental 144- and 220-Mc. communication. However, when greater frequency stability is desired, it is always advisable to place an amplifier or frequency multiplier between the oscillator and the final amplifier which is to be keyed or modulated. Some of the special u.h.f. triodes such as the HK-24, 35TG, HY-75, and 1628 can be operated quite efficiently as push-pull triplers and will allow quite satisfactory neutralization in a push-pull amplifier when the conventional cross connected neutralizing circuit is used. Single ended amplifier stages can be neutralized most satisfactorily by the *coil* or *inductive* neutralization circuit shown under *Transmitter Theory*. The "coil" in this case can best be a short section of closely spaced open-wire line to resonate to the operating frequency by the grid-to-plate capacitance.

U.H.F. Push-Pull Beam Tubes Within the last few years several excellent push-pull u.h.f. beam tubes have made their appearance: 829, 815, etc. These tubes make excellent push-pull r.f. amplifier stages at 50, 144, and 220 Mc., and they have the advantage that, if the input circuit is properly shielded from the output, no neutralization will be required.

144-Mc. Equipment

20-Watt HY-75 Oscillator This little transmitter was primarily designed to replace the final amplifier stage of a 10-meter mobile transmitter and to be modulated by the speech and modulator system which was originally used with

the 10-meter transmitter. It consists of an HY-75 ultra-audion oscillator with conventional coil-and-capacitor tank circuit. A concentric pipe or parallel rod oscillator would undoubtedly give greater stability, but with a low-capacitance high-transconductance tube the stability has been found sufficiently good with the tank circuit shown. The only precautions that need be taken in the construction of the transmitter is to make sure that all r.f. leads are as short as possible, that all parts are mounted rigidly, and that good u.h.f. insulation be used where it is in contact with high potential r.f. The tuning capacitor should be of the ultra midget type, and it should be wired so that the rotor goes to the grid. The exact number of turns for the tank coil will depend somewhat on the physical layout and particular make of components chosen. Some pruning may be required on the coil. It should hit the band when the tuning capacitor is about half meshed. Note that both rotor and stator are hot to ground, both to d.c. and r.f.

The tube socket is not exposed to r.f., and may be of the inexpensive wafer type. It is important that the tube be mounted in a vertical position for good filament life.

Figure 1 shows a back view of the oscillator. It has been mounted upon this small chassis so

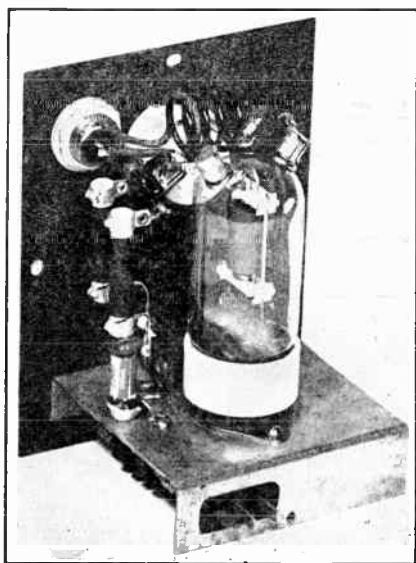

Figure 1.

20-WATT 144-MC. OSCILLATOR.

This diminutive oscillator will take 35 watts input on 144 Mc., and will deliver quite a substantial signal on the band. The tube clips are connected to the tank capacitor by means of narrow copper ribbon. A 1-turn link at the grid end of the tank connects to a coaxial cable connector.

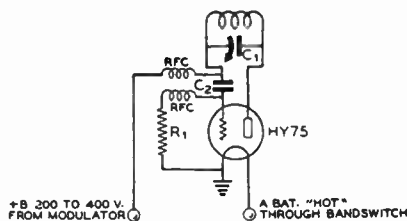

Figure 2.
SCHEMATIC OF THE HY-75 144-MC. OSCILLATOR.

C_1 —13- μ fd. sub-midget capacitor
 C_2 —.0001- μ fd. midget mica
 RFC—U.h.f. choke
 R_1 —2500 ohms, 1½ watts
 Coil—4 t. no. 14 enam., ½" dia., spaced to hit band

as to take up as little space as possible when placed alongside the modulator system for the mobile 10-meter transmitter. Normal operation of the oscillator will be with 300 volts at about 80 ma. on the plate. If desired, the power input may be raised to 425 volts at 80 ma. to give about 35 watts input. The circuit diagram of the oscillator is shown in Figure 2.

100-Watt 75T Resonant-Line 144-Mc. Oscillator

Figures 3 and 4 illustrate a concentric-line controlled 144-Mc. oscillator using a 75T, which will put out approximately 100 watts of stabilized r.f. on any frequency in the 144-148 Mc. amateur band. A short concentric line, which is resonated to the operating frequency by means of a 20- μ fd. midget variable, acts as the frequency determining element; output power is taken from a self-resonant coil in the plate circuit.

The concentric line itself is 9 $\frac{3}{8}$ inches long and 2 $\frac{7}{8}$ inches inside diameter (3 inches o.d. with 1/16-inch wall), and the inner conductor is 10 $\frac{3}{8}$ inches long and 3/4 inches in diameter. Both pieces which make up the line are cut from standard lengths of thin-wall copper water pipe. To make up the line first the inner conductor is soldered to the center of a piece of 20-gauge copper sheet about 3½ inches square, with the aid of a small alcohol torch and a soldering iron. Then the outer conductor is slipped over it and also soldered in place. Considerable heat is required to do the soldering, but if the work is placed on a block of wood as insulation, a small alcohol torch and a conventional electric soldering iron will do the job quite easily. The wood will be well charred when the work is finished but it will have served its purpose. Asbestos would be better but wood will be satisfactory.

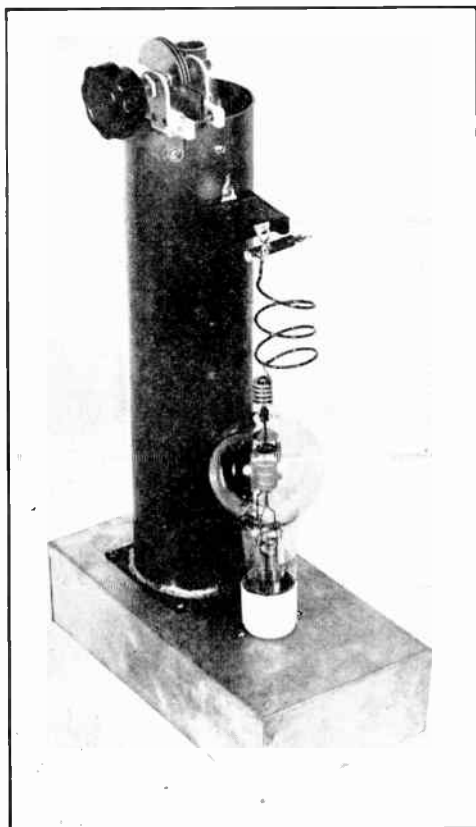
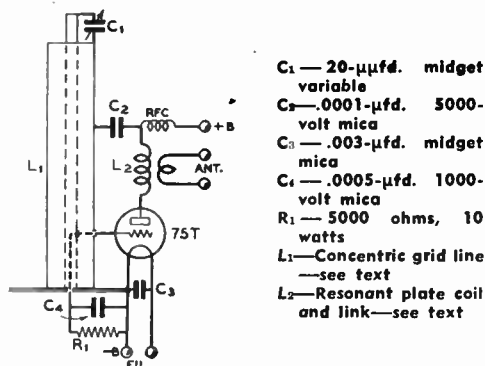

Figure 3.
CONCENTRIC-LINE 75T OSCILLATOR
This concentric-line oscillator with a 75T gives good stability and a quite reasonable power output on the 144-Mc. band.

A hole is drilled in both the inner and the outer conductor $2\frac{1}{4}$ inches up from the base on the line. Then another hole is drilled in the center of the base so that a wire may be run through it, through the inner conductor, and then through the hole $2\frac{1}{4}$ inches up through both the inner and outer conductor to connect to the grid of the tube. This wire is by-passed immediately to ground and one side of the 75T's filament as it leaves the base of the line.

The plate coil consists of 3 turns of no. 12 wire $1\frac{1}{4}$ inches in diameter and 2 inches long. The upper end of this coil is by-passed to the concentric line by means of a .0001- μ fd. 5000-volt mica capacitor. This plate coil was found to resonate over the entire 144-Mc. band with the plate-to-ground capacitance of the 75T and the distributed capacitance of the circuit.

With the circuit constants shown, the grid capacitor will tune the oscillator to the center



of the 144-Mc. band when it is about half meshed. A small rotation of the capacitor will cover the band. Approximately 100 watts output may be obtained from the oscillator at 1250 plate volts, and at a plate efficiency of 50 to 65 per cent.

220-Mc. Equipment

Within the last few years a great deal of interest has been centered on frequencies near 220 Mc. Due to the peculiar conditions which exist upon them, and due to the fact that, for a given amount of power, greater signal strength is obtainable over an optical path than with use of any of the lower frequencies.

A 2-Watt 6C4 Oscillator Figure 5 shows a 220-Mc. oscillator using a 6C4 which can be used either as a transmitter to give about 2 watts output, or as a superregenerative detector to feed an audio amplifier as a receiver. The unit as shown, and as illustrated in the circuit diagram, is set up as a low-power 220-Mc. oscillator. For this use, the grid leak R should be 10,000 ohms and should be connected between the grid of the 6C4 and ground. For the proper method of tuning this oscillator to a given frequency in the 220-Mc. band through the use of Lecher wires, see the chapter *U.H.F. Communication*.

As an oscillator the plate voltage on the 6C4 should be limited to 250 volts and the plate current should not be greater than 25 ma. The resting plate current of the oscillator, unloaded, will be about 18 to 20 ma.; when the circuit is loaded to 25 ma. about 2 watts may be taken from the antenna coupling link.

The plate hairpin of the oscillator is made from no. 10 bare copper wire (actually no. 10 enamelled wire from which the enamel has

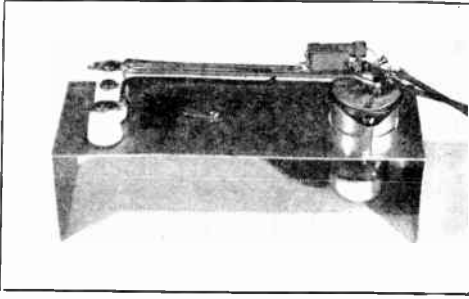

Figure 5.
2-WATT 220-MC. OSCILLATOR

This simple and inexpensive oscillator may be used either as a low-power transmitter on the 220-Mc band or, by a slight circuit alteration, as a 220-Mc. band superregenerative receiver.

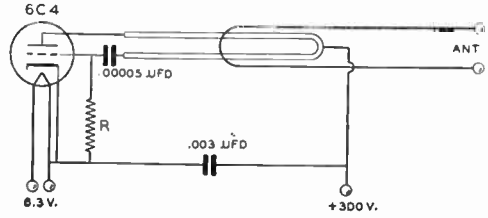

Figure 6.
SCHEMATIC OF THE SIMPLE 6C4
220-MC. OSCILLATOR

The resistance R should be 10,000 ohms for operation of the oscillator as a transmitter. For operation as a superregenerative detector, R should be removed and a 500,000-ohm resistor placed across the grid capacitor. The plate circuit of the 6C4 may then be fed into a conventional audio amplifier.

been scraped); it is bent into a narrow hairpin with about 3/32-inch spacing between the wires. The length from the turn on the loop where the plate voltage connection is made to the plate of the tube is 4½ inches. The length along the other side of the loop from the plate voltage connection to the grid capacitor is 3¼ inches. Quite a wide adjustment in frequency may be obtained by varying the spacing between the wires in the hairpin. Decreasing the spacing increases the frequency, and increasing the spacing decreases the frequency of oscillation. It is quite simple to vary the frequency of oscillation over a 50-Mc. range merely by making a comparatively small adjustment in the spacing from just over 1/8 inch to 3/32 inch.

To convert the oscillator into a superregenerative detector, it is only necessary to remove the 10,000-ohm resistor that goes from the grid to ground and then place a 500,000-ohm resistor directly across the grid capacitor. Making the return of the grid leak to the positive high voltage in this manner greatly increases the output of the tube when operating as a detector, as compared to when it is returned to ground. Note that the .003-μfd. by-pass capacitor must be placed across the plate return and ground for the tube to superregenerate.

An HY-75 8-Watt Oscillator Another 220-Mc. oscillator using a hairpin as the resonant line is illustrated in Figure 7 and diagrammed in Figure 8. The lead lengths from the center of the hairpin to the plate of the HY-75 and to the grid capacitor are the same as for the 6C4 oscillator just described. An r.f. choke is used between the grid and the grid-leak because of

the rather low value of resistance of this leak resistor. It was not required in the 6C4 oscillator because of the considerable higher grid-leak resistance. A grid-leak resistance from 3000 to 4000 ohms has been found to be best for the HY-75 in this circuit.

The operating voltage on the HY-75 should be from 275 to 300 volts. The unloaded plate current of the oscillator will be about 30 to 35 ma., and it can safely be loaded to 75 or 80 ma. before excessive plate heating takes place. With this value of power input, the output will be from 8 to 10 watts.

A Push-Pull HY-75 Oscillator The unusual parallel-rod push-pull oscillator shown in Figure 9 and diagrammed in Figure 10 will prove to be quite a satisfactory source of power for experiments in the 220- to 225-Mc. amateur band. A parallel-rod line is used as the frequency controlling element, and a small self-tuned coil is used in the plate circuit. The resonant line is made up of two 7/8-inch, thin-wall copper pipes spaced 7/8-inch, 95/8 inches long overall and connected together both at the top and bottom to act as a half-wave line instead of the more common quarter-wave arrangement. The base for the line is a piece of 20-gauge sheet copper 1¾ x 4 inches which is mounted above the 9½ x 5 x 1/2-inch chassis by means of 1/2-inch stand-off insulators.

The capacitance to chassis of the copper base plate acts as a by-pass for the center of the parallel-rod line. The copper plate can be proved to be acting normally as a by-pass, since its center will be quite cold to r.f. One of the standoffs which supports the copper plate is of the feedthrough type, and has the

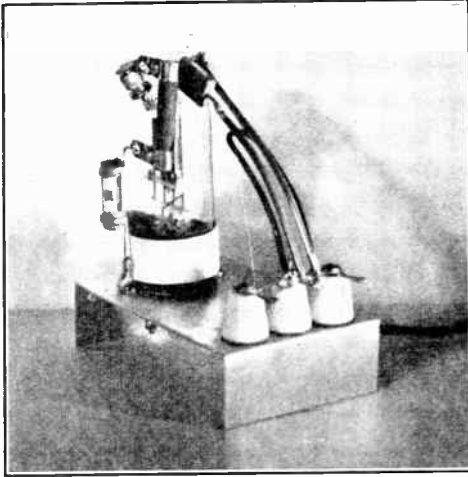

Figure 7.

8-WATT HY-75 220-MC. OSCILLATOR

This small HY-75 transmitter is ideal for the amateur who wishes a medium-power 1¼-meter oscillator for both fixed station and portable use.

grid-leak connected between its lower end and the grounded side of the filaments of the tubes.

The power output of the oscillator as shown is 20 to 25 watts, with 450 volts on the plates of the tubes. The plate efficiency is about 40 per cent with the half-wave line in the grid circuit as shown. The plate efficiency was somewhat less than this until the original quarter-wave grid line was replaced with the capacitance-shortened (grid-to-ground capacitance) half-wave line.

**50-Watt 225-Mc.
829 M.O.P.A.
Transmitter**

Figures 11 and 12 illustrate a very interesting 225-Mc. transmitter of quite respectable power handling capabilities. This transmitter is particularly interesting in the fact that it is an oscillator-amplifier affair instead of being merely an oscillator, as are most transmitters for this high a frequency. The fact that the final stage is an amplifier indicates that it is quite possible to double down to a frequency as high as 225 Mc. for crystal controlled or frequency modulation transmission and still be able to find an arrangement which will be capable of operating as an amplifier at this extremely high frequency. As a matter of fact, the 829 amplifier stage operates with a plate efficiency of about 60 per cent when fully loaded, and requires a driving power of less than 5 watts actual output from the preceding stage.

The 829 tube itself is particularly designed

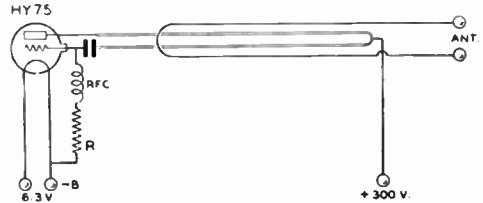

Figure 8.

SCHEMATIC OF THE HY-75 220-MC. OSCILLATOR

The grid-leak R should have a resistance of about 3000 ohms for normal use. The grid capacitor should have a value of .00005 μ fd.

for operation as an r.f. amplifier for frequencies above 50 Mc. It consists of a pair of beam tetrodes with a total plate dissipation of 40 watts mounted inside an envelope in which lead length has been made a primary consideration. The tube has no base, the terminal leads for the tube elements being brought out to tungsten rods which extend through the glass bottom plate of the envelope.

The socket for this tube is also very interesting and it, in addition, is particularly designed for u.h.f. use. The photographs give a

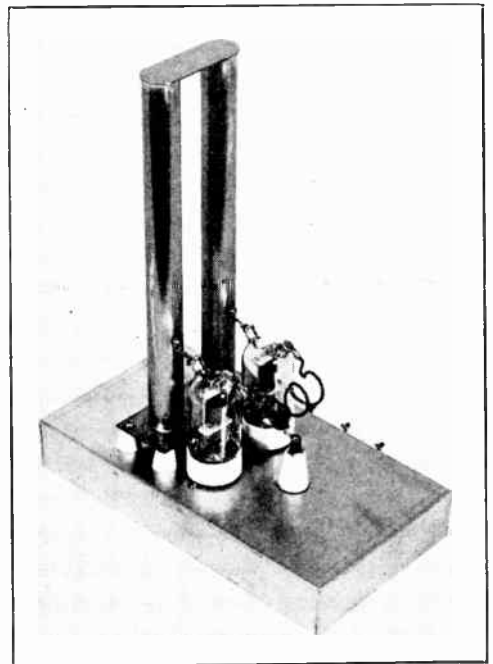

Figure 9.

PUSH-PULL 220-MC. HY-75 OSCILLATOR.

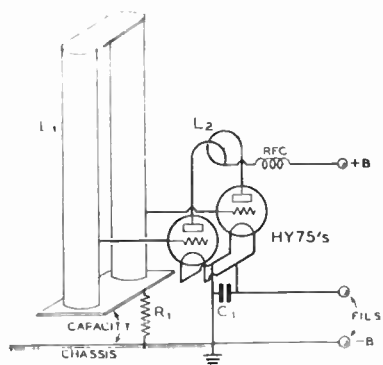

Figure 10.

**SEMI-SCHEMATIC OF THE
PUSH-PULL 220-MC. OSCILLATOR.**

- C₁—0.003- μ fd. midget mica
- R₁—5000 ohms, 10 watts
- L₁—Half-wave parallel-rod line
- L₂—2 turns $\frac{5}{8}$ " dia., 1" long
- RFC—6 turns hook-up wire, $\frac{1}{4}$ " dia.

good general idea of its construction: all the leads which are normally cold, heaters, cathode, and screens, are brought out through large terminal clips which have built-in mica by-pass capacitors. Then, the grid leads to the two elements within the envelope are brought out to a separate Mycalex arbor which is supported away from the base of the socket by means of small ceramic pillars.

The general layout of the HY-75 oscillator which is used as the exciter for the 829 can be seen in the top view photograph. The oscillator circuit is an ultra-audion, with a combination resonant line and coil in the plate circuit. The lead from the plate extends about $1\frac{1}{2}$ inches and the lead from the grid capacitor about $\frac{1}{2}$ inch and then they are crossed over to form a 1-turn coil. Another 1-turn coil is interwound with this and connected to the two grid terminals on the 829 socket. The schematic diagram, Figure 13, gives a general idea of the arrangement of these two circuits but it does not indicate graphically the fact that the two 1-turn coils are interwound—at least in so far as two 1-turn coils can be interwound.

If desired, the frequency of the HY-75 oscillator may be controlled by a quarter-wave concentric line, in the same general fashion as the frequency of the 75T 144-Mc. oscillator is controlled. The grid of the HY-75 should be tapped up a short distance from the bottom of the capacitance loaded line, and the plate return made to the side of the line in the same manner as the 75T oscillator described previously. An alternative arrangement would be to use the HY-75 as a frequency doubler from 112.5 Mc. for crystal controlled or f.m. transmission. The plate and grid circuits of the 829 amplifier would be the same as shown, and the plate tank of the HY-75 would be returned to ground with the 112.5-Mc. excitation fed to the grid.

The normal plate voltage of the 829 is 400 volts, the screen voltage is 200 volts, and the grid bias should be 35 to 45 volts. The grid

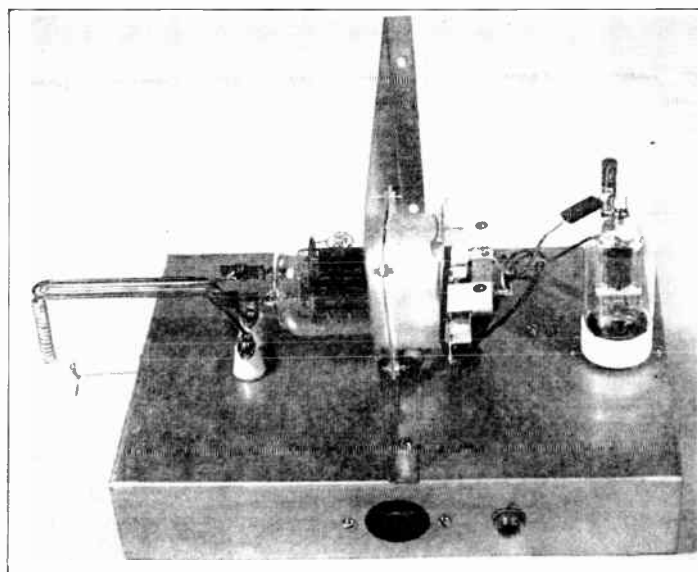

Figure 11.
**TOP VIEW OF THE
829 M.O.P.A. 220-
MC. TRANS-
MITTER.**

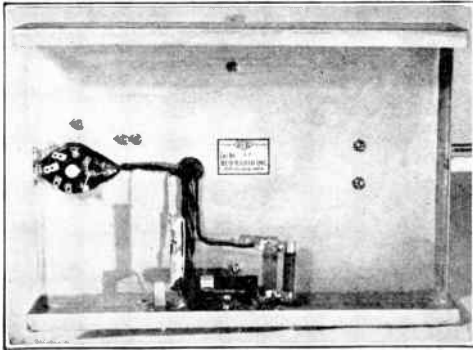

Figure 12.
BOTTOM VIEW OF THE 829
TRANSMITTER.

current of the 829 as shown is about 8 to 9 ma. through a 4000-ohm grid-leak. The amplifier operates very satisfactorily with a plate current of 200 ma.; the plate current may be run as high as 240 ma. if the full rating of the tube is to be used. The output at 200 ma. plate current (400 plate volts) is about 40 watts and at 240 ma. plate current about 50 watts.

The total length of the no. 10 bare wire tank circuit is $4\frac{1}{4}$ inches from the plate seals of the tube to the end of the hairpin. The spacing between wires is $\frac{1}{8}$ inch for about 3 inches until the wires spread out to make soldered connection to the plate clips of the 829. The actual plate clips are small hard copper spring clips of the type supplied with HK24 tubes to make the plate connection to them. The plate line is resonated to the frequency of the oscillator by sliding the line back and forth on the tungsten rods that come out of the 829 envelope as the plate connections. The type of plate clips shown are particularly suited to this application, since they slide back and forth comparatively freely on the plate lead rods.

CRYSTAL-CONTROLLED
U.H.F. TRANSMITTERS

Crystal control provides the same advantages of excellent frequency stability and reliability on the u.h.f. bands that it does on the lower frequencies. However, due to the relatively greater difficulty of getting amplifier and frequency multiplier stages into operation on the higher frequency bands, crystal control is not widely used except in the case of more elaborate transmitters. High-frequency crystals have made their appearance on the market, but due to their inherent instability, high temperature coefficient, and lack of ruggedness, they have fallen into disuse, and, in fact, have been discontinued by some manufacturers. Hence, for

most amateur work, the highest practical operating frequency for the crystal is 6750 Kc. From this comparatively low frequency a rather large number of doublers are required to get down to the u.h.f. bands. However, through the use of beam tetrodes, it is possible to obtain comparatively good operation from triplers and quadruplers, thus simplifying the frequency multiplication problem.

20-Watt Crystal
Controlled
50-Mc. Transmitter
or Exciter

The crystal controlled 50-Mc. r.f. unit illustrated in Figures 14 and 15 and diagrammed in Figure 16

uses conventional circuits and low cost parts. With but three stages and a 6250-kc. crystal, it supplies 20 watts of crystal controlled 50-Mc. r.f. For 'phone operation the output stage may be modulated by a 25-watt modulator. As an exciter it has sufficient output to drive a 50-Mc. final stage to 200 watts input.

The chassis measures 12 x 7 x 2 inches. As can be seen from the photographs, the tubes are evenly spaced along the center of the chassis. Each plate coil is directly in front of the tube with which it operates. The tank capacitors are mounted on the front lip of the chassis directly below their respective coils. Small jack type feed-through insulators are used to support the plug-in coils and at the same time to provide connections to the capacitors. Banana plugs on the coils allow quick and easy band change.

Inasmuch as each tuned circuit is on a different frequency, placing the coils in line along the front of the chassis does not have any adverse effect on the operation of the unit.

Underneath the chassis, parts are placed as convenience dictates. The T21 stage has all its

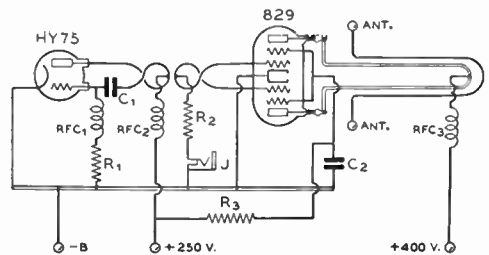

Figure 13.
SCHEMATIC OF THE HY75-829 225-MC.
TRANSMITTER.

- | | |
|--|--|
| C ₁ — .00005-μfd. midget mica | RFC ₁ — Midget u.h.f. choke |
| C ₂ — .0005-μfd. midget mica | RFC ₂ —12 t. hookup wire, 1/4" dia. |
| R ₁ —7500 ohms, 1 watt | RFC ₃ —15 t. no. 14, 1/8" dia. |
| R ₂ —4000 ohms, 1 watt | Coils and lines—See text |
| R ₃ —7500 ohms, 10 watts | |

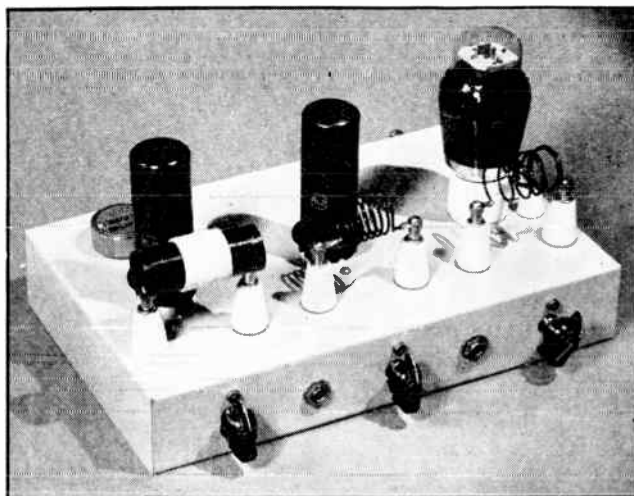

Figure 14.
THREE-STAGE 20-WATT
CRYSTAL-CONTROLLED
50-MC. EXCITER UNIT.

A 6L6 oscillator on 6250 kc. drives a 6L6 quadrupler, which in turn drives a T21 doubler to 50 Mc.

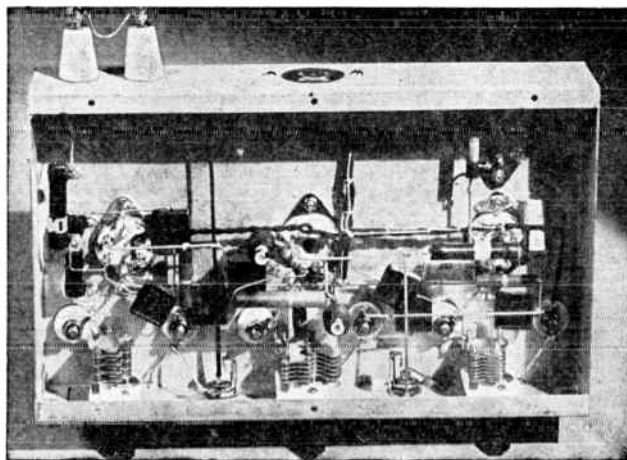

Figure 15.
UNDER-CHASSIS VIEW OF
THE 50-MC. R.F. UNIT.

ground return connections made to the feed-through insulator which is at the cold end of the plate tank. While this does not enhance the appearance, it aids in eliminating coupling in the various ground return circuits.

Two feed-through insulators at the rear of the chassis are provided for the connections from the modulator. If the unit is used as an exciter or c.w. transmitter, these terminals are simply shorted together.

The second 6L6 acts as a quadrupler. Thus, with a 6250-kc. crystal, 50-Mc. output is obtainable from the T21. With a 6750-kc. crystal, 54-Mc. output is obtainable from the T21.

With the meter plugged in the cathode circuit of the T21, the total plate, screen, and grid current is shown. This gives a false indi-

cation as to the plate current "dip" of the stage, which is about 15 milliamperes lower than the cathode current would indicate.

For optimum performance, the T21 stage should be loaded to approximately 90 milliamperes. At this input, the output is approximately 20 watts.

No antenna coupling circuit has been provided as the type of coupling circuit will depend upon the antenna used. Any of the usual capacitive, inductive, or link-coupling circuits will be suitable. When used as an exciter, the unit should be link-coupled to the next stage.

Medium Power 50-Mc. Amplifier

By using tubes having close element spacing, yet low interelectrode capacitance, and a plate tank capacitor espe-

- C₁, C₂—0.01- μ fd. paper
- C₃—75- μ fd. midget
- C₄—0.005- μ fd. mica
- C₅—100- μ fd. mica
- C₆—50- μ fd. mica
- C₇—50- μ fd. midget
- C₈—0.01- μ fd. mica
- C₉—0.02- μ fd. mica
- C₁₀, C₁₁—0.001- μ fd. mica
- C₁₂—15- μ fd. midget, double spaced
- C₁₃—0.001- μ fd. mica
- L₁—22 turns no. 22 d.c.c. close-wound on 1-inch form
- L₂—20 turns no. 14 enam. 1 1/4 in. dia. spaced to 1 1/2 in.
- L₃—5 turns no. 14 enam. 7/8 in. dia. spaced to 1 1/4 in.
- R₁—25,000 ohms, 1/2 watt
- R₂—400 ohms, 10 watts

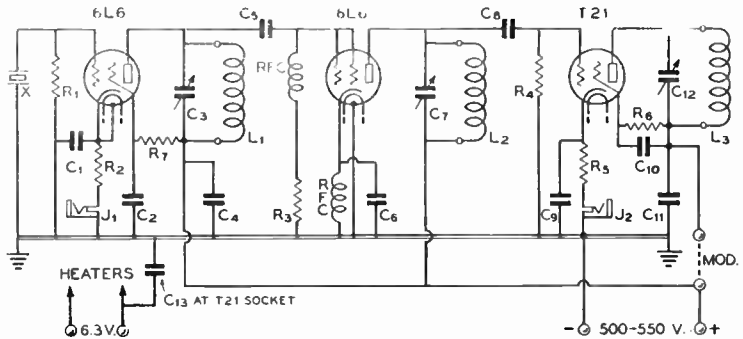

Figure 16. SCHEMATIC OF THE 50-MC. R.F. UNIT.

- R₃—25,000 ohms, 10 watts
- R₄—150,000 ohms, 2 watts
- R₅—100,000 ohms, 1 watt
- R₆—600 ohms, 10 watts
- R₇—30,000 ohms, 10 watts
- J₁, J₂—Closed-circuit jack
- RFC—2.5-mh. r.f. chokes

cially designed for u.h.f. service, it is possible to construct a medium power 50-Mc. amplifier that will exhibit good efficiency without resorting to the use of parallel rods in the plate circuit.

Such an amplifier is illustrated in Figure 18. It utilizes a pair of HK-24's in push-pull, and the efficiency is as good as that obtained with commonly used equipment at 14 Mc. By fastening the plate coil directly to the tuning capacitor stator lugs, losses are minimized.

About 20 watts excitation are required, this amount of excitation permitting approximately 175 watts input on 'phone or 225 watts input on c.w. The T21 exciter of Figure 16 is ideally

suitable for use with this amplifier, the excitation being sufficient so long as the coupling link between exciter plate coil and amplifier grid coil is not too long. The losses are high at 50 Mc. in a twisted pair line, even in a good line. EO-1 cable makes the best coupling line, and it should be not more than 18 inches long unless reserve excitation is available to compensate for the losses in the line.

A conventional resistor-biased circuit is used with circuit balance provided by a grounded-rotor grid capacitor. Plate voltage is fed to the center of the plate coil through a u.h.f. choke. Since the circuit is balanced by grounding the rotor of the grid capacitor, it is possible to let the rotor of the plate capacitor "float," thus increasing the allowable plate voltage for a given capacitor spacing. No filament by-pass capacitors are used, as they were found to be unnecessary. Mechanically, the amplifier differs somewhat from the usual push-pull stage, and the mechanical layout will therefore be discussed in greater detail.

Construction Details An 11 x 7 x 2-inch chassis allows ample room for all the components except the filament transformer, which is mounted externally.

The plate capacitor is one designed for u.h.f. use. The stator terminals are arranged to allow an extremely compact neutralizing capacitor assembly. This capacitor is mounted on its side with the stator terminals toward the tubes. Two angle brackets and small stand-off insulators hold the capacitor above the chassis. Mounting the capacitor in this manner permits short plate leads to the upper stator terminals. The plate coil, 8 turns of no. 14 wire 1 1/4 inches in diameter, is spaced so as to mount directly on these upper terminals.

Two small discs of aluminum, 1 inch in

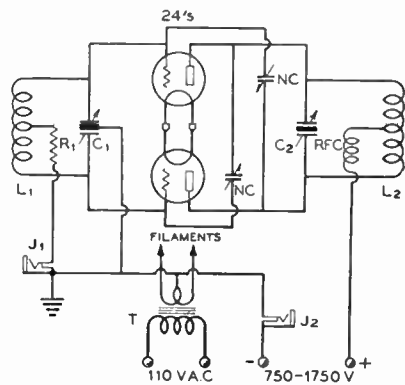

Figure 17. 125-WATT HK-24 U.H.F. AMPLIFIER.

- C₁—30- μ fd. per section midget
- C₂—35- μ fd. per section, 4500-volt spacing
- R₁—3000 ohms, 10 watts
- J₁, J₂—Single closed circuit jacks
- T—Filament transformer, 6.3 v., 6 a.
- NC—See text
- L₁, L₂—See text
- RFC—U.h.f. choke

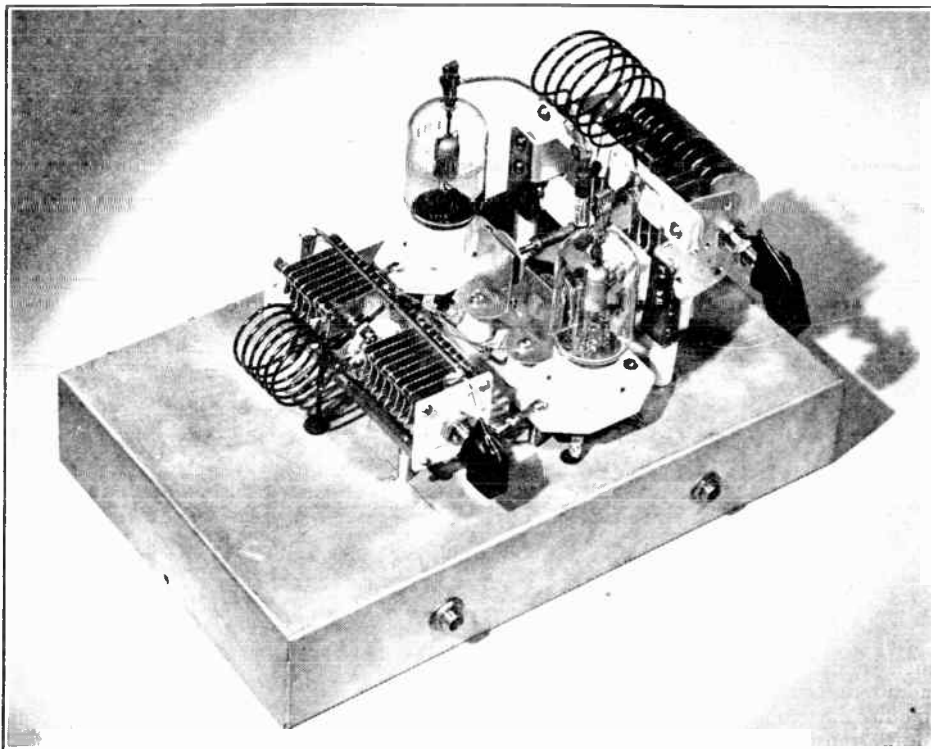

Figure 18.
125-WATT 50-MC. AMPLIFIER.

Extreme simplicity characterizes this 50-Mc. amplifier stage. The neutralizing capacitors may be seen between the tubes. All components with the exception of the grid resistor are above the chassis.

diameter and 1/16-inch thick, are used for the movable plates of the neutralizing capacitors. Each of these plates has a flat-headed 6-32 screw through its center. The screws are held in place by nuts on the back of the discs. The heads are filed smooth with the surface of the discs. The edges of the discs are rounded with a fine-tooth file to prevent corona losses.

Two pieces of hollow rod, threaded with a 6-32 tap, are mounted on the lower stator terminals of the plate capacitor. The screws through the discs are screwed into these rods and neutralizing adjustments are made by running the screws in or out of the threaded rods, thus changing the spacing between the circular plates and the stationary plates, which are simply small rectangular pieces of aluminum mounted on stand-off insulators.

The grid coil is 8 turns of no. 14 enamelled wire 1/8 inches in diameter and 1/8 inches long. This capacitor tunes with its plates about one-third meshed. Both ends of the rotor are grounded for the sake of symmetry.

The amplifier should not be operated for any length of time with the load removed, as the heavy r.f. field within the plate coil will heat and melt the soldered connection at its center. With the tank circuit loaded, however, no trouble of this kind will be experienced.

By slightly exceeding the plate voltage rating and operating the two tubes at 1750 volts, an output of slightly over 200 watts is obtained from the amplifier at the normal plate current of 150 ma. for the two tubes. For modulated operation, the plate voltage should be lowered to 1250 volts, however. Two jacks, J_1 and J_2 , are provided for reading the grid and plate current. A 1-turn link is used between the amplifier and the exciter, and the grid current is adjusted to 50 milliamperes under load by varying the coupling.

FREQUENCY MODULATION TRANSMITTERS AND EXCITERS

Frequency modulation, or f.m., transmission is destined to be one of the major uses of the

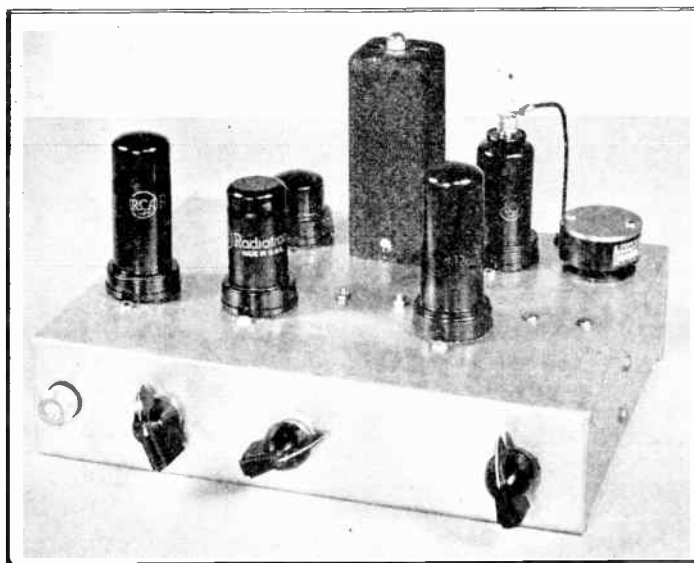

Figure 19.
STABILIZED F.M.
EXCITER.

This exciter uses a reactance-tube modulated oscillator with the frequency of the oscillator held at a constant difference from a crystal oscillator. The speech, modulator, and f.m. oscillator section occupies the front portion of the chassis, while the stabilizing circuit is at the rear. The front drop of the chassis carries, from left to right, the microphone connector, gain control, grid capacitor control, and plate capacitor control.

ultra-high frequency bands. The u.h.f. bands are wide enough so that the wide band of frequencies required for f.m. are amply contained. In addition, a practically infinitesimal amount of modulating power is required to modulate an f.m. transmitter, regardless of its power output, and, a last advantage, frequency multipliers, or class C or Class B amplifiers may carry f.m. r.f., since the amplitude of an f.m. signal is constant. However, a complete explanation of the theory and practice of f.m. has been given in Chapter 9, so this section will be devoted entirely to the description of equipment designed for f.m. transmission.

As this edition of the Handbook goes to press, the F.C.C. has not announced which of the post-war higher-frequency amateur bands will be set aside for frequency modulation. Consequently, we are showing in the following sections a stabilized f.m. exciter and a 50-watt f. m. transmitter, the first unit designed to deliver a 10-meter carrier and the second a 112-Mc. carrier. These excellent units were designed for the pre-war amateur f.m. frequencies. However, by a recalculation of coil values and a substitution of crystal frequency, the exciter and transmitter may be adapted to any other band in the vicinity of those shown here which may subsequently be authorized for amateur frequency modulation. Coil calculation and design data may be found in Chapters 2 and 11 and in the Appendix. Three pieces of equipment are to be described in this chapter: (1) a stabilized reactance-tube frequency-modulated exciter, and (2) a crystal-controlled phase-modulated exciter, either of which is suitable as an exciter for a transmitter on any

of the amateur bands wherein f.m. is permitted, and (3) a complete 112-Mc. f.m. transmitter with one RCA-815 50-watt push-pull beam tubes in the output amplifier.

The frequency multiplying and amplifying stages which will be required between the two exciters which are described, and the output amplifier, can be perfectly conventional in every respect. However, it is important that each stage carrying frequency-modulated r.f. be tuned carefully to resonance if undesirable amplitude modulation is to be kept out of the transmitted signal.

Stabilized F.M. Exciter

By comparing the frequency of a self-controlled oscillator with that of a crystal oscillator, and holding the difference between the two at a constant value by means of a discriminator-reactance tube combination, it is possible to hold the self-controlled oscillator frequency quite constant under changes in load and voltage. A frequency-modulated exciter employing this principle is illustrated in Figures 19 and 20.

The Circuit The exciter is intended to replace a 40-meter crystal stage or v.f.o. to excite transmitters operating in the 10- or 5-meter f.m. bands. The oscillator tube is a 6F6 in a conventional electron-coupled circuit. This stage has its grid circuit in the 80-meter band and its plate circuit tuned to the second harmonic, between 7316 and 7500 kc. A conventional reactance-tube frequency modulator (operation described in Chapter 9) is tied across the oscillator grid tank.

Figure 20.
BOTTOM VIEW OF
STABILIZED F.M.
EXCITER.

In this photo the oscillator grid and plate coils and capacitors may be seen at the center and left edge of the chassis. The speech amplifier is at the lower right, with the reactance tube section to its left. The stabilizing section is at the top, with the converter at the left and the discriminator toward the right.

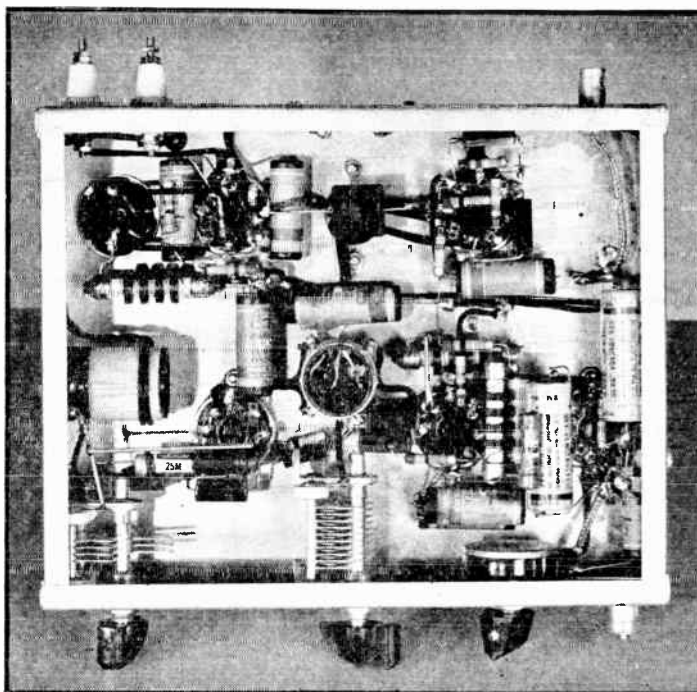

Instead of going directly through a resistor to ground, the control-grid return of the 6SJ7 reactance tube goes through the two discriminator load resistors, R_{12} and R_{13} , to ground. This allows the d.c. voltage developed by the discriminator to be applied to the reactance-tube grid along with the audio from the speech amplifier. Resistor R_{11} and capacitor C_{16} form an R-C filter to remove the audio output of the discriminator.

The 6K8 converter tube receives signal-grid excitation directly from the 6F6 output link, and has a Pierce crystal oscillator circuit in its oscillator section. A signal with a frequency equal to the difference between the crystal and 6F6 output frequencies appears at the 6K8 plate and is applied by means of a discriminator transformer, IFT, to the 6H6 discriminator tube. A voltage which depends upon the difference in frequency between the signal applied to the discriminator transformer and the frequency to which the transformer is tuned, is developed across the discriminator load resistors, R_{12} and R_{13} . When the signal is at the resonant frequency of the transformer, the voltage produced is zero; when the frequency varies one way a positive voltage is produced; a variation in the other direction will give a negative voltage. This voltage is applied as additional positive or negative bias to the reactance tube, and the effect is to cause the reactance tube to restore the frequency back

near a value which gives zero voltage output from the discriminator.

Construction The complete exciter, including the speech amplifier, is built on a 7 x 9 x 2-inch chassis. In Figure 19, the 6N7 2-stage speech amplifier is seen at the left in the front row of tubes, followed to its right by the 6SJ7 reactance-tube modulator and the 6F6 oscillator. The 6K8 and the crystal are at the right rear of the chassis, with the discriminator transformer and the 6H6 to their left. Figure 20 shows how the parts are located under the chassis. The speech amplifier and reactance-tube section is in the lower right in this view, with the oscillator grid tank circuit at the lower center and the output tuned circuit at the lower left. The components at the top of the photo are those associated with the converter and discriminator circuits, with the crystal socket at the left, followed to the right by the 6K8 socket and the 6H6 socket. Two feed-through insulators in the rear drop of the chassis are provided for link connections to the transmitter, while an auto-type connector is used for connection to an external monitoring amplifier. A 4-prong socket is used for connections to the exciter.

Tuning Up To place the exciter in operation, it is best first to disconnect the lead between R_{11} and R_{12} and ground

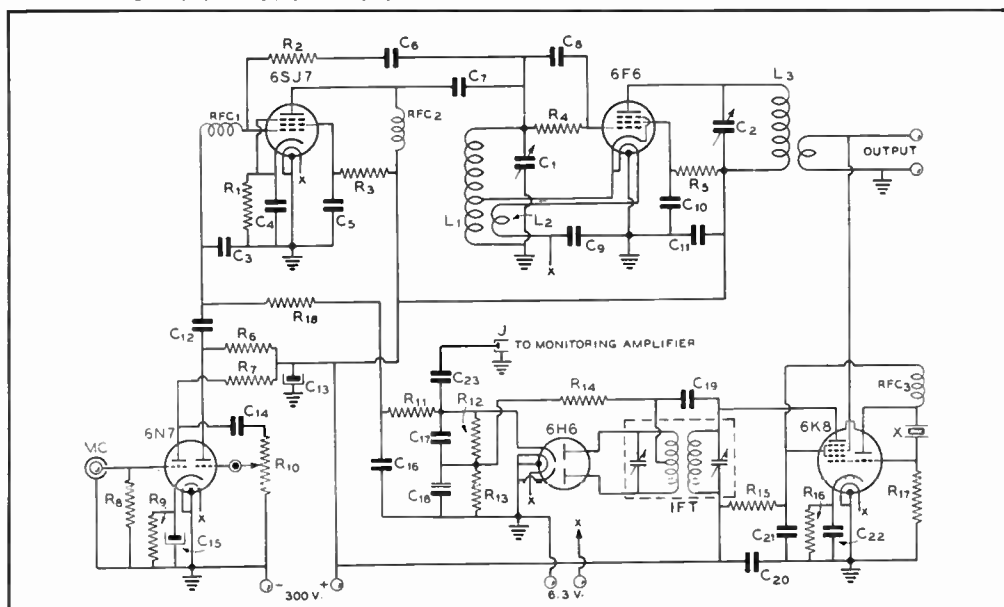

Figure 21.

STABILIZED F.M. EXCITER DIAGRAM

- | | | | |
|--|--|--|--|
| C ₁ —140- μ fd. midget variable | C ₁₅ —25- μ fd. 25-volt electrolytic | R ₉ —1500 ohms, 1/2 watt | IFT—465-kc. "output" i.f. trans. with center-tapped secondary |
| C ₂ —50- μ fd. midget variable | C ₁₆ —.05- μ fd. 600-volt tubular | R ₁₀ —500,000-ohm potentiometer | L ₁ —27 turns of no. 22 d.c.c. close-wound on 1" dia. form, tapped at ninth turn |
| C ₃ —.0001- μ fd. mica | C ₁₇ , C ₁₈ —.0001- μ fd. mica | R ₁₁ —500,000 ohms, 1/2 watt | L ₂ —9 turns of no. 22 d.c.c. over bottom end of L ₁ |
| C ₄ —.01- μ fd. 600-volt tubular | C ₁₉ —.0005- μ fd. mica | R ₁₂ , R ₁₃ —100,000 ohms, 1/2 watt | L ₃ —25 turns of no. 22 d.c.c. close-wound on 1" dia. form. 2-turn link over "cold" end |
| C ₅ —.25- μ fd. 600-volt tubular | C ₂₀ , C ₂₁ , C ₂₂ , C ₂₃ —.05- μ fd. 600-volt tubular | R ₁₄ —50,000 ohms, 1/2 watt | X—Crystal near 7000 kc. for 5- and 10-meter operation, near 7500 kc. for 2 1/2-meter operation |
| C ₆ , C ₇ —.005- μ fd. mica | R ₁ —500 ohms, 1/2 watt | R ₁₅ —30,000 ohms, 1/2 watt | |
| C ₈ —.0001- μ fd. mica | R ₂ , R ₃ , R ₄ —50,000 ohms, 1/2 watt | R ₁₆ —300 ohms, 1/2 watt | |
| C ₉ , C ₁₀ , C ₁₁ —.005- μ fd. mica | R ₅ —25,000 ohms, 2 watts | R ₁₇ —50,000 ohms, 1/2 watt | |
| C ₁₂ —.01- μ fd. 600-volt tubular | R ₆ , R ₇ —250,000 ohms, 1/2 watt | R ₁₈ —500,000 ohms, 1/2 watt | |
| C ₁₃ —8- μ fd. 450-volt electrolytic | R ₈ —1 megohm, 1/2 watt | RFC ₁ , RFC ₂ , RFC ₃ —2 1/2 mhy. | |
| C ₁₄ —.01- μ fd. 600-volt tubular | | | |

the free end of R₁₁. This allows the oscillator to operate without the stabilizing action. A crystal near 7000 kc. should be plugged into the crystal socket, and a pair of headphones or an amplifier and speaker connected to the monitoring output connection. Speaking into the microphone and simultaneously tuning C₁ and C₂, an oscillator frequency will be found which allows the signal to be heard in the phones or speaker. The signal should be tuned for maximum volume by adjusting C₂, and then peaked further by adjusting the primary trimmer on the discriminator transformer, IFT.

Next, R₁₁ should be disconnected from ground and reconnected to R₁₂. A receiver equipped with a b.f.o. should now be used to check the signal from the oscillator. The receiver should be tuned to a frequency near the

sum of the crystal and discriminator transformer frequencies. If the crystal is near 7000 kc. and the transformer is tuned to around 450 kc., the receiver should be tuned near 7450 kc. Now, while slowly changing the oscillator frequency by tuning C₁, and following the signal with the receiver, a frequency should be found where the oscillator suddenly "pulls in" and changes frequency only slightly for quite a variation in C₁, indicating that this is the frequency at which the stabilizing circuit takes hold. If the opposite effect takes place, and the stabilizing circuit throws" the oscillator from one frequency to another when C₁ is varied, it is an indication that the discriminator voltage is of the wrong polarity for stabilization. The remedy for this effect is simply to reverse the polarity of the discriminator voltage by mov-

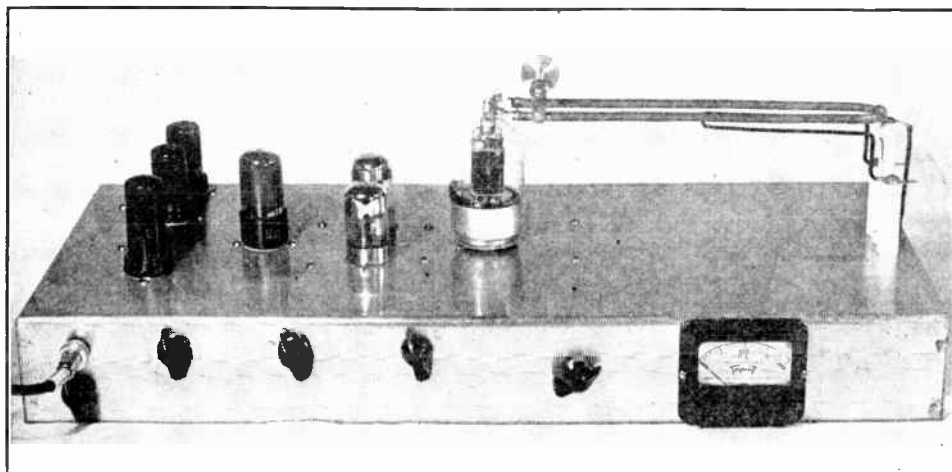

Figure 22.

TOP VIEW OF THE 50-WATT F.M. TRANSMITTER.

The three tubes in the row on the left edge of the chassis are, front to back: the 6F6 oscillator, 6SJ7 reactance tube, and 6SC7 speech amplifier. Then comes the 6V6-GT doubler to 38 Mc. and the push-pull 7A4 tripler to 112 Mc., followed by the 50 watt output tube and its tank circuit. Note the manner in which the plate circuit tuning capacitor has been soldered to the plate rods.

ing the ground connection to R_{13} from R_{12} , and connecting R_{11} and C_{22} to R_{13} , or to reverse the connection from the secondary of IFT to the 6H6 plates. The latter method will usually be found to be the simplest, and these leads should be left long enough when the exciter is wired to allow the change to be made, if necessary.

A check for the operation of the stabilizing circuit may be made by bringing a hand near the 6F6 grid coil. When the crystal is removed from the socket, the frequency will vary greatly when this coil is approached with the hand. With the crystal in the socket, however, only a very slight frequency variation should take place when the hand is brought near the coil.

The oscillator output frequency will, as explained above, depend on the crystal and discriminator transformer frequencies. Since the transformer specified can be tuned over a range from 255 to 550 kc. with its own trimmers, the output frequency may be set anywhere from 7255 to 7550 kc. by simply readjusting the transformer, when a 7000-kc. crystal is used. Frequencies between 7316 and 7500 kc. are the only ones which should be used for the 10- and 5-meter f.m. bands, however. To use the exciter with a $2\frac{1}{2}$ -meter transmitter, the output frequency should be between 7000 and 7250 kc. In this case, the crystal should have a frequency close to 7500 kc., allowing the discriminator to operate on the difference instead of the sum frequency. Changing from difference to sum frequency operation will require

that the discriminator output voltage be reversed, as described above. If the change is to be made often, a switch should be incorporated for that purpose.

The speech amplifier has sufficient gain to give satisfactory operation with any of the ordinary crystal or dynamic microphones. A deviation of 25 kc. on 10 meters may be easily obtained, with proportionally higher deviation on the higher frequencies. The gain control may be calibrated in terms of deviation by the method described in Chapter 9.

50-Watt F.M. Transmitter

The transmitter illustrated in Figures 22 and 23 and diagrammed in Figure 24 has an output of 50 watts, frequency modulated, at 112 Mc. Except for the 500-volt, 250-ma. power supply, the transmitter is all located on the single 10 x 23 x 3-inch chassis.

The Exciter Stages The exciter section of the transmitter, which includes those stages preceding the output stage, employs standard receiving tubes throughout, and is distinguished by the lack of unusual or "trick" circuit arrangements. The frequency modulated oscillator is a 6F6 operating at low plate and screen voltages to assure minimum frequency drift. The grid circuit of this stage is turned to 9.5 Mc., and the plate circuit to the second harmonic, or 19 Mc.

Excitation from the oscillator stage is carried through a small coupling capacitor to the

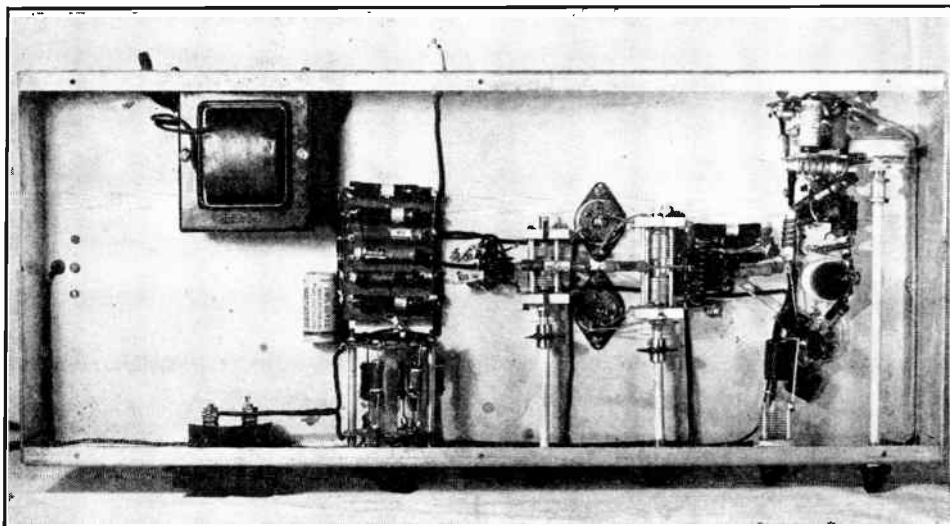

Figure 23.

UNDER-CHASSIS VIEW OF THE 50-WATT F.M. TRANSMITTER.

The filament transformer for the entire rig is shown in the left rear. The meter switch is mounted, with the resistors between its sections, directly in front of the resistor tie plate for the rig.

grid of the following doubler, which is a 6V6-GT. To reduce the number of tuned circuits in the transmitter, the plate circuit of the doubler stage is tuned only by being closely inductively coupled to the grid circuit of the following stage. The close coupling required for proper operation of this type of circuit is achieved by locating the 6V6-GT plate coil, L_a , inside the following grid coil, L_s . There are no rigorous requirements in the choice of the tube used in the doubler stage; a 6V6 or 6L6 may be substituted for the 6V6-GT, if desired, without making any circuit changes. If the plate voltage to the doubler stage is lowered somewhat, a 6F6 may be used. The doubler output frequency is 38 Mc.

Following the doubler stage is a tripler to 114 Mc. employing push-pull 7A4's. Circuit balance in this stage is provided by grounding the rotor of the split stator grid capacitor. It is not necessary to ground the rotor of the plate tank capacitor in this stage. No harm will be done, however, if the type of plate capacitor used makes grounding the rotor more convenient than insulating it.

Tests with an experimental version of this transmitter showed the necessity of placing the tuned input circuit of the tripler directly in the grid circuit, rather than the more conventional method of capacitance coupling from a balanced, tuned plate circuit in the preceding stage. With the latter type of circuit, the trip-

let stage is prone to oscillate, while with the circuit shown in the diagram there is no tendency toward oscillation or instability.

By itself, (the exciter section of the transmitter forms a complete, inexpensive, low power 112-Mc. transmitter with an output of 5 to 7 watts; if the constructor is interested in a transmitter in this power class he could well choose the exciter of the 50-watt transmitter.

Output Stage The 50-watt output stage utilizes an 815 tube, which has two beam tetrodes, each of somewhat lower power rating than an 807, in a single envelope. Excitation to the 815 is obtained by a 2-turn coupling coil pushed between the center turns of L_s . The excitation is adjusted by pushing the coupling coil in and out of L_s —too much coupling will overload the tripler and reduce the excitation and output in the final amplifier, while too little coupling will reduce the excitation and output. It is a simple matter to adjust the excitation properly by observing the output from the transmitter.

The final plate tank circuit consists of a U-shaped piece of $\frac{1}{4}$ -inch copper tubing measuring $9\frac{1}{2}$ inches on each leg, with the two legs separated 1 inch. Tuning of the linear tank circuit is accomplished by varying the spacing between the plates of a small capacitor at the plate ends of the tank circuit. The capacitor plates and their supporting strips were taken

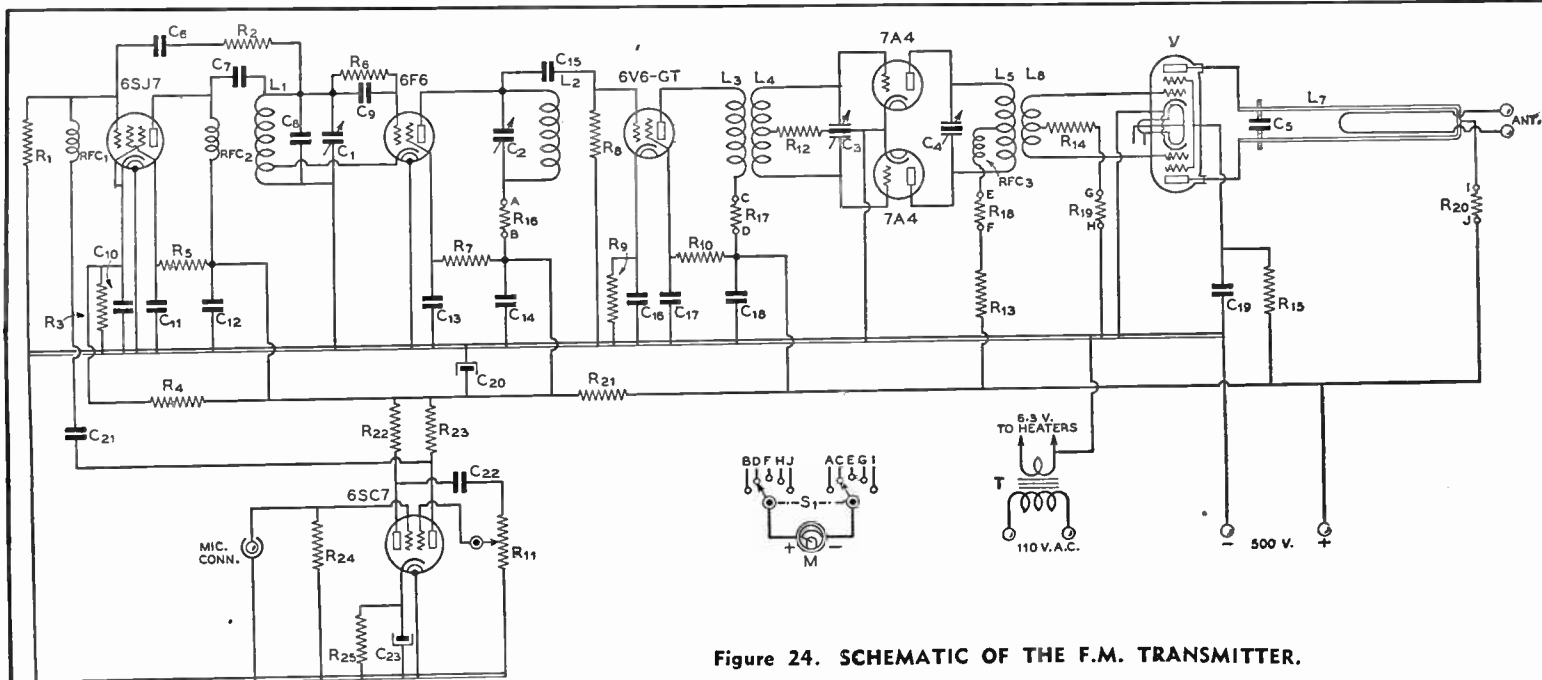

Figure 24. SCHEMATIC OF THE F.M. TRANSMITTER.

C₁, C₂—50- μ fd. mid-gate variable
 C₃—50- μ fd. per section
 C₄—25- μ fd. per section
 C₅—Mid gate circular plate neut. capacitor mounted on plate rods
 C₆, C₇—0.003- μ fd. mid-gate mica
 C₈—0.001- μ fd. zero coeff.
 C₉—0.001- μ fd. mid-gate mica

C₁₀, C₁₁, C₁₂—0.003- μ fd. mica
 C₁₃, C₁₄—0.003- μ fd. mica
 C₁₅—0.0005- μ fd. mica
 C₁₆, C₁₇, C₁₈—0.003- μ fd. mica
 C₁₉—0.0003- μ fd. silver mica
 C₂₀—8- μ fd. 450-volt electrolytic
 C₂₁—0.01- μ fd. 400-volt tubular
 C₂₂—0.005- μ fd. mica
 C₂₃—10- μ fd. 25-volt electrolytic

R₁—500,000 ohms, 1/2 watt
 R₂—50,000 ohms, 1/2 watt
 R₃—1000 ohms, 1/2 watt
 R₄—60,000 ohms, 1 watt
 R₅—100,000 ohms, 1/2 watt
 R₆—50,000 ohms, 1/2 watt
 R₇—25,000 ohms, 1 watt
 R₈—100,000 ohms, 1 watt
 R₉—100,000 ohms, 1 watt
 R₁₀—25,000 ohms, 1/2 watt

R₁₁—25,000 ohms, 1/2 watt
 R₁₂—500,000-ohm potentiometer
 R₁₃—10,000 ohms, 1/2 watt
 R₁₄—5000 ohms, 10 watts
 R₁₅—10,000 ohms, 1/2 watt
 R₁₆—25,000 ohms, 1/2 watt
 R₁₇, R₁₈, R₁₉, R₂₀—100 ohms, 1 watt
 R₂₁—5000 ohms, 10 watts

R₂₂, R₂₃—250,000 ohms, 1/2 watt
 R₂₄—1 megohm, 1/2 watt
 R₂₅—1000 ohms, 1/2 watt
 RFC₁, RFC₂—2.5 mh. 125 ma.
 RFC₃—U.h.f. cheke
 T—6.3-v. 10-a.
 M—0-200 d.c. milliammeter
 L₁—12 t. no. 18 d.c.c. 1" dia. 1" long
 L₂—13 t. no. 14 enam., 5/8" dia. 1" long

L₃—8 turns hookup wire inside L₄
 L₄—8 turns no. 14 enam. 7/8" dia. 1 1/4" long
 L₅—4 t. no. 14 enam. 3/8" dia. 3/4" long
 L₆—2 turns hookup wire wound with L₅
 L₇—20" 1/4" copper tubing bent into a hairpin with 1" center-to-center spacing
 V—815 dual beam tetrode

from a small neutralizing capacitor originally intended for neutralizing a 6L6. The plates and the supporting metal were removed from the insulator assembly which originally served as a mounting for the capacitor, and the metal strips were soldered to the tank circuit with the aid of a small alcohol torch.

The antenna coupling "hairpin" is made up of a length of no. 10 enamelled wire supported by two stand-off insulators which also serve as terminals for connecting the antenna feeders. The antenna coupling is varied by bending the hairpin toward or away from the plate tank.

Modulator and Speech Amplifier The frequency modulator uses a conventional reactance tube circuit. The theory of operation of this type of circuit is described in Chapter 9. Partially fixed bias on the reactance tube is provided by resistor R_4 , which bleeds a constant amount of current through the reactance tube bias resistor R_3 . Varying amounts of positive and negative d.c. voltage may be applied across the grid resistor, R_1 , to determine whether the frequency varies linearly each side of the "carrier" frequency when the control voltage is varied. Non-linearity may be corrected by changing the value of R_4 . In the transmitter shown, the resistor value specified in the diagram caption gave a linear-voltage-frequency characteristic. For a 50-kc. swing under modulation at 112 Mc., the modulator should be linear over a range of slightly more than 4 kc. at the oscillator frequency.

A single 6SC7 dual triode is used as a 2-stage speech amplifier. This tube provides considerably more voltage gain than is necessary to give a 50-kc. swing, when a crystal microphone is used. The 6SC7 may be replaced by a low gain triode (6C5, 6J5, etc.) if a low output single-button microphone or a double-button microphone is used. High output single-button microphones (telephone type) may be coupled directly into the reactance tube control grid by a microphone transformer, with the gain control R_{11} , replacing the fixed grid resistor R_1 .

Construction As the photographs show, all of the wiring except the 815 plate circuit is below the chassis. The oscillator, modulator, and speech amplifier circuit occupy the space toward the left edge of the chassis. The stages following the oscillator are placed along the center line of the chassis, with each circuit placed as close to the preceding one as possible, since short leads are of prime importance in the high- and ultra-high-frequency stages. In each of the stages following the oscillator, all ground returns are brought through separate leads, to a single point on the tube socket.

Operation To place the transmitter into operation, 250 to 300 volts should be applied to the "+500" terminal and the oscillator first tuned to 9500 kc., as indicated by a conventional receiver. After the oscillator grid circuit has been set to the correct frequency, the oscillator plate circuit and following stages should each be tuned to resonance as indicated by minimum plate current. It will be found that tuning the oscillator plate circuit to the second harmonic of the grid circuit frequency will change the oscillator frequency slightly, and it may be necessary to retune the grid circuit after the plate circuit has been resonated. After the complete transmitter has been tuned up, the antenna may be connected and the full 500 volts applied.

Typical current readings, at resonance, are: oscillator plate—15 ma.; doubler plate—35 ma.; tripler plate—40 ma.; final amplifier grid—3 ma.; final amplifier plate—150 ma.

Although it is not to be recommended except for extremely short periods of time, a check on the operation of the output stage may be made by removing the loading and observing the minimum plate current. If the stage is operating correctly, the plate current will be approximately 30 ma. at resonance without load.

MICROWAVE TRANSMITTERS

Microwaves and the general arrangement of microwave transmitters were described in Chapter 17. Microwaves are used by broadcast stations for remote pick-up, by amateurs and experimenters, and for telegraph and telephone communication. Considerable microwave technique was employed in radar operations in World War II. In addition to the microwave equipment described in the last chapter, we present here a special transmitter for the 420-450-Mc. band.

420-Mc. Parallel Rod WE-316-A Transmitter A large variety of circuits could be suggested for microwave operation, but the most simple of these is the one shown in Figures 25 and 26. It consists of two parallel half-wave rods, spaced about $\frac{1}{4}$ inch apart, to provide a 420-Mc. meter tuned circuit of fairly high Q. The grid and plate of the tube are connected to the copper rods; this capacitance causes the physical length to be less than a half wavelength. As can be seen from the photograph, the plate r.f. choke and the grid leak do not connect to the center of the rods, but rather across the voltage node. The distance between this point and the free ends of the rods is a quarter wave-length.

Filament r.f. chokes, or tuned filament leads, are desirable for operation below 1 meter be-

Figure 25.
420-MEGACYCLE NEGATIVE-GRID OSCILLATOR WITH WE-316-A.

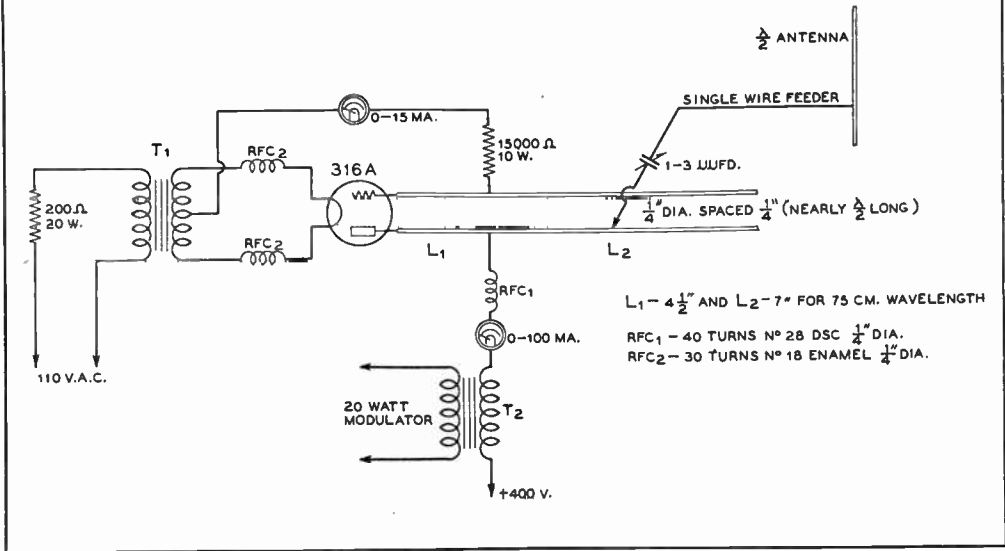

cause the filament is not strictly at a point of ground potential in the oscillating circuit. These filament chokes consist of 30 turns of no. 16 enamelled wire, wound on a $\frac{1}{4}$ -inch rod, then removed from the rod and air-supported, as the picture shows. The length of these chokes is approximately 3 inches. A 200-ohm resistor is placed in series with the 110-volt a.c. line to the filament transformer in order to reduce the transformer secondary voltage from $2\frac{1}{2}$ to 2 volts, because the filament of the tube operates on 2 volts at 3.65 amperes. This particular oscillator gave outputs in excess of 5 watts on $\frac{3}{4}$ meter, even when no filament r.f. chokes were used.

Operation of the Oscillator This oscillator, when loaded by an antenna, draws from 70 to 80 milliamperes at 400 volts plate supply. The oscillator should be tested at reduced plate voltage, preferably by means of a 1000- to 2000-ohm resistor in series with the positive B lead, until oscillation has been checked. A flashlight globe and loop of wire can be coupled to the parallel rods at a point near the voltage node, in order to indicate oscillation. A thermo-galvanometer coupled to a loop of wire makes a more sensitive indicator, but the high cost of this meter prohibits its use in most cases.

A 15-inch antenna rod or wire can be fed by a 1- or 2-wire feeder of the nonresonant type. A single-wire feeder can be capacitively coupled to the plate rod, either side of the voltage node, through a small blocking capacitor. If a 2-wire feeder is employed, a small coupling loop, placed parallel to the oscillator rods with the closed end of the loop near the voltage node of the oscillator, will provide a satisfactory means of coupling to the antenna. U.h.f. antennas are described in a later chapter.

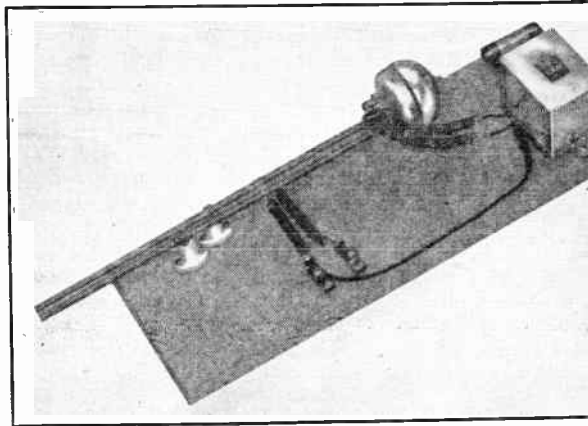

Figure 26.
WE-316-A 420-MEGACYCLE OSCILLATOR.

Antenna Theory and Operation

RADIO waves consist of condensations and rarefactions of energy traveling through space with the speed of light (186,000 miles or 300,000,000 meters per second). These waves have an electrostatic and an electromagnetic component. The electrostatic component may be considered as corresponding to the voltage of the wave and the electromagnetic component to the wave current. Radio waves not only travel with the speed of light but can be refracted and reflected much the same as light waves.

Radio Waves and Their Propagation

Polarization Like light waves, radio waves can have a definite polarization. In fact, while light waves ordinarily have to be reflected or passed through a polarizing medium before they have a definite polarization, a radio wave leaving a simple radiator will have a definite polarization, the polarization being indicated by the orientation of the electrostatic component of the wave. This, in turn, is determined by the orientation of the radiator itself, as the electromagnetic component is always at right angles to a linear radiator, and the electrostatic component is always in the same plane as the radiator. Thus we see that an antenna that is vertical with respect to the earth will transmit a vertically polarized wave, as the electrostatic lines of force will be vertical. Likewise, a simple horizontal antenna will radiate horizontally polarized waves.

Because the orientation of a simple linear radiator is the same as the polarization of the waves emitted by it, the radiator itself is referred to as being either vertically or horizontally polarized. Thus, we say that a horizontal antenna is horizontally polarized.

The Ionosphere A simple transmitting antenna or radiating system sends out radio waves in nearly all directions, though the strength of the waves may be greater in certain directions, and at certain angles above the earth. High frequency energy radiated along the surface of the earth is rap-

idly attenuated, and is of little use for consistent communication over distances exceeding 50 or 75 miles. That portion of the radiated energy which is sent up at an angle above the horizon is partly returned to earth by the bending effect produced by the varying density of the ionized particles in the various layers of the *ionosphere*.

The ionosphere consists of layers of ionized particles of gas located above the stratosphere, and extending up to possibly 750 miles above the earth. Thus we see that high-frequency radio waves may travel over short distances in a direct line from the transmitter to the receiver, or they can be radiated upward into the ionosphere to be bent downward in an indirect ray, returning to earth at considerable distance from the transmitter. The wave reaching a receiver via the ionosphere route is termed a *sky wave*. The wave reaching a receiver by traveling in a direct line from the transmitting antenna to the receiving antenna is commonly called a *ground wave*, or *surface wave*.

The amount of bending which the sky wave undergoes depends upon its frequency, and the amount of *ionization* in the ionosphere, which is in turn dependent upon radiation from the sun. The sun increases the density of the ionosphere layers, and lowers their effective height. For this reason, radio waves act very differently at different times of day, and at different times of the year.

The higher the frequency of a radio wave, the farther it penetrates the ionosphere, and the less it tends to be bent back toward the earth. The lower the frequency, the more easily the waves are bent, and the less they penetrate the ionosphere. 160-meter and 80-meter signals will usually be bent back to earth even when sent almost straight up, and may be considered as being *reflected* rather than *refracted*. As the frequency is raised beyond about 5,000 kc. (dependent upon the critical frequency of the ionosphere at the moment), it is found that waves transmitted at angles higher than a certain critical angle *never return to earth*. Thus, on the higher frequencies, it is usually desir-

able to confine radiation to low angles, since the high angle waves simply penetrate the ionosphere and keep right on going and never return.

Signals above about 45,000 kc. are bent so slightly that they seldom return to earth, regardless of the vertical angle of radiation, although, under exceptional circumstances, radio waves of 75,000 kc. have been known to return to earth for very short periods of time. Thus, sky wave propagation does not permit consistent communication at frequencies of 15,000 kc. In fact, the results on frequencies above 22,000 kc. are not considered consistent enough for commercial use.

Skip Distance The ground wave of a 14,000-kc. transmitter can seldom be heard over 100 miles away. Also, the first bending of the sky wave rarely brings it back down to earth within 300 miles from the 14,000-kc. transmitting antenna at night. Thus, there is an area, including all distances between 100 and 300 miles from the transmitter, in which the signals are not ordinarily heard. The closest distance at which sky waves return to earth is called the *skip distance*. In the skip zone, no reception is possible, but moving closer to or farther away from the transmitter allows the signals to be heard.

Fading The lower the angle of radiation of the wave, with respect to the horizon, the farther away will the wave return to earth, and the greater the skip distance. The wave can be reflected back up into the ionosphere by the earth, and then be reflected back down again, causing a second skip distance area. The drawing of Figure 1 shows the multiple reflections possible. When the receiver receives signals which have traveled over more than one path between transmitter and receiver, the signal impulses will not all arrive at the same instant, as they do not all travel the same distance. When two or more signals arrive in the same phase at the receiving antenna, the resulting signal in the receiver will be quite loud. On the other hand, if the signals arrive 180° out of phase, so they tend to neutralize each other, the received signal will drop,—perhaps to zero, if perfect neutralization occurs. This explains why high-frequency signals fade in and out.

Fading can be greatly reduced on the high frequencies by using a transmitting antenna with sharp vertical directivity, thus cutting down the number of multiple paths of signal arrival. A receiving antenna with similar characteristics (sharp vertical directivity) will further reduce fading. It is desirable, when using antennas with sharp vertical directivity, to use the lowest vertical

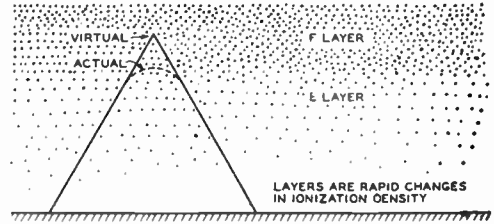
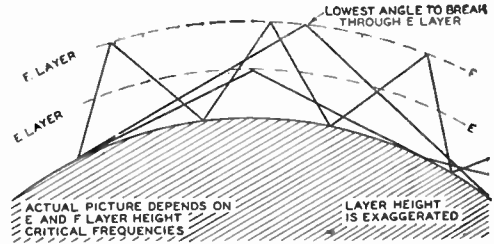

Figure 1.

Illustrating how the ionized atmosphere or ionosphere layer can bend radio waves back to earth, and some of the many possible paths of a high-frequency sky wave signal.

angle consistent with good signal strength for the frequency used. This cuts down the number of hops the signal has to make to reach the receiver, and consequently reduces the chance for arrival via different paths.

Selective Fading Selective fading affects all modulated signals. A modulated signal is not a single frequency signal, but consists of a narrow band of waves perhaps 15 kc. wide. It will be seen that the whole modulated signal band may not be neutralized at any instant, but only part of it. Likewise, most of the carrier may be suppressed, or one sideband may be attenuated more than the other. This causes a peculiar and changing form of audio distortion at the receiver, which is known as *selective fading*.

Angle of Radiation For a certain frequency, ionosphere height, and transmitting distance there is an optimum angle with the horizon at which the radio wave should be propagated. For extremely long distance communication, the angle of radiation should be low (5 to 15 degrees above the horizon), regardless of the frequency used, so that the wave may arrive in the fewest possible jumps. For comparatively short distance communication (between 100 and 400 miles), the optimum angle of radiation will be considerably higher, but because very high frequency waves are not readily bent, and

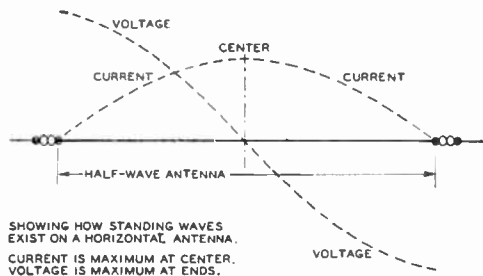

Figure 2.

penetrate the ionosphere when striking it at too steep an angle, we see that the shorter wavelengths are not satisfactory for short distance communication. Thus, we have the skip distance, or zone of silence, previously referred to. Different types of antennas have different major angles of radiation with respect to the earth and the antenna, as will be shown later.

Antenna Radiation

Alternating current passing through a conductor creates an alternating electromagnetic field around that conductor. Energy is alternately stored in the field, and then returned to the conductor. As the frequency is raised, more and more of the energy does not return to the conductor, but instead is radiated off into space in the form of electromagnetic waves, called radio waves. Radiation from a wire, or wires, is materially increased whenever there is a sudden *change* in the *electrical constants* of the line. These sudden changes produce reflection, which places *standing waves* on the line.

When a wire in space is fed radio frequency energy having a wavelength of approximately 2.08 times the length of the wire in meters, it *resonates* as a *dipole* or half-wave antenna at that wavelength or frequency. The greatest possible change in the electrical constants of a line is that which occurs at the open end of a wire. Therefore, a dipole has a great mismatch at each end, producing a high degree of reflection. We say that the dipole is terminated in an infinite impedance (open circuit). An incident radio frequency wave traveling to one end of the dipole is reflected right back towards the center of the dipole after reaching the end, as there is no place else for it to go.

A returning wave which has been reflected meets the next incident wave, and the voltage and current at any point along the antenna are the algebraic sum of the two waves. At the ends of the dipole, the voltages add up, while the currents of the two waves cancel, thus producing *high voltage* and *low current*

at the *ends* of the dipole or half-wave section of wire. In the same manner, it is found that the currents add up while the voltages cancel at the center of the dipole. Thus, at the *center* there is *high current* but *low voltage*.

Inspection of Figure 2 will show that the current in a dipole decreases sinusoidally towards either end, while the voltage similarly increases. The voltages at the two ends of the antenna are 180° out of phase, which means that the polarities are opposite, one being plus while the other is minus at any instant. A curve representing either the voltage or current on a dipole represents a *standing wave* on the wire. If the voltage or current measured the same all along the wire, it would indicate the absence of standing waves. The latter condition can exist only when energy is absorbed from one end of a wire or line exactly at the same rate it is supplied to the other end. The latter condition is covered thoroughly later in the chapter, under the heading of *Untuned Transmission Lines*. Many transmission lines do not have uniform voltage and current along their length, and thus have standing waves the same as a dipole or antenna radiator.

A point of maximum current on a radiator or tuned resonant transmission line ordinarily corresponds to a point of minimum voltage. A *loop* means a point of *maximum* current or voltage, while a *node* refers to a point of *zero* or *minimum* current or voltage. Thus, we see that a voltage loop corresponds to a current node, and vice versa. In a wire or line containing reactance, this is not strictly true, but both antennas and tuned transmission lines ordinarily are operated at resonance, and the reactance, therefore, is negligible.

A 2-wire resonant line does not radiate appreciably in spite of its high reflection and consequent standing waves, because the radiation from the 2 adjacent wires is of opposite polarity or phase, and equal in amplitude, thus cancelling out if the spacing is but a very small fraction of a wavelength. In other words, the radiation from one wire is neutralized by that from the other wire, and vice versa.

Frequency and Antenna Length

All antennas commonly used by amateurs, excepting the terminated rhombic, are based on the fundamental Hertz type, which is a wire in space a half wavelength long electrically. A linear, resonant dipole, which is a half wavelength long *electrically*, is actually slightly less than a half wave long *physically*, due to the capacity to ground, "end effects," and the fact that the velocity of a high-frequency radio wave traveling along the conductor is not quite as high as it is in free space.

If the cross section of the conductor is kept

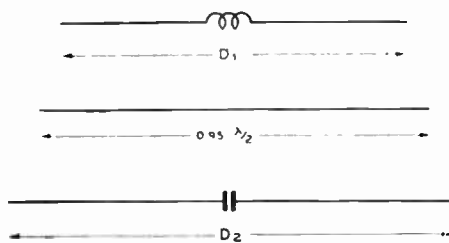

Figure 3.

THREE ANTENNAS ALL EQUAL ELECTRICALLY TO ONE HALF WAVELENGTH.

The top antenna is inductively lengthened. The bottom one is capacitively shortened. A coil will have the most lengthening effect and a condenser the most shortening effect when located at a current loop.

small compared to a half-wavelength, these effects are relatively constant, so that an electrical half wave is a fixed percentage shorter than a physical half-wavelength. This percentage is approximately 5 per cent. Therefore, most linear half-wave antennas are close to 95 per cent of a half wave long physically. Thus, a half-wave antenna resonant at exactly 80 meters would be one-half of 0.95 times 80 meters in length. Another way of saying the same thing is that a wire resonates at a wavelength of about 2.1 times its length in meters. If the diameter of the conductor begins to be an appreciable fraction of a wavelength, as when copper tubing is used as an u.h.f. radiator, the factor becomes slightly less than 0.95. For most purposes, however, the figure of 0.95 may be taken as accurate. This assumes a radiator removed from surrounding objects, and with *no bends*.

Simple conversion into feet can be obtained by using the factor 1.56. To find the physical length of a half-wave 80-meter antenna, we multiply 80 times 1.56, and get 124.8 feet for the length of the radiator.

It is more common to use frequency than wavelength when indicating a specific spot in the radio spectrum. For this reason, the relationship between wavelength and frequency must be kept in mind. As the velocity of radio waves through space is constant at the speed of light, it will be seen that the more waves that pass a point per second (higher frequency), the closer together the peaks of those waves must be (shorter wavelength). Therefore, the higher the frequency the lower the wavelength.

A radio wave in space can be compared to a wave in water. The wave, in either case, has peaks and troughs. One peak and one trough constitute a *full wave*, or *one wavelength*.

Frequency describes the number of wave

cycles or peaks passing a point per second. Wavelength describes the distance the wave travels through space during one cycle or oscillation of the antenna current; it is the distance in meters between adjacent peaks or adjacent troughs of a wave train.

As a radio wave travels 300,000,000 meters a second (speed of light), a frequency of 1 cycle per second corresponds to a wavelength of 300,000,000 meters. So, if the frequency is multiplied by a million, the wavelength must be divided by a million, in order to maintain their correct ratio.

A frequency of 1,000,000 cycles per second (1,000 kc.) equals a wavelength of 300 meters. Multiplying frequency by 10 and dividing wavelength by 10, we find: a frequency of 10,000 kc. equals a wavelength of 30 meters. Multiplying and dividing by 10 again, we get: a frequency of 100,000 kc. equals 3 meters wavelength. Therefore, to change wavelength to frequency (in kilocycles), simply divide 300,000 by the wavelength in meters (λ).

$$F_{kc} = \frac{300,000}{\lambda}$$

$$\lambda = \frac{300,000}{F_{kc}}$$

Now that we have a simple conversion formula for converting wavelength to frequency and vice versa, we can combine it with our wavelength versus antenna length formula, and we have the following:

Wire length of a rectilinear half-wave radiator, in

$$\text{feet} = 1.56\lambda = \frac{467,400}{F_{kc}} = \frac{467.4}{F_{Mc}}$$

The slight discrepancy between the answers that will be obtained by the wavelength formula and by the frequency formula is due to the fact that the factor 1.56 is given only to two decimal places, this degree of accuracy being sufficient for ordinary purposes. Actually the factor is 1.558, but 1.56 is close enough, and simplifies calculations.

Harmonic Resonance A wire in space resonates at more than one frequency. The *lowest* frequency at which it resonates is called its *fundamental* frequency, and at that frequency it is approximately a half wavelength long. A wire can have two, three, four, five, or more standing waves on it, and thus it resonates at approximately the integral harmonics of its fundamental frequency. However, the higher harmonics are not exactly integral multiples of the lowest resonant frequency.

A harmonic operated antenna is somewhat longer than the corresponding integral number of dipoles, and for this reason, the dipole

length formula cannot be used simply by multiplying by the corresponding harmonic. The intermediate half wave sections do not have "end effects." Also, the current distribution is disturbed by the fact that power can reach some of the half wave sections only by flowing through other sections, the latter then acting not only as radiators, but also as transmission lines. For the latter reason, the resonant length will be dependent to an extent upon the method of feed, as there will be less attenuation of the current along the antenna if it is fed at or near the center than if fed towards or at one end. Thus, the antenna would have to be somewhat longer if fed near one end than if fed near the center. The difference would be small, however, unless the antenna were at least 4 wavelengths long.

Under conditions of severe current attenuation, it is possible for some of the nodes, or loops, actually to be slightly greater than a physical half wavelength apart. It is obvious that with so many things affecting the length, the only method of resonating a harmonically operated antenna accurately is by cut and try, or by using a feed system in which both feed line and antenna are resonated at the station end as an integral unit.

A dipole or half-wave antenna is said to operate on its fundamental or first harmonic. A full wave antenna, 1 wavelength long, operates on its second harmonic. An antenna with five half-wavelengths on it would be operating on its fifth harmonic. Observe that the fifth harmonic antenna is $2\frac{1}{2}$ wavelengths long, not 5 wavelengths.

Antenna Impedance In many ways, a half-wave antenna is like a tuned tank circuit. The main difference lies in the fact that the elements of inductance, capacity, and resistance are *lumped* in the tank circuit, and are *distributed* throughout the length of an antenna. The center of a half-wave radiator is effectively at ground potential as far as r.f. voltage is concerned, although the current is highest at that point. See Figure 2.

When the antenna is resonant, and it always should be for best results, the impedance at the center is a pure resistance, and is termed the radiation resistance. Radiation resistance is a fictitious term; it is that value of resistance (referred to the current loop) which would dissipate the same amount of power that is being radiated by the antenna.

The radiation resistance depends on the antenna length and its proximity to nearby objects which either absorb or re-radiate power, such as the ground, other wires, etc.

Before going too far with the discussion of radiation resistance, an explanation of the Marconi (grounded quarter wave) antenna is

in order. The Marconi antenna is a special type of Hertz antenna in which the earth acts as the "other half" of the dipole. In other words, the current flows into the earth instead of into a similar quarter-wave section. Thus, the current loop of a Marconi antenna is at the *base* rather than in the *center*. In either case, it is a quarter wavelength from the end (or ends).

A half-wave dipole far from ground and other reflecting objects has a radiation resistance at the center of about 73 ohms. Radiation resistance usually is referred to a current loop. Otherwise, it has no particular significance, because it could be almost any value if the point on the antenna were not given.

A Marconi antenna is simply one-half of a dipole. For that reason, the radiation resistance is roughly half of 73 ohms.

Because the power throughout the antenna is the same, the *impedance* of the antenna at any point along its length merely expresses the ratio between voltage and current at that point. Thus, the lowest impedance occurs where the current is highest, namely, at the center of a dipole, or a quarter wave from the end of a Marconi. The impedance rises uniformly toward each end, where it is about 2400 ohms for a dipole remote from ground, and about twice as high for a vertical Marconi.

If a vertical half-wave antenna is set up so that its lower end is at the ground level, the effect of the ground reflection is to increase the radiation resistance to approximately 100 ohms. When a horizontal half-wave antenna is used, the radiation resistance (and, of course, the amount of energy radiated for a given antenna current) depends on the height of the antenna above ground, since the height determines the phase angle between the wave radiated directly in any direction and the wave which combines with it after reflection from the ground.

The radiation resistance of an antenna generally increases with length, although this increase varies up and down about a constantly increasing average. The peaks and dips are caused by the reactance of the antenna, when its length does not allow it to resonate at the operating frequency.

Antennas have a certain loss resistance as well as a radiation resistance. The loss resistance defines the power lost in the antenna due to ohmic resistance of the wire, ground resistance (in the case of a Marconi), corona discharge, and insulator losses.

Resonance Most antennas operate best when resonated to the frequency of operation. This does not apply to the terminated rhombic antenna, or to the *parasitic* elements of one popular type of close-spaced ar-

ray, to be described in the next chapter. However, in practically every other case, it will be found that increased efficiency results when the entire antenna system is resonant, whether it be a simple dipole or an elaborate array. The radiation efficiency of a resonant wire is many times that of a wire which is not resonant.

If an antenna is slightly too long, it can be resonated by series insertion of a variable capacitor at a high current point. If it is slightly too short, it can be resonated by means of a variable inductance. These two methods are generally employed when part of the antenna is brought into the operating room.

With an antenna array, or an antenna fed by means of a transmission line, it is more common to cut the elements to exact resonant length by "cut and try" procedure. Exact antenna resonance is more important when the antenna system has low radiation resistance; an antenna with low radiation resistance has higher Q (tunes sharper) than an antenna with high radiation resistance. The higher Q does not indicate greater efficiency: it simply indicates a sharper resonance curve.

CHARACTERISTICS AND CONSIDERATIONS

Radiation Resistance Along a half-wave antenna, the impedance varies from a minimum at the center to a maximum at the ends. The impedance is that property which determines the antenna current at any point along the wire for the value of r.f. voltage at that point, assuming a given antenna power.

The curves of Figure 4 indicate the theoretical center-point radiation resistance of a half-wave antenna for various heights above perfect ground. These values are of importance in matching untuned radio-frequency feeders to the antenna, in order to obtain a good impedance match and an absence of standing waves on the feeders.

Above average ground, the actual radiation resistance of a dipole will vary from the exact value of Figure 4, since the latter assumes a hypothetical, perfect ground having no loss and perfect reflection. Fortunately, the curves for the radiation resistance over most types of earth will correspond rather closely with those of the chart, except that the radiation resistance for a horizontal dipole does not fall off as rapidly as is indicated for heights below an eighth wavelength. However, with the antenna so close to the ground and the soil in a strong field, much of the radiation resistance is actually represented by ground loss; this means that a good portion of the antenna power is being dissipated in the earth, which, unlike the hypothetical perfect ground, has resistance. In

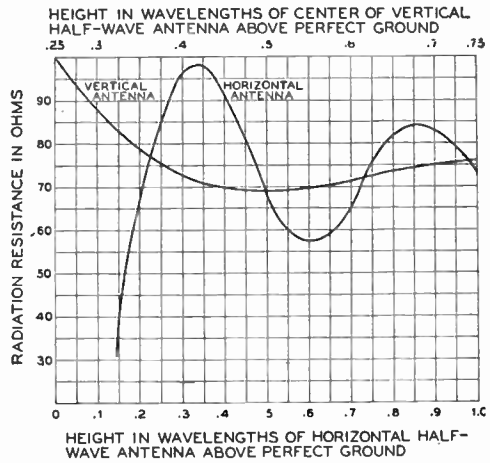

Figure 4.
EFFECT OF HEIGHT ON THE RADIATION RESISTANCE OF A DIPOLE SUSPENDED ABOVE PERFECT GROUND.

this case, an appreciable portion of the "radiation resistance" actually is loss resistance. The type of soil also has an effect upon the radiation pattern, especially in the vertical plane, as will be seen later.

When the radiation resistance of an antenna or array is very low, the current at a voltage node will be quite high for a given power. Likewise, the voltage at a current node will be very high. Even with a heavy conductor and excellent insulation, the losses due to the high voltage and current will be appreciable if the radiation resistance is sufficiently low.

Usually, it is not considered desirable to use an antenna or array with a radiation resistance of less than approximately 10 ohms unless there is sufficient directivity, compactness, or other advantage to offset the losses resulting from the low radiation resistance.

Ground Resistance The radiation resistance of a Marconi antenna, especially, should be kept as high as possible. This will reduce the antenna current for a given power, thus minimizing loss resulting from the series resistance offered by the earth connection. The radiation resistance can be kept high by making the Marconi radiator somewhat longer than a quarter wave, and shortening it by series capacity to an electrical quarter wave. This reduces the current flowing in the earth connection. It also should be removed from ground as much as possible (vertical being ideal). Methods of minimizing the resistance of the earth connection will be found in the discussion of the Marconi antenna.

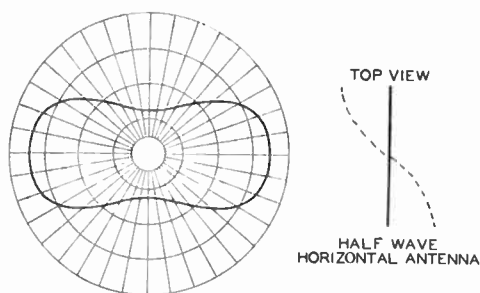

Figure 5.
RADIATION PATTERN OF A HALF-WAVE ANTENNA A HALF WAVE ABOVE PERFECT GROUND, FOR A FIXED VERTICAL ANGLE OF 30°.

Antenna Directivity

When choosing and orienting an antenna system, the radiation patterns of the various common types of antennas should be given careful consideration. The directional characteristics are of still greater importance when a directive antenna array is used.

There are two kinds of antenna directivity: vertical and horizontal. The latter is not generally desirable for amateur work except (1) for point-to-point work between stations regularly communicating with each other, (2) where several arrays are so placed as to cover most useful directions from a given location, and (3) when the beam may be directed by electrical or mechanical rotation.

Considerable horizontal directivity can be used to advantage for point-to-point work. Signals follow the great circle path, or within 2 or 3 degrees of that path most of the time.

For general amateur work, however, *too much* horizontal directivity is ordinarily undesirable, inasmuch as it necessitates having the beam pointed exactly at the station being worked. Making the array rotatable overcomes this obstacle, but arrays having extremely high horizontal directivity are too cumbersome to be rotated, except perhaps above 56 Mc. The horizontal directivity of a horizontal dipole depends upon the vertical angle being considered. Directivity is greater for lower vertical angles. The polar diagram of Figure 5 shows a typical horizontal radiation pattern.

On the 28- and 14-Mc. bands, and to an extent on the 7-Mc. band, the matter of vertical directivity is of as much importance as is horizontal directivity. Only the power leaving the antenna at certain vertical angles is instrumental in putting a signal into a distant receiving antenna; the rest may be considered as largely wasted. In other words, the important thing is the amount of power radiated in a

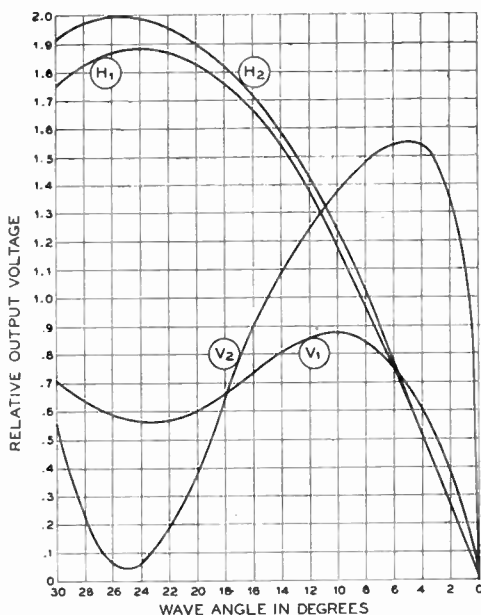

Figure 6.
VERTICAL-PLANE DIRECTIONAL CHARACTERISTICS OF HORIZONTAL AND VERTICAL DOUBLET 0.6 WAVELENGTH AND ABOVE TWO TYPES OF GROUND.

H₁ represents a horizontal doublet over typical farmland, *H₂* over salt water. *V₁* is a vertical pattern of radiation from a vertical doublet over typical farmland, *V₂* over salt water. A salt water ground is the closest approach to an extensive ideally perfect ground that will be met in actual practice.

desired direction at the useful vertical angles, rather than the actual shape of the directivity curves as read on the ground by a field strength meter, the latter giving only a pattern of the ground wave.

A nondirectional antenna, such as a vertical or horizontal dipole, will give excellent results with general coverage on 28 and 14 Mc., if the vertical angle of radiation is favorable. The latter type is slightly directional broadside, especially on 28 Mc. where only very low angle radiation is useful, but nevertheless is considered as a "general coverage" type.

Effect of Average Ground on Antenna Radiation

Articles appearing in journals discussing antenna radiation often are based upon the perfect

ground assumption, in order to cover the subject in the most simple manner. Yet, little has been said about the real situation which exists, the ground generally being anything but

a perfect conductor. Consideration of the effect of a ground that is not perfect explains many things.

When the earth is less than a perfect conductor, it becomes a dielectric or, perhaps in an extreme case, a "leaky insulator."

The resulting change in the vertical pattern of a horizontal antenna is shown in Figure 6. The ground constants, in this case, are for flat farmland, which probably is similar to mid-western farmland. The ocean is the closest practical approach to a theoretically perfect ground. It will be noted that there is only a slight loss in power due to the imperfect ground as compared to the ocean horizontal.

The effect of the earth on the radiation pattern of a vertical dipole is much greater. Radiation from a half-wavelength vertical wire is severely reduced by deficiencies of the ground.

A very important factor in the advantages of horizontal or vertical dipoles, therefore, appears to be the condition of the ground.

The best angle of radiation varies with frequency, layer height, and many other factors. For instance, a lower optimum vertical angle is found to hold for high-frequency communication with South America from the U.S.A. than for Europe and the U.S.A.

FEEDING THE ANTENNA

Usually a high-frequency doublet or directional array is mounted as high and as much in the clear as possible, for obvious reasons. Power can then be fed to the antenna system via one of the various transmission lines discussed in the latter portion of this chapter. However, it is sometimes justifiable to bring part of the radiating system directly to the transmitter, feeding the antenna without benefit of a transmission line. This is permissible when (1) there is insufficient room to erect a 75- or 160-meter horizontal dipole and feed line, (2) when a long wire is operated on one of the higher frequency bands on a harmonic. In either case, it is usually possible to get the main portion of the antenna in the clear because of its length. This means that the power lost by bringing the antenna directly to the transmitter is relatively small.

Even so, it is not best practice to bring the high-voltage end of an antenna into the operating room, especially for phone operation, because of the possibility of r.f. feedback from the strong antenna field. For this reason we dispense with a feed line in conjunction with a Hertz antenna only as a last resort.

End-Fed Antennas The end-fed Fuchs (pronounced "Fooks") antenna has no form of transmission line to couple it to the transmitter, but brings the radiating portion of the antenna right down to the trans-

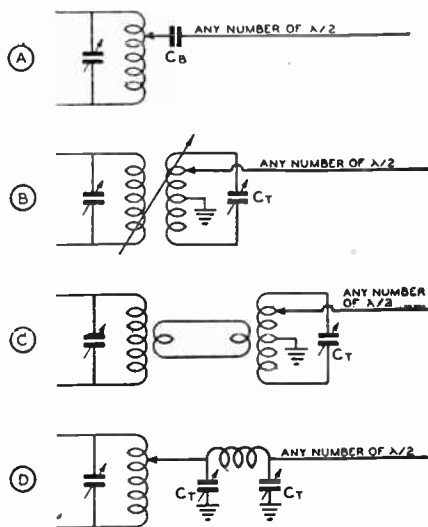

Figure 7.
FOUR METHODS OF END FEEDING AN ANTENNA.

The arrangement of "C" is to be recommended. The legality of arrangement "A" for amateur work is debatable if the blocking condenser is large. It is really a form of direct coupling, permitted by the regulations only when an untuned feed line is used.

mitter, where some form of coupling system is used to transfer energy to the antenna.

This antenna always is voltage-fed, and always consists of an even number of quarter-wavelengths. Figure 7 shows several common methods of feeding the Fuchs antenna or "end-fed Hertz." Arrangement "C" is to be recommended to minimize harmonics, as an end-fed antenna itself offers no discrimination against harmonics, either odd or even.

The Fuchs type of antenna has rather high losses unless at least three-quarters of the radiator can be placed outside the operating room and in the clear. As there is high r.f. voltage at the point where the antenna enters the operating room, the insulation at that point should be several times as effective as the insulation commonly used with low-voltage feeder systems. This antenna can be operated on all of its higher harmonics with good efficiency, and can be operated at half frequency against ground as a quarter-wave Marconi.

As the frequency of an antenna is raised slightly when it is bent anywhere except at an exact voltage or current loop, a Fuchs antenna usually is a few per cent longer than a straight half-wave doublet for the same frequency, because, ordinarily, it is impracticable to bring a wire in to the transmitter without making several bends.

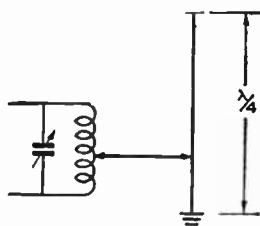

Figure 8.

THE SERIES-TUNED QUARTER-WAVE MARCONI, THE BASIC MARCONI ANTENNA SYSTEM.

The overall length to the earth connection, including lead in, is from 10% to 25% in excess of a quarter wavelength physically. The system is capacity-shortened and resonated by means of the series tuning condenser, with a maximum capacity of at least 3 μfd . per meter of transmitter wavelength unless the antenna is considerably in excess of a quarter wave long.

The Marconi Antenna

A grounded quarter-wave Marconi antenna is widely used on the 160-meter band because a half-wave antenna at that low frequency is around 260 feet long, which is much too long for those confined to an ordinary city lot. It is also widely used by 1700-2500 kc. police services, and in u.h.f. mobile applications, where a compact radiator is required.

The Marconi type antenna allows the use of half of the length of wire used for a half-wave Hertz radiator. The ground acts as a mirror, in effect, and takes the place of the extra quarter wave that would be required to resonate the wire, were it not grounded.

The Marconi antenna generally is not as satisfactory for long distance communication as the Hertz type, and the radiation efficiency is never as great, due to the losses in the ground connection. However, it can be made almost as good a radiator on wavelengths longer than 120 meters, if sufficient care is taken with the ground system.

The fundamental Marconi antenna is shown in Figure 8, and all Marconi antennas differ from this only in the method of feeding energy. Antenna A in Figure 9 is the fundamental vertical type; Type B is the inverted-L type; type C is the T type, with the two halves of the top portion of the T effectively in parallel.

The Marconi antenna should be as high as possible, and too much attention cannot be paid to getting a low resistance ground connection.

Importance of Ground Connection

With a quarter-wave antenna and a ground, the antenna current generally is measured with a meter placed in

the antenna circuit close to the ground connection. Now, if this current flows through a resistor, or if the ground itself presents some resistance, there definitely will be a power loss in the form of heat. Improving the ground connection, therefore, provides a definite means of reducing this power loss, and thus increasing the radiated power.

The best possible ground consists of as many wires as possible, each at least a quarter wave long, buried just below the surface of the earth, and extending out from a common point in the form of radials. Copper wire of any size larger than no. 16 is satisfactory, though the larger sizes will take longer to disintegrate. In fact, the radials need not even be buried; they may be supported just above the earth, and insulated from it. This arrangement is called a counterpoise, and operates by virtue of its high capacity to ground.

Unless a large number of radials is used, fairly close to the ground, the counterpoise will act more like the bottom half of a half-wave Hertz than like a ground system. However, the efficiency with a counterpoise will be quite good, regardless. It is when the radials are buried, or laid on the ground, that a large number should be used for best efficiency. Broadcast stations use as many as 120 radials of from 0.3 to 0.5 wavelength long.

A large number of radials not only provides a low resistance earth connection, but also, if long enough, produces the effect of locating the radiator over highly conducting earth. The importance of the latter with regard to vertical antennas is illustrated in Figure 6.

When it is impossible to extend buried radials in all directions from the ground connection for an inverted-L type Marconi, it is of importance that a few wires be buried directly below the flat top, and spaced at least 10 feet from one another.

If the antenna is physically shorter than a

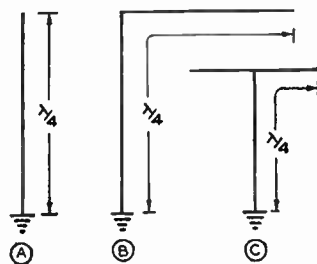

Figure 9.

THREE COMMON VARIATIONS OF THE MARCONI ANTENNA.

The bottom half of the radiator does most of the radiating, regardless of which type is used, because the current is greatest through that portion of the antenna.

quarter wavelength, the antenna current is higher, due to lower radiation resistance. Consequently, the power lost in resistive soil is greater. The importance of a good ground with short, inductive-loaded Marconi radiators is, therefore, quite obvious. With a good ground system, even very short (one-eighth wavelength) antennas can be expected to give upwards from 90 per cent of the efficiency of a quarter-wave antenna used with the same ground system. This is especially true when the short radiator is *top loaded* with a high Q (low loss) coil. In this type radiator, the loading coil is placed near the top of the radiator, rather than at the bottom.

Water Pipe Grounds Water pipe, because of its comparatively large surface and cross section, has as low an r.f.

resistance as copper wire. If it is possible to attach to a junction of several water pipes (where they branch in several directions and run for some distance under ground), a satisfactory ground connection will be obtained. If one of the pipes attaches to a lawn or garden sprinkler system in the immediate vicinity of the antenna and runs hither and thither to several neighboring faucets within a radius of a hundred yards, the effectiveness of the system will approach that of buried copper radials.

The main objection to water pipe grounds is the possibility of high resistance joints in the pipe, due to the "dope" put on the coupling threads. By attaching the ground wire to a junction with three or more legs, the possibility of requiring the main portion of the r.f. current to flow through a high resistance connection is greatly reduced.

The presence of water in the pipe adds but little to the conductivity; therefore it does not relieve the problem of high resistance joints. Bonding the joints is the best insurance, but this is, of course, impracticable where the pipe is buried. Bonding together with copper wire the various water faucets above the surface of the ground will improve the effectiveness of a water pipe ground system hampered by high resistance pipe couplings.

Marconi Dimensions A Marconi antenna is exactly an odd number of electrical quarter waves long (usually only one quarter wave in length), and is always resonated to the operating frequency. The correct loading of the final amplifier is accomplished by varying the coupling, *rather than by detuning the antenna from resonance.*

Physically, a quarter-wave Marconi may be made anything from one-eighth to three-eighths wavelength overall, meaning the total length of the antenna wire and ground lead from the end of the antenna to the point

where the ground lead attaches to the junction of the radials or counterpoise wires, or the water pipe enters the ground. The longer the antenna is made physically, the lower will be the current flowing in the ground connection, and the greater will be the overall radiation efficiency. However, when the antenna length exceeds three-eighths wavelength, the antenna becomes difficult to resonate by means of a series condenser, and it begins to take shape as an end-fed Hertz, requiring a different method of feed than that illustrated in Figure 8 for current feed of a Marconi.

A radiator physically shorter than a quarter wavelength can be lengthened electrically by means of a series loading coil, and used as a quarter-wave Marconi. However, if the wire is made shorter than approximately one-eighth wavelength, the radiation resistance will be so low that high efficiency cannot be obtained, even with a very good ground.

Loading Coils To resonate inductively an inductive-loaded Marconi, the inductance would have to be in the form of a variometer in order to permit continuous variation of the inductance. The more common practice is to use a tapped loading coil and a series tuning condenser. The loading coil should preferably be placed a short distance from the *top or far end* of the radiator; this reduces the current flowing in the ground connection by raising the radiation resistance, resulting in better radiation efficiency. More than the required amount of inductance for resonance is clipped in series with the antenna, and the system is then resonated by means of the series variable condenser, the same as though the radiator were actually too long physically.

To estimate whether a loading coil will probably be required, it is necessary only to note if the length of the antenna wire and ground lead is over a quarter wavelength; if so, no loading coil is needed, provided the series tuning condenser has a high maximum capacity.

Amateurs primarily interested in the higher frequency bands, but who like to work 160 meters occasionally, can usually manage to resonate one of their antennas as a Marconi by working the whole system, feeders and all, against a water pipe ground, and resorting to a loading coil if necessary. A high-frequency zepp, doublet, or single-wire-fed antenna will make quite a good 160-meter Marconi if high and in the clear, with a rather long feed line to act as a radiator on 160 meters. Where two-wire feeders are used, the feeders should be tied together for Marconi operation.

TRANSMISSION LINES

For many reasons, it is desirable to place a radiator as high and as much in the clear as

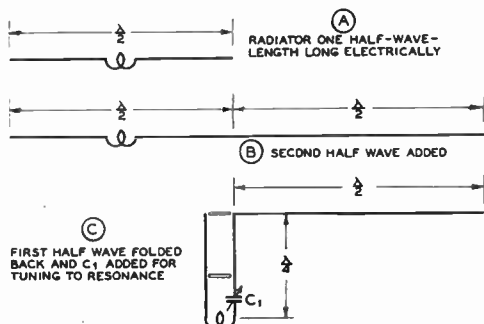

Figure 10.
THE EVOLUTION OF A ZEPPE ANTENNA.

possible, utilizing some form of nonradiating transmission line to carry energy with as little loss as possible from the transmitter to the radiating antenna.

There are many different kinds of transmission lines, and, generally speaking, practically any type of transmission line or feeder system can be used with any type of antenna; however, certain types are often better adapted than others for use with a certain antenna.

Transmission lines are of two general types: resonant and nonresonant. Strictly speaking, the term *transmission line* should really only be applied to a *nonresonant line*. Strictly speaking, a *resonant line* should be termed a *feeder system*, such as zepp feeders, etc. However, *transmission line* has come to refer to either type of line, tuned or untuned.

The principal types of nonresonant lines include the single-wire-feed, the two-wire open and the twisted-pair matched impedance, the coaxial (concentric) feed line, and the multi-wire matched-impedance open line.

Voltage Feed and Current Feed The half-wave Hertz antenna has high voltage and low current at each end, and it has low voltage and high current at its center. As any ungrounded resonant antenna consists merely of one or more half-wave antennas placed end to end, it will be seen that there will be a point of high r.f. voltage approximately every half wave of length measured from either end of the antenna. Also, there will be a point of high r.f. current half-way between any two adjacent high voltage points.

A voltage-fed antenna is any antenna which is excited at one of these high voltage points, or, in other words, a point of high impedance. Likewise, a current-fed antenna is one excited at a point along the antenna where the current is high and the voltage low, which corresponds to a point of low impedance.

The Zepp Antenna

The zepp antenna system is easy to tune up, and can be used on several bands by merely retuning the feeders. The overall efficiency of the zepp antenna system is probably not quite as high for long feeder lengths as for some of the antenna systems which employ nonresonant transmission lines, but where space is limited and where operation on more than one band is desired, the zepp has some decided advantages.

Zepp feeders really consist of an additional length of antenna which is folded back on itself, so that the radiation from the two halves cancels. In Figure 10A is shown a simple Hertz antenna, fed at the center by means of a pick-up coil. Figure 10B shows another half-wave radiator tied directly on one end of the radiator shown in Figure 10A. Figure 10C is exactly the same thing, except that the first half-wave radiator, in which is located the coupling coil, has been folded back on itself. In this particular case, each half of the folded part of the antenna is exactly a quarter-wave long electrically.

Addition of the coupling coil naturally will electrically lengthen the antenna; thus, in order to bring this portion of the antenna back to resonance, we must electrically shorten it by means of the series tuning condenser, C₁. The two wires in the folded portion of the antenna system do not have to be exactly a quarter wave long physically, although the total electrical length of the folded portion must be equal to one-half wavelength electrically.

When the total electrical length of the two feeder wires, plus the coupling coil, is slightly greater than any odd multiple of one-quarter wave, then series condensers must be used to shorten the electrical length of the feeders sufficiently to establish resonance. If, on the other hand, the electrical length of the feeders and the coupling coil is slightly less than any odd multiple of one-quarter wave, then parallel tuning (wherein a condenser is shunted across the coupling coil) must be used in order to increase the electrical length of the whole feeder system to a multiple of one-quarter wavelength.

As the radiating portion of the zepp antenna system must always be some multiple of a half wave long, there is always high voltage present at the point where the live zepp feeder attaches to the end of the radiating portion of the antenna. Thus, this type of zepp antenna system is *voltage fed*.

The idea that it takes two condensers to balance the current in the feeders, one condenser in each feeder, is a common misconception regarding the zepp type end-fed antenna. Balancing the feeders with tuning condensers

for equal currents is useless, anyhow, inasmuch as the feeders on an end-fed zepp can never be balanced for *both* current *and* phase because of the tendency for the end of the "dead" feeder to have more voltage on it than the one attached to the radiator.

Flat Top Length The correct physical length for the flat top (radiating portion) of a zepp is *not* 0.95 of a half wavelength. Instead, it is so close to a half wavelength that it may be taken as that figure. Thus, while a 7300-kc. doublet is 64 feet long, the flat top of a 300-kc. zepp should be 67 feet 3 inches. The reason for this is apparent when it is remembered that the 5 per cent difference between a resonant doublet and a physical half wavelength is principally due to "end effects," $2\frac{1}{2}$ per cent at each end of the radiator.

Obviously there is no end effect at the end of a radiator to which zepp feeders are attached. Hence, we lengthen the radiator $2\frac{1}{2}$ per cent. Now we must take into consideration that the end of the "dead" (unattached) feed wire has end effects, and that the other feeder does not. We want the two voltage loops to come at the same point on the feed line in order to obtain the best possible balance so as to minimize radiation. So we make the dead feed wire $2\frac{1}{2}$ per cent of a half wavelength shorter than the other. This can be done quite easily, merely by lengthening the flat top another $2\frac{1}{2}$ per cent. Thus, as the reader can readily see, the flat top is 5 per cent longer than if it were fed in the center.

The Tuned Doublet

A current-fed doublet with spaced feeders, sometimes erroneously called a center-fed zepp, is an inherently balanced system (if the two legs of the radiator are exactly equal electrically), and there will be no radiation from the feeders regardless of what frequency the system is operated on. A series condenser may be put in *one* feeder (if right at the coupling coil) without affecting the balance of the system. The system can successfully be operated on almost any frequency, if the system as a whole can be resonated to the operating frequency. This is usually possible with a tapped coil and a tuning condenser that can optionally be placed either across the antenna coil or in series with it.

This type of antenna system is shown in Figure 11. It is a current-fed system on the lowest frequency for which it will operate, but becomes a voltage-fed system on all its even harmonics.

The antenna has a different radiation pattern when operated on harmonics, as would be expected. The arrangement used on the second

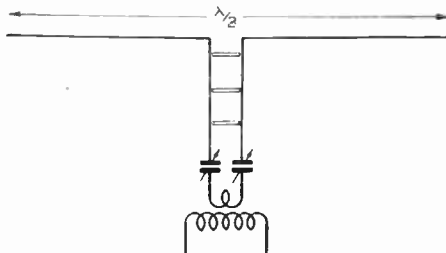

Figure 11.

THE TUNED DOUBLET USES AN OPEN-WIRE FEED SYSTEM.

The flat top need not be exactly an electrical half wave in length so long as the whole system, both flat top and feeders, is resonant as a unit. Only one tuning condenser need be used if desired. Certain feeder lengths will require that the condenser be placed across the coil rather than in series with it.

harmonic is better known as the Franklin colinear array, and is described in the next chapter. The pattern is similar to a half-wave doublet, except that it is sharper in the broadside direction. On harmonics there will be multiple lobes, but the minor lobes are quite small as compared to the major lobe.

Tuned Feeder Considerations

If a transmission line is terminated in its *characteristic surge impedance*, there will be no reflection at the end of the line, and the current and voltage distribution will be uniform along the line. If the end of the line is either open-circuited or short-circuited, the reflection at the end of the line will be 100 per cent, and *standing waves* of very great amplitude will appear on the line. There will still be practically no radiation from the line, but voltage nodes will be found along the line, spaced a half wavelength. Likewise, voltage loops will be found every half wavelength, the voltage loops corresponding to current nodes.

If the line is terminated in some value of resistance other than the characteristic surge impedance, there will be some reflection, the amount being determined by the amount of mismatch. With reflection, there will be standing waves (excursions of current and voltage) along the line, though not to the same extent as with an open-circuited or short-circuited line. The current and voltage loops will occur at the same *points* along the line as with the open- or short-circuited line, and as the terminating impedance is made to approach the characteristic impedance of the line, the current and voltage along the line will become more uniform. The foregoing assumes, of course, a purely resistive (nonreactive) load.

A well built 500- to 600-ohm transmission

line may be used as a resonant feeder for lengths up to several hundred feet with very low loss, so long as the amplitude of the standing waves (ratio of maximum to minimum voltage along the line) is *not too great*. The amplitude, in turn, depends upon the mismatch at the line termination. A line of no. 12 wire, spaced 6 inches with good ceramic or Lucite spreaders, has a surge impedance of approximately 600 ohms, and makes an excellent tuned feeder for feeding anything between 60 and 6000 ohms (at frequencies below 30 Mc.). If used to feed a load of higher or lower impedance than this, the standing waves become great enough in amplitude that some loss will occur unless the feeder is kept short. At frequencies above 30 Mc., the spacing becomes an appreciable fraction of a wavelength, and radiation from the line no longer is negligible.

If a transmission line is not perfectly matched, it should be made *resonant*, even though the amplitude of the standing waves (voltage variation) is not particularly great. This prevents reactance from being coupled into the final amplifier. A feed system having moderate standing waves may be made to present a nonreactive load to the amplifier either by tuning or by pruning the feeders to approximate resonance.

Usually it is preferable with tuned feeders to have a current loop (voltage minimum) at the transmitter end of the line. This means that when voltage-feeding an antenna, the tuned feeders should be made an odd number of quarter wavelengths long, and when current-feeding an antenna, the feeders should be made an even number of quarter wavelengths long. Actually, the feeders are made about 10 per cent of a quarter wave longer than the calculated value (the value given in the tables) when they are to be series tuned to resonance by means of a condenser, instead of being trimmed and pruned to resonance.

When tuned feeders are used to feed an antenna on more than one band, it is necessary to compromise and make provision for both series and parallel tuning, inasmuch as it is impossible to cut a feeder to a length that will be optimum for several bands. If a voltage loop appears at the transmitter end of the line on certain bands, parallel tuning of the feeders will be required in order to get a transfer of energy. It is impossible to transfer energy by inductive coupling unless current is flowing. This is effected at a voltage loop by the presence of the resonant tank circuit formed by parallel tuning of the antenna coil.

Methods of coupling to a transmitter are discussed later in the chapter.

Untuned Transmission Lines

A nonresonant or untuned line is a line with

negligible standing waves. Physically, the line itself should be *identical throughout its length*. There will be a smooth distribution of voltage and current throughout its length, both tapering off very slightly towards the antenna end of the line as a result of line losses. The attenuation (loss) in certain types of untuned lines can be kept very low for line lengths up to several thousand feet. In other types, particularly where the dielectric is not air (such as in the twisted-pair line), the losses may become excessive at the higher frequencies, unless the line is relatively short.

The termination at the antenna end is the only critical characteristic about the untuned line. It is the reflection from the antenna end which starts waves moving back toward the transmitter end. When waves moving in both directions along a conductor meet, standing waves are set up.

All transmission lines have distributed inductance, capacity, and resistance. Neglecting the resistance, as it is of minor importance in short lines, it is found that the *inductance and capacity per unit length* determine the characteristic or surge impedance of the line. Thus, the surge impedance depends upon the nature and spacing of the conductors, and the dielectric separating them.

When any transmission line is terminated in an impedance equal to its surge impedance, reflection of energy does not occur, and no standing waves are present. When the load termination is exactly the same as the line impedance, it simply means that the load takes energy from the line just as fast as the line delivers it, no slower and no faster.

Thus, for proper operation of an untuned line (with standing waves eliminated), some form of impedance-matching arrangement must be used between the transmission line and the antenna, so that the radiation resistance of the antenna is reflected back into the line as a nonreactive impedance equal to the line impedance. It is important that the *radiator itself be cut to exact resonance*: otherwise, it will not present a pure resistive load to the nonresonant line.

An untuned feeder system may consist of one, two, four, or even more parallel wires. Increased constructional difficulties of the multi-wire type of line, where three or more parallel wires are used, and there is danger of appreciable feeder radiation from an improperly adjusted single-wire feeder, make the more familiar two-wire type of line the most satisfactory for general use.

Semi-Resonant Open Lines

As has been stated under *Tuned Feeder Considerations*, a well built *open-wire*

line has low losses, even when standing waves

with a ratio of as high as 10/1 are present. (The standing wave ratio will be found to approximate the ratio of mismatch at the feeder termination.) Of much greater importance is to make sure the line is *balanced*, which means that the antenna system must be electrically symmetrical, or allowance made for the asymmetry. If the currents in the two feed wires are not equal in amplitude and exactly opposite in phase, there will be radiation from the line (or pickup by the line if used for receiving), regardless of the amplitude of standing waves.

Because moderate standing waves can be tolerated on open-wire lines without much loss, a standing wave ratio of 2/1 or 3/1 is considered acceptable with this type of line, *even when used in an "untuned" system*. Strictly speaking, a line is untuned, or nonresonant, only when it is perfectly "flat," with a standing wave ratio of 1 (no standing waves). However, some mismatch can be tolerated with open-wire untuned lines, so long as the reactance is not objectionable, or is eliminated by cutting the line to approximately resonant length.

Thus, we have a line that is a cross between a tuned and an untuned line. Most of the "untuned" open-wire lines used by amateurs fall in this class, because there is usually more or less of a mismatch at the line termination. *Open-wire* lines with a standing wave ratio of *less than 3/1* may be classed as *nonresonant*, or untuned, lines, as standing waves will not seriously affect the operation of an untuned line unless greater than this in magnitude.

The foregoing applies only to *open-wire lines*. The losses in other type lines, especially those having rubber dielectric, go up rapidly with the standing wave ratio, such lines being designed for perfectly "flat" operation. Also, the maximum power handling capability of lines is greatly reduced when standing waves are present, even though of only 2/1 or 3/1 magnitude. The power handling capability of an open line will still be very high, but other lines do not have such a high capability to begin with, and if being worked at full rated power may be punctured by the presence of moderate standing waves. From this we can see that every attempt should be made to eliminate all traces of standing waves on a low impedance, close-spaced line, especially when the power is high enough that there is danger of arc-over at voltage loops, or when the frequency is high enough that the losses are already so great that increased losses will be a serious item.

Construction of Two-Wire Open Lines

A two-wire transmission system is easy to construct. Its surge impedance can be calculated quite easily, and when properly adjusted

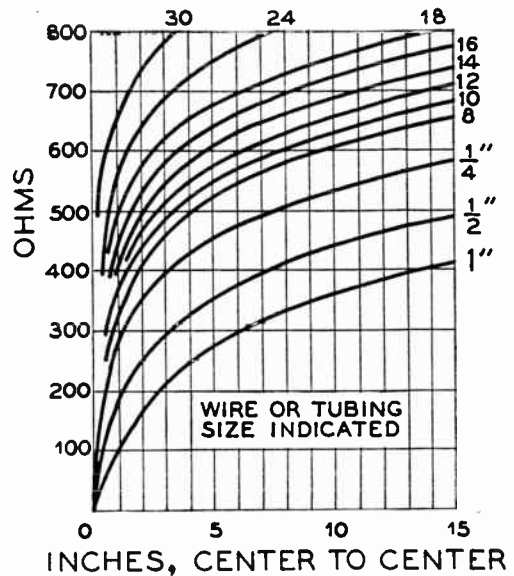

Figure 12.
CONDUCTOR SIZE AND SPACING
VERSUS SURGE IMPEDANCE FOR TWO-
WIRE OPEN LINE OR MATCHING
TRANSFORMER.

and balanced to ground, undesirable feeder radiation is minimized; the current flow in the adjacent wires is in opposite directions, and the magnetic fields of the two wires are in opposition to each other. When a two-wire line is terminated with the equivalent of a pure resistance equal to the surge impedance of the line, the line becomes a nonresonant line.

It can be shown mathematically that the true surge impedance of any two-wire parallel line system is approximately equal to

$$Z_s = 276 \log_{10} \frac{2S}{d}$$

Where:

S is the exact distance between wire centers in some convenient unit of measurement, and d is the diameter of the wire measured in the same units as the wire spacing, S.

Since $\frac{2S}{d}$ expresses a ratio only, the units of measurement may be centimeters, millimeters, or inches. This makes no difference in the answer, so long as the substituted values for S and d are in the *same units*.

The equation is accurate *so long as the wire spacing is relatively large as compared to the wire diameter*.

Surge impedance values of less than 200 ohms are seldom used in the open-type two-wire line, and, even at this rather high value

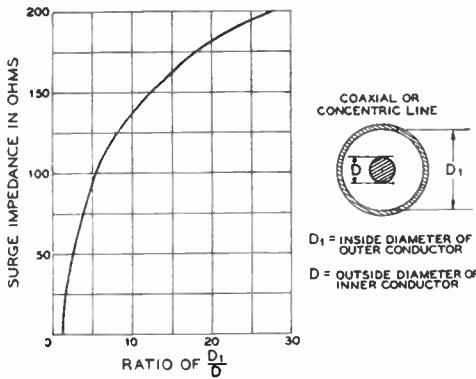

Figure 13.

CURVE FOR DETERMINATION OF SURGE IMPEDANCE OF ANY COAXIAL LINE HAVING AIR DIELECTRIC.

Presence of spacing insulators will lower the impedance somewhat below the calculated value as derived from this chart.

of Z_s , the wire spacing S is uncomfortably close, being only 5.3 times the wire diameter d .

Figure 12 gives in graphical form the surge impedance of any practicable two-wire line. The chart is self-explanatory, and sufficiently accurate for practical purposes.

Twisted-Pair Untuned Lines Low-loss, low-impedance transmission cable, marketed by several manufacturers under the name of "EO-1 cable," allows a very flexible transmission line system to be used to convey energy to the antenna from the transmitter. The low-loss construction is largely due to the use of untinned solid conductors, low-loss insulation, plus a good grade of weatherproof covering.

Twisted no. 12 or no. 14 outside house wire may be used on 160 and 80 meters if the length is not over 50 or 75 feet. On higher frequencies, however, the losses with such "homemade" twisted line will be excessive.

A twisted-pair line should always be used as an untuned line, as standing waves on the line will produce excessive losses, and can easily break down the line insulation at the voltage loops. For turning sharp corners and running close to large bodies of metal, the twisted pair is almost as good at the lower frequencies as the coaxial line.

Above 14 Mc., however, the rubber insulation causes appreciable dielectric loss even with the best EO-1 cable, and the twisted-pair type of low-impedance line should not be used except where the length is short, or where more efficient lines might not be suitable from a mechanical standpoint, as in certain types of rotary arrays,

COMPARATIVE R. F. FEEDER LOSSES

| FREQUENCY | DB LOSS PER 100 FT. | TYPE OF LINE |
|-----------|---------------------|--|
| 7 Mc. | 0.9 | 70-ohm impedance, rubber insulated twisted-pair with outer covering of braid. |
| 14 Mc. | 1.5 | |
| 30 Mc. | 3 | |
| 7 Mc. | 0.6 | 3/8" concentric pipe feeder with inner wire on bead spacers. Impedance, 70 ohms. |
| 30 Mc. | 0.9 | |
| 60 Mc. | 1.3 | |
| 7 Mc. | 0.05 | Open 2-wire line no. 10 wire, 2 in. spacing. |
| 30 Mc. | 0.12 | |
| 60 Mc. | 0.18 | |
| 7 Mc. | 3 | Twisted no. 14 solid weatherproof wire, weathered for six months (telephone wire). |
| 14 Mc. | 4.5 | |
| 30 Mc. | 8 | |
| 7 Mc. | 1.5 | Heavy, flexible coaxial cable, rubber insulation, metal braid outer conductor. |
| 14 Mc. | 2.5 | |
| 30 Mc. | 4.2 | |

The low surge impedance of the twisted-pair transmission line is due not only to the close spacing of the conductors, but to the rubber insulation separating them. The latter has a dielectric constant considerably higher than that of air. This not only lowers the surge impedance but also results in slower propagation of a wave along the conductors. As a result, the voltage loops occur closer together on the line when standing waves are present than for an open-wire line working at the same frequency.

Coaxial Line Several types of coaxial cable have come into wide use for feeding power to an antenna system. A cross-sectional end view of a coaxial cable (sometimes called concentric cable or line) is shown in Figure 13.

As in the parallel-wire line, the power lost in a properly terminated coaxial line is the sum of the effective resistance losses along the length of the cable and the dielectric losses between the two conductors. In a well designed line using air or nitrogen as the dielectric, both are negligible, the actual measured loss in a good line being less than 0.5 db per 1000 feet at 1 megacycle.

Of the two losses, the effective resistance loss is the greater; since it is largely due to the skin effect, the line loss (all other conditions the same) will increase directly as the square root of the frequency.

Figure 13 shows that, instead of having two conductors running side by side, one of the conductors is placed *inside* of the other. Since the outside conductor completely shields the inner one, no radiation takes place. The conductors may both be tubes, one within the

other, or the line may consist of a solid wire within a tube.

In one type of cable (solid or semi-flexible low-loss type), the inner conductor is supported at regular intervals from the outside tube by a circular insulator of either pyrex, polystyrene, or some non-hygroscopic ceramic material with low high-frequency losses. The insulators are slipped over the inner conductor, and held in place either by some system of small clamps, or by crimping the wire immediately in front of and behind each insulator.

Moisture must be kept out of the tube if best results are to be secured. For this reason, it is necessary to solder or otherwise tightly join the line sections together so that no leak occurs. This prevents water from seeping into the line in outdoor installations.

To avoid condensation of moisture on the inside walls of the line, it is general commercial practice to fill the line with dry nitrogen gas at a pressure of approximately 35 pounds per square inch. Filling a line with dry nitrogen gas also greatly increases its power capacity, a power capability rating of 3 to 1 being quite common for the nitrogen-filled line as compared to a line operating under normal atmospheric pressures.

Nearby metallic objects cause no loss, and the cable may be run up air ducts, wire conduit, or elevator shafts. Insulation troubles can be forgotten. The coaxial cable may be buried in the ground or suspended above ground.

Highly flexible coaxial cable having continuous rubber dielectric for maintenance of spacing, and an outer conductor of shield braid of the type used for ordinary shielded wire, has become quite popular for certain applications where cost is an item, or the line is subjected to continual flexing. Because of the rubber dielectric, the losses are about the same as for EO-1 cable on the higher frequencies, while on the lower frequencies (below 4000 kc.) the losses are nearly as low as for the air-dielectric type of coaxial line.

The chief advantage of rubber dielectric coaxial cable over EO-1 cable is its availability in lower values of surge impedance, making it possible to feed certain types of low radiation resistance arrays without need for an impedance matching device. Twisted-pair cable is not commonly available with a surge impedance of less than 70 ohms, while rubber dielectric coaxial cable is available with a surge impedance of as low as 28 ohms.

Coaxial cable, like twisted-pair cable, is most commonly used without a matching system. Cable is chosen to have a surge impedance that approximates the terminal radiation resistance of the antenna (point at which the line is connected).

While coaxial cable is best suited to use with

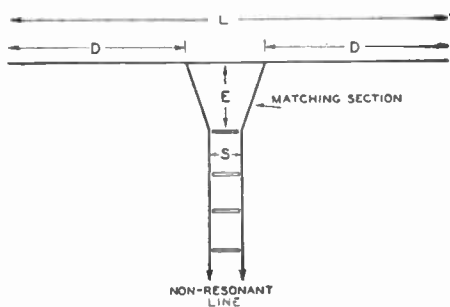

Figure 14.
THE DELTA-MATCHED ANTENNA SYSTEM.

This system is sometimes called a "Y matched" doublet. For dimensions refer to formula in text.

Marconi antennas, because the outside conductor is ordinarily grounded, it can be used successfully to feed a balanced dipole. This is permissible because the impedance is low, and therefore no great unbalance results from such operation. The outer conductor of the coaxial cable connects to one half the dipole, and the inner conductor connects to the other half. In this case, the outer conductor is often left ungrounded.

Matching Nonresonant Lines to the Antenna

From the standpoint of economy and efficiency, the most practical untuned line is an open line having a surge impedance of from 440 to 600 ohms. Unfortunately, it is seldom that the antenna system being fed has an impedance of similar value either at a current loop or at a voltage loop. It is sometimes necessary, with current-fed antennas, to match the line to an impedance as low as 8 or 10 ohms, while with voltage-fed antenna systems and arrays, it is occasionally necessary to match the line to an impedance of many thousands of ohms. There are many ways of accomplishing this, the more common and most satisfactory methods being discussed here.

Delta-Matched Antenna System

The delta type matched-impedance antenna system is shown in Figure 14. The impedance of the transmission line is transformed gradually into a higher value by the fanned-out Y portion of the feeders, and the Y portion is tapped on the antenna at points where the antenna impedance is a compromise between the impedance at the ends of the Y and the impedance of the unfanned portion of the line.

The constants of the system are rather criti-

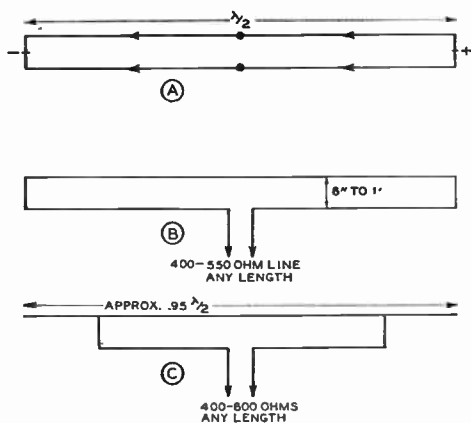

Figure 15.

The two wire doublet, shown at A, can be fed in one leg as shown at B in order to provide high terminal radiation resistance. Arrows indicate current flow on one half the cycle, dots indicate position of current loops. The modified version due to Kraus, shown at C, provides a more accurate match for single frequency operation when the line impedance is over 300 ohms. The latter arrangement is referred to as the "T matched" antenna.

cal, and the antenna must resonate at the operating frequency in order to minimize standing waves on the line. Some slight readjustment of the taps on the antenna is desirable, if appreciable standing waves persist in appearing on the line. It is almost impossible to get the standing wave ratio below 2/1 with this system, and as standing waves of this order are not objectionable on an open line if it is cut to such a length that it is non-reactive, this ratio is considered as indicating the best match that can be expected with a "Y" or delta-matched doublet.

The constants are determined by the following formulas:

$$L_{\text{feet}} = \frac{467.4}{F_{\text{megacycles}}}$$

$$D_{\text{feet}} = \frac{175}{F_{\text{megacycles}}}$$

$$E_{\text{feet}} = \frac{147.6}{F_{\text{megacycles}}}$$

where L is antenna length; D is the distance in from each end at which the Y taps on; E is the height of the Y section.

As these constants are correct only for a 600-ohm transmission line, the spacing S of the line must be approximately 75 times the diameter of the wire used in the transmission line. For no. 14 B & S wire, the spacing will be slightly less than 5 inches. For no. 12 B & S, the spacing should be 6 inches. This system should never be used on either its even or odd

harmonics, as entirely different constants are required when more than a single half wavelength appears on the radiating portion of the system.

The Multi-Wire Doublet

When a doublet consists of two or more wires instead of the more usual single wire, the radiation resistance (impedance at the current loop) is raised slightly. This is due to the fact that each wire tends to induce an opposing current in the opposite wire, but cannot because the two wires are tied together at either end. See "A," Figure 15.

If we split just one wire of such an antenna, as at "B" in Figure 15, and feed the antenna at this point, we find that the terminal radiation resistance is much higher than the theoretical 72 ohms of a conventional doublet. The terminal radiation resistance is the impedance into which the feed system works. Because each wire of the two-wire doublet carries half the total current, and the feed line serves only one wire, the terminal radiation resistance is four times the radiation resistance of the antenna taken as a whole, which already is slightly higher than that of a regular doublet.

The terminal radiation resistance of a two-wire doublet such as that of "B" when well removed from earth is about 300 ohms. This permits use of an ordinary 500 to 600 ohm open line to feed the antenna directly, without need for a matching system. When used with a 500-ohm line (no. 12 spaced 4 inches) the standing waves will be quite low (approximately 2/1 ratio) over a range in frequency of several per cent either side of resonance. The broad tuning characteristic is a result of the high radiation resistance.

The spacing of the two wires is not at all critical, and need not be exactly uniform so long as the system is symmetrical. The overall length of the "loop" is one wavelength. The lower element is split in the exact center for attachment to the feed line.

A useful variation of the two-wire doublet is the "T matched" doublet, which is a cross between a delta matched doublet and a two-wire doublet. It may be considered as a delta matched system without the usual fanning of the feed line at point of attachment. This antenna is illustrated at Figure 15-C. When both radiator length and point of feeder attachment are exactly right (as determined experimentally), the standing waves will be so low as to be almost negligible.

Single Wire Fed Antenna

If one wire is removed from the delta matched impedance antenna of Figure 14 and the remaining feeder is moved

along the doublet to the point giving the lowest standing wave ratio on the single feed wire, the system will still work satisfactorily. However, there will be an appreciable amount of radiation from the feeder, even with the best possible match, and for this reason a single wire feeder is never used to feed directive antenna arrays, and is used primarily for portable and emergency work.

A single-wire feed line has a characteristic surge impedance of from 500 to 600 ohms, depending upon the diameter of the feeder wire. This type feeder makes use of the earth as a return circuit through the earth's capacity effect to the antenna and feeder. The actual earth connection to the transmitter may have a relatively high resistance without causing appreciable loss of r.f. energy. It may even be represented by the capacity of the transmitter and house wiring to earth.

The feeder is normally attached to the radiator about 1/6 or 1/7 of a half wavelength from the center.

The single wire fed antenna not only works well on its fundamental, but is a good radiator on its various harmonics. For this reason, this type antenna system should not be used on the low- and medium-frequency bands, unless a harmonic suppressing antenna coupler is used to prevent radiation of harmonics.

A single wire feeder also can be used to feed a quarter wave vertical Marconi radiator. The best point of attachment for the feeder should be determined by cut and try. Normally it will be about 1/2 of the way up the radiator.

Matching Stubs

By hanging a resonant length of Lecher wire line (called a matching stub) from either a voltage or current loop and attaching 600-ohm nonresonant feeders to the resonant stub at a suitable voltage (impedance) point, standing waves on the line may be virtually eliminated. The stub is made to serve as an autotransformer. Thus, by putting up a half-wave zapp with quarter-wave feeders at a distance from the transmitter, and attaching a 600-ohm line from the transmitter to the zapp feeders at a suitable point, we have a stub-matched antenna. The example cited here is commonly called a J antenna, especially when both radiator and stub are vertical. Many variations from this example are possible; stubs are particularly adapted to matching an open line to certain directional arrays, as will be described later.

Voltage Feed When the stub attaches to the antenna at a voltage loop, the stub should be a quarter wavelength long electrically, and be shorted at the bottom end. The stub can be resonated by sliding the short-

ing bar up and down before the nonresonant feeders are attached to the stub, the antenna being shock-excited from a separate radiator during the process. Slight errors in the length of the radiator can be compensated for by adjustment of the stub if both sides of the stub are connected to the radiator in a symmetrical manner. Where only one side of the stub connects to the radiating system, as in the J antenna example given here, the radiator length must be exactly right in order to prevent excessive unbalance in the untuned line.

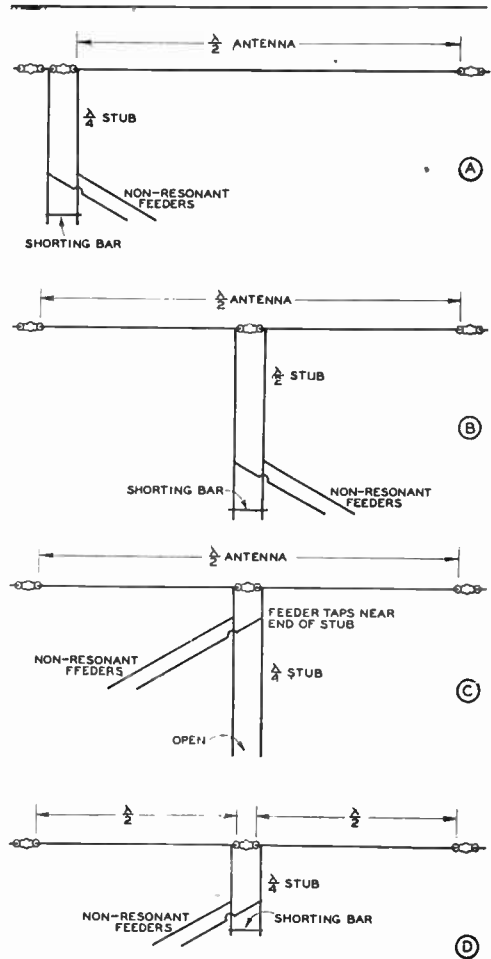

Figure 16.
MATCHING-STUB APPLICATIONS.
 (A) Half-wave antenna with quarter-wave matching stub.
 (B) Center-fed half-wave antenna with half-wave matching stub.
 (C) Center-fed half-wave antenna with stub line cut to exact length without shorting bar.
 (D) Two half-wave sections in phase with quarter-wave stub.

If only one leg of a stub is used to voltage-feed a radiator, it is impossible to secure a perfect balance in the transmission line due to a slight inherent unbalance in the stub itself when one side is left floating. This unbalance, previously discussed under the *Zepp Antenna system*, should not be aggravated by a radiator of improper length.

Current Feed When a stub is used to current-feed a radiator, the stub should either be left *open* at the bottom end instead of shorted, or else made a *half wave* long. The open stub should be resonated in the same manner as the shorted stub before attaching the transmission line; however, in this case, it is necessary to prune the stub to resonance, as there is no shorting bar.

Sometimes it is handy to have a stub hang from the radiator to a point that can be reached from the ground, in order to facilitate adjustment of the position of the transmission-line attachment. For this reason, a quarter-wave stub is sometimes made three-quarters wavelength long at the higher frequencies, in order to bring the bottom nearer the ground. Operation with any *odd* number of quarter waves is the same as for a quarter-wave stub.

Any number of *half waves* can be added to either a quarter-wave stub or a half-wave stub without disturbing the operation, though losses will be lowest if the shortest usable stub is employed. This can be fully understood by inspection of the accompanying table.

| Stub Length (Electrical) | Current-Fed Radiator | Voltage-Fed Radiator |
|--|----------------------|----------------------|
| $\frac{1}{4}$ - $\frac{3}{4}$ - $1\frac{1}{4}$ -etc. wavelengths | Open | Shorted |
| $\frac{1}{2}$ - 1 - $1\frac{1}{2}$ -2-etc. wavelengths | Shorted | Open |

Shorted-Stub Tuning Procedure When the antenna requires a shorted stub (odd number of quarter waves if the antenna is voltage-fed, or an even number if the radiator is current-fed), the tuning procedure is as follows:

Shock-excite the radiator (or one of the half-wave sections, if harmonically operated) by means of a makeshift doublet strung directly underneath where possible, and just off the ground a few inches, connected to the transmitter by means of any kind of twisted-pair or open line handy.

With the feeders and shorting bar disconnected from the stub, slide along an r.f. milliammeter or low-current dial light at about where you calculate the shorting bar should be, and find the point of maximum current (in

other words, use the meter or lamp as a shorting bar).

MAKE SURE IT IS IMPOSSIBLE FOR PLATE VOLTAGE TO BE ON THE FEED LINE BEFORE ATTEMPTING THIS PROCEDURE. *Inductive coupling to the final amplifier by means of a few turns of high tension ignition wire is recommended during any tuning-up process where the operator must come in contact with the antenna or feeders.*

It is best to start with reduced power to the transmitter, until you see how much of an indication you may expect; otherwise, the meter or lamp may be blown on the initial trial. The lamp or meter leads should be no longer than necessary to reach across the stub.

After finding the point of maximum current, remove the lamp or meter and connect a piece of wire across the stub at that point

Starting at a point about a quarter of a quarter wave (8 feet at 40 meters) from the shorting bar, connect the feeders to the stub. Then, move the feeders up and down the stub until the standing waves on the line are at a minimum. The makeshift doublet should, of course, be disconnected, and the regular feeders connected to the transmitter during this process. Slight readjustment of the shorting bar will usually result in further improvement.

The standing wave indicator may be either a voltage device, such as a neon bulb, or a current device, such as an r.f. milliammeter connected to a pickup coil. A high degree of accuracy is not required.

The following rule will indicate in which direction the feeders should be moved in an attempt to minimize standing waves: If the current increases on the transmission line as the indicator is moved away from the point of attachment to the stub, the feeders are attached too far from the shorting bar, and must be moved closer to the shorting bar; if the current decreases, the feeders must be attached farther from the shorting bar.

Open-Ended Stub Tuning Procedure If the antenna requires an open stub (even number of quarter waves if the antenna is voltage-fed, odd number of quarter waves if it is current-fed), the tuning procedure is as follows:

Shock-excite the radiator as described for tuning a shorted-stub system, feeders disconnected from the stub, and stub cut slightly longer than the calculated value. Place a field strength meter (the standing wave indicator can be very easily converted into one by addition of a tuned tank) close enough to one end of the radiator to get a reading, and as far as possible from the makeshift exciting antenna. Now, start folding and clipping the stub wires back on themselves a few inches at a time,

effectively shortening their length, until you find the peak as registered on the field meter.

Next, attach the feeders to the stub as described for the shorted-stub system, but, for the initial trial connection, the feeders will attach at a distance more nearly three-quarters of a quarter wave from the end of the stub instead of a quarter of a quarter wave, as is the case for a shorted stub. After attaching the feeders, move them along the stub as necessary to minimize standing waves on the line. If sliding the feeders along the stub a few inches makes the standing waves worse, it means the correct connecting point is in the other direction.

After the optimum point on the stub is found for the feeder attachment, the length of the stub can be "touched up" for a final adjustment to minimize standing waves. This is advisable because the attachment of the feeder often detunes the stub slightly.

Important Note When a stub is used to match a line to an impedance of the same order of impedance as that of the surge impedance of the stub and line (assuming the stub and line use the same wire size and spacing), it will be found that attaching the feeders to the stub introduces a large amount of reactance. The length of the stub then must be altered considerably to restore resonance.

| Frequency in Kilocycles | Quarter-wave matching section or stub | Half-wave radiator |
|-------------------------|---------------------------------------|--------------------|
| 3500 | 70'3" | 133'7" |
| 3600 | 68'5" | 129'10" |
| 3700 | 67'6" | 126'4" |
| 3800 | 64'10" | 123' |
| 3900 | 63'1" | 119'10" |
| 3950 | 62'3" | 118'4" |
| 4000 | 61'6" | 116'10" |
| 7000 | 35'1" | 66'9" |
| 7150 | 34'5" | 65'4" |
| 7300 | 33'8" | 64' |
| 14,000 | 17'7" | 33'5" |
| 14,200 | 17'4" | 32'11" |
| 14,400 | 17'1" | 32'6" |
| 28,000 | 8'9" | 16'8" |
| 28,500 | 8'7" | 16'5" |
| 29,000 | 8'6" | 16'1" |
| 29,500 | 8'4" | 15'10" |
| 30,000 | 8'2" | 15'7" |

DIMENSIONS FOR HALF-WAVE RADIATOR AND QUARTER-WAVE MATCHING STUB OR Q SECTION.

Dimensions for 1750-2000 kc. may be determined from lengths for 3500-4000 kc. A 2000-kc. radiator or matching transformer is just twice as long as one for 4000 kc.

Unfortunately, alteration of the stub length requires that the position of attachment of the feeders be readjusted. Consequently, the adjustment entails considerable juggling of both stub length and point of feeder attachment, in order to minimize both reactance and standing waves.

If a *shorted* stub is used to feed an impedance of *more* than 3 times that of the surge impedance of the stub and line, this effect will be negligible, and it is not absolutely necessary that the stub length be readjusted after the feeders are attached. Likewise, the length of an *open* stub need not be altered after attachment of the feeders, if the stub feeds an impedance of *less* than 1/3 that of the surge impedance of the stub and line.

As a practical example, this means that if a 600-ohm line and shorted stub are used to feed an impedance of more than 1800 ohms, the length of the stub need not be readjusted after the feeders are attached (in order to eliminate objectionable reactance). If the stub feeds an impedance of less than 1800 ohms, attachment of the feeders to the stub will detune the stub appreciably, making readjustment of the stub length absolutely necessary.

When not sure of the exact order of impedance into which the stub works, it is always advisable to try "touching up" the stub length after the feeders are attached.

Two-Frequency Stub Matching It is practicable to use matching stubs to match an untuned line to an antenna or array on two frequencies. The frequencies need not be harmonically related if the antenna itself is capable of good efficiency on both frequencies. However, the frequencies should be in a ratio not exceeding 4/1 nor less than 1.3/1.

The arrangement is illustrated in Figure 17. The system is tuned up on the lowest frequency for minimum standing waves by means of adjusting the length and point of attachment of stub "A," stub "B" not yet being connected. After the standing waves are reduced to a negligible value, the transmitter is changed to the higher frequency. Stub "B," which is a quarter wave long on the *lower* frequency, then is attached experimentally, and the point of attachment varied until standing waves are at a minimum on the higher frequency. Because stub "B" is exactly a quarter wave long on the lower frequency, its attachment will have virtually no effect upon the operation of the antenna system at the lower frequency.

It should be kept in mind that stub "A" is tuned by varying the distances XY and AY; the stub does not "hang over" as does stub "B." The overall length of stub "B" is not altered; only the distances XZ and BZ are

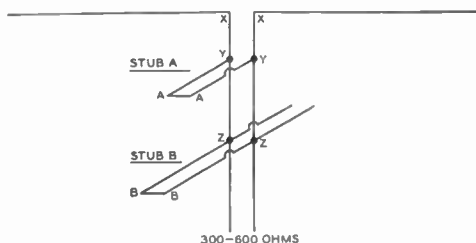

Figure 17.
TWO-FREQUENCY STUB-MATCHED ANTENNA SYSTEM.

Any antenna which has a radiating system capable of efficient operation on two widely separated frequencies may be matched to an open wire transmission line on both frequencies by use of two "reactance stubs" as shown here. Operation and adjustment are explained in the text.

varied when adjusting for minimum standing waves on the higher frequency. It is possible that the position of the two stubs will be reversed from that shown in Figure 17. This depends upon the particular antenna being fed, and the characteristic impedance of the feed line.

Standing Wave Indicators Many simple devices can be used for detecting the presence and approximate ratio of standing waves on a feed line. A 1-turn pickup loop, about 4 or 5 inches in diameter, may be attached to a current indicator, such as a small Mazda bulb or an r.f. thermogalvanometer, to indicate current excursions along the line. The device should be attached to the end of a wood stick at least a foot long in order to minimize body capacity. The loop is moved along the line in inductive relation to the feed line, care being taken to see that the loop always is in *exactly the same inductive relation* to the line. It should be kept in mind that this type of indicator is a *current* indicator.

A small neon bulb also may be used to indicate standing waves on a feed line. In this case, the indicator works on *voltage*, and it should be kept in mind that the voltage on the line normally is highest where the current is lowest. This type of indicator is operated by touching various parts of the bulb to *one* feeder wire until an indication of medium brilliancy is obtained. The bulb is then slid along the wire, in *exactly the same position and point of contact with the wire*. If the enamel insulation is not intact on all portions of the wire and the wire is exposed in spots, deceptive "bumps" will be noticed. The wire should be either uniformly insulated or uniformly bare throughout its length; otherwise,

it will be necessary to place a thickness of insulating material over the exposed metal parts of the neon bulb, the bulb then working by virtue of capacity to the wire, rather than direct contact.

If it is desired to measure the exact rather than relative standing wave ratio and an r.f. meter is not available, a low range d.c. milliammeter may be used instead, if a suitable rectifier is placed in series with the d.c. meter. A 0-1 ma. d.c. milliammeter in series with a carborundum crystal rectifier is commonly used. As noted before, this type of indicator is a *current* indicator.

Linear R. F. Transformers

Q-Matching Section A resonant quarter-wave line has the unusual property of acting much as a transformer. Let us take, for example, a section consisting of no. 12 wire spaced 6 inches, which happens to have a surge impedance of 600 ohms. Let the far end be terminated with a pure resistance, and let the near end be fed with radio-frequency energy at the frequency for which the line is a quarter wavelength long. If an impedance measuring set is used to measure the impedance at the near end while the impedance at the far end is varied, an interesting relationship between the 600-ohm characteristic surge impedance of this particular quarter-wave matching line, and the impedance at the ends will be discovered.

When the impedance at the far end of the line is the same as the characteristic surge impedance of the line itself (600 ohms), the impedance measured at the near end of the quarter-wave line will also be found to be 600 ohms.

Under these conditions, the line would not have any standing waves on it, due to the fact that it is terminated in its characteristic impedance. Now, let the resistance at the far end of the line be doubled, or changed to 1200

CORRECT VALUES OF SURGE IMPEDANCE OF $\lambda/4$ MATCHING SECTIONS FOR DIFFERENT LENGTHS OF ANTENNAS.

| Antenna Length in Wavelength | Surge Impedance for Connection Into Two-Wire Open Lines with Impedance of | |
|------------------------------|---|----------|
| | 500 Ohms | 600 Ohms |
| $\frac{1}{2}$ | 190 | 212 |
| 1 | 210 | 235 |
| 2 | 235 | 257 |
| 4 | 255 | 282 |
| 8 | 280 | 305 |

Matching section connects into center of a current loop, such as middle of a half-wave section.

ohms. The impedance measured at the near end of the line will be found to have been cut in half, to 300 ohms. If the resistance at the far end is made half the original value of 600 ohms, or 300 ohms, the impedance at the near end doubles the original value of 600 ohms, and becomes 1200 ohms. As one resistance goes up, the other goes down proportionately.

It always will be found that the characteristic surge impedance of the quarter-wave matching line is the geometric mean between the impedance at both ends. This relationship is shown by the following formula:

$$Z_{MS} = \sqrt{Z_A Z_L}$$

where

Z_{MS} = Impedance of matching section.

Z_A = Antenna resistance.

Z_L = Line impedance.

Johnson-Q Feed System

The standard form of Johnson-Q feed to a doublet is shown in Figure 18. An impedance match is obtained by utilizing a matching section, the surge impedance of which is the geometric mean between the transmission line surge impedance and the radiation resistance of the radiator. A sufficiently good match usually can be obtained by either designing or adjusting the matching section for a dipole to have a surge impedance that is the geometric mean between the line impedance and 72 ohms, the latter being the theoretical radiation resistance of a half-wave doublet either infinitely high or a half wave above a perfect ground.

Though the radiation resistance may depart somewhat from 72 ohms under actual conditions, satisfactory results will be obtained with this assumed value, so long as the dipole radiator is more than a quarter wave above effective earth, and reasonably in the clear. The small degree of standing waves introduced by a slight mismatch will not increase the line losses appreciably, and any small amount of reactance present can be tuned out at the transmitter termination with no bad effects. If the reactance is objectionable, it may be minimized

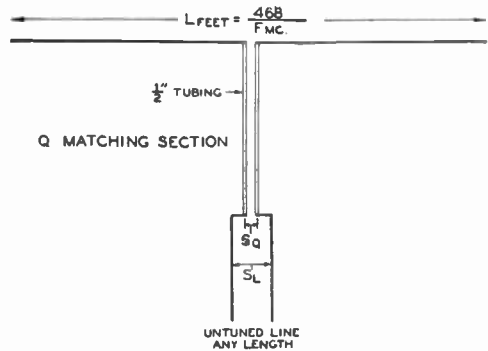

Figure 18.

METHOD OF FEEDING A HALF-WAVE RADIATOR BY MEANS OF Q BARS. REFER TO TABLES FOR DIMENSIONS.

by making the untuned line an integral number of quarter waves long.

A Q-matched system can be adjusted precisely, if desired, by constructing a matching section to the calculated dimensions with provision for varying the spacing of the Q section conductors slightly, after the untuned line has been checked for standing waves.

The Q section usually will require about 200 ohms surge impedance when used to match a half-wave doublet, actually varying from about 150 to 250 ohms with different installations. This impedance is difficult to obtain with a two-wire line, as very close spacing would be required. For this reason, either a four-wire line or a line consisting of two half-inch aluminum tubes is ordinarily used. The four-wire section has the advantage of lightness and cheapness, and can be used where the approximate radiation resistance is known with certainty, thus making it possible to design the matching section for a certain value of surge impedance with some assurance that it will turn out to be sufficiently accurate.

The apparent complexity of the Q-matched dipole comes from the large number of antennas and line combinations which the Q section is able to match.

The untuned transmission line between the transmitter and the input, or lower end of the Q section, can be any length (within reason).

Q System with Four-Wire Transformer

The reduction in impedance obtained by the use of 4 conductors instead of 2 makes the four-wire line highly useful for matching transformer applications. For instance, the order of impedance ordinarily required for Q-matching sections is easily obtained by spacing 4 wires around a circular insulating spacer of suitable diameter.

Plastic iced-tea coasters of suitable diameter

PARALLEL TUBING SURGE IMPEDANCE FOR MATCHING SECTIONS.

| Center to Center Spacing in Inches | Impedance in Ohms for 1/2" Diameters | Impedance in Ohms for 1/4" Diameters |
|------------------------------------|--------------------------------------|--------------------------------------|
| 1 | 170 | 250 |
| 1.25 | 188 | 277 |
| 1.5 | 207 | 298 |
| 1.75 | 225 | 318 |
| 2 | 248 | 335 |

| Z ₀ OHMS | № 12 WIRE | | | № 14 WIRE | | |
|------------------------|-----------------------------|-----------------------------|-------------------------------|-----------------------------|-----------------------------|-------------------------------|
| | COL. 1 SPACING INCHES | COL. 2 SPACING INCHES | COL. 3 CIR. DIA. INCHES | COL. 4 SPACING INCHES | COL. 5 SPACING INCHES | COL. 6 CIR. DIA. INCHES |
| 175 | 1.415 | 1 1/8 | 2.001 | 1.120 | 1 1/8 | 1.585 |
| 184 | 1.495 | 1 1/2 | 2.110 | 1.185 | 1 3/8 | 1.675 |
| 187 | 1.535 | 1 9/16 | 2.175 | 1.215 | 1 1/4 | 1.720 |
| 193 | 1.630 | 1 5/8 | 2.305 | 1.280 | 1 3/8 | 1.820 |
| 200 | 1.720 | 1 3/4 | 2.434 | 1.361 | 1 3/8 | 1.935 |
| 202 | 1.820 | 1 3/8 | 2.560 | 1.440 | 1 7/8 | 2.100 |
| 203 | | | | | | |
| 206 | 2.020 | 2 | 2.858 | 1.600 | 1 5/8 | 2.261 |
| 207 | | | | | | |
| 210 | 2.120 | 2 1/8 | 3.000 | 1.630 | 1 11/16 | 2.378 |
| 211 | | | | | | |
| 212 | 2.301 | 2 5/16 | 3.122 | 1.825 | 1 13/16 | 2.581 |
| 216 | | | | | | |
| 219 | 2.420 | 2 1/4 | 3.421 | 1.920 | 1 13/16 | 2.719 |
| 223 | 2.662 | 2 1/4 | 3.700 | 2.110 | 1 1/8 | 2.890 |
| 224 | | | | | | |
| 225 | 2.910 | 2 15/16 | 4.110 | 2.310 | 2 5/16 | 3.375 |
| 228 | | | | | | |
| 232 | 3.075 | 3 1/8 | 4.350 | 2.435 | 2 7/16 | 3.440 |
| 234 | 3.150 | 3 1/8 | 4.450 | 2.497 | 2 1/2 | 3.530 |
| 238 | 3.320 | 3 5/16 | 4.690 | 2.625 | 2 5/8 | 3.720 |
| 240 | 3.420 | 3 7/16 | 4.835 | 2.721 | 2 11/16 | 3.853 |
| 245 | 3.640 | 3 3/8 | 5.150 | 2.881 | 2 7/8 | 4.075 |
| 250 | 4.040 | 4 1/8 | 5.710 | 3.204 | 3 3/8 | 4.540 |
| 256 | 4.360 | 4 3/8 | 6.160 | 3.460 | 3 7/8 | 4.890 |
| 261 | 4.650 | 4 5/8 | 6.580 | 3.683 | 3 11/16 | 5.202 |

Figure 19.
FOUR-WIRE MATCHING SECTION
DESIGN TABLE.

can be used for spacers. The usual dime store price is 5c each. When purchasing the coasters, one should take precaution to get the correct type of material. It seems that some are made from bakelite, while others are made of a plastic that has much better high frequency insulation qualities than bakelite. The plastic ones can easily be identified; they are translucent, while the bakelite ones are not.

The line is flexible, and must be used under slight tension to keep the wires from twisting. Spacers should be placed approximately every 2 feet. The *diagonally opposite* wires should be connected together at each end of the four-wire section.

Exact dimensions for the four-wire type Q section for common surge impedances are given in Figure 19. The length of the section is the same as for the two-conductor type.

OPERATING AN ANTENNA ON ITS HARMONICS

Zepp-fed, single-wire-fed, and direct-fed antennas have always been the most popular antennas for multi-band operation. This is due

to the fact that practically all of the antennas that are fed by two-wire nonresonant transmission lines reflect a bad mismatch into the line when operated on 2, 4, or 8 times the fundamental antenna frequency. Thus, the twisted-pair doublet, the Johnson Q, the matched-impedance J or T types, all are unsuitable for even-harmonic operation.

As pointed out earlier in this chapter, the radiating portion of an antenna does not resonate on integral harmonics of its fundamental frequency. Also, if the antenna is several wavelengths long, the point of feed has considerable effect upon the correct length for resonance. The best method of adjusting a harmonically operated antenna is by cut and try. To start with, the antenna can be made an integral number of half wavelengths long, and then pruned as necessary in order to obtain resonance at the desired frequency. A full wave antenna will be found to be about 0.97 wavelength long. The physical and electrical length more nearly correspond as the number of half waves is increased.

When designing an antenna for operation on more than one band, it should be cut for harmonic resonance at its highest operating frequency. If it is to be operated off resonance on some band, it is better to have it off resonance on a low frequency band, because any error is then a smaller percentage of a half wave.

Dummy Antennas

The law requires the use of some form of dummy antenna when testing a transmitter, in order to minimize unnecessary interference.

The cheapest form of dummy antenna is a light globe coupled to the plate tank circuit by means of a 4- to 8-turn pickup coil (or even clipped directly across a few turns of the tank coil). Another good form of dummy antenna that is relatively nonreactive is a bar of carbon tapped across enough of the tank turns to load the amplifier properly. Plaque (noninductive) types of wirewound resistors also are ideal for use as dummy antenna loads.

If a lamp or lamps are chosen of such value that they light up to approximately normal brilliancy at normal transmitter input, the output may be determined with fair accuracy by comparing the brilliancy of the lamps with similar lamps connected to the 110-volt line.

It is difficult to obtain a highly accurate measurement of the output by measuring the r.f. current through the light bulb and applying Ohm's law, because the resistance of the bulb cannot be determined with accuracy. The resistance of a light bulb varies considerably with the amount of current passing through it.

For highly accurate measurement of r.f. output, dummy antenna resistors having a resist-

ance that is substantially constant with varying dissipation are offered in 100 watt and 250 watt ratings. These resistors are available in various resistances between 73 and 600 ohms, and can be considered purely resistive at frequencies below 15 Mc. It will be noted that the stock resistance values correspond to the surge impedance of the most common lines. This increases their usefulness.

These resistors are hermetically sealed in glass bulb containers, the latter containing a gas which accelerates the conduction of heat from the resistor element (filament) to the outer surface of the bulb. These resistors glow a dull red at full dissipation rating. Though they somewhat resemble an incandescent lamp physically, they do not produce appreciable light. They may be used in series, parallel, or series parallel to get other resistance values or greater dissipation.

A correction chart is furnished so that one can correct for the slight non-linearity when a high degree of accuracy is required. With an r.f. ammeter of suitable range in series with the resistor, it is necessary only to note the reading, and refer to the chart to determine the exact power being dissipated in the resistance.

At the higher frequencies (above 30 Mc.), the reactance of the connecting leads, etc., will introduce difficulties, but these may be avoided by resonating the load circuit with a variable series condenser.

COMPACT ANTENNAS

Oftentimes, on the lower frequency bands, it is necessary because of space restrictions, to use a compromise antenna,—an antenna that has been folded or otherwise physically shortened to take up less room than required for a conventional antenna of that frequency. Naturally, a constricted antenna will not have as high efficiency, but, by going about the problem scientifically, it is possible to reduce the size of an antenna considerably with very little sacrifice in efficiency.

Oftentimes, it is possible to get the necessary height for a horizontal antenna on 40, 80, or 160 meters, but not the necessary linear span. As the major portion of the radiation from a dipole is from the center half of the dipole, the ends may be bent downward with little effect upon the efficiency and radiation pattern. As much as $\frac{1}{8}$ wavelength at each end of a half-wave dipole may be bent or allowed to hang down, if it is necessary in order to get the antenna to fit the span between poles. For the sake of electrical symmetry, the radiator should be bent the same amount at each end.

As an example, suppose we should like to string a 130-foot dipole (for 80-meter operation) between two 50-foot poles 90 feet apart.

We have 40 feet too much wire; so we shall bend down 20 feet at each end of the dipole. Each bent portion (20 feet) is less than the height of the poles; so there will be no difficulty on that score.

It will be found that when bending a radiator at any point other than a voltage or current loop, the length of the radiator must be increased slightly to restore resonance. Therefore, when bending a half-wave dipole to make it more compact, the length should be increased as necessary to obtain resonance.

Multi-Wire Doublets on Half-Frequency If we bend down the ends of a half-wave dipole until the bent portion at each end is $\frac{1}{8}$ wavelength long, leaving the flat top $\frac{1}{4}$ wavelength long, we have an antenna of the type just discussed. If we carry the bending process further, and bend the ends not only downwards but back in towards the center, we have something that resembles a multi-wire doublet designed for the next higher frequency band. Thus, we see that a multi-wire half-wave doublet antenna can be used as a *folded* antenna on *half* frequency. The feed line is no longer an untuned feeder, but rather a zepp feed system feeding both ends of the antenna at once. This is possible because the two ends of a dipole are of opposite polarity and phase.

A folded antenna of this type, instead of having very high radiation resistance like a multi-wire doublet system, will have rather low radiation resistance. However, it is still sufficiently high to give good radiation efficiency. The folding of the antenna does not cancel the radiation, because the current is so much greater in the main portion of the antenna than in the ends which are bent in toward the center, and also because the currents in the parallel wires are less than 180 degrees out of phase.

Loading Coils An old and still popular method of increasing the electrical length of a wire is by means of a *loading coil*. The customary procedure is to place a loading coil at the current loop (center of a dipole or ground lead of a Marconi) and vary the inductance by means of taps until the desired lengthening effect is obtained.

However, the most desirable place for a loading coil is *not* at the *current loop*, but towards the end (voltage loop) of the radiator. If the coil were placed at the extreme end of the antenna, it would have little loading effect, as there would be virtually no current flowing through it. So the coil is placed about $\frac{1}{20}$ wavelength from the end (or ends in the case of a dipole), instead of at the current loop. Thus, we see that while a Marconi will

still require only 1 loading coil, a dipole will require 2 for end loading.

As an example of the desirability of end loading, let's look at a vertical Marconi as used in broadcast work. It has been found that a $\frac{1}{8}$ -wavelength vertical radiator loaded to an electrical $\frac{1}{4}$ wavelength by means of a loading coil at the bottom or current loop, has a radiation resistance of only 4 or 5 ohms instead of the usual 36 ohms of a $\frac{1}{4}$ -wave vertical Marconi.

If we move the loading coil up nearly to the top of the radiator, and add more turns to the coil to compensate for the decreased current flowing through the coil, we find that the antenna now has a radiation resistance of around 20 ohms. Although the height of the radiator is the same, merely by moving the position of the loading coil we have increased the radiation resistance about 5 times.

The exact position of the coil is not critical; approximately $\frac{1}{20}$ wavelength from the far end of a Marconi is a good place for the coil. As previously mentioned, the coil must have considerably more turns to effect resonance than if it were placed at the current loop.

As it is difficult to make adjustments to the coil when it is placed towards the far end of the antenna, the loading coil for an end loaded Marconi is usually wound with somewhat more than the required turns, and resonance found by means of a series condenser in the ground lead. This eliminates the necessity for taking the coil down several times to get precisely the right amount of inductance for resonance at the operating frequency. The series condenser also allows one to adjust the antenna for maximum efficiency over the entire band.

The loading coil will be exposed to the weather, and hence this should be considered. The exact amount of wire required is difficult to calculate, but it will usually be somewhat more than the amount the radiator (including ground lead) lacks of being a quarter wavelength. The coil should be low loss (high Q) for best efficiency. Considerable power will be wasted in a coil having a low Q.

RECEIVING ANTENNAS

A receiving antenna should feed as much signal and as little noise—both man-made and atmospheric—to the receiver as possible. Placing the antenna as high as possible and away from house wiring, etc., will provide *physical* discrimination if a transmission line is used which has no signal pickup. Using a *resonant* antenna will provide *frequency* discrimination, attenuating signals and noise on frequencies removed from the resonant frequency of the antenna. Using a directional antenna will provide *directional* discrimination, attenuating signals and noise reaching the antenna from di-

rections removed from that of the station transmitting the desired signal.

The ideal antenna has these 3 kinds of discrimination: physical, frequency, and directional, which will thus deliver the most signal and the least amount of noise to the input circuit of the receiver. Such an antenna connected to a mediocre receiver will give better results than will the best receiver made, working on a mediocre antenna.

All of the transmitting antennas previously described are suitable for receiving. A good transmitting antenna meets all three of the desirable requirements set forth above. For this reason, an amateur is seldom justified in erecting a separate antenna system for the purpose of receiving. A d.p.d.t. relay designed for r.f. use, working off the send-receive switch or the communications switch on the receiver, can be used to throw whatever transmitting antenna is being used at the time to the receiver input terminals.

Fortunately, the antenna that delivers the best signal into a certain locality will also be best for receiving from that locality, and, conversely, the antenna which provides the best received signal will be best for transmitting to the same locality. In fact, a rotary antenna can be aimed at a station for maximum gain when transmitting by the simple expedient of rotating the array for maximum received signal.

As most man-made noise is essentially vertically polarized, an antenna or array with horizontal polarization will give minimum noise pickup from that source. For this reason, an array with horizontal polarization is advisable when it is to be used not only for transmission but also for reception.

The problem of noise pickup is most important because it is the signal-to-noise ratio that limits the signals capable of being received satisfactorily. No amount of receiver amplification will make a signal readable if the noise reaching the receiver is as loud as the signal. Peak-limiting devices will improve reception when trouble is experienced from *short-pulse* popping noises, such as auto ignition interference. But no electrical device in the receiver is of avail against the steady buzzing, frying noises present in most urban districts.

For the latter type of interference, caused by power leaks, defective neon signs, etc., a recently developed modification of an old principle is oftentimes of considerable help. A noise antenna, a short piece of wire placed so as to pick up as much of the interfering noise and as little of the desired signal as possible, is fed to the input of the receiver *out of phase* with the energy received from the main antenna. By proper adjustment of coupling and experimentation with the length and placement of the

noise antenna, it is sometimes possible to eliminate the offending noise completely. The system of noise bucking is described in Chapter 4, *Noise Suppression*.

Stray Pickup More care has to be taken in coupling a transmission line to a receiver than to a transmitter. The whole antenna system, antenna and transmission line, may tend to act as a Marconi antenna to ground, by virtue of capacity coupling. When transmitting, this effect merely lowers the maximum discrimination of a directive array with but little effect on the power gain; with a non-directional antenna, nothing will even be noticed when there is a very slight amount of Marconi effect. But if the effect is present when *receiving*, there is little point in using an antenna removed as far as possible from noise sources, because the transmission line itself will pick up the noise.

Faraday Electrostatic Shield There are two simple ways of avoiding the Marconi effect. The first method calls for a grounded *Faraday screen* between the antenna coil of the receiver and the input grid circuit. This eliminates all capacity coupling. This type of electrostatic screen can be constructed by winding a large number of turns of very small insulated wire on a piece of cardboard which has first been treated with insulating varnish. The wire is wound on, then another coating of varnish is applied.

After it has dried, *one edge* is trimmed with tin snips or heavy shears, and the wires are soldered together along the opposite edge. The screen is placed between the two coils and grounded. If properly made, it has little effect on the inductive coupling, as there are no closed loops.

Balancing Coils The second method calls for a center-tapped antenna coil with the center tap grounded. If the coil is not easily accessible, a small center-tapped coil of from 5 to 30 turns is connected across the antenna input to the receiver, and the cen-

ter tap grounded. While not critical, the best number of turns depends upon the type of transmission line, the frequency, and the turns on the antenna coil in the receiver. For this reason, the correct number of turns can best be determined by experiment.

The center tap must be at the *exact* electrical center of the coil. The coil may be scramble wound, and made self-supporting by means of adhesive tape. It should be borne in mind that a twisted-pair or open two-wire line will work *correctly* only if the receiver has provision for balanced (doublet) input. This is especially true of the latter type of line. If one side of the input or antenna coil is grounded inside the receiver, the ground connection must be broken and moved to the center of the coil, or an external balancing coil may be used.

Impedance Matching Another thing to take into consideration is the impedance of the input circuit of the receiver. If the receiver has high impedance input, it will not give maximum performance when a twisted-pair line is used. If it has low impedance input, it will not give maximum performance with an open-wire line. Most receivers are designed with 200- to 300-ohm (medium impedance) input, and will work well with either type line. However, the performance can sometimes be improved by incorporating an impedance matching transformer, even when the receiver has medium impedance (300 ohms) input.

Such a transformer is illustrated in Figure 21. If the line is of lower impedance than the receiver input, the line should be tapped across the fewer number of turns to provide the desired impedance step up. If the line is of higher impedance, the converse applies. Often the coupler will work better if a variable condenser is placed across the entire coil to tune it to resonance.

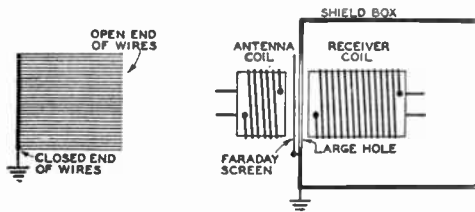

Figure 20. FARADAY ELECTROSTATIC SHIELD.

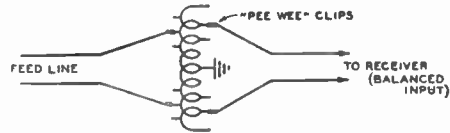

Figure 21. "AUTOTRANSFORMER" IMPEDANCE MATCHING COIL.

Any two-wire line can be matched to any receiver having balanced input by means of this coupling transformer. The best points at which to tap must be determined by experiment. Both antenna and receiver wires should always be tapped the same number of turns each side of center (ground). A 20- or 25-turn coil wound on a 1-inch form will usually be found optimum. The coil should be tapped every 2 turns, and at the exact center.

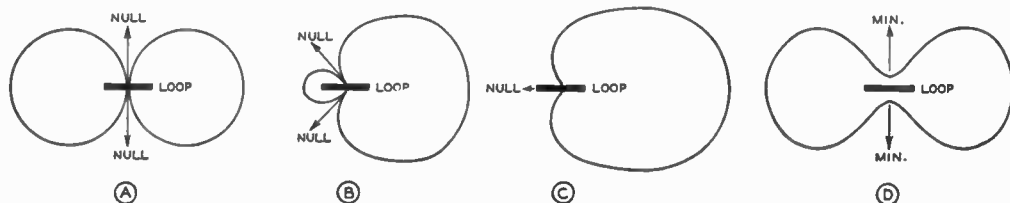

Figure 22.
TYPICAL LOOP ANTENNA PATTERNS.

- A:** Loop antenna, either resonant or nonresonant, perfectly balanced to ground (no antenna effect).
B: Nonresonant loop antenna, moderate antenna effect.
C: Nonresonant loop antenna, critical amount of antenna effect. Minor lobe completely disappears, leaving only one null.
D: Resonant loop antenna, moderate antenna effect. Nulls are changed to minima, but remain separated exactly 180 degrees.

If the line impedance is lower than that of the receiver, the receiver should be tapped across more turns than the line. If the line impedance is higher than that of the receiver input, the converse applies.

Loop Antennas

As a radiation field contains a magnetic component, it is readily apparent that a coil of wire placed in the proper inductive relation to the magnetic component will serve as an antenna. The efficacy as a pickup antenna is low, as compared to a regular receiving antenna, but because of its compactness and directional characteristics, the loop often is used as a portable antenna, or as a direction indicator.

The loop may be in the form of a circle, square, or rectangle whose length and width are not too widely different. It may be wound in the form of a solenoid, or in the form of a "pancake" helix. For true loop operation, however, the circumference of the loop should not be more than a small fraction of a wavelength.

The loop may be either resonant or non-resonant, though there will be considerable increase in signal pickup when the loop is resonant to the frequency of the signal being received. Also, the directional pattern is different for the two loops, except when both are perfectly balanced to ground, and there is no stray receiver pickup. If there is stray pickup, or the loop is not perfectly balanced, an asymmetrical pattern results *except when the loop is tuned to exact resonance*. With a resonant loop, the only effect of circuit unbalance to ground is to result in the absence of complete nulls; instead, there will be found *minima* as the loop is rotated, the minima being 180 degrees apart, the same as the nulls in a perfectly balanced system.

The result of circuit unbalance to ground, or of stray pickup in the input coupling circuit, permits the whole loop to work against ground as a Marconi antenna. The current thus in-

duced combines with the true loop current. If the loop is resonant, the phasing of the two currents is such as to maintain a symmetrical pattern, but there no longer will be complete nulls. If the loop is not resonant, the phasing of the two currents is such as to add in certain directions and cancel in others, resulting in an asymmetrical pattern.

Figure 22 shows the patterns obtained under these various conditions. Pattern A is obtained when there is no Marconi effect (also variously known as "antenna effect" or "vertical effect") with either a resonant or nonresonant loop.

With a nonresonant loop, a moderate amount of Marconi effect will produce the pattern shown at B. If the amount of Marconi effect is increased, a point finally will be reached where the small lobe completely disappears, leaving only one null. This pattern is shown at C.

A moderate amount of Marconi effect produces the pattern shown at D, when the loop is resonant. When the loop is tuned just slightly off exact resonance, a pattern intermediate between B and D is obtained.

For some applications, the entire loop is enclosed in a static shield. For aircraft work, this shield greatly reduces "rain static." It also virtually eliminates Marconi effect, which is important in the special circuits used in aircraft direction indicators. These instruments give a continuous indication, and have "sense"; that is, they do not have 180 degree ambiguity. However, these instruments are rather complicated, and their theory and operation therefore will not be covered here.

For simple direction finding work, in which two or more bearings are taken, and the station is located by observing the point of intersection on a map, an unshielded resonant loop will be found satisfactory. The only requirement is that the Marconi effect be not too great; otherwise the minima will not be sharply enough defined for accurate bearings.

Loops can be used to take accurate bearings only when the ground wave strongly predominates. When there is appreciable sky wave signal in addition to the ground wave signal, the loop will give inaccurate bearings as a result of downcoming horizontally polarized waves exciting the horizontal portion of the loop when it is adjusted for a null. This is commonly called "night effect," because for certain frequencies it is serious only at night.

While loop antennas can be used for high frequency reception, they are useless as *accurate* direction finders when the signal arrives largely or entirely by sky wave propagation, because sky wave signals do not always follow an exact great circle path.

For microwave and ultra high frequency direction finding, compact beam antennas having a sharp null or maximum are preferable to loop antennas, as loop antennas do not work well at these frequencies. U.h.f. direction finding is discussed in the next chapter.

Practical Direction Finding

In Figure 23 is shown a simple loop and method of connection to the receiver for use on the 160-meter amateur band, or the broadcast band. On these frequencies, bearings accurate to less than 2 degrees can be taken if there is no "night effect," which means 100-200 miles during the day, and 50-75 miles at night. The loop also can be used to provide fair pickup (satisfactory on all except very weak signals) up to about 20 Mc. for determining the *approximate* direction of distant stations, or the exact direction of local stations.

For frequencies below 2000 kc., the loop may be from 1 to 2 feet square, the larger size providing somewhat greater pickup. For frequencies between 2000 and 10,000 kc. it should be about 1 foot square, and above 10,000 kc. about 8 or 10 inches square.

The loop is wound with "bell wire" on a wood frame in the form of a "square solenoid," with an exact even number of turns so that the center tap will come at the bottom. The tuning condenser may be an ordinary 350- μfd . broadcast type, fitted with an insulated shaft extension to minimize body capacity.

A twisted-pair line is used to couple the loop to the receiver, which should have balanced (doublet) input; that is, neither side of the antenna coupling coil should be grounded in the receiver. The twisted line is tapped symmetrically either side of the grounded center tap on the loop, the feed line taps being adjusted together a turn at a time for maximum signal strength.

To take a bearing, simply tune the loop to resonance as indicated by the signal strength meter on the receiver, the loop direction being adjusted roughly for maximum pickup of the



Figure 23.
SIMPLE BUT ACCURATE DIRECTION FINDER.

If the loop is always tuned to resonance, it is not necessary to provide shielding or balancing adjustments in order to obtain accurate readings. For dimensions and data, refer to text.

signal. Then check to see if the two minima that are observed as the loop is rotated are exactly 180 degrees apart. If not, the loop is not tuned to exact resonance, and the tuning should be altered slightly as necessary to cause the two minima or nulls to fall exactly 180 degrees apart. When this is done, either null may be taken as a bearing.

Surrounding metal objects have a tendency to distort the directional pattern of the loop; likewise, large metal objects tend to deflect or reradiate the received signal, resulting in deceptive bearings. To be accurate, loop bearings should be taken with the loop as much in the clear as possible.

Sense Determination After an accurate bearing is taken with the loop just described, the 180 degree ambiguity can be eliminated as follows:

Tune in a station whose direction is known, and adjust the loop tuning condenser so that it is considerably on the low capacity side of resonance, as indicated by reduced signal pickup. The pattern then will be similar to B of Figure 22. If the tuning condenser always is tuned to the same side of resonance, and sufficiently off resonance, the small lobe (which is sharper than the large one) will always occur in the direction of the same vertical leg of the loop, which should be given an identifying mark.

Thus, to determine sense, simply detune the condenser to the low capacity side of resonance, and observe the relative positions of the large and small lobes.

Greatest accuracy will be obtained with a loop located high and in the clear, so that the arriving signal is not disturbed by the presence of surrounding objects, such as steel-frame buildings, telephone lines, etc.

Supporting the Antenna

The foregoing portion of this chapter has been concerned primarily with the *electrical* characteristics and considerations of antennas. The actual construction of these antennas is just as important. Some of the physical aspects and mechanical problems incident to

the actual erection of antennas and arrays will, therefore, be discussed.

Up to 60 feet, there is little point in using mast-type antenna supports unless guy wires must either be eliminated or kept to a minimum. While a little harder to erect, because of their floppy nature, fabricated wood poles of the type to be described will be just as satisfactory as more rigid types, *provided* many guy wires are used.

Rather expensive when purchased through the regular channels, 40- and 50-foot telephone poles *sometimes* can be obtained quite reasonably. In the latter case, they are hard to beat, inasmuch as they require no guying if set in the ground six feet (standard depth), and the resultant pull in any lateral direction is not in excess of a hundred pounds or so.

For heights of 80 to 100 feet, either three-sided or four-sided lattice type masts are most practicable. They *can* be made self-supporting, but a few guys will enable one to use a smaller cross section without danger from high winds. The torque exerted on the base of a high self-supporting mast is terrific during a strong wind.

Guy Wires Guy wires should never be pulled taut; a *small* amount of slack is desirable. Galvanized wire, somewhat heavier than seems sufficient for the job, should be used. The heavier wire is a little harder to handle, but costs only a little more and takes longer to rust through. Care should be taken to make sure that no kinks exist when the pole or tower is ready for erection, as the wire will be greatly weakened at such points if a kink is pulled tight, even if it is later straightened.

If "dead men" are used for the guy wire terminations, the wire or rod reaching from the dead men to the surface should be of non-rusting material, such as brass, or given a heavy coating of asphalt or other protective substance to prevent destructive action by the damp soil. Galvanized iron wire will last only a short time when buried in moist soil.

Only strain-type (compression) insulators should be used for guy wires. Regular ones might be sufficiently strong for the job, but it is not worth taking chances, and egg-type strain insulators are no more expensive.

Only a brass or bronze pulley should be used for the halyard, as a nice high pole with a rusted pulley is truly a sad affair. The bearing of the pulley should be given a few drops of heavy machine oil before the pole or tower is raised. The halyard itself should be of good material, preferably waterproofed. Hemp rope of good quality is better than window sash cord from several standpoints, and is less expensive. Soaking it thoroughly in engine oil

of medium viscosity, and then wiping it off with a rag, will not only extend its life but minimize shrinkage in wet weather. Because of the difficulty in replacing a broken halyard (procedure described later), it is a good idea to replace it periodically, without waiting for it to show excessive wear or deterioration.

Screw eyes should not be used in connections where appreciable tension will occur. The bite of the threads is not sufficient to withstand much loading. They should be used only to hold guy wires and such *in position*; the wires should always be wrapped around the mast or pole. Nails will serve just as well, and are cheaper.

Trees as Supports Often a tall tree can be called upon to support one end of an antenna, but one should not attempt to attach anything to the top, as the swaying of the top of the tree during a heavy wind will complicate matters.

If a tree is utilized for support, provision should be made for keeping the antenna taut without submitting it to the possibility of being severed during a heavy wind. This can be done by the simple expedient of using a pulley and halyard, with weights attached to the lower end of the halyard to keep the antenna taut. Only enough weight to avoid excessive sag in the antenna should be tied to the halyard, as the continual swaying of the tree submits the pulley and halyard to considerable wear.

Galvanized iron pipe, or steel tube conduit, is often used as a vertical radiator, and is quite satisfactory for the purpose. However, when used for supporting antennas, it should be remembered that the grounded supporting poles will distort the field pattern unless spaced some distance from the radiating portion of the antenna.

Painting The life of a wood mast or pole can be increased several hundred per cent by protecting it from the elements with a coat or two of paint. And, of course, the appearance is greatly enhanced. The wood should first be given a primer coat of flat white outside house paint, which can be thinned down a bit to advantage with second-grade linseed oil. For the second coat, which should not be applied until the first is thoroughly dry, *aluminum paint* is not only the best from a preservative standpoint, but looks very well. This type of paint, when purchased in quantities, is considerably cheaper than might be gathered from the price asked for quarter-pint cans.

Portions of posts or poles below the surface of the soil can be protected from termites and moisture by painting with creosote. While not

so strong initially, redwood will deteriorate much more slowly when buried than will the white woods, such as pine.

Antenna Wire The antenna or array itself presents no especial problem. A few considerations should be borne in mind, however. For instance, soft-drawn copper should not be used, as even a short span will stretch several per cent after whipping around in the wind a few weeks, thus affecting the resonant frequency. Enameled-copper wire, as ordinarily available at radio stores, is usually soft drawn, but by tying one end to some object such as a telephone pole and the other to the frame of an auto, a few husky tugs can be given and the wire, after stretching a bit, is equivalent to hard drawn.

Where a long span of wire is required, or where heavy insulators in the center of the span result in considerable tension, copper-clad steel wire is somewhat better than hard-drawn copper. It is a bit more expensive, though the cost is far from prohibitive. The use of such wire, in conjunction with strain insulators, is advisable, where the antenna would endanger persons or property should it break.

For transmission lines, steel core wire will prove awkward to handle, and hard-drawn copper should, therefore, be used. If the line is long, the strain can be eased by supporting it at several points.

The use of copper tubing for antennas (except at u.h.f.) is not only expensive but unjustifiable. Though it was a fad at one time, there is no excuse for using anything larger than no. 10 copper or copper-clad wire for any power up to 1 kilowatt. In fact, no. 12 will do the trick just as well, and passes the underwriter's rules if copper-clad steel is used. For powers of less than 100 watts, the underwriter's rules permit no. 14 wire of solid copper. This size is practically as efficient as larger wire, but will not stand the pull that no. 12 or no. 10 will, and the underwriter's rules call for the latter for powers in excess of 100 watts, if solid copper conductor is used.

More important from an electrical standpoint than the actual size of wire used is the soldering of joints, especially at current loops in an antenna of low radiation resistance. In fact, it is good practice to solder *all* joints, thus insuring quiet operation when the antenna is used for receiving.

Insulation A question that often arises is that of insulation. It depends, of course, upon the r.f. voltage at the point at which the insulator is placed. The r.f. voltage, in turn, depends upon the distance from a current node, and the radiation resistance of the antenna. Radiators having low radiation resistance have very high voltage at the voltage loops; consequently, better than usual insulation is advisable at those points.

Open-wire lines operated as nonresonant lines have little voltage across them; hence the most inexpensive ceramic types are sufficiently good electrically. With tuned lines, the voltage depends upon the amplitude of the standing waves. If they are very great, the voltage will reach high values at the voltage loops, and the best spacers available are none too good. $\frac{3}{8}$ -inch Lucite rod, which can be purchased for 18c per foot, permits lightweight spreaders having excellent electrical properties. At the current loops the voltage is quite low, and almost anything will suffice.

When insulators are subject to very high r.f. voltages, they should be cleaned occasionally if in the vicinity of sea water or smoke. Salt scum and soot are not readily dislodged by rain, and when the coating becomes heavy enough, the efficiency of the insulators is greatly impaired.

If a very pretentious installation is to be made, it is wise to check up on both underwriter's rules and local ordinances which might be applicable. If you live anywhere near an airport, and are contemplating a tall pole, it is best to investigate possible regulations and ordinances pertaining to towers in the district, before starting construction.

| LONG-ANTENNA DESIGN CHART | | | | | | | | |
|---|------|------|------|------|------|-----|------|------|
| Approximate Length in Feet—End-Fed Antennas | | | | | | | | |
| Frequency in Mc. | 1λ | 1½λ | 2λ | 2½λ | 3λ | 3½λ | 4λ | 4½λ |
| 30 | 32 | 48 | 65 | 81 | 97 | 104 | 130 | 146 |
| 29 | 33 | 50 | 67 | 84 | 101 | 118 | 135 | 152 |
| 28 | 34 | 52 | 69 | 87 | 104 | 122 | 140 | 157 |
| 14.4 | 66½ | 100 | 134 | 169 | 203 | 237 | 271 | 305 |
| 14.2 | 67½ | 102 | 137 | 171 | 206 | 240 | 275 | 310 |
| 14.0 | 68½ | 103½ | 139 | 174 | 209 | 244 | 279 | 314 |
| 7.3 | 136 | 206 | 276 | 346 | 416 | 486 | 555 | 625 |
| 7.15 | 136½ | 207 | 277 | 347 | 417 | 487 | 557 | 627 |
| 7.0 | 137 | 207½ | 277½ | 348 | 418 | 488 | 558 | 628 |
| 4.0 | 240 | 362 | 485 | 618 | 730 | 853 | 977 | 1100 |
| 3.9 | 246 | 372 | 498 | 625 | 750 | 877 | 1000 | 1130 |
| 3.8 | 252 | 381 | 511 | 640 | 770 | 900 | 1030 | 1160 |
| 3.7 | 259 | 392 | 525 | 658 | 790 | 923 | 1060 | 1190 |
| 3.6 | 266 | 403 | 540 | 676 | 812 | 950 | 1090 | 1220 |
| 3.5 | 274 | 414 | 555 | 696 | 835 | 977 | 1120 | |
| 2.0 | 480 | 725 | 972 | 1230 | 1475 | | | |
| 1.9 | 504 | 763 | 1020 | 1280 | | | | |
| 1.8 | 532 | 805 | 1080 | | | | | |

it into the radio room for direct connection to a tuned antenna circuit which is link-coupled to the transmitter. The antenna can be tuned to exact resonance for operation on any harmonic by means of the tuned circuit which is connected to the end of the antenna. This tuned circuit corresponds to an adjustable, non-radiating section of the antenna. A ground is sometimes made to the center of the tuned coil.

If desired, the antenna can be opened and current-fed at a point of maximum current by means of a twisted-pair feeder, concentric line, or a Q matching system and open line.

The V Antenna

If two long-wire antennas are built in the form of a V, it is possible to make two of the maximum lobes of one leg shoot in the same direction as two of the maximum lobes of the other leg of the V. The resulting antenna is bidirectional (two opposite directions) for the main lobes of radiation. Each side of the V can be made any odd or even multiple of quarter wavelengths, depending on the method of feeding the apex of the V. The complete system must be a multiple of half waves. If each leg is an even number of quarter waves long, the antenna must be voltage-fed at the apex; if an odd number of quarter waves long, current feed must be used.

By choosing the proper angle δ , Figure 2, the lobes of radiation from the two long-wire antennas aid each other to form a bidirectional beam. Each wire by itself would have a radiation pattern similar to that for antennas operated on harmonics. The reaction of one upon the other removes two of the four main lobes,

and increases the other two in such a way as to form two lobes of still greater magnitude.

The correct wire lengths and the degree of the angle δ are listed in the *V-Antenna Design Table* for various frequencies in the 10-, 20- and 40-meter amateur bands.

The legs of a very long wire V antenna are usually so arranged that the included angle is twice the angle of the major lobe from a single wire if used alone. This arrangement concentrates the radiation of each wire along the bisector of the angle, and permits part of the other lobes to cancel each other.

With legs shorter than 3 wavelengths, the best directivity and gain are obtained with a somewhat smaller angle than that determined by the lobes. Optimum directivity for a one-wave V is obtained when the angle is 90° rather than 108°, as determined by the ground pattern alone.

If very long wires are used in the V, the

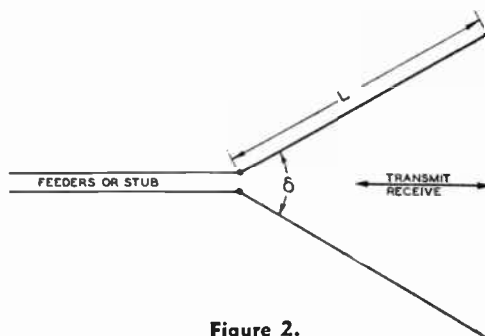

Figure 2.
TYPICAL V-BEAM ANTENNA.

| V-ANTENNA DESIGN TABLE | | | | |
|----------------------------|--------------------------------------|---------------------------------------|---------------------------------------|---------------------------------------|
| Frequency in Kilocycles | L = λ $\delta = 90^\circ$ | L = 2λ $\delta = 70^\circ$ | L = 4λ $\delta = 52^\circ$ | L = 8λ $\delta = 39^\circ$ |
| 28000 | 34'8" | 69'8" | 140' | 280' |
| 28500 | 34'1" | 68'6" | 137'6" | 275' |
| 29000 | 33'6" | 67'3" | 135' | 271' |
| 29500 | 33' | 66'2" | 133' | 266' |
| 30000 | 32'5" | 65' | 131' | 262' |
| 14050 | 69' | 139' | 279' | 558' |
| 14150 | 68'6" | 138' | 277' | 555' |
| 14250 | 68'2" | 137' | 275' | 552' |
| 14350 | 67'7" | 136' | 273' | 548' |
| 7020 | 138'2" | 278' | 558' | 1120' |
| 7100 | 136'8" | 275' | 552' | 1106' |
| 7200 | 134'10" | 271' | 545' | 1090' |
| 7280 | 133'4" | 268' | 538' | 1078' |

angle between the wires is almost unchanged when the length of the wires in wavelengths is altered. However, an error of a few degrees causes a much larger loss in directivity and gain in the case of the longer V than in the shorter one, which is broader.

The vertical angle at which the wave is best transmitted or received from a horizontal V antenna depends largely upon the included angle. The sides of the V antenna should be at least a half wavelength above ground; commercial practice dictates a height of approximately a full wavelength above ground.

The Rhombic Antenna

The terminated *rhombic* or *diamond* is probably the most effective directional antenna that is practical for amateur communication. This antenna is non-resonant, with the result that it can be used on three amateur bands, such as 10, 20, and 40 meters. When the antenna is non-resonant, i.e., properly terminated, the system is unidirectional, and the wire dimensions are not critical. The rhombic antenna can be suspended over irregular terrain without greatly affecting its practical operation.

When the free end is terminated with a resistance of a value between 700 and 800 ohms, as shown in Figures 5, 6, and 7, the backwave is eliminated, the forward gain is increased, and the antenna can be used on several bands without changes. The terminating resistance should be capable of dissipating one-third the power output of the transmitter, and should have very little reactance. A bank of lamps can be connected in series-parallel for this purpose, or heavy duty carbon rod resistances can be used. For medium or low power transmitters, the non-inductive *plaque* resistors will serve as a satisfactory termination. Several manufacturers offer special resistors suitable for terminating a rhombic antenna.

The terminating device should, for technical reasons, present a small amount of inductive reactance at the point of termination. However, this should not be too great. By using a bank of lamps in series-parallel, this qualification will be met. The total power dissipated by the lamps will be roughly a third of the transmitter output.

Because of the high temperature coefficient of resistance for both carbon and Mazda

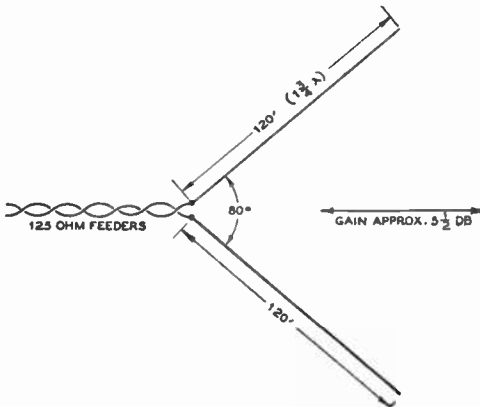

Figure 3.
20-METER V ANTENNA, SMALLEST WORTHWHILE SIZE.

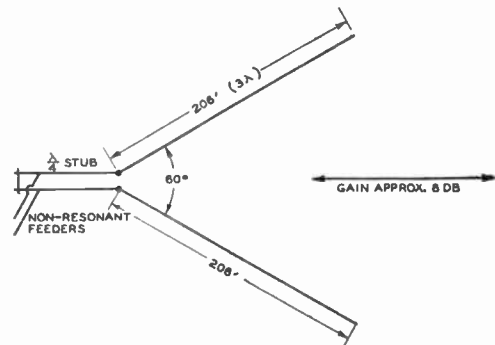
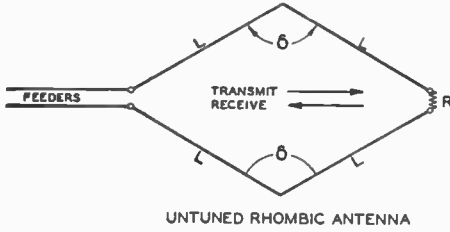
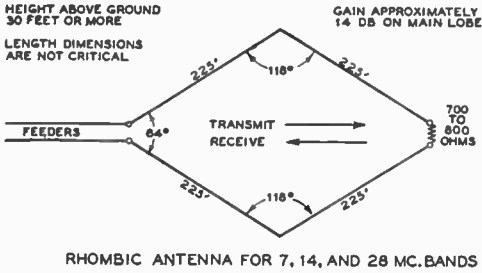

Figure 4.
20-METER V WITH MODERATE GAIN AND DIRECTIVITY.



UNTUNED RHOMBIC ANTENNA

Figure 5.



RHOMBIC ANTENNA FOR 7, 14, AND 28 MC. BANDS

Figure 6.

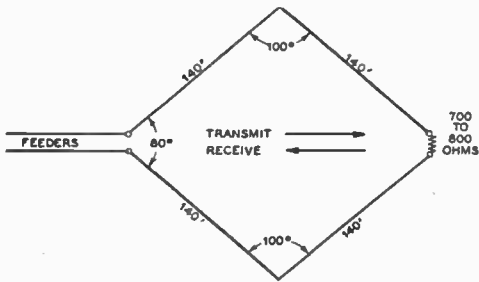

SMALLER RHOMBIC OR DIAMOND ANTENNA SUITABLE FOR 7, 14, AND 28 MC. BANDS

Figure 7.

lamps, neither type is any too satisfactory when used alone, especially in a keyed transmitter. However, by connecting both types in parallel, the resistance can be made fairly constant. This is because the coefficient of one type of lamp is positive, while that of the other is negative. The most constant combination will utilize a 110-volt carbon lamp of 2X watts across each 125-volt Mazda lamp of X watts. Thus, a 60-watt Mazda lamp would have a 120-watt carbon lamp across it. The desired resistance can be obtained by series-connecting or series-paralleling several such units.

A compromise terminating device commonly used consists of a terminated 250-foot or longer length of line, made of resistance wire which does not have too much resistance per unit

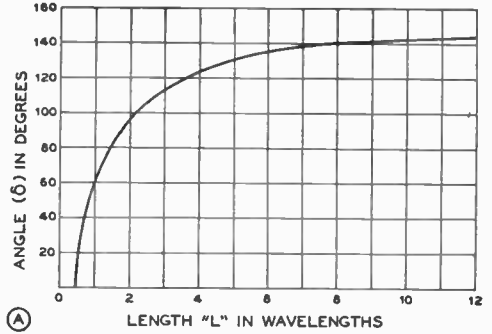

(A)

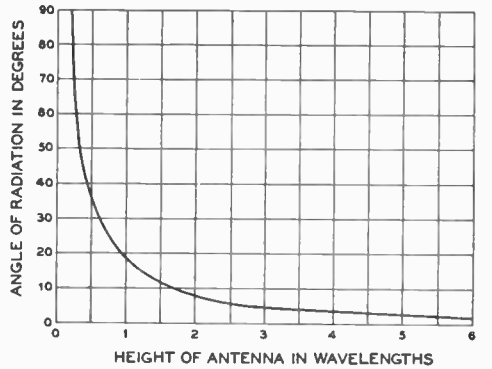

Figure 8. DIAMOND ANTENNA DESIGN CHARTS.

length. If the latter qualification is not met, the reactance of the line will be excessive. A 250-foot line consisting of no. 25 nichrome wire, spaced 6 inches and terminated with 800 ohms, will serve satisfactorily. Because of the attenuation of the line, the lumped resistance at the end of the line need dissipate but a few watts even when high power is used. A half-dozen 5000-ohm 3-watt carbon resistors in parallel will serve for all except very high power. The attenuating line may be either coiled or folded back on itself to take up less room.

The determination of the best value of terminating resistor must be made while *transmitting*, as the input impedance of the average receiver is considerably lower than 800 ohms. This mismatch will *not* impair the *effectiveness* of the array on *reception*, but as a result, the value of resistor which gives the best directivity on reception will not give the most gain when transmitting. It is preferable to adjust the resistor for maximum gain when transmitting, even though there will be but little difference between the two conditions.

The input resistance of the diamond which is reflected into the transmission line that feeds it is always somewhat less than the terminat-

ing resistance, and is around 700 or 750 ohms when the resistor is 800 ohms.

The antenna should be fed with a non-resonant line, preferably with an impedance of approximately 700 ohms. The four corners of the diamond, when possible, should be at least a half wavelength above ground at the lowest frequency of operation. For three-band operation, the proper angle δ for the center band should be observed.

The diamond antenna transmits a horizontally polarized wave at a low angle above the horizon in the case of a large antenna. The angle of radiation above the horizon goes down as the height above ground is increased.

Unless unavoidable, the diamond antenna should not be tilted in any plane. In other words, the poles should be the same height, and the plane of the antenna should be parallel with the ground. Tilting the antenna simply sacrifices about half the directivity, due to the fact that the reflection from the ground does not combine with the incident wave in the desired phase unless the antenna is parallel with the ground.

A good deal of directivity is lost when the terminating resistor is left off and the system is operated as a resonant antenna. If it is desired to reverse the direction of maximum radiation, it is much better practice to run feeders to both ends of the antenna and mount terminating resistors also at both ends. Then, with remote-controlled double-pole double-throw switches located at each end of the antenna, it becomes possible to reverse the array quickly for transmission or reception to or from the opposite direction.

The directive gain of the rhombic antenna is dependent on the height above ground, and the side angle as well as the overall length of each of the 4 radiating wires in the array. Therefore, the gain of a particular array is not easy to calculate.

Stacked Dipole Antennas

The characteristics of a half-wave dipole already have been described. When another dipole is placed in the vicinity and excited either directly or parasitically, the resultant radiation pattern will depend upon the spacing and phase differential, as well as the relative magnitude of the currents. With spacings less than 0.65 wavelength, the radiation is mainly broadside to the 2 wires (bidirectional) when there is no phase difference, and *through* the wires (end fire) when the wires are 180° out of phase. With phase differences between 0° and 180° (45°, 90°, and 135° for instance), the pattern is somewhat unsymmetrical, the radiation being *greater in one direction* than in the opposite direction. In fact, with certain critical spacings, the radiation will be practically uni-

directional for phase differences of 45°, 90°, and 135°. However, phase differences of other than 0° and 180° are difficult to obtain except with parasitically excited elements.

With spacings of more than 0.7 wavelength, more than two main lobes appear for all phasing combinations; hence, such spacings are seldom used.

With the dipoles driven so as to be in phase, the most effective spacing is between 0.5 and 0.65 wavelength. The latter provides greater gain, but minor lobes are present which do not appear at 0.5-wavelength spacing. The radiation is broadside to the plane of the wires, and the gain is slightly greater than can be obtained from two dipoles out of phase. The gain falls off rapidly for spacings less than 0.375 wavelength, and there is little point in using spacing of 0.25 wavelength or less with in-phase dipoles, except where it is desirable to increase the radiation resistance. (See *Multi-Wire Doublet*.)

When the dipoles are fed 180° out of phase, the directivity is through the plane of the wires, and is greatest with *close spacing*, though there is but little difference in the pattern after the spacing is made less than 0.125 wavelength. The radiation resistance becomes so low for spacings of less than 0.1 wavelength that such spacings are not practicable for antenna arrays except for receiving.

The best *unidirectional* pattern is obtained with 0.1- or 0.125-wavelength spacing, and 135° phase lag. As it is rather difficult to get other than 0° and 180° phasing in driven radiators, parasitic directors and reflectors are usually resorted to for odd values of phasing. These are driven parasitically, rather than directly by feeders, and the phasing can be varied by altering the length of the parasitic elements.

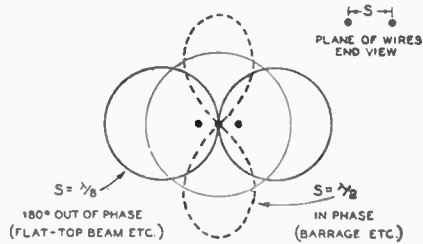

Figure 9.
FIELD STRENGTH PATTERNS OF TWO DIPOLES WHEN IN PHASE AND WHEN OUT OF PHASE.

It can be readily seen that if the dipoles are oriented horizontally most of the directivity will be in the vertical plane; if oriented vertically most of the directivity will be horizontal directivity.

In the three foregoing examples, most of the directivity provided is in a plane at a right angle to the 2 wires, though when out of phase, the directivity is in a line *through* the wires, and when in phase, the directivity is *broadside* to them. Thus, if the wires are oriented vertically, mostly horizontal directivity will be provided. If the wires are oriented horizontally, most of the directivity obtained will be *vertical* directivity.

To increase the sharpness of the directivity in all planes that include one of the wires, additional identical elements are added *in the line of the wires*, and fed so as to be *in phase*. The familiar H array is one array utilizing both types of directivity in the manner prescribed. The 2-section Kraus flat-top beam is another.

These two antennas in their various forms are directional in a horizontal plane, in addition to being low angle radiators, and are perhaps the most practicable of the *bidirectional* stacked-dipole arrays for amateur use. More phased elements can be used to provide greater directivity in planes including one of the radiating elements. The H then becomes a barrage or Sterba array.

For unidirectional work, the most practicable stacked dipole arrays for amateurs are those using close-spaced directors and reflectors (0.1 to 0.125 wavelength spacing).

While there is almost an infinite variety of combinations when it comes to obtaining directivity by means of stacked dipoles, only those systems which are most practical from an amateur standpoint will be discussed at length.

Colinear Antennas

Franklin or *colinear* antennas are widely used by amateurs. The radiation is bidirectional broadside to the antenna. The antenna consists of two or more half-wave radiating sections, with the current *in phase* in each section. This is accomplished by quarter-wave stubs between each radiating section, or by means of a tuned coil and condenser or resonant loading coil between each half-wave radiating section.

Two half waves *in phase* will give a gain of slightly more than 2 db with respect to a single half-wave antenna; three sections will give a gain of approximately 4 db. Additional half-wave sections increase this power gain approximately 1 db per section. The two-section colinear antenna is commonly called a *double zepp*.

Various feeder systems are shown in the accompanying sketches. A tuned feeder can be used in place of a quarter-wave stub and 600-ohm line. The latter will allow a two-section *colinear* antenna to be operated as a single-section half-wave antenna (current-fed doublet) on half frequency. For example, an antenna of this type would be a half-wave antenna on 40 meters and a 2-section *colinear* antenna on 20 meters. The direction of current at a given instant and the location of the current loops are indicated in the sketches by means of arrowheads and dots, respectively.

Practically all directivity provided by colinear sections is in a horizontal plane. The effect on the vertical directivity is negligible when additional sections are provided. For this reason, the Franklin array is useful particularly

Figure 10.

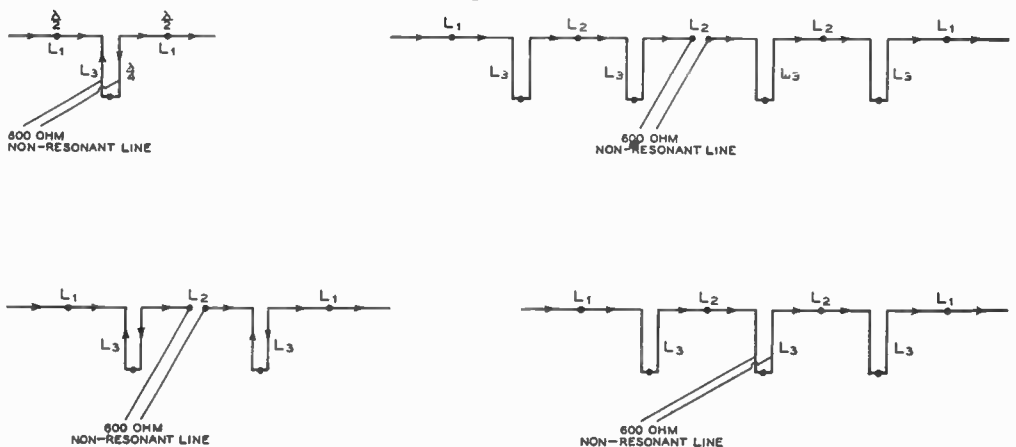

FRANKLIN OR CO-LINEAR ANTENNAS
 HORIZONTAL POLARIZATION · BROADSIDE RADIATION

| COLINEAR ANTENNA DESIGN CHART | | | |
|-------------------------------|----------------|----------------|----------------|
| FREQUENCY IN MC. | L ₁ | L ₂ | L ₃ |
| 30 | 16' | 16'5" | 8'2" |
| 29 | 16'6" | 17' | 8'6" |
| 28 | 17'1" | 17'7" | 8'8" |
| 14.4 | 33'4" | 34'3" | 17'1" |
| 14.2 | 33'8" | 34'7" | 17'3" |
| 14.0 | 34'1" | 35' | 17'6" |
| 7.3 | 65'10" | 67'6" | 33'9" |
| 7.15 | 67' | 68'8" | 34'4" |
| 7.0 | 68'5" | 70'2" | 35'1" |
| 4.0 | 120' | 123' | 61'6" |
| 3.9 | 123' | 126' | 63' |
| 3.6 | 133' | 136'5" | 68'2" |

on the 40-, 80-, and 160-meter bands, where low angle radiation is not so important. On the higher frequency bands, 20 and 10 meters, an array providing *vertical directivity in addition to horizontal directivity is desirable*. Hence, the Franklin antenna is not as suited for use on the latter two bands as are some of the arrays to be described.

As additional colinear elements are added to a doublet, the radiation resistance goes up much faster than when additional half waves are added out of phase (harmonic operated antenna).

For a colinear array of from 2 to 6 elements, the terminal radiation resistance in ohms at any current loop is approximately 100 times the number of elements.

It should be borne in mind that the *gain* from a Franklin antenna depends upon the *sharpness* of the horizontal directivity. An array with several colinear elements will give considerable gain, but will cover only a very limited arc.

Double Extended Zepp

The gain of a conventional 2-element Franklin antenna can be increased to a value approaching that obtained from a 3-element Franklin, simply by making the 2 radiating elements 230° long instead of 180° long. The phasing stub is shortened correspondingly to maintain the whole array in resonance. Thus, instead of having 0.5-wavelength elements and 0.25-wavelength stub, the elements are made 0.64 wavelength long and the stub slightly more than 0.11 wavelength long.

The correct radiator dimensions for a 230° double zepp can be obtained from the *Colinear Antenna Design Chart* simply by multiplying the L₁ values by 1.29. The length for L₃ must be determined experimentally for best results. It will be about 1/8 wavelength.

The *vertical* directivity of a colinear antenna having 230° elements is the same as for one having 180° elements. However, parasitic lobes

in the horizontal pattern are stronger with the extended version. The radiation resistance of the extended version is slightly lower.

It will be observed that the overall length of the extended zepp, including phasing section, is longer than the 3/2 wavelength wire that makes up a conventional double zepp. The reason for this is that when a wire is bent anywhere except at a voltage or current loop, the wire must be lengthened to restore resonance.

Multiple-Stacked Broadside Arrays

Colinear elements may be stacked above or below another similar string of elements, thus providing vertical directivity. Horizontal colinear elements, stacked two above two and separated by half wavelength, form the popular "lazy H" array of Figure 11. It is highly recommended for amateur work on 10 and 20 meters when substantial gain without too much directivity is desired. It has high radiation resistance. This results in low voltages and a broad resonance curve, which permits use of inexpensive insulators and enables the array to be used over a fairly wide range in frequency. For dimensions, see the stacked dipole design table.

The Sterbo "Borroge"

Vertical stacking may be applied to strings of colinear elements longer than 2 half waves. In such arrays, the end quarter wave of each string of radiators usually is bent in to meet a similar bent quarter wave from the opposite end radiator. This provides better balance and better coupling between the upper and lower elements when the array is current-fed. Arrays of this type are shown in Figure 12, and are commonly known as Sterba or barrage arrays.

Correct length for the elements and stubs can be determined for any stacked dipole from the *Stacked-Dipole Design Table*.

| STACKED-DIPOLE DESIGN TABLE | | | |
|-----------------------------|----------------|----------------|----------------|
| FREQUENCY IN MC. | L ₁ | L ₂ | L ₃ |
| 240 | 24" | 24 1/2" | 12" |
| 232 | 25" | 25 1/2" | 12 1/2" |
| 224 | 26" | 26 1/2" | 13" |
| 120 | 4' | 4'1" | 24" |
| 116 | 4'1 1/2" | 4'3" | 25" |
| 112 | 4'3" | 4'5" | 26" |
| 60 | 8' | 8'2" | 4'1" |
| 58 | 8'3" | 8'6" | 4'3" |
| 56 | 8'7" | 8'9" | 4'5" |
| 30 | 16' | 16'5" | 8'2" |
| 29 | 16'6" | 17' | 8'6" |
| 28 | 17' | 17'7" | 8'9" |
| 14.4 | 33'4" | 34'2" | 17' |
| 14.2 | 33'8" | 34'7" | 17' |
| 14 | 34'1" | 35' | 17'6" |
| 7.3 | 65'10" | 67'6" | 33'9" |
| 7.0 | 68'2" | 70' | 35' |

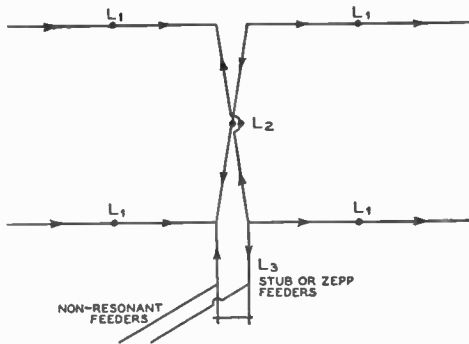

Figure 11.

THE POPULAR "LAZY H" BI-DIRECTIONAL ARRAY.

Stacking the colinear elements results in both vertical and horizontal directivity.

In these sketches, the arrowheads represent the direction of flow of current at a given instant; the dots represent the points of maximum current and lowest impedance. All arrows should point in the *same direction* in each portion of the radiating sections of an antenna, in order to provide a field *in phase* for broadside radiation. This condition is satisfied by the arrays illustrated in Figure 12.

If 4 or more sections are used in a barrage array, the horizontal directivity will be great enough that the array can be used only over a narrow arc (in 2 opposite directions). For this reason such an array should be oriented with great care.

End-Fire Directivity

By spacing 2 half-wave dipoles, or colinear arrays, at a distance of from 0.1 to 0.25 wavelength and driving the two 180° out of phase, directivity is obtained *through the 2 wires at right angles to them*. Hence, this type of bi-directional array is called *end fire*. A better idea of end-fire directivity can be obtained by referring to Figure 9.

Remember that *end-fire* refers to the radiation with respect to the 2 wires in the array, rather than with respect to the array as a whole.

The vertical directivity of an end-fire bi-directional array which is oriented horizontally can be increased by placing a similar end-fire array a half wave below it, and excited in the same phase. Such an array is a combination broadside and end-fire affair. However, most arrays are made either broadside *or* end-fire, rather than a combination of both, though the latter are satisfactory if designed properly.

Kraus Flat-Top Beam

A very effective bidirectional end-fire array is the Kraus *Flat-Top Beam*. Essentially, this antenna consists of 2 close-spaced dipoles or colinear arrays. Because of the close spacing, it is possible to obtain the proper phase relationships in multi-section flat tops by crossing the wires at the voltage loops, rather than by resorting to phasing stubs. This greatly simplifies the array. (See Figure 13.) Any number of sections may be used, though the 1- and 2-section arrangements are the most popular. Little extra gain is obtained by using more than 4 sections, and trouble from phase shift may appear.

A center-fed single-section flat-top beam cut according to the table, can be used quite successfully on its second harmonic, the pattern being similar except that it is a little sharper. The single-section array can also be used on its fourth harmonic with some success, though there then will be four cloverleaf lobes, much the same as with a full-wave antenna.

If a flat-top beam is to be used on more than one band, tuned feeders are necessary.

The radiation resistance of a flat-top beam is rather low, especially when only one section is used. This means that the voltage will be high at the voltage loops. For this reason, especially good insulators should be used for best results in wet weather.

The exact lengths for the radiating elements are not especially critical, because slight deviations from the correct lengths can be compensated for in the stub or tuned feeders. Proper stub adjustment is covered on page 446. Suitable radiator lengths and approximate stub dimensions are given in the accompanying design table.

Figure 13 shows *top views* of 8 types of flat-top beam antennas. The dimensions for using these antennas on different bands are given in the design table. The 7- and 28-Mc. bands are divided into two parts, but the dimensions for either the low- or high-frequency ends of these bands will be satisfactory for use over the entire band.

In any case, the antennas are tuned to the frequency used, by adjusting the shorting wire on the stub, or tuning the feeders, if no stub is used. The data in the table may be extended to other bands or frequencies by applying the proper factor. Thus, for 56- to 58-Mc. operation, the values for 28 to 29 Mc. are divided by two.

All of the antennas have a bidirectional horizontal pattern on their fundamental frequency. The maximum signal is broadside to the flat top. The single-section type has this pattern on both its fundamental frequency and second harmonic. The other types have 4 main lobes of radiation on the second and higher har-

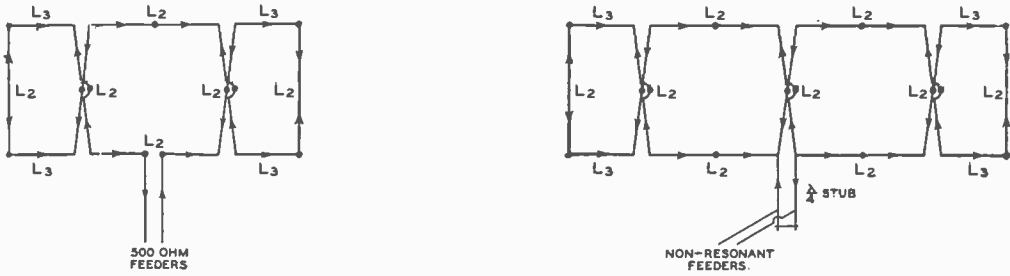

HORIZONTALLY POLARIZED BROADSIDE BARRAGE ANTENNAS

Figure 12.

monics. The nominal gains of the different types over a half-wave comparison antenna are as follows: single-section, 4 db; 2-section, 6 db; 3-section, 7 db; 4-section, 8 db.

The current directions on the antennas at any given instant are shown by the arrows on the wires in the figure. The voltage maximum points, where the current reverses phase, are indicated by small X's on the wires.

The maximum spacings given make the beams less critical in their adjustment. Up to one-quarter wave spacing may be used on the fundamental for the 1-section types and also the 2-section center-fed, but it is not desirable to use more than 0.15 wavelength spacing for the other types.

Although the center-fed type of flat top generally is to be preferred because of its symmetry, the end-fed type often is convenient or desirable. For example, when a flat-top beam is used vertically, feeding from the lower end is in most cases more convenient.

If a multisection flat-top array is end-fed instead of center-fed, and tuned feeders are used, stations off the ends of the array can be worked by tying the feeders together and working the whole affair, feeders and all, as a long-wire harmonic antenna. A single-pole double-throw switch can be used for changing the feeders and directivity.

Unidirectional Arrays

If 2 dipoles or colinear arrays are not exactly 0° or 180° out of phase, the pattern becomes unsymmetrical. For certain phasing combinations and spacings, a very good unidirectional pattern is obtained. The required odd values of phasing can be obtained by cutting a parasitically driven element so as to present just the right amount of reactance. Whether the parasitic element acts as a director or reflector depends upon the spacing, and whether the reactance is inductive or capacitive. A para-

sitic reflector is made just a little longer than an electrical half wavelength, and a director a little shorter than an electrical half wave.

The presence of one or more parasitic elements affects the driven element itself, introducing some reactance, so that slight compensation in the physical length is necessary for resonance. The presence of parasitic elements also reduces the radiation resistance; the more elements, the lower the radiation resistance. Reducing the spacing between the driven dipole and parasitic elements further reduces the radiation resistance. Spacings of 0.1 to 0.125 wavelength are satisfactory for either a director or reflector.

The phasing adjustment (length of parasitic elements) is quite critical with respect to frequency, and can best be accomplished by cut and try, and the help of a field strength meter. This is especially true when more than one parasitic element is utilized. It will be found that the adjustment which gives the best forward gain is not the same as that which gives best front to back discrimination, though they are approximately the same.

If only one parasitic element is used, the nose of the directivity pattern will be quite broad, though the front-to-back radiation ratio can be made quite high. The pattern resembles a valentine heart except that the tip is rounded instead of pointed. If the phasing is adjusted for maximum forward gain, rather than maximum discrimination, a small lobe in the backward direction will appear, and the nose of the main lobe will be slightly sharper.

The foregoing applies to the horizontal directivity when the driven and parasitic dipoles are *vertical*. When the dipoles are oriented *horizontally*, the pattern is somewhat different, the horizontal directivity *depending upon the vertical angle of radiation*. The horizontal directivity is greatest for low vertical angles of radiation when the dipoles are oriented horizontally. For this reason, such an array will

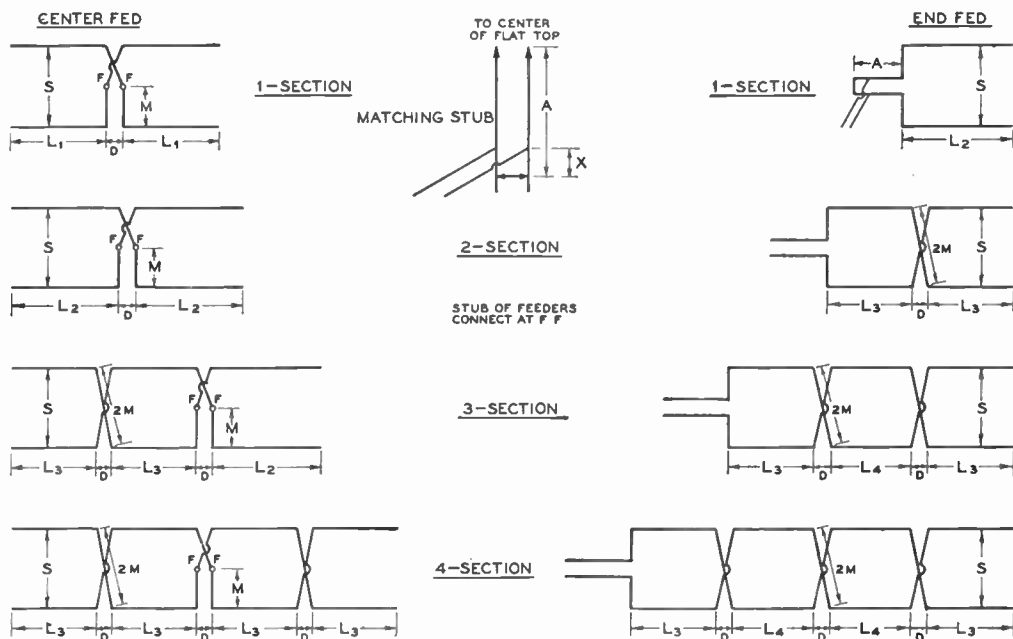

Figure 13
FLAT-TOP BEAM DESIGN DATA.

| FREQUENCY | Spac- ing | S | L ₁ | L ₂ | L ₃ | L ₄ | M | D | A (1/4) approx. | A (1/2) approx. | A (3/4) approx. | X approx. |
|-------------|---------------|--------|----------------|----------------|----------------|----------------|-------|------|--------------------|--------------------|--------------------|--------------|
| 7.0-7.2 Mc. | $\lambda/8$ | 17'4" | 34' | 60' | 52'8" | 44' | 8'10" | 4' | 26' | 60' | 96' | 4' |
| 7.2-7.3 | $\lambda/8$ | 17'0" | 33'6" | 59' | 51'8" | 43'1" | 8'8" | 4' | 26' | 59' | 94' | 4' |
| 14.0-14.4 | $\lambda/8$ | 8'8" | 17' | 30' | 26'4" | 22' | 4'5" | 2' | 13' | 30' | 48' | 2' |
| 14.0-14.4 | .15 λ | 10'5" | 17' | 30' | 25'3" | 20' | 5'4" | 2' | 12' | 29' | 47' | 2' |
| 14.0-14.4 | .20 λ | 13'11" | 17' | 30' | 22'10" | | 7'2" | 2' | 10' | 27' | 45' | 3' |
| 14.0-14.4 | $\lambda/4$ | 17'4" | 17' | 30' | 20'8" | | 8'10" | 2' | 8' | 25' | 43' | 4' |
| 28.0-29.0 | .15 λ | 5'2" | 8'6" | 15' | 12'7" | 10' | 2'8" | 1'6" | 7' | 15' | 24' | 1' |
| 28.0-29.0 | $\lambda/4$ | 8'8" | 8'6" | 15' | 10'4" | | 4'5" | 1'6" | 5' | 13' | 22' | 2' |
| 29.0-30.0 | .15 λ | 5'0" | 8'3" | 14'6" | 12'2" | 9'8" | 2'7" | 1'6" | 7' | 15' | 23' | 1' |
| 29.0-30.0 | $\lambda/4$ | 8'4" | 8'3" | 14'6" | 10'0" | | 4'4" | 1'6" | 5' | 13' | 21' | 2' |

Dimension chart for flat-top beam antennas. The meanings of the symbols are as follows:
 L₁, L₂, L₃ and L₄, the lengths of the sides of the flat-top sections as shown in Figure 13. L₁ is length of the sides of single-section center-fed, L₂ single-section end-fed and 2-section center-fed, L₃ 4-section center-fed and end-sections of 4-section end-fed, and L₄ middle sections of 4-section end-fed.

- S, the spacing between the flat-top wires.
- M, the wire length from the outside to the center of each cross-over.
- D, the spacing lengthwise between sections.
- A (1/4), the approximate length for a quarter-wave stub.
- A (1/2), the approximate length for a half-wave stub.
- A (3/4), the approximate length for a three-quarter wave stub.
- X, the approximate distance above the shorting wire of the stub for the connection of a 600-ohm line. This distance, as given in the table, is approximately correct only for 2-section flat-tops. For single-section types it will be smaller and for 3- and 4-section types it will be larger.

The lengths given for a half-wave stub are applicable only to single-section center-fed flat-tops. To be certain of sufficient stub length, it is advisable to make the stub a foot or so longer than shown in the table, especially with the end-fed types. The lengths, A, are measured from the point where the stub connects to the flat-top.

Both the center and end-fed types may be used horizontally. However, where a vertical antenna is desired, the flat-tops can be turned on end. In this case, the end-fed types may be more convenient, feeding from the lower end.

exhibit greater discrimination on 10 meters than on 40 meters, for instance.

A close-spaced parasitic director or reflector will lower the radiation resistance of the driven element. If two parasitic elements are used, the radiation resistance will be lowered still more. Consequently, the voltage at the ends of the dipoles of such an array is high, and good insulation is essential, not only because of loss, but because the phasing will be affected by wet weather if poor insulators are used at the high voltage points. Self-supporting quarter-wave rods permit construction of 10- and 20-meter arrays of this type, without the need for insulators at high voltage points.

The low radiation resistance makes the problem of current (center) feed quite difficult. Twisted-pair or concentric line cannot be used without incorporating a matching transformer. A linear transformer of tubing (Q section) cannot be practically designed to have a low enough surge impedance to match a 600-ohm line. A *simple* feed method that is satisfactory is a delta-matched or T-matched open-wire line of from 400 to 600 ohms. The feeder should be attached a short distance each side of the center of the driven dipole. The feeders should be slid back and forth equidistant from the center until standing waves on the line are at a minimum.

A horizontal driven dipole and close-spaced director, or director and reflector, are commonly used as a rotatable array on 10 and 20 meters; such an arrangement is discussed at length later in this chapter.

Orientation of Beam Antennas

Directive antennas, especially those sharp enough to give a large effective power gain, should be so oriented that the line or lines of maximum radiation fall in the desired direction or directions.

To do this, the direction of *true north* must be known with reasonable accuracy. This may vary in the United States by as much as 20 degrees from magnetic north as indicated by a compass.

The magnetic declination (variation of magnetic north in degrees east or west of true north) for any locality in the U. S. A. can be obtained by referring to a map compiled by the U. S. Coast and Geodetic Survey, and available from the Superintendent of Documents, Washington, D. C. The number of the map is 3077, and it is sent only on receipt of 20c in coin.

A simpler method of determining declination is to inquire of a city engineer or any surveyor or civil engineer in the locality. Any amateur astronomer can help one to determine the direction of true north.

If a beam antenna is to be aimed at a lo-

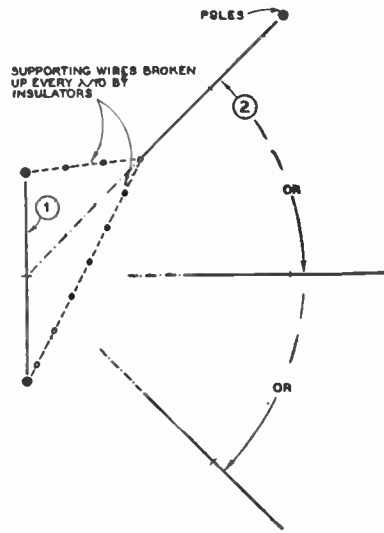

Figure 14.

Illustrating how two dipoles or arrays with horizontal elements can be supported from three poles with a minimum of coupling between the two systems. This is an important consideration if maximum directivity is desired.

cality more than 2000 miles distant, and the array has a sharp pattern, it will be necessary to use *great circle* directions. A simple method is to stretch a thread from the corresponding two points on a large globe (not a cheap one—they often are inaccurate).

Great circle maps also can be used to determine great circle directions, if such a map is available, centered on a point reasonably close to your locality.

Coupling Between Antennas

If two dipoles or bidirectional arrays are used to cover 4 directions, one will excite the other as a result of electrostatic and electromagnetic coupling, *unless* they are well separated, or care is taken in their orientation. This mutual coupling will result in decreased directivity and a slight loss in gain.

To minimize coupling between two horizontally polarized arrays resonant on the same band, they should be oriented so that a line extended through one of them can be made to intersect the center of the other array. This is illustrated in Figure 14. To eliminate the necessity for 4 poles, antenna no. 2 is supported at one end by means of a "V" branching out to both of the other 2 poles. These 2 wires should be broken up thoroughly, with insulators every few feet, as they are right in the field of array or antenna no. 1.

ROTATABLE ARRAYS

The radio amateur confined to an apartment house top or a small city lot is at a marked disadvantage when it comes to erecting antennas that will lay down a strong signal at distant points. Even at 10 and 20 meters it is difficult to string up arrays for various points of the compass, without more ground space than is available to the average city amateur. And if the arrays are not placed just right or separated sufficiently, there will be coupling from one array to another, resulting in poor discrimination and directivity. As a result, the city amateur oftentimes turns to a rotatable affair, one which takes up but little ground space and can be aimed in the desired direction.

Unidirectional Rotary Arrays

An effective unidirectional array which is small enough to be rotated without too much difficulty, consists of a horizontal dipole and close-spaced parasitic reflector and director.

The use of 2 parasitic elements instead of 1 adds little to the mechanical difficulties of rotation, and the gain and discrimination (especially the latter) are considerably improved over that obtained with a single director or a single reflector instead of a combination of both. The 3-element array using a close-spaced director, driven element, and close-spaced reflector will exhibit as much as 30 db front-to-back ratio and 20 db front-to-side ratio for *low angle radiation*. The theoretical gain is approximately 8 db over a dipole in free space. In actual practice, the array will usually show 10 db or more gain over a horizontal dipole placed the same height above ground (at 28 and 14 Mc.).

There is little to be gained by using more than 3 elements (one driven and two parasitic). The gain and discrimination are improved very little, and the radiation resistance becomes somewhat low for good efficiency.

There is little to choose as regards the exact spacing of the parasitic elements. Any spacing from 0.1 to 0.15 wavelength may be used for either the director or reflector. However, changes in the spacing will call for slightly different parasitic element lengths.

While the elements may consist of wire supported on a wood framework, self-supporting elements of tubing are to be preferred. The latter type array is easier to construct, looks better, is no more expensive, and avoids the problem of getting sufficiently good insulation at the ends of the elements. The voltages reach such high values towards the ends of the elements that losses will be excessive, unless the insulation is excellent.

The elements may be fabricated of thin-walled steel conduit, hard drawn thin-walled

copper tubing, or duralumin tubing. Or, if you prefer, you may purchase tapered copper plated steel tubing elements designed especially for the purpose. Kits are available complete with rotating mechanism and direction indicator, for those who desire to purchase the whole "works" ready to put up.

The radiation resistance of a close-spaced 3-element array is quite low—in the vicinity of 10 ohms. Likewise the Q is high, which means that the array is selective as to frequency. This is perhaps the only important disadvantage of the array; it works much better on the exact frequency for which it was cut, the gain and discrimination falling off considerably either side of resonance.

Because of the high Q and close spacing, it is desirable to use tubing of sufficient diameter that it doesn't whip about appreciably in the wind, as any change in spacing will produce considerable detuning effect.

The self-supporting elements are usually supported on husky standoff insulators, mounted on a wooden cross arm of the type illustrated in Figure 15. The voltage at these points is relatively low, but large insulators are used for reasons of mechanical strength. The length of each parasitic element is usually made adjustable by means of at least one sliding telescopic joint on either side of center.

The optimum length for the parasitic elements for a given frequency is quite critical, and difficult to predict for a given installation. It will depend upon the type (diameter) and spacing of the elements, primarily, and is best

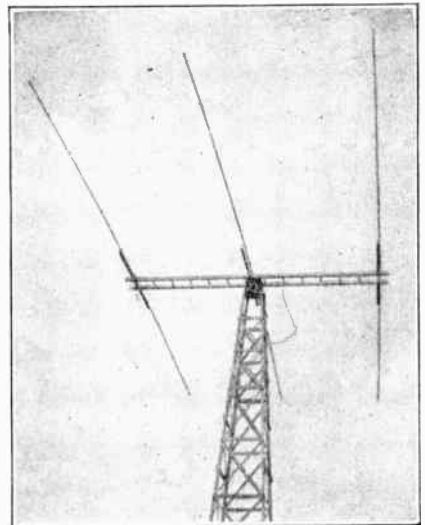

Figure 15.
TYPICAL INSTALLATION OF 3-ELEMENT CLOSE-SPACED ARRAY.

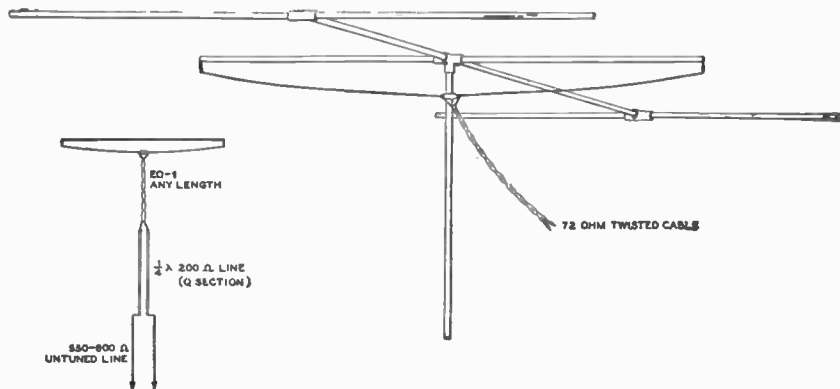

Figure 16.

ALL PIPE VERSION OF 3-ELEMENT CLOSED-SPACED ARRAY.

This type array is widely used on the 28-Mc. amateur band. For long line lengths, an open-wire line is to be preferred in order to minimize losses. The 550-600 ohm line is matched to the 72-ohm cable by means of a quarter-wave "Q" section.

determined by cut and try. For a starter, the reflector may be made exactly $\frac{1}{2}$ wavelength, the driven element 0.96 of a half wavelength, and the director 0.92 of a half wavelength. A half wavelength for a given frequency may be determined by dividing the frequency into 492, the answer being in feet if the frequency is in megacycles.

Set the array temporarily as high above the ground as can be reached conveniently from a ladder or fence. Then, with a local station to give you a check (his receiver must have an "R" meter), adjust the parasitic elements for the best gain. After this point has been found, shorten the director 1 per cent and lengthen the reflector 1 per cent. This improves the discrimination slightly, without reducing the gain appreciably, and makes the array tune more broadly.

Feed Methods The problem of feeding a 3-element unidirectional array is complicated not only by the problem of rotation, but also by the low radiation resistance. Special low-impedance, flexible coaxial cable with built-in quarter-wave matching section for impedance of this order (10-14 ohms) is available for the purpose, and can be used where the line length is not unduly long. Such cable simply is attached to the center of the driven elements, which is split for this type of feed in the same manner as a doublet antenna.

For long line lengths, an open wire line is advisable in the interest of low losses. This type line may be delta matched to the driven element, the same as for a delta matched doublet, except that the points of attachment to the driven element will not be the same as for a

simple dipole. The feeder wires are simply fanned out until standing waves are at a minimum. This type of feed does not permit quite as good discrimination, as there is a slight amount of radiation from the fanned out portion of the line, and the director and reflector have little effect on this radiation.

Flexible coaxial line may be allowed to dangle against the supporting tower or guy wires or almost anything without harm, but an open line must be kept from touching anything or twisting on itself and shorting out. This problem often is solved by the incorporation of slip rings and brushes. Not only does this avoid whipping feeders, but permits continuous rotation. Neither voltage nor current is high for a given power at an impedance of 400 to 600 ohms, and there will be little loss in slip rings working at this impedance, if they are carefully constructed.

For 28 Mc. or 54 Mc. operation, the array may be made entirely of pipe, such as thin-walled electrical conduit. With this type of construction, a method of feed is required which does not necessitate "splitting" the driven element in the center. Such an arrangement is illustrated in Figure 16. If the feed line must be longer than about 2 wavelengths the losses will become appreciable at these frequencies with EO-1 cable, and the arrangement shown in the insert, using a Q section and open wire line, is to be preferred.

The method of feed, shown in the illustration, permits full 360 degree rotation, yet no precautions need be taken with the feed line, as the EO-1 cable can not only touch but even can be wrapped around the supporting pipe without detrimental effects.

U. H. F. Antennas

THE chief difference between the antennas for ultra-high-frequency operation as compared with those for operation in other bands is in their physical size. The fundamental principles are unchanged. For this reason, the reader interested in u.h.f. antennas should first study the discussion of antenna theory in Chapter 20.

Antenna Requirements

Many types of antenna systems can be used for u.h.f. communication. Simple nondirective half-wave vertical antennas are popular for general transmission and reception in all directions. Point-to-point communication is most economically accomplished by means of directional antennas which confine the energy to a narrow beam in the desired direction. If the power is concentrated into a narrow beam, the *apparent* power of the transmitter is increased a great many times.

The useful portion of a signal in the u.h.f. region for short-range communication is that which is radiated in a direction *parallel to the surface of the earth*. A vertical antenna transmits a wave of low angle radiation, and is effective for this reason, not because the radiation is vertically polarized.

Horizontal antennas can be used for receiving, with some reduction in noise. At points close to a transmitter using a vertical antenna, signals will be louder on a vertical receiving antenna. However, at distances far enough from the transmitter that the signal begins to get weak, the transmitted wave has no specific polarization and will appear approximately equal in signal strength on either a vertical or horizontal receiving antenna.

When used for transmitting, horizontal antennas radiate off the ends (in line with the wire) at too high a vertical angle to be effective for quasi-optical u.h.f. work. In fact, even the broadside radiation will be mostly at excessively high angles unless the antenna is far removed from earth (10 or more wavelengths). However, by using several horizontal elements in an array which concentrates the radiation at low angles, results as good or

better than with vertically polarized arrays of the same type will be obtained.

The antenna system, for either transmitting or receiving, should be as high above earth as possible, and clear of nearby objects. Transmission lines, consisting of concentric lines or spaced 2-wire lines, can be used to couple the antenna system to the transmitter or receiver. Nonresonant transmission lines are more efficient at these frequencies than those of the resonant type.

Feed Lines Open lines should preferably be spaced closer than is common for longer wavelengths, as 6 inches is an appreciable fraction of a wavelength at $2\frac{1}{2}$ meters. Radiation from the line will be minimized if $1\frac{1}{2}$ -inch spacing is used, rather than the more common 6-inch spacing.

It is possible to construct quite elaborate u.h.f. directive arrays in a small space; even multi-element beams are compact enough to permit rotation. For this reason, it is more common to employ directional arrays to obtain a strong transmitted signal than to resort to high power. Any of the arrays described in Chapter 21 can be used on 5 meters or $2\frac{1}{2}$ meters, though those with sharp, low angle vertical directivity will give the best results. Of the *simpler* types of arrays, those with their dipole elements vertical give the lower angle of radiation, and are to be preferred. When a multi-element stacked dipole curtain is used, little difference is noticed between vertical and horizontal orientation. The angle of radiation is very low in either case.

Effect of Feed System on Radiation Angle

A vertical radiator for general coverage u.h.f. use should be made either $\frac{1}{4}$ or $\frac{1}{2}$ wave-

length long. Longer antennas do not have their maximum radiation at right angles to the line of the radiator (unless co-phased), and, therefore, are not practicable for use where greatest possible radiation parallel to the earth is desired.

Figure 1.
U.H.F. W8JK ARRAY
ORIENTED FOR VERTI-
CAL POLARIZA-
TION.

For data on this array, refer to preceding chapter. The stub and feed line should be equidistant from the two lower radiating elements.

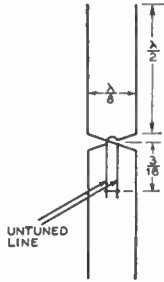

large cross section radiators, the resonant length of the radiator will be somewhat shorter, being only slightly greater than 0.90 of a half wavelength for a dipole when heavy copper pipe is used above 100 Mc.

The matter of using large diameter radiators should not be carried to ridiculous extremes, as detrimental eddy currents will be set up in the conductor. Also, there is little to be gained so far as broadening the resonance characteristic goes after a certain point is reached.

Insulation The matter of insulation is of prime importance at ultra high frequencies. Many insulators that have very low losses as high as 30 Mc. show up rather poorly at frequencies above 100 Mc. Even the low loss ceramics are none too good where the r.f. voltage is high. One of the best and most practical insulators for use at this frequency is polystyrene (Victron, etc.) It has one disadvantage, however, in that it is subject to cold flow.

It is common practice so to design u.h.f. antenna systems that the various radiators are supported only at points of relatively low voltage, the best insulation, obviously, being air. The voltages on properly operated *untuned* feed lines are not high, and the question of insulation is not quite so important, though it still should be of good grade.

Polarization Commercial stations in the U.S.A. favor horizontally polarized antennas for u.h.f. work, both for broadcasting and television. At the present time, however, amateur stations ordinarily use vertically polarized antennas and arrays. As previously mentioned, horizontal polarization results in less noise pickup at the receiver; however, vertical polarization produces greater field strength at relatively short distances and simplifies the problem of getting an omnidirectional antenna for mobile work.

Horizontally Polarized Arrays

With horizontal antennas and arrays, there is little trouble with undesired current being induced in the feed line from the field of the radiator. The currents induced in the feed system from the field of one half the antenna or array are cancelled by the currents induced by the field from the other half. The 3-element close-spaced array, the W8JK flat top beam, the lazy-H, and the X-H array will give excellent results at ultra high frequencies when oriented for horizontally polarized radiation, if a 2-wire balanced feeder is used. Dimensions may be determined from the data given in the previous chapter by dividing the specified di-

Unfortunately, a feed system which is not perfectly balanced and does some radiating, not only robs the antenna itself of that much power, but *distorts the radiation pattern of the antenna*. As a result, the pattern of a vertical radiator may be so altered that the radiation is bent upwards slightly, and the amount of power leaving the antenna *parallel to the earth* is greatly reduced. A vertical half-wave radiator fed at the bottom by a quarter-wave stub is a good example of this; the slight radiation from the matching section decreases the power radiated parallel to the earth by nearly 10 db.

The only cure is a feed system which does not disturb the radiation pattern of the antenna itself. This means that if a 2-wire line is used, the current and voltages *must* be exactly the same (though 180° out of phase) at any point on the feed line. It means that if a concentric feed line is used, there should be no current flowing at all on the outside of the outer conductor.

Means for keeping the feed line out of strong fields where it connects to the radiator are discussed later in the chapter in descriptions of specific antenna systems. The unwanted currents induced in the feed line will be negligible when this precaution is taken.

Radiator Cross Section In the previous chapter, the statement was made that there is no point in using

copper tubing for an antenna (on the medium frequencies). The reason is that considerable tubing would be required, and the cross section still would not be a sufficiently large fraction of a wavelength to improve the antenna characteristics. At ultra high frequencies, however, the radiator length is so short that the expense of large diameter conductor is relatively small, even though copper pipe of 1 inch cross section is used. With such conductors, the antenna will tune much more broadly, and often a broad resonance characteristic is desirable. This is particularly true when an antenna or array is to be used over an entire amateur band.

It should be kept in mind that with such

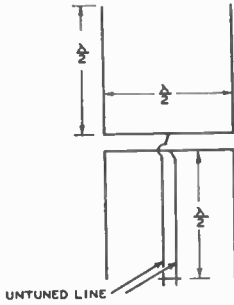

Figure 2.
H TYPE ARRAY ARRANGED FOR VERTICAL POLARIZATION.

The matching stub feeds the center of the phasing section instead of one end as in the case of horizontal orientation. The stub should be equidistant from the two lower radiators.

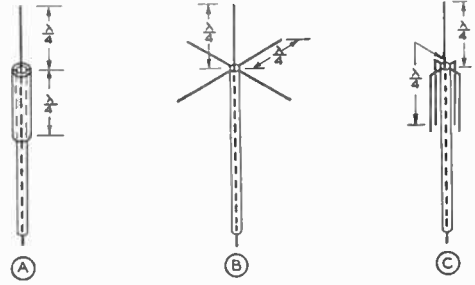

Figure 3.
THREE TYPES OF VERTICAL LOW ANGLE RADIATORS.

At A is shown the "sleeve" type coaxial radiator. The bottom half of the radiator consists of a piece of pipe up through which the coaxial cable runs. At B is illustrated the ground plane vertical, and at C a modification of this antenna.

mensions by the proper factor for a particular u.h.f. band. The feed line should be spaced somewhat closer than is conventional for lower frequencies. One and one-half inch spacing is recommended for 144 Mc., and either 1 1/2 or 2 inch spacing is satisfactory for 50 Mc.

If large diameter conductors are used as the radiating elements, they must be shortened slightly from the calculated radiator lengths, as the figures given assume ordinary wire radiators.

As 220 Mc. and higher frequencies are not ordinarily used except for short distances, vertical polarization is generally to be preferred above 220 Mc.

Vertically Polarized Antennas and Arrays

Vertical arrays such as the W8JK and the lazy-H (when the latter is fed in the center of the phasing section instead of at one end) will not produce undesired currents in the feed line if a 2-wire feed system is used. Typical examples are shown in Figures 1 and 2. The dimensions refer to electrical length. It is important that the stub and feed line be brought straight down for at least 2 wavelengths; if the stub or line is closer to one radiator than the other, undesired currents will be induced in the feed line.

For general coverage with a single antenna, a single vertical radiator is commonly employed. A 2-wire open transmission line is not suitable for use with this type antenna, and low loss concentric feed line is to be recommended. Three practical methods of feeding the radiator with concentric line, with a minimum of current induced in the outside of the

line, are shown in Figure 3. Antenna A is known as the "Sleeve" antenna, the lower half of the radiator being a large piece of pipe up through which the concentric feed line is run. At B is shown the Brown ground plane vertical, and at C a modification of this same array.

The radiation resistance of the ground plane vertical is approximately 21 ohms, which is not a standard impedance for concentric line. To obtain a good match, the first quarter wavelength of feeder may be of approximately 35 ohms surge impedance, and the remainder of the line of approximately 75 ohms impedance. Thus, the first quarter-wave section of line is used as a matching transformer, and a good match is obtained.

In actual practice the antenna would consist of a quarter-wave rod, mounted by means of insulators atop a pole or pipe mast. Elaborate insulation is not required, as the voltage at the lower end of the quarter-wave radiator is very low. Self-supporting quarter-wave rods would be extended out, as in the illustration, and connected together. As the point of connection is effectively at ground potential, no insulation is required; the horizontal rods may be bolted directly to the supporting pole or mast, even if of metal. The concentric line should be of the low loss type especially designed for u.h.f. use. The outside connects to the junction of the radials, and the inside to the bottom end of the vertical radiator.

The modification at C permits matching to a standard 50- or 70-ohm flexible coaxial cable without a linear transformer. If the lower rods hug the line and supporting mast rather closely, the feed-point impedance is about 70 ohms. If they are bent out slightly, as shown by the dotted lines, the impedance is about 50 ohms.

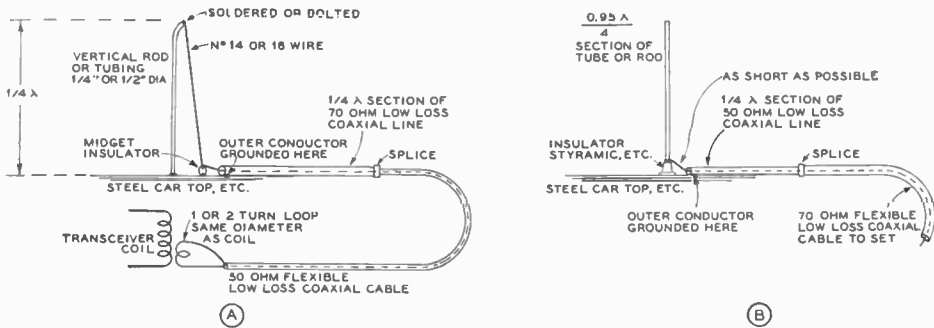

Figure 4.
HIGHLY EFFICIENT MOBILE ANTENNAS.

The coaxial cable should preferably be of the type having low-loss insulation.

Mobile U.H.F. Antennas

For 54- and 144-Mc. mobile work, either a quarter wavelength may be used as a Marconi antenna against the car body, or a half wavelength may be used as a vertical dipole. The latter, while delivering a stronger signal, must be very well insulated at the base.

The Marconi type may be fed either with a single wire feeder tapped 28 per cent up from the base, or by means of coaxial line. Coaxial line constructed of copper tubing, with ceramic or polystyrene centering spacers holding the inner conductor, has the lowest loss. If single-wire feed is used, the Marconi antenna need not be insulated at the base. If coaxial line is used, a base insulator is necessary. However, the voltage at the base of a Marconi is quite low, and the insulation need not be especially good.

The coaxial line is connected across the base insulator; no tuning provision need be provided. The radiator length is adjusted for maximum field strength.

Coaxial line may be coupled to the transmitter or receiver by a 1- or 2-turn link.

The losses in *rubber-insulated* coaxial lines are relatively high at u.h.f.; but because only a short length is ordinarily required in a mobile installation, such a line quite often is used when the feeder must be run conveniently and inconspicuously.

Two antennas highly recommended for 144-Mc. mobile work are illustrated in Figure 4. "A" consists of a piece of tubing or rod, between 1/4 and 1/2 inch diameter, exactly 1/4 wavelength long, mounted vertically just above the center of the windshield atop the car, in about the same position as the auto radio antenna on some of the recent model Ford V-8 cars.

The bottom of the rod or tubing is bolted,

welded or otherwise fastened to the metal portion of the car. The tip of the rod is bent slightly so that when the parallel wire is fastened as shown in the illustration, the wire is held away from the rod sufficiently that it will not whip against the rod as a result of wind or vibration. The wire is anchored by means of a midget insulator, and pulled taut enough that the rod or tubing section bends slightly. Keeping the wire under slight tension will aid in preventing the wire from whipping against the grounded rod or tubing, which would cause the antenna to work erratically.

The outside conductor of the coaxial cable is soldered to the base of the vertical rod, and the inner conductor is soldered to the bottom of the vertical wire where it fastens to the midget insulator. The variation shown at "B" is self-explanatory.

U.H.F. Direction Finders

For locating a u.h.f. transmitter that is radiating either a horizontally or elliptically polarized wave, a simple horizontal dipole can be used as a direction finder. There will be fairly sharp nulls or minima off the ends of the horizontal radiator. When taking bearings, care must be taken to minimize pickup of reflected waves from surrounding buildings, etc.; otherwise an erroneous bearing will result. Best results will be obtained in the clear.

When the polarization of the wave is predominantly or entirely vertical, the antenna illustrated in Figure 5 is recommended. While this array may resemble a loop in mechanical construction, it is a tuned array, and should not be considered as a loop antenna. In effect it is 2 close-spaced dipoles. When the array is turned broadside to the transmitting station, there will be a sharp null. The array is much

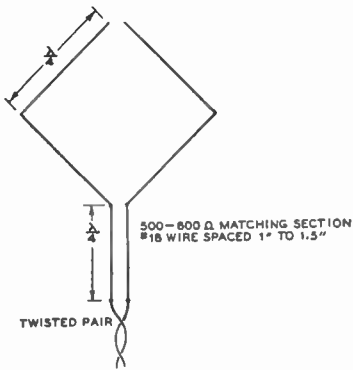

Figure 5.
D.F. ANTENNA SYSTEM FOR U.H.F.
In effect the antenna compares to two vertical close-spaced dipoles 180 degrees out of phase.

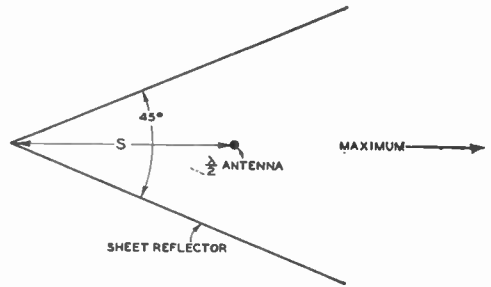

Figure 6.
DIPOLE WITH ANGULAR FLAT SHEET TYPE REFLECTOR.

This array has a very sharp "nose" and may be used for direction finding. It also has considerable gain over a dipole. For dimensions of reflector, refer to text.

more sensitive than a conventional loop antenna at u.h.f., and is, therefore, to be preferred. The whole array can be supported from a pole having a single cross arm, which can be made removable to make the array collapsible.

Microwave D.F. Antennas Microwave antennas are so small physically that a highly directive array can be contained in a small space. Any highly directive array can be used for direction finding. The arrangement of Figure 5 will be satisfactory up to about 250 Mc. Above this frequency, a dipole equipped with a metal parabolic or angular flat sheet reflector is to be preferred. Such an array is rotated for maximum rather than minimum signal, and has the advantage of providing "sense" even though

the accuracy may not be quite as high as that of the various types working on nulls. The angular flat sheet type reflector (also called "square corner" reflector) is easier to construct, and provides better directivity than a parabolic reflector. One suitable for d.f. work is illustrated in Figure 6. The sheets are the same height as that of the dipole, and about 2 wavelengths on a side. The angle and side length are not critical, but the dipole should bisect the angle accurately. The distance S is approximately 1 wavelength. This array, in addition to being highly directional, provides considerable gain. The dipole may be fed either with a delta matched open line (with very close spacing), or coaxial cable. The radiation resistance of the dipole will be about 10 ohms.

Transmitter Adjustment

WHILE there are as many different tuning procedures as there are different types of transmitters, there are certain general rules which should be followed regardless of type. Also, there are certain initial checks that should be made on the transmitter when it is "fired up" for the first time, regardless of type.

Except for very small tubes of the "receiving" classification, it is advisable to permit the filaments to reach operating temperature before applying plate voltage. This takes but a second or two for filament type tubes in the high vacuum class, but about 20 or 30 seconds for heater type tubes and for mercury vapor type rectifiers. It is common practice to allow all filaments to run continuously between consecutive transmissions. Tubes of any type should be allowed to run for at least 15 minutes before applying plate voltage if the tube has not been in service for some time.

In making initial adjustments, it is customary to apply plate voltage to one stage at a time, starting with the oscillator, until the correct tuning adjustments for the whole transmitter have been determined for that frequency or band.

The operation of a crystal oscillator depends to a great extent upon the activity of the crystal, and the activity varies widely with different crystals. The oscillator should be tuned for the greatest output or lowest plate current which will provide strong, stable oscillations. An attempt to adjust the oscillator for every last milliwatt of output will result in the crystal's not starting "cleanly" each time the plate voltage is applied or the key is pressed. A receiver or monitor will be required for this check, during which a check also should be made on the frequency.

The first time the crystal oscillator is operated a check also should be made upon the r.f. crystal current (unless the oscillator is run at very low screen and plate voltages) to make sure that it is not excessive at any setting of the plate tuning condenser.

Tuning of each following stage will depend upon the type of amplifier. However, unless

the tube is of the screened grid type or is used only as a doubler, the first thing that should be done is to neutralize the stage correctly. The correct manner in which to neutralize any type of r.f. amplifier is covered thoroughly in Chapter 7, and the reader is referred to that chapter for procedure.

Amplifier stages always should be tuned for maximum output. This does not mean that the coupling must be adjusted until the stage will deliver the maximum power of which it is capable, but that the tank tuning condenser always should be adjusted to the setting which permits maximum output. If the stage is not heavily loaded, this will correspond closely to minimum plate current. However, if the two do not correspond exactly, the stage should be tuned for maximum output rather than minimum plate current. If the difference is appreciable, especially in that amplifier which feeds the antenna, the amplifier should be redesigned to utilize a higher value of tank capacity.

It is natural that the grid current to an amplifier stage should fall off considerably with application of plate voltage, the drop in grid current becoming greater as the loading and plate current on the stage are increased. If the excitation is adjusted for maximum permissible grid current with the tubes loaded, this value will be exceeded when the plate voltage or load is removed, particularly when no grid leak bias is employed. However, under these conditions, the grid impedance drops to such a low value that the high value of grid current represents but little increase in power, and there is little likelihood that the tube will be damaged unless the grid current increases to more than twice its rated maximum.

Screen grid tubes never should be operated with full screen voltage when the plate voltage is removed, as the screen dissipation will become excessive and the tube may be permanently damaged.

When all stages are operating properly, the filament voltage on all tubes should be checked to make sure that it is neither excessive nor deficient, one being about as bad as the other.

Unless the line voltage varies at least several volts throughout the day, filament meters are not required on all stages of a multi-stage transmitter. An initial check when the transmitter is put into operation for the first time is sufficient; after that a single filament meter permanently wired across the filament or filaments of the final amplifier stage will be sufficient. If the filament voltage reads high on that stage, it can be assumed to be high on all stages if the filament voltages were adjusted correctly in the first place. Filament voltage always should be measured *right at the tube socket*.

Parasitic oscillations are capable of causing bad interference to other stations, and a check for them should be made when initial adjustments have been completed. A check for parasitics in a 'phone transmitter should be made with the transmitter being modulated at the full modulation capability of the transmitter, as oftentimes the parasitic will occur only on peaks of the audio cycle. Parasitic oscillations are covered in Chapter 7, and the reader is referred to that chapter. In fact, the whole of Chapters 7 and 11 should be read thoroughly before attempting to tune up any transmitter, as an understanding of the considerations involved will make the tuning a relatively simple matter. In the case of a 'phone transmitter, the reader is referred also to Chapter 8 for amplitude modulation and 9 for frequency modulation adjustments.

Antenna Coupling

When coupling either an antenna or antenna feed system to a transmitter, the important considerations are as follows: (1) means should be provided for varying the load on the amplifier, (2) the two tubes in a push-pull amplifier should be equally loaded, (3) the load presented to the final amplifier should be nonreactive; in other words, it should be a purely resistive load.

The first item is often referred to as "matching the feeder impedance to the transmitter" or "matching the impedance." It is really a matter of *loading*. The coupling is increased until the final amplifier draws the correct plate current. Actually, all the matching and mismatching we worry about pertains to the junction of the feeders and *antenna*.

The matter of equal load on push-pull tubes can be taken care of by simply making sure that the coupling system is symmetrical, both physically and electrically. For instance, it is not the best practice to connect a single-wire feeder directly to the tank coil of a push-pull amplifier.

The third consideration, that of obtaining a nonreactive load, is important from the standpoint of efficiency, radiated harmonics, and

voice quality in the case of a 'phone transmitter. If the feeders are clipped directly on the amplifier plate tank coil, either the surge impedance of the feeders must match the antenna impedance perfectly (thus avoiding standing waves) or else the feeders must be cut to exact resonance.

If an inductively-coupled auxiliary tank is used as an antenna tuner for the purpose of adjusting load and tuning out any reactance, one need not worry about feeder length or complete absence of standing waves. For this reason, it is always the safest procedure to use such an antenna coupler rather than connect directly to the plate tank coil.

Function of an Antenna Coupler The function of an output coupler is to transform the impedance of the feed line, or the antenna, into that value of plate load impedance which will allow the final amplifier to operate most effectively. The antenna coupler is, therefore, primarily an impedance transformer. It may serve a secondary purpose in filtering out harmonics of the carrier frequency. It may also tune the antenna system.

Practically every known antenna coupler can be made to give good results when properly adjusted. Certain types are more convenient to use than others, and the only general rule to follow in the choice of an antenna coupler is to use the simplest one that will serve your particular problem.

There is practically nothing that an operator can do at the station end of a transmission line that will either increase or decrease the standing waves on the line, as that is entirely a matter of the coupling between the line and the antenna itself. However, the coupling at the station end of the transmission line has a very marked effect on the efficiency and the power output of the final amplifier in the transmitter. Whenever we adjust antenna coupling and thus vary the d.c. plate current on the final amplifier, all we do is vary the ratio of impedance transformation between the feed line and the tube plate (or plates).

Coupling Methods Figure 1 shows several of the most common methods of coupling between final amplifier and feed line.

The fixed condenser C_B is a large capacity mica condenser in every case. It has no effect upon tuning or operation; it is merely a blocking condenser keeping high voltage d.c. off the transmission line.

Copocitive Coupling Figure 1A shows a simple method of coupling a single-wire non-resonant feeder to an unsplit plate tank. The coupling is increased by moving the tap away from the voltage node and

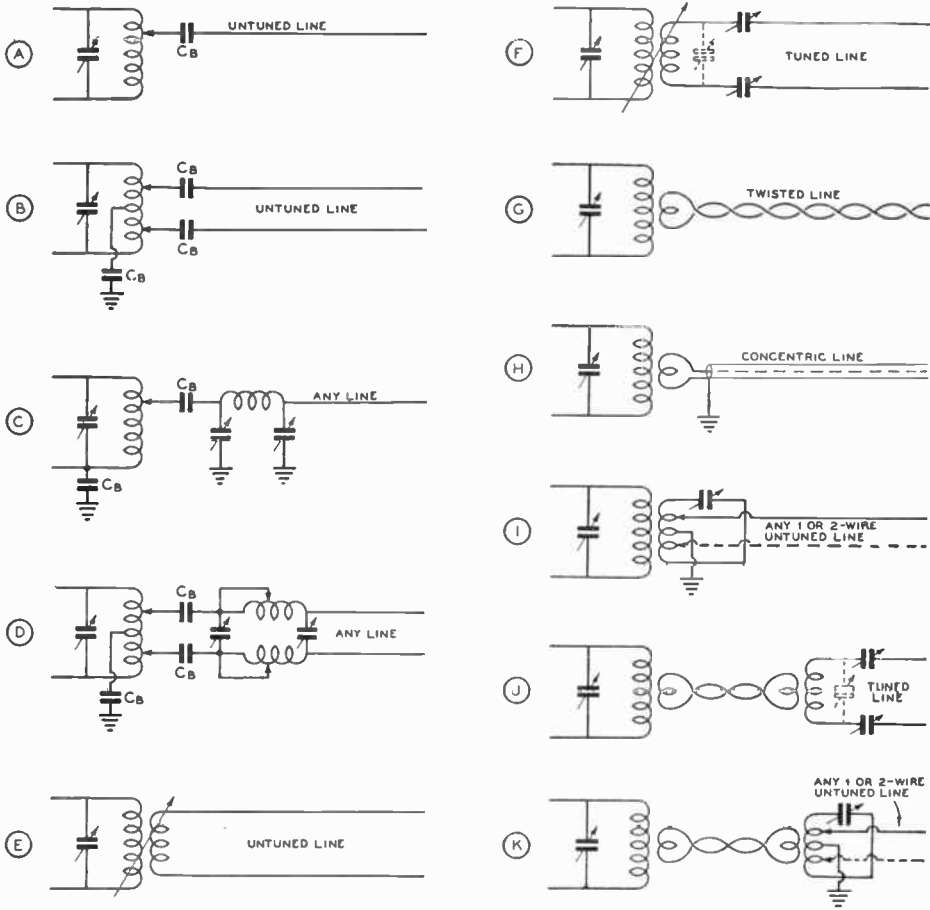

Figure 1.
COMMON METHODS OF COUPLING TRANSMISSION LINES TO THE OUTPUT TANK OF THE TRANSMITTER.

Balanced 2-wire lines are assumed, whether of the resonant or "flat" (untuned) type. Coupling turns should always be placed around the "cold" portion of the coil; whether this is the center or end will be determined by whether the coil has one end grounded or is balanced to ground (center at ground r.f. potential). Tank tuning condensers can be split stator where balanced tanks are shown (center at low r.f. potential) without affecting operation of coupling circuit. C_B indicates mica blocking condenser to keep d.c. plate voltage off the feeder; these condensers should have a working voltage in excess of peak plate voltage and be at least .001 μ fd.

toward the plate end of the plate tank coil. Either the center or the bottom end of the coil may be by-passed to ground.

The system shown in Figure 1B shows a means of coupling an untuned 2-wire line to a split plate tank. If it is desired to couple a 2-wire untuned line to an unsplit plate tank, it will be necessary to use some form of inductive coupling. See Figure 1E.

The circuit of Figure 1C shows a π -section filter coupling an unsplit tank to any end-fed antenna or single-wire line. Figure 1D shows

the 2-wire version of the π -section coupler, sometimes called the *Collins* coupler.

Inductive Coupling Inductive coupling methods may be classified in two types: direct inductive coupling and link coupling. Direct inductive coupling has been very popular for years, but link coupling between the plate tank and the antenna coupler proper is usually more desirable. Figure 1E shows inductive coupling to an untuned 2-wire line. This same arrangement can be used to couple

from a split plate tank to a single-wire untuned feeder by grounding one side of the antenna coil.

The circuit shown in Figure 1F is the conventional method of coupling a zepp or tuned feed line to a plate tank circuit, but the arrangement shown in Figure 1J is easier to adjust. Circuit shown in Figure 1I is for coupling either a single or 2-wire untuned feeder to either a split or unsplit plate tank circuit. The arrangement shown in Figure 1K is easier to adjust. All coupling links anywhere in a transmitter should be coupled at a point of low r.f. potential to avoid undesired capacitive coupling.

Untuned low impedance lines of the twisted pair and coaxial types can best be coupled inductively by means of a 1- or 2-turn coupling link around the plate tank coil at the voltage node.

Tuning Pi-Section Coupler To get good results from the π -section antenna coupler, certain precautions must be followed. The ratio of impedance transformation in π networks depends on the ratio in capacity of the two condensers C_1 (left) and C_2 (right) in Figure 1C or 1D.

The first step in tuning is to disconnect the π -section coupler from the plate tank entirely. Then apply low plate voltage and tune the plate tank condenser to resonance. Remove the plate voltage and tap the π -section connection or connections approximately half-way between the cold point on the coil and the plate or plates. Adjust C_2 to approximately half maximum capacity and apply plate voltage. Quickly adjust C_1 to the point where the d.c. plate current dips, indicating resonance.

At the minimum point in this plate current dip, the plate current will either be higher or lower than normal for the final amplifier. If it is lower, it indicates that the coupling is too loose; in other words, there is too high a ratio of impedance transformation. The plate current can be increased by *reducing* the capacity of C_2 and then restoring resonance with condenser C_1 . At no time after the π -section coupler is attached to the plate tank should the plate tuning condenser be touched. If the d.c. plate current with C_1 tuned to resonance is too high, it may be reduced by *increasing* the capacity of C_2 in small steps, each time restoring resonance with condenser C_1 .

Should the plate current persist in being too high even with C_2 at maximum capacity, it indicates either that C_2 has too low maximum capacity, or that the π -section filter input is tapped too close to the plate of the final amplifier. If the plate current *cannot* be made to go high enough even with condenser C_2 at minimum capacity, it indicates that the input of

the π -section is not tapped close enough to the plate end of the plate tank coil.

Mechanical Considerations If inductive coupling to the final amplifier is contemplated, attention must be given to the mechanical or physical considerations. Variable coupling is a desirable feature which facilitates correct loading of the amplifier. It is more easily incorporated if but a few turns are involved. This explains the popularity of link coupling methods (such as Figure 1K) over directly coupled systems of the type illustrated in Figure 1I. Untuned lines of 600 ohms or less, when operating correctly, seldom require more than a half dozen turns in the coupling link to provide sufficient coupling, especially on the higher frequency bands. Twisted-pair lines or coaxial cable may require only 1 or 2 turns. Marconi antennas (no feed line) may require anywhere from 1 to 10 turns, depending upon the frequency and radiation resistance.

Because sometimes the next integral turn provides too much coupling while without it there is insufficient coupling, it is necessary to provide means for obtaining coupling intermediate between that provided by integral turns. This can be done by adding the next integral turn and then either pulling the coupling coil away from the tank coil a little, or enlarging the turns so that the coupling coil does not fit snugly over the tank coil.

One very satisfactory method of providing continuously variable coupling calls for a set of split tank coils, with 1- or 1½-inch spacing between the two halves of the coils (depending upon diameter of the coils). A swinging coupling link, with sufficient tension or friction on the hinge to maintain the link in position after it has been adjusted, can be inserted between the two halves of the tank coil to give any degree of coupling desired. Manufactured coils can be obtained with this system of adjustable coupling. Another type manufactured coil is wound on a ceramic coil form with an individual link turning inside the form on a shaft supported on bearings inserted in the form. The latter type requires two extra contacts on the coil jack bar.

If one uses the simpler method of pushing coupling turns down between the turns of the tank coil until sufficient coupling is obtained, high tension ignition cable is recommended if the plate voltage of more than 500 volts appears on the plate tank coil. Hookup wire or house wire is satisfactory for lower voltages.

The coupling link should never be placed at a point of high voltage on the tank coil. This means that the coupling link should be placed around the *center* of a *split* plate tank or near the "cold" *end* of an *unsplit* tank coil.

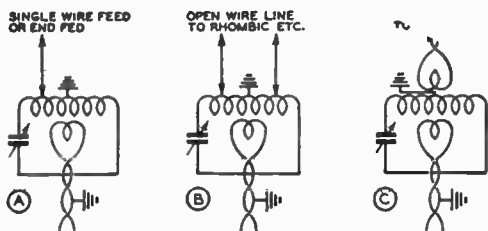

LINK COUPLING FROM SINGLE-ENDED OR P.P. RF. AMPLIFIER

Figure 2.
SIMPLE METHODS OF HARMONIC SUPPRESSION WITH AN AUXILIARY TANK CIRCUIT.

For a given number of turns in the coupling link, greatest coupling will occur when the link is placed around the center of the coil, regardless of the location of the node on the coil. For this reason, it is sometimes difficult to get sufficient coupling with an unsplit tank, as the link must be placed at the cold end of the coil in such a system to prevent detuning of the tank circuit, possible arcing between tank coil and link, and capacity coupling of harmonics.

On the higher frequencies, it is important that superfluous reactance is not coupled into the line by a pick-up link having an excessive number of turns. This means that instead of using a 10 turn link on 28 Mc. to couple to a 72-ohm line and backing off on the coupling coil until the desired coupling is obtained, the number of turns should be reduced and the pick-up coil coupled tighter to the tank coil. For this reason, it is difficult to construct a swinging-link assembly having a single multi-turn coupling coil for coupling on all bands. With this type coupling, it usually will be found that if the pick-up coil has sufficient turns to permit optimum coupling on 160 meters, the coil will be so large that it will couple in an objectionable amount of reactance at 28 Mc. This assumes that the transmitter works into a line of the same surge impedance on all bands.

Suppressing Harmonic Radiation

Harmonics are present in the output of nearly all transmitters, though some transmitters are worse offenders in this respect than others. Those that are strong enough to be bothersome are usually the second and third harmonics.

Current-fed antennas, such as the twisted-pair-fed doublet and the Johnson Q-fed doublet, discriminate against radiation of the even harmonics. This is what keeps these antennas from being used effectively as all-band antennas. However, they are responsive to the odd harmonics, working about as well on the third

take

Most are responsive to both odd and even harmonics, and therefore are still worse than the possibility of harmonic radiation.

The delta-matched antenna, and radiators fed by means of a shorted stub and untuned line, provide about the best discrimination against harmonics, but even these will radiate some third and other odd harmonic energy.

Best practice indicates the reduction of the amount of harmonic component in the transmitter output to as low a value as possible, then further attenuation between the transmitter and antenna regardless of what antenna and feed system is used.

Three definite conditions must exist in the transmitter before harmonic radiation can take place. First, the final amplifier must either be generating or amplifying the undesired harmonics; second, the coupling system between the amplifier and the feeders or antenna system must be capable of either radiating them or transmitting them to the antenna, and third, the antenna system (or its feeders) must be capable of radiating this harmonic energy.

One effective method of reducing capacity coupling is through the use of a Faraday shield. The Faraday shield, however, offers no attenuation to anything but capacity coupling of the undesired energy. Since a great deal of the harmonic energy (the third and other odd harmonics) is inductively coupled to the antenna system, an arrangement which will attenuate both capacitively and inductively coupled harmonics (both odd and even) would be desirable. A Faraday shield is not a cure-all. However, its performance is effective enough to warrant inclusion as standard equipment.

A simple and very effective method of harmonic suppression is shown in Figure 2. The link from the final tank to the antenna tank should consist of either a length of low impedance spaced cable (EO1 or similar) or a closely spaced (1/2 inch) line of no. 12 or larger wire. This link should be loosely coupled by means of a single turn on 10, 20, and 40 meters (2 turns on 80 and 160 meters) at either end to both tank circuits. One side of the link should be effectively grounded near the final tank.

The antenna tank itself should be of medium C (a Q of about 10 or 12) at the operating frequency. At Figure 2C the two links, the one to the final and the one to the antenna, should be spaced about 2 inches or so apart and at equal distances from the grounded center of the antenna coil. The balance of the diagram should be self-explanatory.

For this reason present in the radiated un- other means

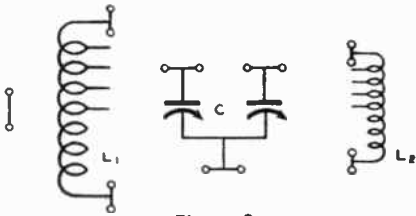

Figure 3.
CIRCUIT DIAGRAM OF THE
UNIVERSAL COUPLER.

The dots indicate heavy Fahnestock clips. For coil and condenser constants, see text.

This coupling system operates by virtue of the fact that capacity coupling between the final tank and the antenna is eliminated by the grounded link and the grounded center tap of the antenna tank; also, due to the selectivity of the antenna tank against the harmonic frequencies, inductive coupling of them into the antenna system will also be attenuated.

In closing, a few general "don'ts" might be in order:

Don't use two tubes in parallel. Put them in push-pull if possible.

Don't use a doubler to feed an antenna unless it is of the push-push type. In a single-ended doubler, there is a high percentage of 1/2 and 2X output frequency present in the output tank.

Don't use more bias and excitation than necessary for reasonable efficiency or (in a 'phone transmitter) good linearity.

Don't use a 75-meter zepp on 160 meters, a 40-meter zepp on 80 meters, etc. Although it is usually the odd harmonics that are inductively coupled, in this case the second harmonic will be inductively coupled and elimination of capacity coupling will not remove the second harmonic.

Don't use an all-band antenna unless you

do not have room for separate antennas. If you must use such an antenna, use a harmonic-attenuating tank as shown in the accompanying diagrams.

Run a test with some local station close enough to give you an accurate check, and see if your harmonics are objectionable.

A Simple Universal Coupler

A split-stator condenser of 200 μ fd. or more per section can be

mounted on a small board along with a large and a small multitapped coil to make a very useful and versatile antenna coupler and harmonic suppressor. With this unit it is possible to resonate and load almost any conceivable form of radiator and tuned feed system, and to adjust the loading and provide harmonic suppression with almost any untuned transmission line. The circuit is shown in Figure 3.

To facilitate connecting the coil and condenser combination in the many different ways possible, 12 large-size dual Fahnestock connectors are mounted on the coils and condenser terminals and generously scattered around. Two are mounted on standoff insulators to act as terminals for ground, antenna, or other wires. A dozen lengths of heavy flexible wire of random lengths between 6 and 18 inches enable one to connect up the components in an almost infinite variety of combinations. Low-voltage auto ignition cable or heavy flexible hookup wire will do nicely.

Because under certain conditions and in certain uses both rotor and stator will be hot with r.f. voltage, an insulated extension is provided for the condenser shaft in order to remove the dial from the condenser by a few inches. This effectively reduces body capacity. It also precludes the possibility of being burned by the dial set-screw.

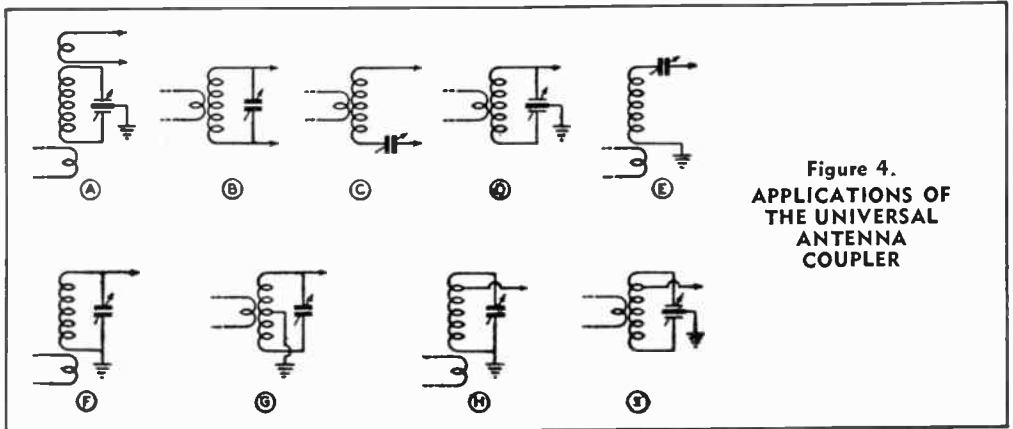

Figure 4.
APPLICATIONS OF
THE UNIVERSAL
ANTENNA
COUPLER

The large coil consists of 30 turns of no. 12 wire, 4 inches in diameter and spaced to occupy $5\frac{3}{4}$ inches of winding space. The small coil consists of 14 turns, 2 inches in diameter, spaced to occupy $3\frac{1}{4}$ inches of winding space. Heavy duty 80- and 20-meter coils of commercial manufacture will serve nicely.

Both coils have taps brought out every other turn from one end to the center to facilitate clipping to the coils. A copper or brass clip is preferable to a steel clip for shorting out turns as the circulating current may be quite high.

Now to cover some of the things one can do with this simple contraption:

At A in Figure 4 the unit is used as a harmonic suppression tank as advocated earlier in this chapter.

Combination B may be used for either an end-fed or center-fed zepp that requires parallel tuning. It may also be used to feed an untuned open line, providing harmonic suppression. It may be used to tune an antenna counterpoise system that has a higher natural frequency than that upon which it is desired to operate. It may be used with any system utilizing tuned feeders where the system cannot be resonated with series tuning (see C).

Combination C may be used for either an end-fed or center-fed zepp that requires series tuning. It may be used to feed an antenna counterpoise system that is too long electrically to resonate at the operating frequency at its natural period. It may be used with a multi-band antenna where the feeders are too long. It may be used for almost any system utilizing tuned feeders where the system cannot be resonated using B.

Arrangement D may be used for feeding an end-fed antenna (even number of quarter waves long). It is usually preferable to F which is sometimes used for the same purpose.

System E is the common method for tuning a Marconi where the antenna is slightly longer than an odd number of quarter waves.

System F also is used to tune a Marconi

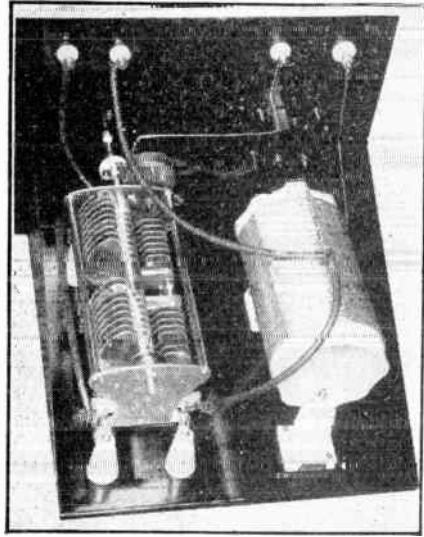

Figure 5.

UNIVERSAL ANTENNA COUPLER.

The unit shown above was designed for use only on the two lower frequency bands, hence the smaller coil (L_2 of Figure 3) was omitted. An r.f. ammeter has been added for convenience in tuning.

that is slightly shorter than an odd number of quarter waves long.

G is commonly used to end-feed an antenna an even number of quarter waves long. It is a variation of D.

H and I are used for feeding either a single-wire-fed antenna or for end-feeding a very long-wire antenna (6 or more wavelengths long). For the latter purpose these are preferable to D, F, and G.

In each case the link is coupled around the coil being used, and one side of the twisted pair feeding the link is grounded. Coaxial cable may be substituted for the twisted pair if the builder so desires.

Test and Measurement Equipment

EVERY radio station must possess certain essential pieces of test equipment in order to insure proper operation of radio receivers, transmitters, amplifiers and antenna systems, and to diagnose trouble when it occurs. How much additional test equipment is required over the minimum will depend upon the amount of money invested in the station, and upon the amount of work other than maintenance that is undertaken by the staff. However, the maintenance test equipment of a station may often be very specialized in its capabilities; it may consist of a frequency monitor capable only of indicating deviations from the assigned carrier frequency of the transmitter, a modulation monitor capable of indicating only the keying characteristic or modulation percentage of the particular transmitter, and certain simple d.c. and audio equipment for the maintenance of the speech or keying system of the transmitter.

On the other hand the measurement equipment used by a testing or research laboratory must be much more versatile in its capabilities. Any sort of problem may be encountered in the testing or alignment of a transmitter, receiver, amplifier, or antenna system. So the equipment must be capable and accurate enough to make the desired tests within the specified limits of accuracy.

The test and measurement equipment to be described in this chapter may be divided into five general classifications: Voltage, Current, and Power Measurement; Measurement of Circuit Constants; Frequency Measurements; Monitoring Equipment and Signal Generators. There is one additional type of measurement equipment which is even more important than any of the above five, primarily because of its versatility; this is the cathode-ray oscilloscope, described in detail in Chapter Twenty-Five.

VOLTAGE, CURRENT AND POWER

The measurement of voltage and current in radio circuits is very important in proper maintenance of equipment. Vacuum tubes of the types used in communications work must be operated within rather narrow limits in regard

to filament or heater voltage, and they must be operated below certain maximum limits in regard to the voltage and current on other electrodes.

Both direct current and voltage are most commonly measured with the aid of an instrument consisting of a coil that is free to rotate in a constant magnetic field (d'Arsonval type

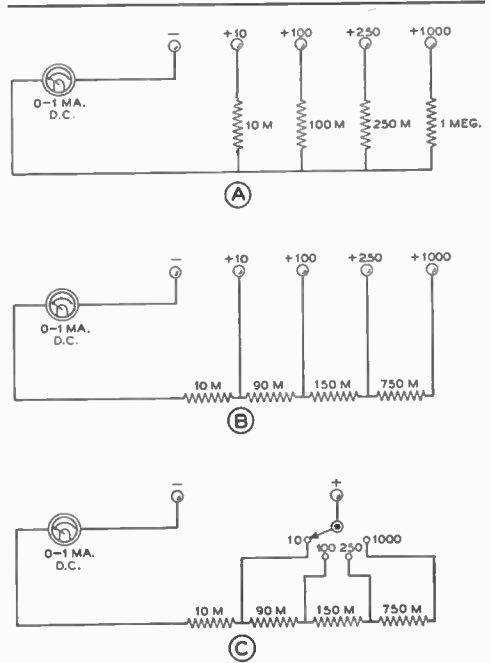

Figure 1.

THE THREE COMMON METHODS FOR WIRING A MULTI-VOLTMETER.

(A) shows the method whereby individual multipliers are used for each range. (B) is the more economical "series multiplier" method. The same number of resistors is required but those for the higher range are of lower resistance (and hence less expensive when precision wirewound resistors are used) than at (A). (C) is essentially the same arrangement as at (B) but a range switch is used to select the different voltage ranges.

meter). If the instrument is to be used for the measurement of current it is called an ammeter or milliammeter. The current flowing through the circuit is caused to flow through the moving coil of this type of instrument. If the current to be measured is greater than 10 milliamperes or so it is the usual practice to cause the majority of the current to flow through a by-pass resistor called a shunt, only a specified portion of the current flowing through the moving coil of the instrument. The calculation of shunts for extending the range of d.c. milliammeters and ammeters is discussed in Chapter Two.

A direct current voltmeter is merely a d.c. milliammeter with a multiplier resistor in series with it. If it is desired to use a low-range milliammeter as a voltmeter the value of the multiplier resistor for any voltage range may be determined from the following formula:

$$R = \frac{1000 E}{I}$$

where: R = multiplier resistor in ohms
E = desired full scale voltage
I = full scale current of meter in ma.

The sensitivity of a voltmeter is commonly expressed in *ohms per volt*. The higher the ohms per volt of a voltmeter the greater its sensitivity. When the full-scale current drain of a voltmeter is known, its sensitivity rating in ohms per volt may be determined by:

$$\text{Ohms per volt} = \frac{1000}{I}$$

where I is the full-scale current drain of the indicating instrument.

Multi-Range Meters It is common practice to connect a group of multiplier resistors in the circuit with a single indicating instrument to obtain a so-called multi-range voltmeter. There are several ways of wiring such a meter, the most common ones of which are indicated in Figure 1. With all these methods of connection, the sensitivity of the meter in ohms per volt is the same on all scales. With a 0-1 milliammeter as shown the sensitivity is 1000 ohms per volt.

Volt-Ohmmeters An extremely useful piece of test equipment which should be found in every laboratory or radio station is the so-called volt-ohmmeter. It consists of a multi-range voltmeter with an additional fixed resistor, a variable resistor, and a battery. A typical example of such an instrument is diagrammed in Figure 2. Tap 1 is used to permit use of the instrument as an 0-1 d.c. milliammeter. Tap 2 permits accurate reading of resistors up to 100,000 ohms; taps 3, 4, 5, and 6 are for making voltage measurements,

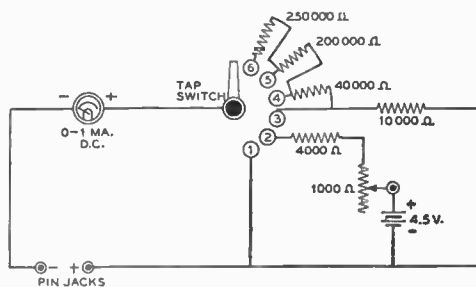

Figure 2. VOLT-OHMMETER CIRCUIT.

| | |
|---------------------------|----------------|
| Position 1 of Switch..... | 0-1 d.c. ma. |
| Position 2 of Switch..... | 0-100,000 ohms |
| Position 3 of Switch..... | 0-10 volts |
| Position 4 of Switch..... | 0-50 volts |
| Position 5 of Switch..... | 0-250 volts |
| Position 6 of Switch..... | 0-500 volts |

the full scale voltages being 10, 50, 250, and 500 volts respectively.

The 1000-ohm potentiometer is used to bring the needle to zero ohms when the terminals are shorted; this adjustment should always be made before a resistance measurement is taken.

Higher voltages than 500 can be read if a higher value of multiplier resistor is added to an additional tap on the switch. The proper value for a given full scale reading can be determined from Ohm's law.

Resistances higher than 100,000 ohms cannot be measured accurately with the circuit constants shown; however, by increasing the ohmmeter battery to 45 volts and multiplying the 4000-ohm resistor and 1000-ohm potentiometer by 10, the ohms scale also will be multiplied by 10. This would permit accurate measurements up to 1 megohm.

0-1 d.c. milliammeters are available with special volt-ohmmeter scales which make individual calibration unnecessary. Or, special scales can be purchased separately and substituted for the original scale on the milliammeter.

Obviously, the accuracy of the instrument either as a voltmeter or as an ammeter can be no better than the accuracy of the milliammeter and the resistors.

Because volt-ohmmeters are so widely used and because the circuit is standardized to a considerable extent, it is possible to purchase a factory-built volt-ohmmeter for no more than the component parts would cost if purchased individually. For this reason no construction details are given. However, anyone already possessing a suitable milliammeter and desirous of incorporating it in a simple volt-ohmmeter should be able to build one from the schematic diagram and design data given here. Special, precision (accurately calibrated) multiplier re-

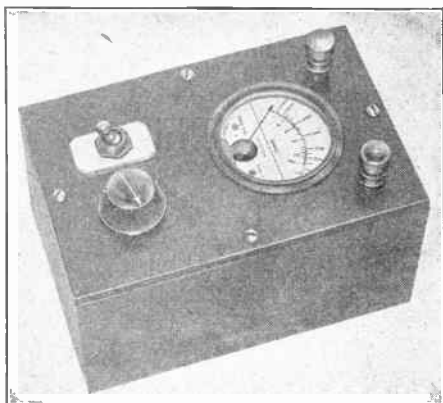

Figure 3.
LOW RANGE OHMMETER.

This ohmmeter is particularly useful for measuring resistances too low to be read accurately on an instrument of the type diagrammed in Figure 2.

sistors are available if a high degree of accuracy is desired.

Medium- and Low-Range Ohmmeter

Most ohmmeters, including the one just described, are not adapted for accurate measurement of low resistances—in the neighborhood of 100 ohms, for instance.

The ohmmeter illustrated in Figure 3 was especially designed for the reasonably accurate reading of resistances all the way down to 1 ohm. Two scales are provided, one going in one direction and the other scale going in the other direction because of the different manner in which the milliammeter is used in each case. The low scale covers from 1 to 100 ohms and the high scale from 100 ohms to 10,000 ohms. The high scale is in reality a medium-range scale. For accurate reading of resistances over 10,000 ohms, an ohmmeter of the type previously described should be used.

The 1-100 ohm scale is useful for checking transformers, chokes, r.f. coils, etc., which often have a resistance of only a few ohms.

The calibration scale will depend upon the internal resistance of the particular make of 1.5-ma. meter used. The instrument can be calibrated by means of a Wheatstone bridge or a few resistors of known accuracy. The latter can be series-connected and parallel-connected to give sufficient calibration points. A hand-drawn scale can be pasted over the regular meter scale to give a direct reading in ohms.

Before calibrating the instrument or using it, the test prods should always be touched together and the zero adjuster set accurately.

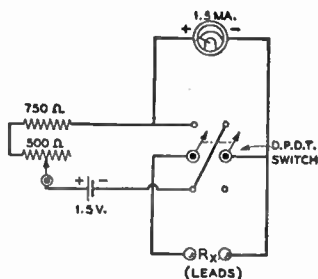

Figure 4.
Diagram of the low-range ohmmeter illustrated in Figure 3.

Measurement of Alternating Current and Voltage

The measurement of alternating current and voltage is complicated by two factors: first, the frequency range covered in ordinary communication channels is so great that calibration of an instrument becomes extremely difficult; second, there is no single type of instrument which is suitable for all a.c. measurements—as the d'Arsonval type of movement is suitable for d.c. The d'Arsonval movement will not operate on a.c. since it indicates the average value of current flow, and the average value of an a.c. wave is zero.

As a result of the inability of the reliable d'Arsonval type of movement to record an alternating current, either this current must be rectified and then fed to the movement, or a special type of movement which will operate from the *effective* value of the current can be used.

For the usual measurements of power frequency a.c. (25-60 cycles) the familiar iron-vane instrument is commonly used. For audio frequency a.c. (50-20,000 cycles) a d'Arsonval instrument having an integral copper oxide rectifier is usually used. Radio frequency voltage measurements are usually made with some type of a vacuum-tube voltmeter, while r.f. current measurements are almost invariably made with an instrument containing a thermocouple to convert the r.f. into d.c. for the movement.

Since an alternating current wave can have an almost infinite variety of shapes, it can easily be seen that the ratios between the three fundamental quantities of the wave (peak, r.m.s or effective, and average after rectification) can also vary widely. So it becomes necessary to know beforehand just which quality of the wave under measurement our instrument is going to indicate. For the purpose of simplicity we can list the usual types of a.c. meters in a table along with the characteristic of an a.c. wave which they will indicate:

Iron-vane, thermocoupleR.m.s.
 Rectifier (CuO) type.....Average after rect.
 V.t.v.m.....Peak, r.m.s., or average depending upon the design of the instrument.

Vacuum-Tube Voltmeters A vacuum-tube voltmeter is essentially a detector in which a change in the signal placed upon the input will produce a change in the indicating instrument (usually a d'Arsonval meter) placed in the output circuit. A vacuum-tube voltmeter may use a diode, a triode, or a multi-element tube, and it may be used either for the measurement of a.c. or d.c.

When a v.t.v.m. is used in d.c. measurement it is used for this purpose primarily because of the very great input resistance of the device. This means that a v.t.v.m. may be used for the measurement of a.v.c., a.f.c., and discriminator output voltages where no loading of the circuit can be tolerated. A simple battery-operated v.t.v.m. circuit for making this type of d.c. measurement is diagrammed in Figure 5. Due to the degeneration introduced by the cathode resistor the calibration of this instrument will be comparatively linear. For the measurement of negative voltages such as appear on an a.v.c. line, the terminal marked + should be grounded and the one marked - should be connected to the bus. For the measurement of discriminator voltages (where the voltage may be either positive or negative with respect to the axis) 10 or 15 volts of positive bias may be placed in series with the test prod, making the voltmeter essentially a zero-center device.

A.C. V.T. Voltmeters There are many different types of a.c. vacuum-tube voltmeters, all of which operate as some type of a rectifier to give an indication on a d.c. instrument (usually a d'Arsonval movement). There are two general types: those which give an indication of the r.m.s. value

of the wave (or approximately this value of a complex wave), and those which give an indication of the peak or crest value of the wave.

The voltmeter diagrammed in Figure 5 can be considered as being representative also of the type of vacuum-tube voltmeter used for giving an r.m.s. indication of the wave being measured. This circuit is very little affected by the shape of the wave under measurement, so it can be used for measurement of complex wave shapes. The unit as shown will have a full-scale range of about 20 volts. If a greater range than this is desired, both the supply voltage and the cathode resistor may be multiplied by the same factor. In any case the maximum voltage which can be measured will be slightly less than the supply voltage to the plate of the tube.

Since the setting up and calibration of a wide-range vacuum-tube voltmeter is rather tedious, in most cases it will be best to purchase a commercially manufactured unit. Several excellent commercial units are on the market at the present time. These feature a wide range of a.c. and d.c. voltage scales at high sensitivity, and in addition several feature a built-in vacuum-tube ohmmeter which will give indications up to 500 or 1000 megohms. However, for applications where the versatility of the manufactured units is not necessary, an adaption of the circuit shown in Figure 5, perhaps with a tube such as a 7A4 and a power supply for a.c. operation, will give excellent results after the calibration chart has been made.

Peak A.C. V.T. Voltmeters There are two common types of peak indicating vacuum-tube voltmeters. The first is the so-called "slide-back" type in which a simple v.t.v.m. such as shown in Figure 5 is used along with a conventional d.c. voltmeter and a source of "bucking" bias

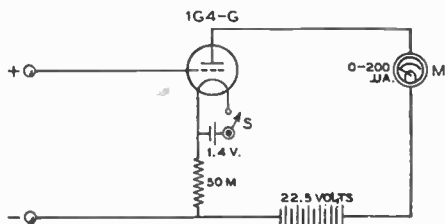

Figure 5.
SIMPLE A.C. OR D.C. V.T. VOLTMETER.

An instrument of this type is suitable for a.v.c., a.f.c., and discriminator output voltage measurements. It may also be used as an a.c. voltmeter.

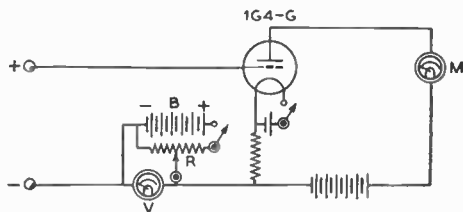

Figure 6.
SIMPLE SLIDE-BACK VOLTMETER.

By connecting a variable source of voltage in series with the input to the simple meter shown in Figure 5, a slide-back a.c. voltmeter for peak voltage measurements is made. The resistor R should be about 1000 ohms per volt at battery B.

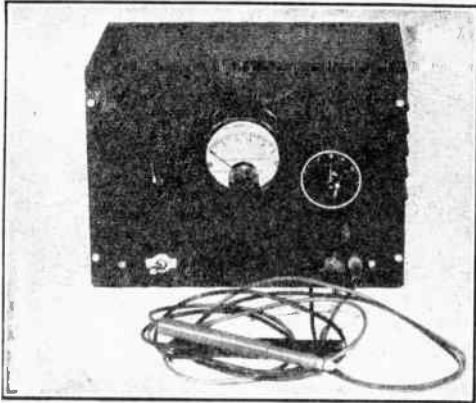

Figure 7.
A.C.-D.C. V.T. VOLTMETER.

The ranges for both a.c. and d.c. are 1, 10, 100, and 500 volts. The left knob operates the bridge-balancing control, and the one on the right operates the range switch.

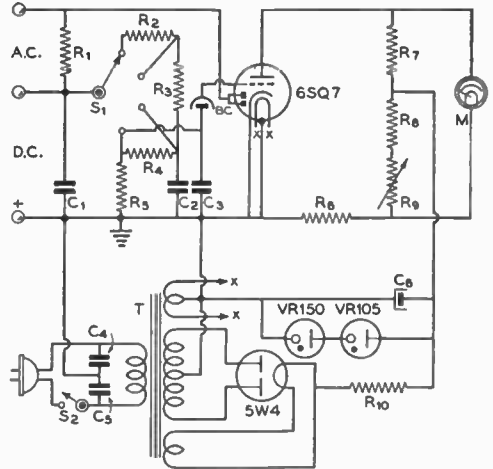

Figure 8.
WIRING DIAGRAM OF THE A.C.-D.C. VACUUM-TUBE VOLTMETER

- | | |
|--|---|
| C ₁ —0.05- μ fd. 600-volt tubular | R ₇ —100,000 ohms, 1/2 watt |
| C ₂ —0.1- μ fd. 600-volt tubular | R ₈ —30,000 ohms, 1 1/2 watts |
| C ₃ —0.5- μ fd. 600-volt tubular | R ₉ —10,000 ohms, 1 1/2 watts |
| C ₄ , C ₅ —0.05- μ fd. 600-volt tubular | R ₁₀ —1500 ohms, 1 1/2 watts |
| C ₆ —8- μ fd. 450-volt electrolytic | R ₁₁ —1000-ohm potentiometer |
| R ₁ —1.0 megohm, 1 watt | R ₁₂ —2000 ohms, 10 watts |
| R ₂ —40 megohms (4 10 - megohm 1/2-watt in series) | T—580 v. c.t., 50 ma.; 5 v., 3 a.; 6.3 v., 2 a. |
| R ₃ —9.0 megohms (5 megohms and 4 megohms 1/2-watt in series) | M—0-1 d. c. milliammeter |
| R ₄ —900,000 ohms (400,000 and 500,000 ohms 1/2-watt in series) | BC—1 1/4-volt bias cell |
| | S ₁ —Single-pole 4-position switch |
| | S ₂ —5.p.s.t. toggle line switch |

in series with the input. With this type of an arrangement (Figure 6) leads are connected to the voltage to be measured and the slider resistor R across the "bucking" voltage is backed down until an indication on the meter (called a false zero) equal to that value given with the prods shorted and the bucking voltage reduced to zero is obtained. Then the value of the bucking voltage (read on V) is equal to the peak value of the voltage under measurement. The slide-back voltmeter has the disadvantage that it is not instantaneous in its indication—adjustments must be made for every voltage measurement. For this reason the slide-back v.t.v.m. is not commonly used, being supplanted by the diode-rectifier type of peak v.t.v.m. for most applications.

Diode-Rectifier Peak-A.C. and D.C. V.T.V.M.

The instrument illustrated in Figures 7, 9, and 10 is designed to permit measurement of a.c. and d.c. voltages on the ranges of 1, 10, 100, and 500 volts.

The input resistance when measuring d.c. voltages remains constant at 100,000 ohms per volt on all ranges. The a.c. input impedance is approximately one-half the d.c. resistance, or 50,000 ohms per volt.

The circuit of the v.t.v.m. is shown in Figure 8. The triode section of the 6SQ7 acts as a linear d.c. voltmeter, while the diode section is used as a rectifier for a.c. voltages. For a.c. measurements, the rectified voltage is applied to the triode grid, while d.c. voltages to be measured are applied directly to the grid.

A bias cell in the grid lead is used as bias

for the triode, and voltages to be measured are applied as additional negative bias. When switch S₁ is in its lowest position the voltage under measurement is applied directly to the grid, giving maximum sensitivity. With a 0-1 milliammeter at M, one volt d.c. at the grid will give full-scale indication; voltages down to .05 volt may be read quite easily on this scale. The additional multiplier resistors R₂, R₃, and R₄ allow full-scale indication at 10, 100, and 500 volts.

To measure a.c. voltages the "A.C." terminals are used. The a.c. voltage is rectified by the 6SQ7 diodes and applied across the grid-cathode circuit of the triode section as a d.c. voltage. Resistors R₂, R₃, and R₄ form the load circuit for the diode rectifier, while the input circuit is completed through the source of a.c. voltage under measurement.

For a.c. measurements, the v.t.v.m. has the same ranges as for d.c., but the *peak* values of the half-cycles are indicated by the meter. In most cases sine-wave a.c. will be measured, so the r.m.s. a.c. voltage will be given by multiplying the meter readings by .707. The full-scale r.m.s. readings for a.c. are .7, 7.07, 70.7, and 555.5 volts on the four ranges.

Condenser C_2 is necessary to eliminate the effects of electrostatic pick-up from the power

supply and nearby a.c. lines on the 10-volt scale.

The power supply is a simple affair employing a small b.c. type replacement transformer and a resistance-capacity filter. The filtering action is aided by the two voltage regulator tubes. These tubes hold the plate voltage constant at 255 volts, thus improving the accuracy under changes in line voltage.

As may be seen from the photographs, the

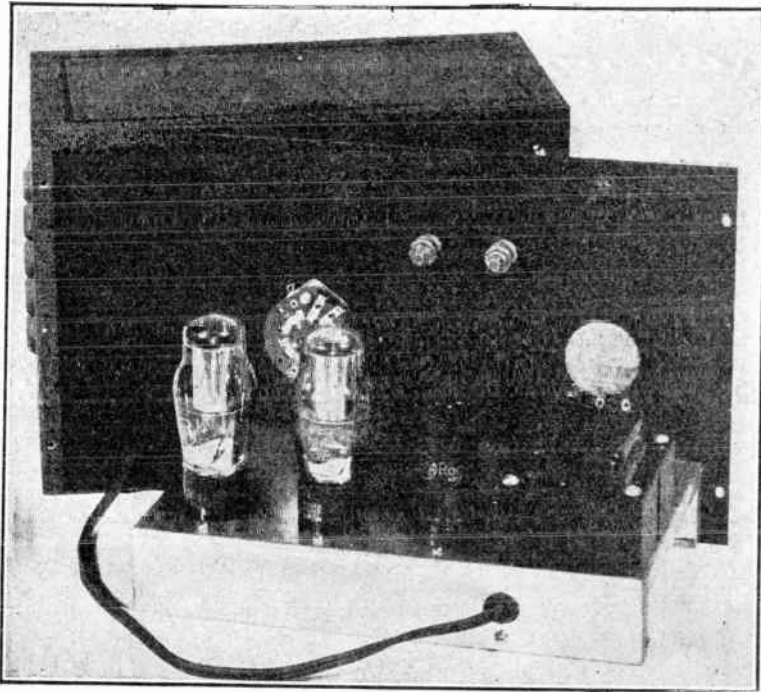

Figure 9.
V.T.V.M. REMOVED FROM ITS CABINET.

The power transformer, metal rectifier tube, and the two voltage regulator tubes are in a line, from right to left across the rear of the chassis. Rubber grommets insulate the meter terminals where they pass through the panel.

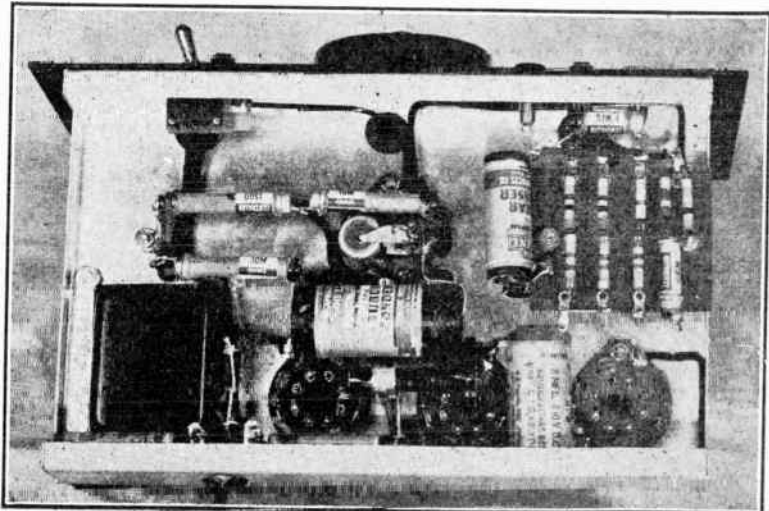

Figure 10.
UNDER-CHASSIS VIEW OF V.T.V.M.

The multiplier resistors are all located on the terminal plate seen at the upper right; a cabled set of leads goes through the chassis from the terminal strip to the range switch above deck. The bias cell holder is supported by having one of its terminals soldered directly to the grid connection on the 6SQ7 socket.

power supply and voltage-regulator section is located at the rear of the chassis, while the 6SQ7 and its associated circuits occupy the section nearest the panel. The three input terminals are located at the lower right edge of the panel, with the power switch in a corresponding location at the left. The knob to the right of the meter operates the range-change switch, while the other knob is for balancing the meter bridge circuit. The cabinet measures 10 x 7 x 6 inches, and the chassis is 9 inches long and 5½ inches deep.

Calibration. Before attempting calibration, the v.t.v.m. power supply should be turned on and the meter adjusted to read zero by means of R_3 . As the 6SQ7 warms up, the meter reading will change somewhat, but a stable condition should be reached in 2 or 3 minutes. After the unit has been warmed up, the range switch should be set to the 1-volt scale and a d.c. voltage of 1 volt applied to the d.c. terminals. The correct voltage may be obtained from a 1.4-volt flashlight cell by means of a potentiometer, an ordinary d.c. voltmeter being used to determine the correct setting of the potentiometer. If all goes well the meter will read exactly full scale with the 1 volt applied. If the meter should read too high or too low, the value of R_6 should be changed slightly, R_6 reset for balance with no input voltage, and the 1-volt indication again checked. The value of R_6 is not very critical; it is probable that the value specified under the diagram will give satisfactory results.

After the instrument has been calibrated on the 1-volt scale, no further calibration is needed, if the multiplier resistors for the other

ranges are known to be accurate. However, it is good practice to check these higher voltage ranges, just in case. As a point of interest, there is one type of measurement for which this v.t.v.m. cannot be used; it is impossible to get a correct reading on the 120-volt a.c. supply line since condensers C_1 and C_2 place the chassis effectively at the center of the a.c. supply voltage, causing an error in the reading.

High-Voltage Diode Peak Voltmeter

A diode vacuum-tube voltmeter suitable for the measurement of high values of a.c. voltage is diagrammed in Figure 11.

With the constants shown, the voltmeter has two ranges: 500 and 1500 volts peak full scale.

Condensers C_1 and C_2 should be able to withstand a voltage in excess of the highest peak voltage to be measured. Likewise, R_1 and R_2 should be able to withstand the same amount of voltage. The easiest and least expensive way of obtaining such resistors is to use several low-voltage resistors in series, as shown in Figure 11. Other voltage ranges can be obtained by changing the value of these resistors, but for voltages less than several hundred volts a more linear calibration can be obtained by using a receiving-type diode. A calibration curve should be run to eliminate the appreciable error due to the high internal resistance of the diode, preventing the condenser from charging to the full peak value of the voltage being measured.

A direct reading diode peak voltmeter of the type shown in Figure 11 will load the source of voltage by approximately *one-half* the value of the load resistance in the circuit (R_1 , or R_1 plus R_2 , in this case). Also, the peak voltage reading on the meter will be slightly less than the actual peak voltage being measured. The amount of lowering of the reading is determined by the ratio of the storage capacitance to the load resistance. If a cathode-ray oscilloscope is placed across the terminals of the v.t.v.m. when a voltage is being measured, the actual amount of the lowering in voltage may be determined by inspection of the trace on the c.r. tube screen. The peak positive excursion of the wave will be slightly flattened by the action of the v.t.v.m. Usually this flattening will be so small as to be negligible. But if it is desired to compensate for the flattening in the wave the following procedure may be gone through: Measure the distance from the center of the c.r. tube trace to the flattened crest with the v.t.v.m. connected. Disconnect the v.t.v.m. and measure again this distance. Multiply the ratio of the two distances (slightly larger than 1.0) by the voltage as read on the v.t.v.m. This procedure will give the actual crest value of the wave.

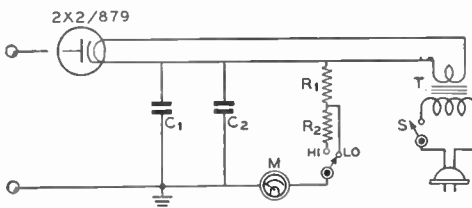

Figure 11.

WIRING DIAGRAM OF HIGH-VOLTAGE PEAK VOLTMETER.

- C_1 — .001- μ fd. high-voltage mica
- C_2 — 1.0- μ fd. high-voltage paper
- R_1 —500,000 ohms (2 0.25-megohm ½-watt in series)
- R_2 —1.0 megohm (4 0.25-megohm ½-watt in series)
- T—2.5 v., 1.75 a. filament transformer
- M—0.1 d.c. milliammeter
- SHI-LO—S.p.d.t. toggle switch
- S—S.p.s.t. toggle switch

(Note: C_1 is a by-pass around C_2 , the inductive reactance of which may be appreciable at high frequencies.)

Measurement of Power Audio frequency or radio frequency power in a resistive circuit is most commonly and most easily determined by the indirect method, i.e., through the use of one of the following formulas:

$$P = EI \quad P = E^2/R \quad P = I^2R$$

These three formulas mean that if any two of the three factors determining power are known (resistance, current, voltage) the power being dissipated may be determined. In an ordinary 120-volt a.c. line circuit the above formulas are not strictly true since the power factor of the line must be multiplied into the result—or a direct method of determining power such as a wattmeter may be used. But in a resistive a.f. circuit and in a resonant r.f. circuit the power factor of the energy is taken as being unity.

For accurate measurement of a.f. and r.f. power, a thermogalvanometer or thermocoupled ammeter in series with a non-inductive resistor of known resistance can be used. The meter should have good accuracy, and the exact value of resistance should be known with accuracy. Suitable dummy load resistors of the "vacuum" type are available in various resistances in both 100- and 250-watt ratings. These are virtually non-inductive, and may be considered as a pure resistance except at ultra-high frequencies. The resistance of these units is substantially constant for all values of current up to the maximum dissipation rating, but where extreme accuracy is required, a correction chart of the dissipation coefficient of resistance (supplied by the manufacturer) may be employed. This chart shows the exact resistance for different values of current through the resistor.

Figure 12 shows a convenient unit for the measurement of r.f. or a.f. power through the use of a "dummy antenna resistor" and a thermogalvanometer. With a thermogalvanometer as the indicating instrument the current flowing through the circuit may be determined (since the full-scale reading of these instruments indicates that 115 ma. is flowing) by: $I = \sqrt{S} \times 11.5$. Or, since our reading on the face of the meter is already squared, power may be determined directly through the use of this formula: $P = S \times 0.000132 \times R$, where S is the scale reading, R is the resistance of the dummy load, and P is the power being dissipated in watts.

If a thermocoupled ammeter is used the current flowing is indicated directly and the power flowing may be determined by: $P = I^2R$. For audio frequency measurements below 15,000 cycles (speech amplifier or modulator output determinations) a conventional bleeder or drop resistor of the type used in power sup-

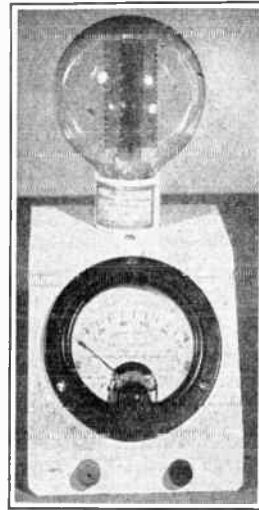

Figure 12.
R.F. and A.F.
POWER MEASURING DEVICE.

A thermogalvanometer or thermocoupled ammeter is placed in series with a non-inductive dummy load resistor whose resistance is known accurately.

plies may be used in place of the non-inductive type required for r.f. measurements—provided the resistance of the load resistor is accurately known.

Sine-wave power measurements (r.f. or single-frequency audio) may also be made through the use of a v.t.v.m. and a resistor of known value. In fact a v.t.v.m. of the type shown in Figure 11 is particularly suited to this work. The formula, $P = E^2/R$ is used in this case. However, it must be remembered that a v.t.v.m. of the type shown in Figure 11 indicates the *peak* value of the a.c. wave. This reading must be converted to the r.m.s. or *heating* value of the wave by multiplying it by 0.707 before substituting the voltage value in the formula.

The use of all three methods of determining power: ammeter-resistor, voltmeter-resistor, and voltmeter-ammeter, gives an excellent cross-check upon the accuracy of the determination and upon the accuracy of the *standards*.

Power may also be measured through the use of a calorimeter, by actually measuring the amount of heat being dissipated. Through the use of a water-cooled dummy load resistor this method of power output determination is being used by some of the most modern broadcast stations. But the method is too cumbersome for ordinary power determinations.

Power may also be determined photometrically through the use of a voltmeter, ammeter, incandescent lamp used as a load resistor, and a photographic exposure meter. With this method the exposure meter is used to determine the relative visual output of the lamp running as a dummy load resistor and of the lamp running from the 120-volt a.c. line. A rheostat in series with the lead from the a.c. line to the lamp is used to vary its light intens-

ity to the same value (as indicated by the exposure meter) as it was putting out as a dummy load. The a.c. voltmeter in parallel with the lamp and ammeter in series with it is then used to determine lamp power input by: $P = EI$. This method of power determination is satisfactory for audio and low-frequency r.f. but is not satisfactory for u.h.f. because of variations in lamp efficiency due to uneven heating of the filament.

Measurement of Circuit Constants

The measurement of the resistance, capacitance, inductance, and Q (figure of merit) of the components used in communications work can be divided into three general methods: the impedance method, the substitution or resonance method, and the Wheatstone bridge method.

The Impedance Method The impedance method of measuring inductance and capacitance can be likened to the ohmmeter method for measuring resistance. An a.c. voltmeter, or milliammeter in series with a resistor, is connected in series with the inductance or capacitance to be measured and the a.c. line. The reading of the meter will be inversely proportional to the impedance of the component being measured. After the meter has been calibrated it will be possible to obtain the approximate value of the impedance directly from the scale of the meter. If the component is a capacitor, the value of impedance may be taken as its reactance at the measurement frequency and the capacity determined accordingly. But the d.c. resistance of an inductor must also be taken into consideration in determining its inductance. After the d.c. resistance and the impedance have been determined, the reactance may be determined from the formula: $X = \sqrt{R^2 - Z^2}$. Then the inductance may be determined from: $L = X_L/2\pi f$.

The Substitution Method The substitution or resonance method is perhaps the most satisfactory system for obtaining the inductance or capacity of high-frequency components. A 500 to 1000 $\mu\mu\text{fd}$. condenser with a good dial having an accurate calibration curve is a necessity for making determinations by this method. If an unknown inductor is to be measured, it is connected in parallel with the standard capacitor and the combination tuned accurately to some known frequency. This tuning may be accomplished either by using the tuned circuit as a wavemeter and coupling it to the tuned circuit of a reference oscillator, or by using the tuned circuit in the controlling position of a two-terminal oscillator such as a dynatron or transi-

tron. The capacity required to tune to this first frequency is then noted as C_1 . The circuit or the oscillator is then tuned to the *second harmonic* of this first frequency and the amount of capacity again noted, this time as C_2 . Then the distributed capacity across the coil (including all stray capacities) is equal to: $C_0 = (C_1 - 4C_2)/3$.

This value of distributed capacity is then substituted in the following formula along with the value of the standard capacity for either of the two frequencies of measurement:

$$L = \frac{1}{4\pi^2 f_1^2 (C_1 + C_0)}$$

The determination of an unknown capacity is somewhat less complicated than the above. A tuned circuit including a coil, and the unknown condenser and the standard condenser in parallel is resonated to some convenient frequency. The capacity of the standard condenser is noted. Then the unknown condenser is removed and the circuit re-resonated by means of the standard condenser. The difference between the two readings of the standard condenser is then equal to the capacity of the unknown condenser.

Another version of the procedure for determining an unknown capacity is to use this capacity as the tank condenser in an oscillator. The signal put out by the oscillator is then brought to zero beat in a receiver. The unknown capacity is then removed from the circuit and the standard condenser substituted. The standard condenser is then carefully tuned until the oscillator is back at zero beat on the original frequency. The capacity of the unknown condenser may then be read directly from the calibration curve of the standard condenser.

The Bridge Method Experience has shown that the most satisfactory method for measuring circuit constants (resistance, capacitance, and inductance) at audio frequencies is by means of the a.c. bridge. The Wheatstone (d.c.) bridge is also the most accurate method for the measurement of d.c. resistance. With a simple bridge of the type shown at Figure 13A it is entirely practical to obtain d.c. resistance determinations accurate to four significant figures. With an a.c. bridge operating within its normal rating as to frequency and range of measurement it is possible to obtain results accurate to three significant figures.

Both the a.c. and the d.c. bridges consist of a source of energy, a standard or reference of measurement, a means of balancing this standard against the unknown, and a means of indicating when this balance has been reached. The source of energy in the d.c. bridge is a battery; the indicator is a sensitive galvanome-

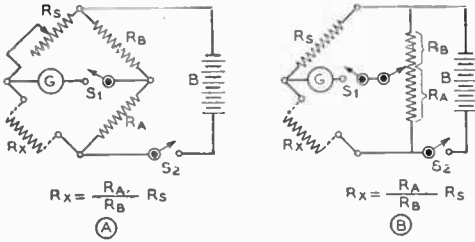
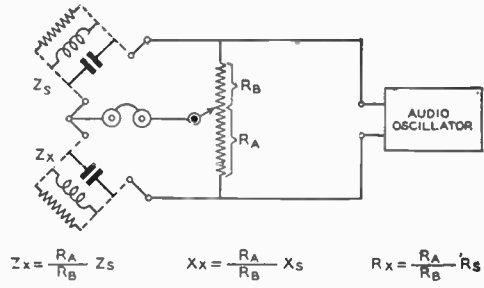

Figure 13.

TWO WHEATSTONE BRIDGE CIRCUITS.

These circuits are used for the measurement of d.c. resistance. In (A) the "ratio arms" R_B and R_A are fixed and balancing of the bridge is accomplished by variation of the standard R_S . The standard in this case usually consists of a decade box giving resistance in 1-ohm steps from 0 to 1110 or to 11,110 ohms. In (B) a fixed standard is used for each range and the ratio arm is varied to obtain balance. A calibrated slide-wire or potentiometer calibrated by resistance in terms of degrees is usually employed as R_A and R_B . It will be noticed that the formula for determining the unknown resistance from the knowns is the same in either case.



$Z_x = \frac{R_A}{R_B} Z_s$ $X_x = \frac{R_A}{R_B} X_s$ $R_x = \frac{R_A}{R_B} R_s$
 Z_x = IMPEDANCE BEING MEASURED, R_S = RESISTANCE COMPONENT OF Z_S
 Z_S = IMPEDANCE OF STANDARD, X_x = REACTANCE COMPONENT OF Z_x
 R_x = RESISTANCE COMPONENT OF Z_x , X_s = REACTANCE COMPONENT OF Z_S

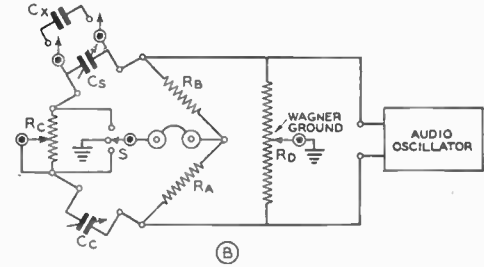

Figure 14.

TWO A. C. BRIDGE CIRCUITS.

The operation of these bridges is essentially the same as those of Figure 13 except that a.c. is fed into the bridge instead of d.c. and a pair of phones is used as the indicator instead of the galvanometer. The bridge shown at (A) can be used for the measurement of resistance, but it is usually used for the measurement of the impedance and reactance of coils and condensers at frequencies from 400 to 1000 cycles. The bridge shown at (B) is used for the measurement of small values of capacitance by the substitution method. Full description of the operation of both bridges is given in the accompanying text.

ter. In the a.c. bridge the source of energy is an audio oscillator (usually in the vicinity of 1000 cycles), and the indicator is usually a pair of headphones. The standard for the d.c. bridge is a resistance, usually in the form of a decade box. Standards for the a.c. bridge can be resistance, capacitance, and inductance in varying forms.

Figure 13 shows two general types of the Wheatstone or d.c. bridge. In (A) the so-called "ratio arms" R_A and R_B are fixed (usually in a ratio of 1-to-1, 1-to-10, 1-to-100, or 1-to-1,000) and the standard resistor R_S is varied until the bridge is in balance. In commercially manufactured bridges there are usually two or more buttons on the galvanometer for progressively increasing its sensitivity as balance is approached. Figure 13B is the so-called "slide wire" type of bridge in which fixed standards are used and the ratio arm is continuously variable. The "slide wire" may actually consist of a moving contact along a length of wire of uniform cross section, in which case the ratio of R_A to R_B may be read off directly in centimeters or inches, or in degrees of rotation if the slide wire is bent around a circular former. Or the "slide wire" may consist of a linear-wound potentiometer with its dial calibrated in degrees or in resistance from each end.

Figure 14A shows a simple type of a.c. bridge for the measurement of capacitance and inductance. It can also, if desired, be used for the measurement of resistance. The four arms of the bridge may be made up in a variety of ways. As before, R_B and R_A make up the ratio

arms of the device and may be either of the slide-wire type, as indicated, or they may be fixed and a variable standard used to obtain balance. In any case it is always necessary with this type of bridge to use a standard which presents the same type of impedance as the unknown being measured: resistance standard for a resistance measurement, capacity standard for capacitance, and inductance standard for inductance determination. Also, it is a great help in obtaining an accurate balance of the bridge if a standard of approximately the same value as the assumed value of the unknown is employed. Also, the standard should be of the same general type and should have approximately the same power factor as the unknown impedance. If all these precautions are observed, little trouble will be experienced in the measurement of resistance and in the

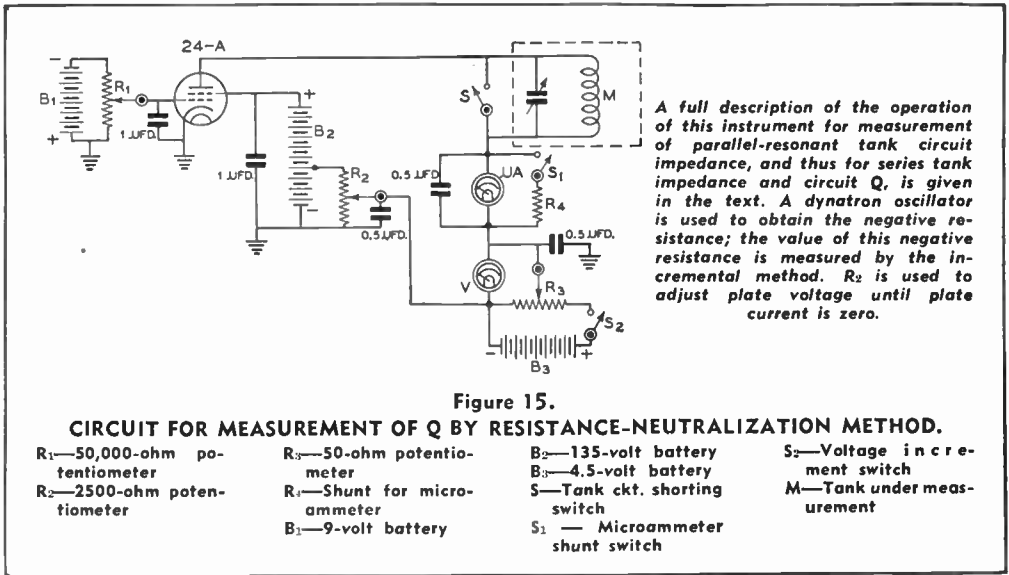

measurement of impedances of the values usually used in audio and low radio frequency work.

However, the bridge shown at 14A will not be satisfactory for the measurement of capacitances smaller than about 1000 μμfd. For the measurement of capacitances from a few micro-microfarads to about 0.001 μfd, a Wagner grounded substitution capacity bridge of the type shown in Figure 14B will be found quite satisfactory. The ratio arms R_A and R_B should be of the same value within 1 per cent; any value between 2500 and 10,000 ohms for them both will be satisfactory. The two resistors R_C and R_D should be 1000-ohm wirewound potentiometers. C_S should be a straight-line capacity condenser with an accurate vernier dial; 500 to 1000 μμfd. will be satisfactory. C_T can be a two or three gang broadcast condenser from 700 to 1000 μμfd. maximum capacity.

The procedure for making a measurement is as follows: The unknown capacitor C_x is placed in parallel with the standard capacitor C_s. The Wagner ground R_D is varied back and forth a small amount from the center of its range until no signal is heard in the phones with the switch S in the center position. Then the switch S is placed in either of the two outside positions, C₀ is adjusted to a capacity somewhat greater than the assumed value of the unknown C_x, and the bridge is brought into balance by variation of the standard condenser C_s. It may be necessary to cut some resistance in at R_C and to switch to the other outside position of S before an exact balance can be obtained. The setting of C_s is then noted, C_x is removed from the circuit (but the leads which went to it are not changed in any

way which would alter their mutual capacity), and C_s is readjusted until balance is again obtained. The difference in the two settings of C_s is equal to the capacity of the unknown condenser C_x.

Measurement of Q There are two commonly used methods for the measurement of the Q or of equivalent series resistance of a tuned circuit which give good results for all frequencies within the communication range. The first is called the Resistance Neutralization Method. It will be described but briefly because a rather specialized piece of equipment must be built up to make the tests. A complete description of the system including certain variations is given in Terman's *Measurements in Radio Engineering*.*

The circuit diagram of the unit is given in Figure 15. With about 3 volts of grid bias on the 24 the potentiometer R₂ is adjusted until the plate current is zero. The circuit under test is placed in the plate circuit of the dynatron oscillator. The grid bias on the dynatron is then varied until the tuned circuit is just on the verge of going into or out of oscillation. The presence of oscillations may be detected with the aid of a radio receiver if the tuned circuit is for r.f.; or the oscillations may be detected by dangling a pair of headphone cords near the circuit if the circuit is an a.f. one. At the point where oscillation is unstable the negative resistance of the dynatron is almost exactly equal to the parallel impedance of the tuned circuit under test. The tuned circuit is

*Available from our book department for \$4.00 postpaid; foreign, \$4.25. 400 pages, 208 illustrations; covers basic principles and specific problems of measurements in radio practice.

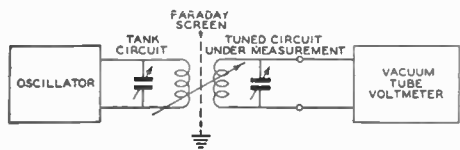

Figure 16.
CIRCUIT FOR MEASUREMENT OF Q
BY FREQUENCY VARIATION METHOD.

then shorted out by the switch S, the shunt is removed from the microammeter, and the plate voltage is increased 1 or 2 volts by potentiometer R₃. This adjustment will cause a small plate current change as indicated by the microammeter. The negative resistance of the dynatron under these conditions of operation is then determined by the ratio: (increase in plate voltage)/(change in plate current). This negative resistance is numerically equal to the resonant impedance of the tank circuit under measurement.

The Q of the tank circuit may then be determined, after the inductance of the coil has been determined by a bridge or other method, through use of the following formula: $Q = R_n/2\pi fL$.

The other method of determining Q is direct indicating and is called the Frequency-Variation Method. This method of Q determination is diagrammed in Figure 16. The output of the oscillator must be constant throughout the measurement, and the coupling between the oscillator and the tank under measurement must be constant and wholly inductive. It is for this reason that a Faraday electrostatic shield is indicated between the two tuned circuits.

The tank circuit is loosely coupled to the oscillator and the response voltage (E₀) at resonance (F₀) is noted by the v.t.v.m. The frequency of the oscillator is then decreased to some value which gives a conveniently lower indication of voltage at the v.t.v.m. This frequency (F₁) and response voltage (E₁) is noted and the frequency of the oscillator is then increased beyond resonance to the point which gives the same v.t.v.m. indication as was found at F₁. This higher frequency is then noted as F₂. It is important that the current in the tank circuit of the oscillator must remain constant throughout the process. The Q of the tank circuit is then determined by the following formula:

$$Q = \frac{F_0}{F_2 - F_1} \sqrt{\frac{E_1^2}{E_0^2 - E_1^2}}$$

It must be remembered that the tank circuit

Q as determined by either of the above two systems is not exactly equal to the Q of the inductor. But if the condenser making up the circuit is air-tuned, or of a high-quality mica type, the tank circuit Q will be approximately the same as the Q of the inductance.

Frequency Measurements

All frequency measurement within the United States is based on the transmission of standard frequency station WWV of the National Bureau of Standards. This station operates 24 hours a day on the standard frequency of 5000 kc., the carrier frequency of this transmission being kept accurate within one part in 10,000,000. This carrier frequency is modulated by the standard of musical pitch of A above middle C, corresponding to 440 cycles per second. This musical pitch standard is maintained with the same accuracy as the carrier frequency.

The application of this standard 5000-kc. transmission to the measurement of all other frequencies within the communications range is accomplished by means of various types of frequency substandards and interpolation oscillators. Two inexpensive types of frequency substandards for obtaining accurate 50, 100, and 1000 kilocycle points throughout the communications spectrum will be described, one crystal controlled and the other self-excited. Temperature-controlled frequency standards and substandards of great accuracy are available from various precision radio equipment manufacturers. Interpolation oscillators, or the so-called "calibrated frequency meters," are re-



Figure 17.
THE SELF-EXCITED 50-KC.
SUBSTANDARD.

The control to the left of the front panel is the trimmer on the 50-kilocycle oscillator. The right-hand control is the harmonic amplifier coil switch, and the center control is the trimmer condenser across this coil.

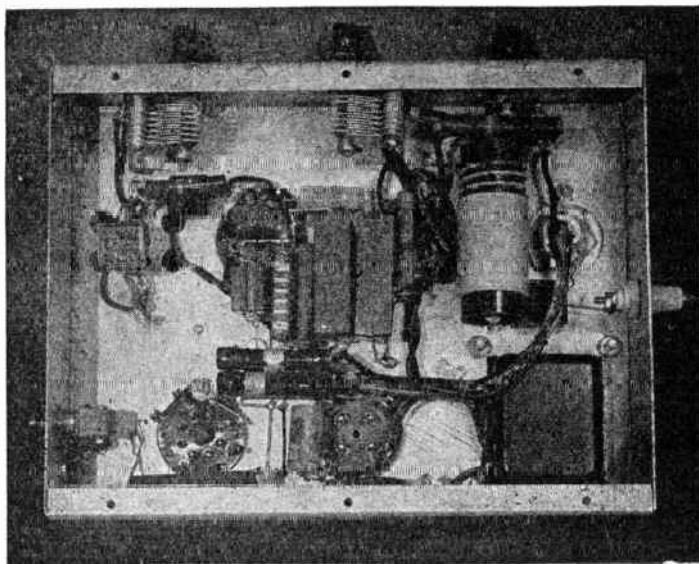

Figure 18.
BOTTOM VIEW OF THE
50-KC. SUBSTANDARD
CHASSIS.

The tapped amplifier output coil is to the right and the r.f. choke with the two paralleled condensers across it, comprising the plate circuit of the 6K8, is just to the left of the center of the chassis.

quired for an accurate determination of frequency in between the spots put out by the standard. For closer calibration in between the standard spots an accurately calibrated audio oscillator is frequently used. The calibrated audio oscillator described later on in this chapter under Signal Generators will be satisfactory for this application. Constructional information on a calibrated frequency meter of a simple battery-operated type is given in the text which accompanies Figures 39, 40, 41, and 42, this chapter. An accurately calibrated commercial receiver will in many cases be more satisfactory as an interpolation oscillator than a composite unit. Well designed interpolation oscillators are available from Lampkin, General Radio, Browning Labs., and various other manufacturers at a wide range of prices.

Self-Excited Frequency Substandard

The instrument diagrammed in Figure 19 and pictured in Figures 17 and 18 consists essentially of a 50-kilocycle self-excited oscillator and a semi-tuned harmonic amplifier operating from a voltage-regulated power supply. The unit provides 50-kc. points of usable and adjustable strength on all frequencies up to and including 30 Mc. If desired, an additional harmonic amplifier stage could be included to extend the frequency range to 100 Mc. and above.

The 50-Kilocycle Oscillator

A 6K8 tube is used as a combined 50-kilocycle oscillator and electron-coupled doubler to 100 kc.

The oscillator coil is a Meissner 456-kilocycle

beat-oscillator unit with the mica trimmer removed. By loading this comparatively high-frequency coil to the low frequency of 50 kc., the oscillator tuned circuit becomes quite high C. The stability with respect to tube and circuit temperature variations and plate voltage variations is greatly improved by the high oscillator lumped capacity. Actually, the capacity required to tune this oscillator coil to 50 kilocycles is very close to 0.00625 microfarads. This capacity is obtained through the use of a .006- μ fd. fixed condenser of the silver-plated mica type in parallel with a .0002- μ fd. negative coefficient condenser of the ceramic type and a 100- μ fd. midget variable. It is important that the identical coil as shown in the *Buyer's Guide* be used (and that the mica trimmer thereon be removed) if the values of capacity shown are to hit 50 kilocycles. It is also important that the specified type fixed condensers be used for lump capacity.

The 100- μ fd. midget trimmer condenser is brought through the chassis and allows the frequency of the oscillator to be tuned about one-half kilocycle either side of the operating frequency of 50 kilocycles. This adjustment will ordinarily compensate for any small variations in coil inductances and in circuit capacity. If, however, it is impossible to tune this circuit to 50 kc. by a variation in the capacity of this condenser, the addition or subtraction of .00005 μ fd. from the fixed value of .00625 will usually allow it to be accomplished.

The oscillator coil, as it comes from the manufacturer, is not a single tapped unit but rather a 2-winding affair with four leads brought out from the coils. It will then be

Figure 19.
WIRING DIAGRAM OF THE 50-KC. OSCILLATOR-MULTIPLIER.

- C₁, C₂—100- μ fd. mid-
get variable
- C₃—.006- μ fd. silvered
mica (close tolerance)
- C₄—.0002- μ fd. negative
coefficient ceramic
capacitor
- C₅—.0005- μ fd. midget
mica
- C₆, C₇—0.1- μ fd. 400
volts
- C₈—.001- μ fd. mica
- C₉—.0001- μ fd. mica
- C₁₀—.001- μ fd. mica
- C₁₁—0.1- μ fd. 400 volts
- C₁₂—.01- μ fd. midget
mica
- C₁₃—25- μ fd. midget
mica
- C₁₄, C₁₅—8-8- μ fd. 450-
volt elect.
- R₁—100,000 ohms, 1
watt
- R₂—25,000 ohms, 2
watts
- R₃—2 megohms, 1 watt
- R₄—50,000 ohms, 2
watts
- R₅—20,000 ohms, 10
watts

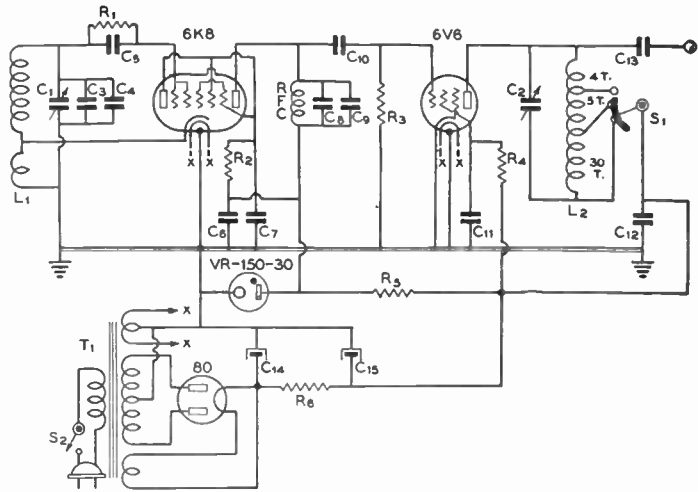

- R₆—10,000 ohms, 10
watts
- S₁—Shorting type 1-
pole 3-position switch
- S₂—S.p.s.t. a.c. line
switch
- L₁—456-kc. b.f.o. coil
with trimmer re-
moved
- L—39 turns no. 20
d.c.c on 1" dia. form
tapped at 9 and 4
- turns; last 4 turns
spaced
- RFC—2.1-mh., 125-ma.
r.f. choke
- T₁—650 v. c.t., 40 ma.;
6.3 v. 2 a.; 5 v. 2 a.

necessary to series these two coils as shown in the manufacturer's diagram as the connection for an electron-coupled oscillator. The cathode of the oscillator-mixer tube is then connected to the tap. The actual connections to the coil are as follows: blue wire, ground; green wire, grid; red and black connect together and go to cathode.

The Harmonic Amplifier

The output circuit of this stage consists of a tapped coil which is resonated by a 100- μ fd. midget variable. With the whole coil in the circuit the output can be peaked at any frequency from about 7500 kc. down to about 3500 kc. Nevertheless, there is ample output with this coil in the circuit down through the broadcast band. It is not necessary to resonate the output circuit at these low frequencies; there is more than ample output for all measurements and for calibration.

With the switch in the second position, all but 9 turns of the inductance are shorted and the coil will resonate at any frequency from about 7000 kc. down through 18,000 kc. This tap peaks in the middle of the dial for strong signals on the 14-Mc. band. With the switch on the last tap, with only 4 turns in the circuit, the circuit peaks up at about 30 Mc.

Coupling of the output circuit to the external load is accomplished by means of a .000025 μ fd. mica condenser which connects

between the plate of the 6V6 and the output terminal. The decrease in the reactance of this condenser with increasing frequency tends to equalize the signal strength output of the unit over a wide range of frequency.

A simple resistance-capacity filtered power supply using an 80 rectifier is used for plate voltage to the unit. Ample filtering for the harmonic amplifier stage is attained through the use of the RC filter. The VR-150-30 voltage regulator with its associated resistors and condensers supplies very pure direct current to the 6K8 oscillator and first multiplier.

Tuning Up and Calibration

If the oscillator coil specified has been used, and if the exact values of capacity specified have been placed across the coil, it is only necessary to get the oscillator going on the proper frequency of 50 kilocycles; when this is once done, all other adjustments become very simple.

For tuning up the unit the only additional piece of equipment required is a calibrated broadcast receiver and a few incoming broadcast signals on frequencies that are integral multiples of 50 kc. With the oscillator operating (with the output coil on the no. 1 tap—all the coil in the circuit) run a wire from the output terminal of the harmonic amplifier to the antenna post on the b.c.l. set and connect a small external antenna to the receiver.

With the trimmer condenser in the oscillator set to about mid-scale, tune the b.c.l. set to the low-frequency end of the dial and pick up the first harmonic of the oscillator that can be tuned in. Mark down the frequency of this harmonic as determined from the calibration of the b.c.l. set. Then tune to the next harmonic (they will be easy to identify because of their lack of modulation) and mark down its frequency as again determined from the b.c.l. set. Keep doing this until 8 or 10 points are determined. Then subtract each frequency from the next higher one all the way down the line and average the resulting differences in frequency between the harmonics. If any one of the differences falls very far out of line, recheck its frequency to see if an error has been made or to see if a harmonic has been missed.

If the average of all the differences in frequency falls very near to 50 kilocycles (say 48 to 52 kc.) the unit is ready for calibration. If not, the values of padding condenser across the oscillator coil will have to be changed.

When the oscillator has been adjusted very closely to 50 kc. by the "difference-between-harmonics" method, pick out a broadcast station that is operating on some multiple of 50 kc.; one in the vicinity of 550 to 1100 kc. will be the best. Tune in this station, turn on the oscillator, and adjust the beat between the harmonic of the oscillator and the broadcast station to zero. Then find another b.c. station on a harmonic of 50 kc. and see if it also is at zero beat. If the second b.c. station is not at zero beat or within a few cycles of it, the oscillator definitely isn't on 50 kc. and the frequency will have to be rechecked by the procedure given in the preceding paragraphs, fixed condensers being added or subtracted, depending on whether the frequency is high or low.

If the second station is at zero beat with the harmonic, check with a few more stations on multiples of 50 kc. just to make sure all is well. As mentioned before, if the values and components given are used, it will only be necessary to adjust the trimmer condenser across the oscillator tank, which is brought out to the front panel, to hit 50 kc. and thereby arrive at this stage of the adjustment.

It will now only be necessary to set the trimmer condenser so that the harmonics in the broadcast band fall exactly at zero beat with the b.c. stations, and the unit will thenceforward be calibrated.

The warm-up time of the unit is very short, a matter of only 5 minutes or so, due to the very high value of capacity in the 50-kilocycle oscillator tank. Once the oscillator has been set, it will not drift more than a few cycles on the broadcast band (less than 100 cycles on 10

meters) in many hours of continuous operation. However, each time the unit is placed in operation from a cold start it will be best to check the setting of the oscillator trimmer condenser against a broadcast station on a multiple of 50 kc. after allowing 5 minutes or so to warm up.

Dual Frequency Crystal Calibrator

At a reasonable price, it is possible to purchase a crystal unit containing a crystal which will oscillate on either 100 or 1000 kc., oscillating along its length for the lower frequency and through its thickness for the higher frequency. The accuracy of the 100 kc. oscillation is very high when installed and adjusted in a calibrator of the type to be described, permitting precision frequency measurement.

The advantage over the 50-kc. self-controlled unit just described is that it is much simpler to get going initially, and one need not allow for warm up or check it each time before taking a measurement. It has the further advantage that it can be made to oscillate with reasonable accuracy (.05 per cent) at 1000 kc., which is of considerable help in identifying the 100 kc. points on the higher frequencies where it is sometimes difficult to determine the order of a particular 100 kc. harmonic. The only disadvantage is that the 100 kc. points are twice as far apart as the points given by the "Self-Excited Substandard" previously described, and the strength of harmonics above 14 Mc. is not as great with the crystal calibrator, due to the lack of a separate harmonic amplifier.

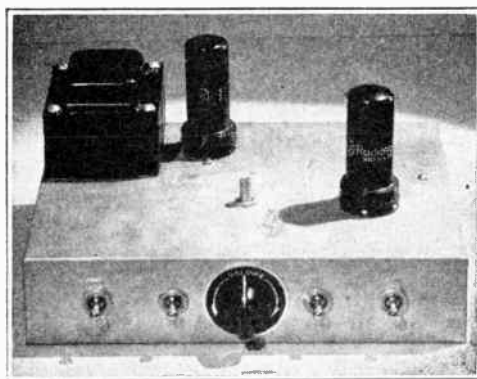

Figure 20.
DUAL FREQUENCY CRYSTAL
CALIBRATOR.

This instrument generates 1000-kc. harmonics up to 56 Mc., and 100-kc. harmonics up to 20 Mc., the latter with a high degree of accuracy. On the front of the chassis is the output control; the slotted shaft projecting out of the top of the chassis is a shunt trimmer across the crystal for adjusting the low frequency oscillations precisely to 100 kc.

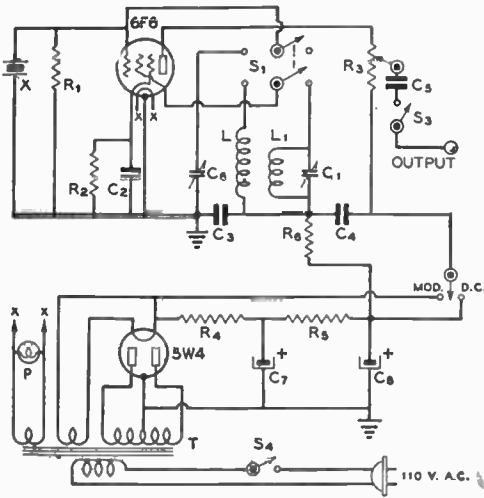

Figure 21.
WIRING DIAGRAM OF CRYSTAL CALIBRATOR.

(as recommended by Bliley Electric Co.)

- | | |
|--|---|
| X—100 and 1000 kc. crystal calibrator unit | C7, C8—Dual 4- μ fd. 450-volt electrolytic |
| R1—5 meg., $\frac{1}{2}$ watt | T—320 v. each side of c.t., 40 ma. and fil. windings |
| R2—500 ohms, 1 watt | S1—D.p.d.t. toggle switch |
| R3—0.5-meg. potentiometer | S2—S.p.d.t. toggle switch |
| R4—10,000 ohms, 1 watt | S3—S.p.s.t. toggle switch |
| R5—20,000 ohms, 1 watt | L—R.F.C., exactly 8 mh. |
| C1—25-100 μ fd. mica trimmer | L1—Pie-wound 2.1 or 2.5 mh. 125 ma. r.f. choke with all sections except one removed |
| C2, C3, C4—0.1- μ fd. tubular | |
| C5—0.01- μ fd. mica | |
| C6—25- μ fd. midget variable | |

It should be borne in mind that the accuracy of the crystal when oscillating on 1000 kc. is not supposed to be sufficient for precision measurements; it is simply for convenience in identifying the highly accurate 100 kc. points.

Construction The only precautions to be observed in construction are to place the crystal away from any components which radiate heat, and to make the leads from the tube to the crystal as short as possible. Mounting the crystal under the chassis close to the 6F6 socket, as illustrated, meets these requirements. The leads to condenser C₆ should also be kept as short as possible.

The coil L₁ is one pie of a midget 125 ma. 2.1 or 2.5 mh. r.f. choke. If the crystal will not oscillate with the switch on the 1000-kc. position, it may be necessary to remove a few turns from the coil. A midget solenoid b.c.l. coil may be substituted if desired.

Adjustments and Use First check for oscillation on both positions of S₁ to make sure the crystal will oscillate both on 1000 and 100 kc. If it does not oscillate on 1000 kc., then the mica trimmer C₁ should be varied. When this trimmer has once been adjusted so that the crystal "comes on" every time the switch is thrown, the trimmer need never be touched again.

Figure 22.
UNDER-CHASSIS VIEW OF THE CRYSTAL CALIBRATOR.
The crystal unit is mounted close to the 6F6 sockets. Power supply components are to the lower left.

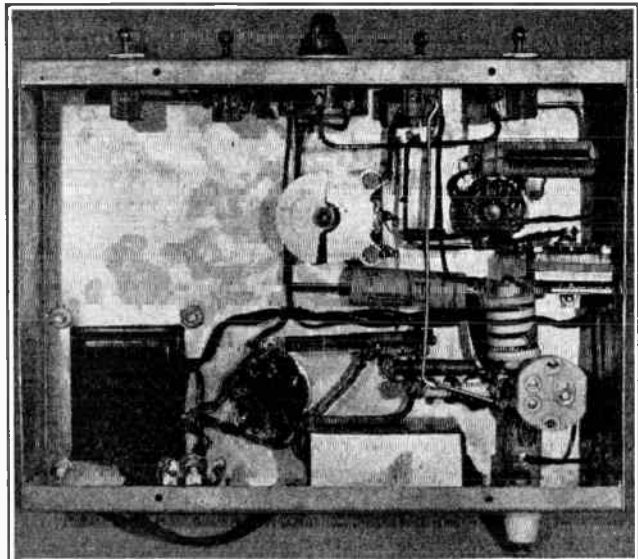

The 100 kc. frequency should then be precisely adjusted by means of the 25- μ fd. air trimmer, C_6 , until harmonics of the 100-kc. oscillator zero beat *exactly* with broadcast stations on multiples of 100 kc. Zero beat can most accurately be determined if the receiver has a tuning eye or "R" meter. The trimmer is first adjusted as close as possible by ear and then further adjusted until the "flutter" of the indicator is reduced to as low a frequency as possible. The adjustment should preferably be checked against three or four broadcast stations and an average taken if there is any deviation for the different stations. No modulation should be applied to the oscillator during this adjustment.

The calibration when thus obtained will hold over a long period of time, and it is not necessary to check the frequency against broadcast stations before taking a measurement so long as the room temperature does not vary too much from the temperature at which the instrument was originally calibrated.

Modulation is accomplished by applying unfiltered r.a.c. to the output circuit of the oscillator, and can be cut in or out by means of the s.p.d.t. toggle switch indicated. The modulation facilitates spotting of the harmonics by making it easier to pick them out from among stray carriers.

Care should be taken with any 50-kc. or 100-kc. oscillator when making measurements on 14 Mc. or above if the receiver used does not have good image rejection. The appearance of images will result in spurious carriers and false readings.

The Absorption-Type Wavemeter

The wavelength of any oscillator, doubler, or amplifier stage can be roughly determined with the aid of a simple absorption wavemeter. It is particularly useful for determining the

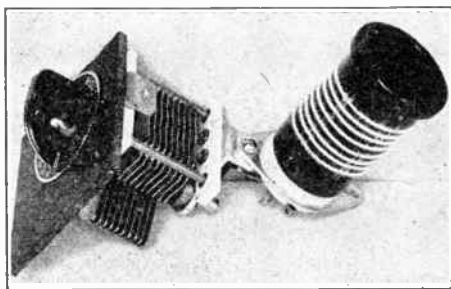

Figure 23.
SIMPLE ABSORPTION TYPE WAVEMETER.

The meter is merely a calibrated tank circuit, using two plug-in coils to cover from 8 to 95 meters. This instrument is very useful for identifying harmonics.



Figure 24.

ABSORPTION WAVEMETER CIRCUIT.

For the range of from 8 to 30 meters, L should consist of 8 turns 1" long on a 1/4" diameter form. For 30 to 95 meters, L should consist of 27 turns 1" long on a 1/4" diameter form.

correct harmonic from a harmonic crystal oscillator or frequency doubler or quadrupler. It consists of a simple tuned circuit which is coupled to the tank circuit under measurement. The wavemeter absorbs a small amount of energy from the transmitter tank circuit; this produces a change in reading of the milliammeter in the plate or grid circuit. A sharp rise or dip in the milliammeter current reading will take place when the wavemeter is tuned to the same wavelength or frequency as that of the circuit under measurement.

The coil socket is bolted to the back mounting flange of the 140- μ fd. midget variable condenser. One coil covers from 8 to 30 meters, another from 30 to 95 meters. The coil turns should be held in place with Duco cement.

The wavemeter can be calibrated by holding it near the secondary coil of an ordinary calibrated regenerative receiver which tunes to the known amateur bands. As the wavemeter condenser is rotated through its range, a point will be found where the receiver is pulled out of oscillation, as indicated by a sharp click in the headphones of the receiver. This point is then marked on the scale of the wavemeter dial. This calibration is sufficiently accurate to insure transmitter operation in the 10-meter band rather than 15-meter operation, which can be easily mistaken for 10-meter output when tuning a transmitter.

The wavemeter can also be calibrated by holding it near the plate coil of a crystal oscillator. A change in oscillator plate current or even a cessation of oscillation will occur when the wavemeter is tuned to the same frequency as that of the oscillator.

Several manufacturers (General Radio in particular) manufacture wavemeters of various degrees of precision and for various frequency ranges. Ultra-high frequency measurements are also sometimes made with a wavemeter, but Lecher wires are more usually employed in the u.h.f. range. The use of Lecher wires for frequency measurement (Lecher wires are essentially a u.h.f. adaptation of the wavemeter) is described in Chapter Seventeen, U.H.F. Communication.

It should be borne in mind that the accuracy

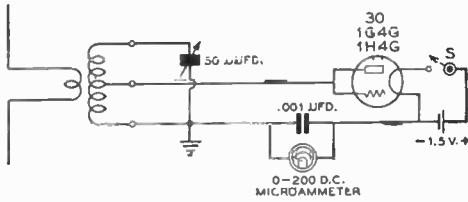

Figure 25.
WIRING DIAGRAM OF THE DIODE-TYPE F. S. METER.

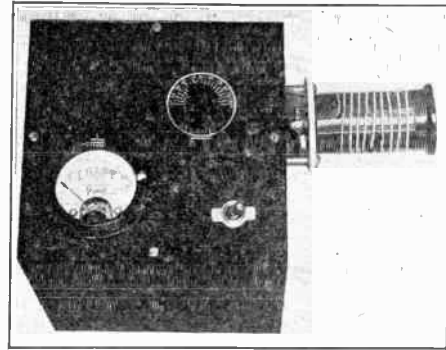

Figure 26.
DIODE-TYPE FIELD STRENGTH METER.
This field strength meter uses a type 30 connected as a diode; a 0-100 or 0-200 microammeter provides good sensitivity. The unit can be used as an absorption wavemeter if calibrated. It also can be used as a neutralizing indicator.

of any absorption type wavemeter is limited by the fact that reactance is coupled into the wavemeter when it is brought near another tuned circuit, and also that the resonance peak covers quite a few kilocycles on the flat portion of the "nose." For this reason, frequency measuring equipment of the heterodyne oscillator type should be used when a high degree of accuracy is required, the absorption meter being used simply to identify harmonics. In the latter case, the absorption wavemeter can be designed so that the desired range covers only a small portion of the dial. Then, when a new oscillator is being tuned up for the first time, it is possible not only to tell if it is out of this range, but in which direction and approximately how much.

MONITORING EQUIPMENT

Under monitoring equipment may be classified instruments for determining the various characteristics of the signal emitted by a transmitter: field strength, quality of modulation or keying, and frequency of the radiated signal. In the following section we will describe several inexpensive portable field-strength meters of varying sensitivity and design, a modulation monitor and general test set for radiophone transmitter, several keying monitors for use with c.w. transmitters, and a simple battery-operated receiver for various monitoring and general applications around the transmitting station. This latter unit may also serve as an emergency portable receiver and as a means of making rough frequency determinations for transmitter tuning.

Field-Strength Meters

Diode-Type F.S. Meter The most practical method of tuning any antenna system, whether a half-wave antenna

or a directional array, is by means of a field-strength meter. Such an instrument gives a direct indication of the actual field strength of a transmitted signal in the vicinity of the antenna. This particular device consists of a tuned circuit and a diode rectifier which is connected in series with a microammeter so that the meter will read the carrier signal strength.

A 0-200 microammeter as an indicator provides higher sensitivity than can be obtained with the more common 0-1 ma. meter ordinarily used for this purpose. A 0-100 microammeter will give still greater sensitivity.

The unit is inexpensive and requires but a single 1½-volt cell for power. Besides serving as a field-strength meter, it can be used as a neutralizing indicator, or calibrated for use as an absorption wavemeter. The entire unit, except coils and coil socket, is housed in a

Figure 27. COIL TABLE FOR THE DIODE F. S. METER.

| | | | |
|---------------|---|-------------|---|
| 1750-2050 Kc. | 88 turns no. 26 d.c.c. 1½" diam., closewound center tap | 14-14.4 Mc. | 10 turns no. 22 d.c.c. 1½" diam., 1½" long center tap |
| 3500-4000 Kc. | 38 turns no. 22 d.c.c. 1½" diam., closewound center tap | 28-30 Mc. | 6 turns no. 22 d.c.c. 1⅛" diam., 1" long center tap |
| 7000-7300 Kc. | 24 turns no. 22 d.c.c. 1½" diam., 1½" long center tap | 50-54 Mc. | 3½ turns no. 18 enam. 1⅛" diam., ¾" long center tap |

metal can 6 inches cubical. The externally mounted coil facilitates coil changing and better adapts the unit for use as a wavemeter, no antenna or pickup wire being necessary in this application.

For service as a field-strength meter, the coil can be coupled to a small doublet by means of 2 or 3 turns of insulated wire wound around the coil. The instrument will be most sensitive if the pickup doublet is made resonant; but such a resonant doublet may, if it is closer than two or three wavelengths, upset the operation of the antenna being adjusted.

The instrument (Figures 25, 26, and 27) was checked against a signal generator. With a type-30 tube, the following calibration in terms of decibels was obtained, using 12½ µa. as an arbitrary zero db reference level:

| | |
|---------------|---------------|
| 12½ µa.— 0 db | 100 µa.—15 db |
| 25 µa.— 5 db | 150 µa.—18 db |
| 50 µa.—10 db | 200 µa.—20 db |

High-Sensitivity F. S. Meter and Simple V.T. Voltmeter

When it is desired to make field-strength readings some distance from the antenna, especially when a low-powered transmitter is used, the

diode-type field meter just described does not have sufficient sensitivity. The field-strength meter illustrated is considerably more sensitive, but requires a plate battery and a more expensive tube than the diode type previously described.

A 1B4 tube, triode connected, is used as a detector. Two small batteries are required for the plate, filament and bias supplies. The plate voltage is 22½ volts, the bias about 2½ volts, and the rated filament voltage, 2 volts.

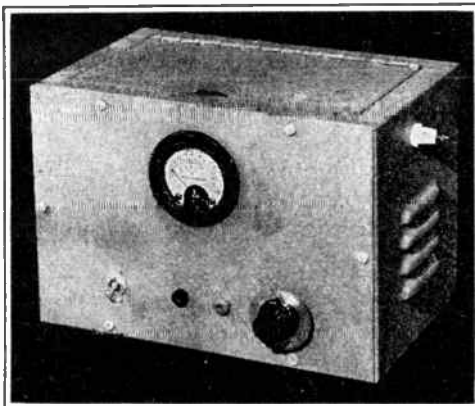

Figure 28.

SENSITIVE FIELD STRENGTH METER.

This is a more sensitive device than the one illustrated in Figures 25, 26 and 27, and also can be used as a simple vacuum tube voltmeter. It requires more batteries, however.

The one tuned circuit in the meter is designed to cover a frequency range of 2 to 1. In the unit shown one coil is used to cover 1700 to 3500 kc., another to cover from 3500 to 7500 kc., and a third coil to cover from 7000 to 15,000 kc. All coils are wound on 1½-inch coil forms. The low-frequency coil is wound of 50 turns of no. 20 d.c.c. wire close-spaced. The intermediate range coil is wound of 15 turns of no. 20 d.c.c., close-wound. And the high-frequency coil consists of 4 turns of no. 20 enamelled spaced to occupy ¾ inch.

When the unit is first turned on, if the batteries and the tube are in good condition, the 0-1 d.c. milliammeter in the common plate and screen circuit of the 1B4 will indicate about 50 microamperes of plate current.

Now, to return the meter to the zero position, with this .05-ma. flow going through it, it is only necessary to turn the zero-adjustment screw until the needle points to zero with the meter in operation. Then, the fact that the meter will always point to zero when all components are in adjustment will serve as a check on the calibration and condition of the batteries. However, as soon as the meter is turned off, the pointer of the milliammeter will fall below the zero on the scale. (Actually it will rest upon the pin on the zero side of the meter.)

If a short length of wire is used for pickup, it may be connected directly to the antenna post, which is a stand-off insulator on the side of the cabinet, wired directly to the stator of the tuning condenser. If it is impossible to get a substantial deflection with a short length of wire, the case of the instrument should be grounded and a longer piece of wire connected to the antenna post through a 3-30 µfd. mica

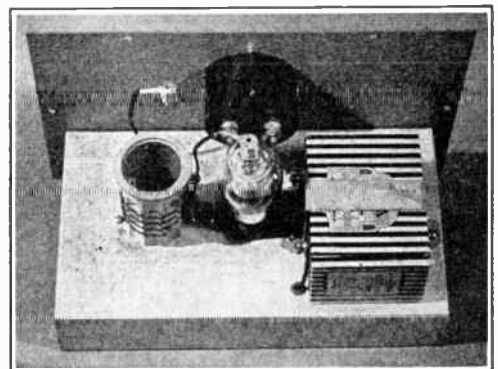

Figure 29.

REAR VIEW OF SENSITIVE FIELD STRENGTH METER.

The plate battery is mounted above the chassis, held firmly in position by means of a strap. Note the extra grid clip, which is brought out to a pin jack for v.t. voltmeter use.

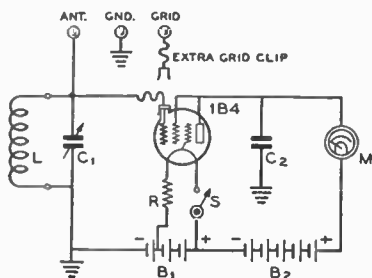

Figure 30.

WIRING DIAGRAM OF SENSITIVE FIELD STRENGTH METER.

- | | |
|--|---|
| C ₁ —140- μ fd. midget variable | B ₁ —4½-volt C battery. Filament leads connected to + and - 3, ground connected to -4½ |
| C ₂ —.002- μ fd. mica | B ₂ —22½-volt C battery |
| R—15-ohm resistor | L—Coils—see text |
| S—On-off switch, s.p.s.t. toggle | |
| M—0.1 d.c. milliammeter | |

trimmer used as a pickup. If the trimmer is not used, a long pickup antenna will detune the meter.

The tuning condenser C₁ can be detuned from resonance if too great a deflection is obtained. It is not necessary that the tank be tuned to resonance for field-strength measurements, though the meter will be most sensitive when C₁ is tuned to exact resonance.

For most work, calibration is not required, a relative indication being sufficient. However, the dial may be calibrated in decibels if desired. The decibel calibration may be marked directly on the meter scale, or a calibration chart may be made. To calibrate the instrument in decibels, simply reduce the input to a class C amplifier in given steps after adjusting the f.s. meter for full scale deflection. Cutting the plate voltage to the class C stage in half would be a power reduction of four times, or 6 db, and so on. The meter covers a useful range of approximately 20 db.

If the instrument is used as a wavemeter, the dial calibration should be made with a short, rigid piece of wire as a pickup. The same wire should then be used whenever subsequent wavelength measurements are made. This wire or rod need not be over a few inches long, as it will receive sufficient pickup when brought near the tank circuit whose frequency is to be determined.

For simple vacuum tube voltmeter measurements it is only necessary to substitute the extra grid clip and make connections from the pin jacks to the device whose voltage is to be measured.

When used as a v.t. voltmeter the instrument should be calibrated by means of an ad-

justable a.c. voltage supply of 0.5 volts and a 5-volt a.c. voltmeter. If desired, the voltage calibration can be converted to decibels, thus making it unnecessary to calibrate it by the method previously described.

Grid-Leak F.S. Meter Slightly greater sensitivity and decibel range may be obtained with a grid-leak type f.s. meter than with the power detector type just described. However, the grid-leak type has the disadvantages that it cannot satisfactorily be used as a vacuum-tube voltmeter, that the circuit is somewhat more complicated, and that this type of f.s. meter has an overload point beyond which measurement is impossible. However, this grid-leak type meter has a useful range of 30 db as compared to the 20 db range of the meter just described.

In tuning up the f.s. meter diagrammed in Figure 32 the plate voltage on the 1T4-GT tube is adjusted so that the milliammeter reads exactly full scale with no signal. This is done by means of the potentiometer R₂. The meter then will give a reverse deflection with signal, the amount of deflection depending upon the strength of the signal. To make the indicating meter forward-reading it is mounted upside down.

The instrument is individually calibrated in db. This can be done by reducing the power to a class C amplifier or a grid leak type oscillator by 50 per cent and taking the displacement of the meter needle as 3 decibels. Full power is restored and the coupling is reduced until the needle is on the lower calibration point. The power is cut in half again and another 3 db point is obtained. The procedure is repeated until calibration points are obtained for the full usable scale.

Only about 3/5 of the meter scale can be used. Beyond a critical point the plate current no longer drops with an increase in r.f.

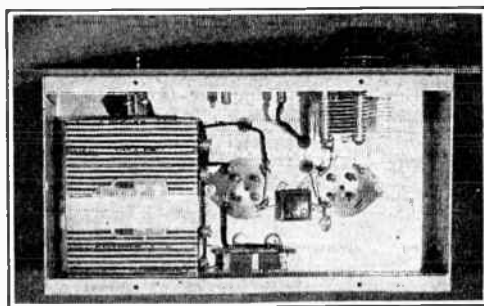

Figure 31.

UNDER-CHASSIS VIEW OF SENSITIVE F.S. METER.

The combined "A" and "C" battery is strapped under the chassis as shown here.

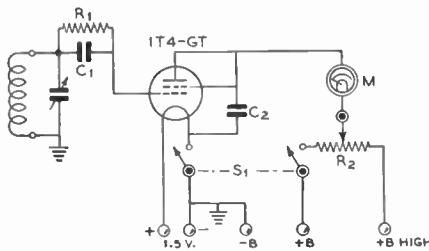

Figure 32.

SENSITIVE, GRID LEAK TYPE F. S. METER.

A 22½ volt Burgess no. 5156 battery is used on the plate. A flashlight cell may be used for filament supply.

| | |
|---|--|
| R ₁ —2 megohms, ½ watt | C ₁ —0.002 μfd. midget mica |
| R ₂ —10,000 ohm pot., linear taper | M—0.1 ma. d.c. |
| C ₂ —100 μfd. midget mica | S ₁ —D.p.s.t. toggle switch |

input; in fact, with sufficient input the plate current may begin to increase. This saturation or blocking point is easily determined simply by gradually increasing the r.f. input until the plate current no longer falls off. The meter then is calibrated just up to this point.

With the tube specified, the instrument may be used up to approximately 125 Mc. if a suitable u.h.f. tank circuit is employed. Needless to say, the leads should be very short for operation at this frequency. A tuned coaxial tank will give noticeably better results than a regular tank at frequencies above 50 Mc.

No antenna coupling is shown, as this will depend upon the type of pickup employed. For greatest sensitivity, the antenna should be resonant and the coupling should be such that maximum voltage is developed across the tank.

Series resistance in the plate circuit, if an appreciable percentage of the plate resistance, will reduce the sensitivity of the meter because of the degenerative effect produced thereby. Series resistance is minimized by making R₂ a potentiometer rather than a straight dropping resistor.

A Burgess type 5156 battery is used because of its many taps. With R₂ turned full on, the "B minus" and the "B plus high" leads are experimentally connected across various taps until the meter reads just slightly more than full scale. The "B plus" lead then is connected to the closest lower "plus" voltage tap and the potentiometer varied until the meter reads exactly full scale.

Under these conditions the maximum series resistance is 2500 ohms, yet the "bleeder" current drawn by the potentiometer itself is less than 0.5 ma. This assumes that the voltage across the potentiometer is not more than 4½

volts, as the voltage across it need not exceed this value if the multi-tapped battery specified is used. To prevent the potentiometer from drawing current when the meter is not in use, a d.p.s.t. switch is used to break the voltage to one side of the potentiometer when the filament circuit is opened.

The mounting of the unit may be similar to that shown in Figures 28 and 29 for the Sensitive F.S. Meter. If the unit is to be used primarily for u.h.f. f.s. measurements it would be advisable to mount a small doublet (resonant to the frequency of test if possible) through the use of standoff insulators on the top of the metal cabinet. If a Faraday shield is used between the antenna coil from the doublet and the tank circuit in the f.s. meter it will be possible to eliminate all capacitive and other undesired coupling into the meter, thus giving an accurate indication of the field strength in the plane of polarization of the doublet.

Radiophone Test Set

A radiophone test set is quite similar to a field-strength meter, yet it lends itself to making several types of additional measurements. It may be used as a carrier-shift indicator, modulation monitor, field-strength meter, neutralizing indicator, and wavemeter.

When the tuned circuit of the test set is coupled to the final amplifier or antenna circuit of the transmitter in such a manner as to obtain about a half-scale deflection of the milliammeter, any upward or downward shift in the meter indication with modulation is called *carrier shift*. Carrier shift in a downward direction may or may not be an indication of overmodulation, depending upon the regulation of the power supplies, the design of the amplifier, and various other considerations. But carrier shift in a positive direction is almost certain to be an indication of overmodulation.

The audio volume with half to full scale meter indication is sufficient to give normal headphone response. A 5,000-ohm resistor is connected into the jack circuit for use when the test set functions as an overmodulation indicator. This resistor is in series with the diode and tends to produce a more linear rectification of the carrier wave.

For neutralizing or field-strength measurements, a short-circuiting plug or brass rod should be inserted into the phone jack to short-circuit the 5,000-ohm resistor and thereby increase the sensitivity of the meter. Neutralizing adjustments are made by coupling the test set's tuned circuit to the transmitter stage under test (without plate voltage applied to the stage). When the stage is completely neutralized, there will be either a minimum or zero deflection of the meter needle.

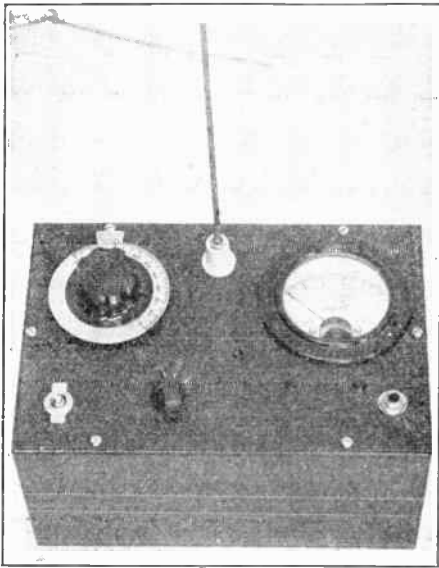

Figure 33.
RADIOPHONE TEST SET.

This versatile instrument can be used as a modulation monitor, absorption wavemeter, field strength meter, carrier-shift indicator, and neutralizing indicator.

A short piece of brass rod, about 10 inches long, protrudes from the chassis as may be seen in Figure 33; this rod acts as a short, fixed antenna. For most purposes the signal pickup with this rod will be sufficient, but when the instrument is used for measuring field strength and there is insufficient meter deflection for an accurate reading, an auxiliary antenna consisting of several feet of insulated wire may be coupled to the pickup rod by wrapping one end of the insulated wire around the pickup rod a few times. The small amount of capacity coupling provided will be sufficient to give a higher meter reading, but will not be enough to disturb the frequency of the tank circuit appreciably.

When using the instrument in the neutralization of an r.f. amplifier, a short piece of flexible wire, about 18 inches long, is clipped directly to the pickup rod. The other end of the wire is brought closer and closer to the plate lead of the stage being neutralized until a substantial deflection is obtained.

The use of 140- μ fd. tuning condenser permits the use of a single coil for coverage of a 2 to 1 frequency range. All coils are built into the set, the particular coil for the desired range being selected by means of a bandswitch. The unit as shown was designed to cover the amateur bands between 1.7 and 60 Mc., but since

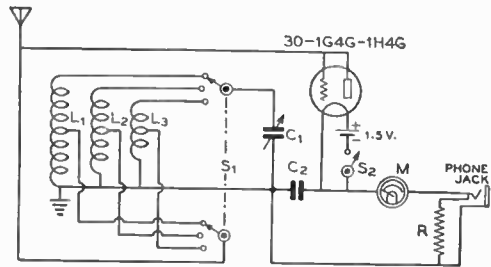

Figure 34.
WIRING DIAGRAM OF THE 'PHONE TEST SET.

- | | |
|--|---|
| C ₁ —140- μ fd. midget | S ₁ —2-pole 3-position rotary switch |
| C ₂ —.001- μ fd. mica | S ₂ —Toggle switch |
| L ₁ , L ₂ , L ₃ —See text | M—0-1 ma. d.c. 3" meter |
| R—5000 ohms, 1/2 watt | |

each coil covers two bands, there are gaps in the coverage of the entire range. However, if it is desired to cover the 10 to 20 and the 40 to 80 meter range, these two additional coils may be wound and a five-position range switch can be used.

For 5 and 10 meters the coil consists of 5 turns of no. 14 wire, 1/2 inch in diameter and spaced to occupy a length of 1 inch. This coil is self-supporting and is soldered directly to the coil switch and tuning condenser rotor.

The 20-40 meter coil consists of 14 turns of no. 22 d.c.c. wire spaced to 1 inch on a 1 1/8-inch diameter form.

The 80-160 meter coil has 55 turns of no. 26 enamelled wire, close-wound on a 1 1/8-inch diameter form.

If the instrument illustrated is duplicated carefully, there will be no need for plotting a calibration curve or table for the individual meter in terms of decibels. The following table will be sufficiently accurate (arbitrary zero db reference level taken as .05 ma. deflection).

| | |
|--------------------|----------------|
| 0.05 ma.—0 db | 0.60 ma.—16 db |
| 0.10 ma.—4 1/2 db | 0.70 ma.—17 db |
| 0.20 ma.—8 1/2 db | 0.80 ma.—18 db |
| 0.30 ma.—11 db | 0.90 ma.—19 db |
| 0.40 ma.—13 db | 1.00 ma.—20 db |
| 0.50 ma.—14 1/2 db | |

An individual frequency calibration must be made to cover use of the instrument as an absorption wavemeter. As a wavemeter, the instrument should be used only for rough measurements, such as determining the order of a harmonic.

Keying Monitor and Code Oscillator

The simple device illustrated in Figure 35 has many uses. It may be used as a keying monitor, facilitating accurate sending of the code characters (speci-

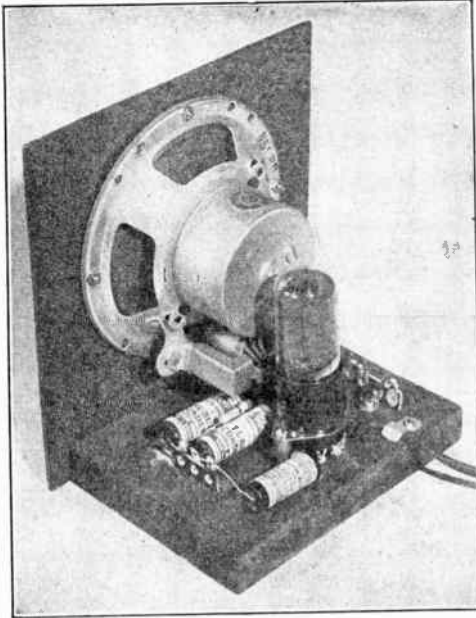

Figure 35.
KEYING MONITOR AND CODE PRACTICE
OSCILLATOR.

This versatile unit may be used as a c.w. monitor, an audio "howler" for code practice, or as a test speaker requiring no field supply.

ally useful with a "bug" key) and as a "watch-dog" on the character of the note. Any ripple or keying chirp present in the carrier in sufficient degree as to be objectionable is readily apparent on the monitor. It also may be used as a code practice oscillator. The speaker itself, requiring no external field supply, will come in handy around the test bench for use as a test speaker. To give the device this wide utility, several connections are brought out to terminals.

The speaker is a 5-inch p.m. dynamic type, complete with midget push-pull output transformer. The output transformer acts as the oscillation transformer for the tetrode section of the 117L7GT, which is used as a conventional Hartley oscillator. For plate voltage, some r.f. carrier voltage is picked up from the final amplifier plate coil by a few turns of heavily insulated wire and fed to the monitor by means of a twisted-pair or coaxial line. This carrier is rectified by the rectifier section of the 117L7GT and utilized as plate voltage. The plate by-pass condenser C_2 filters the rectified carrier into pure d.c. if the carrier itself is free from ripple. However, the time constant of this condenser is fast enough that any ripple in the carrier will show up as modulation of

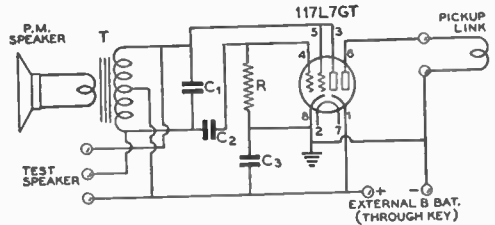

Figure 36.
WIRING DIAGRAM OF VERSATILE
KEYING MONITOR.

The line voltage is applied directly to the heater of the 117L7GT, prongs 2 and 7 on the octal socket.

T—Midget push-pull output transformer (on speaker) higher pitched note
 C_1 —0.01- μ fd. (smaller capacity will give
 C_2 —0.05- μ fd. tubular
 C_3 —0.1- μ fd. tubular
 R—25,000 ohms, $\frac{1}{2}$ watt

the signal generated by the keying monitor. Likewise, any keying lag will be apparent, because the strength of the monitor signal is determined by the strength of the carrier.

The amount of r.f. picked up by the pickup coil is adjusted until the monitor signal is of the desired volume. The r.f. power required is small, less than 1 watt for full room volume. For keying monitor use, the terminals marked "external B bat." should *not* be shorted. With them shorted, damage to the tube may result.

For use as a code practice oscillator, a small B or C battery is connected in series with a key. A 22½-volt battery will give good room volume, and a fair signal is obtained with as little as 4½ volts. The current drain is low and the battery will have long life.

The tone or pitch of the oscillator can be varied by changing the value of C_1 . A smaller capacity will give a higher pitched note, and vice versa. If the condenser is made too large, however, the tube will no longer oscillate.

A "loose" speaker requiring no field supply is often useful for test purposes. By bringing out leads from the three primary wires as shown in the diagram, the speaker may be used for such purposes. For such work, the heater of the 117L7GT is not lighted.

When used as a test speaker the highs will be somewhat attenuated in the manner of "tone control" because of the effect of the shunt condenser C_1 . If suppression of the extremely high voice frequencies is undesirable, provision for opening one lead to C_1 can be made.

If the speaker transformer is of the variable ratio type, the voice coil tap should be chosen to give 14,000 ohms across the full primary, though this adjustment is not especially critical. More volume can be obtained

for a given plate voltage by adjusting the voice coil tap for a lower primary impedance, but if this is carried too far the tube will not oscillate at low plate voltage. To give a true replica of the monitored signal, the monitor should be capable of oscillating on as little as 3 volts.

The unit is constructed on a small wooden baseboard and a Masonite front panel. It may be enclosed in a small cabinet or wooden box if desired.

Two additional versions of this convenient device are illustrated in Figures 37 and 38. Both units feature operation as a code-practice oscillator directly from the a.c. line without the use of batteries, and both feature a volume control and a means of varying the pitch of the oscillator. The unit shown in Figure 37 is designed primarily for use as a code practice oscillator, either for operation into a group of headphones or into a loudspeaker, and is merely a simplification of the unit shown in Figure 38. The Figure 38 unit is designed primarily for use as a c.w. monitor for use with a radio-telegraph transmitter, but by throwing S_2 and plugging a key into J it may also be used as a code-practice oscillator to be operated from the a.c. line without the use of batteries.

Coupling to the output circuit of the transmitter for use as a c.w. monitor is the same for the latter unit as for the one shown in Figures 35 and 36. Also, the mechanical construction of this unit can be similar to that shown in Figure 36.

Combined Monitor, Emergency Receiver, and Frequency Meter

A c.w. monitor is a necessary adjunct to the operation of a c.w. station as a means of checking the emitted signal for chirps, excessive ripple, key clicks, tails, and other undesirable characteristics. An audio-oscillator type of monitor such as the types just described is satisfactory primarily for use as a keying monitor, but for use during transmitter adjustments a shielded oscillating monitor is almost

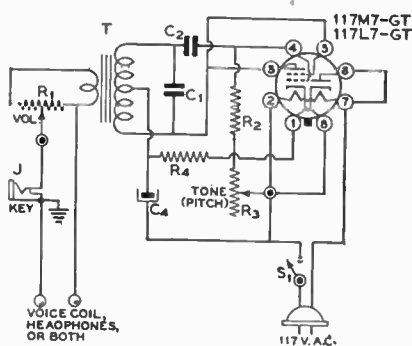

Figure 37.

WIRING DIAGRAM OF A.C.-D.C. CODE PRACTICE OSCILLATOR.

- R_1 —Wire wound potentiometer, resistance equal to 2 or 3 times the rated voice coil impedance of the p.m. speaker used.
- R_2 —50,000 ohms, 1/2 watt
- R_3 —500,000 ohm pot., a.f. taper. Observe correct polarity (see text)
- R_4 —1000 ohms, 1 watt
- C_1 —01 μ d. paper tubular
- C_2 —01 μ d. paper tubular
- C_4 —40 μ d. 150 v. electrolytic
- J—Closed circuit jack
- S_1 —Toggle switch (on-off)
- T—Small p.p. output to voice coil, 8000-10,000 ohms tot. pri. with speaker used

a necessity. A good shielded monitor will enable the operator to tell from within the station what the transmitted signal sounds like at a distance. The simplest monitor of this type consists of a modified autodyne receiver, well shielded.

If the device is stable and well constructed mechanically, it can also serve as a heterodyne frequency meter. An accurate means for determining the frequency of a radio transmitter is essential when the circuit is of the self-excited oscillator type, and useful when the transmitter is of the crystal controlled type, to make certain that the crystal is not oscillating on a spurious frequency.

Figure 38. COMBINATION C.W. MONITOR AND CODE PRACTICE OSCILLATOR

- C_3 —0.1 μ d. paper tubular
 - S_2 —D.p.d.t. rotary switch
- Other constants same as in Figure 37.

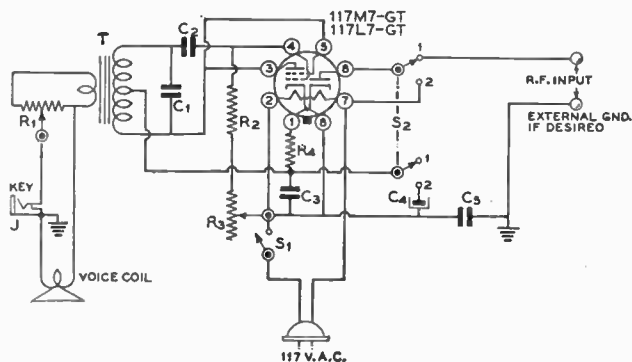

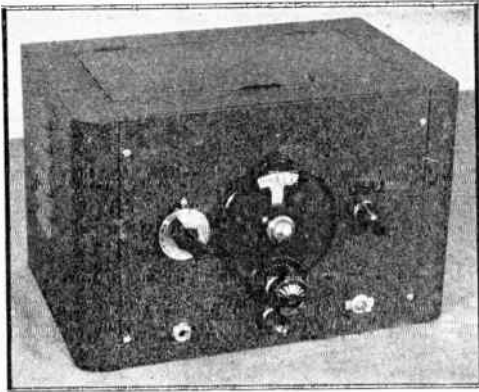

Figure 39.
**FREQUENCY METER, C.W. MONITOR,
EMERGENCY C.W. RECEIVER.**

This unit is completely self-contained and self-powered. Bandswitching is used to eliminate the need for changing coils.

The multi-purpose unit shown in Figure 39 may be used either as an accurate heterodyne frequency meter, as a c.w. monitor, or as an emergency receiver suitable for c.w. reception. Battery powered, the unit is entirely self-contained, the necessary batteries being housed inside the cabinet. As the filament drain is only 0.1 amp. and the total plate current drain about 2 ma., the batteries will last a long time. The output is sufficient to drive an efficient loudspeaker to moderate room volume, but the unit is designed primarily for use with earphones (magnetic type). A closed circuit earphone jack is used so that the tube will not be running with screen voltage but without plate voltage when the earphones are removed, thus preventing damage to the tube.

A rather low value of detector grid-leak is used, and this reduces the sensitivity slightly. However, this is necessary in order to prevent the tube from blocking too easily when the device is employed as a keying monitor. The sensitivity is still sufficient to permit reception of moderately weak c.w. signals when the unit is used as an emergency receiver.

It will be noted that no regeneration control is employed. Such a control would affect the calibration, and therefore would be undesirable when the set was used as a frequency meter. Rather than include one, with provision for cutting it out when the unit is used for frequency measurement, the regeneration is fixed at an optimum compromise value. Because of its effect upon calibration, provision for antenna coupling likewise was omitted. Should the unit be required for emergency use as a portable battery powered receiver, an an-

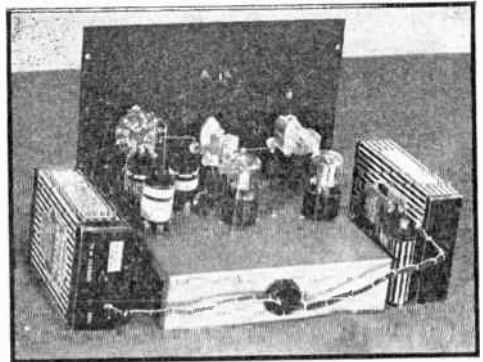

Figure 40.

**FREQUENCY METER-MONITOR,
INTERIOR CONSTRUCTION.**

The cabinet is chosen large enough to accommodate the various batteries. The A battery is good for 300 hours' actual operation, the B and C batteries much more.

tenna is coupled directly to the grid by means of a small compression trimmer or by wrapping a few turns of insulated wire around the grid lead on the coil side of the grid condenser.

The oscillating monitor covers a range from about 3.2 to 20 Mc. in three bands: 3.2 to 6.0 Mc., 5.9 to 11 Mc., and 10 to 20 Mc. All coils are built into the unit, the desired coil being selected by means of a bandswitch. The main (bandset) tuning condenser may be set to any frequency within this range, following which the bandspread condenser will cover a range of about 5 per cent either side of this frequency. For frequency measurement purposes it is advisable that the unit always be operated on the lowest frequency range. If measurement of higher frequencies than 6.0 Mc. is desired, harmonics of the oscillator may be used.

The dial should be of the vernier type, of

COIL TABLE FOR FREQUENCY METER-MONITOR

All coils are wound on 1 in. dia. bakelite forms $1\frac{3}{4}$ in. long, mounted to chassis by spade bolts. All coils wound with no. 24 d.c.c. Tickler polarity must be correct for oscillation.

L₁—3.2 to 6.0 Mc. coil. 23 turns close wound. Tickler 12 turns close-wound, spaced $\frac{1}{8}$ inch from grid coil.

L₂—5.9 to 11 Mc. coil. 12 turns, close-wound. Tickler 5 turns close-wound, spaced $\frac{1}{8}$ inch from grid coil.

L₃—10 to 20 Mc. coil. 8 turns spaced to $\frac{3}{4}$ in. Tickler 4 turns close-wound, spaced $\frac{1}{8}$ in. from grid coil.

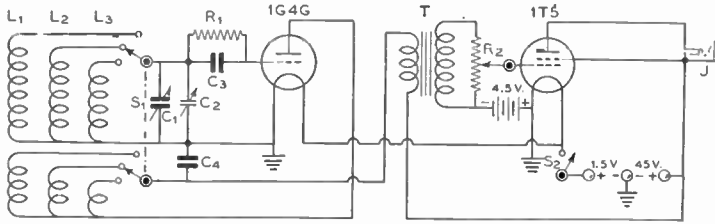

Figure 41.

WIRING DIAGRAM OF MONITOR-FREQUENCY METER UNIT.

- C₁—35-μfd. midget condenser (main tuning)
- C₂—140-μfd. midget condenser (bandset)
- C₃—100-μfd. midget mica
- C₄—0.006-μfd. midget mica
- R₁—250,000 ohms, 1/2 watt
- R₂—500,000-ohm pot., a.f. taper (vol. control)
- T—Midget or replacement type 1:3 ratio a.f. transformer
- J—Closed circuit jack, insulated from panel
- Coils—See coil table
- S₁—Double-pole 3-position selector switch

good quality and capable of being read to a small fraction of a division by interpolation. This permits readings accurate to better than 1 kc. at 80 meters, which is as close as the meter should be depended upon anyway. There is no point in being able to read a frequency meter to 100 cycles if the accuracy of the meter itself cannot be depended upon to closer than 500 cycles.

The unit is calibrated with the aid of broadcast station harmonics, crystals of known frequency, or harmonics of a 100-kc. crystal standard.

Because it is impossible to return *exactly* to the same bandset condenser capacity simply by turning the knob to the same position, and as various components tend to age and cause a slight change in frequency, some sort of *reference* signal is necessary for setting the bandset condenser each time the meter is to be used. This may be a low-drift crystal, a

broadcast harmonic, etc. The measuring condenser, C₁, is set at the reading indicated for that frequency by the calibration graph, then the bandset condenser is slowly tuned near the known approximate setting until the signal is exactly zero beat. The meter then is ready for use. No "warming up" period need be observed before using the meter after it is turned on, as the tubes dissipate so little heat that warm-up drift is infinitesimal.

When measuring one's own transmitter frequency, it is permissible either to listen to the output of the device directly, as is done for monitoring, or it can be used simply as a heterodyne oscillator and the beat note observed in the station receiver. If a sufficiently strong beat is not obtained, the lid to the cabinet may be raised, in which case the calibration curve should be set again against the "reference" signal by means of the bandset condenser. Raising the lid changes the oscillator frequency slightly.

Mechanical construction is of considerable importance; all parts and wiring should be rigid and firmly anchored. As the battery type tubes are somewhat microphonic, it is recom-

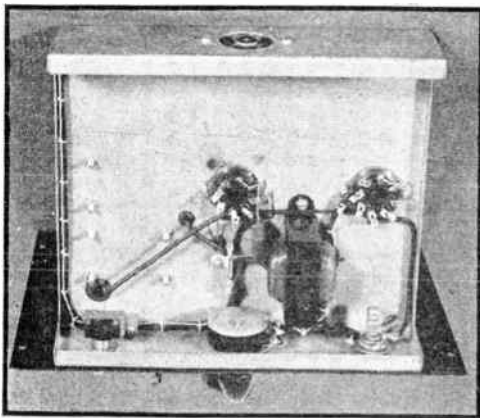

Figure 42.

UNDER-CHASSIS VIEW OF FREQUENCY METER MONITOR.

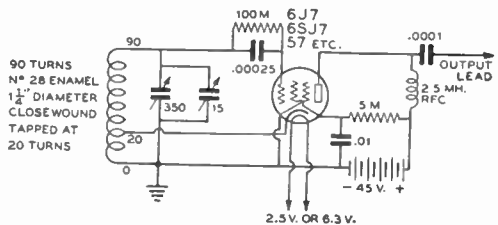

Figure 43.

CALIBRATION OSCILLATOR CIRCUIT FOR USE WITH HEATER TYPE TUBE.

With a.c. tubes, battery plate supply is still used with the calibration oscillator for improved stability.

mended that the unit be placed on a sponge rubber pad.

The batteries should be wedged firmly in place with small pieces of wood, as the calibration will be affected if they are permitted to rattle around. A calibration oscillator suitable for obtaining calibration plotting points is shown in Figure 43.

SIGNAL GENERATORS

A signal generator is, as would be determined from the title, simply a device for the production of a standard and reproducible signal, of any desired character, for use in the measurement of the characteristics of transmitting and receiving equipment. Signal generators consist essentially of an oscillator capable of putting a signal of the desired intensity and frequency on the input of the device to be measured.

A signal generator for the measurement of receiver characteristics consists of an oscillator whose fundamental or harmonics will cover the frequency range of the receiver, usually with the added provision for modulation of the generated signal at some intermediate audio frequency. A signal generator for measurement of the transmission characteristics of a radiophone transmitter consists usually of an audio oscillator covering somewhat more than the normal range of the speech system of the transmitter. An amplitude measurement meter of one type or another and an oscilloscope also are usually used in making transmitter measurements, the former for determining amplitude variations over the frequency range, and the latter unit for determining waveform variations.

Various other specialized types of measurement are frequently used in r.f. and audio measurements of receivers, transmitters and speech equipment. Squarewave generators, harmonic analyzers, gainsets, etc., in audio measurements and sweep oscillators or "wobblers," and signal tracers in receiver adjustment and servicing. But the design and use of these instruments is somewhat too specialized for the more general scope of this chapter. The reader is referred to the John F. Rider publications for receiver measurements and to Terman's *Measurements in Radio Engineering** for advanced transmitter measurement procedure and equipment.

Bandswitching Signal Generator

A signal generator is a useful piece of apparatus for aligning a receiver or calibrating a frequency meter from broadcast harmonics. When the generator is used for calibration purposes, the oscillator must be quite stable if

a high degree of accuracy is required. In alignment work, a modulated signal often is desirable.

The signal generator illustrated in Figure 44 and diagrammed in Figure 45 meets these specifications. A fixed padder condenser (low temperature coefficient type) provides a minimum value of tank capacity which permits high stability at all tuning dial settings. A voltage regulator tube holds the plate voltage virtually constant in spite of line voltage fluctuations; hence the carrier is very stable after a short "warm up" period.

For a modulated signal, as sometimes is desirable for initial or coarse alignment, the filter and voltage regulator (which also provides filtering) are disconnected by means of S_2 . This applies a half-wave rectified voltage which is rich in harmonics, the latter being sufficiently high in frequency to permit their audibility in receivers having poor bass response, yet low enough in frequency that the modulated signal is quite sharp. Because of the inherent stability of the oscillator, very little "wobulation" takes place as a result of the modulated plate voltage.

The layout illustrated need not be adhered to closely; the only requirement is that r.f. leads be rigid and that the coils, tuning condenser, etc. be mounted firmly.

The range 440-1500 kc. is covered in two parts, the dividing line being at about 750 kc. To facilitate the obtaining of exact zero beat, a small vernier condenser is connected across the main tuning condenser. This condenser has only one rotor and one stator plate, double spaced. Almost any midget condenser may be adapted by removing plates as required.

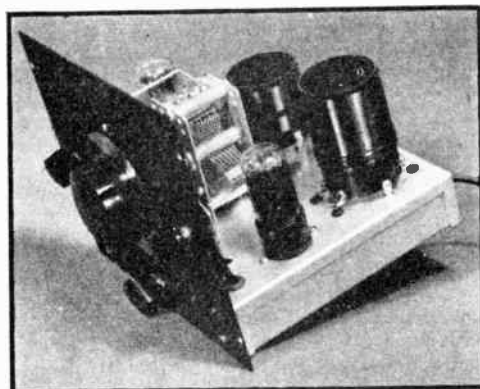

Figure 44.

TEST SIGNAL GENERATOR.

This signal generator covers the range from 440 to 1500 kc. in two jumps. A voltage regulator tube prevents change in plate voltage with line voltage fluctuations.

*See footnote page 478.

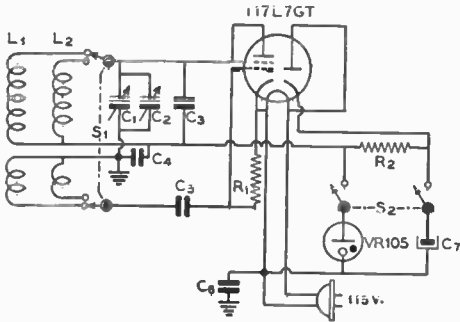

Figure 45.

WIRING DIAGRAM OF SIGNAL GENERATOR.

- C₁—350- or 370- μ fd. broadcast type condenser
- C₂—2- μ fd. vernier (midget condenser with all but two double-spaced plates removed)
- C₃—100- μ fd. zero temperature coefficient padder
- C₄—05- μ fd. 400-volt tubular
- C₅—250- μ fd. mica
- C₆—05- μ fd. 400-volt tubular
- C₇—40- μ fd. 150-volt electrolytic (225-volt peak)
- R₁—50,000 ohms, 1/2 watt
- R₂—1500 ohms, 2 watts
- S₁—D.p.d.t. switch
- S₂—D.p.s.t. switch
- L₁, L₂—Refer to text

Coils The two coils are wound on 2-inch diameter bakelite tubing with No. 24 enamelled wire. The high frequency coil has a plate winding of 36 turns, close-wound, and a tickler winding of approximately 35 turns, closewound. The two windings are separated about 1/8 inch.

The low frequency coil has a plate winding of 85 turns, close-wound, and a tickler of approximately 65 turns, scramble-wound over a length of about 3/8 inch at the ground end of the plate coil. The tickler is placed as close to the plate winding as is possible without danger of a short.

The tickler turns are rather critical, and for this reason only the approximate number is given; a different layout might call for 1 or 2 more or less turns. If too many tickler turns are provided, the oscillator will tend to motorboat or superregenerate over a part of the dial. If too few tickler turns are provided, the oscillator will not oscillate over the whole dial. The tickler polarity must be correct or oscillation will not be obtained.

When a check reveals that the tickler turns are correct, the tickler is treated with coil dope to hold the turns firmly in place.

The strength of the signal can be varied by opening or closing the cabinet lid, by changing the relative distance between signal generator and receiver or receiving antenna, etc.

When making use of a harmonic of the signal generator, it may be difficult to obtain

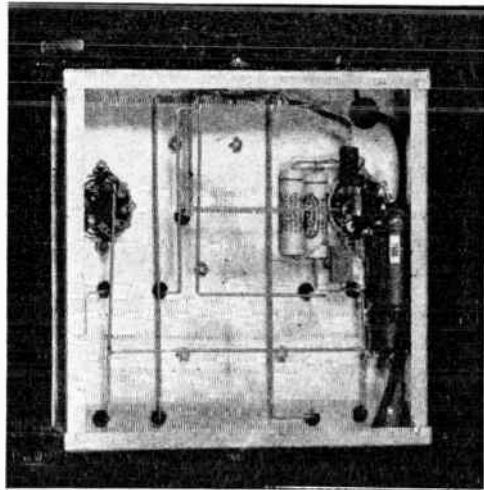

Figure 46.
UNDER-CHASSIS VIEW OF SIGNAL GENERATOR.

sufficient signal without running an "antenna" wire inside the oscillator cabinet. If this is done, the vernier condenser should be adjusted *after* the pick-up wire is in place, as the presence of the wire will change the oscillator frequency slightly (as will opening or closing the cabinet lid).

The harmonics are sufficiently strong to be readily usable down to 8000 kc. when a "pick-up" wire is inserted inside the cabinet. Most heterodyne frequency meters operate on a fundamental frequency lower than 8000 kc., and no standard communications receiver employs an intermediate frequency below 440 kc. Hence, the frequency range is adequate for all normal purposes.

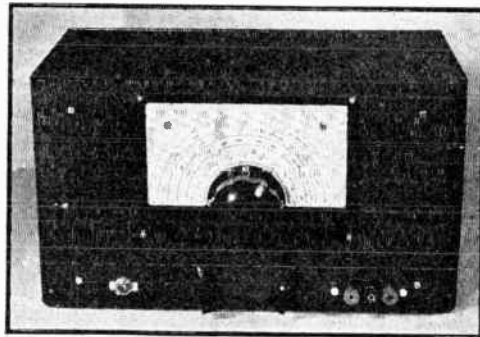

Figure 47.
WIDE RANGE AUDIO OSCILLATOR.
This unit covers the range from 16.6 to over 85,000 cycles, the output remaining substantially constant except at the high-frequency end of the range.

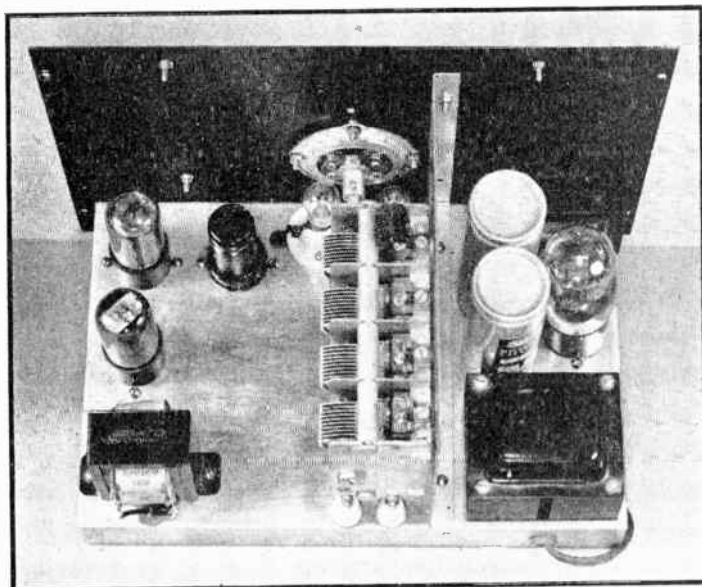

Figure 48.
PLACEMENT OF COMPONENTS ABOVE THE CHASSIS.

Note especially the metal shield, extending almost to the top of the panel, which separates the oscillator portion from the power supply.

Wide Range Audio Oscillator

A source of variable-frequency audio frequency power having negligible harmonic content is of great usefulness in testing audio amplifiers and modulators. Such an oscillator is shown in Figures 47 to 49. It covers from 16.6 to 85,000 cycles, over which range the output remains substantially constant except at the high-frequency end of the range.

The satisfactory operation of the oscillator is dependent upon an automatic adjustment of the ratio between the regenerative and degenerative feedback between the output and the input circuit. The magnitude of the regenerative feedback is fixed and is fed back directly to the grid of the 6SJ7 through the resistance-capacity input circuit. The degenerative feedback is coupled through R_6 into the two lamps RL_1 - RL_2 in the cathode circuit of the 6SJ7. These lamps have a very positive resistance-temperature characteristic, hence the amount of feedback voltage increases more rapidly than does the current through the lamps. The varying voltage drop across the lamp resistor circuit is determined by the change in magnitude of the audio current fed back from the plate circuit of the first 6V6-GT tube.

The output amplifier isolates the oscillator from the external circuit, allowing it to be fed into the primary of a transformer or into a low-impedance line without any reaction upon the oscillator caused by varying output circuit conditions. The voltage available from the low-impedance output terminals is variable up to about 1.25 volts over the audible range, dropping off slightly above 25,000 cycles. The high-

impedance output terminals will supply about 18 to 20 volts.

The frame of the tuning condenser is at grid potential above ground. For this reason it has been found necessary to shield the entire oscillator portion of the unit from the power supply section, and, for that matter, from surrounding fields in general. The shielding was accomplished by placing a large shield directly behind the tuning condenser and between it and the power supply, and by inserting a small shield in an analogous position below the chassis. With these two shields in place, and with the entire unit in its shielding metal cabinet, there is no interaction between the oscillator and the line frequency, and no hum appears in the output. However, when the oscillator is removed from the cabinet the large area of the tuning condenser will pick up a certain amount of hum from surrounding a.c. lines. The result of this a.c. pickup will be quite noticeable on the lowest frequency scale, where the oscillator and its harmonics will tend to lock in with the various harmonics of the a.c. line frequency. For this reason, it is important that the oscillator be operated only when it is thoroughly enclosed in its shielding cabinet.

C_2 is used to maintain a capacity balance of the two sections, since the lower section has a much greater capacity to ground. It is placed across the upper half of the dual tuning condenser, the trimmers on the lower section are turned all the way out, and the trimmers in parallel with C_2 are varied until smooth oscillation is maintained over all bands. The ad-

justment is not particularly critical, although a cathode-ray oscilloscope will be of assistance in determining the best position. If the trimmers are not set correctly, it will be difficult to maintain oscillation in the vicinity of 150 cycles on the lowest scale, and there will be a peculiar dissymmetry in the waveform in the vicinity of 1000 cycles on the second scale.

A range of about 10 to 1 will be covered on each set of resistors, and the coverages of these four ranges are as follows: 1.—16.6 to 150 cycles, 2.—150 to 1,150 cycles, 3.—1,500 to 10,000 cycles, 4.—10,000 to 85,000 cycles. These figures are the end calibration points of the various ranges. The frequency coverage actually is continuous from 16.6 cycles to over 85,000 cycles.

Calibration The most satisfactory and least difficult method of calibration would be to check the unit by the zero-beat method against another audio oscillator which is already accurately calibrated. The unit also can be calibrated by means of an oscilloscope having a linear sweep oscillator going from about 10 to 5000 cycles, by utilizing the power line frequency as a base from which to start. The procedure, though simple, must be followed exactly as given in order that no error be introduced, since any error introduced at the outset would be cumulative throughout the calibration.

First, it is best to have both the phones and the vertical plates of the oscilloscope (through the amplifier in the 'scope) connected across the output of the oscillator. Then, with alternating current directly from the line fed into the horizontal plates of the 'scope, adjust the

frequency of the oscillator on the lowest range until a figure such as is shown in Figure 50A is obtained. This indicates that the vertical deflection frequency is exactly twice the horizontal deflection frequency. If the local supply frequency is 60 cycles, the oscillator is on 120 cycles.

Then turn in the tuning condenser until a circle is obtained on the screen of the 'scope—the audio oscillator is now operating on the *same* frequency as the local line. Now turn the condenser in still further until a figure the same as described in the preceding paragraph *but lying on its side* is obtained—the oscillator is now on *half* the frequency of the local line. If the oscillator condenser is turned in still further it will be possible to obtain a figure which will have 1 loop in the horizontal plane and 3 loops in the vertical plane—the oscillator is then on one-third of the line frequency. These calibration points can then be marked on the proper dial scale by making a dot with a sharp pencil point inserted through the hole in the pointer (with the celluloid cover removed). In-between fractional ratios between the line frequency and the oscillator can be obtained for additional calibration points if Lissajou's figures, as described in the literature and in later paragraphs, are formed on the screen by careful adjustment of the oscillator frequency. The oscillator should now be returned to the position which gives the figure described in the preceding paragraphs, with the oscillator on twice line frequency.

Turn the synchronization control until there is no interlocking between the incoming signal and the sweep oscillator, turn on the sweep oscillator, and adjust its frequency until a sin-

Figure 49.
UNDER-CHASSIS VIEW.

The small metal shield, between the range switch and resistors and the filter condenser leads in the power supply, is important if ripple difficulties are to be eliminated.

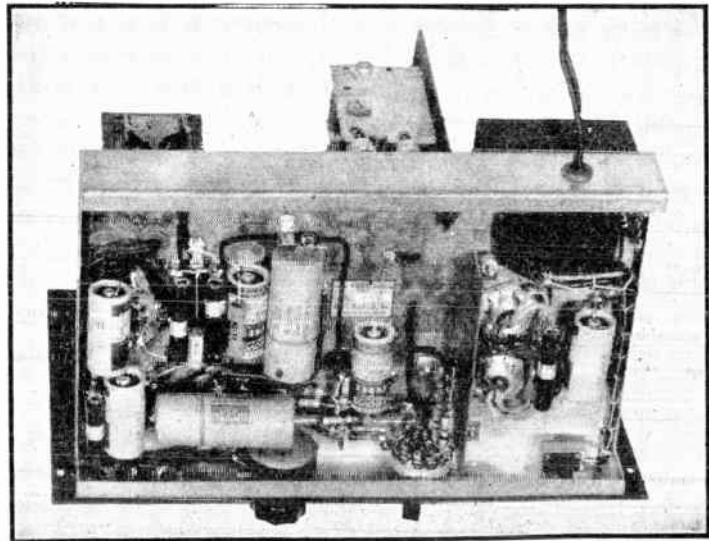

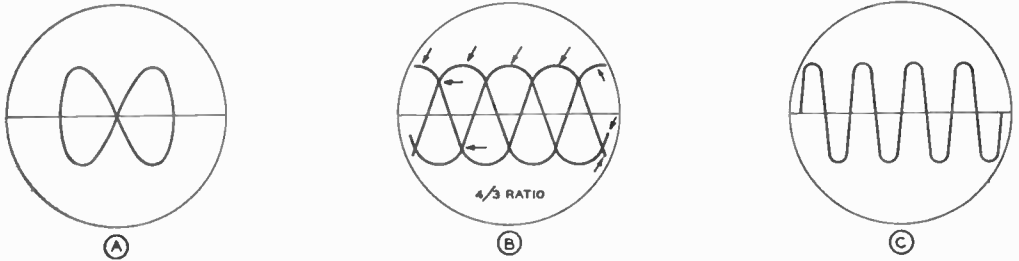

Figure 50. Examples of the oscilloscope patterns used in the calibration of the audio oscillator with the aid of a cathode-ray oscilloscope. (A) Pattern obtained with 60 cycles (sine wave a.c.) on the horizontal plates and 120 cycles (sine wave a.c.) on the vertical plates. (B) Figure showing a relation of 4/3 between the frequency of vertical deflection and the frequency of horizontal saw-tooth sweep. (C) Figure showing a relation of 4/1 between the vertical deflection and horizontal saw-tooth frequencies.

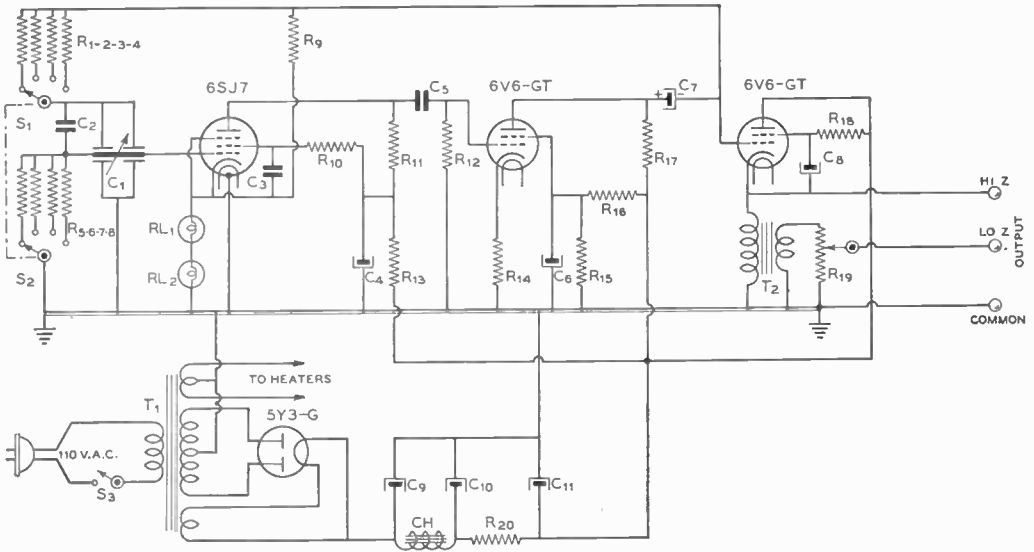

Figure 51.

WIRING DIAGRAM OF THE WIDE RANGE AUDIO OSCILLATOR.

- | | | | |
|---|--|---|---|
| C ₁ —4-gang 365- μ fd. b.c. condenser | R ₁ , R ₇ —10 megohms, 1/2 watt | R ₁₂ —500,000 ohms, 1/2 watt | RL ₁ , RL ₂ —6-watt 120-volt tungsten mazda lamp |
| C ₂ —.000075- μ fd. midget mica | R ₂ , R ₁₀ —1.25 megohms, 1/2 watt (1 megohm and 250,000 ohms in series) | R ₁₃ —100,000 ohms, 1/2 watt | T ₁ —580 v. c.t., 50 ma.; 5 v. 3 a.; 6.3 v. 2 a. |
| C ₃ —1.0- μ fd. 400-volt tubular | R ₃ , R ₈ —150,000 ohms, 1/2 watt | R ₁₄ —200 ohms, 10 watts | T ₂ —Universal output to voice coil trans. |
| C ₄ —8- μ fd. 450-volt electrolytic tubular | R ₄ , R ₆ —20,000 ohms, 1/2 watt | R ₁₅ —40,000 ohms, 1 watt | CH—10-hy. 65-ma. filter choke |
| C ₅ —1.0- μ fd. 400-volt tubular | R ₅ —2500 ohms, 1 watt | R ₁₆ —50,000 ohms, 1 watt | S ₁ , S ₂ —2-pole 6-position switch (only 4 positions used) |
| C ₆ , C ₇ , C ₈ , C ₉ —8- μ fd. 450-volt electrolytic tubular | R ₉ —500,000 ohms, 1/2 watt | R ₁₇ —10,000 ohms, 10 watts | S ₃ —S.p.s.f. a.c. line switch |
| C ₁₀ , C ₁₁ —16- μ fd. 450-volt electrolytic | R ₁₁ —100,000 ohms, 1/2 watt | R ₁₈ —25,000 ohms, 10 watts | |
| | | R ₁₉ —1000-ohm potentiometer | |
| | | R ₂₀ —500 ohms, 10 watts | |

gle stationary sine wave appears on the screen. The sweep oscillator is now on exactly 120 cycles. The standard of frequency has been transferred from the 60-cycle line to the 120-cycle linear sweep oscillator.

The determination of the calibration points for frequencies intermediate (fractional multiples) between the fundamental and integral harmonics, such as the second, third, etc., can be made through a knowledge of certain geometrical patterns which will be seen on the screen of the oscilloscope, called Lissajou's figures. Their interpretation is simple enough since they represent, when standing still, fractional relations between the two frequencies which are being impressed upon the vertical and horizontal plates of the oscilloscope.

The fractional relation between the two frequencies can be determined by a simple inspection of the waveform which appears on the 'scope. First, the number of complete bumps which appear along the top in the horizontal direction is counted; this is the numerator of the fraction. Then the number of traces is counted (this may be determined by counting the number of free "tails" at either end of the figure, or by taking *one more* than the number of crossovers on any ascension or decension of one-half of one of the sine waves) and this value is the denominator of the fraction which represents the relation between the frequency on the vertical plates with respect to the frequency of horizontal saw-tooth sweep.

Figure 50B shows a Lissajou's figure which represents a $4/3$ ratio between the impressed voltage and the horizontal saw-tooth frequency. If the sweep frequency were still 120 cycles in this case, the input frequency would be 160 cycles. Calibration points for frequencies which are intermediate between integral multiples may be obtained in this way.

Now switch to the next higher frequency range and, keeping the *sweep* oscillator on 120 cycles, set the dial of the audio oscillator to the point where 2 complete sine waves appear on the screen. The oscillator will now be on $2/1$ times 120 cycles, or 240 cycles. Put this down in the chart and increase frequency until 3 sine waves appear: this will be $3/1$ or 360 cycles. Next come 4 sine waves or 480 cycles

(the figure for this is shown in 50C), 5 sine waves or 600 cycles, 6 sine waves or 720 cycles, and 7 sine waves or 840 cycles.

Since it becomes difficult to count the number of waves accurately with a small c.r. tube, the standard frequency must be increased to enable the calibration of the higher ranges. This is a very interesting and comparatively simple procedure, but it must be followed carefully, step by step. First, the oscillator is tuned down in frequency again until there are 5 sine waves on the screen indicating 600 cycles. It is important in making all these adjustments to tune the oscillator carefully until the pattern stands quite still. Now retune the *sweep* oscillator in the oscilloscope until there are 6 sine waves on the screen where there were 5 before. The sweep is now on 100 cycles instead of 120—hence the 6 waves instead of the 5. Now retune the audio oscillator until there are 5 waves on the screen instead of 6, the oscillator now being on 500 cycles, and then retune the *sweep* oscillator until there is only 1 sine wave on the screen. This puts the sweep oscillator on 500 cycles, the new base frequency.

Now by switching the oscillator to the third range the frequencies of 1500, 2000, 2500, 3000, etc., may be checked by their multiple sine wave patterns. Then the audio oscillator may be shifted to 1000 cycles, the sweep oscillator shifted to 1000 cycles to give a single wave, and the frequencies from 3000 to 12,000 cycles checked.

For extremely high audio frequencies, the oscillator may be shifted to 5000 cycles and the sweep oscillator increased in frequency until a single sine wave is visible, showing that the sweep is on the same frequency. Then this frequency may be multiplied on up in the manner used for the lower frequencies until calibration up to 75,000 cycles or above is obtained.

As a check upon the entire calibration the entire process may be reversed and the difference between the resulting check line frequency and the actual frequency determined. If it is very far off, the whole process had better be repeated in order to obtain a more accurate calibration.

The Cathode-Ray Oscilloscope

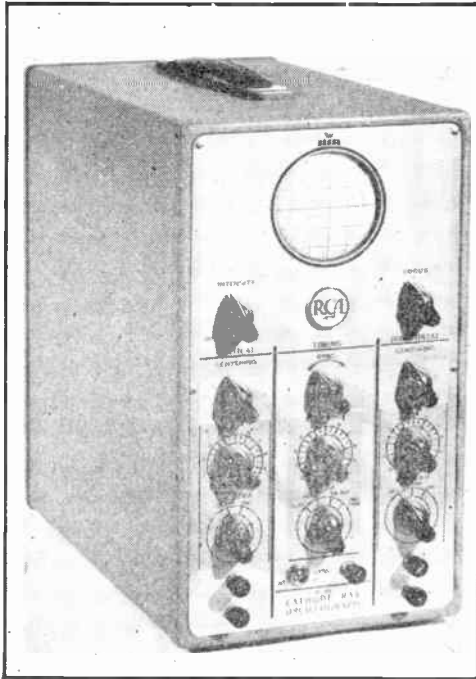

THE cathode-ray oscilloscope (also called *oscillograph*) is an instrument which permits visual examination of various electrical phenomena of interest to the radio or electrical engineer or technician. Instantaneous changes in voltage or current are observable just so long as they take place slowly enough for the eye to follow, or else are *periodic* for a long enough time that the eye can obtain an impression from the cathode-ray tube screen.

The end of the cathode-ray tube is coated with a fluorescent material which glows brightly wherever sufficient electrons strike it with sufficient velocity. A fine stream of electrons is focused on the fluorescent screen, the electrons being emitted from a hot cathode at the

opposite end of the evacuated tube. The electrons are focussed so that the stream makes only a small dot on the screen, under static conditions.

Now it is known that electrons are repulsed or attracted by an electrostatic or electromagnetic field. (Refer to Chapter 2.) Thus, by placing electromagnets or electrostatic "deflector plates" where they can act upon the electron beam, it is possible to make the pencil of cathode rays "write" upon the fluorescent screen, permitting visual observation of the character of the voltages applied to the deflector plates or deflector electromagnet.

This is the general principle of all cathode-ray oscilloscopes, and it readily can be seen why the cathode-ray tube is the heart of the instrument. All other components in the instrument are for supplying the required voltages to the tube, or to generate an a.c. voltage of known frequency and waveform, or to facilitate adjustments, or to switch circuits. As the cathode-ray tube is the important item in a cathode-ray oscilloscope, a more detailed description of it will be given before discussing the oscilloscope as a whole.

The Cathode-Ray Tube

The construction of a typical cathode-ray tube is illustrated in the pictorial diagram of Figure 1. The indirectly heated cathode K releases free electrons when heated by the enclosed filament. The cathode is surrounded by a cylinder G, which has a small hole in its front for the passage of the electron stream. Although this element is not a wire mesh as is the usual grid, it is known by the same name because its action is similar: it controls the electron stream when its negative potential is varied.

Next in order is found the first accelerating anode, H, which resembles another disk or cylinder with a small hole in its center. This electrode is run at a high or moderately high positive voltage, to accelerate the electrons towards the far end of the tube.

The focussing electrode, F, is a sleeve which

usually contains two small disks, each with a small hole.

After leaving the focussing electrode, the electrons pass through another accelerating anode, A, which is operated at a high positive potential. In some tubes this electrode is operated at a higher potential than the first accelerating electrode, H, while in other tubes both accelerating electrodes are operated at the same potential.

The electrodes which have been described up to this point constitute the "electron gun," which produces the free electrons and focusses them into a slender, concentrated, rapidly-traveling stream for projection onto the viewing screen.

The question of electrode voltages and physical dimensions and spacing of the electrodes necessary to produce a fine point of electrons on the viewing screen is tied up with the subject of electron optics. Suffice it to say that these problems have been worked out by the manufacturer when designing the tube, and therefore all one needs to do to obtain a fine, sharply focussed electron "stylus" is to use the tube under the conditions specified by the manufacturer.

To make the tube useful, means must be provided for deflecting the electron beam along two axes at right angles to each other. The more common tubes employ electrostatic deflection plates, one pair to exert a force on the beam in the vertical plane and one pair to exert a force in the horizontal plane. These plates are designated as B and C in Figure 1.

Certain of the larger cathode-ray tubes employ magnetic deflection, utilizing an electromagnet in the form of a yoke to deflect the electron beam. However, these tubes are much less common, and therefore this discussion will be confined to those tubes which employ electrostatic deflection.

The fact that the beam is deflected by a magnetic field is important even in an oscilloscope which employs a tube using electrostatic deflection, because it means that precautions must be taken to protect the tube from the transformer fields and sometimes even the

earth's magnetic field. This normally is done by incorporating a magnetic shield around the tube and by placing any transformers as far from the tube as possible, oriented to the position which produces minimum effect upon the electron stream.

Standard oscilloscope practice with small cathode-ray tubes calls for connecting one of the B plates and one of the C plates together and to the high voltage accelerating anode. With five-inch tubes and larger all four deflecting plates are commonly used for deflection. The *positive* high voltage is grounded, instead of the negative as is common practice in amplifiers, etc., in order to permit operation of the deflecting plates at a d.c. potential at or near ground.

With most tubes, the spot will be very accurately centered if all four deflecting plates are at ground potential. However, a means of varying the d.c. voltage slightly on one of each pair of electrodes oftentimes is provided so as to permit accurate centering of the "spot" under all conditions.

After the spot is once centered, it is necessary only to apply a positive or negative voltage (with respect to ground) to one of the ungrounded or "free" deflector plates in order to move the spot. If the voltage is positive with respect to ground, the beam will be attracted toward that deflector plate, while if negative the beam and spot will be repulsed. The amount of deflection is directly proportional to the voltage (with respect to ground) that is applied to the free electrode.

With the larger-screen higher-voltage tubes it becomes necessary to place deflecting voltage on both horizontal and both vertical plates. This is done for two reasons: First, the amount of deflection voltage required by the high-voltage tubes is so great that a transmitting tube operating from a plate supply of 1500 to 2000 volts would be required to attain this voltage without distortion. By using push-pull deflection with two tubes feeding the deflection plates, the necessary plate supply voltage for the deflection amplifier is halved. Second, a certain amount of de-focussing of the electron stream is always present on the extreme excursions in deflection voltage when this voltage is applied only to one deflecting plate. When the deflecting voltage is fed in push-pull to both deflecting plates in each plane, there is no de-focussing because the *average* voltage acting on the electron stream is zero, even though the *net* voltage (which causes the deflection) acting on the stream is twice that on either plate.

It can be seen that by applying a suitable voltage of suitable polarity to the deflector plates in each plane it is possible to position the spot anywhere on the screen. If the volt-

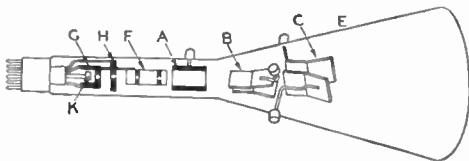

Figure 1.

PICTORIAL DIAGRAM OF TYPICAL CATHODE RAY TUBE.

This tube is of the type employing electrostatic deflection. The various components are described in the text.

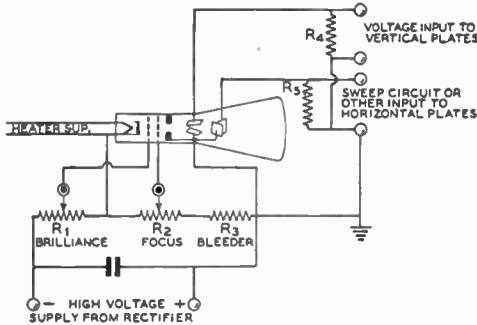

Figure 2.
BASIC CATHODE RAY OSCILLOSCOPE
CIRCUIT.

ages vary slowly, the spot can be followed with the eye. If the voltages vary rapidly, there will be either a blur or a "trace" depending upon whether the spot travels over and over long enough for the eye to retain an image, or for the fluorescent screen to become sufficiently activated so that an image will be retained for the eye to see.

Cathode-ray tubes are obtainable with any one of several types of screen material, each having its characteristic "persistence" and fluorescing color. The persistence is the degree to which the screen material will glow after being bombarded with electrons. The fluorescent material will give off light for an instant after the bombardment is terminated, and the longer the time the longer the "persistence."

Cathode-Ray Tube Circuits Having covered the various elements inside the tube, as well as their functions, let us now consider a typical circuit in which they are used, as shown in Figure 2.

The tube is shown schematically, with both the control grid and focussing electrodes shown by the usual grid symbols, as is customary in cathode-ray tube circuits. The potentiometers, R_1 and R_2 , control the intensity (brilliance) and focussing of the beam. R_3 simply completes the bleeder circuit.

Mention has been made of the two "free" deflector plates where test voltages are connected. Actually, they are connected to ground through resistors of from one to ten megohms. These resistors would not be needed if all circuits under test provided a ground return path. If allowed to "float" entirely free, these plates would soon accumulate enough electrons to give them a negative charge and shift the beam completely off the screen.

The heater supply is connected to a transformer which furnishes 2.5 or 6.3 volts to the filament, depending on tube type. In the small-

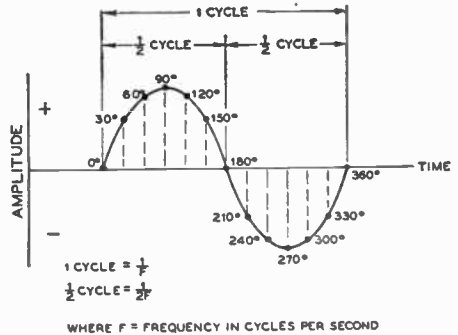

Figure 3.
GRAPH OF A SINE WAVE, AS
CUSTOMARILY INDICATED.
Photographs of several cycles of such a wave, as shown by an oscilloscope, appear on page 216.

er tubes the cathode usually is connected to one side of the filament, within the tube.

The high voltage leads are connected to the rectifier output of the power supply. It should be noted, though, that the *positive* lead is grounded, which is contrary to receiver practice.

Sweeping The reader should be familiar with graphs employed to show the relation of one function to another, graphs such as that of Figure 3. This is the common method of illustrating graphically a sine wave. The vertical axis represents voltage, plus or minus, and the horizontal axis represents time. This particular graph shows one complete cycle of a 60 cycle alternating voltage.

The manner in which the electron beam of a cathode-ray oscilloscope can be made to trace a pictorial representation of this voltage on the fluorescent screen is explained as follows.

Assume that the 60 cycle voltage is derived from the a.c. supply mains, and that this voltage is fed through a transformer to the vertical deflection plates of the c.r. tube as shown in Figure 4. If all electrodes are at proper operating potentials, then the alternating voltage impressed upon the vertical deflection plates will cause the "spot" to move up and down the screen in accordance with the voltage. Movement of the spot will be too rapid for the eye to detect, and therefore only the *trace* of the spot will be observed. If the synchronous motor is stopped, this trace will be a straight vertical line, the length of the line depending upon the amount of voltage impressed upon the vertical deflection plates.

It should be observed that the a.c. voltmeter shown in the diagram will read the r.m.s. volt-

age, but the trace on the screen will represent the *peak* voltage. If the sensitivity of the tube has been determined by applying a known voltage to the vertical deflector plates, then it is possible to measure the peak voltage directly by means of a ruler placed on the screen. For reasons which will be apparent later, the tube always is designed so that the displacement or deflection of the beam is exactly proportional to voltage; in other words it is *linear*. This means that only one known voltage is required in order to calibrate the instrument for voltage, as this will give the sensitivity in millimeters per volt, permitting voltage measurement by means of a ruler.

It should be observed that a d.c. voltage will deflect the spot a certain distance from center, either up or down, depending upon the polarity, but that an a.c. voltage of the same peak amplitude will deflect the spot this distance *in both directions from center*. When the sensitivity of a certain tube is rated in millimeters per volt, it refers to *d.c. voltage*, and when measuring the trace of an a.c. voltage to determine its peak value, it is necessary to divide the length of the trace by 2 before converting to peak a.c. voltage.

So far nothing but d.c. has been applied to the "free" horizontal deflection plate. If it were, our trace of the a.c. voltage applied to the vertical plates no longer would be a straight vertical line.

The remainder of the apparatus in the setup of Figure 4 would not be used in practice; it is simply for illustration of the manner in which the horizontal "time base" operates to give a useful pattern of the waveform applied to the vertical plates. Electrically it consists of a battery with its center terminal grounded and its positive and negative terminals connected across a potentiometer, P, the slider arm, A, of which goes to the free horizontal plate. It is obvious that as the slider arm is moved, the spot will be moved to the left or right to conform to the voltage and polarity applied to the horizontal plates.

If the motor is started, the cam (C) will cause the arm of the potentiometer to sweep across the potentiometer and then fly back almost instantly to the other end, repeating the cycle over again. Actually it would be hard to design a mechanical system with sufficiently low inertia to follow a motor making 60 revolutions per second, but for the purposes of explanation this consideration can be ignored.

By giving the cam the proper contour, the potentiometer arm can be made to move uniformly across the potentiometer winding with respect to time. This will cause the spot on the c.r. tube screen to move across the screen horizontally at a uniform rate, and then fly back almost instantly to move across the screen

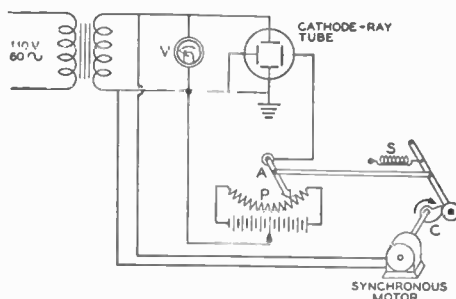

Figure 4.

HYPOTHETICAL SET UP FOR EXPLAINING PRINCIPLE OF SWEEP CIRCUIT.

The contour of the cam (C) is such that the arm (a) of the potentiometer (P) travels across the winding at a uniform rate in one direction and then immediately flies back to repeat the action at regular intervals.

again in the same direction. It is standard practice to arrange the "sweep" so that the spot moves across the screen from left to right, so that time will be represented as being in the same direction as on conventional graphs.

We now have an arrangement which corresponds to the graph of Figure 3, the sine curve of Figure 3 simply being the trace of a point which is operated upon both by time and voltage.

The graph of Figure 3 shows but one cycle. To show, say, five such cycles, the graph simply would be extended to the right, with four more similar cycles added. Likewise any number of cycles could be added so long as the paper were of sufficient length for the time axis.

An oscilloscope screen, however, has limited dimensions. Therefore, the spot is made to make *immediately successive trips* across the screen from left to right instead of going on indefinitely as does the time axis on the graph. This is permissible because an oscilloscope is of use only in viewing *recurrent* waveforms, and if each trace made by the spot as it moves across the screen is so nearly like the preceding one that a single trace appears to be formed, the repetitive nature of the path traveled by the spot only tends to make the trace more brilliant. In fact, a single sweep of the spot across the screen in 1/60 second would not even produce a visible trace unless the spot were intensely brilliant.

In the setup of Figure 4, the beam will traverse the screen 60 times in one second, making a trace each time. But since the sweep mechanism moves in perfect synchronism, each trace will cover the exact position on the screen as did all preceding traces, causing the wave to be "stopped in its tracks." Obviously this calls for a recurrent waveform and a synchronized sweep.

The wave need not be a sine wave, but it must be *periodic*, and the sweep must be synchronized to the fundamental (lowest) frequency component in the recurrent wave or to a submultiple thereof. It is apparent that if the sweep frequency were cut to 30 cycles, the spot would travel across the screen in 1/30 second instead of 1/60 second, and *two* cycles of a sine wave would be traced on the screen when 60 cycle alternating voltage was applied to the vertical deflector plates. If the sweep were made a multiple (instead of a submultiple) of 60 cycles, then only a fraction of the full cycle would be traced during one "horizontal trip" of the spot.

In a practical cathode-ray oscilloscope the sweep voltage is generated electronically, usually by means of a relaxation type oscillator using a gaseous triode. This oscillator will be described later in more detail; for the moment it is necessary only to know that such an oscillator can be used to generate a saw-tooth wave at any frequency up to about 20,000 c.p.s., and that the oscillator can be synchronized or "locked in" with any substantial component in the waveform applied to the vertical plates if this is desired. By making the amplitude and frequency continuously variable, it is possible to permit wide control over the sweep voltage.

The number of cycles contained in the trace will depend upon the ratio of the sweep frequency to the frequency of the voltage under observation. If an attempt is made to put more than about five cycles on the screen, the waveform of one cycle will be so compressed that critical study of the shape of the wave is difficult. This means that the conventional oscilloscope is useful in observing waveforms only when the fundamental frequency is below approximately 100,000 cycles (assuming an upper sweep frequency limit of 20,000 cycles).

If the waveform of the voltage under test is changing, it still is possible to observe the waveform by means of an oscilloscope so long as the waveform does not change so rapidly that the eye cannot follow the change. However, the trace no longer is "frozen." If sweep synchronization is maintained as the waveform is changed, the trace will not travel to the left or right, but will change in character. However, maintaining sweep synchronization under these conditions oftentimes is difficult if not impracticable.

When the sweep frequency is not maintained in exact synchronization with the waveform being tested, the trace or picture will "travel" across the screen. If the synchronization is sufficiently poor, the trace will move across the screen at such a rapid rate that nothing but a blur will be visible.

The sweep circuit being discussed is the so-called *linear timing circuit*, providing "linear

sweep." For some applications, sweep voltage having a sine waveform is employed. However, most applications call for linear sweep. The only very common applications of sine wave sweep are the "trapezoidal" method of checking an amplitude modulated carrier, and frequency measurement by the comparison method. The latter requires the ability to interpret "Lissajous figures." The trapezoidal method of checking modulation, along with some typical trapezoidal modulation patterns, is discussed in conjunction with the *C. R. Modulation Checker*, shown in figures 12 and 13. Lissajous' figures are discussed in the description of the *Wide Range Audio Oscillator* in Chapter 24.

The ideal linear sweep arrangement would be one where the beam would "fly back" instantly. Actually, the gaseous discharge tube takes a finite time to discharge through its protective "current limiting resistor," which means that the "vertical" portion of the saw-tooth wave isn't exactly vertical. The effect isn't particularly noticeable for sweep frequencies below about 5000 cycles, but at higher frequencies has to be considered. The result is a "return trace" and distortion of the pattern, the latter being most objectionable towards the right hand limit of the trace. When a horizontal amplifier is used after the saw-tooth oscillator (as is common practice), the distortion of the saw-tooth waveform at the higher frequencies is exaggerated, because of the inability of the amplifier to pass the higher frequency components of such a high frequency saw-tooth wave without attenuation or phase shift.

Sweep distortion can be prevented from giving trouble by adjusting the sweep so that several full cycles appear on the screen. Not only does this permit a lower sweep frequency (which often is enough to cure the trouble), but it then is possible to pick for observation one or two cycles on that portion of the screen where sweep distortion does not occur.

Sweep Circuits About the simplest form of linear sweep is the neon bulb oscillator shown in Figure 5. Current

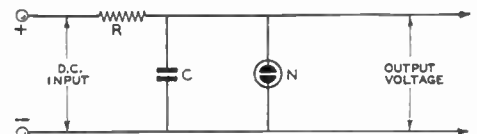

Figure 5.
RELAXATION TYPE OSCILLATOR EMPLOYING NEON BULB.

This type oscillator can be made to deliver good saw tooth waveform, but cannot be synchronized. Therefore it is of but little practical use in an oscilloscope.

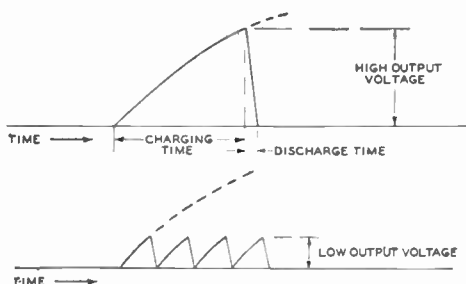

Figure 6.

ILLUSTRATING HOW A LOW FLASHING VOLTAGE IMPROVES LINEARITY.

The rise of voltage across a condenser is not linear with respect to time, but by making the flashing voltage low in proportion to the supply voltage, sufficiently good linearity is obtained.

from the d.c. input circuit, flowing through resistor R , charges condenser C . The neon bulb, N , has no effect until its flashing voltage (usually 50 or 60 volts) is reached. At this point, gas within the bulb ionizes, rendering the bulb a conductor. This discharges condenser C as though it were short circuited. When the voltage across condenser C becomes reduced sufficiently, the bulb becomes de-ionized, and no longer conducts. This permits condenser C to start charging again, and the cycle is repeated.

While extremely simple, this oscillator has various faults. The most serious is that it cannot be synchronized with another signal. The output is not sufficient to swing the beam clear across the c.r. tube screen, but this can be overcome by using an amplifier. The linearity will not be good unless the supply voltage is several times the flashing voltage, but as the required current is small, this is not too serious a problem. The chief disadvantage, and a most serious one, is the impracticability of synchronization.

The reason for using a high supply voltage in order to obtain good linearity is explained as follows: The voltage build-up of a condenser is not linear with respect to time. However, by taking a small enough section of any curve, it is possible to obtain virtually a straight line. This principle is made use of in obtaining good linearity in a gaseous discharge type oscillator. The condenser is discharged by the tube long before the voltage across it approaches the supply voltage.

To facilitate synchronization, a grid controlled gaseous rectifier is used in place of a neon bulb. A gas triode is similar to a neon bulb in its action except that the flashing voltage can be varied over wide limits by control of the negative grid bias. With the common gas triodes the tube will flash when the posi-

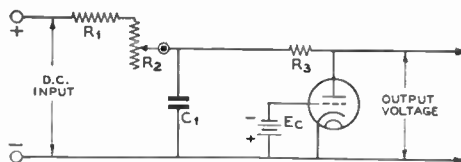

Figure 7.

BASIC CIRCUIT OF SAW TOOTH OSCILLATOR EMPLOYING A GAS TRIODE.

The resistor R_3 is just large enough to limit the discharge current to the maximum safe peak current of the tube. Flashing voltage is determined by the amount of negative bias on the tube.

tive plate voltage is 7 or 8 times the negative grid bias voltage, assuming that the plate voltage is higher than the de-ionization voltage of approximately 16 volts. The basic gas-triode oscillator circuit is shown in Figure 7.

For a given supply voltage, the relative linearity obtained with high flashing voltage and low flashing voltage is illustrated in Figure 6. By sacrificing output voltage, much better linearity is obtained.

Another method of obtaining good linearity, not as widely used now as it once was, is to substitute a pentode vacuum tube for the series charging resistor. When the current flowing into the condenser is kept constant over the charging cycle, the build-up of voltage will be linear. The inherent characteristics of a pentode tend to keep this current constant. The effect is as though an infinitely high supply voltage were used. This system allows much greater output voltage, but the addition of the current limiter complicates the circuit as much as does an amplifier stage. As a horizontal amplifier often is handy for other purposes, when not using linear sweep, it is common practice to use the low flashing voltage method and provide a horizontal amplifier to build the sweep voltage up to the amplitude required by the c.r. tube.

Synchronization If a small a.c. voltage is applied in series with the negative bias on the grid of the gas triode comprising the sweep oscillator, then the oscillator will have a tendency to "lock in" when the frequency of oscillation (as determined by the R/C ratio of the charging circuit) approximates that of the "synchronizing voltage," or a submultiple thereof. Thus, a synchronizing voltage of, say, 6000 cycles, would cause the sweep to lock in at 6000, 3000, 2000, 1500, etc., cycles. If the ratio is greater than about 10 to 1, however, the locking-in action is not so positive, though still usable if the relaxation oscillator is stable to begin with. If the supply

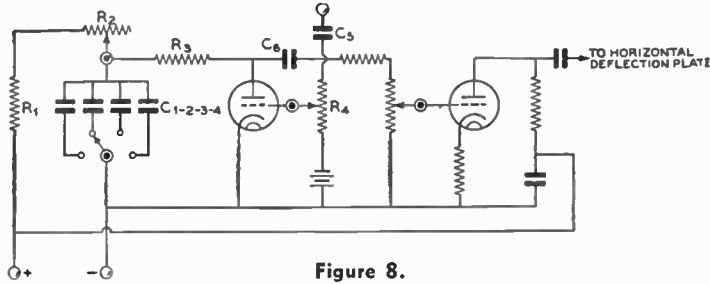

Figure 8.

BASIC CIRCUIT OF SWEEP OSCILLATOR AND HORIZONTAL AMPLIFIER.

Synchronizing voltage is applied to the grid of the oscillator tube through C_6 , the amplitude being adjusted to the optimum value by means of R_1 . Fine control of frequency is by means of R_2 .

voltage varies badly, then it is possible that the oscillator will be sufficiently unstable that synchronization is difficult except at a 1-1 ratio.

A typical sweep oscillator is illustrated schematically in Figure 8. The synchronizing voltage is applied through C_6 , being adjusted in amplitude by means of R_1 , until best action is obtained. If insufficient synchronizing voltage is applied to the gas triode, the locking in will not be positive in action. If too much synchronizing voltage is applied, the waveform of the sweep oscillator will be distorted. Ordinarily a fraction of a volt will be sufficient synchronizing voltage.

In this basic diagram (Figure 8) no provision is shown for switching the amplifier to "external input." In some oscilloscopes this provision is made; in others the amplifier is connected permanently to the saw-tooth oscillator.

Amplifiers The horizontal amplifier should have flat frequency response up to about 100,000 cycles, if practicable, so that the saw-tooth wave will be passed without appreciable distortion when operating at its upper frequency limit. Phase shift or attenuation of the higher frequency components will result in distortion of the saw-tooth wave form.

A conventional resistance coupled amplifier is satisfactory if the load resistance is made sufficiently low to permit sufficiently good high frequency response. Sometimes, with large tubes employing electrostatic deflection, an ordinary receiving tube operating at normal plate voltage will not deliver sufficient undistorted voltage swing. In such a case, a small transmitting tube is employed as a resistance coupled amplifier, with high plate voltage.

The vertical amplifier also must have good frequency response and low distortion, in order to give a true picture of the signal under test. Ordinarily the vertical amplifier is made similar to the horizontal amplifier. In the smaller

oscilloscopes, a single, high-gain amplifier stage is used as a vertical amplifier. In some of the more expensive instruments employing medium or large size c.r. tubes, a two or three stage amplifier is employed as a vertical amplifier. This permits the instrument to be used for checking voltages of very low amplitude.

Commercial Instruments As it is possible to buy a commercially manufactured oscilloscope for no more than the component parts required to construct an

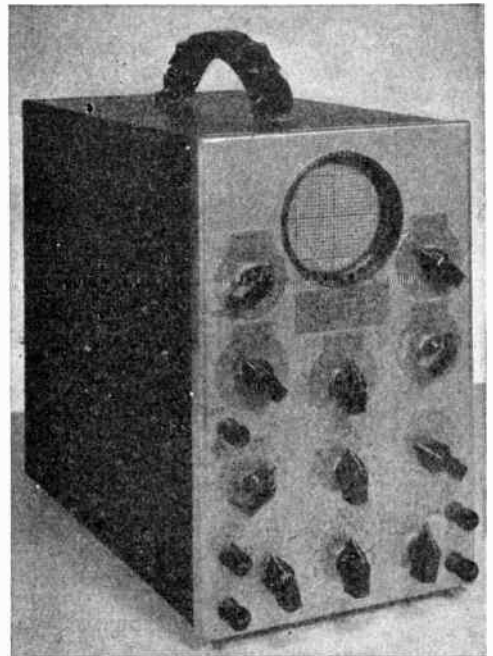

Figure 9.

EXTERIOR VIEW OF TYPICAL MANUFACTURED 3-INCH OSCILLOSCOPE.

equivalent one, there really is no excuse for a home- or custom-constructed instrument unless it must be unconventional in some respect in order to meet particular requirements for which a standard oscilloscope is not suitable.

A typical cathode ray oscilloscope is illustrated in Figure 9, and shown schematically in Figures 10 and 11. A standard 3-inch job usually is provided with potentiometers for controlling the brilliance and focus of the cathode ray tube, potentiometers for centering the beam on the screen, selector switch and fine control for the sweep frequency, synchronizing control, gain controls for horizontal and vertical amplifiers, and switches for cutting either amplifier out of the circuit and for switching the horizontal amplifier from the saw-tooth oscillator to external sweep.

Some of the many uses of the cathode-ray oscilloscope in its various forms are as follows:

- Measurement of d.c. voltage or current.
- Measurement of peak a.c. and r.f. voltage.
- Trouble-shooting in receivers.
- Adjustment of i.f. stages (including band-pass).
- Measurement of audio amplifier distortion, overload and gain.
- Adjustment of phase-inversion circuits.
- Checking of power supplies.
- Checking of harmonic content.
- Measurement of phase angle and phase distortion.
- Measurement for dynamic tube characteristic curves.
- Checking of 'phone signals and per cent modulation by:
 - Modulation envelope
 - Trapezoidal pattern
 - Cat's eye pattern
- Making condenser power factor tests.
- Making overall frequency response tests.
- Determining unknown frequencies.
- Adjusting auto vibrators.
- Studying surges and transients.

Cathode-ray oscilloscopes are extremely useful for measuring percentage modulation and analyzing distortion in a 'phone transmitter.

It is recommended that anyone who wishes more than a superficial knowledge of the applications and proper use of the cathode-ray oscilloscope invest in one of the many excellent books on the subject, available very reasonably from *Rider, RCA Manufacturing Co., Dumont* and others. Because of space limitation, a comprehensive treatise on the theory, construction, and use of oscilloscopes is not within the scope of this book. This will be appreciated when it is realized that there appear books on oscilloscopes which contain over 100 pages devoted to applications of the instrument alone.

One not well experienced in the use of oscilloscopes always should bear in mind that

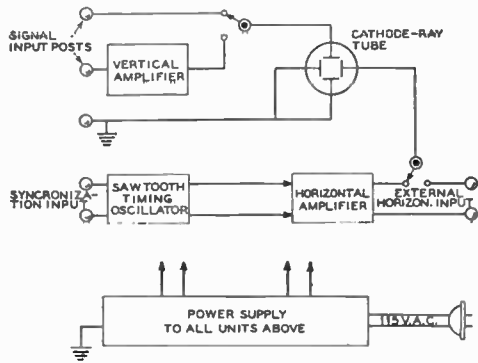

Figure 10.
BLOCK DIAGRAM SHOWING COMPONENT UNITS OF TYPICAL OSCILLOSCOPE.

the accelerating anode potentials used with the larger tubes are high enough to be very dangerous, and also that the fluorescent screen can be damaged permanently by allowing the beam to rest for long on a single spot unless the intensity control is reduced sufficiently to prevent excessive brilliance.

C. R. Modulation Checker

The "modulation checker" shown in Figures 12 and 13 is a very simple oscilloscope which is entirely satisfactory for modulation checking, and which can be built for a fraction of the cost of a "standard" 'scope. It consists of an RCA-913 cathode-ray tube with a fluorescent screen about 1 inch in diameter. This tube, and a suitable power supply, are built into a small metal cabinet measuring 5 x 6 x 9 inches.

A dime magnifying glass obtainable at any five-and-ten-cent store gives a trapezoidal figure comparable in size to that of a 2-inch cathode-ray tube. The magnifying glass is held about 2 inches from the screen of the 913 by a piece of bakelite tubing which is slipped over the 913 and allowed to project slightly beyond the magnifying glass in order to keep out external light. If desired, a 902 (2-inch screen) may be substituted for the 913; no circuit changes will be required.

Three a.f. binding posts allow connection of the 'scope to the modulator of any 'phone transmitter with 5- to 1000-watts carrier power. No external coupling condenser is required; a lead may be connected directly to the class C amplifier plate return circuit at the modulation transformer terminals. *Beware of the high voltage.* Connections for a grid-modulated transmitter are similar, except that the modulation transformer connection is in the grid-return instead of the plate return circuit of the r.f. amplifier. The resistor network adapts the

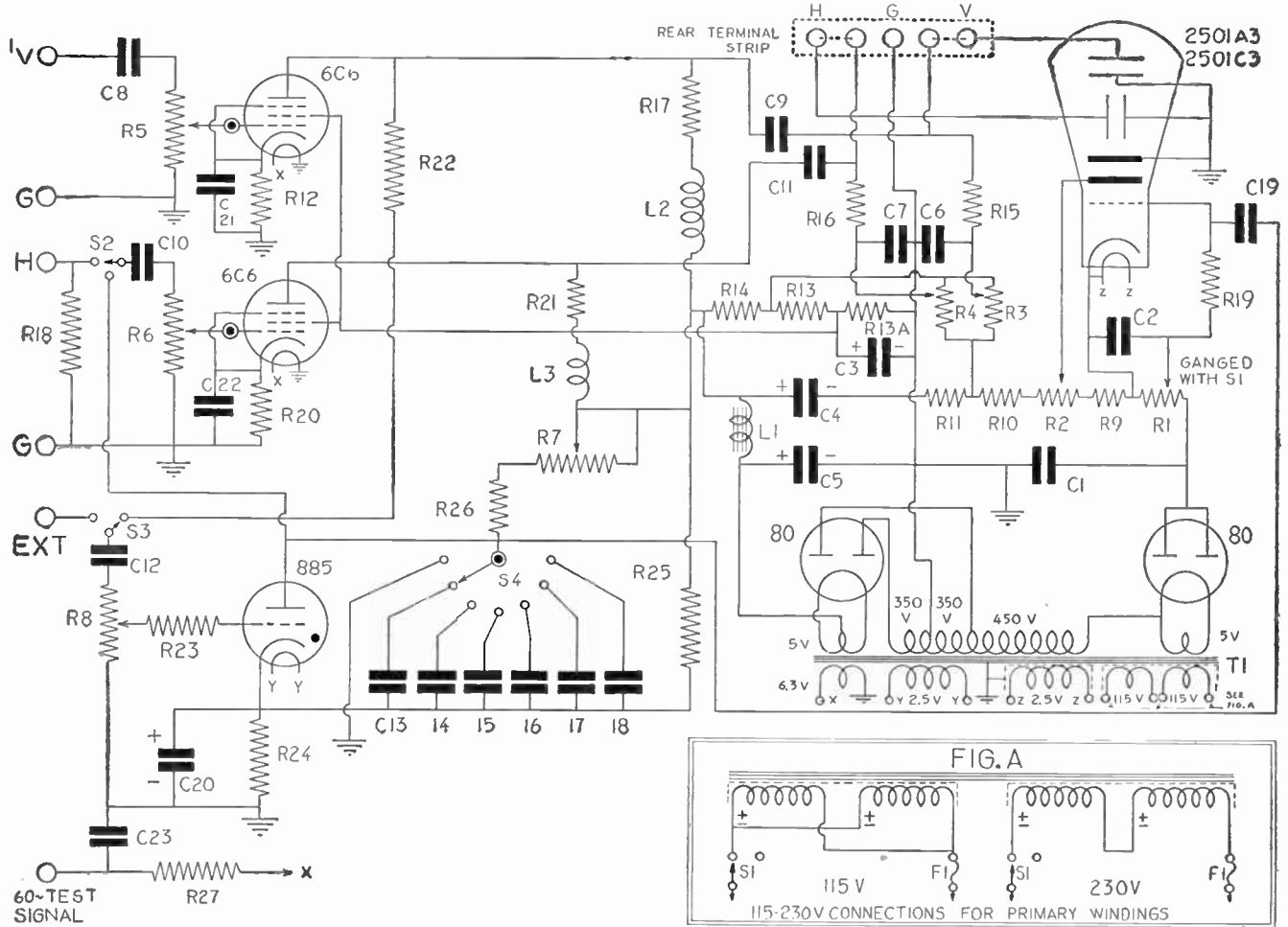

Figure 11.
WIRING DIAGRAM OF OSCILLOSCOPE SHOWN IN FIGURE 9.

- | | | | |
|--|--|--|--|
| C ₁ —0.5 μfd. 1500 volts | C ₂₂ —0.004 μfd. 400 volts | R ₇ —15,000 ohm pot. (synch.) | R ₂₁ —82,000 ohms, 1 watt |
| C ₂ —0.5 μfd. 600 volts | C ₂₃ , C ₂₄ —0.1 μfd. 1000 volts | R ₈ —100,000 ohms, 1/2 watt | R ₂₂ —1 meg., 1/2 watt |
| C ₃ —8 μfd. 150 volts | F ₁ —1 ampere Littelfuse | R ₉ —750,000 ohms, 1 watt | R ₂₃ —100,000 ohms, 1/2 watt |
| C ₄ —4 μfd. 475 volts | L ₁ —10.5 hy. choke | R ₁₀ —250,000 ohms, 1/2 watt | R ₂₄ —1000 ohms, 1/2 watt |
| C ₅ —4 μfd. 475 volts | L ₂ , L ₃ —65 mh. peaking coil | R ₁₁ —850 ohms, 1/2 watt | R ₂₅ —100,000 ohms, 2 watts |
| C ₆ , C ₇ —0.05 μfd. 400 volts | R ₁ —200,000 ohm pot. (intensity) (ganged with S ₁) | R ₁₂ , R _{13A} —10,000 ohms, 2 watts | R ₂₆ —750,000 ohms, 1 watt |
| C ₈ , C ₉ , C ₁₀ , C ₁₁ —0.25 μfd. 400 volts | R ₂ —500,000 ohm pot. (focus) | R ₁₄ —25,000 ohms, 10 watts | R ₂₇ —10,000 ohms, 1/2 watt |
| C ₁₂ —0.05 μfd. 400 volts | R ₃ —4 meg. pot. (V position) | R ₁₅ —500,000 ohms, 1/2 watt | S ₁ —S.p.a.t. toggle switch (power) (ganged with R ₁) |
| C ₁₃ —0.2 μfd. 400 volts | R ₄ —4 meg. pot. (H position) | R ₁₆ —5 meg., 1/2 watt | S ₂ —S.p.d.t. rotary switch (horiz.) |
| C ₁₄ —0.04 μfd. 400 volts | R ₅ —1 meg. pot. (V gain) | R ₁₇ —82,000 ohms, 1 watt | S ₃ —S.p.d.t. rotary switch (synch.) |
| C ₁₅ —0.01 μfd. 400 volts | R ₆ —4 meg. pot. (H gain) | R ₁₈ —1 meg., 1/2 watt | S ₄ —S.p.7.t. rotary switch (freq.) |
| C ₁₆ —0.0025 μfd. 400 volts | R ₇ —4 meg. pot. (freq. vernier) | R ₁₉ —500,000 ohms, 1/2 watt | T ₁ —Power transformer |
| C ₁₇ —600 μfd. 400 volts | | R ₂₀ —850 ohms, 1/2 watt | |
| C ₁₈ —125 μfd. 400 volts | | | |
| C ₁₉ —50 μfd. 1200 volts | | | |
| C ₂₀ —25 μfd. 25 volts | | | |
| C ₂₁ —0.002 μfd. 400 volts | | | |

NOTE: Where 2 watt resistors are specified, two one watt resistors, each having half the resistance value specified, may be used in series.

Figure 12.
CATHODE RAY MODULATION CHECKER.

This inexpensive oscilloscope is useful for obtaining trapezoidal modulation patterns. A cheap magnifying glass and tubular shade to keep out external light give a pattern comparable to that obtained with a 2-inch c.r. tube.

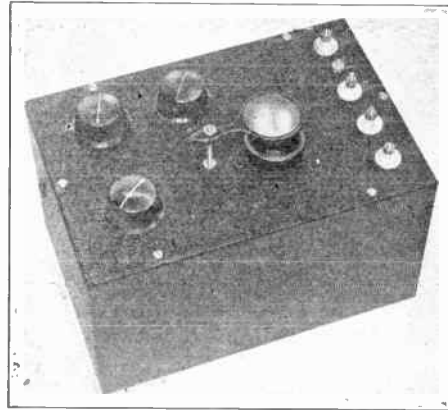
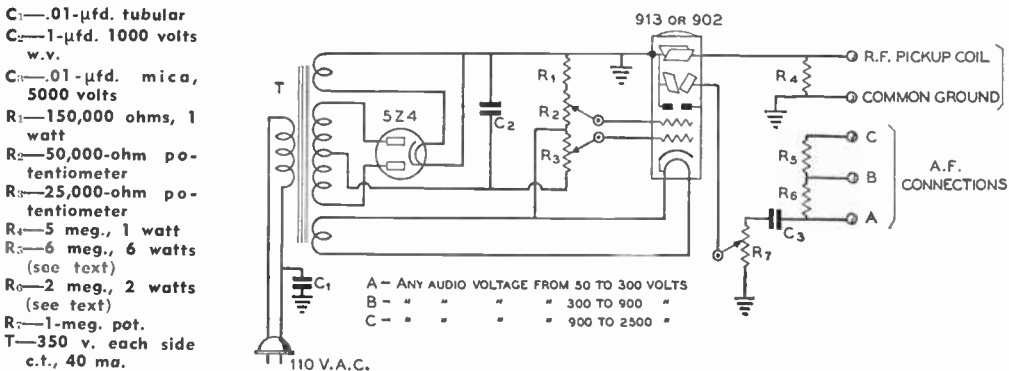

Figure 13.
WIRING DIAGRAM OF THE CATHODE RAY MODULATION CHECKER.



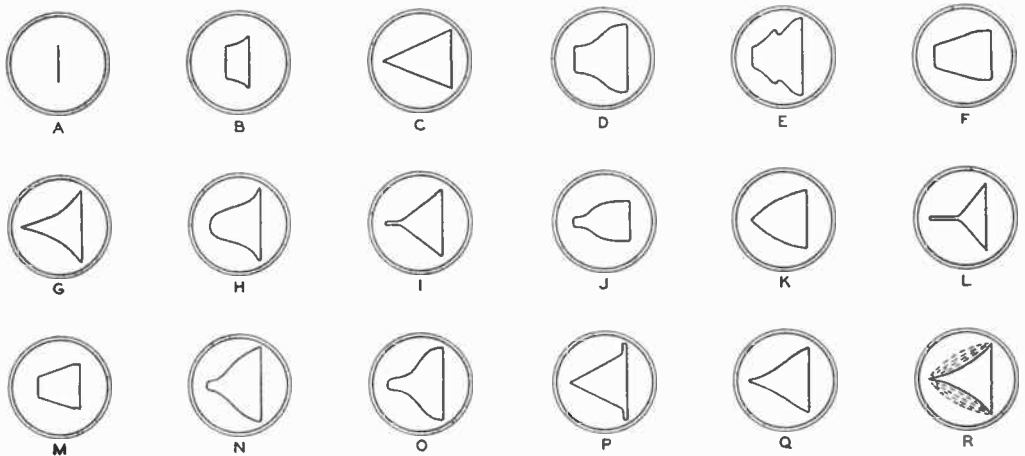

Figure 14.

TYPICAL OSCILLOGRAPHIC MODULATION PATTERNS.

It is assumed that there is negligible distortion in the a.f. voltage fed to the horizontal deflecting plates. (This voltage usually is taken from the last stage in the speech amplifier.) Also, except in the case of Figure R, it is assumed that there is negligible phase shift between the a.f. voltage applied to the horizontal deflecting plates and the a.f. voltage modulating the r.f. amplifier. Often an imperfect trapezoid at 100% modulation is a result of several factors, making it difficult to interpret the pattern and diagnose the particular trouble.

- A:** Unmodulated carrier signal.
- B:** Undistorted plate, grid, or cathode modulation, less than 100%.
- C:** Undistorted 100% plate modulation.
- D:** Plate modulation with inadequate or mismatched modulator.
- E:** Same as D with regeneration in modulated stage.
- F:** Plate modulated, insufficient grid excitation and/or bias to allow over 50% undistorted modulation. Grid modulated, too much excitation to allow over 50% modulation in upward direction.
- G:** Plate modulated, imperfect neutralization permitting regeneration.
- H:** Grid modulated phone with improper neutralization and reactive load.
- I:** Overmodulation of well designed, plate modulated transmitter. Too much audio input.
- J:** Grid modulation, excessive excitation or poor regulation of r.f. driver.
- K:** Insufficient excitation and bias on plate modulated zero bias (very high μ) triode.
- L:** Very bad overmodulation of plate modulated transmitter, resulting in serious clipping of negative peaks and bad splatter.
- M:** Maximum plate modulation of screen grid tube without screen modulation (screen by-passed for a.f.).
- N:** Suppressor modulated phone using separate r.f. driver, modulated approximately 100%.
- O:** Suppressor modulated 802 or 804 with crystal in grid circuit.
- P:** Parasitics in modulated amplifier, not present except on positive modulation peaks.
- Q:** Grid or cathode modulation, properly adjusted, approximately 100% modulation. Very little distortion.
- R:** Phase shift in speech system between point at which voltage is taken for horizontal deflection and the modulator output. No distortion.

instrument for use on any transmitter at a moment's notice; no trouble will be experienced in getting just the right amount of audio deflecting voltage.

The network resistors R_5 and R_6 are not standard items; each is made up of 1-megohm 1-watt carbon resistors in series, R_5 requiring six such resistors and R_6 two. The 1-watt resistors are mounted on terminal strips.

When a voltage is applied to only one set of plates, a thin straight line is obtained on the face of the c. r. tube when the 25,000- and 50,000-ohm potentiometers are correctly adjusted.

When a modulated carrier voltage is applied to one set of plates, and the audio modulating voltage applied to the other, a *trapezoidal figure* will be produced during modulation. With 100 per cent modulation this pattern should be a straight-sided triangle, sharply

pointed. Typical patterns are shown for plate and grid modulation in figure 14.

The audio- or radio-frequency voltage should have an amplitude of at least 50 volts in order to cause good deflection on the screen. The amplitude should be sufficient to give a large pattern on the face of the tube. The 25,000- and 50,000-ohm potentiometers are adjusted to give sharp definition and a reasonable amount of illumination on the screen. The r.f. voltage can be secured by coupling a few turns of wire to the center of the modulated amplifier tank coil or to the antenna coupler.

The tube should not be allowed to run for more than an instant with no deflecting voltages applied, as a burned spot will appear on the screen of the tube if the electron stream is allowed to converge for very long on a single small spot on the screen.

Workshop Practice

WITH a few possible exceptions, such as fixed air condensers and wire-wound transmitting coils, it hardly pays one to attempt to build the components required for the construction of an amateur transmitter. This is especially true when the parts are of the type used in construction and replacement work on broadcast receivers, as mass production has made these parts very inexpensive.

Transmitters Those who have and wish to spend the necessary time can effect considerable monetary saving in their transmitters by building them from the component parts. The necessary data are given in the construction chapters of this handbook.

To many builders, the construction is as fascinating as the operation of the finished transmitter; in fact, many amateurs get so much satisfaction out of building a well-performing piece of equipment that they spend more time constructing and rebuilding equipment than they do operating the equipment on the air.

Those who are not mechanically minded and are more interested in the pleasures of working dx and rag chewing than in experimentation and construction will find on the market many excellent transmitters which require only line voltage and an antenna. If you are one of those amateurs, you will find little to interest you in this chapter.

Receivers There is room for argument as to whether one can save money by constructing his own communications receiver. The combined demand for these receivers by the government, amateurs, airways, short-wave listeners, and others has become so great that it may be argued that there is no more point in building such a receiver than in building a regular broadcast set. Yet, many amateurs still prefer to construct their own receivers—in spite of the fact that it costs almost as much to

build a receiver as to purchase an equivalent factory-made job—either because they enjoy construction work and take pride in the fruits of their efforts, or because the receiver must meet certain specifications and yet cost as little as possible.

The only factory-produced receiver that is sure to meet the requirements of every amateur or short-wave listener is the rather expensive de luxe type having every possible refinement. An amateur of limited means who is interested only in c.w. operation on two or three bands, for instance, can build himself, at a fraction of the cost of a de luxe job, a receiver that will serve his particular purpose just as well. In the receiver construction chapter are illustrated several relatively inexpensive receivers which, for the particular purpose for which they were designed, will perform as well as the costliest factory-built receiver.

Types of Construction

Breadboard The simplest method of constructing equipment is to lay it out in breadboard fashion, which consists of fastening the various components to a board of suitable size with wood screws or machine bolts, arranging the parts so that important leads will be as short as possible.

While this type of construction is also adaptable to receivers and measuring and monitoring equipment, it is used principally for transmitter construction, and remains a favorite of the c.w. amateurs using high power.

Breadboard construction requires a minimum of tools; apparatus can be constructed in this fashion with the aid of only a rule, screwdriver, ice pick, saw, and soldering iron. A hand drill will also be required if it is desired to run part of the wiring underneath the breadboard, or if bolts are used to fasten down the parts. Ordinary carpenter's tools will be quite satisfactory.

Danger from accidental electrical shock usually is greatest with this type construction because of the exposed components.

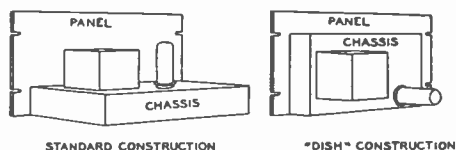

Figure 1.
TWO-TYPES OF RACK-AND-PANEL
CONSTRUCTION.

Metal Chassis Though quite a few more tools and considerably more time will be required for its construction, much neater equipment can be built by mounting the parts on sheet metal chassis instead of breadboards. This type of construction is advisable when shielding of the apparatus is necessary, as breadboard construction does not particularly lend itself to shielding. The appearance of the apparatus may be further enhanced by incorporating a front panel upon which the various controls are placed. A front panel minimizes the danger of shock.

If sufficient pains are taken with the construction, and a front panel is used in conjunction with either a dust cover (cabinet) or enclosed relay rack, the apparatus can be made to resemble or even to rival factory-built equipment in appearance.

Dish type construction is practically the same as metal chassis construction, the main difference lying in the manner in which the chassis is fastened to the panel. Examples of both types are shown in Figure 1.

Special Frameworks For high-powered r.f. stages, many amateur constructors prefer to discard the more conventional types of construction and employ instead special metal frameworks and brackets which they design specially for the parts which they intend to use. These are usually arranged to give the shortest possible r.f. leads and to fasten directly behind a relay rack panel by means of a few bolts, with the control shafts projecting through corresponding holes in the panel.

Tools

Beautiful work can be done with metal chassis and panels with the help of only a few inexpensive tools. However, the time required for construction will be greatly reduced if a fairly complete assortment of metal-working tools is available. Thus, it can be seen that while an array of tools will speed up the work, excellent results may be accomplished with but few tools, if one has the time and patience.

The investment one is justified in making in

tools is dependent upon several factors. If you like to tinker, there are many tools useful in radio construction that you would probably buy anyway, or perhaps already have, such as screwdrivers, hammer, saws, square, vise, files, etc. This means that the money taken for tools from your radio budget can be used to buy the more specialized tools, such as socket punches or hole saws, taps and dies, etc.

The amount of construction work one does determines whether buying a large assortment of tools is an economical move. It also determines if one should buy the less expensive type offered at surprisingly low prices by the familiar mail order houses, "five and ten" stores and chain auto-supply stores, or whether one should spend more money and get first-grade tools. The latter cost considerably more and work but little better when new, but will outlast several sets of the cheaper tools. Therefore they are a wise investment for the experimenter who does lots of construction work (if he can afford the initial cash outlay). The amateur who constructs only an occasional piece of apparatus need not be so concerned with tool life, as even the cheaper grade tools will last him several years, if they are given proper care.

The hand tools and materials in the accompanying lists will be found very useful around the home workshop. Materials not listed but ordinarily used, such as paint, can best be purchased as required for each individual job.

ESSENTIAL HAND TOOLS AND MATERIALS

- 1 Good electric soldering iron, about 100 watts, with "radio" tip
- 1 Spool rosin-core wire solder
- 1 Jar soldering paste (non-corrosive)
- 1 Each large, medium, small, and midget screwdrivers
- 1 Good hand drill (eggbeater type), preferably two speed
- 1 Pair regular pliers, 6 inch
- 1 Pair long nose pliers, 6 inch
- 1 Pair cutting pliers (diagonals), 5 inch or 6 inch
- 1 1½-inch tube-socket punch
- 1 "Boy Scout" knife
- 1 Combination square and steel rule, 1 foot
- 1 Yardstick or steel pushrule
- 1 Scratch awl or ice pick scribe
- 1 Center punch
- 1 Dozen or more assorted round shank drills (as many as you can afford between no. 50 and ¼ or ⅜ inch, depending upon size of hand drill chuck)
- 1 Combination oil stone
- Light machine oil (in squirt can)
- Friction tape

HIGHLY DESIRABLE HAND TOOLS AND MATERIALS

- 1 Good ball peen hammer, 3/4 or 1 pound
- 1 Hacksaw with coarse and fine blades, 10 or 12 inch
- 1 Bench vise (jaws at least 3 inch)
- 1 Spool plain wire solder
- 1 Carpenter's brace, ratchet type
- 1 Square-shank countersink bit
- 1 Square-shank countersink
- 1 Square-shank taper reamer, small
- 1 Square-shank taper reamer, large (The two reamers should overlap; 1/2 inch and 7/8 inch size will usually be suitable.)
- 1 7/8 inch tube-socket punch (for electrolytic condensers)
- 1 Square-shank adjustable circle cutter for holes to 3 inch
- 1 Set small, inexpensive, open-end wrenches
- 1 Pair tin shears, 10 or 12 inch
- 1 Cold chisel (1/2 inch tip)
- 1 Wood chisel (1/2 inch tip)
- 1 Pair wing dividers
- 1 Coarse mill file, flat, 12 inch
- 1 Coarse bastard file, round, 1/2 or 3/4 inch diameter
- 6 or 8 Assorted small files: round, half-round, triangular, flat, square, rat-tail.
- 4 Small "C" clamps
- Steel wool, coarse and fine
- Sandpaper and emery cloth, coarse, medium, and fine
- Rubber cement
- File card or stiff brush

USEFUL BUT NOT ESSENTIAL TOOLS AND MATERIALS

- 1 Cheap carpenter's claw hammer
- 1 Jig or scroll saw (small) with metal-cutting blades
- 1 Small wood saw (crosscut teeth)
- 1 Each square-shank drills: 3/8, 7/16, and 1/2 inch
- 1 Tap and die outfit for 6-32 and 8-32 machine screw threads (A complete set is not necessary, as other sizes seldom will be needed.)
- 4 Medium size "C" clamps
- Lard oil (in squirt can)
- Kerosene
- Duco or polystyrene cement (coil dope)
- Empire cloth
- Alcohol
- Clear lacquer ("industrial" grade)
- Lacquer thinner
- Dusting brush
- Paint brushes
- Sheet celluloid, Lucite, or polystyrene
- Acetone

- 1 Carpenter's plane, 8 inch or larger
- 1 Metal punch
- 1 Each "Spintite" wrenches, 1/4 and 5/16 inch to fit standard 6-32 and 8-32 nuts used in radio work and two common sizes of Parker Kalon metal screws

The foregoing assortment assumes that the constructor does not want to invest in the more expensive power tools, such as drill press, grinding head, etc. If power equipment is purchased, obviously some of the hand tools and accessories listed will be superfluous. A drill press greatly facilitates construction work, and it is unfortunate that a good one costs as much as a small transmitter. A booklet* available from the Delta Manufacturing Co. will be of considerable aid to those who have access to a drill press.

Not listed in the table are several special-purpose radio tools which are somewhat of a luxury, but are nevertheless quite handy, such as various around-the-corner screwdrivers and wrenches, special soldering iron tips, etc. These can be found in the larger radio parts stores and are usually listed in their mail order catalogs. It is not uncommon to find amateurs who have had sufficient experience as machinists to design and produce tools for special purposes.

Tool Hints

Of equal importance in maintaining one's supply of necessary tools and assorted materials is the assignment of each tool to one particular location. The greatest loss of time in any shop is usually incurred by searching for tools which are not in their proper place.

Amateurs in or near the larger cities will often find it profitable to visit that section of the city where may be found many large stores that deal in used machinery and tools. It is quite commonplace to find used tools of high quality in good condition at a low price.

Vises A vise is one of the few things that can be bought second-hand with safety. Brief inspection should settle its fitness: examine the screw, check for wobble and parallel jaws. A used machinist's vise is much better than a new, wobbly "home mechanic's vise." Three-inch jaws are usually large enough for radio work. If the vise is mounted on a corner of the bench a swivel is unnecessary, saving considerable expense. Only a few vises are sold with copper jaw plates, but these easily can be made as shown in Figure 2. It is most essential that a vise constantly used on bakelite, brass, and aluminum does not bite into the work with its steel jaws.

* "Getting the Most Out of Your Drill Press." James Tate, Delta Manufacturing Company, Milwaukee, Wisconsin.

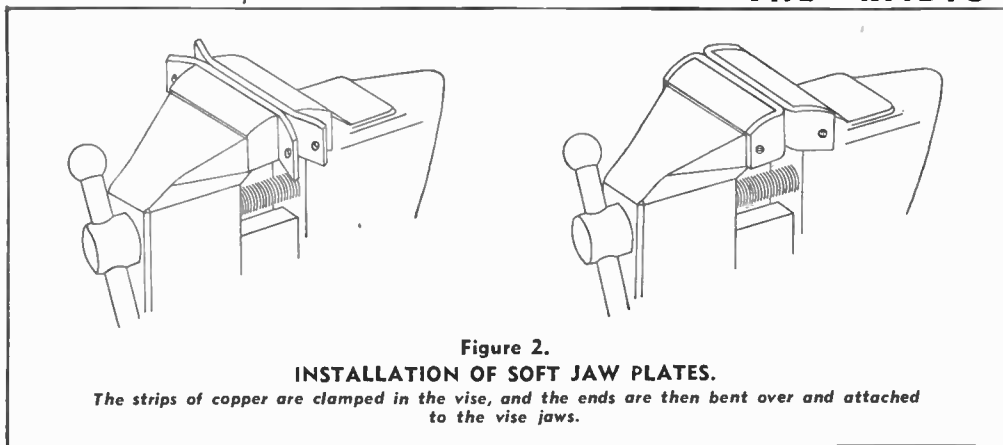

Figure 2.
INSTALLATION OF SOFT JAW PLATES.

The strips of copper are clamped in the vise, and the ends are then bent over and attached to the vise jaws.

Soldering Irons A prerequisite to a good soldering job is a good iron. If one can afford two irons, a 150-watt size for heavy work and a smaller 75-watt size for light work and getting into tight places are highly desirable. However, a single 100-watt iron will do nicely for most purposes.

Do not get a high wattage iron that is relatively small physically. Such an iron must be used continuously to keep it from becoming too hot. When such an iron is left plugged in and is not used for several minutes, the iron will become so hot that it will curdle the solder adhering to the tip, making frequent filing and retinning necessary. An aluminum rest which presents considerable surface to the air and to the iron will prevent an iron from becoming overheated when not in actual use. Such a heat-dissipating rest for the iron can be made from an old aluminum automobile piston by sawing it off diametrically at the center of the wrist pin hole.

For occasional extremely heavy work, a soldering copper such as is used by sheet metal workers (heated in a gas flame) will be found very useful. This type of iron is merely a heavy copper tip fastened to a steel rod which has a wooden handle. Since the mass of the tip is great, it will hold heat for a long time, and is just the thing for working on large, heavy gauge subpanels, and on antennas where no current is available for an electric iron nearby. If heated sufficiently, they can be carried for considerable distance before becoming too cold for satisfactory soldering work.

An alternative for soldering joints at a distance from an a.c. power source is a small alcohol torch, obtainable for about 75 cents.

Wood Saws There are many types of wood saws on the market, but for amateur construction work those listed in the tool tables are usually sufficient. Saws will

work much better and last much longer if properly cared for. Keep the blades in good shape by smearing them with a thin film of vaseline after they are used. A rusty saw will not do good work. When it becomes necessary, as it does from time to time, to have them sharpened, let a good joiner do the work; it is a job for an expert, usually available in local hardware stores.

Metal Saws The hacksaw has become an almost universally standardized tool for the amateur workshop. The replaceable blades are obtainable with varying numbers of teeth. The coarse blades, having 14 or 18 teeth per inch, can be used for bakelite or ebonite; for most metals, a medium tooth blade with about 22 teeth per inch is desirable; and for very thin sheets a blade having 32 teeth per inch is best. Ordinarily, the harder the metal, the finer the blade that should be used.

When replacing saw blades, keep in mind that hacksaw blades should be put in place with the teeth pointing *towards the tip* of the saw, while jig or scroll saw blades should have the teeth *towards the handle*, in order to keep the work pressed on the cutting bench.

Files When using a file, the handle should be grasped firmly in the right hand, with the thumb on top, and the left hand should rest on the tip to guide it. The pressure of the left hand on the file should be eased off and that of the right hand increased as the file proceeds across the work. The return stroke should be made with a minimum amount of pressure, or better, with the file raised from the work. The file should be cleaned often, both during and after work, in order to remove the filings which stick to the teeth. These may scratch the work if allowed to remain. A "file card" is inexpensive and removes the burrs quickly.

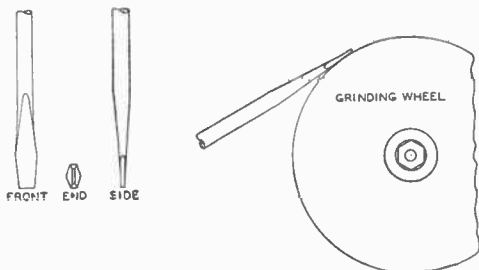

Figure 3.

SHARPENING A SCREWDRIVER.

The way to hold the screwdriver blade on the grinding wheel while sharpening it, and the appearance of a properly sharpened blade.

To Resharpen Old Files Wash the files in warm potash water to remove the grease and dirt, then wash in warm water and dry by heat. Put 1½ pints warm water in a wooden vessel, put in the files, add 3 ounces blue vitriol finely powdered, and 3 ounces borax. Mix well and turn the files so that every one may come in contact with the mixture. Add 10½ ounces sulphuric acid and ½ ounce cider vinegar. Remove the files after a short time, dry, rub with olive oil, wrap in porous paper. Coarse files should be kept in the mixture for a longer time than fine ones. Be careful not to allow the solution to get on the hand.

File Lubricant When filing aluminum, dural, etc., the file should be oiled or rubbed in chalk, but will cut slower than with no lubricant. However, the file will last much longer.

Screwdrivers To do good work, several sizes of screwdrivers are necessary. There should be a blade to fit each of the screwheads in common use. The length of the slot in the screw-head and the width of the screwdriver blade should be as near alike as possible. If the blade is too narrow it will be twisted when the screw is tightened, and if it is too wide the screw is apt to be burred and the work scratched. Remember, also, that the thickness of the blade varies directly with the width. For best results, the blade should fit the slot snugly for its full width. The length of the blade is determined chiefly by the accessibility of the work, and to some extent by the choice of the worker. It should not be longer than necessary. A complete set of high quality screwdrivers with plastic handles (Stanley), which are excellent for radio and electrical work, can be obtained from hardware dealers for about \$2.50.

Screw Lubricant Put hard soap on lag screws, wood screws, or any screw for wood. It will surprise you how much easier they will turn in. The soap also will prevent, or at least reduce, splitting.

Power Drills and Drilling Although most of us do not so consider it, a twist drill is nothing more than a modified jack-knife. It has a cutting edge, an angle of clearance, and an angle of rake, just as has a jack-knife (or a lathe tool). The technique to be followed in drilling is, therefore, a function of the type of material worked on, as well as the speed and accuracy desired. As the drill proceeds, a chip cut out is above the cutting edge. This has the effect of pulling the drill farther into the material. This is determined by the "angle of rake" and the hardness of the material. If the material is hard at the point of cutting, the resistance to downward motion here is great enough to overcome the pulling effect of the angle of rake.

For steel or iron, the shavings which come out of the hole around the drill should be spiral and continuous. For softer metals, especially brass, the drill should have no angle of rake (or lip, as the forward projecting cutting edge is called). The shavings for this drill will be small chips. If this shape drill is not used, the drill will feed into the metal very rapidly and will usually jam.

As the tip of a drill is not a point, but a straight line perpendicular to its major axis, a drill will usually waltz all over before it starts to drill unless a guide hole is punched at the point you wish to drill. The maximum diameter of this hole should be at least equal to the width of the drill tip. A center punch impression will suffice for small holes. With drills of over ¼-inch diameter, this method of starting the drill is usually impractical, as the diameter of the center-punch hole is prohibitively large. This difficulty is avoided by first drilling a smaller guide hole which can be started with a center-punch hole.

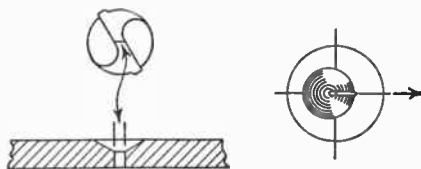

Figure 4.

STARTING THE DRILL.

A drill should always be started with a center punch impression or small hole that is at least as large as the flat portion of the drill tip. If the guide hole is a little off, the drill can be "fudged over" by means of a chisel mark as shown to the right.

A great deal could be said about drilling speeds and feeds, but it would be of little value to the average person. Just remember that in drilling steel or iron, the drill point should be well lubricated with lard oil or a medium grade of machine oil. The weight of oil commonly used in oiling lawn mowers is about correct. This serves a double function for most machinists. The first, of course, is lubrication. The second is to keep the work cool. The oil flows from hot points to cold ones more quickly than heat flows from the hot points of the drill to the cooler ones. But, for amateur use, the oil assumes a third role: that of a temperature indicator. The oil should never evaporate

visibly to form a cloud around the work (this vapor looks like steam).

Another indicator is that you should be able to hold the end of the drill in your hand with no discomfort immediately after you have finished the hole. These considerations are based on the assumption that most hams use the average carbon drill, and not one of the more expensive type designed to operate at high temperatures. Most tool steel will start to lose its hardness at a little over 100° C. At 600°, it is as soft as mild steel, and must be heat treated and tempered again. That means that most hams would have to grind the softened portion off and then attempt to regrind the cutting edges.

Brass should always be drilled with no lubricant. For one thing, the brass slides readily against steel. Bronze is in the same class. Witness the large number of bronze bearings in current use. Almost all of the zinc alloys may so be treated. If a lubricant is used, it usually only makes the particles cling together and thus clog up the drill point. Aluminum and its alloys are sometimes lubricated with kerosene or milk.

The drill speed (number of revolutions per minute of the drill) and the drilling feed (rate at which the drill is pushed into the work) are interdependent. The safe, simple way to determine them is to watch the temperature. If the drill is running too hot, decrease the feed. If it still runs too hot, decrease the speed. In drilling, it is a safe practice never to feed the drill in a distance greater than the diameter of the drill without backing it off until the work is clear. This permits you to examine the point, and permits the drill to clear itself of particles which may be clogging it at the point of cutting. This looks like a waste of time, but actually will be a time saver. You won't have to stop to replace broken and softened drills.

The desired speed for drilling depends on size of hole, kind of stock, rate of feed, etc. A typical job for a ham would be a lot of no. 27 or no. 19 holes in a steel chassis. The second speed on most drills, or about 1200 r.p.m., is about right. For electrical alloy or aluminum a step faster might be used. The 2400 r.p.m. pulley can be used for drills like no. 36 and smaller. First speed, usually about 600 r.p.m., will make those 3/8 inch and 1/2 inch holes. There are tables available about cutting speeds in feet per minute, etc., but experience can best tell you if the speed is right. The speed must match the feed—cut a continuous chip—and the drill should not run hot.

Plastics One can get excellent r.f. insulation in various forms and prepare it with only a little more trouble than our old standby, bakelite. There are two kinds of Mycalex. The

NUMBERED DRILL SIZES

| DRILL NUMBER | Diameter (in.) | Clears Screw | Correct for Tapping Steel or Brass† |
|--------------|----------------|--------------|-------------------------------------|
| 1 | .228 | | |
| 2 | .221 | 12-24 | |
| 3 | .213 | | 14-24 |
| 4 | .209 | 12-20 | |
| 5 | .205 | | |
| 6 | .204 | | |
| 7 | .201 | | |
| 8 | .199 | | |
| 9 | .196 | | |
| 10* | .193 | 10-32 | |
| 11 | .191 | 10-24 | |
| 12* | .189 | | |
| 13 | .185 | | |
| 14 | .182 | | |
| 15 | .180 | | |
| 16 | .177 | | 12-24 |
| 17 | .173 | | |
| 18* | .169 | 8-32 | |
| 19 | .166 | | 12-20 |
| 20 | .161 | | |
| 21* | .159 | | 10-32 |
| 22 | .157 | | |
| 23 | .154 | | |
| 24 | .152 | | |
| 25* | .149 | | 10-24 |
| 26 | .147 | | |
| 27 | .144 | | |
| 28* | .140 | 6-32 | |
| 29* | .136 | | 8-32 |
| 30 | .128 | | |
| 31 | .120 | | |
| 32 | .116 | | |
| 33* | .113 | 4-36 4-40 | |
| 34 | .111 | | |
| 35* | .110 | | 6-32 |
| 36 | .106 | | |
| 37 | .104 | | |
| 38 | .102 | | |
| 39* | .100 | 3-48 | |
| 40 | .098 | | |
| 41 | .096 | | |
| 42* | .093 | | 4-36 4-40 |
| 43 | .089 | 2-56 | |
| 44 | .086 | | |
| 45* | .082 | | 3-48 |

†Use next size larger drill for tapping bakelite and similar composition materials (plastics, etc.).

*Sizes most commonly used in radio construction.

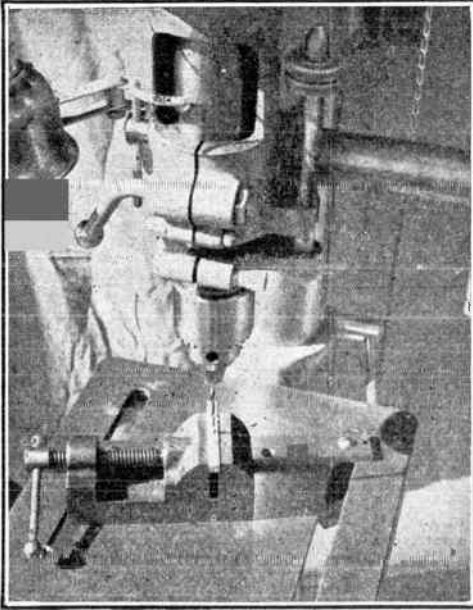

Figure 5.
DRILL PRESS VISE.

Small objects are best handled on a drill press by means of a drill press vise.

kind on Cardwell condensers is known as G.E. 1364; then, there is a softer kind called leadless, which drills easier, but is more apt to chip and crack. The G.E. 1364 kind can be bought in strips of various sizes, and the strips cut up with a hack saw. Sawing a wide piece would be laborious.

Drilling a piece of Mycalex is like drilling a piece of stone, and drills are bound to dull rapidly. There are special drills known as Fosdick drills that can be used to advantage if any great amount is to be drilled. Ordinary twist drills will do if they are sharpened after every hole or two. The powder which results from drilling must be removed by blowing, as fast as it forms. Another way to remove the powder is to drill the piece submerged in water. The powder will float to the top and not clog the drill. Just to lubricate the drill with water or oil in the usual way will make things worse, however. Then the powder will form a paste around the drill. Better to drill dry, with slow speed and frequent stops for cleaning the drill and hole. When the drill point starts to break through, the work should be turned over and finished on the reverse side to prevent chipping.

Lucite and polystyrene products like "Victron," "912-B," etc., drill and tap as easily as bakelite except for their notorious susceptibil-

ity to heat. Drilling speeds can be about the same as for brass or bakelite; slower if heating results. When drilling through a thick piece of the transparent kind, you can see the side wall of the hole turn white and flaky if the point warms up. A little of this roughness isn't objectionable, but keep the point cool. Drills must be sharp, and the flutes kept clear of chips. Frequent sharpening is not necessary, as these plastics are very easy on tools. If any quantity is to be worked, special "bakelite drills" with coarse flutes can be used. Some of these materials are more flexible than others; but it isn't wise to hit the center punch too hard. Use soap and water to wash the work after handling.

Danger Most drill presses are equipped with some means of clamping the work. It is always wise to use these, unless the piece is large and the holes are small. A piece especially of sheet steel, which gets jammed on the drill and tears out of the operator's hands, is a dangerous weapon. With small pieces, it is best to clamp them in a tool maker's vise.

When working with sheet steel (as you usually are on chassis construction), if the piece is large, you may hold it safely by hand. Wear gloves and hold the work *firmly* with both hands. The drill feed may be easily arranged to operate by foot for these operations.

Steel parallels are indispensable when the piece to be drilled is irregular. Under a panel or chassis, parallels have advantages over a block. First, they are more accurate. Then, as the work progresses, they can be moved about so as to miss the burrs that accumulate on the under side. Work that is laid flat on a block or table often gets tilted because of such burrs. Real parallels are expensive, but there are cheaper substitutes: pieces of cold-rolled steel bar and printers' "iron furniture" make excellent parallels.

Workbench Construction While a well-built table can be used for a workbench, the greater convenience and strength obtainable in a bench designed specially for radio work makes the time and effort expended in its construction worth while. The bench may be of the open type,—that is, similar to a table,—but heavier and provided with a tool panel on the back, or it can be of the cabinet type in which drawers and shelves are provided in addition to the tool panel. A smooth flat top is important, the 2-inch laminated type being about the best; but one composed of $\frac{1}{8}$ -inch or $\frac{1}{4}$ -inch "Presdwood" glued to a sheet of $\frac{3}{4}$ -inch or $\frac{7}{8}$ -inch five- or seven-ply panel is very satisfactory. A good back-board can be made of two or three school-type drawing boards, fastened together with a long

batten and held to the bench with large size common shelf angles. Suitable plans are available from some tool manufacturers and home workshop magazines.

Construction Practice

Chassis Layout The chassis first should be covered with a layer of wrapping paper, which is drawn tightly down on all sides and fastened with scotch tape. This allows any number of measurement lines and hole centers to be spotted in the correct positions without making any marks on the chassis itself. Place on it the parts to be mounted and play a game of chess with them, trying different arrangements until all the grid and plate leads are made as short as possible, tubes are clear of coil fields, r.f. chokes are in safe positions, etc. Remember, especially if you are going to use a panel, that a good mechanical layout often can accompany sound electrical design, but that the electrical design should be given first consideration.

All too often parts are grouped to give a symmetrical panel, irrespective of the arrangement behind. When a satisfactory arrangement has been reached, the mounting holes may be marked. The same procedure now must be followed for the underside, always being careful to see that there are no clashes between the two (that no top mounting screws come down into the middle of a paper condenser on the underside, that the variable condenser rotors do not hit anything when turned, etc.).

When all the holes have been spotted, they

should be center-punched *through* the paper into the chassis. Don't forget to spot holes for leads which must also come through the chassis.

For transformers which have lugs on the bottoms, the clearance holes may be spotted by pressing the transformer on a piece of paper to obtain impressions, which may then be transferred to the chassis.

Punching In cutting socket holes, one can use either a fly-cutter or socket punches. These punches are easy to operate and only a few precautions are necessary. The guide pin should fit snugly in the guide hole. This increases the accuracy of location of the socket. If this is not of great importance, one may well use a drill of 1/32 inch larger diameter than the guide pin. Some of the punches will operate without guide holes, but the latter always make the punching operations simpler and easier. The only other precaution is to be sure the work is properly lined up before applying the hammer. If this is not done, the punch may slide sideways when you strike and thus not only shear the chassis but also take off part of the die. This is easily avoided by always making sure that the piece is parallel to the faces of the punch, the die, and the base. The latter should be an anvil or other solid base of heavy material.

A punch by *Greenlee* forces socket holes through the chassis by means of a screw turned with a wrench. It is noiseless, and works much more easily and accurately than most others.

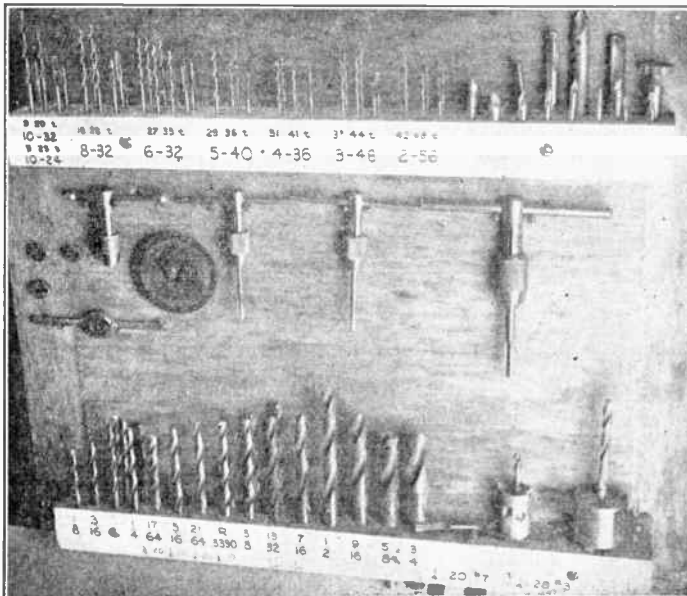

Figure 6.
TOOL MOUNTING BOARD.

An excellent assortment and mounting arrangement for power cutting tools. Note that there is a clearance drill, a tap drill, and a tap, each in its proper place, for each of the common sizes of machine screws.

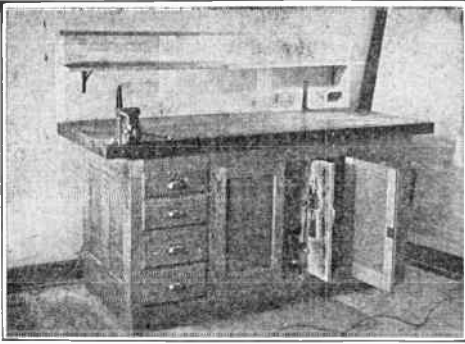

Figure 7.

ENCLOSED-TYPE WORKBENCH.

An enclosed-type workbench with three drawing boards along the rear making up the backboard. The shelf along the backboard serves to strengthen it, and furnishes additional storage space.

It requires the use of a $\frac{3}{8}$ -inch center hole to accommodate the screw.

Transformer Cutouts Cutouts for transformers and chokes are not so simply handled. After marking off the part to be cut, drill about a $\frac{1}{4}$ -inch hole on each of the inside corners and tangential to the edges. After burring the holes, clamp the piece and a block of cast iron or steel in the vise. Then, take your burring chisel and insert it in one of the corner holes. Cut out the metal by hitting the chisel with a hammer. The blows should be light and numerous. The chisel acts against the block in the same way that the two blades of a pair of scissors work against each other. This same process is repeated for the other sides. A file is used to trim up the completed cutout.

Another method is to drill the four corner holes large enough to take a hack saw blade, then saw instead of chisel. The four holes permit nice looking corners.

Removing Burrs In both drilling and punching, a burr is usually left on the work. There are three simple ways of removing these. Perhaps the best is to take a chisel (be sure it is one for use on metal) and set it so that its bottom face is parallel to the piece. Then gently tap it with a hammer. This usually will make a clean job with a little practice. If one has access to a counter-bore, this will also do a nice job. A counter-sink will work, although it bevels the edges. A drill of several sizes larger is a much used arrangement. The third method is by filing off the burr, which does a good job but scratches the adjacent metal surfaces badly.

Mounting Components There are two methods in general use for the fastening of transformers, chokes, and similar pieces of apparatus to chassis or breadboards. The first, using nuts and machine screws, is slow, and the commercial manufacturing practice of using self-tapping screws is gaining favor. For the mounting of small parts such as resistors and condensers, tie strips are very useful to gain rigidity. They also contribute materially to the appearance of finished apparatus.

Grommets of the proper size, placed in all chassis holes through which wires are to be passed, will give a neater appearing job and also will reduce the possibility of short circuits.

Soldering Making a strong, low-resistance solder joint does not mean just dropping a blob of solder on the two parts to be joined and then hoping that they'll stick. There are several definite rules that *must* be observed.

All parts to be soldered must be absolutely clean. To clean a wire, lug, or whatever it may be, take your pocket knife and scrape it thoroughly, until fresh metal is laid bare. It is not enough to make a few streaks; scrape until the part to be soldered is bright.

Make a good mechanical joint before applying any solder. Solder is intended primarily to make a good *electrical* connection; mechanical rigidity should be obtained by bending the wire into a small hook at the end and nipping it firmly around the other part, so that it will hold well even before the solder is applied.

Keep your iron properly tinned. It is impossible to get the work hot enough to take the solder properly if the iron is dirty. To tin your iron, file it, while hot, on one side until a full surface of clean metal is exposed. Immediately apply rosin core solder until a thin layer flows completely over the exposed surface. Repeat for the other faces. Then take a clean rag and wipe off all excess solder and rosin. The iron should also be wiped frequently while the actual construction is going on; it helps prevent pitting the tip.

Apply the solder to the work, not to the iron. The iron should be held against the parts to be joined until they are thoroughly heated. The solder should then be applied against the parts, and the iron should be held in place until the solder flows smoothly and envelops the work. If it acts like water on a greasy plate, and forms a ball, the work is not sufficiently clean.

The completed joint must be held perfectly still until the solder has had time to solidify. If the work is moved before the solder has become *completely* solid, a "cold" joint will result. This can be identified immediately, because the solder will have a dull "white"

appearance rather than one of shiny "silver." Such joints tend to be of high resistance, and will very likely have a bad effect upon a circuit. The cure is simple: merely reheat the joint and do the job correctly.

Wipe away all surplus flux when the joint has cooled if you are using a paste type flux. Be sure it is non-corrosive, and use it with plain (not rosin core) solder.

Finishes If the apparatus is constructed on a painted chassis (commonly available in black crackle and gray crackle), there is no need for application of a protective coating when the equipment is finished, assuming that you are careful not to scratch or mar the finish while drilling holes and mounting parts. However, many amateurs prefer to use unpainted (zinc or cadmium plated) chassis, because it is much simpler to make a chassis ground connection with this type of chassis. A thin coat of clear "linoleum" lacquer may be applied to the whole chassis after the wiring is completed to retard rusting. In localities near the sea coast it is a good idea to lacquer the various chassis cutouts even on a painted chassis, as rust will get a good start at these points unless the metal is protected where the drill or saw has exposed it. If too thick a coat is applied, the lacquer will tend to peel. It may be thinned with lacquer thinner to permit application of a light coat. A thin coat will adhere to any *clean* metal surface that is not too shiny.

An attractive dull gloss finish, almost velvety, can be put on aluminum by sand-blasting it with a very weak blast and fine particles and then lacquering it. Soaking the aluminum in a solution of lye produces somewhat the same effect as a fine grain sand blast.

There are also several brands of dull gloss black enamels on the market which adhere well to metals and make a nice appearance. Air-drying crackle finishes are sometimes successful, but a baked job is usually far better. Crackle finishes, properly applied, are very durable and are pleasing to the eye. If you live in a large community, there is probably an enamelling concern which can crackle your work for you at a reasonable cost. A very attractive finish, for panels especially, is to spray a crackle finish with aluminum paint. In any painting operation (or plating, either, for that matter), the work should be very thoroughly cleaned of all greases and oils.

To protect brass from tarnish, thoroughly cleanse and remove the last trace of grease by

the use of potash and water. The brass must be carefully rinsed with water and dried; but in doing it, care must be taken not to handle any portion with the bare hands or anything else that is greasy. Then lacquer.

Drilling Gloss This is done very readily with a common drill by using a mixture of turpentine and camphor. When the point of the drill has come through, it should be taken out and the hole worked through with the point of a three-cornered file, having the edges ground sharp. Use the corners of the file, scraping the glass rather than using the file as a reamer. Great care must be taken not to crack the glass or flake off parts of it in finishing the hole after the point of the drill has come through. Use the mixture freely during the drilling and scraping. The above mixture will be found useful in drilling hard cast iron.

Etching Solution Add three parts nitric acid to one part muriatic acid. Cover the piece to be etched with beeswax. This can be done by heating the piece in a gas or alcohol flame and rubbing the wax over the surface. Use a sharp steel point or hard lead pencil point as a stylus. A pointed glass dropper can be used to put the solution at the place needed. After the solution foams for two or three minutes, remove with blotting paper and put oil on the piece, and then heat and remove the wax.

Chromium Polish So much chromium is now used in radio sets and on panels that it is well to know that this finish may be polished. The only materials required are absorbent cotton or soft cloth, alcohol, and ordinary lampblack.

A wad of cotton or the cloth is moistened in the alcohol and pressed into the lampblack. The chromium is then polished by rubbing the lampblack adhering to the cotton briskly over its surface. The mixture dries almost instantly and may be wiped off with another wad of cotton.

The alcohol serves merely to moisten the lampblack to a paste and make it stick to the cotton. The mixture cleans and polishes very quickly and cannot scratch the chromium surface. It polishes nickel-work just as effectively as it does chromium. Care should be taken to see that the lampblack does not contain any hard, gritty particles which might produce scratches during the polishing.

Broadcast Interference

RADIO signals which intrude upon a broadcast program constitute a nuisance to which disturbed listeners are bound to object vigorously.

Broadcast interference is a matter of grave importance to all amateurs. Indeed, an amateur station license is placed in considerable jeopardy by repeated citations of interference with broadcast or other commercial stations. The FCC regulations are particularly severe in this respect, and they require that the offending amateur correct the trouble or keep off the air during specified hours of the day or night.

In general, signals from a transmitter operating properly are not picked up by receivers tuned to other frequencies unless the receiver is of inferior design, or is in poor condition. Therefore, if the receiver is of good design and is in good repair, the burden of rectifying the trouble rests with the owner of the interfering station.

Phone and c.w. stations both are capable of causing broadcast interference, key-click annoyance from code transmitters being particularly objectionable. The elimination of key clicks is fully covered in Chapter 7 under *Keying*.

A knowledge of each of the several types of broadcast interference, their cause, and methods of eliminating them is necessary to the successful disposition of this trouble. An effective method of combatting one variety of interference is often of no value whatever in the correction of another type. Broadcast interference seldom can be cured by "rule of thumb" procedure.

Broadcast interference, as covered in this chapter, refers to standard (amplitude modulated, 550-1600 kc.) broadcast. Interference to frequency modulated broadcast is highly unlikely except when there is an f.m. receiver in close proximity to a transmitter afflicted with h.f. parasitics or radiating strong harmonics. As such radiation is illegal, it is assumed that no such interference is experienced except in rare instances. When it does occur, it calls for

suppression of parasitics or harmonics at the transmitter, a subject covered under *Transmitter Theory* and in the *Antenna* chapter.

Interference Classifications

Depending upon whether it is traceable directly to causes within the *station* or within the *receiver*, broadcast interference may be divided into two main classes. For example, that type of interference due to transmitter over-modulation is at once listed as being caused by improper operation, while an interfering signal that tunes in and out with a broadcast station is probably an indication of cross-talk in the receiver, and the poorly-designed input stage of the receiver is held liable. The various types of interference and recommended cures will be discussed separately.

Blanketing This is not a tunable effect, but a total blocking of the receiver. A more or less complete "washout" covers the entire receiver range when the carrier is switched on. This produces either a complete blotting out of all broadcast stations, or else knocks down their volume several decibels—depending upon the severity of the interference. Voice modulation of the carrier causing the blanketing will be highly distorted or even unintelligible. Keying of the carrier which produces the blanketing will cause an annoying fluctuation in the volume of the broadcast signals.

Blanketing generally occurs in the immediate neighborhood (inductive field) of a powerful transmitter, the affected area being directly proportional to the power of the transmitter. This type of interference occurs most frequently where the receiver uses an outside antenna which happens to resonate at a frequency close to that of the offending transmitter. Also it is more prevalent with transmitters which operate in the 80- and 160-meter bands, than with those on the higher frequencies.

The remedies are to (1) shorten the receiving antenna, and thereby shift its resonant fre-

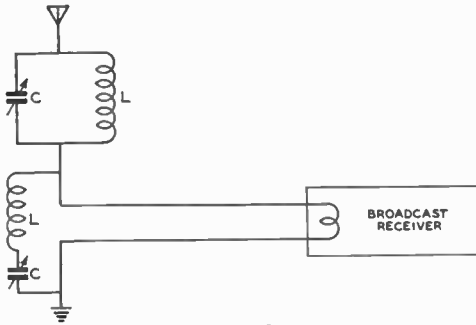

Figure 1.
EFFECTIVE WAVE TRAP CIRCUIT FOR HIGH ATTENUATION OF INTERFERING SIGNAL REACHING RECEIVER VIA ANTENNA.

This type of trap works at full efficiency over but a small range in frequency, and therefore is not effective when several interfering signals of widely different frequencies are present. When only moderate attenuation is required, a single tank (either series or shunt) will often suffice. For coil and condenser values refer to Figure 3.

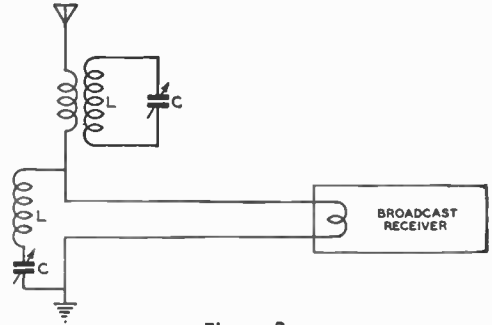

Figure 2.
MODIFICATION OF CIRCUIT SHOWN IN FIGURE 1.

In this case, the parallel resonant tank is coupled to the antenna with 3 to 6 turns of wire instead of being placed in series with the antenna lead. It gives slightly better performance than the circuit of Figure 1 with certain antennas.

quency, or (2) remove it to the interior of the building, (3) change the direction of either the receiving or transmitting antenna to minimize their mutual coupling, or (4) keep the interfering signal from entering the receiver input circuit by installing a wave-trap tuned to the signal frequency (see Figure 1).

A suitable wave-trap is quite simple in construction, consisting only of a coil and midget variable condenser. When the trap circuit is tuned to the frequency of the interfering signal, little of the interfering voltage reaches the grid of the first tube.

The wave-trap must be installed as close to the receiver antenna terminal as practicable, hence it should be as small in size as possible. The variable condenser may be a midget air-tuned trimmer type, and the coil may be wound on a 1-inch dia. form. The table of Figure 3 gives winding data for wave-traps built around a 50- μmfd . variable condenser. For best results, both a shunt and a series trap should be employed as shown.

Figure 2 shows a two-circuit coupled wave-trap that is somewhat sharper in tuning and more efficacious. The specifications for the secondary coil L may be obtained from the table in Figure 3. The primary consists of 3 to 5 closewound turns of the same size wire wound in the same direction on the same form as L and separated from the latter by $\frac{1}{8}$ of an inch.

Overmodulation A carrier modulated in excess of 100 per cent acquires sharp cutoff periods (Figure 4) which

give rise to high damping. This creates a broad signal and often generates spurious frequencies at odd places on the dial. High damping of a radiotelephone signal may at the same time bring about impact or shock excitation of nearby receiving antenna and power lines, transmitting interfering voltages in that manner.

Broadcast interference due to overmodulation is generally common to 160- and 75-meter operation. The remedy is to reduce the modulation percentage.

Cross Modulation Cross modulation or "cross talk" is characterized by the amateur signal "riding in" on top of strong local broadcasts. There is usually no

Figure 3. R. F. WAVE TRAP COIL AND CONDENSER TABLE.

| BAND | COIL L | CONDENSER C |
|------|---|--|
| 160 | 41 turns no. 28 enameled close-wound 1-inch form | 50- μmfd . variable shunted by 200- μmfd . fixed mica |
| 80 | 41 turns no. 28 enameled close-wound 1-inch form | 50- μmfd . variable |
| 40 | 21 turns no. 24 enameled 11/16-inch long 1-inch form | 50- μmfd . variable |
| 20 | 7 turns no. 24 enameled 5/16-inch long 1-inch form | 50- μmfd . variable |
| 10 | 4 turns no. 24 enameled 5/16-inch long 1-inch form | 50- μmfd . variable |

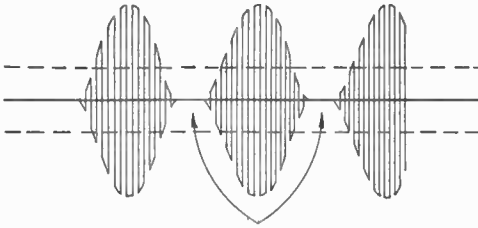

PRODUCES SAME EFFECT AS RAPID KEY CLICKS

Figure 4.
ILLUSTRATING HIGH DAMPING CHARACTERISTIC OF BADLY OVER-MODULATED SIGNAL.

The resulting interference seldom can be cured by wave traps or line filters; it must be corrected at the transmitter.

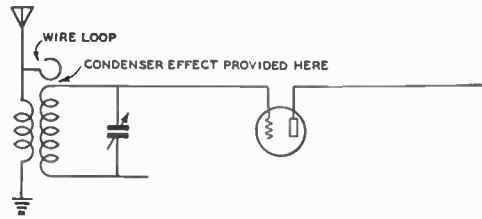

Figure 5.
TYPICAL AUXILIARY CAPACITY COUPLING CIRCUIT USED IN B.C. SETS TO BOOST GAIN AT 1500 KC. END OF BAND.

Even though the coupling capacity may be small, it will have a fairly low reactance at high frequencies, and will aggravate interference from amateur stations, particularly those working on 14 and 28 Mc.

heterodyne note, the amateur signal being tuned in and out with the program carriers.

This effect is due entirely to a faulty input stage in the affected receiver. Modulation of the interfering carrier will swing the operating point of the input tube. This type of trouble is seldom experienced when a variable- μ tube is used in the input stage.

Where the receiver is too ancient to incorporate such a tube, and is probably poorly shielded at the same time, it will be better to attach a wave-trap of the type shown in Figure 1 than to attempt rebuilding of the receiver. The addition of a good ground and a shield can over the input tube often adds to the effectiveness of the wave-trap.

Transmission via Capacity Coupling A small amount of capacity coupling is now widely used in receiver r.f. and detector transformers as a gain booster at the high-frequency end of the tuning range. The coupling capacity is obtained by means of a small loop of wire cemented close to the grid end of the secondary winding, and with one end directly connected to the plate or antenna end of the primary winding (see Figure 5).

From the relations of capacitive reactance, it is easily seen that a small condenser will favor the higher frequencies, and it is evident that capacity coupling in the receiver coils will tend to pass amateur short-wave signals into a receiver tuned to broadcast frequencies.

The amount of capacity coupling may be reduced to eliminate interference by moving the coupling turn farther away from the secondary coil. However, a simple wave-trap of the type shown in Figures 1 and 2, inserted at the antenna input terminal, will generally accomplish the same result and is more to be recommended than changing the capacity coupling (which lowers the receiver gain at the high

frequency end of the broadcast band). Should the wave-trap alone not suffice, it will be necessary to resort to a reduction in capacity coupling.

In some simple broadcast receivers, capacity coupling is unintentionally obtained by too closely coupled primary and secondary coils, or as a result of running a long primary or antenna lead close to the secondary coil of an unshielded antenna coupler.

Phantoms When two strong local carriers are separated by a certain number of kilocycles, the beat note resulting between them may fall on some frequency within the broadcast band and, if rectified by any means, be audible at that point. If such a "phantom" signal falls on a local broadcast frequency, there will be heterodyne interference as well. This is a common occurrence with broadcast receivers in the neighborhood of two amateur stations, or an amateur and a police station. It also sometimes occurs when only one of the stations is located in the immediate vicinity.

As examples: the beat note between amateur carriers on 2000 kc. and 3500 kc. falls on 1500 kc., and an 1812-kc. amateur signal might beat with a local 1712-kc. police carrier to produce a 100-kc. phantom. And, if the latter two carriers are strong enough, harmonics will be encountered every 100 kilocycles throughout the broadcast band,—that is, if rectification of the signals takes place anywhere in the vicinity. A poor contact between two oxidized wires can produce rectification.

Two stations must be transmitting simultaneously to produce a phantom signal; when either station goes off the air the phantom disappears. Hence, this type of interference is apt to be reported as highly intermittent, and might be difficult to duplicate unless a test

oscillator is used "on location" to simulate the missing station. Such interference cannot be remedied at the transmitter, and often the rectification takes place some distance from the receivers. In such occurrences it is most difficult to locate the source of the trouble.

It will also be apparent that a phantom might fall on the intermediate frequency of a simple superhet receiver and cause interference of the untunable variety if the manufacturer has not provided an i.f. wave-trap in the antenna circuit. Examples of this occurrence are the 175-kc. beat between 1887 (amateur) and 1712 kc. (police) or between amateur signals on 1820 kc. and 1995 kc.

This particular type of phantom may, in addition to causing i.f. interference, generate harmonics which may be tuned in and out with heterodyne whistles from one end of the receiver dial to the other. It is in this manner that "birdies" often result from the operation of nearby amateur stations.

When one component of a phantom is a steady, unmodulated carrier, only the intelligence present on the other carrier is conveyed to the broadcast receiver.

Phantom signals almost always may be identified by the suddenness with which they are interrupted, signaling withdrawal of one party to the union. This is especially baffling to the inexperienced interference-locator, who observes that the interference suddenly disappears, even though its own transmitter remains in operation.

If the mixing or rectification is taking place in the receiver itself, a phantom signal may be eliminated by removing either one of the contributing signals from the receiver input circuit. A wave-trap of the types shown in Figures 1 and 2, tuned to either signal, will do the trick. If the rectification is taking place outside the receiver, the wave-trap should be tuned to the frequency of the phantom, instead of to one of its components. I.f. wavetraps may be built around a 2.5-millihenry r.f. choke as the inductor, and a compression-type mica padding condenser. The condenser should have a capacity range of 250—525 $\mu\mu\text{fd.}$ for the 175- and 206-kc. intermediate frequencies; 65—175 $\mu\mu\text{fd.}$ for 260 kc. and other intermediates lying between 250 and 400 kc.; and 17—80 $\mu\mu\text{fd.}$ for 456, 465, 495, and 500 kc. Slightly more capacity will be required for resonance with a 2.1 millihenry choke.

Spurious Emissions This sort of interference arises from the transmitter itself. The radiation of any signal (other than the intended carrier frequency) by an amateur station is prohibited by FCC regulations. Spurious radiation may be traced to imperfect neutralization, parasitic oscillations in

the r.f. or modulator stages, or to "broadcast-band" v.f. oscillators.

Low-frequency parasitics may actually occur on broadcast frequencies or their near sub-harmonics, causing direct interference to programs. An all-wave monitor operated in the vicinity of the transmitter will detect these spurious signals.

The remedy will be obvious in individual cases. Elsewhere in this book are discussed methods of complete neutralization and the suppression of parasitic oscillations in r.f. and audio stages.

Stray Receiver Rectification A receiver in the immediate neighborhood of a strong transmitter is subject to stray rectification within the receiver. It is due to the interfering signal being rectified by the second detector in a superhet (detector in a tuned r.f. set), or an audio stage of the receiver if poorly shielded or containing too long a grid lead.

This type of interference is most commonly caused by ultra-high-frequency transmitters, doubtless because at those frequencies lengthy connections in the receiver can easily become fractions of the transmitter wavelength. The interfering signal is not tunable, and generally covers the entire dial.

If the receiver is not a series-filament set, the trouble may be localized by removing the tubes, starting with the input stage and working toward the audio output stage. The interfering signal will cease when the tube rectifying it is removed from its socket.

Signal rectification in an audio stage may be cured by connecting a 2.5-millihenry pi-wound r.f. choke in series with the control-grid lead and input terminal and a .0001 $\mu\text{fd.}$ condenser from grid to ground. But the task is not so simple when rectification occurs in one of the other stages. Here, complete shielding of the set, tubes, and exposed r.f. leads (such as top-cap grid leads) will have to be provided. In addition, it may be necessary to lower the bias of the offending stage.

"Floating" Volume Control Shafts Several sets have been encountered where there was only a slightly interfering signal; but, upon placing one's hand up to the volume control, the signal would greatly increase. Investigation revealed that the volume control was installed with its shaft insulated from ground. The control itself was connected to a critical part of a circuit, in many instances to the grid of a high-gain audio stage. The cure is to install a volume control with *all* the terminals insulated from the shaft, and then to ground the shaft.

| BAND | COIL L | CONDENSER C |
|------|---|-------------------------|
| 160 | 26 turns no. 14 enameled 4-inch diameter 3-inch length | 100- μ fd. variable |
| 80 | 17 turns no. 14 enameled 3-inch diameter 2 1/4-inch length | 100- μ fd. variable |
| 40 | 11 turns no. 14 enameled 2 1/2-inch diameter 1 1/2-inch length | 100- μ fd. variable |
| 20 | 4 turns no. 10 enameled 3-inch diameter 1 1/8-inch length | 100- μ fd. variable |
| 10 | 3 turns 1/4-inch o.d. copper tubing 2-inch diameter 1-inch length | 100- μ fd. variable |

Figure 6. POWERLINE WAVE TRAP COIL AND CONDENSER TABLE.

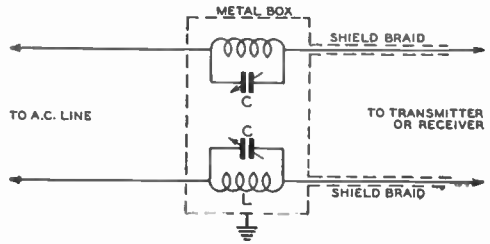

Figure 7. METHOD OF CONNECTING POWER LINE WAVE TRAP.

A parallel resonant circuit is more effective than an r.f. choke in keeping r.f. from getting from a transmitter into the power line, or from the power line into a receiver. A .05- μ fd. tubular condenser connected from each 110-volt wire to ground often will increase the effectiveness of the traps. They may be connected on either side of the line traps.

Spray-Shield Tubes

Although they are no longer made, there are yet quite a few sets in use which employ spray-shield tubes. These are used in both r.f. and in audio circuits. In some audio applications of this type of tube, the cathode and the spray-shield (to which the cathode is connected) are not at ground potential, but are bypassed to ground with an electrolytic condenser of large capacity. This type of condenser is a very poor r.f. filter and, in a strong r.f. field, some detection will take place, producing interference. The best cure is to install a standard glass tube with a glove shield, which is then actually grounded, and also to shield the grid leads to these tubes. As an alternative, bypassing the electrolytic cathode condenser with a .05 μ fd. tubular paper condenser may be tried.

Power-Line Pickup

When radio-frequency energy from a radio transmitter enters a broadcast receiver through the a.c. power lines, it has either been fed back into the lighting system by the offending transmitter, or picked up from the air by overhead power lines. Underground lines are seldom responsible for spreading this interference.

To check the path whereby the interfering signals reach the lines, it is only necessary to replace the transmitting antenna with a dummy antenna and adjust the transmitter for maximum output. If the interference then ceases, overhead lines have been picking up the energy. The trouble can be cleared up only by installing wave-traps in the power lines at the receiver. These are then tuned to the interfering

signal frequency. If the receiver is reasonably close to the transmitter, it is very doubtful that changing the direction of the transmitting antenna to right angles with the overhead lines will eliminate the trouble.

If, on the contrary, the interference continues when the transmitter is connected to the dummy antenna, radio-frequency energy is being fed directly into the power line by the transmitter, and the station must be inspected to determine the cause.

One of the following reasons for the trouble will usually be found: (1) the r.f. stages are not sufficiently bypassed and/or choked, (2) the antenna coupling system is not performing efficiently, (3) the power transformers have no electrostatic shields; or, if shields are present, they are ungrounded, (4) power lines are running too close to an antenna or r.f. circuits carrying high currents. If none of these causes apply, wave-traps must be installed in the power lines at the transmitter to remove r.f. energy passing back into the lighting system.

The wave-traps used in the power lines at transmitter or receiver must be capable of passing relatively high amperage. The coils are accordingly wound with heavy wire. Figure 6 lists the specifications for power line wave-trap coils, while Figure 7 illustrates the method of connecting these wave-traps. Observe that these traps are enclosed in a shield box of heavy iron or steel, well grounded.

All-Wave Receivers

Each complete-coverage home receiver is a potential source of annoyance to the transmitting amateur. The novice short-wave broadcast-listener who tunes in an amateur station often considers it an interfering signal, and complains accordingly.

Neither selectivity nor image rejectivity in most of these sets is in any wise comparable to those properties in a communication receiver. The result is that an amateur signal will occupy too much dial space and appear at more than one point, giving rise to interference on adjacent channels and removed channels as well.

If carrier-frequency harmonics are present in the amateur transmission, serious interference will result at the all-wave receiver. The harmonics will, if the carrier frequency has been so unfortunately chosen, fall directly upon a favorite short-wave broadcast station and arouse warranted objection.

The amateur is apt to be blamed, too, for transmissions for which he is not responsible, so great is the public ignorance of short-wave allocations and signals. Owners of all-wave receivers have been quick to ascribe to amateur stations all signals they hear from tape machines and V-wheels, as well as stray tones and heterodyne flutters they hear.

The amateur cannot be held responsible when his carrier is deliberately tuned in on an all-wave receiver. Neither is he accountable for the width of his signal on the receiver dial, or for the strength of image repeat points, if it can be proven that the receiver design does not afford good selectivity and image rejection.

If he so desires, the amateur (or the owner of the receiver) might sharpen up the received signal somewhat by shortening the receiving antenna. Set retailers often supply quite a sizable antenna with all-wave receivers, but most of the time these sets perform almost as well with a few feet of inside antenna.

The amateur *is* accountable for harmonics of his carrier frequency. Such emissions are unlawful in the first place, and he must take all steps necessary to their suppression. Practical suggestions for the elimination of harmonics will be found elsewhere in this book (see *Index*).

Superheterodyne Interference

In addition to those types of interference already discussed, there are two more which are common to superhet receivers. The prevalence of these types is of great concern to the amateur, although the responsibility for their existence more properly rests with the broadcast receiver.

The first is the production of broadcast-band images by 160-meter amateur stations. This is possible since the separation between the broadcast band and the 160-meter region is small enough to establish image-frequency relationships.

The mechanism whereby image production is accomplished may be explained in the following manner: when the first detector is set

to the frequency of an incoming signal, the high-frequency oscillator is operating on another frequency which differs from the signal by the number of kilocycles in the intermediate frequency. Now, with the setting of these two stages undisturbed, there is another signal which will beat with the high-frequency oscillator to produce an i.f. voltage. This other signal is the so-called image, which is separated from the desired signal by twice the intermediate frequency.

Thus, in a receiver with 175-kc. i.f., tuned to 1000 kc.: the h.f. oscillator is operating on 1175 kc., and a signal on 1350 kc. (1000 kc. plus 2×175 kc.) will beat with this 1175 kc. oscillator frequency to produce the 175-kc. i.f. signal. Similarly, when the same receiver is tuned to 1400 kc., an amateur signal on 1750 kc. can come through. The dial point where any 160-meter signal will produce an image can be determined from the equation:

$$F_b = (F_{am} - 2 \text{ i.f.})$$

Where F_b = receiver dial frequency

F_{am} = amateur transmitter frequency,
and

i.f. = receiver intermediate frequency.

If the image appears only a few cycles or kilocycles from a broadcast carrier, heterodyne interference will be present as well. Otherwise, it will be tuned in and out in the manner of a station operating in the broadcast band. Sharpness of tuning will be comparable to that of broadcast stations producing the same a.v.c. voltage at the receiver.

The second variety of superhet interference is the result of harmonics of the receiver h.f. oscillator beating with amateur carriers to produce the intermediate frequency of the receiver. The amateur transmitter will always be found to be on a frequency equal to some harmonic of the receiver h.f. oscillator, *plus or minus the intermediate frequency*.

As an example: when a broadcast superhet with 465-kc. i.f. is tuned to 1000 kc., its high-frequency oscillator operates on 1465 kc. The third harmonic of this oscillator frequency is 4395 kc., which will beat with an amateur 'phone signal on 3950 kc. to send a signal through the i.f. amplifier. The 3950 kc. signal would be tuned in at the 1000-kc. point on the dial.

Some oscillator harmonics are so related to amateur frequencies that more than one point of interference will occur on the receiver dial. Thus, a 3500-kc. signal may be tuned in at six points on the dial of a nearby broadcast superhet having 175 kc. i.f. and no r.f. stage.

Insofar as remedies for image and harmonic superhet interference are concerned, it is well to remember that *if* the amateur signal did not in the first place reach the input stage of the

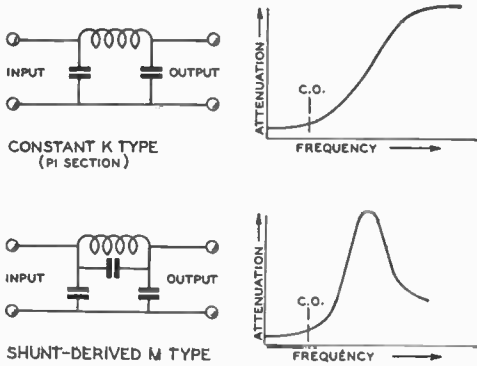

Figure 8.

TWO TYPES OF LOW PASS FILTERS AND THE KIND OF ATTENUATION CURVE OBTAINED WITH EACH.

The M-derived type has sharper cut-off but not as great attenuation at frequencies two or more octaves above the cut-off frequency.

receiver, the annoyance would not have been created. It is therefore good policy to try to eliminate it by means of a wave-trap. Broadcast superhets are not always the acme of good shielding, however, and the amateur signal is apt to enter the circuit through channels other than the input circuit. If a wave-trap or filter will not cure the trouble, the only alternative will be to attempt to select a transmitter frequency such that neither image nor harmonic interference will be set up on favorite stations in the susceptible receivers. The equation given earlier may be used to determine the proper frequencies.

Low Pass Filters

The greatest drawback of the wave-trap is the fact that it is a single-frequency device; i.e.—it may be set to reject at one time only one frequency (or, at best, an extremely narrow band of frequencies). Each time the frequency of the interfering transmitter is changed, every wave-trap tuned to it must be retuned.

A much more satisfactory device is the *wave filter* which requires no tending. One type, the low pass filter, passes all frequencies below one critical frequency, and eliminates all higher frequencies. It is this property that makes the device ideal for the task of removing amateur frequencies from broadcast receivers.

A good low pass filter designed for maxi-

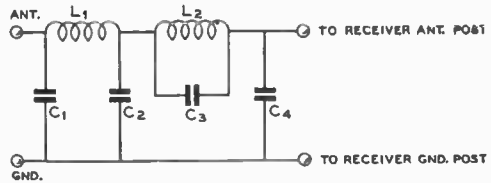

Figure 9.

COMPOSITE LOW PASS FILTER POSSESSING ADVANTAGES OF BOTH K SECTION AND M DERIVED FILTER.

This filter is highly effective in reducing broadcast interference from all high frequency stations, and requires no tuning. Constants for 400 ohm terminal impedance and 1600 kc. cut-off are as follows: L₁, 65 turns no. 22 d.c.c. close wound on 1 1/2 in. dia. form. L₂, 41 turns ditto, not coupled to L₁. C₁, 250 μfd. fixed mica condenser. C₂, 400 μfd. fixed mica condenser. C₃ and C₄, 150 μfd. fixed mica condensers, former of 5% tolerance. With some receivers, better results will be obtained with a 200 ohm carbon resistor inserted between the filter and antenna post on the receiver. With other receivers the effectiveness will be improved with a 600 ohm carbon resistor placed from the antenna post to the ground post on the receiver. The filter should be placed as close to the receiver terminals as possible.

imum attenuation at some frequency inside the lower frequency edge of the 160-meter band will pass all broadcast carriers, but will reject signals originating in any amateur band. Naturally such a device should be installed only in standard broadcast receivers, never in all-wave sets.

Two types of low pass filters are shown in Figure 8. A composite arrangement comprising a section of each type is more effective than either type operating alone. A composite filter composed of one K-section and one shunt-derived M-section is shown in Figure 9, and is highly recommended. The M-section is designed to have maximum attenuation in the middle of the 160-meter 'phone band, and for that reason C₃ should be of the "close tolerance" variety. Likewise, C₃ should not be stuffed down inside L₂ in the interest of compactness, as this will alter the inductance of the coil appreciably, and likewise the resonant frequency.

If a fixed 150 μfd. mica capacitor of 5 per cent tolerance is not available for C₃, a compression trimmer covering the range of 125—175 μfd. may be substituted and adjusted to give maximum attenuation at about 1900 kc.

Radio Mathematics and Calculations

RADIOMEN often have occasion to calculate sizes and values of required parts. This requires some knowledge of mathematics. The following pages contain a review of those parts of mathematics necessary to understand and apply the information contained in this book. It is assumed that the reader has had some mathematical training; this chapter is not intended to teach those who have never learned anything of the subject.

Fortunately only a knowledge of fundamentals is necessary, although this knowledge must include several branches of the subject. Fortunately, too, the majority of practical applications in radio work reduce to the solution of equations or formulas or the interpretation of graphs.

Arithmetic

Notation of Numbers In writing numbers in the Arabic system we employ ten different symbols, digits, or figures: 1, 2, 3, 4, 5, 6, 7, 8, 9, and 0, and place them in a definite sequence. If there is more than one figure in the number the *position* of each figure or digit is as important in determining its value as is the digit itself. When we deal with whole numbers the righthandmost digit represents units, the next to the left represents tens, the next hundreds, the next thousands, from which we derive the rule that every time a digit is placed one space further to the left its value is multiplied by ten.

| | | | |
|-----------|----------|------|-------|
| 8 | 1 | 4 | 3 |
| thousands | hundreds | tens | units |

It will be seen that any number is actually a sum. In the example given above it is the sum of eight thousands, plus one hundred, plus

four tens, plus three units, which could be written as follows:

| | |
|------|--|
| 8 | thousands ($10 \times 10 \times 10$) |
| 1 | hundreds (10×10) |
| 4 | tens |
| 3 | units |
| 8143 | |

The number in the units position is sometimes referred to as a *first order* number, that in the tens position is of the *second order*, that in the hundreds position the *third order*, etc.

The idea of letting the position of the symbol denote its value is an outcome of the abacus. The abacus had only a limited number of wires with beads, but it soon became apparent that the quantity of symbols might be continued indefinitely towards the left, each further space multiplying the digit's value by ten. Thus any quantity, however large, may readily be indicated.

It has become customary for ease of reading to divide large numbers into groups of three digits, separating them by commas.

6,000,000 rather than 6000000

Our system of notation then is characterized by two things: the use of positions to indicate the value of each symbol, and the use of ten symbols, from which we derive the name *decimal system*.

Retaining the same use of positions, we might have used a different number of symbols, and displacing a symbol one place to the left might multiply its value by any other factor such as 2, 6 or 12. Such other systems have been in use in history, but will not be discussed here. There are also systems in which displacing a symbol to the left multiplies its value by

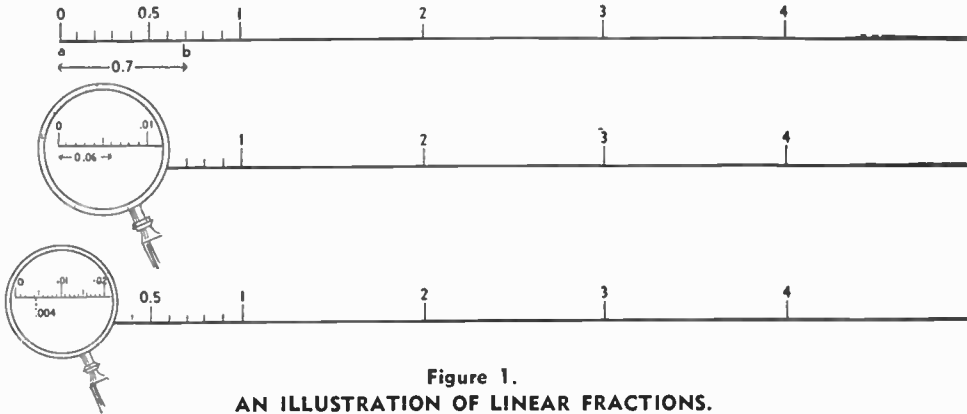

Figure 1.
AN ILLUSTRATION OF LINEAR FRACTIONS.

varying factors in accordance with complicated rules. The English system of measurements is such an inconsistent and inferior system.

Decimal Fractions Since we can extend a number indefinitely to the left to make it bigger, it is a logical step to extend it towards the right to make it smaller. Numbers smaller than unity are *fractions* and if a displacement one position to the right divides its value by ten, then the number is referred to as a *decimal fraction*. Thus a digit to the right of the units column indicates the number of *tenths*, the second digit to the right represents the number of *hundredths*, the third, the number of *thousandths*, etc. Some distinguishing mark must be used to divide unit from tenths so that one may properly evaluate each symbol. This mark is the *decimal point*.

A decimal fraction like *four-tenths* may be written .4 or 0.4 as desired, the latter probably

being the clearer. Every time a digit is placed one space further to the right it represents a ten times smaller part. This is illustrated in Figure 1, where each large division represents a unit; each unit may be divided into ten parts although in the drawing we have only so divided the first part. The length *ab* is equal to seven of these tenth parts and is written as 0.7.

The next smaller divisions, which should be written in the second column to the right of the decimal point, are each one-tenth of the small division, or one one-hundredth each. They are so small that we can only show them by imagining a magnifying glass to look at them, as in Figure 1. Six of these divisions is to be written as 0.06 (six hundredths). We need a microscope to see the next smaller division, that is those in the third place, which will be a tenth of one one-hundredth, or a thousandth; four such divisions would be written as 0.004 (four thousandths).

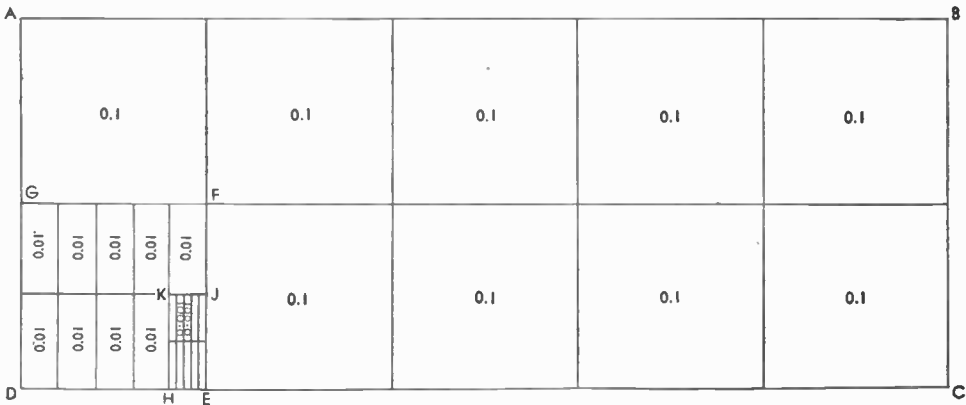

Figure 2.

IN THIS ILLUSTRATION FRACTIONAL PORTIONS ARE REPRESENTED IN THE FORM OF RECTANGLES RATHER THAN LINEARLY.
 $ABCD = 1.0$; $GFED = 0.1$; $KJEH = 0.01$; each small section within $KJEH$ equals 0.001 .

It should not be thought that such numbers are merely of academic interest for very small quantities are common in radio work.

Possibly the conception of fractions may be clearer to some students by representing it in the form of rectangles rather than linearly (see Figure 2).

Addition When two or more numbers are to be added we sometimes write them horizontally with the plus sign between them. + is the sign or *operator* indicating addition. Thus if 7 and 12 are to be added together we may write $7+12=19$.

But if larger or more numbers are to be added together they are almost invariably written one under another in such a position that the decimal points fall in a vertical line. If a number has no decimal point, it is still considered as being just to the right of the units figure; such a number is a whole number or *integer*. Examples:

| | | |
|--|--|---|
| $\begin{array}{r} 654 \\ 32 \\ \hline 53041 \end{array}$ | $\begin{array}{r} 0.654 \\ 3.2 \\ \hline 53.041 \end{array}$ | $\begin{array}{r} 654 \\ 32 \\ \hline 5304.1 \end{array}$ |
| $\hline 53727$ | $\hline 56.895$ | $\hline 5990.1$ |

The result obtained by adding numbers is called the *sum*.

Subtraction Subtraction is the reverse of addition. Its operator is - (the *minus* sign). The number to be subtracted is called the *minuend*, the number from which it is subtracted is the *subtrahend*, and the result is called the *remainder*.

$$\begin{array}{r} \text{subtrahend} \\ - \text{minuend} \\ \hline \text{remainder} \end{array}$$

Examples:

| | |
|--|--|
| $\begin{array}{r} 65.4 \\ - 32 \\ \hline 33.4 \end{array}$ | $\begin{array}{r} 65.4 \\ - 32.21 \\ \hline 33.19 \end{array}$ |
|--|--|

Multiplication When numbers are to be multiplied together we use the X, which is known as the *multiplication* or the *times* sign. The number to be multiplied is known as the *multiplicand* and that by which it is to be multiplied is the *multiplier*, which may be written in words as follows:

$$\begin{array}{r} \text{multiplicand} \\ \times \text{multiplier} \\ \hline \text{portial product} \\ \text{portial product} \\ \hline \text{p r o d u c t} \end{array}$$

The result of the operation is called the *product*.

From the examples to follow it will be obvious that there are as many partial products as there are digits in the multiplier. In the following examples note that the righthandmost digit of each partial product is placed one space farther to the left than the previous one.

| | |
|--|---|
| $\begin{array}{r} 834 \\ \times 26 \\ \hline 5004 \\ 1668 \\ \hline 21684 \end{array}$ | $\begin{array}{r} 834 \\ \times 206 \\ \hline 5004 \\ 000 \\ 1668 \\ \hline 171804 \end{array}$ |
|--|---|

In the second example above it will be seen that the inclusion of the second partial product was unnecessary; whenever the multiplier contains a cipher (zero) the next partial product should be moved an *additional* space to the left.

Numbers containing decimal fractions may first be multiplied exactly as if the decimal point did not occur in the numbers at all; the position of the decimal point in the product is determined after all operations have been completed. It must be so positioned in the product that the number of digits to its right is equal to the number of decimal places in the multiplicand plus the number of decimal places in the multiplier.

This rule should be well understood since many radio calculations contain quantities which involve very small decimal fractions. In the examples which follow the explanatory notations "2 places," etc., are not actually written down since it is comparatively easy to determine the decimal point's proper location mentally.

$$\begin{array}{r} 5.43 \quad 2 \text{ places} \\ \times 0.72 \quad 2 \text{ places} \\ \hline 1086 \\ 3801 \\ \hline 3.9096 \end{array}$$

$2 + 2 = 4$ places

$$\begin{array}{r} 0.04 \quad 2 \text{ places} \\ \times 0.003 \quad 3 \text{ places} \\ \hline 0.00012 \end{array}$$

$2 + 3 = 5$ places

Division Division is the reverse of multiplication. Its operator is the ÷, which is called the *division sign*. It is also common to indicate division by the use of the fraction bar (/) or by writing one number over the other. The number which is to be divided is called the *dividend* and is written before the division sign or fraction bar or over the horizontal line indicating a fraction. The num-

ber by which the dividend is to be divided is called the *divisor* and follows the division sign or fraction bar or comes under the horizontal line of the fraction. The answer or result is called the *quotient*.

$$\begin{array}{r} \text{quotient} \\ \text{divisor} \overline{) \text{dividend}} \\ \text{or} \\ \text{dividend} \div \text{divisor} = \text{quotient} \\ \text{or} \\ \frac{\text{dividend}}{\text{divisor}} = \text{quotient} \end{array}$$

Examples:

$$\begin{array}{r} 126 \\ 834 \overline{) 105084} \\ \underline{834} \\ 2168 \\ \underline{1668} \\ 5004 \\ \underline{5004} \end{array} \qquad \begin{array}{r} 49 \\ 29 \overline{) 2436} \\ \underline{196} \\ 476 \\ \underline{441} \\ 35 \text{ remainder} \end{array}$$

Note that one number often fails to divide into another evenly. Hence there is often a quantity left over called the *remainder*.

The rules for placing the decimal point are the reverse of those for multiplication. The number of decimal places in the quotient is equal to the difference between the number of decimal places in the dividend and that in the divisor. It is often simpler and clearer to remove the decimal point entirely from the divisor by multiplying both dividend and divisor by the necessary factor; that is we move the decimal point in the divisor as many places to the right as is necessary to make it a whole number and then we move the decimal point in the dividend exactly the same number of places to the right regardless of whether this makes the dividend a whole number or not. When this has been done the decimal point in the quotient will automatically come directly above that in the dividend as shown in the following example.

Example: Divide 10.5084 by 8.34. Move the decimal point of both dividend and divisor two places to the right.

$$\begin{array}{r} 1.26 \\ 834 \overline{) 1050.84} \\ \underline{834} \\ 2168 \\ \underline{1668} \\ 5004 \\ \underline{5004} \end{array}$$

Another example: Divide 0.000325 by 0.017. Here we must move the decimal point three places to the right in both dividend and divisor.

$$\begin{array}{r} 0.019 \\ 17 \overline{) 0.325} \\ \underline{17} \\ 155 \\ \underline{153} \\ 2 \end{array}$$

In a case where the dividend has fewer decimals than the divisor the same rules still may be applied by adding ciphers. For example to divide 0.49 by 0.006 we must move the decimal point three places to the right. The 0.49 now becomes 490 and we write:

$$\begin{array}{r} 81 \\ 6 \overline{) 490} \\ \underline{48} \\ 10 \\ \underline{6} \\ 4 \end{array}$$

When the division shows a remainder it is sometimes necessary to continue the work so as to obtain more figures. In that case ciphers may be annexed to the dividend, brought down to the remainder, and the division continued as long as may be necessary; be sure to place a decimal point in the dividend before the ciphers are annexed if the dividend does not already contain a decimal point. For example:

$$\begin{array}{r} 80.33 \\ 6 \overline{) 482.00} \\ \underline{48} \\ 20 \\ \underline{18} \\ 20 \\ \underline{18} \\ 2 \end{array}$$

This operation is not very often required in radio work since the accuracy of the measurements from which our problems start seldom justifies the use of more than three significant figures. This point will be covered further later in this chapter.

Fractions Quantities of less than one (unity) are called *fractions*. They may be expressed by decimal notation as we have seen, or they may be expressed as *vulgar fractions*. Examples of vulgar fractions:

$$\frac{\text{numerator}}{\text{denominator}} \quad \frac{3}{4} \quad \frac{6}{7} \quad \frac{1}{5}$$

The upper position of a vulgar fraction is called the *numerator* and the lower position the *denominator*. When the numerator is the smaller of the two, the fraction is called a *proper fraction*; the examples of vulgar fractions given above are proper vulgar fractions. When the numerator is the larger, the expression is an *improper fraction*, which can be reduced to an integer or whole number with a proper fraction, the whole being called a mixed number. In the following examples improper fractions have been reduced to their corresponding mixed numbers.

$$\frac{7}{4} = 1 \frac{3}{4} \qquad \frac{5}{3} = 1 \frac{2}{3}$$

Adding or Subtracting Fractions Except when the fractions are very simple it will usually be found much easier to add and subtract fractions in the form of decimals. This rule likewise applies for practically all other operations with fractions. However, it is occasionally necessary to perform various operations with vulgar fractions and the rules should be understood.

When adding or subtracting such fractions the denominators must be made equal. This may be done by multiplying both numerator and denominator of the first fraction by the denominator of the other fraction, after which we multiply the numerator and denominator of the second fraction by the denominator of the first fraction. This sounds more complicated than it usually proves in practice, as the following examples will show.

$$\frac{1}{2} + \frac{1}{3} = \left[\frac{1 \times 3}{2 \times 3} + \frac{1 \times 2}{3 \times 2} \right] = \frac{3}{6} + \frac{2}{6} = \frac{5}{6}$$

$$\frac{3}{4} - \frac{2}{5} = \left[\frac{3 \times 5}{4 \times 5} - \frac{2 \times 4}{5 \times 4} \right] = \frac{15}{20} - \frac{8}{20} = \frac{7}{20}$$

Except in problems involving large numbers the step shown in brackets above is usually done in the head and is not written down.

Although in the examples shown above we have used proper fractions, it is obvious that the same procedure applies with improper fractions. In the case of problems involving mixed numbers it is necessary first to convert them into improper fractions. Example:

$$2 \frac{3}{7} = \frac{2 \times 7 + 3}{7} = \frac{17}{7}$$

The numerator of the improper fraction is equal to the whole number multiplied by the denominator of the original fraction, to which

the numerator is added. That is in the above example we multiply 2 by 7 and then add 3 to obtain 17 for the numerator. The denominator is the same as is the denominator of the original fraction. In the following example we have added two mixed numbers.

$$2 \frac{3}{7} + 3 \frac{3}{4} = \frac{17}{7} + \frac{15}{4} = \left[\frac{17 \times 4}{7 \times 4} + \frac{15 \times 7}{4 \times 7} \right]$$

$$= \frac{68}{28} + \frac{105}{28} = \frac{173}{28} = 6 \frac{5}{28}$$

Multiplying Fractions All vulgar fractions are multiplied by multiplying the numerators together and the denominators together, as shown in the following example:

$$\frac{3}{4} \times \frac{2}{5} = \left[\frac{3 \times 2}{4 \times 5} \right] = \frac{6}{20} = \frac{3}{10}$$

As above, the step indicated in brackets is usually not written down since it may easily be performed mentally. As with addition and subtraction any mixed numbers should be first reduced to improper fractions as shown in the following example:

$$\frac{3}{23} \times 4 \frac{1}{3} = \frac{3}{23} \times \frac{13}{3} = \frac{39}{69} = \frac{13}{23}$$

Division of Fractions Fractions may be most easily divided by inverting the divisor and then multiplying.

Example:

$$\frac{2}{5} \div \frac{3}{4} = \frac{2}{5} \times \frac{4}{3} = \frac{8}{15}$$

In the above example it will be seen that to divide by $\frac{3}{4}$ is exactly the same thing as to multiply by $\frac{4}{3}$. Actual division of fractions is a rather rare operation and if necessary is usually postponed until the final answer is secured when it is often desired to reduce the resulting vulgar fraction to a decimal fraction by division. It is more common and usually results in least overall work to reduce vulgar fractions to decimals at the beginning of a problem. Examples:

$$\frac{3}{8} = 0.375 \qquad \frac{5}{32} = 0.15625$$

$$\begin{array}{r} 0.15625 \\ 32 \overline{) 5.00000} \\ \underline{32} \\ 180 \\ \underline{160} \\ 200 \\ \underline{192} \\ 80 \\ \underline{64} \\ 160 \\ \underline{160} \\ 0 \end{array}$$

It will be obvious that many vulgar fractions cannot be reduced to exact decimal equivalents. This fact need not worry us, however, since the degree of equivalence can always be as much as the data warrants. For instance, if we know that one-third of an ampere is flowing in a given circuit, this can be written as 0.333 amperes. This is not the exact equivalent of 1/3 but is close enough since it shows the value to the nearest thousandth of an ampere and it is probable that the meter from which we secured our original data was not accurate to the nearest thousandth of an ampere.

Thus in converting vulgar fractions to a decimal we unhesitatingly stop when we have reached the number of significant figures warranted by our original data, which is very seldom more than three places (see section *Significant Figures* later in this chapter).

When the denominator of a vulgar fraction contains only the factors 2 or 5, division can be brought to a finish and there will be no remainder, as shown in the examples above.

When the denominator has other factors such as 3, 7, 11, etc., the division will seldom come out even no matter how long it is continued but, as previously stated, this is of no consequence in practical work since it may be carried to whatever degree of accuracy is necessary. The digits in the quotient will usually repeat either singly or in groups, although there may first occur one or more digits which do not repeat. Such fractions are known as *repeating fractions*. They are sometimes indicated by an oblique line (fraction bar) through the digit which repeats, or through the first and last digits of a repeating group. Example:

$$\frac{1}{3} = 0.3333 \dots = 0.\overline{3}$$

$$\frac{1}{7} = 0.142857142857 \dots = 0.\overline{142857}$$

The foregoing examples contained only repeating digits. In the following example a non-repeating digit precedes the repeating digit:

$$\frac{7}{30} = 0.2333 \dots = 0.2\overline{3}$$

While repeating decimal fractions can be converted into their vulgar fraction equivalents, this is seldom necessary in practical work and the rules will be omitted here.

Powers and Roots When a number is to be multiplied by itself we say that it is to be *squared* or to be *raised to the second power*. When it is to be multiplied by itself once again, we say that it is *cubed* or *raised to the third power*.

In general terms, when a number is to be multiplied by itself we speak of *raising to a power* or *involution*; the number of times which the number is to be multiplied by itself is called the *order of the power*. The standard notation requires that the order of the power be indicated by a small number written after the number and above the line, called the *exponent*. Examples:

$$2^2 = 2 \times 2, \text{ or } 2 \text{ squared, or the second power of } 2$$

$$2^3 = 2 \times 2 \times 2, \text{ or } 2 \text{ cubed, or the third power of } 2$$

$$2^4 = 2 \times 2 \times 2 \times 2, \text{ or the fourth power of } 2$$

Sometimes it is necessary to perform the reverse of this operation, that is, it may be necessary, for instance, to find that number which multiplied by itself will give a product of nine. The answer is of course 3. This process is known as *extracting the root* or *evolution*. The particular example which is cited would be written:

$$\sqrt{9} = 3$$

The sign for extracting the root is $\sqrt{\quad}$, which is known as the *radical sign*; the order of the root is indicated by a small number above the radical as in $\sqrt[4]{\quad}$, which would mean the fourth root; this number is called the *index*. When the radical bears no index, the square or second root is intended.

Restricting our attention for the moment to square root, we know that 2 is the square root of 4, and 3 is the square root of 9. If we want the square root of a number between 3 and 9, such as the square root of 5, it is obvious that it must lie between 2 and 3. In general the square root of such a number cannot be *exactly* expressed either by a vulgar fraction or a decimal fraction. However, the square root can be carried out decimally as far as may be necessary for sufficient accuracy. In general such a decimal fraction will contain a never-ending series of digits without repeating groups. Such a number is an *irrational number*, such as

$$\sqrt{5} = 2.2361 \dots$$

The extraction of roots is usually done by tables or logarithms the use of which will be described later. There are longhand methods of extracting various roots, but we shall give only that for extracting the square root since the others become so tedious as to make other methods almost invariably preferable. Even the longhand method for extracting the square root will usually be used only if loga-

rithm tables, slide rule, or table of roots are not handy.

Extracting the Square Root First divide the number the root of which is to be extracted into groups of two digits starting at the decimal point and going in both directions. If the lefthandmost group proves to have only one digit instead of two, no harm will be done. The righthandmost group may be made to have two digits by annexing a zero if necessary. For example, let it be required to find the square root of 5678.91. This is to be divided off as follows:

$$\sqrt{56' 78.91}$$

The mark used to divide the groups may be anything convenient, although the prime-sign (') is most commonly used for the purpose.

Next find the largest square which is contained in the first group, in this case 56. The largest square is obviously 49, the square of 7. Place the 7 above the first group of the number whose root is to be extracted, which is sometimes called the *dividend* from analogy to ordinary division. Place the square of this figure, that is 49, under the first group, 56, and subtract leaving a remainder of 7.

$$\begin{array}{r} 7 \\ \sqrt{56' 78.91} \\ 49 \\ \hline 7 \end{array}$$

Bring down the next group and annex it to the remainder so that we have 778. Now to the left of this quantity write down twice the root so far found (2×7 or 14 in this example), annex a cipher as a trial divisor, and see how many times the result is contained in 778. In our example 140 will go into 778 5 times. Replace the cipher with a 5, and multiply the resulting 145 by 5 to give 725. Place the 5 directly above the second group in the dividend and then subtract the 725 from 778.

$$\begin{array}{r} 7 \quad 5 \\ \sqrt{56' 78.91} \\ 49 \\ \hline 140 \\ 145 \times 5 = \quad 725 \\ \hline 53 \end{array}$$

The next step is an exact repetition of the previous step. Bring down the third group and annex it to the remainder of 53, giving 5391. Write down twice the root already

found and annex the cipher (2×75 or 150 plus the cipher, which will give 1500). 1500 will go into 5391 3 times. Replace the last cipher with a three and multiply 1503 by 3 to give 4509. Place 3 above the third group. Subtract to find the remainder of 882. The quotient 75.3 which has been found so far is not the exact square root which was desired; in most cases it will be sufficiently accurate. However, if greater accuracy is desired groups of two ciphers can be brought down and the process carried on as long as necessary.

$$\begin{array}{r} 7 \quad 5 \quad 3 \\ \sqrt{56' 78.91} \\ 49 \\ \hline 140 \\ 145 \times 5 = \quad 725 \\ \hline 1500 \\ 1503 \times 3 = \quad 4509 \\ \hline 882 \end{array}$$

Each digit of the root should be placed directly above the group of the dividend from which it was derived; if this is done the decimal point of the root will come directly above the decimal point of the dividend.

Sometimes the remainder after a square has been subtracted (such as the 1 in the following example) will not be sufficiently large to contain twice the root already found even after the next group of figures has been brought down. In this case we write a cipher above the group just brought down and bring down another group.

$$\begin{array}{r} 7 \quad 0 \quad 8 \quad 2 \\ \sqrt{50.16' 00' 00} \\ 49 \\ \hline 1400 \\ 1408 \times 8 = \quad 11264 \\ \hline 14160 \\ 14162 \times 2 = \quad 28324 \\ \hline 5276 \end{array}$$

In the above example the amount 116 was not sufficient to contain twice the root already found with a cipher annexed to it; that is, it was not sufficient to contain 140. Therefore we write a zero above 16 and bring down the next group, which in this example is a pair of ciphers.

Order of Operations One frequently encounters problems in which several of the fundamental operations of arithmetic which have been described are to be performed. The order in which these operations

must be performed is important. First all powers and roots should be calculated; multiplication and division come next; adding and subtraction come last. In the example

$$2 + 3 \times 4^2$$

we must first square the 4 to get 16; then we multiply 16 by 3, making 48, and to the product we add 2, giving a result of 50.

If a different order of operations were followed, a different result would be obtained. For instance, if we add 2 to 3 we would obtain 5, and then multiplying this by the square of 4 or 16, we would obtain a result of 80, which is incorrect.

In more complicated forms such as fractions whose numerators and denominators may both be in complicated forms, the numerator and denominator are first found separately before the division is made, such as in the following example:

$$\frac{3 \times 4 + 5 \times 2}{2 \times 3 + 2 + 3} = \frac{12 + 10}{6 + 2 + 3} = \frac{22}{11} = 2$$

Problems of this type are very common in dealing with circuits containing several inductances, capacities, or resistances.

The order of operations specified above does not always meet all possible conditions; if a series of operations should be performed in a different order, this is always indicated by *parentheses* or *brackets*. for example:

$$\begin{aligned} 2 + 3 \times 4^2 &= 2 + 3 \times 16 = 2 + 48 = 50 \\ (2 + 3) \times 4^2 &= 5 \times 4^2 = 5 \times 16 = 80 \\ 2 + (3 \times 4)^2 &= 2 + 12^2 = 2 + 144 = 146 \end{aligned}$$

In connection with the radical sign, brackets may be used or the "hat" of the radical may be extended over the entire quantity whose root is to be extracted. Example:

$$\begin{aligned} \sqrt{4 + 5} &= \sqrt{4} + 5 = 2 + 5 = 7 \\ \sqrt{(4 + 5)} &= \sqrt{4 + 5} = \sqrt{9} = 3 \end{aligned}$$

It is recommended that the radical always be extended over the quantity whose root is to be extracted to avoid any ambiguity.

Cancellation In a fraction in which the numerator and denominator consist of several factors to be multiplied, considerable labor can often be saved if it is found that the same factor occurs in both numerator and denominator. These factors cancel each other and can be removed. Example:

$$\frac{\cancel{2} \times \cancel{3} \times \cancel{5} \times 5}{\cancel{6} \times \cancel{5} \times \cancel{7}} = \frac{5}{7}$$

In the foregoing example it is obvious that the 3 in the numerator goes into the 6 in the denominator twice. We may thus cross out the three and replace the 6 by a 2. The 2 which we have just placed in the denominator cancels the 2 in the numerator. Next the 5 in the denominator will go into the 25 in the numerator leaving a result of 5. Now we have left only a 5 in the numerator and a 7 in the denominator, so our final result is 5/7. If we had multiplied $2 \times 3 \times 25$ to obtain 150 and then had divided this by $6 \times 5 \times 7$ or 210, we would have obtained the same result but, with considerably more work.

Algebra

Algebra is not a separate branch of mathematics but is merely a form of *generalized arithmetic* in which letters of the alphabet and occasional other symbols are substituted for numbers, from which it is often referred to as *literal notation*. It is simply a shorthand method of writing operations which could be spelled out.

The laws of most common electrical phenomena and circuits (including of course radio phenomena and circuits) lend themselves particularly well to representation by literal notation and solution by algebraic equations or formulas.

While we may write a particular problem in Ohm's Law as an ordinary division or multiplication, the general statement of all such problems calls for the replacement of the numbers by symbols. We might be explicit and write out the names of the units and use these names as symbols:

$$\text{volts} = \text{amperes} \times \text{ohms}$$

Such a procedure becomes too clumsy when the expression is more involved and would be unusually cumbersome if any operations like multiplication were required. Therefore as a short way of writing these generalized relations the numbers are represented by letters. Ohm's Law then becomes

$$E = I \times R$$

In the statement of any particular problem the significance of the letters is usually indicated directly below the equation or formula using them unless there can be no ambiguity. Thus the above form of Ohm's Law would be more completely written as:

$$E = I \times R$$

where E = e.m.f. in volts
 I = current in amperes
 R = resistance in ohms

Letters therefore represent numbers, and for any letter we can read "any number." When the same letter occurs again in the same expression we would mentally read "the same number," and for another letter "another number of any value."

These letters are connected by the usual operational symbols of arithmetic, +, -, ×, ÷, and so forth. In algebra, the sign for division is seldom used, a division being usually written as a fraction. The multiplication sign, ×, is usually omitted or one may write a period only. Examples:

$$2 \times a \times b = 2ab$$

$$2.3.4.5a = 2 \times 3 \times 4 \times 5 \times a$$

In practical applications of algebra, an expression usually states some physical law and each letter represents a variable quantity which is therefore called a *variable*. A fixed number in front of such a quantity (by which it is to be multiplied) is known as the *coefficient*. Sometimes the coefficient may be unknown, yet to be determined; it is then also written as a letter; *k* is most commonly used for this purpose.

The Negative Sign In ordinary arithmetic we seldom work with negative numbers, although we may be "short" in a subtraction. In algebra, however, a number may be either negative or positive. Such a thing may seem *academic* but a negative quantity can have a real existence. We need only refer to a *debt* being considered a negative possession. In electrical work, however, a result of a problem might be a negative number of amperes or volts, indicating that the direction of the current is opposite to the direction chosen as positive. We shall have illustrations of this shortly.

Having established the existence of negative quantities, we must now learn how to work with these negative quantities in addition, subtraction, multiplication and so forth.

In addition, a negative number added to a positive number is the same as subtracting a positive number from it.

$$\begin{array}{r} 7 \\ -3 \\ \hline 4 \end{array} \text{ (add) is the same as } \begin{array}{r} 7 \\ 3 \\ \hline 4 \end{array} \text{ (subtract)}$$

or we might write it

$$7 + (-3) = 7 - 3 = 4$$

Similarly, we have:

$$a + (-b) = a - b$$

When a minus sign is in front of an expression in brackets, this minus sign has the effect of reversing the signs of every term within the brackets:

$$-(a - b) = -a + b$$

$$-(2a + 3b - 5c) = -2a - 3b + 5c$$

Multiplication. When both the multiplicand and the multiplier are negative, the product is positive. When only one (either one) is negative the product is negative. The four possible cases are illustrated below:

$$\begin{array}{ll} + \times + = + & + \times - = - \\ - \times + = - & - \times - = + \end{array}$$

Division. Since division is but the reverse of multiplication, similar rules apply for the sign of the quotient. When both the dividend and the divisor have the same sign (both negative or both positive) the quotient is positive. If they have unlike signs (one positive and one negative) the quotient is negative.

$$\begin{array}{ll} \frac{+}{+} = + & \frac{+}{-} = - \\ \frac{-}{+} = - & \frac{-}{-} = + \end{array}$$

Powers. Even powers of negative numbers are positive and odd powers are negative. Powers of positive numbers are always positive. Examples:

$$-2^2 = -2 \times -2 = +4$$

$$-2^3 = -2 \times -2 \times -2 = +4 \times -2 = -8$$

Roots. Since the square of a negative number is positive and the square of a positive number is also positive, it follows that a positive number has two square roots. The square root of 4 can be either +2 or -2 for (+2) × (+2) = +4 and (-2) × (-2) = +4.

Addition and Subtraction *Polynomials* are quantities like $3ab^2 + 4ab^3 - 7a^2b^4$ which have several terms of different *names*. When adding polynomials, only terms of the same name can be taken together.

$$\begin{array}{r} 7a^3 + 8ab^2 + 3a^2b \quad + 3 \\ a^3 - 5ab^2 \quad - b^3 \\ \hline 8a^3 + 3ab^2 + 3a^2b - b^3 + 3 \end{array}$$

Collecting terms. When an expression contains more than one term of the same name, these can be added together and the expression made simpler:

$$5x^2 + 2xy + 3xy^2 - 3x^2 + 7xy =$$

$$5x^2 - 3x^2 + 2xy + 7xy + 3xy^2 =$$

$$2x^2 + 9xy + 3xy^2$$

Multiplication Multiplication of single terms is indicated simply by writing them together.

$a \times b$ is written as ab

$a \times b^2$ is written as ab^2

Bracketed quantities are multiplied by a single term by multiplying each term:

$$a(b + c + d) = ab + ac + ad$$

When two bracketed quantities are multiplied, each term of the first bracketed quantity is to be multiplied by each term of the second bracketed quantity, thereby making every possible combination.

$$(a + b)(c + d) = ac + ad + bc + bd$$

In this work particular care must be taken to get the signs correct. Examples:

$$(a + b)(a - b) = a^2 + ab - ab - b^2 = a^2 - b^2$$

$$(a + b)(a + b) = a^2 + ab + ab + b^2 = a^2 + 2ab + b^2$$

$$(a - b)(a - b) = a^2 - ab - ab + b^2 = a^2 - 2ab + b^2$$

Division It is possible to do longhand division in algebra, although it is somewhat more complicated than in arithmetic. However, the division will seldom come out even, and is not often done in this form. The method is as follows: Write the terms of the dividend in the order of descending powers of one variable and do likewise with the divisor. Example:

$$\text{Divide } 5a^2b + 21b^3 + 2a^3 - 26ab^2 \text{ by } 2a - 3b$$

Write the dividend in the order of descending powers of a and divide in the same way as in arithmetic.

$$\begin{array}{r} \overline{) 2a^3 + 5a^2b - 26ab^2 + 21b^3} \\ \underline{2a^3 - 3a^2b} \\ + 8a^2b - 26ab^2 \\ \underline{ + 8a^2b - 12ab^2} \\ - 14ab^2 + 21b^3 \\ \underline{ - 14ab^2 + 21b^3} \\ + 0 \end{array}$$

Another example: Divide $x^3 - y^3$ by $x - y$

$$\begin{array}{r} x - y \overline{) x^3 + 0 + 0 - y^3} \\ \underline{x^3 - x^2y} \\ + x^2y \\ \underline{ + x^2y - xy^2} \\ + xy^2 - y^3 \\ \underline{ + xy^2 - y^3} \\ + 0 \end{array}$$

Factoring Very often it is necessary to simplify expressions by finding a factor. This is done by collecting two or more terms having the same factor and bringing the factor outside the brackets:

$$6ab + 3ac = 3a(2b + c)$$

In a four term expression one can take together two terms at a time; the intention is to try getting the terms within the brackets the same after the factor has been removed:

$$\begin{aligned} 30ac - 18bc + 10ad - 6bd &= \\ 6c(5a - 3b) + 2d(5a - 3b) &= \\ (5a - 3b)(6c + 2d) & \end{aligned}$$

Of course, this is not always possible and the expression may not have any factors. A similar process can of course be followed when the expression has six or eight or any even number of terms.

A special case is a three-term polynomial, which can sometimes be factored by writing the middle term as the sum of two terms:

$$\begin{aligned} x^2 - 7xy + 12y^2 &\text{ may be rewritten as} \\ x^2 - 3xy - 4xy + 12y^2 &= \\ x(x - 3y) - 4y(x - 3y) &= \\ (x - 4y)(x - 3y) & \end{aligned}$$

The middle term should be split into two in such a way that the sum of the two new terms equals the original middle term and that their product equals the product of the two outer terms. In the above example these conditions are fulfilled for $-3xy - 4xy = -7xy$ and $(-3xy)(-4xy) = 12x^2y^2$. It is not always possible to do this and there are then no simple factors.

Working with Powers and Roots When two powers of the same number are to be multiplied, the exponents are added.

$$a^2 \times a^3 = aa \times aaa = aaaaa = a^5 \text{ or } a^2 \times a^3 = a^{(2+3)} = a^5$$

$$b^3 \times b = b^4$$

$$c^5 \times c^7 = c^{12}$$

Similarly, dividing of powers is done by subtracting the exponents.

$$\frac{a^3}{a^2} = \frac{aaa}{aa} = a \text{ or } \frac{a^3}{a^2} = a^{(3-2)} = a^1 = a$$

$$\frac{b^5}{b^3} = \frac{bbbbb}{bbb} = b^2 \text{ or } \frac{b^5}{b^3} = b^{(5-3)} = b^2$$

Now we are logically led into some important new ways of notation. We have seen that when dividing, the exponents are subtracted. This can be continued into negative exponents. In the following series, we successively divide by *a* and since this can now be done in two ways, the two ways of notation must have the same meaning and be identical.

| | | |
|-------|-----------|--------------------------|
| a^5 | a^2 | $a^{-1} = \frac{1}{a}$ |
| a^4 | $a^1 = a$ | $a^{-2} = \frac{1}{a^2}$ |
| a^3 | $a^0 = 1$ | $a^{-3} = \frac{1}{a^3}$ |

These examples illustrate two rules: (1) any number raised to "zero" power equals one or unity; (2) any quantity raised to a negative power is the inverse or reciprocal of the same quantity raised to the same positive power.

$$n^0 = 1 \quad a^{-n} = \frac{1}{a^n}$$

Roots. The product of the square root of two quantities equals the square root of their product.

$$\sqrt{a} \times \sqrt{b} = \sqrt{ab}$$

Also, the quotient of two roots is equal to the root of the quotient.

$$\frac{\sqrt{a}}{\sqrt{b}} = \sqrt{\frac{a}{b}}$$

Note, however, that in addition or subtraction the square root of the sum or difference is *not* the same as the sum or difference of the square roots.

$$\text{Thus, } \sqrt{9} - \sqrt{4} = 3 - 2 = 1$$

$$\text{but } \sqrt{9 - 4} = \sqrt{5} = 2.2361$$

Likewise $\sqrt{a} + \sqrt{b}$ is not the same as $\sqrt{a + b}$

Roots may be written as fractional powers. Thus \sqrt{a} may be written as $a^{1/2}$ because

$$\sqrt{a} \times \sqrt{a} = a \text{ and, } a^{1/2} \times a^{1/2} = a^{1/2+1/2} = a^1 = a$$

Any root may be written in this form

$$\sqrt{b} = b^{1/2} \quad \sqrt[3]{b} = b^{1/3} \quad \sqrt[4]{b} = b^{1/4}$$

The same notation is also extended in the negative direction:

$$b^{-1/2} = \frac{1}{b^{1/2}} = \frac{1}{\sqrt{b}} \quad c^{-1/3} = \frac{1}{c^{1/3}} = \frac{1}{\sqrt[3]{c}}$$

Following the previous rules that exponents add when powers are multiplied,

$$\sqrt[3]{a} \times \sqrt[4]{a} = \sqrt[12]{a^7} \text{ but also } a^{1/3} \times a^{1/4} = a^{7/12} \text{ therefore } a^{7/12} = \sqrt[12]{a^7}$$

Powers of powers. When a power is again raised to a power, the exponents are multiplied;

$$(a^2)^3 = a^6 \quad (b^{-1})^3 = b^{-3} \\ (a^3)^4 = a^{12} \quad (b^{-2})^{-4} = b^8$$

This same rule also applies to roots of roots and also powers of roots and roots of powers because a root can always be written as a fractional power.

$$\sqrt[3]{\sqrt{a}} = \sqrt[6]{a} \text{ for } (a^{1/2})^{1/3} = a^{1/6}$$

Removing radicals. A root or radical in the denominator of a fraction makes the expression difficult to handle. If there must be a radical it should be located in the numerator rather than in the denominator. The removal of the radical from the denominator is done by multiplying both numerator and denominator by a quantity which will remove the radical from the denominator, thus *rationalizing* it:

$$\frac{1}{\sqrt{a}} = \frac{\sqrt{a}}{\sqrt{a} \times \sqrt{a}} = \frac{1}{a} \sqrt{a}$$

Suppose we have to rationalize

$$\frac{3a}{\sqrt{a} + \sqrt{b}} \text{ In this case we must multiply}$$

numerator and denominator by $\sqrt{a} - \sqrt{b}$, the same terms but with the second having the opposite sign, so that their product will not contain a root.

$$\frac{3a}{\sqrt{a} + \sqrt{b}} = \frac{3a(\sqrt{a} - \sqrt{b})}{(\sqrt{a} + \sqrt{b})(\sqrt{a} - \sqrt{b})} = \frac{3a(\sqrt{a} - \sqrt{b})}{a - b}$$

Imaginary Numbers Since the square of a negative number is positive and the square of a positive number is also positive, the square root of a negative number can be neither positive nor negative. Such a number is said to be *imaginary*; the most common such number ($\sqrt{-1}$) is often represented by the letter *i* in mathematical work or *j* in electrical work.

$$\sqrt{-1} = i \text{ or } j \text{ and } i^2 \text{ or } j^2 = -1$$

Imaginary numbers do not exactly correspond to anything in our experience and it is best not to try to visualize them. Despite this fact, their interest is much more than academic, for they are extremely useful in many calculations involving alternating currents.

The square root of any other negative number may be reduced to a product of two roots, one positive and one negative. For instance:

$$\sqrt{-57} = \sqrt{-1} \sqrt{57} = i\sqrt{57}$$

or, in general

$$\sqrt{-a} = i\sqrt{a}$$

Since $i = \sqrt{-1}$, the powers of *i* have the following values:

$$i^2 = -1$$

$$i^3 = -1 \times i = -i$$

$$i^4 = +1$$

$$i^5 = +1 \times i = i$$

Imaginary numbers are different from either positive or negative numbers; so in addition or subtraction they must always be accounted for separately. Numbers which consist of both real and imaginary parts are called *complex* numbers. Examples of complex numbers:

$$3 + 4i = 3 + 4\sqrt{-1}$$

$$a + bi = a + b\sqrt{-1}$$

Since an imaginary number can never be equal to a real number, it follows that in an equality like

$$a + bi = c + di$$

a must equal *c* and *bi* must equal *di*

Complex numbers are handled in algebra just like any other expression, considering *i* as a known quantity. Whenever powers of *i* occur, they can be replaced by the equivalents given above. This idea of having in one equation two separate sets of quantities which must

be accounted for separately, has found a symbolic application in vector notation. These are covered later in this chapter.

Equations of the First Degree Algebraic expressions usually come in the form of equations, that is, one set of terms equals another set of terms. The simplest example of this is Ohm's Law:

$$E = IR$$

One of the three quantities may be unknown but if the other two are known, the third can be found readily by substituting the known values in the equation. This is very easy if it is *E* in the above example that is to be found; but suppose we wish to find *I* while *E* and *R* are given. We must then rearrange the equation so that *I* comes to stand alone to the left of the equality sign. This is known as *solving the equation for I*.

Solution of the equation in this case is done simply by transposing. If two things are equal then they must still be equal if both are multiplied or divided by the same number. Dividing both sides of the equation by *R*:

$$\frac{E}{R} = \frac{IR}{R} = I \text{ or } I = \frac{E}{R}$$

If it were required to solve the equation for *R*, we should divide both sides of the equation by *I*.

$$\frac{E}{I} = R \text{ or } R = \frac{E}{I}$$

A little more complicated example is the equation for the reactance of a condenser:

$$X = \frac{1}{2\pi fC}$$

To solve this equation for *C*, we may multiply both sides of the equation by *C* and divide both sides by *X*

$$X \times \frac{C}{X} = \frac{1}{2\pi fC} \times \frac{C}{X}, \text{ or } C = \frac{1}{2\pi fX}$$

This equation is one of those which requires a good knowledge of the placing of the decimal point when solving. Therefore we give a few examples: What is the reactance of a 25 μfd . condenser at 1000 kc.? In filling in the given values in the equation we must remember that the units used are farads, cycles, and ohms. Hence, we must write 25 μfd . as 25 millionths of a millionth of a farad or 25×10^{-12} farad; similarly, 1000 kc. must be converted to 1,000,000 cycles. Substituting these values in the original equation, we have

$$X = \frac{1}{2 \times 3.14 \times 1,000,000 \times 25 \times 10^{-12}}$$

$$X = \frac{1}{6.28 \times 10^6 \times 25 \times 10^{-12}} = \frac{10^6}{6.28 \times 25}$$

$$= 6360 \text{ ohms}$$

A bias resistor of 1000 ohms should be bypassed, so that at the lowest frequency the reactance of the condenser is 1/10th of that of the resistor. Assume the lowest frequency to be 50 cycles, then the required capacity should have a reactance of 100 ohms, at 50 cycles:

$$C = \frac{1}{2 \times 3.14 \times 50 \times 100} \text{ farads}$$

$$C = \frac{10^6}{6.28 \times 5000} \text{ microfarads}$$

$$C = 32 \text{ } \mu\text{fd.}$$

In the third possible case, it may be that the frequency is the unknown. This happens for instance in some tone control problems. Suppose it is required to find the frequency which makes the reactance of a 0.03 $\mu\text{fd.}$ condenser equal to 100,000 ohms.

First we must solve the equation for f . This is done by transposition.

$$X = \frac{1}{2 \pi f C} \qquad f = \frac{1}{2 \pi C X}$$

Substituting known values

$$f = \frac{1}{2 \times 3.14 \times 0.03 \times 10^{-6} \times 100,000} \text{ cycles}$$

$$f = \frac{1}{0.01884} \text{ cycles} = 53 \text{ cycles}$$

These equations are known as first degree equations with one unknown. First degree, because the unknown occurs only as a first power. Such an equation always has one possible solution or *root* if all the other values are known.

If there are two unknowns, a single equation will not suffice, for there are then an infinite number of possible solutions. In the case of two unknowns we need *two independent simultaneous equations*. An example of this is:

$$3x + 5y = 7 \qquad 4x - 10y = 3$$

Required, to find x and y .

This type of work is done either by the *substitution method* or by the *elimination method*. In the substitution method we might write for the first equation:

$$3x = 7 - 5y \therefore x = \frac{7 - 5y}{3}$$

(The symbol \therefore means *therefore* or *hence*).

This value of x can then be substituted for x in the second equation making it a single equation with but one unknown, y .

It is, however, simpler in this case to use the elimination method. Multiply both sides of the first equation by two and add it to the second equation:

$$\begin{array}{r} 6x + 10y = 14 \\ 4x - 10y = 3 \\ \hline 10x = 17 \end{array} \text{ add} \qquad x = 1.7$$

Substituting this value of x in the first equation, we have

$$5.1 + 5y = 7 \therefore 5y = 7 - 5.1 = 1.9 \therefore y = 0.38$$

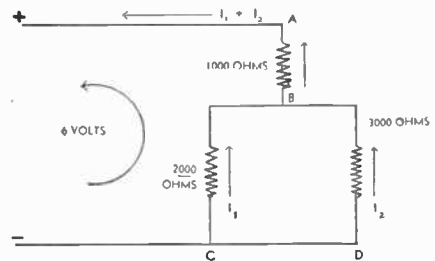

Figure 3.

In this simple network the current divides through the 2000-ohm and 3000-ohm resistors. The current through each may be found by using two simultaneous linear equations. Note that the arrows indicate the direction of electron flow as explained on page 18.

An application of two simultaneous linear equations will now be given. In Figure 3 a simple network is shown consisting of three resistances; let it be required to find the currents I_1 and I_2 in the two branches.

The general way in which all such problems can be solved is to assign directions to the currents through the various resistances. When these are chosen wrong it will do no harm for the result of the equations will then be negative, showing up the error. In this simple illustration there is, of course, no such difficulty.

Next we write the equations for the meshes, in accordance with Kirchoff's second law. All voltage drops in the direction of the curved arrow are considered positive, the reverse ones negative. Since there are two unknowns we write two equations.

$$1000 (I_1 + I_2) + 2000 I_1 = 6$$

$$-2000 I_1 + 3000 I_2 = 0$$

Expand the first equation

$$3000 I_1 + 1000 I_2 = 6$$

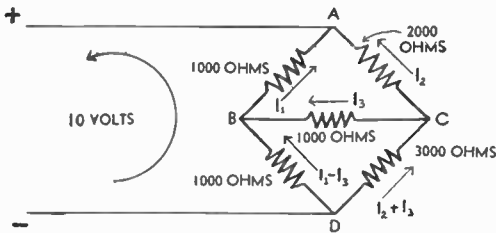

Figure 4.

A MORE COMPLICATED PROBLEM REQUIRING THE SOLUTION OF CURRENTS IN A NETWORK.

This problem is similar to that in Figure 3 but requires the use of three simultaneous linear equations.

Multiply this equation by 3

$$9000 I_1 + 3000 I_2 = 18$$

Subtracting the second equation from the first

$$11000 I_1 = 18$$

$$I_1 = 18/11000 = 0.00164 \text{ amp.}$$

Filling in this value in the second equation

$$3000 I_2 = 3.28 \quad I_2 = 0.00109 \text{ amp.}$$

A similar problem but requiring three equations is shown in Figure 4. This consists of an unbalanced bridge and the problem is to find the current in the bridge-branch, I_3 . We again assign directions to the different currents, guessing at the one marked I_3 . The voltages around closed loops ABC [eq. (1)] and BDC [eq. (2)] equal zero and are assumed to be positive in a counterclockwise direction; that from D to A equals 10 volts [eq. (3)].

(1)

$$-1000 I_1 + 2000 I_2 - 1000 I_3 = 0$$

(2)

$$-1000 (I_1 - I_3) + 1000 I_3 + 3000 (I_2 + I_3) = 0$$

(3)

$$1000 I_1 + 1000 (I_1 - I_3) - 10 = 0$$

Expand equations (2) and (3)

(2)

$$-1000 I_1 + 3000 I_2 + 5000 I_3 = 0$$

(3)

$$2000 I_1 - 1000 I_3 - 10 = 0$$

Subtract equation (2) from equation (1)

(a)

$$-1000 I_2 - 6000 I_3 = 0$$

Multiply the second equation by 2 and add it to the third equation

(b)

$$6000 I_2 + 9000 I_3 - 10 = 0$$

Now we have but two equations with two unknowns.

Multiplying equation (a) by 6 and adding to equation (b) we have

$$-27000 I_3 - 10 = 0$$

$$I_3 = -10/27000 = -0.00037 \text{ amp.}$$

Note that now the solution is negative which means that we have drawn the arrow for I_3 in Figure 4 in the wrong direction. The current is 0.37 ma. in the other direction.

Second Degree or Quadratic Equations

A somewhat similar problem in radio would be, if power in watts and resistance in ohms of a circuit are given, to find the voltage and the current. Example: When lighted to normal brilliancy, a 100 watt lamp has a resistance of 49 ohms; for what line voltage was the lamp designed and what current would it take.

Here we have to use the simultaneous equations:

$$P = EI \text{ and } E = IR$$

Filling in the known values:

$$P = EI = 100 \text{ and } E = IR = I \times 49$$

Substitute the second equation into the first equation

$$P = EI = (I) \times I \times 49 = 49 I^2 = 100$$

$$\therefore I = \sqrt{\frac{100}{49}} = \frac{10}{7} = 1.43 \text{ amp.}$$

Substituting the found value of 1.43 amp. for I in the first equation, we obtain the value of the line voltage, 70 volts.

Note that this is a second degree equation for we finally had the second power of I . Also, since the current in this problem could only be positive, the negative square root of $100/49$ or $-10/7$ was not used. Strictly speaking, however, there are two more values that satisfy both equations, these are -1.43 and -70 .

In general, a second degree equation in one unknown has two roots, a third degree equation three roots, etc.

The Quadratic Equation

Quadratic or second degree equations with but one unknown can be reduced to the general form

$$ax^2 + bx + c = 0$$

where x is the unknown and $a, b,$ and c are constants.

This type of equation can sometimes be solved by the method of factoring a three-term expression as follows:

$$2x^2 + 7x + 6 = 0$$

$$2x^2 + 4x + 3x + 6 = 0$$

factoring:

$$2x(x + 2) + 3(x + 2) = 0$$

$$(2x + 3)(x + 2) = 0$$

There are two possibilities when a product is zero. Either the one or the other factor equals zero. Therefore there are two solutions.

$$2x_1 + 3 = 0$$

$$x_2 + 2 = 0$$

$$2x_1 = -3$$

$$x_2 = -2$$

$$x_1 = -1\frac{1}{2}$$

Since factoring is not always easy, the following general solution can usually be employed; in this equation $a, b,$ and c are the coefficients referred to above.

$$X = \frac{-b \pm \sqrt{b^2 - 4ac}}{2a}$$

Applying this method of solution to the previous example:

$$X = \frac{-7 \pm \sqrt{49 - 8 \times 6}}{4} = \frac{-7 \pm \sqrt{1}}{4} = \frac{-7 \pm 1}{4}$$

$$X_1 = \frac{-7 + 1}{4} = -1\frac{1}{2}$$

$$X_2 = \frac{-7 - 1}{4} = -2$$

A practical example involving quadratics is the law of impedance in a.c. circuits. However, this is a simple kind of quadratic equation which can be solved readily without the use of the special formula given above.

$$Z = \sqrt{R^2 + (X_L - X_C)^2}$$

This equation can always be solved for $R,$ by squaring both sides of the equation. It should now be understood that squaring both sides of an equation as well as multiplying both sides with a term containing the unknown may add a new root. Since we know here that Z and R are positive, when we square the expression there is no ambiguity.

$$Z^2 = R^2 + (X_L - X_C)^2$$

$$\text{and } R^2 = Z^2 - (X_L - X_C)^2$$

$$\text{or } R = \sqrt{Z^2 - (X_L - X_C)^2}$$

$$\text{Also: } (X_L - X_C)^2 = Z^2 - R^2$$

$$\text{and } \pm (X_L - X_C) = \sqrt{Z^2 - R^2}$$

But here we do not know the sign of the solution unless there are other facts which indicate it. To find either X_L or X_C alone it would have to be known whether the one or the other is the larger.

Logarithms

Definition and Use

A logarithm is the power (or exponent) to which we must raise one number to obtain another.

Although the large numbers used in logarithmic work may make them seem difficult or complicated, in reality the principal use of logarithms is to *simplify* calculations which would otherwise be extremely laborious.

We have seen so far that every operation in arithmetic can be reversed. If we have the addition:

$$a + b = c$$

we can reverse this operation in two ways. It may be that b is the unknown, and then we reverse the equation so that it becomes

$$c - a = b$$

It is also possible that we wish to know $a,$ and that b and c are given. The equation then becomes

$$c - b = a$$

We call both of these reversed operations *subtraction*, and we make no distinction between the two possible reverses.

Multiplication can also be reversed in two manners. In the multiplication

$$ab = c$$

we may wish to know $a,$ when b and c are given, or we may wish to know b when a and c are given. In both cases we speak of *division*, and we make again no distinction between the two.

In the case of powers we can also reverse the operation in two manners, but now they are not equivalent. Suppose we have the equation

$$a^b = c$$

If a is the unknown, and b and c are given, we may reverse the operation by writing

$$\sqrt[b]{c} = a$$

This operation we call *taking the root*. But there is a third possibility: that a and c are given, and that we wish to know $b.$ In other

words, the question is "to which power must we raise a so as to obtain c ?" This operation is known as *taking the logarithm*, and b is the logarithm of c to the base a . We write this operation as follows:

$$\log_a c = b$$

Consider a numerical example. We know $2^3=8$. We can reverse this operation by asking "to which power must we raise 2 so as to obtain 8 ?" Therefore, the logarithm of 8 to the base 2 is 3, or

$$\log_2 8 = 3$$

Taking any single base, such as 2, we might write a series of all the powers of the base next to the series of their logarithms:

Number: 2 4 8 16 32 64 128 256 512 1024
Logarithm: 1 2 3 4 5 6 7 8 9 10

We can expand this table by finding terms between the terms listed above. For instance, if we let the logarithms increase with $\frac{1}{2}$ each time, successive terms in the upper series would have to be multiplied by the square root of 2. Similarly, if we wish to increase the logarithm by $1/10$ at each term, the ratio between two consecutive terms in the upper series would be the tenth root of 2. Now this short list of numbers constitutes a small logarithm table. It should be clear that one could find the logarithm of any number to the base 2. This logarithm will usually be a number with many decimals.

Logarithmic Bases The fact that we chose 2 as a base for the illustration is purely arbitrary. Any base could be used, and therefore there are many possible systems of logarithms. In practice we use only two bases: The most frequently used base is 10, and the system using this base is known as the system of *common* logarithms, or Briggs' logarithms. The second system employs as a base an odd number, designated by the letter e ; $e = 2.71828$ This is known as the *natural* logarithmic system, also as the Napierian system, and the hyperbolic system. Although different writers may vary on the subject, the usual notation is simply $\log a$ for the common logarithm of a , and $\log_e a$ (or sometimes $\ln a$) for the natural logarithm of a . We shall use the common logarithmic system in most cases, and therefore we shall examine this system more closely.

Common Logarithms In the system wherein 10 is the base, the logarithm of 10 equals 1; the logarithm of 100 equals 2, etc., as shown in the following table:

| | | | |
|------------|------------------|-----------------------------|------------|
| log | 10 | = log 10¹ | = 1 |
| log | 100 | = log 10² | = 2 |
| log | 1,000 | = log 10³ | = 3 |
| log | 10,000 | = log 10⁴ | = 4 |
| log | 100,000 | = log 10⁵ | = 5 |
| log | 1,000,000 | = log 10⁶ | = 6 |

This table can be extended for numbers less than 10 when we remember the rules of powers discussed under the subject of algebra. Numbers less than unity, too, can be written as powers of ten.

| | | |
|-------------------|------------------------------|-------------|
| log 1 | = log 10⁰ | = 0 |
| log 0.1 | = log 10⁻¹ | = -1 |
| log 0.01 | = log 10⁻² | = -2 |
| log 0.001 | = log 10⁻³ | = -3 |
| log 0.0001 | = log 10⁻⁴ | = -4 |

From these examples follow several rules: The logarithm of any number between zero and + 1 is negative; the logarithm of zero is minus infinity; the logarithm of a number greater than + 1 is positive. *Negative numbers have no logarithm.* These rules are true of common logarithms and of logarithms to any base.

The logarithm of a number between the powers of ten is an irrational number, that is, it has a never ending series of decimals. For instance, the logarithm of 20 must be between 1 and 2 because 20 is between 10 and 100; the value of the logarithm of 20 is 1.30103. . . . The part of the logarithm to the left of the decimal point is called the *characteristic*, while the decimals are called the *mantissa*. In the case of 1.30103 . . ., the logarithm of 20, the characteristic is 1 and the mantissa is .30103 . . .

Properties of Logarithms If the base of our system is ten, then, by definition of a logarithm:

$$10^{\log a} = a$$

or, if the base is raised to the power having an exponent equal to the logarithm of a number, the result is that number.

The logarithm of a *product* is equal to the *sum* of the logarithms of the two factors.

$$\log ob = \log o + \log b$$

This is easily proved to be true because, it

Figure 5. FOUR PLACE LOGARITHM TABLES.

| N | 0 | 1 | 2 | 3 | 4 | 5 | 6 | 7 | 8 | 9 | N | 0 | 1 | 2 | 3 | 4 | 5 | 6 | 7 | 8 | 9 |
|----|------|------|------|------|------|------|------|------|------|------|----|------|------|------|------|------|------|------|------|------|------|
| 10 | 0000 | 0043 | 0086 | 0128 | 0170 | 0212 | 0253 | 0294 | 0334 | 0374 | 55 | 7404 | 7412 | 7419 | 7427 | 7435 | 7443 | 7451 | 7459 | 7466 | 7474 |
| 11 | 0414 | 0453 | 0492 | 0531 | 0569 | 0607 | 0645 | 0682 | 0719 | 0755 | 56 | 7482 | 7490 | 7497 | 7505 | 7513 | 7520 | 7528 | 7536 | 7543 | 7551 |
| 12 | 0792 | 0828 | 0864 | 0899 | 0934 | 0969 | 1004 | 1038 | 1072 | 1106 | 57 | 7559 | 7566 | 7574 | 7582 | 7589 | 7597 | 7604 | 7612 | 7619 | 7627 |
| 13 | 1139 | 1173 | 1206 | 1239 | 1271 | 1303 | 1335 | 1367 | 1399 | 1430 | 58 | 7634 | 7642 | 7649 | 7657 | 7664 | 7672 | 7679 | 7686 | 7694 | 7701 |
| 14 | 1461 | 1492 | 1523 | 1553 | 1584 | 1614 | 1644 | 1673 | 1703 | 1732 | 59 | 7709 | 7716 | 7723 | 7731 | 7738 | 7745 | 7752 | 7760 | 7767 | 7774 |
| 15 | 1761 | 1790 | 1818 | 1847 | 1875 | 1903 | 1931 | 1959 | 1987 | 2014 | 60 | 7782 | 7789 | 7796 | 7803 | 7810 | 7818 | 7825 | 7832 | 7839 | 7846 |
| 16 | 2041 | 2068 | 2095 | 2122 | 2148 | 2175 | 2201 | 2227 | 2253 | 2279 | 61 | 7853 | 7860 | 7868 | 7875 | 7882 | 7889 | 7896 | 7903 | 7910 | 7917 |
| 17 | 2304 | 2330 | 2355 | 2380 | 2405 | 2430 | 2455 | 2480 | 2504 | 2529 | 62 | 7924 | 7931 | 7938 | 7945 | 7952 | 7959 | 7966 | 7973 | 7980 | 7987 |
| 18 | 2553 | 2577 | 2601 | 2625 | 2648 | 2672 | 2695 | 2718 | 2742 | 2765 | 63 | 7993 | 8000 | 8007 | 8014 | 8021 | 8028 | 8035 | 8041 | 8048 | 8055 |
| 19 | 2788 | 2810 | 2833 | 2856 | 2878 | 2900 | 2923 | 2945 | 2967 | 2989 | 64 | 8062 | 8069 | 8075 | 8082 | 8089 | 8096 | 8102 | 8109 | 8116 | 8122 |
| 20 | 3010 | 3032 | 3054 | 3075 | 3096 | 3118 | 3139 | 3160 | 3181 | 3201 | 65 | 8129 | 8136 | 8142 | 8149 | 8156 | 8162 | 8169 | 8176 | 8182 | 8189 |
| 21 | 3222 | 3243 | 3263 | 3284 | 3304 | 3324 | 3345 | 3365 | 3385 | 3404 | 66 | 8195 | 8202 | 8209 | 8215 | 8222 | 8228 | 8235 | 8241 | 8248 | 8254 |
| 22 | 3424 | 3444 | 3464 | 3483 | 3502 | 3522 | 3541 | 3560 | 3579 | 3598 | 67 | 8261 | 8267 | 8274 | 8280 | 8287 | 8293 | 8299 | 8306 | 8312 | 8319 |
| 23 | 3617 | 3636 | 3655 | 3674 | 3692 | 3711 | 3729 | 3747 | 3766 | 3784 | 68 | 8325 | 8331 | 8338 | 8344 | 8351 | 8357 | 8363 | 8370 | 8376 | 8382 |
| 24 | 3802 | 3820 | 3838 | 3856 | 3874 | 3892 | 3909 | 3927 | 3945 | 3962 | 69 | 8388 | 8395 | 8401 | 8407 | 8414 | 8420 | 8426 | 8432 | 8439 | 8445 |
| 25 | 3979 | 3997 | 4014 | 4031 | 4048 | 4065 | 4082 | 4099 | 4116 | 4133 | 70 | 8451 | 8457 | 8463 | 8470 | 8476 | 8482 | 8488 | 8494 | 8500 | 8506 |
| 26 | 4150 | 4166 | 4183 | 4200 | 4216 | 4232 | 4249 | 4265 | 4281 | 4298 | 71 | 8513 | 8519 | 8525 | 8531 | 8537 | 8543 | 8549 | 8555 | 8561 | 8567 |
| 27 | 4314 | 4330 | 4346 | 4362 | 4378 | 4393 | 4409 | 4425 | 4440 | 4456 | 72 | 8573 | 8579 | 8585 | 8591 | 8597 | 8603 | 8609 | 8615 | 8621 | 8627 |
| 28 | 4472 | 4487 | 4502 | 4518 | 4533 | 4548 | 4564 | 4579 | 4594 | 4609 | 73 | 8633 | 8639 | 8645 | 8651 | 8657 | 8663 | 8669 | 8675 | 8681 | 8686 |
| 29 | 4624 | 4639 | 4654 | 4669 | 4683 | 4698 | 4713 | 4728 | 4742 | 4757 | 74 | 8692 | 8698 | 8704 | 8710 | 8716 | 8722 | 8727 | 8733 | 8739 | 8745 |
| 30 | 4771 | 4786 | 4800 | 4814 | 4829 | 4843 | 4857 | 4871 | 4886 | 4900 | 75 | 8751 | 8756 | 8762 | 8768 | 8774 | 8779 | 8785 | 8791 | 8797 | 8802 |
| 31 | 4914 | 4928 | 4942 | 4955 | 4969 | 4983 | 4997 | 5011 | 5024 | 5038 | 76 | 8808 | 8814 | 8820 | 8825 | 8831 | 8837 | 8842 | 8848 | 8854 | 8859 |
| 32 | 5051 | 5065 | 5079 | 5092 | 5105 | 5119 | 5132 | 5145 | 5159 | 5172 | 77 | 8865 | 8871 | 8876 | 8882 | 8887 | 8893 | 8899 | 8904 | 8910 | 8915 |
| 33 | 5185 | 5198 | 5211 | 5224 | 5237 | 5250 | 5263 | 5276 | 5289 | 5302 | 78 | 8921 | 8927 | 8932 | 8938 | 8943 | 8949 | 8954 | 8960 | 8965 | 8971 |
| 34 | 5315 | 5328 | 5340 | 5353 | 5366 | 5378 | 5391 | 5403 | 5416 | 5428 | 79 | 8976 | 8982 | 8987 | 8993 | 8998 | 9004 | 9009 | 9015 | 9020 | 9025 |
| 35 | 5441 | 5453 | 5465 | 5478 | 5490 | 5502 | 5514 | 5527 | 5539 | 5551 | 80 | 9031 | 9036 | 9042 | 9047 | 9053 | 9058 | 9063 | 9069 | 9074 | 9079 |
| 36 | 5563 | 5575 | 5587 | 5599 | 5611 | 5623 | 5635 | 5647 | 5658 | 5670 | 81 | 9085 | 9090 | 9096 | 9101 | 9106 | 9112 | 9117 | 9122 | 9128 | 9133 |
| 37 | 5682 | 5694 | 5705 | 5717 | 5729 | 5740 | 5752 | 5763 | 5775 | 5786 | 82 | 9138 | 9143 | 9149 | 9154 | 9159 | 9165 | 9170 | 9175 | 9180 | 9186 |
| 38 | 5798 | 5809 | 5821 | 5832 | 5843 | 5855 | 5866 | 5877 | 5888 | 5899 | 83 | 9191 | 9196 | 9201 | 9206 | 9212 | 9217 | 9222 | 9227 | 9232 | 9238 |
| 39 | 5911 | 5922 | 5933 | 5944 | 5955 | 5966 | 5977 | 5988 | 5999 | 6010 | 84 | 9243 | 9248 | 9253 | 9258 | 9263 | 9269 | 9274 | 9279 | 9284 | 9289 |
| 40 | 6021 | 6031 | 6042 | 6053 | 6064 | 6075 | 6085 | 6096 | 6107 | 6117 | 85 | 9294 | 9299 | 9304 | 9309 | 9315 | 9320 | 9325 | 9330 | 9335 | 9340 |
| 41 | 6128 | 6138 | 6149 | 6160 | 6170 | 6180 | 6191 | 6201 | 6212 | 6222 | 86 | 9345 | 9350 | 9355 | 9360 | 9365 | 9370 | 9375 | 9380 | 9385 | 9390 |
| 42 | 6232 | 6243 | 6253 | 6263 | 6274 | 6284 | 6294 | 6304 | 6314 | 6325 | 87 | 9395 | 9400 | 9405 | 9410 | 9415 | 9420 | 9425 | 9430 | 9435 | 9440 |
| 43 | 6335 | 6345 | 6355 | 6365 | 6375 | 6385 | 6395 | 6405 | 6415 | 6425 | 88 | 9445 | 9450 | 9455 | 9460 | 9465 | 9469 | 9474 | 9479 | 9484 | 9489 |
| 44 | 6435 | 6444 | 6454 | 6464 | 6474 | 6484 | 6493 | 6503 | 6513 | 6522 | 89 | 9494 | 9499 | 9504 | 9509 | 9513 | 9518 | 9523 | 9528 | 9533 | 9538 |
| 45 | 6532 | 6542 | 6551 | 6561 | 6571 | 6580 | 6590 | 6599 | 6609 | 6618 | 90 | 9542 | 9547 | 9552 | 9557 | 9562 | 9566 | 9571 | 9576 | 9581 | 9586 |
| 46 | 6628 | 6637 | 6646 | 6656 | 6665 | 6675 | 6684 | 6693 | 6702 | 6712 | 91 | 9590 | 9595 | 9600 | 9605 | 9609 | 9614 | 9619 | 9624 | 9628 | 9633 |
| 47 | 6721 | 6730 | 6739 | 6749 | 6758 | 6767 | 6776 | 6785 | 6794 | 6803 | 92 | 9638 | 9643 | 9647 | 9652 | 9657 | 9661 | 9666 | 9671 | 9675 | 9680 |
| 48 | 6812 | 6821 | 6830 | 6839 | 6848 | 6857 | 6866 | 6875 | 6884 | 6893 | 93 | 9685 | 9689 | 9694 | 9699 | 9703 | 9708 | 9713 | 9717 | 9722 | 9727 |
| 49 | 6902 | 6911 | 6920 | 6928 | 6937 | 6946 | 6955 | 6964 | 6972 | 6981 | 94 | 9731 | 9736 | 9741 | 9745 | 9750 | 9754 | 9759 | 9763 | 9768 | 9773 |
| 50 | 6990 | 6998 | 7007 | 7016 | 7024 | 7033 | 7042 | 7050 | 7059 | 7067 | 95 | 9777 | 9782 | 9786 | 9791 | 9795 | 9800 | 9805 | 9809 | 9814 | 9818 |
| 51 | 7076 | 7084 | 7093 | 7101 | 7110 | 7118 | 7126 | 7135 | 7143 | 7152 | 96 | 9823 | 9827 | 9832 | 9836 | 9841 | 9845 | 9850 | 9854 | 9859 | 9863 |
| 52 | 7160 | 7168 | 7177 | 7185 | 7193 | 7202 | 7210 | 7218 | 7226 | 7235 | 97 | 9868 | 9872 | 9877 | 9881 | 9886 | 9890 | 9894 | 9899 | 9903 | 9908 |
| 53 | 7243 | 7251 | 7259 | 7267 | 7275 | 7284 | 7292 | 7300 | 7308 | 7316 | 98 | 9912 | 9917 | 9921 | 9926 | 9930 | 9934 | 9939 | 9943 | 9948 | 9952 |
| 54 | 7324 | 7332 | 7340 | 7348 | 7356 | 7364 | 7372 | 7380 | 7388 | 7396 | 99 | 9956 | 9961 | 9965 | 9969 | 9974 | 9978 | 9983 | 9987 | 9991 | 9996 |

was shown before that when multiplying to powers, the exponents are added; therefore,

$$a \times b = 10^{\log a} \times 10^{\log b} = 10^{(\log a + \log b)}$$

Similarly, the logarithm of a quotient is the difference between the logarithm of the dividend and the logarithm of the divisor.

$$\log \frac{a}{b} = \log a - \log b$$

This is so because by the same rules of exponents:

$$\frac{a}{b} = \frac{10^{\log a}}{10^{\log b}} = 10^{(\log a - \log b)}$$

We have thus established an easier way of multiplication and division since these operations have been reduced to adding and subtracting.

The logarithm of a power of a number is equal to the logarithm of that number, multiplied by the exponent of the power.

$$\log a^2 = 2 \log a \text{ and } \log a^3 = 3 \log a$$

or, in general:

$$\log a^n = n \log a$$

Also, the logarithm of a root of a number is equal to the logarithm of that number divided by the index of the root:

$$\log \sqrt[n]{a} = \frac{1}{n} \log a$$

It follows from the rules of multiplication, that numbers having the same digits but different locations for the decimal point, have logarithms with the same mantissa:

$$\log 829 = 2.918555$$

$$\log 82.9 = 1.918555$$

$$\log 8.29 = 0.918555$$

$$\log 0.829 = -1.918555$$

$$\log 0.0829 = -2.918555$$

$$\log 829 = \log (8.29 \times 100) = \log 8.29 + \log 100 = 0.918555 + 2$$

Logarithm tables give the mantissas of logarithms only. The characteristic has to be determined by inspection. The characteristic is equal to the number of digits to the left of the decimal point *minus one*. In the case of logarithms of numbers less than unity, the characteristic is negative and is equal to the number of ciphers to the right of the decimal point *plus one*.

For reasons of convenience in making up

logarithm tables, it has become the rule that the mantissa should always be positive. Such notations above as -1.918555 really mean $(+0.918555 - 1)$ and -2.981555 means $(+0.918555 - 2)$. There are also some other notations in use such as

$$\bar{1}.918555 \text{ and } \bar{2}.918555$$

$$\text{also } 9.918555 - 10 \quad 8.918555 - 10 \\ 7.918555 - 10, \text{ etc.}$$

When, after some addition and subtraction of logarithms a mantissa should come out negative, one cannot look up its equivalent number or *anti-logarithm* in the table. The mantissa must first be made positive by adding and subtracting an appropriate integral number. Example: Suppose we find that the logarithm of a number is -0.34569 , then we can transform it into the proper form by adding and subtracting 1

$$\begin{array}{r} 1 \\ -0.34569 \\ \hline 0.65431 - 1 \text{ or } -1.65431 \end{array}$$

Using Logarithm Tables

Logarithms are used for calculations involving multiplication, division, powers, and roots. Especially when the numbers are large and for higher, or fractional powers and roots, this becomes the most convenient way.

Logarithm tables are available giving the logarithms to three places, some to four places, others to five and six places. The table to use depends on the accuracy required in the result of our calculations. The four place table, printed in this chapter, permits the finding of answers to problems to four significant figures which is good enough for most constructional purposes. If greater accuracy is required a five place table should be consulted. The five place table is perhaps the most popular of all.

Referring now to the four place table, to find a common logarithm of a number, proceed as follows. Suppose the number is 5576. First, determine the characteristic. An inspection will show that the characteristic should be 3. This figure is placed to the left of the decimal point. The mantissa is now found by reference to the logarithm table. The first two numbers are 55; glance down the *N* column until coming to these figures. Advance to the right until coming in line with the column headed 7; the mantissa will be 7459. (Note that the column headed 7 corresponds to the *third figure* in the number 5576.) Place the mantissa 7459 to the right of the decimal point, making the logarithm of 5576 now read 3.7459. *Important:* do not consider the last figure 6 in the

| N | L. | 0 | 1 | 2 | 3 | 4 | 5 | 6 | 7 | 8 | 9 | P.P. |
|-----|----|-----|-----|------|------|------|------|------|------|------|------|-------|
| 250 | 39 | 794 | 811 | 829 | 846 | 863 | 881 | 898 | 915 | 933 | 950 | |
| 251 | | 967 | 985 | *002 | *019 | *037 | *054 | *071 | *088 | *106 | *123 | 18 |
| 252 | 40 | 140 | 157 | 175 | 192 | 209 | 226 | 243 | 261 | 278 | 295 | 1 1.8 |
| 253 | | 312 | 329 | 346 | 364 | 381 | 398 | 415 | 432 | 449 | 466 | 2 3.6 |
| 254 | | 483 | 500 | 518 | 535 | 552 | 569 | 586 | 603 | 620 | 637 | 3 5.4 |
| | | | | | | | | | | | | 4 7.2 |
| 255 | | 654 | 671 | 688 | 705 | 722 | 739 | 756 | 773 | 790 | 807 | etc. |

Figure 6.
A SMALL SECTION OF A FIVE PLACE LOGARITHM TABLE.

Logarithms may be found with greater accuracy with such tables, but they are only of use when the accuracy of the original data warrants greater precision in the figure work. Slightly greater accuracy may be obtained for intermediate points by interpolation, as explained in the text.

number 5576 when looking for the mantissa in the accompanying four place tables; in fact, one may usually disregard all digits beyond the first three when determining the mantissa. (*Interpolation*, sometimes used to find a logarithm more accurately, is unnecessary unless warranted by unusual accuracy in the available data.) However, be doubly sure to include all figures when ascertaining the magnitude of the characteristic.

To find the anti-logarithm, the table is used in reverse. As an example, let us find the anti-logarithm of 1.272 or, in other words, find the number of which 1.272 is the logarithm. Look in the table for the mantissa closest to 272. This is found in the first half of the table and the nearest value is 2718. Write down the first two significant figures of the anti-logarithm by taking the figures at the beginning of the line on which 2718 was found. This is 18; add to this, the digit above the column in which 2718 was found; this is 7. The anti-logarithm is 187 but we have not yet placed the decimal point. The characteristic is 1, which means that there should be two digits to the left of the decimal point. Hence, 18.7 is the anti-logarithm of 1.272.

For the sake of completeness we shall also describe the same operation with a five-place table where interpolation is done by means of tables of proportional parts (P.P. tables). Therefore we are reproducing here a small part of one page of a five-place table.

Finding the logarithm of 0.025013 is done as follows: We can begin with the characteristic, which is -2. Next find the first three digits in the column, headed by *N* and immediately after this we see 39, the first two digits of the mantissa. Then look among the headings of the other columns for the next digit of the number, in this case 1. In the column, headed by 1 and on the line headed 250, we find the next three digits of the logarithm, 811. So far,

the logarithm is -2.39811 but this is the logarithm of 0.025010 and we want the logarithm of 0.025013. Here we can interpolate by observing that the difference between the log of 0.02501 and 0.02502 is 829 - 811 or 18, in the last two significant figures. Looking in the P.P. table marked 18 we find after 3 the number 5.4 which is to be added to the logarithm.

$$-2.39811$$

$$5.4$$

$$-2.39816, \text{ the logarithm of } 0.025013$$

Since our table is only good to five places, we must eliminate the last figure given in the P.P. table if it is less than 5, otherwise we must add one to the next to the last figure, rounding off to a whole number in the P.P. table.

Finding the anti-logarithm is done the same way but with the procedure reversed. Suppose it is required to find the anti-logarithm of 0.40100. Find the first two digits in the column headed by *L*. Then one must look for the next three digits or the ones nearest to it, in the columns after 40 and on the lines from 40 to 41. Now here we find that numbers in the neighborhood of 100 occur only with an asterisk on the line just before 40 and still after 39. The asterisk means that instead of the 39 as the first two digits, these mantissas should have 40 as the first two digits. The logarithm 0.40100 is between the logs 0.40088 and 0.40106; the anti-logarithm is between 2517 and 2518. The difference between the two logarithms in the table is again 18 in the last two figures and our logarithm 0.40100 differs with the lower one 12 in the last figures. Look in the P.P. table of 18 which number comes closest to 12. This is found to be 12.6 for $7 \times 1.8 = 12.6$. Therefore we may add the digit 7 to the anti-logarithm already found; so we have 25177. Next, place the decimal point according to the rules: There are as many digits to the left of the decimal point as indicated in the characteristic plus one. The anti-logarithm of 0.40100 is 2.5177.

In the following examples of the use of logarithms we shall use only three places from the tables printed in this chapter since a greater degree of precision in our calculations would not be warranted by the accuracy of the data given.

In a 375 ohm bias resistor flows a current of 41.5 milliamperes; how many watts are dissipated by the resistor?

We write the equation for power in watts:

$$P = I^2R$$

and filling in the quantities in question, we have:

$$P = 0.0415^2 \times 375$$

Taking logarithms,

$$\log P = 2 \log 0.0415 + \log 375$$

$$\log 0.0415 = -2.618$$

$$\text{So } 2 \times \log 0.0415 = -3.236$$

$$\log 375 = 2.574$$

$$\log P = -1.810$$

$$\text{antilog} = 0.646. \text{ Answer} = 0.646 \text{ watts}$$

Caution: Do not forget that the negative sign before the characteristic belongs to the characteristic only and that mantissas are *always* positive. Therefore we recommend the other notation, for it is less likely to lead to errors. The work is then written:

$$\log 0.0415 = 8.618 - 10$$

$$2 \times \log 0.0415 = 17.236 - 20 = 7.236 - 10$$

$$\log 375 = 2.574$$

$$\log P = 9.810 - 10$$

Another example follows which demonstrates the ease in handling powers and roots. Assume an all-wave receiver is to be built, covering from 550 kc. to 60 mc. Can this be done in five ranges and what will be the required tuning ratio for each range if no overlapping is required? Call the tuning ratio of one band, x . Then the total tuning ratio for five such bands is x^5 . But the total tuning ratio for all bands is 60/0.55. Therefore:

$$x^5 = \frac{60}{0.55} \text{ or } : x = \sqrt[5]{\frac{60}{0.55}}$$

Taking logarithms:

$$\log x = \frac{\log 60 - \log 0.55}{5}$$

$$\log 60 = 1.778$$

$$\log 0.55 = -1.740$$

$$\frac{\quad}{\quad} \text{ subtract}$$

$$2.038$$

Remember again that the mantissas are positive and the characteristic alone can be negative. Subtracting -1 is the same as adding $+1$.

$$\log x = \frac{2.038}{5} = 0.408$$

$$x = \text{ontilog } 0.408 = 2.56$$

The tuning ratio should be 2.56.

| db | Power Ratio |
|----|-------------|
| 0 | 1.00 |
| 1 | 1.26 |
| 2 | 1.58 |
| 3 | 2.00 |
| 4 | 2.51 |
| 5 | 3.16 |
| 6 | 3.98 |
| 7 | 5.01 |
| 8 | 6.31 |
| 9 | 7.94 |
| 10 | 10.00 |
| 20 | 100 |
| 30 | 1,000 |
| 40 | 10,000 |
| 50 | 100,000 |
| 60 | 1,000,000 |
| 70 | 10,000,000 |
| 80 | 100,000,000 |

Figure 7.
A TABLE OF DECIBEL GAINS VERSUS POWER RATIOS.

The Decibel

The decibel is a unit for the comparison of power or voltage levels in sound and electrical work. The sensation of our ears due to sound waves in the surrounding air is roughly proportional to the logarithm of the energy of the sound-wave and not proportional to the energy itself. For this reason a logarithmic unit is used so as to approach the reaction of the ear.

The decibel represents a *ratio* of two power levels, usually connected with gains or loss due to an amplifier or other network. The decibel is defined

$$N_{db} = 10 \log \frac{P_o}{P_i}$$

where P_o stands for the output power, P_i for the input power and N_{db} for the number of decibels. When the answer is positive, there is a gain; when the answer is negative, there is a loss.

The gain of amplifiers is usually given in decibels. For this purpose both the input power and output power should be measured. Example: Suppose that an intermediate amplifier is being driven by an input power of 0.2 watt and after amplification, the output is found to be 6 watts.

$$\frac{P_o}{P_i} = \frac{6}{0.2} = 30$$

$$\log 30 = 1.48$$

Therefore the gain is $10 \times 1.48 = 14.8$ decibels. The decibel is a logarithmic unit; when the power was multiplied by 30, the power level in decibels was increased by 14.8 decibels, or 14.8 decibels *added*.

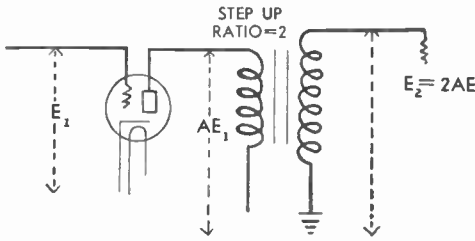

Figure 8.
STAGE GAIN.

The voltage gain in this stage is equal to the amplification in the tube plus the step-up ratio of the transformer, both expressed in decibels.

When one amplifier is to be followed by another amplifier, power gains are multiplied but the decibel gains are added. If a main amplifier having a gain of 1,000,000 (power ratio is 1,000,000) is preceded by a pre-amplifier with a gain of 1000, the total gain is 1,000,000,000. But in decibels, the first amplifier has a gain of 60 decibels, the second a gain of 30 decibels and the two of them will have a gain of 90 decibels when connected in cascade. (This is true only if the two amplifiers are properly matched at the junction as otherwise there will be a reflection loss at this point which must be subtracted from the total.)

Conversion of power ratios to decibels or vice versa is easy with the small table shown on these pages. In any case, an ordinary logarithm table will do. Find the logarithm of the power ratio and multiply by ten to find decibels.

Sometimes it is more convenient to figure decibels from voltage or current ratios or gains rather than from power ratios. This applies especially to voltage amplifiers. The equation for this is

$$N_{db} = 20 \log \frac{E_o}{E_i} \text{ or } 20 \log \frac{I_o}{I_i}$$

where the subscript, *o*, denotes the output voltage or current and *i* the input voltage or current. Remember, this equation is true only if the voltage or current gain in question represents a power gain which is the square of it and not if the power gain which results from this is some other quantity due to impedance changes. This should be quite clear when we consider that a matching transformer to connect a speaker to a line or output tube does not represent a gain or loss; there is a voltage change and a current change yet the power remains the same for the impedance has changed.

On the other hand, when dealing with voltage amplifiers, we can figure the gain in a stage by finding the voltage ratio from the grid of the first tube to the grid of the next tube.

Example: In the circuit of Figure 8, the gain in the stage is equal to the amplification in the tube and the step-up ratio of the transformer. If the amplification in the tube is 10 and the step-up in the transformer is 3.5, the voltage gain is 35 and the gain in decibels is:

$$20 \times \log 35 = 20 \times 1.54 = 30.8 \text{ db}$$

Decibels as Power Level The original use of the decibel was only as a *ratio* of power levels—not as an absolute measure of power. However, one may use the decibel as such an absolute unit by fixing an arbitrary “zero” level, and to indicate any power level by its number of decibels above or below this arbitrary zero level. This is all very good so long as we agree on the zero level.

Any power level may then be converted to decibels by the equation:

$$N_{db} = 10 \log \frac{P_o}{P_{ref.}}$$

where *N_{db}* is the desired power level in decibels, *P_o* the output of the amplifier, *P_{ref.}* the arbitrary reference level.

The zero level most frequently used (but not always) is 6 milliwatts or 0.006 watts. For this zero level, the equation reduces to

$$N_{db} = 10 \log \frac{P_o}{0.006}$$

Example: An amplifier using a 6F6 tube should be able to deliver an undistorted output of 3 watts. How much is this in decibels?

$$\frac{P_o}{P_{ref.}} = \frac{3}{.006} = 500$$

$$10 \times \log 500 = 10 \times 2.70 = 27.0$$

Therefore the power level at the output of the 6F6 is 27.0 decibels. When the power level to be converted is less than 6 milliwatts, the level is noted as negative. Here we must remember all that has been said regarding logarithms of numbers less than unity and the fact that the characteristic is negative but not the mantissa.

A preamplifier for a microphone is feeding 1.5 milliwatts into the line going to the regular speech amplifier. What is this power level expressed in decibels?

$$\text{decibels} = 10 \log \frac{P_o}{0.006} = 10 \log \frac{0.0015}{0.006} = 10 \log 0.25$$

Log 0.25 = -1.398 (from table). Therefore, 10 × -1.398 = (10 × -1 = -10) + (10 × .398 = 3.98); adding the products algebraically, gives -6.02 db.

The conversion chart reproduced in this chapter will be of use in converting decibels to watts and vice versa.

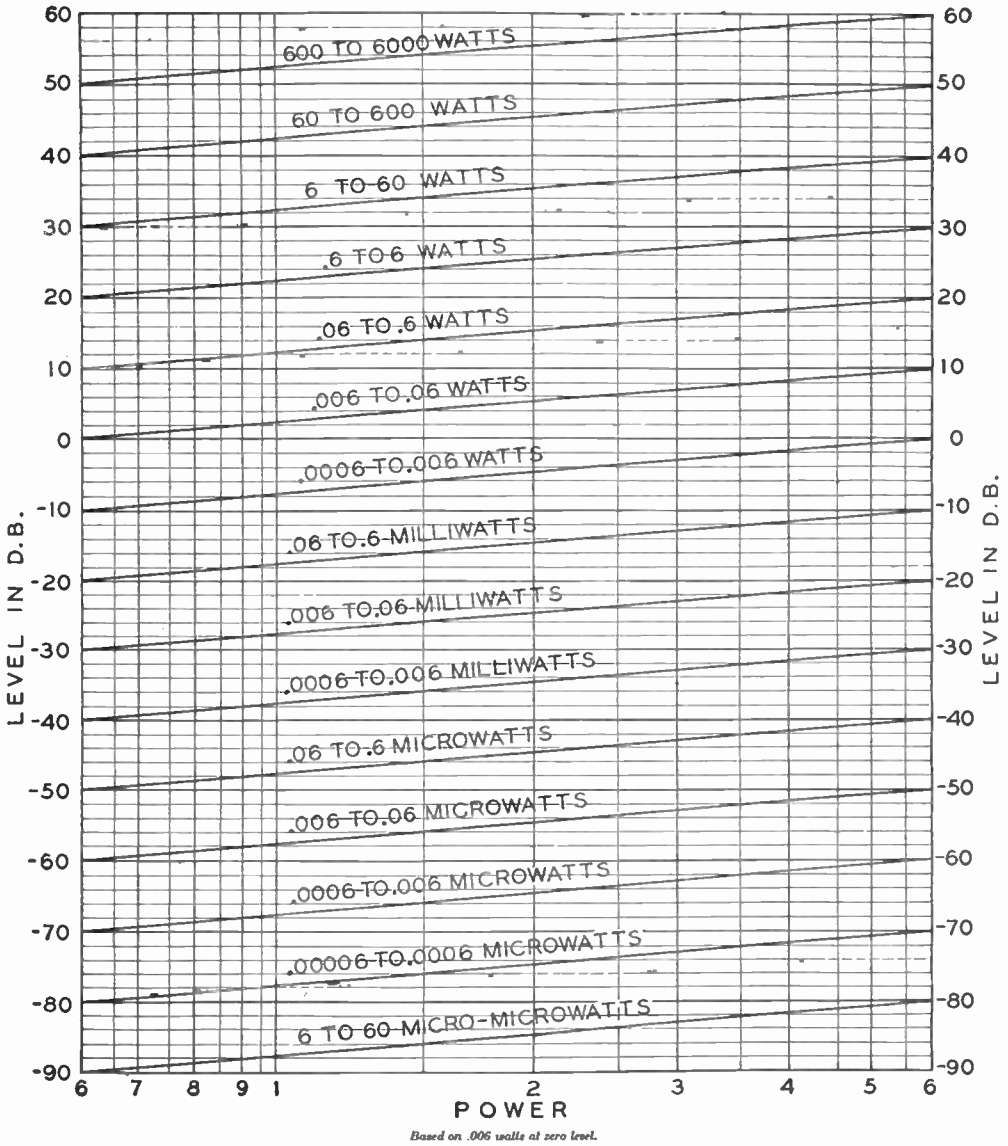

Figure 9.
CONVERSION CHART: POWER TO DECIBELS

Power levels between 6 micromicrowatts and 6000 watts may be referred to corresponding decibel levels between -90 and 60 db, and vice versa, by means of the above chart. Fifteen ranges are provided. Each curve begins at the same point where the preceding one ends, enabling uninterrupted coverage of the wide db and power ranges with condensed chart. For example: the lowermost curve ends at -80 db or 60 micromicrowatts and the next range starts at the same level. Zero db level is taken as 6 milliwatts (.006 watt).

Converting Decibels to Power It is often convenient to be able to convert a decibel value to a power equivalent. The formula used for this operation is

$$P = 0.006 \times \text{antilog} \frac{N_{db}}{10}$$

where P is the desired level in watts and N_{db} the decibels to be converted.

To determine the power level P from a decibel equivalent, simply divide the decibel value by 10; then take the number comprising the antilog and multiply it by 0.006; the product gives the level in watts.

Note: In problems dealing with the conversion of *minus* decibels to power, it often happens that the decibel value $-N_{db}$ is not divisible by 10. When this is the case, the numerator in the factor $-\frac{N_{db}}{10}$ must be made evenly divisible by 10, the negative signs must be observed, and the quotient labeled accordingly.

To make the numerator evenly divisible by 10 proceed as follows: Assume, for example, that $-N_{db}$ is some such value as -38 ; to make this figure evenly divisible by 10, we must add -2 to it, and, since we have added a negative 2 to it, we must also add a positive 2 so as to keep the net result the same.

Our decibel value now stands, $-40 + 2$. Dividing both of these figures by 10, as in the equation above, we have -4 and $+0.2$. Putting the two together we have the logarithm -4.2 with the negative characteristic and the positive mantissa as required.

The following examples will show the technique to be followed in practical problems.

(a) The output of a certain device is rated at -74 db. What is the power equivalent? Solution:

$$\frac{N_{db}}{10} = \frac{-74}{10} \text{ (not evenly divisible by 10)}$$

Routine:

$$\begin{array}{r} -74 \\ -6 \quad +6 \\ \hline -80 \quad +6 \end{array}$$

$$\frac{N_{db}}{10} = \frac{-80 + 6}{10} = -8.6$$

$$\text{antilog } -8.6 = 0.000\ 000\ 04$$

$$\begin{aligned} .006 \times 0.000\ 000\ 04 &= \\ 0.000\ 000\ 000\ 24 &\text{ watt or} \\ 240 &\text{ micro-microwatt} \end{aligned}$$

(b) This example differs somewhat from that of the foregoing one in that the mantissas are added differently. A low-powered amplifier has an input signal level of -17.3 db. How many milliwatts does this value represent?

Solution:

$$\begin{array}{r} -17.3 \\ -2.7 \quad +2.7 \\ \hline -20 \quad +2.7 \end{array}$$

$$\frac{N_{db}}{10} = \frac{-20 + 2.7}{10} = -2.27$$

$$\text{Antilog } -2.27 = 0.0186$$

$$\begin{aligned} 0.006 \times 0.0186 &= 0.000\ 1116 \text{ watt or} \\ &0.1116 \text{ milliwatt} \end{aligned}$$

Input voltages: To determine the required input voltage, take the peak voltage necessary to drive the last class A amplifier tube to maximum output, and divide this figure by the total overall voltage gain of the preceding stages.

Computing Specifications: From the preceding explanations the following data can be computed with any degree of accuracy warranted by the circumstances:

- (1) Voltage amplification
- (2) Overall gain in db
- (3) Output signal level in db
- (4) Input signal level in db
- (5) Input signal level in watts
- (6) Input signal voltage

When a power level is available which must be brought up to a new power level, the gain required in the intervening amplifier is equal to the difference between the two levels in decibels. If the required input of an amplifier for full output is -30 decibels and the output from a device to be used is but -45 decibels, the pre-amplifier required should have a gain of the difference, or 15 decibels. Again this is true only if the two amplifiers are properly matched and no losses are introduced due to mismatching.

Push-Pull Amplifiers To double the output of any cascade amplifier, it is only necessary to connect in push-pull the last amplifying stage, and replace the inter-stage and output transformers with push-pull types.

To determine the voltage gain (voltage ratio) of a push-pull amplifier, take the ratio of one half of the secondary winding of the push-pull transformer and multiply it by the μ of one of the output tubes in the push-pull stage; the product, when doubled, will be the voltage amplification, or step-up.

Other Units and Zero Levels When working with decibels one should not immediately take for granted that the zero level is 6 milliwatts for there are other zero levels in use.

In broadcast stations an entirely new system is now employed. Measurements made in

acoustics are now made with the standard zero level of 10^{-16} watts per square cm.

Microphones are often rated with reference to the following zero level: *one volt at open circuit when the sound pressure is one millibar.* In any case, the rating of the microphone must include the loudness of the sound. It is obvious that this zero level does not lend itself readily for the calculation of required gain in an amplifier.

The VU: So far, the decibel has always referred to a type of signal which can readily be measured, that is, a steady signal of a single frequency. But what would be the power level of a signal which is constantly varying in volume and frequency? The measurement of voltage would depend on the type of instrument employed, whether it is measured with a thermal square law meter or one that shows average values; also, the inertia of the movement will change its indications at the peaks and valleys.

After considerable consultation, the broadcast chains and the Bell System have agreed on the *VU*. The level in *VU* is the level in decibels above *1 milliwatt* zero level and measured with a carefully defined type of instrument across a 600 ohm line. So long as we deal with an unvarying sound, the level in *VU* is equal to decibels above 1 milliwatt; but when the sound level varies, the unit is the *VU* and the special meter must be used. There is then no equivalent in decibels.

The Neper: We might have used the natural logarithm instead of the common logarithm when defining our logarithmic unit of sound. This was done in Europe and the unit obtained is known as the *neper* or *napier*. It is still found in some American literature on filters.

- 1 neper = 8.686 decibels
- 1 decibel = 0.1151 neper

AC Meters With Decibel Scales Many test instruments are now equipped with scales calibrated in decibels which is very handy when making measurements of frequency characteristics and gain. These meters are generally calibrated for connection across a 500 ohm line and for a zero level of 6 milliwatts. When they are connected across another impedance, the reading on the meter is no longer correct for the zero level of 6 milliwatts. A correction factor should be applied consisting in the addition or subtraction of a steady figure to all readings on the meter. This figure is given by the equation:

$$\text{db to be added} = 10 \log \frac{500}{Z}$$

where *Z* is the impedance of the circuit under measurement.

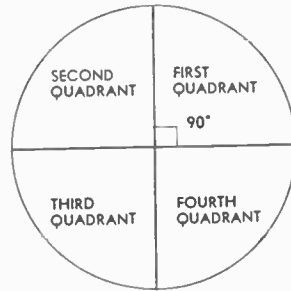

Figure 10.
THE CIRCLE IS DIVIDED INTO FOUR QUADRANTS BY TWO PERPENDICULAR LINES AT RIGHT ANGLES TO EACH OTHER.

The "northeast" quadrant thus formed is known as the first quadrant; the others are numbered consecutively in a counterclockwise direction.

Trigonometry

Definition and Use Trigonometry is the science of mensuration of *triangles*. At first glance triangles may seem to

have little to do with electrical phenomena; however, in a.c. work most currents and voltages follow laws equivalent to those of the various trigonometric relations which we are about to examine briefly. Examples of their application to a.c. work will be given in the section on *Vectors*.

Angles are measured in *degrees* or in *radians*. The circle has been divided into 360 degrees, each degree into 60 minutes, and each minute into 60 seconds. A decimal division of the degree is also in use because it makes calculation easier. Degrees, minutes and seconds are indicated by the following signs: °, ' and ". Example: 6° 5' 23" means six degrees, five minutes, twenty-three seconds. In the decimal notation we simply write 8.47°, eight and forty-seven hundredths of a degree.

When a circle is divided into four quadrants by two perpendicular lines passing through the center (Figure 10) the angle made by the two lines is 90 degrees, known as a *right angle*. Two right angles, or 180° equals a *straight angle*.

The radian: If we take the radius of a circle and bend it so it can cover a part of the circumference, the arc it covers subtends an angle called a *radian* (Figure 11). Since the circumference of a circle equals 2 times the radius, there are 2π radians in 360°. So we have the following relations:

- 1 radian = 57° 17' 45" = 57.2958° π = 3.14159
- 1 degree = 0.01745 radians
- π radians = 180° π/2 radians = 90°
- π/3 radians = 60°

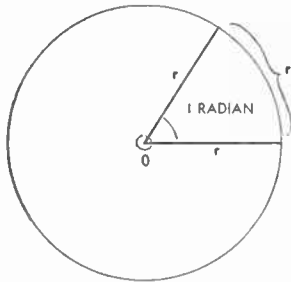

Figure 11.
THE RADIAN.

A radian is an angle whose arc is exactly equal to the length of either side. Note that the angle is constant regardless of the length of the side and the arc so long as they are equal. A radian equals 57.2958°.

In trigonometry we consider an angle generated by two lines, one stationary and the other rotating as if it were hinged at 0, Figure 12. Angles can be greater than 180 degrees and even greater than 360 degrees as illustrated in this figure.

Two angles are complements of each other when their sum is 90°, or a right angle. *A* is the complement of *B* and *B* is the complement of *A* when

$$A = (90^\circ - B)$$

and when

$$B = (90^\circ - A)$$

Two angles are supplements of each other when their sum is equal to a straight angle, or 180°. *A* is the supplement of *B* and *B* is the supplement of *A* when

$$A = (180^\circ - B)$$

and

$$B = (180^\circ - A)$$

In the angle *A*, Figure 13A, a line is drawn from *P*, perpendicular to *b*. Regardless of the point selected for *P*, the ratio *a/c* will always be the same for any given angle, *A*. So will all the other proportions between *a*, *b*, and *c* remain constant regardless of the position of point *P* on *c*. The six possible ratios each are named and defined as follows:

$$\text{sine } A = \frac{a}{c} \qquad \text{cosine } A = \frac{b}{c}$$

$$\text{tangent } A = \frac{a}{b} \qquad \text{cotangent } A = \frac{b}{a}$$

$$\text{secant } A = \frac{c}{b} \qquad \text{cosecant } A = \frac{c}{a}$$

Let us take a special angle as an example. For instance, let the angle *A* be 60 degrees as in Figure 13B. Then the relations between the sides are as in the figure and the six functions become:

$$\sin 60^\circ = \frac{a}{c} = \frac{1/2 \sqrt{3}}{1} = 1/2 \sqrt{3}$$

$$\cos 60^\circ = \frac{b}{c} = \frac{1/2}{1} = 1/2$$

$$\tan 60^\circ = \frac{a}{b} = \frac{1/2 \sqrt{3}}{1/2} = \sqrt{3}$$

$$\cot 60^\circ = \frac{1/2}{1/2 \sqrt{3}} = \frac{1}{\sqrt{3}} = 1/3 \sqrt{3}$$

$$\sec 60^\circ = \frac{c}{b} = \frac{1}{1/2} = 2$$

$$\csc 60^\circ = \frac{c}{a} = \frac{1}{1/2 \sqrt{3}} = 2/3 \sqrt{3}$$

Another example: Let the angle be 45°, then the relations between the lengths of *a*, *b*, and *c* are as shown in Figure 13C, and the six functions are:

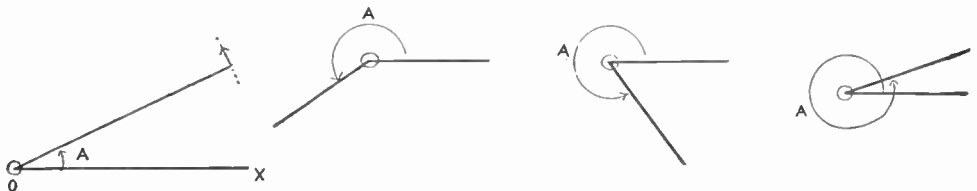

Figure 12.

AN ANGLE IS GENERATED BY TWO LINES, ONE STATIONARY AND THE OTHER ROTATING.

The line OX is stationary; the line with the small arrow at the far end rotates in a counterclockwise direction. At the position illustrated in the lefthandmost section of the drawing it makes an angle, A, which is less than 90° and is therefore in the first quadrant. In the position shown in the second portion of the drawing the angle A has increased to such a value that it now lies in the third quadrant; note that an angle can be greater than 180°. In the third illustration the angle A is in the fourth quadrant. In the fourth position the rotating vector has made more than one complete revolution and is hence in the fifth quadrant; since the fifth quadrant is an exact repetition of the first quadrant, its values will be the same as in the lefthandmost portion of the illustration.

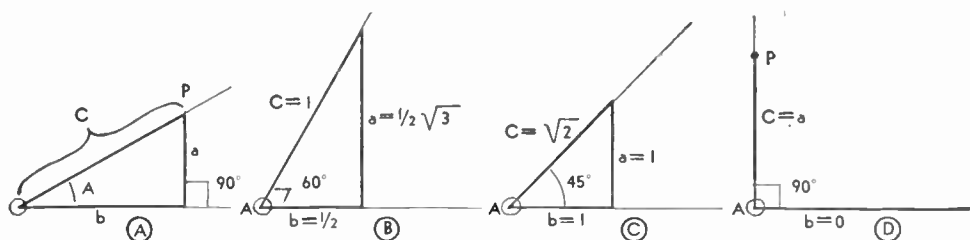

Figure 13.

THE TRIGONOMETRIC FUNCTIONS.

In the right triangle shown in (A) the side opposite the angle A is a, while the adjoining sides are b and c; the trigonometric functions of the angle A are completely defined by the ratios of the sides a, b and c. In (B) are shown the lengths of the sides a and b when angle A is 60° and side c is 1. In (C) angle A is 45°; a and b equal 1, while c equals $\sqrt{2}$. In (D) note that c equals a for a right angle while b equals 0.

$$\sin 45^\circ = \frac{1}{\sqrt{2}} = \frac{1}{2}\sqrt{2}$$

$$\cos 45^\circ = \frac{1}{\sqrt{2}} = \frac{1}{2}\sqrt{2}$$

$$\tan 45^\circ = \frac{1}{1} = 1$$

$$\cot 45^\circ = \frac{1}{1} = 1$$

$$\sec 45^\circ = \frac{\sqrt{2}}{1} = \sqrt{2}$$

$$\operatorname{cosec} 45^\circ = \frac{\sqrt{2}}{1} = \sqrt{2}$$

There are some special difficulties when the angle is zero or 90 degrees. In Figure 13D an angle of 90 degrees is shown; drawing a line perpendicular to b from point P makes it fall on top of c. Therefore in this case a = c and b = 0. The six ratios are now:

$$\sin 90^\circ = \frac{a}{c} = 1 \quad \cos 90^\circ = \frac{b}{c} = \frac{0}{c} = 0$$

$$\tan 90^\circ = \frac{a}{b} = \frac{a}{0} = \infty \quad \cot 90^\circ = \frac{0}{a} = 0$$

$$\sec 90^\circ = \frac{c}{b} = \frac{c}{0} = \infty \quad \operatorname{cosec} 90^\circ = \frac{c}{a} = 1$$

When the angle is zero, a = 0 and b = c. The values are then:

$$\sin 0^\circ = \frac{a}{c} = \frac{0}{c} = 0 \quad \cos 0^\circ = \frac{b}{c} = 1$$

$$\tan 0^\circ = \frac{a}{b} = \frac{0}{b} = 0 \quad \cot 0^\circ = \frac{b}{a} = \frac{b}{0} = \infty$$

$$\sec 0^\circ = \frac{c}{b} = 1 \quad \operatorname{cosec} 0^\circ = \frac{c}{a} = \frac{c}{0} = \infty$$

In general, for every angle, there will be definite values of the six functions. Conversely, when any of the six functions is known, the angle is defined. Tables have been calculated giving the value of the functions for angles.

From the foregoing we can make up a small table of our own (Figure 14), giving values of the functions for some common angles.

Relations Between Functions

It follows from the definitions that

$$\sin A = \frac{1}{\operatorname{cosec} A} \quad \cos A = \frac{1}{\sec A}$$

$$\text{and } \tan A = \frac{1}{\cot A}$$

From the definitions also follows the relation

$$\cos A = \sin (\text{complement of } A) = \sin (90^\circ - A)$$

because in the right triangle of Figure 15, $\cos A = b/c = \sin B$ and $B = 90^\circ - A$ or the complement of A. For the same reason:

$$\cot A = \tan (90^\circ - A)$$

$$\operatorname{csc} A = \sec (90^\circ - A)$$

Relations in Right Triangles

In the right triangle of Figure 15, $\sin A = a/c$ and by transposition

$$a = c \sin A$$

For the same reason we have the following identities:

$$\begin{aligned} \tan A &= a/b & a &= b \tan A \\ \cot A &= b/a & b &= a \cot A \end{aligned}$$

In the same triangle we can do the same for functions of the angle B

| Angle | Sin | Cos. | Tan | Cot | Sec. | Cosec. |
|-------|-----------------------|-----------------------|-----------------------|-----------------------|-----------------------|-----------------------|
| 0 | 0 | 1 | 0 | ∞ | 1 | ∞ |
| 30° | $\frac{1}{2}$ | $\frac{1}{2}\sqrt{3}$ | $\frac{1}{3}\sqrt{3}$ | $\sqrt{3}$ | $\frac{2}{3}\sqrt{3}$ | 2 |
| 45° | $\frac{1}{2}\sqrt{2}$ | $\frac{1}{2}\sqrt{2}$ | 1 | 1 | $\sqrt{2}$ | $\sqrt{2}$ |
| 60° | $\frac{1}{2}\sqrt{3}$ | $\frac{1}{2}$ | $\sqrt{3}$ | $\frac{1}{3}\sqrt{3}$ | 2 | $\frac{2}{3}\sqrt{3}$ |
| 90° | 1 | 0 | ∞ | 0 | ∞ | 1 |

Figure 14.

Values of trigonometric functions for common angles in the first quadrant.

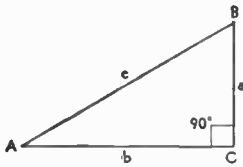

Figure 15.

In this figure the sides *a*, *b*, and *c* are used to define the trigonometric functions of angle *B* as well as angle *A*.

| | |
|----------------|----------------|
| $\sin B = b/c$ | $b = c \sin B$ |
| $\cos B = a/c$ | $a = c \cos B$ |
| $\tan B = b/a$ | $b = a \tan B$ |
| $\cot B = a/b$ | $a = b \cot B$ |

Functions of Angles Greater than 90 Degrees

In angles greater than 90 degrees, the values of *a* and *b* become negative on occasion in accordance with the rules of Cartesian coordinates. When *b* is measured from 0 towards the left it is considered negative and similarly, when *a* is measured from 0 downwards, it is negative. Referring to Figure 16, an angle in the *second quadrant* (between 90° and 180°) has some of its functions negative:

| | |
|---------------------------------------|---|
| $\sin A = \frac{a}{c} = \text{pos.}$ | $\cos A = \frac{-b}{c} = \text{neg.}$ |
| $\tan A = \frac{a}{-b} = \text{neg.}$ | $\cot A = \frac{-b}{a} = \text{neg.}$ |
| $\sec A = \frac{c}{-b} = \text{neg.}$ | $\text{cosec } A = \frac{c}{a} = \text{pos.}$ |

For an angle in the third quadrant (180° to 270°), the functions are

| | |
|--|--|
| $\sin A = \frac{-a}{c} = \text{neg.}$ | $\cos A = \frac{-b}{c} = \text{neg.}$ |
| $\tan A = \frac{-a}{-b} = \text{pos.}$ | $\cot A = \frac{-b}{-a} = \text{pos.}$ |

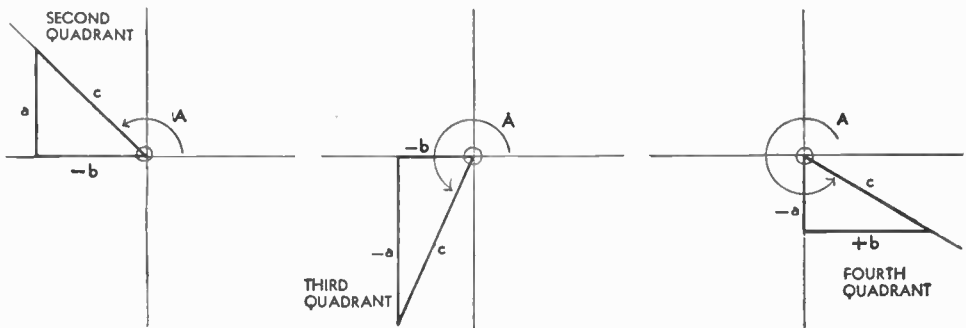

Figure 16.

TRIGONOMETRIC FUNCTIONS IN THE SECOND, THIRD, AND FOURTH QUADRANTS.

The trigonometric functions in these quadrants are similar to first quadrant values, but the signs of the functions vary as listed in the text and in Figure 17.

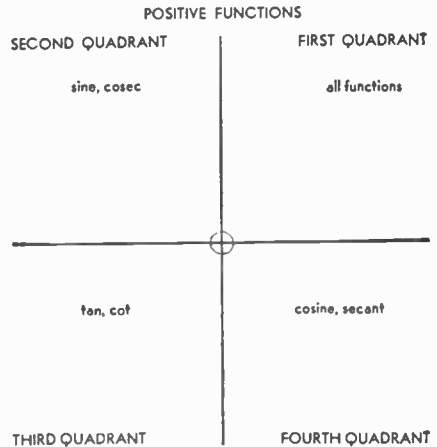

Figure 17.

SIGNS OF THE TRIGONOMETRIC FUNCTIONS.

The functions listed in this diagram are positive; all other functions are negative.

$\sec A = \frac{c}{-b} = \text{neg.}$ $\text{cosec } A = \frac{c}{-a} = \text{neg.}$

And in the fourth quadrant (270° to 360°):

| | |
|--|--|
| $\sin A = \frac{-a}{c} = \text{neg.}$ | $\cos A = \frac{b}{c} = \text{pos.}$ |
| $\tan A = \frac{-a}{-b} = \text{neg.}$ | $\cot A = \frac{b}{-a} = \text{neg.}$ |
| $\sec A = \frac{c}{b} = \text{pos.}$ | $\text{cosec } A = \frac{c}{-a} = \text{neg.}$ |

Summarizing, the sign of the functions in each quadrant can be seen at a glance from Figure 17, where in each quadrant are written the names of functions which are positive; those not mentioned are negative.

Figure 18.
SINE AND COSINE CURVES.
In (A) we have a sine curve drawn in Cartesian coordinates. This is the usual representation of an alternating current wave without substantial harmonics. In (B) we have a cosine wave; note that it is exactly similar to a sine wave displaced by 90° or $\pi/2$ radians.

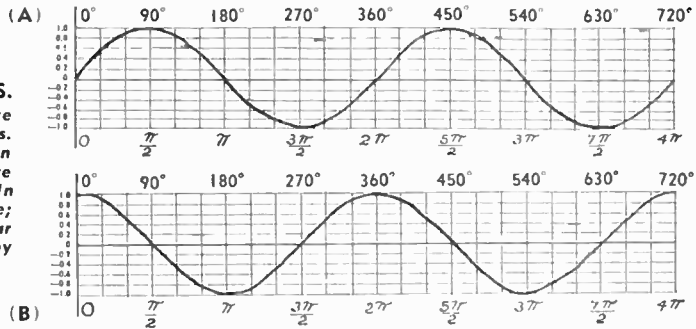

Graphs at Trigonometric Functions

The sine wave. When we have the relation $y = \sin x$, where x is an

angle measured in radians or degrees, we can draw a curve of y versus x for all values of the independent variable, and thus get a good conception how the sine varies with the magnitude of the angle. This has been done in Figure 18A. We can learn from this curve the following facts.

1. The sine varies between +1 and -1
2. It is a periodic curve, repeating itself after every multiple of 2π or 360°
3. $\sin x = \sin (180^\circ - x)$ or $\sin (\pi - x)$
4. $\sin x = -\sin (180^\circ + x)$, or $-\sin (\pi + x)$

The cosine wave. Making a curve for the function $y = \cos x$, we obtain a curve similar to that for $y = \sin x$ except that it is displaced by 90° or $\pi/2$ radians with respect to the Y-axis. This curve (Figure 18B) is also periodic but it does not start with zero. We read from the curve:

1. The value of the cosine never goes beyond +1 or -1
2. The curve repeats, after every multiple of 2π radians or 360°

3. $\cos x = -\cos (180^\circ - x)$ or $-\cos (\pi - x)$

4. $\cos x = \cos (360^\circ - x)$ or $\cos (2\pi - x)$

The graph of the tangent is illustrated in Figure 19. This is a discontinuous curve and illustrates well how the tangent increases from zero to infinity when the angle increases from zero to 90° . Then when the angle is further increased, the tangent starts from minus infinity going to zero in the second quadrant, and to infinity again in the third quadrant.

1. The tangent can have any value between $+\infty$ and $-\infty$
2. The curve repeats and the period is π radians or 180° , not 2π radians
3. $\tan x = \tan (180^\circ + x)$ or $\tan (\pi + x)$
4. $\tan x = -\tan (180^\circ - x)$ or $-\tan (\pi - x)$

The graph of the cotangent is the inverse of that of the tangent, see Figure 20. It leads us to the following conclusions:

1. The cotangent can have any value between $+\infty$ and $-\infty$
2. It is a periodic curve, the period being π radians or 180°
3. $\cot x = \cot (180^\circ + x)$ or $\cot (\pi + x)$
4. $\cot x = -\cot (180^\circ - x)$ or $-\cot (\pi - x)$

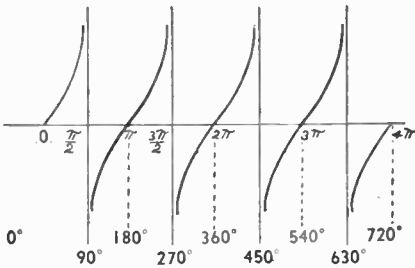

Figure 19.
TANGENT CURVES.

The tangent curve increases from 0 to ∞ with an angular increase of 90° . In the next 180° it increases from $-\infty$ to $+\infty$.

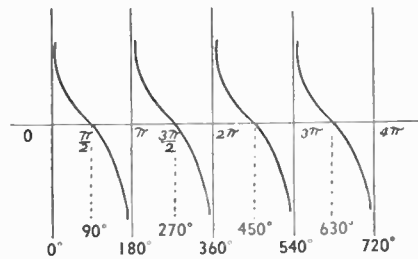

Figure 20.
COTANGENT CURVES.

Cotangent curves are the inverse of the tangent curves. They vary from $+\infty$ to $-\infty$ in each pair of quadrants.

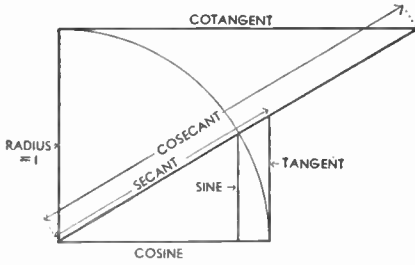

Figure 21.

ANOTHER REPRESENTATION OF TRIGONOMETRIC FUNCTIONS.

If the radius of a circle is considered as the unit of measurement, then the lengths of the various lines shown in this diagram are numerically equal to the functions marked adjacent to them.

The graphs of the secant and cosecant are of lesser importance and will not be shown here. They are the inverse, respectively, of the cosine and the sine, and therefore they vary from +1 to infinity and from -1 to -infinity.

Perhaps another useful way of visualizing the values of the functions is by considering Figure 21. If the radius of the circle is the unit of measurement then the lengths of the lines are equal to the functions marked on them.

Trigonometric Tables There are two kinds of trigonometric tables. The first type gives the functions of the angles, the second the logarithms of the functions. The first kind is also known as the table of natural trigonometric functions.

These tables give the functions of all angles between 0 and 45°. This is all that is necessary for the function of an angle between 45° and 90° can always be written as the co-function of an angle below 45°. Example: If we had to find the sine of 48°, we might write

$$\sin 48^\circ = \cos (90^\circ - 48^\circ) = \cos 42^\circ$$

Tables of the logarithms of trigonometric functions give the common logarithms (\log_{10}) of these functions. Since many of these logarithms have negative characteristics, one should add -10 to all logarithms in the table which have a characteristic of 6 or higher. For instance, the $\log \sin 24^\circ = 9.60931 - 10$. $\log \tan 1^\circ = 8.24192 - 10$ but $\log \cot 1^\circ = 1.75808$. When the characteristic shown is less than 6, it is supposed to be positive and one should not add -10.

Vectors

A scalar quantity has magnitude only; a vector quantity has both magnitude and direction. When we speak of a speed of 50 miles per hour, we are using a scalar quantity, but when we say the wind is Northeast and has a

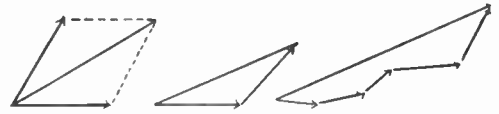

Figure 22.

Vectors may be added as shown in these sketches. In each case the long vector represents the vector sum of the smaller vectors. For many engineering applications sufficient accuracy can be obtained by this method which avoids long and laborious calculations.

velocity of 50 miles per hour, we speak of a vector quantity.

Vectors, representing forces, speeds, displacements, etc., are represented by arrows. They can be added graphically by well known methods illustrated in Figure 22. We can make the parallelogram of forces or we can simply draw a triangle. The addition of many vectors can be accomplished graphically as in the same figure.

In order that we may define vectors algebraically and add, subtract, multiply, or divide them, we must have a logical notation system that lends itself to these operations. For this purpose vectors can be defined by coordinate systems. Both the Cartesian and the polar coordinates are in use.

Vectors Defined by Cartesian Coordinates

Since we have seen how the sum of two vectors is obtained, it follows from Figure 23, that the vector \vec{Z}

equals the sum of the two vectors x and y . In fact, any vector can be resolved into vectors along the X- and Y-axis. For convenience in working with these quantities we need to dis-

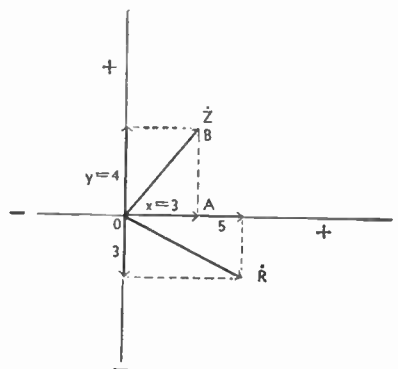

Figure 23.

RESOLUTION OF VECTORS.

Any vector such as \vec{Z} may be resolved into two vectors, x and y , along the X- and Y-axes. If vectors are to be added, their respective x and y components may be added to find the x and y components of the resultant vector.

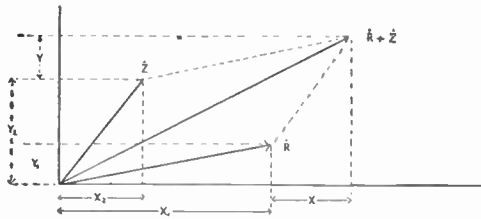

Figure 24.

ADDITION OR SUBTRACTION OF VECTORS.

Vectors may be added or subtracted by adding or subtracting their *x* or *y* components separately.

istinguish between the *X*- and *Y*-component, and so it has been agreed that the *Y*-component alone shall be marked with the letter *j*. Example (Figure 23):

$$\dot{Z} = 3 + 4j$$

Note again that the sign of components along the *X*-axis is positive when measured from 0 to the right and negative when measured from 0 towards the left. Also, the component along the *Y*-axis is positive when measured from 0 upwards, and negative when measured from 0 downwards. So the vector, \dot{R} , is described as

$$\dot{R} = 5 - 3j$$

Vector quantities are usually indicated by some special typography, especially by using a point over the letter indicating the vector, as \dot{R} .

Absolute Value of a Vector

The absolute or scalar value of vectors such as \dot{Z} or \dot{R} in Figure 23 is easily found by the theorem of Pythagoras, which states that in any right-angled triangle the square of the side opposite the right angle is equal to the sum of the squares of the sides adjoining the right angle. In Figure 23, *OAB* is a right-angled triangle; therefore, the square of *OB* (or *Z*) is equal to the square of *OA* (or *x*) plus the square of *AB* (or *y*). Thus the absolute values of *Z* and *R* may be determined as follows:

$$|Z| = \sqrt{x^2 + y^2}$$

$$|Z| = \sqrt{3^2 + 4^2} = 5$$

$$|R| = \sqrt{5^2 + 3^2} = \sqrt{34} = 5.83$$

The vertical lines indicate that the absolute or scalar value is meant without regard to sign or direction.

Addition of Vectors An examination of Figure 24 will show that the two vectors

$$\dot{R} = x_1 + j y_1$$

$$\dot{Z} = x_2 + j y_2$$

can be added, if we add the *X*-components and the *Y*-components separately.

$$\dot{R} + \dot{Z} = x_1 + x_2 + j (y_1 + y_2)$$

For the same reason we can carry out subtraction by subtracting the horizontal components and subtracting the vertical components

$$\dot{R} - \dot{Z} = x_1 - x_2 + j (y_1 - y_2)$$

Let us consider the operator *j*. If we have a vector *a* along the *X*-axis and add a *j* in front of it (multiplying by *j*) the result is that the direction of the vector is rotated forward 90 degrees. If we do this twice (multiplying by j^2) the vector is rotated forward by 180 degrees and now has the value $-a$. Therefore multiplying by j^2 is equivalent to multiplying by -1 . Then

$$j^2 = -1 \text{ and } j = \sqrt{-1}$$

This is the imaginary number discussed before under algebra. In electrical engineering the letter *j* is used rather than *i*, because *i* is already known as the symbol for current.

Multiplying Vectors When two vectors are to be multiplied we can perform the operation just as in algebra, remembering that $j^2 = -1$.

$$\begin{aligned} \dot{R}\dot{Z} &= (x_1 + jy_1)(x_2 + jy_2) \\ &= x_1x_2 + jx_1y_2 + jx_2y_1 + j^2y_1y_2 \\ &= x_1x_2 - y_1y_2 + j(x_1y_2 + x_2y_1) \end{aligned}$$

Division has to be carried out so as to remove the *j*-term from the denominator. This can be done by multiplying both denominator and numerator by a quantity which will eliminate *j* from the denominator. Example:

$$\begin{aligned} \frac{\dot{R}}{\dot{Z}} &= \frac{x_1 + jy_1}{x_2 + jy_2} = \frac{(x_1 + jy_1)(x_2 - jy_2)}{(x_2 + jy_2)(x_2 - jy_2)} \\ &= \frac{x_1x_2 + y_1y_2 + j(x_2y_1 - x_1y_2)}{x_2^2 + y_2^2} \end{aligned}$$

Polar Coordinates A vector can also be defined in polar coordinates by its magnitude and its vectorial angle with an arbitrary reference axis. In Figure 25

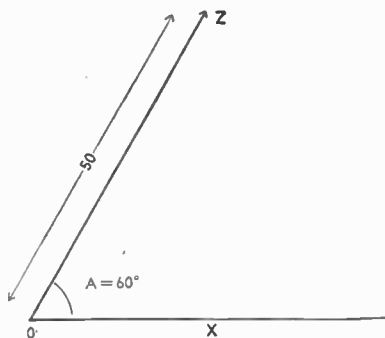

Figure 25.

IN THIS FIGURE A VECTOR HAS BEEN REPRESENTED IN POLAR INSTEAD OF CARTESIAN COORDINATES.

In polar coordinates a vector is defined by a magnitude and an angle, called the vectorial angle, instead of by two magnitudes as in Cartesian coordinates.

the vector \dot{Z} has a magnitude 50 and a vectorial angle of 60 degrees. This will then be written

$$\dot{Z} = 50 \angle 60^\circ$$

A vector $a + jb$ can be transformed into polar notation very simply (see Figure 26)

$$\dot{Z} = a + jb = \sqrt{a^2 + b^2} \angle \tan^{-1} \frac{b}{a}$$

In this connection \tan^{-1} means *the angle of which the tangent is*. Sometimes the notation *arc tan b/a* is used. Both have the same meaning.

A polar notation of a vector can be transformed into a Cartesian coordinate notation in the following manner (Figure 27)

$$\dot{Z} = p \angle A = p \cos A + jp \sin A$$

A sinusoidally alternating voltage or current is symbolically represented by a rotating vector, having a magnitude equal to the peak voltage or current and rotating with an angular velocity of $2\pi f$ radians per second or as many revolutions per second as there are cycles per second.

The instantaneous voltage, e , is always equal to the sine of the vectorial angle of this rotating vector, multiplied by its magnitude.

$$e = E \sin 2\pi ft$$

The alternating voltage therefore varies with time as the sine varies with the angle. If we plot time horizontally and instantaneous voltage vertically we will get a curve like those in Figure 18.

In alternating current circuits, the current

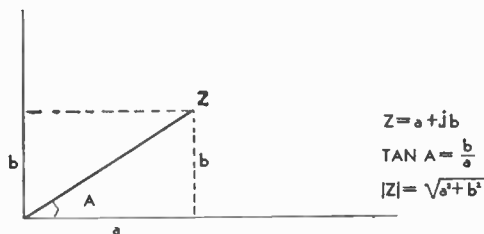

Figure 26.

Vectors can be transformed from Cartesian into polar notation as shown in this figure.

which flows due to the alternating voltage is not necessarily in step with it. The rotating current vector may be ahead or behind the voltage vector, having a *phase difference* with it. For convenience we draw these vectors as if they were standing still, so that we can indicate the difference in phase or the *phase angle*. In Figure 28 the current lags behind the voltage by the angle θ , or we might say that the voltage leads the current by the angle θ .

Vector diagrams show the phase relations between two or more vectors (voltages and currents) in a circuit. They may be added and subtracted as described; one may add a voltage vector to another voltage vector or a current vector to a current vector but not a current vector to a voltage vector (for the same reason that one cannot add a force to a speed). Figure 28 illustrates the relations in the simple series circuit of a coil and resistor. We know that the current passing through coil and resistor must be the same and in the same phase, so we draw this current I along the X-axis. We know also that the voltage drop IR across the resistor is in phase with the current, so the vector IR representing the voltage drop is also along the X-axis.

The voltage across the coil is 90 degrees ahead of the current through it; IX must therefore be drawn along the Y-axis. \dot{E} the applied voltage must be equal to the vectorial sum of the two voltage drops, IR and IX , and we have so constructed it in the drawing. Now expressing the same in algebraic notation, we have

$$\dot{E} = IR + jIX$$

$$I\dot{Z} = IR + jIX$$

Dividing by I

$$\dot{Z} = R + jX$$

Due to the fact that a *reactance* rotates the voltage vector ahead or behind the current vector by 90 degrees, we must mark it with a j in vector notation. Inductive reactance will have a plus sign because it shifts the voltage vector forwards; a capacitive reactance is neg-

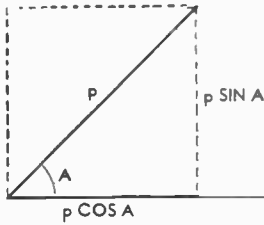

Figure 27.

Vectors can be transformed from polar into Cartesian notation as shown in this figure.

ative because the voltage will lag behind the current. Therefore:

$$X_L = +j 2\pi fL$$

$$X_C = -j \frac{1}{2\pi fC}$$

In Figure 28 the angle θ is known as the phase angle between E and I. When calculating power, only the real components count. The power in the circuit is then

$$P = I (IR)$$

$$\text{but } IR = E \cos \theta$$

$$\therefore P = EI \cos \theta$$

This $\cos \theta$ is known as the power factor of the circuit. In many circuits we strive to keep the angle θ as small as possible, making $\cos \theta$ as near to unity as possible. In tuned circuits, we use reactances which should have as low a power factor as possible. The merit of a coil or condenser, its Q , is defined by the tangent of this phase angle:

$$Q = \tan \theta = X/R$$

For an efficient coil or condenser, Q should be as large as possible; the phase-angle should then be as close to 90 degrees as possible, making the power factor nearly zero. Q is almost but not quite the inverse of $\cos \theta$. Note that in Figure 29

$$Q = X/R \quad \text{and} \quad \cos \theta = R/Z$$

When Q is more than 5, the power factor is less than 20%; we can then safely say $Q = 1/\cos \theta$ with a maximum error of about 2½ percent, for in the worst case, when $\cos \theta = 0.2$, Q will equal $\tan \theta = 4.89$. For higher values of Q , the error becomes less.

Note that from Figure 29 can be seen the simple relation:

$$\dot{Z} = R + jX_L$$

$$|Z| = \sqrt{R^2 + X_L^2}$$

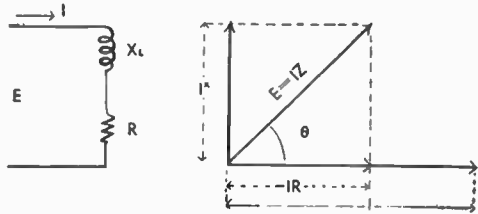

Figure 28.

VECTOR REPRESENTATION OF A SIMPLE SERIES CIRCUIT.

The righthand portion of the illustration shows the vectors representing the voltage drops in the coil and resistance illustrated at the left. Note that the voltage drop across the coil X_L leads that across the resistance by 90° .

Graphical Representation

Formulas and physical laws are often presented in graphical form; this gives us a "bird's eye view" of various possible conditions due to the variations of the quantities involved. In some cases graphs permit us to solve equations with greater ease than ordinary algebra.

Coordinate Systems All of us have used coordinate systems without realizing it. For instance, in modern cities we have numbered streets and numbered avenues. By this means we can define the location of any spot in the city if the nearest street crossings are named. This is nothing but an application of Cartesian coordinates.

In the Cartesian coordinate system (named after Descartes), we define the location of any point in a plane by giving its distance from each of two perpendicular lines or axes. Figure 30 illustrates this idea. The vertical axis is called the Y-axis, the horizontal axis is the X-axis. The intersection of these two axes is called the origin, O. The location of a point, P, (Figure 30) is defined by measuring the respective distances, x and y along the X-axis and the Y-axis. In this example the distance along the X-axis is 2 units and along the Y-axis is 3 units. Thus we define the point as

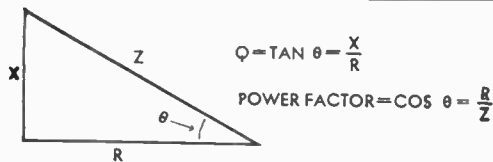

Figure 29.

The figure of merit of a coil and its resistance is represented by the ratio of the inductive reactance to the resistance, which as shown in this diagram is equal to $\frac{X}{R}$ which equals $\tan \theta$. For large values of θ (the phase angle) this is approximately equal to the reciprocal of the $\cos \theta$.

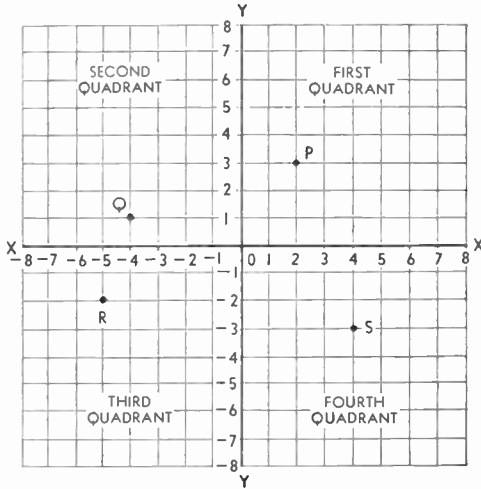

Figure 30.

CARTESIAN COORDINATES.

The location of any point can be defined by its distance from the X and Y axes.

P 2, 3 or we might say $x = 2$ and $y = 3$. The measurement x is called the *abscissa* of the point and the distance y is called its *ordinate*. It is arbitrarily agreed that distances measured from 0 to the right along the X-axis shall be reckoned positive and to the left negative. Distances measured along the Y-axis are positive when measured upwards from 0 and negative when measured downwards from 0. This is illustrated in Figure 30. The two axes divide the plane area into four parts called quadrants. These four quadrants are numbered as shown in the figure.

It follows from the foregoing statements, that points lying within the first quadrant have both x and y positive, as is the case with the point P. A point in the second quadrant has a negative abscissa, x , and a positive ordinate, y . This is illustrated by the point Q, which has the coordinates $x = -4$ and $y = +1$. Points in the third quadrant have both x and y negative. $x = -5$ and $y = -2$ illustrates such a point, R. The point S, in the fourth quadrant has a negative ordinate, y and a positive abscissa or x .

In practical applications we might draw only as much of this plane as needed to illustrate our equation and therefore, the scales along the X-axis and Y-axis might not start with zero and may show only that part of the scale which interests us.

Representation of Functions In the equation:

$$f = \frac{300,000}{\lambda}$$

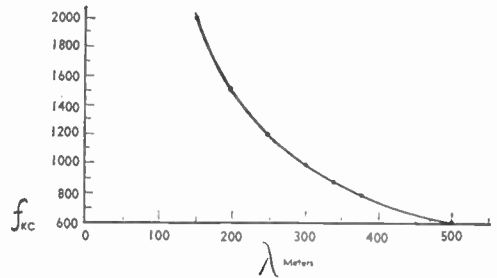

Figure 31.
REPRESENTATION OF A SIMPLE FUNCTION IN CARTESIAN COORDINATES.

In this chart of the function $f_{kc} = \frac{300,000}{\lambda_{meters}}$ distances along the X axis represent wavelength in meters, while those along the Y axis represent frequency in kilocycles. A curve such as this helps to find values between those calculated with sufficient accuracy for most purposes.

f is said to be a function of λ . For every value of f there is a definite value of λ . A variable is said to be a function of another variable when for every possible value of the latter, or *independent* variable, there is a definite value of the first or *dependent* variable. For instance, if $y = 5x^2$, y is a function of x and x is called the independent variable. When $a = 3b^3 + 5b^2 - 25b + 6$ then a is a function of b .

A function can be illustrated in our coordinate system as follows. Let us take the equation for frequency versus wavelength as an example. Given different values to the independent variable find the corresponding values of the dependent variable. Then plot the *points* represented by the different sets of two values.

| f_{kc} | λ_{meters} |
|----------|--------------------|
| 600 | 500 |
| 800 | 375 |
| 1000 | 300 |
| 1200 | 250 |
| 1400 | 214 |
| 1600 | 187 |
| 1800 | 167 |
| 2000 | 150 |

Plotting these points in Figure 31 and drawing a smooth curve through them gives us the *curve* or *graph* of the equation. This curve will help us find values of f for other values of λ (those in between the points calculated) and so a curve of an often-used equation may serve better than a table which always has gaps.

When using the coordinate system described so far and when measuring linearly along both axes, there are some definite rules regarding

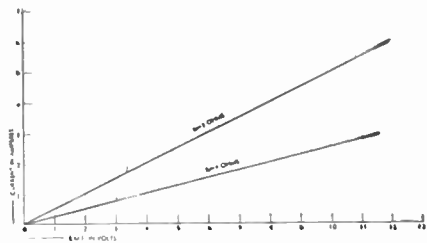

Figure 32.

Only two points are needed to define functions which result in a straight line as shown in this diagram representing Ohm's Law.

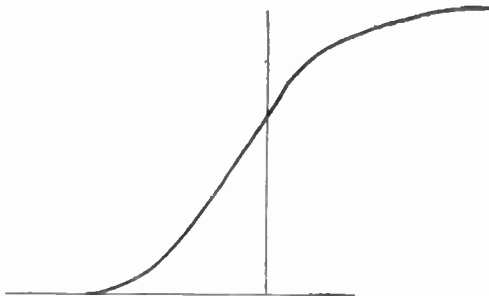

Figure 33.

A TYPICAL GRID - VOLTAGE
PLATE-CURRENT CHARACTER-
ISTIC CURVE.

The equation represented by such a curve is so complicated that we do not use it. Data for such a curve is obtained experimentally, and intermediate values can be found with sufficient accuracy from the curve.

the kind of curve we get for any type of equation. In fact, an expert can draw the curve with but a very few plotted points since the equation has told him what kind of curve to expect.

First, when the equation can be reduced to the form $y = mx + b$, where x and y are the variables, it is known as a *linear* or *first degree* function and the curve becomes a straight line. (Mathematicians still speak of a "curve" when it has become a straight line.)

When the equation is of the second degree, that is, when it contains terms like x^2 or y^2 or xy , the graph belongs to a group of curves, called *conic sections*. These include the circle, the ellipse, the parabola and the hyperbola. In the example given above, our equation is of the form

$$xy = c, \quad c \text{ being equal to } 300,000$$

which is a second degree equation and in this case, the graph is a hyperbola.

This type of curve does not lend itself readily for the purpose of calculation except near the middle, because at the ends a very large change in λ represents a small change in f and vice versa. Before discussing what can be done about this let us look at some other types of curves.

Suppose we have a resistance of 2 ohms and we plot the function represented by Ohm's Law: $E = 2I$. Measuring E along the X-axis and amperes along the Y-axis, we plot the necessary points. Since this is a first degree equation, of the form $y = mx + b$ (for $E = y$, $m = 2$ and $I = x$ and $b = 0$) it will be a straight line so we need only two points to plot it.

| | | | | | |
|------------------------------|---|---|---|---|----|
| | $\frac{I}{E}$ | | | | |
| (line passes through origin) | <table border="0" style="margin-left: auto; margin-right: auto;"> <tr> <td style="padding-right: 10px;">0</td> <td style="padding-right: 10px;">0</td> </tr> <tr> <td style="padding-right: 10px;">5</td> <td style="padding-right: 10px;">10</td> </tr> </table> | 0 | 0 | 5 | 10 |
| 0 | 0 | | | | |
| 5 | 10 | | | | |

The line is shown in Figure 32. It is seen to be a straight line passing through the origin.

If the resistance were 4 ohms, we should get the equation $E = 4I$ and this also represents a line which we can plot in the same figure. As we see, this line also passes through the origin but has a different slope. In this illustration the slope defines the resistance and we could make a protractor which would convert the angle into ohms. This fact may seem inconsequential now, but use of this is made in the drawing of loadlines on tube curves.

Figure 33 shows a typical, grid-voltage, plate-current static characteristic of a triode. The equation represented by this curve is rather complicated so that we prefer to deal with the curve. Note that this curve extends through the first and second quadrant.

Families of curves. It has been explained that curves in a plane can be made to illustrate the relation between two variables when one of them varies independently. However, what are we going to do when there are three variables and two of them vary independently. It is possible to use three dimensions and three axes but this is not conveniently done. Instead of this we may use a *family of curves*. We have already illustrated this partly with Ohm's Law. If we wish to make a chart which will show the current through any resistance with any voltage applied across it, we must take the equation $E = IR$, having three variables.

We can now draw one line representing a resistance of 1 ohm, another line representing 2 ohms, another representing 3 ohms, etc., or as many as we wish and the size of our paper will allow. The whole set of lines is then applicable to any case of Ohm's Law falling within the range of the chart. If any two of the three quantities are given, the third can be found.

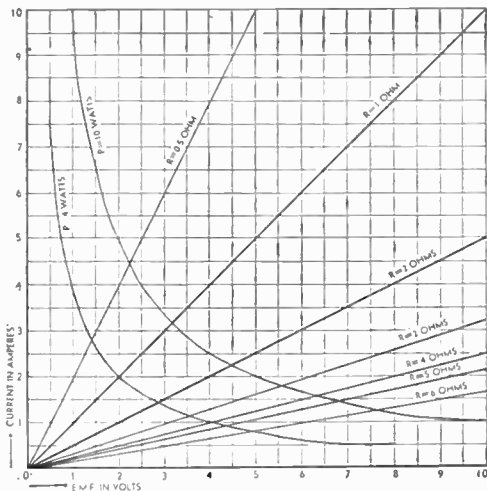

Figure 34.
A FAMILY OF CURVES.

An equation such as Ohm's Law has three variables, but can be represented in Cartesian coordinates by a family of curves such as shown here. If any two quantities are given, the third can be found. Any point in the chart represents a definite value each of E , I , and R , which will satisfy the equation of Ohm's Law. Values of R not situated on an R line can be found by interpolation.

Figure 34 shows such a family of curves to solve Ohm's Law. Any point in the chart represents a definite value each of E , I , and R which will satisfy the equation. The value of R represented by a point that is not situated on an R line can be found by interpolation.

It is even possible to draw on the same chart a second family of curves, representing a fourth variable. But this is not always possible, for among the four variables there should be no more than two independent variables. In our example such a set of lines could represent power in watts; we have drawn only two of these but there could of course be as many as desired. A single point in the plane now indicates the four values of E , I , R , and P which belong together and the knowledge of any two of them will give us the other two by reference to the chart.

Another example of a family of curves is the dynamic transfer characteristic or plate family of a tube. Such a chart consists of several curves showing the relation between plate voltage, plate current, and grid bias of a tube. Since we have again three variables, we must show several curves, each curve for a fixed value of one of the variables. It is customary to plot plate voltage along the X-axis, plate current along the Y-axis, and to make different curves for various values of grid bias. Such a

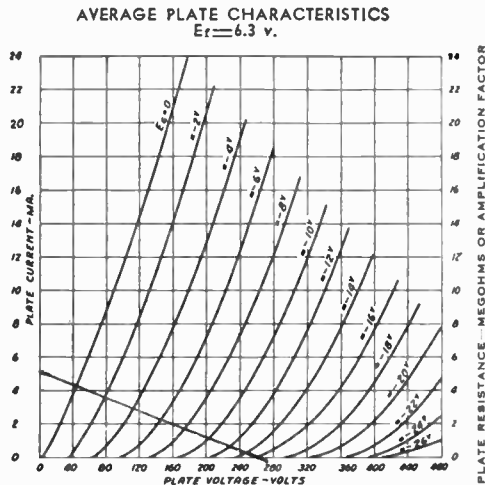

Figure 35.
"PLATE" CURVES FOR A
TYPICAL VACUUM TUBE.

In such curves we have three variables, plate voltage, plate current, and grid bias. Each point on a grid bias line corresponds to the plate voltage and plate current represented by its position with respect to the X and Y axes. Those for other values of grid bias may be found by interpolation. The loadline shown in the lower left portion of the chart is explained in the text.

set of curves is illustrated in Figure 35. Each point in the plane is defined by three values, which belong together, plate voltage, plate current, and grid voltage.

Now consider the diagram of a resistance-coupled amplifier in Figure 36. Starting with the B-supply voltage, we know that whatever plate current flows must pass through the resistor and will conform to Ohm's Law. The voltage drop across the resistor is subtracted from the plate supply voltage and the remainder is the actual voltage at the plate, the kind that is plotted along the X-axis in Figure 35. We can now plot on the plate family of the

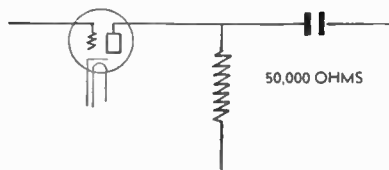

Figure 36.
PARTIAL DIAGRAM OF A RESIS-
TANCE COUPLED AMPLIFIER.

The portion of the supply voltage wasted across the 50,000-ohm resistor is represented in Figure 35 as the loadline.

tube the *loadline*, that is the line showing which part of the plate supply voltage is across the resistor and which part across the tube for any value of plate current. In our example, let us suppose the plate resistor is 50,000 ohms. Then, if the plate current were zero, the voltage drop across the resistor would be zero and the full plate supply voltage is across the tube. Our first point of the loadline is $E = 250, I = 0$. Next, suppose, the plate current were 1 ma., then the voltage drop across the resistor would be 50 volts, which would leave for the tube 200 volts. The second point of the loadline is then $E = 200, I = 1$. We can continue like this but it is unnecessary for we shall find that it is a straight line and two points are sufficient to determine it.

This loadline shows at a glance what happens when the grid-bias is changed. Although there are many possible combinations of plate voltage, plate current, and grid bias, we are now restricted to points along this line as long as the 50,000 ohm plate resistor is in use. This line therefore shows the voltage drop across the tube as well as the voltage drop across the load for every value of grid bias. Therefore, if we know how much the grid bias varies, we can calculate the amount of variation in the plate voltage and plate current, the amplification, the power output, and the distortion.

Logarithmic Scales Sometimes it is convenient to measure along the axes the *logarithms* of our variable quantities. Instead of actually calculating the logarithm, special paper is available with logarithmic scales, that is, the distances measured along the axes are proportional to the logarithms of the numbers marked on them rather than to the numbers themselves.

There is semi-logarithmic paper, having logarithmic scales along one axis only, the other scale being linear. We also have full logarithmic paper where both axes carry logarithmic scales. Many curves are greatly simplified and some become straight lines when plotted on this paper.

As an example let us take the wavelength-frequency relation, charted before on straight cross-section paper.

$$f = \frac{300,000}{\lambda}$$

Taking logarithms:

$$\log f = \log 300,000 - \log \lambda$$

If we plot $\log f$ along the Y-axis and $\log \lambda$ along the X-axis, the curve becomes a straight line. Figure 37 illustrates this graph on full logarithmic paper. The graph may be read with the same accuracy at any point in con-

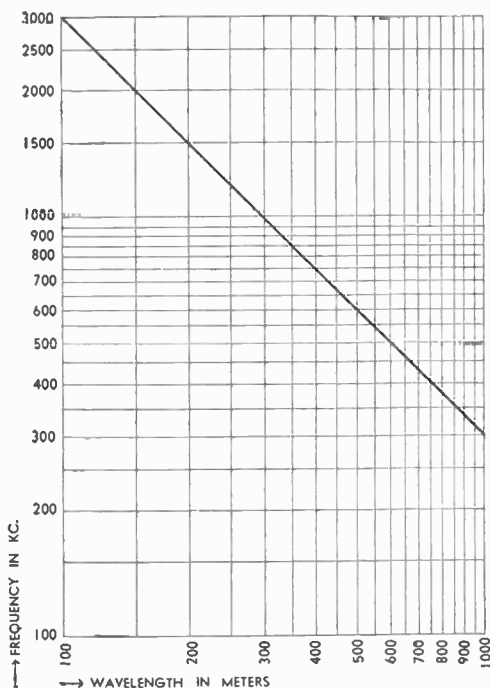

Figure 37.
A LOGARITHMIC CURVE.

Many functions become greatly simplified and some become straight lines when plotted to logarithmic scales such as shown in this diagram. Here the frequency versus wavelength curve of Figure 31 has been replotted to conform with logarithmic axes. Note that it is only necessary to calculate two points in order to determine the "curve" since this type of function results in a straight line.

trast to the graph made with linear coordinates.

This last fact is a great advantage of logarithmic scales in general. It should be clear that if we have a linear scale with 100 small divisions numbered from 1 to 100, and if we are able to read to one tenth of a division, the possible error we can make near 100, way up the scale, is only 1/10th of a percent. But near the beginning of the scale, near 1, one tenth of a division amounts to 10 percent of 1 and we are making a 10 percent error.

In any logarithmic scale, our possible error in measurement or reading might be, say 1/32 of an inch which represents a fixed amount of the log depending on the scale used. The net result of adding to the logarithm a fixed quantity, as 0.01, is that the anti-logarithm is multiplied by 1.025, or the error is 2½%. No matter at what part of the scale the 0.01 is added, the error is always 2½%.

An example of the advantage due to the use

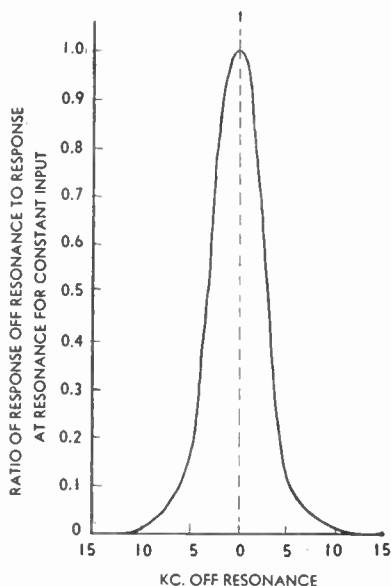

Figure 38.

A RECEIVER RESONANCE CURVE.

This curve represents the output of a receiver versus frequency when plotted to linear coordinates.

of semi-logarithmic paper is shown in Figures 38 and 39. A resonance curve, when plotted on linear coordinate paper will look like the curve in Figure 38. Here we have plotted the output of a receiver against frequency while the applied voltage is kept constant. It is the kind of curve a "wobulator" will show. The curve does not give enough information in this form for one might think that a signal 10 kc. off resonance would not cause any current at all and is tuned out. However, we frequently have off resonance signals which are 1000 times as strong as the desired signal and one cannot read on the graph of Figure 38 how much any signal is attenuated if it is reduced more than about 20 times.

In comparison look at the curve of Figure 39. Here the response (the current) is plotted in logarithmic proportion, which allows us to plot clearly how far off resonance a signal has to be to be reduced 100, 1,000, or even 10,000 times.

Note that this curve is now "upside down"; it is therefore called a *selectivity* curve. The reason that it appears upside down is that the method of measurement is different. In a selectivity curve we plot the increase in signal voltage necessary to cause a standard output off resonance. It is also possible to plot this increase along the Y-axis in decibels; the curve then looks the same although linear paper can

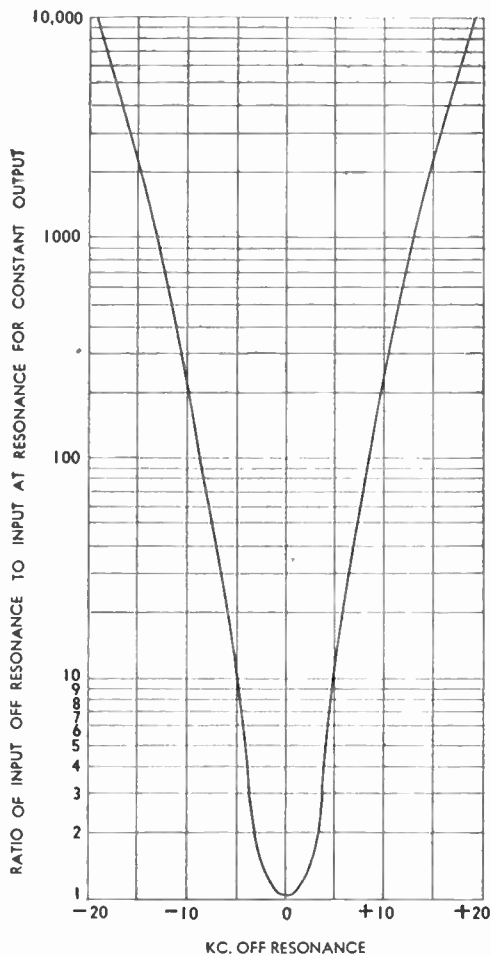

Figure 39.

A RECEIVER SELECTIVITY CURVE.

This curve represents the selectivity of a receiver plotted to logarithmic coordinates for the output, but linear coordinates for frequency. The reason that this curve appears inverted from that of Figure 38 is explained in the text.

be used because now our unit is logarithmic.

An example of full logarithmic paper being used for families of curves is shown in the reactance charts of Figures 40 and 41.

Namagrams or Alignment Charts

An alignment chart consists of three or more sets of scales which have been so laid out that to solve the formula for which the chart was made, we have but to lay a straight edge along the two given values on any two of the scales, to find the third and unknown value on the third scale. In its sim-

Figure 40.
REACTANCE-FREQUENCY CHART FOR AUDIO FREQUENCIES
 See text for applications and instructions for use.

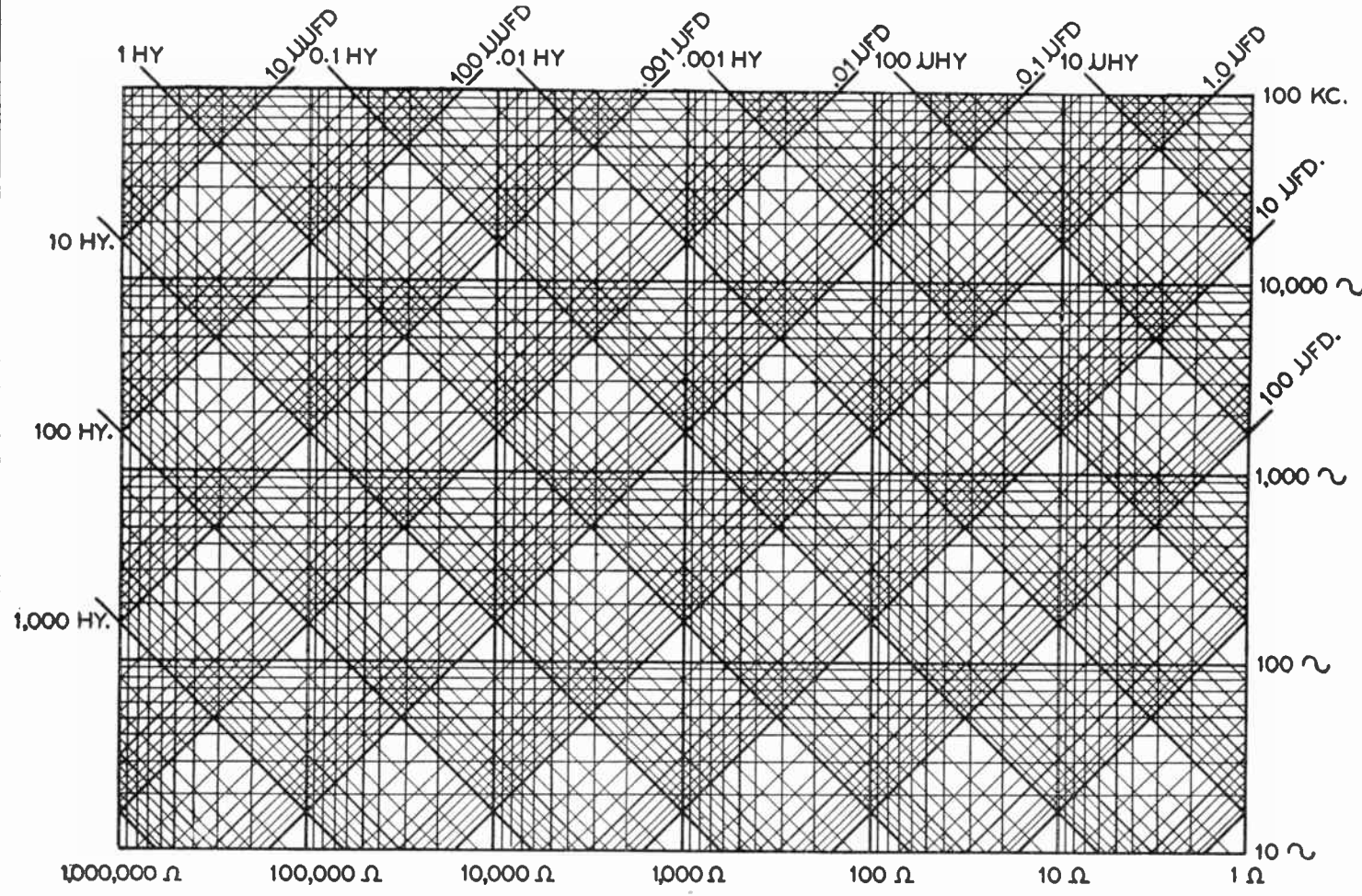

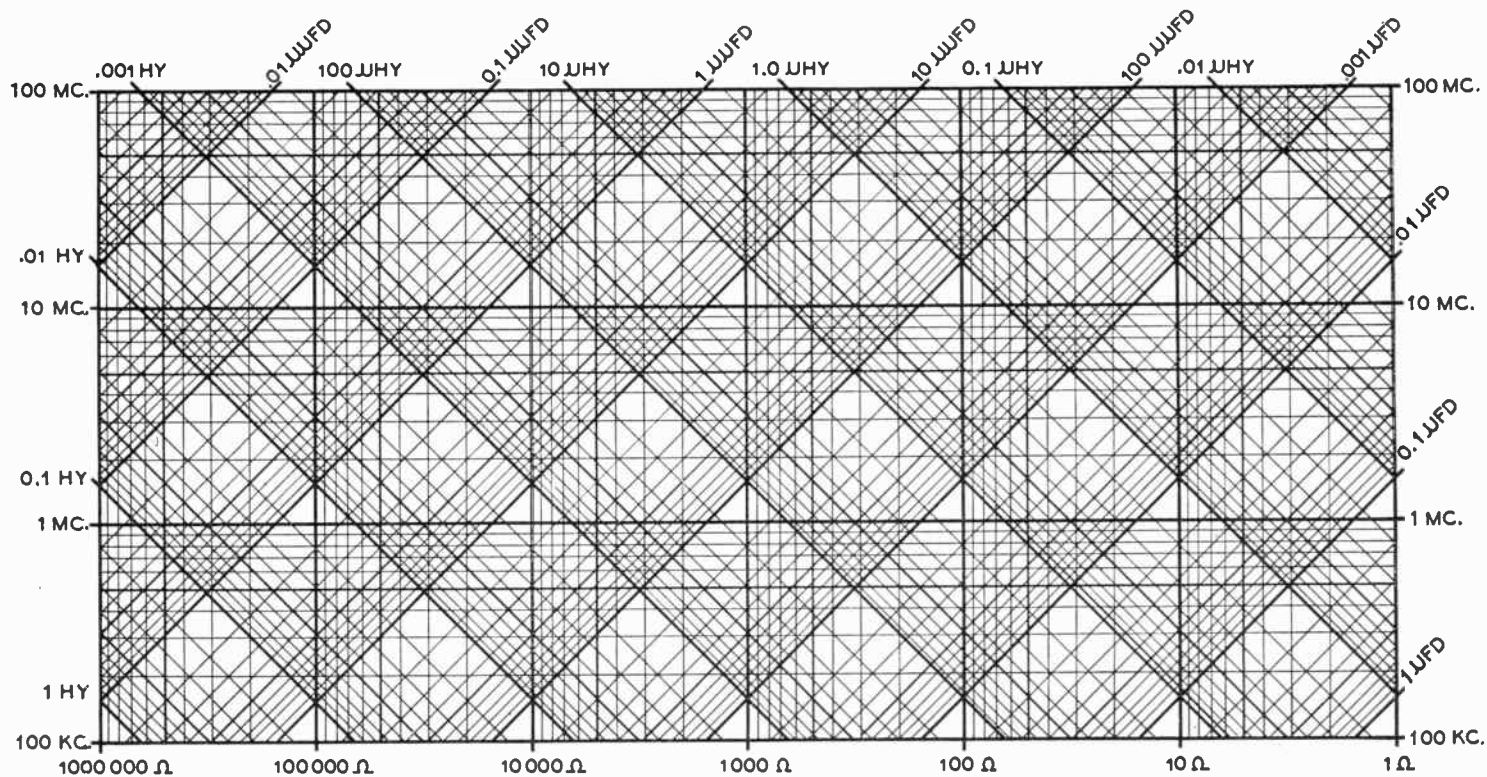

Figure 41.

REACTANCE-FREQUENCY CHART FOR R.F.

This chart is used in conjunction with the nomograph on page 569 for radio frequency tank coil computations.

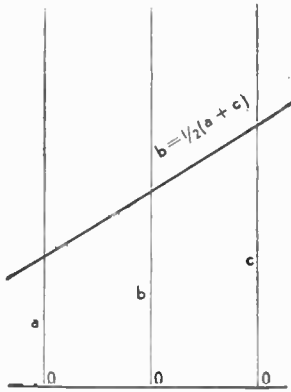

Figure 42.
THE SIMPLEST FORM OF NOMOGRAM.

plest form, it is somewhat like the lines in Figure 42. If the lines a , b , and c are parallel and equidistant, we know from ordinary geometry, that $b = \frac{1}{2}(a + c)$. Therefore, if we draw a scale of the same units on all three lines, starting with zero at the bottom, we know that by laying a straight-edge across the chart at any place, it will connect values of a , b , and c , which satisfy the above equation. When any two quantities are known, the third can be found.

If, in the same configuration we used logarithmic scales instead of linear scales, the relation of the quantities would become

$$\log b = \frac{1}{2}(\log a + \log c) \text{ or } b = \sqrt{ac}$$

By using different kinds of scales, different units, and different spacings between the scales, charts can be made to solve many kinds of equations.

If there are more than three variables it is generally necessary to make a double chart, that is, to make the result from the first chart serve as the given quantity of the second one. Such an example is the chart for the design of coils illustrated in Figure 45. This nomogram is used to convert the inductance in microhenries to physical dimensions of the coil and vice versa. A pin and a straight edge are required. The method is shown under "R. F. Tank Circuit Calculations" later in this chapter.

Polar Coordinates Instead of the Cartesian coordinate system there is also another system for defining algebraically the location of a point or line in a plane. In this, the polar coordinate system, a point is determined by its distance from the origin, O , and by the angle it makes with the axis $O-X$. In Figure 43 the point P is defined by the length of OP , known as the radius vector and

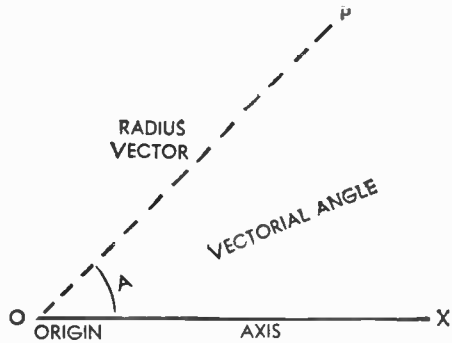

Figure 43.
THE LOCATION OF A POINT BY POLAR COORDINATES.

In the polar coordinate system any point is determined by its distance from the origin and the angle formed by a line drawn from it to the origin and the $O-X$ axis.

by the angle A the vectorial angle. We give these data in the following form

$$P = 3 \angle 60^\circ$$

Polar coordinates are used in radio chiefly for the plotting of directional properties of microphones and antennas. A typical example of such a directional characteristic is shown in Figure 44. The radiation of the antenna represented here is proportional to the distance of the characteristic from the origin for every possible direction.

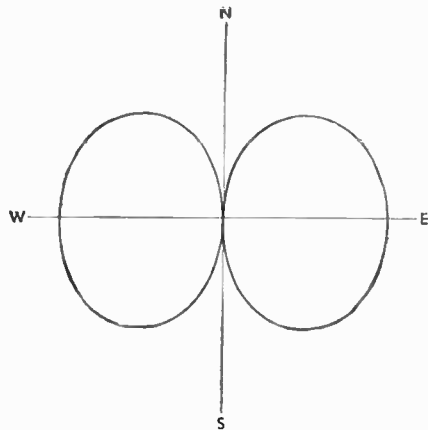

Figure 44.
THE RADIATION CURVE OF AN ANTENNA.

Polar coordinates are used principally in radio work for plotting the directional characteristics of an antenna where the radiation is represented by the distance of the curve from the origin for every possible direction.

Reactance Calculations

In audio frequency calculations, an accuracy to better than a few per cent is seldom required, and when dealing with calculations involving inductance, capacitance, resonant frequency, etc., it is much simpler to make use of reactance-frequency charts such as those on pages 565-566 rather than to wrestle with a combination of unwieldy formulas. From these charts it is possible to determine the reactance of a condenser or coil if the capacitance or inductance is known, and vice versa. It follows from this that resonance calculations can be made directly from the chart, because resonance simply means that the inductive and capacitive reactances are equal. The capacity required to resonate with a given inductance, or the inductance required to resonate with a given capacity, can be taken directly from the chart.

While the chart may look somewhat formidable to one not familiar with charts of this type, its application is really quite simple, and can be learned in a short while. The following example should clarify its interpretation.

For instance, following the lines to their intersection, we see that 0.1 hy. and 0.1 μ fd. intersect at approximately 1,500 cycles and 1,000 ohms. Thus, the reactance of either the coil or condenser taken alone is about 1000 ohms, and the resonant frequency about 1,500 cycles.

To find the reactance of 0.1 hy. at, say, 10,000 cycles, simply follow the inductance line diagonally up towards the upper left till it intersects the horizontal 10,000 kc. line. Following vertically downward from the point of intersection, we see that the reactance at this frequency is about 6000 ohms.

To facilitate use of the chart and to avoid errors, simply keep the following in mind: The vertical lines indicate reactance in ohms, the horizontal lines always indicate the frequency, the diagonal lines sloping to the lower right represent inductance, and the diagonal lines sloping toward the lower left indicate capacitance. Also remember that the scale is *logarithmic*. For instance, the next horizontal line above 1000 cycles is 2000 cycles. Note that there are 9, not 10, divisions between the heavy lines. This also should be kept in mind when interpolating between lines when best possible accuracy is desired; halfway between the line representing 200 cycles and the line representing 300 cycles is *not* 250 cycles, but approximately 230 cycles. The 250 cycle point is approximately 0.7 of the way between the 200 cycle line and the 300 cycle line, rather than halfway between.

Use of the chart need not be limited by the physical boundaries of the chart. For instance, the 10- μ fd. line can be extended to find where

it intersects the 100-hy. line, the resonant frequency being determined by projecting the intersection horizontally back on to the chart. To determine the reactance, the logarithmic ohms scale must be extended.

R. F. Tank Circuit Calculations

When winding coils for use in radio receivers and transmitters, it is desirable to be able to determine in advance the full coil specifications for a given frequency. Likewise, it often is desired to determine how much capacity is required to resonate a given coil so that a suitable condenser can be used.

Fortunately, extreme accuracy is not required, except where fixed capacitors are used across the tank coil with no provision for trimming the tank to resonance. Thus, even though it may be necessary to estimate the stray circuit capacity present in shunt with the tank capacity, and to take for granted the likelihood of a small error when using a chart instead of the formula upon which the chart was based, the results will be sufficiently accurate in most cases, and in any case give a reasonably close point from which to start "pruning."

The inductance required to resonate with a certain capacitance is given in the chart on page 566. By means of the r.f. chart, the inductance of the coil can be determined, or the capacitance determined if the inductance is known. When making calculations, be sure to allow for stray circuit capacity, such as tube interelectrode capacity, wiring, sockets, etc. This will normally run from 5 to 25 micro-microfarads, depending upon the components and circuit.

To convert the inductance in microhenries to physical dimensions of the coil, or vice versa, the nomograph chart on page 569 is used. A pin and a straightedge are required. The inductance of a coil is found as follows:

The straightedge is placed from the correct point on the turns column to the correct point on the diameter-to-length ratio column, the latter simply being the diameter divided by the length. Place the pin at the point on the plot axis column where the straightedge crosses it. From this point lay the straightedge to the correct point on the diameter column. The point where the straightedge intersects the inductance column will give the inductance of the coil.

From the chart, we see that a 30 turn coil having a diameter-to-length ratio of 0.7 and a diameter of 1 inch has an inductance of approximately 12 microhenries. Likewise any one of the four factors may be determined if the other three are known. For instance, to determine the number of turns when the desired in-

Figure 45. COIL CALCULATOR NOMOGRAPH

For single layer solenoid coils, any wire size. See text for instructions.

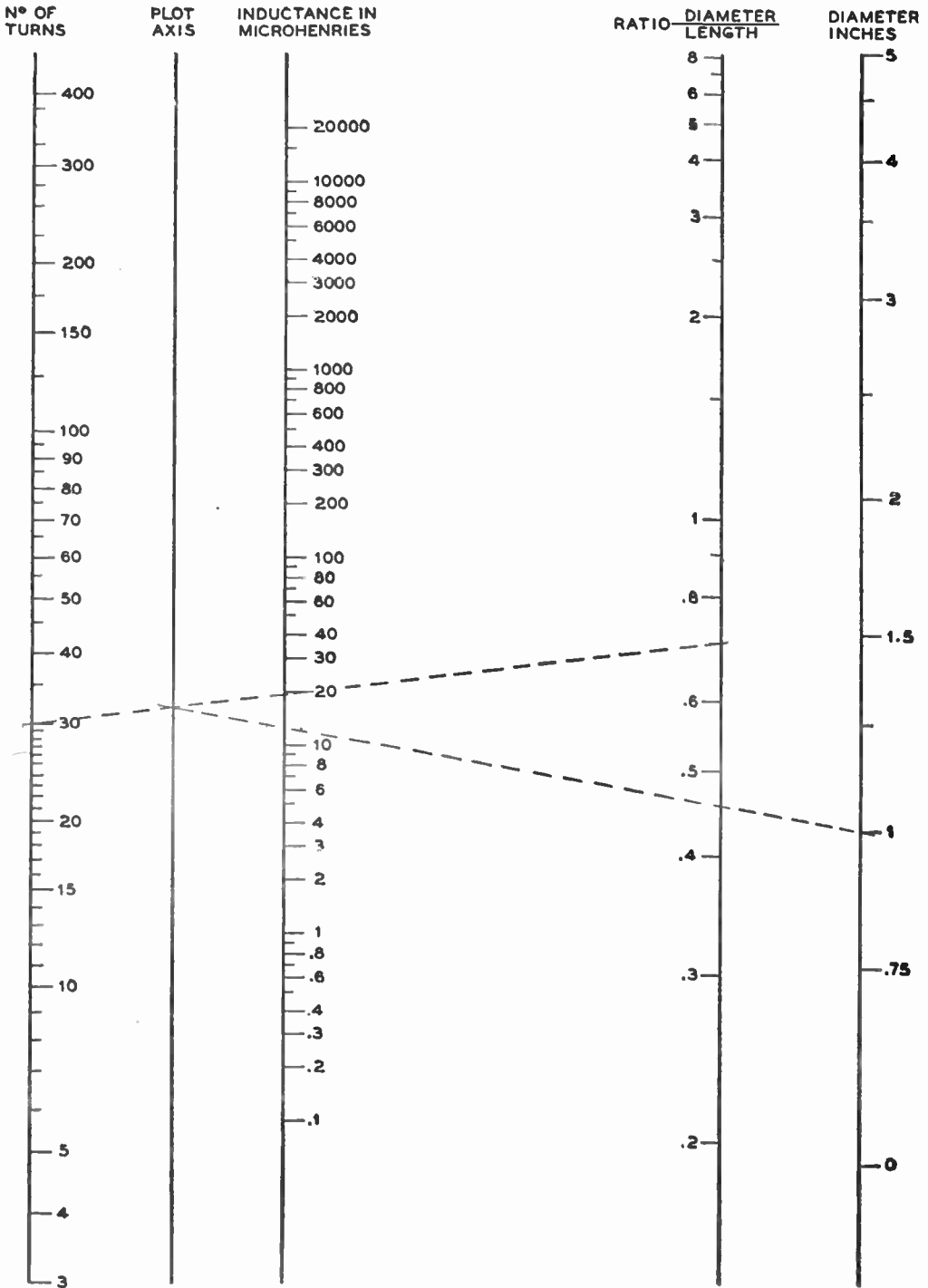

ductance, the D/L ratio, and the diameter are known, simply work backwards from the example given. In all cases, remember that the straightedge reads either turns and D/L ratio, or it reads inductance and diameter. It can read no other combination.

The actual wire size has negligible effect upon the calculations for commonly used wire sizes (no. 10 to no. 30). The number of turns of insulated wire that can be wound per inch (solid) will be found in the copper wire table on page 324.

Significant Figures

In most radio calculations, numbers represent quantities which were obtained by measurement. Since no measurement gives absolute accuracy, such quantities are only approximate and their value is given only to a few significant figures. In calculations, these limitations must be kept in mind and one should not finish for instance with a result expressed in more significant figures than the given quantities at the beginning. This would imply a greater accuracy than actually was obtained and is therefore misleading, if not ridiculous.

An example may make this clear. Many ammeters and voltmeters do not give results to closer than $\frac{1}{4}$ ampere or $\frac{1}{4}$ volt. Thus if we have $2\frac{1}{4}$ amperes flowing in a d.c. circuit at $6\frac{3}{4}$ volts, we can obtain a theoretical answer by multiplying 2.25 by 6.75 to get 15.1875 watts. But it is misleading to express the answer down to a ten-thousandth of a watt when the original measurements were only good to $\frac{1}{4}$ ampere or volt. The answer should be expressed as 15 watts, not even 15.0 watts. If we assume a possible error of $\frac{1}{8}$ volt or ampere (that is, that our original data are only correct to the nearest $\frac{1}{4}$ volt or ampere) the true power lies between 14.078 (product of $2\frac{1}{8}$ and $6\frac{5}{8}$) and 16.328 (product of $2\frac{3}{8}$ and $6\frac{7}{8}$). Therefore, any third significant figure would be misleading as implying an accuracy which we do not have.

Conversely, there is also no point to calculating the value of a part down to 5 or 6 significant figures when the actual part to be used cannot be measured to better than 1 part in one hundred. For instance, if we are going to use 1% resistors in some circuit, such as an ohmmeter, there is no need to calculate the value of such a resistor to 5 places, such as 1262.5 ohm. Obviously, 1% of this quantity is over 12 ohms and the value should simply be written as 1260 ohms.

There is a definite technique in handling these approximate figures. When giving values obtained by measurement, no more figures are

given than the accuracy of the measurement permits. Thus, if the measurement is good to two places, we would write, for instance, 6.9 which would mean that the true value is somewhere between 6.85 and 6.95. If the measurement is known to three significant figures, we might write 6.90 which means that the true value is somewhere between 6.895 and 6.905. In dealing with approximate quantities, the added cipher at the right of the decimal point has a meaning.

There is unfortunately no standardized system of writing approximate figures with many ciphers to the left of the decimal point. 69000 does not necessarily mean that the quantity is known to 5 significant figures. Some indicate the accuracy by writing 69×10^3 or 690×10^2 etc., but this system is not universally employed. The reader can use his own system, but whatever notation is used, the number of significant figures should be kept in mind.

Working with approximate figures, one may obtain an idea of the influence of the doubtful figures by marking all of them, and products or sums derived from them. In the following example, the doubtful figures have been underlined.

$$\begin{array}{r} 603 \\ 34.6 \\ \underline{0.120} \\ 637.720 \end{array} \quad \text{answer: } 638$$

Multiplication:

$$\begin{array}{r} 654 \\ \underline{0.342} \\ 1308 \\ 2616 \\ \underline{1962} \\ 223.668 \end{array} \quad \text{answer: } 224$$

It is recommended that the system at the right be used and that the figures to the right of the vertical line be omitted or guessed so as to save labor. Here the partial products are written in the reverse order, the most important ones first.

In division, labor can be saved when after each digit of the quotient is obtained, one figure of the divisor be dropped. Example:

$$\begin{array}{r} 1.28 \\ 527 \overline{) 673} \\ \underline{527} \\ 53 \overline{) 146} \\ \underline{106} \\ 5 \overline{) 40} \\ \underline{40} \end{array}$$

RADIO SYMBOLS USED IN CIRCUIT DIAGRAMS

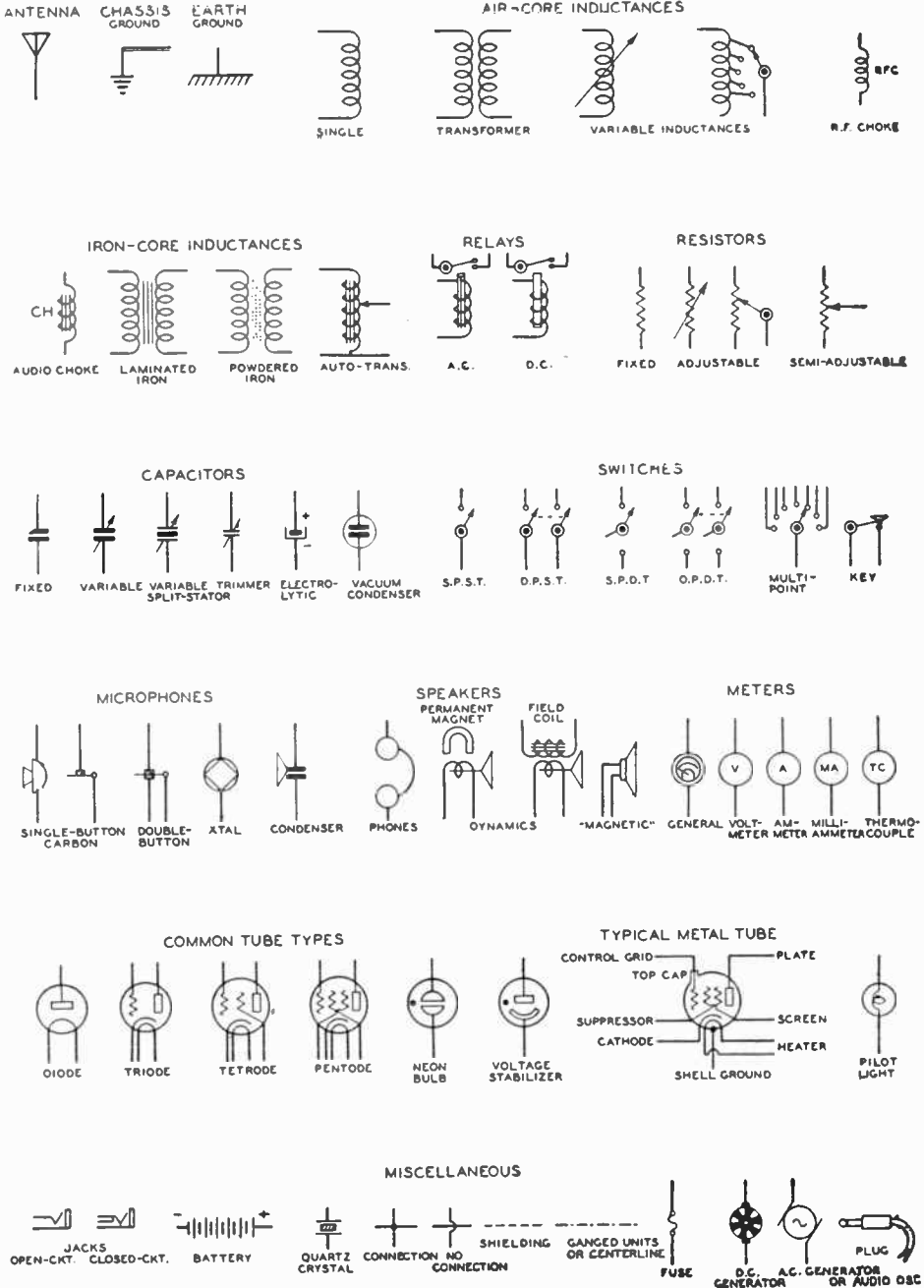

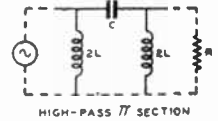
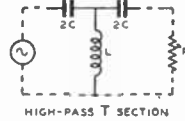
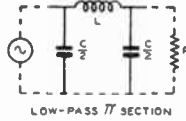
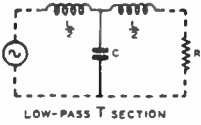

FREQUENCY SCALE
LOW-PASS HIGH-PASS

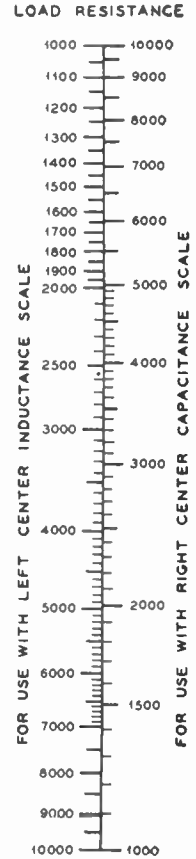
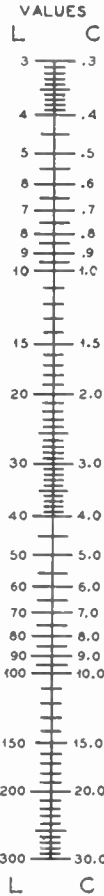
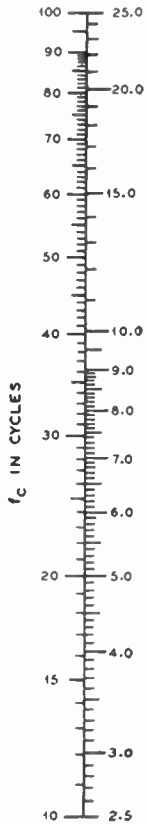

Courtesy, Pacific Radio Publishing Co.

FILTER DESIGN CHART

For both Pi-type and T-type Sections

To find L, connect cut-off frequency on left-hand scale (using left-side scale for low-pass and right-side scale for high-pass) with load on left-hand side of right-hand scale by means of a straight-edge. Then read the value of L from the point where the edge intersects the left side of the center scale. Readings are in henries for frequencies in cycles per second.

To find C, connect cut-off frequency on left-hand scale (using left-side scale for low-pass and right-side scale for high-pass) with the load on the right-hand side of the right-hand scale. Then read the value of C from the point where the straightedge cuts the right side of the center scale. Readings are in microfarads for frequencies in cycles per second.

For frequencies in kilocycles, C is expressed in thousands of micromicrofarads, L is expressed in millihenries. For frequencies in megacycles, L is expressed in microhenries and C is expressed in micromicrofarads.

For each tenfold increase in the value of load resistance multiply L by 10 and divide C by 10. For each tenfold decrease in frequency divide L by 10 and multiply C by 10.

THE "Q" SIGNALS

| <i>Abbreviation</i> | <i>Question</i> | <i>Answer</i> |
|---------------------|--|---|
| QRA | What is the name of your station? | The name of my station is |
| QRB | How far approximately are you from my station? | The approximate distance between our stations is nautical miles (or kilometers). |
| QRC | What company (or Government Administration) settles the accounts for your station? | The accounts for my station are settled by the company (or by the Government Administration of). |
| QRD | Where are you bound and where are you from? | I am bound for from |
| QRG | Will you tell me my exact frequency (wavelength) in kc/s (or m)? | Your exact frequency (wavelength) is kc/s (or m). |
| QRH | Does my frequency (wavelength) vary? | Your frequency (wavelength) varies. |
| QRI | Is my note good? | Your note varies. |
| QRJ | Do you receive me badly? Are my signals weak? | I cannot receive you. Your signals are too weak. |
| QRK | Do you receive me well? Are my signals good? | I receive you well. Your signals are good. |
| QRL | Are you busy? | I am busy (or I am busy with). Please do not interfere. |
| QRM | Are you being interfered with? | I am being interfered with. |
| QRN | Are you troubled by atmospherics? | I am troubled by atmospherics. |
| QRO | Shall I increase power? | Increase power. |
| QRP | Shall I decrease power? | Decrease power. |
| QRQ | Shall I send faster? | Send faster (..... words per minute). |
| QRR | | Amateur "SOS" or distress call (U.S.A.). Use only in serious emergency. |
| QRS | Shall I send more slowly? | Send more slowly (..... words per minute). |
| QRT | Shall I stop sending? | Stop Sending. |
| QRU | Have you anything for me? | I have nothing for you. |
| QRV | Are you ready? | I am ready. |
| QRW | Shall I tell that you are calling him on kc/s (or m)? | Please tell that I am calling him kc/s (or m). |
| QRX | Shall I wait? When will you call me again? | Wait (or wait until I have finished communicating with). I will call you at o'clock (or immediately). |
| QRY | What is my turn? | Your turn is No. (or according to any other method of arranging it). |
| QRZ | Who is calling me? | You are being called by |
| QSA | What is the strength of my signals (1 to 5)? | The strength of your signals is ... (1 to 5). |
| QSB | Does the strength of my signals vary? | The strength of your signals varies . |
| QSD | Is my keying correct; are my signals distinct? | Your keying is incorrect; your signals are bad. |
| QSG | Shall I send telegrams (or one telegram) at a time? | Send telegrams (or one telegram) at a time. |
| QSJ | What is the charge per word for including your internal telegraph charge? | The charge per word for is francs, including my internal telegraph charge. |
| QSK | Shall I continue with the transmission of all my traffic; I can hear you through my signals? | Continue with the transmission of all your traffic; I will interrupt you if necessary. |
| QSL | Can you give me acknowledgment of receipt? | I give you acknowledgment of receipt. |
| QSM | Shall I repeat the last telegram I sent you? | Repeat the last telegram you have sent me. |
| QSO | Can you communicate with direct (or through the medium of)? | I can communicate with direct (or through the medium of). |
| QSP | Will you retransmit to free of charge? | I will retransmit to free of charge. |
| QSR | Has the distress call received from been cleared? | The distress call received from has been cleared by |
| QSU | Shall I send (or reply) on kc/s (or m) and/or on waves of Type A1, A2, A3, or B? | Send (or reply) on kc/s (or m) and/or on waves of Type A1, A2, A3, or B. |
| QSV | Shall I send a series of V V V ? | Send a series of V V V |

| <i>Abbreviation</i> | <i>Question</i> | <i>Answer</i> |
|---------------------|---|---|
| QSW | Will you send on kc/s (or m) and/or on waves of Type A1, A2, A3 or B? | I am going to send (or I will send) on kc/s (or m) and/or on waves of Type A1, A2, A3 or B. |
| QSX | Will you listen for (call sign) on kc/s (or m)? | I am listening for (call sign) on kc/s (or m). |
| QSY | Shall I change to transmission on kc/s or m) without changing the type of wave? or Shall I change to transmission on another wave? | Change to transmission on kc/s (or m) without changing the type of wave. or Change to transmission on another wave. |
| QSZ | Shall I send each word or group twice? | Send each word or group twice. |
| QTA | Shall I cancel telegram No. as if it had not been sent? | Cancel telegram No. as if it had not been sent. |
| QTB | Do you agree with my number of words? | I do not agree with your number of words; I will repeat the first letter of each word and the first figures of each number. |
| QTC | How many telegrams have you to send? | I have telegrams for you (or for). |
| QTE | What is my true bearing in relation to you? or What is my true bearing in relation to (call sign)? or What is the true bearing of (call sign) in relation to (call sign)? | Your true bearing in relation to me is degrees or Your true bearing in relation to (call sign) is degrees at (time). or The true bearing of (call sign) in relation to (call sign) is degrees at (time). |
| QTF | Will you give me the position of my station according to the bearings taken by the direction-finding stations which you control? | The position of your station according to the bearings taken by the direction-finding stations which I control is latitude longitude. |
| QTG | Will you send your call sign for fifty seconds followed by a dash of ten seconds on kc/s (or m) in order that I may take your bearing? | I will send my call sign for fifty seconds followed by a dash of ten seconds on kc/s (or m) in order that you may take my bearing. |
| QTH | What is your position in latitude and longitude (or by any other way of showing it)? | My position is latitude longitude (or by any other way of showing it). |
| QTI | What is your true course? | My true course is degrees. |
| Q TJ | What is your speed? | My speed is knots (or kilometers) per hour. |
| QTM | Send radioelectric signals and submarine sound signals to enable me to fix my bearing and my distance. | I will send radioelectric signals and submarine sound signals to enable you to fix your bearing and your distance. |
| QTO | Have you left dock (or port)? | I have just left dock (or port). |
| QTP | Are you going to enter dock (or port)? | I am going to enter dock (or port). |
| Q TQ | Can you communicate with my station by means of the International Code of Signals? | I am going to communicate with your station by means of the International Code of Signals. |
| QTR | What is the exact time? | The exact time is |
| QTU | What are the hours during which your station is open? | My station is open from to |
| QUA | Have you news of (Call sign of the mobile station)? | Here is news of (call sign of the mobile station). |
| QUB | Can you give me in this order, information concerning: visibility, height of clouds, ground wind for (place of observation)? | Here is the information requested..... |
| QUC | What is the last message received by you from (call sign of the mobile station)? | The last message received by me from (call sign of the mobile station) is..... |
| QUD | Have you received the urgency signal sent by (call sign of the mobile station)? | I have received the urgency signal sent by (call sign of the mobile station) to (time). |
| QUF | Have you received the distress signal sent by (call sign of the mobile station)? | I have received the distress signal sent by (call sign of the mobile station) at (time). |
| QUG | Are you being forced to alight in the sea (or to land)? | I am forced to alight (or land) at (place). |
| QUH | Will you indicate the present barometric pressure at sea level? | The present barometric pressure at sea level is (units). |
| QUJ | Will you indicate the true course for me to follow, with no wind, to make for you? | The true course for you to follow, with no wind, to make for me is degrees at (time). |

Buyer's Guide

Parts Required for Building Equipment Shown in This Book

The parts listed are some of those actually used by our laboratory in constructing the models shown. Other parts of equal merit and equivalent electrical characteristics may usually be substituted without materially affecting the performance of the units.

CHAPTER 6 Radio Receiver Construction

Figure 3, page 140
Two-Tube Autodyne

C₁—Hammarlund SM-15
C₂—Hammarlund SM-100
C₃, C₇—Solar type MT
C₄, C₆—Solar "Sealdtite"
R₁—Centralab 710
R₂—Centralab "Radiohm"
R₃, R₄—Centralab 514
BC—Mallory 1.25 v.
CH—Stancor type C-2300
Panel—Bud PS1201
Tuning dial—Bud D-103B

Figure 8, page 142
Three-Tube Simple Super

C₁, C₂—Hammarlund MC-50-S
C₃—Hammarlund MC-140-S
C₄, C₅, C₁₁, C₁₄—Cornell-Dubilier DT-4P1
C₆, C₉—Cornell-Dubilier DT-4T1
C₇, C₁₂—Cornell-Dubilier DT-4S1
C₁₀—Cornell-Dubilier DT-4D1
C₁₃—Cornell-Dubilier BR-252
C₁₅—Cornell-Dubilier EDJ-9040
R₁, R₂, R₄, R₇, R₉—Centralab 516
R₃, R₆—Centralab 514
R₈—Yaxley L
R₅, R₁₁—Ohmite "Brown Devil"
IFT—Meissner 16-8092
CH—Stancor C-2300
J—Mallory-Yaxley 705
Dial—Crowe 123M

Figure 11, page 146
Economical 5-Tube Super

C₁, C₂—Cardwell ZR-50-AS
C₃—Cardwell ZR-25-AS
C₄—Cardwell ZU-140-AS
C₅, C₇, C₈, C₉, C₁₀, C₁₁, C₁₄, C₁₇—Cornell-Dubilier DT-4P1
C₆, C₁₃—Cornell-Dubilier SW-5T1
C₁₂—Cornell-Dubilier SW-5TS
C₁₅—Cornell-Dubilier BR-845
C₁₆—Cornell-Dubilier BR-102-A
R₁, R₂, R₇, R₉, R₁₁, R₁₃, R₁₄—Centralab 710
R₃—Centralab 516
R₄, R₁₀—Centralab 514
R₅, R₆—Mallory-Yaxley G
R₈—Ohmite "Brown Devil"
IFT₁—Meissner 8091
IFT₂—Meissner 8099
Tubes—RCA

Figure 13, page 147
6K8-6J5 Converter

C₁—National ST-50
C₂—National ST-100

C₃—National ST-35
C₄, C₇, C₈, C₁₁—Aerovox 1467
C₅, C₆, C₉—Aerovox 484
R₁, R₃, R₄, R₅, R₆—Centralab 710
R₂—Centralab 514
S—Bud SW-1115
L₁, L₂ Forms—Bud S95
IFT—Meissner 16-8100
BOT—Meissner 17-8175
Chassis—Bud CB-41
Cabinet—Bud C-973
Dial—National "B"

Figure 17, page 151
High-Performance Converter

C₁, C₂, C₃—Bud 1852
C₄, C₅—Sprague 45-12
C₆—Bud LC-1682, 1683
C₇, C₈, C₉, C₁₂, C₁₃, C₁₅—Aerovox 484
C₁₁, C₁₄—Aerovox 1467
R₁—Centralab 62-113
R₂, R₃, R₄, R₇, R₈, R₉—Centralab 710
R₅, R₆—Ohmite "Brown Devil"
S₂—Centralab 1462
T—Thordarson T-13R12
CH—Thordarson T-13C27
Coil forms—Bud 126
Tubes—RCA
Chassis—Bud 793
Shield partitions—Bud 1246, see text

Figure 19, page 153
Variable-Selectivity Crystal Filter

C₁, C₂—Aerovox 1467
C₃, C₆—Hammarlund APC
C₄, C₇, C₈—Aerovox 484
C₅—Sprague SM-31
R₁, R₂—Centralab 710
T₁, T₂—Made from Meissner 16-5740 or 16-6131, see text
X—Bliley CF-1
Cabinet—Bud 728

Figure 23, page 157
High-Gain Preselector

C₁, C₂—Bud MC-903
C₃—Cornell-Dubilier DT-4P1
C₄, C₅—Cornell-Dubilier DT-4S1
R₁—Centralab 514
R₂—Centralab 710
R₃—Centralab 72-113
R₄—Centralab 514
Coil sockets—Hammarlund S-5
Coil forms—Hammarlund CF-5-M and SWF-5

CHAPTER 12

Exciters and Low Powered Transmitters

Figure 2, page 277

One-Tube Exciter

C₁, C₂—Cardwell ZR-50-AS

C₂, C₃—Aerovox 1450
 C₄, C₅, C₇—Aerovox 684
 R₁—Centralab 516
 R₂, R₃, R₄—Ohmite "Brown Devil"
 RFC—Bud 920
 X—Bliley LD2
 Coil forms—Hammarlund XP-53
 Tube—Taylor T21

Figure 3, page 277

Power Supply for Figure 2

T—Thordarson T-13R13
 CH—Thordarson T-57C53
 C—Sprague LR-88
 R—Ohmite "Brown Devil"

Figure 5, page 278

160-Meter 5-Watt V.F.O.

C₁—National STH-335
 C₂—National SS-150
 C₃—Sprague SM-31
 C₄, C₅, C₇—Sprague 1FM26
 C₆, C₇, C₈—Sprague TC-15
 R₁—Centralab 710
 R₂, R₃, R₄—Centralab 714
 RFC—National R-100
 Coil form—National XR-13
 Dial—National type ACN

Figure 11, page 282

Shuart 25-Watt V.F.O.

Osc. grid tank—Hammarlund ECO-160
 Osc. plate tank—Hammarlund ETU-80
 Buffer tank—Hammarlund 6014
 C₁—Hammarlund MC-140-S
 C₂—Hammarlund MC-100-S
 RFC—Hammarlund CHX
 L₁ coil forms—Hammarlund SWF-5
 807 Shield—Hammarlund PTS
 Ceramic sockets—Hammarlund type S
 T—Thordarson type 75R50
 CH—Thordarson 75C51
 Dial—National type N
 Tubes—RCA throughout

Figure 14, page 284

Cascade Frequency Multiplier

C₁, C₂—Cardwell ZR-35-AS
 C₃, C₄—Cardwell ZR-25-AS
 C₅ to C₇—Solar type MW
 R₁ to R₄—Centralab 516
 R₅—Ohmite "Brown Devil"
 S₁—Bud SW-1005
 S₂—Centralab 1405
 Chassis—Bud CB-997
 Panel—Bud PS-1202
 Tubes—RCA throughout

Figure 17, page 285

807 Utility Unit

C₁—Hammarlund MC-100M
 C₂—Hammarlund MTC-350C
 C₃, C₄—Cornell-Dubilier 1-W
 C₅—Cornell-Dubilier DT-451
 C₆—Cornell-Dubilier type 4-12050
 R₁—Centralab 714
 R₂, R₃, R₄—Ohmite "Brown Devil"
 T—Thordarson 19F81
 Coils—Bud OEL

Sockets—Johnson 225
 Crystal—Bliley BC3
 807—General Electric
 RFC—Bud CH9205

Figure 23, page 289

814 Bandswitching Exciter

R₁, R₇, R₁₁—Ohmite "Brown Devil"
 R₁₂, PC—Ohmite P-300
 C₁—Cardwell EU-140-AD
 C₂—Cardwell EU-100-AD
 C₃—Cardwell MT-100-GS
 C₄ to C₁₃—Solar MO and MW
 C₁₄—Solar XM-25-22
 C₁₅—Cardwell JD-50-OS
 T₁—Kenyon T-351
 T₂—Kenyon T-365
 Coil turret—Barker & Williamson type 2-A
 S₁—Centralab 1461
 S₂—Centralab 1460
 S₃—Heintz & Kaufman 892
 S₄—Mallory-Yaxley 151-L
 Chassis—Par-Metal C-4526
 Panel—Par-Metal G-3606
 Crystals—Bliley B5 and LD2
 Tubes—RCA throughout

CHAPTER 13

Medium and High Power
R.F. Amplifiers

Figures 2 and 3, pages 295 and 296

C₁—National TMS-50D
 C₂—National TMH-75D
 C₃, C₄—National NC-75
 C₅, C₆—Solar MW-1235
 C₇—Solar XM-25-22
 R₁—Ohmite "Brown Devil"
 L₁—National AR-16 series
 L₂—Socket—National XB-16
 L₃—Plug—National PB-15
 L₄—Socket—National XB-15
 RFC—National R-154U
 Tube sockets—National CIR-4
 Tube caps—National SPP-9
 Dials—National "O"
 Chart frame—National, size "B"
 Chassis—Par-Metal C-4528
 Panel—Par-Metal 3604
 Feed-through insulators—Johnson 50
 Tubes—RCA

Figures 1 and 4, pages 293 and 297

400-Watt Amplifier

C₁—Hammarlund MCD-100-S
 C₂—Hammarlund HFBD-65-E
 C₃, C₄—Hammarlund N-10
 C₅, C₆—Aerovox 1450
 L₁—Barker & Williamson MCL series
 L₂—Barker & Williamson TVL series
 Tubes—Eimac

Figures 1 and 5, pages 293 and 298

C₁—Johnson 150FD20
 C₂—Johnson 150DD70
 C₃, C₄—Johnson 6G70
 RFC—Johnson 752
 Tube sockets—Johnson 211
 L₁ socket—Johnson 225

L₂ supports—Johnson 67
 L₂ coil jacks—Johnson type 70
 L₂ coil plugs—Johnson type 71
 Control handles—Johnson 204
 Tubes—H & K type HK-254

Figures 1 and 6, pages 293 and 299

1-Kw. Amplifier

C₁—Bud 1576
 C₂—Bud 1818
 C₃, C₄—Bud 1000
 C₅, C₆—Solar XM-6-24
 L₁—Bud VCL series
 L₂—Bud MCL series
 RFC—Bud 568
 Sockets—Bud 226
 Tubes—Taylor

Figures 7, 8, and 9, pages 300 and 301

Single-Ended Amplifier

C₁—Cardwell MT-100-G5
 C₂—Cardwell XG-50-XD
 C₃—Bud 1519
 C₄, C₅, C₆—Aerovox 1450
 C₇—Aerovox 1457
 L₁—Barker & Williamson BL series
 L₂—Barker & Williamson HDVL series
 R—Ohmite 50 Watt
 RFC—Hammarlund CH-500
 T—Thordarson T-19F96
 Socket—Johnson 213

CHAPTER 14

Speech and Modulation Equipment

Figure 3, page 304

25-Watt Modulator

Tubular condensers—Aerovox 484
 C₂, C₃—Aerovox PRS450 12 μfd.
 C₇—Aerovox 1467 mica
 C₅, C₇—Aerovox PB-10-10 25 volt
 C₆—Aerovox 600-LU 4 μfd.
 C₁—Aerovox GL-475 8 μfd.
 Carbon resistors—Centralab 1 watt
 Wirewound resistors—Ohmite "Brown Devil"
 R₇—Mallory-Yaxley M control
 T₁—Stancor A-4721
 T₂—Stancor A-3892
 T₃—Stancor P-3005
 CH—Stancor C-1001
 Bias cell—Mallory-Yaxley
 Tubes—RCA throughout

Figure 5, page 306

60-Watt T-21 Modulator

C₁, C₄—Solar S-0240
 C₂—Solar S-0215
 C₃, C₇—Solar S-0263
 C₅, C₁₃, C₁₄, C₁₅—Solar LG5 8-8
 C₂₁, C₁₂—Solar M116
 C₈—Solar M010
 R₁—Centralab 72-116
 All 1/2-watt resistors—Centralab 710
 All 1-watt resistors—Centralab 714
 R₁₆, R₁₀, R₂₁—Centralab 516
 R₁₇, R₁₈, R₁₉, R₂₀—Ohmite "Brown Devil"
 BC—Mallory-Yaxley Bias Cell
 T₁—Thordarson T-84D59
 T₂—Thordarson T-11M75

T₃—Thordarson T-79F84
 T₄—Thordarson T-84P60
 CH₁—Thordarson T-75C49
 CH₂—Thordarson T-75C51
 CH₃—Thordarson T-68C07
 Tubes—RCA 6J5, 6L7, 83, 45. Taylor T-21

Figure 8, page 308

6-Watt 6L6 Grid Modulator

C₁, C₄, C₅—Cornell-Dubilier EDJ-3100
 C₂, C₃, C₆—Cornell-Dubilier BR-845
 C₇—Cornell-Dubilier DT-681
 C₈—Cornell-Dubilier DT-4P1
 C₉—Cornell-Dubilier SM-6S5
 1-watt resistors—Centralab 714
 1/2-watt resistors—Centralab 710
 R₁₂, R₁₃, R₁₄—Ohmite "Brown Devil"
 R₁₀—Centralab 72-105 potentiometer
 T₁—Stancor A-4406
 T₂—Stancor P-3005
 CH—Stancor C-1421
 Feed-thru insulators—Bud I-436
 Chassis—Bud CB-1194
 Pilot light—Mallory-Yaxley 310R
 Tubes—RCA throughout

Figure 10, page 310

Push-Pull 2A3 Amplifier-Driver

C₁, C₃, C₅—Aerovox 484
 C₂, C₄—Aerovox PBS-25 10
 C₆, C₇—Aerovox PBS-5 8-8
 C₈, C₉—Aerovox WG-5 8
 R₁, R₂, R₃, R₄—Centralab 710
 R₅—Centralab 72-105
 R₆—Centralab 710
 R₇, R₈—Ohmite "Brown Devil"
 Input trans.—Stancor A-72-C
 T—Stancor P-4049
 CH—Stancor C-1421
 Tubes—RCA throughout

Figure 13, page 311

Class B 809 Modulator

T₁—Stancor A-4762
 T₂—Stancor A-3894
 T₃—Stancor P-3064
 Tubes—General Electric

Figure 17, page 315

TZ-40 Modulator

T₁—Thordarson 81D42
 T₂—Thordarson 15D79
 T₃—Thordarson 11M77
 T₄—Thordarson 70R62
 T₅—Thordarson 16F13
 CH₁—Thordarson 74C29
 CH₂—Thordarson 13C28
 All tubular condensers—Cornell-Dubilier DT
 All filter condensers—Cornell-Dubilier EDJ
 Tubes—RCA. TZ-40's Taylor

Figure 19, page 317

203Z Modulator

All tubular condensers—Cornell-Dubilier DT
 All resistors—I.R.C. BT-1/2 and BT-1
 R₇—Mallory-Yaxley O control
 R₁₄—Mallory-Yaxley Y50MP
 T₁—Thordarson T-57A41
 T₂—Thordarson T-75D10

T₃—Thordarson T-11M77
 T₄—Thordarson T-19F96
 203Z—Taylor, Rest—RCA
 Sockets for 203Z—Johnson 211

CHAPTER 15 Power Supplies

Figure 14, page 328

Voltage Regulated Power Supply

C₁—Solar M-508
 C₂—Solar M-408
 R₁—Centralab 710
 R₂, R₃, R₄, R₅—Centralab 714
 R₆—Centralab 72-115
 T—Thordarson T-13R14
 CH—Thordarson T-57C53
 Tubes—RCA

Figure 16, page 329

Voltage Regulated Bias Pack

C₁, C₂, C₃, C₄—Solar DAA-704
 R₁—Centralab 72-103
 R₂, R₃, R₄, R₅, R₆, R₇—Centralab 710
 R₈, R₉—Centralab 714
 T—Thordarson T-13R19
 S₂—Centralab 1401

Figure 28, page 334

350-Volt Power Supply

T—Thordarson T-13R14
 CH—Thordarson T68C07
 C—Cornell-Dubilier EH-9808
 R—Ohmite "Brown Devil"
 83—Hytron

Figure 31, page 335

500-Volt Power Supply

Transformers—Stancor P-3699 and P-5009
 Chokes—Stancor C-1401 and C-1411
 Condensers—Cornell-Dubilier TLA-6040
 83—Hytron

Figure 32, page 336

Rack Mounted Supply

Transformers—Kenyon T-line
 Chokes—Kenyon T-line
 Bleeders—Ohmite "Dividohm"
 866's—General Electric
 Condensers—Cornell-Dubilier TJU-200-20 and PE-CH-4008

Figure 35, page 337

1500-Volt Power Supply

T₁—Kenyon T-672
 T₂—Kenyon T-360
 CH₁—Kenyon T-512
 CH₂—Kenyon T-176
 C₁, C₂—General Electric 26F194
 866A/866's—General Electric
 R—Ohmite 0924

Figure 36, page 339

Modulator and Power Supply

Transformers—Kenyon T-line
 Chokes—Kenyon T-line
 TZ-40's—Taylor
 866's—Taylor

Condensers—Aerovox

Figure 37, page 341

Dual Power Supply

Transformers and Chokes—Thordarson "19" type
 Tubes—GL-866 and RCA 83
 Condensers—Mallory

Figure 38, page 342

Compact Power Supply

Transformers and Chokes—Thordarson "CHT" type
 Condensers—Aerovox
 Bleeders—Ohmite "Dividohm"
 Tubes—RCA-866

CHAPTER 16 Transmitter Construction

Figure 3, page 347

Exciter-Transmitter R.F. Section

C₁, C₂—Hammarlund MC-325-M
 C₃—Hammarlund MTCD-25-C
 C₄, C₅, C₆—Sprague TC-11
 C₇—Sprague 1FM-21
 C₈, C₉, C₁₀, C₁₁—Sprague 1FM-24
 C₁₀—Sprague 1-FM-35
 R₁, R₂, R₃, R₄—Ohmite "Brown Devil"
 R₅, R₆, R₇—Centralab 516
 RFC₁, RFC₂, RFC₃—Hammarlund CHX
 S₁—Centralab 1462
 X—Bliley LD2
 6L6's—RCA
 HY69—Hytron
 Bias battery—Burgess B30
 Coil turret—Bud XCS-1
 Chassis—Bud 772
 Panel—Bud 1254
 Panel brackets—Bud 460
 Cabinet—Bud CR-1743

Figure 6, page 349

Speech Amplifier-Modulator

C₁—Sprague 2FM-31
 C₂, C₃—Sprague TA-10
 C₄—Sprague TC-11
 C₅—Sprague TC-2
 C₆, C₇, C₁₁—Sprague UT-8
 C₈, C₉—Sprague TC-15
 C₁₀—Sprague TA-510
 R₁ to R₆, inclusive—Centralab 710
 R₇, R₈, R₉—Centralab 714
 R₁₀—Centralab 72-121
 R₁₁, R₁₂—Centralab 516
 R₁₃—Ohmite "Brown Devil"
 T₁—Kenyon T-254
 T₂—Kenyon T-493
 T₃—Driver transformer—Kenyon T-271
 Tubes—RCA throughout
 Chassis—Bud CB-1762
 Panel—Bud 1254

Figure 7, page 350

Power Supply

T₁—Kenyon T-655 (Use "low" pri. tap)
 T₂—Kenyon T-367
 CH₁, CH₂—Kenyon T-153
 CH₃—Kenyon T-152
 C₁, C₂—Sprague PC-46

C₃, C₄—Sprague SC-8
 C₅—Sprague UT-161
 R₁, R₂—Centralab 516
 R₃, R₄—Ohmite "Brown Devil"
 Tubes—Hytron

Figure 9, page 351

R. F. Amplifier and Modulator

C₁—Bud 912
 C₂—Bud BC-1629
 C₃, C₄, C₅—Aerovox 1450
 C₆, C₇—Bud MC-567
 C₈—Aerovox 1457
 C₉, C₁₀—Aerovox 1509
 R₁, R₂—Ohmite "Brown Devil"
 R₃, R₄, R₅—Centralab 714
 RFC—Bud 569
 L₁—Bud OLS series
 L₂—Bud VLS series
 L₃—Coupling and jack assembly—Bud AM-1352
 T₁—Stancor A-3894
 T₂—Stancor P-6309
 T₃—Stancor P-3060
 T₄—Stancor P-6152
 RY—Staco T-10E
 S₁—Centralab 2542
 S₂—Bud 1270
 PC—Ohmite P-300
 811's—General Electric
 812's—General Electric
 R.F. Chassis—Bud 643
 R.F. Panel—Bud 1257
 Modulator and Power Supply:
 Chassis—Bud CB-1762
 Panel—Bud 1256
 Cabinet—Bud CR-1744
 812, 866 Sockets—Johnson 210
 Feed-through insulators—Johnson 44
 866's—General Electric

Figure 16, page 356

150-Watt C.W. Transmitter

C₁—Bud MC-905
 C₂—Bud JC-1534
 C₃—Bud MC-907
 C₄, C₅, C₆, C₇, C₈, C₉, C₁₀, C₁₁, C₁₂, C₁₃—Aerovox 1467
 C₁₄—Aerovox 484
 C₁₅, C₁₆—Aerovox 1450
 C₁₇—Aerovox 1446
 C₁₈, C₁₉—Aerovox PBS450
 C₂₀—General Electric 23F71
 C₂₁—Bud MC-567
 R₁, R₂, R₃, R₄—Centralab 514
 R₅, R₆, R₇, R₈—Ohmite "Brown Devil"
 R₉, R₁₀—Centralab 516
 R₁₁, R₁₂—Ohmite 0585
 R₁₃—Centralab 514
 T₁—Inca J-13
 T₂—Inca B-46
 T₃—Inca J-31
 CH₁—Inca D-40
 CH₂—Inca D-2
 S₁—Bud SW-1270
 S₂—Bud SW-1115
 S₃—Bud SW-1119
 S₄—Mallory 151-L
 S₅—Centralab 1405
 L₂, L₃ Forms—Bud CF-126
 L₄, L₅—Bud RCL series
 L₆ Forms—Bud CF-595

X—Bliley LD2 and B5
 RFC—Bud CH-9205
 Cabinet—Bud CR-1742
 Panel—Bud PS-616
 Chassis—Bud CB-662
 Feed-through insulators—Johnson 42
 SZ3's—RCA
 807 and 812—General Electric

Figure 24, page 362

250-Watt 'Phone-C.W. Transmitter

C_A—Cardwell XG-50-XD
 C₁, C₂—Cardwell ZR-50-AS
 C₃—Cardwell ZR-35-AS
 C₄—Cardwell ZT-15-A5
 C₅, C₆—Cardwell MT-70-GS
 C₇, C₈, C₉, C₁₀—Aerovox 1467
 C₁₁, C₁₂, C₁₃—Aerovox 1450
 C₁₄ to C₂₁, inclusive—Aerovox 1467
 C₂₂—Aerovox 1457
 C₂₃—Cornell-Dubilier BR-255
 C₂₄, C₂₅—General Electric Pyranol
 C₂₆—Aerovox 1467
 C₂₇, C₂₈—Solar S-0256
 C₂₉, C₃₀, C₃₁—Solar MW-1210
 C₃₂—Solar S-0223
 C₃₃, C₃₄—Solar S-0238
 C₃₅—Solar DT-883
 C₃₆—Solar DT-859A
 C₃₇, C₃₈—Solar DT-879
 C₃₉, C₄₀—Solar D-820
 C₄₁—General Electric 23F167
 C₄₂—Solar XM-25-22
 C₄₃, C₄₄—General Electric 23F194
 R₁, R₂, R₃, R₄, R₅, R₆, R₇, R₈, R₉, R₁₀, R₁₁, R₁₂, R₁₃ to R₂₀, inclusive,
 R₂₁, R₂₂, R₂₃, R₂₄—Centralab 710
 R₂₅—Centralab 514
 R₇ to R₁₄, inclusive, R₁₅, R₁₆—Centralab 516
 R₁₇, R₁₈, R₁₉, R₂₀—Ohmite "Brown Devil"
 R₂₁—Centralab 72-116
 R₂₂—Ohmite 0625
 T₁—Thordarson T-19F96
 T₂—Thordarson T-19F76
 T₃—Thordarson T-84P60
 T₄—Thordarson T-19F81
 T₅—Thordarson T-19F99
 T₆, T₇—Thordarson T-19F90
 T₈—Thordarson T-19P60
 T₉—Thordarson T-17AO2
 T₁₀—Thordarson T-15D77
 T₁₁—Thordarson T-11M76
 CH₁, CH₂—Thordarson T-75C51
 CH₃—Thordarson T-15C31
 CH₄—Thordarson T-16C07
 CH₅—Thordarson T-19C36
 CH₆—Thordarson T-19C43
 RFC₁, RFC₂—Hammarlund CHX
 S₁—Centralab 2543
 S₂—Centralab 2505
 S₃—Centralab 2544
 S₄, S₅—Bud SW-1115
 S₆, S₇—H & H
 S₈—Bud 1270
 Rack—Bud CR-1745
 Panels—Bud
 Chassis—Bud 773, 643, and 770
 Brackets—Bud 451 and 460
 813 Socket—Johnson 237
 813—General Electric
 866/866A's—General Electric

Crystal—Bliley LD2
 RY₁—Ward-Leonard 507-507
 RY₂—Ward-Leonard 507-503

Figure 35, page 370
 400-Watt 'Phone Transmitter

All variable condensers—Bud
 All mica fixed condensers—Cornell-Dubilier type 9
 All paper by-pass condensers—Solar "Domino"
 Electrolytic condensers—Mallory-Yaxley
 Ceramic sockets—Hammarlund type S
 All wirewound resistors—Ohmite
 All carbon resistors—Centralab insulated type
 Tubes—Heintz & Kaufman, Ltd. HK-254's or Eimac
 100TH's, HK-54 or Eimac 35T, Taylor 203's. All
 others RCA
 RFC—Bud type 920
 RFC₁—Bud type 569
 R₁₁, R₂₁—Yaxley universal type
 Tuning dials—Bud type 165
 Coil forms—Bud type 126
 C₃₃, C₄₁, C₅₀—Mallory oil type
 Transformers—Thordarson as follows:
 T₁—19F83
 T₂—19F85
 T₃—33A91
 T₄—75D10
 T₅—11M77
 T₆—7SR50
 T₇—19F96
 T₈—19P59
 T₉—19F90
 T₁₀—19P62
 T₁₁—19F90
 CH₁, CH₂—19C42
 CH₃—19C36
 CH₄—19C43
 CH₅—19C36
 Crystal—Bliley LD2 or B5
 Other tubes—RCA

CHAPTER 18

U.H.F. Receivers and Transceivers

Figure 2, page 396
 Five-Meter Converter

C₁, C₂—Rebuilt Cardwell ER-25-AD, see text
 C₃, C₄—Cornell-Dubilier 1W-551
 C₅, C₆—Cornell-Dubilier 5W-5T5
 C₇—Meissner 22-7002
 C₈—Hammarlund APC-25
 C₉—Hammarlund HF-15
 C₁₀—Cornell-Dubilier EDJ-9080
 R₁, R₂—Centralab 710
 R₃, R₄, R₅—Centralab 714
 Chassis and cabinets—Bud 870-A
 Tubes—RCA

Figure 4, page 397
 U.H.F. Superregenerator

C₁—Johnson type 15J12 (altered)
 C₂—Cornell-Dubilier type 5W-5Q5
 C₃—Cornell-Dubilier 1W-3D6
 C₄, C₅—Cornell-Dubilier BR-102-A
 C₆—Cornell-Dubilier DT-455
 R₁, R₂, R₃—Centralab 710
 R₄—Centralab 72-122
 R₅—Centralab 516
 T—Thordarson 13A35
 Tubes—RCA

Dial—National type O

Figure 9, page 400
 112-Mc. F.M.—A.M. Superhet

C₁, C₂, C₃, C₄, C₁₂, C₁₇, C₁₈, C₂₈—Sprague 2FM-31
 C₅—Johnson 7J12
 C₆—Johnson 15J12
 C₇ to C₁₁, inclusive, C₁₃, C₁₄, C₁₅, C₁₉, C₂₁, C₂₆—Sprague
 TC-11
 C₁₀—Sprague 2FM-45
 C₂₀, C₂₇—Sprague TA-10
 C₂₂—Sprague TC-1
 C₂₃—Sprague TX45-35
 C₂₄, C₂₅—Sprague 2FM-35
 C₂₉—Sprague UT-8
 R₁, R₂, R₃, R₄, R₅, R₆, R₇, R₈, R₉, R₁₀, R₁₂, R₁₃, R₁₄, R₁₅, R₁₈, R₁₉,
 R₂₀, R₂₁, R₂₂, R₂₃, R₂₄—Centralab 710
 R₂₅, R₂₇, R₃₁, R₃₀, R₂₉, R₂₁—Centralab 714
 R₁₇—Mallory-Yaxley G
 R₂₇, R₂₈—Ohmite "Brown Devil"
 R₂₆—Mallory-Yaxley N
 T₁, T₂, T₃, T₄—Meissner 16-4261
 S₁—Mallory-Yaxley 8
 RFC—Hammarlund CHX
 Tubes—RCA throughout

Figure 19, page 406
 112-Mc Receiver

C₁—Johnson 7J12
 R₁, R₂—Centralab 710, 714
 R₃, R₄—Centralab Midget Radiohm
 R₅—Sprague 5-K "Koolohm"
 BC—Mallory bias cell
 T₁—Thordarson T-13A35
 Cabinet—Bud CU-728
 RFC—Bud CH-925

Figure 22, page 408
 224-Mc. Receiver

C₁—Modified Cardwell "Trim-Air"
 C₂—Aerovox 1468
 C₃, C₄—Aerovox type 84
 C₅, C₆—Aerovox type PRS
 C₇—Aerovox 1467
 R₁, R₂, R₃—Centralab 710
 R₄—Centralab 714
 R₅—Centralab 72-122
 R₆—Ohmite "Brown Devil"
 T₁—Thordarson T-13A35
 HY615 and 6J5GT—Hytron
 6F6—RCA

Figure 24, page 409
 112-Mc. Mobile Transceiver

C₁—Cardwell ZV-5-T5 with unsplit stator
 C₂—Sprague 2FM-31
 C₃, C₄—Sprague TC
 C₅—Sprague TA-10
 C₆—Sprague UT-8
 R₁—Centralab 516
 R₂, R₄, R₅—Centralab 714
 R₃—Centralab 710
 R₇, R₈—Mallory-Yaxley type L
 RFC—Ohmite Z-1
 S₁—Centralab type 1450
 T₁—Thordarson T-72A59
 T₂—Thordarson T-13538
 Power supply—Mallory Vibrapack

CHAPTER 19

U.H.F. Transmitters

Figure 2, page 411

HY75 112-Mc. Oscillator

C₁—Johnson 15J12
C—Solar type MO
RFC—Bud CH-925
Tube—Hytron
R₁—Centralab 516

Figure 6, page 412

75-T Oscillator

C₁—Bud MC-902
C—Aerovox 1457
C₂—Aerovox 1467
C₃—Aerovox 1450
R₁—Ohmite "Brown Devil"
RFC—Bud CH-925

Figure 10, page 415

P.P. 224-Mc. Oscillator

C₁—Cornell-Dubilier 1-W
R₁—Ohmite "Brown Devil"
Tubes—Hytron

Figure 13, page 416

829 224-Mc. Transmitter

C₁—Solar MO
C—Solar MT
R—Ohmite "Brown Devil"
RFC₁—Ohmite Z-1
HY75—Hytron
829—RCA

Figure 16, page 418

56-Mc. Transmitter Exciter

C₁, C₂—Solar MP-4119
C₃—Cardwell ZU-75-AS
C₄—Solar MW-1239
C₅—Solar MW-1216
C₆—Solar MW-1210
C₇—Cardwell ZR-50-AS
C₈, C₁₀, C₁₁, C₁₂—Solar MW-1227
C₉—Solar MW-1233
C₁₃—Cardwell ZT-15-AS
R₁, R₂, R₃—IRC "BT"
R₄, R₅, R₆—Ohmite "Brown Devil"
RFC—Bud 920
Crystal—Bliley B-5
Tubes—RCA 6L6, Taylor T21

Figure 17, page 418

125-Watt Amplifier

C₁—Cardwell ET-30-ADI
C₂—Cardwell NP-35-ND
R₁—Ohmite "Brown Devil"
J₁, J₂ Yaxley 702
RFC—Johnson 760
T—Thordarson, T 19F98
Sockets—Hammarlund S-4
Tubes—Heintz & Kaufman
Bar knobs—Crowe

Figure 21, page 422

F.M. Exciter

C₁—Hammarlund MC-140-S
C₂—Hammarlund MC-50-S

C₃, C₄, C₇, C₁₁—Sprague 1FM-31

C₆, C₁₂, C₁₃—Sprague TC-11

C₁₀—Sprague TC-2

C₈, C₇, C₉, C₁₀, C₁₁—Sprague 1FM-25

C₁₈—Sprague UT-8

C₁₅—Sprague TA-25

C₁₆—Sprague TC-15

C₁₄—Sprague 1FM-35

C₂₀, C₂₁, C₂₂, C₂₃—Sprague TC-15

R₁, R₂, R₃, R₄, R₅, R₇, R₈, R₉, R₁₁ to R₁₈, inclusive—
Centralab 710

R₁₀—Centralab 516

R₁₉—Centralab 72-105

RFC₁, RFC₂, RFC₃—National R-100

IFT—Meissner 16-6211

Figure 24, page 425

815 F.M. Transmitter

C₁, C₂—Bud LC-1682

C₃—Bud LC-1662

C₄—Bud LC-1661

C₅—Dismantled Bud NC-890

C₆, C₇—Sprague 1FM

C₈—Centralab 910-Z

C₉ to C₁₁—Sprague 1FM

C₁₂—Sprague SM33

C₁₃—Sprague UT-8

C₁₄—Sprague TC

C₁₅—Sprague 1FM

C₁₆—Sprague TA-10

R₁, R₂, R₃, R₄, R₅, R₆, R₇, R₈, R₉, R₁₀, R₁₁, R₁₂—Centralab 710

R₁₃, R₁₄, R₁₅, R₁₆, R₁₇, R₁₈, R₁₉, R₂₀—Centralab 714

R₂₁, R₂₂, R₂₃—Ohmite "Brown Devil"

R₂₄, R₂₅, R₂₆, R₂₇—Centralab 516

R₂₈—Mallory-Yaxley type N

RFC₁, RFC₂—Hammarlund CHX

RFC₃—Ohmite Z-1

T—Thordarson T-19F99

Meter Sw.—Mallory-Yaxley 151-L

Tubes—RCA throughout

CHAPTER 24

Test and Measuring Equipment

Figure 2, page 485

Ohmmeter

Resistors—Ohmite

Switch—Mallory-Yaxley 3100-J

Figure 8, page 488

Vacuum-Tube Voltmeter

C₁, C₄, C₅—Sprague TC-15

C₂—Sprague TC-1

C₃—Sprague TC-5

C₆—Sprague UT-8

R₁—Centralab 514

R₂, R₃, R₄, R₅—Centralab 710

R₆, R₇, R₈—Centralab 516

R₉—Centralab 72-107

R₁₀—Ohmite "Brown Devil"

T—Thordarson T-13R11

BC—Mallory

S₁—Centralab 1401

S₂—Bud SW-1115

Cabinet—Bud 993

Chassis—Bud CB-996

Tubes—RCA

Figure 12, page 491

R.F. and A.F. Power Meter

R—Ohmite D-100

M—Weston 425

Figure 19, page 497

Frequency Spotter

C₁, C₂—Hammarlund "Star" SM-100C₁, C₃—Solar type MWC₆, C₇—Solar type MP "Domino"C₈, C₉, C₁₀—Solar type MWC₁₁, C₁₂—Solar type MP "Domino"C₁₃—Solar type MWC₁₄, C₁₅—Solar D-820 electrolyticR₂, R₃—Ohmite "Brown Devil"S₁—Centralab 1465L₁—Meissner 17-6752 b.f.o. coilT₁—Thordarson T-13R11

Figure 21, page 499

Crystal Calibrator

X—Billiey SMC-100

L—Hammarlund CH-8

L₁—Hammarlund CH-X (altered)C₁—Meissner 22-7002C₂, C₃, C₄—Solar "Sealdtite"C₅—Hammarlund SM-25C₇, C₈—One Solar LGS-44

T—Thordarson T-13R01

Tubes—RCA

Figure 25, page 501

Field Strength Meter

Variable condenser—Hammarlund "Star"

Coil form—Bud type 906

Tube—RCA

Figure 30, page 503

Sensitive F.S. Meter

C₁—Hammarlund "Star"C₂—Cornell-Dubilier 1-W

Coil form—Hammarlund XP-53

Figure 34, page 505

'Phone Test Set

S₁—Yaxley selector typeC₁—Bud type 906

Dial—Crowe type 292

Tube—RCA

Figure 36, page 506

Keying Monitor

Speaker—Wright DeCoster NSLBU

C₁, C₂, C₃—Sprague TC

R—Centralab 710

Figure 41, page 509

Frequency Meter, Monitor

C₁—Bud type MC-1852C₂—Bud type MC-1876C₃, C₄—Cornell-Dubilier type WR₁—Centralab 710R₂—Centralab 72-105

T—Thordarson T-13A34

S₁—Centralab 1405

Cabinet—Bud type 1746, with panel

Chassis—Bud CB-39

Batteries—Burgess type 4FL, 5360, and M30

Tuning dial—National type B

Tubes—RCA

Figure 45, page 511

Test Signal Generator

C₁—Meissner 21-5224C₂—Meissner 21-5164 with 3 plates removedC₃—Solar MOS-100C₄, C₅—Solar S-0228C₆—Solar type MWC₇—Solar type M-240R₁—Centralab 710R₂—Centralab 516S₁, S₂—Centralab 1462

Figure 51, page 514

Audio Oscillator

C₁—Radio Condenser Co., 4 gangC₂—Solar MO-1406 and MO-1410 in parallelC₃, C₄—CD or Solar S-0267C₄, C₅, C₇, C₈, C₉—Solar DT-859AC₁₀, C₁₁—Solar D-820 in parallel

1/2-watt resistors—Centralab 710

1-watt resistors—Centralab 714

10-watt resistors—Ohmite "Brown Devil"

R₂₀—Centralab 72-107RL₁, RL₂—General Electric Mazda type 56T₁—Thordarson T-13R11T₂—Thordarson T-57501

CH—Thordarson T-13C28

S₁, S₂—Yaxley 3226J

Cabinet—Bud C-1747

Chassis—Bud CB-997

Dial—National type ACN

Tubes—RCA

CHAPTER 25

The Cathode-Ray Oscilloscope

Figure 13, page 525

Cathode-Ray Modulation Checker

Resistors—Centralab 514, 516

T—Thordarson T-92R33

C₂—General Electric Pyranol typeR₂, R₃, R₄—Yaxley universal typeC₁—Solar "Domino"

Tubes—RCA

NATIONAL RADIO PRODUCTS 1946

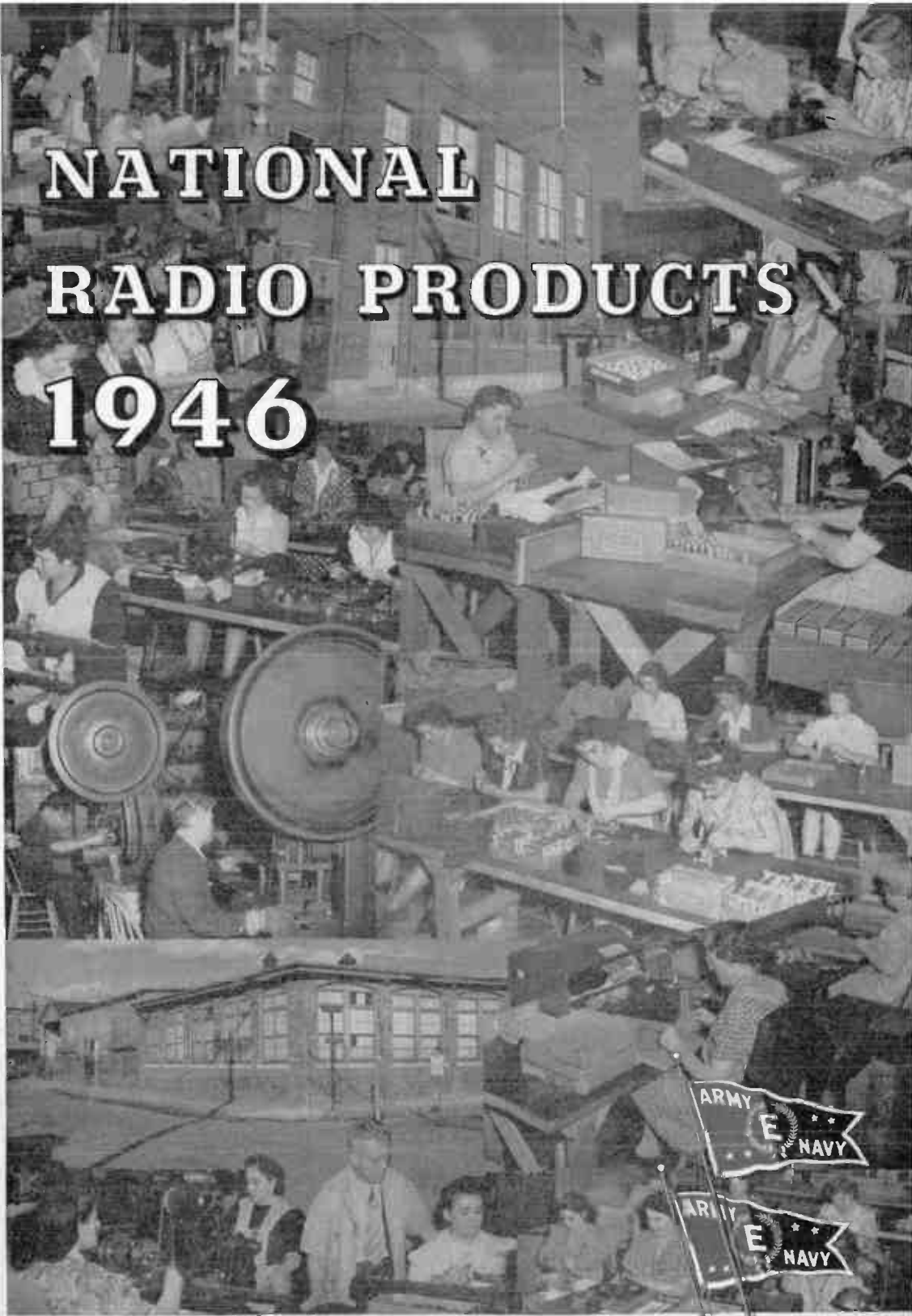

NATIONAL COMPANY, INC.

MALDEN, MASSACHUSETTS, U.S.A.

MALDEN
MELROSE
★★★★

NATIONAL DIALS

The four-inch N Dial has an engine divided scale and vernier. The vernier is flush with the scale. The planetary drive has a ratio of 5 to 1, and is contained within the body of the dial. Fits 1/4" shaft. **Specify scale.**

N Dial List \$

The original "Velvet Vernier" mechanism is now available in a metal skirted dial 3" in diameter. The planetary drive has a ratio of 5 to 1. It is available with 2, 3, 4, 5 or 6 scale and fits 1/4" shaft **Specify scale.**

AM Dial List \$

"Velvet Vernier" Dial, Type B, has a compact variable ratio 6 to 1 minimum, 20 to 1 maximum drive that is smooth and trouble free. An illuminator is available. The case is black bakelite. 1 or 5 scale. 4" diam. Fits 1/4" shaft. **Specify scale.**

B Dial List \$
Illuminator, extra List \$

The BM Dial is a smaller version of the B Dial (described in the opposite column) for use where space is limited. The drive ratio is fixed. Although small in size, the BM Dial has the same smooth action as the larger units. 1 or 5 scale. 3" diam. Fits 1/4" shaft. **Specify scale.**

BM Dial List \$

INEXPENSIVE DIALS

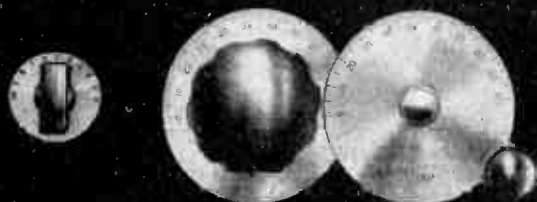

TYPE R
List \$
1 5/8" Dia.
Etched Nickel
Silver

TYPE O
List \$
3 1/2" Dia.
TYPE L
List \$
5" Dia.

TYPE K
List \$
3 1/2" Dia.
TYPE M
List \$
5" Dia.

FOR INDIVIDUAL CALIBRATING

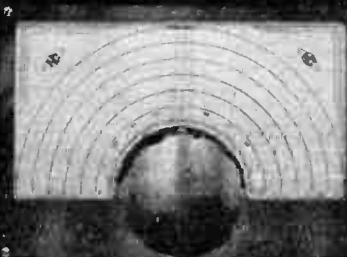

For experimenters who "build their own" and des direct calibration. Fine for Freq. Monitors and ECC

- Dial bezel size 5" x 7 1/4"
- Five blank scales for direct calibration
- Employs Velvet Vernier Drive
- Easy to mount

TYPE ACN List \$

R Dial scale 3 only but marked 10-0; O, K, L, M scale 2. All fit 1/4" shafts

KNOBS

HRK (Fits 1/4" shaft) List \$
Black bakelite knob 2 3/8" diam.

HRP-P (Fits 1/4" shaft) List \$
Black bakelite knob 1 1/4" long and 1/2" wide. Equipped with pointer.

HRP List \$
The Type HRP knob has no pointer, but is otherwise the same as the knob above.

| DIAL SCALES | | | |
|-------------|-----------|----------|--|
| Scale | Divisions | Rotation | Direction of Condenser Rotation for increase of dial reading |
| 1 | 0-100-0 | 180° | Either |
| 2 | 0-100 | 180° | Counter Clockwise |
| 3 | 100-0 | 180° | Clockwise |
| 4 | 150-0 | 270° | Clockwise |
| 5 | 200-0 | 360° | Clockwise |
| 6 | 0-150 | 270° | Counter Clockwise |

ACCESSORIES

ODL List \$
A locking device which clamps the rim of O, K, L and M Dials. Brass, nickel plated.

ODD List \$
Vernier drive for O, K, L, M or other plain dials.

SB (Fits 1/4" shaft) List \$
A nickel plated brass bushing 1/2" diam.

RSL (Fits 1/4" shaft) List \$
Rotor Shaft Lock for TMA, TMC and similar condensers.



NATIONAL PRECISION CONDENSERS

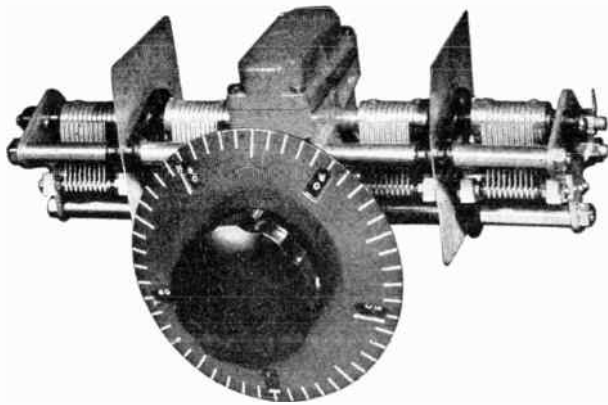

The Micrometer dial reads direct to one part in 500. Division lines are approximately $\frac{1}{4}$ " apart. The dial revolves ten times in covering the tuning range, and the numbers visible through the small windows change every revolution to give consecutive numbering by tens from 0 to 500. The condenser is of extremely rigid construction, with four bearings on the rotor shaft. The drive, at the mid-point of the rotor, is through an enclosed preloaded worm gear with 20 to 1 ratio. Each rotor is

individually insulated from the frame, and each has its own individual rotor contact. Stator insulation is Steatite. Plate shape is straight-line frequency when the frequency range is 2:1.

PW Condensers are available in 2, 3 or 4 sections, in either 160 or 225 mmf per section. Larger capacities cannot be supplied.

A single-section PW condenser with grounded rotor is supplied in capacities of 150, 200, 350 and 500 mmf, single spaced, and capacities up to 125 mmf, double spaced.

PW condensers are all with rotor shaft parallel to the panel.

- | | | | | | |
|-------|--------------------------|---------|-------|-----------------------------------|---------|
| PW-1R | Single section right | List \$ | PW-3R | Double section right; single left | List \$ |
| PW-1L | Single section left | List \$ | | | |
| PW-2R | Double section right | List \$ | PW-3L | Double section left; single right | List \$ |
| PW-2L | Double section left | List \$ | | | |
| PW-2S | Single section each side | List \$ | PW-4 | Double section each side | List \$ |

NPW MODELS with micrometer dial

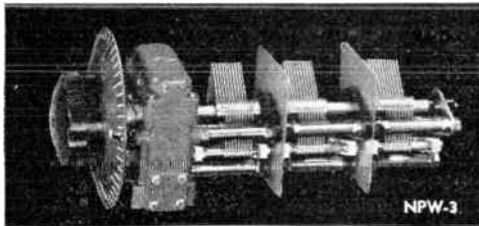

NPW-3. Three sections, each 225 mmf.
List \$

NPW-X. Three sections, each 25 mmf.
List \$

Both condensers are similar to PW models, except that rotor shaft is perpendicular to panel.

GEAR DRIVE UNITS with micrometer dial

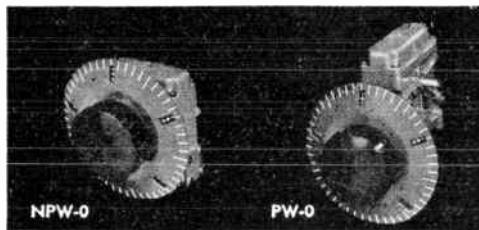

NPW-O List \$

Uses parts similar to the NPW condenser. Drive shaft perpendicular to panel. One TX-9 coupling supplied.

PW-O List \$

Uses parts similar to the PW condenser. Drive shaft parallel to panel. Two TX-9 couplings supplied.



MICROMETER DIAL

PW-D List \$

Identical with the dials used on the condensers and drives above. It revolves ten times in covering the complete range and as there is no gear reduction unit furnished, the driven shaft will revolve ten times, also. The PW-D dial fits a shaft $\frac{5}{16}$ " in diameter.

NATIONAL RECEIVING CONDENSERS

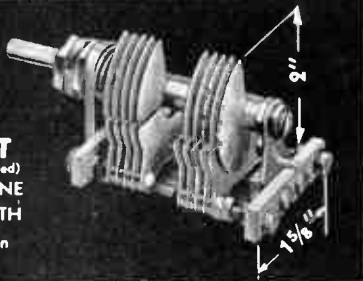

TYPE ST
(Type STD Illustrated)
STRAIGHT-LINE
WAVELENGTH
180° Rotation

| Capacity | Minimum Capacity | No. of Plates | Air Gap | Length | Catalog Symbol | List | |
|---|------------------|---------------|---------|--------|----------------|------|----|
| SINGLE BEARING MODELS | | | | | | | |
| 15 Mmf. | 3 Mmf. | 3 | .018" | 1 3/8" | STHS- 15 | \$ | |
| 25 | 3.25 | 4 | .018" | 1 3/8" | STHS- 25 | | |
| 50 | 3.5 | 7 | .018" | 1 3/8" | STHS- 50 | | |
| DOUBLE BEARING MODELS | | | | | | | |
| 35 Mmf. | 6 Mmf. | 8 | .026" | 2 1/4" | ST- 35 | \$ | |
| 50 | 7 | 11 | .026" | 2 1/4" | ST- 50 | | |
| 75 | 8 | 15 | .026" | 2 1/4" | ST- 75 | | |
| 100 | 9 | 20 | .026" | 2 1/4" | ST-100 | | |
| 140 | 10 | 27 | .026" | 2 1/4" | ST-140 | | |
| 150 | 10.5 | 29 | .026" | 2 1/4" | ST-150 | | |
| 200 | 12.0 | 27 | .018" | 2 1/4" | STH-200 | | |
| 250 | 13.5 | 32 | .018" | 2 1/4" | STH-250 | | |
| 300 | 15.0 | 39 | .018" | 2 1/4" | STH-300 | | |
| 335 | 17.0 | 43 | .018" | 2 1/4" | STH-335 | | |
| SPLIT STATOR DOUBLE BEARING MODELS | | | | | | | |
| 50-50 | 5-5 | 11-11 | .026" | 2 1/4" | STD- 50 | | \$ |
| 100-100 | 5.5-5.5 | 14-14 | .018" | 2 1/4" | STHD-100 | | |

NOTE — Type SS Condensers, having straight-line-capacity plates but otherwise similar to the Type ST, are available. Capacities and Prices same as Type ST.

The ST Type condenser has Straight-Line Wavelength plates. All double-bearing models have the front bearing insulated to prevent noise. On special order a shaft extension at each end is available, for ganging. On double-bearing single shaft models, the rotor contact is through a constant impedance pigtail. Isolantite insulation.

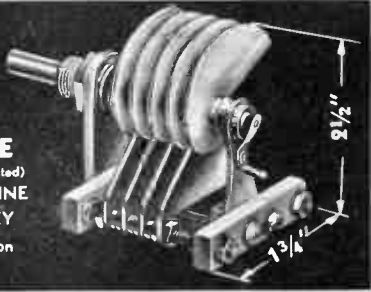

TYPE SE
(Type SEU Illustrated)
STRAIGHT-LINE
FREQUENCY
270° Rotation

| Capacity | Minimum Capacity | No. of Plates | Air Gap | Length | Catalog Symbol | List |
|----------|------------------|---------------|---------|--------|----------------|------|
| 15 Mmf. | 7 Mmf. | 6 | .055" | 2 1/4" | SEU- 15 | \$ |
| 20 | 7.5 | 8 | .055" | 2 1/4" | SEU- 20 | |
| 25 | 8 | 9 | .055" | 2 1/4" | SEU- 25 | |
| 50 | 9 | 11 | .026" | 2 1/4" | SE- 50 | \$ |
| 75 | 10 | 15 | .026" | 2 1/4" | SE- 75 | |
| 100 | 11.5 | 20 | .026" | 2 1/4" | SE-100 | |
| 150 | 13 | 29 | .026" | 2 1/4" | SE-150 | |
| 200 | 12 | 27 | .018" | 2 1/4" | SEH-200 | |
| 250 | 14 | 32 | .018" | 2 1/4" | SEH-250 | |
| 300 | 16 | 39 | .018" | 2 1/4" | SEH-300 | |
| 335 | 17 | 43 | .018" | 2 1/4" | SEH-335 | |

TYPE SE — All models have two rotor bearings, the front bearing being insulated to prevent noise. A shaft extension at each end, for ganging, is available on special order. On models with single shaft extension, the rotor contact is through a constant impedance pigtail. The SEU models (illustrated) are suitable for high voltages as their plates are thick polished aluminum with rounded edges. Other SE condensers do not have polished edges on the plates. Isolantite insulation.

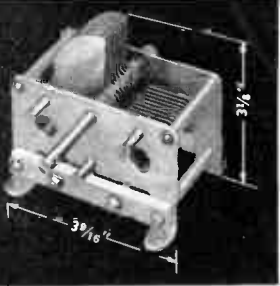

TYPE EM
STRAIGHT-LINE
CAPACITY
180° Rotation

| Capacity | Minimum Capacity | No. of Plates | Length | Catalog Symbol | List |
|----------|------------------|---------------|--------|----------------|------|
| 350 Mmf. | 12 Mmf | 20 | 9 1/4" | EM-350 | \$ |
| 500 | 16 | 29 | 4 3/8" | EM-500 | |
| 1000 | 22 | 56 | 6 3/4" | EM-1000 | |

TYPE EM — A general purpose condenser available in large sizes and having Straight-Line capacity plates. They are similar in construction to the TMC Transmitting condenser, and have high efficiency and rugged frames. Insulation is Isolantite, and Peak Voltage Rating is 1000 volts.

NATIONAL MINIATURE CONDENSERS



PSR — See table —

Type PSR condensers are small, compact, low-loss units with silver plating on conducting parts. Their soldered construction makes them particularly suitable for applications where vibration is present. Adjustment is made with a screw driver. Steatite base.

PSE — See table —

Type PSE condensers are similar to Type PSR, but are provided with a 1/4" diameter shaft extension at each end.

PSL — See table —

Type PSL condensers are similar to Type PSR, but are provided with a rotor shaft lock, so that the rotor can be clamped at any setting.

MSR, MSE, MSL —

See table — Condensers of the MS series are similar in appearance to the PS series described above, but they differ in making use of plates which are like those of the UM condenser. This and other small changes result in a more robust and rigid assembly. Other details of the MSR, MSE, and MSL are the same as the PSR, PSE, and PSL respectively.

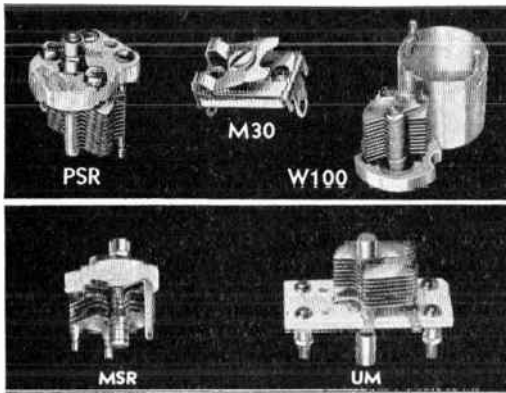

M-30

List \$

Type M-30 is a small adjustable mica condenser with a maximum capacity of 30 mmf. Dimensions 13/16" x 9/16" x 1/2". Isolantite base.

W-75, 75 mmf.

List \$

W-100, 100 mmf.

List \$

Small padding condensers having very low temperature coefficient. Mounted in an aluminum shield 1 1/4" in diameter.

The UM CONDENSER

is designed for ultra high frequency use and is small enough for convenient mounting in PB-10 and RO shield cans. They are particularly useful for tuning receivers, transmitters, and exciters. Shaft extensions at each end of the rotor permit easy ganging when used with one of our flexible couplings. The UM/B-25 Condenser is a balanced stator model, two stators act on a single rotor. The UM can be mounted by the angle foot supplied or by bolts and spacers. See table for sizes.

Dimensions: Base 1" x 2 1/4", Mounting holes 5/8" x 1 23/32", Axial length 2 1/8" overall.

Plates: Straightline capacity, 180° rotation.

| Capacity | Catalog Symbol | | | List |
|----------|----------------|---------|---------|------|
| 25 mmf. | PSR-25 | PSE-25 | PSL-25 | \$ |
| 50 | PSR-50 | PSE-50 | PSL-50 | |
| 75 | PSR-75 | PSE-75 | PSL-75 | |
| 100 | PSR-100 | PSE-100 | PSL-100 | |
| 140 | PSR-140 | PSE-140 | PSL-140 | |

| Capacity | Catalog Symbol | | | List |
|----------|----------------|---------|---------|------|
| 25 mmf. | MSR-25 | MSE-25 | MSL-25 | \$ |
| 50 | MSR-50 | MSE-50 | MSL-50 | |
| 75 | MSR-75 | MSE-75 | MSL-75 | |
| 100 | MSR-100 | MSE-100 | MSL-100 | |

| Capacity | Minimum Capacity | No. of Plates | Air Gap | Catalog Symbol | List |
|----------|------------------|---------------|---------|----------------|------|
| 15 mmf. | 1.5 | 6 | .017" | UM-15 | \$ |
| 35 | 2.5 | 12 | .017" | UM-35 | |
| 50 | 3 | 16 | .017" | UM-50 | |
| 75 | 3.5 | 22 | .017" | UM-75 | |
| 100 | 4.5 | 28 | .017" | UM-100 | |
| 25 | 3.4 | 14 | .042" | UMA-25 | |

BALANCED STATOR MODEL

| | | | | | |
|----|---|-------|-------|--------|----|
| 25 | 2 | 4-4-4 | .017" | UMB-25 | \$ |
|----|---|-------|-------|--------|----|

NATIONAL NEUTRALIZING CONDENSERS

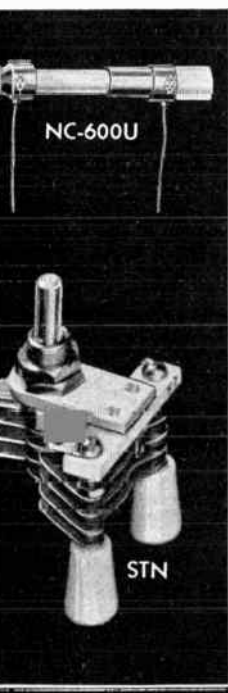

NC-600U List \$

With standoff insulator

NC-600 List \$

Without insulator

For neutralizing low power beam tubes requiring from .5 to 4 mmf., and 1500 max. total volts such as the 6L6. The NC-600U is supplied with a GS-10 standoff insulator screwed on one end, which may be removed for pigtail mounting.

STN List \$

The Type STN has a maximum capacity of 18 mmf. (3000 V), making it suitable for such tubes as the 10 and 45. It is supplied with two standoff insulators.

NC-800 List \$

The NC-800 disk-type neutralizing condenser is suitable for the RCA, 800, 35T, HK-54 and similar tubes. It is equipped with a micrometer thimble and clamp. The chart below gives capacity and air gap for different settings.

NC-75 List \$

For 75T, 808, 811, 812 & similar tubes.

NC-150 List \$

For HK354, RK36, 300T, 852, etc.

NC-500 List \$

For WE-251, 450TH, 450IL, 750TL, etc.

These larger disk type neutralizing condensers are for the higher powered tubes. Disks are aluminum, insulation steatite.

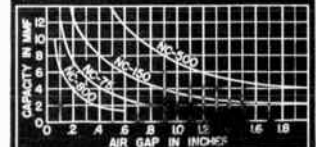
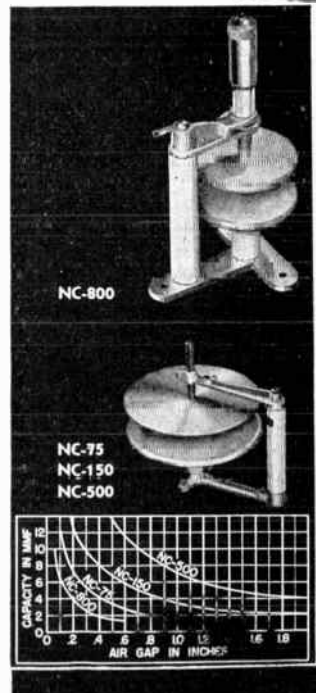

NATIONAL TRANSMITTING CONDENSERS

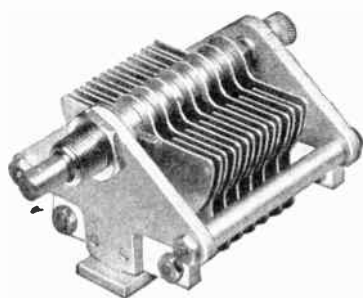

TYPE TMS

is a condenser designed for transmitter use in low power stages. It is compact, rigid, and dependable. Provision has been made for mounting either on the panel, on the chassis, or on two stand-off insulators. Insulation is Isolantite. Voltage ratings listed are conservative.

| Capacity | Minimum Capacity | Length | Air Gap | Peak Voltage | No. of Plates | Catalog Symbol | List Price |
|-----------------------------|------------------|--------|---------|--------------|---------------|-----------------|------------|
| SINGLE STATOR MODELS | | | | | | | |
| 100 Mmf. | 9.5 | 3" | .026" | 1000v. | 9 | TMS-100 | |
| 150 | 11 | 3" | .026" | 1000v. | 14 | TMS-150 | |
| 250 | 13.5 | 3" | .026" | 1000v. | 22 | TMS-250 | |
| 300 | 15 | 3" | .026" | 1000v. | 27 | TMS-300 | |
| 35 | 8 | 3" | .065" | 2000v. | 7 | TMSA-35 | |
| 50 | 11 | 3" | .065" | 2000v. | 11 | TMSA-50 | |
| DOUBLE STATOR MODELS | | | | | | | |
| 50-50 Mmf. | 6-6 | 3" | .026" | 1000v. | 5-5 | TMS-50D | |
| 100-100 | 7-7 | 3" | .026" | 1000v. | 9-9 | TMS-100D | |
| 50-50 | 10.5-10.5 | 3" | .065" | 2000v. | 11-11 | TMSA-50D | |

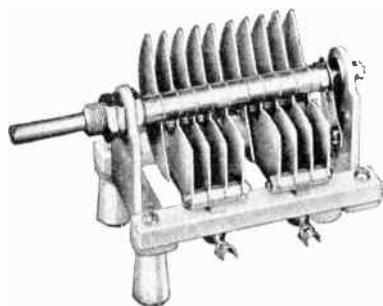

TYPE TMH

features very compact construction, excellent power factor, and aluminum plates .040" thick with polished edges. It mounts on the panel or on removable stand-off insulators. Isolantite insulators have long leakage path. Stand-offs included in listed price.

| Capacity | Minimum Capacity | Length | Air Gap | Peak Voltage | No. of Plates | Catalog Symbol | List |
|-----------------------------|------------------|---------------------------------|---------|--------------|---------------|----------------|------|
| SINGLE STATOR MODELS | | | | | | | |
| 50 Mmf. | 9 | 3 ³ / ₄ " | .085" | 3500v. | 15 | TMH-50 | |
| 75 | 11 | 3 ³ / ₄ " | .085" | 3500v. | 19 | TMH-75 | |
| 100 | 12.5 | 5 ¹ / ₈ " | .085" | 3500v. | 25 | TMH-100 | |
| 150 | 18 | 6 ¹ / ₂ " | .085" | 3500v. | 37 | TMH-150 | |
| 35 | 11 | 5 ¹ / ₈ " | .180" | 6500v. | 17 | TMH-35A | |
| DOUBLE STATOR MODELS | | | | | | | |
| 35-35 Mmf. | 6-6 | 3 ³ / ₄ " | .085" | 3500v. | 9-9 | TMH-35D | |
| 50-50 | 8-8 | 5 ¹ / ₈ " | .085" | 3500v. | 13-13 | TMH-50D | |
| 75-75 | 11-11 | 6 ¹ / ₂ " | .085" | 3500v. | 19-19 | TMH-75D | |

NATIONAL TRANSMITTING CONDENSERS

TYPE TMK

is a new condenser for exciters and low power transmitters. Special provision has been made for mounting AR-16 coils in a swivel plug-in mount on either the top or rear of the condenser, (see page 10). For panel or stand-off mounting. Isolantite insulation.

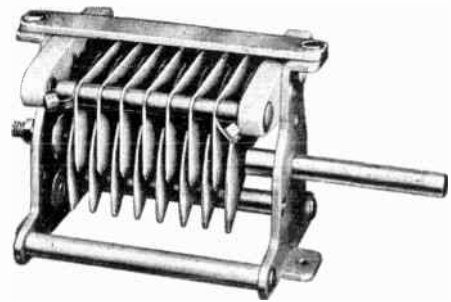

| Capacity | Minimum Capacity | Length | Air Gap | Peak Voltage | No. of Plates | Catalog Symbol | List Price |
|--|------------------|--------------------|---------|--------------|---------------|----------------|------------|
| SINGLE STATOR MODELS | | | | | | | |
| 35 Mmf. | 7.5 | 2 $\frac{7}{32}$ " | .047" | 1500v. | 7 | TMK-35 | |
| 50 | 8 | 2 $\frac{3}{8}$ " | .047" | 1500v. | 9 | TMK-50 | |
| 75 | 9 | 2 $\frac{1}{16}$ " | .047" | 1500v. | 13 | TMK-75 | |
| 100 | 10 | 3" | .047" | 1500v. | 17 | TMK-100 | |
| 150 | 10.5 | 3 $\frac{5}{8}$ " | .047" | 1500v. | 25 | TMK-150 | |
| 200 | 11 | 4 $\frac{1}{4}$ " | .047" | 1500v. | 33 | TMK-200 | |
| 250 | 11.5 | 4 $\frac{1}{8}$ " | .047" | 1500v. | 41 | TMK-250 | |
| DOUBLE STATOR MODELS | | | | | | | |
| 35-35 Mmf. | 7.5-7.5 | 3" | .047" | 1500v. | 7-7 | TMK-35D | |
| 50-50 | 8-8 | 3 $\frac{5}{8}$ " | .047" | 1500v. | 9-9 | TMK-50D | |
| 100-100 | 10-10 | 4 $\frac{1}{4}$ " | .047" | 1500v. | 17-17 | TMK-100D | |
| Swivel Mounting Hardware for AR 16 Coils | | | | | | SMH | |

TYPE TMC

is designed for use in the power stages of transmitters where peak voltages do not exceed 3000. The frame is extremely rigid and arranged for mounting on panel, chassis or stand-off insulators. The plates are aluminum with buffed edges. Insulation is Isolantite. The stator in the split stator models is supported at both ends.

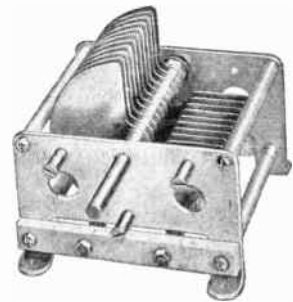

| Capacity | Minimum Capacity | Length | Air Gap | Peak Voltage | No. of Plates | Catalog Symbol | List Price |
|-----------------------------|------------------|-------------------|---------|--------------|---------------|----------------|------------|
| SINGLE STATOR MODELS | | | | | | | |
| 50 Mmf. | 10 | 3" | .077" | 3000v. | 7 | TMC-50 | |
| 100 | 13 | 3 $\frac{1}{2}$ " | .077" | 3000v. | 13 | TMC-100 | |
| 150 | 17 | 4 $\frac{5}{8}$ " | .077" | 3000v. | 21 | TMC-150 | |
| 250 | 23 | 6" | .077" | 3000v. | 32 | TMC-250 | |
| 300 | 25 | 6 $\frac{3}{4}$ " | .077" | 3000v. | 39 | TMC-300 | |
| DOUBLE STATOR MODELS | | | | | | | |
| 50-50 Mmf. | 9-9 | 4 $\frac{5}{8}$ " | .077" | 3000v. | 7-7 | TMC-50D | |
| 100-100 | 11-11 | 6 $\frac{3}{4}$ " | .077" | 3000v. | 13-13 | TMC-100D | |
| 200-200 | 18.5-18.5 | 9 $\frac{1}{4}$ " | .077" | 3000v. | 25-25 | TMC-200D | |

NATIONAL TRANSMITTING CONDENSERS

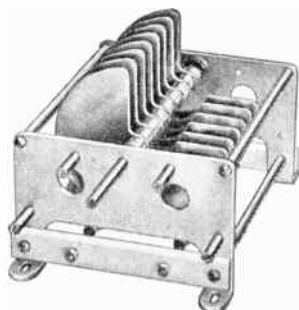

TYPE TMA

is a larger model of the popular TMC. The frame is extremely rigid and arranged for mounting on panel, chassis or stand-off insulators. The plates are of heavy aluminum with rounded and buffed edges. Insulation is Isolantite, located outside of the concentrated field.

| Capacity | Minimum Capacity | Length | Air Gap | Peak Voltage | No. of Plates | Catalog Symbol | List Price |
|-----------------------------|------------------|---------|---------|--------------|---------------|----------------|------------|
| SINGLE STATOR MODELS | | | | | | | |
| 300 Mmf. | 19.5 | 4 3/8" | .077" | 3000v. | 23 | TMA-300 | |
| 50 | 15 | 4 3/8" | .171" | 6000v. | 7 | TMA-50A | |
| 100 | 19.5 | 6 7/8" | .171" | 6000v. | 15 | TMA-100A | |
| 150 | 22.5 | 6 7/8" | .171" | 6000v. | 21 | TMA-150A | |
| 230 | 33 | 9 1/2" | .171" | 6000v. | 33 | TMA-230A | |
| 100 | 30 | 9 1/2" | .265" | 9000v. | 23 | TMA-100B | |
| 150 | 40.5 | 12 1/2" | .265" | 9000v. | 33 | TMA-150B | |
| 50 | 21 | 7 1/8" | .359" | 12000v. | 13 | TMA-50C | |
| 100 | 37.5 | 12 7/8" | .359" | 12000v. | 25 | TMA-100C | |
| DOUBLE STATOR MODELS | | | | | | | |
| 200-200 Mmf. | 15-15 | 6 7/8" | .077" | 3000v. | 16-16 | TMA-200D | |
| 50-50 | 12.5-12.5 | 6 7/8" | .171" | 6000v. | 8-8 | TMA-50DA | |
| 100-100 | 17-17 | 9 1/2" | .171" | 6000v. | 14-14 | TMA-100DA | |
| 60-60 | 19.5-19.5 | 12 1/2" | .265" | 9000v. | 15-15 | TMA-60DB | |
| 40-40 | 18-18 | 12 7/8" | .359" | 12000v. | 11-11 | TMA-40DC | |

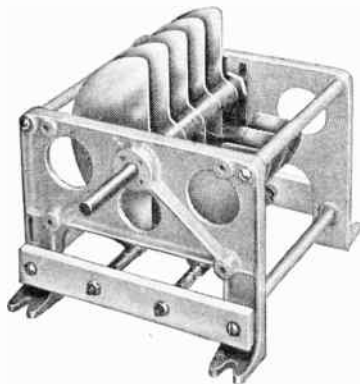

TYPE TML

condenser is a 1 KW job throughout. Isolantite insulators, specially treated against moisture absorption, prevent flashovers. A large self-cleaning rotor contact provides high current capacity. Thick capacitor plates, with accurately rounded and polished edges, provide high voltage ratings. Sturdy cast aluminum end frames and dural tie bars permit an unusually rigid structure. Precision end bearings insure smooth turning and permanent alignment of the rotor. End frames are arranged for panel, chassis or stand-off mountings.

| Capacity | Minimum Capacity | Length | Air Gap | Peak Voltage | No. of Plates | Catalog Symbol | List Price |
|-----------------------------|------------------|---------|---------|--------------|---------------|----------------|------------|
| SINGLE STATOR MODELS | | | | | | | |
| 75 Mmf. | 25 | 18 1/2" | .719" | 20,000v. | 17 | TML-75E | |
| 150 | 60 | 18 1/2" | .469" | 15,000v. | 27 | TML-150D | |
| 100 | 45 | 13 5/8" | .469" | 15,000v. | 19 | TML-100D | |
| 50 | 22 | 8 3/4" | .469" | 15,000v. | 9 | TML-50D | |
| 245 | 54 | 18 1/2" | .344" | 10,000v. | 35 | TML-245B+ | |
| 150 | 45 | 13 5/8" | .344" | 10,000v. | 21 | TML-150B+ | |
| 100 | 32 | 10 3/4" | .344" | 10,000v. | 15 | TML-100B+ | |
| 75 | 23.5 | 8 3/4" | .344" | 10,000v. | 11 | TML-75B+ | |
| 500 | 55 | 18 1/2" | .219" | 7,500v. | 49 | TML-500A+ | |
| 350 | 45 | 13 5/8" | .219" | 7,500v. | 33 | TML-350A+ | |
| 250 | 35 | 10 3/8" | .219" | 7,500v. | 25 | TML-250A+ | |
| DOUBLE STATOR MODELS | | | | | | | |
| 30-30 Mmf. | 12-12 | 18 1/2" | .719" | 20,000v. | 7-7 | TML-30DE | |
| 60-60 | 26-26 | 18 1/2" | .469" | 15,000v. | 11-11 | TML-60DD | |
| 100-100 | 27-27 | 18 1/2" | .344" | 10,000v. | 15-15 | TML-100DB+ | |
| 60-60 | 20-20 | 13 5/8" | .344" | 10,000v. | 9-9 | TML-60DB+ | |
| 200-200 | 30-30 | 18 1/2" | .219" | 7,500v. | 21-21 | TML-200DA+ | |
| 100-100 | 17-17 | 10 3/8" | .219" | 7,500v. | 11-11 | TML-100DA+ | |

NATIONAL RF CHOKES

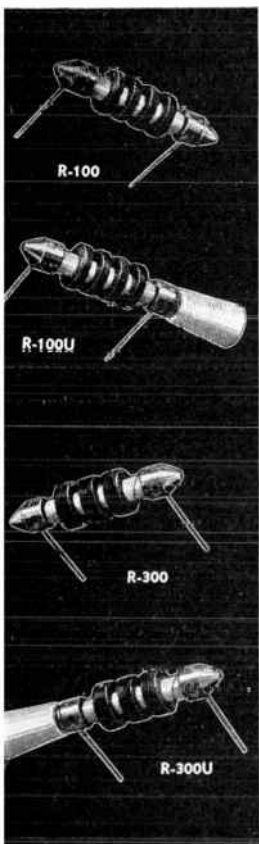

R-100 List \$
Without standoff insulator

R-100U List \$
With standoff insulator

R.F. chokes R-100 and R-100U are identical electrically, but the latter is provided with a removable standoff insulator screwed on one end. Both have Isolantite insulation and both have a continuous universal winding in four sections. Inductance $2\frac{1}{2}$ m.h.; distributed capacity 1 mmf.; DC resistance 50 ohms; current rating 125 ma.

R-300 List \$
Without insulator

R-300U List \$
With insulator

R.F. chokes R-300 and R-300U are similar in size to R-100U but have higher current capacity. The R-300U is provided with a removable standoff insulator screwed on one end. Inductance 1 m.h.; distributed capacity 1 mf.; DC resistance 10 ohms; current rating 300 ma.

R.F. chokes are available in a variety of inductance values, ranging from 6 microhenries to 10 millihenries, in addition to those shown above. Various mounting arrangements are also available. Full information will be furnished on request.

R-152 List \$

For the 80 and 160 meter bands. Inductance 4 m.h., DC resistance 10 ohms, DC current 600 ma. Coils honeycomb wound on Isolantite core.

R-154 List \$

R-154U List \$

For the 20, 40 and 80 meter bands. Inductance 1 m.h., DC resistance 6 ohms, DC current 600 ma. Coils honeycomb wound on Isolantite core. The R-154U does not have the third mounting foot and the small insulator, but is otherwise the same as R-154. See illustration.

R-175 List \$

The R-175 Choke is suitable for parallel-feed as well as series-feed in transmitters with plate supply up to 3000 volts modulated or 4000 volts unmodulated. Unlike conventional chokes, the reactance of the R-175 is high throughout the 10 and 20 meter bands as well as the 40, 80 and 160 meter bands. Inductance $225 \mu\text{h}$, distributed capacity 0.6 mmf., DC resistance 6 ohms, DC current 800 ma., voltage breakdown to base 12,500 volts.

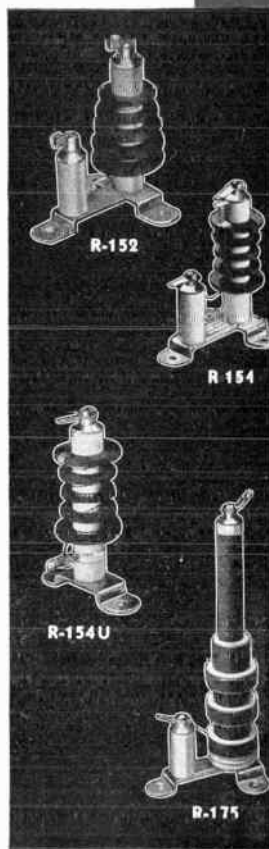

National has manufactured a great many sizes and styles of chokes not shown above, during the war. A complete line of chokes will be available in the near future but full technical data had not been prepared at the time this edition of the RADIO Handbook went to press. Complete information will be found in later catalogs or can be obtained by writing us direct.

NATIONAL SHAFT COUPLINGS

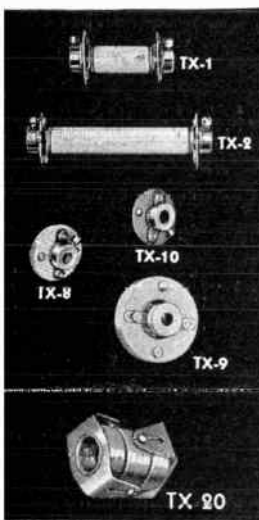

TX-1, Leakage path 1" List \$

TX-2, Leakage path $2\frac{1}{2}$ " List \$

Flexible couplings with glazed Isolantite insulation which fit $\frac{1}{4}$ " shafts.

TX-8 List \$

A non-flexible rigid coupling with Isolantite insulation. 1" diam. Fits $\frac{1}{4}$ " shaft.

TX-9 List \$

This small insulated flexible coupling provides high electrical efficiency when used to isolate circuits. Insulation is Sreelite. $1\frac{5}{8}$ " diam. Fits $\frac{1}{4}$ " shaft.

TX-20 List \$

A small insulated flexible coupling of the Hooke's joint type

which will accommodate angular misalignment up to five degrees as well as $\frac{1}{64}$ " transverse misalignment between the shafts.

TX-10 List \$

A very compact insulated coupling free from backlash. Insulation is canvas Bakelite. $1\frac{1}{16}$ " diam. Fits $\frac{1}{4}$ " shaft.

TX-11 List \$

The flexible shaft of this coupling connects shafts at angles up to 90 degrees, and eliminates misalignment problems. Fits $\frac{1}{4}$ " shafts. Length $4\frac{1}{4}$ ".

TX-12, Length $4\frac{5}{8}$ " List \$

TX-13, Length $7\frac{1}{8}$ " List \$

These couplings use flexible shafting like the TX-11 above, but are also provided with Isolantite insulators at each end.

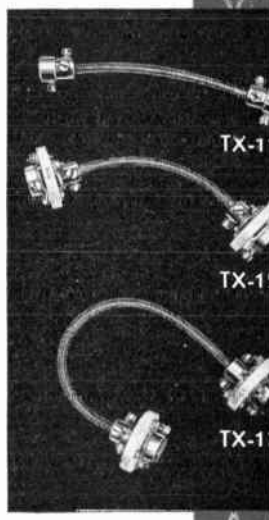

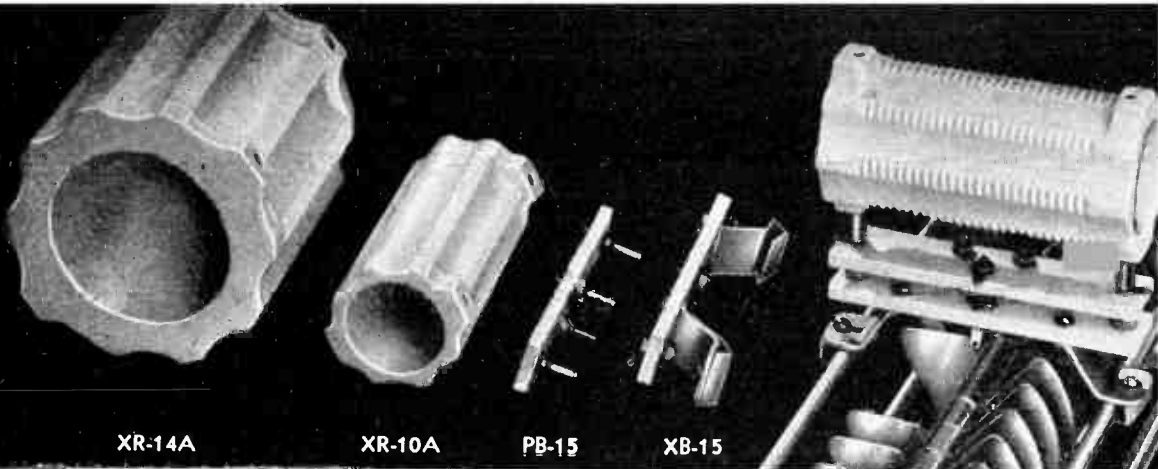

XR-14A

XR-10A

PB-15

XB-15

TRANSMITTER COIL FORMS

The Transmitter Coil Forms and Mounting are designed as a group, and mount conveniently on the bars of a TMA condenser. The larger coil form, Type XR-14A, has a winding diameter of 5", a winding length of 3 3/4" (30 turns total) and is intended for the 80 meter band. The smaller form, Type XR-10A, has a winding length of 3 3/4" and a winding diameter of 2 1/2" (26 turns total). It is intended for the 20 and 40 meter bands.

Either coil form fits the PB-15 plug. For higher frequencies, the plug may be used with a self-supporting coil of copper tubing. The XB-15 Socket may be mounted on breadboards or chassis, as well as on the TMA Condenser.

SINGLE UNITS

- XR-10A, Coil Form only List \$
- XR-14A, Coil Form only List \$
- PB-15, Plug only List \$
- XB-15, Socket only List \$

ASSEMBLIES

- UR-10A, Assembly (including small Coil Form, Plug and Socket) List \$
- UR-14A, Assembly (including large Coil Form, Plug and Socket) List \$

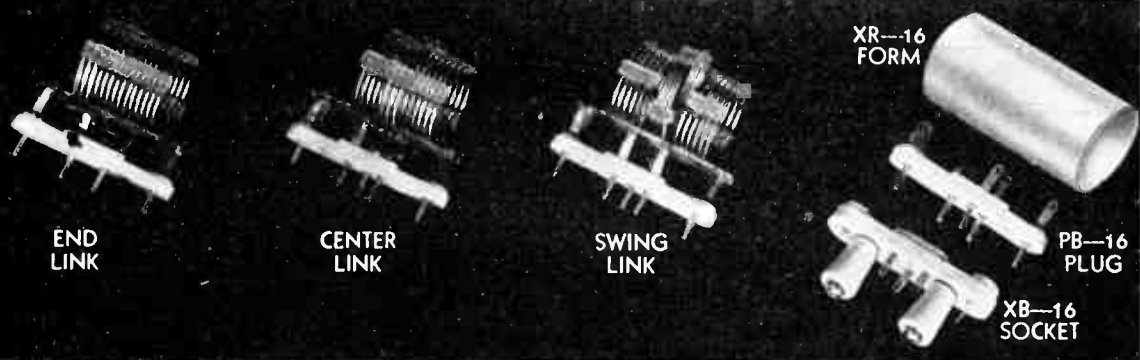

END LINK

CENTER LINK

SWING LINK

XR-16 FORM

PB-16 PLUG

XB-16 SOCKET

EXCITER COILS AND FORMS — TYPE AR-16 (Air Spaced)

These air-spaced coils are suitable for use in stages where the plate input does not exceed 50 watts and are available in the sizes tabulated below. Capacities listed will resonate the coils at the low frequency end of the band and include all stray circuit capacities. All have separate link coupling coils and all fit the PB-16 Plug and XB-16 Socket.

The XR-16 Coil Form also fits the PB-16 Plug and XB-16 Socket. It has a winding diameter of 1 1/4" and a winding length of 1 3/4".

- XR-16, Coil Form only List \$
- PB-16, Plug-in Base only List \$
- XB-16, Plug-in Socket only List \$
- AR-16, Coils — Any type (see table). Include PB-16 Plug as illustrated Each, List \$

Exciter coil on TMK condenser

| Band | End Link | Cap Mmf | Center Link | Cap Mmf | Swinging Link | Cap Mmf |
|-----------|-----------|---------|-------------|---------|---------------|---------|
| 5 meter | AR16-5E | 20 | AR16-5C | 20 | | |
| 10 meter | AR16-10E | 20 | AR16-10C | 20 | AR16-10S | 25 |
| 20 meter | AR16-20E | 26 | AR16-20C | 26 | AR16-20S | 40 |
| 40 meter | AR16-40E | 33 | AR16-40C | 33 | AR16-40S | 55 |
| 80 meter | AR16-80E | 37 | AR16-80C | 37 | AR16-80S | 60 |
| 160 meter | AR16-160E | 65 | AR16-160C | 65 | | |

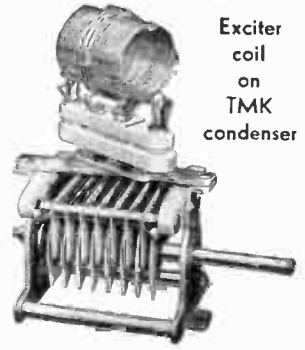

When final allocation of the amateur bands has been made the exciter coils will be redesigned to provide coverage.

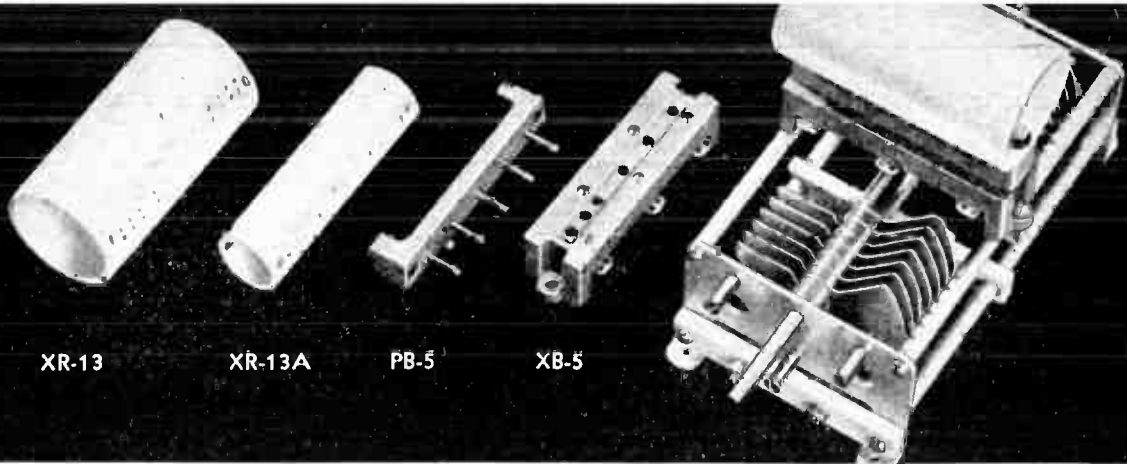

XR-13

XR-13A

PB-5

XB-5

BUFFER COIL FORMS

National Buffer Coil Forms are designed to mount directly on the tie bars of a TMC condenser using the PB-5 Plug and XB-5 Socket. Plug and Socket are of molded R-39.

The two coil forms are of Isolantite, left unglazed to provide a tooth for coil dope. The larger form, Type XR-13, is 1 3/4" in diameter and has a winding length of 2 3/4". The smaller form, Type XR-13A, is 1" in diameter and provides a winding length of 2 3/4". Both forms have holes for mounting and for leads.

SINGLE UNITS

- XR-13, Coil Form only List \$
- XR-13A, Coil Form only List \$
- PB-5, Plug only List \$
- XB-5, Socket only List \$

ASSEMBLIES

- UR-13A, Assembly (including small Coil Form, Plug and Socket) List \$
- UR-13, Assembly (including large Coil Form, Plug and Socket) List \$

FIXED-TUNED EXCITER TANK

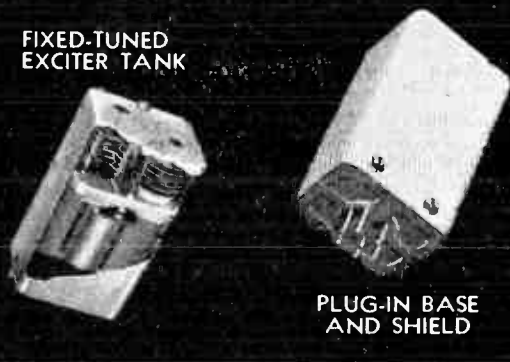

PLUG-IN BASE AND SHIELD

FIXED TUNED EXCITER TANK

Similar in general construction to National I.F. transformers, this unit has two 25 mmf., 2000 volt air condensers and an unwound XR-2 coil form.

- FXT, without plug-in base List \$
- FXTB-5, with 5 prong base List \$
- FXTB-6, with 6 prong base List \$

PLUG-IN BASE AND SHIELD

The low-loss R-39 base is ideal for mounting condensers and coils when it is desirable to have them shielded and easily removable. Shield can be 2" x 2 3/8" x 4 1/8".

- PB-10-5, (5 Prong Base & Shield) List \$
- PB-10-6, (6 Prong Base & Shield) List \$
- PB-10A-5, (5 Prong Base only) List \$
- PB-10A-6, (6 Prong Base only) List \$

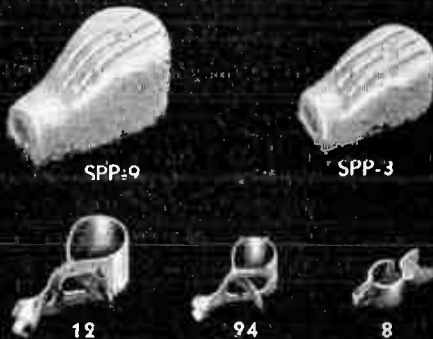

SPP-9

SPP-3

12

24

8

SAFETY GRID AND PLATE CAPS

National Safety Grid and Plate Caps have a ceramic body which offers protection against accidental contact with high voltage caps on tubes.

- SPP-9 List \$
Ceramic insulation. Fits 9'16" diameter.
- SPP-3 List \$
Ceramic insulation. Fits 3/8" diameter.

GRID AND PLATE GRIPS

National Grid and Plate Grips provide a secure and positive contact with the tube cap and yet are released easily by a slight pressure on the ear.

- Type 12, for 9/16" Caps List \$
- Type 24, for 3/8" Caps List \$
- Type 8, for 1/4" Caps List \$

NATIONAL PARTS

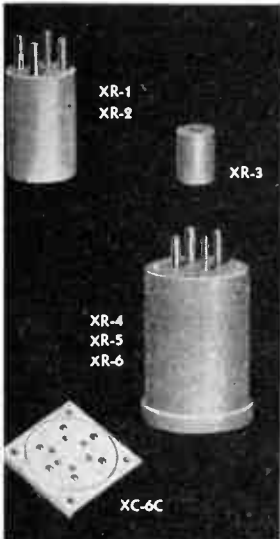

COIL FORMS

XR-1, Four prong, List \$
XR-2, without prongs List \$

Molded of R-39, permitting them to be grooved and drilled. Coil form diameter 1", length 1 1/2".

XR-3 List \$

Molded of R-39. Diameter 9/16", length 3/4". Without prongs.

XR-4, Four prong, List \$
XR-5, Five prong, List \$
XR-6, Six prong, List \$

Molded of R-39, permitting them to be grooved and drilled. Coil form diameter 1 1/2", length 2 1/4". A special socket is required for the six-prong form.

XC6C, Special six-prong socket for XR-6 Coil Form, List \$



IMPEDANCE COUPLER

S-101 List \$
 A plate choke, coupling condenser and grid leak sealed in one case, for coupling the output of a regenerative detector to an audio stage. Used in SW-3U.

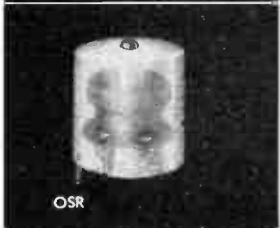

OSCILLATOR COIL

OSR List \$
 A shielded oscillator coil which tunes to 100 KC with .00041 Mfd. Two separate inductances, closely coupled. Excellent for interruption-frequency oscillator in super-regenerative receivers.

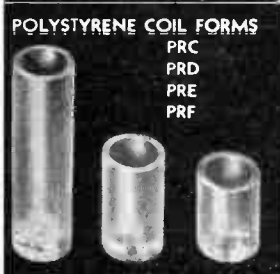

H. F. COIL FORMS

| Symbol | Outside Diameter | Length | List |
|--------|------------------|--------|------|
| PRC-1 | 3/8" | 3/8" | \$ |
| PRC-2 | 3/8" | 1/2" | |
| PRC-3 | 3/8" | 3/4" | |
| PRD-1 | 1/2" | 1/2" | \$ |
| PRD-2 | 1/2" | 1" | |
| PRE-1 | 9/16" | 3/4" | \$ |
| PRE-2 | 9/16" | 1" | |
| PRE-3 | 9/16" | 2" | |
| PRF-1 | 3/4" | 3/2" | \$ |
| PRF-2 | 3/4" | 1 1/4" | |

COIL SHIELDS

RZ, coil shield List \$
 1 3/8" square x 4" high.

RS, coil shield List \$
 1 7/16" x 1 7/8" x 3 1/2" high.

RO, coil shield List \$
 2" x 2 3/8" x 4 1/8" high.

B-30, coil shield List \$
 3" dia. x 3 3/4" high without mounting base.

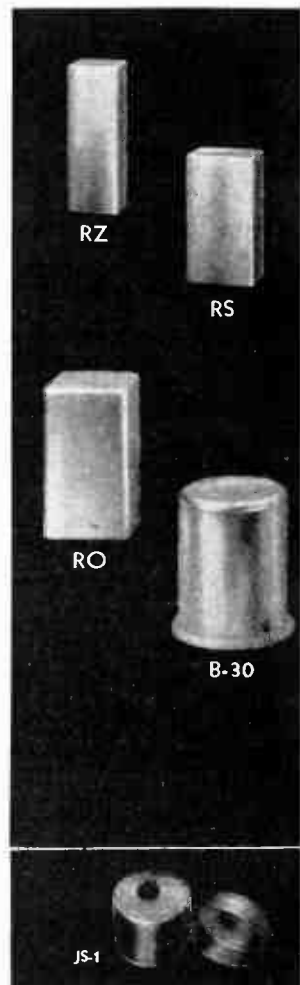

National coil shields are formed from a single piece of pure aluminum. They are mechanically strong and have ample thickness to mount small parts on the walls.

The RZ, RS and RO coil shields are supplied with two threaded studs extending downward from the open end for attaching to the chassis. The B-30 coil shield is supplied with an aluminum base which not only provides a convenient mounting, but also completes the coil enclosure.

JACK SHIELD

JS-1, Jack shield List \$
 For shielding small standard jacks mounted behind a panel, or on the ends of extension cords.

NATIONAL CABINETS

The National Cabinets listed below are the same as those used in National Receivers, except that they are supplied in blank form. They are made of heavy gauge steel, and the paint is unusually well bonded to the metal. Sub-bases and bottom covers are included in the price.

| Type | Width | Height | Depth | List Price |
|----------------|---------|--------|---------|------------|
| Type C-SW3 | 9 3/4" | 7" | 9" | |
| Type C-NC100 | 17 1/4" | 8 3/4" | 11 1/4" | |
| Type C-HRO | 16 3/4" | 8 3/4" | 10" | |
| Type C-One-Ten | 11" | 7" | 7 1/4" | |
| Type C-SRR | 7 1/2" | 7" | 7 1/2" | |



NATIONAL CABINETS

NATIONAL PARTS



CHART FRAME



COIL DOPE



TOUCH-UP PAINT

CHART FRAME

The National Chart Frame is blanked from one piece of metal, and includes a celluloid sheet to cover the chart. Size $2\frac{1}{4}'' \times 3\frac{1}{4}''$, with sides $\frac{1}{4}''$ wide.

Type CFA List \$

COIL DOPE

CD-1, $\frac{1}{4}$ pint can List \$
Liquid Polystyrene Cement — is ideal for windings as it will not spoil the properties of the best coil form.

TOUCH-UP PAINT

A high quality air-drying paint that may be applied with a brush. It is especially suited to touching up places on radio equipment where the paint may have become marred through abrasion.

CP-1, gray List \$
CP-2, black List \$

SPEAKER CABINETS

NDC-8 for 8" speaker List \$
NDC-10 for 10" speaker List \$
NDC-2 for 10" speaker List \$

These metal speaker cabinets are acoustically correct. They are lined with acoustic felt, and are of welded construction to eliminate rattles. Finish is black wrinkle on NDC-8 and NDC-10. NDC-2 is finished in two-tone gray to match the NC-200 TG receiver.

National Oscilloscopes have power supply and input controls built in. A panel switch permits use of the built-in 60-cycle sweep or external audio sweep for securing the familiar trapezoid pattern for modulation measurements.

CRM, less tubes List \$
1" screen, using RCA-913 and 6X5 rectifier. Table model, $4\frac{1}{8}'' \times 6\frac{1}{8}'' \times 8''$.

CRR, less tubes List \$
2" screen, using RCA-902 and 6X5 rectifier. Relay rack mounting.

I. F. TRANSFORMERS

IFC, Transformer, air core List \$
IFCO, Oscillator, air core List \$

Air dielectric condensers isolated from each other by an aluminum shield. Litz wound coils on a moisture proof ceramic base. Shield can $4\frac{1}{8}'' \times 2\frac{3}{8}'' \times 2''$. Available for either 175 KC or 450-550 KC. Specify frequency.

IFD, Diode Transformer, air core List \$

Tuned primary and untuned, closely-coupled secondary for full wave diode rectifiers. For noise silencing circuits, etc. 450-550 KC, air core only.

IFE, Transformer List \$
Same as IFC but iron core, 450-550 KC only.

IFG, IF Transformer List \$
IFH, Discriminator List \$

High frequency IF transformers, similar in construction to the IFC above. They are intended for FM receivers and others requiring a high IF frequency. Frequency is 3 MC. When definite assignment of the bands has been made these transformers will be available in a frequency which gives the minimum images in the FM and television bands.

IFJ, with variable coupling List \$
IFK, with fixed coupling List \$

15 MC IF transformers suitable for ultra high frequency superheterodynes. They are made in two models, with and without variable coupling.

National TRF units are designed as a single channel high fidelity TRF receiver for reception in the broadcast band. Each RF transformer is similar in construction to the IFC transformer above and is tuned both primary and secondary. The coupling is adjustable to include 10 KC with less than 1 db variation in the audio range. Sensitivity is adjustable from 5 microvolts to 1 volt. Three models cover ranges of 540-875, 740-1230, and 1100-1700 KC.

DLT, RF Transformer, set of four required. List, each \$



IFC



IFD

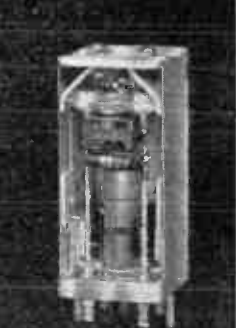

IFK



DLT
SET OF
FOUR
REQUIRED

NATIONAL OSCILLOSCOPES



CRM

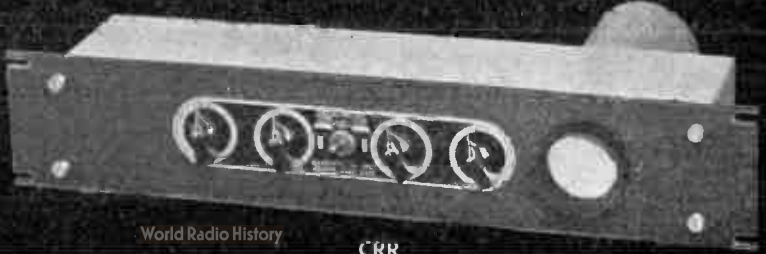

CRR

NATIONAL LOW-LOSS SOCKETS AND INSULATORS

XLA

List \$

A low-loss socket for the 6F4 and 950 series acorn tubes for frequencies as high as 600 MC. Conventional by-pass condensers may be compactly mounted between the contact terminals and the chassis. Low contact resistance, short and direct leads and low and constant inductance are features of the design.

XLA-S

List \$

An internal shield fitting the XLA socket and suitable for tubes such as the 956.

XLA-C

List \$

This miniature by-pass condenser may be mounted inside the socket, directly below the contact.

XCA

List \$

A low-loss socket for acorn triodes.

XMA

List \$

For pentode acorn tubes, this socket has built-in by-pass condensers. The base is a copper plate.

XM-10

List \$

A heavy duty metal shell socket for tubes having the UX base.

XM-50

List \$

A heavy duty metal shell socket for tubes having the Jumbo 4-pin base ("fifty watt-ers").

JX-50S

List \$

Without Standoff Insulators

JX-50S

List \$

With Standoff Insulators

A low-loss wafer socket for the 813 and other tubes having the Giant 7-pin base.

HX-100

List \$

HX-100S

List \$

A low-loss wafer socket suitable for the EIMAC-4-125-A, 4-250-A and other tubes using the Giant 5-pin base.

GS-1, 1/2" x 1 3/8" List \$

GS-2, 1/2" x 2 7/8" List \$

GS-3, 3/4" x 2 7/8" List \$

GS-4, 3/4" x 4 7/8" List \$

GS-4A, 3/4" x 6 7/8" List \$

Cylindrical low-loss steatite standoff insulators with nickel plated caps and bases.

GSJ, (not illustrated) List \$

A special nickel plated jack top threaded to fit the 3/4" diameter insulators GS-3, GS-4 & GS-4A.

GS-5, 1 1/4" List, each \$

GS-6, 2" List, each \$

GS-7, 3" List, each \$

GS-10, 3/4", package of 10 List \$

These cone type standoff insulators are of low-loss steatite. They have a tapped hole at each end for mounting.

GS-8, with terminal List \$

GS-9, with jack List \$

These low-loss steatite stand-off insulators are also useful as lead-through bushings.



XC Series Sockets

XC-4

List \$

XC-5

List \$

XC-6

List \$

XC-7S

List \$

XC-7L

List \$

XC-8

List \$

National wafer sockets have exceptionally good contacts with high current capacity together with low loss Isolatant insulation. All types have a locating groove to make tube insertion easy.

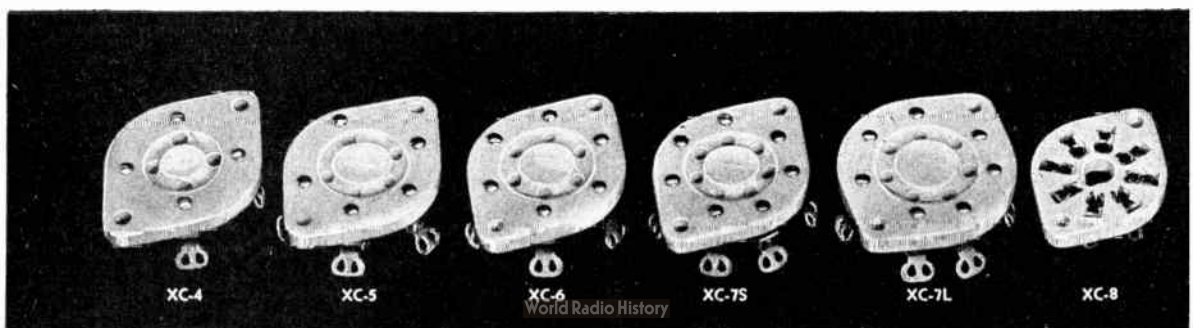

NATIONAL LOW-LOSS SOCKETS AND INSULATORS

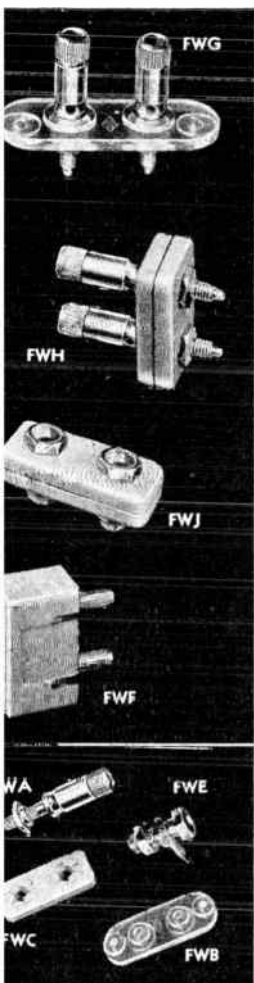

FWG List \$

A Victron terminal strip for high frequency use. The binding posts take banana plugs at the top, and grip wires through hole at the bottom, simultaneously, if desired.

FWH List \$

The insulators of this terminal assembly are molded R-39 and have serrated bosses that allow the thinnest panel to be gripped firmly, and yet have ample shoulders. Binding posts same as FWG above.

FWJ List \$

This assembly uses the same insulators as the FWH above, but has jacks. When used with the FWF plug (below), there is no exposed metal when the plug is in place.

FWF List \$

This molded R-39 plug has two banana plugs on $\frac{3}{4}$ " centers and fits FWH or FWJ above. Leads may be brought out through the top or side.

FWA, Post List, each \$ Brass Nickel Plated

FWE, Jack List, each \$ Brass Nickel Plated

FWC, Insulator List, per pair \$ R-39 Insulation

FWB, Insulator List, each \$ Polystyrene insulation

AA-3 List \$

A low-loss steatite spreader for 6 inch line spacing. (600 ohms impedance with No. 19 wire.)

AA-5 List \$

A low-loss steatite aircraft-type strain insulator.

AA-6 List \$

A general purpose strain insulator of low-loss steatite.

XS-6 List, each \$

A low-loss isolantite bushing for $\frac{1}{2}$ " holes.

XP-6

Same as above but Victron. List, box of ten \$

TPB List, per dozen \$

A threaded polystyrene bushing with removable .093 conductor moulded in, $\frac{1}{4}$ " diam., 32 thread.

XS-7, ($\frac{3}{8}$ " Hole) List \$

XS-8, ($\frac{1}{2}$ " Hole) List \$

Steatite bushings. Prices include male and female bushings with metal fittings.

XS-1, (1" Hole) List \$

XS-2, (1 $\frac{1}{2}$ " Hole) List \$

Prices listed are per pair, including metal fittings. Insulation steatite.

XS-3, (2 $\frac{3}{4}$ " Hole) List \$

XS-4, (3 $\frac{3}{4}$ " Hole) List \$

Prices are per pair, including metal fittings. These low-loss steatite bowls are ideal for lead-in purposes at high voltages.

XS-5, Without Fittings List, each \$

XS-5F, With Fittings List, per pair \$

These big low-loss bowls have an extremely long leakage path and a 5 $\frac{1}{4}$ " flange for bolting in place. Insulation steatite.

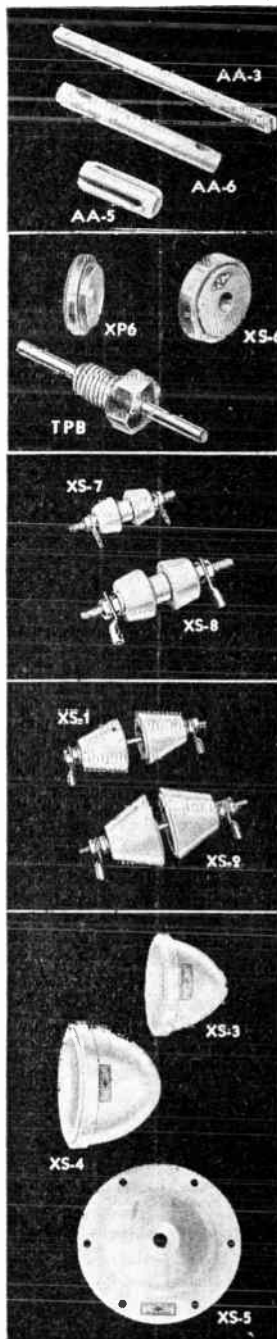

CIR Series Sockets

Any Type List \$

Type CIR Sockets feature low-loss isolantite or steatite insulation, a contact that grips the tube prong for its entire length, and a metal ring for six position mounting.

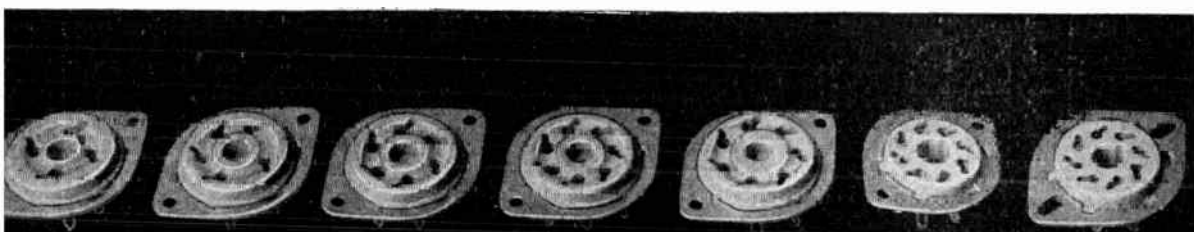

NATIONAL NC-2-40C

NATIONAL NC-2-40CS

The NC-2-40C is a twelve-tube superheterodyne covering a continuous frequency range of 490 to 30,000 KC. The NC-2-40CS is identical but covers from 200 to 400 KC and from 1000 to 30,000 KC.

The circuit employed on all bands consists of one stage of radio frequency amplification, a separate first detector and stabilized high frequency oscillator, two intermediate frequency stages, an infinite impedance second detector, a self-balancing phase inverter and audio amplifier, and an 8-watt push-pull audio output stage.

Auxiliary circuits include a crystal filter with exceptionally wide selectivity range for use on both CW and phone, a series valve noise limiter, AVC, beat oscillator, tone control, and signal strength meter. The power supply is built in.

These receivers have a number of new features of recent design. A new high frequency oscillator design of extreme stability eliminates detuning effects of RF gain control and motorboating or fluttering which occurs in some receivers when tuning in strong signals. A line voltage shift from 100 to 120 volts produces less than 1000 cycles at ten meters.

Sensitivity is particularly high, an input signal of 1 microvolt providing 1 watt of audio output, and full sensitivity is maintained up to the highest frequencies. Signal-to-image ratio is better than 30 db at ten meters. The AVC is flat within 2 db for signals from 10 to 100,000 microvolts. Moulded polystyrene

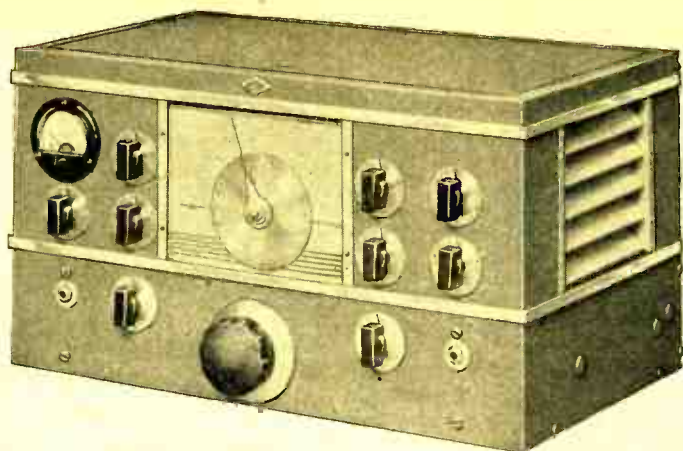

coil forms are used in both RF and IF circuits and padding and tuning condensers are of the air-dielectric type.

There are six calibrated coil ranges, controlled by a knob on the front panel which moves the desired coils into position below the tuning condenser and plugs them into the circuit. No coil switch is used. The tuning control has a ratio of 60 to 1 approximately, and is designed to have enough fly-wheel effect to facilitate spinning the knob for quick changes in frequency.

All models of the NC-2-40 are suitable for either AC or battery operation, having both a built-in AC power supply and a special detachable cable and plug for battery connection. Removal of the speaker plug disconnects both plate and screen circuits of the audio power stage thus providing maximum battery economy. The B supply filter and the standby switch are wired to the battery terminals, so that the filter is available for vibrator or dynamotor B supplies.

The ten-inch speaker is housed in a separate cabinet specially designed to harmonize with the trim lines of the receiver. The undistorted output is 8 watts.

- NC-2-40C, Table model, receiver only **List \$**
- NC-2-40CS, Table model, receiver only **List \$**
- NC2-TS, Table model 10" PM speaker to match receiver **List \$**

NATIONAL NC-46

The NC-46 receiver is a ten tube superheterodyne combining capable performance with low price. Features include a series valve noise limiter with automatic threshold control, CW oscillator, separate RF and AF gain controls, and amplified and delayed AVC. Power supplies are self contained and operate on 105 to 130 volts AC or DC. An audio output of 3 watts is provided by push-pull 25L6's.

A straight-line-frequency condenser is used in conjunction with a separate band spread condenser. This combination plus the full vision dial calibrated in frequency for each range covered and a separate linear scale for the band spread condenser, makes accurate tuning easy. Both condensers have inertia type drive. A coil switch with silver plated contacts selects the four ranges from 550 KC to 30 MC. Provision is made for either headphone or speaker.

Like all receivers which have no preselector stage, the NC-46 is not entirely free from images. However, where price is an important considera-



tion, the NC-46 will be found a very satisfactory receiver.

NC-46 — Receiver only, complete with tubes, coils covering from 550 KC to 30 MC for 105-130 volts AC or DC operation — gray finish.

List \$

NC-46TS — Loud Speaker in table mounting cabinet to match above receiver.

List \$

RRA — Relay Rack Adapters designed for mounting these receivers in a standard relay rack.

List \$



HRO-5TA table model, receiver only, complete with four sets of coils having bandspread on amateur bands as well as general coverage (1.7-4.0, 3.5-7.3, 7.0-14.4, 14.0-30.0 MC). List \$

HRO-5RA rack model, other details same as for HRO-5TA above. List \$

COILS

- HRO Type E, Range 900-2050 kc List \$**
- HRO Type F, Range 480-960 kc List \$**
- HRO Type G, Range 180-430 kc List \$**
- HRO Type H, Range 100-200 kc List \$**
- HRO Type J, Range 50-100 kc List \$**
- HRO Type A, Range 14.0-30.0 mc List \$**
- HRO Type B, Range 7.0-14.4 mc List \$**
- HRO Type C, Range 3.5-7.3 mc List \$**
- HRO Type D, Range 1.7-4.0 mc List \$**

MCS Table model cabinet, 8" PM dynamic speaker and matching transformer. List \$

697 Table power unit; 115 volt, 60 cycle input; 6.3 volt heater and 230 volt, 75 ma. output, with tube. List \$

See General Catalogue for relay rack mounting, coil containers and accessories

NATIONAL HRO

The HRO Receiver is a high-gain super-heterodyne designed for communication service. Two preselector stages give remarkable image suppression, weak signal response and high signal-to-noise ratio. Air-dielectric tuning capacitors account, in part, for the high degree of operating stability. A crystal filter with both variable selectivity and phasing controls

makes possible adjustment of selectivity over a wide range. Heterodynes and interfering c.w. signals may be "phased out" (attenuated) by correct setting of the phasing control. A signal strength meter, connected in a vacuum tube bridge circuit, is calibrated in S units from 1 to 9 and in db above S9 from 0 to 40. Also included are automatic and manual volume control, a beat oscillator, a headphone jack and a B+ stand-by switch. Power supply is a separate unit. The standard models, HRO-5TA and HRO-5RA, are supplied with four sets of coils covering all frequencies from 1.7 to 30 MC and have bandspread on the 10, 20, 40 and 80 meter amateur bands.

All models of the HRO are supplied with 6.3 volt heater type metal tubes. Table models and accessories are finished in black wrinkle enamel.

A technical bulletin covering completely all details will be supplied upon request.



NATIONAL } SCR-4 } SCR-4A

flat within 6 db for inputs from 1 microvolt to 1 volt. Being crystal controlled, frequency stability is excellent. The IF channel has a wide-band characteristic to allow for slight transmitter drift.

As the SCR-4 receiver is intended for communication work, the audio channel has been made flat only from 100-3000 cycles, with increasing attenuation of higher frequencies, thus providing good intelligibility with maximum reduction of unwanted signals and noise.

NATIONAL SCR-4A List \$

The SCR-4A receiver is similar to the SCR-4 but has no beat oscillator and no signal strength meter. Both receivers are available for use at fixed frequencies between 100 KC and 40 MC.

NATIONAL SCR-4 List \$

The SCR-4 is an extremely compact crystal controlled receiver for single channel reception. It is mounted on a 5 1/4" panel and uses 13 tubes. Two stages of tuned RF amplification are followed by a separately excited converter with crystal controlled oscillator, three stages of IF amplification, a detector and two audio stages. The power supply is self-contained. Auxiliary circuits include amplified and delayed AVC, CW oscillator, noise limiter, CONS and signal strength meter. Signal-to-noise ratio averages 6 db for 1 microvolt. The AVC is



1-10 Receiver and 6 sets of coils, without tubes, speaker or power supply. List \$

5886 Power Supply for above receiver, with tube. List \$

NATIONAL ONE-TEN

The One-Ten Receiver fulfills the need for an adequate receiver to cover the field between one and ten meters.

A four-tube circuit is used, composed of one tuned R.F. stage, a self-quenching super-regenerative detector, transformer coupled to a first stage of audio which is resistance coupled to the power output stage. Tubes required: 954-R.F.; 955-Detector; 6C5-1st Audio, 6F6-2nd Audio.

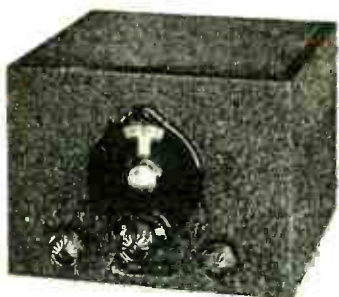

NATIONAL SW-3

The SW-3U Receiver employs a circuit consisting of one R.F. stage transformer coupled to a regenerative detector and one stage of impedance coupled audio. This circuit provides maximum sensitivity and flexibility with the smallest number of tubes and the least auxiliary

equipment. The single tuning dial operates a precisely adjusted two gang condenser; the regeneration control is smooth and noiseless, with no backlash or fringe howl; the volume control is calibrated from one to nine in steps corresponding to the R scale.

ONE UNIVERSAL MODEL — The circuit of the SW-3U is arranged for either battery or AC operation without coil substitution or circuit change. Battery operation utilizes two 1N5-G and one 1A5-G tubes. AC operation utilizes two 6J7-G and one 6C5-G tubes. Type 5886 AB power supply is recommended.

SW-3U, Universal model, without coils, phones tubes or power supply. List \$

5886-AB, Power Supply, 115 V., 60 cycle, with 80 Rectifier. List \$

General Coverage Coils

| Cat. No. | Range | Meters | List Per Pair \$ |
|----------|--------------|--------|------------------|
| 30 | 9 to 15 | | \$ |
| 31 | 13.5 to 25 | | |
| 32 | 23 to 41 | | |
| 33 | 40 to 70 | | |
| 34 | 65 to 115 | | |
| 35 | 115 to 200 | | |
| 36 | 200 to 360 | | |
| 37 | 350 to 550 | | |
| 38 | 500 to 850 | | |
| 39 | 850 to 1200 | | |
| 40 | 1200 to 1500 | | |
| 41 | 1500 to 2000 | | |
| 42 | 2000 to 3000 | | |

Band Spread Coils

| | | |
|-----|-------------|----------|
| 30A | — 10 meter | \$ |
| 31A | — 20 meter | |
| 33A | — 40 meter | |
| 34A | — 80 meter | |
| 35A | — 160 meter | |



POWER SUPPLIES

NATIONAL POWER SUPPLIES

National Power Supplies are specially designed for high frequency receivers, and include efficient filters for RF disturbances as well as for hum frequencies. The various types for operation from an AC line are listed under the receivers with which they are used.

High voltage power supplies can be supplied for National Receivers for operation from batteries. These units are of the vibrator type.

686, Table model (165 V., 50 MA.), for operation from 6.3 volts DC, with vibrator. List \$

NATIONAL



COMPANY

61 SHERMAN STREET, MALDEN, MASS., U. S. A.

ABBREVIATIONS COMMON IN INFORMAL RADIO TRAFFIC

| | | | |
|-----------------|-----------------------------|-------------|-----------------|
| ABT | About | MO | More |
| AGN | Again | MSG | Message |
| AHD | Ahead | MT | Empty |
| AHR | Another | N | No |
| ANI | Any | ND | Nothing Doing |
| APRX | Approximate-Approximately | NG | No Good |
| BC | Broadcast | NIL | Nothing |
| BD | Bad | NM | No More |
| B4 | Before | NR | Number |
| BK | Break | NW | Now |
| BN | Been | OB | Old Boy |
| BND | Band | OL | Old Lady |
| BCUZ | Because | OM | Old Man |
| BTWN | Between | OP | Operator |
| BIZ | Business | OT | Old Top—Timer |
| C | See, Yes | OW | Old Woman |
| CLR | Clear | PLS | Please |
| CN | Can | PSE | Please |
| CNT | Can't | PX | Press |
| CK | Check | R | OK |
| CKT | Circuit | RCD | Received |
| CMG | Coming | RCVR | Receiver |
| CUD | Could | RI | Radio Inspector |
| CW | Continuous Wave | SA | Say |
| CUL | See You Later | SEZ | Says |
| CUAGN | See You Again | SM | Some |
| DE | From | SW | Short-wave |
| DA | Day | SIG | Signal |
| DNT | Don't | SKED | Schedule |
| DINT | Did Not | TFC | Traffic |
| DH | Deadhead | TMW | Tomorrow |
| DX | Long Distance | TR | There |
| ES | And | TT | That |
| EZ | Easy | TK | Take |
| FB | Fine Business | TKS | Thanks |
| FM | From | TNK | Think |
| FR | For | TNX | Thanks |
| FRQ | Frequency | U | You |
| GA | Go Ahead | UD | You Would |
| GB | Good-Bye | UL | You Will |
| GM | Good Morning | UR | Your |
| GN | Good Night | VT | Vacuum Tube |
| GG | Going | VY | Very |
| GT | Got—Get | WA | Word After |
| GND | Ground | WB | Ward Before |
| HA or HI | Laughter | WD | Would |
| HM | Him | WF | Word Following |
| HR | Here—Hear | WK | Work |
| HV | Have | WL | Will—Would |
| HW | How | WN | When |
| IC | I See | WT | What |
| ICW | Interrupted Continuous Wave | WX | Weather |
| K | Go Ahead | X | Interference |
| LID | Poor Operator | XMTR | Transmitter |
| LIL | Little | XTAL | Crystal |
| LFT | Left | YF | Wife |
| LST | Last—Listen | YL | Young Lady |
| LTR | Letter | YR | Your |
| MG | Motor Generator | 30 | Finish—End |
| MI | My | 73 | Best Regards |
| MK | Make | 88 | Love and Kisses |

LE A eon

High Frequency Transmitting Triodes

Filament.....Thariated Tungsten
 Voltage.....6.3 ac or dc volts
 Current.....3.0 amps
 Amplification factor.....25

Direct Interelectrode Capacitances:

| | 3C24 | 3C34 | 3C28 |
|---------------------|------|------|-----------|
| Grid-Plate..... | 1.6 | 1.7 | 1.8 mmfds |
| Grid-Filament..... | 2.0 | 2.5 | 2.1 mmfds |
| Plate-Filament..... | 0.2 | 0.4 | 0.1 mmfds |

Class "C" R-F Amplifier Frequency Limits

| | 3C24 | 3C34 | 3C28 |
|-----------------------|------|------|---------|
| Full power input..... | 60 | 60 | 100 mcs |
| Half power input..... | 250 | 200 | 350 mcs |

Licensed under R.C.A. Patents

Filament voltage.....6.3 AC or DC volts
 Filament current.....3.0 amperes
 Amplification factor.....65
 Mutual conductance.....2,750
 Plate dissipation.....35 watts
 Medium 4 pin ceramic base.....
 Maximum power output.....130 watts
 Approx. driving power.....4.5 watts

Inter-Electrode Capacities

Input to Plate.....2 mmfd
 Input, 6.5 mmfd.....output, 1.8 mmfd
 Licensed under R.C.A. Patents

Filament voltage.....5 volts
 Filament current.....7.5 amperes
 Mutual conductance.....2800
 Plate voltage.....maximum 2000 v.
 Screen voltage.....maximum 500 v.
 Grid voltage.....maximum -500 v.
 Plate current.....maximum 150 ma.
 Grid current.....maximum 25 ma.
 Plate dissipation......75 watts
 Driving power.....1.5 watts
 Power output.....250 watts

Inter-Electrode Capacities

Grid-plate......1 mmfd
 Grid-filament.....11 mmfd
 Plate-filament.....5.5 mmfd

The 4DX1 is a transmitting beam power tet-
 rode, suitable for use in a final amplifier. Two
 tubes will provide power handling capabilities
 sufficient for a 1000 watt carrier. This tube is
 also applicable to Class "B" audio frequency
 modulation service. Further descriptive ma-
 terial on this new tube will be available soon.

1. Three high frequency
transmitting triodes

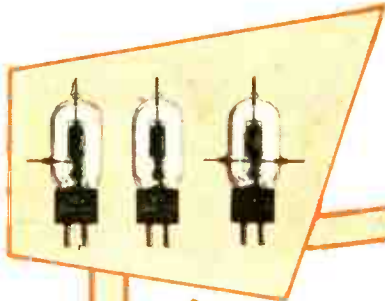

2. New beam tetrode

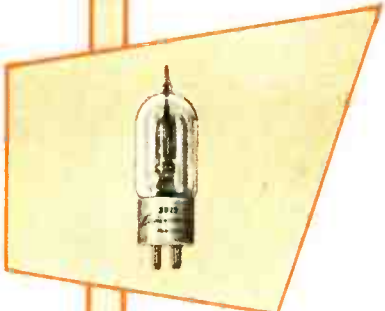

3. Beam pentode of
many uses

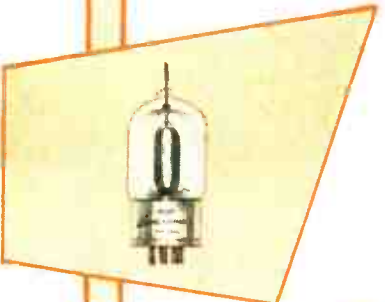

4. High frequency beam
power tetrode



Air eon

MANUFACTURING CORPORATION

General Offices: KANSAS CITY

Branches: NEW YORK • GREENWICH • CHICAGO • OKLAHOMA CITY

BURBANK • WASHINGTON • LOS GATOS • SAN FRANCISCO • SLATER, MISSOURI

SUPPLY YOUR NEEDS

Lewis **ELECTRONICS**

by **Air eon**

Cinaudagraph Speakers

by **Air eon**

PIEZOELECTRIC CRYSTALS

by **Air eon**

COMMUNICATION SYSTEMS

by **Air eon**

Air eon is proud to announce its acquisition of three distinguished firms of the radio field . . . LEWIS ELECTRONICS, INC., CINAUDAGRAPH SPEAKERS, INC. and OXFORD SPEAKERS.

Air eon and its subsidiaries can now supply the needs of radio "hams" in transmitting and rectifying tubes through Lewis of Los Gatos . . . in speakers through Cinaudagraph Speakers . . . and in crystals and communication systems through Aireon.

Air eon Lewis and Cinaudagraph Speakers have meritorious war records—hard earned experience that means better products for your peacetime communications.

Write, wire or phone one of our representatives today for more information.

Air eon

MANUFACTURING CORPORATION

General Offices: KANSAS CITY

Branches: NEW YORK • GREENWICH • CHICAGO • OKLAHOMA CITY
BURBANK • WASHINGTON • LOS GATOS • SAN FRANCISCO • SLATER, MISSOURI

LET Aireon SUPPLY

Tomorrow's Speaker Today!

THE Aireon Cinaudagraph Speaker is a product of deft engineering, vast experience, daily profound research and proven performance. It has an International reputation for tone, stamina and working perfection under even the most adverse conditions. During the war years Cinaudagraph Speakers were made in many army and navy styles — always to do the big vital job for which they were designed. From small watch-like “Walkie-Talkie” receivers to huge naval projection speakers the highest manufacturing standards prevailed — that’s the background of recognized integrity you get with each Aireon Cinaudagraph Speaker, today.

Cinaudagraph Speakers

a subsidiary of Aireon

Aireon

MANUFACTURING CORPORATION

General Offices: KANSAS CITY

Branches: NEW YORK • GREENWICH • CHICAGO • OKLAHOMA CITY

BURBANK • WASHINGTON • LOS GATOS • SAN FRANCISCO • SLATER, MISSOURI

YOUR NEEDS

TURNING once more to peacetime production, Cinaudagraph Speaker Engineers present a superior line of precision manufactured and highly efficient loud speakers. Every unit is made from the finest raw materials — each finished unit must pass the most rigid inspection tests. Plans now include the making of models in many types and sizes — a full line of high-fidelity P.M. and dynamic speakers. All P.M. models of Aireon Cinaudagraph Speakers use Alnico 5, the "miracle metal" that gives you 4 times the performance without size or weight increase. No set-up is complete without at least one — write for information, now.



Cinaudagraph Speakers
a subsidiary of **Aireon**

Aireon

MANUFACTURING CORPORATION

General Offices: KANSAS CITY

Branches: NEW YORK • GREENWICH • CHICAGO • OKLAHOMA CITY
BURBANK • WASHINGTON • LOS GATOS • SAN FRANCISCO • SLATER, MISSOURI

JOINT ARMY-NAVY STANDARD
SPECIFICATION JAN-C-5
"CAPACITORS, MICA-DIELECTRIC, FIXED"

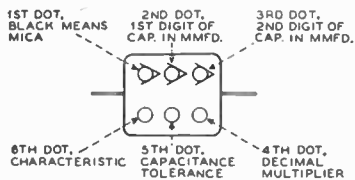

EXAMPLE

1ST DOT BLACK, 2ND DOT GREEN, 3RD DOT BROWN, 4TH DOT BROWN, 5TH DOT GOLD, 6TH DOT RED = 510 MMFD. \pm 5% CHARACTERISTIC "C"

| COLOR | DIGIT NUMERAL | CHARACTERISTIC | DECIMAL MULTIPLIER | TOLERANCE |
|--------|---------------|----------------|--------------------|-----------|
| BLACK | 0 | A | 1 | 20% (M) |
| BROWN | 1 | B | 10 | |
| RED | 2 | C | 100 | 2% (G) |
| ORANGE | 3 | D | 1000 | |
| YELLOW | 4 | E | | |
| GREEN | 5 | | | |
| BLUE | 6 | | | |
| VIOLET | 7 | | | |
| GRAY | 8 | | | |
| WHITE | 9 | | | |
| GOLD | | | 0.1 | 5% (J) |
| SILVER | | | 0.01 | 10% (K) |

DESCRIPTION OF CHARACTERISTIC

| CHARACTERISTIC | TEMPERATURE COEFFICIENT PARTS/MILLION DEGREES C | CAPACITANCE DRIFT |
|----------------|---|--------------------------------|
| A | NOT SPECIFIED | NOT SPECIFIED |
| B | NOT SPECIFIED | NOT SPECIFIED |
| C | -200 TO +200 | \pm 0.5 PERCENT |
| D | -100 TO +100 | \pm 0.3 PERCENT |
| E | -20 TO +100 | \pm (0.1 PERCENT + 0.1 MMFD) |

MICA CAPACITOR COLOR CODE
RMA STANDARDS
SIX DOT RMA COLOR CODE

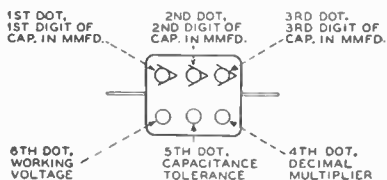

EXAMPLE

1ST DOT BROWN, 2ND DOT ORANGE, 3RD DOT RED, 4TH DOT BROWN, 5TH DOT RED, 6TH DOT GREEN = 1320 MMFD \pm 2%, 500 V.W.

| COLOR | DIGIT NUMERAL | DECIMAL MULTIPLIER | TOLERANCE | VOLTS WORKING |
|--------|---------------|--------------------|-----------|---------------|
| BLACK | 0 | 1 | 20% | — |
| BROWN | 1 | 10 | 1% | 100 |
| RED | 2 | 100 | 2% | 200 |
| ORANGE | 3 | 1000 | 3% | 300 |
| YELLOW | 4 | 10000 | 4% | 400 |
| GREEN | 5 | | 5% | 500 |
| BLUE | 6 | | 6% | 600 |
| VIOLET | 7 | | 7% | 700 |
| GRAY | 8 | | 8% | 800 |
| WHITE | 9 | | 9% | 900 |
| GOLD | | 0.1 | | 1000 |
| SILVER | | 0.01 | 10% | |

FOUR DOT RMA COLOR CODE

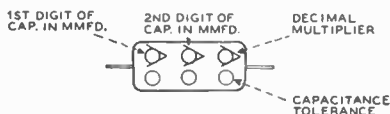

LIGHT BULB RESISTORS

Ordinary tungsten-filament light bulbs make good r.f. and a.f. load resistors since they are relatively non-inductive. Their resistance is not constant with varying power; the table gives the resistance of common bulbs at various wattages. The color is dull red at about one-third rated wattage and bright yellow at two-thirds wattage.

A 30-watt a.f. amplifier with 500-ohm output may be connected to two 40-watt bulbs in series; each will dissipate 15 watts and will glow dull red.

Bulbs make good terminating resistors for untuned feed lines while making coupling adjustments to the final amplifier; the color also serves as an indicator of maximum current. The resistors may be clipped across a few turns of the tank coil, or connected to a tuned circuit which in turn is coupled to the tank.

Bulbs make excellent dummy antennas, whereby the transmitter can be completely checked without putting interfering signals on the air. If the dummy's resistance closely equals the antenna's radiation resistance no change in transmitter adjustments need be made when the antenna is substituted for the dummy. A d.p.d.t. should be provided to shift from one to the other.

LIGHT BULB RESISTANCE CHART

Resistance of 115-Volt Tungsten Bulbs

| Watts | WATTAGE RATING | | | | | |
|-------|----------------|-----|-----|-----|-----|-----|
| | 25 | 40 | 50 | 60 | 75 | 100 |
| 5 | 349 | 195 | 148 | 119 | 90 | 65 |
| 10 | 412 | 228 | 175 | 139 | 106 | 74 |
| 15 | 470 | 255 | 194 | 153 | 116 | 81 |
| 20 | 497 | 273 | 207 | 163 | 124 | 87 |
| 25 | 529 | 291 | 220 | 172 | 132 | 92 |
| 30 | | 306 | 231 | 181 | 137 | 96 |
| 35 | | 319 | 241 | 189 | 143 | 100 |
| 40 | | 331 | 249 | 197 | 148 | 103 |
| 45 | | | 257 | 204 | 153 | 106 |
| 50 | | | 265 | 211 | 158 | 110 |
| 55 | | | | 215 | 162 | 112 |
| 60 | | | | 220 | 166 | 115 |
| 65 | | | | | 169 | 117 |
| 70 | | | | | 173 | 120 |
| 75 | | | | | 176 | 122 |
| 80 | | | | | | 124 |
| 85 | | | | | | 126 |
| 90 | | | | | | 128 |
| 95 | | | | | | 130 |
| 100 | | | | | | 132 |

(Table courtesy "Thordarson Transformer Guide")



Model S-37.



Model S-36.



Model SX-28A.



Model S-22R.

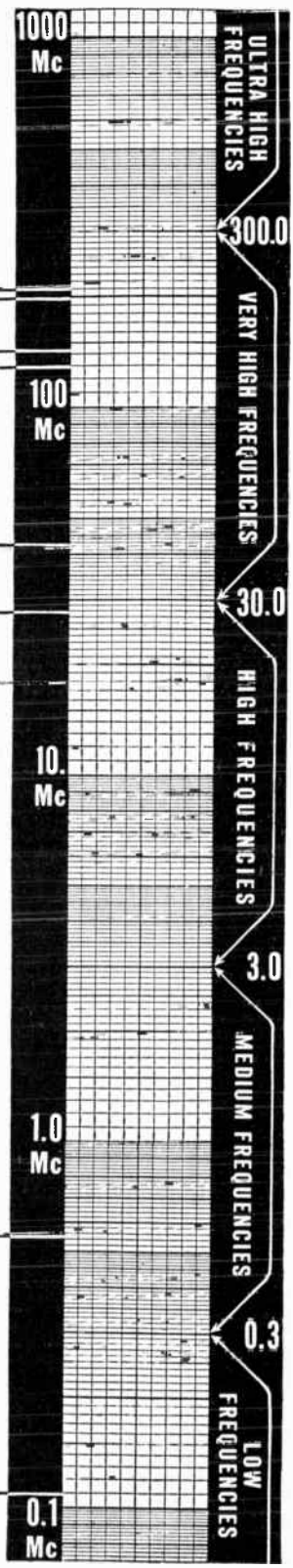

hallicrafters equipment covers the spectrum

• Hallicrafters equipment covers the radio spectrum. From low to ultra high frequencies there is a Hallicrafters receiver ready to meet your special requirements. Although certain equipment operating in the ultra high frequencies cannot be described at present for security reasons, the characteristics of Hallicrafters standard line of receivers may be disclosed. This line includes:

Model S-37. FM-AM receiver for very high frequency work. Operates from 130 to 210 Mc. Highest frequency range of any general coverage commercial type receiver.

Model S-36. FM-AM-CW receiver. Operates from 27.8 to 143 Mc. Covers old and proposed new FM bands. Only commercially built receiver covering this range.

Model SX-28A. Operates from 550 kc to 42 Mc continuous in six bands. Combines superb broadcast reception with the highest performance as a versatile communications receiver.

Model S-22R. Completes Hallicrafters coverage in the lower end of the spectrum. Operates from 110 kc to 18 Mc in four bands. A.c./d.c. operation.



hallicrafters

THE HALLICRAFTERS CO., MANUFACTURERS OF RADIO AND ELECTRONIC EQUIPMENT - CHICAGO 16, U. S. A.

HOW hallicrafters EQUIPMENT COVERS THE SPECTRUM

MODEL SX-28A — from 550 kc to 42 Mc



HALLICRAFTERS Super-Skyrider, Model SX-28A, covers the busiest part of the radio spectrum—standard broadcast band, international short wave broadcast bands, long distance radio telegraph frequencies, and all the other vital services operating between 550 kilocycles and 42 megacycles. Designed primarily as a top flight communications receiver the SX-28A incorporates every feature which long experience has shown to be desirable in equipment of this type.

The traditional sensitivity and selectivity of the pre-war SX-28, ranking favorite with both amateur and professional operators, have been further improved in this new Super Skyrider by the use of "micro-set" permeability-tuned inductances in the RF section. The inductances, trimmer capacitors and associated components for each RF stage are mounted on small individual sub-chassis, easily removable for servicing.

Full temperature compensation and positive gear drive on both main and band-spread tuning dials make possible the accurate and permanent logging of stations. Circuit features include two RF stages, two IF stages, BFO, three stage Lamb-type noise limiter, etc. Six degrees of selectivity from BROAD IF (approximately 12 KC wide) for maximum fidelity to SHARP CRYSTAL for CW telegraphy are instantly available. Speaker terminals to match 500 or 5000 ohms are provided and the undistorted power output is 8 watts.

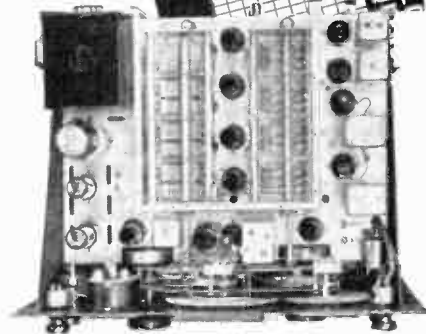

hallicrafters RADIO

COPYRIGHT 1945 THE HALLICRAFTERS CO.

THE HALLICRAFTERS CO., MANUFACTURERS OF RADIO AND ELECTRONIC EQUIPMENT • CHICAGO 16, U. S. A.

624

HOW hallicrafters EQUIPMENT COVERS THE SPECTRUM

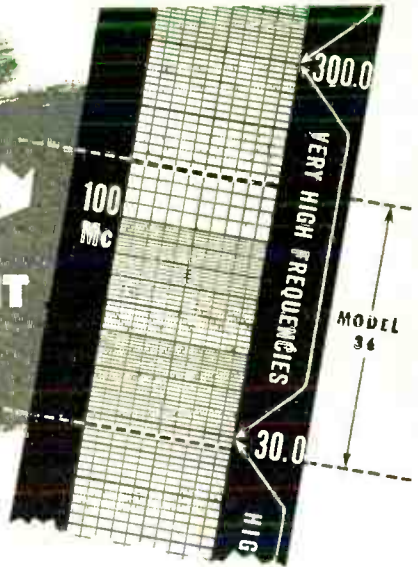

THE Model S-36 is probably the most versatile VHF receiver ever designed. Covering a frequency range of 27.8 to 143 megacycles it performs equally well on AM, FM, or as a communications receiver for CW telegraphy. Equipment of this type was introduced by Hallicrafters more than five years ago and clearly anticipated the present trend toward improved service on the higher frequencies.

Fifteen tubes are employed in the S-36 including a voltage regulator and three acorn tubes in the RF section. The type 956 RF amplifier in conjunction with an intermediate frequency of 5.25 megacycles assures adequate image rejection over the entire range of the receiver. The average overall sensitivity is better than 5 microvolts and the performance of the S-36 on the very high frequencies is in every way comparable to that of the best communications receivers on the normal short wave and broadcast bands.

The audio response curve is essentially flat within wide limits and an output of over 3 watts with less than 5% distortion is available. Output terminals for 500 and 5000 ohms are provided.

Model S-36

FM-AM-CW

27.8 to 143 Mc.

Covers old and new FM Bands

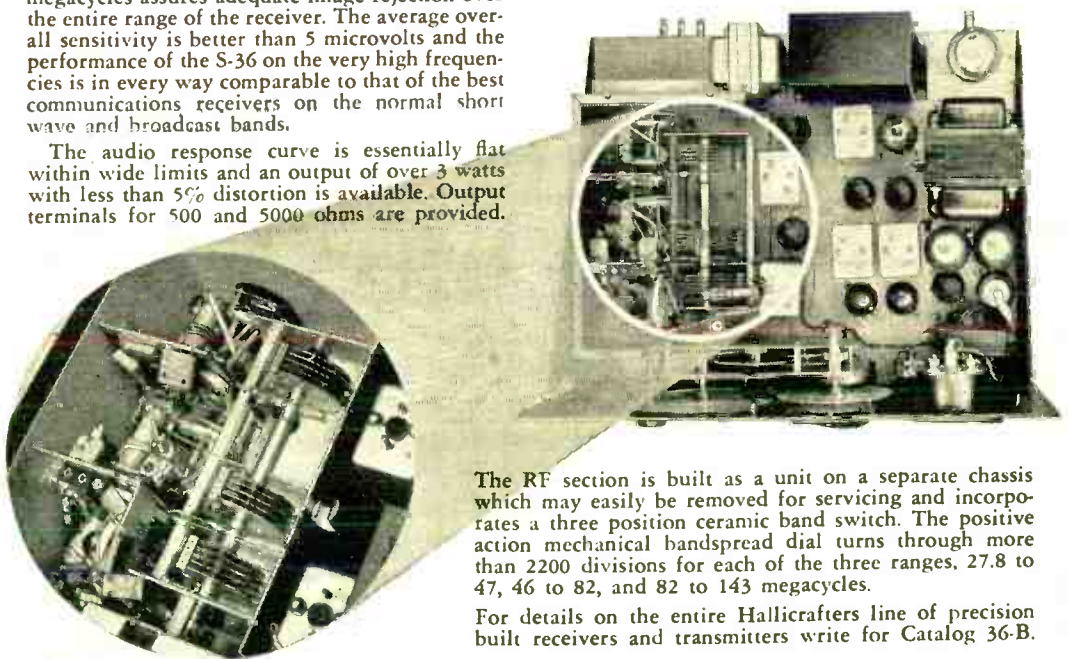

The RF section is built as a unit on a separate chassis which may easily be removed for servicing and incorporates a three position ceramic band switch. The positive action mechanical bandspread dial turns through more than 2200 divisions for each of the three ranges, 27.8 to 47, 46 to 82, and 82 to 143 megacycles.

For details on the entire Hallicrafters line of precision built receivers and transmitters write for Catalog 36-B.

COPYRIGHT 1945 THE HALLICRAFTERS CO.

hallicrafters RADIO



THE HALLICRAFTERS CO., MANUFACTURERS OF RADIO AND ELECTRONIC EQUIPMENT • CHICAGO 16, U. S. A.

The NEW RME

45 RECEIVER



PERFORMANCE BACKED BY PRECISION



THE XC-2 PLUG-IN UNIT

A unit for fixed frequency operation of RME communications receivers. A crystal ground to a frequency either 455KC higher or lower than the frequency of the signal to be received, is an integral part of the XC-2. The XC-2 is inexpensive, easily adapted and very effective in locations where fixed frequency operation of a general coverage receiver is desired.

INDIVIDUAL EQUIPMENT BULLETINS
WITH PRICES AVAILABLE ON ALL
RME UNITS.

Every control is conveniently located, all scales are illuminated and distinctive, the chassis is mounted on a relay rack panel, and the cabinet is attractively designed in a two-tone finish.

The RME • 45 is the type of receiver by which radio amateurs the world over judge dependability and performance; **PRIDE OF OWNERSHIP MUST BE BUILT INTO EVERY SET**—that has been our creed in the past twelve years.

The RME • 45 is truly your postwar receiver dream come true! It has been so engineered that it delivers peak performance on all frequencies 550 to 33,000 KC. Loctal tubes, short leads, temperature compensating padders, triple spaced condensers and advances made while producing for the armed forces— all these details have collaborated to give you the “finest” and most stable reception you have ever listened to.

There is bandsread aplenty for the most exacting ham or



RME

FINE COMMUNICATIONS EQUIPMENT

RADIO MFG. ENGINEERS, INC.

Provia 6, Illinois U. S. A.

commercial operator. The 20 meter band, 14,000 to 14,400 KC., for instance, covers 20 divisions on the translucent dial—equivalent to 72 degrees on a five-inch diameter disc.

The appearance of the RME-45 is consistent with its performance. The receiver is housed in a new streamlined two-toned cabinet and supplied with a matched acoustically designed speaker housing.

These and a multitude of additional features make the new RME-45 the receiver you have long been waiting for!

Features

- Streamline Two-Tone Cabinet
- Acoustically Designed Speaker Housing
- Relay Rack Mounting Panel
- Six Bands, 550 to 33,000 KC
- Automatic Noise Limiter
- Relay Control and Break-In Terminals
- Signal Level Meter
- Variable Crystal Filter
- Bandspread Equivalent To 75 Linear Inches For Every 180° Sweep Of Main Pointer

R. M. E. S P E A K E R

A new housing to match the new receiver, built in a sturdy design, open in the rear, the eight-inch electrodynamic speaker in every way gives true and balanced performance, no matter whether used for CW, voice or music!

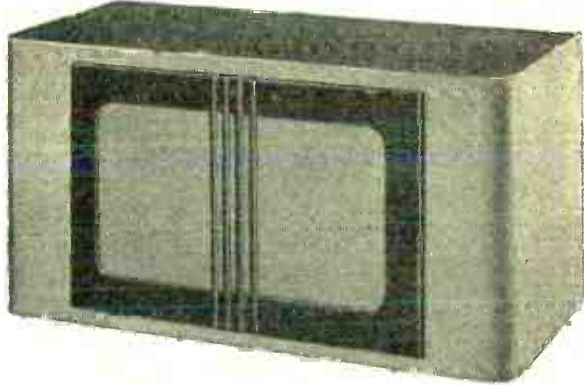

The new VHF-152, with the addition of a good communications receiver, will give you the best in all band amateur reception.

VHF-152 CONVERTER

During pre-war days, thousands of hams were introduced to the five meter band through the use of the DM 36, High Frequency Converter.

This instrument gave exceptional performance, at low cost, on the 5 and 10 meter bands when used with a good communications receiver.

To make VHF operation really practical and worthwhile for the new FCC allocations, an entirely new version of the DM 36 is now introduced covering 28 to 30MC, 50 to 54MC and the new 144 to 148 MC band. At modest cost, the VHF 152 far exceeds any present day method offered for working these frequencies. Your RME-45 is an excellent receiver to use with the VHF-152. RME has always pioneered with the finest first!

Stay on the air with

RAYTHEON Tubes

Amateurs like to work their rigs *hard*—overload power tubes to get more output. Raytheon tubes stand up under such conditions—because they're built to operate well beyond their minimum performance standards, as described by ratings or Army-Navy specifications.

Remember the first power pentodes? They were built by Raytheon. And now Raytheon is ready to go back to work for amateurs . . . providing you with tubes of new design, built to keep you on the air.



RAYTHEON

Excellence in Electronics

RAYTHEON MANUFACTURING COMPANY
Amateur Radio Division, Waltham 54, Mass.



Peak Performance

Look for the Raytheon trademark on the best tubes of all types for amateur use. Special advanced design developments, particularly in the ultra-high frequency range, have been engineered to meet your needs.

• • •

Copyright 1943
Raytheon Manufacturing Company
 RADIO RECEIVING TUBE DIVISION
 NEWTON, MASS. • LOS ANGELES • NEW YORK • CHICAGO • ATLANTA



Watch for
 Raytheon
 Announcements

DEVOTED TO RESEARCH AND THE MANUFACTURE OF TUBES FOR THE NEW ERA OF ELECTRONICS

BURGESS BATTERIES

for every purpose

RECOGNIZED BY THEIR STRIPES • REMEMBERED FOR THEIR SERVICE

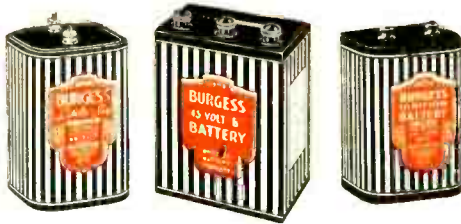

No. 4FA

No. 5308

No. F4BP

No. 4FA LITTLE SIX—1½ volts—replaces one round No. 6 cell. Radio "A" type; is recommended for the filament lighting of vacuum tubes. Size, 4¼" x 2⁹/₁₆" x 2⁹/₁₆". Weight, 1 lb. 5 oz.

No. 5308—45 volt "B" battery equipped with insulated junior knobs. Taps at —, +22½, +45 volts. Size, 5⁷/₈" x 4³/₁₆" x 2⁹/₁₆". Weight, each—2 lbs. 15 oz.

No. F4BP—A 6 volt, heavy-duty portable battery, designed for Burgess X109 headlight. Contains four F cells connected in series. Screw terminals and brass knurled nuts. Size, 2²/₃₂" x 2²/₃₂" x 4⁷/₃₂". Weight, 1 lb. 6 oz.

No. 2308—A 45 volt super-service, standard size radio "B". Designed for receivers with plate current drain of 10 to 15 milliamperes. Size, 7¹/₈" x 8" x 2⁷/₈". Weight, 7 lbs. 6 oz.

No. Z30N—45 volt "B" battery. Improved small size. Adapted to radio, portable receivers and transmitters. Screw terminals. Size, 3" x 1⁷/₈" x 4³/₃₂". Weight, 1 lb. 4 oz.

No. 2F2H—A 3 volt radio "A" battery used with portable radios, amplifiers, and special instruments. Size, 2⁵/₈" x 2⁵/₈" x 4³/₈". Weight, 1 lb. 6 oz.

No. W30BPX—45 volts. Extremely small and light in weight. Very suitable for personal transceivers used by amateur clubs and radio stations. Equipped with insulated junior knobs. Size, 1⁷/₃₂" x 2²/₃₂" x 4¹/₁₆". Weight, 10 oz.

No. Z30N

No. 2F2H

No. W30BPX

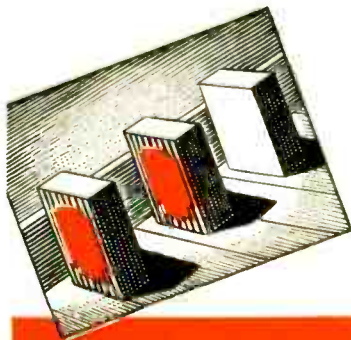

VOTED FIRST CHOICE

IN NATIONAL POLL OF ELECTRONIC ENGINEERS

2 out of 3! That's the way electronic engineers voted for Burgess Batteries in a recent survey. Use the brand the experts choose...**BUY BURGESS!**

Fresh Stocks at Your Local Burgess Distributor

BURGESS BATTERY COMPANY

F R E E P O R T • I L L I N O I S

632



For Quality Leadership in

1

AM and FM communications equipment.

2

**AM and FM broadcast transmitters, remote amplifiers,
and studio accessories.**

3

Amateur Radio Equipment.

THE COLLINS RADIO COMPANY

Cedar Rapids, Iowa

11 West 42nd St., New York 18, N. Y.

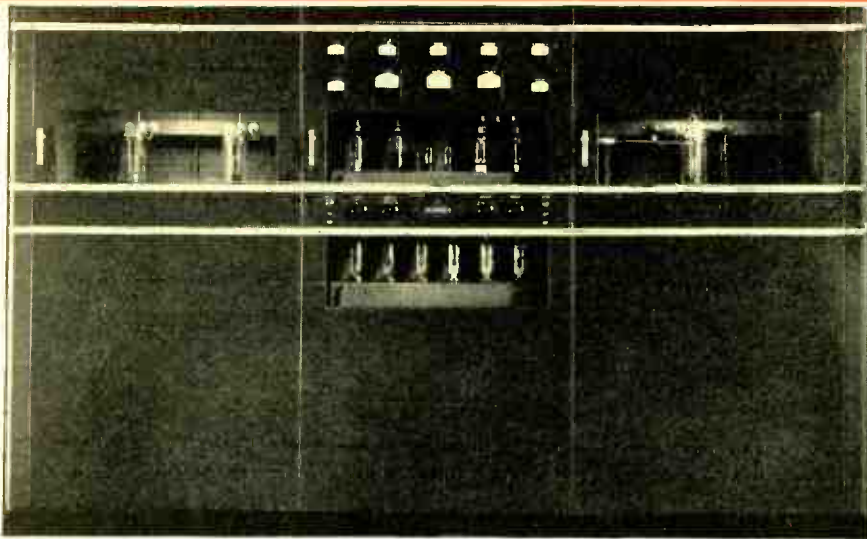

The Collins 21A 5 KW AIR COOLED BROADCAST TRANSMITTER

AM Broadcast Transmitters and Accessories

featuring high fidelity, and increased safety factors through use of oversize components



1. 21A, 5 kw, automatic reduction to 1 kw.
2. 20T, 1 kw, automatic reduction to 500w.
3. 300G, 250w, automatic reduction to 100w.
4. 12Y remote amplifier, 1 channel, a.c.
5. 12Z remote amplifier, 4 channel, a.c./d.c.
6. Three types of studio consoles.
7. Program, limiting, and line amplifiers and monitors.

FM COMMUNICATION AND BROADCAST TRANSMITTERS

1. 250 watt and 25 watt fixed and mobile communication transmitters, 30-162 Mc. range.
2. FM communication receivers for specific applications.
3. Complete line of FM broadcast equipment, including both transmitting and studio equipment.

AMATEUR RADIO EQUIPMENT

In prewar years, Collins came to be known as headquarters for highest quality amateur equipment. Continuing that tradition, our new contributions to ham radio will have the added experience and knowledge gained by supplying radio equipment for war time usage. Look to Collins for a versatile transmitter that is complete in every respect, and for a receiver of higher performance under the exacting conditions of ham radio.

The Collins 231D

3-5 KW
AUTOTUNE
COMMUNICATION
TRANSMITTER

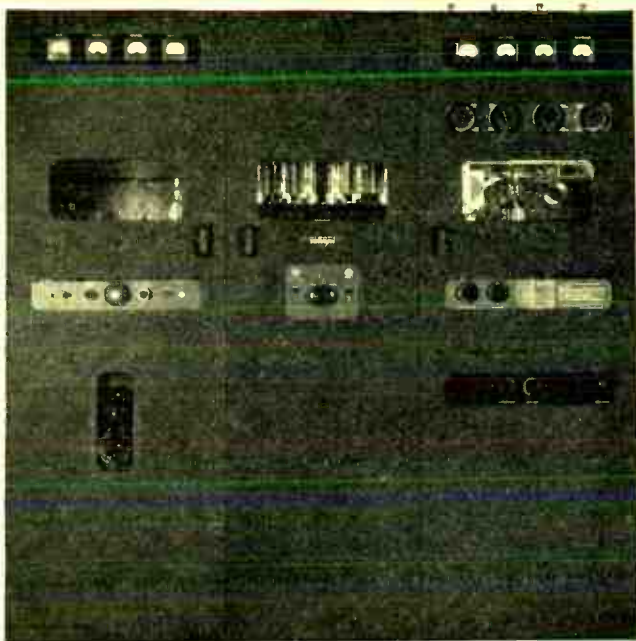

Collins AM Communication Equipment

1. 231D, 10 channel, 3-5 kw, 2-18.1 Mc. Autotune Transmitter, crystal or sealed M.O. control.
2. 16F, 10 channel, 300-500 watts, 2-20 Mc. Autotune Transmitter, crystal or sealed M.O. control.
3. 32RA, 4 channel, band switching, 50-75 watts, 1.5-15 Mc. Transmitter.
4. 51K-1, 10 channel, 2.4-18.3 Mc., crystal controlled Autotune Aircraft Receiver.
5. 51H-2, 20-30,000 Kc. Communications Receiver.

The Collins Autotune

The Collins Autotune is an electrically controlled means of mechanically repositioning adjustable rotary elements. Any combination of such components can be returned to any one of a number of preselected positions. By means of the Collins Autotune system, radio transmitters and receivers can be completely re-tuned in a matter of a very few seconds. The Autotune system is readily adaptable to a variety of industrial control requirements.

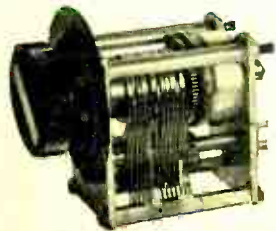

..... IN RADIO COMMUNICATION IT'S

Cent

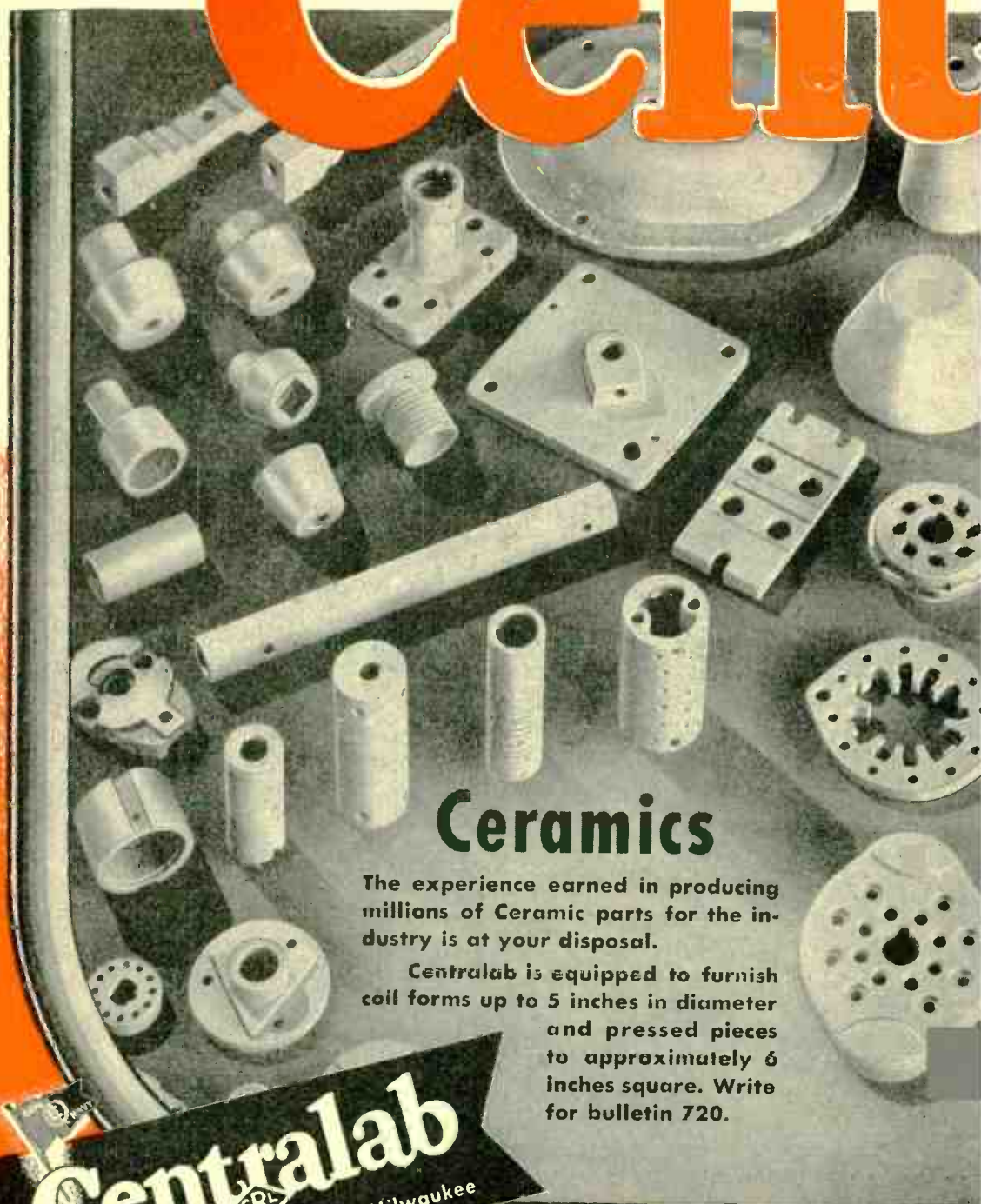

Ceramics

The experience earned in producing millions of Ceramic parts for the industry is at your disposal.

Centralab is equipped to furnish coil forms up to 5 inches in diameter and pressed pieces to approximately 6 inches square. Write for bulletin 720.

Centralab
Division of GLOBE-UNION INC., Milwaukee

Centralab

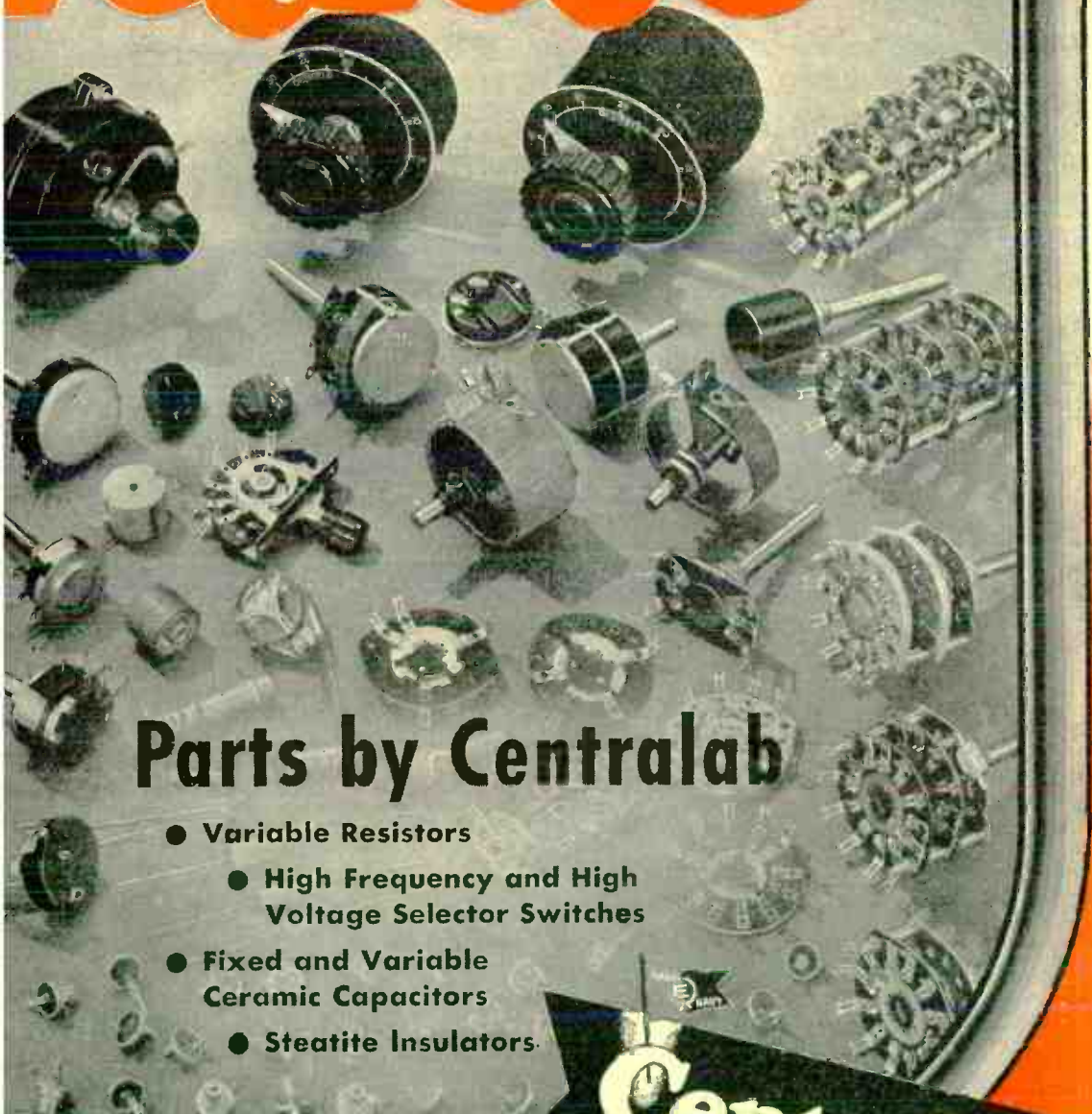

Parts by Centralab

- Variable Resistors
- High Frequency and High Voltage Selector Switches
- Fixed and Variable Ceramic Capacitors
- Steatite Insulators

Centralab
Division of GLOBE-UNION INC., Milwaukee



WL 678

15,000 Volt Grid Controlled Rectifier for Power Supply.



WL 460

For Radio Broadcast and Therapy Application.



WL 473

For FM, Standard Broadcast and RF Heating Application.



WL 892

Water Cooled Tube for Radio Transmitting and RF Heating Application.



WL 833A

For Power Output and Modulator Stage of 1 kw Transmitters; Intermediate Stage of higher kw Transmitters.

Westing

Offers you a complete line of broadcast tubes...available through local Westinghouse tube distributors

The Westinghouse Survey and Supply plan makes it possible for you to obtain any tube you need, regardless of make, from your local Westinghouse radio tube distributor. His stocks are based on a survey of your requirements.

Westinghouse

WL 803

*Transmitting Power;
Pentode Amplifier,
for Broadcast. Popu-
lar all-purpose tube.*



WL 807

*Transmitting Beam
Power Amplifier
for Broadcast.
Popular all-pur-
pose tube.*



house

Phone or visit your Westinghouse tube distributor today and inquire about this plan . . . it saves you dollars and days.

For specific data on the complete Westinghouse line of radio and industrial tubes write for the "ELECTRONIC TUBE EASY GUIDE" . . . a booklet which provides detailed information on each tube. Electronic Tube Sales Department, Westinghouse Electric Corporation, East Pittsburgh, N. J.

© 1957 John Charles Thomas Sunday, 2:30 P. M. EST - NBC
Ted Malone - Mon. through Fri. 11:33 A. M., EST - ABC

Electronic Tubes at Work

WL 866A/866

*Popular Mercury
Vapor Rectifier.*



WL 895R

*Used in final stage
of 50 kw Broad-
cast transmitters.*



WL 892R

*Forced Air Cool-
ed Tube for Radio
Transmitting and
RF Heating Ap-
plication.*





FOR YOUR NEWEST RIG-

— Sylvania Electric makes the tubes you want.

Now that you're back on the air, you'll need the kind of electronic equipment that will help you keep up with the many advances made in the field of communications. Now's the time to prepare for the increase in television transmitting stations all over the nation . . . higher frequencies, FM.

You'll welcome the news, then, that cathode ray tubes are now available through Sylvania distributors, retailers or radio servicemen. Our constant research in this field, combined with wide experience in large-scale production to meet war needs, has placed us in a position to manufacture cathode ray tubes to a much higher stand-

The advertisement features a central white rectangular area containing text, surrounded by a collage of various Sylvania vacuum tubes. The tubes are shown from different angles, some with their labels clearly visible, including 'SYLVANIA MADE IN U.S.A.' and 'SYLVANIA'. In the center of the collage, behind the text box, is a circular graphic containing a radio tower with several lightning bolts radiating from its top, symbolizing radio transmission. The background is a light, textured surface.

ard than it has ever been possible before.

And concerning higher frequencies, the Sylvania Lock-In Radio Tube was *built* to handle high and ultra-high frequencies — yet be more than perfectly suitable for sets working with the “regular” bands.

Yes, Sylvania Electric makes the tubes you want—dependable, precision-built tubes of every description. And each tube you buy is backed by over 40 years of the kind of research and development that have made Sylvania Radio Tubes the perfect electronic units they are today.

SYLVANIA ELECTRIC

Makers of Radio Tubes; Cathode Ray Tubes; Electronic Devices;
Fluorescent Lamps, Fixtures, Wiring Devices; Electric Light Bulbs

PERFORMANCE

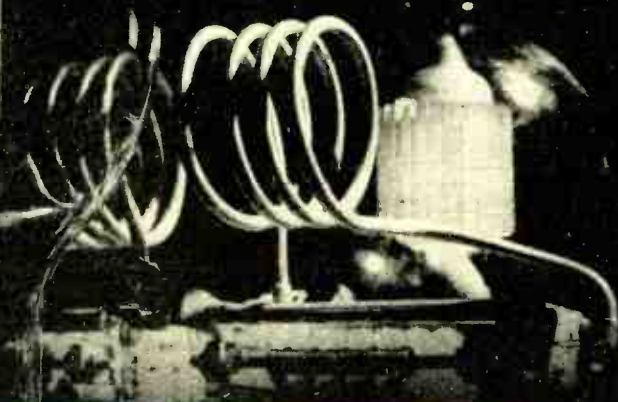

EIMAC TRANSMITTING TUBES

| EIMAC TUBE TYPES | ELECTRICAL | | | | | | | MECHANICAL | | | | MAX. RATINGS | | | | | PRICE | |
|------------------------|------------|------------|-------------|-----------------|------------|-------------|-----------------------------|------------|--------|-----------------------|------------------------|--------------|------------------|----------------|-----------------------------|----------------------------|---------|--------------------------|
| | FIL. VOLTS | FIL. AMPS. | AMP. FACTOR | GRID-PLATE, UUF | INPUT, UUF | OUTPUT, UUF | TRANSCONDUCTANCE, UMHROS | BASE | BASING | MAX LENGTH, INCHES | MAX DIAMETER INCHES | PL. VOLTAGE | PL. CURRENT, MA. | SCREEN VOLTAGE | SCREEN DISSIPATION WATTS | GRID DISSIPATION, WATTS | | PL. DISSIPATION WATTS |
| 3-25A3 (25T) | 6.3 | 3.0 | 29 | 1.6 | 2.4 | 0.4 | 2500 | MB-071 | 3G | 4.38 | 1.43 | 2000 | 75 | ... | 7 | 25 | \$ 6.00 | |
| 3-25D3 (25TG) | 6.3 | 3.0 | 25 | 1.6 | 1.8 | 0.2 | 2500 | MB-071 | 3G | 4.38 | 1.43 | 2000 | 75 | ... | 8 | 25 | 6.00 | |
| 3-50A4 (35T) | 5.0 | 4.0 | 30 | 1.9 | 4.0 | 0.2 | 2850 | MB-078 | 3G | 5.5 | 1.81 | 2000 | 150 | ... | 15 | 50 | 6.00 | |
| 3-50D4 (35TG) | 5.0 | 4.0 | 30 | 1.9 | 1.9 | 0.2 | 2850 | MB-078 | 2M | 5.75 | 1.81 | 2000 | 150 | ... | 15 | 50 | 6.75 | |
| 3-50G2 (UH50) | 7.5 | 3.25 | 13 | 2.4 | 2.2 | 0.4 | ... | MB-078 | 2M | 7.0 | 2.69 | 1250 | 125 | ... | 13 | 50 | 12.50 | |
| 3-75A3 (75TH) | 5.0 | 6.5 | 20 | 2.3 | 3.5 | 0.25 | 4150 | MB-078 | 2M | 7.25 | 2.81 | 3000 | 225 | ... | 16 | 75 | 9.00 | |
| 3-75A2 (75TL) | 5.0 | 6.5 | 11 | 2.3 | 2.2 | 0.4 | 3350 | MB-078 | 2M | 7.25 | 2.81 | 3000 | 225 | ... | 13 | 75 | 9.00 | |
| 3X100A11 (2C39)* | 6.3 | 1.1 | ... | 1.95 | 6.5 | 0.30 | 21,000 | ... | ... | 2.75 | 1.26 | 1000 | 1000† | ... | 3 | 100 | 30.00 | |
| 3-100A4 (100TH) | 5.0 | 6.2 | 40 | 2.0 | 2.9 | 0.4 | 5500 | MB-078 | 2M | 7.75 | 3.19 | 3000 | 225 | ... | 20 | 100 | 13.50 | |
| 3-100A2 (100TL) | 5.0 | 6.5 | 12 | 2.3 | 2.0 | 0.4 | 2300 | MB-078 | 2M | 7.75 | 3.19 | 3000 | 225 | ... | 15 | 100 | 13.50 | |
| 3-150A3 (152TH) | 5 or 10 | 13 or 6 | 20 | 4.7 | 7.0 | 0.5 | 8300 | 5000B | 4BC | 7.63 | 2.56 | 3000 | 450 | ... | 30 | 150 | 20.00 | |
| 3-150A2 (152TL) | 5 or 10 | 13 or 6 | 11 | 5.0 | 4.8 | 0.8 | 7150 | 5000B | 4BC | 7.63 | 2.56 | 3000 | 500 | ... | 25 | 150 | 20.00 | |
| 3X150A3 (3C37)* | 6.3 | 2.4 | ... | 3.50 | 4.25 | 0.60 | 8000 | ... | ... | 3.10 | 1.50 | 1000 | ... | ... | ... | 150 | 45.00 | |
| 3-250A4 (250TH) | 5.0 | 10.5 | 37 | 2.9 | 5.0 | 0.7 | 6650 | 5001B | 2N | 10.13 | 3.81 | 4000 | 350 | ... | 40 | 250 | 24.50 | |
| 3-250A2 (250TL) | 5.0 | 10.5 | 13 | 3.5 | 3.0 | 0.5 | 2650 | 5001B | 2N | 10.13 | 3.81 | 4000 | 350 | ... | 35 | 250 | 24.50 | |
| 3-300A3 (304TH) | 5 or 10 | 26 or 13 | 20 | 9.4 | 14.0 | 1.0 | 16,700 | 5000B | 4BC | 7.63 | 3.56 | 3000 | 900 | ... | 60 | 300 | 50.00 | |
| 3-300A2 (304TL) | 5 or 10 | 26 or 13 | 11 | 10.0 | 10.0 | 1.5 | 16,700 | 5000B | 4BC | 7.63 | 3.56 | 3000 | 1000 | ... | 50 | 300 | 50.00 | |
| 3-450A4 (450TH) | 7.5 | 12.0 | 38 | 4.7 | 8.1 | 0.8 | 6650 | 5002B | 4AQ | 12.63 | 5.13 | 6000 | 500 | ... | 80 | 450 | 60.00 | |
| 3-450A2 (450TL) | 7.5 | 12.0 | 19 | 5.0 | 6.6 | 0.9 | 6060 | 5002B | 4AQ | 12.63 | 5.13 | 6000 | 500 | ... | 65 | 450 | 60.00 | |
| 3-750A2 (750TL) | 7.5 | 21.0 | 15 | 4.5 | 6.0 | 0.8 | 3500 | 5003B | 4BD | 17.0 | 7.13 | 6000 | 1000 | ... | 100 | 750 | 135.00 | |
| 3-1000A4 (1000T) | 7.5 | 16.0 | 30 | 4.0 | 6.0 | 0.6 | 9050 | 5004B | 4AQ | 12.63 | 5.13 | 6000 | 750 | ... | 80 | 1000 | 100.00 | |
| 3-1500A3 (1500T) | 7.5 | 26.0 | 24 | 7.0 | 9.0 | 1.3 | 10,000 | 5005B | 4BD | 17.0 | 7.13 | 6000 | 1250 | ... | 125 | 1500 | 185.00 | |
| 3-2000A3 (2000T) | 10.0 | 26.0 | 20 | 9.0 | 13.0 | 1.5 | 11,000 | 5006B | 4BD | 17.75 | 8.13 | 6000 | 1750 | ... | 125 | 2500 | 225.00 | |
| 3X2500A3- | 7.5 | 48 | 20 | 20 | 48 | 1.2 | 20,000 | ... | ... | 9.0 | 4.25 | 5000 | 2000 | ... | 125 | 2500 | 135.00 | |
| 4-125A | 5.0 | 6.2 | 6.2 | 0.03 | 10.3 | 3.0 | 2450 | 5008B | ... | 5.69 | 2.72 | 3000 | 225 | 400 | 30 | 5 | 125 | 20.00 |
| 4-250A | 5.0 | 14.5 | ... | 0.06 | 12.7 | 4.5 | 4000 | 5008B | ... | 6.38 | 3.56 | 4000 | 350 | 600 | 50 | 5 | 250 | 30.00 |
| 4X500A* | 5.0 | 12.2 | ... | 0.05 | 11.1 | 3.75 | 5200 | ... | ... | 4.32 | 2.57 | 4000 | 300 | 450 | 30 | 5 | 500 | 80.00 |

*External Anode requiring forced-air-cooling.
†Cathode Current.

CAUTION: Check serial numbers on Eimac tubes before you buy. Be sure you're getting newest types. Look for latest serial numbers.

The Only Criterion

On merit and on merit alone, Eimac tubes have achieved a position of leadership throughout the world. Their outstanding performance characteristics have set and maintained an extremely high standard for more than a decade.

Standing behind Eimac tubes are a prewar performance record second to none and a wartime achievement record of the highest order both in production and development. Today Eimac stands at the threshold of the great new era of electronics with a family of electron vacuum tubes embodying all the original Eimac concepts in addition to highly advanced techniques and developments gained by the concentrated efforts of the past five years.

In the final analysis, performance is the only criterion. It's what the tubes do in your application that really counts. Below is a brief listing of the basic data on many Eimac tubes. Eimac stands ready to provide additional information or assistance without cost or obligation. Please let us hear from you.

EIMAC RECTIFIERS

| | MV RECTIFIERS | | HIGH VACUUM RECTIFIERS | | | |
|-------------------------------|------------------|------------------------------------|------------------------|-------------------|--------------------|-------------------|
| | RX21A (RX-21) | KY21A (KY-21) (Grid Control) | 2-100A (100-R) | 2-150A (152-R) | 2-150D (152-RA) | 2-250A (250-R) |
| 1. Filament Voltage..... | 2.5 | 2.5 | 5.0 | 5.0 | 5.0 | 5.0 |
| 2. Filament Current..... | 10 amperes | 10 amperes | 6.5 | 13.0 | 13.0 | 10.5 |
| 3. Peak Inverse Voltage..... | 11,000 | 11,000 | 40,000 | 30,000 | 30,000 | 60,000 |
| 4. Peak Plate Current..... | 3 amperes | 3 amperes | | | | |
| 5. Average Plate Current..... | .75 amperes | .75 amperes | .100 amperes | .130 amperes | .150 amperes | .250 amperes |
| Price..... | \$7.50 | \$10.00 | \$13.50 | \$15.00 | \$15.00 | \$20.00 |

EIMAC VACUUM CAPACITORS

| | | | | | | | | |
|---------------|---------|---------|---------|---------|---------|---------|---------|---------|
| Type..... | VC6-20 | VC12-20 | VC25-20 | VC50-20 | VC6-32 | VC12-32 | VC25-32 | VC50-32 |
| Capacity..... | 6-mmfd | 12-mmfd | 25-mmfd | 50-mmfd | 6-mmfd | 12-mmfd | 25-mmfd | 50-mmfd |
| Rating..... | 20-KV | 20-KV | 20-KV | 20-KV | 32-KV | 32-KV | 32-KV | 32-KV |
| RF Peak..... | | | | | | | | |
| Price..... | \$10.00 | \$11.30 | \$14.00 | \$16.70 | \$12.00 | \$13.30 | \$16.00 | \$18.70 |

EIMAC VACUUM SWITCHES

| TYPE | GENERAL DATA | PRICE |
|-----------|---|---------|
| VS-1..... | Single pole double throw switch within a high vacuum making it adaptable for high voltage switching. The contact spacing is .016". In spite of the close spacing this switch will handle R. F. potentials as high as 20-KV. In D. C. switching circuits the contacts will handle approximately 1.5 amperes at 5 KV. | \$12.00 |
| VS-2..... | Same as above except for slightly longer glass tubulation..... | \$12.00 |

EIMAC DIFFUSION PUMP

| | |
|---------------------------|-----------------------------|
| HV-1 DIFFUSION PUMP | PRICES ON APPLICATION |
| EIMAC PUMP OIL | |

FOLLOW THE LEADERS TO

Eimac
TUBES

EIMAC-McCULLOUGH, INC., 1114 San Mateo Avenue, San Bruno, Calif.
Plants located at: San Bruno, California and Salt Lake City, Utah
Export Agents: Brazier & Hanson, 301 Clay St., San Francisco 11, Calif., U. S. A.

GET THIS AUTHORITY



MAIL THIS COUPON TODAY

Section 62-79R, Commercial Engineering Department
Radio Corporation of America
Harrison, N. J.

Please send me a copy of the RCA GUIDE FOR TRANSMITTING TUBES. I am enclosing 35¢.

Name

Address

City Zone..... State.....

62-6484-79

TO BE SURE YOU GET YOUR COPY OF RCA GUIDE FOR TRANSMITTING TUBES—AT THE POPULAR PREWAR PRICE OF ONLY 35¢ — CLIP AND MAIL THIS CONVENIENT ORDER FORM TODAY!

GUIDE TO TRANSMITTING— TUBE SELECTION AND APPLICATION

Contains helpful information on ratings, circuits, basing, and applications of RCA transmitting tubes

NO HAM LIBRARY is complete without the **RCA GUIDE FOR TRANSMITTING TUBES**. You need this convenient, practical book because it contains just the information you require on up-to-the-minute tubes and circuits.

Originally published in 1939 as the "RCA Ham Guide," this book has gone through several editions and has been eagerly purchased by thousands of hams.

Only a few thousand copies of the present revised edition have been printed. The supply is limited—get your copy early!

Here is a summary of the contents of this invaluable book:

- Photographs, basing diagrams, circuits, complete technical data, and prices of all RCA transmitting tubes of interest to amateurs
- Tested, economical transmitter circuits designed by radio's foremost engineers
- Complete instructions for building a u-h-f transmitter and other types of equipment
- Condensed tables giving essential characteristics of RCA transmitting tubes, cathode-ray tubes, phototubes, thyratrons, voltage-regulator tubes, rectifier tubes, and special amplifiers

Here, in 72 pages crammed with vital information, you have one of the most popular books ever published on transmitting tubes—backed by all the years of engineering and application know-how of the RCA organization.

CONTENTS

Technical data, prices, application information on transmitting tubes, filter design curves.

Tables giving data, prices, and ratings of transmitting tubes, rectifiers, cathode-ray tubes, phototubes, voltage regulators, special amplifiers, and relay tubes.

General tube and transmitter data—including choice of tube types, grid-bias considerations, inductance and capacitance for tuned circuits, neutralizing, tuning Class C r-f amplifiers, how tube ratings are determined, interpretation of tube ratings, circuits, mathematical calculations, and other vital information.

How To Build—

- A variable-frequency oscillator with an r-f power output of 10 to 25 watts over a frequency range from 1.75 to 30 mc.
- The RCA "economy" transmitter with 70-watt c-w output over frequency range from 3.7 to 7.5 mc.
- The RCA-815 u-h-f transmitter with 30 to 45 watts phone output over frequency range from 15 to 120 mc.
- The RCA single-control 360-watt transmitter (360 watts input on c-w and 240 watts input on phone) over frequency range from 1.9 to 7.5 mc.
- The RCA 5-band plate-modulated transmitter with 450 watts input on c-w and 310 watts input on phone over frequency range from 1.7 to 30 mc.

THE FOUNTAINHEAD OF MODERN TUBE DEVELOPMENT IS RCA

DO YOU HAVE THESE OTHER RCA PUBLICATIONS?

Designed to Keep You Up To The Minute in Technical Information.

RCA HB3 TUBE HANDBOOK—An invaluable, loose-leaf, engineering reference book on all RCA tubes—transmitting, receiving, cathode-ray, and special types. Kept up to date with periodic revisions. Sold on subscription basis—write for descriptive folder and order form.

RCA RC-14 RECEIVING-TUBE MANUAL—Data on 340 different RCA receiving-tube types. 256 pages containing application data, circuits, charts, and simplified tube theory. Net price \$0.25.

RCA PHOTOTUBES BOOKLET—A clear exposition of phototube theory, including data on 15 types, curves, and circuits for light-operated relays, light measurement, and sound reproduction. Free upon request.

RCA RADIOTRON DESIGNER'S HANDBOOK—Fundamental principles of practical circuit design, prepared especially for the radio-set designer. Valuable to amateurs interested in the subject. Illustrated, and contains reference charts, tables, and miscellaneous data. Stiff cover. 356 pages. Net price \$1.00.

RCA POWER AND SPECIAL-TUBES BOOKLET (TT-100)—An illustrated catalog of air- and water-cooled transmitting tubes, rectifiers, television tubes, phototubes, oscillograph tubes, thyratrons, voltage regulators, and special amplifier tubes. Free upon request.

RCA RECEIVING TUBES AND ALLIED SPECIAL-PURPOSE TYPES BOOKLET (1275-B)—Characteristics and socket connections of 327 receiving types and 38 allied types. Free upon request.

All of these publications are available from RCA tube distributors, or direct from Radio Corporation of America. Write Commercial Engineering Department, Section 62-79R, Harrison, N. J.



RADIO CORPORATION OF AMERICA

TUBE DIVISION • HARRISON, N. J.

IN THE 144-148 Mc. Band . . .

USE THE

Coaxial Dipole

MODEL 105

FOR BEST RESULTS

Here's the vertically polarized antenna that gives you everything you need for convenience and efficiency in fixed and mobile installations.

- **LOAD MATCHING . . .** for 50 to 55 ohm solid-dielectric co-ax cables or bead-supported lines (also usable with 72 ohm lines)
- **CONTINUOUSLY ADJUSTABLE . . .** upper $\frac{1}{4}$ wavelength element slides in 4-jaw chuck; knurled nut locks whip at exact adjustment for best operation.
- **LOW LOSSES . . .** polyethelene insulation for minimum dielectric loss.
- **EASY INSTALLATION . . .** antenna base screws onto standard $\frac{3}{8}$ " pipe thread; junction box fits 49194 receptacle; bumper mount available.
- **DURABLE CONSTRUCTION . . .** tubes, pipes, and fittings are brass with chromium, rhodium, and silver plating to prevent corrosion and ensure high conductivity; spring-steel whip can flex repeatedly without damage.
- **LOW COST . . .** only \$12.50 net F.O.B. Boston.

This remarkable new antenna is sold only thru the RADIO SHACK. Order today—immediate delivery.

Write for
FREE 108 PG.
CATALOG
on all ham gear

The RADIO SHACK
★ 167 WASHINGTON ST. ★
BOSTON, MASS., U.S.A.

Centralab *Bliley*

Get Acquainted
with

The RADIO SHACK

WHEN YOU NEED radio gear of any kind—from the tiniest parts to the finest communications receivers and transmitters—you can depend on us to take care of your needs promptly and accurately. We've been doing it since 1922 for amateurs and experimenters the world over and we're sure you'll enjoy our friendly service.

RECEIVERS . . . by Hallicrafters, Hammarlund, National, Echophone, and other leading makers, are stocked in all models at the Radio Shack, ready for immediate shipment. Equipment for every frequency band—in modern, efficient design—is nationally distributed thru our facilities.

COMPONENTS . . . of every description—tubes, capacitors, resistors, relays, plugs, cables, sockets, transformers, speakers, crystals—in all nationally famous brands, are shown in our big 108-page catalog. It's practically a reference library on radio construction and it's free on request. Just send us your complete mailing address and we'll put this valuable handbook in the mail for you.

DON'T DELAY . . .

GET ACQUAINTED WITH
THE RADIO SHACK TODAY!



AMATEUR • COMMERCIAL • MILITARY

COMMUNICATIONS RECEIVERS

Prepare now to fit Hammarlund communications receivers into your postwar program. This new line of receiving equipment will include highly specialized single band VHF and UHF models for commercial and amateur use, several models of the well known "Super-Pro", and a new "HQ-129-X" amateur receiver, selling at \$129.00, net to the amateur. The "HQ-129-X" is basically the same as the original "HQ-120-X", but has several improvements and modifications.

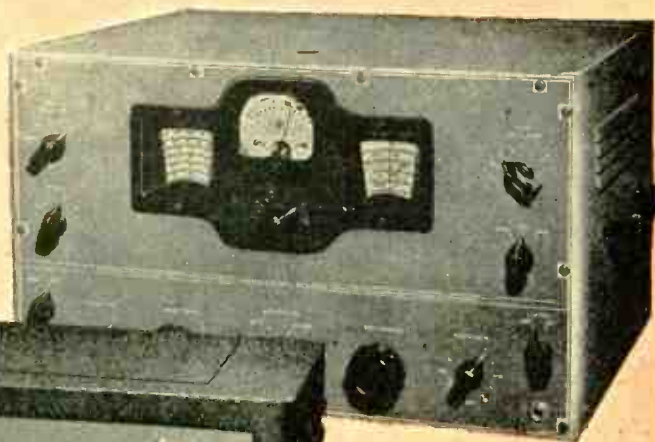

New "HQ-129-X"



"Super-Pro"



ESTABLISHED 1910

... 35 YEARS OF
RESEARCH
KNOW HOW *EXPERIENCE*



Single Band UHF



Amateur VHF



Single Band VHF



Wide Range VHF



An entire new group of VHF and UHF receivers for point to point, relay, facsimile, and other services in those ranges.

HAMMARLUND

THE HAMMARLUND MFG. CO., INC., 460 W. 34TH ST., NEW YORK 1, N.Y.
MANUFACTURERS OF PRECISION COMMUNICATIONS EQUIPMENT

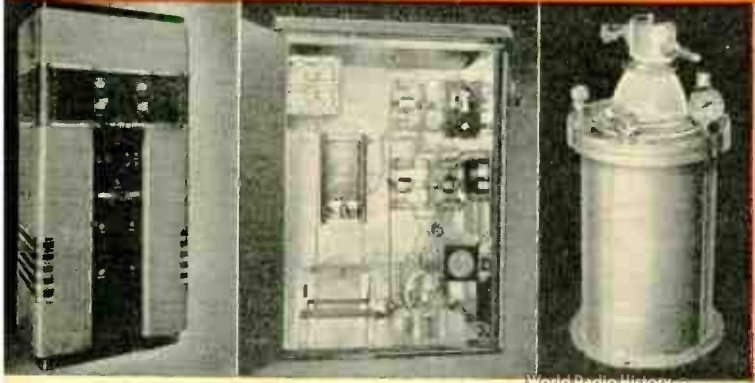
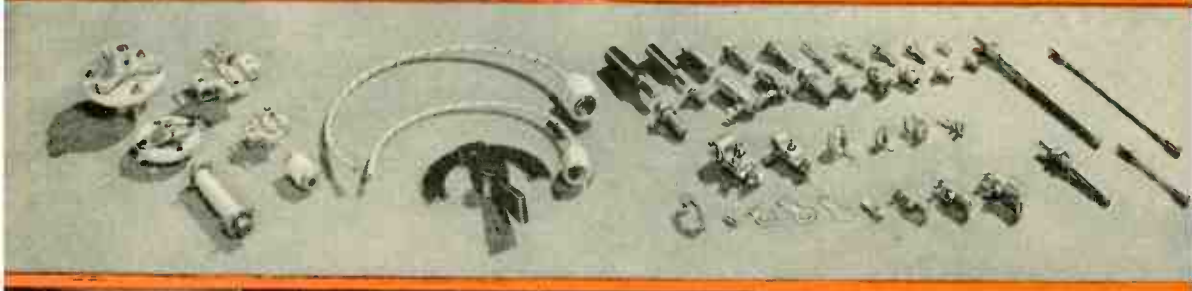
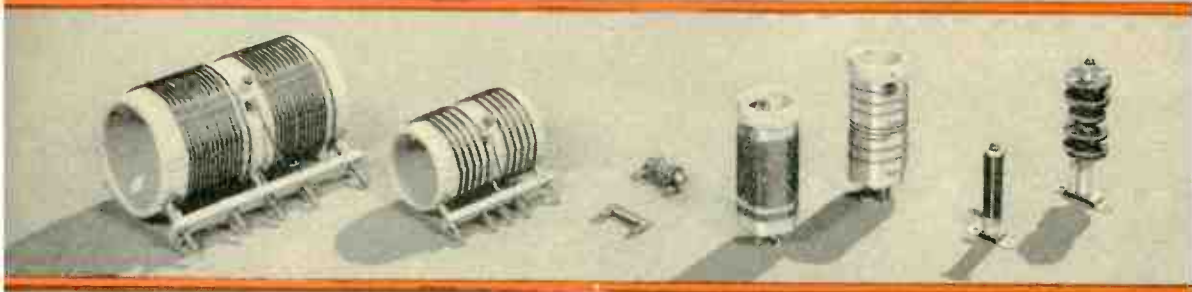

BROADCAST EQUIPMENT

Illustrated at left is a Johnson Directional Antenna Phasing Unit, an Antenna Coupling Unit and a Variable Pressure Condenser.

These are representative of the popular Johnson products widely used by Commercial Broadcast stations.

Write for specific information.

Johnson Condensers are rigidly constructed and engineered to meet the most exacting requirements of amateur, commercial broadcast and industrial applications. They are the choice of amateurs who demand the highest quality and latest in condenser design.

Johnson Tube Sockets have been known for more than twenty years as tops in the field.

Johnson's superior mechanical and electrical design never fails to meet the rigid requirements of present day radio-electronic circuits and equipment.

Johnson Insulators are designed to obtain the greatest possible mechanical strength and highest breakdown voltages.

Materials used in the manufacture of Johnson insulators are selected after laboratory tests prove conclusively that they

Johnson Inductors and Chokes are available in the popular standard types for amateur radio requirements and special types are available to meet any broadcast or industrial application.

The famous Johnson rotating coil and tube socket, "Hi Q," inductors are de-

Johnson Hardware Items are manufactured of the highest grade materials and with top quality workmanship throughout.

The Johnson line includes the following items: couplings, tube caps, plugs and jacks, inductor clips, soldering terminals, tube locking clamps, panel bearings, flexi-

In Johnson Condensers there are many superior features, helping to assure top performance of equipment in which they are employed.

There is a Johnson condenser for every stage of the amateur transmitter from oscillator through the final amplifier.

The complete line of Johnson sockets meet every amateur tube socket requirement. Johnson standard and "special" sockets are also supplied for a wide variety of commercial broadcast and industrial applications.

meet all of Johnson's rigid specifications.

The Johnson line includes stand-off, cone, thru-panel, antenna, feeder and strain insulators. There's a Johnson insulator for every amateur need and there isn't a better insulator than Johnson's available.

A special highly glazed low-loss electrical porcelain is used for the coil forms assuring maximum efficiency.

Johnson RF chokes are uniformly flat in response and are the most effective chokes available.

ble shafts, fuse clips, handle indicators, cable connectors, pilot and dial lights.

Johnson products can be obtained from radio-electronic parts Jobbers, or write directly for further information about Johnson components and assemblies.

Send for the latest Johnson Catalog—Dept. A, Johnson Co., Waseca, Minnesota.

JOHNSON

a famous name in Radio



E. F. JOHNSON COMPANY • WASECA • MINNESOTA

World Radio History

In Service Everywhere!..



DUMMY ANTENNA RESISTORS

To check R. F. power, determine transmission line losses, check line to antenna impedance match. Helps tune up to peak efficiency. Non-inductive, non-capacitive, constant in resistance. 100 and 250 watt sizes in various resistances.



BROWN DEVIL RESISTORS

Small, extra sturdy, wire wound vitreous enameled resistors for voltage dropping, bias units, bleeders, etc. Proved right in vital installations the world over. 10 and 20 watt sizes in resistances up to 100,000 ohms.



PARASITIC SUPPRESSOR

Small, light, compact non-inductive resistor and choke, designed to prevent u.h.f. parasitic oscillations which occur in the plate and grid leads of push-pull and parallel tube circuits. Only 1 3/4" long overall and 3/8" in diameter.



CENTER-TAPPED RESISTORS

For use across tube filaments to provide an electrical center for the grid and plate returns. Center tap accurate to plus or minus 1%. Wirewatt (1 watt) and Brown Devil (10 watt) units, in resistances from 10 to 200 ohms.



R. F. PLATE CHOKES

Single-layer wound on low power factor steatite cores, with moisture-proof coating. Built to carry 1000 M.A. 5 stock sizes from 2 1/2 meters to 160 meters. 2 1/2 and 5 meter chokes mount by wire leads. Larger sizes mount on brackets.



ADJUSTABLE DIVIDOHMS

You can quickly adjust these handy Dividohms to the exact resistance you want, or put on one or more taps wherever needed. 7 sizes from 10 to 200 watts. Many resistance values up to 100,000 ohms.



R. F. POWER LINE CHOKES

Keep R.F. currents from going out over the power line and causing interference with radio receivers. Also used at receivers to stop incoming R.F. interference. 3 stock sizes, rated at 5, 10 and 20 amperes.



FIXED RESISTORS

Resistance wire is wound over a porcelain core, permanently locked in place, insulated and protected by Ohmite vitreous enamel. Available in 25, 50, 100, 160 and 200 watt stock sizes, in resistances from 1 to 250,000 ohms.

Be Right with OHMI[®]. E

RHEOSTATS ★ RESISTORS ★ CHOKES ★ TAP SWITCHES

Ohmite Vitreous Enamel is unexcelled as a protective and bonding covering for resistors and rheostats.

OHMITE Rheostats * Resistors * Chokes * Switches

CLOSE-CONTROL RHEOSTATS



Insure permanently smooth, close control of communications, electronic and electrical devices. Widely used in industry and in war equipment. All ceramic, vitreous enameled. 25, 50, 75, 100, 150, 225, 300, 500, 750 and 1000 watt sizes. Approved Army & Navy types.

HIGH-VOLTAGE SWITCH



For general use where high voltage insulation is required. Suitable for circuits up to 1 K.W. rating. Used for band changing, meter switching, tapped transformer circuits, etc. Ceramic construction.

LITTLE DEVIL INSULATED COMPOSITION RESISTORS

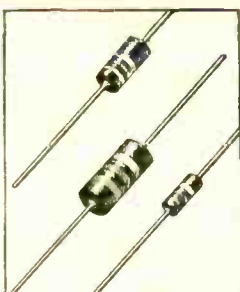

New, tiny, molded fixed resistors provide extra ruggedness and stability. 1/2 watt, 1 watt and 2 watt sizes. 10% tolerance. Meet Army-Navy Specification JAN-R-11, including salt water immersion cycling and high humidity tests. Can be used at full wattage rating at 70°C (158°F) ambient temperature. Dissipate heat rapidly. Low noise level. Low voltage coefficient. Stocked in Standard RMA values from 10 ohms to 22 megohms.

HANDY OHMITE OHM'S LAW CALCULATOR



Very useful in training schools, in laboratories and in industry. Figures ohms, watts, volts, amperes — quickly, easily. Solves any Ohm's Law problem with one setting of the slide. All values are direct reading. No slide rule knowledge is necessary. Scales on two sides cover the range of currents, resistances, wattages and voltages commonly used in radio and electronic applications. Size only 4 1/8" x 9". Send only 10c in coin to cover handling cost.

HIGH-CURRENT TAP SWITCHES



Compact, all ceramic, multi-point rotary selectors for A.C. use. Silver to silver contacts. Rated at 10, 15, 25, 50 and 100 amperes with any number of taps up to 11, 12, 12, 12, and 8 respectively. Single or tandem assemblies.

LC-2 LINK CONTROL



Simplified, compact, convenient panel regulation of the transfer of R.F. energy thru the link or low impedance line used in many transmitters. Eliminates swinging coupling coils. All ceramic vitreous enameled construction.



SEND FOR FREE CATALOG 18 — Gives helpful information and data on Ohmite stock units for essential applications — lists hundreds of stock values. Very handy for quick reference.

OHMITE MANUFACTURING COMPANY
4966 Flournoy Street, Chicago, U.S.A. Cable "Ohmiteco"

WIRELESS

1910-1946

Welcome back to the air waves, friends! Hams, it's like old times to hear your calls again. Remember when you first began to make "wireless" history? That's when C-D built the first capacitors. You were an inspiration then . . . as you are today.

While your CQ's have been silent, many of you have made radio history in war . . . have ceased to be "amateurs" in the old sense. You have acquired a professional concept of how radio parts must perform. That's as it should be.

We anticipated your demands for more in capacitors, too . . . and we are prepared to continue to uphold your faith in C-D's. We value the confidence you have shown in them for thirty-six years. Cornell-Dubilier Electric Corporation, New Bedford, Mass. Other Plants: So. Plainfield, New Jersey; Worcester, Brookline, Mass. and Providence, R. I.

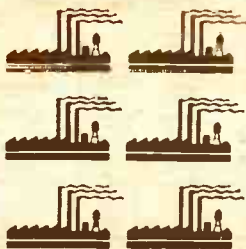

SIX MODERN PLANTS

The C-D Capacitors you buy today are products of one of our six great plants, centrally located to speed deliveries to your dealer. He can supply you quickly with any C-D type you require.



MANUFACTURING SKILL

C-D quality has kept up despite our tremendous growth and quantity production. Our skilled craftsmen, many of whom have been with us five to twenty years, are outstanding technicians. They make C-D Capacitors to precision standards.

CORNELL-DUBILIER

CORNELL-DUBILIER CAPACITORS *for every radio need*



**TYPE
9**

Moulded mica capacitor for r.f. by-pass, grid and plate blocking in low power transmitters and amplifiers. Strong, well-insulated, moisture-resistant, with short, heavy terminals, minimum r.f. and contact resistance. Stable in capacity and high insulation resistance.



**TYPE
TJU**

Dykanol transmitting filter capacitor, compact, lightweight, safety-rated, furnished with universal mounting clamp, well-insulated terminals, fire-proof, and attractively priced. Hermetically sealed against any climatic conditions, in sturdy steel container, aluminum-painted, non-corrosive, can be mounted in any position. Extra high dielectric strength. Conservative D.C. rating — triple tested. Wide range of voltage ratings.



**TYPE
6**

Medium power mica transmitter capacitor for r.f. applications where size and weight must be minimized. Patented series stack mica construction. Permanent non-magnetic clamps. Vacuum-impregnated — results in low loss, high insulation — no air voids. Low loss filter reduces stray losses. Suited to grid, plate, coupling, tank and by-pass uses.



**TYPE
59**

Mica transmitting capacitor — improved design — extremely adaptable, dependable under the most severe operating conditions. In low-loss, white glazed ceramic cases, with low-resistance, wide path terminals. Can be mounted individually or in groups in series or parallel combinations. For grid, plate blocking, coupling, tank and by-pass applications in high power transmitters.

SEND FOR CATALOG 195 also "The C-D Capacitor," a monthly digest of developments in radio, articles, engineering data, helpful facts . . . yours free for the asking.

Copyright Map Courtesy Rand McNally & Co., Chicago



CAPACITORS

MICA • DYKANOL • PAPER • ELECTROLYTIC

HYTRON TUBES



Whether you are interested in the low or high frequencies—c.w. or 'phone—high or medium mu triodes—the popular beam tetrodes—pentodes—rectifiers—acorns—miniatures—or gaseous voltage regulators—there are Hytron tubes just right for your new rig.

TRIODES You find a wide range of plate dissipation, filament and plate potentials, and amplification factors. Standard replacements, such as the 801A, 801, are included, as well as carefully engineered triodes with graphite anodes, dual grid stem leads, filament heat radiators, low-loss lava insulation, and low-loss bases. The twin triodes, 3A5, HY31Z, and HY1231Z, offer special application economies.

V-H-F TRIODES The HY75, HY114B, and HY615 with their familiar grid and plate top caps are automatically associated with Hytron. Suitable for transmitting or receiving, they are extremely popular for efficient v-h-f portable and mobile equipment. The 955 acorn and 9002 miniature are also widely known.

PENTODE The 837 is a popular transmitting pentode with 12.6-volt filament and 12-watt plate dissipation. It is particularly suited for suppressor grid modulation.

R.F. BEAM TETRODES Instant-heating or cathode types for 6 or 12 volt AC or DC filament supplies are offered in a generous variety of plate voltages and plate dissipations. Ideal for mobile use where battery power must be conserved during standby, are the instant-heating 2E25, HY69, and HY1269. Low driving power requirements, freedom from neutralization and ease of band switching on frequencies up to 60 megacycles (100 mc. for the 2E25)—are attractive features of all these beam tetrodes.

ACORN AND MINIATURE PENTODES The 954, 9001, and 6A5 assure top receiver performance on those higher frequencies.

RECTIFIERS Mercury vapor types are supplemented by the 1616 for applications where filament and plate potentials must be applied simultaneously. The v-h-f 6AL5 has many interesting possibilities: rectifier, detector and avc, clipper, limiter, and fm frequency discriminator.

VOLTAGE REGULATORS Literally millions of the Hytron OC3/VR105 and OD3/VR150 have been sold. They are economical, simple to use, and sure-fire in maintaining steady potentials. The OC3 and OD3 may be used in series for regulating a 250-volt supply. New Hytron miniatures, OA2 and OB2, are compact and closely approximate in performance the standard regulators.

And that's not all! Hytron's wartime experience is bringing you many new tubes—particularly in the u-h-f field—tubes engineered for your exacting needs. Watch for them.

For better reception, it's
radio receiving tub

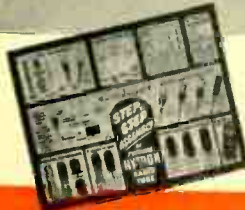

Ever wonder just how tubes are put together? Hytron has a 17 by 21 inch sheet for you which shows the step-by-step assembly of a typical Hytron tube.

HYTRON RADIO AND ELECTRONICS

YOUR NEW RIG

HYTRON TRANSMITTING AND SPECIAL PURPOSE TUBES

| Description | Type No. | Filament Volts | Filament Amps | Rating Type | Max. Plate Volts | Max. Plate Ma. | Max. Plate Dis. |
|-------------|-----------|---------------------------|--------------------|--------------------|-----------------------|-----------------------|-----------------|
| LOW | 3A5 | 1.4 | 0.22 | Oxide | 150 | 30* | 2* |
| | 6J5GTX | 2.8 | 0.11 | Cath. | 330 | 20 | 3.5 |
| | 10Y | 7.5 | 1.25 | Thor. | 450 | 65 | 15 |
| MEDIUM | HY24 | 2 | 0.13 | Oxide | 180 | 20 | 2 |
| | HY40 | 7.5 | 2.25 | Thor. | 1000 | 125 | 40 |
| HIGH-MU | HY51A | 7.5 | 3.55 | Thor. | 1000 | 175 | 65 |
| | HY51B | 10 | 2.25 | Thor. | 1000 | 175 | 65 |
| | 801A/801 | 7.5 | 1.25 | Thor. | 600 | 70 | 20 |
| | 841 | 7.5 | 1.25 | Thor. | 450 | 60 | 15 |
| | 864 | 1.1 | 0.25 | Oxide | 135 | 5 | — |
| HIGH-MU | 1626 | 12.6 | 0.25 | Cath. | 250 | 25 | 5 |
| | HY30Z | 6.3 | 2.25 | Thor. | 850 | 90 | 30 |
| | HY31Z | 6 | 2.55 | Thor. | 500 | 150* | 30* |
| HIGH-MU | HY40Z | 7.5 | 2.6 | Thor. | 1000 | 125 | 40 |
| | HY51Z | 7.5 | 3.55 | Thor. | 1000 | 175 | 65 |
| | HY1231Z | 6 | 3.2 | Thor. | 500 | 150* | 30* |
| HIGH-MU | 12 | 1.6 | | | | | |
| | 2C26A | 6.3 | 1.15 | Cath. | 3500 | NOTE | 10 |
| HIGH-MU | HY75 | 6.3 | 2.6 | Thor. | 450 | 80 | 15 |
| | HY114B | 1.4 | 0.155 | Oxide | 180 | 12 | 1.8 |
| | HY615 | 6.3 | 0.175 | Cath. | 300 | 20 | 3.5 |
| | 955 | 6.3 | 0.15 | Cath. | 200 | 8 | 1.8 |
| | E1148 | 6.3 | 0.175 | Cath. | 300 | 20 | 3.5 |
| | 9002 | 6.3 | 0.15 | Cath. | 200 | 8 | 1.8 |
| | HIGH-MU | 2E25 | 6 | 0.8 | Thor. | 450 | 75 |
| 6AR6 | | 6.3 | 1.2 | Cath. | 630 | 60 | 10 |
| 6L6GX | | 6.3 | 0.9 | Cath. | 500 | 115 | 21 |
| 6V6GTX | | 6.3 | 0.45 | Cath. | 350 | 60 | 13 |
| HY60 | | 6.3 | 0.5 | Cath. | 425 | 60 | 15 |
| HY61/807 | | 6.3 | 0.9 | Cath. | 600 | 120 | 25 |
| HY65# | | 6 | 0.8 | Thor. | 450 | 75 | 15 |
| HY67 | | 6 | 4.5 | Thor. | 1250 | 175 | 65 |
| HY69 | | 12 | 2.25 | Thor. | 750 | 120 | 30 |
| HY1269 | | 6 | 3.2 | Thor. | 750 | 120 | 30 |
| HIGH-MU | 1625 | 12.6 | 0.45 | Cath. | 600 | 120 | 25 |
| | 837 | 12.6 | 0.7 | Cath. | 500 | 80 | 12 |
| | 6AK5 | 6.3 | 0.175 | Cath. | Sharp cut-off pentode | | |
| HIGH-MU | 954 | 6.3 | 0.15 | Cath. | Sharp cut-off pentode | | |
| | 9001 | 6.3 | 0.15 | Cath. | Sharp cut-off pentode | | |
| HIGH-MU | Type No. | Filament Volts | Filament Amps | Type | Peak Plate Ma. | Max. D.C. Ma.† | Inv. Peak Pot. |
| | HY866 Jr. | 2.5 | 2.5 | Mer. | 500 | 250 | 5000 |
| | 866A/866 | 2.5 | 5.0 | Mer. | 1000 | 500 | 10000 |
| | 1616 | 2.5 | 5.0 | Vac. | 800 | 260 | 6000 |
| 8AL5 | 6.3 | 0.3 | Vac. | 60 | 20 | 460 | |
| HIGH-MU | Type No. | Average Operating Voltage | Operating Ma. Min. | Operating Ma. Max. | Av. Volts Reg. | Min. Starting Voltage | |
| | OA2 | 150 | 5 | 30 | 2 | 185 | |
| | OB2 | 108 | 5 | 30 | 1 | 133 | |
| | OC3/VR105 | 108 | 5 | 40 | 2 | 133 | |
| | OD3/VR150 | 150 | 5 | 40 | 3.5 | 185 | |

*Both sections of twin triode. #Discontinued; 2E25 supersedes and replaces. †Current for full wave.
NOTE: Not recommended for C.W. Consult Hytron Commercial Engineering Dept. for data.



Best manufacturer specializing in
of the popular BANTAM GT.

WRITE TODAY for your copy of the Hytron
transmitting and special purpose tube
catalogue. You should have it for plan-
ning your new gear.



PHONICS CORP., SALEM, MASS.

World Radio History

Taylor Tubes

100% for Amateurs!



Frank J. Hajek, Pres.
W9ECA

For Amateurs—by Amateurs—that expresses Taylor Tubes basic policy in a nutshell. Since our beginning; our main efforts have been to develop tubes that would give "More Watts Per Dollar" to Amateur Radio Operators. Of course, we do have countless tubes in Broadcast and Police Radio Transmitters and in many industrial and medical units, but our main efforts have been, and always will be, "good old Ham Radio." Taylor Tubes pioneered new standards of tube values with such tubes as the 866 Jr., 866A, T-20 —TZ-20, T-40—TZ-40, T-55, T-200 and others. Tay-

lor Tubes inaugurated a generous replacement policy and was the first to give Hams a complete transmitter manual. You can count on continued leadership by Taylor Tubes.

FREE FOR THE ASKING!

New Taylor Tube Manual gives full information on all Taylor Tubes and has 32 pages of valuable technical data. Get one at your Radio Parts Distributor or write to us.



Rex L. Munger, Sales Mgr.
W9LIP

"MORE WATTS PER DOLLAR"

Taylor HEAVY **CUSTOM BUILT** DUTY **Tubes**

TAYLOR TUBES INC., 2312-18 WABANSIA AVE., CHICAGO 47, ILL.

WORLD'S LARGEST and OLDEST MANUFACTURERS OF

Antenna Systems

AND RADIO-ELECTRICAL PRODUCTS

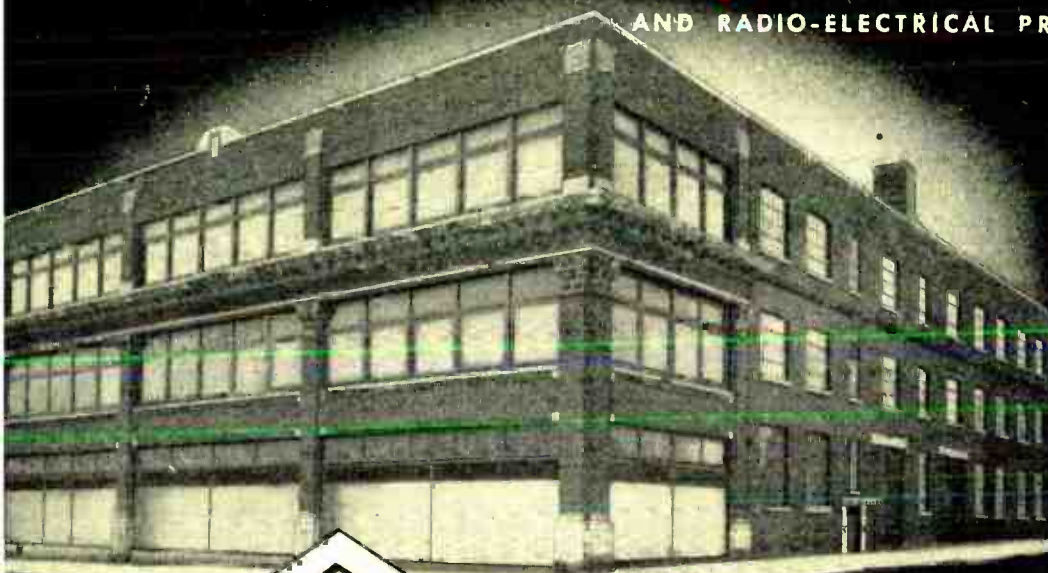

NEW
PLANT
AND
OFFICES

40

YEARS' DEPENDABILITY

BRACH

ESTABLISHED

1906

ANTENNAS

and MOUNTINGS

FOR

AUTOMOBILE, F.M.,

TELEVISION, POLICE,

and MARINE

COLLAPSIBLE . . . SECTIONAL . . . DIRECTION FINDING . . . RADAR
AND CO-AXIAL TYPE. ALL SIZES, LENGTHS and MATERIALS

OTHER BRACH PRODUCTS INCLUDE: LIGHTNING PROTECTIVE DEVICES • JUNCTION
BOXES • POT HEADS • GAS RELAYS • ARRESTER HOUSINGS • PROTECTIVE
PANELS • TERMINALS & HOUSINGS • HIGH TENSION DETECTORS • SOLDER-
ALL & FLUX • SOLDERLESS BEE TERMINAL BLOCKS "LOCK A WIRE TO A WIRE"

TEST-O-LITE, quickly locates trouble in Circuits 100-550 A.C. or D.C.

L. S. BRACH MFG. CORP.

NEW PLANT & OFFICE: 200 CENTRAL AVE., NEWARK, N. J.

World Radio History

P. R. MALLORY & CO. Inc.
MALLORY

Approved Precision Products



The Vibrapack line includes models for input voltages of 6, 12, and 32 volts DC and nominal output voltages from 125 to 400. Models available with switch for four output voltages in 25-volt stages. Hermetically sealed vibrators. High efficiency—low battery drain.

Vibrapacks* Provide Dependable Plate Power for Portable Equipment

Mallory Vibrapacks provide economical, efficient and dependable plate power for operating radio receivers, transmitters, PA systems, direction finders and other electronic equipment on vehicles, farms, portable equipment, or wherever commercial AC power is unavailable.

Write for Form E-555 for detail information



Mallory
Transmitting
Capacitors



Built with adequate safety factor for long life. Round and square can styles. Available in 20 stock sizes, working voltages from 600 to 6,000.



Vitreous Enamel Resistors

Mallory fixed and adjustable power resistors provide maximum efficiency in operation with excellent temperature and humidity characteristics. Available in rated capacities from 10 to 200 watts, resistances from 1 to 100,000 ohms.

Ham Band Switches

Ceramic insulation provides low losses at high frequencies. The Mallory Ham Band Switch is rated for use in transmitter plate circuits using up to 1,000 volts DC with power up to 100 watts, inclusive.



OTHER MALLORY PRODUCTS INCLUDE:

Attenuators
Battery Chargers
Capacitors, Dry Electrolytic
Capacitors, Paper

Ham Band Switches
Jacks
Jack Switches
Knobs
"L" Pad Attenuators
Noise Filters

Plugs
Potentiometers
Push Button Switches
Rectifiers, Dry Disc
Resistors
Rheostats

"T" Pad Attenuators
Variohm* Resistors
Vibrators
Vitreous Resistors
Volume Controls
**Reg. U. S. Pat. Off.*

All Mallory standard parts available from Mallory Distributors
Write for Catalog

FOR IMPROVED PERFORMANCE USE MALLORY APPROVED PRECISION PRODUCTS

P. R. MALLORY & CO., Inc., INDIANAPOLIS 6, INDIANA

Engineered

FOR **DEPENDABLE PERFORMANCE**



Quality

Since 1923

Birnbach has won recognition by specializing *exclusively* in the engineering, design and manufacture of

**Ceramic—Porcelain
& Steatite**

INSULATORS

also in the manufacture of

RADIO HARDWARE AND ANTENNAS

We also carry a complete line of

WIRES, CABLES

and

HOOK-UP WIRES

Birnbach products continue to win top honors for uniformly dependable performance



Send for your
copy of our
Catalog R-46

BIRNBACH NO 470W

BIRNBACH NO 471W

BIRNBACH RADIO CO., Inc.

145 HUDSON ST. NEW YORK, N. Y., U. S. A.

SINCE 1925



HEADQUARTERS FOR HAMS

FACTORY DISTRIBUTORS OF

- ABBOTT
- ADVANCE
- AEROVOX
- ALADDIN
- ALLIANCE
- ALPHA
- AMERICAN
- AMPHENOL
- AHRCO
- ARRL
- ATR
- AMPEREX
- AMPERITE
- ASTATIC
- ATLAS
- B & W
- BELDEN
- BELL
- BIRNBACH
- BLILEY
- BOGEN
- BRUSH
- BUD
- BURGESS
- CARDWELL
- CENTRAL
- CINAUDAGRAPH
- CONTINENTAL
- CORNELL
- CROWE
- DRAKE
- DUMONT
- DUNCO
- ECHOPHONE
- EIMAC
- ESICO
- ELECTRONIC
- ERIE
- GAMMATRON
- GC
- GE
- GENERAL
- GUARDIAN
- HALLICRAFTERS
- HAMMARLUND
- HICKOK
- HOWARD
- ICA
- IRC
- JACKSON
- JANETTE
- JENSEN
- JOHNSON
- JONES
- KENYON



Yes—for more than twenty years Amateurs in all parts of the world have relied on us for all their equipment. As authorized factory Distributors for all leading manufacturers, we carry only the best and the newest—Receivers, Transmitters, Parts, etc.

Our years of experience, our tremendous stock, and . . . above all, our sincere desire to render friendly and helpful service make HARRISON your most satisfactory source for all of your requirements.

Your orders are welcomed. They will be quickly filled at the very lowest Amateur prices. May we serve you?

73 de

Bill Harrison, W2AVA

A postcard will put you on the list to receive mailings of "Harrison Has It" . . . our bulletins of new items, hard-to-get gear, and "Harrison Specials"—those famous money-saving values! Send it now. Just write "H H I"!

Do you have "Electronic Parts and Equipment" . . . the NEW 800 page Buyers Guide? You can obtain one without charge—write today.



Do you have "Electronic Parts and Equipment" . . . the NEW 800 page Buyers Guide? You can obtain one without charge—write today.

- KRAEUTER
- LECTROHM
- LITTELFUSE
- MEISSNER
- MILLER
- MILLER
- MUELLER
- NATIONAL
- OHMITE
- PARMETAL
- PIONEER
- PRECISION
- PREMAX
- PRESTO
- PYREX
- RADIART
- RCP
- TMR
- RAYTHEON
- RCA
- SANGAMO

- SHURE
- SIGNAL
- SIMPSON
- SPEED X
- SPRAGUE
- STANCOR
- SUPREME
- SULYANIA
- TAYLOR
- THORDARSON
- TRIMM
- TRIPLETT
- TURNER
- UNITED
- UTC
- UNIVERSAL
- UNIVERSITY
- UTAH
- VIBROPLEX
- WARD LEONARD
- WESTINGHOUSE
- WESTON



HARRISON RADIO CORPORATION

12 WEST BROADWAY • NEW YORK CITY 7
BARCLAY 7-9854

JAMAICA BRANCH — 172-31 Hillside Ave. — REPUBLIC 9-4102

"SEALED LIKE A

VACUUM TUBE"

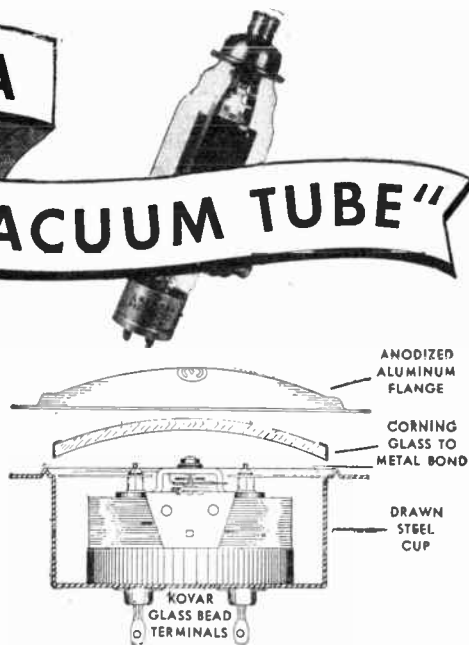
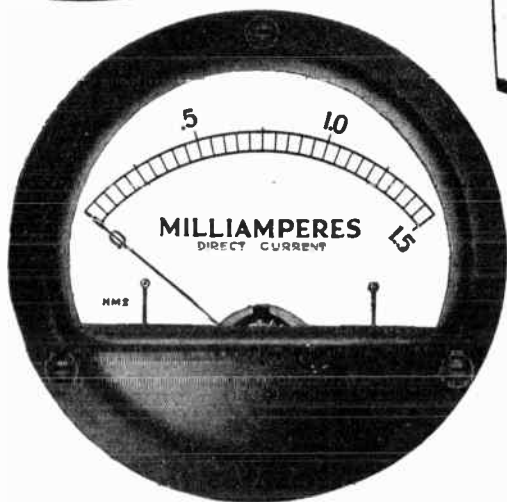

Marion Glass-to-Metal Truly Hermetically Sealed 2½" and 3½" Electrical Indicating Instruments

By building the mechanism into a one-piece, drawn steel cup, and then sealing the glass cover to the metal rim, perfect hermetic sealing has been achieved with a minimum number of seals. *Marion "hermetics" are positively interchangeable, and cost no more than standard unsealed instruments.* Not only do we offer these instruments in standard ranges, but we also specialize in supplying them with special and unusual characteristics for new and unusual applications.

- There are no rubber gaskets, no cement seals.
- Can be immersed in boiling brine solution for weeks without deterioration of seals.
- Windows are of double thickness *tempered* glass processed for solder sealing, and are highly resistant to shock.
- Instruments are completely dehydrated and are filled with dry air at sea level pressure.
- A newly designed crowned crystal permits greater scale length, reduces shadows, and makes for better visibility.
- Magnetic shielding permits interchangeability on any type of panel without affecting calibration; can be supplied silver plated for extra R.F. shielding.
- Silver clad beryllium copper hair springs reduce zero shift at all temperatures.
- Standard Kovar glass bead type terminals with solder lugs.
- Special enamel finish on cases meets two-hundred-hour salt spray test.
- Window sealing process developed and perfected in cooperation with engineers of the Corning Glass Co.
- Instruments manufactured in accordance with Jan-1-6 Specs. plus hermetic sealing.

TYPE HM 2 DIRECTLY INTERCHANGEABLE WITH AWS TYPE MR 24 AND 25
TYPE HM 3 DIRECTLY INTERCHANGEABLE WITH AWS TYPE MR 34 AND 35

Available in all DC ranges. Write for booklet.



MARION ELECTRICAL INSTRUMENT CO.

MANCHESTER, NEW HAMPSHIRE

EXPORT DIVISION 458 BROADWAY • NEW YORK 13, N. Y., U. S. A.

CABLE ADDRESS: MORHANEX



Preferred for Performance

FOR TWO DECADES



Since the inception of modern broadcasting IRC resistors have been the overwhelming choice of discriminating amateurs. Scientifically designed and engineered to highest quality standards, IRC units "belong" in the finest rigs and can be depended upon to function with complete satisfaction.

IMPROVED NEW TYPES

While continuous laboratory research to constantly improve both design and characteristics of IRC products is no new venture with us, war requirements greatly accelerated the pace and today many new types of resistances are available which might not have reached marketing stage for months to come. Among these are the Type BTS ($\frac{1}{2}$ watt) and Type BTA (1 watt) resistors. Both are smaller than their older counterparts and have other definite advantages:

SERVICE CATALOG No. 50

Most of the resistor items you'll need frequently will be found pictured and described in detail in IRC's new Service Catalog No. 50. All units listed are "in stock" on your favorite IRC jobber's shelves or can be obtained for you by him almost overnight. If you do not have your copy of the IRC Service Catalog No. 50, stop in at your IRC Distributor's today or drop a line to Dept. RH-6.

INTERNATIONAL RESISTANCE CO.

401 N. Broad Street, Philadelphia 8, Pa.

In Canada: International Resistance Co., LTD., Toronto

IRC makes more types of resistance units, in more shapes, for more applications, than any other manufacturer in the world.



GAMMATRON TUBES

24G
LATE DISS.
25 W.



257B
LATE DISS.
75 W.



454
PLATE DISS.
250 W.



This complete line, covering a power range of 50 to 5,000 watts, embodies 19 years of pioneering and experience in the design and manufacture of tantalum tubes.

Special plate, grid, and filament design, and new metal-to-glass seals, give Gammatrons remarkable VHF performance. Other features: ability to withstand high plate voltages, complete protection against tube failure due to overloading, and long, efficient operating life.

The Gammatron engineers responsible for these developments will be glad to help you with your special problems.



| TYPE NO. | 24 | 24G | 54 | 254 | 257B* | 304L | 304H | 354C | 354E | 454L | 454H | 654 | 854L | 854H | 1054L | 1554 | 2054A | 3054 |
|--|----------|----------|---------|--------------|-------------|--------------|--------------|--------------|--------------|--------------|--------------|--------------|--------------|--------------|--------------|--------|----------|--------|
| MAX. POWER OUTPUT, Class 'C' R.F. | 90 | 90 | 250 | 500 | 230 | 1220 | 1220 | 615 | 615 | 900 | 900 | 1400 | 1800 | 1820 | 3000 | 3600 | 2000 | 5300 |
| PLATE DISSIPATION: Watts | 25 | 25 | 50 | 100 | 75 | 300 | 300 | 150 | 150 | 250 | 250 | 300 | 450 | 450 | 750 | 1000 | 1200 | 1500 |
| AVERAGE AMPLIFICATION FACTOR | 25 | 25 | 27 | 23 | | 10 | 19 | 14 | 35 | 14 | 30 | 22 | 14 | 30 | 13.5 | 14.5 | 10 | 20 |
| MAX. RATINGS: Plate Volts | 2000 | 2000 | 3000 | 4000 | 4000 | 3000 | 3000 | 4000 | 4000 | 5000 | 5000 | 4000 | 6000 | 6000 | 6000 | 5000 | 3000 | 5000 |
| Plate M.A. | 75 | 75 | 150 | 225 | 150 | 1000 | 1000 | 300 | 300 | 375 | 375 | 600 | 600 | 600 | 1000 | 1000 | 800 | 2000 |
| Grid M.A. | 25 | 25 | 30 | 40 | 25 | 150 | 150 | 60 | 60 | 85 | 85 | 100 | 80 | 110 | 125 | 250 | 200 | 500 |
| MAX. FREQUENCY, Mc.: Power Amplifier | 200 | 300 | 200 | 175 | 150 | 175 | 175 | 50 | 50 | 150 | 150 | 50 | 125 | 125 | 100 | 30 | 20 | 30 |
| INTERELECTRODE CAP: Cg-p v.v.f. | 1.7 | 1.6 | 1.8 | 3.6 | 0.08 | 9 | 10.5 | 3.8 | 3.8 | 3.4 | 3.4 | 5.5 | 5 | 4 | 5 | 11 | 18 | 15 |
| Cg-f v.v.f. | 2.5 | 1.8 | 2.1 | 3.3 | 10.5 In | 12 | 14 | 4.5 | 4.5 | 4.6 | 4.6 | 6.2 | 6 | 8 | 8 | 15.5 | 15 | 25 |
| Cp-f v.v.f. | 0.4 | 0.2 | 0.5 | 1.0 | 4.6 Ou | 0.8 | 1.0 | 1.1 | 1.1 | 1.4 | 1.4 | 1.5 | 0.5 | 0.5 | 0.8 | 1.2 | 7 | 2.5 |
| FILAMENT: Volts | 6.3 | 6.3 | 5.0 | 5.0 | 5.0 | 5.10 | 5.10 | 5 | 5 | 5 | 5 | 7.5 | 7.5 | 7.5 | 7.5 | 11 | 10 | 14 |
| Amperes | 3 | 3 | 5 | 7.5 | 7.5 | 26.13 | 26.13 | 10 | 10 | 11 | 11 | 15 | 12 | 12 | 21 | 17.5 | 22 | 45 |
| PHYSICAL: Length, Inches | 4 3/4 | 4 3/4 | 5 1/16 | 7 | 5 1/16 | 7 3/4 | 7 3/4 | 9 | 9 | 10 | 10 | 10 1/8 | 12 3/8 | 12 3/8 | 16 3/8 | 18 | 21 3/8 | 30 3/8 |
| Diameter, Inches | 1 3/8 | 1 3/8 | 2 | 2 3/8 | 2 3/8 | 3 3/8 | 3 3/8 | 3 3/8 | 3 3/8 | 4 | 4 | 4 1/4 | 5 | 5 | 7 | 6 | 6 | 9 |
| Weight, Oz. | 1 1/2 | 1 1/2 | 2 1/2 | 6 1/2 | 6 | 9 | 9 | 6 1/2 | 6 1/2 | 7 | 7 | 14 | 14 | 14 | 42 | 56 | 66 | 200 |
| Base | Small UX | Small UX | Std. UX | Std. 50 Watt | Giant 7 Pin | Johnson #213 | Johnson #213 | Std. 50 Watt | Std. 50 Watt | Std. 50 Watt | Std. 50 Watt | Std. 50 Watt | Std. 50 Watt | Std. 50 Watt | Johnson #214 | HK 255 | W.E. Co. | HK 255 |

*Beam Pentode.

WRITE FOR FULL DATA ON ALL GAMMATRONS

K-2
Crystal

D-104
Crystal

T-3
Crystal

WR
Crystal

PICKUP CARTRIDGE

FP SERIES
PICKUP

GDN SERIES
Dynamic

The Astatic Corporation
CONNEAUT, OHIO.

ASTATIC

ASTATIC CRYSTAL DEVICES
MANUFACTURED UNDER BRUSH
DEVELOPMENT CO. PATENTS



A real choice of capacitor types

FOR STILL BETTER "RIGS"...



Metal case paper capacitors in widest range of containers, terminals, mountings, capacities, voltages, combinations. These capacitors give you that professional touch while providing the super dupe performance and life you want.



Dependable high-frequency jobs can best be handled with these heavy-duty Aerovox mica. Available in bakelite-metal and ceramic cases including the slide-mounting units. Current rating data at various frequencies can prove invaluable in your engineering.



For ultra-high-frequency work, there are Aerovox low-loss capacitors such as Type 186U here shown. Aluminum case. Mica dielectric. 100,000 p.f. at 100 Mc. 100,000 p.f. at 100 Mc. 100,000 p.f. at 100 Mc. There's also Type 186S with ceramic-insulated terminal and cast aluminum case. Refined sulphur dielectric.



Aerovox molded-in-bakelite mica capacitors are available in voltage ratings up to 10,000 v. Also in widest range of mountings, terminals, meter-mounting brackets, with ceramic mounting washers, etc. Aerovox selection certainly is at his best in these molded-in bakelite mica capacitors.



You build on a solid foundation when you select Aerovox Type 09" rectangular oil capacitor. Although mass-produced or lowest cost, these quality units are built for tough going and longest service. Choice of mountings, voltage ratings from 600 to 7500 v. High voltage leak proof terminals.



They're available again those heavy-duty metal case Aerovox electrolytics. Widest selection of cans, mountings, terminals, capacities, voltages, combinations. Positively the outstanding choice today. And where compactness and lowest cost are prime requisites, there are the midsize "Dandee" and Type PBS cardboard-case units.



Do you want to make your own capacitor banks or combinations? Type 11C increased paper sections are the answer. These compact paper sections are thoroughly impregnated and sealed in varnished paper jackets, and have long pigtail leads. Mount them and case them as you wish. Here's the most paper capacitance for the money.



The war made Aerovox more space conscious than ever. Type 14 miniature oil-filled transmitting capacitor is typical. Single pillar terminal. Grounded case. Ring mounting. 3000 v. There's also Type 12 with two pillar terminals and ribbed cover 2000 to 7500 v. D.C.W. Here's high-voltage insurance in miniature bulk and at popular prices.

• The Aerovox line offers you a greater selection of capacitor types than ever before. Yes, capacitors that were special before—those extra-heavy-duty types you envied in commercial X-mitting "rigs"—and definitely too high-priced for your pocketbook—are now available to you and at within-reach prices.

The latest Aerovox catalog contains many new

as well as earlier types. And for your extra-special requirements, your Aerovox jobber can tell you what's available beyond the listings in the General catalog.

Consult your Aerovox jobber. He can tell you what types to use for that "rig." Ask for our latest catalog. Also ask for a free subscription to the Aerovox Research Worker. Or write us direct.

Buy branded merchandise! And look for the yellow label!

FOR RADIO-ELECTRONIC AND INDUSTRIAL APPLICATIONS

AEROVOX CORPORATION, NEW BEDFORD, MASS., U.S.A.

SALES OFFICES IN ALL PRINCIPAL CITIES - EXPORT: 13 E. 40th ST., NEW YORK 16, N. Y.

Code: ARLAN World Radio History AEROVOX CANADA LTD., HAMILTON, ONT.



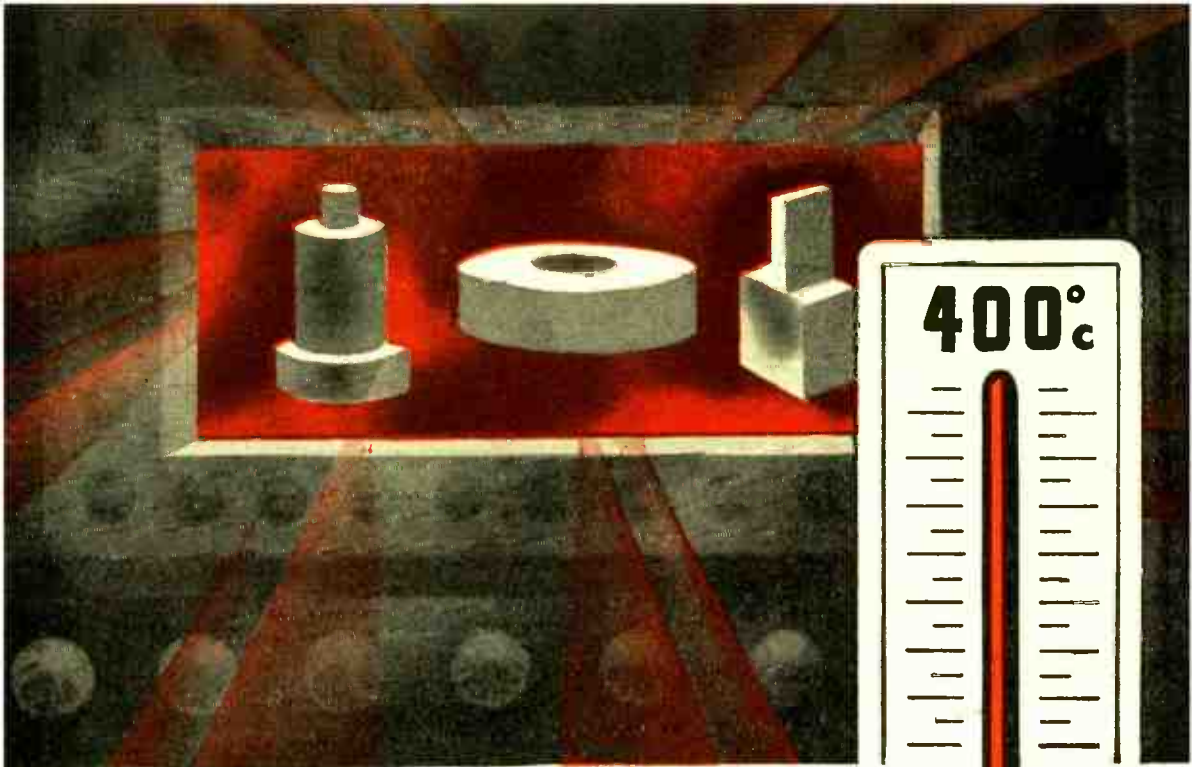

MYCALEX 400

WITHSTANDS HIGH TEMPERATURES

An outstanding characteristic of MYCALEX 400 is that it can withstand temperatures above 400° C. without softening or any permanent change in dimensions or properties.

Thus MYCALEX 400 has proved of great value as a low loss insulator in communications and other high frequency apparatus intended for use at elevated operating temperatures.

MYCALEX 400 is inorganic, free of carbonization... impervious to oil and water... not subject to cold flow. It meets all Army and Navy specifications as Grade L-4 material (JAN-I-10). It combines low loss factor with machinability to close tolerances. In sheets and rods. Fabricated to specifications.



OTHER MYCALEX CORPORATION PRODUCTS

MYCALEX K

A series of ceramic radio-frequency dielectrics, with dielectric constants selectable from 8 to 80. Low power factor, high dielectric strength. K-10 is approved Army-Navy grade HIC5H4 (JAN-I-12). Available in sheets and rods or injection molded to specification.

MYCALEX 410

Low loss, high temperature injection molded insulation. Molded in union with metals in irregular shapes. High production rates result in economical prices. All MYCALEX products withstand 400°C., are free from carbonization, not subject to cold flow. Perfect ceramic insulation.

MYCALEX CORPORATION OF AMERICA

"Owners of 'MYCALEX' Patents"

Plant and General Offices, CLIFTON, N. J.

Executive Offices, 30 ROCKEFELLER PLAZA, NEW YORK 20, N. Y.

The WESTLINE CRYSTAL



ACTUAL SIZE

Perfected through four years of war production, the Westline crystal is as fine as modern technology can produce.

Every blank is precisely orientated by X-ray and polaroid, assuring a low drift crystal. Drift is less than 1 cycle/mc/°F. Each is dimensioned to produce highest activity. Each is finished to exact frequency and specially treated to prevent its changing frequency or activity with use.

Amateur crystals are available in the 40, 80, and 160 meter bands or to multiply into any higher frequency amateur band. The price is \$3.50 complete with holder,* supplied within 1 kc of frequency you specify with frequency stamped to nearest 100 cycles. Holder plugs into either 8 prong or 5 prong socket. Holder dimensions are 1 1/8" x 13 16" x 7/16". Each crystal carries an unconditional money back guarantee. Send your orders for whatever crystals you want, specifying frequency. Shipment will be made the day order is received — shipment C.O.D. if you wish.

We can promptly supply commercial and special crystals of any type in any quantities. Tell us what you want — ask us to quote prices.

Bob Henry offers his record of seventeen years service to amateur radio as your guarantee of 100% satisfaction.

Send your orders and inquiries to Henry Radio, Butler, Missouri, or to Henry Radio, Los Angeles 25, California.

*Price subject to change without notice.

HENRY RADIO

BUTLER, MO., and LOS ANGELES 25, CALIF.

"WORLD'S LARGEST DISTRIBUTOR OF SHORT WAVE RECEIVERS"

The Name that signifies

BUD

RADIO PRODUCTS

advanced product engineering

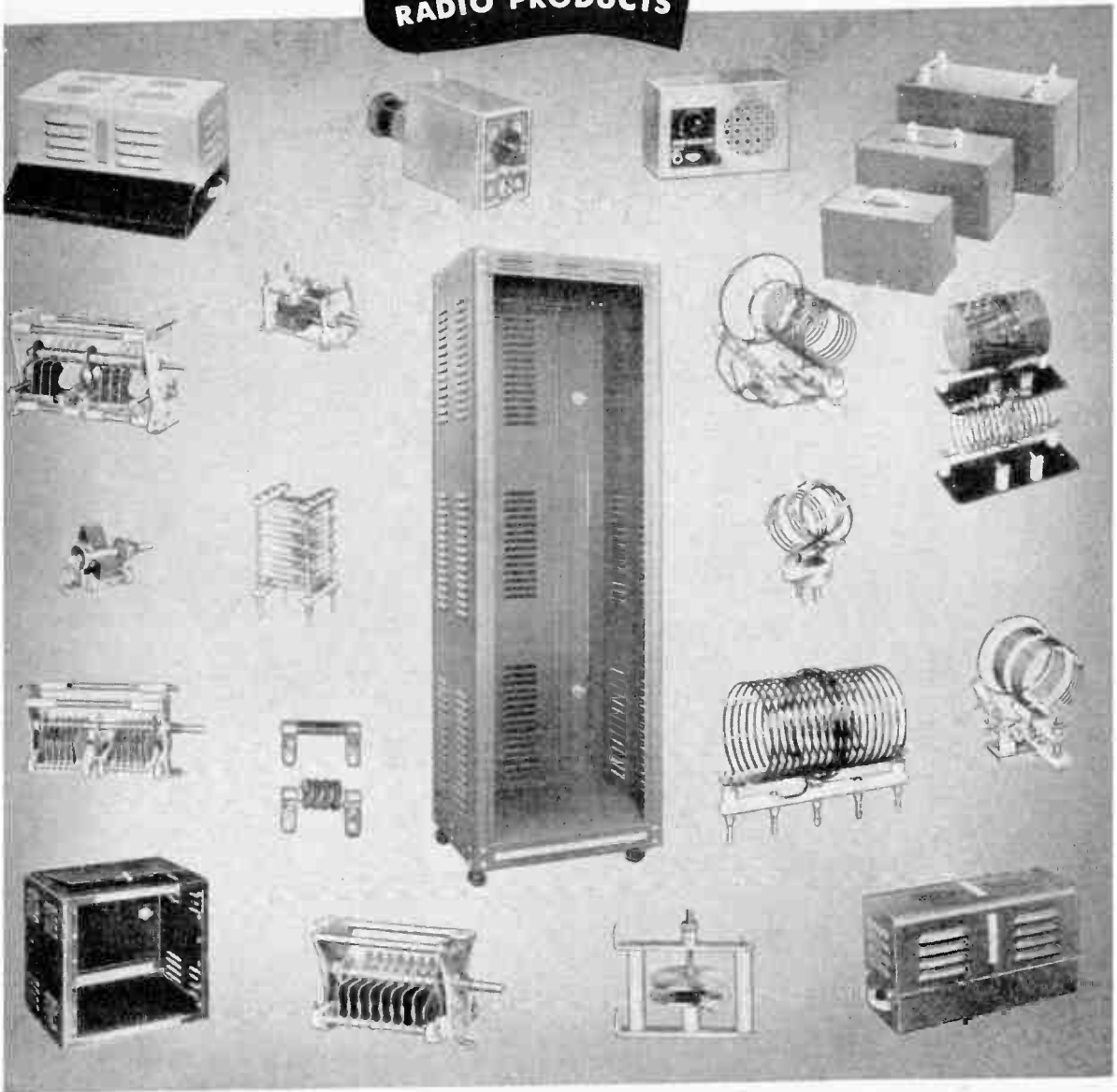

BUD SCIENTIFICALLY DESIGNED RADIO PRODUCTS

Continuous engineering enables BUD to provide you with the latest in radio and electronic equipment. You can fill all your needs more satisfactorily . . . save yourself time and trouble . . . by standardizing on BUD. See the complete display of hundreds of items in the new BUD catalog. Write for free copy!

METAL CABINETS, CHASSIS, PANELS, VARIABLE CONDENSERS, COILS, R.F.CHOKES, SPEAKER CASES, INSULATORS, PLUGS, JACKS, SWITCHES, DIALS, TEST LEADS, COUPLERS, JEWEL LIGHTS and scores of other items in a wide range of types and sizes.

BUD RADIO, INC.



CLEVELAND, OHIO

World Radio History



capacitors

**EXCEL IN
QUALITY !**

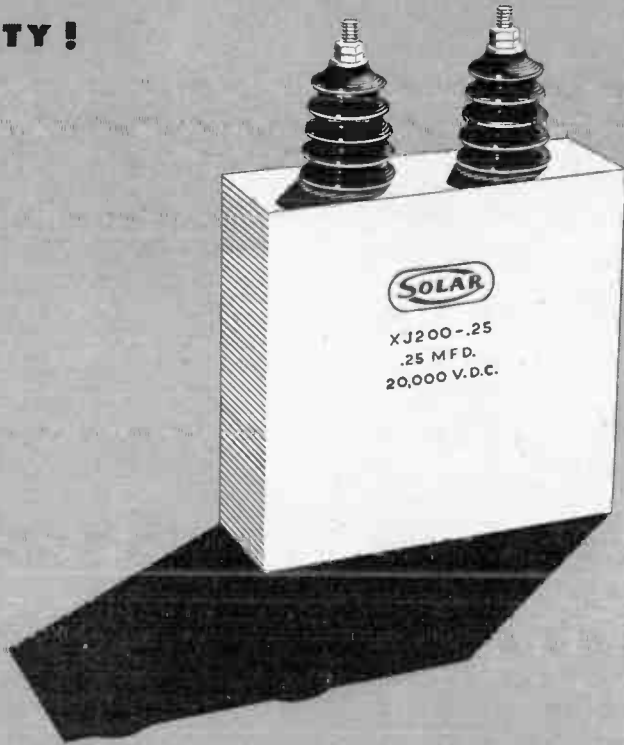

The size varies but the *quality* of Solar Capacitors is constant. From the famous tiny "Minicap" dry electrolytic capacitor shown, all Solar Capacitors are guaranteed "Reliable in Every Climate." That they live up to that guarantee is evident in the acceptance Solar enjoys throughout the world. Type XJ Capacitors range in D. C. voltage ratings from 6,000 to 25,000. **Solar Capacitor Sales Corporation**, 285 Madison Avenue, New York 17, N. Y.



U.S. & FOREIGN
PLANT & PRODUCT
A TOTAL OF TEN
ARMY-NAVY EXCELLENCE AWARDS

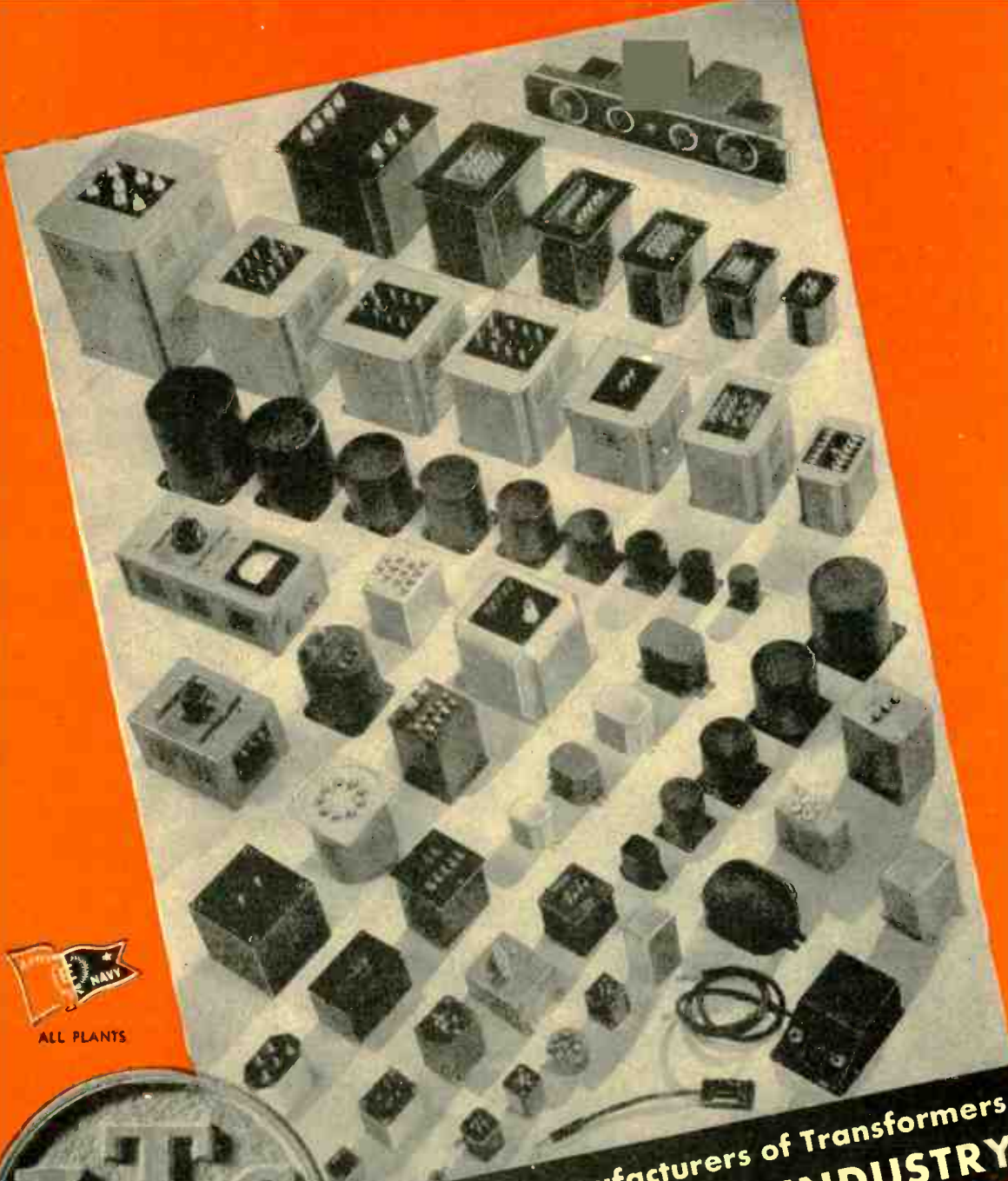

Foremost Manufacturers of Transformers
to the **ELECTRONIC INDUSTRY**



United Transformer Corp.
150 VARICK STREET NEW YORK 13, N. Y.

EXPORT DIVISION: 13 EAST 40th STREET, NEW YORK 16, N. Y., CABLES: "ARLAB"

FAST...EFFICIENT...CENTRALIZED SERVICE

at **ALLIED** *Everything in* **RADIO**

FOR THE

HAM

FOR THE BEGINNER

For years, Allied has encouraged and helped thousands of beginners to become licensed radio amateurs. Specialists on our staff are experienced in radio training. From our large stocks you can get everything you need . . . Transceiver, Transmitter and Oscillator Kits, Code Equipment, Books, etc. We also have a complete Parts List Service for any kit in the Radio Handbook

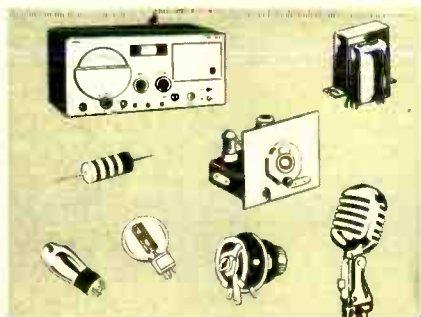

FOR THE VETERAN AMATEUR

Whether you plan to rebuild that old rig and "get back on the air" . . . or want to try a new Ham band in the U.H.F.—you can get faster delivery from Allied on the latest available components and equipment—and you are certain of guaranteed quality at the lowest prices. Our experienced staff of licensed radio amateurs is always ready to assist you in every way.



LARGEST AND MOST COMPLETE STOCKS UNDER ONE ROOF!

Allied is a leader in the distribution of Communications equipment. Ready here for rush delivery are the largest and most complete stocks under one roof . . . nationally known quality products . . . available at lowest prices, and fully guaranteed. Save time, work and money. Get everything you need from this one dependable, central source. You are sure of fast, efficient, conscientious service.

For Earliest Delivery . . . Order Your New
COMMUNICATIONS RECEIVER

Now from ALLIED

Available on Time Payments • Trade-ins Accepted



| | |
|------------------------------------|-----------------------------------|
| Hallicrafters S-40* . . . \$ 79.50 | National HRD . . . \$197.70 |
| Hallicrafters SX-25 . . . 94.50 | Hallicrafters SX-28A . . . 223.00 |
| RME-45 . . . 166.00 | Hallicrafters S-36A . . . 415.00 |
| RME DB-20 . . . 59.30 | Hammarlund 400X . . . 318.00 |
| Hammarlund HQ-129X . . . 129.00 | Hammarlund 400SX . . . 318.00 |
| National NC-2-40C . . . 225.00 | Hallicrafters S-37 . . . 591.75 |

Net F.O.B. Chicago. Prices subject to possible change.
*S-40 subject to OPA approval



Send Now for Your
NEW 1946

Radio Parts and Equipment

CATALOG

Free

Today's handiest, most complete Buying Guide. Includes latest communications receivers, parts, kits, tubes, tools, books, test instruments, public address and other equipment. Places everything you need right at your finger tips—brings you the finest values in Radio.

**ALLIED
RADIO**

833 W. Jackson Blvd., Dept. 67-46, Chicago 7, Ill.

Everything in Radio and Electronics

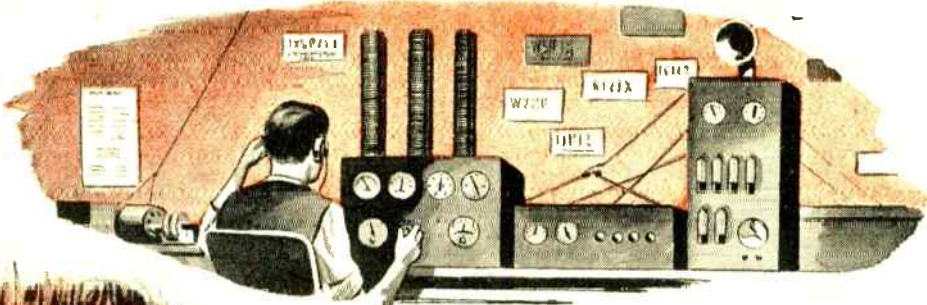

AMERTRAN...

Old Timer's Favorite

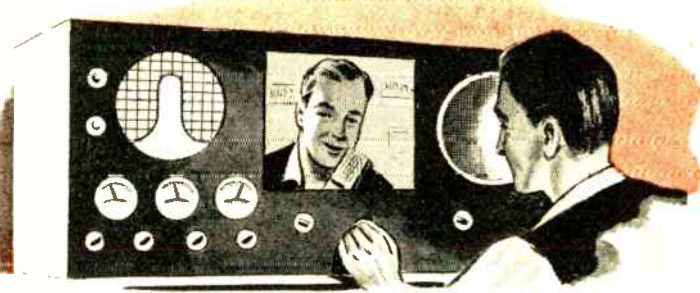

● Old time hams have fond memories of AmerTran and many radio and radar operators found the AmerTran name on their most dependable components during the recent war. Now, AmerTran, associated for more than forty years with quality transformers, returns to amateur radio.

Many improvements will be found in the new, complete, line of audio and power transformers now being offered.

THE AMERICAN TRANSFORMER COMPANY, 178 Emmet St., Newark 5, N. J.

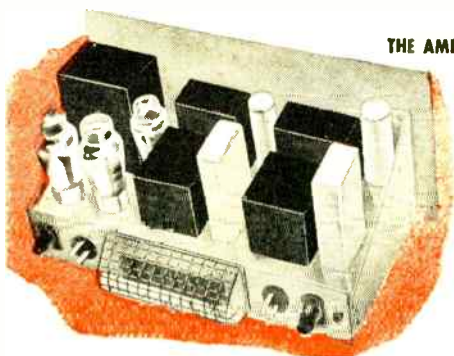

AMERTRAN
REG. U. S. PAT. OFF.
 MANUFACTURED SINCE 1901 IN NEWARK, N. J.

Pioneer Manufacturers of Transformers, Reactors and Rectifiers for Electronics and Power Transmission



For Unexcelled Quality..

RADIART AERIALS

RADIART "DeLuxe" Aerials are outstanding for their many fine features—highest quality materials and super values—Built for rugged service.

There are models for cowl, fender and under hood mounting—in 3 and 4 sections—63", 92" and 102" lengths—with "Static Muffer Ball"—"Plasti-Loom" Lead—Coaxial lead efficiency. Highest "Q" and lowest capacity insures maximum signal transfer.—In short, with features that make them the best buy of the year. Every RADIART AERIAL is complete—no extras to buy—with ample lead for cowl or fender mounting—This year and every year RADIART AERIALS are THE STANDARD OF COMPARISON.

RADIART VIPOWER UNITS

High Voltage D.C. from low voltage D.C. Input. 15, 30 and 60 watt models to operate from storage battery potentials of 6, 12, 24 and 32 volts. D.C. Outputs as great as 300 V. (a 200 ma or 400 V. (a 150 ma.

Built to power mobile transmitters, receivers, public address equipment, etc.

Completely R. F. filtered. Available with or without audio filtering.

RADIART VIBRATORS

The secret of the success of RADIART VIBRATORS is in the individual engineering of each type. Each is made to definite specifications and is not an adaptation of some other type. That accounts for their long life and engineering perfection. Radiart has a complete line of Vibrators for auto radios as well as for all types of vibrator operated power supply units.



Contact the nearest Radiart Distributor for these well known radio products. He has them in stock. Ask for complete catalog.



Radiart Corporation

3571 W. 62nd STREET

CLEVELAND 2, OHIO

Export Division
25 Wagon St. New York 7, N.Y.

Canadian Office
455 Craig St. W., Montreal, Canada

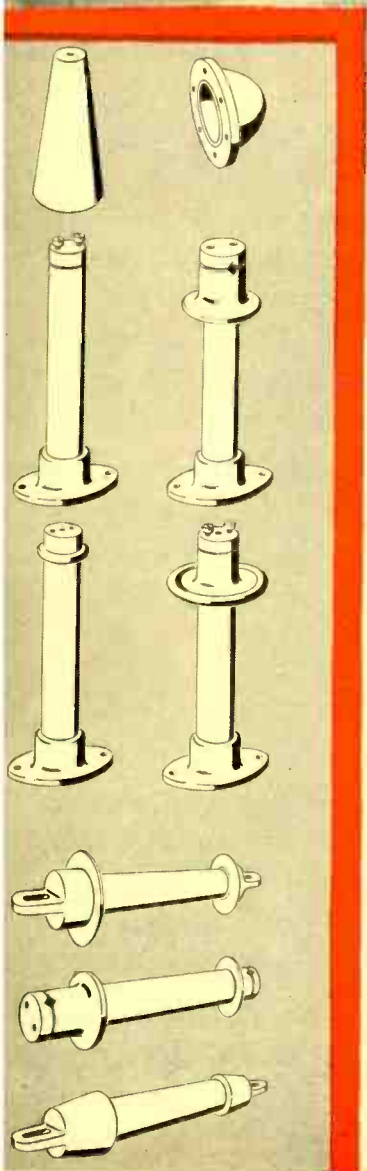
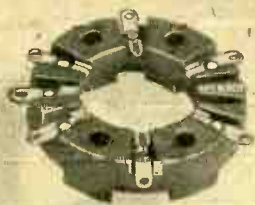

THE BEST INSULATION TO USE WHERE EVERY FRACTIONAL WATT OF POWER COUNTS

To Hams who are going to invade the higher frequency bands, energy conservation throughout circuits will be essential to efficient operation. This means that the use of Mykroy component parts such as: Sockets, Stand-off and Strain Insulators, Feed-through Bowls, Feeder Spreader Insulators, Coil and Choke Winding Forms Bushings and Chassis Panels . . . is a must in building rigs that will deliver the utmost in power.

The loss factor of Mykroy is 1 and it is particularly adaptable to ham construction needs since it can be cut, sawed, drilled, tapped in

the home workshop with the use of conventional tools just as easily as you would fabricate parts out of soft metals. Since it remains physically stable under the most adverse conditions, it will not warp or change its shape, thus preventing changes in circuit characteristics and minimizing frequency drift.

Sold as component parts . . . also in the forms of sheets and rods at reputable radio dealers throughout the country. If your dealer does not stock Mykroy write to us for the name and address of your nearest supplier.

ELECTRONIC MECHANICS INC.

70 Clifton Boulevard
Clifton, New Jersey

Chicago 47, 1917 North Springfield Avenue

E-L Power Supplies

FOR PORTABLE AND MOBILE OPERATION

**Maximum Efficiency!
Low Battery Drain! Low Noise Level!
Long Life!**

If you're planning a portable or mobile set-up—or any other layout for which standard 110 v AC is unavailable—E-L Power Supplies will provide the necessary voltages most efficiently and economically. In addition, they are excellent for mobile public address systems.

A complete line of E-L Converters (DC-DC) and Inverters (DC-AC) is available for radio amateurs. E-L Converters and Inverters are of the vibrator type, offering the highest efficiencies, longest service life, and very low battery drain. They are especially filtered to meet amateurs' circuit requirements, resulting in an exceptionally low noise level.

E-L Converters and Inverters have been proven completely dependable during the war where they came through the toughest battle conditions with flying colors.

Contact your local distributor for these efficient, reliable units.

E-L Converters. E-L Converters are offered in a full line of models to provide high DC voltages from 6, 12 and 24 volts DC, in output wattages ranging from 19 to 200 watts. They are compact in design and ruggedly built to withstand the toughest service. Typical of the E-L Converter line are the three models illustrated here.



Model 601

Input Voltage: 6 Volts DC
Output Voltages:
225 Volts DC at 50 ma.
250 Volts DC at 65 ma.
275 Volts DC at 80 ma.
300 Volts DC at 100 ma.
Size: 4 3/4" x 4" x 6"
Weight: 6 lbs.

Model 605

Input Voltage: 6 Volts DC
Output Voltages:
150 Volts DC at 35 ma.
200 Volts DC at 40 ma.
250 Volts DC at 50 ma.
275 Volts DC at 65 ma.
Size: 5 1/2" x 3 1/4" x 6"
Weight: 5 1/2 lbs.



Model 619

Size: 9 3/4" x 5 3/4" x 6"
Weight: 14 1/2 lbs.

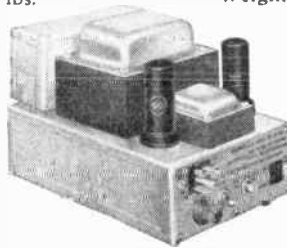

Input Voltages: 6 Volts DC
and 115 Volts AC
Output Voltages: 300 Volts
DC at 100 ma.; 6.3 Volts
AC at 4.75 amps.

E-L Inverters. A complete line of E-L Inverters is also available to permit operation of 115 VAC equipment from 6, 12, 32, 110 and 220 volts DC. Output wattages range from 5 to 1000 watts. The Inverters are engineered and manufactured for long, dependable service under all conditions. The two models shown here are typical of these efficient E-L units.

Model 303

Input: 6 Volts DC
Output: 115 Volts AC
25 Watts
Size: 7 1/8" x 4 1/4" x 5 1/4"
Weight: 6 lbs.

Model 307

Input: 6 Volts DC
Output: 115 Volts AC
100 Watts
Size: 10 3/4" x 7 1/2" x 8 1/4"
Weight: 23 1/2 lbs.



Contact your local distributor

COPYRIGHT 1945 ELECTRONIC LABORATORIES, INC.

Electronic



LABORATORIES, INC.

INDIANAPOLIS, INDIANA



VIBRATORS AND VIBRATOR POWER EQUIPMENT FOR LIGHTING, COMMUNICATIONS, ELECTRIC AND ELECTRONIC APPLICATIONS



**The Line That Reaches
Round the World**



• Among other radio experts, "hams" now welcome the return of the Amphenol line from honorable service on far-flung battlefronts around the world. Amphenol components—greatly improved by wartime experience and augmented in number, style and type—are currently available for civilian applications. Simplifying buying, this wider selection of high-quality, tested items can be procured from one manufacturer.

To know these popular Amphenol products better—write today for the new Condensed Catalog No. 72.

AMERICAN PHENOLIC CORPORATION
In Canada • Amphenol Limited • Toronto

CHICAGO 50, ILL.

**U. H. F. CABLES AND CONNECTORS • CONDUIT • CABLE ASSEMBLIES
CONNECTORS (A-N, U. H. F., BRITISH) • RADIO PARTS • PLASTICS FOR INDUSTRY**

Laboratory Standards

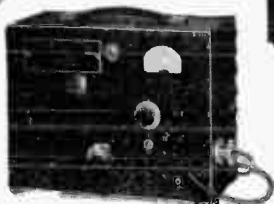

MODEL 76-B STANDARD SIGNAL GENERATOR
Two Frequency Bands between 15 and 250 megacycles

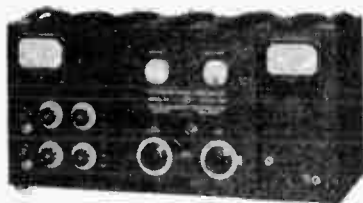

MODEL 84
U.H.F. STANDARD SIGNAL GENERATOR
300 to 1000 megacycles, AM and Pulse Modulation

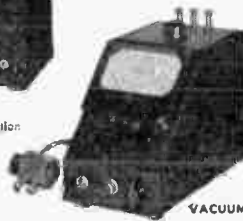

MODEL 62
VACUUM TUBE VOLTMETER
0 to 100 volts AC, DC and RF

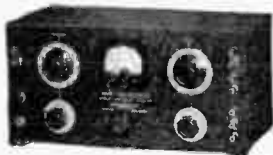

MODEL 71 SQUARE WAVE GENERATOR
5 to 100,000 cycles
Rise Rate 400 volts per microsecond

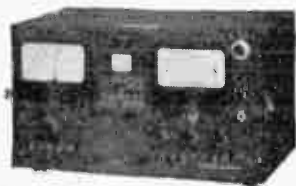
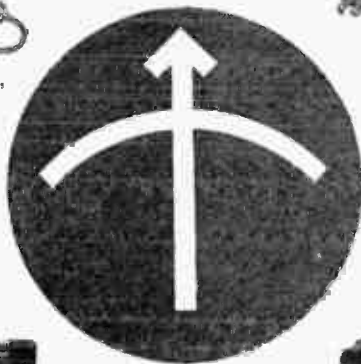

MODEL 58 U.H.F. RADIO NOISE
AND FIELD STRENGTH METER
15 to 150 megacycles



MODEL 65-B
STANDARD SIGNAL GENERATOR
75 to 30,000 kilocycles
M.O.P.A., 100% Modulation

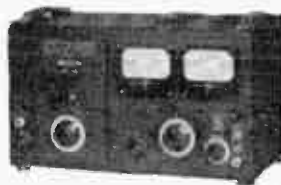

MODEL 80
STANDARD SIGNAL GENERATOR
2 to 400 megacycles
AM and Pulse Modulation

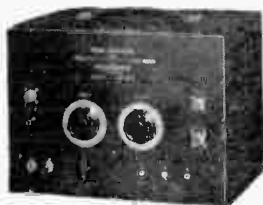

MODEL 79-B PULSE GENERATOR
50 to 100,000 cycles
0.5 to 40 microsecond pulse width

Standards are only as reliable as the reputation of their maker

MEASUREMENTS CORPORATION
BOONTON • NEW JERSEY

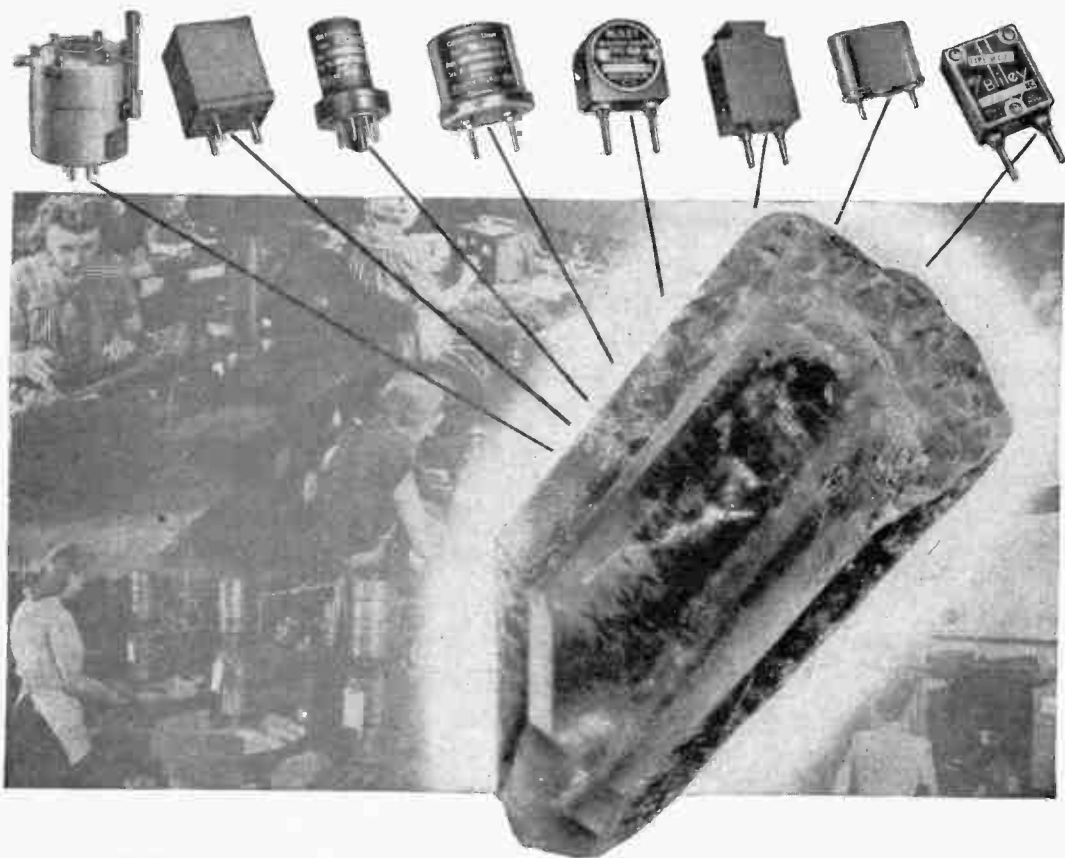

You name the application...

BLILEY has the crystals

For over 15 years the Bliley organization has devoted its talent exclusively to the production of quartz crystals. From this long experience have come many of the "firsts" that have contributed substantially to the rapid growth and development of world-wide communications.

With the Bliley acid etched* crystal units now available it is

possible to cover the entire frequency spectrum in which frequency control with quartz crystals is practicable

The best crystal unit for your particular application can easily be determined by consideration of the operating conditions. All details, such as oscillator circuit, grid drive to following stage, frequency tolerance, ambient tem-

perature range, vibration and humidity, must be analyzed to obtain completely satisfactory performance. Faster service is assured when this information accompanies your inquiry.

Make it a habit to consult Bliley engineers on all frequency control problems. Your product will benefit from this background of creative experience.

*Acid etching quartz crystals to frequency is a patented Bliley process.

Bliley
CRYSTALS

Be sure your name is on Bliley's list to receive announcements of new developments

BLILEY ELECTRIC COMPANY • UNION STATION BUILDING • ERIE • PENNSYLVANIA

680

YOU NAME IT
WE'LL SUPPLY IT



EVERYTHING IN THIS RADIO HANDBOOK

EVERYTHING THAT'S MADE IN RADIO AND

ELECTRONIC EQUIPMENT AND COMPONENTS

*We've got it
and
we'll ship it fast!*

R. W. T., world's oldest and largest Radio Supply House is ready again with tremendous stocks of sets, parts and equipment. You can depend on our quarter-century reputation for quality, sound values and super-speed service. Orders shipped out same day received. All standard lines already here or on the way, including: National, Hammarlund, R.C.A., Hallicrafters, Bud, Cardwell, Bliley and all the others you know so well.

Radio Wire Television Inc.

100 Avenue of the Americas, New York 13 • Boston, Mass. • Newark, N. J.

ORIGINATORS AND MARKETERS OF THE FAMOUS *Safayette Radio*

**SEND
TODAY!**

R.W.T. DEPT. KL5, 100 AVENUE OF THE AMERICAS, NEW YORK 13, N. Y.

I want your big new post-war Catalogue.

NAME _____

ADDRESS _____

HAM? (CALL LETTERS) _____ ENGINEER? SERVICE MAN? STUDENT?

Every TECHNICIAN NEEDS THIS ALL-PURPOSE SOLDERING PENCIL

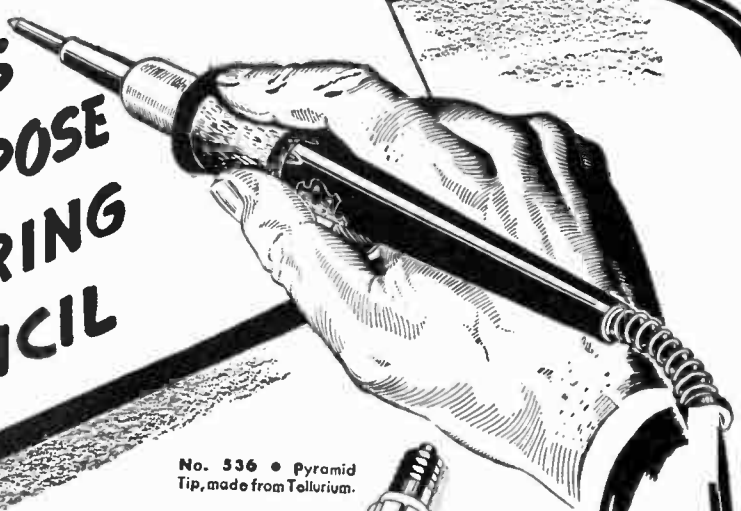

No. 536 • Pyramid
Tip, made from Tellurium.

RADIO AMATEUR'S HANDBOOK lists soldering equipment as one of the radio technician's indispensable tools. And out of the crucible of war came the Electrical Industry's newest, trimmest, slimmest soldering tool . . . the Ungar light-as-a-feather Soldering Pencil—available in FOUR INTERCHANGEABLE TIPS . . . each designed to solve a particular problem, which makes it a "MUST" for the amateur now that peacetime activity is here.

For speedy precision on intricate, hard-to-reach jobs, you can't beat this ruggedly built Ungar Soldering Pencil! Takes plenty of punishment . . . weighs only 3.6 ounces . . . perfectly balanced; length 7 inches . . . heats in 90 seconds . . . draws only 17 watts and handles with fountain pen ease. No. 776 Handle-Cord set with No. 536 tip sells for considerably less than \$2. Please order only from your Electronics Distributor.

No. 776 • Handle-
Cord Set. Plastic,
6 ft. cord. For all
tips.

No. 537 • PencilTip
made from Elkaloy A,
tip 1/4" dia.

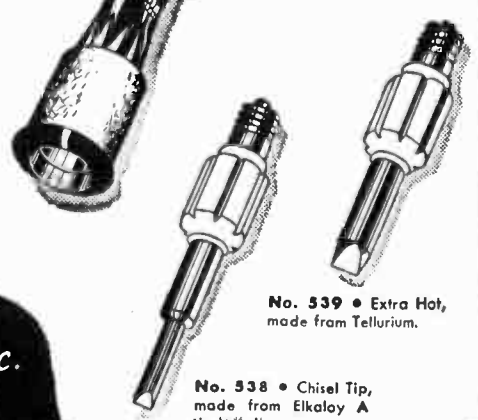

No. 539 • Extra Hot,
made from Tellurium.

No. 538 • Chisel Tip,
made from Elkaloy A
tip 1/4" dia.

Ungar Electric Tools, Inc.
Formerly Harry A. Ungar, Inc.
LOS ANGELES 54, CALIF.

METAL HOUSINGS

for COMMUNICATION APPARATUS

Custom-quality is a characteristic of skillful workmanship—the result of years of specialization.

Par-Metal Products have this quality—plus the virtues of ruggedness and economy as well.

Write for Catalogue No. 41-A.

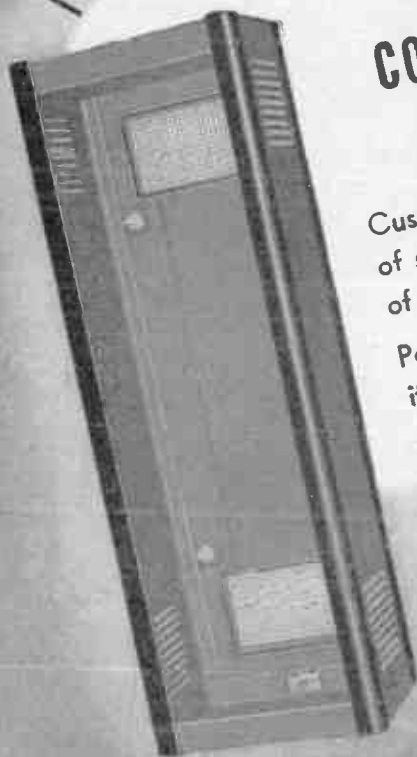

• CABINETS • CHASSIS
• PANELS • RACKS

PAR-METAL PRODUCTS CORPORATION

32-62—49th STREET . . . LONG ISLAND CITY, N. Y.
Export Dept. 100 Varick St., N. Y. C.

SILVER



1. Brand new post-war design . . . positively not a "wormed-over" pre-war model.
2. More than an "electronic" voltmeter, **VOMAX** is a true vacuum tube voltmeter in every voltage/resistance/db. function.
3. Complete signal tracing from 20 cycles through over 100 megacycles by withdrawable r.f. diode probe.
4. 3 through 1200 volts d.c. full scale in 6 ranges at 50, and in 6 added ranges to 3000 volts at 125 megohms input resistance.
5. 3 through 1200 volts a.c. full scale in 6 ranges at honest effective circuit loading of 6.6 megohms and 8 mmfd.
6. 0.2 through 2000 megohms in six easily read ranges.
7. -10 through +50 db. (0 db. = 1 mw. in 600 ohms) in 3 ranges.
8. 1.2 ma through 12 amperes full scale in 6 d.c. ranges.
9. **Absolutely stable**—one zero adjustment sets all ranges. No probe shorting to set a meaningless zero which shifts as soon as probes are separated. Grid current errors completely eliminated.
10. Honest, factual accuracy: $\pm 3\%$ on d.c.; $\pm 5\%$ on a.c.; 200 through 100 megacycles; $\pm 2\%$ of full scale, $\pm 1\%$ of indicated resistance value.
11. Only five color-differentiated scales on 4 $\frac{1}{2}$ " D'Arsonval meter for 51 ranges (including d.c. volts polarity reversal) eliminate confusion.
12. Meter 100% protected against overload burnout on volts/ohms/db.
13. Substantial leather carrying handle. Size only 12 $\frac{3}{8}$ "x-7 $\frac{1}{8}$ "x5 $\frac{1}{8}$ "

SEND FOR FREE CATALOG
SEE YOUR JOBBER

OVER 34 YEARS OF RADIO ENGINEERING ACHIEVEMENT

McMurdo Silver Company

1240 MAIN STREET,

HARTFORD 3,

CONNECTICUT

"VOMAX"

Measures **EVERY** Voltage

The secret of the overwhelming demand for "VOMAX" is just that simple. With it you can measure every voltage in radio receiver design and servicing.

"VOMAX" handles a wide range of d.c. and a.c. voltages at meter resistance so astronomically high that you can measure directly and accurately every such voltage. It goes far beyond conventional volt-ohm-meters. For "VOMAX" will measure every a.f., i.f. and r.f. voltage from 20 cycles right up to beyond 100 megacycles.

This remarkable post-war instrument gives you vitally important visual dynamic signal tracing. Read the briefed specifications at left

practically a complete service station by itself . . . see how "VOMAX" makes you the master, no longer the victim, of tough service jobs. Imagine the time you'll save, the increased efficiency, the multiplication of your profits when you put "VOMAX" to work and can at last measure every voltage.

Requiring no priority and despite heavy demand, your favorite jobber can arrange quick delivery . . . if you act fast.

**NET PRICE \$59.85
ONLY**

AMATEUR PARTS & KITS

Born out of the war are many more money-saving new SILVER developments. As an up-to-the-minute amateur you'll want to know all about the new 904 resistance-capacitance bridge . . . new 1.6 thru 30mcs. "all-band" 5 to 500 watt transmitting inductors . . . u.h.f. tuners "harnessing" 112 thru 470 mcs. . . the new SILVER am/fm receiver/kit covering 1.6 thru 150 mcs. . . new "progressive" 5 to 500 watt xmitter/kit . . . 1.6 thru 500 mcs. absorption frequency meter.

NOTICE TO
Engineers, Purchasing Agents, Experimenters, Amateurs

There's only one

RADIO'S MASTER

The only official
Radio and Electronic
equipment source-book

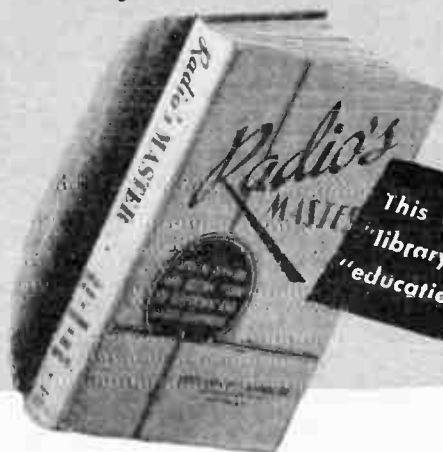

New 11TH EDITION

This complete 800 page, one volume
"library" of facts and data is a veritable
"education" itself on Radio & Electronics!

CONTAINS

Electronic Devices
Antennas
Photoelectric Units
Test Equipment
Recording Devices
Switches, Plugs
Coils, Relays
Transmitting &
Receiving Tubes
Transmitters
P.A. Equipment
Transformers
Controls, Condensers
Insulators
and many thousands of
other items

RADIO'S MASTER tells you:

What

the product does, its specifications, comparable and competing items . . . Thousands of illustrations . . . Data covers 90% of all products in the industry, each item indexed and cross indexed.

How much

Prices on thousands of items, all clearly catalogued for easy buying.

Who

makes it. Directory of manufacturers alphabetically listed, with page numbers for instant reference.

Where

you can get it. Your nearest sources that can supply your radio and electronic requirements. Saves time . . . Eliminates bulky files.

You'll find it **FASTER** in RADIO'S MASTER

\$4⁵⁰

\$5.00 outside of U.S.A.

UNITED CATALOG

PUBLISHERS INC.

106 Lafayette St. • New York 13, N. Y.



A SECTION OF THE WEST'S BEST EQUIPPED ELECTRONICS LABORATORY
... THE KLUGE LABORATORY

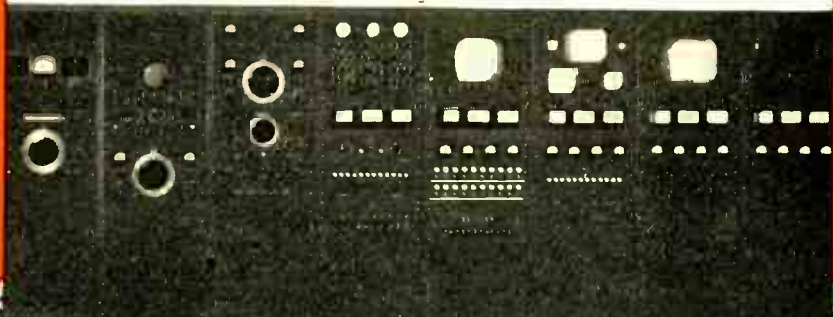

Peacetime 1946 ushers in a new era for amateur and professional engineers... an era of greater efficiency, range and accuracy in electronic development... an era in which KLUGE design and engineering advancements will make increasingly important contributions to the radio field.

KLUGE ELECTRONICS COMPANY
1031 N. Alvarado St., Los Angeles 26, Calif.

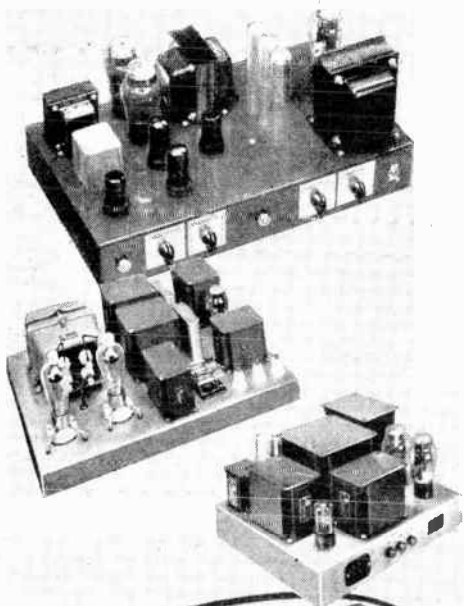

The Symbol of
**QUALITY, VALUE AND
 GUARANTEED PERFORMANCE**
 in Amplifier Kits . . . Transmitter Kits
 and Component Parts

THESE time-tested STANCOR Kits for Amateurs are designed for simplicity, efficiency and usefulness. Backed by the recognized and respected STANCOR guarantee against defects in material and workmanship, they render complete satisfaction.

Full data furnished on each unit . . . description, diagram, illustration . . . for proper assembly, wiring and operation. "Standardized" punched chassis simplifies set-up . . . accommodates variety of equipment without structural change. STANCOR units make possible maximum performance with minimum labor and expense. See your Jobber or write for full details.

STANCOR
 STANDARD TRANSFORMER CORPORATION
 1500 NORTH HALSTED ST. CHICAGO 22, ILLINOIS

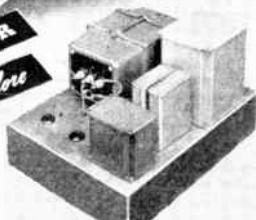

**ENDORSED
 BY CHAMPIONS**

Skill, speed, accuracy free of nervous tension brings big pay.

The One and Only Candler System

Nothing else like it. It is the course that has made code champions. Will help any sincere man gain greater speed, accuracy and skill. Learn the Candler way.

Fast, Efficient Operators Needed

If you need additional speed to be classed as an expert, try the Candler method. It is endorsed by champions. It has produced phenomenal results with a minimum of effort. Why not learn the faster and easier way. Get your copy of the Book of Facts for Code students, Telegraph and Radio Operators.

CANDLER SYSTEM CO.

P. O. Box 928, Dept. 14-A, Denver (1), Colo.
 and at 121 Kingsway, London, W.C. 2, Eng.



**Champion Endorses
 CANDLER SYSTEM**

T. R. McElroy, Official Champion Radiotelegraph Operator of the world with a speed of 75.2 w.p.m., claims his success is due to the Candler System.

RELAYS BY STACO

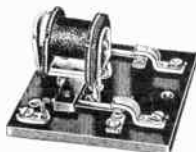

#ABA:—Antenna Change-over Relay, 3/16" pure silver DPDT Contacts, 110 volt A.C. coil, \$3.75 net, 6 Volt A.C. coil, \$3.00 net. Other units to \$6.00 net.

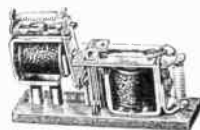

#LEA:—Latching Relay, electrical reset, 110 volt coils, spot 3/16" fine silver contacts, \$3.75 net, 6 Volt A.C. and 6 volt D.C. models available.



#MR-11:—Miniature Relays, 3/16" pure silver SPDT Contacts, 110 volt A.C. Coil, net price \$1.50. Plate Circuit and DPDT models, available at from \$1.50 to \$3.60 net.

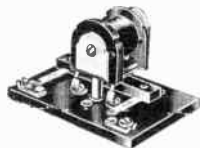

#RBA-1:—General Purpose and R.F., SPST (double-break) 3/16" fine silver contacts, 110 volt A.C. Coil, \$2.10 net. Other models to \$5.00 net.

SEE YOUR JOBBER OR WRITE FOR CATALOG

Standard Electrical Products Co.

403 LINDEN AVE.

DAYTON 3, OHIO

EASY TO LEARN CODE!

Beginners, Amateurs and Experts alike recommend the **INSTRUCTOGRAPH**, to learn code and increase speed.



The Instructograph

ACCOMPLISHES THESE PURPOSES:

- FIRST:** It teaches you to receive telegraph symbols, words and messages.
- SECOND:** It teaches you to send perfectly.
- THIRD:** It increases your speed of sending and receiving after you have learned the code.

MAY BE PURCHASED OR RENTED

The INSTRUCTOGRAPH is made in several models to suit your purse and all may be purchased on convenient monthly payments if desired. Machines may also be rented on very reasonable terms and if when renting you should decide to buy, the first three months rental may be applied in full on the purchase price of the equipment.

Postal Card WILL BRING FULL PARTICULARS IMMEDIATELY

INSTRUCTOGRAPH COMPANY

4713 Sheridan Road, Chicago 40, Ill.

NEW

HICKOK

Radio Service Instruments

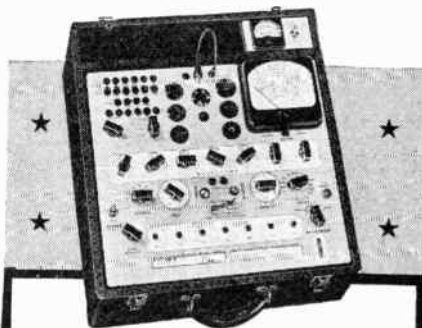

*If It Isn't A Hickok Indicating
Michromhos It's Not
Dynamic Mutual Conductance*

These new 1946 HICKOK radio tube and set testers make still closer tests, with finer accuracy, rejecting tubes that might get by with an ordinary tester. 7 selector switches instead of 2, aims to prevent obsolescence. These are the instruments that are held in highest esteem. Order from your jobber.

The Hickok Electrical Instrument Co.
10588 Dupont Ave., Cleveland 8, Ohio

For That Thorough KNOW HOW!

Take one of these unique home study courses developed by DR. RUFUS P. TURNER, Assoc. I.R.E., Registered Professional Engineer, former instructor of ESMWT and Signal Corps Trainee classes.

- ★ **INTRODUCTORY RADIO.** Starts at rock-bottom fundamentals and covers entire field in interesting manner. Up to date lesson material. Any serious student with knowledge of English language may enroll.
- ★ **ADVANCED RADIO.** For students who already know fundamentals. "Up-grading" course for hams, servicemen, factory workers.
- ★ **PROFESSIONAL OPERATOR COURSE.** Theory and code coaching for Government radiotelegraph and radiotelephone operator license examinations.
- ★ **AMATEUR OPERATOR COURSE.** Theory and code coaching for Government amateur radio operator license examinations. Inexpensive.
- ★ **RADIO ENGINEERING.** Mathematical and physical treatment. Applicants must show 2 years college training in science or mathematics.
- ★ **ELECTRONICS.** Complete, modern. Emphasis on industrial applications. Radiomen and electricians may enroll.

No War-Time Streamlining

DIPLOMAS GRANTED ONLY AFTER SUPERVISED FINAL EXAMINATIONS

Write Today For Free Literature—No Obligation

The TURNER SCHOOL

Post Office Box 925 New Bedford, Mass.

BOOKS ON RADIO AND ALLIED SUBJECTS

A well-chosen if small library of good books is a necessity to any radioman. It is better to study carefully and thoroughly a few books than to be superficially acquainted with a large number of them.

We recommend the texts listed below, which are available by mail from our Book Department at the prices stated, plus 4% for domestic postage; foreign 10%; please add any applicable taxes.

Fundamentals, Theory, and Engineering

RADIO ENGINEERING, by F. E. Terman. A comprehensive treatment of all phases of radio communication written from the engineering viewpoint; both qualitative and quantitative analyses are included. 813 pages. Book No. 101. \$5.50.

FUNDAMENTALS OF RADIO, by F. E. Terman. An elementary version of Terman's "Radio Engineering," especially for those whose knowledge of mathematics is limited. 458 pages. Book No. 102. \$3.75.

PRINCIPLES OF RADIO, by Keith Henney. Combines both theory and practice—begins with the fundamental principles of electricity, and develops the subject of radio in a clear, logical manner. One of the most popular basic texts; selected (among others) for government-sponsored radio training courses. 534 pages. Book No. 302. \$3.50.

RADIO PHYSICS COURSE, by A. A. Ghirardi. Basic fundamentals of electricity, radio, television and sound especially adapted to home instruction; a minimum of mathematics; contains many self-review questions. Covers every branch of radio including broadcasting, servicing, aviation, marine, police, military, public address, and electronics applications. 972 pages. Book No. 501. \$5.00.

APPLIED ELECTRONICS. This book by the Electrical Engineering Staff of M.I.T. is written for those engineers with little previous knowledge of electronics. It is written especially for those who specialize in power, communications, control, measurement and other phases of electrical engineering. The viewpoint is that of the engineer and the physical processes are treated in detail as a necessary basis for thorough understanding. 772 pages. Book No. 305. \$6.50.

ENGINEERING ELECTRONICS, by D. G. Fink. A text for the practicing electrical engineer who has little specific training in electronic concepts. The treatment is midway between simple equipment descriptions and elaborate technicalities. A series of typical problems illustrate practical applications. 358 pages. Book No. 103. \$3.50.

ELECTRONICS, by J. Millman and S. Seely. Basic electronic principles and applications to problems in electrical engineering and physics; theory of operation of electronic devices, both gas filled and vacuum. 721 pages. Book No. 104. \$5.00.

ELEMENTS OF RADIO, by A. & W. Marcus. An extensive course prepared for those without previous training in physics or mathematics, and in conformity with pre-induction training outlines recommended by the armed services. One of the best for this purpose. 699 pages. Book No. 602. \$4.00.

Commercial and Aeronautical Radio

THE RADIO MANUAL, by G. E. Sterling. A comprehensive and practical handbook written especially for commercial and broadcast operation. Covers not only principles and methods but also a wide variety of apparatus. 1120 pages. Book No. 202. \$6.00.

RADIO OPERATING QUESTIONS AND ANSWERS, by A. R. Nilson and J. L. Hornung. 1300 questions and answers on theory, apparatus, circuits, laws, and regulations to prepare the student for radio operator's license examinations. 415 pages. Book No. 107. \$3.00.

PRACTICAL RADIO COMMUNICATION, by A. R. Nilson and J. L. Hornung. Covers the entire spectrum of radio waves including operators' license requirements; combines theoretical principles and practical radio operating; intended for both home study and radio schools. Covers transmitting, receiving, and power equipment for all types of stations including marine, broadcasting, and ultra-shortwave. 927 pages. Book No. 106. \$6.00.

RADIO CODE MANUAL, by A. R. Nilson. A complete radio code course for home study. 20 lessons take the student step-by-step from formation of characters up through handling of actual messages. 174 pages. Book No. 108. \$2.50.

Radio Receiver Servicing and Allied Subjects

MODERN RADIO SERVICING, by A. A. Ghirardi. A complete radio servicing reference library in one volume. It is designed particularly for those who wish to enter radio service work. But it is also used by those already in such work to add to their fundamental knowledge and to bring their methods up to date. Also includes hints on sales and merchandising methods. 1300 pages. Book No. 502. \$5.00.

RADIO TROUBLESHOOTER'S HANDBOOK, by A. A. Ghirardi. A timesaving data handbook containing tabulated service data of all kinds; contains symptoms and remedies for common troubles in more than 4800 receivers and record changers; ignition-service interference data for more than 80 cars; comprehensive tube charts, resistor and condenser tables, color codes, trade directories, etc. 744 pages. Book No. 503. \$5.00.

BOOKS by John F. Rider:
Vacuum Tube Voltmeters. 180 pages. Book No. 402. \$2.50.

Servicing by Signal Tracing. Covers thoroughly the only method of locating difficulties applicable to all types of electrical communications systems both of audio and radio frequencies. 360 pages. Book No. 403. \$4.00.

Frequency Modulation. A general discussion with special attention to f.m. receiver and maintenance problems. 136 pages. Book No. 404. \$2.00.

The Meter at Work. 152 pages. Book No. 405. \$2.00.

The Oscillator at Work. 256 pages. Book No. 406. \$2.50.

The Cathode Ray Tube at Work. The leading practical work on the many common service and other applications of the c.r. tube in oscillographs. 388 pages. Book No. 407. \$4.00.

Servicing Superheterodynes. 307 pages. Book No. 408. \$2.00.

Automatic Frequency Control Systems. 144 pages. Book No. 409. \$1.75.

Servicing Receivers by Means of Resistance Measurement. 203 pages. Book No. 410. \$2.00.

D. C. Voltage Distribution in Radio Receivers. 96 pages. Book No. 411. \$1.25.

Alternating Currents in Radio Receivers. 96 pages. Book No. 412. \$1.25.

Resonance and Alignment. 96 pages. Book No. 413. \$1.25.

Automatic Volume Control. 96 pages. Book No. 414. \$1.25.

Vacuum Tubes and Associated Circuits

THEORY AND APPLICATION OF ELECTRON TUBES, by **H. J. Reich**. A thorough ground work in tube and circuit theory. Emphasis both on fundamental principles and applications to communication and industrial engineering. 670 pages. Book No. 113. \$5.00.

FUNDAMENTALS OF VACUUM TUBES, by **A. V. Eastman**. The principal types of vacuum tubes, the laws underlying their operation, and engineering analysis of their more important applications. Mathematics has been restricted to a minimum. 584 pages. Book No. 118. \$4.50.

INDUSTRIAL ELECTRONIC CONTROL, by **W. D. Cockrell**. Its title tells the story. One of the first books in a rapidly expanding field; excellent basic principles with some applications. 247 pages. Book No. 140. \$2.50.

AUDEL'S ELECTRONIC DEVICES. An unusually simple treatment of electronic and photo-electric tubes, particularly for non-radio uses such as candlepower and color determination, electric counters and controls, "electric eyes," sound reproduction and the like. Book No. 805. \$2.00.

High Frequencies

MICROWAVE TRANSMISSION, by **J. C. Slater**. A thorough exposition of the characteristics of microwaves with emphasis on the use of Maxwell's equations as a means of handling transmission line design problems; hollow pipes and coaxial lines are treated extensively. 310 pages. Book No. 129. \$3.50.

ULTRA HIGH FREQUENCY TECHNIQUES. This book by professors of electricity at four different universities explains the principles.

U. H. F. RADIO SIMPLIFIED, by **Milton S. Kiver**. U.h.f. radio simply and clearly explained, in plain English, without mathematics. Covers principles, applications, and equipment; adapted for home study. 242 pages. Book No. 206. \$3.25.

Reference Works

RADIO ENGINEERING HANDBOOK, by **Keith Henney and 23 collaborators**. The leading handbook of the radio engineering profession. A large amount of reference material in concise form with emphasis on design data and many tables, charts, equations, formulas, and diagrams, pertaining to all phases of radio. 945 pages. Book No. 121. \$5.00.

RADIO ENGINEERS' HANDBOOK, by **F. E. Terman**. This book is a unique combination of the tabular-data type of handbook plus concise extracts of the explanatory type of material such as features the author's "Radio Engineering." Its thirteen sections concentrate on tubes, circuits, transmitters, power supplies, antennas, fundamentals, formulas, design data, tables, and diagrams; a considerable amount of data is included which is not readily found in other texts. 1019 pages. Book No. 122. \$6.00.

THE RADIOTRON DESIGNER'S HANDBOOK. This book, published by the Australian "Radiotron" people, probably contains more useful handbook-type information in its 352 pages than any book of similar size and cost published in this country. Tabular and mathematical

data are expanded by more explanatory data than is customary in such books. There are thirteen chapters on audio frequencies, eight on radio frequencies, and several each on rectification, receivers, tests and measurements, tube characteristics, general theory and miscellaneous. Book No. 803. \$1.00.

REFERENCE DATA FOR RADIO ENGINEERS, by **Federal Telephone and Radio Corporation**. Though much less comprehensive than some of the other books listed in this section it contains the information most often needed by radio engineers in concise and inexpensive form. 200 pages. Book No. 809. \$1.00.

STANDARD HANDBOOK FOR ELECTRICAL ENGINEERS, by **A. E. Knowlton and 102 specialists**. 2303 pages. 1700 illustrations, 600 tables on all phases of electricity including radio. Book No. 123. \$8.00.

ELECTRICAL ENGINEERS' HANDBOOK—Communication and Electronics volume, by **E. Harold Pender, Knox McIlwain, and 47 contributors**. This volume covers the whole field of communications as a unit; it includes telegraph, telephony, radio broadcasting, point-to-point radio telephony, facsimile transmission and reception, public address systems, sound motion pictures, aviation radio, and television. Book No. 312. \$5.00.

Specialized Topics and Miscellaneous

MATHEMATICS FOR ELECTRICIANS AND RADIO-MEN, by **N. M. Cooke**. Algebra through quadratic equations, logarithms, trigonometry, plane vectors, elementary vector algebra, and other mathematics needed to solve everyday radio and electrical problems, with emphasis on direct applications. 604 pages. Book No. 124. \$4.00.

MATHEMATICS ESSENTIAL TO ELECTRICITY AND RADIO, by **Cooke and Orleans**. Essentially an abridgement of the above; we think the larger book is more than worth the difference in cost. Book No. 137. \$3.00.

TELEVISION SIMPLIFIED, by **Milton S. Kiver**. A simplified explanation of modernized television, especially as it pertains to the operation and maintenance of television receivers. A "simple language" text readily understood by those with fair radio knowledge. 432 pages. Book No. 207. \$4.75.

MEASUREMENTS IN RADIO ENGINEERING, by **F. E. Terman**. A comprehensive discussion of measurement problems commonly encountered by radio engineers. Complete and practical with emphasis on the design of laboratory equipment and upon those methods requiring the least equipment. 400 pages. Book No. 125. \$4.00.

FREQUENCY MODULATION, by **August Hund**. Basic principles and applications of frequency modulation engineering; complete treatment but with many useful references. Shows how to simplify the complicated mathematics of this field with curves and charts. 375 pages. Book No. 127. \$4.00.

TELEVISION—The Electronics of Image Transmission, by **V. K. Zworykin and G. A. Morton**. The first part of the book is devoted to a consideration of the fundamental physical phenomena involved in television, followed by a discussion of the fundamentals. The third part takes up the details of an electronic television system, and the book concludes with a description of the working system. Book No. 316. \$6.00.

To EDITORS AND ENGINEERS, Ltd.
1300 Kenwood Road, Santa Barbara, Calif.

Please send me the books whose names (or numbers) are listed below. 4% domestic postage (including A.P.O.'s) [or 10% foreign postage], and any applicable taxes, have been added.
Amount enclosed \$....."Radio Handbooks". Other books.....

Name and address:

INDEX

A

| | | |
|--|-----------------|--|
| Absorption-Type Wavemeter..... | 500, 504 | |
| A.c. Component..... | 322 | |
| A.c. Generator..... | 27 | |
| Aerom Tubes—See "Receiving Tube Characteristics" | | |
| Addition, Algebraic..... | 552 | |
| Addition, Arithmetical..... | 546, 548 | |
| Addition, Vectorial..... | 573 | |
| Adjustment of Crystal Oscillators..... | 166 | |
| Adjustment of Receivers..... | 79, 92 to 94 | |
| Adjustment of Transmitters, Safety in..... | 274 | |
| Aerial—See "Antennas" | | |
| A.f. Power Measuring Device..... | 401 | |
| Air Core..... | 31, 42 | |
| Air Gap, Filter Choke..... | 325 | |
| Air Gap, Tuning Condenser..... | 34, 176 | |
| Algebra..... | 551 | |
| Alignment Chart..... | 580 to 582 | |
| Alignment, Receiver: | | |
| I.F..... | 93 | |
| Multiband..... | 94 | |
| Superheterodyne..... | 92 | |
| Tuned R.F..... | 92 to 95 | |
| All-Wave Receivers, Interference in..... | 541 | |
| Alternating Current..... | 27 | |
| Angular Velocity..... | 27 | |
| Effective Value..... | 29 | |
| Generation..... | 27 | |
| Rectified..... | 29 | |
| Transformers..... | 42 | |
| Alternator..... | 27 | |
| Aluminum Drilling..... | 532 | |
| Aluminum Paint..... | 536 | |
| A.M..... | 188 to 190 | |
| Amateur Licenses..... | 6 | |
| Amateur Operators..... | 5 | |
| Ampere, Definition..... | 19 | |
| Amplification..... | 57 | |
| Amplification Factor (μ)..... | 58 | |
| Amplifier: | | |
| Action of Vacuum Tube..... | 57 | |
| Adjustment..... | 172 | |
| A.f..... | 59, 61, 71, 302 | |
| Beam Power Tube..... | 56 | |
| Bias..... | 180, 181 | |
| Cathode Ray Oscilloscope..... | 522 | |
| Class A..... | 59 | |
| Class AB..... | 60 | |
| Class B..... | 60, 63, 166 | |
| Class C..... | 167 | |
| Degenerative Feedback (see also—Inverse Feedback)..... | 212 | |
| Efficiency..... | 202 | |
| Excitation..... | 172 | |
| Gain..... | 497 | |
| Harmonic..... | 417 | |
| High Frequency R.F..... | 384 | |
| Hints, U.H.F..... | 82 | |
| I.f..... | 302 | |
| Input..... | 209, 212 | |
| Inverse Feedback..... | 63, 166 | |
| Linear..... | 60, 172 | |
| Load Impedance..... | 391 | |
| Microwave..... | 61 | |
| Parallel Rod—See "U.H.F. Transmitters" | | |
| Parallel Tube..... | 291 | |
| Power..... | 291, 566 | |
| Push-Pull Tube..... | 63, 70, 166 | |
| R.F..... | 171 | |
| R.F., Neutralization..... | 175 | |
| R.f. Tank Circuit Capacities..... | 184 | |
| Series Feed..... | 184 | |
| Shunt Feed..... | 294 | |
| Single-Ended r.f..... | 566 | |
| Specifications..... | 207 | |
| Speech (see also—Modulators)..... | 291 | |
| Standard Push-Pull Circuit..... | 56 | |
| Television Pentodes..... | 563, 564 | |
| Voltage..... | 188 | |
| Amplitude..... | 191 | |
| Amplitude Modulation..... | 188 to 191 | |
| Systems..... | 191 to 200 | |
| Angle of Plate Current Flow..... | 63, 173 | |
| Angular Velocity..... | 28 | |
| Antennas..... | 428 | |
| Angle of Radiation..... | 429, 472 | |
| Broadside Arrays..... | 465 | |
| Broadside Radiation..... | 465 | |
| Characteristics and Considerations..... | 433 | |
| Colinear..... | 439, 464 | |
| Compact..... | 451 | |
| Coupler, Simple Universal..... | 482 | |
| Coupling Between Antennas..... | 469 | |
| Coupling to Transmitter..... | 479 | |
| Current Fed..... | 438, 446 | |
| Delta-Matched..... | 443 | |
| Diamond..... | 461 | |
| Dipole..... | 430, 463 | |
| Directional Arrays..... | 458 | |
| Aperiodic Long Wire..... | 459 | |
| Barrage..... | 466 | |
| Close-Spaced—See "Kraus Flat-Top" | | |
| Colinear..... | 464 | |
| Diamond..... | 461 | |
| Double Extended Zepp..... | 465 | |
| Franklin..... | 439, 464 | |
| Kraus Flat-Top..... | 467 | |
| Loop..... | 454 | |
| Multiple-Stacked Broadside..... | 465 | |
| Orientation of..... | 469 | |
| Rhombic..... | 461 | |
| Rotatable Arrays..... | 469 | |
| Stacked Dipole..... | 463 | |
| Sterba Barrage..... | 468 | |
| Unidirectional..... | 469 | |
| Unidirectional Rotary, Feed Methods..... | 470 | |
| V..... | 160 | |
| W8JK Rotary Flat-Top..... | 471 | |
| X-H Array..... | 465 | |
| Directivity..... | 434 | |
| "Don'ts"..... | 482 | |
| Double Extended Zepp..... | 465 | |
| Doublet..... | 439 | |
| Doublet, Two Wire..... | 444 | |
| Doublet Multi-Wire..... | 451 | |
| Dummy..... | 450 | |
| Effect of Ground..... | 434 | |
| Electrical Length..... | 430 | |
| End Fed..... | 435 | |
| End-Fire Directivity..... | 467 | |
| Field Strength Meters—See "Test and Measuring Equipment" | | |
| Flat-Top Beam..... | 167 | |
| Four-Wire R.F. Transformer..... | 449 | |
| Franklin..... | 439, 464 | |
| Fuchs..... | 435 | |
| Fundamental Frequency..... | 431 | |
| Ground Connection..... | 436 | |
| Ground Effect..... | 434 | |
| Ground Resistance..... | 433 | |
| Grounded Antennas—See "Marconi" | | |
| Guy Wires..... | 456 | |
| Half-Frequency Operation..... | 451 | |
| Half Wave..... | 430 | |
| Harmonic Operation..... | 460 | |
| Harmonic Resonance..... | 431 | |
| Harmonic Radiation Suppression..... | 481 | |
| Hertz..... | 432, 435 | |
| Horizontal Pattern vs Vertical Angle..... | 434, 458 | |
| Impedance..... | 432 | |
| Insulation..... | 457, 473 | |
| J Type..... | 445 | |
| Johnson Q..... | 449 | |
| Kraus Flat-Top Beam..... | 467 | |
| Length..... | 430 | |
| Linear r.f. Transformer..... | 448 | |
| Loading Coils..... | 437, 451 | |
| Loading of Transmitter..... | 478 | |
| Long Wire Directive Antennas..... | 459 | |
| Loop..... | 454 | |
| Marconi (Grounded) Antennas..... | 433, 436, 437 | |
| Masts, Fixed..... | 455 | |
| Masts, Rotatable..... | 469 | |
| Matching Non-Resonant Lines..... | 443 | |
| Matching Stubs..... | 465 | |
| Mechanisms, Rotatable..... | 469 | |
| Mobile U.H.F..... | 474 | |
| Multiple-Stacked..... | 463, 465 | |
| Multi-Wire Doublet..... | 444, 451 | |
| Non-Resonant (Rhombic)..... | 461 | |
| Open-Ended Stubs..... | 469 | |
| Orientation..... | 469 | |
| Phased Arrays..... | 463 | |
| Polarization, Vertical vs. Horizontal (U.H.F.)..... | 473 | |
| Portable—See "Mobile U.H.F."..... | 474 | |

| | |
|---|---------------|
| Q-Matching Section..... | 448 |
| Radiation..... | 429, 472 |
| Radiation Characteristics..... | 433 |
| Radiation, End-Fire..... | 467 |
| Radiation Resistance..... | 433 |
| Receiving..... | 452 |
| Resonance..... | 432 |
| Rhombic..... | 461 |
| Rotary (Rotatable)..... | 469 |
| Shorted Stubs..... | 446 |
| Single-Wire Fed..... | 444 |
| Stacked Dipole..... | 463 |
| Standing Wave Indicator..... | 448 |
| Stubs..... | 445, 446, 447 |
| Support..... | 456 |
| Transformers, Matching..... | 448 |
| Transmission Lines..... | 437 |
| Tuned Doublet..... | 439 |
| Tuned Feeder Considerations..... | 439 |
| Two-Wire Doublet..... | 444 |
| U.H.F..... | 472 |
| Unidirectional..... | 469 |
| Universal Coupler..... | 482 |
| V Type..... | 460 |
| Vertical..... | 432, 474 |
| Voltage-Fed..... | 438, 445 |
| Wavelength..... | 432 |
| W8JK Rotary Flat-Top..... | 471 |
| Wire..... | 457 |
| X-H Array..... | 465 |
| Zepp..... | 438 |
| Antilogarithm..... | 561 |
| Appendix..... | 587 |
| Application for Licenses..... | 6 |
| Application of the Vacuum Tube..... | 57 |
| Arithmetic..... | 544 |
| Arithmetical Selectivity..... | 72 |
| Armstrong System of Frequency Modulation..... | 223 |
| Arrays (See—"Antennas, Directional Arrays") | |
| AT-Cut Crystals..... | 162 |
| Atomic Number..... | 17 |
| Atomic Theory..... | 17 |
| Atoms..... | 17 |
| AUDIO BANDWIDTH, F.M..... | 228 |
| Audio-Frequency Amplifiers..... | 88, 302 |
| Distortion in..... | 61 |
| Audio-Frequency Impedance Matching..... | 42 |
| Audio-Frequency Interstage Coupling..... | 62 |
| Audio-Frequency Power Measuring Device..... | 491 |
| Audio Gain Calculations..... | 207 |
| Audio Oscillator, Wide Range..... | 512 |
| Audio System, Transmitter..... | 271 |
| Aurora Type DX..... | 376 |
| Auto Transformer..... | 43 |
| Auto Transformer, r.f..... | 43 |
| Autodyne Detector..... | 69, 138 |
| Automatic Bias..... | 181 |
| Automatic Gain Control..... | 313 |
| Automatic Modulation Control..... | 214, 316 |
| Automatic Peak Limiting..... | 89, 90 |
| Automatic Volume Control..... | 87, 92 |
| Average D.C. Value..... | 29 |
| Average Power..... | 189 |
| Axis, Crystallographic..... | 162 |

B

| | |
|--|----------|
| Back E.m.f..... | 30 |
| Balanced Lines (See—"Transmission Lines") | |
| Balancing Coils..... | 453 |
| Balancing Noise, Systems for..... | 89 |
| Bandpass Circuits (See "Intermediate Frequency Amplifiers") | |
| Bandset Condenser..... | 80 |
| Bandspread..... | 80 to 82 |
| Electrical..... | 80, 81 |
| Mechanical..... | 81 |
| Tapped-Coil..... | 81 |
| Bandswitching..... | 80 to 82 |
| Bandswitching Exciter, 100 Watt..... | 286 |
| Bandswitching Test Oscillator..... | 510 |
| Bandwidth, Audio for F.M..... | 228 |
| Bandwidth, for F.M..... | 218 |
| Barkhausen-Kurtz Oscillator..... | 389 |
| Barrage Array, Sterba..... | 466 |
| Bass Suppression..... | 213 |
| Battery Bias..... | 181 |
| Battery, Dry..... | 48 |
| Battery, Storage..... | 49 |
| Beam Power Amplifier—See "Medium and High Power R.F. Amplifiers" | |
| Beam Power Tubes..... | 56 |
| Beams (See—"Antennas, Directional Arrays") | |
| Beat-Frequency Oscillator..... | 86 |
| Beat-Frequency Oscillator Adjustment..... | 94 |
| Beat-Note..... | 71 |
| Bending Effect..... | 374, 428 |
| Bending Ends of Antenna..... | 451 |

| | |
|--|---------------|
| Bias: | |
| Automatic..... | 181 |
| Battery..... | 181 |
| Cathode..... | 181 |
| Considerations..... | 181, 332 |
| Cutoff..... | 54 |
| Definition..... | 54 |
| Detector..... | 65 |
| Doubler..... | 173 |
| For Cathode Modulation..... | 201 |
| Grid Leak..... | 180 |
| Separate Supply..... | 181, 328, 331 |
| Transmitter..... | 180, 181 |
| Voltage Regulated..... | 328 |
| Blanketing..... | 537 |
| Bleeder Resistor..... | 326 |
| Bleeder, Safety..... | 274 |
| Blocked-Grid Keying..... | 186 |
| Bombardment, Filament..... | 50, 55 |
| Bonding Water Pipe Grounds..... | 437 |
| Brass Drilling..... | 532 |
| Brassboard Construction..... | 527 |
| Breakdown, Dielectric..... | 33 |
| Breakdown Potential, Mercury Vapor..... | 64 |
| Breakdown Ratings of Transmitting Condensers..... | 176 to 178 |
| | 186 |
| Break-In Keying..... | 326, 329, 330 |
| Bridge Rectifier..... | 537 |
| Broadcast Interference..... | |
| Broadside Antenna Arrays (See—"Antennas, Directional") | |
| Brute Force Filter..... | 322 |
| Bug Key..... | 12 |
| Butterfly Circuit..... | 387, 388 |
| Buzzers, Code Practice..... | 15 |

C

| | |
|---|-----------------------------|
| C Value for Crystal Oscillator Tanks..... | 165, 166 |
| C Value for R.F. Amplifier Tanks..... | 175 to 177 |
| Cable, Coaxial (Concentric)..... | 442 |
| Cable, EOI Transmission..... | 442 |
| Calculations (General)..... | 544 |
| Calibration: | |
| Frequency Meter..... | 497, 500 |
| Monitor..... | 508 |
| Oscillator..... | 513 |
| Signal Generator..... | 510 |
| V.T. Voltmeter..... | 490 |
| Wavemeter..... | 500 |
| Calibrator, Dual Frequency Crystal..... | 498 |
| Cancellation..... | 551 |
| Capability, Modulation..... | 190 |
| Capacitance, Vacuum Tube..... | 54 |
| Capacities: | |
| Circuit..... | 82 |
| Interelectrode..... | 54 |
| Capacitive Coupling..... | 182 |
| Capacitive Reactance..... | 34 |
| Comparison to Inductive Reactance..... | 36 |
| Capacity: | |
| Calculation of..... | 33 |
| Circuit..... | 82 |
| Coupling—"Interference"..... | 539 |
| Definition..... | 33 |
| Distributed..... | 432 |
| Formulas..... | 33, 34 |
| Tank Circuit..... | 175 to 177 |
| Unit of..... | 33 |
| Carbon Microphone..... | 203 |
| Carrier..... | 158, 188 to 190 |
| Carrier Power..... | 189 |
| Carrier Shift Indicator..... | 504 |
| Cartesian Coordinates..... | 575, 576 |
| Cathode..... | 51 |
| Cathode Bias..... | 335 |
| Cathode Follower..... | 212 |
| Cathode, Heater Type..... | 51, 52 |
| Cathode Impedance..... | 200 |
| Cathode Modulation..... | 198 to 201 |
| Cathode Modulator..... | 200 |
| Cathode Ray Oscilloscope..... | 516 |
| Cathode Ray Tubes (Characteristics)..... | 516 |
| Cathode Regeneration..... | 69 |
| Cavity Resonance..... | 377, 386, 387 |
| Cavity Resonator..... | 386, 387 |
| Cell, Dry..... | 48 |
| Cell, Edison..... | 49 |
| Cell, Lead..... | 49 |
| Cell, Primary..... | 48 |
| Cell, Secondary..... | 49 |
| Center-Tap Keying..... | 187 |
| Centimeter Waves and Micro-waves..... | 374, 380 to 382, 385 to 394 |
| Characteristic Impedance, Feeder..... | 439 |
| Characteristic, of Logarithm..... | 559 |
| Characteristics and Considerations of Antennas..... | 433 |
| Characteristics of Vacuum Tubes: | |
| Discussion..... | 53 |

| | | | |
|---|------------------------|---|--------------------|
| Receiving | 96 | Choke Input | 323 |
| Rectifiers—see "Transmitting Tubes" or "Receiving Tubes" | | Choke, R.f. | 183 |
| Transmitting | 231 | Choke, Smoothing | 34, 343 |
| Voltage Regulators—See "Receiving Tubes" | | Choke, Swinging | 34, 343 |
| Charts: | | Chokes, Types of | 304 |
| Amateur Abbreviations—see "Appendix" | | Chromium Polish | 536 |
| Antenna Coupling to Transmitter | 479 | Circuit: | |
| Antenna and Feeder Lengths | 447 | A.V.C. | 87, 88 |
| Antenna Feeding Methods | 435 | A.M.C. | 316 |
| Antenna Transformer | 441 | Analysis—See Particular Circuit Under "Theory" | |
| Antenna Field Patterns | 459 | Bridge Rectifier | 326 |
| Cathode Modulation Operation | 198 to 201 | Capacities | 82 |
| Choke Design (Filter) | 242 | Coupling | 44, 45, 62 |
| Circular Plate Condensers | 34 | Feedback (Modulator) | 211 |
| Coaxial Lines (See also: "Concentric Lines") | 442 | Filter | 85 |
| Coil Inductance, Nomograph | 585 | Flywheel Effect in | 42 |
| Coil Tables (These are included in all Constructional Chapters) | | F.M. Modulator | 218 |
| Colinear Antenna Design | 465 | Impedance of | 37 |
| Concentric Line Impedance | 442 | Neutralizing | 168, 169 |
| Concentric Line Resonance | 378 | Noise Balancing | 89 |
| Condenser Air Gap | 178 | Noise Limiting | 89, 90 |
| Condenser Breakdown Voltage | 178 | Phase Inverter | 207 |
| Construction, Types of | 527 | Phase Modulation | 223 |
| Continental Code | 8 | Push-Pull Audio | 61 |
| Copper Wire Tables | 338, 340 | Push-Pull r.f. | 291 |
| Coupling into Transmission Lines | 378 | Q | 40 |
| Coupling Transmission Lines to Antennas | 479 | Reactance-Resistance Modulator | 219 |
| Db Power Levels | 565 | Rectifier | 322, 326, 329, 333 |
| Db Power Ratios | 563 | Relation to Tank Current (Parallel Resonance) | 40 |
| Detector Circuits | 70 | Resonant | 38 |
| Diamond (Rhombic) Antenna Design | 462 | Series | 39 |
| Dielectric Constants | 33 | Stabilization, F.M. | 220 |
| Drill Sizes | 532 | Circulating Tank Current | 41 |
| Filter Choke Design | 343 | C-L Ratios | 41, 176 |
| Flat-Top Antenna Design | 468 | Class A Amplifier | 59 |
| Four-Wire Matching Section | 450 | Class A Modulator | 195 |
| Franklin Antenna | 464 | Class AB Amplifier | 60 |
| Horizontal Doublet, Vertical Directivity | 434 | Class B Amplifier | 60, 66, 166 |
| Inductance | 585 | Class B Bias | 60, 66 |
| Johnson Q | 449 | Class B Modulator | 195 to 198 |
| L-C Data | 177 | Class B Modulator Voltage Regulation | 320 |
| Logarithms | 558 | Class C Amplifier | 63, 167 |
| Long-Antenna Design | 460 | Class C Bias | 63, 167 |
| Matching Section Surge Impedance | 441 | Class C Grid Modulation | 191 to 193 |
| Matching Stub Applications | 445 | Clickless Keying Methods | 185 |
| Mixer-Oscillator Combinations | 74 | Clicks, Key | 185 |
| Modulated Class C Input Values | 197 | Close-Spaced Directional Array | 471 |
| Modulator Data | 197 | Coaxial Line | 378 to 384, 442 |
| Oscilloscopic Patterns | 526 | Code: | |
| Q-Antenna Dimensions | 449 | Buzzer | 13, 15 |
| Q Signals—See "Appendix" | | Classes | 9 |
| Radiation Resistance | 433 | Continental | 8 |
| Radio Symbols—See "Appendix" | | Correct Position for Sending | 10 |
| Reactance, Frequency | 581, 582 | Learning the | 6 |
| Receiving Tubes | 96 to 137 | Monitor | 505 |
| Rectifier-Filter | 331, 333 | Practice Oscillator | 60F |
| R.F. Feeder Losses | 442 | Coefficient of Coupling | 31 |
| Rhombic Antenna Design | 462 | Coil, Balancing | 453 |
| R-S-T Reporting System—See "Appendix" | | Coil, Loading | 437, 451 |
| Selectivity | 40 | Coil Tables (These accompany each of the Constructional Chapters) | |
| Series Circuit Reactance-Frequency Variation | 38 | Coil Windings, Transformer | 340 |
| Socket Connections | 127 to 131, 137 to 232 | Coil Windings | 42, 585 |
| Stacked Dipole Design | 465 | Colinear Antenna | 430, 464 |
| Stub Length | 445 | Colinear Antenna Design Chart | 465 |
| Surge Impedance: | | Collecting Terms | 553 |
| Coaxial Line | 442 | Collins Antenna Coupler | 479 |
| Multiconductor Transmission or Matching Transformer | 449 | Colpitts Oscillator | 159 |
| Open Line | 441 | Communication, U.H.F. | 374 |
| Q Section | 448 | Compact Antennas | 451 |
| Tank Circuit Voltage | 178 | Comparative Feeder Losses | 442 |
| Tools | 528 | Complex Numbers | 555 |
| Transformer Design | 340 | Complex Waves | 189 |
| Transformers, Antenna | 448 | Component, A.C. | 322 |
| Tube Tables: | | Components, Basic Receiver—See "Radio Receiver Theory" | |
| Receiver Types | 96 to 137 | Components, Mounting | 535 |
| Rectifier Types—See "Transmitting" or "Receiving" Tube Tables | | Concentric Lines—See also "Coaxial Lines" | 379 |
| Transmitting Types | 231 to 265 | Concentric-Line Oscillators | 383 |
| V-Antenna Design | 460 | Condenser: | |
| Vacuum Tube Characteristics, Receiving | 96 to 137 | Air Gap | 34, 178 |
| Vacuum Tube Characteristics, Transmitting | 231 | Bandset | 80 |
| Vertical Directivity, Horizontal Doublet | 434 | Breakdown Rating | 178 |
| Wire Tables | 338, 340 | Capacitance | 32 |
| Chassis Building: | | Definition | 32 |
| Assembly | 527 | Discharge | 32 |
| Dish Type | 528 | Dry Electrolytic | 325 |
| Layout | 534 | Electrolytic | 325 |
| Metal | 534 | Energy Stored in | 32 |
| Plating and Painting | 536 | Filter | 325 |
| Punching | 534 | Ganged Tuning | 80 |
| Choke Air Gap | 324 | Input (Rectifier) | 323 |
| Choke Coil | 325 | Microphone | 204 |
| Choke Considerations | 324 | Oil Filled | 325 |
| Choke, Core Material | 31, 324 | Padder—See also "Trimmer Condenser" | 80 |
| Choke Design | 342 | Paper Dielectric | 325 |
| Choke, Filter | 324 | Parallel Connection | 35 |
| | | Plug-In | 268 |
| | | Rating (Series Connection) | 35 |

| | |
|--|---------------|
| Diode Detector..... | 66, 69 |
| Diode Feedback Rectifier..... | 212 |
| Diode-Type F.S. Meter..... | 501 |
| Diode V.T. Voltmeter..... | 490 |
| Dipole..... | 430, 403 |
| Dipole Antenna, Stacked..... | 463 |
| Direct Current..... | 18, 47 |
| Direct Current, Pulsating..... | 29, 64 |
| Direction of Current Flow..... | 331 |
| Directional Effects of Microphones..... | 206 |
| Direction Finders..... | 455 |
| Directive Antennas..... | 458 |
| Directive Properties of Antennas..... | 434, 458 |
| Dish-Type Construction..... | 528 |
| Discharge, Condenser..... | 32 |
| Discharge, Glow..... | 327 |
| Discriminator, Travis..... | 226 |
| Discriminator, Foster-Seeley..... | 226 |
| Dissipation, Plate..... | 231 |
| Distorted Drive Multiplier..... | 174 |
| Distortion..... | 61, 92 |
| Distributed Capacity..... | 432 |
| Distributed Inductance..... | 432 |
| Distributed Resistance..... | 432 |
| Dividers, Voltage..... | 22 |
| Division, Algebraic..... | 552, 553 |
| Division, Arithmetical..... | 546, 548 |
| Division, Vectorial..... | 573 |
| Doherty, Linear Amplifier..... | 201 |
| Double-Button Microphone..... | 204 |
| Double Conversion..... | 77 |
| Double Extended Zepp..... | 466 |
| Doublers: | |
| Angle of Plate Current Flow in..... | 173 |
| Bias..... | 173, 174 |
| Frequency..... | 173 to 175 |
| Push-Push..... | 174 |
| Regenerative..... | 173 |
| Tube Requirements..... | 173 |
| Doublet Antenna..... | 439, 444, 451 |
| Drift, Frequency..... | 160 |
| Drill Sizes..... | 532 |
| Drilling..... | 531 |
| Drilling Glass..... | 536 |
| Driving Mechanism, Antenna Rotating..... | 470 |
| Driving Power, R.F. Grid..... | 267 |
| Drop, Voltage..... | 19, 22 |
| Dry Cell..... | 48 |
| Dry Electrolytic Condensers..... | 325 |
| Dual Frequency Crystal Calibrator..... | 498 |
| Dual Rotor Bandspread..... | 81 |
| Dual Tubes..... | 57 |
| Dummy Antennas..... | 450 |
| DX, Aurora Type..... | 376 |
| Dynamic Characteristic..... | 60 |
| Dynamic Microphone..... | 205 |
| Dynatron..... | 160 |

E

| | |
|--|--------------|
| E.C.O. Harmonics in Superheterodyne..... | 73 |
| Eddy Current Losses..... | 81, 800, 887 |
| Edison Cell..... | 49 |
| Edison Effect..... | 50 |
| Effect of Average Ground on Antenna Radiation..... | 434 |
| Effect of L/C Ratio, Parallel Circuits..... | 41 |
| Effect of Coupling upon Impedance..... | 41 |
| Effect of Coupling upon Resonance..... | 44 |
| Effect of Loading upon Q..... | 176 |
| Effect, Piezoelectric..... | 161 |
| Effective Resistance..... | 21 |
| Effective Value of Voltage..... | 29 |
| Efficiency, Amplifier..... | 59, 166, 167 |
| Efficiency Modulation..... | 191 |
| Efficiency, Plate..... | 59, 166, 167 |
| Efficiency, Rectifier..... | 65, 66 |
| Electric Charge..... | 32 |
| Electric Current, the..... | 19 |
| Electric Field..... | 25 |
| Electric Power..... | 24 |
| Electrical Bandspread..... | 80 to 82 |
| Electrical Length..... | 430 |
| Electrical Storage of Energy..... | 32 |
| Electrical Units..... | 19 |
| Electricity..... | 18 |
| Electrolyte..... | 325 |
| Electrolytic Condensers..... | 325 |
| Electrolytic Conduction..... | 48 |
| Electromagnetism..... | 25 |
| Electromagnetic Component..... | 428 |
| Electromagnetic Radiation..... | 428 |
| Electromagnetic Waves..... | 428 |
| Electromotive Force (E.M.F.)..... | 18 |
| Electron..... | 19, 47 |
| Electron Coupled Oscillator..... | 160 |
| Electron Flow..... | 17, 47 |
| Electron, Free..... | 17 |

| | |
|---|------------|
| Electron Orbit Oscillator..... | 389 |
| Electron Ray Tube..... | 88 |
| Electronic Conduction..... | 17, 47 |
| Electronic Emission..... | 50 |
| Electronic Saturation..... | 53 |
| Electrostatic Component..... | 428 |
| Electrostatic Energy..... | 32 |
| Electrostatic Shield..... | 453 |
| Elements, Rotatable Antenna..... | 469, 570 |
| Elimination of Harmonics..... | 481 |
| Elimination of Interference..... | 537 |
| Emergency C. W. Receiver..... | 508 |
| E.M.F., Counter (Back)..... | 30 |
| E.M.F., Unit of..... | 18 |
| Emission, Electronic..... | 50 |
| Emission, Secondary..... | 55 |
| Emitters, Types of..... | 51 |
| End-Fed Antennas..... | 435 |
| End-Fire Directivity..... | 467 |
| Energy Stored in Condensers..... | 32 |
| Energy Stored Electrostatically..... | 32 |
| EO1 Cable..... | 442 |
| Equations, First Degree..... | 555 |
| Equipment Considerations..... | 377 |
| Equivalent Circuit, Crystal Filter..... | 84 |
| Etching Solution..... | 536 |
| Excitation, Grid..... | 294 |
| Excitation Keying..... | 186 |
| Exciter Design..... | 266 |
| Exciters and Low Powered Transmitters..... | 275 to 290 |
| Exciters—See also "Oscillators and Crystal Oscillators" | |
| Multiband Frequency Multiplier..... | 282 |
| Multiband 100 Watt..... | 286 |
| Multiband 25-Watt V.F.O..... | 280 |
| Simple 15-Watt Two Band..... | 275 |
| Five-Watt 160-Meter V.F.O..... | 277 |
| Stabilized P.M. Exciter..... | 420 |
| 807 Utility Unit..... | 284 |
| Exposed Components and Wires in Transmitters..... | 273 |
| External Load..... | 322 |

F

| | |
|--------------------------------------|------------|
| Factor, Amplification (mu) (u)..... | 58 |
| Factor of Merit (Q)..... | 575 |
| Factor, Power..... | 37 |
| Factoring..... | 553 |
| Fading..... | 429 |
| Fading, Selective..... | 429 |
| Farad, Definition..... | 33 |
| Faraday Screen (Shield)..... | 453, 481 |
| Feed | |
| Current..... | 438, 446 |
| Series..... | 184, 291 |
| Shunt (Parallel)..... | 184 |
| Voltage..... | 438, 445 |
| Feedback Circuit (Modulator)..... | 209 to 211 |
| Feedback, Degenerative..... | 209 |
| Feedback Rectifier, Diode..... | 212 |
| Feedback, Inverse..... | 209 |
| Feeder Losses..... | 442 |
| Feeders, Antenna—See also "Antennas" | |
| for Rotary Antennas..... | 470 |
| Johnson Q..... | 449 |
| Single-wire..... | 444 |
| Tuned (Zepp)..... | 438 |
| Untuned..... | 440 |
| Feeding the Antenna..... | 435, 470 |
| Field, Electric..... | 25 |
| Field Strength Meter..... | 501, 502 |
| Filament..... | 51 |
| Filament Reactivation..... | 51 |
| Filament Supply..... | 291 |
| Files..... | 531 |
| Filter..... | 321 |
| Bandpass (See "I.F. Tuned Circuits") | |
| Brute Force..... | 322 |
| Choke Considerations..... | 343 |
| Choke-Input..... | 322 |
| Chokes..... | 324, 343 |
| Circuit Considerations..... | 323 |
| Circuits..... | 321 |
| Condensers (Discussion)..... | 325 |
| Crystal..... | 38 to 86 |
| Double Section..... | 323 |
| Key-Click..... | 185 |
| Line..... | 89 |
| Low Pass..... | 322, 543 |
| Noise..... | 89 |
| Pi-Section..... | 323 |
| R-C..... | 87 |
| R.F. Filter..... | 89 |
| Resonance in..... | 322 |
| Resonant..... | 322, 323 |
| Single Section..... | 323 |
| Two Section..... | 323 |
| Variable Selectivity..... | 153 |

| | |
|---|---------------|
| Final Amplifier—See Also "Transmitter Construction" | |
| Finishes | 536 |
| First Degree Equation | 555 |
| First Detector | 71, 72 |
| Flat-Top Beams | 467 |
| Flat-Top Length, Zepp Antenna | 488 |
| Floating Volume Control | 540 |
| Flow, Current | 332 |
| Flux | 25 |
| Flux Density | 25 |
| Flux, Magnetic | 25 |
| Flywheel Effect | 42 |
| F.M. | 215 |
| Formulas—See "Calculations" | |
| Foster-Seeley Discriminator | 226 |
| Four-Wire Q Sections | 449 |
| Fractions | 545, 547, 539 |
| Frame, Lecher | 381 |
| Franklin Antenna | 464 |
| Franklin Oscillator | 161 |
| Frequency | 29 |
| Antenna | 430 |
| Calibrator | 498 |
| Conversion (to wavelength) | 430 |
| Converters | 75 |
| Cutoff | 321 |
| Detector | 225 |
| Determination | 380, 500 |
| Doublers | 173 to 175 |
| Drift | 160 |
| Formula | 39 |
| Fundamental | 39 |
| Interruption | 70 |
| Measurement, U.H.F. | 380 |
| Meters | 500 |
| Mixers | 73 |
| Modulation | 215 |
| Multipliers | 282 |
| Radio | 29 |
| Rejection | 76 |
| Relation to Wavelength | 481 |
| Resonance, Antenna | 431 |
| Resonance, of Coil (Inductance) | 582, 585 |
| Resonance (Formula) | 30 |
| Resonant Line | 439 |
| Spotting | 497 |
| U.H.F. | 374 |
| Frequency Converter (Mixer) | 73 to 75 |
| Frequency Detector | 225 |
| Frequency, Interruption | 70 |
| Frequency Measurement: | |
| 50-Kc. Oscillator | 497 |
| 100-Kc. Oscillator | 498 |
| Absorption Frequency Meters | 500 |
| Checking Transmitter Frequency | 497, 498, 506 |
| Frequency-Calibrated Signal Generator | 510 |
| Frequency Meter Calibration | 484, 500, 506 |
| Heterodyne Frequency Meters | 506 |
| Lecher Frame | 381 |
| Lecher Wires | 381 |
| Meters (Monitors) | 500 |
| Self-Excited Frequency Substandard | 497 |
| U.H.F. | 380 |
| Frequency Modulation | 215 |
| Frequency Modulation Receiver | 225 |
| Frequency Modulation Reception | 225 |
| Frequency Modulation Terms | 216 |
| Frequency Modulation Transmitters: | |
| Stabilized F.M. Exciter | 420 |
| 50-Watt 112-Mc. | 423 |
| Frequency Multipliers | 282 |
| Frequency-Wavelength Conversion | 431 |
| Front-End Alignment | 94 |
| Fuchs Antenna | 435 |
| Full-Wave, Radiation | 430 |
| Full-Wave Rectification | 321 |
| Full-Wave Rectifier | 321, 330 |
| Full-Wave Three-Phase Rectifier | 331 |
| Functions, Representation of | 576 |
| Functions, Trigonometric | 568, 569, 570 |
| Fundamental Frequency | 431 |
| Fuse | 333 |

G

| | |
|---|-----|
| Gain: | |
| A.F. Calculation | 564 |
| Decibels | 564 |
| Effect of L/C Ratio (Parallel Circuits) | 41 |
| R.F. | 63 |
| Tube | 58 |
| Ganged Condensers | 80 |
| Gas Filled Transmission Lines | 443 |
| Gaseous Conduction | 47 |
| Gears, Rotating Antenna Mechanisms | 470 |
| Generator: | |
| A.C. | 27 |
| Signal | 510 |

| | |
|---------------------------------------|---------------|
| Gilbert | 26 |
| Gill-Morrell Oscillator | 389 |
| Glass Drilling | 536 |
| Glow-Discharge Voltage Regulator | 327 |
| Graphical Representation | 576 |
| Great Circle Direction | 484 |
| Grid | 50, 53 |
| Grid Bias | 54, 167, 291 |
| Grid Bias Modulation | 191 to 193 |
| Grid Bias Pack Considerations | 332 |
| Grid Controlled Rectifiers | 185 |
| Grid Detection | 65, 69 |
| Grid Excitation | 167, 172 |
| Grid Injection | 56, 73 |
| Grid Leak | 69 |
| Grid Leak Bias | 180 |
| Grid Loading Effect | 79 |
| Grid Modulated Amplifier | 167, 192 |
| Grid Modulation | 191 to 194 |
| Grid Modulation Coupling Transformers | 193 |
| Grid Modulation, Tubes for | 53 |
| Grid Saturation | 436 |
| Ground Connection, Importance | 437 |
| Ground, Radial Type | 433 |
| Ground Resistance | 374, 428 |
| Ground Wave | 436 |
| Grounded Antennas (Marconi) | 172 |
| Grounded Grid Amplifier | 272, 434, 437 |
| Grounds | 456 |
| Guy Wires | 456 |

H

| | |
|---------------------------------------|------------|
| H (Lazy) Antenna | 488 |
| Half-Frequency Antenna Operation | 451 |
| Half-Wave Radiators | 450 |
| Half-Wave Rectification | 321 |
| Half-Wave Rectifiers | 321 |
| Half-Wave Three-Phase Rectifier | 331 |
| Hard Drawn Copper Wire | 457 |
| Harmonic Amplifier | 497 |
| Harmonic Content | 61 |
| Harmonic—Cut Crystals | 163 |
| Harmonic Distortion | 61 |
| Harmonic Elimination | 481 |
| Harmonic Frequency Determination | 380 |
| Harmonic Operation of Antennas | 450 |
| Harmonic Oscillation, Crystal | 163 to 165 |
| Harmonic Radiation vs. Q | 176 |
| Harmonic Resonance | 431 |
| Harmonic Suppression | 481 |
| Harmonic Tolerance | 61 |
| Hartley Oscillator | 15 |
| Hazeltine Neutralization | 169 |
| Heater Cathode | 52, 53 |
| Heising Modulation | 56 |
| Henry, The | 30 |
| Heptode Tube | 435 |
| Hertz Antenna | 69 |
| Heterodyne Reception | 395 |
| High-Frequency Converters | 163 |
| High-Frequency Crystals | 155 |
| High-Gain Preselector | 56 |
| High-Mu Tubes (Receiving Type) | 201 to 201 |
| High Powered Amplifiers | 324 |
| High Vacuum Rectifier | 325 |
| High Voltage Filter Condensers | 272 |
| High Voltage, Safety Precautions | 165 |
| Holders, Crystal | 434 |
| Horizontal Directivity | 458 |
| Horizontal Pattern vs. Vertical Angle | 428 |
| Horizontal Polarization | 434 |
| Horizontal vs. Vertical Antennas | 307 |
| Hum Difficulties | 384 |
| Hysteresis | 384 |

I

| | |
|--------------------------------|----------|
| I.F. Amplifier | 82 to 81 |
| I.F. Amplifier Alignment | 91 |
| I.F. Amplifier Noise Silencers | 89 to 91 |
| I.F. Transformer | 81 |
| Image | 76, 541 |
| Imaginary Numbers | 551 |
| Image Interference | 541 |
| Image Ratio | 7 |
| Impedance | 37, 7 |
| Antenna | 43 |
| Calculation | 441, 44 |
| Calculation of Parallel | 4 |
| Calculation of Series | 37, 3 |
| Cathode | 20 |
| Characteristic Surge | 43 |
| Coupling | 6 |
| Definition | 3 |
| Effect of L/C Ratio upon | 4 |

| | |
|---|-------------------|
| Feeder—see also "Transmission Lines"..... | 438 |
| Four-Wire R.F. Transformer..... | 449 |
| Johnson Q Matching Section..... | 449 |
| Load..... | 42, 60 |
| Matching (A.F. Circuits)..... | 42, 61 |
| Matching (R.F. Circuits)—see also "Antennas"..... | 438 |
| Parallel Resonance..... | 40 |
| Receiver Input Matching..... | 453 |
| Reflected..... | 43 |
| Series Resonance..... | 39 |
| Single-Wire Feeder..... | 444 |
| Surge..... | 442 |
| Tank Circuit..... | 42 |
| Transformer Coupling Method..... | 62 |
| Transmission Line..... | 441 |
| Tube Plate Circuit..... | 42 |
| Index to Transmitting Tubes..... | 281 |
| Indicator, Field Strength..... | 501 |
| Indicator, Modulation..... | 504, 523 |
| Indicator, Neutralizing..... | 504 |
| Indicator, Signal Strength (Resonance)..... | 88, 501, 502, 504 |
| Indicator, Tuning..... | 88 |
| Indirectly Heated Cathode..... | 52 |
| Induced Current, Losses from..... | 337 |
| Induced Voltage..... | 30, 41 |
| Inductance: | |
| Calculation..... | 585 |
| Definition..... | 30 |
| Frequency of Resonance..... | 581, 582 |
| Mutual..... | 30 |
| Parallel Connection..... | 30 |
| Self..... | 30 |
| Series Connection..... | 30 |
| Tapped..... | 179 |
| Unit of..... | 30 |
| Inductive Coupling..... | 30, 44, 182 |
| Inductive Reactance..... | 32, 37 |
| Comparison to Capacitive Reactance..... | 38 |
| Infinite-Impedance Detector..... | 66 |
| Injection..... | 56, 73 |
| Injector Grid..... | 56, 73 |
| Input Choke..... | 322, 323 |
| Input Condenser..... | 323 |
| Input Coupling Circuit, Receiver..... | 453 |
| Input Impedance, Receiver..... | 453 |
| Input Modulation Systems..... | 194 |
| Input Power Control..... | 334 |
| Input Resistance..... | 78 |
| Input Voltages..... | 566 |
| Instantaneous Voltage..... | 28 |
| Instantaneous Power Output..... | 189 |
| Instruments..... | 484 to 515 |
| Insulation, Antenna..... | 457 |
| Insulation, Transformer..... | 342 |
| Insulation, Transmitter..... | 268 |
| Insulators..... | 268 |
| Interelectrode Capacitance..... | 54 |
| Interference Classifications..... | 537 |
| Interference Elimination..... | 537 |
| Blanketing..... | 537 |
| Electrical Noise..... | 537 |
| Image..... | 542 |
| Key Clicks—See also "Keying"..... | 195 |
| Radiotelephone Interference..... | 537 |
| Rejection..... | 537 |
| R.F. Filters..... | 89 |
| Superheterodyne Harmonics..... | 76 |
| Thermal (In Vacuum Tubes)..... | 76 |
| Wavetraps..... | 538 |
| Intermediate Frequency..... | 72 |
| Intermediate Frequency Amplifiers..... | 82 |
| Internal Noise..... | 76 |
| Interruption Frequency..... | 70 |
| Interstage Coupling..... | 181 to 183 |
| Introduction to Radio..... | 5 |
| Inverse Feedback (A.F.)..... | 209 |
| Inverse Feedback (R.F.)..... | 211 |
| Inverse Peak Voltage..... | 323 |
| Inversion, Temperature..... | 374 |
| Inverter, Phase..... | 207 |
| Ionization..... | 47 |
| Ionosphere..... | 428 |
| Iron Core..... | 31, 42 |
| Iron Core I.F. Transformer..... | 31 |

J

| | |
|-------------------------|-----|
| J Antenna..... | 445 |
| Jacks, Meter..... | 270 |
| Johnson Q Antennas..... | 449 |
| Joule..... | 32 |

K

| | |
|--------------------------------|--------|
| Key Clicks..... | 185 |
| Key, Semi-Automatic (Bug)..... | 12, 15 |

| | |
|-------------------------------|----------|
| Key, Use of..... | 10, 11 |
| Keying: | |
| Blocked Grid..... | 186 |
| Break-in..... | 186 |
| Cathode..... | 187 |
| Center Tap..... | 187 |
| Click Elimination..... | 186 |
| Click Filters..... | 185 |
| Controlled Rectifier..... | 186 |
| Excitation..... | 186 |
| Grid..... | 186 |
| Keying Tubes..... | 187 |
| Lag..... | 185 |
| Manipulation of Hand Key..... | 10, 11 |
| Primary..... | 186 |
| Monitor..... | 505 |
| Oscillator..... | 186 |
| Kilocycle..... | 29 |
| Kirchhoff's Laws..... | 23 |
| Klystron Oscillator..... | 390, 391 |
| Kozanowski Oscillator..... | 389 |
| Kraus Flat-Top Beam..... | 467 |

L

| | |
|--|-------------|
| Lag, Current..... | 36 |
| Law, Ohm's..... | 19, 37 |
| Layer Height (Ionosphere)..... | 428 |
| Layouts, Chassis..... | 293 |
| Lazy H. Antenna..... | 465 |
| L-C Circuits..... | 39, 175 |
| L/C Ratio..... | 39, 41, 175 |
| Lead Cell..... | 49 |
| Lead and Lag..... | 36 |
| Learning the Code..... | 6 |
| Lecher Frames..... | 381 |
| Lecher Wires..... | 381 |
| Lecher Wire Antenna Transformer..... | 445 |
| Length, Antenna..... | 430 |
| Level, Power..... | 564 |
| License, Amateur..... | 6 |
| License, Examination for..... | 6 |
| License Requirements..... | 6 |
| Lightning..... | 48 |
| Limiter, Automatic Peak..... | 214 |
| Limiter, F.M..... | 227 |
| Limiting (Noise) Circuits..... | 88 to 91 |
| Line, Transmission..... | 379, 437 |
| Linear Amplifier..... | 194 |
| Linear Amplifier, Doherty..... | 201 |
| Linear Tank Circuits..... | 383 to 385 |
| Linear Transformers (Antenna)..... | 448 |
| Linearity of Class C Amplifiers..... | 63 |
| Linearity Test, F.M..... | 222 |
| Lines of Force, Magnetic..... | 25 |
| Link Coupling..... | 183 |
| Load Impedance (Resistance)..... | 42, 60 |
| Loading Coil..... | 437, 451 |
| Loading, Transmitter..... | 172 |
| Logarithm Tables, Four Place..... | 560, 561 |
| Logarithmic Curves..... | 579 |
| Logarithms..... | 558 |
| Long Skip..... | 376, 429 |
| Long-Wire Radiators..... | 459 |
| Loop Antenna..... | 454 |
| Loop, Current..... | 430 |
| Loops, Coupling..... | 183 |
| Loops, Voltage..... | 430 |
| Loss, Decibel..... | 563 |
| Losses, Core..... | 337 |
| Losses, Eddy Current..... | 336, 337 |
| Losses, Feeder..... | 442 |
| Losses, Hysteresis..... | 336 |
| Low-Frequency Parasitics..... | 179 |
| Low-Pass Filter..... | 321, 543 |
| Low-Power Transmitters and Exciters..... | 275 |
| Lubricants, Drill..... | 521 |
| Lubricants, File..... | 531 |
| Lubricants, Screw..... | 531 |

M

| | |
|---|--------|
| Magnetic Current..... | 25 |
| Magnetic Fields..... | 25, 28 |
| Magnetic Flux..... | 25 |
| Magnetic Line of Force..... | 26 |
| Magnetism..... | 25 |
| Magnetomotive Force..... | 26 |
| Magnetron Oscillator..... | 390 |
| Mains, Supply..... | 271 |
| Mantissa..... | 559 |
| Marconi Antenna..... | 436 |
| Masts, Rotatable—See "Rotatable Antennas"..... | |
| Matched Impedance Lines..... | 438 |
| Matched Impedance (A.F. Circuits)..... | 42 |
| Matched Impedance (R.F. Circuits)—See also "An- | |

| | |
|---|-------------------|
| tennas' | 44 |
| Matching Section, Q | 448 |
| Matching Stubs | 445 |
| Material, Core | 31 |
| Mathematics and Calculations, radio | 334 |
| Measurements: | |
| A.F. Power | 491 |
| Deviation | 224 |
| R.F. Power | 491 |
| Ripple Voltage (Filter) | 323, 325 |
| Wavelength | 380, 500 |
| Measuring Equipment | 484 |
| Mechanical Bandspread | 81 |
| Mechanics of Modulation | 189 |
| Medium and High Powered Amplifiers | 291 to 301 |
| Megacycle | 29 |
| Megohm | 19 |
| Memorizing the Code | 7 |
| Mercury Vapor Rectifier | 331 |
| Metal Chassis | 527 |
| Metal Saws | 530 |
| Meter, Field Strength | 501, 502, 503 |
| Meter Jacks | 270 |
| Meter Switching | 269 |
| Metering, Transmitter Circuit | 269, 291 |
| Meters—See "Instruments" | |
| Microfarad | 33 |
| Microhenry | 30 |
| Micromicrofarad | 33 |
| Microphone | 203 to 207 |
| Microwave Amplifiers | 391 |
| Microwave Antennas | 475 |
| Microwave Equipment | Chapters 17 to 19 |
| Microwave Transmitters | 426 |
| Microwaves | 410 |
| Mil-Foot, Definition | 18 |
| Miller Effect | 84 |
| Millihenry | 30 |
| Minus Sign | 552 |
| Mixer | 67 |
| Mixer Noise | 76 |
| Mixer-Oscillator Circuits | 74 |
| Mixer Stage, Superheterodyne | 72, 73 |
| Mixer Tube | 56, 57 |
| Mobile Communication | 408, 411 |
| Mobile U.H.F. Antenas | 474 |
| Mobile U.H.F. Receivers—See "U.H.F." | |
| Mobile U.H.F. Transmitters—See "U.H.F." | |
| Modulation: | |
| Amplitude | 188 to 190 |
| Automatic Control | 214 |
| Bass Suppression in | 213 |
| Calculations | 190 |
| Capability | 190 |
| Cathode | 198 |
| Checker | 523 |
| Circuits for F.M. | 218 |
| Class A | 195 |
| Class B | 195 |
| Class B, Linear | 194 |
| Constant Efficiency | 194 |
| Control, Automatic | 316 |
| Cross | 538 |
| Diode Feedback Rectifier | 212 |
| Doherty | 201 |
| Efficiency (Variable) | 191 |
| Equipment | 302 to 320 |
| Feedback, Degenerative | 209 |
| Frequency (Armstrong) | 215 |
| Grid | 191 to 193 |
| Heising | 195 |
| Indicator | 504, 523 |
| Monitor | 523 |
| Patterns, Oscilloscopic | 526 |
| Peaks | 188 to 189 |
| Percentage | 189 |
| Phase | 223 |
| Phase Inverter Circuit | 305 |
| Plate | 195 |
| Plate and Screen | 198 |
| Ratings—See "Modulators" | |
| Screen Grid | 193 |
| Sidebands | 188 |
| Splatter Suppressor | 214, 318 |
| Suppressor Grid | 193 |
| Terman-Woodyard | 201 |
| Transformers | 193, 197 |
| Tubes | 197 |
| Modulators | 302 to 320 |
| Molecule | 17 |
| Monitor | 505, 507 |
| M.O.P.A. Transmitters, U.H.F. | 410 |
| Mounting Components | 535 |
| Movement Electronic | 17, 50 |
| Mu (Amplification Factor) | 58 |
| Multi-Band Antenna | 450 |
| Multi-Band Exciter | 275 |
| Multi-Band Frequency Multiplier | 282 |

| | |
|-----------------------------------|----------|
| Multiple-Stacked Broadside Arrays | 465 |
| Multiplication, Algebraic | 552, 553 |
| Multiplication, Arithmetical | 546, 548 |
| Multiplication, Vectorial | 573 |
| Multipliers, Frequency | 172 |
| Multi-Range Volt-Ohmmeter | 485 |
| Multi-Wire Doublet Antenna | 444 |
| Multi-Wire Transmission Lines | 450 |
| Mutual Conductance | 58 |
| Mutual Coupling Antenna | 469 |
| Mutual Inductance | 30 |

N

| | |
|---------------------------------|------------|
| Negative and Positive | 18 |
| Negative Grid Oscillators | 158 |
| Negative Resistance Oscillators | 160 |
| Negative Sign | 552 |
| Neper | 562 |
| Neutralization: | |
| Circuits | 168 to 170 |
| Grid | 168 |
| Indicator | 504 |
| Plate | 168, 169 |
| Problems | 171 |
| Procedure | 170 |
| Push-Pull | 169 |
| Shunt | 170 |
| Node | 430 |
| Noise-Balancing Systems | 89 |
| Noise-Cancelling Microphones | 206 |
| Noise, Internal | 76 |
| Noise-Limiting Circuits | 89, 90 |
| Noise, Mixer | 76 |
| Noise, Ratio | 76 |
| Noise Silencers | 89, 90 |
| Noise Suppression | 89, 90 |
| Noise, Tube (Shot Effect) | 76 |
| Nomograms | 580 |
| Nomograph, Coil Calculator | 585 |
| Non-Amplifying Detectors | 66 |
| Non-Inductive Resistor | 462 |
| Non-Resonant Line (Untuned) | 440 |
| North Pole | 27 |
| Notation of Numbers | 544 |
| Nuclear Charge | 17 |
| Nucleus | 17 |
| Null Indicator | 448 |
| Numbers | 544 |
| Numbers, Complex | 555 |
| Numbers, Imaginary | 555 |

O

| | |
|------------------------------|----------------|
| Ohm | 18 |
| Ohm's Law: | |
| A.C. | 37 |
| Application | 19, 20, 26, 37 |
| D.C. | 19 |
| Ohmmeter | 485, 486 |
| Oil-Filled Condensers | 325 |
| Open-End Stub Tuning | 446 |
| Open Lines | 441 |
| Operations, Order of | 550 |
| Optimum Angle of Radiation | 421 |
| Orbital Electrons | 17 |
| Order of Operations | 550 |
| Orientation of Quartz Plates | 162 |
| Oscillation: | |
| Frequency of | 38 |
| Parasitic | 179 |
| Piezoelectric | 161 |
| Triode | 151 |
| Vacuum Tube | 151 |
| Oscillator-Doubler Circuits | 164, 166 |
| Oscillator-Mixer Circuits | 74 |
| Oscillators: | |
| Barkhausen-Kurtz | 381 |
| Beat Frequency | 9 |
| Calibration | 497, 498, 511 |
| Circuits | 151 |
| Code Practice | 501 |
| Colpitts | 15 |
| Concentric Line | 38 |
| Crystal Controlled | 163 to 164 |
| Electron-Coupled | 164 |
| Electron Orbit | 38 |
| Franklin | 16 |
| Gill-Morrell | 38 |
| Harmonic | 164, 166 |
| Hartley | 7 |
| Interruption Frequency | 15 |
| Kozanowski | 38 |
| Linear Tank | 38 |
| Magnetron | 39 |
| Microwave | 389 to 399 |

| | |
|---------------------------------|-----------------|
| Negative Grid | 158 |
| Negative Resistance | 160 |
| Pierce | 164 |
| Quench | 70 |
| Regenerative | 69, 70 |
| Saw Tooth | 521 |
| Self-Excited | 158 |
| Signal Generator | 510 |
| Superregenerative | 402, 405, 407 |
| Test | 93, 512 |
| Triode | 158 to 160 |
| Tritet | 165 |
| Tuned-Plate Tuned-Grid | 159 |
| U.H.F. | 410 |
| Variable-Frequency | 277 to 280, 512 |
| Wide Range Audio | 512 |
| Oscilloscope, C. R. | 516 to 526 |
| Oscilloscope Patterns | 526 |
| Overload Protection | 333 |
| Overmodulation: | |
| Indication | 504, 523 |
| Interference | 538 |
| Oxide-Coated Cathode (Filament) | 52 |

P

| | |
|--|-----------------|
| Padder Condenser—See also "Trimmer Condenser" | 80 |
| Painting Antenna Masts | 456 |
| Paper Condenser | 325 |
| Parallel Amplifiers | 61 |
| Parallel and Push-Pull Amplifiers | 61 |
| Parallel Bandspread | 80 |
| Parallel Circuits, Circulating Current | 175, 176 |
| Parallel Circuits, Effect of L/C ratio in | 175 |
| Parallel Condensers (Capacities) | 175, 177 to 179 |
| Parallel Feed | 184 |
| Parallel Inductances | 30 |
| Parallel Inverse Feedback | 210 |
| Parallel Resistors | 21 |
| Parallel Resonance | 40 |
| Parallel Resonance, Circulating Current | 40 |
| Parallel Resonance in Power Supply Filters | 322 |
| Parallel Rod Amplifier—See "U.H.F. Transmitters" | |
| Parallel Rod Oscillators—See "U.H.F. Transmitters" | |
| Parallel Tube Circuits | 61 |
| Parasitic Suppressors | 180 |
| Parasitics (Oscillations) | 179 |
| Patterns, Oscilloscopic | 526 |
| Patterns (Radiation)—See "Antennas" | |
| Peak Current | 30 |
| Peak Inverse Voltage | 323 |
| Peak Limiters | 89, 90 |
| Peak Power | 189 |
| Peak Values | 29 |
| Peak Voltage | 323 |
| Peak Voltmeter, Diode | 490 |
| Peaked Wave Form | 174 |
| Pentagrid Converter | 75 |
| Pentode | 55 |
| Pentode Crystal Oscillator | 165, 166 |
| Pentode, Television Amplifier | 56 |
| Percentage Modulation | 189 |
| Percentage Modulation Checker | 523 |
| Performance, Receiver | 91, 92 |
| Permeability | 26 |
| Phantoms | 539 |
| Phase | 36 |
| Phase Angle | 575 |
| Phase Inverter | 207 |
| Phase Modulation | 223 |
| Phase Shift, F.M. | 220 |
| Phased Antennas | 463 |
| Phasing Condenser | 85 |
| Phenomena, Wave Propagation | 428 |
| Phone Test Set | 504 |
| Phone Transmitters—See "Transmitters, Phone" | |
| $\frac{1}{2}$ (π) Section Antenna Coupler | 479 |
| $\frac{1}{2}$ (π) Type Filter | 323 |
| Pierce Crystal Oscillator | 164 |
| Piezoelectric Effect | 161 |
| Pipes, Concentric—See "Concentric Line" | |
| Placement of Coils | 268 |
| Plaque Resistors | 450 |
| Plastics, Drilling | 532 |
| Plate Circuit Tuning | 291 |
| Plate Current | 53 |
| Angle of Flow | 63, 173 |
| Plate Detection | 65 |
| Plate Dissipation | 62 |
| Plate Dissipation, Transmitting Tube | 231 |
| Plate Efficiency | 166 to 167 |
| Plate Modulation | 195 |
| Plate Neutralization | 168, 169 |
| Plate Resistance | 58, 60 |
| Plate and Screen Grid Modulation | 198 |
| Plate Spacing, Condenser | 176 to 178 |

| | |
|---|---------------|
| Points of Saturation | 26 |
| Polar Coordinates | 573, 574, 583 |
| Polarity | 27 |
| Polarization, Radio Wave | 428 |
| Polarized Condenser | 325 |
| Poles, Antenna | 455 |
| Poles, Generator | 27 |
| Portable Equipment—See "U.H.F." and "Mobile" | |
| Positive and Negative | 18 |
| Positive Peak Modulation | 189 |
| Potential Difference | 18 |
| Potential Energy | 32 |
| Powdered Iron Core | 31 |
| Power, A. C. | 37 |
| Power, Actual | 24 |
| Power Amplification | 62 |
| Power Amplifiers: | |
| A.F. | 62 |
| R.F.—See "Transmitters, Final Amplifiers" | |
| Power, Apparent | 37 |
| Power, Audio | 563 |
| Power, Average | 188 to 189 |
| Power, D.C. | 24 |
| Power Detector | 65 |
| Power Dissipated in Resistors | 24 |
| Power Drills | 531 |
| Power Factor | 575 |
| Power Gain, Amplifier | 207 |
| Power Input Control, Transmitter | 334 |
| Power, Instantaneous | 188, 189 |
| Power Levels | 564 |
| Power Line Pickup | 541 |
| Power Line R.F. Filters | 89 |
| Power Measurements | 491 |
| Power Output | 189 |
| Power, Peak | 188, 189 |
| Power Ratings, Transmitting Tubes | 231 |
| Power Relation in Speech Waveforms | 196 |
| Power Supplies | 321 |
| Power to Decibel Conversion | 321 |
| Power Transformer Design—See "Transformer Design" | |
| Power, Watts | 24, 37 |
| Powers, Algebraic | 554 |
| Powers, Arithmetical | 549 |
| Practice, Code | 8, 11, 16 |
| Practice, Workshop | 527 |
| Preamplifiers—See "Speech and Modulation Equipment" | |
| Preselector | 157 |
| Preselector, High-Gain 5-Band | 157 |
| Primary | 42 |
| Primary Cell | 48 |
| Primary Keying | 186 |
| Primary Winding | 42 |
| Protection from High Voltage | 272 |
| Protection, Overload | 333 |
| Protective Bias—See also "Bias" | |
| Propagation of Radio Waves | 428 |
| Propagation of Ultra High Frequencies | 374 |
| Proton | 17 |
| Pulsating D.C. | 321 |
| Pulse-Time Modulation | 228 |
| Punching Chassis | 534 |
| Push-Pull Amplifier | 291 |
| Push-Pull R.F. Circuits | 291 |
| Push-Push Doubler | 174 |

Q

| | |
|---|------------|
| Q | |
| Calculation of | 575 |
| Circuit | 175 to 177 |
| Effect of Loading on | 176 |
| Relation to Circulating Current (Parallel Circuits) | 41, 175 |
| Q Antennas | 448 |
| Q Bars | 448 |
| Q Matching Section | 448 |
| Q Signals—See "Appendix" | |
| Quadratic Equations | 557 |
| Quarter-Wave Antenna U.H.F. Mobile | 474 |
| Quarter-Wave Antenna Transformer | 474 |
| Quarter-Wave Matching Stub | 445 |
| Quartz Crystals | 161 |
| Quench | 70 |
| Quench Frequency | 70 |
| Quench Oscillator | 70 |
| Quenching Action | 70 |

R

| | |
|-------------------------|----------|
| R | |
| Meter | 87, 88 |
| Rack Panel Construction | 528 |
| Radar | 393, 394 |
| Radial Ground | 437 |

| | |
|--|--------------------|
| Radian | 567, 568 |
| Radiation | 428, 472 |
| Radiation, Angle of | 429 |
| Radiation, Antenna | 430 |
| Radiation, Broadside | 465 |
| Radiation, End-Fire | 467 |
| Radiation, Harmonic vs. Q | 176 |
| Radiation, Patterns | 433, 439, 459, 473 |
| Radiation Range, U.H.F. | 374 |
| Radiation Resistance | 433 |
| Radiation, Suppression of Harmonic | 481 |
| Radiator, Long Wire | 459 |
| Radiators, Vertical vs. Horizontal | 434 |
| Radio Calculations and Mathematics | 544 |
| Radio Frequency Amplifiers—See also "Transmitters" | |
| Class B | 63, 166 |
| Class C | 63, 167 |
| Grid Bias | 291 |
| Neutralization | 168 to 170 |
| Parasitics in | 179 |
| Push-Pull | 291 |
| U.H.F. | 384 |
| Radio Frequency Chokes | 183 |
| Radio Frequency Current | 29 |
| Radio Frequency Inverse Feedback | 212 |
| Radio Frequency Tank Circuit Calculations | 584 |
| Radio Mathematics and Calculations | 544 |
| Radio Receiver Alignment | 92, 95 |
| Radio Receiver Construction | 138 to 157 |
| Radio Receiver Theory | 68 to 95 |
| Radio Receiver Tube Characteristics | 96 to 137 |
| Radio Waves | 428 |
| Radiophone Transmitters—See "Transmitter Construction" | |
| Radiotelegraph Code | 6 |
| Radio Telegraph Transmitters—See "Transmitters" | |
| Radiotelephony, Power Supplies for | 319 |
| Radiotelephony Theory | 188 to 214 |
| Ratings, Rectifier | 331 |
| Ratio, Deviation | 217 |
| Ratio, Image | 76 |
| Ratio, L/C | 39, 41, 175 |
| Ratio, Signal to Image | 76 |
| Ratio, Signal to Noise | 76 |
| Ratio, VA/W | 175 |
| R-C Filters | 87 |
| Reactance | 584 |
| Calculations | 584 |
| Capacitive | 34, 35 |
| Inductive | 27, 32 |
| Reactance-Frequency Chart | 581, 582 |
| Reactance and Resistance in Combination | 38 |
| Reactance-Tube Modulator | 219 |
| Reactivation of Filaments | 51 |
| Receiver: | |
| Adjustment | 92, 95 |
| Alignment | 92, 95 |
| Amplifiers | 88 |
| Antennas | 452 |
| Bandspread in | 80 to 82 |
| Construction | 138 to 157 |
| Coupling | 453 |
| Frequency Modulation | 225 |
| Input Coupling Circuit | 453 |
| Input Resistance | 78 |
| Presclector | 155 |
| Regenerative | 69, 70 |
| R.F. Amplifiers | 77 |
| Superheterodyne | 382 |
| Superregeneration | 382 |
| Test Instruments | 484 |
| Theory | 381 |
| Tracking | 94 |
| Tubes, Characteristics of | 96 to 137 |
| Tubes, Discussion | 50 |
| U.H.F. | 381, 395 |
| Receivers: | |
| 24-Mc. Superregenerative Receiver | 396, 397 |
| 400-Mc. Superregenerator | 402 |
| and Transceivers, U.H.F. | 395 |
| Antennas for | 452 |
| Converter, High Performance | 149 |
| Converter, 56-Mc. | 395 |
| Economical Five Tube Superheterodyne | 144 |
| Emergency, C.W. | 508 |
| F.M.-A.M. 112-Mc. Superheterodyne | 397 |
| High Frequency Converters | 395 |
| High Gain 5-Band Presclector | 157 |
| Microwave—See "U.H.F." | |
| Mobile, 112-Mc. Superregenerative | 408 |
| Simple Two-Tube Autodyne | 138 |
| Simple Three-Tube Superheterodyne | 141 |
| Superheterodyne | 382, 397, 405 |
| Superregenerative | 381, 396, 402 |
| U.H.F. | 381, 395 |
| Reception, Frequency Modulation | 225 |
| Rectification | 321 |
| Rectification Efficiency | 64 |
| Rectified A.C. | 29 |
| Rectifier | 321 |
| Rectifier and Filter Circuit Considerations | 323 |
| Rectifier, Bridge Type | 326, 329, 330 |
| Rectifier Circuits | 330 |
| Rectifier-Filter System | 321 |
| Rectifier, Full Wave | 330 |
| Rectifier-Grid Controlled | 185 |
| Rectifier, Half Wave | 321, 330 |
| Rectifier, High Vacuum | 324 |
| Rectifier, Mercury Vapor—See also "Tubes" | |
| Rectifier Rating (Discussion) | 330 |
| Rectifier, Three-Phase, Full Wave | 333 |
| Rectifier Tubes (for High Power Service)—See Chapter Ten | |
| Reflected Impedance (resistance) | 43 |
| Reflection of Radio Waves | 428 |
| Refraction of Radio Waves | 428 |
| Regeneration: | |
| Cathode | 70 |
| Methods | 69 |
| Regenerative Crystal Oscillator | 165 |
| Regenerative Detector | 69 |
| Regenerative Doubler | 173 |
| Regenerative Oscillators, U.H.F. | 389 |
| Regulation, Power Supply | 327 |
| Selectivity, Effect of L/C Ratio (Parallel Circuits) | 41 |
| Rejuvenation of Filaments | 51 |
| Reluctance | 26 |
| Representation of Functions | 576 |
| Residual Magnetism | 26 |
| Resistance and Reactance in Combination | 38 |
| Resistance | 18 |
| Resistance, Effective | 21 |
| Resistance, Input | 76 |
| Resistance, Plate | 58, 60 |
| Resistance, Radiation | 138 |
| Resistances: | |
| Bleeder | 326 |
| Equations | 20 to 21 |
| Ground | 435 |
| Molecular Theory of | 15 |
| Parallel | 21 |
| Plate | 58, 60 |
| Radiation | 434 |
| Radio-Frequency | 44 |
| Series | 24 |
| Series-Parallel | 24 |
| Unit of | 11 |
| Voltage Dividers | 27 |
| Wattage | 27 |
| Resistive Coupling | 6 |
| Resistors | 24 |
| Resistors, Bleeder | 326 |
| Resistors, Non-Inductive | 46 |
| Resistors, Plaque | 450, 461 |
| Resistors, Terminating For Rhombic Antenna | 46 |
| Resistors, Voltage Equalizing | 31 |
| Resonance: | |
| Antenna | 43 |
| Cavity | 37 |
| Curve | 40, 4 |
| Formula | 3 |
| Harmonic | 43 |
| Of Inductance | 3 |
| Parallel | 4 |
| Series | 3 |
| Sharpness of | 4 |
| Resonant Circuit Impedance | 40, 3 |
| Resonant Circuits | 3 |
| Resonant Filter | 32 |
| Resonant Frequency | 3 |
| Resonant Line (Tuned) | 43 |
| Resonant Line Circuits—See "Antennas, Receiving" and "U.H.F." | |
| Resonant Tank Current | 4 |
| Resonant Trap Circuit | 32 |
| Resonator, Crystal (See "Crystal Filter") | |
| Resonativity | 2 |
| R.F. Amplifier—See also "Radio Frequency Amplifiers" | |
| R.F. Auto Transformer | 4 |
| R.F. Choke | 18 |
| R.F. Coupling Systems—See listings under Capacitive, Inductive, etc. | |
| R.F. Inverse Feedback | 21 |
| R.F. Power Measuring Device | 45 |
| R.F. Tank Circuit Calculations | 58 |
| Rhombic Antenna | 4 |
| Ribbon Microphone | 2 |
| Ripple | 3 |
| Ripple Voltage | 322, 3 |
| R.M.S. | 3 |
| Root Mean Square Value | 3 |
| Roots, Algebraic | 5 |
| Roots, Arithmetical | 5 |
| Rotatable Antennas | 4 |

S

| | |
|---|------------|
| Safety Bleeder..... | 274 |
| Safety Precautions..... | 272 |
| Safety Signal and Switch..... | 273 |
| Saturation, Core..... | 26 |
| Saturation, Electronic..... | 53 |
| Saturation, Plate Current..... | 51 |
| Saturation, Transformer..... | 337 |
| Saw, Metal..... | 432 |
| Saw Tooth Oscillator..... | 521 |
| Saw, Wood..... | 530 |
| Screen, Faraday..... | 453 |
| Screen Grid..... | 55 |
| Screen Grid Modulation..... | 193 |
| Screen Grid Tube..... | 55 |
| Screwdrivers..... | 531 |
| Second Degree Equations..... | 557 |
| Secondary Cell..... | 49 |
| Secondary Emission..... | 55 |
| Secondary Winding..... | 42 |
| Selective Fading..... | 429 |
| Selectivity..... | 41, 91 |
| Selectivity Curve..... | 40 |
| Selectivity, Effect of L/C Ratio (Parallel Circuits)..... | 41 |
| Self-Bias—See "Bias"..... | |
| Self-Excited Frequency Substandard..... | 497 |
| Self-Excited Oscillator..... | 158 |
| Self-Inductance..... | 30 |
| Self-Quenching..... | 70 |
| Semi-Flexible Transmission Line..... | 442 |
| Semi-Resonant Transmission Lines..... | 440 |
| Sensitivity..... | 91 |
| Separate Bias Supply..... | 332 |
| Series Circuits..... | 20, 35, 39 |
| Series Condensers..... | 35 |
| Series Feed..... | 184 |
| Series Inductances..... | 30 |
| Series Loading Coil..... | 437, 451 |
| Series Parallel Condensers..... | 35, 36 |
| Series Parallel Resistance..... | 22 |
| Series Resistance..... | 20 |
| Series Resonance..... | 39 |
| Series Resonant Circuits..... | 39 |
| Series Resonant Filter..... | 322 |
| Series Tracking Condensers..... | 95 |
| Set Noise..... | 76 |
| Sharpness of Resonance..... | 40 |
| Sheet Metal Working..... | 528, 534 |
| Shield, Electrostatic..... | 453 |
| Shield, Faraday..... | 453 |
| Shielding..... | 318 |
| Short Line Tuning (U.H.F.)..... | 379 |
| Short Skip..... | 376 |
| Shorted Stub Tuning..... | 446 |
| Shot Effect..... | 76 |
| Shunt Feed..... | 184 |
| Sidebands..... | 188 |
| Signal-Frequency Tuned Circuits..... | 78 |
| Signal Generator..... | 510 |
| Signal-Image Ratio..... | 76 |
| Signal-Noise Ratio..... | 76 |
| Signal Skip—See "Skip"..... | |
| Signal Strength Meters..... | 501, 502 |
| Significant Figures..... | 586 |
| Splencers, Noise..... | 98 to 99 |
| Simple 15-Watt Exciter..... | 275 |
| Simple Universal Coupler, Antenna..... | 482 |
| Simple V.T. Voltmeter..... | 502 |
| Simplified A.M.C..... | 316 |
| Sine..... | 29 |
| Sine Curve..... | 571 |
| Sine Wave..... | 29 |
| Single-Ended Amplifiers, R.F..... | 294, 299 |
| Single-Ended Tubes..... | 57 |
| Single-Phase Full-Wave Rectifier..... | 330 |
| Single-Section Filter..... | 325, 326 |
| Single-Wire Transmission Line..... | 444 |
| Skip Effect..... | 40 |
| Skip Distance..... | 376, 429 |
| Skip, Long..... | 377 |
| Skip, Short..... | 376 |
| Sky Wave..... | 373, 428 |
| Slack, Guy Wire..... | 456 |
| Smoothing Choke..... | 325, 343 |
| Socket Connections, "Receiving Tubes"..... | 127 to 131 |
| Socket Connections, "Transmitting Tubes"..... | 232 |
| Socket Holes, Punching..... | 534 |
| Soldering..... | 535 |
| Soldering Irons..... | 529 |
| Sound Waves..... | 185 |
| South Pole..... | 27 |
| Space Charge Effect..... | 53 |
| Spacing, Condenser Plate..... | 176 |
| Spacing, Rotatable Antenna Element..... | 469 |
| Special Framework, Transmitter..... | 528 |
| Special Purpose Vacuum Tubes..... | 56 |
| Speech Amplifiers—See also "Modulators"..... | |
| Speech Equipment..... | 302 |

| | |
|--|---------------|
| Speech and Modulation Equipment..... | 302 |
| Splatter Suppressor..... | 318 |
| Spray-Shield Tubes..... | 441 |
| Sprayers, Feeder..... | 549 |
| Spurious Emissions..... | 530 |
| Square Root..... | 550 |
| Stability, Crystal..... | 103 |
| Stability, Transmitter: | |
| Crystal..... | 163 |
| E.C. Oscillator..... | 160 |
| Oscillator..... | 160, 163 |
| Stabilization, F.M. Circuits..... | 220 |
| Stacked Dipole Antennas..... | 463 |
| Standard Push-Pull Amplifier..... | 291 |
| Standing Wave Indicator..... | 438 |
| Standing Waves..... | 430 |
| Starting Voltage, Rectifier..... | 327 |
| Static Characteristics..... | 53 |
| Static Charge..... | 32 |
| Station Arrangement (Photographs)..... | 6, 7, 16 |
| Station Control System..... | 273 |
| Station License..... | 6 |
| Steel Core Wire..... | 457 |
| Steel Drilling..... | 531 |
| Stepped Array..... | 406 |
| Storage Batteries..... | 49 |
| Storage of Electrical Energy..... | 82 |
| Stray Capacity..... | 82 |
| Stray Pickup, Receiver..... | 453, 540 |
| Stress, Dielectric..... | 33 |
| Stubs, Matching..... | 445, 447 |
| Subtraction, Algebraic..... | 552 |
| Subtraction, Arithmetical..... | 546 |
| Subtraction, Vectorial..... | 573 |
| Sun, Effect on Ionosphere..... | 428 |
| Superheterodyne Alignment..... | 92 |
| Superheterodyne Interference..... | 542 |
| Superheterodyne Receiver—See also "Receivers"..... | |
| Superheterodyne Theory..... | 382 |
| Superheterodyne Tracking..... | 79, 94 |
| Superregenerative Receivers..... | 381, 396, 402 |
| Supply, A.C. Mains..... | 271 |
| Supply, Bias..... | 328, 331 |
| Supply, Power—See "Power Supplies"..... | |
| Supporting the Antenna..... | 455 |
| Suppression, Bass..... | 213 |
| Suppression, Harmonic..... | 481 |
| Suppression, Noise..... | 88 |
| Suppressor Grid..... | 56 |
| Suppressor Grid Modulation..... | 193 |
| Suppressor, Parasitic..... | 180 |
| Suppressor, Splatter..... | 318 |
| Surface Wave..... | 428 |
| Surge Impedance..... | 438 |
| Sweep Circuit..... | 518, 520 |
| Swinging Choke..... | 325, 343 |
| Switching, Control System..... | 273 |
| Switching, Meter..... | 260 |
| Symbols, Radio—See "Appendix"..... | |
| Synchronization, C.R. Oscilloscope..... | 521 |
| Systems, Amplitude Modulation..... | 191 to 200 |
| Systems, Noise Reduction..... | 88 to 91 |

T

| | |
|---|------------|
| Tables—See "Charts"..... | |
| Tank Circuit..... | 178 |
| Tank Circuit Capacities..... | 175 to 177 |
| Tank Circuit, Flywheel Effect..... | 42 |
| Tank Circuits, Linear..... | 383 |
| Tank Current..... | 42 |
| Tapped Circuits..... | 81 |
| Tapped Inductances..... | 81, 168 |
| Telephone Poles, Antenna Support..... | 456 |
| Television Amplifier Pentodes..... | 56 |
| Temperature Coefficient, Crystal..... | 161, 162 |
| Terman-Woodyard Amplifier..... | 201 |
| Terminating Resistor, Rhombic Antenna..... | 463 |
| Termination, Transmission Line..... | 463 |
| Test and Measuring Equipment..... | 483 |
| Test Instruments for Receivers..... | 92 |
| Test Oscillator..... | 93 |
| Test Set, Phone..... | 504 |
| Testing, Receiver..... | 92 to 94 |
| Tetrode..... | 55 |
| Theory, Fundamental Electrical and Radio..... | 17 |
| Thermal Agitation..... | 76 |
| Thermal Noise..... | 76 |
| Thermionic Emission..... | 50 |
| Thoriated-Tungsten Filament..... | 51 |
| Three-Phase Full-Wave Rectifier..... | 331 |
| Three-Phase Half-Wave Rectifier..... | 331 |
| Thump Filters..... | 185 |
| Tickler Coils..... | 69 |
| Tool Hints..... | 529 |
| Tools..... | 528 |
| Tools, Receiver Alignment..... | 92 |
| Tourmaline Crystals..... | 162 |

| | |
|---|--------------------|
| Oscillator Circuits..... | 383 |
| Propagation..... | 374 |
| Push-Pull Beam Tubes..... | 410 |
| Receivers..... | 395 to 408 |
| Receivers and Transceivers..... | 395 |
| Resonant-Line Construction..... | 439 |
| R.F. Amplifiers..... | 382 |
| Short Line Tuning..... | 379 |
| Short Skip..... | 376 |
| Superheterodyne Receivers..... | 382, 397 |
| Superregenerative Receivers..... | 382, 396, 405, 407 |
| Transceivers..... | 408 |
| Transmission Line Circuits..... | 379 |
| Transmission Range..... | 374 |
| Transmitters..... | 410 to 427 |
| Wavemeters—See "Lecher Wires" and "Frequency Measurement" | |
| Unidirectional Array..... | 469 |
| Units, Electrical..... | 19 |
| Unity Coupling..... | 182 |
| Universal Antenna Coupler..... | 482 |
| Untuned Transmission Lines..... | 440 |

V

| | |
|--|---------------------------------|
| V Antenna..... | 460 |
| Vacuum Tube: | |
| Amplifier..... | 58 |
| Amplification Factor (μ)..... | 58 |
| Application..... | 57 |
| Detectors..... | 65 |
| Operation..... | 56 |
| Oscillator..... | 65, 158 |
| Reactivation..... | 51 |
| Rectifier..... | 64 |
| Theory..... | 50 |
| Vacuum Tube Keying..... | 187 |
| Vacuum Tube Operation: | |
| As Amplifier..... | 58 |
| Class A..... | 59 |
| Class AB..... | 60 |
| Class B..... | 60, 63 |
| Class C..... | 63 |
| As Detectors..... | 65 |
| As Measuring Device..... | 67 |
| As Oscillator..... | 158 |
| As Rectifier..... | 64 |
| Vacuum Tube Theory..... | 50 |
| Vacuum Tube Voltmeters..... | 487, 488, 490, 502 |
| Vacuum Tubes..... | 50 to 67, 96 to 137, 231 to 265 |
| Valve (Action of Vacuum Tubes)..... | 54, 55 |
| Variable Condenser, Transmitter..... | 268 |
| Variable Efficiency Modulation..... | 191 |
| Variable Frequency Oscillator..... | 277, 280 |
| Variable Selectivity..... | 85 |
| Variation of Ionosphere Height..... | 428 |
| V/A/W Ratio..... | 175 |
| Vectors..... | 572 |
| Velocity, Angular..... | 28 |
| Velocity, Microphone..... | 205 |
| Velocity of Radio Waves..... | 428 |
| Vertical Angles vs. Horizontal Pattern, Antenna..... | 458 |
| Vertical Polarization..... | 428 |
| Vertical vs. Horizontal Antennas..... | 434 |
| V.F.O. Exciter..... | 277, 280 |
| Vibration, Piezoelectric..... | 161, 162 |
| Vises..... | 529, 533 |
| Volt, Definition..... | 18 |
| Volt-Ohmmeter..... | 485 |
| Voltage, Across Coil and Condenser..... | 40 |
| Voltage Amplification..... | 62 |
| Voltage Amplifier..... | 62 |
| Voltage, A.V.C..... | 87, 92 |
| Voltage, Bias..... | 332 |
| Voltage, Bias Supply..... | 322 |
| Voltage, Breakdown (Of Mercury Vapor)..... | 65 |
| Voltage Control, Transmitter..... | 334 |
| Voltage, Cutoff Bias..... | 54, 59, 63 |
| Voltage-Decibel Ratio..... | 564 |
| Voltage Dividers..... | 22 |
| Voltage Drop..... | 19, 22 |
| Voltage Feed..... | 438, 445 |
| Voltage, Induced..... | 30, 41 |
| Voltage, Input..... | 566 |
| Voltage, Inverse Peak..... | 323 |

| | |
|---|--------------------|
| Voltage Loops..... | 430 |
| Voltage Nodes..... | 430 |
| Voltage, Peak..... | 323 |
| Voltage Equalizing Resistors..... | 35 |
| Voltage Rating of Series Condensers..... | 35 |
| Voltage Regulation for Class B Modulator..... | 320 |
| Voltage Regulator Tubes..... | 427 |
| Voltage, Ripple..... | 323 |
| Voltage, R.M.S..... | 30 |
| Voltage in Series Resonant Circuit..... | 39 |
| Voltage-Turns Ratio..... | 339 |
| Voltage, Working, D.C..... | 325 |
| Voltmeter..... | 485 |
| Voltmeter, A.C. Ripple..... | 323 |
| Voltmeter, Vacuum Tube..... | 487, 488, 490, 502 |
| Volt-Ohmmeter..... | 485 |
| Volume Compressor (Automatic Peak Limiters)..... | 318 |
| Volume Control, Automatic..... | 87, 92 |
| Volume Control, Floating (Interference Relationship)..... | 540 |
| VU..... | 567 |

W

| | |
|---|---------------|
| Water Pipe Ground..... | 437 |
| Watt..... | 24 |
| Watt-Decibel Chart..... | 563, 565 |
| Wave Guides..... | 385 |
| Wave Propagation..... | 428 |
| Wave Propagation, U.H.F..... | 374 |
| Wave, Sine..... | 531 |
| Wave, Speed of Radio..... | 428 |
| Waveform: | |
| Class A..... | 59 |
| Class B..... | 60 |
| Class C..... | 63 |
| Peaked..... | 174 |
| Power Relations in..... | 196 |
| Rectifier..... | 30 |
| Sine..... | 29 |
| Speech..... | 196 |
| Waveform Distortion..... | 174 |
| Wavelength..... | 430, 431 |
| Wavelength Determination..... | 380, 500 |
| Wavelength-Frequency Conversion..... | 431, 576, 579 |
| Wavemeters..... | 500, 504 |
| Wavemeters, U.H.F.—See also "Lecher Wires"..... | 500 |
| Waves, Standing..... | 430 |
| Wave Trap..... | 538 |
| Wet Electrolytic Condensers..... | 325 |
| Wide Range Audio Oscillator..... | 512 |
| Wind, Guying Against..... | 456 |
| Wind, Torque Developed by..... | 456 |
| Winding Transformer..... | 340 |
| Wire, Antenna..... | 457 |
| Wire, Copperweld..... | 457 |
| Wire, Guy..... | 456 |
| Wire Tables..... | 338, 340 |
| Wiring, Transmitter..... | 268 |
| Wood Saw..... | 530 |
| Working Voltage..... | 33 |
| Workshop Practice..... | 527 |

X

| | |
|---------------------|-----|
| X Axis..... | 162 |
| X-Cut Crystals..... | 162 |

Y

| | |
|----------------------------------|-----|
| Y Axis..... | 162 |
| Y-Cut Crystals..... | 162 |
| Y-Matched Impedance Antenna..... | 443 |

Z

| | |
|---------------------------------------|----------|
| Z Axis..... | 162 |
| Zepp Antenna..... | 438 |
| Zepp Feeders..... | 438 |
| Zero Beat..... | 60 |
| Zinc Alloy Drilling..... | 532 |
| Zone of Silence (Skip Distances)..... | 376, 429 |

INDEX TO ADVERTISERS

The following advertisers are recommended to our readers. Their products and services are nationally known and respected. Similar books in other technical fields sell for \$5.00 upwards—mostly upwards. Whatever value this book may have for you above its purchase price is a gift to you from these advertisers, who have made such a policy possible. We suggest that you patronize them when purchasing parts for construction of equipment.

- Aerovox Corp. 667
- Aireon Mfg. Corp. 618 to 621
- Allied Radio 673
- American Phenolic Corporation . . . 678
- American Transformer Co., The . . . 674
- Astatic Corp., The 666
- Birnbach Radio Co., Inc. 661
- Bliley Electric Co. 680
- Brach Mfg. Corp., L. S. 659
- Bud Radio, Inc. 670
- Burgess Battery Co. 632
- Candler System Co. 687
- Centralab, Div. of Globe-Union,
Inc. 636, 637
- Collins Radio Co., The 633 to 635
- Cornell-Dubilier Electric Corp.
. 654, 655
- Editors & Engineers 689, 690
- Eitel-McCullough, Inc. 642, 643
- Electronic Laboratories, Inc. 677
- Electronic Mechanics, Inc. 676
- Hallicrafters Co., The 623 to 626
- Hammarlund Mfg. Co., Inc. . . . 648, 649
- Harrison Radio Corp. 662
- Heintz and Kaufman, Ltd. 665
- Henry Radio 669
- Hickok Electrical Instrument Co. . . 688
- Hytron Radio & Electronics
Corp. 656, 657
- International Resistance Co. 664
- Instructograph Co. 688
- Johnson Co., The E. F. 650, 651
- Kluge Electronics Co. 686
- Mallory & Co., P. R. 660
- Marion Electrical Instrument Co. . 663
- Measurements Corp. 679
- Mycalex Corp. of America 668
- National Co., Inc., The 599 to 616
- Ohmite Mfg. Co. 652, 653
- Par-Metal Products Corp. 683
- Radiart Corp. 675
- Radio Corp. of America, Tube
Div. 644, 645
- Radio Manufacturing Engi-
neers, Inc. 627 to 629
- Radio Shack, The 646, 647
- Radio Wire Television, Inc. 681
- Raytheon Mfg. Co., Receiving
Tube Div. 630, 631
- Silver Co., McMurdo 684
- Solar Capacitor Sales Corp. 671
- Standard Electric Products Co. . . . 687
- Standard Transformer Corp. 687
- Sylvania Electric Corp. 640, 641
- Taylor Tubes, Inc. 658
- Turner School, The 688
- Ungar Electric Tools, Inc. 682
- United Catalog Publishers, Inc. . . . 685
- United Transformer Corp. 672
- Westinghouse Electric Corp. . . . 638, 639