

# antenna handbook

by Ken "Judge" Glanzer, K7GCO

IR  
6

de Historie v/d Ra

VOLUME I-Theory and Practice

\$4.00

# ANTENNA HANDBOOK

by  
KEN "JUDGE" GLANZER  
K7GCO



COWAN PUBLISHING CORP.  
14 VANDERVENTER AVE. PORT WASHINGTON, N. Y.

## **DEDICATION**

**This book is dedicated to Ken Graves, W7FA; without his constant encouragement and many suggestions of material, personal interest, assistance and foresight, the book would not have been possible.**

© 1966 by Cowan Publishing Corp. All rights reserved.  
This book or any parts thereof may not be reproduced in any form or any language without permission of the publisher.

**Library of Congress Catalog Number 66-14723**

**Printed in the United States of America  
by Colonial Press of Miami, Inc.**

# CONTENTS

<b>Introduction</b> .....	7
<b>Transmission Lines</b> .....	11
<b>Properties of Transmission Lines</b> .....	12
Distributed Constants .....	12
Electromagnetic Fields .....	13
Characteristic Impedance .....	14
General Derivation of $Z_0$ .....	15
Attenuation and Losses .....	16
Wave Motion on Transmission Lines .....	18
Reflection of Energy and Standing Waves .....	18
Line Impedance .....	18
Velocity of Propagation .....	19
Traveling Waves on an Infinite Line .....	20
Traveling Waves on a Properly Terminated Line .....	20
Standing Waves on a Shorted Line .....	21
Standing Waves on an Open Line .....	22
Standing Waves For Other Conditions .....	22
<b>Standing Wave Ratio (SWR)</b> .....	24
Effect of Various Standing Wave Ratios .....	25
<b>Resonant and Nonresonant Lines</b> .....	25
General Applications .....	26
Various Lengths of Open and Shorted Lines .....	26
<b>Summary of Characteristics of Properly Matched Line</b> .....	29
Summary of Characteristics of Unmatched Line .....	30
<b>Single Wire And Two Wire Parallel Lines</b> .....	31
<b>Coaxial (Coax) Lines</b> .....	32
Shielded Pair Coaxial Line .....	34
Characteristic Impedance of Coaxial Line .....	35
<b>Characteristic Impedance of Practical Lines</b> .....	35
<b>Other Applications of Transmission Lines</b> .....	37
Quarter Wave Line as a Metallic Insulator .....	37
Quarter Wave Line as a Filter .....	38
Transmission Line as a Reactance .....	38
Stub Matching .....	40

# 2

<b>Antenna Fundamentals</b> .....	46
<b>Fundamental Concepts of Radiation</b> .....	46
Induction Field .....	48
Radiated Field .....	48
Reception .....	50
Reciprocity .....	50
Gain .....	50
Radiation Resistance .....	51
General Discussion of Half Wave Dipoles .....	53
Determining The Electrical Ground .....	54
Free Space Dipole Radiation Patterns .....	58
Tilting Wire Antennas .....	59
Directional Characteristics of Long Wire Antenna .....	60
Multiple Wavelength Antennas .....	60
Terminated Long Wires .....	63
The Effect of the Feedpoint on Current .....	
Distribution And Field Pattern .....	64
Antenna Length .....	66
Half Wave Antenna Characteristics .....	66
Decibels .....	68

# 3

<b>Matching Devices</b> .....	71
Some Fundamental Facts .....	71
Antenna Tuners .....	73
Home Brewed Tuner .....	74
Johnson Match Box .....	78
The Gamma Match .....	80
General Tune Up Procedure .....	83
The T Match .....	84
The Delta Match .....	87
Hairpin (Inductance) Matching .....	88
Capacitance Matching .....	89
Folded Dipole Matching .....	91
Quarter Wave Stub Matching .....	92
Quarter Wave Stub Matching to .....	
Untuned Lines .....	93
One Band (1 to 1) Bazooka .....	96
One Band (4 to 1) Balun .....	98
The Use of Baluns .....	98
The 52 Ohm Tri-Axial Switching Harness .....	100
Feed Systems for Stacked Beams .....	104
Link Coupling .....	101
Index .....	110

# Introduction

Although advances in antenna design are being made almost every day, not many of these breakthroughs reach the ham and other interested parties through articles or books. Developments generally lag behind the needs of the ham, CB'er, and the industry as a whole. Antenna research requires good measuring equipment, a good test site, a sound background in antenna theory, and a fair amount of insight. The industry is in dire need of competent engineers and students should seriously consider entering this field.

To test a design concept, the antenna must be constructed either in model form at high frequencies or a full-size array at the design frequency. An individual designer must be able to construct such models. This requires some mechanical ability, availability of hardware, and a suitable test range. All of these requirements and others must be fulfilled before any *reliable* data can be obtained, and all data must be carefully interpreted. These conditions are often not met and, unfortunately, inaccurate conclusions are often deduced by those not sufficiently grounded in basic concepts. Even with a solid background, accurate evaluations can be very difficult and full of surprises and disappointments.

Antenna theory is not taught in all schools and those interested in the subject must obtain their knowledge by graduate work or by independent study. All antenna texts and trade journals should be studied.

The only "secret" successful designers have is a thorough knowledge of applicable theory and the ability to keep from getting sidetracked. With this background there are few, if any, unexplained phenomena. Some of the author's own observations, short-cuts, insight and little known concepts, are described as a result of 15 years of independent intensive antenna research, always seeking for the ideal or optimum antenna for a particular requirement. From this book one can actually construct an effective and working antenna. In the research and development of the designs offered, every effort was made to present the theory and construction details as simply and clearly as possible within practical limits. No expense was spared to verify the many fresh new ideas and techniques included herein; every effort was made to keep the manuscript from degenerating into a rehash.

When constructing a new design one should be constantly aware of the many informed and misinformed experts who say, "It can't be done," or "It won't work." If the design is based on fundamentals and sound reasoning, build it! There is an old Glanzer Axiom which states, "One test may be worth 1,000 opinions." Even if

it doesn't work, the knowledge gained will generally be well worth the effort. More often than not the design will be good. For some unexplained reason those who have not spent 5 minutes of their time, or 5 pennies of their own money, or have very little basic knowledge of antenna design, can come up with more reasons than anyone else why something will not work. If one listens to these "experts" long enough they will begin to influence one's thinking and at times have been responsible for killing many productive and advanced ideas. There is nothing more powerful than a new and useful idea and in time it will (but with some effort) beat down the "It won't work" crowd.

The size of the book deemed that it be printed in three volumes. Each volume covers major phases of antenna design and practice. Volume I treats transmission lines, antenna theory, and matching devices. These basic topics are most important to the antenna man.

Each antenna described in later volumes has been thoroughly tested either by the author or others. From the material in this book one can build an antenna from readily available materials. Many new construction techniques and new design breakthroughs are shown. Antennas built with these designs and techniques have given years of trouble-free service.

It goes without saying that the performance of one's equipment depends to a large extent on the antenna used. Further, with the tremendous number of stations on the air the signal level must be equal to or preferably stronger than other stations in order to be heard. If the signal cannot be heard one will lose interest fast or try to put up a better antenna. This book was written for those who want the best possible antenna.

It has been observed many times that poor antenna performance resulted in loss of interest to the point where the equipment was seldom used or eventually sold and other interests pursued. This means the investment was indeed a costly one and little return from it was received. There are many others, who by design, foresight or other factors, constructed or purchased good antennas which resulted in a very competitive signal level. The operator derived substantial pleasure from his equipment which indeed made the investment very worthwhile. Interest even increased and in many instances new designs were attempted in order to advance the state of the art. Amateur Radio provides a creative environment where one's station performance can profit from a new design or idea. The competitive ham bands offer one of the best testing sites to determine the effectiveness of a new idea.

As a shortwave listener one listens mostly to the stronger signals and often dreams of how nice it would be if he had a signal of that strength. So the SWL studies hard and gets his license and finds that he does not get out. What the SWL failed to realize is that the average top signal was due to many factors, and perhaps the most important being the antenna. This book will show you how to put up the best antenna for every purpose and purse.

This writer would like to thank Dr. David E. Hemington, OA6AB (ex-K6TSR, W7RSY), who first encouraged me way back in 1953 that a book of this kind was needed. Walt Nettles, W7ARS (ex-W0AJL) became a sounding board for the many ideas and questions of this writer. The antenna designs of Walt vividly demonstrated how to make theory work and that it "always works" contrary to what some others claim. In 15 years of research not one case of "theory doesn't always work" was found. The theory that "doesn't always work" is the theory that requires some serious review!

In addition to W7FA, to whom the book is dedicated, I would also like to thank all those who assisted the author in one way or another. Many of those listed below have made major contributions to the field on their own by independent research and development. They are:

Dale Graber of EL2F; Mert Hasse, W0DKJ; Jim Prusha and Steve Graff of KUSD; Darius "Diz" Hofer, W0EXX; Melvin L. Hofer, W0GWA; Ray Daly, W0ZRA; Ray Jorgensen, W0MMQ; Ken Simmons, W0NTU; Milt Schradsky, W0CND; Duke

Olsen, W0BLZ; Bill Coder, W0HWS; Ed "Nip" Neppel, W0CVG; Ed Wier, W0OEV; Al Cowan, W0PHR; Harris Raley, W0EHE; Major Colman, K0OAO; Bob Kitsmiller, W0DPK; Carl Smith, W0BWJ; Joe Semkow, W8IIP (ex-W7IIP); John Allyn, W7YGN; Jim Cunningham, W7ZXL; Dick LeMassena, W7WVE; Robert Hoffman, W7DL; Stan Cleary, W7SSQ; Louey Seay, W7TLB; Ward Wieland, W7GEY; Carl Braun, W7HRV; Tom Erdman, W7DND; Dick Thomas, W7IKY; Bill Gibson, W7BVV; Ed Middleton; Ken Noel; Ken Bale, W7VCB (ex-DL4IO, EL4A); Bob Gervenack, W7FEN; John L. Armstrong, K6RWC; Jo Jennings, W6EI; Lawrence Collins, W6VAD; Donald Jackson, W6JZP; Dwight Williams, W6RO; Russ Hillen, W6DA; Matt McCoy, W6WTJ; Frank Jones, W6AJF; Loyd Colvin, W6KG; Earl Hobson, W6LI; Donald Farnsworth, W6TTB; J. W. Buckley, W6JPO; Gordon Peck, W5YGI; John Watson, W4GD; Reuben E. Gross, W2OXR; Gene Lombardi, W2KFA; Bill Leonard, W2SKE; Frank Harrington, W1ERX; Laurie Parkhurst, VE7IT; Jack Elston, VE3SJ; Charles Gyenes, VE7BOC; and Dr. Donald K. Reynolds, W7DBA of the University of Washington for all his help and to many of my instructors back in college, Professors H. E. Brookman, Frank Stout, Millard Foor, G. I. Moller, William Eckman, Howard Connors, William Dunbar, and Dr. William Bender. A little encouragement goes a long way.

Finally, many thanks to the editor of the book, Art Seidman K2BUS, for his expert job in getting the manuscript together in book form.

Ken Glanzer, K7GCO

Seattle, Washington  
November, 1966





# TRANSMISSION LINES

When the antenna is situated in your backyard or on a nearby hill, you are faced with the problem of transferring the r.f. energy from the output of the transmitter to the antenna with as little loss as possible. The device which accomplishes this transfer is known as a *transmission* or *feedline*. It is defined as a power carrying and matching device between the transmitter (or receiver) and the antenna. The line should have low loss for greatest efficiency. A transmission line can also be considered as a device for transmitting or guiding electrical energy from one point to another. A lossy line decreases the amount of energy available at the transmitting antenna for radiation or at the receiver for reception. Conversely, a perfect transmission line (no losses) would deliver the entire transmitter output to the antenna or the entire received signal to the receiver.

All transmission lines have two ends. The end of the line where the energy to be transferred is injected is known as the *input* end. This end is also referred to as the transmitter end, the sending end, the generator end, or the source. The end at which the energy is taken from the line and used is termed the *output* end. This end is also known as the load end, or sink.

The transmission line is perhaps the least understood phase of antenna practice. Careful study of this chapter will bring greater understanding of this important topic.

## PROPERTIES OF TRANSMISSION LINES

### Distributed Constants

A transmission line is considered to be short when its physical length is small compared to a quarter wavelength frequency of the energy which it is to carry. A line is long when its length is greater than a quarter wavelength. It is important to understand that the terms "short" and "long" are relative ones. For example, a line whose physical length is 34 feet would be considered quite short if it were to carry radio frequencies in the standard broadcast band (from 550 kc to 1,600 kc). On the other hand, if this same length of transmission line were used on 28 mc, the line would be about one wavelength long.

When power is applied to a very short transmission line, practically all the power gets to the load at the output end of the line if proper matching is achieved at the input end. This very short transmission line is usually considered to have practically no electrical properties of its own except perhaps for a small amount of resistance. However, the picture changes drastically when a long transmission line is used. As most transmission lines to be considered in this chapter are long, it is of interest to examine the properties of such a line. There is a good reason for doing this. It frequently happens that the voltage necessary to drive current through such a long line is sometimes considerably greater than can be accounted for by the impedance of the load.

A transmission line has all the properties of more conventional circuits, such as inductance, capacitance, and resistance. In most cases, however, the constants in conventional circuits are *lumped* into a single device or component. For example, a coil of wire has the property of inductance, so that when a certain amount of inductance is needed in a circuit, a coil of certain dimensions can be selected. The circuit's entire inductance is lumped into one component. Two metal plates separated by a small space can be used to supply the circuit capacitance. In such a case, the circuit's capacitance is lumped into this one component. Similarly, a fixed resistor can be used to supply a certain value of circuit resistance.

A transmission line also has the properties of inductance, capacitance, and resistance. However, these are not lumped. Instead, they are said to be *distributed* constants or parameters. Such constants are spread along the entire length of the transmission line and cannot be distinguished separately. A typical two wire transmission line, for example, has electrical resistance all along its length. This resistance is usually expressed in ohms per foot. In Fig. 1.1a, resistance is depicted as existing continuously from one end of the line to the other.

These same two wires also possess inductance. Any current in the wires set up magnetic lines of force which encircle the wires as shown in Fig. 1.1b. When the current drops, the field collapses, and a certain amount of energy is applied to the wires which tends to keep the current flowing a little longer in the same direction. This represents an inductance which is expressed in microhenries per foot.

There also exists between the two wires an electric field similar to the field that exists between the two plates of a capacitor. In other words, the two wires of the line act as a capacitor, with air or other insulating materials being the dielectric between them. This is illustrated in Fig. 1.1c. The capacitance between the wires is usually expressed in micromicrofarads per foot.

Because any dielectric or insulator, including air, is not perfect, a small current flows between the two wires. This current is known as *leakage current*. In effect, the insulator acts as a high resistance, permitting some current to pass between the wires. This is illustrated in Fig. 1.1d. This property is usually expressed

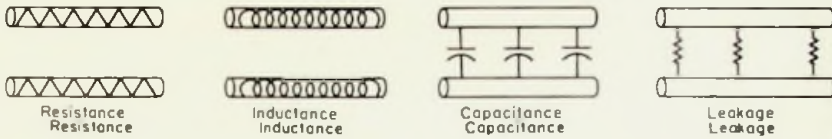

Fig. 1.1—Distributed constants of a transmission line. (a) Resistance; (b) Inductance; (c) Capacitance; (d) Leakage conductance.

as the reciprocal of resistance (conductance) for ease in computation. Conductance, in transmission lines is often expressed in micromicromhos per foot.

### Electromagnetic Fields

The distributed constants (resistance, inductance, capacitance and conductance) which have been discussed are basic properties of all transmission lines and exist whether or not there is current flowing. As soon as current flows and voltage exists in a transmission line, another property becomes evident. This property is the existence of a field, or lines of force, about the conductors which make up the transmission line. While the lines of force themselves are imaginary, the force an electron would experience while in their vicinity is very real, indeed. Actually,

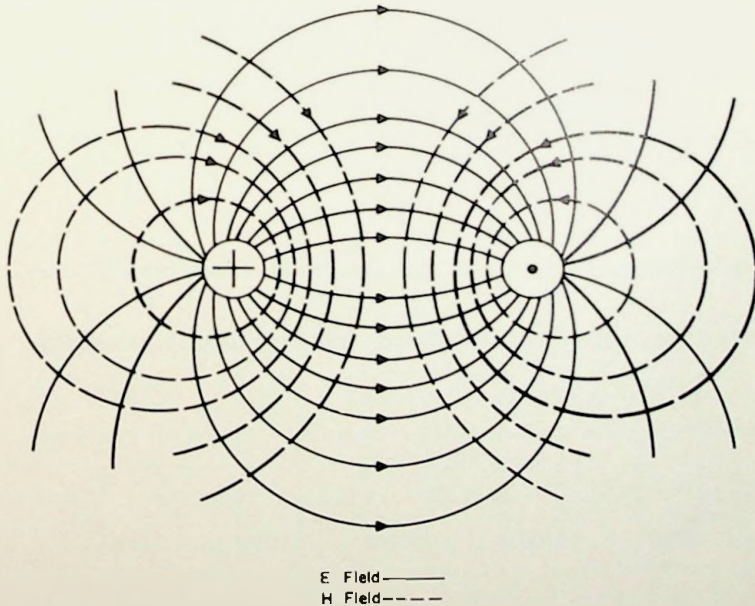

Fig. 1.2—Electric and magnetic fields between conductors carrying current.

there are two kinds of fields, one of which is associated with the voltage and the other with the current. The field associated with the voltage is called the *electric field*, because it tends to exert a force on any electric charge (such as an electron or ion) placed in the neighborhood of the field. The field associated with the current is called a *magnetic field*, because it tends to exert a force on any magnetic pole (such as is associated with a magnet or another wire with current flowing in it) placed in its vicinity.

Figure 1.2 illustrates the manner in which the electric or *E*-field, and the magnetic or *H*-field, tend to orient themselves between conductors of a typical two-wire transmission line. The transmission line is shown in cross-section with the *E* field (electric) shown by the solid lines and the *H* field (magnetic) illustrated by the dashed lines. The arrows indicate the direction of the lines of force. Both fields usually exist together and are spoken of, collectively, as the *electromagnetic field*.

### Characteristic Impedance

Every transmission line, in addition to the properties already mentioned, also possesses a *characteristic impedance*, normally designated by the symbol  $Z_0$ . The characteristic impedance determines the amount of current that can flow when a given voltage is applied to an infinitely long line. This is much the same as resistance limiting the amount of current that flows in a d.c. circuit when a given voltage is applied.

To understand the significance of  $Z_0$ , consider the equivalent circuit of an infinitely long transmission line shown in Fig. 1.3. Assume all inductors and capacitors have the same value. If an electrical impulse is applied to the input end of the line, the combination of  $L$  and  $C$  appears to have an impedance—called the characteristic impedance—this is approximately equal to  $\sqrt{L/C}$  (neglecting the resistance and leakage conductance of the line), where  $L$  and  $C$  are the inductance and capacitance per unit length of the line, respectively. This impedance turns out to be purely resistive, and its value is a constant for a given line.

The inductance and capacitance per unit length of line depend upon the size of the conductors and the spacing between lines. The closer the two conductors

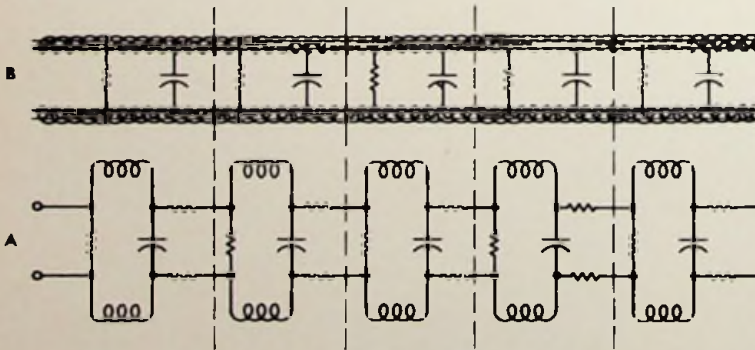

Fig. 1.3—Infinite transmission line. (a) Schematic; (b) Equivalent circuit.

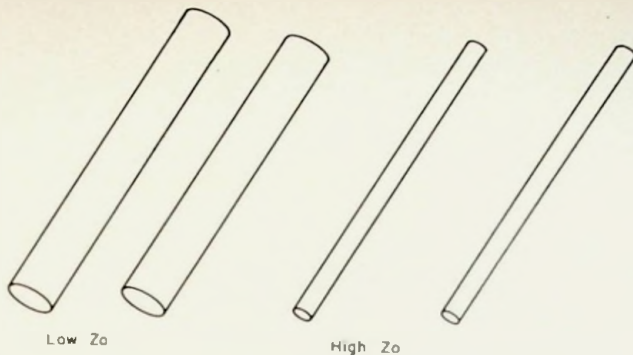

Fig. 1.4—Effects of conductor size and spacing on  $Z_0$ .

are to each other and the greater their diameter, the higher is the capacitance and the lower is the inductance. The characteristic impedance will therefore be lower. These facts are summarized in Fig. 1.4, where a line with large conductors closely spaced exhibits a low value of  $Z_0$ , while one with small conductors widely spaced has a relatively high value of  $Z_0$ .

### General Derivation of $Z_0$

To demonstrate, by means of a numerical example, the manner in which small sections of line can be added successively until the line finally behaves as though it were infinitely long, consider a line made up of pure resistances. Assume a network of series and shunt resistances shown in Fig. 1.5, where all series resistors have a value of 10 ohms and all shunt resistors have a value of 100 ohms.

If an ohmmeter is placed across the line from X to Y (the input to the first section), it will read different values, depending upon how many sections follow the first. For example, in part (b) of the drawing only one section is used and the ohmmeter reads 110 ohms, according to the law for series resistances. In part (c), two sections are shown and the ohmmeter now reads 62.4 ohms. This is due to the additional 110 ohms which is placed in parallel with the 100 ohm shunt resistor of the first section. In part (d), another identical section has been added to the first two, making three sections in all. Now the ohmmeter reads 48.4 ohms. Similarly, as more sections are added the ohmmeter reading becomes progressively lower. For this particular example, the values are 42.6 ohms for a 4 section line, 39.9 ohms for a 5 section line, 38.6 ohms for a 6 section line and 37 ohms for an infinite line. It is apparent then that as more sections are added, the readings become less and less. Even with only six sections, it becomes difficult to detect where more sections are being added. The value which the readings tend to approach as more and more sections are added is the characteristic resistance of the line. In this example the value would be 37 ohms.

If the first section had a 37 ohm resistor placed across its output instead of the additional sections, the ohmmeter would read exactly 37 ohms. In fact, if a 37 ohm resistor is connected across the output end of any of the sections, the ohmmeter would still read 37 ohms, the same value as the input resistance of the line when it is infinitely long. This can be verified by simple Ohm's law calcula-

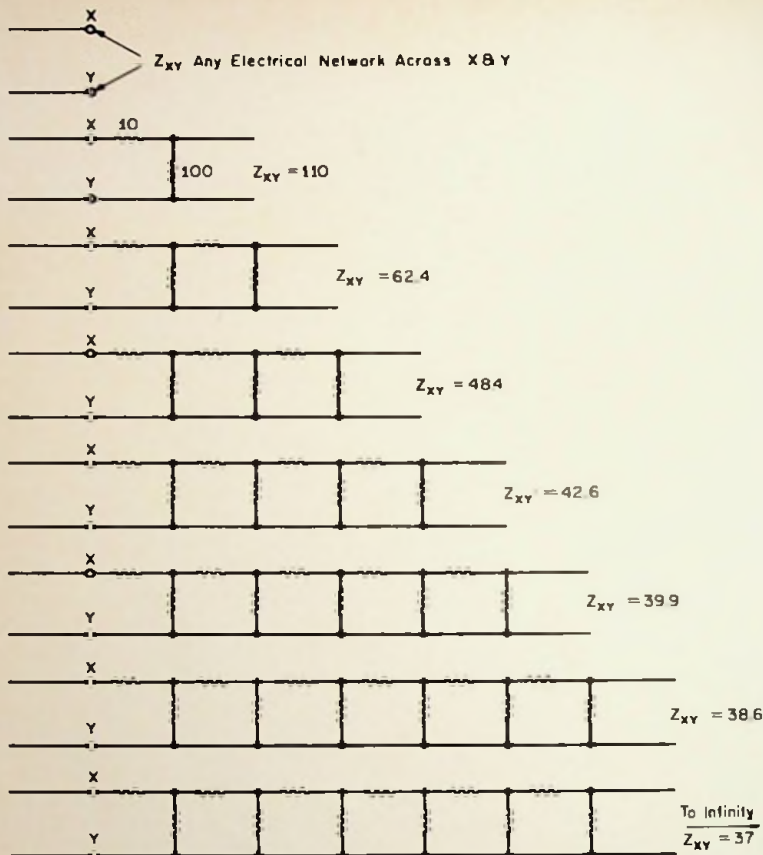

Fig. 1.5—Approaching an infinite line.

tions. From the above results, one can assert that *when a line is terminated in a resistance equal to its characteristic resistance, the line acts as if it were infinitely long.*

In the previous example, resistors were used for the sake of simplicity. However, the performance of a line having reactance is very similar, with inductance taking the place of the series resistors and capacitance taking the place of the shunt resistors. The values of characteristic impedance, of course, may be different from those given in the example. The characteristic impedance of lines used in actual practice generally lies between 50 and 600 ohms.

### Attenuation and Losses

A lossless transmission line would deliver the entire transmitter output to the antenna, or the entire received signal to the receiver. For this ideal case, no power is lost in the line. In practice, however, there are inevitable losses in a transmission line. The loss or attenuation of power may be due to three causes: radiation,

heating ( $I^2R$  loss), and dielectric losses. In the case of coaxial line there is no appreciable radiation even with a high standing-wave ratio (to be explained later) if the line is properly terminated, because the fields are confined within a shield.

In an open wire line, radiation losses are negligible if the load is balanced, the wires are the same size, and the line is properly installed. This results in equal and  $180^\circ$  out of phase currents in each wire of the transmission line. The spacing of the wires must be 0.01 wavelength or less (about 4 inches on 10 meters). The magnetic fields surrounding each wire are equal and out of phase, therefore canceling each other. If the currents are not balanced and are other than  $180^\circ$  out of phase the feedline will radiate—the amount depending on the current unbalance and/or the phase difference (other than  $180^\circ$ ). Heat losses in both conductors due to resistance and "skin effect" increase as the frequency is increased.

Conductor losses are greater in lines of lower characteristic impedance, because, for a given voltage at the input end, the current which flows is greater. A higher current means greater  $I^2R$  losses unless the conductors are increased in size proportionally. Dielectric losses and possible damage increase rapidly with high standing wave ratios (particularly in coax cable). The higher the characteristic impedance of the line, the greater will be the voltages and corresponding dielectric losses. The dielectric losses and possible damage in open-wire lines using poly rods for spacers is very low and isn't worth consideration. However, dielectric loss (that increases with frequency) is a major problem with 300 ohm ribbon and coaxial lines.

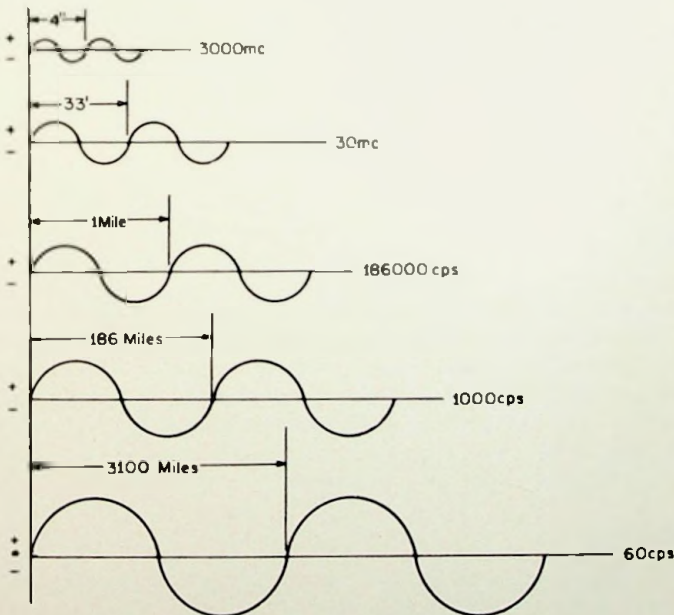

Fig. 1.6—Wavelengths at different frequencies.



## Wave Motion on Transmission Lines

Waves exist on a transmission line because a certain amount of time is required for electrons to transfer their energy along a wire. At radio frequencies, it is possible that a number of waves will appear on a transmission line of practical length as shown in Fig. 1.6. For example, at 30 mc the distance between positive voltage or current peaks on the line is about 33 feet. If a transmitter producing 3,000 mc r.f. energy is connected to the line, the distance between peaks will be 4 inches. In other words, the transmitter puts a positive voltage peak into the line, the peak moves along the line, and four inches behind it another positive peak is formed. The waves are not stationary, but they are actually moving along the line, much as water ripples move when a stone is dropped into a pool. In an infinitely long line, the points of maximum voltage and current appear at the same places on the line; the voltage and current are therefore in phase. But line losses cause power to be dissipated in the form of heat which results in the amplitude of waves becoming progressively smaller. If the line is infinite, the power is completely expended in the line.

## Reflection of Energy and Standing Waves

Up to this point, lines of infinite length have been described. Suppose that an infinite line is cut at some point. How will this affect the waves traveling down the line? The line which has been cut is called an open-circuited line because there is no load at its output end. In this type of line, the impedance at the output end can be considered to be practically infinite because there is no connected load. When energy is applied to the input end, the first wave (consisting of current and voltage in phase) travels along the line. As the first wave moves toward the output end, the characteristics that the line displays are the same as those of an infinite line. However, when the wave reaches the open-circuited end, the current must collapse to zero.

As the current wave collapses, the magnetic field associated with the current also collapses. In collapsing, the field cuts the conductors near the output end of the line and induces an additional voltage across the line. This voltage sets up new current and voltage waves which travel back on the line toward the input end. This is known as *reflection*, and the wave thus set into motion is the reflected wave. It will be shown that reflection may also be caused by certain types of loads on the line as well as by a short circuit.

Whenever both forward (incident) and reflected waves exist on a line, *standing waves are created*. Therefore, when the termination of the line causes reflection of energy, one can expect to find standing waves on the line. Typical standing voltage and current waves are shown in Fig. 1.7. The voltage standing wave looks just like the current standing wave but it is displaced by a quarter wavelength. This is the case on any line containing standing waves; that is, voltage loops occur at current nodes and vice versa.

## Line Impedance

The impedance of a line at any point is equal to the voltage divided by the current at the point ( $Z=E/I$ ). With d.c. or at audio frequencies, the ratio of

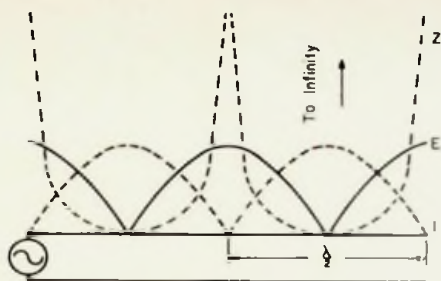

Fig. 1.7—Standing waves on an open-circuit line.

voltage to current is the same at all points on the line. The impedance is therefore constant at any point. This is also true of lines carrying r.f. energy which are terminated in their characteristic impedance,  $Z_0$ . However, if there are reflections on the line, the ratio of voltage to current varies along the line. This occurs because the voltage and current are not in phase. As will be shown, the impedance at one point on the line may be zero, while at another point the impedance may be infinite.

Furthermore, the impedance at any point on the line may be resistive, reactive, or resistive and reactive, depending on the nature of the reflection. If all the energy is reflected at the output end of the transmission line, and hence no power is absorbed by the load, the line impedance is *reactive* at every point. If some of the wave energy is absorbed by the load and the rest is reflected, then the impedance has a resistive as well as a reactive component. The impedance will be resistive at the voltage peaks and voltage nulls (high and low impedance, respectively).

### Velocity of Propagation

Radio frequency energy travels with the speed of light, approximately 186,000 miles per second. However, this is true only in free space. In a transmission line, factors in the construction of the line modify this velocity of propagation. The ratio of the speed of r.f. energy in a given line to the speed of r.f. energy in free space is known as the *velocity factor*. The symbol for the velocity factor is  $K$  (sometimes labelled  $Vel$ ). This factor is dependent on the characteristics of the dielectric material used for the spacing of the line and/or supporting insulators used in the construction of the line. Table 1.1 provides a tabulation of velocity factors for various types of lines.

If an electrical wavelength is measured on a transmission line, it will be different from a wavelength at the same frequency measured in free space. Because the frequency of r.f. energy remains constant whether the wave is traveling in free space or on a conductor, the wavelength must change when the velocity of propagation varies. The velocity factor of the specific transmission line shows the amount by which a wavelength measured on the line will be different from a wavelength at the same frequency measured in free space.

**Table 1.1 — VELOCITY FACTORS**

Type of Line	Velocity Factor, K
Two-wire open line (wire with air dielectric)	0.96—0.98
Parallel tubing (air dielectric)	0.95
Coaxial line (air dielectric)	0.85
Coaxial line (polythelene dielectric)	0.64—0.67
(polyfoam center dielectric)	0.75—0.86
Two-wire line (wire with plastic dielectric)	0.68—0.82
Twisted-pair line (rubber dielectric)	0.56—0.65

**Traveling Waves on an Infinite Line**

Let us examine what happens when a wave is moving down a transmission line. Several different situations will be considered, each being dependent on the condition at the output end of the line. The infinite line will be examined first.

When r.f. energy is sent along a transmission line that is infinitely long, the ratio of voltage to current at every point along the line is equal to the characteristic impedance. In practical lines, this impedance is purely resistive, i.e., the line acts as a simple resistor. The voltage and current decrease in amplitude as they travel down the line as shown in Fig. 1.8 because of losses previously mentioned. The voltage and current are equally attenuated as a result of these losses, and the waves are in phase. Therefore, their ratio and impedance remain constant throughout the length of the line.

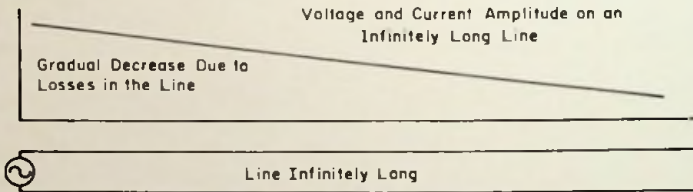

Fig. 1-8—Effect of line losses on voltage and current.

**Traveling Waves on a Properly Terminated Line**

A line that is terminated in an impedance or a resistance ( $R_L$ ) equal to the characteristic impedance ( $R_L = Z_0$ ) as shown in Fig. 1.9, behaves like an infinite line. That is, no reflections occur at the load end and the impedance is constant at every point along the line. Because there are no reflections, all the energy (except for line losses) is absorbed by the load. Hence a line terminated in a resistive load equal to  $Z_0$  provides maximum energy transfer.

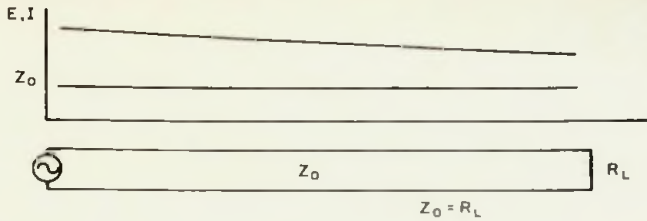

Fig. 1.9—Line terminated in its characteristic impedance.

### Standing Waves on a Shorted Line

A transmission line which is short-circuited at the output end ( $R_L = 0$ ) behaves quite differently. No voltage can exist across a perfect short circuit. In order to obtain zero voltage at the shorted end at all times, a reflected wave is initiated there, the magnitude of which is equal to the magnitude of the forward or incident wave but opposite phase. Hence, the forward and reflected waves cancel out at the shorted end and the net voltage (or standing wave voltage) is zero at this point.

Because both waves are traveling in opposite directions, the two voltages do not cancel out at every point on the line. At a point a quarter wavelength from the shorted end, for example, the two voltages are in phase with each other. In this case, the amplitude of the resultant standing wave is twice the amplitude of either incident or reflected wave alone.

Figure 1.10 shows the distribution of standing waves of voltage and current. At the short circuit, the voltage is zero. The voltage rises sinusoidally to a maximum a quarter wavelength from the short, drops to zero at the half wavelength point, and then repeats for each half wavelength of line. Because the incident and reflected waves (which are not shown) are equal in magnitude, the standing wave voltage goes from zero to a value of twice the amplitude of the original wave. A standing wave pattern of this type indicates that all of the energy traveling down the line is reflected by the load, i.e., the load does not absorb any of the energy.

The current  $I$ , at the short-circuit point is at a maximum value because the resistance of the short circuit is zero. Hence, the development of the current stand-

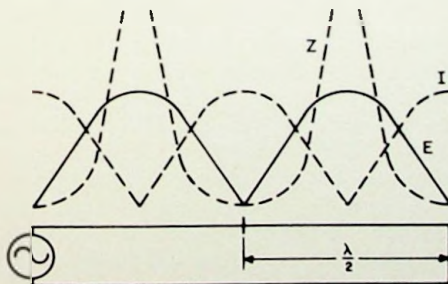

Fig. 1.10—Standing waves on a shorted line.

ing wave is different from that of the standing wave of voltage. In the case of current, the reflected wave is in phase and of equal magnitude with the incident wave at the point of short circuit. Therefore, the standing wave of current is at its maximum amplitude at the short circuit. A quarter wavelength away from the short circuit, the current waves are  $180^\circ$  out of phase and the value of the standing wave is zero. The standing wave of current, therefore, has the same form as the voltage standing wave, but is displaced by a quarter wavelength.

At the short circuit, where the voltage is zero and the current maximum, the impedance  $Z$ , is zero. As the ratio of voltage to current changes along the line, the impedance changes. As the voltage amplitude rises and current falls, the impedance rises. At a point a quarter wavelength from the short circuit, where the voltage is maximum and the current zero, the impedance is infinite. In the next quarter wavelength the impedance of the line drops from infinity to zero as the voltage current ratio is reversed. One can see that the impedance varies from point to point.

### **Standing Waves on an Open Line**

When a line is terminated in an open circuit, complete reflection of energy occurs and standing waves are developed just as in the case of the short-circuited line. However, the distribution of voltage and current for an open-circuited line is opposite to that for the short-circuit termination. At the open circuit, the voltage  $E$ , is at maximum amplitude and the current  $I$ , is zero (See Fig. 1.7). The voltage standing wave falls to zero a quarter wavelength away and rises to a maximum at the half wavelength point. The current standing wave is zero at the open end. It rises to a maximum at the quarter wavelength point, and it falls again to zero at the half wavelength point. The impedance  $Z$ , is infinite at the open circuit. It decreases to zero at the quarter wavelength point, and it increases to infinity again at the half wavelength point.

### **Standing Waves For Other Conditions**

The foregoing examples illustrate the production of traveling waves on a properly terminated line and the generation of standing waves on lines which represent the extreme departures from proper termination or matching. There are other instances, however, between the matched and completely mismatched conditions. In these cases, the load on the line is neither zero, infinite, nor equal to  $Z_0$ , which is typical in actual practice.

Figure 1.11a shows the standing wave pattern when the line is terminated in a pure resistance of a value less than  $Z_0$ . A comparison with Fig. 1.10 shows that the voltage loops and nulls are set up in the same manner as on a shorted line, but the maximum and minimum voltages are different. The voltage does not quite fall to zero nor does it rise to quite twice the amplitude of the incident wave. Figure 1.11b shows the distribution of standing waves when a transmission line is terminated in a pure resistance of a value greater than the characteristic impedance of the line. Comparing this with the representation of standing waves on the open line of Fig. 1.7 shows that the voltage loops and nulls are set up in the same manner as in an open line, but again the maximum and minimum voltages are different.

These conditions represent loads which are purely resistive. Antennas, however, which form the loads at the output ends of transmission lines are resistive

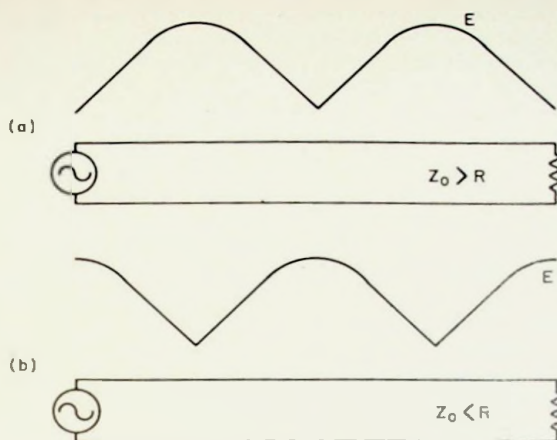

Fig. 1.11—Standing waves on a transmission line. (a)  $Z_0 > R$ ; (b)  $Z_0 < R$ .

only at the resonant frequency of the antenna. Above and below the resonant point, the feedpoint exhibits a reactive, as well as a resistive component. If a transmission line is terminated in a reactive load only, standing waves will still be present on the line because a reactive load absorbs no energy. Figure 1.12 shows these standing waves. If the line is terminated in a capacitance, as in Fig. 1.12a, the current standing wave leads the voltage standing wave as seen from the output end of the line. As the capacitive reactance increases (capacitance is reduced), the voltage loop approaches the output end of the line. Note that these curves are similar to those obtained on an open-circuit line, except that they do not start at the output end with the voltage maximum and the current zero.

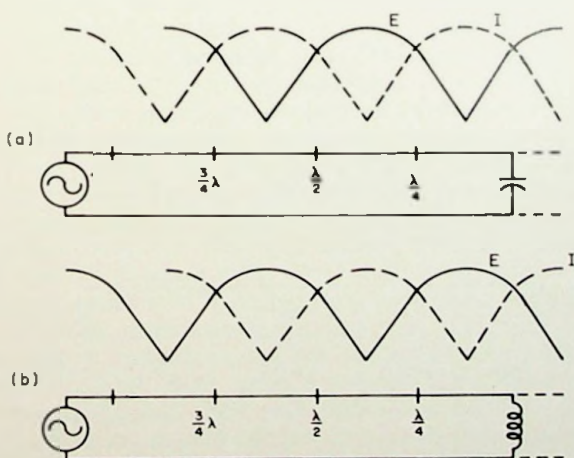

Fig. 1.12—Standing waves for pure reactive loads. (a) Capacitive; (b) Inductive.

If the line is terminated in an inductance, as in Fig. 1.12b, the voltage standing wave leads the current standing wave when viewed from the output end. In this case, the curves are similar to those on a shorted line, except that the current at the output end does not start at maximum, and the voltage does not start at zero. As the value of inductance is increased, the voltage loop occurs nearer to the output end of the line. Therefore, if capacitive or inductive reactance is present in the load, the standing wave pattern is shifted one way or the other along the length of the line.

In practice, it is common to find that loads present both reactive and resistive components to the line. The standing waves on the line, therefore, may be considered as being the sum of the standing waves resulting from reactance and resistance alone.

## STANDING WAVE RATIO (SWR)

The ratio of maximum voltage to minimum voltage along a line is called the *standing-wave ratio* (abbreviated *SWR*). The same ratio holds for maximum current and minimum current. This ratio is a measure of the amount of energy reflected or of the amount of mismatch between the load and the line. When the line is perfectly matched and all the energy is absorbed by the load, the maximum and the minimum values are the same. Because there is no reflection, the current and voltage do not vary along the line. In this case, the standing-wave ratio is equal to 1.0 (1 to 1).

Examine the condition indicated in Fig. 1.13. The  $Z_0$  of each transmission line is 300 ohms, while the load resistance used in (a) is 150 ohms and that used in (b) is 600 ohms. If the standing-wave current shown is measured on one line at points B and C and on the other at points B' and C', it will be found that the current at B and B' is twice that measured at C and C'. In this case, the SWR is 2 to 1. This is exactly the same relationship that exists between the characteristic impedance of the line and the resistance of the load.

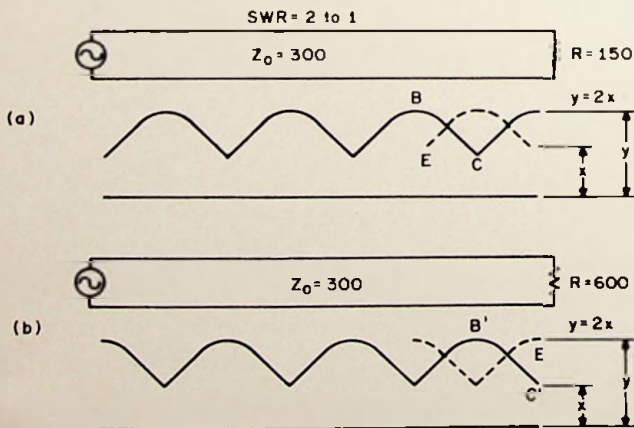

Fig. 1.13—Standing waves for SWR = 2:1. (a)  $R = 150$  ohms; (b)  $R = 600$  ohms.

## Effect of Various Standing Wave Ratios

In general, the higher the SWR, the greater the mismatch between the line and the load, and vice versa. A high SWR discloses that the power reflected in the line is high. In addition, a knowledge of the position of the loops and nodes along the line tells whether the load resistance is less than or greater than the characteristic impedance. For example, Fig. 1.13a shows that there is a voltage null (dashed line) at the load. The load resistance in this case is less than the characteristic impedance of the line and behaves like a short.

If a standing wave measuring device is available it is a simple matter to determine whether the load resistance is greater or smaller than  $Z_0$  and its approximate value. If the load resistance is greater than  $Z_0$ , the output end of the line will appear almost like an open circuit, and a measuring device will indicate maximum voltage or minimum current at the point. If the load resistance is smaller than  $Z_0$ , the output end of the line will behave almost like a short circuit, and measurements at that point will show minimum voltage or maximum current. Measurements of this type should be conducted at the resonant frequency of the antenna to insure a pure resistive load.

## RESONANT AND NONRESONANT LINES

A *nonresonant line* is a line which has no standing waves of current and voltage. Such a line is either infinitely long or terminated in its characteristic impedance. Because there are no reflections, all the energy traveling down the line is absorbed by the load. There are no standing waves present, and this type of line is sometimes spoken of as a *flat* line. The load impedance of such a line is equal to  $Z_0$  and no special tuning devices are generally required to effect maximum power transfer. The line is also called *untuned* because its length is not critical.

A *resonant line*, on the other hand, is a line which has standing waves of current and voltage. The line is generally of finite length and is *not* terminated in its characteristic impedance; hence, reflection of energy occurs. The load impedance is different from the characteristic impedance of the line. The input impedance may not be purely resistive as there may be reactive components present depending on the feedline length and/or the load impedance. To eliminate or tune out the reactance and to bring about maximum power transfer from the source to the line, antenna tuners are used. A resonant line is therefore sometimes called a *tuned* line. Another reason for the use of this term is that the line may be used as a resonant or tuned circuit.

Actually even a coax line with just a slight SWR is a form of a *tuned* or resonant line. If the SWR is not over, say 2 to 1, a 50 ohm pi network will still match the impedance presented to it and does not require an additional tuner. A higher SWR will in most cases require a tuner.

The losses due to standing waves are of concern only with solid dielectric coax and polyethylene twin lead. At high voltage points the dielectric losses are considerable and at the high current peaks the excess current can melt the dielectric allowing the conductor to shift. This will occur if the power level is excessive. In general, the power level used when a SWR exists should not allow the current value at the current loops to exceed the 1 to 1 SWR maximum current rating. If



the current rises to twice the maximum rating due to standing waves the power must be reduced to one fourth to prevent damage to the line. Open wire line can withstand substantial overload because it is air cooled. The dielectric loss with spacers every 2 or 3 feet or so is negligible.

There is a common misconception that reflected power is lost. If it were all lost there would be no measurable SWR at the input end. It merely alters the impedance at the end of the feedline from what it would be if matched. If the feedline losses are low such as in open wire lines, and the tuner is able to match the impedance presented to it at the input end of the feedline, maximum transfer of power occurs just as if a 1:1 SWR existed. Tuners of good design handle a wider range of resistive and/or reactive loads than do the conventional pi networks. By using a feedline that is a quarter or half wave multiple, a resistive load is presented to the tuner if the antenna is resonant.

### **General Applications**

A resonant line is sometimes said to be resonant at a particular frequency. This means that at *one* frequency the line behaves like a resonant circuit. It appears either as a high-resistive circuit (parallel resonant) or as a low-resistive circuit (series resonant). In order to act in this manner, the line is either open—or short-circuited at the output end and it is cut to some multiple of a quarter wavelength. If the length is not some multiple of a quarter wavelength, the short- or open-circuited line is not in resonance. It then behaves as a capacitor or as an inductor. A resonant transmission line, therefore, may assume the characteristics of a resonant circuit composed of lumped capacitance and inductance. If the antenna is resonant, a resonant line (odd or even multiple of a quarter wavelength) will present a resistive load to an antenna tuner.

Examination of Fig. 1.14 reveals the conditions for various lengths of open transmission lines. The impedance which the generator sees for various lengths of line is shown at the top. The curves above the letters of various heights indicate the relative values of the impedances presented to the generator for the various lengths. The circuit symbols indicate what the equivalent electrical circuits are for the transmission lines at each particular length. The standing waves of voltage and current are shown on each length of line.

### **Various Lengths of Open and Shorted Lines**

At all *odd* quarter-wave points ( $1\lambda/4$ ,  $3\lambda/4$ , etc.) measured from the output end of the *open line*, the current is maximum, the voltage is minimum, and the impedance is minimum. Thus, at all odd quarter-wave points, the open-end transmission line acts like a series resonant circuit. The impedance is a very low resistance, prevented only by small circuit losses from being zero.

At all even quarter-wave points ( $1\lambda/2$ ,  $\lambda$ ,  $3\lambda/2$ , etc.); the voltage is maximum, the current is minimum, and the impedance is maximum. Comparison of the transmission lines with an LC resonant circuit shows that at even quarter-wave lengths, an *open* line acts like a parallel resonant circuit; the impedance is very high.

In addition, resonant *open* lines may also act as nearly pure capacitances or inductances. Figure 1.14 shows that for less than a quarter wavelength long, an open line acts as a capacitance. Also, it acts as an inductance from  $1/4$  to  $1/2$  wavelength, as a capacitance from  $1/2$  to  $3/4$  wavelength, and as an inductance from  $3/4$

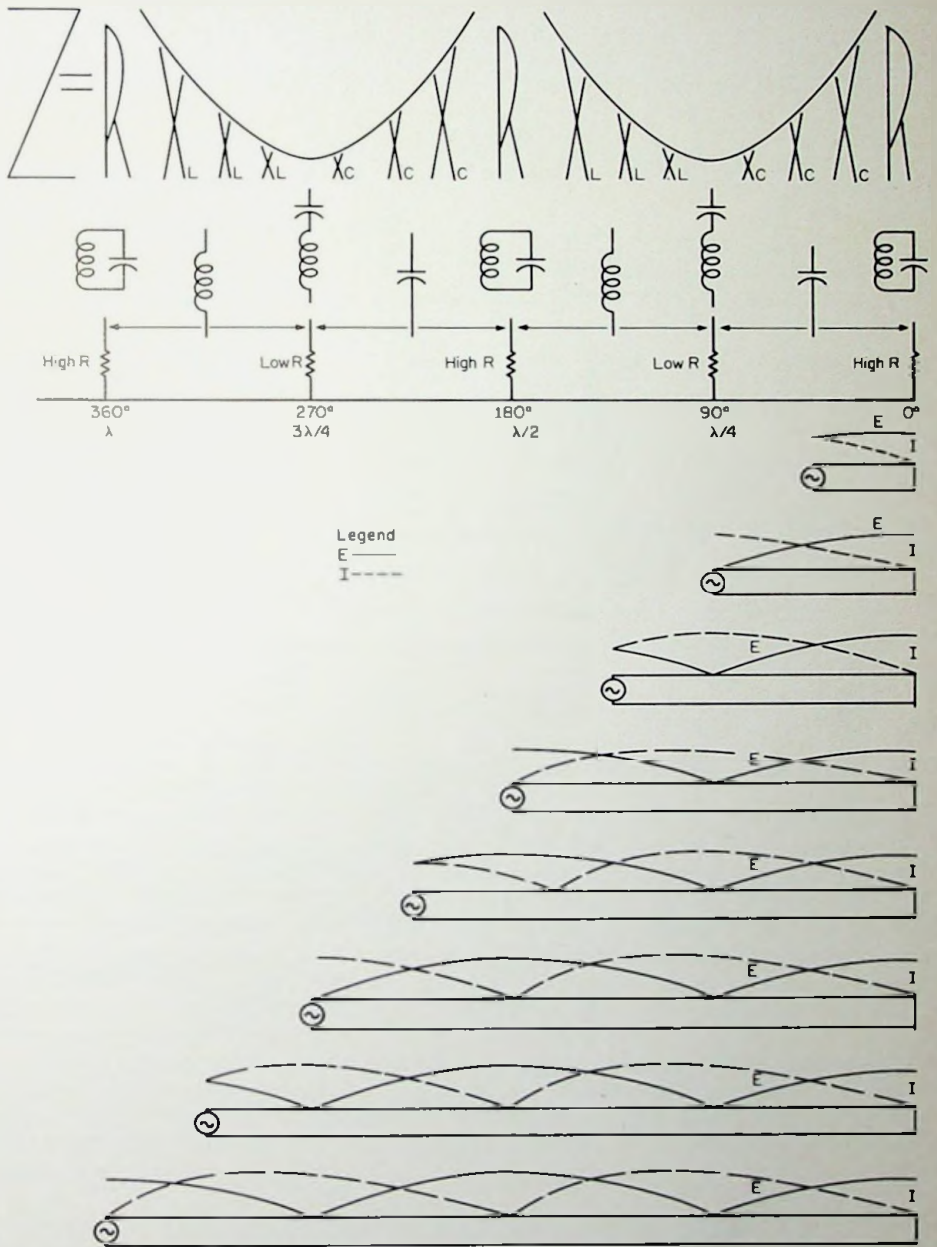

Fig. 1.14—Properties of an open line.

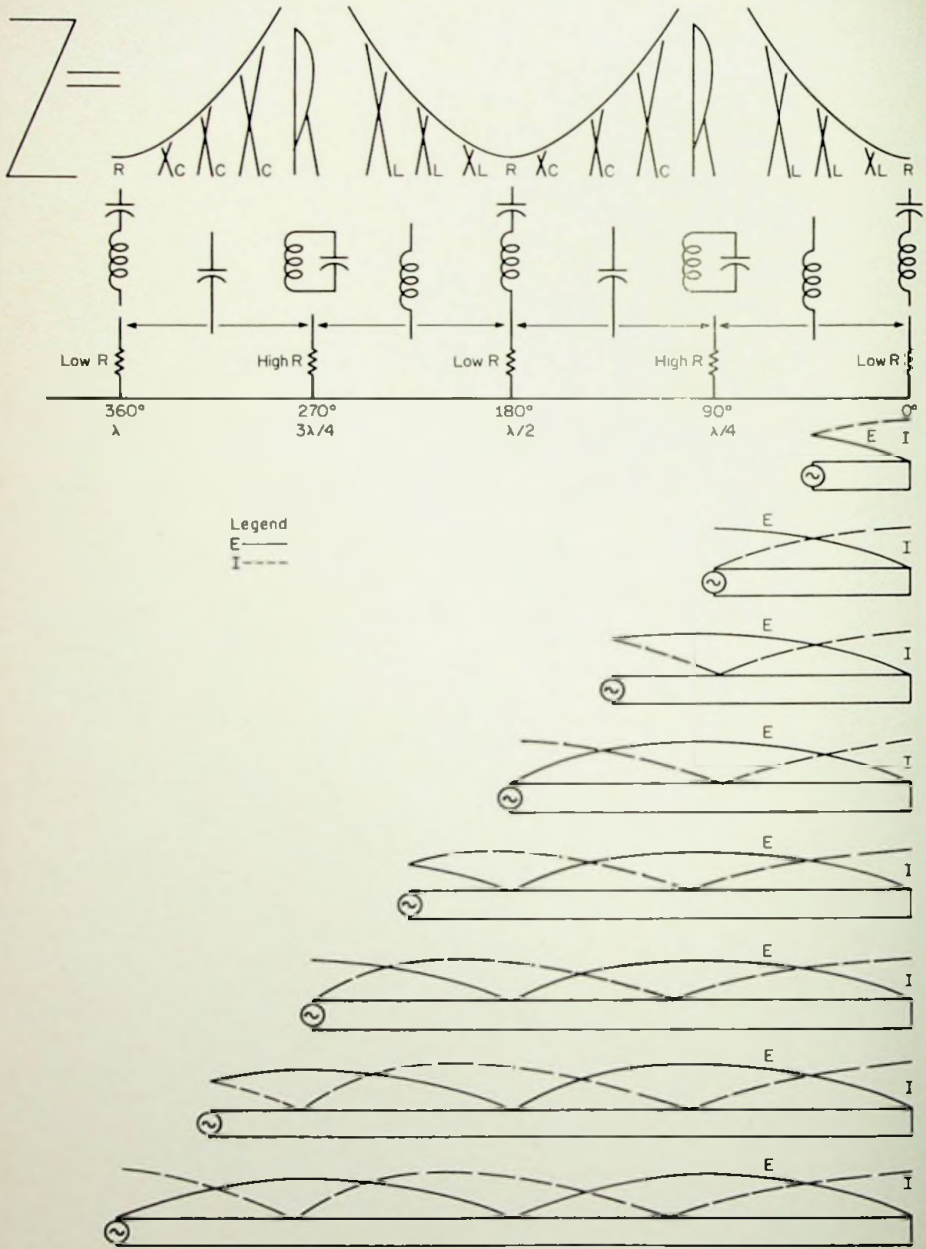

Fig. 1.15—Properties of a shorted line.

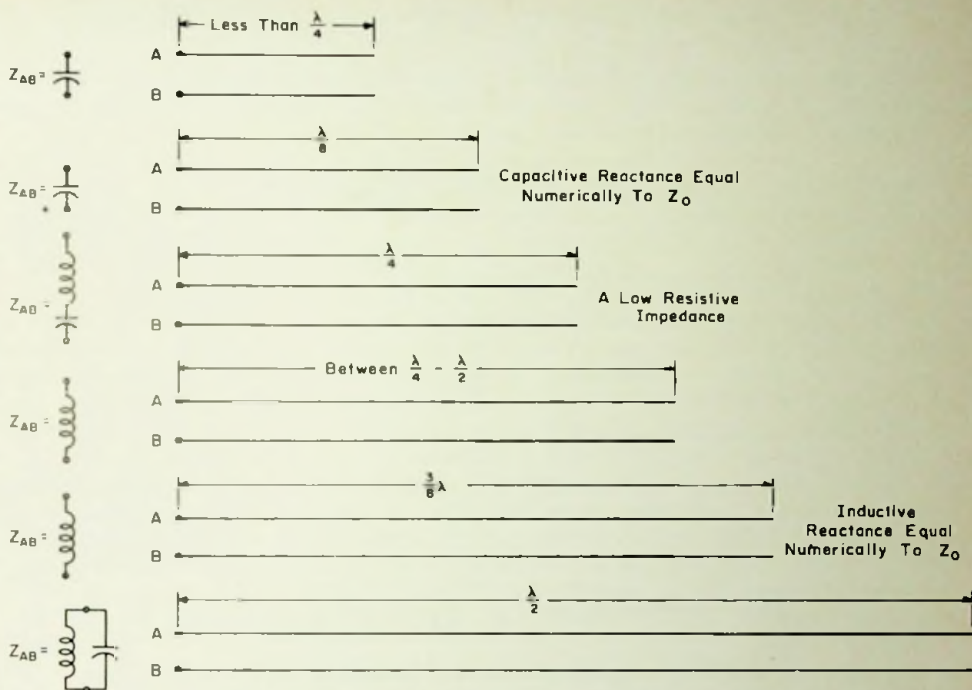

Fig. 1.16—Equivalent circuits for open lines.

to 1 wavelength, and so on. A number of open transmission lines with their equivalent circuits are given in Fig. 1.16.

The *shorted* line may be studied with the aid of Fig. 1.15. At *odd* quarter-wavelength points the voltage is high, the current low, and the impedance high. Because these conditions are similar to those found in a parallel resonant circuit, the *shorted* transmission line acts like a parallel resonant circuit at these lengths.

At the *even* quarter wave points, the voltage is minimum, the current is maximum, and the impedance is minimum. These characteristics are similar to those obtained by a series resonant *LC* circuit. Consequently, a shorted transmission line whose length is an even number of quarter wavelengths long acts like a series resonant circuit.

Resonant shorted lines, like the open-end lines, also may act as pure capacitances or inductances. Figure 1.15 illustrates a shorted line less than  $\frac{1}{4}$  wavelength long acting as an inductance. It behaves as a capacitance from  $\frac{1}{4}$  to  $\frac{1}{2}$  wavelength long, and so on. The equivalent circuits of shorted line of various lengths are summarized in Fig. 1.17.

### Summary of Characteristics of Properly Matched Line

1. The voltage and current are in phase throughout the line. The length is not critical.

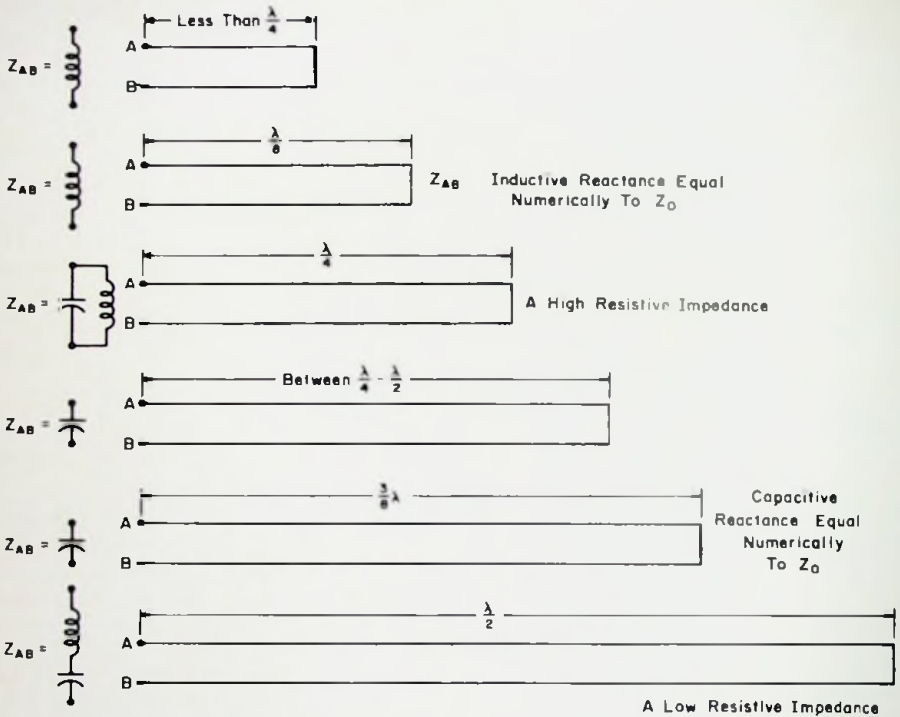

Fig. 1.17—Equivalent circuits for shorted lines.

2. The ratio of the voltage to the current is constant over the entire line. This ratio is known as the characteristic impedance ( $Z_0$ ).
3. The input impedance is equal to the characteristic impedance.
4. Because the voltage and current are in phase, the line operates with minimum loss and maximum power transfer is achieved.
5. The line behaves as though it were an infinite line and the SWR is unity (there are no standing waves).

### Summary of Characteristics of Unmatched Line

1. There are standing waves present on the line. Amplitude of the waves depends on the degree of mismatch.
2. The voltage and current of the standing waves are  $90^\circ$  out of phase with each other.
3. The ratio of voltage to current varies along the line causing the impedance to vary. Resistive points are found only at quarter wavelength multiples.
4. The input impedance is not equal to the characteristic impedance of the line.
5. Because reflections are present, the voltage and current peaks are much greater than if the line were flat.

## SINGLE WIRE AND TWO WIRE PARALLEL LINES

So far in this chapter a transmission line has been depicted as being made up of two parallel conductors. In practice, however, a transmission line may take a number of other forms. The type of line used depends upon the antenna, the frequency, and equipment requirements.

The simplest type of transmission line that can be utilized is the *single-wire* line such as used on the early Windom antenna. A half-wave dipole was fed at approximately 33% from one end with a single wire. The impedance at this point (about 280 ohms) matches the impedance of a single wire line. The disadvantage of this type of feed is that the feedline radiates even though the SWR may be low. This decreases the amount of energy supplied to the antenna. Additionally, the coupling system usually employed for this type of feedline does not lend itself to harmonic reduction.

The two-wire parallel line is relatively simple to construct and install. It provides a reasonably good balance and constant  $Z_0$ . This line consists of two parallel conductors which are maintained at a fixed distance from each other. To obtain good line balance, the spacing between conductors must be constant all along the line. This is usually accomplished by insulating spacers, or spreaders, at suitable intervals, as illustrated in Fig. 1.18a. In practice, such lines are generally spaced from 2 to 6 inches apart for radio frequencies below 15 mc. The spacing for 30 mc should be kept to a maximum of 4 inches. This kind of line is often called an open wire line. It is highly efficient and has many applications.

Another method of ensuring a uniform spacing is to embed the conductors in a low-loss dielectric, such as polyethylene, all along the length of the line. This type of line is often called a two-wire ribbon, as shown in Fig. 18b. It has the advantages of light weight, close and uniform spacing, flexibility, and neat appearance. However, the dielectric losses in such a line are higher than in the line that uses separating spacers with air as the principal dielectric. Hence, the ribbon type of line generally has a greater attenuation. When this dielectric becomes coated with moisture or dirt there is a change in the dielectric constant which determines the velocity of propagation. This in turn changes the charac-

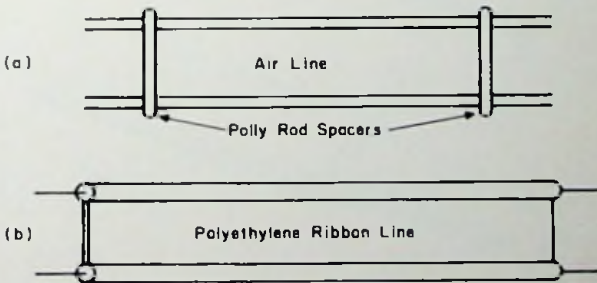

Fig. 1.18—Two wire transmission lines. (a) With spacers; (b) Ribbon.

teristic impedance of the line, resulting in an increase of the SWR if the line was previously matched. In addition there may be some losses due to minor eddy currents within the dirt layer. In salt water areas this can be a real problem. Tubular 300 ohm line has less losses because the polyethylene occupies the same general area of the field. Any surface coating on the line therefore has less effect on the field.

Seventy-five ohm ribbon is very closely spaced. The polyethylene surrounds the wire much in the same way as the polyethylene does in tubular 300 ohm line. Because of this, moisture has little effect on the impedance of 75 ohm ribbon. The impedance of the line is low, and additional dielectric of moisture, salt spray, dirt, etc., has less effect.

The principal disadvantage of parallel wire transmission lines is that if outside objects such as the mast, tower, and windows are placed too close it can affect its balance, disrupt the field, cause impedance "bumps," and hence increase its radiation losses. An unshielded line should not be run under a closed window because of the convenience, although it may appear to be operating properly. The abrupt change in the dielectric and/or field will introduce an impedance discontinuity or bump at that point and prevents a 1 to 1 SWR even though the line is matched. A balanced open line should be no closer to the tower or other objects than the spacing of the wire.

## COAXIAL (COAX) LINES

The coaxial line consists of a wire inside of, and coaxial with, a tubular conductor as illustrated in Fig. 1.19a. In some cases, the inner conductor is also tubular. The inner conductor is insulated from the outer conductor by insulating spacers or beads at regular intervals. The spacers are made of pyrex, polystyrene,

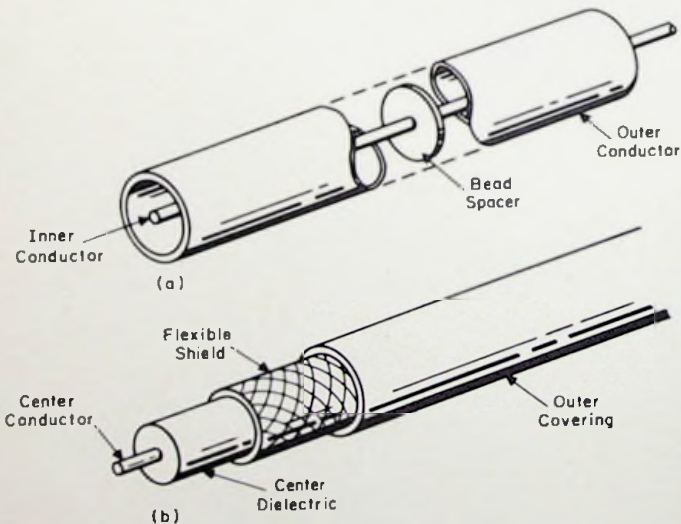

Fig. 1.19--Coaxial line construction. (a) Bead spacers; (b) Solid dielectric.

## Table 1.2: FLEXIBLE COAXIAL LINES

class of cables	Army-Navy type number	dielectric material	nominal diam of shield	inner conductor	shielding braid	protective covering	nominal over-all diam inches	weight lb/ft	nominal impedance ohms	nominal capacitance uuf/ft	maximum operating voltage rms	remarks
50-55 OHMS	Single braid	RG-8/U	A	0.285 copper	Copper	Vinyl	0.405	0.106	52.0	29.5	4,000	General-purpose medium-size flexible cable
		RG-10/U	A	0.285 copper	Copper	Vinyl (non-contaminating) Armor	(max) 0.475	0.146	52.0	29.5	4,000	Same as RG-8/U armored for naval equipment
		RG-17/U	A	0.680 copper	Copper	Vinyl (non-contaminating)	0.870	0.460	52.0	29.5	11,000	Large high power low-attenuation transmission cable
		RG-18/U	A	0.680 copper	Copper	Vinyl (non-contaminating) Armor	(max) 0.945	0.585	52.0	29.5	11,000	Same as RG-17/U armored for naval equipment
50-55 OHMS		RG-19/U	A	0.910 copper	Copper	Vinyl (non-contaminating)	1.120	0.740	52.0	29.5	14,000	Very large high-power low-attenuation transmission cable
		RG-20/U	A	0.910 copper	Copper	Vinyl (non-contaminating) Armor	(max) 1.195	0.925	52.0	29.5	14,000	Same as RG-19/U armored for naval equipment
		RG-58/U	A	0.116 copper	Tinned Copper	Vinyl	0.195	0.025	53.5	28.5	1,900	General-purpose small-size flexible cable
		RG-5/U	A	0.185 copper	Copper	Vinyl	0.332	0.087	52.5	28.5	3,000	Small microwave cable
55-60 OHMS		RG-9/U	A	0.280 silvered copper	Inner—Silver coated copper Outer—copper	Vinyl (non-contaminating)	0.420	0.150	51.0	30.0	4,000	Medium-size low-level-circuit cable
		RG-55/U	A	0.116 copper	Tinned copper	Polyethylene	(max) 0.206	0.034	53.5	28.5	1,900	Small-size flexible cable
		RG-54A/U	A	0.152 copper	Tinned copper	Polyethylene	0.250	0.0580	58.0	26.5	3,000	Small-size flexible cable with light-weight jacket
70-80 OHMS	Single braid	RG-59/U	A	0.146 copper/weld	Copper	Vinyl	0.242	0.032	73.0	21.0	2,300	General-purpose small-size video cable

\*Note on dielectric. A = stabilized polyethylene.



or some other material possessing good insulating qualities at high frequencies. This type of line is known as an air coaxial cable and is frequently used in high power commercial applications.

Coaxial cables are also made with the inner conductor of flexible wire insulated from the outer conductor by a solid and continuous insulating material. This type of line is called a solid coaxial cable (Fig. 1.19b). Flexibility of the cable may be gained if the outer conductor is made of metal braid. The losses in this type of coaxial line are greater than the former type. Its relative low cost makes it very popular for amateur use. A tabulation of characteristics of coax line is given in Table 1.2. (Other useful tables will be found at the end of this chapter.)

The chief value of the coaxial line is that it minimizes radiation losses providing it is properly terminated. In the two-wire parallel line, the electric and magnetic fields can extend out beyond the area of the wire. In coaxial construction, however, no electric or magnetic fields of any concern extend outside of the outer shield below 200 MC or so, and all fields being confined, exist within the space between the two conductors. The coaxial line is therefore a shielded line.

The advantage of an efficient properly terminated coaxial line is that it has practically no radiation loss. Consequently, near-by objects cause no difficulty in operation. Some of its disadvantages are: it is more expensive for a given length of line; its attenuation at extremely high frequencies limits its use except for short distances; it must be treated with special care to prevent water entry; and most coax has an effective life of only a couple of years.

### Shielded Pair Coaxial Line

The shielded pair consists of two parallel conductors separated from each other and surrounded by an insulating dielectric material. The conductors are contained within a copper braid tubing which acts as a shield. The advantages of the shielded pair are that the two conductors are balanced to ground and the wires are shielded against radiation. Type RG-22 is a typical balanced shielded pair coax line of 95 ohms impedance. Two RG-8 (52 ohms each) or RG-11 (72 ohms each) cables can be made into a shielded pair of twice the individual characteristic impedance (104 and 144 ohms), as shown in Fig. 1.20, by connecting the shields together at each end.

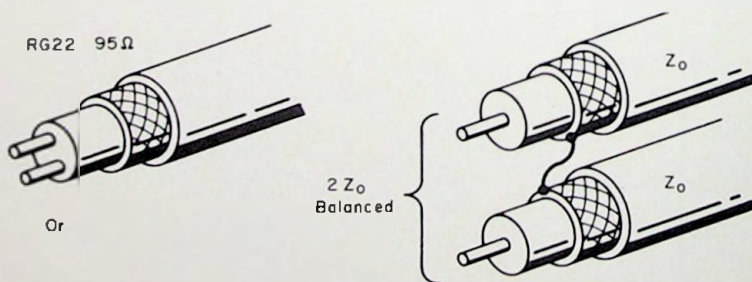

Fig. 1.20—Balanced coax line.

## Characteristic Impedance of Coaxial Line

The characteristic impedance of a coaxial line also varies with its construction. The following formula is used to determine the characteristic impedance of this type of line:

$$Z_0 = 138 \log_{10}(D/d) \quad (1.1)$$

where  $D$  is the inner diameter of the outer conductor and  $d$  is the outer diameter of the inner conductor.

This formula for coaxial lines is approximately correct for lines in which bead spacers are used provided the beads are not too closely spaced. When the line is filled with a solid dielectric, the characteristic impedance as given by (1.1) should be multiplied by  $1/\sqrt{k}$ , where  $k$  is the dielectric constant of the material. Note that when  $k$  is greater than 1, the characteristic impedance is reduced. The formula for coax lines with solid dielectric is therefore:

$$Z_0 = \frac{138}{\sqrt{k}} \log_{10}(D/d) \quad (1.2)$$

## CHARACTERISTIC IMPEDANCE OF PRACTICAL LINES

Basically, the characteristic impedance of a transmission line is equal to the square root of  $L/C$ . This implies that a transmission line having almost any desired characteristic impedance can be produced by a physical construction which gives the required values of  $L$  and  $C$ .

In a two-wire line, there are two factors which affect  $L$  and  $C$  and consequently determine  $Z_0$ . One is the spacing between the wires, and the second is the diameter of the wires. Increasing the spacing between the wires increases the inductance and decreases the capacitance. An increase in  $Z_0$  is therefore obtained by increasing the spacing. A reduction in the diameter of the wires also increases the characteristic impedance, because the capacitance between conductors is reduced. In effect, this is similar to decreasing the size of the plates of a capacitor.

Any change in the dielectric material between the two wires also changes the characteristic impedance. If a change in dielectric material increases the capacitance between the wires, the characteristic impedance is reduced. For example, a polyethylene insulated two-wire line has a lower  $Z_0$  than an air line with the same spacing and wire size, because polyethylene increases the line capacitance. Consequently, a practical polyethylene line has a  $Z_0$  of from 75 to 300 ohms while most practical air lines have characteristic impedances which vary from 400 to 600 ohms. The lower  $Z_0$  of the polyethylene line is also due to the closer spacing of wires that can be obtained in these lines.

The characteristic impedance of a two-wire line with air as the dielectric may be calculated from the equation:

$$Z_0 = 276 \log_{10}(2S/d) \quad (1.3)$$

where  $S$  is the spacing between the centers of the conductors and  $d$  is the diameter of the conductors.

Example 1.1

If two #12 wires are spaced 4 inches apart, what is  $Z_0$ ?

Solution:

$$Z_0 = 276 \log_{10}(2S/d)$$

The diameter of #12 wire is 0.0808 inches. Therefore,

$$Z_0 = 276 \log_{10}(8/0.0808) \\ = 276 \log_{10}99$$

From a table of logarithms,  $\log_{10}99 = 1.996$ . Hence,  $Z_0 = 276 \times 1.996 = 551$  ohms. For approximate calculations the graph of Fig. 1.21 will be of great aid in using various sizes of wires and tubing.

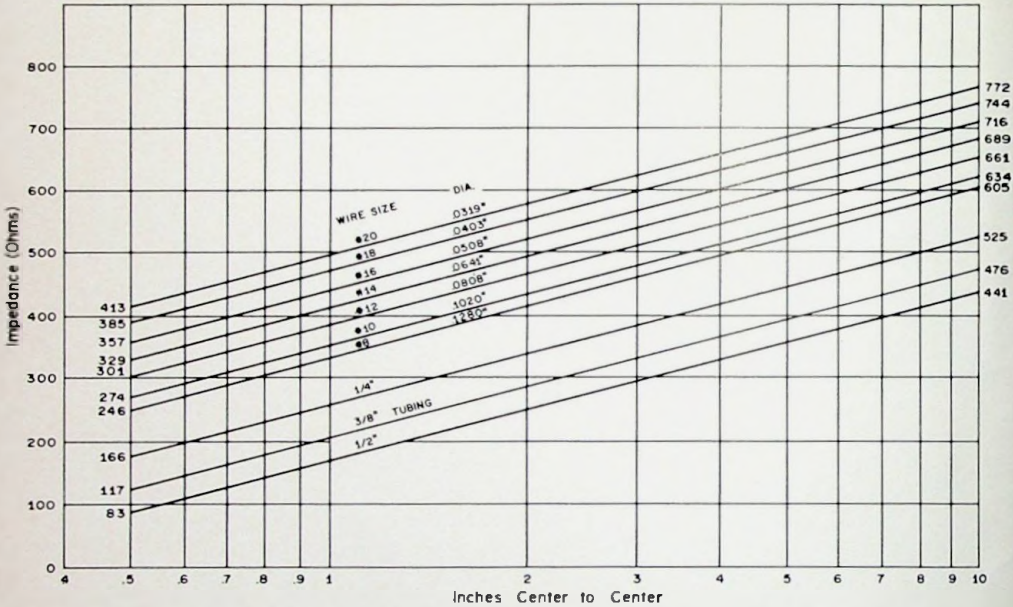

Fig. 1.21—Characteristic impedance of two wire open lines.

The open-wire line is very easy to construct and is economical. The spacers can be made of poly rods available at most parts supply houses. They are generally available in one foot lengths and can be cut to the desired size. For example, the one foot rod may be cut into three 4 inch lengths. From one quarter inch at each end a hole slightly larger than the wire that is to pass thru the hole is drilled. The two wires that will form the transmission line are stretched between two supports such as trees. The spacers (about one spacer for every 2 feet) are slipped on the two wires and the wires pulled tight. Now one or two at a time, the spacers are slipped in place. The spacers are tied in place with some waxed nylon cord or other cord that will not rot.

The top view of Fig. 1.22 illustrates a recommended construction that has proved successful using 1/4-inch poly rods. For tie points or points where some strain will be exerted, larger rods can be used. If a rod is accidentally broken, a soldering iron may be used to seal the wire to the rod for an emergency repair.

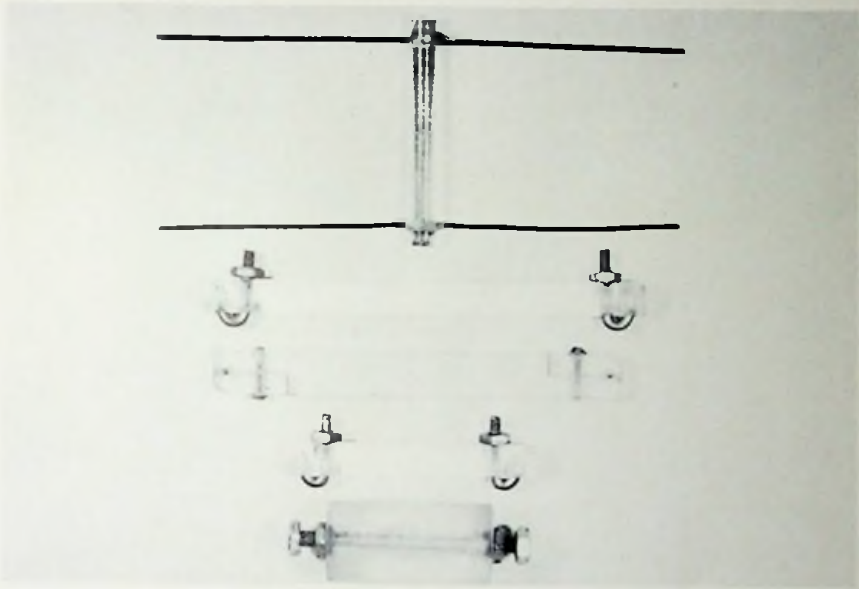

Fig. 1.22—Different types of spacers used for open wire line. Spacer on top is made from  $\frac{1}{4}$  inch poly rod with holes drilled in each end for wire. The spacer is held in place by waxed nylon cord. The middle three are commercial units. The bottom one is a feed-through insulator made from a length of 1 inch dia. poly rod cut and drilled down the center for a bolt. Always coat bolt and nuts with Penatrox, as plating will rust in time.

## OTHER APPLICATIONS OF TRANSMISSION LINES

Transmission lines have many important uses in addition to the transmission of power. These include: Metallic insulators; lightning protection and static drain; wave filters; reactors; impedance matching devices; phases shifter; decoupling stubs, and broad banding. A few of these applications will now be examined.

### Quarter Wave Line as a Metallic Insulator

When a quarter wave line is shorted at one end and excited at resonance at the open end by the correct frequency, standing waves of both current and voltage exist on the line. At the short circuit, the voltage is zero while the current is maximum. At the input end, the current is nearly zero and the voltage is a maximum. Therefore, the input impedance is quite high. An exceedingly high impedance across the terminals looks like an insulator to another line connected to the input end. Such a line may be used as an insulator at its two open terminals. Note that it will act as such an insulator only at the quarter wavelength resonant frequency and any odd multiple thereof.

Figure 1.23 shows a quarter wave section of line acting as a standoff insulator for a two wire transmission line. Naturally, for direct current, this section acts

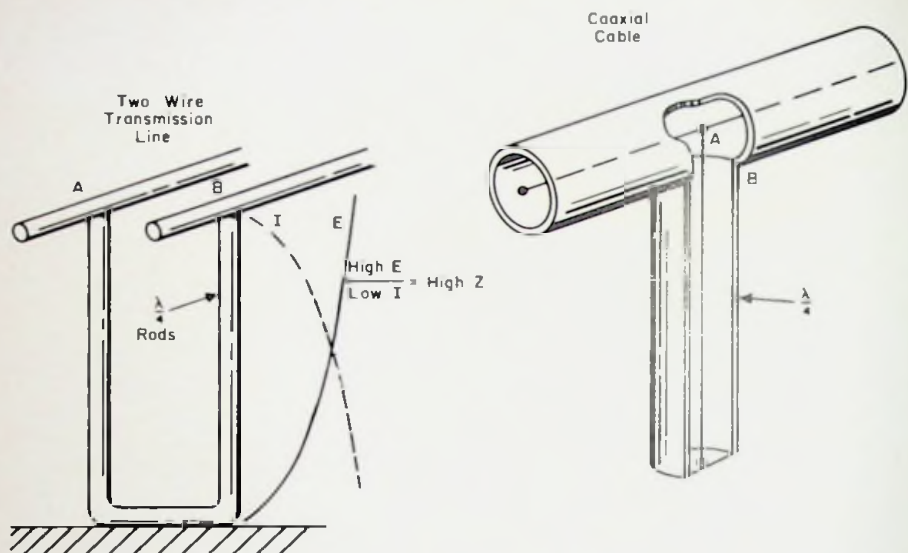

Fig. 1.23—Quarter-wave insulators.

as a short circuit across the line, but at the resonant frequency it acts as a highly efficient insulator. At terminals A and B there is a high voltage and a low current. Because  $Z = E/I$ , the impedance between A and B must be very high, just as though a conventional insulator were used. If the frequency of the signal transmitted down the line varies greatly, the section becomes a poor insulator across the line. There are relatively few amateur applications for a quarter wave stub used in this manner. The stub has wider applications when it is used in this manner for lightning protection. It also provides a discharge path for static electricity.

The same technique can be employed with coax lines. Because coaxial cable does not need insulation from surrounding objects it is only necessary to install a T connector to connect the quarter wave shorted coax stub to the line. This provides lightning protection and a static drain just as in the case of open wire line. It is particularly recommended for vertical antennas.

### Quarter Wave Line as a Filter

The characteristics of a shorted quarter wavelength line also permits its use as an efficient filter to suppress even harmonics. This has many applications where the second or any even harmonic is disturbing a commercial service, causing TVI, or interference to another amateur. It also has applications at field day sites where several transmitters may be operating in close proximity. It can be installed at the transmitter using a T connector.

### Transmission Line as a Reactance

In order to match a transmission line to an antenna, it is often necessary

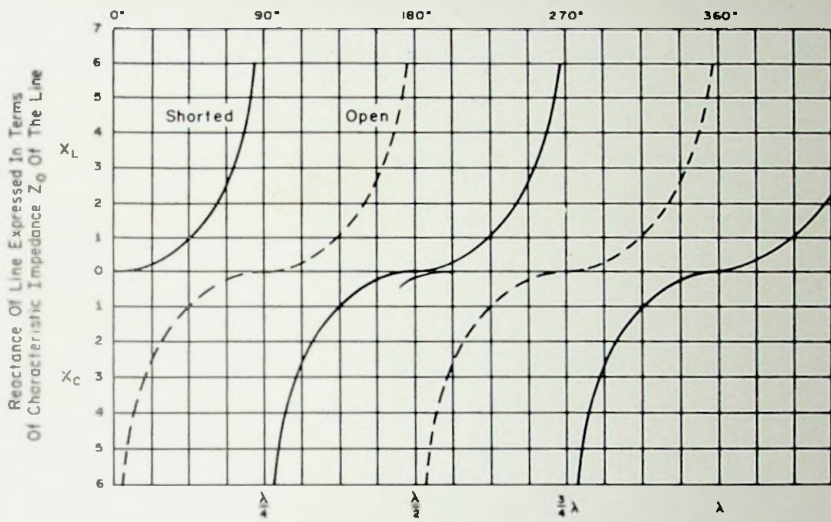

Fig. 1.24—Transmission line reactance.

to use either a reactive element, an impedance transformer, or both. These matching elements are frequently made up of sections of transmission line. For example, it is easy to obtain any desired inductive or capacitive reactance by the use of an appropriate length of opened or shorted transmission line.

Figure 1.24 shows the variation in reactance of open and short circuited lines as a function of the length of the lines in terms of wavelength. The reactance of the open circuit line in this graph is indicated by the dashed lines. The open line acts as a capacitive reactance at lengths shorter than a quarter wavelength. The graph shows a very high capacitive reactance for small lengths which decreases in value until the length reaches one quarter wavelength, at which point, the reactance is zero. When the line length becomes one eighth wavelength, it has a capacitive reactance equal in magnitude to  $Z_0$ . An open wire line less than a quarter wavelength long can be used as a capacitor. When the line is greater than a quarter wavelength, but less than one half wavelength, it acts as an inductive reactance.

A short circuited line behaves as an inductive reactance for lengths less than a quarter wavelength, as shown by the solid line. It starts at a very low value of reactance for small lengths and increases to a very high reactance as the line length approaches a quarter wavelength. Note that this line has an inductive reactance equal in value to  $Z_0$  for a one eighth wavelength line.

It is convenient to express the length of the line in terms of electrical degrees, rather than as eighth, quarter, or half wavelengths. One wavelength corresponds to 360°, and so on. Note that the graph also shows the length of the line in terms of electrical degrees.

## **Stub Matching**

It is possible to match a line to an antenna by first determining the point along the line where the resistive component is equal to  $Z_0$  and by then tuning out the reactance that exists at this point. The reactance can be tuned out by using a section of line, or stub, as it is called. If the line reactance is inductive, a capacitive stub must be used. If the line is capacitive, an inductive stub is used. Actually, most amateur antennas will have a resistive feed point, reactance canceling with a stub is rarely used. The extended double Zepp antenna is one exception.

**TABLE 1.3—POWER RATINGS OF COAXIAL CABLES**

RG/U CABLE	MAXIMUM INPUT POWER RATING—WATTS AT FREQUENCIES (MC):									
	1.0	1.0	50	100	200	400	1000	3000	5000	10,000
5, 5A, 5B, 6, 6A, 212	4,000	1,500	800	550	160	250	150	65	50	25
7	4,100	1,550	810	540	370	250	140	70	50	30
8, 8A, 10, 10A, 213, 215	11,000	3,500	1,500	975	585	450	230	115	70	—
9, 9A, 9B, 214	9,000	2,700	1,120	780	550	360	200	100	65	40
11, 11A, 12, 12A, 13, 13A, 216	8,000	2,500	1,000	690	490	340	200	100	60	—
14, 14A, 7A, 7AA, 217, 224	20,000	6,000	2,400	1,600	1,000	680	380	170	110	40
17, 17A, 18, 18A, 177, 218, 219	50,000	14,000	5,400	3,600	2,300	1,400	780	360	230	—
19, 19A, 20, 20A, 220, 221	110,000	28,000	10,500	6,800	4,200	2,600	1,300	620	410	—
21, 21A, 222	1,000	340	160	115	83	60	35	15	—	—
22, 22B, 111, 111A	7,000	1,700	650	430	290	190	110	50	—	—
29	3,500	1,150	510	340	230	150	95	50	35	—
34, 34A, 34B	19,000	7,200	2,700	1,650	1,100	700	390	140	80	—
35, 35A, 35B, 164	40,000	13,500	5,500	3,800	2,500	1,650	925	370	210	—
54, 54A	4,400	1,580	675	450	310	210	120	60	40	—
55, 55A, 55B, 223	10,000	1,700	700	480	320	215	120	60	40	—
57, 57A, 130, 131	10,000	3,000	1,250	830	570	370	205	95	—	—
58, 58B	3,500	1,000	450	300	200	135	80	40	20	—
58A, 58C	3,200	1,000	425	290	190	105	60	25	20	—
59, 59A, 59B	3,900	1,200	540	380	270	185	110	50	30	—
62, 62A, 71, 71A, 71B	4,500	1,400	630	440	320	230	140	65	40	15
62B	3,800	1,350	600	410	285	195	110	50	31	15
63, 63B, 79, 79B	8,200	3,000	1,300	1,000	685	455	270	130	75	35
67A, 116, 165, 166, 223, 227	42,000	15,000	6,250	4,300	3,000	2,050	1,200	620	480	250
94	62,000	15,500	5,900	4,300	2,900	1,900	1,400	650	480	200
94A, 226	64,000	18,000	9,600	6,800	4,600	3,300	1,750	775	540	250
108, 108A	1,300	360	145	100	70	45	30	15	5	—
114, 114A	5,300	1,350	475	345	230	150	85	40	25	15
115, 115A, 235	33,000	9,900	4,200	2,900	2,000	1,380	830	600	450	170
117, 118, 211, 228	200,000	66,000	25,000	19,000	12,800	8,500	4,800	2,200	1,400	490
119, 120	100,000	31,000	13,000	9,000	6,100	4,100	2,400	1,100	770	250
122	1,000	240	100	65	45	30	15	10	5	—
125	8,500	2,300	910	620	435	285	165	75	45	—
140, 141, 141A	19,000	6,300	2,700	1,700	1,200	830	450	220	140	65
142, 142A, 142B	19,000	5,700	2,600	1,800	1,300	900	530	265	175	100
143, 143A	26,000	8,700	3,750	2,600	1,800	1,250	750	390	275	160
144	51,000	17,000	7,500	5,400	3,700	2,500	1,400	700	440	20
149, 150	7,100	1,900	740	485	315	200	105	45	25	—
161, 174	1,000	350	150	110	80	60	35	15	10	—
176, 176A, 196	1,300	640	330	240	180	120	75	40	—	—
179, 179A, 187	3,000	1,400	750	480	420	320	190	100	73	—
180, 180A, 195	4,500	2,000	1,100	800	570	400	240	130	90	50
186, 186A	1,500	770	480	400	325	275	150	80	55	—
209	180,000	55,000	22,000	15,000	8,500	6,000	3,400	1,600	1,000	310
281	150,000	47,000	19,000	13,500	8,800	6,000	3,300	1,650	1,150	625







NOTE: Power Rating Conditions: Ambient Temperature 104° F. Center Conductor Temperature 175° F. with Polyethylene Dielectric. Center Conductor Temperature 400° F. with Teflon dielectric. Altitude-Sea Level.









**TABLE 1.4  
ATTENUATION RATINGS OF COAXIAL CABLES**

RG/U CABLE	NOMINAL ATTENUATION DB/100 FT. AT FREQUENCIES (MC):									
	1.0	10	50	100	200	400	1000	3000	5000	10,000
5, 5A, 5B, 6, 6A, 212	.26	.83	1.9	2.7	4.1	5.9	9.8	23.0	32.0	56.0
7	.18	.64	1.6	2.4	3.5	5.2	9.0	16.0	25.0	43.0
8, 8A, 10, 10A, 213, 215	.15	.55	1.3	1.9	2.7	4.1	8.0	16.0	27.0	>100.0
9, 9A, 9B, 214	.21	.66	1.5	2.3	3.3	5.0	8.8	18.0	27.0	45.0
11, 11A, 12, 12A, 13, 13A, 216	.19	.66	1.6	2.3	3.3	4.8	7.8	16.5	26.5	>100.0
14, 14A, 74, 74A, 217, 224	12	41	1.0	1.4	2.0	3.1	5.5	12.4	19.0	50.0
7, 17A, 18, 18A, 177, 218, 219	.06	.24	.62	.95	1.5	2.4	4.4	9.5	15.5	>100.0
19, 19A, 20, 20A, 220, 221	.04	.17	.45	.69	1.12	1.85	3.6	7.7	13.3	>100.0
21, 21A, 222	1.5	4.4	9.3	13.0	18.0	26.0	43.0	65.0	>100.0	>100.0
22, 22B, 111, 111A	.24	.80	2.0	3.0	4.5	6.8	12.0	25.0	>100.0	>100.0
29	.32	1.20	2.95	4.4	6.5	9.6	16.2	30.0	44.0	>100.0
34, 34A, 34B	.08	.32	.85	1.4	2.1	3.3	5.8	16.0	28.0	>100.0
35, 35A, 35B, 164	.08	.24	.58	.85	1.27	1.95	3.50	8.6	15.5	>100.0
54, 54A	.33	.92	2.15	3.2	4.7	6.8	13.0	25.0	37.0	>100.0
55, 55A, 55B, 223	.30	1.2	3.2	4.8	7.0	10.0	16.5	30.5	46.0	>100.0
57, 57A, 130, 131	.18	.65	1.6	2.4	3.5	5.4	9.8	21.0	>100.0	>100.0
58, 58B	.33	1.25	3.15	4.6	6.9	10.5	17.5	37.5	60.0	>100.0
58A, 58C	.44	1.4	3.3	4.9	7.4	12.0	24.0	54.0	83.0	>100.0
59, 59A, 59B	.33	1.1	2.1	3.4	4.9	7.0	12.0	26.5	42.0	>100.0
62, 62A, 71, 71A, 71B	.25	.85	1.9	2.7	3.8	5.3	8.7	18.5	30.0	83.0
62B	.31	.90	2.0	2.9	4.2	6.2	11.0	24.0	38.0	92.0
63, 63B, 79, 79B	.19	.52	1.1	1.5	2.3	3.4	5.8	12.0	20.5	44.0
87A, 116, 165, 166, 225, 227	.60	1.4	2.1	3.0	4.5	7.6	15.0	30.0	48.0	>100.0
94	.15	.60	1.6	2.2	3.3	5.0	7.0	16.0	25.0	60.0
94A, 226	.15	.55	1.2	1.7	2.5	3.5	6.6	15.0	23.0	50.0
108, 108A	.70	2.3	5.2	7.5	11.0	16.0	26.0	54.0	86.0	>100.0
114, 114A	.95	1.3	2.1	2.9	4.4	6.7	11.6	26.0	40.0	65.0
115, 115A, 235	.17	.60	1.4	2.0	2.9	4.2	7.0	13.0	20.0	33.0
117, 118, 211, 228	.09	.24	.60	.90	1.35	2.0	3.5	7.5	12.0	37.0
119, 120	1.2	.43	1.0	1.5	2.2	3.3	5.5	12.0	17.5	54.0
122	.40	1.7	4.5	7.0	11.0	16.5	29.0	57.0	87.0	>100.0
125	.17	.50	1.1	1.6	2.3	3.5	6.0	13.3	23.0	>100.0
140, 141, 141A	.30	.90	2.1	3.3	4.7	6.9	13.0	28.0	40.0	90.0
142, 142A, 142B	.34	1.1	2.7	3.9	5.6	8.0	13.5	27.0	39.0	70.0
143, 143A	.25	.85	1.9	2.8	4.0	5.8	9.5	18.0	25.5	52.0
144	.19	.60	1.3	1.8	2.6	3.9	7.0	14.0	22.0	50.0
149, 150	.24	.88	2.3	3.5	5.4	8.5	16.0	38.0	65.0	>100.0
161, 174	2.3	3.9	6.6	8.9	12.0	17.5	30.0	64.0	99.0	>100.0
178, 178A, 196	2.6	5.6	10.5	14.0	19.0	28.0	46.0	85.0	>100.0	>100.0
179, 179A, 187	2.4	5.3	8.5	10.0	12.5	16.0	24.0	44.0	64.0	>100.0
180, 180A, 195	2.4	3.3	4.6	5.7	7.6	10.8	17.0	35.0	50.0	88.0
186, 188A	3.1	6.0	9.6	11.4	14.2	16.7	31.0	60.0	92.0	>100.0
209	.08	.27	.68	1.0	1.6	2.5	4.4	9.5	15.0	48.0
281	.09	.32	.78	1.1	1.7	2.5	4.5	9.0	13.0	24.0

**TABLE 1.5—TWIN-LEAD TRANSMISSION LINES**

AMPHENOL Number	Imp.	Conductors	Description
214-080	75	7/28TC	 <p>8 Flat type for low impedance applications.</p>
214-023	75	7/21C	 <p>Oval Type, low impedance capable of handling 1 KW of RF power in amateur applications.</p>
214-079	150	7/28C	 <p>Flat Type for 150 ohm applications.</p>
214-022	300	16CW	 <p>Flat type with extra high tensile strength.</p>
214-056	300	7/28C	 <p>Flat Type, standard for TV and FM antenna lead-in.</p>
214-100	300	7/28C	 <p>Flat Type, heavy duty.</p>
214-185	300	7/26C	 <p>Oval Type, extra heavy duty.</p>

AMPHENOL Number	Imp.	Conductors	Description
214-318	300	7/28C	 <p>Flat Type, clear polyethylene for indoor applications.</p>
214-559	300	7/28CW	 <p>Flat Type, high tensile strength.</p>
214-076	300	7/26C	 <p>AIR CORE Tubular Twin-Lead, excellent in applications where moisture adversely affects flat twin-lead. Capable of handling 1 KW of RF power.</p>
214-271	300	7/28C	 <p>AIR CORE Tubular Twin-Lead, same as above except this is capable of handling 500 watts of RF power.</p>
214-103	300	7/28C	 <p>MARINE CORE Twin-Lead, outstanding for applications under adverse conditions such as moisture, salt spray and industrial contamination.</p>
214-298	—	7/28C	 <p>4-Conductor-Rotator Cable, 28 volt rating, one conductor tinned for identification.</p>

Courtesy Amphenol Cable Division  
Amphenol Corporation

**TABLE 1.6—TABLE OF STANDARD ANNEALED BARE COPPER WIRE USING AMERICAN WIRE GAUGE (B & S)**

Gauge (AWG) or (B & S)	DIA.	AREA	WEIGHT	LENGTH	RESISTANCE AT 68° F		
	Inches (Nom.)	Circular Mils	Pounds per M	Feet per Lb.	Ohms per M	Feet per Ohm	Ohms per Lb.
0000	4600	211600	640 5	1 561	04901	20400	00007652
000	4096	167800	507 9	1 968	06180	16180	0001217
00	3648	133100	402 8	2 482	07793	12830	0001935
0	3249	105500	319 5	3 130	09827	10180	0003076
1	2893	83690	253 3	3 947	1239	8070	0004891
2	2576	66370	200 9	4 977	1563	6400	0007778
3	2294	52640	159 3	6 276	1970	5075	001237
4	2043	41740	126 4	7 914	2485	4025	001966
	250	62500	189 1	5 286	1659	6025	000877
5	1819	33100	100 2	9 980	3133	3192	003127
6	1620	26250	79 46	12 58	3951	2531	004972
7	1443	20820	63 02	15 87	4982	2007	007905
8	1285	16510	49 98	20 01	6282	1592	01257
	188	35344	106 98	9 425	2934	3407	00276
8	1144	13090	39 63	25 23	7921	1262	01999
10	1019	10380	31 43	31 82	9989	1001	03178
11	09074	8234	24 92	40 12	1 260	794	05053
12	08081	6530	19 77	50 59	1 588	629 6	08035
13	07196	5178	15 68	63 80	2 003	499 3	1278
14	06408	4107	12 43	80 44	2 525	396 0	2032
15	05707	3257	9 858	101 4	3 184	314 0	3230
16	05082	2583	7 818	127 9	4 016	249 0	5136
17	04576	2048	6 200	161 3	5 064	197 5	8167
18	04030	1624	4 917	203 4	6 385	156 5	1 299
19	03589	1288	3 899	256 5	8 051	124 2	2 065
20	03196	1022	3 092	323 4	10 15	98 5	3 283
21	02846	810 1	2 452	407 8	12 80	78 11	5 221
22	02535	642 4	1 945	514 2	16 14	61 95	8 301
23	02257	509 5	1 542	648 4	20 36	49 13	13 20
24	02010	404 0	1 223	817 7	25 67	38 96	20 99
25	01790	320 4	9699	1031	32 37	30 90	33 37
26	01594	254 1	7692	1300	40 81	24 50	53 06
27	01420	201 5	6100	1639	51 47	19 43	84 37
28	01264	159 8	4837	2067	64 90	15 41	134 2
29	01126	126 7	3836	2607	81 83	12 22	213 3
30	01003	100 5	3042	3287	103 2	9 691	339 2
31	008928	79 7	2413	4145	130 1	7 685	539 3
32	007950	63 21	1913	5227	164 1	6 095	857 6
33	007080	50 13	1517	6591	206 9	4 833	1364
34	006305	39 75	1203	8310	260 9	3 833	2168
35	005615	31 52	09542	10480	329 0	3 040	3448
36	005000	25 00	07568	13210	414 8	2 411	5482
37	004453	19 83	06001	16660	523 1	1 912	8717
38	003965	15 72	04759	21010	659 6	1 516	13860
39	003531	12 47	03774	26500	831 8	1 202	22040
40	003145	9 888	02993	33410	1049	0 9534	35040
41	00280	7 8400	02373	42140	1323	7559	55750
42	00249	6 2001	01877	53270	1673	5977	89120
43	00222	4 9284	01492	67020	2104	4753	141000
44	00197	3 8809	01175	85100	2672	3743	227380
45	00176	3 0976	00938	106600	3348	2987	356890
46	00157	2 4649	00746	134040	4207	2377	563900

**TABLE 1.7**

A. W. GAUGE	O.D.	STRANDING
22	0.30	7/30
22	.030	27/36
21	.034	19/.0071
20	0.37	7/28
20	.035	10/30
18	.046	7/.0152
18	.048	7/26
17	.054	7/25
16	.060	7/25
16	.060	7/.020
16	.058	19/.0117
16	.058	26/30
15	.067	7/.022
14	.073	19/.0147
13	.085	7/21
12	.096	7/20
7	.162	7/.054

STANDARD WIRE STRANDINGS USED IN RG/U CABLES

# 2

## ANTENNA FUNDAMENTALS

A current flowing in a wire of finite length and alternating at a radio frequency rate produces electromagnetic fields. The fields separate themselves from the wire and radio waves are set free in space. The principles of electromagnetic energy radiation are based on the laws that a moving electric field creates a magnetic field and a moving magnetic field creates an electric field. The resultant is a combination of electric and magnetic fields which are perpendicular to each other. Although a conductor is always considered to be present when a moving electric or magnetic field is mentioned, the laws which govern these fields say nothing about a conductor. The laws are true, whether a conductor is present or not.

### FUNDAMENTAL CONCEPTS OF RADIATION

In Fig. 2.1 a piece of wire is cut in half and attached to the terminals of a high frequency a.c. generator. The frequency of the generator output is selected so that each half of the wire is one quarter wavelength of the generator frequency. The two quarter wavelength wires make up what is called a *half-wave dipole antenna*.

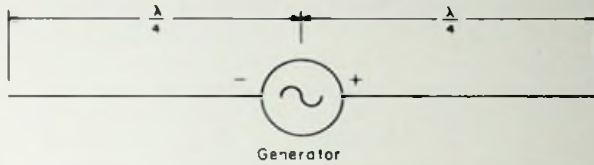

Fig. 2.1—A basic half wave dipole antenna connected to a sinusoidal source.

At a given instant, assume the right side of the generator is positive (+) and the left side negative (-). Because like charges repel each other, electrons will flow away from the negative terminal as far as possible, while the positive terminal will draw electrons to it. Figure 2.2 shows the direction and distribution of electron flow. The distribution curve (standing wave) indicates that the greatest current flows in the center and there is no current flowing at the ends of the wires.

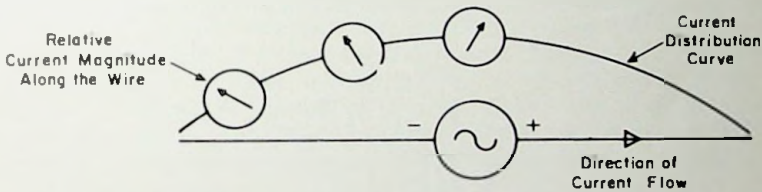

Fig. 2.2—Distribution of current in a half wave dipole antenna.

There is no place for electrons to go when they reach the end and the alternating current must be zero there. The current distribution over the antenna will always be the same no matter how much or how little current is flowing. The current amplitude, however, will vary directly with the developed voltage at a given point on the antenna. The output of the generator is a sine wave and the current amplitude will vary sinusoidally.

One quarter of a cycle after electrons have begun to flow (because of the presence of the generator), the generator will develop its maximum voltage and the current will decrease to zero. At that time, the condition illustrated in Fig. 2.3

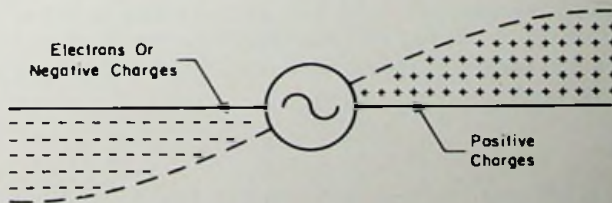

Fig. 2.3—Charge distribution in a half wave dipole antenna.

exists. No current is flowing, but there is a maximum number of electrons at the left end of the line and a minimum at the right end. The distribution of the charges (and consequently voltage) will be as shown with most of the charges at the ends trying to get as far away as possible from the generator terminals. As for the case of current distribution, the charge distribution along the wire will always be the same, although the magnitude of the charge at any given point on the antenna will vary as the generator voltage varies.

The above discussion may be summarized as follows:

1. A current flowing in the antenna varies sinusoidally in amplitude with the generator voltage. Its distribution must always be as shown in Fig. 2.2.
2. A sinusoidal distribution of charge, as shown in Fig. 2.3 exists on the antenna. Every half cycle the charges reverse position.
3. The sinusoidal variation in charge magnitude (voltage) lags the sinusoidal variation in current by one quarter cycle or  $90^\circ$ .

### Induction Field

Because of current flow in the antenna, a magnetic field  $H$  is established around and perpendicular to the antenna, as shown in Fig. 2.4. Positive and nega-

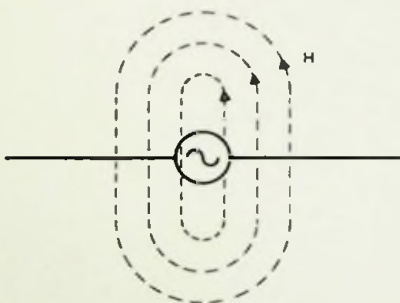

Fig. 2.4—Magnetic field  $H$ , surrounding antenna.

tive charges also appear on the antenna, causing an electric field  $E$  to be established. This field is represented by lines of force drawn between the positive and negative charges as illustrated in Fig. 2.5. The current and charges producing these fields are  $90^\circ$  out of phase. Consequently the two fields are also  $90^\circ$  out of phase. Despite the fact that the fields are perpendicular to each other, they do not constitute the radiated electromagnetic field. The present fields constitute an *induction field*, the energy of which cannot be separated from the antenna. Its amplitude varies inversely as the square of the distance from the antenna, and consequently its effect is localized.

### Radiated Field

Consideration will now be given to the electric field surrounding the antenna. The charges producing this field are constantly moving from one end of the antenna to the other as the polarity of the generator voltage reverses. At one

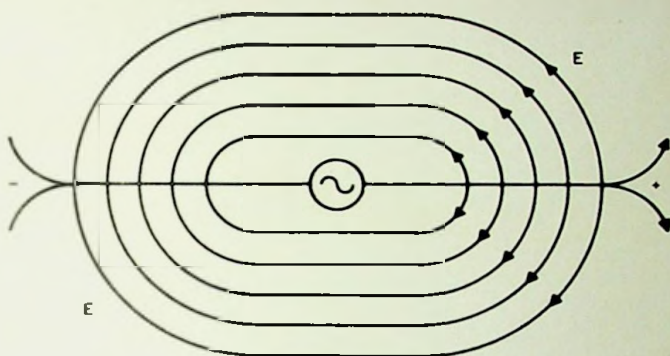

Fig. 2.5—Electric field  $E$ , between positive and negative charges.

instant, one end of the antenna is positive. An instant later, the antenna is uncharged. A negative charge appears next where the positive charge was, then the antenna is again uncharged and the whole cycle repeats itself.

In Fig. 2.6(a) flux lines are drawn between positive and negative charges. An instant later, Fig. 2.6(b) shows the antenna as being nearly discharged as the charges approach each other and bring together the two ends of the flux lines associated with them. When the charges do touch, they seem to disappear and their flux lines should disappear, too. Some flux is repelled by other lines nearer the antenna and the repelled lines are left with their heads touching their tails. A

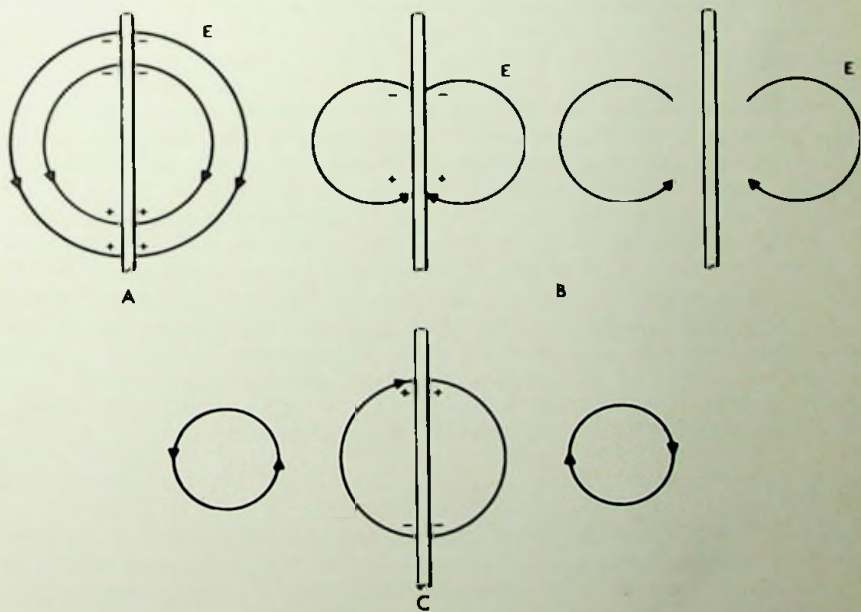

Fig. 2.6—Formation of the radiated field. (a) Electric flux lines between positive and negative charges; (b) Antenna nearly discharged; (c) Repelling lines of force produced.



closed electric field is created without an associated electric charge.

An instant after the independent electric field has been formed, the antenna charges again in the opposite direction. Lines of force are produced which repel the recently formed independent electric fields. Figure 2.6(c) shows that the repelling field is of the proper polarity to do this. The radiated field is forced away from the antenna at the speed of light and we have radiation (radio waves)!

In considering the electric field, the magnetic field produced by the antenna current was ignored as a factor in the generation of radiated fields. By similar reasoning, magnetic lines of force are also detached from the antenna. The electromagnetic radiated wave from the antenna is made up of two components: The electric generated field and the magnetic generated field. The two fields are identical in composition, but occur  $90^\circ$  out of phase in time. It can be shown that these fields will add and give a single sinusoidally varying radiated field. When the electric field is perpendicular to the ground, the wave is said to be *vertically* polarized; if the electric field is parallel to the ground, we have a *horizontally* polarized wave.

### **Reception**

If a radiated electromagnetic field is intercepted by a conductor, some of the energy in the field will set electrons in motion along the conductor. This electron flow constitutes a current that varies in accordance with the variations of the field. Hence, a variation of current in a radiating antenna causes a similar varying current in a conductor at a distant location. Any intelligence produced as current in a transmitting antenna will be reproduced as current in a receiving antenna. The characteristics of receiving and transmitting antennas are quite similar. A good transmitting antenna is also a good receiving antenna.

### **Reciprocity**

The various properties of an antenna apply both to transmitting and receiving. The more efficient the antenna is for transmitting, the more effective it will be for receiving. Directive properties will be the same for both transmission and reception, and in the case of directive systems, the gain will be the same on both transmitted and received signals. Current distribution and impedance will likewise be identical whether the energy is fed directly to a half wave antenna from the transmitter or whether it is picked up from passing waves of the same frequency.

In long distance transmissions the observed behavior may sometimes be at variance with this rule because the waves may not take exactly the same paths through the ionosphere when going in opposite directions. Therefore an incoming wave may not arrive at the antenna from the same angle as that wave which is transmitted from it. Thus, the two waves may be utilizing different parts of the directive pattern with some departure from complete reciprocity.

### **Gain**

The effective power gain or directive gain of an antenna is the ratio between the power required in the specified antenna and the power required in a reference antenna (usually a half wave) to obtain the same field strength in the favored direction of the antenna under measurement. Directive gain may be expressed either as an actual power ratio, or as more common, the power ratio may be

expressed in decibels (db). The reference dipole must be erected at the same height and with the same type of polarization as the antenna under consideration.

## RADIATION RESISTANCE

The amount of energy radiated from or induced in an antenna can be directly related to a factor called *radiation resistance*. This is a fictitious resistance which, when substituted for the antenna, will consume the same amount of power that is actually radiated.

The r.f. current flowing in an antenna is made up of two components. One component  $I_1$ , is determined by the free space\* radiation resistance and the power supplied by the transmitter. The second component  $I_2$ , is produced by radio waves which have a high vertical radiation angle. After the waves are directed downward from the antenna they are reflected upward from the earth. Upon passing back across the antenna, the reflected waves induce current  $I_2$ , in the antenna. The phase and strength of the induced current depend on the height of the antenna above ground or reflecting surface, and how lossy the reflecting medium was to the radio wave.

Although the induced current in the antenna is small (particularly in beam antennas) compared to that supplied by the transmitter, it cannot be neglected. At some antenna heights, the two currents are in phase and they combine to produce a resultant current which is greater than what is expected from the free space radiation resistance. The radiation resistance therefore will be lower. At other heights, the two currents are out of phase so that the resultant current is reduced and the radiation resistance is higher. If the antenna is at an electrical height which is a multiple of a quarter wavelength, the reflected component is neither in nor out of phase with antenna current  $I_1$ . Under this condition, no change of current or radiation resistance occurs from the free-space value. The graph of Fig. 2.7 shows that the radiation resistance is 72 ohms (for a half-wave dipole) at antenna heights that are one quarter wave multiples. Thus it can be seen that the current flowing in an antenna can be changed by varying the antenna height above ground.

Radiation resistance is expressed as:

$$R_r = P/I^2 \quad (2.1)$$

where  $P$  = power in watts;  $I$  = current in amps; and  $R_r$  = radiation resistance, in ohms. If the antenna current is varied by changing the antenna height, while maintaining the power input constant, it is equivalent to changing the radiation resistance of the antenna (see Eq. 2.1).

When a dipole is installed over an actual ground, the variations in radiation resistance will not be as great as indicated by the graph of Fig. 2.7.

Practical grounds are lossy and the amplitude of the reflected components is reduced. There will also be some additional phase shift (other than the 180° phase shift suffered at the ground reflection for horizontally polarized waves) which average about 6°. This will alter measured impedances slightly. Loss and additional phase shift are maximum at high angles for horizontal polarization.

---

\*Free space implies no objects are close to the antenna.

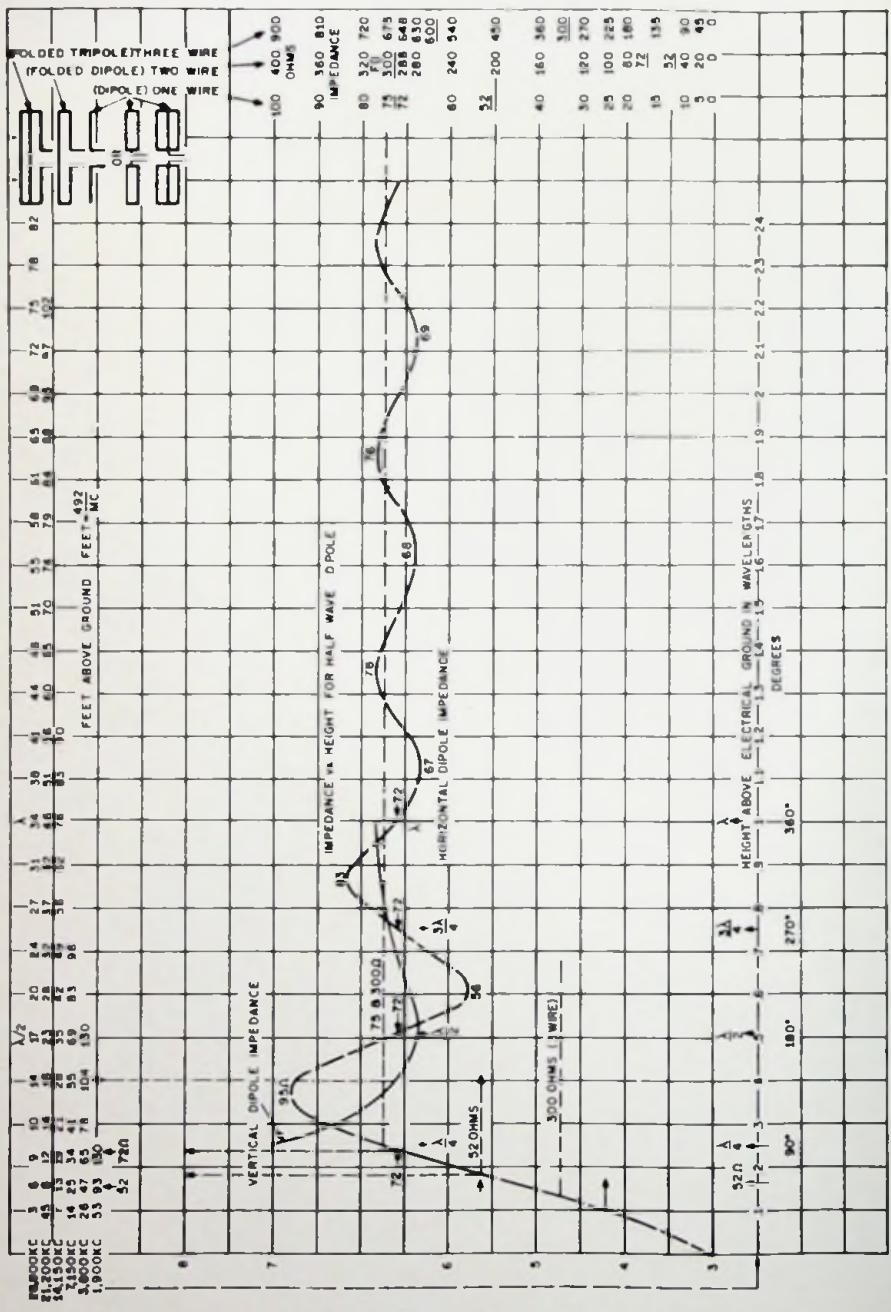

Fig. 2.7.—Graph of impedance vs height for horizontal and vertical dipole antennas.

The effect of a perfect ground can be simulated by installing a radial system consisting of a metal screen or mesh of wires (of the same polarization) near or on the surface of the ground, under the antenna. This effectively establishes the electrical height of the antenna and eliminates the loss of the reflected component  $I/2$  when the reflecting medium is a lossy ground. In actual practice, the curve of Fig. 2.7 has checked out very close with measured values of impedance over the ground. Electrical ground usually averages from 1 to 5 feet below the physical ground.

## GENERAL DISCUSSION OF HALF WAVE DIPOLES

The graph of Fig. 2.7 forms the basis for this discussion. When talking about antenna heights, electric ground will be assumed. On top of the graph of Fig. 2.7, the heights above electrical ground in feet are given for various frequencies. The figures below the graph are in terms of wavelengths. The important 52 and 72 ohm heights are shown for the popular amateur frequencies. Without a radial system, the depth of the electrical ground below physical ground will vary with frequency and condition of ground. This effect will be neglected in the ensuing discussion.

Consider first a half wave dipole starting at a height of 26 feet above electrical ground. Assume it is resonant at 3,800 kc. It is desired to know the impedance of the dipole. Referring to the heights on top of the graph, 26 feet is located on the line to the right of 3,800 kc. This corresponds to a height of 0.1 wavelength. From this point, a perpendicular line is dropped down to the Impedance vs Height for Half Wave Dipole curve. From the point of intersection with the curve, a straight line is extended to the far right where the impedance values for a dipole, folded dipole, and a folded tripole are tabulated. The impedance will be 25 ohms for a dipole, 100 ohms for a folded dipole, and 225 ohms for a folded tripole. These results are summarized in Fig. 2.8.

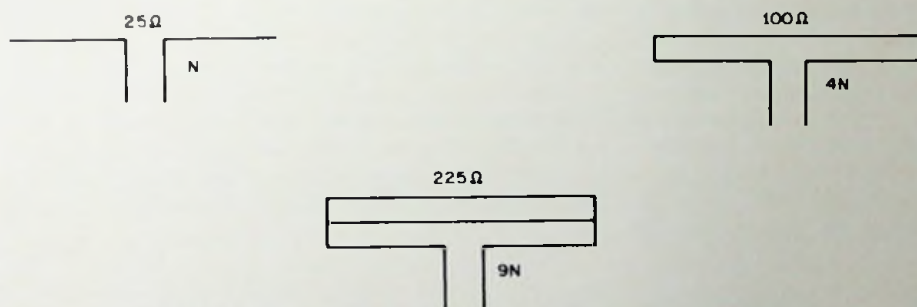

Fig. 2.8—Impedance values of dipole type antennas resonant at 3.8 mc and 26 ft. above ground.

A little higher on the curve at 0.13 wavelength (34 feet), it is seen that a folded tripole has an impedance of 300 ohms—a perfect match for 300 ohms line. The three-wire tripole is extremely broad. It has a low  $I^2R$  feedline loss because the impedance of the line is high. This results in low feedline currents.

These antennas are often fed with 600 ohms line as recommended in many of the handbooks. However, at a height of 34 feet, a 2 to 1 mismatch results (but not at all serious with an open wire line and a tuner). A little higher on the curve at 0.18 wavelength, it is seen that a three-wire tripole is a perfect match for 450 ohm line. This is commercially available in open wire feedline for a few cents per foot. This type of feedline is ideal for long feed lengths up to 300 to 400 feet. Its losses are very low, particularly at the lower frequencies.

A little higher on the curve the 52 ohm impedance point for a horizontal dipole occurs. Following the dashed line upward, the value of dipole impedance (52 ohms) first occurs at 93, 47, 25, 13, 8 and 6 feet on 1,900, 3,800, 7,150, 14,150, 21,200, and 28,800 kc, respectively. The 47 foot height has checked out quite well on several antennas tested on 75 meters.

Now consider the 72 ohm feed point. This value of impedance occurs at heights of 130, 65, 34, 19, 12, and 9 feet on the above frequencies. The 72 ohm point occurs at a quarter wavelength in height. So for a perfect match to a dipole resonant at 3,800 kc with 72 ohm transmission line, the height above electrical ground should be 65 feet (perhaps 60 feet above the physical ground).

Just a little higher on the curve the 75 ohm point for a dipole, which is also the 300 ohm point for a folded dipole, is found on the curve. By following the dashed line across the graph, a dipole or a folded dipole at any of the heights where the dashed line crosses the curve, will have an impedance of 75 or 300 ohms.

At a high point on the curve (0.6 wavelength above ground) the impedance of a dipole will be 95 ohms. In practice it will be a few ohms less due to ground losses. A folded dipole at this height will have an impedance of 380 ohms.

Continuing on the curve, at one half wavelength, the impedance is again 72 ohms—occurring now for the dipole whose height above ground is 130 feet for 3,800 kc. Farther along the curve at 0.6 wavelength, the impedance drops as low as 56 ohms. A folded dipole at a height of 83 feet on 3,800 kc or 42 feet on 7,150 kc will have an impedance of 244 ohms.

A dipole has an impedance of 72 ohms, a folded dipole 288 ohms, at multiples of standardize  $\lambda/4$  above electrical ground. From the graph it is possible to determine the impedance of a horizontal dipole, folded dipole, or a folded tripole at any given height. The impedances for a vertical dipole, folded dipole and folded tripole are determined in the same manner from its respective curve.

With an antennascope (described in the volume on Test Equipment) and half wave pieces of feedline cut for the different bands, the impedance of various dipoles can be measured. After comparing the measured and calculated values on several antennas, one is able to estimate very accurately the effect of surrounding objects on future antennas.

## **DETERMINING THE ELECTRICAL GROUND**

The Impedance vs Height curve may be used to estimate fairly close the depth of the electrical ground at the lower frequencies. For example, if a dipole is resonant at 3,800 kc and is 60 feet high and the measured impedance is 72 ohms, the procedure is as follows: From the graph it is seen that a 75 meter dipole resonant at 3,800 kc should be 65 feet high for an impedance of 72 ohms. Therefore, the electrical ground in this case is 5 feet below the physical ground.

Nearby objects underneath affect the measurement and it may be found that the *effective* or *apparent* electrical ground is one foot above physical ground. These objects in this case had sufficient effect on the antenna to cause this. If these objects are metal, the wave will then reflect off them and the antenna sees this as part of the electrical ground. A radial system underneath the antenna will represent the electrical and physical ground.

The impedances for center fed dipoles of lengths other than a half wave length are given in Fig. 2.9. This graph is useful for determining the expected

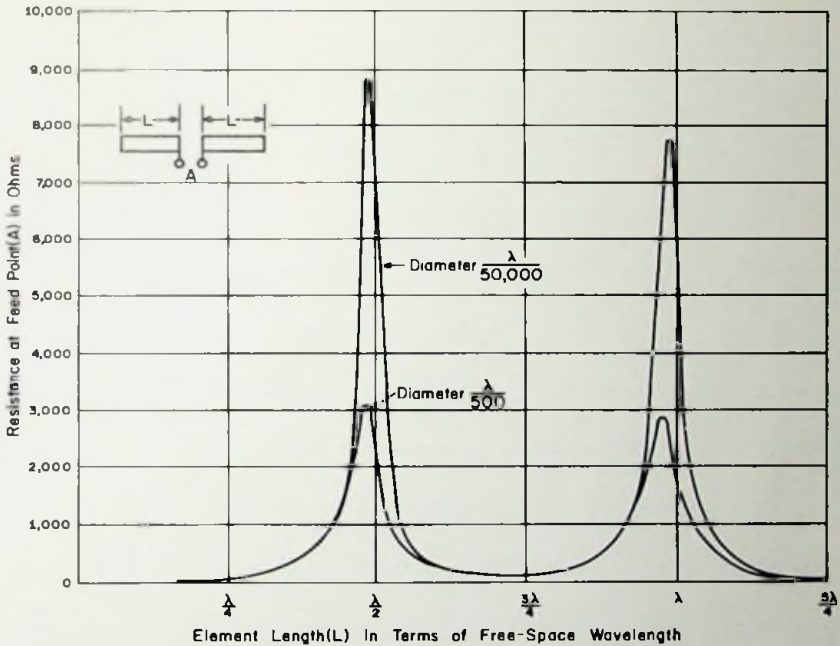

Fig. 2.9—Feedpoint impedance vs element length for center-fed dipole.

impedance when the antenna is fed at the high impedance point, such as center feeding 2 half wave sections in phase. The antenna is sometimes said to be "voltage" fed whereas a center fed half wave dipole is considered to be "current" fed. *It should be pointed out that all antennas are basically voltage fed.* A low voltage will cause a large amount of current to flow at the feedpoint of the antenna if the impedance is low. A high voltage is needed to cause a current to flow in a high impedance feedpoint. Although the current in a high impedance feedpoint may be low, the actual power input may be the same as in a low impedance-high current feedpoint. The power level is always determined from the equation,  $P = I^2 R_r$ .

Figure 2.9 also shows the effect different conductor diameter ratios have on impedance. This is an important consideration. A low  $Q$  (large diameter) radiator or driven element is not an indicator of low efficiency. It increases band-

with, usually has lower r.f. losses, and it is easier to match. However, it is desirable to have high  $Q$  (small diameter) parasitic elements for maximum gain, but at the sacrifice of bandwidth.

As the element diameter is increased it is necessary to shorten its length to maintain resonance. The foreshortening is required to compensate for the increased capacitance associated with the elements. When several different sizes of tubing are used for an element, its length must be increased over what it would be if its entire length were the same as the center diameter.

Figure 2.10 illustrates how the reactance varies at the feedpoint with length

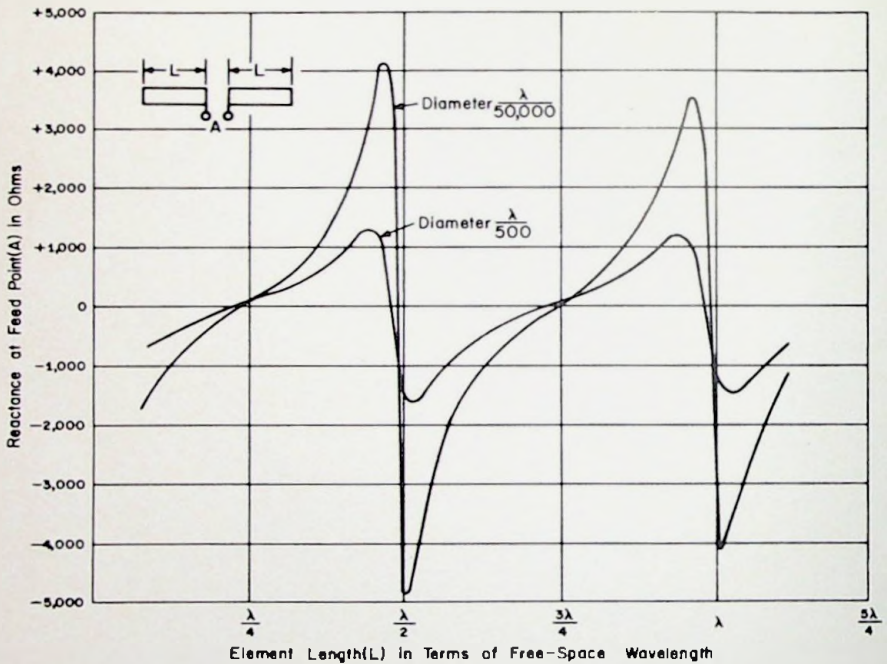

Fig. 2.10 - Reactance variation at antenna feedpoint.

and element diameter. The antenna may be either inductive or capacitive, depending on its length. Abrupt changes of impedance occur at multiples of a half wavelength. The points where the reactance curves cross the zero axis indicate the resonant lengths of the antenna. Because the curves are plotted in terms of the free space wavelength, the effect of the reduced velocity of the wave motion along the antenna is shown by the curves. For example, a half wave antenna element is resonant only when it is less than the free space half wavelength. This foreshortening is caused by the increased capacitance associated with the elements. If the diameter of the radiator is large, for example  $\lambda/500$ , the increased capacitance is greater than for a thin element. As a result, the large

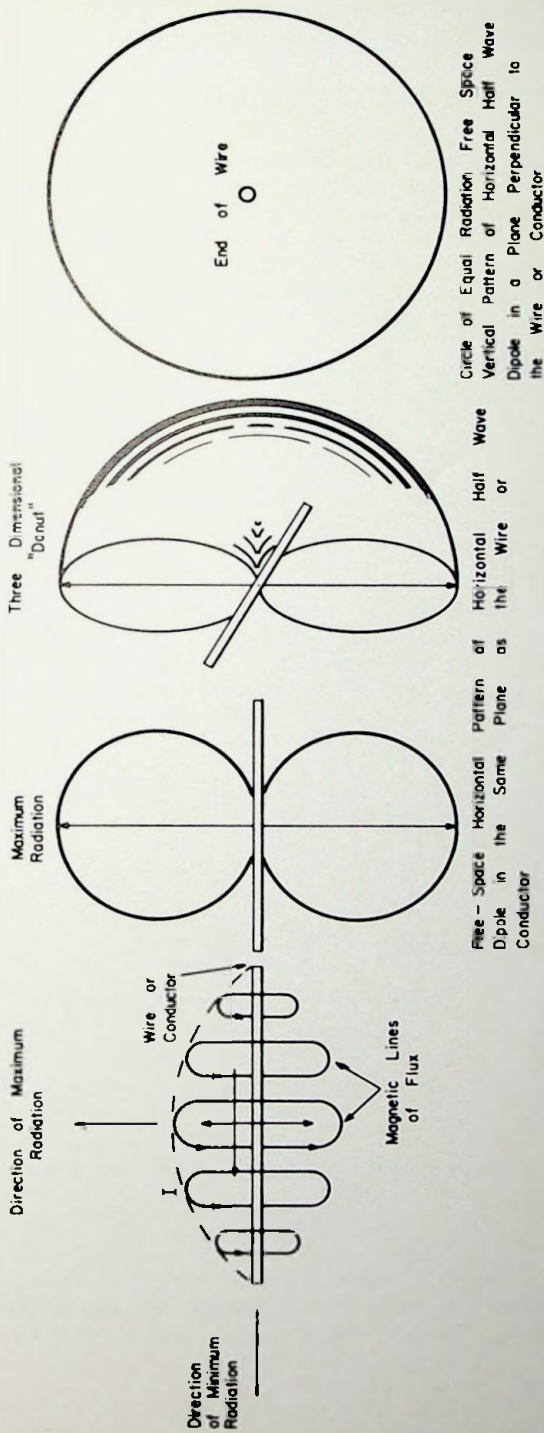

Fig. 2.11—Radiation pattern for a half wave dipole antenna.



diameter radiator is foreshortened more than the thin radiator. These are important factors to consider when building an antenna.

## FREE SPACE DIPOLE RADIATION PATTERNS

As a result of standing waves on a half wave dipole, the current is not the same throughout its length. This results in uneven radiation, the intensity of radiation being maximum where the current is maximum, such as in the middle of a half wave dipole. Figure 2.11 shows the radiation field and the resulting pattern for the half wave dipole. The field radiates broadside to the wire of the antenna and a figure "8" pattern or 3-dimensional "donut" results. The pattern in the plane perpendicular to the antenna is a circle—equal power being radiated in all directions.

In Fig. 2.12 a full wave antenna and how its pattern is developed are shown. At point P the two fields are equal but  $180^\circ$  out of phase and therefore cancel each other. This results in zero radiation. However, at point  $P_1$  the two fields

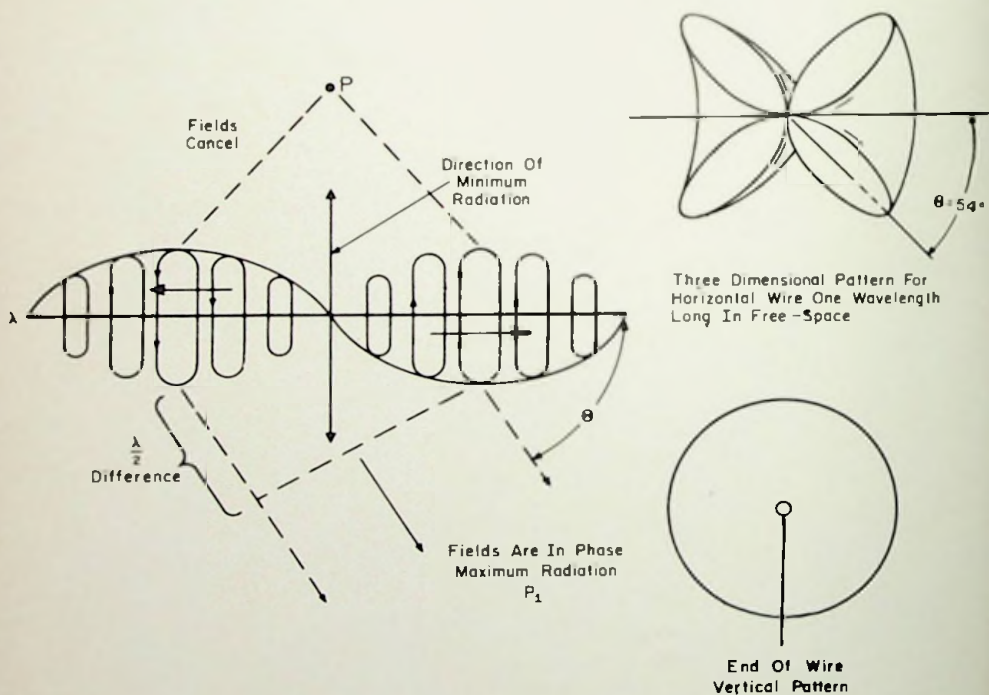

Fig. 2.12—Radiation pattern for a full wave dipole antenna.

are in phase and add, yielding maximum radiation. As the wire is lengthened or the frequency increased, the major lobes approach the axis of the wire and minor lobes form broadside.

## TILTING WIRE ANTENNAS

The free space pattern and resulting angle of radiation can be changed so as to effectively lower the radiation angle. This is generally desirable for long distance (DX) communication. Figure 2.13 shows an end fed antenna which is one

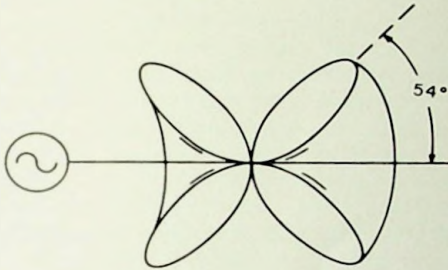

Fig. 2.13—Free space 3 dimensional pattern of an end fed antenna one wavelength long.

wavelength long. The principle lobes are 54° from the wire axis. By tilting the wire the free space pattern changes and the resultant angle of radiation (depending on the reflecting factor) is correspondingly lower (Fig. 2.14).

It is seen that as a wire is made longer in terms of wavelength, the principle free space lobes come closer to the direction of the wire and less tilting will be required to develop a lower angle of radiation. This technique is effective with

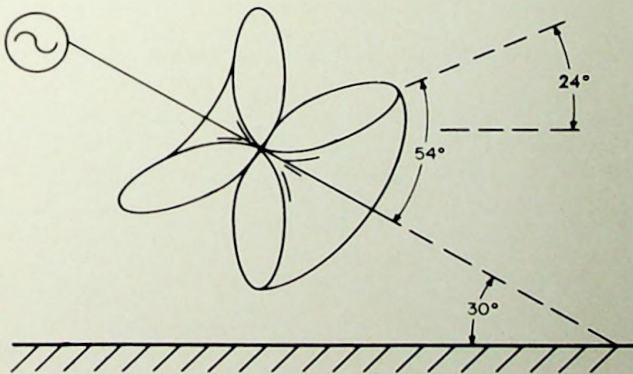

Fig. 2.14—Free space three dimensional pattern showing the effect of tilting the antenna 30°. The antenna's free space lobe is now 24° from the ground.

half or full wave dipoles and in either case there will be some experimentation required to find the optimum angle of tilt. In the case of a half wave dipole, if

the antenna is tipped beyond  $45^\circ$  the radiation characteristic approaches that of a vertical. On the low frequencies, this is an effective method of reducing the angle of radiation without raising the antenna height. However, the antenna should be mounted as high as possible for greatest operating efficiency.

## DIRECTIONAL CHARACTERISTICS OF LONG WIRE ANTENNA

A simple definition of a directional antenna is that it is an antenna from which the magnitude of radiated energy is not uniform in all directions. From this definition it is observed that the basic half wave antenna is a form of directional antenna, because there is no radiation from its ends.

The directional antenna, through concentration of energy in the direction of a distant receiving antenna, produces a stronger signal than a nondirectional type. To realize the same signal strength at the receiver with a nondirectional antenna requires raising the power output of a transmitter to excessive values. It can therefore be said that a directional antenna has a definite amount of power gain compared to a basic half wave dipole, which is used as a reference. The gain of a long wire, or any group of antennas comprising an array, may be defined as *the ratio of the radiated power produced by the antenna in its most favored direction to that of a half-wave dipole*. See Table 2.1 for gain values. One method of obtaining directional characteristics with power gain using a single wire, is to increase its length to more than a half wave length.

## MULTIPLE WAVELENGTH ANTENNAS

Figure 2.15 shows the voltage and current distribution on an antenna one wavelength long and the resulting radiation pattern. Note that the voltage is

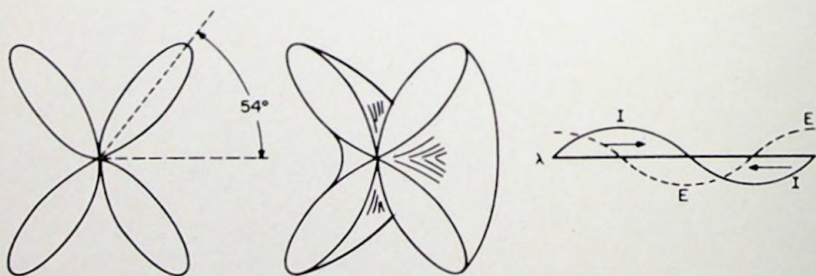

Fig. 2.15—Radiation pattern of a single wire antenna  $1\lambda$  long.

maximum and the current minimum at the ends of the antenna. There is a marked change in the antenna pattern and directivity as compared to a half wave dipole. The maximum radiation is no longer broadside to the axis of the antenna. Each

of the lobes represents a greater concentration of radiated energy (therefore more gain) than either of the lobes appearing with the half wave antenna. Figure 2.16

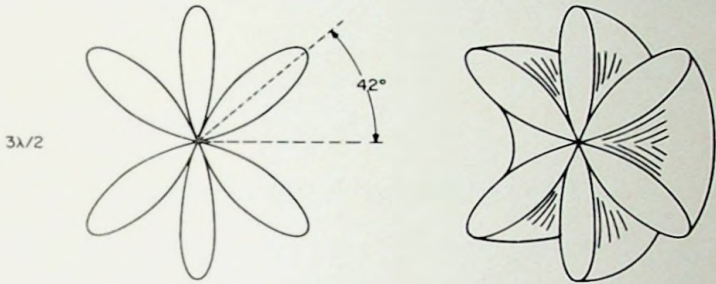

Fig. 2.16—Radiation pattern for an antenna  $3\lambda/2$  long.

illustrates the pattern of an antenna  $\frac{3}{2}$  wavelengths long. There is one lobe perpendicular to the antenna and two lobes that are  $42^\circ$  from the antenna itself. Figure 2.17 shows the pattern of an antenna 2 wavelengths long. Here again, radiation is not at right angles to the axis of the antenna as in the case of the half wave dipole.

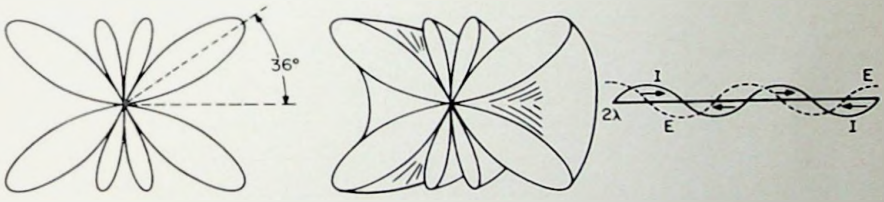

Fig. 2.17—Radiation pattern for an antenna  $2\lambda$  long.

In Fig. 2.18 the patterns of long wires of 4 and 8 wavelengths long are illustrated. In addition to the main lobes of the radiation pattern, note the appearance of the small minor lobes. In long wires that are an odd multiple

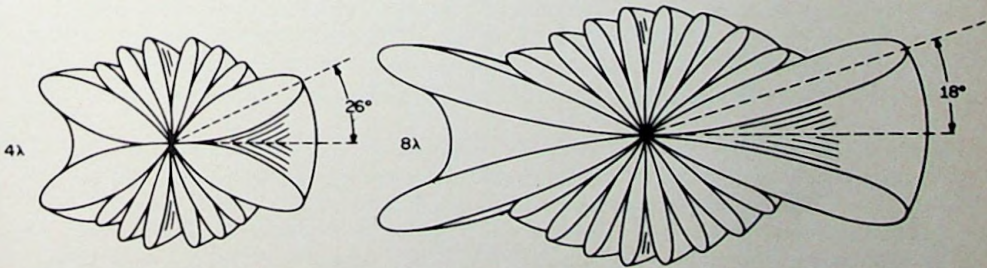

Fig. 2.18—Radiation patterns for antennas  $4\lambda$  and  $8\lambda$  long.

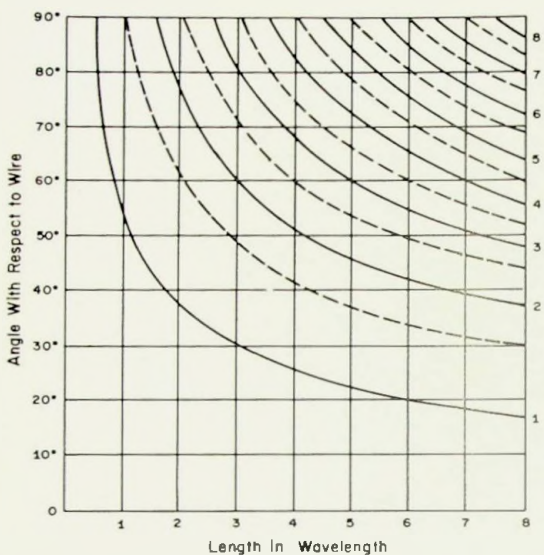

Fig. 2.19—Long wire antennas have major and minor lobes. The graph gives the angle of the major lobes (solid lines) and the minor lobes (dashed lines) to the wire.

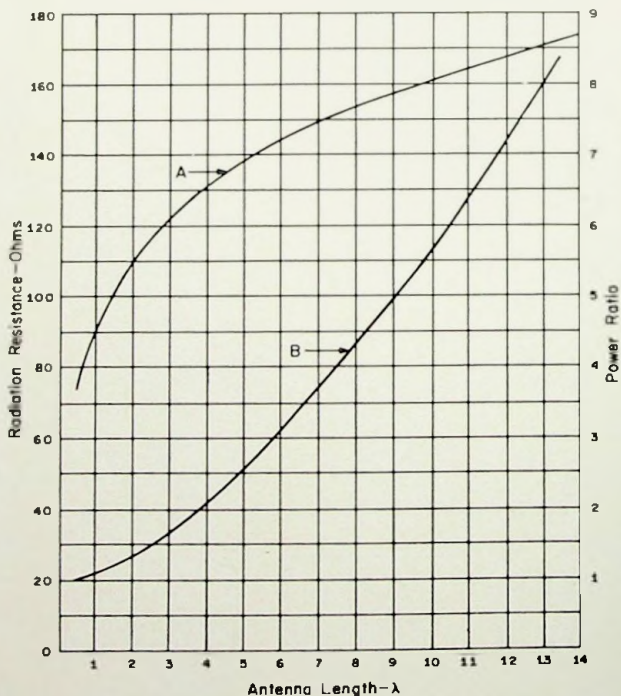

Fig. 2.20—Curve A shows the value of radiation resistance as the antenna is lengthened beyond  $\lambda/2$ . These values are at the feedpoint of a current loop. Curve B shows the gain over a half wave dipole as the antenna is lengthened.

of a quarter wavelength these lobes are greatly reduced in amplitude. However, having the antenna length in half wave multiples, multiband operation is simplified because an antenna which is an odd multiple of a quarter wavelength on one frequency will not even be near resonance on the harmonic frequencies.

If a long wire were to be used only on one band there would be a definite advantage of cutting it to a multiple length of odd quarter wavelengths insofar as minor lobe reduction is concerned. The antenna would be current fed (low impedance feedpoint). Other properties of long wire antennas are summarized in Figs. 2.19 and 2.20.

## TERMINATED LONG WIRES

Terminating a long wire with a resistive load equal to the antenna characteristic impedance (Fig. 2.21) eliminates standing waves and results in equal current flow in the antenna. The back half of the lobe is not formed as there is no reflected component on the wire. Most all of the power reaching the end of the long wire is absorbed in the load resistance. The terminated long wire then has the characteristics of a two-wire transmission line properly terminated. In this case the two conductors (the wire and the ground return path), are spaced

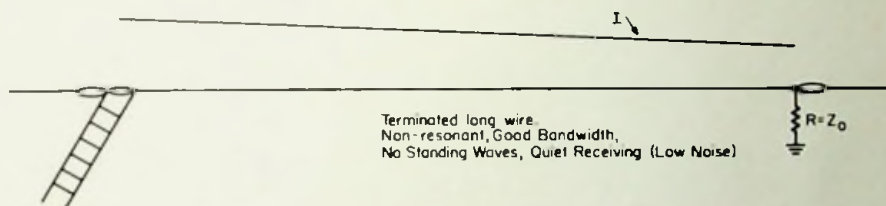

Fig. 2.21—Terminated long wire antenna.

far enough apart so that there is no cancellation of fields between the two. As a result, the long wire antenna (with transmission line characteristics) radiates. Bandwidth is exceptional as the antenna is resistive over a wide frequency range. Because of the termination, a large percentage of the noise picked up by the antenna never reaches the receiver.

Another method is to lay the end of the wire on the ground for about 100 to 300 feet as shown in Fig. 2.22. This acts as an effective termination when suitable termination resistors are not available. The one disadvantage is that additional space is needed, although the wire could be zig zagged in a smaller space.

An alternate method of termination that has proved effective is to install a resistance equal to the radiation resistance at a point one quarter wavelength from the end of the wire (Fig. 2.23). This termination is primarily effective on one band as its location is important. Actually, it would probably be fairly effective on the other bands as well. The optimum resistance and position could be determined by installing different values of 2 watt carbon resistors and noting

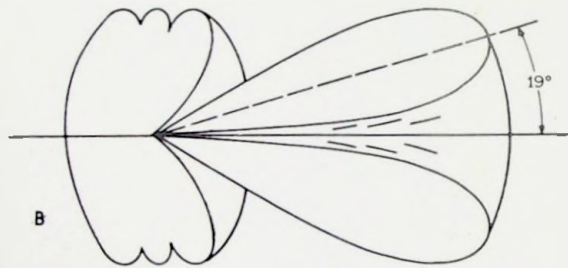
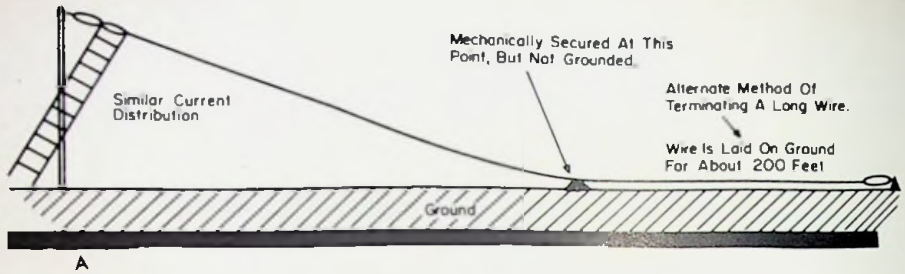

Fig. 2.22—Terminating a long wire antenna. (a) Alternate method ; (b) Three dimensional view of lobe pattern.

how much signal is received from an r.f. source (such as a portable grid dip meter) installed at the back of the long wire and about 20° to one side.

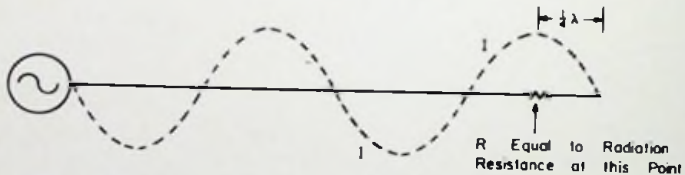

Fig. 2.23—Another method of termination.

### THE EFFECT OF THE FEEDPOINT ON CURRENT DISTRIBUTION AND FIELD PATTERN

In an antenna of one wavelength and longer there is considerable effect on the current distribution with variation in the antenna feedpoint. In addition, unsymmetrical feed always produces an unsymmetrical pattern. Figure 2.24 illustrates the effect on the pattern of end and center feeding. Pattern tilt of end feeding is also shown.

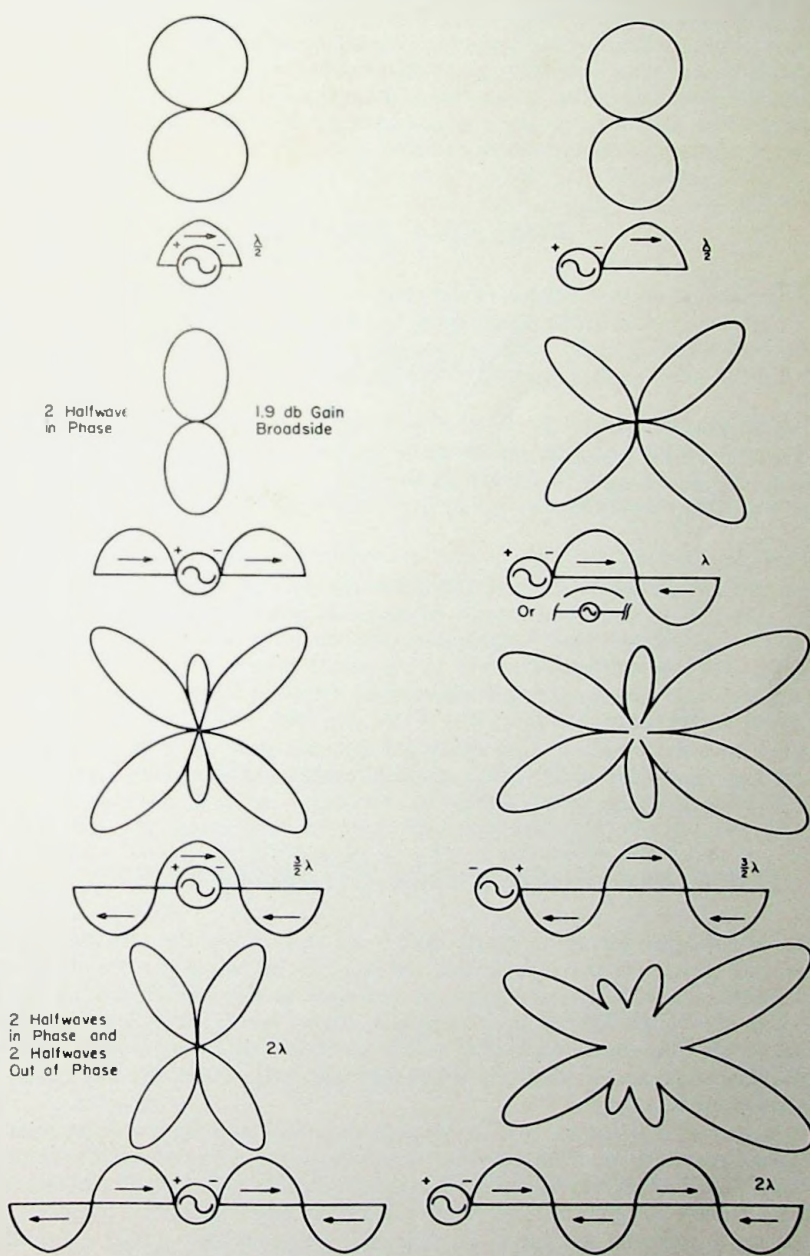

Fig. 2.24—Different radiation patterns produced by center and end feeding of antennas.



The pattern tilt does not become severe until a length of about 2 wavelengths is used. The prime reason for this is that the current in an end fed long wire of several half wavelengths is not the same. Some energy is lost along the wire because of radiation and  $I^2R$  losses. Therefore, each current loop removed from the generator has slightly less current. The same effect applies to the reflected component. If the wire were of high resistance, the tilt effect would be even more pronounced. The back lobe gets smaller and smaller and the main lobe is also attenuated. For an infinitely long wire there are no reflections and the pattern is similar to that of a terminated long wire.

## ANTENNA LENGTH

An antenna does not necessarily radiate or receive more energy if it is made longer. Certain specific dimensions must be used for efficient antenna operation.

The wavelength ( $\lambda$ ) in meters is equal to the velocity of radio waves in free space (300,000,000 meters/second) divided by the frequency of the wave ( $f$ ) in cps:

$$\lambda = 300,000,000/f \quad (2.2)$$

When the frequency is measured in kilocycles or megacycles, the formulas for calculating the wavelength in meters are:

$$\lambda = 300,000/f(\text{kc}) \quad (2.3)$$

or

$$\lambda = 300/f(\text{mc}) \quad (2.4)$$

Because the common unit of length in the United States is the foot rather than the meter, it is more convenient to calculate wavelength in feet. To do this, the basic formula is modified as follows:

$$\lambda(\text{in feet}) = 984/f(\text{mc}) \quad (2.5)$$

Therefore, the half wavelength formula is:

$$\lambda/2 = 492/f(\text{mc}) \quad (2.6)$$

These formulas apply to true electrical distance such as used for determining beam element spacing, stacked beam spacing, height above ground, etc. Modifications of the formulas are given later.

## HALF WAVE ANTENNA CHARACTERISTICS

The wavelength formulas given above are based on the velocity of radio waves in free space. If these formulas are used to calculate the length of a half wave antenna, one will find the antenna resonant at a lower frequency than the desired one. To make the antenna resonate at the correct frequency it becomes necessary to shorten the antenna by a few percent. In other words, the length of a practical half wave antenna is slightly less than that of theoretical half wave antenna in free space.

There are several factors which cause a practical antenna to be shorter than its free space counterpart. The velocity of a radio wave along a metallic conductor is less than in air or a vacuum. The amount by which the velocity is reduced is determined by the dimensions and structure of the material. The physical length of a half wave antenna decreases as the ratio of electrical length to conductor

diameter is decreased. The larger the diameter of the conductor the more the antenna has to be shortened.

A further shortening of the physical length of a half wave antenna is caused by the presence of insulators, supporting wires, guys, metallic reflecting surfaces, the mast, and other structures located near the ends of the antenna. The effect of such stray capacitance is called *end-effect*. Most of the end-effect of a half wave dipole is caused by the capacitance between the ends of the antenna and the insulator, supporting wire, and the capacitance to ground. At frequencies up to about 30 mc, the net effect of the factors just discussed is to reduce the physical length of a half wave antenna to approximately 95% of its electrical length. The following formula should be used to calculate the length of a practical half wave antenna:

$$\begin{aligned} \text{Length in feet} &= 492 \times 0.95/f(\text{mc}) \\ &= 468/f(\text{mc}) \end{aligned} \quad (2.7)$$

$\lambda$  in meters  $\frac{300.000 \times 0.95}{f(\text{mc})}$

**DECIBELS**

A good understanding of the *decibel* will aid the antenna man in analyzing antenna performance. The decibel (abbreviated *db*) is derived from the original international transmission unit the bel, in honor of the inventor of the telephone. The *db* is probably the most widely used and misunderstood unit in communication work.

The decibel is equal to one-tenth (deci) of a bel. A difference of 1 *db* between two sound intensities is just discernible to the human ear. By definition:

$$\text{db} = 10 \log_{10} (P_2/P_1) \quad (2.8)$$

where  $P_2/P_1$  is the ratio of the two powers being compared.

**EXAMPLE:** If the power input to an antenna is increased from 100 watts to 600 watts, what is the increase in power in *db*?

**Solution:** Let  $P_2 = 600$  and  $P_1 = 100$ . Substituting these values in Eq. 2.8, one obtains

$$\text{db} = 10 \log_{10} (600/100) = 10 \times 0.778 = 7.78 \text{ db.}$$

Decibels can also be calculated from voltage or current ratios providing the impedances are taken into account. The equations for voltage and current ratios are derived from Eqn. 2.8 Let  $P_1$  and  $P_2$  equal the power input and output, and  $R_1$  and  $R_2$  equal the input and output impedances, respectively. Therefore, in terms of voltage:

$$P_1 = E_1^2/R_1 \quad (2.9)$$

and

$$P_2 = E_2^2/R_2 \quad (2.10)$$

Substituting Eqns. 2.9 and 2.10 in Eqn. 2.8 and simplifying:

$$\text{db} = 20 \log_{10} (E_2/E_1) + 10 \log_{10} (R_1/R_2) \quad (2.11)$$

Power can also be expressed in terms of current:

$$P_1 = I_1^2 R_1 \quad (2.12)$$

and

$$P_2 = I_2^2 R_2 \quad (2.13)$$

Substituting these expressions in Eqn. 2.8 and simplifying, one obtains:

$$\text{db} = 20 \log_{10} (I_2/I_1) + 10 \log_{10} (R_2/R_1) \quad (2.14)$$

If  $R_1 = R_2$ ,  $R_2/R_1 = R_1/R_2 = 1$ , the expression  $\log_{10} (1) = 0$ .

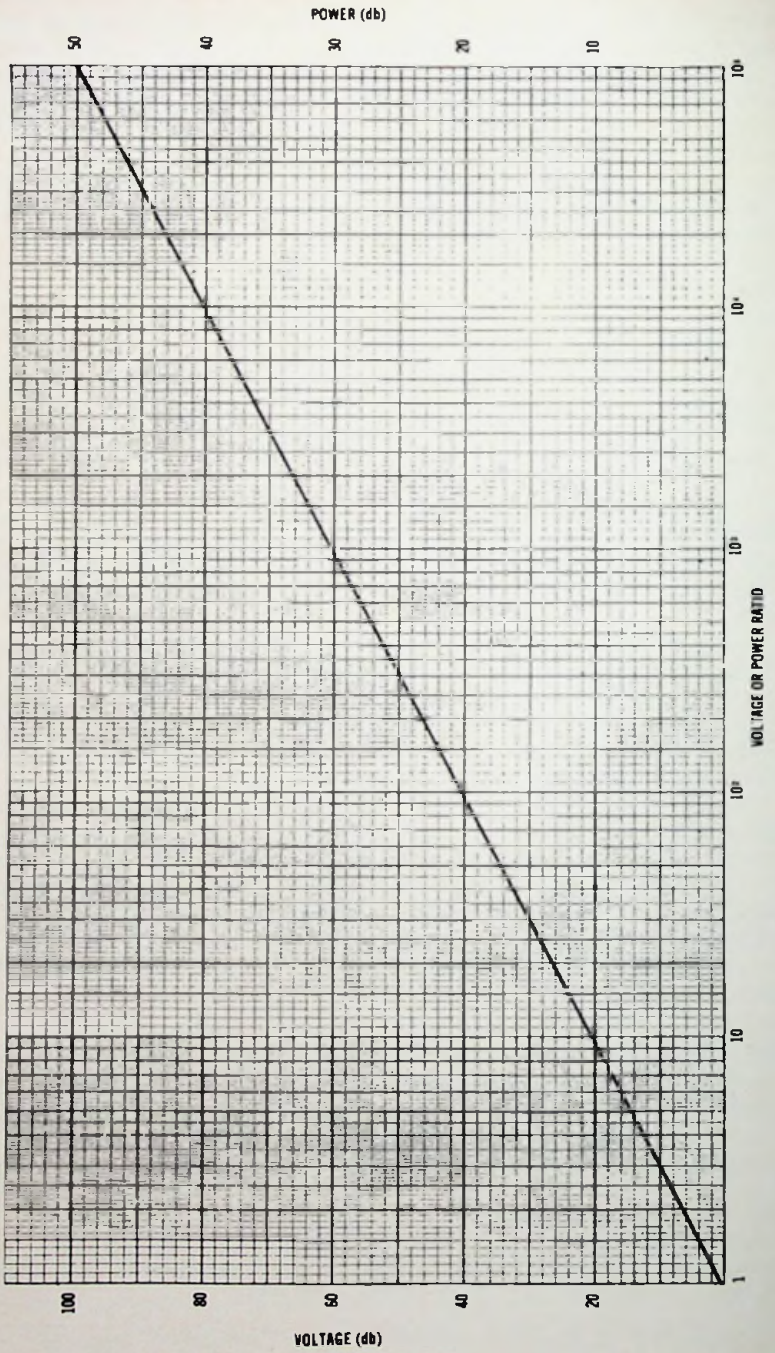

Fig. 2.25—Conversion of voltage power ratio to db.

Consequently, Eqns. 2.11 and 2.14 reduce to:

$$db = 20 \log_{10} (E_2/E_1) \tag{2.15}$$

and

$$db = 20 \log_{10} (I_2/I_1) \tag{2.16}$$

See Fig. 2.25 for db conversions.

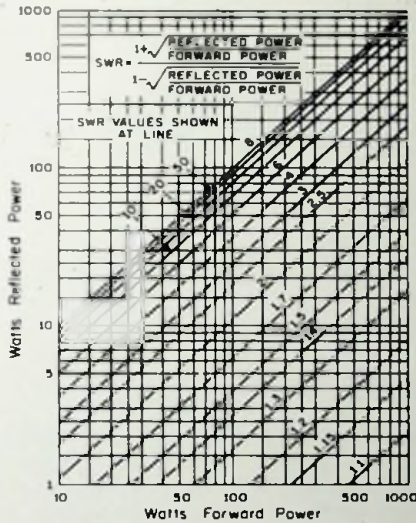

Fig. 2.26 Relationship of SWR to incident and reflected power.

### The Effect of Feedline Attenuation on VSWR

Any loss or attenuation in a feedline or the insertion of an attenuator will reduce the VSWR (*voltage* standing wave ratio) value. Therefore, the VSWR value read at the end of a feedline will be lower than the actual value at the antenna. It is possible to determine the actual VSWR at the antenna if the attenuation in db of the feedline is known and the apparent VSWR value is known. Feedline attenuation can be measured or predicted from manufacturers' charts. It is also possible to predict the VSWR at the end of the feedline if the VSWR at the antenna and the feedline attenuation is known. Fig. 2.26.

The nomogram of Fig. 2.27 will give these values of VSWR previously described. For example, assume a measured or input VSWR of 1.2 to 1 and a feedline loss of 4 db. The line drawn on the nomogram shows an actual VSWR of slightly over 1.6 to 1.

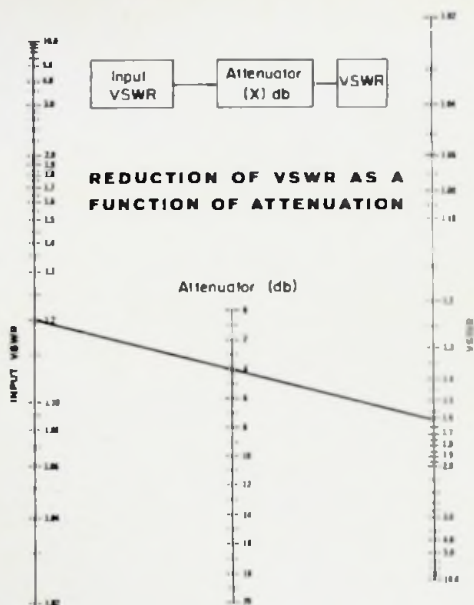

Fig. 2.27 Nomagram for determining the reduction of VSWR as a function of attenuation.

**TABLE 2.1—GAIN VALUES OF LONG WIRE ANTENNAS**

Antenna Length in Wavelengths	Gain over $\frac{1}{2}$ wave dipole in favored direction	Angle of Major Lobe with wire in degrees	Radiation Resistance at current maximums in ohms
$\frac{1}{2}$	0 db	$90^\circ$	72 ohms
1	.5 db	$54^\circ$	90
$1\frac{1}{2}$	.86 db	$42^\circ$	100
2	1.4 db	$36^\circ$	109
3	2.2 db	$30^\circ$	122
4	3.1 db	$26^\circ$	132
5	3.9 db	$23^\circ$	138
6	4.8 db	$21^\circ$	144
7	5.4 db	$19^\circ$	150
8	6.3 db	$18^\circ$	154
9	6.9 db	$17.8^\circ$	157
10	7.5 db	$17.7^\circ$	161
12	8.4 db	$17.3^\circ$	168
14	9.3 db	$17.1^\circ$	173

# MATCHING DEVICES

Impedance matching devices are required for optimum results when the transmission line impedance is not equal to the antenna impedance or to the impedance of the transmitter or receiver. If an impedance mismatch exists between the antenna and feedline, a reflected voltage occurs and standing waves will exist on the line. This reflected voltage is by no means lost, which is a common misconception. To avoid standing waves, particularly for *untuned* lines like coax, impedance matching devices are inserted in the antenna system. One device may be used to match the output impedance of the transmitter matching network to the transmission line input impedance. Another device may be used for matching the output impedance of the line to the input impedance of the antenna.

By common usage, the term *matching device* customarily refers to an r.f. transformer or a section of a transmission line acting as a transformer. The term *loading device* usually refers to a reactive element, such as an inductor, capacitor, or a length of transmission line acting as a reactance. The loading device, however, frequently serves to match impedance.

## SOME FUNDAMENTAL FACTS

Modern transmitters and many commercial antennas are designed to match

52 ohm coax cable. Coax cable cannot withstand a high SWR near its maximum power rating. In addition, a high SWR will often present a reactive impedance other than 52 ohms at the end of the feedline (depending on the line length). Pruning the coax length *does not* change the SWR but merely changes the impedance at the end of the feedline and sometimes to a value which is easier for the transmitter to match. Low-pass (TVI) filters are designed for 52 ohm lines and their effectiveness is reduced by the presence of standing waves.

Reflected voltage and/or power due to a mismatch at the antenna creates standing waves on a line. The bulk of this reflected energy is by no means lost. It merely changes the impedance above and below the characteristic impedance ( $Z_0$ ) of the line by an amount dependent on the SWR value. *If the transmitter output network can provide an optimum impedance match to the end of the feedline, regardless of its value, full transmitter output power minus feedline losses to the antenna still occurs.* The power lost in an open wire feedline because of high standing waves is negligible. In a conservatively rated coaxial cable this loss is also small with moderate SWR, but with light coax the heat loss could damage the line. In an ideal lossless line, 100% transfer of transmitter output power to the antenna will occur as long as the transmitter imped-

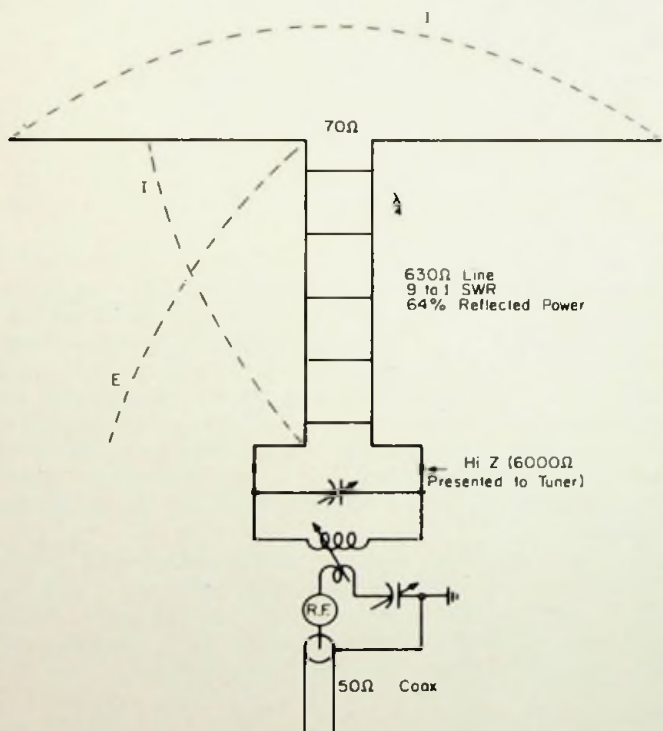

Fig. 3.1 — Half wave dipole fed by an open line. SWR = 9:1 (64% reflected power), yet maximum transfer of energy occurs. See text.

ance matching network provides an optimum match to the impedance presented to it at the *end* of the feedline, regardless of the SWR value.

Consider the half wave dipole fed with 630 ohm open line of Fig. 3.1. The SWR on the line is about 9 to 1 and represents a substantial amount (64%) of reflected power. By using a feedline that is a quarter wavelength long, it raises a 70 ohm resistance dipole impedance to about 6000 ohms resistive, which is not difficult to match when using an antenna tuner.

A matching device is needed to match the low impedance unbalanced coax from the transmitter to the balanced 6000 ohms. With the proper selection of inductor and capacitor values in the tuner or matching device this is easily accomplished and maximum power transfer is obtained. The only losses in the system are the very low tuner and feedline losses. If 64% reflected power were lost in the feedline, tuner, or generator output network, only 36% would be delivered to the antenna (4.4 db loss), which is not true. For 750 watt output power (1 KW input) this would represent 480 watts dissipated somewhere in the feedline, tuner, etc., in the form of heat. If a low SWR exists on the coax feedline between the transmitter and antenna matching network, and the matching network coils and transmission line are not warm due to  $I^2R$  loss (high SWR or not), maximum power is received by the antenna.

Quarterwave matching transformers are efficient unless poorly designed or overloaded. Negligible feedline radiation occurs from open wire line if the currents are balanced and  $180^\circ$  out of phase. It becomes apparent that the ability of the transmitter or tuner to match the impedance at the *end* of the feedline is more important than the feedline matching the antenna (although this is desirable). Even with a perfect match between feedline and antenna (SWR = 1:1), the amount of power transfer to the antenna still depends on how close the tuner matches the impedance at the end of the feedline.

Some of the more popular and successful impedance matching devices are described in this chapter. The two basic types of matching devices (and/or antennas) are *balanced* and *unbalanced*. An unbalanced feedline such as coax, and an unbalanced feed system, such as a *gamma match*, can be successfully matched to the center of the driven element (balanced system) of a beam antenna if properly adjusted. However, complete success is seldom achieved in matching a balanced line to an unbalanced feedpoint, such as end feeding a dipole or feeding coax straight into a dipole center. Unbalanced currents in the feedline usually occur with resulting radiation and disturbance of the antenna pattern. In case of coax cable, the currents on the outside of the shield are not canceled by the field of the inner conductor and therefore the cable radiates freely.

## ANTENNA TUNERS

With regard to the many feedlines in use today, generally speaking the open wire line is still the most efficient and has many applications. It is easy to construct, is low in cost, and will last many years. The power delivered to the antenna, for all practical purposes, depends entirely on how well the antenna tuner matches the load presented to it by the feedline. An antenna tuner, installed at the transmitter end of the feedline, *cannot*, and is *not intended* to correct the standing waves on the transmission line attached to the tuner. The



tuner's function is to *match* the impedance at the *end* of the open wire feedline to the coax transmission line that feeds the modern transmitter or receiver. Upon matching, there will be 100% transfer of power to the antenna minus very low transmission line and tuner losses.

Open wire line losses due to high SWR are nil. Standing waves *do not* cause radiation from open wire feedline if the line currents are balanced, such as with center feed. Losses in coax are comparatively high even with a moderate SWR. With excessive SWR, the power handling capabilities are substantially reduced. This is not true for open wire line of proper design because it is air cooled and has very low dielectric losses.

Impedance matching of *tuned* lines is important only at the antenna tuner. If the open wire feedline length is any multiple of a *half wavelength*, the impedance presented to the tuner by the feedline will be the same as the impedance of the antenna. As far as the tuner is concerned, it is looking directly at the feedpoint of the antenna. This is not true, however, if the feedline length is an *odd* multiple of a quarter wavelength. In this case, the impedance presented to the tuner by the feedline will be either high or low depending on whether the impedance of the antenna is low or high. The impedance values will follow the formula:

$$Z \text{ (quarter wave feedline)} = \sqrt{Z_1 Z_2} \quad (3.1)$$

where  $Z_1$  = impedance of the antenna

$Z_2$  = impedance at the end of an odd quarter wave multiple of feedline presented to the tuner or other matching device.

Impedance values presented to the tuner will vary between 30 and 2000 to 6000 ohms for a typical multiband dipole antenna. The load will be resistive if the antenna is resonant and the feedline is some multiple of a quarter or half wavelength. If the antenna is not resonant and/or if the feedline is not a multiple length, a reactive component will also be presented to the tuner.

A length of feedline other than a quarter or half wavelength multiple will compensate for a non-resonant antenna. Pruning of the feedline is suggested for ease of loading in this case. As a result, the tuner will still "see" something close to resistive load, usually at a single frequency.

The conventional home brewed tuner cannot tune out large values of reactance without arcing, high circulation currents, and provide critical tuning unless external inductance or capacitance is paralleled across the line. In addition, the home brewed tuner's configuration must be able to change from series (low impedance) to parallel (high impedance) in order to match the various impedances usually encountered.

The tuner should be also capable of high or low *LC* ratios for both series and parallel tuning. For ease of tuning there should also be an SWR bridge in the line going to the tuner. A tuner should also have provisions for r.f. sampling on a scope, and be shielded for harmonic reduction. The controls of the tuner should be calibrated so that when a particular antenna is used the controls can be set to predetermined settings without the necessity of repeating the tune-up procedure each time. This is particularly important when listening in on the different bands. With all these requirements, it is quite an engineering task to design a tuner.

### **Home Brewed Tuner**

The tuner of Fig. 3.2 has proved flexible in matching a fair range of im-

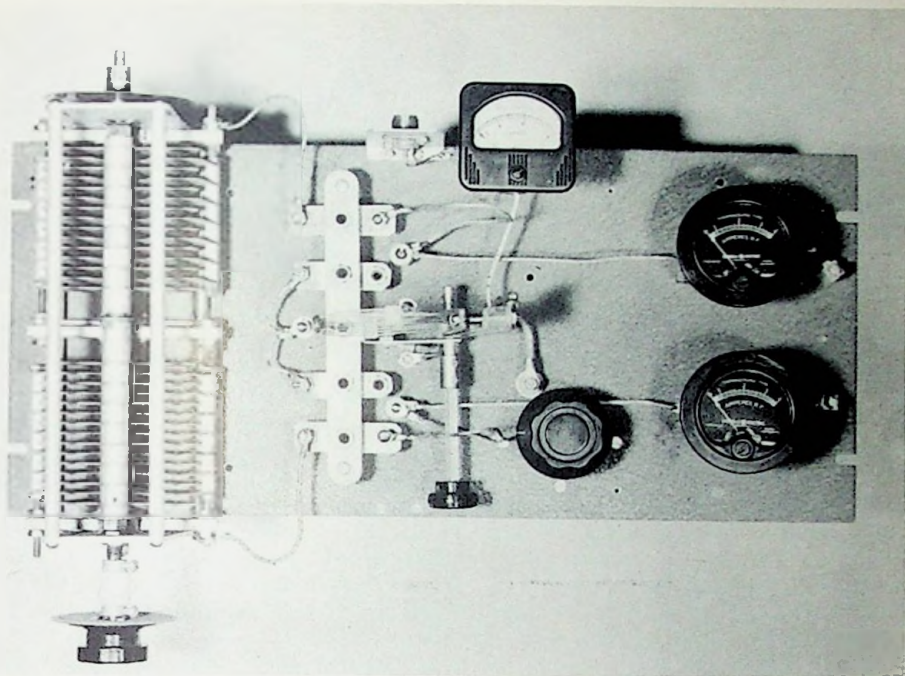

Fig. 3.2 — Pictorial view of home brewed tuner showing r.f. ammeters in link and antenna circuits. Series capacitor in link circuit is mounted behind panel with control knob a left of lower r.f. ammeter.

pedances. The basic circuit of the tuner is given in Fig. 3.3a; Figs. b and c provide the connections for parallel and series tuning. Other combinations for the tuner are included in Fig. 3.4. To use all these combinations, the rotor of the variable capacitor must be insulated from the mounting panel and an insulated coupling installed on the rotor shaft. If the variable capacitor has the rotor grounded to the panel, as the one shown in Fig. 3.4, external fixed capacity can be easily paralleled across the variable when needed.

Referring to Fig. 3.3a, the lead from the r.f. ammeter (RF2) in series with the 52 ohm coax connector goes to the variable link and then to a variable capacitor with the rotor grounded. This capacitor is necessary for proper matching and is adjusted for minimum SWR, as is the main variable tuning capacitor.

A 5 turn link is required on 75 and 40 meters and a 2 or 3 turn link on 20, 15, and 10 meters. The series variable capacitor should have a value of at least 500 uufd. If a variable of smaller range is used, the total capacity can be increased by paralleling across the variable a fixed capacitor of 100 to 250 uufd rated at 2500 to 5000 volts. A range of 200 to 500 uufd will be required on 75 meters, 150 to 300 uufd on 40 meters, 100 to 200 uufd on 20 meters, and 50 to 100 uufd on 15 and 10 meters. The spacing between plates need not be any greater than 0.075 inches for normal SWR values.

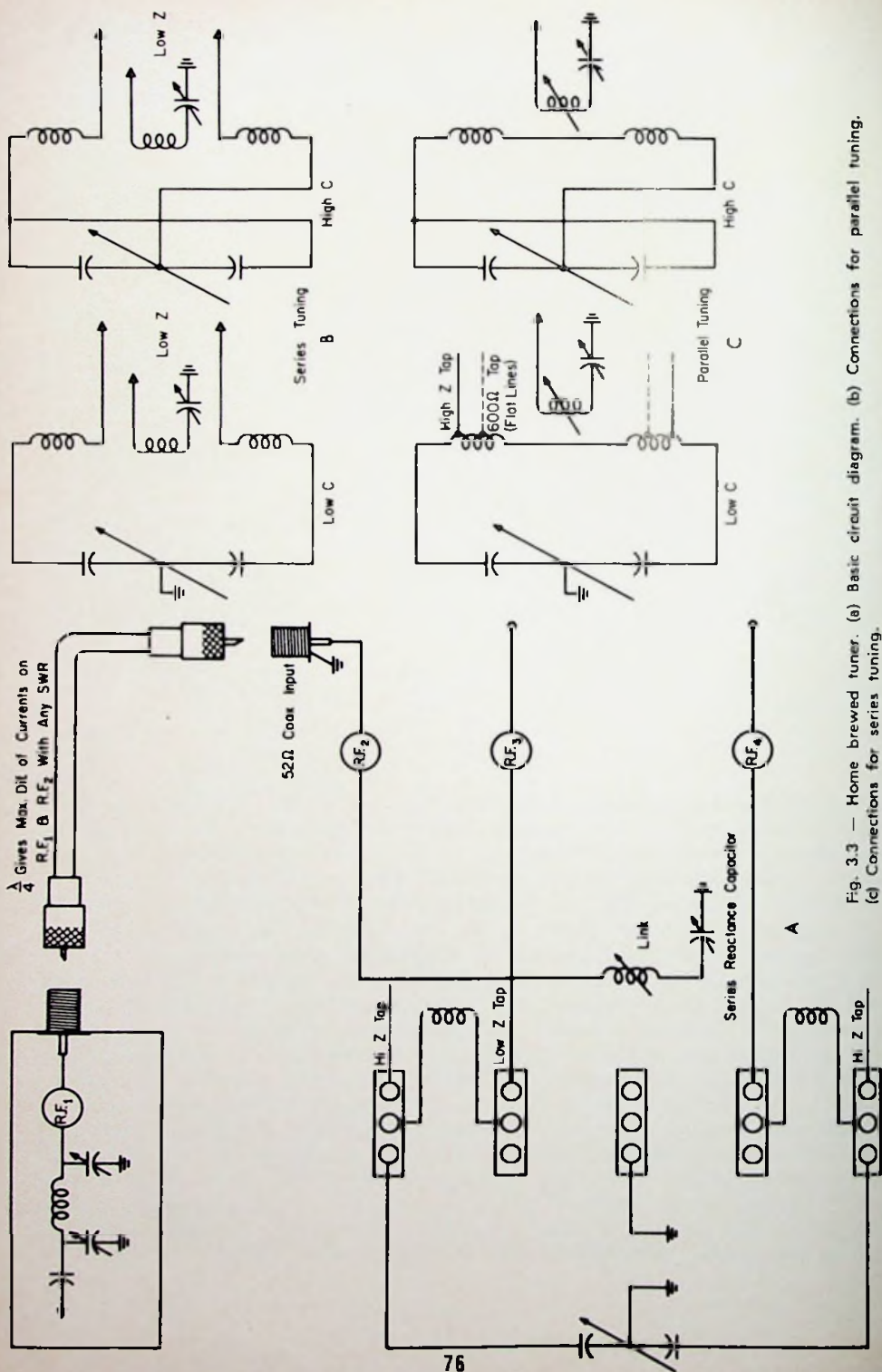

Fig. 3.3 — Home brewed tuner. (a) Basic circuit diagram. (b) Connections for parallel tuning. (c) Connections for series tuning.

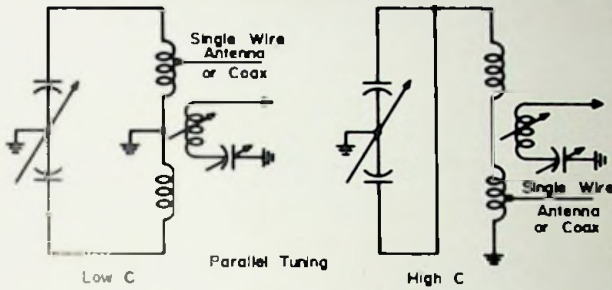

Fig. 3.4 — Other tuning combinations that may be used with the tuner.

An r.f. ammeter (RF2) in the link circuit is extremely useful. If there is another r.f. ammeter at the transmitter, (RF1), no SWR bridge is needed for adjusting the tuner. If these two meters read the same value of current, no standing waves exist on the feedline. The power output can be calculated from the formula  $P = I^2 Z_0$  where  $Z_0$  is the impedance of the feedline and  $I$  the value of current read on the r.f. ammeters. For transmitters running 1000 watts input, class C output power results in an output current of about 3.8 amperes in a 52 ohm feedline. Class B linear power outputs will be lower.

Under certain conditions, both meters may read equal but greater current than 3.8 amperes. To obtain 3.8 amperes the number of turns in the link may have to be changed or the paralleling of an inductive or capacitive reactance across the load may be necessary. It is often a "cut and try" solution, but there is a combination that will produce the correct value of current in the link circuit and therefore optimum loading.

A close approximate value of the resonant frequency of the antenna using tuned feeders can be determined by observing the two r.f. ammeter (RF3 and RF4) current values in the feedline while loading the antenna at different frequencies across the band. If the feedline is some multiple of a half wavelength, the same current and impedance values as are at the antenna feedpoint will be reflected at the other end of the line to the tuner. At the resonant frequency the r.f. ammeters will read the highest values of current for a low impedance feedpoint (assuming the same input power level is maintained and the feedline is a half wave multiple close to this frequency). If the feedpoint is of high impedance, such as would exist when center feeding two half wave antennas in phase, the resonant frequency occurs where the meters read a minimum of current.

The approximate antenna impedance can be calculated by first determining the power in the link circuit previously described. Then subtract about 3% of the power to account for coupler losses and use the formula  $Z = P/I^2$ , where  $P$  is the calculated power in the link circuit less 3%, and  $I$  the value read on the meters in the feedline with unity SWR. The antenna should be balanced as indicated by equal meter readings, resonant, and the feedline in halfwave multiples, in order to obtain reasonable accuracy in the calculation.

For legal power limits, 500 watt coils are large enough to handle the output power levels from the transmitter. Only r.f. current exists in the tank circuit, since there is no d.c. plate current flowing in the coil. The coils just get

perceptibly warm on a.m. operation; however, the loss is negligible and is even less when operating s.s.b. or cw. Coils rated at 1000 watts would be ideal but these are large and expensive.

### Johnson Match Box

The Johnson Match Box (Fig. 3.5a) with its unique design has all the desired features required in a tuner. This versatile device is designed for match-

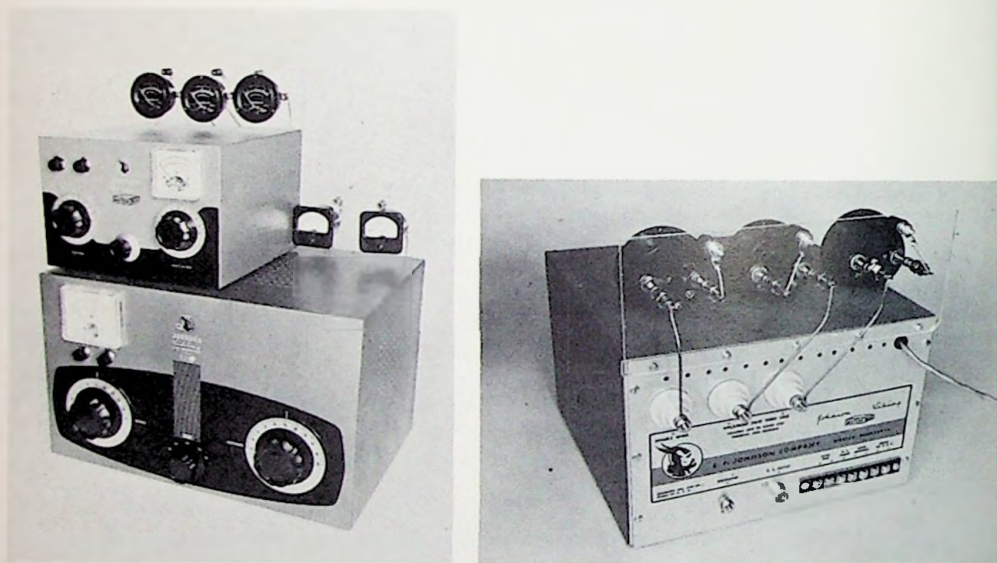

Fig. 3.5 — Johnson 275 watt and 1 KW Match Boxes with external r.f. meters for checking line balance. (a) Front view. (b) Rear view of 275 watt Box showing meter connections.

ing a wide range of antenna and transmission line impedances (40 to 3000 ohms) to a 52 ohm impedance, without elaborate switching and adjustments, within the amateur bands from 3.5 to 30 mc. The circuit schematic is given in Fig. 3.6

The tuner circuit consists of a parallel resonant network using an inductor with a coaxial wound coupling link, a dual tuning capacitor, and a dual differential matching capacitor which is the heart of the circuit. Impedance matching for either balanced or unbalanced transmission lines and antennas is accomplished by front panel controls without the need of resorting to coil taps, link adjustments, etc. Proper adjustment of the controls is simplified by the use of a directional coupler (SWR bridge).

In addition to matching balanced transmission lines, the unit matches coaxial lines and single wire transmission lines. When matching single wire lines, it is possible that a point will be reached where, regardless of the settings of the front panel controls, unity SWR cannot be obtained. For this condition,

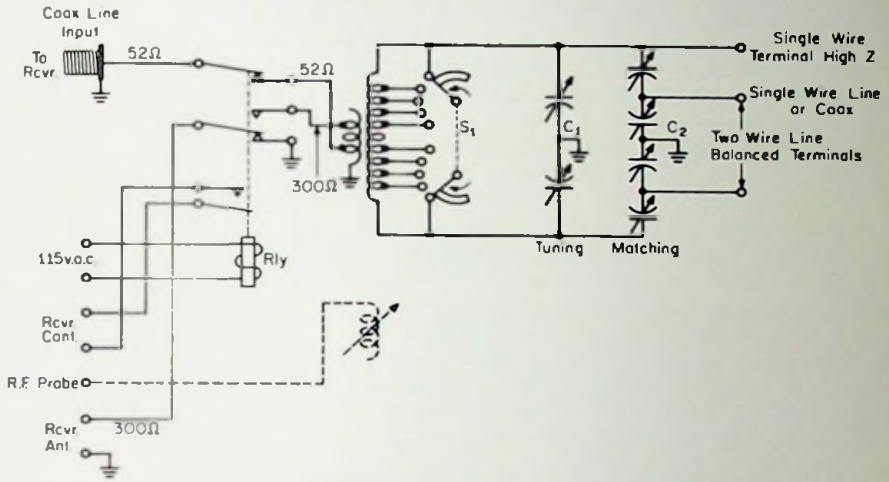

Fig. 3.6 — Schematic of Johnson Matchbox.

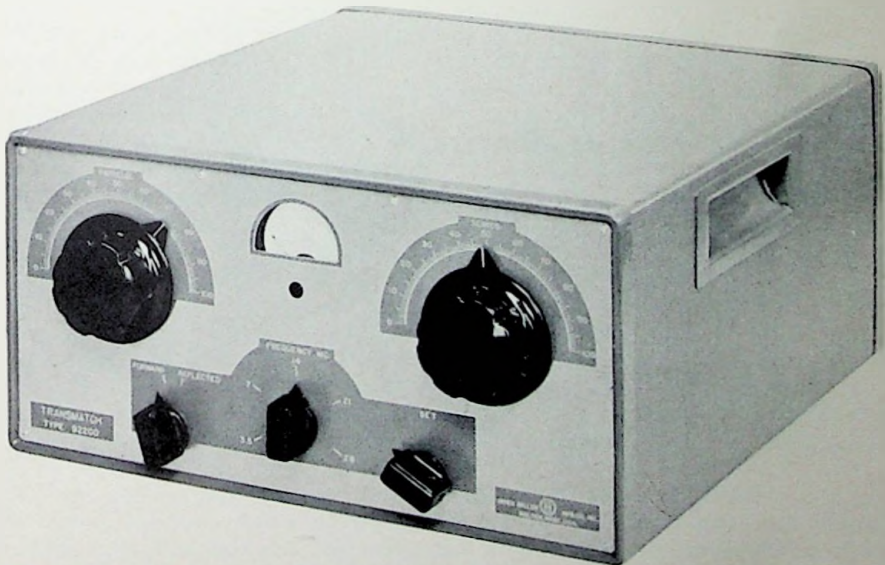

Fig. 3.7 — Millen's Transmatch contains a built-in SWR bridge and meter, handles 2 KW, and is band switching. It will match any antenna system impedance between 25 and 500 ohms to a transmitter impedance of 50 to 70 ohms.

the insertion of a variable capacitor or inductor in series and/or parallel with the feedline will tune out the excess reactance and unity SWR will be realized. If a long wire is used on all bands the variable capacitor or inductor value if needed, will most likely vary for different bands. When erecting a long wire antenna, the length should be a multiple of a half wavelength on all bands. This will aid in having a voltage point (high impedance) at the Match Box and eliminate the need for series inductance or capacitance in most cases. In some instances, pruning of the feedline may prove effective.

The versatility of the Match Box is enhanced by the addition of r.f. ammeters as shown in Fig. 3.5c. The meter range in amperes will depend on the impedance and power level at the insertion point. The r.f. ammeters will show unbalance in the feedline (unequal currents), indicate modulation percentage, relative impedance, and adequate grid drive.

The Johnson Company has indicated that, in their opinion, the use of r.f. ammeters are superfluous to satisfactory operation of the Match Box. This is correct; however, their addition as shown will increase the usefulness of the Match Box for the more exacting user.

Example of another commercial antenna tuner is given in Fig 3.7.

## THE GAMMA MATCH

The gamma match permits an unbalanced feedline (coax) to be matched to a balanced antenna. For example, consider the driven element of a beam. If the element is split in the center (balanced feedpoint) and fed with coax (unbalanced line), the beam must be *broadbanded* to raise the impedance. R.f. "spill over" also occurs on to the coax shield. Broadbanding means that the director must be shortened and the reflector lengthened more than the usual amount to raise the impedance for a direct match to coax cable. However, gain, front-to-back, and side ratios are appreciably decreased. Interference QRM bad enough from the front, let alone from the back and the two sides.

For these reasons, any system that employs broadbanding for direct feed should be avoided. Many contest operators complain bitterly about interference from the back and two sides. The gamma match is one of the standard techniques of overcoming the disadvantages of broadbanding and still maintaining a good match for the feedline. This means that gain, front-to-back, and side ratios are not sacrificed in matching the beam to the feedline.

The basic gamma match is illustrated in Fig. 3.8. The center of the driven element is grounded to the boom along with the coax shield. Between the center point and the end of the antenna there exists a range of impedance values from a few ohms to several thousand of ohms. Fortunately the 52 ohm point is fairly close to the center.

Using anything from #12 wire to half-inch tubing, the clamp is moved along the element until the 52 ohm point is reached. The gamma arm has inductive reactance "built in" at radio frequencies which must be tuned out. This is accomplished by inserting a variable capacitor (capacitive reactance) in series with the gamma arm. A series resonant circuit is formed with the inductive gamma arm and part of the driven element. The capacitor can be a variable mounted in a weatherproof box, or a coaxial type capacitor (telescop-

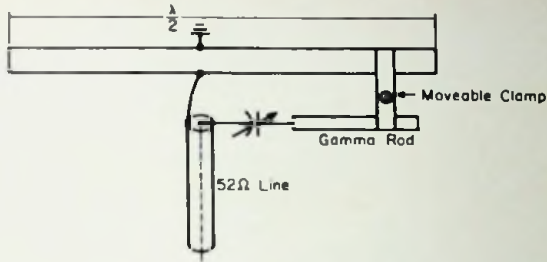

Fig. 3.8 — Basic gamma match.

ing tubing). Commercially, the Cesco gamma match is easy to mount and is rugged. It is completely weatherproof and handles a kilowatt of power. Figure 3.9 shows the Cesco gamma match attached to a 10 meter beam.

A home brewed gamma match, using a fuse clip bolted to a feed thru

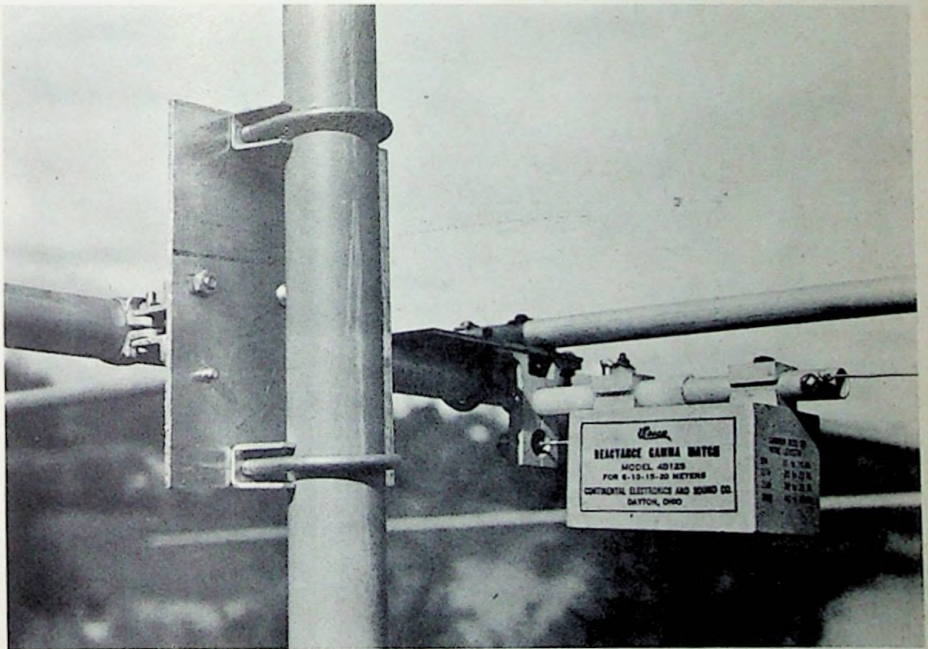

Fig. 3.9 — Using a Cesco gamma match on a 10 meter beam.

insulator, is illustrated in Fig. 3.10. The clip firmly grips the gamma rod and also allows easy adjustment for initial tune-up. The gamma rod is attached to the element with a hose clamp (Fig. 3.11). This arrangement allows rapid adjustment during initial tune-up and it can be used permanently, if the fuse



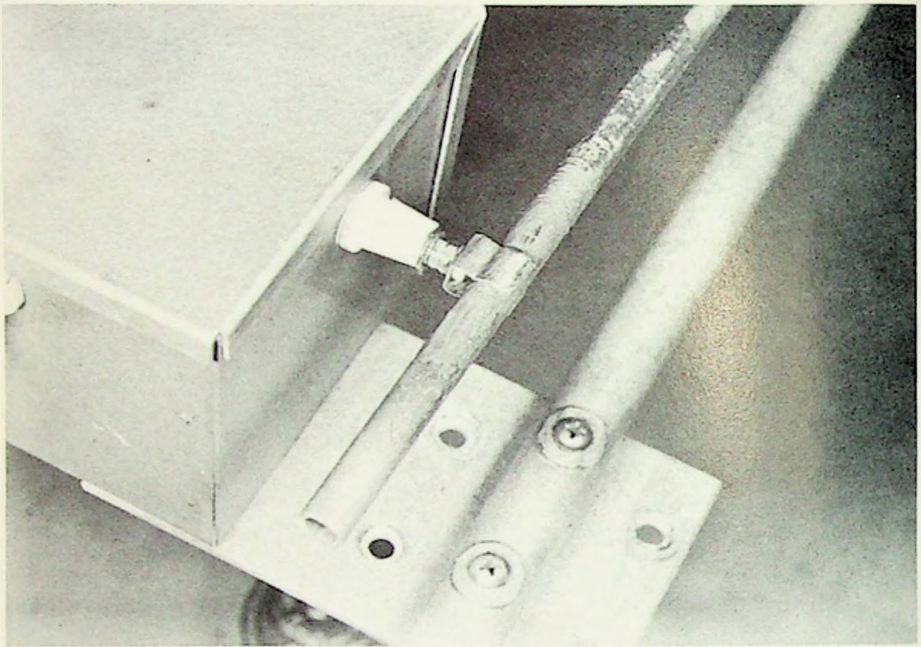

Fig. 3.10 — Fuse clip used to grip gamma rod.

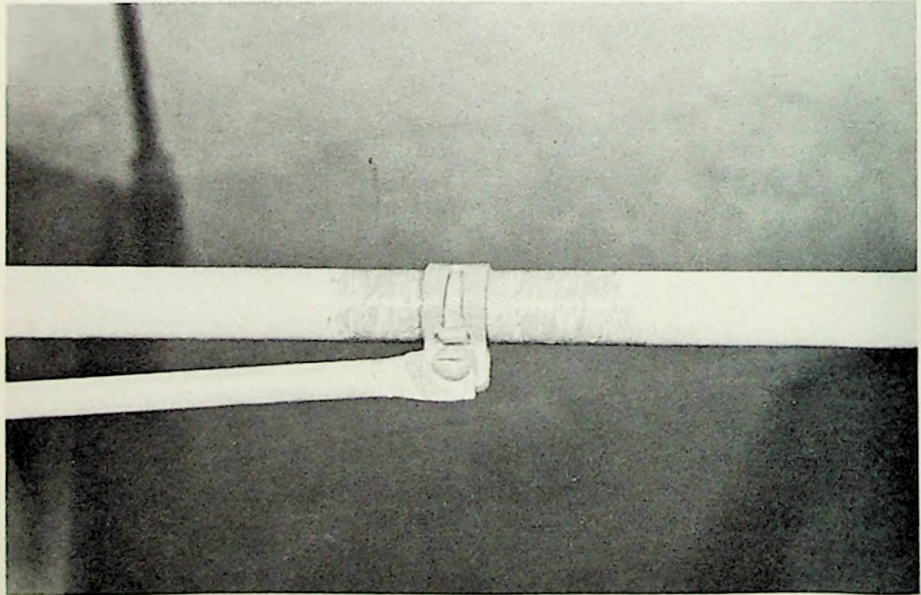

Fig. 3.11 — Gamma rod attached to antenna element with a hose clamp and weatherproofed with Penetrox.

clip and hose clamp are coated with Penetrox, an anti oxidation compound. After final adjustment, a hole is drilled through the clip and rod and then bolted to prevent vibration from loosening the clip. A selsyn may be coupled to the shaft of the capacitor to permit remote tuning from the shack during and after the tune-up on the tower (Fig. 3.12).

One of the most important points to keep in mind when tuning a gamma is this: Do not try to "pull" in the resonant frequency. Even though the beam is cut for say, 28.6 mc, nine times out of ten it won't be resonant there. Many still insist in trying to get unity SWR at that frequency. The correct procedure is to let the resonant frequency go where it wants to. A 1:1 SWR generally

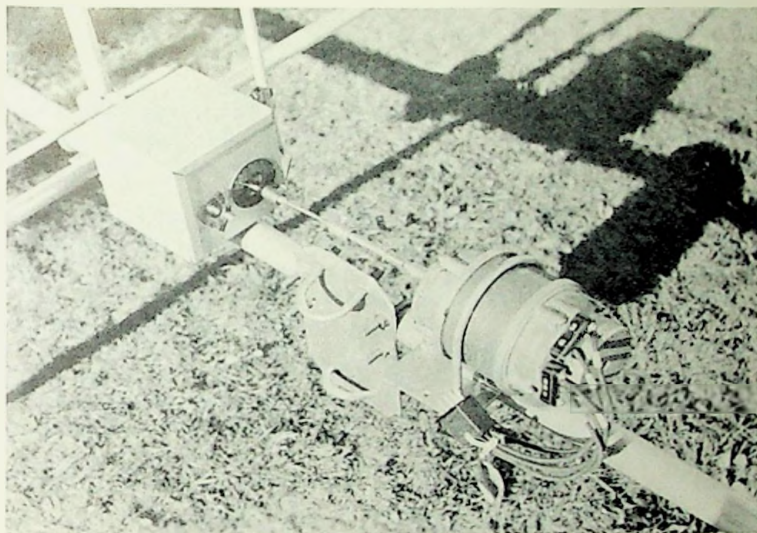

Fig. 3.12 — A selsyn with flexible shaft used for remote tuning of gamma capacitor.

will be obtained only at the *true* resonant frequency, which may turn out to be say, 28.4 or 28.7 mc. Occasionally certain combinations of gamma rod length and capacity will give unity SWR on other than the resonant frequency. However, the bandwidth under this condition will be quite narrow.

If the resonant frequency is found to be 28.4 mc and resonance at 28.6 mc is desired, all the element lengths should be changed in proportion rather than just the driven element. This is especially necessary if the beam is to be tuned for a specific pattern. If the driven element alone is shortened, the effect is the same as lengthening the director and reflector. This will produce a different beam pattern at the new resonant frequency.

### **General Tune Up Procedure**

In adjusting the gamma match, the following procedure is recommended:

1. Sweep the transmitter frequency above and below the "cut" frequency of

the beam. Stop at that frequency where the SWR is a minimum.

2. Adjust the variable capacitor for minimum SWR and then repeat steps 1 and 2 until no further improvement is obtained.
3. Vary the gamma rod one inch at a time, one way or the other, and repeat steps 1 and 2. A starting point for 10 meters is about 24 inches; 35 inches for 15 meters; and about 50 inches for 20 meters. These figures depend upon several factors. It's a guess which way to move first, unless the impedance at the feedpoint is known. When the impedance is nearing 52 ohms, adjust the gamma rod in increments of less than one inch. When this is completed, it is a good idea to have someone start out with new settings and check the final settings of the capacitor and gamma rod.

If unity SWR cannot be attained, it may be due to a defective coax, an inaccurate bridge, loose connector, surrounding objects too close to the antenna, or an incorrect driven element length. If the gamma rod is in the same plane as the driven element, it may not be possible to get a 1:1 SWR with this configuration. In this case, it is recommended that the entire driven element be shifted toward the boom by an inch or two. If the gamma rod is directly below the driven element, no trouble should be experienced providing the beam is balanced electrically and mechanically.

It may be found that unity SWR is obtained on the bridge in the shack during initial tune-up but upon bringing the bridge directly to the gamma feedpoint, the bridge may indicate an SWR greater than 1 to 1. This may be attributed to the fact that coax has losses to the reflected r.f. returning through the coax. Because of losses in the coax, the reflected energy is attenuated when it reaches the shack and the SWR meter indicated the optimum value of unity. A final check should be made of the SWR with a bridge at the beam. Actually, this is the best place for making all measurements and adjustments.

It is almost mandatory to have some form of communications between the beam and the shack when making adjustments. Many economical intercoms and walkie-talkies are available and they will do the job nicely. Two earphones and some double lamp cord will also serve in a pinch.

With low power, all adjustments can be made with the power on. It might be noted that tuning a gamma can be a 10 minute or a 10 hour job, depending on how things are prepared.

## THE T MATCH

The T match permits the matching of balanced or coax feedlines with half wave baluns (to be described later), to balanced antennas. Like the gamma match, the T is resonant at one frequency and can be adjusted in a similar manner. The basic T match (with coax feed and a balun) is shown in Fig. 3.13. The arms are inductively reactive just as in a gamma match. A variable capacitor is required in each leg of the arms to cancel out the inductive reactance. Another technique that may be used to accomplish the same result is to shorten slightly the driven element, making it capacitive reactive. For simplicity the gamma match is recommended.

One distinct advantage of the T over the gamma match is that the T permits the use of a balanced coaxial transmission line. For example, RG-22 or two lengths of RG-8AU (Fig 3.14) can be paralleled and series connected

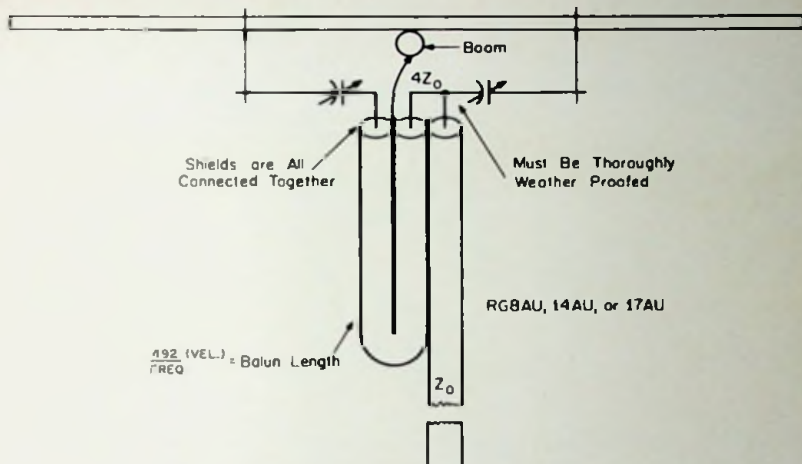

Fig. 3.13 — Basic T match with balun.

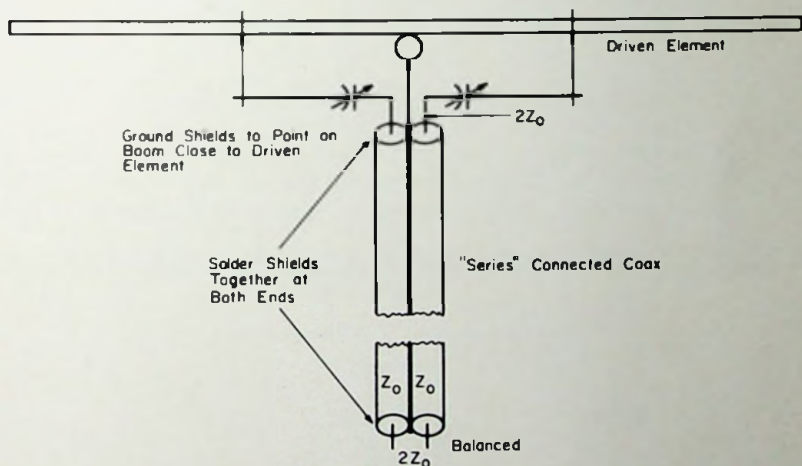

Fig. 3.14 — Using balanced coax lines with T match results in low noise pickup.

(only the shields are connected) to form a balanced, 100 ohm, shielded transmission line. This type of feedline has substantially less noise pickup than a single coax line used with a gamma match. This feature improves considerably the signal-to-noise ratio. Very weak signals can therefore be copied where other antenna installations not using this kind of feed fail. This feedline is of great advantage in a high noise area.

T-matched yagis with existing 208 ohms feedpoints can be fed with a balanced coaxial transmission line by using the systems illustrated in Fig. 3.15.

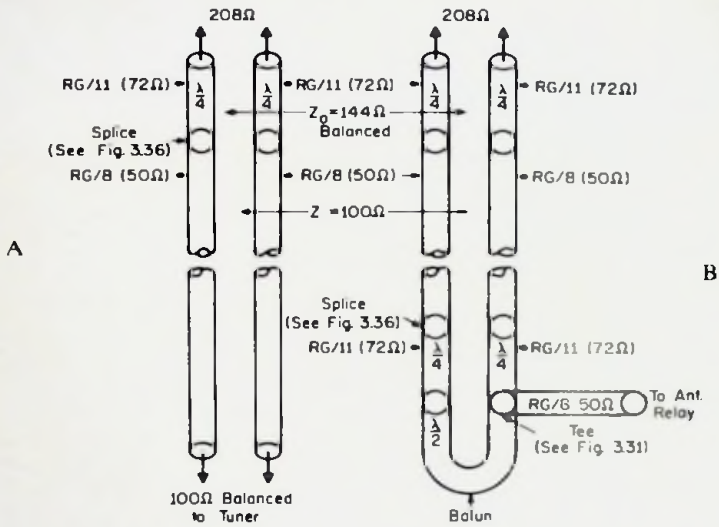

Fig. 3.15 — Two methods for feeding a 208 feedpoint with a balanced coaxial transmission line for low noise pickup. In (a) the tuner gives additional noise reduction and reduced harmonic output.

This permits one to connect balanced feedlines to an existing T match without retuning the system. However, if a T match is to be newly installed and a balanced coaxial line used, the two quarter wavelength 75 ohms matching stubs can be eliminated and the T match adjusted for the balanced  $Z_0$  of the feedline. A T match is not the easiest system to tune and if balanced coaxial feed

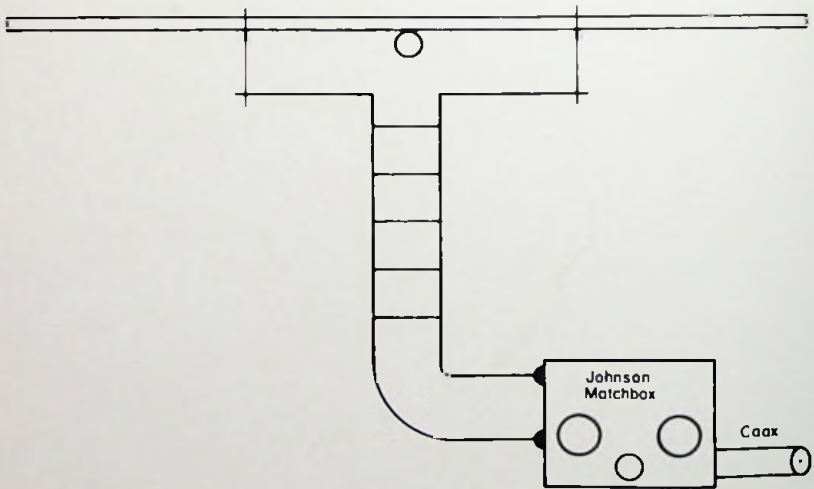

Fig. 3.16 — An antenna tuner used with an open feedline and T match.

is desired on a newly constructed yagi, the capacitive match (considered later in this chapter) is recommended.

A disadvantage of the T match is that some form of tuner is needed to match the balanced feedline to the usual unbalanced pi-network that is so popular in today's transmitters. An antenna tuner, such as the Johnson Match Box, is suitable for this application.

If the antenna installation is some distance from the transmitter say, 300 feet or more, open wire feedline is highly recommended. It is not necessary that the feedline impedance be equal to that of the T match, providing the feedline is some multiple of 67.5 feet in length and an antenna tuner is used for matching the impedance at the end of the open wire line to the 52 ohm coax going to the transmitter (Fig. 3.16).

## DELTA MATCH

The delta match (Fig. 3.17), which has been somewhat superseded by the T match, has the disadvantage of undesirable radiation from the feedline where it is fanned out to connect to the driven element. Approximate feedpoints are given in Fig. 3.17 for 600 ohm line. Some final adjustment may be necessary to obtain a minimum SWR, but with an antenna tuner low SWR is not necessary.

Lower impedance feedlines are matched simply by moving the tap points closer together. This will result in less radiation from the feedline at this point. In an emergency, one could tap the element at most any point if the open wire line is a half wave multiple in length and a tuner is used.

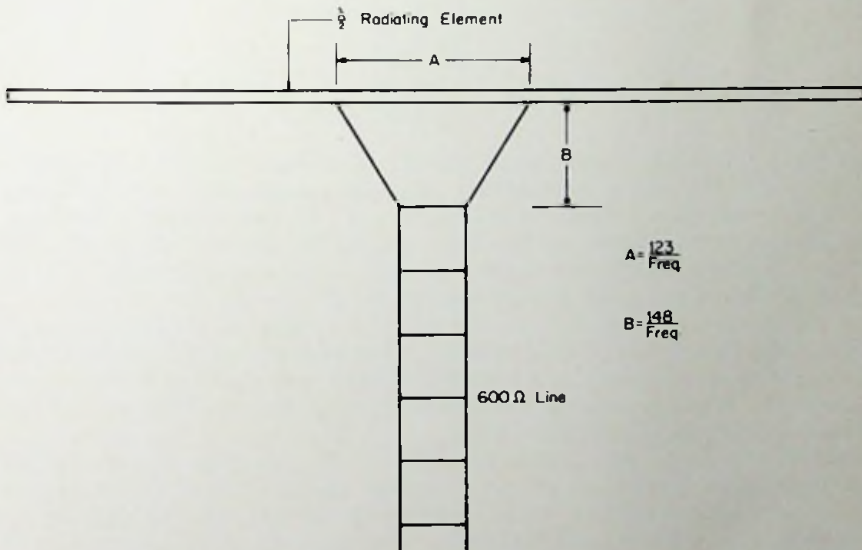

Fig. 3.17 — Delta match for a 600 ohm load.

## HAIRPIN (INDUCTANCE) MATCHING

Hairpin matching (Fig 3.18) is basically the same as the T or delta match, with the exception that the feedpoints are physically close. This feature eliminates the need for series capacity as in the T match since the inductance of the short feed wire is negligible. Consequently, initial adjustments are fewer than those with the T match. Also, radiation from a coaxial feedline using a bazooka or balun is nil.

Any desired impedance can be developed by a hairpin or a coil. A three

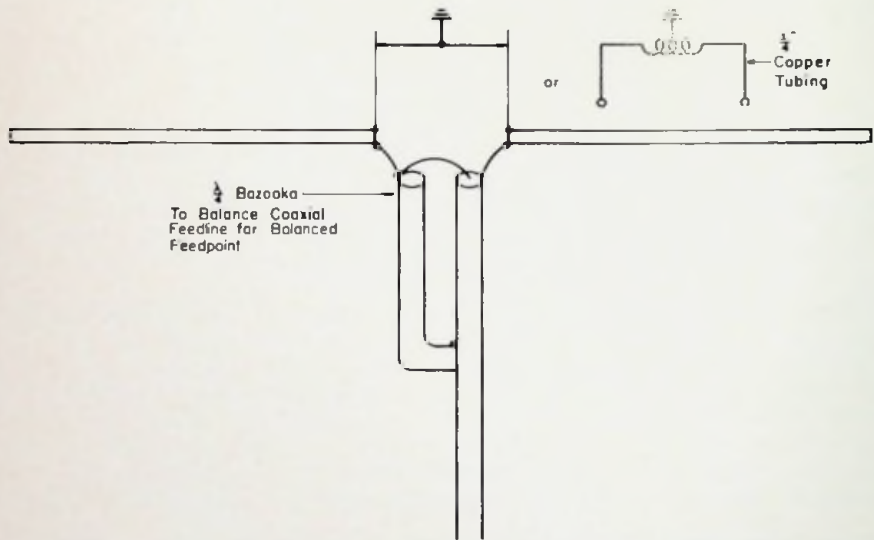

Fig. 3.18 — Hairpin matching.

band hairpin, having a low SWR, for 52 ohm coax was first developed by Hy-Gain for their TH4 Thunderbird tri-bander which has proved successful. The hairpin presents a balanced feedpoint and, if coax is used, a bazooka or a broadband balun should be installed right at the antenna. Without the balun, a "hot" feedline will often result, possibly causing considerable TVI and varying SWR as the antenna is rotated.

The hairpin or coil shortens the physical length of the antenna slightly, which could be a factor when considering the construction of a 40 meter beam. This requires the elements to be physically split and insulated from the boom, but with the Hy-Gain element mounting hardware, the mounting and insulating problem is virtually eliminated.

Low impedance feed points are close to the movable shorting bar while high impedance feedpoints are at a greater distance from the shorting bar. The exact distances depend on the hairpin tubing size, spacing distance, band of operation, and the desired impedance. It is basically a cut and try procedure to find the correct point. In addition, moving the feedline to a different point, or lengthening the hairpin, or increasing the number of turns in the coil, for

a lower SWR will reduce the resonant frequency. This must be considered when observing the SWR bridge after each adjustment.

For additional information, refer to "The Hairpin Match" in April 1962 *QST*, page 11.

## CAPACITANCE MATCHING

This technique of matching is seldom used (because it is not considered in most texts) and is perhaps the best match of all. The driven element is

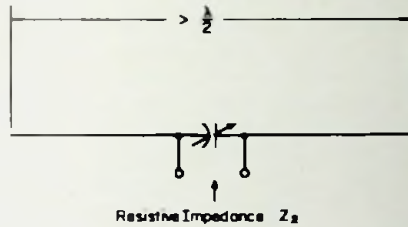

Fig. 3.19 — Capacitance matching.

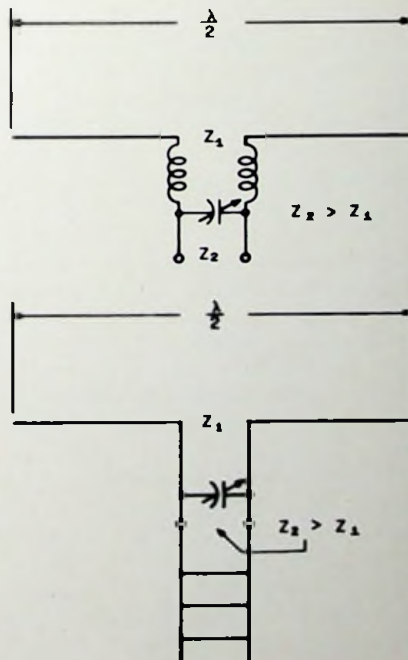

Fig. 3.20 — Coil loading added to capacitance match.



made longer than a half wavelength thereby making it inductive reactive. A variable capacitor is connected across the feedpoint as shown in Fig 3.19. When the antenna inductive reactance equals the capacitive reactance, the remaining resistive impedance will be higher than what it would be if the driven element were resonant by itself. This is advantageous in a parasitic array where the split element may be any value from 10 to 30 ohms. Since the driven element is now a bit longer, a greater portion of the high current area of the antenna is radiating and a sharper horizontal pattern is therefore obtained. The vertical pattern of the driven element alone is still a donut.

The tune-up procedure is as follows:

1. Measure the impedance of the antenna, e.g., with the aid of an antennascope.
2. Lengthen the driven element about 5% of its half wavelength value.
3. With a balanced feedline connected to the antenna, tune the variable cap-

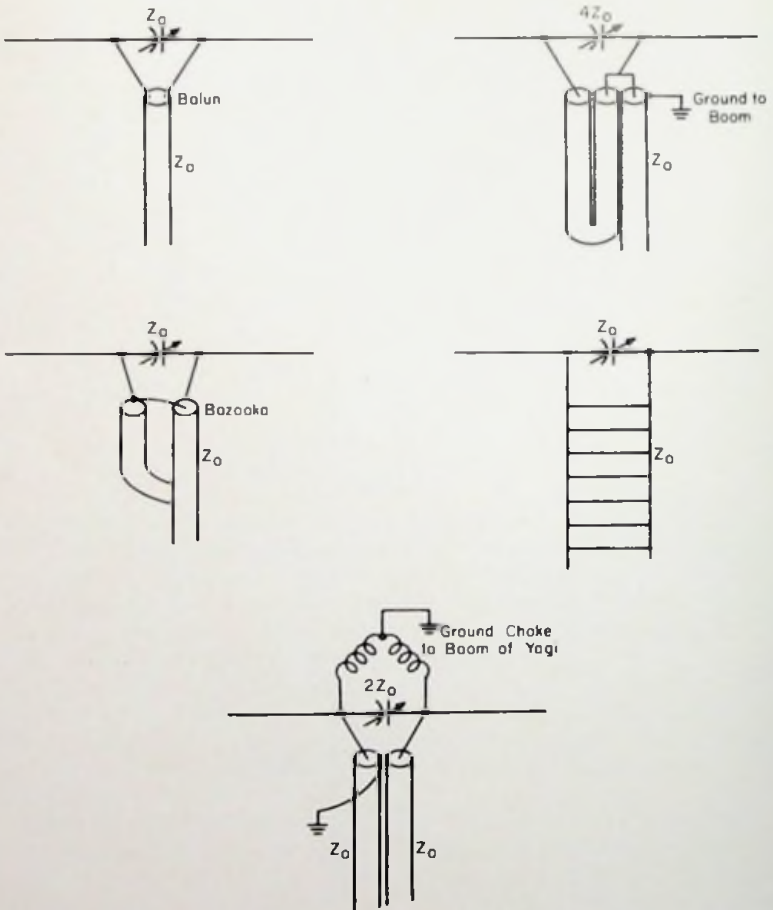

Fig. 3.21 — Examples of feedline combinations for the capacitance match.

- acitor for minimum SWR. Measure the new impedance value.
4. If the impedance is less than the desired value, increase the element length and repeat the above steps until the desired impedance value and minimum SWR are obtained.

When a selsyn motor is connected to the variable capacitor shaft, SWR measurements are greatly simplified. With proper weatherproofing, the selsyn can be permanently attached for broadbanding the driven element.

If the element length cannot be increased due to structural problems and a higher impedance is desired, the schemes illustrated in Fig 3.20 can be used. The radiating area is not increased but the desired feedpoint impedance is easily obtained.

Figure 3.21 provides examples of feedline combinations for the capacitance match. Chokes connected to the feedpoint and grounded to the boom of the yagi provide a low d.c. resistance path for static electricity discharge. With a wire dipole, grounding is not possible except with the inverted vee supported in center by a metal tower. On wood towers or trees, a heavy strap can be run from ground to the feedpoint. In order to achieve various  $Z_0$  values, the length of the dipole will have to be increased proportionally and the capacitor adjusted accordingly. If relatively high  $Z_0$  values, are desired, a combination of load and element lengthening can be used.

## FOLDED DIPOLE MATCHING

Folded dipole driven elements for beam antennas have many advantages. If the second conductor is of the same diameter, the impedance step-up ratio is 4 times that of a single element. Normally, a higher step-up ratio is desirable and this may be accomplished by reducing the diameter of one of the conductors, the conductor that is split and connected to the feedline. The larger, supporting conductor is not altered. Figure 3.22 shows the general construction and a nonogram is provided for determining the impedance step-up for any conductor diameter and spacing.

A suggested impedance with a folded dipole driven element on a beam antenna is 208 ohms. This can be fed directly with 52 ohms coax by employing a half wave (4 to 1) balun. The coax shield is grounded to the boom, resulting in an unbalanced feedline matching a balanced feedpoint.

Assume that a step-up ratio of 15 is desired on the driven element of a 20 meter beam using  $1\frac{1}{4}$  inch tubing and #12 wire (0.08 inch diameter). Since the only unknown is the spacing, the nonogram will provide the answer. The  $D_2/D_1$  value is  $1.25/0.08=15.6$ . Because the tubing will get smaller toward the ends of the element, the value of 15 for  $D_2/D_1$  is used. Place a straight edge on the 15 in the left hand column and across 15 on the impedance step-up line and read 64 on the right had column. Since  $S/0.08 = 64$ , solving for the spacing,  $S = 64 \times 0.08/2 = 2.56$  inches. The radius of the tubing is 0.625 inch, so the actual spacing between the wire and tubing is 1.935 inches.

One advantage of the folded dipole over a single dipole is that the final impedance may be varied to compensate for errors or other factors just by changing the spacing or the wire size. The impedance is easily measured (with an antennascope) directly or at the end of a half wave length of feedline.

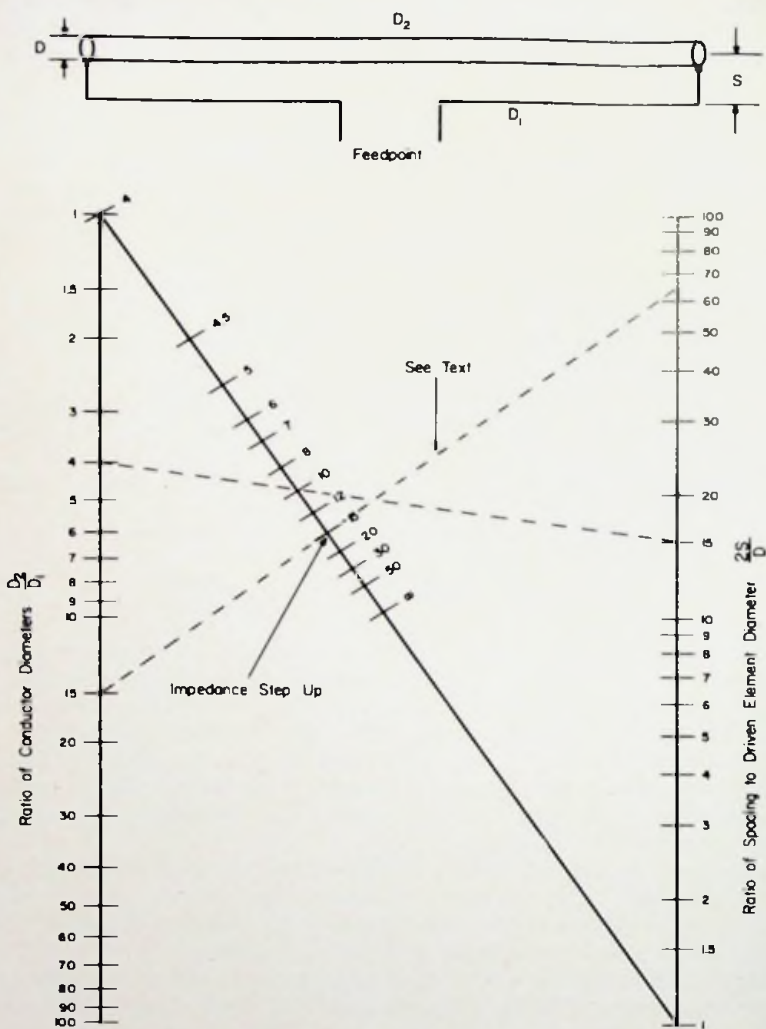

Fig. 3.22 — Nomogram for finding impedance step-up for a folded dipole element.

## QUARTER WAVE STUB MATCHING

The existence of a resistive feedpoint simplifies antenna feedline matching by the use of a quarter wave stub. If the feedpoint impedance of the antenna  $Z_A$ , is greater than the characteristic impedance  $Z_0$  of a quarter (or any odd multiple) wavelength matching stub, the stub is shorted at the input end (Fig. 3.23a or b). The resonant frequency of the antenna can be measured at the shorted end with a grid dipper. An untuned line, such as coax with a balun

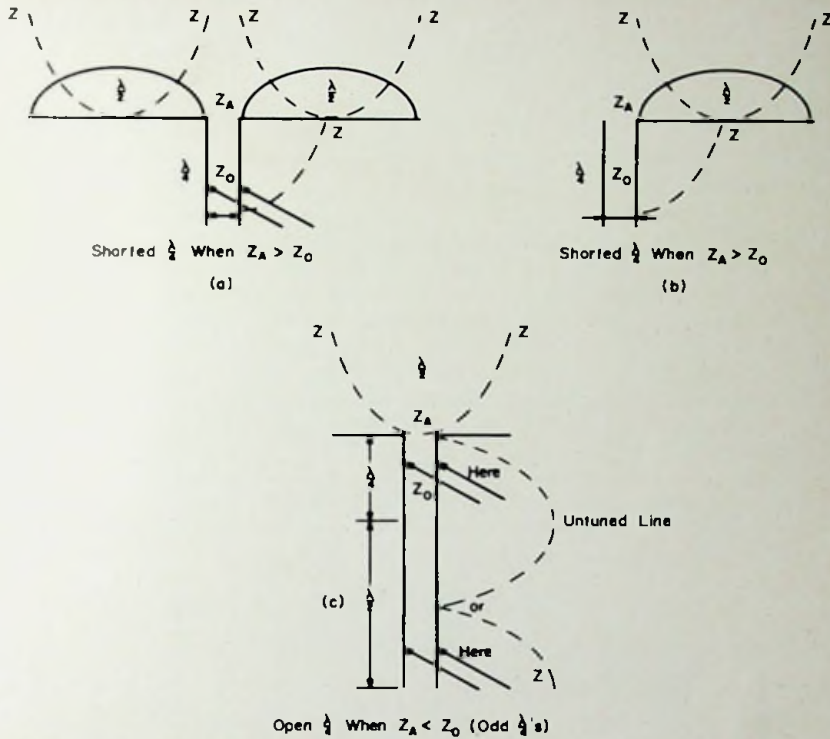

Fig. 3.23 — Quarter wave stub matching. (a) and (b) Shorted stubs for  $Z_A > Z_0$ . Open stubs for  $Z_A < Z_0$ .

or bazooka, or a 300-600 ohm line, can be connected at a point on the stub for a direct match.

When the impedance of the antenna is less than the characteristic impedance of the stub (most likely a high current point), an open circuit stub is used. The open stub will raise the antenna impedance permitting the matching of feedlines having a greater characteristic impedance than the antenna. It may be more convenient to use a  $3/4$  wavelength stub, as shown in Fig. 3.23c. The lower impedance points on the stub will be close to the feedpoint when using a quarter wavelength stub.

### Quarter Wave Stub Matching to Untuned Lines

Another technique that is widely used is to select the quarter wave stub impedance such that it will match the antenna impedance to any desired input impedance. Equation 3.1 may be used for calculating the correct impedance of the quarter wave stub. The resulting impedance is the geometric mean between the antenna and desired input impedances. If the antenna and matching stub impedances are equal, the input impedance will be unchanged regardless

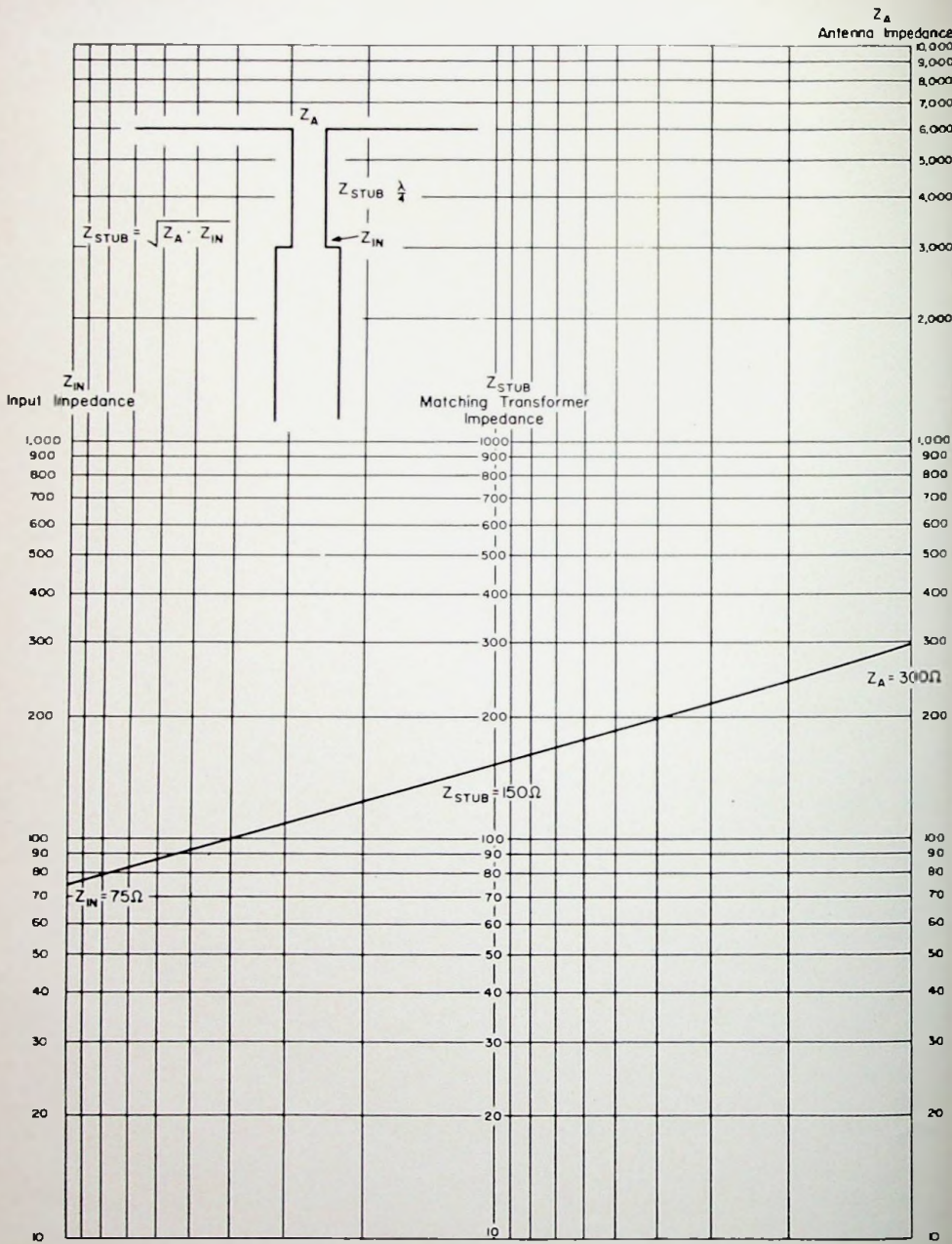

Fig. 3.24 — Nomogram for finding quarter-wave matching transformer impedances.

of the length of the stub. However, the greater the impedance difference between the matching stub and antenna, the greater is the input and matching stub impedance difference and less is the bandwidth. The matching transformer's characteristics must also be capable of handling the maximum current at the low impedance end and the maximum voltage at the high impedance end and without exceeding the power ratings of the line.

One disadvantage of this system of matching is that the range of matching impedances are generally limited by available transmission line impedances. This can be a problem with coaxial lines. However, most any impedance line can be developed by the proper diameter and spacing of a balanced two wire line.

The velocity factor of the line used must be considered when determining the exact length of the quarter wavelength. It is recommended that the matching transformer be cut a few inches longer than the calculated length and then griddip (shorting end for measurement) to find the exact resonant length.

The nomogram of Fig. 3.24 provides a simple method for determining the matching transformer impedance if the desired input and antenna impedances are known. The chart illustrates how a matching transformer of 150

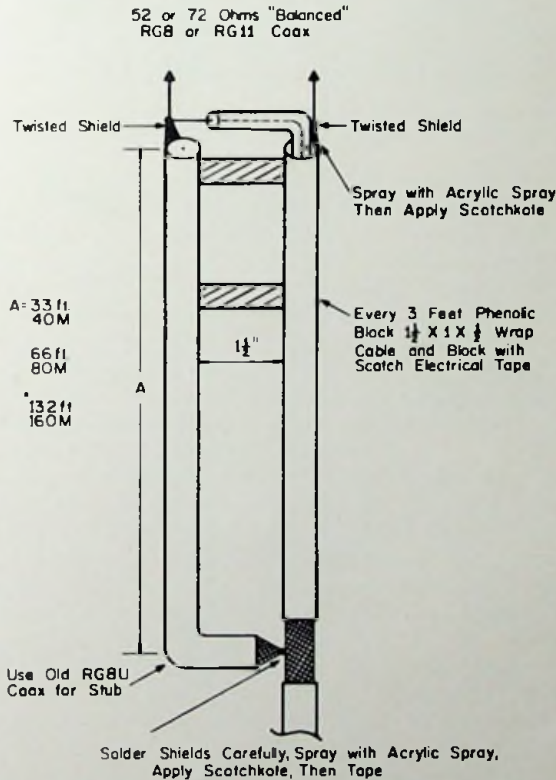

Fig. 3.25 — Construction of bazooka.

ohms will match a 75 ohm input impedance to a 300 ohm antenna.

The nomogram can also be used to find the impedance of an antenna by measuring the impedance at the input end of the matching transformer with an antennascoper. By placing a straight edge on the measured input impedance and the transformer impedance, the antenna impedance is found in its column. This technique is useful when it is desired to measure impedances greater than the range of the antennascoper.

## ONE BAND (1 to 1) BAZOOKA

When a balanced antenna is connected to an unbalanced line such as coax, unbalanced currents exist at the feedpoint and spurious radiation from the coax shield results. The radiation pattern of the antenna is thereby altered. Figure 3.25 shows a decoupling and balancing stub, frequently called a *bazooka*, that presents a high impedance to r.f. leaking from the shield, balances the

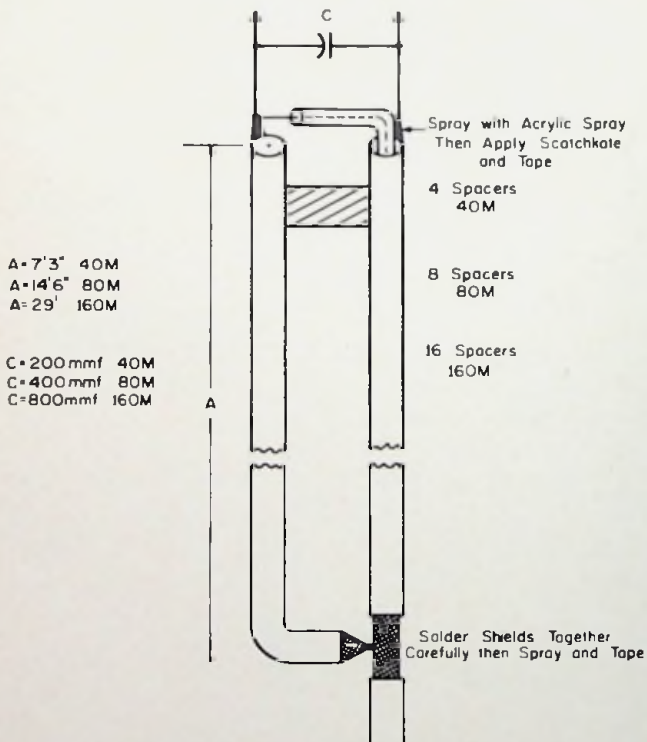

Fig. 3.26 — A "short" bazooka for 40, 80, or 160 meters.

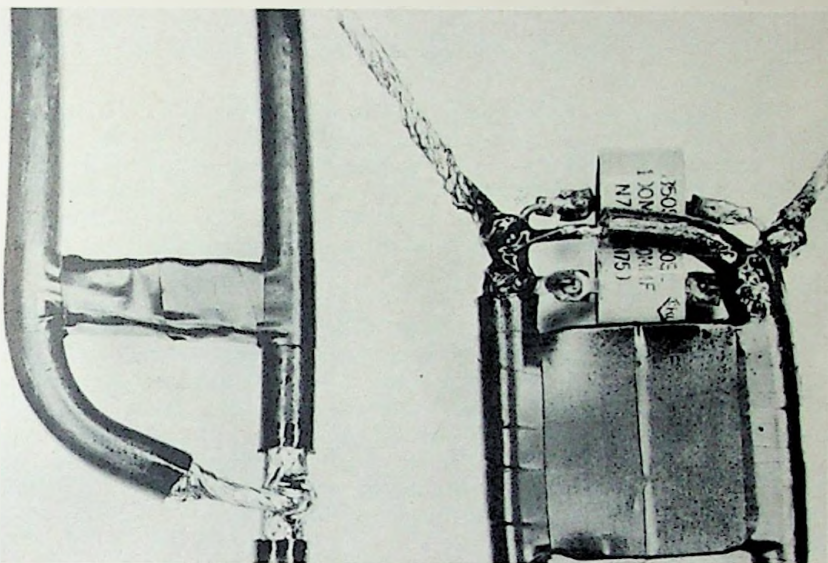

Fig. 3.27 — Photograph showing construction details of a "short" bazooka with capacitor for 40 or 80 meter operation. Capacitance loading is not used on full length bazookas.

feedpoint currents, and improves substantially the antenna bandwidth.

The shorted quarter wave decoupling sleeve has the opposite impedance-frequency characteristics of the antenna (which has the same characteristics as an open quarter wave stub). This is highly desirable because the rate of change of reactance with frequency for a center fed half wave single wire dipole is greater than the rate of change of radiation resistance with frequency. The decoupling stub must be a quarter wavelength at the resonant frequency of the antenna. At a frequency slightly lower than the resonant frequency, the stub is inductive and the antenna is capacitive; therefore, the reactances tend to cancel. This prevents the impedance from changing rapidly and helps maintain a low SWR over the entire band.

Figures 3.26 and 27 show a "shortened" bazooka for 160, 80, and 40 meters which is recommended for beams such as the Hy-Gain Hy Seven two element beams. The 7½ foot stub can be looped before the single coax is rerun parallel to the boom and mast. The full size bazooka would be hard to mount properly when installed on a rotary beam although it can be done and performance improved. The stub should be handled as open wire transmission line.

The quarter wave parallel stub should be of the same diameter as the coax transmission line and equally as flexible. Therefore, the same type of coax cable is ideal for the stub. Since the shield is only used, old coax may be employed for the stub for economy reasons.

The performance of a quad or any other type balanced feedpoint antenna is improved by the use of a bazooka when only one band operation is desired. The bazooka will also work on it's odd harmonics. For example, a 40 meter full size bazooka will operate on 15 meters.



## ONE BAND (4 to 1) BALUN

Often it is desired to balance a coax feedline and also obtain an impedance step-up. By connecting a half wavelength of coax as shown in Fig. 3.28, a half wave *balun* with a 4 to 1 impedance step-up is obtained. With 52 ohm coax a 208 balanced impedance results and with a 75 ohm coax a 300 ohm impedance is obtained. Half wave baluns of this kind are widely used and particularly recommended for beam antennas to ensure clean lobe patterns.

### The Use of Baluns

The importance of using a balun (or bazooka) with a coaxial transmission line feeding a balanced antenna, is amply illustrated in Fig. 3.29. A 3 element tri-band antenna with a driven element which is physically and electrically split in the center (no hairpin) was fed with coax cable. Two identical r.f. ammeters were installed as shown in the figure. To determine the effect of surrounding objects, such as power lines, a number of current values were recorded on each band with the beam pointing in different directions. The power lines were at the same height as the antenna and were about 50 feet from the beam.

Not only was there substantial unbalance in the feedline currents (at 45 degrees, a 1 ampere difference was noted on 20 meters) but also a 0.4 ampere variation in the currents was observed as the beam rotated (Fig. 3.29a).

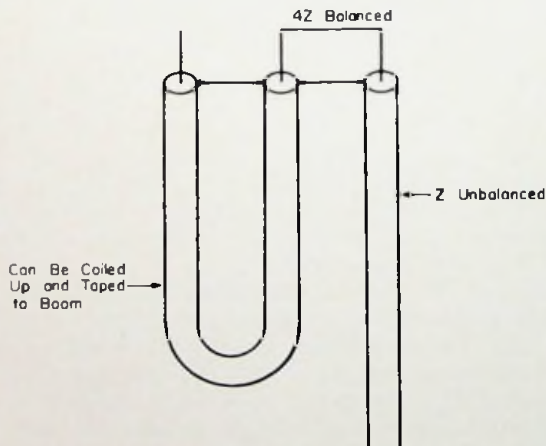
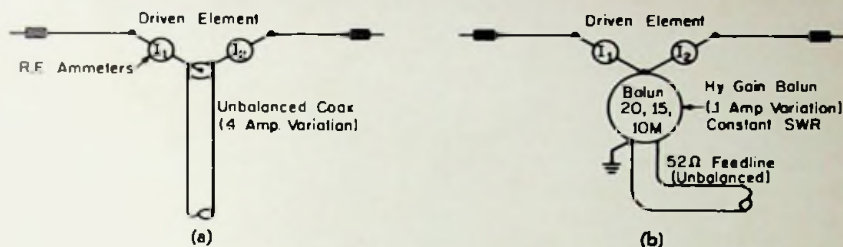

Fig. 3.28 — Construction of a 4 to 1 balun.

Unbalanced currents at a balanced feedpoint cause an unsymmetrical pattern and, in the case of coaxial cables, there is a substantial amount of r.f. spillover to the outside of the shield. In other words, the shield is not working as a good shield should!

Since the shield is connected to one of the feedpoints, the shield becomes



	20M		15M		10M	
	I <sub>1</sub>	I <sub>2</sub>	I <sub>1</sub>	I <sub>2</sub>	I <sub>1</sub>	I <sub>2</sub>
0°	3.8-3		3.05-2.6		3.9-3.3	
45°	4-3		3.1-2.6		3.8-3.2	
90°	3.8-3.1		3.1-2.65		3.75-3.3	
135°	3.7-3.1		3.2-2.65		3.7-3.25	
180°	3.6-3		3.15-2.55		3.85-3.3	
225°	3.7-3.1		3.1-2.4		3.8-3.3	
270°	3.8-3.1		3.1-2.45		3.8-3.3	
315°	3.6-3		3.1-2.6		3.8-3.3	
360°	3.8-3		3.05-2.6		3.9-3.3	

Amp

	20M		15M		10M	
	I <sub>1</sub>	I <sub>2</sub>	I <sub>1</sub>	I <sub>2</sub>	I <sub>1</sub>	I <sub>2</sub>
0°	3.45-3.5		3-3		3.9-3.8	
45°	3.45-3.5		3-3		3.9-3.8	
90°	3.45-3.55		3-3.05		3.9-3.75	
135°	3.4-3.5		3.1-3		3.9-3.75	
180°	3.4-3.5		3-3		3.9-3.8	
225°	3.45-3.5		3-3		3.9-3.8	
270°	3.45-3.5		3-3.05		3.85-3.8	
315°	3.45-3.5		3-3		3.95-3.8	
360°	3.45-3.5		3-3		3.9-3.8	

Amp

Fig. 3.29 — Feedpoint currents of a tri-bander beam. (a) Without balun. (b) With balun

part of the antenna even though it may run at right angles to the antenna. The r.f. currents on the shield radiate and distort the pattern of the beam. This radiation is often a source of TVI. If a feedline will radiate, it will also receive. Because the feedline will be vertical for the most part, the line will be particularly susceptible to noise pick-up. One answer to this problem is to use the Hy Gain 3 band balun for 52 ohms coax. In fact, the name balun was derived from the words "balanced to unbalanced."

Figure 3.29b lists feedpoint currents which result from the use of the balun. There was less than 0.1 ampere variation in addition to almost perfect balanced currents. The balun eliminated r.f. spillover on the outside of the coax shield, which is now connected to the metal case of the balun which in turn is grounded to the boom. The shield is no longer connected to the antenna feedpoint and is therefore no longer part of the antenna. The shield acts as a good shield! Generally speaking, the only currents that now flow on the outside of the shield are currents induced by the field of the antenna itself because of proximity effects.

The small variation in feedpoint currents and SWR indicate that power lines have less effect on an antenna installation than is commonly believed. The variation of feedpoint currents when not using the balun is the result of currents being induced by the antenna on the coax shield. Referring to Fig. 3.30, the voltage induced on the outside of the horizontal coax shield (A) laying on the roof will vary in amplitude, depending on its relative orientation or polariza-

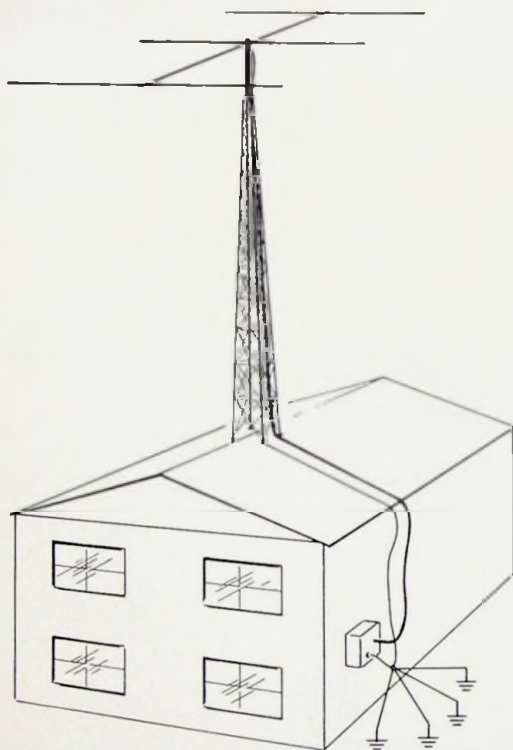

Fig. 3.30 — Inducing voltage on outside of coaxial shield.

tion to the beam. A  $90^\circ$  rotation of the beam from its shown position will cause minimum voltage to be induced on the shield. With direct feed, i.e., without a balun, this induced voltage is one cause of unbalanced currents in the feedpoints as the beam is rotated. With a balun, the shield is not connected to either feedpoint. Therefore, currents on the outside of the coax shield have no effect on feedpoint currents. The balun behaves as a buffer or choke.

With the balun, in addition to stabilized feedpoint currents, the SWR value is virtually unchanged when the beam is rotated even when the beam is close to power lines, etc. It has been experienced that when balanced antennas are fed with an unbalanced feedline, TVI developed in sets not normally disturbed and sometimes as far away as one mile. As soon as a balun was used, the interference stopped.

## **THE 52 OHM TRI-AXIAL SWITCHING HARNESS**

The feed system illustrated in Fig. 3.31 for feeding two antennas simultan-

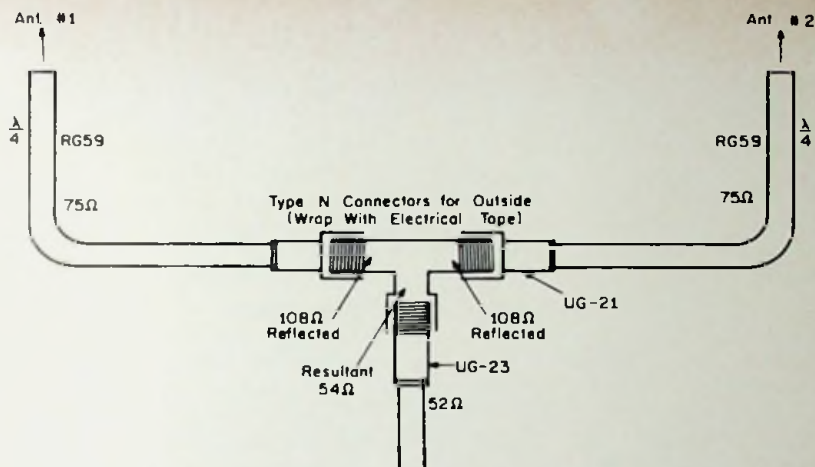

Fig. 3.31 — System for feeding two antennas simultaneously.

ously is both simple and flexible. Unity SWR will be seen by the transmitter, thus minimizing the need for retuning the final amplifier. It has been found in many tests that two stacked antennas together are usually better than one alone. A change in pattern is easily noted when switching two different antennas by the decrease or increase in signal strength and heterodynes.

The problem illustrated in Fig. 3.31 is the feeding of two unbalanced or balanced 52 ohm feedpoint with a single 52 ohm unbalanced line from the transmitter and still achieve a low SWR. Each 75 ohm quarter wave stub raises the 52 ohm antenna impedance to 108 ohms. These two resistive 108 ohm impedances are paralleled in a tee connector and 54 ohms obtained which is close enough to 52 ohms for all practical purposes. For higher power than 1 kw, 72 ohm coax (R 11A/U) can be used. The value of antenna impedance then becomes 100 ohms at each side of the tee connector and the parallel combination is 50 ohms. In this manner, one half of the power is fed to each antenna and a very low SWR is maintained on the coax going to the transmitter or receiver.

The total physical length of the two 72 or 75 ohm coax stubs is only about  $\frac{1}{3}$  wavelength long. It is obvious that this will not be long enough to reach the antennas which can be  $\frac{1}{2}$  or  $\frac{3}{8}$  wavelengths apart. Each stub can be made  $\frac{3}{4}$  wavelength long, or a 15 or 20 foot length of 52 ohm coax can be run from each beam towards the mast and then connected to the 72 or 75 ohm stubs. Another method consists of using equal lengths of 52 ohm line extended all the way to the shack and connected to a coax switch as shown in Fig. 3.32. This configuration permits selection of either antenna or both at the same time with little, if any, change in SWR as seen by the transmitter or receiver.

In position #3, the circuit is equivalent to Fig. 3.31. The center 52 ohm stub is a quarter wavelength in position #3 but this is of no significance because it connects to a longer length of 52 ohm coax again. This 52 ohm wave stub has a very important function when the switch is in position #1 or #2. With the switch in position #1, the two 75 ohm stubs total a half wave in length and present to tee #1, the same impedance as it sees at #2, which is 52 ohms.

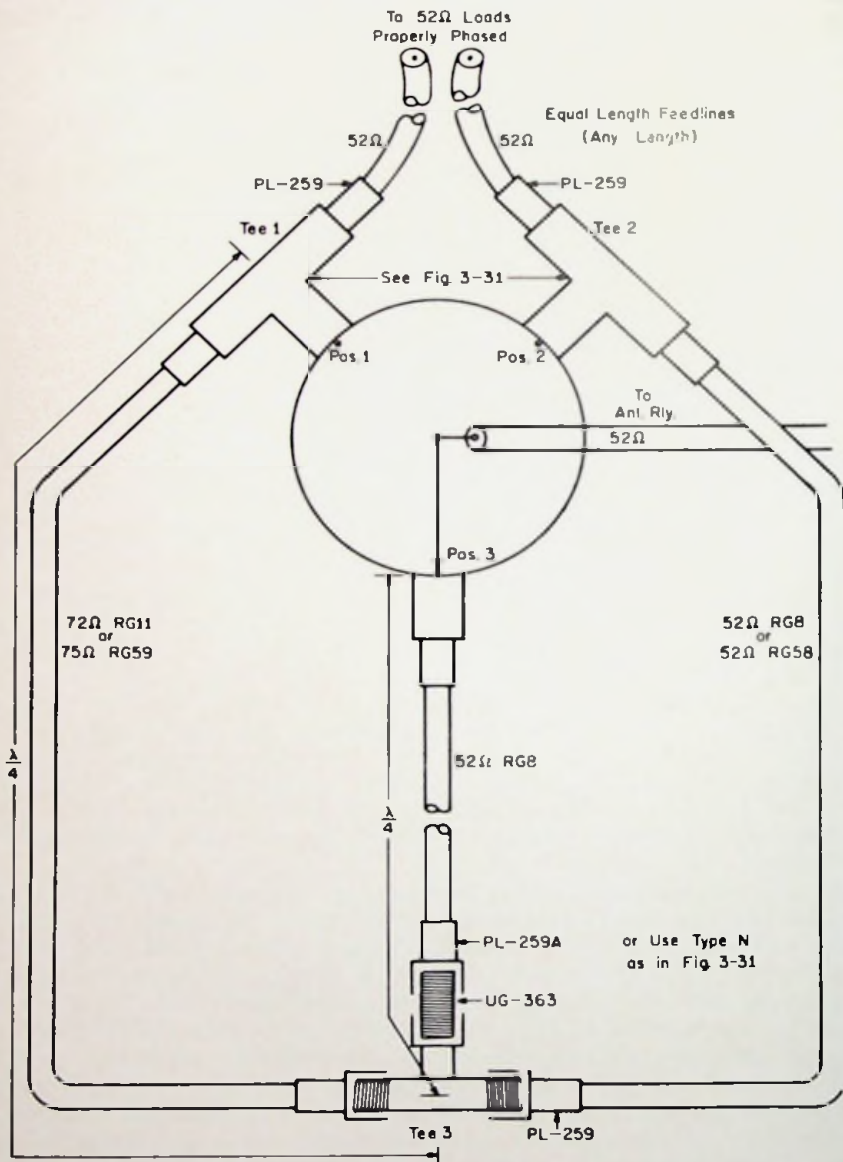

Fig. 3.32 — A more flexible arrangement for feeding two antennas.

This 52 ohms parallels with the 52 ohms from the antenna yielding 26 ohms for a 2:1 SWR. Because of this, some method of disconnecting the stubs from the tee connector must be used when the coax switch is in position #1 or #2. Here is where the 52 ohm quarter wave stub comes to the rescue.

If a quarter wave stub of transmission line is shorted at one end, the stub will reflect an infinite impedance at the other end. Conversely, if such a stub is open at one end, a "dead short" will be reflected to the other end. When the coax switch is in position #1 or #2 there is an infinite load on the quarter wave 52 ohm stub connected at position #3, since nothing is connected to it. At the other end of the coax stub (tee #3), a dead short occurs. As a result of this, an infinite impedance is presented to tees #1 and #2 by the 72 or 75 ohm quarter wave stubs. This disconnects the cables electrically so that the switch only sees the low 52 ohm impedance at position #1 or #2. The 52 ohm quarter wave stub behaves like an automatic coaxial switch.

With a receiver connected to the feedline, a very interesting experiment can be performed by placing the coax switch in position #2 75 ohm stub from

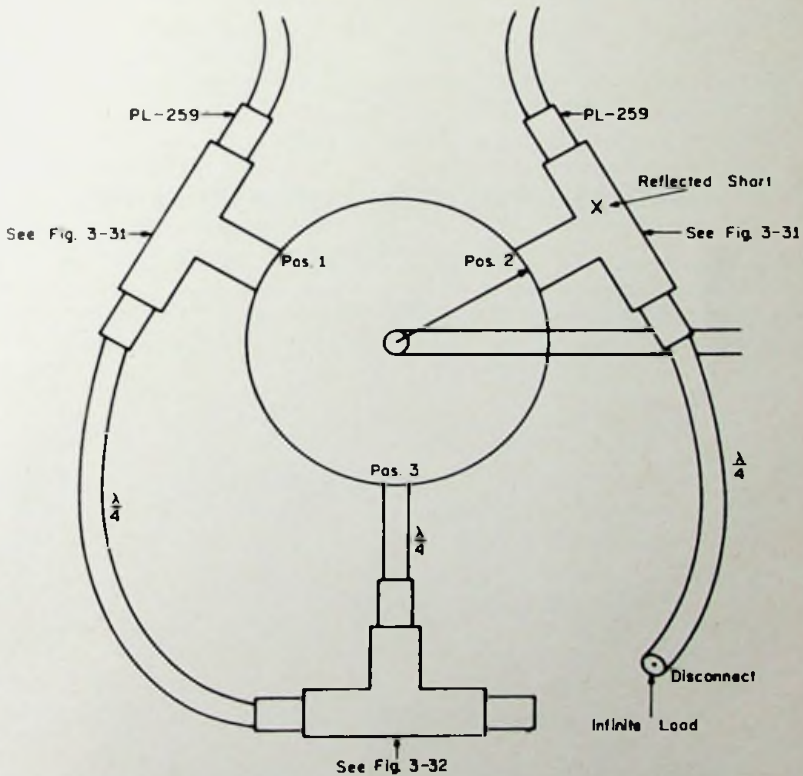

Fig. 3.33 — Open end of a quarter-wave 75 ohm matching stub reflects dead short across feedline. No signal will be heard from receiver.

the position #2 75 ohm stub from tee #3 as shown in Fig. 3.33. For this condition, a short is reflected to tee #2 and the receiver will be "dead." As the receiver is tuned on either side of the resonant frequency of the quarter wave stub, signals will again be heard stronger and stronger as the frequency is increased or decreased away from resonance. This dramatically illustrates the action of a quarter wave stub.

If both beams are gamma matched, the gamma arms must be on the same side. This along with equal length feedlines will ensure that the driven element currents are in phase (Fig. 3.34).



Fig. 3.34 — To keep driven elements in phase with equal length feedlines, gamma matches must be located on same side of antenna element.

## FEED SYSTEMS FOR STACKED BEAMS

The basic system for matching 2 antennas is illustrated in Fig. 3.35. Because of the 0.66 velocity factor of regular coax, the physical length of the two quarter wave matching stubs is about 0.32 wavelength. This length is too short to reach the feedpoints of two antennas spaced a half wave apart.

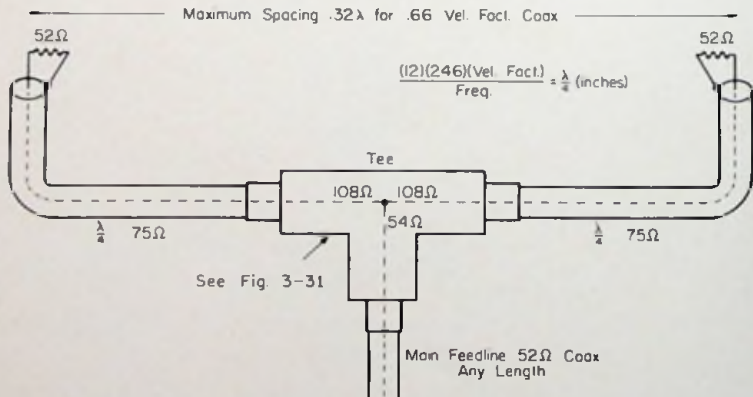

Fig. 3.35 — Basic system for matching two antennas.

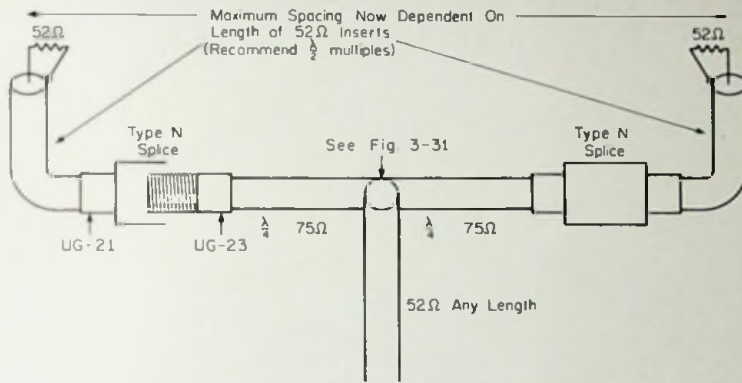

Fig. 3.36 — Using quarter-wave 75 ohm matching stubs.

There are several solutions to this problem. First, a short length of 52 ohm coax can be inserted before the two 75 ohm matching stubs as illustrated in Fig. 3.36. Another technique (Fig. 3.37) is to use 75 ohm matching stubs which are  $\frac{3}{4}$  wavelength long. This procedure eliminates the splices before the two 75 ohm stubs in the method previously described. Every attempt should be made to simplify construction, eliminate splices, etc. The disadvantage of this system is that the bandwidth is slightly reduced by using  $\frac{3}{4}$  wavelength rather than  $\frac{1}{4}$  wavelength matching stubs. This, however is not serious and may perhaps be the better choice of the two systems.

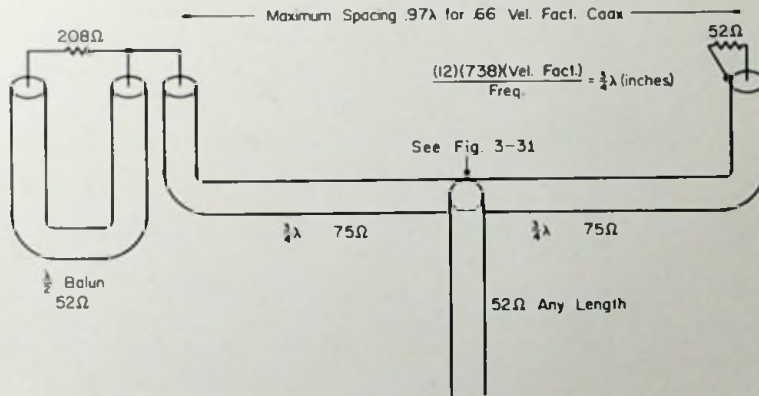

Fig. 3.37 — Using three quarter-wave 75 ohm matching stubs.

Any combination of this system can be used to match any number of antennas so long as the number of antennas is 2, 4, 8, 16, etc. If the number of antennas is three, in-phase and equal currents can be fed to them by using the feed system illustrated in Fig. 3.38. The main feedline in this case is a 75 ohm



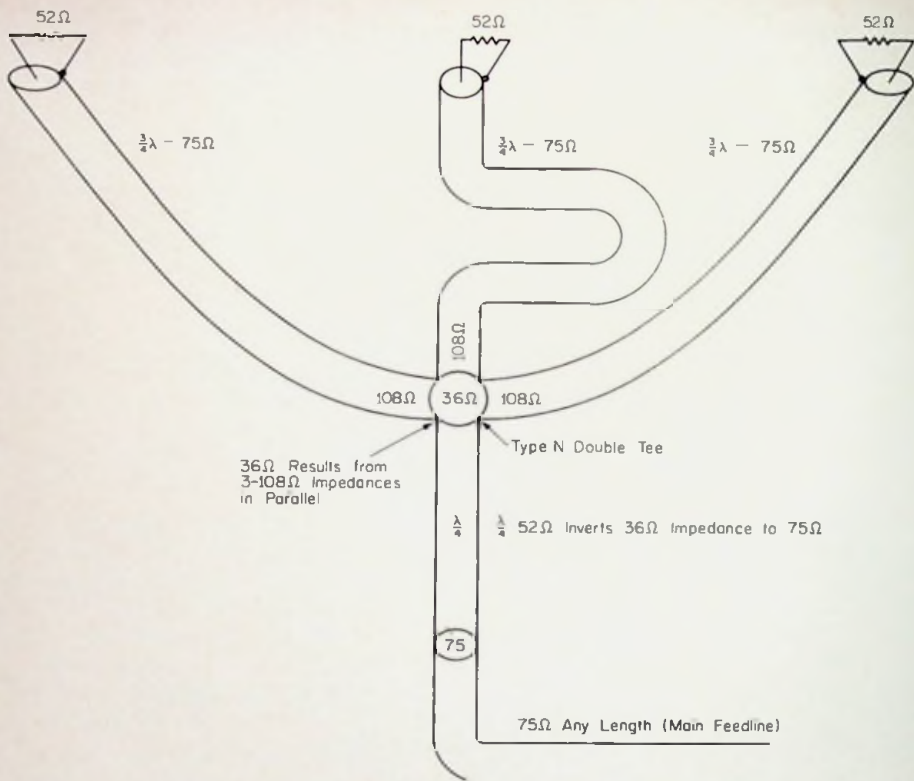

Fig. 3.38 — System used for matching three antennas.

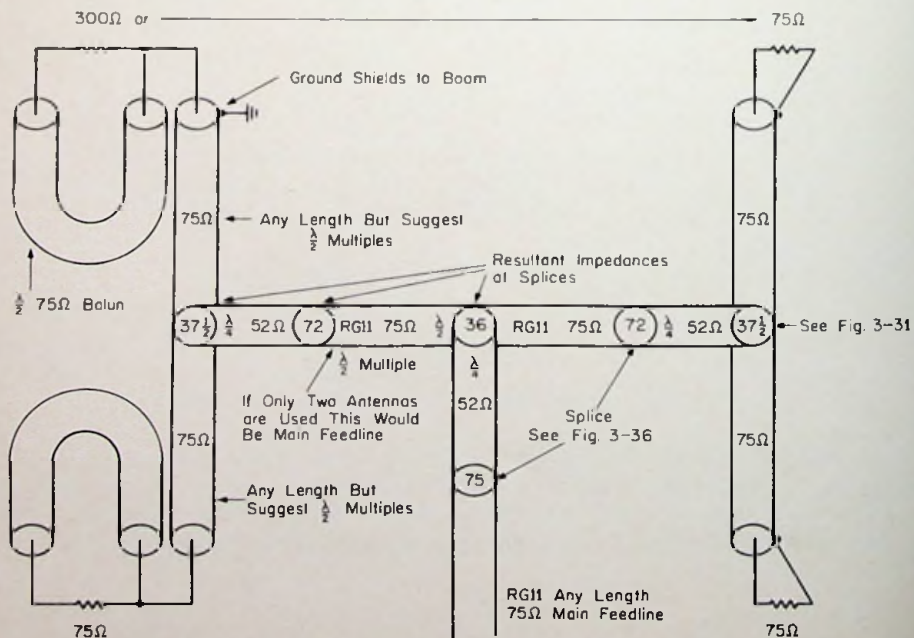

Fig. 3.39 — System for feeding two or four antennas having 75 or 300 ohm feedpoint impedance.

line. For a main coaxial feedline impedance of 75 ohms to be used with 2 or 4 antennas having a 75 or 300 ohm feedpoint impedance, the system of Fig. 3.39 is recommended. If a main feedline (balanced Amphenol ribbon) impedance of 75 ohms is required for 2 or 4 antennas with a 300 ohm impedance, the hookup shown in Fig. 3.40 is offered.

These systems do not permit selection of either antenna or both together. The 52 ohm tri-axial harness connected to a coaxial switch provides this flexibility.

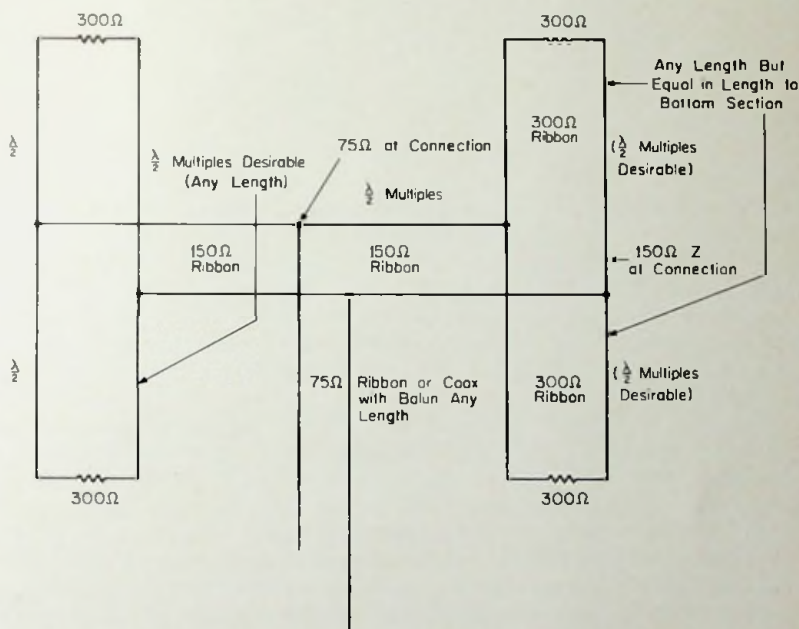

Fig. 3.40 — Feeding four antennas having 300 ohms impedance.

## LINK COUPLING

The pi-network is the most popular impedance matching scheme for coupling power from the transmitter final to a coaxial transmission line. If correct LC ratios are used, little trouble is experienced in coupling power into a transmission line with an SWR of 2:1 or less.

In spite of the popularity of pi-network coupling, link coupling is still used today. With link coupling one may have trouble obtaining adequate loading for reasons such as an insufficient number of turns in the link or a high SWR with certain lengths of feedline. Even with unity SWR (pure resistive load) coupling power to the feedline can be difficult. Ease of loading is often associated with resonant frequency which is generally *not* a true indicator. Common practice mandates grounding one lead of the link and connecting the other

lead to the center lead of the coax. The key to proper coupling is to connect a variable capacitor in series with the inductance of the link and also to use a variable link, as shown in Fig. 3.41.

The inductance and capacitance of a series circuit will present a resistive load to the final tank if the link circuit is resonant and the load is resistive. The resonant condition for the circuit exists when the capacitive reactance  $X_{C_2}$  of the variable capacitor equals the inductance  $X_{L_2}$  of the link. The two re-

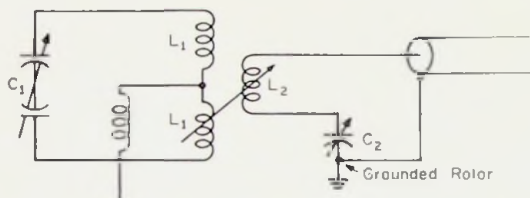

Fig. 3.41 — A workable link coupling circuit.

actances cancel leaving only a resistive component presented by the feedline. If 52 ohm feedline is used and the SWR is 1 to 1, the resistive load presented to the link circuit is 52 ohms. This 52 ohm load increases in value as seen by the plate circuit. The increase depends on the turns ratio of link  $L_2$  and tank coil  $L_1$ . Loading of the final tank circuit is influenced by this reflected load and the amount of coupling. The reflected resistive load lowers the Q of the tank circuit and the resulting impedance (which is resistive at resonance) is lower than it is without load.

The reason for a low plate current at dip or resonance with no load (link set at minimum coupling) is that the no-load Q of the tank circuit is very high. The resulting high impedance of the tank circuit is in series with the plate resistance of the r.f. amplifier tube. The power sees a high resistive load in series with the plate resistance  $R_p$  of the final tube. The resulting plate current flow is quite close to an Ohm's law function of two resistance in series connected as a load to a power supply. As the coupling is *increased*, the impedance of the tank circuit is *decreased*. The final tank circuit remains in resonance and, as a result, the resonant plate current increases. In other words, the plate current will *not* have to be redipped for purely resistive loads regardless of loading.

Assume the load presented by the transmission line has a reactive component (either  $X_c$  or  $X_L$ ) as well as a resistive component, as is the case when the SWR is other than unity. The reactive load will detune the final tank circuit each time the degree of coupling is changed unless the reactance is tuned out at the feedpoint of the transmission line.

The series capacitor will tune out the reactive component either by increasing or decreasing its capacity. Unless the link circuit is resonant (purely resistive), a change in loading will detune the "tank" or plate circuit, requiring the plate circuit to be retuned. The procedure for adjusting the coupling and variable capacitor in a link coupled circuit is as follows:

1. With minimum coupling, apply plate voltage to the final and resonate the final tank circuit. Tune for a plate current dip.
2. Rotate the series variable capacitor  $C_2$  and observe the plate current for an increase in value. If no increase is noted, increase the coupling (an external link adjustment is preferred). Rotate capacitor  $C_2$  through its range of capacity

and look for a rise in current. If an increase in plate current is observed while varying the link capacitor, stop at the peak and again dip the plate current with the final tank capacitor,  $C_1$ . Repeat this procedure until the desired plate current at the dip is obtained. If a plate current peak occurs at a minimum or maximum setting of  $C_2$  with a series or parallel value of capacity and repeat decrease or increase  $C_2$  the previous steps.

3. The link circuit is now resonant. Increase or decrease the coupling of the link or plate voltage for the desired plate current at the dip. Note that at any value of coupling, the final tank circuit will remain in resonance. When a change of coupling detunes the final tank, it is a sure sign the link circuit is not resonant. In this case, the reactive component is coupled into the tank circuit and detunes it, whereas a resistive load will not detune the circuit. Remember that a capacitor load appears as an inductive load and visa versa to the final tank because of transformer action of the tank coil.

When using 52 or 75 ohm coaxial cable, a 1 turn link with a series 100 uufd capacitor is usually sufficient on 20, 15, and 10 meters. On 75 and 40 meters, a 3 to 5 turn link along with a 500 uufd variable capacitor is generally is used. A link with a greater number of turns requires a larger capacitor. In addition, arcing may develop. Loading, however, is easier with a link of many turns. The plate spacing for  $C_2$  is small since the voltage on low impedance lines is fairly low. A spacing of 1/16 inch is usually sufficient for transmitters operating within the maximum of one kilowatt.

If full loading is obtained with a small amount of coupling, this can be indicative of too many turns in the link or a high SWR. If insufficient loading at full coupling occurs this is a sign of an insufficient number of turns in the link, the link circuit being out of resonance, or a high SWR (low impedance point). Note that with the link circuit resonant, a fairly wide shift in frequency can be made without the final swinging too far off resonance.

# INDEX

Antenna:	Distributed Constants	12
Dipole, Half-Wave	Electric Field	14
Directional Characteristics, Long Wire	Electrical Ground, Determination of	54
Feedpoint	Electromagnetic Field	13
Gain	Electromagnetic Radiation	46, 48
Half-Wave Characteristics	End Effects	67
Impedance vs. Height	Feeding Stacked Beams	104
Length	Feedline (see Transmission Line)	
Multiple Wavelength	Feedpoint and Field Pattern	64
Radiation Patterns	Fields:	
Terminated	Electric	14
Tilting Long Wire	Electromagnetic	13
Tuners	Induction	48
Balun	Magnetic	14
Bazooka	Radiated	48
Broadbanding	Folded Dipole Matching	91
Capacitance Match	Free Space	51
Characteristic Impedance:	Gain, Antenna	50
Definition	Gamma Match	80
Derivation of	Hairpin Match	88
Construction:	Half-Wave Antenna	66
Bazooka	Induction Field	48
Gamma Match	Infinite Line	15, 20
Open-Wire Line	Johnson Match Box	78
Tri-Axial Switch	Lightning Protection	38
Tuner	Line Impedance	18
Coaxial Lines:	Link Coupling	107
Characteristic Impedance	Long Wire Antennas:	
Shielded Pair	Directional Characteristics	60
Single	Terminated	63
Decibel	Tilting	59
Delta Match	Lossless Line	16
Dipole, Antenna:	Lumped Constants	12
Folded	Magnetic Field	14
Half-Wave		
Radiation Patterns		

Matched Lines .....	29
Matching:	
Capacitance .....	89
Definition .....	71
Delta .....	87
Folded Dipole .....	91
Gamma .....	80
Hairpin .....	88
Quarter-Wave Stub .....	92
T .....	84
Millen Transmatch .....	79
Multiple Wavelength Antenna .....	60
Nonresonant (Flat) Lines .....	25
Open Lines .....	22, 26, 27, 29, 36
Polarization .....	50
Pruning .....	74
Quarter-Wave Line:	
Filter .....	38
Metallic Insulator .....	37
Stub .....	92
Radiation Patterns, Antenna 57, 58, 65	
Radiation Resistance .....	51
Reception .....	50
Reciprocity .....	50
Reflection of Energy .....	18
Resonant Line .....	25
Ribbon Line .....	31, 32
Shorted Line .....	21, 26, 28, 30
Single Wire Lines .....	31
Stacked Beams, Feeding of .....	104
Standing Waves:	
Open Line .....	22
Other Conditions .....	22, 23
Shorted Line .....	21
Standing Wave Ratio (SWR):	
Definition .....	24
Effects of .....	25
Feedline Attenuation .....	69
Stub Matching .....	40, 92
T-Match .....	84

Tables:	
AWG .....	44
Attenuation Ratings of Coax Cables .....	42
Flexible Coax Lines .....	33
Gain Values of Long Wire Antennas .....	70
Power Ratings of Coax Cables .....	41
Twin-Lead Transmission Lines .....	43
Velocity Factors .....	20
Wire Strandings in RG/U Cables .....	45
Tilting Wire Antennas .....	59
Transmission Lines:	
Applications of .....	37, 38, 40
Attenuation and Losses .....	16, 69
Characteristic Impedance .....	14, 15, 44
Coax .....	32, 34, 35
Definition .....	11
Distributed Constants .....	12
Impedance .....	18
Infinite .....	15, 20
Losses .....	25, 26
Lossless .....	16
Matched .....	29
Open and Shorted .....	26
Parallel .....	31
Pruning .....	74
Reactance .....	38
Resonant and Non-Resonant .....	25
Ribbon .....	31, 32
Single Wire .....	31
Standing Waves .....	18
Two-Wire .....	31
Unmatched .....	30
Wave Motion .....	18
Traveling Waves:	
Infinite Line .....	20
Terminated Line .....	20
Tri-Axial Switch .....	100
Tuner, Antenna .....	73, 74
Two-Wire Lines .....	31
Unmatched Lines .....	30
Velocity Factor .....	19
Velocity of Propagation .....	19

