

**Audio  
Measurements**

**Norman H. Crowhurst**



**Audio  
Measurements**

**Norman H. Crowhurst**

# Audio Measurements

**Norman H. Crowhurst**

GERNSBACK LIBRARY, INC.  
NEW YORK, N. Y.

© 1958 Gernsback Library, Inc.  
All rights reserved under Universal,  
International, and Pan-American  
Copyright Conventions.

Library of Congress Catalog Card No. 57-14486



# contents

chapter

page

1

**Measurement techniques** 7  
Absolute and comparative criteria. Relative output level. Instrument limitations. Standards. Method of establishing equipment accuracy. Voltage comparisons. Waveform effects. Invalidation of reading due to waveform change. Loading. Spurious effects. Invalidation of readings. Faults in making audio measurements. Avoiding ground loops and spurious effects.

2

**Test equipment** 13  
Audio oscillators. Heterodyne or beat-frequency audio oscillator. Zero beat. R-C feedback oscillators. Characteristics of various types of audio generators. Vacuum-tube voltmeters. Scales. Audio wattmeter. Calibrated attenuators. Oscilloscopes. Square-wave generators. Harmonic-distortion meters. Intermodulation test meters. Wave analyzers. Bridge circuits. Flutter and wow meters.

3

**Basic measurements** 45  
Frequency. Instrument calibration. Voltage and current. Phase. Resistance and impedance. Commonly used ac bridges. Drysdale, Hay and Maxwell bridges. Wheatstone bridge. Direct-reading capacitance checker. Direct-reading impedance meter. Impedance-admittance bridge. Acoustic velocity and pressure. Groove velocity. Disc compliance and viscosity. Tape magnetization. Tube and transistor dynamic characteristics.

4

**Basic amplifiers** 81  
Frequency response. Audio-oscillator comparator techniques. Gain. Power output characteristic. Power response. Harmonic distortion. Intermodulation distortion. Intermodulation tests. Hum and noise. Measuring input impedance characteristics. Output impedance. Impedance reflection. Effect of supply variation.

5

**Output transformers** 119  
Specifying transformer performance. Efficiency factors. Insertion loss of an output transformer. Measurement of core loss. Frequency response. Low-frequency performance. High-frequency performance. Measuring magnetizing current and waveform. Leakage inductance. Checking winding capacitance. Notch in transformer response.

6

**Preamplifiers** 133  
Frequency response. Method for checking equalization characteristics. Automatic plotting of response curves. Interaction between bass and treble tone controls. Variable-slope controls. Loudness contours. Incorrect loudness compensation. Gain and sensitivity. Distortion. Noise. Dynamic range. Cross-talk termination. Microphony. Supply changes.

7

**Pickups and arms**

151

Arm resonance. Frequency response. Pickup performance. Frequency discrimination. Stylus compliance. Measuring the response of a pickup. Shadowgraph techniques. Sensitivity. Impedance. Compliance and dynamic mass. Checking arm mechanical impedance characteristic. Stylus force. Distortion. A-N IM test. Utilization features. Counterbalanced arms.

8

**Turntables and changers**

167

Speed constancy. Cyclic changes. Flutter and wow. Test with stroboscope for speed fluctuation. Frequency test discs. Flutter and wow meter. Relative sensitivity of human hearing. Frequency response of weighting network. Rumble. Setup for testing for rumble. Vibration pickup. Hum radiation. Measuring motor field radiation. Measuring drag produced by a tone arm.

9

**Tape recorders**

179

Speed constancy. Varying tape tension. Flutter and wow. Method of preparing a standard tape for a speed constancy test. Tape handling. Setup for measuring start and stop times electronically. Incorrect alignment. Response of a good head. Frequency response. Distortion characteristic for a typical tape. High-frequency bias. Maximum density levels of different tapes. Dynamic range.

10

**Microphones**

195

Acoustic properties. Using the Rayleigh disc. Deducing microphone response. Reciprocal test method. Using a calibrated microphone. Anechoic chamber for testing. Taking microphone response automatically. Adding a warble tone to heterodyne-type audio oscillator. Proximity of microphones. Symmetrical placement. Directivity. Transient response. Phase response. Impedance. Distortion and noise. Vibration isolation. Effect of housing.

**Index**

219

# introduction

**T**HESSE days everything seems to be an offshoot from something else: radio started as an offshoot from electricity; electronics and television were offshoots from radio; and somewhere in the picture audio got its start as a separate branch.

But with time the pattern changes: now electronics is seen as the more basic field, and audio pertains not only to frequencies that have been or will be sound—although that is its most obvious application—but it is characterized particularly by the handling of frequencies over an exceptionally wide band, for whatever purpose.

With the development of a new field, at the beginning, whoever is concerned jumps into the breach and does his best. Many musicians got their feet wet in electronics because they were not satisfied with the efforts of electrical hams at recording and transmission. But as the audio “art” grew, the necessity for proper instrumentation became evident. Here again methods were devised to meet the need by those who had gotten involved in this rapidly developing field.

Now, after several decades of audio as an entity in its own right, it seems there is no single documentation of audio measurements—largely because everyone “in the business” has been too busy doing it to write about it! As a result, much time is spent in passing out, individually, information on this subject. To save this waste of time, the author has organized as much as possible of this information into the present book, to provide a handy reference on the subject.

The book is arranged so it can easily be used as a textbook. But the sequence has also been chosen as a logical one for reference or handbook purposes. Its coverage ranges from types of measurements used professionally and for standardization purposes, to



simplified ones that can use a minimum of equipment. In this way it will serve engineers at all levels and at the same time technicians and hobbyists.

In collating material for presentation in a book such as this, it is inevitable that one finds it necessary to use a guillotine to meet space requirements. The textual treatment has been kept concise, as far as is consistent with maintaining lucidity, and references are given at the end of each chapter where further information may be obtained, if necessary. But this does not mean the book is a precis, or simplification, of material already published: a very large proportion of it is completely original.

Even this usage of the guillotine was not sufficient. Subject matter had to be cut. In the original plan, loudspeakers and crossovers were to have been included. But for successful coverage, they need a book for themselves. In a sense too, they are not strictly audio, but get rather more involved in acoustics than do other items in the book; and there is already more in the literature covering this area than there is for some of the things we have covered.

Acknowledgement should be made here to the many people who have helped in the preparation of this book. Credit is given under individual illustrations where these have been supplied. Many readers who have written the author over the years, and people with whom he has worked, have helped him to get the practical slant—knowing just where you'll need help—that runs through the book.

NORMAN H. CROWHURST

# measurement techniques

ONE of the most important things to learn about measurements in general is the distinction between absolute and comparative criteria. In audio, for some measurements it is important to obtain a degree of precision in absolute terms. For example, suppose you want to know how much power output an amplifier produces. The formula for power output is volts times amperes equals watts. If an instrument is used with a series of markings across the scale which are not calibrated accurately in electrical units, any calculation of power must be indefinite.

If a voltmeter reads 10 volts, when the actual voltage is 9.5, and the ammeter reads 5 amperes when the current is really only 4.7, the calculated power is  $10 \times 5 = 50$  watts while the actual power is only  $9.5 \times 4.7 = 44.65$  watts.

For this reason it is important to know the exact voltage and current delivered by the amplifier. However, when measuring other aspects of the performance of an amplifier, precision of this kind is not needed. An example of this is frequency response, which is an expression of the *relative* output level at various frequencies.

## Instrument limitations

If an input of 0.5 volt produces an output of 10 volts and the circuit is arranged so that the same meter is used for both measurements, then it is relatively unimportant (when determining frequency response) whether the input is exactly 0.5 volt. If it is 0.4 volt, then the output will be 8 volts, but the ratio between the two measurements remains at 20 to 1.

readings when connected to the odd-shaped waveform at the output because of the different kinds of rectification used.

The difference in readings can sometimes be observed before it is realized that the output is distorted. This difference supplies

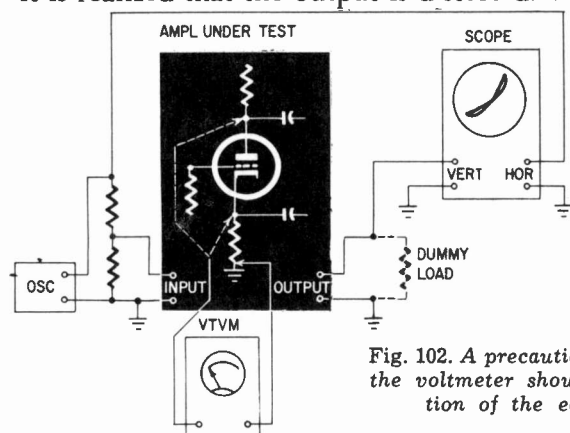

Fig. 102. A precautionary measure. Connecting the voltmeter should not disturb the operation of the equipment under test.

the clue that the waveforms of the amplifier should be examined. Obviously what is being measured must be seen to determine whether the waveform is the sine wave it is thought to be.

### Loading

Sometimes the ac voltage measured at the cathode of a split-load phase inverter (or the grid of the tube it feeds, as the case may be) will appear to be much more than that measured at the plate (or the grid of the following tube). From this measurement it can be erroneously concluded that the phase inverter is faulty in some way. In point of fact, the difference in reading is due to the different loading effect of the voltmeter on the two circuits.

But you can't measure the voltage at these points without applying the voltmeter or some other measuring instrument. How is one to know whether the connection affects the voltage reading? In this example, a simple method of checking is to put a scope or voltmeter (or both) across the output of the amplifier. If connection of the voltmeter to any test point affects the reading, it will also affect the signal from that point on throughout the amplifier. The technique, then, is to connect a scope to the output terminals of the amplifier with the voltmeter applied alternately to the plate and cathode of the phase inverter (Fig. 102). Watch what happens on the scope. Probably the scope will remain steady when the voltmeter is connected to the cathode, but a considerable change in waveform will occur when it is applied to the plate.



## Spurious effects

Loading, however, is not the only way in which the measuring instrument can invalidate the measurement. The capacitance of the connecting leads can produce enough extra capacitive coupling from one point in the amplifier to another to make it become

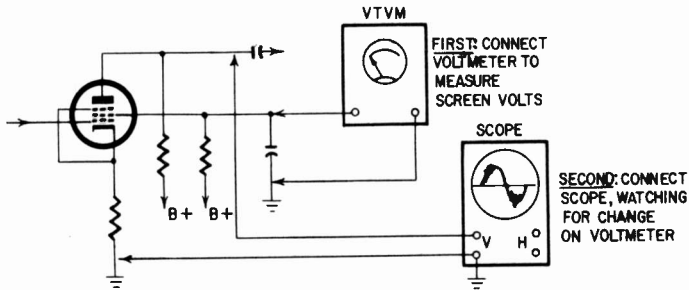

Fig. 103. Using a voltmeter to check that connecting a scope does not disturb the circuit.

unstable. This again means that the reading on the voltmeter is completely misleading.

Sometimes the loading effect of the voltmeter does not alter the output voltage, but it can still invalidate the reading. For example,

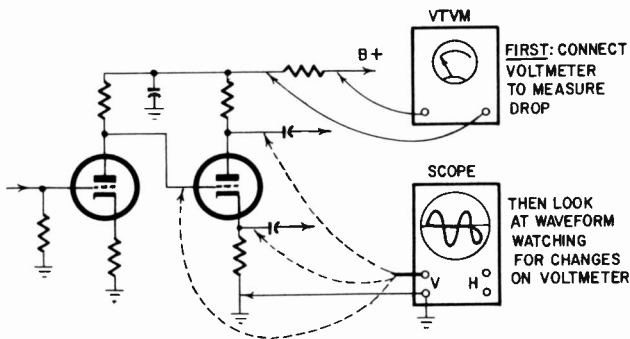

Fig. 104. Another method of using a voltmeter to check whether a scope disturbs the circuit.

when the amplifier is equipped with a large degree of negative feedback the amplifier input will automatically be adjusted so that the output remains the same. The wave may change slightly (which can be observed on a scope) or it may only flicker.

Such a change can be detected with a dc meter connected to a high-voltage supply point (the screen of a pentode) which may be adversely loaded in its plate circuit when a scope is applied (Fig.

103) or by measurement of the voltage drop across a series feed resistor in the decoupling circuits of the B-plus supply (Fig. 104). If connecting a scope or voltmeter at some point causes any change in the supply voltage or current, it is evident that the operating condition of the amplifier is disturbed by the connection.

### What, as well as how much

What has been said in this chapter can be summarized in just one sentence. Check *what* you are measuring as well as *how much*. The scope must be a complement to measuring techniques.

A run on the distortion characteristics of an amplifier may show that distortion progressively reduces down to the half-power point. Below this point, according to the readings on the distortion meter, the distortion seems to come up as the level is reduced

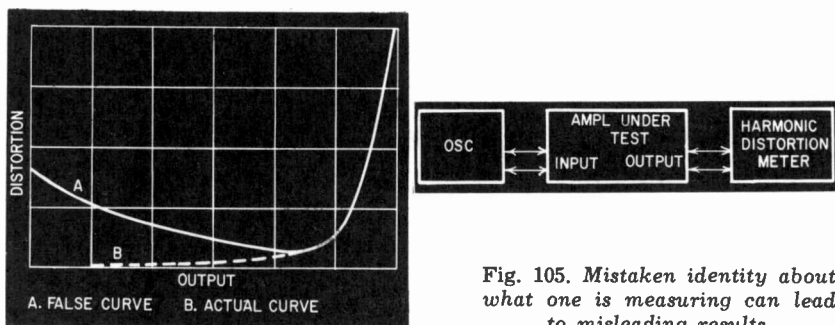

Fig. 105. Mistaken identity about what one is measuring can lead to misleading results.

further (Fig. 105). Of course, there are amplifiers in which this really happens. Most probably the distortion meter is not measuring distortion components of the input, but some stray component such as hum. Use of a scope in conjunction with the distortion meter avoids an error of this kind.

Filters can be used to eliminate the hum component so that, in theory, all that remains in the distortion meter residue are the harmonics. Nevertheless a scope must still be used since hum can be introduced through the ground return system in such a way that the filter will not eliminate it.

Some faults in making audio measurements arise from using complicated equipment. It isn't always advantageous, except for repetitive tests under well-established conditions, to use the most complicated or elaborate test equipment you can get. Sometimes this can invalidate the results through faulty ground techniques. For laboratory measurements it is sometimes easier to use simpler and less expensive equipment to avoid ground loops and other spurious effects.

## test equipment

**W**HATEVER the audio measurement, there are usually two, three or more ways of making it, dependent upon the equipment you have and upon the personnel doing the job. If it is of a laboratory nature, requiring precision results, one kind of equipment will serve the purpose best, while routine production measurements call for equipment that makes the procedure possible while making minimum demands on the skill of the operator. Within these limits, however, there are variations of method according to purpose and application.

In high-fidelity and other equipment in the audio field, two trends appear. One is toward individual test components that can be put together in a variety of ways to perform a multiplicity of checks; and the other is toward package units which contain everything necessary for audio testing.

The advantages of individual components are their versatility and the fact that they are usually much easier to check in the event of failure of one of the components. With the composite "system checker," the failure of an individual component will often throw out several of the tests for which the equipment is intended and will make it difficult to ascertain just why correct results are not being achieved.

However, the composite system does have the advantage of simplicity in routine use. Most better-class manufacturers prefer to build their own production test equipment to fit in with their own particular schedules. They may use ready-made components built into a composite testing system, or they may build the complete unit from the bottom up.



## Audio oscillator

For most of the audio tests you may want to make, you will need an audio sine-wave generator. It is necessary for checking frequency response, measuring power output and almost all tests except those involving some other type of generator, such as a square-wave generator. With modern standards of distortion in audio equipment, it is vital that the audio sine-wave generator itself have low distortion.

But the term "low" can have different connotations according to application. For some purposes and methods of test, a distortion of 2% would be considered low, while for testing a high-fidelity amplifier with a rated distortion of 0.1% and using a harmonic-distortion meter, a distortion of 2% would be considered very much too high in an oscillator.

However, there may be another way of making the measurement—using an oscilloscope, for example, that enables an oscillator with, say, 2% distortion to be utilized for checking the distortion of an amplifier producing only 0.1%. But this is rather unconventional and certainly not adapted to routine testing. So for routine applications it is essential that the sine-wave generator have a distortion figure of at least an order of magnitude better than the distortion in the equipment to be tested, otherwise filters will have to be utilized to eliminate the residual harmonics at the input end.

For taking frequency runs the audio sine-wave generator must have a flat frequency response. By this we mean that the output should not vary as the frequency control is rotated. This is sometimes a difficult requirement to meet, although many modern signal generators come pretty close to achieving it. But when making frequency measurements to an accuracy of, say, 0.1 db (which is necessary if the response is specified to within 0.5 db, for example), very few audio sine-wave generators, if any, are good enough without some further method of checking their accuracy.

For most audio test purposes, precision of frequency calibration is not vital to maintain low drift. However, in many measurements drift from the calibration can be disconcerting, to say the least, even though it may not be vital.

Three basic types of audio signal generator are now on the market. These use the heterodyne or beat-frequency principle and two types of R-C feedback. The feedback principle can vary in a number of other ways, but from the viewpoint of overall

performance the two types result in a multirange and single-range oscillator, respectively.

With the heterodyne type of oscillator two high frequencies, usually 100 kc or higher, are heterodyned and the audio frequency is the beat-note resultant (Fig. 201). The usual practice is to swing the frequency of the stronger oscillator and maintain

Fig. 201. Basic principle of the heterodyne, or beat frequency, audio oscillator.

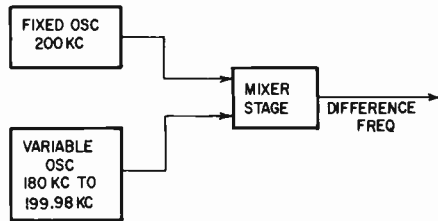

a distortionless waveform in the weaker one. This results in the best audio waveform in the output and also gives the best control of frequency to provide a frequency-stable output.

Of course it is necessary to use temperature-compensated components and, if possible, to maintain a reasonably uniform operating temperature in the oscillator itself. Any drift in the high frequencies results in a much bigger percentage drift of the audio-frequency output. The drift is related to the high fre-

Fig. 202. The scale for a good beat frequency oscillator is logarithmic for most of its range, but is linear at the bottom end, down to zero.

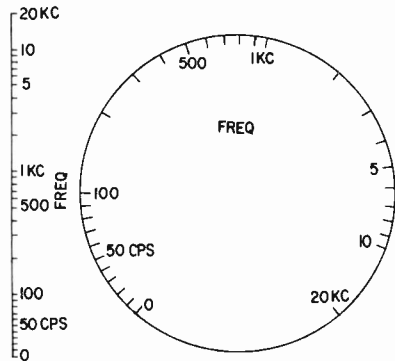

quencies rather than to the audio output frequency of the moment. For example, if the high frequencies are 100 kc and the drift is 0.1%, this represents a 100-cycle change. If the audio oscillator swings from 20 cycles to 20 kc, a change of 100 cycles is 0.5% of 20 kc. But it is 500% of 20 cycles! In fact, it will result in the oscillator being difficult to maintain on zero at the low-frequency end.

For this reason an oscillator of this type requires a much better stability than 0.1%. It should maintain its stability to within a

cycle or two in the 100-kc fundamental frequencies, otherwise the drift at the low-frequency end will be considerable.

Usually this type of oscillator employs either a variable inductor, with the inductance being changed by some kind of loss arrangement that expands the rate of change at the low end, or else a variable capacitor in which the rate of change of capacitance is expanded over the scale at the low end to produce an approximation to a logarithmic frequency scale, usually from about 100 cycles to the top end of the range (Fig. 202). It is difficult to maintain the logarithmic characteristic right down to, say, 20 cycles. A beat-note oscillator, unlike the other types, goes right down to zero so it cannot be logarithmic to the bottom of its scale. Somewhere there has to be a transition to an approximately linear scale, usually at about 100 cycles.

The use of "zero beat" is a good test of the ability of the oscillator to produce good waveform right down to the lowest wanted frequency, generally 20 cycles. If there is any "pulling" between the fundamental frequencies, due to stray coupling, this will destroy the waveform and also make the zero-beat point indeterminate. The result is a "spread" over which the oscillators will not produce a beat. Also, at a relatively high frequency (say 10 cycles or higher) suddenly a rather poor waveform will appear. By maintaining good isolation between the fundamental frequencies and using a detector which produces no cross-coupling between the two, the resultant output will maintain good waveform and an accurate zero beat becomes possible within the range of the zero adjustment.

Fig. 203 shows the photo and basic schematic of a well-engineered beat-frequency instrument, using capacitive tuning.

The best way for setting up the correct frequency calibration with the zero adjustment is to use the 60-cycle line frequency to inject a small quantity of a 60 cycle sine-wave from the power supply. This will result in a beat between the 60 cycles produced by the oscillator and the 60 cycles from the line frequency, which can be adjusted to zero. Use care to avoid possible confusion for the oscillator can produce 60 cycles in two places—one on each side of zero. We need to be sure that the 60 cycles obtained is on the right side of zero.

If it is on the wrong side, then 60 cycles will be an "inversion" of the true 60 cycles. The zero beat will occur at about 120 cycles on the scale and 60 cycles will appear at a scale reading of about 180 cycles. Providing a zero position on the scale makes it easier

to zero-adjust the oscillator by turning the ZERO ADJUST until the output needle dips to zero, then adjusting to 60 cycles, switching in the 60-cycle beat and adjusting again to zero beat at this point, taking care not to go through zero. Then the oscillator is accurately set.

Apart from the drift problem, heterodyne oscillators maintain calibration very closely. Once you have set the calibration by

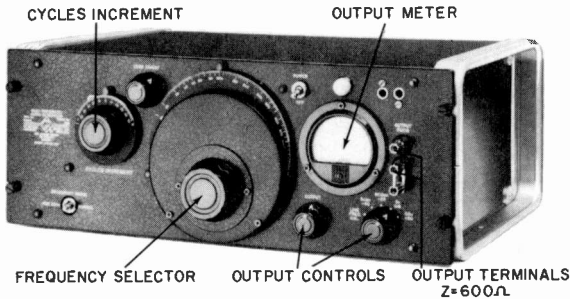
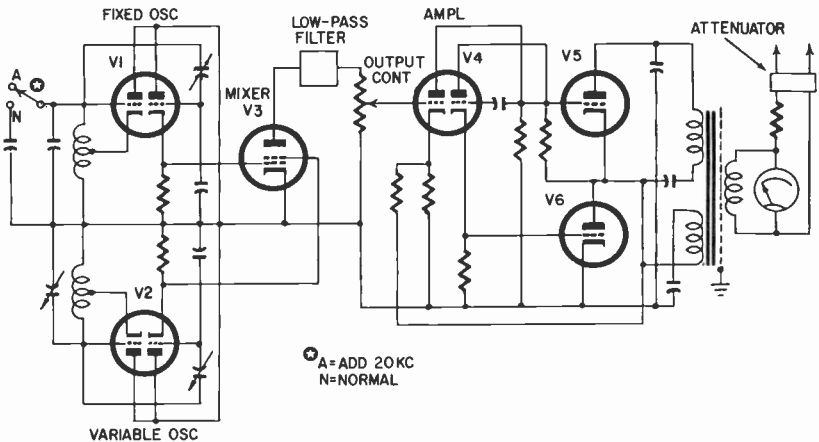

Fig. 203. Front view (above) and basic schematic (below) of beat-frequency audio oscillator, type 1304-B (Courtesy General Radio Co.)



this procedure, the percentage error throughout the rest of the scale will be very small. If the error due to line frequency is off, say, 1%, this means the 60 cycle calibration will be 1% off of its true value, but the error at 1,000 cycles will usually be considerably less than 1% (probably as close as the dial can be read).

This type of instrument has the advantage that the whole audio range is covered in one sweep of the scale. It is difficult to get the low distortion figures obtainable with resistance-capacitance

oscillators, however, and 2% is a good figure for a beat-note oscillator. With special care and design the distortion can be reduced to considerably less than 1%, but is liable to increase drastically if the instrument goes out of adjustment in any way.

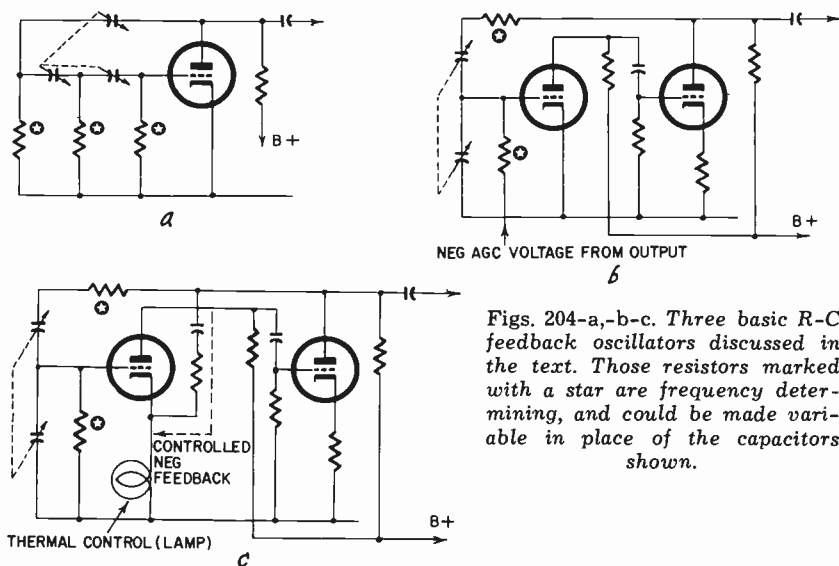

Figs. 204-a,-b-c. Three basic R-C feedback oscillators discussed in the text. Those resistors marked with a star are frequency determining, and could be made variable in place of the capacitors shown.

Most R-C oscillators cover the required range in overlapping frequency sweeps of not more than a 10-to-1 ratio. Some increase the precision of their control by utilizing steps of a little more than 3.5 to 1, so two steps are required for each decade of frequency. Most modern R-C oscillators, however, cover just a little more than a decade of frequency, so one sweep of the main dial is necessary to cover each decade of frequency. A little overlap is usually provided, to insure that no frequencies are omitted and to avoid the necessity of switching from one end of the range to the other to see what happens between, say, 190 and 210 cycles, just because 200 cycles is at the opposite end of consecutive ranges.

Modern R-C oscillators achieve very low distortion figures because they utilize both negative and positive feedback. Three basic circuits are shown in Fig. 204. The first is an early one that produces a progressive 180° shift at the frequency of oscillation. The second uses positive feedback with zero shift and automatic bias to control oscillation magnitude. Neither of these has particularly low distortion and the first is subject to drift. The third uses positive and negative feedback, the latter being thermally controlled.

The use of combined feedback (the third circuit of Fig. 204) makes it possible to produce extremely high frequency accuracy, especially when close-tolerance high-stability components are used in the frequency-discriminating elements of the positive feedback

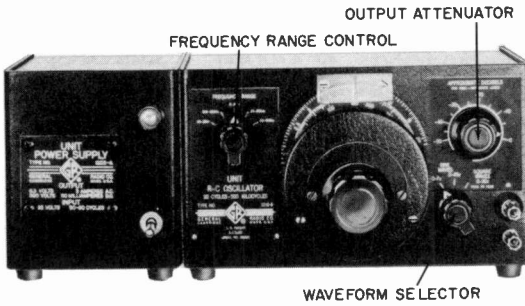

Fig. 205. An R-C oscillator employing the basic circuit of Fig. 204-b. (Courtesy General Radio Co.)

circuits and the high negative feedback reduces the harmonic content of the output to any level desired. These facts, together with avoiding the necessity for a zero-beat adjustment of the

Fig. 206. An R-C oscillator employing the basic circuit of Fig. 204-c. (Courtesy Hewlett-Packard Co.)



heterodyne type, have resulted in the great popularity of R-C oscillators in recent years. Figs. 205 and 206 show typical examples.

A comparatively recent development is the "single-sweep" R-C oscillator. This uses the same basic circuitry as Fig. 206 but, instead of using only fixed resistances with variable capacitances (or vice versa) to produce the phase shifts, the fixed elements are

combined to make the overall phase-shifting networks combinations of complex impedances. Thus the same multi-gang capacitor, which covers a sweep range of about 10 to 1 in the simpler circuit, covers a sweep range of a little over 1,000 to 1 in this revised circuit. This is illustrated in Fig. 207.

With the simple arrangement the relationship between the phase-shifting components of a single network is a quadrature one, and the phase angle of both impedances of the voltage divider at the operating frequency is usually at least  $45^\circ$ . By using

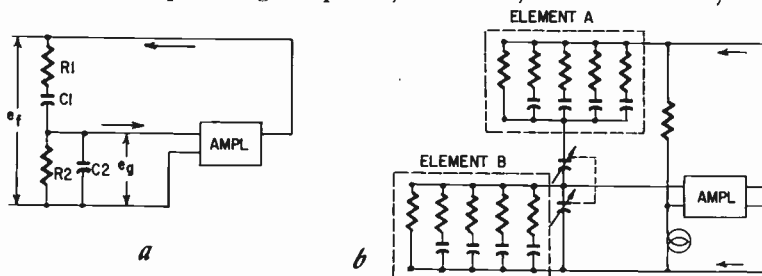

Figs. 207-a,-b. The circuit change necessary to make the R-C oscillator circuit of Fig. 204-c cover the audio range in a single sweep: (a) simple circuit covering ranges of 10:1 frequency ratio; (b) as modified to cover a 1000:1 frequency ratio.

complex impedances, the phase angle of both impedances of the dividing network is much less than  $45^\circ$  (in the region of  $15^\circ$  or less). Thus, it is possible to make 10-to-1 change in capacitance (or maybe a little more than this) produce the same phase and attenuation relationship over a range of more than a 1,000-to-1 change in frequency (Fig. 208).

The precision of frequency control of this oscillator is not as good as the simple R-C oscillators that cover only about a 10-to-1 frequency range in one sweep. But it avoids the disadvantage of the heterodyne type oscillator which requires periodic zero adjustment. So here we have an oscillator with another kind of characteristic: it does not require zero adjustment to calibrate it at any time, but its precision in frequency calibration is not as close as either the multirange or the heterodyne type (with careful attention to zero setting). Its harmonic generation however, can be consistently as good as the multirange R-C types of better design.

Oscillators of this type (Fig. 209) will become popular for routine testing in the near future—testing in which the precision of individual frequencies up and down the scale is not of great importance, but where being able to cover the entire audio range



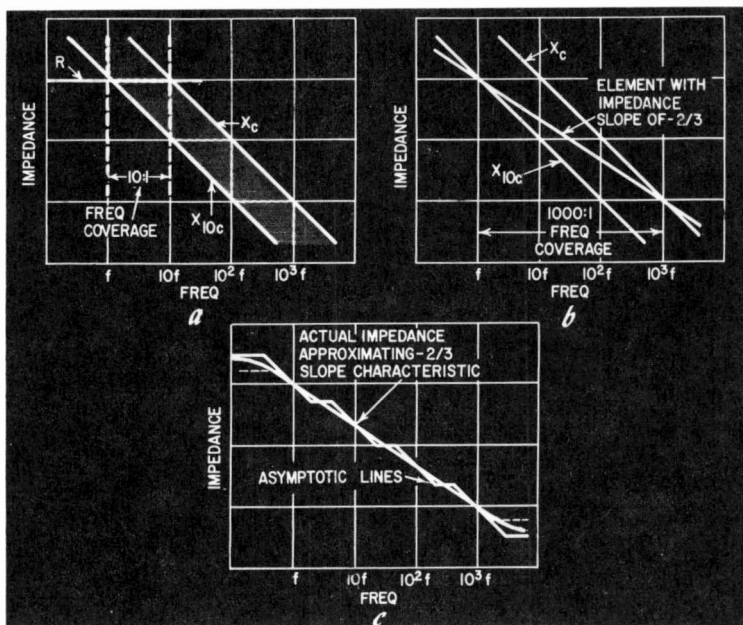

Figs. 208-a, b-c. Explanation of the development shown in Fig. 207. At (a) the impedance against which  $X_c$  is matched is a resistance, and three ranges are needed to cover a 1000:1 ratio; at (b) a theoretical impedance having a slope of  $-2/3$  replaces fixed  $R$ , and same capacitance change covers 1000:1 ratio in one range; (c) shows how an impedance with  $-2/3$  slope is synthesized by elements in Fig. 207-b.

in a single sweep is a valuable time-saving asset. Table 2-1 shows the relative features of audio sine-wave generators.

**Table 2-1. Characteristics of Various Types of Audio Generators**

Type	Frequency Ratio per Range from zero as high as desired	Calibration Precision	Drift	Distortion	Need for Zero Adjust
Heterodyne	as high as desired	very good	poor	fair	yes
Simple Phase Shift	10:1	fair	fair	poor	no
Positive feedback with agc	10:1	very good	low	fair	no
Positive and controlled negative feedback	10:1	very good	low	low	no
Single-sweep R-C positive and negative feedback	1,000:1	fair	fair	low	no

## Vacuum-tube voltmeters

This is a subject that can occupy a complete book on its own—in fact it occupies several such books—so we will not devote much space to it here. The requirements of a vacuum-tube voltmeter

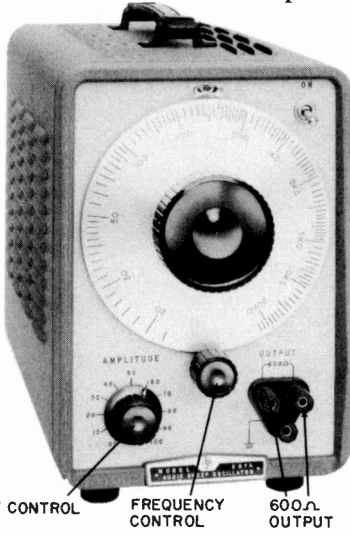

Fig. 209. An R-C oscillator using the method shown in Figs. 207 and 208 to obtain a 1000:1 coverage in single sweep. (Courtesy Hewlett-Packard Co.)

for audio measurements are similar to those of other test instruments and the ways in which readings can be modified or invalidated by differences in waveform are discussed elsewhere.

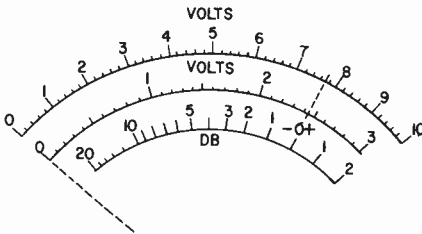

Fig. 210. Scale construction details for an audio voltmeter, using two scales (0—10 and 0—3) to cover a decade of voltage values.

What may be discussed in this connection is the difference in types of scale used for different vacuum-tube voltmeters designed for audio measurements.

Some use a basically linear scale, with range switches, generally arranged over half-decade values, so there will be ranges, starting maybe at 10 millivolts full scale, and then 30 mv, 100 mv, 300 mv, 1 volt, 3 volts, 10 volts, etc. This is a very convenient division and usually two scales are arranged so that the difference in reading from one to the next is actually 10 db or a ratio of 3.16 in volts. This means the 10-volt full scale does not coincide

exactly with the 3-volt full scale, but the 3 corresponds to about 9.5 volts on the 10-volt scale (Fig. 210). A db scale is included to

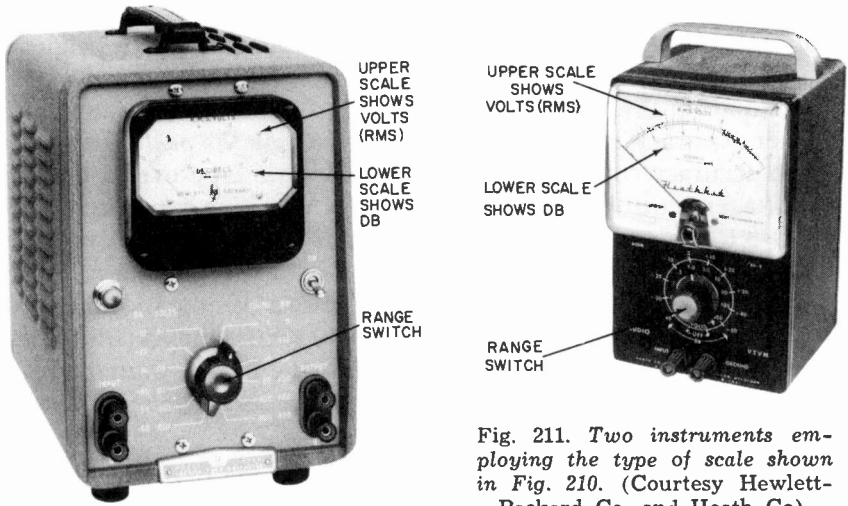
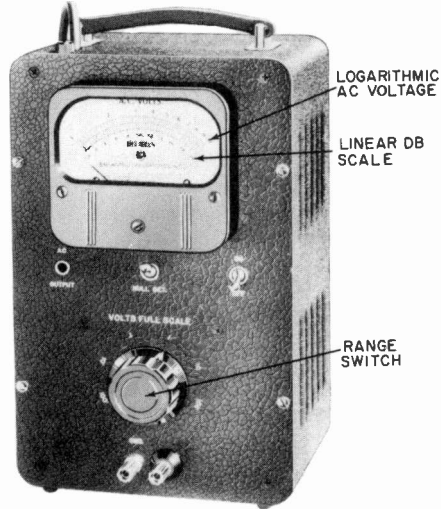

Fig. 211. Two instruments employing the type of scale shown in Fig. 210. (Courtesy Hewlett-Packard Co. and Heath Co.)

facilitate references in terms of db. Two examples of this type are shown in Fig. 211.

An alternative form of audio voltmeter utilizes an instrument

Fig. 212. Audio voltmeter using the special logarithmic scale movement developed by Stuart Ballantine. (Courtesy Ballantine Laboratories, Inc.).



with a logarithmic scale. This has 1, not 0, at the bottom end of the scale and each range of the instrument covers 20 db, a 10-to-1 ratio. This is achieved by use of a special microammeter with logarithmic scale sensitivity. This type of instrument has the

advantage, within the limits of its construction, of providing uniform accuracy in reading over its entire range because 1 db represents the same scale arc whether it is just above the lowest reading the instrument will register or just below the highest (Fig. 212).

Comparing the two types, the linear scale has the advantage of greater accuracy in reading *at the top end of the scale only*. To attain accuracy comparable to the logarithmic type over a decade of voltages requires two scales, which is why this type uses 0-10 and 0-3 to cover a decade. The logarithmic scale has the advantage of attaining comparable accuracy but only needs half the number of ranges to cover a given scope of levels—a saving in time and frustration. Also the accuracy is uniform, which makes allowance for instrument error easier to visualize. But if you want to read to small fractions of a db, use the linear type and work as near the top of the scale as possible.

Whichever of these types is preferred, its reading is based on a bi-phase rectified signal. The meters are calibrated in the universally accepted rms volts, but this is based on the signal

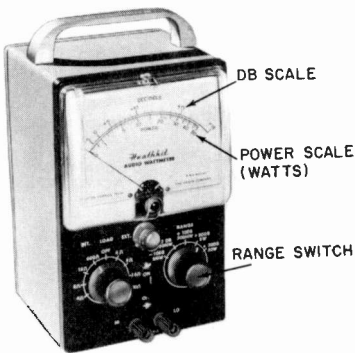

Fig. 213. An audio wattmeter combined with internal and external load switching to give power readings in watts or db. (Courtesy Heath Company).

measured being sinusoidal. For no other waveform will the reading given really be rms—in fact, it becomes practically meaningless. To be academic, it might be called a “bi-phase rectified equivalent of sine-wave rms value”!

For those few cases where rms readings are important, a true rms meter has been developed using a scale that is logarithmic. However, the scale of this instrument covers only 10 db linearly and then requires a range switch to cover the next power decade. This is necessary only in certain rather specialized applications which will not be considered in this book.

A variation of the simple vtvm is the audio wattmeter. This incorporates, into the same instrument, a variety of resistance

loads so it measures the power output of the amplifier, providing an internal load for it as well as measuring the voltage output. One such instrument is shown in Fig. 213. It is particularly helpful on the service bench, where high precision is usually not important but versatility and simplicity of reading count.

Fig. 214. Method of using a calibrated attenuator, or "gain-set" to measure the response of an amplifier or other equipment.

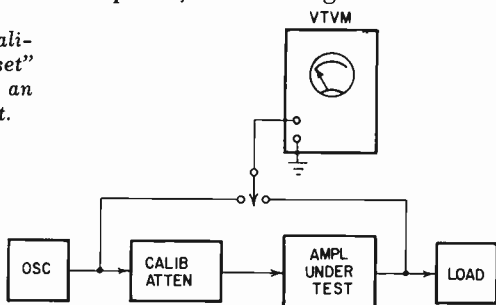

### Calibrated attenuators

The accepted way of measuring the gain of an amplifier, or any part of an audio system, uses the same vtvm to measure both input and output, and uses the meter on the same range and at the same voltage reading. This means that exactly the same voltage at the same frequency is present at both input and output. To make this possible, a calibrated attenuator is introduced between the input voltage reading and the input to the amplifier or system being measured. The attenuation is then adjusted to attain precisely the same reading at input and output. In this way the insertion loss of the attenuator is equal to the insertion gain of the amplifier.

If the insertion gain of the amplifier is uniform at all frequencies, then the attenuation required in the attenuator—or "gain set" as it is called when provided in a combined instrument—will also be constant. If more attenuation is required to produce the same output, this means the amplifier has more gain at this frequency, and so on.

This method (Fig. 214) appears to be fairly foolproof but it is not as foolproof as it appears. If the components of the gain set are all contained on the same panel, it is possible to get spurious results because of common ground effects between the input and output of the amplifier or system under test which would not occur if complete separation were obtained. These effects may or may not be due to faulty design of the gain set.

As it sometimes requires considerable checking to be sure whether defective performance is due to faulty techniques or com-

ponents, this setup is ideal where a specific type of equipment is going to be repetitively tested. The test equipment can be bugged out to make sure that the technique and the equipment are functioning properly before the procedure is instituted. Otherwise the best plan is to use a separate attenuator unit of the type shown in Fig. 215, together with separate metering and switching facilities.

## Oscilloscopes

The oscilloscope is an almost indispensable instrument for audio measurements. It can be employed to make various measurements instead of merely to supplement or monitor them.

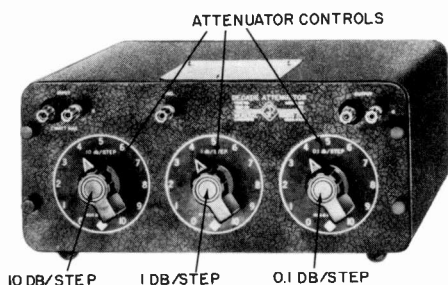

Fig. 215. A convenient type of calibrated attenuator. (Courtesy General Radio Co.).

The precision of some of the measurement techniques described in this book rely entirely on the accuracy of the oscilloscope with its attendant deflection amplifiers. This accuracy can, of course, be checked back against itself in the oscilloscope by methods that will be described. But it is always an advantage to have a scope of as high precision as possible. If you want the oscilloscope merely to observe waveforms, then one of the lower-cost ones with average, low-cost deflection amplifiers will probably serve adequately. But if you intend to use it as a measuring instrument in itself, to measure such things as phase angle, harmonic distortion etc., then you should obtain an oscilloscope whose deflection amplifiers are precision-engineered to give calibrated amplification over a specified frequency range with a minimum of phase deviation.

It is advantageous to have a decade-calibrated input attenuator or level switch on both vertical and horizontal input circuits. The calibration signal provided on some oscilloscopes is an asset. It should never be relied upon for instrumental accuracy, but merely be used as a guide.

For low-frequency measurements, a direct-coupled input is necessary as well as the more widely used ac or capacitor-coupled input. Sometimes the equivalent can be achieved by using direct connection to the deflection plate of the cathode-ray tube. For

some applications, the best approach is to use an oscilloscope with provision for direct connection, and then use laboratory-standard amplifiers as external deflection amplifiers. Fig. 216 shows a representative high-quality modern scope.

### Square-wave generator

A square-wave generator is sometimes specified as an important piece of audio measurement equipment. Actually, by itself it does not tell very much beyond how the equipment being tested performs on square waves. When square-wave testing was first introduced it was pointed out that the behavior of an amplifier on a

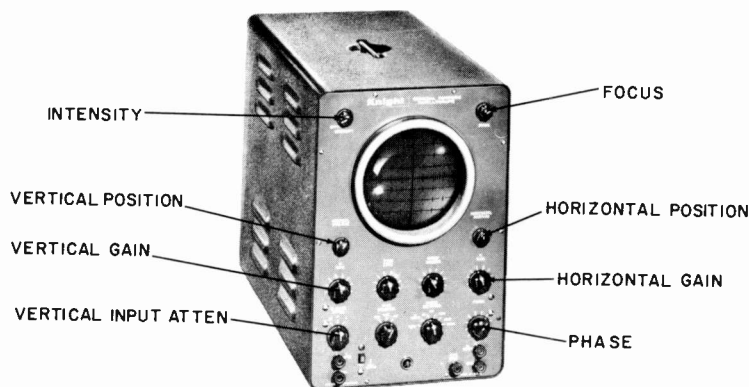

Fig. 216. *Typical example of modern oscilloscope suitable for use in audio measurements.*  
(Courtesy Allied Radio Corp.).

square wave told more about the overall performance of the amplifier than a simple frequency response.

By merely looking at a square wave of a certain frequency, one could tell what kind of rolloff the amplifier had (whether it was sharp or gradual) and whether it possessed any appreciable phase characteristic of abnormal character. At the same time the square wave was supposed to show the performance of the amplifier on transients. From this statement one might conclude that the square wave does almost as much as all of the previous tests put together. But this is not quite true.

It does not even properly show all of the information required about the performance of an amplifier on transients, as we shall see later. It does not show anything about distortion characteristics. This means that the sine wave test is still necessary, together with an IM test if so desired, to determine the distortion characteristic of an amplifier.



If the amplifier has any nonlinearity of its transfer characteristic *without associated phase shifts*, this cannot show up at all on a square wave. There is no means of knowing whether the velocity of the spot in the vertical part of the wave changes during the traverse. It changes virtually instantaneously from the negative to

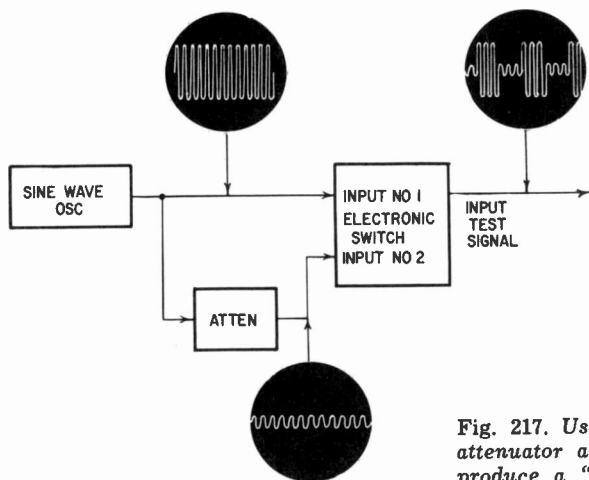

Fig. 217. Using an audio oscillator, attenuator and electronic switch to produce a "tone-burst" test signal.

the positive value—consequently any distortion in this part of the travel does not show up on a square wave.

The horizontal part of the wave presupposes an amplifier in a virtually static condition. The wave should not show any distortion due to the transfer characteristic unless there is a phase, or integrator or differentiator action that causes the part of the waveform that should be horizontal to possess a slope or curvature. Then nonlinear distortion will distort the curvature in this part of the wave. But as this part of the wave now represents another kind of distortion anyway, its utility as part of the square-wave test disappears. One has no means of knowing whether a particular wiggle on a square wave is due to a transient effect in an amplifier or nonlinearity in its transfer characteristic.

However, a square wave is a composite waveform, consisting of a wide range of frequencies, fundamental and harmonic, and as such does provide a form of shock-excited waveform which can test the performance of an amplifier in a way different from separate sine waves. But performance on a square wave is not necessarily any criterion of the amplifier's performance on other kinds of transient—a square wave is a rhythmically repeated transient, which produces a virtually steady state in the amplifier, rather

than a "momentary" one as produced by more conventional musical forms.

Nevertheless, exploring the performance of an amplifier with a square wave at the input can be very revealing and therefore an instrument that will produce square waves is quite useful. It is suggested, however, that an electronic switch will also produce

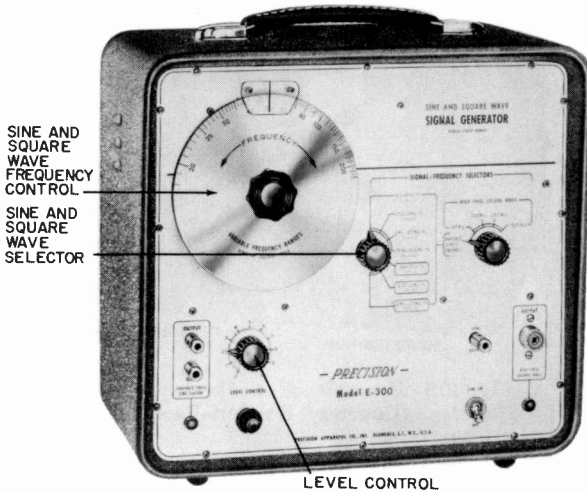

Fig. 218. A combined audio-sine and square-wave generator suitable for service or technician use. (Courtesy Precision Apparatus Co.)

square waves and, if the switching frequency is continuously variable it can be quite as useful as a square-wave generator and provide additional functions. The advantage of an electronic switch over a simple square-wave generator is that it can also square-wave-modulate sine waves to produce the input signal for tone-burst testing using the arrangement shown in Fig. 217.

Another combined instrument that can be quite useful is a sine-wave-square-wave generator (Fig. 218). Probably, for servicing or maintenance purposes, it is more useful than the other combination because the average maintenance engineer will not want to get into tone-burst testing and more complicated things of this nature, but will appreciate the facility of a square wave.

### Harmonic-distortion meter

The function of a harmonic-distortion meter is to measure separately the fundamental and harmonic content of any waveform. It does not tell you where the distortion or harmonic originates.

The usual arrangement uses a rejection filter to eliminate the fundamental. This is tunable over a range of frequency so that harmonic-distortion measurements can be made at different fundamental frequencies.

But the distortion meter provides no means of identifying what

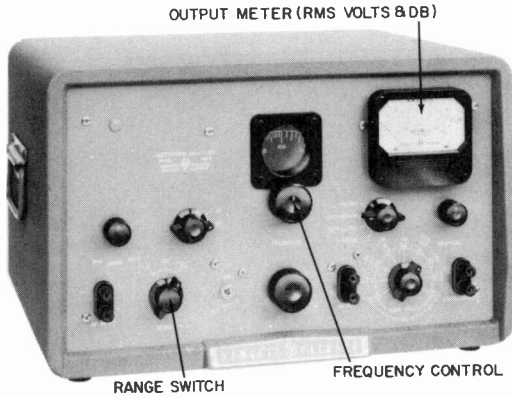

Fig. 219. Example of a harmonic distortion meter. (Courtesy Hewlett-Packard Co.).

the residue is. It usually filters the fundamental and leaves frequencies both lower and higher than this. If hum is present below the fundamental frequency, this will register on the indicator as part of the harmonic distortion, just the same as true distortion components. Low-frequency filters can be used to eliminate hum components so the reading obtained is just that due to distortion.

Even then the harmonic-distortion meter tells little of the nature of distortion. But it can be very useful if an output terminal is arranged so that the residue being measured as harmonic distortion can be observed on an oscilloscope. Most harmonic distortion meters make this provision (Fig. 220). Then it is easily possible,

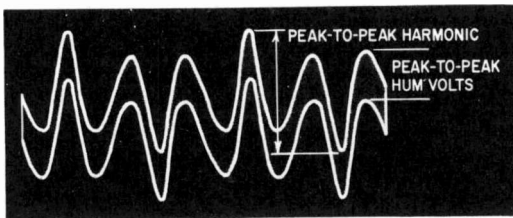

Fig. 220. Method of estimating the relative magnitudes of hum and harmonic in the measured result of a harmonic meter on a 'scope.

by observing the waveform, to determine whether the residue measured is hum or harmonic distortion or partly both. An estimate can be made (Fig. 221) of how much is hum and how much is distortion. At the same time, the distortion can be estimated from the kind of waveform presented, whether it is due to clipping, to curvature of a second-, third- or other high-order harmonic. Examples of this are illustrated in Fig. 222.

As we have just said, the meter merely measures what is present in the waveform. If the reading tells us that the waveform contains 2.5% harmonic, we do not know whether this harmonic is due to

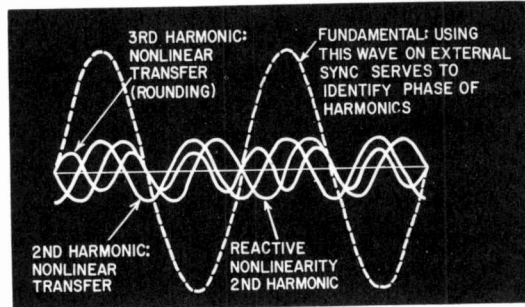

Fig. 221. The 'scope can be used to identify harmonic components of the measured result on a distortion meter.

the amplifier or whether some of it may already be in the waveform at the input. We can transfer the harmonic-distortion meter to the input of the amplifier and measure the input waveform, if the meter is sensitive enough. Some harmonic-distortion meters are not capable of analyzing waveforms of low enough level to make measurements at the input as well as the output.

But even if the input harmonic measures a little lower than the output harmonic, it can still invalidate the reading. The input reading should be *considerably* below the level of the output reading for the output reading to have any validity.

If the harmonic content is of a completely different order—say the input reading is second harmonic, while the output reading

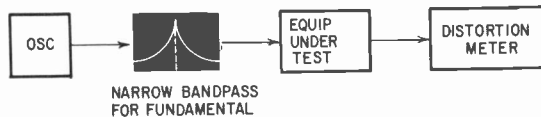

Fig. 222. For really low harmonic measurement, a filter may be needed between the oscillator and input.

balance which provides complete null in the feedback for the fundamental frequency, may cause fluctuations of 10 db or more in the effective forward gain of the stage. This results in increased distortion.

Suppose the maladjustment of the twin-T network yields a null which is 0.5% instead of zero. This means the feedback at the fundamental will be only 46 db less than that at harmonic. If the feedback at harmonic represents a loop gain of 60 db, then there is a feedback for the fundamental of 14 db, which represents this much attenuation of the fundamental. To produce the required output from the filter five times as much input is needed, which means some of the circuit has to operate at a much higher level than would be the case with zero feedback. Consequently, although the electronic filter may be designed to operate the tubes under conditions where distortion is 2% or less, it can produce 5% or 10% distortion, and provides a discrimination between the fundamental and distortion of only 46 db. So this 5% to 10% distortion will only be cut by a factor of about 200.

Assuming that the input waveform is pure enough for the purpose, there still remains the manner of presentation of the distortion component in the output waveform and the problem of discovering whether this reading is due to hum or harmonics of the signal. This is determined by interpretation of the oscilloscope trace. For routine distortion measurements, personnel may not be capable of making such interpretations, a throw switch which will give readings on a meter representing the different components. For this purpose, high- and low-pass filters or rejection filters to eliminate hum frequencies are needed, so the hum frequencies and distortion components can be measured separately.

This is not as difficult a problem as the filters for purifying the fundamental at the input. Here the fundamental is rejected in the distortion meter, so the residue consists of hum frequencies and distortion, both of similar orders of level. Consequently simple filters can readily separate the two and produce independent readings for hum and distortion.

A disadvantage of the harmonic distortion meter is that, even though interpretive measures are used, we have no means of assessing directly the annoyance factor of the harmonics measured. Second, third or any particular order of harmonic by itself will give an indication which is the true rms value of the difference

(or average or whatever designation we like to give to the waveform relationships) between the fundamental and the harmonic in question. Combinations of uniformly distributed harmonics also produce a virtual rms reading within fairly close limits.

Fig. 224. Readings obtained on a harmonic distortion meter for values of peak clipping distortion to peak fundamental.

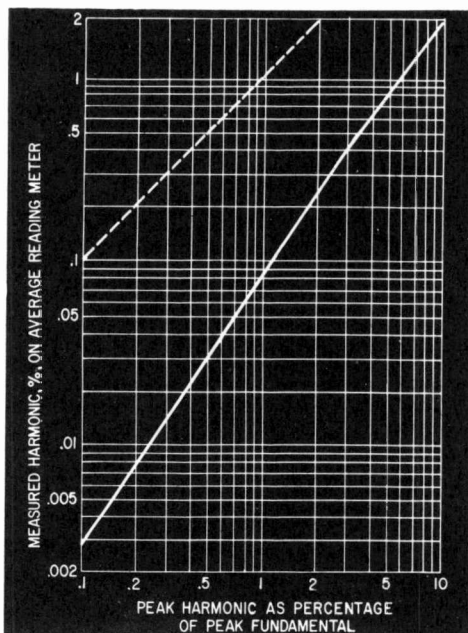

But modern feedback amplifiers are apt to produce orders of distortion that are very low until the clipping point is reached—the point at which the amplifier suddenly ceases to amplify the input waveform proportionately. This means that the bulk of the input waveform is accurately amplified and only a small portion near each peak is suddenly clipped right off. On a harmonic distortion meter that measures average or rms voltages, this gives a reading that is deceptively low compared with a comparison between the peak harmonic component to the peak fundamental waveform. Fig. 224 is a graph of the correlation between peak relationship and average or rms readings, as given by the average distortion meter.

As clipping on an audio waveform reproduced over a speaker is apt to sound like a separate sound—as if the voice coil were knocking at its end stops—it is not appreciably masked by the fundamental, because it has a completely different frequency component. This means its annoyance factor can be very much greater than the simple relationship of higher-order harmonics

in what may be analyzed as a normal overtone structure. Consequently the peak-to-peak relationship more closely approximates the annoyance factor than does the accepted average or rms relationship.

A method of measuring distortion that compares input against output has been developed by the author, using simple comparative traces on the oscilloscope. This is easily refined by means of fine and coarse resistance balance controls and phase compensation so that quite precise readings can be obtained.

As some operators find difficulty in interpreting readings on an oscilloscope it is suggested that the same principle be applied to the evolution of a simpler distortion meter which is independent of the purity of the input signal. This method compares the output waveform against the input waveform, balancing off a proportion of the input waveform against the output waveform. It then determines the distortion residue in the output waveform *due to the intervening amplifier*. This method is illustrated in skeleton form in Fig. 225.

Two or three of its features recommend it. One is that the distortion meter does not require a frequency adjustment to balance out the fundamental. Over small ranges of frequency the adjustment for balance of the input waveform does not vary considerably as with the average distortion meter. With the conventional method, if the oscillator drifts at all, the distortion meter begins

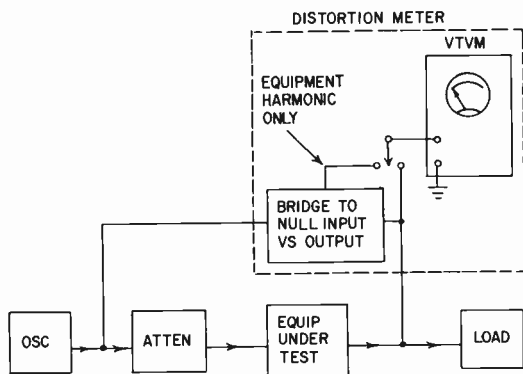

Fig. 225. A suggested modification to the regular distortion meter to make it independent of small harmonic content in test oscillator.

to show a reading due to the fundamental creeping in. So experimentation on equipment to see the effect on distortion of various



circuit changes or adjustments requires continuous adjustment of the conventional distortion meter to balance out the fundamental

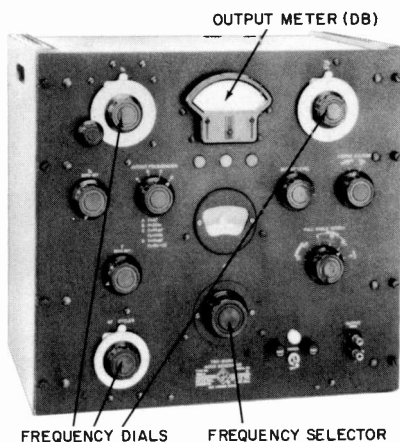

Fig. 226. A two-signal audio generator provides signal source for a variety of IM measurements. (Courtesy General Radio Co.)

and make sure that the distortion reading really is just distortion. Using this recommended method, such a critical balance does not become necessary.

The main feature of the method is that, whether or not the input waveform has a lower distortion component than the expected output waveform, it does not contribute to the reading in the ambiguous manner discussed earlier.

A third advantage is the simplification of the harmonic-distortion meter circuit, reducing the likelihood of the instruments developing errors due to faults in the circuit itself.

A method of measuring distortion preferred for some laboratory purposes uses a wave analyzer to measure the precise magnitude of the fundamental and of each successive harmonic detected. This requires computation—squaring, summing and taking the square root—to obtain an rms value.

### Intermodulation test meters

These take quite a variety of forms according to the kind of distortion to be measured, whether it is the sum and difference tones using a low and high frequency, or the difference tone measurement using two high frequencies. Either measurement can be made by using one composite instrument which generates both the required input signals and also performs the analysis on the output signal, or by a collection of instruments that perform the separate functions: for example, the two-sine-wave audio generator (Fig. 226) together with a separate analysis meter for the output;

or individual audio signal generators, mixers and the required filters and other components as separate entities can be

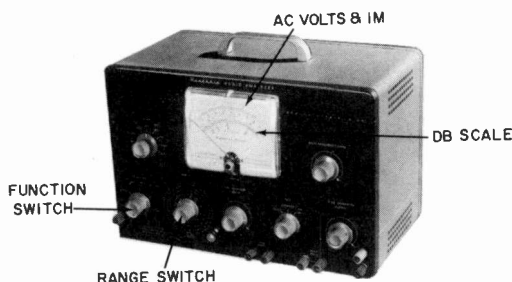

Fig. 227. A common type of composite IM test set. (Courtesy Heath Company).

combined to make the required measurements. The alternative is an instrument that combines the functions in one unit (Fig. 227).

The choice of methods will depend on the desired amount of versatility and whether the equipment has to be used for multiple purposes. Either way, the method itself has restrictions as to its usefulness which are noted in the various chapters in which IM distortion measurements are discussed.

Intermodulation meters have the advantage—using the first

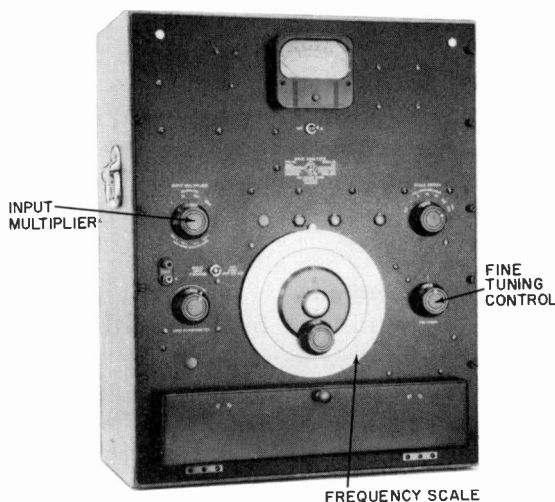

Fig. 228. The well-known wave analyzer uses a crystal gate frequency filter. (Courtesy General Radio Co.).

method—that the measurement is not dependent on the purity of either frequency, provided it is reasonably sinusoidal. But the

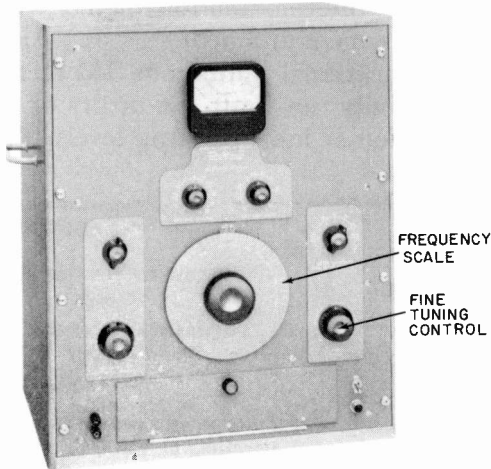

Fig. 229. An alternative circuit uses a feed-back frequency filter of adjustable width. (Courtesy Hewlett-Packard Co.).

accuracy and significance of the indication are dependent on a number of other factors.

Choice of test frequencies can limit the margin for picking up

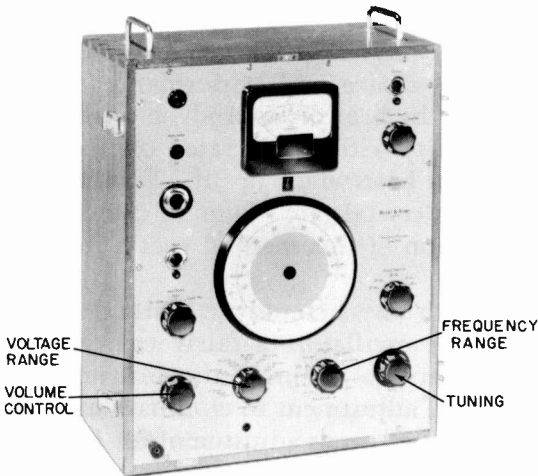

Fig. 230. Another type of wave analyzer uses a direct, adjustable, twin-T feedback frequency filter, of variable percentage, (rather than cycles) width. (Courtesy Bruel and Kjoer, Brush Electronics Co.).

intermodulation products, and the indication produced by any specific frequencies will depend on the filter characteristics. This is why almost no two intermodulation meters will produce the same reading for the same equipment.

Apart from these functional limitations, IM meters can vary in other respects. Sensitivity can limit the utility of the instrument for measuring distortion at low operating levels. The author con-

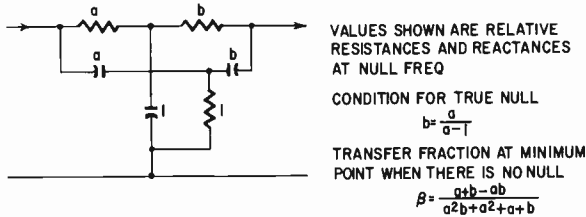

Fig. 231. Relevant quantities for determining the characteristic of a parallel, or twin-T, filter.

siders the principal usefulness of an IM meter is in the development laboratory, where it will tell whether a specific change in an amplifier circuit results in reduced IM distortion. The numerical values measured do not have any absolute significance when compared with similar measurements taken on other instruments.

### Wave analyzers

From the laboratory viewpoint, a wave analyzer can be regarded as complementary to a signal generator. This fact shows up in the similarity of circuit choice and performance comparisons. One type corresponds to the beat or heterodyne oscillator. It combines the unknown quantity with a calibrated oscillator and measures the output of a fixed heterodyne or "if." Fig. 228 shows one that uses a very narrow "crystal-gate" filter to channel off the output frequency. A variation of this method uses a feedback type filter (Fig. 229).

The problem with any heterodyne method is similar to that with the heterodyne oscillator: a fairly critical zero-adjustment procedure is necessary to calibrate the instrument. The crystal gate needs additional adjustment to eliminate null-transfer effects, while the feedback filter needs adjustment for both frequency and sharpness. The heterodyne method does have the advantage that the bandwidth, in cycles, can be adjusted over a certain range of sharpness.

But either heterodyne type produces a response whose bandwidth is a constant (or adjustable) number of cycles. A filter 2

cycles wide, for example, represents 10% of the frequency or a  $Q$  of 10, at 20 cycles, and .01% or a  $Q$  of 10,000 at 20,000 cycles. For many purposes it is better to have a bandwidth that is a con-

Fig. 232. A wave analyzer using third octave filters to cover the audio range. (Courtesy Bruel and Kjoer, Brush Electronics Co.).

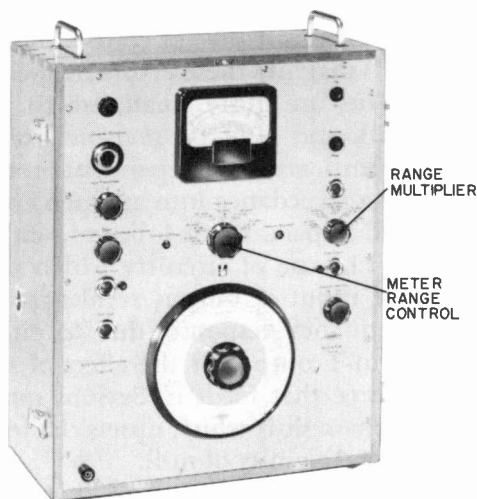

stant percentage of the operating frequency. A circuit that achieves this and at the same time avoids the zero-adjustment procedure of the heterodyne type has an adjustable-frequency feedback filter (Fig. 230).

The usual type of feedback filter for this purpose employs a twin-T filter (Fig. 231), which has the property of producing a null at its output for just one frequency. The conventional arrangement uses values in each series limb twice that of the shunt

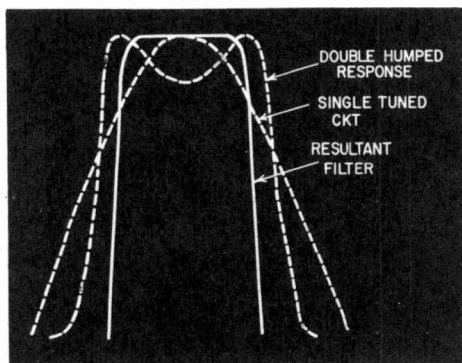

Fig. 233. Synthesis of third octave filters for the analyzer of Fig. 232 is achieved by combining a single tuned circuit with a double-humped band-pass.

limb. Consequently, 1% components will result in 0.5% balance error if all the components have their maximum error in such

a direction as to be additive. Deviation of any one series element by 1% causes the resultant null to be in error by .0625%, while error of one shunt element by 1% causes a resultant error of 0.125%.

As against this, of course, the large amount of negative feedback will magnify these errors by the loop gain factor. Frequency-of-null errors are quite small, which is an advantage. The accuracy of null, and also the *sharpness* of the resultant frequency response or null, are both dependent on the twin-T working out of virtually zero impedance into an open circuit. Ideally it should work out of and into a cathode follower, with a gain stage sandwiched between.

The use of circuitry which produces appreciable impedance at the input or output results in distortion of the symmetry of the frequency response, due to either the effect of the load on the twin-T output or the effect of the twin-T circuit as a load on the source that feeds it. Serious modification of this nature produces a phase shift which upsets the feedback stability criteria, especially in the vicinity of null.

Further variations of this type of circuit use values in which the transfer characteristic of the twin-T either does not go down

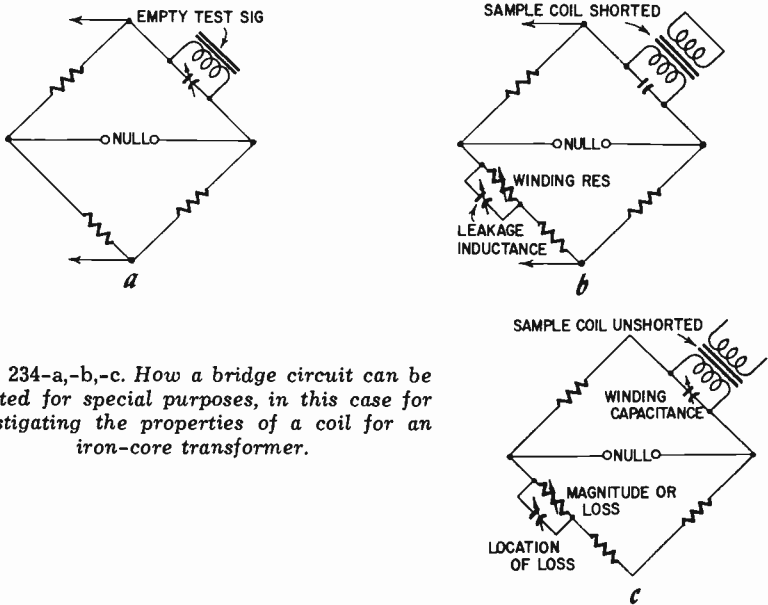

Figs. 234-a, b, c. How a bridge circuit can be adapted for special purposes, in this case for investigating the properties of a coil for an iron-core transformer.

to zero or true null, and positive feedback, under precision control, which is used to adjust the null point. Sometimes the circuit is arranged to go through a phase reversal instead of a true null,

with negative feedback to offset the excess positive feedback that results. Or else a lower basic amplification is used so the effective positive feedback in the vicinity of null increases the gain at this point, while reducing it everywhere else.

Another approach to frequency analysis (for quite different purposes) uses a set bandpass filter to separate the unknown frequency or frequencies into predetermined bands. Fig. 232 shows one using third-octave filters that covers the audio range from 40 cycles to 20 kc in 27 steps. It can be used for making the spectrum-analysis type of presentation, which only identifies components as lying within a certain one-third octave of frequency range. This instrument has L-C type bandpass filters and a single-tuned circuit to "fill in" a double-hump-coupled circuit (Fig. 233).

### Flutter and wow meters

Instruments in this class are virtually an adaptation of various FM detector circuits. A constant frequency is applied to a suitable recording, which is played on the device suspected of flutter or wow. The detector then measures any fluctuation in the output frequency, giving a reading in percentage deviation. The principal problems involved in this type of meter concern obtaining satisfactory sensitivity to minute deviations without making the instrument extremely subject to normal and legitimate drifts. In general, a satisfactory instrument falls into the laboratory class and requires a certain amount of skill in handling.

### Bridges

Varieties of the basic bridge circuit are used extensively for audio measurements. Apart from those used for measuring basic

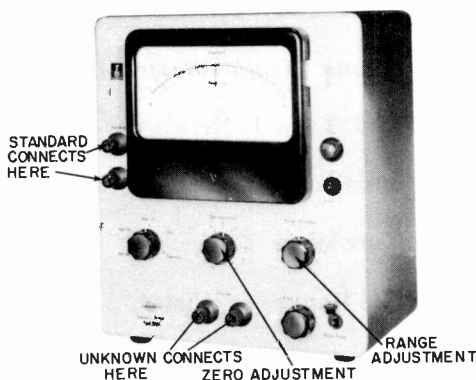

Fig. 235. A deviation bridge, useful in production for selecting components of any type within desired tolerances. (Courtesy Bruel and Kjoer, Brush Electronics Co.).

quantities (described in the next chapter) specialized bridge circuits have found application in almost every branch of audio. A



modification of the Wien bridge is used in some resistance-capacitance oscillators for feedback.

The great asset of the bridge method of measurement is that careful arrangement can always compensate for or eliminate the effect of extraneous quantities that invalidate other methods. For example, one application is in a particular kind of shorted-turns tester used for laboratory checking of coils for audio application, before their cores are inserted. A bridge technique enables the precise location of a shorted-turns form of loss and the effective cross-section of winding involved, however small (Fig. 234). This arrangement is useful for finding weak spots in winding construction that are difficult to locate by other methods. It also shows up distributed loss effect due to impregnating material interacting with enamel insulation, a state of affairs difficult to detect by normal leakage tests.

For production purposes, it is convenient to have a bridge set up so individual components can be checked for tolerance, especially where close tolerances are necessary. Fig. 235 shows a simple type of ac bridge arranged so that any component can be compared against a standard. The bridge is set up to give a direct-reading indication (in percentage) of any deviation from standard. A useful feature is the easily replaceable scale that enables any desired method of acceptance or rejection to be set up in a minimum of time.

#### Recommended Reading

1. Rhys Samuel, *The V. T. V. M.*, Gernsback Library Book No. 57, 1956.
2. E. N. Bradley, *Radio Servicing Instruments*, Norman Price Publishers, 1953.
3. F. E. Terman and J. M. Pettit, *Electronic Measurements*, McGraw-Hill Book Co., 1952.
4. Norman H. Crowhurst, "The Use of Twin-T Networks," *Audio Magazine*; May, 1958.
5. Darwin H. Harris, "Phase-Shift Oscillator," *RADIO-ELECTRONICS Magazine*; January, 1954.
6. P. N. Markantes, "Sine- and Square-Wave Generator," *RADIO-ELECTRONICS Magazine*; May, 1954.
7. Richard Graham, "Compact Wide-Range Oscillator," *RADIO-ELECTRONICS Magazine*; July, 1954.
8. John W. Straede, "R-C Controlled Oscillator," *RADIO-ELECTRONICS Magazine*; December, 1955.
9. "An R-C Oscillator that Covers the 20-cps-20 kc Range in a Single Dial Sweep," *Hewlett-Packard Journal*; January, 1957.

# basic measurements

**B**EFORE we can make any measurements we have to establish the quantities by which we measure the performance of the individual items of equipment. Because the modern concept of audio takes in much more than just equipment for the reproduction of a sound program we need to lay the ground work for measurement in a wide variety of applications.

In high-fidelity work exact frequency is not usually important because the equipment must respond uniformly, or as near uniformly as possible, over a very wide band of frequencies, from 20 to 20,000 cycles or from 40 to 10,000 cycles, etc. It is relatively unimportant whether the exact measurement frequency is 20 or 20.1 cycles—the equipment is not likely to behave radically different with such a small relative change in frequency.

On the other hand, sometimes we need to know the frequency with great precision. Perhaps we are concerned with providing equipment for a musicologist, who needs to know the pitch of a musical tone within 1 cent. As 1 cent in musical terminology is  $1/1,200$  of an octave, it represents a frequency change of only .058%; this would be the difference, for example, between 100 cycles and 100.058 cycles. Identification of frequency with this precision requires more careful measuring methods than those generally used for measuring the frequency response of high-fidelity equipment.

Whatever we are measuring, whether it is frequency, voltage, current, resistance, impedance or acoustic quantities, such as velocity and pressure, the degree of accuracy required in the measure-

ment method depends to a considerable extent on the application of the equipment. Most often however, the accuracy of frequency measurement never needs to be as close as one part in a million.

### **Frequency**

Frequency is basically a measure of time. So measurement of frequency is dependent upon accurate establishment of a standard interval of time, which, for audio purposes is 1 second. The establishment of the time standard is conducted at observatories such as Washington and Greenwich. Standard frequencies determined at these observation posts serve as world-wide reference. WWV broadcasts standard frequencies of 440 and 600 cycles, as well as the actual carrier frequencies on which these modulated tones are imposed. An accuracy in the region of one part in one hundred million is maintained. A plot of the standard time radiated by WWV shows that the maximum error over a whole year reaches, at one point, almost  $1/8$  second. For the great majority of the time the accuracy holds within  $1/50$  second.

These very high accuracy standards can be used to calibrate standards for making measurements. For close accuracy work a tuning-fork oscillator will provide a stable signal in the region of one part in a million. Use of checks against WWV can determine just how far the signal deviates. Oscillators using quartz crystals, precision cut in one of a variety of manners, can afford a greater accuracy than this, achieving results comparable with the radiation of WWV.

The latest step forward toward standardization of frequency utilizes the molecular resonances of certain gases, such as ammonia and cesium. These are operated in conjunction with a klystron oscillator to synchronize its frequency. It is expected that such devices will reach long-term stability in the order of one part in a trillion.

For most audio work the standard of time measurement can be taken from the line supply, nominally 60 cycles in most American and 50 in most European countries. To a person used to operating in the order of accuracy afforded by WWV or a crystal oscillator this may seem an extremely erratic frequency standard. But most power lines are used as a basis for timing electric clocks and any self-respecting electric light and power company maintains the accuracy of frequency such that clocks relying on it will always tell correct time within 15 seconds.

The disadvantage of this method of standardization is that a sudden increase or decrease in the load on a power station is likely

to slow down or speed up the generators and automatic or manual control has to be applied to maintain the correct speed and frequency. A sudden load, or removal of load, can produce a temporary deviation in frequency much larger than that used for corrective measures to bring "time" back to its correct position.

Thus, a sudden increase in load may momentarily drop the frequency from 60 to 59.5 cycles, or a sudden removal of load may raise it to 60.5 cycles. The corrective measures bring the frequency

Fig. 301. Use of circular time base to produce the spot-wheel pattern for frequency comparison.

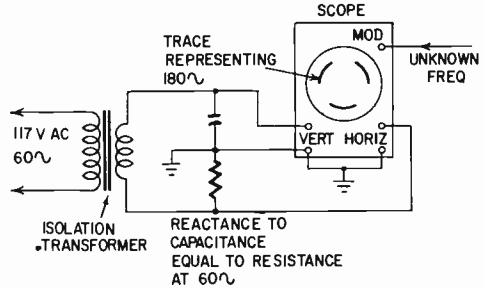

back close to 60 cycles after only a minute or two, but meanwhile the change in frequency may have put the timing of the clock several seconds off. So now the control has to bring the clock back to correct time over a longer period so as to achieve greater stability in frequency.

When the frequency is held steady, its accuracy is usually within about 0.1%. But for short periods the frequency can vary as much as 1%.

This can be quite disconcerting in making accurate frequency comparison, but if you operate during a period when the frequency is more stable, the result will probably be within 0.1%, which is closer than most of oscillators are calibrated.

### Instrument calibration

An oscillator or other variable frequency device can be calibrated by a variety of means according to individual preference. Some prefer the wheel method on the oscilloscope. Using the 60-cycle standard as a reference, it makes the spot travel in a circle by applying 90° phase-shifted voltages to the vertical and horizontal plates (Fig. 301).

The unknown frequency is then fed into the modulation grid (Z-axis input) of the tube and causes the circular trace to vary in intensity at the frequency to be measured. If the frequency being measured is a multiple of 60 cycles, it will produce a proportionate pattern of light and dark variations around the circle. This makes

the method convenient for measuring 120, 180, 240, 300 and further multiples of 60 cycles to a fair degree of precision. If the pattern of light and dark markings around the circle seems to rotate, the frequency is slightly above or below the multiple in question. The rate of rotation can be used to approximate just how much the frequency deviates from the exact multiple—the faster it is the greater the deviation.

An alternative method applies the unknown frequency to a sensitivity-modifying circuit in the scope, producing the cog-wheel patterns of Fig. 302.

The use of Lissajous patterns has the advantage that definite fractional relationships can be more easily observed than with the "wheel" method. Fig. 303 shows a whole family of Lissajous patterns for calibrating an oscillator using 60 or 1,000 cycles alternatively as the standard reference frequency. If 60 cycles is used as the basic reference—it is certainly the cheapest—then it is a good plan to set up a secondary standard of 1,000 cycles, which can be checked by using as an intermediate either 200 or 300 cycles. Check the variable oscillator first with the 60-cycle patterns and then adjust the secondary standard against this setting for the 1,000-cycle pattern, using the sequence shown in Fig. 304.

In Fig. 303 the patterns identified by numbers in large type are intended for use in calibrating an audio oscillator. The patterns identified in smaller characters are merely to aid in distinguishing between the ones desired, indicated in the bold characters.

From a musical standpoint quite an interesting and useful alternative to the scope and Lissajous patterns is the Conn strobe frequency indicator (Fig. 305). This uses a synchronous motor driven from a tuning-fork controlled frequency. The fork frequency can be adjusted over a range of  $\pm 3.5\%$  from the standard of 60 cycles by a sliding-weight arrangement. This control is so precise that the exact frequency can be read to within 1 cent.

The synchronous motor drives, through a sequence of gears, 12 stroboscopic discs. Each disc has a pattern of black and white segments that provide for identification of octavally related frequencies over the entire audio band. The 12 rotating discs, arranged in positions similar to the black and white keys of a keyboard instrument, identify each tone in the octave and in which octave a particular tone falls.

The tone is provided by illuminating a neon lamp with the amplified frequency being investigated. The exact pitch of the tone is determined by adjusting the tuning fork until the partic-

ular scope pattern appears to stand perfectly stationary. Its exact pitch relative to the standard can be then measured in cents, within a range of  $\pm 50$  from standard pitch. Thus, the instrument has an accuracy comparable with the Lissajous pattern method.

### Voltage and current

Standards of voltage and current were historically established in terms of direct voltage or current. Direct voltage is specified in terms of a standard cell, of which there are a variety, and the

Fig. 302. Another method produces the cog-wheel pattern shown here.

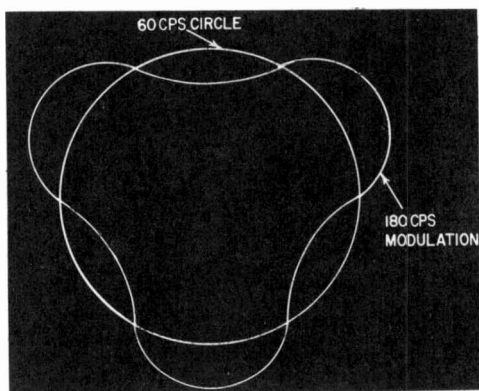

reader is referred to suitable texts which describe the standard voltage determined and its degree of accuracy.

Standard current is determined by electrolytic methods—how much copper or silver is deposited by an electrolytic process when a fixed current is passed for a standard period of time. These methods establish a standard-reference for direct voltage or current.

Alternating voltage or current, however, can be measured in terms of its peak value, its rectified average value, either half-wave or full-wave rectification, or its rms value. The only two references accepted as standard are the peak and rms values.

Rms value is measured by a thermal instrument—one that determines the effective heating value over the period of the wave. The old hot-wire ammeter (now obsolete) was such an instrument. This instrument was easily calibrated on direct current. It then gave a correct reading on alternating current, provided the frequency was not such as to allow the instrument to be bypassed partially by the self-capacitance of the system.

For audio purposes, thermal instruments require too much current or are too elaborate. Using a vacuo-thermo junction, these methods have been applied, but currently preferred methods use

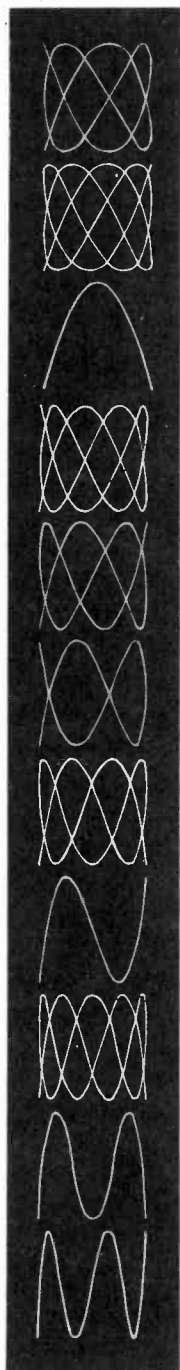

12	15	18	20	225	24	25.7	26.7	30	33.3	34.3
200	250	300	333	375	400	429	444	500	556	571

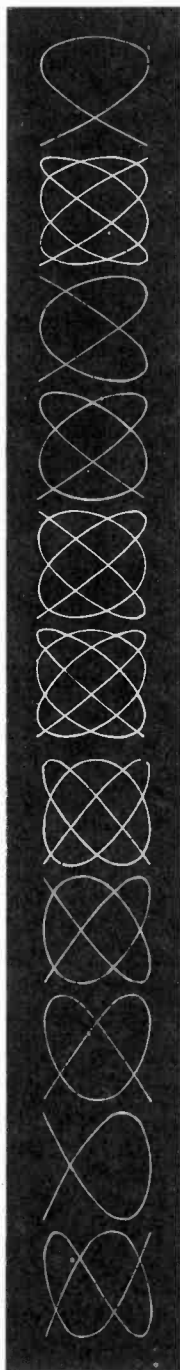

36	40	45	48	50	70	72	75	80	84	90
600	667	750	800	833	1067	1200	1250	1333	1400	1500

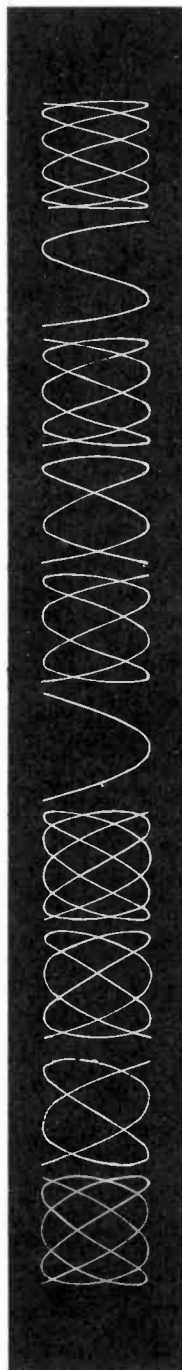

96	100	105	108	120	140	150	160	180	200
1600	1667	1750	1800	2000	2333	2500	2667	3000	3333

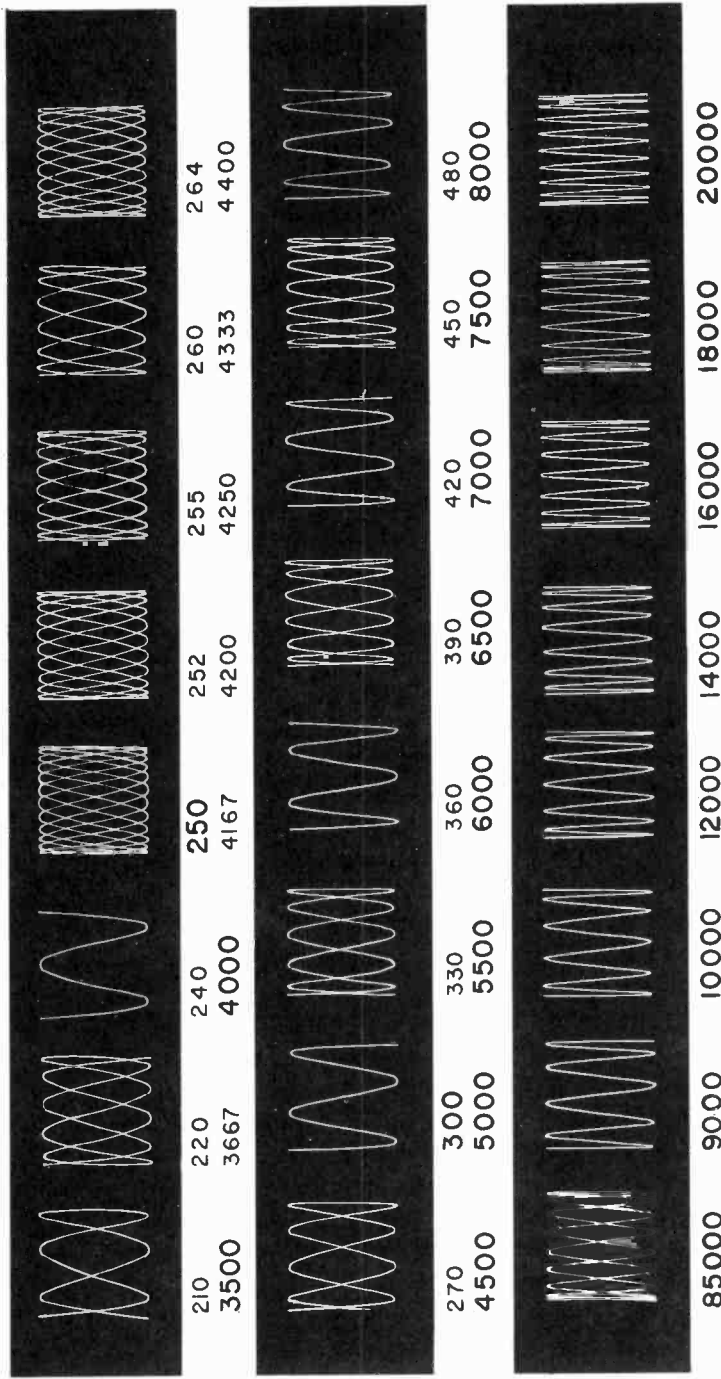

Fig. 303. Recognition patterns for using Lissajous figures for calibrating an audio oscillator; the upper number under each figure indicates the frequency displayed with 60 cps as a reference; the lower number is for 1,000 cps reference. Numbers in large characters indicate the patterns useful for calibration points, while the smaller numbers identify less important frequencies that may be used in finding the calibration points.



a vtvm or a direct rectifier voltmeter. In either case rectifier action produces the reading with a moving-coil instrument calibrated on direct current.

However, where a rectifier is used, it also needs calibration. If it behaved as a perfect rectifier, it could be calibrated simply from

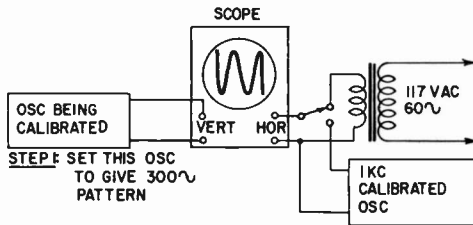
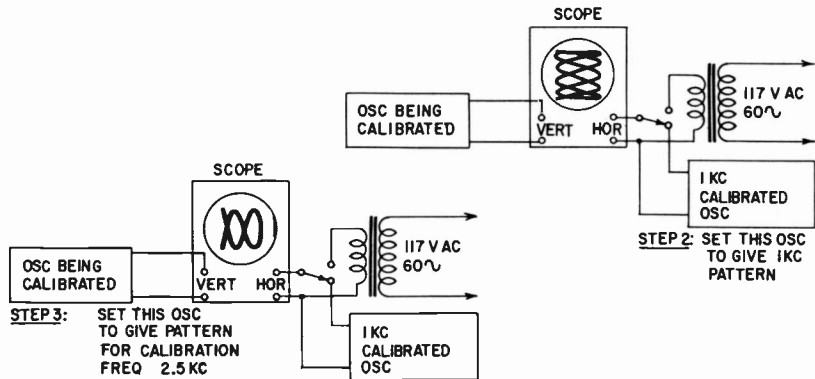

Fig. 304. Method used for getting calibration of higher frequencies (above 1,000 cycles) from a 60-cycle line.



a theoretical basis. But a rectifier does not rectify perfectly: it provides a finite resistance path for the current in the forward direction and a very high resistance (but not infinite) to current in a reverse direction. This means the rectifier itself possesses a scalar characteristic.

With most instrument rectifiers, the reverse-current resistance is so high that only the very lowest part of the scale (at very small currents) is modified appreciably from the theoretical value (Fig. 306). But the forward-resistance characteristic makes the effective resistance of the instrument vary considerably with current reading. If a large multiplier resistance is used, the voltage scale is almost as linear as the current scale, but for low-voltage-full-scale readings, the scale is distorted (Fig. 307).

Using, as an example, a 20 microampere–full-scale movement (50,000 ohms-per-volt), the series multiplier needed to make the instrument read 10 volts full scale dc would be  $10 \times 50,000 =$

500,000 ohms, less the movement resistance. Using a bridge rectifier, which is a full-wave rectifier, (Fig. 308-a) the theoretical value to give an rms reading on a sine wave (the way these instruments are calibrated) is calculated as follows:

The rms value of a sine wave is 0.707 times its peak value; the

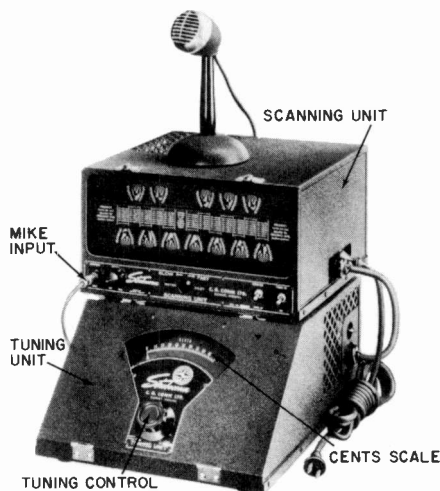

Fig. 305. The Stroboconn is a musicologist's frequency (or pitch) comparator of great precision.

rectified value (in theory) is 0.637 times its peak value. The meter will take 0.637 times the peak value of a sine wave, but we want it to read 0.707 times the peak, or  $\frac{0.707}{0.637} = 1.11$  times the

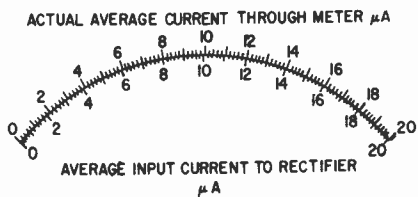

Fig. 306. Reverse resistance of rectifier invalidates the reading slightly, as shown here, of alternating average current.

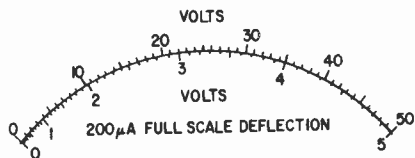

Fig. 307. Comparison between scales for higher and lower voltage readings, using a rectifier instrument.

current the movement actually passes. For a voltmeter, this is achieved by dividing the multiplier resistance by 1.11 (or multi-

plying it by 0.9) so the actual current of  $20 \mu\text{a}$  full scale is equivalent to  $22.2 \text{ rms } \mu\text{a}$ . So the theoretical multiplier resistance will be  $0.9 \times 500,000 = 450,000$  ohms, less the resistance of the meter with its rectifier.

In practice, instrument rectifiers do not work very efficiently at only  $20 \mu\text{a}$  full scale. It is customary to shunt the dc movement to some higher value, usually so the same voltage multiplier can be used for ac. For example, the shunt may be arranged so the full-scale current is  $180 \mu\text{a}$  ( $20 \mu\text{a}$  through the meter and  $160$  through the shunt). This would then be equivalent to a meter requiring  $200 \mu\text{a}$  rms full scale. This is still a theoretical value, based on a rectifier efficiency of 100%. Some slight modification of the shunt is necessary in practice to compensate for deviation.

The other type of rectifier in ac instruments uses only two elements (Fig. 308-b). On a sine wave this halves the average current. So to make an instrument with  $200 \mu\text{a}$  rms full scale, the meter shunt needs to take a theoretical  $70 \mu\text{a}$ , to bring the total average

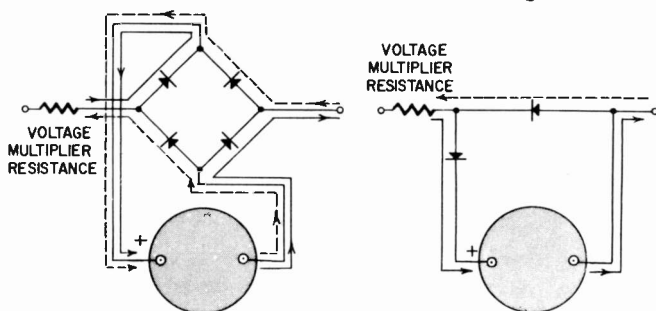

Fig. 308. Two commonly used rectifier circuits for ac measurements in audio: (a) full bridge; (b) two-unit, half wave. The solid and dashed lines indicate current paths for alternate half-waves of the ac cycle.

current up to  $90 \mu\text{a}$ . In practice the current passed by the shunt is a little lower than this, because rectifier efficiency is not 100%.

At higher frequencies an instrument rectifier possesses effective self-capacitance that reduces the reading produced by a given alternating current. This is partly due to actual capacitance and partly to a "hysteresis" effect in rectification. It varies with rectified current as well as frequency.

A useful instrument for measuring voltage is the cathode-ray oscilloscope. Some scopes can also be used to measure current with good precision, but the only completely satisfactory way of doing this is to use deflection coils instead of plates. Most modern scopes

for measurement work employ plates for deflecting the spot in each direction.

By using direct connection to the plates, (provided for on most scopes), the deflection of the spot with the application of direct voltage is easy to see, and an alternating voltage of sinusoidal form can be applied to produce the same peak or peak-to-peak deflection. From the theoretical relationship between rms and peak or peak-to-peak voltages the scope can be calibrated, if desired, in terms of sinusoidal rms input.

Fig. 309. Using a calibrated series resistance to measure alternating current by voltage drop it produces.

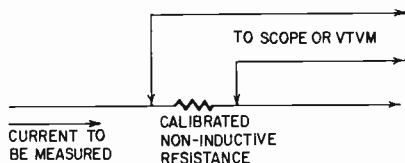

By applying the voltages measured directly to the scope, there is no variation in response due to the scope amplifier. Although the capacitance of connecting leads can load the circuit to which the scope is connected, the voltage reading is always that actually present when the scope is connected. With any other type of instrument, or even when using the scope with its internal amplifier, one has to remember that the instrument itself may be inaccurate in its reading, either due to deviation from calibration or because of frequency response, in addition to the possibility of circuit loading.

Both ac and dc voltage measurements are relatively easy, using either a vtvm with a very high input resistance that will not appreciably load the circuit being measured, or by using a regular volt-ohm meter with a relatively high resistance—in modern instruments in the region of 20,000 to 100,000 ohms-per-volt. Current readings, however, are not so readily provided for.

Direct current can be read quite conveniently, using the instrument with its arrangement of shunts, but even this involves a small voltage drop that can interfere with the operation of the circuit being tested, invalidating the reading. For ac readings, the most satisfactory method is to insert a small resistance in the circuit and then measure the voltage drop across it, either with a scope or vtvm (Fig. 309). Either way, the voltage drop is something not normally present in the circuit until the resistance is inserted.

When using a resistor in this way, it is important, if the current reading is to be meaningful in absolute terms, to measure the resistance precisely. It is also important that the resistance be non-

inductive, otherwise a rising current characteristic occurs during measurement at higher frequencies.

### Phase

For high fidelity reproduction, relative phase angle is not important. But it can be in the design and development of feedback amplifiers and in audio applications not connected with high fidelity. The method used in measuring relative phase angle depends to some extent on the type of signal involved and the purpose of the measurement.

If both signals, the reference one and the one whose phase is to be compared with it, are sinusoidal, the scope can be arranged to give quantitative data from which the phase relationship can easily be calculated. If one signal is applied to the horizontal and the other to the vertical plates, either a line or an ellipse will appear. Adjusting the trace so its height is equal to its width, and both are some convenient dimension (which we will designate twice unity) the trigonometrical functions of the phase angle can be measured (Fig. 310) and the corresponding angle identified by the use of trig tables.

Alternatively, the phase can be estimated (by comparing the trace observed with the ellipses shown in Fig. 303) to within about

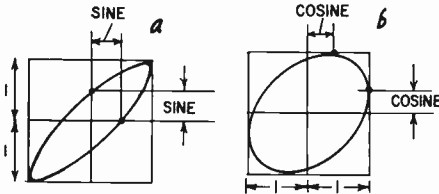

Fig. 310. Oscilloscope ellipses can be used to obtain quantitative measurement of phase angle: (a) less than  $45^\circ$ ; (b) between  $45^\circ$  and  $90^\circ$ .

$10^\circ$ . This also identifies the ellipses at points corresponding to measurements for sine (along the center lines) and cosine (along the edges).

With angles between  $0^\circ$  and  $45^\circ$  or the corresponding half of other quadrants, the sine is the most useful function. For angles between  $45^\circ$  and  $90^\circ$ , and the corresponding half of other quadrants, the cosine is more useful. Having read the appropriate function, the angle can be obtained from trig tables or a slide rule that gives trig functions. For angles close to  $45^\circ$ , particularly between  $35^\circ$  and  $55^\circ$ , it is well to cross-check by using both.

In using this method, particularly at low or high frequencies, it is important to check the phase accuracy of the scope. When the same input is applied to both sets of plates, the reading should show zero phase angle.

While this method is particularly useful where both waveforms are sinusoidal, it can be modified by a bridge technique for use where only one is sinusoidal.

Where neither waveform is sinusoidal, a different technique must be adopted. It is also important to define what is meant by phase angle, as ambiguities arise when the waves are complex. Fig. 311 shows two possible reference points on a relatively simple waveform.

A range of phase meters has been marketed using automatic mark-space ratio control. This uses a limiter on each waveform,

Fig. 311. This waveform illustrates the possible ambiguity of reference points on a non-sinusoidal waveform, where the phase between mid-points and "tops" and "bottoms" is no longer  $90^\circ$ . Here mid-points have been chosen to give  $180^\circ/180^\circ$  spacing, but the other spacings are altogether different.

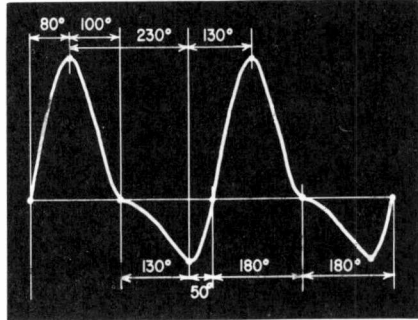

with a feedback that automatically adjusts limiter bias so the top of the resultant square wave has equal duration with the bottom. The significance of this on a waveform is shown in Fig. 312.

A block schematic of such a phase meter is shown in Fig. 313. Both input waveforms are passed through a limiter with automatic mark-space control, to produce a square wave. Its vertical lines are timed by the points on the input waveform that have the same

Fig. 312. How a mark-space ratio control works. The correct bias, which will produce symmetrical square-wave output, is represented by dashed line A; incorrect bias, which will make the square wave asymmetrical, as indicated by the angles noted, is represented by dashed lines B and C, and will produce a correction bias to bring operation back to A.

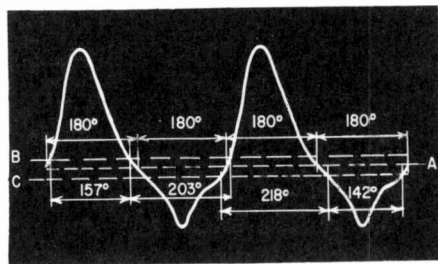

instantaneous value  $180^\circ$  apart. These are then combined in a "product" type mixer, which gives a positive-going output only for the time when both inputs are positive-going. Thus, an integrating meter on the output will give a direct indication of how much of the total time for one cycle the two waves are positive-going together.

Such an instrument can be directly calibrated in phase, with a practically linear scale, and it will be independent of frequency over a wide range. The only limitation is whether the interpretation of phase on which the reading is based happens to be what you want.

## Resistance and impedance

The established standard for resistance is in terms of a column of mercury of standard dimensions at a specified temperature. All resistances and impedances can be compared to it by means of various types of bridges.

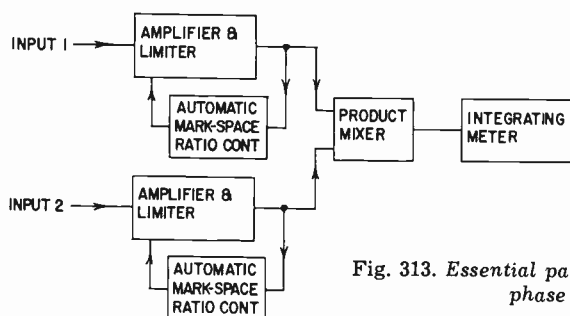

Fig. 313. Essential parts of a direct-reading phase meter.

Practical measurements of resistance and impedance are performed with a variety of instruments. The most accurate method is always a calibrated bridge. For resistance checks this can be dc operated, but for all impedance measurements ac must be used and the frequency is important because impedance is never constant with frequency. Measurements of impedance are specified in a variety of terms.

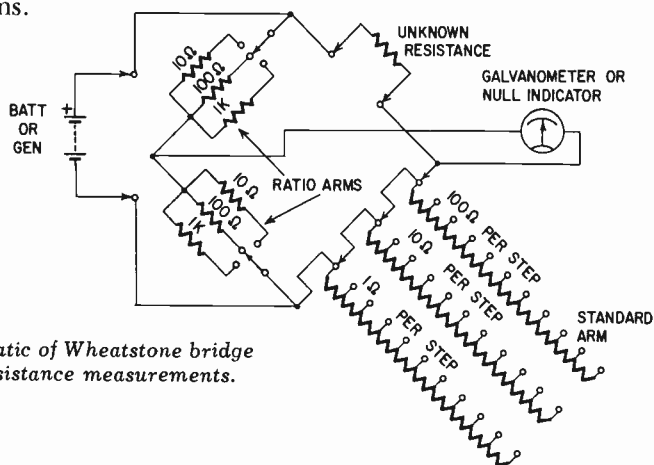

Fig. 314. Schematic of Wheatstone bridge used for dc resistance measurements.

They may be in terms of impedance value in ohms in conjunction with a phase angle, or this complex impedance may be broken down into resistive and reactive components at  $90^\circ$ . Sometimes it is desirable to specify the various reactive components in terms of their equivalent inductance or capacitance at the frequency in question. Some impedance bridges are designed to measure each of these quantities in their basic terms; others require conversion from the terms given to the terms desired.

The simple Wheatstone bridge for measuring resistance is shown in Fig. 314. It also appears in a variety of forms, such as the well-

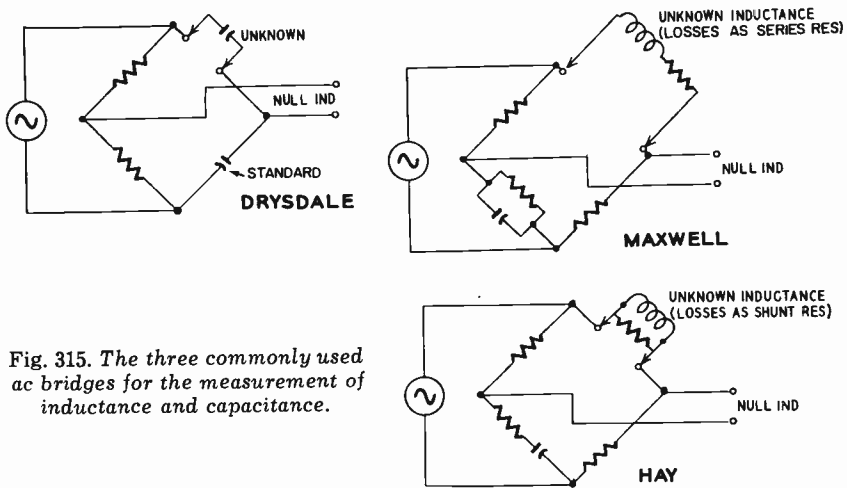

Fig. 315. The three commonly used ac bridges for the measurement of inductance and capacitance.

known Leeds-Northrup bridge, used in this country, or the "post-office box" used in England. The common bridge uses ratio arms that pick out specific ratios between the standards resistors and the unknown, giving the instrument wide useful range. The resistors in the ratio arms bear relationships of multiples of 10, so the reading obtained is multiplied or divided by 1, 10, 100, or sometimes 1,000.

The standard arm is made so that resistance can be measured, usually to three significant places. It can take the form of decade dial switches or a plug system, the removal of any plug inserting the resistance designated on the panel.

For the ac measurement of different kinds of impedance, a variety of bridges are used. The most useful ones for audio measurements are the Drysdale bridge, for the measurement of capacitance, and the Maxwell and Hay bridges for measurement of inductance (Fig. 315).



The capacitance bridge can be modified (Fig. 316) to allow a polarizing voltage to be applied to the capacitor being measured. This is useful for measuring electrolytic capacitors. The capacitance bridge can take two variations. One uses resistance ratio arms and employs a standard capacitance in decade arrangement to balance the unknown. The usually preferred method is to use

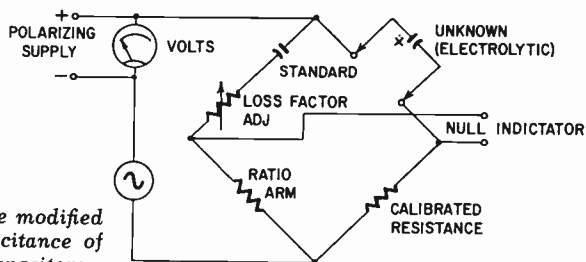

Fig. 316. Drysdale bridge modified for measuring the capacitance of polarized electrolytic capacitors.

a single standard capacitance with a resistance ratio arm to compare against it, and a standard resistance to compare against the un-

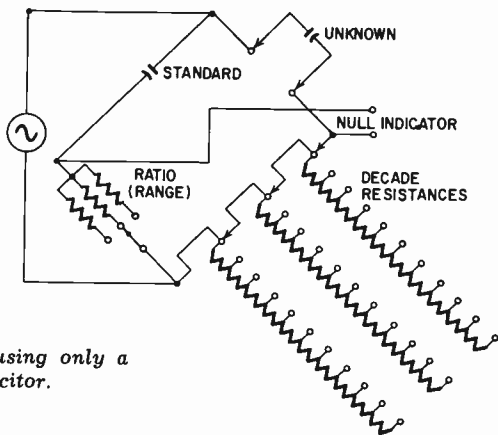

Fig. 317. Capacitance bridge using only a single "standard" capacitor.

known capacitance (Fig. 317). The standard resistance is arranged in decades or calibrated to give a precise reading of capacitance, whose value is multiplied or divided by the factor produced by the ratio arm.

For the larger values of capacitance provision is made for balancing loss components in the unknown capacitor. It can consist of an adjustable resistance either in series or in parallel with the standard capacitor (Fig. 318). The advantage of having the resistance in series is that it enables the polarizing supply to be inserted in series with the alternating test frequency. Then the standard capacitor, having a high voltage rating, prevents the polarizing

supply from driving current through the remaining arms of the bridge.

For measuring inductance the choice of configuration depends

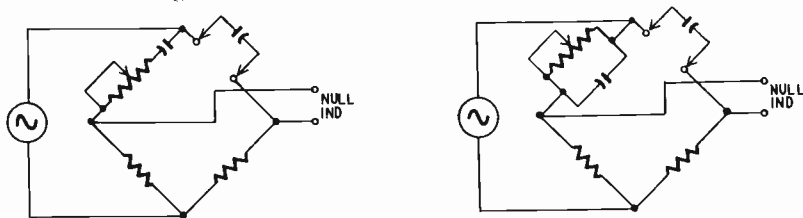

Fig. 318. Two ways of including resistance in a capacitance bridge to compensate for losses in the capacitor under test.

upon the kind of inductance to be measured. For measuring inductances intended for use on ac only, whether air- or iron-cored, the Maxwell bridge, is usually the more useful. In theory at least it gives an inductance reading independent of frequency. In the formula for balance with a Maxwell bridge, the resistance shunting the standard capacitor produces the same phase deviation at all frequencies as does a series resistance element in an inductance. In the case of an air-cored inductance, the same balance should hold throughout the entire frequency range.

The value is usually read from a variable resistance in one of the arms, while a ratio resistor is employed in the other. The reading is given in terms of inductance, based on the multiplying factor derived from the resistance relationship in conjunction with the capacitor in the balancing arm.

While the Maxwell bridge will give a balance that is independent of frequency for an air-cored coil (provided capacitance effects in the coil are negligible), it does not do so with an iron-core coil—the losses due to the core appear as an effective *shunt* resistor. For an iron-cored inductance, the Hay bridge often proves best, especially in the frequency range at the low end of the audio spectrum, where the principal component of losses is the core loss. This bridge will then give the nearest approximation to a balance independent of frequency (Fig. 319).

Another advantage of the Hay bridge is that it can readily be adapted to pass polarizing current through the inductance, for measuring with fair precision the inductance of a smoothing or coupling choke, designed to pass a polarizing current and at the same time to achieve a given inductance value. The choke across the generator and the capacitor across the polarizing supply serve only to isolate the supply.

A practical limitation occurs here because the inductance produces some distortion of the test frequency. In practice one has to use a sinusoidal test frequency, if possible, of 120 cycles, but a smoothing choke distorts even this, so that when balance or null is achieved at 120 cycles, components of 240 cycles and other even-order harmonics of the test frequency are present.

Another adaptation of the Hay bridge is a scalar version in which the resistance arm in series with the test terminals across the generator supply is very small in value, so the voltage drop is less than one-tenth of the applied voltage (Fig. 320). With the special switching arrangement shown, it is possible to analyze in detail, not only the phase and loss components in the inductance being tested, but also its effective harmonic generation. This is achieved by critical examination of the residue at the null.

The best method of examining the residue is to apply the null output from the bridge to a calibrated scope, which is then ad-

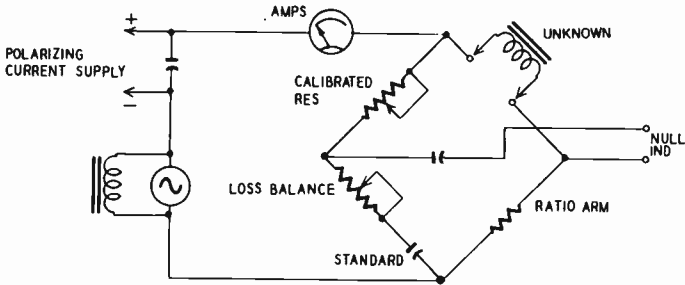

Fig. 319. The Hay bridge is useful for measurement of iron-cored inductances.

justed so that the residue waveform falls conveniently between two parallel horizontal lines when appropriately amplified. Switching the scope so the vertical and horizontal deflections give the voltages across two sides of the bridge completes the information. The resistance and capacitance section is switched to produce vertical deflection, while the large resistance section in series with it produces horizontal deflection to give an ellipse that indicates the magnitude and phase angle of the current in the coil without the distortion introduced by its harmonic generation. Switching the scope inputs across the other two arms, the current in the arm adjoining the test inductance will contain the distortion component.

A further refinement consists of a  $90^\circ$  phase shift introduced into the voltage component across the coil to produce the hys-

teresis loop for the sample at this particular frequency (Fig. 321).

Using this method, it is possible to produce a precise analysis of the core material on which the inductance is wound. This has

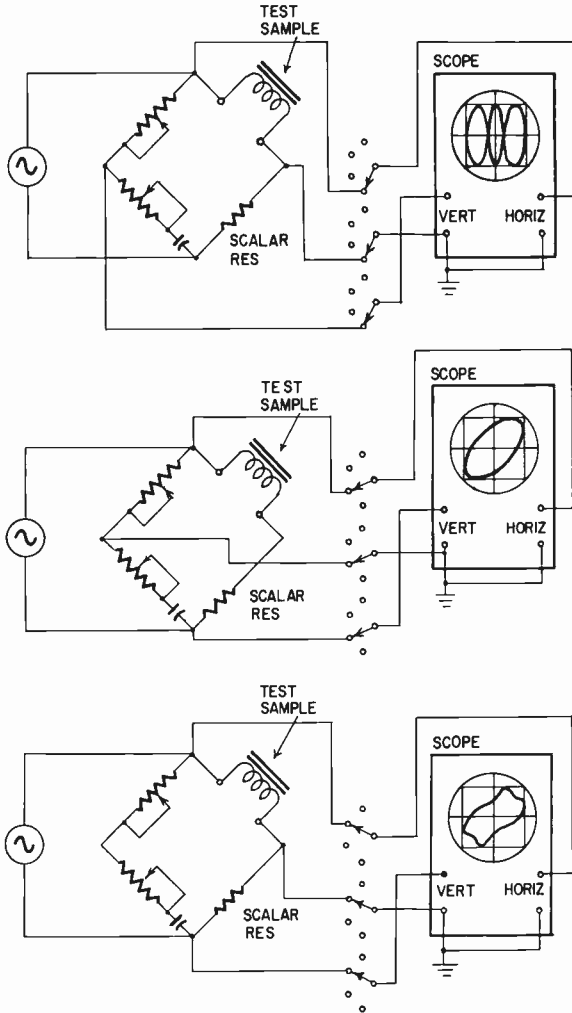

Fig. 320. Measurement procedure for obtaining full details of characteristics of core materials on ac magnetization.

been used as a method of analyzing the behavior of different core materials and of predicting the performance of a coil wound on it. It is useful in the design of iron-cored audio components such as output and other audio transformers.

Other instruments for measuring, in much more approximate terms, resistance and impedance, inductance and capacitance, are the so-called direct-reading types. The disadvantage of all bridge type instruments is that they rely upon attaining a null deflection, either with a meter or some other kind of indicator, and then reading from the dials (with which the adjustment has been made) the value of the component measured.

Direct-reading resistance meters, called ohmmeters, utilize either a battery or a rectified line-voltage source and measure the current flowing through the unknown resistance from a known voltage, or the voltage developed across a resistance when a known current is passed through it. Basic ohmmeter circuits are illustrated in Fig. 322.

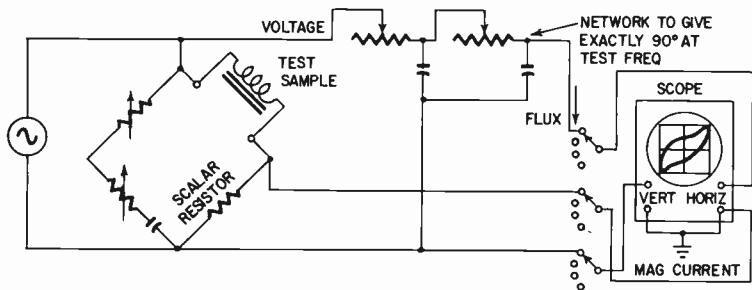

Fig. 321. Additional phase-shift network in configuration of Fig. 320 enables hysteresis loop to be displayed.

The methods of adjustment are arranged so that a variation in supply voltage does not interfere appreciably with accuracy of the reading. The adjustment is made in such a way that it modifies the deflection of the instrument so full-scale reading can easily be obtained for an open or closed circuit, while not materially affecting the "standard" resistance value with which the unknown is compared when connected to the terminals of the instrument.

An ohmmeter as an instrument is severely restricted in accuracy. In the center-scale region a deviation of 1% in the accuracy of current indication, normal for a first-grade instrument, represents approximately an 8% error in resistance reading—assuming the calibration is accurate in the first place. Errors in component values add to the inaccuracy of reading. Consequently it is not advisable to rely on the resistance reading of an ohmmeter to closer than 10%.

However, the meter can be read to closer than 10%, at least in the middle of the scale of a good instrument. This makes it

useful as a means of *comparing* resistance values. This is often valuable in audio work, because what are needed are balanced or matched resistors—two or more resistors, having values within a certain percentage of *one another*, the absolute value of the resistors not being important.

In a push-pull amplifier, the value of the resistors in the plate circuit of the two driver tubes should be within certain limits. But it is more important that the resistors be within a certain percentage of one another than that they be within a certain percentage of a specified value.

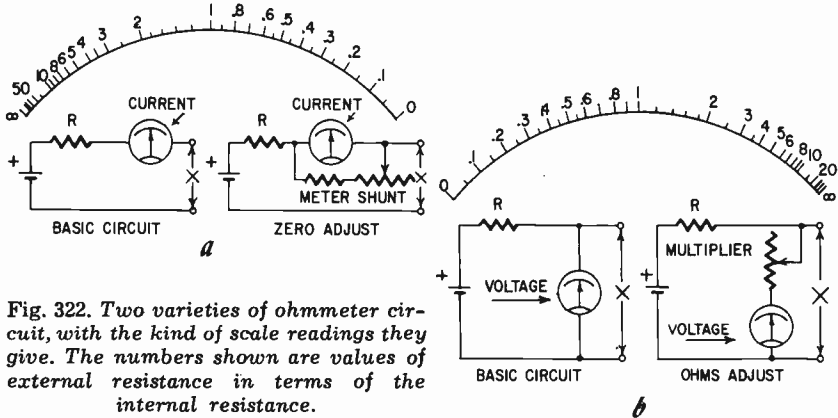

Fig. 322. Two varieties of ohmmeter circuit, with the kind of scale readings they give. The numbers shown are values of external resistance in terms of the internal resistance.

For convenience in production, it is usual to specify component values of close tolerance, because this enables the operation to be set up without the necessity for matching values in the same amplifier. For home-construction, it is simpler to use a resistance meter and match a couple of values to one another, without being sure that the values come within a specific tolerance of their coded value.

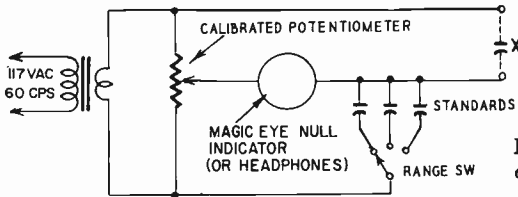

Fig. 323. General arrangement of a simple, easy-to-read capacitance bridge.

A simple capacitance bridge is also easy to use. It consists of a high-accuracy potentiometer which takes the place of the normal ratio arm and performs a comparison check between the unknown and a "standard." Switching in different values for the "standard"

acts as a range change and enables a quick null to be obtained on whichever range is appropriate. This type usually comes with a built-in magic-eye null indicator and uses the 60-cycle line voltage as a generator supply (Fig. 323). This resistance-balancing method

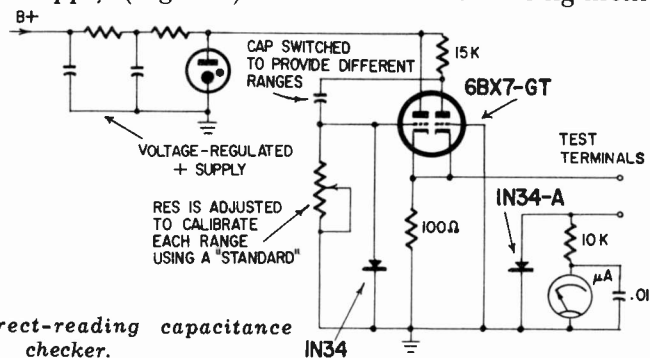

Fig. 324. Direct-reading capacitance checker.

achieves an accuracy comparable to that given by an ohmmeter type instrument for resistance. It is not actually direct-reading, but is much simpler to use than the regular type bridge.

Another type of capacitance checker is really direct reading. It works by repetitively discharging the capacitor and measuring the pulse required to charge it again. The circuit is shown in Fig. 324. The 6BX7-GT works as a cathode-coupled multivibrator, whose frequency is coarse-controlled by the range switch (not shown) that charges the capacitor. It is fine-controlled by the grid resistor associated with it, and a separate resistor switched in with range obviates the necessity for calibration every time the range is switched.

The circuit is fed from a voltage-regulated supply to assure (as near as possible) pulses of constant magnitude. Pulse shape is improved by use of the 1N34A diode (shown at the left) which prevents that grid from ever going positive from ground and thus limits the positive-going pulse in the 100-ohm cathode resistor. The short positive-going pulse, sends a charge into the capacitor connected to the test terminals, which is measured by the microammeter. The negative-going pulse discharges the capacitor again through the 1N34A shown at the right. The  $.01 \mu\text{f}$  capacitor across the microammeter serves to steady the meter reading, which otherwise would try to indicate a succession of very sharp pulses.

This instrument is capable of good accuracy in the "checking" sense and has a convenient linear scale. This means that each range is limited to about a decade of capacitance values, as com-

pared with about two decades for the other type. The choice rests largely on preference and purpose.

For smoothing or coupling-choke inductance checks, a better method is a simple impedance comparison setup, feeding the ac to the choke through a resistance and comparing the voltage de-

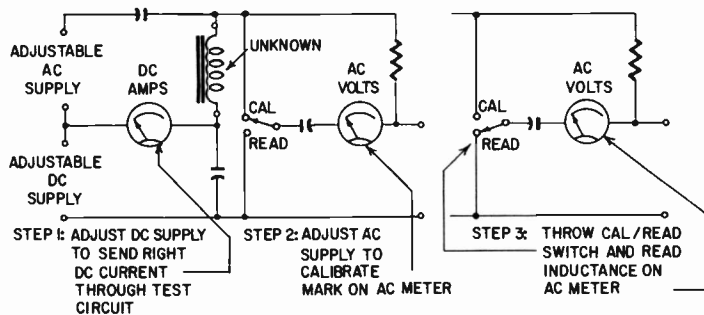
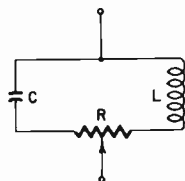

Fig. 325. A simple setup for "measuring" (or checking) the inductance of chokes carrying dc.

veloped across the choke with that across the "standard" resistance. At the same time direct current of measured value is fed through the choke, so the "inductance" is measured at the specified current (Fig. 325).

The "ohmmeter principle" can also be applied to impedance measurements. Instead of using a "standard" resistance for comparison, the direct-reading impedance meter uses a variable-phase constant impedance, the element for which is shown in Fig. 326. The impedance is not quite constant, but comes as close as can

Fig. 326. Elements of the variable-phase constant impedance used in a direct-reading impedance meter.



$$R = 2.74Z_0 = 2.828X$$

$$X_L = X_C = .97Z_0 = .3535R$$

be utilized in an ohmmeter type instrument. Fig. 327 shows how the magnitude and phase of the impedance of the "standard" vary with phase-adjustment setting. The accuracy can be improved considerably by including some fixed resistance with each reactance element (Fig. 328). The inductance naturally has some losses, so the capacitor can have some resistance added to match the inductor losses.

The standard variable-phase impedance can be incorporated into an "ohmmeter" circuit in one of two ways (Fig. 329). Of



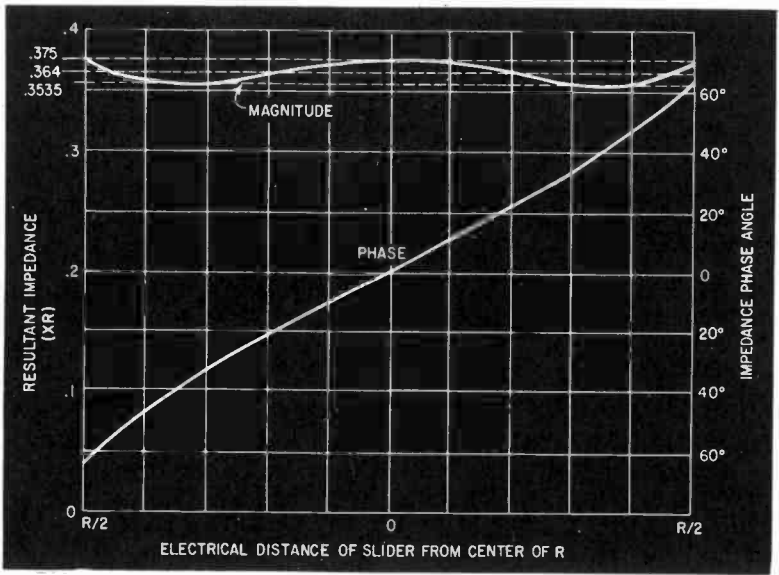

Fig. 327. The magnitude and phase will vary, depending upon the electrical distance of the potentiometer slider from the center of  $R$  (shown in Fig. 326).

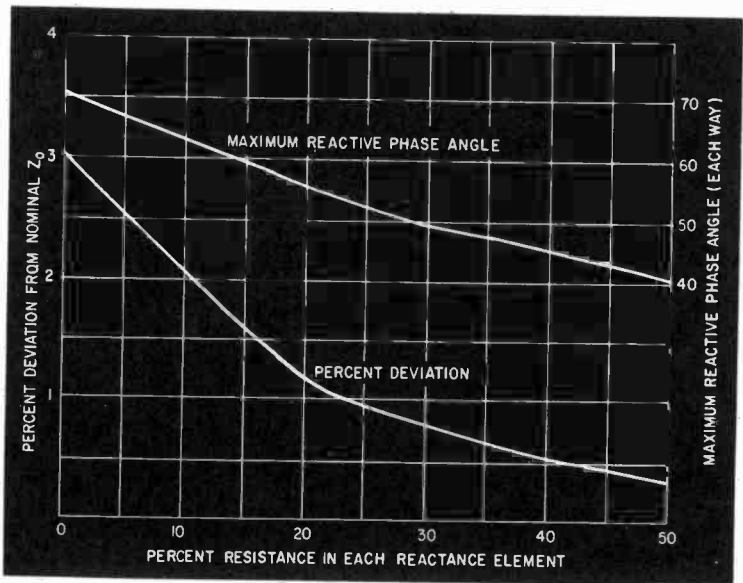

Fig. 328. Using some resistance in the reactance arms of the direct-reading impedance bridge improves the constancy of magnitude more than it restricts phase coverage.

course, this circuit will read correctly only at a fixed frequency. Different frequencies can be used only by switching the L and C components of the "standard" impedance.

The instrument is read much like an ohmmeter, except that the phase-adjustment knob is turned to obtain a maximum or minimum reading (according to which of the circuits of Fig. 329 is used). Then the phase knob indicates the phase of the unknown impedance, while the dial reading gives its magnitude.

A precision type of bridge that overcomes some of the disadvantages of other bridges has recently been introduced. This uses a substitution method: the unknown component is substituted for known and calibrated values inside the bridge, which are taken out of the circuit when the set/measure switch is thrown. This enables impedances to be measured right down to zero. At the same time, by using a different configuration, admittances can also be measured right down to zero (which takes impedance up to infinity).

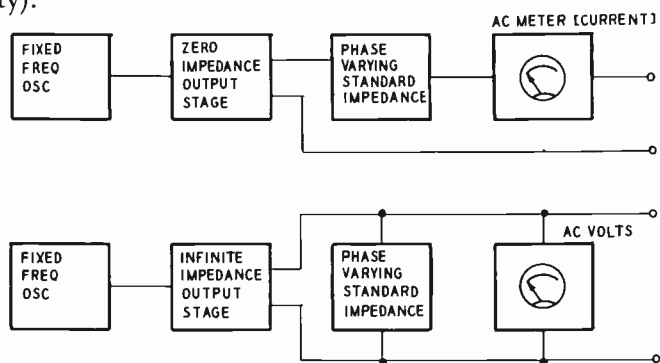

Fig. 329. Two basic ways of using the standard variable-phase impedance in a practical meter. One requires a zero resistance and the other an infinite resistance stage, just at the operating frequency.

This particular bridge is calibrated in terms of resistance and reactance for the impedance measurement, and in terms of conductance and susceptance for the admittance measurement (Fig. 330). The calibration on reactance and susceptance is based on set frequencies of 100, 1,000 or 10,000 cycles. If different frequencies are used, a correction factor has to be applied to determine the actual reactance or susceptance values. The calibration for resistance and conductance is independent of frequency. The bridge is designed around components in the region of 1,000 ohms (or 1,000 micromhos) so it achieves its highest precision when

measuring impedances or susceptances in this region. Basically, the precision with which it will measure zero resistance or admittance is as a percentage of the reference impedances of the bridge.

For production purposes, specialized bridge circuits have been developed. The bridge is set up for the accurate value (design center) required, and its indicator is calibrated to read deviation from standard value. The dial is usually marked in go-no-go terms, so an operator without technical skill or knowledge can pass or reject components. While equipment of this type is used to test

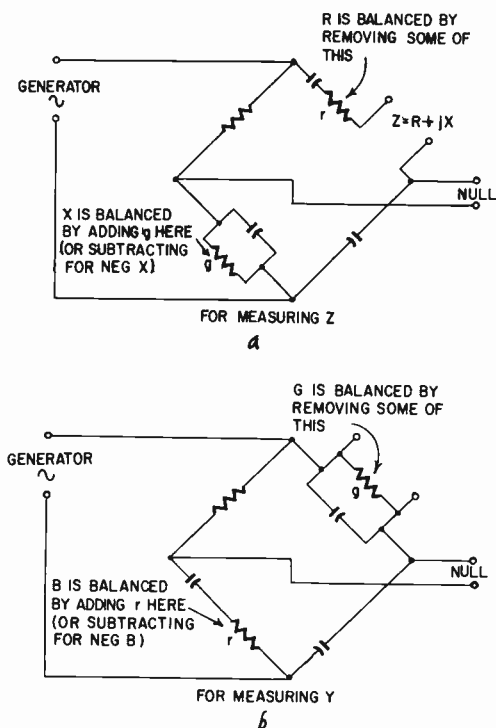

Fig. 330. Basic configurations of the impedance-admittance bridge that carries through zero values by using a substitution or incremental technique.

almost all components used in audio circuits, it is rather specialized and beyond the scope of the present book.

So much for electrical quantities to be measured. Other basic measurements connected with audio concern the acoustic velocity and pressure of a sound wave, groove velocity in disc recording, and

the compliance and viscosity of the disc material, the characteristics of magnetic tape and, for research work preparatory for design of equipment, the measurement of dynamic characteristics of non-linear amplifying components such as tubes and transistors.

### Acoustic velocity and pressure

The properties of sound waves are extremely difficult to measure in absolute terms and yet this is necessary if we are to have a satisfactory starting point. The problem remains that we have a speaker and a microphone, with electronic equipment in between which may include recorders, broadcast transmitters and other items. How can we know we have a linear relationship between the original sound wave and the electrical audio signal? How can we be sure we have *either* a flat microphone *or* a flat speaker? We can use a microphone assumed to have a flat frequency response to calibrate a speaker, or we can use a speaker assumed to have a flat frequency response to calibrate a microphone, but how do we know just where we stand? The only way is to have some independent method of measuring either sound velocity or pressure.

Books on acoustic theory explain the basic wave phenomena and formulas which have been substantiated quite well by experimental research. It is possible quite easily to measure *linear* velocity of air particles or to maintain air particles at a known linear velocity. The difficulty is measuring the velocity that occurs back and forth due to the passage of a sound wave. Similarly it is

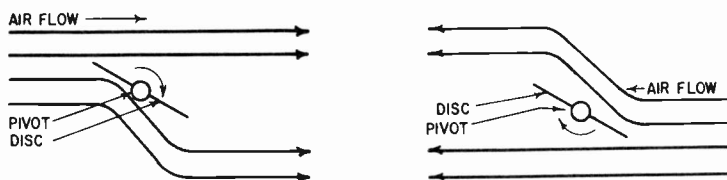

Fig. 331. Air flowing in opposite directions past an inclined disc tends to make it rotate in the same direction.

readily possible to measure the static pressure of air. The difficulty is in precision measurement of air-pressure *fluctuation*. The difficulty can better be appreciated when we realize that the pressure fluctuations are no more than about 1-millionth of the static pressure.

The best form of standardization is based on the use of a simple device called a Rayleigh disc. This is a small disc suspended in the air so that the movement of air particles tends to turn it. You may have noticed that the wind causes leaves suspended on a tree to

flutter back and forth. The tendency of air striking a surface free to pivot is to set the surface at right angles to the direction of air travel, to produce a maximum opposition. This happens if a disc is suspended in a column of moving air (Fig. 331).

The velocity of vibration due to the passage of a sound wave tends to turn the disc just the same as a steady flow, and the torsion or force produced is proportional to the average effect of the velocity through the cycle of the wave's passage.

Provided the size of the disc is kept small compared to the wavelength of the sound being measured, this principle remains true. A static torsion can be set up, as measured by the thread supporting the disc, and compared with the torsion produced by a known steady draft of air past the disc.

In this way it is possible to calibrate accurately the acoustic velocity of air particles in a wave. To do this, of course, it is necessary to exclude direct drafts, which will have an effect on the disc completely swamping that due to sound waves passing. For this purpose, the Rayleigh disc is inserted in a large tube and the sound wave is produced by a sound generator from one end of the tube. This enables a calibrated acoustic velocity to be established in the tunnel in which the Rayleigh disc is contained.

From the established properties of air (its density and elasticity) the acoustic pressure can also be calculated at this same point in the tunnel. By placing a microphone for calibration in such a position as not to obstruct the passage of air, a pressure or velocity calibration of the microphone can be obtained. The microphone must be placed in a position where the intensity is the same as at the Rayleigh disc. This, in essence, is the standard method of calibrating a microphone.

### **Groove velocity**

Groove velocity in disc recording is probably one of the easiest things to measure in audio. Some refinements which give better precision are beyond the scope of this book, but, in simple terms, the velocity of projected stylus movement in disc recording can be measured by examination under a point source of light (Fig. 332).

When the groove is unmodulated, the point source of light will be reflected at a single point in the whole succession of grooves right across the disc, so as to produce a narrow straight-line reflection. When the groove is modulated by a tone of known frequency, light is reflected from the groove at an angle dependent on the maximum slope the groove makes with a constant radius. So the

angular width of the band of light is proportional to the maximum angle of the groove and to its original unmodulated radius. The maximum angle of the groove multiplied by the linear velocity of the record at this radius gives the lateral groove velocity. This maximum occurs at the mid-point of its excursion and is the maximum groove velocity of the wave.

The record does not rotate so as to produce constant *linear* velocity, but a constant rpm or angular velocity. Consequently, the same maximum stylus velocity must be accompanied by an increase in angle at a smaller radius, so the linear velocity times the groove angle gives the same product for stylus velocity. As a result,

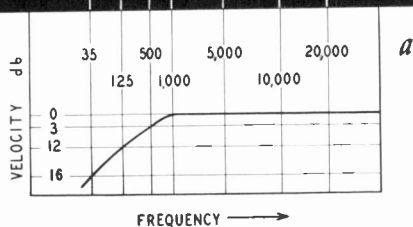
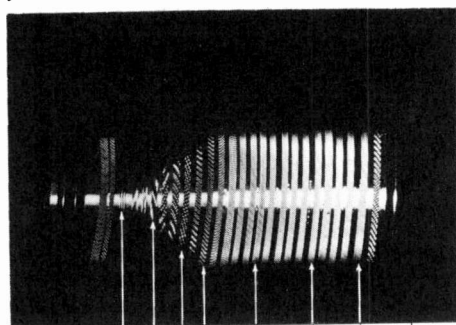
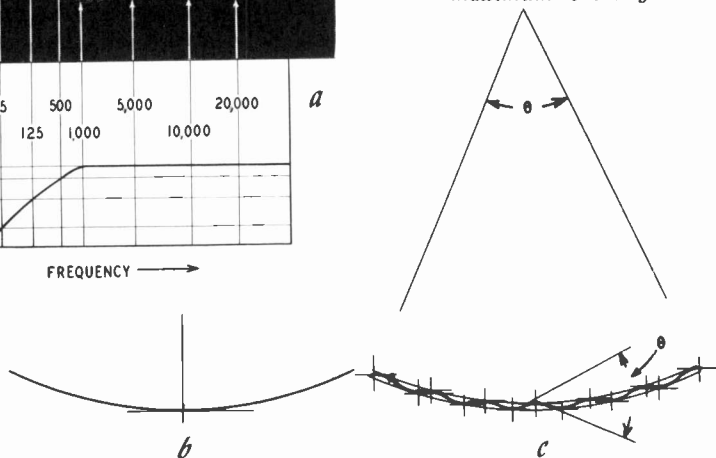

Fig. 332. Basis for the light-pattern calibration of velocity characteristic of records: (a) complete pattern of a test record shows its frequency response; (b) single reflection from an unmodulated groove; (c) width of reflection from modulated groove depends on maximum velocity.



a disc recorded with the same frequency all the way through, at the same maximum velocity, will produce a parallel band of light from inside to outside.

Because the product of the angle and linear velocity gives the maximum stylus velocity without reference to frequency, the width of the band is also independent of the frequency at which the disc is recorded and dependent only on the maximum groove velocity.

Maximum amplitude, of course, is another thing, since this will

be inversely proportional to frequency for a constant maximum velocity.

### Disc compliance and viscosity

Compliance and viscosity of disc material are important because they contribute to the performance of a pickup. Just as the compliance and viscosity of the stylus support control the movement in the pickup itself, so the compliance and viscosity of the materials of which the disc is made enter the picture in determining the performance of the overall arrangement (Fig. 333).

At the date of writing, no standard has been established in this regard and consequently different discs recorded with the same

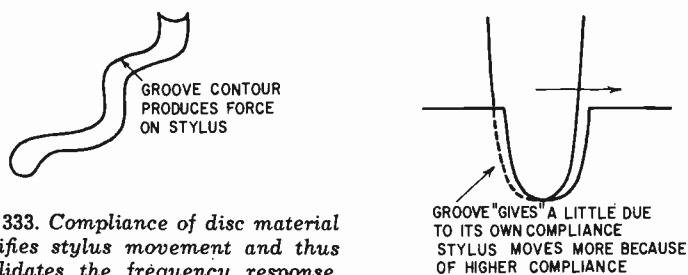

Fig. 333. Compliance of disc material modifies stylus movement and thus invalidates the frequency response.

characteristics, as measured by the same basic velocity method just described, used with different pickups, produce apparently conflicting results. This is due to the lack of standardization between pickup and record material.

Naturally, each pickup manufacturer will choose a test record that makes his pickup look best. This does not say that there is necessarily any major discrepancy between test records in terms of groove velocity. But different test records will not give consistent results with various pickups because of the different way the material of the disc contributes to the performance of the pickup.

The compliance and mass, or rotational mass, of a pickup can be measured or computed from measurements that will be discussed in detail in Chapter 7. The best method is to apply the drive force through the coil of the pickup and note the frequency and magnitude relationships between the drive force and the stylus movement as measured by a projection method using the shadow produced optically to indicate the movement magnitude relative to the driving force. Extra calibrated mass is added to the stylus and the experiment repeated. This can produce a characteristic mass—compliance relationship by analysis (Fig. 334).

Applying the same pickup to the groove of a disc and maintain-

ing the same method of measurement will show in what way the compliance and viscosity of the disc material modify the stylus movement. Naturally the compliance of the disc material should be very much lower than the compliance of the pickup, and hence will tend to stop its movement altogether. If the disc material had zero compliance, it would rigidly lock the stylus and no movement would be observed.

This comparative measurement can be made at a variety of frequencies to determine the compliance characteristics of the record material in comparison with the compliance characteristic of the stylus mechanism.

Viscosity produces a loss effect, much the same as introducing resistance into an L-C circuit. This is determined by the phase relationship of the movement through the drive force provided by

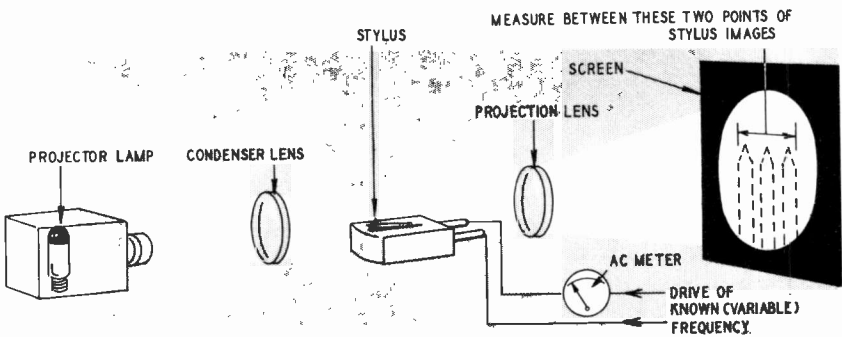

Fig. 334. Setup for computing the compliance of a pickup.

the coil or whatever type of drive is used. It is, obviously, essential for this kind of measurement to use the simplest type of mechanism in which there are the minimum of mechanical effects to compensate or calculate for, so the basic compliance properties are readily separated from other properties in the unit.

### Tape magnetization

Measuring the velocity of groove movement on a disc is relatively simple because it can be done optically. Tape is not so simple because the precise measurement of a rate of fluctuation of magnetic field along a magnetic oxide is extremely difficult. The only way of making a measurement in which compensation can be supplied by calculation alone for the characteristics of the measuring device, is to use a single-loop pickup of the smallest possible dimension (Fig. 335).



The output from a regular iron-cored playback head is quite small, so one can imagine how small would be the output from a single-turn pickup. Such an approach may be possible for academic verification of first principles, over a comparatively narrow frequency range and at fairly high-level magnetization on the tape.

However, all is not as difficult as it may seem. It is relatively easy to compute or measure the losses of both recording and playback heads by means independent of the tape. The use of high-frequency bias helps by decreasing the complications involved. Because the audio component is a small current riding on top of the bigger bias current, various stray losses that otherwise might become important can be ignored.

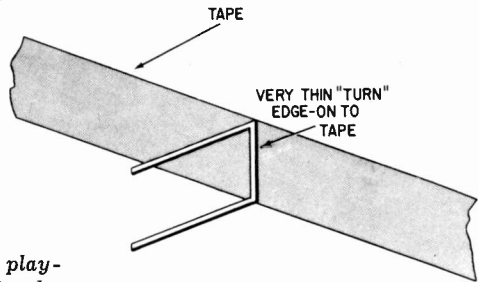

Fig. 335. *Single-loop magnetic playback head has academic interest only.*

The electrical characteristics of the head can be measured without the presence of tape, so a correction can be evaluated for production of constant magnetizing force at the air gap against the magnetizing current. With a perfect, loss-free head (in which the capacitance of the winding and any losses in the core material have no effect) the magnetization at the gap is directly proportional to the current flowing in the coil at all frequencies. The correction factor is easy to calculate and is the only thing requiring compensation.

To know the magnetization actually put on the tape, we need to know the losses that occur in the tape. These are principally due to self-demagnetization of the tape, an effect which occurs increasingly at the higher frequencies because of the progressive shortness of the effective magnets induced on it.

Playback-head characteristics can be calculated on the basis of the gap width of the playback head, there being theoretical frequencies where nulls occur in the playback because the gap is just a wavelength, or an exact multiple of a wavelength, long. Experimental verification of this principle shows that an adjustment has to be made according to the configuration of the gap,

so the precise null points do not occur at these harmonically related intervals.

However, the precise frequencies at which null points occur above the cutoff point of the head do enable the effective gap to be calculated, and the effect of high-frequency rolloff due to gap width can be interpolated. Thus, a secondary measure of magnetization on the tape can be obtained.

Results using these two approaches prove that it is possible to determine the strength of the field placed on the tape within fairly close limits. Of course, subsidiary losses in the playback head also require compensation. The precise density of magnetization on the tape can be calculated from the knowledge of the precise gap dimension, deduced from the basic induction formula.

All that remains now is to deduce the characteristics of the magnetic tape itself. These can be derived by magnetizing the tape under different combinations of bias and audio current and determining the point where distortion reaches various levels so as to derive figures for the coercivity of the tape and also the magnetization level at which distortion reaches a predetermined figure, such as 2% or 4%. Of course, the tape magnetization characteristic can also be measured by the method employed for determining the magnetic properties of samples of other magnetic material.

### **Tube and transistor dynamic characteristics**

One more type of basic measurement concerns the setup for determining the dynamic characteristic of amplifier components such as tubes and transistors. These can sometimes be satisfactorily derived from published curves, but it often happens that all of the data needed are not available. This is particularly true of transistors.

Sometimes the transfer characteristics, in terms of collector voltage and current against base current, for grounded-emitter operation, are published, and perhaps various thermal characteristics also. What may not be given is the way the input resistance varies with input current at the base and with output loading. So, although we may have enough data to calculate a working current gain of the transistor, we do not have the data necessary to find the ideal working source resistance to maintain a specific degree of distortion with a voltage input rather than a current input.

In tube operation, a typical problem may be determining satisfactory transformer taps, working voltage and load value for Ultra-Linear operation. Characteristics are given for pentode or triode

### Recommended Reading

1. E. N. Bradley, *The Oscilloscope Book*, Norman Price Publishers Ltd.; London, 1951.
2. Norman H. Crowhurst, "Calibrating Audio Oscillators," *RADIO-ELECTRONICS Magazine*; November, 1952.
3. F. D. Lewis, "Frequency and Time Standards," *Proceedings of the IRE*; September, 1955.
4. National Bureau of Standards, "Standard Frequencies and Time Signals WWV and WWVH," *Proceedings of the IRE*; October, 1956.
5. Fritz A. Kuttner, "Toward the Perfect-Pitch Machine," *High Fidelity*; August, 1956.
6. E. N. Bradley, *Radio Servicing Instruments*, Norman Price Publishers Ltd.; London, 1953.
7. Norman H. Crowhurst, "Transformer Iron Losses," *Electronic Engineering*; October, 1951.
8. Norman H. Crowhurst, "High-Accuracy Ohmmeter," *RADIO-ELECTRONICS Magazine*; August, 1954.
9. Norman H. Crowhurst, "A Direct-Reading Impedance Meter," *Electronic Engineering*; January, 1949.
10. "A New Approach to Audio-Frequency Impedance Measurement," *General Radio Experimenter*; July, 1955.
11. Leo L. Beranek, *Acoustics*, McGraw-Hill, 1954.
12. P. E. Axon, "An Investigation into the Mechanism of Magnetic Tape Recording," *Proceedings of the IRE*; May, 1952.
13. P. E. Axon, "Some Problems of Magnetic Tape Reproduction," *Sound Recording & Reproduction*; May 1954.
14. G. A. Briggs, *Sound Reproduction*, Wharfedale Wireless Works, 1953.
15. F. P. Moss, "An Audio Frequency Phase Meter," *Electronic Engineering*, August, 1954.

# basic amplifiers

**W**E will first deal with amplifier measurements because these are necessary to establish the basis for tests on equipment that we will come to later in the book. We have to rely on calibrated basic amplifiers with a flat frequency response and linear performance (or known deviation), before we can interpret other measurements.

## Frequency response

The important thing in making a frequency response check is to eliminate possible sources of error due to measuring equipment. The classic way of determining response uses some kind of meter to indicate voltage levels at various frequencies. Most voltage measuring instruments are subject to a 1% or 2% deviation in calibration as well as a response that will vary at different frequencies. So, if this kind of instrument is used for precision measurement of frequency response, we must devise a means of eliminating its own characteristic variations.

The common method is to use a calibrated attenuator. (See Fig. 215 in Chapter 2.) The simplest is one with three decade steps: one in 10-db per position, the next in 1-db units and a final decade of 0.1-db units. This enables the attenuation to be read to within 0.1 db over a range up to 100 db. An input voltage *equal* to the desired output voltage is applied to the input terminals of the attenuator. The amplifier output is loaded with the required nominal dummy load resistance and a dpdt switch is connected between the input to the attenuator and the output from the

amplifier, so the vtvm can be switched between these two positions (Fig. 401).

The procedure consists of setting the oscillator input to the predetermined voltage on the vtvm. It may be half the maximum output voltage of the amplifier. Maximum attenuation is inserted. Then the switch is thrown to measure the output, and the attenuator is adjusted until exactly the same reading is obtained. The gain of the amplifier must then be equal to the loss in the attenuator. This operation is repeated at a number of frequencies from the lowest to the highest required and the result is plotted in the form of a frequency response.

The frequency response of an amplifier is measured, at a variety of levels, representing from somewhere in the region of one-tenth

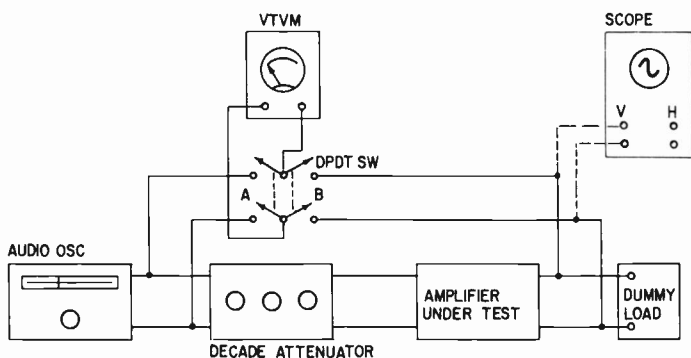

Fig. 401. Basic arrangement for taking the frequency response measurement of an amplifier.

of maximum output up to full output. In the region of maximum output monitor the output voltage with a scope to be sure the waveform remains reasonably sinusoidal. If appreciable distortion occurs, the vtvm will introduce a waveform error and we will have no means of knowing precisely when the input voltage, which is sinusoidal, is equal to the output voltage, which is not. So a frequency response taken at a level where some frequencies are distorted becomes invalidated because of the output waveform distortion.

Using this method of measuring frequency response, some manufacturers have produced an instrument called a "gain set." It consists of a vtvm, an input-to-output switch and the calibrated attenuator, all in one instrument.

If the gain set has been well built, there is no reason why it should not perform as well as the separate components. However,

the author's experience has been that most available gain sets show some form of deficiency. Either the attenuator is off calibration or the vtvm does not work correctly, etc. There is no reason why such faults should develop more readily in a packaged unit, than in a set of separate components, but the problem does exist.

While this measurement technique may be academically more accurate (once you have checked the equipment) a method that is gaining acceptance because of its more informative nature is the input-output comparator used with a scope. If you already have the calibrated attenuator, this can still be used; otherwise an uncalibrated attenuator will serve just as well. As the scope does not rely on rectifying the signal it displays, but gives a linear deflection of the spot for input voltage, and the scope amplifiers can be calibrated to give as near flat frequency response as desired, the scope method of measuring can be made independent of frequency errors characteristic of the vtvm.

To use this method connect the oscillator output directly to both scope inputs, and adjust the scope's vertical and horizontal

Fig. 402. The audio oscillator—comparator method of measuring frequency response and other details of amplifier performance.

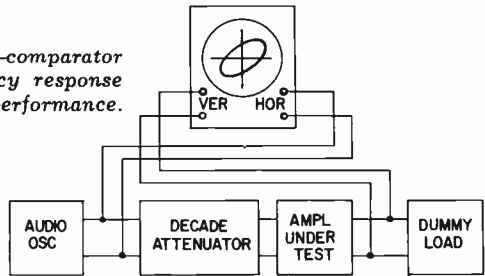

gain controls to get a line at  $45^\circ$  that almost fills the screen. Sweep up and down in frequency over the range to be used in measurements, to see whether the line opens out into an ellipse or changes slope. If it does, careful calibration of the gain and phase differentials involved must be made, on each range of the scope amplification, by the method outlined in the chapter on basic measurements. This has to be applied as a correction factor to all measurements, carefully working out whether the adjustment is added or subtracted. A response that rises with increasing frequency is accompanied by phase advance, while one that falls corresponds with phase delay.

Most precision scopes will not need appreciable correction of this nature. To make the actual measurements, connect the input point that went to point A of the switched vtvm (Fig. 401) to the horizontal input, and the output of the equipment under test to

the vertical input (see Fig. 402). Having set the attenuation and oscillator levels to get the required operating condition at 1,000 cycles, adjust the scope amplifiers to obtain a 45° trace of convenient length. Now the frequency can be swept, and the effect observed without resetting the scope gain controls.

The advantage of this method is that it compares, not only the relative magnitudes of input and out-put voltages, but also indicates the *transfer phase* of the system. This can be useful in determining whether the stability characteristic of the amplifier is satisfactory. A good rule for this is to check the frequency response to the point where the phase transfer angle from input to output is

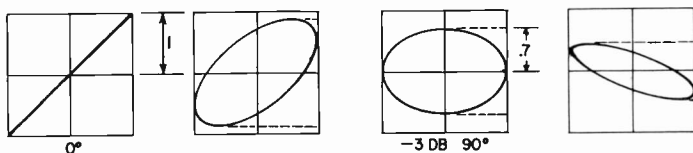

Fig. 403. Display pattern sequence (left-hand pattern is mid-band, others progressively higher or lower) showing how to identify a characteristic where -3db and a 90° phase shift coincide.

90°. The condition for maximum flatness in the pass range which corresponds with the ideal stability margin occurs with an attenuation of 3 db (at the 90° point) compared with mid-range.

This is quite easy to observe on the pattern. As the oscillator frequency is varied from mid-range (1,000 cycles), watch for the points where the ellipse lies in a horizontal plane rather than its usual sloping aspect. By means of the oscillator output control adjust the length of the ellipse to the same horizontal length as the original sloping line. Then its height will be about 0.7 of the mid-range height of the sloping line (Fig. 403) if the loss is 3 db at this point. For practical purposes, if the ellipse becomes a circle at the 90° point, and if the peak between mid-range and this point is not more than 1 or 2 db, the amplifier will give acceptable performance.

These measurements should be made using a resistive load. As a further check, a similar run may be made into a speaker or other reactive load, when more latitude in the precision of the measurement can be tolerated. For reasonable performance the peak at 90° should never exceed 6 db (twice the original height of the trace).

In addition to measuring the frequency response of the amplifier at different levels with the gain control wide open, check the

amplifier with the gain control in other positions. The position in which it is likely to make the greatest difference in the frequency response is at precisely 6 db below the wide open position. To find this point turn down the gain control until the output voltage is just half its previous value. Then recheck the frequency response by either of the methods just described to see what effect the gain control has.

### Gain

The same setup for measuring frequency response can be used for checking either gain or sensitivity. Gain is usually output divided by input. This may be given in terms of voltage or power, specified, respectively, as voltage gain or power gain. For example: if the attenuator reading is 46 db, (which corresponds to a ratio of 200) the voltage gain is 46 db and the input sensitivity is the full output voltage (say 15 volts) divided by 200 (75 mv).

Power gain is obtained simply by making a transformation to account for the change in impedance between input and output.

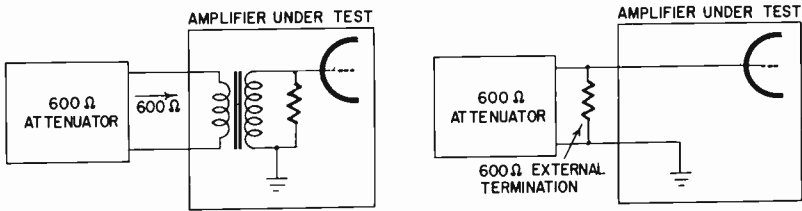

Fig. 404. For 600-ohm amplifier input, this provides the termination for the attenuator (a), but for a high-impedance input (b) an external terminating resistor must be used.

The output is usually a speaker impedance of 4, 8 or 16 ohms (or it may be 600 ohms) while the input impedance with tube type amplifiers is usually high or it may be transformer-matched to a 600-ohm line.

Where input and output impedances are both 600 ohms, the voltage gain is precisely the same as the power gain. Under this condition it is important that the attenuator be designed for 600-ohm operation. If the input impedance is high, a 600-ohm attenuator will also be used, but it will require a terminating resistance of 600 ohms because the amplifier does not provide this. This distinction is illustrated in Fig. 404.

Where the input is a high impedance, it is normal to specify a *voltage* gain for the amplifier or to specify the sensitivity in terms of output power for a given input voltage. The input voltage



can be calculated from the voltage used for measurement and the amount of attenuation used in the gain set. With the comparator method, the attenuation between the takeoff point for the scope and the actual input to the amplifier must be calibrated and the voltage at the scope takeoff point measured so that the actual input voltage to the amplifier can be calculated.

If the input is 600 ohms and the output some other value, a correction factor must be used to calculate the gain. This is obtained by adding 10 times the logarithm of the impedance stepdown ratio. If the input impedance is 600 ohms and the output impedance 16 ohms, then the impedance stepdown ratio is 37.5 to 1. This means the power gain will be 15.75 db more than the voltage gain ( $10 \times \log 37.5/1 = 15.75$  db). If the voltage gain is 26 db (which will mean, for example, that 0.25-volt input will produce a 5-volt output), the power gain of this particular amplifier would be  $26 + 15.75 = 41.75$  db.

Another term often encountered is the "insertion gain" of an amplifier or system. This, unfortunately, has two definitions. It is best, of course, to use the modern one, but keep in mind that past literature may refer to either.

The modern definition states simply that insertion gain is the *increase* in power transfer produced by connecting the amplifier between the source and load. The older definition states that the comparison should be between the transfer when the amplifier is connected and when an ideal matching transformer is connected in its place.

Suppose the input impedance is 600 ohms and the output 16 ohms, and that 1-volt input at the amplifier terminals gives an output across a 16-ohm load of 10 volts. This is a voltage gain of 20 db, or a power gain of  $20 + 15.75 = 35.75$  db. Now we are faced with the question—how much power would be delivered to the 16-ohm load by direct connection?

There are various answers to this question. Assume that the source resistance is also 600 ohms, as it will be with the gain-set method. Then 1 volt at the amplifier input terminals is equivalent to 2 volts applied through a series resistor of 600 ohms, assuming the amplifier presents an input load of 600 ohms. In this case, using the modern definition, feeding 2 volts through 600 ohms into the 16-ohm load will deliver:

$$2 \times \frac{16}{16 + 600} = .052 \text{ volt or } 0.17 \text{ milliwatt (watts} = \frac{E^2}{R}\text{)}$$

The 10 volts across 16 ohms when the amplifier is connected is

an output of 6.25 watts. So the insertion gain, by modern definition, is the ratio between 0.17 mw and 6.25 watts, or 45.7 db.

Following through with the same example, for the old definition we should use a theoretical ideal transformer to convert the 16-ohm load to 600 ohms. The hypothetical substitution will still produce 1 volt across the 600-ohm primary in place of the amplifier's 10 volts across 16 ohms, an insertion gain that represents the same increase in power as our definition of power gain, 35.75 db.

These figures are on the assumption that the source resistance, as well as amplifier input resistance, is 600 ohms. Other extreme possibilities for this example are either that the source resistance is much lower than 600 ohms—zero in the ultimate, or that the input load of the amplifier is much higher than its nominal 600 ohms—open circuit in the ultimate. Either way, the input voltage will be 1, whether or not the amplifier is connected.

In the first case, using the new definition, connecting the 16-ohm load directly to the input source will still produce the 1 volt delivered to the amplifier input (in theory, at least), instead of the 10 volt output the amplifier gives. So the insertion gain is a straight 20 db by modern definition, while it is still the power gain figure of 35.75 db by the old definition.

In the second case, connecting the original 1-volt input with a 600-ohm source resistance to 16 ohms in place of the amplifier's open-circuit input will produce half the voltage originally assumed (or one-fourth the power) based on a 600-ohm input load, with an open-circuit input voltage of 2. Thus, the insertion gain figures will be 6 db more than before. By modern definition it results in 51.7 db (it was 45.7 db) or the old rating of 41.75 db (it was 35.75 db).

These examples illustrate the possible confusion due to inadequate specification of conditions. Between the extreme cases presented are many other possibilities. With a high impedance input, as the indeterminate nature of the impedance makes the old definition untenable, we can either have a rather indefinite statement of insertion gain (which depends on the nature of the source feeding it more than on the amplifier gain) or else specify simply the voltage gain, according to our original definition, which is much simpler.

### **Power output characteristic**

This usually consists of taking a response of output against input as the level is varied, generally at a constant frequency. Often the distortion characteristic is measured at the same time. The

purpose of a power output characteristic is to ascertain whether the amplifier is linear—that is, assuming 1-volt input produces 10-volts output, does 0.1 volt produce 1-volt output?

It might be assumed that because an amplifier has a very small amount of measurable distortion at the 10-volt output, that it must be linear and, because it is linear, a smaller input must produce a proportionately smaller output. But this does not always follow. Sometimes the degree of power drive necessary to achieve the larger output produces a bigger drain on the supply circuits, causing the supply voltage to drop. This, in turn, alters the operating conditions for the various tubes or transistors in the amplifier, which may modify the amplification produced. Thus, it is entirely possible that an amplifier with very low distortion may give an

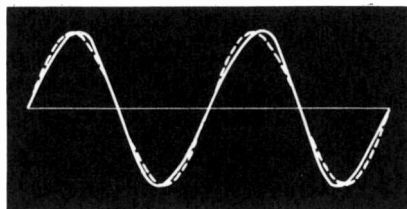

Fig. 405. *Second harmonic in quadrature produces a sloping effect on the fundamental.*

output of 10 volts for 1-volt input but, on reducing the input to 0.1 volt, the output may be as much as 1.2 volts because the gain will rise by 20% when the heavy drain is removed from the power supply.

Of course, the use of negative feedback tends to correct gain fluctuations of this type, as well as leveling off other variations. But it is part of testing the performance of an amplifier to check that its amplification is linear as the signal level is changed, as well as changing the frequency.

This can be checked approximately by an input-output comparison on the scope turning the oscillator output down so the 45° line “shrinks” and watching carefully for its angle to change, which would indicate a nonlinear relationship. A more precise method is to measure gain (Fig. 401) at a variety of levels.

### **Power response**

The simplest method of measuring the maximum-power response curve of the amplifier is to use a voltmeter, of reasonable accuracy, over the frequency range required. Measure the output

voltage or power and monitor it with the scope so the clipping point, or the point where any form of distortion begins to set in can be clearly observed.

The input-output comparator method is a good way of observing distortion at its onset, because it is easier to see than with just the straightforward sine wave. For example, if some asymmetry should take place at high frequencies, due to imbalance in the drive, this will produce a second harmonic in the output which may, due to phase shift, change the "slope" of the sine wave by an almost imperceptible degree (see Fig. 405).

This would be difficult to detect and one might not be sure whether it was second harmonic in the input to the scope or whether, due to the high frequency, a breakthrough was occurring between the vertical and horizontal deflections in the scope. Using the input-output comparator leaves no room for doubt. The same

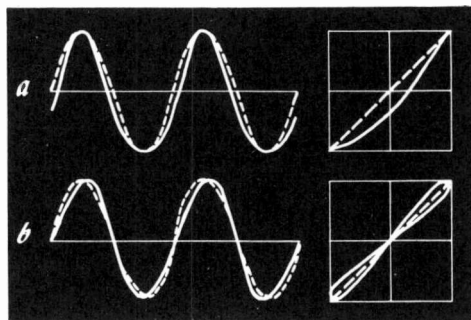

Fig. 406. Comparison between waveforms and input/output comparator displays with second harmonic causing transfer curvature (a) and sloping wave (b).

difference in waveform would produce a curved line if the asymmetry was broadening the bottoms and narrowing the tops (Fig. 406-a). But, if it is producing a "slope" effect, it produces a sloping figure of 8, shown in Fig. 406-b. Even a very small effect of this nature can very easily be observed using the comparator technique. (Refer, also, to page 101.)

The procedure, then, is to work the amplifier at the maximum output level before any form of distortion occurs and measure the output voltage to which this corresponds at different frequencies. Plotting this in terms of power or db (which amounts to the same thing when measured across a resistance load) gives the power response of the amplifier. It will droop a little more than the

straightforward frequency response, because there is usually some limitation to maximum power at the ends of the frequency range not accompanied by a corresponding droop in the frequency response of the amplifier when measured below the point where distortion begins. Comparison between a typical frequency and power response curve is shown in Fig. 407.

### Harmonic distortion

There are two accepted ways of measuring harmonic distortion (Figs. 408-a,-b). The first of these uses a wave analyzer to measure each of the harmonics present in the output of the amplifier. First, it is necessary to insure that the input waveform is a pure sinusoid. Any harmonics present will invalidate readings of the same harmonics in the output. We have no means of knowing whether the

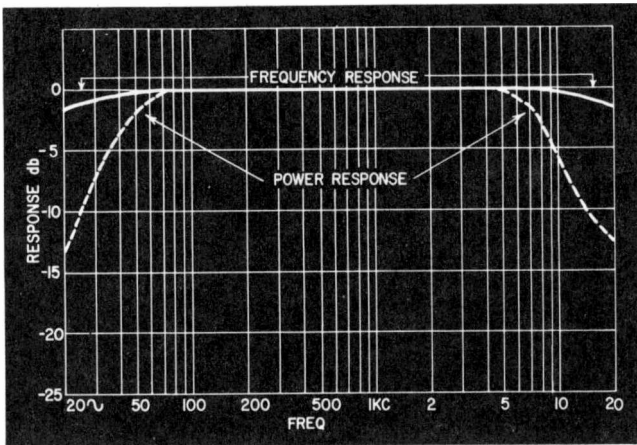

Fig. 407. Typical frequency and power response curves for an amplifier.

difference observed in the reading between input and output is to be added, subtracted or taken in quadrature. Consequently the output reading is ambiguous by plus or minus the input reading. If we get an output reading of, say, 2% second harmonic and the input reading measured 0.5% of the same harmonic, then the value measured at the output can be 2% plus or minus 0.5%.

The rms value of the total harmonic is obtained by taking the root mean square of the individual harmonics. This means that each of the harmonic values is squared, the numbers added and the square root taken. For example, 2% second, 0.5% third, 0.2% fourth "adds up" to:

$$\sqrt{2^2 + .5^2 + 0.2^2} = \sqrt{4 + 0.25 + .04} = 2.07\%$$

The alternate method of measuring harmonic distortion is much simpler. It consists of using a harmonic-distortion meter which filters the fundamental and measures the residue, which should be harmonic. Again, it is necessary to insure that the input waveform is considerably purer than the expected output waveform.

Using the instrument just as it is, a minor problem is to determine whether the indication is harmonics or hum. Or, if it is all harmonics, just what are the harmonics? This can be deter-

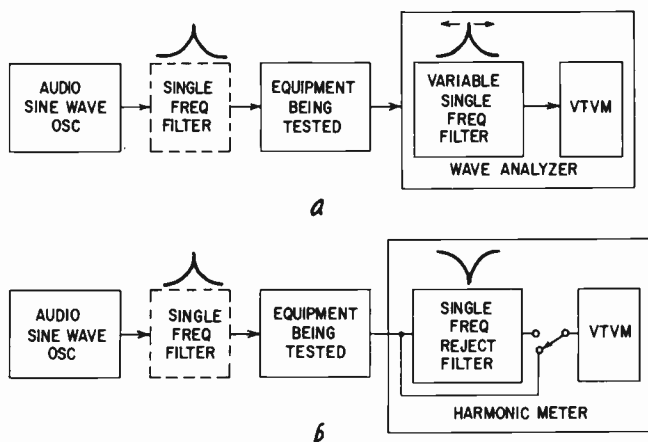

Fig. 408. Two ways of measuring harmonic distortion: (a) using a wave analyzer and (b) using a harmonic meter. Use of the filter shown in dashed lines depends on the quality of the sine wave, and on the smallness of the distortion to be measured.

mined with most instruments by connecting the output residue to a wave analyzer or a scope. A scope is probably the more informative and Fig. 409 shows a variety of displays, each using a time base so that, when switched to the fundamental, the scope gives two sine waves across the trace, together with an interpretation of what the displays indicate.

A third method consists of balancing the fundamental between input and output in the vertical input to the scope. This is achieved by applying a voltage approximately equal to the output voltage, but in opposite phase as part of a mixture for the vertical trace (Fig. 410).

This method has two advantages: Its results are more visual, indicating specifically the way in which the harmonic distortion affects the transfer characteristic of the amplifier. Also, it is not

dependent upon the extreme purity of the input waveform. Measurement of harmonic distortion in the region of 0.1% can be made, using this method, with an oscillator that may have an input distortion of 1% or 2%. Using the other methods, the input waveform can be purified by a narrow bandpass filter. But, as mentioned in an earlier chapter, one has to be sure that these filters are used correctly and that they really do minimize the distortion to the extent anticipated. With this third method of measuring harmonic distortion, the necessity for such filtration is avoided. All that is necessary is an oscillator with a reasonably *sinusoidal-looking* waveform.

If there is no phase reversal between the input and output terminals of the amplifier, then an input voltage opposite in phase to

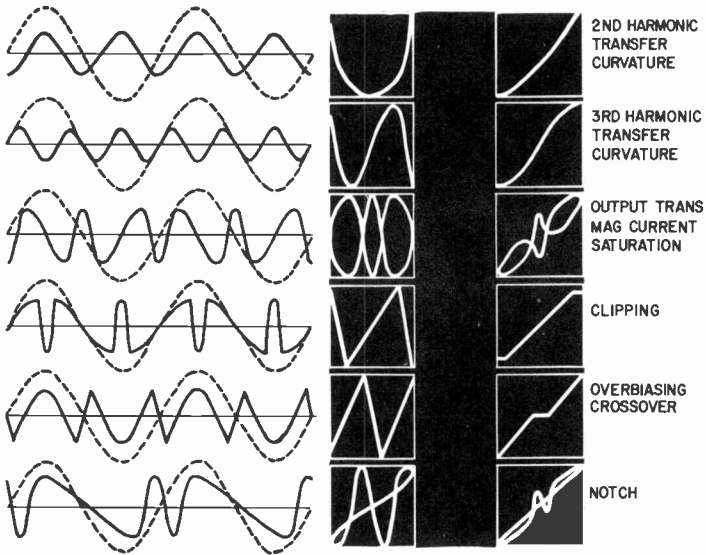

Fig. 409. Scope displays showing left; different residual waveforms as seen at the output terminals of a harmonic-distortion meter; center; display with method of Fig. 410; right; transfer—output vertical against input horizontal.

that attenuated for the amplifier input must be used (Fig. 410-a). If the amplifier does introduce a phase reversal between input and output, then the actual input voltage applied to the horizontal deflection terminals can be utilized (Fig. 410-b).

If there were no distortion in the amplifier, a center setting on the adjustable potentiometer feeding the vertical deflection terminals would produce an absolute null. However much scope amplification we were to use, the trace would be a simple hori-

zontal line produced only by the input to the horizontal amplifier. If there is any harmonic in the output that is not present in the input, the vertical trace will be this harmonic component which is not balanced by the potentiometer.

Actually, the harmonic components are attenuated by 6 db, or 2 to 1, because the input and output voltages are equal, so there is an equal resistance from each side of the potentiometer to its slider. This fact permits the scope to be calibrated so the deflection observed can be used as a direct indication of the percentage harmonic read. The value will be a peak, as compared with the original peak indication of the overall waveform.

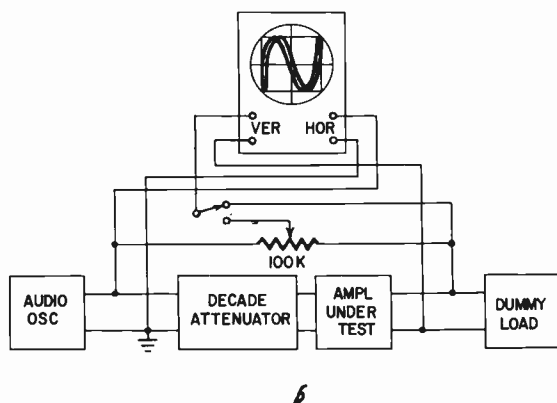
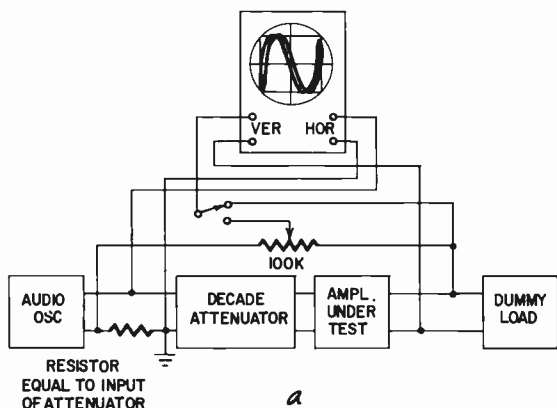

Fig. 410. Comparator method of measuring distortion when the amplifier does not produce phase reversal between input and output. (a) When phase reversal between the input and output of the amplifier does occur, test setup (b) is used.



This distinction in measurement has an advantage in measuring clipped waveforms in the region of maximum output. It gives an indication much nearer to the aural effect of the distortion than does the usual *average-reading* distortion meter or the rms result obtained by using the analyzer. For a clipped waveform the relationship between the reading on a distortion-meter type instrument, comparing average harmonic residue with average fundamental, is plotted against the peak relationship between peak harmonic residue and peak fundamental in Fig. 411.

This shows that, for low orders of distortion, more than a 10-to-1 ratio can exist. A reading on the distortion meter of 0.1% harmonic distortion can, in fact, mean more than 1% of harmonic peak against the fundamental. This means the pulse peaks represented by the clipping are less than 40 db below the level of the

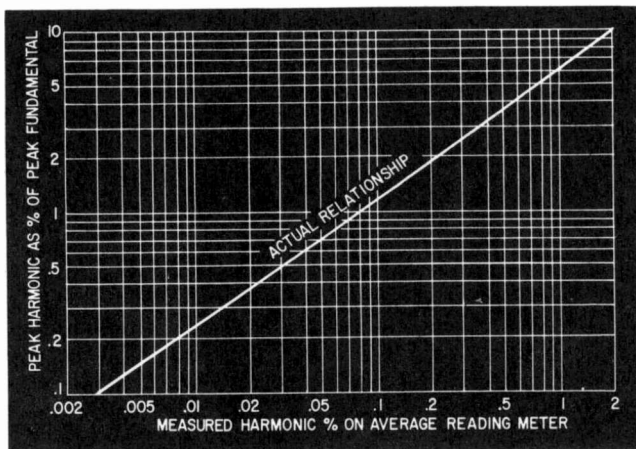

Fig. 411. Relation between measured harmonic, using harmonic meter, and peak clipping to peak waveform, when the distortion is entirely due to clipping.

fundamental which in some frequency ranges can be heard, although one would imagine by obtaining a reading of 0.1% with the harmonic meter that the result should be quite inaudible.

Harmonic-distortion measurement, using any of the foregoing methods, is plotted by measuring the distortion at different levels to see how it varies. This yields a characteristic curve of the type shown in Fig. 412. The significance of such a measurement varies according to the type of measuring equipment used—whether the harmonic reading is a peak, rms or rectified average value.

If this measurement is repeated at different frequencies, the

equipment needs to provide a null for the fundamental at these various frequencies. Some harmonic-distortion meters are arranged to provide harmonic-distortion measurement over quite a range.

In the scope method there may be some phase shift between

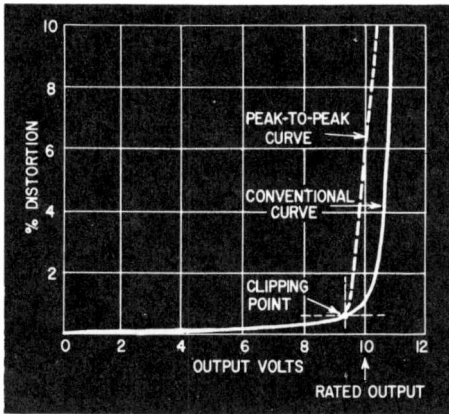

Fig. 412. Typical distortion curve for a power amplifier.

input and output, usually slight. This phase shift will necessitate a phase adjustment of the balancing arrangement. This addition

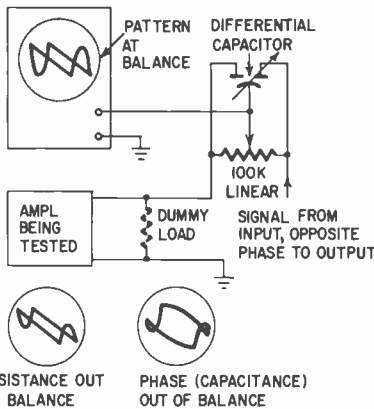

Fig. 413. An additional phase balance control is sometimes necessary.

is shown in Fig. 413. Usually small differential capacitors will serve this purpose. If difficulty is encountered in obtaining this, two separate capacitors could be used—possibly one variable, one fixed.

## Intermodulation distortion

There are two kinds of test signal used for determining intermodulation distortion. One uses a low and a high frequency. Typical frequencies are 40, 50, 60, 70, or 100 cps for the low and from 1,000 to 7,000 cps for the high. When these frequencies are combined, they produce the waveform of Fig. 414-a. The other method uses two high frequencies which, when combined, produce the waveform of Fig. 414-b. In this case the high frequencies, both of which may be arranged to vary simultaneously, have a fixed difference of suitable value between 100 and 5,000 cps. Both methods of measurement postulate nonlinearity of the transfer characteristic of the amplifier producing certain kinds of spurious components which will be measured in the output.

The type of test signal shown in Fig. 414-a produces sum and

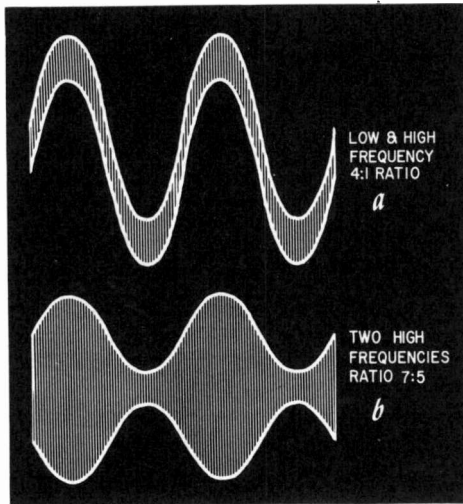

Fig. 414. Wave envelopes used for the two main methods of intermodulation test.

difference frequencies which are virtually "sidebands" of the higher input frequency. The lower input frequency, being of the greater magnitude, modulates the high frequency due to the *slope* of the transfer characteristic changing at different points (Fig. 415).

One reason for adopting this method of measurement is that it is assumed to be more sensitive to deviations from uniform slope than the harmonic-measurement method. Basically that method measures deviation from a mean straight line, whereas the inter-

modulation method measures deviation in *slope*. This is based on the assumption that a very small high frequency signal is used,

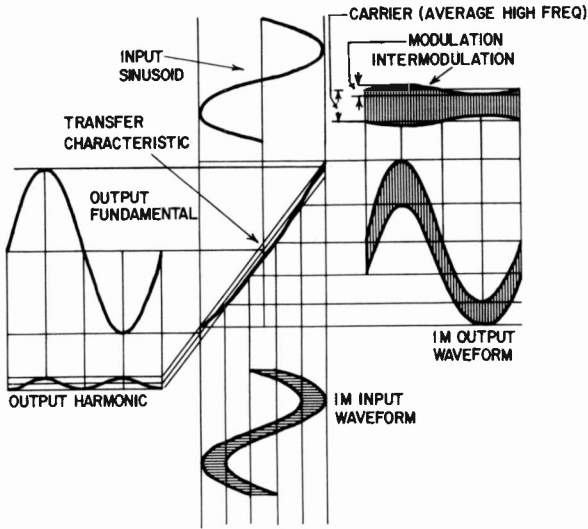

Fig. 415. Illustration shows how harmonic distortion is a measure of the magnitude of transfer-characteristic deviation (top and left), while the IM test tends to show slope deviation (bottom and right).

such that the length of transfer characteristic continuously explored by the high-frequency signal, is short compared to the

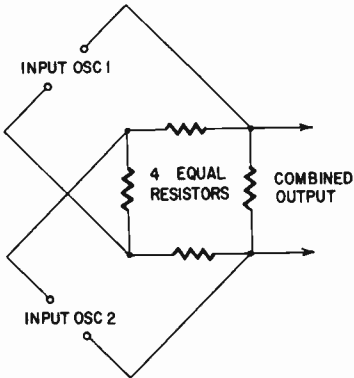

Fig. 416. Basic bridge circuit for mixing the two frequencies used in either form of IM measurement.

overall transfer characteristic. The frequencies need mixing in a way that will prevent their generator circuits from interacting. This is usually guaranteed by utilizing circuits based on the bridge

principle, so that each oscillator input to the bridge is at a point where the voltage from the other oscillator is a null. The output is then taken from one arm of the bridge, which contains currents (and voltages) due to both oscillators (Fig. 416).

Two standards are used. One employs frequencies in a 1-to-1 amplitude ratio and the other in a 4-to-1 ratio, the low frequency being four times the amplitude of the higher frequency. Even this is not ideal for detecting higher-order irregularity in the transfer characteristic. The portion explored by the high frequency can well "smother" some of the shorter irregularities and thus minimize the reading. A hypothetical possibility producing zero IM reading with very considerable harmonic reading is illustrated in Fig. 417.

As with the harmonic measurement, there are several methods of interpreting the results of this test. A series of readings can be taken on a wave analyzer at successive frequencies in the resultant

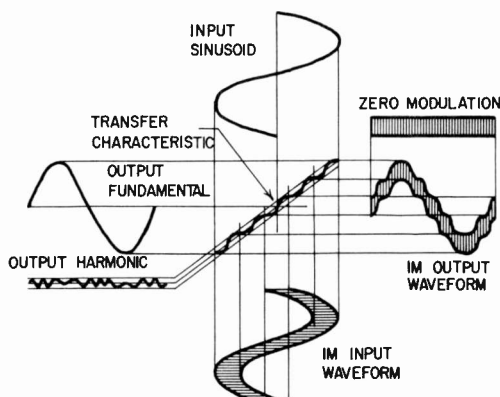

Fig. 417. A hypothetical case showing that the IM test can mask certain forms of transfer deviation.

output to find the intermodulation products as individual components. This is rather protracted and takes some time to evaluate. The better method is to pass the output waveform through a high-pass filter which removes the low-frequency component and then through a rectifier and high-frequency filter to remove the high-frequency component. This will then leave just the modulation products—in theory, at least. This is provided that none of them are of such a frequency as to get filtered on the way, along with the original components.

An alternative method is somewhat simpler. It consists simply of filtering the low-frequency component and measuring the mod-

ulated high-frequency component on a scope, as shown in Fig. 418-a. This measures the peak of the modulation waveform in comparison with the carrier or high-frequency waveform and gives a result similar to that of the scope method of peak-to-peak reading for harmonic measurement.

Positions 1 and 2 of the meter switch measure each component of test frequency at the mixed point by temporarily "killing" the other one (not shown). This measurement also lends itself to the comparator technique by balancing both input components against the output so that only spurious components remain. This can be done by the basic scope method, as an adaptation of Figs. 410 and 413, or it can be arranged to give a direct reading, using

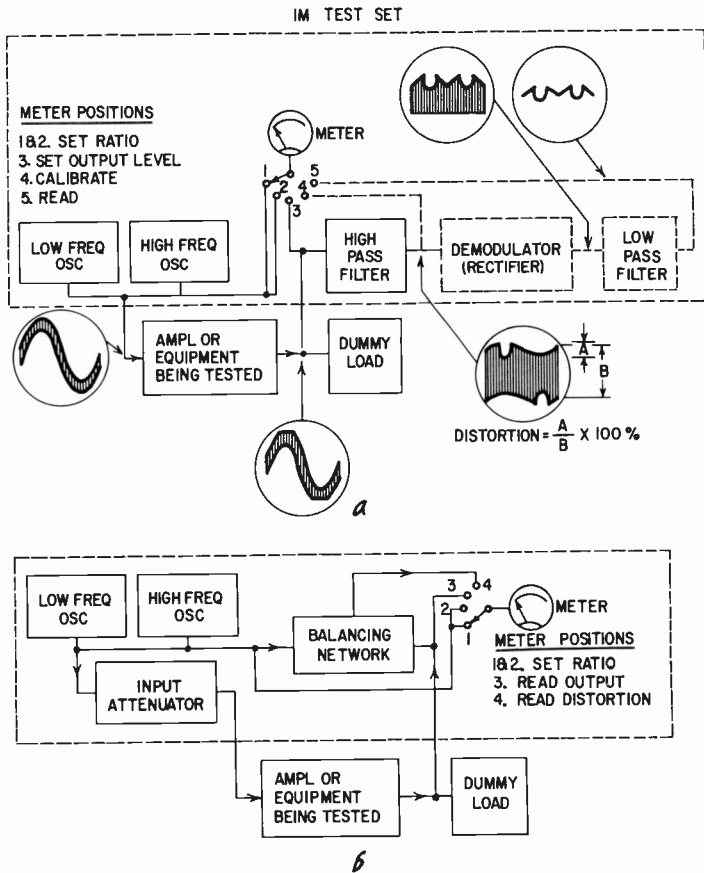

Fig. 418. Different ways of making the first form of IM measurement: (a) dashed lines show conventional meter method with alternative 'scope reading; (b) shows an input-output comparator method.

the setup shown in Fig. 418-b. This method would have the advantage that, unlike any filtering arrangement, it “catches” all

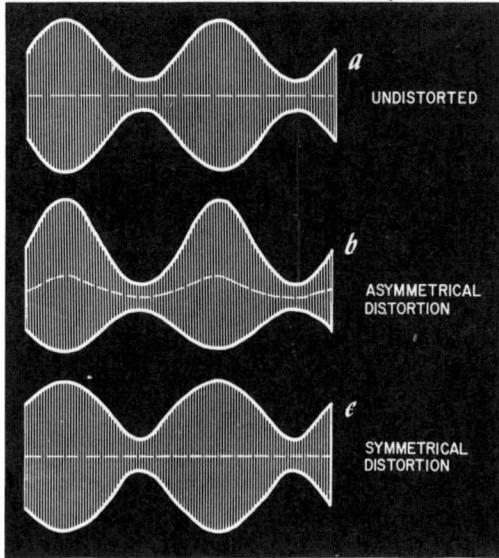
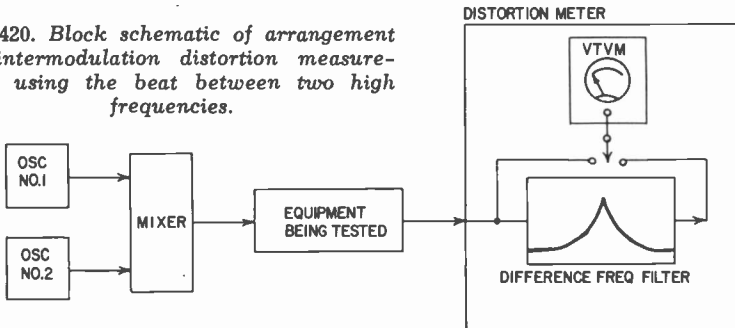

Fig. 419. Illustration showing that the second form of IM test detects only asymmetrical forms (b), while symmetrical forms (c) produce no reading (indicated by central dashed lines).

spurious components, even those that are close to one or the other of the test frequencies.

The second method of IM measurement, using the beat between

Fig. 420. Block schematic of arrangement for intermodulation distortion measurement using the beat between two high frequencies.



the two high frequencies, relies essentially on asymmetry of the transfer characteristics to produce any reading at all. However

nonlinear the characteristic may be, if it is symmetrical there will be no difference-frequency component or harmonics of the difference frequency. This is illustrated in Fig. 419. The complete setup is shown in Fig. 420.

If the transfer characteristic is asymmetrical—for instance, has a square-law component—then it will produce a difference frequency of the first order. If the asymmetry is sharper than this, the difference frequency will contain a second-harmonic or higher-order harmonics of itself. But all of these represent *even-order* products in the transfer characteristic, producing an asymmetry.

An interesting point to note is that this does not necessarily mean the method will even locate *all* forms of distortion of a second-harmonic nature—only those whose effect is to produce an asymmetrical distribution of the transfer characteristic about the center line. Sometimes second-harmonic distortion can be due to a reactive nonlinearity which causes the transfer characteristic to change its slope in alternate traverses. This means the overall transfer characteristic is symmetrical-looking, like an elongated figure 8 as shown in Fig. 421. This kind of transfer characteristic, which frequently occurs—at least as a component of the resultant transfer characteristic—will not yield any difference component to the second form of intermodulation test. (See also Fig. 405 and Fig. 406.)

Equipment for making either of these basic measurements can take a variety of forms. As for harmonic measurement, the equip-

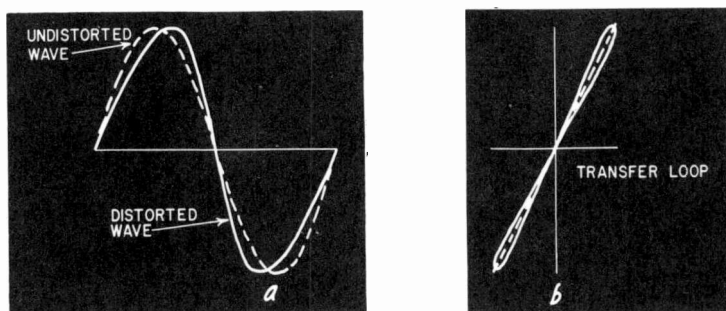

Fig. 421. A transfer characteristic that introduces quadrature second harmonic will not show a reading with the second form of IM test.

ment can come as complete test units with multiple frequencies and adjustments so the magnitude of the individual frequencies can be individually controlled. It can also come as a separate oscillator, capable of generating two frequencies at once. The measurements on the output are made by a vtvm, scope and indi-



vidual filters, as necessary. This method has certain advantages for laboratory use in that the individual components can be calibrated as separate entities in connection with any individual measurement that may be desired.

The composite type of instrument designed to make only one form of IM measurement (one or the other) comes already calibrated. Any relative error due to the interrelationship between the spurious components cannot readily be determined without a complicated calibration procedure. One just has to accept the reading it gives and compare it with other readings obtained on the same instrument. Comparing it with other readings obtained on a *similar type* of instrument, but not the identical model, may not be valid. The relationship dependent upon distribution of spurious components may not be the same in the two instruments.

This is one advantage of using the simpler method of measurement, such as the scope, to make the final measurement on the modulated high frequency, after the low frequency only has been removed. (Fig. 419-a).

The difference-tone measurement using two high frequencies has the advantage of simplicity although its meaning is somewhat valueless. All that is necessary is a two-frequency oscillator with constant spacing or even a two-frequency disc, such as used for testing the intermodulation properties of pickups. A difference-tone detector consisting of a filter tuned to the difference frequency plus a vtvm is used to find the quantity of difference tone generated by the system. This can be a wave analyzer or, in the case of the disc, an audible listening comparison, knowing just what tone you are listening for.

These are the basic methods of measuring intermodulation, but not the only forms of intermodulation that can occur. Many others arise in the amplification of program material which are not revealed by either of these intermodulation tests. These will be discussed later.

### **Hum and noise**

The accepted method of measuring amplifier hum and noise is to use a high-sensitivity audio vtvm and measure the voltage at the output when the input of the amplifier is terminated with a standard-value resistor, which should be shielded to avoid stray pickup. This, however, measures the *total* reading of the hum and noise. Use of a scope will indicate how much of each is present, while some further work with the amplifier may help to track it down if the value is too high.

For example, short-circuiting the input grid will eliminate static or electric hum picked up in the grid circuit. It may also introduce a further component of inductive hum, which has the characteristic of being, almost invariably, pure 60 cycles. Shorting the grid of a stage will determine whether any noise voltage occurs before this point or in this stage. Shorting the grid to ground or to its bias point will eliminate noise generated ahead of this point, but any noise generated by the tube will still show in the output.

Hum can often be traced to ground-return wiring and similar causes. This can be checked by lifting certain grounds, such as those of the input circuit, and trying various ground return points to see whether this affects either the waveform or the quantity of hum present in the output.

The frequency distribution of hum and noise determines their annoyance value to some extent. For example, 60-cycle hum can

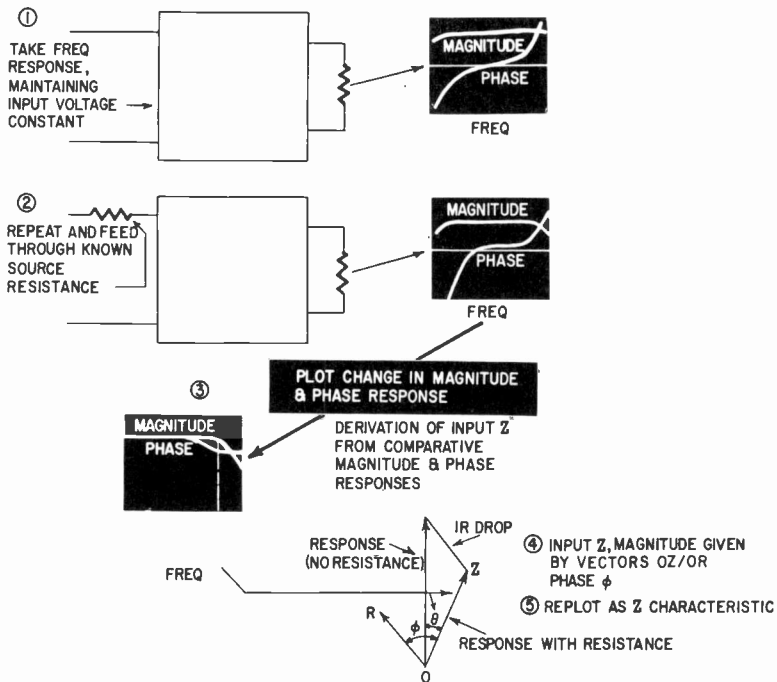

Fig. 422. Sequence for using frequency response characteristics for measuring input impedance characteristic.

be of considerably greater magnitude than, say, 180-cycle hum or higher-order harmonics of line frequency because the latter has much greater audibility. This explains why sometimes readings

which may show a hum level of  $-60$  db sound considerably louder than other readings showing perhaps less than  $-50$  db of hum level. If the latter are predominantly 60 cycles, they may still be inaudible, unless a speaker happens to have a resonance at this

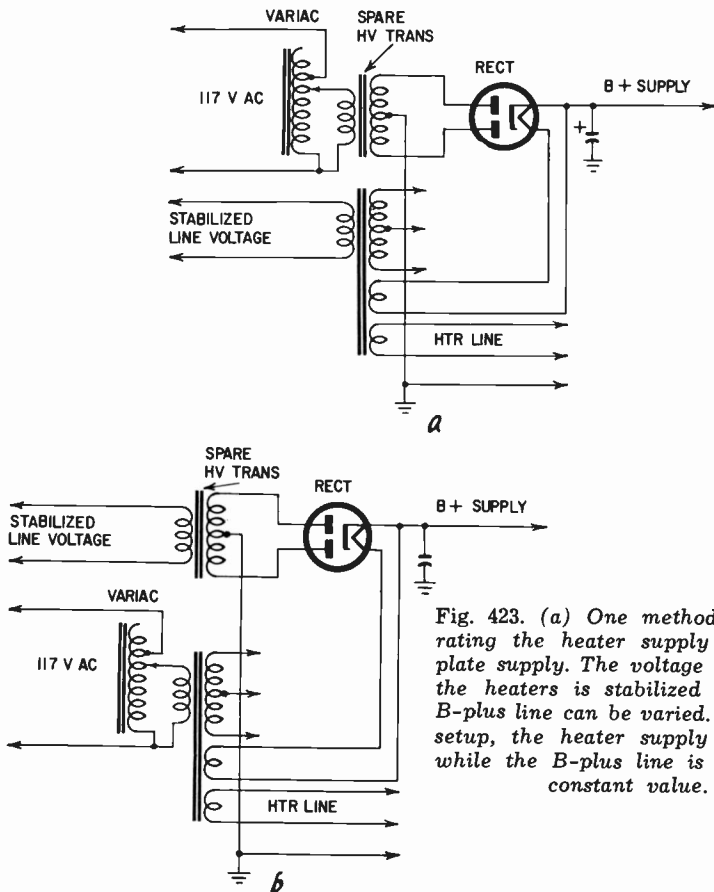

Fig. 423. (a) One method of separating the heater supply from the plate supply. The voltage applied to the heaters is stabilized while the B-plus line can be varied. (b) In this setup, the heater supply is varied while the B-plus line is held to a constant value.

point. But the higher-order components can still be audible with hum levels as good as  $-70$  db.

### Input impedance

The term input impedance is sometimes used with two different significances. The true meaning is the impedance measured looking *into* the amplifier. But often the term is used to designate the impedance which should be connected to the amplifier input. This is particularly true when the input of a tube amplifier is other than high impedance. The term high impedance is used to

designate a circuit that connects either directly to the grid or through a high-resistance potentiometer used as a volume control.

When low impedances are used, a value rating is given, such as 50 or 600 ohms. In professional equipment this usually means the input impedance looks like this value as well as requiring an impedance of this value to be connected to it. But in many amplifiers for nonprofessional use, improved gain characteristics, without deterioration of frequency response, can be achieved by operating the input virtually open-circuit. That is, the transformation in the input is such that the performance is correct when the designated impedance is connected, but the input loading is not necessarily of the same impedance.

The actual input impedance of an amplifier can be measured by a bridge, provided the voltage applied over the frequency range used does not exceed the input voltage that will fully load the amplifier. It is essential to measure the input impedance with the amplifier turned on and warmed up, because the conduction of the tube can considerably modify the measured input impedance.

If it is not possible to measure the input impedance directly by a bridge method in this way, sometimes the measurement can be achieved by taking two frequency characteristics of phase and magnitude of the overall amplifier. First connect so as to apply a constant voltage to the input of the amplifier without any source resistance. Then apply the input through a known source resistance and measure the phase and magnitude characteristic again. This combination measurement is shown in Fig. 422. First, the response is taken in magnitude and phase, with the input applied directly to the amplifier—or with the input measured where it actually enters the amplifier (1). Then a known resistance is inserted in series with the input and another response taken, with the input voltage measured ahead of this input resistance (2). In this step, the actual input is modified by the loading effect of the amplifier input impedance on the series input resistance. The important thing here is the *change* in response, both in magnitude and phase, between (1) and (2). This is replotted (3).

This is not a direct plot of impedance, but of the effect of input impedance in loading the input voltage, due to the drop in the series resistor. This is illustrated vectorially, for one frequency, at (4). The vector  $OZ$ , with the vertical line as reference, represents the different response, as plotted at (3), magnitude  $OZ$ , phase  $\theta$ . The input impedance is given, in magnitude, by  $OZ/OR$ ,

and in phase by  $\phi$ . Values obtained by this construction, or by the equivalent mathematical procedure (dealt with more fully under "Output impedance") can be replotted as the input impedance characteristic (5).

In feedback amplifiers, where the feedback loop goes from the output stage right back into the input cathode (a feature of a considerable number of modern amplifiers) one has to take into account not only amplifier operation but also the characteristics of the feedback loop, which in turn may be modified by the output loading. This means the measured input resistance may change according to whether the output is loaded with a resistance, whether it is open-circuit or whether it is loaded with some kind of speaker or other reactive component.

### **Output impedance**

In theory too, internal output impedance or resistance can also be measured by a bridge or an impedance meter by merely connecting the "unknown" terminals of the bridge or meter to the amplifier output terminals. Here again, it is important to have the amplifier switched on and operating before such a measurement is made. It is also important to pay attention to the source resistance connected to the *input* of the amplifier. The amplifier should not have any *signal* input; but the input to the amplifier should be terminated with whatever customary source resistance is appropriate.

However, measurement of the *output source resistance* of the amplifier, which, referred to the nominal load impedance, is the inverse of its damping factor, may also be invalidated by making the measurement with some impedance other than the nominal connected to the output, so if the bridge or  $Z$  meter fails to provide this, the result will not be the nominal value. The characteristic of the amplifier is dependent upon the amount of feedback present and in turn, with many amplifiers, the amount of feedback is dependent upon the output loading.

In a good amplifier the effective source resistance or damping factor of the output stage should be as independent as possible of the output loading. But many amplifiers which use a single, relatively long-loop feedback do show considerable variation of damping factor or source resistance, according to the method of measurement employed. An amplifier using short-loop feedback to bring the damping factor to the region of unity and then a longer-loop feedback to modify it further, as desired, has more stable operation and is less dependent upon the load resistance.

So with this type, different measurement methods will yield consistent results.

Again, the effective value of source resistance can be calculated by applying a constant input and taking a magnitude and phase-frequency response with different output loading values. The difference between the output load resistance or impedance is an incremental value of the nominal, using a method similar to that for input impedance in Fig. 422. For example, the 16-ohm tap could be loaded with the true 16-ohm value and then with a resistance of 20 ohms. The effective source resistance is then computed on the basis of the differential between the magnitude and phase response thus measured.

The following formula can help in this calculation: If the load impedance is raised by a factor  $a$  (in the example, from a nominal 16 ohms to 20 ohms, making  $a = 1.25$ ) and this results in an output voltage increase by a factor  $b$  (suppose the increase is from 10 to 10.5 volts,  $b = 1.05$ ), the formula for source resistance is:

$$\frac{R_s}{R_L} = \frac{a(b - 1)}{a - b}$$

Substituting in this example:  $\frac{R_s}{R_L} = \frac{1.25 \times .05}{0.2} = 0.3125$ .

As  $R_L$  is 16 ohms,  $R_s$  must be  $0.3125 \times 16 = 5$  ohms.

Although both values of load may be resistive so  $a$  is always a simple ratio, the voltage change may include a phase angle. Thus,  $b$  will become complex. Suppose the voltage rise is the same, but there is also a change in phase transfer angle of  $4^\circ$ . The quantity  $b$  is now  $1.05 \angle 4^\circ = 1.045 + j.073$ . We can now find the source impedance by the same formula:

$$\frac{Z_s}{R_L} = \frac{a(b - 1)}{a - b} = \frac{1.25(.045 + j.073)}{0.205 - j.073}$$

Rationalizing, this becomes:

$$\frac{1.25(.045 + j.073)(0.205 + j.073)}{0.205^2 + .073^2} = 0.103 + j.48$$

This means the source impedance, over this range of load change, consists of  $0.103 \times 16 = 1.65$  ohms resistance, with  $0.48 \times 16 = 7.68$  ohms reactance at the frequency of test, inductive (postulated on the  $4^\circ$  being a delay, higher resistance load compared to lower, implied by the  $+j$  component of  $b$  and yielding a  $+j$  component of  $Z_s$ . (Other combinations can be similarly deduced).

The same method can be used to measure the working plate resistance of a tube, in this case changing the grid resistor of the following stage by a known amount and using the same formula.

The result, expressed as a resistance will, of course, include the plate coupling resistor as a parallel component.

### **Impedance reflection**

Besides measuring the actual input and output source impedances of an amplifier, it is often necessary to determine the effect of legitimate variations in source and load impedance at the input and output. The high-impedance input should operate satisfactorily with any source resistance from a few hundred ohms (representing a cathode follower) up to around 100,000 ohms. An amplifier with transformer input (designated as 600-ohm input) can operate from any source resistance from 300 to 600 ohms and the variation over this range should be carefully checked. Sometimes, for example, a 600-ohm attenuator is internally terminated with 600 ohms so the impedance looking back may be only 300 ohms. If the internal terminating resistance is removed, the impedance looking back will be 600 ohms. Therefore, an amplifier designed to make laboratory measurements under these conditions should be able to accommodate this variation in impedance.

With modern feedback amplifiers, changes in output impedance can be more critical. Also, under practical operating conditions, it is likely to shift more. Not only the variation of *resistance* value above and below the nominal should be checked, but also the effect of incorporating reactances into the load, particularly for basic power amplifiers designed to operate speakers.

### **Effect of supply variation**

Two forms of supply variation can affect the performance of an amplifier. If the line voltage from which the supply is drawn fluctuates, then the various supplies to the amplifier will change to correspond unless special stabilizing components are added to control the change. Sometimes the variation in voltage does not affect the performance—at least the gain of the amplifier—although it may affect the maximum output that can be obtained. At other times changes in plate or heater voltage supplies will alter the performance of the amplifier.

Two things are important about the change produced; the amount of change and the time constant involved in the transition. If the heater voltage changes, the magnitude of space charge in the tubes will vary. This will take time, according to the thermal capacity of the heater. Therefore there will be a delay in the change in gain produced by a change of space charge after the heater voltage that causes it varies. Correspondingly, the plate

voltage has a time constant due to various filter capacitors and resistances.

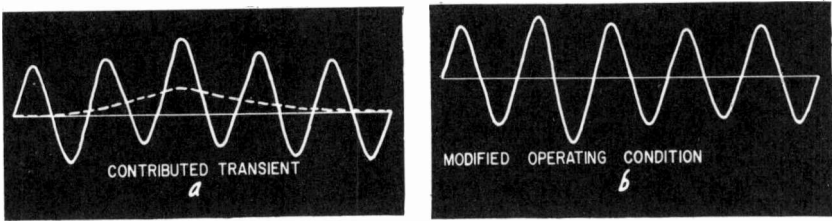

Fig. 424. Two possible forms of effect due to supply voltage change.

To measure the effect of these components on the performance of an amplifier usually requires the assistance of subsidiary supplies. For example, the plate voltage needs to be changed while the heater voltage remains constant. To achieve this, the heater

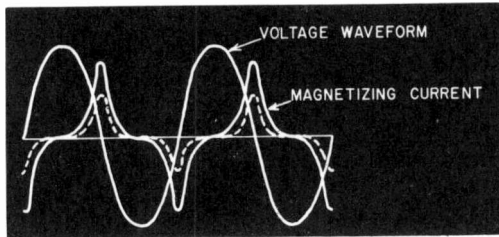

Fig. 425. Relationship between saturating magnetizing current and its voltage waveform.

voltage is obtained from a stabilized line supply while the plate voltage is derived from a circuit in which the input can be controlled by a Variac or similar component (Fig. 423-a). Conversely, the plate voltage and dc supplies can be kept steady while the heater voltage is altered by a separate filament transformer fed from a Variac (Fig. 423-b). This permits changes in gain, plate resistance and all of the other components to be measured along with the time constant involved in the transition.

The other cause for a change in supply voltages is due to the presence of a peak signal. This applies particularly to amplifiers in class-B. The increased current drain from the B-plus supply causes its voltage to drop unless measures are taken to improve its regulation. The result is a change in plate voltage (possibly also a change in grid voltage, according to the kind of supply used).

If the amplifier is intended for precision application, one of two measures must be taken. Either the supplies must be stabilized or the changes produced must be offset so that the net result can-



cells. With the latter approach, it is necessary that the time constants involved be of the same order, so there is no transition to higher gain and then back again. This could result in a change in performance during the duration of a peak signal. Maybe when the signal is first applied, the gain drops momentarily and then comes back up or perhaps the reverse could happen. Either way, the result is a distortion of transients and it is important to trace and eliminate these effects.

To do this, changes in voltage supply due to sudden changes in the signal level must be carefully documented and adjustments

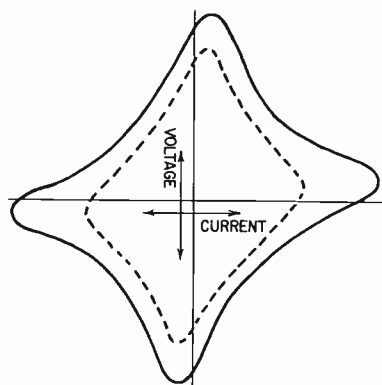

Fig. 426. Impedance loops for different degrees of saturation in magnetizing current.

made so the overall effect is satisfactory. To achieve this, measure the effect of a change in operating voltage, as regards contributing a pulse or transient to the audio waveform and also in modifying the operating condition (amplification factor or circuit resistances of the stage). See Fig. 424.

If several supply voltages, such as bias and plate supply, change due to a variation in signal level, it may be necessary to isolate the effect of each by using auxiliary external supplies to hold the remaining ones constant.

### Other possible defects

Finally, it is important to check some of the things that the usual performance tests do not find. For example, what happens to low-frequency performance under practical loading conditions? With modern amplifiers, having a low source resistance achieved by a large amount of negative feedback, it is quite possible to use an output transformer in which the magnetization characteristic exceeds saturation point. This means the magnetizing current will have some severe peaks. These peaks occur approximately at the zero point of the *voltage* waveform (Fig. 425). The imped-

ance loop for this kind of saturation current is a sort of trapezoid progressing into a star wheel (Fig. 426).

When this is combined with the normal resistance load, it may not produce excursion into areas of the transfer characteristic of the

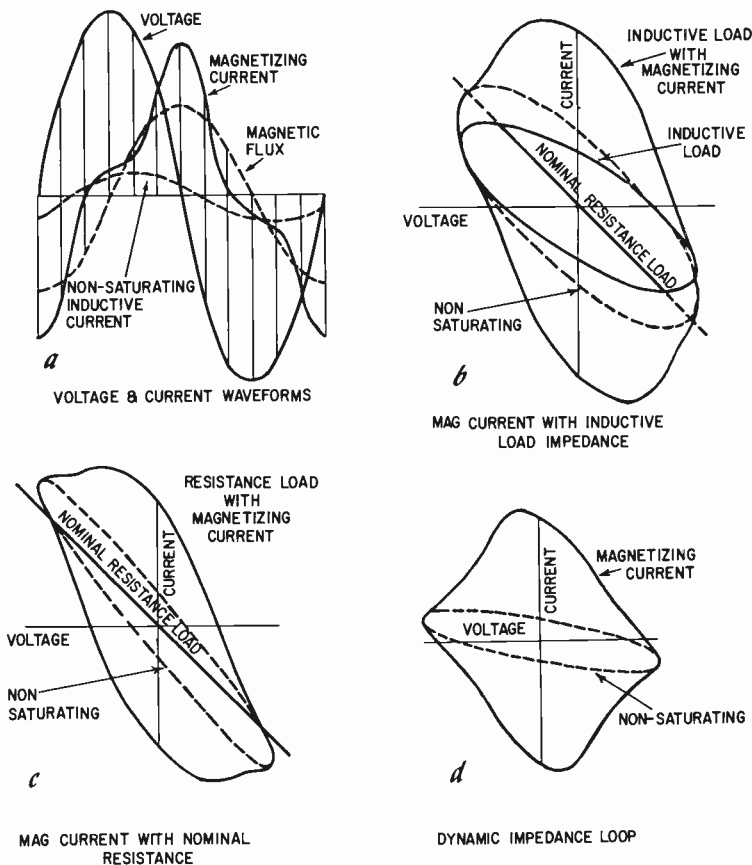

Fig. 427. How saturation current can increase distortion in a practical inductive load (b), although it may be satisfactory for resistive load (c), or open circuit (d). Dashed curves indicate effect of a nonsaturating transformer for comparison.

amplifier that cause distortion. Similarly, the simple impedance loop for the magnetizing current by itself does not cause excursion into a distortion region. As the amplifier appears to work satisfactorily at the low frequencies where this occurs, it may be concluded that the amplifier will work successfully in this frequency range.

Unfortunately, this omits one very practical possibility—an in-

ductive load combination consisting of the nominal resistance load with an effective series inductance, which is the effective character of all dynamic speakers below their acoustic resonance. This possibility is illustrated in Fig. 427. Note that the combination of inductive load with the magnetizing current produces an excursion which suddenly becomes much more than either the nominal resistance-load arrangement or the magnetizing current loop by itself.

An important thing to check, especially in professional amplifiers, is the stability margin and whether the amplifier behaves satisfactorily on this account at both ends of the frequency response. These require separate consideration due to the different effects they can produce, and because each is essentially independent of the other. For some time it has been thought that square-wave testing is an adequate means of checking transient response. This is not true. It does not even give a guaranteed check of the performance of high-frequency transients.

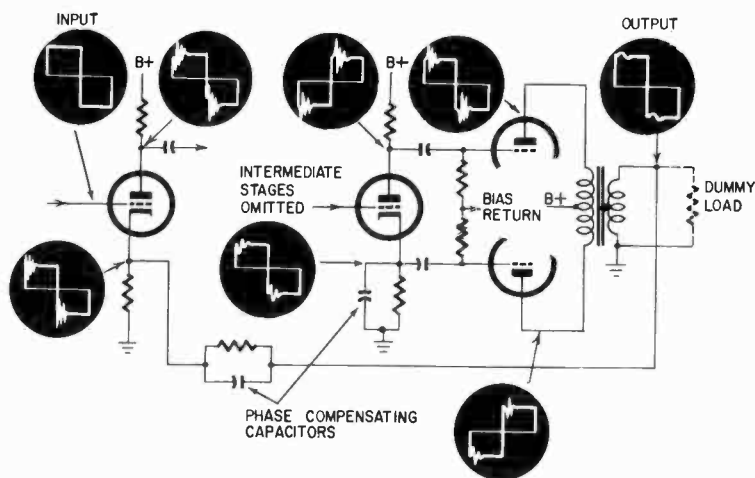

Fig. 428. Checking waveforms at places other than input and output shows how square waves can be "faked".

A test consisting of measuring waveforms at points, similar to that shown in Fig. 428, will readily find whether this kind of deviation exists. Notice that the output waveform, like the input, is almost a pure square wave. It comes near enough to a square wave to pass the square wave test, which usually specifies the limits of rise time and deviation (Fig. 429). It is not practical to specify the precise shape of the waveform beyond such limits.

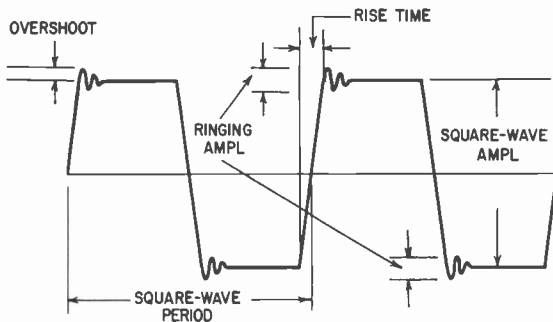

Fig. 429. This illustration shows the quantities of a "square-wave" output that are usually specified.

But to achieve this response some very sharp ringing peaks occur at various other points in this amplifier. This is due to the excessive use of phase compensating capacitors, two of which are shown in this sample circuit, one across the feedback resistor itself and the other across the lower portion of the phase-inverter load (Fig. 428).

If the square wave is keyed, the output waveform will usually show a "rippling" effect. The peaks will bounce in and out of phase until they eventually settle down to the convenient approxi-

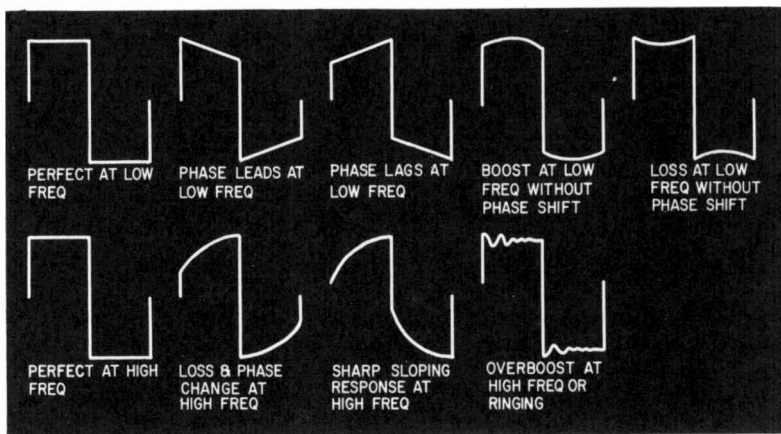

Fig. 430. Square-wave testing of an audio amplifier may reveal these waveforms at various frequencies. The significance of the shapes is indicated in the illustration.

mation that has been achieved by careful circuit balance. This is no guarantee that the amplifier performs satisfactorily under practical transient conditions.

Square-wave tests have a certain validity, and the significance of several indications is shown in Fig. 430. It is important to check the input waveform with the scope to make sure a square wave is going in. Incidentally, this will also check the ability of the scope to handle a square wave—some do not. Often there is a breakthrough to the horizontal that causes peculiar “jerks” on the wave.

While square waves of appropriate frequency can serve as a quick check of the approximate nature of both magnitude and phase response in the vicinity of low- and high-frequency turn-overs, too much trust should not be placed in a good resultant square wave response. It gives absolutely no indication of non-linear distortion.

A valid application of the technique is that illustrated in Fig. 429. This is better than a simpler waveform in tracing the round-loop behavior of a feedback amplifier.

The best approach is to eliminate phase-compensating capacitors, utilizing rolloffs and step circuits in the forward gain characteristic of the amplifier until a satisfactory turnover point at the upper extremity (with feedback applied) produces a  $90^\circ$  phase shift with the attenuation not less than 3 db below the normal 1000-cycle level. This is illustrated by the pattern sequences of Fig. 431. If there is any tendency to peak before the  $90^\circ$  point is reached, or at the  $90^\circ$  point, then the amplifier needs its stability



Fig. 431. *Input-output comparator response sequence for an amplifier with the stability margin satisfactorily adjusted. (See also Fig. 403.)*

characteristic reworked to eliminate possible high-frequency transient effects.

Performance on low-frequency transients is another question. It has been suggested that tone-burst testing would help. (Fig. 432). This method, using a square-wave-modulated sine wave obtained with the setup of Fig. 433, is useful for finding the things that happen due to changes in performance with the duration of peak signal. It is a dynamic way of finding some of the effects that occur due to supply voltage changes with signal level. It may also find transient distortion at high frequencies not shown by plain square-waves.

While the former is one form of low-frequency transient, a change in signal level for a duration of several cycles of the lowest component frequency of the signal is also a low-frequency transient. This too may produce one form of distortion that shows up on tone-burst testing.

There is another kind of change which does not necessarily involve a change in signal level, although it may sometimes coin-

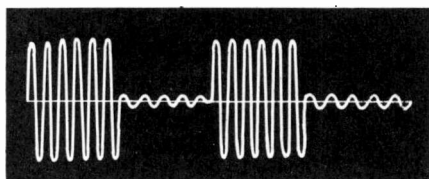

Fig. 432. Waveform of tone-burst testing signal.

cide with it. This occurs in program material that has an asymmetrical component to its waveform. Most wind instruments produce such a component. The presence of asymmetry means the acting bias on different stages has to readjust itself after such a change in waveform occurs, from symmetrical to asymmetrical,

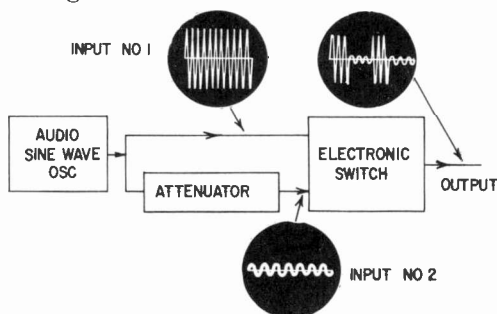

Fig. 433. Basic set-up for generating the tone-burst type of test signal. Results are assessed, qualitatively or quantitatively, on an oscilloscope.

or back again. (Fig. 434). In old amplifiers (without feedback), this does not cause any particular trouble. It might set off motor-boating, if the amplifier has this kind of instability, but usually

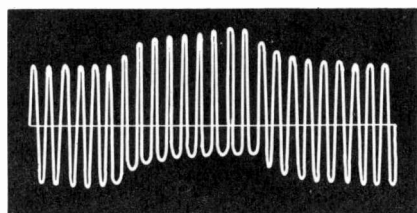

Fig. 434. Effect of asymmetry of waveform in a nonfeedback amplifier; the low-frequency component introduced is nonoscillatory.

it is accompanied by a gradual readjustment of the individual stage biases. This might be reflected in the reading of average plate current in individual tubes, if these were monitored.

This means the earlier stages of the amplifier suddenly have to handle many times their normal signal level immediately clipping occurs. For example, a 10% increase in input signal, beyond the clipping point, and assuming 20-db feedback, results in a 100% increase in the signal level handled by the first stage (Fig. 438). This is a drastic requirement. At the drive stage, for example, there is usually very little margin and this sudden demand for increased handling capacity may exaggerate the clipping which already occurs.

It may also run the amplifier into a sudden overbias condition with the result that, not only clipping occurs, but crossover and other distortions at the same time. It is unnecessary in this book to go into the possible things that can happen. The important thing is to establish whether an amplifier's performance is satisfactory if a certain permissible overload occurs in the input voltage.

#### Recommended Reading

1. N. H. Crowhurst, *Amplifiers*, Norman Price Publishers Ltd., London, 1951.
2. N. H. Crowhurst, *Feedback*, Norman Price Publishers Ltd., London, 1952.
3. Norman H. Crowhurst, "Frequency Response Errors in Hi-Fi Audio Amplifiers," *Electronic Technician*, December, 1956.
4. Mannie Horowitz, "Hum Specification Measurements," *Audio*, June, 1957.
5. Harold Reed, "More About Hum," *Audio*, January, 1957.
6. Norman H. Crowhurst, "Why Do Amplifiers Sound Different?" *Radio & Television News*, March, 1957.
7. Charles P. Boegli, "Transient and Frequency Response in Audio Equipment," *Audio Engineering*, February, 1954.
8. Norman H. Crowhurst, "A New Approach to Negative Feedback," *Audio Engineering*, May, 1953.
9. Norman H. Crowhurst, "Unique Relationships," *Audio*, October, 1955.
10. Norman H. Crowhurst, "Interaction Concept in Feedback Design," *Audio*, October and November, 1956.
11. Norman H. Crowhurst, "Check List for High-Fidelity Systems," *Audiocraft*, September, 1957.
12. Norman H. Crowhurst, "Why Feed Back So Far?" *RADIO-ELECTRONICS Magazine*, September, 1953.
13. Norman H. Crowhurst, "Stabilizing Feedback Amplifiers," *RADIO-ELECTRONICS Magazine*, December, 1956.
14. Norman H. Crowhurst, "Test Equipment For Second-Echelon Hi-Fi Servicing," *Electronic Technician*, October, 1957.

# output transformers

THE measurement of the characteristics of output transformers is essential, both to transformer and amplifier manufacturers, so that adequate specifications can be laid down for transformers intended to be used in specific amplifier circuits. The necessity for a proper understanding of this is underlined by a common but frequently unsatisfactory practice, not justifiable on a true engineering basis. This specifies the performance of a transformer in terms of a specific production type amplifier, although this qualification may be implied rather than directly stated.

Before the advent of feedback, the frequency response and power-handling capacity, as well as the distortion of an amplifier could be specified in terms of its input and output impedances. (We shall see later, there can be confusion even about this.) But such specification is no longer possible as soon as any kind of feedback is applied which includes the transformer within the feedback loop. Under these circumstances, the properties of the transformer affect the overall performance of the entire feedback amplifier. This means that transformer design can be quite critical to the amplifier performance and that the use of a wrong transformer design can result in very serious deterioration of amplifier performance or even absolute instability.

Because of this practice the *wrong choice* of a transformer might not necessarily be an *inferior* transformer in terms of its own characteristic. It is possible for a superior transformer to result in inferior amplifier performance, if the rest of the amplifier is not designed for such a "good" output transformer. Not only does the transformer contribute a considerable amount to the amplifier's performance, but the transformer's performance, when feedback is included, *cannot be completely specified without a knowl-*



fed through a standard resistor of value equal to the referred primary impedance. Say the transformer has a ratio of 20 to 1 (turns) to transform impedance by 400 to 1. Then the primary impedance is 400 times the secondary impedance, or 6,400 ohms (Fig. 502).

But the response of a transformer can deviate considerably, even in nonfeedback amplifiers, from that obtained in this circuit. If the output tube or tubes are of the triode type, the source resistance is usually less than the optimum load resistance. A tube, or tubes, with optimum load (single-ended or plate to plate) of 6,400 ohms would have an effective plate resistance in the region of 2,000 ohms. With this change, the low-frequency response (not the power response) would extend to about one-third the rolloff under standard test. The high-frequency response might vary either way, according to the relative magnitudes of winding capacitance and leakage inductance. But, in almost every instance, it would extend a little further, sometimes perhaps showing peaking which the idealized test would not.

With pentode or tetrode output tubes, the source (effective plate) resistance is many times nominal impedance, and the change in response would be in the opposite direction: the low-frequency response extends to a little less than twice the former cutoff, and the high-frequency response is most likely to be restricted, but with possibility of peaking.

For this reason, output transformers should have the parameters listed or tested that control the low-frequency performance and high-frequency performance, respectively. The transformer can be considered as a contributing component to amplifier response similar to components such as capacitors.

### **Low-frequency performance**

If the transformer is for single-ended output stage operation, low-frequency response is determined by the primary inductance at the operating plate current of the output tube. However, this condition is seldom encountered. Most modern amplifiers use some variety of push-pull operation, so the quiescent plate currents (and screen current in the case of various unity-coupled and Ultra-Linear configurations) produce a balanced magnetization of the core.

Under these circumstances the primary inductance is one due to magnetization under ac conditions only. If there is an imbalance of plate currents, due to a slight inaccuracy in the adjustment of balance between tubes, this is usually so small as to be negligible.

especially at large output values. It may reduce the low-level inductance of the transformer, but the high-level inductance is practically unaffected.

Important to the low-frequency performance of the amplifier is the possible *deviation* in primary inductance, either with slight imbalance currents in the primary or with the magnitude of ac

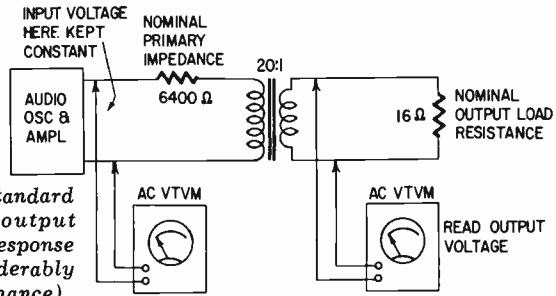

Fig. 502. Basic setup for standard method of measuring output transformer frequency response (which may differ considerably from its practical performance).

magnetization due to change in signal level. These inductance values can readily be measured by a modified inductance bridge of the type described in the chapter on basic measurement. They can be measured at different levels of ac and small dc magnetization.

Two kinds of measurement may be used here. Either the value should exceed a certain minimum under all conditions, or else the inductance must be held between both maximum and minimum limits. The pertinent one will depend upon the way transformer inductance interacts with the rest of the amplifier. There are two schools of thought on the way this should be done. The choice between them should be coupled with the amplifier design approach but, as transformer design is one man's job and amplifier design another's, often this desirable collaboration is lacking.

Low-frequency *response* should not be confused with low-frequency *power-handling capacity*, which is controlled by the magnetizing current the transformer draws at low frequencies. But both must be considered together in determining how low-frequency transformer performance should be measured.

Sometimes it is stated that distortion occurs when the transformer magnetizing current runs into the saturation region. With modern feedback amplifiers, this is not always true. Often the source resistance of the amplifier is reduced by feedback to such a low value that a magnetizing current comparable with the load current can be drawn before appreciable increase in distortion is noticed, at least when measuring the performance into either open circuit or a resistance load.

The addition of the magnetizing-current dynamic loop to the resistance-load dynamic line produces a trapezoidal form of load loop. This permits the transformer to be operated at a higher maximum flux density at the low-frequency limit and still give satisfactory output under specified amplifier operating conditions.

If this feature is used in amplifier design, there are two ways of specifying the magnetizing current at the low-frequency limit and maximum output. One gives the maximum current peak, which involves the use of a peak-current indication to measure it, while the other specifies the maximum magnetizing current as measured on an ac meter of specified characteristics and the harmonic component of this magnetizing current. This can be measured by a standard resistance connected in series with the primary when the full voltage is applied to the transformer at lowest frequency. The resistance value is such that the expected magnetizing current will produce a voltage drop not more than about  $1/20$  of the working primary voltage. This voltage is then used to calculate the current value. Its harmonic component is measured by a regular harmonic meter of a circuit similar to Fig. 317. (See Fig. 503). Either method sensibly achieves the same objective and it is principally a matter of convenience as to which form of specification is used.

This approach to the problem may be questionable when it comes to deciding the contribution of the transformer to amplifier performance at maximum output and lowest frequency. It may result in satisfactory performance into a resistance load, but give serious limitation of power when the load contains inductive reactance.

When the transformer is designed to meet a minimum inductance by using a laminated (not gapped) core, so that operation at low-frequency maximum level approaches saturation of the core the approach used in Fig. 503 is useful. With the other approach, which controls inductance within limits by gapping the core, saturation is not usually a limitation, because a greater number of turns and a larger core size are needed to achieve adequate inductance.

In the second case measurement of inductance using a modified Hay bridge (Fig. 316) with the required primary current flowing (unless it is push-pull operation) is all that is needed to check the low-frequency end. If adequate inductance has been provided to avoid reducing the output from the tubes at the lowest frequencies, the maximum power-handling requirement will auto-

matically be met. If not, the fault is in the value of inductance chosen for the particular output tubes.

### High-frequency performance

For high-frequency response two characteristics of an output transformer contribute to the overall effect; leakage inductance and winding capacitances. According to the method of operation used, the leakage inductance will be that between whole primary and secondary for class A, or between each half primary and secondary for class B. The winding capacitance is particularly that of the primary winding, since this has the highest impedance.

Fig. 503. Magnetizing current and waveform can be measured by inserting a resistance in series with the transformer, such that the voltage drop due to the magnetizing current is small.

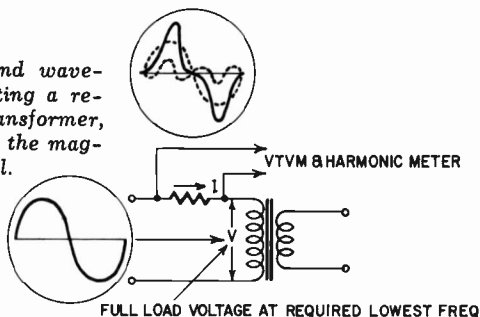

As most modern amplifiers utilize a relatively low plate-to-plate impedance, primary-winding capacitance is not usually a serious feature in amplifier design. Its effect on performance is marginal and often insufficient to warrant attention in the transformer performance specification.

Leakage inductance, however, can perform an important role in the stability characteristic of the amplifier. Sometimes it may not be important with a resistance load, but can be the controlling factor in approaching instability when the amplifier is operated with an inductive or capacitive load, as when driving an electrostatic tweeter.

Before the advent of feedback amplifiers, leakage inductance in combination with primary capacitance were the sole controlling factors for high-frequency response. Any combination of these two values that would result in an acceptable high-frequency response with the operating impedances, primary plate resistance and secondary load resistance would be considered acceptable for a particular amplifier. Thus transformers with different combinations of leakage inductance and winding capacitance, with the same circuit resistances, could each be acceptable (Fig. 504). This shows that in a practical circuit, three combinations of leakage inductance

and winding capacitance (at least) are acceptable, while two of them, widely divergent, give identical response. This is not the standard test circuit, in which different possible combinations would prevail.

In feedback amplifiers, these are not the only factors that control the *overall* frequency response when the transformer is included in the amplifier feedback. There is also the combined effect of the time constants produced by the leakage inductance and primary capacitance with the associated circuit resistances, in combination with the time constants of the interstage couplings in the earlier part of the amplifier. Serious deviation beyond design-allowed variation in any can result in deterioration of amplifier performance and possibly even in instability under certain circumstances. Consequently, it is more important to specify and measure within limits values of leakage inductance and winding capacitance, both ways if necessary, or as minimum *or* maximum values where these form the controlling limitations.

Besides interfering with correct feedback operation, incorrect transformer design can cause spurious effects. These have frequently been specified in terms of overall performance of the amplifier with the transformer connected in it. Often it is implied that the transformer causes notches in the waveform or peaks and valleys in response at some high frequency.

Usually a transformer *measured from whole primary to whole secondary* produces no such deviation in waveform or frequency response. Deviation in waveform can be due to a defect such as shorted turns; deviation in response to very poor winding layout. These types of distortion usually occur only when the transformer is operated in a push-pull amplifier, especially one using some special cross-coupled pentode circuit or Ultra-Linear taps, and when sufficient care has not been given to proper electrical balance.

The percentage tapping (in the case of Ultra-Linear) varies at the high frequencies so the tubes do not maintain a linear characteristic. Also, phase deviation that accompanies such variation in magnitude can cause nonlinear operating conditions between pairs of a push-pull output stage so as to cause distortion of quite a serious nature. This is not due to the transformer's internal non-linearity, but to its causing the tubes to operate under conditions widely deviant from their specifications.

The same kind of thing can also happen with class-B or even class-AB operation, particularly when the output tubes are pentodes. At some point on higher-frequency waveforms, the different

phase shifts the transformer produces in plate loading cause them to work momentarily push-push, instead of push-pull, resulting in a form of frequency doubling.

Consequently, we need some means of specifying and measuring output transformer operation that will control this situation and eliminate the possibility of such deviations when the transformer is connected into a practical amplifier. The leakage inductance

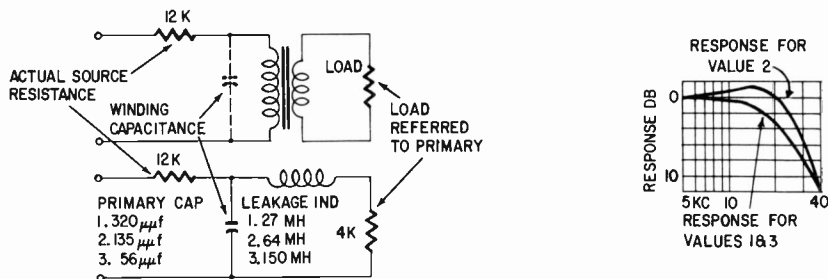

Fig. 504. In amplifiers without feedback, a wide variety of combinations of leakage inductance and winding capacitance might be acceptable.

of different components of the primary winding to various other components can be specified. But this, unfortunately, is not satisfactory unless it is specified *in combination with* the major leakage inductance components.

For example, if the leakage inductance from one half primary to the secondary is 10 millihenries, referred to that half primary, and the leakage inductance from the same plate tapping to the corresponding screen tapping is 2 millihenries referred to the same section of plate winding, the transformer will probably be satisfactory for Ultra-Linear operation. The coupling is maintained relatively tight until the leakage inductance between primary and secondary loosens the coupling as a major amplifier.

Such a transformer could be specified as having a maximum leakage inductance from half primary to secondary of 10 millihenries and a maximum leakage inductance of 2 millihenries from plate to screen tap of the same winding. However, such a specification would be adequately met by a transformer that has a measured leakage inductance of 2 millihenries from plate to screen tap and of only 2 millihenries or so from plate to secondary. This would not be a satisfactory transformer because now the coupling between plate and screen is not adequate up to the highest frequency the transformer can handle as an energy transfer device. The important feature of a design in this case is not that the leak-

age inductance between plate and screen referred to the plate winding should be less than 2 millihenries, but that it should be less than a specified *fraction* of the leakage inductance between the plate and secondary winding from which the overall feedback is taken.

This, then, is the way the transformer should be specified and measured: The leakage inductance between half the primary and the secondary should not be more than 10 millihenries (in this example). And the leakage inductance between the same half primary winding and its screen tap, referred to the whole winding, should be not more than one-fourth of the leakage inductance to the secondary. This has been called "coupling factor," but should really be spelled out to avoid possible ambiguity. If primary to secondary is 8 millihenries, 2 millihenries to the tap is satisfactory. If it is less than 8 millihenries, the leakage to the tap must be proportionately smaller.

Similarly, in most push-pull stages, the leakage inductance between halves should be specified in terms of the leakage inductance between primary and secondary, rather than as an absolute maximum value. The specification of leakage inductance between primary and secondary, either half primary and whole secondary or between the two whole windings, should be controlled to specified values in the interest of overall stability of the amplifier over the required loading range.

Such a method of specification and basis for measurement is obviously more satisfactory than the more common method of specifying the transformer's performance in a specific amplifier. It obviates the problems that arise when certain transformers fail to perform to specifications in certain units of the "same" prototype amplifier. In short, it enables the transformer to be specified in the same kind of terms used for tubes and other components in an amplifier, so it is readily possible to determine what it is that causes an amplifier to fail in meeting its specifications.

Leakage inductance between primary and secondary can be measured by short-circuiting one winding and measuring the inductance at the other winding, to which the value is referred, by a suitable inductance bridge (Fig. 505).

An alternative method consists of finding the leakage inductance by resonance. The signal from an audio oscillator is injected from a low-impedance (preferably near zero) source provided by a suitable power amplifier into one winding and applying the resonant capacitance to the other winding—the one to which the

leakage inductance is required to be referred (Fig. 506). This method has two advantages: (1) with slight adaptation, it can also be used to determine the primary capacitance; (2) it is simple to apply to the relative values discussed.

Fig. 505. Leakage inductance can be measured by shorting one winding (right) and measuring the inductance at the terminals of the other (left). Leakage inductance between these two windings is referred to the winding at which it is measured.

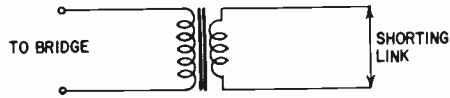

If the amplified audio oscillator signal is injected in the secondary winding, to find the primary-to-secondary leakage inductance referred to the primary, the capacitance is connected across the primary and the resonant frequency for different values of capacitance is measured. This resonance is due to the leakage inductance resonating with the total capacitance formed across the primary by the additional external capacitance with the primary's own self-capacitance.

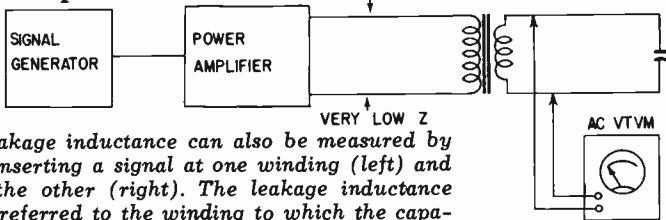

Fig. 506. Leakage inductance can also be measured by resonance, inserting a signal at one winding (left) and resonating the other (right). The leakage inductance obtained is referred to the winding to which the capacitance is connected (right).

First, a reading should be taken of the natural resonance of the transformer without external capacitance. Then external capacitance should be added, just sufficient to halve the resonant

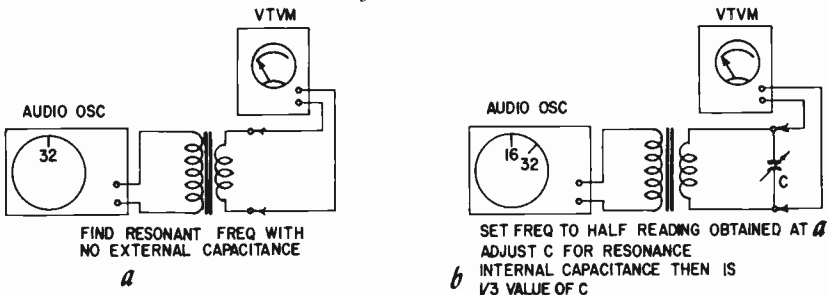

Fig. 507. Checking winding capacitance and leakage inductance. After calculating the internal winding capacitance, the leakage inductance is obtained from the resonant frequencies used.



frequency. This external capacitance will be just three times the effective self-capacitance of the winding (Fig. 507). From this the internal capacitance can be calculated and the leakage inductance found from this formula:

$$L = \frac{1}{4\pi^2 f^2 C}$$

Suppose, for example, the self-resonance is 38 kc and an additional capacitance of 360  $\mu\mu\text{f}$  is needed to bring this down to 19 kc. Then the self-capacitance is 1/3 of 360  $\mu\mu\text{f}$ , or 120  $\mu\mu\text{f}$ . And leakage inductance is given by

$$\begin{aligned} L &= \frac{1}{4\pi^2 f^2 C} \\ &= \frac{1}{39.5 \times 1.44 \times 10^9 \times 1.2 \times 10^{-10}} \\ &= 0.147 \text{ h, or } 147 \text{ mh} \end{aligned}$$

In making these measurements, the points on the windings that normally are at ground, B-plus or some potential normally decoupled to ground, should be connected together so the distribution of alternating voltages within the transformer is correct. Changes in effective ground points can modify the effective self-capacitance of windings, although the effective leakage inductance between windings is unmodified.

If all leakage inductances and capacitances are to be referred

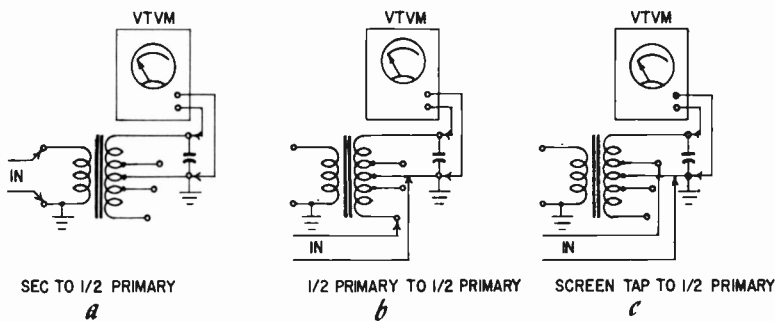

Fig. 508. Checking relative leakage inductance referred to the same section of winding (in this case the upper half of the primary) from other parts of the transformer.

to either one-half or the whole primary winding, the extra external capacitances can be connected to these windings in all cases. But the input can be connected at different points, according to the specific leakage inductance being measured.

For example, to measure the secondary-to-half-primary leakage

inductance, the additional capacitance is connected across one-half the primary and the signal injected in the secondary. To measure leakage inductance between half primaries, the signal is injected in one-half of the primary and the additional capacitance connected across the other. To measure leakage inductance between the screen tap and plate of the same half primary, the signal is

Fig. 509: Sometimes unevenly distributed effects can cause a notch in the transformer's transfer response, after it has started rolling off.

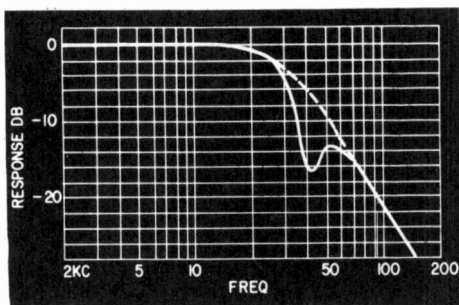

injected in the screen tap and the additional capacitance connected between plate and the B-plus tap. These conditions are illustrated in Fig. 508.

Fig. 510. Some of the peculiar response curves obtainable with an Ultra-Linear transformer of poor design (only frequency response curves shown—the phase curves are much more involved).

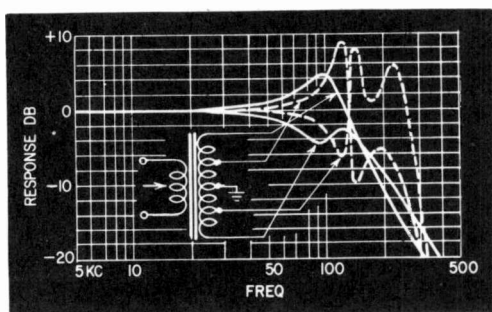

When relative coupling is the important factor, this can be determined from the relative values of capacitance that tune to the same frequency when the input is connected to the tap in question. If the capacitance is five times, the leakage inductance referred to that winding is one-fifth. To check that the coupling factor meets specified requirements, the capacitance can be changed by the minimum acceptable factor, and then a recheck made that the resonance is not lower than for the whole winding. If it goes higher, it is within limits.

An advantage of this method of measurement is that a vtvm can be used as the indicating device. A vtvm will usually have a very high input impedance and low input capacitance and thus is suitable for connecting in parallel with the additional external

capacitance. This point is one where resonance is marked by a voltage maximum and thus is easy to measure without interposing any additional resistance between the generator source and the input winding.

Leakage inductance between windings is not subject to variation like primary inductance, either with dc magnetization or with different values of signal level. Neither does it change with frequency. Consequently, the methods of measurement just set out can produce quite accurate results, provided the leakage inductances and self-capacitances are not so complicated that it becomes impossible to measure one without the interference of various other components in the same transformer. Even then there may be a "kink" in the rolloff curve (Fig. 509).

In some instances this occurs due to quite violent interaction of various internal self-resonances of the transformer. These disappear (if at all) only when the full transformer is loaded between the whole windings. A method of detecting this characteristic is to inject signals on the secondary side of the transformer and measure the output voltage as a frequency characteristic from the different taps of the primary. Typical results taken in this way on a poor transformer are shown in Fig. 510. With such a transformer, using the measurement techniques just described, it is impossible to get a consistent reading of leakage inductance between different sections of the primary. The interfering resonances make any one apparent value of leakage inductance deviate in the most inconsistent and impossible manner.

#### Recommended Reading

1. "The Use of A. F. Transformers." Norman Price Publishers Ltd., London, 1953.
2. "Leakage Inductance," *Electronic Engineering*, April, 1949.
3. "Winding Capacitance," *Electronic Engineering*, November, 1949.
4. "Measuring Up an Audio Transformer," *Audio Engineering*, November, 1952.
5. "Making the Best of an Audio Transformer," *Audio Engineering*, January, 1953.
6. "Audio Transformers Can Be Good," *Audio*, May, 1956.
7. "Output Transformer Design," *Audio*, September, 1956.
8. "How an Output Transformer Causes Distortion," *Audio*, February and March, 1957.
9. "Electrical Adjustment in Fitting a New Output Transformer," *Audio*, April, 1957.

\*In all instances, the author is Norman H. Crowhurst.

# preamplifiers

**T**HE procedures for testing preamplifiers are quite similar to those for basic amplifiers. The principal differences consist of variations in the precautions necessary to insure that the measurements mean what they say. The chapter on basic amplifiers dealt with an amplifier without any frequency-compensating device, either equalization or tone control, and with an input of line level (that is to say, in the region of 1 volt, possibly as low as 0.1 and not higher than 2, such as would normally be delivered by a preamp).

Quite a number of high-fidelity amplifiers incorporate the functions of both preamplifier and amplifier in a single unit for purpose of economy. Such units can either be tested in two "halves" or as an entity. The principal difference between testing a preamplifier by itself and measuring the characteristics of a complete amplifier which includes both functions is that, from the preamplifier, one measures the output voltage delivered to a basic amplifier while, in the complete unit, the output will be measured across the dummy load for the power amplifier section.

## Frequency response

The procedure for checking the frequency response of a preamplifier in its flat position is precisely similar to the method adopted for basic amplifiers. It is, however, even more important to be sure that the measurement technique does not introduce spurious effects, such as a ground loop formed between the instrument and the amplifier producing hum. This is likely to be more difficult to control because of the much lower level employed at

the input of a preamplifier. Therefore it is important to practice looking at what you measure with the aid of a scope.

When measuring frequency response with equalization characteristics or tone control circuits included, the question of level must be considered. For example, some methods of measurement may insert a constant input voltage and measure the frequency response by plotting the output voltage. This often is an unsatisfactory procedure because the large voltage output required at the

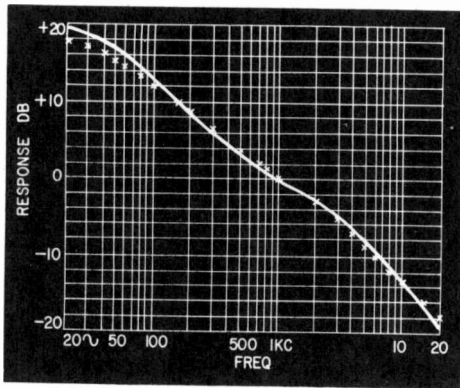
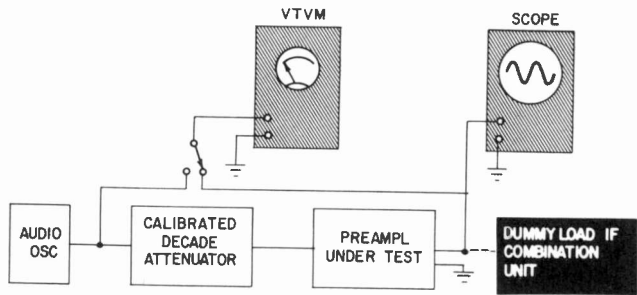

Fig. 601. Method for checking the equalization characteristics of a preamplifier. A gain characteristic curve can be plotted.

low-frequency end, to get a measurable voltage output at the high-frequency end, will drive the preamplifier into distortion.

In deciding how to measure characteristics such as this, the purpose of the frequency compensation provided must be understood. In an equalization characteristic, low-frequency boost is provided because low frequencies are de-emphasized in the input signal. In phono equalization, the low frequencies are deficient in a velocity pickup because of the 500-cycle turnover of the RIAA characteristic. So the playback has to receive a 6-db-per-octave boost below this frequency.

Similarly, pre-emphasis is provided on the record for frequencies above 2,120 cycles to improve the signal-to-noise ratio in this

region. This produces a boost of the high frequencies in the input signal as compared with the 1,000 cycle reference point.

Therefore the purpose of equalization, as well as boosting the low frequencies, is to cut down the high frequencies so the overall response of the preamplifier comes out flat. This being the case, the method of measuring the frequency response of a preamplifier with its equalization characteristic requires that the output voltage be maintained at a *constant* level.

Using a decade attenuator at the input of the amplifier is quite satisfactory for this purpose. The input and output voltages (input to the attenuator and output from the preamplifier), are maintained constant and the gain characteristic of the amplifier is plotted by reading the values from the attenuator (Fig. 601).

AMPL INPUT    ZERO LEVEL ADJUST    CALIBRATED POTENTIOMETER SET

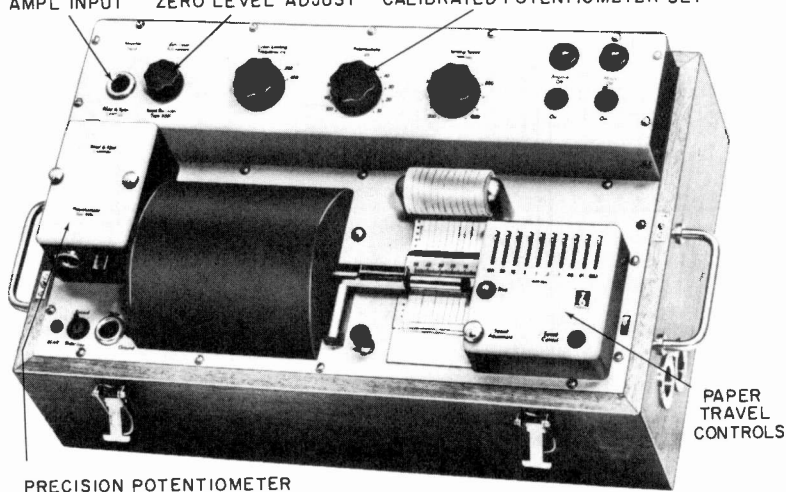

PRECISION POTENTIOMETER

Fig. 602. A servo-type recording voltmeter, useful for automatic plotting of response curves. (Courtesy Bruel & Kjoer)

Where there is a higher gain, such as at the extreme low-frequency end, there is also a higher attenuation and consequently the amplifier input voltage is correspondingly reduced.

It is advisable to look at the signal measured at the output because the extreme attenuation can reduce the signal to a point where noise or some other component is measured instead of the frequency applied at the input. Where the response curve of production preamplifiers must be taken in routine fashion, it may be advantageous to use an automatic response-checking instrument (Fig. 602). However, a modification is needed if the output level is to be maintained constant.

The instrument measures the variation in voltage at the output. It is necessary to transfer the instrument's calibrated potentiometer from the output to the input circuit. The potentiometer is servo-

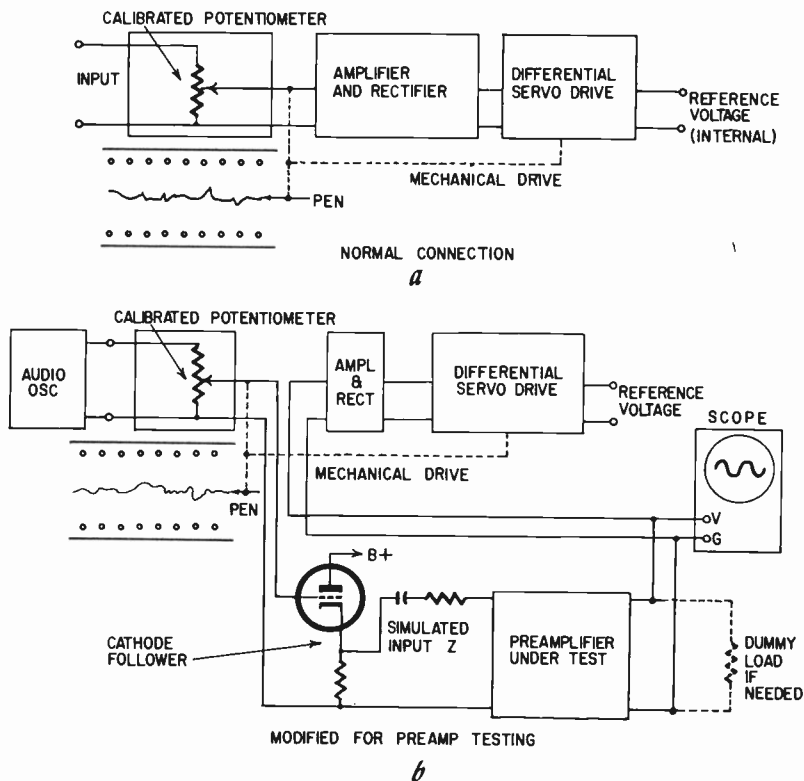

Fig. 603. Modification of the basic circuit of a recording voltmeter to permit plotting the curves at constant output voltage rather than constant input voltage.

coupled to the recorder and this mechanical coupling must be retained. But, electrically, the potentiometer is placed to work as the input attenuator to the preamplifier (Fig. 603).

Appropriate matching or isolation arrangements may be necessary if the input impedance of the preamplifier loads the attenuator and invalidates its calibration, as may happen with relatively low-impedance inputs intended for magnetic cartridges. Then a cathode follower can be interposed between the potentiometer and the preamplifier input, a suitable padding resistor being applied between the cathode follower and the preamp to simulate the input impedance required by the preamplifier.

The preamplifier output is connected to the point in the recorder circuit where the potentiometer tap is normally connected. This enables the servomechanism of the recorder to adjust the input to the preamp so its output remains constant and the curve plotted indicates the precise adjustment of the input at all frequencies. In this way a curve will be plotted equivalent to that

Fig. 604. Possible deviation from flat frequency response (solid and dot-and-dash curves) when tone controls are set for equal gain at three points: 20, 1,000, and 20,000 cycles.

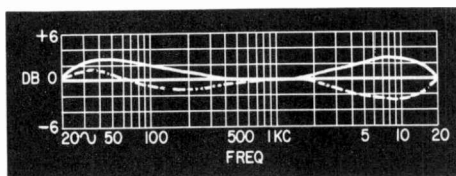

which will be taken by the manual method, adjusting the output of all frequencies to a constant level and measuring the attenuation necessary to do this.

Modern equipment usually has at least two tone control knobs,

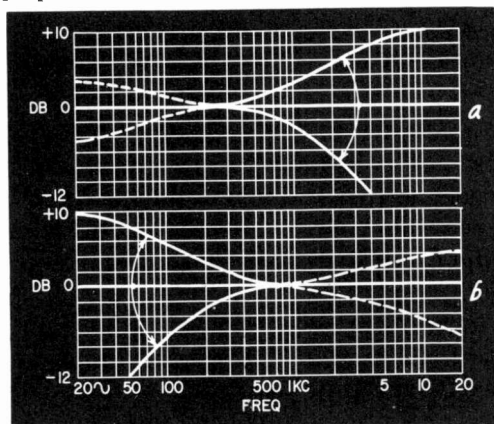

Fig. 605. Checking for possible interaction (dashed lines) between bass and treble tone controls.

one for bass and the other for treble. Measuring the overall performance of a tone control system can become quite complex. The best method is to determine how close to a flat response the tone control provides. To do this, adjust both controls until the gain measures the same at, say, 20, 1,000 and 20,000 cycles, or whatever extremes of frequencies the preamplifier is intended to handle, as well as the 1,000-cycle reference.

Having adjusted the tone control circuit so spot measurements of gain at these three points give the same answer, the complete



frequency response can be taken. It is sometimes erroneously concluded that, having set up a tone control to achieve the same gain at three spot frequencies, the response must automatically be flat. Unfortunately this is not always true, and many tone controls in the nominally flat position produce deviations of the kind shown in Fig. 604.

After the response in the nominally flat position is determined the next step is to leave the bass control in the flat position and

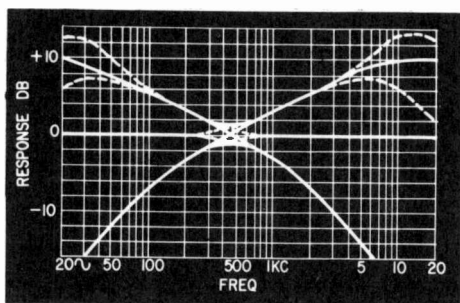

Fig. 606. Checking for interaction between controls when both are moved away from flat position together.

check the overall response with the treble control at maximum and minimum. Then restore the treble control to its nominally flat position and check the overall response with the bass control at maximum and minimum.

This reveals any possible interaction of the control varied on the one left at its nominally flat position (Fig. 605). The remain-

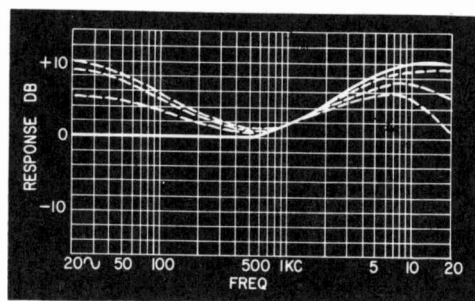

Fig. 607. Deviation when both controls are at extreme setting (dot-and-dash curve) may occur suddenly in the last few degrees of the bass control (short-dash curve) or more gradually (long-dash curve). Solid-line curve shows treble control with bass control at level.

ing thing to check is possible interaction between controls in other positions. This can be done (for extreme conditions at any rate) by taking the response with both controls at maximum, both controls at minimum and then with one each way (Fig. 606).

If there is serious interaction at some point, where it would not normally be expected, determine whether this extreme interaction takes place progressively or whether it is only an effect that shows up in the last few degrees of rotation of one of the controls (Fig.

607). This will depend upon the relative values of the circuit components.

Some preamplifiers come with a special tone control intended for playing old records which takes the form of a variable low-pass filter. Sometimes only the frequency at which this filter turns over can be varied and sometimes both frequency and slope are adjustable. A representative series of responses should be taken to determine that the filter behaves at least approximately according to specifications. Often the curves published for such filters look very ideal with a turnover point that stays constant, and the slope adjust-

Fig. 608. *Ideal response variation of variable-slope turnover type of control.*

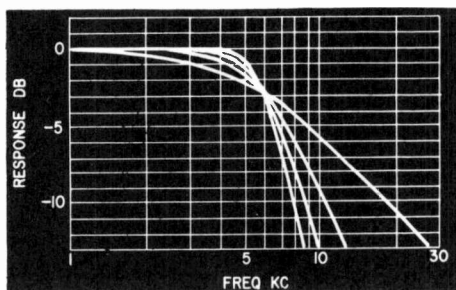

ment varies the rate at which attenuation takes place above turnover (Fig. 608).

When the actual instrument is measured, however, the slope

Fig. 609. *Some variable-slope controls may produce undesirable peaking.*

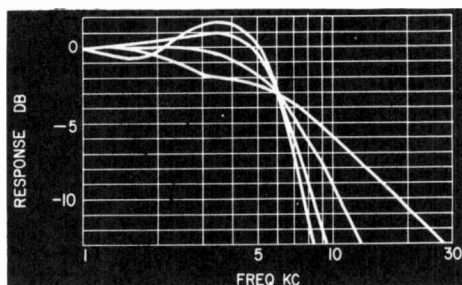

adjustment may affect not only the attenuation slope above turnover but may also introduce undesirable peaking and other variations in the response below the turnover frequency (Fig. 609). The only way to explore such possibilities is to take a fairly large number of representative characteristics at different frequency and slope settings to see just how the circuit behaves.

There are two types of loudness control and the method of checking depends upon which is used. One uses a continuously variable control so the loudness control can be used in place of the older "volume" control. In this case, check the frequency

response at a number of representative levels on the control.

First, take the response with the control wide open and then check the level so it is, say, 10 db lower at 1,000 cycles and take another response. Repeat this procedure for successively lower levels at intervals of about 10 db.

The alternate form of loudness control uses fixed values with a switch, marked "low" "medium" "high" or "volume" and "loudness", relying on the gain control for minor loudness adjustment. In this case the response in the fixed positions will be taken.

Some engineers are sticklers for making the loudness control give a response as close as possible to the Fletcher-Munson characteristics (Fig. 610). At the low-frequency end this procedure is probably justified because the loudness contour characteristics are

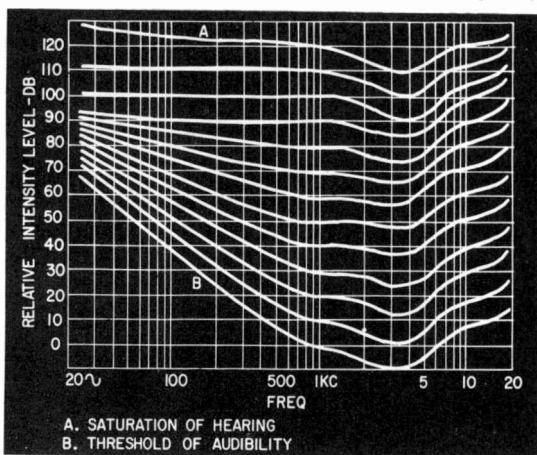

Fig. 610. The well-known Fletcher-Munson loudness contours on which the theory of loudness controls is based. Each curve represents a different phon level.

reasonably representative of general acceptance. But at the high-frequency end the Fletcher-Munson characteristics are average curves from which individual ears are likely to deviate quite considerably. Consequently, there seems to be little point in going to great engineering trouble and expense in duplicating the high-frequency end of the Fletcher-Munson characteristics.

If the particular kinks in these curves are to be reproduced, as a frequency response, considerable electronic circuitry is needed. It is important to realize that the curves at the high end of the Fletcher-Munson contour diagram run very nearly parallel. For this reason, it is not necessary or even desirable to compensate for the wiggles in the Fletcher-Munson curves because these are com-

mon to all characteristics. The loudness compensation is required to take account of the *difference* between individual contours and not their actual shape (Fig. 611).

What is more important than the precise high-frequency correction is to endeavor to get the steeper slope indicated at the low-frequency end for general effect there. Some are altogether too critical in adjusting loudness contours. If the response deviates from the Fletcher-Munson characteristics for the appropriate loudness contour by as much as, say 2 db, this must be corrected. On the other hand, many loudness controls go to the opposite extreme and make no attempt to achieve the *kind* of contour provided by the Fletcher-Munson characteristics even at the low-frequency end.

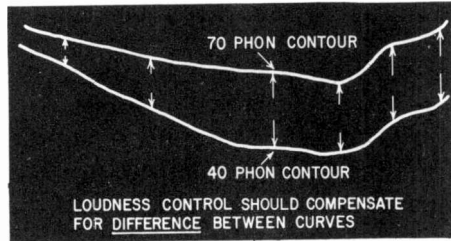

Fig. 611. The important thing in loudness compensation is to equalize for difference between loudness contours.

In the vicinity of the threshold of hearing, necessary for low-level listening, the Fletcher-Munson contour in the low-frequency region has a slope of approximately 18 db per octave. If a slope approaching this order is not achieved, then the result

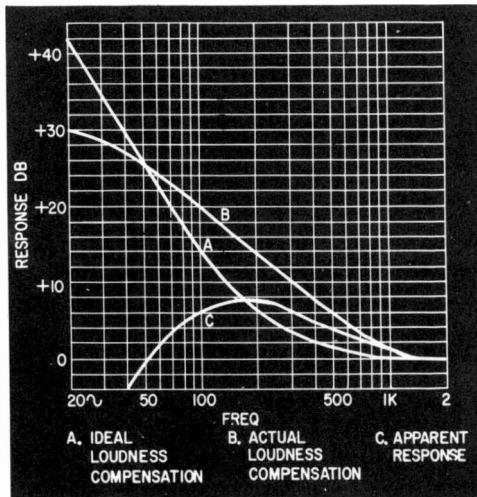

Fig. 612. The result of incorrect loudness compensation: over-emphasis of middle-low frequencies and loss of extreme lows.

of the loudness control will be an apparent middle-low-frequency heaviness (in the region of 100 to 250 cycles). Because the boost for the extreme low end is too gradual, the middle-low end will receive more boost than it should (Fig. 612). This adds an unnatural coloration to low-level music.

Some loudness controls make no variation in the high-frequency response at all with level. Actually the Fletcher-Munson contours for the high end do not justify a very large compensation. The most that is necessary is a gradual "lift" of between 3 and 10 db.

Most recordings sound balanced if played at approximately a 70-phon level because this is the level at which they were recorded. Consequently this level should not have any loudness compensation in a preamplifier. The level at which the program is played must be adjusted (by a gain control and not a loudness control) so the level at which an uncompensated program is played comes out at about 70 phons. Then, as the loudness control turns the gain down, compensation should be made for the *difference* between the Fletcher-Munson curve at the precise level being played and the contour for 70 phons.

In the fixed type loudness control, "high" plays flat, "medium" introduces compensation for about 15 db and "low" for about 30 to 35 db. The loudness switch also introduces necessary attenuation.

On this basis, the high-frequency compensation will never need to be more than about 10 db at the extreme high end, of extremely gradual slope. Even this, in fact, is quite uncritical. Some may provide no more than a maximum compensation of 6 db while others may give as much as 12 or 14. This becomes somewhat a matter of individual preference since ears are not sufficiently consistent to warrant deciding on one or another.

### **Gain and sensitivity**

Before we leave the question of frequency response, it is well to measure the gain of the system, presumably at the nominal reference frequency of 1,000 cycles. In measuring the gain, which goes along with the sensitivity, it is important, in any amplifier where the gain control or loudness control is later than the first stage, to determine the *range* of sensitivity which the amplifier can satisfactorily accept.

In discussing basic amplifiers in which the gain control is usually a potentiometer before the first-stage input, this is not of great importance. It is difficult, of course, for the average potentiometer to accept 100 volts input and apply 0.25 volt to the grid of the

first tube. This is probably a greater range than the potentiometer will accept and the 100 volts may readily burn out the low-rated potentiometer with audio taper, used for the input control. But a range up to say 10 volts, which is more than 20 db (and may be as much as 40 db) higher than the nominal input for the amplifier, can usually be handled by a control in this position.

But when the gain or loudness control is somewhere in the middle of the amplifier, this means the earlier stages have to handle the full input without attenuation. So it is important, not only to know the maximum sensitivity of the amplifier, but also the maximum input it can handle without distortion (Fig. 613).

1 millivolt at the input, with the gain control wide open, may

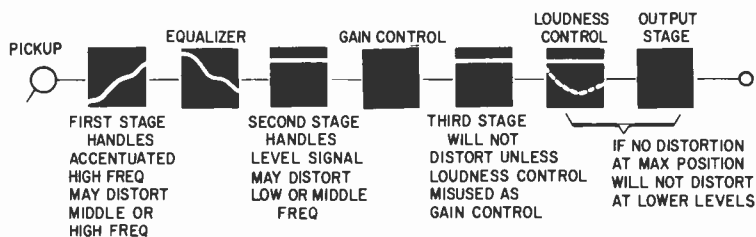

Fig. 613. Block schematic of typical well-designed preamplifier, showing points at which distortion can occur, according to the level of operation.

give the full power output in the case of a combination amplifier, or the rated voltage output in the case of the preamplifier. The gain control may be located at a position where the level is say 0.5 volt. Perhaps the stage that feeds 0.5 volt to the gain control that receives an input of 100 millivolts and is capable of handling up to 1 volt before distortion is encountered. Working backward, this means the input can be 10 times the value required at maximum sensitivity before distortion will occur at this stage.

It is not necessarily the stage immediately before the gain control that will run into distortion. This depends upon other factors. Usually the equalization controls come after the first stage of a preamplifier and the distortion may occur in the first stage, due to the large amount of attenuation in the equalizer. However, this possibility must be considered in combination with the normal level accepted by the input at different frequencies.

If equalization gives a 20-db boost to the low frequencies and 20-db attenuation to the high frequencies, then an input of 20 millivolts at 1,000 cycles should be regarded as commensurate with

an input of 2 millivolts at 20 cycles or 200 millivolts at 20,000 cycles.

The easiest way to check this is to adjust the gain control to different settings and take frequency runs at each setting, observing at the same time possible distortion. In this way the highest input level (or the lowest position on the gain control that can be operated), can be determined before distortion occurs at some frequency with the tone controls set for flat position. The frequency response will be taken in each case so as to produce the nominal output of the preamplifier.

The loudness control cannot be used for the same function as a gain control—to adjust for different input levels received by the preamplifier. This will result in what is termed scale distortion, because the program will be played according to the wrong loudness contour for the level delivered by the preamplifier. When the loudness control, properly used, is turned down, the output level is reduced correspondingly and consequently is not likely to cause any distortion not present at the maximum setting.

### **Distortion**

Measurement of distortion in a preamplifier requires a more sensitive meter than that used for basic amplifiers because of the lower voltage levels handled. Distortion is measured, not only at maximum output and a level 6 to 10 db lower, but also at very low levels, because some tubes seem to have an inherent hysteresis type of distortion, which is a minimum value produced in low-level operation.<sup>1</sup>

It is not customary to operate a preamplifier as close to its distortion point as a basic amplifier is normally operated. This is partly because preamplifiers do not run into distortion as suddenly as amplifiers do. This results in considerable latitude in the operational level of a preamplifier, which may generally be determined by the input level required by the basic amplifier although, where these come as separate units, it is possible to adjust for the best combination level.

If a preamplifier will deliver an output of 1 volt before distortion begins to rise appreciably, the input control to the amplifier should be adjusted so that the maximum loudness required with a particular speaker is achieved when the preamplifier delivers about 1 volt. The best overall dynamic range of a system is

---

<sup>1</sup> Hysteresis distortion in a tube is a type of "residual nonlinearity," in which, at extremely low levels, current changes lag voltage changes.

achieved by keeping preamplifier noise at as low a level as possible at its output.

## Noise

The measurement of preamplifier noise generally includes background hiss, due to tubes and other components, and hum. But we will consider these separately as they have a different nature. Both should be measured under a variety of conditions. Noise and hum can be measured at the same time by using a meter with a scope to analyze the content of the noise (Fig. 614) or with a wave analyzer if this is preferred for its precision.

Hum and noise are measured with the gain or loudness control in the off position so as to measure the noise and hum output of the stages following this point. They should also be measured with

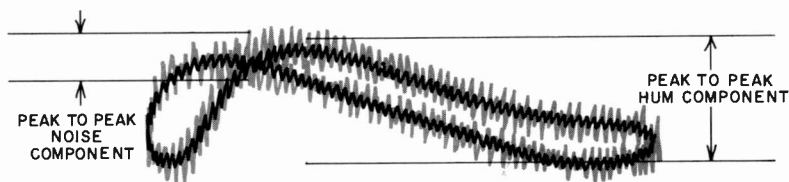

Fig. 614. Typical scope display, using line time base, to assess relative quantities of hum and noise.

the gain or loudness control wide open and the input terminated with an appropriate input resistor suitably shielded to avoid unnecessary hum pickup.

Sometimes noise or hum is due to the circuit resistance of the control. In this case, both may show minimum values when the control is turned either off or wide open and a higher value when operated part way up. To check for this, analyze the condition when the control is turned so as to give 6 db less than the maximum gain. This results in the maximum circuit resistance at this point in the circuit and consequently will normally give the maximum noise or hum pickup.

Occasionally hum pickup is exaggerated at some point in the control rotation due to proximity of the gain or loudness control slider to the power switch, which happens to be housed on the back of the same control. The only way to check for this is to use as much gain following the system as possible and rotate the control to see if there is any point at which hum becomes abnormally louder. If the line switch is located on another control, such as one of the tone controls, it must be checked for the same kind of defect too.



Hum should be checked quite early in the measurement of a preamplifier because it can often invalidate readings. When abnormally high hum is found, it is necessary to trace and eliminate it.

One cause of hum, particularly the 120-cycle variety, is defective filter capacitors in the power supply, or even defective grounding of the filter capacitors, where electrolytic capacitors with a case ground are employed. Under these circumstances the case cannot be relied upon to provide a ground to the chassis by the twist-lock lug normally carried on the capacitor. A ground return using a soldered connection should always be used.

This brings up the question of the part played by the chassis in ground return. If the inputs are grounded by phono plugs and the amplifier's negative line is also grounded by the electrolytic capacitors, this can provide a ground loop—two paths for supply negative currents to get back from their individual tube circuits to supply negative; one through the ground line of the amplifier and the other by the grounding of the phono sockets, the chassis and the grounding of the electrolytic capacitors.

This can be avoided by isolating the ground side of the phono input jacks from the chassis, relying on the circuit ground to provide the ground connection or by mounting the electrolytic capacitors in insulating wafers so these rely only on the ground connection to their lugs and not on the metallic contact with the chassis.

Sometimes hum becomes evident as soon as test equipment is connected to the input of the preamplifier. The best remedy is to get better-isolated test equipment, but this may not always be practical. A simpler remedy is to use some kind of isolating transformer between the oscillator input and the input to the preamplifier. This can be connected between the oscillator output and the input to the attenuator (Fig. 615).

It is important to measure the input voltage *after* such an isolating transformer, because it invariably has a frequency response of its own, which invalidates any response curves plotted if it is included in the measurement between input and output.

### **Dynamic range**

Having measured both the distortion and noise characteristics of the preamplifier, it is possible to evaluate its dynamic range. To do this compare the normal maximum signal level at any particular control setting with the noise level at the same setting. The ratio between these voltages, expressed in db, gives the dynamic

range of preamplifier at this setting. Usually the maximum dynamic range will be when the preamplifier is operated to give full output for whatever input is provided.

### Cross-talk

Another form of noise or interference to be checked in preamplifiers having more than one input is cross-talk between inputs. If no switching is provided between inputs, then obviously the preamplifier is not intended to be connected to more than one input simultaneously, because then the inputs would be mixed and there is no means of determining which one is selected. But if the preamplifier comes with a number of inputs and a selector switch, cross-talk must be checked.

Usually a good preamplifier of this type will provide for grounding any inputs not being used, thus effectively preventing or at least considerably reducing cross-talk between one input and another.

One disadvantage of this practice is that the same input may be needed for more than the one preamplifier. Perhaps a radio chassis can be provided with an outlet to a preamplifier input for playing over the hi-fi system and also with an alternative connection to another amplifier and speaker for use in another room, so the same radio tuner can be employed for delivering program material to alternative rooms. Under these circumstances a short-

Fig. 615. How to use an isolating transformer to avoid a spurious hum problem, introduced by the measuring equipment connection.

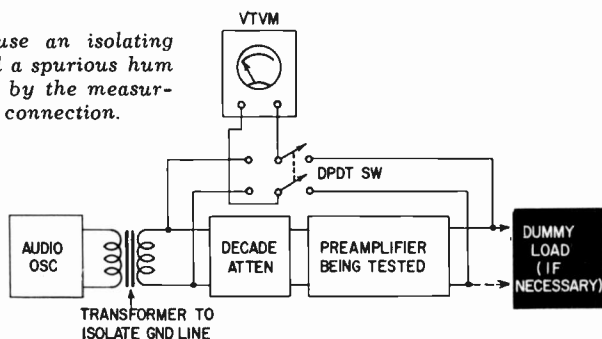

ing switch would effectively kill the program in both places. Suitable isolation should be provided so the shorting switch does not short the actual input terminals but prevents leakage from this input into the signal path of the preamplifier.

Another form of cross-talk to check is in dual preamplifiers intended primarily for stereo use. Take the frequency response from one input to the other output when both are set for the

same gain. Compare the gain and response of each channel with this cross-talk response. The cross-talk ratio may be given either as the ratio in db at 1,000 cycles or the minimum ratio at the worst point, in which case it is termed "minimum cross-talk" (Fig. 616).

### Termination

Another thing to check in a preamplifier is the effect of different input and output impedances. The preamplifier is usually designed to accept input from a variety of pickups or tuners as sources, but the effect of different input resistances on the frequency response and noise level of the preamplifier should be checked independently, to see how dependent its characteristics are upon such changes.

Similarly its output performance should be checked against changes of loading provided by the basic amplifier. If a preamplifier is provided with a cathode follower of nominal impedance in the region of 600 ohms, this does not necessarily mean it will operate satisfactorily into a basic amplifier with a 600-ohm input. Usually this will result in considerably higher distortion.

A low-impedance cathode follower is intended to be operated into a high-impedance input of 50,000 ohms or higher at least. The purpose of the low impedance is to avoid high-frequency losses due to shielded cable connectors, which occurs when the output of the preamplifier is at high impedance as well as the input to the basic amplifier.

The use of a 600-ohm load on a 600-ohm cathode-follower output cause considerably more distortion, and also severely restricts the output voltage. A preamplifier that might give as much as 5 volts with a certain (low) amount of distortion before going into severe distortion when operating into a high impedance, may give less than 0.5 volt when operated into 600 ohms. Even at this voltage, the distortion will be considerably higher than the 5-volt output into high impedance. So this is something that should be measured in assessing the effect of output matching on the performance of the preamplifier.

In tube type preamplifiers, the input resistance or impedance is unlikely to affect the distortion produced by the preamplifier. It will affect only the noise components, hum and hiss, to any appreciable degree. But in preamplifiers using transistors the input impedance connected to the preamplifier can affect distortion as well as hum and noise. Consequently, a transistor preamplifier should also be checked for the effect of input loading on other character-

istics of the amplifier—its frequency response and distortion, as well as hum and noise.

Most transducers or sources that are fed into preamplifiers are voltage-producing devices. Consequently, it is important to check the effect of feeding from a low source resistance rather than a very high one. Crystal or capacitance transducers, however, can sometimes better be regarded as current type sources. For measuring the effect of impedance differences here it may be advan-

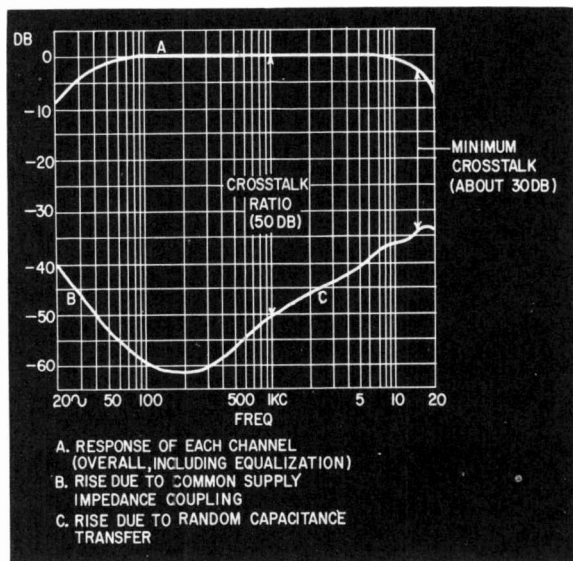

Fig. 616. Typical cross-talk curves.

tageous to check the effect of feeding the preamplifier from a very high source resistance, in the region of megohms, and then applying, as a supplementary source impedance, parallel capacitance to simulate the source impedance provided by the transducer.

With tube amplifiers these changes are likely to affect hum, noise and frequency response, but not distortion. But, with transistor preamplifiers, distortion also may be affected by such changes.

### Microphony

In tube amplifiers microphony sometimes is encountered. This is a difficult thing to measure and give numbers to because the magnitude of output produced by the microphonic effect depends on how hard the tube is hit or the intensity of the vibration picked up by the chassis. Also, the microphony is of complex frequency construction because it sets up a complex vibration in the elec-

trodes that produce it. The only thing that can be done is to investigate whether it is something inherent to the component used or just the particular sample that happens to be defective.

### **Supply changes**

Preamplifiers must also be checked for the same kind of deviation that was discussed in the chapter on basic amplifiers, due to supply change or changes in signal level. Usually neither of these has such drastic effects on preamplifier performance as it can have on the basic amplifier. No preamplifier has such large amounts of overall feedback as do basic amplifiers.

Some preamplifiers in fact have no overall feedback loops at all. Maybe individual stages utilize feedback to linearize them as individual stages, hence supply changes produce practically no effect whatever. Sometimes feedback may be used to produce tone compensation or equalization characteristics. Occasionally such circuits will produce a stability margin problem, but usually they are well enough designed to insure that no peaking occurs outside the range of frequencies for which the equalization is provided. This being the case, the kinds of transient effects noted in basic-amplifier performance do not usually arise in feedback preamplifiers. However it is well to check these things, especially in a preamplifier where the schematic shows that feedback is employed to achieve tone-compensating or equalization characteristics.

### **Recommended Reading**

1. W. B. Barnard, "Distortion in Voltage Amplifiers," *Audio Engineering*, February, 1953.
2. L. Fleming, "Distortion Measurements Without Tubes," *Radio & Television News*, March, 1951.
3. L. Fleming, "Voltage Amplifier Distortion," *Radio & Television News*, September, 1956.
4. Norman H. Crowhurst, "Why Loudness Control?" *Radio & Television News*, April, 1957.

See also references at the end of Chapter 4, many of which are also applicable to this chapter.

## pickups and arms

IT is impossible to consider pickups and arms as separate entities from a performance point of view. This can be illustrated by considering the possible effect of arm resonance.

Resonance may be considered as a mode of vibration dependent upon the dimensions and structure of the arm itself. But whether this resonance has any *effect* on reproduction depends upon the degree of coupling between the pickup mechanism and the arm. This in turn is controlled by the reaction of the stylus to movement imposed on it by the record groove.

If the stylus produces zero reaction at all frequencies (that is, it moves infinitely easily), then the vibration transmitted from the record grooves will produce no vibration in the body of the pickup cartridge. This being the case, it cannot transmit any vibration to the arm, so any resonances in the structure of the arm are unimportant because the pickup mechanism will never excite them. All the arm is called upon to do, under these hypothetical circumstances, is to carry the pickup across the record so the stylus keeps pace with the spiral groove.

This is an *impossible* idealization. However compliant the pickup mechanism, it always produces some reaction at the stylus point and there is some tendency to transmit vibration from the stylus to the body of the pickup, which in turn is transmitted to the arm. The amount of such transmission is relative and is determined by the characteristic of the pickup.

Consequently the effect of arm resonance upon the performance of the whole unit is dependent most upon the characteristics of

the pickup. This does not alter the fact that it is desirable to eliminate arm resonances. It merely changes the relative importance of any that may be present.

### **Frequency response**

Mechanical features usually cause pickups and arms to deviate from their ideal frequency response. If the pickup stylus could be rigidly coupled to the transducer mechanism and the body of the transducer mechanism be held equally rigid, then in most instances the electromechanical frequency response would be perfect.

A coil moving in a magnetic field is not in itself frequency-discriminative in the voltage output it produces. A certain rate of movement will always produce the same output voltage. Thus, a moving coil pickup is inherently a velocity pickup device and its only *electrical* contribution to frequency response will be due to the resistance, inductance and self-capacitance of the coil itself.

The same is true of the magnetic construction. The output is due to the changing magnetic field which varies in conformity with the movement of the magnetic components controlling it. Within the audio range, this is not appreciably frequency-discriminative. So the magnetic pickup also is basically a velocity device.

Crystal and ceramic pickups produce a voltage proportional to their deflection, provided they are operated open-circuit. The resistance into which they operate will tend to discharge this voltage according to a specific bass-loss characteristic that can be determined quite readily from the electrical characteristics of the unit. But the basic transducer is a constant-amplitude transfer device without frequency discrimination in itself.

With each type of pickup, any frequency discrimination observed, particularly the difficult, resonant types, are due to the mechanical properties of the coupling between the stylus and the transducer, including of course the stiffness of the crystal or ceramic itself.

The most convenient means for taking frequency response, measuring sensitivity and other characteristics of a pickup, uses one of the wide range of test records available on the market. They contain calibrated test frequencies and also standard velocity magnitudes for determining sensitivity.

However, tests with a variety of these discs may produce apparently conflicting results. Fortunately, it is simple to check the frequency response recorded onto the disc by the light-calibration method described earlier. This utilizes the fact that the width of a

light reflection pattern is dependent upon the maximum velocity of the groove. This makes it relatively easy to construct a test record of known calibration, and there are quite a number of good records of this type on the market. Unfortunately, this is not quite the whole story. . . .

The complete performance of the pickup includes the performance of the stylus in the groove itself. If the record were completely rigid, so the stylus riding in the groove *had* to move in conformity with the modulation in the groove, there would be no reason for

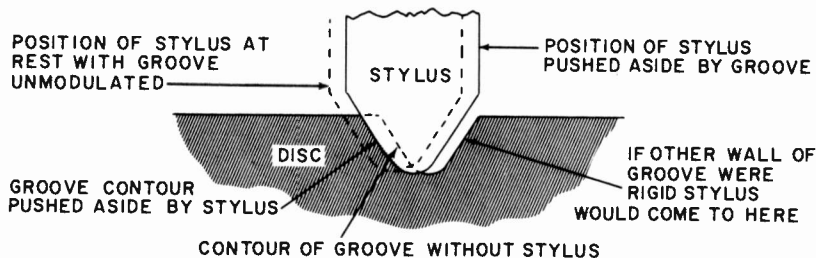

Fig. 701. The position taken by the stylus at any instant depends on both disc and pickup compliances.

discrepancy between one test record and another, provided the maximum signal-handling capacity of the pickup is not exceeded at any point.

But with practical discs, which are not infinitely rigid, the stylus movement is determined by the ratio of two compliances: the compliance of the groove walls pushing it, and that of the pickup tending to stop it from moving (Fig. 701). If the compliance measured at the stylus point due to both these causes is equal, then the output from the pickup will be reduced 6 db as compared with the same grooves driving the pickup, but with completely rigid grooves.

In modern pickups, the stylus compliance is invariably much greater than that of any disc material. But it is evident that the figures obtained from different test discs, both as to frequency response and sensitivity of the pickup, may disagree due to difference in the compliance of the pickup compared to the disc.

To obtain standards in this regard it is necessary to establish more accurately the stylus movement itself. For this purpose the stylus is driven, not by a record groove, but some other type of transducer, possibly a moving coil from a speaker, coupled mechanically to the stylus point. The important thing is to estab-



lish the magnitude of movement of the stylus point and from this deduce the transfer characteristic of the complete pickup.

The simplest way of establishing the magnitude of stylus movement is to use a projection microscope and throw the shadow of

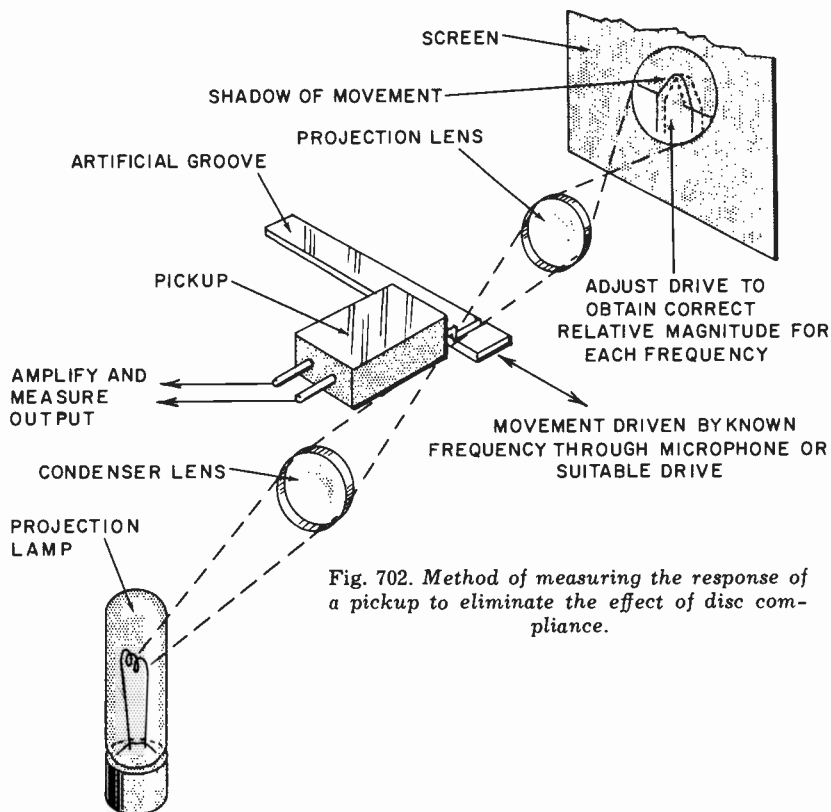

Fig. 702. Method of measuring the response of a pickup to eliminate the effect of disc compliance.

the stylus complete with its movement on a screen. Then with known optical magnification the magnitude of movement can be accurately measured and adjusted by the driving force to a specified value. In this way, a frequency response of the pickup can be taken independently of the effect of record material (Fig. 702).

Technically, this may be regarded as the response that should be published for the pickup. But of course it has no practical value because pickups do not play in grooves with infinitely rigid walls. Consequently a response measured with a practical test disc is more acceptable—if less definite as to its meaning.

One advantage of driving the pickup mechanically so the stylus movement can be controlled is that it eliminates one variable from

the measurement and thus enables more ready evaluation of the contribution of different components of the pickup performance.

As far as the pickup mechanism is concerned, two factors, broadly speaking, contribute to the frequency response: the mechanical reactance 'seen' at the stylus point and the effectiveness of coupling between the stylus point and the transducer element.

Some pickups, such as the G-E for example, concentrate on getting the transducer as close as possible to the stylus point. This then means the output voltage is determined almost entirely by the relative movement between the stylus and its cartridge. In other words, this almost eliminates the second possible cause of frequency discrimination. However, close coupling in this way does not eliminate the first possible cause—the fact that the stylus presents a mechanical impedance to the stylus point, and consequently may require considerably harder driving at some frequencies than others.

Technically such a pickup will produce the best frequency response when measured by driving the stylus mechanically and holding the cartridge rigidly. But by the same token this kind of pickup can show a greater deviation in performance when test records are used instead of such a mechanical drive. It does not necessarily mean that this type of pickup will also show greater variation in frequency response according to whose test record you happen to use.

The other trend in construction uses a mechanical coupling between the stylus point and the transducer element. Moving coils employ such a construction because a leverage is required between the stylus point and the coil, which is located in a magnetic gap. Various types of construction are used, each of which has its own mechanical resonances.

A mechanical resonance in the stylus arm coupling the stylus itself to the coil can result in excessive movement of the coil compared to the drive motion at the stylus. This will produce a large resonant peak in the output response, which will occur with equal force whether driven by a relatively compliant disc or by an almost rigid one. But the magnitude and frequency of the peak, particularly the latter, may be shifted by using a disc of different compliance.

We could pursue this discussion through the relative types of pickup construction. Some of the ceramics use quite a complicated lever system to transfer the stylus movement to the "distorting element" in the crystal that produces an output voltage. To design the resonances out of his system as far as possible is the pickup

manufacturer's job. What we are concerned with here is measuring the performance. The only reason for going thus far into the mechanical aspect is that it is very helpful in visualizing what can be causing certain resonances when interpreting the results measured.

The arm usually produces a sequence of resonances toward the low-frequency end of the audio range. This can be checked independently, if desired, in designing the arm, by driving at the point where the pickup is inserted mechanically and measuring the motion produced at different points along the arm. Alternatively, the mechanical driving-point impedance can be measured as a frequency response.

The latter method is probably the most satisfactory because it determines what mechanical reaction the arm presents to the cartridge mounting. The best approach is to use a strain-gauge crystal in the drive coupling, so the drive force applied to the application point can be measured while using the shadowgraph method of determining the magnitude of movement induced (Fig. 703). A plot of these relative magnitudes will give the mechanical impedance characteristic of the arm measured at this point.

This impedance should be a rising one, characterized by less movement (with a constant drive force) with increasing frequency. The thing to watch for is any dips in impedance due to resonances that would allow the arm to pick up more motion than it should from the drive to the pickup stylus.

These measurements are said to be most important in the lateral plane. But spurious vertical effects can also interfere with lateral performance due to mechanical translation effects. With the advent of stereo discs, measurement in both planes becomes even more vital.

The vertical mechanical impedance characteristic can be measured in just the same way as the horizontal, by applying the force vertically and measuring the movement by a shadowgraph.

### **Sensitivity**

This is measured by driving the pickup at known amplitude and measuring its electrical output with a calibrated amplifier. Frequency is important, as sensitivity is usually expressed in terms of output volts per unit velocity of drive. *Magnitude* of movement is connected with velocity on a 6-db-per-octave basis.

Assume the peak-to-peak movement amplitude is 2A, as measured by the shadowgraph. This means the movement is given by:

$$S = A \times \sin \omega t = A \times \sin 2\pi f t$$

where  $f$  is frequency in cycles. Then velocity will be:

$$\frac{ds}{dt} = 2\pi A f \times \cos 2\pi f t$$

When we speak of stylus velocity, we mean the maximum instantaneous velocity which will be  $2\pi A f$ .

To take an example, assume the peak-to-peak movement is .01 cm at 1,000 cycles. Then  $A$  is .005 cm, and velocity is  $2\pi \times .005 \times 1,000 = 31.42$  cm/sec. The same magnitude of movement at twice the frequency would be twice the velocity, and should, in a velocity type pickup, produce twice the output voltage.

### **Impedance**

Pickup impedance can be measured by normal bridge methods and the electrical impedance of a pickup indicates quite accurately how the termination at the input to the preamplifier can modify the frequency response of the pickup.

If the pickup contains inductance, as most moving-coil and magnetic types invariably do, then terminating the pickup with a lower value of resistance will result in a high-frequency turnover at lower frequency.

If the pickup is of relatively low impedance (less than, say, 5,000 ohms), then its own capacitance is not likely to bother it as regards frequency response. But the capacitance of a connecting cable can always cause high-frequency loss, unless the impedance of the pickup is kept to a low enough figure to avoid this. All of these effects can be computed on simple frequency-response parameters of the circuit elements involved.

In ceramic and crystal pickups the source impedance of the pickup is approximately that of a capacitor. Consequently, termination in different values of resistance will result in different degrees of bass loss. The pickup is regarded as a constant-amplitude rather than a constant-velocity device as are moving-coil and magnetic types.

### **Compliance and dynamic mass**

Pickup compliance is not a very easy thing to measure, largely because of the very minute size of the components. It is impossible to connect an additional compliance to the stylus point, either in the form of the disc that drives it or a compliant driving source such as a rubber pad, without also adding to the stylus point mass as well as compliance.

Static compliance is measured fairly simply by applying a small

force and noting the movement it produces. But dynamic compliance is complicated by the various other factors involved.

It can be measured by comparative means, using a driving source of known compliance and determining how much the movement

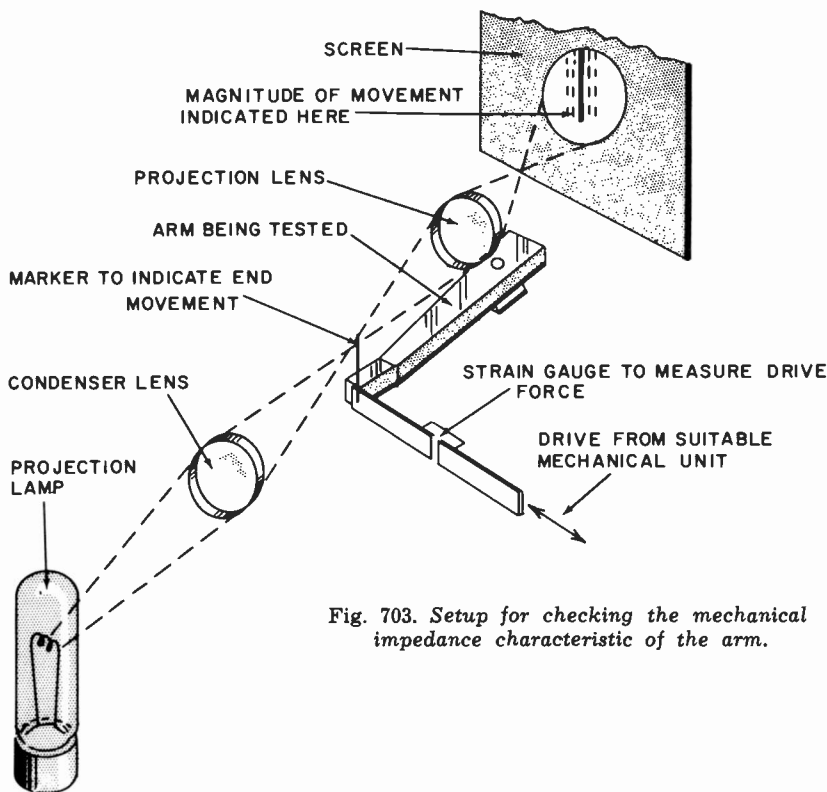

Fig. 703. Setup for checking the mechanical impedance characteristic of the arm.

of the stylus is reduced, by allowing it to be driven by a compliant source as compared with a rigid one. The change in magnitude of movement then, gives the relative compliance of the driving source and of the pickup movement itself. However, this has to be interpolated on the basis of measurement over a range of frequencies, so the contributing masses can also be calculated as well as the compliances.

Dynamic mass or inertia of a solid moving part, such as a stylus arm, can usually be calculated reliably from the mechanical formula for the mode of movement used. An alternative approach in discovering compliance, at least in the region of the resonant frequency of the device, is to check by means of a strobe whether the mode of movement remains according to theory as the driving

frequency is passed through resonance. Then the frequency characteristic can be taken and analyzed from the known value of mass and other circuit elements to provide a characteristic for the compliance value.

Completely detailed calculations of compliance values are beyond the scope of this book and the reader is referred to the further reading at the end of the chapter for appropriate literature.

However, it will soon be important (more so than heretofore) to measure the vertical as well as the horizontal compliance, as this will determine the compatibility of an LP pickup for playing stereophonic discs without ruining the grooves for playing by a stereo pickup. This is more important than has sometimes been realized even for playing lateral recordings. Lack of adequate vertical compliance increases the susceptibility of the pickup to spurious effects, including some varieties of intermodulation, due to vertical vibration modes in the mechanical system.

Measuring the characteristics of stereo pickups involves measurement of dynamic mass (inertia) as well as the compliance in both directions. It also involves measuring the frequency response and sensitivity of the pickup to motion in both directions.

For single-channel pickups a variety of combinations of vertical and lateral characteristics can be used and the choice varies considerably. Some have almost zero vertical compliance while some have a compliance almost equal to the lateral. The mass required in both directions varies with different hypotheses too.

A relatively high dynamic arm mass laterally is usually employed to minimize vibration transfer from the stylus due to the stylus compliance. Vertically, however, the pickup has to track the warpage on a bent record without any tendency to leave the groove when it gets to the top of its excursion. This is usually achieved by minimizing the vertical dynamic mass so the pickup follows the groove down again.

If a larger tracking force is used, equal to the actual mass of the pickup for example, there is no problem. But modern pickups have been working toward smaller tracking forces. For some time it seemed as if 5 or 6 grams was about the minimum. But several pickups now available utilize a tracking force in the region of 1 or 2 grams. This means the dynamic mass in a vertical direction must be correspondingly smaller, otherwise the pickup will be left in the air because of a sudden vertical undulation due to warpage.

Smaller tracking forces which can be measured with some kind

of balance (see Fig. 704) mean that all the corresponding masses can be reduced in the same proportion. This not only reduces record wear but makes it simpler to achieve wide-range frequency response with good precision.

While reduction of vertical tracking force reduces wear on the

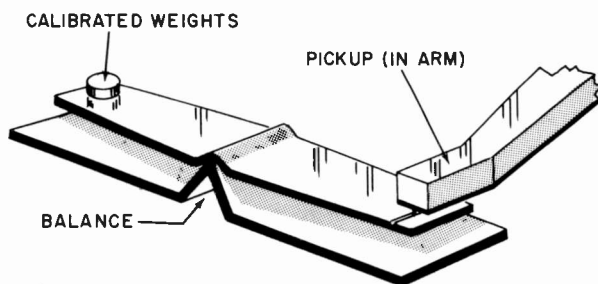

Fig. 704. A simple stylus balance for measuring stylus force.

bottom of the record groove, making it too light will cause the stylus to ride up the groove wall, producing distortion and also damaging the wall. This wall-riding tendency would be stimulated by lateral velocity at frequencies where lateral stylus motion is compliance-controlled. These are usually the low frequencies, where velocity is low; but where the stylus motion is mass-controlled the riding tendency is acceleration stimulated.

This means the safe-handling signal magnitude, set by the stylus tracking force, is inversely proportional to frequency at the high end, on a velocity basis, or to the square of frequency on an amplitude basis. An alternative thing that happens at these high frequencies is that the record compliance absorbs the "motion," losing these frequencies from the reproduction. This action may also "clean off" these frequencies from the disc, especially by repeated playing.

### **Distortion**

As well as the effect on frequency response of the pickup acting as a transducer, we need to consider possible forms of distortion that a pickup can produce. If a harmonic method of measurement is used, the term of distortion involved is relatively less important than if an IM method is employed.

To measure the distortion of a pickup it is necessary to drive the stylus mechanically, usually by very carefully prepared records, and then measure the distortion present in its output. The fact

that the input to a pickup is a mechanical one precludes the input/output comparator method that has been suggested for amplifiers and preamplifiers. We have to be content with making the mechanical input as pure as possible and then measuring the distortion components in the output.

The same variety of IM distortion signals can be used for testing pickups as for other items of equipment, either the low- and high-frequency or the beat-tone combination. With any measurement in which the input signals are removed from the output and the residue measured as a distortion component, some precaution, such as checking on an unmodulated groove, is necessary to insure the quantity measured is not due to rumble or hum.

The beat-tone combination in a form of disc that gives an A-N indication that can be heard has been very popular, largely because

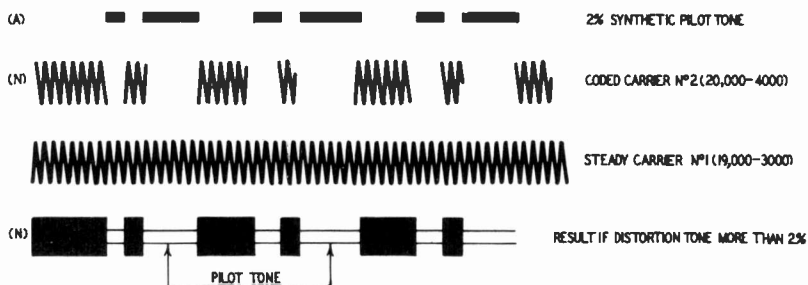

Fig. 705. Operation of the A-N IM test for a pickup-playback system.

no additional test equipment is necessary. The disc can be put on a turntable and the pickup played on it. Careful listening to the beat tone to determine whether the Morse code A or N is heard establishes whether the distortion is above or below limits (Fig. 705).

The disadvantage of this method is that the only distortion it indicates is that due to asymmetrical nonlinearity in the mechanical-to-electrical transfer characteristic of the pickup. If the pickup is out of alignment (in the case of a magnetic type nearer to one pole piece than the other, for example), then there will be a very definite asymmetrical nonlinearity. Sometimes nonlinearity is due to the side force produced by the drag component of friction relative to the disc. It is true a variety of possible asymmetrical nonlinearities is inherent in pickups as distinct from other audio devices. But this does not alter the fact that damping material and other components of the pickup may well cause symmetrical nonlinearity, which this particular type of distortion measurement does not detect.



For this reason either the harmonic method of measurement or an IM method employing the low- and high-frequency tones is preferable as it detects both forms of nonlinearity.

One cause of asymmetrical nonlinearity is that contributed by arm tracking. At certain points the stylus movement is not perpendicular to the direction of groove travel. By using correct offset angles and operating the arm within the range for which the offset is designed, this kind of distortion can be kept within known minimum values.

Most presentations on the subject assume that this kind of distortion is the principal one and analyze it as a separate entity. If, however, this asymmetrical nonlinear distortion should combine

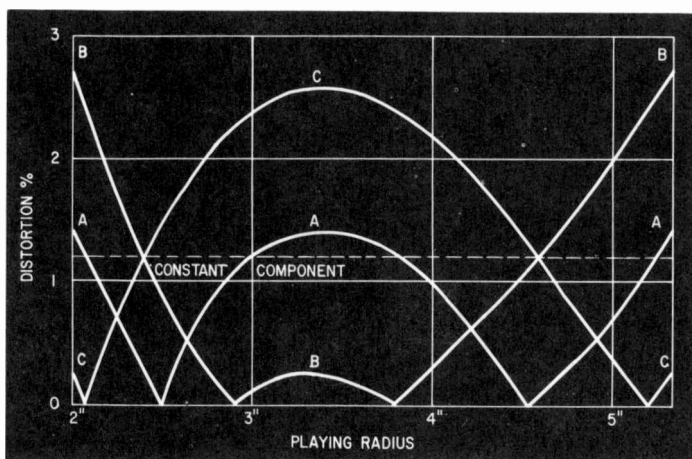

Fig. 706. How so-called tracking distortion due to arm mounting (offset angle and overhang) can be invalidated by other distortions. Here the dashed line represents a constant distortion due to other factors. Curve A is the ideal curve for tracking distortion. A combination of the two produces curve B or C, according to the phase relationship. By altering the arm mount so tracking distortion would theoretically come out to curve B or C, the result can be modified to curve A.

with another residual asymmetrical nonlinear distortion inherent in the pickup itself or due to record drag, then some degree of cancellation may occur with one phasing of the tracking distortion, while addition will occur at points on the disc where the phasing of tracking distortion is reversed (Fig. 706). This may well mean that the ideal offset angle and degree of overhang for one pickup may differ from that for another because of the tendency of the tracking distortion to interact with other forms of distortion which are also asymmetrical in nature.

This is a region where an A-N test (which detects asymmetrical forms of distortion specifically with the test signal inscribed over the entire range of radii to be used) can be helpful in determining the best tracking condition for this particular compromise.

### **Utilization features**

Finally, in testing pickups and arms we come to some factors that do not lend themselves to specific measurements, but which require assessment as to their practical performance value. One of these is the possible danger to records from wear or accidental damage.

One would presume wear to be proportional according to some relationship to the stylus tracking force used. A 6-gram pickup will produce six times more wear than a 1-gram pickup, or it may follow some other relationship. But this is not the only factor that controls the degree of wear. Increased vertical force on the stylus, if it causes the stylus contour only to rest more firmly on the bottom of the groove, will necessarily increase wear on the groove bottom. But, if insufficient stylus force is used and the diamond does not rest at the bottom of the groove at all times but rides up a little and bounces around, this can result in increased wear for *reduced* tracking force. This can usually be indicated at the same time by distortion measurements because, when the stylus rides up the groove, considerable distortion will be present. But there are other factors that contribute to the wear imposed on the disc.

Among these is the compliance of the stylus, which is a measure of how readily it follows the undulations recorded in the disc. A stiffer pickup will naturally tend to wear the walls of the disc more than one that is more compliant. Further than this, possible frequency-discriminative reactions to stylus movement, due to resonances and other features of the stylus arm assembly, may also contribute to frequency-discriminative wear that may tend to score out particularly high frequencies, for example.

Reactions of this nature will usually be accompanied by two other effects. If considerable force is transmitted back to the stylus point due to a resonant effect, it will also produce a strong force at the other end of the stylus movement, causing considerable force to be applied to the cartridge body. This in turn means, when the electrical reproduction is turned off, that increased needle talk will be noticeable due to radiation of this particular sound component from the vibrating cartridge body. Then, whether or not the cartridge body vibrates, increased force on the

disc surface may also increase effective needle talk due to the actual vibration induced in the groove walls.

So it is a fairly safe generalization to say that the relative wear

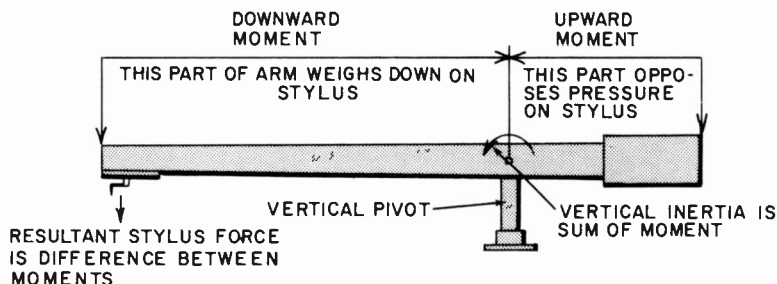

Fig. 707. Mechanics of a mass- (or weight-) counterbalanced arm.

prospect of a pickup can be approximately estimated by listening to the relative needle talk with the amplification turned off. This

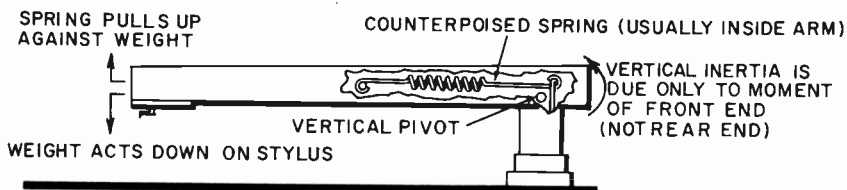

Fig. 708. Mechanics of a spring-counterbalanced arm.

is something that cannot be given a figure, but can readily be listened to, comparing one pickup with another.

Another thing that can happen with a phono assembly is due to vibration picked up from other sources. This may cause the pickup arm mounting board to transmit vibration, vertically or in other directions, that ultimately reaches the stylus point. Such vibration can be transcribed in this way as a spurious pickup effect, making the whole assembly sensitive to floor vibrations and producing a form of microphony. This can be prevented to some extent by absorbent mounting and mechanical filtering.

But vertical components of this kind of force may produce a resonant effect causing the stylus to jump out of the groove or to be uncertainly pressured into the groove, resulting in distortion and additional wear. With the modern extremely low tracking forces, it would seem to be ideal to have a pickup and arm assembly which is dynamically balanced so that external vibrational forces produce no resultant output of this kind.

Some arms use gravity to provide the necessary tracking force, using a mass differential fore and aft of the vertical pivot, so the stylus force is precisely the required value (Fig. 707). Others use a spring counterbalance for the gravity vertical component, thus avoiding the necessity for a large counterpoise weight, which does have the effect of increasing the vertical component of dynamic mass (Fig. 708).

Whichever method is employed, a feature that can be of importance in possible accidental damage due to careless lowering of the stylus onto the disc is the way in which the stylus force

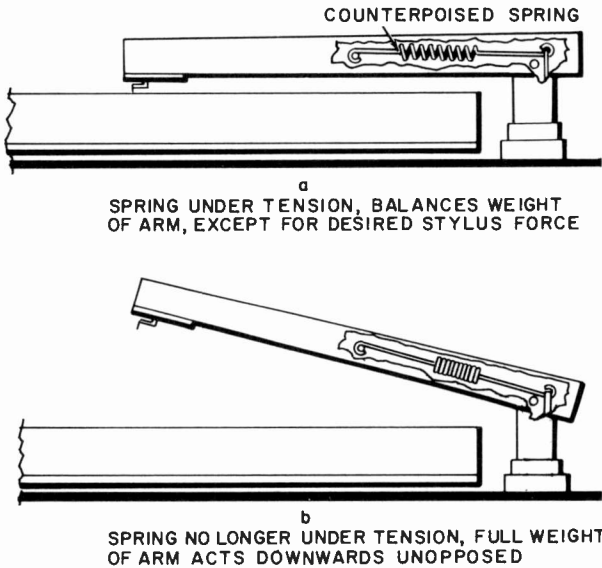

Fig. 709. A disadvantage of some spring-counterbalanced arms is the greater downward acceleration from a small distance above the disc. This disadvantage can also appear in certain designs of mass counterbalancing.

changes with height of the stylus above the record. With a carefully counterbalanced gravity scheme, using fairly long arms, the stylus force does not vary appreciably over a height even of several inches.

But, with the spring counterbalance method and some forms of gravity methods, there can be a more rapid change. A force of 1 gram *at the surface of the disc* may be increased to 10 grams from  $\frac{1}{2}$  to 1 inch above the disc (Fig. 709). This is dangerous because it means that the dynamic mass is accelerated toward the disc with a force of the order of 10 grams, although the acceleration

force when it reaches the disc is only 1 gram. The cumulative effect on the dynamic mass can produce destructive impact of the diamond into the groove.

One does not normally lower a stylus this carelessly, but the fact that such a design makes it subject to accident in this way is a detrimental performance factor, especially if the instrument is to be used by nonprofessional people unskilled in the application of stylus to record. Alternatively, too great a vertical dynamic mass can produce similar results, as well as being detrimental to operation on warped records.

We cannot close this chapter without reference to viscous damping in arms. As with other features, it must be related to pickup performance, particularly the stylus compliance. While one can generalize, the only real answer to the problem is in overall performance tests, as outlined in this chapter, for the individual arm-pickup combination.

#### Recommended Reading

1. Norman Pickering, "Effect of Load Impedance on Magnetic Pickup Response," *Audio Engineering*, March, 1953.
2. J. G. Woodward and J. B. Halter, "The Lateral Mechanical Impedance of Phonograph Pickups," *Audio Engineering*, June and July, 1953.
3. W. A. Fitzmaurice and W. Joseph, "Pickup Loading and Its Effect on Frequency Response," *Audio*, July, 1954.
4. John M. Salani, "Evaluation of High-Fidelity Pickups," *Audio*, March, 1955.
5. F. V. Hunt and D. A. Barlow, "On Stylus Wear and Surface Noise in Phonograph Playback Systems," *Journal of the Audio Engineering Society*, January, 1955; July, 1956.
6. John D. Seagrave, "Minimizing Pickup Tracking Error," *Audio-craft*, December, 1956; January and August, 1957.
7. Joseph Marshall, "Loading Phono Pickups," *RADIO-ELECTRONICS Magazine*, October, 1956.
8. Norman H. Crowhurst, "Buying a Tone Arm," *Radio & Television News*, January, 1957.
9. Bent Gehlshøj, "Electromechanical and Electroacoustical Analogies," *Akademiet for de Tekniske Videnskaber*, Copenhagen, 1947.
10. Harry F. Olson, *Acoustical Engineering*, D. Van Nostrand Co., New York, 1957.

# turntables and changers

**T**HE most important function of a turntable or record changer is to turn the record at constant speed so the program material inscribed on the disc is accurately transcribed by the pickup traversing the groove. Besides inconsistency of speed, a turntable or record changer can introduce other possible forms of interference, such as rumble, which induces an output from the pickup just the same as modulation in the groove; hum radiation, due to the magnetic field of the motor which may induce hum into the pickup circuit magnetically, and various other forms of vibration which can cause serious effects. In record changers, the mechanism can complicate the operation of the system, making constancy of speed more difficult to achieve and affecting the performance of the arm.

## **Speed constancy**

Speed can deviate in two ways from the standard intended. One is a cyclic change due to friction, or nonuniformity in the mechanical sense, that produces flutter or wow. Flutter is the name given to fairly rapid changes in speed which produce a fairly fast frequency modulation of the program recorded in the groove, like a venetian blind fluttering in the breeze.

Wow is a slower fluctuation in speed that causes the pitch to move up and down at an audible rate. This may be due to a stiffness at one point in the turntable rotation, or possibly to a stiffness that occurs three or four times per revolution of the turntable. It results in an up-and-down variation in pitch that occurs from one to five or six times per second.

The other kind of inconsistency in speed occurs with changes in the supply voltage. If it drops, the speed falls a little; if it rises, the speed increases. This produces a nonrecurrent change in the speed. Suppose someone switches on an extra group of lights in the same building. This may cause the voltage to drop from 115 to 110, and possibly the speed will drop from  $33\frac{1}{3}$  to 33.

These two kinds of speed variations require separate investigation from a measurement point of view. Speed variation with

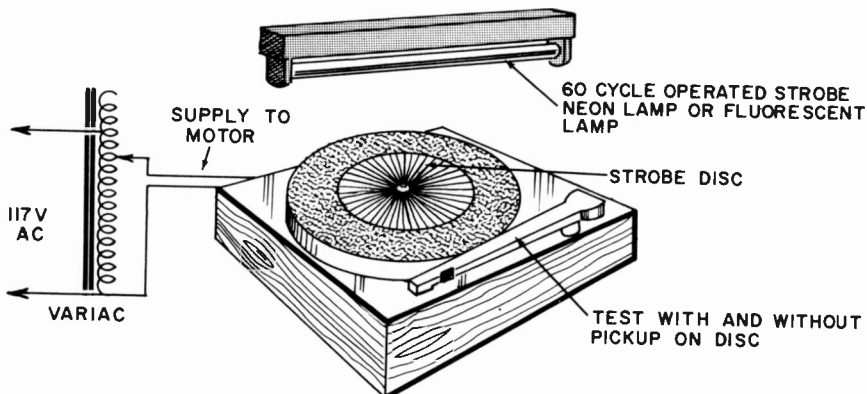

Fig. 801. Test with stroboscope for speed fluctuation with change in supply voltage.

change of supply voltage can readily be checked with a stroboscope and a Variac (see Fig. 801). The voltage supplied to the turntable is varied over a legitimate range, for example from 105 to 125, and the variation in speed noted on the stroboscope.

While a stroboscope can be used to compute the magnitude of speed error, a simpler method (if speed error is required as a numerical value) is to use a disc with a fixed frequency recorded on it, possibly 1,000 cycles. Then the output from the pickup is compared against an oscillator of fixed frequency. This can be done quite conveniently with the Lissajous pattern producing a 1-to-1 loop. Reading off the scale of the oscillator will then tell the percentage of deviation in speed with respect to a change in voltage (Fig. 802).

With synchronous motors, changes in supply voltage does not produce speed variations. However, changes in frequency will affect speed. With induction motors, however, changes in frequency or voltage are liable to produce changes in speed.

For precision control, the only satisfactory way seems to be to

use an electronic frequency source that is independent of supply variations. For practical purposes, a synchronous drive from a line source of 60 cycles provides a satisfactory speed control on the long-term variation. The frequency of the line supply cannot change very abruptly, because one virtually has to vary the inertia of the generators at the power house to produce a change in speed.

But this only refers to the long-term fluctuation. It is possible for a turntable to fluctuate back and forth by considerable phase angle from actual synchronism with the alternator rotor. Also, if a rubber idler wheel or a belt is used to transfer the drive from the motor to the turntable, there is a possibility of some slippage

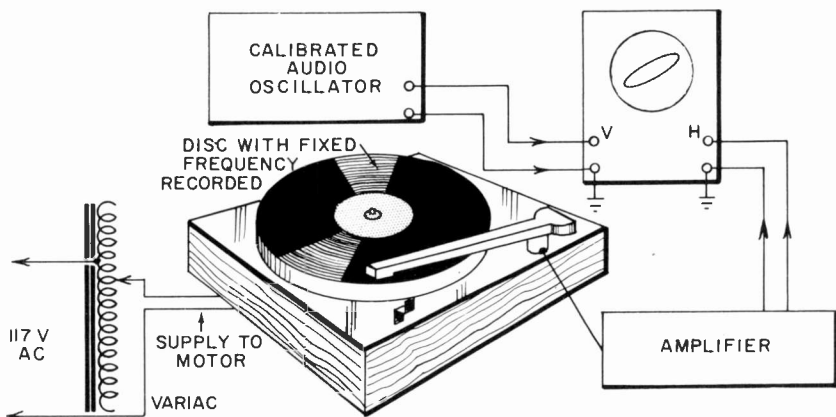

Fig. 802. The scope can be used to make a more precise determination of speed.

between the two. These variations are not likely to occur with changes in supply voltage or frequency. They come under the category of flutter and wow.

### Flutter and wow

Most flutter and wow meters employ a frequency-modulation principle to detect variation in speed. Usually a 3,000-cycle note recorded on a disc is played back by a pickup on the turntable and fed to the flutter and wow meter. This feeds the 3,000-cycle tone to an FM detector tuned to 3,000 cycles, with a very critical ratio-detector or discriminator designed to indicate fluctuations of the order of 1 cycle. The output from this detector is then amplified as an audio frequency and indicated in magnitude as percent deviation of flutter or wow. This arrangement is illustrated in Fig 803.



The effect of flutter or wow on reproduced music depends to some extent upon the frequency at which the speed deviates and

DISC RECORDED WITH CONSTANT 3000 CYCLE TONE

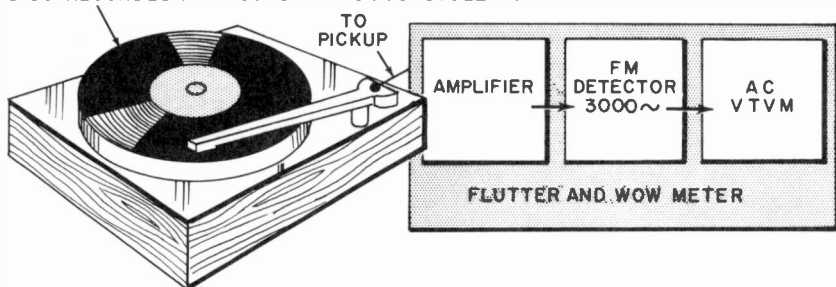

Fig. 803. Basic arrangement of flutter and wow meter.

the kind of program its deviation modulates. Instruments with constant, *almost* perfect, intonation, such as the piano, make this

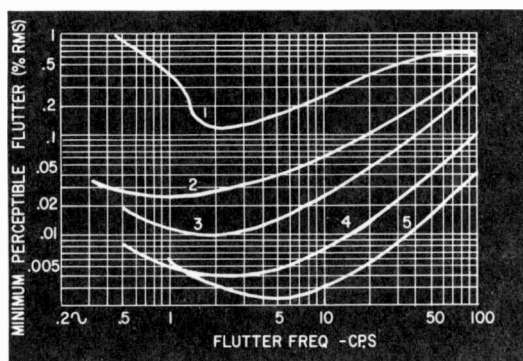

Fig. 804. Different curves for the relative sensitivity of the human hearing faculty to flutter speed deviation: Curve 1: According to Schecter, single tone of 1000 cps. Curve 2: According to Albersheim & MacKenzie, 500 cps. Curve 3: According to Albersheim & MacKenzie, 1000 cps. Curve 4: According to Albersheim & MacKenzie, 3000 cps. Curve 5: According to Albersheim & MacKenzie, 7000 cps. The difference in level could also be due to the use of a different loudness level in the test.

kind of deviation much more noticeable than instruments that normally have some tremolo or vibrato effect.

The most noticeable frequency is in the region of 2 to 3 cycles. A cyclic change in speed at a slower or faster rate than this tends

to be less noticeable (Fig. 804). Making the measurement with a weighting network that causes the indication to be modified according to the annoyance value of the frequency at which it occurs seems a good idea (Fig. 805). The problem is in finding an agreed weighting characteristic that will be accepted as a stand-

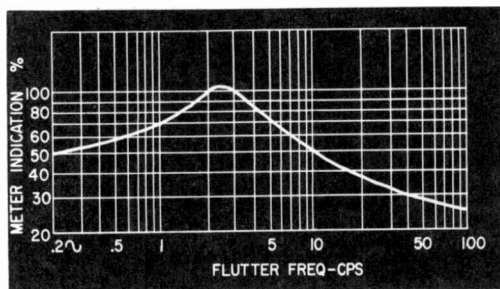

Fig. 805. Frequency response of weighting network used in a meter developed by the Material Laboratory, New York Naval Shipyard.

ard, and the avoiding of possible ambiguity until the new standard is fully accepted in place of the straight measurement.

This problem, both in relation to measuring flutter and wow and in noise measurement (particularly hum), has, to date, prevented an effective transfer to a subjective type of standard. Most measurements are given in straight percentage or db, without frequency discrimination.

When measuring speed constancy, flutter and wow, turntable loading must be considered. With most modern pickups having a stylus force of not more than 5 or 6 grams (in many instances as low as 1 or 2 grams), the loading due to the pickup is extremely low and unlikely to affect speed. With earlier pickups, placing the stylus in the groove of the record would slow the turntable by a visible amount. However, when measuring the characteristics of a turntable, just how much loading the turntable will stand before it begins to show signs of serious speed deviation or flutter and wow must be determined.

Some prefer to specify the pullout torque—the point at which the loading causes the turntable to come to a standstill—either by stopping the motor or causing the drive to slip. But for practical purposes the pullout torque is far less important than the effect of lesser degrees of loading on the speed constancy.

Considerable force may have to be used to stall a motor and

yet it can develop quite an appreciable amount of flutter and wow with relatively low values of loading. On the other hand, another motor may require considerably less force to stop it altogether and yet give quite satisfactory performance with the same

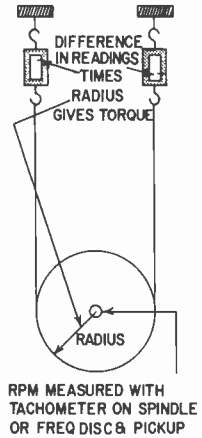
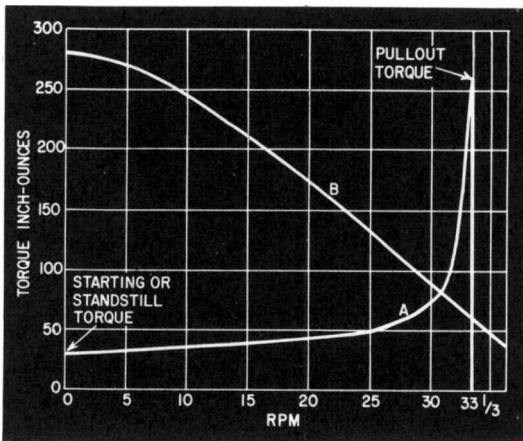

Fig. 806. Speed/torque measurements show the difference in motor performance. Curve A, a hysteresis synchronous motor with very constant speed. Curve B, an induction motor with high stalling torque, but poor practical performance.

amount of loading likely to be achieved by the stylus of a pickup (Fig. 806).

An example of this difference was encountered in some checks using a turntable to drive a simple tape recording device designed to fit over the turntable. When this was tested in conjunction with a turntable that gave practically the lowest value of flutter or wow in the industry, a very large amount of flutter and wow was noticed on the tape. It was due to the tape drive mechanism imposing considerably larger loading on the turntable than it was designed for.

## Rumble

Rumble is a form of spurious vibration generated by the motor and transmitted to the turntable. It can produce an output in the pickup. It can be measured by using a disc with an unmodulated groove so that any vibration transferred through the turntable and the disc to the stylus will produce an output which can be analyzed (Fig. 807).

While one of the troublesome rumble frequencies is in the region of 30 cycles—and this can cause considerable trouble if

there is an arm resonance in this region—bad cases of rumble can also occur at higher frequencies, such as 120 or even 180 cycles. These then give an impression very similar to electrical hum. The difference is that the hum appears only as the stylus touches the unmodulated groove of the record.

Vertical, as well as lateral, vibration must be checked. This

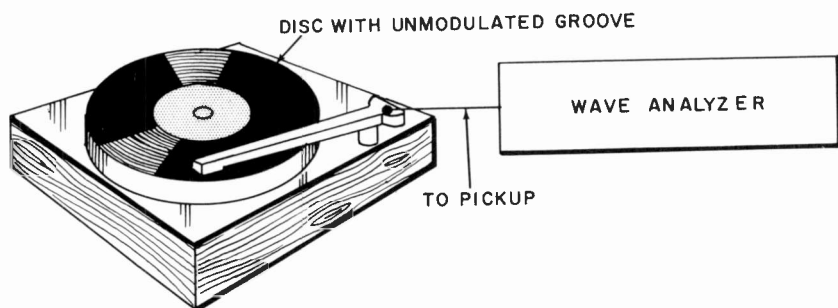

Fig. 807. Setup for testing for rumble.

requires a vertical type pickup, one designed for playing vertical or hill-and-dale recordings. With the advent of the stereo disc, it is even more important to check that turntable drives are as free of rumble vertically as laterally.

There are two possible approaches to minimizing flutter, wow and rumble from turntable drives. Measurement techniques may need to be applied to the determination of effectiveness of work in this area and to investigation of possible design approaches.

The approach in the great majority of designs to date uses what is virtually a mechanical filter to reduce fluctuations and vibration produced by the motor to an absolute minimum in transferring the motion to the turntable. The motor itself must have a minimum of these undesirable qualities to start with. But it has been generally conceded that it is impossible to get a motor good enough without further filtering in the drive.

Careful attention to dynamic balance in the motor and to absolute freedom of friction, eccentricity or lateral "slop" is essential as a starting point to a good design. Some axial motion in the motor shaft is sometimes advantageous in achieving freedom from the development of uneven friction as the components wear.

Having selected the best possible motor, the next step is to use a mechanical filter, of which the most popular are the belt and the idler wheel. The resilience of this intermediate link, in conjunction with the mass or inertia of the turntable, serves as a mechan-

ical filter to attenuate residual speed fluctuations in the form of flutter and vibration that would cause rumble.

The use of vibration pickups with a frequency analyzer can prove useful here in measuring the vibration at each point in the system, so the effectiveness of the mechanical filter can be checked.

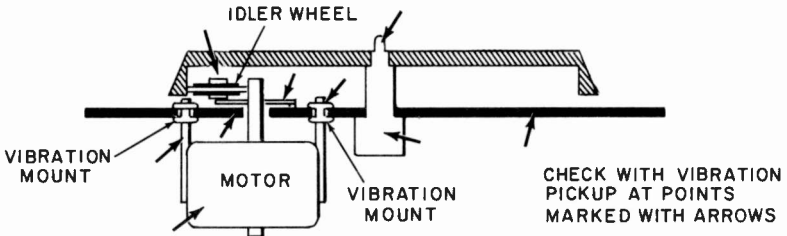

Fig. 808. Points to check with vibration pickup are indicated by arrows.

It may also serve to locate sources of stray coupling that may "bypass" the filter action (Fig. 808). Mechanical filtering action is required, not only for the drive, but for the motor mounting,

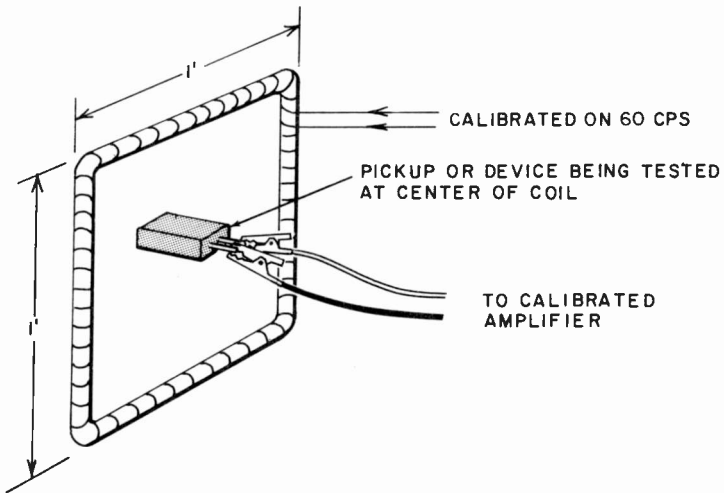

Fig. 809. The standard setup for measuring sensitivity to a hum field.

so the vibration will not travel through the motorboard instead of the drive.

## Hum

Hum radiation is rather difficult to tie down in terms of measurement. It is not picked up mechanically but electrically or magnetically, due to the stray field from the turntable motor. It de-

depends on the position in which the pickup is mounted and also on the susceptibility of the pickup to electrical or magnetic pickup.

In general, crystal or ceramic pickups are insensitive to any form of magnetic hum, while magnetic and moving-coil types are insensitive to electrical hum. Many pickups are deliberately designed to avoid hum pickup, but often this works only provided the magnetic field is of sufficiently low order. If the pickup is placed close to a fairly intense magnetic field, the hum-balancing device can be saturated and still produce an induced hum.

The only standardized form of hum field is not really representative of the effects produced in practice. The standard method of measuring sensitivity to hum pickup is by placing the pickup (or other device) at the center of a coil 1 foot square of a known number of turns and passing a known alternating current through the coil (Fig. 809). This produces a calibrated magnitude of magnetic field at the center of the coil.

Such a test fixture produces a conveniently symmetrical and linear form of field. The output from a device placed in this

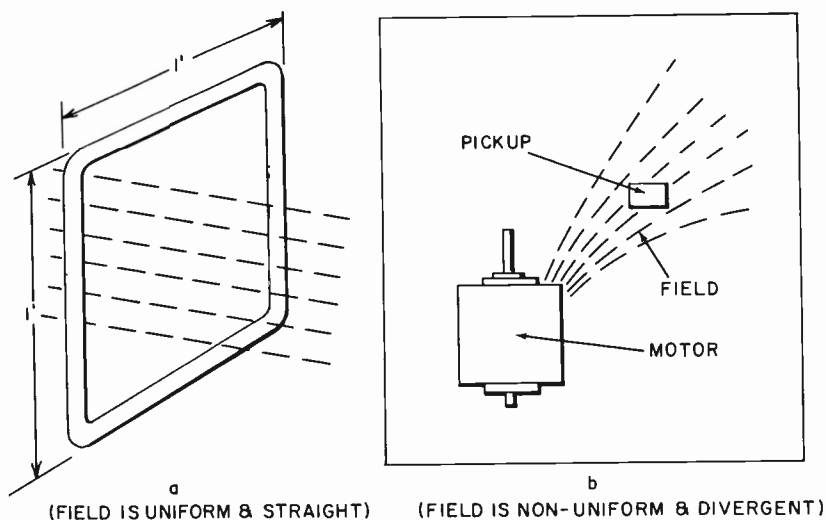

Fig. 810. This illustration indicates why a measurement with the setup of Fig. 809 may not be valid for practical application.

position may well be perfectly balanced due to an astatic or hum-balancing construction. But the same device is not equally efficient in rejecting nonlinear asymmetrical hum.

About the only place where such an academically balanced and

symmetrical field would be encountered in an electric motor is right inside the motor. Outside, the field is always divergent, spreading out away from the motor. Consequently, measurements taken with a calibrated coil of this type are not always indicative of the effect of a practical hum field (Fig. 810).

This means that it is impossible to give absolute figures for the sensitivity of any particular type of pickup to hum field. Similarly, since the pickup cannot be given a calibrated sensitivity value, it is not plausible to give a radiation value to the motor. True, the magnitude of hum field can be measured by a suitable search coil of known dimensions placed crosswise on the

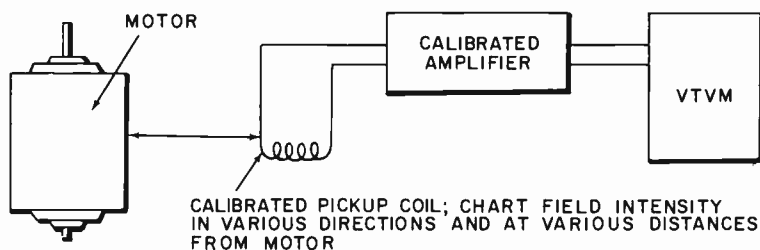

Fig. 811. A direct method of measuring field radiation from a motor.

field by rotating it to find a maximum, and then measuring the output from the coil through an amplifier.

Using this method (Fig. 811), figures can be given to the hum field radiated from the motor in different directions. Thus comparisons can be made between one turntable and another.

Most measurements and tests performed on record changers do not strictly come within the purview of audio—or even electrical—measurements. They come more under the heading of reliability and endurance testing—finding out how consistently the arm “finds” the start groove of records of different sizes and how well the operation maintains different aspects of its mechanical performance. These are quite complicated and sometimes difficult things to evaluate.

From the audio point of view there are effects that a record changer produces which require measuring or evaluating. For example, immediately after the changer mechanism has operated and the stylus first descends into the groove of a new disc, there may be speed fluctuations that do not occur normally during the steady running of the turntable. The normal type of flutter and wow meter is used to check this. Another possibility which is not strictly dependent upon the mechanism itself is slippage between

discs. This depends largely on the stylus force and how much drag it produces on the top disc.

Another important thing in record-changer performance is whether the mechanism interferes in any way with the normal freedom of arm movement. This must be checked to see that there is no drag that may produce a side stress on the pickup. It is particularly important for changers that are intended to be used with modern high-compliance pickups.

The *effect* of drag is tested with any pickup, using an A-N test record to see how side stress increases the IM compared to

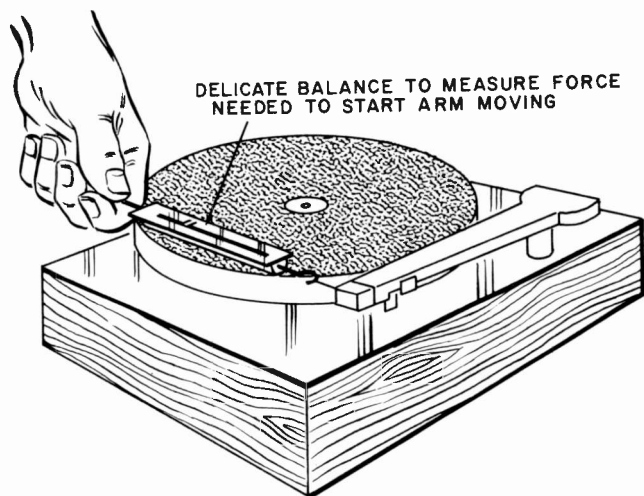

Fig. 812. *Measuring the drag produced by a tone arm.*

playing the same pickup in a simple arm on a turntable. But the effect varies with drag and pickup types.

To measure drag only requires the use of quite delicate force-measuring equipment (Fig. 812) to measure static friction which resists the commencement of movement or dynamic friction that occurs while the arm is moving. The latter requires more elaborate equipment and fortunately the former measurement gives the information most important to arm operation—unless viscous damping is used.

Associated with this “handling” aspect is the possible damage to the beginning of the record due to a too sudden lowering of the stylus into the groove. Again this feature is not something one can give figures to. There is no definite figure of safe rate at



move at constant speed, but also the points where the tape passes the record and playback heads (Fig. 901). These, after all, are the important points where the tape has to perform correctly.

Because all magnetic recording tape is an elastic material, its motion must be completely smooth. If any of the guide posts used to direct it around its transport parts cause the tape to shudder, even though the tape drive at the capstan is perfectly constant in its speed, this varying tension will be reflected at the point where the tape passes the playback and record heads.

### Flutter and wow

Measurement of speed constancy is relatively simple, following the same method employed for turntables and record changers.

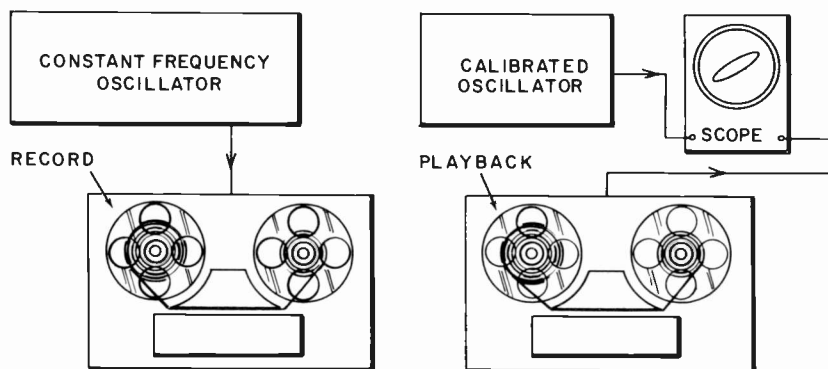

Fig. 902. A method of checking for overall relative speed constancy as well as flutter and wow.

A flutter and wow meter is used to determine all kinds of speed fluctuation. First, the constant frequency has to be applied to the tape and then it has to be played back and measured (Fig. 902). To achieve perfect constancy of the played-back tone, complete freedom from flutter or wow in both the recording and playback process is necessary.

The degree of flutter and wow induced by the transport of the tape may differ on record or playback either because the tape heads occupy a different position along with tape motion, or the mechanisms are slightly different (applying different pressure or tension in some way). In most instances the degree of flutter or wow produced both in recording and playback will be of the same order. Consequently, an advantage in measuring flutter and wow on a tape recorder by using a constant-frequency oscillator to record and then playing the same tapes back is that it doubles the sensitivity of the measuring apparatus.

There is the possibility that flutter and wow components are out of phase, so the resultant output becomes almost constant. Usually there is some deviation so that, at other points along the tape, the two components of flutter and wow get into the opposite phase relationship and so there is twice as much frequency deviation due to flutter and wow results (Fig. 903).

Constancy of speed needs checking throughout the entire length of the spool of tape that the machine handles. The tension applied by the takeup motor varies from the beginning to the end of the tape. At the beginning a given torque produces more tension on

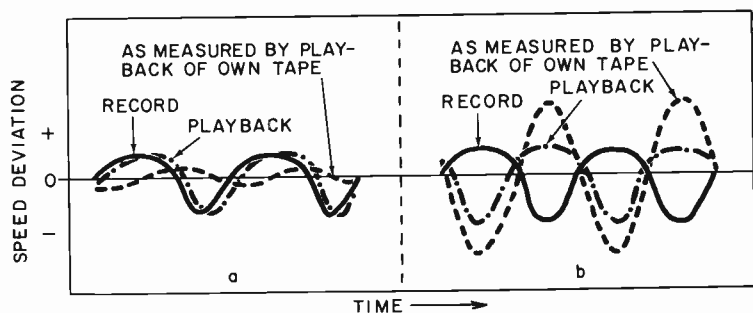

Fig. 903. How an overall relative flutter or wow test (Fig. 902) can vary according to a time relationship, although the actual deviation on both record and playback may be the same.

the tape than at the end because the spool is operating at a much larger radius. Consequently, the takeup tension can alter the speed throughout the run of the tape.

This really calls for a calibrated tape since in using a constant frequency to record and play back with the same recorder, any error in speed is likely to repeat in playback. For example, if the nominal speed is  $7\frac{1}{2}$  inches per second, the spool may start operating at  $7\frac{3}{4}$  inches per second and finish in the region of  $7\frac{1}{4}$ . If this operation occurs or repeats identically on record and playback, the constant frequency used to record from beginning to end will be reproduced precisely on playback.

If there is a slight difference between record and playback speeds (for example, the beginning playback speed may drop from  $7\frac{3}{4}$  to  $7\frac{5}{8}$  ips while the end will drop from  $7\frac{1}{4}$  to  $7\frac{1}{8}$ ), this results in an approximately uniform drop in frequency on playback and no indication is given that the speed *varies* throughout the duration of the tape. It just seems as though the playback is slower than the record.

For this reason we need a calibrated tape with the frequency

recorded on it at a calibrated speed. This can be achieved by using a tachometer (see Fig. 904)—a precision instrument that indicates exactly the speed at which the tape passes. By using a tape recorder that provides for speed adjustment a specified frequency can be recorded on the tape for use in testing the speed constancy of tape recorders.

Performance on record can be deduced, either by comparison

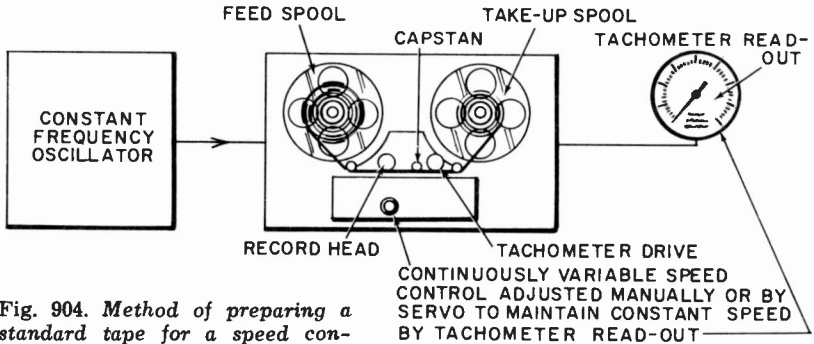

Fig. 904. Method of preparing a standard tape for a speed constancy test.

of self-recorded tape with precalibrated, or by analyzing the recording made on the tape with the machine under test (Fig. 905).

### Tape handling

A mechanical utility feature of a tape recorder is the speed at which it can start and stop the tape, both from normal playing

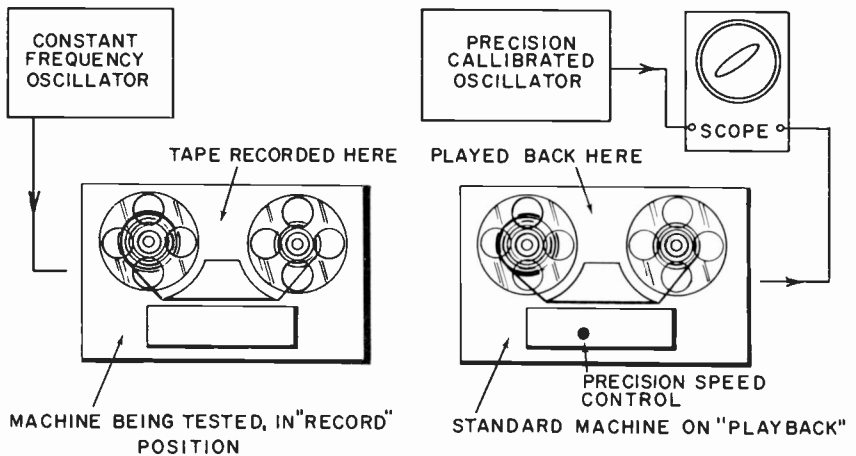

Fig. 905. Method of testing the record speed constancy of a machine (left) against a precision standard (right).

speed and also from the fast forward and rewind speeds. Tape, unfortunately, is not as convenient to handle in this respect as disc, where all that is needed to pick off a particular piece of program is to lower the stylus to the desired groove. In tape, finding

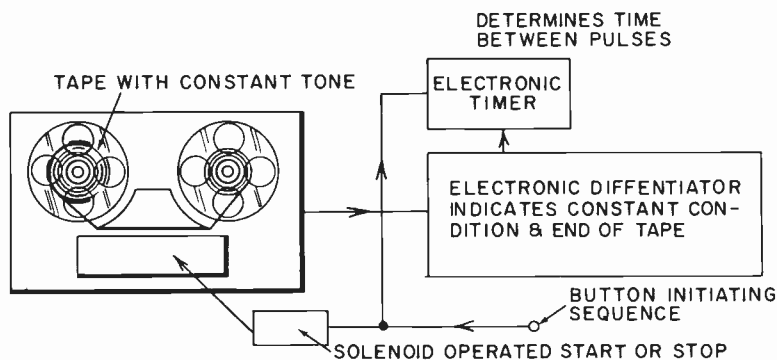

Fig. 906. Setup for measuring start and stop times electronically.

a desired position in a 1,200-foot (or more) length of tape requires fast forward or rewind until the desired position is located. This requires good acceleration on the motors that provide the fast forward and rewind action and also careful but rapid braking to stop the tape very quickly without breaking it. This information is usually given as the time taken to start or stop from each

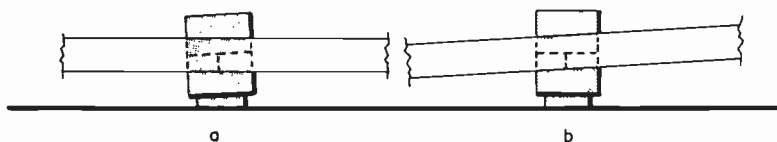

Fig. 907. Incorrect alignment can be due to error in the head mounting (a), or in the tape transport past the head (b).

running speed, which can readily be measured with a stopwatch and calibrated tape (Fig. 906).

The tape transport mechanism is also responsible for that very important aspect in tape recorder performance, maintaining correct tape alignment. The normal alignment of a tape uses a magnetic gap which runs transversely across the tape to produce a longitudinal magnetization. The angle of the gap should be at precisely  $90^\circ$  to the direction of tape motion.

Maintaining this precise  $90^\circ$  angle is important to the reproduction of the very high frequencies whose wavelength is comparable

with the magnetic length of the playback head. Consequently, precise alignment is necessary to high-quality reproduction. This requires not only insuring that the playback head does not move in any way with the operation of the recorder so as to change this alignment, but also that the transport mechanism guiding the tape past the head does not allow it to change its angle of transit at this position (Fig. 907). This means the tape must cross the guide posts in such a way that it cannot slide to and fro and change the angle of transit past the heads.

The basic method of checking alignment is by precision measurement of the head angle and parallelism of tape transport. This establishes a standard. Then for routine checking, which is used practically all the time, a tape recorded with high frequency—the higher the better—at precision alignment is played on the machine

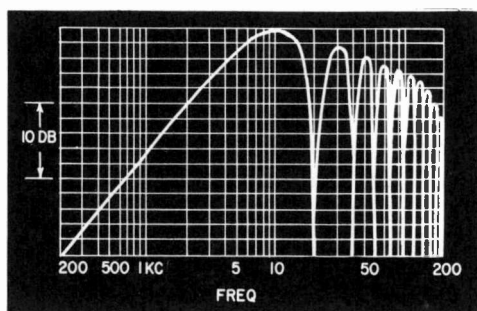

Fig. 908. Response of a very good head, showing successive nulls that indicate the effective gap length.

being tested, and adjustments made to produce maximum high-frequency output. For rough alignment, a frequency as low as 5,000 cycles is sufficient, since the output will be obtained even if the head is several degrees off and it will be possible to see “which way to go” to correct it. For fine alignment, a high frequency is used, which may be 7,500 or 10,000 cycles (or even higher) depending on the tape speed and the head response anticipated.

The important physical properties of heads are in the gap that comes in contact with the tape. A microscope is used for physical examination and appropriate analysis of frequency responses made with the heads.

For a playback head, the gap needs to be very narrow, parallel, straight and at  $90^\circ$  to the tape motion. When a good-quality gap is

so aligned, its magnetic width is measured by the location of nulls which occur at wavelength intervals (Fig. 908). A poor gap will show up by not producing definitive null points in the response.

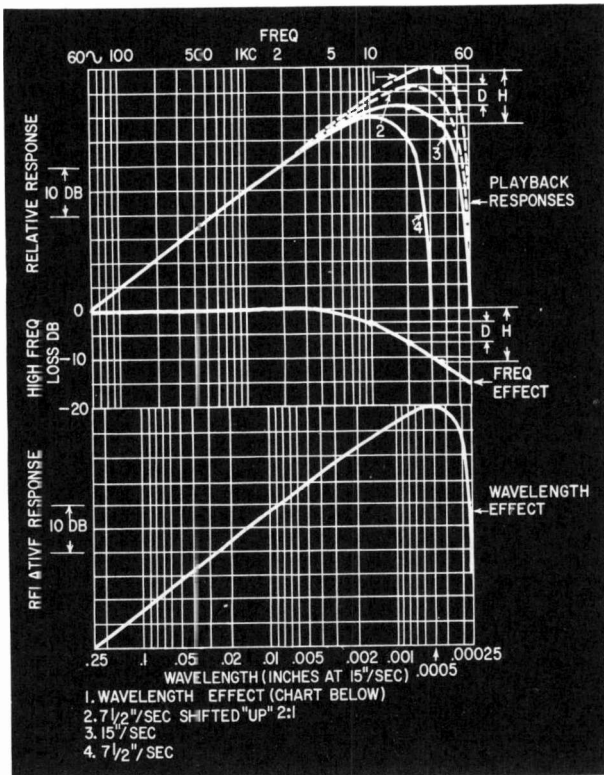

Fig. 909. Playing tapes with different frequencies recorded, at different speeds, can be used to separate frequency and wavelength effects. The dimensioned points 'D' show how the frequency effect is isolated from the two solid curves by construction; dimensions 'H' show how wavelength effect is then found from 15"/sec. curve and frequency effect, replotted below to a wavelength scale (which then becomes applicable to any speed).

Effects due to gap width can be separated from other frequency-discriminative effects by varying the tape speed. While wavelength is dependent on both frequency and tape speed, once a frequency is recorded on tape its wavelength does not change: frequency and speed change together. Thus a combination of different frequencies, recorded with the tape played at different

speeds, shows two kinds of variation, according to whether the effect is due to frequency or to wavelength (Fig. 909).

For a record head, the trailing edge of the gap is most important (Fig. 910). It is not important for the gap to be very narrow, because the bias frequency is cyclically magnetizing the tap at a frequency whose wavelength is a small fraction of the gap length anyway, so that a number of cycles of bias magnetization occur while the tape passes the gap, even when it is as narrow as possible. With a wider gap, a greater number of cycles occur during this transit. What is important is the way the bias magnetization is tapered off and this is determined by the trailing edge of the gap.

### Frequency response

Measuring the overall frequency response, distortion and dynamic range characteristics of the tape recorder is very similar to the corresponding operation on a disc recorder. The big difference

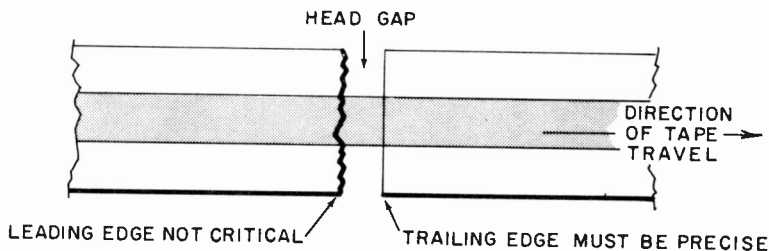

Fig. 910. The trailing edge of a record head gap is the important feature. (In combination record/playback heads, limitations are set by playback requirements.)

is that tape has a precisely restricted dynamic range, limited in one direction by the maximum magnetization the tape can receive without running into distortion and in the other direction by the inherent noise of the system.

Maximum magnetization on the tape is limited by the onset of saturation. At a certain magnetic density the recorded distortion, as measured on playback, makes a rapid increase (Fig. 911). This will occur at approximately the same record *current*, regardless of frequency. (The only thing that invalidates this relationship is the record-head loss, which is quite small over most of the range in a well designed head).

The impedance of a head is basically inductive; a constant current at varying frequency is accompanied by a voltage proportional to frequency. Correspondingly, the output from a playback head is proportional to the *rate of change* of magnetization. If the tape

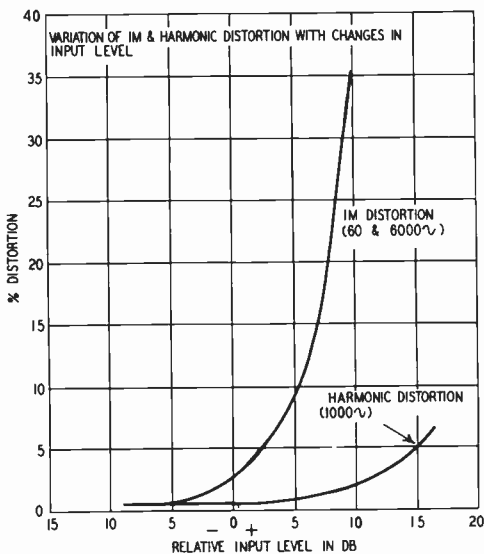

Fig. 911. Distortion characteristic for a typical tape, measured by the two most-used methods.

is magnetized to the same density at all frequencies, the playback head produces an output that rises at 6-db-per-octave with frequency. In practice, the response is modified by various losses to a typical curve shown in Fig. 912.

Thus, assuming the maximum anticipated signal is the same

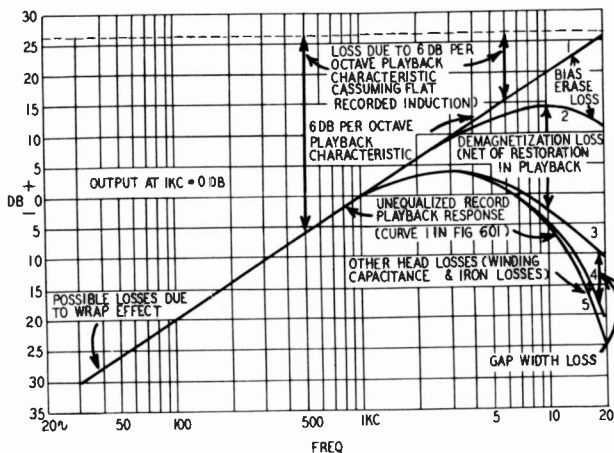

Fig. 912. An analysis of typical playback losses in a tape and playback head at a speed of 7.5"/sec.



electrical voltage at all frequencies, this should be converted to constant current in the record operation and requires a 6-db-per-octave boost on playback.

This means the chosen equalization characteristic must be closely adhered to, and also the record level must be carefully monitored to see that useful "headroom" is not wasted so as to reduce the effective dynamic range of the tape. For this reason, even the cheaper home tape recorders are provided with level indicators, usually in the form of a peak-reading device such as a neon lamp or a "magic-eye" cathode-ray tube which will indicate



Fig. 913. The type of indication given by a "magic-eye" level indicator.

precisely when the maximum permissible level is reached (Fig. 913). Professional machines usually employ the regular VU type meter, which is a mean-reading indicator. While this is not so precise, most people associated with the recording and broadcasting industries have become so used to its characteristics that they un-

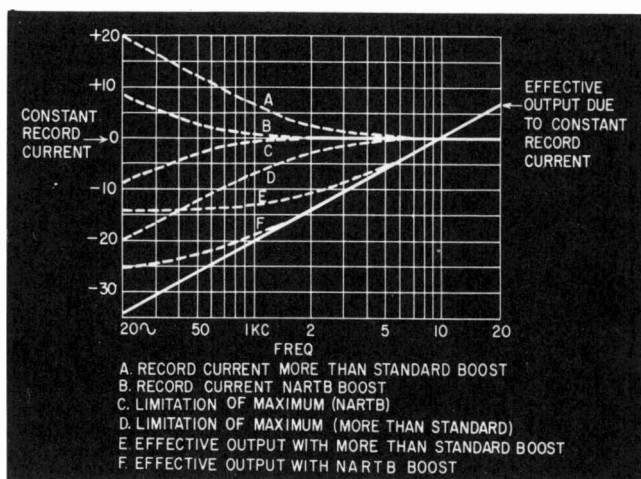

Fig. 914. Deviation from the ideal "constant current record" condition, by using bass boost, results in limitation of maximum density, but allows a larger relative output on playback at low frequency. Two deviations from the ideal are shown, the NARTB standard, and a much-increased boost.

derstand what they are doing with it better than they would with a peak-indicating device.

Consequently, they are able to operate at a reading below the maximum saturation level, according to the program content being recorded. This allows a satisfactory margin. It is a matter of experience and one which a skilled operator can achieve quite successfully. For the unskilled operator, the peak-reading type of indication is much more useful because it indicates to him exactly when a permissible degree of magnetization is reached.

The equalization of tape recording must take into account a velocity compensation very similar to that encountered in disc recording. The important relationships in tape recording are based upon a basic linear relationship between record current and magnetization and, on playback, the relationship is at 6 db per octave due to a velocity effect. The output voltage is proportional to the rate of change of magnetization.

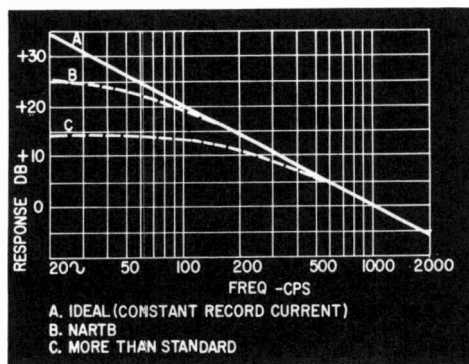

Fig. 915. The deviations of Fig. 914 allow a turnover to be used in the playback equalization.

Consequently, somewhere in the overall equalization characteristic, there has to be introduced a 6-db-per-octave slope virtually from one end of the frequency range to the other. If in *record* a constant-current basis were used for the whole frequency range, this would require 6-db-per-octave boost on *playback* for the whole range, with a consequent very high gain for the lowest frequencies. The alternative is to provide some low-frequency boost on *record*, with a consequent reduction of maximum signal that can be accepted in this range (Fig. 914). This permits a turnover to be used on *playback* (Fig. 915).

On playback a 6-db-per-octave falling characteristic is required

to convert the constant current (which is a constant-magnetization density) into a constant-voltage output. At a certain frequency how-

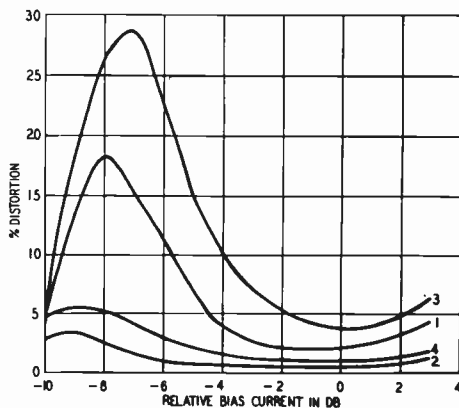

Fig. 916. Variation of IM and harmonic distortion with changes in bias current. Curve 1: IM distortion at a playback level corresponding to +3 on the VU meter. Curve 2: IM distortion at playback level corresponding to 0 on the VU meter. Curve 3: Harmonic distortion at a playback level corresponding to +3 on the VU meter. Curve 4: Harmonic distortion at playback level corresponding to 0 on the VU meter. (Source: Audio, October, 1956.)

ever, usually between 1,000 and 2,000 cycles, there is a turnover point due to the playback characteristics of the head and various other losses. Eventually a null is reached because both edges of the head occupy a similar point of magnetization and there is no magnetic "difference" to play. This is illustrated in Fig. 912. To compensate for this the 6-db-per-octave downward slope is leveled off and a high-frequency boost is inserted to produce the required overall frequency response.

### High-frequency bias

This introduces another important factor in the performance of magnetic tape—the high-frequency bias. It minimizes nonlinear distortion due to the magnetic material on the tape. Lack of high-frequency bias produces excessive distortion. Fig. 916 shows a typical characteristic. Unfortunately, however, excessive high-frequency bias also tends to swamp the high-frequency response. This depends on the tape characteristics, the bias frequency and the record head gap. Fig. 917 shows typical results.

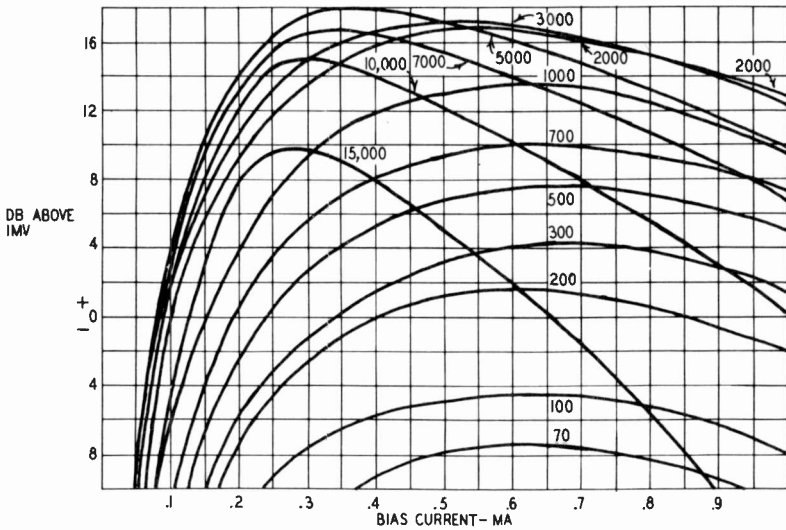

Fig. 917. Variation of output with bias current at various frequencies. Data are for a Brush BK-1090 head, operated at 7.5 ips. (Source: Otto Kornei, "Structure and performance of Magnetic Transducer Heads," Journal of the Audio Engineering Society, July, 1953.)

The record-head gap width is greater than the equivalent wavelength of the high-frequency bias, consequently only a small residual bias appears upon the tape. What the high-frequency

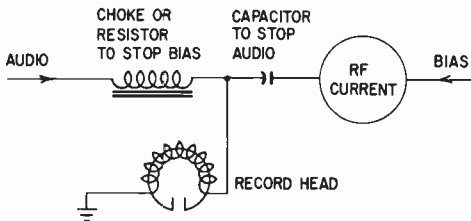

Fig. 918. Method for connecting a bias current meter in series with bias current feed to the record head.

bias does is to virtually "demagnetize" the tape to a "static" value of magnetization corresponding with the instantaneous audio signal. But there still is a residue of high-frequency bias and, if the tape is played back slowly enough, it becomes audible. Loss of the high frequencies by use of excessive bias seems to be associated with some kind of swamping effect that occurs due to the residual recorded bias when too much is used.

Whatever the exact explanation of this deterioration in high-frequency response with excessive bias may be, the result from a practical viewpoint is that high-frequency bias needs to be carefully controlled to achieve minimum distortion with minimum loss of high-frequency response. The effective high-frequency bias is dependent upon the current passed through the record coil. Consequently, where adjustment is made to measure according to a meter, the meter is arranged to measure the high-frequency bias current (Fig. 918).

However, the correct adjustment for one type of tape may be an incorrect adjustment for another. Usually a recorder is adjusted to some nominal value which achieves best average results with the types of tape commonly used. If optimum results are required with all types of tape, some experimentation is necessary to determine the optimum high-frequency bias for each tape used, and also the maximum density or audio record current that can be used.

These can be noted as meter readings and any time the tape is changed the recorder can have its bias reset to suit this particular type tape and the maximum level adjusted accordingly. This is one advantage of using a meter, rather than the simple indicator. A refinement for the indicator is to make it adjustable, with calibration (Fig. 919).

Getting down to details of the response characteristics of record and playback heads is much easier in a tape recorder than it is in a record player. The only contributing factors to frequency response are those related to the physical dimensions of the head and the gap effect between the magnetization on the tape and the air-gap width of the head. Also, the electrical characteristics can readily be measured: the inductance, resistance, core losses and

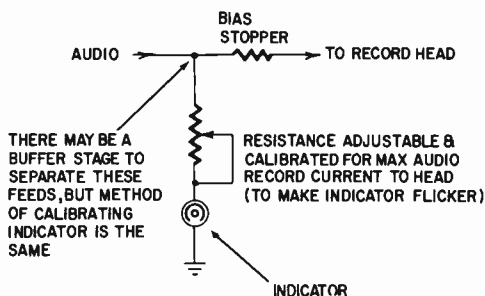

Fig. 919. Making the record level indicator adjustable to suit the maximum density levels of different tapes.

capacitance of the head windings.

The distortion characteristics of a tape recorder and more particularly of the magnetic tape used in the recorder can be measured in the same way as for any other audio equipment except that the input-output comparator method is not practical because of mechanical transport problems.

### **Dynamic range**

Dynamic range is evaluated in much the same way by measuring the residual noise level and its frequency distribution and also determining the maximum signal that can be handled. In general, the dynamic range of tape recorders is dependent on the quality of the recorder.

With a high-quality recorder, better dynamic range is achieved because the full range of recording magnitude is better utilized over the whole frequency range. This involves an extreme low-frequency boost, which runs the designer into quite serious hum problems. For this reason, in inexpensive tape recorders, to avoid the necessity for expensive hum shielding and other steps to eliminate hum in the early stages of the amplifier, a compromise characteristic has to be adopted—one that employs a certain amount of low-frequency boost in the recording operation and that requires less low-frequency boost in the playback operation. While this eases the hum problem, it does definitely reduce the ultimate dynamic range of which the machine is capable.

### **Recommended Reading**

1. P. E. Axon, "An Investigation Into the Mechanism of Magnetic Tape Recording," *Proceedings of the IEE*, May, 1952.
2. E. D. Daniel and P. E. Axon, "The Reproduction of Signals Recorded on Magnetic Tape," *Proceedings of the IEE*, May, 1953.
3. E. D. Daniel, "The Influence of Some Head and Tape Constants on the Signal Recorded on a Magnetic Tape," *Proceedings of the IEE*, May, 1953.
4. H. J. Houlgate, "Testing and Adjusting Magnetic Tape Recorders," *Sound Recording and Reproduction*, May, 1952.
5. P. E. Axon, "Some Problems of Magnetic Tape Reproduction," *Sound Recording and Reproduction*, May, 1954.
6. S. J. Begun, *Magnetic Recording*. Murray Hill Books, New York, N.Y., 1949.
7. Herman Burstein and Henry C. Pollack, "Distortion in Tape Recording," *Audio*, October, 1956.
8. James A. McRoberts, "Tracking Hum and Noise in Magnetic Recorders," *RADIO-ELECTRONICS Magazine*, June, 1957.
9. Herman Burstein and Henry C. Pollak, *Elements of Tape Recorder Circuits*. Gernsback Library, Inc., New York, N.Y., 1957.

10. Richard Graham, "Measuring Tape Wow and Flutter," *Radio & TV News*; January, 1958.
11. Robert E. Glendon, "An Analysis of Tape Noise in a 100-Kc Bandwidth," *AES Journal*; January, 1958.
12. Herman Burstein, "Equalization in Tape Recorders," *Audio*; March, 1958.
13. R. Lee Price, "Modulation Noise in Magnetic Tape Recordings," *IRE Transactions on Audio*; March-April 1958.
14. Herman Burstein and Henry C. Pollak, "Improving the Tape Amplifier," *Audio*; July, 1958.

# microphones

**T**HE basic measurements on microphones concern frequency response, directional characteristics and sensitivity. Other measurements deal with its electrical properties, but these are the ones in which acoustic performance is specifically involved.

## Acoustic properties

The electro-acoustic frequency response of a microphone can mean either the response to a wave arriving from a specific direction or the total response of the microphone to sound energy

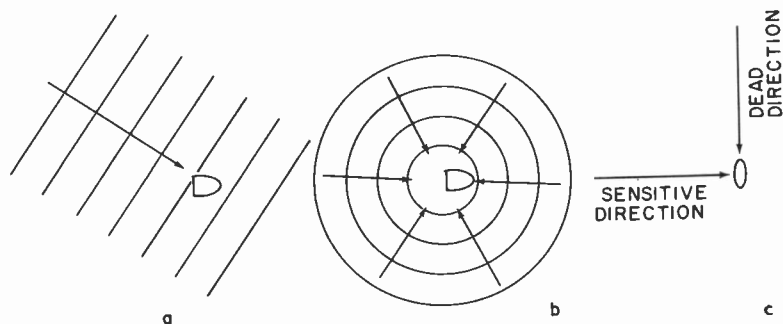

Fig. 1001. The electro-acoustic response of a microphone can refer (a) to its sensitivity from a particular direction, (b) to its overall pickup from all directions, or (c) to a specifically direction-sensitive characteristic.

arriving in all directions. This is closely related to the terms of reference used for sound waves, whether velocity or pressure (Fig. 1001). A microphone that is basically pressure-sensitive (by having



only one side of its diaphragm communicating with the sound field) is not appreciably directional, and indicates the average sound pressure at its surface.

While the dimensions of such a microphone remain small relative to the wavelength of operating frequencies, there is little discrepancy between the two forms of frequency response. But if the microphone employs a deliberately directional characteristic, such as a bi-directional ribbon or a unidirectional cardioid type that is, or includes a velocity-sensitive element, direction can make considerable difference.

A microphone that is essentially pressure-operated and gives an output proportional to pressure fluctuations on one side of its

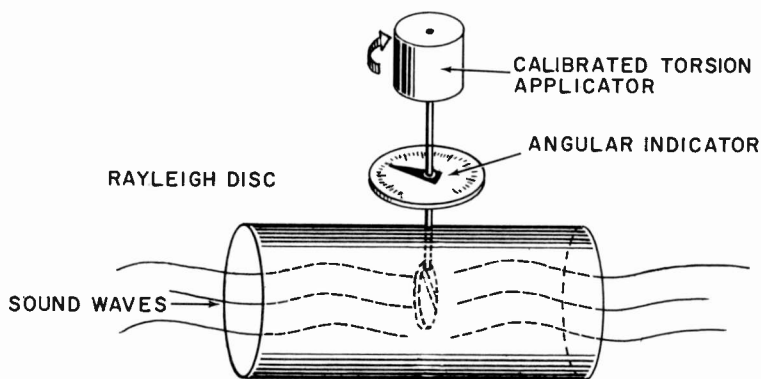

Fig. 1002. Method of using Rayleigh disc to calibrate the particle velocity in a sound wave.

diaphragm performs independently of the direction of arrival of the wave provided the frequencies used are such that the dimensions of the microphone, particularly its diaphragm, are always small compared to wavelength.

The classic way of calibrating a sound field uses a Rayleigh disc which gives a measurement of particle velocity (see Fig. 1002). The corresponding sound pressure can be calculated from the measured air constants, density and pressure (or elasticity). The relevant formulas are:

$$p = c\rho\mu \text{ and } c^2 = \frac{\gamma P_0}{\rho}$$

where  $p$  = sound pressure in dynes per  $\text{cm}^2$ ,  $c$  = propagation velocity of sound in  $\text{cm}/\text{sec.}$ ,  $\rho$  = density of air,  $\text{grams}/\text{cm}^3$ ,  $\mu$  = particle velocity (measured on Rayleigh disc)  $\text{cm}/\text{sec.}$ ,  $p_0$  = static air pressure,  $\text{dynes}/\text{cm}^2$ ,  $\gamma$  = specific heat ratio (1.4 for air).

An average value for  $c_p$  in air is 42.

By using substitution or symmetrical arrangements (Fig. 1003), the performance of the microphone in an identical position can be obtained. This will detect the sensitivity characteristic and thus its frequency response from this particular direction.

The response can be taken by orienting the microphone in dif-

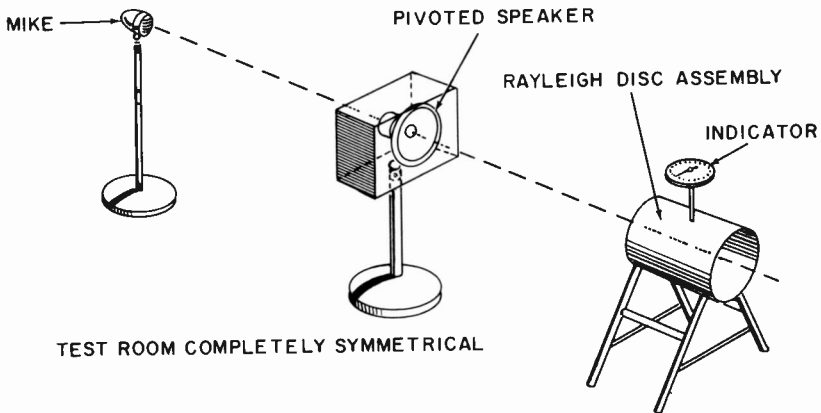

Fig. 1003. Use of Rayleigh disc in a symmetrical arrangement to calibrate microphone response.

ferent positions to find where deviation occurs (particularly at higher frequencies) due to the angle at which the wave approaches.

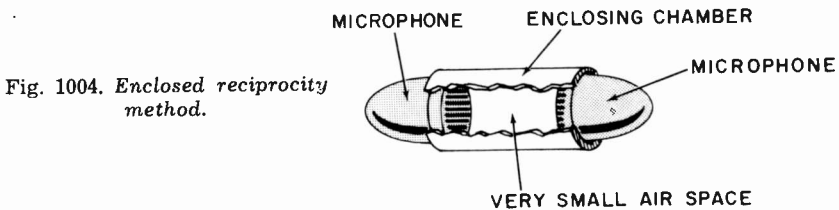

Fig. 1004. Enclosed reciprocity method.

It is important, in making a measurement at each frequency, to adjust the sound velocity, and thus the pressure, at the point where the microphone is placed, to the required value. Wave reflections occurring in the test apparatus (if the equipment is put in a tunnel for example, from the surfaces of the tunnel) can produce accentuation of certain frequencies. This must be compensated for in taking the frequency response and this is also why we need an absolute measure of sound velocity or pressure such as the Rayleigh disc.

An alternative approach to calibrating a pressure-operated mi-

crophone uses the reciprocity method. In this case the microphone has no access to free space. Two identical microphones are closely coupled, one being used as a speaker and the other as a microphone that picks up the total sound "radiated" by the first (Fig. 1004). The contained air volume must be such that there is no time for the development of an appreciable portion of a wave at any test frequency. In other words, all the drive microphone does is to produce pressure variations in the enclosed chamber, which the other microphone then detects.

Microphones may be regarded as having reciprocal characteristics. If they are identical, the frequency response of the unit

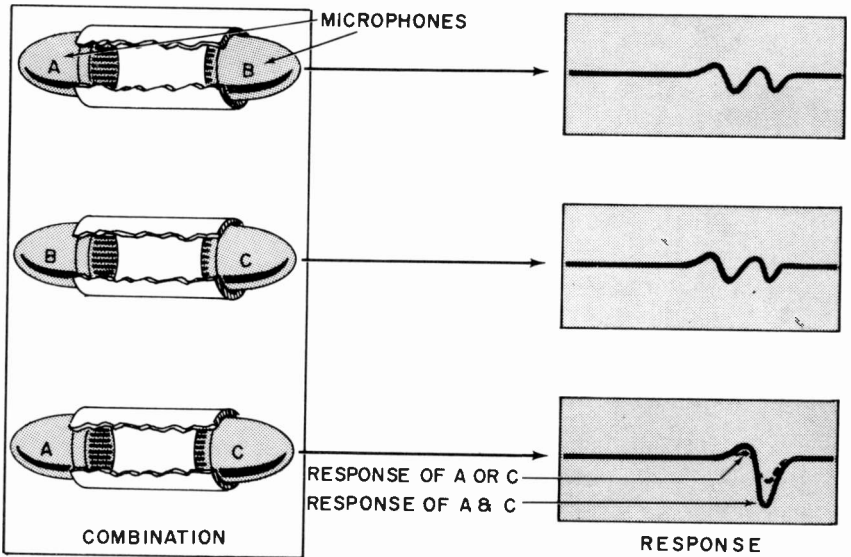

Fig. 1005. Deducing the response when two out of three microphones prove to be identical.

driving the air as a transducer is identical with the pickup response of the other detecting the pressure variations produced. Thus the overall frequency response plotted in this way is due half to the drive unit and half to the pickup unit (on a db basis).

This is true provided the dimensions of the enclosed air are small compared to wavelengths of the test frequencies. Obviously this applies only to microphones where the diaphragm is correspondingly small. It is useful for very small capacitor type microphones and some of the more modern miniature dynamic kinds.

Of course, the two microphones must be identical. To check

identity use three microphones and all three possible combinations of two to check that the reciprocity result is the same between all pairs. If only two of three possible combinations produce identical responses, the identical pair is the third combination (Fig. 1005).

Because microphones are such delicate instruments, it is almost impossible to produce two units, however carefully constructed, having identical performance. Slight internal stresses in the dia-

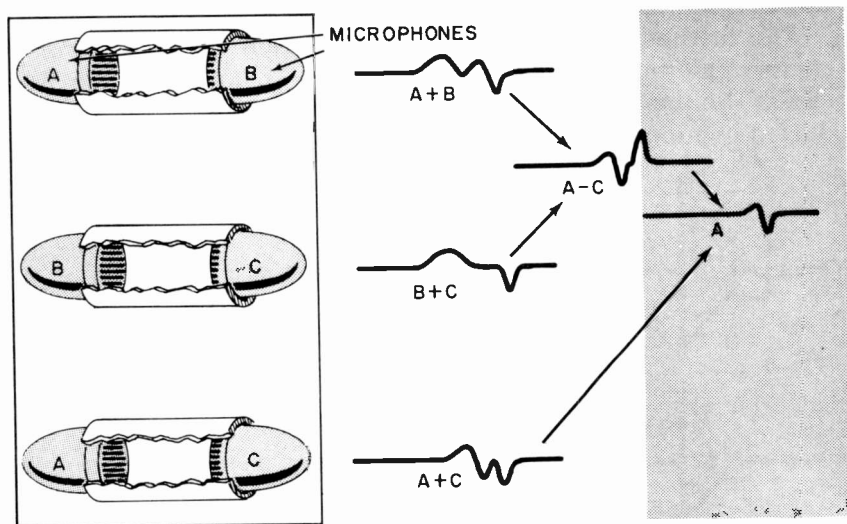

Fig. 1006. Deducing the response of one microphone, when none of the three are identical.

phragm structure, that do not make any noticeable difference in its dimensions, can result in variation in frequency characteristic. If all three transducers have different characteristics, the results of any one can be computed by comparison of the three (Fig. 1006). But this becomes quite an "interpretation" problem and offers considerable opportunity for inaccuracy.

The reciprocity, either with identical or different units, can also be used in free instead of enclosed space. The requirements for validity are that distances be such that the units do not interact on the sound field at any frequency. For this to be true at lower frequencies, the spacing is such that it is impossible to operate a microphone as a "speaker" sufficiently above ambient noise to make measurements. The only method is to use a speaker, a speaker that will double as a microphone, and the microphone to

be calibrated (Fig. 1007), obtaining the resultant response of the desired unit from the three actual responses taken.

A method has been suggested for overcoming this identity or interpretation problem by employing the same microphone as a transmitting transducer and a receiving transducer or pickup by using the radar pulse technique. A very short burst of tone of a particular frequency is transmitted to a reflecting surface (Fig. 1008) which sends this pulse back. By the time it reaches the microphone it is connected to the input of the amplifier which measures the sound magnitude picked up.

This method depends on complete reflection of the sound-pulse energy and no loss due to diffraction. It is no longer one that checks the total energy input and output as when the test is conducted in a totally enclosed chamber of such small dimensions that

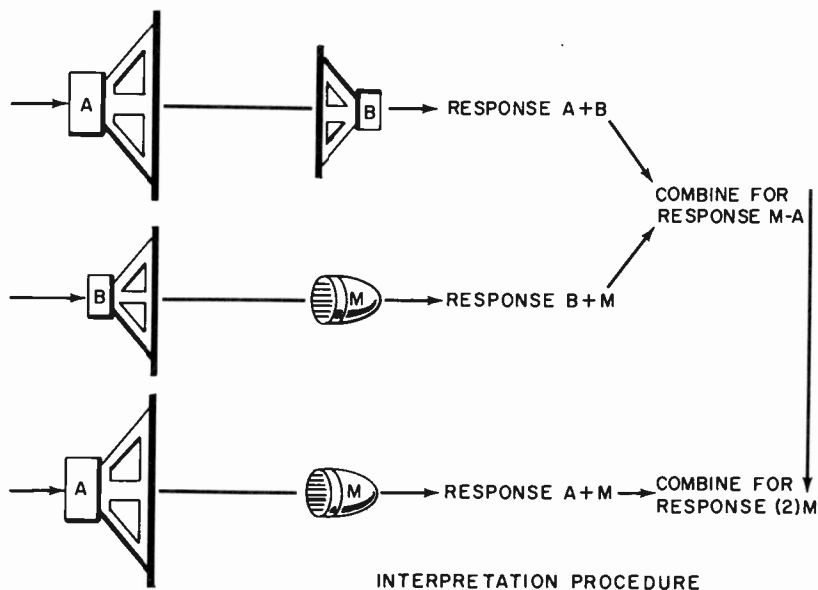

Fig. 1007. Reciprocal method (with access to air) using a speaker, a reversible unit and a microphone to determine the microphone response.

no sound escapes. A considerable distance must be provided for an appreciable number of cycles of the lower frequencies to be radiated and time to be given for the change of connections so that they can first be radiated and then picked up by the same microphone.

To the author's knowledge this method has only been postulated but not actually used. It would seem that the obstacles in the way

of ascertaining precise characteristics, reflecting surfaces, etc., would make the method at least as difficult as the straightforward reciprocity method using two identical microphones.

These techniques are applicable to pressure type microphones

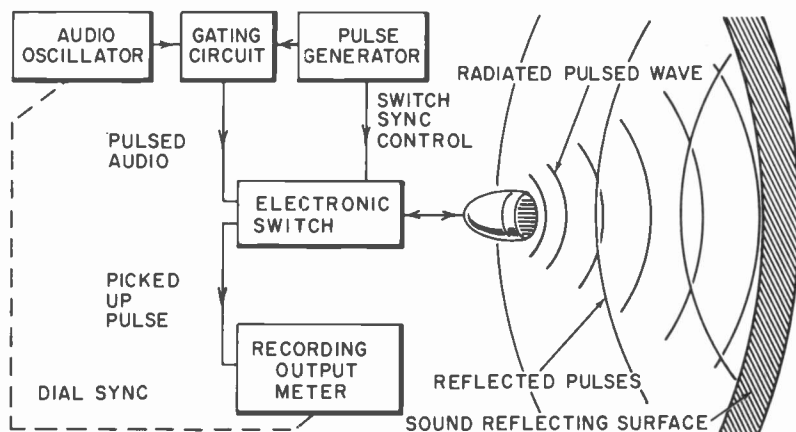

Fig. 1008. A projected method of using a microphone as a two-way transmission unit to get a reciprocity calibration.

Any types that utilize the velocity principle in whole or in part are not amenable to test methods based on pressure measurement. A free-moving diaphragm, in which motion of air is permitted

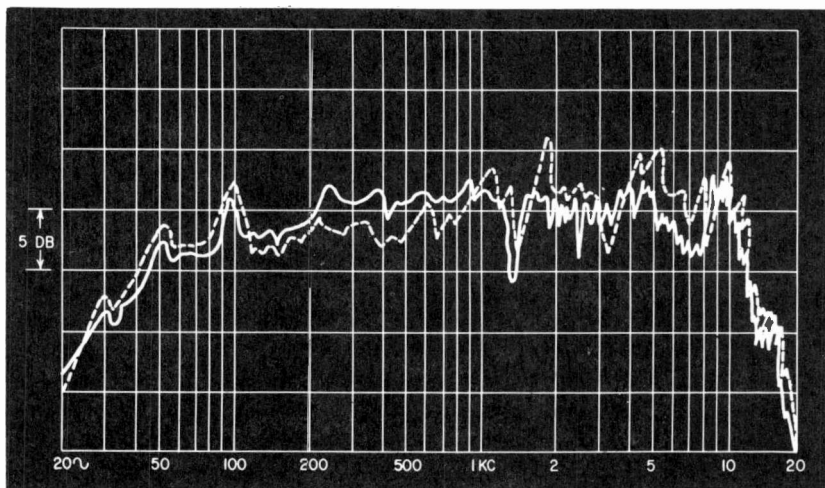

Fig. 1009. Comparing the response of a calibrated microphone (dashed line) with one under test (solid line) gives the response of the latter.

round its edges, may have a reciprocity arrangement, but it is not so simple as with devices that are influenced only by sound pressures.

The only satisfactory absolute technique for these is to use a comparator method with the Rayleigh disc (Fig. 1003) and make

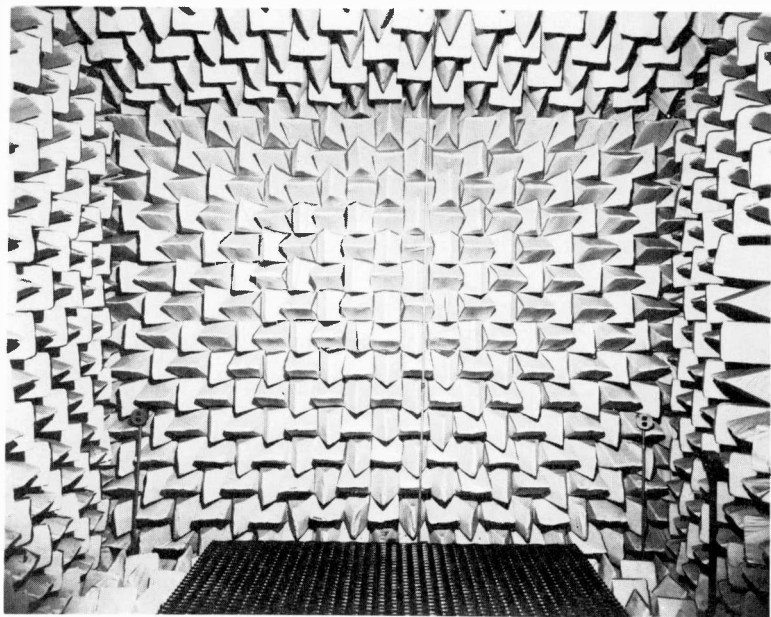

Fig. 1010. Anechoic chamber used for testing purposes. (Courtesy Electro-Voice, Inc.)

responses at different angles, or else take polar responses at different frequencies. Relative methods (sometimes called secondary

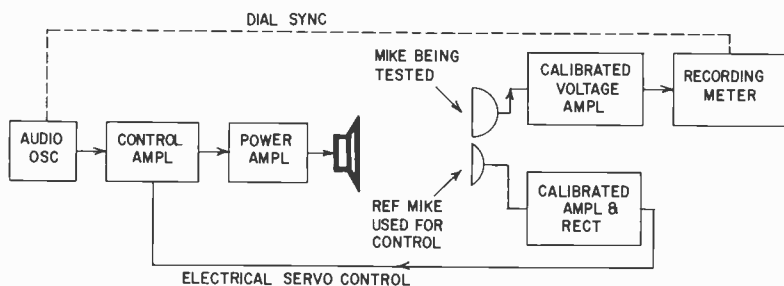

Fig. 1011. Complete setup for taking microphone response automatically, using a control microphone to produce a uniform sound field.

methods and dealt with later in the chapter) are more commonly used for this purpose.

All the methods so far described aim at producing absolute standards of microphone frequency response and sensitivity. In most instances, such absolute results are not necessary. If a reasonably good calibrated microphone can be produced by this method with a known and stable calibration, a much quicker method of taking the response of each of these varieties is to use the calibrated microphone as a standard. This can always be recalibrated by one of the foregoing methods from time to time just to check its performance.

Then the method of making a test consists of comparing the performance of any other microphone with that of the "standard." Here we have two possibilities. One is to produce a sound field that fluctuates, however it may, due to the radiation pattern of the speaker used to produce it, and compare the pickup of this sound field at the same point by the standard microphone and by the

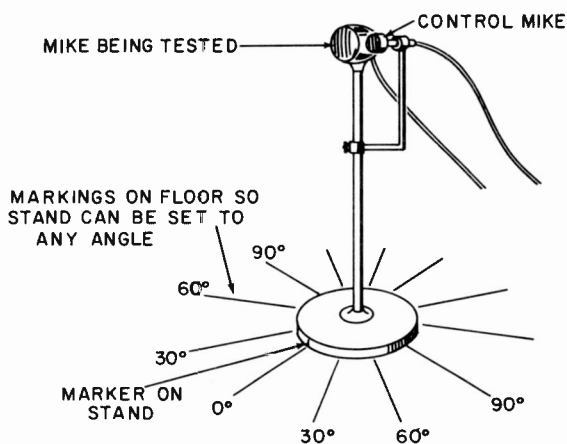

Fig. 1012. Arrangement of the mount for the two microphones in the setup of Fig. 1011.

one under test (Fig. 1009). By careful subtraction of the characteristics due to the speaker and to the calibrated microphone (which will be shown by the combination of the responses produced with the calibrated microphone and its own calibration, respectively), we can deduce the resultant response of the microphone under test.

This is a laborious process and reasonably valid only when the test is conducted in free space so there are no reflections. An alternative is to use an anechoic room (Fig. 1010), but the slight reflec-



tion from the acoustically "soft" surfaces of an anechoic room can invalidate the responses obtained unless some means is used to standardize pressure.

A controlled sound field is a big help in eliminating errors due to fluctuation in the radiation from the speaker and residual reflections in a good test room, leaving only corrections for the calibration of the standard microphone. To do this a number of calibrated amplifiers are needed (Fig.1011).

The oscillator is fed to the speaker through a control amplifier which varies the gain so that the output from the speaker can be adjusted to a desired sound pressure. The calibrated control microphone is connected to an amplifier whose output is rectified and used to govern the output from the speaker. In this way, as frequency is varied, the sound pressure at the control microphone is adjusted to what would be a constant value if the control microphone were perfectly flat. Now, by placing the microphone under test in the same sound field, as close as possible to the control microphone, we can take a frequency response which will show directly the difference between the response of the control microphone and the one under test.

If the control microphone is a good approximation to flat, then the response may be regarded as coming close to being an accurate

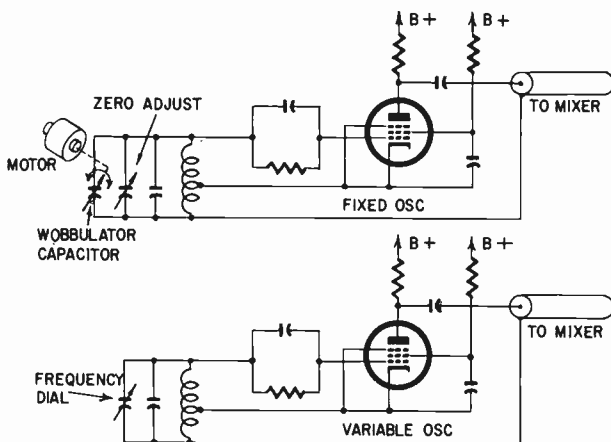

Fig. 1013. *Electronic method of adding a warble tone to a heterodyne-type audio oscillator.*

frequency response of this particular microphone, taken in the direction in which it is oriented. A complete directionality pattern can be obtained by setting the microphone at different angles and

using the control microphone in each case (Fig. 1012). If more accurate response is required, correction can be made for the calibration of the control microphone.

Even using this method, it is best to take the response either in the open air with no reflections occurring or in an anechoic room which will minimize reflections. In the average room, where wall reflections occur all around, the pressure gradients can be so strong in some standing waves, which may take up angles at all directions to the initial propagation from the speaker, that the pressure at the control microphone can be quite different from that at the microphone under test, and this difference will vary widely as frequency is changed. The resultant frequency response will look erratic. The same response in open air is much smoother; in an anechoic chamber the result comes somewhere in between.

Sometimes it isn't practical to use an anechoic chamber or open

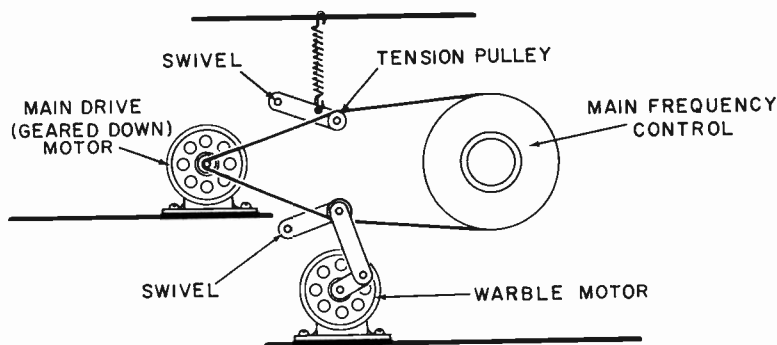

Fig. 1014. *The mechanical method of providing a warble tone.*

air. An alternative is a warble tone. The frequency is continuously varied up and down by a small amount, and the frequency range is run up to plot the curve. In this way no standing-wave pattern has time to grow and produce troublesome pressure gradients.

Two kinds of warble can be added. If the oscillator is a heterodyne type, a simple method is to use a fluctuating capacitance in parallel with the control capacitance for the fixed oscillator. This will make the fixed oscillator warble up and down by perhaps  $\pm 10$  cycles, while the variable oscillator goes up and down to change the overall frequency (Fig. 1013). The disadvantage is that  $\pm 10$  cycles may not be sufficient to prevent standing waves in the region of 5 to 10 kc while at the low-frequency end a warble of  $\pm 10$  cycles means that the 20-cycle tone is fluctuating periodically between 10 and 30 cycles. Thus the low-frequency becomes

rather invalidated by the presence of the warble. What would be more nearly ideal is a warble of fixed *percentage* of the frequency at the moment.

The only sensible way to approach this requires a mechanical drive that will vibrate the frequency control knob a fixed proportion of its momentary position. If the scale is logarithmic, a fixed angle will achieve this and make the problem simple. A belt drive could be used with a jockey pulley between the drive pulley and the control knob to impose a fluctuating movement in addition to the slow steady increase in frequency (Fig. 1014).

This means that a fluctuation in frequency will be a constant percentage of the frequency at the moment. If the fluctuation is

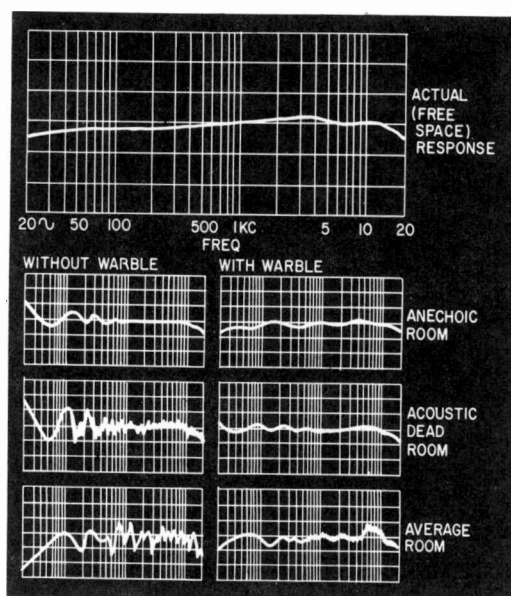

Fig. 1015. Comparison of the responses obtained in various test rooms, with and without warble.

50 cycles when the frequency is 2 kc, it will be 0.5 cycle when the frequency is 20 cycles, and 500 when the frequency gets up to 20 kc. This is a fairly satisfactory arrangement for minimizing the effect of standing waves. The actual amount and desirable rate of warble will depend upon the reverberation time and similar characteristics of the room in which the measurement is made.

In an anechoic room, a very small amount of warble is sufficient to produce results that compare almost exactly with measurements taken without warble in the open air. A larger amount of warble

will be necessary to achieve comparable results in a room with less effective absorption. Fig. 1015 shows some typical effects.

An important feature in making all of these measurements is the method of setting up the gear; it can invalidate the sound pressure being measured. Hence the control microphone should be as small as possible and it should definitely be smaller than the one being tested.

If two microphones are placed side by side so their total volume is twice that of one microphone, then pressure-doubling effects due to the fact that the microphone presents an obstacle to the wave will start at half the frequency at which they would occur with one microphone standing by itself (Fig. 1016). This means that both the response of the control microphone and of the one under test are invalidated.

Assume the control microphone is very small compared to the

Fig. 1016. Proximity of microphones to one another influences the pressure/velocity relationship in a certain frequency range so as to modify the response obtained slightly.

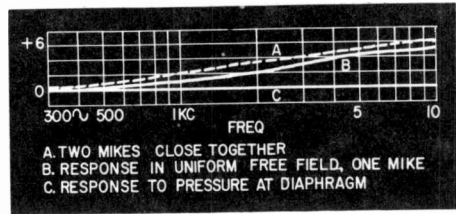

one under test. Placing the two close together does not give what may be regarded as an ideal result from all viewpoints. The control microphone will now determine that the pressure *at the point*

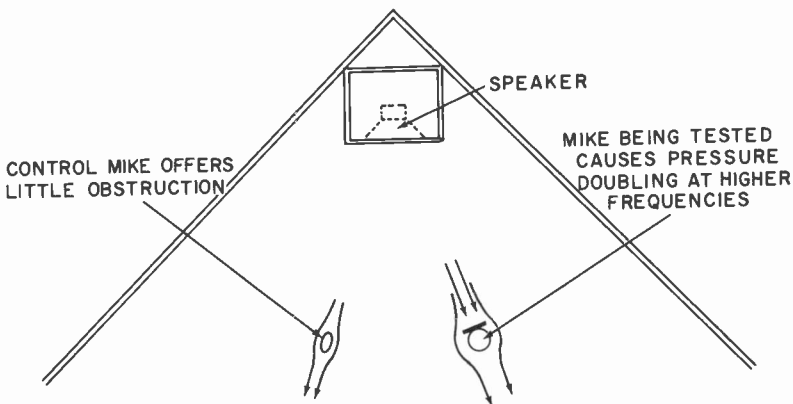

Fig. 1017. Symmetrical placement of microphones with respect to the speaker and room geometry gives each freedom from displacement effect due to the other.

where it is placed is maintained constant at all frequencies. But the microphone under test, acting in a free field, may tend to increase the pressure at its surface due to its obstacle effect. The control microphone will make at least partial adjustment for this increase and maintain a constant pressure at the surface of the microphone.

This appears to be an argument for separating the microphones so there is no interaction in the wave where it strikes both microphones simultaneously. By careful arrangement in symmetry it may be possible to insure that the free-field pressure passing both microphones is the same. The response now obtained will correctly show any pressure-doubling effect due to the obstacle effect of the microphone under test, because the control microphone, being much smaller, will avoid pressure-doubling at its own surface (Fig. 1017).

If both microphones are pressure types, problems due to wave configuration are simplified. Each responds only to the *pressure* fluctuations at its surface and the only way the microphone itself can affect pressure fluctuation is due to its obstacle effect.

A microphone is a purely pressure-operated device if only one side of the diaphragm has access to the sound wave. In many microphones, partly for release or partly to achieve some other

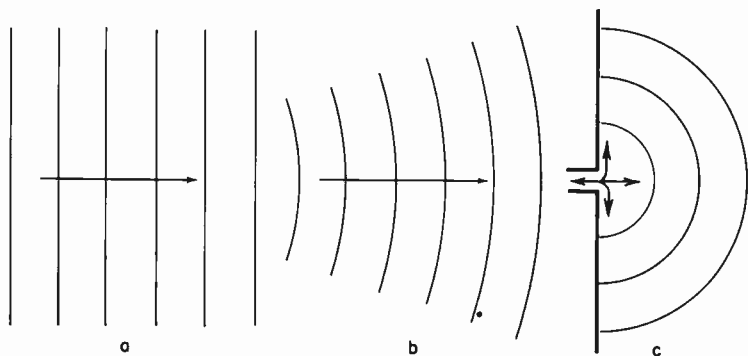

Fig. 1018. Difference in properties of sound waves due to wave configuration: (a) uniform relationship in a plane wave; (b) similar relationship in spherical wave at large radius; (c) excessive air movement at source, or small radii, of spherical wave.

effects, some access is provided from the rear of the diaphragm to the space where the sound is, as well as from the front. In some instances, the design is deliberately arranged to produce a cardioid or similar characteristic. The microphone is then no longer a pressure device but works on the basis of a pressure gradient—the dif-

ference in pressure between the wave at the points where access is to the diaphragm.

Microphones of this type show marked differences in response according to the distance of the microphone from the source of sound. Sound waves near their source are spherical (that is, rapidly expanding) while sound waves at a distance approximate plane waves. This means the pressure and velocity characteristics of the wave progress forward without changing their relationship appreciably, at least over the distance represented by the dimensions of the microphone.

Near a sound source the relationship between pressure and velocity is quite different from that when the wave becomes almost a plane wave. The air near the sound source actually works as a

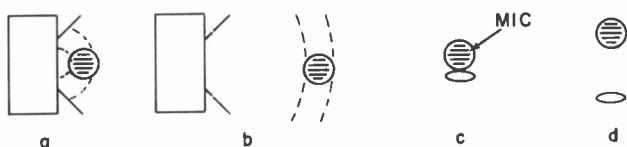

Fig. 1019. Difference in response should be investigated due to the variation in distance from sound source (a) and (b), and to the microphones own interference with the sound field (c) and (d).

communicating medium with air farther out. Consequently it moves over a greater distance for corresponding pressure fluctua-

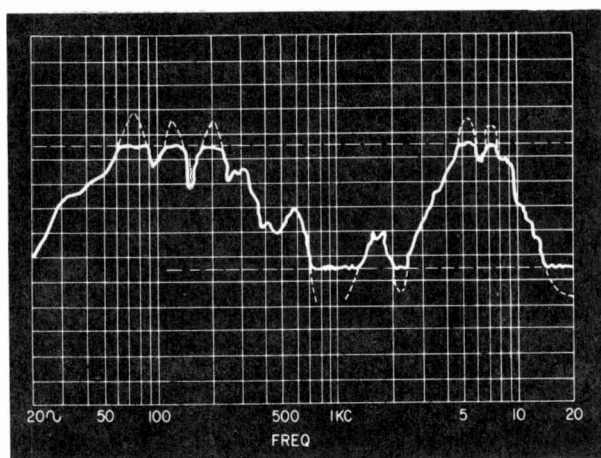

Fig. 1020. When a response levels off above and/or below a certain level, as shown here, results may be invalidated by overload or ambient noise effects.

tion than does air in a plane wave (Fig. 1018). All of this can be evaluated from basic sound theory, using the wave propagation formula, at least for the simple case when no obstacles are present.

The whole thing is somewhat more complicated by the presence of a microphone to measure these waves. So, in making measurements of this type we have to consider whether the method of test invalidates the results. By taking measurements at different distances and comparing the results both at different distances and at different angles, it is possible to measure just what is the performance of the microphone in various separate respects: what effect distance to the sound source from the microphone will have on its performance, what its response is to the sound field, and the way its presence "obstructs" or modifies the free-field configuration (Fig. 1019).

Any of these microphones, partially velocity-sensitive, do exhibit differences in frequency response according to their distance from the sound source because, at the low-frequency end particularly, there is a velocity rise (compared to the pressure response) when the measurement is made closer to the source of sound (Fig. 1018).

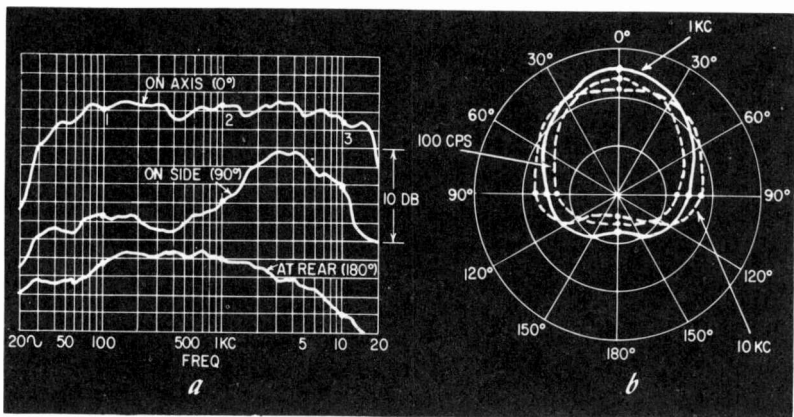

Fig. 1021. The directivity of microphones may be presented as a response curve taken at different angles (a), or a polar diagram taken at different frequencies (b).

In all these measurements, it is important to check that the indicated results are valid throughout the frequency range and that ambient noise does not swamp low-level points, or distortion limit peaks (Fig. 1020).

Directional properties of the microphone can be taken in one of two ways. The setup is quite similar for each. It is a matter of taking the readings in accordance with the method of presenting

the information intended. It can be presented as a frequency response taken at different angles, on axis, and at  $30^\circ$ ,  $60^\circ$  and  $90^\circ$ , for example; or else the directional polar pattern can be taken at a variety of frequencies. These two methods are shown in Fig. 1021.

The method of plotting is in accordance with the way the information is presented. If the polar method is used, then the frequency is kept constant and the microphone rotated, measuring the output at different angles. If the frequency response at dif-

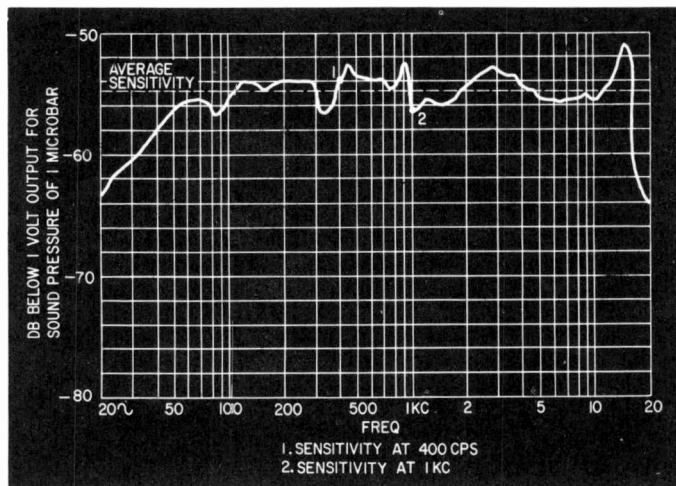

Fig. 1022. Possible ambiguity about a sensitivity figure taken at a specific frequency; an average figure is more informative.

ferent angles is used, the microphone is set to precisely measured angles and frequency response is taken in each position.

For measuring microphone sensitivity, it is necessary to calibrate the sound field. The standard microphone, which has been calibrated against a known sound field, must be used with a carefully measured quantitative gain. This means that the output of the microphone in microvolts or millivolts must be precisely measured by the amplifier that is used on its output, to set up the gain so that a known sound pressure will produce a specific voltage reading at the output. In this way the sensitivity of the unknown microphone can be determined against the reference standard.

Sensitivity is not a constant figure in making these measurements. It will vary according to the frequency response of both instruments. Consequently, a sensitivity measurement should be made at some frequency, such as 400 or 1,000 cycles. The figure



obtained will vary in significance slightly, according to whether this happens to be at a maximum or minimum point in the frequency characteristic of each microphone.

Whether it is a sound cell crystal, a ribbon or a flat diaphragm capacitor type, a reference microphone will have practically no peaks or valleys in this region and thus will not bias the sensitivity reading. But the microphone under test may well have either a peak or dip at the measurement frequency that makes the reading not representative of the response in this general frequency range. For this reason it is well to assess the *average* sensitivity by comparing the sensitivity at a known frequency with the measured frequency response (Fig. 1022). Such an average sensitivity reading is an interpolation and not something that can be measured at any particular frequency.

### **Transient response**

To date, no known means exists for establishing the precise waveform of an acoustic wave of transient form. Even the best speaker has such considerable transient distortion, compared to a reasonably good microphone (because of the relative dimensions involved) that it is impossible to generate a transient acoustic wave of precisely determined form.

Comparative measurements could be made between microphones, using a speaker or some other source of transient sound of indeterminate form, but such measurement is limited in validity by the inability of determining the acoustic waveform. Fortunately, as microphones are invariably small in dimension compared to the sound wavelengths they pick up, the kind of transient distortion that occurs in speakers due to breakup can be virtually eliminated, at least from the best units. Thus the transient response can be predicted within fairly good limits.

### **Phase response**

Phase response is unimportant for most applications. Correct phasing may be necessary where several microphones cover the same general area. But, because of the physically small dimensions of good microphones, phase deviation is always fractional. However, in design work such as for developing cardioid microphones using multiple elements, relatively small phase deviations can be important. For this purpose, comparative phase measurements can be made by the method of Fig. 1023. Positioning is adjusted until the outputs are precisely in phase. The phase difference, and thus the wavelength, is then computed from a knowledge of the frequency of test.

## Impedance

Microphone impedance can be measured by any of the standard methods, provided the signal used does not drive the diaphragm physically to such an extent as to cause acoustic reflection into the electrical circuit.

Any transducer reflection that occurs normally appears as part of the equivalent electrical impedance of the microphone. But, as microphones are much less efficient transducers than speakers, (because of the much smaller size necessary to achieve the desired frequency response), there is much less reflection from the acoustic impedance to the electrical circuit than occurs with speakers. Most microphones have an electrical impedance governed principally by the electrical characteristic of the microphone. In moving-coil and reluctance types, this is due to the resistance of the coil or windings and the inductance due to the magnetic components in the instruments. In crystal or capacitor microphones, the impedance is almost a pure capacitance and any resistance components are usually due to losses in the capacitance as an electrical device rather than acoustic reflections.

With some microphones, such as the capacitor type, a preamplifier is necessary. Recently also dynamic microphones have been

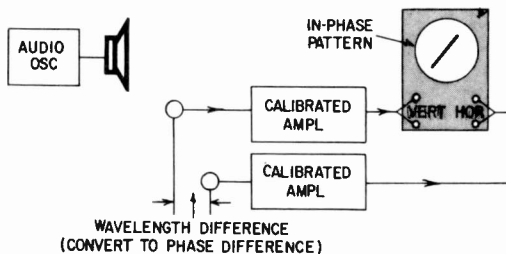

Fig. 1023. Method of measuring the phase response of microphones (relative).

built with an incorporated transistor preamplifier. With these, it may be necessary to take the overall response including the characteristics of the associated amplifier. In this case, the direct impedance of the microphone itself is unimportant except in considering its possible contribution to the overall performance.

Impedance can be read, at any one frequency, by a bridge or by a direct-reading impedance meter, taking care not only to apply sufficient audio to the microphone to cause excessive diaphragm movement. The direct-reading impedance meter is convenient only for making an impedance check at the one frequency for

which it is designed. More complete information requires the use of a bridge or else a simplified setup (Fig. 1024) and taking readings at a number of frequencies, so an impedance, magnitude and phase angle response can be plotted (Fig. 1025).

From such information, if desired, the equivalent circuit can be deduced (Fig. 1026) and the elements identified. This can then be useful as a design adjunct. It can aid in predicting the electrical

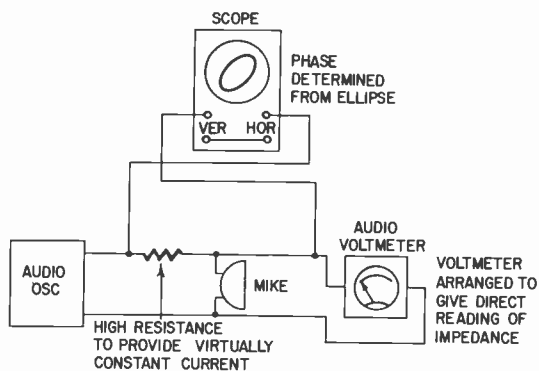

Fig. 1024. A simple setup for measuring the impedance characteristic of a microphone.

frequency response with various terminations—a more precise approach than repetitive acoustic response measurement with different terminations.

### Distortion and noise

Distortion should always be measured in conjunction with the

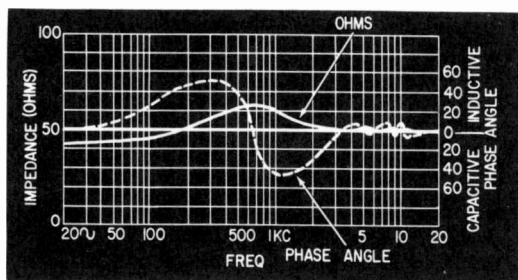

Fig. 1025. A typical impedance characteristic, plotted in ohms and phase angle.

distortion of the amplifier used in making the test. Most microphones produce very little distortion unless excessive sound levels

are used—much greater than normally encountered unless the microphone is used in conjunction with a sound-level meter or as part of a vibration test or pickup device.

First check the amplifier with a simulated electrical input, then with an acoustic input through the microphone. This will need a high-quality speaker, whose distortion, measured on a calibrated microphone, is lower than the indication obtained on the one under test (Fig. 1027).

Also, it is necessary to check the noise level from the micro-

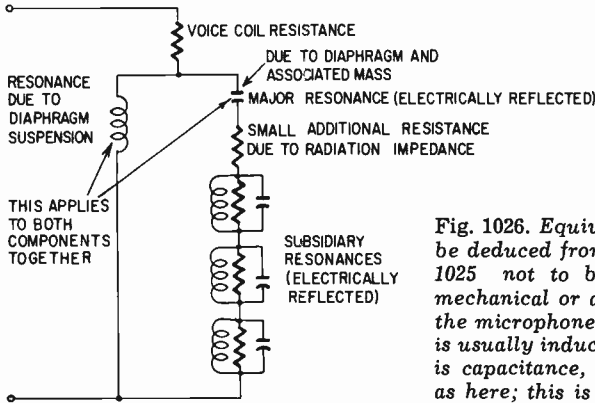

Fig. 1026. Equivalent circuit that can be deduced from the response of Fig. 1025 not to be confused with the mechanical or acoustical analogy for the microphone, itself, in which mass is usually inductance and compliance is capacitance, instead of vice versa, as here; this is the electrical impedance equivalent.

phone. This requires the use of an anechoic chamber or isolated room which permits putting the microphone where there is abso-

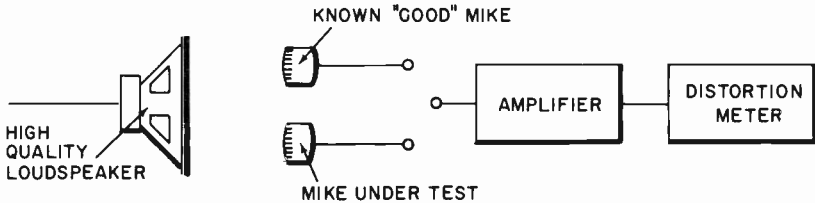

Fig. 1027. A possible method for measuring microphone distortion: all other components must be of extremely high quality for this measurement.

lutely no sound pickup, or where the sound pickup is of lower level than the noise level from the microphone itself. This can best be checked by listening to the output to determine that it is pure noise and that there is no break-through sound of an ambient nature. It is also necessary to check that the noise level of the amplifier, when terminated by an impedance corresponding to the microphone impedance, is not of sufficient magnitude to

swamp the noise level measured from the microphone. Microphone noise measurement is valid only if the amplifier noise measures much lower—at least 10 db.

Measurements of the maximum level the microphone can handle in conjunction with its minimum level which is just above the noise will enable a dynamic range figure to be given. Of course, not all of this is always practical dynamic range, because the higher levels may be much greater intensity of sound than can be used for practical purposes—except maybe for listening to the intensity of noise in a boiler factory! The more useful figure is an equivalent noise level in terms of the acoustic pickup intensity. In other

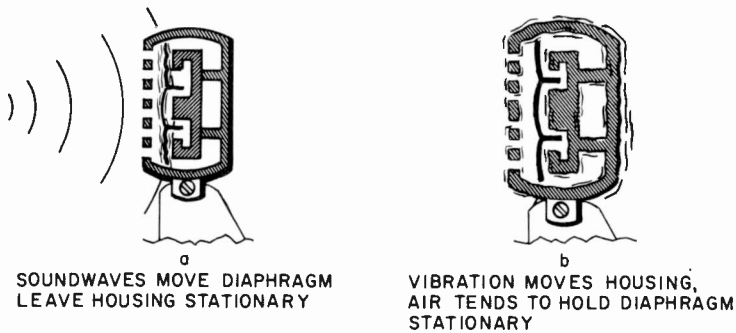

Fig. 1028. *The difference in action between picking up a sound wave (a) and a vibration from the mount (b).*

words, the output noise level from the microphone is referred to an equivalent sound level, according to the sensitivity of the microphone.

### Vibration isolation

A final important feature of microphones is their isolation of various forms of vibration not sound borne to the diaphragm and transmitted either through the microphone stand or the connecting cable.

Most microphones will have a different frequency response to vibrational than to acoustic sound pickup. This is because the function of the instrument is reversed (Fig. 1028). Vibration of the microphone housing tends to leave the diaphragm standing still. But this reverse action is controlled by the acoustic impedances reflecting to the diaphragm, some of which are coupled to the vibrating element and some of which may not be. The result is a completely different frequency characteristic from that using the microphone in its correct sense.

To find this frequency characteristic without any vibration isolation put the microphone in a stand and use a vibration generator. This is a special kind of transducer similar to a speaker coupled to produce mechanical vibration. At the same time use a vibration pickup, which is similar to a microphone (but intended for contact pickup) to measure the vibration produced (Fig. 1029). Use the vibration generator as a calibrated source similar to the control microphone in taking microphone frequency response. Measure the output from the microphone insuring that none of the pickup is due to acoustic effects, by operating in an anechoic chamber. Then measure the output at different frequencies to obtain the frequency response of the vibration pickup of the microphone itself. This will naturally differ between various units.

Appropriate vibration-isolating units can be inserted in the microphone stand and the response repeated. The effectiveness of vibration isolation is the difference between these responses. The

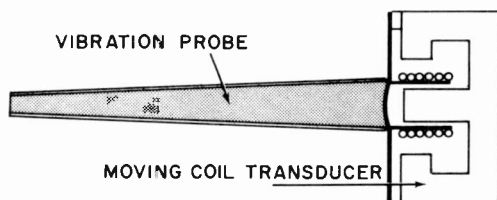

Fig. 1029. Basic construction of a vibration pickup.

question as to whether the overall vibration pickup response, including the isolation or the actual reduction produced by the isolation, is of importance is one that has to be settled by looking at the individual responses concerned. If a particular microphone proves particularly susceptible to one frequency, which quite frequently happens due to the mechanical construction of the microphone or its housing, then it is important that the isolation should give good rejection to this frequency.

### Effect of housing

Many microphone responses published by manufacturers appear to have been taken with the development unit produced in the laboratory before the styling people designed the housing for it. Unfortunately, as the manufacturers of better microphones know quite well, housing can considerably modify frequency response, both acoustic and vibration pickup. So if you take the response

of a microphone and find that it does not agree with the published curve, check whether the microphone without housing agrees with the published curve.

Microphones are one component that cannot, after satisfactory laboratory development, be "handed over" to styling people for "packaging." Close collaboration with the development laboratory, taking careful measurements, is necessary right up to the evolution of the final product, if the benefit of original development is to be retained.

#### Recommended Reading

1. Frederick V. Hunt, *Electroacoustics*, Harvard University Press, 1954.
2. Leo L. Beranek, *Acoustics*, Mc-Graw Hill Book Co., Inc., 1954.
3. Harry F. Olson, *Acoustical Engineering*, D. Van Nostrand Co., Inc., 1957.
4. J. W. S. (Lord) Rayleigh, *The Theory of Sound*, Macmillan Co. (London) 1877, reprinted by Dover Publications, Inc., 1945.

# index

<b>A</b>		<b>C</b>	
Ac Audio Meter, Rectifier Circuits .....	54	Calculated Power .....	7
Acoustic:		Calibrated:	
Feedback .....	164	Attenuator .....	81
Properties .....	195	Tape .....	181
Velocity and Pressure .....	71	Calibrating:	
Actual Power .....	7	Heterodyne Oscillator .....	16
Air-Pressure Fluctuation .....	71	Microphone with Rayleigh Disc ...	72
Alignment, Gap .....	184	Calibration:	
Ambient Noise Effects .....	209	Instrument .....	47
Ammeter, Hot-Wire .....	49	Lissajous Patterns .....	48
Amount of Warble .....	206	of Microphone Response .....	197
Amplifiers, Basic .....	81	Oscilloscope .....	93
A-N Indication .....	161	Scope Wheel .....	47
A-N Test .....	177	Capacitance:	
Analysis of Core Material .....	63	Bridge .....	60, 65
Analzers, Wave .....	40	Checker, Direct Reading .....	66
Anechoic Chamber .....	202	Fluctuating .....	205
Angle, Gap .....	183	Winding .....	125
Arm, Mechanical Impedance of .....	158	Capacitor Microphones .....	198
Arm Resonance .....	151	Capacitors, Differential .....	95
Arms and Pickups .....	151	Cardioid Microphones .....	212
Asymmetrical Nonlinearity, Arm and ..	162	Cent, Musical .....	45
Attenuator, Calibrated .....	25, 81	Chamber, Anechoic .....	202
Attenuator, Decade .....	135	Changer Speed Variations .....	176
Audio:		Changers and Turntables .....	167
Generators, Characteristics of		Characteristic:	
Various Types .....	21	Equalization .....	188
Oscillator .....	14	Fletcher-Munson .....	140
Oscillator-Comparator for		Impedance .....	214
Measuring Frequency Response ..	83	Power Output .....	87
Sine and Square-Wave Generator ..	29	Transfer .....	101
Wattmeter .....	24	Characteristics:	
Average-Reading Distortion Meter .....	94	Equalization .....	134
		Reciprocal .....	198
		Transfer .....	78
		Various Types of Audio Generator ..	21
<b>B</b>		Checking:	
Balance, Dynamic .....	173	Leakage Inductance .....	129
Bandpass Filters .....	32	Peak Overload .....	117
Bandpass Filters, L-C .....	43	Transistor Gain .....	79
Bandwidth, Constant .....	40	Winding Capacitance .....	129
Basic Amplifiers .....	81	Choice of Test Frequencies .....	39
Basic Measurements .....	45	Choke Inductance, Measurement of ..	67
Beat-Frequency Oscillator .....	16	Circuits, Ohmmeter .....	65
Bias:		Circular Time Base .....	47
Current Meter .....	191	Clipping in Feedback Amplifier ...	35, 117
High-Frequency .....	190	Cog-Wheel Patterns .....	48
Optimum High-Frequency .....	192	Compensation:	
Bi-Phase Rectified Signal .....	24	Frequency .....	134
Bridge:		Velocity .....	189
Capacitance .....	60, 65	Complex Equipment .....	12
Drysdales .....	59	Compliance:	
for Mixing in IM Measurement ...	97	Dynamic Mass .....	157
Hay .....	59	Pickup .....	74
Impedance-Admittance .....	70	Stylus .....	153
Wheatstone .....	58, 59	Viscosity, Disc .....	74
Leeds-Northrup .....	59	Composite IM Test Set .....	38
Maxwell .....	59	Computing Compliance of Pickup ..	75
Wien .....	44	Conn Strobe Frequency Indicator ..	48
Bridges .....	43	Constancy, Speed .....	167



Constant:				Waveform	9
Bandwidth	40			Efficiency Factors	120
Frequency Oscillator	180			Electrical Characteristics of Tape Head	76
Impedance Variable Phase Element	68			Electro-Acoustic Response	195
Control:				Electronic Filters	33
Gain	143			Electronic Switch as Square-Wave Generator	29
Microphone, Size of	207			Equalization Characteristics	134, 188
Phase Balance	95			Equalization Turnover	189
Controlled Sound Field	204			Equipment:	
Controls, Loudness	139			Complex	12
Core:				Test	13
Losses	120, 121			<b>F</b>	
Material, Analysis of	62, 63			Factor, Coupling	128, 131
Coupling Factor	128, 131			Factor, Damping	106
Cross-Talk	147			Factors, Efficiency	120
Crystal:				Feedback:	
and Ceramic Pickups	152			Amplifier, Clipping in	117
Gate Filter	38			Frequency Filter	33, 39
Strain-Gauge	156			Network, Twin-T	33
Current:				Field Radiation, Motor	176
Measuring Instruments	55			Filter:	
and Voltage	49			Crystal Gate	38
Curve, Distortion	95			High-Pass	98
Curves:				Mechanical	173
Cross-Talk	149			Narrow Bandpass	92
Frequency and Power Response	90			Twin-T	41
<b>D</b>				Filters:	
Damping:				Bandpass	32
Factor	106			Electronic	33
Viscous	166			Single-Frequency	32
Decade:				Third Octave	41
Attenuator	135			Fixed Frequency Disc	168
Calibrated Input Attenuator	26			Fletcher-Munson Characteristic	140
Deviation:				Fluctuating Capacitance	205
Bridge	43			Fluctuation, Air-Pressure	71
Phase	126			Flutter and Wow	169, 180
Slope	97			Flutter and Wow Meters	43
Diaphragm, Free Moving	201			Flutter, Overall Relative	181
Difference-Tone Intermodulation Measurement	102			Free Air Reciprocity	199
Differential Capacitors	95			Free Moving Diaphragm	201
Direct Reading:				Frequencies, Standard	46
Capacitance Checker	66			Frequency:	
Impedance Meter	67			and Power Response Curves	90
Directional Properties	210			Compensation	134
Directionality Pattern	204			Distribution, Hum and Noise	103
Disc:				Filter, Feedback	39
Compliance and Viscosity	74			Indicator, Conn Strobe	48
Rayleigh	71, 196			Oscillator Constant	179
Displacement Effect	207			Response	81, 121, 133, 152, 186
Distortion:				<b>G</b>	
Curve	95			Gain:	
Harmonic	90			Control	143
Hysteresis	144			Insertion	25, 86
Intermodulation	96			Power	85
Intermodulation and Harmonic	190			and Sensitivity	142
and Noise	214			Set	25, 82
Peak Clipping	35			Gap:	
and Saturation Current	111			Alignment	184
Distortion Meter:				Angle	183
Average-Reading	94			Magnetic Width, Measurement of	185
Harmonic	29			Trailing Edge, Record Head	186
Limitations of Harmonic	30			Generation of Tone-Burst	115
Drive, Constance-Speed	179			Generator, Square-Wave	27
Drysdale Bridge	59			Gradient, Pressure	208
Dummy Load	81			Groove Velocity	72
Dynamic:				Ground Loops	146
Characteristics, Tube and Transistor	77			Grounded-Emitter Transistor Amplifier, Setup for Measuring Data in	78
Mass and Compliance	157				
Range	146, 193				
<b>E</b>				<b>H</b>	
Effect:				Handling Tape	182
Displacement	207			Harmonic:	
of Housing	217			Distortion	90
of Supply Variation	108			Distortion Meter	29, 30
Ripple	113			Input	31
Effective Plate Resistance	122			Nature of	31
Effects:				Output	31
Ambient Noise	209			Harmonics and Hum	91
Harmonic Content of Test Oscillator	36				
Spurious	11, 126				

Hay Bridge	59
Head Impedance	186
Head Response	184
Hearing, Threshold of	141
Heterodyne Oscillator, Calibrating	16
Heterodyne Type Oscillator	15
High-Frequency:	
Bias	190
Performance	125
Transients	112
High Impedance	105
High-Pass Filter	98
Horizontal Compliance	159
Hot-Wire Ammeter	49
Housing, Effect of	217
Hum:	
and Crystal and Ceramic Pickups	175
and Harmonics	91
and Noise	102
and Noise, Frequency Distribution	103
and Noise Levels, Relative	145
Pickup	145
Hysteresis Distortion	144
Hysteresis Loop	64

## I

IM (see Intermodulation)	
Impedance:	
Admittance Bridge	70
and Resistance	58
Head	186
High	105
Input	104
Loops, Saturation	110
Low	105
Matching	85
Meter, Direct Reading	67
Output	106
Pickup	157
Reflection	108
Indicator, Level	188
Inductance:	
Leakage	125, 127
Measuring	61
Measuring with Hay Bridge	62
Input:	
Attenuator, Decade Calibrated	26
Harmonic	31
Impedance	104
Output Comparator Intermodulation	
Measurement	99
Resistance, Transistor	79
Insertion Gain	26, 86
Insertion Loss	120
Instrument:	
Calibration	47
Limitations	7
Rectifiers	52
Instruments, Current Measuring	55
Intermodulation:	
and Harmonic Distortion	190
Distortion	96
Measurement, Bridge for Mixing	87
Measurement, Input-Output	
Comparator	99
Test Meters	37
Test Set, Composite	38
Internal Self-Resonance	132
Inverter, Slit-Load	10
Isolation, Vibration	216

## L

Lateral Vibration	173
L-C Bandpass Filters	43
Leakage Inductance	125, 127
Leeds-Northrup Bridge	59
Level:	
Indicator	188
Maximum Density	192
Switch	26
Light-Pattern Calibration	73
Limitations:	
Instrument	7

of Harmonic Distortion Meter	30
of Square-Wave Tests	27, 28
Linear Scale Voltmeter	22
Lissajous Figures,	
Recognition Patterns	50, 51
Load:	
Dummy	81
Loop, Trapezoidal	124
Loading	10
Loading, Turntable	171
Logarithmic Scale	15
Logarithmic Scale Voltmeter	23
Longitudinal Magnitization	183
Loop, Hysteresis	64
Loop, Trapezoidal Load	124
Loss, Insertion	120
Losses, Core	120, 121
Losses, Playback	187
Loudness Controls	139
Low-Frequency:	
Measurements	26
Performance	122
Power-Handling Capacity	123
Transients, Waveforms for Testing	116
Low Impedance	105

## M

Magnetizing Current	110
Magnetization:	
Characteristics and Saturation	110
Longitudinal	183
Rate of Change	186
Tape	75
Margin, Stability	112
Mark-Space Ratio	57
Matching Impedance	85
Maximum Density Level	192
Maximum Magnetization, Tape	186
Maxwell Bridge	59
Measurement:	
of Choke Inductance	67
of Gap Magnetic Width	185
Techniques	7
Measurements:	
Basic	45
Tone Control	136
Measuring:	
Frequency Response,	
Audio Oscillator-Comparator	83
Harmonic Distortion	91
Inductance	61
Inductance with Hay Bridge	62
Phase Angle with the Oscilloscope	56
Voltage with the Oscilloscope	55
Mechanical:	
Filter	173
Impedance of Arm	158
Production of Warble Tone	205
Meter, Bias Current	191
Meter, Phase	57
Meters, Flutter and Wow	43
Microphone:	
Calibrating with Rayleigh Disc	72
Impedance	213
Pressure-Operated	208
Response, Calibration	197
Standard	203
Microphones	195
Microphones, Capacitor	198
Microphones, Cardioid	212
Microphony	149
Minimizing Standing Waves	206
Motor Field Radiation	176
Motors, Synchronous	168
Multiplier, Series	52

## N

Narrow Bandpass Filter	33, 92
Noise	145
Noise:	
and Distortion	214
and Hum	102
Null, Twin-T	42

<b>O</b>		<b>R</b>	
Ohmmeters	64, 65	Range, Dynamic	146
Oscillator:		Ratio, Mark-Space	57
Audio	14	Rayleigh Disc	71, 196
Beat-Frequency (Heterodyne)	16	Rayleigh Disc, Comparator Method	202
Heterodyne Type	15	R-C Oscillator, Single-Sweep	19
R-C	18	R-C Oscillators	18
Oscilloscope:		Reactance Arms, Direct Reading	
Calibration	93	Impedance Meter	68
Ellipses	56	Reactance, Mechanical	155
Used in Voltage Measurement	54, 55	Reciprocal Characteristics	198
Oscilloscopes	26	Reciprocity in Free Air	199
Output:		Recognition Patterns for Lissajous	
Harmonic	31	Figures	50, 51
Impedance	106	Record Head, Gap Trailing Edge	186
Source Resistance	106	Recorders, Tape	179
Transformers	119	Recording Voltmeter, Servo-Type	135
Transformer Specifications	127	Records, Test	152
Overall Relative Flutter	181	Rectified Bi-Phase Signal	24
Overall Relative Wow	181	Rectifier:	
<b>P</b>		Circuits, Audio Ac Meters	54
Parallel Filter	40	Reverse Resistance	53
Particle Velocity	196	Scaler Characteristic	52
Pattern:		Rectifiers, Instrument	52
Directionality	204	Reflection, Impedance	108
Polar	211	Reflections, Wave	197
Peak:		Relative Hum and Noise Levels	145
Clipping Distortion	35	Relative Output Level at Various	
Overload Check	117	Frequencies	7
Performance:		Residual Waveforms	92
High-Frequency	125	Resistance and Impedance	58
Low-Frequency	122	Resonance, Arm	151
Phase	56	Response:	
Phase:		Curves, Ultra-Linear Transformer	131
Balance Control	95	Electro-Acoustic	195
Deviation	126	Frequency	81, 121, 133, 186
Meter	57	Head	184
Response	212	Phase	212
Transfer	84	Power	88
Pickup:		Transient	212
Compliance	74	Reverse Resistance of Rectifier	53
Computing Compliance of	75	Rumble	172
Impedance	157		
Transfer Characteristic	154		
Wear	164		
Pickups:			
and Arms	151	<b>S</b>	
Crystal and Ceramic	152	Saturating Magnetizing Current	109
Plate Resistance, Effective	122	Saturation Current and Distortion	111
Playback:		Scaler Characteristic, Rectifier	52
Head Characteristics	76	Scale, Logarithmic	15
Losses	187	Scope Used to Measure Phase Angle	
Polar Pattern	211	(See also Oscilloscope)	56
Power:		Second Harmonic:	
Gain	85	in Quadrature	88
Handling Capacity, Low-Frequency	123	Transfer Curvature	89
Line as a Frequency Standard	46	Self-Capacitance	130
Output Characteristic	87	Self-Resonance, Internal	132
Response	88	Sensitivity:	
Supply Variations in	108	and Gain	142
Preamplifiers	133	to Hum Field	174
Preamplifiers:		Shadow Graph Measurement	156
Feedback	150	Series Multiplier	52
Stereo	147	Servo-Type Recording Voltmeter	135
Precision of Frequency Calibration	14	Set, Gain	82
Precision Substitution Bridge	69	Shadow Graph Measurement of	
Pressure:		Sensitivity	156
Gradient	208	Single-Frequency Filters	32, 33
Operated Microphone	208	Single-Sweep:	
Sensitive Microphone	196	Oscillator, Calibration	20
and Velocity, Relationship		R-C Oscillator	19
Between	209	Size of Control Microphone	207
Properties:		Slope Deviation	97
Acoustic	195	Sound Field:	
Directional	210	Calibration of	211
		Controlled	204
		Uniform	202
		Source Resistance, Output	106
		Specifications, Transformer	119
<b>Q</b>		Speed:	
Quadrature, Second Harmonic in	88	Constancy	167, 179
Values of Q	33	Torque Measurements	172
		Split-Load Inverter	10

Spring-Counterbalanced Arms	165
Spurious Effects	11, 126
Square Wave:	8
Generator	27
Generator, Electronic Switch as	29
Quantities of a	113
Testing	112
Tests, Limitations	27, 28
Stability Margin	84, 112
Standard:	
Current	49
Frequencies	46
Microphone	203
Standards	8
Standards, Subsidiary	8
Standing Waves, Minimizing	206
Stereo Preamplifiers	147
Strain-Gauge Crystal	156
Stroboscope	168
Stylus:	
Compliance	152
Performance	153
Transducer Coupling	155
Subsidiary:	
Standards	8
Supplies	109
Supplies, Subsidiary	109
Supply Variation, Effect of	108
Synchronous Motors	168
<b>T</b>	
Tachometer	182
Tape:	
Calibrated	181
Distortion Characteristic	187
Handling	182
Head, Electrical Characteristics of	76
Magnetization	75
Maximum Magnetization	186
Recorders	179
Transport	183
Techniques, Measurement	7
Termination	148
Test:	
Equipment	13
Frequencies, Choice of	39
Meters, Intermodulation	37
Records	152
Testing, Tone-Burst	114
Third Octave Filters	41
Threshold of Hearing	141
Tone:	
Burst, Generation of	115
Burst Testing	114
Control Measurements	137
Warble	204
Tracking Force	159
Transfer:	
Characteristic of Pickup	154
Characteristics	78, 101
Curvature, Second Harmonic	89
Phase	84
Transformer Specifications	119
Transformers, Output	119
Transient Response	212
Transients, High-Frequency	112
Transistor Dynamic Characteristics	77
Transistor Gain, Checking	79
Transistor Preamplifiers	148
Transport, Tape	183
Trapezoidal Load Loop	124
Tube and Transistor Dynamic Characteristics	77
Tube, Working Plate Resistance	107
Turnover, Equalization	189

Turntable Loading	171
Turntables and Changers	167
Twin-T:	
Feedback Network	33
Filter	41
Null	42
Two-Signal Audio Generator	37

## U

Ultra-Linear Operation	127
Uniform Sound Field	202
Utilization Features	163

## V

Vacuum-Tube Voltmeters	22
Variable-Phase Constant-Impedance Element	68
Variable-Slope Turnover	139
Velocity:	
and Pressure, Acoustic	71
Compensation	189
Groove	72
Light-Pattern Calibration of	73
Microphones	201
Particle	196
Sensitivity	210
Vertical:	
Compliance	159
Tracking Force	160
Vibration	173
Vibration:	
Isolation	216
Lateral	173
Vertical	173
Vibration Pickup	216
Viscosity	74
Viscous Damping	166
Voltage and Current	49
Voltage Changes	109
Voltmeter:	
Inaccuracies	9
Linear Scale	22
Logarithmic Scale	23
Voltmeters, Vacuum-Tube	22
Vtvm (see Vacuum-Tube Voltmeters)	

## W

Warble, Amount of	206
Warble Tone	204
Warble Tone, Mechanical Production of	205
Wattmeter, Audio	24
Wave Analyzers	38, 40
Wave Reflections	197
Waveform Effects	9
Waveforms:	
for Testing Low-Frequency Transients	116
Residual	92
Wheatstone Bridge	58, 59
Wien Bridge	44
Winding Capacitance	125
Wow and Flutter	169, 180
Wow Meters	43
Wow, Overall Relative	181
WWV	46

## Z

Zero Beat	16
-----------	----

Printed in the United States of America