

Erie

BLILEY ELECTRIC COMPANY

PENNSYLVANIA



FREQUENCY CONTROL
with
QUARTZ CRYSTALS

ENGINEERING BULLETIN E-6
PRICE 10 CENTS

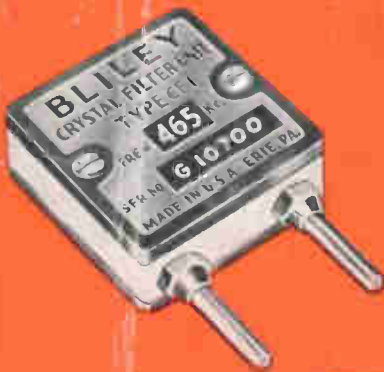

Frequency Control

WITH

Quartz Crystals

ENGINEERING BULLETIN E-6

This booklet, prepared by the engineering staff of the Bliley Electric Company, covers the general theory and application of quartz piezoelectric crystals. Its purpose is to provide engineers, experimenters and amateurs with information not otherwise easily obtainable in any one publication. Naturally, some of the material presented does not appear elsewhere.

No attempt has been made to recommend or to present specific designs complete with constructional details. The intent is to provide generalized information which will enable the reader to have a broad understanding of the subject. In this way, individual designs or problems can be attacked with better understanding and greater assurance of successful solution.

Extracts or reproductions of all, or any part, of this booklet are restricted to individuals or organizations to whom direct permission has been extended by the Bliley Electric Company.

Catalogs describing the complete line of Bliley Crystals, Holders and Ovens for amateur and general communication frequencies can be obtained from your distributor.

1st printing April, 1938
2nd printing August, 1938
3rd printing July, 1939
Revised edition October, 1940
6th Printing April, 1942

Table of Contents

	Page
Theoretical Considerations.....	2
Crystals at Anti-Resonance.....	4
Crystals at Resonance.....	5
Effects of Temperature.....	7
Modes of Vibration.....	7
Crystal Holders.....	8
Crystal Power.....	11
Crystal Activity.....	13
Crystal Cleaning.....	14
Crystal Controlled Oscillators.....	14
18 Mc. to 30 Mc. Crystal Oscillators.....	21
Low Frequency Oscillators.....	23
Oscillator Keying.....	25
Frequency Standards.....	27
Primary Standards of Frequency.....	27
Secondary Standards of Frequency.....	29
The Multivibrator.....	31
General Operating Notes.....	33

FREQUENCY CONTROL with QUARTZ CRYSTALS

THEORETICAL CONSIDERATIONS

Certain crystalline substances, such as quartz, Rochelle Salts and tourmaline, exhibit a most interesting property. In brief, if any one of these substances is distorted mechanically an electric charge will be developed; and, conversely, mechanical distortion will result if the substance is placed in an electric field. This property, the Piezoelectric Effect, makes possible precision frequency-control of radio transmitting equipment.

There are a surprisingly large number of crystalline substances which do exhibit piezoelectric properties but, out of the entire group, quartz is the only material which is truly satisfactory for frequency control purposes. Rochelle Salts exhibits the most intense piezoelectric properties but is not a suitable material for it is too unstable both physically and electrically. Tourmaline, a gem material, has been employed but due to its relatively high cost and the superior qualities of quartz, it is no longer in general use.

Quartz is silica (silicon dioxide) and is found throughout the world in many different forms. It appears most commonly in the sands

and sandstones of the earth and occurs in various rocks of igneous origin such as granite. Some varieties of quartz, including amethyst and rose quartz, are cut into gems and ornaments. Amongst its many commercial applications, quartz is used in the manufacture of piezoelectric devices, lenses, balance weights, chemical ware and abrasives. Because of its extremely low internal friction and small thermal expansion coefficient, quartz, fused and drawn into very fine threads, is highly valued for suspensions in scientific apparatus.

Quartz is an exceptionally hard material having a rating of 7 in Moh's Scale of Hardness where the diamond is rated at 10. It is very stable both physically and chemically; it is not affected by common acids and can be fused only with considerable difficulty. For general scientific and

piezoelectric applications, comparatively large natural crystals of high purity are required. Although natural crystals can be found in many different parts of the world, including the U. S. A., Brazil, at present, has the only suitable source of supply.

To take advantage of the piezoelectric effect of quartz, it is necessary to cut small "plates" from the raw natural crystals. These plates must be cut in certain definite directions with respect to the axes of the raw crystals, they must be free from mechanical and electrical flaws, and each must be carefully ground such that its major faces are essentially plane and parallel. If one of these plates is placed in an oscillating electric field, it will vibrate mechanically and produce a counter-voltage at the frequency of the applied field. The magnitude of this action will be quite small, but, should the frequency of the applied field be adjusted to correspond with a natural vibrating period of the plate, the vibrations will become vigorous and have an appreciable amplitude. In fact, should the strength of the applied field be sufficiently great, the vibrations can easily become so strong that the plate will be physically ruptured.



Figure 1—Group of Natural Quartz Crystals

This same plate, if distorted by physical force, will develop an electric charge. If the plate is X-cut (that is, the planes of its faces perpendicular to the direction of one of the side faces of the natural crystal and parallel to the axis of the crystal along its length and through the peak) and the force is normal to the major faces, the charge developed will be very nearly 10^{-11} coulombs per pound (6.36×10^{-8} e.s.u./dyne). This charge will be essentially independent of crystal face area or thickness and of temperature for any value up to about 550°C .; at 573°C ., piezoelectric action will cease. For pressure measurement purposes, the amount of charge, or the voltage resulting from the charge, can be determined. The voltage is, of course, proportional to the charge divided by the circuit capacity ($Q = CE$).

It is most important that a finished quartz plate be entirely free from mechanical or electrical flaws if best results are to be obtained. If flaws are present, the crystal cannot vibrate freely and, as a result, it may oscillate very weakly or not at all. Should the crystal be intended for measuring pressures or forces, flaws can greatly decrease the developed charge and can cause the crystal to fracture under a relatively light mechanical load.

Flaws which commonly appear in the raw quartz are bubbles, needles, veils, strains, fractures, phantoms and twinning. Bubbles are a physical defect in the quartz material and appear in random sizes and formations. Veils and needles are small bubbles and striations occurring in groupings which suggest the descriptive terms given to them. Strains are permanent internal stresses which cannot be relieved. Fractures are definite cracks caused during formation of the crystals or by physical breakage during mining and handling. Phantoms are a variation in cross sectional appearance of the quartz such that, to the eye, one crystal appears to have grown inside another; they are apparently the result of a change in growth of the crystal during formation. Twins are the definite result of one crystal growing within another, either totally or partially.

Practically all natural quartz has at least some of the possible flaws outlined. To prevent the appearance of these flaws in the final product, the raw quartz must be very carefully selected and then only the sound portions used.

Finished quartz plates are popularly termed 'crystals' and will be so designated throughout this book. The greatest practical value of quartz crystals is derived from the unusual fact that they can be produced as mechanical vibrators having electrical characteristics not fully attainable by any ordinary electrical circuit or component. In radio-frequency oscillatory systems, the quartz crystal has no peer for determining and maintaining circuit frequency. In filter circuits, where it is desired to pass only a relatively narrow band of frequencies, great simplification and better results can be obtained through the use of quartz crystals.

The electrical action of an oscillating quartz crystal may be most readily analyzed by reference to its equivalent electrical network as shown in figure 2. This equivalent network, while theoretical in nature, can be used to exactly define the electrical behavior of a crystal. As a matter of fact, it provides the basis for mathematically designing certain types of crystals prior to their manufacture. The inductance, L , represents the mass of the crystal, the capacity, C , the resilience, and the resistance, R , the frictional losses. C_1 , is the capacity due to

the crystal electrodes with the crystal as the dielectric while C_2 represents the series capacity between the crystal and its electrodes.

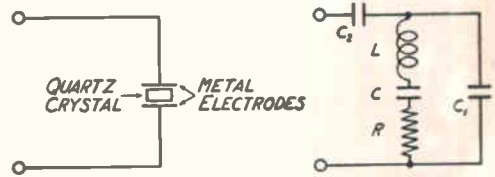

Figure 2—Equivalent Electrical Circuit of the Oscillating Quartz Crystal

Neglecting C_2 , it should be noticed that the equivalent electrical network made up of L , C , C_1 , and R has the properties of either a series or a parallel resonant circuit. At some definite frequency, for a given crystal, the reactances of L and C will be numerically equal. This is the requirement for a series resonant circuit and the frequency at which this resonance occurs is the series resonant or natural frequency of the crystal. At a slightly higher frequency, the effective reactance of L and C combined will be inductive and numerically equal to the reactance of C_1 . At this frequency anti-resonance occurs and the crystal acts as a parallel or anti-resonant electrical circuit. C_2 is only effective when the crystal electrodes are not in intimate contact with the crystal faces. As the value of C_2 is decreased, the resonant frequency will increase.

The inductance, L , of quartz crystals is very large; it varies from 0.1 henry to 100 henries with individual crystals and depends on the manner in which the crystal is cut from the raw quartz, its physical proportions, and the frequency. Because the inductive reactance, X_L , is many times greater than the resistance, R , quartz crystals have a very high Q factor [$Q = (\frac{2\pi FL}{R})$]. Commercially produced crystals have Q factors ranging from about 6000 to about 30,000 while, under laboratory control, crystals with Q factors up to 400,000 have been reported.

In an oscillator circuit operating at radio frequencies, the frequency stability is largely determined by the Q of the frequency determining 'tank'. The Q of quartz crystals is many times greater than can be obtained with conventional inductance-capacity tanks, and it follows, therefore, that crystal frequency-control offers the highest degree of frequency stability. In explanation, it may be pointed out that the oscillating frequency of a conventional oscillator circuit is that frequency at which the total circuit reactance reduces to zero. Any circuit changes caused by varying voltages,

aging of the tube or circuit components, or other causes, necessitates a change in frequency to again bring the net circuit reactance to zero. Because quartz crystals have a very steep resonance curve, a large change in reactance can be brought about with only a small shift in circuit frequency.

CRYSTALS AT RESONANCE

In oscillator circuits, employed for the majority of radio transmitter installations, the crystal operates in the same manner as a parallel, or anti-resonant, electrical circuit. For this reason, quartz crystals employed for frequency control of vacuum tube oscillators usually are calibrated at their anti-resonant frequencies.

The effective value of the capacity, C_1 , changes when a crystal is placed in a vacuum tube oscillator circuit. In the theoretical analysis, C_1 represents the capacity between the crystal electrodes with the crystal acting as the dielectric. When, however, the crystal is connected in an actual circuit, the value of C_1 will vary with different crystal holders and will, in addition, be affected by the dynamic input impedance of the oscillator tube and the capacity added by connecting wires between the crystal and the tube. The impedance in the plate circuit of the tube will, naturally, also influence the dynamic impedance of the grid circuit to an extent dependent on individual operating conditions.

It is evident that the total capacity added to C_1 by the oscillator will vary between different circuits and layouts, thereby causing the crystal frequency to assume different values in each particular oscillator setup. Because of the possible variations in frequency, Bliley Crystals normally are guaranteed to operate within a certain variation from the calibrated frequency (generally .02%-.03%, including customary manufacturing frequency tolerance) when operated in the purchaser's equipment despite the fact that each crystal is accurately calibrated in the manufacturing laboratory. The crystals are, for the same reason, supplied complete with holders only. For details concerning crystal specifications to meet definite frequency accuracy requirements, reference should be made to Bliley Catalog G-12. This publication contains pertinent information relative to the choice of crystals and mountings for all services other than amateur.

When a quartz crystal is required for a specific service or application where frequency accuracy is most important, the possible change in frequency between the manufacturer's calibrating oscillator and the final equipment must be considered. This

is especially important where the allowable frequency tolerance is very small.

By taking advantage of the fact that the parallel capacity will influence the frequency of a crystal, it is possible to include a variable frequency feature. This is invaluable to radio broadcast services in the standard broadcast band where the carrier must be held within 20 cycles of the assigned value. It is an equally valuable feature in many other services where the frequency must be held within close limits and in amateur service where a simple method of shifting the station frequency often permits contacts under ordinarily impossible conditions of interference.

There are two methods of effecting the change in the oscillating frequency of a crystal operating at, or near, anti-resonance. The obvious arrangement is to connect a variable air-condenser in parallel with the crystal to bring about a variation in C_1 , (figure 2). As the capacity of the condenser is increased, the frequency will be lowered until the capacity becomes sufficiently large to effectively short out the crystal. In any event, the added capacity will 'load up' the crystal thereby decreasing its oscillating ability. For small ranges of frequency adjustment the effect of the condenser will not be harmful, however, and the decrease in the oscillating properties of the crystal is readily offset by the variable frequency feature. This method of shifting the frequency is generally applied with crystals higher than 2000kc. but can be used at lower frequencies if desirable. At the very high frequencies it is not particularly satisfactory because the amount of capacity sufficient to stop oscillation is quite small. This, of course, greatly limits the amount by which the frequency can be varied.

A variable air-gap crystal holder offers the most convenient method for shifting frequency. In a typical holder of this type, one of the crystal electrodes is mounted on a micrometer screw such that the electrode may be raised or lowered over the crystal. This brings about a simultaneous change in the values of C_1 and C_2 (figure 2). When the air-gap between the movable electrode and the crystal is increased, the frequency will be raised with an accompanying decrease in oscillating properties. For small ranges of frequency adjustment, the detrimental effect of the air-gap is not serious and the only essential consideration is that the crystal be used in a circuit where the driving voltage will not reach high values. Unless this precaution is taken, an arc will be developed across the air-gap causing erratic oscillation and, sometimes, damaging the crystal because of the concentrated heat of the arc.

CRYSTALS AT RESONANCE

The impedance of a quartz crystal, in the region near its natural frequency, is lowest at the resonant frequency and highest at anti-resonance. At frequencies remote from these values the crystal acts merely as a fixed condenser. This is illustrated by the representative reactance curve shown in figure 3. The property of a crystal to act as a resonant circuit, with an extremely rapid increase in impedance on either side of resonance, is most useful in radio frequency filters and for frequency control of certain types of oscillator arrangements.

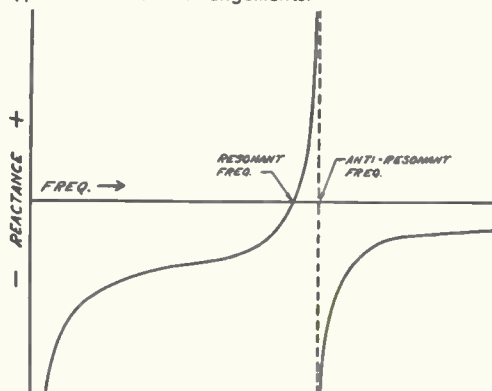

Figure 3—Reactance Curve of a Quartz Crystal

Relaxation oscillators, which rely on the time constant of resistance-capacity networks, have characteristics which are desirable in some applications. Such oscillators are mechanically simple and have a high harmonic output but are not very stable. They can, however, readily be stabilized by substituting a quartz crystal for one of the coupling condensers. The crystal, acting as a resonant circuit, determines and controls the frequency of oscillation. Because of practical limitations in obtaining resistance-capacity combinations with a very short time constant, circuits of this type are limited to frequencies below about 150kc.

Another arrangement, more widely used, employs an inductance-capacity tank with the crystal connected directly into the tank circuit. This is the modified Colpitt's Oscillator shown in figure 16 and discussed in the section LOW FREQUENCY OSCILLATORS. The crystal acts as a filter and controls the frequency of oscillation by virtue of its impedance-frequency characteristic. Circuits of this type are outstanding for high frequency stability and, for that reason, are used in precision frequency standards.

The frequency of a crystal oscillating purely at resonance cannot be varied by means of a parallel condenser. It can, however, be shifted by effecting

a change in C_0 (figure 2). This may be accomplished with a variable air-gap holder or by connecting either a variable air-condenser or an inductance in series with the crystal. Increasing the value of a series inductance will lower the frequency while an increase in frequency will result if the capacity of a series condenser is decreased. A series condenser, with its greater stability and ease of adjustment, provides more satisfactory control than a variable inductance. Whether a condenser or an inductance is used, it must be stable in itself or the frequency stability brought about by the use of a quartz crystal will be considerably lessened. The amount of possible frequency adjustment is limited by the fact that the impedance of the series element reduces the voltage across the crystal (excitation) and by the natural consequence that circuit frequency stability is lowered as the series impedance is increased.

The resonant properties of quartz crystals are advantageously employed in modern communications receivers to obtain a very high degree of selectivity. Since crystals ground for filter purposes have an extremely high Q (9000 to 16,000) the frequency discrimination, or selectivity, will be many times better than could be obtained with ordinary tuned circuits. As a matter of fact the selection is so great that it is not difficult to limit the pass band to 50 cycles.

Figure 4 shows the fundamental arrangement of a quartz-crystal-filter stage in a modern super-heterodyne communications receiver. It will be noticed that the tapped transformer, the crystal, and the variable condenser, C_1 , form a bridge circuit. The use of a tapped transformer can be avoided by employing a dual condenser for C and grounding the common connection between the two; the final effect, however, is the same. At frequencies remote from the resonant frequency of the crystal, the bridge circuit is balanced and no voltage appears on the grid of the following amplifier tube. When, however, the transformer voltage is at the resonant frequency, the crystal

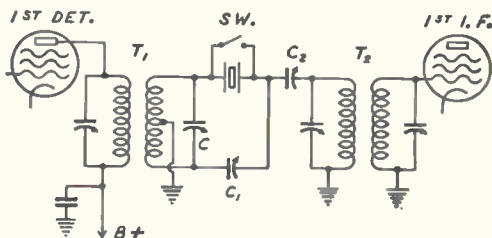

Figure 4—Quartz Crystal Filter Circuit

C_1 —Phasing control; 20 mmf.— 30 mmf.
 C_2 —Coupling control for impedance matching; 50 mmf.

impedance drops to a low value thereby upsetting the balance and permitting a signal voltage to appear on the grid of the amplifier tube.

Despite the apparent simplicity of the filter circuit, an exact analysis of its operation is most difficult; practically all filters of this type are designed empirically on the basis of experimental data. For a basic understanding of the principles involved, however, it is convenient first to assume that the bridge is perfectly balanced. The lower portion of the bridge, including the balancing condenser C_1 , can then be ignored for practical purposes. It now can be seen that the induced voltage in the upper half of the secondary of transformer T_1 is in series with the impedance of the transformer secondary, the crystal, and the output transformer T_2 as shown in figure 5.

An inspection of figure 5 reveals that a voltage divider exists such that the output signal voltage is proportional to $\frac{Z_{T_2}}{Z_{T_1} + Z_C + Z_{T_2}}$. The impedance of the crystal, Z_C , is, of course, a variable highly dependent on frequency and, on this fact, is derived the circuit action. If Z_{T_1} and Z_{T_2} are chosen to have high values, the effect of the varying Z_C is lessened and the selectivity is relatively broad. Likewise, if the impedances are low, the influence of Z_C is pronounced and selectivity is high. As a matter of fact, it is an easy matter to realize high selectivity whereas it is difficult to reduce the selectivity to a point satisfactory for reception of radiotelephony.

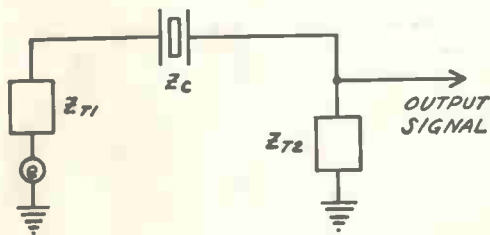

Figure 5—Simplified Filter Circuit

In the foregoing discussion, it has been presumed that the induced voltage would be the same regardless of total circuit impedance and that the impedances Z_{T1} , Z_{T2} , possess constant values independent of frequency. This, of course, is not strictly true. A full consideration of the vectorial values of all impedances and the magnitude of input voltage would, however, greatly complicate an initial analysis without altering the generalized conclusions.

It is generally understood that transformer T_1 should not be tuned to exact resonance if maximum

selectivity is to be realized. This is due to the fact that the secondary impedance is highest at that point, thereby causing an actual decrease in selectivity because of the voltage divider action; sharpest selectivity occurs with the transformer slightly detuned such that the developed voltage is still high but the secondary impedance is lowered. Advantage of this influence on filter sharpness can be taken to establish a degree of control over selectivity. The procedure is to provide a panel control for the secondary tuning condenser of T_1 so that the secondary impedance can be varied by tuning.

The impedance and impedance-frequency characteristic presented to the filter circuit by T_2 will, naturally, also influence selectivity. This is advantageously employed for controlling selectivity by the insertion of a variable resistance in series with the primary winding of T_2 .¹ The variable resistance alters the Q , or impedance-frequency characteristic, resulting in variable selectivity. By means of the voltage divider theory, and taking into account the variation of Z_C and Z_{T_2} with frequency, it can be shown that maximum selectivity occurs at lowest Q while minimum selectivity results when the resistance is entirely out of the circuit.

Condenser, C_1 , usually termed the phasing control, is primarily for the purpose of balancing the bridge circuit. It does, however, have some influence on selectivity when set away from the balance position. It will be noted from figure 4 that the phasing condenser, in series with the crystal holder capacity, is in parallel with the secondary of T_1 . This means that C_1 has an influence on the tuning of T_1 . Such influence is, as a matter of fact, undesirable for best filter performance and is normally minimized by keeping the crystal holder capacity at a low value. A further divorcing of the effect can be accomplished through the use of a so-called constant-capacity variable condenser.² Such a condenser has two rotor sections ganged oppositely; that is, when one condenser section is approaching maximum capacity the other is nearing minimum capacity. The net series capacity of such an arrangement can be made to remain substantially constant with rotation, and, if the common rotor terminal is connected to the crystal, one stator to the lower end of T_1 and the other stator to ground or to the upper end of T_1 , little detuning by the phasing control will occur. Of course, without detuning present, the phasing control will have little or no influence on overall selectivity.

When the phasing control is set for bridge balance, signals on either side of the crystal resonant frequency will be almost equally attenu-

¹ See OST, December, 1938, page 33

² See OST, September, 1937, page 24

ated. If, however, the control is set somewhat away from balance position, the attenuation at some side frequency will be considerably increased. This is a useful feature in communications because it enables the operator to emphasize attenuation on a particular interfering signal whose frequency is close to the one desired.

The action of the phasing control in rejecting signals is simply a matter of circuit balance. For any particular setting of the phasing control, other than for perfect balancing of the crystal holder capacity, there will be one frequency which will be passed in nearly equal magnitude, but in opposite phase, through the crystal arm and through the phasing control arm of the filter circuit. Because the voltage in each arm is out of phase at the common terminal, cancellation occurs. Whether the rejection point exists above or below the resonant frequency of the crystal depends, of course, on the actual capacity of the phasing condenser with respect to the capacity required for perfect bridge balance.

EFFECTS OF TEMPERATURE

The frequency of a crystal is influenced to an appreciable extent by the temperature at which it is operated. The magnitude of this effect is determined by the manner in which the crystal is cut from the natural quartz, the shape and size of the crystal, the precision of grinding, and the characteristics of the quartz itself. It is expressed as the number of cycles change per million cycles of crystal frequency per degree Centigrade variation in temperature and is termed the temperature coefficient of frequency or the frequency-temperature coefficient. A positive (+) temperature coefficient indicates that the crystal frequency increases with increasing temperature, whereas a negative (—) coefficient indicates that the frequency will decrease with increasing temperature.

The frequency-temperature coefficient of a quartz crystal varies, with individual cuts, from minus 25 to plus 100 cycles per megacycle per degree Centigrade. With X-, C-, or E-cut crystals, the frequency at any temperature can be determined from a knowledge of the frequency-temperature coefficient and the crystal frequency at any other temperature. Such calculations are not accurately possible with low frequency-temperature coefficient crystals (often referred to as "zero" temperature coefficient crystals) because the curve of frequency versus temperature is not generally a straight line; in fact, the coefficient may be positive over one part of the total temperature range and negative over other portions. It is

commercial practice, with these crystals, to state the average frequency-temperature coefficient over a given range of temperature (generally 20°C. to 55°C.).

The operating temperature of a crystal is dependent on the ambient temperature, the amount of heat developed by the crystal in oscillating and the rate of heat dissipation by the crystal holder. It can be seen, therefore, that for highest frequency stability, unless automatic temperature control is employed, a crystal holder having high heat dissipating abilities should be used. In addition, the intensity of vibration should be maintained at the lowest possible value to keep the developed heat at a minimum. Where a very high degree of frequency stability is required, the crystal temperature should be controlled by a constant-temperature oven.

MODES OF VIBRATION

Any quartz crystal has two, and sometimes three, widely separated possible frequencies of oscillation. This is due to the fact that a vibrating body of this general type can be caused to vibrate in at least two different manners (modes). Furthermore, an improperly finished plate-type crystal may have one or two additional frequencies close to the thickness frequency. This is possible when the faces are insufficiently plane and parallel such that the crystal may oscillate at slightly different frequencies over small portions of the surface.

By properly choosing the mode of vibration, it is possible to manufacture quartz crystals of practical dimensions over a very wide frequency range. In the present state of development, they are produced in the full range from 16kc. to 30,000kc.

X-cut plates, also known as the Curie Cut, were the first type of quartz oscillating crystals to be developed. These crystals oscillate through the thickness at a frequency largely determined by that dimension. They have a negative frequency-temperature coefficient which ranges from 20 to 25 cycles per megacycle per degree Centigrade. The manufacture of X-cut plates is practical for frequencies from 250kc. to about 10,000kc.

For the lower radio frequencies from 16kc. to 250kc., the physical dimensions of X-cut plates, and other plate-type crystals, become too great to be practical. To reduce the crystal size to satisfactory dimensions, the crystals are cut as "bars" in which one dimension is considerably greater than the remaining two. Such crystals oscillate along the greatest dimension and their oscillating frequency is largely controlled by that dimension. When

properly designed, X-cut bars have a negative frequency-temperature coefficient ranging from about 4 to 15 cycles per megacycle per degree Centigrade.

Y-cut plates, which oscillate in shear, can be made in the frequency range from 200kc. to about 8000kc. A simple illustration of shear vibration can be performed by sliding the palm of one hand back and forth over the other. This, however, is not a perfectly true picture since the center plane in such a crystal is theoretically motionless while the two outer faces have maximum motion in opposite directions (see figure 6). The frequency-temperature coefficient of Y-cut plates is positive and can be from 60 to 100 cycles per megacycle per degree Centigrade. This high frequency change with temperature, coupled with the fact that the crystals will suddenly change frequency at various points over a wide temperature range, has caused the use of Y-cut crystals to be discontinued in favor of other types.

Both X- and Y-cut crystals in the frequency range from 85kc. to 10,000kc. have been almost entirely superseded by low frequency-temperature coefficient crystals. These crystals, which oscillate in shear, have a very small frequency change with temperature thereby affording excellent frequency stability under varying temperature conditions.

Three types of low temperature coefficient crystals are employed to cover the entire frequency range, each type being particularly suited to its own range. From 85kc. to 400kc. special bar-type crystals,³ developed by Bliley Engineers, are employed. A-cut plates are used from 400kc. to 4000kc. and B-cut plates from 4000kc. to 11,000kc. A- and B-cut plates have similar electrical characteristics but the B-cut plates are better for the higher frequencies since they have, for a given frequency, a considerably greater thickness than the A-cut plates.

Above 11,000kc., fundamental low-drift plates become quite thin and fragile. The upper frequency range of such crystals is, however, extended to 18,000kc. by using A-cut plates and finishing them such that they can be excited at the third harmonic of their fundamental frequency. Such crystals are most practical but do not oscillate quite as freely as the fundamental plates (refer to section entitled CRYSTAL ACTIVITY). In figure 6 is illustrated the motion of a shear oscillating crystal at the fundamental and at the third harmonic.

The Bliley C⁴ and E-cut⁵ crystals were developed to increase the upper frequency limit of quartz oscillating crystals. These are harmonic-type crystals

cut and finished such that they are excellent oscillators at the calibrated harmonic frequency. C-cut crystals, which have a frequency-temperature coefficient of plus 20 cycles per megacycle per degree Centigrade, are employed to cover the frequency range from 11,000kc. to 23,000kc. E-cut crystals, which have a frequency-temperature coefficient of plus 43 cycles per megacycle per degree Centigrade, are thicker, for a given frequency, than any other crystal and are used to cover the frequency range from 23,000kc. to 30,000kc.

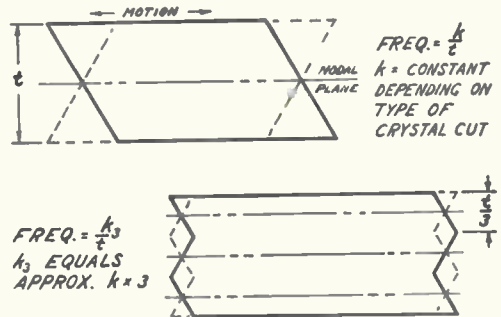

Figure 6—Illustration of Fundamental and Third Harmonic Shear Vibration

An interesting fact concerning harmonically vibrating crystals is that a strict harmonic relation does not exist between the fundamental and the working frequency. That is, the working frequency is not necessarily exactly three times the fundamental in a third-harmonic crystal. The variation from a true harmonic relationship is caused by the difference in the manner of vibration and is not constant for all crystals; the frequency deviation between the third harmonic and three times the fundamental can be as high as 50kc.

CRYSTAL HOLDERS

As previously pointed out, the resonant and antiresonant properties of a quartz crystal are manifested when the crystal is placed in a radio frequency field. This is true whether the field is produced by an external source of energy or by feed-back action in an oscillator circuit. The direct, and obvious, method of producing the necessary field is to place the crystal between two metal electrodes connected to the source of radio-frequency potential. The complete assembly consisting of the two electrodes and a dust-proof insulating body is known as a crystal holder or crystal mounting. The crystal holder, when supplied complete with a calibrated crystal, is termed a crystal unit.

³ Patent No. 2,213,031

⁴ Patent Pending

⁵ Patent No. 2,157,808

There are four types of crystal holders in general use today: (1) pressure mountings, (2) air-gap mountings, (3) knife-edge mountings, and (4) temperature-controlled mountings. An additional type is the pressure-air-gap which combines 1 and 2.

The pressure-type holder is best suited for installations where the crystal is to develop comparatively high potentials or where the mounting will be subject to external vibration or shock as would be encountered in mobile or portable applications. In the pressure holder, the electrodes are maintained in intimate contact with the crystal faces under pressure exerted by a spring. Holders used with a wide range of crystal frequencies sometimes are provided with a variable spring pressure feature such that optimum pressure can be obtained for each particular crystal. Crystal units manufactured in production for a given frequency, or a given band of frequencies, often incorporate fixed electrode pressure since the optimum pressure can be predetermined and does not vary widely from crystal to crystal.

Pressure holders are suitable for frequencies from 400kc. to 30,000kc. In the frequency range from 400kc. to about 7000kc., both electrodes have essentially the same face area as the crystals. At higher frequencies, however, one electrode is made in the form of a disc, generally with a diameter in the neighborhood of $\frac{1}{2}$ inch, so as to reduce the holder capacity (C_1 , figure 2). This reduction of capacity promotes better crystal oscillation.

To offset the obvious difficulty of manufacturing a disc electrode holder having high mechanical stability (which is a requisite for stable crystal performance) a new type of disc electrode⁶ was developed by Bliley Engineers. This electrode is formed by recessing a portion of the active face of a full sized electrode such that the remaining center portion has the shape of a disc while a small raised section remains at each extreme corner. The relieved area reduces holder capacity, the center section acts as a disc electrode in the usual manner, and the corners serve to clamp the crystal for mechanical stability. This type of electrode is employed for frequencies up to 11,000kc. At higher frequencies, the simple disc electrode presents the only practical arrangement.

In the air-gap crystal holder, there is an air gap between the crystal and either one, or both, of the electrodes. Holders of this type, which are manufactured for oscillator frequency control crystals, are generally provided with a means for varying the spacing of the air gap. This is usually accomplished by attaching one electrode to a mi-

cometer screw such that the electrode can be moved in a direction parallel to the plane of the crystal faces. A variation of this arrangement, employed in 80-meter and 40-meter amateur frequency crystal units (Bliley types VF1 and VF2), makes use of an adjustable angular air gap.⁷ The angular air gap, by discouraging arcing and greatly reducing the detrimental effects of air-gap air resonance, extends the usefulness of the crystal for variable frequency purposes. This arrangement is superior to the parallel air gap where the crystal is expected to develop comparatively high potentials and where a relatively wide adjustable frequency range is wanted. The holder design does not, however, readily lend itself to the precise mechanical assembly possible with the parallel air-gap mounting. For this reason, the use of the angular air-gap holder is largely confined to amateur applications for which it is admirably suited.

The specific advantage of the variable air-gap holder lies in the fact that the oscillating frequency can be varied over an appreciable range. This is a most convenient feature in applications where the oscillating frequency must be accurately maintained within very close limits of a specified value. It is not always conveniently possible to finish a crystal directly for each particular transmitter but, through the use of a variable air-gap holder, the crystal can be calibrated in a standard test oscillator. The station engineer can then make any necessary readjustments of frequency simply by changing the air-gap setting.

The variable air-gap holder is particularly useful in amateur transmitting equipment for the purpose of shifting frequency to avoid severe interference. It is equally advantageous for operating near the edge of any band of frequencies because the operator can set his frequency much closer to the edge than would be possible by working with a fixed-frequency crystal.

Variable air-gap holders can be used with crystals from 100kc. to 11,000kc. At frequencies much above 5000kc., however, the holder must be very carefully manufactured and special efforts taken in the finishing of the crystal. In view of the limited frequency swing which can be realized at high frequencies, the major advantage in the use of a variable air-gap holder is in enabling the manufacturer to work to a closer finishing frequency tolerance.

The total frequency range over which a crystal can be adjusted by means of an air gap varies with frequency and is somewhat dependent on the amount of circuit capacity appearing in parallel with the crystal. At 4000kc., with a type VF1

⁶ Patent Pending

⁷ Patent No. 2,079,540

unit, the range is about 6kc. while with a type VF2 unit, the range is extended to 12kc. The frequency swing obtainable with the parallel-gap holder, which is used primarily for fixed frequency operation, is considerably less than with the angular gap mounting. With either arrangement, as the air gap is increased, the effective activity of the crystal is decreased (refer to section entitled CRYSTAL ACTIVITY). If the air gap is made too large, the crystal will not oscillate.

Fixed air-gap holders, in the exact sense of the term, are not widely used. Their application is confined mostly to crystals at relatively low frequencies where the cost of a variable air-gap or knife-edge holder is not warranted for the particular application (low frequency crystals are quite sensitive to electrode pressure and, accordingly, are best mounted in an air-gap or knife-edge holder). Mechanically, the fixed air-gap holder consists of two electrodes spaced apart by insulating washers or by an insulating ring. The distance between the electrodes is made a few thousandths of an inch greater than the crystal thickness creating, thereby, the fixed air gap.

In modified form, the fixed air-gap mounting is rather extensively applied in pressure-type holders. An oscillating quartz plate seldom vibrates uniformly over its entire facial surfaces; maximum motion usually occurs at the central area and minimum motion exists at the corners. This means that it is possible to apply greater pressure at the corners than at the center before vibration will be impeded. An obvious method for taking advantage of this fact to increase mechanical stability and to improve general performance is to cut away the central portion of the holder electrodes. This results in the development of a fixed air gap (no electrode pressure) over the major portion of the crystal faces while permitting high pressure to be applied at the extreme corners of the crystal. A practical further modification consists of distorting the electrodes such that the faces toward the crystal are concave surfaces. Either method is applicable to crystals having frequencies from 400kc. to about 7000kc. At higher frequencies, the modified disc electrode previously described, is applied.

The principle of corner clamping can also be followed with variable air-gap mountings in which it is usual practice to locate the crystal with respect to the electrodes by means of a loosely fitting retainer ring. In this case, a ring or frame is used to apply pressure only to the corners of the crystal while leaving the center free for the variable upper electrode. By clamping the crystal in such a manner,

small frequency changes, which could occur by shock or vibration causing displacement of the crystal relative to its electrodes, can be eliminated. Corner clamping for air-gap mounted crystals is practical for frequencies above approximately 1500kc.

The knife-edge holder is applicable to bar type crystals in the frequency range from 16kc. to 275kc. Briefly, the crystal electrodes are formed directly on the crystal faces with a pure metal, generally silver, and the crystal is rigidly supported between knife-edges placed at a nodal point (position on the crystal where zero motion exists as a result of standing waves). Knife-edge mounting is advantageous because fairly heavy shocks cannot harm the crystal or change its frequency and because the crystal activity is less affected by the holder than by other types. Furthermore, the crystal never requires cleaning.

Temperature control is employed where the crystal frequency must be held essentially constant under widely varying temperature conditions. Temperature-controlled mountings combine an automatic temperature control feature with a crystal holder. The holder generally consists of a large metal block, whose temperature is regulated by a heater and thermostat, a second electrode and an enclosing protective casing. The crystal holder proper can be variable air-gap, variable- or fixed-pressure, or knife-edge mounting. Temperature control can also be accomplished by placing any type of crystal holder in a box-type constant temperature oven. The box-type oven possesses the closest degree of temperature regulation since better heat distribution and insulation is possible. The self-contained temperature controlled mounting is, however, more regularly employed because of its compactness and lower cost. When used with low-drift crystals, it is adequate for all applications but those requiring the utmost in frequency stability.

Stainless steel, Monel metal and Duralumin are the metals most commonly used for the electrodes in crystal holders. The choice of material is based on corrosion resistance, machinability, uniformity, hardness, freedom from warpage and lack of foreign substances, such as oil, which might work out from the metal and interfere with normal crystal performance. Stainless steel is most widely used and is usually heat treated to discourage warping. In temperature-controlled mountings, where thermal conductivity is an important factor, Duralumin is employed

CRYSTAL POWER

An oscillating quartz crystal is a mechanically vibrating body. Internal stresses are present and heat is developed as a result of the motion. If the vibration amplitude is permitted to become great, the stresses can reach a value sufficient to shatter the crystal and, thereby, destroy its oscillating properties. The shattering is a physical rupture of the quartz and is brought about by the crystal literally tearing itself to pieces under the extreme stresses set up by the vibrations. Typically, the rupture appears as a ragged crack, or series of cracks, in the crystal. In some instances, especially with harmonic-type crystals, the fracture may occur at a single point as though the crystal had been punctured by high voltage.

The heat developed by an oscillating crystal is the direct result of frictional losses. Heating is undesirable for it causes the crystal temperature to change while the crystal is oscillating. The change in temperature brings about a corresponding frequency shift such that the frequency will 'drift' as the crystal warms up. Naturally, the amount of frequency drift is determined by the frequency-temperature coefficient of the crystal and by the final operating temperature attained.

Crystals having a high frequency-temperature coefficient are best stabilized by employing automatic temperature control but this, of course, increases the cost of the transmitter. If temperature control is not used, the crystal should be operated at a low amplitude of vibration and the holder should have good heat dissipating abilities. A simple, but effective, expedient is to mount the crystal holder with the heat dissipating surface in contact with the metal chassis of the transmitter or in contact with a metal block, preferably of copper or aluminum. Where the heat dissipating surface is in electrical contact with one crystal electrode, that electrode should be at ground potential.

At any given frequency, the vibration amplitude of a crystal is a direct function of the radio frequency voltage which it develops, or of the radio frequency voltage applied to it (excitation). The amplitude is also a function of the current through the crystal but only directly so under conditions of constant phase angle between the current and the exciting voltage. The phase angle varies between different types of circuits and, also, with the individual conditions in any one circuit. The error introduced by change in phase angle is small, however, and may be neglected for all practical purposes. Since accurate measurement of radio-frequency voltages is generally inconvenient, it is accepted practice to rate quartz oscillating crystals

for power limits by a statement of the maximum safe crystal current.

In frequency multiplying circuits where there is a cathode tank or condenser which carries currents at both the fundamental and harmonic frequencies, regeneration at harmonic frequencies is obtained. As the crystal circuit then carries currents both at the fundamental and harmonic frequencies, the crystal current will be somewhat higher than if only the fundamental current were present. The harmonic current does not contribute to the crystal excitation and the current reading will, therefore, infer a greater amplitude of vibration than actually exists. For practical purposes, it is fortunate that the crystal current reading is increased by the presence of the harmonic current; if the current actually flowing is assumed to fully indicate the excitation to the crystal, it is certain that the crystal is not being excited in excess of the indications.

The presence of parasitic oscillations in an oscillator will also increase the reading of the crystal current. Parasitics are not only undesirable from the standpoint of stability and efficiency but, also, because it is possible, under severe conditions, for the parasitics to become sufficiently intense to fracture the crystal.

The operating crystal current, or more correctly, the crystal excitation, will vary considerably between oscillators of different types and also between oscillators of apparently identical construction. It is best practice, therefore, especially when trying out new circuits, to check the crystal current with a thermo-milliammeter. The circuit operating conditions should then be set such that the crystal current will not exceed the maximum safe value under any possible condition of operation.

If a thermo-milliammeter is not available, a fair approximation of the crystal current can be made by connecting a low current radio dial lamp in series with the crystal. Knowing the characteristics of the particular lamp in use, the current can be estimated from the brilliancy of the filament.

Standard radio dial lamps having ratings of 6.3 volts, 0.15 ampere, and 2 volts, 0.06 ampere, are recommended for checking crystal current. The 2-volt type is especially advantageous because of its rapid breakdown when the normal rated current is exceeded. By using one 2-volt lamp with crystals rated under 100 ma. and two 2-volt lamps in parallel for crystals over 100 ma., there will be some protection against excessive current. It is a good rule to use a single 2-volt lamp with any crystal rated at 60 ma. or more, at least when making preliminary tests or adjustments.

Figure 7 shows how the light developed by the lamp filament varies with current for the two recommended types of lamps. At the bottom point of the curves, representing 0.1% of normal light, the filaments will be very dull red in considerably subdued light. If the current is reduced a little more, the filaments become non-luminous.

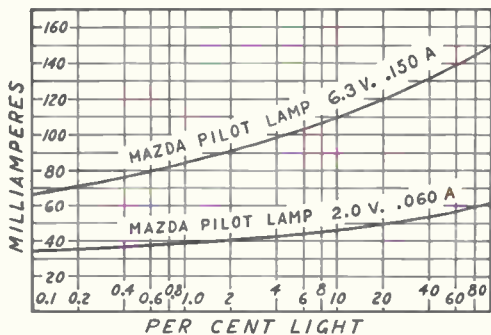

Figure 7—Pilot Lamp Current Characteristics

(Data furnished through the courtesy of General Electric Company and Westinghouse Lamp Company)

A common misconception is that the brilliancy varies directly as the current; that is, at one-half normal brilliancy the current is one-half the rated value. An inspection of the curves will readily show the extreme error of this assumption. Under conditions of subdued daylight, the 2-volt lamps show a dull red glow at about 41 ma. (0.041 ampere) while the 6.3-volt lamps reach this condition at about 75 ma. (0.075 ampere). Half brilliancy, as judged by the eye, occurs at about 52 ma. with the 2-volt lamps and 118 ma. with the 6.3-volt (0.15 ampere) lamps. Under steady current conditions, the filament will burn out at approximately 100 ma. with the 2-volt series and 250 ma. with the 6.3-volt series. It should be realized that these current values stated are subject to variation and are not absolute; the characteristics of individual lamps are not identical and the estimation of brilliancy by the human eye is subject to considerable error.

Reasonably accurate measurements can be made by comparing the brilliancy of the filament directly against the brilliancy of a similar lamp connected in series with a milliammeter and a source of variable voltage. By adjusting the variable voltage until the brilliancy of the two lamps is identical, the radio-frequency current will be equal, assuming identical lamps and no radio-frequency by-passing, to the reading of the milliammeter. This is a good procedure to follow when first using lamp indicators

as it will teach the operator how to estimate the current by a direct observation of the filament brilliancy.

While pilot lamps serve as an economical and effective substitute for a thermo-milliammeter, these lamps must not be considered as foolproof devices in the same class as thermo-milliammeters and fuses. The characteristics of individual lamps vary and there will always be some by-passing of the radio-frequency current around the lamp filament due to stray circuit capacities appearing in parallel with it. To keep these capacities at a minimum, it is essential that the leads to the lamp be as short and direct as possible; that they be well separated and not twisted; and that they be soldered directly to the lamp base without the use of a socket.

The lamps will, if properly chosen and installed, offer some protection against excessive crystal current. They are not, however, perfectly reliable; the breaking point of the filaments varies with individual lamps and, most important, the actual current for failure is dependent on the nature of the current itself. If conditions are such that the current is rising at a relatively slow rate, the current required for rupture will be close to the figures previously stated and the lamp will open the circuit. Should the current be rising at a high rate, a much greater value can be reached before the filament ruptures and there is every possibility that the crystal will be factured before the lamp has a chance to burn out. Conditions of this latter type will occur when a crystal is first plugged in a circuit having excessive feedback, when a radio-frequency surge is fed back into the oscillator stage, during the tuning process in a circuit with too much feedback, or during keying of an oscillator which has excessive feedback or strong parasitics.

With some transmitters, in which the oscillator is keyed for radiotelegraphy, the added resistance of the lamp may affect the ability of the oscillator to be keyed at high speeds. If this occurs, the lamp should be shorted out during transmissions.

It is always best practice in conventional triode, tetrode or pentode crystal oscillators to operate the circuit such that the crystal current is within the maximum safe rating with no load on the oscillator. The amount of feedback to the crystal is controlled, among other factors, by the radio frequency voltage across the oscillator tank. At no load this voltage is maximum and, therefore, the crystal excitation and current will be greatest. If the crystal current is well under the maximum safe rating with no load on the oscillator, there will be little chance of its becoming excessive with any degree of loading.

The crystal current does not vary in the same manner with the Tri-tet circuit. With the plate tank tuned to the crystal frequency, the crystal current will increase as the oscillator is loaded and will be maximum at full load. When, however, the plate tank is tuned to some harmonic of the crystal, the crystal current will not vary widely from the no-load value under any degree of loading.

CRYSTAL ACTIVITY

The term "activity" is usually employed in describing, or comparing, the oscillating qualities of crystals. The general interpretation of the term is somewhat vague, however, because there has been no specific definition commonly adopted for it.

Activity is, in the broad sense, the ability of a crystal to oscillate. It is controlled by the type of cut, the frequency, the precision of grinding, and the method of mounting. For a given cut, frequency, and holder of good design, the ability to oscillate is dependent on proper grinding. As would be expected, the power output of a given test oscillator will vary widely between crystals of the same frequency unless special efforts are made to grind the crystals with respect to some standard. Originally, crystal activity was determined by comparing the power output, or the oscillator d.c. grid current, of various crystals in a test oscillator. Crystals showing relatively high power outputs had, on this basis, a high activity.

A power output or d.c. grid current test is not wholly sufficient; an important consideration is whether the crystals will be positive in starting under load. If a group of "active" crystals of approximately the same frequency is checked in a loaded keyed oscillator, some of the crystals may accurately follow the keying while others may lag behind or refuse to follow at all. The activity of a crystal is most closely associated with its ability to start rapidly and Bliley Engineers, therefore, have adopted a definition which includes both power output and keying ability. That definition is: Activity is the ability of a crystal to start rapidly and to accurately follow keying in a loaded test oscillator at a given degree of loading.

Activity, when comparing crystals of essentially identical frequencies, is a measure of the effective crystal Q ; the higher the activity, the higher the Q . To the engineer and amateur, high activity means high frequency stability.

It is impossible to express activity as an exact mathematical quantity because it is only a comparative quality. Of course, activity could be specified

by a statement of the minimum keying speed at which a crystal will accurately follow the characters in a definite test oscillator with a given loading. This, however, is significant only in that particular test circuit since the characteristics of oscillator circuits vary. As a manufacturing standard, however, the keyed loaded test oscillator is a valuable instrument for maintaining high standards of uniformity and activity. Such instruments are used regularly in the manufacture of Bliley Crystal Units.

The proper operating conditions for a crystal controlled oscillator are determined by the relative activity of the crystals to be used. A crystal, having a low activity for its particular frequency, can be made to oscillate by adjusting the oscillator voltages, the grid bias, and the circuit feedback for conditions of maintained oscillation. The frequency stability will, however, be relatively poor and the crystal may be sluggish in starting and following characters when the oscillator is keyed. Should a highly active crystal of approximately the same frequency be substituted, without any circuit changes, the chances are that the crystal would oscillate so vigorously as to shatter itself. This is simply due to the fact that the active crystal is more easily excited.

Obviously, a relatively inactive crystal will withstand considerably more abuse than a highly active crystal. This, on the surface, might seem to indicate that low activity is desirable. Such a premise is most incorrect. With proper operating conditions, the active crystal will follow keying more faithfully, it will provide much better frequency stability and will give equal, or better, power output at a higher circuit efficiency.

The relative activity of quartz crystals varies with frequency over the practical frequency range from 16kc. to 30,000kc. At 16kc. the activity is lowest while maximum activity occurs at about 3000kc. Bar-type crystals, which are used in the frequency range from 16kc. to 150kc., are relatively sluggish in starting and can be used only in low powered oscillator circuits. This is largely due to the mass of the crystals because their Q remains high (6000 to 18,000). At about 6000kc. the apparent activity starts to fall off due partly to the characteristics of the crystals themselves and partly to the increasing circuit and tube losses as the frequency is raised.

It is always best practice to take precautions when first connecting a crystal, known to have a high activity, into a circuit which might cause excessive excitation. This is particularly true where new or experimental circuits are being tested.

Under such conditions, the comments given in the section GENERAL OPERATING NOTES should be followed.

CRYSTAL CLEANING

Foreign matter on a crystal can cause erratic performance or prohibit oscillation entirely. A crystal will not oscillate if there is any grease, oil, wax, or similar substance on its faces. Such substances are removed during manufacture by a special degreasing process but can be deposited by handling of the crystal after manufacture.

Dust is probably the greatest offender. It can cause erratic performance or prevent oscillation entirely. Corona can develop when particles of dust separate the crystal and its electrodes since points of high potential naturally appear at each particle. If the crystal is subjected to rather high excitation, a radio-frequency arc can result. The arc will modulate the oscillator output giving it a rough note, and, if allowed to continue, the concentrated heat of the arc may fracture the crystal.

To protect the crystals from dust, modern crystal holders are designed to have close-fitting assemblies. In addition, each holder is thoroughly washed before actual use. Sometimes, however, due to handling in shipment, minute particles of dust may be deposited on the crystal causing non-oscillation. This is more common with very high frequency crystals for, naturally, they will be more sensitive to foreign matter than crystals at lower frequencies. A simple cleaning of the crystal and electrodes is usually all that is necessary to restore correct oscillation; further cleanings generally will be unnecessary for long periods of service.

The best cleansing agent is carbon tetrachloride but other solvents such as Carbona Cleaning Fluid may be used providing they have no dissolved or suspended impurities. Clean soap and water is effective but requires greater care as a more vigorous scrubbing action is necessary. The crystal should be carefully washed and then dried with a clean lint-free cloth. In drying, care should be exercised to prevent the crystal from becoming entangled in the cloth and subsequently broken. After cleaning, the fingers should not be allowed to come into contact with the major faces as the oil from the fingers will offset the cleaning operation; the crystal can be handled by grasping it by its edges, or, by employing a pair of tweezers. The same procedure should be followed with the electrodes but, as they are not fragile and have only one active face, the operation is considerably simplified.

Care must be exercised, when replacing the crystal in its holder, so as not to chip the corners or to break the crystal by placing it in such a position that it will bind. Where both of the crystal electrodes are separate from the holder assembly, the crystal is merely placed between its two electrodes and inserted into the holder cavity, the edge of the crystal should not protrude beyond the edge of the electrodes as chipping might result. It should be noticed that one face of each electrode is very finely finished while the other face is rough, in comparison — it is imperative that the finely finished faces be in contact with the crystal.

In some types of holders, one electrode is part of the assembly and cannot be removed. This electrode may be slightly larger than the crystal or it may be a small circular 'button'. It generally fits into a recess in the holder body and has a spiral spring beneath it. The button-type holders such as the Bliley BC3 and HF2, necessitate the exercise of care in reassembly to prevent binding the crystal when the cover electrode is placed in position. If the spiral spring prevents the electrode from seating in its recess, the electrode can be held in position, for reassembly, by the tip of a screw driver.

In other types of holders, such as Bliley BC6 and CM2, the bottom electrode is fixed and the removable top electrode is held by a flat spring in the top of the assembly. The spring pressure is adjustable by bending the spring until the desired tension is obtained. If the second electrode is a small disc, for use with high-frequency crystals, the position of the disc electrode, and its pressure, should be determined by experiment for optimum crystal performance.

CRYSTAL CONTROLLED OSCILLATORS

Crystal controlled oscillators have their origin in some basic self-excited oscillator arrangement; frequency control is brought about by connecting a quartz crystal into the circuit in such a manner that the crystal becomes the frequency determining element. The conventional triode or pentode crystal oscillator, as shown in figures 8 and 13, is merely the well-known tuned-plate tuned-grid circuit with a quartz crystal substituted for the grid tank. For purposes of discussion, such circuits are sometimes called tuned-plate crystal-grid oscillators.

Oscillator circuits are remarkably self-regulating; the circuit values can be varied over wide ranges and the oscillator will continue to function. With any set of component values which do not prohibit oscillation entirely, the various currents and gener-

ated voltages will distribute themselves for best performance under those conditions. Of course, there are circuit values which will give optimum performance and efficiency; but, for practical applications, these require no great consideration. Representative components are generally chosen and then, by cut-and-try methods, the most satisfactory values determined.

The crystal controlled oscillator is equally self-regulating, and, for that particular reason, it requires more care in design and operation. A quartz crystal, as previously explained, has mechanical limitations in that an excessive vibration amplitude will cause the crystal to be shattered. It is necessary to design a crystal controlled oscillator such that the circuit, in attempting to correct for varying operating conditions, will not cause the crystal excitation to become excessive. This consideration necessitates a reasonably careful choice of circuit values and, in addition, limits crystal control to comparatively low powered oscillators.

The crystal excitation in the usual type of oscillator circuit depends on the amplification factor of the tube, the bias, the d.c. operating potentials, the circuit feedback, and the activity of the crystal. For a given power output, the tube with the highest amplification factor will generally require the least excitation (lowest crystal current). This is immediately apparent in the performance of pentode crystal oscillators as compared to triode oscillators; screen-grid tubes, having the highest amplification factor, require much less crystal excitation for a given power output.

Beam-power tubes are excellent crystal oscillators due to the very small amount of excitation required for full output. In the conventional tetrode crystal oscillator circuit, good output and performance are easily obtained. Where the tube performs as a combination crystal oscillator and frequency multiplier, however, beam-power tubes such as the 6L6 have a strong tendency toward the development of parasitics, especially at the higher frequencies. This is due to the power sensitivity and to the fact that the screen grid in such tubes is not fully effective at radio frequencies.

The crystal excitation in a particular oscillator setup is determined by the r.f. voltage across the oscillator tank. Because this voltage is applied to the crystal circuit, the excitation naturally will increase as the r.f. tank voltage is raised. The L to C ratio of the oscillator tank determines its impedance and, as the ratio is increased, the r.f. voltage will also increase. A reasonably high L to C ratio is desirable with conventional pentode or tetrode oscillators, while a lower ratio is better

with triode tubes. The greater internal plate-to-grid capacity and the low amplification factor of most triodes, requires that the tank voltages be limited such that the crystal excitation will not become excessive. This applies also to the cathode tank of the Tri-tet circuit because the oscillating portion is a triode.

The feedback in conventional tuned-plate crystal-grid oscillators is brought about by the internal plate-to-grid capacity of the tube. The excitation requirements of active quartz crystals are so small that, even with screen-grid tubes, this internal capacity is usually sufficient to bring about ample excitation of all but low frequency crystals. Some tubes, such as the 802 and RK23, have very low internal capacities and a small amount of external feed-back capacity is recommended by the manufacturer. Most active crystals above 1500kc. will oscillate without the addition of the external capacity; every effort should be made to operate the circuit without the added capacity before any attempt is made to increase the feedback. Excessive feedback, whether through the intentional use of a condenser or through the presence of stray circuit capacities, will bring about high excitation and endanger the crystal. With screen-grid tubes, proper by-passing of the screen grid is essential. If the by-passing is inadequate, the grid will assume an r.f. potential greatly increasing the feedback to the crystal.

The bias on the tube is an important consideration. In general, the higher the bias the greater will be the crystal current and the power output. Beyond certain limits, however, an increase in bias will cause a considerable increase in crystal current with only a small gain in power output. Too much bias can bring about excessive excitation.

Bias is most generally obtained by the use of a grid-leak resistor, a cathode resistor, or a combination of both. With grid-leak bias, an increase of resistance will be accompanied by an increase in the crystal current. Also, the crystal starts oscillating under conditions of zero bias with a continually increasing bias as the crystal excitation becomes greater. This means that the crystal current will be greatest when the oscillator is not loaded because the plate tank voltage, and the bias, will be highest under that condition. As a result of the zero bias in a non-oscillating condition, the crystal may be hard starting and may not key well, especially when a low value resistor is employed. By resorting to cathode bias, the crystal will start oscillating under more favorable conditions. The initial bias provided has a tendency to increase the effective plate-to-grid feedback and also

brings about a grid condition more conducive to the starting of oscillation. Too much bias of this type, however, will produce the opposite effect; the crystal will be hard starting and the current will be high. The correct value of cathode resistor generally lies between 200 and 500 ohms, 350 ohms being a good all-around value.

With pentode or tetrode type tubes, best performance usually is obtained by combining grid-leak and cathode bias. In general, the grid-leak resistor should not be higher than 20,000 ohms while the cathode resistor will lie between the values already given. It is customary practice to insert an r.f. choke in series with the grid-leak resistor so as to offset the low impedance otherwise presented to the crystal. This procedure is recommended where the grid resistor has a value of less than 50,000 ohms. Standard quality multiple-pie 2 mh. to 3 mh. chokes are excellent for frequencies above 1500kc.

When using triode tubes in the tuned-plate crystal-grid circuit with high frequency crystals, it is best to connect an r.f. choke directly across the crystal to provide a path to ground for the d.c. grid current, and then employ cathode bias exclusively. The addition of a grid resistor usually will greatly increase the crystal current without effecting a corresponding increase in power output.

The d.c. plate voltage on an oscillator will, naturally, influence the crystal excitation. As the potential is raised, the developed r.f. voltage will increase bringing about additional excitation. With pentode and tetrode type tubes the screen-grid voltage becomes an important factor; the higher this voltage the greater will be the crystal current and the power output.

Crystal activity is an equally important factor in the design of crystal oscillator circuits. This subject has been fully discussed in the section entitled CRYSTAL ACTIVITY and need not be repeated.

Circuit losses must be properly considered in the design of a crystal oscillator. The circuit should be carefully arranged so that there will be a minimum of stray feed-back capacities which may increase the crystal excitation. It is readily possible, with improper layout, to fracture a crystal because of additional feedback brought about by stray circuit capacities. If any appreciable coupling exists between the oscillator and other stages of the transmitter working at the same frequency, the crystal excitation may easily be increased to an excessive amount; thorough inter-stage shielding in high power transmitters is imperative. At the higher frequencies, especially above 6000kc., the

tank circuit should be well constructed and preferably made self-supporting. If coil forms are used, these should be of the best quality. The copper wire in the tank inductance should be sufficiently large to carry the circulating tank current, for, if the wire is too small, the resultant losses will effect a considerable decrease in power output. When the cathode of the oscillator tube is operated at an r.f. potential, the heater leads should be by-passed to ground at the tube socket.

While it is often desirable to obtain relatively high power outputs from crystal oscillators, it should be remembered that a crystal oscillator is fundamentally a frequency controlling stage; the "heart" of a transmitter. With the present low cost of tubes, it is much better to work the crystal easily by using a low powered oscillator and adding an additional tube to obtain sufficient driving power for the following stages. This assures good frequency stability and removes the danger of crystal failure through excessive excitation in an attempt to obtain sufficient power output.

TRIODE OSCILLATORS: The conventional triode crystal oscillator is shown in figure 13. It is a universal circuit because it performs well with crystals at all frequencies. Cathode bias, as indicated, is best for crystals above 1500kc. while grid-leak bias is preferable at lower frequencies. The proper cathode resistor varies with different type tubes but normally will be between 200 and 500 ohms. Grid-leak bias, in addition to cathode bias, is recommended only for low frequencies.

A relatively low L to C ratio tank should be employed for best stability and reduced crystal current. The d.c. plate potential directly influences the crystal current and the voltage, therefore, should not be too high. Some tubes may be operated at potentials up to 350 volts while with others, the potential must be limited to 250 volts or less. In any event, maximum safe potential for any individual triode oscillator will depend on the amplification factor of the tube, the bias and the tank L to C ratio.

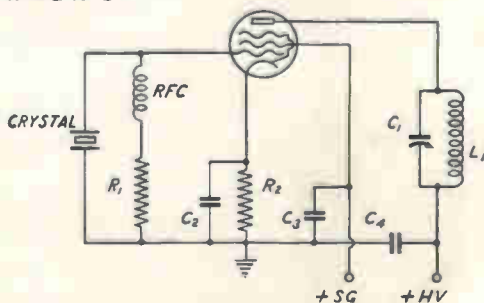

Figure 8—Pentode Crystal Oscillator

The dual-triode crystal-oscillator frequency-multiplier is an excellent arrangement for frequency multiplying. This circuit is shown in figure 14. Although the tank circuit values are given for 10- and 5-meter operation, the circuit can be adapted for any crystal frequency by choosing the correct tank constants. If it is desired to use the second section as a buffer at the crystal frequency, neutralization must be incorporated. This is necessary to prevent feedback into the oscillator. The maximum oscillator plate voltage for tubes such as the 6E6 and RK34, is 325 volts while tubes such as the 53 and 6A6 may be operated with a maximum of 350 volts. It is best practice, however, to limit the plate voltage of the oscillator section of all dual-triode circuits to a maximum of 300 volts; the multiplier section can be operated at a higher voltage if greater harmonic output is desired.

Because the excitation requirements of most triode tubes are quite high, their power output as crystal oscillators is relatively low under conditions of safe crystal current. Power outputs of up to 5 watts are normal with the usual type of triode tube at frequencies above 1000kc. In the dual-triode circuit the power output, when frequency doubling, is in the neighborhood of $3\frac{1}{2}$ watts.

PENTODE AND TETRODE OSCILLATORS: The conventional pentode or tetrode crystal oscillator is the most practical and commonly employed circuit. A representative pentode oscillator is diagrammed in figure 8. The general characteristics of pentode and tetrode oscillators are identical inasmuch as the essential difference between the tubes lies in the method of suppressing secondary emission from the plate.

A combination of grid-leak and cathode bias gives the most satisfactory results with all crystals above 1500kc. The correct value for the grid resistor usually will be between 5000 and 20,000 ohms, while the cathode resistor will be from 200 to 500 ohms. A representative combination for most pentode and tetrode tubes is a 20,000 ohm grid resistor and a 350 ohm cathode resistor. At low frequencies, best performance is generally obtained with simple grid-leak bias.

The screen-grid voltage has a considerably greater influence on the crystal current than the plate voltage. A potential of 250 volts is generally maximum for normal plate potentials while a lower value is preferable when the plate potential is greater than 400 volts. Proper by-passing of the screen grid is important, especially so with beam-power tubes. The by-pass condenser, preferably of the mica type, should be placed directly at the tube socket. With pentode tubes, where the sup-

pressor grid is connected to one of the base terminals, an increase in power output can be accomplished by operating the suppressor grid at a low positive voltage.

Pentode and tetrode tubes, having a high amplification factor, will provide the greatest power output for a given crystal current. Furthermore, the frequency stability with such tubes is much better than obtainable in the conventional triode oscillator due to the action of the screen grid. This grid reduces the internal plate-to-grid feedback and also has a compensating action on the tube impedance under conditions of changing power supply voltages. With tubes such as the RK23, 802 and 807, which are designed specifically for use at radio frequencies, power outputs of 10 to 15 watts can be obtained at frequencies above 1000kc. with a reasonably low crystal current.

PUSH-PULL OSCILLATORS: A push-pull pentode crystal oscillator is diagrammed in figure 9. Oscillators of this type are only advantageous in that the output circuit is balanced and even harmonics are cancelled out.

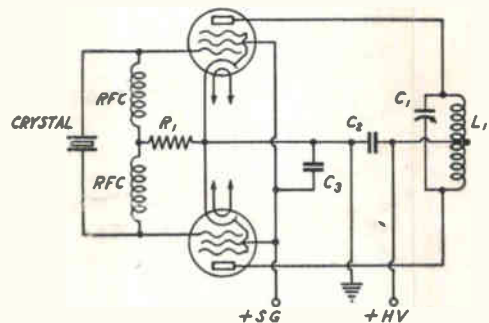

Figure 9—Push-Pull Pentode Crystal Oscillator

Only with tubes which require very low grid drive is it possible to obtain a substantial increase in power output with the push-pull arrangement. The two tubes will require approximately twice as much driving power as a single tube of the same type and it follows, therefore, that the crystal must vibrate more intensely to drive both tubes to full output. As a result, it is necessary, with most tubes, to reduce the operating voltages so that the crystal current will be within safe limits under all conditions of performance. The final effect is only a small power output increase over the use of a single tube oscillator.

TRI-TET OSCILLATORS: Developed by James Lamb, the Tri-tet is an excellent frequency multiplying arrangement. It is, as shown in figure 15, a combination triode crystal oscillator and pentode (or tetrode) frequency multiplier—the oscillating

portion is a triode with the screen grid serving as the plate. By inserting the tuning tank in series with the cathode, the screen grid is grounded to r.f. At the same time, some regeneration results at harmonic frequencies by reason of the fact that the common tank circuit carries currents at both the crystal and the harmonic frequencies.

Since the oscillating portion of the Tri-tet is a triode, the usual consideration of employing a low L to C ratio applies to the cathode tank. For lowest crystal current and highest output at harmonics, the tank should be tuned to a frequency considerably higher than that of the crystal. As a matter of fact, the circuit should not be operated with the cathode tuned close to the crystal frequency for the result will be high crystal current and decreased output. For proper results, the tank should be tuned for greatest power output at the particular harmonic without serious regard to the relation between cathode tuning and d.c. plate current.

For each particular type of tube there will be an optimum cathode tank L to C ratio. This is discussed by James Lamb in the April, 1937 issue of QST magazine. In general, the higher the multiplying factor employed, the higher should be the cathode L to C ratio. If the capacity is too high, the voltage drop at the harmonic frequency will be low and regeneration will, therefore, be small. Likewise, if high stray circuit capacity is allowed across the crystal, regeneration will be lowered. When a Tri-tet is to be used both for multiplying and working straight through, it should be noted that the best cathode tank L to C ratio for multiplying is too high when working straight through; the low C can bring about high crystal current and, possibly, cause fracturing of the crystal. When the plate tank is operated at the crystal frequency, the use of a high-C cathode tank is essential.

It will be seen that, as far as r.f. is concerned, the cathode and plate tanks are in series. For this reason, when the plate tank is tuned to the crystal frequency, the crystal current will be lowest at no load and will increase with loading. The crystal current, when frequency multiplying, remains substantially constant with loading because the oscillator portion then functions nearly independently of the remainder of the circuit.

A condition of decreased power output at the second harmonic can exist if the cathode tank should happen to be tuned to that frequency. This condition is obviously corrected by slightly retuning the cathode tank.

Since the screen grid serves as the plate of the crystal oscillator, the screen-grid d.c. potential will influence the crystal current to a large extent. A potential of 250 volts is considered maximum, while a lower value is preferable. The proper bias conditions are somewhat different from a simple triode oscillator due to the fact that the bias also influences the power output on harmonics. In general, bias recommendations given for the pentode and tetrode crystal oscillators should be followed with the Tri-tet.

The effectiveness of the screen grid in tubes employed as Tri-tet oscillators requires consideration. If the shielding is poor at radio frequencies, the circuit should be used only for frequency multiplying—this is most important with crystal frequencies much above 3000kc. When poor internal shielding does exist, the crystal excitation can become excessive as a result of additional feedback when the plate tank is tuned to the crystal frequency. Tubes such as the 802 and RK23 have excellent radio frequency characteristics while others, such as the 6L6, 6F6, 2A5, 42, 59 and 89, are poorly shielded since they were designed primarily for use at audio frequencies. When operating at the crystal frequency, especially with poorly shielded tubes, it is best practice to convert the circuit to a conventional pentode or tetrode oscillator by shorting out the cathode tank. This is easily accomplished by bending the tips of the cathode condenser rotor plates such that the condenser can be shorted out simply by rotating it to full capacity position.

The Tri-tet has excellent frequency stability inasmuch as the coupling between the oscillator and the output circuit is brought about electronically within the tube. The power output, when operating straight through with a suitable tube such as the 802 or RK23 and at a crystal frequency above 1000kc., is in the neighborhood of 12 watts. When frequency doubling, it is about 8 watts.

PIERCE OSCILLATORS: In the Pierce circuit, as shown in figure 10, the crystal is connected between the plate and control grid of the tube. This arrangement is essentially a Colpitt's Oscillator with the crystal displacing the usual tank inductance.

It can be seen that the crystal is connected, in series with the feed-back condenser C₁, directly across the plate circuit. The crystal excitation, therefore, will be largely influenced by the value of C₁. Increasing the feed-back capacity decreases the circuit reactance and brings about higher crystal current while a decrease in capacity will have the opposite effect. Accompanying the change

crystal current, there will be a shift in the oscillating frequency which may amount to about 2kc. at 4000kc. If C_1 is made too large, excessive excitation can result, even though the plate voltage may be low. At 500kc., C_1 should be about 250 mmf. while 20 mmf. to 30 mmf. is ample at 7000kc.

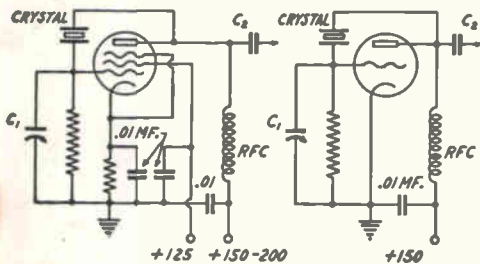

Figure 10—Pierce Crystal Oscillators

In addition to properly determining the feedback capacity C_1 , it is necessary to operate the oscillator at low voltages to limit the r.f. voltage developed in the plate circuit. The d.c. potentials indicated in the circuit diagrams should be considered maximum values.

The plate circuit must have a capacitive reactance to satisfy conditions for oscillation. A capacitive reactance can be obtained with a detuned tank, an r.f. choke having a resonant frequency lower than the crystal frequency, or a resistance. A pure resistance, of course, has no reactance, and, by itself, would not satisfy the conditions for oscillation. The internal plate-to-grid capacity of the tube is in parallel with the resistance, however, and this provides the necessary capacitive reactance. For the amateur frequencies, a 2.1 mh. or 2.5 mh. r.f. choke is generally employed while a considerably larger inductance is required at lower frequencies.

The crystal current, as in other circuits, will be influenced by the amount of grid bias. Bias, when using pentode or tetrode tubes, can be obtained with a grid-leak resistor alone or in combination with a cathode resistor. Best performance, however, is generally obtained with the combination of grid-leak and cathode bias. In the triode circuit, grid-leak bias is best. The grid resistor, in either case, should be limited to a maximum of 50,000 ohms for crystals above 1500kc. while 100,000 ohms is better at the lower frequencies. When using cathode bias, the resistor must be considerably smaller than would be employed with other circuits; about 250 ohms is sufficient for pentode or tetrode tubes and 125 ohms for triodes. It is possible to reduce the crystal current by employing a low value grid resistor in series with an r.f.

choke but this is not always satisfactory because the circuit may oscillate as a tuned-plate tuned-grid oscillator with the grid and plate chokes determining the frequency.

Tuned tanks are not required in the simple Pierce circuit and, therefore, a rather wide range of crystal frequencies can be used without any serious change in circuit values. This is advantageous in some types of transmitters but limits the choice of crystal frequencies to fundamental crystals. Harmonic-type crystals will not perform properly because such crystals will oscillate at the true fundamental rather than at the intended harmonic frequency. This is due to the fact that a frequency discriminating tank is not present and, therefore, the crystal automatically will work at its most active resonant frequency.

The outstanding advantage of the Pierce circuit is simplicity of circuit components. It is limited, however, to low power output and requires careful circuit adjustment to prevent excessive excitation. Also, because the circuit frequency is influenced to an appreciable extent by the values of the circuit components, the overall frequency stability is somewhat dependent upon the oscillator construction and upon the electrical stability of the component parts.

PIERCE OSCILLATOR-MULTIPLIERS: Pentode or tetrode tubes can be used in a crystal-oscillator frequency-multiplier circuit with a Pierce oscillator rather than the conventional triode oscillator as employed in the Tri-tet. A circuit of this type is illustrated in figure 11. In the Reinartz arrangement of this circuit the tank, L_2 C_2 , is tuned to approximately $1/2$ the crystal frequency. With the Jones' arrangement, a small r.f. choke is tuned, by an associated condenser, to a frequency in the neighborhood of 300kc.

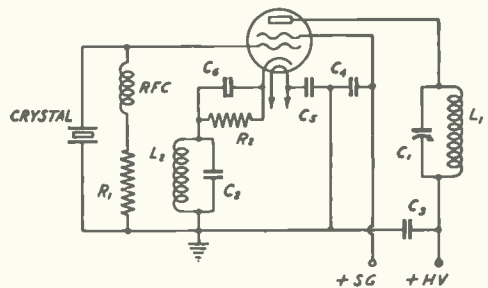

Figure 11—Oscillator-multiplier Circuit with Pierce Oscillator

Both arrangements have the same essential characteristics and provide power outputs comparable to the Tri-tet. At frequencies below

4000kc., the cathode capacity C_g may have any suitable value from 100 mmf. to 250 mmf. The circuits are quite critical at higher frequencies, however, and the value of C_g becomes an important factor. For each type of tube, tank L to C ratio, degree of loading, and crystal, there is an optimum value of C_g which will give greatest power output consistent with good circuit stability. If C_g is smaller than the critical capacity, there will be a strong tendency to develop parasitics, especially with beam-power tubes, and the crystal current will be high. In fact, it is possible for the parasitics to become sufficiently intense to fracture a crystal. Capacities greater than the critical value will result in lowered crystal current and decreased power output.

C_g should preferably be a variable condenser with a maximum capacity of about .00025 mf. In any event, the actual amount of capacity in use should be no less than .0001 mf. and, even then such a low value should be employed only when frequency multiplying. Representative values are .00015 mf. when multiplying and .00025 mf. when working straight through. In some instances, it may be necessary to increase the capacity to as much as .0005 mf. for proper performance.

In addition to influencing the crystal current and circuit stability, C_g affects the power output at harmonics. At the higher harmonics, greatest power output is obtained with low values of C_g . It must be remembered, however, when operating the circuit at a harmonic with a very low value of C_g , that the capacity must be increased when changing to fundamental operation—the conditions for best harmonic output are not generally satisfactory for fundamental operation and excessive excitation may result. **The importance of carefully determining the proper operating value of C_g for crystal frequencies above 4000kc. cannot be too strongly emphasized.**

The oscillator portion of this circuit, like the simple Pierce circuit, has no positive choice of crystal frequency. Harmonic type crystals, therefore, normally will oscillate at the fundamental rather than the calibrated frequency. With the proper value for C_g , however, a harmonic crystal can be caused to work at its intended frequency by tuning the plate tank to that frequency; at all other settings, the crystal will oscillate at its fundamental frequency.

When the output tank is tuned to the fundamental crystal frequency, the operating characteristics are similar to the Tri-tet; that is, the crystal current rises with load and excessive feedback can result when

tubes with insufficient internal shielding are employed for working straight through.

The bias considerations for the Pierce circuit in general, apply to the oscillator portion of these arrangements. For frequency multiplying, a combination of grid-leak and cathode bias generally results in best performance.

An improvement in circuit performance can be realized by adding a small amount of external capacity directly between the oscillator control-grid and cathode. This capacity is equivalent to C_1 in figure 10 and stabilizes the crystal feedback. The amount of capacity added, however, should be much smaller in order to prevent excessive crystal excitation and to avoid a reduction of harmonic output. About 10 mmf. to 15 mmf. is sufficient at 7000kc. In general, the value of C_g (figure 11) should be raised somewhat when the additional feedback is applied to an existing oscillator.

Grid-cathode feedback is particularly advantageous when variable frequency crystals, such as the Bliley VF1, are to be used in the oscillator. The presence of the feedback helps to offset the falling off of effective crystal activity as the crystal frequency is raised. The result is decreased power output variation over the full adjustable frequency range and better keying at high frequency settings.

MODIFIED PIERCE OSCILLATORS: A unique modification of the Pierce oscillator is shown in figure 12a. It will be noticed that the circuit has the same components as the Pierce oscillator-multiplier (figure 11) but the screen grid is tied to the control grid. As a matter of fact, any triode tube can be used but, by using a pentode tube in this manner, a high- μ triode is formed such that the plate current is nearly zero with the circuit non-oscillating. When the crystal goes into oscillation, the plate current will rise to normal operating value.

Excitation of the crystal is brought about by the r.f. drop across $L_g C_g$. This tank is, in the same manner as in the Pierce oscillator-multiplier (figure 11), tuned to a frequency considerably lower than that of the crystal. The crystal will tend to oscillate almost independently of the tuning of $L_1 C_1$ (by shorting out $L_1 C_1$, the circuit becomes a simple Pierce oscillator). Output will be developed when $L_1 C_1$ is tuned to the crystal frequency or, with a harmonic-type crystal, to the intended harmonic oscillating frequency. With fundamental oscillating crystals, frequency multiplying can be accomplished by tuning to any harmonic of the crystal frequency.

An increase in power output can be brought about by by-passing the screen grid and applying

a small positive voltage. Along with the increase in output, there may be an actual decrease in crystal current. If the screen-grid voltage is raised appreciably, however, the circuit performance reverts to the original Pierce oscillator-multiplier arrangement previously discussed. With a 1 megohm screen dropping resistor, good output can be obtained with low crystal current.

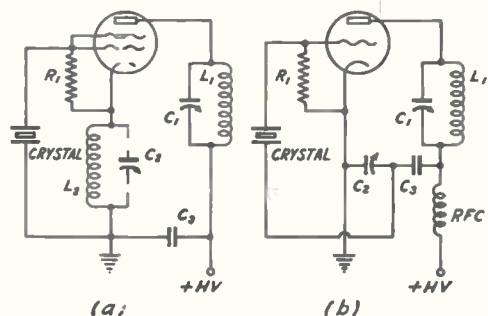

Figure 12—Modified Pierce Oscillators

At high frequencies this modified Pierce circuit is prone to develop self-oscillation. In fact, when a 10-meter crystal is used, the circuit tends to perform in the same manner as a locked oscillator; that is, the circuit may self-oscillate at a frequency largely determined by the plate tank, but, when the circuit tuning is brought to the crystal frequency, the crystal will assume control.

Figure 12b shows a circuit arrangement developed by Jones. It is electrically equivalent to the modified Pierce circuit just discussed and the operating characteristics are the same; the capacity, C_2 , functions in the same manner as the cathode tank, L_2C_2 . The crystal is excited by the r.f. voltage drop across C_2 and, therefore, the value of C_2 directly influences the crystal current. If C_2 is made too small, excessive excitation easily can result. The condenser, C_3 , is merely a blocking condenser to prevent the d.c. plate voltage from being applied to the crystal.

The optimum value for C_2 varies with individual circuit arrangements, depending upon actual circuit conditions encountered. As a general rule, the correct capacity will lie between 150 mmf. and 500 mmf. As should be expected, a relatively low capacity is desirable for bringing about harmonic regeneration when frequency multiplying. At the same time, however, the crystal excitation will undoubtedly be excessive should the plate tank be tuned for output at the fundamental frequency.

By using a pentode or tetrode tube rather than the triode, and operating the screen grid at a normal potential, there will be a considerable

increase in power output. Either the triode or the pentode arrangement can be used as a frequency multiplying circuit with fundamental crystals or for operating harmonic-type crystals at their intended harmonic frequencies.

Both of these arrangements will also develop self-oscillation at high frequencies. Circuits of this general type, therefore, are best limited to crystal frequencies below approximately 4000kc.

18MC. TO 30MC. CRYSTAL OSCILLATORS

At these high frequencies, careful consideration must be paid to the design and construction of the oscillator. Factors which are not serious at lower frequencies rapidly become important as the frequency is increased.

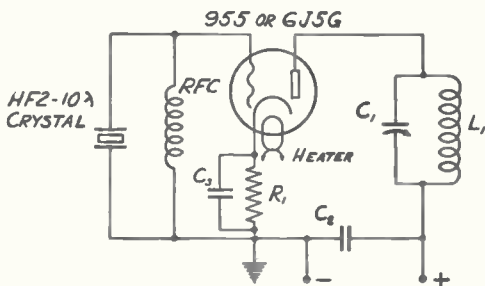

Figure 13—28mc. Triode Crystal Oscillator

- L1—8 turns No. 12 wire, single spaced, $\frac{3}{8}$ " dia.
- C1—75 mmf. variable condenser
- C2—.005 mf. mica condenser
- C3—.005 mf. mica condenser
- R1—200 ohm carbon resistor
- RFC—2.5 mh. r.f. choke
- Plate Voltage—180V for the 955, 220V. for the 6J5G

Not all tubes are satisfactory as crystal oscillators at frequencies greater than 18mc. With some tubes, especially the high-mu and pentode types, the crystal may be effectively shorted out by the high input capacity. Others, having a low feedback capacity and a large electrode spacing, do not operate efficiently. High frequency triode tubes, such as the 955, 6J5G, HY615, 6E6 and RK34, are the best for all-around performance. Pentodes, in general, are not to be recommended although some types can be employed in the Tri-tet or a modified Pierce circuit with fairly good results.

Parallel feed of the oscillator is seldom successful due to the difficulty of obtaining really good r.f. chokes. This means that the tuning condenser will be at a high potential and must be insulated from ground. The somewhat common arrangement of inserting a mica condenser in the tank circuit to

block the d.c. voltage so that the tuning condenser can be grounded is not particularly satisfactory; mica condensers have appreciable losses, at very high frequencies and, if used to carry circulating tank current, there may be a serious drop in power output.

All r.f. leads must, obviously, be short and direct. By-pass and tank condensers should be of the best quality. To minimize tank circuit losses, the coil should be self-supporting and wound with heavy copper wire or tubing. Use nothing smaller than number 12 wire.

The low plate impedance of the recommended triode tubes necessitates the use of a high-C tank for maximum power output. Along with the increased output, the high C greatly improves the circuit stability; in fact, pentode stability is approached when the proper tank values are chosen. The cathode tank of the Tri-tet must also have a relatively high C, inasmuch as the oscillating portion is a triode.

Circuits designed for use with 18mc. to 30mc. crystals are shown in figures 13, 14, and 15. The circuits are basically conventional but all component values should be followed as these have been found to give the best output and stability. The oscillator tank inductances are specified for 10-meter crystals, but for other high frequencies, it is only necessary to choose appropriate coils. With the simple triode oscillator a 955 tube will provide about 1 3/4 watts output while approximately 2 1/2 watts can be obtained with the 6J5G. Either of these tubes will produce sufficient output to drive an 80Z, RK23, 807, RK39 or 6L6 tube as a buffer or doubler.

The dual-triode circuit is advantageous for frequency multiplying. As a matter of fact, a single RK34 with a 10-meter crystal, forms an excellent low power 5-meter transmitter. A 6E6 tube will supply an output of about 3 watts on 5 meters with a 10-meter crystal while the RK34 will give about 3 1/2 watts. The types 53 and 6A6 tubes are not comparable for output or performance.

An 80Z or RK23 tube can be used in the Tri-tet circuit as shown. The output on 5 meters is approximately 2 1/2 watts with the 80Z and 3 1/2 watts with the RK23; a slightly greater output can be obtained by applying up to 45 volts positive to the suppressor grid. The 6L6 and 6L6G beam-power tubes are not particularly recommended because their poor internal shielding causes the development of parasitics which are difficult to eliminate.

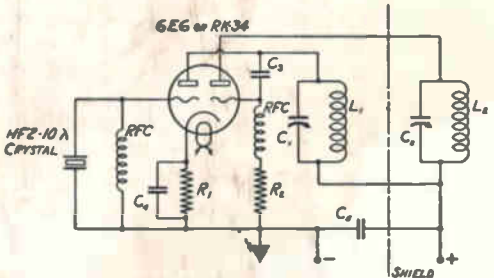

Figure 14—Dual-Triode Oscillator-Doubler for 56mc. Output

- L1—6 turns No. 12 wire, single spaced, 3/8" dia.
- C1—75 mmf. variable condenser
- L2—4 turns No. 12 wire, double spaced, 3/8" dia.
- C2—35 mmf. variable condenser
- C3—.0001 mf. mica condenser
- C4, C5—.005 mf. mica condenser
- RFC—2.5 mh. r.f. choke
- R1—400 ohms
- R2—30,000 ohms
- Plate Voltage—6E6—300, RK34—325

For higher power output than obtainable with a triode oscillator, an oscillator-multiplier circuit arrangement similar to one of those previously described (figures 11 and 12) might be used. By tuning the plate tank to the crystal frequency, the resulting regeneration inherent in the circuit offsets some of the circuit and tube losses such that pentode or tetrode tubes can be employed with fairly satisfactory results. Frequency multiplying, when using harmonic-type crystals, is, of course, not feasible due to the fact that such crystals will oscillate at their intended frequencies only when the plate tank is tuned accordingly.

In most cases, the use of a regenerative oscillator is best avoided where transmitter design permits the incorporation of a simple triode circuit. While satisfactory performance can be realized with a regenerative circuit, the complete elimination of self-oscillation and high crystal current is difficult, particularly with beam-power tubes.

The E-cut crystal, which is employed for frequencies above 23mc., has a frequency-temperature coefficient of +43 cycles/mc./°C. To avoid objectionable frequency drift where temperature control is not applied to the crystal, the oscillator tube should be operated at the lowest plate voltage consistent with required power output. This minimizes crystal heating and subsequent frequency drift. Where a low grid-drive tube such as the 807 or 6L6 follows the oscillator, an oscillator d.c. plate potential of 100 or 125 volts is adequate if efficient coupling exists between the two stages. With such a reduced plate voltage, direct crystal heating is quite low. Possible heating of the

crystal from other sources should also be considered. It is well to locate the crystal in such a position in the transmitter that heat transfer from other components will be at a minimum.

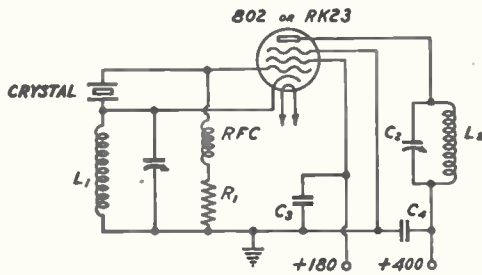

Figure 15—Tri-tet Oscillator-Doubler for 56mc. Output

- L1—3 turns No. 12, diameter 1", spaced twice wire diameter
- L2—4 turns No. 12 wire, double spaced, 3/8" dia.
- C1—75 mmf. variable
- C2—35 mmf. variable
- C3, C4—0.01 mf. mica
- R1—30,000 ohm carbon
- RFC—2.5 mh. r.f. choke

Constructional details of practical ultra-high frequency transmitters are given in the January, 1938 issue of QST in an article entitled, "56mc. Crystal-Control With 28mc. Crystals." Additional articles appeared in the April issue of the same publication.

LOW FREQUENCY OSCILLATORS

Quartz crystals in the frequency range from 16kc. to approximately 500kc. are classed as low frequency crystal. They are placed in this definite classification due to the fact that their oscillating characteristics are somewhat different from crystals in the most commonly used range from 500kc. to 10,000kc.

Low frequency crystals have, in comparison, a low activity. The activity rapidly decreases with frequency and is lowest at 16kc. This decrease is the natural result of the increased mass of the crystals since the ability of any body to follow rapid changes in motion is directly connected with the mass of that body. The lower activity does not, however, infer low Q ($Q = 2\pi FL \div R$) for the inductance of a crystal is directly related to its mass, i.e., the greater the mass the higher the inductance.

Because of their greater mass, low frequency crystals cannot vibrate as vigorously as crystals at higher frequencies without danger of being shattered. This means that the crystals must be used in low powered oscillators to keep the vibration amplitude at low values. Tubes such as

the 27, 56, 6C5, 57, 185 Ω (6AC7) or 6J7 with rated voltages are generally employed although other types can be used with reduced voltages. Low grid-drive tubes such as the 837, 80 Ω and RK23 are often used in transmitting equipment (150kc. and higher) to obtain a reasonable amount of power without endangering the crystal.

Any of the oscillator circuits previously discussed can be used with low frequency crystals providing proper circuit values are chosen. To insure sufficient excitation, the tuning tank circuit must have a high L to C ratio. This is often accomplished by employing an untuned inductance coil which has a suitable self-resonant frequency. No direct formula can be given for such inductances as the distributed capacity of various types of coils is dependent on the method of winding; the proper size is best determined by cut-and-try methods. Bias is best obtained by means of a grid-leak resistor but this resistor must be considerably larger than would be required for higher frequency crystals. At 500kc., 100,000 ohms is satisfactory while values up to 5 megohms are necessary at the lowest frequencies. An improvement in circuit performance sometimes can be obtained through the addition of a small amount of cathode bias. Too much cathode bias, however, will be detrimental rather than helpful.

Triode tubes have sufficient internal plate-to-grid capacity that additional feedback is seldom necessary. With pentode or tetrode tubes, however, this capacity is too small to provide sufficient excitation for low frequency crystals. The additional feedback required can be obtained by connecting a coil in series with the crystal and inductively coupling it to the tank, by neutralization circuits, or merely by adding an external plate-to-grid capacity. The latter method is the simplest and is most generally employed. The correct capacity usually will be between 2 mmf. and 10 mmf. depending on the crystal activity and individual circuit conditions.

The Tri-tet circuit is useful due to its high harmonic output and inherently good stability. The cathode tank does not require a very high L to C ratio and, therefore, can be a conventional tuned circuit. If the plate tank is a choke coil with small distributed capacity, the output will be rich in harmonics which can be used for frequency calibrating purposes. The apparent crystal activity can be increased, wherever necessary, by connecting a coil in series with the crystal and inductively coupling it to the cathode circuit.

Good harmonic output can be obtained with triode and pentode oscillators by using an untuned

tank. The higher the L to C ratio, the greater will be the harmonic output. Also, the higher the grid-leak resistance, the more distorted will be the output and, thereby, the greater the harmonic strength.

In conventional triode, tetrode or pentode oscillator circuits with grid-leak bias, maximum output occurs when the circuit is tuned for minimum plate current. This point is, however, unstable and operation must be below it on the low C side (tank tuned towards a higher frequency). For best performance, the circuit should be operated, whether the tank is tuned or untuned, at the lowest plate current consistent with positive starting of the crystal. With low frequency crystals, this generally will occur at 50% to 60% of the maximum drop in plate current which can occur by tuning.

A circuit often used in frequency standards, and particularly recommended for use with Bliley low temperature-coefficient crystals from 85kc. to 150 kc., is the modified Colpitt's Oscillator shown in figure 16. This arrangement has a relatively low power output but is exceptional for frequency stability. The crystal is connected directly into the frequency determining tank where it serves as a filter element. When the tank is tuned to a frequency at, or close to, the resonant frequency of the crystal, the crystal will assume control by reason of the fact that its impedance is lowest at its resonant frequency and rises very rapidly for other nearby frequencies. The crystal will maintain control over a comparatively large tuning range of the tank but, beyond that range, it no longer controls the oscillations, serving only as a series condenser in the tank circuit.

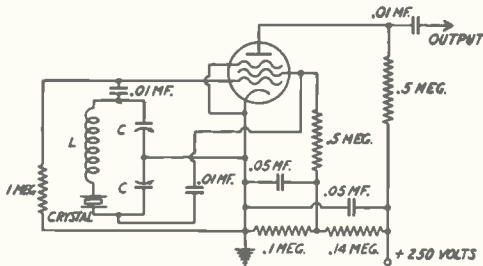

Figure 16—Standard Frequency Oscillator

The oscillating frequency of the circuit, with the crystal assuming control, can be varied over a limited range by the tuning condenser. At 100kc. this amounts to about ± 8 cycles which is sufficient to correct for any frequency changes which might result from aging of the circuit components or from moderate variations in operating

temperature. Any receiver-type pentode tube, such as the 6J7, is satisfactory for use in this circuit but the 185Z (6AC7) is particularly recommended because of its high transconductance.

The circuit values shown in the diagram are suitable for frequencies from 20kc. to 300kc. L and C should be of such values that, with the crystal shorted out, the circuit can be made to oscillate at a frequency slightly below the resonant frequency of the crystal at the approximate mid-position of the tuning condenser. The exact L to C ratio is not extremely critical but it does affect the frequency stability. Greatest frequency stability will occur with a fairly low L to C ratio because the crystal impedance can then rapidly become large in proportion to the reactance of L if there is any tendency of the circuit frequency to deviate appreciably from the resonant frequency of the crystal. Of course, as the L to C ratio is lowered, the range over which the circuit frequency can be adjusted is also decreased. A net operating tank capacity of about 85 mmf. (working value, 170 mmf. per section) is best for crystals at 100kc. and gives a total frequency range of about 16 cycles. If the frequency range appears to be too large with any crystal, reduce the L to C ratio; and, conversely, if a greater frequency range is desired (at the expense of frequency stability), the L to C ratio can be increased.

The modified Colpitt's Oscillator is not particularly suitable for frequencies much above 300kc. As the frequency is increased, it becomes more difficult to keep the circuit 'locked-in' with the crystal — the circuit will have a strong tendency to self-oscillate at other frequencies and the tuning range of the condenser over which the crystal assumes control becomes increasingly narrowed. Also, since the crystal is required to carry the circulating tank current, the circuit power must, of a necessity, be kept at a low level.

The modified Pierce circuit, shown in figure 12b, is excellent for low frequencies because of the positive feedback afforded. This arrangement is recommended particularly for use with low drift crystals from 150kc. to 400kc. A self-resonant inductance can be used for purposes of circuit simplicity but, where design permits, it is preferable to employ a conventional tuned tank.

It is characteristic of the bar-type crystals employed for low frequencies to possess two definite modes of vibration: the intended length oscillation and a thickness vibration. When the bars are mounted without mechanical restriction, such as in fixed or variable air-gap holders, either mode of oscillation can be excited by tuning the oscillator

circuit to either frequency. This property is utilized in dual frequency calibrator crystal units (Bliley SMC100, 100kc.—1000kc.). If the bar is clamped, say between knife edges, the thickness mode often can be completely discouraged such that, in effect, it becomes non-existent.

The two possible oscillating frequencies of freely mounted bar-type crystals are generally so well separated that the correct frequency, in a 'single' frequency crystal, is easily identified and no confusion results. In some circuit arrangements, however, where self-resonant tanks are employed, conditions can be encountered whereby the thickness rather than the length frequency will be excited. Particularly troublesome is the situation where the crystal frequency will start at one value and then hop to the other during operation. In any case of this nature, the performance can be corrected by increasing the size of the self-resonant coil or by placing fixed capacity in parallel with it. The effect of either alternative is, of course, to tune the oscillator toward the desired frequency and, simultaneously, detune it away from the thickness frequency of the crystal. Representative values of the plate coil and condenser for a simple Pierce circuit to operate at frequencies from 150kc. to 400kc. are 10 mh. to 16 mh. (single pi r.f. choke) and 400 mmf. In the same circuit, the grid-to-cathode feed-back capacity should be in the order of 150 mmf.

OSCILLATOR KEYING

Crystal oscillators, operating at all but very low frequencies, can be directly keyed for radiotelegraphy. Keying is accomplished in a variety of manners, although interruption of the cathode circuit is most common. Other methods include breaking the primary circuit of the oscillator power supply, opening the screen-grid circuit with pentode or tetrode tubes, applying high negative bias to the suppressor grid of pentodes, control-grid blocking, and shorting or opening the crystal circuit.

To prevent "chirping" when keying to the oscillator, the screen-grid potential for tetrode or pentode tubes should be obtained by means of a voltage divider rather than a series dropping resistor. This prevents the existence of high screen-grid voltage at the instant the key is depressed. When keying in the cathode circuit, best results are obtained when the cathode of both the oscillator and the first buffer are simultaneously interrupted. The two cathode leads can be tied together beyond their individual biasing resistors and r.f. by-pass condensers such that the key can be connected between the common lead and ground. A key

click filter is ordinarily necessary whether one or both cathode circuits are keyed but, usually, the use of a condenser and resistor in series across the key terminals is sufficient (C, $\frac{1}{4}$ to 2 mfd., R, 200 to 20,000 ohms). If further filtering is necessary, a choke with an inductance of from 1 to 5 henries can be connected in series with the keying circuit. The choke should, of course, be relieved of r.f.

An effective but not commonly employed keying system consists of directly shorting the crystal or of opening one crystal connection. Either arrangement naturally requires the use of a keying relay located close to the crystal such that very short connecting leads can be realized. When the crystal is to be shorted, a good quality mica condenser with a capacity of .002 mf. or greater should be connected in series with the crystal circuit to prevent disturbance of normal bias conditions in the oscillator.

Keying can also be effected by control-grid blocking; that is, through the application of a high negative voltage to the control grid when the key is open. Unless the keying bias is high and can be applied instantly, however, clean characters may not result. This is caused by the fact that an increase of bias generally will be accompanied by higher crystal excitation and some increase in output. If the bias change is not instantaneous, the output may increase momentarily before dropping to zero upon opening of the keying contacts. In addition, if the time of full application is sufficiently slow (caused by delay in resistance-capacity combinations), the crystal might be fractured as a result of operation under a high bias condition. Suppressor-grid blocking has less influence on crystal performance but, in the Tri-tet and similar circuits, the crystal will continue to oscillate when the key is open. This may or may not be undesirable, depending upon individual operating conditions.

Low frequency crystal oscillators (below 200kc.) cannot be satisfactorily keyed at reasonable speeds because of the relatively slow rate at which the crystal goes into oscillation. Also, at very high frequencies, it often is difficult to obtain a signal entirely free from chirping. Either of these difficulties can be eliminated in a multi-stage transmitter by keying one or more of the intermediate stages and allowing the crystal oscillator to run continuously. Under such conditions, the ability of the crystal to follow keying has no bearing on transmitter performance. Furthermore, if a buffer stage exists between the oscillator and the keyed stages, small changes in operating frequency (chirping) caused by varying oscillator loading under keying are eliminated. In this respect, it should be

noted that oscillator circuits such as the Tri-tet (figure 15) and the Pierce oscillator-multiplier (figure 11) possess some buffering action by virtue of the electronic coupling existing between the oscillator proper and the output circuit.

An objection to keying stages other than the oscillator lies in the fact that a local radiation may exist from the continuously running portion of the transmitter. This is undesirable for break-in operation or for local monitoring and can be eliminated only by thorough shielding of the radiating stages or by remote control of the transmitter. Also, unless the transmitter is carefully designed and adjusted, a back wave may be transmitted.

Figure 17 illustrates a method whereby the desirable features of direct oscillator keying and of inter-stage keying can be combined. This system, like simple inter-stage keying, is excellent for high speed telegraphy even with sluggish crystals. An added feature, however, is that the oscillator is 'dead' during the time the key is open.

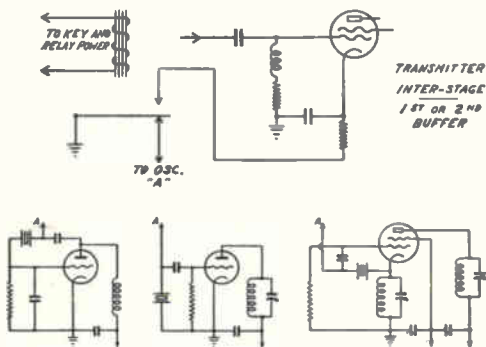

Figure 17—Double-Action Keying Circuit

Referring to the diagram, it will be seen that, when the key is open, the cathode circuit of the keyed interstage is incomplete and the crystal oscillator is inoperative because the crystal circuit is shorted to ground. Upon depressing the key, the oscillator is permitted to function but a signal is not transmitted until the relay contacts complete the cathode circuit of the additionally keyed stage. The time interval introduced by the relay allows the crystal oscillation to approach full operating value before a signal is radiated by the transmitter. This time delay reduces the possibility of a ragged signal due to slow crystal starting, or chirping due to changing oscillator loading. As in simple inter-stage keying, it is desirable, of course, to have at least one buffer stage between the oscillator and the keyed amplifier.

The time delay is adjustable by the relay contact spacing and should be set at the minimum value

consistent with clean characters. Naturally, the relay should be well designed such that bouncing of the contacts will not occur. If oscillator control is obtained by crystal shorting as shown in the diagram, the leads to the relay contacts, particularly from the oscillator, must be very short. Under proper conditions of adjustment and operation, the transmitted characters can be made to approach a square wave in characteristics without the presence of disturbing keying transients which would otherwise normally occur.

It is not necessary, incidentally, to key the oscillator by crystal shorting as shown. By the use of appropriate relay contacts or multiple relays, the oscillator can be keyed by any other desirable method. The primary consideration is to introduce a time interval between the starting of the oscillator and the actual transmission of a signal.

The oscillator arrangement in the Bliley Vari-X⁸ is an example of circuit design for clean keying characteristics and very low crystal excitation with reasonable power output. Figure 18 shows the wiring diagram of the oscillator and indicates correct values for 40-meter and 80-meter crystals. Through the use of the high transconductance 6AC7 tube in conjunction with proportioned control-grid and screen-grid feedback, excellent keying ability is realized. At the same time, essentially constant power output occurs with variable frequency crystals over the adjustable frequency range and the power output at 40 meters is nearly the same whether a 40-meter crystal be used or an 80-meter crystal be employed for doubling to 40 meters.

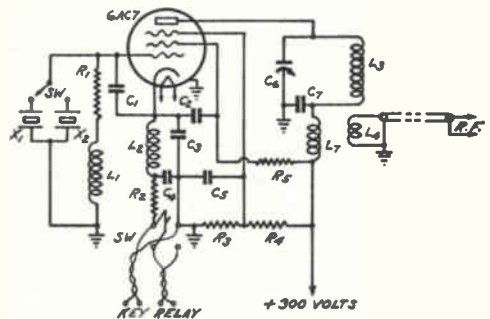

Figure 18—Vari-X Oscillator Circuit

- | | |
|----------------------|--------------------------|
| R1—20,000 ohms | C2—.01 mf. |
| R2—150 ohms | C3—.00015 mf., mica |
| R3—20,000 ohms | C4—.1 mf. |
| R4—100,000 ohms | C5—.01 mf. |
| R5—30,000 ohms | C6—.000140 mf., variable |
| C1—.000015 mf., mica | C7—.01 mf., mica |

- L1, L2, L7—2.1 mh. r.f. choke
 *L3—26 T. No. 18 enamel, 1½" D., space wound
 *L4— 5 T. No. 18 enamel, 1¼" D., space wound
 *For 80 and 40 meters (3500kc.-7500kc.)

In general, when a crystal oscillator is to be keyed, the oscillator should be considerably detuned from resonance and operated with a relatively light load. If the oscillator is loaded heavily and tuned for maximum output, chirping and skipping of characters can result.

FREQUENCY STANDARDS

Early frequency standards were simply variable tuned circuits, known as wavemeters. These instruments were calibrated against the output of a rotary high-frequency alternator whose frequency, and its harmonics, was determined from the constants of the machine and its speed of rotation — at that time, the alternator was the only source of accurate calibrating frequencies. The wavemeter is subject to considerable error and, even with present precision manufacturing and calibrating facilities, the dependable accuracy is in the neighborhood of only 0.1% to 0.25%. While the wavemeter does have a definite place in radio engineering, its inherent inaccuracies are far too great for frequency standardization purposes.

The first true standards of frequency were electrically excited tuning forks. These forks were maintained in vibration by a regenerative vacuum-tube oscillator circuit and were temperature controlled to provide the highest degree of frequency stability. Frequency was determined by direct reference to the basic element, time, through the medium of connecting a synchronous motor-driven clock to the output of the oscillator circuit and comparing the time, as indicated by that clock, with true time as determined by astronomical observatories such as the U. S. Naval Observatory. The average frequency of the tuning forks was then calculated from the time-rate of the oscillator clock. The fundamental accuracy of the tuning-fork standard could be held within about 7 parts in one million (0.0007%) which is far greater accuracy than obtainable with wavemeters. For frequency measurement purposes, the output of the tuning-fork oscillator was multiplied by vacuum-tube frequency multipliers to produce a series of standard frequencies.

The development of the quartz oscillating crystal entirely changed the conception of practical frequency stability and accuracy. Quartz crystals, having a large equivalent inductance and a high Q , possess a degree of frequency stability unattainable with other types of oscillator frequency control; the oscillating frequency is almost entirely determined by physical dimensions, it is unaffected by magnetic fields or gravity, and is influenced to only a very small extent (much less than with a tuning fork) by variations in atmospheric pressure.

Furthermore, a quartz crystal has the physical, chemical and electrical stabilities which are obvious prerequisites for permanence in a frequency standard.

Frequency standards are divided into two classifications: (1) primary standards of frequency and, (2) secondary standards of frequency. The primary standard, as its name implies, is a fundamental standard against which all other frequency determinations are made. It is an independent standard because it is checked for accuracy and stability by direct measurements against time. Quartz crystal control has so simplified the construction of frequency standards that primary standards are commercially practicable and are regular equipment in many laboratories, schools and government bureaus. The secondary standard has no provisions for checking its frequency directly with time and it, therefore, must be calibrated by reference to some primary standard.

PRIMARY STANDARDS OF FREQUENCY

Fundamentally, a primary standard of frequency consists of a temperature controlled crystal oscillator, a series of multivibrators for subdividing the oscillator frequency, and a synchronous motor-driven clock. The oscillator frequency may be 20kc., 30kc., 50kc. or 100kc., but 50kc. is more common. The crystal temperature is held to within a maximum variation of 0.01 degree Centigrade in a heated chamber while the oscillator circuit components are temperature controlled to a lesser degree. No provisions are made in commercial instruments to eliminate the effects of varying atmospheric pressure but, in the high precision instruments maintained by the U. S. Bureau of Standards, the crystals are operated at a substantially constant pressure in glass enclosed chambers.

The oscillator frequency is subdivided by multivibrators to provide a series of standard frequencies and to obtain a suitable low frequency for driving the synchronous motor clock. Since the time as indicated by the clock is entirely dependent on the frequency of the exciting current, and since the driving frequency is derived from the crystal oscillator, the clock actually serves as a counter for the number of oscillator cycles which occur in a given passage of time. By comparing the clock time with true time, the average frequency of the oscillator can be determined. The time comparison can be made to within a very small fraction of a second and the oscillator frequency, therefore, can be known within close limits of absolute.

The frequency of commercial primary standards can be held to within 2 parts in 10 million

(0.00002%) if carefully checked, while better stabilities can be obtained with more elaborate equipment such as employed by the U. S. Bureau of Standards. This figure refers to the fundamental accuracy of the crystal oscillator but does not directly indicate the accuracy to which frequencies can be measured. As a result of accumulative errors in associated measuring equipment, the overall accuracy may be reduced to 1 part in 1 million (.0001%) depending on the manner in which the measurement is made.

A primary standard is merely a generator of standard frequencies; to perform actual measurements, additional equipment is required. A calibrated receiver is, of course, a necessity. For general frequency measurements the receiver should preferably be the simple regenerative type but superheterodyne receivers can be used when desired. If a superheterodyne receiver is used, extreme care must be taken to make certain that the signal being measured is properly tuned in as erroneous measurements can easily result from false reception through images, harmonics, or odd beats between the signal and the receiver oscillator. This is most troublesome when the intensity of the signal being measured is quite high.

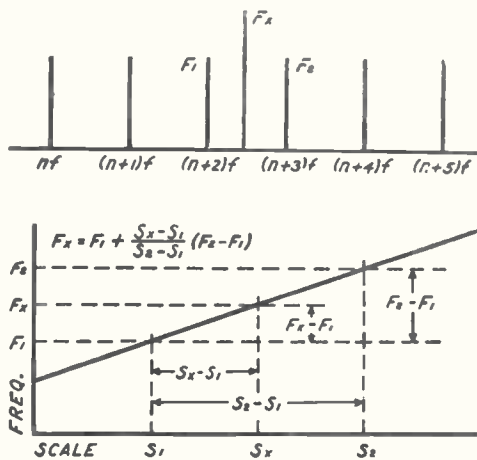

Figure 19—Charts Illustrating the Mechanics of Frequency Measurements

The process of measuring a certain radio frequency against a primary standard is, briefly, to locate that frequency with respect to two adjacent harmonics of the standard frequency generator. This is illustrated in figure 19. Measurements can be made with a fair degree of accuracy by using only the receiver and the frequency standard. The signal to be measured (f_x) is tuned in and the receiver dial setting carefully noted. The output

from the standard is then connected to the receiver and the dial setting noted for the two harmonics of the standard which are immediately adjacent to the frequency, f_x . If a regenerative receiver is employed, the detector should be in an oscillating condition and tuned to zero beat with each signal. The frequency of the two standard harmonics is known from the approximate receiver calibration and, by interpolation, f_x can be determined. A graphical picture, and correct formula, is given in figure 19.

The same general process can be followed by beating a calibrated oscillator against f_x , and the two adjacent standard frequencies, in the receiver. The interpolation is then carried out from dial settings of the oscillator corresponding to f_1 , f_2 and f_x . This latter method is advantageous where the signal strength of f_x is very low or where it is varying widely due to such effects as fading. The accuracy of the measurements will depend on the linearity of the receiver or oscillator calibration, the frequency stability during the measurements, and the precision to which the dial settings can be determined.

It is generally necessary, with the direct interpolation method, to use harmonics of the standard frequency oscillator rather than of a 10kc. multivibrator. The harmonic spacing of 10kc. is usually covered by such a small rotation of the tuning dial that the position of the various frequencies cannot be precisely determined. If greater accuracy is desired, f_x afterwards can be mixed in a receiver with harmonics of the 10kc. multivibrator. f_x , beating with each of the adjacent 10kc. harmonics, will produce two audio-frequency notes in the output of the receiver and either of these notes can be measured by zero-beating with a calibrated audio oscillator or by the use of an audio-frequency measuring instrument. The frequency of either one of these notes will, of course, be the frequency difference between f_x and the corresponding 10kc. harmonic. A knowledge of the approximate frequency can serve to show which beat is being measured, but the preferable and more accurate method is to employ a calibrated oscillator as described and raise its frequency slightly above f_x . If the audio note increases in frequency, the beat is against the lower 10kc. harmonic, and vice versa.

When mixing frequencies, it is preferable to use a regenerative receiver in a non-oscillating condition. If a superheterodyne receiver is used, adjust for minimum selectivity and tune to either one of the 10kc. harmonics or to f_x , whichever is weakest.

If f_x is below the fundamental frequency of the standard, or if it is higher than the usable harmonics of the standard and the multivibrator, a calibrated oscillator, termed a frequency meter or heterodyne frequency meter, must be employed. The frequency of this instrument is set such that it is equal to some harmonic of f_x , or such that f_x is some harmonic of the frequency meter. Then the procedure is to measure the frequency of the frequency meter and determine the value of f_x by multiplying or dividing that value by the harmonic number. It is, of course, necessary to know the approximate frequency of f_x so that the harmonic order can be determined. This can be done with a wavemeter or by determining several successive frequencies which will give harmonics or sub-harmonics at f_x . If f_x is lower than the frequency meter, f_x will be equal to the difference between any two successive frequency meter settings. Should f_x be higher, its frequency will be nf , where n is a harmonic number and f the reading of the frequency meter. It also follows that f_x will be equal to $(n+1)f_1$, $(n+2)f_2$, $(n+3)f_3$, etc. where f_1 , f_2 and f_3 are successive frequencies of decreasing values whose harmonics are equal to f_x . Therefore, $nf = (n+1)f_1$ or, $n = \frac{f_1}{f - f_1}$ where n is the harmonic order for frequency f (the higher of the two successive frequency meter frequencies).

The frequency meter, the receiver (heterodyne detector) and the audio oscillator (interpolation oscillator) are regular equipment for a complete primary standard frequency measuring assembly. In practically all cases the measurements are made as described and herewith summarized for a complete accurate measurement: (1) determine the approximate value of f_x by interpolation with the frequency meter, (2) set the frequency meter such that its fundamental, harmonic or sub-harmonic frequency is at zero beat with f_x , (3) mix the output of the frequency meter and of the 10kc. multivibrator in a receiver, (4) measure one of the audio frequencies produced in the output of the receiver by means of the interpolation oscillator and, (5) calculate f_x from all known values. To determine whether the measured audio beat is produced against the upper or lower 10kc. harmonic, it is necessary only to slightly raise the frequency of the frequency meter. The audio note will increase if the beat is with the lower harmonic or it will decrease if the beat is against the upper harmonic.

SECONDARY STANDARDS OF FREQUENCY

Any previously calibrated frequency determining instrument is a secondary standard of frequency.

Through common usage, however, secondary standards are considered to be crystal controlled oscillators of high stability employed for frequency measurements.

Secondary standards are used where the extreme precision and flexibility of the primary standard is not required and more simplified equipment is adequate. They have no provision for directly determining frequency and must be both calibrated and checked against some primary standard. When the fundamental frequency is appropriate, secondary standards can be checked directly against the transmissions of stations offering standard frequency services. The outstanding station of this type is WWV, the U. S. Bureau of Standards, which transmits on frequencies of 5000kc., 10,000kc. and 20,000kc. with an accuracy of better than 1 part in 5 million.

The primary standard, less the timing equipment, is a secondary standard. If the frequency stability need not be extremely high the constant temperature oven can be simplified or dispensed with entirely. The associated frequency measuring equipment can be complete for all types of measurements or abbreviated for specific applications. A simple 100kc. or 1000kc. crystal controlled oscillator in conjunction with a calibrated receiver or a calibrated frequency meter is often adequate and gives better accuracy than could be obtained with precision wavemeters. Whether the equipment is complete or reduced to essentials, measurements are wholly or partially made in accordance with one of the methods outlined in PRIMARY STANDARDS OF FREQUENCY.

The frequency monitors used in transmitting stations to check the operating frequency or frequencies are secondary standards. They are designed for one, or a group of, particular frequencies and the measurements are, therefore, considerably simplified. Some frequency monitors, especially those for use in broadcasting stations, are direct reading in terms of cycles per second deviation from the assigned value.

Secondary standards are useful in any application dealing with radio frequencies. With the increasing complexity of modern radio receiving equipment, radio servicemen find that the usual type of calibrated service oscillator is not sufficiently accurate for precision alignments. Through the use of a standard frequency oscillator in conjunction with the service oscillator, frequency accuracy of alignments can be greatly increased and better receiver performance assured. Harmonics of the standard can be directly employed for accurately checking dial calibrations since there will be a series of

harmonics over each band at a frequency spacing equal to the fundamental frequency of the oscillator. Up to about 4000kc. a fundamental frequency of 100kc. is excellent while a 1000kc. fundamental is to be preferred for the higher frequencies.

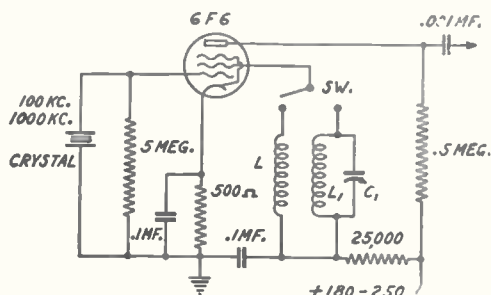

Figure 20—100kc.-1000kc. Standard Frequency Oscillator with High Harmonic Output

L—8 mh. r.f. choke (for 100kc.)

L₁—single pie of 2.5 mh. or 2.1 mh. r.f. choke (for 1000kc.)

C₁—100 mmf. trimmer condenser

NOTE: For a modulated signal, connect the oscillator plate circuit to the input of the power supply filter. With a full-wave rectifier, this will give 120 cycle modulation (60 cycle supply). To prevent frequency modulation, the screen-grid should always be fed with d.c.

For alignment of the intermediate frequency stages, the service oscillator is set to the intermediate frequency by interpolation between 100kc. harmonics. This is best performed by picking up a harmonic of the service oscillator in the broadcast band of any suitable receiver. Suppose the intermediate frequency is 460kc. Set the service oscillator to 460kc. by its calibrated dial and pick up the second harmonic (920kc.) in a receiver. Note the dial settings for two adjacent 100kc. harmonics (900kc. and 1000kc.) and, by interpolation, determine the correct dial setting for 920kc. Then set the oscillator such that its second harmonic falls at the dial setting corresponding to 920kc. Or, beat the output (2nd harmonic) of the service oscillator with the 900kc. and 1000kc. standard harmonics in a receiver and note the oscillator dial settings. By interpolation, the correct oscillator dial setting for 460kc. can be calculated. For better accuracy, a 10kc. multivibrator may be employed. This, however, is generally unnecessary. If the intermediate frequency is such that one of its harmonics falls at an even 100kc. (such as 450kc. $\times 2 = 900$ kc.), interpolation will be unnecessary because the oscillator harmonic can then be set to zero beat with the proper standard frequency.

The Bliley type SMC100 crystal unit was designed especially for service work. It contains a

specially ground crystal which will oscillate at either 100kc. or 1000kc. and, in a simple inexpensive circuit, gives dependable accuracy. The circuit and recommended values are shown in figure 20.⁹

Amateurs will find a 100kc. secondary standard to be a most valuable instrument for locating the edges of the bands and subdividing them into 100kc. points. Any amateur expecting to operate close to the edge of a frequency band should, by all means, have a method of accurately checking frequency to make certain that operation is within the legal requirements. The secondary standard can be easily and economically constructed with a Bliley SOC100, SOC100X or SMC100⁹ 100kc. Standard Frequency Crystal Unit.

The type SOC100 crystal unit is well suited for primary or secondary standards of frequency for it incorporates a low temperature-coefficient bar-type crystal mounted between knife edges. The crystal is calibrated for use in the Colpitt's Circuit shown in figure 16 and discussed in LOW FREQUENCY OSCILLATORS. To insure best performance and accuracy, a correctly designed tank coil (L) is an integral part of the unit. The capacity C should be a dual 350 mmf. tuning condenser. The output at 100kc. is approximately 1.5 volts R.M.S. and the harmonics will be usable up to the 30th or greater, depending on the sensitivity of the receiving equipment employed.

For greater output and higher harmonics from the secondary standard, one or two untuned amplifier stages should follow the oscillator. These, as shown in figure 21, are simply resistance-coupled amplifiers with r.f. chokes in series with the plate and grid-coupling resistors, and biased to give a distorted output. The r.f. chokes cause the amplifier gain to increase somewhat with frequency thereby

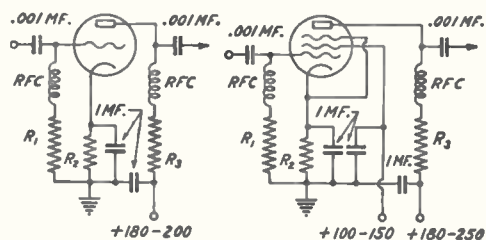

Figure 21—Resistance-Coupled Amplifiers for use with Standard Frequency Oscillators and Multivibrators

RFC—2.1 mh. to 60 mh.

R₁—50,000 ohms to 500,000 ohms

R₂—1500 ohms to 4000 ohms

R₃—5000 ohms to 100,000 ohms

⁹ Refer to Engineering Bulletin E-7 for complete details on construction and application

accentuating the higher harmonics. Either triode or pentode tubes may be used although pentodes provide the greatest gain and harmonic output. The circuit values are not critical but are best adjusted by trial for greatest output at the highest harmonic desired. For increasing the output at any given harmonic, or harmonics, the plate circuit of the amplifier can be tuned.

The following references are suggested as possible sources of helpful information covering the construction of secondary standards:

- QST, June, 1938, page 21
- RADIO, July, 1939, page 16
- ELECTRONICS, January, 1939, page 22
- ARRL RADIO AMATEUR'S HANDBOOK
- 'RADIO' HANDBOOK

THE MULTIVIBRATOR

The multivibrator is an oscillating system having special advantages applicable in frequency measuring equipment. It is, essentially, a two stage resistance-coupled amplifier with the output circuit coupled back to the input such that the feedback causes the amplifier to oscillate (motor-boat) at a frequency determined by the time constants of the resistance-capacity combinations in the circuit. Because the oscillations are brought about by the charging and discharging of condensers through resistance, the waveform of the oscillatory currents is irregular and distorted as compared to a sine wave. This means that the output voltage must be rich in harmonics.

Operating by itself, the multivibrator possesses no particular advantages because the circuit action is unstable and the output contains no usable frequencies. The performance changes, however, when a small voltage from a stable oscillator is injected into the circuit. If the frequency of the oscillator is made approximately equal to the natural frequency of the multivibrator, the injected voltage assumes control and brings about stable performance. The multivibrator frequency is then dependent on the controlling voltage and is independent of small changes in circuit values. When so stabilized, the multivibrator becomes a useful instrument in that it serves as an excellent harmonic generator.

The most important property of the multivibrator is that synchronization can be brought about when the frequency of the controlling voltage is harmonically related to the natural circuit frequency. In this way, the device may be employed for frequency division or multiplication. Its application is, however, usually limited to frequency division

and harmonic generation since there are preferable multiplying arrangements.

Because of its stability when synchronized, and the fact that the frequency is determined by the controlling voltage, the multivibrator is widely used to produce a series of standard frequencies from a single crystal controlled oscillator. Frequency division can be carried out to a ratio of about forty to one but, for assured stability, it is best limited to a factor of 10. Where a total division factor greater than 10 is required, a number of multivibrators can be operated in cascade. If the total division ratio is large, the factor per stage should best be limited to 5, or less. This is to insure positive locking-in of each stage every time the device is placed in operation; the necessity for a frequent stage-by-stage checkup to trace incorrect locking is inconvenient as well as undesirable.

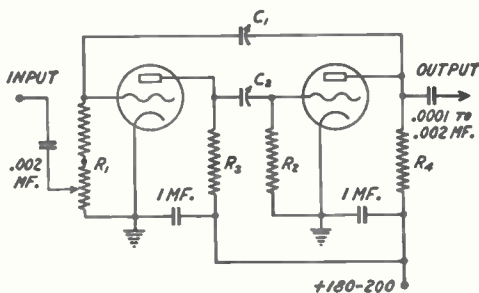

Figure 22—Multivibrator Circuit

	50kc.	10kc.
R1	10,000 ohms (total)	R1—25,000 ohms (total)
R2	10,000 ohms	R2—25,000 ohms
C1	750 - 1500 mmf.	C1—1000-3000 mmf.
C2	750 - 1500 mmf.	C2—1000-3000 mmf.
R3	20,000 - 25,000 ohms	
R4	200,000 - 250,000 ohms	

Input potentiometer 5000 ohms, wire-wound
Use wire-wound resistors throughout

Figure 22 illustrates a representative multivibrator circuit. The tubes can be standard triodes such as the 27, 56, 37 or 6C5 or, for simplicity, twin-triodes such as the 6N7, 53 or 6A6. The grid resistors R1, R2, and the coupling condensers C1, C2, are the major frequency determining elements. There is no simple formula which will give the exact

values but the approximation, $F = \frac{1000}{R_1 C_1 + R_2 C_2}$ is sufficient for practical purposes. F is the frequency in kilocycles per second, R the resistance in ohms and C the capacity in microfarads. For purposes of simplification, it is usual practice to choose $R_1 = R_2$ and $C_1 = C_2$.

R_1 , in the diagram, is shown as a potentiometer and a fixed resistor in series. The potentiometer, which has a value of 5000 ohms, offers a simple method of injecting the controlling voltage and regulating its value. In the formula given R_1 should be the total value of the two resistances in series.

Other than grid circuit injection as illustrated, the controlling voltage can be inserted in the plate circuit. A common method for accomplishing this is to include a portion of either, or both, plate resistors in the output circuit of the driving source. The resistor, common to both the driver and the multivibrator, provides the necessary coupling. Naturally, a by-pass condenser should not appear at the coupling point for such would decrease, or possibly destroy, the function of the coupling resistor. An equivalent alternate method for injection is to magnetically couple a coil in the driver output to a coil in series with either one, or both, of the multivibrator plate resistors.

There is a difference in the controlling action of the injected voltage depending on whether the frequency ratio is an odd or even number. This is due to the phase relationship between the injected voltage and the multivibrator oscillations. In general, a multivibrator, which has symmetrical components and is symmetrically fed (control voltage applied equally to both tubes), has the strongest tendency for operation at even ratios. If the symmetry is destroyed, the circuit functions better at odd ratios. The symmetry can be disturbed by choosing unequal circuit values for the two tubes or by the simple expedient of injecting the control voltage into the circuit of only one tube. This suggests the use of a snap switch for connecting the control voltage optionally to one or both of the tubes where a single multivibrator is intended to work at more than one frequency. For practical purposes, however, satisfactory control at either odd or even ratios can be obtained by choosing the value of one plate resistor 10 to 50 times greater than the other.

Either the grid-coupling condensers or the grid-coupling resistors should be made variable so that the multivibrator can be adjusted to the correct frequency. The use of variable condensers is most practical and these are shown in the diagram. Should it be inconvenient to obtain adjustable mica condensers of the proper capacities, the largest available sizes may be used in parallel with appropriate fixed condensers.

To adjust the multivibrator, the input controlling voltage is reduced to zero and the condensers C_1 and C_2 simultaneously varied until the fundamental

frequency is very close to the desired value. As the capacities are increased the frequency will decrease, while a decrease in capacity will cause the frequency to increase. The most convenient method to check the frequency is to couple the output to a radio receiver and estimate the frequency difference between the harmonics (the harmonics will be quite "rough" but discernible). As an aid in rapidly determining the frequency, the dial settings for two adjacent harmonics of the standard oscillator may be used as marker points. The multivibrator frequency can then be determined by counting the number of harmonics which appear between these points. For instance, if the crystal oscillator is at 100kc. and the desired multivibrator frequency is 10kc., there should be 9 multivibrator harmonics between any two adjacent 100kc. harmonics. If there are less than 9, the frequency is too high whereas more than 9 indicates that the frequency is too low. When the multivibrator is operating at 10kc., there will be a harmonic at each 100kc. point and 9 in between.

After the multivibrator has been adjusted to the correct frequency, a small voltage from the crystal oscillator should be injected into the circuit. As the voltage input is increased, a point will be noticed at which the multivibrator becomes stable and the output voltage resolves into definite frequencies. For best performance, the input should be increased slightly beyond that point. An excessive increase, however, will cause the multivibrator to jump to another frequency; when the crystal oscillator is assuming full control, the variable circuit elements can be varied appreciably without loss of synchronization. The frequency hop which can occur when the controlling voltage is excessively raised is the result of the fact that anything which is done to retard or accelerate the condenser charge or discharge time has the same effect as altering the value of the condensers.

The design of a multivibrator is not complicated and, as far as results are concerned, requires less engineering than an equivalent resistance-coupled amplifier. In construction, only high quality stable condensers and resistors should be employed. To keep stray capacities and inductances at low unvarying values, all interconnections should be short, rigid and isolated from ground. The use of number 12 radio bus-wire is recommended. The power supply should have good regulation inasmuch as the multivibrator frequency can be caused to change by varying the applied d.c. voltage just as it can be altered by varying the injected voltage or the values of the resistance-capacity combinations.

Although not a necessity, it is best practice to employ a resistance-coupled input and output

amplifier stage with each multivibrator. The input amplifier serves to decouple the oscillator and prevents circuit reactions from influencing the frequency. The output amplifier protects the multivibrator in the same manner and also increases the output. Radio-frequency chokes should be connected in series with the grid- and plate-coupling resistors of the output amplifier to bring about accentuation of the higher harmonics. These are shown in figure 21 and the circuit is discussed in SECONDARY STANDARDS OF FREQUENCY.

GENERAL OPERATING NOTES

Excitation is the most important consideration in the application of quartz crystals for frequency control of oscillators having appreciable power output. A quartz crystal can be applied to any type of oscillator circuit with any type of tube as long as the crystal excitation is kept within reasonable limits. Or, in other words, if the maximum rated crystal current is not exceeded under any possible condition of operation. This does not necessarily infer that it is possible to use high power oscillator tubes and obtain unusually large power outputs. The conditions for safe crystal current generally will be such that the power output will be no greater than obtainable with smaller tubes.

In testing a crystal oscillator circuit, especially when the excitation characteristics of that particular circuit are not well known, always make preliminary adjustments with reduced voltages. The crystal current should be measured under these conditions and, if sufficiently low, the voltages can then be raised to the desired values or to such values at which the crystal current approaches the maximum safe rating, whichever is the limiting factor. It is always best practice to set the operating conditions for the lowest crystal current consistent with required power output.

Figure 23a indicates the effects of tuning a crystal oscillator (except the Tri-tet). As the crystal goes into oscillation there will be a pronounced drop in the plate current. Maximum output will occur at the point of least plate current but operation should be between points B and C — point A is unstable and, if the circuit is operated under that condition, erratic performance will result. When cathode bias is used, the plate current, under load, may rise with tuning and exceed the non-oscillating value. If this occurs operation should be between the equivalent points B and C on the corresponding rising plate current curve.

The crystal oscillator portion of the Tri-tet circuit will show a characteristic tuning curve somewhat

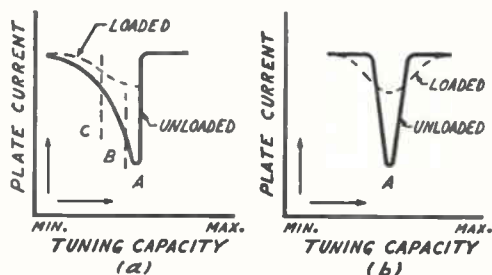

Figure 23—Oscillator Tuning Characteristics (a) Conventional triode, tetrode or pentode (b) Tri-tet

different from the conventional circuit. This tuning curve is shown in figure 23b. When first placing the circuit in operation, it should be tuned approximately to point A. After the plate tank circuit has been tuned to the desired harmonic, the cathode tank should be retuned for greatest output in the plate circuit regardless of the actual plate current.

Tubes such as the 802, RK23, 807 and RK37 which have a very low internal plate-to-grid capacity may require the use of external feedback to bring about sufficient excitation of the crystal, especially at the lower frequencies. This is usually accomplished by connecting a capacity of 2 mmf. to 10 mmf. between the control grid and the plate of the tube. Such a capacity, however, should be used only when necessary and with considerable care. Add the smallest amount of capacity which is consistent with good performance only after all other circuit values are found to be correct and in proper working order.

The 6L6 is preferable to the 6L6G as a crystal oscillator. Lowest crystal current with good output is obtained when the metal shell is connected to the cathode pin directly at the tube socket.

When using beam-power tubes in Tri-tet and conventional tetrode or pentode oscillator circuits at the higher crystal frequencies, a considerable reduction in crystal current can be obtained by the simple expedient of connecting a 50 mmf. to 100 mmf. condenser in series with the crystal. Most tubes of this type are easily overdriven due to their high power sensitivity; the condenser reduces the excitation with no appreciable loss in power output. If the capacity is too small the crystal will stop oscillating, while too much capacity will be ineffectual.

When using variable frequency crystal units, such as the Bliley VF1 or VF2, the oscillator power output normally will drop off as the frequency is varied over the adjustable range from the lowest to

the highest values. The actual amount of power output variation which can be encountered may be as high as 25% in some circuit arrangements. In conventional triode, tetrode or pentode oscillators, the power output can be made to approach a constant value by the use of a relatively high C tank. With the Pierce oscillator-multiplier arrangement (figure 11), power output constancy can be improved through grid-to-cathode feedback as pointed out in the discussion of that circuit.

Harmonic generating power oscillators usually make use of a pentode (or tetrode) tube as a combination triode crystal oscillator and pentode frequency multiplier. It should be remembered that the development of harmonics in such circuits is basically dependent on the choice of circuit conditions to bring about a distorted output. Only in instances where the crystal has a very low activity does the crystal affect the harmonic generation. The most foolproof harmonic generator is a low-power crystal oscillator driving a beam-power tube. A simple low-voltage oscillator, using a tube such as the 6C5, 6J5G or 6F6, driving a 6L6, 807, RK39 or RK49 frequency multiplier is an excellent combination.

It has been pointed out that the frequency of an oscillating quartz crystal can be altered by changing its effective equivalent electrical network through application of external reactance. This fact is often useful in instances where it is advisable to slightly change the frequency of a 'fixed' frequency crystal unit. In triode, tetrode or pentode oscillators of the tuned-plate crystal-grid type, the circuit frequency can be lowered by connecting capacity directly in parallel with the crystal. It is desirable that an air-condenser be used and it should, naturally, be variable. The maximum amount of possible frequency lowering varies with frequency, type of holder and circuit characteristics; it amounts to about 200 cycles/second at 800kc., 1500 cycles/second at 4000kc., 800 cycles/second at 6500kc. and 250 cycles/second at 10,000kc. The effect of the added capacity, is to lower the effective crystal activity as the capacity is increased. In any event, 75 mmf. represents the maximum usable capacity at any crystal frequency; at high frequencies 25 mmf. is maximum.

When a variable air-gap holder is used in services such as broadcast where very close frequency adjustment is necessary, it is sometimes advantageous to connect a very small variable air-condenser across the crystal. The air-gap adjustment then serves as a coarse frequency adjustment whereas the condenser acts as a trimmer for final frequency setting.

In Pierce oscillators, frequency variation is best obtained by connecting reactance directly in series with the crystal. The use of capacity will raise the frequency while inductance has the opposite effect. Also, changing the value of the grid-cathode feedback capacity will influence the frequency. A capacity in parallel with the crystal likewise will cause a frequency change due to the fact that the crystal does not work purely at its natural resonant frequency; the use of such capacity, however, very rapidly decreases the effective crystal activity.

Occasionally, kinks will be found in various radio periodicals to the effect that the frequency of a crystal can be lowered by coating its faces with India ink, iodine or some other material. The effectiveness of such a process is dependent upon the fact that the coating dampens the crystal and increases its effective mass; the result is a lowering of frequency. Oppositely, the frequency can be raised by inserting a piece of paper between the crystal and one of its electrodes to, in effect, create an air-gap. In either case, the total amount of possible frequency change is quite limited and is accompanied by a rapid decrease in activity. If the crystal is subjected to relatively high excitation, arcing might occur finally causing fracturing as a result of the concentrated heat of the arc. Also, with some crystals, erratic performance and encouragement of a frequency jump can occur. Simple reasoning dictates that altering crystal frequency by physical means as described should be applied only as an emergency measure where a special situation demands such action.

As explained in previous sections, excessive excitation will fracture a quartz crystal rendering it useless. The following are the outstanding sources of excessive excitation: (1) high tube voltages, (2) too much bias, grid-leak, cathode or combinations of both, (3) insufficient by-passing of the screen-grid circuit, (4) stray oscillator plate-to-grid feedback brought about by improper circuit layout, (5) the existence of strong parasitics in the oscillator, (6) operating straight through on the crystal frequency in the Tri-tet circuit with poor internally shielded tubes such as the 59, 47, 42, 6L6, 6F6, (7) improper interstage shielding bringing about undesirable coupling between the oscillator and some other stage of the transmitter, (8) feedback into the oscillator stage brought about by self-oscillation in one of the buffer stages or the final amplifier, (9) improper circuit values with oscillators in which the crystal feedback is considerably dependent on circuit adjustments, (10) failing to place the band switch in its proper position with the Bi-Push Exciter, or, (11) in certain instances, by removing the plate voltage from a

Pierce Oscillator employing an untuned tank. This is a unique situation in that the buffer stage, which follows the oscillator, can act as a crystal controlled oscillator. The crystal is effectively connected between the control grid and ground of the buffer tube and, if the buffer plate tank is tuned to the crystal, that stage can act as a crystal oscillator when the voltage is removed from the oscillator stage proper. If conditions in the buffer stage are incorrect for a crystal oscillator, the crystal may be fractured.

A somewhat common cause of crystal fracturing is self-oscillation in a buffer or amplifier stage (item No. 8), particularly in the stage following the crystal oscillator. The damaging self-oscillation may occur during initial neutralization if plate voltage is applied to the neutralized stage before the adjustment has been perfectly made. Likewise, it might occur during operation if neutralization is not complete. Also, it might be caused by poor layout in a tetrode or pentode stage not normally requiring neutralization to prevent oscillation. As a general rule, it is recommended that plate voltage should not be applied to any stage working at the crystal frequency until the usual tests indicate proper neutralization and full freedom from self-oscillation.

If a transmitter is to be built on the basis of published constructional information, the crystal oscillator portion should be carefully checked with respect to the crystal frequencies intended to be used. This precaution is advisable in view of the fact that some circuits, designed on the basis of certain oscillator frequencies, are not satisfactory for crystals at higher frequencies. For instance, a certain oscillator which functions well with 80-meter amateur crystals, can have characteristics such as to cause fracturing of 40-meter crystals due to excessive feedback at the higher frequencies. Particular attention, in this respect, should be paid to Pierce and modified-Pierce oscillators. If harmonic type crystals might be employed for some frequencies (all present Bliley crystals for frequencies above 11mc. are harmonically operated), the oscillator should be capable of causing the crystal to work at the correct frequencies.

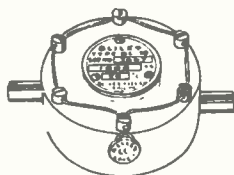

Quartz crystals are, fundamentally, devices for the purpose of frequency control and stabilization. While modern crystals will control a considerable amount of power, best operation and frequency stability can be obtained only when the oscillator is operated lightly loaded and under conditions which bring about very low crystal current.

A large number of amateurs attempt to work close to the edge of the various amateur bands to obtain certain operating advantages. When choosing a crystal frequency for such purposes, there are several considerations which are important:

1. The frequency of any crystal is somewhat dependent upon the characteristics of the circuit in which it is used. Variations, under operating conditions, may be as great as .03% from the laboratory calibration, depending upon the particular oscillator arrangement. The calibrated crystal frequency should be such that a possible difference of $\pm .03\%$ will not place the actual operating frequency outside of the band limits.
2. The frequency of any crystal will be affected by its temperature. All Bliley Amateur Crystal Units are calibrated at approximately 80°F. Therefore, make allowance for frequency drift due to other possible crystal operating temperatures as a result of direct crystal heating, heating by transmitter components and varying ambient temperatures. Low temperature-coefficient crystals can have a positive or negative drift depending on the characteristics of the individual crystal. If the sign of the drift is unknown, assume that the drift will be towards the band edge.
3. The Federal Communications Commission requires that all modulation frequencies be within the band limits. In addition to allowances as in 1 and 2, leave sufficient frequency difference to accommodate any side bands. Allow at least 4kc. for radiotelephony and approximately 500 cycles for radiotelegraphy.
4. Edge of band operation should be attempted only when the station is equipped with a means for accurately measuring the operating frequency.
5. For working extremely close to a band edge, the use of a variable frequency crystal unit is to be preferred. All possible effects of circuit characteristics and operating temperature on crystal frequency can then be offset by direct frequency adjustment. Under such conditions, the limitation for proximity to the band edge depends to the largest extent upon the accuracy to which the absolute frequency can be measured.



NOTES





Bliley **ELECTRIC COMPANY**
Crystals

Manufacturers of QUARTZ

UNION STATION BUILDING, ERIE, PENNSYLVANIA

June 22, 1939.

Mr. Bertram Aaron,
6811 Huntington Avenue,
Newport News, Virginia.

Dear Sir:

This will acknowledge and thank you for your remittance of \$5.75 and your letter of June 15, specifying one HF2 10-meter crystal unit at approximately 29.25mc. Your order has been released for production and shipment of the crystal went forward to you on June 20 under our packing slip No. 33672.

In answer to your question, we would suggest that you use a 2 volt .06 ampere lamp in series with the crystal as a protective device. In order to keep stray circuit capacities to a minimum, it is essential that the lamp leads be soldered directly to the lamp base and be made as short and direct as possible. Such a lamp properly installed will insure reasonable protection against excessive crystal current.

It is, however, quite possible for a sudden surge of current to fracture the crystal without damaging the lamp in any way. For a complete discussion of this subject, it is suggested that you obtain a copy of our Engineering Bulletin entitled, "Frequency Control With Quartz Crystals." This bulletin may be secured from any Bliley distributor or direct from our factory at the regular charge of 10¢.

We appreciate the opportunity of furnishing the type HF2 crystal, and hope that our service will meet with your approval.

Very truly yours,

W. S. Riblet

W. S. Riblet,
Sales Department.

WSR:GC



Fruit and Veg
market

Shopping

Shopping