

# FUNDAMENTALS OF RADIO

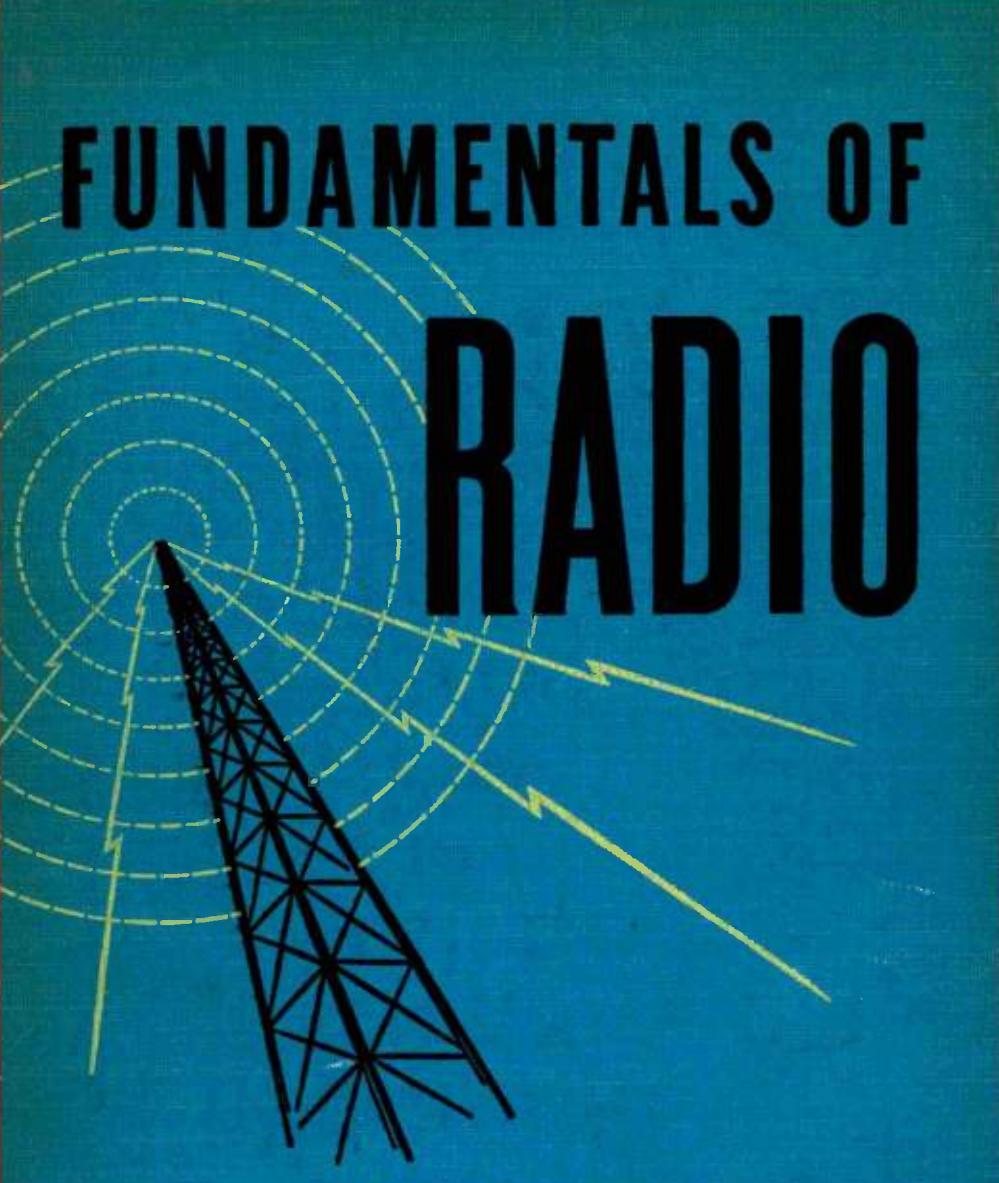

★ **GORDER**

★ **HATHAWAY**

*FUNDAMENTALS OF*

**R A D I O**

---

L. O. GORDER, Consulting Radio Engineer

KENNETH A. HATHAWAY, Managing Director of Radio Parts, Manufacturers National Trade Show, Inc.; Formerly Executive Secretary, Institute of Radio Service Men; Associate Member, Institute of Radio Engineers; Formerly Radio Technical Advisor, The Chicago Daily News

CARL H. DUNLAP, Head, Electrical Engineering Department, American School; Associate Member, American Institute of Electrical Engineers

---

*1945*

AMERICAN TECHNICAL SOCIETY

CHICAGO, U.S.A.

[ ILLUSTRATED ]

---

Copyright, 1943, by  
AMERICAN TECHNICAL SOCIETY

---

Copyrighted in Great Britain  
All Rights Reserved

Reprinted November, 1943

Reprinted, 1945

No portion of this book may be reproduced by the mimeograph process or by any other process without permission from the publishers.

*This book is produced in conformity with government regulations for saving paper. It is complete and unabridged in contents.*

Printed in the U. S. A.



**INSPECTING HIGH FREQUENCY RADIO TRANSMITTING TUBES USED IN COMMUNICATING MESSAGES BETWEEN SHIPS AND SHORE RADIO STATIONS. THERE ARE NEARLY THIRTY TYPES OF TRANSMITTING TUBES MADE OF WHICH ONLY TWO ARE SHOWN**

*Courtesy of Westinghouse Electric & Mfg. Co., East Pittsburgh, Pa.*



---

## PREFACE

---

The aim of this book is to prepare the reader for entering the highly technical and specialized radio field by giving him a thorough understanding of the fundamental principles of radio. The authors have followed the outline recommended by a committee of educators, many of whom have spent years in teaching the fundamental principles of radio to students and practical radio men.

First, principles underlying individual parts of a radio receiver and transmitter are taken up. Following this, the assembly of the parts is explained, and then the complete assembly is presented. The student is thus led by easy stages to understand how individual parts integrate and operate as a complete radio.

Radio work involves the use of many diagrams to indicate wiring of circuits and electrical connections for the various parts. In making these diagrams, the draftsman uses symbols of objects and parts. Several pages of conventional symbols are included in this book to help the student learn these; a picture of the object represented is shown beside each symbol, and an explanation is given of the function of each of these objects. This enables the student to associate each symbol with the part of the radio it represents. These pages of symbols are near the front of the book where they can be referred to quickly.

In this book the mathematics of radio work has been held to the substitution of numbers for the letters occurring in the formulas, so that their solution is reduced to simple arithmetic.

The reader will find the glossary of radio terms at the back of the book an invaluable aid when he encounters a new term or wishes to refresh his memory. Following the dictionary, handy tables are given; these include conversion tables, copper wire data, a chart for converting Centigrade units to Fahrenheit units, and others that will prove useful.

*Much of the text material is included in the cyclopedia "Applied Electricity."*

# CONTENTS

	Page
<b>Development of Modern Radio</b> . . . . .	1
SOS—Radio in War and Industry—Wireless Telegraphy—Radio Telephony—Radio Communication.	
<b>Standard Radio Symbols</b> . . . . .	5
(Illustrations and Definitions.)	
<b>Principles of Electricity</b> . . . . .	17
Electrical Energy—Electrostatic Energy—Electron Theory—Molecules—Atoms—Protons and Electrons—Sources of Electrical Energy—Voltaic Cell—Primary Cells—Storage Batteries—Electromagnetic Generation—Electrical Terms—Circuits—Insulators—Conductors—Conductance—Resistance—Reactance—Impedance—Electrical Units of Measure—Ohm's Law—Electrical Connections: Series, Parallel, and Series-Parallel.	
<b>Magnetism and Electromagnetism</b> . . . . .	37
Magnets: Bar, Horseshoe, Temporary, and Permanent—Electromagnets—Magnetic Fields—Magnetic Lines of Force—Terrestrial Magnetism—Electromagnetic Field—Electromagnetic Induction—Mutual Induction—Inductance Coils—Magnetic Field around a Coil.	
<b>Resistance</b> . . . . .	49
Resistors, Wire-Wound and Carbon—Rheostats—Wattage Rating—Resistances in Series, Parallel, and Series-Parallel—Current Flow through a Circuit—Voltage Drop.	
<b>Direct and Alternating Current</b> . . . . .	61
Direct, Pulsating Direct, and Alternating Currents—Effective Voltage—Counter-Electromotive Force—Effect of Inductance and Capacity—Phase—Calculating Reactance—Inductance in AC Circuit—Radio Transformer.	
<b>Electrical Measuring Instruments</b> . . . . .	75
Galvanometer—Voltmeter and Ammeter—D'Arsonval—Moving-Vane Type—Dynamometer—Oxide Rectifier—Hot-Wire, Thermocouple, and Vacuum-Tube Types—Volt-Ohm-Milliammeter—Oscilloscope.	
<b>Inductance and Electromotive Force</b> . . . . .	93
Self-Inductance—Inductance Coils—Unit of Inductance—Radio-Frequency Choke Coils—Calculation of Inductance—Formula for Solenoid—Coils in Series, Parallel, and in Series-Parallel—Iron-Core Choke Coil—Eddy Currents.	
<b>Condensers and Capacitance</b> . . . . .	105
Leyden Jar—Dielectric Materials, Air, Mica, Paper—Dielectric Constant—Protection of Condensers—Color Coding—Electrolytic Condensers—Electrolytes and Electrodes—Variable Condensers—Voltage Equalizer—Air as Basic Dielectric—Dielectric Constant Values—Farad as Unit of Measure—Calculating Capacity—Condensers in Series, Parallel, and in Series-Parallel.	
<b>Oscillatory Circuits and Resonance</b> . . . . .	123
How Oscillations Are Produced and Stopped—Mutual Inductance—Coefficient of Coupling—Tight and Loose Coupling—Methods of Coupling Circuits: Direct-Inductive, Direct-Capacitive, Resistance, Indirect-Inductive, Indirect-Capacitive—Indication of Resonance—Resonance of Coupled Circuits—AC-DC Filter—Choke Coil—Radio-Frequency Filters—Series-Resonant Circuit—Parallel-Resonant Circuit—Use of Wave Traps.	
<b>Vacuum Tubes</b> . . . . .	143
Electronic Emission—Diode Tubes—Edison Effect—Triode Tubes—Construction of Grid and Plate—Amplification Factor—Grid Control of Current	

	Page
—Effect of Gas in Tube—Plate Resistance—Plate Impedance—Mutual Conductance—Multi-Element Tubes—Types of Filaments—Cathodes—Exhausting the Tube—Dissipating Heat—Interelectrode Capacitance—Construction of Tetrode Tubes—Pentode Tubes—Special Purpose Tubes.	
<b>Amplifiers and Amplification</b> . . . . .	161
Input and Output Circuits—Voltage Amplification—Voltage Gain—Calculating Amplification—Power Amplifiers—Distortion Signals—Distortion by Tube—Changing Grid Bias—Effect of Overloading Tube—Types of Amplification—Changing Amplifiers to Different Class—Class A Amplifier—Tubes in Parallel and Push-Pull—Class B Amplifier—Power Output Calculations—Frequency Response and Measurement—Tone Control—Push-Pull Amplification.	
<b>Acoustics, the Science of Sound</b> . . . . .	185
Sound Waves—Speed of Sound—Amplitude—Music and Noise—Production and Transmission of Sound—Tuning Fork—Reflection, Echoes and Their Prevention—Harmonious Tones—Music—Vibration Frequencies—How We Hear—Range of Audibility.	
<b>Microphones</b> . . . . .	201
Carbon-Button—Condenser—Crystal—Dynamic—Velocity (Ribbon)—Frequency Response.	
<b>Oscillators</b> . . . . .	209
Action of Amplifier—Oscillators—Armstrong Circuit, Colpitts, Tuned-Grid Tuned-Plate, Quartz-Crystal, Dynatron, Electron-Coupled.	
<b>Radiotelegraph Transmitters</b> . . . . .	219
Transmitters: Spark, Arc, Vacuum Tube.	
<b>Amplitude-Modulated Broadcast Transmitters</b> . . . . .	227
Telephone and Telegraph Transmitters—Carrier Wave—Modulation—Parts of Radiophone Transmitters—Western-Electric Transmitter.	
<b>Transmitting Antenna Systems</b> . . . . .	237
Types of Antenna Systems—Antenna Feed Systems.	
<b>Radio Receivers</b> . . . . .	243
Radio Signals—Tuning Circuits—Radio-Frequency Amplification—Regeneration—Audio Amplifiers—Manual and Automatic Volume Control.	
<b>Superheterodyne Receivers</b> . . . . .	265
Circuits—Operation—Antenna Connections—Mixer-Oscillator—Intermediate-Frequency Amplifier—Detector-Amplifier—Power Amplifier—Aligning Intermediate and Radio-Frequency Stages.	
<b>Sound-Reproducing Devices</b> . . . . .	277
Telephone Receiver—Headphone—Loud-Speakers: Magnetic, Balanced-Armature, Dynamic, Moving-Coil, Permanent-Magnet—Baffles.	
<b>Receiving Antennas</b> . . . . .	285
Types—Action of Radio Waves—Efficiency—Doublet—Length of Doublet—Double-Doublet—Radio Interference—Atmospheric Static—Radio-Waves and Static—Man-Made Static—Static Eliminators—Antenna Transmission Lines—Noise-Reducing Antennas: Outdoor, Indoor, Short-Wave.	
<b>Radio Power Supply</b> . . . . .	299
Diode Tube as a Rectifier—Half-Wave and Full-Wave Diode Rectifier Tubes—Mercury Vapor Tubes—Power Supply Units—Filters—Voltage Divider—Direct-Current Supply.	
<b>Frequency Modulation</b> . . . . .	309
Advantages—Transmitters—Reactance Modulator—Control of Oscillator—Noise Reduction—F. M. Reception—F. M. Receiving Circuit—R. F. Amplifier—Mixer and Oscillator—I. F. Amplifier—Discriminator—Audio Amplifier.	
<b>Glossary of Terms</b> . . . . .	325
<b>Reference Tables, Formulas, Abbreviations, etc.</b> . . . . .	342
<b>Index</b> . . . . .	352



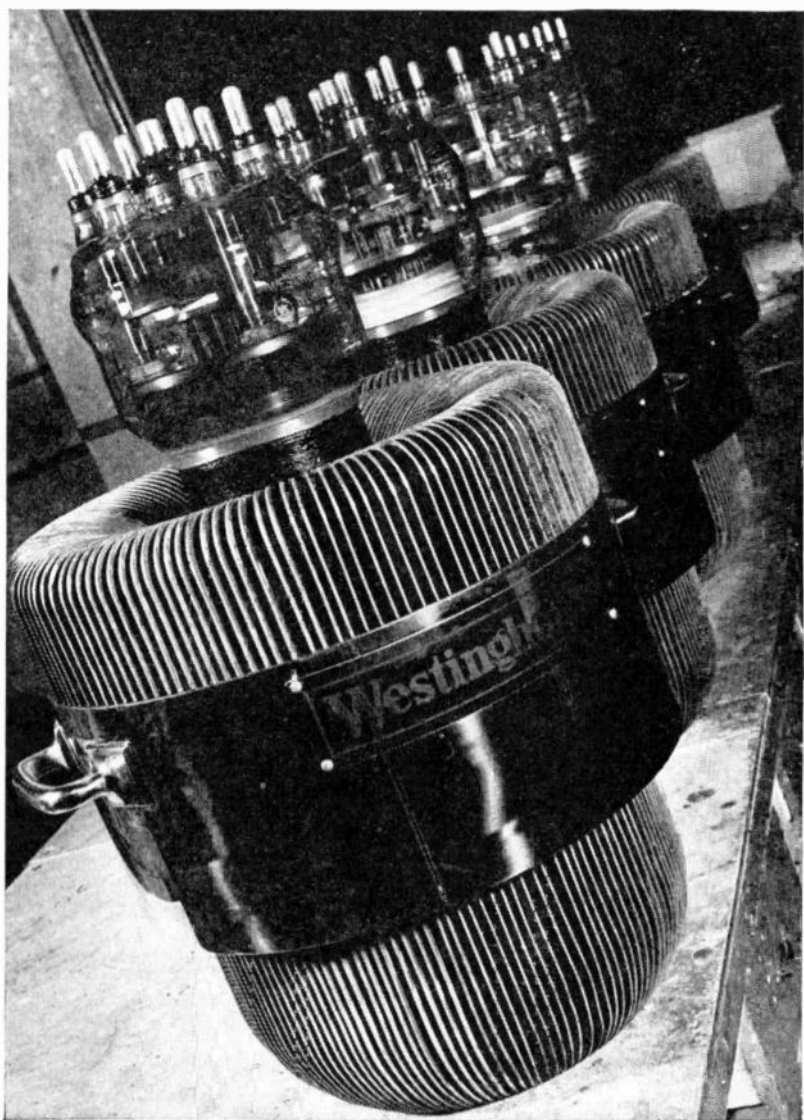

**FOUR LARGE RADIO TUBES HAVING A TOTAL OF 100,000 WATTS OF RADIO TRANSMITTING POWER; USED IN BROADCASTING FROM U. S. TO SOUTH AMERICA**  
*Courtesy of Westinghouse Electric & Manufacturing Company, East Pittsburgh, Pa.*

# FUNDAMENTALS OF RADIO

---

## CHAPTER I

### DEVELOPMENT OF MODERN RADIO

---

Since its inception, radio has made gigantic strides as a means for effecting communication with isolated places. Originally it was brought into use to communicate with ships having no other contact with shore. Before the advent of *wireless telegraphy* (the original name given to the art of communication without wires) a ship would leave port and be completely out of contact with the world until the next port was reached. Many ships foundered and were never heard of again—it was simply assumed that all aboard were lost, which was generally the case. Other ships were undoubtedly in a position to give assistance if there had been any way for the distressed ship to make its plight known.

**S O S.** In 1912 the International Radiotelegraphic Convention endorsed *S O S* as an international wireless signal of distress. These letters were selected because they can easily be sent, even by an amateur. The code is three dots, three dashes, and three dots. This signal constantly repeated is not likely to be mistaken for anything else. The letters are not an abbreviation and do not stand for any such phrases as, "Save Our Ship," "Send Out Succor," or "Save Our Souls." Several major marine disasters, notably the sinking of the great liner "Titanic" brought this type of communication to the fore, and governmental aid was obtained for extending the services thus rendered.

**Radio in Time of War.** Radio communication received an added impetus in World War I, in providing a convenient communication service not only at the scene of battle operations but also from continent to continent when the undersea cables carrying communication channels from Europe to North America were purposely cut to hamper the exchange of war plans.

Today, radio is the world's greatest medium for mass com-

munication. It ranks with the press in bringing the latest developments in world events to every home and in fact reaches far-flung outposts of civilization more effectively than can be done by the newspapers. We depend upon radio to bring us not only entertainment but important information concerning our conduct during emergencies as well as education and cultural programs of high merit. Education programs are being sent to schools from centralized distribution points to augment the studies given in the standard curriculum.

The importance of radio in time of war is unquestioned. At the present time radio devices are being used to detect, at distances formerly considered impossible, the presence of enemy planes, submarines, and surface vessels. Without adequate communication correlating attacks, confusion would result and failure would be inevitable. Every branch of our armed forces has large numbers of radio technicians in training, for the upkeep and operation of communication equipment.

**Radio in Industry.** Radio devices have been adopted in industry where they perform difficult tasks rapidly and efficiently. Adaptations of radio circuits are used to protect the lives of operators of various machines.

**Wireless Telegraphy.** A predetermined sequence of dots and dashes is employed in wireless telegraphy to effect communication. This rather cumbersome system requires highly skilled operations at the transmitter and receiver to transcribe and translate the dots and dashes into the letters for which they stand. Automatic transmitters and receiving devices are being used for high-speed communication circuits between stations having a large volume of traffic, but in isolated places such as on ships, the skilled operator is required to adjust transmitting and receiving apparatus and carry on communication by code.

**Radio Telephony.** Radio telephony, or simply *radio* as it is popularly called, refers to radio communication through the use of voiced sounds as in ordinary wire telephony. The popularity of this method of effecting communication began shortly after the end of World War I. Several purely experimental transmitting stations were placed in operation and programs of various forms of enter-

tainment were sent out to the few receivers capable of picking them up. The response was so successful that transmission facilities were greatly expanded; the "era of broadcasting" had dawned.

**Process of Radio Communication.** The following simplified diagram, Fig. 1, illustrates the process of radio communication.

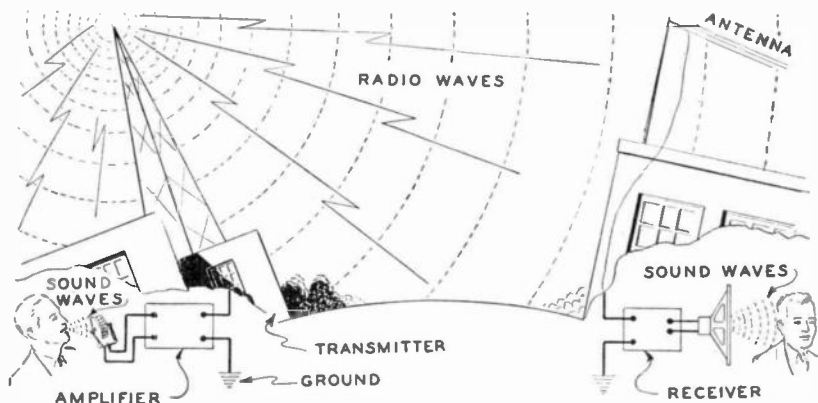
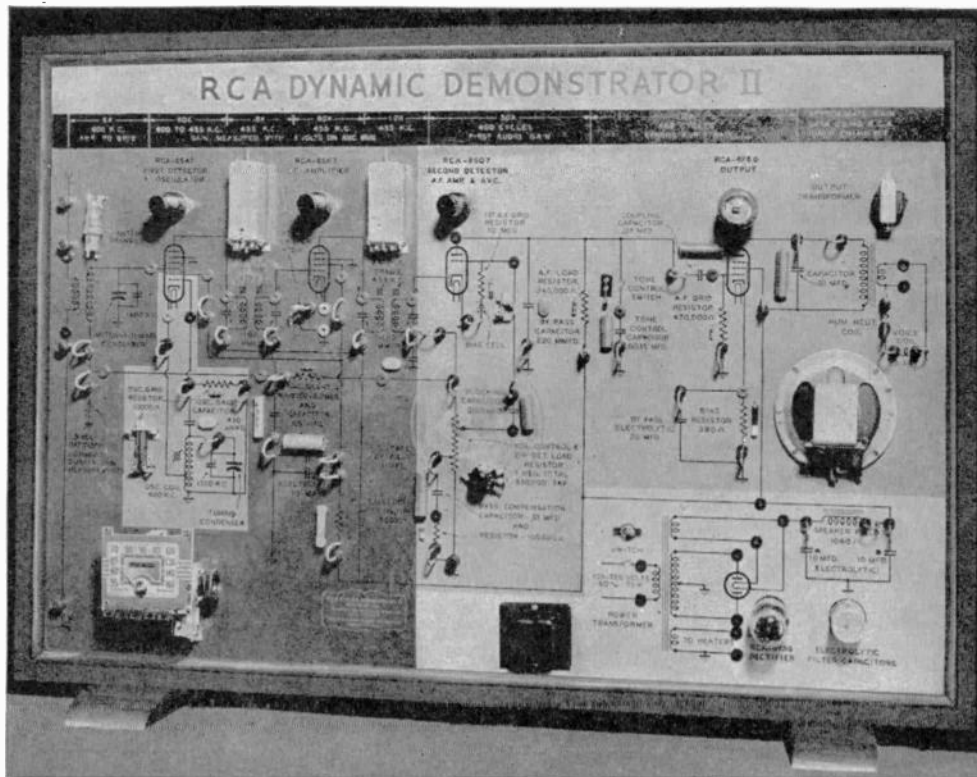

Fig. 1. How Radio Programs Are Transmitted to the Listener

*Sound waves* reaching the *microphone* are changed into electrical impulses and impressed on a radio-frequency carrier wave, *i.e.*, a wave capable of disturbing the ether and traveling great distances from the *transmitter*. *Radio waves*, which are formed when the audio-frequency impressions impinge on the microphone, travel outward into space with the speed of light (186,000 miles per second) diminishing in amplitude as the distance from the transmitter increases. On reaching the distant *antenna* of the *receiver*, the waves set up feeble electrical impulses which are amplified by the receiver circuits and finally emerge from the *loud-speaker* as sounds that are similar to the original sounds striking the microphone.

The foregoing description of the method of effecting communication does not indicate the multiplicity of complex circuits necessary to carry out the operation. It is the purpose of this book to describe in detail the various actions taking place in such a system.



### R.C.A. DYNAMIC DEMONSTRATOR BOARD

A cathode ray oscillograph can quickly be plugged into the jacks on this board, and the shape of the wave form can be observed at any desired point.

*Courtesy of R.C.A. Manufacturing Company, Inc., Camden, N. J.*

## STANDARD RADIO SYMBOLS

---

**Antenna.** A metallic structure or arrangement of conductors used for receiving or transmitting radio waves; sometimes referred to as an *aerial*. The structure may be a simple elevated conductor or a complex arrangement of conductors used to provide special directional characteristics. (Fig. 1)

**Ground.** An earth connection. Also used to indicate a return circuit to a point of low potential, such as the chassis of a receiver, transmitter, or amplifier. An actual ground return is not necessary to carry on radio communication. (Fig. 1)

**Loop Antenna.** A compact antenna generally in the form of a large coil of wire which is sometimes used for indicating the direction of arrival of radio waves. It is also used in compact portable receivers in place of an elevated antenna structure. (Fig. 1)

**Wiring Symbols.** Two systems of indicating wire connections are used in the wiring diagrams depicting radio receiver circuits. In one system, a half circle is made in one wire to show that it crosses without contacting the other wire. Where a connection is to be made the two wires are crossed omitting the half circle. In the other system, two wires which connect are crossed and a prominent dot is placed at their intersection. If the wires are not connected the dot is omitted at the cross-over point. (Fig. 1)

**Cell.** A chemical unit capable of producing an electromotive force. The cell generally consists of two dissimilar metals immersed in a fluid or paste called the *electrolyte*. A cell is a *single unit*. (Fig. 1)

**Battery.** A combination of two or more chemical cells generally connected in series to produce an output voltage greater than that of a single unit. When designed for specific services, the battery may be called by a more descriptive name, such as, *A battery*, *B battery*, and *C battery*. A *multi-cell* or *storage battery* is shown in Fig. 1.













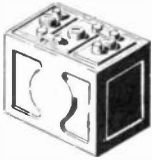





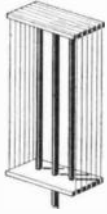

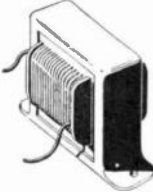

SYMBOL	OBJECT	SYMBOL	OBJECT
 <b>ANTENNA (AERIAL)</b>		 <b>MULTI-CELL BATTERY</b>	
 <b>GROUND (CHASSIS CONNECTION)</b>		 <b>INDUCTANCE (AIR CORE)</b>	
 <b>LOOP ANTENNA</b>		 <b>A. F. CHOKE (IRON CORE)</b>	
 <b>FIRST METHOD      SECOND METHOD</b> <b>WIRES CROSSING WITHOUT CONNECTION</b>		 <b>R. F. TRANSFORMER (AIR CORE)</b>	
 <b>FIRST METHOD      SECOND METHOD</b> <b>WIRES CONNECTED</b>		 <b>A. F. TRANSFORMER (IRON CORE)</b>	
 <b>SINGLE CELL</b>		 <b>POWER TRANSFORMER</b>	

Fig. 1. Symbols of Antenna, Ground, Wires, Cells, Batteries, Transformers

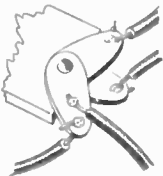
**Inductance (Air Core).** A coil of wire wound in such a manner that a concentrated magnetic field is set up about it when current is caused to flow through its conductor. The purpose of an inductance may be to impede the flow of varying current in a circuit, set up a magnetic field, either variable or constant according to the current flowing through it, or, in conjunction with a capacitor, to resonate to a given frequency. (Fig. 1)

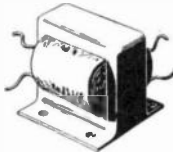
**Audio-Frequency Choke Coil.** An inductance known as an A. F. choke, with an iron core, the core serving to greatly increase the resultant magnetic field caused by current flowing through the conductor. The use of the iron core limits the upper frequency at which the inductance is effective, this frequency generally falling in the higher audible range. The principal purpose of such a device is to limit the flow of alternating current at audio frequencies while allowing the passage of direct current. (Fig. 1)

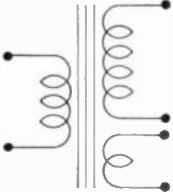
**Radio-Frequency Transformer.** A radio-frequency (R. F.) transformer is a device consisting of two coils in proximity such that a variable field set up about one coil will link with the turns of the second coil. Air or pulverized iron is used as the core. The device is used to transfer radio-frequency energy from one circuit to another by means of electromagnetic lines of force. (Fig. 1)

**Audio-Frequency Transformer.** The audio-frequency (A. F.) transformer performs the same function at audible frequencies that the radio-frequency transformer performs at radio frequencies. The core of this transformer is usually made of laminated soft iron or silicon steel sheets. (Fig. 1)

**Power Transformer.** A transformer used to furnish various operating voltages to the circuits of an electronic device. It generally consists of a single primary energizing several secondaries, the primary being connected to the power supply line. Two secondaries are shown in the symbol. (Fig. 1)

**Crystal Detector.** A device known as a *crystal detector* was used prior to the advent of the vacuum tube for the rectification of radio signals. Certain crystals such as galena, silicon, carborundum, or iron pyrites were found to possess unilateral conductivity, *i. e.*, they offered high resistance to the passage of current in one direction but a greatly reduced opposition to a current flow in the oppo-

























SYMBOL	OBJECT	SYMBOL	OBJECT
 CRYSTAL DETECTOR		  RHEOSTAT	
 GALVANOMETER		 POTENTIOMETER	
 VOLTMETER		 FIXED CONDENSER	
 AMMETER		 ELECTROLYTIC CONDENSER (POLARIZED)	
 THERMO-COUPLE AMMETER		 VARIABLE CONDENSER	
 FIXED RESISTOR		 GANG-TUNING CONDENSER	

Fig. 2. Symbols of Indicating Instruments, Resistors, Rheostats, Condensers

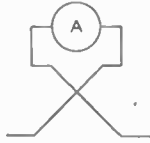
site direction. Crystals are again being used in radio circuits, in the detection of micro-waves. (Fig. 2)

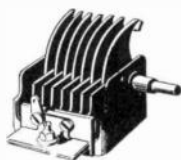
**Galvanometer.** The basic qualitative electrical measuring instrument is the galvanometer. It generally has an arbitrary set of indicating numerals on its scale, the numbers not corresponding to any electrical unit. It is most frequently found with a center zero, the indicating pointer being capable of movement to the left or right from zero. (Fig. 2)

**Voltmeter.** The voltmeter is a device used to measure electrical pressure. It is a galvanometer which has been calibrated to read potential difference or voltage. The voltmeter is connected across the potential to be measured. (Fig. 2)

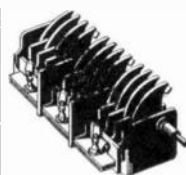
**Ammeter.** A galvanometer calibrated to indicate current flow. The ammeter is connected in series with the circuit under measurement. Fractional ammeters called milliammeters (1 milliampere = .001 ampere) and micro-ammeters (1 microampere = .000001 ampere) are frequently used in radio circuits and test equipment. (Fig. 2)

**Thermo-Couple Ammeter.** This device is used to indicate radio-frequency energy. Electrical energy of any frequency flowing through the thermo-couple heats the joint and generates an e.m.f. which is indicated on a conventional direct-current meter. The thermo-couple consists of two dissimilar metals welded or otherwise joined together. (Fig. 2)

**Fixed Resistor.** A device purposely designed to oppose the flow of electricity in a circuit is known as a *fixed resistor*. Its value remains fixed under normal operating conditions. (Fig. 2)

**Rheostat.** A resistor whose value may be varied by rotating a sliding contactor. The rheostat allows an adjustment of the opposition to current flow in a circuit. (Fig. 2)

**Potentiometer.** A variable resistor used as a voltage divider. The total pressure is connected across the terminals of the device and any portion of this total may be obtained between one terminal and the movable arm. The potentiometer usually has three terminals while a rheostat usually has only two terminals. (Fig. 2)

**Fixed Condenser.** A capacitor whose value remains constant is known as a *fixed condenser*. Inclusion in a specific circuit may















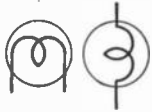



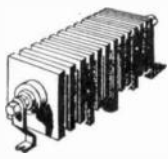

SYMBOL	OBJECT	SYMBOL	OBJECT
 <p>FUSE</p>		 <p>NEON LAMP</p>	
 <p>PILOT LIGHT</p>		 <p>TELEGRAPH KEY</p>	
 <p>HEADPHONES</p>		 <p>FULL-WAVE RECTIFIER</p>	
 <p>ROTARY SWITCH</p>		 <p>INTERMEDIATE FREQUENCY TRANSFORMER</p>	
 <p>THROW SWITCH</p>		 <p>PHONO PICKUP</p>	
 <p>MICROPHONE</p>		 <p>CLOSED-CIRCUIT JACK</p>	

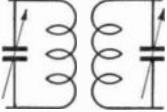
Fig. 3. Radio Symbols for Fuse, Lamps, Switches, Microphone, Rectifier, and Jack

give to the device a special name such as *filter condenser*, *by-pass condenser*, *coupling condenser*, or *de-coupling condenser*. A condenser in a series circuit blocks the passage of direct current through the circuit while apparently allowing alternating current to pass. (Fig. 2)

**Electrolytic Condenser.** A special type of fixed condenser requiring observance of polarity hence the polarizing indication (+ and -). If this polarity is not observed, the condenser breaks down and becomes a conductor. This type of condenser should not be used on alternating-current circuits. (Fig. 2)

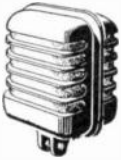
**Variable Condenser.** A condenser whose capacitance may be conveniently varied. Used for tuning radio-frequency circuits, adjusting regenerative feedback, neutralization, etc. Some types are semivariable, *i.e.*, variation of capacity is accomplished by adjusting a compression screw or nut. Air is generally used as the dielectric although in the semivariable types, mica is used. (Fig. 2)

**Gang-Tuning Condensers.** Several variable condensers arranged mechanically so that turning a common control will simultaneously vary all condensers in the unit. (Fig. 2)

**Fuse.** A protective device designed to open a circuit should excessive current flow through the circuit. The fuse operates on the principle of heat melting an alloy housed in a suitable container. (Fig. 3)

**Pilot Light.** A pilot light is used for illuminating the tuning dial and controls of a receiving set or the operating controls of an amplifier. (Fig. 3)

**Headphones.** Telephone receivers for wearing on the head, a headband holding the receiver, or receivers directly against the ear. The chief function of such a device is to change electrical impulses into sound impulses within the audible-frequency range. (Fig. 3)

**Rotary Switch.** A selector switch used to connect different portions of a circuit to various operational devices. The manipulation of the switch is accomplished by rotating a central knob which turns a contact blade over a succession of contacts. (Fig. 3)

**Throw Switch.** A device to open or close electrical circuits. A single pole, single throw (SPST) switch is illustrated. A *throw*

*switch* may be made in any combination of poles for more complex circuit breaking. (Fig. 3)

**Microphone.** The microphone changes sound impulses to electrical impulses. It consists of a flexible diaphragm which moves in accordance with the sound-wave variations striking it. This movement causes a change of resistance or capacitance in an electrical circuit or may actually bring about the generation of an electromotive force as in the case in the dynamic and crystal microphones. (Fig. 3)

**Neon Lamp.** A two-element gaseous lamp containing neon (an inert gas). An electrical potential applied across the elements causes the gas to ionize producing a pink glow. (Fig. 3)

**Telegraph Key.** The device known as a *telegraph key* consists of a pivotal lever capable of being manipulated by hand to rapidly open and close an electrical circuit. The fingers of the hand rest on a knob located at one end of the lever and downward pressure causes a movement of the lever closing the circuit. A coil spring returns the lever to its original position on releasing the pressure, thereby breaking the circuit. (Fig. 3)

**Full-Wave Rectifier.** A combination of half-wave rectifiers connected in a bridge circuit to provide full-wave rectification. (Fig. 3)

**Intermediate-Frequency Transformer.** A transformer consisting of a primary and secondary inductance, each tuned to the same frequency by the use of semivariable condensers. Air or pulverized iron serves as the core. (Fig. 3)

**Phonograph Pickup.** A phonograph pickup, sometimes called a *phono pickup*, is used to convert the variations in the grooves of a phonograph record to corresponding electrical impulses. A needle is pulled through the groove indentations and causes the generation of an impulse which is amplified by suitable amplifier circuits and converted into sound by the loud-speaker. (Fig. 3)

**Closed-Circuit Jack.** This is a type of jack which closes a circuit upon withdrawing the associated plug. Insertion of the plug diverts the circuit through the device connected to the plug such as a telephone receiver or microphone. (Fig. 3)

**Magnetic Speaker.** A radio loud-speaker which operates by virtue of a pivotal-magnetic arm being subjected to the action of a permanent magnet whose field strength is being increased and decreased by an electromagnet. The resultant motion of the magnetic arm is transferred to a driving pin which in turn is fastened to the speaker cone. (Fig. 4)

**Moving-Coil Electrodynamical Speaker.** A loud-speaker whose driving coil is rigidly attached to the speaker cone. The cone coil is free to move in a constant annular magnetic field set up electrically or by a permanent magnet. Oppositional action between the variable field produced by the voice coil and the stationary field causes a movement of the voice coil, with its attached cone. (Fig. 4)

**High-Vacuum Tube.** A vacuum tube of any number of elements enclosed in a container, either glass or metal, from which substantially all the air has been pumped. (Fig. 4)

**Gas Tube.** A vacuum tube of any number of elements in a container which has had gas added to produce increased conduction through ionization, after all air has been removed. (Fig. 4)

**Quartz Crystal.** A piece of quartz accurately ground to predetermined dimensions used to control the frequency of a vacuum-tube oscillator. (Fig. 4)

**Electrostatic Shield.** A conducting sheet placed between the coils of a transformer to prevent static (capacitive) coupling between the coils. (Fig. 4)

**Filament.** A resistance wire through which current is sent to produce sufficient heat for electron emission, as in the case of a vacuum tube, or to produce light, as in a light bulb. (Fig. 4)

**Cathode.** The source of electron emission in a vacuum tube. The cathode may be directly heated as in the filament type of tube or it may be indirectly heated as in the unipotential-surface type. (Fig. 4)

**Grid.** An electrode in a vacuum tube mounted in the space between the cathode and the anode. A grid generally takes the form of a loose spiral of wire but it may be a perforated sheet of metal. (Fig. 4)

**Plate.** The element in a vacuum tube to which the electrons emitted by the cathode are drawn. Also called the *anode*. Cus-













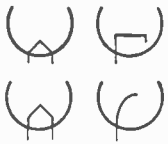



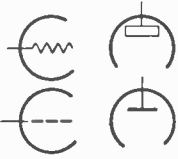
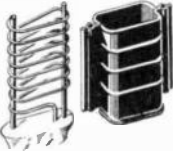

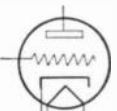

SYMBOL	OBJECT	SYMBOL	OBJECT
 <p>MAGNETIC SPEAKER</p>		 <p>FILAMENT CATHODE</p>	 <p>FILAMENT CATHODE</p>
 <p>MOVING-COIL ELECTRO-DYNAMIC SPEAKER</p>		 <p>GRID      PLATE</p>	 <p>GRID      PLATE</p>
 <p>HIGH-VACUUM TUBE</p>		 <p>DIODE</p>	
 <p>GAS TUBE</p>		 <p>TRIODE</p>	
 <p>QUARTZ CRYSTAL</p>		 <p>TETRODE</p>	
 <p>ELECTROSTATIC SHIELD BETWEEN COILS</p>		 <p>PENTODE</p>	

Fig. 4. Radio Symbols for Speaker, Shield, and Tubes

tomarily the anode has a positive potential with respect to the cathode. (Fig. 4)

**Diode.** A two-element vacuum tube consisting of a cathode and an anode enclosed in an evacuated shell. The diode is used for rectification. It is sometimes called a *Fleming valve*. (Fig. 4)

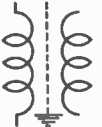
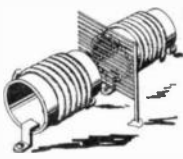
**Triode.** A three-element vacuum tube containing a cathode, anode, and grid. The grid controls the density of the electron stream. A triode may be used as a rectifier, amplifier, modulator, or oscillator. (Fig. 4)

**Tetrode.** A four-element tube containing a screen grid in addition to the elements in a triode. The screen may be used to electrostatically shield the grid from the plate to prevent interaction of the input and output circuits. (Fig. 4)

**Pentode.** A tube containing five active elements, a suppressor grid having been added to the elements in a tetrode. The purpose of the suppressor grid is to prevent the emission of secondary electrons from the plate. (Fig. 4)



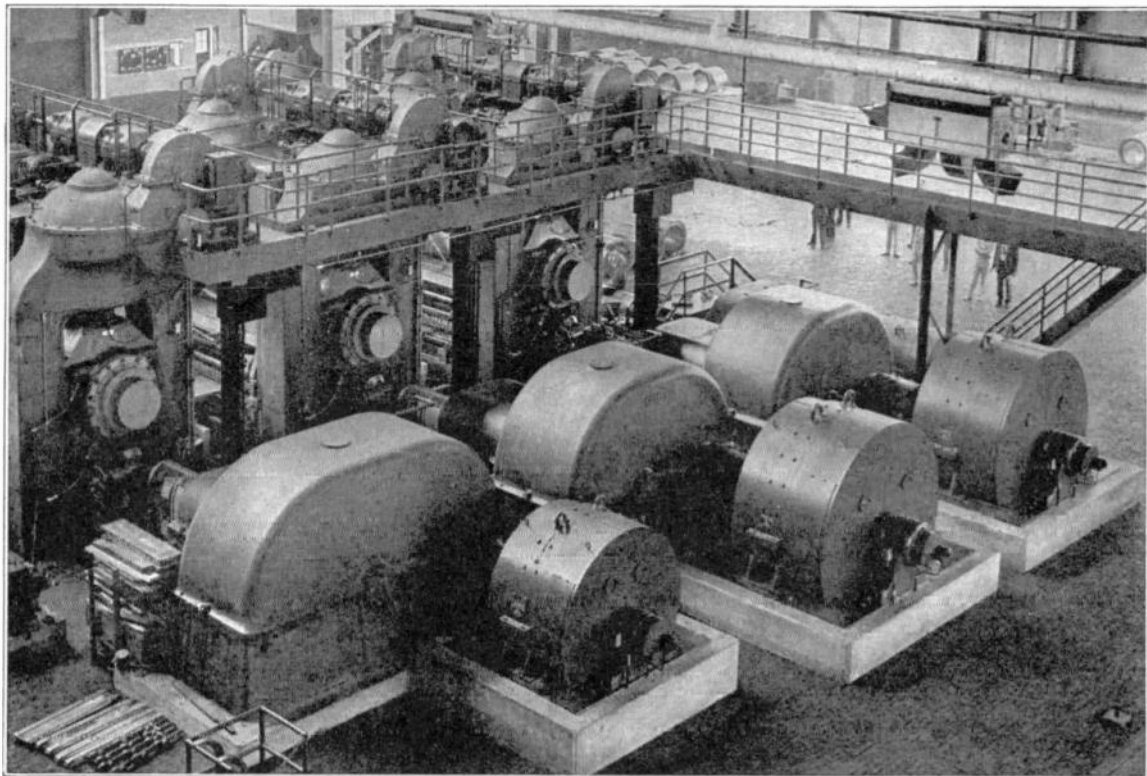

**THE FULLY ENCLOSED DIRECT-CURRENT MOTORS ARE USED TO DRIVE A 98-INCH SHEET STEEL ROLLING MILL AT THE REPUBLIC STEEL CORPORATION PLANT AT CLEVELAND, OHIO**

*Courtesy of Westinghouse Electric & Manufacturing Company, East Pittsburgh, Pa.*

## PRINCIPLES OF ELECTRICITY

---

### ELECTRICAL ENERGY

In order to understand the theory and practice of radio, a person must know a few of the fundamental facts about electricity, since radio is one small branch of a much broader field, electrical engineering. In all civilized countries a majority of the people are familiar with the use of electrical energy in electric lights, electric motors, electrical household appliances, the sending of messages by means of telegraph instruments, and the transmission of the human voice by the telephone and radio. Electricity then is a *form of energy*—beyond that, even the scientists know little about it except theoretically. However, experience and research have given man the knowledge of how to produce and direct electrical energy so as to serve his purposes. For example, as shown in the illustration, Fig. 1, the sound-wave energy from the speaker's voice is changed into electrical impulses by the *microphone*. The sound waves are then transmitted through the air by radio waves to the receiver and from there to the listener.



Fig. 1. Diagram Showing Microphone Used to Change Sound Energy into Audio-Frequency Electrical Energy

**Discovery.** The first recorded discovery of any of the electrical phenomena appears to have occurred about 600 B.C., when Thales, a Greek, found that a piece of amber rubbed with fur had the property of attracting and holding light objects. The Greek name for amber was *elektron*, from which is derived the term *electricity*.

It was not until about A.D. 1600 that Gilbert discovered that glass and certain other materials could be *electrified*, and so given the ability to pick up bits of paper, cork, and similar light objects,

as shown in Fig. 2. He concluded, however, that metals could not be electrified. In 1730, Gray demonstrated that metals had not been electrified because they allowed the electricity to escape by

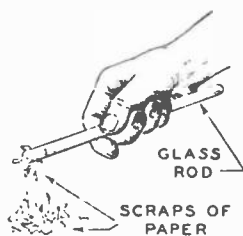

Fig. 2. Electrically Charged Glass Rod Picking Up Bits of Paper

*conduction*, and concluded that substances which thus permit the electricity to escape must necessarily be used in conjunction with substances which do not permit the escape of electricity. Here was the first differentiation between *conductors*, media that carry or conduct electricity, and non-conductors, or *insulators*, substances that do not conduct electricity, such as glass, silk, and rubber.

About twenty years after Gray's discovery, when Benjamin Franklin *drew* electricity from the clouds with his historic kite with a metal key attached to its string, the discharge from the key knocked him to the ground. A Russian scientist, who attempted to repeat the experiment a short time later, was killed by the charge. Franklin was extremely fortunate, but it is doubtful if he was aware of the risk he took.

**Development.** The development of electricity began to make real progress with the beginning of the nineteenth century, when Alessandro Volta combined copper and zinc in cells containing an acid solution to make the first electrochemical cell (1800). Other applications rapidly appeared: telegraph, electric generator, electric motor, arc lights, telephone, incandescent lamps, electric railway, railway signals, wireless telegraph, household appliances, medical treatments, and, one of the most popular, radio.

Electricity is produced in two forms: first, *electrostatic energy*; and, second as *electrodynamical energy*.

**Electrostatic Energy.** *Electrostatic energy* is electricity at rest. It is a charge of electrical energy that is produced when a piece of amber, glass, or hard rubber is rubbed with a piece of silk, fur, or flannel. The electrical charges collect upon the surface of the substance rubbed, as well as upon the material with which the rubbing is done. Electrostatic charges are polarized; that is, the charge is either *positive* or *negative*, according to the substances

with which it has been produced. For instance, a piece of glass rod, rubbed with a piece of silk, will carry a positive charge. On the other hand, the charge on the glass will be negative if the rod is rubbed with flannel or fur.

A glass rod that has been rubbed with a piece of silk will repel another glass rod that has also been rubbed with silk. Fig. 3, at (A). Contrariwise, a glass rod that has been rubbed with a piece of silk will attract another glass rod that has been rubbed with a piece of fur. Fig. 3, at (B). Similarly, a glass rod that has been rubbed

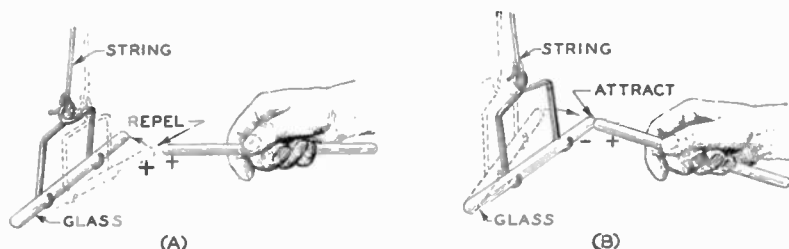

Fig. 3. Illustration Proving Law of Electrostatics

with a piece of fur will repel another rod that has also been rubbed with fur. Here, then (Fig. 3), we have proof of the law of electrostatics:

*Like charges repel—unlike charges attract.*

**Electrodynamic Energy.** *Electrodynamic energy* is electricity in motion. It is electricity that is collected—produced—either by some chemical action or by some means of mechanical generation. Electrostatic energy has little or no value except for its use in experiments and for providing a basis of proof of theories or phenomena. Electrodynamic energy is that form of electricity that serves the needs of man in furnishing power, light, heat, entertainment, and in many other ways.

## THE ELECTRON THEORY

The *molecular theory* and the *atomic theory* are closely associated with the latest and now accepted scientific explanation of electrical phenomena, the *electron theory*.

**Molecules.** That all matter consists of small particles called *molecules* has been accepted in scientific circles for many years.

**Atoms.** Scientists have also agreed that the molecules consist of still smaller subdivisions called *atoms*; but until recent years it was held that the atom could not be divided.

**Protons and Electrons.** The invention of the radio, with the resulting intensive research, brought forth the theory that an atom consists of electrical charges, one of which is positive in nature, while other parts are negative. The positive charge—the nucleus, as it were—is known as the *proton*. The negative charges, which are thought to revolve around the positively charged proton, are called *electrons*, and their arrangement is believed to be similar

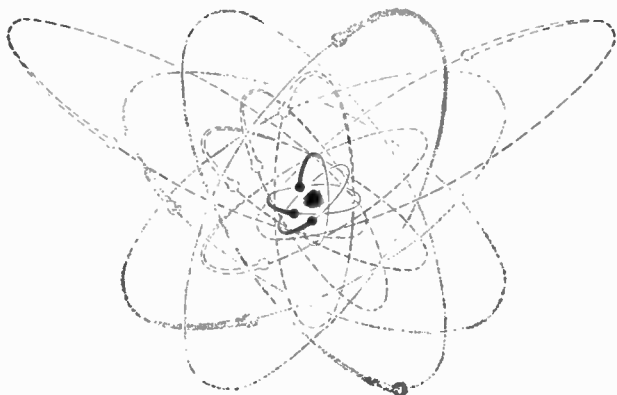

Fig. 4. Diagram Showing Movement, within Atom, of Electrons around the Proton

to the solar system, with the sun corresponding to the proton, and the planets represented by the electrons. The movement of the electrons around the proton is illustrated in Fig. 4.

Thus all matter is believed to consist of varying combinations of electrical charges, and the substance is considered to be charged negatively if an oversupply of electrons is present; or charged positively, if the number of electrons is less than enough to balance exactly the intensity of the positive charge on the proton.

**Weight of Electrons.** The electron has a mass of  $9.03 \times 10^{-28}$  grams and a negative electrical charge of  $16 \times 10^{-20}$  coulomb.\* All

\*Note the negative exponent. Thus  $9.03 \times 10^{-1}$  is the same as  $9.03 \div 10$  or .903; also  $9.03 \times 10^{-4}$  is the same as  $9.03 \div 10,000$  or .000903. Then  $9.03 \times 10^{-28}$  is the same as 9.03 divided by 1 followed by 28 zeros. Hence the answer is a decimal fraction with 27 zeros between the decimal point and 903.

electrons are exactly alike in size, weight, and the amount of electrical energy they possess. Thus an electron existing in a piece of hard steel is identical with an electron found in a gas, such as hydrogen. This fact allows an interchange of electrons without a change of the characteristics of a substance.

Electrons are free to move about within the substance of which they are a part. In fact, anything that is done to disturb the molecular or atomic structure of the substance—such as heating, for example—causes a greater movement of the electrons, with the result that they may be able to leave the home atom. If the heating continues until the temperature of the substance becomes sufficiently high, the electrons will leave the surface of the substance and fly off into space in a manner similar to the evaporation of water as heat is applied.

According to the electron theory, then, any passage of electricity is really a movement of electrons within the conducting medium. Electrons are subject to the fundamental law of electrical charges, *Like charges repel—unlike charges attract*. Thus it is that the negative particles, or electrons, are attracted to the proton which has a positive charge, and move about from atom to atom only when disturbed, or when it is necessary to effect a balance between the positive and negative charges.

## SOURCES OF ELECTRICAL ENERGY

Electrostatic energy may be created by friction. Electrodynamical energy is produced either by chemical action or by mechanical generation. Electricity that is produced by chemical action is constant in its potential; that produced mechanically generally varies in amplitude and may change direction of flow periodically.

**Voltaic Cell.** The electrochemical method of producing an electric current was invented by Alessandro Volta, an Italian physicist, in 1800. His invention, now known as the *voltaic cell*, consisted of two plates of different metals—copper and zinc, for instance—immersed in a suitable solution or electrolyte, such as sulphuric acid, as shown in Figs. 5 and 6.

When zinc is immersed in a solution of sulphuric acid, the acid attacks the zinc, which may be said to provide fuel for the cell. The

chemical symbol for zinc is  $Zn$ ; for the sulphuric acid,  $H_2SO_4$ , which means that a molecule of sulphuric acid contains two atoms of hydrogen (which is positive), one atom of sulphur (which is

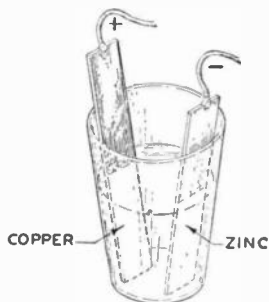

Fig. 5. Simple Voltaic Cell

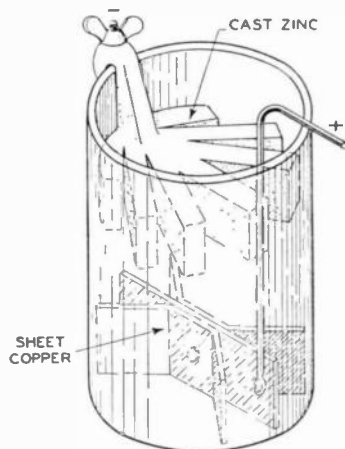

Fig. 6. Diagram Shows a Closed Circuit of a Gravity Cell

negative), and four atoms of oxygen (which is negative). The negative charges embodied in the sulphur and the oxygen balance the positive charge of the hydrogen, because every normal molecule contains a positive electrical charge equal to its negative charge.

When the sulphuric acid attacks the zinc plate in the voltaic cell, the hydrogen in the sulphuric acid is liberated, and may be seen to collect on the copper plate, rise to the surface, and disappear. The zinc then associates with the solution to form zinc sulphate,  $ZnSO_4$ . Thus it is that through the dissociation of the metal and the solution, the removal of the positively charged zinc particles from the zinc plate leaves that electric terminal, or *electrode*, with an excess of electrons, which are negative charges of electricity. The positively charged hydrogen atoms on the copper plate tend to increase the intensity of the positive charge on that electrode, so that a difference of potential is established between the copper and the zinc electrodes, with the result that current will flow between them when they are connected by a conductor.

The passage of the current through the conductor is a trans-

mission or movement of negative charges—electrons—which pass from the zinc plate through the wire to the copper plate. This explanation is different from the theory in vogue until recent years, which considered the current as flowing from the positive terminal through an external circuit to the negative terminals of a cell. In other words, the flow of electricity is now known to be the electron flow, which is exactly opposite to what was formerly considered as current conduction or current flow. In order to prevent confusion, however, the conventional method of designating current flow will be used, *i.e.*, from a positive source through the external circuit, to the negative terminal. Where it becomes necessary to consider the electron flow, as in vacuum-tube theory, proper notations will be made.

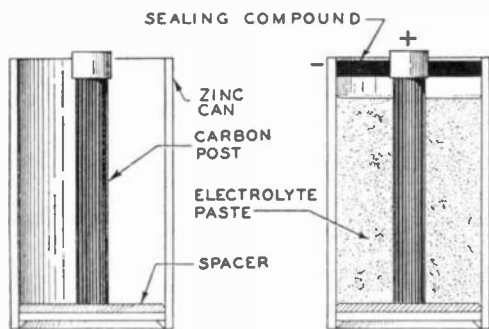

Fig. 7. Outer Shell of a Dry Cell

Fig. 8. Cross-Section of a Dry Cell



Fig. 9. Exterior View of a Dry Cell

**Primary Cells.** A *cell* is an individual unit. When cells are combined for any purpose, the combination is called a battery. The dry cell in common use today is an adaptation of the voltaic cell. The outer shell, Fig. 7, is made of zinc. At the center of the cell is a *carbon post*, or *rod*. The *zinc shell* is filled with *electrolyte paste* and a combination of various porous materials. When thus filled the zinc shell which constitutes the form of the cell becomes the *negative electrode*; the carbon post becomes the *positive electrode*, Fig. 8. Then a *sealing compound* is placed over the top of the paste. A *spacer* at the bottom of the cell prevents the carbon rod from touching the zinc shell. The electrolyte reacts upon the



zinc shell as previously explained, setting up a difference of electrical pressure between the positive and the negative electrodes, so that current will flow when the electrodes are connected. The exterior view of a dry cell is shown in Fig. 9.

**Storage Batteries.** A storage, or secondary, cell is a chemical cell whose chemical action is reversible. The storage cell consists of two plates, or several pairs of plates assembled in dovetailed fashion, with thin wooden separators to prevent the adjacent plates from touching one another. The entire assembly is immersed in a solution of sulphuric acid that has a specific gravity of 1.280. The plates are of two distinct types: one type forms the positive electrode, the other type forms the negative electrode. The plates are constructed by preparing a *skeleton* or *grid* upon which is laid a compound that will react chemically to the acid solution. Although the materials used may vary, one commercial type of storage battery uses a lead plate for the negative electrode, and for the positive electrode a plate with a coating of reddish-brown lead peroxide,  $PbO_2$ . If the battery uses the grid type of plate for the negative electrode, the pores in the grid are filled with sponge lead.

During discharge, the sulphuric acid attacks the active material of the plates forming lead sulphate,  $PbSO_4$ , which coats both the positive and negative plates. When both plates have become coated with an equal quantity of the same material, the battery is said to be discharged and will not produce a voltage. However, connecting the battery to a source of outside energy, and passing a direct current through the battery in the direction opposite to that of discharge, will remove the lead sulphate from the plates, leaving them as they were originally—lead for the negative electrode, lead peroxide for the positive electrode. The battery will again produce a voltage.

During the process of charging and discharging, hydrogen gas is evolved which must be allowed to escape. Filler plugs have vent holes for this purpose. Water must be added from time to time to replenish that lost through evaporation; and it is quite important that the water be pure and free from harmful substances, such as metals in suspension, or chemicals that would react on the battery plates or neutralize the acid. Hence, distilled water should be used.

**Electromagnetic Generation.** If a coil of wire were passed through the magnetic field, as shown in Fig. 10, an electrical voltage would be produced because of the movement of the coil in cutting the lines of force. When the terminals of the coil are connected to a closed electrical circuit, Fig. 10, the current flow will be

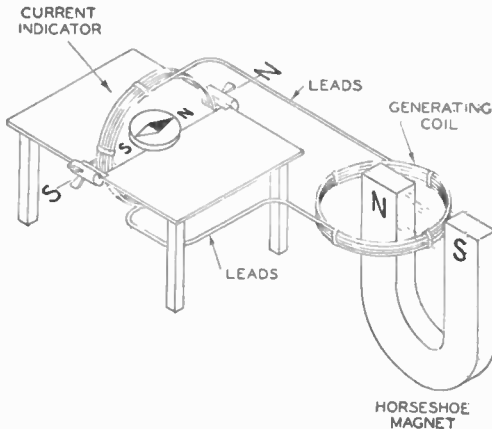

Fig. 10. Diagram Showing Generating Coil, Leads of Coil, and Indicating Instrument

indicated by the movement of the compass needle. This illustrates the principle involved in the *mechanical generation* of electricity, in which several wires formed into a coil are passed through magnetic fields, thereby setting up an electric voltage that may be used in a number of ways. This text discusses electrical phenomena only as they may apply to radio. Further information regarding the details of generators and the generation of electrical energy by mechanical means can be obtained from any electrical engineering text.

Mechanically produced electric current differs from the steady-flowing current produced by chemical action, and is fluctuating in nature. There are two kinds of mechanically produced current, known as *direct current* and *alternating current*, both of which have extensive commercial applications. Direct current flows through a circuit in the same direction at all times. Alternating current, on the other hand, flows first in one direction and then in the other, at regular intervals.

## ELECTRICAL TERMS

**Circuits.** An *electric circuit* is a path through which an electric current flows. A circuit is said to be *shorted*—or a *short circuit* is said to exist—when conductors touch one another to divert the current flow from its normal path. A circuit is said to be *open*—or an *open circuit* is said to exist—when the continuity of the circuit is broken so that the electric current does not have free flow to all parts of the circuit.

**Insulators.** An *insulator* is a substance which sets up an exceedingly high resistance to the flow of electric current and which, for all practical purposes, actually prevents the flow of current. The electrons in an insulating substance are forcibly held within their atoms and can only be caused to move from one atom to another by the application of considerable force. Glass, rubber, mica, and fabricated phenol compounds (Bakelite) are commercial types of insulating material.

**Conductors.** A *conductor* is a substance, usually metal, that offers little resistance to the free flow of an electric current. It is a substance whose internal structure is such that the electrons can readily free themselves from their atoms. A conductor is said to be *good* or *bad*, according to the facility with which it conducts electric current. However, some metals that are exceedingly good electric conductors are impractical for general use, because of their high cost. Copper, because it is abundant and easily shaped into wire and other forms, is the metal most widely used as a conducting medium.

**Conductance.** Conductance is the ease or readiness with which a substance will pass a current of electricity. It is the reciprocal of the resistance in ohms. The reciprocal of a number is *one* divided by that number. Thus the reciprocal of 5 is  $1 \div 5$  which is  $\frac{1}{5}$ . The unit of measure is the *mho*. Thus, a resistor that has a resistance of two ohms is said to have a conductance of one-half mho. Similarly, a resistor that has a resistance of three ohms will have a conductance of one-third mho.

It will be seen, therefore, that a conductor having three times as much resistance as another conductor, will conduct only one-

third as much electric current. It is also true that the conductance of a conductor is always determined by dividing *one* by the resistance of the conductor.

**Resistance.** Anything that tends to oppose the free flow of electric current is said to possess *resistance*. Carbon, graphite, nichrome, and similar substances constitute the principal commercial resistance materials.

**Reactance.** The additional opposition, other than ohmic resistance, to the flow of alternating or pulsating direct current in a circuit caused by an inductance (coil) or capacitance (condenser) is termed *reactance*. The unit of reactance is the *ohm*.

**Impedance.** The total opposition to the flow of a varying current caused by reactance and resistance is called *impedance*. The symbol for impedance is  $Z$  and the unit of measure for impedance is the *ohm*.

## ELECTRICAL UNITS OF MEASURE

**Coulomb.** The *coulomb* is the unit of electrical quantity. It represents the total electrical charge contained by  $6.28 \times 10^{18}$  electrons. The coulomb represents a charge of electricity at rest and as such has relatively little commercial application. We are interested principally in electricity in motion.

**Volt.** The *volt* is the unit of electrical pressure or electromotive force. It is defined as the pressure required to force a current of one ampere (measure of current flow) through a resistance of one ohm.

**Ampere.** The *ampere* is the unit of electrical current flow or strength. It may be defined as the current which will flow through a resistance of one ohm under a pressure of one volt. The ampere represents the passage of one coulomb of electricity past a given point in a circuit per second. A *milliampere* is one one-thousandth (.001) of an ampere. A *microampere* is one-millionth (.000001) of an ampere, or one one-thousandth (.001) of a milliampere.

**Ohm.** The *ohm* is the unit of electrical resistance. It is defined as the opposition offered by a circuit in which a pressure of one volt causes one ampere of current to flow. Specifically it is the resistance offered to an unvarying electric current by a column of

mercury of constant cross-sectional area having a length of 106.3 centimeters, 14.4521 grams mass, at a temperature of 0° C.

**Watt.** The *watt* is the unit of consumption of electric power, represented by a current of one ampere at a pressure of one volt. The number of watts is found by multiplying the current in amperes by the pressure in volts. Thus, an incandescent lamp that draws one ampere of current on a 110-volt line is called a 110-watt lamp. Similarly, an electric iron that draws five amperes of current on a 110-volt line will consume 550 watts of energy.

**Mho.** The unit of conductance. It is the reciprocal of resistance in ohms.

**Ohm's Law.** Ohm's law, one of the most useful and most widely used rules in electrical engineering, concerns the relation existing between volts, amperes, and resistance. If any two of the three properties of a circuit are known, the third can be readily determined by applying Ohm's law.

By Ohm's law, we find that the electromotive force—the pressure or voltage—is equal to the current in amperes multiplied by the resistance in ohms. Expressed in symbol form, this is

$$E = IR$$

This means

$$E = I \times R$$

Here  $E$  designates the electromotive force (voltage),  $I$  designates the current (amperes), and  $R$  designates the resistance, measured in ohms.

To illustrate the application of this formula, let us assume that the resistance of a circuit is 10 ohms, and that 5 amperes of current, as measured with an ammeter, are flowing through the circuit. We wish to know the voltage across the circuit. According to the formula, the voltage is equal to the current multiplied by the resistance. Therefore, multiplying 10 by 5, we find the electrical pressure is 50 volts.

Ohm's law may be expressed, also, by the following forms which are obtained by algebraic manipulation. Any one of the three formulas may be used, as preferred.

$$E = IR$$

or

$$I = \frac{E}{R} \qquad R = \frac{E}{I}$$

Numerous applications of Ohm's law to radio work will be found in this volume. This rule is so important that it should be firmly fixed in the mind of everyone engaged or interested in radio as a profession.

**Learning Ohm's Law.** Since Ohm's law is one of the most commonly used fundamentals of electricity, it is essential that it

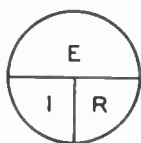

Fig. 11. Ohm's Law Formula

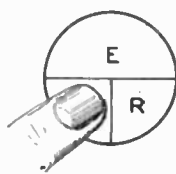

Fig. 12. How to Find the Current

be memorized. An ingenious way of representing and of memorizing Ohm's law is embodied in Figs. 11 to 14. If any one part is removed or covered, the relative position of the other two gives the value of the one covered, in terms of the other two.

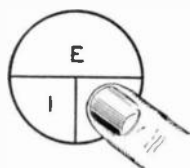

Fig. 13. How to Find the Resistance



Fig. 14. How to Find the Voltage

Thus if you want to find the current ( $I$ ) when you know the voltage and the resistance of the circuit, you put your finger on  $I$  as in Fig. 12. You now see  $\frac{E}{R}$  and this means that the voltage,  $E$ , is divided by resistance  $R$ , of the circuit. It may also be written  $E \div R$ . The unit of current, or  $I$ , is the *ampere*. Thus when you

perform the division your answer will be in amperes or a fraction of an ampere.

When you desire to find the resistance of a circuit or device and know the voltage ( $E$ ) across that circuit or device and the current ( $I$ ) through it, you put your finger on the  $R$  as in Fig. 13.

You then have uncovered  $\frac{E}{I}$  which is the same as  $E \div I$ . When you perform the division, your answer will be in *ohms*, which is the unit of resistance.

In a similar manner if you want to find the voltage ( $E$ ) required to force a current ( $I$ ) of so many amperes, through a resistance ( $R$ ) of so many ohms, you would put your finger on the  $E$ , Fig. 14. Then you have  $I$  and  $R$  uncovered and below the horizontal line. It means  $I$  times  $R$  ( $I \times R$ ) or that  $I$  is multiplied by  $R$ . The best way to learn Ohm's law is by using it and applying it to simple problems.

**Example 1.** A rheostat having a resistance of 3 ohms is connected to a battery of 6 volts. How much current will flow through the rheostat?

*Solution.* We want to find the current ( $I$ ). Then put your finger on  $I$  as in Fig. 12. You have  $\frac{E}{R}$  uncovered. From the example we know that  $E$  is 6 volts and  $R$  is 3 ohms. Then you can write it as follows

$$I = \frac{E}{R} = \frac{6}{3} = 2 \text{ amperes}$$

**Example 2.** What voltage is required to force a current of 1 ampere through the filament of a radio tube whose resistance is 5 ohms.

*Solution.* Since you want to find voltage or electromotive force, you put your finger on  $E$  as shown in Fig. 14. Thus you find the voltage required is  $I \times R$  and you use the formula

$$E = I \times R$$

From the example you know  $I$  equals 1 ampere and  $R$  equals 5 ohms. Substituting these values in the formula gives

$$E = 1 \text{ ampere times } 5 \text{ ohms} = 5 \text{ volts}$$

**Example 3.** In order to force a current of 1 ampere through a radio choke coil a voltage of 2 volts is required. What is the resistance of the choke coil?

*Solution.* Since you want to find the resistance, you put your finger on the letter  $R$  as shown in Fig. 13. You then have  $\frac{E}{I}$  so you use the formula

$$R = \frac{E}{I}$$

From the example we learn that  $E$  equals 2 volts and  $I$  equals 1 ampere. Substituting these values in the formula we have

$$R = \frac{2}{1} = 2 \text{ ohms}$$

**Example 4.** An audio-filter choke has a resistance of 200 ohms and a full-load current of 120 milliamperes, *i.e.*,  $\frac{120}{1000}$  or .12 amperes. What will be the voltage across the terminals of the choke when full-load current is flowing through it?

*Solution.* Since you want voltage, put your finger on  $E$  as shown in Fig. 14. Then the formula is

$$E = I \times R$$

Substituting values given in the example you have

$$E = \frac{120}{1000} \times 200 = \frac{24000}{1000} = 24 \text{ volts}$$

You can also solve this example by using decimal fractions, then you have

$$E = .120 \times 200 = 24.00 \text{ or } 24 \text{ volts}$$

**Example 5.** What is the resistance of the filament winding of a full-wave rectifier tube that requires a current of 2 amperes at 5 volts?

*Solution.* Since you desire resistance, put your finger on  $R$  as shown in Fig. 13. The formula is

$$R = \frac{E}{I}$$

Then

$$R = \frac{5}{2} = 2\frac{1}{2} \text{ or } 2.5 \text{ ohms}$$



**Example 6.** The rating of a radio pilot-light bulb is 2.5 volts and .50 amperes. What is its resistance?

*Solution.* You desire to find the resistance represented by  $R$ . Place your finger over  $R$  as shown in Fig. 13. Then you have the formula

$$R = \frac{E}{I}$$

Substituting the values given in the example gives

$$R = \frac{2.5}{.50} \text{ or } \frac{2.50}{.50} = 5 \text{ ohms}$$

**Applications of Ohm's Law.** Ohm's law may be applied to a circuit as a whole or it may be applied to any part of the circuit—a circuit being the path through which a current flows from its source through a conductor back to its source. A great amount of caution and practice is required to apply this law correctly in all cases. Accordingly, there is no part of radio work where so many mistakes are made as in the application of this simple law. Once the principle is firmly grasped, you are prepared to handle correctly a wide range of electrical problems.

Many of the difficulties will be cleared up if you will keep in mind the following two statements and will use them intelligently.

When applying the law to the *entire* circuit, state the law as follows:

1. *The current in the entire circuit equals the voltage across the entire circuit divided by the resistance of the entire circuit.*

Notice that the term *entire* applies to current, voltage, and resistance. Not to one of them, but to *all* the factors of the equation.

When applying the law to a part of the circuit, state the law as follows:

2. *The current in a certain part of a circuit equals the voltage across that same part divided by the resistance of that same part.*

Notice here again that the values for current, voltage, and resistance are taken from the *same part* of the circuit. By far the greatest number of mistakes in applying Ohm's law come from dividing the voltage across one part of the circuit by the resistance of some other part of the circuit and expecting to get the correct current reading.

The circuit consisting of a radio power *transformer*, a *resistor* and *tube* is shown in Fig. 15. The voltage readings at different parts of the circuit are shown by the voltmeters connected to those points in the circuit.

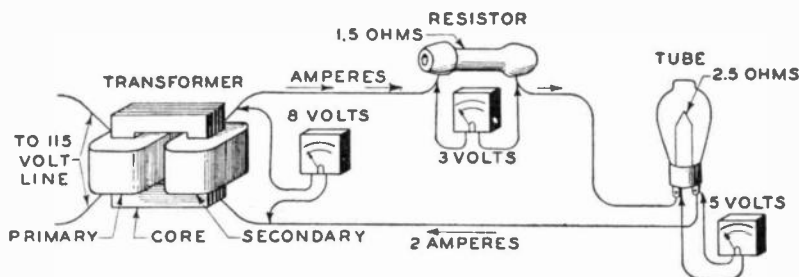

Fig. 15. Diagram Shows Circuit Consisting of Radio-Power Transformer, Resistor, and Tube

**Example 7.** What is the current through the *resistor* shown in Fig. 15?

*Solution.* Since the resistor is part of the circuit and not the entire circuit, we must use the voltage across the terminals of the resistor, 3 volts, and its resistance 1.5 ohms to find the current.

Thus the formula is  $I = \frac{E}{R}$ . Then  $I = \frac{3}{1.5}$  or  $\frac{3.0}{1.5} = 2$  amperes.

**Example 8.** What is the current through the *tube* shown in Fig. 15?

*Solution.* The voltage across the filament terminals of the tube is 5 volts. The resistance of the filament of the tube is 2.5 ohms. Then by Ohm's law,  $I = \frac{E}{R}$ . At the tube  $E$  is 5 volts

and the resistance  $R$  is 2.5 ohms. Then the current is  $I = \frac{E}{R}$  or

$I = \frac{5}{2.5} = 2$  amperes.

**Example 9.** What is the resistance of the entire circuit in Fig. 15?

*Solution.* The entire circuit being considered is the *secondary coil*, the *resistor*, and the *tube*. The *primary coil* which is connected to the 115-volt line is another circuit. The secondary coil which supplies the voltage to this circuit is of low resistance and considered

zero to simplify the problem. Thus the entire resistance in the circuit is  $1.5 + 2.5 = 4$  ohms.

**Example 10.** What is the current through the entire circuit in Fig. 15?

*Solution.* The current through the entire circuit is the voltage of the entire circuit, 8 volts, divided by the resistance of the entire circuit, 4 ohms.

Thus 
$$I = \frac{E}{R} \text{ or } I = \frac{8}{4} = 2 \text{ amperes}$$

You will notice that the current through the entire circuit 2 amperes is the same as in each part of the circuit. This is because all the parts of the circuit are connected in *series* with each other. These examples illustrate the importance of using the right values of voltage and resistance when applying Ohm's law.

## ELECTRICAL CONNECTIONS

**Series and Parallel Connections.** Electrical devices are said to be connected in *series* when they are joined end to end so

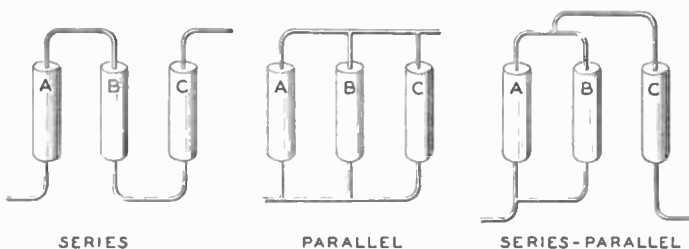

Fig. 16. Diagram Showing Difference between Series, Parallel, and Series-Parallel

that current passing through any part of the circuit must also pass through all other parts as through the *resistors* shown in Fig. 16. Electrical devices are said to be connected in *parallel* when they are connected so as to provide more than one path over which the current may flow through the circuit, thus dividing it among the various branches during its flow.

Fig. 16 shows, also, the difference between series connections and parallel connections. Here the units *A*, *B*, and *C* represent three resistances, three condensers, or three inductance units—a resistance,

a condenser, and an inductance—or any combination that may be desired. It is evident, however, as explained previously, that current flowing through the series circuit must flow through *A*, *B*, and *C*; but that in the parallel circuit the current is divided among *A*, *B*, and *C*, so that either one or two of the units could be disconnected and still leave a complete path for the current to flow.

The effects produced by connecting the various electrical functions in series differ greatly from those produced by connecting them in parallel.

**Series-Parallel Connections.** Fig. 16 also shows the arrangement of electrical devices in a *series-parallel* circuit. Here units *A* and *B* are connected in parallel with each other, while these two are connected in series with unit *C*.

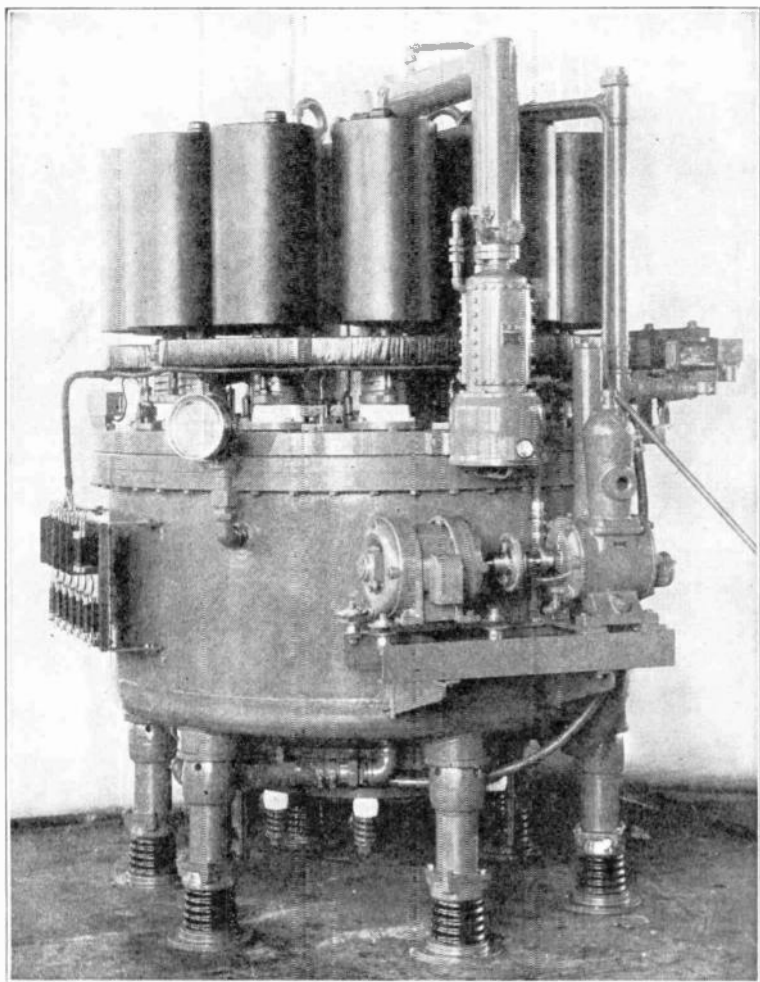

**MERCURY-ARC RECTIFIER**

A 2000-Kw., 4000-ampere, 500-volt, 12-cathode, grid controlled mercury-arc rectifier with motor operated vacuum pump built on the side.

*Courtesy of Allis-Chalmers Mfg. Co.*

## MAGNETISM AND ELECTROMAGNETISM

### MAGNETS

A thorough understanding of the principles of magnetism is a necessary foundation for subsequent analyses of electrical phenomena.

**Bar Magnets.** A *magnet* is a bar of iron or steel that has been subjected to a magnetizing force, which has given it the property of attracting iron, steel, and certain other metals. The *bar magnet*, as it is usually called, also has the property of assuming a north-to-south position when suspended by a thread; for this reason, the ends of the magnet are commonly referred to as the *north pole* and *south pole*.

If either end of a bar magnet is dipped into a pile of iron filings and then withdrawn, that end will be covered with the iron particles, as shown in Fig. 1. Investigation reveals that many of the particles are not touching the bar itself, but are clinging to other filings, showing that the filings also have become magnetized so that they, too, have the same magnetic properties as the bar.

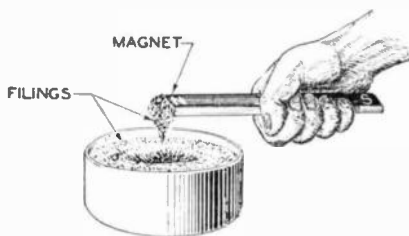

Fig. 1. Iron Filings Clinging to End of a Bar Magnet

The properties of attraction, repulsion, and polarity are collectively called *magnetism*.

If the bar magnet were broken in two, it would retain its magnetism, Fig. 2. The north pole (*N*) would continue to function in that capacity, and the other end of the broken half would become a south pole (*S*). Similarly, the south pole (*S*) of the bar would be the south pole of its half of the bar, and the other end of the

half would become a north pole (*N*). The molecular theory of magnetism indicates that each individual bar as shown in Fig. 2 can be broken again and again until only a single molecule remains. This molecule will be found to be a miniature magnet exhibiting all magnetic properties. This is shown by the iron filings clinging to the ends of the broken parts of the magnet.

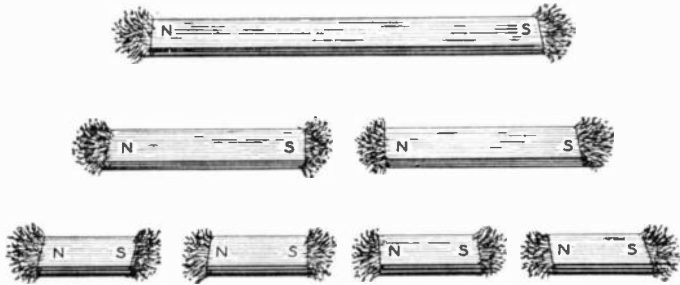

Fig. 2. Results of Breaking a Bar Magnet. Showing Iron Filings Clinging to Ends of Broken Bars

Although magnets have the property of attracting and holding certain metals, they also have the property of repelling them, under proper conditions. For instance, if the north pole of one magnet is brought close to the north pole of another magnet, the two will tend to repel one another; on the other hand, if the south pole of one magnet is brought close to the north pole of the other, they will attract one another and cling together. This experiment demonstrates an accepted magnetic law:

*Like poles repel—unlike poles attract.*

**Horseshoe Magnets.** A *horseshoe magnet* is a bar magnet



Fig. 3. A Horseshoe Magnet

bent in the shape of a horseshoe, as shown in Fig. 3. Its properties are identical with those of the bar magnet. An iron or steel nail placed on either pole of the magnet will adhere to it and tend to

be attracted toward the other pole, Fig. 4. If more than one iron nail is placed on either pole, the ends of the nails tend to repel one another, in accordance with the rule just explained.

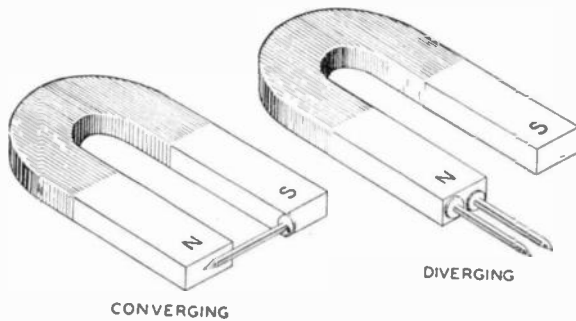

Fig. 4. Diagram Illustrating Laws of Attraction and Repulsion

**Temporary and Permanent Magnets.** A *temporary magnet* is one which holds its magnetism only while under a magnetizing stress. A *permanent magnet* is one which retains its magnetism indefinitely. Soft iron is used for temporary magnets; but if a permanent magnet is desired, a piece of hard steel is placed inside a coil of wire through which direct current is passing. Such a magnet, if properly seasoned and cared for, will continue to hold its strength over a long period of years.

**Electromagnets.** An *electromagnet* is made by winding a coil of wire around a piece of soft iron and passing a current through the coil, as shown in Fig. 5. So long as the circuit is connected as shown, the polarity of the magnet will be as indicated; but if the connections to the source of supply are reversed, the poles will be reversed also so that the one marked *N* (north) in the diagram will become the south pole, and the pole marked *S* (south) will become the north pole. An electromagnet will attract iron and steel when electric current is passing through the coil winding, and will release the metal when the circuit is opened and current ceases to flow.

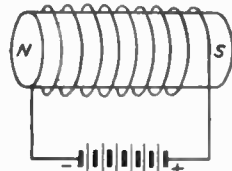

Fig. 5. An Electromagnet

## MAGNETIC FIELDS

An interesting experiment can be conducted by placing a bar magnet under a sheet of paper and then sprinkling iron filings over



the paper. The filings will take very definite positions with respect to the bar. Those directly over the ends of the magnet will adhere very tightly—bunched up, as it were, with a tendency to spread out in a fan-shaped design. Away from the ends of the magnet, the filings will line up parallel with the sides of the bar, assuming the design shown in Fig. 6.

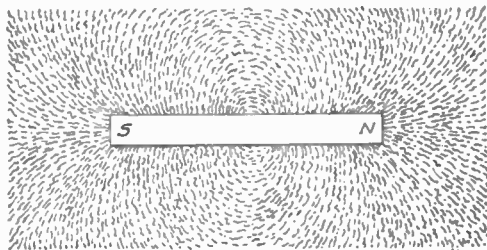

Fig. 6. Magnetic Field of a Bar Magnet

The same phenomenon holds true with the horseshoe magnet, except that the shape of the design differs because of the proximity and relative position of the two poles.

The iron filings clustered about the bar magnet demonstrate the presence of what is called the *magnetic field*. It can be shown just as graphically by moving a compass slowly along the length of the bar, and observing the movement of the needle.

Because of the proximity of the poles of a horseshoe magnet, the magnetic field between its poles is considerably stronger than that existing around the poles of a bar magnet. It is this property of horseshoe magnets that makes them adaptable to so many uses in electrical machines, in headphones and certain magnetic types of loud-speaker units, and in electrical instruments.

**Magnetic Lines of Force.** The bar magnet and compass can also be used to demonstrate what is meant by *magnetic lines of force*. If the compass is held at one end of the magnet and then moved in the direction toward which the needle points, Fig. 7, a pencil that follows the compass needle will inscribe an elliptical figure. This curved line represents a *magnetic line of force*, which may be defined as a line drawn through a magnetic field in such a

manner that all points on the line are in the direction of the field. Actually, the line represents the path that the north pole of the magnet would follow if it were free to move.

When the first line has been completed, start from another point on the end of the magnet and inscribe another such line. If the starting point is nearer to the center of the end of the magnet, the line will be farther removed from the bar than the first one; if the second starting point is toward one edge of the end, the second line will be closer to the bar. In either case, the line will be elliptical in shape.

The lines of force, taken as a unit, are also known as *magnetic flux*, which is dependent in quantity upon the intensity of the magnetic field or the field strength.

**Terrestrial Magnetism.** That a magnetic field surrounds the entire earth, is demonstrated by the fact that a compass will always point in a north-and-south direction, unless disturbed by some other type of magnetic field stronger than that which envelops the earth.

Although it is commonly thought that the compass needle points due north, it does not actually do so; instead, it points to the magnetic pole which does not coincide with the earth's geographical north pole. Magnetic meridians do not follow geographical meridians, and in some localities the compass needle *may* point to the geographical north; in other places it declines to the east, or to the west, of north.\*

\*Through a confusion of terms that dates back to the early discoverers of electricity, we are accustomed to label as *north* everything lying above the equator, while everything lying below it is labeled *south*. As a matter of fact, the north pole of a magnet or compass needle is attracted by the south magnetic pole of the earth, which is located somewhere near Hudson Bay; while the south pole of the magnet or compass is attracted by the earth's north magnetic pole, which is located near the earth's geographical south pole. Full explanation will be found in any standard work on magnetism.

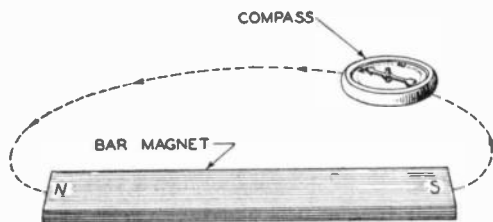

Fig. 7. Diagram Showing Method of Plotting Lines of Force in a Magnetic Field

**Electromagnetic Field.** When an electric current is flowing through a conductor, a *magnetic field* is created in the form of *lines of force* that whirl around the conductor, throughout its length, as indicated by the arrows in Fig. 8. The lines of force

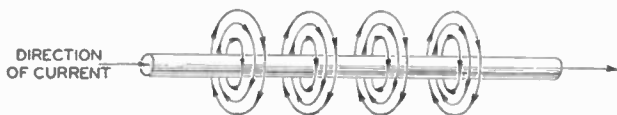

Fig. 8. Diagram Showing Lines of Force around a Wire

move in a definite direction with respect to the direction of flow of the current through the conductor.

The direction in which the lines of force travel around the conductor is determined by the use of *Fleming's Right-Hand Rule*, which is illustrated in Fig. 9. When the conductor is grasped in

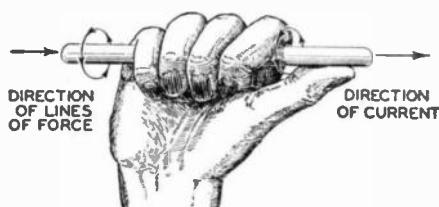

Fig. 9. Application of the Right-Hand Rule

the right hand, with the thumb pointing in the direction in which the current is flowing, lines of force are circling around the conductor in the direction indicated by the fingers.

If a circuit such as that shown in Fig. 10 were set up, so long as the key—or switch—remained open there would be no current flow, nor would lines of force surround the conductor *AA'*. However, closing the key would cause the current to begin to flow; and during the period required for the energy to attain its maximum value of current, the lines of force would expand outward, as shown by the arrows of different size. To demonstrate the expansion of the magnetic field, grasp the conductor with the right hand and then loosen the grip so that the fingers move outward. The outward

movement of the fingers corresponds to the expansion of the magnetic field during the period required for current to reach its maximum value.

The phenomenon just explained can be further emphasized by means of a hydraulic experiment. In Fig. 11, the conductor shown in Fig. 10 has been replaced by a rubber tubing connected to a pump; this pump represents the battery, to the extent of supplying the water (current) and the pressure (voltage). When

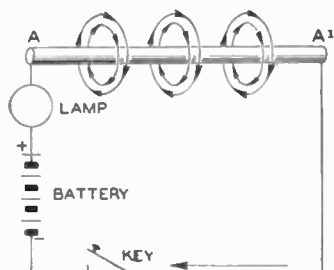

Fig. 10. An Electric Circuit

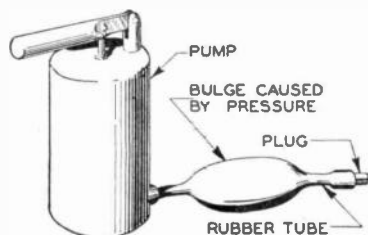

Fig. 11. Diagram Illustrating Effect of Applying Pressure to a Soft Rubber Tube

the pump is not operating, the rubber tube is at rest and in its normal state. If the pump is started, the pressure rises until the rubber tube expands, as indicated by the illustration. The extent to which the tube expands will depend upon the amount of water forced into it, and the amount of pressure at the pump.

Similarly, the lines of force surrounding an electrical conductor carrying a continuous current, such as that delivered by a battery or a direct-current generator, will expand outward in accordance with the amount of current in the circuit. Also, just as the rubber hose expanded gradually during the period in which the pressure attained the maximum, so in the electrical circuit, as the current is built up, the lines of force expand outward to the maximum.

Stopping the pump would relieve the pressure and allow the rubber hose to resume its normal state. Similarly, in the electrical circuit, raising the key would open the circuit and cause the current to stop flowing, so that the lines of force would collapse just as the rubber hose did when the pump stopped operating.

**Electromagnetic Induction.** If, as shown in Fig. 12, one end of a bar magnet is passed over the conductor *BC*, to which a

galvanometer is connected, the pointer of the instrument will move. As the magnet swings back in the opposite direction, the pointer will swing toward the other side of the zero point. This experiment

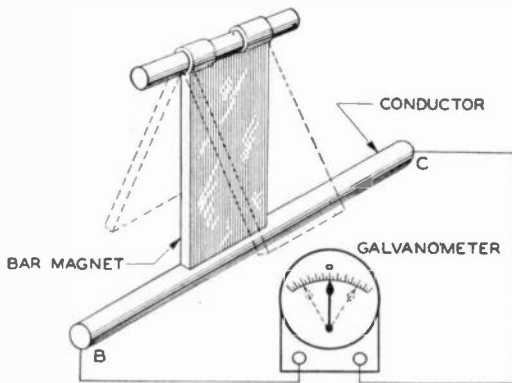

Fig. 12. Electromotive Force Produced by a Moving Magnetic Field

shows that a voltage is being induced in the conductor which causes current to flow—a phenomenon that occurs when lines of force are cut by a conductor.

The same result would be obtained by passing the conductor up and down through the magnetic field surrounding the end of the magnet.

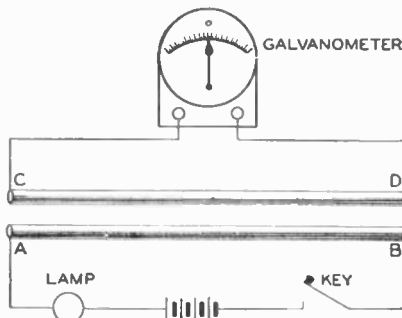

Fig. 13. Mutual-Induction Experiment

**Mutual Induction.** It has been shown that a voltage will be set up in a conductor when it is passed through the lines of force surrounding the poles of a magnet. It was also shown that a magnetic field is produced around a conductor when a current

is flowing in a circuit. Therefore, if conductor  $CD$ , Fig. 13, is laid alongside conductor  $AB$ , which is connected to a battery, and if the ends of conductor  $CD$  are connected to a galvanometer as shown, the pointer of the galvanometer will move from the zero point when the key is closed. However, the pointer will return almost instantaneously to its zero position when the current flowing through conductor  $AB$  attains its maximum value. Releasing the key will open the circuit and again cause the pointer on the galvanometer to move, but this time in the direction opposite from the normal position, to which it moved when the key was closed. Again the pointer of the instrument will return to zero when the current no longer supports the magnetic field about  $AB$ .

The foregoing experiment shows graphically that a voltage is induced in a conductor when that conductor is cut by lines of force. The fact that the pointer on the indicating instrument moved at the time when the key was closed and then returned to zero, shows that the magnetic field surrounding the conductor  $AB$  was being built up and that the lines of force were expanding outward. That there was no movement after the current had attained the maximum value, indicates that the electromagnetic field surrounding the conductor was stationary—that is, it was not moving inward or outward. Again, when the key was opened, the lines of force that had been whirling around the conductor as a center, collapsed—that is, they moved inward, and the lines of force cutting the conductor caused the current to flow instantaneously in conductor  $CD$ .

Similarly, if a varying current of electricity is flowing through a conductor, the lines of force surrounding the conductor are constantly moving inward and outward, so that if another conductor were placed alongside the one carrying the varying current, a voltage would be induced in the second conductor. This can be determined by connecting a galvanometer in circuit with it, as shown in Fig. 13. It is interesting to note that voltage alone can be induced in a circuit, never current. Current flows, however, in a closed circuit in which a voltage is induced. Thus it is sometimes mistakenly assumed that the current is also induced.

**Inductance Coils.** *Coil* is the term applied to the form into which a conductor is wound to concentrate the electromagnetic

field produced by current flow. If the conductor *AB* in Fig. 13 is wound around a stick—a pencil, for example—and suspended so that it remains fairly taut, and if the terminals are connected to a battery as shown in Fig. 14, it can be used for some very interesting experiments.

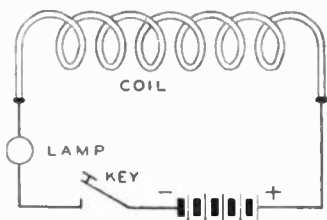

Fig. 14. An Inductance Coil

First, place one end of a steel needle on the first turn of the coil, and hold the other end with a finger. Then push the key and the needle will fly into the coil. If the needle used is heavy, it will gain enough momentum to throw it through the coil to the other side. This is the principle upon which relays and

circuit breakers operate.

Second, run a steel rod through the coil, holding it firmly at both ends, then push the key to close the circuit. The windings of the coil will be seen to pull together.

Third, place one end of the steel rod within the coil, and hold the other end in the hand. Then push the key and note the pull that is exerted on the rod.

Fourth, place the steel rod within the coil; then hold a needle in the palm of the hand and close to the rod. Push the key to close the circuit, and the needle will jump to the end of the rod and adhere to it. This shows that the rod has become magnetized as a result of the lines of force caused by the flow of electric current through the coil.

These, and many similar experiments, can be conducted with this simple set-up. All of them are direct applications of the creation of an electromagnetic field around the conductor, as already described.

In this creation of the electromagnetic field about the turns of a coil, the latter may be regarded as though it were a straight conductor. Fig. 15 shows part of a conductor wound into a coil. It can be seen that the lines of force whirl about each turn of the coil and add to one another, thus setting up a highly intensified field within the coil.

**Magnetic Field around a Coil.** The form taken by the magnetic field about a bar magnet has already been discussed. A similar phenomenon is found in the electromagnetic field surrounding a coil, as illustrated in Fig. 15. Note that one end of the coil

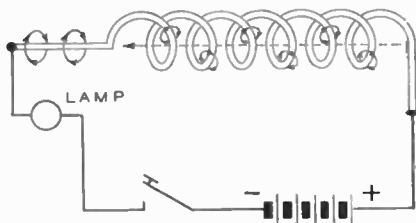

Fig. 15. Magnetic Fields around a Conductor and Coil

corresponds to the north pole of a magnet, as shown by the arrow-head, and the other end corresponds to the south pole.

**Unit of Inductance.** A circuit is said to possess inductance when it opposes any change of current flow in the circuit. The unit of inductance is the *henry*. When a current change of one ampere per second produces an induced electromotive force of one volt in a circuit, the circuit is said to have an inductance of one henry.





#### CONTROL PANEL

This control panel, which is the heart of the A.C. calculating board (shown at right), enables an engineer to determine the current that will flow when a short circuit occurs at any point on a large power system.  
*Courtesy of Westinghouse Electric and Mfg. Co., East Pittsburgh, Pa.*

Resistance has been defined as that which tends to retard the flow of electric current. Its applications are many and varied, and there are several types.

**Wire-Wound Resistors.** Since metal resistance materials have a relatively high current-carrying capacity, before the introduction of radio practically all resistance elements were required to carry heavy currents, and therefore were of the wire-wound type. In resistors of this type, the resistance wire is wound on a hollow porcelain tube which permits the dissipation of heat. In some cases, the entire assembly (wire on porcelain) is coated with a vitreous enamel substance and subjected to a heat treatment to bake the

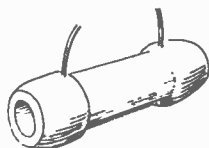

Fig. 1. A Vitreous Enamel Wire-Wound Resistor

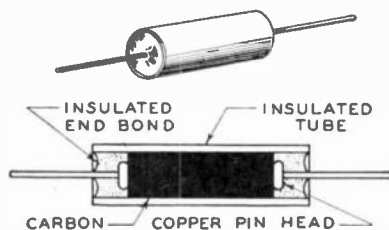

Fig. 2. A Carbon Resistor

covering, in order to protect the wire and to prevent oxidation and changes due to moisture and temperature. *Vitreous resistors*, Fig. 1, are used in many radio circuits, particularly in transmitters and power units for larger installations.

**Carbon Resistors.** In Fig. 2 is shown a type of *carbon resistor* used extensively in radio circuits—both in receivers and transmitters. The resistance of carbon is about 2200 times as great as the resistance of copper. By mixing finely divided carbon particles with a non-conductor, resistance values of several million ohms may be obtained in a unit only half an inch long and one-eighth of an inch in diameter.

An inspection of the bottom of a radio receiver chassis will show numerous resistors of various sizes colored to indicate their ohmic values. The physical size of the resistor indicates the wattage it is capable of safely dissipating. Too much current through a carbon resistor will heat it to the point where it will be permanently damaged. A slight overload will invariably change the resistance of a carbon unit.

One-watt carbon resistors are approximately one inch in length; partial wattage resistors are made in one-half, one-third, and one-fifth watt sizes, and may be only three-eighths of an inch in length and three-sixteenths of an inch in diameter.

Connections are made to carbon resistors by wire leads fastened to each end of the unit. The compact size and low cost account for the popularity of this type of resistor.

The resistance of a substance varies in direct proportion to its length. For example, a piece of resistance wire two feet long has twice the resistance of a piece of the same wire only one foot long. The resistance also varies inversely with the cross section of the conductor—a conductor with a cross-sectional area of one square inch has only one-half the resistance of a conductor of the same material with a cross-sectional area of one-half square inch. Thus a circular wire .010 of an inch in diameter has four times the resistance of a wire of the same material with a diameter of .020 of an inch, because the wire with a diameter of .020 inch has a cross-sectional area four times that of the wire which is .010 inch in diameter.

**Rheostats.** A resistor whose resistance value may be varied—in other words, a variable resistor—is called a *potentiometer* or a *rheostat*. A *potentiometer* is a device in which both extremities of the resistance element are connected across the circuit and any intermediate point obtained by the *sweeper arm*. Operated by a control *knob*, the sweeper arm makes contact over the range of resistance element to vary the amount of resistance in another related circuit. A potentiometer has three *terminals*, Fig. 3. The rheostat has only two terminals—one at the end of the resistance element, the other connected to a sweeper arm so that the resistance introduced into the circuit may be varied. Fig. 3 shows a wire-

wound rheostat-potentiometer such as may be used to control an electrical circuit.

A *wire-wound rheostat* usually consists of a circular-shaped resistance element which is made by winding the resistance *wire* on an insulating material—fiber, for example. The resistance element is mounted on a form in such manner that the edge of the resistance element protrudes slightly above any physical part of the mounting. The sweeper arm, which is pivoted in the center, establishes contact by bearing lightly but firmly against the bare resistance wire. Since the wire used to form the rheostat has a definite resistance for each turn of the spirally wound unit, it is evident that each successive turn causes the resistance to vary in accordance with the resistance per turn.

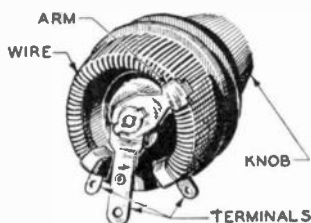

Fig. 3. Wire-Wound Rheostat-Potentiometer Used in Radio

There is another form of rheostat and potentiometer in which the sweeper arm rolls along a piece of thin metal that springs away from the resistance material—a carbonized sheet—so that contact is made only at the point where the arm holds the thin spring metal closely upon the carbon-treated plate. The spring-metal sheet actually rolls down upon the carbon-treated surface and does not in any way rub it.

In still another type of variable resistor, the carbon, combined with graphite and other substances to give it pliability, is placed in a container provided with a piston that compresses the resistance compound. When the carbon particles are packed closely together, the value of the resistance is lower than when they are less compressed.

Variable resistors of the carbon type used in radio circuits are not designed to carry high electric currents. They serve to vary the resistance gradually and are made in values from one thousand to several millions of ohms.

**Wattage Rating.** Heat is developed whenever an electric current flows through a resistance, and unless the heat is dissipated into the surrounding air, the resistance may become extremely hot.

A resistance should operate within its temperature limits in order to be efficient. The heat developed by the flow of an electric current is determined by the formula:

$$W = EI = I^2R = \frac{E^2}{R}$$

and one of the three forms may be used depending upon the factors given.

The *wattage rating* (a resistor is a 25-watt unit, for example) of a resistor is the maximum number of watts of energy required to produce a temperature rise of 482 degrees Fahrenheit, when the unit is provided with one foot of free air which has a temperature not to exceed 104 degrees Fahrenheit. Most resistors used in radio circuits are rated according to their ability to dissipate heat (wattage), as well as to their ohmic resistance.

To apply the foregoing formula, let us assume that two-tenths of an ampere of current are flowing through a 1000-ohm resistor. To find the wattage:

$$W = .2 \times .2 \times 1,000 = .04 \times 1,000 = 40.00 \text{ or } 40 \text{ watts}$$

Therefore, 40 watts of energy are being dissipated if the resistor operates at the allowable steady temperature.

Also, if the wattage dissipation and the resistance are known, the current that is flowing may be determined by using the same formula. Assume, for example, that the heat dissipated is known to be 7.5 watts and that the resistance is 3,000 ohms. To find the current:

$$7.5 = I^2 \times 3,000$$

From this we find that

$$\begin{aligned} I^2 &= \frac{7.5}{3000} \\ &= .0025 \\ I &= .05 \quad \text{amperes} \end{aligned}$$

or 50 milliamperes of current.

The same calculation will show how much current a resistor of a given rating will carry. For instance, to find how much current a 25-watt resistor of 2,500 ohms will carry:

$$25 = I^2 \times 2,500$$

or

$$I^2 = \frac{25}{2500} = .01$$

$$I = .1 \quad \text{amperes}$$

or 100 milliamperes of current.

**Resistances in Series.** When resistances are connected in series, the total value of the resistance is the sum of all the individual units. For example, if three resistors— $A = 65$  ohms,  $B = 100$  ohms, and  $C = 85$  ohms—are connected in series as shown in Fig. 4, the



Fig. 4. Diagram Showing Resistances in Series

total resistance is 250 ohms.  $A$  and  $B$  combined would be 165 ohms,  $A$  and  $C$  combined would be 150 ohms, and  $B$  and  $C$  combined would be 185 ohms.

**Resistances in Parallel.** The action of resistances in parallel can best be shown by analogy. Fig. 5 shows a roadway 28 feet in width, just wide enough for a platoon of infantry (16 men) to march abreast. The road divides into four branches at  $O$  to form a parkway, and for a short distance consists of 4 roads,  $A$ ,  $B$ ,  $C$ , and  $D$ , each of which is wide enough for 4 men to march abreast. When the column, moving in the direction of the arrow, arrives at  $O$ , it divides: the 4 men at the right march through road  $D$ , the next 4 through road  $C$ , the next 4 through road  $B$ , and the 4 on the left through road  $A$ . The men reassemble at  $P$ .

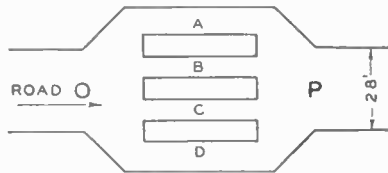

Fig. 5. An Illustration of Parallel Roads

Assume, now, that the roadway narrowed at point  $O$ , and that each of the roads permitted only one man to pass. It is evident that the rate of travel will be impeded—that the number of troops that can pass point  $P$  within a given length of time will be less. In other words, the current flow will be decreased, because there will

be a resistance to the flow of marchers. Only 4 men can pass point *P* in the same length of time that 16 men could pass if each of the roads were wide enough for 4 men to march abreast. If road *A* were wide enough for 2 men to march abreast, then 5 men would pass point *P* in the same length of time required for 4 to pass, under the former conditions. Similarly, if road *D* were wide enough to allow 3 men to pass, a total of 7 men could pass *P*. Therefore, the number of men who will pass point *P* at the same time will depend upon the width of the paths. It is also evident that even if three of the roadways were closed, there would still be a path for the passage of men between *O* and *P*.

Suppose we assume that each man represents one ampere of electric current, and the roadways represent resistance to the flow of electric current. Since 16 men can march abreast on the main artery, or roadway, then a corresponding artery for electric current will allow the passage of 16 amperes. But if the narrowness of the four branches of the roadway prevents passage of the full 16 men, and if the 4 paths will accommodate only one man each, then only 4 men can pass the point *P* at the same time. Similarly, if each of 4 parallel resistances, to the passage of electric current, will accommodate only one ampere, then only 4 amperes of current can flow through the circuit. In the case of the men, a block in traffic would be created. However, electric current will adjust its flow to the minimum path created by a resistance circuit. Since conduct-

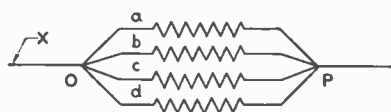

Fig. 6. Circuit Showing Parallel Resistances

ance is governed by the resistance offered by a circuit, then in a case such as the foregoing, only one ampere of current will pass through each of the four parallel circuits, or a total of four amperes.

Applying this analogy to electric circuits, as in Fig. 6, a circuit which includes conductor *X* divides into 4 branches, represented by resistance elements, *a*, *b*, *c*, and *d*, diverging at point *O*, and converging again at point *P*. Following the analogy of the troops on the road, where one of the paths permitted the passage of 2 men, it is evident that the narrower roads offered greater resistance to the

passage of men. It can be said, therefore, that the narrow roads correspond to resistance to the flow of electric current and that, as the resistance increases, the current flow will decrease.

Since, again following the analogy, doubling the width of the roadway lowered the resistance to the passage of men and permitted twice as many as before to pass through, we can say that the conductance of current is inversely proportional to the resistance value. In other words, since twice as many men passed through road *a*, its resistance to the passage of men must have been one-half that of the other roads, which permitted only one man to pass. Therefore, the conductance is inversely proportional to resistance, designated by the reciprocal of the resistance,  $\frac{1}{R}$ . The unit for conductance is the *mho*.

Thus, in order to determine the resistance that exists between the points *O* and *P*, we find first the *conductance* of the network. This, as has been stated, is a measure of conductivity, and therefore the reciprocal of the resistance. The formula for determining the conductance, and from which the *equivalent resistance*\* is obtained, is:

$$\frac{1}{R} = \frac{1}{R_a} + \frac{1}{R_b} + \frac{1}{R_c} + \frac{1}{R_d} + \text{etc.}$$

in which *R* is the equivalent resistance, *R<sub>a</sub>* is the resistance of *a*, *R<sub>b</sub>* is the resistance of *b*, and so on.

If the resistance of each of the resistors is 20 ohms, we can substitute the numerical value, 20, for the symbols in the formula and then have:

$$\begin{aligned} \frac{1}{R} &= \frac{1}{20} + \frac{1}{20} + \frac{1}{20} + \frac{1}{20} \\ &= \frac{4}{20} = \frac{1}{5} \text{ mho} \end{aligned}$$

From this we find that the resistance *R* is 5 ohms, or one-fourth of the resistance of each of the individual elements.

---

\*By *equivalent resistance* is meant the actual resistance that results from connecting resistances in parallel.



Thus it is evident that, *if all the resistors of a parallel network are of equal value, the equivalent resistance may be determined by dividing the ohmic value of one of the resistors by the number of resistance units in the network.*

If the values of the resistances are not identical, the equivalent resistance of the network may be determined by using the formula given. For instance, assuming that the resistance value of *a* is 10 ohms, of *b* is 20 ohms, of *c* is 30 ohms, and of *d* is 40 ohms, then:

$$\frac{1}{R} = \frac{1}{10} + \frac{1}{20} + \frac{1}{30} + \frac{1}{40}$$

The lowest common multiple of 10, 20, 30, and 40, is 120. Therefore, the equation becomes:

$$\begin{aligned} \frac{1}{R} &= \frac{12}{120} + \frac{6}{120} + \frac{4}{120} + \frac{3}{120} \\ &= \frac{25}{120} = \frac{5}{24} \text{ mho} \end{aligned}$$

Stated in the form of a proportion, the equation is:

$$1 : R = 5 : 24$$

Calculating:

$$\begin{aligned} 5R &= 24 \\ R &= 4.8 \text{ ohms} \end{aligned}$$

Thus we find that the equivalent resistance of a network of four parallel resistors having values of 10, 20, 30, and 40 ohms respectively, is 4.8 ohms which is *less than* the value of the lowest resistance in the circuit. Since the values were taken at random, it has been proved that: *The equivalent resistance of parallel resistances is less than the ohmic value of any element of the network.*

**Resistances in Series-Parallel Circuit.** When resistances are connected in series-parallel, as shown in Fig. 7, the equivalent value of each parallel network is calculated first and the results

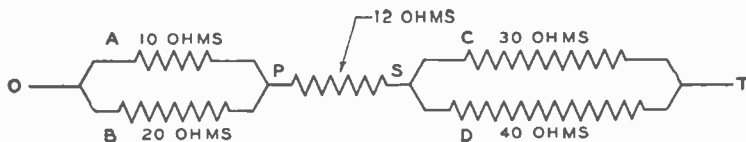

Fig. 7. Resistors Connected in Series-Parallel Circuit

obtained are added together to obtain the total resistance, as from  $O$  to  $T$ . Substituting the values given in the diagram for those of the given formula, we find that the resistance of the section  $OP$  would be 6.67 ohms; that of the section  $PS$  would be 12 ohms; that of  $ST$  would be 17.14 ohms. Adding the three values, the total resistance of  $O$  to  $T$  would be 35.81 ohms.

**Current Flow through a Circuit.** In order to calculate the amount of current flowing through a circuit, it is necessary to know the electromotive force—that is, the voltage—and the resistance. These values, substituted for the symbols of Ohm's law,  $I = \frac{E}{R}$ , will give the value of the current in amperes. Let us first consider a circuit which has a single resistance.

If the value of the resistance ( $R$ ) is 1,000 ohms, and there is an impressed electromotive force of 50 volts, the equation becomes:

$$I = \frac{50}{1000} = .05 \text{ amperes}$$

Thus, in a simple circuit in which there is a resistance of 1,000 ohms and in which the voltage is 50 volts, .05 amperes (50 milliamperes) of current will flow.

In Fig. 4, three resistances of 65 ohms, 100 ohms, and 85 ohms respectively, are connected in series, making the total resistance 250 ohms. If, now, we assume a circuit in which the electromotive force is 50 volts, and substitute in the equation the known values for  $E$  and  $R$ , we have:

$$I = \frac{50}{250} = .2 \text{ amperes}$$

That is, two-tenths of an ampere (200 milliamperes) is flowing in the circuit.

Similarly, a network of parallel resistances is shown in Fig. 6. Four resistance elements,  $a$ ,  $b$ ,  $c$ , and  $d$ , having values of 10, 20, 30, and 40 ohms respectively, are connected in parallel, giving an equivalent resistance of 4.8 ohms. Here again, assuming an electromotive force of 50 volts, the equation becomes:

$$I = \frac{50}{4.8} = 10.42 \text{ amperes}$$

This shows that 10.42 amperes are flowing in the circuit.

It may be desired, however, to know the current flowing in any part of the parallel circuit—for example, that part which has 20 ohms resistance. Each element of the parallel network can be considered individually, and the current flow can be determined by applying Ohm's law as shown, thus:

$$I = \frac{50}{20} = 2.5 \text{ amperes}$$

Therefore, 2.5 amperes are flowing through the leg of the network which has a resistance of 20 ohms.

If similar calculations were made for each element of the network, the current flow would be found to be:

For *a* (resistance 10 ohms), 5 amperes

For *b* (resistance 20 ohms), 2.5 amperes

For *c* (resistance 30 ohms), 1.67 amperes

For *d* (resistance 40 ohms), 1.25 amperes

Adding the separate values of current flow, we obtain a total of 10.42 amperes, the same result that was obtained by using the equivalent resistance (4.8 ohms) as the value for *R*.

It has been shown that the value of the current flow can be determined by using the equivalent resistance in parallel circuits; the current flow in a circuit having series resistances is determined by using the total resistance value which is the sum of the resistances. It is evident, then, that the current flow in a series-parallel circuit can be found by first obtaining the equivalent resistance of those circuits, or devices, that are in parallel with each other. Then the total resistance of the circuit is obtained by adding the equivalent resistance (or resistances) and the resistance (or resistances) of the series parts of the circuit. As an example, in Fig. 7 the equivalent resistance of *A* and *B* is 6.67 ohms. The equivalent resistance of *C* and *D* is 17.14. The total resistance in this series-parallel circuit is the sum of the equivalent resistances *AB* and *CD* plus resistance *PS*, which is  $6.67 + 17.14 + 12 = 35.81$  ohms. With an impressed potential of 50 volts, the current will be  $50 \div 35.81$  or 1.4 amperes.

**Voltage Drop.** Resistance may be employed to regulate voltage, and in this capacity it performs the function known as

*dropping the voltage.* For instance, early types of radio receiving sets employed the voltage-drop method of reducing the voltage delivered by a storage battery (6 volts) to the value required for the filament of tubes of the "99" type (3.3 volts).

In making a calculation of this kind, it is necessary to know both the current consumption, and the required drop in voltage. The "99" type tube draws six one-hundredths (.06) of an ampere, and the required drop in voltage is  $6 - 3.3$ , or 2.7 volts. Therefore, applying Ohm's law:

$$\begin{aligned} R &= \frac{E}{I} \\ &= \frac{2.7}{.06} = 45 \text{ ohms} \end{aligned}$$

So, if a single tube of the "99" type were used in a circuit fed by a 6-volt storage battery, a fixed resistor of 45 ohms would drop the voltage to 3.3 volts, which is the maximum voltage that the filament element is capable of withstanding.

If two tubes of the "99" type were used, the current consumption would be twice that of a single tube, or .12 amperes. Therefore, to calculate the resistance required to drop the voltage from 6 volts to 3.3 when two tubes were to be used, .12 would be the value of  $I$  in the foregoing illustration. Similarly, .18 would be the value of  $I$ , if three tubes were used; .24, if four tubes were used, and so on.

The general practice is to connect a rheostat in series with a fixed resistance, such as we have been discussing. The purpose of this is to control the volume output of the set by further reducing the voltage applied to the filaments of the tubes.

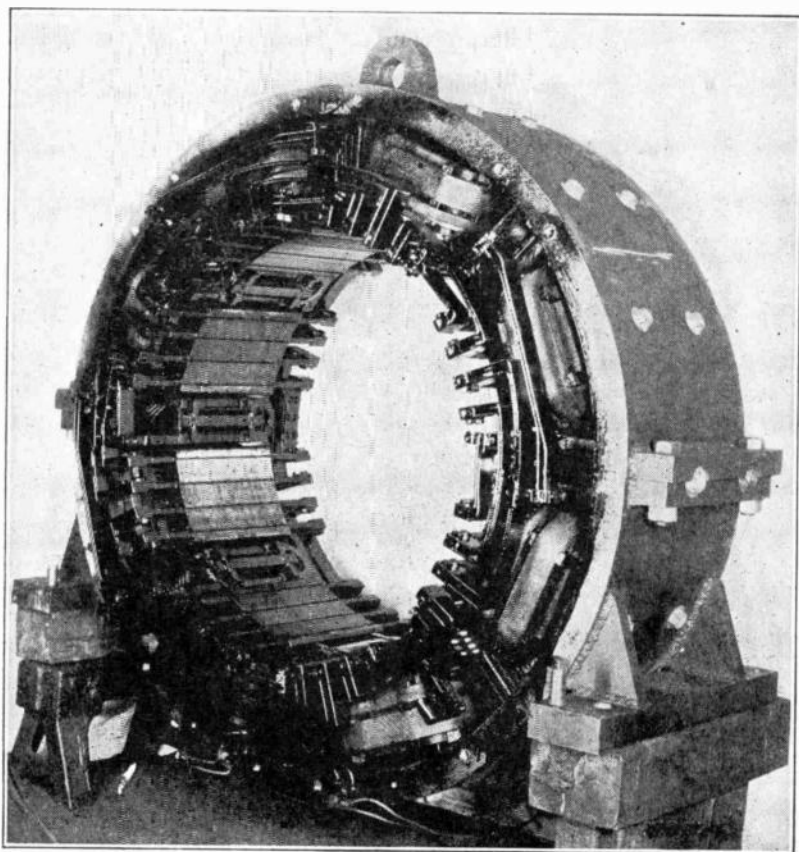

### **CONSTRUCTING A DIRECT-CURRENT GENERATOR**

The compensating field winding is placed in slots cut in the face of the main shunt and series field pole pieces.

*Courtesy of Westinghouse Electric and Manufacturing Co.*

## DIRECT AND ALTERNATING CURRENT

There are three types of dynamic electricity, that is, electricity in motion, known as *direct current*, *pulsating direct current*, and *alternating current*. Fig. 1 illustrates the three types.

**Direct Current.** *Direct current* is defined as a current which always flows through a circuit in the same direction. Its amplitude remains substantially constant although it may undergo non-periodic changes. It includes the energy that is supplied by batteries—chem-

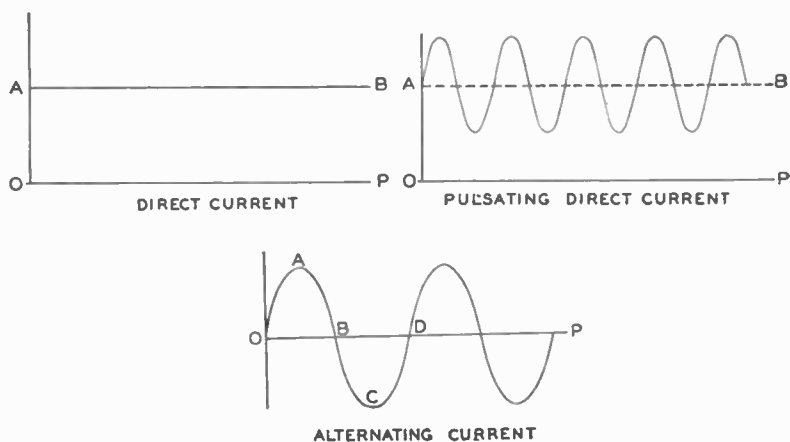

Fig. 1. Diagrammatic Views of Direct Current, Pulsating Direct Current, and Alternating Current

ical action—as well as the rectified and filtered output of devices used in radio circuits. Battery current does not vary in strength so long as the battery is in good condition and the elements are not broken down chemically.

A wave-form picture of a steady uniform direct current is shown in the diagram, Fig. 1, by the straight horizontal line *AB*. The amount of the voltage or current is indicated by the height of

this line  $AB$  above the zero or base line  $OP$ . Thus the higher the line  $AB$  is above the base line  $OP$ , the greater is the voltage or current. When the exact numerical value of the voltage or current is known it is indicated by a series of numbers placed at the left, along the vertical line  $OA$ .

If a single loop of wire were rotated in a magnetic field the electricity generated would be alternating in direction and of constantly changing amplitude. The changing direction may be rectified, *i.e.*, caused to flow in one direction, by the use of a commutator which is a system of copper bars connected to the coil terminals. Carbon brushes make a slipping contact with the commutator as the armature rotates. The commutator reverses the current flow at the proper instant to maintain the unidirectional flow in the external circuit. A single loop of wire connected to a two-bar commutator would produce a highly pulsating type of current. The use of a multi-coil armature, with its multiple-bar commutator, produces a series of pulses in the external circuit each acting a short time interval out of step with the others. This results in a fairly smooth average value of current which for all practical purposes is termed *direct current*. The slight variation—called *commutator ripple*—is insignificant in power and lighting circuits but must be further smoothed or filtered when the supply is to be used to operate vacuum-tube amplifier equipment.

**Pulsating Direct Current.** *Pulsating direct current* is that kind of electrical energy that flows in the same direction through a circuit, but does not maintain a constant voltage value. It may vary only in slight amounts, and, again, it may vary greatly. This type of energy is encountered in the plate circuit of vacuum-tube amplifiers and has many of the characteristics of alternating current. It can be shown to be the result of combining alternating- and direct-current components.

The wave-form picture of a pulsating current is also shown in Fig. 1. Pulsating current is indicated by the wavy line extending above and below the dash line  $AB$  that indicates the average values such as would be read on a voltmeter or ammeter. Since the lowest dip of the wavy line is above the *zero* or base line  $OP$ , it indicates that the current does not reverse its direction of flow and is, there-

fore, a direct current. This pulsating current is sometimes referred to as a direct current with an alternating-current component. If the dips extend below the zero or base line  $OP$  as with alternating current, Fig. 1, it indicates a reversal of polarity and current flow. Thus the loop  $OAB$  is considered the positive part of the wave and that below the line,  $BCD$ , as the negative part.

**Alternating Current.** *Alternating current* is a form of electrical energy that reverses its direction of flow through a circuit at regular periods. It is said to flow in cycles, and the reversals in direction are called alternations. Alternating current is rated in accordance with its *frequency*, that is, the number of cycles that

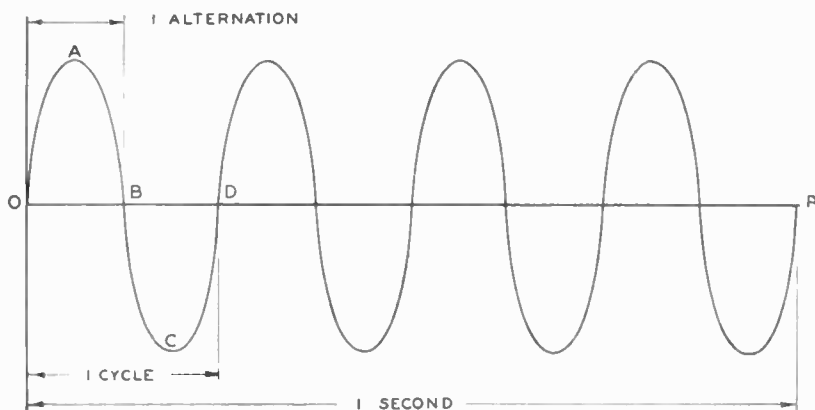

Fig. 2. Diagram Showing Four Cycles of Alternating Current

occur in a second, a sixtieth part of a minute. For instance, in a 60-cycle alternating-current circuit the current flows in one direction 60 times and in the reverse direction 60 times in a second. Reversing the direction of flow causes one side of an alternating-current circuit to be at positive and negative polarity alternately.

Alternating current is symbolized in Fig. 2, which indicates the changing value of the voltage, or current, and the polarity for any given position of the coils of the generator. Starting from zero, point  $O$ —no voltage or current—the amplitude increases gradually in a positive direction until it reaches a maximum,  $A$ , after which it decreases gradually until it comes again to zero at  $B$ . At this point, the action reverses its direction and follows the same



procedure that has just been explained, except that the current is flowing in the opposite direction, as shown by *BCD*. At *C* it has reached its maximum negative value.

Referring to Fig. 2, the distance along the horizontal line, *OP*, represents time, the distance above and below the line, *OP*, represents the strength of the energy, the amplitude. That part of the curve included in *OAB* is one alternation, and that included in *BCD* is another alternation. The two combined constitute a cycle, indicating that the current has passed through the circuit in one direction and then the other. It will be noted also that there are twice as many alternations as there are cycles, there being two alternations to each cycle.

**Effective Voltage.** Effective values are a measure of the heating effect of the current, or, in other words, the rate at which the electrical energy is converted into heat, regardless of the direction of the flow of the current, compared to the same heating effect produced by direct current.

In view of the fact that the voltage in an AC circuit always rises from zero to maximum positive, back to zero potential, thence to maximum negative and again back to zero potential, the amount of energy for the same maximum voltage and current values is less than is obtained when direct or continuous current is used. Calculations will show that the effective voltage or current is .707 of the maximum value, or, in other words, an alternating peak value of 100 volts will actually have an effective value of 70.7 volts. Similarly, if the peak current is 10 amperes, the effective-current flow is 7.07 amperes. These effective values will be shown by a measuring device, such as a meter.

An alternating-current voltmeter connected across an alternating-current circuit will indicate, for example, 70.7 volts. The peak voltage across the circuit will be 100 volts, inasmuch as the measuring instrument indicates the effective value.

**Effect of Resistance in a Circuit.** Alternating current will flow through a resistance, and the relationship of the current to the voltage will be identical with that found to exist within a DC circuit at any given instant. The relationship may be found by applying Ohm's law,  $E = IR$ , to the instantaneous voltage and current.

Thus, to apply Ohm's law to the action of resistance in an alternating-current circuit, it is only necessary to determine the instantaneous voltage and, knowing the resistance, Ohm's law in its simple form may be applied to determine the instantaneous value of current.

The terminals of a resistance are always of opposite polarity. That is, when one end of the resistance is of positive polarity, the opposite end is negative, and vice versa.

**Counter-Electromotive Force.** The flow of alternating current through a circuit causes a fluctuating electromagnetic field around the conductor. This fluctuating field sets up another force known as *counter-electromotive force* which tends to oppose the change of the current that created it.

Counter-electromotive force (*c.e.m.f.*), the force that is directly opposite to the electromotive force impressed upon the circuit, is produced by reactance in an alternating-current circuit, in which case the impressed electromotive force is said to be  $180^\circ$  out of phase with the counter-electromotive force.

**Effect of Inductance in a Circuit.** Inductance limits the change of flow of alternating current through a circuit because of the self-induced counter-electromotive force set up in the coil. Inductance creates a strong counter-electromotive force, a force which tends to retard the change of flow of the current. This retarding force is not due to resistance, because in most cases the ohmic resistance of the inductance is negligible.

**Inductive Reactance.** Inductive reactance is the term applied to the opposition to the flow of alternating current caused by inductance. Inductive reactance is indicated by the symbol  $X_L$ . It is measured in ohms, and its effect depends upon the frequency of the current—the number of cycles per second—as well as the electrical size of the inductance.

**Effect of Capacity in a Circuit.** Although a condenser comprises two plates or sets of plates separated by an insulator, therefore constituting an open circuit, its action in an alternating-current circuit would lead one to assume that the alternating current is passing through the insulation. However, actually the electrons are being transmitted first to one plate and then to the other.

through the circuit in which the condenser is connected. If the condenser is connected into a 60-cycle alternating-current circuit, the electrons are passing through the circuit in one direction and back again 60 times per second.

*Capacitive Reactance.* Capacitive reactance is the term applied to the effect upon the flow of alternating current caused by the introduction of capacity into the circuit. As the capacity of the condenser increases, the number of electrons that flow from one plate or set of plates to the other increases, so that the current is greater. Capacitive reactance,  $X_c$ , is expressed in ohms.

*Phase.* The position of a point on an alternating-current cycle is known as the *phase* of that point and is measured in electrical degrees,  $180^\circ$  being an alternation,  $360^\circ$  being a complete cycle. Thus, the relationship of current and voltage at any given instant may be measured as a number of electrical degrees. When two waves start from zero at the same time and rise—or fall—simultaneously, so that they reach the maximum values—and all other corresponding positions—at the same time, they are said to be *in phase*. When one falls behind the other, it is said to *lag*, and the one that is leading is said to *lead*. Thus, if the current flow precedes the pressure in the circuit, it is said to *lead* the voltage; on the other hand, if the current flow is retarded so that it follows behind the pressure, it is said to *lag*.

*Effect of Resistance on Phase Relationship.* When resistance only exists in an alternating-current circuit, the current flow corresponds to the pressure and they are said to be in phase. This condition exists when there is neither inductance nor capacity in the circuit, or when both are present in the same magnitude and their effect cancels.

*Effect of Inductance on Phase Relationship.* Inductance in an alternating-current circuit causes the current to lag behind the voltage, (*A*) of Fig. 3, due to the counter-electromotive force, which, as has been shown, retards the change of flow of current. The amount of lag is  $90^\circ$ , which means that when the voltage is at its maximum value the current flow is at zero, and when the pressure or voltage is at zero potential, the current flow is greatest.

*Effect of Capacity on Phase Relationship.* Capacity in an

alternating-current circuit causes the current to lead the voltage by  $90^\circ$ , so that the current is at its maximum value when the pressure begins to rise, and is at its maximum value in the opposite direction when the pressure has returned to zero at the end of its first alternation. Fig. 3 shows diagrammatically the effect of either inductance

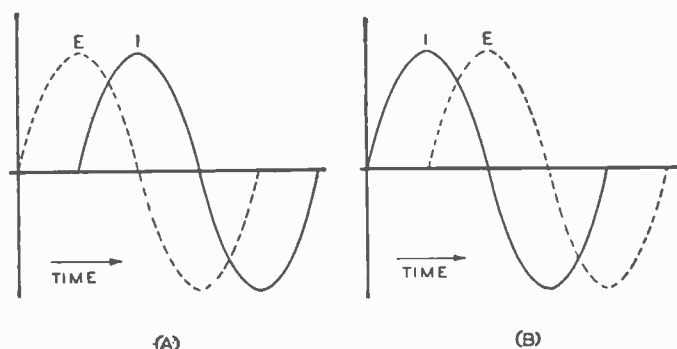

Fig. 3. Diagram Showing Effect of Inductance and Capacitance in an Alternating-Current Circuit

(A) Shows current lagging voltage due to inductance in circuits. (B) Shows current leading voltage due to capacitance in circuits.

or capacity upon the phase relationship in an alternating-current circuit.

*Effect of Combinations of Resistance, Inductance, and Capacity on Phase Relationship.* If the alternating-current circuit has resistance and capacity in series—but no inductance—the current will lead the voltage, (B) of Fig. 3. However, the presence of the resistance will reduce the phase angle, which is the term applied to the number of electrical degrees between the current and the voltage. If the alternating-current circuit has resistance and inductance—but no capacity—the current lags behind the voltage, but, again, the resistance tends to reduce the phase angle.

If the alternating-current circuit contains capacity and inductance, the phase angle will be governed by the amount of capacitive or inductive reactance. Thus, if the capacitive reactance is greater than the inductive reactance, the current will lead the voltage. On the other hand, if the inductive reactance exceeds the capacitive

reactance, the current will lag. If the inductive reactance and the capacitive reactance are equal, the current and voltage are in phase, and the circuit is said to be in *resonance*. Resonance is highly important in radio circuits and is treated fully in another chapter.

These conditions will hold also when the circuit contains resistance, inductance, and capacity, except that the resistance will tend to reduce the phase angle.

**Calculation of Reactance.** Reactance is measured in ohms, and is dependent upon the frequency of the current as well as the magnitude of the reactance. Thus, the reactance of an inductance in a 60-cycle circuit will be half of what it would be in a 120-cycle circuit. The formula to determine capacitive reactance is:

$$X_c = \frac{1}{2\pi fC}$$

in which  $X_c$  is the capacitive reactance in ohms,  $f$  is the frequency



Fig. 4. Diagram Showing the Effect of Resistance and Reactance

of the current in cycles per second,  $C$  is the capacity of the condenser in farads, and  $\pi$  is the value, 3.1416.

The formula for inductive reactance is:

$$X_L = 2\pi fL$$

in which  $X_L$  is the inductive reactance in ohms,  $f$  is the frequency in cycles per second,  $L$  is the inductance in henrys, and  $\pi$  is the value, 3.1416.

**Impedance.** Impedance is the equivalent opposition to the flow of alternating current through a circuit, due to the effect of resistance and reactance. Its calculation is simplified because the natural phase angles due to capacitive or inductive reactance, as stated previously, are  $90^\circ$  in both instances. Thus, it is that the calculation of impedance is a geometrical function in which the

resistance constitutes one leg of a right-angled triangle, and the reactance constitutes the other leg, while the impedance is represented by the hypotenuse, as shown in Fig. 4.

It has been shown that the current and voltage are in phase when there is resistance in the circuit; that the current leads the voltage when capacity exists; and that the current lags the voltage when inductance exists. Hence, if we lay out a straight line, and indicate thereon the ohmic resistance, and consider that inductive reactance is positive reactance, placed above the base line, while capacitive reactance is negative reactance, placed below the base line, then the calculations can be visualized more readily.

*Calculation of Impedance.* First, let us consider a case of a circuit in which resistance and inductive reactance are present. The resistance, we shall say, is 100 ohms. The inductive reactance is 50 ohms. If we consider that one inch on the base line is 100 ohms, then the length of the base of the right-angled triangle (line  $AB$ ) is one inch, Fig. 4. On the same scale, the inductive reactance is represented by a one-half inch line ( $BC$ ) perpendicular to the base line. The impedance is represented by the hypotenuse ( $AC$ ). The phase angle, or the number of electrical degrees that the current lags the voltage is represented by the angle at  $A$ .

Since the square of the hypotenuse of a right-angled triangle is equal to the sum of the squares of the other two sides, we find the length of line  $AC$  by extracting the square root of 12,500 ( $100^2 + 50^2$ ), or 111.8 ohms. Thus, the impedance in a circuit which has 100 ohms resistance and 50 ohms inductive reactance is 111.8 ohms and the current will lag the voltage by 27 degrees. On the other hand, if the circuit has 100 ohms resistance and 50 ohms capacitive reactance, there will be 111.8 ohms impedance, but the current will lead the voltage 27 degrees.

The phase angle, 27 degrees, is obtained by a trigonometric operation. In a right-angled triangle, as illustrated in Fig. 4, the angle at  $A$  may be found by obtaining the value of its tangent and referring this value to a trigonometric table of tangents. The tangent of the angle at  $A$  is defined as the value of the opposite side divided by the adjacent side or  $\frac{CB}{AB}$ . Substituting values, tangent

$A = \frac{50}{100} = .5$ . Referring to a table of tangents the angle whose tangent is .5 is found to be approximately 27 degrees.

If the circuit contains resistance, inductance, and capacity, it is necessary first to find the difference between the inductive reactance and the capacitive reactance. If the circuit had 100 ohms resistance, and 50 ohms of inductive reactance and 50 ohms of capacitive reactance, the inductive and capacitive reactance would neutralize each other. The impedance would be 100 ohms (the same as the resistance) and the current and voltage would be in phase.

However, if the resistance is 100 ohms, the inductive reactance 50 ohms, and the capacitive reactance 25 ohms, the triangle is as

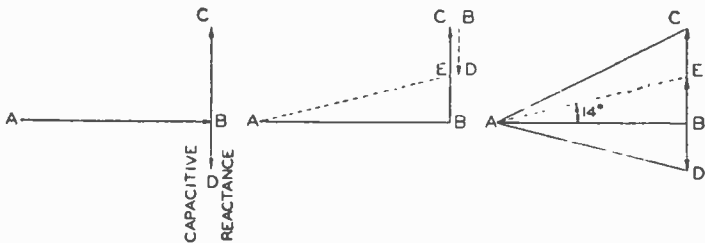

Fig. 5. Effect of Resistance, Reactance, and Capacity

shown in Fig. 5, line  $AB$  representing the resistance,  $BC$  the inductive reactance,  $BD$  the capacitive reactance.  $BE$  is the difference between the inductive reactance and the capacitive reactance. The dash line  $AE$  is the impedance, which, when calculated, is found to be 103 ohms, and the angle of lag will be approximately 14 degrees because the inductive reactance is greater than capacitive reactance. If, on the contrary, the value of the capacitive reactance shown in the illustration had been 50 ohms, and the value of the inductive reactance had been 25 ohms, the phase angle would have been that as shown, but the current would lead the voltage by about 14 degrees.

In calculating the impedance of a certain unit connected into an alternating-current circuit, it is necessary to know the ohmic resistance it represents as well as the inductance or capacity. Thus,

to calculate the impedance in a circuit containing a choke coil, it is necessary to find the resistance of the coil in ohms, measured on a bridge or with an ohmmeter, and to use this value together with any other value of resistance in the circuit.

**Inductance in an Alternating-Current Circuit.** If an alternating current is passed

through a coil, a varying electromagnetic field is set up around the coil, as shown in Fig. 6. The electromagnetic field not only varies by expanding and contracting with relation to the axis of the coil, but the lines of force change their direction in accordance with each reversal of direction

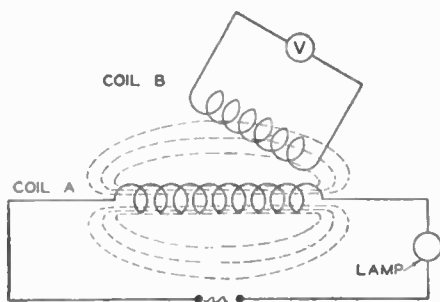

Fig. 6. Method of Exploring a Magnetic Field around a Coil

of current flow through the coil. If an experimental set-up is made, be sure that an incandescent lamp, or another current-consuming device is connected in series.

If another coil, *B*, is brought close to coil *A* and a measuring device is connected across its terminals, it will be found that a voltage is established in the circuit, of which coil *B* is a part, even though there is no physical connection with coil *A*. The secondary voltage—that in coil *B*—is known as induced voltage, and the transference of the energy is said to take place by induction. The coil through which the current is applied is always called the *primary*; that in which voltage is induced is called the *secondary*. Thus, in the illustration, coil *A* is the primary coil; coil *B* is the secondary coil. Similarly, the circuit of which coil *A* is a part is known as the primary circuit; that of which coil *B* is a part is known as the secondary circuit.

The phenomenon which has just been explained fundamentally is the basis of a very important electrical unit, so far as radio is concerned, the *transformer*. A transformer can be used in a circuit through which alternating current—or a varying current—is passing but cannot be adapted to a continuous direct-current circuit.



The amount of energy that may be transferred from the primary to the secondary circuit depends upon the relationship that exists between the coils. If coil *B* is moved around coil *A* (which is allowed to remain fixed), the measuring device will show that the voltage is greater or less according to the relative position of the two coils. For instance, if coil *B* is placed parallel with coil *A*, the magnetic lines of force along one side of coil *A* cut the windings of coil *B* and set up a voltage in the circuit. But, if coil *B* is placed some distance away from coil *A*, all of the lines of force around

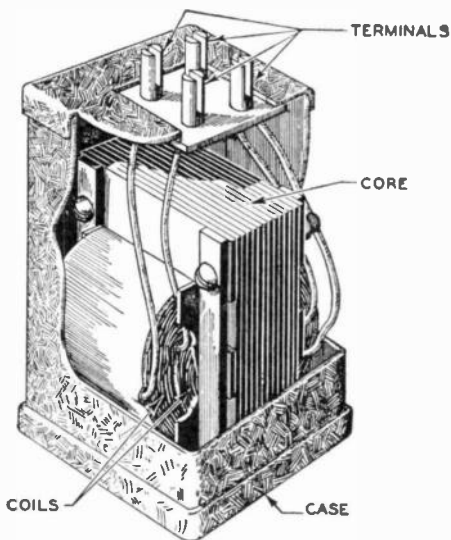

Fig. 7. Iron-Core Transformer

coil *A* do not cut the windings of coil *B*, and the voltage induced in the secondary circuit is very small. The combination of coil *A* and coil *B* is called a transformer, the purpose of which is to act as a means to transfer energy from one alternating-current circuit to another.

**Radio Transformers.** Transformers for use in a radio are of two types, known as *air-core transformers*, and *iron-core transformers*, Fig. 7. Air-core transformers are used in circuits through which high-frequency currents are flowing. Iron-core transformers are used in low-frequency circuits. An air-core transformer is, as

the name implies, one in which the windings are formed with a means of support that is non-magnetic. An iron-core transformer is one in which the windings are formed on a core that will increase the magnetic lines of force, and may be iron or silicon steel.

The voltage induced in the secondary coil of an iron-core transformer is dependent largely upon the ratio that exists between the turns of the secondary coil and the primary coil. If there are ten times as many turns in the secondary coil as in the primary, the voltage induced in the secondary coil is ten times that impressed upon the primary windings (theoretically speaking), due to the fact that the lines of force set up around the turns of the primary coil cut ten times as many turns in the secondary winding. If, however, the voltage induced in the secondary coil is greater than that impressed on the primary circuit, the current flow is decreased, since the power—watts of energy—drawn from the secondary cannot exceed the power that is consumed by the primary circuit. Thus, a transformer, having a step-up ratio of 1-10, and consuming 50 watts of energy on the primary side (100 volts at one-half ampere), will deliver .05 of an ampere at 1,000 volts, which, again, is 50 watts since  $\text{watts} = \text{volts} \times \text{amperes}$ .

The illustration given is for a hypothetical case in which conditions are ideal—one in which all of the lines of force set up around the primary windings cut all the turns of the secondary winding—one in which there are no losses of any kind. While such a condition meets the requirements for explanatory purposes, in practice it is found that correction must be made to compensate for losses sustained due to the fact that some of the lines of force cut only part of the windings in which voltage is being induced, some of them cut all of the windings, and some of them do not cut any windings. This type of loss is known as *flux leakage*. Also, in the case of transformers of the iron-core type there are losses caused by the generation of heat due to eddy currents in the laminations, and the inability of the core to respond to the rapid changes in magnetization.

There is no rule by which we may determine the extent of the losses, inasmuch as the physical characteristics of the materials and the design of the transformer are the principal factors. However,

in general practice, transformers are designed with the secondary windings placed over the primary windings in order that the maximum number of lines of force—flux—set up by the current flowing through the primary windings will cut the maximum number of turns of the secondary coil.

The voltage may be increased or decreased—stepped up or stepped down—by providing the proper number of turns on the secondary coil with respect to the number of turns in the primary winding. Also, a transformer may be designed with several secondary windings in which voltage will be induced by the lines of force set up by current flowing through a single primary winding, but the total power available—that is, the sum of the number of watts of energy drawn from all secondary windings—cannot be more than the power consumed by the primary winding of the transformer.

*Phase Relationship in Transformers.* The voltage in the secondary of a transformer is  $180^\circ$  out of phase with that in the primary winding. The current flow in the secondary sets up a magnetic field which at every instant opposes the magnetic field set up by the primary current.

*Effect of Pulsating Current.* Pulsating direct current—or pulsating current—is one which flows in the same direction through a circuit but whose amplitude rises and falls at intervals. In view of the fact that the electromagnetic field varies in accordance with the changes in current, pulsating direct current passing through the primary winding of a transformer will induce an alternating voltage in the secondary winding, which will have characteristics that vary according to the fluctuations in the primary circuit.

*Frequency of Induced Current.* The frequency of the induced voltage is always the same as that of the current in the primary circuit. For example, if 60-cycle alternating current is passed through the primary winding, the induced voltage in the secondary winding will be 60-cycle alternating voltage also. Similarly, if the primary current is 600-cycle alternating current, that in the secondary circuit will be 600-cycle alternating current.

## ELECTRICAL MEASURING INSTRUMENTS

---

The study of electrical circuits and the effects of electricity in motion requires an accurate quantitative measurement of potential, or voltage, and current strength, or amperage. It is understood that electricity must be in motion before you can measure its strength. A stationary charge of electricity, *i.e.*, a static charge, exhibits none of the characteristics of dynamic-current flow which enables its value to be measured.

It might be thought that the fundamental-measuring unit of electricity should be the electron, inasmuch as it is a basic particle of electricity. The electron is far too small to be of practical value and furthermore the electron may be in a state of rest insofar as a progressive movement along a conductor is concerned.

**Unit of Quantity.** The *coulomb* represents the nearest approach to a fundamental unit of electrical quantity. If electricity were of finite substance, a coulomb container would be similar to a gallon measuring jar for liquids. It would represent a definite quantity of electricity. However, electricity is a form of energy and instead of measuring its quantity it becomes necessary to measure its effect. In this respect it is similar to heat energy. We have no container which will hold a fixed amount of heat. When we wish to evaluate heat, it is necessary to refer to the effect of heat upon some finite substance.

The coulomb represents the sum total of all the electrical charges on  $6.28 \times 10^{18}$  electrons. Again this exceedingly large number of electrons takes the form of a stationary or static charge of electricity and is of little interest to us until we force this charge to move along a conductor.

A static charge of electricity is difficult to measure accurately. As such it shows an attraction for other unlike bodies, but the extent of this attraction must be mechanically measured in gram-centime-

ters which involves intricate apparatus for even approximate values. As the electricity is forced to move along a conductor, however, it produces various effects such as (a) it sets up a magnetic field around its conductor; (b) it produces heat; and (c) it causes chemical changes. The magnitude of any one of these effects may be used as a quantitative measure of the amount of current entering into the action.

By definition, the *ampere* is rated according to the chemical activity it causes; actually this method of measurement, while accurate is neither quick nor convenient. The ampere represents a flow of 1 coulomb past a given point in a circuit per second. This, of course, means that if the strength of current in a circuit is 1 ampere,  $6.28 \times 10^{18}$  electrons will pass a given point in the circuit each second. The magnetic effect of the current flow is a direct function of the current strength, hence, an evaluation of the magnetic field can be conveniently used to measure current flow. Measuring the heating effect has several advantages, but this type of measuring instrument is reserved for high-frequency measurement.

**Galvanometer.** The basic electrical-measuring instrument is

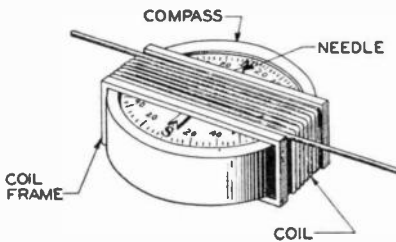

Fig. 1. A Tangent Galvanometer

the *galvanometer*. It represents a device which merely indicates the presence of dynamic electricity and does not give a quantitative value. Early experimenters used the muscular contraction of frogs' legs to tell of the presence of a current flow.

Possibly the first usable measuring instrument was the *tangent galvanometer*. It consisted of a loop or *coil* of wire with a magnetic *compass* placed within its field, Fig. 1. As current flowed through the coil the compass *needle* was deflected, the tangent of the angle of deflection being proportional to the strength of the current flow, hence the name, *tangent galvanometer*. This type of instrument had several disadvantages. One of these was the necessity of observing the proper original orientation to allow the com-

pass needle to point along the axis of the coil, also it is affected by external fields, and it lacks sensitivity. The tangent galvanometer has been supplemented by other more sensitive types.

**Voltmeter and Ammeter.** It has been stated that a galvanometer is the basic electrical instrument. A *voltmeter* is merely a galvanometer which has been calibrated to read electrical pressure and an *ammeter* is one which has been calibrated to indicate current strength.

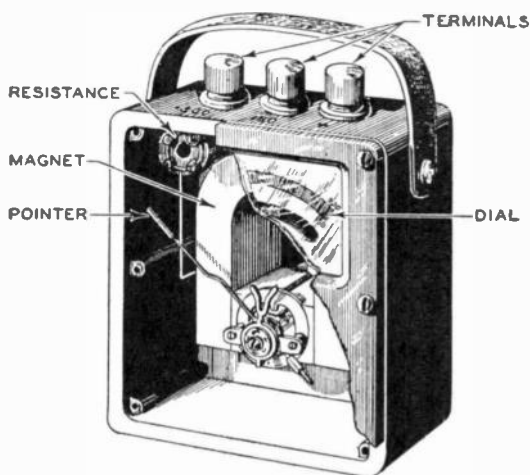

Fig. 2. Cutaway View of a Portable Type Direct-Current Voltmeter with Scales of 0 to 150 or 0 to 300 Volts

**D'Arsonval Type Meter.** Possibly the most extensively used type of meter movement for use in direct-current circuits is the moving coil or *D'Arsonval* movement. Fig. 2 illustrates the construction of this type of meter, and Fig. 3 shows an enlarged detail.

**Magnets.** One of the most important factors in a direct-current instrument is the *permanent magnet*. Upon the strength of this magnet depends the accuracy and sensitivity of the instrument. A great deal of study and research has been expended to develop magnets as used in present-day meters.

It has long been known that iron and steel are the most highly magnetic substances. The problem was to produce a magnet of

high strength and of uniform or permanent strength. Some materials retain magnetism better than others. The softer and purer a piece of iron, the greater the amount of magnetism which can be developed in it, but the shorter will be the time it will retain this magnetism after the magnetizing force is withdrawn. Cast iron and hard steel retain magnetism for a much longer time after the removal of the magnetizing force. This ability to retain magnetism is known as *retentivity*.

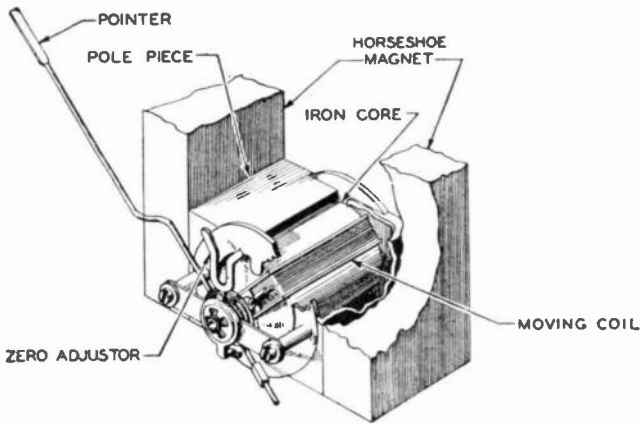

Fig. 3. Enlarged Detail of D'Arsonval-Meter Movement

*Aging of Magnets.* For the greatest sensitivity of the instrument the magnet should be as strong as possible. However, strength is not the only thing to be considered for it is well known that so-called permanent magnets gradually lose their strength, that is they *age*. The aging depends upon the quality of steel, the design of the magnetic circuit and upon the temperature variations and mechanical jarring to which the magnet is subjected. After a sufficiently long period of aging the magnet reaches a nearly permanent state. Sufficient natural aging would require that the magnets be magnetized and then stored for a long period of time which is an expensive process. Since any deterioration will influence the accuracy of the instrument, the magnets are aged by resorting to artificial means.

Artificial aging may be obtained by one of the following methods. After being fully magnetized the magnet may be heated

in a steam bath for four or five hours; partially demagnetized by passing alternating current through a coil surrounding the magnet, or by mechanically vibrating the magnet. Of these the alternating-current method is most used today.

Magnets for less expensive instruments are sometimes made of cast iron while higher-grade instruments use special magnet steel. The strength of aged cast-iron magnets is less than the strength of those of equal weight made of special magnet steel.

*Moving Coil.* The *moving coil* is made of a number of turns of insulated wire wound on a rectangular aluminum frame as shown in Fig. 4. Hardened steel pivots attached to the aluminum frame turn in jeweled bearings (glass or sapphire) to provide almost frictionless rotational movement of the moving coil. The coil is accurately pivoted in the space between the poles of a strong permanent magnet. Current is led to and from the coil by means of a top and bottom flat *spiral spring* as shown in Fig. 4. The springs are coiled in opposite directions so that as one spring winds tighter the other uncoils and the overall tension remains constant. When current flows through the moving coil, a magnetic field is set up about it which

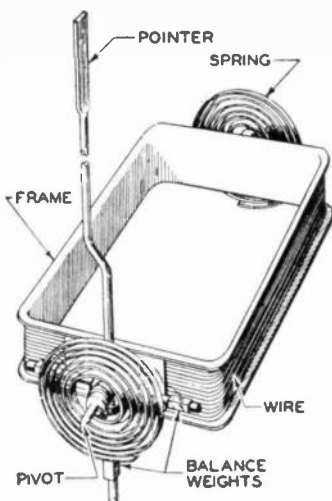

Fig. 4. Enlarged Detail of the Moving Coil of a D'Arsonval Instrument

opposes the field of the permanent magnet and causes a rotation of the coil. The coil will take up a position where the force due to the oppositional-magnetic fields is just equal to the force of the coiled springs in trying to return the coil to its original position. A *pointer* which may be a light aluminum tube or strip is fastened to the moving coil to indicate its deflection. This pointer moves over an indicating scale which is substantially uniform in its graduation because the electromagnetic field is practically proportional to the current strength in the moving coil.

*Damping.* If the moving coil (Fig. 4.) which is mounted on



jeweled bearings, starts to swing, it will continue swinging back and forth similar to a pendulum for some time unless it is in some way retarded or *damped*. One method of damping is to attach an air vane to the coil. This air vane is enclosed so that it swings in a restricted space and damps any swinging movement of the coil. The most satisfactory method is electrical damping. If the coil be wound on an aluminum bobbin, the motion of the bobbin through the magnetic field will induce magnetic currents within itself, and these will be in such a direction as to put an electric load on the moving coil. This opposes the motion of the coil and thus brings the pointer to rest at the value to be read .

An instrument for test work should be well damped but not over damped. The pointer of an over-damped meter is slow in reaching its position of rest, while the pointer of a properly damped instrument moves very quickly and comes to rest with only about two or three over swings. Not only does proper damping give faster readings, but these slight oscillating swings serve to assure the user of the instrument that there is no friction present.

## DIRECT-CURRENT INSTRUMENTS

From the foregoing we have learned that the deflection of a direct-current instrument is a measure of the current passing through it. The field of the moving coil tends to rotate the coil to include as much of the flux from the permanent magnet as possible. This motion is opposed by the phosphor-bronze springs.

A highly sensitive meter must have a moving coil system which is as light in weight as possible. To reduce the weight to a minimum, a relatively few turns of fine wire are used on the moving coil. This fine wire is not capable of carrying a great amount of current, therefore, the amount through the meter proper must be limited.

**Voltmeter.** A *voltmeter* is designed to measure the potential difference between two points in a circuit. In order to reduce the current through the meter to a safe value, a resistor or resistance, Fig. 2, is placed in series with the meter coil and the terminals. This resistor is termed a *multiplier*. Various multipliers may be used to change the meter scale as desired. Several multipliers may

be connected to a selector switch so that a multiple range instrument may be obtained.

In most radio circuits, the amount of current available is limited and the measuring equipment may impose a load on the source which actually reduces the voltage. As an example, a radio-power supply system using a conventional high-vacuum rectifier may have a voltage output of 300 volts when delivering a normal-load current of 50 milliamperes. Upon attempting to measure this voltage with a low-resistance voltmeter, which requires 15 milliamperes through its actuating or moving coil for full-scale deflection, the voltage indicated will be considerably less than the known value. The additional current drain imposed on the power supply by the meter, exceeded the amount which the source was capable of producing, hence a drop in voltage resulted. For this reason a voltmeter should be employed which requires as little current as possible for its operation.

*Sensitivity.* It is customary to rate the *sensitivity* of a meter in terms of the voltage drop across the moving coil necessary to bring about full-scale deflection.

Thus a meter which required a 50-millivolt drop for full-scale deflection would be referred to as having a 50-millivolt movement. If the resistance of the moving coil of the meter in question was 50 ohms, it would require a current strength of 1 milliampere, by Ohm's law, to produce the proper magnetic field to deflect the pointer completely across the scale. This consideration provided another method of rating meters as to their sensitivity.

*Applying Ohm's Law.* Let us assume that a meter requires a current strength of 1 milliampere for full-scale deflection. To convert this meter to a voltmeter, with a full-scale indication of 1 volt, it becomes necessary to limit the current through the meter to the 1 milliampere value previously given. This is done by the use of a *multiplier resistor*. The value of this resistor is obtained by Ohm's law:

$$R = \frac{E}{I} = \frac{1}{.001} = 1000 \text{ ohms}$$

If the scale required is 5 volts, application of the same formula would show a 5000-ohm multiplier necessary; for 100 volts

100,000 ohms would be required, and so on. A definite relation exists between the resistance of the multiplier and the voltage range desired. In the foregoing example the relation is obviously 1000 ohms per volt. Thus the sensitivity of the meter may be referred to as *1000 ohms per volt*. It must be remembered that the value of the resistance obtained by Ohm's law includes the ohmic resistance of the moving coil. For low-voltage ranges this is generally considered but for the higher values the moving-coil resistance becomes insignificant with respect to the multiplier value.

A 1-milliampere meter then becomes a 1000-ohm-per-volt voltmeter; one requiring only 50 microamperes (.00005 ampere) for full-scale deflection becomes a 20,000-ohm-per-volt device. As the sensitivity increases the meter construction becomes more exacting and the practical limit of sensitivity is reached when the moving system becomes too fragile for portable use.

A meter having a sensitivity of 1000 ohms per volt would not upset the voltage reading of the power-supply system used in the previous example. The supply delivering 50 milliamperes could furnish an additional milliampere without becoming unduly loaded. It must be remembered that regardless of the voltage being measured with this instrument the current through it must not exceed the one milliampere value given. A current flow in excess of this amount will drive the pointer off the scale and may otherwise damage the instrument.

**Ammeter.** The basic-measuring instrument may also be used to indicate any value of current strength by providing *shunts* of accurately determined values to be placed in parallel with the moving coil of the meter. An ammeter is placed in series with the circuit in which it is used. According to the law of parallel circuits, the current flow will divide in an inverse proportion to the resistance of the various parallel or shunt paths. Assume that our basic 1-milliampere meter having a coil resistance of 50 ohms is to be made into an instrument to indicate 2-milliamperes full-scale deflection. If this current were allowed to flow directly through the coil, the indicating pointer would be driven completely off scale. It therefore becomes necessary to allow only 1 milliampere to pass through the coil, the additional milliampere must be provided with

a path around the coil. A shunt of exactly the same value as the moving-coil resistance, *i.e.*, 50 ohms, will allow the passage of the additional milliampere, as shown in Fig. 5. Consequently the full-scale deflection of the meter *pointer* shows that 2 milliamperes of current are flowing through the circuit, although we know only a single milliampere is traversing the meter coil.

*Shunts.* By the use of various shunts the meter scale may be extended to any desired value, in fact, thousands of amperes may be inducted on the apparently delicate mechanism of our fundamental meter.

The method of operation of an ammeter may be compared to the use of a water-flow meter. Such a meter is used to determine the rate of flow of water in a confined circuit or in a river. To count each gallon of water passing a given point per second would be practically an impossibility. However, a small volume is deflected to the measuring circuit and the relation between the amount diverted and the main stream evaluated. A simple proportion then produces the desired value.

*Voltammeter.* Combination voltammeters are available in which shunts and multipliers are provided for several ranges of each function. Care must be exercised in using such an instrument to always connect the ammeter in series with the circuit under measurement and not across the line.

The foregoing meters are, as explained, for use in direct-current circuits only. The measurement of alternating voltage and current requires a structural change in the meter movement. An alternating voltage applied to the moving-coil type of meter would simply cause the pointer to vibrate around the zero point as the

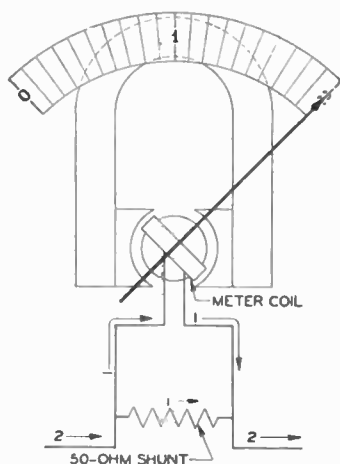

Fig. 5. Circuit Connections of Shunt and Moving Coil in an Ammeter

magnetic field of the coil would reverse with each change of direction of current flow.

### ALTERNATING-CURRENT INSTRUMENTS

**Ampere.** The value of an alternating current is not based on its average value but on its heating effect and may be defined as follows:

An *alternating-current ampere* is that current which, flowing through a given ohmic resistance, will produce heat at the same rate as a direct-current ampere.

Heating is proportional to the watts dissipated. Since the equation for watts is current squared (or times itself) multiplied by the resistance, the alternating-current ampere is proportional to the square of the current. An alternating-current meter must therefore have a deflection proportional to the current squared.

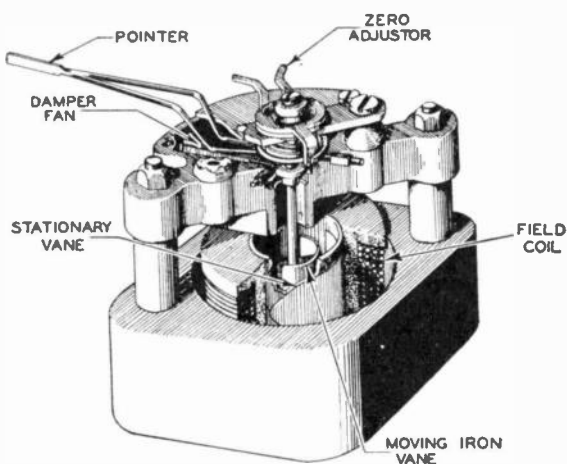

Fig. 6. Cutaway Interior View of a Moving-Vane Alternating-Current Instrument

**Moving-Vane Type.** Alternating-current meters for use in low-frequency circuits are either of the *moving vane* or *dynamometer type*. The *moving-vane* structure, Fig. 6, makes use of a circular coil having an air core with a pivoted vane of magnetic material placed in the field of the coil. As current is led through

the coil the resultant magnetic *field* attracts the soft-iron vane which has an indicating *pointer* attached. Regardless of the direction of current flow through the coil or the fact that the direction may be rapidly changing, the attraction will exist and a movement of the vane results in a movement of the pointer across the scale. *Damping* is usually accomplished by causing a flat piece of metal attached to the *moving vane* being forced to move in a restricted enclosure. The compression of the air in front of the flat piece of metal retards its motion to produce damping. This type of meter is not particularly sensitive and does not find extensive use in radio test circuits.

**Dynamometer.** The dynamometer type of instrument, Fig. 7, makes use of a fixed *field* and a movable *coil*, the current flowing through the two coils. The resulting magnetic fields react to cause a movement of the pivoted coil to which is attached the indicating

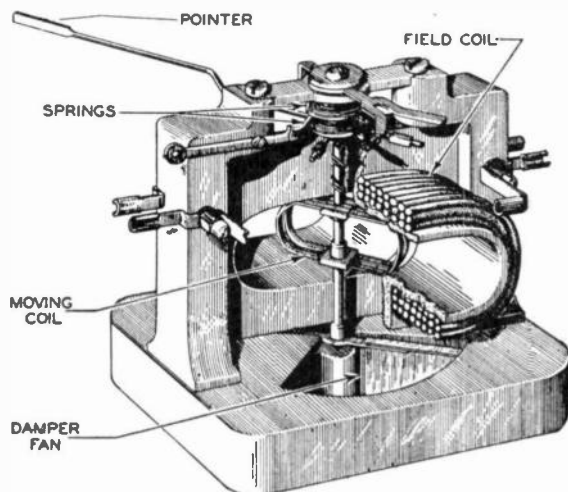

Fig. 7. Interior View of a Dynamometer Type Instrument

*pointer*. This type of instrument can be made more sensitive than the moving-vane type, but its use in radio circuits is limited by the fact that the coils possess a differing reactance to different frequencies, hence it can only be used at a fixed frequency without re-calibration.

Both the *moving-coil* and dynamometer-type instruments may be made to act as voltmeters or ammeters by proper design of multipliers and shunts. The dynamometer type, Fig. 7, is also used as a wattmeter, in which case the stationary or field coil is used as the current coil and the movable coil responds to potential differences. In alternating-current circuits the power indicated by such an instrument is the true power, phase relationship between current and voltage being taken into account by the fact that the pointer movement is a function of the average instantaneous values of current and voltage.

**Oxide Rectifier.** A type of instrument used for current and

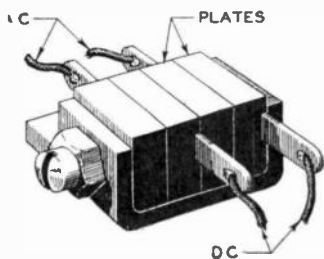

Fig. 8. Enlarged View of a Copper Oxide Rectifier Used with a D'Arsonval Instrument

voltage measurements at low and medium frequencies makes use of a copper-oxide full-wave rectifier, Fig. 8, connected to a standard direct-current D'Arsonval meter. This rectifier is connected in a bridge circuit and can be quite small physically because the current to be rectified never exceeds a few milliamperes. The scale of a rectifier-type multi-range voltmeter is fairly uniform except for the lowest range. Calibration at 60 cycles will be found to hold with reasonable accuracy, up to

several thousand cycles, in fact, till the capacity of the rectifier starts to by-pass the energy instead of bringing about rectification. This type of alternating-current instrument can be made with practically the same sensitivity as direct-current meters. Combination service instruments are available with an alternating-current rectifier voltmeter sensitivity of 2000 ohms per volt. Such an instrument may be used in the output of a radio receiver or amplifier for indicating output values in fidelity measurements. It may also be calibrated in decibels or transmission units for output measurements.

**Hot-Wire Type.** In the measurement of large amounts of radio-frequency energy two types of meters are encountered. The hot-wire meter makes use of the expansion of a piece of wire as current passes through it. The expansion effect is increased by a

mechanical arrangement which in turn drives the pointer across the scale. This type of meter is sluggish in action and is not particularly sensitive nor is it perfectly accurate. While quite popular for radio-frequency measurements some years ago, it is seldom found in present-day equipment.

**Thermocouple.** The thermocouple type of meter has supplanted the hot-wire type for radio-frequency measurements. In construction, the thermocouple meter consists of the *thermojunction* connected to a sensitive direct-current meter movement having a *moving coil*. The theory of the generation of an electromotive force by contact of dissimilar metals is made use of in the thermojunction.

Two dissimilar metals, such as bismuth and antimony, are welded together. The current to be measured passes through the *heater coil* which heats this junction at the point of contact of the two metals. This generates an electromotive force which is led to the direct-current meter.

The electromotive force produced is proportional to the heat generated. The thermocouple is frequently enclosed in an evacuated *glass bulb*, Fig. 9, to prevent errors due to external temperature effects.

A *thermocouple meter* is most frequently used as a current-indicating device. These current meters are available in sizes from a few milliamperes to many amperes. They are used in antenna circuits of transmitters to show radiation current and are also used in wavemeters and neutralizing circuits.

**Ohmmeter.** A useful device for determining quickly the value of a resistor in a radio circuit is called an *ohmmeter*. Although the scale may be calibrated in ohms, the measurement as actually made is a ratio of voltage drops. In simple form the ohmmeter consists of a sensitive direct-current meter in series with a source of electromotive force and the proper multiplier resistor. The resistor is generally made in two sections, one of which is variable

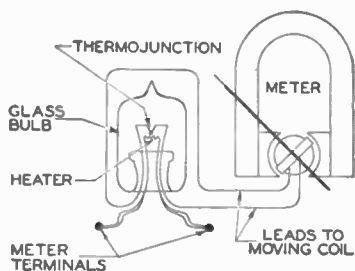

Fig. 9. This Diagram Shows Connections of a Thermocouple-Type Meter



to compensate for decreasing terminal voltage as the battery is used. As a practical example, suppose the basic meter has a 1-milliampere movement with a resistance of 50 ohms. A  $4\frac{1}{2}$  volt C battery is to be used as a source of potential. In order to limit the current through the meter to 1 milliampere the circuit resistance will have to be:

$$R = \frac{E}{I} = \frac{4.5}{.001} = 4500 \text{ ohms}$$

Of this value, 2,000 ohms may be in the form of a fixed resistor while a 3000-ohm variable rheostat will allow compensation of a higher battery voltage as well as

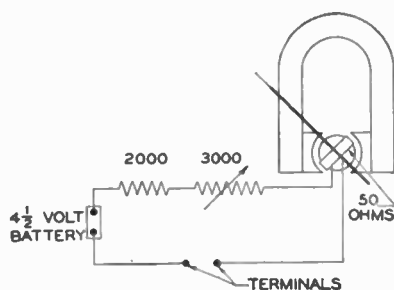

Fig. 10. Circuit Diagram of an Ohmmeter

the dropping voltage encountered during use. It must be remembered that the total 4500-ohm resistance which includes the 50-ohm coil resistance must be placed in series with the 4.5-volt source as shown in Fig. 10. Closing the series circuit (joining the terminals together) will permit 1 milliampere of current to flow and the pointer of the

meter will show a full-scale deflection. This is the *zero* mark on the ohmmeter scale. If the circuit is opened and another 4500 ohms of resistance are inserted in series with that already in the circuit, by connecting it to the *terminals*, Fig. 10, the meter pointer will indicate only a half milliampere or a half-scale deflection. Thus the mid-scale point may be termed the *4500-ohm* mark and a suitable notation made of this value. Other points may likewise be obtained until the calibration is complete. It is convenient to connect test leads to an open point in the circuit of the ohmmeter (terminals in Fig. 10) to allow measurements to be made external to the circuit proper. It will be noted that in this ohmmeter circuit a resistor of zero resistance connected in the external circuit will drive the pointer of the meter completely across the scale to its maximum reading, while an infinitely high resistance (an open circuit) will leave the pointer

at its left-hand zero position. Thus the ohmmeter scale is a reversed one, the low-resistance values being on the right-hand side while the high values are on the left. The variable resistor is used to zero adjust, *i.e.*, the test prods connected to the terminals, Fig. 10, are shorted together and an adjustment made to make the meter pointer line up exactly with the zero-ohms line on the right-hand side of the meter scale.

Various modifications of the foregoing simple ohmmeter instrument may be made. Higher voltages produce higher-resistance ranges; shunt circuits make possible the accurate measurement of lower values of resistance; combination series and shunt circuits produce a higher degree of accuracy. The instrument is extremely valuable for the rapid determination of resistance values with an accuracy of possibly 5 to 10 per cent, which is ample for general-testing purposes. Where a higher degree of accuracy is necessary, bridge circuits are used.

**Volt-Ohm-Milliammeter.** A valuable radio-service instrument combines the three instruments, most frequently used, in a

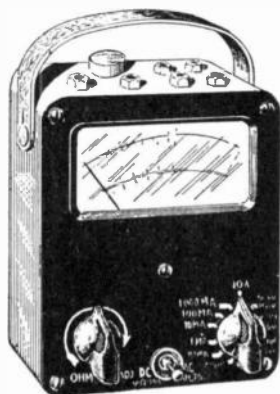

Fig. 11. Volt-Ohm-Milliammeter Radio-Service Instrument. Three Instruments Combined in One Meter

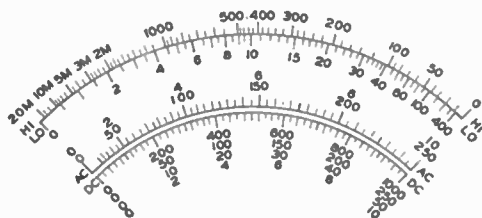

Fig. 12. Scale of Combined Meter

single meter movement housed in a convenient case with selector switches for obtaining the instrument desired, Fig. 11. This device is the volt-ohm-milliammeter, abbreviated VOM. Several alternating-current and direct-current voltage ranges are provided,

direct-current milliamperere ranges are available and in some instruments alternating-current milliamperes may also be read, as shown on the scale, Fig. 12. At least two- and possibly four-ohmmeter ranges are obtainable, allowing the reading of resistors from a few tenths of an ohm to millions of ohms. A device of this type invariably uses a rectifier type of alternating-current instrument to provide a good degree of sensitivity.

**Oscilloscope.** The study of wave forms and shapes cannot be obtained with the conventional type of indicating instruments.

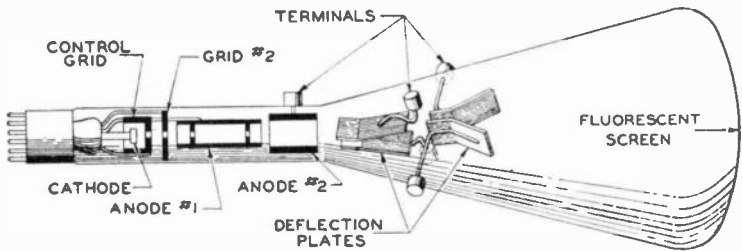

Fig. 13. Cathode-Ray Tube of an Oscilloscope

A special instrument has been developed for this purpose called the *cathode-ray oscilloscope*. The oscilloscope may be considered a type of indicating meter and in fact it lends itself to both voltage and current measurements. The heart of the oscilloscope is the *cathode-ray tube*, one type of which is illustrated in Fig. 13. Electrons emitted by the heated cathode are projected through a small aperture in the *control grid*. The control grid is kept at a negative potential with respect to the cathode and the adjustment of this negative potential determines the density of the electron stream projected toward the screen. This control is marked *Intensity* on the operating panel. After passing the control grid the electrons come under the influence of a screen grid which narrows the beam and accelerates the electrons toward the anodes. Anode No. 1 is a medium-voltage anode, while Anode No. 2 has the full positive voltage from the power source applied. The stream of electrons which now has the form of a narrow beam, the individual electrons of which are traveling at high velocities, pass through the horizontal

and vertical deflecting plates, finally to arrive at the fluorescent screen where the impinging electrons give off light impulses.

Alternating voltages applied to the deflecting plates will cause the electron beam to trace a path on the screen in accordance with the successive instantaneous values of applied voltage. Thus it is possible to investigate complex wave shapes which would otherwise be impossible or difficult to view.

The cathode-ray tube is made in a variety of sizes, the smallest having a 1-inch screen while the largest for general oscilloscopic use has a 9-inch screen.

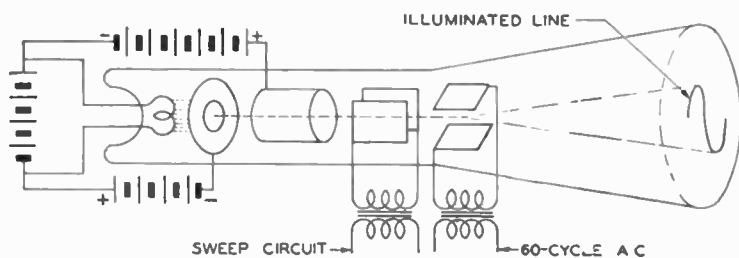

Fig. 14. Sweep Circuit Used to Produce Pattern on Fluorescent Screen

Magnetic fields as well as electrostatic charges may be used for deflecting the electron beam. With magnetic-electrostatic deflection, coils are used to provide the magnetic fields.

In order to provide a linear-time axis to drive the electron beam across the screen of the tube at a uniform rate, a sweep circuit, Fig. 14, using a gaseous triode must be provided. The output wave shape of the sweep circuit has a saw-tooth form which forces the beam from left to right at a uniform rate and then returns it so quickly that the screen-return trace is obliterated. When the frequency of the sweep circuit is a small whole-number ratio of the wave form being investigated, a stationary pattern is obtained upon the screen which allows detailed study. A small portion of the voltage of the wave being investigated may be led to the gaseous-discharge tube to lock the sweep frequency to the frequency of the investigated wave. Slight changes in frequency are then possible while retaining the stationary pattern.

The oscilloscope is used for studying distortion characteristics

of amplifiers, for lining up radio- and intermediate-frequency circuits, for modulation studies and in fact for all purposes where a substantially inertialess indicator must follow rapid impulse changes.

**Vacuum-Tube Voltmeter.** The vacuum-tube voltmeter is an instrument of considerable utility where the use of an ordinary type of voltmeter would result in a change of the characteristics of the circuit under measurement. Practically all meters of this type operate on the same principle—a vacuum tube with its high-impedance input circuit is used to isolate the circuit from the measuring equipment. The tube may then rectify the voltage to be measured or bring about a change in the average value of current flowing through a sensitive indicating meter. Calibration at easily obtained frequencies will be found to be accurate to extremely high frequencies, making the device invaluable for the quantitative measurement of high-frequency receiver and transmitter voltages. Capacitance in the input circuit must be kept at a minimum, hence, the isolating tube is often placed in a probe which is applied directly to the point under measurement. Amplification may be employed to extend the range of a vacuum-tube voltmeter to almost unbelievable limits.

## INDUCTANCE AND ELECTROMOTIVE FORCE

---

The ability of a circuit to cause the generation of an electromotive force in that circuit or one nearby is *electromagnetic induction*. It is effective only when there is an increase or decrease in the flow of electric current (and the attending rise or fall of the electromagnetic field) through the circuit.

It has been shown (Lenz's law) that a magnetic field is produced around a conductor through which an electric current is flowing, and that if the current varies, the magnetic field varies (rises or falls) correspondingly. The varying magnetic field acts to create an induced electromotive force or voltage which always opposes the change which produced it.

**Self-Inductance.** It has also been shown that if a conductor is turned back upon itself, the electromagnetic field surrounding the conductor is confined within a small area, and that the lines of force surrounding the conductor, moving in and out from the conductor, cut the conductor as they rise and again as they fall. Thus when current of a fluctuating nature is flowing through the conductor which has been wound in coil form, a secondary electromotive force or voltage is generated in the circuit, which phenomenon is due to *self-inductance*. The voltage thus induced by the current flowing through the conductor is called *counter-electromotive force*, because it tends to oppose the flow of the current that produces the magnetic field.

**Inductance Coils.** When a conductor is turned back upon itself a number of times, it is formed into what is known as a *coil*, otherwise referred to as an *inductance* or an *inductor*. Coils, in general, consist of a number of turns of insulated wire wound upon a suitable supporting structure. Fig. 1 illustrates a self-supporting space-wound coil. Such coils are used in high-frequency circuits. A coil may also be made by placing the wire haphazardly

upon a spool, much as the thread is wound upon the shuttle of a sewing machine. Inductances used in present-day receivers are quite compact. They are generally of the *universal type*, *i.e.*, the wire is woven back and forth over the length of the winding form, as shown in Fig. 2. This produces a high-inductance value with low-distributed capacity and reduced resistance.

Regardless of the form into which a coil is wound, the principle of its function is the same—the conductor, turned back upon itself, provides a means to generate an electromotive force in the circuit of which it is a part, or in a nearby circuit. This EMF of self-induction opposes the applied voltage at every instant.

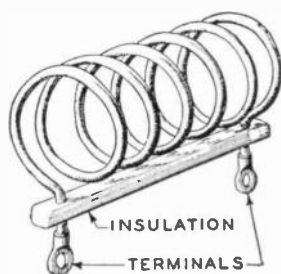

Fig. 1.

High-Frequency Inductance Coil



Fig. 2.

Universal-Type Coil

The induced electromotive force generated by an electric current flowing through the turns of a coil, tends to prevent the applied current from undergoing variations. For instance, the induced voltage may prevent the applied current from increasing, even though it may have a tendency to do so. On the other hand, the induced voltage may prevent a decrease in the applied current flowing through the circuit.

An interesting experiment to illustrate the presence of counter-electromotive force in a coil is shown in Fig. 3. If the switch, *S*, is closed, current supplied by the *battery* will flow through the *coil*, and also through the *voltmeter*, which will indicate the voltage across the terminals of the coil, *A* and *B*. However, when the switch is opened, the pointer on the voltmeter will be deflected in the direction opposite that which indicated the voltage across the terminals of the coil when the switch was closed. This will demon-

strate that when the current flowed through the turns of the coil, it set up an electromagnetic field, which, owing to the fact that the current flowed in the same direction (it did not flow in first one direction and then the other, or fluctuate), remained constant until the switch was opened, when the lines of force, in collapsing, created a secondary voltage opposite to that of the applied voltage.

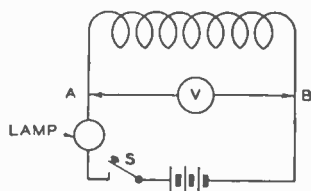

Fig. 3. Experiment Illustrating Counter-Electromotive Force

The voltage thus generated in a circuit such as used in the experiment is momentary, and the pointer will again come to rest at its zero position.

**Henry—Unit of Inductance.** The unit of inductance is the *henry*, which is the inductance producing an electromotive force of one volt in a circuit when the current is changing its flow at the rate of one ampere per second. The henry is a comparatively large value, however, and is found in those parts of radio circuits which have to do with providing power for the operation of the receiver. The *millihenry* is one-thousandth ( $\frac{1}{1000}$ ) of a henry. A *microhenry* is one-thousandth of a millihenry.

**Radio-Frequency Choke Coils.** Inductances of many forms are found in radio circuits. A tuned circuit, *i.e.*, one resonant to a given frequency, makes use of an inductance in conjunction with a condenser to obtain the desired effect. If the desired frequency lies in the radio-frequency portion of the spectrum the inductance will take the form of an *air-core coil* while for the lower frequencies the coil will have an *iron core*.

*Radio-frequency choke coils* are inductances which are designed to prevent radio-frequency energy from entering a circuit where it might cause a harmful effect.



The power transformer in a receiver designed for alternating-current operation uses iron-core inductances for the primary and secondary circuits. These inductances differ from the radio-frequency inductances only in the magnitude of values.

**Calculation of Inductances.** It is difficult to make accurate calculations of inductance, and formulas developed to determine it are only approximate. Furthermore, it would not be feasible to attempt to discuss here the calculation of inductance of all forms of coils, inasmuch as to do so would involve the introduction of lengthy mathematical formulas found in treatises on radio engineering.

**Formula for Air-Core Solenoid.** The inductance of a solenoid coil in microhenrys may be calculated, with fair accuracy, however, by the use of the following formula:

$$L = \frac{.03948 a^2 n^2}{b} \times K$$

where  $L$  = inductance in microhenrys

$n$  = number of turns in the winding

$a$  = radius of coil in centimeters (measured from axis of coil to center of wire)

$b$  = length of coil in centimeters

$K$  = constant (for value of  $K$  see Table I—function of  $\frac{2a}{b}$ )

(1 inch = 2.54 centimeters)

Applying the formula, let us assume a coil of 50 turns on a form that is 5 centimeters in diameter and that the length of the coil is 10 centimeters. To find the inductance:

$$L = \frac{.03948 \times (2.5 \times 2.5) \times (50 \times 50)}{10} \times K$$

Since the coil is 5 centimeters in diameter, and the formula specifies the radius, we divide the diameter by 2 to obtain the value for  $a$  in the formula. To determine the value for  $K$  it is necessary to calculate the fraction  $\frac{2a}{b}$ , which, in the example given, is

$$\frac{2 \times 2.5}{10} = \frac{5}{10} = .50. \text{ Now referring to Table I which gives the}$$

TABLE I  
VALUES FOR CALCULATING THE INDUCTANCE OF A SINGLE-LAYER  
COIL OR SOLENOID

Diameter	K	Diameter	K	Diameter	K
Length		Length		Length	
$\frac{2a}{b}$		$\frac{2a}{b}$		$\frac{2a}{b}$	
0.00	1.0000	2.00	0.5255	7.00	0.2584
.05	.9791	2.10	.5137	7.20	.2537
.10	.9588	2.20	.5025	7.40	.2491
.15	.9391	2.30	.4918	7.60	.2448
.20	.9201	2.40	.4816	7.80	.2406
0.25	0.9016	2.50	0.4719	8.00	0.2366
.30	.8838	2.60	.4626	8.50	.2272
.35	.8665	2.70	.4537	9.00	.2185
.40	.8499	2.80	.4452	9.50	.2106
.45	.8337	2.90	.4370	10.00	.2033
0.50	0.8181	3.00	0.4292	10.0	0.2033
.55	.8031	3.10	.4217	11.0	.1903
.60	.7885	3.20	.4145	12.0	.1790
.65	.7745	3.30	.4075	13.0	.1692
.70	.7609	3.40	.4008	14.0	.1605
0.75	0.7478	3.50	0.3944	15.0	0.1527
.80	.7351	3.60	.3882	16.0	.1457
.85	.7228	3.70	.3822	17.0	.1394
.90	.7110	3.80	.3764	18.0	.1336
.95	.6995	3.90	.3708	19.0	.1284
1.00	0.6884	4.00	0.3654	20.0	0.1236
1.05	.6777	4.10	.3602	22.0	.1151
1.10	.6673	4.20	.3551	24.0	.1078
1.15	.6573	4.30	.3502	26.0	.1015
1.20	.6475	4.40	.3455	28.0	.0959
1.25	0.6381	4.50	0.3409	20.0	0.0910
1.30	.6290	4.60	.3364	35.0	.0808
1.35	.6201	4.70	.3321	40.0	.0728
1.40	.6115	4.80	.3279	45.0	.0664
1.45	.6031	4.90	.3238	50.0	.0611
1.50	0.5950	5.00	0.3198	60.0	0.0528
1.55	.5871	5.20	.3122	70.0	.0467
1.60	.5795	5.40	.3050	80.0	.0419
1.65	.5721	5.60	.2981	90.0	.0381
1.70	.5649	5.80	.2916	100.0	.0350
1.75	0.5579	6.00	0.2854	.....	.....
1.80	.5511	6.20	.2795	.....	.....
1.85	.5444	6.40	.2739	.....	.....
1.90	.5379	6.60	.2685	.....	.....
1.95	.5316	6.80	.2633	.....	.....

values for  $K$ , we find in the column under  $K$  and directly opposite .50, the value .8181, which is the numerical value to be substituted for the letter  $K$  in the formula. Hence, we have:

$$\begin{aligned} L &= \frac{.03948 \times (2.5 \times 2.5) (50 \times 50)}{10} \times .8181 \\ &= \frac{.03948 \times 6.25 \times 2500}{10} \times .8181 \\ &= \frac{616.875}{10} \times .8181 \\ &= 61.6875 \times .8181 \\ &= 50.47 \text{ microhenrys} \end{aligned}$$

If in the calculation of the shape ratio—diameter to length,  $\frac{2a}{b}$ —the value is between those given in Table I, it will be necessary to approximate the values. For example, assume that the value is .52, for which there is no value listed for  $K$ . Reference to Table I shows that for .50 the value is .8181 and for .55 it is .8031. The difference in these values of  $K$  is .0150. It is necessary to divide the value .0150 by 5 in order to find the difference between .50 and .51, .51 and .52, etc. Thus  $.0150 \div 5 = .0030$ , and the value of  $K$  will be lowered in steps of .0030. Since we are to consider the ratio of .52, the value for  $K$  will be .8181 minus  $2 \times .0030$  or .8121. This value is only approximate, but, as previously stated, all calculations of inductance are approximations, and the slight discrepancy is negligible.

*Air-Core Solenoid.* The foregoing calculation is for an *air-core solenoid*, that is, one which is wound upon a supporting structure that does not affect the magnetic field. The self-inductance of a coil will be increased greatly if metal is introduced in the windings of the coil to form what is called an *iron-core inductance*. Such a device is treated separately.

## INDUCTANCE IN CIRCUITS

Inductances may be connected in series, in parallel, or in series-parallel, in exactly the same manner as condensers and re-

sistors. The value of the inductance of a circuit is determined for the entire circuit of which it is a part—a circuit is said to have a certain amount of inductance, or there are  $x$  henrys (millihenrys or microhenrys) of inductance in the circuit.

**Coils Connected in Series.** Inasmuch as inductance constitutes a means to oppose the flow of electric current, it is evident that in many respects it may be treated in the same manner as a resistance. Hence, when inductances are connected in series, the total inductance in the circuit is obtained by adding the inductance values of each of the units so connected. Thus, in Fig. 4, the three inductances having values of 50 millihenrys, 12 millihenrys, and

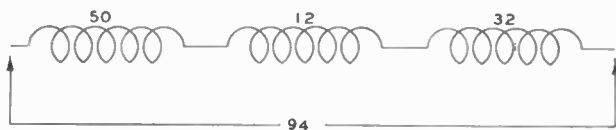

Fig. 4. Inductance Coils Connected in Series

32 millihenrys will give an equivalent inductance of 94 millihenrys in the circuit.

**Coils Connected in Parallel.** Inductances connected in parallel constitute as many paths for the flow of electric current, but since they serve to retard the flow of the current in exactly the same manner as though resistors were used, the equivalent inductance in a circuit containing inductances in parallel is based upon conductance, which has been discussed. The following formula is used to determine the equivalent inductance of a network of inductances in parallel:

$$\frac{1}{L} = \frac{1}{L_a} + \frac{1}{L_b} + \frac{1}{L_c} + \frac{1}{L_d} + \frac{1}{L_e} + \dots, \text{ etc.}$$

The equivalent inductance is  $L$ , and  $L_a$ ,  $L_b$ ,  $L_c$ ,  $L_d$ , and  $L_e$  represent the inductance of each of the inductances connected in parallel. Thus, if in Fig. 5, which shows inductances in parallel,  $L_a$  is 10 microhenrys, and  $L_b$  is 20 microhenrys,  $L_c$  is 25 microhenrys,  $L_d$  is 50 microhenrys, and  $L_e$  is 5 microhenrys.

$$\frac{1}{L} = \frac{1}{10} + \frac{1}{20} + \frac{1}{25} + \frac{1}{50} + \frac{1}{5}$$

The least common multiple is 100

$$= \frac{10}{100} + \frac{5}{100} + \frac{4}{100} + \frac{2}{100} + \frac{20}{100}$$

$$= \frac{41}{100} = .41$$

Hence,  $.41L = 1$

$L = 2.44$  microhenrys, the equivalent inductance

It was shown under the heading "Resistances in Parallel" that if the resistances are all of equal value, the equivalent resistance is found

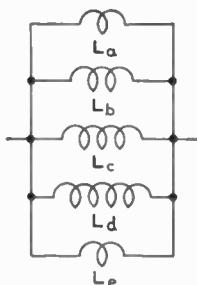

Fig. 5. Inductance Coils Connected in Parallel

by dividing the value of the resistance by the number of resistance units connected in parallel. Similarly, if all the inductances connected in parallel are of equal value, the equivalent inductance is

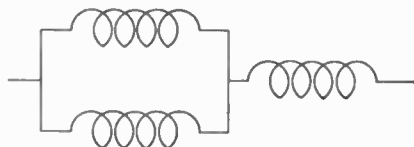

Fig. 6. Inductance Coils Connected in Series-Parallel

obtained by dividing the value of one unit by the number of inductances in the parallel network. The equivalent inductance of a parallel network is always less than the inductance of any individual inductance in the parallel circuit.

**Coils Connected in Series-Parallel.** When inductances are connected in series-parallel as shown in Fig. 6, the equivalent inductance is obtained by finding first the equivalent inductance of each parallel network, and then adding the values together as for a series circuit.

## CHOKE COILS

**Air-Core Coil.** The foregoing discussion of the subject of inductance considered inductance units known as the *air-core* type, that is, the wire was turned back upon itself on a supporting structure consisting of an insulating material, or the coils were made to be self-supporting. Such coils have a definite use in radio design and operation, but there is also the coil that is wound upon a core of iron or steel, called the *iron-core* inductance coil.

**Iron-Core Coil.** The iron core used in the iron-core inductance coils varies considerably in shape and design. First of all,

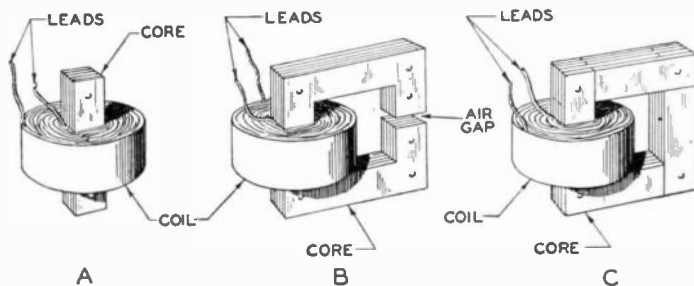

Fig. 7. Construction of Iron-Core Inductance or Choke Coil

there is the straight iron bar, as in *A* of Fig. 7, or, the bar may be bent in the shape of the letter *C*, as in *B* of Fig. 7. Again, the core may be closed entirely, as in *C* of Fig. 7. The iron core may be a solid bar of iron or steel, but it is usually constructed of a number of thin pieces of iron or steel, each of which is called a *lamination*.

**Laminated Core.** A core constructed of thin sheets of metal is known as a *laminated core*.

**Open-Core and Closed-Core Types.** Generally speaking, there are two types of iron-core inductances, the *open-core* type, and the

*closed-core* type. An open-core inductance is one in which the ends of the core are not joined together to form a complete path for the flow of magnetic flux. A closed-core inductance is one in which the ends are joined so that continuous path is provided for the flow of magnetic flux. The space between the ends of the open-type core is called the *air gap*, across which the magnetic flux will flow, but not so readily as through the metal that forms the major portion of the core. The purpose of the air gap is to create stability in the action of the iron-core inductance, and to insure greater uniformity of characteristics, regardless of variations in voltage, current, and frequency, as is shown in another chapter of this book.

**Eddy Currents.** Most iron-core inductance units employ laminated cores. These consist of several thin sheets of steel or iron. The reason for constructing the core as described is to minimize losses due to *eddy currents*.

If an iron bar is placed inside the windings of a solenoid through which an electric current having fluctuating characteristics is flowing, the magnetic lines of force pass through it longitudinally. Their flow creates a current that travels at right angles to the flow of flux—cross-sectionally—the current being called an *eddy current*. The cross-sectional current has the property of opposing the flow of the magnetic flux, and thereby causing lower efficiency—eddy-current losses.

By building an iron core of several pieces of thin steel, each of which is coated with an insulating compound—an oxide, shellac, or insulating varnish—the path for eddy currents is greatly reduced, and the losses are minimized. It can be seen readily that if there are two iron cores, one of solid steel, the other fabricated of several thin sheets, their length and width being equal, the longitudinal path for the flow of magnetic flux would be the same, but the path for the flow of eddy currents (currents perpendicular to the flow of the magnetic flux) would be reduced materially in the fabricated core, so much so as to render them practically negligible. Eddy currents produce heat, and since a solid-steel core provides a greater path for the flow of eddy currents, an inductance having a solid core will become much hotter than one of the same size

made up of laminations, both inductances being operated under identical voltage and current conditions.

**Iron-Core Inductance Calculations.** The self-inductance of a coil having an iron core depends upon what is known as the *permeability* of the core—the measure of the ability of the metal to carry the magnetic lines of force—the number of turns of wire, the area of the core, and the size of the air gap. Permeability, as applied in inductance calculations, is a ratio of the number of lines of force conducted by the material, to the number of lines of force that will pass through air under identical circuit conditions as to current flowing and voltage impressed. The permeability of air is 1. If, in the experimental set-up shown in Fig. 3, a small nail were inserted into the coil, the deflection of the voltmeter pointer when the switch is opened and closed, would be found to be much greater than if the nail were not present. Similarly, if a larger piece of soft iron were inserted, the deflection would be found to be still greater. This result is due to the ability of the iron to conduct the lines of force with greater facility than the air conducts them. Silicon steel is a commonly used core material, and operates at a flux density of about 20,000 lines of force per inch.

Generally speaking, the inductance of an iron-core coil may be determined by the following formula:

$$L = 0.4\pi n^2 \times \frac{\mu A}{l} \times 10^{-2}$$

where  $L$  = inductance in microhenrys

$n$  = number of turns of winding

$A$  = cross-sectional area of core in square centimeters

$\mu$  = effective permeability of core material

$l$  = length of magnetic path in centimeters

Thus the inductance of a coil of 100 turns wound on a silicon-steel core of 6 square centimeters cross-sectional area, a length of 30 centimeters and a permeability of 725 is found by substitution in the formula as follows:

$$\begin{aligned} L &= 0.4\pi(100)^2 \times \frac{725 \times 6}{30} \times 10^{-2} \\ &= 18221 \text{ microhenrys} \\ &= .018221 \text{ henrys} \end{aligned}$$



The use of the foregoing formula assumes that the magnetic circuit is entirely through silicon steel and that no air gap is included in the circuit. An additional factor,  $K$ , is used in the formula as a *stacking factor* which has a maximum value of 1 when no gap is included.

The permeability,  $\mu$ , varies with the flux density and must be determined for each condition of use. Approximate values may be obtained from handbooks dealing with magnetic-core materials.

## CONDENSERS AND CAPACITANCE

---

The device known as a *condenser* consists of two conducting plates separated by an insulating material called a *dielectric*. A condenser is capable of storing electrical energy, that is, it will receive and hold a charge of electricity until it is released. The property of two electrical conductors, separated by a dielectric, to receive and retain electrical charges is known as *capacity*. In other words, capacity is the electrical size of a condenser. In a given circuit, *capacitance* depends upon the dimensions of the conductors and upon the nature and dimensions of the dielectric.

The dielectric material used in condensers may be any sort of electrical insulator, but usually it is paper, mica, glass, air, or oil; or, in the case of electrolytic condensers, a film of gas. The dielectric must have the ability to insulate the plates from each other, and to withstand the potential difference that exists between them.

**Leyden Jar.** A convenient form of condenser for experimental purposes can be constructed with a fruit jar and enough foil—tin, lead, or aluminum—to cover half or more of the inner and outer surfaces of the glass. Such a device is known as a *Leyden jar*, Fig. 1. The pieces of foil constitute the *plates* of the condenser; the glass serves as the dielectric. A strip of conducting material—it may be a piece of the foil—should be joined to the plate on the inside of the jar and brought out at the top as a terminal.

If the terminals of the Leyden jar are connected to a source of electric energy such as a battery, the inside of the jar connected to the positive terminal of the battery, and the outer foil to the negative battery terminal, the inner foil will become charged positively, and the outer foil will be charged negatively. However, if a current indicating meter—an ammeter—is placed in the circuit, it will be found that the current will flow for only an instant and that the pointer will then come to rest at zero, showing there is no current flow. Since there is no connection between the two pieces

of foil, there is not a continuous path over which the current can pass, so that the ammeter will indicate a flow of current only during the time required to charge the plates. Having thus charged the plates of the Leyden jar, the connections to the battery may be removed. If a conductor is now touched to the outer foil of the jar, and then brought up slowly toward the conductor that is connected to the inner foil, a spark will *jump* across the gap, when the terminal to the inner plate is touched, showing that the charge has

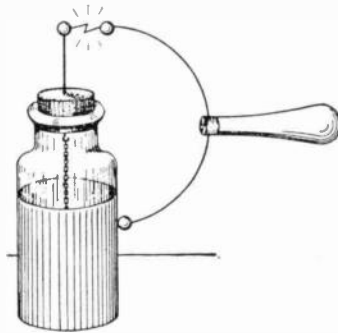

Fig. 1. Discharging Leyden Jar

been dissipated. Thus, charging the plates of the jar created a potential difference, which was neutralized when the conductor connected the two pieces of foil, and provided a path for the charge to follow.

The charging of the plates of the Leyden jar results from a flow of electrons: the negative electrons leave one plate, which then becomes charged positively, and settle on the other plate, which becomes negatively charged because of the excessive number of electrons on it.

The Leyden jar is an experimental device which lends itself to numerous interesting investigations of the phenomena of this electrical function.

**Dielectric Materials.** Condensers for radio use are designed according to the purpose they are to serve. The selection of the dielectric material depends upon many factors, such as the differ-

ence in potential that will exist between the plates, space limitations, and other factors.

Of all the dielectric materials available, paper, mica, air, and the gas film are most widely used in radio work. Mica is used in condensers where relatively high capacities are needed in circuits in which the voltage is high and space is an important factor. Mica is usually equivalent to glass as an insulator and dielectric—some forms are even more efficient than glass. It may be used in its natural state. Paper is used as the dielectric material in condensers of the ordinary type, such as those used in filter circuits. Air is the dielectric for condensers of the variable type, such as those used in the tuning circuits of radio receiving apparatus, and in the fixed or variable condensers in transmitters where precautions must be taken to prevent arcing between the plates. The gas film is employed in condensers of the electrolytic type, such as are found in power filter circuits.

**Mica as an Insulator and Dielectric.** Since a condenser is, in fact, an open circuit, it is imperative that every precaution be taken to prevent the plates from being *shorted*, or connected, through the dielectric. Mica is particularly free from metallic particles, and it rarely happens, even during process of manufacture, that it gives any trouble of this kind. Air and the gas film are naturally free from metallic substances that would cause a short circuit. Paper, however, is different in this respect, and the development of a special paper for use in condensers with paper dielectric, required the closest cooperation between the condenser manufacturers and the paper makers.

**Paper as a Dielectric.** Regardless of all that is done at the paper mill to prevent minute particles of metal from imbedding themselves in the paper, it is not entirely free of metal when finished. However, the metallic particles may be readily detected by immersing a piece of paper in a solution of copper sulphate, which turns the iron and steel particles a reddish brown. If two or three layers of paper are used as the dielectric material in a condenser, the possibility of metallic particles causing contact between the plates is minimized. By using this method, contacts which would effectively short circuit the condenser plates are rarely made. However,

in order to reduce the number of metallic particles to the minimum—not more than eleven to the square foot—the liquid paper pulp is passed over several electromagnets during its flow from the vats, and in this way the particles of iron, steel, and other metals that respond to magnetic fields are withdrawn from the paper fibers. Also, the material from which condenser tissue is fabricated is new fabric, carefully selected mill scraps, that contain little metal of any sort.

**Dielectric Constant.** The capacity of a condenser is determined by the size of the plates and the distance between them, together with a factor known as the *dielectric constant* explained in detail under the heading, “Air as a Basic Dielectric.” If it were necessary to stretch the plates out flat, an exceedingly wide area

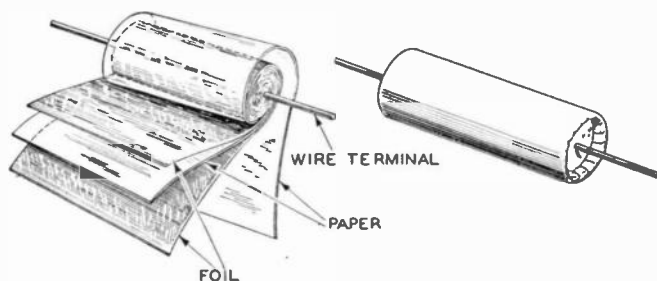

Fig. 2. Paper Condenser

would be required for a unit of relatively low capacity. So, in making *paper condensers*, the sheets of *foil*, which are separated by the dielectric, are made in the form of a roll, Fig. 2; the spacing between the sheets of foil is determined by the number of layers of *paper* which are used. A further discussion of this subject is found under “Air as a Basic Dielectric.”

**Plates of Paper and Foil.** When making paper condensers, a specially designed type of machine is used to wind the foil and paper together, placing one, two, three, or more sheets of paper between the sheets of foil. After the foil and paper have been wound together, the roll is flattened and connecting *terminals* are attached, one for each sheet of foil or set of sheets. In some cases, however, this operation is performed during the winding process.

The rolls are then placed on trays in a drying oven to drive out the greater part of any moisture that may be present; after that they are placed in vacuum tanks, into which a molten wax compound is injected under pressure. Because of the vacuum created in the tank, the wax makes its way into the folds of the condenser, sealing it against moisture. The wax also acts as a dielectric.

**Protection of Condensers.** The condensers are finally sealed into cans, and otherwise protected with sealing compounds that prevent moisture from collecting on the plates and destroying their efficiency. Moisture is detrimental to the action of a condenser and will cause considerable changes in its capacity.

**Color Coding to Indicate Capacity.** The capacity of a mica condenser if not indicated otherwise, may be found by a

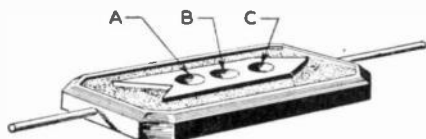

Fig. 3. Color Code for Mica Condenser

color-code system similar to that used for coding resistors. The capacity is indicated in micro-microfarads (one millionth of a microfarad) by a row of colored dots, the following sequence being used:

The first dot at the left, *A* in Fig. 3, indicates the first significant figure of the capacity; the second dot, *B*, indicates the second significant figure; the third dot, *C*, indicates the number of zeros to be added to the first two figures. The color code shown indicates the values of the colors.

Thus a .001-mfd or 1000-micro-microfarad condenser would have a *brown* first dot, *A*; *black* second dot, *B*; and the third dot, *C*, would be *red*. On a condenser using the color code marking there is usually an arrow indicating the order in which the dots should be read, or a trademark indicates the order of reading, left to right.

STANDARD COLOR CODE

Color	Significant Figure	Zeros
Black	0	None
Brown	1	0
Red	2	00
Orange	3	000
Yellow	4	0 000
Green	5	00 000
Blue	6	000 000
Violet	7	0 000 000
Gray	8	00 000 000
White	9	000 000 000

A condenser having a *green* dot (5) at the left, *red* dot (2) at the center, and an *orange* dot (3) at right would be read as 52,000 micro-microfarads, or .052 microfarads.

This identifying coloring system is also extended to small bakelite and encased paper condensers. An additional colored dot is sometimes used to indicate the working voltage in hundreds of volts according to the foregoing chart. For example, an additional red dot, placed above the row of three dots previously mentioned, would indicate the working voltage to be 200 volts.

**Electrolytic Condensers.** There are two types of electrolytic condensers, the *wet* and the *dry*. The wet type, which contains a liquid electrolyte, was the first used and is being superseded by the dry type which uses a paste electrolyte. Generally speaking, a wet electrolytic condenser consists of an electrode, usually aluminum immersed in a liquid electrolyte. The electrolyte in the aluminum container constitutes one plate of the condenser, the aluminum electrode the other. The dielectric in an electrolytic condenser is a film of gas that surrounds the aluminum electrode. In the dry type of electrolytic condenser, both plates are aluminum, and their surfaces become covered with a thin layer of oxide when the plates are placed in contact with a piece of gauze carrying the electrolyte in paste form. A thin layer of gas, which has an exceedingly high resistance, forms on the layer of oxide, and serves as the dielectric.

The dry electrolytic types of condensers are made in many shapes and sizes, Fig. 4. They may be built in a rectangular cardboard-case section containing four leads, as shown at (A), of Fig. 4; or in tubular shape which has two sections with three leads, as shown at (B), of Fig. 4; or in three sections, with four leads (C) of Fig. 4. At (D), of Fig. 4, is shown an early type of electrolytic condenser. This was an aluminum can with prongs which would fit into a socket in the chassis of the radio receiver.

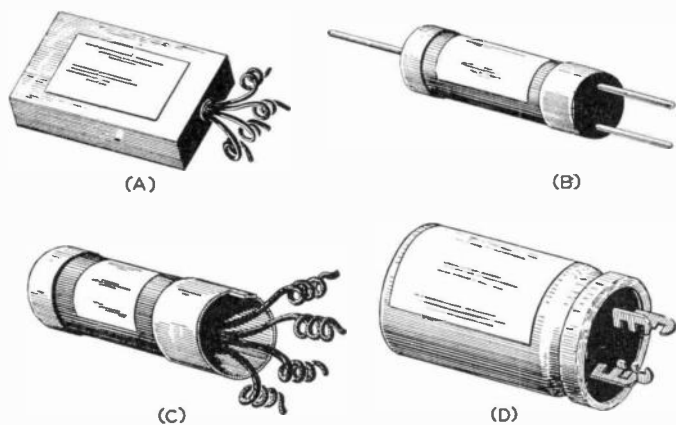

Fig. 4. Typical Electrolytic Condensers Having Multiple Electrodes

*Gas as a Dielectric.* The effective capacity of an electrolytic condenser depends upon the area of the plates, the thickness of the gas layer, and the insulation resistance between the plates. The thickness of the gas layer is determined by the value of the voltage that is impressed across the condenser during the process of *forming*.

The condenser electrodes are thoroughly cleaned with chemical baths during the process of manufacture and are subjected to a forming process which causes the formation of the gas film. The forming process requires about eight to ten hours or more. Higher voltages applied to the plates will create a thicker gas film, and a consequent higher resistance to the flow of electric current. The working voltage of the condenser must always be less than the voltage used to form the plates.



**Electrolytes and Electrodes.** Electrolytic condensers have the property of permitting the flow of electric current from the electrolyte to the electrode, but present an exceedingly high resistance to the flow of current in the opposite direction. In this respect, the action of the electrolytic condenser is identical with that of the electrolytic type of rectifier used in some of the early models of power supply devices for radio apparatus.

The commercial forms of condensers already explained are not, however, the only form of capacity units. Any two conductors across which there is a difference of electrical potential will form a condenser, and capacity will exist between them. While this particular form of capacity is of little or no consequence in ordinary electrical work, it is an important factor in the design of radio apparatus.

**Fixed and Movable Plates.** A *fixed condenser* is one in which neither the plates nor the dielectric are movable—hence, it is one in which the capacity is not changed. A *variable condenser* is one in which one or both plates—or sets of plates—can be moved to vary the existing capacity. The condensers used in the tuning stages of radio receiving sets are examples of variable condensers. The capacity of the condenser increases as the plates are enmeshed and decreases as they are pulled apart. Even at the full open position, however, capacity exists between the plates when there is a difference of potential between them.

A *semivariable condenser* is one in which one or both of the plates may be moved for purposes of making adjustments, although the plates can be locked in position. Most condensers of this type consist of two brass plates, one solid, the other in the form of a spring, separated by a mica dielectric. The adjustment is made by means of a screw which brings the plates closer together or permits them to spring apart.

**Voltage Equalizer.** In a sense, a condenser is a form of equalizer. It is placed in circuits where it is necessary to equalize the voltage to produce a constant current flow. Fig. 5 shows an analogy of a stream of water forced through a hydraulic system with a pump. With each upward stroke of the piston, the force is so great that all the water cannot rush through the pipe. There-

fore, the tank above the pipe line first acts as a reservoir to receive the excess water, and then empties it into the pipe as the piston of the pump makes its downward stroke.

A condenser acts in the same manner. As the electric pressure varies in a circuit, the plates of the condenser absorb or store a part of the force that is not needed, and allow it to feed off into the circuit when the pressure is lowered; thus equalizing the flow

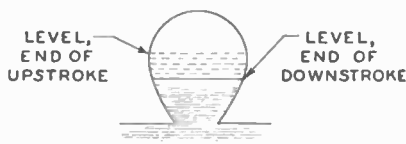

Fig. 5. Illustrating How Energy Is Stored and Then Released in a Water-Pipe System

and stabilizing the circuit. Fig. 6 shows a circuit containing two conductors carrying a direct current that pulsates as indicated by the wavy line at the left. As it passes the condenser,  $C$ , the high voltages are absorbed or stored on the plates of the condenser during the time that the peak voltages are passing. Then, when the pres-

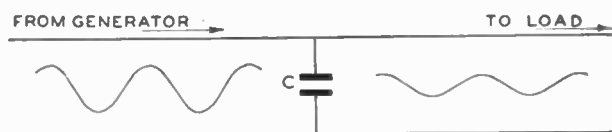

Fig. 6. Diagram Showing How a Condenser Smooths Out Alternating Current

sure is lower, as indicated by the valley between the crests, the condenser discharges the energy that it is holding; as a result, the flow of the current is made more uniform, as indicated by the shallow waves at the right. These indications in the flow of the current are only relative, and serve merely to illustrate the change that takes place through the action of the condenser. They do not represent current values.

**Dielectric Insulators and Current Flow.** Since the dielec-

tric of a condenser is an insulator, it is evident that a condenser is an open circuit and that current cannot flow *through* it. This actually is the case with direct current, where the applied pressure is continuous and in the same direction at all times. Alternating current, however, flowing through the circuit, as it does, first in one direction and then in the other, reacts differently, and at least appears to pass through the condenser. When a condenser is connected into a circuit through which alternating current is flowing, the plates of the condenser are alternately charged negatively or

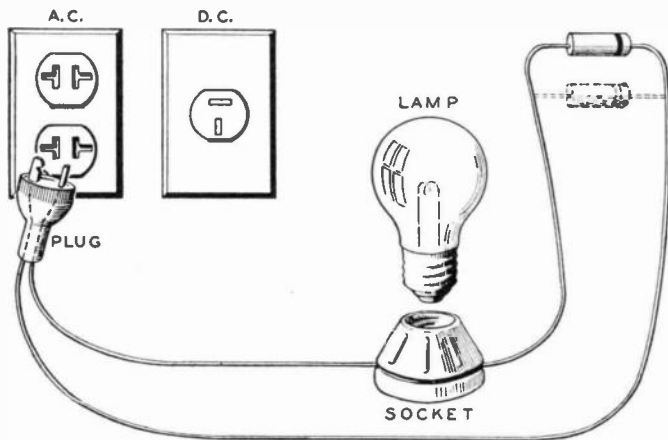

Fig. 7. Diagram of Condensers in Series with Lamp

positively, according to the changes in direction of the current flow; this gives rise to the apparent ability of alternating current to flow through the condenser.

In order to demonstrate the action of a condenser in an alternating current line, connect a condenser (2 mfd, say) in series with an incandescent *lamp* and plug into the *alternating-current* lighting circuit, Fig. 7. The lamp will glow, provided its resistance does not prevent. Then connect another similar condenser in parallel with the first one, as shown by *dotted lines*, Fig. 7, and the glow will become brighter. Adding more condensers—and thereby increasing the capacity—will increase the brilliancy of the illumination produced by the lamp. Thus, while the condensers appear to

be allowing the alternating current to pass, they are really opposing the flow of the current. Actually, however, the current is flowing through the lamp, storing on the plate of the condenser, being discharged from that plate, passing through the lamp, in the reverse direction, storing on the other plate of the condenser, being discharged therefrom, and so on. Thus, in effect the alternating current flows through a condenser, even though the current itself does not do so.

On the other hand, if the lamp and condensers connected in series in the circuit shown in Fig. 7 were plugged into a direct-current (usually polarized) outlet such as that shown, there would be an instantaneous flash from the lamp as the plates of the condenser were charged; then there would be no further illumination or evidence of current passing through the circuit, no matter how long the connection to the direct-current lighting system was sustained. However, if the connection to the lighting system were severed, and the terminals were shorted with a conductor, there would be another flash as the plates of the condenser gave up their charge, at which time current would flow through the circuit.

**Air as a Basic Dielectric.** It has been stated that the amount of charge that a condenser can receive and retain depends upon the area of the plates, the distance between the plates, and the *dielectric constant*. The area of the plates and their separation require no explanation—they are fixed values. The dielectric constant, however, is a variable factor, actually a ratio.

In calculations to determine the ability of a condenser to store electrical energy, air is assumed to be the standard or *basic dielectric*. But it has been found that when other materials are used—such as mica, paper, wax, oil, and the gas film—if the area of the plates and the separation of the plates are equal, the capacity will be greater. It has also been found that, relatively speaking, the ratio will remain reasonably constant for the same substance. Consequently, the *dielectric constant* is the ratio that exists between the capacity of a condenser in which some dielectric other than air is used, to the capacity of the same condenser if air were the dielectric. For instance, a condenser that has a capacity of one microfarad with air as the dielectric, may be found to have a

capacity of five microfarads with  $X$  material as the dielectric; in that case, substance  $X$  would be said to have a dielectric constant of 5.0.

Therefore, the capacity of a condenser with air dielectric is to the capacity of a condenser having a dielectric of some other substance, as one (1) is to the unknown factor,  $K$ , the dielectric constant of the substance. The ratio may be expressed

$$C_a : C_x = 1 : K$$

In this formula,  $C_a$  is the capacity of the condenser having air as its dielectric,  $C_x$  is the capacity of the condenser having another substance as its dielectric, 1 is *unity*, and  $K$  is the dielectric constant of the substance used in the condenser which has the capacity  $C_x$ . The dielectric constant is usually designated by the letter  $K$ , and is also known as *specific inductive capacity*.

**Dielectric Constant Values.** The value of  $K$  as an invariable quantity cannot be given for the reason that the substance itself may vary somewhat insofar as its density, temperature coefficient, and purity are concerned. Even air, the standard dielectric, which nominally has a value of 1, will vary if the atmospheric pressure is greater or less than normal. The dielectric constant of a vacuum is 0.999; of air with a pressure of 20 atmospheres, it is 1.022.

The value of the dielectric constant will also vary slightly with the kind of electromotive force applied to the plates of the condenser. When direct current of constant voltage is supplied, the dielectric constant will vary according to the length of time the voltage is applied. If the charging is done with alternating current, the frequency of the alternations will determine the apparent value of the dielectric constant. Therefore, it is necessary that the conditions under which the substance is measured should be known in order to interpret the values properly. The values given in the accompanying table are for radio frequencies.

It is evident, therefore, that a condenser which has a given value when used in one circuit, will have a slightly different value when it is used in a circuit at a widely different frequency.

The values for  $K$  have been calculated within given limits,

and Table I shows the dielectric constant for the more common substances used in the construction of a radio receiver condenser.

TABLE I  
DIELECTRIC CONSTANTS

Substance	Dielectric Constant
Air	1.000—Pressure, 1 atmosphere Temperature, 32° F.
Vacuum	.999
Carbon Dioxide	1.001—Pressure, 1 atmosphere Temperature, 32° F.
Transformer Oil	2.5
Fiber	5.0 —8.0
Flint Glass	6.6 —9.9
Lead Glass	5.4 —8.0
Mica	5.6 —8.0
Paper	1.5 —3.0
Paraffin	2.1 —2.3
Shellac	3.0 —3.7
Wood, Dry	3.0 —6.0

**Farad as Unit of Measure.** The capacity of a condenser is measured in *farads*. A condenser is said to have a capacity of *one farad* when a charge of *one coulomb* will raise the potential, between its plates, *one volt*. This definition is the converse of the one previously given. A *microfarad* is one-millionth (.000001) of a farad. A *micro-microfarad* is one-millionth (.000001) of a microfarad. An *electrostatic unit*, another term applied to the charge on the plates of a condenser, is 1.1124 micro-microfarads.

For many years, it was common practice to refer to the capacity of a condenser in terms of microfarads. For instance, a condenser rated at .00025 microfarads was called a *triple-0-two-five* condenser. Later, however, terms expressed in micro-microfarads became more common, so that a .00025 microfarad condenser is known as a condenser having 250 micro-microfarads capacity, .00025 microfarads being 250 millionths of a microfarad. The symbol for microfarad is *mfd*, *mf*, or  $\mu fd$ ; that for micro-microfarads is *mmfd*, *mmf*, or  $\mu\mu f$ .

**Calculating Capacity.** It has been stated that the capacity of a condenser depends upon the area of the plates, the distance be-

tween the plates, and the dielectric constant. This is shown in the formula for determining condenser capacity:

$$C = \frac{.0885 \times S \times K}{t} \text{ or } \frac{.0885 SK}{t}$$

in which  $S$  = area of smaller plate in square centimeters

$K$  = dielectric constant of insulating material

$t$  = thickness of dielectric (distance between plates) in centimeters

$C$  = capacity in micro-microfarads

Attention is called to the *smaller plate* for the reason that one plate of a condenser may be exceedingly large and the other very small, yet the effective capacity will be that produced because of the smaller area, and capacity effect beyond that area will be negligible.

**Application of Formula.** To cite an application of the formula, a condenser is formed of two sheets of foil, five centimeters wide and 80 and 90 centimeters long respectively, separated by .02 centimeters of paper which has a dielectric constant of 2. (In winding a condenser of this type, one sheet may be given another wrap or two, but it does not increase the capacity; as stated, the shortest one is used in the calculation.) Therefore, substituting in the formula, we have:

$$\begin{aligned} C &= \frac{.0885 \times 400 \times 2}{.02} \\ &= \frac{70.80}{.02} = 3540.00 \text{ mmf} \end{aligned}$$

Or, a condenser having the physical specifications as stated, would have a capacity of 3,540 micro-microfarads (.00354 microfarads).

The numerical term .0885 is a constant. The original formula for determination of condenser capacity was based upon spherical bodies, which gave the value in electrostatic units instead of micro-microfarads. Inasmuch as the spherical body was considered, the calculation necessarily took into account the spherical surfaces, and was stated:

$$C = \frac{KS}{4\pi t}$$

in which  $C$  is the capacity in electrostatic units,  $K$  is the dielectric constant for the dielectric substance,  $S$  is the area of the plate in

square centimeters,  $t$  is the separation of the plates in centimeters, and  $\pi$  is 3.1416.

From the foregoing it will be seen that the latter part of the equation includes the fraction,  $\frac{1}{4 \times 3.1416}$ , which, calculated, will give the value, .07958. If we used this calculation at this point the formula would become:

$$C = \frac{.07958 K S}{t}$$

but the result would still be the value in electrostatic units. In order that the result may be in micro-microfarads, it is necessary

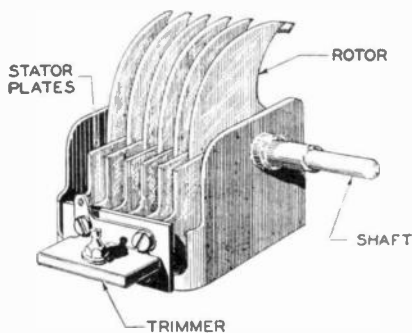

Fig. 8. Variable Condenser for Tuning Radio Circuits

to divide  $C$  by 1.1124 (one electrostatic unit equals 1.1124 micro-microfarads) so that the formula resolves into:

$$\frac{C}{1.1124} = \frac{.07958 K S}{t}$$

Simplifying:

$$C = \frac{.0885 K S}{t}$$

as already stated.

In the event that the condenser is *multi-plate*, such as, for example, a *variable condenser* for tuning radio circuits, Fig. 8, the value for  $S$  is determined by multiplying the area of one plate by the number of plates, less one. The formula, then, is stated:

$$C = \frac{.0885 K S (N - 1)}{t}$$



in which  $C$  is the capacity in micro-microfarads,  $K$  is the dielectric constant (usually 1, inasmuch as air is the common dielectric),  $S$  is the surface area of one plate, in square centimeters, the quantity  $(N - 1)$  is the number of plates less one, and  $t$  is the separation of the plates in centimeters. Thus, in a condenser having 11 plates, the enmeshed portion of which has an area of 22.6 square centimeters, the plates separated .08 of a centimeter, will be found by substituting in the given formula:

$$\begin{aligned} C &= \frac{.0885 \times 1 \times 22.6 \times (11 - 1)}{.08} \\ &= \frac{.0885 \times 1 \times 22.6 \times 10}{.08} \\ &= \frac{20}{.08} \\ &= 250 \text{ micro-microfarads,} \end{aligned}$$

in other words, a .00025 mfd variable condenser.

Increasing the number of plates, increasing the area of the plates, or decreasing the distance between the plates, will create an increase in the capacity of a condenser—an increase in the amount of electrical energy the condenser will receive and retain. The capacity will be increased also if a dielectric substance having a higher dielectric constant is used.

**Condensers Connected in Series and in Parallel.** Connecting condensers in series decreases the amount of capacity in the circuit. In fact, the equivalent capacity in a circuit containing condensers in series will always be less than that of the condenser having the least capacity in the series circuit.

The formula to determine the equivalent capacity of condensers connected in series is the counterpart of that for resistances connected in parallel, thus:

$$\frac{1}{C} = \frac{1}{C_a} + \frac{1}{C_b} + \frac{1}{C_c} + \frac{1}{C_d} + \frac{1}{C_e} + \frac{1}{C_f} + \text{etc.}$$

For example, if four condensers, having capacities of 200, 400, 600, and 800 micro-microfarads, are connected in series, we may find

the equivalent capacity by substituting in the foregoing formula as follows:

$$\frac{1}{C} = \frac{1}{200} + \frac{1}{400} + \frac{1}{600} + \frac{1}{800}$$

The lowest common multiple is 2400

$$\frac{1}{C} = \frac{12}{2400} + \frac{6}{2400} + \frac{4}{2400} + \frac{3}{2400}$$

$$\frac{1}{C} = \frac{25}{2400} = .010417$$

$$C = 96 \text{ micro-microfarads}$$

or expressed in microfarads, .000096 mfd.

If more than one condenser having the same capacity are connected in series, the equivalent capacity will equal the capacity of one condenser divided by the number of condensers in the circuit. Thus, for a circuit containing four condensers, each of which has a capacity of 200 micro-microfarads,

$$\begin{aligned} \frac{1}{C} &= \frac{1}{200} + \frac{1}{200} + \frac{1}{200} + \frac{1}{200} \\ &= \frac{4}{200} = .02 \end{aligned}$$

$$C = 50 \text{ micro-microfarads,}$$

one-fourth the capacity of *any* of the condensers. If two condensers, each of which has 200 micro-microfarads capacity are connected in series, the equivalent capacity would be 100 micro-microfarads. If five were connected in series, the equivalent capacity would be 40 micro-microfarads, and so on.

Connecting condensers in parallel produces the same effect as increasing the number of plates. Therefore, the equivalent capacity is the sum of the capacities, as for example, if the same group of condensers mentioned in the foregoing example were connected in parallel, the equivalent capacity would be  $200 + 400 + 600 + 800 = 2,000$  micro-microfarads, or .002 mfd.

**Condensers Connected in Series-Parallel.** When condensers are connected in series-parallel, the capacities of the parallel combinations are determined first, and then the equivalent values are calculated according to the formula given for series connections.

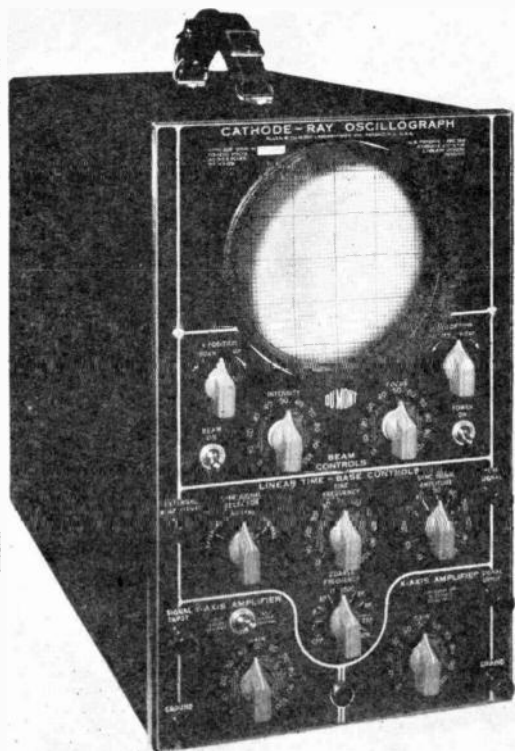

### CATHODE-RAY OSCILLOGRAPH

Used to observe wave shape of electrical voltages. Height of electron beam on screen is controlled by switches and knobs.

Courtesy of Allen B. Du Mont Laboratories, Inc., Passaic, N.J. [www.worldpress.com/history](http://www.worldpress.com/history)

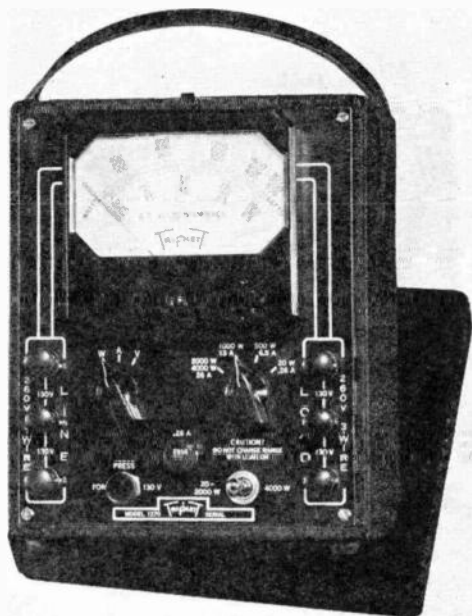

### VOLTMETER, AMMETER, AND WATTMETER

The desired unit is selected with the left-hand pointer knob desired ampere or watt scale, with the right pointer.

Courtesy of Triplet Electrical Instrument Company

# OSCILLATORY CIRCUITS AND RESONANCE

## OSCILLATIONS

An oscillatory circuit is one in which alternating current may surge back and forth at extremely high frequency. It is a combination of inductance, capacitance, and resistance. Such a circuit is shown in Fig. 1. The oscillatory circuit is the foundation

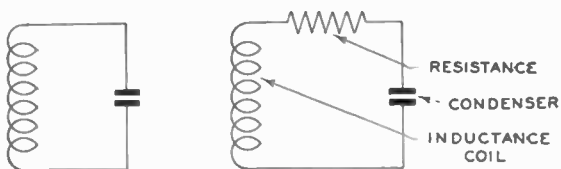

Fig. 1. Oscillatory Circuit

of all radio circuits. Therefore, it is essential that the action be thoroughly understood.

**How Oscillations Are Produced.** *Oscillation* is the term applied to high-frequency alternating current. However, it may be

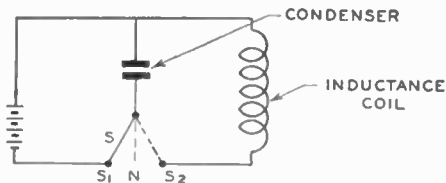

Fig. 2. Method of Charging and Discharging Condenser

caused or produced by continuous direct current supplied by a battery, as shown in Fig. 2. Two separate circuits are included in Fig. 2. If the switch arm *S* is thrown to position *S*<sub>1</sub>, current will flow from the battery to the condenser until the potential difference

between the plates of the condenser equals that which exists between the terminals of the battery. If the switch arm  $S$  is thrown to position  $N$ , the battery circuit is open and the charge remains upon the condenser—there is no complete circuit. But, if the switch arm is thrown to position  $S_2$ , a circuit consisting of the condenser and an inductance coil is completed, and there is a path through which current may flow.

Suppose the condenser were charged with energy from the battery and the switch arm were thrown to complete the circuit with the coil—to position  $S_2$ . In this condition the condenser would act as a source of electrical energy. With a path to follow, current would flow from the condenser through the windings of the coil. It has been shown how the flow of current through a coil creates a magnetic field around the coil, and it has also been shown that the magnetic field will increase as the current flow increases.

*Magnetic Fields Created.* With the switch arm at position  $N$ —an incomplete circuit—the current flow in either circuit is zero. Assume that the upper plate of the condenser has an abundance of negative charges, and that the lower plate is lacking an equal number of negative charges—the upper plate then is negative, the lower plate is of positive polarity. When the circuit with the coil is completed by placing the switch arm at  $S_2$ , the negative charges on the upper plate move through the circuit toward the positively charged plate. Current flowing through the coil builds up the magnetic field as previously stated, so that what had been a static charge is converted into a magnetic field. When the current flow has attained its maximum, the magnetic field is also at maximum.

*Magnetic Fields Collapsed.* At this point, the condenser having equalized the charge on its plates, causes the magnetic field to collapse and creates a flow of current in a direction opposite to that originally used to charge the condenser. This is in accordance with the law of electromagnetically induced voltages. If the switch could be opened at the exact instant that the electrons have stored themselves upon the lower plate of the condenser, the condition would stand thus: Electrons which *had* been stored on the upper plates of the condenser have passed through the circuit, and have

been stored upon the lower plate of the condenser, which coincides with what occurs in an alternating-current circuit in which the current flows in one direction through the circuit from zero to maximum flow and back again to zero to complete one alternation.

With the switch arm again at position  $S_2$ , the negative electrons on the lower plate of the condenser move back through the circuit and again build up a magnetic field in the coil, which, upon attaining maximum coincidental with the maximum flow of current, collapses and forces the current onward through the circuit placing the negative charges again upon the upper plate of the condenser. If the switch arm could be thrown to position  $N$  instantaneously, the charges which had first been stored on the upper plate of the condenser, having passed through the coil and having been stored upon the lower plate of the condenser—one alternation—have now passed through the coil in the reverse direction and are again stored on the upper plate to complete a cycle. The process continues again and again until the energy is exhausted.

**How Oscillations Are Stopped.** It would seem that the process—oscillation—could and would go on indefinitely. It would do so, were it not for the losses sustained by heat dissipation and the radiation of energy—lines of force around the coil that pass off into space instead of collapsing with the magnetic field. Heat dissipation is caused by the resistance of the circuit, which, although there may be no resistance element, will be present nevertheless—the wire used for connections and the windings of the coil offer resistance to the flow of current in any event.

*Resistance Introduced.* A circuit that has little resistance will oscillate over a greater period of time than one which has more resistance. If it is desired that a circuit shall oscillate only a few times, a fairly high value of resistance can be introduced into the circuit in order that the energy may be dissipated quickly in the form of heat. In fact, a circuit that contains a high enough resistance will not oscillate, and all the energy stored upon the condenser plates will be absorbed or dissipated in the resistance itself.

The discharge of a condenser under any circumstances tends to be oscillatory. That which appears in the form of a spark when the terminals of a charged condenser are connected by a conductor

is actually a large number of reversals of current flow between the plates.

## COUPLED CIRCUITS

Two electric circuits are said to be *coupled* when a means is provided for the transfer of electrical energy from one circuit to the other. Circuits may be coupled by electromagnetic induction, using inductance; by electrostatic induction, using capacitance; or by direct connection. Circuits may be coupled so that the coupling element is common to and in series with both circuits. Such circuits are said to be *directly coupled—direct coupling*. Or, circuits may be coupled so that the transfer of energy is accomplished by means of electromagnetic or electrostatic induction in which the coupling elements are not common to, or in series with, both circuits and are said to be *indirectly coupled—indirect coupling*.

Electric current, in order to be transferred from one circuit to another, must have pulsating characteristics. It may be alternating current or it may be direct current which, though the direction of flow is always in the same direction, varies as to the voltage or amount of current flow. Continuous direct current is not applicable to the conditions under which the energy may be transferred from one circuit to another, except by means of direct connection through conductors.

**Mutual Inductance.** It has been shown how the flow of a varying current through the windings of a coil induces a counter-electromotive force which opposes the flow of the current which caused it, and that the ability to generate the counter-electromotive force is called the *self-inductance* of the coil. It has also been shown that if two coils are brought close together, a varying current flowing through one of them induces a voltage in the other, due to the linkage of flux—lines of force—cutting the windings of the coil in the secondary circuit. This linkage of flux creates a *mutual inductance* between the two circuits, the value of which depends upon the size and shape of the coils, and their position with respect to one another. If the coils are placed so that only a few of the lines of force, produced by the flow of current through the primary, cut the windings of the secondary coil, the mutual inductance is

low. On the other hand, if the coils are arranged so that the lines of force cut all or nearly all of the windings of the secondary, the mutual inductance is high. Thus, the mutual inductance increases as the design of the coil permits greater flux linkage—less flux leakage.

**Coefficient of Coupling.** The coefficient of coupling is a measure of the degree of coupling that exists between two circuits—a numerical expression of the ease with which electrical energy is transferred from one circuit to another. The relationship is determined by the formula:

$$K = \frac{L_M}{\sqrt{L_1 \times L_2}}$$

in which  $K$  is the coefficient of coupling,  $L_1$  is the inductance of the primary coil,  $L_2$  is the inductance of the secondary coil, and  $L_M$  is the mutual inductance.

**Tight and Loose Coupling.** Circuits are said to be *tightly coupled* or *loosely coupled* according to the amount of energy that is transferred from one circuit to the other—or the ease with which the transfer is accomplished. If the coils are close together so that little of the flux around the primary coil is lost, the coupling will be *tight*, but if the coils are separated or set at an angle, so that only a small part of the flux cuts the secondary windings, the coupling is *loose*. Tight coupling is also referred to as *close coupling*.

## METHODS OF COUPLING CIRCUITS

**Direct-Inductive Coupling.** Circuits are said to be *inductively coupled* when the transfer of energy is accomplished by means of inductance. They are said to be *direct-inductively coupled* when the inductance, by means of which the transfer of energy is made, is common to both circuits, and is in series with the other elements that comprise the circuits. See Fig. 3.

A direct-inductively coupled circuit has a relatively high mutual inductance and a high coefficient of coupling, increasing with the efficiency of design of the inductance  $L_M$ , which is common to both circuits. Referring to Fig. 3 it will be seen that the



primary circuit consists of inductances  $L_1$  and  $L_M$  and capacitance  $C_1$ , and that the circuit is energized by a varying electrical source. The secondary circuit consists of  $L_2$  and  $L_M$  with the capacitance  $C_2$ . As the varying current flows through the primary circuit, it produces a varying voltage across the common inductance  $L_M$ , which is transferred to the secondary circuit. The self-inductance of the coil  $L_M$  is equal to the mutual inductance that exists between the two circuits.

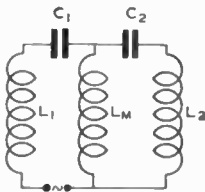

Fig. 3. Direct-Inductively Coupled Circuit

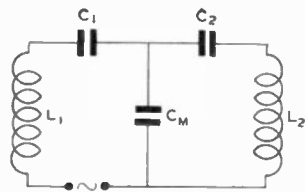

Fig. 4. Direct-Capacitively Coupled Circuit

**Direct-Capacitive Coupling.** Similar to direct-inductive coupling is the transfer of energy by capacitive coupling—that form of coupling that employs capacitances. Fig. 4 shows a circuit in which the capacitance  $C_M$  is common to the primary and the secondary circuits, thus forming a *direct-capacitively coupled* circuit. The transfer of energy in such a circuit is obtained by electrostatic means, and utilizes the effect of alternately charging and discharging the condenser  $C_M$ .

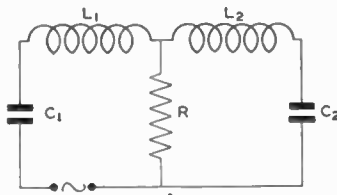

Fig. 5. Direct-Resistance Coupled Circuit

**Resistance Coupling.** Resistance coupling is another form of direct coupling, the resistance being common to both the primary and secondary circuits as shown in Fig. 5. The transfer of energy by means of resistance is accomplished by using the voltage

drop across the resistance. This difference of potential causes a current to flow in the secondary circuit, thereby effecting a transfer of energy from one circuit to the other.

In order that the transfer of energy may be accomplished by resistance alone, it is necessary that the resistance unit be non-inductive. If the resistance is inductive, the coupling will be that obtained by a combination of resistance and inductance, and the action will be considerably different from that obtained when pure resistance is the coupling element.

**Indirect-Inductive Coupling.** Indirect-inductive coupling is a means of transferring electrical energy from one circuit to another by utilizing the electromagnetic field that surrounds the inductance through which a varying current is flowing. The

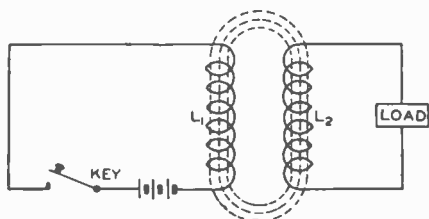

Fig. 6. Indirect-Inductively Coupled Circuit

coupling device is commonly known as a *transformer* which consists of two windings, the *primary* and the *secondary*, which may be wound upon the same form or on separate forms, but which are placed in such relation as to permit linkage of the lines of force around the primary coil through the windings of the secondary coil. A transformer may be arranged so that the coupling is *tight* or *loose*, according to the arrangement of the coils. Tight coupling is employed where it is desired to conserve power; loose coupling is employed where certain frequencies of alternation are to be selected or rejected.

Fig. 6 shows an indirect-inductively coupled circuit in which the secondary circuit is closed—that is, the terminals of the secondary coil  $L_2$  are shorted either directly or through a *load*. A battery is connected in the primary circuit, and a *key* is provided

with which to close or open the circuit. Such a set-up can be made very readily. When the key is closed, the battery supplies energy to the coil in the primary circuit  $L_1$  and while the current is increasing the lines of force build up around the coil. Since the current from the battery is continuous, there will be no change in the magnetic field after the current has reached its maximum value, but it will remain stationary. During the build-up period, the moving lines of force will induce an electromotive force in the secondary coil, but when the current has built up in the primary so that the field remains stationary, there will be induction of electromotive force in the secondary coil. However, if the key is

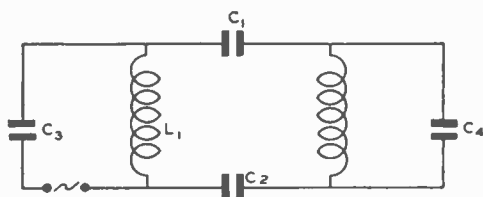

Fig. 7. Indirect-Capacitively Coupled Circuit

opened, the magnetic field around the primary coil collapses and again induces a voltage in the secondary coil. If the connection between the terminals of the secondary coil is severed and the ends held between the fingers while closing and opening the primary circuit, the effect can be felt distinctly.

The circuits as shown would be coupled indirectly regardless of whether the source of varying energy were impressed upon the circuit which has been referred to as the *primary circuit*, or that which is considered the secondary circuit. In either case, also, the mutual inductance existing between the circuits would be the same no matter which circuit is connected to the electrical source.

**Indirect-Capacitive Coupling.** Indirect-capacitive coupling does not differ greatly from direct-capacitive coupling. A circuit is shown in Fig. 7, and in many instances the capacitance  $C_2$  is replaced with a direct connection between the two inductances. It is to be understood that the inductances shown in the circuit are not inductively coupled, so that the transfer of energy

between the circuits is through the condenser  $C_1$ , or  $C_1$  and  $C_2$  if both condensers are used.

### RESONANCE

It has been shown that the flow of alternating current through a circuit meets with opposition caused by three electrical functions—inductance, capacitance, and resistance. It has also been shown that the opposition set up by inductance is called *inductive reactance*; that set up by capacitance is called *capacitive reactance*; and that set up by resistance is *resistance*. Too, inductive reactance and capacitive reactance have been shown to have opposite characteristics—that whereas the inductive reactance is increased by increasing the inductance, the capacitive reactance is decreased when the capacitance is increased. Inductive reactance has been referred to as *positive reactance*; capacitive reactance has been referred to as *negative reactance*. In other words, whereas they both act to oppose the flow of alternating current through the circuit there is a point where one neutralizes the other so that there is no opposition—or minimum opposition—to current flow.

Since inductive reactance and capacitive reactance tend to neutralize one another, even though each opposes the flow of alternating current, it is evident that if the inductive reactance and the capacitive reactance are equal, they will be entirely neutralized and will permit the greatest flow of current through the circuit. When such a condition exists, the circuit is said to be in *resonance* with the applied frequency. However, since inductive and capacitive reactance both vary with the frequency of the alternating current (see formulas given under the heading, "Calculation of Reactance"):

$$X_L = 2\pi fL$$

$$X_C = \frac{1}{2\pi fC}$$

it is evident that *the circuit will be in a state of resonance at one particular frequency*, and that the flow of current at all other frequencies will be opposed by the inductive or capacitive reactance in the circuit. If provision is made to vary the value of either the

inductance or the capacity, the circuit may be adjusted to resonance at any given frequency within the range of the reactance values.

Although theoretically, the circuit is in resonance with a single frequency, it will appear to be in resonance with other adjacent frequencies. In fact, resonance can never be so sharply defined that the reactance is completely eliminated. But, the reactance is at its lowest value when the circuit is in resonance, and the flow of current is greater than for any other frequency for a given applied voltage. If the frequency is changed, it is necessary to change either the amount of inductance or the amount of capacity, or both, in the circuit to bring the circuit into resonance again.

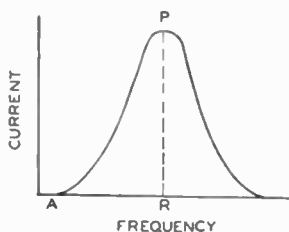

Fig. 8. Curve Showing Increase of Current as Resonant Frequency Is Increased

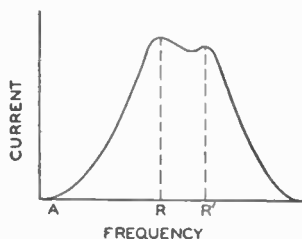

Fig. 9. Curve Showing How Mutual Inductance Effects the Resonance Frequency

**Indication of Resonance.** Resonance is indicated graphically as shown in Fig. 8, in which the frequency is represented by the horizontal line and the current flow through the circuit is represented vertically. Thus, at *A*, as the resonant frequency is approached, the equivalent reactance of the circuit—the difference between the inductive and the capacitive reactance—is approaching zero, there is less opposition to the flow of alternating current in the circuit, and as a result current begins to flow. As the adjustment of either the capacitance or the inductance, or both, brings the reactances closer to neutralization, the amount of current flowing increases, until at resonance, *R*—where the inductive and capacitive reactances are equal—there is the maximum flow of current as indicated by the peak at *P*.

**Resonance of Coupled Circuits.** It is evident that while energy may be transferred from one circuit to another by employ-

ing one of the several forms of coupling previously discussed, the greatest amount of current will flow when the frequency of alternations is such that the circuit into which the energy is transferred is at resonance.

When two coupled circuits are tuned to resonance, the resonant peak takes a form different from that shown under the heading, "Indication of Resonance." The mutual inductance, for instance, that exists between the two circuits, adding to and then subtracting from the value of the inductance in the individual circuits causes the circuit to be in resonance at two frequencies instead of one, as shown in Fig. 9. However, the double peak can be minimized, and even eliminated by loosening the coupling between the circuits to reduce the amount of energy transferred from one circuit to the other.

## FILTERS

**Wave Traps.** It is possible by the use of the principle of resonant circuits to separate one or more types of current from other types of current in order that they may be directed according to the purpose they are to serve. This applies not only to a differentiation between direct and alternating current, but to alternating current of varying frequencies.

Several kinds of current may flow through a common conductor—the chassis of a radio receiver, for instance, serves to conduct practically every type of current flowing through the receiver circuit. Yet, through suitable *wave traps* or filters and arrangements of circuits, the different currents and types of currents are directed to the proper places, where they serve to receive and amplify the radio signals to produce sound.

Resonant circuits and coupled circuits have already been explained. The circuits illustrated and explained were all of the *series* type, that is, the inductance and the capacity—as well as the resistance, if present—were in series with one another. The oscillatory circuit, for instance, consisting of a condenser and a coil, was a series circuit. The coupled circuits, taken individually, consisted of combinations of condensers, coils, and resistances, connected in series. In filter circuits, we deal with parallel circuits as well as

series circuits, and as shall be shown, the action is very different in the series and parallel circuits.

**Alternating-Direct Current Filter.** Take first a filter to separate direct current from alternating current. In Fig. 10 is shown a network of three wires, the center one of which is common to an alternating-current source of supply and a direct-current source of supply. The upper wire is the other side of the alternating-current circuit, the lower wire is the other side of the direct-current circuit. Since the center wire is common to both circuits, it is evident that the direct current flowing through it is flowing constantly in one direction, while the alternating current is reversing its direction of flow periodically. It is assumed that at a certain point in the circuit either direct current or alternating current is

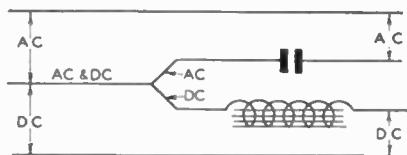

Fig. 10. Simple Filter Circuit

desired, but not both. Hence, it is necessary to separate one from the other.

**Choke Coil.** Direct current will not pass through a condenser due to the fact that the plates of the condenser are insulated from one another thereby creating an open circuit so far as the continuous flow of current is concerned. Alternating current, on the other hand, while not passing through the condenser, appears to do so, due to the alternate charging and discharging of the plates with each reversal in the flow of the current. Consequently, if a condenser is inserted in the alternating-current line, the alternating-current circuit is complete, but the flow of the direct current is effectively stopped. At the same time, in order to stop the flow of alternating current through the direct-current circuit, a *choke coil* is inserted in the branch of the filter that is to carry the direct current. *Choke coil* is the term applied to an inductance of suitable characteristics to prevent the flow of alternating current in a circuit through the generation of a large value of counter-electromotive

force. When used in low-frequency circuits a choke coil usually has an iron core while a radio-frequency choke is of the air-core type. Since the flow of direct current is continuous—and of unvarying amplitude—there is no self-inductance to set up a counter-electromotive force to oppose the flow of direct current through it. The alternating current, on the other hand, passing into the windings of the coil, sets up a varying magnetic field which induces a counter-electromotive force that opposes the flow of the current which produces it. Thus, in a filter as shown in Fig. 10, the direct current is separated from the alternating current and directed to serve its proper function.

**Radio Frequency Filters.** Of equal importance in radio circuits, and used more extensively, is the filter network for the selection or rejection of certain frequencies of alternating current. It has been shown how capacitance opposes the flow of alternating current, and that the effect is termed *capacitive reactance*.

*Capacitive Reactance.* It has also been shown that the reactance of a condenser is determined by its capacity and by the frequency of the applied voltage. From the formula to determine capacitive reactance:

$$X_c = \frac{1}{2\pi fC}$$

it will be seen that a condenser of low capacity will have a greater reactance to the flow of alternating current than a condenser of high capacity. Also a given condenser will have a greater reactance to currents at low frequency than at high frequency. In other words, a condenser of, say, two microfarads will offer little opposition to the flow of alternating current at 100,000 cycles, but will oppose greatly the flow of alternating current at 1,000 cycles. And, a condenser of two microfarads will offer greater opposition to the flow of alternating current at 1,000 cycles than would a condenser of four microfarads.

*Inductive Reactance.* Inductive reactance,  $X_L$ , depends likewise upon the frequency of the current and upon the value of the inductance, in accordance with the formula:

$$X_L = 2\pi fL$$



TABLE I  
CALCULATIONS OF RESONANT CIRCUITS

Wave Length Meters	Frequency Kilocycles	LC Value	Wave Length Meters	Frequency Kilocycles	LC Value
1	300,000	.00000028	39	7,692	.000428
2	150,000	.00000113	40	7,500	.000450
3	100,000	.00000253	41	7,317	.000473
4	75,000	.00000450	42	7,143	.000497
5	60,000	.00000704	43	6,977	.000520
6	50,000	.00001013	44	6,818	.000545
7	42,857	.00001379	45	6,666	.000570
8	37,500	.00001801	46	6,522	.000596
9	33,333	.0000228	47	6,374	.000622
10	30,000	.0000281	48	6,250	.000649
11	27,273	.0000341	49	6,123	.000676
12	25,000	.0000405	50	6,000	.000704
13	23,077	.0000476	51	5,880	.000732
14	21,428	.0000552	52	5,770	.000761
15	20,000	.0000633	53	5,660	.000791
16	18,750	.0000721	54	5,560	.000821
17	17,647	.0000813	55	5,450	.000851
18	16,666	.0000912	56	5,360	.000883
19	15,789	.0001016	57	5,260	.000912
20	15,000	.0001126	58	5,170	.000947
21	14,286	.0001241	59	5,080	.000980
22	13,636	.0001362	60	5,000	.001013
23	13,044	.0001489	61	4,918	.001047
24	12,500	.0001621	62	4,839	.001082
25	12,000	.0001759	63	4,762	.001117
26	11,538	.0001903	64	4,688	.001153
27	11,111	.0002022	65	4,615	.001189
28	10,714	.0002207	66	4,546	.001226
29	10,345	.0002367	67	4,478	.001263
30	10,000	.000253	68	4,412	.001301
31	9,677	.000270	69	4,348	.001340
32	9,375	.000288	70	4,286	.001379
33	9,091	.000307	71	4,225	.001419
34	8,824	.000325	72	4,167	.001459
35	8,571	.000345	73	4,110	.001500
36	8,333	.000365	74	4,054	.001541
37	8,108	.000385	75	4,000	.001583
38	7,894	.000406	76	3,947	.001626

TABLE I (Continued)  
CALCULATIONS OF RESONANT CIRCUITS

Wave Length Meters	Frequency Kilocycles	LC Value	Wave Length Meters	Frequency Kilocycles	LC Value
77	3,896	.001669	115	2,609	.00372
78	3,846	.001712	116	2,586	.00379
79	3,798	.001757	117	2,564	.00385
80	3,750	.001801	118	2,542	.00392
81	3,704	.001847	119	2,521	.00399
82	3,659	.001892	120	2,500	.00405
83	3,615	.001939	121	2,479	.00412
84	3,571	.001986	122	2,459	.00419
85	3,529	.002034	123	2,439	.00426
86	3,488	.002082	124	2,419	.00433
87	3,448	.002130	125	2,400	.00440
88	3,409	.002180	126	2,381	.00447
89	3,371	.002229	127	2,362	.00454
90	3,333	.002280	128	2,344	.00461
91	3,297	.002331	129	2,326	.00468
92	3,261	.002382	130	2,308	.00476
93	3,226	.002434	131	2,290	.00483
94	3,192	.002487	132	2,273	.00490
95	3,158	.00254	133	2,256	.00498
96	3,125	.00259	134	2,239	.00505
97	3,993	.00265	135	2,222	.00513
98	3,061	.00270	136	2,206	.00521
99	3,030	.00276	137	2,190	.00528
100	3,000	.00281	138	2,174	.00536
101	2,970	.00287	139	2,158	.00544
102	2,941	.00293	140	2,143	.00552
103	2,913	.00299	141	2,128	.00560
104	2,885	.00304	142	2,113	.00568
105	2,857	.00310	143	2,098	.00576
106	2,830	.00316	144	2,083	.00584
107	2,804	.00322	145	2,069	.00592
108	2,778	.00328	146	2,055	.00600
109	2,752	.00334	147	2,041	.00608
110	2,727	.00341	148	2,027	.00617
111	2,703	.00347	149	2,013	.00625
112	2,679	.00353	150	2,000	.00633
113	2,665	.00359	151	1,987	.00642
114	2,632	.00366	152	1,974	.00650

TABLE I (Continued)  
CALCULATIONS OF RESONANT CIRCUITS

Wave Length Meters	Frequency Kilocycles	LC Value	Wave Length Meters	Frequency Kilocycles	LC Value
153	1,961	.00659	191	1,571	.01027
154	1,948	.00668	192	1,563	.01038
155	1,936	.00676	193	1,554	.01048
156	1,923	.00685	194	1,546	.01059
157	1,911	.00694	195	1,539	.01070
158	1,899	.00703	196	1,531	.01081
159	1,887	.00712	197	1,523	.01092
160	1,875	.00721	198	1,515	.01103
161	1,863	.00730	199	1,508	.01115
162	1,852	.00739	200.0	1,500	.01126
163	1,841	.00748	201.4	1,490	.01142
164	1,829	.00757	202.7	1,480	.01157
165	1,818	.00766	204.1	1,470	.01173
166	1,807	.00776	205.5	1,460	.01189
167	1,796	.00785	206.9	1,450	.01205
168	1,786	.00794	208.3	1,440	.01222
169	1,775	.00804	209.8	1,430	.01239
170	1,765	.00813	211.3	1,420	.01256
171	1,754	.00823	212.8	1,410	.01274
172	1,744	.00833	214.3	1,400	.01292
173	1,734	.00842	215.7	1,390	.01311
174	1,724	.00852	217.4	1,380	.01330
175	1,714	.00862	218.9	1,370	.01350
176	1,705	.00872	220.6	1,360	.01370
177	1,695	.00882	222.2	1,350	.01390
178	1,685	.00892	223.1	1,340	.01411
179	1,676	.00902	225.6	1,330	.01432
180	1,667	.00912	227.3	1,320	.01452
181	1,658	.00922	229.0	1,310	.01476
182	1,648	.00932	230.8	1,300	.01499
183	1,639	.00943	232.6	1,290	.01522
184	1,630	.00953	234.4	1,280	.01546
185	1,622	.00963	236.2	1,270	.01571
186	1,613	.00974	238.1	1,260	.01596
187	1,604	.00984	240.0	1,250	.01622
188	1,596	.00995	242.8	1,240	.01648
189	1,587	.01005	243.9	1,230	.01675
190	1,579	.01016	245.9	1,220	.01702

TABLE I (Continued)  
CALCULATIONS OF RESONANT CIRCUITS

Wave Length Meters	Frequency Kilocycles	LC Value	Wave Length Meters	Frequency Kilocycles	LC Value
247.9	1,210	.01731	361.4	830	.03684
250.0	1,200	.01760	365.9	820	.03774
252.1	1,190	.01789	370.0	810	.03866
254.2	1,180	.01821	375.0	800	.03960
256.3	1,170	.01852	379.7	790	.04060
258.2	1,160	.01882	384.6	780	.04164
260.8	1,150	.01914	389.6	770	.04268
263.4	1,140	.01946	394.8	760	.04380
265.5	1,130	.01980	400.0	750	.04495
267.8	1,120	.02016	405.4	740	.04630
270.3	1,110	.02052	410.9	730	.04767
272.7	1,100	.02090	416.7	720	.04907
275.2	1,090	.02130	422.5	710	.05051
277.8	1,080	.02171	428.6	700	.05198
280.4	1,070	.02213	434.9	690	.05348
283.4	1,060	.02255	441.2	680	.05501
285.7	1,050	.02299	447.7	670	.05658
288.5	1,040	.02343	454.5	660	.05823
291.3	1,030	.02389	461.5	650	.05998
294.1	1,020	.02436	468.7	640	.06185
297.0	1,010	.02483	476.2	630	.06383
300.0	1,000	.02532	483.9	620	.06593
303.0	990	.02582	491.8	610	.06808
306.1	980	.02634	500.0	600	.07040
309.3	970	.02688	508.5	590	.07288
312.5	960	.02746	517.2	580	.07551
315.8	950	.02804	526.3	570	.07827
319.1	940	.02864	535.8	560	.08119
322.6	930	.02926	545.5	550	.08428
326.0	920	.02991			
329.7	910	.03059			
333.3	900	.03129			
337.1	890	.03201			
340.9	880	.03275			
344.9	870	.03351			
348.8	860	.03429			
352.9	850	.03511			
357.1	840	.03596			

**Series-Resonant Circuit.** An increase in the value of the inductance will increase the inductive reactance—offer greater opposition to the flow of alternating current at a given frequency. Similarly, an increase in the frequency of the alternating current will increase the inductive reactance of a coil having a given inductance value. If we combine the two forms of reactances, as in Fig. 11, there is formed a series circuit containing inductance and capacity, which will be resonant at whatever frequency the inductive and the capacitive reactances balance each other out, and

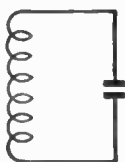

Fig. 11. Series-Resonant Circuit

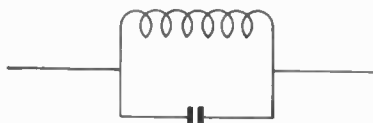

Fig. 12. Parallel-Resonant Circuit

they will offer little opposition to the flow of alternating current at that particular frequency. At resonance

$$X_L = X_C$$

therefore 
$$2\pi fL = \frac{1}{2\pi fC}$$

Solving for the frequency,

$$f = \frac{1}{2\pi\sqrt{LC}}$$

where  $f$  = frequency in cycles per second

$L$  = inductance in henrys

$C$  = capacity in farads

Thus for any value of  $L \times C$  a resonant frequency will exist. Calculations of resonant circuits showing  $LC$  values for various frequencies are given in Table I, see page 136.

**Parallel-Resonant Circuit.** On the other hand, if the condenser and the coils are connected in series as shown in Fig. 12, and the combination is connected into the circuit, they represent what is

known as a parallel resonant circuit which offers a high resistance to the flow of alternating current at the resonant frequency.

*Rejctor Circuit.* Such a circuit is termed a *rejctor circuit* because of its ability to pass all but a narrow band of frequencies about its resonant valve. When included in an antenna circuit it is termed a *wave trap*. Its function in such a case is to eliminate undesirable frequencies which may be interfering with normal reception.

**Use of Wave Traps.** There are numerous types of wave traps or filters used in radio circuits. They are all combinations of

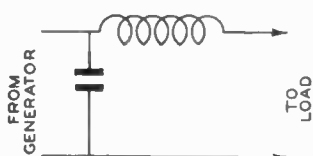

Fig. 13. Filter Which Passes Low Frequencies

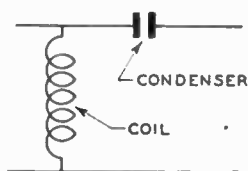

Fig. 14. Filter Which Passes High Frequencies

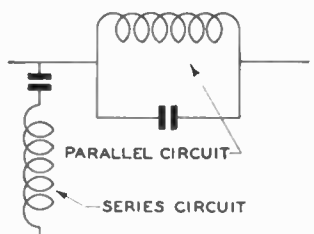

Fig. 15. Filter Circuit Designed to Reject a Particular Frequency

the series-resonant or parallel-resonant circuits. Citing a few concrete examples: If it is desired to pass only the low frequencies through a circuit and cut off the high frequencies, a combination such as that shown in Fig. 13 would be used. The inductance offers little opposition to the flow of low-frequency alternating currents, but opposes the flow of high-frequency currents. The condenser, on the other hand, allows the high-frequency currents to pass, but opposes the flow of low-frequency impulses. If it were desired to re-

tain the high frequencies and eliminate the low frequencies, the condenser would be placed in the line and the inductance would serve to by-pass the low frequencies, as in Fig. 14.

In order to reject a given frequency, a *parallel-resonant circuit* is placed in the line (see Fig. 15), and a *series-resonant circuit* serves to by-pass the current at that frequency. Conversely, if it is desired to select a particular frequency, the series-resonant circuit is in series with the line and a parallel-circuit resonant to that particular frequency serves to keep the current directed through the series circuit.

## VACUUM TUBES

---

A *vacuum tube*, as defined by the Institute of Radio Engineers, is a device consisting of a number of electrodes contained within an evacuated inclosure. Its usefulness is made possible by certain natural phenomena, including applications of the electron theory and the fundamental laws governing electricity and magnetism.

**Electronic Emission.** In accordance with the Electron Theory, all metals are said to consist of minute particles called *molecules*; the molecules, in turn, are subdivided into *atoms*; and atoms consist of combinations of positive and negative electric charges, called *protons* and *electrons*, respectively. Scientists have agreed that electrons are free to move within the metal, and if the molecular or atomic structure is disturbed, the electrons leave the protons to which they are attached and move about. It has also been stated that heat, among other things, will cause the electrons to move, and if sufficient heat is applied over a long enough period of time, the electrons will leave the metal and fly off into space. Herein lies a phenomenon that occurs in a vacuum tube in operation—*electronic emission*, caused by heat.

If a piece of wire is connected across the terminals of a source of electric energy—a battery, for example—it will become heated quickly, will glow, perhaps, and may burn in two. If the wire is made of metal that offers a high resistance to the flow of electrical energy, it will become hot, and the power it consumes will be dissipated in the form of heat. However, another phenomenon occurs through the process of heating. Electrons, or negative charges of electricity, disturbed by the heat, leave the proton to which they are attached. If the heat is sufficiently intense they will leave the surface of the metal and fly off into space. Eventually, these electrons will attach themselves to other protons, or they may return to the metal and associate again with the positive charges contained therein.



*Thermionic Tube and Phototube.* One of the electrodes of the vacuum tube is known as the *filament*. It is on the order of the filament that is a part of an incandescent lamp. When electric current is passed through the filament, it becomes heated and glows, giving off negative charges which fill the space within the glass inclosure, or envelope. Movement of the *electrons* is indicated by short arrows in Fig. 1A. Thus it is that the vacuum tube that is

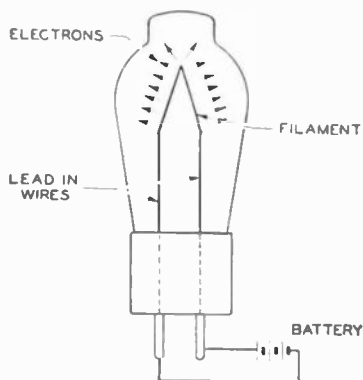

Fig. 1A. Diode Tube Showing Filament

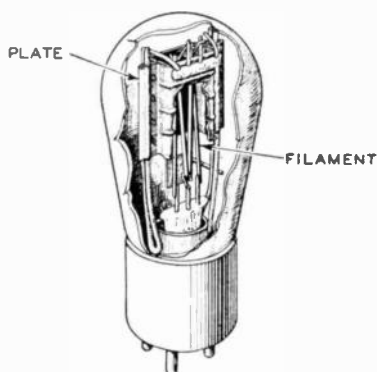

Fig. 1B. Diode or Two-Element Tube

used in radio circuits is known as a *thermionic tube*, one in which the emission of electrons is caused by heat, as differentiated from *phototube*, one in which the emission of electrons is caused by the presence of light.

If the *wire* used as the filament in a vacuum tube were not inclosed within the vacuum, it would burn in two almost immediately, due to the presence of oxygen. The space within the glass envelope having been evacuated—the air and gases pumped out—no oxygen being present, the wire remains intact to act as a source of electrons set free by heat.

**Diode Tubes.** The simplest form of a vacuum tube is the *diode*, a tube which has two electrodes, known as the *filament* and the *plate*, Fig. 1B. There are three terminals for external connections, two for the filament and one for the plate element. If a *battery* of proper voltage is connected across the terminals of the

filament, the wire becomes heated, setting electrons in motion. As the temperature of the filament element rises, the electrons moving about with the first application of heat, break through the surface of the filament wire and fly off into the space within the tube. Then if a connection is made from the plate terminal through a sensitive measuring device, a milliammeter, and to the positive terminal of the battery, a minute current will be found to flow through the circuit of which the plate is a part, even though there is no physical connection between the plate and the filament within

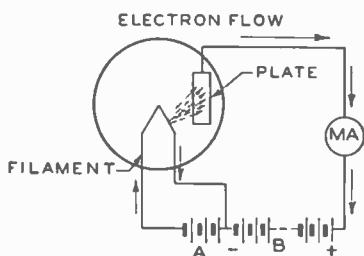

Fig. 2. Direction of Electron Flow in a Vacuum-Tube Circuit

the tube. If the plate circuit is opened and another battery is connected in series with the measuring device, so that the positive terminal of the battery is connected to the plate of the tube, as in Fig. 2, an appreciable current will flow in the plate circuit.

**Edison Effect.** Here we have an example of the fundamental action of a vacuum tube. The filament, heated by the flow of electricity through it, emits electrons. The plate, given a positive charge because it is connected to the positive terminal of a battery, the negative terminal of which is connected to one side of the filament circuit, attracts the electrons given off by the filament and causes a flow of current through the plate circuit. The electrons are moving from the *filament* to the *plate* and through the circuit to the battery, through the battery to the filament circuit, thence to the filament itself, shown diagrammatically in Fig. 2. The electrons serve to complete the circuit within the tube.

The discovery of this phenomenon, known as the *Edison effect*, is attributed to Thomas A. Edison, who, in 1883, could find no use

to make of his discovery. It was not until twenty-one years later, in 1904, that J. A. Fleming of London found that the diode could be used for the detection of radio signals.

**Triode Tubes.** The introduction of the *grid*—a third element, or electrode—into a vacuum tube by Lee DeForest increased its utility tremendously by giving it the properties of amplifying and oscillating. This tube with three elements—*filament*, *plate*, and *grid*—is known as a *triode tube*.

*DeForest's Improvement.* The grid, so named because of its appearance, serves to control the flow of electrons between the filament and the plate elements. Fig. 3 shows the three elements placed in their respective relative positions—the *filament* on the

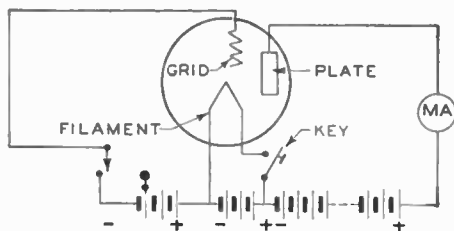

Fig. 3. Radio-Tube Circuit

left, the *grid* in the center, and the *plate* at the right. A battery is connected to the terminals of the filament. A second battery is connected into the plate circuit in exactly the same manner as shown in the paragraph describing the diode—the positive terminal connected to the plate terminal of the tube, and a measuring device, a milliammeter (*MA*) connected in series. The negative terminal of the plate battery is connected to one of the terminals of the filament battery. The negative side of a third battery, the positive terminal of which is connected to the negative terminal of the filament battery, goes to the grid terminal on the tube. Note that there is a third terminal on the battery by means of which we may vary the voltage delivered to the grid.

*Action of Triode Tube.* When the *key* in the filament circuit is closed, the current passes through the filament element, heating it, causing the electrons to be emitted. The positive charge upon

the plate attracts them, even as it did in the foregoing example. If the connection to the grid is removed, the current flowing through the plate circuit will be found to increase greatly. Reconnecting the grid battery into the circuit will cause the plate current to drop. Remove the connection from the negative terminal on the grid battery and place it on the center terminal—which is a lower voltage output—then the current in the plate circuit will be found to increase over that which was passing when the entire battery was in circuit, but less than when the battery is out of circuit.

The explanation of the foregoing experiment is as follows: The electrons driven out of the filament are attracted to the plate because of the positive charge. The grid, however, carries a negative charge which repels the negatively charged electrons, and allows only a limited number of them to pass through to the plate. Hence, when the negative charge is increased, the number of electrons passing between the filament and the plate is decreased, with a consequent drop in current flow. Practically no current flows in the grid circuit as long as the grid is negative with respect to the filament and the plate. If, however, a positive charge is impressed on the grid, a milliammeter placed in the grid circuit would indicate the flow of grid current, due to the fact that the positive charge on the grid would attract electrons in exactly the same manner as the plate.

**Construction of Grid and Plate.** The *grid* is made of a fine wire wound in the form of a spiral, the turns held in position by *supporting wires*, Fig. 4. It may be flat, round, or oval to meet requirements of design. The surface is relatively small compared to that of the *plate*. Hence, although it sets up a negative charge that repels part of the electrons and prevents them from passing on to the plate element, it cannot stop all of them—in fact, if it did so, the tube would not function.

Nickel is used extensively in tube construction, due principally to the facility with which it can be formed and the ease with which it is freed of gases that cling to its surface. While it is formed into different shapes readily, it is at the same time substantial, and is not particularly susceptible to damage.

*Space Charge.* Not all of the electrons which leave the *fila-*

ment with sufficient velocity make their way to the plate, even though the grid element may be at zero potential, owing to a phenomenon called the *space charge*. After the electron stream between the filament and plate has been established, the electrons—acting in accordance with the fundamental law, *like charges repel*—have a tendency to repel other electrons that are coming from the filament. This tendency is counteracted by the positive charge upon the plate, so that those electrons that get close enough to the plate are attracted to it while those closer to the filament are pushed

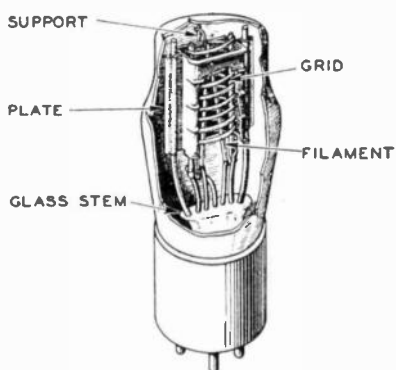

Fig. 4. Illustration Showing Triode Tube and Arrangement of Filament, Grid, and Plate

backward. Increasing the value of the positive charge upon the plate, up to a limiting value, tends to overcome the space-charge effect.

**Amplification Factor.** There is a definite relationship between the value of the voltage on the grid element of the tube and the flow of current in the plate circuit. Any change whatsoever in the value of the voltage applied to the grid will cause a corresponding change in the plate current. Changing the value of the voltage applied to the plate element will likewise affect the amount of current flowing in the plate circuit—the greater the voltage, the greater the current, within certain limits. These two facts give rise to the determination of one of the characteristics of the tube, the *amplification factor*, which is a measure of its ability to amplify

the signals that are impressed upon it through the grid circuit, and which may be further defined as the ratio of the effect of change in grid voltage to change in plate voltage on the flow of plate current. In order to determine the amplification factor of the tube, a set-up such as that shown in Fig. 5 may be supplied.

Citing as a hypothetical case, a tube of the 99 type which requires 3 volts on the filament: Having made the connections as shown, with a 200-ohm potentiometer at *P-1* and a 10,000-ohm (or higher resistance) at *P-2*, adjust the variable resistors until there are 4 volts on the grid and 90 volts on the plate. Then adjust potentiometer *P-1* until there is a change of 1 milliampere in the plate current, noting the amount of change in the grid voltage that

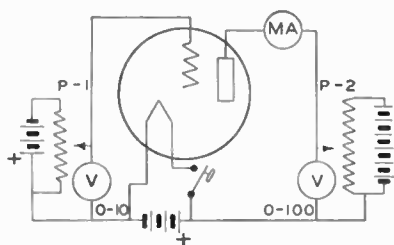

Fig. 5. Radio-Tube Test Circuit for Determining the Amplification Factor of the Tube

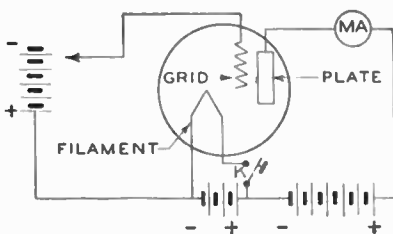

Fig. 6. Circuit Connection for Determining the Amplification Factor of Tube Circuit Connection Arranged for Varying the Grid Voltage

caused the change in current. Reset the potentiometer until there are again 4 volts on the grid and 90 volts on the plate, and adjust potentiometer *P-2* until the same change in plate current—1 milliampere—occurs. You will find that the plate voltage required to cause a variation of 1 milliampere in plate current is much greater than the grid voltage required to cause the same variation in plate current. Note the reading on the voltmeter in the plate circuit.

If the difference in plate voltage required to cause the change of 1 milliampere of current flow is divided by the change in grid voltage required to cause the same change in plate current, the amplification factor of the tube is determined. For example, if it has been found that a change of 1.5 volts on the grid caused a drop of 1 milliampere in the plate current, and that a change of 9 volts on the plate caused a corresponding change, the amplifica-

tion factor of the tube would be 9 divided by 1.5 which equals 6. In other words, a given signal impressed upon the grid of the tube would be amplified 6 times in passing through the tube, as would each change in the amplitude of the signal.

**Grid Control of Current.** It has been shown that the grid acts to control the flow of electrons to the plate, and that it thereby controls the flow of current in the plate circuit. The conditions, as set forth in the case cited, will not hold for all values, however, and in order to ascertain the action throughout a variation of voltages,

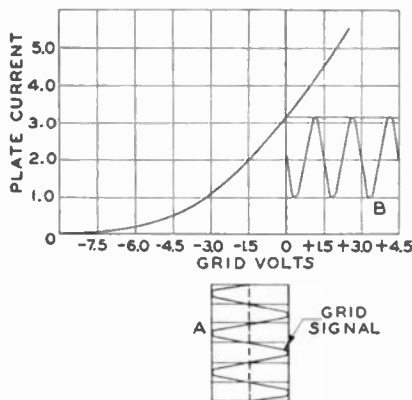

Fig. 7. Graph Showing Characteristic Curve of a Vacuum Tube

we have set up a simple test circuit as shown in Fig. 6, from which we can determine what is going on in the circuit as the voltage is varied. The potential applied to the plate is 45 volts. The record of the results is shown in Fig. 7. When the charge on the grid is 7.5 volts negative, the milliammeter in the plate circuit indicates a flow of .05 of a milliamperes of current, practically zero. When a potential of 6.0 volts negative is applied to the grid, the plate current increases to .1 of a milliamperes. With the grid at 4.5 volts negative, the plate current has increased to .5 of a milliamperes; at 3.0 volts it is 1.0 milliamperes; at 1.5 volts it is 2.0 milliamperes; at zero volts it is 3.2 milliamperes; and at 1.5 volts positive potential on the grid the plate current is 4.5 milliamperes.

Assume that there is a potential of 1.5 volts negative upon the

grid, and that an alternating voltage of 1.5 volts peak is also impressed upon the grid circuit. That would mean that the potential on the grid would vary between zero and 3.0 volts negative, neutralizing the negative charge at the time when the alternating current was at maximum-positive potential, and adding to the charge on the grid when the cycle swung over to maximum-negative potential. Referring to Fig. 7 it will be found that the plate current will vary from 3.2 milliamperes to 1.0 milliampere.

*Sine Wave.* The alternating voltage is considered to assume values corresponding to the sine of an angle as the angle rotates through  $360^\circ$ . The *sine of an angle* is a trigonometric function and when considering alternating-current circuits the action is considered to follow this perfect curve. Hence the term *sine wave* or *sinusoidal wave*. The sine wave is shown at *A* in Fig. 7. The current in the plate circuit will vary in accordance with the values shown on the graph in Fig. 7, and may be represented as shown at *B* in Fig. 7. Note that the form of the curve representing the flow of current plotted against time follows that of the alternating voltage impressed upon the grid.

However, if we assume that the potential impressed upon the grid is 4.5 volts negative and that an alternating voltage of 1.5 peak is impressed upon the grid circuit, then the plate current will vary between .1 of a milliampere and 1.0 milliampere. In view of the fact that the change in plate current is much less between 4.5 volts and 6.0 volts on the grid than it is between 3.0 volts and 4.5 volts on the grid, the wave form is distorted as shown in Fig. 8. Hence, it is evident that in order to prevent distortion, it is essential that the tube be operated with a potential on the grid that will permit the use of that portion of the grid-voltage, plate-current characteristic curve that is straight, or approximately so, when the tube is used as an amplifier.

The variations in the plate current will follow the fluctuations in voltage at the grid regardless of whether the grid signal is sinusoidal or irregular. In the illustration given, the voltage value of the impressed alternating-current signal is greater than those found normally in the circuit of a radio receiver, but was made sufficiently high for illustrative purposes.



Referring again to Fig 7, it will be seen that the average plate current is 2.0 milliamperes, which is the same current that would be flowing with 1.5 volts negative bias—the normal operating bias of the tube according to the illustrative values given previously.

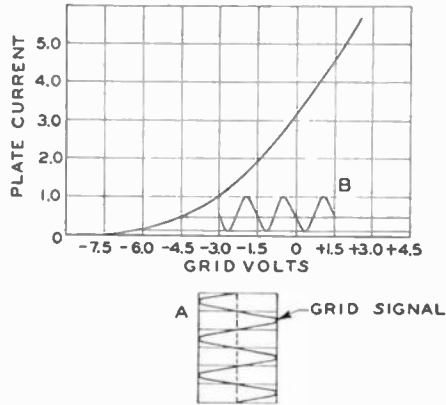

Fig. 8. Characteristic Curve of a Vacuum Tube Showing Result of Operating the Grid Signal Voltage on the Bend of the Curve

Therefore, it is shown that the plate current is divided into two components—one the alternating-current component, the other the direct-current component. The direct-current component is the one that would be shown by a measuring instrument, which measures the average value—in this case, 2.0 milliamperes. The alternating-current component has an amplitude of 2.2 milliamperes.

**Effect of Gas in Tube upon Phase Relationship.** The alternating component of the plate current will always be in phase with the alternating component of the grid voltage in a tube that is free from gas. But, in the event that gas is present, the ionization in the tube that occurs as a result thereof, causes the plate current to lag. Since the current and voltage of an alternating current are in phase when resistance only is present, it is evident that the tube acts as a pure resistance—or conductance.

*Plate resistance* and *plate impedance*, though considered commonly to be more or less synonymous, are actually quite different, both as to value and effect.

**Plate Resistance.** *Plate resistance* is the measure of the resistance to the flow of direct current through the tube—in other words, the direct-current resistance. It is determined by applying

Ohm's law,  $R_p = \frac{E_p}{I_p}$ ,  $E_p$  representing the plate voltage,  $I_p$  repre-

senting the plate current in amperes, and  $R_p$  representing the plate resistance. Thus, if it is found that with a plate voltage of 90 volts the plate current is five milliamperes, the plate resistance will be that shown by dividing 90 by .005 or 18,000 ohms. If, on reducing the potential applied to the plate to 45 volts, the current in the plate circuit is three milliamperes, .003 amperes, the resistance under such conditions would be 15,000 ohms. Hence, it is necessary to know the conditions under which the tube will function to determine its plate resistance. The plate resistance, for a given plate potential, changes for every change of grid voltage. Therefore, when measuring plate resistance, the steady value of applied grid voltage must be specified.

**Plate Impedance.** *Plate impedance* is a measure of the resistance to the flow of varying currents in the plate circuit, thereby differentiated from plate resistance which is a measure of the resistance to direct current flow. It is determined by dividing the change made in the value of the plate voltage by the resulting change in plate current. Thus, if a change of 45 volts on the plate caused a change of two milliamperes in the current flow, the plate impedance would be 22,500 ohms, and if the reduction had been from 90 volts to 45 volts, the tube would be said to have a plate impedance of 22,500 ohms at 45 volts, and it would also be necessary to state the potential upon the grid. Plate impedance changes with each change in the value of either the voltage on the grid or upon the plate. Hence, it is necessary to know the conditions under which the tube is to function in order to determine the value of the plate impedance, as in the case of the plate resistance shown.

**Mutual Conductance.** In order for a vacuum tube to serve its purpose as an amplifier most efficiently, it is necessary that it be capable of producing the maximum undistorted change in the flow

of plate current with very small changes in grid potential. Such changes are a measure of the tube's ability to conduct electricity, and the effect is a ratio of the changes in grid potential with the changes in plate current. The ratio is known as the *mutual conductance* of the tube.

It has been shown that the amplification factor of a tube is the number of times the tube will amplify a given signal, determined by dividing the change in plate potential required to cause a certain change in plate current by the change in the grid potential required to create the same change in plate current. It has also been shown that the plate impedance is the ratio of the change in plate voltage to the change in plate current, found by dividing the change in potential applied to the plate to create whatever change in plate current it may cause. It is evident that the ratio of the plate current change to the plate potential change is a measure of the ability of the plate circuit to conduct electricity. *Mutual conductance* is defined as the ratio of the change in plate current to the change in grid voltage which caused it. The mutual conductance of a tube may be determined by dividing the amplification factor by the plate impedance.

Mutual conductance is measured in *mhos*, or, to be more specific *micromhos* (millionths of a mho). Thus, a tube that has an amplification factor of 6 and a plate resistance of 15,000 ohms will have a mutual conductance of .0004 mhos, or 400 micromhos. Inasmuch as the value of the plate resistance varies with changes in the value of the plate potential, it is evident that the mutual conductance of the tube will vary likewise. It is necessary, then, to know the constants of the circuit in which the tube is to function in order to specify its mutual conductance, otherwise known as the  $G_m$ . *Mutual conductance* or *grid-plate transconductance* is defined as the rate of change of plate current with respect to a change in grid voltage.

Generally speaking, a tube that has a high mutual conductance will serve better as an amplifier than one which has a low mutual conductance. However, a tube that has a high mutual conductance will not serve so well as an output tube, as one with a low mutual conductance.

**Multi-Element Tubes.** The discussion up to this point has concerned tubes of the types known as the *diode* and the *triode*, those having two and three elements, upon which the fundamental principle of tube operation is based. Engineering practice has brought about the development of tubes with a multiplicity of elements, each of which serves a definite purpose, and, as this treatise continues, the uses for the multi-element tubes will become evident.

**Types of Filaments.** Practically all vacuum tubes used in radio and associated electronic devices make use of an electron-emitting source which is supplied with heat to bring about emission. The source of electrons is called the *cathode*, regardless of the method of producing the emission. The element to which the electrons are drawn, due to its having a positive potential applied, is called the *anode*. Cathodes may be directly or indirectly heated. In the directly heated type, the filament not only supplies the necessary heat, but also acts as the source of electrons.

The material of the filament in the directly heated type of emitter must be chosen to combine suitable electrical characteristics together with proper emission qualities. Not all substances emit electrons in sufficient quantities to be usable at reasonable operating temperatures. Tungsten, the original filament material, requires a high temperature (2400°C.) to provide sufficient emission. This exceeds the safe operating temperature for most metals and alloys.

The use of a thoriated-tungsten filament, a combination of tungsten and thorium, results in suitable emission at a temperature of 1700°C. with a consequent saving in filament operating power.

Alkaline-earth oxides are also used as a coating for tungsten-wire filaments to permit free flow of liberated electrons at low-filament temperatures. The operating temperature is reduced to approximately 750°C. This results in increased filament life. These oxides are seen as a whitish covering.

**Cathodes.** The indirect-heater *cathode* is one in which the *filament* which acts merely as a *heater* element is inclosed in a sleeve upon which is a coating of oxide that supplies the electronic stream under sufficiently high temperatures, Fig. 9. The indirect-heater cathode was developed shortly after the introduction of alternating-current tubes, as a means to better control the tube

action and to eliminate the difficulties that arose due to direct connection with the low-frequency alternating-current circuits.

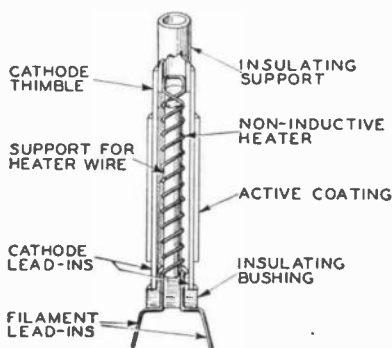

Fig. 9. Illustration Showing the Construction of Heater-Type Filament and Cathode

**Exhausting the Tube.** It is necessary that the space within the glass envelope be devoid of all traces of gas—air, it will be understood, is a gas, also. During the process of manufacture the air is pumped out of the inclosure, and the elements of the tube are heated by surrounding the tube with a coil through which a high-frequency current is flowing, thus driving the gases out of the metal and thence out of the tube. Even after all these precautions are taken, what traces of gas may remain are absorbed and made inactive by a device known as the *getter* which causes the silvery coating on the inside of the bulb. Magnesium is a commonly used *getter*. A small tablet placed in a cup is discharged by heat generated by a high-frequency current flowing through a coil placed around the outside of the tube. The exploding magnesium combines with the residual gas and renders it inactive.

The connections to the elements are brought out through airtight seals, using a specially developed wire for sealing through the glass. If ordinary wire were used, the contraction and expansion due to variations in temperature would crack the seal and allow air to be admitted to the inside of the tube. A great deal of research was required to develop a connecting wire that would serve the purpose.

**Dissipating Heat.** In view of the fact that high temperatures are generated inside the tube, first by the heat of the filament, and second, by the electronic bombardment of the plate element, the other elements of the tube, particularly the plate, may become so hot as to liberate electrons, also. Consequently, it is necessary to provide a means to dissipate the heat and prevent a reverse flow of negative charges. Oxidation of the plate element—the black coating—is one means employed. Another method is to use a perforated element. The large transmitting tubes use a water jacket around the plate through which cool water is circulated to dissipate the heat due to the causes mentioned.

**Interelectrode Capacitance.** The direct capacitance between two electrodes known as *interelectrode capacitance* or *intertube capacity* exists in all vacuum tubes. In some instances, the intertube capacitance is an aid in circuit design, whereas again it presents serious obstacles. Each electrode—element—of the tube constitutes one plate of a condenser of low capacity, the value of which depends upon the size of the elements and the space between them. The interelectrode capacitance existing between the plate and the grid of the tube is probably of greatest importance, due to the fact that in high-gain high-frequency amplifier circuits, the capacity is likely to produce a coupling between the input and output circuit of the tube which will result in a return of energy from the plate to the grid circuit. If this returned energy is in phase with the original signal voltage, a strengthening of the signal results. This is called *regeneration*. If too great a value is returned, the tube circuit becomes a generator of radio-frequency energy. As such it is termed an *oscillator* and reception will be seriously impaired. Oscillators are discussed in another chapter. Fig. 10 shows the capacitances as they exist in the triode.

**Construction of Tetrode Tubes.** The *tetrode* or four-element tube is commonly known as the *shield-grid*, or *screen-grid*, tube. This tube was developed to provide a means to obtain high gain in a high-frequency amplifier circuit, especially in the radio-frequency stages, without the *feedback* previously referred to as *regeneration*. It has been shown how interelectrode capacitances exist, and how they are likely to cause regeneration in high-gain

amplifier circuits. In order to overcome the effect of plate-to-grid capacity, another grid was inserted between the two elements, so that the capacitances then became plate-to-shield, shield-to-grid, and grid-to-filament, minimizing the objectionable grid-to-plate

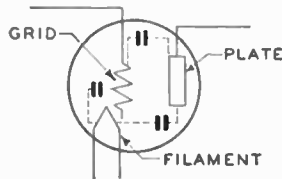

Fig. 10. Capacity Effect between the Different Tube Elements

capacitance. The screen or shield operates at a positive potential lower than that applied to the plate, and is grounded to the signal voltage by connecting a condenser from the source to ground.

In constructing the tube, two *screens* are used, one placed near and around the *grid coil* (*inner screen*), Fig. 11, and the

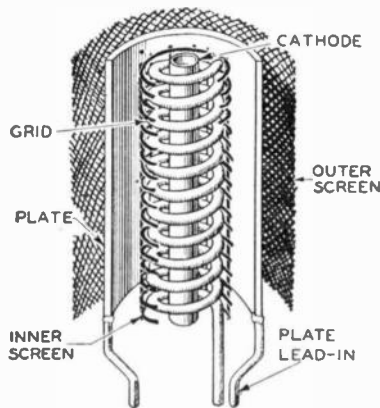

Fig. 11. Interior Construction of a Tetrode or Screen-Grid Tube

other around the outside of the plate of the tube (*outer screen*). These screens are joined together either inside the tube or at the tube socket.

The use of the tetrode facilitates greatly the stabilization of high-gain amplifier circuits, particularly in high-frequency circuits. Stabilization refers to the operation of preventing an amplifier from going into self-oscillation. The use of a screen-grid tube makes unnecessary the use of special stabilizing circuits. The amplification factor of the tetrode is many times higher than the triode.

**Pentode Tubes.** The *pentode*, so named because it contains five electrodes, Fig. 12, was developed to provide a means to elim-

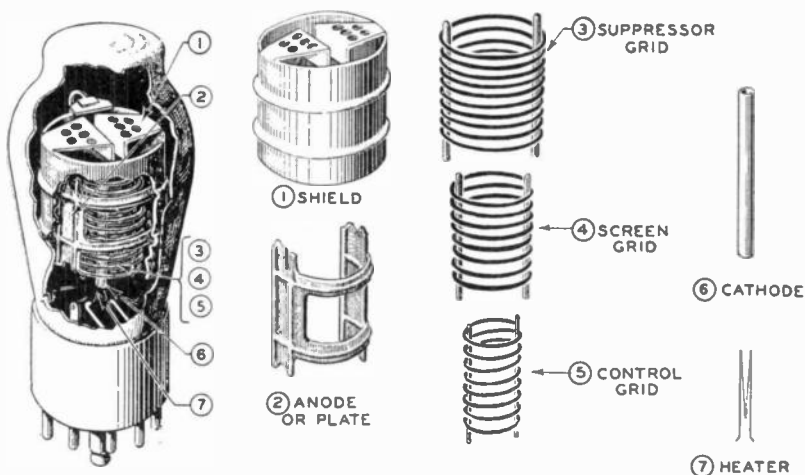

Fig. 12. A Cutaway View of a Pentode Tube and Enlarged Detail of the Separate Parts

inate or minimize *secondary emission*, an emission of electrons caused by the bombardment of the plate by high-velocity electrons. This emission of electrons is called *secondary emission* to differentiate from the flow of electrons coming from the *cathode*, which is the primary electronic flow (Edison effect). Naturally, secondary emission would have a tendency to retard the flow of electrons from the filament, thus jeopardizing the operation of the tube.

The presence of the *screen* or shield in the tetrode—carrying a positive charge, as well as the *plate*—increases the secondary emission because of the greater velocity attained by the electrons, thereby lowering the plate current, particularly at times when the plate voltage drops lower than the constant potential applied to the



screen. Hence, a fifth electrode, a *suppressor grid*, placed between the *screen* and the plate, Fig. 13, and usually connected to the cathode, returns the secondary electrons to the plate because of the negative charge impressed upon it—the same as that of the cathode.

High amplification gain with relatively low potentials on the plate and screen are made possible by the use of the suppressor. Some of the pentode tubes are provided with a separate terminal

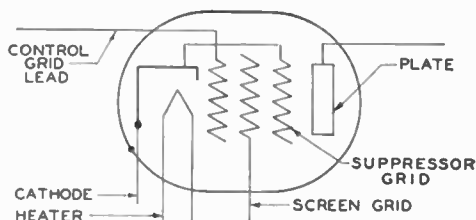

Fig. 13. The Symbol for a Pentode Tube

for the suppressor grid to permit variations in circuit design, by allowing varying potentials to be applied to the electrode for the purpose of producing certain effects.

**Special-Purpose Tubes.** During the course of the development of radio, the vacuum tubes used in radio circuits came to be known by such terms as *general-purpose tubes*, *detector*, *high-mu*, and so on. Although the detector and the high-mu tubes were of a special class, it was equally true that the general-purpose tube would serve in any stage, including the output until the introduction of the output power tubes.

Eventually, however, it became common practice to design tubes to meet specific requirements. Also, as a means to conserve space on the chassis, as well as reduce the cost of manufacture, it was found advisable to combine tubes—that is, provide a single tube with sufficient elements to serve more than one purpose. These tubes came to be known as the *multi-electrode tubes* or *multi-purpose—multi-unit—tubes*. Their purposes and the method of using them is specified in each case by the manufacturer.

## AMPLIFIERS AND AMPLIFICATION

*Amplification* is the term applied to the result obtained by increasing the voltage or current, or both, through successive stages of oscillatory circuits, coupled circuits, filters, and vacuum tubes, which, combined, constitute a device called an *amplifier*.

**Kinds of Amplifiers.** Amplification is accomplished by means of creating a gain of voltage or power. Voltage gain is obtained by means of *voltage amplifiers*; a gain in power is obtained by *power amplifiers*. Amplifiers are of two general classes, those for the amplification of radio frequencies—called *radio-frequency amplifiers*—and those for the amplification of voice frequencies—called *audio amplifiers*. Voltage amplifiers or power

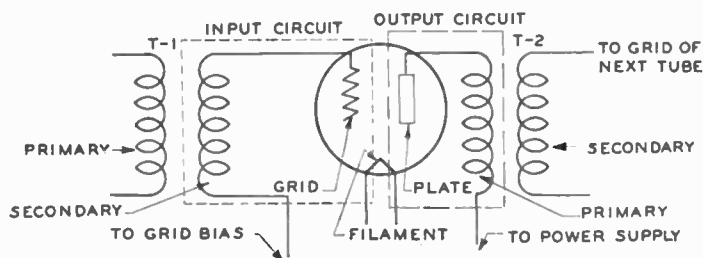

Fig. 1. Radio-Frequency Amplifier Circuit

amplifiers may be employed in either class of service, if desired, but since, in a radio-frequency amplifier, it is necessary to build up an extremely weak signal to one which has a high enough potential to cause an appreciable change in plate-current flow, the principle of voltage amplification is usually employed for the purpose. Voltage amplifiers are used to build up the grid potentials—and, as a consequence, create greater variations in the flow of plate current—in successive stages of an audio amplifier, using an increase in power to furnish the energy needed to actuate the sound creating devices.

**Input and Output Circuits.** A typical radio-frequency amplifier stage, shown in Fig. 1, consists of a *transformer* and a *vacuum tube*, and for purposes of illustration and more complete explanation the transformer for the succeeding stage is shown also. The *input circuit* is that which comprises the *secondary* winding of transformer *T-1*, feeding into the *grid* of the vacuum tube, and the necessary connections with the *filament* to complete the circuit. This is shown inside the dash lines. The *output circuit* of the stage is otherwise known as the *plate circuit* and consists of the *primary* winding of transformer *T-2*, connected from the plate of the vacuum tube to the source of energy—the *power-supply unit*—to complete the circuit. This circuit is shown inside the dash lines, Fig. 1.

The *grid bias* is a direct-current potential applied to the grid element of the tube. The *input signal* is the potential that is induced in the secondary winding of the transformer *T-1* because of the variations in current flowing through the *primary* windings of this transformer *T-1*.

The plate voltage is the direct-current potential supplied to the *plate* of the vacuum tube to attract the electrons emitted by the cathode. The plate current, also, has been described as the current which flows through the plate circuit under specific conditions of plate voltage and grid voltage. The *output signal* is represented by the varying flow of plate current caused by the fluctuations of the voltage induced in the secondary of transformer *T-1*, and impressed upon the grid of the tube.

It is evident that as the alternating voltage applied to the grid of the tube is of greater amplitude, it will cause greater variations in the flow of plate current. Also, as the variation in the flow of plate current is increased a higher voltage will be induced in the secondary of the next transformer, *T-2*, which, in turn, will create still greater variations in the flow of current in the output circuit of the succeeding stage, and so on. Thus, by building up the amplitude of the input signal, the signal in the output circuit of each stage is amplified, and the amplitude of the input signal impressed upon the grid of the tube in each succeeding stage is increased proportionately.

**Voltage Amplification.** Voltage amplification is the ratio of the alternating voltage in the output circuit of an amplifier stage to the alternating voltage that is impressed upon the input circuit. Or, taking into account an amplifier, voltage amplification is the ratio between the alternating voltage at the output terminals of the amplifier to the alternating voltage that is impressed upon the input circuit of the amplifier.

**Voltage Amplifiers.** The ability of a vacuum tube to respond to minute changes in the value of the voltage applied to the grid element by causing corresponding variations in the current flowing in the plate circuit has been explained. The measure of a tube's ability to amplify is the *amplification factor*, which is the

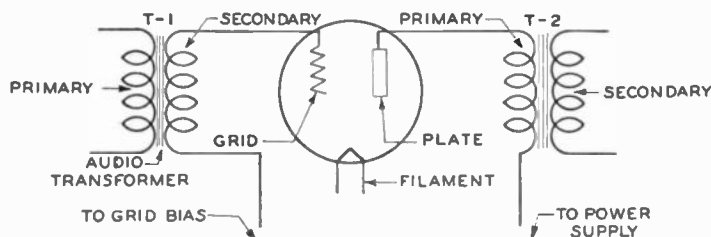

Fig. 2. Audio-Amplifier Circuit

ratio between change in plate voltage and change in grid potential required to cause a given variation in the flow of plate current.

In Fig. 2, there is a circuit containing (reading from left to right) an *audio transformer*, *T-1*, a *vacuum tube*, and another *audio transformer*, *T-2*. Assume that the *primary* of the first transformer, *T-1*, is connected to a source of direct current, suitably protected with resistance. There would be no action on the *secondary* side of the transformer. However, if an alternating or fluctuating voltage is impressed upon the circuit, there will be a rise and fall in the voltage and consequently the current flow, which creates a varying magnetic field around the primary of transformer *T-1*, inducing a voltage in the secondary windings of the transformer.

**Audio Transformers.** If the transformer is of the *iron-core type*, Fig. 3, such as used in audio circuits, there will be a voltage

gain in the transformer itself, which gain will be in the order of the ratio existing between the number of turns in the secondary to the number of turns in the primary. If, on the other hand, the transformer is one used in radio-frequency circuits—the air-core type—there is little or no voltage gain in the transformer because of the losses due to flux leakage and loose coupling.

The voltage that is induced in the secondary winding of transformer *T-1* (Fig. 2), changing in amplitude in accordance with the variations in the flow of current through the primary circuit,

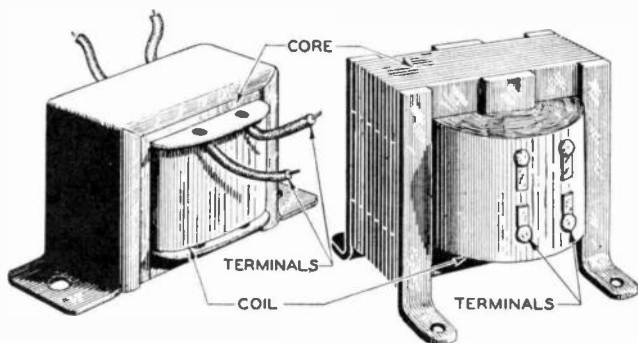

Fig. 3. Audio Transformers (Iron Core)

increases and decreases, alternately, the potential upon the grid of the vacuum tube. The rise and fall of the grid voltage cause a greater or less amount of current to flow through the output or plate circuit, amplified, however, according to the ability of the tube to cause changes in current flow with variations in the grid voltage. Hence, for example, if the tube has an amplification factor of six, the alternating component of the plate current will have an amplitude six times greater than that in the secondary circuit of transformer *T-1* (Fig. 2), theoretically speaking, but in practice this maximum is seldom obtained.

What has happened in the amplifier stage illustrated and previously discussed will continue in the successive stages of the amplifier, building up the low alternating impulses until they are of sufficient amplitude to swing the grid enough to cause powerful changes in the flow of current in the plate circuit.

*Radio-Frequency Transformers.* The voltage gain obtained

by transfer from primary to secondary in a radio-frequency transformer is negligible. However, a high-value inductance having a low ohmic resistance to the flow of direct current, used in place of the primary of transformer *T-2* in a radio-frequency amplifier, will have a high impedance to the flow of the varying current and will serve to cause a gain in the voltage through the coupling device. The inductance may be a choke coil—universal or lateral wound—having a large number of turns. An illustration of a radio-frequency choke coil is shown in Fig. 4.

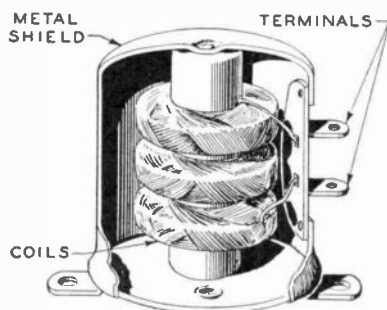

Fig. 4. Radio-Frequency Choke Coil

An inductance, while permitting the free flow of direct current—allowance being made for the ohmic resistance of the wire—effectively resists the flow of alternating, or fluctuating, current because of the counter-electromotive force caused by the self-inductance of the coil. Hence, the coil having little, or negligible, effect upon the value of the positive potential upon the plate of the tube, acts as a resistance to the flow of the alternating component of the plate current, and establishes a varying potential difference across the terminals of the coil. This varying potential may be transferred to the input circuit of the succeeding tube.

**Obtaining Voltage Gain.** The voltage amplification, or gain, obtained by means of a voltage amplifier is determined by the combined effect of the amplification factor of the tube, the plate resistance of the tube, and the load resistance of the output circuit. This condition is to be differentiated from that shown by taking into account only the static characteristics of the tube, from which

the value of the amplification factor is obtained, and which would indicate that the input voltage in each succeeding stage of a voltage amplifier would be that of the previous stage multiplied by the amplification factor.

It has been shown that the plate impedance of the tube is a measure of the ratio of change in plate voltage to the change in the flow of plate current caused by the variations in potential. Due to the *plate impedance*, which is resistance to the flow of alternating current in the plate circuit, and which normally is of high ohmic value, the full advantage of the amplification factor cannot be taken.

**Calculating Amplification.** The formula used for determining the voltage amplification is as follows:

$$E_{Amp} = \frac{Mu \times R_L}{R_L + R_p}$$

in which  $E_{Amp}$  is the voltage gain,  $Mu$  is the amplification factor of the tube,  $R_L$  is the plate-load resistance, and  $R_p$  is the alternating-current plate resistance—the opposition to the flow of alternating (or varying) current through the circuit. For example, in an amplifier stage using a tube that has an amplification factor of 10, an alternating-current plate resistance of 10,000 ohms, and in which the load resistance is 100,000 ohms, the voltage amplification obtained would be:

$$\frac{10 \times 100,000}{100,000 + 10,000} = 9.1$$

If the plate-load resistance is increased to 200,000 ohms, the voltage amplification would be:

$$\frac{10 \times 200,000}{200,000 + 10,000} = 9.5$$

showing that the gain increases, and approaches the amplification factor of the tube, as the resistance of the plate load is increased. The same condition would hold for impedance also. In fact, inductance is more popular than resistance in practice due to the fact that resistance, as resistance, reduces direct-current potential upon the plate in proportion to the value of the resistance, which necessitates the use of high-supply potential. The inductance used in the

plate circuit may be a choke coil, or it may be the primary of a transformer.

It is evident that the desirable objective in a voltage amplifier is to build up the voltage through successive stages without regard for power gain—power as measured in watts (volts times amperes).

**Power Amplifiers.** When an increase in the strength of a signal is accomplished by an actual increase in the power as measured in watts (volts times amperes) such increase is said to be an *amplification of power*, as differentiated from the *amplification of voltage*. The purpose of power amplifiers is to develop sufficient dynamic energy to drive mechanical devices that create disturbances of the air to form sound waves.

Power amplifiers, unlike voltage amplifiers, usually require a high flow of plate current. The voltage gain, on the other hand, is generally low in the power stage. The voltage amplifier has presumably served its purpose in building up the voltage so that the amplitude of the signal impressed upon the grid of the power tube is sufficient to cause an appreciable swing of the grid to create a corresponding variation in the plate current flow.

The amplification factor of triode vacuum tubes used to produce power is low, in the order of 3 to 3.5, as compared with 8 to 30 or more for tubes designed to be used in voltage amplifiers.

**Distortion of Signals.** Any sort of variation between the original signal and the amplified signal is known as *distortion*. It may be caused in any one or more of several ways—in fact, it may be introduced into the circuit purposely—but in any event it represents a departure of the resultant wave shape of electrical energy from that which is impressed upon the input circuits.

Distortion may exist in a circuit, yet may not be aurally perceptible. In fact, there are few, if any, amplifiers which transfer the energy through successive stages so faithfully that there is no measurable difference between the characteristics of the input signal and the output signal. However, the human ear is unable to detect such distortion until it becomes pronounced—a relatively high percentage of change in signal characteristics.

**Distortion by Tube.** A great deal of amplifier distortion is due to the vacuum tubes—not because of improper design of the



tubes, but because of the application of improper potentials to the various elements. It has been shown how the value of the current flowing in the plate circuit depends upon the potential applied to the grid, and how by introducing an alternating voltage to the input circuit of the tube, the potential on the grid changes during the cycle, adding to the *negative bias* during the period that the alternating current is flowing through the negative alternation, and subtracting from the value of the *grid bias* during the positive alternation.

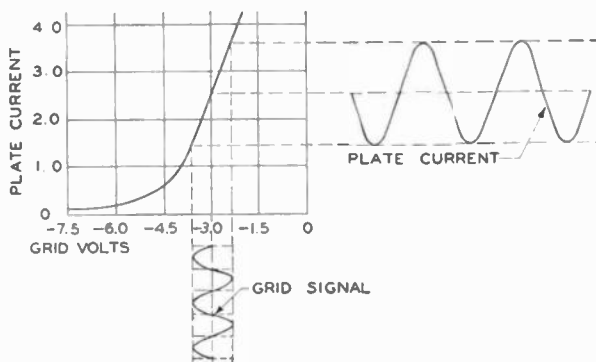

Fig. 5. Showing Type of Signal Produced When a Tube Is Operated on Straight Portion of Characteristic Curve

Fig. 5 shows a typical example of the phenomenon, in which, from all practical standpoints, there is minimum distortion. The curved heavy line represents the *grid-voltage plate-current characteristic curve*, showing little flow of current when the potential on the grid is highly negative, rising as the charge on the grid approaches zero. The vertical line 0 indicates zero grid potential, negative to the left, and positive to the right. Note that the curve rising gradually at first makes an abrupt rise when the grid is at about 4.5 volts negative, and has become practically linear at 4.0 volts. If a steady negative potential of 3.0 volts (called the *grid bias*), is applied to the grid and an alternating voltage having a peak amplitude at .5 volt is introduced into the input circuit, the potential on the grid will swing from 3.5 volts negative ( $-3.5$ ) to 2.5 volts negative ( $-2.5$ ). The curve between the vertical

lines at the bottom of the illustration indicates the swing of the alternating voltage. Since a potential of 3.5 volts on the grid causes a certain amount of plate current to flow (1.5 milliamperes) and a potential of 2.5 volts on the grid causes a greater amount of plate current to flow (3.5 milliamperes) it is evident that the variations in the potential on the grid will cause a fluctuation in the flow of current in the plate circuit as shown by the plate-current curve at the right.

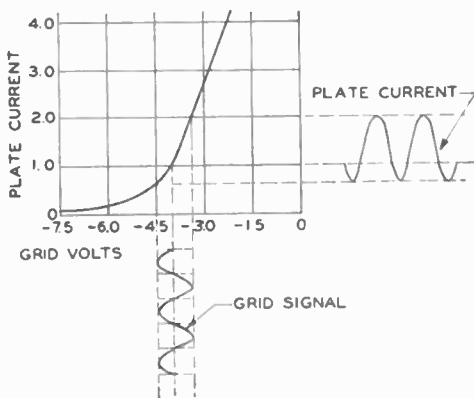

Fig. 6. Curves Showing Result of Changing the Grid Bias

**Effect of Changing Grid Bias.** Suppose now that the grid is at 4.0 volts negative ( $-4.0$ ), and that an alternating voltage having a peak amplitude of .5 volt is introduced into the input circuit, see Fig. 6. The grid swings from 4.5 volts negative ( $-4.5$ ) to 3.5 volts negative ( $-3.5$ ), as shown by the curve below the horizontal line. But the plate-current changes caused by varying the grid voltage from 4.5 to 3.5 volts are greatly different from those caused by changing the grid potential from 3.5 to 2.5 volts negative, Fig. 5, as in the previous example. Here, Fig. 6, the alternating component will not correspond to the input voltages, but will follow the path as shown at the right, the alternations below the line being very much lower in amplitude than those above the line (1.0 line extended). This variation will cause a distorted signal, and demonstrate that in order to deliver an undistorted signal it is

necessary that the tube be operated on the straight portion of the grid-voltage plate-current curve, except as shown in the next and in later paragraphs.

Assume again that a negative bias of 1.0 ( $-1.0$ ) volt is applied to the grid and that an alternating voltage with a peak amplitude of 1.25 volts is impressed upon the input circuit. This means

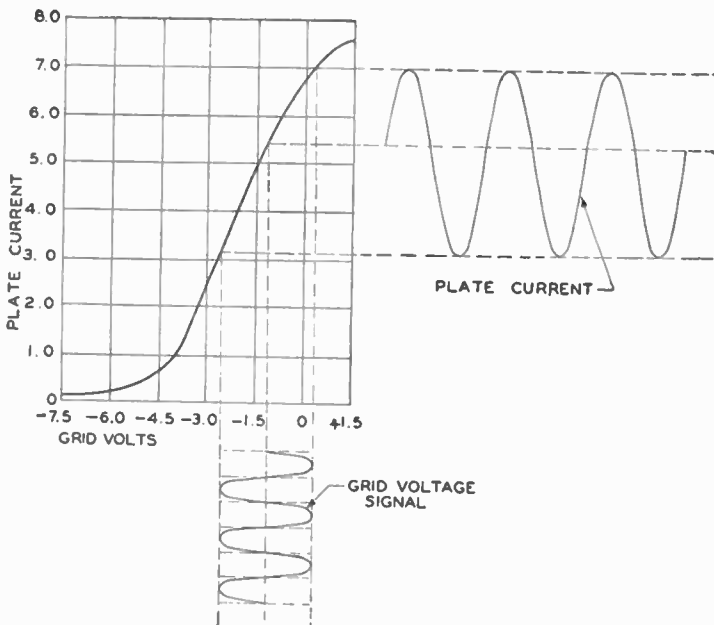

Fig. 7. Diagram Showing Result of Operating a Tube without Enough Negative Grid Bias

that when the impressed alternating voltage is positive, the grid will be at one-fourth volt positive ( $-1.0 + 1.25$ ), in which case, it, too, will attract the electrons emitted by the cathode, causing current to flow in the grid circuit as well as in the plate circuit. Hence, the relationship existing between the grid voltages and the plate currents will be as represented in Fig. 7, and the current flowing in the plate circuit will not be a reproduction of the input signal.

We have considered only those alternating potentials on the grid which are of sine-wave shape. If they were of varying ampli-

tude—as caused by the variations in speech and music—the effect would be more pronounced in that some of the sounds would be over-exaggerated and others would be under-emphasized, while a few, within a given range would not be changed.

**Effect of Overloading Tube.** A tube is said to be overloaded when the applied alternating voltages drive the grid potential so far negative or positive that the tube is forced to operate on the curved portion of the grid-voltage plate-current curve. Unless the amount of energy supplied to the grid is too great, changing the normal grid bias—making it more or less negative—will place alternating component swing on the straight portion of the curve and correct the difficulty, if the tube has been operating on the curved portion of the grid-voltage plate-current curve. Naturally, however, if the energy that is applied to the grid drives the grid potential too highly negative, and at the same time drives the grid positive with the next alternation, the only alternative is to reduce the amplitude of the alternating voltage applied to the grid or to change the operating characteristics or possibly use a different type of tube capable of accommodating a larger signal input.

**Types of Amplification.** Engineers recognize three distinct types of amplifiers, known as and referred to universally as *Class A*, *Class B*, and *Class C*. The differentiation lies principally in the relationship between input voltages and plate-current flow, and the resulting wave form. The selection of the type of amplifier to be used depends on the results which the engineer wishes to attain.

*Class A Amplifier.* When the grid of an amplifier tube is biased so that the alternating voltage impressed upon the input circuit will swing the grid voltage within the linear portion of the grid-voltage plate-current characteristic curve the plate-current wave form is substantially identical with the input-voltage wave form, as shown in Fig. 5. Such an amplifier—known as a *Class A Amplifier*—is characterized as having low efficiency and output with minimum distortion. Reference to Fig. 5 will show that plate current flows in the output circuit at all times.

*Class B Amplifier.* A *Class B Amplifier* is one in which the grid is biased so that with no excitation upon the grid there is

practically no flow of plate current. When the alternating potential is applied to the grid of the tube, plate current will flow during the positive half of the cycle. Then during the alternation when the excitation voltage is negative, there is practically no current flow in the plate circuit. An ideal Class B amplifier would be one in which there is *no* plate-current flow during the negative alternation—complete cut-off—or plate-current flow during 180 electrical degrees of the exciting-voltage cycle. Class B amplifiers are characterized as having medium efficiency and output with a relatively low ratio of power amplification.

*Class C Amplifier.* A *Class C Amplifier* is one in which the grid is biased considerably beyond the cut-off so that plate current flows through less than 180 electrical degrees of the cycle. The use of a Class C amplifier permits the use of exceedingly high alternating-current potentials on the grid, thus passing plate current of high amplitude during a portion of the positive alternation of the grid-excitation voltage. Class C amplifiers are characterized as having high plate-circuit efficiency and output with relatively low ratio of power amplification.

*Class A Prime Amplifiers.* A *Class A Prime Amplifier*, otherwise known as a *Class AB Amplifier*, is one in which plate current flows through substantially more than 180 electrical degrees of the cycle, but less than 360 electrical degrees as in the Class A Amplifier. Hence, it will be seen that the tube in a Class A prime amplifier will be biased so that a portion of the negative half of the cycle will swing the grid past cut-off and that during that part of the cycle no plate current will flow. A Class A prime amplifier has characteristics midway between a Class A amplifier and a Class B amplifier.

*Class BC Amplifier.* A *Class BC Amplifier* is one in which the grid is biased so that plate current flows during less than 180 electrical degrees of the alternating-current cycle, but over a greater portion of the cycle than in a Class C amplifier. The characteristics are intermediate to a Class B amplifier and a Class C amplifier.

**Changing Amplifiers to Different Class.** There is no distinct line of demarcation between the classes of amplification. In fact, it can be seen very readily that a Class A amplifier may be

changed slightly and become a Class AB amplifier, or even a Class B amplifier. The vacuum tube may be the key to the type of amplification employed, and an amplifier may operate as a Class A amplifier with one type of tube, but by substituting another tube, especially designed to shift the operating characteristics, the amplifier may fall into Class AB or Class B classifications.

Therefore, remember that plate current flows in the output circuit in amplifiers, as follows:

Class A —through 360 electrical degrees of the cycle

Class AB—through more than 180 electrical degrees, but less than 360 electrical degrees of the cycle

Class B —(theoretically) through 180 electrical degrees of the cycle

Class BC—through little less than 180 electrical degrees of the cycle

Class C: —through appreciably less than 180 electrical degrees of the cycle

Thus the distinguishing characteristics of any amplifier may be kept well in mind, and its classification may be determined by analyzing the grid-voltage plate-current characteristics of the tube used in the circuit, together with the operating potentials on the grid and on the plate.

**Use of Class A Amplifier.** A Class A amplifier may be used either as a voltage amplifier or as a power amplifier, the differentiation being determined by the tube used and the constants of the circuit. If the tube is one having a high-amplification factor feeding into a high-resistance load, it will serve to amplify the alternating voltage impressed on the input circuit of the succeeding stage. On the other hand, if the tube has a low-amplification factor—such as triode power tubes have—and feeds into a relatively low-load resistance—as required in output circuits—it will develop appreciable power to drive the mechanical sound creating devices. The tubes which operate in voltage amplifiers draw little plate current from the power-supply device, and the signal output power of a voltage-amplifier stage is considerably less than the direct-current plate input power.

A Class A amplifier may also be used as a voltage amplifier to

drive an output-power stage using Class B amplification. The Class A amplifier would be called a *driver stage* in this connection. In view of the fact that low distortion is one of the characteristics of Class A amplifiers, it is evident that the wave form of the alternating voltage impressed upon the grid or grids of the tube or tubes in the output or power stage will be substantially identical with the wave form of the originating signal, and, therefore, the distortion at the output terminals will be low. Such a combination provides a means to develop higher power in the output, because of the increased

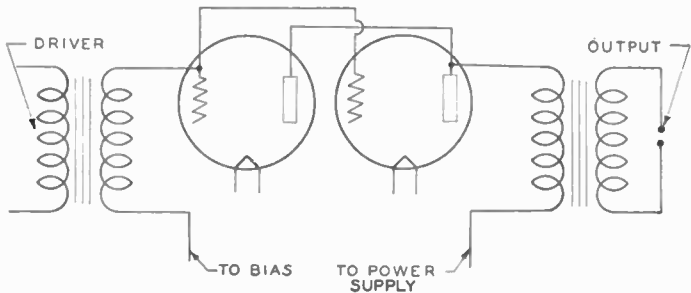

Fig. 8. Diagram Showing a Plate Circuit Using Two Power Tubes in Parallel

efficiency of Class B amplifiers. The power-output circuit may be designed so that the distortion occurring in the output stage will not exceed the permissible 5 per cent.

**Tubes in Parallel and Push-Pull.** A Class A audio amplifier is the only classification of amplifiers that permits the use of a single tube in the power output stage without perceptible distortion. However, the power available may be increased considerably by using tubes connected in parallel or in *push-pull*. Fig. 8 shows two triodes connected in parallel in a power stage. Twice the output may be obtained from such a parallel connection with no increase in the input voltage over that required for a single tube. The plate current will be that of two tubes. A push-pull stage shown in Fig. 9 will likewise develop twice the power of a single tube, but requires twice the signal input voltage of one tube. The push-pull circuit has advantages over either single-tube or parallel-tube operation particularly in the elimination of distortion due

to even-order harmonics, and the cancellation of hum due to plate-voltage-supply fluctuations.

**Use of Class B Amplifier.** A Class B amplifier is used where large power output is required. In view of the fact that a relatively low plate current flows with no excitation on the grid, a signal of sufficient magnitude will cause an output wave which is very small during the negative half of the cycle and high during the positive half of the cycle. Thus, it is essential in a Class B audio

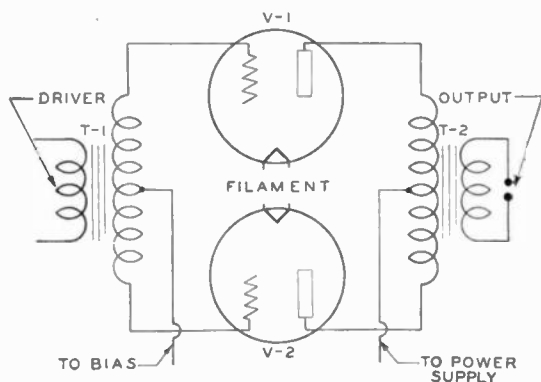

Fig. 9. Diagram Showing a Push-Pull Amplifier Stage

amplifier to use a push-pull output stage to minimize distortion, and it is essential, too, that the push-pull stage be well-balanced.

The transformer connecting the driver stage and the Class B output-power stage is usually of the step-down type, ranging between a ratio of 1.5 to 1 and 5.5 to 1. The design of the transformer and the step-down ratio are dependent upon the type of the tube in the driving stage, the type of tube used in the power stage, the load on the power tube, the permissible distortion, and the efficiency of the transformer.

It is evident that so far as circuit design is concerned, the principles are identical in all classes of amplification. The difference lies in the constants of the circuits and in the type of tubes used. All classes of amplification may be adapted to resistance-coupled amplifiers, impedance-coupled amplifiers, transformer-coupled amplifiers,



or any circuit that may be selected. The fundamental idea is that first the alternating voltage must be built up to cause a substantial swing of the grid potential in order to create maximum fluctuations in plate-current flow. The load resistance through the voltage-amplifier plate circuits must be high in order to provide a high signal-voltage drop for transference to the succeeding stage. Tubes having a high-amplification factor are desirable in order to obtain the maximum variation of plate current with relatively small changes in the grid potential. The power is developed in the final stage which feeds the sound producing devices, using additional current obtained from an external source of electrical energy.

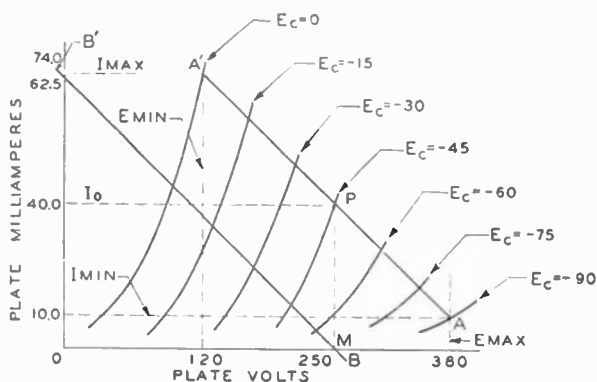

Fig. 10. A Group of Plate-Voltage Plate-Current Curves Obtained with Different Grid-Bias Voltages

**Power-Output Calculations.** Power is measured in watts, and is a function of voltage and current—watts equals volts times amperes ( $W = EI$ ). Calculations of the power output of amplifiers, while not accurate, give results that are not seriously in error and serve to give a basis for practical computations.

The manufacturers of tubes usually furnish charts showing all characteristics of their products, among which is one which shows the relationship that exists between plate current and plate voltage with different grid bias—called the plate family of curves.

Let us assume that an output tube feeds into a load resistance of 4,000 ohms; that it is drawing 40 milliamperes of current with 250 volts on the plate and a negative grid bias of 45 volts. In Fig. 10

there is shown a plate family of curves—hypothetical for purposes of illustration. Plate voltages are indicated along the horizontal axis with plate current in milliamperes indicated vertically. We shall say that the tube is to be operated with a minimum plate current of 10 milliamperes—the minimum current at which it will develop measurable power.

From the point indicating the plate voltage at which the tube is operating, 250 volts, a line is drawn to a point on the plate current axis, determined by dividing the plate voltage by the value of the load resistance, in this case  $250 \div 4,000 = .0625$ , or 62.5 milliamperes. This line  $BB'$ , serves as the base.

The tube, it has been stated is drawing 40 milliamperes at 250 volts on the plate. Therefore, at the intersection of the dotted lines indicating the two values (40 milliamperes and 250 volts) locate point  $P$ . The grid-voltage curve  $E_c$  for a negative bias of 45 volts intersects at the same point. If now a line is drawn parallel with  $BB'$  through point  $P$ , the necessary factors to make the calculation may be determined.

The formula to determine the power output for triodes is:

$$\text{Power Output} = \frac{(I_{\text{max}} - I_{\text{min}}) \times (E_{\text{max}} - E_{\text{min}})}{8}$$

The maximum current flow at any point along the line  $AA'$  will be at the intersection of the line with the curve indicating zero grid bias—in this case 74 milliamperes at 120 volts. The minimum current flow has been given as 10 milliamperes which is intersected by the line  $AA'$  at 380 volts. Substituting the values as found in the foregoing formula:

$$\text{Power Output} = \frac{(.074 - .010) \times (380 - 120)}{8} = 2.08 \text{ watts}$$

Due to the fact that the plate voltage applied to a tube in dynamic operation is not constant but is varying due to the changing voltage drop in the load, the tube does not operate in a strictly linear manner. This produces harmonic distortion, *i.e.*, the generation of frequencies a whole number multiple of the fundamental frequency. While these frequencies are not unpleasant to the ear they nevertheless represent a form of distortion. The most signifi-

cant harmonic is the second, with higher order harmonics diminishing rapidly in amplitude.

It is possible to determine the percentage of second harmonic distortion from the values given in Fig. 10 using the following formula:

$$\text{Per cent Second Harmonic Distortion} = \frac{\frac{I_{\max} + I_{\min}}{2} - I_o}{I_{\max} - I_{\min}} \times 100$$

Substituting,

$$\frac{\frac{.074 + .010}{2} - .040}{.074 - .010} \times 100 = 3.1\%$$

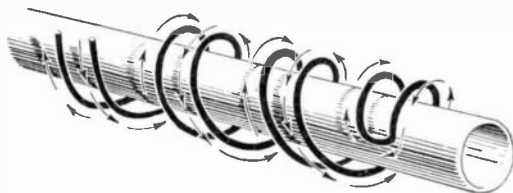

Fig. 11. Non-Inductive Wire-Wound Resistance

The value of the load resistance should be such that the distortion shall not exceed 5 per cent, and may be determined more accurately by experiment from the results of the foregoing calculation. Ordinarily, with triodes, the plate-load resistance will be approximately twice the value of the plate resistance.

**Frequency Response.** An audio-frequency amplifier should be designed to pass as efficiently as possible a relatively wide range of audible frequencies. Otherwise, the reproduction will be greatly distorted and lacking in quality—timbre and overtones.

The most efficient amplifier from the standpoint of frequency response is that using resistance coupling—a resistance-coupled amplifier. However, in order for a resistance-coupled amplifier to be the most efficient, it is necessary to use noninductive resistances—carbon or special noninductive wire-wound units. A noninductive wire-wound resistance is made as shown in Fig. 11, the resistance wire doubled back to neutralize the inductive effect

that would be produced. Similarly, the capacitance or condenser used should be of the noninductive type.

The essentials of a resistance-coupled amplifier are shown in Fig. 12. The resistance in the plate circuit, the value of which may be determined with relative accuracy by applying the formula for determining voltage amplification, causes a varying voltage drop across the resistance with each change in the flow of current in the plate circuit. The variations in potential are conveyed to the input circuit of the following stage through the *coupling condenser*, which may vary between values of .1 microfarad and .006 microfarads, and the grid resistor, which generally has a value be-

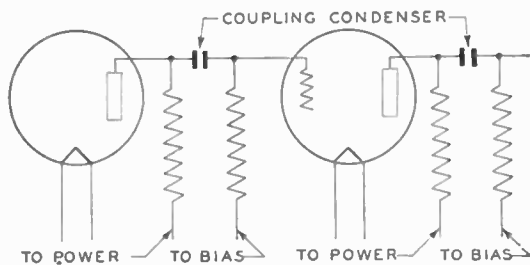

Fig. 12. A Resistance-Coupled Amplifier

tween 100,000 ohms and 2 megohms. Low values of capacity require large values of resistance and vice versa for good frequency characteristics. Too high a value of resistance will cause some instability while a reduced value results in decreased gain in the following stage.

A properly designed resistance-coupled amplifier—with resistances of correct value in the output circuit and in the input circuit and the proper capacity of coupling condenser—will be characterized by highly efficient frequency response, low distortion, and relatively low gain, the last-named characteristic being due to the inadvisability of using too high resistance in the plate circuit, thereby reducing the voltage on the plate.

The principles governing oscillatory circuits as previously explained pertain to circuits carrying audio frequencies as well as those through which radio frequencies are passing. Hence, the relationship that exists between the inductive and capacitive values

in an audio circuit is a limiting factor in the ability of the amplifier to transfer from one stage to another the electrical interpretations of the sound variations.

**Response Measurement.** There are two methods in common use for determining the frequency response of an amplifier. First, a signal of known characteristics is impressed upon the input circuits of the amplifier and measured with an output meter at the output terminals of the amplifier. Such a method requires a signal generator of the type known as an audio oscillator which may be tuned to deliver voltages of various frequencies. The ratio between the input signal and the output signal may be recorded on a curve or graph from which it may be determined how faith-

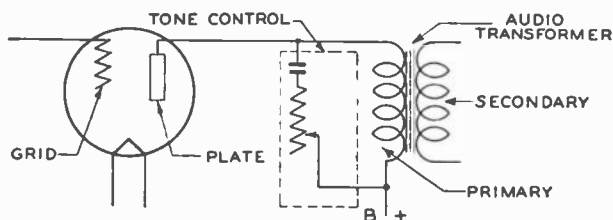

Fig. 13. Tone Control Connected Across Primary of Audio Transformer

fully the amplifier is transferring the energy at given audio frequencies. The second method is that which requires the use of the reproducing device delivering sound to a microphone that is connected to a recording unit, the characteristics of which have been checked. The former method, giving as it does the characteristics of the amplifier itself, enables the engineer to design a reproducer that will flatten out the curve—drop its response where the amplifier shows high gain, and increase its response where the amplifier gain is low—and adjust the overall performance. The second method gives an immediate true (as true as the variables in circuit design will permit) picture of the action of the amplifier and the sound creating devices.

**Tone Control.** In order to compensate for the likes and the dislikes of the users of radio and its allied accessories, such as amplifiers, engineers have developed means to control the tone delivered by the amplifier and the reproducer. A *tone control* serves

to change the constants of the circuit in such a way that the higher frequencies may be either emphasized or eliminated, or the lower frequencies may be accentuated or reduced.

Engineers and acousticians have learned that the human ear is extremely erratic in its functioning. It has been found that there are no two persons whose hearing is identical—therefore, it is logical that their tastes will differ in the matter of tonal response.

There are various methods for controlling the tone of an amplifier, any of which constitutes deliberate introduction of distortion

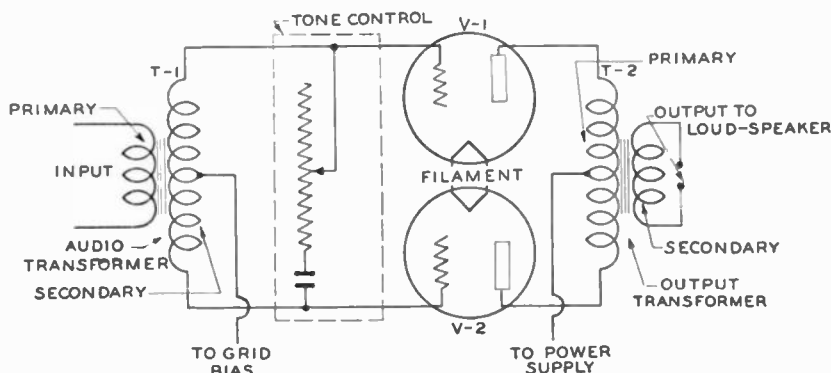

Fig. 14. Tone Control Connected Across the Secondary of Audio or Input Transformer in a Push-Pull Amplifier Stage

into the circuit. Usually, however, it consists of a variable resistance and condenser—in series—placed in parallel with the *primary*, Fig. 13, or the *secondary*, Fig. 14, of the first *audio transformer*. The variation of the value of the resistance changes the constants of the circuit, and effectively shifts the frequency response of the circuit either up or down, as it cuts off more or less of the high frequencies. A *tone control* may also consist of a network of condensers of varying capacity shunted across an inductance providing a means to change the resonant period of the circuit.

**Push-Pull Amplification.** Mention has been made of push-pull stages of amplification, and it is deemed advisable to describe briefly the principle upon which it functions.

A push-pull stage requires the use of two vacuum tubes—or a single tube designed with multi-electrodes to be used in place of the

two tubes—and transformers of special design for both the input and the output circuits. Fig. 14 shows a stage of push-pull amplification in which transformer  $T-1$  consists of a primary winding and a center-tapped secondary; transformer  $T-2$  consists of a center-tapped primary and a secondary to feed the reproducing device. Note that each of the outer terminals of the secondary winding of transformer  $T-1$  is connected to the grid of a vacuum tube, and that each of the outer terminals of the primary winding of transformer  $T-2$  is connected to the plate of the vacuum tubes. The grid bias for the tubes is provided through the center-tap of the secondary winding of  $T-1$ ; the plate voltage is applied to the plates of the tubes through the center-tap of the primary of  $T-2$ .

As voltage is induced into the input circuit of the stage, let us say, for example, that the terminal at the top of the transformer  $T-1$  is positive, which would mean that the polarity at the lower terminal is negative. Thus, the voltage on the grid of tube  $V-1$  would be made more positive, while the voltage on the grid of tube  $V-2$  would be made more negative. As shown in previous paragraphs, more plate current would flow through the plate circuit of tube  $V-1$ , and less plate current would flow through the plate circuit of tube  $V-2$ .

As the alternating voltage swings, the upper terminal of transformer  $T-1$  becomes negative and the lower terminal becomes positive. Here now the grid of tube  $V-1$  is more negative, causing less plate-current flow, and the grid of tube  $V-2$  is less negative causing greater plate-current flow. With perfectly matched tubes and components the resulting magnetic field set up about the primary of the output transformer is zero with no signal input, due to the oppositional current flow in the two primary sections. The signal causes a difference in plate current flow to  $V_1$  and  $V_2$  and the resultant magnetic field change is twice the change that would be obtained with a single tube, hence the doubled output.

**Uses of Amplification.** The discussion of amplification has been taken up in a general way. In the succeeding pages applications of the principles explained in this chapter will be discussed. It will be shown how the radio signals are amplified through radio-frequency amplifiers, through intermediate amplifiers, and through

audio amplifiers. Regardless of the application of the principle of amplification, fundamentally an amplifier stage receives an impressed signal in its input circuit and amplifies either the voltage or the current, or both, and delivers to the succeeding stage or circuit a signal that has the characteristics necessary to meet the requirements of the design.

The selection of the classification of amplifier is at the discretion of the engineer who designs the circuit, as is the type of tube to be used, and the constants of the circuit. If low distortion is desired, it is logical, as shown in the preceding paragraphs, to employ a Class A amplifier. If it is desired to secure high-voltage gain, tubes having a high amplification factor feeding into high resistance loads would be the normal selection. If greater power is required, and it can be obtained without introducing a too high percentage of distortion, a Class B amplifier may be used. In any event, the design of the circuit and the selection of the constants are determined by the use to be made of the device, and the purpose it is to serve.





According to the physiologist or the psychologist, sound is a sensation produced in the ear. But according to the physicist, sound is a disturbance of the air—a motion of the air in the form of waves which, if they strike certain parts of the ear, create the sensation of hearing. The physiologist and the psychologist emphasize the presence of the ear as necessary to the existence of sound, while the physicist believes that sound can exist even if there is no ear to hear it.

### ACOUSTICS, THE SCIENCE OF SOUND

Sound is produced usually by the vibrations of a material body—as, for example, the vibrating string of a musical instrument. It may also be produced by one substance striking another as, for instance, a stone striking the pavement. When a drumhead is struck by a drum stick, the resulting vibrations create a different sort of sound.

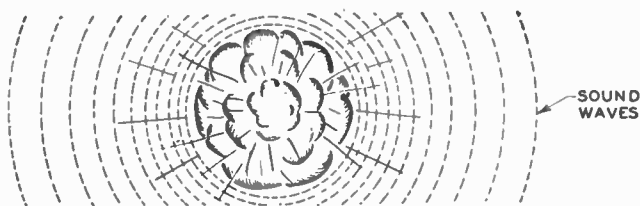

Fig. 1. Sound Waves from a Bomb Bursting in Mid-Air

**Sound Waves.** Sound travels in *waves* that can best be described as similar to those resulting from throwing a stone into a pool of water. The water, disturbed at the point of impact, forms in ripples circling outward from the stone. A bomb, when exploded in the air, instantaneously releases a quantity of gas under high pressure, thereby compressing the air immediately surrounding the point of explosion, as shown in Fig. 1. The air at normal

pressure rushes in as rapidly as its pressure will permit, to fill the rarefied space caused by the compression; thus a succession of variations in pressure, above and below normal, travel outward in all directions from the point of disturbance. The wave of compressed air strikes the eardrum, causing it to be pressed inward; and when it reacts outward almost instantaneously to the rarefied area (that below normal pressure), the succession of movements of the eardrum, through the mechanical lever system of the middle and the inner ear, causes the sensation which we know as *hearing*—in this case producing a *crack* or a *boom*.

Sound, then, may be defined as a *wave motion* consisting of areas of more or less than normal pressure (compressions and rare-

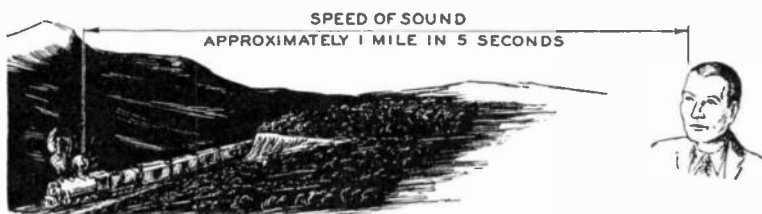

Fig. 2. Diagram Illustrating Speed of Sound through Air

factions), which are produced by a vibrating body and transmitted through an elastic medium.

Practically all substances are elastic—air, metals, wood, and water. When a piece of metal is struck with a hammer, the impact causes the displacement of molecules which, in turn, strike those next to them, and so on, so that the sound is transmitted through the metal.

**Speed of Sound.** The speed of sound is rated according to the distance it travels in still air (there is no sound in a vacuum, because there is no elastic medium to be disturbed) at about 1,100 feet per second. This means that nearly five seconds elapse between the time we see the steam emitted by the whistle of a locomotive a mile away, and the time we hear the sound—in still air. A diagram illustrating *speed of sound* is shown in Fig. 2. The velocity of sound in air varies slightly with temperature and barometric pressure.

**Amplitude.** The degree of loudness, or volume, of sound is known as *amplitude*. It is determined by the degree to which the particles of the transmitting medium are disturbed. For instance, a bomb in which the gas is at high pressure (either because of the method of manufacture or because of high temperature), if exploded in mid-air, would cause a much greater rush of air than a similar bomb in which the gas pressure was lower (due to the method of manufacture or because of low temperature). The amplitude of the sound of the first bomb would be greater than that of the second one; but the velocity with which the sound of the two explosions traveled through the air would be the same.

The intensity of a sound wave varies inversely as the square of the distance from the source of disturbance. Thus doubling the distance from the source reduces the intensity to one-fourth of its value.

The relation between velocity, density, and elasticity of the transmitting medium is expressed as follows:

$$V = \frac{e}{p}$$

where:  $V$  = the velocity of the sound wave (compressional);  $e$  = the volume modulus of elasticity of the medium;  $p$  = the density of the medium. The modulus of elasticity is equal to stress divided by strain where *stress* refers to the force per unit area and *strain* means the deformation produced by the stress.

Water conducts sound waves with greater speed and greater intensity than air. The sound of a gun which is fired from offshore into a body of water is heard by a person standing on the bank as two distinct sounds (the second is often mistaken for the echo). The first sound is carried by the water—the second one through the air. Sound travels about four times as fast in water as in air.

Also, a tapping on a piece of wood, inaudible through air, can be heard distinctly by placing the ear to the wood at quite a distance from the point where the tapping is done.

**Music and Noise.** If the successive compression or high-pressure areas and the rarefactions or low-pressure areas occur at regular intervals, the sound created is called a *musical note* or

*sound*. However, if the compression and the rarefactions are irregularly timed, the resulting sound is usually called a *noise*. A string on a musical instrument will vibrate so that it produces disturbances that are timed equally, creating a musical tone. The shuffling of feet, on the other hand, produces irregularly timed disturbances and, therefore, is a noise. Some noises are used to advantage in combination with the playing of musical instruments and, as an accompaniment, blend in with the regularly timed waves that create music and so become a part of the music itself.

### PRODUCTION AND TRANSMISSION OF SOUND

Since we are concerned with sounds of a musical nature (which include the human voice), we will consider chiefly the production of musical sounds.

**Tuning Fork.** A tuning fork is carefully made so that the length and mass of its prongs determine the number of vibrations it will produce per second.

When the tuning fork is struck against an object—for example, a table or the palm of the hand—the prongs begin vibrating as shown by the *dotted lines* in Fig. 3, and their movement sets up a disturbance of the surrounding air particles. Following the action

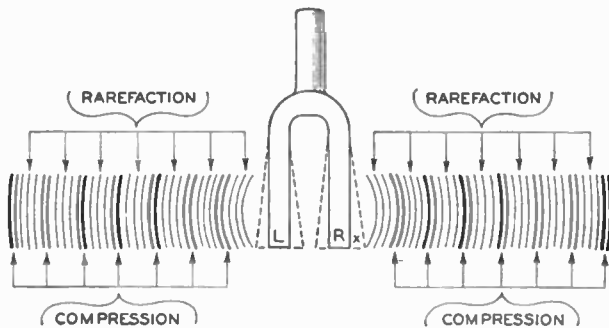

Fig. 3. Sound Waves from a Tuning Fork

from a state of rest, we see the result more readily. As prong *R* moves to the right, it produces a movement in the air at its right which causes that air to assume a pressure higher than normal. This is called a *compression*. As the prong springs back to its

normal position, the pressure in the space at  $x$  behind the compressed area is below normal. When the prong reaches its normal position, it does not stop but continues moving to the left until its momentum has been overcome, reducing the pressure in the area through which it has been passing, causing a *rarefaction*. Then, from the extreme left-hand position, it swings once more to the right, again causing a compression of the air particles. The peaks of the two compressed areas (maximum pressure) may be termed the *crests* of the sound waves; the rarefied space between them may be termed the *valley* of the wave.

The particles of air thus set in motion by the prongs of the tuning fork do not move any appreciable distance. On the contrary, they transmit their movement to other particles of air, which likewise move only slightly, and in turn cause other particles to move. Thus, the particles at any given position vibrate back and forth in accordance with the movement of the prongs of the tuning fork. As the waves continue moving outward from the tuning fork, each successive wave is weaker than the one immediately preceding, because of friction and other losses, until finally the pressure is equal to the normal air pressure, after which there is no movement to produce sound.

Similarly, the prongs of the tuning fork gradually lose their motive force and come to rest, so that there is a gradual tapering off of the amplitude of the sound wave. However, the frequency of vibration remains the same as long as the prongs are vibrating, so that, although the pressure in the compressed areas may be gradually lowered, the distance between each pair of crests remains constant. As a result, the sound that is *heard* is produced by the same number of vibrations per second, although its amplitude is steadily decreasing.

Although the waves set up by the tuning fork create sound that can be heard in all directions, the greatest intensity of the sound is directly in front of the flat portion of the prong, and the area of least intensity is directly opposite the side of the prong.

**Reflections and Echoes.** Sound follows the same natural laws as light, so far as reflection is concerned, but it is much more difficult to demonstrate the law, because of our inability to con-

fine disturbances of the air particles. It has been determined, however, that sound waves are reflected from an obstruction and, as with light, that *the angle of incidence equals the angle of reflection*. The angle of incidence is the angle between the perpendicular to

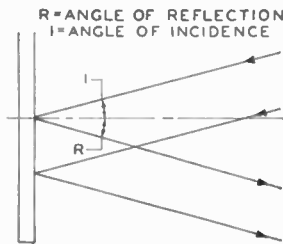

Fig. 4. Reflection of Sound Waves from a Hard Smooth Plane Surface

the obstructing surface and the direction of the wave at the point of reflection, as shown in Fig. 4. Concave or convex reflectors either carry the sound to a focal point or spread it, as also shown in Fig. 5 at (A) and (B) respectively.

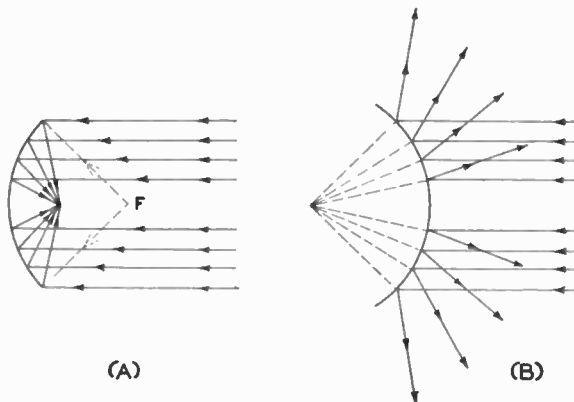

Fig. 5. Reflection of Sound Waves from Curved Surfaces

A sound wave projected against a flat wall or other surface will be reflected from the surface, and the sound may be heard more than once—a phenomenon that is called an *echo*. If the wall

were so close to the listener's position that the echo wave reached him before the original sound had died away, the echo either would not be heard, or else would be heard as a rumble. The hard, smooth wall surfaces of improperly designed lecture halls or auditoriums cause reflections of sound waves that make it difficult, and in many instances impossible, to understand the speaker.

An analysis of conditions in such a hall would show that, while the sound passes from the speaker directly to the listener, another part of the sound wave is reflected from a wall surface; and since it travels a greater distance represented by two sides of a triangle, the reflection of the first sound reaches the ears of the listener at the same time that another and different sound—that of another syllable or another word—reaches the listener. The two sounds combine to create a jargon of unintelligible sounds. Hence, in improperly designed halls—provided they are not treated acoustically—only those persons who occupy the first few rows ahead of the reflection area can hear clearly the words of the speaker.

**Prevention of Sound Reflections.** The prevention of sound reflections can well be termed sound control. Materials and substances that have the property of absorbing or diffusing sound will prevent or break up the reflections so that their effect is negligible. When radio broadcasting began, it was common practice to drape the walls of the studios with heavy cloth, such as velvet. The floors, too, were heavily padded, and the ceilings were covered with flowing drapery. More recently, however, wall materials have been developed that eliminate the need for such drapings.

Commercial acoustic materials—such as felt, velvet, gypsum, burlap, cork, hair, and other fibrous substances—are used for treating walls, floors, and ceilings of rooms so as to give them sound-absorbing properties. Substances that appear to be hard on the surface may prove to be efficient acoustic materials because of their porosity, such as spun glass. One of the commercial acoustic wall blocks consists of spun-glass particles embedded in a binding substance.

An empty auditorium does not usually possess the same acoustic properties that it has when the seats are occupied. The clothing on the people in the seats serves to absorb the sound waves and so



prevent the reflections that are cast by seats with bare wooden backs or non-sound-absorbing upholstery. Hence, it frequently happens that the first attempt to install radio or public-address equipment in a hall or auditorium will not be entirely successful, and that in certain places the reflections will be so pronounced as to require additional adjustment, because of the acoustical changes that occur when the seats are occupied.

**Harmonious Tones—Music.** Musical sounds have three differing characteristics—pitch, amplitude, and quality—which provide the means for the production of melodies and other harmonious tones.

The *pitch* of a tone is determined by the number of vibrations produced per second. A note that is produced by 400 vibrations per second is said to have a higher pitch than one which is produced by 200 vibrations per second.

The determining factor in *amplitude* is the impression on the auditory system of the individual. An impulse that may sound loud to one person may not be so loud to another. However, *intensity* or *loudness* of sound is a definite quantity, measured as the rate of the flow of energy through a cross section normal to the direction of propagation. The intensity of sound is proportional to the square of the amplitude of the vibration of the medium.

Musical sounds have *quality* as the result of blending a number of simple tones of different but related wave frequencies, any one of which alone would not appear to be musical or pleasant. The lowest of the related tones is called the *fundamental*; all others are called *overtones*. Practically all musical instruments produce sounds that are abundant in overtones, which serve to give what might be called a *richness* of sound. Quality is often referred to as *timbre*.

*Harmonics.* An overtone whose frequency is an integral number multiplied by the frequency of the fundamental tone is a *harmonic*. Thus, if a string on a musical instrument vibrates 200 times per second, it may, and probably will, produce also an overtone—a harmonic—of 400 vibrations per second. Similarly, if the string vibrates 400 times per second, it may produce an overtone—again, a harmonic—of 800 vibrations per second. In the first instance, harmonics at 600 and 800 vibrations per second may be

present also; and in the latter case, there may be additional harmonics of 1,200 and 1,600 vibrations per second.

The term *harmonic* should not be confused with *octave*. Harmonics are overtones having any integral number times the frequency of the fundamental, but an octave is a tone having twice the frequency of the original tone. Therefore, an octave above middle C (256 vibrations per second) is also C, having  $2 \times 256$ , or 512 vibrations per second. Two octaves above middle C would be  $2 \times (2 \times 256)$ , or 1024 vibrations per second—again C. Or, the tone produced by 400 vibrations would be an

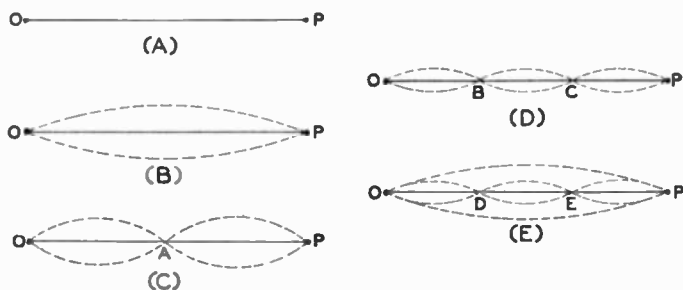

Fig. 6. Diagram Showing How Harmonics and Overtones Are Produced

octave above the fundamental of 200 vibrations per second, and two octaves above the fundamental would be a tone produced by 800 vibrations per second.

On some musical instruments, a single string may produce several overtones in addition to the fundamental. As an example, take a string on the musical instrument shown in Fig. 6(A). When at rest, the string creates no sound. But if held tightly at points O and P, and plucked near its center point, the string will vibrate as shown in Fig. 6(B), the dotted lines representing the displacement of the string as it vibrates.

If, after the string has been plucked and caused to vibrate, the finger or a piece of soft rubber is placed exactly midway between O and P—at point A—the string will vibrate in two units, as shown in Fig. 6(C). There will be no movement at the midway point, and each half of the string will vibrate as a unit. Since

$OA$  (or  $PA$ ) is one-half of  $OP$ , it will vibrate at twice the frequency as the string  $OP$ , with the result that the first overtone will be created.

Going a step farther, see ( $D$ ). If string is touched at  $B$  (one-third the distance from  $O$  to  $P$ ), it will vibrate in three segments, thereby creating the second overtone. Touching the string one-fourth the distance from  $O$  to  $P$  will make four segments and create the third overtone; and so on.

While, in general, the overtones produce a pleasing quality, some of the higher harmonics create discord because of their interference with other harmonics and overtones. Consequently, musical instruments are so designed that the string will be struck or plucked at a selected position in order to prevent setting up high harmonics that would detract from the quality of the tone. For instance, the strings of a piano are struck about one-seventh of the distance from one end, so that this point on the string will be in motion and cannot become a node. Nodes are the points of no vibration—as positions  $O$ ,  $B$ ,  $C$ , and  $P$  in Fig. 6 ( $D$ )—which limit the number of harmonics that the string is capable of creating.

It should be understood, however, that while the string on a musical instrument is vibrating to create harmonics, at the same time it is also vibrating as a single unit (fundamental frequency), as indicated in Fig. 6( $E$ ). This fundamental frequency is also called the *first harmonic*. The second harmonic, twice the frequency of the fundamental, is the *first overtone*; the third harmonic is the *second overtone*, and so forth.

In Fig. 6( $E$ ) note that there are two frequencies, the fundamental and the third harmonic. Another frequency of vibration is established through a combination of the two shown; that is, the frequency of the fundamental is added to the third harmonic or second overtone to create a disturbance of the air; and even though the string does not itself establish the disturbance, a third sound, related to the two sounds created mechanically, and harmonious with them, is produced. For instance, if the fundamental frequency of vibration were that of middle C (256 vibrations per second), the second harmonic would be 512 vibrations per second—one octave higher than the fundamental. The sum of 256 and

512 is 768, a frequency of vibration which the ear would hear in addition to the fundamental of 256 vibrations per second, and the harmonic 512 vibrations per second. Both of the latter frequencies are harmonics, but only one of them is produced mechanically. Reference to the major diatonic scale (invented by Bach), would show that a vibration of 768 times per second is the tone described as G, or, in terms of the scale, *sol*, in the second octave above middle C, the fundamental tone in this illustration. The calculations carried out here could be applied to a sound due to any frequency of vibration.

*Pitch.* Since pitch is determined by the number of vibrations produced per second, it is evident that melodies or tunes can be

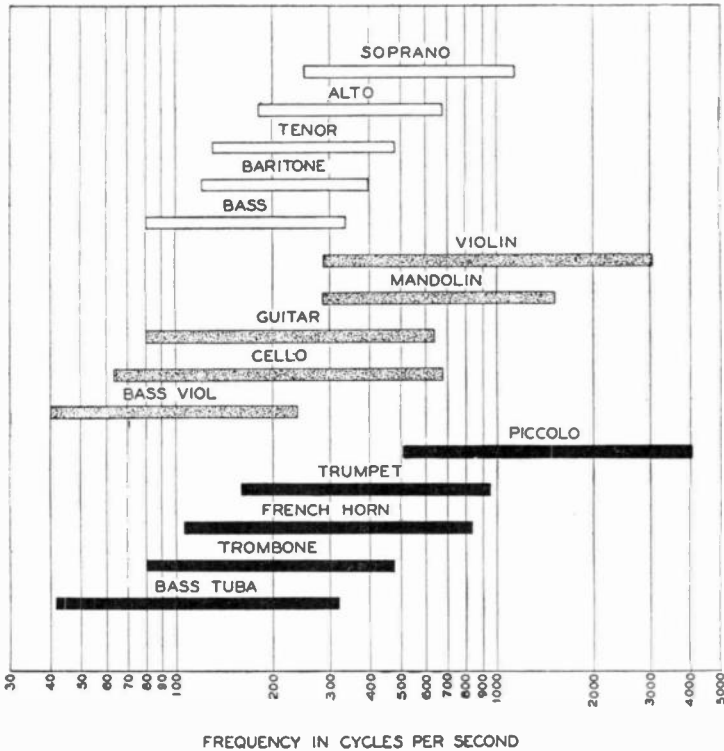

Fig. 7. Chart Showing the Range Frequencies of Wind and String Instruments and Human Voice

produced by varying the pitch as desired. Vocal sounds, too, are rated according to the pitch—bass, baritone, tenor, alto, soprano, and so on, as shown in Fig. 7. Some bass singers can sustain notes as low as 60 vibrations per second; and some soprano singers have been reasonably accurate around 1,300 vibrations per second. Musical instruments also have fundamental pitch limits, with the piano and organ covering the greatest span of vibration frequencies. The lowest tone produced by a piano or an organ is about 27 vibrations per second; the highest note on an ordinary instrument is about 4,100 vibrations per second, produced on a piccolo.

Other instruments cover only certain portions of the foregoing range of pitches as shown in Table I (ranges according to the major diatonic scale).

TABLE I  
RANGE OF PITCHES ACCORDING TO THE MAJOR DIATONIC SCALE

Instrument	Low	High	Type of Instrument
Banjo	288	768	String
Bassoon	60	480	Wind
Bass Tuba	42.67	341.33	Wind
Bass Viol	40	240	String
Cello	64	682.67	String
Clarinet	160	1536	Wind
Flute	256	2304	Wind
French Horn	106.67	853.33	Wind
Guitar	80	640	String
Kettle Drums	85.33	170.67	Percussion
Mandolin	288	1536	String
Mandolin Cello	64	256	String
Piccolo	512	4068	Wind
Trombone	80	480	Wind
Trumpet	160	960	Wind
Violin	288	3072	String

The pitch of wind instruments is determined by the length of the air column. Bass horns have a much longer tube than horns that are pitched higher. The pitch of the tones emitted by a pipe organ is determined by the length of the pipe which governs the number of compressions and rarefactions of the air within the pipe. Vibrations of the air column in a clarinet are set up by a reed on

the mouthpiece. The length of the air column determines the pitch, which is varied by opening apertures through which air is deflected and instantaneously changes the number of times the air particles are disturbed. The valves on the cornet and similar wind instruments act to lengthen or shorten the tube through which the air passes, and thereby change the pitch. The tones produced by string instruments are created mechanically by either striking or plucking the strings.

The method of combining different kinds of instruments, as well as the selection of instruments to be combined, determines the type of musical ensemble that results. For instance, a military band differs from any other kind of band (a brass band, for example) because of its different combination of instruments. Similarly, a concert orchestra differs from a dance orchestra. The objective of the director of the band or orchestra is the governing factor in determining the type of instruments to be used and the number of each. His selection is based upon the effect he wishes to produce.

**Vibration Frequencies.** There are several standard musical scales, among them those known as the *international* and the *major diatonic*. Because of its simpler calculations, the major diatonic scale is the one most commonly used in textbooks for the purpose of comparing vibration frequencies. However, although according to the major diatonic scale, the first note on a piano or organ produces a tone of 26.67 vibrations per second, the piano may be tuned to produce a tone of more or less than that number of vibrations; and in that case, the other strings would be adjusted to produce tones higher than those specified in the major diatonic scale. But since, in order that instruments may be played simultaneously and harmoniously, they must be tuned to the same tones or related ones, it is necessary for an orchestra to tune its instruments to the piano being used.

Most musical instruments are tuned according to the *tempered scale*, in which the vibration frequencies assigned to the notes differ slightly from those of the major diatonic scale. A comparison of the frequencies for a single octave—beginning with middle C: is given in Table II.

TABLE II  
COMPARISON OF FREQUENCIES FOR A SINGLE OCTAVE

Note	Major Diatonic Scale	Tempered Scale	
		C = 256	A = 435
C	256	256	258.3
D	288	278.3	290.3
E	320	322.5	325.9
F	341.3	341.7	345.3
G	384	383.6	387.4
A	426.7	430.6	435
B	480	483.2	488.3
C	512	512	517.2

**The Siren.** The siren is probably the best-known illustration of sound creation by means of air particle disturbance. If a column of air is directed upon a disc in which regularly spaced holes have been drilled around a given radius (Fig. 8), and the disc is rotated, each time one of the holes comes in front of the air column there will be a rush of air, followed immediately by a rarefaction; another compression at the next hole; and so on. If the column of

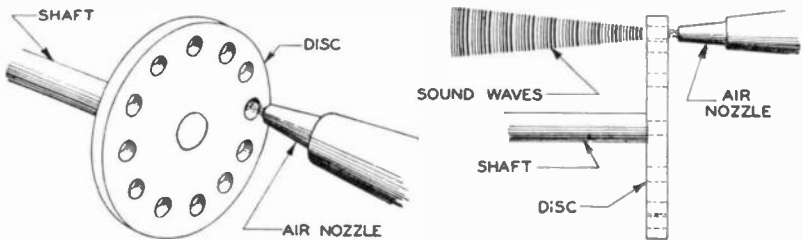

Fig. 8. Diagram of Simple Siren and Sound Waves Produced

air is directed to a series of holes spaced the same distance apart as the first row, but on another radius, and the disc is rotated at the same speed as before, the compression and rarefactions will occur at different intervals, because the distance to be traveled differs from that shown in the first case, and so the pitch will be changed. If the second row of holes is nearer the center of the disc, their pitch will be lower; while if they are nearer the circumference, their pitch will be raised. Also, if the speed of the disc is increased, the pitch will be raised; while if the speed of the disc

is decreased, the pitch will be correspondingly lower. The pitch of a siren such as that shown in Fig. 8 can easily be determined by multiplying the number of holes in the disc by the number of revolutions which the disc makes per second.

It is evident that the action of the siren consists in the projection of puffs of air at regular intervals; and that the puffs register upon human ears as sound waves.

Another example of the creation of sound by means of disturbing the air is furnished by the propeller of an airplane. The sound coming from an airplane is caused by the propeller rotating in the air into which the plane is rushing and not, as is commonly believed, from the exhaust of the motors. We might say, then, that the electric fan should create a similar disturbance; but the fan is taking air at normal pressure, and increasing its speed only enough to create a breeze. A noise similar to the cracking sound made by an airplane propeller can be produced by blowing on the blades of an electric fan that is running. In fact, the speed of the fan blades is great enough to produce a musical note, if the air projected against them were of sufficient and constant strength. In experimenting with the fan blades, note also that, although the intensity of the sound may vary with the same pressure of air, the pitch remains the same, no matter at what part of the blade the stream of air is projected. This is because the stream of air is being cut the same number of times each second, regardless of whether it is projected against the blades near the hub or near the circumference.

**How We Hear.** Hermann von Helmholtz, a German scientist, physiologist, mathematician, and physicist of the 19th century, advanced the theory that the cochlea of the inner ear contains about 3,000 or more fibers; that each fiber vibrates in resonance with a given frequency of vibration, thus transmitting to the brain the effect of that particular impulse, and thereby creating the sensation of hearing. This theory appeared to clear up the mystery of the ability of the ear to hear a complexity of sounds—such as, for example, a fundamental frequency together with the first, second, and other overtones; or a combination of more than one fundamental with their attending overtones striking the ear simultaneously.



Further, because of the ability of the human auditory system to respond to complicated sounds, the individual has the power to distinguish between different instruments by differentiating them from the *quality* standpoint.

**Range of Audibility.** The normal range of audibility—that is, the range of vibration frequencies heard by the human being—is from between 15 and 20 vibrations per second to approximately 12,000 vibrations per second. Few people, in fact, can distinguish sounds produced by 12,000 vibrations; although some can hear as high as 15,000 vibrations per second.

There are also very few persons whose auditory system will respond with equal efficiency over the entire range of frequencies; some frequencies will register with greater intensity than others, and vice versa, which explains the differences of opinion regarding the quality of a particular type of reproduction.

## MICROPHONES

A device known as a *microphone* receives and converts sound waves into electrical impulses which are impressed on a radio-frequency carrier wave. This wave is capable of disturbing the ether and traveling great distances from the transmitter. The changes in electrical characteristics thus created are amplified through the successive stages of the amplifying system.

Inasmuch as it is possible to change the characteristics of an electrical circuit by effecting a variation of the resistance, capacity

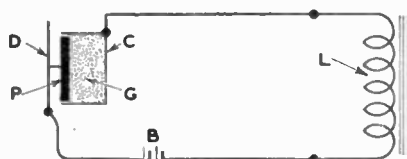

Fig. 1. Circuit for a Simple Carbon-Button Microphone

or inductance, the design of a microphone depends upon which one of the three characteristics it is to change.

**Carbon-Button Microphone.** The simplest form of a microphone is that used in the telephone, known as the *carbon-button microphone*. Its relative construction and principle of operation may be observed by referring to Fig. 1, in which *D* is the *diaphragm*, *P* is the *plunger*, *C* is the *cup*, and *G* represents the *carbon granules* with which the cup is filled. One side of the circuit containing a battery *B* and a coil *L* is connected to the cup *C* and the other side of the circuit is connected to the plunger *P*. Thus, the current passes through the carbon granules to complete the circuit, the cup and the plunger being insulated from one another otherwise.

Carbon offers a relatively high resistance to the flow of an electric current; if it is closely packed, the resistance is less than

when the granules are loose. When the plunger  $P$  is caused to move into the cup because of the vibration of the diaphragm  $D$  inward, the granules become more closely packed and the current flows more freely through the circuit. As the diaphragm moves outward, the pressure against the granules is decreased, the resistance in the circuit is increased, and less current flows. The changes in the current flow cause the magnetic field surrounding coil  $L$  to rise and fall so that the energy that is transferred to the coupled circuit has varying characteristics also.

The diaphragm of a carbon-button microphone is usually made of duralumin. As the sound waves strike the surface of the diaphragm, the alternate compressions and rarefactions cause the metal disc to vibrate also. If the vibrations of the air are occurring at the rate of 500 times per second, the diaphragm will vibrate at that frequency. Likewise, if the vibrations are occurring at intervals of one five-thousandth of a second (5,000 times per second), the diaphragm must be capable of vibrating at the same frequency. Thus, it is evident that the function a microphone is to perform serves as a gauge to determine its design, both as to structure and materials used in its fabrication.

The microphone that is used in the telephone is designed to cover the voice frequencies which are relatively low. It would not be suitable for broadcast or for a public-address system in which the requirements are more rigid.

*Two-Button Carbon Microphones.* Fig. 2 shows a more advanced application of the same type of microphone unit found in Fig. 1. Instead of a single cup containing the carbon granules, there are two cups,  $C_1$  and  $C_2$ , each of which has a plunger that presses against the carbon granules that fill each cup. You will notice that, in Fig. 2, a single diaphragm is connected to the two plungers.

In Fig. 3 are shown connections for a two-button microphone. The input transformer has a center tap to which the plungers  $P_1$  and  $P_2$  are connected through a battery or other source of electrical supply. A rheostat (not shown) is also connected in series with the battery to control the current passing through the microphone.

The action of the single-button microphone is relatively easy to visualize. When the diaphragm moves inward, the resistance of the circuit is reduced, because the carbon granules are packed tighter and make better contact with one another. Again, when the diaphragm moves outward, the resistance is increased. The same action takes place in the double-button microphone, but at the time when the resistance of the circuit including  $C_1$  is low, the resistance of the circuit including  $C_2$  is high, and vice versa. Thus, through section  $A$  of the transformer, the maximum amount of current would flow at the same time that there would be a minimum flow of current in section  $B$ .

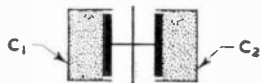

Fig. 2. Diagram of a Two-Button Carbon Microphone

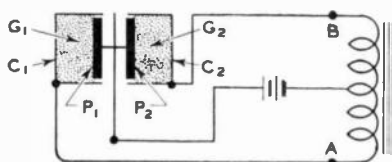

Fig. 3. Circuit Diagram of a Two-Button Carbon Microphone

The resultant magnetic field set up in the core of the transformer is, at any instant, the difference between the two opposing fields set up by current flow through the two buttons. When no sound impinges on the diaphragm the current through the two buttons should be equal and the magnetic fields should cancel. An increase of current through  $C_1$  and a consequent decrease of current through  $C_2$  produces the differential field in the core.

*Note:* Such a microphone may be designed so that the cups are attached to the diaphragm, while the plungers are held rigidly by the framework of the microphone unit.

**Condenser Microphone.** The *condenser microphone* is a pressure type unit in which the vibrations of the diaphragm cause variations in the value of the capacity existing in the circuit. It is known also as an *electrostatic type microphone*.

The general construction of the condenser microphone is shown in Fig. 4. Essentially it consists of two plates, a *diaphragm* and a *back plate*, spaced a specific distance apart, approximately

.002 of an inch. The diaphragm made of duralumin is tightly clamped to, but is insulated from the thick back plate; it serves as one of the plates of the microphone, while the thick back plate

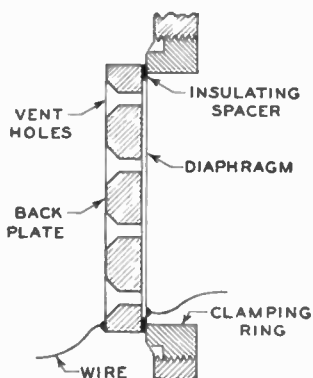

Fig. 4. Cross-Section of a Condenser Type Microphone

serves as the other. Thus, the diaphragm acts as the moving plate and the thick back plate acts as the stator of the condenser.

In order to prevent a varying degree of pressure against the back surface of the diaphragm, holes, called *vent holes*, are drilled

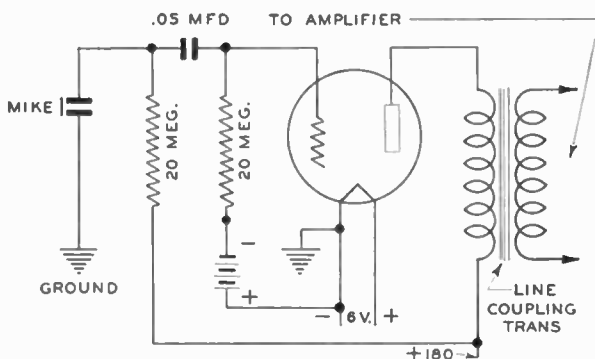

Fig. 5. Circuit Diagram of Condenser Microphone with One Stage of Amplification

through the heavy back plate to prevent extra pressure because of the expansion of the air between the plates. Thus, the capacity of the unit is maintained practically constant under all conditions

Some types of condenser microphones seal the rear of the back plate with an air-tight flexible and resilient covering, such as a specially treated membrane.

The output of a condenser type microphone is so small that it is necessary to have a *preamplifier*, that is, a stage of amplification immediately adjoining the microphone unit to step up the energy so that it can be transmitted to the main *amplifier*. Fig 5 shows the circuit for the condenser microphone, together with one type of preamplifier.

**Crystal Microphone.** The action of the *crystal microphone* depends upon the piezo-electric effect possessed by Rochelle-salt crystals. Certain crystals, chief among them being quartz, tourmaline, and Rochelle salt, possess the ability to generate an electromotive force when stressed, and conversely, produce mechanical motion when an alternating voltage is applied. In the *crystal microphone*, see Fig. 6, small *plates* of the *crystal* (approximately

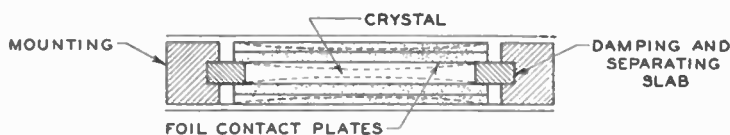

Fig. 6. Cross-Section of a Crystal Type Microphone

$\frac{1}{4}$  by  $\frac{1}{4}$  by .01 inch) are cut from the larger crystal along an axis that exhibits the greatest mechanical change for a given applied electrical pressure. *Contact* plates are coated with *foil* or contact is made by sputtering a thin film of metal on the plates. A single plate may be used or a number of plates may be connected to make their effect additive. The plates are sealed with a *membrane* to prevent moisture absorption.

As the sound wave produces a pressure normal to the surfaces of the plates, the plates are stressed and an electromotive force is generated between the foil electrodes.

The output of this type of microphone is relatively low while its impedance is high enough to operate directly into the grid of a tube through a grid leak resistance of approximately 5 megohms.

The frequency response of this type of microphone is very good, showing a slight tendency to increase its output at frequen-

cies over 5,000 cycles per second. Its compactness makes it suitable for lapel and throat microphones where size and weight are important factors.

**Dynamic Microphone.** This type of microphone depends for its action on the production of a voltage in a *coil* which is

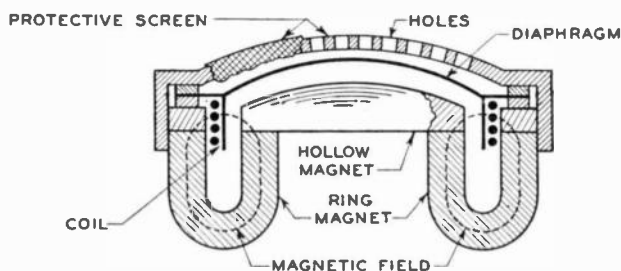

Fig. 7. Cross-Section of a Dynamic Type Microphone

moving in a *magnetic field*. The *dynamic microphone* acts in the reverse manner to a dynamic or moving-coil speaker. A small coil is attached to the *diaphragm* and as sound waves impinge on the

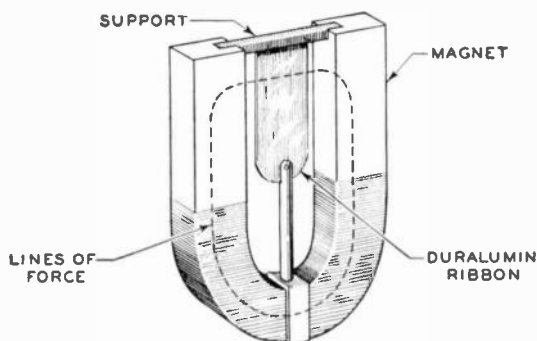

Fig. 8. Diagram Illustrating Principle of a Velocity Microphone

diaphragm the coil is forced to move in a very strong field, shown by dash lines in Fig. 7, produced by a *permanent magnet*. The voltage generated is proportional to the rate of cutting of lines of force. By keeping the weight of the moving portion as low as possible, a response is obtained which is fairly flat within the desired

audible band. The impedance of this microphone is low, which makes its circuit immune to hum and transient interference pick-up.

**Velocity (Ribbon) Microphone.** A thin corrugated duralumin ribbon is suspended in a transverse magnetic field, Fig. 8. As the sound impulse disturbs the air particles, the ribbon is caused to move and an e.m.f. is generated in the ribbon. Inasmuch as the ribbon responds to the velocity of the air particles, the device is termed a *velocity microphone*. This type of microphone is used for bi-directional pickup purposes. Its frequency response can be made very excellent by the proper design of the ribbon structure. It is a low-impedance device and a matching transformer is included in its structure to raise the impedance level to a value suitable for transmission over a line. This type of microphone is encountered more frequently than other types in broadcast studios.

**Frequency Response of Microphones.** A microphone is definitely limited in its ability to respond to sound frequencies. While it is possible to stretch the diaphragm (the vibrating element) so that the microphone will have a high resonant peak, it is evident that a metal disc cannot be expected to vibrate with equal amplitude at all frequencies within the audible range.

Microphones of the carbon and condenser types, especially, both of which have a depression in front of the diaphragm—the diaphragm is set back into the frame-work—are subject to what is known as *cavity resonance*, which introduces a rising characteristic at the high-frequency end of the audible range. Just where the rise will occur on the frequency scale, as well as the amount of increase, depends on the relative depth of the depression, and the distance between the source of sound and the microphone.

Diffraction of air, caused by sound waves striking the frame parts of the microphone, will also affect the frequency response, a phenomenon that occurs usually in the same region as cavity resonance.





**WORKMAN INSTALLING ONE OF THE ELECTRONIC TUBES THAT CONTROL RESISTANCE WELDING OF ALUMINUM AND STEEL. A RESISTANCE WELDING SYSTEM MEASURES OUT ELECTRIC CURRENT AT FRACTION-OF-A-SECOND INTERVALS TO WELD SHEET METAL AS A SEWING MACHINE STITCHES—LENGTH OF "STITCHES" AND SPACE BETWEEN THEM ARE CONTROLLED BY THE OPERATOR**

*Courtesy of Westinghouse Electric & Manufacturing Company, East Pittsburgh, Pa.*

## OSCILLATORS

---

One of the most important functions of a vacuum tube having three or more electrodes is its use as a generator of alternating voltages of a frequency determined by the LC (inductance  $\times$  capacity) constants of the circuit to which it is connected. As a generator of alternating-current power at frequencies beyond a few thousand cycles per second the vacuum-tube generator has no competitor, below this frequency, other forms of generators are capable of supplying larger amounts of power more efficiently.

In common with other forms of energy converters, the vacuum tube changes one form of energy, direct-current plate-power, to another form, *alternating power*. It is understood that the actual *generation* of energy is impossible according to the law of the conservation of energy. A vacuum tube and its associated circuit designed to bring about this conversion is called an *oscillator*, the operation being referred to as the generation of oscillations.

**Low-Frequency Oscillations.** Steady power is supplied to the vacuum-tube plate-circuit in a manner similar to the steady power supplied to the escapement mechanism of a clock by the main spring. The escapement mechanism feeds this steady power to the balance wheel in a series of impulses in a manner similar to the action of the vacuum-tube oscillator in changing the steady plate power to variable impulses. The mechanical operation of the clock mechanism limits its operation to a relatively low frequency while the vacuum tube is capable of functioning millions of times per second under easily controllable conditions.

Output, approximately three times the input, is shown in Fig. 1. Most vacuum-tube oscillators require that a portion of the variable energy in the plate circuit be returned to the grid circuit in such a phase relationship that the original grid tendency is reinforced. The return of energy to the grid circuit is called *feedback*. This is shown in Fig. 2. The feedback in a vacuum-tube circuit

may be positive, negative, or zero depending on the result desired. In order to cause the generation of oscillations, the feedback must be positive in phase and of sufficient amplitude to overcome the losses existing in the grid circuit. Then the input will be taken

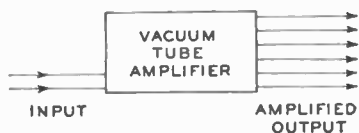

Fig. 1. Block Diagram of Vacuum-Tube Amplifier Showing Amplified Output

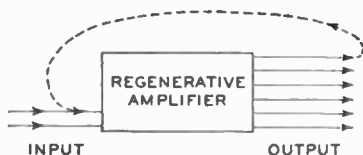

Fig. 2. Regenerative Amplifier. Portion of Output Returns to Input to Strengthen Original Input

entirely from the output, as shown in Fig. 3. If the feedback is not in phase, it may become a degenerative amplifier, Fig. 4. Feedback may be accomplished by coupling the plate to the grid circuit, capacitively, inductively, or by a direct-coupling method.

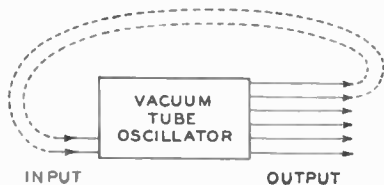

Fig. 3. Vacuum-Tube Oscillator. Sufficient Output Energy Returns to Grid Circuit to Avoid Additional Excitation from Outside Source

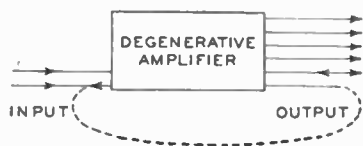

Fig. 4. Degenerative Amplifier. Portion of Output Returns to Input Side, but Out of Phase with Original Signal

This is used to improve frequency response at the expense of gain.

**Action of Amplifier.** A vacuum-tube amplifier requires the application of a signal voltage in the grid-filament circuit where it alternately adds to and subtracts from the fixed-grid bias. The plate current is caused to vary in accordance with this variation, rising as the signal voltage makes the resultant grid voltage less negative and falling as the signal voltage adds to the steady grid bias making the total grid voltage more negative. This variable plate current is caused to produce a variable voltage drop across a resistor in the plate circuit called the load resistor and this variable

voltage is passed on to the next circuit. As long as the input and output circuits are isolated from one another no feedback will occur and the circuit functions normally as an amplifier. If the frequency of the input signal is increased, the input and output circuit will be found to be coupled through the inter-electrode capacity existing between the grid and plate elements within the tube itself. This coupling may be sufficient to re-energize the grid circuit if the external plate load takes the form of an inductance with its resultant high impedance to the higher frequencies.

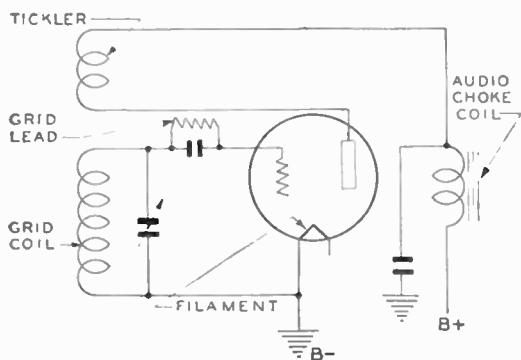

Fig. 5. Armstrong Regenerative Circuit  
The plate circuit coil is called the "tickler coil" and provides feedback.

**Armstrong Circuit.** One of the simplest methods of coupling the plate circuit to the grid circuit is shown in Fig. 5. This is the familiar *Armstrong-regenerative circuit* in which the amount of feedback is controlled by varying the physical distance between the plate and grid coil. The signal is reinforced as feedback below the oscillation point is applied, reaching the greatest intensity just before the point where oscillation starts. It is estimated that the increase at this point may be as much as 300 times that of a non-regenerative circuit. As soon as oscillation starts, the received signal is heterodyned by the locally generated oscillation and reception of a modulated signal is attended with the heterodyning distortion.

The feedback coil is called a *tickler coil*. If the connections to the tickler coil are reversed, the opposite action to regeneration will

take place, *i.e.*, degeneration. In a degenerative circuit, the feedback is in phase opposition bringing about a decrease of output which prevents regeneration or oscillation. Note that in the Armstrong circuit, the feedback takes place by virtue of the magnetic lines of force about the tickler coil cutting the grid coil. This is referred to as *inductive coupling*.

The Armstrong circuit found its chief use in a circuit capable of receiving both damped and undamped or continuous waves. For CW (continuous wave) reception, the circuit was put into oscillation by advancing the tickler coupling beyond the regeneration point. This locally generated oscillation would beat with the incoming signal and by a heterodyning action, produce an audible beat note.

The Hartley oscillator uses inductive feedback to return plate energy to the circuit by coupling an inductance to coil *L*. This

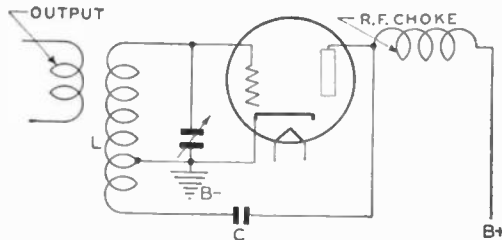

Fig. 6. Hartley Oscillator

circuit is shown in Fig. 6. It must be remembered that coupling the output coil to the grid coil changes the inductance of the grid coil and therefore causes a change in frequency of the oscillator. Also varying the loading of the output coil results in a change of reflected impedance with its attendant frequency shift. This is a defect of self-excited oscillators and must always be recognized when making use of such a device.

**Colpitts Oscillator.** A method of electrostatically coupling the feedback energy necessary to produce oscillation is incorporated in the *Colpitts oscillator*. Such a device is shown in Fig. 7. In this type of oscillator, the feedback takes place through capacitive coupling. Radio-frequency (R.F.) energy returned to *B* — through condenser *C*<sub>1</sub> produces a charge across *C*<sub>2</sub> which is across the grid

of the tube. This feedback energizes the grid and sustains the oscillatory condition. Resistor *R* serves to bleed the grid to prevent an accumulation of charges on this element.

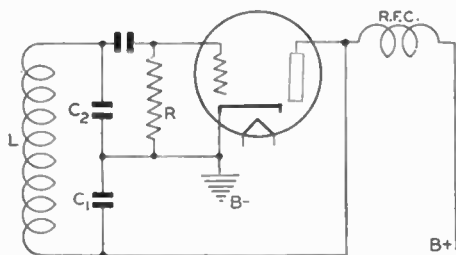

Fig. 7. Colpitts Oscillator Using Capacitive Feedback

**Tuned-Grid, Tuned-Plate Oscillator.** An oscillator of this type makes use of the internal grid to plate capacity to sustain oscillation. As shown in Fig. 8, the plate and grid circuits are both tuned. As the plate circuit is brought near to the resonant frequency of the grid circuit, its impedance to this frequency rises sharply and the voltage across the plate tank circuit is impressed

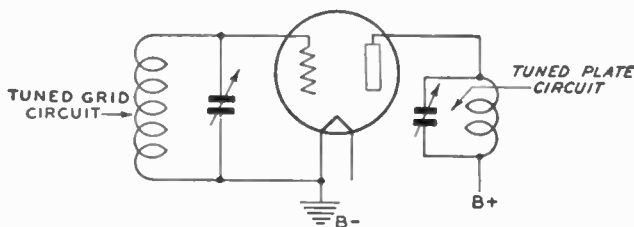

Fig. 8. Tuned-Grid, Tuned-Plate Oscillator

between the plate and grid of the tube. Sufficient energy will be returned to the grid circuit through the interelectrode capacity between the grid and plate to re-excite the grid and produce an oscillating condition. The LC (inductance  $\times$  capacity) components in the grid circuit determine the oscillation frequency, the plate-

circuit values simply being used to build up the necessary impedance to this frequency.

**Quartz-Crystal Oscillator.** A variation of the tuned-grid tuned-plate oscillator is obtained in the *quartz-crystal oscillator*. Here a thin slab of quartz takes the place of the tuned-grid circuit, feedback taking place as before by virtue of the grid to plate capacity existing within the tube. The circuit is illustrated in Fig. 9.

Certain materials are found to possess the phenomena of generating an electrical pressure when mechanically stressed and conversely, to vibrate mechanically when an electrical potential is impressed across their surfaces. These materials are said to possess

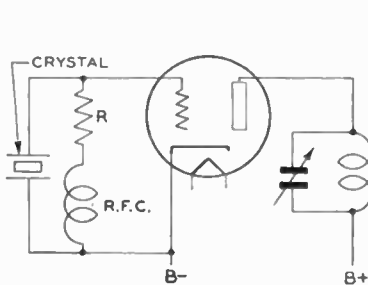

Fig. 9. Quartz-Crystal Oscillator

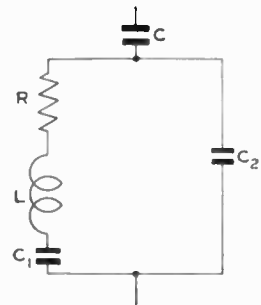

Fig. 10. Equivalent Circuit of a Quartz Crystal

piezoelectric qualities. Quartz, Rochelle-salt and tourmaline crystals possess this effect sufficiently to be used in control and generating circuits.

If an alternating voltage is applied to two metal plates pressing on the surface of a quartz crystal, the crystal will expand and contract at a rate dependent upon the impressed electromotive force provided the mechanical period of the crystal is equal to the alternating-voltage frequency. A thin piece of quartz may have a vibration frequency of several million cycles per second. The combination of mechanical and electrical vibration produces a frequency stability which makes the crystal oscillator supreme for fixed-frequency transmission purposes.

Inasmuch as the frequency of vibrations of a quartz crystal is a function of its mechanical dimensions, a change of tempera-

ture, causing an expansion or contraction of the crystal, will result in a change of frequency. To provide a greater degree of frequency stability, quartz crystals are housed in temperature-control cabinets. This makes possible a constancy of oscillation to within one or two cycles per million cycles.

Fig. 10 shows the equivalent circuit of a quartz-crystal circuit, see Fig. 9. While the crystal possesses inductance and capacitance, it lacks direct-current conductivity. For this reason, it is necessary to furnish a path for the direct current to ground. In Fig. 9, resistance  $R$  in series with the radio-frequency choke ( $RFC$ ) provide the direct-current grid return.

Tuning the plate circuit to a frequency approximately equal to that of the crystal, causes the circuit to oscillate in the same manner that the tuned-grid tuned-plate oscillator operates. The output is taken from the plate circuit generally by capacitive coupling to the following stage.

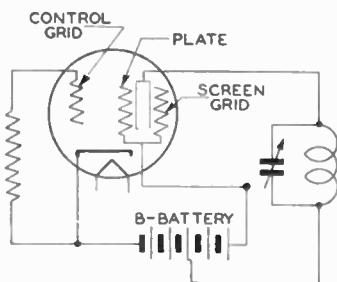

Fig. 11. Dynatron Oscillator

**Dynatron Oscillator.** Fig. 11 shows a type of oscillator making use of the negative resistance characteristics of a tetrode tube. A higher potential is placed on the screen electrode than on the plate. Primary electrons are accelerated by the high potential on the screen and on arrival at the plate they dislodge secondary electrons which are drawn to the screen. This produces the apparent contradictory condition of an increase of plate voltage causing a decrease in plate current. This is contrary to standard electrical circuits, hence the name *negative resistance*. This oscil-



lator possesses a remarkable frequency stability but of course falls short of that provided by a crystal oscillator.

**Electron-Coupled Oscillator.** An electron coupled oscillator overcomes the frequency instability caused by coupling the oscillator to an output circuit. Fig. 12 shows an electron-coupled oscillator. A tetrode tube is used as shown, and the oscillator proper makes use of the cathode, control grid, and screen grid to provide the generated electromotive force. The plate is coupled to the oscillatory circuit by the stream of electrons in transit between the cathode and plate, hence the name *electron-coupled oscillator*. The

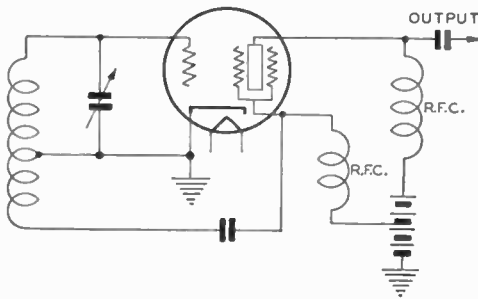

Fig. 12. Electron-Coupled Oscillator

oscillator may be coupled to an external circuit by a connection to the plate. This isolates the oscillatory portion of the circuit from the load and consequently the load does not exercise a frequency control over the oscillatory circuit.

There are many different types of oscillators designed for specific purposes as well as countless variations of the types outlined. Of the oscillators described, the quartz-crystal type is most universally used in transmitter circuits.

**Signal Generator.** The type of oscillator used for aligning the radio and intermediate frequency circuits of radio receivers is termed a *signal generator* or *service oscillator*. It consists generally of an electron-coupled oscillator circuit with a band switching arrangement that allows frequencies from possibly 100 kilocycles to 50 megacycles to be covered in six or more overlapping



Fig. 13. Modern Service Oscillator

bands. The output is obtainable as a steady continuous wave or it may be modulated by a self-contained audio-frequency generator which produces a 400-cycle note. Provisions are sometimes made to provide a variable audio frequency for testing audio amplifiers. A modern service oscillator is shown in Fig. 13.



## RADIOTELEGRAPH TRANSMITTERS

**Spark Transmitter.** The original method of creating the energy required for radiotelegraph transmission purposes was by the use of a *spark coil*; the broad interfering wave created by this device was capable of communicating over only relatively short distances. This induction coil was followed by an improved form of spark transmitter using a high-voltage transformer energized by the output of a suitable alternator. The output of the secondary of the high-voltage transformer charged a condenser which discharged

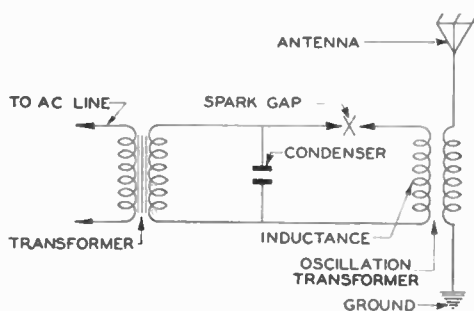

Fig. 1. An Early Spark-Gap Transmitter

through a spark gap in series with a high-frequency inductance, as illustrated in Fig. 1. The combination of condenser and inductance determined the frequency of the generated oscillations.

The spark gap underwent many improvements from its simple original form. *Rotary gaps* were used to produce a higher modulating frequency from a low-frequency alternator source and also to provide cooling of the sparking surfaces. The *quenched gap* was another improved form of gap; this type produced a spark between two surfaces which were sealed in an airtight enclosure. Large metal fins were provided to radiate the heat generated by the spark action. The use of these gaps resulted in the production of a clear tone modulation practically free from the transient surges which

occurred when using other types of spark gaps and which produced a rough tone.

The high-frequency inductance referred to formed the primary of a radio-frequency transformer, called an *oscillation transformer*, see Fig. 1. The secondary of this transformer was connected to the antenna and ground, forming the open radiating system. By adjusting the value of inductance and capacity of the secondary circuit, resonance with the primary could be obtained, which resulted in maximum radiation. The coupling between the primary and secondary of the oscillation transformer was adjustable, thereby permitting a variation in the sharpness of the resonance curve of the radiated wave.

*Radiation of Damped Waves.* The spark transmitter sends out a wave called a *damped wave*, as shown at the left in Fig. 2. A damped wave is defined as one in which the successive oscillations are of decreasing amplitude. The decrease follows a logarithmic curve, comparable to a mechanical motion in which a freely suspended body is acted upon by a momentary force which puts it into motion. The sharpness of a radiated damped wave is defined as *the Napierian logarithm of the ratio of one oscillation to the next in a uniformly damped wave train*. The Federal Communications Commission designates such a wave as a Type *B* wave.

The damped-wave type of transmission had several disadvantages. Due to the decreasing amplitude of successive oscillations, the antenna circuit was fully energized only a portion of the transmission time; the transmission of discontinuous *wave trains* produced a wave which lacked sharpness. Each transmitter occupied a wide band in the spectrum during transmission periods, which prevented other transmitters from operating during this time. These factors have outlawed the spark type of transmitter in commercial radiotelegraphy.

**Arc Transmitter.** A *continuous wave (CW)* is one in which the successive oscillations are of equal amplitude, see Fig. 2 at right; it is called a Type *A* wave by the Federal Communications Commission. The earliest type of transmitter to produce a continuous wave was the arc transmitter. This type used a direct-current generator to sustain an arc between two electrodes. The arc

was operated in an atmosphere of hydrogen produced by dripping alcohol on the heated electrodes. A transverse electromagnetic field was used to sweep the ions from the space between the electrodes in the nonconductive periods. The arc operated on the negative resistance characteristic of an electric arc—as the current

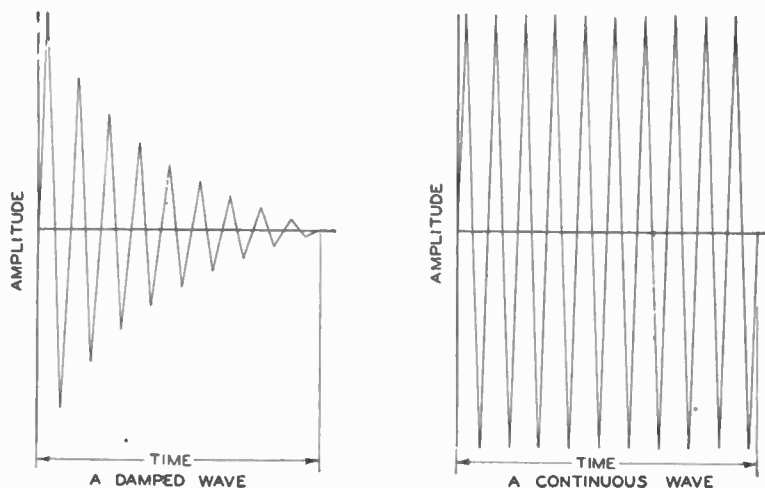

Fig. 2. Curves Showing Difference Between Damped Wave (Type B) and Continuous Wave (Type A)

across the arc space increases, the voltage across the electrode decreases. The arc was connected to an oscillatory circuit consisting of the antenna and ground circuit, with additional inductance and capacitance as necessary.

In operation, the arc transmitter required considerable auxiliary equipment. A complete water circulating system was necessary to cool the arc chamber and copper anode. The keying system for the formation of telegraph characters was somewhat complex. Because of the large capacity necessary across the electrodes, the arc transmitter did not operate efficiently on wave lengths below 600 meters. These limitations of capacity curtailed the use of arc transmitters to a large extent, and, since the advent of the vacuum-tube types, the arc transmitters are infrequently found in commercial telegraph service.

**Vacuum-Tube Transmitters.** Vacuum-tube transmitters emit a much sharper wave than the spark and arc types, and, for a given power input, the tube transmitter covers a much greater distance.

The service for which a transmitter is to be used governs its design. For commercial ship-to-shore service, a transmitter must have certain characteristics which are specified by international law. The transmitter must be capable of transmitting a signal on 500 kilocycles (600 meters) which can be received on a receiver in a nonoscillating condition; this requirement is filled by a transmitter putting out an interrupted continuous wave (*ICW*) or an *AC* modulated continuous wave (*ACCW*).

*Maritime Requirements.* In the maritime service, all ship transmitters are normally tuned to 500 kilocycles for calling and distress purposes and are provided with one or more additional frequencies for message handling. The calling and distress wave must be a broad wave to reach receivers not tuned exactly to the 500-kilocycle frequency. A continuous wave would tune too sharply to satisfy this condition, therefore it must be broken up into groups by means of a *chopper* or *rotating commutator*. This broadens the wave and allows its reception even though the receiver may not be tuned exactly to the frequency of the transmitted wave.

*Self-Rectifying Transmitters.* In converting spark transmitters to vacuum tube use, it was found convenient to make use of many parts of the original transmitter. One of the simplest conversion methods is to use alternating current on the plate of the oscillator tube or tubes. This produces an output which is modulated by the frequency of the alternating current which is applied to the plates. Such an output, as previously stated, is termed an alternating-current continuous wave, or *ACCW*. It, of course, can also be heard on a nonoscillating detector. The oscillator tubes act as rectifiers of the alternating current supplied to the plates, hence a transmitter of this type is referred to as a self-rectifying type of transmitter.

Fig. 3 shows a simplified diagram of a self-rectifying type of tube transmitter using both halves of the alternating-current cycle. As one tube has a positive potential applied to its plate, it produces

oscillations, while during this time interval the other tube has a negative potential applied to its plate and is therefore inoperative. As the polarity of the transformer secondary reverses, the oscillation function is transferred alternately from one tube to the other.

The circuit shown in Fig. 3 is a conventional Colpitts oscillator type, feedback from plate to grid being accomplished by electrostatic coupling. The primary circuit of the high-voltage plate supply transformer is keyed for signaling purposes. A wattmeter in this circuit gives an immediate visual check on the operation of the power supply circuit. Radio-frequency chokes (R.F.C.) are in-

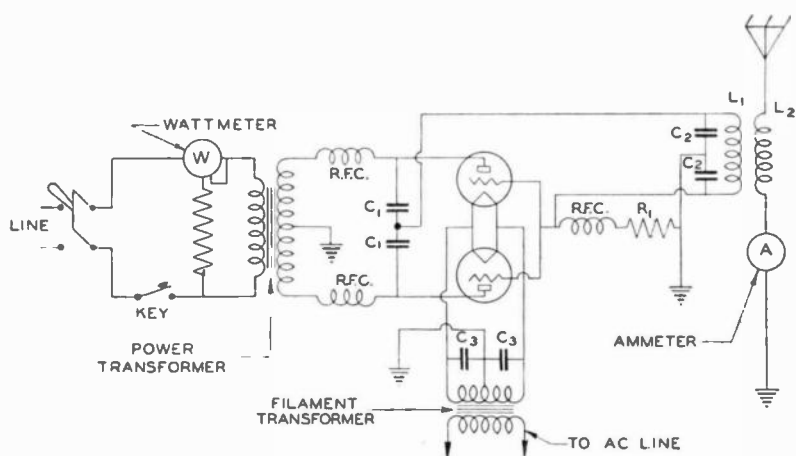

Fig. 3. Self-Rectifying Radiotelegraph Transmitter

cluded in the high-voltage plate leads to prevent radio-frequency feedback to the low-frequency circuits. A rotary converter is generally used to furnish an alternating-current voltage for application to the transformer supplying filament voltage to the tubes. Plate blocking condensers,  $C_1$ , prevent the plate potential from being impressed on the grid. These condensers also pass the radio-frequency energy to the tank circuit consisting of condensers  $C_2$  and the primary of the oscillation transformer  $L_1$ . The secondary of the oscillation transformer  $L_2$  is connected to the antenna circuit. A radio-frequency ammeter is included in the antenna circuit. This provides an indication of resonance between the closed and open circuits which are adjusted by taps on the inductances  $L_1$  and  $L_2$ .



Resistor  $R_1$  is placed in the grid circuit and the grid-current flow provides an automatic self-bias for the proper tube operation. The radio-frequency choke in the grid circuit builds up an impedance to the oscillating frequency and prevents grounding of the grids of the tubes to radio frequency. The grid choke also prevents the generation of *parasitic oscillations*. These are high-frequency oscillations generated by some portion of the grid circuit resonating to an ultrahigh frequency.

Filament by-pass condensers,  $C_3$ , allow the radio-frequency energy a low impedance path around the filament transformer winding.

A low-frequency alternating-current input to the plates of the tubes such as a 60-cycle supply would produce a low-frequency note which would be difficult to copy through heavy atmospheric interference. The most advanced spark transmitters used 500-cycle generators, and, as these transmitters were converted to a tube type, the 500-cycle generators were retained. This 500-cycle frequency impressed on the plates of the tubes, after passing through the power transformer, produces a pleasing high-frequency note which allows an interchange of signals through severe interference.

*CW—ICW Tube Transmitter.* The second type of vacuum-tube transmitter is constructed specifically to make the most efficient use of vacuum-tube equipment, and no compromise is necessary as was the case in converting spark equipment to vacuum-tube use.

Fig. 4 shows a simplified diagram of a CW—ICW telegraph transmitter of the master-oscillator, power-amplifier type. The oscillator circuit is a Colpitts type (capacity coupled). Condenser  $C_1$  is the feedback condenser but also, in conjunction with  $C_2$  and inductance  $L_1$ , determines the frequency of operation.  $C_3$  is the plate-blocking condenser. Inductance  $L_2$  is radio-frequency choke to keep the high-frequency energy out of the direct-current circuits. The two tubes in the power amplifier are energized through condenser  $C_4$ . These tubes are connected in parallel. Resistor  $R_1$  serves to bias the power-amplifier tubes for correct operation. Inductance  $L_3$  is a radio-frequency choke used to build up the input impedance of the amplifier grid circuit.

The output of the power amplifier energizes the tank circuit which in turn transfers the energy to the antenna circuit. These circuits are tuned to the frequency of the master oscillator and proper adjustment is indicated by the maximum reading of the antenna ammeter *A*.

Inasmuch as the plate supply to the tubes is direct current, generally supplied by a high-voltage, direct-current generator, the transmitted wave is continuous. This type of wave is highly effi-

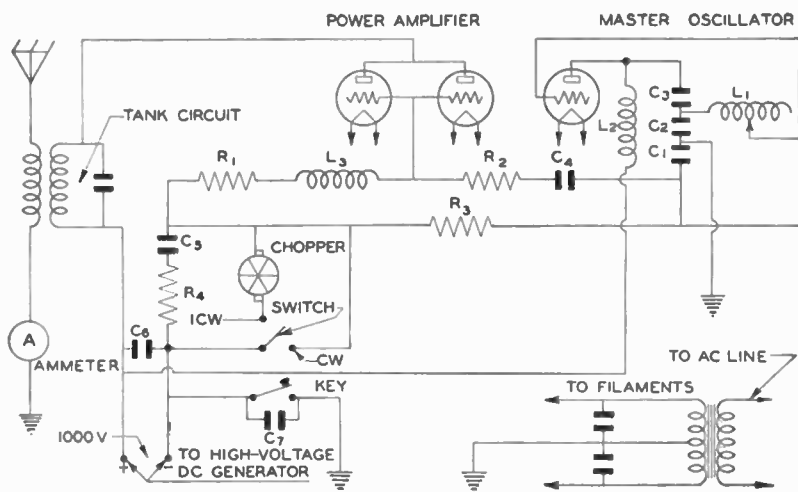

Fig. 4. Master-Oscillator, Power-Amplifier Radiotelegraph Transmitter

cient but requires careful tuning of a receiver to be heard. For this reason, the continuous wave is undesirable for calling and distress purposes and must be provided with an interrupter to break up the continuous wave into audible groups. A chopper (rotating commutator) serves to break up the continuous wave into discontinuous groups. After the calling contact has been established, the transmitter may cut out the chopper and use continuous waves at some other predetermined frequency to reduce interference to other communications.

*Keying Transmitters.* Transmitters of this vacuum-tube type may be keyed by breaking the negative high-voltage lead or by providing a blocking voltage to the grids of the tubes. The trans-

mitter illustrated breaks the return lead to the negative high-voltage source. A keying relay may be used which connects the antenna to the transmitter when the key is pressed while upon releasing the key the antenna is connected to the receiver. This provides *break-in* operation and allows the receiving operator to *break* the transmitting operator for a word repetition. This greatly expedites the handling of traffic.

It is desirable to obtain a given operating power by using a number of small tubes in parallel rather than using a single large tube. The use of smaller tubes reduces the value of high-voltage necessary for plate supply and also allows operation of the transmitter at reduced power should one or more of the tubes burn out. This is highly important on shipboard where additional tubes can only be obtained on return to port.

## AMPLITUDE-MODULATED BROADCAST TRANSMITTERS

---

While several early attempts were made to transmit voice sounds over a radio channel before the advent of vacuum-tube transmitters, the results were generally considered unsatisfactory. Prior to the tube transmitter, only two methods were in use for the generation of a continuous wave which was the principal requisite for the application of voice modulation—the Alexanderson alternator and the oscillating arc.

The Alexanderson alternator was an inductor type of alternator, the rotor of which was driven at an exceedingly high rate of rotation. Due to mechanical limitations, this generator produced a wave of relatively low frequency. The low-frequency wave generated required an elaborate, costly antenna system, hence few installations were made. Apparently no attempt was made to voice-modulate transmitters of this type; their use was restricted to long-distance radio telegraphy.

The arc transmitter produced a continuous wave with less elaborate equipment. A direct-current arc was made to produce oscillations by connecting an oscillatory circuit across the arc electrodes and making use of the negative resistance characteristics of an electric arc. Records show that numerous attempts were made to voice-modulate arc transmitters, some of which were fairly successful. These experiments were conducted at about the time the tube transmitter was making its first appearance. The simplicity with which modulation could be applied to tube transmitters caused the abandonment of the arc as a possible source of voice-modulated signals.

**Comparison of Telephone and Telegraph Transmitters.** A radiotelephone transmitter differs from a continuous-wave, radio-telegraph transmitter in several important aspects. The phone transmitter is assigned a definite frequency in the radio

spectrum, and, in the standard broadcast band, any deviation beyond a 20-cycle plus or minus value from the assigned frequency results in the possible loss of the station's transmitting license. This strict adherence to frequency is necessary in order to prevent interference between stations. Stations in the standard broadcast band are spaced at 10-kilocycle intervals, and a deviation from the assigned frequency would result in the modulated components of one station encroaching upon a station on the adjacent channel; this would make a clear reception of either station difficult if not impossible.

In a continuous-wave telegraph transmitter, the wave is sent out in constant amplitude groups at a group frequency depending on the keying sequence. The phone transmitter must provide a modulation characteristic which not only varies as to frequency but which has an amplitude variation as well. The audio-frequency channel of a radiophone transmitter may be considered as a keying system whose purpose is to key or condition the carrier wave to correspond to instantaneous sound impulses striking the microphone.

**Carrier Wave of Broadcast Transmitter.** The carrier wave is the train of oscillations—high-frequency alternating current—sent into the ether from the antenna of a transmitting station. It has voltage and current characteristics identical with those of any alternating current, and its frequency is that at which the oscillatory circuit of the transmitter is resonant. The carrier has only one frequency, even though the resonance curve will show a current flow at frequencies adjacent to the resonant frequency. Thus a broadcasting station operating on 800 kilocycles transmits a carrier of only 800,000 cycles during nonmodulation periods.

The carrier wave virtually acts as a conductor over which the audio signals are made to pass. Being a succession of high-frequency alternations, it sets in motion electrically charged particles in space; and with the speed of light, the wave, or its effect, travels in all directions from the antenna of the transmitter.

**Modulation.** Modulation is the process by means of which the frequency, amplitude, or phase of a carrier wave is varied according to the fluctuations of a signal impulse.

It has been shown that the microphone serves to cause variations in the flow of current through the circuit of which it is a part, in accordance with the changes in pressure against its diaphragm as created by sound waves in speech or other sounds. It has been shown, also, how an oscillator sustains the flow of a high-frequency alternating current which passes from the antenna of a transmitting station as the carrier wave.

When the carrier wave alone is transmitted, a receiving set tuned to the carrier will deliver no sound, but each such successive carrier passed, in tuning a receiving set, will cause a *click* similar to that obtained by closing any electric circuit.

On the other hand, when the changes in the flow of current caused by the changes in the microphone circuit are impressed upon the carrier frequency, the amplitude of the carrier is caused to vary in the commonly used system of modulation. These variations are later translated into perceptible sounds by a receiver; sound impulses correspond to variations in microphone current.

*Side-Band Frequencies.* Due to the process of modulation, the band of frequencies required to transmit sound is caused to assume measurable proportions. When a carrier wave is amplitude modulated, additional frequencies, called *side-band frequencies*, are generated on either side of the carrier. The side-band frequencies will be numerically equal to the carrier frequency plus and minus the modulating frequency at any particular instant. Thus, when a 1,000-cycle tone is impressed upon a carrier of 800,000 cycles (800 kilocycles), the side-band frequency will be 800,000 plus 1,000, or 801,000 cycles on one side, and 800,000 minus 1,000, or 799,000 cycles on the other side. The width of the band is  $801,000 - 799,000 = 2,000$  cycles.

There are musical and voice sounds that have frequencies of 5,000 cycles per second. When these frequencies are impressed on the 800,000-cycle carrier wave, the side-band frequencies produced are (800,000 plus 5,000) 805,000 and (800,000 minus 5,000) 795,000 cycles; the width of this band is 10,000 cycles, which is twice the frequency of the sound impressed on the carrier wave.

Fig. 1 shows graphically the effect of amplitude modulation of the radio-frequency carrier. It must be remembered that side-

band frequencies are generated by this modulation process, and the tuned circuits of both transmitter and receiver must pass a wide enough band of frequencies, when tuned to resonance, to completely encompass the entire side-band channel.

*Modulation Process.* The process of modulation adds power

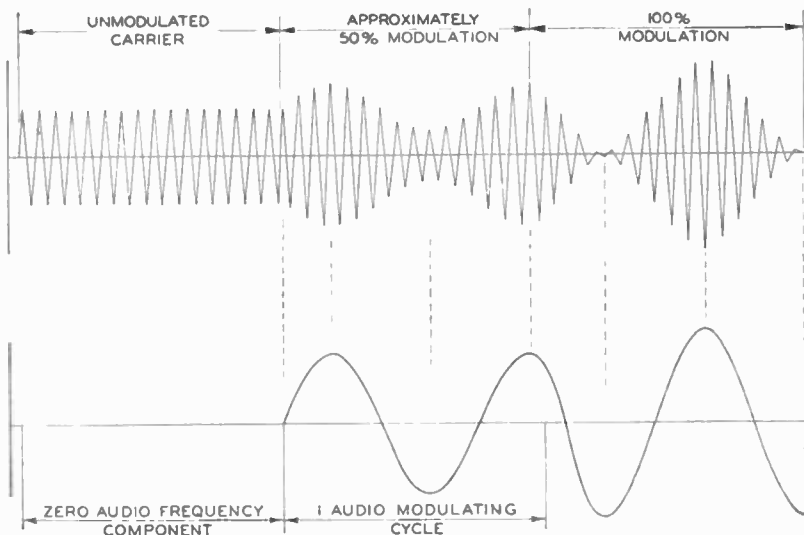

Fig. 1. Radio Frequency Carrier Modulated by Audio Frequency. Increased Amplitude of Audio Signal Increases Percentage of Modulation of Carrier

to the modulated amplifier. The ratio of radio-frequency power to audio-frequency power being delivered to the modulated amplifier can be evaluated to express the degree of modulation as a percentage.

Obviously, the carrier wave alone is incapable of transmitting intelligence. The degree to which the carrier is modulated is a measure of the ability of transmitter to cover a given service area. A 1-kilowatt transmitter modulated 100% is capable of servicing approximately the same area as a 3-kilowatt transmitter modulated 30%. Low percentages of modulation were used in the early broadcasting era principally because of the distortion caused by the type of detection used in the first receivers. The square law detector, which was universally used, produced an amount of dis-

tortion which was proportional to the square of the modulation percentage. Actually, the distortion was found to be 25% for a 100% modulated signal while it dropped to 7% for a signal which was modulated 30%. With improved receiving circuits, the modulating percentage of transmitters has been increased with a resulting increase in service area. Federal Communications Commission rules require that a transmitter be capable of 80% modulation.

*High and Low-Level Modulation.* High-level modulation is the application of the audio signal to the plate circuit of the final radio-frequency amplifier while low-level modulation indicates the application of the audio signal to any previous stage. The audio-signal voltage may be applied to any tube element which is capable of influencing the plate current. Thus it is possible to modulate the control grid, screen grid, suppressor grid, or plate voltage of a tube. Modulating the plate voltage of the final amplifier requires the use of audio equipment which has a high output level. This is costly but results in a minimum of distortion. To provide 100% modulation in a high-level system, it is necessary to supply 50% as much audio power as is being produced by the unmodulated carrier. Thus if the unmodulated output is 10 kilowatts, one-half, or 5 kilowatts of audio power must be supplied, and the total output for 100% modulation peaks is 15 kilowatts. One-third of this power is used to generate side-band frequencies. An ammeter in the antenna circuit will indicate a 22.4% rise for 100% modulation.

**Parts of Radiophone Transmitters.** A radiotelephone transmitter may be divided into several different parts as shown in the block diagram Fig. 2. Two distinct channels are shown, one producing the radio-frequency energy which is capable of disturbing the ether while the other channel produces the audio-frequency energy corresponding to the sound impulses reaching the microphone. These two channels are combined where modulation takes place; the audio component modulates or molds the radio-frequency carrier to correspond with audio frequencies.

*Crystal Oscillator.* Because of the strict frequency deviation limitations imposed, a quartz crystal oscillator forms the first link in the radio-frequency channel. In order to maintain this oscillator at an exact frequency, the crystal, and in some cases the



complete oscillator, is housed in a temperature-controlled cabinet. The quartz crystal changes its physical dimensions with a change of temperature, and the frequency will shift accordingly; so a constant temperature will stabilize the frequency of oscillation.

Modern transmitters are equipped with two identical quartz oscillators which are under temperature control continually. One oscillator is maintained as a spare and is ready for use in case of a failure of the principal oscillator.

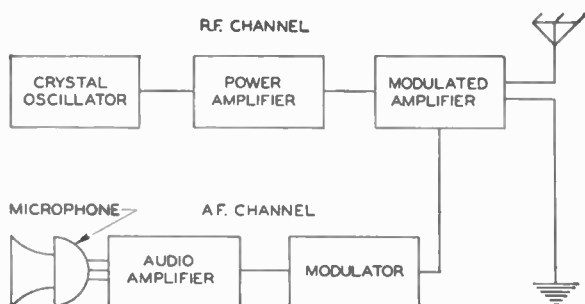

Fig. 2. Block Diagram of Radiotelephone Transmitter

The output of a crystal oscillator seldom exceeds one or two watts, hence it is necessary to build this power up to the authorized value in a series of power-amplifier stages. The output of the crystal oscillator is coupled to an intermediate power amplifier by any convenient coupling method. It will be noted that the output frequency of the transmitter is fixed by the crystal frequency inasmuch as the crystal produces the original drive. Any detuning of successive stages merely results in a loss of power and not a frequency shift. This assumes that the amplifier stages are properly neutralized so that self-oscillation does not exist.

**Western Electric Transmitter.** A simplified schematic diagram of a Western Electric 5-kilowatt transmitter is shown in Fig. 3. The power supply systems are not shown. This transmitter makes use of stabilized feedback to reduce harmonic distortion and provide high-fidelity performance.

In Fig. 4 is shown an assembly of the units of this radio transmitter. Fig. 5 shows the power amplifier unit with doors open. The doors provide access to tubes and other transmitter parts.

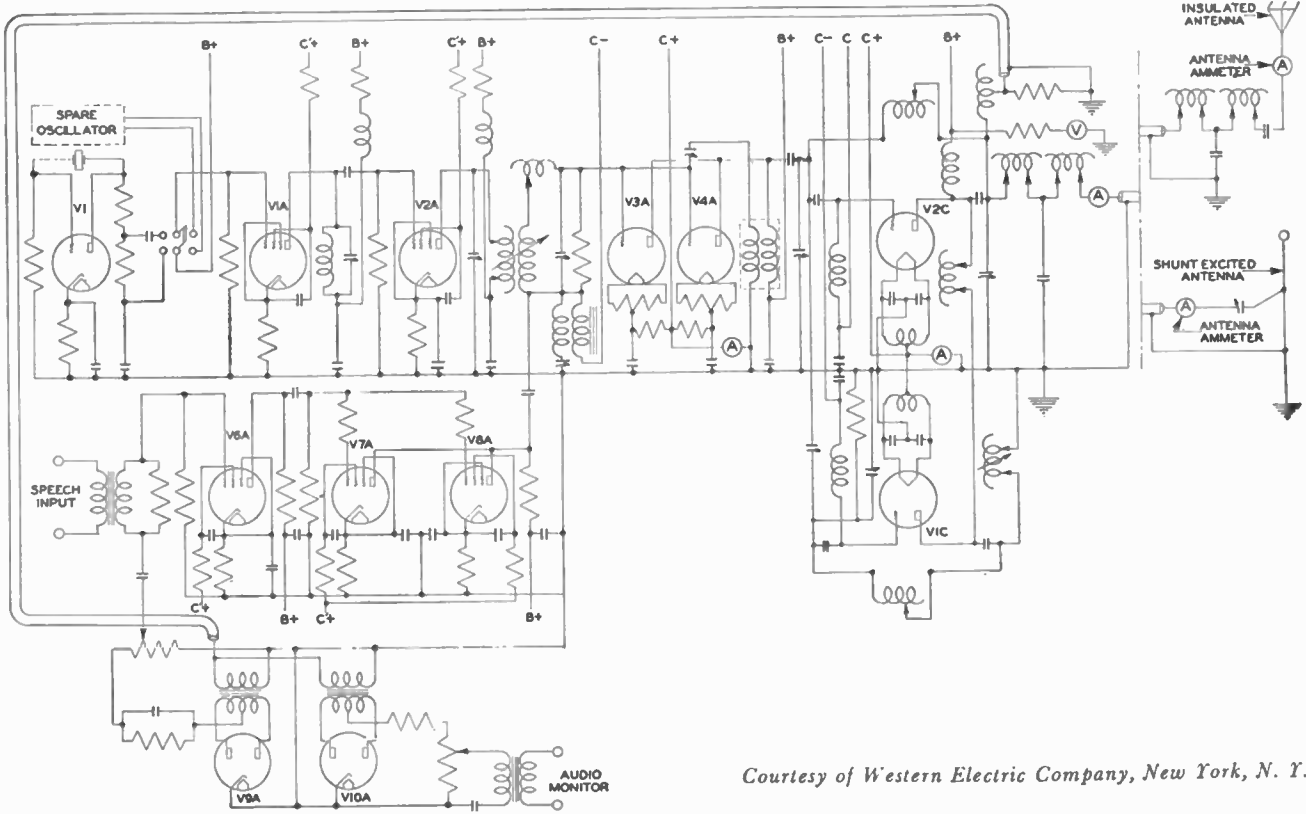

Fig. 3. Schematic Circuit Diagram of 405B-2, 5-Kilowatt Radio Transmitting Equipment

*Courtesy of Western Electric Company, New York, N. Y.*

The high-voltage rectifier unit and power apparatus, see Fig. 6, are installed in a protective enclosure behind the transmitter.

The crystal-controlled oscillator is resistance-capacitance coupled to the first buffer amplifier. The crystal is housed in a temperature-controlled cabinet to maintain its correct frequency. The first buffer amplifier is capacitively coupled to the second buffer

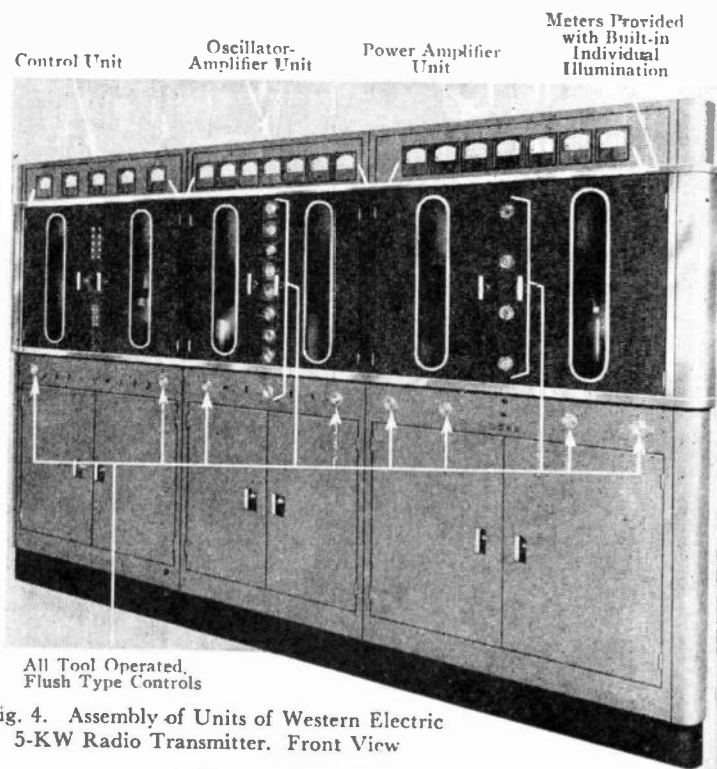

Fig. 4. Assembly of Units of Western Electric 5-KW Radio Transmitter. Front View

*Courtesy of Western Electric Company, New York, N. Y.*

stage. These two stages use pentode tubes which do not require neutralization. The second buffer amplifier drives a pair of triodes in the modulated amplifier stage; these triodes are connected in parallel, the modulating voltage being applied to the grid circuit. Low-level modulation is used. The final radio-frequency amplifier uses two tubes in a neutralized push-pull circuit. This is a Doherty high-efficiency circuit, which reduces tube cooling requirements.

Air cooling is provided for tubes in the final stage; a motor-

driven blower forces filtered air through the cooling fins of tubes.

*Power Supply.* The oscillator and the buffer amplifiers are supplied grid and plate voltages by two half-wave mercury vapor rectifiers connected in a full-wave arrangement. Four similar tubes

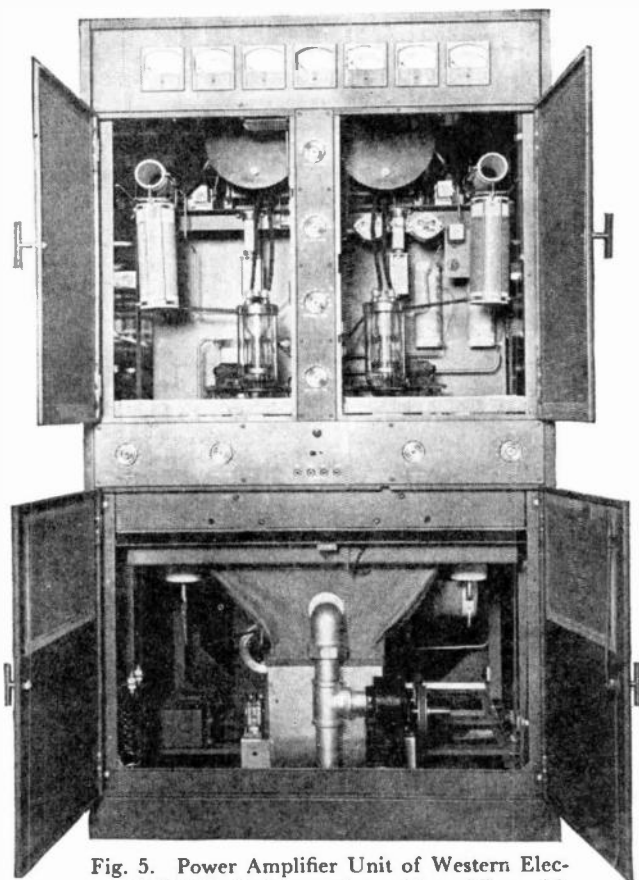

Fig. 5. Power Amplifier Unit of Western Electric 5-KW Radio Transmitter. Front View with Door Open

*Courtesy of Western Electric Company, New York, N. Y.*

in a bridge circuit furnish plate voltages for the second buffer amplifier and the modulating amplifiers. An automatic arrangement allows the filaments of the rectifier tubes to reach normal operating temperature before the high voltages are applied. Grid bias voltages are supplied to the amplifier tubes before the plate

voltages are applied. The rectifier system for the high-voltage power amplifier stage employs six mercury vapor rectifier tubes in a bridge connection, operating from a three-phase supply system.

High Voltage  
Plate Transformer  
3 Single Phase  
Transformers in  
one Case—(Non-  
Inflammable  
Oil-Filled)

Busses to High  
Voltage Rectifier  
and Power  
Amplifier

High Voltage  
Filter Retard Coil  
(Non-Inflam-  
mable Oil-Filled)

Automatic Volt-  
age Regulator  
(Air Cooled)

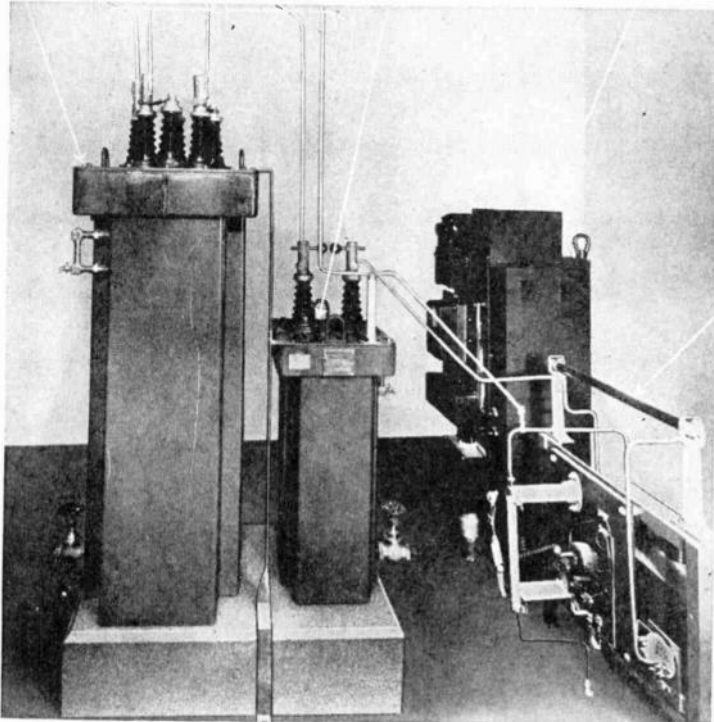

Tubular  
Plate  
Volt-  
meter  
Multiplier

High  
Voltage  
Filter  
Con-  
denser  
and  
Charging  
Switch  
Assembly

Fig. 6. Power Apparatus Assembly Adjacent to Rear of Units Assembly of Western Electric 5-KW Radio Transmitter

*Courtesy of Western Electric Company, New York, N. Y.*

**Power Input.** The total input power to the transmitter operating from a 230-volt, three-phase supply system is approximately 19.5 kilowatts for full 5-kilowatt output. Means are provided for reducing the output power of the transmitter to 1 kilowatt, in which case the power drawn from the line is 9.5 kilowatts.

## TRANSMITTING ANTENNA SYSTEMS

---

Having generated radio frequency energy by some suitable method, it becomes necessary to project this energy from a radiating medium to establish a communication system. The link which couples the radio-frequency generator to the transmission medium is variously referred to as the *antenna*, *aerial* or *radiator*. Its prime function is to provide an intimate contact with the transmission medium, generally considered the ether, so that any electrical disturbance taking place in the antenna will produce a disturbance in the ether, which will be projected into space with the velocity of light radiation, i.e., 186,000 miles per second.

**Types of Antenna Systems.** In general, antenna systems may be divided into two distinct classes: the Marconi type, in which the earth plays an important part, and the Hertz antenna which functions without an earth connection. The Marconi antenna is generally used with medium- and low-frequency wave transmission, while the Hertzian type is almost exclusively employed for high frequencies.

The Marconi antenna system was used extensively in the early system of radio communication because of the general belief that only long waves were of value in carrying on communications. Prior to the establishment of commercial radio or wireless systems, however, Hertz demonstrated that short-distance transmission could take place without a grounded conductor and on extremely short waves. After the initial experiments of Hertz, however, lack of proper receiving equipment delayed the investigation of high frequencies for many years. At the present time, the high-frequency bands carry the preponderance of radio communications, the very low frequencies having been almost abandoned for this purpose.

**Marconi Antenna Systems.** In a Marconi antenna, Fig. 1, an open oscillatory system is used, consisting of the inductance of

the antenna and its lead-in, together with any coils included for coupling the transmitter to the antenna and the capacity existing between the antenna and earth or ground. The physical dimensions of the antenna determine the amount of inductance and capacity existing in the circuit and, consequently, the frequency to which the antenna system resonates. The height of the antenna above ground, the length of the flat top portion, distance from the flat top to the transmitter, and the ground lead, all combine to determine this resonant frequency. The contact with the ground must

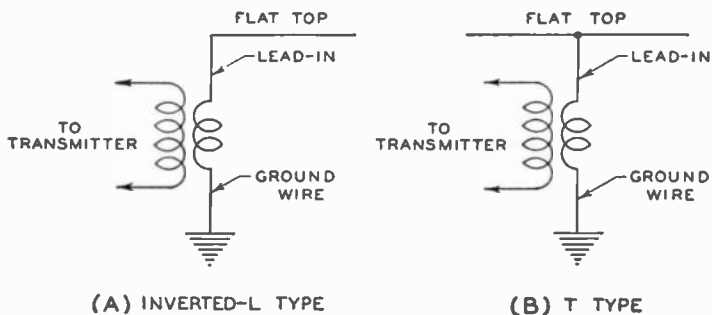

Fig. 1. Two Types of Marconi Transmitting Antennas

be of low resistance to prevent the loss of power which would result from a high-resistance contact. To insure a good ground connection, it is common practice to bury sheets of metal in moist earth in the vicinity of the station to insure a low-resistance contact.

*Inverted-L and T Forms.* A number of different forms of the Marconi antenna may be used, two of which are shown in Fig. 1. The inverted-L type has the lead-in wire attached to one extremity of the flat top portion, while the T-type antenna has the lead-in joined to the middle of the flat top portion. These two types are met with most frequently in practice, although variations and other types are occasionally encountered. The general characteristics of the Marconi antenna system are: (1) fairly uniform radiation in all directions from the transmitter; (2) high voltages at the free end or ends of the flat top portion; (3) high current at the ground; (4) fairly good radiation efficiency. This type of antenna is frequently used in medium-frequency shipboard installations.

**Hertz Antennas.** The Hertz or Hertzian antenna consists essentially of a straight conductor which is in itself an oscillatory circuit, the distributed inductance and capacity of the conductor determining the resonant frequency. Radio-frequency energy is fed to the wire from a suitable source. Since a ground is not used, the capacity existing between the conductor and ground does not play a part in determining the resonant frequency of such an antenna.

It must be remembered that a ground system used in radio communication is not for the purpose of acting as a return conductor between receiver and transmitter, as is the case in wire telegraph systems and power lines. The ground simply acts as one plate of a condenser, the other plate being the antenna wires. The radio transmitter and receiver are linked only by a wave motion of the medium of transmission.

The distributed inductance and capacity of a straight piece of wire is small unless its length is very great. Consequently, the Hertzian antenna, being short, is used conveniently on short waves.

For simple calculations, the fundamental wave length of a straight conductor is approximately 2.1 times its length. Thus a wire 50 feet in length, corresponding to a metric length of 15.24 meters, will have a fundamental wavelength of  $15.24 \times 2.1 = 32.004$  meters. The factor 2.1 is responsible for the Hertzian antenna being termed a half-wave antenna. The physical length of the antenna is approximately one-half of the longest wavelength which can be radiated from it.

In common with conventional oscillatory circuits containing lumped inductance and capacity, the Hertz antenna may be operated efficiently at harmonic frequencies. It will function effectively under any condition which produces an integral number of half waves upon it. Thus it may be used as a full-wave antenna (two half waves), or any other whole-number multiple of its half-wave length.

It must be remembered that any circuit containing inductance and capacity can be forced to operate at any frequency, provided the resistance in the circuit is not too great. The power necessary to drive a nonresonant circuit rises rapidly as the departure from resonance is increased.



An investigation of the current and voltage distribution in a Hertz antenna will show that a voltage loop and current node always exist at the free ends of the antenna. A point of maximum

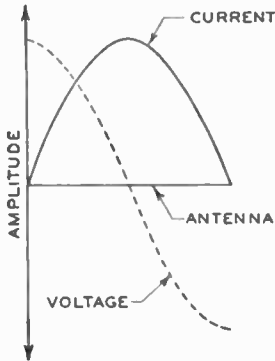

Fig. 2. Voltage and Current Distribution in Hertz Antenna Operating as a Half-Wave Antenna System

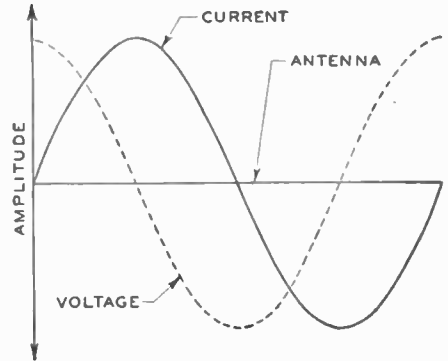

Fig. 3. Voltage and Current Distribution in Hertz Antenna Operating as Full-Wave Antenna System

amplitude is called a *loop* whether referring to voltage or current, while a minimum or zero indication is termed a *node*. Fig. 2 indicates the voltage and current distribution in a half-wave system, while Fig. 3 shows the distribution in a full-wave system.

**Antenna Feed Systems.** The energy generated by the transmitter may be led to the antenna by any one of several systems. The three methods most commonly used in practice are: (1) the voltage feed; (2) current feed; and (3) the matched impedance type of feed system.

In the *voltage-feed* system, the radio-frequency energy is applied to the antenna at a voltage loop. In a half-wave antenna, this voltage loop exists at the ends only, but in an antenna operating at a harmonic frequency, other loops will exist along the antenna length. The feeder system may consist of one or two wires. In the two-wire feeder system, the feeder wires may be tuned to the radiating frequency of the antenna system. This is called a Zeppelin type of antenna. Fig. 4 shows such a feed system.

If the *current feed* system is to be used on an antenna, the

radio-frequency energy from the transmitter must be applied at a current loop point. In the half-wave Hertz antenna this will be at the center of the antenna. Transfer of energy from the feeder wires

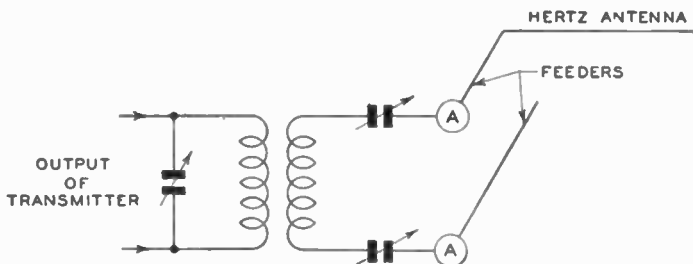

Fig. 4. Series-Tuned Zeppelin Type of Feed System for Antenna

to the antenna proper may be accomplished inductively by the coupling unit, as shown in Fig. 5.

The *matched impedance* system is based upon the coupling of two circuits at a point of impedance match. In considering the Hertz antenna system, it is found that wherever a voltage loop occurs, a current node will exist; this obviously must be a maximum impedance point. Also, wherever a voltage node occurs a

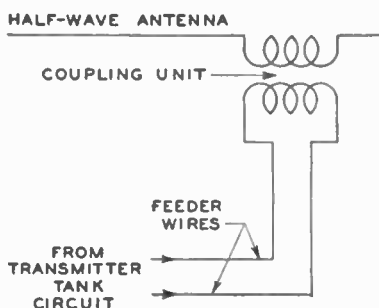

Fig. 5. Current Fed to Antenna by Tuned Feeders

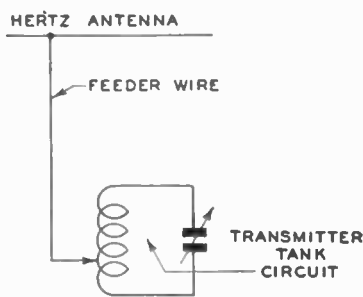

Fig. 6. Matched Impedance Feed System

current loop will exist; this must be a point of minimum impedance value. Between these two extremes, intermediate impedance values are found, and an antenna may be efficiently fed by matching the

impedance of the feeder system with the point of coupling to the antenna. Fig. 6 shows a diagram of a Hertz antenna having a matched impedance feed system.

Antenna systems for broadcast transmitters are commonly of the vertical type in which the antenna tower proper is the radiator. This type of antenna produces the maximum coverage in the service area of the transmitter because of its nondirectional characteristics and excellent ground-wave component.

## RADIO RECEIVERS

The Institute of Radio Engineers defines a radio receiver as *a device for converting radio waves into perceptible signals*. Perceptible signals are, or may be, manifested in the form of sound waves corresponding to those which caused the variations to exist in the radio wave. We say *may* be manifested because in laboratory or experimental work the output of a radio receiver is often connected to a visual-indicating device for purposes of observation. On the other hand, if the same receiver were connected to a sound-reproducing device, the variations noted on the indicating instrument would set the air into motion to create sound waves. The antenna serves to collect radio waves and conduct them to the input circuit of the receiving set in which they are selected, amplified, demodulated, and further amplified as desired.

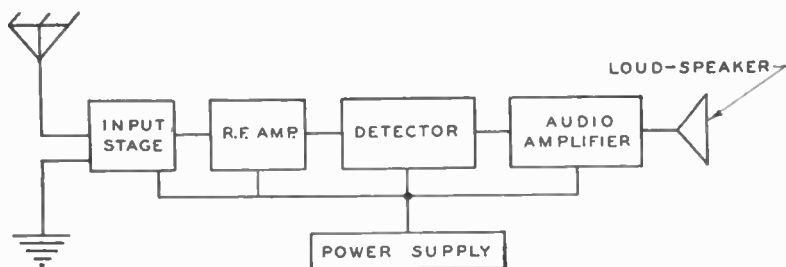

Fig. 1. Block Diagram of Units of Radio Receiver

Generally speaking, the radio receiver is divided into six fundamental units: (1) the input stage, (2) the radio-frequency amplifier, (3) the demodulator (detector), (4) the audio amplifier, (5) the sound reproducer, and (6) the power-supply device; see Fig. 1. In the superheterodyne circuit, the oscillator and the mixer are added—sometimes referred to as the modulator stage. The intermediate amplifier of the superheterodyne receiver is a radio-frequency amplifier.

**Radio Signals.** Radio waves may be converted into perceptible signals without further amplification, provided the strength of the radio wave in the vicinity of the receiver antenna is of sufficient strength. However, reception under such conditions is very limited; aside from those used for experimental investigations, receivers that do not amplify the signals are rarely used, therefore, they shall not be taken into consideration here, except for illustrative purposes.

*Collecting Signal.* It must be understood that the radio wave emitted from the antenna of a transmitter is a succession of impulses of varying peak amplitudes, the variations being caused by the modulation of the sound frequencies upon the carrier wave. It has been shown how an electromotive force is established in a conductor when magnetic lines of force *cut* that conductor, and how the induced voltage rises and falls in accordance with the variations of the inducing impulse. Here, then, is the explanation of how the signal is impressed upon the antenna circuit of a radio receiver. Due to the alternations of the carrier wave, the movement of electrical charges acts upon the antenna, setting up a flow of energy that varies in amplitude in accordance with modulation and which has the same frequency as the carrier.

*Selecting Desired Signal.* It is evident that inasmuch as there are hundreds—in fact, thousands—of radio stations sending signals into space simultaneously, some means must be provided to isolate one particular wave from all the rest to avoid receiving an unintelligible jargon. The process of effecting the isolation is called *tuning*, and the circuits employed for the purpose are called *tuning circuits*. Furthermore, not only is it necessary to select one frequency from the lot, but it is essential to block out all other frequencies, and thus prevent current at the undesired frequencies from passing through the circuit.

**Tuning Circuits.** There are four electrical properties to be taken into account in the design of a tuning circuit, namely: inductance, capacity, resistance, and frequency. Frequency represents the basis for all determinations, and inductance and capacity constitute the determining factors. Resistance does not affect the frequency of the circuit, but affects only the efficiency of operation.

The effect of inductance and capacity in an alternating-current circuit and the relationship they bear to resistance to the flow of alternating current have been shown together with an explanation of what is necessary to permit the circuit to oscillate. Also, it has been explained how a condenser of greater capacity requires a longer period of time to give up or receive the full charge, and, likewise, how a larger inductance requires a longer period of time in which to convert the current, which is being discharged by the condenser, into a magnetic field.

The time element introduced by the size of the inductance and the capacity is a determination of the frequency to which the circuit resonates. The current may be alternating at 1,000,000 cycles (2,000,000 alternations) per second, in which case the condenser must be capable of being charged and being discharged 2,000,000 times each second (once per alternation). If, however, the condenser is so large or the resistance in the circuit is so great that one five-hundred-thousandth of a second ( $\frac{1}{500,000}$ ) is required before the condenser becomes fully charged, effective capacity of the condenser is decreased and it cannot operate effectively at the higher frequency.

There will be one frequency at which the inductive reactance and the capacitive reactance are equal, in which event the reactances offset one another, and current at that particular frequency will flow readily through the circuit, being limited only by the ohmic resistance that exists in the circuit.

In the tuning circuits of a radio receiver, the components are arranged so that one or the other—or both—may be varied; thus currents at different frequencies will pass through the circuits, excluding the undesirable ones. In Fig. 2 there is an inductance,  $L_p$ , which, for purposes of illustration, will be considered the antenna inductance. The current that is flowing in the antenna circuit causes an electromagnetic field around the inductance, indicated by the dotted lines. Inductance  $L_s$  is coupled to  $L_p$  in such a manner that a voltage is induced in the inductance  $L_s$ .

If the inductive and capacitive reactances in the circuit  $L_s$ ,  $A, C$  are adjusted so that they balance out at the frequency of

the inducing voltage, an induced voltage will excite this circuit and current will flow through the circuit,  $L, A, C$ . If, on the other hand, the capacitive reactance is changed so that it opposes the flow of current at that frequency, little or no current will flow through the circuit, as will be shown on the ammeter  $A$ , which is placed in series with the coil and the condenser. For all practical purposes, the slight current flow at a frequency other than the resonant frequency would be useless, and the circuit would be at its maximum efficiency at the time when it was properly tuned.

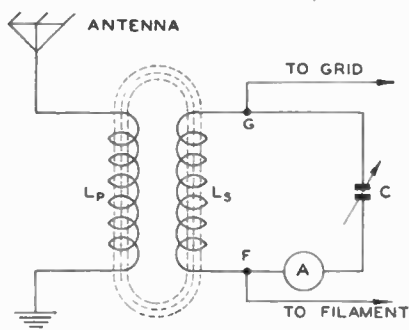

Fig. 2. Antenna Tuning Circuit

*Calculations.* Although the calculations involved in the design of tuning circuits is usually an engineering problem, it is well to include a brief summary here. It has been shown how the value of the inductance and that of the capacity are determining factors in the resonant frequency at which the circuit will permit the free flow of alternating current. Since the symbol for inductance is  $L$  and the symbol for capacity is  $C$ , the inductance-capacity relationship of a circuit is known as the  $LC$  value, which is the product of the value of the inductance and the capacity.

If the  $LC$  value of a circuit required to be resonant at a given frequency is known and a condenser of a given capacity is available for the purpose, the inductance necessary to provide a resonant circuit with the given capacity may be determined by dividing the  $LC$  value by the value of the capacity of the condenser. Then knowing the value of the inductance, the coil can be wound

to suit the need. These *LC* values are shown in a table on *Calculations of Resonant Circuits* (see Index). The values in this table have been calculated on the basis of wave length in meters, from one meter to 200 meters. Beyond 200 meters, the values are given for each of the 96 broadcast channels from 550 kilocycles to 1,500 kilocycles.

To determine what range a certain condenser will cover with a given amount of inductance, multiply the maximum capacity of the condenser in microfarads by the amount of the inductance in microhenrys; refer again to the table on *Calculations of Resonant Circuits* to determine the lowest resonant frequency. Then multiply the minimum capacity value of the condenser by the amount of the inductance and find the maximum resonant frequency by referring to the table. The values represent the product of the value of the inductance in microhenrys times the value of the capacity in microfarads. For example, a 200-microhenry coil will require .000127 microfarads of capacity to be resonant at 1,000 kilocycles ( $.02532 \div 200 = .000127$ ). The inductance of coils used in radio-frequency coupling transformers, for the standard broadcast band, usually ranges from 175 to 350 microhenrys. Values for long or short wave bands differ from these.

The formula for determining the amount of inductance in a given coil, or to find the number of turns required on a coil of a given size to give the proper amount of inductance has been shown previously, but is repeated here for convenience:

$$L = \frac{.03948a^2n^2}{b} K \text{ microhenrys}$$

in which *a* is the radius of the coil in centimeters, *n* is the number of turns in the winding, *b* is the length of the coil in centimeters, and *K* is a constant (the value of which is found in a table on *K Values for Calculating Inductance*—see Index) and is shown to be a function of  $\frac{2a}{b}$ . The radius of the coil (*a*) is the distance from the axis of the coil to the center of the wire. Also, one inch = 2.54 centimeters.



**Radio-Frequency Amplification.** After having effected a means to select the signal carried by one carrier frequency, at the same time blocking out all other carriers, the next step is to amplify the signal by means of a radio-frequency amplifier in order that it may be built up to sufficient strength to produce the proper effects in the demodulation stage—detector. The fundamental principles governing amplification have been explained, and it should be pointed out that a radio-frequency amplifier in a radio receiver is usually a voltage amplifier; one in which tubes that have a high amplification factor are most often used. In other words, the primary purpose of the radio-frequency amplifier is to build up the signal voltage through successive stages until it will cause an appreciable swing in the grid voltage in the circuit where the signal is demodulated or in other words, where the audio component is removed from the radio-frequency component.

While it is true that a radio-frequency amplifier is required to increase the voltage, it is imperative that it do so without introducing appreciable distortion. Therefore, it is necessary to adjust the values of the component parts of the circuits so that the increase in voltage will not be so great as to cause the tubes to operate in such a manner that they change the wave form of the signal.

*Types of R.F. Amplifiers.* In general there are two types of radio-frequency amplifiers, those known as the *tuned* type and those that are *untuned*. The tuned type of radio-frequency amplifier is one that may be adjusted to the desired signal. The untuned amplifier is a series of cascade stages so designed that they will permit the passage of a wide variation of preselected signals, or it may be used to build up all signals, the selection to be made after the build-up.

Refer again to Fig. 2. Now, assume that if, at a given setting of the value of the condenser, the circuit is tuned to permit the free flow of current at 1,000 kilocycles (1,000,000 cycles), a difference of potential will exist between the points *G* and *F*, and, inasmuch as the adjustment of the reactances is not such that will allow the flow of current at other frequencies, there will be no appreciable potential difference at any except the frequency to which the circuit is adjusted.

In Fig. 3 we have taken the circuit as shown in Fig. 2 and combined with it the input elements of a vacuum tube of the triode type. The output elements are connected to an inductance indicated by  $L_{p2}$ . Hence, as the current flows through the inductance and capacity that make up the circuit  $L_s C$ , point  $G$  of the circuit is alternately positive and negative with respect to  $F$ . It will be noticed that  $G$  of circuit  $L_s C$  is connected to the grid of the vacuum tube and that  $F$  of the same circuit is connected to the filament of the

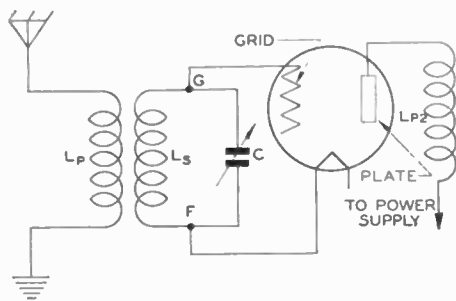

Fig. 3. Antenna Circuit Coupled to Input Elements of Vacuum Tube of Triode Type

tube. The C-bias (steady grid voltage) has not been shown but is understood to be necessary in practice. Thus, there exists a potential difference across the elements of the vacuum tube, a varying difference of potential, which causes the potential upon the grid to change, and as a result to cause a varying current to flow through the plate circuit of which inductance  $L_{p2}$  is a part.

It is evident that the natural function of the radio-frequency amplifier is to build up the voltage in successive stages, and also that the output of a stage is a reproduction of the input, including the audio component that is modulated upon the radio-frequency carrier wave.

In the earlier models of radio receivers, known as the *tuned radio-frequency type*, the individual stages of radio-frequency amplification were provided with a means for adjusting the reactances, and usually employed a variable condenser for the purpose, the variation in capacity being more easily controlled than changes

in the inductance. As the processes of manufacture were developed, all stages were tuned by means of a single control. Unless some additional method for increasing the amplification, such as regeneration, were used, such receivers usually required at least two stages of radio-frequency amplification to give the proper increase in voltage to operate the detector efficiently, due largely to the relatively low amplification factor of tubes that were available. The tuned radio-frequency type of receiver, however, if well designed, was simple in construction, and relatively efficient.

**Regeneration.** Regeneration is a form of feedback by means of which a *portion* of the energy in the plate or output circuit is

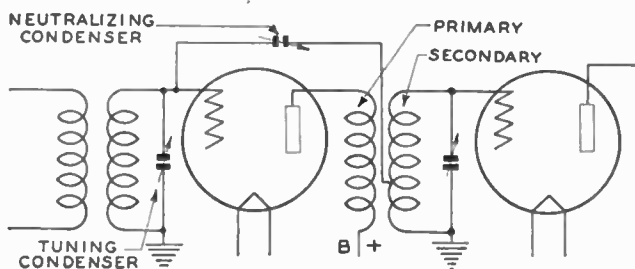

Fig. 4. Neutrodyne Method of Controlling Feedback

returned to the input circuit and serves to build up the strength of the signal. Excessive regeneration results in oscillation, which, being uncontrolled, prevents the tube from performing its function as an amplifier or demodulator. Regeneration was used extensively in the earlier designs of radio receivers and was effected by coupling the output and input circuits inductively or capacitively.

Regeneration may be caused by the coupling provided between the plate and grid elements of the triode, representing the output and input circuits, respectively. Hence, in sets using *neutrodyne* circuits, an external capacity was inserted between stages to compensate for the feedback due to interelectrode capacity, and to thereby prevent self-oscillation. The neutralizing condenser, as it was called, was usually connected as shown in Fig. 4. It was of low capacity and was usually of the semifixed type which permitted its adjustment to compensate for the changing of tubes having interelectrode capacities of differing values.

**Detection.** Detection is the name applied to the demodulation of the radio signal, that is, the separation of the audio component from the modulated wave. It is necessary that the signal be divided thus, in view of the fact that a means must be provided to set up motions of the air to create sound, and mechanical devices will not respond to the high-frequency impulses as represented by the radio-frequency signal.

Strictly speaking, detection is a process of rectification in which the high-frequency alternating wave is converted into a series of fluctuating direct-current impulses. The most efficient detector would be one in which the process of rectification would be complete, one in which only one side of the alternating wave would be retained in its original form, and whose output was a linear function of the input. However, such efficiency of operation is very difficult, if not impossible, to attain in practice.

The modulation of a radio-frequency signal by an audio-frequency impulse creates a series of varying impulses known as *wave trains*. Thus, when a 500-cycle note is impressed upon a carrier of, say, 1,000,000 cycles, there is a changing of the amplitude of the carrier with each of the alternations of the 500-cycle note so that there exists a series of wave trains. When these two frequencies are combined in a nonlinear circuit such as the modulated amplifier stage of a radio transmitter, the result is as shown in Fig. 5. It is the function of the detector to disassociate the audio impulses from the remaining portion of the signal and to pass these impulses to the amplifier stages, following the detector, for final distribution to the loud-speaker.

*Types of Detection.* In general there are two types of detection—*grid detection* and *plate detection*. In the former, the rectification process takes place in the grid circuit and the signal passed to the output circuit as pulsating direct current. In the latter method, the rectification process is effected in the plate or output circuit.

In receivers of earlier design in which the amplification in the radio-frequency amplifier was not so great, much emphasis was placed upon the sensitivity of the detector. However, by using tubes of high-amplification factor and with efficiently designed radio-

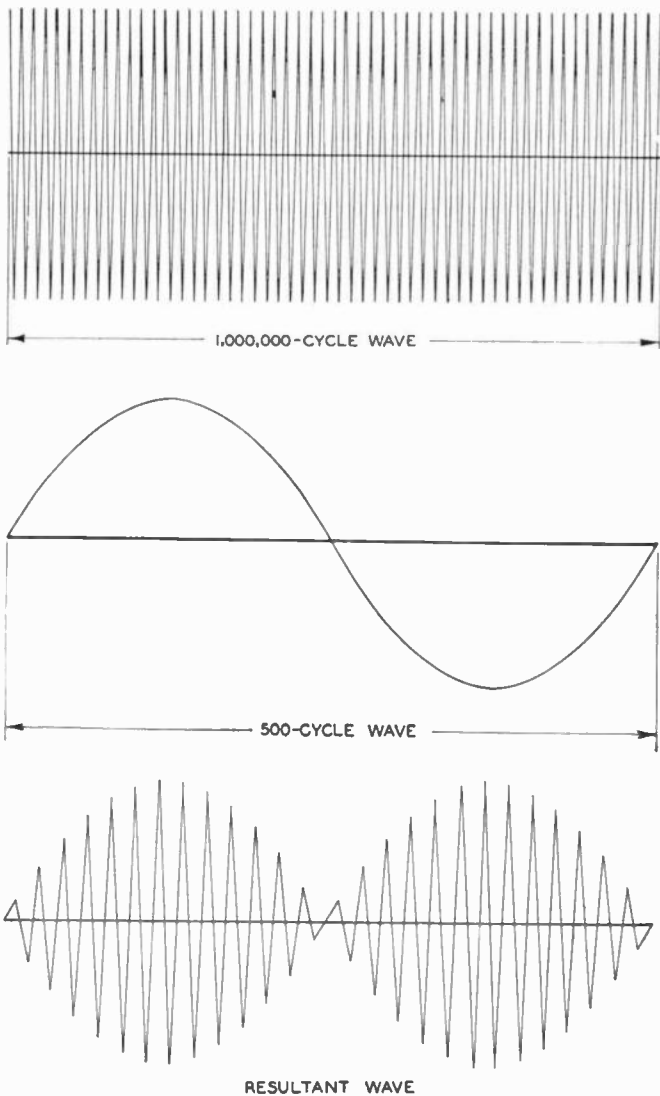

Fig. 5. Result of Combining 1,000,000-Cycle Frequency with 500-Cycle Frequency in Nonlinear Amplifier

frequency amplifiers, it is not so essential that a sensitive detector be employed; more attention is placed upon the action of the circuit from the standpoint of distortion.

*Grid Leak and Condenser.* The circuit which employs a grid leak and condenser (grid detection) was considered highly satisfactory when modulation percentages were low. However, with an increase in the percentage of modulation, the inability of the charges to leak off the grid causes the tube to *block* and introduces a large amount of distortion.

There are numerous methods of explaining the operation of the detector employing the grid leak and condenser, all of which are more or less complex because, to understand the action, it is necessary to visualize a process that takes place over a very short period of time. The most easily comprehended explanation has to do with the movement of electrons and the application of electrical charges.

Consider a circuit, as shown in Fig. 6, containing an induc-

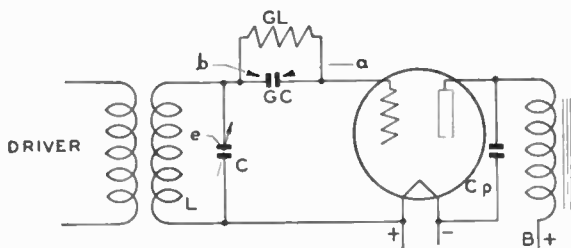

Fig. 6. Diagram of Grid-Leak, Condenser Detector Circuit

tance,  $L$ , tuned by a condenser,  $C$ , connected to a vacuum tube through a grid leak,  $GL$ , and a condenser,  $GC$ . The resonant circuit,  $LC$ , coupled to a driver circuit, has an alternating current flowing through it at a given radio frequency. An audio frequency is impressed upon the radio-frequency carrier, however, so that the amplitude of the alternations is increased—and decreased—according to the frequency of the audio signal. Hence, the alternating current flowing through the circuit  $LC$  is modulated. The grid return is to the positive side of the source of filament supply, which means that the grid is slightly positive with respect to the average potential of the filament.

As the current passes through circuit  $LC$ , connection  $e$  is alternately positive and negative. The grid and filament of the tube constitute the two elements of a diode rectifier. The resonant fre-

quency produces a current flow in the  $LC$  circuit, which is increased by the gain, or  $Q$ , of the tuned circuit. The voltage drop  $e$  across the tuned circuit rises and falls in conformity with the input signal, and it is this voltage which is applied across the grid and filament for rectification.

As the signal drives the grid positive with respect to the filament, current will pass through the grid leak  $GL$ . This produces a potential drop across the resistor which serves to charge condenser  $GC$ . The side of this condenser indicated as  $a$  becomes negatively charged, which places a similar charge on the grid of the tube. The negatively charged grid causes a decrease in plate current, the magnitude of which is determined by the signal voltage and the amplifying capability of the tube.

During the time interval when  $e$  assumes a polarity which prevents the passage of current through resistor  $GL$ , the grid returns to its normal potential; plate current increases to its original value.

Condenser  $GC$  serves to filter the current through resistor  $GL$ , thereby removing the individual radio-frequency variations and causing the circuit to be responsive to the average value of a number of impulses rather than to each individual impulse.

It has been explained how the modulation of a radio-frequency carrier with an audio-frequency signal caused a series of wave trains. Due to the action of the grid leak and the condenser, the signal in the input circuit of the detector consists of half-wave A.F. impulses. As a result of the change in the form of the signal wave, the output of the detector tube naturally follows a similar shape, with the result that there is effected a predominance of the audio signal, which signal may still retain a radio-frequency component.

Any remaining R.F. component is then removed by a combination of two elements. First, there is the condenser  $C_p$  connected between the plate of the tube and the filament; and second, there is the primary of the transformer in the first audio stage. The primary of the transformer acts as a choke to the flow of the pulsating current of high frequency; the condenser provides a path for the radio-frequency impulses to go to ground.

*Grid-Bias Detection.* In the grid-bias method of detection, also called plate rectification and power detection, the grid of the

detector tube is biased so that it operates on the lower curved portion of the grid-voltage, plate-current curve. The *average* plate-current change is thus much greater than the normal plate current, and the positive swings of the grid voltage cause far greater increases in the plate current during the positive half of the cycle than decreases during the negative half of the cycle. This is illustrated in the curves showing the result of changing the grid bias on a tube.

In using the grid-bias method of detection, distortion is deliberately introduced into the circuit. This distortion, while it causes a deviation of the wave form from that of the original, merely emphasizes the amplitude of one side of the wave train and minimizes that of the other side.

Grid-bias detection is more satisfactory for receivers operated where the station-signal strength is high, due to the fact that it is capable of handling a stronger signal without creating objectionable distortion. Hence the principal advantage of grid-bias detection—plate rectification—is the ability to handle great volume.

The grid-bias detector is less sensitive than the detector employing the grid condenser and grid leak as described previously. However, in receivers having a high gain in the radio-frequency amplifier, the need for a detector of high sensitivity is less pronounced, and greater stress can be laid upon the efficiency of the detector in rectifying the signal and effecting demodulation.

*Diode Detector.* A simple two-element tube consisting of a cathode and plate may be used as a detector or rectifier of modulated radio-frequency signals. Half-wave rectification is usually used, and the tube becomes conducting when the signal makes the plate positive with respect to the cathode. Negative alternations are completely suppressed. The output of such a detector consists of a direct current pulsating at modulated radio-frequency amplitudes. The characteristics of the diode detector are low sensitivity and low distortion. This type of detection is almost universally used in present-day, high-gain receivers where fidelity of reproduction is of greater value than sensitivity in a detector circuit.

*Detectors—General Summary.* Detection is demodulation, the separation of the audio component from the radio-frequency



carrier. It is in effect a rectification process which changes the alternating current into a pulsating direct current, the rectified portion of the wave having the same general wave form as that part of the alternating wave that is on the positive side of the zero potential line. Various types of circuits are employed, depending upon the design of the tube to be used. With the general ideas of detector action in mind, the engineering data furnished by the tube manufacturers will be understood readily.

**Audio Amplifiers.** Having demodulated the signal, it is necessary to amplify the resultant series of waves and provide sufficient energy to actuate the mechanical device to create sound waves. The type of amplifier used depends to a certain extent upon the kind of demodulation used; in the case of power detection, for instance, it is possible to feed from the detector directly into the power output tube if high-gain circuits precede the detector. The value of the plate-resistance should be selected in accordance with the recommendations of the tube engineers as shown in tube engineering data furnished by the manufacturers.

**Manual Volume Controls.** In a radio receiver it is necessary to have some means of changing the volume of sound delivered by the set, because some of the stations which are near and of high power deliver a strong signal to the set; others are many miles away and of lower power. This control of volume is usually done by introducing resistance in the circuits. In the early radio receivers when the batteries were new, their voltages were high. Then as the batteries were used, the voltage decreased to a low value. In order to prevent the filament of the tubes from receiving too much voltage and current from these new batteries, thus causing them to burn out, it was necessary to add resistance in the circuit. Also this resistance had to be made so it could be easily adjusted. Thus it was made into a rheostat. This rheostat not only controlled the voltage and current to the filament of the radio tube but it also served as a control of the volume of the set.

With the use of alternating current from the house lighting circuits as a source of current supply for the radio receiver, a very steady voltage was obtained, and the rheostat was not needed or used. Thus it was necessary to use other methods of controlling the

volume. To meet this need, seven general methods of volume control have been developed. They are referred to as:

1. Antenna-circuit resistance controls
2. Grid-bias voltage-control circuits
3. Antenna grid-bias combination controls
4. Screen-grid voltage controls
5. Plate-circuit voltage control
6. Radio-frequency control circuits
7. Audio-frequency control circuits

*Antenna-Circuit Control.* This is the simplest type of control. It operates in the antenna circuit of the radio receiver to control amount of signal fed to the grid of the first radio-frequency amplifier tube. There are many ways in which this control can be connected in the antenna circuit; three of these are shown in Fig. 7. The letters *R*, *L*, and *C* refer to the right, left, and center terminals on the rear of the rheostat which can be used as a potentiometer since it has three terminals.

In Fig. 7 at (*A*), the antenna is connected directly at *R* to the right-hand end of the control; the ground, which is usually the metal chassis of the set, is connected at *L* to the left terminal; the moving arm at *C* (center terminal) is connected directly to the grid of the first radio-frequency (R.F.) amplifier tube. The maximum volume is obtained when the control knob is rotated toward the right (clockwise) from the front of the panel (*C* is moved toward *R*). The amount of resistance between *R* and *L*, Fig. 7 at (*A*), is between 450 and 10,000 ohms. This type of control was used on several of the early model AC receiving sets which were sold in large quantities.

In Fig. 7 at (*B*), the primary of the first radio-frequency coil (sometimes called the antenna coil) is connected to the center terminal at *C*, which is the moving arm of the potentiometer, while the other terminal of the radio-frequency primary coil and terminal *L* are connected together or separately to ground.

The resistance value of this type of control is usually from 2,000 to 20,000 ohms, depending in a large degree upon the impedance of the primary of the radio-frequency coil.

The primary of the radio-frequency coil, is sometimes con-

connected to terminals  $R$  and  $L$  with the center terminal  $C$  connected to ground. This circuit usually does not give as good results as the connections shown in Fig. 7 at (B).

In Fig. 7 at (C), a radio-frequency choke coil has been added

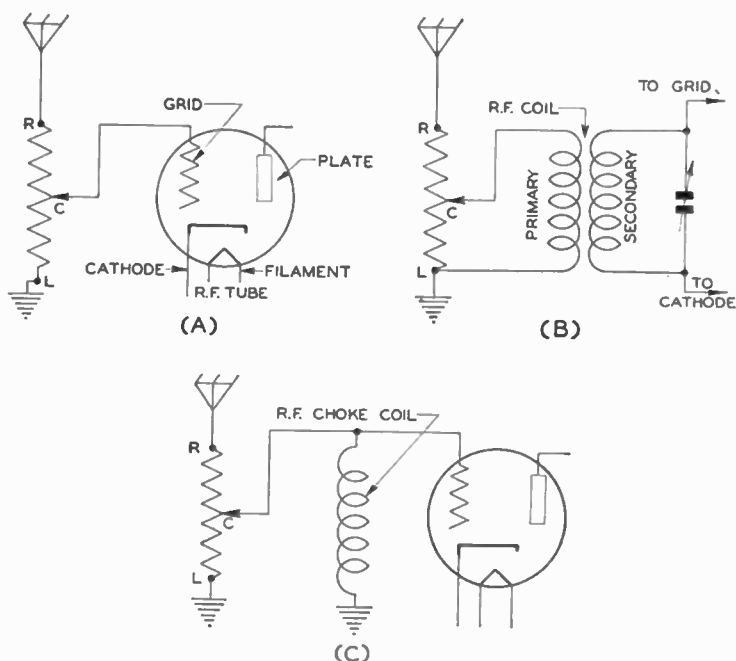

Fig. 7. Methods of Connecting Resistance Control in Antenna Circuit

to the circuit. The purpose of this choke may be either to give a *rising response* at the low-frequency end of the broadcast band or to allow the use of a higher resistance in the control without hum trouble. Control resistances as high as 50,000 ohms are sometimes used in this circuit.

*Grid-Bias Volume Control.* This type of control was used in the early battery sets and consisted of a potentiometer of 200 to 400 ohms with the  $R$  and  $L$  terminals connected across the filament of the radio tube which was supplied by an A battery. The center terminal, which is the movable contact, is connected to cathode terminal of the radio-frequency coil. Thus, the output of the radio

tube is changed by changing the grid bias of the tube. The result of such a change is best understood by looking at a characteristic curve of a vacuum tube and shifting the grid signal along the base line of that curve, and by observing the effect on the output curve of that tube.

*Antenna and Grid-Bias Control.* This is a combination of the two distinct actions of the antenna control and the grid-bias control. The first action is the control of the volume by means of increasing

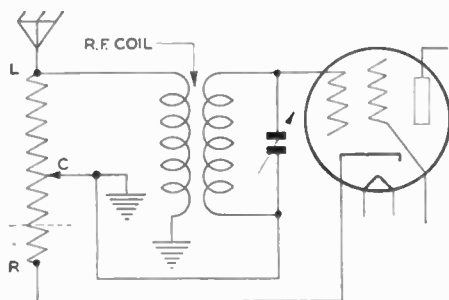

Fig. 8. Combination of Antenna and Grid-Bias Control

the bias on the tubes that are being controlled. The second action is the *shorting out* or by-passing the input signal at the antenna. A circuit of this type is shown in Fig. 8. There may be a stop on the potentiometer at the point indicated by the dotted line, so that part of the resistance is retained for use as a minimum bias resistor in order to supply correct bias to the tube at full-volume position.

*Screen-Grid Voltage Control.* The output of the tube or tubes is controlled by varying the voltage on the screen grid of the tube.

This change in screen-grid voltage changes the mutual conductance of the tube in a manner similar to a change in grid voltage. It cannot be used on triode (three-element) tubes since they do not have any screen grids. It is used with the tetrode (four-element) tube and those having more than four elements. A circuit diagram is shown for a screen-grid tube in Fig. 9. The control could be extended to several tubes by connecting their screen grids to the

dash line in Fig. 9. This control is used to a limited extent in battery receivers. A potentiometer resistance of 50,000 ohms has been used predominantly, although for replacement purposes 100,000-ohm units are being used satisfactorily.

*Plate-Circuit Voltage Control.* If the *C* terminal of the potentiometer is connected to the *B+* terminal of the plate coil, (primary of the radio-frequency coil) instead of to the screen grid of the tube as in Fig. 9, the volume can be controlled by varying the voltage on the plate circuit of the tube. The current handled by the plate circuit is much greater than in the screen-grid circuit, and *burned* spots usually develop on the potentiometer in service, re-

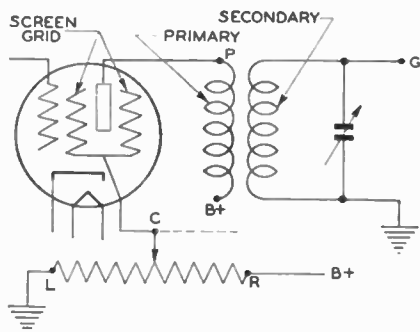

Fig. 9. Screen-Grid and Plate-Circuit Control

sulting in noise. This defect caused the use of this type of control to be discontinued.

*Radio-Frequency Control Circuits.* There are two ways of connecting the potentiometer for this type of control. One is to connect it across the primary terminals (*B+* and *P*) of the radio-frequency coil, Fig. 9, and thus shunt out or *short out* part of the current flowing through that coil. The other method is to connect the potentiometer across the secondary terminals (*G* and *ground*) of the radio-frequency coil, Fig. 9. The primary shunt control was a popular method on the later battery sets and early alternating-current sets. The resistance of the potentiometer used in the primary circuit is from 1,000 to 10,000 ohms, while the lowest resistance to use in the secondary circuit is 100,000 ohms. The usual resist-

ance in the secondary circuit is about 250,000 ohms while some sets have used resistances of 500,000 ohms. Thus the higher the current through that circuit, the lower the resistance. The current through the secondary of a radio-frequency coil is much lower than that through the primary.

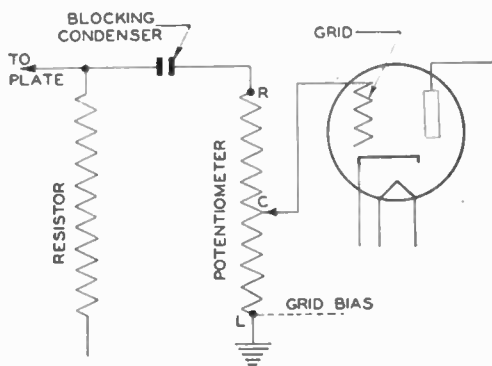

Fig. 10. Resistance-Coupled, Audio, Volume-Control Circuit

*Audio-Frequency Volume Controls.* There are two general types of audio-frequency amplification—resistance coupled and transformer (iron core) coupled. The circuit connection of a vol-

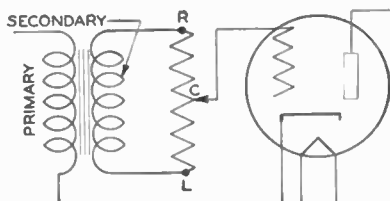

Fig. 11. Method of Connecting Volume-Control to Audio Transformer

ume control (potentiometer) to a resistance-coupled amplifier is shown in Fig. 10. Here the potentiometer takes the place of the resistor usually used to the right of the blocking condenser. Thus, the control is part of the plate load of the preceding tube, and its resistance is determined by the required plate load of the preceding tube and by the admittance of the grid circuit of the tube. A modi-



and a portion of  $R_3$  to the ground and back to the cathode of the detector tube.  $R_3$ , it will be noted, is a variable resistance and serves as the manual volume control by varying the value of the resistance network. Any point on the circuit from  $R_1$  to  $R_3$  is negative with respect to the ground when current is flowing in the circuit.

The current passing through  $R_1$ ,  $R_2$ , and a part of  $R_3$  increases as the strength of the signal voltage applied to the detector anode increases. And, as the current increases, the voltage drop across the resistance  $R_2$  and a part of  $R_3$  increases so that point  $O$  is made more negative with respect to ground than when a feeble current is flowing in the circuit. Hence, if point  $O$  is connected to the grid of tubes in the amplifier stages through a suitable resistor  $R_4$ , and if the signal strength increases, the bias on the grid of the amplifier tubes will be increased, less plate current will flow, and the signal level will drop. However, if the signal voltage applied to the detector anode drops, current passing through the resistance network will decrease, voltage drop will decrease, and the lowered grid bias will cause a higher gain in the controlled amplifier.

There are numerous types of automatic volume-control circuits. Some of them employ a separate tube, others do not. Regardless of the design, the principle involved is as shown herein, the rectified current causing a higher or lower voltage drop, and a resulting higher or lower bias on the grid of tubes in the amplifier stages.





## SUPERHETERODYNE RECEIVERS

The theory underlying the development of the superheterodyne circuit is founded principally on the changing efficiency of radio-frequency amplifiers at different frequencies. A radio-frequency circuit consisting of a fixed coil and variable condenser, while relatively efficient over a comparatively wide band of frequencies, will be most efficient at some given frequency. Hence, engineers reasoned that if a means could be provided to produce a carrier of a given frequency and modulate it with the incoming signal, a radio-frequency (R.F.) circuit designed to resonate at a single given frequency would amplify more efficiently.

It has been shown how an alternating voltage of one frequency could be modulated upon an alternating voltage having another frequency to give a resulting wave form. In the case of modulating a radio-frequency carrier with audio frequencies, the resulting wave form is a series of wave trains, the integral parts of which have

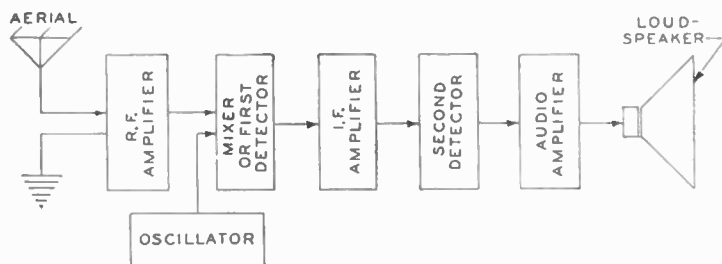

Fig. 1. Route of Radio Signal Through Superheterodyne Receiver

varying amplitude in accordance with the summation or subtraction of the amplitude of the impulses of the carrier and modulated frequency.

**Superheterodyne Circuits.** The superheterodyne circuit, recognized as the most efficient receiving circuit, combines all the

integral parts which have been described previously with two additional stages, known as the *oscillator* and the *mixer stages*. The mixer stage is often called the *first detector stage*. Fig. 1 shows the route of a radio signal through a superheterodyne receiver.

The phenomenon of beating frequencies is made use of in the superheterodyne circuit to produce amplification at a fixed intermediate frequency. In effect, the frequency of the desired signal is mixed with a locally generated frequency in a nonlinear circuit and the difference in frequency is extracted. The locally generated oscillation must be changed in frequency to correspond with the frequency of each signal to be received.

As a specific example, suppose one desires to receive a signal having a frequency of 1000 kilocycles on a superheterodyne receiver having an intermediate frequency of 456 kilocycles. The local oscillator circuit in the receiver must be adjusted to 1456 kilocycles. These two frequencies, 1000 kilocycles and 1456 kilocycles, are combined in the first detector or mixer stage and the output circuit of the mixer, which is sharply tuned to 456 kilocycles, extracts this frequency difference. If a 1200-kilocycle signal is desired, the oscillator must be tuned to 1200 kilocycles plus 456 kilocycles, or 1656 kilocycles. The difference between the oscillator frequency and the desired signal frequency must always be 456 kilocycles in the receiver under consideration.

This frequency difference undergoes amplification in the fixed-frequency amplifier, this stage being called the *intermediate-frequency-amplifier stage* or stages, and is passed on to the second detector or demodulator where the audio component is extracted for additional amplification. The output of the audio amplifier is fed to the loud-speaker.

A stage of radio-frequency amplification may, and often does, precede the mixer stage (the first detector) to serve as a means to build up the incoming signal so that it will modulate more effectively the wave produced by the oscillator circuit.

The following description of the action and alignment of a superheterodyne receiver gives a detailed account of its operation.

**Superheterodyne Operation.** Fig. 2 shows the circuit connections of a superheterodyne receiver. This receiver is designed



kilocycles is provided; the loop-type antenna may be supplemented by connection to an external antenna in localities where the signal strength may be low. The intermediate frequency (I.F.) is 456 kilocycles, a value which has become fairly standard for broadcast band receivers. When used on a 120-volt direct-current line, proper polarity of the line cord must be obtained to insure placing the positive line potential on the plate of the rectifier tube. The rectifier in this condition simply acts as a resistor, rectification of course being unnecessary on direct-current operation. The metal chassis is used as a return or ground connection for the various circuits including the 120-volt-line circuit. This makes it imperative that the chassis be kept away from grounded objects, such as radiators and water lines, to prevent shorting the supply line.

*Antenna Connections.* We will now make a detailed analysis of the operation of the receiver. The antenna (external) is capacitatively coupled to the loop by twisting the antenna lead around the wire leading to the control grid of the 12SA7. This method of connection de-couples the antenna sufficiently to prevent the antenna capacity from loading the tuning condenser. A small condenser could have been used for coupling purposes, but the twisted wire serves the same purpose and reduces the cost. If the antenna is too closely coupled to the receiver circuit, the first tuned circuit would be changed with each value of antenna used. This would prevent the use of a gang condenser in tuning.

The loop serves as the signal pickup medium as well as the inductance to be tuned by the first variable condenser in the gang assembly. The purpose of this circuit is to select and increase the voltage of the desired station while excluding all others. This is due to the effect of resonance, the signal voltage at resonance being many times the original input voltage. The increase is due to the Q factor of the circuit and in well-designed circuits reaches a value of from 100 to 250 times the input voltage.

*Mixer-Oscillator.* The 12SA7 is a pentagrid converter tube which acts as a combination mixer-oscillator. This tube has an indirectly heated cathode, five grids, and a plate and uses twelve volts for filament excitation. Grid number one is used as the oscillator grid, feedback taking place by returning the cathode to the tapped

oscillator coil. The signal input circuit of the type 12SA7 tube is shown in Fig. 3.

The purpose of C4 is to ground the loop to radio frequency while isolating it (the loop) from ground for direct current. It will be seen that C4 is in series with the variable condenser tuning the loop. The total capacity of this combination is substantially that of the variable condenser due to the large value of C4.

The oscillator portion of the 12SA7 makes use of cathode feedback, wherein the varying energy passing to the cathode causes a magnetic field to be set up in a coil which is coupled to the grid coil of the oscillator. The variable condenser tunes the oscillator

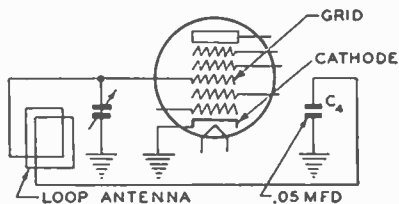

Fig. 3. Signal Input Circuit of Type 12SA7 Tube

circuit to the proper frequency for each setting of the station-selector control. The .0001-microfarad condenser is a blocking condenser which prevents a grid-current flow through the tuning inductance as the grid is driven positive. The 20,000-ohm resistor is used for the purpose of returning the grid to ground to prevent an accumulation of negative electrons on the otherwise free grid. This resistor also acts as an automatic biasing resistor which limits the amplitude of oscillation in the tube. The plate circuit of the 12SA7 includes the tuned primary of the first intermediate-frequency transformer, which must be accurately adjusted to the intermediate frequency, in this case 456 kilocycles. The suppressor grid of the 12SA7 is grounded. The screen grid shields the control grid from interference by either the oscillator or input circuits. The oscillator and output circuit of the 12SA7 is shown in Fig. 4.

*Intermediate-Frequency Amplifier.* The load in the plate circuit of the 12SA7 consists of a tuned circuit, resonant to 456 kilocycles, which is the intermediate frequency. This tuned circuit con-

stitutes the primary of the first intermediate-frequency transformer, the secondary of which is also tuned to 456 kilocycles. The secondary output feeds the input circuit of the 12SK7 which is called the *intermediate-frequency amplifier*. The intermediate-frequency transformer, together with its tuning condensers, is generally housed

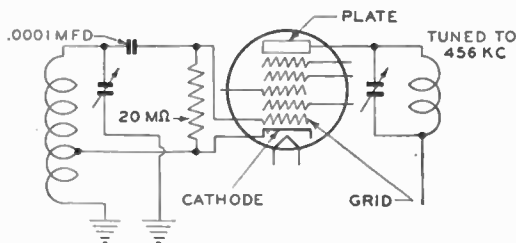

Fig. 4. Oscillator and Output Circuit of 12SA7 Tube

in a metallic shield, holes being provided over the intermediate-frequency tuning condenser screw adjustments for the insertion of an adjusting tool.

The intermediate-frequency amplifier tube, 12SK7, has its cathode grounded, indicating that the bias for this tube is completely under the control of the automatic volume-control circuit. This tube operates as a conventional voltage amplifier. The output

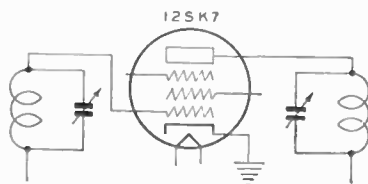

Fig. 5. Intermediate-Frequency Amplifier

of the intermediate-frequency amplifier is a resonant circuit tuned to 456 kilocycles and constitutes the primary of the second intermediate-frequency transformer. The intermediate-frequency amplifier stage is shown in Fig. 5.

*Detector-Amplifier.* The secondary of this intermediate-fre-

quency transformer, also tuned to 456 kilocycles, feeds the 12SQ7 which is a combination detector, automatic volume control, and amplifier stage. The 12SQ7 is a double diode-triode. The output of the secondary of the intermediate-frequency transformer is connected to the two diode plates in parallel, producing a half-wave rectifier. The rectified current passes through a 500,000-ohm variable resistor which acts as the manual volume control.

The .00025-microfarad condenser connected across the volume control serves to extract an average direct-current potential, free of radio-frequency pulses. In this manner it acts as a filter. Fig. 6 shows the diode section of the 12SQ7.

The three- and fifteen-megohm resistors (shown in Fig. 2) are isolating resistors which prevent interaction between the stages

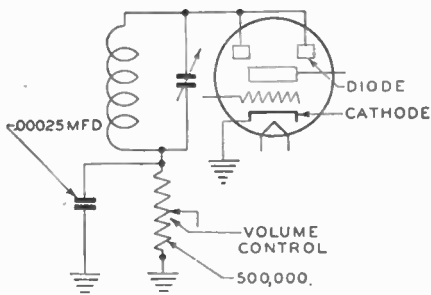

Fig. 6. Connections of Diode Section of 12SQ7

which are otherwise connected together through the automatic volume-control system.

A portion of the voltage drop across the 500,000-ohm volume control is fed through the .002-microfarad condenser and applied to the control grid of the triode section of the 12SQ7. The control grid is bled to ground through a 15-megohm resistor. The .002-microfarad condenser is large enough to pass the audio-frequency variations appearing across the volume control. The load in the plate circuit of the triode section of the 12SQ7 is a 500,000-ohm resistor which allows the maximum possible gain of the triode section to be made use of.

*Power Amplifier.* A .00025-microfarad condenser is connected from plate to ground to by-pass any radio-frequency varia-



tions that may occur in the plate circuit. This prevents the radio frequency from entering the power supply system. The voltage drop appearing across this load resistor is applied through a .02-microfarad coupling condenser to the grid of the 50L6GT. The grid circuit is completed to ground through a one-half megohm resistor. The cathode of the 50L6GT is connected to ground through a 150-ohm resistor which supplies the biasing voltage for the control grid of this tube. The resistor is not by-passed to ground. This produces a degenerative effect which improves the quality of reproduction.

A .02-microfarad condenser connected from the plate of the 50L6GT to cathode serves to by-pass high frequencies and improves tonal quality. The output-transformer primary acts as the plate load for the 50L6GT and the secondary of this transformer matches the impedance of the loud-speaker voice coil. The transformer is of the step-down type.

The 35Z5GT is a half-wave rectifier whose filament is tapped for pilot-light connection. The full-line voltage is applied between the plate of the 35Z5GT and ground, the cathode forming the positive side of the rectified output. A .05-microfarad condenser is connected from plate to ground to by-pass any interference that might otherwise be led to the receiver from the power lines. The filtering system consists of two 20-microfarad condensers with a working voltage of 150 connected on either side of the loud-speaker field which provides adequate filtering. The filaments are connected in series as in the lower right-hand corner of Fig. 2.

*Alignment.* The alignment of the circuits of a superheterodyne receiver requires the use of an oscillator or signal generator, an output meter, and an alignment tool. The oscillator must be capable of putting out a signal of constant amplitude, with or without modulation, over a frequency range covering the intermediate frequencies as well as broadcast and short-wave bands. The output meter may be a rectifier type of instrument connected in place of the loud-speaker voice coil. A visual indication of maximum adjustment is thus provided, this being more accurate than an aural indication. The alignment tool is an insulated screw driver or wrench possessing a minimum of metal in its structure.

*Procedure.* Tubes should be tested and proven to be in good working order. The voice coil of the loud-speaker should be unsoldered and the automatic volume-control circuit de-energized if necessary. This is done by grounding the lower end of the loop.

The operation consists of lining up, first, the intermediate-frequency stages, and secondly, the radio-frequency stages at the high-frequency end of the band, and, in some receivers (but not all) the radio-frequency stages at the low-frequency end of each band. In many receivers, the oscillator tuning condenser has shaped plates to compensate for the different tuning range. These receivers do not require adjustment at the low-frequency end of the bands. It is understood that the radio-frequency stage lineup also refers to the oscillator circuit.

*Aligning Intermediate-Frequency Stages.* To adjust the intermediate-frequency circuits, connect the output meter in place of the loud-speaker voice coil and connect a lead from the high side of the oscillator or signal generator to the control grid of the first detector. The low side of the oscillator will be connected to the ground of the circuit. In case the circuit is upset too greatly by a direct connection from the oscillator to the control grid, an isolating condenser should be used in series with the lead to the control grid. This can be .0001 microfarad in size.

The signal generator sends a 456-kilocycle modulated signal through the intermediate-frequency portion of the receiver and an indication will be observed on the output meter, providing the second detector and audio-amplifier section are in working condition. The adjustment tool is used to change the setting of the tuning condensers in the first intermediate-frequency transformer, shown in Fig. 7, the proper adjustment being obtained when the output meter indicates its maximum value. If the increase in gain causes the output-meter pointer to go off scale, a readjustment of the receiver volume control or output of the signal generator will be necessary to bring the indicator back to a usable portion of the scale. After adjusting the first intermediate-frequency transformer trimmers, the operation is repeated on the second intermediate-frequency stage, the signal generator remaining connected as before. Adjustment of the second intermediate-frequency trimmers

is made to obtain maximum output. It will be noted that the semi-variable condensers in these tuned circuits are called trimmers, intermediate-frequency padders, or intermediate-frequency variables. After adjusting the second intermediate frequency, a slight readjustment of the first stage may result in an increased reading on the output meter. Several repetitions of the tuning procedure

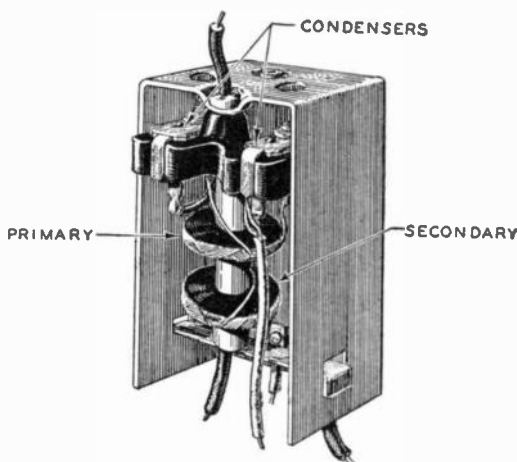

Fig. 7. Intermediate-Frequency Transformer

will finally result in the highest reading of the output meter with a given volume control setting.

The intermediate-frequency portion of the receiver is now in condition to accept the proper frequency. It now becomes necessary to make sure that this frequency is sent to these stages. This function is performed by the first detector or mixer stage and the receiver oscillator.

*Aligning Radio-Frequency Stages.* The output of the signal generator is now connected to the antenna input of the receiver, and it is adjusted so as to put out a modulated signal whose frequency falls somewhere near the high-frequency end of the receiver band, the exact frequency being unimportant. In the receiver in question, this would fall somewhere near the 1500-kilocycle portion of the band. The receiver-tuning condenser is adjusted as carefully as possible to this frequency to produce the greatest de-

flection on the output meter for a given volume-control setting. Again, if necessary, reduce the volume control to keep the meter pointer on scale.

The trimmer condensers associated with the gang assembly are now adjusted to provide maximum output meter deflection. It will be noted that while the trimmer associated with the signal input circuit is not particularly critical, the oscillator trimmer adjustment is highly susceptible to small changes. This is because a change of oscillator frequency changes the intermediate frequency produced, while detuning the radio-frequency circuit merely decreases the efficiency of the heterodyne action.

This operation completes the line-up procedure for this receiver. If a receiver is encountered in which all condensers in the gang are the same shape, one additional adjustment must be made. The low-frequency pad condenser must be adjusted.

Tune the signal generator and receiver to the low-frequency end of the band and adjust the pad condenser for maximum-output meter reading. This pad condenser is not on the gang assembly but will be found located in the vicinity of the oscillator coil assembly.

In the case of an all-wave receiver, the foregoing operation, i.e., adjustment of the radio frequency and oscillator sections, must be performed for each band.



## SOUND-REPRODUCING DEVICES

**Noise and Music.** A discussion of the principles of acoustics has brought out the fact that sound is created by the repeated compression and rarefaction of the air at successive intervals. When the compressions and rarefactions occur at irregular intervals, the sound produced is known as *noise*; when they occur at regular intervals, the sound produced is known as a *musical tone*. Other discussions showed how sound pressures are made to cause fluctuations in the flow of electrical currents, and how the varying electric currents are modulated on a carrier wave that is transmitted through space, picked up by the antenna of a radio receiver, amplified, and finally demodulated so that the current flow again becomes an electrical representation of the original sound pressures.

The fluctuating electric current, however, cannot act to set up a movement of the air to create the sound waves; it is necessary to provide a device that will react to the variations in current flow, causing the vibration of physical bodies that have the ability to create compressions and rarefactions of the air surrounding them.

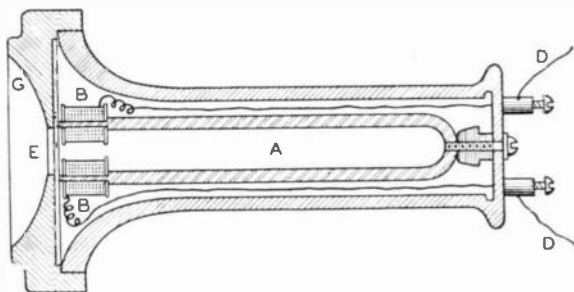

Fig. 1. Early Telephone Receiver

**Telephone Receiver.** The early telephone receiver shown in Fig. 1, is such a device. It consists of a permanent horseshoe

magnet, *A*, around each pole of which there is placed a coil of wire, *B*, the coils being connected in series so that current flows through both of them. The open terminals, *D*, of the two coils are then connected to the source of fluctuating current. Near the pole pieces is a thin metal disc of soft iron, *E*, held tightly in position by the case, *G*, of the receiver.

As the fluctuating current passes through the coils around the pole pieces, the magnetic field is increased and decreased with each successive part of the wave train, described elsewhere, so that the metal disc is caused to vibrate. The vibrations create varying pressures of the air to create sound.

**Headphone.** The headphone, used widely in the early days of radio, and which constitutes a necessary piece of laboratory equipment, is an adaptation of the telephone receiver. It differs only in that it is shaped differently to enable the operator to hold it next to his ear by means of a band passing over the head, and in the amount of resistance in the coils surrounding the pole pieces—the headphone used for radio being of much greater resistance than that used in telephone circuits.

**Loud-Speakers.** As the development of radio progressed, the need became apparent for a reproducer that would permit several persons to hear the programs simultaneously. Consequently, there came the loud-speaker, a device that is capable of setting large quantities of air in motion, but which requires more energy to actuate it. The first loud-speakers were crude affairs, adaptations of the headphone. Generally speaking, there are four types of loud-speakers, each of which is differentiated from the others by its design and construction.

*Magnetic Type.* Fig. 2 shows the essential construction of a magnetic type of loud-speaker unit. It consists of a permanent magnet, *M*, on each pole of which is a coil, *C*<sub>1</sub> and *C*<sub>2</sub>, containing a large number of turns of very fine wire. The coils are mounted in such a way that the pole pieces of the magnet are relatively close together to confine the field. A short distance from the pole pieces, a matter of a few thousandths of an inch, is the diaphragm, *D*, which is held rigidly in position by the cap that is made of insulating material and which screws over the entire assembly. The

coils are connected in such a way that when the current from the amplifier passes through them, both poles of the magnet attract or repel simultaneously. The output of the audio amplifier, passing through the coils, causes a varying current to flow in the circuit so that the metal diaphragm is attracted or repelled, setting the air immediately surrounding it in motion to create sound waves.

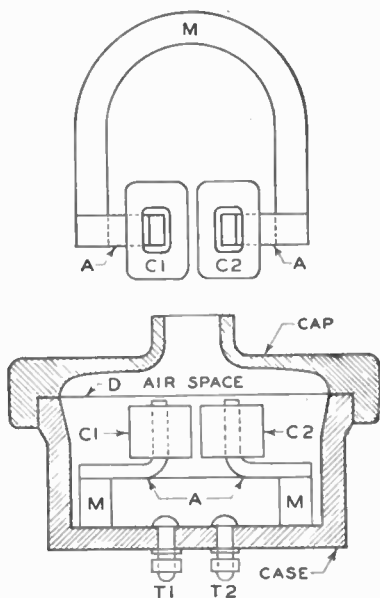

Fig. 2. Magnetic Speaker Unit

There are numerous variations of the magnetic type of speaker. While in some instances a unit, such as the one shown, is placed at the end of a horn, the diaphragm may also be connected to a cone which sets up the motion of the air when actuated, instead of depending upon the small surface of the diaphragm of the head-phone-like unit. With the cone, a greater amount of air is set in motion, thus giving a wave front of larger cross-sectional area.

The magnetic type of speaker is adaptable to many installations because it is not necessary to have a source of direct current to energize a magnetic field, as in the case of the dynamic speaker. Its efficiency is very low, however.



*Balanced-Armature Type.* The balanced-armature type of speaker is another device that depends upon the magnetic properties of iron and steel for its operation. This type is a variation of the magnetic type of speaker. Fig. 3 shows a balanced-armature type of speaker unit. Here again there is a permanent magnet to which there is attached at each pole a sort of horseshoe so that the poles of the magnet are brought near each other with a narrow gap between them. In the gap lies the armature around which is

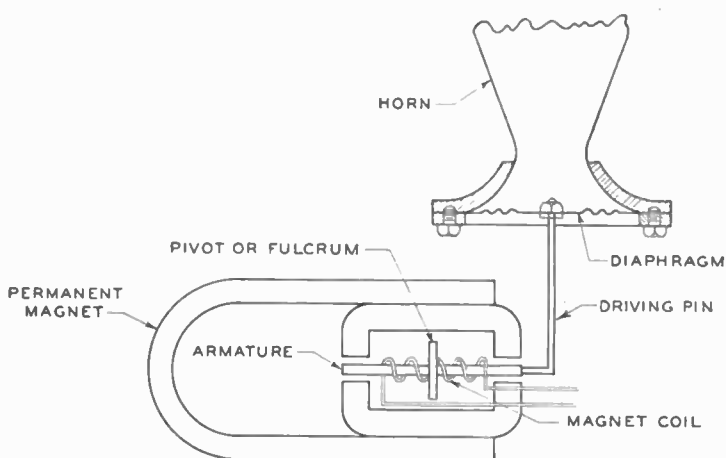

Fig. 3. Balanced-Armature Type of Speaker Unit

a coil of wire that is connected to the output of the amplifier; the armature is in a magnetic field of constant intensity.

When the fluctuating current from the amplifier passes through the coil, the armature becomes the core of an electromagnet, the ends of which are magnetized according to the direction of current flow. When one end of the armature is at a given polarity, it is naturally repelled from that pole piece having the same polarity and attracted to the other pole which has the opposite polarity. A reversal in the direction of current flow will cause the armature to be repelled from the pole to which it has just been attracted and to move toward the other pole which has opposite polarity. The movement of the armature is transmitted to a diaphragm, or cone,

by means of a driving pin, and the air is set in motion because of the movement of the diaphragm.

Like the magnetic type of speaker, the balanced-armature speaker unit is adaptable to certain public address installations where a source of direct current is not readily available to generate a flow of magnetic flux, as is required in a dynamic type of speaker. Its efficiency, though higher than that of the diaphragm type speaker, is relatively low.

The balanced armature type of speaker is more flexible in its application than one of the diaphragm type, especially in its ability to respond to a wider range of audible frequencies. It may be adapted to use with horn projectors or cone diaphragms as desired.

*Dynamic or Moving-Coil Type.* The most popular type of loud-speaker is that which is misnamed the dynamic speaker. Actually the device should be known as an electrodynamic or moving-coil speaker, but popular use of the former appellation has made it an acceptable term. The dynamic speaker derives its name from the fact that instead of having a moving vane or disc such as found in the headphone and in other types of loud-speaker units, a magnetic field is produced by any suitable means, and a coil of wire attached to a cone is caused to move in this field.

The construction of the dynamic speaker is illustrated in Fig. 4. Direct current passing through the field coil which is around the core sets up a flow of magnetic flux that passes through the core to the outside case. The case continues around in front of the field coil until it nearly touches—but does not quite touch—the front end of the core. Thus, there is an air gap across which the magnetic flux flows, as shown by short dash lines.

Into the air gap there is inserted a small coil attached to a cone. The terminals of this coil are connected to the output of the receiver or amplifier. When no current is flowing through the voice coil, there is no movement of the cone. However, when a signal is passed through the voice coil, the magnetic field set up around the turns of the voice coil reacts with the steady magnetic flux produced by the field coil and causes a movement inward and outward in the space that exists in the air gap. The movement of

the voice coil causes the air next to the cone to be compressed or rarefied accordingly, and if the variations of the current flowing through the voice coil are within the audible frequencies, the compressions and rarefactions of the air will be represented as sound.

The formation of an electromagnet by passing a current through a coil of wire surrounding an iron core and the creation of a disturbance in the flux by passing a conductor through a magnetic field are the two principles constituting the fundamentals of

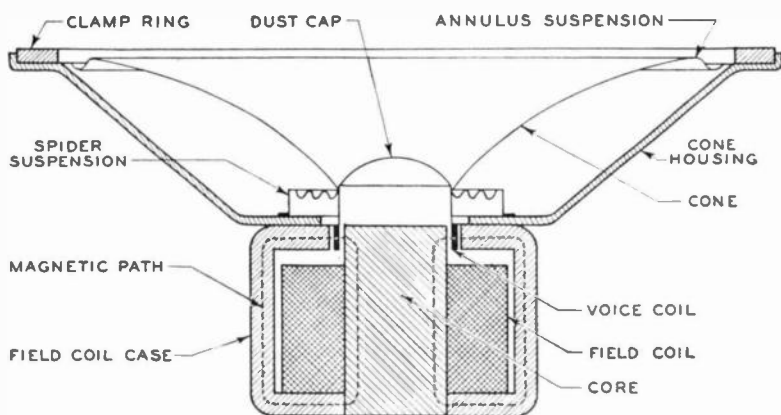

Fig. 4. Cross Section of Electrodynamic Speaker

the operation of the dynamic type of loud-speaker. Although the dynamic type of speaker is usually thought to be a more or less bulky piece of apparatus, it may also be designed very compactly to use a stretched diaphragm instead of the customary cone. The entire assembly may then be enclosed in a case which may be fastened on the end of a horn through which the sound waves are projected.

*Permanent-Magnet Type.* Moving-coil speakers having permanent-magnet field structures have become increasingly popular with the advent of highly improved steel alloys. In operation they are identical with the electromagnetic type described. Their chief advantages are a reduction in cost of manufacture and the elimination of electrical power loss encountered in electrodynamic type.

**Baffles.** The ability of a loud-speaker to reproduce low fre-

quencies is determined largely by the size of the baffle. The purpose of the baffle is to prevent a collision between the sound wave emanating from the front of the cone and that which is produced at the back of the cone. Such a collision would neutralize, to a certain extent, the effect of air compressions and rarefactions, and would prevent the reproduction of low-frequency impulses.

There are two general types of baffles, the flat type and the box type. The box-type baffle must be well ventilated in the rear

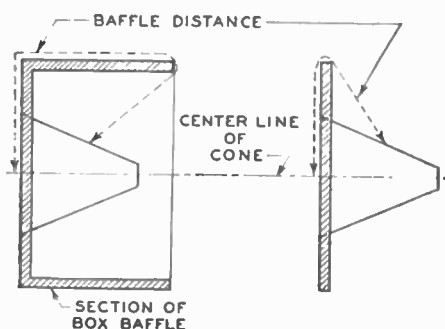

Fig. 5. Box- and Flat-Type Baffles

to prevent distortion caused by the sound waves rebounding from the hard surface of a back wall and collision with new waves being given off. Fig. 5 shows the two types of baffles used, the one at the right being a flat-type baffle and the one at the left being a box-type baffle.

The approximate minimum frequency that a speaker will reproduce with a given baffle can be determined by measuring the free distance, as shown by the arrows in the illustration. A speaker having a baffle that measures approximately 32 inches is capable of reproducing tones of about 100 cycles. If the baffle is 64 inches it will permit the speaker to reproduce tones of about 50 cycles. In either case, it is necessary that the amplifier be capable of delivering the low frequencies to the speaker unit. It is not often that frequencies lower than 50 cycles are desired outside of experimental laboratories.



## RECEIVING ANTENNAS

Generally speaking, the principal purpose of a radio receiving antenna is to collect radio signals (extract as much electrical energy as possible from passing electromagnetic waves) and direct them to the circuits of a receiving set.

**Types.** A simple form of antenna consists of a conductor (usually placed in a horizontal position) connected to a radio receiver by means of another conductor called the lead-in, as shown in Fig. 1. Inasmuch as the lead-in in the illustration is connected at one end of the overhead conductor, the entire structure forms

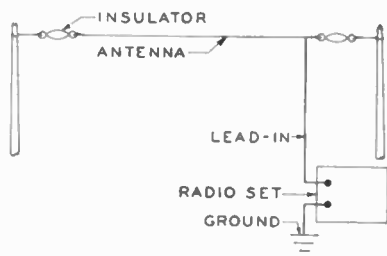

Fig. 1. Simple Antenna System

an **L**, which gives rise to its being called an **L-type antenna**. It is sometimes called the *Marconi* type. Had the lead-in been connected at the center of the horizontal wire, instead of at one end, the construction would have formed a **T**, known as a **T-type antenna**.

Both the **L**-type and the **T**-type antennas are highly efficient in collecting radio signals, but they are equally efficient in picking up electrical interference such as atmospheric and man-made static.

**Radio Waves.** *Radio wave* is a term commonly used to designate the energy of varying amplitude that is radiated from a transmitting antenna in the form of electromagnetic waves. Unless directional characteristics are incorporated in the transmitting an-

tenna design, the waves of electrical energy that escape into free space travel in all directions from the transmitter at a speed of 300,000,000 meters (186,000 miles) per second.

Radio waves consist of an electrostatic field and an electromagnetic field. The electrostatic field is perpendicular to the surface of the earth and is carried along with the electromagnetic field which moves parallel with the earth's surface and therefore at a right angle with respect to the static field. The waves travel through a hypo-

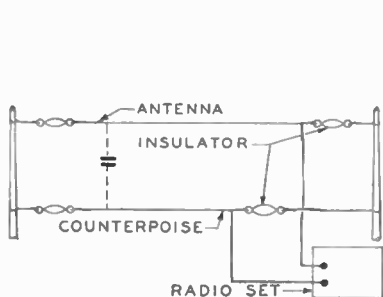

Fig. 2. Counterpoise Antenna System

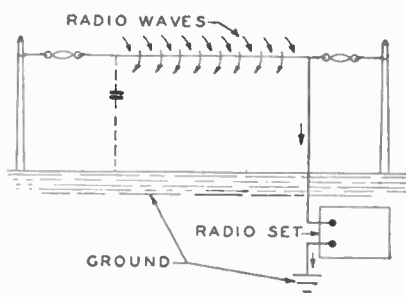

Fig. 3. Action of Radio Waves on Antenna

thetical medium known as the *ether*, but when they come in contact with a conducting medium, such as a radio receiving antenna, they serve to induce a voltage in the conductor and establish a flow of current that is directed through the input circuit of a receiving set by way of the lead-in.

**Action of Radio Waves in Antenna.** The antenna system for a radio receiving set consists of the conductor that serves as the antenna, the lead-in, and the ground. In some cases, a device known as a *counterpoise*, as shown in Fig. 2, is used instead of the ground, in which event there exists between the antenna and the counterpoise a potential difference that makes possible the induction of a voltage and the flow of current in the antenna circuit.

Fig. 3 shows how the waves, coming in contact with the wire that serves as the antenna, cut the conductor and induce a voltage in accordance with the principles explained in the earlier parts of this treatise.

Assuming that the antenna circuit consists of the overhead conductor and the ground, the condition shown in Fig. 3 is established. The overhead conductor becomes one plate of a condenser of low capacity, the exact value of which is dependent upon the length of the antenna and the distance it is placed above the ground or any metallic substance connected to the ground.

It must be remembered that in the installation of an antenna on the roof of a house, the electrical distance from the antenna to the ground is not necessarily the physical distance, due to the presence of grounded masses of material within the structure.

**Antenna Efficiency.** Any antenna system will be more efficient at one given frequency than at any other, due to the fact that the antenna circuit will be resonant to that frequency or one of its harmonics. Therefore, since it is evident from the foregoing explanation that the antenna system is an oscillatory circuit comprising an inductance and a condenser in series, and in which inductive and capacitive reactances exist as in all series resonant circuits, the resonant frequency will be that at which the reactances balance, permitting the free flow of current through the circuit.

In addition to the inductive and capacitive reactances, there exists a resistance to the flow of high-frequency alternating current. This high-frequency resistance may be high enough to reduce to a low value the flow of current, even though the circuit may be resonant to a given frequency. Hence, in order that the circuit may be tuned sharply, the high-frequency resistance should be reduced to a minimum by the use of stranded conductors, well-soldered connections, and an efficient ground connection.

In order to provide a resonant condition to insure the maximum extraction of energy from passing radio waves, the antenna should have an electrical length corresponding to one-fourth, one-half, or an exact multiple of the full wave length of the signal being received. As long as radio receivers were designed to operate in one band—broadcast, 60-meter, 30-meter, or police, for example—an antenna resonant at a frequency midpoint in the band was considered satisfactory. Multi-band receivers introduce com-



plexities, however, but even so, by making a proper choice of dimensions, an antenna system can be designed to resonate at one-half wave length in one of the short-wave bands, and at one-fourth wave length in the broadcast band. Quarter-wave antennas are generally of the *Marconi* type (Fig. 1), which makes use of a ground at the lower terminal, but half-wave and full-wave antennas are usually of the *Hertzian* type, in which the ground connection is not necessary.

**Doublet Antenna.** The doublet type of antenna, shown in

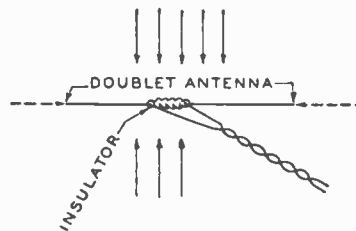

Fig. 4. Doublet Type of Antenna

Fig. 4, is used almost exclusively for short-wave reception. Such an antenna consists of two conductors of equal length separated by an insulator in its flat-top construction. It is highly efficient when signals to which it is resonant are received. A half-wave doublet consists of two flat-top parts, each of which is one-fourth the wave length of the signal to be received, but if the full directional effects of the antenna are to be made use of, the maximum over-all length of the flat-top portion should be  $1\frac{1}{4}$  wave lengths. The solid arrows (Fig. 4) indicate the plane of maximum doublet pick-up, while dotted arrows show the plane of minimum pick-up. Proper orientation may be used to reduce the pick-up of noise interference. The doublet is frequently referred to as a *di-pole antenna*.

**Length of Doublet.** The length of a doublet antenna may be ascertained by means of the following formula:

$$l = 1.25 \frac{v}{f}$$

where  $l$  = over-all length of the flat top.

$v$  = velocity of the radio wave in meters per second.

$f$  = frequency in cycles per second.

Doublet antennas obtainable on the market have an over-all length of about 60 feet. If the foregoing formula is applied, it will be found that the over-all length of a doublet antenna to resonate at 21 megacycles (21,000,000 cycles) will be 17.8 meters or 58.4 ft., each half-section being 8.9 meters or 29.2 ft.

*Double-Doublet Antenna.* Another development, known as the double-doublet type of antenna, is designed for use in the short-

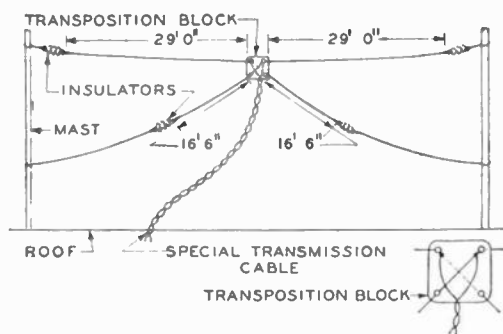

Fig. 5. Double-Doublet Type of Antenna

wave bands to resonate at frequencies not harmonically related. Such an antenna is shown in Fig. 5. The terminals of the transmission cable are often connected to an antenna transformer.

**Radio Interference.** Interference, as applied to radio reception, can be classified, generally, as *atmospheric static* and *man-made static*. It causes annoying sounds to emanate from the loudspeaker of the receiving set, interfering with the clarity of reproduction of radio programs. Atmospheric static causes irregular crackling sounds; man-made static usually is more regular, a buzz, for example, or a series of clicks, or some similar noise.

*Atmospheric Static.* Atmospheric static, present in the atmosphere at all times in greater or lesser degrees, is caused by friction between clouds or dust particles, and may originate at a point many miles from the receiving set. Clouds consist of minute bodies, each of which may be electrically charged. When two groups of such electrically charged bodies collide, the transference of energy from one to the other sets up an electrical disturbance that is radiated

through the ether for great distances. Similarly, when a cloud passes through a region of dust-saturated atmosphere, the cloud and the dust particles have a tendency to attain an electrical balance; that is, to bring about a normal relationship between the positive and negative charges on the surface of the cloud and the dust particles. Changes in temperature also cause dust particles, as well as clouds, to travel at varying rates of speed, so that the charge carriers move more haphazardly and collide more frequently. A transference of electrical charges, all for the purpose of striking the normal electrical balance, results from each collision or rubbing.

*Radio Waves and Static.* The electrical discharge between clouds or dust particles, as well as that caused by lightning, is a high-frequency transference of energy—an electrostatic discharge.

When the radio wave, traveling through the hypothetical ether, passes through an area in which an electrical disturbance is taking place, the electrostatic discharge may be impressed on the radio wave. It is generally, though not universally, believed that the combination of the electrostatic discharge with the radio signal changes the shape of the radio wave, that the amplitude characteristics are acted upon by the electrostatic charge, and that the influence of such variations in amplitude will be extended to every receiving antenna beyond the place where the electrical disturbance occurs. Thus, suppose a radio wave originating in New York City and traveling west passes through an electrical storm centering about Cleveland. Although the storm itself does not reach as far as Chicago, the electrical discharges in and around Cleveland may change the form of the radio wave so that the signal impacted on antennas in Chicago, or other points west of Cleveland, combine the original signal with its amplitude component changed in accordance with the strength of the electrostatic discharges.

Atmospheric static tends to paralyze temporarily the circuits of a receiver, thereby blotting out reception for a brief interval. The impulse, energizing the antenna system, forces it to operate at the resonant frequency of the system until the energy has been dissipated. Each tuned circuit in the receiver, in turn, is forced to respond at whatever frequency it may be tuned at the instant, and the length of time required for the energy to reach a minimum will

be greater in tuned circuits having high gain. Atmospheric static appears to have what might be called a universal frequency, which makes it virtually impossible to keep it out of receiver circuits by means of a wave trap.

*Man-Made Static.* Man-made static is caused by the operation or the switching on and off of electrical machines and appliances. Certain types of motors, flashing signs, door-bells, electrically operated toys, electric railways operated by overhead or otherwise exposed trolleys, and various types of motor-driven home appliances are common interference-creating devices. Wherever an arc appears, such as between the brushes and the commutator of a motor, switch contacts, or electric trolley and feeder wire, a high-frequency discharge occurs. Again, in certain types of heating units, such as heating pads, the surging of electric current through the control element brings about variations that change the electrical constants of the circuit, thereby creating varying electromagnetic waves, which, on reaching the radio receiver, are amplified and emitted as scratching, buzzing, or crackling sounds from the loudspeaker. Usually the effects of man-made static are confined to small areas, although it frequently happens that wide areas are affected, chiefly by transmission over power lines or other conducting media.

Man-made static, on the other hand, usually has a definite frequency determined by the length of the power line it energizes, and from which the interference is radiated, and the length of time that such static is sustained depends entirely on its nature. A click caused by the turning off of a switch will last only an instant, but may be of high or low intensity, depending on the extent of power line energized by the electrical disturbance. The pitch of the frying noise created by a given motor does not vary as long as its installation is not disturbed; and the noise continues as long as the motor is operated.

Assuming that the receiving antenna is installed in accordance with recommended practice, the horizontal portion may be placed high enough to be out of range of man-made static. In such installations, then, some of the interference of the man-made type is combined with the radio signal in the lead-in (see Fig. 6) which

may pass through one or more interference regions between the overhead structure and the receiving set.

Man-made static may also enter the receiving circuits by way of the power line that supplies the receiver, but in such cases the

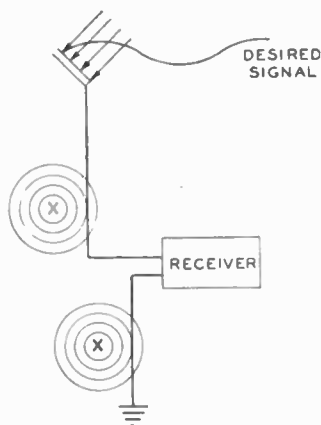

Fig. 6. Electrical Disturbances at Points Marked *X* Enter Receiver with Desired Signal and Issue from Speaker as Annoying Interference

interference can usually be trapped out by means of a condenser of from .001 to .1 microfarad connected from one side of the power line to the chassis of the receiver, provided the chassis is well grounded.

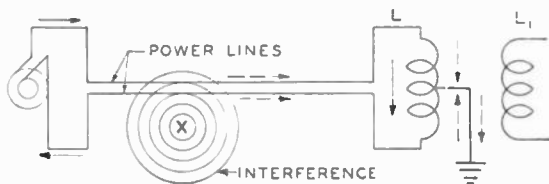

Fig. 7. Desired Current, Indicated by Full Arrows, Flows Around Complete Circuit Setting Up Magnetic Field Around Coil *L*. Interference Current Flows Through Coil *L* in Phase Opposition, Preventing Setting Up of Magnetic Field. Energy Appearing in *L* Will Be Due Only to Desired Current Flow in *L*.

Fig. 7 shows the desired current and interference current entering a set by way of the power line.

Most radio receivers incorporate the filter condenser in the power circuit to prevent the entrance of interference due to line surges and transients when doorbells are rung, telephones dialed, or electric lights turned on or off.

**Static Eliminators.** From time to time since radio was popularized, so-called *static eliminators* have appeared on the market. Such devices usually were advertised as antenna eliminators as well, and claims were made that the device would do away with the antenna as well as eliminate the annoyance of static crashes. However, it is obvious that since the form of the radio wave is

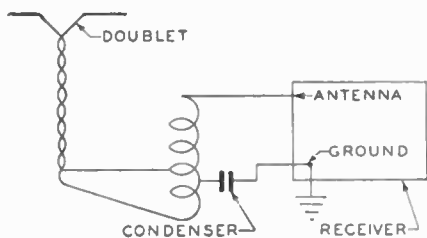

Fig. 8. Antenna System Providing Noise Reduction on Only Short-Wave Bands

changed by electrostatic discharges, any reduction in the static will likewise reduce the signal pickup, and that additional amplification will result in the reappearance of the static.

**Antenna Transmission Lines.** Cross talk and inductive effects in telephone circuits are eliminated by means of a balanced transmission line, which has made possible the use of multi-wire cables.

The same principle is applied to noise-reducing antennas, a balanced transmission line replacing the single-conductor lead-in to eliminate extraneous noises or signals picked up by the lead-in.

A transmission line is a conductor or system of conductors used to transfer electrical energy from one device to another without adding or imposing its characteristics on either device. Its most common form is a twisted pair of conductors. The coaxial cable is another example. A balanced transmission line is one employing a transmission line in combination with transformers.

One method of using the balanced transmission line in noise-reducing antennas is shown in Fig. 8. One of the conductors in the transmission line is connected to each of the separate parts of the flat top, and to its respective terminal of the primary winding of a coupling transformer. The center of the primary winding of the coupling transformer is connected to ground directly or else through a condenser.

*Noise-Reducing Antennas.* It has been stated that atmospheric static appears to have a universal frequency; and it has been indicated how the characteristic of the radio wave may be changed when the wave passes through an area in which an electrical disturbance is taking place. It is logical to assume, therefore, that as long as amplitude modulation is the governing factor in the shape of a radio wave, little can be done by way of developing an antenna system that will eliminate the effects of atmospheric electrical disturbances from the desired signal. The use of frequency modulation promises to accomplish the elimination of most, if not all the interference caused by electrostatic discharges in free space. Noise-reducing antennas are designed to reduce as far as possible the effects of man-made static on radio reception.

*Outdoor Antennas.* Early models of radio receiving sets were so lacking in sensitivity that they required an antenna with a horizontal conductor anywhere from 100 feet to 150 feet in length in order to obtain enough signal pickup for efficient operation. It was further recommended that the installation be made in such a way that the lead-in would be as short as possible.

The need for large antenna signal pickup was obviated by the development of more highly sensitive multi-band receiving circuits. More compact antennas were made possible, since the length of the horizontal portion was materially reduced. However, there was no appreciable improvement in the signal-to-noise ratio of the received signal, and such slight improvement as did occur was due to the fact that although both signal and noise pickup were reduced proportionately in the shortened antenna, the amplification and selector stages in the receiving circuits gave added impetus to the broadcast signal, due to the resonance gain in the tuned circuits.

*Indoor Antenna.* The indoor type of antenna is generally a

poor collector of signal energy, and at the same time may be located in the heart of a noise area. The use of such an antenna with all-wave radio receivers is not recommended under any circumstances. If a receiver operating on an indoor antenna is free from noise, it means only that the antenna is not in a static area; it does not mean that noise has been eliminated by such methods.

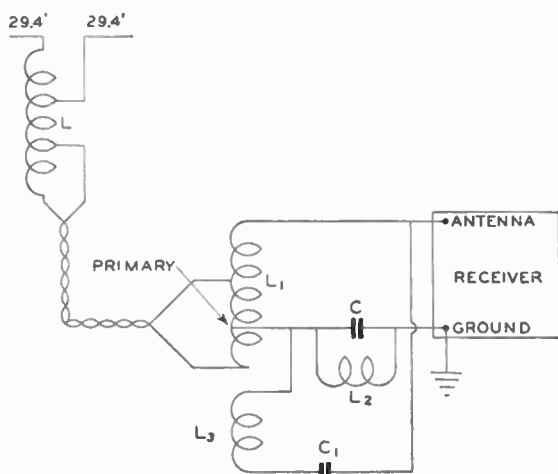

Fig. 9. Antenna System Providing Noise Reduction in Broadcast and Short-Wave Bands

*Short-Wave Antenna.* One type of noise-reducing antenna that produces a cancellation of noise in the short-wave bands, but not in the long-wave bands, is shown in Fig. 8, while a more elaborate type that is effective in broadcast as well as short-wave bands is shown in Fig. 9.

*How Noise Is Reduced by Antenna.* The signal energy picked up in the doublet portion of the antenna is fed to the receiving circuits by a transmission line, which, according to definition, does not add its dimensional characteristics to those of the flat-top portion, provided that its length is not a multiple of the length of the doublet. The transmission line, which is a twisted pair of wires in weatherproof covering, terminates at its base in a coupling transformer, preferably of the autotransformer type, because of less leakage and also because of the simplification in construction.



If the doublet is to be used for the reception of short-wave signals only, the center tap of the primary of the autotransformer can be connected directly to ground. However, if such a connection is made, a switching arrangement to disconnect the ground must be provided in order to adapt the doublet to broadcast frequencies, at which time the doublet is used as a conventional T-type antenna. Therefore, in order to accomplish automatic switching, the center tap is connected to the ground through a small condenser, which permits the flow of high-frequency signal energy and allows operation in the short-wave bands, but isolates the coil from ground at broadcast frequencies because of the high reactance of the condenser to the relatively low frequencies of the broadcast band. The condenser in the circuit causes a slight loss of signal energy in the broadcast band, but the reduction of noise in the short-wave bands is so great (from 5 to 50 times) that it is better than would be obtainable by using a standard antenna and lead-in arrangement.

The all-wave noise-reducing antenna system requires the use of a second autotransformer at the junction of the flat-top portion of the antenna and the transmission line. The lower transformer has two secondaries, the broadcast band using half the primary and the remaining turns of the secondary of the autotransformer, the short-wave band employing a separate coil that is inductively coupled to the primary winding.

The complete system is shown in Fig. 9. Short-wave signal energy picked up in the doublet causes a flow of current which produces a voltage drop in the upper few turns of transformer  $L$ , induces a voltage in the lower turns of  $L$  by electromagnetic induction, and causes a difference of potential across the upper terminals of the transmission line, which in turn produces a current flow in the transmission line and the primary turns of  $L_1$  of the lower transformer. Voltage is induced in  $L_3$  and is coupled to  $L_1$  by electromagnetic induction. This voltage is applied to the receiver terminals through a condenser,  $C_1$ , that has low impedance at the high frequencies.

Noise that is picked up in the transmission line produces like polarization, or, in other words, a potential difference is not established between the two wires at any given point. Thus, if at any

given position a wire is positive with respect to the upper terminal of the transmission line, a like point on the other wire will also be positive with respect to its upper terminal. A flow of noise current is set up in the transmission line, but, as the current traverses the lower transformer primary, it will set up magnetic fields in phase opposition. Each, therefore, cancels the other, so that no noise energy is induced in short-wave coil secondary  $L_3$ , and the noise energy is passed to ground through  $C$  and  $L_2$ .  $C_1L_3$  resonates in the short-wave band,  $C_1$  being relatively small (.0001 microfarad) while  $L_3$  is large.  $C_1$  is designed to have high impedance to broadcast frequencies.

In the broadcast band the doublet acts as a T-type antenna with the vertical lead-in picking up the signal while the flat-top portion acts as a capacity load. Signal energy that is picked up in the lead-in flows down the transmission line in phase; that is, it travels down both wires in the same direction. A cancellation of this part of the received energy is brought about in the primary of the lower transformer. Signal current also flows into the flat top, traversing the large section of inductance  $L$  in its movement.

An out-of-phase voltage is produced in the transmission line through transformer action, the large portion of coil  $L$  being intimately coupled with the lower few turns. The reinduced transmission-line voltage causes a flow of current down the transmission line through the primary of the  $L_1$ , and voltage is induced across the whole of coil  $L_1$  by autotransformer action. The voltage thus produced is applied to the antenna and ground posts of the receiver, the upper portion of  $L_1$  being connected directly to the antenna terminal of the receiver while the lower part connects to the ground through coil  $L_2$ . Coil  $L_2$  loads the antenna causing a partial resonating effect in the broadcast band. The inphase currents, originally picked up by the lead-in, cancel out as explained in the preceding paragraph.

The noise-discrimination effect of the system is workable in the broadcast band when the source of pickup is near the receiver end of the transmission line, the reduction being inversely proportional to the distance from the receiver to the noise-coupling point. If the noise is coupled near the upper transformer, no reduction

will be effected, and noise picked up in the flat top will be conducted to the receiver the same as is the broadcast signal energy.

The condenser  $C$  and the coil  $L_2$  are in the nature of a trap circuit resonating in the four-megacycle (4,000,000-cycle) band, which is desirable because of the poor efficiency of the T-type antenna and doublet at this frequency. No noise reduction can be obtained in the band.

An efficient ground is highly desirable in using all-wave antenna systems. The ground wire should be as short as possible, for it also is a portion of the complete antenna system and as such is capable of picking up interfering noise and carrying it to the receiver (see Fig. 6). Actual earth connection, cold-water pipes, metal building frames, and steam or hot-water radiators make effective ground connections, stated in the order of preference.

## RADIO POWER SUPPLY

---

In order that the feeble signals impressed upon the antenna connected to a radio receiver—or produced by the microphone connected to an audio amplifier—may be effectively amplified, it is necessary to introduce power from an external source, which source is known as a power-supply unit or device. Batteries of the wet or dry variety served to furnish the power required to operate radio apparatus in the beginning, and continue to be used for the purpose in areas where electric power is not available. Electrically operated power-supply devices have been developed for use in those areas where electric power is provided.

In previous chapters in discussions of vacuum tubes, it has been shown how the positive potential upon the plate element of the tube serves to attract the negative electrons given off by the cathode—or filament—thereby causing a current to flow in the output circuit of the tube. It is evident that if the potential upon the plate element were alternately positive and negative, as it would be if an alternating voltage were impressed upon the plate, the plate would attract the electrons during the positive half of the cycle and repel them during the negative alternation, with the result that the signal impressed upon the speaker would have a regular vibrating period corresponding to the frequency of the alternating voltage.

**Diode Tube as a Rectifier.** Direct current is required to supply constant potentials to the plate and grid elements of the vacuum tubes used in radio circuits. Therefore, it becomes desirable to convert the alternating current used in lighting circuits into direct current. This is accomplished by means of the diode tube serving as a rectifier. At the same time, it is desirable to have voltages higher than those available on the lighting and power lines.

Higher voltages can be obtained by the use of transformers with alternating current. Direct current cannot be stepped up through a transformer. This means that in order to secure the higher direct-current voltages, it is necessary to provide a higher voltage alternating current and convert it into direct current.

**Half-Wave Diode Rectifier Tube.** There are two forms of rectification—*half-wave rectification* and *full-wave rectification*. The name given the rectifier depends upon whether the process

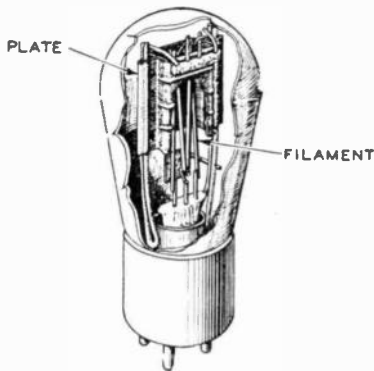

Fig. 1. Half-Wave Diode Rectifier Tube

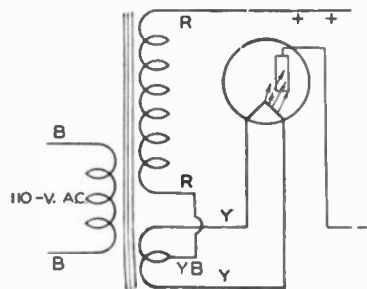

Fig. 2. Diagram of Half-Wave Rectifier Tube Circuit

uses only one side or both sides of the alternating-current wave. Half-wave rectification requires the use of a vacuum tube consisting of a *filament* and a single *plate*, as shown in Fig. 1. While the construction is different, the principle of operation is the same as the tungar rectifier.

Fig. 2 shows a diagram of a *half-wave rectifier tube* in conjunction with a *transformer*. The transformer consists of a primary winding, *B-B*, and two secondaries, one of which is to step up the voltage, the other to step down the voltage. The voltage delivered by the secondary winding marked *Y, YB, Y* is that required on the *filament* of the rectifier tube according to the specifications of the tube manufacturer. The voltage delivered by the secondary winding marked *RR* will vary according to the requirements of the circuit—the value of the direct-current voltage needed to operate the device with which the rectifier is connected. The letters are the ab-

breviations of the color of the insulated leads coming out of the case; thus *B* is for *black*, *R* is for *red*, *Y* is for *yellow*, and *YB* is for a *yellow* and *blue* striped design.

It will be seen that the terminals of the high-voltage secondary will be alternately positive and negative as the alternating current reverses its direction of flow, which means that the charge upon the plate—through the external circuit—will be positive and then negative with each alternation of the current.

When current is passed through the filament of the tube, electrons are liberated into the space. During the positive alternation

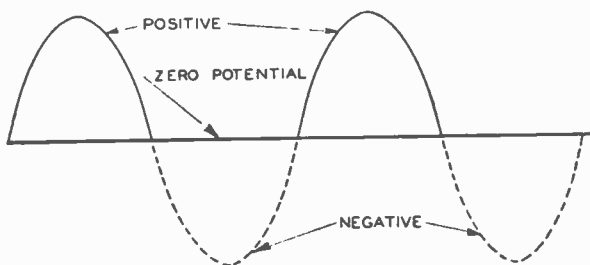

Fig. 3. Sine-Wave Alternating Current

there will be a positive charge upon the plate, with respect to the filament, at which time the plate will attract the *negative* charges given off by the filament, thus causing a flow of current. However, as the voltage reverses its polarity, the plate becomes charged *negatively* so that it repels the electrons, and there is no current flow. Thus, a condition such as represented by Fig. 3 is created. Each of the alternations above the *zero potential* line is retained, while the alternations indicated by dash lines below the zero potential line are eliminated. This means that the current flowing through the circuit, though pulsating, is flowing in the same direction and does not reverse its direction of flow. The pulsations are eliminated—or minimized—by the use of filter circuits.

The electron flow from the rectifier circuit is shown by the polarity symbols (Fig. 2). The negative charges, or flow of electrons, pass from the filament to the plate, Fig. 2, and out through the external circuit, returning through the high-voltage winding of

the transfer  $RR$  to the center tap of the filament supply secondary,  $YB$ , and thence to the filament. All this action takes place only during that part of the cycle when there is a positive charge upon the plate of the rectifier tube.

**Full-Wave Diode Rectifier Tube.** A vacuum tube that has a *filament* and two separate *plate elements* is required with full-wave rectification. The construction of such a rectifier tube is shown in Fig. 4. The two filaments inside the glass bulb are joined in series with each other. The principle of the *full-wave rectifier* and that of the half-wave rectifier are identical. The difference

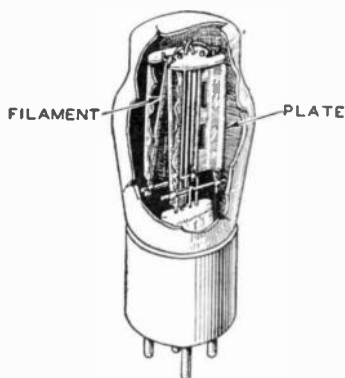

Fig. 4. Full-Wave Diode Rectifier Tube

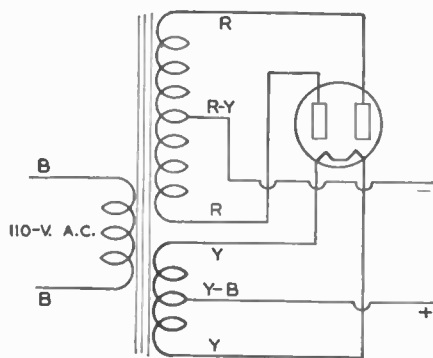

Fig. 5. Full-Wave Rectifier Tube Circuit

lies in the fact that both sides of the wave are converted, one of them being transposed to the opposite side of the zero potential line.

A typical circuit for a transformer and tube for full-wave rectification is shown in Fig. 5. The high-voltage and the low-voltage secondaries are both center tapped. As the voltage is induced in the secondary of the transformer, the opposite ends of the high-voltage winding are at opposite polarity—when one terminal is positive the other is negative, and vice versa. Thus, it is evident that each of the plates of the rectifier tube will be charged positively and then negatively as the voltage alternates. It is also true that at the time one of the plates has a positive charge, the other plate will have a negative charge of equal value.

Electrons that are emitted by the filament are attracted toward the plate element on which there is a positive charge and are repelled by the plate on which there is a negative charge. As the voltage reverses, the electrons pass first to one plate and then to the other.

Terminal or lead *R-Y* of the secondary winding *RR*, Fig. 5, is at the electrical center of the high-voltage winding. As the electrons flow from the filament they pass to the plate which is charged positively—say, for example, the right-hand plate—they pass through the upper portion of the high-voltage secondary and out at *R-Y*. The lower half of the winding at this time is negative, which repels the flow of the electrons, and this half of the transformer and the left-hand plate of the tube are inactive during this alternation. As the current reverses its direction of flow, the left-hand plate becomes charged positively and the electrons, again passing from the filament to the plate, flow through the lower portion of the high-voltage winding. Returning to the filament circuit, it is only necessary that they find their way back to the filament—thereby replacing the electrons being emitted during the operation. Hence, the polarities are as shown on the diagram, negative off the center tap of the high-voltage secondary, and positive off the filament circuit.

**Mercury Vapor Tubes.** The effect of the space charge is present in rectifier tubes as well as in those tubes used for other purposes. The negative charges liberated by the filament tend to repel other electrons so liberated and force them backward away from the plate. Higher plate voltages will counteract the effect to some extent, but not entirely. In order to overcome the effect of space charge, a drop of mercury is placed in some rectifier tubes. The mercury gives off a vapor—minute particles or atoms moving freely inside the tube. When the filament is heated, the electrons moving at enormous velocity strike the mercury atoms and dislodge electrons by collision. The freeing of the negative charges from the mercury atoms causes the vapor to become ionized—carrying a positive charge—thereby neutralizing the space charge and allowing increased flow of current to the external circuit.



## RADIO POWER SUPPLY UNITS

In order to furnish the proper voltages for operating the tubes of a radio set, a radio supply unit is used. This unit consists of a *radio power-pack transformer*, a *rectifier tube*, a *filter*, and a *voltage divider*. A wiring diagram of this combination of units is shown in Fig. 6. The transformer connections are similar to those previously

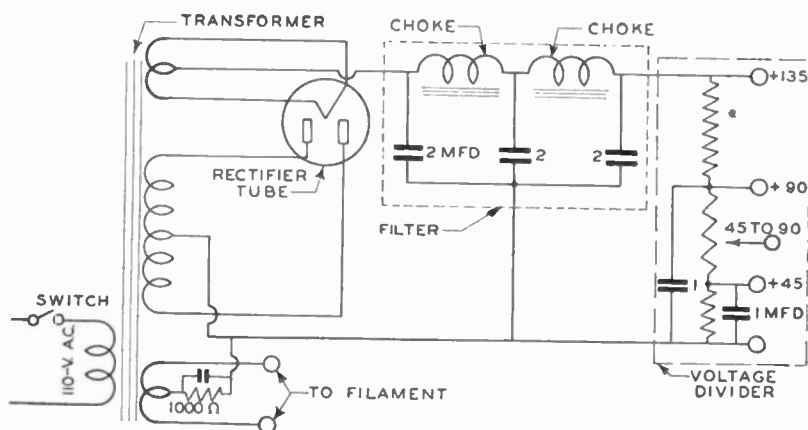

Fig. 6. Wiring Diagram of Power-Supply Unit of Radio Set

studied in connection with half-wave and full-wave rectifier tube circuits. The added units in Fig. 6 are the filter and voltage divider.

**Filters.** Voltage pulsations, such as delivered by rectifier tubes, and shown in the wave-form pictures at (A) and (B) of Fig. 7, cause variations in the output of a circuit. Each of the pulsations causing a varying plate voltage produces a corresponding rise and fall in the flow of plate current. Therefore, it is necessary to introduce apparatus to eliminate the variations and to provide direct current as nearly pure as possible.

Due to the action of a full-wave *rectifier tube*, a 60-cycle alternating current will produce 120 pulsations per second, which must be filtered if the current flow is to be continuous. A half-wave rectifier produces 60 pulsations. In other words, a full-wave rectifier, shown in (B) of Fig. 7, produces twice as many pulsations as the original current; a half-wave rectifier produces the same number of pulsations as the frequency of the current supplied to

the device. A full-wave rectifier output is filtered with greater ease than that of a half-wave device, due to the greater time during which the current flows.

A *filter*, as applied to a radio power-supply device, is a combination of the proper electrical units to effectively produce a pure

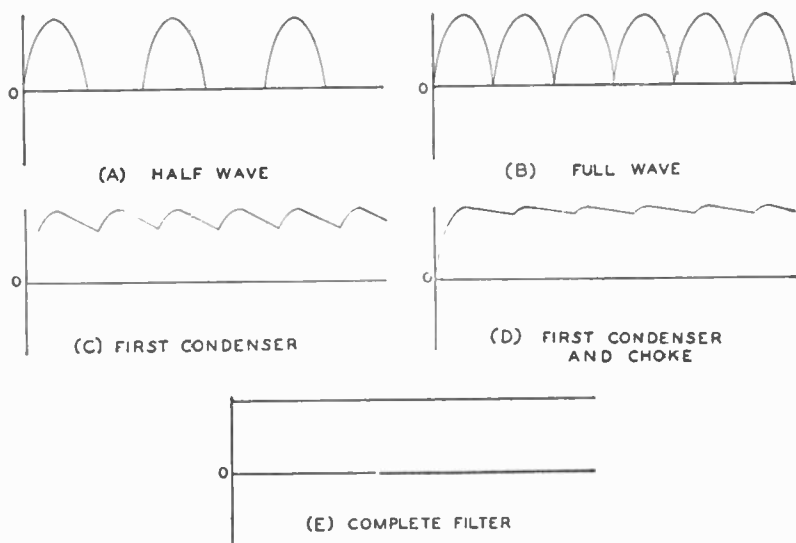

Fig. 7. Wave-Form Picture Showing How Pulsations Are Smoothed Out by Condensers and Choke Coils

direct current for distribution to the plate circuits of the various stages of a receiver or amplifier. It consists of condensers and inductance units.

A fluctuating current flowing through an inductance causes a counter-electromotive force that opposes the change of flow of the fluctuating current. A condenser stores an electrical charge and then releases it into the circuit when the pressure is reduced. Both of these phenomena are applied to the operation of a filter in a power-supply device.

**Low-Pass Filter.** In the design of a smoothing circuit, it is necessary to design what is known as a low-pass filter circuit to eliminate the ripple in the current delivered by a rectifier tube. This filter will prevent the flow of pulsating current and at the same time permit the free flow of direct current. The pulsations

are prevented from occurring by the counter-electromotive force generated in the *choke coil*—an iron core inductance.

The filter condenser or condensers store up a charge which is equivalent to the peak voltage of the pulsating direct current; and when the applied voltage tends to fall, the condenser delivers its charge to the load circuit. Thus by a combination of choke coil and condenser, the filtering action takes place.

Referring now to Fig. 6, the full-wave pulsations delivered by the *rectifier tube* are effectively stopped by the inductance units (*chokes*) connected in the circuit. However, the condensers connected between the positive and the negative sides of the circuit provide a storage reservoir for the impulses by alternately charging and discharging the plates of the condensers.

Fig. 3 shows the relative wave form of the voltage in the primary and secondary windings of the transformer in a power-supply device. That in the primary winding of the power transformer, Fig. 6, is usually 115-volt alternating current. One of the secondary windings steps down the voltage for the filament of the rectifier tube. Another secondary winding steps up the voltage in order to provide voltages needed for the circuits of the radio receiver or amplifier. The two secondary windings deliver an alternating voltage that has a wave form identical with that which is passing through the primary windings, Fig. 3.

However, after passing through the rectifier tube, the wave form changes perceptibly, as shown at (A) in Fig. 7. Each of the alternations above the zero potential line, Fig. 3, has been retained, and the space between them has been filled with the reverse alternations, as in (B) of Fig. 7. The current is now pulsating, but does not reverse its direction of flow.

The first condenser in the filter network assumes a charge during the time when the voltage is increasing in each of the alternations, and gives up its charge during the period when the voltage is decreasing, so that it has a wave form similar to that shown at (C) of Fig. 7, before it reaches the left-hand terminal of the *first choke coil*, Fig. 6.

The counter-electromotive force set up in the choke coil retards

the change of flow of the pulsating current, and the peak voltages tend to increase the charge upon the plates of the first condenser, thus giving it a still greater charge to fill in the valleys between the peaks of the wave. So, at the output of the first choke coil, the voltage has assumed the form as shown at *D*, Fig. 7.

After the current has passed through the second portion of the filter network, during which time it is subjected to the same process as during the first half of the filter, it assumes a practically steady

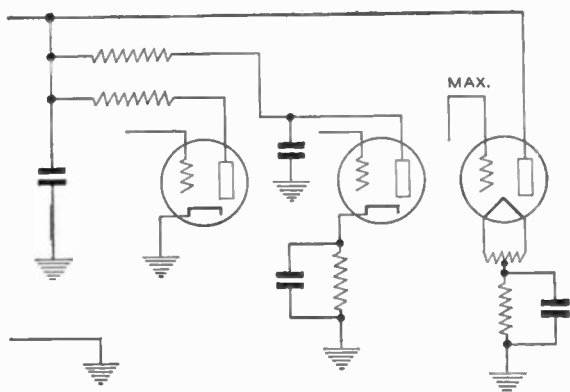

Fig. 8. Method of Using Individual Resistance Units to Obtain Different Voltages for Plate Circuits of Radio Set

voltage at (*E*) of Fig. 7, such variations as remain being negligible in their effect upon the radio or amplifier circuits.

The circuit shown in Fig. 6 represents the fundamental type of power-supply unit. In practice, it may be found unnecessary to use more than one choke because a single choke may serve to effectively produce a continuous flow of direct current. The field coil of a loud-speaker may be used as one of the choke coils; or, because of its high inductance, the field coil may serve as the only choke coil required.

**Voltage Divider.** In order to supply the proper potentials to the various elements of the vacuum tubes in the radio or amplifier stages, it is necessary to make provision for voltages of different values. Fig. 6 shows the *voltage divider* used in earlier models of power units in radio receiving sets, the resistance unit being con-

nected directly between the positive and negative sides of the line so that there is a constant load on the circuit.

Calculation of the values of the resistance units to provide a given voltage, involves an application of Ohm's law,  $E = IR$ . Thus, by knowing the value of the drop in voltage and the current that will be drawn at that potential, the resistance may be calculated.

Another method to provide for the distribution of the voltages is to use a resistance unit for each voltage value. Here again, the amount of resistance is determined by applying Ohm's law, taking into account the current drain and the drop in the voltage from the *maximum potential*. An example of a circuit using individual potential-drop resistance units is shown in Fig. 8.

**Direct-Current Supply.** A power supply unit to provide power for a receiver or amplifier to operate directly off the power lines supplying direct current differs from one that is used in an alternating-current circuit only in the elimination of the rectifier circuit, including the transformer. The ripple that has been shown to exist in a rectified alternating current is present also in commercial direct current, although it is not so predominant. Filters consisting of condensers and filter chokes serve to eliminate the ripple and provide a continuous-flowing direct current which may be divided and directed to serve the respective purposes as shown in the preceding paragraphs.

In view of the fact that most of the direct current used commercially is 110 volts, and since it has been shown that direct-current voltage cannot be "stepped up" by means of transformers, the radio receiver or amplifier must be designed to operate at a little less than 110 volts, or a means must be provided to obtain a higher voltage. There are three methods of obtaining the higher voltages. First, a circuit incorporating a voltage-doubling vacuum tube may be used; second, a generator operating off the 110-volt direct-current system and generating a higher direct-current voltage may be used; or third, a vibrator similar to that used to provide the power for automobile radio receivers may be employed. In any event, the principles embodied in their use have been explained in this text, and it is necessary to ascertain the physical specifications of the particular device that is used.

## FREQUENCY MODULATION

Radio communication is accomplished by changing the form of a radio-frequency carrier wave, the carrier alone being unable to transmit intelligence. A simple unmodulated carrier wave, one of constant amplitude and unvarying frequency, is capable of being used as a frequency standard or as a marker or timing wave and, in fact, the Federal Communications Commission recognizes the utility of such a wave by providing for its licensing for special purposes. However, such a wave is incapable of conveying other forms of information and therefore is of limited use. The modulation of a radio wave by varying the amplitude of the carrier has been

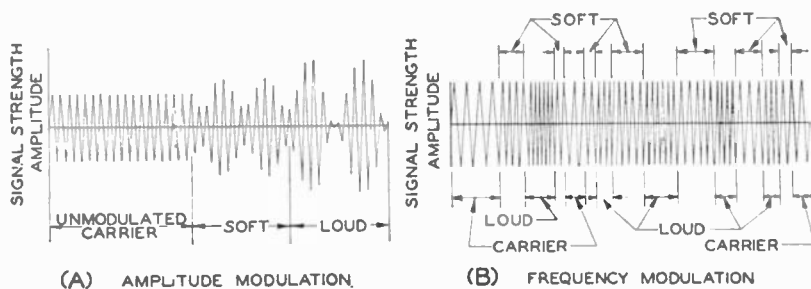

Fig. 1. Comparison of Amplitude Modulation and Frequency Modulation. (A) Shows, at Left, the Unmodulated Carrier; Next, Low-Percentage Modulation of Carrier Produced by Soft Tone; at Right, High-Percentage Modulation Produced by Loud Tone. Note That Frequency Is Unchanged. (B) Frequency Deviation of Carrier Caused by Application of Modulation. Note That Amplitude Remains Constant.

discussed and represents the more familiar method of accomplishing modulation. A carrier wave which has been modulated by a soft and a loud sound using amplitude modulation is at (A) in Fig. 1; at (B) is a similar carrier modulated by frequency modulation.

**Amplitude-Modulation Transmission.** An amplitude-modulation system, as previously stated, makes use of an oscilla-

tory circuit of low power but exceedingly high-frequency stability in the form of an oscillator controlled by a quartz crystal. In the standard broadcast band, the Government Regulations allow a frequency tolerance of only 20 cycles plus or minus the assigned frequency. The crystal output, from 5 to 10 watts, is amplified by succeeding stages until the requisite power output is obtained. In one type of transmitter, six amplifier stages are used to obtain the final carrier power of 50,000 watts. The frequency of the carrier remains constant, any detuning of the amplifier circuits merely resulting in a loss of efficiency and a consequent reduction of power output. The use of a temperature control cabinet to maintain the quartz crystal at a constant temperature results in a still more rigid control of frequency. Many of the broadcast stations are able to maintain their assigned frequency to within two cycles over long periods of time.

The application of the audio frequency modulating power to the carrier results in a change of the instantaneous power output of the transmitter and the generation of the sidebands on either side of the carrier. Thus, in *amplitude modulation* (A.M.), a source of variable frequency, variable power (frequencies in the audible spectrum), is applied to a constant radio frequency of constant amplitude in a special circuit to accomplish the desired result. The term *modulation* means to mold, or to form, and in this system the molding process is the shaping of the amplitude of the radio-frequency carrier to audio components.

**Amplitude-Modulation Receiver.** The requirements of a receiver to translate A.M. signals have also been discussed. The radio-frequency (R.F.) circuits of such a receiver are sharply tuned to the carrier of the station it is desired to receive. Because of the resistance of the receiver tuned circuits, principally brought about by the ohmic resistance of the conductors used in the construction of the inductances, a band of frequencies will be passed on either side of the carrier and will be sufficiently extensive to reproduce speech and music with a fair degree of fidelity. The carrier separation of ten kilocycles, in the broadcast band, limits the highest audio component which can be transmitted to 5,000 cycles. This frequency limitation does not impair the transmission of speech, but

for an accurate reproduction of musical selections, frequencies in excess of 10,000 cycles are required. The loss of the frequencies above those capable of being transmitted, *i.e.*, above 5,000 cycles, gives to a radio reproduction its peculiar characteristics. Thus an audience in attendance at a concert hears frequencies which must be suppressed for radio transmission purposes. The suppression is partially accomplished by the loss in the lines carrying the program from the concert hall to the radio transmitter. These lines are generally a pair of telephone wires leased from the telephone company, and because they parallel one another over long distances, they possess a highly capacitive effect. This serves to by-pass the high frequencies in much the same manner that a filter condenser acts to by-pass high frequencies. Further suppression is brought about by the use of special filter circuits called line equalizers. The process of reducing the amplitude level of transmitted energy is termed *attenuation*. In the operation just described, the high musical frequencies are said to be *attenuated*.

**Volume-Level Distortion.** Still another factor prevents the radio audience from hearing an exact duplication of the sound originating in the studio. This factor deals with the inability of a radio transmission system to transmit effectively the large power changes produced in certain types of musical numbers. The ratio between the maximum and minimum sound output in a given musical number may be in excess of one million; *i.e.*, the loudest passage may have over one million times the amplitude of the softest passage. These loud passages may be of very short duration as in the crashing of cymbals, and may directly precede or follow very soft passages. This action places a severe load on the transmission circuits and may overmodulate the carrier, with resultant distortion. Skilled operators monitor the programs, reducing the gain of the microphone amplifier as these passages are encountered and increasing the gain for the softer passages. This quite obviously produces a volume distortion and again causes the radio program to deviate from the actual reproduction. Circuits have been developed to compress the volume level at the transmitter and expand it at the receiver, thus producing a more realistic version of the original composition.



The foregoing limitations placed upon the amplitude system of modulation have long been recognized and led directly to the development of frequency modulation.

**Advantages of Frequency Modulation.** Frequency-modulation systems are almost completely free from the annoying effects of atmospheric static and interference caused by electrical circuit switching. The frequency band allotted to frequency modulation allows a greater volume range and a wider audio frequency range than is possible in the standard broadcast bands for amplitude-modulated transmission. The principal disadvantage is the necessity of using an ultra-high carrier frequency, which reduces the usable transmission range to approximately 100 miles. A contemplated system of repeaters properly spaced would extend this range to any desired distance.

**Frequency-Modulation Transmitters.** The general design of the frequency-modulation transmitter is conventional, with the exception of the method of accomplishing modulation. In amplitude modulation, the combining of the radio and audio frequency energy takes place in the circuits of a modulated amplifier tube; in frequency modulation, the modulator is a vacuum tube working as a variable reactance (either inductance or capacitance) connected in such a manner that it varies the frequency of a self-excited oscillator. Audio voltages fed to the modulator tube cause it to act as a larger or smaller reactor, thereby shifting the frequency of the oscillator. The output of the oscillator passes through doubler and amplifying stages. These stages must be capable of passing a wide band of frequencies to provide equal amplification for all frequency deviations within the modulation range.

The amplitude of the audio frequency modulating voltage determines the amount the carrier frequency will move from its resting frequency. Standards have been established limiting each frequency-modulation station to a channel width of 200 kilocycles, which would mean that the carrier could be swung 100 kilocycles on either side of the resting frequency. In practice, the full swing is not used however, the stations limiting the deviation to a 150-kilocycle channel or 75 kilocycles on each side of the resting frequency. The modulation percentage of a frequency-modulation sta-

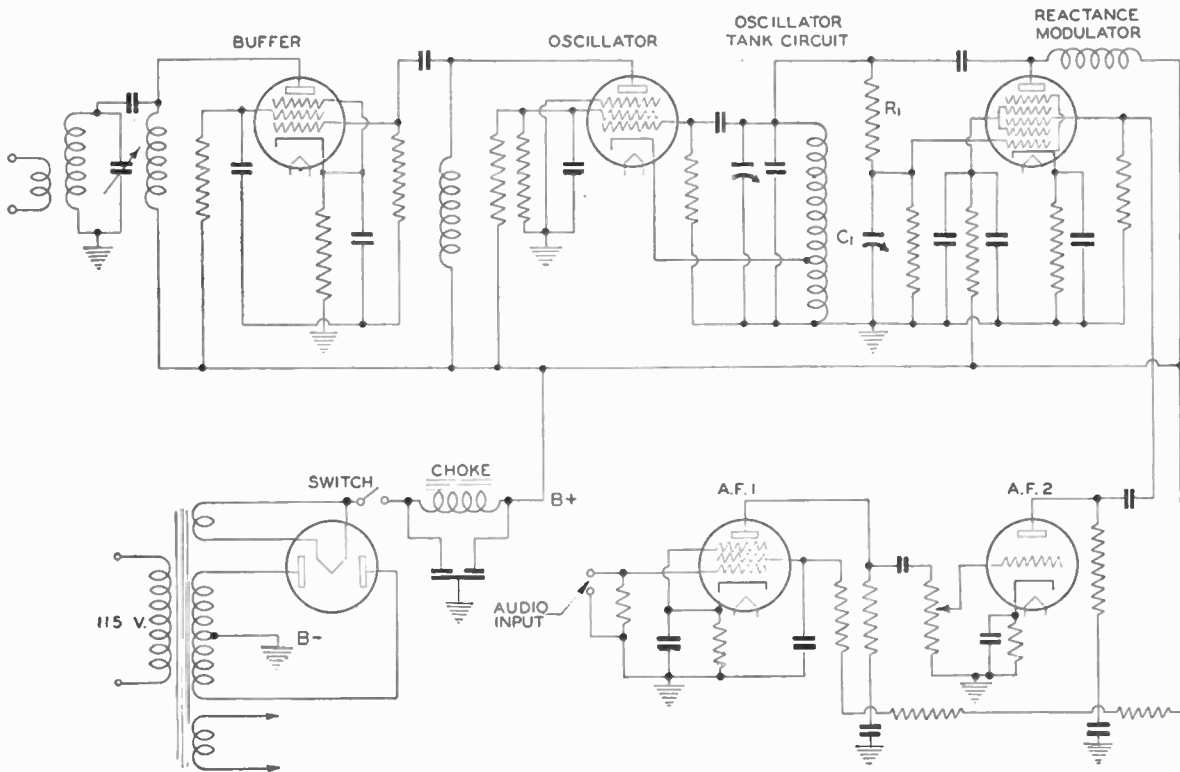

Fig. 2. Circuit Diagram of Frequency-Modulation Transmitter, with Reactance Modulator and Oscillator

tion is the percentage of this 150-kilocycle channel that is being used at any given time. Overmodulation in this type of transmission results only in using a larger portion of the assigned channel; while in an amplitude modulated transmitter, overmodulation results in the generation of spurious frequencies and interference with transmission in adjacent channels.

*Reactance Modulator.* One type of reactance-modulator circuit is shown diagrammatically in Fig. 2. The audio input is fed to *A.F.1* and *A.F.2*, which are conventional audio amplifier stages. The output of *A.F.2* is applied to a grid of the reactance-modulator stage. The control grid is connected across a small capacity,  $C_1$ , which is in series with a resistor,  $R_1$ , the combination of resistance and capacity being connected across the tank circuit of the oscillator stage. The output of the modulator causes a current flow in the  $R_1$ - $C_1$  circuit; the current through  $R_1$  will be in phase with the voltage across the tank circuit, but the voltage across  $C_1$  will lag this current by  $90^\circ$ . This is due to the property of a condenser that causes the voltage across it to be in quadrature with the current through it. The radio-frequency current in the modulator plate circuit (obtained from the oscillator) will be in phase with the radio-frequency voltage on the grid and, as a result, lags the current through  $C_1$  by  $90^\circ$ . This lagging current is drawn through the oscillator tank circuit and, since a lagging current represents the property of an inductance, the modulator tube acts as an inductance across the frequency-determining portion (tank circuit) of the oscillator tube. The amplitude of the lagging current can be varied by the audio-frequency output of the modulator stage; hence the inductive action, which controls oscillator frequency, can be varied by the audio input to *A.F.1*. Variations of the foregoing action may be used, but the principle will be substantially the same.

*Control of Oscillator.* Fig. 3 shows a diagram of a frequency-modulated transmitter. Audio frequencies are fed from the audio amplifier to the modulator, the modulator reacting on the oscillator in the manner previously described. The oscillator drives a buffer stage which serves to decouple it from the high-power stages to follow. The buffer works into a pair of frequency triplers in sequence, which increases the oscillator frequency to nine times

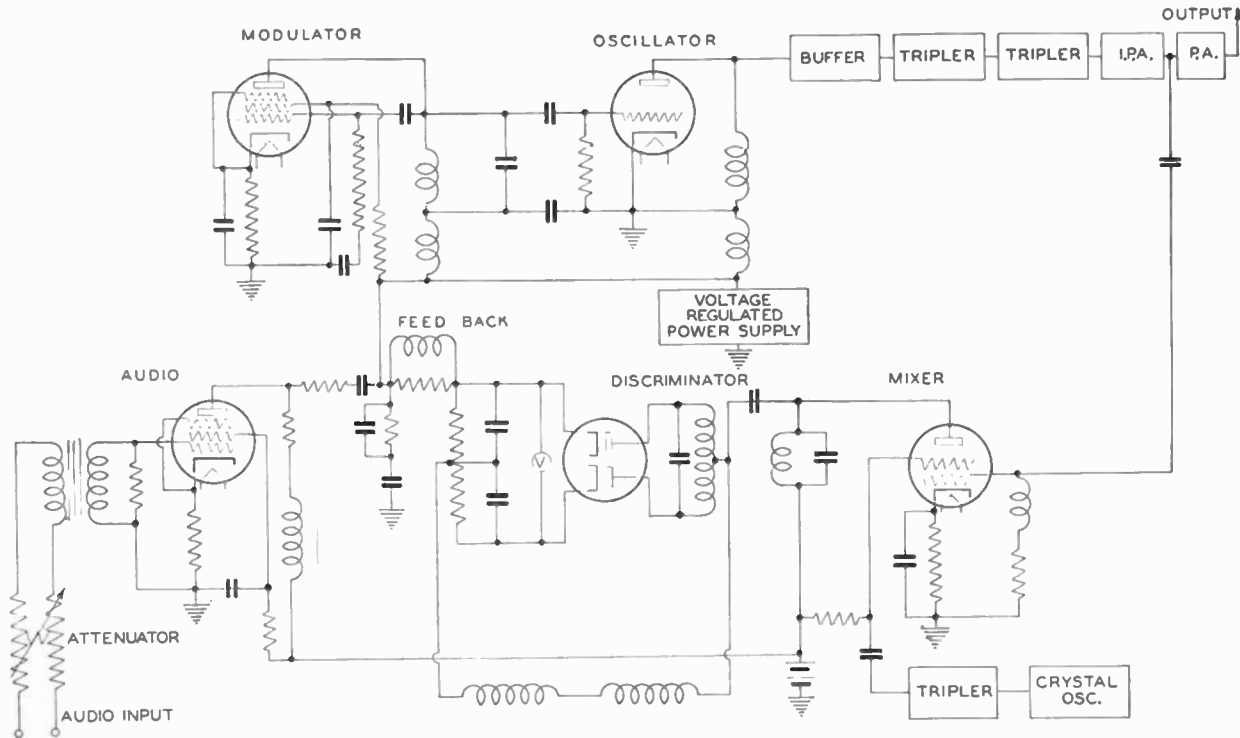

Fig. 3. Schematic Diagram of Frequency-Modulated Transmitter

its original value. The final tripler works into the intermediate power amplifier (*I.P.A.*) which in turn drives the final power amplifier (*P.A.*). Frequency tripling is used to reach the final high frequency (43 to 50 megacycles) without the use of small LC components in the oscillator stage proper. The output of the intermediate power amplifier in the transmitter under consideration is 250 watts. This may be used directly in an antenna system for low-power operation, or it may be used to drive the final power amplifier which has an output of 1 kilowatt.

A self-excited oscillator such as is used in this transmitter is not stable as to frequency, changes in operating voltages causing a frequency drift. A regulated power supply is required to insure stability. This takes the form of voltage-regulator tubes across the power supply output.

It is important that the oscillator return to its specified resting frequency during non-modulation periods. If correction is necessary, it may be accomplished manually, mechanically, or by electronic means. To determine when such correction is necessary, the output of the transmitter and the output of a crystal oscillator, after tripling, are brought together in a mixer circuit which in turn feeds a frequency-discriminator circuit. Any difference in frequency will be due to a drift of the transmitter oscillator, the quartz-crystal frequency remaining constant. This difference in frequency is shown on a frequency meter and corrections are made as indicated.

*Noise Reduction.* A pre-emphasis filter network is used on the audio output at the transmitter to provide an increase in modulation for the higher audio frequencies. It has been noted that a large proportion of noise accompanying high-fidelity transmission, regardless of the type of modulation, lies in the upper portion of the audio spectrum. The unfavorable signal-to-noise ratio at modulating frequencies above 5,000 cycles can be corrected by increasing the modulation effect at these frequencies. Pre-emphasis at the transmitter must be followed by de-emphasis at the receiver; *i.e.*, the receiver must be made less sensitive to the upper audio register. This results in a marked improvement in the signal-to-noise ratio of the over-all system. Fig. 4 shows a block diagram of a complete frequency-modulation transmitter.

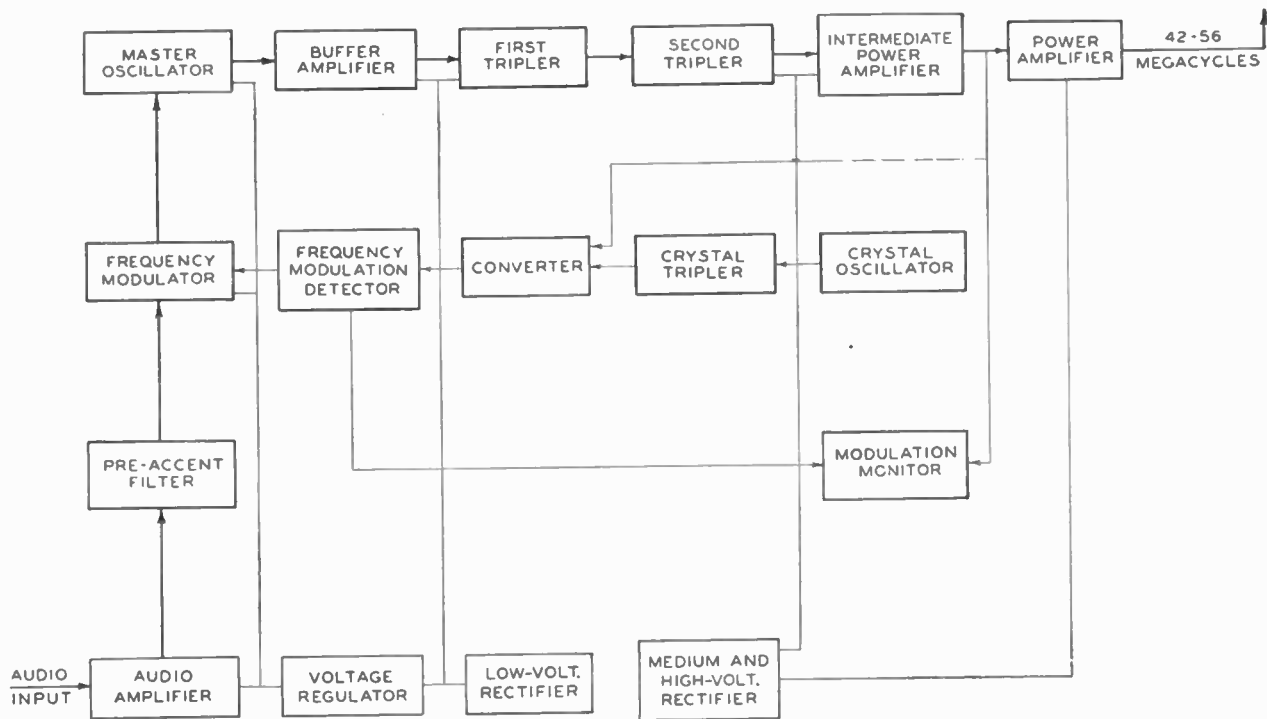

Fig. 4. Block Diagram of Frequency-Modulation Transmitter

**Frequency-Modulation Reception.** Frequency modulation may be defined as a means of varying the frequency of the carrier in accordance with the audio modulating frequencies at a rate proportional to the frequency of the modulating signal and by an amount proportional to the amplitude of the modulating signal. In other words, the higher audio frequencies will change the frequency of the carrier faster, and the louder audio signals will swing, or deviate, the carrier frequency farther from the mean frequency.

Until quite recently, amplitude modulation was considered the most practical type of modulation, and every effort was made to reduce or eliminate the frequency modulation sometimes introduced in amplitude-modulation systems. However, it has been demonstrated that with the proper type of receiver, frequency modulation can result in the reduction or elimination of atmospheric static, as well as man-made noise, to a much greater degree than is possible with the other types of modulation. Since noise is generally an amplitude variation, a receiver that is insensitive to amplitude modulation will not be affected by noise voltages. Such a type of receiver is used for the reception of frequency-modulated signals, and it results in virtually noise-free reception.

Frequency modulation can be received on an ordinary receiver by tuning to one side of the carrier frequency, but it is only by using a regular frequency-modulation receiver that the noise-limiting action can be obtained.

**Frequency-Modulation Receiving Circuit.** A frequency-modulation receiving circuit differs from an amplitude-modulation receiver in that, instead of the detector (or second detector in the case of a superheterodyne), it uses a limiter to remove all traces of amplitude variation, and a discriminator which is a variety of full-wave rectifier. A block diagram of the flow of the signal through a receiver is shown in Fig. 5.

To take a definite example, let us assume that the receiver is tuned to receive a 43-megacycle, 400-cycle, 100% modulated signal. Accordingly, the 43-megacycle frequency-modulated signal will vary between 43.075 and 42.025 megacycles at a rate of 400 times per second. This signal with its side bands occupies a total

band of 150 kilocycles, and is amplified in the radio-frequency stage (if one is used) and fed to the grid of the mixer tube. Assuming that the receiver has an intermediate frequency of 4 megacycles, the oscillator would be operated at either 47 or 39 megacycles to produce a beat frequency of 4 megacycles in the plate circuit of the mixer tube. This resulting 4-megacycle intermediate frequency signal has the same characteristics as the original 43-megacycle signal, in that its frequency varies at the same 400-cycle rate from 3.025 to 4.075 megacycles. This intermediate frequency signal is amplified and is then impressed on the grid of the limiter tube. The limiter tube has no counterpart in the amplitude-modulation

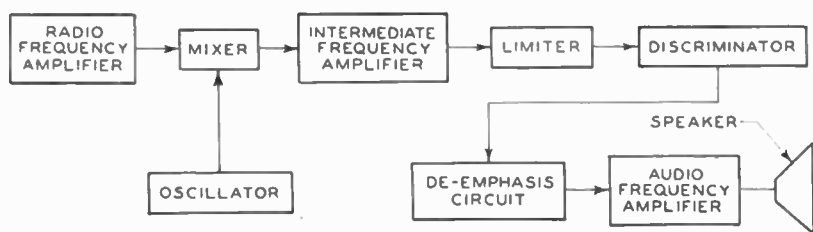

Fig. 5. Block Diagram of Frequency-Modulation Receiver

receiver. It is designed to suppress the very thing which is required in the operation of an amplitude-modulation receiver; that is, the function of the limiter is to remove all amplitude modulation in the signal and to leave only the frequency variations.

The constant amplitude output of the limiter is fed to the discriminator or frequency-detector stage of the receiver, Fig. 5. This stage corresponds to the second detector stage in the amplitude-modulation receiver, but the discriminator is designed to translate the frequency variations into the original audio signal, whereas the amplitude-modulation detector translates the amplitude variations into the desired audio signal.

With the recovery of the 400-cycle note in the output of the discriminator, the signal is passed to a de-emphasis circuit, Fig. 5, in the input circuit of the first audio stage. From this point on, the 400-cycle note passes through the various stages of the audio amplifier and finally reaches the voice coil of the speaker.



*Radio-Frequency Amplifier.* The purpose of radio-frequency amplification in frequency-modulation receivers is to provide increased selectivity; this has the advantage of reducing image and other interference. At the same time, the gain provided by using the radio-frequency stage provides a greater signal at the limiter grid, so more effective limiting action is obtained for weak signals.

*Mixer and Oscillator.* The present general practice in frequency-modulation receivers is to use a single tube as mixer-oscillator. The tube performs satisfactorily as both oscillator and mixer at frequencies as high as 50 megacycles, the upper limit of the present frequency-modulation band.

Special attention has been paid to the design of the oscillator circuit in frequency-modulation receivers in order to secure stable operation. Because of the high frequency at which the oscillator operates, even a small percentage variation or drift in its frequency will cause a considerable amount of detuning and prevent operation on the central portion of the discriminator characteristic curve.

To reduce the effect of variations in operating voltage to a minimum, a voltage regulator tube may be used to regulate the plate supply to the oscillator.

*Intermediate Frequency Amplifier.* The intermediate frequency amplifier in frequency-modulation receivers is more complex than in amplitude-modulation receivers because of the higher frequency and because of the greater gain which is necessary in order to secure enough signal for the proper operation of the limiter. Again the greater band width required (150 kilocycles) does not present a difficult problem because the intermediate frequency is considerably higher than the intermediate frequency customarily used in amplitude-modulation receivers. To take an average frequency-modulation intermediate frequency of 4 megacycles (4,000 kilocycles), it is no more difficult to secure a band width of 150 kilocycles at this frequency than it is to secure a band width of 15 kilocycles at 400 kilocycles; the latter problem corresponds generally to that encountered in the high-fidelity amplitude-modulation receivers. Actually, the requirement for flat response over the intermediate frequency band is less severe in frequency-modulation receivers, since the limiter removes the effect of nonuniformity in

amplification. In addition to providing a band width of roughly 150 kilocycles, the frequency-modulation intermediate-frequency amplifier must have sufficient selectivity so that adjacent-channel interference is prevented. This condition is common to amplitude-modulation receivers also.

*Limiters.* The limiter is an ordinary amplifier stage, usually a sharp cutoff pentode, which is operated at zero bias and with a low plate and screen voltage. As a result of these operating conditions, the output of the stage is limited in the downward direction

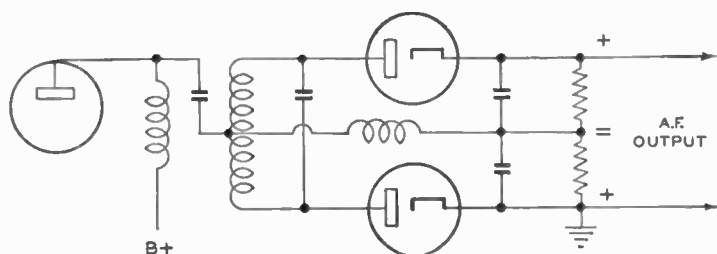

Fig. 6. Discriminator Stage of Frequency-Modulation Receiver

by plate-current cutoff and in the other by the fact that the plate current of the limiter tube can never rise above a value corresponding to the zero bias value. Thus, provided the signal at the limiter grid is always in excess of about 7 volts, the output of the limiter will not exceed the value corresponding to a grid swing between cutoff and zero bias. If the signal falls below about 5 volts, however, the limiter will not have sufficient signal to function properly, and the noise-reducing operation of the frequency-modulation system will fail.

*Discriminator.* A typical discriminator circuit is shown in Fig. 6. When a signal is applied having the same frequency as that to which the discriminator input is tuned, the voltage across each diode load resistor is the same, and no audio-frequency voltage will be obtained. As the applied signal varies in frequency about this resting frequency, an audio-frequency component will appear, which will be proportional to the deviation from the resting frequency, as shown in Fig. 7.

*Audio Amplifier.* Because of the wider range covered in fre-

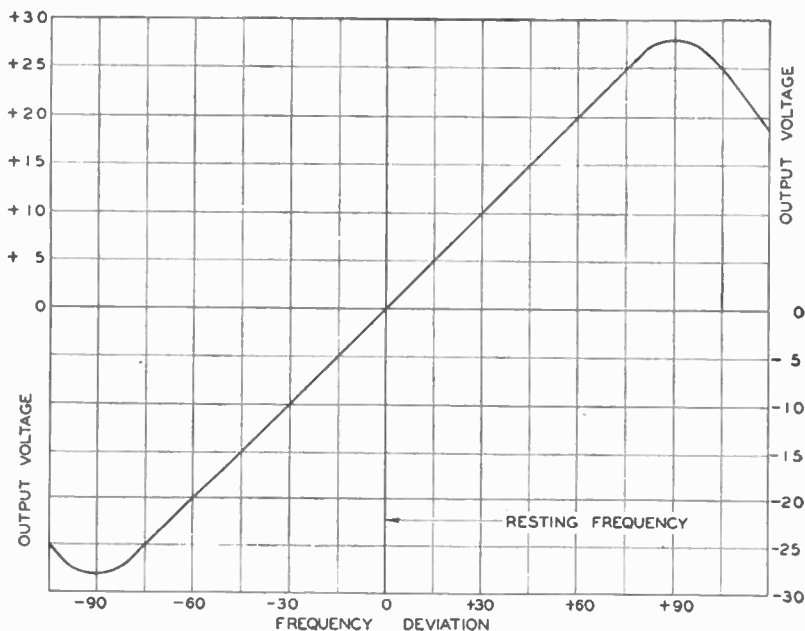

Fig. 7. Curve Showing Output Voltage Produced Due to Variation in Frequency of Signal

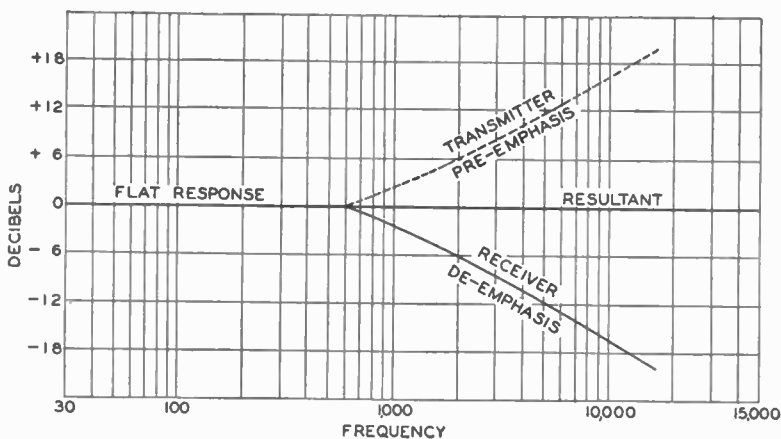

Fig. 8. Curve Showing Resultant in Response to Pre-emphasis at Transmitter and De-emphasis at Receiver

quency modulation, the design of the amplifier and speaker system differs somewhat from those used in amplitude-modulation receivers. The over-all frequency response, unlike that of the amplitude-modulation amplifiers, is not flat, but the gain in amplification is progressively lower for the higher audio frequencies, as illustrated by the receiver de-emphasis curve, in Fig. 8.

It will be noted that the de-emphasis, as this progressive attenuation is called, is the reverse, or opposite, of the pre-emphasis of the higher audio frequencies introduced at the transmitter. As a result, the over-all audio response of the frequency-modulation system is flat, since the de-emphasis in the receiver's audio amplifier compensates exactly for the pre-emphasis in the transmitter.

Usually the de-emphasis in frequency-modulation receivers is accomplished by a series resistor and shunt condenser in the input circuit of the audio amplifier. When this is done, the desired de-emphasis is obtained in the input circuit so that the frequency response of the audio amplifier and speaker can be essentially flat. The advantage of putting the de-emphasis circuit in the input is that the response of the remainder of the audio system will be flat for amplitude-modulation reception and for record reproduction.



---

# Dictionary of Radio Terms

---

## A

**A-battery:** The battery used to supply heating current to the filament of a thermionic vacuum tube.

**A-B power pack:** A combination of batteries of devices designed to furnish operating potentials for the A (cathode) and B (anode) circuits of vacuum tube equipment.

**A.C. (alternating current):** A current of constantly changing value which reverses its direction of flow at periodic intervals. Also used to designate a voltage, as A.C. voltage.

**A.C.-D.C.:** Pertaining to a device which will operate satisfactorily on alternating or direct current.

**acoustics:** Pertaining to the production and transmission of sound.

**aerial:** An antenna.

**A.F. (audio frequency):** Pertaining to frequencies normally capable of producing an audible sensation.

**air condenser:** A condenser, generally variable or adjustable, in which air serves as the dielectric.

**air core coil:** A type of coil construction in which no magnetic material is used to increase the magnetic effect.

**alloy:** A mechanical mixture of two or more metals.

**alternating current:** A.C.

**alternation:** The portion of an alternating-current cycle between two successive zero values.

**alternator:** An alternating-current generator.

**ammeter:** An instrument which measures the current flow in amperes in a circuit.

**ampere:** The practical unit of current flow in an electrical circuit. Equivalent to the passage of  $6.28 \times 10^{18}$  electrons past a given point in a circuit per second.

**ampere hour:** A current of one ampere flowing for one hour or its equivalent.

**ampere turn:** A measure of electromagnetic field strength. A current strength of one ampere passing through a turn of wire or its equivalent.

**amplification:** The process of increasing the strength of a voltage, current or power.

**amplification factor:** The factor by which a given value may be increased generally by the use of a vacuum tube.

**amplifier:** A connection of devices generally including one or more vacuum tubes capable of producing amplification.

**amplitude:** The highest value reached by voltage, current, or power during one cycle.

**amplitude modulation (A.M.):** A system of modulation whereby the amplitude of a carrier wave is varied in accordance with an applied signal. This type of modulation results in the production of side bands.

**anode:** The element in an electrical device to which electrons are drawn.

**antenna:** A structure of arrangement of conductors used for receiving or radiating radio waves.

**antenna coil:** The inductance either in a receiver or transmitter through which antenna current passes.

- aperiodic:** Not resonant to a definite frequency. The antenna circuit of most broadcast receivers is an aperiodic circuit inasmuch as it is not tunable to various frequencies.
- armature:** Generally the moving portion of a magnetic structure. More specifically the rotor of an electrical generator, the moving portion of a loud speaker, or the reed of a relay.
- atmospherics:** Disturbances to radio transmission circuits due to the free electricity (static) in the atmosphere.
- attenuation:** To reduce the amplitude of an electrical impulse.
- audio amplifier:** An amplifier generally consisting of one or more vacuum tubes with associated equipment designed to amplify electrical impulses in the audible frequency band.
- audio frequency:** A frequency normally capable of producing an audible sound. The limits of audibility vary with the individual, but they are generally considered as encompassing the band of frequencies between 30 and 20,000 cycles per second.
- audio oscillator:** An oscillator capable of producing audio frequencies.
- audio transformers:** A laminated iron core transformer used as a coupling device between two audio frequency circuits.
- auto transformer:** A transformer having a single-tapped coil acting as both primary and secondary.
- automatic tuning:** An electrical or mechanical arrangement which tunes a radio circuit or circuits to a predetermined frequency when the actuating control is operated.

## B

- B-battery:** A battery supplying potential to the plate circuit of a vacuum tube.
- back E.M.F.:** A pressure or voltage which opposes the voltage being applied to a circuit. It may be caused by reactive components in the circuit or it may be actually due to a prime voltage generator.

- background noise:** Extraneous noise heard along with a desired signal due to any cause whatsoever.
- baffle:** Any device such as a horn, cabinet, or flat surface which is used to prevent the sound wave, projected from the rear of a loud speaker, from acting in conjunction with the wave projected from the front of the speaker.
- balanced armature speaker:** A loud speaker in which the driving armature is pivoted between the poles of a permanent magnet.
- balancing condenser:** A trimmer condenser.
- ballast resistor:** A resistor of special alloy wire designed to present a variable opposition to an applied voltage. The ohmic resistance of such a device increases with an increased flow of current through it, thereby increasing the voltage drop across the resistor. When used in series with a device connected to an A.C. or D.C. line, it tends to prevent line fluctuations from appearing across the device with which it is used.
- ballast tube:** A ballast resistor mounted in a tube envelope. The tube may or may not be evacuated.
- band switch:** A switch or control which shifts the operation of a transmitter or receiver from one band of frequencies to another.
- band, wave:** All frequencies lying within two more or less rigidly defined limits. Thus the standard broadcast band refers to all frequencies from 550 to 1600 kilocycles.
- bandsread:** A method of creating a finer degree of control over the tuning of a given frequency band generally accomplished by a low capacity variable condenser in parallel with the main tuning condenser.
- battery:** Two or more chemical cells.
- battery charger:** A device used to charge a secondary cell. When designed to operate from alternating current, it must contain a rectifier.
- beat frequency:** The resultant frequency obtained by combining two frequencies.

**beat frequency oscillator:** An oscillator used to provide a locally generated frequency to beat with a signal frequency. Generally used in a radio receiving circuit to make continuous wave signals audible.

**B-eliminator:** A device used to replace B-batteries in radio circuits. For A.C. operation it must include a rectifier and filter system.

**bias:** An operating voltage. Most generally used to designate the steady value of negative potential applied to the control grid of a vacuum tube device.

**bleeder current:** The current flowing in a bleeder resistor of a power supply device for regulation of the voltage output.

**blocking condenser:** A condenser used to prevent the application of a direct-current voltage on an element while allowing the impression of an A.C. voltage.

**body capacity:** The electrostatic capacity between the human body and a radio device.

**bonding:** Soldering or welding various parts of a device to a common conductor to prevent a potential difference between them.

**breakdown voltage:** The voltage at which an insulator becomes conductive.

**bridge:** A circuit arrangement consisting of resistors, capacitors, or inductors, generally used for measuring purposes.

**broad tuning:** A condition of a circuit in which a broad band of frequencies is accepted equally well.

**broadcast band:** A band of frequencies used for the transmission of voice and musical frequencies modulated on a radio frequency carrier.

**broadcast station:** A station transmitting broadcast programs.

**bucking coil:** A coil, generally in a radio loud speaker, in which a voltage is produced in opposition to the voltage in the principal coil.

**buffer:** A circuit or connection of devices used to prevent interaction between two additional circuits.

**buffer stage:** An amplifier stage designed to prevent interaction between a power stage and an intermediate stage or oscillator.

**by-pass condenser:** A condenser used to present a low impedance path to one or more frequencies while preventing the passage of other frequencies or direct current.

## C

**C:** Letter used to designate an electrostatic capacitor.

**C-battery:** A source of potential furnishing the biasing voltage to the control grid of a vacuum tube.

**capacitance:** The ability of a device to store electricity in the form of electrostatic lines of force.

**capacitive coupling:** A method of coupling between circuits whereby energy is transferred through electrostatic lines of force.

**capacitive feedback:** Energy returned from the output of a circuit to the input by means of a condenser.

**capacitive reactance:** The opposition to the flow of alternating current or pulsating direct current caused by a capacitor. The unit of capacitive reactance is the ohm.

**capacitor:** A device specifically designed to exhibit the effect of capacitance.

**capacity:** A quantitative measure of the ability of a condenser to store an electrostatic charge.

**capacity, distributed:** The capacitive effect between adjacent turns of a coil or between lengths of parallel conductors.

**carbon:** One of the 92 elements. Differs from other metal elements in that its resistance decreases with an increase in temperature.

**carbon resistor:** A resistor widely used in radio circuits composed of finely divided carbon particles held together by a suitable binder. They are cylindrical in shape and are made in various wattage ratings.

**carborundum:** A fused crystal of carbon and silicon used to rectify low values of high frequency voltage such as a radio signal. Used as a crystal detector.



- carrier:** A series of electrical impulses of constant amplitude used to carry transmitted intelligence by conditioning the carrier amplitude, frequency or phase.
- cathode:** The element in an electrical device from which electrons are extracted.
- cathode ray:** A stream of electrons projected in the form of a ray or beam from a cathode.
- cathode ray oscilloscope (C.R.O.):** A combination of devices including a cathode ray tube used to investigate the characteristics of alternating voltages and to indicate correct alignment of resonant circuits.
- cathode ray tube:** A vacuum tube in which a stream of electrons is projected toward a fluorescent screen to produce a visible trace.
- cell, chemical:** A single unit consisting of two dissimilar electrodes immersed in an electrolyte which converts chemical energy into electrical energy.
- channel:** A group or band of frequencies included between two more or less definitely defined limiting frequencies.
- charge:** An isolated electric charge held on an insulated body. The space surrounding the charged body is considered as being traversed by lines of force.
- choke coil:** An inductor which, through the production of a counter e.m.f., prevents the passage of a variable current through its circuit.
- coaxial cable:** A two-conductor cable in which a central conductor is supported within the outer conductor, in the form of a conducting tube, by insulating beads.
- coil:** A conductor wound in the form of a progressive spiral designed to concentrate the magnetic field set up by the passage of current through the conductor.
- compass, radio:** A radio device operating with a loop antenna which permits the determination of the direction or plane of a received signal.
- condenser:** A device consisting of two conducting surfaces separated by an insulator, called the dielectric, which is capable of storing a charge of electricity in the form of electrostatic lines of force.
- conductance:** A quantitative measure of the ability of a material to conduct electricity. The unit of conductivity is the mho.
- conductance, mutual:** In a vacuum tube, a measure of the ability of a voltage applied to one electrode to control the current flow to another electrode.
- conductivity:** An expression of the ability of a material to conduct electricity.
- conductor:** A material which allows the free passage of an electric current through its structure.
- cone:** The portion of a radio loud speaker driven by the actuating armature which sets in motion the air particles to produce a sound wave.
- Continental Code:** Also called the International Morse Code. A system of dots and dashes used in radio-telegraphy.
- control grid:** The element in a vacuum tube to which a signal is applied for amplification or rectification.
- converter:** A device or circuit for changing a given frequency to one of a different value. Also a rotary or vibrating machine for converting one type of electricity to another, as direct current to alternating current.
- core:** The center of a coil.
- counter E.M.F.:** A reactive voltage.
- coupling:** A means of transferring electrical energy from one circuit to another.
- crystal, quartz:** A piece of quartz which exhibits piezo-electric properties. Its mechanical dimensions determine the frequency at which it is capable of controlling an oscillator.
- crystal control:** The control of the frequency of the voltage produced by an oscillator by the use of a piezo-electric crystal.
- crystal detector:** A rectifier of radio frequency signals. The crystals possessing unilateral conductivity are carborundum, silicon, galena, iron pyrites, zincite-bornite, chalcopyrite, etc.

**crystal filter:** A highly selective receiving circuit using a quartz crystal. Generally used in communication receivers for receiving through intensive interference.

**crystal microphone:** A type of microphone using Rochelle salt crystals for converting mechanical motion to electrical energy.

**crystal pickup:** A phonograph pick-up using the stress produced on a Rochelle salt crystal to generate an E.M.F. which varies in conformity with the indentations on the phonograph record.

**current:** The passage or movement of electrons in an electrical circuit.

**C. W.:** A continuous wave, that is, one in which the amplitude of successive oscillations remains constant.

**cycle:** A complete series of events. In alternating current the portion of a wave between two points which are identical in amplitude and sense.

## D

**DB:** Decibel.

**D.C.:** The abbreviation for direct current.

**damped wave:** A radio frequency wave in which the successive oscillations are of progressively decreasing amplitude. A spark transmitter generates a damped wave.

**decibel:** A unit used to express a power ratio.  $DB = 10 \log \frac{P_2}{P_1}$ .

**degeneration:** A feedback system in which energy is fed back to the input of a circuit in such phase that the original signal is reduced.

**demodulation:** The operation of separating the modulating component from the modulated carrier.

**detector:** The circuit in a receiving system in which demodulation takes place.

**detuning:** Changing the constants of a circuit so that it no longer resonates to the impressed frequency.

**diaphragm:** A flexible membrane capable of being put into motion

when acted upon by a sound wave or conversely, it is capable of projecting a sound wave when put into motion.

**dielectric:** The insulating medium between the conducting plates of a condenser.

**diode:** A two-element vacuum tube.

**direct coupling:** A coupling method wherein two circuits are directly joined by a conductor.

**direct current:** An electric current having an unidirectional flow but not necessarily of constant amplitude.

**directional antenna:** An antenna or system of antennae designed to transmit the major portion of its output in a given direction. Also an antenna designed to receive signals most effectively from a given direction.

**discriminator:** A circuit in which the output varies in accordance with the deviation of a received signal from an original resting frequency. Used in F.M. receivers as a demodulator.

**distortion:** Departure of an output wave shape from the input wave in form neglecting amplitude changes.

**doublet antenna:** An antenna system composed of two elements, the physical length of each bearing a definite relation to its resonant frequency.

**dry cell:** A primary chemical cell in which the electrolyte is in paste form.

**dry electrolytic condenser:** An electrolytic condenser in which the electrolyte is in the form of a paste instead of a liquid.

**dummy antenna:** A device having the inductance, capacity and resistance of an antenna in lumped form. Used for coupling a signal generator to a radio receiver under test or for radiating the output of a transmitter into during test periods.

**DX:** An abbreviation meaning distant reception or communication with or from a distant station.

**dynamic speaker:** A term used to describe a loud speaker in which an actuating coil is caused to move in an intense magnetic field.

**dynamotor:** An electro-mechanical device consisting of a motor and generator using a common armature to carry both motor and generator coils. The field winding is common to both units.

**dyne:** The unit of force.

## E

**E:** Symbol for voltage.

**eddy current:** A current flow caused by inducing a voltage in the metallic portion of an electromagnetic device such as the core of a transformer or the shield around an inductor.

**Edison cell:** A secondary chemical cell also called a nickel-iron-alkaline cell.

**efficiency:** Power output divided by power input. To express efficiency as a percentage, multiply this ratio by 100.

**electric eye:** A type of electronic tube which is actuated by light impulses.

**electric field:** The space surrounding a charged body through which electrostatic lines of force are said to pass.

**electrode:** An active element of an electrical device such as an electrode in a vacuum tube or one of the elements of a chemical cell.

**electrodynamic speaker:** A dynamic speaker in which the intense stationary field is produced by an electromagnet.

**electrolyte:** The actuating chemical solution in an electrochemical device.

**electrolytic condenser:** A polarized condenser using a thin gas film as the dielectric. The film is formed by the action of a liquid or paste electrolyte upon an aluminum electrode.

**electrolytic rectifier:** A rectifier in which two electrodes are immersed in an electrolyte, the rectification being brought about by a chemical action.

**electromagnet:** A magnet produced by causing a current of electricity to flow through a coil of wire which generally has an iron core.

**electromotive force:** Voltage.

**electron:** A small active particle of negative electricity. A flow of

electrons constitute an electric current.

**electron emission:** The extraction or evaporation of electrons from a material through the application of heat, light, or high voltage.

**electron tube:** A tube which makes use of a stream of electrons in its operation.

**E.M.F.:** Electromotive force.

**energy:** The capability of doing work. The ability to displace a weight through a distance.

**ether:** The hypothetical medium thought to occupy all space by means of which heat, light, and radio waves are transmitted.

## F

**F or f:** Symbol for frequency, generally in cycles per second.

**facsimile:** The transmission of signal waves produced by the scanning of fixed graphic material, including pictures, for reproduction in record form.

**fading:** A change in the intensity of a received radio program due to variations in the transmission path through the medium of transmission. Also, to change from one signal channel to another without interruption.

**farad:** The unit of electrostatic capacity. A condenser is said to have a capacity of one farad when a charge of one coulomb stored on its plates raises the potential across the plates one volt.

**F.C.C.:** The Federal Communications Commission. A government body vested with powers to supervise and control communications of any type in the United States and its possessions.

**feedback:** The transfer of energy from a point in a circuit to a preceding point.

**fidelity:** The degree to which an electrical system transfers energy without distorting its wave form.

**field:** The electrostatic or electromagnetic effect about a stationary or moving electric charge.

**field coil:** A coil, generally in an electrodynamic speaker, which is used to produce an intense magnetic field.

**filament:** The element in an electrical device in which electrical energy is transformed to heat energy. In a vacuum tube the purpose of the filament may be to emit electrons.

**filament voltage:** A-battery or circuit.

**filament winding:** A transformer winding designed to furnish filament voltage.

**filter:** A device or combination of devices designed to prevent the passage of frequencies above or below a designated cut-off value. The device may be electrical or mechanical. In radio power supply systems a combination of condensers and chokes or resistors which serves to pass direct current while preventing the passage of pulsating direct current.

**first detector:** In a superheterodyne receiver the circuit in which the received signal is combined with a locally generated oscillation to produce the intermediate frequency.

**fixed condenser:** A condenser whose value is not adjustable.

**fixed resistor:** A resistor whose value is not adjustable.

**fluorescent screen:** A screen coated with a material which produces light impulses when energized by an electron stream.

**flux:** The sum total of the magnetic lines of force existing in a magnetic field.

**flux density:** Lines of force per unit area.

**free electrons:** The electrons which are not rigidly bound to a given atom. They are capable of movement from atom to atom when acted upon by an electrical force.

**frequency:** The number of complete cycles taking place per unit of time.

**frequency converter:** A circuit in which a given frequency is changed to a different value. Generally accomplished by combining two frequencies to form a third.

**frequency distortion:** A type of distortion in which all frequencies are not transmitted or amplified equally well.

**frequency modulation:** A system of modulation in which the modulat-

ing component changes the frequency of the radiated wave while maintaining the amplitude constant.

**frequency response:** A measure of the ability of a device or circuit to reproduce the desired band of frequencies.

**full wave:** Making use of both halves of an A.C. cycle. By electrical or mechanical methods the reverse flow of current is changed to correspond to the desired directional flow.

**fuse:** A protective device designed to open an electrical circuit when excessive current flows in the circuit.

## G

**gain:** The ability of a circuit or device to increase the energy applied to its input.

**galena:** A lead ore used to rectify high frequency signals.

**galvanometer:** A sensitive instrument which indicates a current flow.

**gang condenser:** Two or more variable condensers the motors of which are driven by a common control.

**gaseous tube:** An electronic tube using a gas to produce some special operational function.

**generator:** A device which converts mechanical energy to electrical energy or electrical energy to a desired frequency.

**getter:** A material used in a vacuum tube which absorbs residual gases in the tube after evacuation.

**glow lamp:** A gaseous tube generally having two electrodes mounted in an evacuated glass tube to which an inert gas has been added. On application of an ionizing potential a characteristic glow results.

**gram:** The unit of weight in the metric system.

**grid:** An electrode in a vacuum tube placed between the cathode and anode, used to control or modulate the stream of electrons passing from cathode to anode.

**grid bias:** The steady value of operating voltage applied to the control grid of a vacuum tube.

**grid leak:** A high value of resistance placed between control grid and cathode in a vacuum tube circuit.

**grid-leak condenser detector:** A type of detection circuit in which the modulating voltage produces a voltage drop across a resistor of high ohmic value shunted by a low capacity condenser. The resulting voltage is applied to the grid of a vacuum tube where it causes variations in plate current.

**grid return:** The D.C. circuit path by means of which the grid is connected to the cathode.

**ground:** Generally the low potential side of an electrical circuit. Also an actual earth connection.

**ground clamp:** A metal clamp or strap used to contact a grounded object such as a water pipe.

**ground wave:** The portion of a transmitted wave which follows the surface of the earth.

## H

**H:** Symbol used to denote magnetic flux density.

**half wave:** A circuit or device which, through its characteristic of unilateral conductivity, uses only one alternation of an A.C. cycle.

**harmonic:** An integral multiple of a fundamental frequency. The first harmonic is also the fundamental, the second harmonic is twice the fundamental, etc.

**harmonic distortion:** The generation of spurious frequencies, generally integral multiples of the fundamental frequency, in an electronic device.

**Hartley oscillator:** A vacuum tube oscillator in which feedback is accomplished inductively.

**headphone:** A device to be worn on the head which changes electrical impulses into sound energy. It may consist of two watch case receivers attached to an adjustable headband, the electrical circuits of the receivers being connected in series and terminating in a phone cord.

**heater:** A circuit in a vacuum tube used to supply heat to an electron emitting surface.

**Heaviside layer:** A layer of ionized gas above the earth's surface which acts as a reflecting medium for radio waves.

**henry:** The unit of inductance. A circuit is said to have an inductance of one henry when a current change of one ampere per second generates a counter e.m.f. of one volt. The millihenry is one-thousandth of a henry while a microhenry is one-millionth of a henry.

**heterodyne:** To combine forces or frequencies.

**high fidelity:** The ability of a circuit to pass a band of audio frequencies from 30 to 15,000 cycles per second without amplitude discrimination.

**hook-up:** A diagram showing the inter-connection of components in an electrical device.

**hum:** A low frequency audio signal accompanying the desired signal, generally due to direct or inductive pick-up from an A.C. source.

**hydrometer:** A device to measure the specific gravity of a liquid.

**hysteresis loss:** A loss in the core of an electromagnetic device caused by the inability of the individual molecules to instantly change their direction. Molecular friction.

## I

**I:** Symbol used to denote the current flow in amperes.

**I.F.:** Intermediate frequency.

**impedance:** The total opposition to the flow of alternating or pulsating direct current in a circuit. It is the combined effect of resistance and reactance and is measured in ohms.

**impulse:** A momentary surge of current or voltage in an electrical circuit.

**induced voltage:** The production of a voltage in a circuit due to its interaction with other circuits or devices.

**inductance:** The property of a device to produce an opposition to a change of current flow through it. Also a device such as a coil which produces the effect of inductance.

**Induction:** The ability of a device or circuit to project its effect into a nearby circuit or object without physical or electrical contact between them.

**Inductive coupling:** Two electrical circuits coupled by electromagnetic lines of force.

**Inductive reactance:** The oppositional effect to a change of current flow in a circuit due to the inductive properties of the circuit. The unit of inductive reactance is the ohm.

**Insulation:** A material which by virtue of its electronic structure opposes the free flow of current through it.

**Inter-electrode capacity:** The electrostatic capacity existing between any two electrodes of a vacuum tube.

**Interference:** Any mechanical or electrical disturbance interfering with the reception of a radio signal.

**Intermediate frequency (I.F.):** In a superheterodyne receiver, the frequency obtained by combining the incoming signal frequency with a locally generated frequency.

**Intermediate frequency amplifier:** The portion of a superheterodyne receiver which amplifies the intermediate frequency. This portion is included between the first and second detectors.

**I.F. transformer:** A transformer tuned to pass a particular frequency. It is used for coupling purposes in the intermediate frequency amplifier.

**Intermediate power amplifier (I.P.A.):** In a radio transmitter, any stage used for amplification purposes between the driving oscillator and the final power amplifier.

**International Morse Code:** The Continental Code.

**Inverse feedback:** Feedback from an output circuit to an input circuit in such a phase relation that the original signal input is decreased.

**Ion:** An electrified atom.

**Ionization:** A condition wherein large numbers of atoms in a gas or electrolyte are ionized generally by the application of an electrical potential.

**IR drop:** The potential drop or voltage appearing across the terminals of a resistor.

## J

**jack:** A device for conveniently connecting phones, microphones, or meters temporarily to circuits. It may also act as a switch.

**jamming:** Intentional interference with radio signals.

**J-operator:** An operational factor used to indicate that the value which it precedes is the out-of-phase component of a complex expression.

**joule:** The unit of electrical energy equal to one watt second.

## K

**Kc:** Kilocycle—1000 cycles.

**Kennelly-Heaviside layer:** See Heaviside layer.

**key:** A pivoted lever type of switch which is operated by hand in radio telegraphic signaling.

**kilocycle:** See Kc.

**kilowatt:** One thousand watts of electrical power or its equivalent.

## L

**L:** Symbol for inductance.

**laminated:** Built up of small parts or thin sheets as in the construction of the core of a power transformer.

**lamp, pilot:** A low wattage bulb used in radio and associated equipment to illuminate controls or to indicate an "on" condition.

**lead-in:** The conductor connecting the elevated portion of an antenna system with the receiving equipment it is to energize.

**leakage:** A current flow through a path nominally of high insulation value.

**leakage flux:** Electromagnetic lines of force which do not link the mutual inductances in a device operating on the principal of electromagnetic induction.

**leakage resistance:** The opposition encountered by a leakage current. Generally high in ohmic value.

**lightning arrester:** A device which passes to ground the high value of electrical energy developed in an antenna during an electrical storm or when the antenna is actually struck by lightning. This protects the equipment connected to the antenna, such as a radio receiver.

**limiter:** A circuit in which amplitude variations are removed from a modulated wave. Generally used in F.M. receivers to remove amplitude variations from the frequency modulated wave.

**line cord:** A two-wire cable used to connect portable electrical devices to a service outlet.

**line cord resistor:** A third circuit added to a line cord in the form of a wire resistor for producing a voltage drop.

**line filter:** A filtering device to prevent electrical disturbances which exist in the line from entering a receiving chassis.

**line voltage:** The voltage appearing at the terminals of an electrical service line.

**lines of force:** Imaginary lines in space along which electrical or magnetic phenomena is said to take place.

**log:** A detailed record, required by law, of the operation of a radio transmitter.

**loop antenna:** An antenna constructed in the form of a large diameter coil used generally for its directive characteristics.

**loud speaker:** A device for converting electrical impulses into sound waves.

## M

**Ma:** Milliamperere.

**magnet:** A piece of iron or steel or a special compound possessing the properties of attraction, repulsion and polarity.

**magnetic flux:** The sum total of the magnetic lines of force in a given field.

**magnetic lines of force:** Imaginary lines or paths along which magnetic effects take place.

**magnetic path:** The complete path through which magnetic lines of force pass in a given magnetic de-

vice. The path may be wholly through a magnetic material or through a combination of magnetic and non-magnetic materials.

**magnetic phono pickup:** A type of phonograph pick-up in which the record indentations actuate a moving iron vane pivoted between the poles of a permanent magnet. The resulting change in magnetic reluctance causes the production of an e.m.f. in a nearby coil.

**magnetic speaker:** A type of loud speaker in which the actuating mechanism is a lever or reed pivoted between the poles of a permanent magnet.

**magnetomotive force:** In an electromagnet, the product of current flow and the number of turns of wire in the magnet coil.

**matching:** The operation of regulating or fitting a given load to its source of supply. An impedance match is generally assumed.

**maximum undistorted power output (Max. U.P.O.):** The greatest amount of power output obtainable from a given vacuum tube without the generation of undesirable harmonics.

**meg:** Prefix meaning one million.

**megacycle (Mc):** One million cycles, the time interval generally being considered the second.

**megohm:** One million ohms.

**mercury vapor rectifier tube:** A rectifier tube containing mercury which greatly increases the current carrying ability through ionization.

**meter:** The unit of length in the C.G.S. system of units. One meter equals 39.37 inches. Also a device used for measuring electrical quantities such as voltage, current, power, etc.

**mica condenser:** A condenser generally fixed or semi-adjustable using mica as a dielectric.

**micro:** A prefix used to denote one millionth.

**microampere:** One millionth of an ampere.

**microhenry:** One millionth of a henry.

**micro-microfarad (Mmf):** One millionth of a millionth of a farad.

**microphone:** A device designed to change audible sound energy to electrical impulses.

**microphonic:** An audible sound issuing from an amplifier due to the independent vibration of various elements in one or more tubes or parts in the amplifier.

**milli:** A prefix denoting one thousandth.

**milliammeter:** A meter calibrated in thousandths of an ampere.

**milliampere:** One thousandth of an ampere.

**millihenry:** One thousandth of a henry.

**millivolt:** One thousandth of a volt.

**mixer:** A control or circuit which allows the combination of the output of two audio devices such as microphones in the desired proportion.

**modulated amplifier:** The stage in a radio transmitter in which the audio or video signal is impressed on the carrier wave.

**modulated wave:** A continuous wave which has been conditioned by the application of a modulating signal.

**modulation:** The process of varying the frequency, phase or amplitude of a continuous wave by the application of a modulating signal.

**modulator stage:** The final audio frequency amplifier stage in a radio transmitter. The output of this stage produces the amplified modulating signal.

**molecule:** The smallest particle of a substance which retains all of the characteristics of the substance.

**motor:** A machine or device which converts electrical energy to mechanical energy.

**motorboating:** Low frequency oscillation of an audio amplifier.

**motor-generator:** A combination of electrical motor and generator using a common armature shaft.

**Mu:** Greek letter used to denote the amplification factor of a vacuum tube.

**multiplier:** A precision resistor used in series with a voltmeter to extend its voltage range.

## N

**negative:** A terminal or point in a circuit having an excess of electrons.

**negative bias:** A negative potential applied to the control element of a vacuum tube with respect to the cathode.

**negative feedback:** Inverse feedback.

**neon:** An inert gas used in ionization tubes.

**neutralizing circuit:** A circuit designed to prevent amplifier tubes from going into self-oscillation.

**nichrome:** An alloy of nickel, chromium, and iron which possesses high resistivity.

**noise:** Any combination of sound impulses which is not regular in frequency.

**noise limiter:** A circuit designed to prevent noise impulses from reaching abnormally high values.

**non-conductor:** An insulator.

**non-magnetic:** Any material which does not aid the production of magnetic lines of force.

## O

**ohm:** The unit of electrical resistance. It is defined as the "opposition offered to an unvarying electric current by a column of mercury at the temperature of melting ice (0° C), 14.4521 grams in mass, of a constant cross-sectional area and having a length of 106.3 cm."

**ohmmeter:** A combination of electrical parts including an indicating meter which has been calibrated to read directly in ohms, the value of a resistor placed between two terminals.

**Ohm's Law:** A fundamental electrical law expressing the relation between volts, ohms and amperes in an electrical circuit. It is stated as "The intensity of current flow, in a constant current circuit, measured in amperes, is directly proportional to the pressure in volts and inversely proportional to the resistance in ohms."

$$I = \frac{E}{R}$$

where  $I$  = current intensity in amperes

$E$  = pressure in volts

$R$  = resistance in ohms.



**ohms-per-volt:** A method of expressing the current sensitivity of a voltmeter. It refers to the number of ohms of external resistance which must be added in series with the meter to extend the reading one volt.

**oscillation:** A vibratory motion. In electrical circuits, a condition whereby electrical energy is alternately transferred from an inductance to a capacitance. Also the condition in a circuit whereby high frequency oscillations are produced.

**oscillator:** A device designed to produce electrical oscillations from a direct-current source. The frequency of oscillation is controlled by the components in the circuit.

**oscillograph:** An instrument which produces a permanent visual tracing of a wave shape or form.

**oscilloscope:** A device which produces a visual trace on a screen of a wave shape or form.

**output:** The energy measured as a voltage, amperage, wattage, or mechanical movement, delivered by a device.

**output meter:** An electrical meter which indicates the output of an electrical device. It may be calibrated in volts, amperes, watts, or decibels.

**output transformer:** A transformer used to couple the final amplifier stage in a system to the output device.

**output tube:** The final tube in an amplifier system which generally converts a large input signal voltage to a large power output.

## P

**P:** Symbol used to denote electrical power in watts. Used alternately with W.

**parallel:** A type of electrical connection wherein current directed to a given point in a circuit may return to the source through two or more paths.

**peak:** The highest value of voltage, current or power reached during a given cyclic sequence.

**pentode:** A five-element vacuum tube.

**permanent magnet:** A piece of hardened steel or special alloy which retains its magnetic effect after the magnetizing force has been removed.

**permanent magnet dynamic speaker:** A dynamic or moving coil speaker in which the steady magnetic field is produced by a permanent magnet.

**permeability:** The ease or readiness with which a material will conduct magnetic lines of force.

**permeability tuning:** A type of electrical circuit tuning in which the inductance of a coil is varied by the insertion of a magnetic core.

**phase:** Referring to a position on a wave or the sense of a moving point.

**phone:** A headphone.

**phono pickup:** A device which converts the record indentations into electrical or mechanical audio impulses.

**phonograph:** A combination of devices which converts mechanical vibrations into sound impulses. A vacuum tube amplifier and loud speaker are generally included in the conversion.

**photoelectric cell:** A device for converting variations in light to electrical impulses.

**piezo electric effect:** The production of an e.m.f. through the mechanical deformation of certain crystals. Conversely, an applied e.m.f. causes a mechanical deformation.

**pilot lamp:** A small electric bulb which is used to indicate or illuminate the controls of electrical devices.

**plate:** The anode in an electronic tube. The place to which electrons are projected or drawn.

**plate circuit:** The complete circuit in which plate energy is dissipated including the external load, power supply device, and internal element connections.

**plate current:** The direct current flowing in the plate circuit.

**plate supply:** The device supplying potential to the plate circuit. It may be a battery, rectifier device, or generator.

**plug:** A terminal connection device used for insertion in a jack.

**plug-in coil:** A coil wound on a form with prong connections for insertion in a socket receptacle.

**polarity:** Having a definite sign such as positive or negative or, as in magnetism, a north or south pole.

**pole:** An electrode in a cell or one end of a magnet.

**positive:** In an electrical circuit the terminal of a device which lacks electrons.

**positive feedback:** Feedback which is in phase with the original signal voltage.

**potential:** The voltage or electrical pressure existing between one point in a circuit and another point.

**potentiometer:** A variable resistor used as a voltage divider. The two outside fixed terminals are connected to the source of voltage and the center movable arm contacts any intermediate voltage point.

**power:** The rate of doing work. In direct current electrical circuits the power expended is the product of the voltage and current.

**power factor:** The ratio of true power to apparent power in a reactive circuit.

**power pack:** A combination of devices used to deliver operating potentials to a vacuum tube circuit.

**power transformer:** The transformer in an A.C. operated electronic device which supplies operating voltages to the various circuits. The transformer obtains its operating power from the A.C. line.

**primary:** In a transformer, the circuit to which electrical energy is led.

**primary cell:** A chemical cell whose chemical action is non-reversible.

**proton:** The positively charged portion of an atom.

**pulsating:** Changing in magnitude but not in direction.

**pulsating current:** A direct current whose amplitude is not constant.

**push pull:** A connection of vacuum tube devices in which the signal input divides between two tubes, recombining in the output with increased amplitude.

**push-pull transformer:** A transformer used to couple push-pull circuits.

## Q

**Q:** The symbol used to denote electrical quantity in coulombs.

**Q factor:** A rating used to express the ability of a tuned circuit to increase the value of voltage induced in it, through a resonant rise.

**Q meter:** An electronic test instrument used to determine the "Q" of radio components.

**Q signals:** An International List of Abbreviations for expediting radio communication.

**quartz crystal:** A crystal exhibiting piezo electric effects.

## R

**R:** The symbol for resistance.

**radiation:** In radio, the process of sending out a radio wave by exciting the medium through which transmission is thought to take place.

**radio compass:** A device to determine the direction of transmission or reception of a radio wave.

**radio frequency:** A frequency sufficiently high to be usable for radio transmission purposes.

**radio frequency amplifier:** An amplifier which is used to increase the strength of radio frequencies.

**radio frequency choke:** An inductor which presents high impedance to a radio frequency impulse while allowing the passage of low frequencies and direct current.

**radio frequency transformer:** A coupling device, generally with an air core, used to inductively couple two radio frequency circuits.

**radio receiver:** A combination of vacuum tubes and associated components used to increase the strength of a received radio signal and to reproduce audibly the modulating component.

**radio telegraphy:** A system of radio communication using a series of dots and dashes to form the various letters of the alphabet.

**radio wave:** The complex electromagnetic and electrostatic fields radiated from a radio transmitting antenna. The velocity of wave travel is the same as that of light—186,000 miles per second.

**reactance:** The opposition to the flow of a varying current due to the inclusion of an inductance or capacitance in the circuit.

**recorder:** A device which makes a record of electrical impulses. In its most common form, an electrical system with a microphone input, the output of an amplifier driving a recording needle or stylus over the surface of a disk, the resulting indentations representing the characteristics of the sound wave striking the microphone.

**rectifier:** A device which allows the passage of an electrical current in one direction only.

**regeneration:** The reinforcement of a radio signal by returning a portion of its amplified output to the input.

**regenerative detector:** A vacuum tube detector combined with regenerative feedback.

**relay:** An electromagnetic device used to control the action of circuits by the application of an electrical impulse. Relays are used for control of circuits at a distance, for protective purposes and to actuate heavy-duty circuits by the use of relatively low power.

**remote control:** The control of devices at a distance through the use of relays.

**resistance:** The opposition offered to the flow of an electric current resulting in the production of heat.

**resistance coupling:** A method of coupling two vacuum tube circuits in which resistors are used as the input and output impedances. A coupling condenser is generally necessary between the resistors.

**resistivity:** Specific resistance.

**resistor:** A device used in electrical circuits to produce a voltage drop and to reduce current flow.

**resonance:** A condition in an electrical circuit containing inductance and capacity where the actuating frequency encounters only

ohmic resistance, the reactances cancelling.

**resonant frequency:** The frequency to which a tuned circuit is resonant.

**resting frequency:** In a frequency modulation transmitter, the frequency to which the carrier returns during non-modulation intervals.

**R.F.:** Radio frequency.

**rheostat:** A variable resistor.

**R.M.S.:** Root mean square. The effective value of alternating-current units.

**rotary switch:** A switch in which contact is made to various terminals by rotating a central control.

## S

**schematic diagram:** A circuit diagram showing the interconnection of the various components using conventional symbols to represent the parts.

**screen:** In a cathode ray tube it is the surface on which the visual trace appears.

**screen grid:** An element in a vacuum tube used to shield one element from another.

**secondary:** In a transformer the winding in which a voltage is induced.

**secondary cell:** A chemical cell whose chemical action is reversible.

**secondary emission:** Emission of electrons from a surface under bombardment of high velocity electrons.

**selectivity:** The ability of a circuit to differentiate between desired and undesired frequencies.

**self-bias:** A bias produced by the flow of grid current through a resistor. Most commonly found in transmitting circuits.

**sensitivity:** The ability of a circuit to produce a given output signal with a minimum input voltage. In a radio receiver, the ability to amplify weak signals to usable volume.

**series circuit:** An electrical circuit in which the various devices are connected in tandem. The same cur-

rent flows through all parts of the circuit.

**S.G.:** Screen grid.

**shield:** A metallic housing for a device to prevent external electromagnetic or electrostatic fields from affecting the operation of the device or to prevent its fields from affecting other nearby circuits.

**shielded cable:** A wire or cable covered with a braided copper mesh.

**short circuit:** Electrical energy returning to its source without accomplishing the useful work it was intended to do.

**short waves:** Electromagnetic waves in the high frequency portion of the spectrum, generally frequencies above 1600 kilocycles.

**shunt:** In an ammeter, a low resistance placed across the meter movement to carry a proportional part of the total current flow.

**side-band:** A frequency produced by the amplitude modulation of a radio frequency carrier.

**signal:** An intelligence carrying radio wave.

**signal generator:** An oscillator.

**sine wave:** The wave traced by the sine of an angle as the angle is rotated through 360°. Alternating-current values follow a sine wave with respect to time.

**single pole switch:** A knife or rotary switch having a single movable contact blade.

**skip distance:** The space between two successive reflections of a radio wave from the Kennelly-Heaviside ionized layer.

**socket:** A device into which radio tubes or various other components may be inserted to provide convenient replacement.

**solder:** An alloy of tin and lead with a low melting point used to permanently bond wires and parts.

**sound wave:** A vibration whose frequency is capable of exciting the sensation of hearing.

**source:** A device supplying electrical energy.

**space charge:** The accumulative effect of a group of electrons in transit between cathode and anode.

**static:** Atmospheric electricity.

**stator:** Stationary part.

**storage cell:** A secondary cell.

**superheterodyne:** A type of receiving circuit in which the incoming signal is changed to a different frequency for amplification.

**switch:** A device for conveniently making and breaking an electrical circuit.

**symbol:** A design or character used to denote a given component.

**synchronous:** Two or more operations occurring simultaneously.

## T

**tank circuit:** The tuned circuit, usually in the plate circuit of a transmitter stage, in which oscillations are produced.

**television:** The transmission and reception of objects in motion by means of radio waves.

**terminal:** A point to which electrical connections may be made.

**test lead:** A flexible lead usually used in conjunction with test equipment to investigate circuit constants.

**tetrode:** A four-element vacuum tube.

**toggle switch:** A small switch operated by means of a lever.

**transformer:** A device in which a varying current introduced in the first or primary circuit produces, by electromagnetic induction, a voltage in the second or secondary circuit.

**transmission line:** A system of conductors used to carry signal impulses from one place to another.

**transmitter:** In general, the complete system of components from microphone to transmitting antenna.

**T.R.F. receiver:** A receiver in which the signal frequency is led through several amplifying stages each of which is tuned to resonance with the incoming signal.

**trimmer condenser:** A small semi-variable condenser used to adjust the minimum capacitance of a variable tuning condenser.

**triode:** A three-electrode vacuum tube.

**tube:** A vacuum tube.

**tuned circuit:** A circuit in which one or more components are adjustable to produce resonance to a desired frequency.

**tuning:** The process of resonating a circuit to a given frequency by adjusting one or more variable components.

**turn:** A complete loop of wire.

## U

**ultra-high frequency:** The following table gives the accepted frequency bands and designations.

Frequency in Kilocycles	Designa- tion	Abbrevia- tion
10 to 30 inc.	Very low	VLF
30 to 300 "	Low	LF
300 to 3000 "	Medium	MF
3000 to 30000 "	High	HF
30000 to 300000 "	Very high	VHF
300000 to 3000000 "	Ultra high	UHF
3000000 to 30000000 "	Super high	SHF

**unmodulated carrier:** A carrier wave in which the amplitude of successive oscillations is constant.

## V

**V:** Voltage. Volts.

**vacuum tube:** An electronic device consisting of two or more electrodes mounted within an evacuated tube or bulb. The device makes use of electron emission in its operation.

**vacuum tube voltmeter:** A test instrument utilizing one or more vacuum tubes. It is capable of measuring potential differences in circuits without imposing an additional load on the source.

**variable condenser:** A condenser in which the capacity may be conveniently varied by the movement of one set of plates.

**variable resistor:** A rheostat.

**vernier condenser:** A small variable condenser with a reduced capacity change for a given mechanical movement of the rotor plates.

**vertical antenna:** A vertical rod or mast used to radiate or receive radio waves.

**vibrator:** A mechanical interruptor.

**video:** In television, pertaining to the picture or picture channel.

**voice coil:** The actuating coil in a loud speaker. It is rigidly attached to the cone so that a movement of the voice coil results in a resulting movement of the cone.

**volt:** The unit of electrical pressure. A pressure of one volt will force one ampere of current through one ohm of resistance.

**voltage amplifier:** An amplifier using one or more vacuum tubes, the purpose of which is to increase a given input signal voltage.

**voltage divider:** A single resistor or network of resistors used to provide intermediate voltage values from a given voltage source.

**voltage drop:** The potential developed across a component by the passage of current through it.

**voltmeter:** A meter designed to measure electrical pressure.

**volume:** The intensity of sound issuing from a sound source.

**volume unit:** The power level of a system with respect to a reference level of one milliwatt.

## W

**W:** Symbol for electrical power in watts.

**watt:** The unit of electrical power. The power in watts is obtained by the product of the current in amperes and the pressure in volts.

**wattage rating:** The amount of power a given device is capable of dissipating.

**wattmeter:** An instrument used to measure electrical power.

**wave:** A disturbance in a medium by which energy may be transmitted.

**wave trap:** A resonant circuit designed to dissipate the energy of one particular frequency while passing all others.

**wavelength:** The physical distance between two points on a wave which are identical in sense and amplitude.

**Wheatstone bridge:** A type of circuit in which the value of an unknown component is obtained by balancing one circuit against another.

**X**

**X:** Symbol for reactance.

**X<sub>c</sub>:** Capacitive reactance.

**X<sub>L</sub>:** Inductive reactance.

**X-cut crystal:** Referring to a quartz crystal oscillator plate cut from the mother crystal in such a manner that the X-axis is perpendicular to its faces.

**X-rays:** The rays produced by a stream of electrons projected at high velocity against a target. The frequency is considerably higher than those used in radio communication.

**Y**

**Y:** Symbol used to denote admittance in ohms.

**Y-cut crystal:** A quartz crystal oscillator plate cut in such a manner that the Y-axis is perpendicular to its faces.

**Z**

**Z:** The symbol for electrical impedance measured in ohms.

**zero beat:** A condition wherein two frequencies being mixed have exactly the same numerical value.

TABLE I. RANGE OF PITCHES ACCORDING TO THE MAJOR DIATONIC SCALE

Instrument	Low	High	Type of Instrument
Banjo	288	768	String
Bassoon	60	480	Wind
Bass Tuba	42.67	341.33	Wind
Bass Viol	40	240	String
Cello	64	682.67	String
Clarinet	160	1536	Wind
Flute	256	2304	Wind
French Horn	106.67	853.33	Wind
Guitar	80	640	String
Kettle Drums	85.33	170.67	Percussion
Mandolin	288	1536	String
Mandolin Cello	64	256	String
Piccolo	512	4068	Wind
Trombone	80	480	Wind
Trumpet	160	960	Wind
Violin	288	3072	String

TABLE II. COMPARISON OF FREQUENCIES FOR A SINGLE OCTAVE

Note	Major Diatonic Scale	Tempered Scale	
		C = 256	A = 435
C	256	256	258.3
D	288	278.3	290.3
E	320	322.5	325.9
F	341.3	341.7	345.3
G	384	383.6	387.4
A	426.7	430.6	435
B	480	483.2	488.3
C	512	512	517.2

TABLE III. STANDARD COLOR CODE

Color	Significant Figure	Zeros
Black	0	None
Brown	1	0
Red	2	00
Orange	3	000
Yellow	4	0 000
Green	5	00 000
Blue	6	000 000
Violet	7	0 000 000
Gray	8	00 000 000
White	9	000 000 000

TABLE IV. *International Morse Code, with Extracts from Punctuation and Other Signs Contained in the Telegraph Regulations of the Cairo Conferences, 1938*

Letters			
a . —	g — — — .	n — .	u .. —
b — . . .	h . . . .	o — — — —	v . . . —
c — . . — .	i ..	p . — — — .	w . — — —
d — . .	j . — — — —	q — — — . —	x — . . —
e .	k — . —	r . — .	y — . — — —
f .. — .	l . — . .	s . . .	z — — — . .
	m — — —	t —	

Figures		
1 . — — — — —	4 . . . . —	8 — — — — . .
2 .. — — — —	5 . . . . .	9 — — — — — .
3 . . . — — —	6 — . . . .	0 — — — — — —
	7 — — — . . .	

#### Punctuation and Other Signs

Period .....	.	. — . — . — —
Comma .....	,	— . — . — — — —
Colon .....	:	— — — — . . . .
Question mark, or request for repetition of a transmission not understood.....	?	.. — — — . .
Apostrophe .....	'	. — — — — — . .
Dash or hyphen.....	—	— . . . . —
Fraction bar.....	/	— . . . . .
Parenthesis (before and after words).....	( )	— . — — — — —
Underscore (before and after words or part of sentence) . .	_	. . — — — — —
Equal sign .....	=	— . . . . —
Understood .....		. . . — .
Error .....		. . . . .
Cross or end-of-telegram or end-of-transmission signal.....		. — . — . —
Invitation to transmit.....		— . —
Wait .....		. — . . . .
End of work.....		. . . — . —
Starting signal (beginning every transmission).....		— . — . — . —
Separation signal for transmission of fractional numbers (between the ordinary fraction and the whole number to be transmitted) and for groups consisting of figures and letters (between the figure groups and the letter groups) .....		. — . . . —

The following optional letters and signals may be used exceptionally on connections between countries allowing them:

ä . — . —	ñ — — . — — —
á or â . — — . —	ö — — — — .
ch — — — — —	ü .. — — —
ć .. — . .	



COPPER MAGNET WIRE DATA

B. & S. Gage No.	TURNS PER LINEAR INCH			TURNS PER SQUARE INCH			FEET PER POUND		Capacity at 1500 Cm. per Amp.	Current Required to Fuse	B. & S. Gage No.
	Enamel	D.S.C. or S.C.C.	D.C.C.	Enamel	D.S.C. or S.C.C.	D.C.C.	Bare	D.C.C.			
10	9.6	9.3	8.9	90	85	80	32	31	6.9	330	10
11	10.7	10.3	9.8	113	110	97	40	39	5.5	285	11
12	12.0	11.5	10.9	140	136	120	50	49	4.4	235	12
13	13.5	12.0	11.8	175	170	150	64	61	3.5	200	13
14	15.0	13.5	13.1	220	210	183	80	77	2.7	165	14
15	16.8	15.	14.6	275	262	222	101	97	2.2	140	15
16	19.	17.	16.4	350	320	270	128	119	1.7	120	16
17	21.2	19.	18.1	435	400	330	162	150	1.3	100	17
18	23.6	21.	20.0	550	490	400	203	188	1.1	85	18
19	26.4	24.	21.8	680	590	480	256	237	.86	70	19
20	29.4	26.	23.9	850	775	625	323	300	.68	58	20
21	33.1	29.	26.2	1060	940	750	408	370	.54	50	21
22	37.0	31.	28.5	1340	1150	910	514	460	.43	42	22
23	41.3	34.	31.1	1660	1400	1080	648	585	.34	34	23
24	46.3	38.	33.6	2100	1700	1260	817	745	.27	30	24
25	51.7	41.	36.2	2630	2060	1510	1030	900	.21	25	25
26	58.0	45.	39.9	3320	2500	1750	1300	1180	.17	20	26
27	65.0	50.	42.6	4140	3030	2020	1640	1420	.13	17	27
28	72.7	54.	45.5	5250	3670	2310	2060	1750	.11	15	28
29	81.7	58.	48.	6500	4300	2700	2600	2200	.08	12	29
30	90.5	65.	51.1	8100	5040	3000	3275	2530	.07	10	30

D.S.C. = Double Silk Covering.

S.C.C. = Single Cotton Covering.

D.C.C. = Double Cotton Covering.

## COPPER WIRE TABLE

Gauge No. *	Diameter in Mils	Cross Section Area		Ohms per 1000 Feet 25° C (= 77° F)	Pounds per 1000 Feet
		Circular Mils	Square Inches		
0000	460.	212000.	0.166	0.0500	641.
000	410	168000.	.132	.0630	608.
00	365.	133000.	.105	.0795	403.
0	325.	106000.	.0829	.100	319.
1	289.	83700.	.0657	.126	253.
2	258.	66400.	.0521	.159	201.
3	229.	52600.	.0413	.201	159.
4	204.	41700.	.0328	.253	126.
5	182.	33100.	.0260	.319	100.
6	162.	26300.	.0206	.403	79.5
7	144.	20800.	.0164	.508	63.0
8	128.	16500.	.0130	.641	50.0
9	114.	13100.	.0103	.808	39.6
10	102.	10400.	.00815	1.02	31.4
11	91.	8230.	.00647	1.28	24.9
12	81.	6530.	.00513	1.62	19.8
13	72.	5180.	.00407	2.04	15.7
14	64.	4110.	.00323	2.58	12.4
15	57.	3260.	.00256	3.25	9.86
16	51.	2580.	.00203	4.09	7.82
17	45.	2050.	.00161	5.16	6.20
18	40.	1620.	.00128	6.51	4.92
19	36.	1290.	.00101	8.21	3.90
20	32.	1020.	.000802	10.04	3.09
21	28.5	810.	.000636	13.1	2.45
22	25.3	642.	.000505	16.5	1.94
23	22.6	509.	.000400	20.8	1.54
24	20.1	404.	.000317	26.2	1.22
25	17.9	320.	.000252	33.0	0.970
26	15.9	254.	.000200	41.6	.789
27	14.2	202.	.000158	52.5	.610
28	12.6	160.	.000126	66.2	.484
29	11.3	127.	.0000995	83.4	.384
30	10.0	101.	.0000789	105.	.304
31	8.9	79.7	.0000626	133.	.241
32	8.0	63.2	.0000496	167.	.191
33	7.1	50.1	.0000394	211.	.152
34	6.3	39.8	.0000312	266.	.120
35	5.6	31.5	.0000248	335.	.0954
36	5.0	25.0	.0000196	423.	.0757
37	4.5	19.8	.0000156	533.	.0600
38	4.0	15.7	.0000123	673.	.0476
39	3.5	12.5	.0000098	848.	.0377
40	3.1	9.9	.0000078	1070.	.0299

\*The gauge number refers to American Wire Gauge, often called Brown & Sharpe Gauge, that is used for copper wire. A mil is  $\frac{1}{1000}$  of an inch.

## HANDY TABLES

In the following tables the values of different units are given so that you may be able to express the value of one unit in an equivalent term of another unit. As 1 foot = 12 inches = 0.333 yards, etc. In order to change the values from one set of units to another, all that is required is to multiply by the equivalent or equal value given in these tables. For example: It is desired to change 4 meters to feet, or to find how many feet there are in 4 meters. From the table, 1 meter = 3.28 feet. Then 4 meters =  $4 \times 3.28 = 13.12$  feet.

### Length

- 1 mil = .0254 millimeters = .001 inches
- 1 millimeter = 39.37 mils = .03937 inches
- 1 centimeter = .3937 inches = .0328 feet
- 1 inch = 25.4 millimeters = .083 feet = .0278 yards = 2.54 centimeters
- 1 foot = 304.8 millimeters = 12 inches = .333 yards = .305 meters
- 1 yard = 91.44 centimeters = 36 inches = 3 feet = .914 meters
- 1 meter = 39.37 inches = 3.28 feet = 1.094 yards
- 1 kilometer = 3281 feet = 1094 yards = .6213 miles
- 1 mile = 5280 feet = 1760 yards = 1609 meters = 1.609 kilometers

### Area

- 1 circular mil = .7854 square mils = .0005067 square millimeters  
= .000007854 square inches
- 1 square mil = 1.273 circular mils = .000645 square millimeters  
= .000001 square inches
- 1 square millimeter = 1973 circular mils = 1550 square mils  
= .00155 square inches
- 1 square centimeter = 197300 circular mils = .155 square inches  
= .00108 square feet
- 1 square inch = 1273240 circular mils = 6.451 square centimeters  
= .0069 square feet
- 1 square foot = 929.03 square centimeters = 144 square inches  
= 0.1111 square yards = .0929 square meters
- 1 square yard = 1296 square inches = 9 square feet = .000207 acres
- 1 square meter = 1550 square inches = 10.7 square feet  
= 1.195 square yards = .000247 acres
- 1 acre = 43560 square feet = 4840 square yards = 4047 square meters  
= .004047 square kilometers = .001562 square miles
- 1 square kilometer = 10,760,000 square feet = 1,196,000 square yards  
= 247 acres = .3861 square miles
- 1 square mile = 27,880,000 square feet = 3,098,000 square yards  
= 2,590,000 square meters = 640 acres = 2.59 square kilometers

## Volume

- 1 circular mil-foot** = .000,009,424 cubic inches.
- 1 cubic centimeter** = .061 cubic inches = .0021 pint (liquid)  
= .0018 pint (dry)
- 1 cubic inch** = 16.39 cubic centimeters = .0346 pint (liquid)  
= .0298 pint (dry) = .0043 gallons = .0005787 cubic feet
- 1 pint (liquid)** = 473.17 cubic centimeters = 28.87 cubic inches
- 1 pint (dry)** = 550.6 cubic centimeters = 33.60 cubic inches
- 1 quart (liquid)** = 946.36 cubic centimeters = 57.75 cubic inches  
= 2 pints (liquid) = .25 gallons
- 1 liter** = 1000 cubic centimeters = 61.023 cubic inches  
= 2.1133 pints (liquid) = 1.8162 pints (dry) = .098 quarts (dry)  
= .2642 gallon (liquid) = 0.03531 cubic feet
- 1 quart (dry)** = 1101 cubic centimeters = 67.20 cubic inches  
= .03889 cubic feet
- 1 gallon** = 3785 cubic centimeters = 231 cubic inches = 8 pints  
= 4 quarts = .1337 cubic feet = .004951 cubic yards
- 1 cubic foot** = 28317 cubic centimeters = 1728 cubic inches  
= 28.32 liters = 7.48 gallons = .02832 cubic meters
- 1 cubic yard** = 46656 cubic inches = 27 cubic feet = .7646 cubic meters
- 1 cubic meter** = 61023 cubic inches = 1000 liters = 35.31 cubic feet  
= 1.308 cubic yards

## Weight

- 1 milligram** = .01543 grains = .001 grams
- 1 grain** = 64.80 milligrams = .002286 ounces\* (avoirdupois)
- 1 gram** = 15.43 grains = .03527 ounces = .002205 pound\*
- 1 ounce** = 437.5 grains = 28.35 grams = .0625 pound = 16 drams
- 1 pound** = 7000 grains = 453.6 grams = 256 drams = 16 ounces  
= 0.4536 kilograms
- 1 ton** = 2000 pounds = 907.2 kilograms = 0.9072 metric tons  
= .8928 long tons
- 1 metric ton** = 2205 pounds = 1000 kilograms = 1.102 short tons  
= .9842 long tons
- 1 long ton** = 2240 pounds = 1.12 short tons = 1.016 metric tons

\*The pound and ounces are avoirdupois weight.

## Energy and Torque

- 1 watt-second** = 1 joule = .7376 foot-pound  
= .0009480 British thermal units = .0002778 watt hours
- 1 foot-pound** = 1.356 watt-seconds = .001285 British thermal units  
= .0003766 watt-hours = .000000505 horsepower-hours
- 1 British thermal unit** = 1055 watt-seconds = 778.1 foot-pounds  
= .293 watt-hours = .000393 horsepower-hours
- 1 watt-hour** = 3600 watt-seconds = 2655.4 foot-pounds  
= 3.413 British thermal units = .001341 horsepower-hours
- 1 horsepower-hour** = 2,685,600 watt-seconds = 1,980,000 foot-pounds  
= 273,700 kilogram-centimeters = 746 watt-hours

## Power

- 1 foot-pound per minute** = .02260 watts = .0000303 horsepower
- 1 watt** = 44.26 foot-pounds per minute = .001 kilowatts
- 1 horsepower** = 33,000 foot-pounds per minute = 746 watts  
= 550 foot-pounds per second
- 1 kilowatt** = 44256.7 foot-pounds per minute = 1.341 horsepower

## Circles

- Circumference of a circle** = diameter  $\times$  3.1416
- Circumference of a circle** = radius  $\times$  6.2832
- Area of a circle** = diameter squared  $\times$  .7854
- Area of a circle** = circumference squared  $\times$  .07958
- Area of a circle** = half the circumference  $\times$  half its diameter
- Radius of a circle** = circumference  $\times$  .159
- Diameter of a circle** = circumference  $\times$  .3183
- Diameter of a circle** = square root of the area  $\times$  1.128

## Sphere

- Volume of a sphere** = surface of a sphere  $\times$   $\frac{1}{6}$  its diameter
- Volume of a sphere** = the cube of the diameter  $\times$  .5236
- Volume of a sphere** = the cube of the radius  $\times$  4.188
- Volume of a sphere** = the cube of the circumference of the sphere  
 $\times$  .0168
- Area of the surface of a sphere** = the circumference  $\times$  its diameter
- Area of the surface of a sphere** = diameter squared  $\times$  3.1416

## ABBREVIATIONS AND LETTER SYMBOLS

A list of abbreviations useful to the radio student, although these abbreviations have not been standardized for radio work. Many of those given are in lower-case letters. Obviously, however, there will be occasions such as when the abbreviations are used in titles where the original word would have been capitalized. In these cases, the abbreviations should be similarly capitalized.

A—	..... A negative or A minus	M	..... mega (1,000,000)
A+	..... A positive or A plus	M	..... mutual inductance
a.c. or a c.	..... alternating current	m	..... meter
amp or a	..... ampere	m	..... milli, $\frac{1}{1000}$
AM	..... amplitude modulation	$\mu$	..... micro, $\frac{1}{1,000,000}$
a.f.	..... audio frequency	$\mu\mu$	..... micromicro, $\frac{1}{1,000,000,000,000}$
ant.	..... antenna	ma	..... milliamperere
a.v.c.	..... automatic volume control	$\mu a$	( $\mu$ Greek letter <i>mu</i> , lower case)
a.v.e.	..... automatic volume expansion		..... microampere
B—	..... B negative or B minus	Mc	..... megacycle
B+	..... B positive or B plus	m.c.w.	..... modulated continuous wave
b.f.	..... beat frequency	$\mu f$ , mfd	..... microfarad
b.f.o.	..... beat-frequency oscillator	mh	..... millihenry
C	..... capacitance	$\mu h$	..... microhenry
C—	..... C negative or C minus	$\mu\mu f$ , mmfd	..... micromicrofarad
C+	..... C positive or C plus	$M\Omega$	..... megohm
c.e.m.f. or CE <sub>m</sub> f	..... counter electromotive force	Mu	..... amplification factor of tube
cm.	..... centimeter	$\mu v$	..... microvolt
c.p.s.	..... cycle per second	mv	..... millivolt
c.r.	..... cathode ray	$\mu v/m$	..... microvolt per meter
c. w.	..... continuous waves	mv/m	..... millivolt per meter
db	..... decibel	$\mu w$	..... microwatt
d.c. or d c	..... direct current	mw	..... milliwatt
d.c.c.	..... double cotton covered	$\Omega$	..... ohm
d.p.d.t.	..... double pole, double throw	$\omega$	( $\omega$ Greek <i>omega</i> lower case) .....
d.s.c.	..... double silk covered		..... angular velocity ( $2\pi f$ )
E	..... electric field intensity	P	..... power
E, e	..... voltage	p.f.	..... power factor
E <sub>amp</sub>	..... voltage gain in tube	$\pi$	( $\pi$ Greek letter <i>pi</i> , lower case) 3.1416
e.m.f.	..... electromotive force	R	..... resistance
f	..... frequency	r.f.	..... radio frequency
F.C.C.	..... Federal Communications Commission	r.m.s.	..... root mean square
fd	..... farad	r.p.m.	..... revolutions per minute
FM	..... frequency modulation	s.c.c.	..... single cotton covered
G	..... conductance	s.c.e.	..... single cotton enamel
G <sub>m</sub>	..... mutual conductance in tubes	s.p.d.t.	..... single pole, double throw
gnd.	..... ground	s.p.s.t.	..... single pole, single throw
H	..... magnetic field intensity	s.s.c.	..... single silk covered
h	..... henry	s.w.	..... short wave
h.f.	..... high frequency	t.r.f.	..... tuned radio frequency
I, i	..... current	u.h.f.	..... ultra high frequency
i.c.w.	..... interrupted continuous waves	v	..... volt
i.f.	..... intermediate frequency	v.o.m.	..... volt-ohm-milliammeter
k	..... kilo (1000)	v.t.v.m.	..... vacuum tube voltmeter
kc	..... kilocycle	w	..... watt
k $\Omega$	( $\Omega$ Greek letter <i>omega</i> cap.) kilohm	X	..... reactance
kv	..... kilovolt	X <sub>c</sub>	..... capacitive reactance
kva	..... kilovolt ampere	X <sub>L</sub>	..... inductive reactance
kw	..... kilowatt	Y	..... admittance
L	..... inductance	Z	..... impedance
L	..... self-inductance		
l.f.	..... low frequency		

# Electrical Formulas

## OHM'S LAW

Ohm's Law is a method of explaining the relation existing between voltage, current, and resistance in an electrical circuit. It is practically the basis of all electrical calculations. The term "electromotive force" is often used to designate pressure in volts. This formula can be expressed in various forms.

**To find the current in amperes:**

$$\text{Current} = \frac{\text{Voltage}}{\text{Resistance}} \quad \text{or} \quad \text{Amperes} = \frac{\text{Volts}}{\text{Ohms}} \quad \text{or} \quad I = \frac{E}{R}$$

The flow of current in amperes through any circuit is equal to the voltage or electromotive force divided by the resistance of that circuit.

**To find the pressure or voltage:**

$$\text{Voltage} = \text{Current} \times \text{Resistance} \quad \text{or} \quad \text{Volts} = \text{Amperes} \times \text{Ohms}$$
$$\text{or} \quad E = I \times R$$

The voltage required to force a current through a circuit is equal to the resistance of the circuit multiplied by the current.

**To find the resistance:**

$$\text{Resistance} = \frac{\text{Voltage}}{\text{Current}} \quad \text{or} \quad \text{Ohms} = \frac{\text{Volts}}{\text{Amperes}} \quad \text{or} \quad R = \frac{E}{I}$$

The resistance of a circuit is equal to the voltage divided by the current flowing through that circuit.

## POWER FORMULAS

One horsepower = 746 watts      One kilowatt = 1000 watts

### DIRECT-CURRENT CIRCUITS

Power in Watts = Volts  $\times$  Amperes

**To find current in amperes:**

$$\text{Current} = \frac{\text{Watts}}{\text{Voltage}} \quad \text{or} \quad \text{Amperes} = \frac{\text{Watts}}{\text{Volts}} \quad \text{or} \quad I = \frac{W}{E}$$

$$\text{Current (of a motor)} = \frac{\text{Horsepower} \times 746}{\text{Volts} \times \text{Efficiency}} \quad \text{or} \quad I = \frac{\text{hp.} \times 746}{E \times \text{Eff.}}$$

**To find the pressure or voltage:**

$$\text{Voltage} = \frac{\text{Watts}}{\text{Current}} \quad \text{or} \quad \text{Volts} = \frac{\text{Watts}}{\text{Amperes}} \quad \text{or} \quad E = \frac{W}{I}$$

## Comparison of Centigrade and Fahrenheit Thermometers

Water boils at..... { 100 degrees Centigrade (C. or Cent.)  
 { 212 degrees Fahrenheit (F. or Fahr.)

Water freezes at..... { 0 degrees Centigrade (C. or Cent.)  
 { 32 degrees Fahrenheit (F. or Fahr.)

## Decimal Equivalents

Cent.	Fahr.	Cent.	Fahr.	Cent.	Fahr.		
0	32.0						
1	33.8	33	96.8	71	159.8		
2	35.6	37	98.6	72	161.6		
3	37.4	38	100.4	73	163.4		
4	39.2	39	102.2	74	165.2		
5	41.0	40	104.0	75	167.0		
6	42.8	41	105.8	76	168.8		
7	44.6	42	107.6	77	170.6		
8	46.4	43	109.4	78	172.4		
9	48.2	44	111.2	79	174.2		
10	50.0	45	113.0	80	176.0		
11	51.8	46	114.8	81	177.8		
12	53.6	47	116.6	82	179.6		
13	55.4	48	118.4	83	181.4		
14	57.2	49	120.2	84	183.2		
15	59.0	50	122.0	85	185.0		
16	60.8	51	123.8	86	186.8		
17	62.6	52	125.6	87	188.6		
18	64.4	53	127.4	88	190.4		
19	66.2	54	129.2	89	192.2		
20	68.0	55	131.0	90	194.0		
21	69.8	56	132.8	91	195.8		
22	71.6	57	134.6	92	197.6		
23	73.4	58	136.4	93	199.4		
24	75.2	59	138.2	94	201.2		
25	77.0	60	140.0	95	203.0		
26	78.8	61	141.8	96	204.8		
27	80.6	62	143.6	97	206.6		
28	82.4	63	145.4	98	208.4		
29	84.2	64	147.2	99	210.2		
30	86.0	65	149.0	100	212.0		
31	87.8	66	150.8				
32	89.6	67	152.6				
33	91.4	68	154.4				
34	93.2	69	156.2				
35	95.0	70	158.0				

	$\frac{1}{32}$	$\frac{1}{64}$	.015625
			.03125
		$\frac{3}{64}$	.046875
			.0625
		$\frac{5}{64}$	.078125
			.09375
		$\frac{7}{64}$	.109375
			.125
		$\frac{9}{64}$	.140625
			.15625
		$\frac{11}{64}$	.171875
			.1875
		$\frac{13}{64}$	.203125
			.21875
		$\frac{15}{64}$	.234375
			.25
		$\frac{17}{64}$	.265625
			.28125
		$\frac{19}{64}$	.296875
			.3125
		$\frac{21}{64}$	.328125
			.34375
		$\frac{23}{64}$	.359375
			.375
		$\frac{25}{64}$	.390625
			.40625
		$\frac{27}{64}$	.421875
			.4375
		$\frac{29}{64}$	.453125
			.46875
		$\frac{31}{64}$	.484375
			.5
		$\frac{33}{64}$	.515625
			.53125
		$\frac{35}{64}$	.546875
			.5625
		$\frac{37}{64}$	.578125
			.59375
		$\frac{39}{64}$	.609375
			.625
		$\frac{41}{64}$	.640625
			.65625
		$\frac{43}{64}$	.671875
			.6875
		$\frac{45}{64}$	.703125
			.71875
		$\frac{47}{64}$	.734375
			.75
		$\frac{49}{64}$	.765625
			.78125
		$\frac{51}{64}$	.796875
			.8125
		$\frac{53}{64}$	.828125
			.84375
		$\frac{55}{64}$	.859375
			.875
		$\frac{57}{64}$	.890625
			.90625
		$\frac{59}{64}$	.921875
			.9375
		$\frac{61}{64}$	.953125
			.96875
		$\frac{63}{64}$	.984375
			1.





# INDEX

	Page		Page
<b>A</b>			
Abbreviations, radio . . . . .	325-341, 349	<b>Amplifier</b> circuit, intermediate-	
AC circuit, inductance in . . . . .	71	frequency . . . . .	270
Acoustics . . . . .	185-200	stage, push-pull, with tone con-	
<b>Action</b> of amplifier . . . . .	210	trol . . . . .	181
of radio waves in antenna . . . . .	286	unit of transmitter . . . . .	235
Advantages of frequency modula-		<b>Amplifiers</b> , action of . . . . .	210
tion . . . . .	312	audio . . . . .	161, 256
Aging of magnets . . . . .	78	audio frequency-modulation re-	
Air as basic dielectric . . . . .	115	ceiving circuit . . . . .	321
<b>Air-core</b> choke coil . . . . .	101	changing to different class . . . . .	172
solenoid . . . . .	98	Class A . . . . .	171, 173
solenoid, formula for . . . . .	96	Class A prime . . . . .	172
symbol . . . . .	6, 7	Class B . . . . .	171, 175
transformer . . . . .	72	Class BC . . . . .	172
Alignment of circuits of superhet-		Class C . . . . .	172
erodyne . . . . .	272-275	intermediate-frequency . . . . .	269, 320
<b>Alternating current</b> . . . . .	25, 63	kinds of . . . . .	161
diagram of four cycles . . . . .	63	nonlinear . . . . .	252
direct and . . . . .	61-74	power . . . . .	167, 271
<b>Alternating-current</b> ampere . . . . .	84	radio-frequency . . . . .	161, 320
instruments . . . . .	84-92	radio-frequency, types of . . . . .	248
Alternating-direct current filter . . . . .	134	resistance-coupled . . . . .	179
<b>Ammeter</b> . . . . .	77, 82	vacuum tube, and output . . . . .	210
symbol, thermo-couple . . . . .	8, 9	voltage . . . . .	161, 163
symbols . . . . .	8, 9	Amplifiers and amplification . . . . .	161-183
<b>Ampere</b> . . . . .	76, 84	<b>Amplitude</b> . . . . .	187, 192
defined . . . . .	27	modulation . . . . .	310
<b>Amplification</b> , amplifiers and . . . . .	161-183	modulation, diagram . . . . .	309
calculating . . . . .	166	modulation, transmission . . . . .	309
defined . . . . .	161	Amplitude-modulated broadcast	
push-pull . . . . .	181	transmitters . . . . .	227-236
radio frequency . . . . .	248	Amplitude-modulation receiver . . . . .	310
types of . . . . .	171	Angle, sine of an . . . . .	151
uses of . . . . .	182	Anode . . . . .	155
voltage . . . . .	163	<b>Antenna</b> . . . . .	3
Amplification factor . . . . .	148, 163	circuit diagram . . . . .	249
Amplifier, defined . . . . .	161	circuits, resistance control in . . . . .	258
		connections of superheterodyne	
		receiver . . . . .	268

- |  | Page     |   | Page          |
|--|----------|---|---------------|
| <b>Antenna—continued</b>                 |          | <b>Audio—continued</b>                  |               |
| efficiency .....                         | 287      | transformers .....                      | 163, 164      |
| feed systems .....                       | 240      | <b>Audio-amplifier</b> circuit .....    | 163           |
| symbol .....                             | 5, 6     | frequency-modulation receiving          |               |
| symbol, loop .....                       | 5, 6     | circuit .....                           | 321           |
| system, counterpoise diagram ..          | 285      | <b>Audio-frequency</b> choke coil sym-  |               |
| system diagram .....                     | 285      | bol .....                               | 6, 7          |
| system providing noise reduc-            |          | transformer symbol .....                | 6, 7          |
| tion, diagram .....                      | 293, 295 | volume controls .....                   | 261           |
| systems, transmitting .....              | 237-242  | Automatic volume control .....          | 262           |
| transmission lines .....                 | 293      |   |               |
| tuning circuit .....                     | 246      | <b>B</b>                                |               |
| Antenna and grid-bias control ..         | 259      | Baffles .....                           | 282           |
| Antenna-circuit control .....            | 257      | Balanced-armature speaker unit ..       | 280           |
| <b>Antennas</b> , double-doublet type .. | 289      | Bar magnets .....                       | 37            |
| doublet .....                            | 288      | Basic dielectric, air as .....          | 115           |
| doublet, diagram .....                   | 288      | Batteries, storage .....                | 24            |
| Hertzian type .....                      | 288      | Battery symbol .....                    | 5, 6          |
| indoor .....                             | 294      | <b>Bias</b> , grid .....                | 161, 162, 168 |
| length of doublet .....                  | 288      | grid, change in .....                   | 169           |
| L-type .....                             | 285      | Block diagrams 232, 243, 265, 317, 319  |               |
| Marconi type .....                       | 285, 288 | Box-type baffles .....                  | 283           |
| noise reduced by .....                   | 295      | <b>Broadcast</b> bands, noise reduction |               |
| noise-reducing .....                     | 294      | in .....                                | 295           |
| outdoor .....                            | 294      | bands and short-wave bands              |               |
| radio waves in .....                     | 286      | diagram .....                           | 295           |
| receiving .....                          | 285-298  | transmitters, amplitude-modula-         |               |
| short-wave .....                         | 295      | ted .....                               | 227-236       |
| transmitting, Hertz .....                | 239      | transmitters, carrier wave of ..        | 228           |
| T-type .....                             | 285, 298 |   |               |
| types of .....                           | 285      | <b>C</b>                                |               |
| Apparatus, power, for units of           |          | <b>Calculating</b> amplification .....  | 166           |
| radio transmitter .....                  | 236      | inductance, table of values for         |               |
| Application of Ohm's law .....           | 32, 81   | wattage .....                           | 52            |
| Arc transmitter .....                    | 220      | <b>Calculation</b> of capacity .....    | 117           |
| Area, units of measurement for ..        | 346      | of current flow in circuit .....        | 57            |
| Arm sweeper .....                        | 50       | in designing tuning circuits ..         | 246           |
| Armstrong circuit .....                  | 211      | of impedance .....                      | 69            |
| Arrangement of filament, grid and        |          | of inductances .....                    | 96            |
| plate in triode tube .....               | 148      | of iron-core inductance .....           | 103           |
| Atmospheric static .....                 | 289      | of length of doublet .....              | 288           |
| Atoms .....                              | 20, 143  | of power-output .....                   | 176           |
| Attraction and repulsion .....           | 39       | of reactance .....                      | 68            |
| Audibility, range of .....               | 200      | of resistance .....                     | 55            |
| <b>Audio</b> amplifiers .....            | 161, 256 | of resonant circuits .....              | 136-139       |
| transformer, tone control across         |          | of voltage drop .....                   | 59            |
| transformer, tone control across         |          | <b>Capacitance</b> .....                | 105           |
| secondary .....                          | 181      | condensers and .....                    | 105-121       |

	Page		Page
<b>Capacitance—continued</b>		Circuit, vacuum tube, diagram of	145
interelectrode	157	<b>Circuit diagram of ohmmeter</b> ...	88
<b>Capacitive feedback</b>	213	diagram of two-button carbon	
reactance	66, 131, 135	microphone	203
<b>Capacity</b>	105	<b>Circuits, alignment of</b> .....	272-275
calculating	117	antenna tuning	246
in a circuit	65	Armstrong	211
effect on phase relationship	66	audio-amplifier	163
indicated by color coding	109	coupled	126
intertube	157	coupled, resonance of	132
Capacity effect, diagram	158	coupling, methods of	127-131
<b>Carbon microphones, two-button</b>	202	current flow through	57
post	23	defined	26
resistors	49	effect of capacity in	65
Carbon-button microphone	201	effect of inductance in	65
<b>Carrier wave, broadcast transmit-</b>		filter	141
ters	228	frequency-modulation receiving	318
modulation of	228, 230	inductance in	98
<b>Cathode</b>	155	input and output	162
symbol	13, 14	oscillator and output	270
thimble	156	oscillatory	123
<b>Cathode-ray oscilloscope</b>	90	oscillatory, and resonance	123-142
tube	90	parallel-resonant	140
Cavity resonance	207	radio-frequency control	260
<b>Cell</b>	23	rejector	141
dry	23	resistance in	64
gravity	22	resonant, calculations of	136-139
symbol	5, 6	series-resonant	140
voltaic	21	superheterodyne	265
Centigrade and Fahrenheit ther-		tuning	244
mometers	351	<b>Class A amplifier</b> .....	171
<b>Changing amplifiers to different</b>		amplifier, use of	173
class	172	prime amplifiers	172
grid bias	169	Class B amplifier	171, 175
<b>Characteristic curve, grid-voltage</b>		Class BC amplifier	172
plate-current	168	Class C amplifier	172
signal on	168	Closed-circuit jack symbol	10, 12
of vacuum tube	150	Closed-core inductance	101
Charge, space	147	Code, Morse	343
Charges, electrostatic, positive and		Coding, color	109, 342
negative	18	Coefficient of coupling	127
Charging and discharging con-		Coil symbol, choke	6, 7
denser	123	<b>Coils, choke</b>	101-104, 134, 306
<b>Choke coils</b>	101-104, 134, 306	choke, radio-frequency	95, 165
air-core	101	connected in parallel	99
radio-frequency	95, 165	connected in series	99
symbol, audio-frequency	6, 7	high-frequency inductance	94
Circles, rules for measurement of	348	inductance	45, 93

	Page		Page
<b>Coils—continued</b>		<b>Conductance—continued</b>	
inductance, universal type.....	94	mutual .....	153
iron-core .....	101	Conduction .....	18
magnetic field around.....	47	Conductors .....	18, 26
moving .....	79	<b>Connections, antenna</b> .....	268
tickler .....	211	electrical .....	34
Collapsing magnetic fields.....	124	parallel .....	34
Collecting signal .....	244	series .....	34
Color coding .....	109, 342	series-parallel .....	35
Colpitts oscillator .....	212	<b>Constant, dielectric</b> .....	108, 115
Combinations of resistance, induc-		K .....	96, 97
tance capacity on phase re-		<b>Construction of crystal micro-</b>	
lationship .....	67	phone .....	205
Combined meter, scale of.....	89	of diode tube.....	144
Commission, Federal Communica-		of dynamometer .....	85
tions .....	309	full-wave diode rectifier tube..	302
Communication, radio .....	3	of grid and plate.....	147
Communications Commission, Fed-		half-wave diode rectifier tube..	300
eral .....	309	iron-core transformer .....	72
<b>Comparison of frequencies for an</b>		of moving-vane AC instrument	84
octave .....	342	of paper condenser .....	108
of telephone and telegraph		of pentode tube .....	159
transmitters .....	227	of tangent galvanometer ....	76
of thermometers .....	351	of triode tube .....	157
Compound, sealing .....	23	of triode tube .....	148
Compression of air.....	188	of variable condenser .....	119
<b>Condenser</b> .....	105	<b>Construction diagram, carbon re-</b>	
electrolytic, symbol .....	8, 11	sistor .....	49
fixed, symbol for.....	8, 9	dry cell .....	23
gang-tuning, symbol for.....	8, 11	gravity cell .....	22
grid leak and.....	253	oscilloscope .....	90
variable, symbol for.....	8, 11	of pentode tube.....	159
<b>Condenser action diagram</b> .....	113	tetrode tube .....	158
detector circuit, grid leak.....	253	voltaic cell .....	22
microphone .....	203	Continuous wave .....	220, 221
<b>Condensers connected in parallel</b>	120	<b>Control, antenna-circuit</b> .....	257
connected in series.....	120	current, grid .....	150
connected in series-parallel....	121	plate-circuit voltage .....	260
electrolytic .....	110	screen grid voltage.....	259
mica, color code for.....	109	tone .....	180
paper .....	108	volume, grid-bias .....	258
protection of .....	109	<b>Control circuits, radio-frequency</b> ..	260
semivariable .....	112	oscillator .....	314
in series with lamp, diagram...114		Controlling feedback .....	250
variable .....	112	<b>Controls, volume, audio-frequency</b>	261
variable, for tuning radio.....119		volume, manual .....	256
Condensers and capacitance.....105-121		<b>Conversion table, Centigrade and</b>	
<b>Conductance, defined</b> .....	26	Fahrenheit thermometers...351	

	Page		Page
<b>Conversion—continued</b>		<b>Current—continued</b>	
table, decimal equivalents.....	351	flow diagram .....	292
<b>Copper magnet wire data.....</b>	344	flow and dielectric insulators..	113
wire table .....	345	supply, direct .....	308
<b>Core, air, symbol for.....</b>	6, 7	Current-feed system .....	240
iron, calculation of inductance		Currents, eddy .....	102
for .....	103	<b>Curve, showing output voltage,</b>	
iron, coil with.....	101	diagram .....	322
iron, transformers with.....	72, 164	showing result of change in grid	
laminated .....	101	bias .....	169
<b>Coulomb .....</b>	75	of vacuum tube, graph.....	152
defined .....	27	Curves obtained with different	
<b>Counter-electromotive force ..</b>	65, 93	grid-bias voltages.....	176
experiment with .....	95	CW-ICW tube transmitter.....	224
Counterpoise antenna system dia-			
gram .....	286	<b>D</b>	
<b>Coupled circuits .....</b>	126	Damped waves, radiation of.....	220
resonance of .....	132	Damping .....	79, 85
<b>Coupling, coefficient of.....</b>	127	D'Arsonval type meter.....	77
direct .....	126	Decimal equivalents .....	351
direct capacitive .....	128	<b>Definitions .....</b>	26, 325
direct-inductive .....	127	of electrical terms .....	26, 325
indirect .....	126	of electrical units of measure..	27
indirect-capacitive .....	130	DeForest's improvement in triode	
indirect-inductive .....	129	tubes .....	146
inductive .....	212	Degenerative amplifier .....	210
loose .....	129	Designing tuning circuits, calcula-	
resistance .....	128	tions in .....	246
tight .....	129	Desired current flow, diagram....	292
Coupling circuits,		<b>Detection .....</b>	251
methods of .....	127-131	grid-bias .....	254
Creation of magnetic fields .....	124	types of .....	251
Crest of sound wave.....	189	<b>Detector amplifier .....</b>	270
Crystal, quartz, symbol for....	13, 14	symbol, crystal .....	7, 8
<b>Crystal detector symbol.....</b>	7, 8	<b>Detectors, diode .....</b>	255
microphone .....	205	summary of .....	255
oscillator .....	231	<b>Development of electricity.....</b>	18
<b>Current, alternating .....</b>	25, 63	of modern radio.....	1-3
in amperes, formula.....	350	Devices, sound-reproducing ..	277-283
direct .....	25, 61	<b>Diagram, action of a condenser..</b>	113
direct and alternating.....	61-74	alternating current .....	61
effect of pulsating.....	74	amplitude modulation .....	309
finding .....	29, 30	antenna circuit coupled to input	
grid control of.....	150	elements of triode tube...249	
induced, frequency of.....	74	antenna system, noise reduc-	
pulsating direct .....	62	tion .....	295
<b>Current filter, alternating-direct..</b>	134	antenna system providing noise.293	
flow through circuit.....	57	antenna tuning circuit.....	246

	Page		Page
<b>Diagram—continued</b>		<b>Diagram—continued</b>	
Armstrong regenerative circuit.	211	cross-section, electro-dynamic speaker	282
audio-amplifier circuit	163	current fed to antenna by tuned feeders	241
automatic volume-control circuit	262	curve, frequency signal	322
balanced-armature speaker unit.	280	curve, output voltage	322
box- and flat-type baffles.	283	curve, resultant in response to transmitter and receiver changes	322
capacity effect between tube elements	158	curve resulting from changing grid bias	169
characteristic curve, signal produced on	168	damped wave	221
characteristic curve of vacuum tube	150	D'Arsonval-meter movement.	78
circuit for carbon-button microphone	201	degenerative amplifier	210
circuit of condenser microphone	204	desired current flow.	292
circuit connections in ammeter.	83	diode tube	144
circuit of frequency-modulation transmitter	313	direct current	61
circuit, of ohmmeter.	88	direct-capacitively coupled circuit	128
circuit, radio-frequency amplifier	161	direct-inductively coupled circuit	128
circuit to test amplification factor of tubes.	149	direct-resistance coupled circuit	128
circuit, two-button carbon microphone	203	discriminator stage, receiver.	321
circuit to vary grid voltage.	149	double-doublet type of antenna.	289
Colpitts oscillator with capacitive feedback	213	doublet type of antenna.	288
combination antenna and grid-bias control	259	dynatron oscillator	215
condensers in series with lamp.	114	effect of inductance and capacitance in AC circuit.	67
connecting volume-control to audio transformer	261	effect of resistance and reactance	68
connections of diode section of 12SQ7	271	effect of resistance, reactance and capacity	70
connections of thermocouple-type instrument	87	electrical disturbances	292
construction of condenser-type microphone	204	electron flow in tube circuit.	145
construction of crystal microphone	205	electron-coupled oscillator	216
continuous wave	221	electrons about proton.	20
counter-electromotive force	95	energy storage	113
counterpoise antenna system.	286	equivalent circuit of quartz-crystal	214
cross section of dynamic microphone	206	filter circuit to reject a frequency	141
		filter to pass high frequencies.	141
		filter to pass low frequencies.	141
		four cycles of alternating current	63
		frequency curve	322

	Page
<b>Diagram—continued</b>	
frequency-modulated trans- mitter .....	315
frequency-modulation .....	309
frequency-modulation receiver..	319
frequency-modulation trans- mitter .....	317
full-wave antenna system....	240
full-wave diode rectifier tube circuit .....	302
grid-leak, condenser detector circuit .....	253
half-wave antenna system....	240
half-wave rectifier tube circuit.	300
harmonics and overtones.....	193
Hartley oscillator circuit.....	212
indirect-capacitively coupled circuit .....	130
indirect-inductively coupled cir- cuit .....	129
inductance coils connected in parallel .....	100
inductance coils connected in series-parallel .....	100
inductance coils in series.....	99
intermediate-frequency amplifier .....	270
lines of force in magnetic field.	41
magnetic field around a coil..	71
magnetic speaker unit.....	279
Master-oscillator, power-ampli- fier, radiotelegraph trans- mitter .....	225
matched impedance feed sys- tem .....	241
movement within atom.....	20
moving coil .....	79
mutual inductance, experiment.	44
mutual inductance and reso- nance frequency .....	132
neutrodyne method of control- ling feedback .....	250
nonlinear amplifier .....	252
operation of tube without enough negative grid bias.	170
oscillator and output circuit..	270
oscillator and reactance modu- lator .....	313

	Page
<b>Diagram—continued</b>	
oscillatory circuits .....	123
output voltage in frequency of signal .....	322
parallel resistances .....	54
parallel-resonant circuit.....	140
pentode tube .....	160
plate circuit with two tubes in parallel .....	174
plate-voltage, plate-current curves .....	176
principle of velocity micro- phone .....	206
pulsating current .....	61
push-pull amplifier stage.....	175
quartz-crystal oscillator .....	214
radio communication .....	3
radio signal through superhet- erodyne receiver .....	265
radio waves on antenna.....	286
radio-frequency carrier modu- lated by audio frequency.	230
radiotelephone transmitter ...	232
range frequencies of instruments and voice .....	195
reflection of sound from curved surfaces .....	190
reflection of sound waves from plane .....	190
regenerative amplifier .....	210
resistance control in antenna circuits .....	258
resistance-coupled amplifier ...	179
resistance-coupled audio, vol- ume-control circuit .....	261
resistance units in radio set....	307
resistances in series.....	53
resistors in series-parallel cir- cuit .....	56
resonant frequency .....	132
screen-grid and plate-circuit control .....	260
self-rectifying radiotelegraph transmitter .....	223
series-resonant circuit .....	140
series-tuned Zeppelin feed sys- tem for antenna.....	241
signal input circuit of tube....	269



- |                                  | Page     |   | Page   |
|----------------------------------|----------|---|--------|
| <b>Diagram—continued</b>         |          | <b>Diode—continued</b>                    |        |
| signal produced by tube operat-  |          | rectifier tube, full-wave.....            | 302    |
| ing on straight portion of       |          | rectifier tube, half-wave.....            | 300    |
| curve .....                      | 168      | section of superheterodyne....            | 271    |
| simple antenna system .....      | 285      | tube as rectifier .....                   | 299    |
| simple filter circuit .....      | 134      | tube symbol .....                         | 14, 15 |
| sine-wave alternating current..  | 301      | tubes .....                               | 144    |
| siren and sound waves.....       | 198      | <b>Direct coupling</b> .....              | 126    |
| sound waves .....                | 185      | current .....                             | 25, 61 |
| spark-gap transmitter .....      | 219      | current, pulsating .....                  | 62     |
| speed of sound.....              | 186      | Direct and alternating current..          | 61-74  |
| superheterodyne receiver .....   | 267      | <b>Direct-capacitive coupling</b> .....   | 128    |
| sweep circuit .....              | 91       | <b>Direct-current instruments</b> .....   | 80-84  |
| telephone receiver .....         | 277      | supply .....                              | 308    |
| thermocouple .....               | 87       | <b>Direct-inductive coupling</b> .....    | 127    |
| tone control across primary of   |          | <b>Discharging Leyden jar</b> .....       | 106    |
| audio transformer .....          | 180      | <b>Discharging and charging con-</b>      |        |
| tone control across secondary of |          | denser .....                              | 123    |
| audio transformer .....          | 181      | <b>Discovery, electricity</b> .....       | 17     |
| transmission .....               | 3        | <b>Discriminator, frequency-modula-</b>   |        |
| triode tube .....                | 148      | tion receiving circuit....                | 321    |
| tube test circuit.....           | 149      | <b>Discriminator stage frequency-mod-</b> |        |
| tuned-grid, tuned-plate oscilla- |          | ulation receiver, diagram..               | 321    |
| tor .....                        | 213      | <b>Dissipating heat</b> .....             | 157    |
| two-button carbon microphone..   | 203      | <b>Distortion, signals</b> .....          | 167    |
| units of radio receiver.....     | 243      | tube .....                                | 167    |
| vacuum-tube amplifier and out-   |          | volume-level .....                        | 311    |
| put .....                        | 210      | <b>Divider, voltage</b> .....             | 307    |
| vacuum-tube oscillator .....     | 210      | <b>Double-doublet antenna</b> .....       | 289    |
| voltage and current in Hertz     |          | <b>Doublet antenna</b> .....              | 288    |
| antenna .....                    | 240      | <b>Drop, voltage</b> .....                | 58     |
| wave form .....                  | 61       | <b>Dry cell</b> .....                     | 23     |
| wave-form picture of pulsations  |          | <b>Dynamic loud-speaker or moving-</b>    |        |
| smoothed out .....               | 305      | coil type .....                           | 281    |
| Western Electric transmitter...  | 233      | microphone .....                          | 206    |
| wiring power-supply unit....     | 304      | <b>Dynamometer</b> .....                  | 85     |
| <b>Dielectric</b> .....          | 105      | type instrument .....                     | 84     |
| basic, air as.....               | 115      | <b>Dynatron oscillator</b> .....          | 215    |
| gas .....                        | 111      |   |        |
| mica .....                       | 107      |   |        |
| paper .....                      | 107      |   |        |
| <b>Dielectric constant</b> ..... | 108, 115 |   |        |
| constant values .....            | 116      |   |        |
| constants, Table of.....         | 117      |   |        |
| insulators and current flow....  | 113      |   |        |
| materials .....                  | 106      |   |        |
| <b>Diode detector</b> .....      | 255      |   |        |
| rectifier tube, diagram.....     | 300      |   |        |

## E

- |                                  |     |
|----------------------------------|-----|
| Echoes and reflections.....      | 189 |
| Eddy currents .....              | 102 |
| Edison effect .....              | 145 |
| <b>Effect, Edison</b> .....      | 145 |
| gas in tube upon phase relation- |     |
| ship .....                       | 152 |
| overloading tube .....           | 171 |
| Effective voltage .....          | 64  |

	Page
Efficiency, antenna .....	287
<b>Electrical connections</b> .....	34
disturbances, diagram .....	292
energy .....	17-19
energy, sources .....	21-25
formulas .....	350
measuring instruments .....	75-92
terms .....	26
units of measure.....	27-34
<b>Electricity, development</b> .....	18
discovery .....	17
principles of .....	17-35
Electrodes .....	23, 112
<b>Electrodynamic energy</b> .....	19
speaker, symbol for.....	13, 14
Electrolyte paste .....	23
Electrolytes .....	112
<b>Electrolytic condenser symbol</b> .....	8, 11
condensers .....	110
<b>Electromagnetic field</b> .....	42
field around a coil.....	47
generation .....	25
Electromagnetism and mag- netism .....	37-47
Electromagnets .....	39
<b>Electromotive force and induct- ance</b> .....	93-104
force, production of.....	44
Electron theory .....	19-21
Electron-coupled oscillator .....	216
Electronic emission .....	143
<b>Electrons</b> .....	143
about proton, diagram.....	20
weight of .....	20
Electrons and protons.....	20
<b>Electrostatic energy</b> .....	18
shield symbol .....	13, 14
type microphone .....	203
unit .....	117
Electrostatics, law of.....	19
Elements, tube, capacity effect be- tween .....	158
Eliminators, static .....	293
<b>Emission, electronic</b> .....	143
secondary .....	159
<b>Energy, electrical</b> .....	17-19
electrical, sources of .....	21-25
electrodynamic .....	19

	Page
<b>Energy—continued</b>	
electrostatic .....	18
Energy and torque, units of meas- ure for .....	348
Energy storage .....	113
Equalizer, voltage .....	112
<b>Equivalent circuit of quartz crys- tal</b> .....	214
resistance .....	55
Equivalents, decimals and frac- tions .....	351
Exhausting the tube.....	156
<b>Experiment, counter-electromotive force</b> .....	95
electrically charged glass rod..	18
electromotive force .....	44
exploring magnetic field around coil .....	71
iron filings and magnet.....	37, 38
law of electrostatics.....	19
with magnetic field around coil.	71
mechanical generation of elec- tricity .....	25
mutual inductance .....	44
Experiments with an inductance coil .....	46

**F**

Factor, amplification .....	148, 163
Fahrenheit and centigrade ther- mometers .....	351
Farad, unit of measure.....	117
Federal Communications Commis- sion .....	309
Feed systems, antenna.....	240
<b>Feedback</b> .....	209, 250
capacitive .....	213
<b>Field around a coil, magnetic</b> ....	47
electromagnetic .....	42
Fields, magnetic .....	39-47, 124
<b>Filament</b> .....	144
types of .....	155
Filament symbol .....	13, 14
<b>Filter, low-pass</b> .....	305
to pass high frequencies, dia- gram .....	141
to pass low frequencies, dia- gram .....	141

- |   | Page     |   | Page          |
|---|----------|---|---------------|
| <b>Filter circuit</b> .....                 | 141      | <b>Frequency—continued</b>                  |               |
| circuit diagram .....                       | 134      | modulation transmitters .....               | 312           |
| <b>Filters</b> .....                        | 133, 304 | modulation transmitters, circuit            |               |
| current, alternating-direct .....           | 134      | diagram .....                               | 313           |
| radio-frequency .....                       | 135      | response .....                              | 178           |
| <b>Finding current values</b> .....         | 29, 30   | response of microphones.....                | 207           |
| resistance .....                            | 29, 31   | <b>Full-wave diode rectifier tube, con-</b> |               |
| voltage .....                               | 29, 30   | struction of .....                          | 302           |
| <b>Fixed condenser plates</b> .....         | 112      | rectification .....                         | 300           |
| condenser symbol .....                      | 8, 9     | rectifier symbol .....                      | 10, 12        |
| resistor symbol .....                       | 8, 9     | rectifier tube .....                        | 302           |
| <b>Flat-type baffles</b> .....              | 283      | <b>Fundamental tone</b> .....               | 192           |
| <b>Fleming's right-hand rule</b> .....      | 42       | <b>Fuse symbol</b> .....                    | 10, 11        |
| <b>Fluorescent screen</b> .....             | 91       |   |               |
| <b>Flux, magnetic</b> .....                 | 41       | <b>G</b>                                    |               |
| <b>Flux leakage</b> .....                   | 73       | <b>Gain, voltage</b> .....                  | 165           |
| <b>Foil, plates of paper and</b> .....      | 108      | <b>Galvanometer</b> .....                   | 44, 76        |
| <b>Force, counter-electromotive</b> .       | 65, 93   | symbol .....                                | 8, 9          |
| electromotive .....                         | 44       | <b>Gang-tuning condenser symbol</b> ..      | 8, 11         |
| electromotive, and induct-                  |          | <b>Gaps, quenched</b> .....                 | 219           |
| ance .....                                  | 93-104   | rotary .....                                | 219           |
| magnetic lines of.....                      | 40       | <b>Gas, a dielectric</b> .....              | 111           |
| <b>Fork, tuning</b> .....                   | 188      | phase relationship and.....                 | 152           |
| <b>Formula for air-core solenoid</b> ...    | 96       | <b>Gas tube symbol</b> .....                | 13, 14        |
| for finding current in amperes.             | 350      | <b>General purpose tubes</b> .....          | 160           |
| Ohm's law .....                             | 350      | <b>Generation, electromagnetic</b> .        | 25            |
| <b>Formulas, electrical</b> .....           | 350      | mechanical, of electricity.....             | 25            |
| power .....                                 | 350      | <b>Generator, signal</b> .....              | 216           |
| <b>Fractional equivalents</b> .....         | 351      | <b>Geographical north</b> .....             | 41            |
| <b>Frequencies, high, filter to pass</b> .. | 141      | <b>Getter</b> .....                         | 156           |
| low, filter to pass.....                    | 141      | <b>Glossary of Terms</b> .....              | 325-341       |
| for an octave.....                          | 198, 342 | <b>Graph, characteristic curve of vac-</b>  |               |
| of resonant circuit.....                    | 136-139  | uum tube .....                              | 150           |
| side-band .....                             | 229      | operating grid signal voltage on            |               |
| vibration .....                             | 197      | bend of curve.....                          | 152           |
| <b>Frequency, induced current</b> .....     | 74       | plate-voltage, plate-current                |               |
| nonlinear amplifier .....                   | 252      | curves .....                                | 176           |
| resonant, diagram of increase..             | 132      | <b>Gravity cell</b> .....                   | 22            |
| <b>Frequency amplifier, intermediate</b>    | 320      | <b>Grid</b> .....                           | 146           |
| amplifier, radio .....                      | 320      | suppressor .....                            | 159, 160      |
| filters, radio .....                        | 135      | <b>Grid and plate, construction of</b> ..   | 147           |
| modulation .....                            | 309-323  | <b>Grid bias</b> .....                      | 161, 162, 168 |
| modulation, advantages .....                | 312      | bias, change in.....                        | 169           |
| modulation, diagram .....                   | 309      | control of current.....                     | 150           |
| modulation receiver, discrimina-            |          | detection .....                             | 251           |
| tor stage, diagram.....                     | 321      | leak and condenser.....                     | 253           |
| modulation receiving circuit ..             | 318      | leak and condenser detector                 |               |
| modulation reception .....                  | 318      | circuit .....                               | 253           |

	Page		Page
<b>Grid—continued</b>		Increase of resonant frequency	
symbol .....	13, 14	diagram .....	132
<b>Grid-bias detection</b> .....	254	Indication of resonance .....	132
voltages, plate-voltage, plate-		Indirect coupling .....	126
current curves with.....	176	Indirect-capacitive coupling .....	130
volume control .....	258	Indirect-inductive coupling .....	129
Grid-plate transconductance .....	154	Indoor antenna .....	294
Grid-voltage plate-current charac-		Induced current, frequency of... 74	
teristic curve .....	168	<b>Inductance</b> in AC circuit..... 71	
Ground symbol .....	5, 6	calculation of .....	96
		calculations of iron-core.....	103
<b>H</b>		in circuits .....	98
<b>Half-wave diode rectifier tube</b> ...	300	effect in a circuit..... 65	
rectifier tube circuit diagram..	300	effect on phase relationship... 66	
Handy tables .....	346	mutual .....	44, 126
Harmonics .....	192	symbol of .....	6, 7
Harmonics and overtones, dia-		table of values for calculating..	97
gram .....	193	unit of .....	47, 95
Harmonious tones—music .....	192	Inductance and electromotive	
<b>Headphone</b> .....	278	force .....	93-104
symbol .....	10, 11	<b>Inductance coils</b> .....	45, 93
Hearing .....	199	connected in parallel .....	99
Heat, dissipating .....	157	connected in series .....	99
Heater-type filament and		connected in series-parallel ...	101
cathode .....	156	experiments .....	46
Henry .....	47, 95	high-frequency .....	94
Hertz transmitting antennas.....	239	Universal type .....	94
Hertzian type antenna.....	288	<b>Inductive coupling</b> .....	212
High frequencies, diagram of filter		reactance .....	65, 131, 135
to pass .....	141	Industry, radio in..... 2	
High-frequency inductance coil.. 94		Input, power .....	236
High-level and low-level modula-		Input and output circuits.....	162
tion .....	231	Input signal .....	162
High-mu tubes .....	160	<b>Instrument, hot-wire type</b> ..... 86	
High-vacuum tube symbol.....	13, 14	moving-vane type .....	84
Horseshoe magnets .....	38	oxide rectifier .....	86
Hot-wire type instrument..... 86		<b>Instruments, alternating-</b>	
How we hear.....	199	current .....	84-92
Human voice, range of.....	195	direct-current .....	80-84
		measuring, electrical .....	75-92
<b>I</b>		range of pitch for.....	196
<b>Impedance</b> .....	68	<b>Insulators</b> .....	18
calculation of .....	69	defined .....	26
defined .....	27	dielectric, and current flow... 113	
matched .....	241	mica .....	107
plate .....	152, 153, 166	Intensity of sound.....	192
Improvement in tubes, DeFor-		Interelectrode capacitance .....	157
est's .....	146	Interference, radio .....	289

- |   | Page     |   | Page     |
|---|----------|---|----------|
| Interference diagram .....              | 292      | <b>Loud-speakers</b> — <i>continued</i>   |          |
| <b>Intermediate-frequency amplifier</b> |          | permanent-magnet type .....               | 282      |
| .....                                   | 269, 320 | Low frequencies, diagram of filter        |          |
| amplifier stage .....                   | 266      | to pass .....                             | 141      |
| stages, aligning .....                  | 273      | Low-frequency oscillations .....          | 209      |
| transformer symbol .....                | 10, 12   | Low-level modulation .....                | 231      |
| International Morse code.....           | 343      | Low-pass filter .....                     | 305      |
| Intertube capacity .....                | 157      |   |          |
| Introduced resistance .....             | 125      | <b>M</b>                                  |          |
| Inverted-L transmitting antenna..       | 238      | Magnet wire data, copper.....             | 344      |
| <b>Iron-core coil</b> .....             | 101      | <b>Magnetic field around a coil</b> ....  | 47       |
| inductance calculations .....           | 103      | fields .....                              | 39-47    |
| transformers .....                      | 72, 164  | fields, collapsed .....                   | 124      |
| <b>J</b>                                |          | fields, created .....                     | 124      |
| Jack, closed-circuit, symbol for.       | 10, 12   | fields, moving .....                      | 44       |
| Jar, Leyden .....                       | 105      | flux .....                                | 41       |
|   |          | lines of force.....                       | 40       |
| <b>K</b>                                |          | speaker, symbol .....                     | 13, 14   |
| K values .....                          | 97       | speaker, unit .....                       | 279      |
| Key, telegraph, symbols for...10, 12    |          | <b>Magnetic-type, loud-speakers</b> ..    | 278      |
| Kinds of amplifiers.....                | 161      | <b>Magnetism, terrestrial</b> .....       | 41       |
|   |          | <b>Magnetism and electro-</b>             |          |
| <b>L</b>                                |          | magnetism .....                           | 37-47    |
| L-type antenna .....                    | 285      | <b>Magnets</b> .....                      | 77       |
| Laminated core .....                    | 101      | aging of .....                            | 78       |
| Lamp, neon, symbol for.....10, 12       |          | bar .....                                 | 37       |
| <b>Law, electrostatics</b> .....        | 19       | horseshoe .....                           | 38       |
| Ohm's .....                             | 28, 81   | permanent .....                           | 39       |
| Ohm's, application .....                | 32       | temporary .....                           | 39       |
| Laws, attraction and repulsion... 39    |          | Major diatonic scale.....                 | 197, 198 |
| LC values of resonant                   |          | Man-made static .....                     | 289, 291 |
| circuits .....                          | 136-139  | Manual volume controls.....               | 256      |
| Leakage, flux .....                     | 73       | <b>Marconi antenna systems</b> .....      | 237      |
| Learning Ohm's law.....                 | 29       | type antenna .....                        | 285, 288 |
| Length, units of measurement for.       | 346      | Maritime requirements .....               | 222      |
| Leyden jar .....                        | 105      | <b>Master-oscillator, power-amplifier</b> |          |
| Light, pilot, symbol for.....10, 11     |          | radiotelegraph transmitter.               | 225      |
| Limiters, frequency-modulation re-      |          | Matched impedance .....                   | 241      |
| ceiving circuit .....                   | 321      | Materials, dielectric .....               | 106      |
| <b>Lines, antenna transmission</b> .... | 293      | <b>Measure, electrical units of</b> ....  | 27-34    |
| of force, magnetic.....                 | 40       | unit of .....                             | 117      |
| Loop antenna symbol.....                | 5, 6     | <b>Measurement of area</b> .....          | 346      |
| Loose coupling .....                    | 127, 129 | of circles .....                          | 348      |
| <b>Loud-speakers</b> .....              | 3, 278   | of energy and torque.....                 | 348      |
| balanced-armature type .....            | 280      | of length .....                           | 346      |
| dynamic, moving-coil type....           | 281      | of power .....                            | 348      |
| magnetic type .....                     | 278      | response .....                            | 180      |
|   |          | sphere .....                              | 348      |

	Page		Page
<b>Measurement—continued</b>		<b>Moving-coil</b> electrodynamic	
units of .....	346-348	speaker symbol .....	13, 14
<b>Measuring instruments,</b>		type, loud-speaker .....	281
electrical .....	75-92	<b>Moving-vane</b> type instrument....	84
<b>Mechanical</b> generation of electri-		<b>Multi-cell</b> battery symbol.....	5, 6
city .....	25	<b>Multi-electrode</b> tubes .....	160
<b>Mercury</b> vapor tubes.....	303	<b>Multi-element</b> tubes .....	155
<b>Meter</b> D'Arsonval .....	77	<b>Multiplier</b> .....	80
thermocouple .....	87	<b>Multi-purpose</b> tubes .....	160
<b>Methods</b> of coupling circuits.127-131		<b>Multi-unit</b> tubes .....	160
<b>Mho</b> .....	26, 28	<b>Music</b> .....	192
<b>Mhos</b> .....	154	<b>Music and noise</b> .....	187, 277
<b>Mica,</b> insulator and dielectric....	107	<b>Mutual</b> conductance .....	153
<b>Mica</b> condenser, color code for..	109	inductance .....	44, 126
<b>Microfarad</b> .....	117	inductance and resonance fre-	
<b>Micromhos</b> .....	154	quency .....	132
<b>Micro-microfarad</b> .....	117		
<b>Microphone</b> .....	3, 17	<b>N</b>	
carbon-button .....	201	<b>Negative</b> charges .....	18
condenser .....	203	grid bias .....	170
crystal .....	205	resistance .....	215
dynamic .....	206	<b>Neon</b> lamp symbol.....	10, 12
electrostatic type .....	203	<b>Neutrodyne</b> method of controlling	
ribbon .....	207	feedback .....	250
velocity .....	207	<b>Nodes</b> .....	194
<b>Microphone</b> symbol .....	10, 12	<b>Noise,</b> reduced by antenna.....	295
<b>Microphones</b> .....	201-207	reduction of .....	316
frequency response of.....	207	<b>Noise and music</b> .....	187, 277
<b>Mixer</b> and oscillator.....	320	<b>Noise</b> reduction in broadcast and	
<b>Mixer-oscillator</b> .....	268	short-wave bands .....	295
<b>Modern</b> radio, development of..	1-3	reduction in short-wave bands.293	
<b>Modulation,</b> advantages of fre-		<b>Noise-reducing</b> antennas .....	294
quency .....	312	<b>Noninductive</b> wire-wound resist-	
amplitude .....	309, 310	ance .....	178
carrier wave .....	228	<b>Nonlinear</b> amplifier .....	252
frequency .....	309-323	<b>North,</b> geographical .....	41
high- and low-level.....	231	<b>North</b> pole .....	37
receiving circuit frequency....	318		
<b>Modulation</b> diagram .....	230	<b>O</b>	
process .....	230	<b>Octave,</b> frequencies for.....	198, 342
reception, frequency .....	318	<b>Ohm,</b> defined .....	27
transmitters, frequency .....	312	<b>Ohmmeter</b> .....	87
<b>Modulator,</b> reactance .....	314	<b>Ohm's law</b> .....	28, 81
<b>Molecules</b> .....	19, 143	application .....	32, 153
<b>Morse</b> code, international.....	343	formula .....	350
<b>Movable</b> condenser plates.....	112	learning .....	29
<b>Moving</b> coil .....	79	<b>Open-core</b> inductances .....	101
magnetic field .....	44		

- |  | Page         |  | Page          |
|--|--------------|--|---------------|
| Operating grid signal voltage on           |              | <b>Pentode</b> tube symbol.....        | 14, 15        |
| bend of curve, graph.....                  | 152          | tubes .....                            | 159           |
| Operation, superheterodyne.....            | 266          | Permanent magnets .....                | 39, 77        |
| <b>Oscillations</b> .....                  | 123-126      | Permanent-magnet loud-speaker..        | 282           |
| low-frequency .....                        | 209          | <b>Phase</b> .....                     | 66            |
| parasitic .....                            | 224          | relationship, effect of capacity       |               |
| production of .....                        | 123          | on .....                               | 66            |
| stopping .....                             | 125          | relationship, effect of gas in tube    |               |
| Oscillator, reactance modulator,           |              | upon .....                             | 152           |
| diagram .....                              | 313          | relationship, effect of inductance     |               |
| Oscillator and output circuits.....        | 270          | on .....                               | 66            |
| Oscillator diagram .....                   | 212          | relationship, effect of resistance     |               |
| <b>Oscillators</b> .....                   | 157, 209-217 | on .....                               | 66            |
| Colpitts .....                             | 212          | relationship, effect of resistance,    |               |
| control .....                              | 314          | inductance and capacity                |               |
| crystal .....                              | 231          | on .....                               | 67            |
| dynatron .....                             | 215          | relationship in transformers....       | 74            |
| electron-coupled .....                     | 216          | Phonograph pickup symbol....           | 10, 12        |
| mixers and .....                           | 320          | Phototube .....                        | 144           |
| quartz-crystal .....                       | 214          | Pickup, phonograph, symbol....         | 10, 12        |
| service .....                              | 216          | Pilot light symbol.....                | 10, 11        |
| tuned-grid, tuned-plate .....              | 213          | Pitch .....                            | 192, 195      |
| vacuum tube, diagram .....                 | 210          | Pitches, range of.....                 | 196           |
| <b>Oscillatory</b> circuits, diagram....   | 123          | <b>Plate</b> circuit with two tubes in |               |
| circuits and resonance....                 | 123-142      | parallel .....                         | 174           |
| <b>Oscilloscope</b> .....                  | 90           | current in diagram.....                | 170           |
| cathode-ray .....                          | 90           | detection .....                        | 251           |
| Outdoor antennas .....                     | 294          | impedance .....                        | 152, 153, 166 |
| <b>Output</b> circuits .....               | 162          | resistance .....                       | 152, 153      |
| signal .....                               | 162          | symbol .....                           | 13, 14        |
| Overloading tube, effect of.....           | 171          | Plate-circuit voltage control....      | 260           |
| <b>Overtones</b> .....                     | 192          | <b>Plates</b> , condenser .....        | 112           |
| diagram .....                              | 193          | paper and foil.....                    | 108           |
| Oxide rectifier .....                      | 86           | of tube .....                          | 144           |
| <b>P</b>                                   |              |  |               |
| Paper, a dielectric .....                  | 107          | <b>Pole</b> , north .....              | 37            |
| Paper and foil, plates of.....             | 108          | south .....                            | 37            |
| Paper condenser .....                      | 108          | Portable radio transmitter.....        | 60            |
| <b>Parallel</b> , condenser connected in.. | 120          | Positive charges .....                 | 18            |
| inductance coils connected in..            | 99           | Post, carbon .....                     | 23            |
| resistances in .....                       | 53           | Potential line, zero.....              | 301           |
| Parallel and push-pull, tubes in..         | 174          | <b>Potentiometer</b> .....             | 50            |
| Parallel connections .....                 | 34           | symbol .....                           | 8, 9          |
| Parallel-resonant circuit .....            | 140          | <b>Power</b> amplifier .....           | 271           |
| Parasitic oscillations .....               | 224          | amplifier unit of transmitter...       | 235           |
| Parts of radiophone transmitters..         | 231          | amplifiers .....                       | 167           |
| Paste, electrolyte .....                   | 23           | apparatus for radio transmitter..      | 236           |
|  |              | input .....                            | 236           |
|  |              | supply, radio .....                    | 299-308       |

	Page
<b>Power</b> — <i>continued</i>	
supply units, radio.....	304
transformer symbol .....	6, 7
units of measure for.....	348
Power formulas .....	350
Power-output calculations .....	176
Preamplifier .....	205
Pre-emphasis at transmitter, dia- gram .....	322
Pressure, formula for.....	350
Prevention of sound reflection...	191
Primary winding .....	129
Principles of electricity.....	17-35
Process, modulation .....	230
Producing oscillations .....	123
Production and transmission of sound .....	188-200
Protection of condensers.....	109
Protons .....	143
Protons and electrons.....	20
<b>Pulsating</b> current, effect of.....	74
direct current .....	62
Pulsations smoothed out, diagram.	305
Push-pull and parallel, tubes in..	174
<b>Push-pull</b> amplification .....	181
amplifier stage, diagram..	175, 181

**Q**

Quality of tone.....	192
Quantity, unit of.....	75
Quartz crystal, symbol.....	13, 14
Quartz-crystal oscillator .....	214
Quenched gap .....	219

**R**

Radiation of damped waves.....	220
<b>Radio</b> , development of.....	1-3
in industry .....	2
in war .....	1
<b>Radio</b> abbreviations .....	349
communication, diagram.....	3
communication, process of...	3
interference .....	289
power supply .....	299-308
power supply units .....	304
power-pack transformer .....	304
receivers .....	243-263

	Page
<b>Radio</b> — <i>continued</i>	
set, wiring diagram of power supply unit .....	304
signal, diagram .....	265
signals .....	244
symbols .....	5-15
telephony .....	2
transformers .....	72
transmitter, portable .....	60
waves .....	3, 285
waves in antenna .....	286
waves on antenna, diagram...	286
waves and static .....	290
<b>Radio-frequency</b> amplification ..	248
amplifier .....	161, 320
amplifiers, types of.....	248
choke coils .....	95, 165
control circuits .....	260
filters .....	135
stages, aligning .....	274
transformer symbol .....	6, 7
transformers .....	164
Radiophone transmitters, parts of.	231
Radiotelegraph transmitters..	219-226
<b>Range</b> of audibility.....	200
of pitches according to major diatonic scale .....	196, 342
Range frequencies diagram.....	195
Rarefaction .....	188
Rating, wattage .....	51
<b>Reactance</b> , calculation of.....	68
capacitive .....	66, 135
defined .....	27
inductive .....	65, 135
<b>Reactance</b> modulator .....	314
modulator and oscillator dia- gram .....	313
<b>Receiver</b> .....	3
amplitude modulation .....	310
de-emphasis, diagram .....	322
frequency-modulation diagram.	319
<b>Receivers</b> , radio .....	243-263
superheterodyne .....	265-275
telephone .....	277
tuned radio-frequency type...	249
<b>Receiving</b> antennas .....	285-298
circuit, frequency-modulation..	318
Reception, frequency modulation..	318



	Page		Page
Rectification, full-wave .....	300	<b>Resistors—continued</b>	
<b>Rectifier</b> , diode tube.....	299	variable .....	50
full-wave, symbol for.....	10, 12	vitreous .....	49
oxide .....	86	wire-wound .....	49
<b>Rectifier tube</b> .....	306	<b>Resonance</b> .....	131-133
tube, full-wave diode .....	302	cavity .....	207
tube, half-wave diode .....	300	coupled circuits .....	132
tube, circuit, diagram .....	300	indication of .....	132
tube circuit, full-wave		Resonance and oscillatory cir-	
diagram .....	302	cuits .....	123-142
<b>Reduction</b> , noise .....	316	Resonance frequency and mutual	
noise on short-wave bands, dia-		inductance diagram ....	132
gram .....	293	<b>Resonant</b> circuits, calculations of	
<b>Reflection</b> of sound, prevention..	191	.....	136-139
of sound waves.....	190	frequency diagram .....	132
Reflections and echoes.....	189	<b>Response</b> , frequency .....	178
Regeneration .....	157, 250	measurement of .....	180
Regenerative amplifier, diagram..	210	Resultant, curve showing.....	322
Rejection of a frequency by filter		Retentivity .....	78
circuit .....	141	Rheostat symbol .....	8, 9
Rejector circuit .....	141	<b>Rheostats</b> .....	50
Relationship, phase, effect of gas		wire-wound .....	51
in tube upon.....	152	Ribbon microphone .....	207
Repulsion, attraction and.....	39	Richness of tone.....	192
Requirements, maritime .....	222	Right-hand rule, Fleming's.....	42
<b>Resistance</b> .....	49-59, 131	<b>Rotary</b> gaps .....	219
in a circuit.....	64	switch symbol .....	10, 11
defined .....	27	Rule, right-hand, Fleming's.....	42
effect on phase relationship...	66		
equivalent .....	55	<b>S</b>	
finding .....	29, 31	Scale, major diatonic.....	197, 198
introduced .....	125	<b>Schematic diagram</b> , frequency-	
non-inductive wire-wound ....	178	modulated transmitter ...	315
plate .....	152, 153	Western Electric transmitter...	233
reactance and capacity, diagram		Screen, fluorescent .....	91
of effect .....	70	<b>Screen-grid</b> .....	157
in series-parallel circuit.....	56	voltage control .....	259
Resistance and reactance, diagram	68	Screens in tetrode tube.....	158
<b>Resistance control</b> in antenna cir-		Sealing compound .....	23
cuits .....	258	<b>Secondary</b> emission .....	159
coupling .....	128	winding .....	129
formula for .....	350	Selecting signal .....	244
units in radio set, diagram....	307	Self-inductance .....	93, 126
Resistance-coupled amplifier ....	179	Self-rectifying transmitters .....	222
<b>Resistances</b> in parallel.....	53	Sensitivity .....	81
in series .....	53	<b>Series</b> , condensers connected in...	120
Resistor, fixed, symbol for.....	8, 9	inductance coils connected in..	99
<b>Resistors</b> , carbon .....	49	resistances in .....	53

	Page		Page
Series connections .....	34	Sources of electrical energy....	21-25
<b>Series-parallel</b> circuit, resistance in	56	South pole .....	37
condensers connected in.....	121	Space change .....	147
connections .....	35	Spacer .....	23
inductance coils connected in..	101	Spark transmitter .....	219
Series-resonant circuit .....	140	<b>Speaker</b> , electrodynamic, symbol	
Service oscillator .....	216	for .....	13, 14
<b>Shield</b> , electrostatic, symbol for.	13, 14	magnetic, symbol for.....	13, 14
pentode tube .....	159	<b>Speaker</b> unit, balanced-armature	
Shield-grid .....	157	type .....	280
Shorting out .....	259	unit, magnetic .....	279
<b>Short-wave</b> antenna .....	295	Special purpose tubes.....	160
bands, noise reduction in..	293, 295	Speed of sound.....	186
bands, reduction .....	293	Sphere, rules for measurement of.	348
Shunts .....	82, 83	<b>Standard</b> color code.....	110, 342
Side-band frequencies .....	229	radio symbols .....	5-15
<b>Signal</b> , collecting .....	244	<b>Static</b> , atmospheric .....	289
input .....	162	eliminators of .....	293
input circuit of tube.....	269	man-made .....	289-291
output .....	162	radio waves and.....	290
produced by tube operating on		Stationary vane .....	84
straight portion of curve..	168	Stopping oscillations .....	125
radio, diagram .....	265	<b>Storage</b> batteries .....	24
selecting .....	244	battery symbol .....	5, 6
Signal generator .....	216	String instruments, range frequen-	
<b>Signals</b> , distortion of.....	167	cies .....	195
radio .....	244	Summary of detectors.....	255
sine of angle .....	151	Superheterodyne, alignment of cir-	
Sine wave .....	151	cuits .....	272-275
Sine-wave alternating current dia-		<b>Superheterodyne</b> antenna connec-	
gram .....	301	tions .....	268
Siren .....	198	circuits .....	265
<b>Solenoid</b> , air-core .....	98	detector-amplifier .....	270
air-core, formula for.....	96	diagram .....	267
inductance of .....	97	intermediate-frequency	
SOS .....	1	amplifier .....	269
<b>Sound</b> , intensity of.....	192	mixer-oscillator .....	268
production and transmission..	188	operation .....	266
science of .....	185-200	power amplifier .....	271
speed of .....	186	receivers .....	265-275
speed of, diagram .....	186	<b>Supply</b> , direct-current .....	308
<b>Sound</b> reflection, prevention of..	191	radio power .....	299-308
wave, crest of .....	189	Supply units, radio power.....	304
wave, valley of.....	189	Suppressor grid .....	159, 160
waves .....	3, 185	Sweep circuit diagram.....	91
waves, reflection of .....	190	Sweeper arm .....	50
waves, and siren .....	198	<b>Switch</b> , rotary, symbol for.....	10, 11
<b>Sound-reproducing devices</b> ...	277-283	throw, symbol for.....	10, 11

- |                                 | Page   |                                    | Page    |
|---------------------------------|--------|------------------------------------|---------|
| <b>Symbol, air core</b> .....   | 6, 7   | <b>Symbol—continued</b>            |         |
| ammeter .....                   | 8, 9   | transformer, power .....           | 6, 7    |
| antenna .....                   | 5, 6   | transformer, radio-frequency ..    | 6, 7    |
| antenna, loop .....             | 5, 6   | triode tube .....                  | 14, 15  |
| audio-frequency choke coil....  | 6, 7   | variable condenser .....           | 8, 11   |
| battery .....                   | 5, 6   | voltmeter .....                    | 8, 9    |
| cathode .....                   | 13, 14 | wiring .....                       | 5, 6    |
| cell .....                      | 5, 6   | <b>Systems, antenna feed</b> ..... | 240     |
| closed-circuit jack .....       | 10, 12 | transmitting antenna .....         | 237-242 |
| crystal detector .....          | 7, 8   |                                    |         |
| diode tube .....                | 14, 15 | <b>T</b>                           |         |
| electrodynamic speaker ....     | 13, 14 | <b>Tables</b>                      |         |
| electrolytic condenser .....    | 8, 11  | Calculations of resonant circuits  |         |
| electrostatic shield .....      | 13, 14 | .....                              | 136-139 |
| filament .....                  | 13, 14 | Comparison of frequencies for a    |         |
| fixed condenser .....           | 8, 9   | single octave .....                | 198     |
| fixed resistor .....            | 8, 9   | Copper wire .....                  | 345     |
| full-wave rectifier .....       | 10, 12 | Dielectric constants .....         | 117     |
| fuse .....                      | 10, 11 | Handy .....                        | 346     |
| galvanometer .....              | 8, 9   | Range of pitches according to      |         |
| gang-tuning condenser .....     | 8, 11  | major diatonic scale.....          | 196     |
| gas tube .....                  | 13, 14 | Values for calculating induc-      |         |
| grid .....                      | 13, 14 | tance .....                        | 97      |
| ground .....                    | 5, 6   | Tangent galvanometer .....         | 76      |
| headphones .....                | 10, 11 | Telegraph key symbols.....         | 10, 12  |
| high-vacuum tube .....          | 13, 14 | Telegraph and telephone trans-     |         |
| inductance .....                | 6, 7   | mitters, comparison of....         | 227     |
| intermediate-frequency trans-   |        | Telegraphy, wireless .....         | 2       |
| former .....                    | 10, 12 | Telephone receiver .....           | 277     |
| magnetic speaker .....          | 13, 14 | Telephone and telegraph trans-     |         |
| microphone .....                | 10, 12 | mitters, comparison of....         | 227     |
| multi-cell battery .....        | 5, 6   | Telephony, radio .....             | 2       |
| neon lamp .....                 | 10, 12 | Temporary magnets .....            | 39      |
| pentode tube .....              | 14, 15 | <b>Terms, electrical</b> .....     | 26      |
| phonograph pickup .....         | 10, 12 | Glossary .....                     | 325-341 |
| pilot light .....               | 10, 11 | Terrestrial magnetism .....        | 41      |
| plate .....                     | 13, 14 | Test circuits for tubes.....       | 149     |
| potentiometer .....             | 8, 9   | <b>Tetrode tube symbol</b> .....   | 14, 15  |
| quartz crystal .....            | 13, 14 | tubes, construction of.....        | 157     |
| radio .....                     | 5, 15  | T-form transmitting antenna....    | 238     |
| rheostat .....                  | 8, 9   | Theory, electron .....             | 19-21   |
| rotary switch .....             | 10, 11 | Thermionic tube .....              | 144     |
| storage battery .....           | 5, 6   | <b>Thermocouple</b> .....          | 87      |
| telegraph key .....             | 10, 12 | ammeter symbol .....               | 8, 9    |
| tetrode tube .....              | 14, 15 | meter .....                        | 87      |
| thermo-couple ammeter .....     | 8, 9   | Thermojunction .....               | 87      |
| throw switch .....              | 10, 11 | Thimble, cathode .....             | 156     |
| transformer, audio-frequency .. | 6, 7   | Throw switch symbol.....           | 10, 11  |

	Page		Page
Tickler coil .....	211	<b>Transmitters—continued</b>	
Tight coupling .....	129	vacuum-tube .....	222
Tight and loose coupling.....	127	Western Electric .....	232-236
Timbre .....	192	Transmitting antenna systems	
<b>Tone</b> , fundamental .....	192	.....	237-242
quality of .....	192	<b>Traps</b> , wave .....	133
<b>Tone control</b> .....	180	wave, use of.....	141
control, primary of audio trans-		<b>Triode</b> tube symbol.....	14, 15
former .....	180	tubes .....	146
Tones, harmonious .....	192	T-type antenna .....	285, 298
Torque, units of measure.....	348	<b>Tube</b> , cathode-ray .....	90
Trains, wave .....	251	diode, as rectifier.....	299
Transconductance, gridplate ...	154	diode, symbol for.....	14, 15
<b>Transformer</b> .....	129	distortion of .....	167
audio tone control across pri-		exhausting the .....	156
mary of .....	180	gas, symbol for.....	13, 14
intermediate-frequency, symbol		graph showing curve of.....	150
for .....	10, 12	half-wave diode rectifier.....	300
iron-core .....	72	high-vacuum, symbol for....	13, 14
radio .....	72	overloading .....	171
<b>Transformer</b> , diagram .....	300	pentode, symbol for.....	14, 15
symbol, audio-frequency .....	6, 7	rectifier .....	306
symbol, power .....	6, 7	tetrode, symbol for.....	14, 15
symbol, radio-frequency .....	6, 7	thermionic .....	144
<b>Transformers</b> , audio .....	163, 164	triode, symbol for.....	14, 15
phase relationship in.....	74	Tube elements, capacity between.	158
radio frequency .....	164	<b>Tubes</b> , diode .....	144
<b>Transmission</b> , amplitude modula-		general-purpose .....	160
tion .....	309	high-mu .....	160
sound .....	188-200	mercury vapor .....	303
Transmission lines, antenna.....	293	multi-electrode .....	160
<b>Transmitter</b> .....	3	multi-element .....	155
arc .....	220	multi-purpose .....	160
master-oscillator, power-ampli-		multi-unit .....	160
fier radiotelegraph .....	225	in parallel in plate circuit....	174
portable .....	60	in parallel and push-pull.....	174
pre-emphasis, diagram .....	322	pentode .....	159
spark .....	219	special purpose .....	160
<b>Transmitters</b> , broadcast, amplitude-		test circuits for.....	149
modulated .....	227-236	tetrode .....	157
broadcast, carrier wave of....	228	triode .....	146
CW-ICW tube .....	224	two-element .....	144
frequency-modulation .....	312	vacuum .....	143-160
frequency-modulation, dia-		<b>Tuned</b> grid, tuned-plate oscillator.	213
gram .....	313	radio-frequency type receivers.	249
radiophone .....	231	<b>Tuning</b> circuit, antenna.....	246
radiotelegraph .....	219-226	circuits .....	244
self-rectifying .....	222	fork .....	188

- |  | Page     |
|--|----------|
| <b>Tuning—continued</b>                                |          |
| radio circuits, variable condensers for .....          | 119      |
| Two-button carbon microphones.....                     | 202      |
| Two-element tubes .....                                | 144      |
| <b>Type</b> antenna, Marconi.....                      | 285, 288 |
| B wave .....   | 220      |
| <b>Types</b> of amplification.....                     | 171      |
| of antenna systems for transmitters .....              | 237      |
| of antennas .....                                      | 285      |
| of detection .....                                     | 251      |
| of filaments .....                                     | 155      |
| of R.F. amplifiers .....                               | 248      |
| <b>U</b>   |          |
| <b>Unit</b> of inductance.....                         | 47, 95   |
| of measure, farad .....                                | 117      |
| of quantity .....                                      | 75       |
| <b>Units</b> of measure.....                           | 346-348  |
| of measure, electrical .....                           | 27-34    |
| of radio power-supply unit....                         | 304      |
| of radio transmitter assembled.....                    | 234      |
| Universal type inductance coil...                      | 94       |
| Uses of amplification.....                             | 182      |
| <b>V</b>   |          |
| Vacuum tubes .....                                     | 143-160  |
| <b>Vacuum-tube</b> amplifier and output .....          | 210      |
| oscillator, energy diagram.....                        | 210      |
| transmitter .....                                      | 222      |
| voltmeter .....  | 92       |
| Valley of sound wave.....                              | 189      |
| <b>Values</b> for calculating inductance.              | 97       |
| dielectric constant .....                              | 116      |
| Vane, stationary .....                                 | 84       |
| Vapor tubes, mercury.....                              | 303      |
| <b>Variable</b> condenser .....                        | 112      |
| condenser, symbol .....                                | 8, 11    |
| condenser for tuning radio....                         | 119      |
| resistor .....   | 50       |
| Velocity microphone .....                              | 207      |
| Vibration frequencies .....                            | 197      |
| Vitreous resistors .....                               | 49       |
| Voice, range of.....                                   | 195      |
| Volt, defined .....                                    | 27       |
| <b>Voltage</b> , effective .....                       | 64       |
| <b>Voltage—continued</b>                               |          |
| finding .....  | 29, 30   |
| formula for .....                                      | 350      |
| <b>Voltage</b> amplification .....                     | 163      |
| amplifier .....  | 161      |
| amplifiers .....                                       | 163      |
| control, plate-circuit .....                           | 260      |
| control, screen-grid .....                             | 259      |
| divider .....  | 307      |
| drop .....   | 58       |
| equalizer .....  | 112      |
| gain .....   | 165      |
| Voltage-feed system .....                              | 240      |
| Voltaic cell .....                                     | 21       |
| Voltammeter .....                                      | 83       |
| <b>Voltmeter</b> .....                                 | 77, 80   |
| vacuum-tube .....                                      | 92       |
| Voltmeter symbol .....                                 | 8, 9     |
| Volt-ohm-milliammeter .....                            | 89       |
| Volume, units of measurement...                        | 347      |
| <b>Volume</b> control, automatic.....                  | 262      |
| control, grid-bias .....                               | 258      |
| controls, audio-frequency .....                        | 261      |
| controls, manual .....                                 | 256      |
| Volume-level distortion .....                          | 311      |
| VOM .....  | 89       |
| <b>W</b>   |          |
| Walkie-talkie .....                                    | 48       |
| War, radio in.....                                     | 1        |
| Watt, defined .....                                    | 28       |
| Wattage, calculating .....                             | 52       |
| Wattage rating .....                                   | 51       |
| <b>Wave</b> , carrier, of broadcast transmitters ..... | 228      |
| continuous .....                                       | 220, 221 |
| sine .....   | 151      |
| Type B .....   | 220      |
| <b>Wave</b> trains .....                               | 251      |
| traps .....  | 133      |
| traps, use of.....                                     | 141      |
| <b>Waves</b> , damped, radiation of....                | 220      |
| radio .....  | 3, 285   |
| sound .....  | 3, 185   |
| sound, diagram .....                                   | 185      |
| <b>Weight</b> of electrons.....                        | 20       |
| units of measurement.....                              | 347      |
| Western Electric transmitter.....                      | 232-236  |



