

PB-111586-R

HANDBOOK OF PIEZOELECTRIC CRYSTALS FOR RADIO
EQUIPMENT DESIGNERS

John P. Buchanan

Philco Corporation

October 1956

DISTRIBUTED BY:

CLEARINGHOUSE
FOR FEDERAL SCIENTIFIC AND TECHNICAL INFORMATION

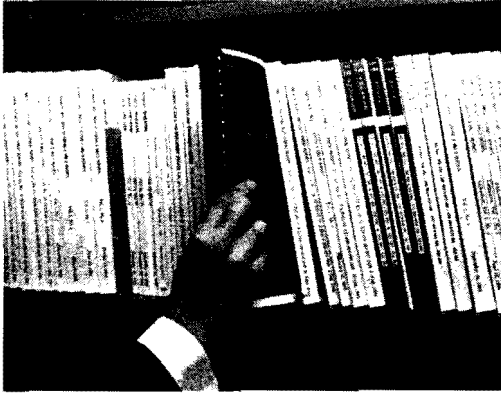

REPORT selection aids

Pinpointing R & D reports for industry

Clearinghouse, Springfield, Va. 22151

U.S. GOVERNMENT RESEARCH AND DEVELOPMENT REPORTS (USGRDR)---SEMI-MONTHLY JOURNAL ANNOUNCING R&D REPORTS. ANNUAL SUBSCRIPTION \$30.00 (\$37.50 FOREIGN MAILING). SINGLE COPY \$3.00.

U.S. GOVERNMENT RESEARCH AND DEVELOPMENT REPORTS INDEX---SEMI-MONTHLY INDEX TO U.S. GOVERNMENT RESEARCH AND DEVELOPMENT REPORTS. ANNUAL SUBSCRIPTION \$22.00 (\$27.50 FOREIGN MAILING). SINGLE COPY \$3.00.

FAST ANNOUNCEMENT SERVICE---SUMMARIES OF SELECTED R&D REPORTS COMPILED AND MAILED BY SUBJECT CATEGORIES. ANNUAL SUBSCRIPTION \$5.00, TWO YEARS: \$9.00, AND THREE YEARS: \$12.00. WRITE FOR AN APPLICATION FORM.

DOCUMENT PRICES---ALMOST ALL OF THE DOCUMENTS IN THE CLEARINGHOUSE COLLECTION ARE PRICED AT \$3.00 FOR PAPER COPIES AND 65 CENTS FOR COPIES IN MICROFICHE.

COUPONS---THE CLEARINGHOUSE PREPAID DOCUMENT COUPON SALES SYSTEM FOR PURCHASING PAPER COPIES AND MICROFICHE PROVIDES FASTER, MORE EFFICIENT SERVICE ON DOCUMENT REQUESTS. THE PREPAID COUPON IS A TABULATING CARD WITH A FACE VALUE OF THE PURCHASE PRICE OF A CLEARINGHOUSE DOCUMENT (\$3.00 PAPER COPY OR 65 CENTS MICROFICHE). IT IS YOUR METHOD OF PAYMENT, ORDER FORM, SHIPPING LABEL, AND RECEIPT OF SALE.

COUPONS FOR PAPER COPY (HC) DOCUMENTS ARE AVAILABLE AT \$3.00 EACH OR IN BOOKS OF 10 COUPONS FOR \$30.00. COUPONS FOR MICROFICHE COPIES OF CLEARINGHOUSE DOCUMENTS ARE AVAILABLE IN BOOKS OF 50 COUPONS FOR \$32.50. WRITE FOR A COUPON ORDER FORM.

NOTICE

This is your copy of the latest edition of "Handbook of Piezo Electric Crystals for Radio Equipment Designers" prepared by Philco for the Air Force as a WADC Technical Report. The Report WADC TR-56-156 covers material considered useful in the design of crystal oscillators for electronic equipment. It will serve well in the hands of the electronic design engineers of your organization. The report applies to the application of "Military Type" crystal units in equipments designed for the Armed Services. The report strongly indorses the use of military type crystal units, however, does not discourage use of non-military types if a need exists. It does recommend that your organization bring to the attention of the "Frequency Control Group" of the individual service organization needs for non-military types before the design application is frozen so that military types currently in development may in turn be offered for your consideration. This cooperation is strongly requested so as to effectively make use of the military types which have established sources of supply. In the event this action is not taken, the special, non-military, type crystal unit may not be procurable when production quantities are most needed. Your support and cooperation is appreciated.

Sincerely yours



JOHN B. RIPPERE
Colonel, USAF
Chief, Comm & Nav Laboratory
Directorate of Development
Wright Air Development Center

**HANDBOOK
OF
PIEZOELECTRIC CRYSTALS
FOR
RADIO EQUIPMENT DESIGNERS**

This Report Supersedes WADC TR 54-248, Dated December 1954

John P. Buchanan

Phileo Corporation

OCTOBER 1956



WRIGHT AIR DEVELOPMENT CENTER

WADC TECHNICAL REPORT 56-156
ASTIA DOCUMENT NO. AD 110448

HANDBOOK
OF
PIEZOELECTRIC CRYSTALS
FOR
RADIO EQUIPMENT DESIGNERS

This Report Supersedes WADC TR 54-248, Dated December 1954

John P. Buchanan

Phileo Corporation

OCTOBER 1956

Communications and Navigation Laboratory

Contract No. AF 33(616)—2453

ARDC PROJECT 4155, TASK No. 43033

Wright Air Development Center
Air Research and Development Command
United States Air Force
Wright-Patterson Air Force Base, Ohio

FOREWORD

This handbook was prepared by the Technical Publications Department, TechRep Division, Philco Corporation under Contract AF33 (616)-2453. Mr. F. W. Wojcicki served as project director, with Mr. M. W. Nachman assuming these duties during the final processing stage. Mr. J. P. Buchanan was project engineer and author. Credit for assembling the data on specific crystal units and holders in Sections II and III belongs to Mr. C. W. Henry.

This Task No. 43033, titled Handbook of Piezoelectric Crystals for Radio Equipment Designers, ARDC Project 4155 was administered under Mr. V. J. Carpentier as chief of the Specialties Section, Communication Branch of the Communications and Navigation Laboratory, Wright Air Development Center.

Appreciation is extended to Gentile Air Force Depot, Squier Signal Laboratory, Armour Research Foundation at Illinois Institute of Technology, New York University College of Engineering, and to the many individuals and other organizations whose generous cooperation has proved so important during the preparation of the handbook. In particular, the successful conclusion of the project is heavily indebted to the interest, administrative assistance, and many valuable suggestions of Mr. E. H. Borgelt of the Frequency Control Group, Wright Air Development Center, and to Mr. R. A. Sykes and assistants at Bell Telephone Laboratories for freely giving of their time and knowledge in reviewing the text and contributing important corrective comments for improving the usefulness and accuracy of the text.

COPYRIGHT CREDITS

Many of the illustrations used in the general information section of the handbook are copyrighted by D. Van Nostrand Co., 250 Fourth Ave., New York, N. Y. and are identified by an asterisk (*) after each title. Reproduction of any of these photographs is prohibited without the express permission of the copyright holder.

COPIES

Copies of this report may be obtained from the Office of Technical Services, U. S. Department of Commerce, Washington, D. C. at a nominal cost.

ABSTRACT

A comprehensive manual of piezoelectric control of radio frequencies is offered. It is directed toward the design of oscillator circuits having optimum operating conditions when employing Military Standard crystal units. Included is a survey of the development of the piezoelectric crystal art; descriptions and characteristics of all crystal elements and mounting methods that have found commercial application; a detailed study of the equivalent circuit characteristics of crystal units; analyses of basic piezoelectric oscillator principles and of the effects of changes in various circuit parameters, using the Pierce oscillator as a reference circuit; analyses and recommended design procedures for all types of piezoelectric oscillator circuits used, or tested for use, in USAF equipments; schematic diagrams and tables giving actual circuit parameters of all available nonclassified piezoelectric oscillators now being used in USAF equipments; descriptions of all crystal units and crystal holders now being used in USAF equipments, containing references and schematics of circuits employing those crystal units recommended for equipments of new design; a brief discussion of crystal ovens and descriptions of ovens currently available for use with Military Standard crystal units; and a comprehensive index to increase the utility of the handbook as a reference manual. Circuit analyses, derivations of equations, and suggestions for design innovations whose sources are not directly acknowledged have originated with the author and so far as is known have not been specifically confirmed in practice.

PUBLICATION REVIEW

This report has been reviewed and is approved.

FOR THE COMMANDER:

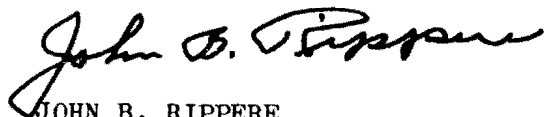

JOHN B. RIPPERE
Colonel, USAF
Chief, Comm & Nav Laboratory
Directorate of Development
Wright Air Development Center

TABLE OF CONTENTS

SECTION I—GENERAL INFORMATION.....	1
SECTION II—CRYSTAL UNITS.....	430
SECTION III—CRYSTAL HOLDERS.....	569
SECTION IV—CRYSTAL OVENS.....	601
APPENDIX I—ACKNOWLEDGMENTS.....	629
APPENDIX II—BIBLIOGRAPHY.....	635
APPENDIX III—LIST OF MANUFACTURERS.....	654
APPENDIX IV—RELATED SPECIFICATIONS, STANDARDS, PUBLICATIONS AND DRAWINGS.....	658
APPENDIX V—DEFINITIONS OF ABBREVIATIONS AND SYMBOLS.....	662
INDEX	683

SECTION I—GENERAL INFORMATION

TABLE OF CONTENTS

<i>Subject</i>	<i>Page</i>
INTRODUCTION	
Purpose and Scope of Manual.....	1
Control of Radio Frequency.....	1
The Piezoelectric Effect.....	1
Development of Piezoelectric Devices.....	2
PHYSICAL CHARACTERISTICS OF PIEZOELECTRIC CRYSTALS	
Descriptions of Useful Piezoelectric Crystals.....	5
Theory of Piezoelectricity.....	12
Modes of Vibration.....	15
Orientation of Crystal Cuts.....	18
Piezoelectric Elements.....	20
STANDARD QUARTZ ELEMENTS	
Types of Cuts.....	21
The X Group.....	22
The Y Group.....	34
FABRICATION OF CRYSTAL UNITS	
Initial Inspection of Raw Quartz.....	45
Inspection for Optic Axis and Optical Twinning.....	46
Use of Conoscope for Exact Determination of Optic Axis.....	46
Sectioning the Stone.....	47
Determination of X Axis.....	49
Cutting X Block.....	50
Determination of Twinning.....	51
Preparation of Wafers.....	51
Preparation of Crystal Blanks.....	51
Methods of Mounting Crystal Blanks in Crystal Holders.....	52
Housing of Crystal Units.....	67
Aging of Crystal Units.....	67
ELECTRICAL PARAMETERS OF CRYSTAL UNITS	
Equivalent Circuit of Crystal Unit.....	70
Simplified Equivalent Circuit of Air-Gap Crystal Unit.....	71
Effect of R-F Leakage Resistance.....	71
Effect of Distributed Inductance.....	72
Effect of Distributed Capacitance.....	73
Effect of Distributed Resistance.....	74

TABLE OF CONTENTS—Continued

<i>Subject</i>	<i>Page</i>
ELECTRICAL PARAMETERS OF CRYSTAL UNITS (Cont)	
Rule-of-Thumb Equations for Estimating Parameters.....	74
Impedance Characteristics versus Frequency.....	77
Resonant Frequency of Crystal Unit.....	78
Antiresonant Frequency of Crystal Unit.....	80
Impedance Curves of Crystal Unit.....	80
Parallel-Resonant Frequency, f_p , of Crystal Unit.....	81
Typical Operating Characteristics of Crystal Unit.....	85
Measurement of Crystal Parameters.....	86
Methods for Expressing the Relative Performance of Crystal Units	90
Activity Quality of Crystal Unit.....	91
Frequency Stabilization Quality of Crystal Unit.....	98
Bandwidth and Selectivity Parameter of Crystal Unit.....	102
Crystal Quality Factor, Q.....	103
Stability of Crystal Parameters.....	105
CRYSTAL OSCILLATORS	
Fundamental Principles of Oscillators.....	113
Fundamental Requirements of Stable Forced-Free Oscillations.....	113
Application of Fundamental Oscillator Principles in the Design of Electronic Oscillators.....	114
Phase Rotation in Vacuum-Tube Oscillators.....	116
Types of Crystal Oscillators.....	119
Parallel-Resonant Crystal Oscillators.....	119
The Pierce Oscillator.....	120
The Miller Oscillator.....	187
Two-Tube Parallel-Resonant Crystal Oscillator.....	218
Oscillators with Crystals Having Two Sets of Electrodes.....	222
Crystal and Magic-Eye Resonance Indicator.....	223
Series-Resonant Crystal Oscillators.....	225
Meacham Bridge Oscillator.....	226
Capacitance-Bridge Oscillators.....	236
The Butler Oscillator.....	244
Transformer-Coupled Oscillator.....	258
Grounded-Grid Oscillator.....	266
The Grounded-Plate Oscillator.....	274
Transitron Crystal Oscillator.....	276
Impedance-Inverting Crystal Oscillators.....	277
Grounded-Cathode Two-Stage Feedback Oscillator.....	280
Colpitts Oscillators Modified for Crystal Control.....	281
Crystal Calibration.....	286
Synthesizing Circuits.....	288
Transistor Oscillators.....	342
Packaged Crystal Oscillators.....	356
Factors Involved in Oscillator Limiting.....	370
CROSS INDEX OF CRYSTAL-OSCILLATOR SUBJECTS.....	375

SECTION I—GENERAL INFORMATION

INTRODUCTION

PURPOSE AND SCOPE OF MANUAL

1-1. The purpose of this manual is to provide the design and developmental engineer of military electronic equipment with a reference handbook containing background material, circuit theory, and components data related to the application of piezoelectric crystals for the control of radio frequencies.

1-2. This manual is composed of the following sections:

- I. GENERAL INFORMATION
- II. CRYSTAL UNITS
- III. CRYSTAL HOLDERS
- IV. CRYSTAL OVENS
- V. APPENDIXES

1-3. Section I contains a brief historical account of the discovery of the piezoelectric effect and of the application of crystal resonators as frequency-control devices, discussions covering the theory and physical properties of piezoelectric crystals, descriptions and performance characteristics of the more important quartz crystal elements, general discussions of the various crystal-unit fabrication processes and types of mounting, detailed discussions of the equivalent electrical parameters and performance characteristics of crystal units, and comprehensive qualitative and mathematical analyses of the various types of crystal oscillators, summarized with recommended design procedures.

1-4. Sections II, III, and IV provide the technical and logistical data, and information concerning the application of the crystal units, crystal holders, and crystal ovens currently recommended for use in equipments of new design.

1-5. The Appendixes contain the acknowledgments; a bibliography; a list of manufacturers associated with the piezoelectric crystal industry; a list of related U. S. Government specifications, standards, and publications; a table of definitions for the abbreviations and symbols used in the Handbook; conversion charts; and an alphabetical index.

CONTROL OF RADIO FREQUENCY

1-6. The greatly increased demand for military radio channels, with the consequent crowding of

the radio-frequency spectrum, is, in the final analysis, a problem for the design engineer of frequency-control circuits. The problem is essentially one of providing a maximum frequency stability of the carrier at the transmitting station, and a maximum rejection of all but the desired channel at the receiving station. In each instance optimum results are obtained by the use of electromechanical resonators — maximum carrier stability is achieved by the use of crystal master oscillators, and maximum receiver selectivity is achieved by the use of crystal heterodyne oscillators and crystal band-pass filters.

1-7. The design of a constant-frequency generator has been an ideal of radio engineers almost from the beginning of radio science. Although many purely electrical oscillators have been devised which closely approach the ideal, none surpass the performance of the high-quality circuits employing mechanical oscillators. Temperature-controlled oscillators having a sonic-frequency tuning fork as the frequency controlling element and followed by a number of frequency multiplying stages were the first of the radio-frequency generators employing the high precision of mechanical control. The cumbersomeness and expense of the many multiplier stages, however, have made the tuning fork oscillators impracticable insofar as the control of any but sonic frequencies are concerned. Today, precision control of radio frequencies has been made possible through the development of piezoelectric resonators, where the frequency-controlling elements, usually quartz plates, have normal vibrations in the radio-frequency range.

THE PIEZOELECTRIC EFFECT

1-8. The word *piezoelectricity* (the first two syllables are pronounced pie-ee') means "pressure-electricity," the prefix *piezo-* being derived from the Greek word *piezein*, meaning "to press."

1-9. "Piezoelectricity" was first suggested in 1881 by Hankel as a name for the phenomenon by which certain crystals exhibit electrical polarity when subjected to mechanical pressure.

1-10. That such a phenomenon probably existed seems to have been suggested first by Coulomb in

Section I Introduction

the latter part of the 18th century. His suggestions prompted Haüy, and later A. C. Bequerel, into undertaking a series of experiments to see if electric effects could be produced purely by mechanical pressure. Although both Haüy and Bequerel reported positive results, there is some doubt as to whether these were not due to contact potentials rather than to piezoelectric properties of the substances investigated—particularly since electrical polarities were reported in crystals that are now known to be non-piezoelectric.

1-11. It is to the Curie brothers, Jacques and Pierre, that the honor goes for having been the first (in 1880) to verify the existence of the piezoelectric effect. (For the initial report of their discovery, see paragraph 1-56.)

1-12. The Curie brothers tested a number of crystals by cutting them into small plates that were then fitted with tin-foil electrodes for connection to an electrometer. When subjected to mechanical pressure, several of the crystals caused the leaves of the electrometer to be deflected. Among those crystals showing electrical polarities were quartz, tourmaline, Rochelle salt, and cane sugar. In the year following these experiments, a prediction by Lippmann that the effect would prove reversible prompted the Curies to further investigations. The results verified Lippmann's prediction by revealing that the application of electric potentials across a piezoelectric crystal would cause deformations in the crystal which would change in sign with a change in electric polarity. Furthermore, it was found that the piezoelectric constant of proportionality between the electrical and mechanical variables was the same for both the *direct* (pressure-to-electric) and the *converse* effects. In other words, the same polarization at the surface of the electrodes that results from a particular deformation of the crystal can, in turn, if applied from an external source, produce the deformation.

1-13. It should be mentioned that the piezoelectric effect, which occurs only in certain asymmetrical crystals, is not to be confused with *electrostriction*, a property common to all dielectrics. Although electrostriction is a deformation of a dielectric produced by electric stress, it is unlike the converse piezoelectric effect in that its magnitude varies, not linearly with the electric field, but with the square of the field, and is unaffected by a change in the applied polarity. Electrostriction is the type of deformation a capacitor undergoes on being charged. In piezoelectric crystals this effect is normally small compared with the piezoelectric properties.

DEVELOPMENT OF PIEZOELECTRIC DEVICES

1-14. From the time of its discovery until World War I, the piezoelectric effect found few practical uses. Those applications it did find appeared in the form of occasional laboratory devices for measuring pressure or electric charges. For the most part, however, little attention was attracted to piezoelectricity outside the crystallographer's study. Nevertheless, during this time considerable theoretical progress was made, due chiefly to the efforts of Lord Kelvin, Duhem, Pockels, and Woldemar Voigt. Voigt's comprehensive *Lehrbuch der Kristallphysik*, published in 1910, is still considered the reference authority on the mathematical relationships among crystal variables.

1-15. It was after the outbreak of World War I before serious attention was given to the practical application of piezoelectric crystals. During the war Professor Paul Langevin of France initiated experiments with the use of quartz crystal plates as underwater detectors and transmitters of acoustic waves. Although Langevin's immediate purpose was to develop a submarine detecting device, his research became of vital importance to many other developments. Not only did it attract the applied sciences to the possibilities of piezoelectric crystals, but also it initiated the modern science of ultrasonics.

1-16. The detecting apparatus that Langevin eventually devised employed quartz "sandwiches" which were coupled electrically to vacuum-tube circuits, and could be exposed under water where they would vibrate at the frequency of an applied voltage, or at the frequency of an incident acoustic wave. The first function was employed to emit ultrasonic waves, and the second function to receive and reconvert the echo into electrical energy for detection.

1-17. At the same time that Langevin was experimenting with quartz as a supersonic emitter and detector, Dr. A. M. Nicolson, at Bell Telephone Laboratories, was independently investigating the use of Rochelle salt to perform the same functions at sonic frequencies. Indeed, his first application for a patent on a number of piezoelectric acoustic devices, April 1918, preceded by five months Langevin's initial application for a French patent. Employing Rochelle salt instead of quartz, because of its greater piezoelectric sensitivity, Nicolson constructed a number of microphones, loudspeakers, phonograph pickups, and the like. Among the circuits included in his 1918 patent application, was one that later proved of particular interest — an oscillator employing a Rochelle

salt crystal as shown in figure 1-1. With this exception, all the early applications of the piezoelectric crystal involved its use as a simple electro-mechanical *transducer*. That is, it was used either to transform mechanical energy in one system to electrical energy in another, or vice versa. Nicolson's oscillator was a distinct innovation in that it employed a piezoelectric crystal as a transformer of electrical energy to mechanical energy and back to electrical energy.

1-18. When Nicolson devised his oscillator, none of the possible functions of a piezoelectric vibrator had previously been investigated or discussed. His patent application offered no description of the crystal's function, although presumably the crystal performed in some way to transfer part of the plate circuit energy to the grid circuit. Evidence that the normal vibrations of the crystal actually controlled the frequency seems to have existed, but no mention was made of this fact. The circuit, however, embodies the combined principles of coupler, filter, and resonator. Obviously the crystal acts as a coupler between the plate and grid circuits; and, inasmuch as the crystal may block the feedback of all plate energy except that at the frequency of the crystal's normal mode of vibration, the crystal may be imagined to perform the function of a filter, even though the over-all operation is that of an oscillator. Finally, if the plate

tap is connected at the bottom of the coil, so that the only feedback is through the plate-to-grid capacitance of the vacuum tube, the crystal may function as a conventional resonator, controlling the frequency as would a tuned grid tank circuit—the complete vacuum-tube circuit being the equivalent of a tuned-plate, tuned-grid oscillator. Thus, to Dr. Nicolson belongs the honor of being the first to employ the piezoelectric crystal purely as a circuit element, in all its principal circuit functions.

1-19. Although Nicolson was the father of the piezoelectric crystal circuit, Professor Walter G. Cady, of Wesleyan University, was its greatest prophet. In 1918 during a series of experiments being conducted to investigate the use of Rochelle salt plates for underwater signaling, Dr. Cady became interested in the electromechanical behavior of crystals vibrating in their normal modes. Out of the resonant properties that he discovered, he came to visualize the great possibilities that the piezoelectric crystal afforded as a resonator of high stability. After experimenting with several circuits, including the first quartz-controlled oscillator, Dr. Cady, in January 1920, not aware that Dr. Nicolson considered his oscillator controlled by the resonance of its crystal, submitted a patent application for the piezoelectric resonator, in which he reported its possibilities as a frequency standard, filter, and coupler, and described the principles

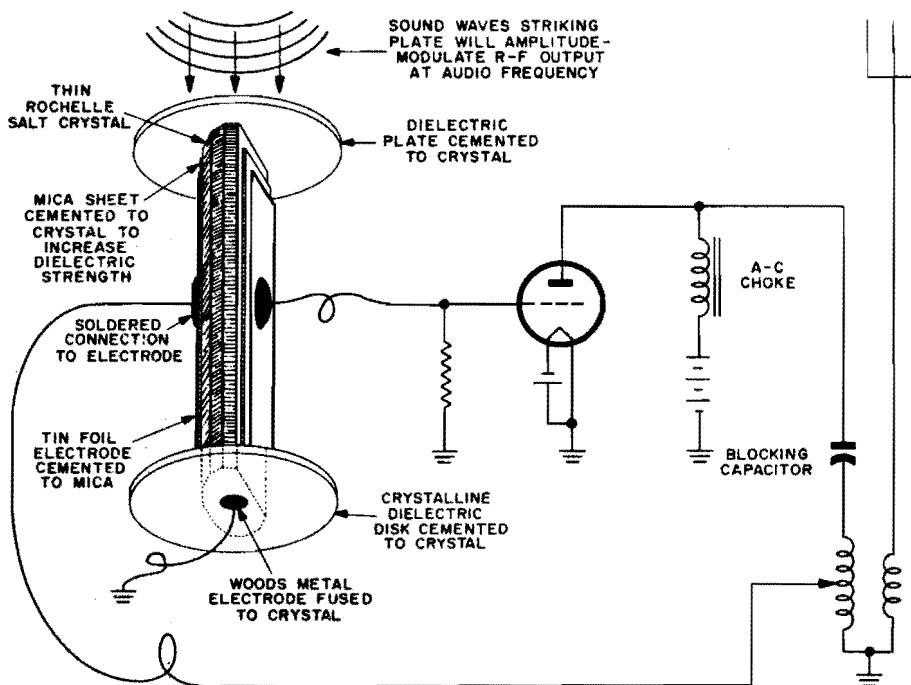

Figure 1-1. The first crystal- (Rochelle salt) controlled oscillator. Invented by A. M. Nicolson, 1918

of its operation. Although subsequent litigation concerning the discovery of the piezoelectric-resonator principle was decided in Dr. Nicolson's favor, it is distinctly to Dr. Cady's credit that he was the first to fully grasp the import of the piezoelectric resonator and to publish a public report of its principles and possibilities. His early pioneering in the field and his many later contributions have made Dr. Cady the American dean of piezoelectricity.

1-20. It soon became apparent that quartz crystals were the most stable and practical for use as resonators. Many investigators were attracted to the field, and progress was made both in the design and theory of crystal circuits. Professor G. W. Pierce of Harvard showed that quartz crystal oscillators could be constructed with a single amplifier stage, as Nicolson had already done using Rochelle salt. This marked a considerable improvement over Cady's oscillators, which had consisted of two or more vacuum-tube stages. Of particular note was the analysis by K. S. Van Dyke, in 1925, of the electrodynamic characteristics of a crystal resonator in terms of an equivalent electrical network; for the first time a way was opened to an understanding of the crystal resonator. In 1928, E. M. Terry showed that the frequency of a crystal oscillator was not entirely controlled by the crystal characteristics, but to a small degree was also dependent upon the other circuit constants. F. B. Lewellyn, in 1931, presented a classic analysis of oscillators showing the circuit impedance relationships that are necessary if the frequency is to be independent of variations in the voltage supply and vacuum-tube characteristics. Although the subject matter of this treatise deals with oscillators in general, the principles are applicable to the design of crystal oscillators, if the electrical parameters of the crystal are known.

1-21. The tuned-circuit oscillators of the early transmitters normally operated with heavy and variable loads. Many of the oscillators operated directly into an antenna, and in broadcast transmitters, modulation was performed in the oscillator stage. This resulted in considerable frequency instability, and broadcast reception was often unintelligible because of the frequency difference in radio waves arriving by different paths. It was in the determination of the cause and the correction of such interference that Messrs. R. Bown, D. K. Martin, and R. K. Potter of the Research and Development Department of the American Telephone and Telegraph Company recommended the use of lightly loaded crystal-controlled oscillators followed by amplifiers. Under their supervision, Station WEAJ in New York, in 1926, became the first

crystal-controlled broadcasting station.

1-22. The principal factor limiting the stability of the early quartz oscillator was the relatively large frequency-temperature coefficient of the crystal, which allowed small changes in the ambient temperature to cause excessive changes in the resonant frequency. The immediate method of obtaining stability, of course, was to mount the crystal in an oven where the temperature could be controlled thermostatically. However, to decrease the temperature coefficient of the crystal, itself, also became the goal of a number of researchers. Because some quartz plates exhibited positive temperature coefficients, whereas others exhibited negative coefficients, according to the orientation of the plate with respect to the axes of the mother crystal, the possibility arose that there should be some shape or median angle of cut which would have a zero coefficient. The first empiricists to enter the field were E. Giebe and A. Scheibe in Germany. In the United States, Mr. W. A. Morrison of Bell Telephone Laboratories turned his attention to the problem of achieving the maximum precision possible in frequency control, and by 1929 had perfected a 100-kc frequency standard using a doughnut-shaped crystal (originally pioneered by Giebe) with a nearly zero temperature coefficient. This success encouraged the Bell Laboratories research staff to launch a concerted investigation into all phases of quartz crystal physics. Out of this program have arisen most of the principal advances in the design and production of quartz crystal units in the United States; although the early pioneering of S. A. Bokovoy and C. F. Baldwin at RCA has also been of notable significance.

1-23. Originally only the Curie, or X-cut, quartz plate was used—a plate in which the thickness dimension is parallel to the crystal's X axis. Later the Y cut, where the thickness dimension is parallel to a Y axis, developed by E. D. Tillyer of the American Optical Co., began to compete with the Curie cut as the frequency-control element in commercial oscillators. By 1934, Messrs. F. R. Lack, G. W. Williard, and I. E. Fair of Bell Telephone Laboratories announced the discovery and development of two types of plates, called the *AT* and *BT cuts*, with such small temperature coefficients that they could operate stably under normal conditions without the use of temperature-controlled ovens. Concurrently, Bokovoy and Baldwin at RCA were experimenting with a series of crystals that they named the V cut, and their work, although of a less rigorous theoretical approach, substantially paralleled much of the research that was done at

Bell Laboratories. In 1937, Messrs. G. W. Williard and S. C. Hight announced the development of the CT, DT, ET, and FT cuts; and by 1940 Mr. W. P. Mason had discovered the GT cut, the most stable resonator ever devised. The time-keeping standards at both the Greenwich Observatory and the U. S. Bureau of Standards now use this crystal. Where other cuts exhibit a zero temperature coefficient only at certain temperatures, the GT cut has almost a zero temperature coefficient over a range of 100°C. Besides the cuts discussed above, a number of others have been investigated which have proved particularly applicable for special uses. Among these are the AC, BC, MT, NT, 5-degree X, and the -18-degree X cuts.

1-24. Paralleling the development of the new crystal cuts were the improvements made in the design of crystal holders. The early holders provided no means of "clamping" a crystal, for they were designed originally to accommodate X-cut plates whose favored modes of vibration required that the edges be free to move. Since the crystal in such a holder will slide about if used in equipment subject to mechanical vibrations, a method of clamping was needed before the crystal could be used in vehicular or airborne radio sets. Mr. G. M. Thurston of Bell Telephone Laboratories was led to the solution of this problem when he discovered that a crystal would not be restricted if clamped only at the mechanical nodes of its normal vibrations. The exact positions of these points, where the standing-wave amplitude is zero, depend, of course, on the particular mode of vibration. The low-frequency -18-degree X-cut crystal, for instance, can be held by knife-edged clamps running along its center, whereas AT- and BT-cut crystals can be clamped at their corners. Cantilever and wire supports which resonate at the crystal frequency have been devised for holding crystals at their centers. Although the mounting of crystals requires a far more exacting technique than for-

merly, the crystal holder today provides support and protection sufficient to insure high performance stability, even under the severe conditions of vibration that exist in military aircraft and tanks. 1-25. Unfortunately, the extremely critical nature of the design and production of crystal units has made it impracticable for manufacturers to mass-produce units with such exactitude that all the equivalent electrical parameters are standardized with an accuracy comparable to that now achieved in the case of vacuum tubes or other circuit components. However, definite progress has been made in this direction, and, if the need warrants the additional cost, reasonably exact characteristics may be obtained. For several years, each crystal unit had to be tested in a duplicate of the actual circuit in which it was to be used. This procedure was disadvantageous from the points of view of both the radio design engineer and the crystal manufacturer. On the one hand, the radio engineer, knowing little more than the nominal frequency of the crystal unit to be installed in his circuit, could not achieve that degree of perfection in oscillator design which was otherwise theoretically possible. On the other hand, the task of making a given oscillator perform correctly effectively became the responsibility of the crystal manufacturer, since it was necessary for him to fit each crystal unit by trial and error to the particular circuit for which it was intended. In recent years this cut-and-try procedure has been alleviated considerably by the development of standard test sets and by improvements in production techniques that permit more critical specifications. It is hoped that this handbook, by providing a more comprehensive description of the technical characteristics of the crystal units recommended for new design, will contribute in removing the limitations that too often in the past have forced the practical design engineer to approach his crystal circuits philosophically, rather than scientifically.

PHYSICAL CHARACTERISTICS OF PIEZOELECTRIC CRYSTALS

DESCRIPTIONS OF USEFUL PIEZOELECTRIC CRYSTALS

1-26. The piezoelectric effect is a property of a non-conducting solid having a crystal lattice that lacks a center of symmetry. Of the 32 classes of symmetry in crystals, 20 are theoretically piezoelectric, and the actual crystals which have been found in this category are numbered in the low hundreds.

1-27. Until the time of World War II only three crystals were commercially employed for their piezoelectric properties—quartz, Rochelle salt, and tourmaline. Today, the number is being increased by the development and application of synthetic crystals. Of these, the principal ones used in frequency selective circuits are ethylene diamine tartrate (EDT), dipotassium tartrate (DKT), and ammonium dihydrogen phosphate (ADP). See figure 1-2.

Section 1
Physical Characteristics of Piezoelectric Crystals

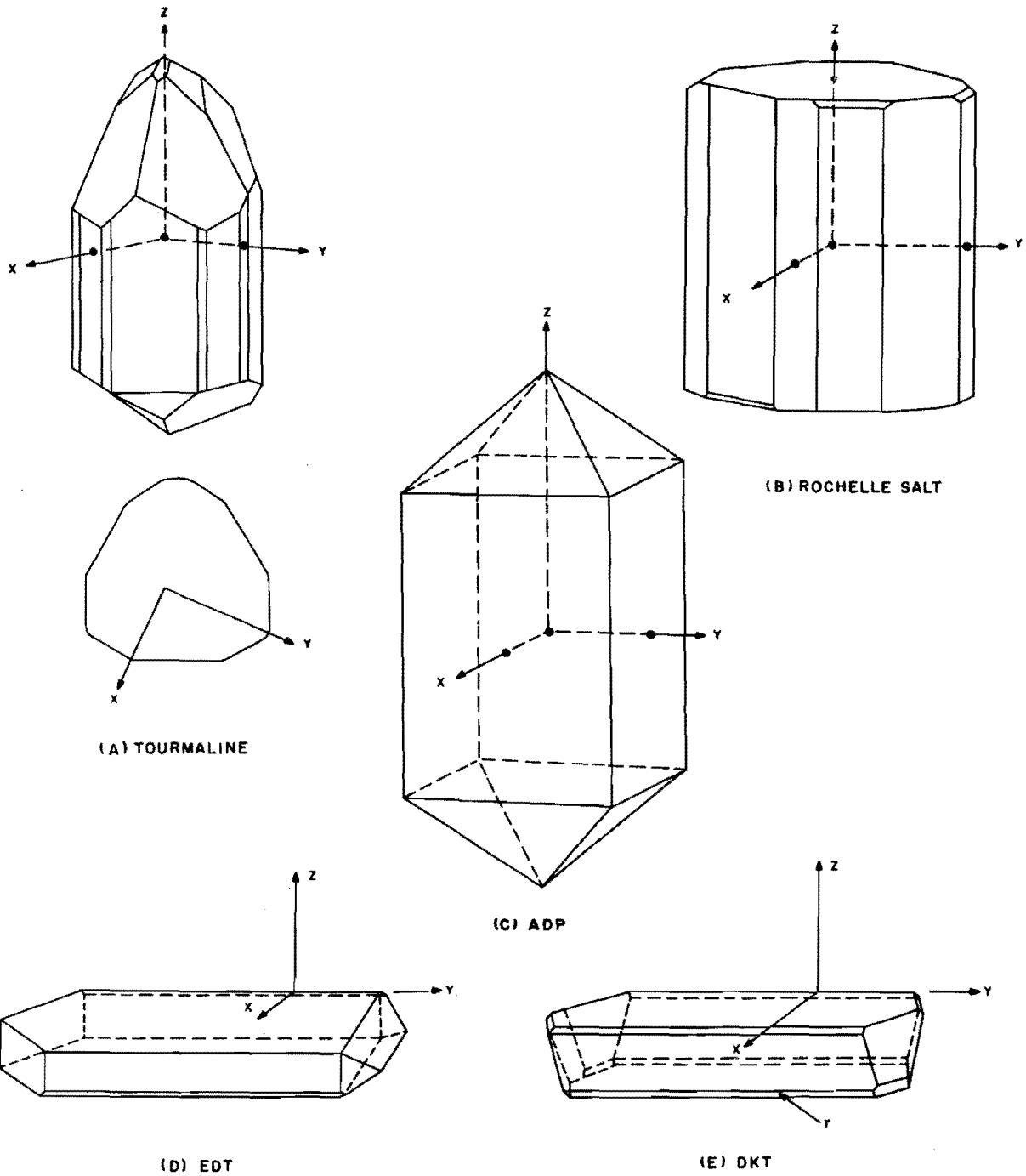

Figure 1-2. Commercially used piezoelectric crystals other than quartz

1-28. Piezoelectricity is still in its infancy, and until more data have been collected and coordinated into a comprehensive atomic theory of the phenomenon, the chemist will have few clues to direct his search for a crystal having the maximum possible piezoelectric effect.

Tourmaline

1-29. Tourmaline is a semiprecious stone which at one time was called the "Ceylon Magnet." This title seems to have been given it by early 18th century traders who introduced the stone to Europe, with the story of its strange magnetic property. If placed in hot ashes, tourmaline behaves as if it were electrified—first attracting ashes and then throwing them off. This is the phenomenon of pyroelectricity, closely associated with piezoelectricity, and was possibly the first electrical effect, other than lightning and St. Elmo's fire, ever to be noticed by man. According to the theory proposed by Lord Kelvin, the pyroelectric effect of tourmaline is due to a permanently polarized lattice in the crystal, so that when heated, an unneutralized increase in the dipole moment occurs, proportional to the change in temperature and the coefficient of expansion. It was this pyroelectric theory of permanently polarized crystals that eventually prompted the Curie brothers to test for the piezoelectric effect.

1-30. Tourmaline is unsuitable for wide commercial use because of its expense and the scarcity in the number of large-sized natural crystals. Also, the temperature coefficients are negative for all tested modes of vibrations, which fact rules out the possibility of zero-coefficient cuts.

1-31. Tourmaline does have the advantage of durability and a large thickness-frequency coefficient, so that for a given frequency it permits a more rugged crystal unit than quartz. For this reason it is sometimes used for the control of very high frequencies. However, the chief piezoelectric application of tourmaline is in the measuring of hydrostatic pressures.

Rochelle Salt

1-32. Rochelle salt ($\text{NaKC}_4\text{H}_4\text{O}_6 \cdot 4\text{H}_2\text{O}$) is sodium potassium tartrate with four molecules of water of crystallization. The crystals are grown commercially by seeding saturated solutions of the salt and decreasing the temperature of the solutions a few tenths of a degree per day. They were first synthesized in 1672 by Pierre Seignette, an apothecary of La Rochelle, France, and until the time of Nicolson's inventions the salt was used primarily for its

medicinal value. Its exceptionally great piezoelectric effect—a blow with a hammer can generate as much as five thousand volts—has made Rochelle salt the principal crystal for use as a transducer in acoustic devices, such as microphones, loudspeakers, pickups, hearing aids, and the like. As a stable resonator it is far inferior to quartz, not only because of a greater sensitivity to temperature variations, but also because of its tendency to disintegrate during extremes of humidity. If the ambient humidity drops below 35 per cent at room temperature, the water of crystallization will begin to evaporate, leaving a dehydrated powder on the crystal surface. Should the humidity rise above 85 per cent at room temperature, the salt will absorb moisture and begin to dissolve. For these reasons a Rochelle salt crystal should be mounted in a hermetically sealed container, or, if this is not possible, at least coated with wax. In the case of the former, if powders of both the crystalline and dehydrated forms of Rochelle salt are also enclosed within the sealed chamber, the humidity of the chamber will automatically increase or decrease with corresponding changes of temperature, and a stable balance between the crystal and chamber vapor pressures will be maintained. However, at a temperature of 55°C (130°F) the crystal, which is a double salt of tartaric acid, breaks down into sodium tartrate, potassium tartrate, and water. The solution formed will remain a viscous liquid for some time if super-cooled, and, as such, makes an effective glue for binding together plates of the crystal.

1-33. Although Rochelle salt, between the temperatures of -18°C and $+24^\circ\text{C}$, has a greater piezoelectric effect than any other crystal, it seems that eventually it will be replaced by other synthetic crystals, in particular, ADP ($\text{NH}_4\text{H}_2\text{PO}_4$), which requires no water of crystallization. Nevertheless, as an electromechanical transducer, Rochelle salt is still the most widely used of the piezoelectric crystals.

ADP

1-34. ADP ($\text{NH}_4\text{H}_2\text{PO}_4$), ammonium dihydrogen phosphate, was discovered and used during World War II as a substitute for Rochelle salt in underwater sound transducers. Like Rochelle salt, ADP crystals can be grown commercially; but unlike Rochelle salt, it requires no water of crystallization, and hence has no dehydration limitations, being able to stand temperatures up to 100°C (212°F). Also, ADP is more durable mechanically than Rochelle salt.

1-35. Although the crystal's principal application

Physical Characteristics of Piezoelectric Crystals

has been in submarine-detecting apparatus, its greater stability suggests the probability that it will eventually replace Rochelle salt as the principal transducer in other sonic devices.

EDT

1-36. EDT ($C_6H_{14}N_2O_8$), ethylene diamine tartrate, was discovered and developed during World War II as a substitute for quartz in low-frequency filter units. Quartz crystals at this time were in such great demand for the frequency control of military communication equipment, that a shortage developed in the supply of large-sized natural crystals which were needed for cutting filter plates of $1\frac{1}{2}$ to 2 inches in length. This shortage was acutely felt in the telephone industry, where there exists the chief demand for such plates for use in the band-pass filters of carrier systems. The discovery of EDT was the solution to this problem, for this crystal can be grown to any size desired, and it has the chemical stability (no water of crystallization), low mechanical loss, zero temperature coefficient, and small aging effects that make it a suitable substitute for quartz.

1-37. EDT is not as rugged mechanically, nor does it have quite as high a Q as quartz—although the EDT crystal units operating as filter elements in the 20- to 180-kc range do have Q's in the neighborhood of 30,000. Moreover, for use as the frequency-control element in high-frequency oscillators, EDT is inferior to quartz because of its greater sensitivity to temperature changes. Even though high-frequency modes of vibration have been found with zero temperature coefficients, the temperature shift to either side of the optimum value must be kept approximately one-fifth that for a comparable quartz plate (BT cut, for example) in order to maintain the same frequency tolerance. Where only a minimum of temperature control might be needed for quartz, EDT will require fairly accurate control. Because of these disadvantages, EDT does not threaten at this time to replace quartz in high-frequency oscillators, but it does have promising possibilities for use in oscillators of the frequency-modulated type. Here, EDT plates have the advantage of a relatively wide gap between their resonant and antiresonant frequencies, thus permitting a large percentage swing of the oscillator frequency. If temperature-controlled, the EDT crystal can thus give crystal stability to a frequency-modulated transmitter.

DKT

1-38. DKT ($K_2C_4H_4O_6 \cdot \frac{1}{2}H_2O$), dipotassium tartrate, is another synthetic crystal which was in-

vestigated at Bell Telephone Laboratories during World War II. The DKT molecule is similar chemically to that of Rochelle salt except that the sodium atom has been replaced by another potassium atom. The crystal, however, differs from Rochelle salt in that it contains only one molecule of water for each two DKT molecules, as compared with a water-to-salt molecular ratio of four-to-one in the Rochelle salt crystal, and it exhibits no tendency to dehydrate below $80^\circ C$ ($176^\circ F$). Also, the piezoelectric characteristics of DKT are less like those of Rochelle salt than of quartz. Indeed, in the lower-frequency filter circuits, DKT seems as promising as EDT as a substitute for quartz.

1-39. As compared with EDT, DKT has the advantage of better temperature-frequency characteristics. Zero temperature coefficients are possible where the frequency deviation on either side of the zero point is only one-third that for EDT. However, DKT crystals are more difficult to grow than the EDT crystals, and primarily for this reason the development of a small EDT industry has already been established, whereas the DKT crystals are still in the laboratory stage.

Raw Quartz

1-40. Quartz is silicon dioxide (SiO_2) crystallized in hard, glass-like, six-sided prisms. The normal crystal structure is called *alpha quartz*; if the temperature is raised above $573^\circ C$ ($1063^\circ F$) most of the piezoelectric property is lost with a crystal transformation to *beta quartz*. At $1750^\circ C$ ($3182^\circ F$) the crystal structure is permanently lost, and the melted quartz assumes the fused amorphous form of silica. The density of alpha quartz at $20^\circ C$ ($68^\circ F$) is 2.649 grams per cubic centimeter. The hardness of quartz is rated at 7 on Mohs' scale—a greater hardness than glass or soft steel, but less than hard steel.

1-41. Silicon dioxide is believed to constitute approximately one-tenth of the earth's crust. It occurs in many crystalline forms such as quartz, flint, chalcedony, agate, onyx, etc., and in the fused amorphous state of silica, called "quartz glass." Although quartz is an abundant mineral—sand and sandstone consist largely of quartz granules—large crystals of good quality are to be found in only a few areas. The chief source of supply has been Brazil, although large deposits of lower quality are also to be found in Madagascar and in the United States. Progress has been made in growing quartz crystals artificially. Such crystals are now commercially available, although this quartz source is still primarily in the developmental stage. The tremendous pressures required

and the slow rate of growth have, until very recently, prevented quartz manufacture from being commercially feasible. Advances are now being made in growing imperfection-free quartz stones having major dimensions so oriented relative to the principal crystal axes that a desired type of quartz cut can be obtained with minimum waste. The future possibilities of quartz manufacture appear quite promising.

1-42. The large quartz crystals of geological origin are the products of long ages of growth under great pressure. The growing crystal assumes the shape of a hexagonal prism with each end pyramiding to a point. The prismatic faces are designated as *m* faces, see figure 1-4, and adjacent *m* faces always intersect at angles of 120 degrees. The opposite *m* faces of the prism are always parallel, but are rarely of the same dimensions. These faces are not perfectly planar, but are streaked with small horizontal growth lines, or striae. Parallel to the growth lines are the bases of the six end faces—three *r* and three *z* faces—which form a hexagonal pyramid, but with only the *r* faces meeting at the apex. The end faces are quite smooth, with the *r*, or major, faces usually appearing more polished than the *z*, or minor, faces. Figure 1-3 shows a mother crystal with one of the pyramidal ends missing. Complete crystals are rarely found except in very small sizes. More likely both pyramidal ends will be missing, and frequently crystals are

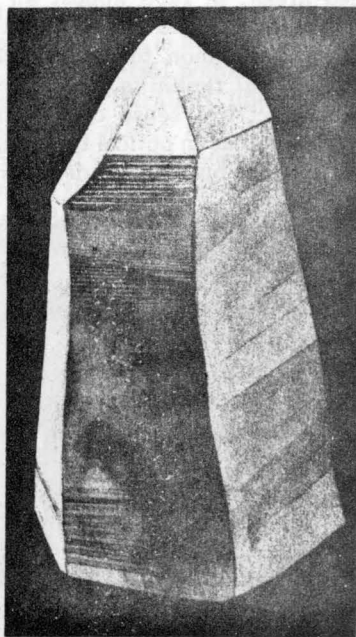

Figure 1-3. Raw quartz stone

found with all the natural faces broken or eroded away. The largest quartz crystal that has been recorded was found in Brazil. It is described as a crystal of smoky quartz, 7 ft 2 in. long, 11 ft 2 in. in circumference, and weighing more than 5 tons. 1-43. Quartz is enantiomorphous—that is, it occurs in both right-handed and left-handed forms, which are mirror images of each other. The enantiomorphic faces of two ideal alpha-quartz crystals are represented in figure 1-4. The left-handed and right-handed forms are indicated by the direction in which the small upper *x* and *s* faces appear to be pointing. Note that this rule is valid regardless of which end of the crystal is turned up. However, the *x* and *s* faces are rarely found, so that the handedness of a crystal is usually determined by noting the optical effects when polarized light is passed through the crystal parallel to the optic (lengthwise) axis.

IMPERFECTIONS IN QUARTZ

1-44. Pure quartz of structural perfection is a transparent, colorless crystal—such that the early Greek physicists believed it to be a perfected form of ice. Through the centuries quartz has been cut and ground into many ornaments, and was mystically respected in the ancient art of crystal gazing.

1-45. The presence of impurities can convert quartz into a variety of gem-like colors. Amethyst, agate, and jasper are all quartz crystals colored by impurities. A different form of coloring is that which gives a smoky appearance to quartz. This effect differs in degree from crystal to crystal, and in extreme cases a crystal may be so dark that it cannot be inspected for defects nor for the alignment of axes. However, by heating a smoky crystal from 350°C (662°F) to 500°C (932°F) it becomes

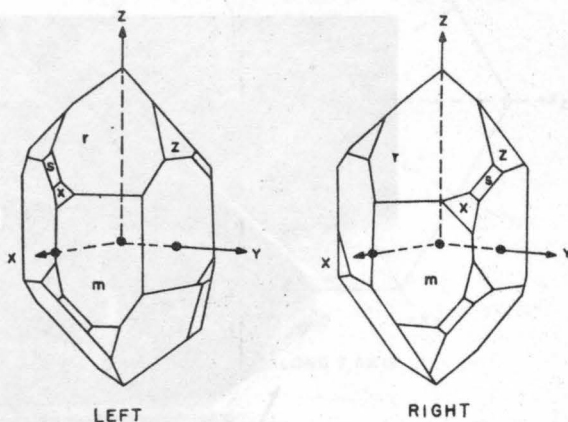

Figure 1-4. Left and right quartz crystals

Physical Characteristics of Piezoelectric Crystals

quite as clear as the purest stone. Possibly the coloration is due to the dissociation of some of the silicon dioxide molecules, which recombine on heating; in any event, crystals which have been cleared of smokiness, remain clear, and have the same physical properties as the normal colorless crystals. 1-46. Other than those arising from chemical impurities, there are three types of structural defects to be avoided when cutting blanks from the raw quartz. These are *cracks*, *inclusions*, and *twinning*.

Cracks

1-47. All raw crystals contain cracks to some extent, particularly near their surfaces, where fractures are easily caused by impacts. Temperature variations and growth conditions are also causes of cracking. The larger cracks are readily visible, but not the separations with dimensions comparable to a wave-length of light. For this reason, any detected crevice should be assumed to extend somewhat beyond its visible length. Raw quartz should be handled with particular care, for the large crystals are more vulnerable to fracturing than are the small finished plates. No finished plate, however, should be permitted to contain a crack.

Inclusions

1-48. Inclusions are small pockets, often sub-microscopic, holding foreign matter which was entrapped during the crystal's period of growth. The trapped material may be a gas, liquid, solid, or any combination thereof. The pockets are often too small to be seen individually, but are readily detected by the shapes and coloring of the clusters

they form. Groups of the smallest-size inclusions have a bluish cast; groups of medium-size inclusions appear as a white frosting; and the larger inclusions are individually visible as small bubbles. Some of the clusters appear as small *clouds*; others appear as *needles*, which may be fine or feathery, and which may form parallel rows or spread comet-like from a bubble origin; still other groups are draped in sheets or folds like *veils*; and, finally, there are those inclusions that arrange themselves in surfaces parallel to the natural crystal faces, outlining former growths, and appearing as crystal *phantoms* within a crystal. See figure 1-5. Not a great deal is known concerning the effect of inclusions upon the performance of finished plates. However, the fine textured (blue) inclusions are the least objectionable, and the isolated bubbles are more to be tolerated than a veil or phantom. Blue needles are permissible in large, low-frequency plates that are not to be driven at high levels. Nevertheless, any inclusion weakens a crystal, and will not be present in a high-quality, finished plate.

Twinning

1-49. Twinning is the intergrowth of two crystal regions having oppositely oriented axes. This abnormality is rarely detectable by a casual visual inspection, and a crystal that appears homogeneous throughout may, indeed, have several twinned areas; in fact, almost all large crystals have twinning to some extent. There are two types of twinning common to quartz—*electrical twinning* and *optical twinning*. In electrical twinning, only the electrical sense of the crystal axes is reversed, whereas in optical twinning, not only the electrical sense, but the handedness of the crystal

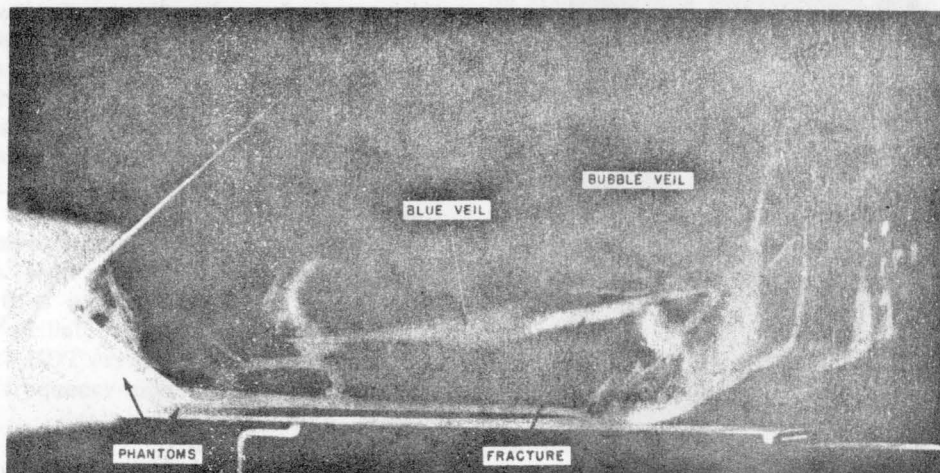

Figure 1-5. Quartz crystal containing inclusions and fractures *

structure is reversed—that is, one area will be right-handed and the other left-handed.

1-50. A finished plate, if it is to have predictable characteristics, must be cut entirely from a region having the same crystal structure; otherwise, the piezoelectric properties of one region will interfere with those of the other. Electrical twins are usually large, so both areas may be used separately for crystal blanks. Optical twinning, on the other hand, is usually confined to pockets, which are normally too small to provide crystal blanks, themselves, so that only the predominant crystal region can be utilized.

THE AXES OF QUARTZ

1-51. There are several crystallographic conventions by which the reference axes of crystals may be chosen, and much confusion has resulted in the past because of the various preferences of different crystallographers. Insofar as the over-all piezoelectric properties are concerned, the orientations of quartz have been universally measured according to rectangular sets of X, Y, and Z axes, with the XY, XZ, and YZ planes determined according to the crystal symmetries. However, even in this case, the choice of positive and negative axial and angular directions for right and left quartz remained more or less a matter of preference until the system proposed by the I.R.E. in 1949 became generally adopted. It is the I.R.E. system that will be followed here. It should be remarked first, however, that a crystal axis is not intended necessarily to coincide with a central point in the crystal, but may represent any straight line parallel to the axial direction. It might also be noted that the different types of crystal faces are designated in this manual by the small letters m, r, s, x, and z, and these should not be confused with the capital letters X, Y, Z which denote the axes, nor with the small letters, x, y, z, when used to denote dimensions of a crystal in the axial directions.

Z Axis

1-52. The Z axis is the lengthwise direction of the quartz prism and is perpendicular to the growth lines of all the m faces. It is an axis of three-fold symmetry, so that there are three sets of XY axes for each crystal (figure 1-6), with the direction of the Z axis common to all three. No piezoelectric effects are directly associated with the Z axis, and an electric field applied in this direction produces no piezoelectric deformation in the crystal, nor will a mechanical stress along the Z axis produce a difference of potential. Because the growth lines

are generally missing, optical effects are usually employed to locate the Z axis in raw quartz. (See paragraphs 1-121 to 1-124.) Quartz properties are such that light waves passing through a crystal are effectively divided into two rectilinear components, with one component traveling faster than the other except when the light ray is directed parallel to the Z axis. The optical effects are found to be symmetric about the Z axis, and thus whereas optical instruments may be used to determine this axis, they cannot be used to distinguish an X from a Y axis. For this reason the Z axis is commonly designated as the *optic axis*. The optical effects associated with the propagation of polarized light parallel to the optic axis not only are used to locate the Z axis in unfaced quartz (crystals, such as river quartz, whose natural faces have been destroyed), but to identify left from right quartz, and to locate twinned regions. Plane polarized light traveling parallel to the optic axis will be rotated in one direction or the other according to whether the crystal is left or right. To an observer looking toward the light source the rotation will be clockwise for right-handed quartz and counterclockwise for left-handed quartz, with the amount of rotation depending upon the wavelength, being greater for blue light (short wavelength) and less for red light (long wavelength). Since the crystal lattice along the optic axis has no properties that distinguish one direction from the other, the choice of the +Z and the -Z reference directions are entirely arbitrary for either right or left crystals.

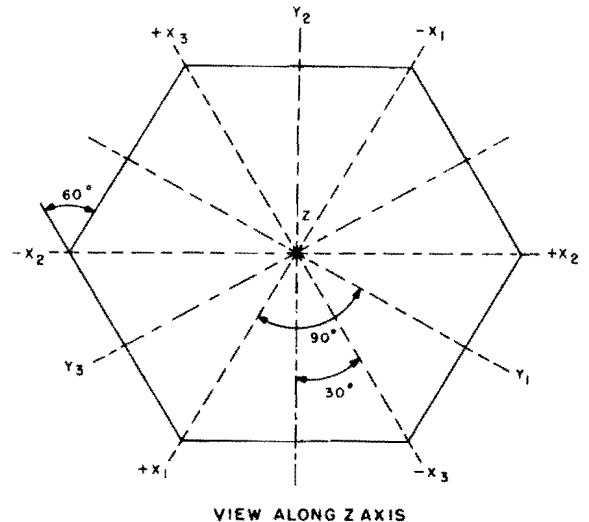

Figure 1-6. XY plane of quartz showing three sets of rectangular axes: X_1Y_1Z , X_2Y_2Z , X_3Y_3Z (Z axis is perpendicular to plane of paper)

Section I

Physical Characteristics of Piezoelectric Crystals

Y Axis

1-53. The Y axes are chosen at right angles to the Z axis and to the growth lines of the m faces. See figure 1-4. For either left or right quartz, the positive end of a Y axis emerges from an m face that is adjoined by a z face at the end selected as the +Z direction. The Y axes are generally called the *mechanical axes* in contradistinction to the X axes, which are called the *electrical axes*. These names originated from the fact that simple compressional and tensional mechanical stresses along either an X axis or a Y axis would cause a polarization of the X axis, but not of the Y axis. The names are somewhat misleading, for polarization in the Y direction is also possible if a crystal undergoes shearing or flexural strains. In practice, the Y axis of a quartz stone is usually determined after the Z and X axes have been located.

X Axis

1-54. The X axes are parallel to the growth lines of the m faces, and to the lines bisecting the 120-degree prism angles. The positive end of an X axis is the direction that forms a right-handed coordinate system (see figure 1-4) with the Y and Z axes. This makes the directional sense of the X axis in right quartz the reverse, rather than the mirror image, of that in left quartz. Thus, in right quartz the negative ends of the X axes emerge from the prism corners that lie between the x faces, whereas, in left quartz the positive ends emerge from these corners.

1-55. In either right or left quartz when the X axis undergoes a tensional strain (stretching), a positive charge appears at the end emerging between the x faces; and when the X axis is compressed, this end becomes negatively charged. The X axis of raw quartz is usually determined by optical and x-ray methods. See paragraphs 1-126 and 1-127.

THEORY OF PIEZOELECTRICITY

Report Announcing Discovery of the Piezoelectric Effect

1-56. The theory of the cause of piezoelectricity stated in the most general terms is substantially the same today as it was at the time of its discovery. The following is the original report by Pierre Curie on the piezoelectric effect, which includes a statement of the theory that led to its discovery. The paper was read at the April 8, 1880, meeting of the *societe mineralogique de France*, and is recorded in the *Bulletin, soc. min. de France*, volume 3, 1880.

1-57. "Crystals which have one or more axes whose ends are unlike, that is to say, hemihedral crystals with inclined faces, have a special physical property, that they exhibit two electric poles of opposite names at the ends of those axes when they undergo a change of temperature: this is the phenomenon known as pyroelectricity.

1-58. "We have found a new way to develop electric polarization in crystals of this sort, which consists of subjecting them to different pressures along their hemihedral axes.

1-59. "The effects produced are analogous to those caused by heat: during a compression, the ends of the axis along which we are acting are charged with opposite electricities; when the crystal is brought back to the neutral state and the compression is relieved, the phenomenon occurs again, but with the signs reversed; the end which was positively charged by compression becomes negative when the compression is removed and reciprocally.

1-60. "To make an experiment we cut two faces parallel to each other, and perpendicular to a hemihedral axis, in the substance which we wish to study; we cover these faces with two sheets of tin which are insulated on their outer sides by two sheets of hard rubber; when the whole thing is placed between the jaws of a vise, for example, we can exert pressure on the two cut surfaces, that is to say, along the hemihedral axis itself. To perceive the electrification we used a Thomson electrometer. We may show the difference of potential between the ends by connecting each sheet of tin with two of the sectors of the instrument while the needle is charged with a known sort of electricity. We may also recognize each of the electricities separately; to do this we connect one of the tin sheets with the earth, the other with the needle, and we charge the two pairs of sectors from a battery.

1-61. "Although we have not yet undertaken the study of the laws of this phenomenon, we are able to say that the characteristics which it exhibits are identical with those of pyroelectricity, as they have been described by Gaugain in his beautiful work on tourmaline.

1-62. "We have made a comparative study of the two ways of developing electric polarization in a series of non-conducting substances, hemihedral with inclined faces, which includes almost all those which are known as pyroelectric.

1-63. "The action of heat has been studied by the process indicated by M. Friedel, a process which is very convenient.

1-64. "Our experiments have been made on blende, sodium chlorate, boracite, tourmaline, quartz, calamine, topaz, tartaric acid (right handed), sugar, and Seignette's salt.

1-65. "In all these crystals the effects produced by compression are in the same sense as those produced by cooling; those which result from relieving the pressure are in the same sense as those which come from heating.

1-66. "There is here an evident relation which allows us to refer the phenomena in both cases to the same cause and to bring them under the following statement:

1-67. "Whatever may be the determining cause, whenever a hemihedral crystal with inclined faces, which is also a non-conductor, contracts, electric poles are formed in a certain sense; whenever the crystal expands, the electricities are separated in the opposite sense.

1-68. "If this way of looking at the matter is correct, the effects arising from compression ought to be in the same sense as those resulting from heating in a substance which has a negative coefficient of dilation along the hemihedral axis."

Asymmetrical Displacement of Charge

1-69. The atomic lattice of piezoelectric crystals is assumed to consist of rows of alternating centers of positive and negative charges so arranged that the structure as a whole has no center of symmetry. When such a lattice undergoes a deformation, a displacement will result between the "centers of gravity" of the positive and negative charges. It is this displacement that results in a net unneutralized dipole moment, the polarity of

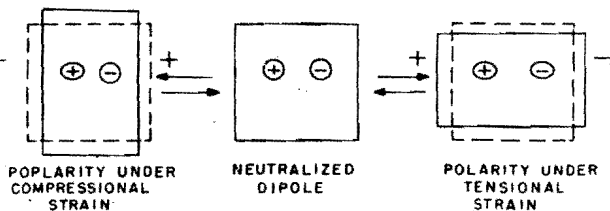

Figure 1-7. Effective polarities resulting from sudden displacements of the centers of charge of a neutralized dipole. (If after displacement, the crystal were maintained indefinitely in the strained position, the effective polarity would eventually be neutralized by an accumulation of ions at the poles. A sudden return from such a state would thus result in an effective polarization in the unstrained position)

which depends upon the previous equilibrium positions of the positive and negative centers of charge and the direction of the displacement, as indicated in figure 1-7.

1-70. In the case of a crystal with a center of symmetry, a uniform strain in the crystal will always result in as much displacement of like charges in one direction as in another, and hence there will be no net shift of the centers of opposite charge relative to each other. A distribution of charges having a center of symmetry is illustrated in figure 1-8. Note that the centers of charge, both positive and negative, are at the geometrical center. If a uniform stress—compressional, or shearing—is applied along any axis, it can be seen that the center of either type of charge will at all times remain undisturbed, and thus the net piezoelectric effect will be null.

1-71. Lord Kelvin was the first to propose a molecular model with a charge distribution designed to explain the physical and electrical characteristics of alpha quartz. See figure 1-9. This model was accepted generally by the crystallographers until the theory failed to conform to X-ray tests. When a beam of X-rays enters a crystal, the intersecting atomic planes can be likened to partially silvered mirrors, each passing part of the beam, but reflecting the rest. Since the distance between adjacent parallel planes is on the order of an X-ray wavelength, the waves reflected from adjacent planes will tend to alternately annul and reinforce each other as the angles of incidence vary. The interference pattern on a photographic film will show an array of spots indicating the angles at which the reflected waves from different planes arrive in phase. From such data, with the X-ray wavelength known, it is possible to determine the relative orientation of atomic planes, and hence to reconstruct the arrangement of the atoms in the crystal. The X-ray data on alpha quartz reveals a

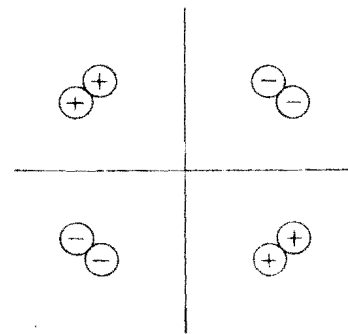

Figure 1-8. Example of distribution of charges having a center of symmetry *

Section I
Physical Characteristics of Piezoelectric Crystals

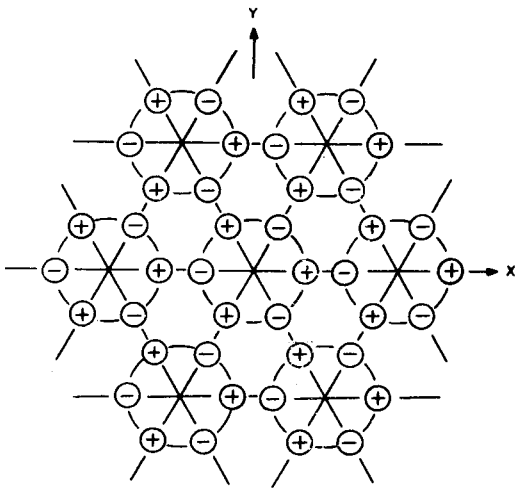
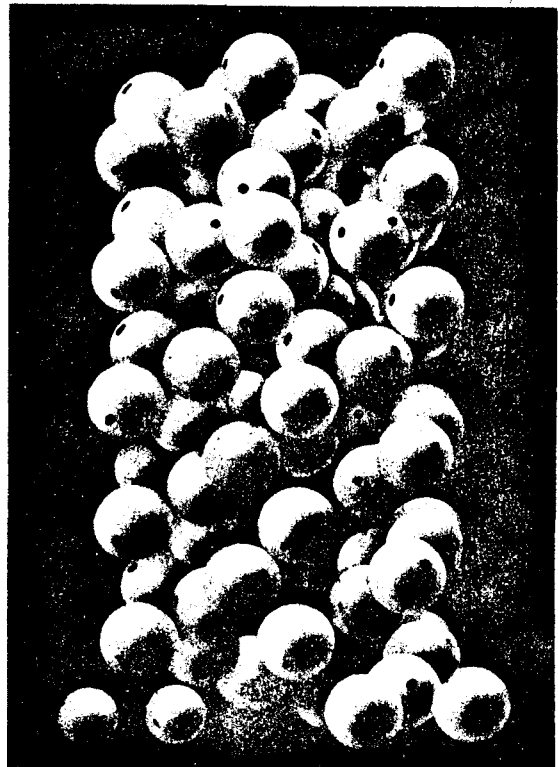

Figure 1-9. Kelvin's molecular model of the charge distribution of alpha quartz. The positive direction shown for the X axis corresponds to that of right quartz, for a compression of the crystal along that axis will cause the piezoelectric polarities to coincide in sign with the X-axial directions. For left quartz, the sign of the Y, as well as the X, axis must be reversed in order to maintain a right-handed coordinate system *



ARRANGEMENT OF ATOMS IN ALPHA QUARTZ, VIEWED ALONG AN X AXIS

Figure 1-10. Arrangement of atoms in alpha quartz. Plane of paper corresponds to YZ plane in crystal

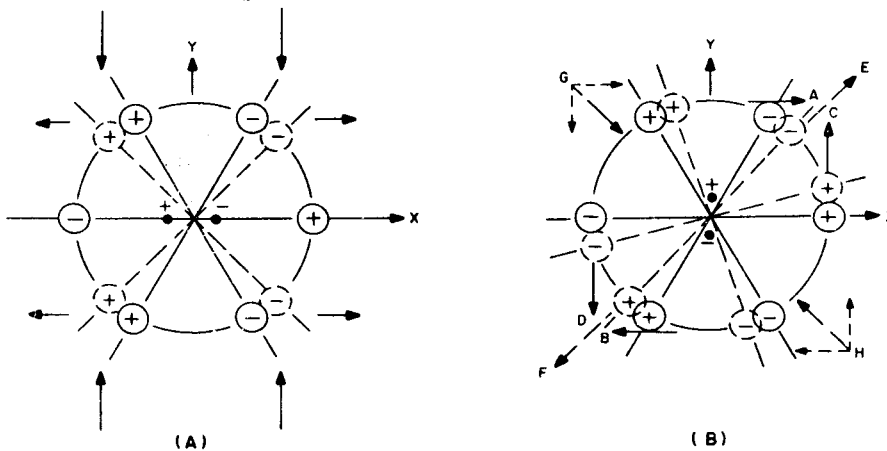

Figure 1-11. Equivalent distribution of charges that account for observed piezoelectric effects of alpha quartz. (A) Piezoelectric polarity along X axis of right quartz due to compression along Y axis. (B) Piezoelectric polarity of Y axis of right quartz due to shearing stress, where the resultant strain is equivalent to a compression along the axis designated GH. (Note that in both A and B, the piezoelectric effect is due to a rocking of the axial dipoles, and not to their compression or extension. To achieve the same deformations by the converse effect, equal voltages, but opposite in sign to the polarizations indicated, are applied across the respective axes) *

more complex structure than was once suspected. See figure 1-10. Nevertheless, the early crystal model, as postulated by Lord Kelvin, still can be accepted as an approximation if we treat a single one of his molecules as representing simply the equivalent charge distribution within the lattice, as indicated in figure 1-11.

1-72. Figure 1-11A shows the displacement occurring when a compressional stress is applied along the Y axis, or a tensional stress is applied along the X axis of a right-handed crystal. Note that the center of positive charge shifts in the negative direction of the X axis, and that the center of negative charge shifts in the positive direction; however, there is no net displacement along the Y axis. If the direction of the stress is reversed, so also is the effective polarity.

1-73. The polarization of the Y axis due to a shearing strain is illustrated in figure 1-11B. Assume that vectors A and B represent a simple shearing stress applied at right angles to the Y axis. If A and B are equal and opposite forces, there will be no displacement of the center of mass; however, since these forces are not directed in the same straight line, they create a couple which would maintain a rotational acceleration about the center of mass unless opposed by an equal and opposite couple. This counter-couple is represented by vectors C and D. If now, the forces are combined vectorially, they may be represented as a longitudinal tension in the EF direction, or as a longitudinal compression in the GH direction. Consider the charge displacement from the point of view of a GH compression. Note that each of the positive charges is forced to shift slightly in the +Y direction, whereas each of the negative charges is displaced in the -Y direction. The net separation of the centers of charge thus causes the Y axis to become positively polarized at its geometrically positive end, and negatively polarized at its geometrically negative end.

1-74. Since the compression can be further analyzed into two components of equal magnitude—one horizontal, and the other vertical—it can be seen (figure 1-11A) that the polarities which these would induce along the X axis tend to cancel (for reinforcement to occur, one of the rectangular components would need to be tensional and the other compressional), and hence little or no polarization will appear in this direction.

MODES OF VIBRATION

1-75. If a piezoelectric crystal is suddenly released from a strained position, the inertia and elasticity

of the crystal will tend to maintain a state of mechanical oscillation of constant frequency about one or more nodal points, lines, or planes of equilibrium, and alternating voltages will appear according to the particular mode of vibration. These are called the normal, or free, vibrations of a crystal, as distinct from the forced vibrations due to applied alternating mechanical or electrical forces that may differ in frequency from the crystal's natural resonance. The normal vibrations may, in turn, be of two general types: the free-free and the clamped-free vibrations. Free-free vibrations are those which would occur if a vibrating crystal were floating in empty space, where, regardless of the particular mode, the center of gravity is a nodal point. Clamped-free vibrations are those that would occur if a crystal were clamped at some point, or points, thereby preventing all normal modes except those at which nodes occur at the clamped points. For example, in a free-free vibration the ends of the crystal are free to move; however, if these ends are clamped, the resonant vibrations must be such that the ends become nodes. However, if a crystal is clamped only at those points which would be nodes in a free-free vibration, in the ideal case no interference results, and the resonance is still that of a free-free mode.

1-76. There are three general modes of vibration for which quartz crystal units are commercially designed: extensional, shear, and flexure. Fundamental vibrations of each of these modes are illustrated in figure 1-12. Higher harmonics up to and including the fifth are also widely used. Harmonic vibrations higher than the seventh have special high-frequency applications, but are rarely employed commercially.

1-77. A variation of the shear vibration is the torsional mode, which is readily excited in cylindrical crystals; however, except for laboratory

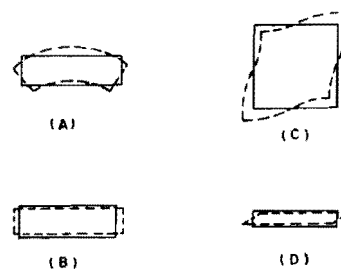

Figure 1-12. Useful fundamental modes of quartz plates. (A) Flexural. (B) Extensional or longitudinal. (C) Face (or length-width) shear. (D) Thickness shear.*

Section I
Physical Characteristics of Piezoelectric Crystals

measurements of the properties of solids and liquids this mode is not in general use.

Frequency of Quartz Vibrations

1-78. The frequencies of the normal mechanical oscillations of a quartz plate may be considered as those at which standing waves will be established by reflection from the crystal boundaries. The positions of the nodes of the standing waves are predetermined by the geometry of the crystal, and by any difference that may exist in the velocities of propagation for the different wave components. The wavelength of a particular mode (but not the wave shape, if the velocity of one component differs from that of another) conforms only to the dimensions of the crystal faces. The frequency is related to the wavelength by the equation:

$$f = \frac{v}{\lambda} \quad 1-78 (1)$$

where: v = velocity of propagation
 λ = wavelength

The fundamental equation of the velocity of propagation is:

$$v = \sqrt{\frac{c}{\rho}} \quad 1-78 (2)$$

where: c = stiffness factor in the direction of propagation

ρ = density

or:
$$v = \sqrt{\frac{1}{\rho s}} \quad 1-78 (3)$$

where: $s = \frac{1}{c}$ = elastic compliance factor in the direction of propagation

Length- (or Width-) Extensional Mode

1-79. The motion of the atoms in an extensional mode is parallel to the direction of propagation. In the case of rectangular plates, stationary waves are established in the length direction by the interference of reflections from the opposite ends, where the wavelength is given by the formula:

$$\lambda = \frac{2l}{n} \quad 1-79 (1)$$

where l is the length and n is an integer (1, 2, 3, etc.) equal to the harmonic. Thus, the frequency

of a length-extensional mode is:

$$f = \frac{nv}{2l} \quad 1-79 (2)$$

or, as expressed in terms of a frequency constant:

$$f = \frac{nk_1}{l} \quad 1-79 (3)$$

where: $k_1 = \frac{v}{2}$ = frequency constant
for length-extensional mode

This formula, as well as the similar formulas for the shear and flexure modes, can be used to indicate the approximate dimensions required for a particular frequency when the appropriate frequency constant is known. Although the velocity of propagation decreases somewhat as the frequency increases, because of an increase in the frictional losses, this decrease is negligible for most purposes, and the same frequency constants that hold for the fundamental are also valid for the first few overtones. However, because of the coupling that exists between the length-extensional mode and other modes, the effective value of k will vary with changes in the w/l (width/length) ratio. Equation (3) also applies to width-extensional modes except that l is replaced by the width, w .

Thickness-Extensional Mode

1-80. This mode is little used today because of the close coupling that exists between it and the overtones of other modes. It is a mode that can be excited in a crystal whose thickness dimension is parallel to the electrical (X) axis (X-cut crystal)—the vibrations being such that the crystal alternately becomes thicker and thinner. Formerly, when X-cut crystals were widely used, the same crystal was often employed for the control of either a high- or a low-frequency circuit—using the thickness-extensional mode for the former and the length-extensional mode for the latter. Today, however, the more stable thickness-shear mode has almost entirely replaced the thickness-extensional mode in high-frequency circuits. The thickness-extensional frequency is given by the formula:

$$f = \frac{nv}{2t} = \frac{nk_2}{t} \quad 1-80 (1)$$

where v is the velocity of propagation in the thickness direction, n is the harmonic ($n = 1, 3, 5,$ —for practical cases, although even harmonics of very small intensities have been observed), and k_2 is

the generalized frequency constant. Actually, the effective thickness, t , decreases somewhat for the overtones, so that the correct value of k_2 is slightly greater for the harmonics than for the fundamental.

Thickness-Shear Mode

1-81. The motion of the atoms in a thickness-shear mode is parallel to the major (length-width) faces of the crystal, whereas the wave propagation is parallel to the thickness dimension. The equation for the fundamental frequency when the thickness is very small compared with the length and width is:

$$f = \frac{v}{2t} \quad 1-81 (1)$$

where: v = velocity of propagation along thickness dimension

t = thickness

or, as expressed in terms of a thickness-shear frequency constant:

$$f = \frac{k_3}{t} \quad 1-81 (2)$$

The thickness-shear is also called the "high-frequency shear" in contradistinction to the "face," "length-width," or "low-frequency" shear. The overtones of the thickness-shear mode may have components (reversals of phase) in the length and width directions as well as along the thickness. The more general formula for the frequency is:

$$f = k_3 \sqrt{\frac{m^2}{t^2} + \frac{n^2}{l^2} + \frac{p^2}{w^2}} \quad 1-81 (3)$$

where m , n , and p are integers representing the harmonic component in the t , l , and w directions, respectively. The above equation applies to an isotropic medium; however, since the elastic constants in quartz are not the same in all directions, the thickness-shear formula has been modified to:

$$f = k_3 \sqrt{\frac{m^2}{t^2} + a_1 \frac{n^2}{l^2} + a_2 \frac{(p-1)^2}{w^2}} \quad 1-81 (4)$$

where a_1 and a_2 are constants to be determined empirically. For most applications, t is much smaller than l and w , and $n = p = 1$, so that the formula, $f = \frac{k_3 m}{t}$, is sufficiently accurate.

Face-Shear Mode

1-82. The face-shear mode involves a more com-

plex relation among the crystal dimensions. A complication arises from the fact that the wave is effectively divided into two components—one propagated along the length, and the other along the width. Each of these separate components has its own series of possible harmonics, so that the resultant frequencies of the face-shear modes are not necessarily integral multiples of the fundamental. The approximate-frequency equation is:

$$f = \frac{v}{2} \sqrt{\frac{m^2}{l^2} + a_1 \frac{n^2}{w^2}} = k_4 \sqrt{\frac{m^2}{l^2} + a_1 \frac{n^2}{w^2}} \quad 1-82 (1)$$

where m and n are integers representing the length and width harmonics, respectively. The symbol a_1 is a constant of proportionality, approximately equal to one, which is inserted when the velocity of propagation along w is not the same as that along l . If the face of the plate is square, the formula for the fundamental frequency is reduced to approximately:

$$f = \frac{k_4}{w} \quad 1-82 (2)$$

where: $k_4 = k_4' \sqrt{2}$

The fundamental vibration, where $m = n = 1$, is shown in figure 1-12C. Note that the shape of the deformation is not that of a parallelogram, as it would be if the plate were slowly compressed along a diagonal. Rather, the vibrational distortion is a dynamic one, and the resultant wave must be in the same phase at all points. Figure 1-13 represents the face-shear mode for $m = 6$, $n = 3$. Note that the number of nodes in each row is equal to m , and the number in each column is equal to n .

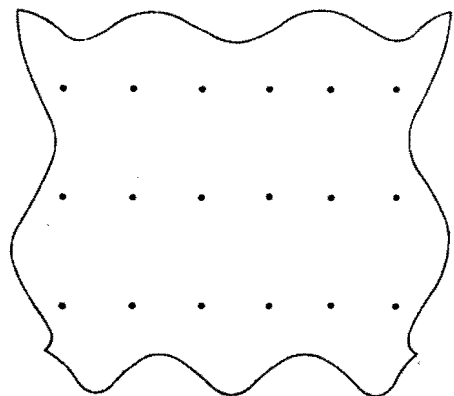

Figure 1-13. Face-shear mode for $m = 6$, $n = 3$. Dots indicate nodes *

Section I

Physical Characteristics of Piezoelectric Crystals

Length-Width-Flexural Mode

1-83. The length-width-flexural mode is a bending of the crystal in the length-width plane. Normally, the crystal is so mounted that the ends are free to vibrate in a free-free mode. The formula for the frequency involves the root of a transcendental equation, but expressed in terms of a frequency constant, the equation becomes:

$$f = \frac{k_6 w}{l^2} \quad 1-83 (1)$$

The convenience of a common frequency constant for all practicable harmonics is not realized in the case of length-width flexures, where the "constant" k_6 is a function not only of the particular harmonic, but also of l and w . However, for long, thin rods ($\frac{nw}{l}$ less than 0.1, where n is the harmonic) k_6 is approximately independent of the dimensions, and fixed values of k_6 can be assumed for the particular harmonics of different types of cuts. Because of the elastic cross constants in quartz, which relate a field in one direction to a polarization in a perpendicular direction, a flexure may be accompanied by a torsion. To prevent this, the length of a crystal to be operated in a flexural mode should lie somewhere in a YZ plane.

Length-Thickness-Flexural Mode

1-84. Length-thickness flexures are used to control frequencies in the audio range. To obtain this mode, two long, thin plates of the same cut are cemented together with the electrical axes opposed, so that, when an alternating voltage is applied across the outer faces, one crystal strip expands as the other contracts, and vice versa—the over-all effect being a flexural vibration. The normal frequency of a free-free length-thickness flexure is given by an equation similar to that for the length-width flexure, except that the thickness, t , is substituted for the width, w . Thus:

$$f = nk_6 \left(\frac{t}{l^2} \right) \quad 1-84 (1)$$

Frequency Range of Normal Modes

1-85. Standard quartz crystal units are designed for frequencies from 400 cycles to 125 megacycles per second. Laboratory devices have employed thickness flexure crystals for the control of frequencies as low as 50 cycles per second, and, by exciting the higher thickness-shear modes, control of frequencies higher than 200 megacycles per second have been realized. At these high frequen-

cies, however, so many interlocking modes are possible that it is difficult to prevent a crystal from jumping from one mode to another during slight variations of temperature, unless a very precise fabrication of the crystal unit has been achieved. The high-frequency limit of the lower harmonics is reached when the dimensions are so small that either the crystal cannot be driven without the risk of shattering, or that the impedances introduced by the mounting become proportionately too large for practicable operation.

1-86. The practical frequency ranges of the different modes are as follows:

Flexure Mode—

Length-thickness: 0.4 to 10 kc

Length-width: 10 to 100 kc

Extensional Mode—

Length: 40 to 350 kc

Thickness: 500 to 15,000 kc

Shear Mode—

Face: 100 to 1800 kc

Thickness (fundamental): 500 to 20,000 kc

Thickness (overtones): 15,000 to 125,000 kc

ORIENTATION OF CRYSTAL CUTS

Right-Handed Coordinate System

1-87. With the positive sense of the quartz X, Y, and Z axes determined as in paragraphs 1-52, 1-53, and 1-54, the positive sense of rotation about the axes is fixed by the conventions of a right-handed

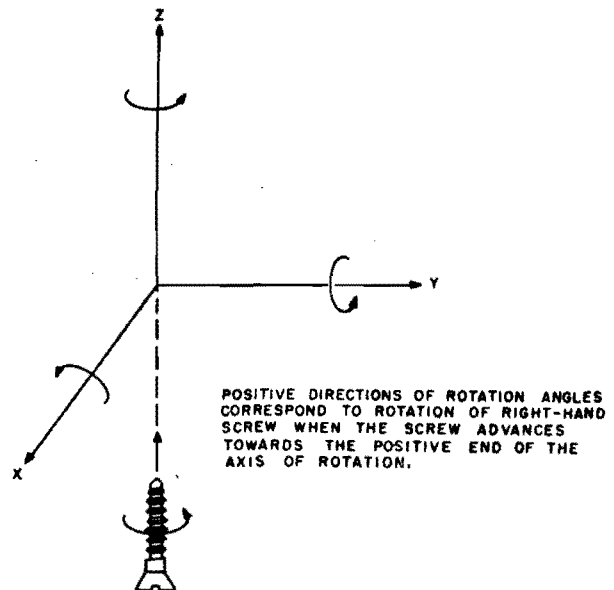

Figure 1-14. Positive directions of angles of rotation according to conventions of right-handed coordinate system

coordinate system for both right and left quartz. If one imagines a right-handed screw pointing towards the positive end of an axis of rotation, as represented in figure 1-14, the direction of an angle of rotation is considered positive if the rotation advances the screw in a positive direction—this corresponds to a clockwise rotation if observed when looking towards the positive end of the axis of rotation. The reverse, or counterclockwise, angles of rotation are taken as negative. The sense of the axes are such that the angles of rotation are positive when the directions of rotation are from +X to +Y, +Y to +Z, and +Z to +X. The axial and rotational conventions permit a particular cut of crystal to have the same rotation symbol for both right and left quartz.

Rotation Symbols

1-88. To specify the orientation of a piezoid cut, the following system, as recommended by the I. R. E. in 1949 is in general use. The crystal blank to be described is assumed to have a hypothetical initial position, with one corner at the origin of the coordinate system, and the thickness, length, and width lying in the directions of the rectangular axes. There are six possible initial positions, each of which is specified by two letters, the first letter indicating the thickness axis, and the second letter indicating the length axis. These positions are thus designated xy, xz, yx, yz, zx, and zy. The xy and yx positions are shown in figures 1-15 and 1-16, respectively. The starting position is so chosen that the final orientation may be reached with a minimum number of rotations. These rotations are taken successively about axes that parallel the

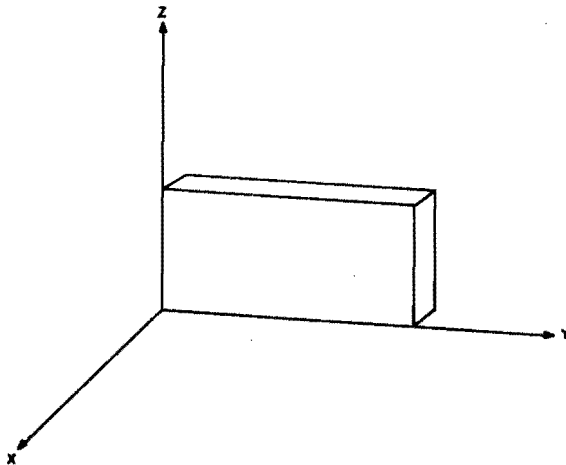

Figure 1-15 xy initial position for designating orientation of crystal cut

dimensions of the crystal at the time of rotation. Only the first rotational axis will coincide with a rectangular axis; however, the positive direction of any axis of rotation is that defined by the XYZ system for the initial position. A single rotation is sufficient for describing the majority of standard cuts, and three rotations is the maximum in any case. The dimensions and axes of rotation are indicated by the symbols, t, l, and w, for thickness, length, and width, respectively. The Greek letters ϕ , θ , and ψ designate the first, second, and third angles of rotation, respectively. The following example, illustrated in figure 1-17, is a complete geometrical specification of a crystal plate:

$$\begin{aligned} & yztlw \ 30^\circ/15^\circ/25^\circ \\ & t = 0.80 \pm 0.01 \text{ mm} \\ & l = 40.0 \pm 0.1 \text{ mm} \\ & w = 9.00 \pm 0.03 \text{ mm} \end{aligned}$$

The lettered combination at the beginning of the specification is called the "rotation symbol." The first two letters, yz, of the symbol indicate the initial position, and the next three letters, twl, state the axes of rotation and the order in which the rotations are taken. The three angles, all positive in this case, give the orientation and are listed in the same order as the respective rotations. The dimensions listed are those of the particular plate, and are not to be considered as necessary specifications for that type of cut. For circular plates, the initial position will indicate which directions are to be considered thickness and length, so that the same rotation symbol is used as for rectangular

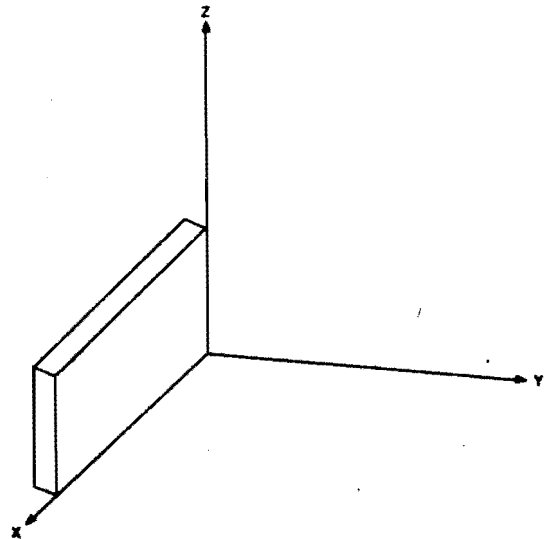

Figure 1-16 yx initial position for designating orientation of crystal cut

Section I
Standard Quartz Elements

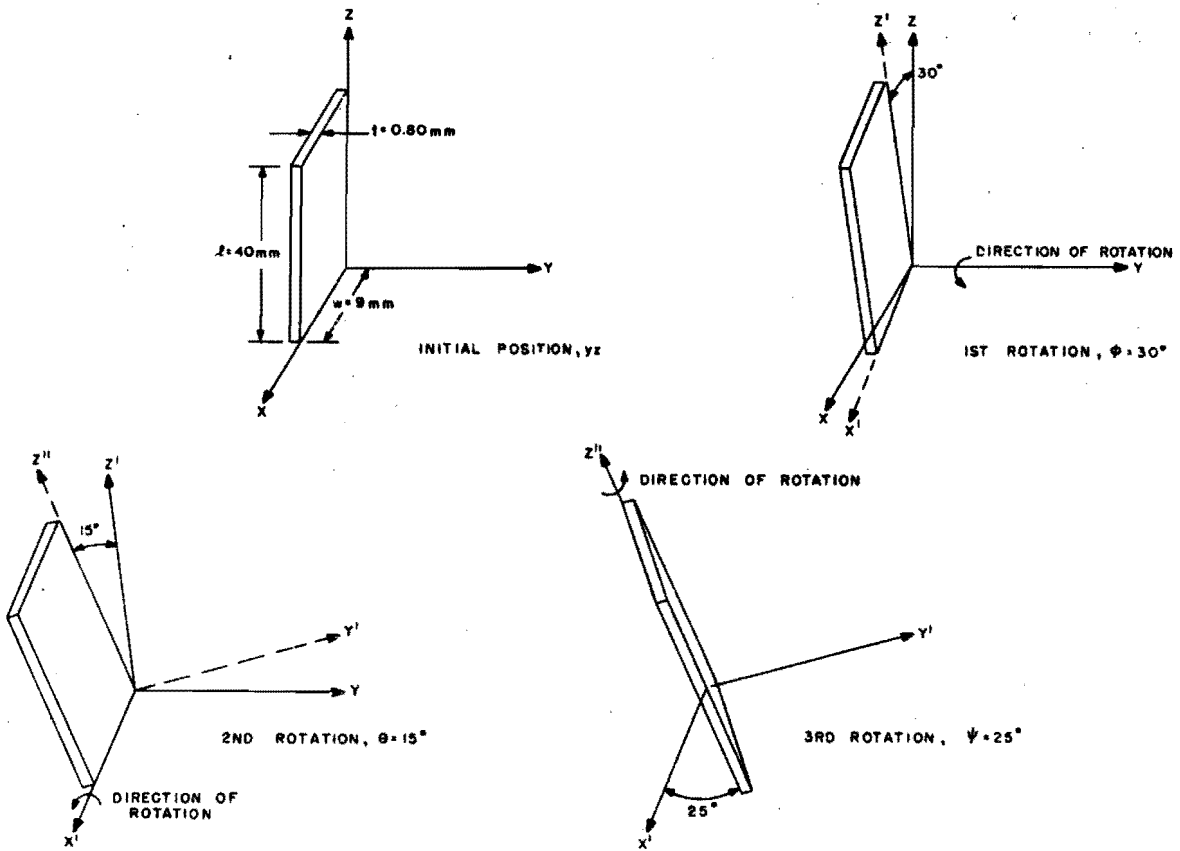

Figure 1-17 Orientation of crystal having the rotational specifications *yzwtl*: 30°/15°/25°

plates; in specifying the dimensions, however, *l* and *w* are replaced by the diameter.

PIEZOELECTRIC ELEMENTS

1-89. The performance characteristics of a crystal plate are dependent on both the particular cut and

the mode of vibration. For convenience, each "cut-mode" combination is considered a separate "piezoelectric element," and the more commonly used elements have been assigned a letter symbol. For example, the thickness-shear mode of the AT cut is designated as element A.

STANDARD QUARTZ ELEMENTS

1-90. The principal quartz elements are given below, with those which have been assigned element

symbols listed first.

<i>Element Symbol</i>	<i>Name of Cut</i>	<i>Rotation Symbol and Orientation</i>	<i>Mode of Vibration</i>	<i>Frequency Range in KC</i>
A	AT	<i>yx</i> l 35°21' or <i>yzw</i> 35°21'	thickness-shear	500 to 125,000
B	BT or YT*	<i>yx</i> l -49°8' or <i>yzw</i> -49°8'	thickness-shear	1,000 to 75,000
C	CT	<i>yx</i> l 37°40' or <i>yzw</i> 37°40'	face-shear	300 to 1,100
D	DT	<i>yx</i> l -52°30' or <i>yzw</i> -52°30'	face-shear	60 to 500
E	+5°X	<i>xyt</i> 5°	length-extensional	50 to 500

* The YT cut, which is essentially the same as the BT cut, was developed independently by Yoda in Japan.

Element Symbol	Name of Cut	Rotation Symbol and Orientation	Mode of Vibration	Frequency Range in KC
F	-18.5°X	xyt -18.5°	length-extensional	60 to 300
G	GT	yxlt -51°7.5'/45°	width-extensional	100 to 550
H	5°X	xyt 5°	length-width flexure	10 to 50
J	Duplex 5°X	xyt 5° (right quartz) and xyt 5° (left quartz)	length-thickness flexure	0.4 to 10
M	MT	xytl 0° to 8.5°/±34° to ±50°	length-extensional	50 to 500
N	NT	xytl 0° to 8.5°/±38° to ±70°	length-width flexure	4 to 100
—	AC	yx1 31° or yzw 31°	thickness-shear	1,000 to 15,000
—	BC	yx1 -60° or yzw -60°	thickness-shear	1,000 to 20,000
—	ET	yx1 66°30' or yzw 66°30'	combination flexure and face-shear	600 to 1,800
—	FT	yx1 -57° or yzw -57°	combination flexure and face-shear	150 to 1,500
—	V	xzlw or xywl 15° to 29°/-14° to -54° and 13° to 29°/27° to 42°	thickness-shear	1,000 to 20,000 (fundamental)
—	V	xzlw or xywl 0° to 30°/±45° to ±70°	face-shear	60 to 1,000
—	X	xy	length-extensional	40 to 350
—	X	xz	width-extensional	125 to 400
—	X	xy or xz	thickness-extensional	350 to 20,000
—	Y	yx or yz	thickness-shear	500 to 20,000

TYPES OF CUTS

1-91. The standard quartz elements can be divided into two groups: in the first group belong those crystals which are most conveniently described as being rotated X-cut crystals, and in the second group belong those crystals which are most conveniently described as being rotated Y-cut crystals. The first will hereafter be designated as the *X group*, and the second as the *Y group*.

1-92. The X and Y cuts have their thickness dimensions parallel to the X and Y axes, respectively, with the length and width dimensions parallel to the two remaining axes. See figure 1-18. Thus, in describing a crystal orientation, the X cut is the equivalent of the two initial positions xy and xz, and the Y cut is represented by the initial positions yx and yz. Belonging to the X and Y groups, then, are those crystals whose rotation symbols begin with the letters x and y, respectively. As a general rule, from the X group, the low-frequency crystal units are obtained, and from the Y group, the medium- and high-frequency units. A third group

of crystals is theoretically possible, where the initial position is a Z cut (thickness parallel to the Z axis); however, because the piezoelectric effect

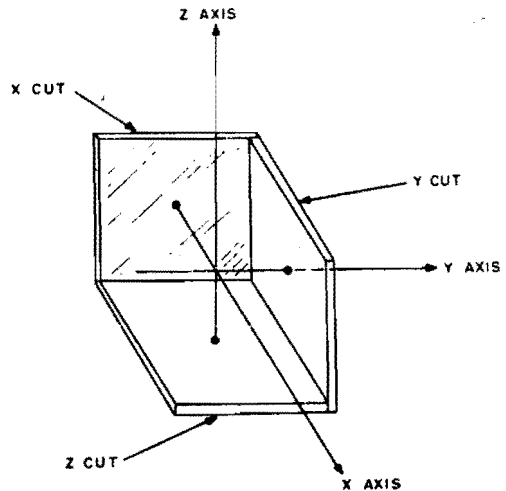

Figure 1-18 Orientation of X, Y, and Z cut plates

Section I
Standard Quartz Elements

is restricted to the X and Y axes, the electrodes must be placed across one of these axes, which for the Z cut, would be at the edges—not a convenient location. Nor have other cuts, more or less simply oriented relative to a Z cut, been found to have optimum performance characteristics. However, there are experimental Z cuts, such as some of the ring-shaped crystals, which have proven of high quality, even though not practical for general use.

The X Group

1-93. The principal crystals of the X group are listed below with the frequency ranges for which they have found commercial application:

Name of Cuts	Frequency Range in KC
X	40 to 20,000
5°X	0.9 to 500
-18°X	60 to 350
MT	50 to 100
NT	4 to 50
V	60 to 20,000

Figure 1-19 shows the orientations of an xy initial position (X cut with the length parallel to the Y axis) for the various cuts.

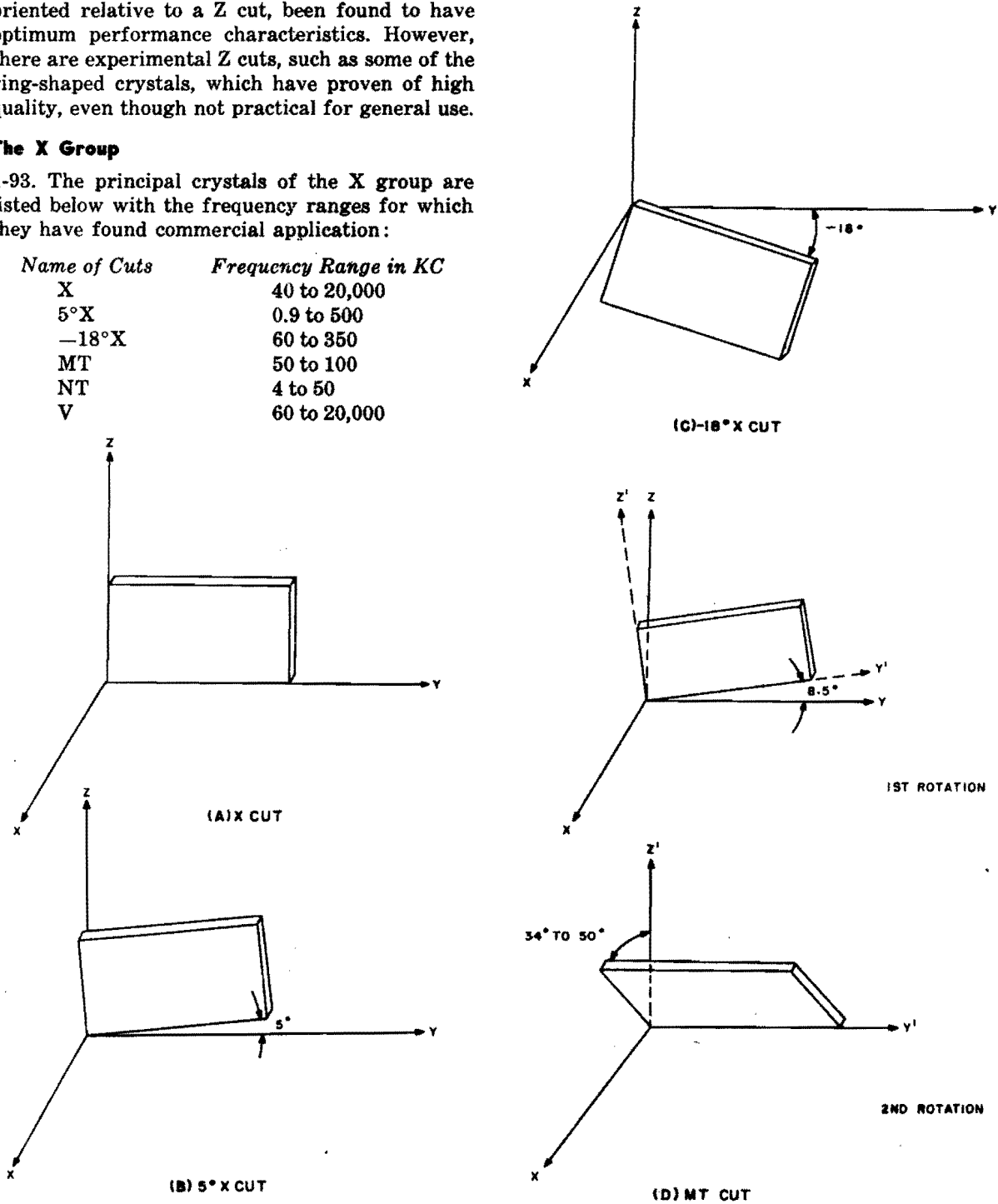
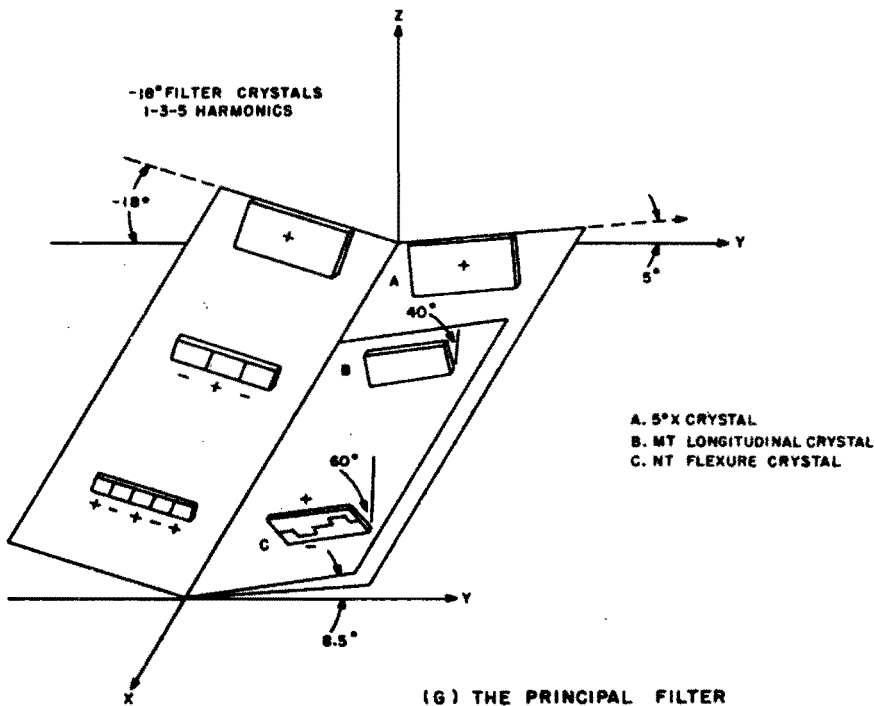
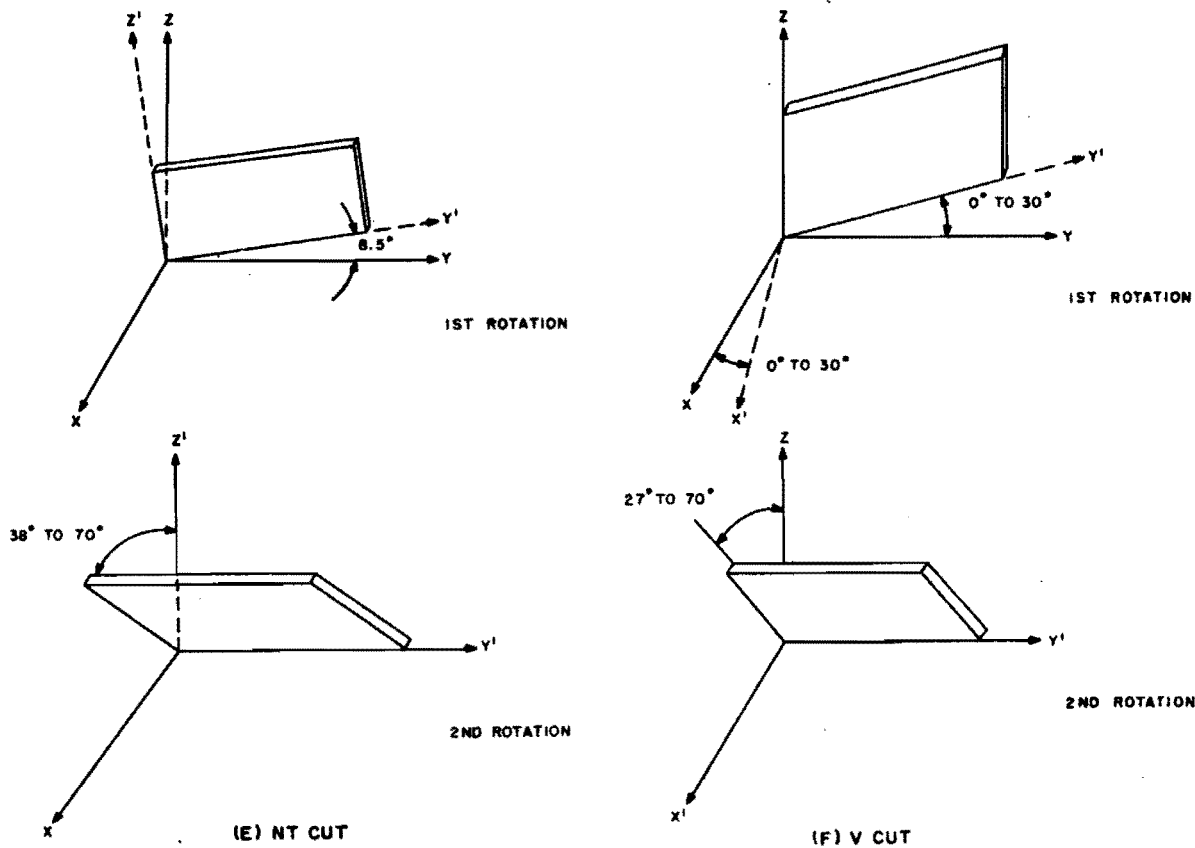

Figure 1-19. The X group. (The second rotations of the MT, NT, and V cuts are shown only for the positive angles) *



Section I
Standard Quartz Elements

THE X CUT

1-94. The X cut was the original quartz plate investigated by Curie, and thus is sometimes called the "Curie cut." This cut was also the first to be used as a transducer of ultrasonic waves and as the control element of radio-frequency oscillators. However, because of its comparatively large coefficient of temperature, the X-cut plate is now rarely used in radio oscillators. As a transducer of electrical to mechanical vibrations, especially at high frequencies of narrow bandwidth, the X cut has a high electromechanical coupling efficiency, and is still widely used to produce ultrasonic waves in gases, liquids, and solids. These applications are largely for testing purposes, such as the measurement of physical constants and the detection of flaws in metal castings.

1-95. CHARACTERISTICS OF X-CUT PLATES IN THICKNESS-EXTENSIONAL MODE

Description of Element: X cut; xy or xz; thickness-extensional mode.

Frequency Range: 350—20,000 kc (fundamental vibration); lower frequencies when coupled as transducer for generating vibrations in liquids and solids.

Frequency Equation: $f = \frac{nk_2}{t}$ ($n = 1, 3, 5, \dots$)

Frequency Constant: $k_2 = 2870$ kc-mm.

Temperature Coefficient: 20 to 25 parts per million per degree centigrade; negative (i.e. for each degree increase or decrease in temperature, the frequency respectively decreases or increases 20 to 25 cycles for each megacycle of the initial frequency—a rise in temperature of 10°C would thus cause the frequency of a 5000-kc crystal to drop 1000 to 1250 cycles per second.)

**Methods of Mounting:* Sandwich and unclamped air-gap—for oscillator circuit; transducer mounting depends upon particular type of mechanical load.

Advantages: Mechanical stability, economy of cut, efficiency of conversion of electrical to mechanical energy, and large frequency constant make this piezoelectric element preferred for the radiation of high-frequency acoustic waves when the ratio of the highest to the lowest frequency need not exceed 1.1.

Disadvantages: Large temperature coefficient, tendency to jump from one mode to another, and the difficulty of clamping crystal in a fixed position without greatly damping the

* See paragraphs 1-132 to 1-171.

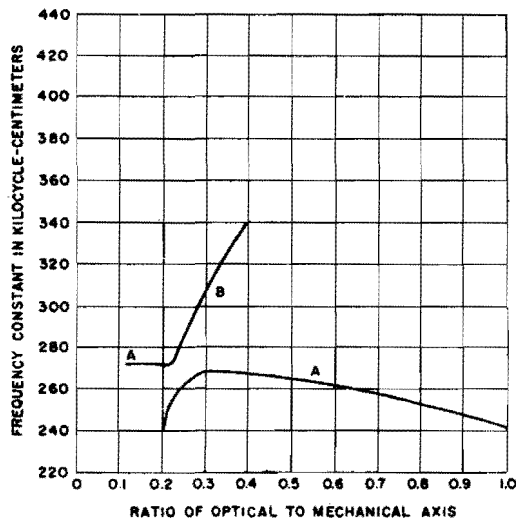

Figure 1-20. Frequency constant for length-extensional mode (curve A) of X-cut crystal where the width and length are parallel to the Z and Y axes, respectively. Curve B is the frequency constant of a face-shear mode coupled to a second flexural mode, whose interference makes the crystal useless for w/l ratios between 0.2 and 0.3, unless the thickness approaches the dimensions of the width *

normal vibration prevent this element from being preferred for oscillator control. An electromechanical coupling factor of 0.095, which is only one-fourth that of the best synthetic crystals, makes this element inefficient as a radiator of a wide band of frequencies.

1-96. CHARACTERISTICS OF X-CUT PLATES IN LENGTH-EXTENSIONAL MODE

Description of Element: X-cut; xy; length-extensional mode.

Frequency Range: 40—350 kc.

Frequency Equation: $f = \frac{nk_1}{l}$ ($n = 1, 2, 3, \dots$)

Frequency Constant: Varies with w/l ratio—see figure 1-20.

Temperature Coefficient: Negative**, varies with w/l ratio—see figure 1-21; zero coefficient if $w/l = 0.272$ and $w = t$.

Methods of Mounting: Sandwich, air gap, wire, knife-edge clamp, pressure pins, cantilever clamp; more than one pair of electrodes required for overtones; transducer mounting depends upon particular type of mechanical load.

** All quartz bars have negative temperature coefficients for pure length-extensional vibrations, although a zero coefficient is obtainable for certain cuts.

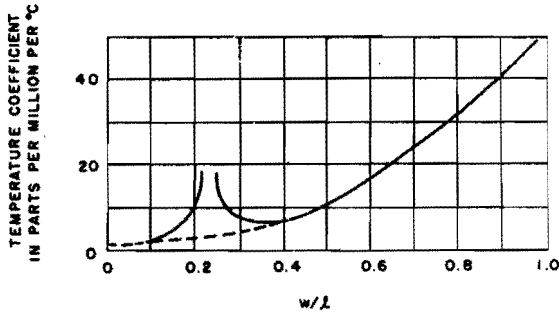

Figure 1-21. Temperature coefficient for length-extensional mode of X-cut crystal, where w is parallel to the Z axis, and $t = 0.051$

Advantages: For w/l ratios from 0.35 to 1.0, the fundamental length-extensional vibration is not strongly coupled to other modes, and hence the resonance is easily excited and of good stability except for drift during temperature variations. Although not preferred over zero-temperature-coefficient cuts, this element, with temperature control, is reliable for use in low-frequency oscillators, and for long, thin bars, for use in filters. However, its most important application is to produce ultrasonic vibration in gases, liquids, and solids, when the ratio of highest to lowest frequency need not exceed 1.1.

Disadvantages: Inefficient as transducer of any but narrow frequency band, since electro-mechanical coupling is only one-fourth that of the better synthetic crystals. Strong coupling with a flexural mode makes the crystal useless at w/l ratios between 0.2 and 0.3 (see figure 1-20), and a weak coupling with a shear mode causes the frequency constant to decrease as the w/l ratio approaches 1.0. This coupling to other modes interferes with the frequency response of the element when used in filters, unless the w/l ratio is 0.1 or less. Although for long thin bars the temperature coefficient is only about 2 parts per million per degree, this is greater than the minimum obtainable with 5° X-cut bars.

1-97. CHARACTERISTICS OF X-CUT PLATES IN WIDTH-EXTENSIONAL MODE

Description of Element: X-cut; xz; width-extensional mode.

Frequency Range: 125 to 400 kc.

Frequency Equation: $f = \frac{nk_1}{w}$ ($n = 1, 2, 3, \dots$)

Frequency Constant: Varies with w/l ratio; see

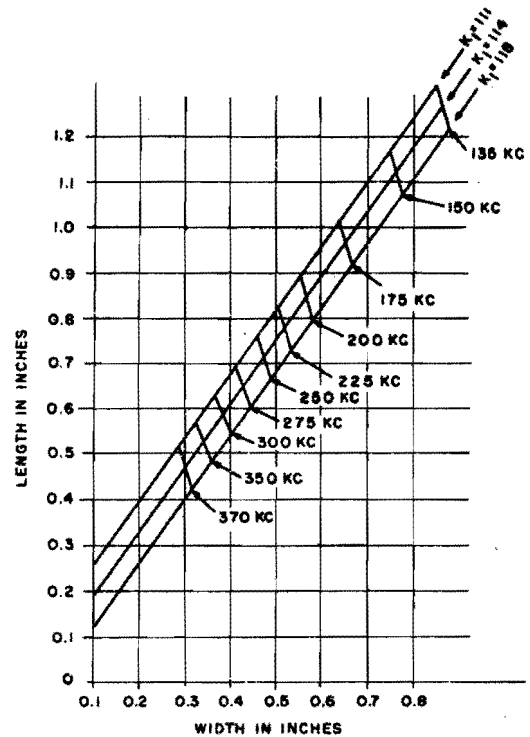

Figure 1-22. Frequency characteristics of X-cut crystal vibrating in width-extensional mode, where the width is parallel to the Y axis. w/l ratios not included between the two outer curves will have interfering modes. K_1 is in kc-inches

figure 1-22, which shows the face dimensions that will have a single frequency near the desired resonance. Plates with dimensions not included between the two outer curves will have interfering modes.

Temperature Coefficient: Negative; approximately 10 parts per million per degree centigrade, but varies with w/l ratio.

Methods of Mounting: Sandwich, air gap, wire, knife-edge clamp, pressure pins, cantilever clamp.

Advantages: If cut with dimensions within the single-frequency range shown in figure 1-22, this element can be used in temperature-controlled low-frequency oscillators and narrow-band-pass filters. With the thickness dimension ground for a particular high frequency, the same crystal unit may be used to generate either of two widely separate frequencies.

Disadvantages: Relatively large temperature coefficient prevents this element from being preferred over the low-coefficient cuts.

Section I
Standard Quartz Elements

THE 5° X CUTS

1-98. The 5°X cut is the orientation that provides a zero temperature coefficient for the lengthwise vibrations of long, thin X bars, as shown in figure 1-23. Thus, this cut is preferred over the non-rotated X cut for use in low-frequency filters and control devices. Its length-extensional, length-width-flexural, and duplex length-thickness-flexural modes are defined as the elements E, H, and J, respectively; the last named element, J, providing the lowest frequencies. However, the 5°X elements are also coupled to the other modes, so that for w/l ratios much greater than 0.1 the frequency spectrum is little improved over that of the length-extensional mode of the X cut. Furthermore, as the w/l ratio increases, so also does the temperature coefficient. For these reasons the 5°X elements are especially advantageous only when the w/l ratio is 0.1 or less. These long, thin bars are used commercially for the control of low-frequency oscillators and as filters, and are particularly adaptable for use in telephone carrier systems.

1-99. CHARACTERISTICS OF ELEMENT E

Description of Element: 5°X cut; xyt: 5°; length-extensional mode.

Frequency Range: 50 to 500 kc.

Frequency Equation: $f = \frac{nk_1}{l}$ (n = 1, 2, 3, ...)

Frequency Constant: Varies with w/l ratio (see figure 1-24).

Temperature Coefficient: Varies with w/l ratio (see figure 1-25, which holds for temperatures between 45 and 55 degrees centigrade). The

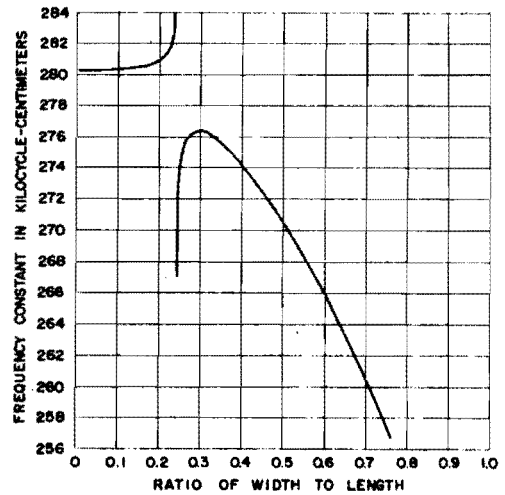

Figure 1-24. Frequency constant versus w/l ratio for element E *

frequency deviation of representative E elements of different w/l ratios is shown in figure 1-26, where the initial frequency is taken at 25°C.

Note that the temperature coefficient in parts per hundred per degree is the slope of a curve, and varies from positive to zero to negative as the temperature increases.

Methods of Mounting: Wire, knife-edge clamp, pressure pins, cantilever clamp; more than one pair of electrodes required for overtones.

Advantages: The low temperature coefficient and a large ratio of stored mechanical to electrical energy make this element preferred for filter networks. Long, thin bars have only a very

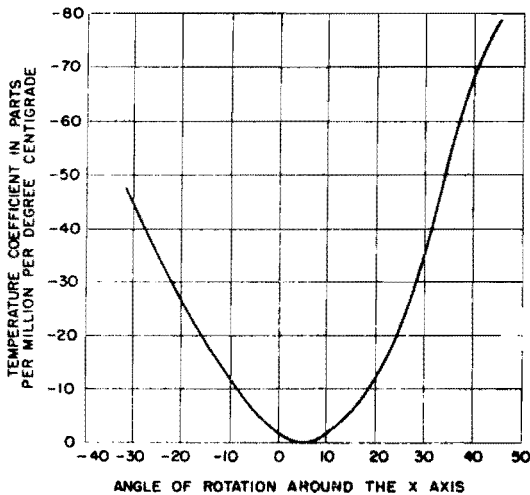

Figure 1-23. Temperature coefficient for length-extensional mode of long, thin X-group bars versus angle of rotation *

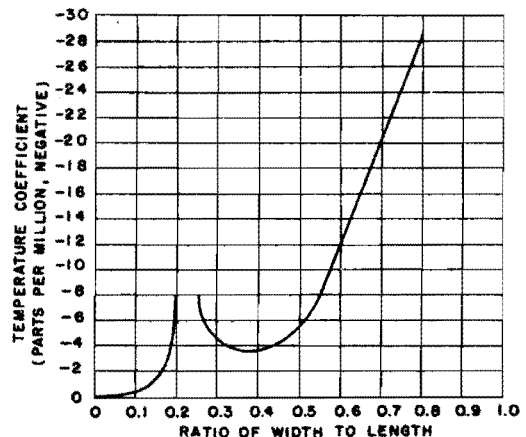

Figure 1-25. Temperature coefficient versus w/l ratio for element E at temperatures between 45° and 55°C *

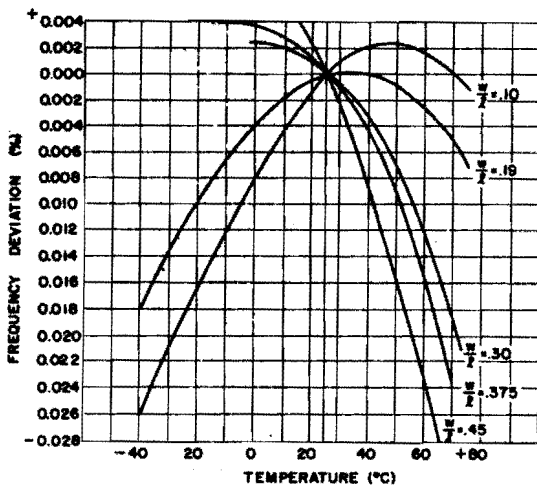

Figure 1-26. Percentage frequency deviation for E elements of various w/l ratios. Initial temperature = 25°C

weak coupling to other modes and are used for both filter networks and low-frequency oscillators. If a w/l ratio greater than 0.15 is desired, a ratio of approximately 0.39 is optimum insofar as a low temperature coefficient is concerned.

Disadvantages: At w/l ratios between 0.2 and 0.3 the length-extensional mode is so closely coupled to the length-width flexure that the crystal is useless; as the width is increased the coupling of the length-extensional to the face-shear mode becomes stronger, and the temperature coefficient becomes larger. However, because of the large electro-mechanical coupling of this element, w/l ratios of 0.35 to 0.5 can still be favorably used in filters if a temperature coefficient less than 4 parts per million is not required.

1-100. CHARACTERISTICS OF ELEMENT H

Description of Element: 5°X cut; xyt: 5°; length-width flexure mode.

Frequency Range: 10 to 100 kc.

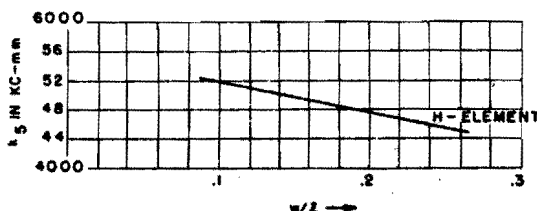

Figure 1-27. Frequency constant versus w/l ratio for element H

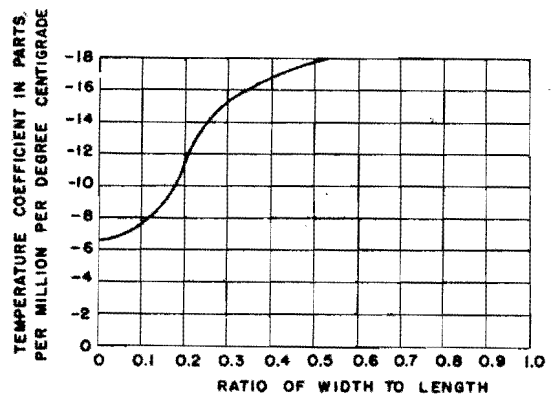

Figure 1-28. Temperature coefficient versus w/l ratio for element H *

Frequency Equation: $f = nk_s w/l^2$. ($n = 1, 2, 3, \dots$)

Frequency Constant: Varies with w/l ratio (see figure 1-27).

Temperature Coefficient: Varies with w/l ratio (see figure 1-28).

Methods of Mounting: Wire, in vacuum; free-free flexures of long, thin bars have nodal points for the fundamental vibration at a distance of $0.224 \times l$ from the ends; two electrically opposite pairs of electrodes are plated on each side of the YZ faces, with "ears" at the nodal points for soldering to the mounting wires. See figure 1-29. When the polarity of the lower electrodes causes a contraction of the bar, the polarity of the upper electrodes causes an extension, and vice versa—the over-all result being a flexural deformation.

Advantages: For long, thin bars the length-width flexural mode is resonant at much lower frequencies than is the length-extensional mode. This advantage, combined with the favorable electro-mechanical coupling, and reasonably low temperature coefficient, has made this element useful in very-low-frequency filters where only a single frequency is to be selected. When mounted in vacuum, a Q of 30,000 is obtainable.

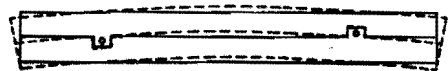

Figure 1-29. Element H, showing division of electrode plating for exciting fundamental mode. Similarly divided electrodes are on reverse side. The nodal "ears," where the mounting wires are attached, are at a distance of approximately 0.224 times the length from the ends *

Section I
Standard Quartz Elements

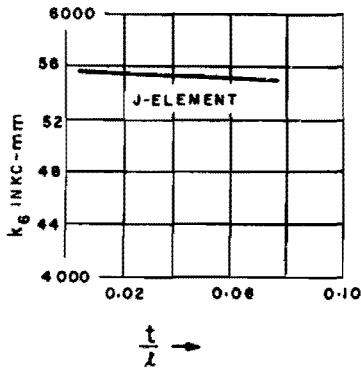

Figure 1-30. Frequency constant versus t/l ratio for element J

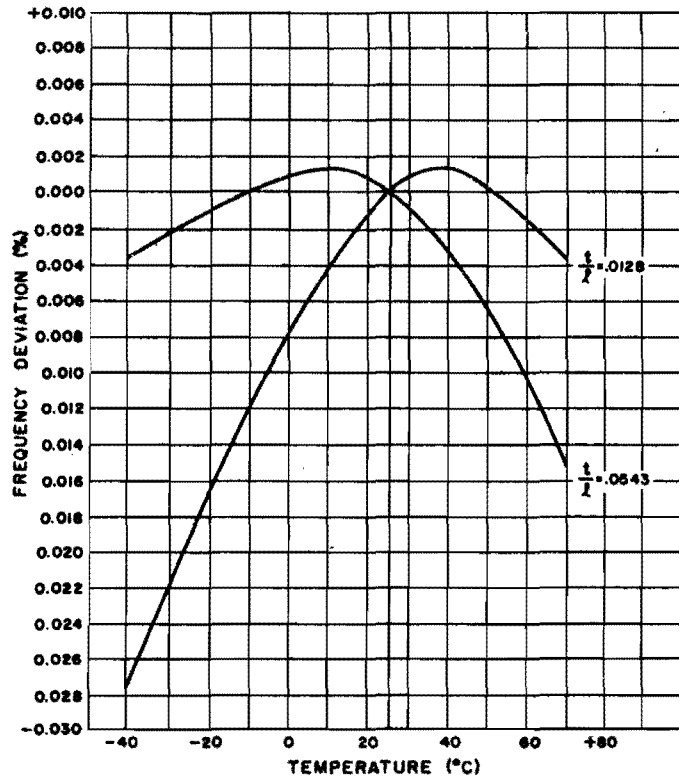

Figure 1-31. Percentage frequency deviation for J elements. The smaller t/l ratio is representative of a 1.2-kc element, and the larger t/l ratio is representative of a 10-kc element

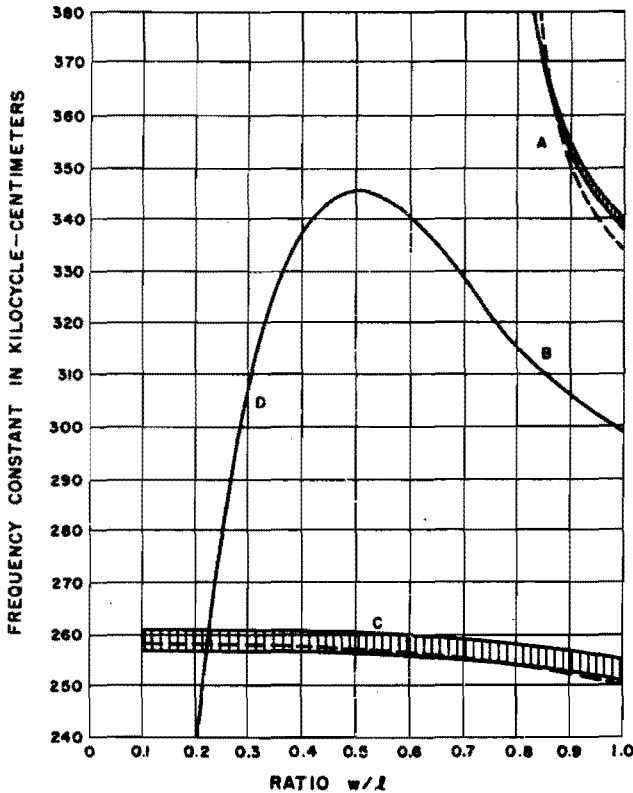

Figure 1-32. Frequency constant versus w/l ratio for various resonances of -18° X-cut crystal. A is the width-extensional mode. B is the face-shear mode, which, at small w/l ratios, is strongly coupled to D, the second flexural mode. C represents the band between the antiresonant (upper curve) and the resonant (lower curve) frequencies of the length-extensional mode of element F. Note the weak coupling between C and D-B *

Disadvantages: The ratio of stored mechanical to electrical energy is not as large as that of the length-extensional mode, and because of this, the element does not give as broad a band-pass spectrum. Also, the effect of the shear stresses causes the temperature coefficient to become highly negative as the w/l ratio is increased. Finally, the damping effect of the air is greater for flexural than for other vibrations, so that flexure crystals should be mounted only in evacuated containers.

1-101. CHARACTERISTICS OF ELEMENT J

Description of Element: Duplex 5°X cut; xyt: 5° (right quartz), and xyt: 5° (left quartz); length-thickness flexure mode.

Frequency Range: 0.4 to 10 kc.

Frequency Equation: $f = nk_s t/l^3$ ($n = 1, 2, 3, \dots$)

Frequency Constant: Varies with t/l ratio (see figure 1-30).

Temperature Coefficient: Varies with both the t/l ratio and the temperature; figure 1-31 shows the total relative frequency deviation of two elements of different t/l ratios, the initial frequencies being those at 25°C. The temperature coefficients in parts per hundred at a given temperature are the slopes of the curves at that point. Note that the temperature at which a zero coefficient is obtained increases as the t/l ratio decreases. At temperatures below that of a zero-coefficient point, the coefficient is positive; at temperatures above, it is negative.

Methods of Mounting: Headed-wire, in vacuum; two thin plates are cemented together with polarities opposed so that only one pair of electrodes, plated on opposite YZ faces, are required; the crystal element is supported at the nodal points, which for the fundamental vibration are at a distance $0.224 \times l$ from each end.

Advantages: Small temperature coefficient and low resonant frequencies (among the lowest obtainable with quartz) make this element useful in providing stable control for sonic-frequency oscillators, and as a component of single-frequency filters.

Disadvantages: Not economical for control of frequencies above 10 kc.

1-102. CHARACTERISTICS OF ELEMENT F

Description of Element: -18.5°X cut; xyt: -18.5°; length-extensional mode.

Frequency Range: 60 to 300 kc.

Frequency Equation: $f = \frac{nk_s}{l}$ ($n = 1, 2, 3, \dots$)

Frequency Constant: Varies slightly with w/l ratio (see figure 1-32).

Temperature Coefficient: 25 parts per million per degree centigrade—varies very little with changes in the w/l ratio.

Methods of Mounting: Wire, knife-edge clamp, pressure pins, cantilever clamp; more than one pair of electrodes required for overtones.

Advantages: The extremely weak coupling of this element to the face-shear and second flexure modes, represented by curves B and D, respectively, in figure 1-32, permits a better frequency spectrum than can be obtained with element E for w/l ratios greater than 0.1. For this reason, the F element used to be preferred over the E element as a filter plate, and was the principal quartz element in the channel filters of coaxial telephone systems. This is no longer true because channel filters now use +5°X plates which are smaller and conserve quartz.

Disadvantages: Relatively large temperature coefficient prevents this element from being preferred for oscillator control or as a channel filter if wide variations in temperature are to be expected. Also, the F plate is larger than the E plate of the same frequency and thus consumes more quartz.

1-103. CHARACTERISTICS OF ELEMENT M

Description of Element: MT cut; xytl: 0° to 8.5°/±34° to ±50°; length-extensional mode.

Frequency Range: 50 to 500 kc.

Frequency Equation: $f = \frac{nk_s}{l}$ ($n = 1, 2, 3, \dots$)

Frequency Constant: Varies with w/l ratio and angles of rotation (see figure 1-33).

Temperature Coefficient: Varies with w/l ratio and angles of rotation (see figure 1-34), and with the temperature. The total relative frequency deviation of an 8.5°/±34° M element, where the initial frequency is taken at 40°C, is shown in figure 1-35. Note that the temperature coefficient, which is the slope of the curve, changes from positive to negative as the temperature increases, with the zero coefficient occurring at 63°C.

Methods of Mounting: Wire, knife-edge clamp, pressure pins, cantilever clamp; more than one pair of electrodes required for overtones.

Advantages: The MT crystals were developed in an effort to overcome the large negative temperature coefficients of the X-cut and the 5°X-

Section I
Standard Quartz Elements

cut length-extensional modes for the larger w/l ratios. See figures 1-21 and 1-25. The unfavorable temperature characteristics are caused by the coupling of the extensional to the face-shear mode, the latter having a high negative temperature coefficient. However, if the crystal is rotated about its length, an orientation will be found where the face-shear mode has a zero temperature coefficient; that is, the coefficient will pass from negative to positive values. The low temperature coefficient of the length dimension will thus be preserved even though the coupling to the shear-mode has not, itself, been diminished. The low temperature coefficient makes the M element advantageous for oscillator control in the 50-to-100 kc range, and for use in narrow band filters, such as pilot-channel filters in carrier systems, where wide temperature ranges are to be encountered. The 8.5°/34° rotation with a w/l ratio of approximately 0.42 provides the greatest electromechanical coupling of the M elements, and hence the broadcast bandpass of the MT cut for use in filters.

Disadvantages: The electromechanical coupling rapidly decreases as the w/l ratio increases, so that at ratios greater than 0.7 the element is too selective for filter use, and of too small a piezoelectric activity to be advantageous for oscillator control. Maximum electromechanical coupling is obtained with w/l ratios of 0.39 to 0.42; but for a maximum bandwidth the E element is preferred. Although the interference of the face-shear temperature coefficient is reduced, the coupling to that mode remains relatively strong; so where the temperature varies very little, or where the secondary frequency effects are undesirable, the F element is preferred.

1-104. CHARACTERISTICS OF ELEMENT N

Description of Element: NT cut; xytl: 0° to 8.5°/±38° to ±70°; length-width flexure mode.

Frequency Range: 4 to 100 kc.

Frequency Equation: $f = \frac{nk_s w}{l^3}$ (n = 1, 2, 3, ...)

Frequency Constant: Varies with w/l ratio (see figure 1-36).

Temperature Coefficient: For w/l ratios of 0.2 to 0.5, low coefficients are obtained by double rotations of 0° to +8.5°/±50°. Typical frequency deviation curves are shown in figure 1-37, where the initial temperature is taken at 25°C. Note that a zero temperature coefficient occurs at approximately 10°C. To produce a zero temperature coefficient at 25°C for w/l ratios of 0.05, the angles of rotation should be as shown in figure 1-38.

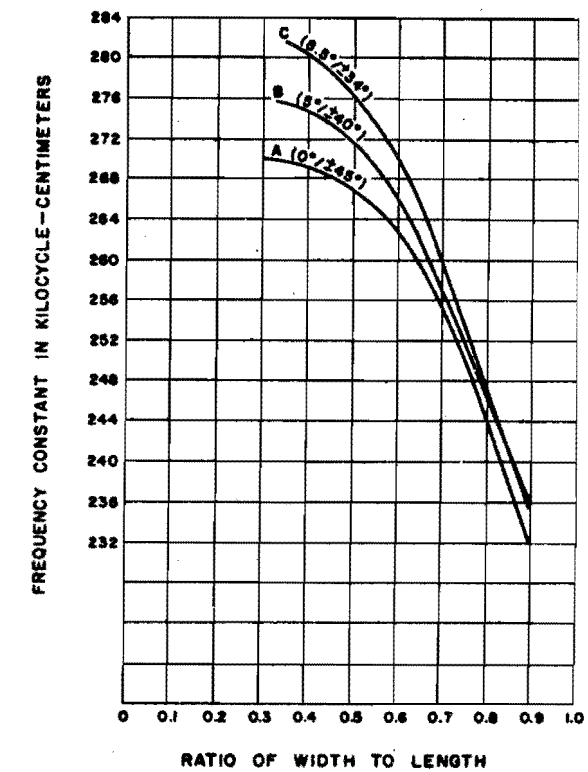

Figure 1-33. Frequency constant versus w/l ratio for M elements having low temperature coefficients. C is the curve of the most commonly used MT orientation *

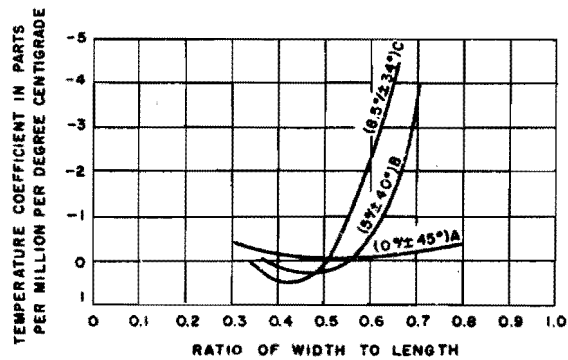

Figure 1-34. Temperature coefficient versus w/l ratio for M elements *

cient occurs at approximately 10°C. To produce a zero temperature coefficient at 25°C for w/l ratios of 0.05, the angles of rotation should be as shown in figure 1-38.

Methods of Mounting: Wire, in vacuum; special characteristics are the same as for the H element. See paragraph 1-100.

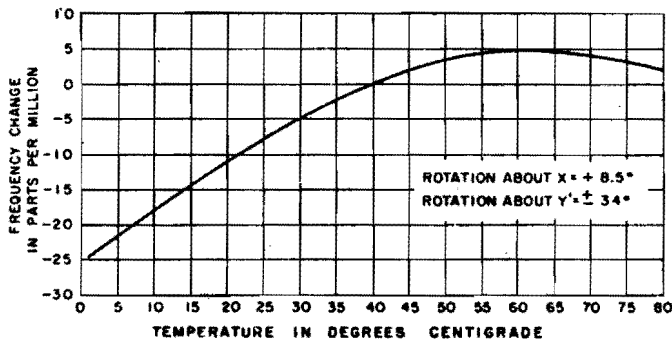

Figure 1-35. Frequency-temperature characteristics of element M*

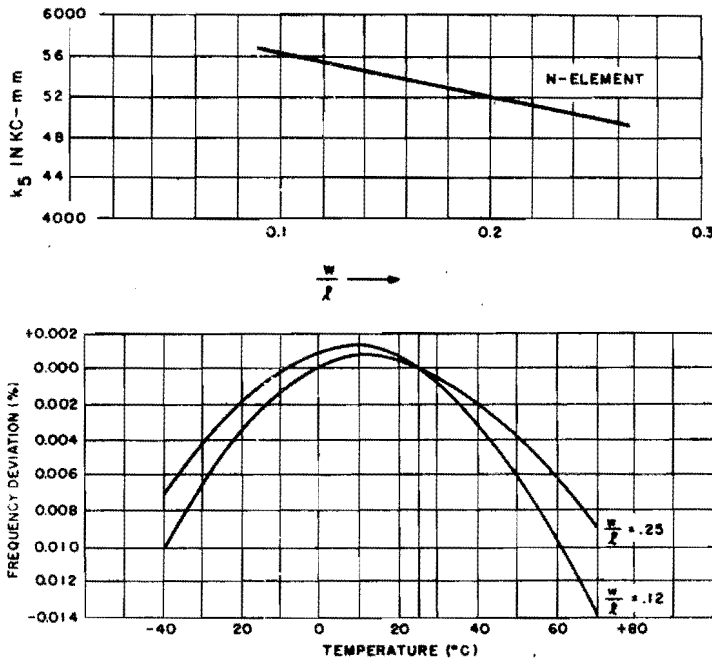

Figure 1-36. Frequency constant versus w/l ratio for element N

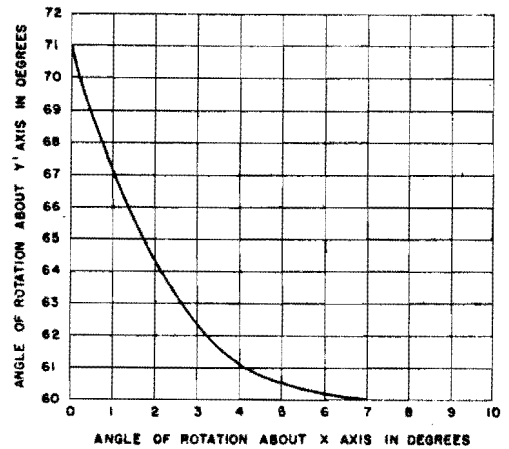

Figure 1-38. Angles of rotation for N element with a w/l ratio of 0.05 which will provide zero temperature coefficient at 25°C*

Figure 1-37. Frequency-temperature characteristics of element N. The larger w/l ratio is typical of 100-kc elements, and the smaller w/l ratio is typical of 16-kc elements

Advantages: The principal advantage of the N element is that the second rotation reduces the temperature coefficient for the flexure vibration of long, thin crystals. This is accomplished by changing the width from near parallelism to the Z axis to near parallelism to the X axis. Theoretically the ideal rotation would be 90°, except that the piezoelectric effect would be reduced to zero. As a compromise, secondary rotations, about the length, of 39° to 70° are made. Besides reducing the flexure-mode temperature coefficient of the long, thin crystals, the rotation also reduces the negative coefficient for the shear modes at the higher w/l ratios, as in the case of the M element. Where wide temperature ranges

must be met, this element is preferred for very-low frequency oscillators, and in single-frequency filter selectors. As the control element of an oscillator, it can maintain the frequency within $\pm 0.0025\%$ over a normal room-temperature range without temperature control.

Disadvantages: The electromechanical coupling is rather weak, more so for the larger than for the smaller w/l ratio. As a consequence, the bandwidth is too narrow for the element to be used as a band-pass filter of communication channels, and the piezoelectric activity is so low that special circuits are required for its use in oscillators.

THE V CUT

1-105. The V cut, developed by S. A. Bokovoy and C. F. Baldwin of RCA, is actually an entire series of cuts obtained by a sequence of double rotations of an initial X-cut plate. The first rotation angle, ϕ , is taken about the Z axis, and the second rotation angle, θ , is taken about the Y' axis (the dimension of the crystal that is initially parallel to the Y axis). For each angle ϕ , there is an angle θ at which the crystal will have a given temperature coefficient for a particular mode of vibration. Normally, the combination of angles desired is one that will provide a zero temperature coefficient; however, it may be that a small positive or negative coefficient is required to counterbalance an opposite temperature coefficient inherent in the external circuit to which the crystal is to be connected. For this purpose curves of θ plotted against ϕ are shown in figures 1-40 to 1-41 for small positive and negative temperature coefficients, as well as for a zero temperature coefficient. Other ϕ and θ combinations may be extrapolated to give temperature coefficients differing from the actual values shown. It should be noted that when the rotation about the Z axis is equal to $\pm 30^\circ$, the thickness dimension becomes parallel to a Y axis, and hence the crystal is in the position of the Y cut, with the Y' axis coinciding with an X axis. Thus, if $\phi = \pm 30^\circ$, the V cut is essentially the same as a rotated Y cut, and in this case would embrace practically the entire Y family. On the other hand, if $\phi = 0^\circ$, the V cut becomes simply a singly rotated X cut—but with rotations about the Y axis, not the X axis as in the case of the 5°X and the -18°X cuts. However, when $\phi = 0^\circ$, the V cut does overlap the MT and NT cuts.

1-106. CHARACTERISTICS OF V-CUT PLATES IN THICKNESS-SHEAR MODE

Description of Element: V cut; xzlw or xywl: 15° to 29° / -14° to -54° and 13° to 29° / 27° to 42° (see temperature coefficient curves in figure 1-40 for exact ϕ and θ combinations); thickness-shear mode.

Frequency Range: 1000 to 20,000 kc (fundamental); higher frequencies on overtones.

Frequency Equation: $f = \frac{k_3}{t}$ (fundamental vibration when $t \ll l$ and w). Figure 1-39 shows the frequency constant of the zero-temperature-coefficient series of V cuts as a function of the first rotation angle. The upper curve, designated $k_3(+\theta)$, applies to positive angles of θ , the second rotation, whereas the lower

curve, designated $k_3(-\theta)$, applies to negative angles of θ .

Temperature Coefficient: Figure 1-40 shows the combinations of ϕ with positive values of θ that provide temperature coefficients of +15, 0, and -15 parts per million per degree centigrade, and those combinations of ϕ with negative values of θ that provide temperature coefficients of +5, 0, and -5 parts per million per degree centigrade.

Methods of Mounting: Sandwich, air gap, clamped air-gap, button.

Advantages: The principal advantage of the V cut is that a given temperature coefficient may be obtained from a large choice of orientations, and with a minimum in trial-and-error procedure. Not only can a series of zero-coefficient plates be obtained, but also plates with coefficients of desired sign and magnitude for annulling the known frequency-tem-

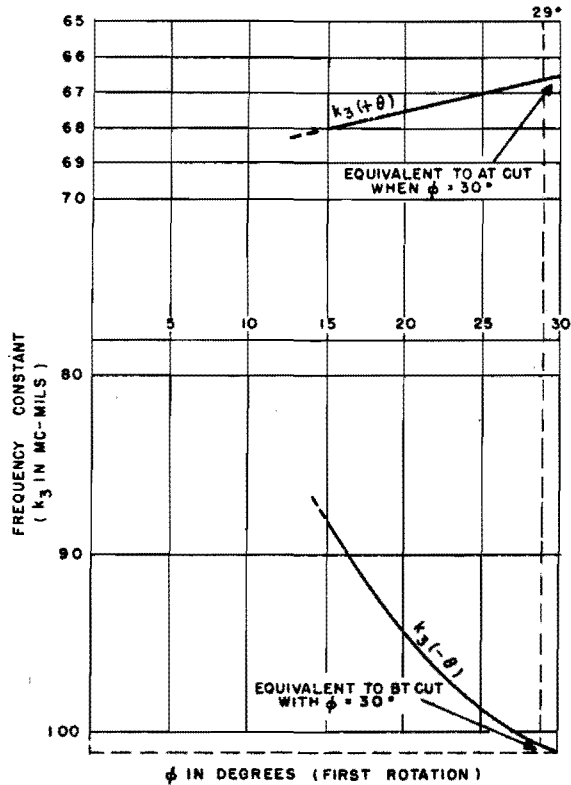

Figure 1-39. Frequency constant versus ϕ (angle of rotation about Z axis) for the thickness-shear mode of V-cut crystals when θ , the second angle of rotation, is so chosen that a zero temperature coefficient is obtained. The upper and lower curves are for positive and negative values of θ , respectively

perature effects of the circuits in which the plates are to be used. The V cut is the only member of the X group that provides a zero temperature coefficient for high-frequency vibrations; and because of the large choice of rotation angles, one or the other of the V orientations will frequently permit the maximum use of an unfaced or badly twinned mother crystal. Because their larger frequency constants permit a thicker and less fragile crystal, the orientations with a negative θ are preferred for the higher frequencies. Also, small deviations in negative values of θ produce less variation in the temperature coefficient than do the same deviations in positive values of θ . Hence, the negative orientations of θ are also generally more dependable for obtaining a desired temperature coefficient. On the other hand, positive values of θ permit a less bulky crystal for the lower frequencies, a less critical frequency constant, less interference from spurious frequencies, and for accurately determined orientations, a broader temperature deviation for a given deviation in frequency. At $\phi = 30^\circ$, the values of $\theta = -49^\circ, +31^\circ$, and $+35^\circ 31'$ are substan-

tially the same as the BT, AC, and AT cuts, respectively, of the Y group, as described in paragraphs 1-114, 1-111, and 1-112. The chief use of the thickness-mode V cut is for the control of high-frequency oscillators.

Disadvantages: The possibility of spurious frequencies close to the desired fundamental is the most troublesome limitation of the V cut operating in a thickness-shear mode. As a general rule, the coupling between the desired and the stray modes diminishes as the initial rotation ϕ is increased. At values of ϕ less than 13° , the interference is too great for stable operation. Because of the relatively poor frequency spectrum, the V cut is not readily adaptable for use in selective networks. With a certain amount of cut-and-try experimentation, the more objectionable modes may be reduced by grinding down the width and length dimensions. For angles of ϕ close to 30° the length and width dimensions most important to avoid are approximately the same as those given in paragraphs 1-112 and 1-114 for the AT and BT cuts, respectively.

1-107. CHARACTERISTICS OF V-CUT PLATES IN FACE-SHEAR MODE

Description of Element: V cut; xzlw or xywl: 0° to $30^\circ/\pm 45^\circ$ to $\pm 70^\circ$ (see temperature coefficient curves in figure 1-41 for exact ϕ and θ combinations); face-shear mode.

Frequency Range: 60 to 1000 kc.

Frequency Equation: $f = k_s/w$ (fundamental for square plates).

Frequency Constant: Insufficient data exist to plot the curve of k_s for all the combinations of ϕ and θ corresponding to this element. However, in the case of the zero-coefficient plates, as the positive value of θ approaches 37.5° , k_s approaches 3070 kc-mm, and as the negative value of θ approaches -52.5° , k_s approaches 2070 kc-mm.

Temperature Coefficient: Figure 1-41 shows the combinations of ϕ and θ that provide temperature coefficients of +5, 0, and -5 parts per million per degree centigrade.

Methods of Mounting: Wire, cantilever clamp.

Advantages: The principal advantage is the low temperature coefficient, which makes the element useful for low-frequency oscillators and filters. The large choice of orientation angles is also advantageous for obtaining the maximum number of cuts from a given mother crystal, particularly if the presence of twinning or other defects limit the dimensions in

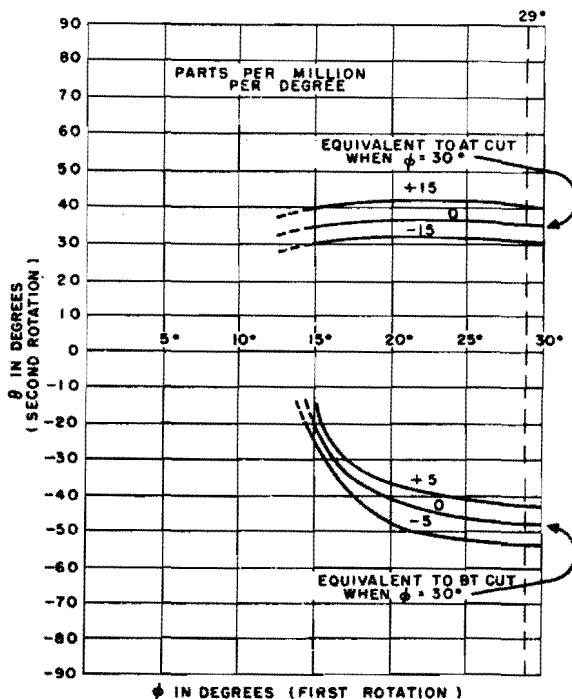

Figure 1-40. Relations of θ to ϕ , for thickness-shear mode of V cut, which provide the temperature coefficients indicated for each curve

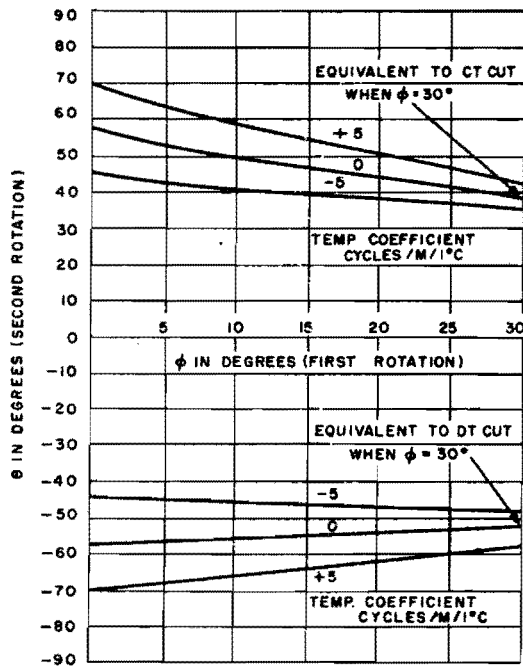

Figure 1-41. Relations of θ to ϕ , for face-shear mode of Y cut, which provide temperature coefficients of 0, +5, and -5 parts, per million per degree centigrade

the directions at which rough bars would normally be cut. Also, the angles for small predetermined positive and negative coefficients permit a crystal to be cut which can exactly annul the known temperature effects of the external circuit. As indicated in figure 1-41, small deviations in the orientations angles will cause minimum deviations in the temperature coefficient when $\phi = 0^\circ$ to 15° , and θ is negative. On the other hand, maximum piezoelectric activity is obtained when ϕ is large, and θ is positive. As a general rule, the positive values of θ are used for the higher frequencies and the negative values of θ for the lower frequencies. The zero-temperature cuts for $\phi = 30^\circ$ are substantially the same as the CT and DT cuts of the Y group. See paragraphs 1-115 and 1-116, respectively.

Disadvantages: Care must be taken that flexure modes are not strongly coupled to the face-shear mode. Such coupling may be reduced by making the plates square, or nearly so. For angles of ϕ approaching 30° , the thickness should be approximately within the limits given for the C and D elements in paragraphs 1-115 and 1-116.

The Y Group

1-108. The principal crystals of the Y group are listed below with the frequency range for which they have found commercial application:

Name of Cut	Frequency Range in KC
Y	1000 to 20,000
AC	1000 to 15,000
AT	500 to 100,000
BC	1000 to 20,000
BT	1000 to 75,000
CT	300 to 1100
DT	60 to 500
ET	600 to 1800
FT	150 to 1500
GT	100 to 550

Figure 1-42 shows the orientations of a yx initial position (Y cut with the length parallel to the X axis) for the various cuts. In special cases the width may be parallel to the X axis, but this is the exception rather than the rule, unless the plate is square or circular. With the exception of the GT cut, the crystals of the Y group are used in their shear modes—face shear for the low-frequency elements, and thickness shear for the high-frequency elements. The Y cut, itself, has a large positive temperature coefficient; and, because of coupling between the thickness-shear mode and the overtones of the face-shear mode, it also exhibits sharp irregularities in its frequency spectrum. However, by rotation about the X axis, zero temperature coefficients may be obtained, and the coupling between the shear modes can be greatly diminished. This coupling becomes zero at the angles of the AC and BC cuts, and the frequency constant of the thickness-shear mode has minimum and maximum values, respectively, for these two orientations. Figure 1-43 shows the thickness-shear frequency constant, and figure 1-44 the thickness-shear temperature coefficient, with each plotted as a function of the angle of rotation. For the face-shear mode, the frequency constant and the temperature coefficient are shown in figures 1-45 and 1-46, respectively, plotted as functions of the angles of rotation.

THE Y CUT

1-109. The Y cut was introduced commercially in the late 1920's, at which time its principal advantage was that it could be clamped at its edges, whereas the X cut would not oscillate if the edge movement were even slightly restricted. The use of a Y cut, vibrating in a shear-mode, was originally suggested by E. D. Tillyer of the American Optical Company, to whom a U. S. patent was

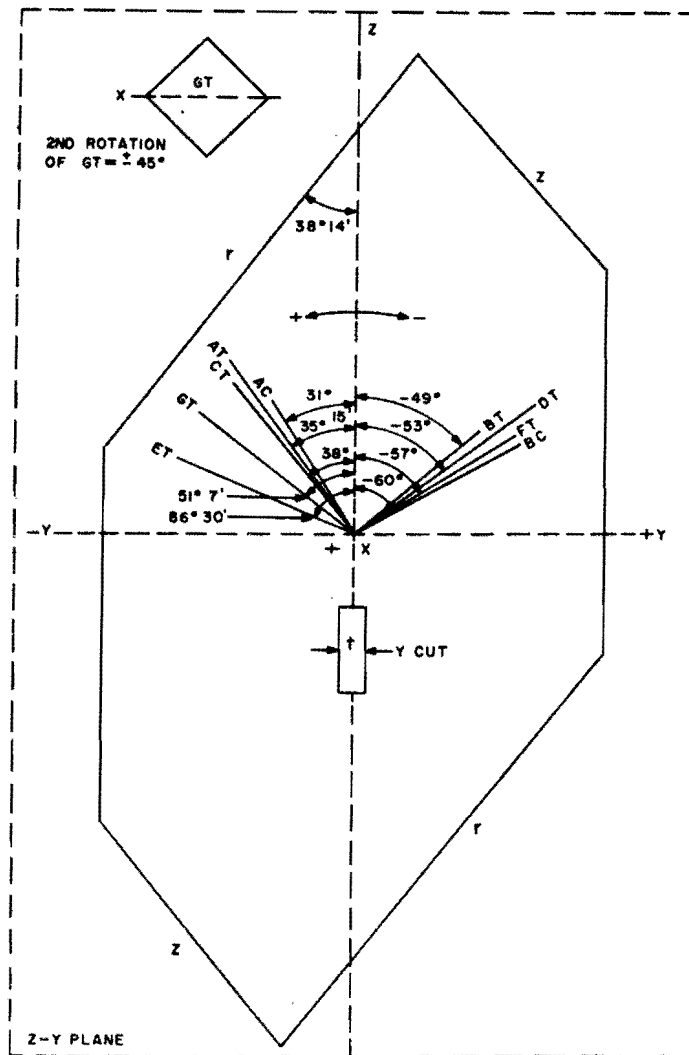

Figure 1-42. Rotation angles of Y cut about X axis which provide the principal members of the Y group. The GT cut is the only member having a second rotation ($\pm 45^\circ$ about the Y' axis). The +X sign indicates that the positive end of the X axis points toward the observer

issued in 1933. For this reason, the Y cut is sometimes called the *Tillyer cut*. For several years this crystal was used extensively in commercial and military transmitters mounted in mobile equipment, and also in commercial broadcast transmitters where the Y cut's readily excited oscillations permitted the use of crystal oscillators with low plate voltages. However, due to the strong coupling between the thickness-shear and the overtones of the face-shear and flexure modes, the Y cut's frequency spectrum is very poor. Also, small irregularities in the dimensions of the crystal readily produce abrupt changes in the frequency.

A typical frequency-temperature curve of a Y-cut crystal is shown in figure 1-47. Today, the Y cut has been almost entirely replaced by the rotated cuts having small temperature coefficients, and the Y cut's only major application now is that of transducer for generating shear vibrations in solids.

1-110. CHARACTERISTICS OF Y-CUT
PLATES IN THICKNESS-SHEAR MODE

Description of Element: Y cut; yx or yz; thickness-shear mode.

Frequency Range: 500 to 20,000 kc; much lower

Section I
Standard Quartz Elements

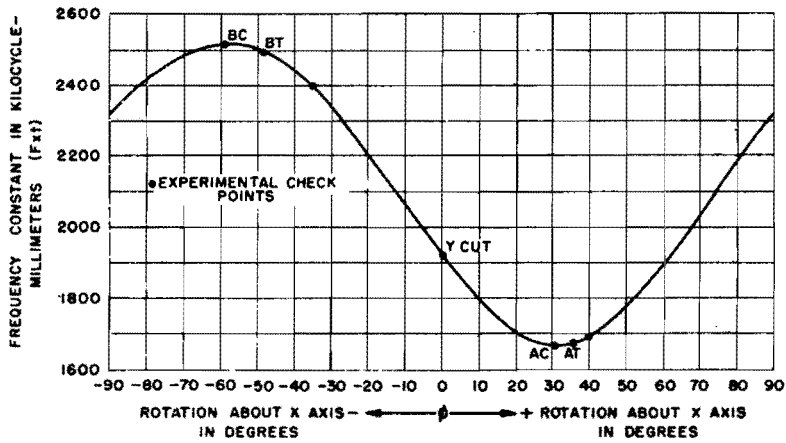

Figure 1-43. Frequency constant versus angle of rotation about X axis for thickness-shear elements of Y group. (Values shown for Y, BT, and BC cuts are smaller than the average) *

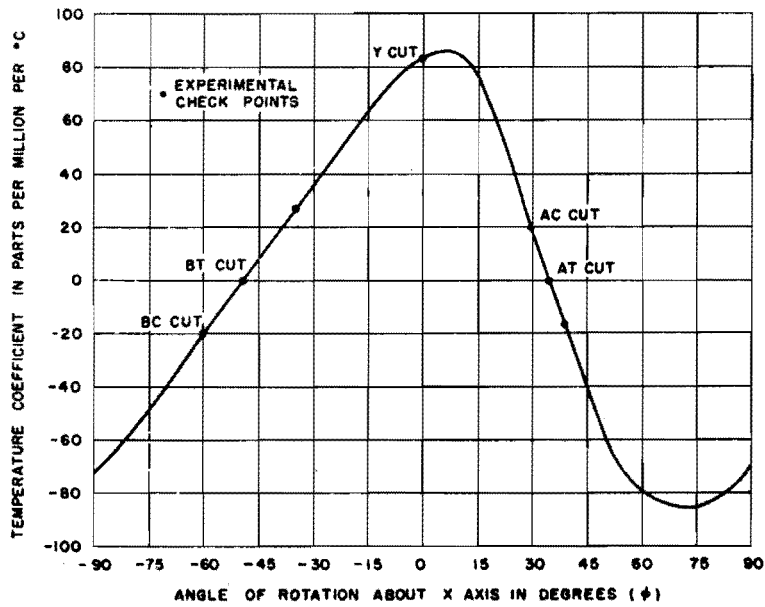

Figure 1-44. Temperature coefficient versus angle of rotation about X axis for thickness-shear elements of Y group *

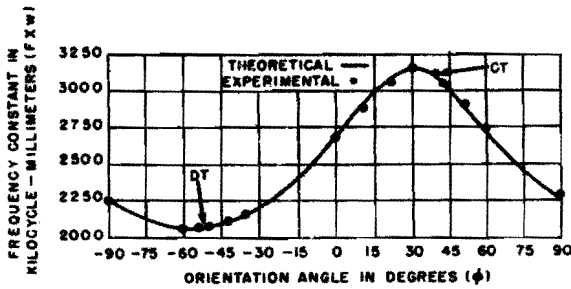

Figure 1-45. Frequency constant versus angle of rotation about X axis for face-shear elements of Y group

frequencies when bonded to solids for use as transducer.

Frequency Equation: $f = \frac{k_s}{t}$ (fundamental vibration).

Frequency Constant: $k_s = 1981$ kc-mm (average value).

Temperature Coefficient: Varies with dimensions of crystal and with temperature but is usually between 75 and 125 parts per million per degree centigrade, and is positive, with an average value of 86 parts per million per degree centigrade.

Methods of Mounting: Sandwich; air gap, clamped air gap; bonded to solids when used as transducer.

Advantages: Ratio of stored mechanical to electrical energy is larger than that of any other

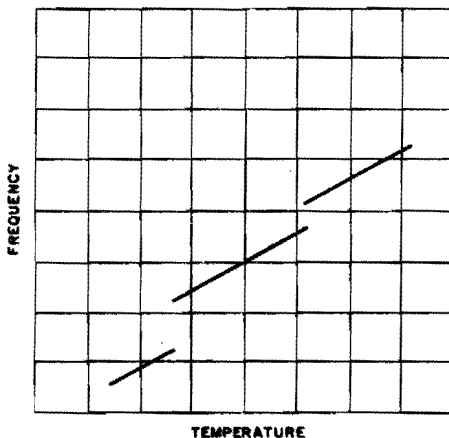

Figure 1-47. Temperature-frequency characteristics typical of the Y-cut, thickness-shear element. The frequency jumps are most apt to occur when small discrepancies are present in the thickness-dimension

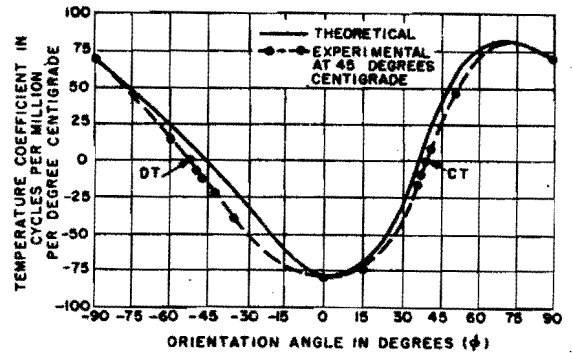

Figure 1-46. Temperature coefficient versus angle of rotation about X axis for face-shear elements of the Y group

quartz element; this large ratio, combined with the quartz crystal's superior strength, makes the Y cut desirable as a generator of shear vibrations in solids for the purpose of measuring or testing the solids' physical properties. This element is the easiest of all quartz cuts to excite into vibration, and thus requires the lowest voltages for operation. Large temperature coefficient makes element useful as a sensitive detector of variations in temperature.

Disadvantages: Large temperature coefficient, discontinuities of resonant frequencies, and poor frequency spectrum make this element a secondary choice for use in either oscillator or filter circuits. Special Y cuts, such as the block- and doughnut-shaped crystals in figure 1-48, vibrate in a combination mode composed of coupled shear and flexure modes, and have zero temperature coefficients at certain temperatures. However, because of the prevalence of spurious frequencies, the large volume of quartz used per cut, and the difficulties of mounting, these crystals have little practical use.

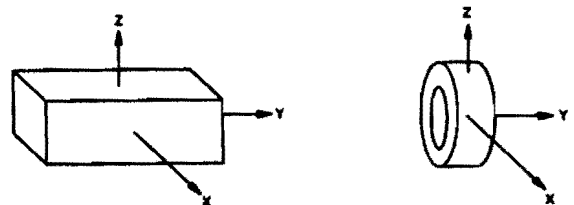

Figure 1-48. Y-cut block and doughnut-shaped crystals which can provide zero temperature coefficients for certain combination modes

Section I
Standard Quartz Elements

1-111. CHARACTERISTICS OF AC-CUT PLATES IN THICKNESS-SHEAR MODE

Description of Element: AC cut; γ xl: 31° ; length-thickness-shear mode.

Frequency Range: 1000 to 15,000 kc (fundamental vibration).

Frequency Equation: $f = \frac{k_3}{t}$ (fundamental vibration when $t \ll l$ and w).

Frequency Constant: $k_3 = 1656$ kc-mm.

Temperature Coefficient: 20 parts per million per degree centigrade; positive.

Methods of Mounting: Sandwich, air gap, clamped air gap, button.

Advantages: This element vibrates in a very pure length-thickness mode with an excellent frequency spectrum. It has the lowest frequency constant of all the quartz thickness modes and thus permits a smaller thickness, and hence a more economical cut, for use at the low end of the high-frequency spectrum. For a given temperature, the electrical parameters of an AC crystal unit can be predetermined with an accuracy equal to, or greater than, that of the more commonly used AT units.

Disadvantages: The principal disadvantages of the AC cut is its relatively large temperature coefficient; because of this the element has found little commercial use, and the low-coefficient AT cut, with an orientation close enough to that of the AC for the coupling between the shear modes to be small, is generally preferred.

1-112. CHARACTERISTICS OF ELEMENT A

Description of Element: AT cut; γ xl: $35^\circ 21'$; length-thickness-shear modes; or, γ zw: $35^\circ 21'$; width-thickness-shear mode.

Frequency Range: 500 to 1000 kc (special cuts); 1000 to 15,000 kc (fundamental vibration); 10,000 to 100,000 kc (overtone modes).

Frequency Equation:

$f = k_3/t$ (fundamental vibration when $t \ll l$ and w)

$$f = k_3 \sqrt{\frac{m^2}{t^2} + a_1 \frac{n^2}{l^2} + a_2 \frac{(p-1)^2}{w^2}}$$

where m , n , and p are integers.

Frequency Constant: $k_3 = 1660$ kc-mm.

Temperature Coefficient: 0.0 at 25°C ; figure 1-49 shows the total relative frequency deviation for the normal maximum, minimum, and average angles of this element; the temperature coefficient at each point on a curve is the slope at that point in parts per hundred. At $\phi = 35^\circ 15'$, the temperature coefficient will vanish at 45°C , changing from negative to positive as the temperature increases. Optimum orientations for zero coefficients at other temperatures are given below:

Deg. C	ϕ
20	$35^\circ 18'$
20	$35^\circ 27'$ (overtones)
75	$35^\circ 31'$
75	$35^\circ 33'$ (overtones)
85	$35^\circ 33'$
85	$35^\circ 36'$ (overtones)
100	$35^\circ 36'$
190 (max.)	$36^\circ 26'$

Methods of Mounting: Sandwich, air gap, clamped air gap, button.

Advantages: The excellent temperature-frequency characteristics make this element preferred for high-frequency oscillator control wherever wide variations of temperature are to be encountered; it is particularly applicable

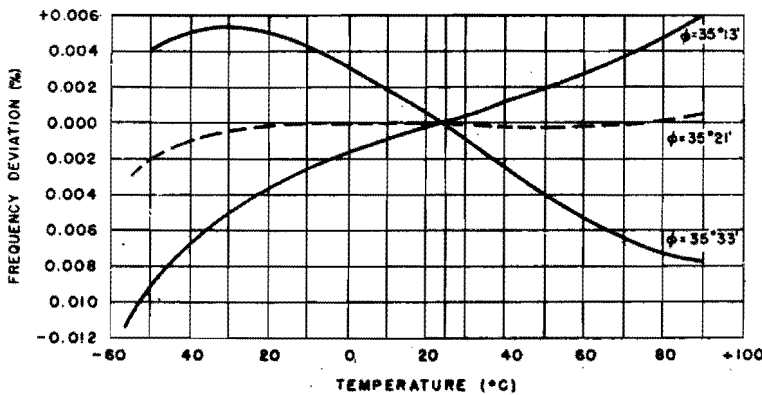

Figure 1-49. Temperature-frequency characteristics of element A

for aircraft radio equipment where sharp changes in temperature may be frequent, but where the added weight of constant-temperature ovens is undesirable. The angle of orientation is sufficiently close to that of the AC cut for the coupling between the shear modes to be weak, so that the resonant frequency can be isolated from that of other modes, except for certain dimensions of w and l . The A element also shares the low frequency constant of the AC element, and this is preferred for frequencies at the low end of the high-frequency spectrum. However, because of its superior temperature-frequency and piezoelectric characteristics as compared with the BT characteristics, the A element may well be preferred for the control of frequencies in the vhf range, even though the BT cut has the larger frequency constant.

Disadvantages: Because of the large thickness dimensions that would be required, the A element is generally not economical for the generation of frequencies below 1000 kc, although special circular cuts have been used at frequencies as low as 500 kc. In its normal high-frequency range, the most troublesome problem is to find the proper length and width dimensions which will permit the desired frequency to be widely separated from other modes. Although the orientation of the AT cut is close to that of the AC cut, there still exists a fair amount of coupling to the face-shear modes, and to the extensional and flexural modes along the X axis. Sufficient information is not available to avoid a certain amount of trial and error in grinding and finishing an AT blank to provide an optimum frequency spectrum at a desired frequency; however, there are certain X and Z' (the dimension parallel to the Z axis before rotation) values that can be avoided by use of the frequency equations which hold approximately for the less complex of the unwanted modes. The following equations give the face dimensions of an AT cut which will produce unwanted resonances at the same frequency, f , as the thickness-shear mode.

For extensional modes along X:

$$X = \frac{2438 n}{f} \quad (n = 1, 3, 5, \dots)$$

For flexure modes along X:

$$X = \frac{1338.4 n}{f} \quad (n = 2, 4, 6, \dots)$$

For shear modes along X:

$$X = \frac{2542.0 n}{f} \quad (n = 1, 3, 5, \dots)$$

For shear modes along Z':

$$Z' = \frac{2540.0 n}{f} \quad (n = 1, 3, 5, \dots)$$

With f expressed in kc, X and Z' are given in mm. Either X or Z' may be the length, with the other dimension being the width. It has been found that the unwanted modes are somewhat restricted by giving the plate a convex contour, and also by the use of circular plates. The convex contour is possible for all but the very thin plates that are used at frequencies above 15,000 kc. A 1000-kc crystal may have a contour of 3 to 5 microns. The equations above hold for flat plates, and become increasingly in error as the contour is increased.

1-113. CHARACTERISTICS OF BC-CUT PLATES IN THICKNESS-SHEAR MODE

Description of Element: BC cut; γ xl: -60° ; length-thickness-shear mode.

Frequency Range: 1000 to 20,000 kc (fundamental vibration).

Frequency Equation: $f = \frac{k_s}{t}$ (fundamental vibration when $t \ll l$ and w).

Frequency Constant: $k_s = 2611$ kc-mm.

Temperature Coefficient: 20 parts per million per degree centigrade; negative.

Methods of Mounting: Sandwich, air gap, clamped air gap, button.

Advantages: The advantages and disadvantages of the BC cut are similar to those of the AC cut, except that the BC thickness-shear frequency constant is the highest obtainable for a rotated Y cut. A BC cut may thus have a greater thickness for the same frequency, and hence be less likely to be shattered from overdrive or mechanical shock—a distinct advantage at the higher fundamental frequencies where very thin crystals are used. Since the BC orientation is the negative angle of rotation which provides zero coupling between the shear modes, the element vibrates in a very pure length-thickness mode with an excellent frequency spectrum. For a given temperature, the electrical parameters of a BC crystal unit can be predetermined with an accuracy equal to or greater than that of the more commonly used BT units.

Disadvantages: As in the AC cut, the principal disadvantage of a BC cut is its relatively large

Section I
Standard Quartz Elements

temperature coefficient. Because of this, the element is not widely used, and the zero-coefficient BT cut, with an orientation sufficiently near to that of the BC cut to have a weak coupling between the shear modes, is used instead. An added disadvantage is that the magnitude of the rotation away from the Y axis is approximately double that for the AC cuts. For this reason the piezoelectric coefficient is smaller for the BC than for the AC or AT cuts, and, hence, somewhat higher voltages are required to maintain oscillations.

1-114. CHARACTERISTICS OF ELEMENT B

Description of Element: BT cut; γ xl: $-49^{\circ}8'$; length-thickness-shear mode; or, γ zw: $-49^{\circ}8'$; length-width-shear mode.

Frequency Range: 1000 to 20,000 kc (fundamental vibration).

15,000 to 75,000 kc (overtone modes).

Frequency Equation:

$f = k_3/t$ (fundamental vibration when $t \ll l$ and w)

$$f = k_3 \sqrt{\frac{m^2}{t^2} + a_1 \frac{n^2}{l^2} + a_2 \frac{(p-1)^2}{w^2}}$$

where m , n , and p are integers.

Frequency Constant: $k_3 = 2560$ kc-mm.

Temperature Coefficient: 0.0 at 25°C ; figure 1-50

shows the total relative frequency deviation for the normal maximum, minimum, and average angles of this element; the temperature coefficient in parts per hundred per degree centigrade at each point on a curve is the slope at that point. Zero coefficients are obtained at 20°C and 75°C when ϕ is $-49^{\circ}16'$ and $-47^{\circ}22'$, respectively.

Methods of Mounting: Sandwich, air gap, clamped air gap, button.

Advantages: The temperature-frequency characteristics make this element useful for high-frequency oscillator control where the temperature is not expected to vary too widely from the mean value. It is particularly applicable for use in radio equipment which is to operate at the high end of the high-frequency spectrum. Most of the high-frequency crystal oscillators employ either the BT or the AT cut, with the B element, because of its larger frequency constant, often preferred at frequencies from 10 to 20,000 kc. Since the orientation angle is near that of the BC cut, the shear modes are not too strongly coupled together; and, when ground to proper dimensions, the B element exhibits a reasonably satisfactory frequency spectrum.

Disadvantages: Like the A element, the B element is not suitable for use at the lower frequencies because of the large thickness dimensions

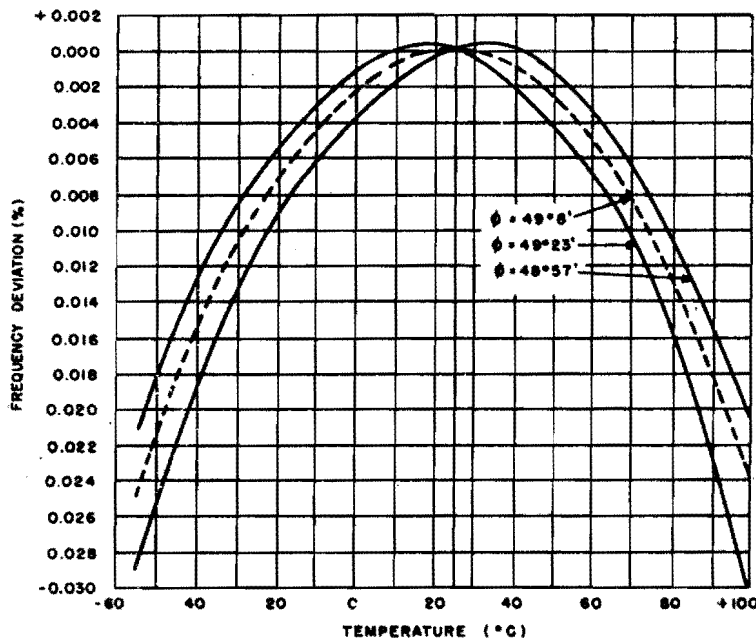

Figure 1-50. Temperature-frequency characteristics of element B

that would be required. Because of its greater angle of rotation from the Y axis, the BT has a smaller piezoelectric coefficient than the AT cut, and hence requires a higher voltage to maintain oscillations. Also, the temperature coefficient of the BT cut increases more rapidly than that of the AT cut when the temperature varies to either side of the zero point. Moreover, zero temperature coefficients cannot be obtained at as widely separated temperatures, as can be done with the AT cut by slightly varying the orientation angle. This limitation, however, becomes an advantage inasmuch as it reduces the percentage error when cutting a crystal to provide a given temperature-frequency characteristic. The greatest problem in preparing a B element is to avoid those length and width dimensions that cause the frequencies of unwanted modes to approach the frequency of the desired mode. As in the case of the AT cut, a BT blank with a good frequency spectrum will require a certain amount of trial and error in the finishing process. For the simpler modes of lower order, the following equations give the face dimensions of a BT cut which produce unwanted resonances of the same frequency, f , as that of the thickness-shear mode.

For flexure modes along X:

$$X = \frac{1810 n}{f} \quad (n = 2, 4, 6, \dots)$$

For shear modes along X:

$$X = \frac{1635.14 n}{f} \quad (n = 1, 3, 5, \dots)$$

For shear modes along Z':

$$Z' = \frac{1664.5 n}{f} \quad (n = 1, 3, 5, \dots)$$

With f expressed in kc, X and Z' are given in millimeters. (Z' is the dimension of the rotated Y cut that originally was parallel to the Z axis.) Either X or Z' may be the length, with the other dimension being the width. As in the case of the A element, a convex contour of a plate will aid in restricting unwanted modes. At 1000 kc the contour may be as great as 5 microns; the thin, 20,000-kc plates, however, must be flat. The equations above hold only for flat plates, but are approximately correct if the contour is very small.

1-115. CHARACTERISTICS OF ELEMENT C

Description of Element: CT cut; yx_l or yz_w : 37° to 38° ; face-shear mode.

Frequency Range: 300 to 1100 kc.

Frequency Equation: $f = k_4/w$ (fundamental of square plate).

$$f = k_4' \sqrt{\frac{m^2}{l^2} + a_1 \frac{n^2}{w^2}} \quad \left(\begin{array}{l} m = 1, 2, 3, \dots \\ n = 1, 2, 3, \dots \end{array} \right)$$

Frequency Constant: $k_4 = 3070$ kc-mm. (Square plates are preferred since they have fewer secondary frequencies.)

Temperature Coefficient: 0.0 at 25°C for rotation angle of $37^\circ 40'$. Figure 1-51 shows the total relative frequency deviation with temperature for maximum, minimum, and average angles of rotation for a nominal cut of $37^\circ 40'$; the initial temperature is taken at 25°C . The slope of a curve at any point is the temperature coefficient in parts per hundred per degree centigrade at that point. Note that as the rotation angle is increased, the zero coefficient is shifted to a higher temperature;

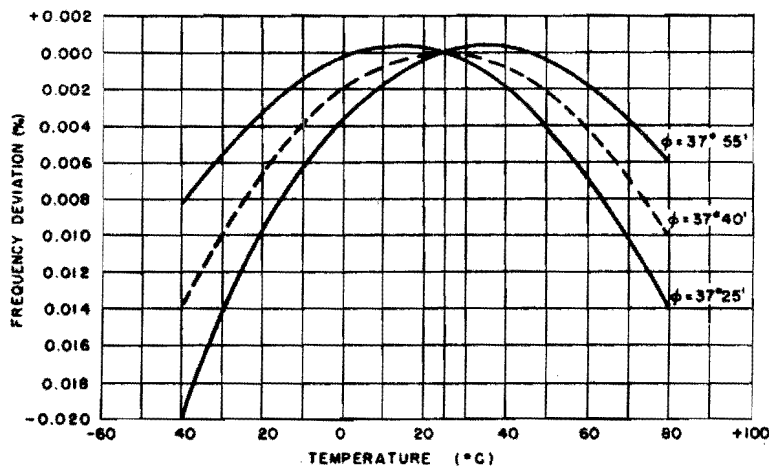

Figure 1-51. Temperature-frequency characteristics of element C

Section I
Standard Quartz Elements

the same is true when the $\frac{Z'}{X}$ ratio is increased. For square plates, zero coefficients can be obtained at higher temperatures (50°C to 200°C) by rotation angles from 38°20' to 41°50', respectively.

Methods of Mounting: Wire, cantilever clamp.
Advantages: The CT cut is essentially a BT cut rotated approximately 90° so that the face shear of the C element corresponds to the thickness shear of the B element. This orientation provides a zero-temperature-coefficient shear mode for generating low frequencies, without requiring a crystal of large thickness dimension. The frequency characteristics of the C element, as compared with the D element, are roughly analogous to those of the B with the A element, except that the former pair vibrate at low frequencies, and the latter at high frequencies. The C element has the higher frequency constant, so is generally preferred over the D element at the high end of the low-frequency range. The C element is widely used both for low-frequency oscillator control and in filters, and does not require constant temperatures control under normal operating conditions. One of its principal applications has been as the control element in frequency-modulated oscillators.

Disadvantages: Because of its larger frequency constant, the C element must be cut with larger face dimensions than the D element to provide the same frequency of vibration. Thus, for the generation of very low frequencies the smaller DT cut is the more economical to use. Care must be taken that flexure modes are not strongly coupled to the face-shear mode. To prevent a coincidence of resonance

between the two modes, the following thicknesses have been used:

Frequency Range in KC	Thickness in Mils
370 to 428	18.5 to 19.9
428 to 475	16.0 to 17.5
475 to 540	18.5 to 19.9
730 to 875	12.0 to 14.0
875 to 1040	16.0 to 17.5

1-116. CHARACTERISTICS OF ELEMENT D

Description of Element: DT cut; yx1 or yzw; -52° to -53°; face-shear mode.

Frequency Range: 60 to 500 kc.

Frequency Equation: $f = k_4/w$ (fundamental of square plate).

$$f = k_4 \sqrt{\frac{m^2}{l^2} + a_1 \frac{n^2}{w^2}} \quad (m = 1, 2, 3, \dots)$$

$$(n = 1, 2, 3, \dots)$$

Frequency Constant: $k_4 = 2070$ kc-mm. (Square plates are preferred since they have fewer secondary frequencies.)

Temperature Coefficient: 0.0 at 25°C for rotation angle of -52°30'. Figure 1-52 shows the total relative frequency deviation with temperature for maximum, minimum, and average angles of rotation for a nominal cut of -52°30', where the initial temperature is taken at 25°C. The slope of a curve at any point is the temperature coefficient in parts per hundred per degree centigrade at that point. Note that as the rotation angle is increased, the zero coefficient is shifted to a higher temperature. The upper limit for a zero coefficient is approximately 200°C, when $\phi = -54^\circ$.

Methods of Mounting: Wire, cantilever clamp.

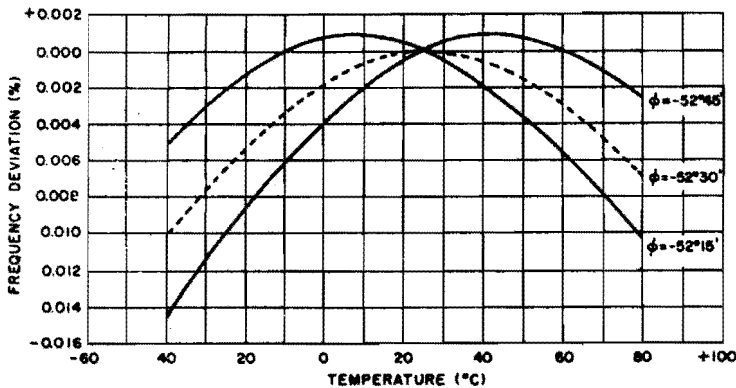

Figure 1-52. Temperature-frequency characteristics of element D

Advantages: The DT cut is essentially an AT cut rotated approximately 90° so that the face shear of the D element corresponds to the thickness shear of the A element. This orientation provides a zero-temperature-coefficient shear mode for generating low frequencies, without requiring a crystal of large thickness dimension. Because the frequency constant is less than that of element C, the face dimensions of element D are smaller for a given frequency, and hence the DT is the more economical cut for use at very low frequencies. Like the C element, the D element is widely used in both oscillators and filters, and does not require constant temperature control under normal operating conditions.

Disadvantages: At frequencies above 500 kc, the impedance effects introduced by the mounting become excessive, since the contact surfaces between the crystal and the supporting wires become rather large compared with the area of the crystal faces. Hence, the C is preferred over the D element in the 500—1000 kc range, since the higher frequency constant of the former permits a larger crystal face. To avoid strong coupling of the face-shear mode with flexure modes, certain thicknesses must be avoided. For most frequencies, however, a thickness of approximately 17 mils is satisfactory.

1-117. CHARACTERISTICS OF ET-CUT PLATES IN COMBINATION MODE

Description of Element: ET cut, with $\frac{w}{l}$ ratio approximately equal to 1.0; $yx1$ or yzw : 66°30'; combination of coupled modes with second flexural vibration appearing to dominate a face-shear harmonic.

Frequency Range: 600 to 1800 kc.

Frequency Equation: $f = k/w$ (square plate).

$$f = \frac{2k}{1+w} \text{ (nearly square plate).}$$

Frequency Constant: $k = 5350$ kc-mm.

Temperature Coefficient: 0.0 at 75°C; see figure 1-53 for total relative frequency deviation.

Methods of Mounting: Wire; preferably mounted in vacuum.

Advantages: Besides its zero temperature coefficient, the principal advantage of the ET cut is its high frequency constant, which is almost 1.8 times that of the C element. This permits an effective extension of the frequency range for this type of plate and mounting. Optimum performance is obtained at temperatures near

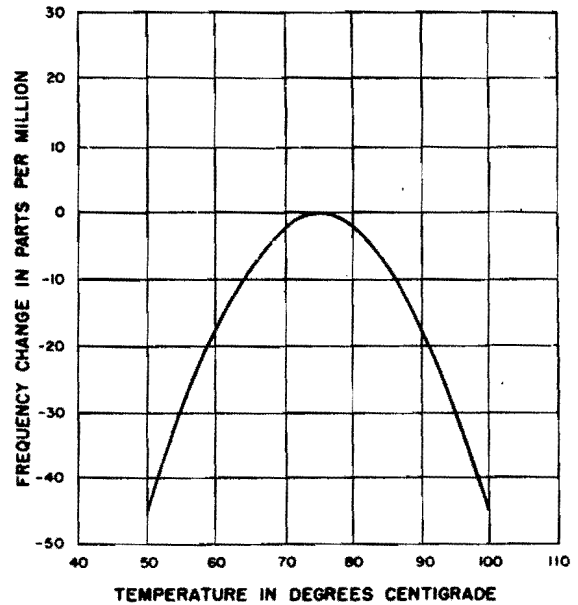

Figure 1-53. Temperature-frequency characteristics of ET-cut plate vibrating in combination mode *

75°C, so that the element is particularly advantageous where crystal ovens are used.

Disadvantages: Stability and general performance are inferior to those that can usually be obtained by using, according to the particular frequency, either an A or a C element.

1-118. CHARACTERISTICS OF FT-CUT PLATES IN COMBINATION MODE

Description of Element: FT cut, with w/l ratio approximately equal to 1.0; $yx1$ or yzw : -57°; combination of coupled modes with second flexural vibration appearing to dominate a face-shear harmonic.

Frequency Range: 150 to 1500 kc.

Frequency Equation: $f = \frac{k}{w}$ (square plate);

$$f = \frac{2k}{1+w} \text{ (nearly square plate).}$$

Frequency Constant: $k = 4710$ kc-mm.

Temperature Coefficient: 0.0 at 75°C; see figure 1-54 for total relative frequency deviation.

Methods of Mounting: Wire; preferably mounted in vacuum.

Advantages: The advantages of the FT cut are approximately the same as that of the ET, except that the FT has a lower frequency constant. The FT is related to the ET in approximately the same way that the DT is

Section I
Standard Quartz Elements

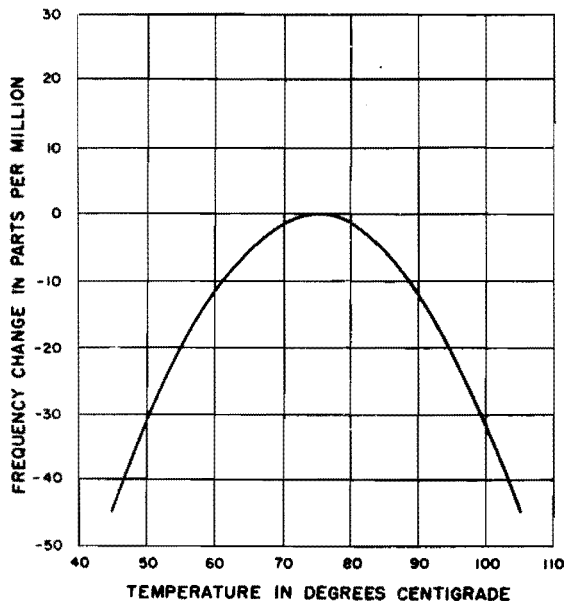

Figure 1-54. Temperature-frequency characteristics of FT-cut plate vibrating in combination mode *

related to the CT. However, the frequency constants of the ET and FT are approximately twice that of the low-frequency shear elements, so that these cuts can be made in practical sizes for twice the frequencies obtainable from the CT and DT crystals. Like the ET, the FT cut is particularly suited for use in ovens at temperatures between 70° and 80°C.

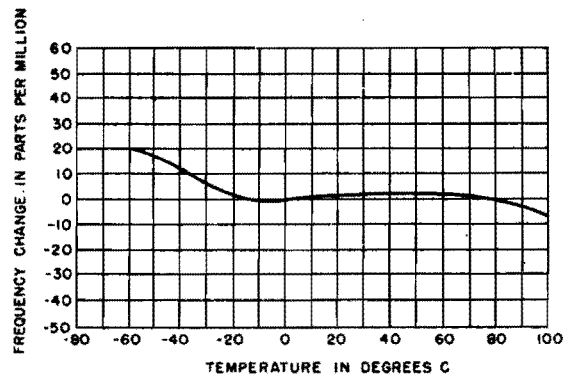
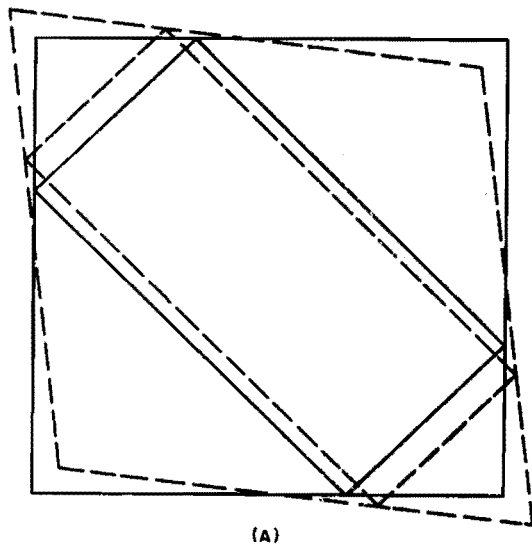

Figure 1-55. Temperature-frequency characteristics of element G *

Disadvantages: Stability and general performance are inferior to those that can usually be obtained by using, according to the particular frequency, either an A, C, or a D element.

1-119. CHARACTERISTICS OF ELEMENT G

Description of Element: GT cut, with ratio $\frac{w}{l} = 0.859$; $yxlt: 51^\circ 7.5'/45^\circ$; width-extensional mode.

Frequency Range: 100 to 550 kc.

Frequency Equation: k_1/w (fundamental).

Frequency Constant: $k_1 = 3370$ kc-mm.

Temperature Coefficient: Very nearly zero over the range from -25° to $+75^\circ$. Figure 1-55 shows the total relative frequency deviation from the initial frequency at 0°C . Note that

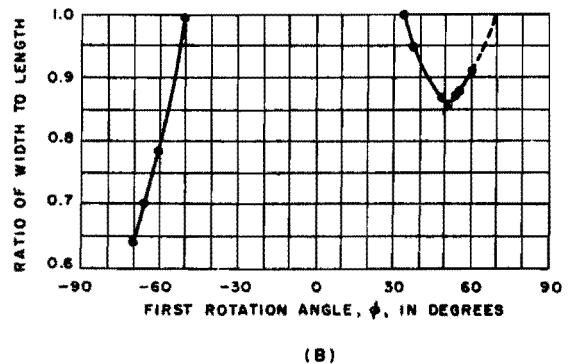

Figure 1-56. (A) Diagram illustrating the equivalence between a face-shear mode and the length- and width-extensional modes of a rectangular plate which has been cut diagonally with respect to the face-shear element. (B) w/l ratio vs rotation angle, ϕ , of element G providing zero temperature coefficient *

for a span of 100°C the frequency does not vary more than one part in a million from the center frequency. The midpoint of the flat portion of the curve can be shifted from 25°C to 50°C by increasing the initial orientation angle from 51°7.5' to 51°30'; the zero coefficient range will thus extend from 0°C to 100°C. A temperature variation of $\pm 15^\circ\text{C}$ on either side of the midpoint will not change the frequency more than 0.1 part in a million.

Methods of Mounting: Wire, knife-edge clamp, pressure pins, cantilever clamp.

Advantages: The GT cut provides the greatest frequency stability that has yet been obtained from a quartz plate. Where other quartz elements have zero temperature coefficients at only one temperature, the G element will not vary more than one part in a million over a range of 100°C. This element was originally suggested by the fact that a face-shear mode consists of two extensional modes coupled together. When a face-shear element is rotated 45° the vibrations lose their shear effect and appear as two extensional modes—one along the width, and the other along the length. See figure 1-56 (A). Since all *pure* extensional modes must have a negative or zero temperature coefficient, a positive coefficient of a face-shear mode must be due to the coupling between its two extensional components. If the cut of a face-shear crystal having a positive coefficient has been rotated 45°, the coupling between the extensional modes can be reduced by grinding down one edge so that one of the modes will increase in frequency. As the frequencies become more widely separated, the extensional modes will approach their true

negative temperature coefficients. At some ratio of width to length a zero coefficient will be obtained. The GT cut is properly a $\pm 45^\circ$ rotation of any positive-coefficient face-shear crystal in the Y group. Although the most satisfactory cut is the one described above, a number of other GT cuts have been investigated where the initial angle of rotation, ϕ , has had negative as well as positive values. Figure 1-56 (B) shows the w/l ratios for both positive and negative angles that will provide a zero temperature coefficient. For negative values of ϕ , the dominant mode is the one of lower frequency, whereas for positive angles of ϕ , the higher-frequency mode is dominant. The G element is used for the control of oscillators where the most precise accuracy is required, such as in the frequency standards of loran navigational systems, the time standards at the U. S. Bureau of Standards and at Greenwich Observatory, and in both fixed and portable frequency standards of general use. Other than in frequency and time standards, the GT cut is employed in filters that are designed for use under very exacting phase conditions.

Disadvantages: The principal disadvantage of a GT cut is its expense. To obtain optimum temperature-frequency characteristics requires pains-taking labor in cutting and grinding to the exact orientation and dimensions. Furthermore, the excellence of a particular cut will be of little advantage unless the mounting and the external circuit are also of superior design. For these reasons a G element is not particularly practical except when the utmost frequency precision is mandatory.

FABRICATION OF CRYSTAL UNITS

1-120. The production stages during the fabrication of a crystal unit may differ somewhat from one manufacturer to the next because of variations in the instruments, techniques, and the type of mounting employed. However, the general procedure is fundamentally the same throughout the industry—first, the inspection and cutting of the raw quartz; next the lapping and etching of the diced blanks; and finally, the mounting and testing of the crystal unit in its holder.

INITIAL INSPECTION OF RAW QUARTZ

1-121. The manufacture of a crystal unit begins

with the inspection of the raw quartz for impurities, cracks, and inclusions. For this purpose, the arc lamp of the inspectoscope shown in figure 1-57 is used.

1-122. The inspectoscope tank is filled with a clear, colorless oil mixture having an index of refraction approximately the same as the average in quartz (1.52 to 1.56). Such a medium for transmitting the light to and from the raw crystal, or "stone," is necessary in order to see the interior, for otherwise reflections and refractions at the rough surface will not only create an excessive glare, but will diminish the intensity of light penetrating beyond.

Section I
Fabrication of Crystal Units

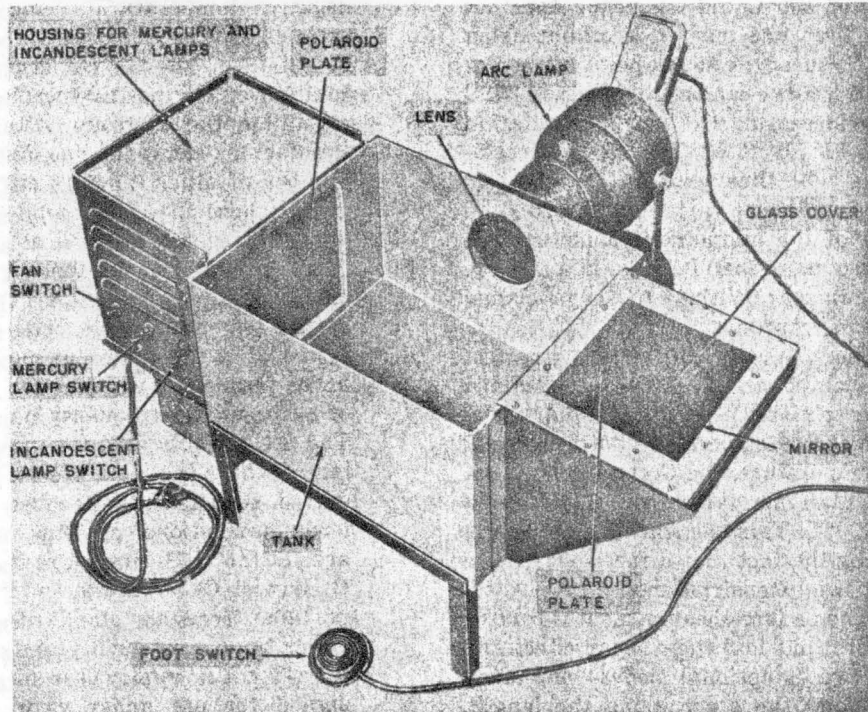

Figure 1-57. Polariscope-inspectoscope. Used for examining raw quartz

The lamp incorporates a high-powered (500- to 1000-watt) projection system of white light, and inspection of the stone is performed by direct observation. The usable parts of the stone are marked; or if too many imperfections are present, the stone is discarded.

INSPECTION FOR OPTIC AXIS AND OPTICAL TWINNING

1-123. If a stone has retained some of its natural faces, the optic (Z) axis may be readily located by direct observation. In the usual case, however, it is necessary to use the plane-polarized light system that is provided by the inspectoscope. The light from a mercury or incandescent lamp is plane polarized by a polaroid plate placed between the lamp and the tank. On the opposite side of the tank is a second polaroid plate with its transmission axis perpendicular to that of the first, so that if a stone is not in the tank to rotate the polarity of the light, the rays will be stopped at the second plate. Light that does filter through, however, is reflected upward by a mirror, and the pattern may be observed through the glass cover shown in figure 1-57. When a stone is placed in the tank and oriented so that its optic axis is parallel to the rays, the polarity of the rays will be rotated and a bright

image will be reflected from the mirror. If white light is used, a pattern of concentric rainbow colors will appear; and if monochromatic light is used, a pattern of concentric rings of light and darkness will appear. The optic axis will be exactly parallel with the light rays when the stone is in the position that yields the fewest and broadest bands. If optical twinning is present, it will be revealed by a fine-toothed pattern cutting across the rings, as indicated in figure 1-58. The twinning areas are more clearly indicated when white light is used, and when viewed slightly off the optic axis. On the other hand, monochromatic light produces ring patterns of maximum clarity for the determination of the optic axis itself. Flat surfaces are ground on opposite sides of the stone, parallel to the optic axis; and, with the stone resting on one of the flat surfaces at the bottom of the inspectoscope tank, a line is drawn on the upper surface to indicate the approximate Z-axis direction.

USE OF CONOSCOPE FOR EXACT DETERMINATION OF OPTIC AXIS

1-124. After the approximate optic (Z) axis is determined, the stone is cemented to a glass plate, and a small-end-section of the crystal is sliced off with a diamond saw, leaving a flat surface approxi-

111 586

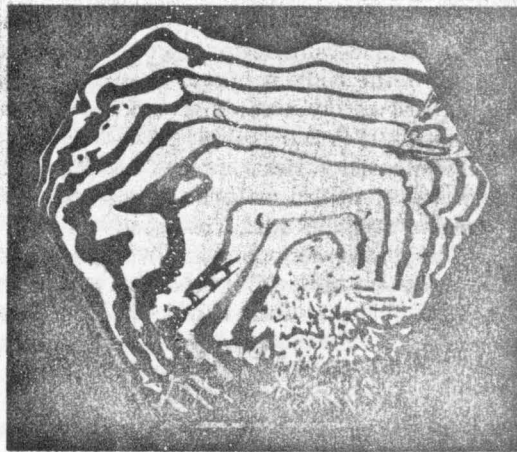

A. VIEW ALONG THE OPTIC AXIS



B. VIEW SLIGHTLY OFF THE OPTIC AXIS

mately perpendicular to the optic axis. The stone is then mounted on an adjustable orienting jig, which is placed against the reference edge in a conoscope tank. The conoscope (see figure 1-59) provides a polarized light system with which the optic axis may be accurately located by observing a concentric ring system. The principle of the conoscope is similar to that of the polarizing system of the inspectoscope, except that a converging lens system and a vernier system are provided that permit the optic axis to be determined with an accuracy of one degree. The handedness of the crystal is readily determined by rotating the second polaroid plate, or *analyzer*, of the conoscope. The quartz is right or left according to whether the concentric rings appear to expand or contract for a given direction of analyzer rotation. When the Z axis is accurately determined, each end is trimmed to form plane surfaces ("windows") exactly perpendicular to the Z direction.

SECTIONING THE STONE

1-125. There are three general methods of cutting the stone to obtain crystal blanks of desired orientation: the direct-wafering, X-block, and Z-section-Y-bar methods. In direct wafering, shown in figure 1-60, wafers are sliced directly from the stone at the desired orientation, and the blanks are diced from the wafer. The X-block method, as indicated in figure 1-61, is similar to that of direct

Figure 1-58. Polarized-light view of pyramidal cap indicating optical twinning *

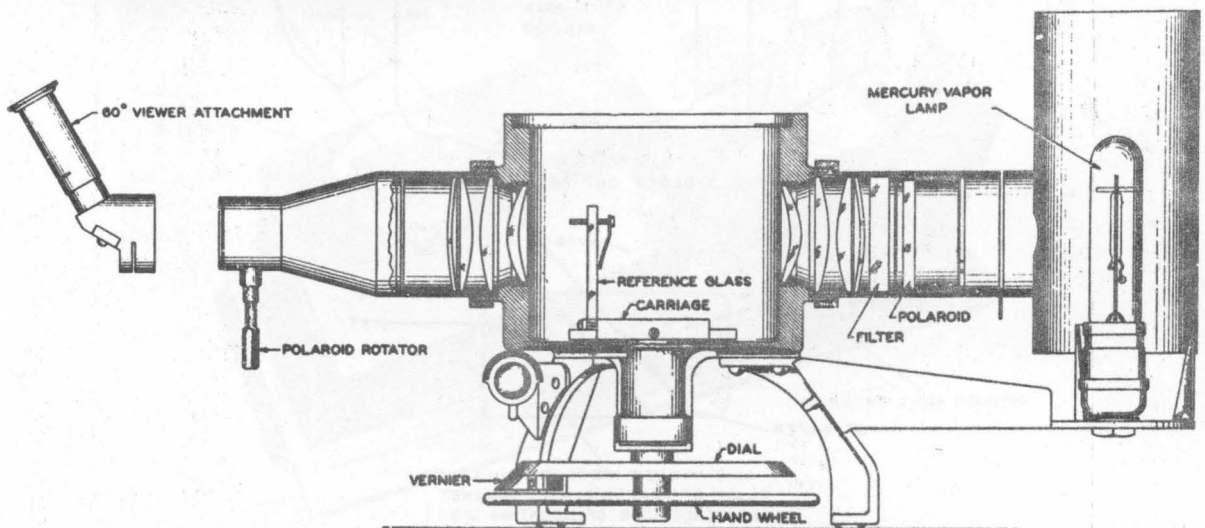
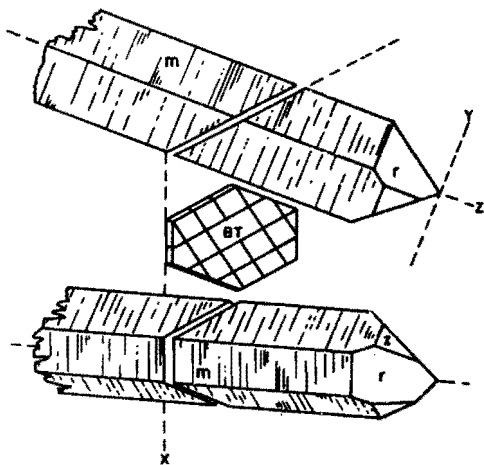

Figure 1-59. Conoscope. Used for locating accurately the optic axis and for determining the handedness of quartz stones *

Section I
Fabrication of Crystal Units



wafering, except that, before being sliced into oriented wafers, the stone is cut into one or more blocks with plane surfaces at each end of the Z axis; and at the ends of one of the X axes; each surface is accurately cut at right angles to the axis it terminates. It is from these "X" blocks that the properly oriented wafers are cut and then diced into blanks. The third method of cutting proceeds as indicated in figure 1-62. The stone is sliced into Z sections (cross-sectional slabs with plane faces perpendicular to the Z axis); the Z sections are cut into Y bars (bars with the length parallel to the Y axis); and crystal blanks are sliced at the desired

Figure 1-60. Direct-wafering method of cutting crystal blanks

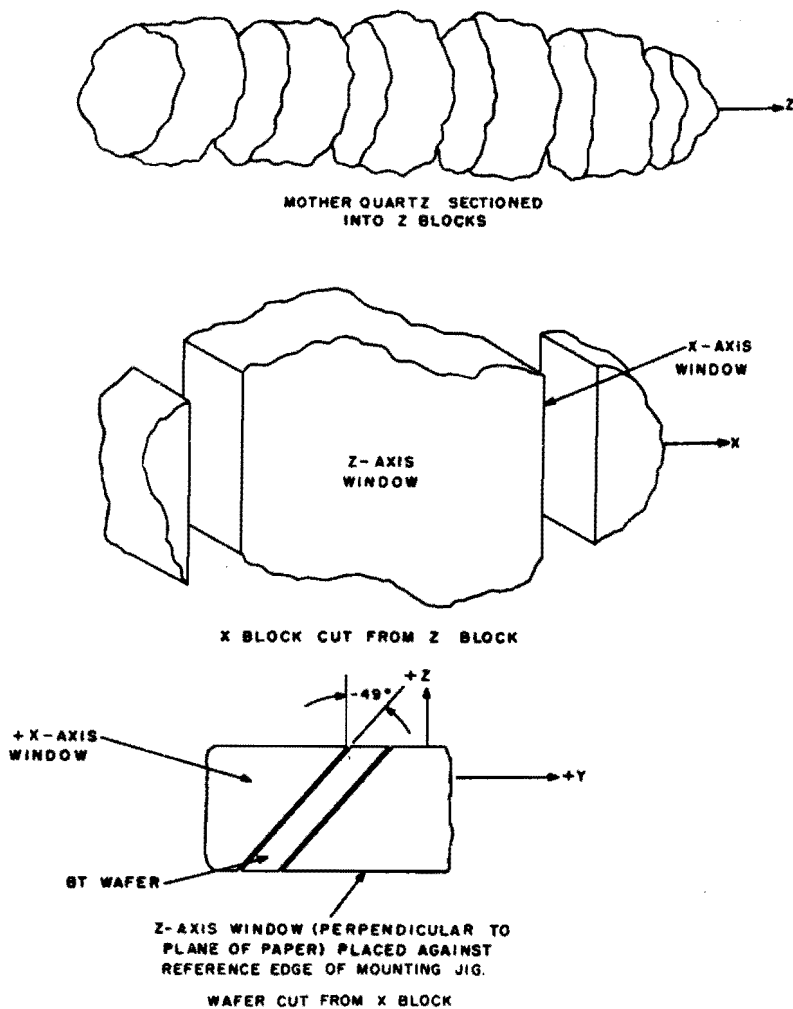

Figure 1-61. X-block method of cutting wafers from unfaced stone. Wafers, on being diced, provide crystal blanks of the proper orientation

orientation from the Y bar. Of the three methods of cutting, the X-block method is the one most commonly used, and will be the one assumed in the following paragraphs.

DETERMINATION OF X AXIS

1-126. A reasonably accurate method for a preliminary determination of the X axis of an unfaced quartz is by observing the cleavage lines of a thin Z section when it fractures after being heated and dropped into cold water. The intersections of the fractures with the XY plane of the Z section are normally parallel to an X axis. A more useful procedure, however, is to first etch a Z block (block or section with Z windows, before X windows have been cut) in a bath of 30% hydrofluoric acid, and determine the approximate X axis with a pin-hole oriascope, shown in figure 1-63. The oriascope provides a pin-point source of ordinary light which will cause a triangular image to appear on the upper XY window when the lower window of the Z block is placed over the pin hole. The sides of the triangle are approximately parallel to the X axes, and matching windows and a template are provided to aid in marking the crystal.

1-127. With the X axis approximately located by

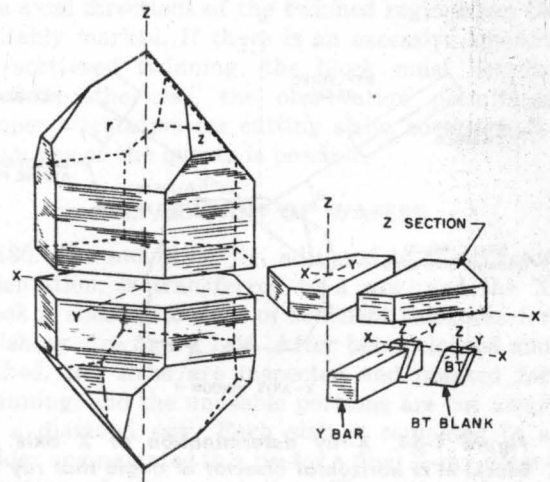

Figure 1-62. Z-section-Y-bar method of cutting properly oriented crystal blanks

the cleavage or oriascope methods, an exact orientation is determined by use of X-ray apparatus. The Z block is cemented to a glass plate, which in turn is placed on an adjustable orienting jig that can later be transferred to a saw. As indicated in

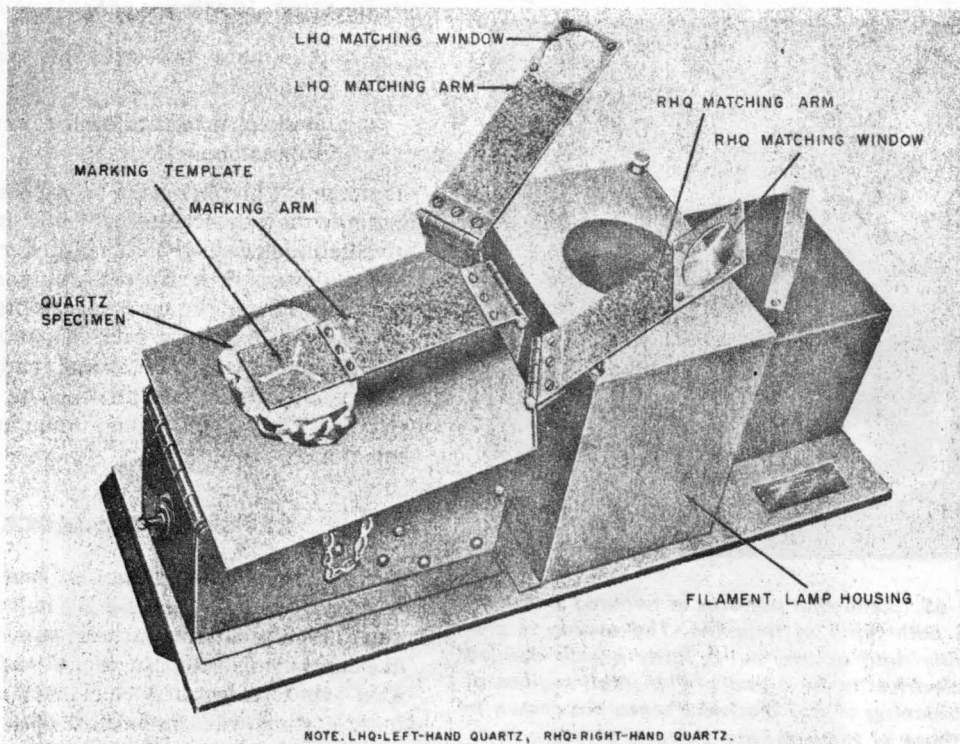

Figure 1-63. Pinhole oriascope with matching and marking arms for use on Z sections *

111 586

Section I
Fabrication of Crystal Units

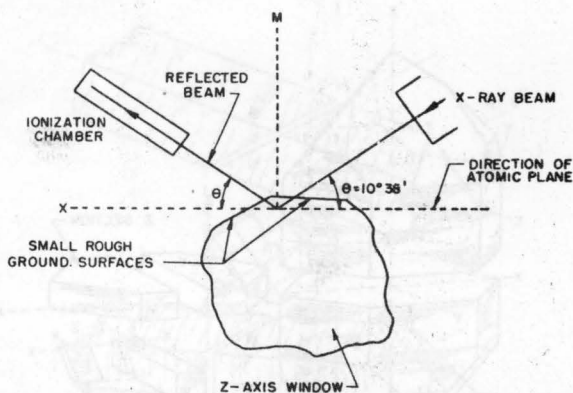

Figure 1-64. X-ray determination of X axis in Z block. M is horizontal bisector of angle that ray must make if reflected beam is to enter ionization chamber. θ , the Bragg angle of X-ray reflection for copper-anode K_{α} radiation, is predetermined according to the particular atomic plane to be identified. For plane that is parallel to an m face, and hence to an X axis, $\theta = 10^{\circ}38'$. With positions of X-ray source and ionization chamber fixed, rotation of Z block about Z axis will cause maximum current to flow through ionization chamber when an X axis becomes perpendicular to M

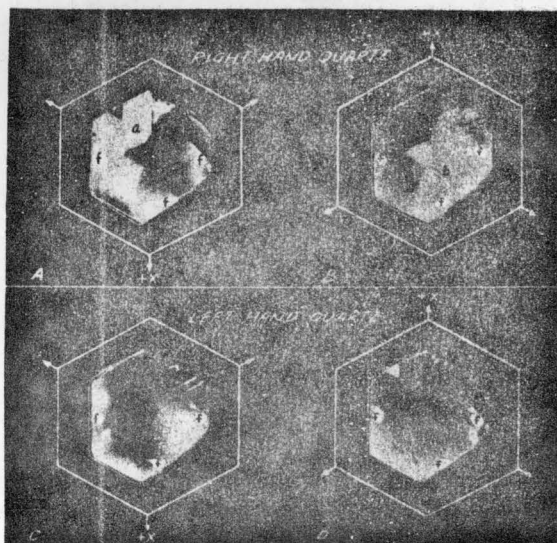

Figure 1-65. Reflection patterns of twinned Z section, showing both types of twinning. The section is predominantly right quartz, but is fairly evenly divided by the electrical twins a and b. The small regions of optical twinning of one electrical sense are shown in C, and those of the opposite sense are shown in D. The X-axis polarities indicated apply only to the respective bright regions. The regions marked f contain flaws *

figure 1-64, an X-ray beam is directed toward the crystal's vertical surface, which deflects part of the beam into the window of an ionization chamber, causing a current to flow that has an amplitude proportional to the intensity of the rays entering the chamber. X-rays of constant wavelength are propagated in a narrow pencil from a properly filtered source, which consists of a special high-voltage cathode-ray tube having a copper anode. The X-rays are emitted by virtue of the high-energy electrons' striking the copper target, and a thin nickel plate is inserted in the X-ray path to eliminate unwanted wavelengths. The atomic planes of the crystal lattice effectively serve as reflecting surfaces, except that interference between the reflected rays from adjacent parallel planes eliminates all angles of reflection except those that permit the path lengths of coinciding rays to differ by an integral number of wavelengths. The above condition is satisfied when the distance between the atomic planes is related to the wavelength and the angle of incidence of the X rays in a manner that can be expressed by Bragg's law:

$$n\lambda = 2d \sin \theta$$

where: $n = 1, 2, 3, \dots$

λ = wavelength of X rays

d = distance between parallel atomic planes

θ = angle of incidence of X rays with atomic plane

The ionization chamber is a gas-filled metallic cylinder having an electrode which is maintained at a voltage relative to the cylinder. X rays entering the chamber will ionize the gas, permitting a current to flow through the external circuit. With θ predetermined for a particular atomic plane, the exact direction of the plane, and hence of the crystal's orientation, can thus be determined by rotating the Z block for a maximum reading on the ammeter.

CUTTING X BLOCK

1-128. When the X direction has been precisely determined, the mounting jig is locked in position and transferred to a diamond saw, where windows are cut perpendicular to, and at each end of, the X axis—thereby forming an X block. After the alignment of the windows is rechecked with the X-ray apparatus, the X block is cleaned, and then etched in 48% hydrofluoric acid or a saturated solution of ammonium difluoride.

DETERMINATION OF TWINNING

1-129. Electrical and optical twinning boundaries can be observed directly by shining a spot lamp upon the etched Z windows of the X block. The light should be directed at approximately a 30-degree angle with the surface being examined, with the line of sight of the observer perpendicular to the surface. As the block is rotated about the axis perpendicular to the surface, there will be four particular orientations, each corresponding to a reflection of maximum brightness from the etched area of one of the four possible twins—right-hand quartz of either electrical sense, and left-hand quartz of either electrical sense. See figure 1-65. Normally a crystal is predominantly right or left, so that optical twinning usually appears only in small scattered regions. Electrical twinning, however, normally divides a crystal into large regions of opposite electrical sense. The polarities of the various twinned areas can be readily determined by noting the angles of rotation at which maximum brightness is observed. The axial polarities of an X block may also be determined by examining the X windows with the aid of a pin-hole oriascope having matching and marking arms designed especially for X sections. The images observed will differ according to the electrical sense of the particular area—also, according to whether hydrofluoric acid or ammonium difluoride was used in etching. By a proper interpretation of the patterns,

the axial directions of the twinned regions can be suitably marked. If there is an excessive amount of scattered twinning, the block must be discarded; otherwise, the observation permits a proper orientation for cutting slabs, so that optimum use of the quartz is possible.

PREPARATION OF WAFERS

1-130. The mounting jig, adjusted to the correct orientation, is transferred to a saw, and the X block is sliced into slabs of sufficient thickness for finishing. See figure 1-66. After being cleaned and etched, the slabs are inspected and marked for twinning, and the unusable portions are cut away by a diamond saw. Each slab is cemented to a holder and mounted in a jig for a final X-ray determination of the orientation. The adjusted slab holders are transferred to the jig of a lapping machine, and the slabs are lapped on one surface, using an abrasive of 400-grain carborundum, until the lapped faces have the desired orientation. The slabs are then cemented to a large plate with the corrected faces down, and the uncorrected faces are lapped until parallel with the bottom faces. The "wafers," as the slabs are now called, are next cemented to a glass-topped steel plate for dicing.

PREPARATION OF CRYSTAL BLANKS

1-131. The wafers are diced to the approximate crystal blank size with a dicing saw, as shown in

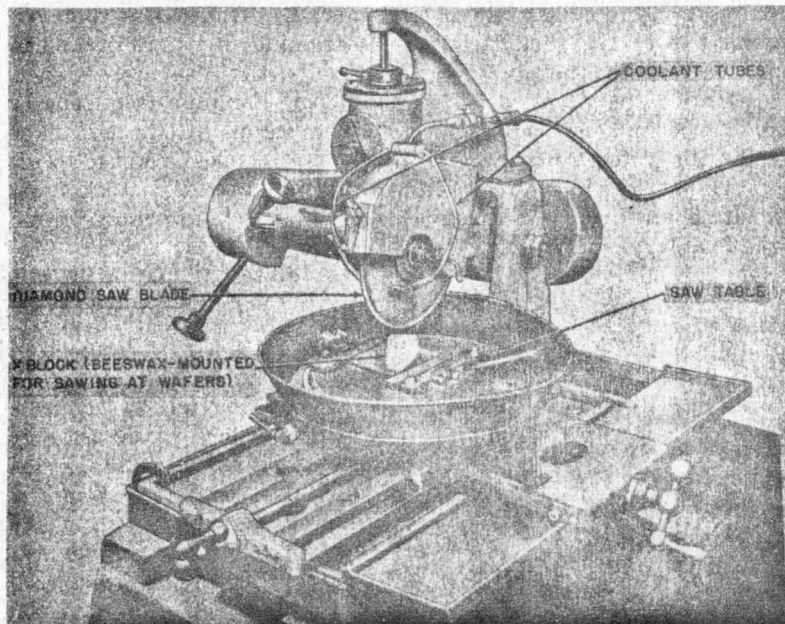

Figure 1-66. Diamond saw for cutting wafers from X block

111 586

Section I
Fabrication of Crystal Units

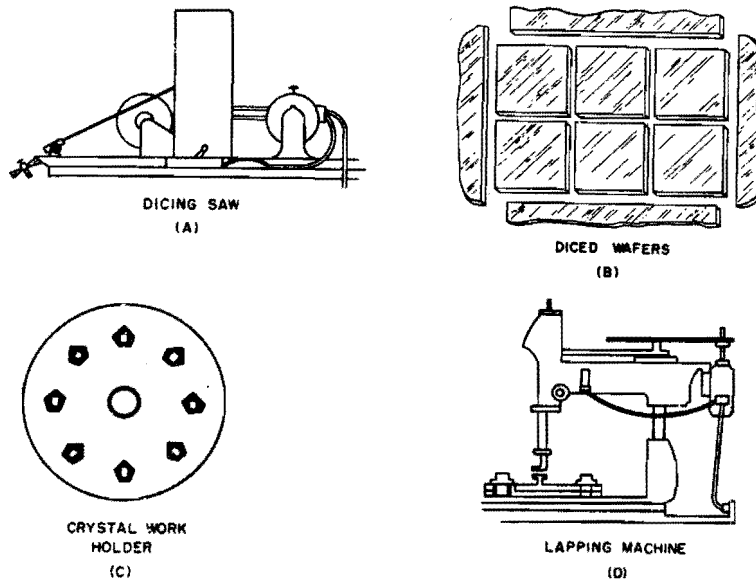

Figure 1-67. (A) Dicing saw. (B) Diced wafer. (C) Nest of lapping machine. (D) Lapping machine

figure 1-67. The dice are then transferred to the nest of a lapping machine, where they are lapped to a thickness equivalent to several kilocycles below the desired frequency. The lapping proceeds in three stages: rough, semifinishing, and finishing. However, the rough stage is accomplished prior to dicing, if the slabs are first lapped to wafers as described in paragraph 1-130. The semifinishing is done with 600-grain carborundum or equivalent, and the finishing requires 1000- to 1200-grain abrasive. Each of the last two stages should completely remove the surface left by the preceding stage. (Where extreme care is required, as when finishing thin harmonic mode plates, 3000 mesh aluminum oxide mixed with water, cosmetic talc and powdered white rouge provides high-precision results, with the ultimate operating dependability greatly increased if the final lapping is followed by

a brief semi-polishing with a mixture of water, rouge, and small amounts of rust preventative and wetting agent.) In the case of high-frequency blanks, the final lapping should bring the blanks within 25 to 50 kilocycles of the desired frequency. Next, a stack of 25 to 100 dice are clamped into a loaf, with all the blanks oriented in the same direction. See figure 1-68. Two exposed edges are then ground parallel to locating surfaces by an edging machine. The loaf is then reversed and the two remaining edges are ground to square the blanks. Finally, the blanks are etched to the proper frequency. For high-frequency crystals, a frequency tolerance of ± 0.002 percent will require that the finished blanks be etched to within ± 0.00001 millimeter of the ideal thickness. After cleaning, the crystal blanks are ready for mounting.

METHODS OF MOUNTING CRYSTAL BLANKS IN CRYSTAL HOLDERS

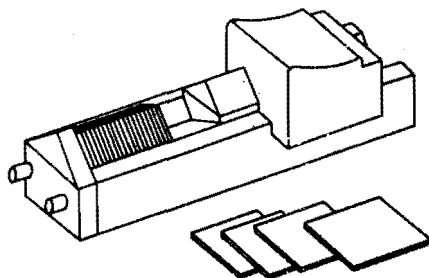

Figure 1-68. Loaf of crystal dice, all blanks oriented in the same direction in preparation for edge grinding by edging machine *

1-132. In the past, some confusion has resulted among radio engineers because of a mixed usage of the terms *crystal holder* and *crystal unit* by manufacturers in describing and naming their products. However, it is now generally agreed that the term *crystal holder* is to be used only in reference to the mounting and housing assembly, whereas the term *crystal unit* is to designate a complete assembly—that is, a crystal holder containing a mounted crystal plate.

1-133. Crystal holders have been variously classified by different specialists in the field, and in the

absence of a standard nomenclature, a certain amount of overlapping has resulted among the different classifications. The procedure to be followed here is to treat each particular method of mounting as a separate category. The holders to be discussed are described according to the following types of mounting: gravity-sandwich, pressure-sandwich, gravity-air-gap, corner-clamped-air-gap, nodal-clamped-air-gap, dielectric-sandwich, plated-dielectric-sandwich, button-sandwich, knife-edge-clamp, pressure-pin, cantilever-clamp, solder-cone-wire, headed-wire, and edge-clamped. Only two general classifications of mounting, *wire* and *pressure*, are specified for Military Standard crystal units currently recommended for use in equipments of new design. The wire-mounted crystals are cemented directly to supporting wires. The pressure-mounted crystals are clamped in place by frictional contact with electrodes or other supporting elements. The wire mounts include the solder-cone-wire, the headed-wire, and the cemented-lead types, the latter being a particular kind of edge-clamped support cemented to the crystal. The pressure mounts include all other types listed above except the gravity-sandwich and the gravity-air-gap.

Gravity Sandwich

1-134. A "crystal sandwich" is simply a crystal plate sandwiched between two flat electrodes. In the simple gravity type of holder the crystal plate is placed on one electrode, with the second electrode resting on top and connecting to the external circuit through a flexible wire. See figure 1-69. A small clearance is provided around the sides to permit the crystal to vibrate freely. The clearance must not be too large, however, else the crystal will slide around in the holder, and may become chipped, or, at least, cause the electrical constants of the crystal unit to vary. The electrodes must be perfectly plane and made of noncorrosive metal, such as stainless steel, brass, or titanium. Brass is inferior to the other two metals, and titanium is largely a future possibility. The top electrode is considerably lighter than the bottom electrode, and is usually specifically dimensioned to fit a par-

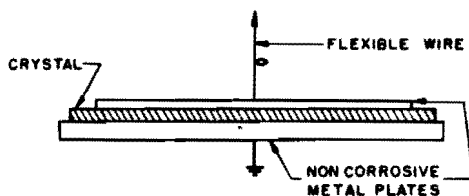

Figure 1-69. Gravity sandwich

ticular crystal size. If the top electrode is too heavy, the impedance it introduces will be excessive, preventing the crystal from vibrating near its normal mode; on the other hand, if the top electrode is too light, firm contact will not be made with the crystal, and the operation of the crystal unit will be unstable. The edges of the crystal are slightly rounded to insure that they are free of burrs. Both the crystal and the electrodes must be perfectly clean, and the entire unit must be mounted in a hermetically sealed chamber. Normally, the grid terminal of the unit connects to the flexible wire of the top electrode, and the ground or cathode terminal to the bottom electrode. 1-135. The gravity holder was at one time widely used, but has now been largely replaced by holders that can maintain the crystal in a relatively fixed position if subjected to external vibration, such as might be encountered in vehicular or aircraft equipment. Occasionally, even when mounted in vibration-free equipment, a gravity crystal unit may fail to operate because one edge of the crystal has become closely pressed against one of the sides of the chamber. However, a light tap of the holder is usually sufficient to start oscillations. Compared with the holders in which flat inflexible electrodes are pressed against the crystal, the activity of the gravity holder is generally superior, and requires less voltage to maintain a state of oscillation.

Pressure Sandwich

1-136. In holders of the pressure-sandwich type, the crystal is held more or less firmly between two flat electrodes under the pressure of a spring. In a typical assembly, the electrodes, which normally are of identical size and shape, are in turn sandwiched between two very thin contact plates. The contact plates connect to two metal prongs that serve as electrical terminals and plugs for mounting the crystal holder in a socket. An insulating washer is placed over one of the contact plates, a coil spring is placed over the washer, and a neoprene gasket is placed between the spring and the cover to provide hermetic sealing. Except for the glass spacers, the pressure holder described above is very similar to the air-gap holder shown in figure 1-70.

1-137. Although the activity of a pressure-type crystal sandwich normally is not as great as that of the gravity type, it is much preferred because of its greater ruggedness and less critical requirements concerning the orientation and vibration of the equipment in which it is to be mounted. Another advantage of the pressure holder is its relative simplicity of design—fewer of its compo-

Section I
Fabrication of Crystal Units

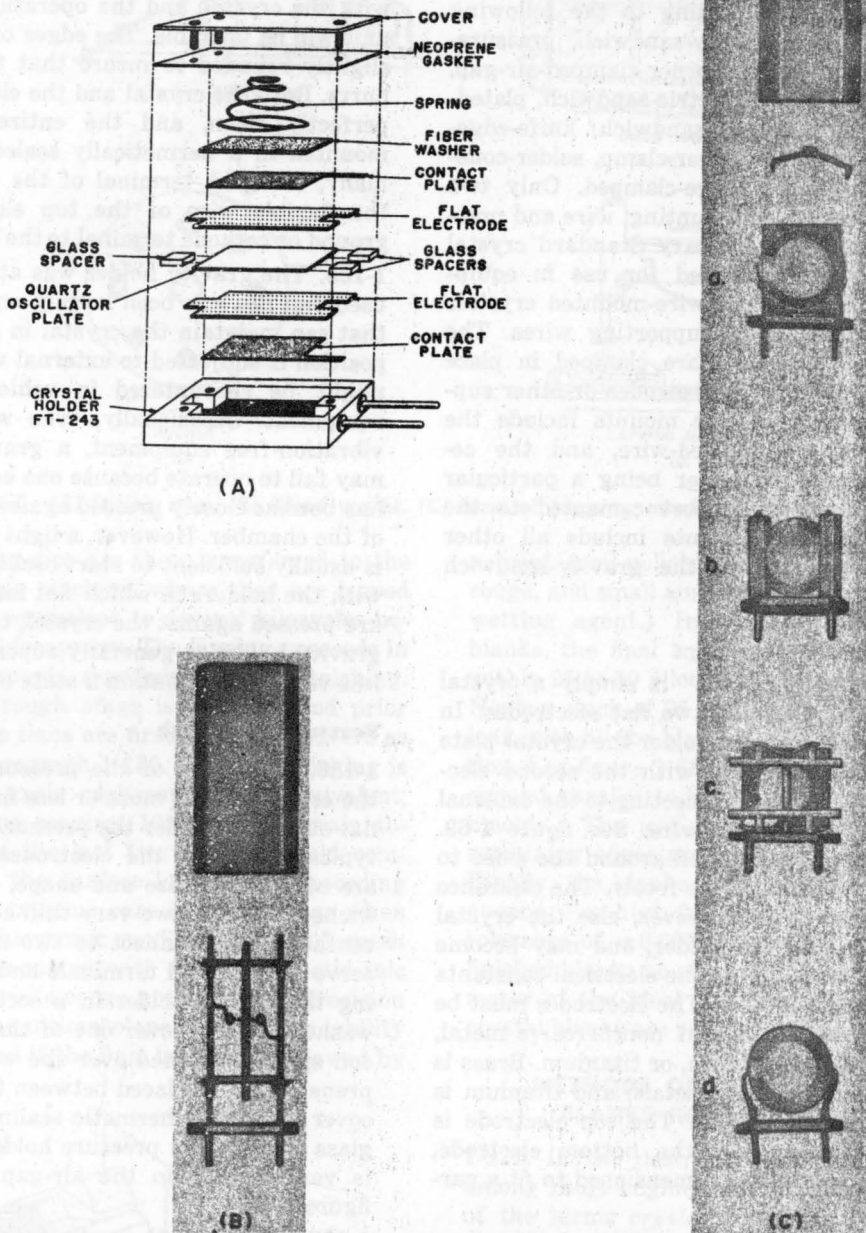

Figure 1-70. Methods, old and new, for mounting crystal units. (A) Construction of early model crystal unit employing the gravity air-gap type of mounting, now largely outmoded. The crystal holder shown is the type FT-243. (B) Solder-cone wire mount for v-l-f length-flexure crystal. (Courtesy HEEMCO). (C) Recently developed techniques for mounting shock-proof, 1-mc, A elements in the miniature HC-6/U metal holder to meet the specifications for 1-mc CR-18/U crystal units: a. Reeves-Hoffman flexible nylon mount. b. Hupp loose-slotted edge-clamped mount. c. Bliley molded nylon bumper mount. d. RCA edge-clamping spring mount. (Courtesy McCoy Electronics.)

III 580

nents require separate and exact dimensions for each particular frequency than is true of the majority of holders. If the holder is constructed so that the spring pressure may be adjusted, very slight variations in the frequency are possible; the activity, however, will decrease proportionally as the pressure is increased. Although the pressure holder is widely used and is less expensive than most of the other types of holders, it has the disadvantage of low activity and comparatively large damping of the oscillations. Thus, crystal units of this construction are not as sharply selective, nor as electrically predictable, as crystal units of more critical design.

Gravity Air-Gap Mounting

1-138. A gravity air-gap crystal unit is essentially a gravity sandwich, but with an air space separating the crystal from the upper electrode. The air gap may be variable or fixed. In the variable type, the frequency can be adjusted slightly by raising or lowering the upper electrode, by means of a screw. The fixed air gap, however, is more commonly used. As shown in figure 1-70, the fixed gap is maintained by glass or other insulating spacers placed between the electrodes. It is important that the thickness of the air gap not be an even quarter-wavelength of the acoustic vibrations which the crystal will generate in the air. Otherwise, the air waves, on reflection from the upper electrode, will return to the crystal 180 degrees out of phase with the normal vibrations, thereby introducing a high impedance and greatly reducing the activity. Maximum activity is obtained when the air gap is an odd quarter-wavelength in thickness. The exact dimension, however, is not particularly critical in the case of shear modes, and a variation of $\pm 1/8$ wavelength will cause little change in the amplitude of the vibrations. The quarter-wavelength

formula is $\frac{\lambda}{4} = \frac{v}{4f}$, where v is the sound velocity in air, and f is in cycles per second. At room temperature and pressure, $v = 330,000$ mm/sec = 12,992,000 mils/sec. The gap thickness should not exceed 3 mils, else the piezoelectric coupling will be too weak to maintain oscillations at reasonable voltages. Where it is necessary to have as large a piezoelectric coupling as possible, the air gap must be reduced to the minimum of $1/8$ wavelength.

1-139. The advantage of the air-gap mounting is that it shares the simplicity of design of the sandwich holders, but eliminates the damping effect caused by the frictional contact of the upper electrode with the crystal. The presence of the air gap also effectively inserts in the crystal circuit a

series capacitance equal to that between the upper electrode and the crystal face, thereby increasing the ratio of the stored electrical to the stored mechanical energy, and thus decreasing the electromechanical coupling. The reduction of the frictional losses (i.e., the effective electrical resistance) and the electromechanical coupling serves to give the crystal unit a higher Q , and thus to make it more selective and stable, and less affected by small variations on the external circuit. However, with the decrease in electromechanical coupling, the tendency of the crystal to vibrate is reduced; and also reduced is the bandwidth for use in filters. On the credit side, the gravity-air-gap mounting is particularly convenient for the preliminary testing of crystals at the time they are being ground, and it has also been widely used in fixed-plant equipment with thickness-mode crystals operating at frequencies between 200 and 1500 kc. The principal disadvantages of the gravity-air-gap holder are the loose mounting of the crystal, the reduced piezoelectric coupling, and the possibility that a momentary overdrive will cause arcing across the air gap, or a corona discharge, thereby damaging the crystal and electrode surfaces, or even puncturing the crystal completely.

Corner-Clamped, Air-Gap Mounting

1-140. The principal features of the corner-clamped, air-gap mounting are indicated in figure 1-71. Note that air gaps exist at both the major faces of the crystal, except at the corners where the electrode risers, or lands, clamp the crystal in position. If the length of a thickness-shear plate, such as an AT or BT cut, is not less than twenty times the thickness, a firm pressure may be applied at the corners without greatly reducing the activity. The same precaution for avoiding an air column with dimensions approaching a multiple of a half-wavelength is necessary for the clamped as for the unclamped holder. The lands at the corners normally provide a gap of 0.5 to 2 mils.

1-141. The corner-clamped, air-gap method is widely used for mounting high-frequency thickness-shear crystals. Its operating characteristics

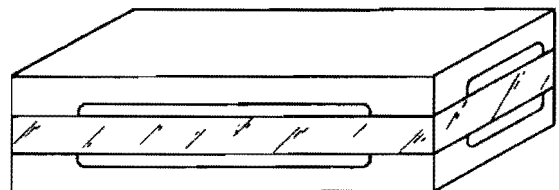

Figure 1-71. Typical corner-clamped, air-gap method of mounting crystals *

Section I Fabrication of Crystal Units

are similar to those of the unclamped holder; and, in addition, it has the important advantage of clamping the crystal in a fixed position, thus permitting its use in aircraft and vehicular equipment. However, the clamping at the corners introduces an excessive amount of impedance when used for the lower-frequency, thickness-shear crystals where the l/t ratio is less than 20; hence, this type of mounting is generally confined to crystals with frequencies above 1500 kc.

Nodal-Clamped, Air-Gap Mounting

1-142. The principal features of the nodal-clamped, air-gap mounting are indicated in figure 1-72. This method may be used for mounting low-frequency piezoelectric elements vibrating in an extensional mode and having a nodal area at the center of the crystal. Each electrode has two risers for clamping the crystal at each end of its nodal axis, and thus provides a secure mounting with a minimum of damping from direct contact between the crystal and the electrodes. A general advantage of any "zone-type" clamping, such as the nodal or corner methods where particular areas of a crystal are subjected to pressure, is that spurious frequencies requiring free vibrations in the clamped zones will be suppressed.

Dielectric Sandwich

1-143. This type of holder is essentially a crystal sandwich with a "lettuce" of high dielectric material inserted between the crystal and the electrodes. The sandwich and air-gap holders previously described do not permit a crystal to operate

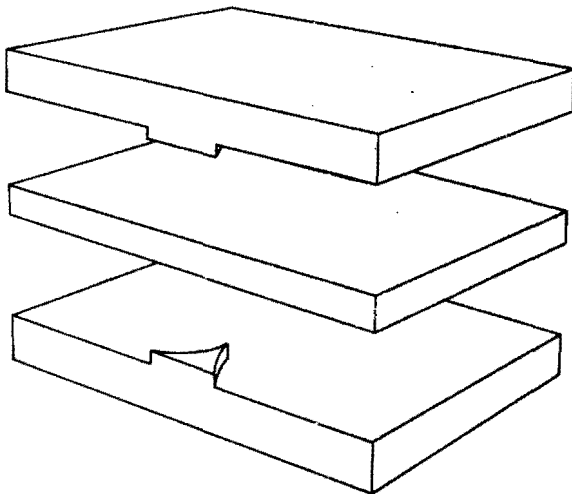

Figure 1-72. Typical nodal-clamped, air-gap method of mounting crystals

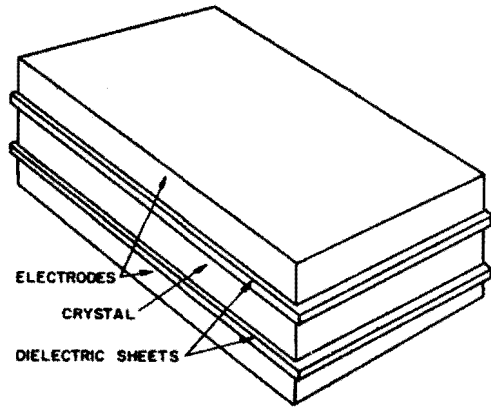

Figure 1-73. Pressure type of dielectric sandwich for mounting crystals

near its elastic limit, for otherwise arcing would occur between the electrodes and the crystal. Low drive levels are particularly necessary at frequencies above 4000 kc, for the likelihood of corona discharge or arcing increases with the frequency. Even if the arcing is insufficient to puncture the crystal, its presence will cause either wet or dry oxides to form on the crystal and the electrodes, thereby reducing the activity and greatly shortening the crystal's useful lifetime, if not preventing its operation entirely. Many factors contribute to the possibility of a breakdown: type of holder, presence of sharp edges, smoothness and parallelism of crystal and electrode faces, type of cut, air-gap dimensions, d-c and r-f voltages, frequency, and the like. However, since the arcing in all cases is the direct result of ionization of the air between the electrodes and the crystal, this danger may be removed if the more vulnerable air spaces are filled with an elastic cushion that has little tendency to ionize. It is necessary that the material have a dielectric constant much higher than that of air, and preferably higher than that of the crystal, and that it have low dielectric losses at the operating frequency; otherwise the special advantages of the particular types of mounting with which dielectric material is used would be destroyed by an increase in damping. The dielectric filler may consist of insulating sheets cut to fit a particular mounting, or it may be coated over the electrode faces. In either case, a material of high dielectric constant will permit a crystal to be driven near its elastic limit without the danger of corona effects, and with much less restraint of the normal vibrations than occurs when the crystal is in direct contact with the electrode faces. Suitable dielectric materials are mica, thin sheets of glass or fused quartz or other ceramics, "Cellophane," nonsul-

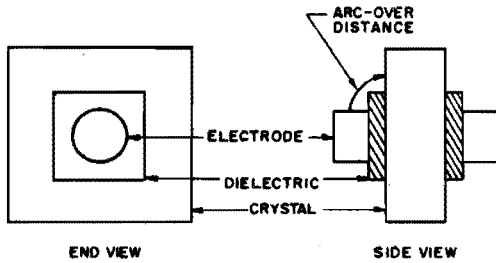

Figure 1-74. Center-pressure type of dielectric sandwich for mounting crystals

furious rubber sheeting, cellulose esters and ethers, varnishes, lacquers, vitreous enamels, metallic oxides, rubber coatings applied by electro-deposition, rubber containing resin and other fillings, or fused coatings of natural or synthetic resins. The sheets or coatings should be from 1 to 5 mils in thickness, but care should be taken that the thickness of the insulating material does not approach a multiple of a half-wavelength of the acoustic waves that will be generated. In any event, the addition of the dielectric material will tend to raise the impedance and frequency slightly, so that in extreme cases it may be necessary to grind the crystal to a frequency lower than that at which it is to operate.

1-144. Figures 1-73 to 1-77 indicate different methods in which the dielectric fillers may be used in mounting a crystal. Figure 1-73 illustrates a pressure type of mounting with two sheets of dielectric material—mica, for instance—inserted between each electrode and crystal. Note that the mica extends beyond the edges of both electrodes. This feature is important, for although in a well-designed pressure sandwich no air spaces exist between the crystal and electrode faces, so that ionization and arcing do not occur at the major surfaces, corona discharges can and do occur at the edges, particularly if the sides of the chamber are close in, as is usual, causing the alternating field around the edges to be more intense. However, with the insulating sheet of high dielectric constant overlapping the electrode edges, the intensity of the electric field will be greatly diminished. That part of the dielectric directly between the crystal and the relatively inelastic electrode, acts as an elastic cushion, and thus serves much the same function as an air gap, but without increasing the possibility of corona or arcing effects.

1-145. Figure 1-74 shows a top and a side view of a center-pressure type of mounting, where two circular electrodes of small cross section are separated from the crystal faces by insulating sheets

of high dielectric constant. Again, it is important that the insulation extend well beyond the edges of the electrodes. This arrangement increases the length of the shortest possible arcing path, and, in so doing, diminishes the chance of the occurrence of a discharge.

1-146. Figure 1-75 illustrates two methods by which a corner-clamped air-gap holder can be converted into a dielectric sandwich while still retaining the principal advantages of the air-gap mounting. Figure 1-75A shows an insulating sheet cut to the dimensions of the air gap, and figure 1-75B shows a corner view of the assembled sandwich. Figure 1-75C is a side view of a similar sandwich,

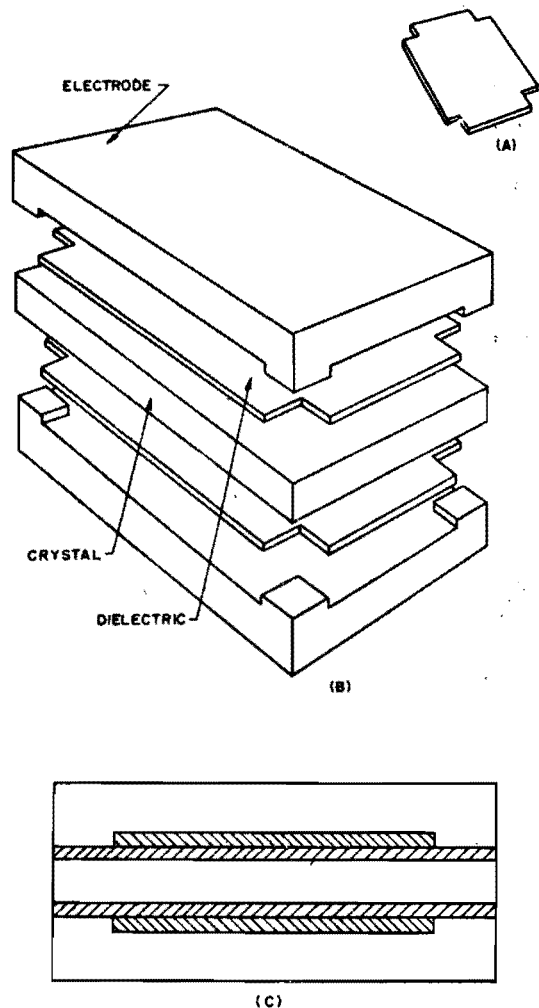

Figure 1-75. Two methods (B and C) by which a corner-clamped, air-gap holder can be converted into a dielectric sandwich. Figure A shows a dielectric sheet cut to the dimensions of the air gap

Section I
Fabrication of Crystal Units

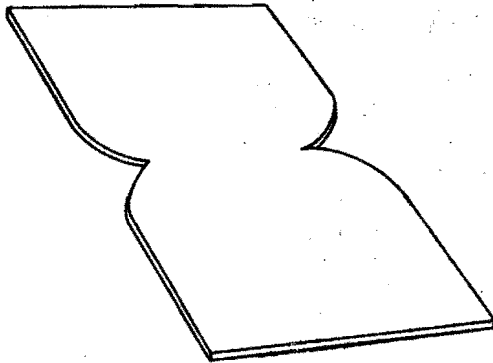

Figure 1-76. Dielectric sheet cut to fill air gap of nodal-clamped mounting

but with two additional insulating sheets inserted to cushion the crystal entirely from direct contact with the electrode risers.

1-147. Figure 1-76 illustrates the cut of an insulating sheet for converting a nodal-clamped, air-gap mounting into a dielectric sandwich. Two niches in the edges of the sheet are cut to fit the two risers of an electrode. When assembled, the sandwich is similar to the corner-clamped model of figure 1-75B; or, if additional rectangular sheets are inserted next to the crystal, the assembly will resemble the arrangement in 1-75C. With either method, maximum rigidity is obtained for the nodal mounting with a minimum in damping.

1-148. Figure 1-77 is a cross-sectional view of a gravity type air-gap mounting with the electrodes coated with an insulating material of high dielectric constant. It is characteristic of air-gap holders that the smaller the thickness of the air gap, the higher the r-f voltage that can be applied before arcing occurs between the crystal and electrode faces. When the electrodes make perfect contact with the crystal, not only are the opposing surfaces theoretically at the same potential, but no ionizable substance lies between them in which an arc can form. However, the introduction of an air gap not only inherently reduces the electromechanical coupling of a crystal unit, but also effectively lowers the voltage that can be practicably applied. To remove the latter restriction without diminishing the advantages the air gap provides, the arrangement shown in figure 1-77 can be used. Note that the coating covers the edges of the electrodes—an important consideration since it is at the points of sharpest curvature that ionization is most likely to arise.

1-149. The use of insulating sheets and coatings of high dielectric constant permits a crystal to be operated near its elastic limit without the danger

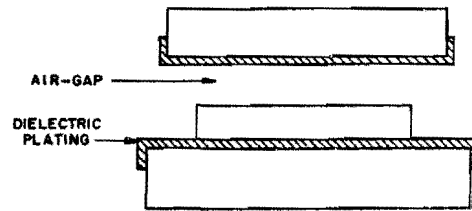

Figure 1-77. Cross-sectional view of gravity-air-gap mounting with electrode surfaces protected by coating of high-dielectric material

of arcing, and hence this type of crystal unit can be operated at higher drive levels than would otherwise be possible. The dielectric sandwich would be advantageous in filter circuits where high amplitude signals are to be encountered; or in small portable transmitters where several amplifier stages are not possible, and the excitation level must be as high as possible; or in any radio transmitter designed to be keyed in the oscillator stage where it is important that the oscillations built to peak amplitude in a minimum number of cycles. The insertion of the dielectric sheets also improves the stability and selectivity of the sandwich-type holders, inasmuch as they eliminate direct contact between the crystal and the relatively inelastic electrodes. The principal disadvantages of the dielectric sandwich are the reduced piezoelectric coupling caused by the separation of the electrodes from the crystal, and the damping effect of the frictional and small dielectric losses which are slightly greater than those of the air—provided the crystal is operated well below its elastic limit.

Plated-Dielectric Sandwich

1-150. This type of mounting is essentially the same as the previously described dielectric sandwich except that a thin layer of conducting material is interposed between the dielectric sheets and the electrodes, or between the dielectric sheets and the crystal, or both. The conductive surfaces may be strips of metal foil not more than 1 mil in thickness, or they may be plated, painted, or sprayed directly on the insulating material. Suitable conducting substances are copper, nickel, silver, gold, platinum, and their alloys. The conducting layer may be coated on one or both major surfaces of the insulating sheet, or it may completely cover the edges as well as the major surfaces, thus effectively converting the sheet into a highly compliant metal plate.

1-151. Figure 1-78A illustrates the corner-clamped-air-gap mounting using dielectric plates having conducting films on both major surfaces. The two

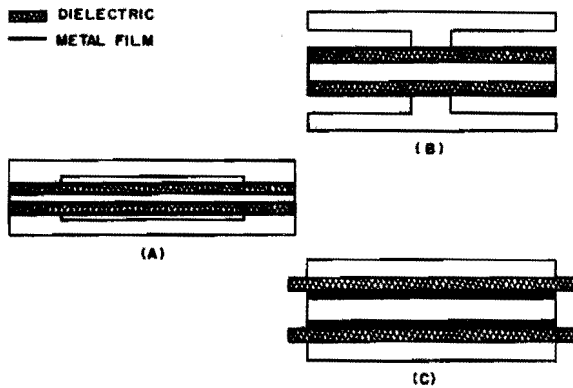

Figure 1-78. (A) Air-gap mounting using dielectric sheets having conducting films on each major surface. (B) Air-gap mounting using dielectric sheets having a conducting film on major surface in contact with electrode. (C) Dielectric sandwich in which leaves of metal foil are inserted between dielectric and crystal

films that are in direct contact with the electrode risers prevent the establishment of differences of potential across the air gaps, and hence obviate the possibility of arcing or corona discharges in these spaces. Figure 1-78B illustrates the nodal-clamped, air-gap mounting using dielectric plates having a conducting film on only one surface. In the case of air-gap mountings, if only one conducting surface is to be interposed between a crystal and each electrode, it is preferable that this surface make contact with the electrode rather than the crystal, so that possible electric fields will be "shorted" around the air gap. Figure 1-78C illustrates a dielectric sandwich mounting in which leaves of metal foil are inserted between the dielectric plates and the crystal. The metal foil, being very thin and flexible, snugly fits the crystal surface and interferes but little with the crystal's vibrations. On the other hand, its presence insures a uniform potential at all points on the crystal's surface, thus protecting the surface from the effects of excessive electric stresses.

1-152. The plated-dielectric sandwich combines the advantages of the plain dielectric sandwich with improvements in the frequency stability, crystal life, frequency spectrum, and piezoelectric coupling. The improvement in frequency stability is greatest in the case of the air-gap crystal units, for the danger of arcing or corona discharge in an air gap is removed without the insertion of a dielectric sheet to fill the gap. Since the damping effect of the air is less than that of the insulating material, the use of conducting film permits a

closer approach to the high selectivity of the pure air-gap mounting for crystals which are to be driven near their elastic limit. The insertion of a metallic film next to the crystal surface serves to reduce possible electrical stresses at the surface which might indirectly aid the production of small fractures, or cause ionization and chemical effects that would lead to a weathering of the crystal's face. The insurance of a uniform potential at all points on the surface of the crystal also improves the frequency spectrum, particularly at very high frequencies, where many possible overtone modes can vibrate at frequencies close to that of the desired mode. However, the majority of the unwanted modes will have changes of phase and differences in amplitude along the major plane of the crystal, so that the resulting eddy currents that they induce in the conducting surfaces will aid in damping them out. Where the interfering modes might otherwise lead to a frequency drift or jump, the damping effect will be reflected principally as an increase in the effective electrical resistance and as a decrease in activity. Finally, closer piezoelectric coupling is achieved if the entire insulating material is given a metallic coating. The dielectric sheet thus effectively becomes an extension of the electrodes, and the close coupling of the simple sandwich mounting is approached, but without the heavy damping caused by friction between the crystal and solid metal.

Button Mounts

1-153. The ceramic button crystal mount represents the ultimate in crystal-holder design yet to be reached via the sandwich and air-gap evolutionary chain. Originally, the button electrode was developed as an all-metal modification of the corner-clamped, air-gap type. As illustrated in figure 1-79A, the all-metal electrode is provided with conventional lands at the corners, but the effective center area has been reduced by surrounding the center with a relatively deep circular groove. The effect is to reduce the shunt capacitance across the crystal while retaining a central area of sufficient size for adequate excitation; the reduction in shunt capacitance is particularly desirable if the crystal is to be operated in the v-h-f range. Also, since the principal excitation is confined to a central circular area, the likelihood of spurious modes is somewhat reduced, because the vibrating part of the crystal tends to exhibit the properties of a circular plate. The superior frequency spectrum of the circular plate is probably even more closely approached by using electrodes having solid ring-shaped lands that completely surround the circular

Section I
Fabrication of Crystal Units

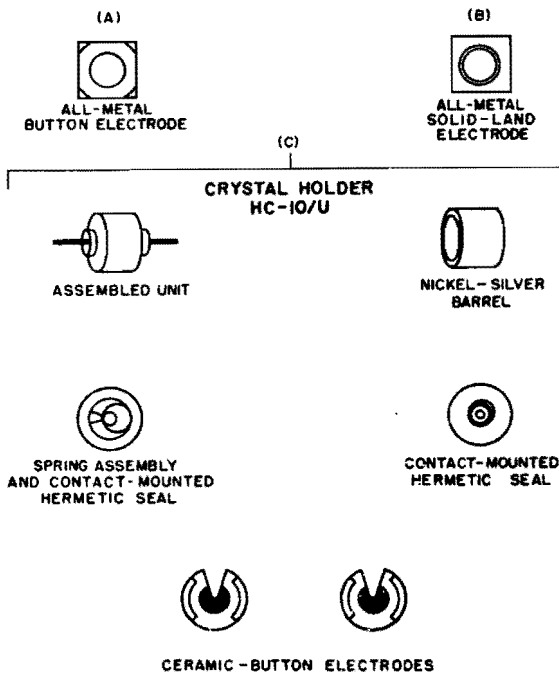

Figure 1-79. Button electrodes and methods of mounting

air gap at the center. See figure 1-79B. However, it is by combining the advantages of the button mounting with those of the plated-dielectric sandwich and circular quartz plates that optimum performance is obtained for thickness-shear modes at very high frequencies. Figure 1-79C shows the principal parts and the complete assembly of Crystal Holder HC-10/U. The shunt capacitance is held to a minimum, first, by the use of ceramic supporting plates in place of all-metal electrodes, and second, by the use of a coaxial electrode system in place of the conventional method where the crystal leads parallel each other through the base assembly. The ceramic-button electrodes are usually very thin metallic platings that cover a small circular area at the center of each ceramic plate. Although the lands may be provided by forming thickened sections at the rim of the ceramic disks, usually they are obtained by plating metal risers on the surface of the ceramic; these plated risers are not connected electrically to the center metallic section. The air-gap thickness is normally between three and five microns. A notch in each ceramic button permits an extension of the electrode plating to the opposite side, so that contact with the crystal leads can be made with a minimum of increase in electrode capacitance. This type of crys-

tal holder is unequalled in performance when used with harmonic-mode crystals in the very-high-frequency range. It should be noted, however, that one of the original advantages of the plated-dielectric sandwich mounting is not fully realized in the case of ceramic-button electrodes — namely, the protection against arcing or corona discharges. For this reason, the ceramic-button crystal units will not withstand as high a drive level as might otherwise be possible. On the other hand, the thin air gap that can be obtained, the presence of a high-dielectric material almost flush with the edges of the plated electrodes, and the firm mechanical support by which the crystal is held and cushioned against shock make this unit more durable under high drive levels than conventional air-gap holders. One of the more important advantages of the ceramic-button is the reduction of spurious modes through the use of circular quartz plates and small electrodes. The small electrode dimensions serve to concentrate the activity at the center of the crystal, where the crystal is most likely to be of uniform thickness; thus, sudden frequency jumps are prevented, for these seem to be due primarily to abrupt shifting of the center of activity between areas having slightly different average thicknesses.

Plated Crystals

1-154. Since 1940 the designers of crystal units have increasingly favored the use of electrodes in the form of extremely thin metal films deposited directly on the crystal. Coatings of silver and gold have been successfully applied by spraying and baking, but in general the most advantageous method is by evaporating the metal in a vacuum and allowing it to condense on the exposed surfaces of the crystal. Sputtering processes are being used increasingly, particularly for base plating, where the crystal is plated in vacuum by ionic bombardment from high-voltage negative electrodes composed of the desired plating metal. Electroplating of crystals also finds application. The noble metals, gold and silver, are the elements most commonly used in plating crystals because of their resistance to oxidation, their relative ease of plating, and the strength of their soldered junctions. Other metals that are used in plating are nickel and copper. Aluminum plating is preferred if a crystal is to be held in position by pressure pins or knife-edge clamps. This is because aluminum is more durable to frictional wear, and because its lesser density permits an electrode of lighter weight. However, aluminum is the more difficult to apply, has a tendency to oxidize, and its soldered connections are not as strong as those of

silver or gold. For these reasons, silver is more widely used if the crystal is to be soldered between wire supports, and gold is used if the wire-supported unit requires maximum stability and resistance to aging. Aluminum coatings are commonly applied at 1 milligram per square inch, which is equivalent to a thickness of approximately 0.0225 mil; silver is applied at 4 milligrams per square inch, a thickness of approximately 0.0232 mil; and gold is applied at 3 milligrams per square inch, a thickness of approximately 0.0114 mil. The actual plating procedure may be divided into two or more steps involving more than one plating process. As an example, the Signal Corps Engineering Report E-1108 by J. M. Roman recommends as many as three different plating stages during the fabrication of low-resistance, 50-mc harmonic-mode crystal units of the CR-23/U type. The base plating is accomplished by a sputtering machine in which a group of crystal blanks are mounted in a rectangular metallic mask midway between two gold electrodes, which are $5\frac{1}{2}$ inches square and $6\frac{1}{4}$ inches apart. A bell jar is placed over the electrode assembly and is evacuated to 0.05 to 0.02 millimeters of mercury. 2200 volts dc are applied between the crystal mask and the electrodes; first for 30 minutes at 100 ma with the mask negative in order to clean the crystals by ionic bombardment, and next, for 37 minutes at 100 ma with the electrodes negative for the actual gold plating operation. A second sputtering machine is used to clean the crystal mask of the gold deposited upon it during the plating procedure. This latter operation requires an hour at 100 ma. After being mechanically mounted on HC-6/U bases between 9-mil, edge-clamping spring wires, the crystals are given a preliminary performance test. If a crystal is more than 0.1 per cent off its nominal frequency it is subjected to an additional plating process. This time it is plated electrolytically with nickel. The electroplating of 50-mc crystals proceeds at a rate of 0.9 ma, which is equivalent to a harmonic frequency change of 100 kc per minute. The electrolytic solution consists of chemically pure nickel ammonium sulphate, boric acid, ammonium chloride, and water in a weight ratio, respectively, of 75/15/15/1000. After mounting, testing, and electrically bonding the plated crystal electrodes to the supporting wires with silver cement, the crystals are given a final spot plating with gold in an evaporation type plater to bring them to their specified frequency. This final plating process is accomplished in vacuum while the crystal is connected in a test oscillator circuit.

1-155. The advantages of using metal-film elec-

trodes are several fold: maximum piezoelectric coupling is achieved; the possibility of arcing between the electrodes and the crystal is reduced to a minimum; variations of frequency due to a shift of the position of the crystal relative to the electrodes are eliminated; frictional losses and wear due to inelastic contact between the crystal and the electrodes are removed; the metallic film aids in protecting the crystal from erosion; the film is readily adaptable for various types of nodal mounting, and is easily divided into several electrodes for use in exciting particular harmonic modes. All in all, the plated crystal is the most practical for obtaining optimum crystal performance at low and fundamental-mode high frequencies. The metal-film electrodes, however, have certain disadvantages: the metal has a tendency to absorb moisture, thereby causing the frequency to change; when clamp supports are used, friction at the clamped points will eventually wear away the metal coating; and generally, the mounting techniques are more critical for plated crystals.

Pressure-Pin Mounting

1-156. Pressure-pin holders (see figure 1-80) are used to support low-frequency (up to 200 kc), electrode-plated crystals, particularly those crystals used in telephone filters. Each crystal is clamped at the center of a nodal zone by one or more pairs of opposing pins. For crystal plates one-half inch square and smaller, the diameter of the pins is approximately 10 mils, and the clamping force varies from one to two pounds; for larger plates, pins of larger dimensions exerting somewhat greater clamping forces are used. It is important that the plated electrode be of aluminum, for the greater hardness of aluminum is required to resist the wear at the points of contact with the pins. Normally, these holders are designed for mounting a complete set of filter crystals within

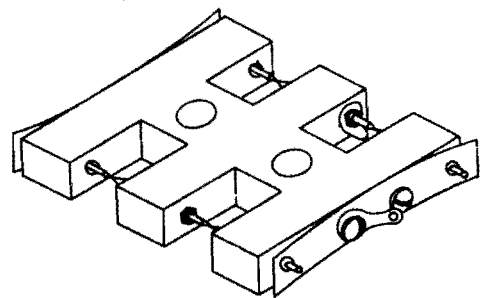

Figure 1-80. Pressure-pin mounting, with provisions for supporting four plated filter crystals *

Section I
Fabrication of Crystal Units

a single hermetically sealed container. The holder shown in figure 1-80 mounts four crystal elements. The pressure is applied by the springs mounted at the ends, and the pins serve as electrical connections as well as mechanical supports. For greater mechanical stability, slight niches may be made in the quartz at the clamped points.

1-157. The pressure-pin holder has the advantages and disadvantages of the plated electrodes, and is used primarily for low- and medium-frequency filter crystals. It is particularly applicable for use with face-shear elements, since these have but one practicable nodal spot for clamping. The chief limitation of the pressure-pin mounting is the mechanical impedance it introduces. If the diameter of the pin is made too small, the crystal will tend to rotate about its axis of support; however, the larger the diameter is made, the more the clamping area will extend beyond the nodal point. To obtain optimum performance with this type of mechanical support, a resonant-cantilever design for pressure pins was invented by J. M. Wolfskill of the Bliley Electric Company (U.S. Patent 2,240,453, 1941). This step was quite significant, not only in its own right, but because it provided a forerunner of the resonant-wire type of mounting. The following discussion is based on an analysis of the cantilever clamp by R. A. Sykes (Bibliography No. 741).

The Cantilever Clamp

1-158. The cantilever clamp is a pressure-pin support designed to resonate at or near the crystal frequency. Figure 1-81 illustrates a pin mounted as a cantilever, and figure 1-82 indicates the motion of the cantilever as a quarter-wavelength bar with a node at the fixed base and a loop at the point of contact with the crystal. It is important that even quarter-wavelengths be avoided, else the mechanical energy returning to the crystal will

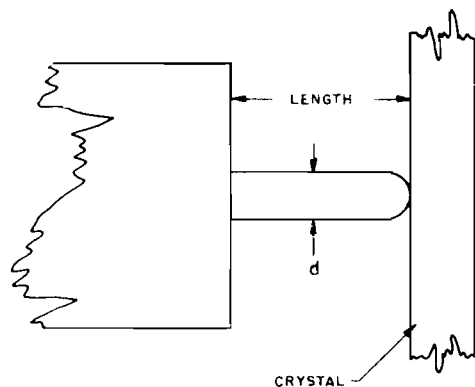

Figure 1-81. Cantilever clamp for providing a resonant-pin support for the crystal *

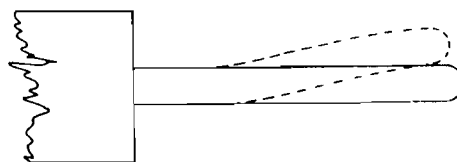

Figure 1-82. Resonant motion of cantilever pin when its length is equal to one-quarter wave-length of clamp-free flexural vibration. Note that the effective free end of the pin is that end supporting the crystal (not shown) *

oppose its motion, thereby greatly increasing the impedance and lowering the activity. The length of a cantilever pin that will present a loop to the crystal can be determined approximately from the frequency formula of a clamp-free rod in flexural vibrations:

$$f = \frac{m^2 dv}{8\pi l^2}$$

where: $m = 1.875$ for the 1st node of vibration of the rod (pin)

$$m = \left(n - \frac{1}{2}\right) \text{ for } n = 2, 3, \dots$$

$d =$ diameter of pin

$v =$ velocity of propagation along pin

$l =$ length of pin

For phosphor-bronze pins, $v = 3.6 \times 10^5$ cm/sec; therefore, to support a 100-kc crystal, pins 1 mm in diameter should be 2.25 mm long to resonate in the mode indicated in figure 1-82. To resonate as a three-quarter-wavelength rod, $n = 2$, and $l = 5.67$ mm for a pin of 1-mm diameter. The pin should be rounded at the end, as shown in figure 1-81, so that firm contact is made without the risk of having all the clamping force concentrated momentarily at a sharp point.

1-159. A properly designed cantilever clamp should extend the useful range of the pressure-pin type of mounting to somewhat higher frequencies, and this has proved to be true in actual practice; however, at the present time no data is available concerning its frequency application above 350 kc. Theoretically, a pair of pins could be used at any of their clamp-free harmonic modes, and thus pins of the same design need not be restricted to use at a single frequency. The principal promise of the cantilever clamp, however, is that it can provide a firm mechanical support while presenting a minimum of interference to the normal vibration of the crystal.

Knife-Edged Clamp

1-160. The knife-edged clamp is similar to the pressure-pin method of mounting, except that the

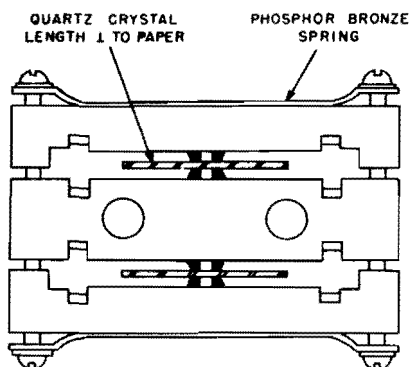

Figure 1-83. Knife-edge clamp support for two crystal plates. Each crystal has two pairs of plated electrodes, and is so mounted that each pressure blade makes electrical contact with a different electrode. This arrangement effectively provides four crystal elements for use in a balanced filter circuit*.

clamping prongs are blade-shaped, as indicated in figure 1-83. The dimensions of the clamping points are, on the average, about 35 mils in length, and 10 to 15 mils in width. These blades are used with crystal elements that have a nodal axis parallel to the plane of the major faces, and care must be taken to make certain that the blades are centered along the nodal line. Pressure is applied by phosphor-bronze springs, with the blades serving as electrical connections as well as mechanical supports for the crystal. The holder shown in figure 1-83 mounts two crystals, but, because the plated metal films are divided to provide two electrode pairs for each crystal, the equivalent of four crystal plates is effectively available for use in a balanced filter circuit.

1-161. The advantages of the knife-edge clamp are essentially the same as those of the pressure-pin mounting, except that the greater surface of contact between the crystal and the clamp permits a firmer mechanical support. However, the knife-edge clamp is limited to use with those crystal elements that have well-defined nodal lines. Its most important application has been as a mounting for the -18° X-cut filter crystal, a crystal that can vibrate in a very pure length-extensional mode, and which has a nodal axis at the center parallel to the width dimension. The knife-edge clamp is generally useful only at frequencies below 120 kc.

Wire Mounting

1-162. Wire-mounted crystal units are of two kinds: those that employ wire supports designed to resonate at the crystal frequency in a manner

similar to that described in paragraph 1-158 for cantilever clamps, and those that clamp the crystal at the edges by non-resonant spring wire. This latter type of wire support is the cemented-lead mount, which is classified here as an edge-clamped mount. The wire mounting provides a firm but flexible support that serves to cushion the crystal from external vibration and shock. In addition, it can combine the advantages of the metal-film electrode with the low impedance of resonant supports, and can be used to mount any of the crystal elements, both high- and low-frequency plates, vibrating in extensional, shear, or flexural modes. Because of these advantages, the wire-type mounting is generally favored for crystal units used in military equipment.

1-163. There are two principal types of resonant wire mounts, the solder-cone and the headed-wire. In general, the solder-cone support is restricted to relatively small crystal plates—for example, to frequencies above 300 kc for C elements. The headed-wire type is more suited to larger plates.

Solder-Cone Wire Support

1-164. A diagram of the solder-cone type of wire mounting is shown in figure 1-84, and a mounted crystal is shown in figure 1-85. The crystal to be mounted is first spotted with small silver footings, 40 to 90 mils in diameter, at the nodal points where the wires are to be attached. Next, the electrodes are plated on the crystal by an evaporation or other process. Silver is generally used, although gold may be preferred where resistance to corrosion is paramount. Aluminum has not been widely used in wire-mounted units, because of the weak junction it makes with the solder. However, recent experiments indicate that an aluminum junction with a solder of indium (a rare, fusible metal, chemically similar to aluminum) is quite strong, so that eventually greater application may be found for aluminum-plated crystals. The mounting wires are normally of phosphor bronze, because of its high tensile strength and resistance to fatigue. A eutectic tin-lead solder is used that would normally be an alloy of approximately 63 percent tin and 37 percent lead by weight; however, to prevent an excessive diffusion of silver molecules from the silver spot into the solder during the soldering operation, the solder should contain 0.1 percent silver if the soldering is performed by hot-air blast, or a 59.5—34.5—6 percent tin-lead-silver combination if performed by hot iron. A solder cone in the shape of a bell (see figure 1-84) has been found to provide the best performance characteristics, and is the type of cone that

Section I
Fabrication of Crystal Units

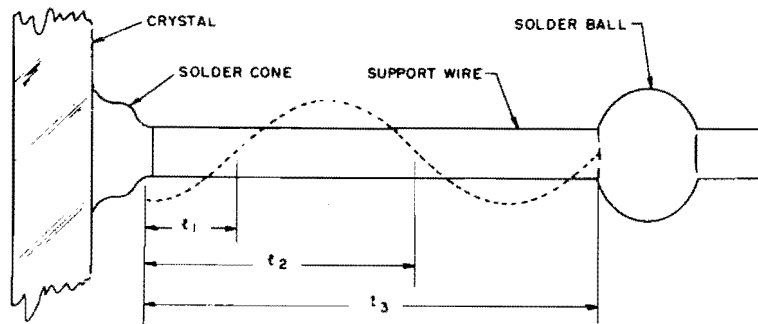

Figure 1-84. Solder-cone resonant-wire support. The solder ball "tunes" the wire to the crystal frequency if it is placed at a distance equal to an odd multiple of a quarter wavelength ($l_1, l_2,$ etc.) from the peak of the solder cone *

is least likely to rupture at the peak to form a "crater." For small crystals, the part of the wire enclosed by the cone may be straight, but for larger crystals sufficient anchorage requires that the end of the wire form a small hook. The wire is tuned to resonance by fixing the position of a solder ball at an odd quarter-wavelength from the peak of the cone; the solder ball serves as a "clamped" point for reflecting the wave energy back to the crystal. The "free" end of the wire is effectively at the point where it enters the solder cone. The distances $l_1, l_2,$ and l_3 indicated in figure 1-84 mark "free lengths" of wire that will be resonant at the given wavelength. Note that each of the lengths defines a distance from the "free" end of the wire to a node where the solder ball should be placed.

1-165. Theoretically, the resonant lengths l_1, l_2, l_3, \dots obey the same clamp-free frequency equation that is given for the cantilever clamp in paragraph 1-158. Experiment, however, has demonstrated that somewhat longer lengths are required for optimum performance. Normally, the free length of the wire is made a quarter-wave section, l_1 , in the frequency range of 20 to 250 kc, and a three-quarter-wave section, l_2 , in the range of 250 to 1000 kc. For phosphor-bronze wire, the empirical formulas for these distances are:

$$l_1 = 5.42 \sqrt{\frac{d}{f}} \text{ inches}$$

$$l_2 = 12.4 \sqrt{\frac{d}{f}} \text{ inches}$$

where: d = diameter of wire in inches (usually 0.0035, 0.005, 0.0063, or 0.008 in.).

f = frequency in kc.

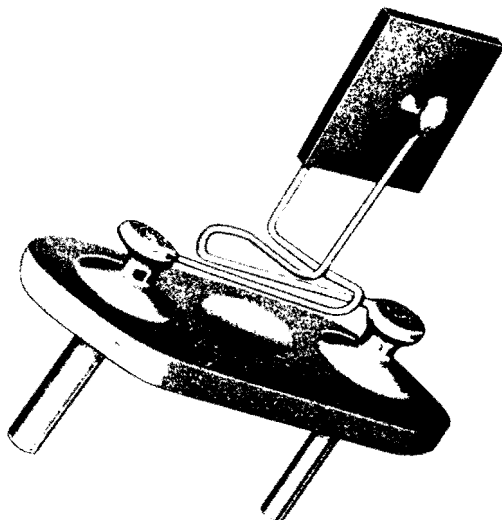

Figure 1-85. Solder-cone wire mounting of face-shear element

1-166. After soldering to the crystal, the supporting wires are bent to make them serve as springs. One, two, or three bends are carefully spaced and directed so that the displacement per unit force will be the same for all directions. The ends of the wires are then soldered without tension to metal rods, or "straights," which in turn are welded to eyelets staked in a mica or bakelite base. In mounting small crystal plates, the straights are little more than short, metal stubs, but larger crystals are mounted in "cages" having a mica roof as well as a mica base. Figure 1-86 shows the cage assembly of a 40-kc length-width flexure crystal. The cage is formed by two mica plates at each end, and four straights. Besides providing for the proper mounting of the straights, the mica plates also serve as "bumpers" for the crystal. The inner and outer plates limit the horizontal and vertical

displacements respectively, thereby protecting the unit from wire or crystal damage in the event of severe shock or vibration. The spacing between bumper and crystal is normally between 25 and 30 mils. Where the operating frequency is below 3 kc, the wavelength is usually sufficiently long for the entire wire to be cut to a resonant length, so that the soldered junction at the straight can serve as the nodal terminal. However, the optimum free length of wire becomes increasingly critical as the frequency is raised. Solder balls are used to establish resonance, but at low frequencies small metal disks are threaded on the wire to provide greater mass while permitting a precise adjustment to the correct position; after adjustment, the disks are loaded at the back with the correct amount of solder. Better control is obtained at the higher frequencies without the disk. The solder weights range from approximately 80 milligrams for 8-mil wire, for large crystals, to 6 milligrams for 3.5-mil wire, for small crystals.

1-167. The principal disadvantages of the solder-cone wire support arise from the effects of the solder cone upon the electrical characteristics of the crystal. To provide a junction of given mechanical strength, a certain quantity of solder is required. The solder, however, considerably increases the effective resistance of the crystal circuit as the temperature becomes high; if a high

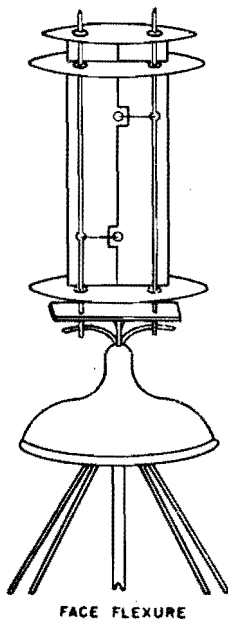

Figure 1-86. Cage assembly for solder-cone wire mounting of low-frequency length-width flexure crystal *

WADC TR 56-156

crystal Q at high operating temperatures is required, the solder cone must be small, and, consequently, the crystal unit cannot be as rugged mechanically as would otherwise be possible. Conversely, if the crystal unit is to withstand severe mechanical vibrations and high operating temperatures, the solder cone must be of maximum size, so that the Q and frequency stability will necessarily be at a minimum. Furthermore, as the volume of solder is increased appreciably, the temperature-frequency characteristics of the crystal may be considerably changed. Normally, the tendency will be for the zero temperature coefficient to shift to a lower temperature; in extreme cases, the zero point may be lost altogether. The temperature-frequency effects of hooked wire are generally more pronounced than those of straight wire, when equal volumes of solder are used. Another consideration is the difficulty experienced in making two cones of the same dimensions.

Headed-Wire Support

1-168. The headed-wire support (see figure 1-87) was developed to obviate the disadvantages of the solder cone, while preserving all the advantages of the wire type of mounting. The head of the wire, which resembles that of a common pin, has a diameter of approximately 22 mils for 6-mil wire. It is pretinned, and a small globule of solder is left at the end for sweating to the crystal; the volume of solder varies from 1000 to 7000 cubic mils, according to the size of the crystal. Phosphor-bronze wire is used, and all other mounting details are substantially the same as those for the solder-cone type of support.

1-169. The headed-wire is superior to the solder-cone mounting, because it provides a greater and more uniformly distributed mechanical support with a smaller quantity of solder; in the case of low-frequency crystals, the Q is improved by as much as twenty-five percent. Furthermore, the

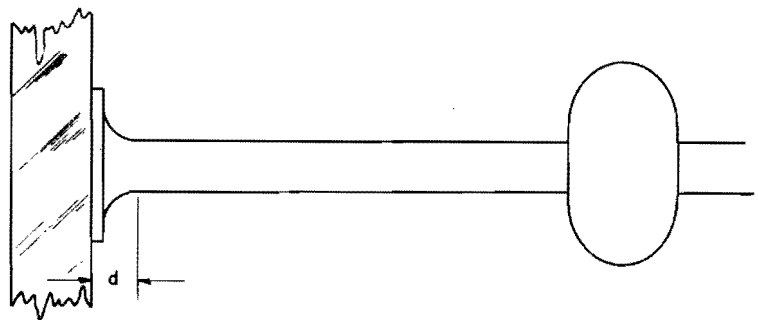

Figure 1-87. Headed-wire crystal support *

Section I Fabrication of Crystal Units

distance d (figure 1-87) is a constant for all crystal units of the same design, so that the resonant free length of the wire can be predetermined accurately, thus permitting smaller tolerance in the rated characteristics. An additional advantage is that the headed wire diminishes the mechanical coupling between the vibrating systems represented by the crystal and the wires. Standing waves are caused, not only by reflections between solder ball and crystal, but also to a certain extent by reflections from one solder ball, through the crystal, to the solder ball on the opposite side. By reducing the coupling between crystal and wires, the impedance effects due to the interfering through-waves are reduced, and a purer frequency spectrum is possible. Headed wire may be used to replace any other type of low- and medium-frequency crystal mounting, and a well-designed headed-wire crystal unit will generally surpass the other types in all-round performance. However, at the higher frequencies a clamped air-gap holder is still to be preferred for greater activity and frequency stability, and at low frequencies, ultimately the cantilever clamp may prove superior for general use.

Edge-Clamped Mounts

1-170. Two variations of the edge-clamped type of mounting are illustrated in figure 1-88. The mount

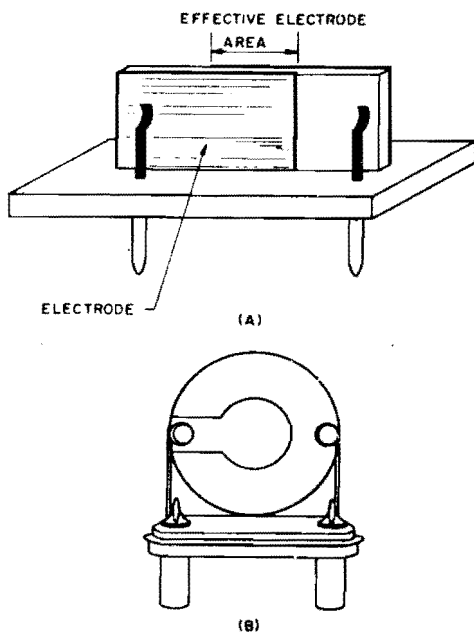

Figure 1-88. Edge-clamped systems of mounting. (A) Mounting for low-frequency crystals. (B) Cemented-lead mounting for high-frequency crystals

shown in (A) has been used with low-frequency crystals vibrating in extensional or flexure modes; the mount in (B), known as the cemented-lead mount, is widely used as an alternate to air-gap holders in mounting high frequency, thickness-shear elements. Although edge-clamped mounts have been successfully used in the production of high-activity crystal units for both high- and low-frequency applications, this type of mounting when used with low-frequency crystals, is probably somewhat inferior to well-constructed headed-wire or resonant-pin supports. However, a special feature of the edge-clamped mounting system is the method of dimensioning the electrodes (a method also adaptable for use with resonant pins), by which optimum performance characteristics can be obtained with high-frequency crystals. Plated electrodes (or metal foil cemented to the crystal) are used, but, as shown in figure 1-88 (B), the crystal faces are only partially plated, and the plating on opposite faces is extended to opposite edges only, so that the effective electrode area is concentrated within a small circular region at the center of the crystal. By this means the capacitance is kept small, and the principal activity is confined to the central region, where the crystal is most likely to be of uniform thickness. Both of these factors are advantageous in improving the frequency stability. Also by reducing the activity in the vicinity of the edges, much of the damping due to the impedances of the supporting structure is obviated. Mechanical support and electrical connection is supplied by tinned, high-quality spring piano wire, which is clamped and cemented to the crystal at the edge where electrical contact can be made with the lead-outs from the electrodes. The cementing is used principally for the purpose of insuring good electrical connection, and not for supplying mechanical support, which should be provided by spring-wire clamps. The base ends of the spring wire are coiled around and soldered or welded to the base stubs. Although the supporting wires are not designed to be resonant elements of the crystal unit, they do provide the protection against shock and external vibration afforded by the other types of wire mounting. As compared with the performance of fundamental-mode, thickness-shear crystals, such as elements A and B, that are mounted in corner-clamped air-gap holders, the performance of the same elements, when wire-mounted, will generally be superior. In addition, the wire mounting permits the use of smaller crystal holders. The elimination of the air gap reduces the likelihood of arcing, but this does not mean that the wire-mounted units can be operated

at higher voltages than the conventional air-gap crystal units. This is because the wire-mounted crystal is more isolated thermally and tends to become hotter. The advantages of the cemented-lead over the ceramic-button mounting system are less pronounced than the advantages over the other air-gap systems. For operation at frequencies from 1 to 10 mc, the wire-supported crystal usually has the better operating characteristics. As the frequency increases, however, the metal plating of the wire-mounted element becomes an increasingly greater factor in damping the oscillations; and in the upper very-high-frequency range, above 100 mc, non-plated crystals that are pressure-mounted between ceramic buttons are definitely to be preferred. Even in the fundamental frequency range, the ceramic-button mounts, which provide the better mechanical protection, may be used with good effect, and optimum performance characteristics for given operating conditions might better be achieved by combining the merits of wire-mounted edge clamps with those of plated dielectric buttons.

HOUSING OF CRYSTAL UNITS

1-171. The principal function of the housing is to provide a hermetically sealed, moisture-resistant container. Plastic housings of sandwich, air-gap, and clamp-type holders are normally sealed with neoprene gaskets. Natural rubber is not recommended, as the sulphur used in processing the rubber will ultimately contaminate other parts of the holder. Wire-mounted units are readily adaptable for housing in metal or glass tubes, employing standard radio parts; however, small, two-pin holders are generally preferred. Before sealing, a crystal unit is exposed to high temperature in an evacuated oven, in order to drive off adsorbed gasses. The sealing itself is usually performed in dry air, although certain crystals, particularly the flexure-elements, are sealed in vacuum. Optimum performance is obtained when a crystal is mounted in an evacuated container, since the damping effect of the air is eliminated.

1-172. If metal, rather than glass, housing is employed, it is difficult and expensive to seal a crystal unit so perfectly that not even minute leaks will develop due to stresses on the pins and the glass-sealing of the eyelets. For this reason most crystal units are sealed in dry air, so that if very small leaks are present, the crystal characteristics will not be appreciably affected for a long period of time. Leakage is minimized if the base is rigidly protected against deformation, and if the glass

sealing fills the entire eyelet cavity uniformly. However, if a crystal is to be mounted in vacuum, a glass housing is to be preferred.

AGING OF CRYSTAL UNITS

1-173. "Aging" is a general term applying to any cumulative process which contributes to the deterioration of a crystal unit and which results in a gradual change in its operating characteristics. There are, of course, many interrelated factors involved in aging—minute leakage through the container, adsorption of moisture, corrosion of the electrodes, ionization of the air within the container, wire fatigue, frictional wear, spurious electrolytic processes, small irreversible alterations in the crystal lattice, outgassing of the materials composing the unit, over-drive, presence of foreign matter, various thermal effects, pin strain due to socket stresses, and erosion of the surface of the crystal. However, if a crystal unit is well designed and carefully constructed, the rated operating characteristics may well outlast the equipment in which the crystal is used.

1-174. Usually the first effects of aging can be traced to changes at the surface of the crystal. These changes may be due directly or indirectly to almost any combination of the factors mentioned in paragraph 1-173, and their occurrence can be avoided or greatly diminished only if proper precautions and techniques are employed during manufacture, and if low driving voltages are employed during operation. To produce a crystal unit of long life, the final stages of production require particular precautions. These concern the finishing processes of lapping, etching, cleaning, mounting, heat cycling, and protecting against moisture.

Lapping to Reduce Aging

1-175. Whether a crystal is being ground with abrasives which are cemented or imbedded in a grinding disk, or lapped with loose abrasives under a lapping disk, the cutting proceeds by virtue of the small fractures and chips which result when the hard, sharp edges of the abrasive particles are rubbed against the surface of the crystal. Commercial crystals are usually produced by lapping with loose abrasives, instead of grinding by "grindstones," except in the initial cutting stages and the final edging process, where diamond saws are commonly used. Each succeeding lapping stage employs a finer grade of abrasive, and must completely remove the surface left by the preceding stage. The final lapping requires very fine abrasive particles, such as 1000- to 1200-grain carborundum, and should preferably be performed in a

Section I

Fabrication of Crystal Units

mixture of abrasive, castile soap, and water. To reduce aging, soap and water are preferred as the coolant in the finishing stage, rather than kerosene or other oils, although kerosene permits a faster cutting rate for the same abrasive and lapping speed. Apparently, the residue of fractures remaining after a soap-water-abrasive lapping does not penetrate as deeply as that remaining after a kerosene-abrasive lapping. Regardless of how fine the abrasive, small fractures and cracks will be left in the surface of the crystal after the final lapping, and in time these cracks will spread, absorb moisture, and ultimately result in a weathering of the surface. Additional care must be taken to ensure

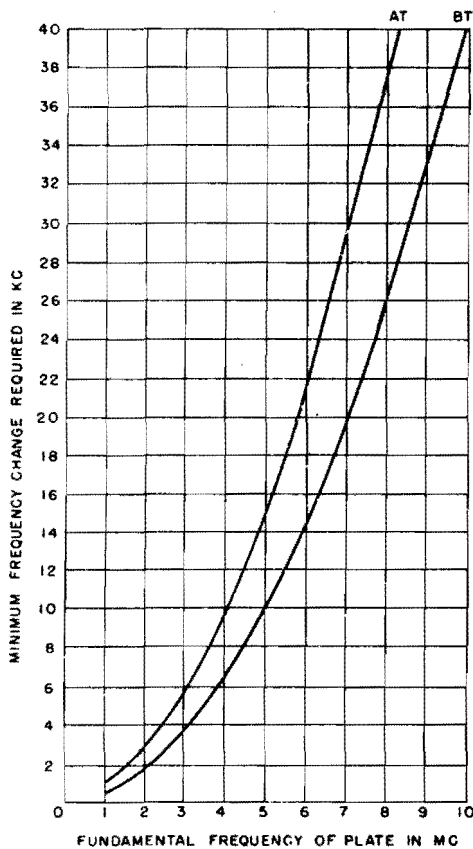

Figure 1-89. Minimum change in frequency that AT and BT plates must undergo due to etching, if the etching is to be sufficient to remove all surface cracks and fissions remaining from the final lapping stage. Note that, as the crystal becomes thinner, a given change in the thickness dimension means a greater change in the frequency. The frequency change for a BT cut is less than that for an AT cut of the same initial frequency, since the larger frequency constant of the BT cut permits a thicker plate

that the crystal is not finished with slight concavities in the surfaces, or with one end lapped down more than the other, making the crystal wedge-shaped. Although optimum performance is to be obtained with perfectly planar surfaces, greater insurance against unwanted non-parallelisms is gained if the lapping is controlled to give the plates a symmetrical convex contour of approximately 5 microns for lower-frequency crystals, and approximately $10^7/f$ (cycles) microns for crystals above 3 mc.

Etching to Reduce Aging

1-176. After the final lapping stage, the crystal is normally given an etching bath to remove all foreign particles. An eight-minute bath in forty-seven percent hydrofluoric acid is sufficient for the average crystal, and will permit a firm contact between the crystal and its electrode coating. An etching time of at least thirty minutes is necessary, however, if a minimum aging and a maximum Q, stability, and drive level are desired. The longer etching period is required to ensure that the deeper fissions in the surface caused by the final lapping are thoroughly removed. However, the deep etch is difficult to control, and particular care must be exercised if the desired dimensions of the crystal are to be achieved. It is customary to divide the deep-etching process into two, or more, steps: (1) to etch the crystal to within 1 kc of the desired frequency; and (2) in the succeeding steps, to bring the crystal within its tolerance limits. Figure 1-89 indicates the degree of etching required to prevent aging in AT and BT cuts.

Cleanliness to Reduce Aging

1-177. The protection of a crystal from foreign matter and moisture is of paramount importance if the crystal is to operate with stability and long life. Only minute traces of dirt, dust, or fingerprints on a crystal will cause the performance to be erratic. Cleanliness is necessary throughout the final production period, but particular emphasis is required during the stages immediately prior to sealing. Before and after etching, each crystal blank should be scrubbed thoroughly in soap, or trisodium phosphate, and water with a soft brush; rinsed in 0.5 percent ammonium hydroxide solution, and again washed thoroughly in running water; dried in an oven heated to 100 degrees centigrade, or in a warm, clean, air stream; washed again in distilled carbon tetrachloride or other solvent; rinsed in hot distilled water; and finally, carefully dried in an oven. The electrodes and holder must be similarly cleaned, and neoprene

tweezers should be used in handling the parts during the final assembly. If the crystal is to be metal-plated, the complete mounting must be cleaned again before sealing. A hot spray of distilled trichloroethylene for one-half minute is sufficient. The plated crystal will normally require a small amount of edge-grinding with fine emery paper to bring the mounted unit to the proper frequency. This step unfortunately weakens the aging resistance of the treated surfaces at a stage when further etching is no longer feasible for commercial crystals. However, before testing and sealing, a retouched crystal unit should be thoroughly washed and scrubbed, with every precaution taken to ensure that no foreign matter remains on the crystal or mounting. Where the facilities are available, cleaning can be performed by exciting the bath with supersonic acoustic waves, which can clean the crystal by shaking all loose fragments off its surface. In fact, a supersonic bath can be quite as effective as an etching bath in reducing aging.

Mounting to Reduce Aging

1-178. As a general rule, any deviation in the mounting which causes an increase in the frictional losses will shorten the useful life of a crystal unit. Thus, in the nodal types of mounting, small deviations from the nodal point in the position at which a crystal is held will shorten the life of the crystal. Wire-mounted crystals require additional precautions during fabrication to avoid local changes or stresses at the surface of the crystal. Particular care must be taken to avoid electrical "twinning," which will occur if the temperature is raised above the inversion point, 573°C, and then lowered again; or twinning may be induced at a much lower temperature if a sharp temperature gradient is present in the crystal. These precautions are necessary during the baking of the silver spots, the division of the electrode coating by electric stylus, and the soldering operation. In baking the silver spots, the temperature should be kept forty to fifty degrees centigrade below the inversion point, and care must be taken to make certain that the crystals are heated uniformly. Some twinning is inevitable when using an electric stylus to divide an electrode coating; however, if straight-line division is required, the twinning may be avoided by using an abrasive tool or sand blasting in place of the stylus. To avoid thermal stresses during the soldering operation, a heated support should be provided for heating the crystal uniformly to a temperature of approximately 100°C. Twinning, regardless of its cause, primarily affects the steady-state electrical characteristics of

a crystal element, and only indirectly contributes to gradual changes in the performance of the crystal. At least, no statistical data has been collected to show a correlation between twinning and aging; nevertheless, a series of small twinned spots at the surface is likely to make the area more susceptible to erosion. Readjustments of the crystal lattice at the twinning boundaries after long periods of electrical, mechanical, and thermal stresses might be expected; but if these are due to occur, they can probably be made to take place by a process of artificial aging before the crystal is placed into operation. Twinning, however, raises the inductance and effective resistance of an element, and hence, decreases its activity for a given operating voltage. Since the ultimate requirement of a higher operating voltage can lead to a shortening of the life of the crystal unit, an undue amount of twinning indirectly becomes a factor in the aging. Twinning will also raise or lower the frequency, according to the particular type of element. If the twinning is introduced during the final stages, this may require a substantial amount of edge-grinding during the final frequency-adjustment stage, and more of the etched surface may need to be removed than otherwise. Thus, although "heat" twinning is considered primarily in connection with its immediate effect upon the characteristics of the crystal, it should also be avoided as an indirect factor in aging. A more direct factor in shortening the life of a wire-mounted crystal unit is a nonuniformity in the soldered junction, which is more likely to occur in a solder-cone than in a headed-wire support. When the stresses are unevenly distributed, the soldered junction itself will tend to age; and even if mechanical breakage does not occur, the changes in the electrical characteristics will lead to poor performance and instability. Special care must be taken to make certain that the silver spots are of uniform density. The containers of liquid silver should be agitated for several hours immediately prior to application. Also, the critical nature of the soldering operation requires the aid of a machine and accessories of special design.

Heat Cycling to Reduce Aging

1-179. A newly mounted crystal will normally appear to age more rapidly than one that has been in operation for a long period of time. This effect is not due to an actual deterioration of the crystal unit, but merely to an initial adjustment of the crystal, particularly at its surface, to its operating environment and changes in temperature. The stabilization period can be reduced to one of very

Section I

Electrical Parameters of Crystal Units

short duration by subjecting the crystal unit to a series of slow heating and cooling cycles varying between 24°C and 116°C. Metal-plated elements are frequently heat-cycled during the final frequency-adjustment period, and again after sealing. In a series of tests at the Hunt Corporation, it was found that negative aging (frequency decreases with time) is generally due to insufficient cleaning of the crystal unit. When this was remedied, it was found that the crystal units would then age positively. The cause of the positive aging was traced to the outgassing of the metal plating of the crystal, and its elimination has been achieved by pre-aging the plated crystal for 3 minutes in a 300°C oven. After a sufficient period of artificial aging, a properly fabricated and operated crystal unit will maintain its final temperature-frequency characteristics indefinitely.

Low Relative Humidity to Reduce Aging

1-180. A low relative humidity is of paramount importance if excessive aging is to be prevented. Even if a crystal is perfectly mounted and clean, an ambient relative humidity higher than 40 percent will sharply increase the insulation resistance, and will greatly accelerate the weathering of the

surface of the crystal and the corrosion of the electrodes. For optimum performance and long life, every precaution must be taken to ensure that the interior of the sealed crystal unit is as free as possible from moisture. Prior to sealing, all components of the crystal unit should be heated in vacuum to drive off absorbed water vapor and other gases; and if the sealing is performed in air, the atmosphere should not have a relative humidity higher than 5 percent.

Low Drive Level to Reduce Aging

1-181. As a general rule, the lower the drive level, the longer will be the useful life of a crystal unit. This is true because the cumulative effects of almost all of the previously discussed aging factors are considerably more pronounced when the crystal is operated at high drive levels. Also, the higher operating voltages greatly increase the tendency toward corona discharge and other ionization effects, and the vibrations of greater amplitude are more likely to result in crystal or wire fatigue. To ensure maximum lifetime, a piezoelectric resonator should be driven at the lowest practicable level consistent with the circuit requirements.

ELECTRICAL PARAMETERS OF CRYSTAL UNITS

EQUIVALENT CIRCUIT OF CRYSTAL UNIT

1-182. A crystal unit may be represented by the equivalent electrical circuit shown in figure 1-90. R_I represents the terminal-to-terminal r-f insulation resistance of the crystal unit. C_L , L_L , and R_L represent, respectively, the distributed capacitance, inductance, and resistance of the electrical leads and terminals of the mounted crystal. C_L , in addition, includes the capacitance across any elec-

trode parts that extend beyond the quartz. C_{H1} and C_{H2} represent the distributed capacitance of the crystal circuit to the holder H. C_A represents the capacitance between the electrodes and the crystal faces when they are separated by an air gap or other dielectric. If a dielectric exists on both sides of the crystal, C_A would equal the total capacitance of the two capacitances in series. Thus, if the air-gap capacitances on the opposite sides of the crystal were equal, as would normally be the case, C_A

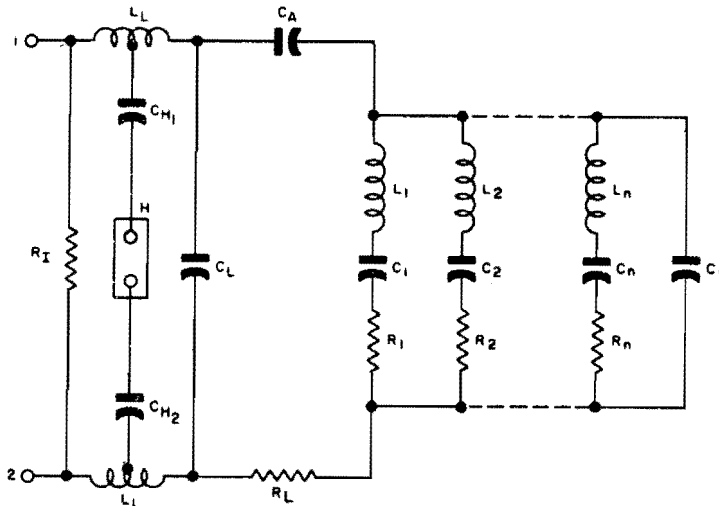

Figure 1-90. Equivalent circuit of crystal unit

would be equal to one-half the value of either one. C_e is the electrostatic capacitance across the quartz plate, where the quartz serves as the dielectric. The series LCR branches represent the piezoelectric properties of the crystal as they appear to the external circuit when the crystal is undergoing mechanical vibrations. For this reason, these values are called the "motional-arm" (also, "series-arm") parameters, in contradistinction to the parameters such as C_e that are not of piezoelectric origin.

1-183. The motional-arm values of L are closely associated with the mass of the crystal, those of C are closely associated with the elasticity of the crystal, and the motional-arm values of R indicate the tendency of the crystal to dissipate heat during vibration. Each of the motional-arm branches is associated with a different mode or harmonic of vibration, and the normal frequency of each of the modes coincides with the series-resonant frequency of the respective LCR branch. It will be assumed that the branch indicated by L_1 , C_1 , and R_1 represents the equivalent circuit of the desired mode, and that all of the higher subscript branches L_n , C_n , R_n , represent unwanted modes.

1-184. Since a crystal unit is normally intended for use only within a very narrow frequency range centered at a specified nominal frequency, the equivalent circuit may be greatly simplified to that shown in figure 1-91. If the crystal is mounted so that the electrodes are in direct contact with the crystal faces, C_A will not be effective, and the values of L , C , and R in figure 1-91 will normally be approximately the same as those of L_1 , C_1 , and R_1 in figure 1-90, and C_o will approximately equal

$$C_e + C_L + \frac{C_{H1} C_{H2}}{C_{H1} + C_{H2}}. \text{ For these assumptions to}$$

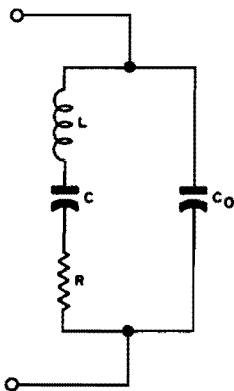

Figure 1-91. Simplified equivalent circuit of crystal unit

hold, R_1 must be much greater than the impedance of the crystal when parallel resonance is established between the motional arm and C_o . Also, the operating frequency must not be so high that the reactance of L_L becomes significant; and the normal frequencies of all the unwanted modes must be sufficiently removed from the nominal frequency, if each of the unwanted branches is to present a high impedance at the desired operating frequency.

SIMPLIFIED EQUIVALENT CIRCUIT OF AIR-GAP CRYSTAL UNIT

1-185. C_o is normally much greater than the distributed capacitance across the leads, so an air-gap or dielectric-sandwich type of crystal unit may be represented by the equivalent circuit shown in figure 1-92. This circuit, in turn, may be reduced to the equivalent circuit of figure 1-91 by assigning the following values to L , C , R , and C_o :

$$L = \left(\frac{C_A + C_e}{C_A} \right)^2 L_1$$

$$C = \frac{C_A^2 C_1}{(C_A + C_e)(C_1 + C_e + C_A)}$$

$$R = \left(\frac{C_A + C_e}{C_A} \right)^2 R_1$$

$$C_o = \frac{C_A C_e}{C_A + C_e}$$

THE EFFECT OF R-F LEAKAGE RESISTANCE

1-186. The principal effect of R_1 , the terminal-to-terminal r-f leakage resistance shunting the crys-

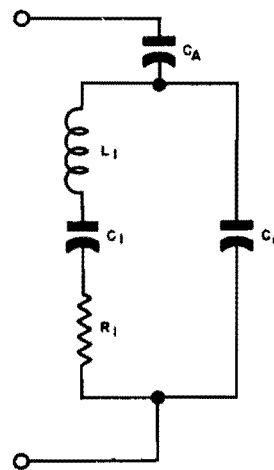

Figure 1-92. Simplified equivalent circuit of air-gap crystal unit

Section I

Electrical Parameters of Crystal Units

tal, is to reduce the effective Q of the crystal unit. For all practical purposes this effect is negligible when the crystal is being operated at, or very near, the resonant frequency of the series arm. Under these conditions the electrical impedance of the crystal is so small by comparison that R_1 can be ignored. On the other hand, as the frequency rises above the resonant point, the impedance increases sharply, and the greater the impedance becomes, the greater is the effect of a given R_1 . Insofar as the equivalent circuit of figure 1-91 is concerned, the effect will be to increase the value of R . The extent of this increase will depend upon how large the effective reactance of the crystal becomes, relative to R_1 . For the sake of simplification, most of the discussion given later concerning the equivalent circuit assumes that the increase in R due to R_1 is negligible, or at least, is constant, regardless of the frequency, an assumption that can produce reasonably accurate results in the case of well-fabricated crystal units. The leakage resistance of military crystal units has a specified minimum d-c value of 500 megohms. As long as this minimum d-c value is maintained, R_1 at low frequencies will be comparable to this value. However, if an accumulation of moisture, dirt, or the like seriously reduces the d-c insulation resistance below the allowed minimum, the off-resonance characteristics will undergo a noticeable change. For instance, low-frequency filter crystals may have impedances at antiresonance in the neighborhood of 50 to 100 megohms. If R_1 decreases below 500 megohms, the equivalent R of the motional arm will increase markedly. In the case of high-frequency crystal units, the effective dielectric losses may become relatively large, particularly when plastic holders are used, so that, at off-resonant frequencies, R_1 can become a significant parameter of the over-all effective resistance. However, for high-frequency crystal units employing modern methods of mounting and construction, R_1 can generally be ignored. In the very-high-frequency range, crystal units are almost always operated at series resonance, so that, even if R_1 were on the order of 100,000 ohms, as might easily be the case, the effect would still be relatively minor. However, where the shunt resistance cannot be ignored, a more concrete analysis of its effect is to let R_1 , in figure 1-90, represent only the d-c leakage resistance, and to account for the r-f dielectric losses by inserting other equivalent resistances in series with the various shunt capacitances. In the simplified equivalent circuit in figure 1-91, the d-c leakage resistance could still be ignored, but non-negligible r-f shunt losses could be interpreted as

being due to a single resistance in series with the shunt capacitance, C_s . The Q of the equivalent shunt arm will effectively equal the Q of the crystal unit when the unit is operated at frequencies well removed from resonance. The crystal units that are mounted in metal or glass holders of the type described in Section II, and are recommended for use in equipments of new design, can be expected to have shunt-arm Q 's greater than 1000 at all frequencies within their specified range. This assurance, however, cannot be given for the crystal units mounted in plastic holders, particularly the old-style phenolic holder, or for those employing all-metal sandwich or air-gap electrodes. However, the lower Q 's of the older types of crystal holders are not entirely due to greater dielectric losses and larger values of shunt capacitance. An equally important factor is the effective inductance of the circuit effectively in series with the shunt capacitances. For example, a corner-clamped air-gap mounting, such as that provided in a DC-31 crystal unit, has an effective shunt-arm Q of approximately 80 or 180 at 30 mc, depending upon whether the clamping pressure is applied by a coiled or a flat spring, respectively. Apparently, the reactance and resistance of a coil spring can be quite detrimental to the quality of a crystal holder at very high frequencies, since it can cause not only an effective increase in the shunt capacitance, but also an increase in the effective dielectric losses. These losses would become prohibitive if the inductance of the spring and its stray capacitance should approach the properties of a series-resonant arm shunting the crystal. However, except in such abnormal cases, and in cases where the insulation is weakened by extremes in humidity and temperature, the shunt resistance will have a negligible effect upon the performance of a crystal circuit.

EFFECT OF DISTRIBUTED INDUCTANCE

1-187. The effective self-inductance of the crystal leads, L_L , is normally not sufficient to seriously affect the crystal parameters, except in the case of very high operating frequencies where it is necessary to operate the crystal at series resonance. At resonance, the reactance of the crystal unit will be zero, so that the crystal, in combination with its shunt capacitance, must have a net equivalent series X_C equal in magnitude to the X_{L_L} of the distributed inductance. This means that the resonant frequency will be slightly lower than would be the case if there were no distributed inductance. The net effect on the equivalent circuit of figure 1-91 is that the LC product is increased very slightly (lower resonant frequency), and that C_s

is increased to a greater extent. If the distributed inductance is completely negligible, the resonant frequency of the crystal will be slightly higher than the normal resonant frequency of the series arm, because of the reactive component of current through C_o . However, the distributed X_L of the lower-frequency crystal units may be sufficient to approximately cancel the reactance due to the true C_o . Under these conditions, the resonant frequency of the crystal unit as a whole would coincide with the natural vibration frequency of the crystal—an ideal operating state. In the case of the higher-frequency crystal units, the distributed inductive reactance may be sufficient to lower the frequency below the natural resonance point by several cycles. If the crystal unit were being operated at series resonance in a capacitance-bridge circuit, for example, such an effect would lead to frequency jumps with slight changes in the tuning adjustments. Under such conditions it would be desirable to add a capacitance in series with the crystal, with a reactance just sufficient to cancel the unwanted X_{LL} . The distributed inductance, L_L , of the lower-frequency crystals, and of practically any crystal unit which is to be operated above series resonance, has only a minor effect. The maximum effect will always be at very high frequencies near series resonance. In analyzing the behavior of a crystal unit where the distributed X_{LL} cannot be neglected, the simplest approach is to consider X_L as a separate fixed reactance in series with the crystal unit. From this point of view, as long as X_{LL} is very small, as compared with X_{C_o} , it can be seen that L_L will not seriously affect the rate at which the net crystal reactance will change with frequency, and, therefore, will not influence the stabilizing effect of the crystal on the frequency. Crystal oscillators can operate successfully up to frequencies as high as 200 mc. However, crystal-control of the frequency can be stable only when the impedance at series resonance is much smaller than the reactance of the effective shunt capacitance C_o . The larger the value of X_{LL} , the smaller this ratio will be. Thus, the higher the frequency, the greater the importance of keeping the crystal leads as short as possible, not only to reduce L_L , but also to reduce the distributed capacitance and the r-f resistance of the wires. The small coaxial-electrode type of mounting, such as the HC-10/U, is the most satisfactory for achieving a minimum effective C_o , and hence, a maximum frequency stability in the very-high-frequency range. It should be remembered, however, that since the distributed X_{LL} will increase with the frequency, the effective C_o will also increase with the frequency,

so that a measurement of C_o at a frequency far lower than that of resonance will not alone give a reliable indication of the effective parameter near the operating frequency.

EFFECT OF DISTRIBUTED CAPACITANCE

1-188. The effect of the distributed capacitance on the parameters of the simplified equivalent circuit is merely to increase the value of C_o . However, it should be noted that the amount of the increase will depend somewhat upon how the crystal unit is connected in the external circuit. For example, assume that the holder and terminal 1 in figure 1-90 are grounded. C_{H1} , which would otherwise be in series with C_{H2} , is now effectively short-circuited, so that the total shunt capacitance C_o is increased. If C_{H1} were assumed to be equal to C_{H2} , the amount of the increase due to grounding terminal 1 and the holder would equal $C_{H1}/2$. On the other hand, grounding the holder can result in an effective decrease in C_o . Assume, for instance, that a crystal unit is connected in a circuit equivalent to that shown in figure 1-93. With the metal holder ungrounded, C_{H1} and C_{H2} are effectively connected in series, so that, if $C_{H1} = C_{H2}$, the total capacitance of the series combination is $C_{H1}/2$. If switch S is closed, thereby grounding the holder, the effective total C_o becomes larger or smaller, depending upon the point of view of the observer. Since C_{H1} is no longer in series with C_{H2} , but, instead, is shunted across the entire circuit, whereas C_{H2} is shunted across the load Z, the total capacitance facing the generator is increased (assuming that Z is the reactance of a capacitor). When S is closed, the current through M_1 increases; however, the current through M_2 decreases. An observer at M_1 would say that grounding the holder increased C_o , whereas an observer at M_2 would say that C_o has decreased. At frequencies well removed from the nearest resonant frequency of the motional arms, the branch impedances are so

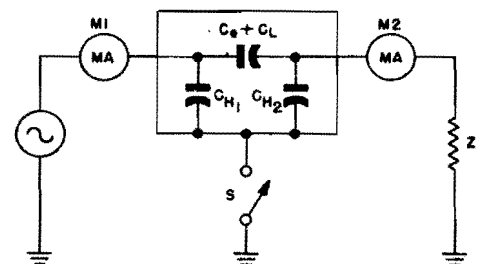

Figure 1-93. Circuit diagram indicating the effect that grounding a metal holder may have on shunt capacitance

Section I

Electrical Parameters of Crystal Units

high that the crystal unit behaves essentially as a capacitor of value C_0 . It can be seen that if a measurement were being made of the change in C_0 due to the grounding of the holder, it would be important to know exactly how the measurements were made. For example, low-frequency crystal units mounted in the HC-13/U have been reported as having $0.8 \mu\mu\text{f}$ less shunt capacitance, and medium-frequency crystal units mounted in the HC-6/U holder have been described as having $0.5 \mu\mu\text{f}$ less shunt capacitance with the holder grounded. However, it should be noted that crystal units so specified are intended primarily for use in circuits where the crystal operates in a series-resonant rather than a parallel-resonant circuit. Even so, the grounded holder alters the entire circuit, not simply C_0 . Thus, in the circuit of figure 1-93, suppose that it is necessary for the current through Z to be in phase with the generator voltage. If the circuit is properly adjusted with an ungrounded holder, grounding the holder will detune the circuit by effectively decreasing C_0 , on the one hand, and on the other, by shunting the load with C_{H2} . The over-all effect cannot be predicted simply by specifying an effective change in C_0 , since the end result will depend upon the impedance characteristics of the entire circuit. If the frequency of a crystal oscillator is being measured by beating its output with the output of a frequency standard, it is common practice to touch the crystal holder with the hand in order to determine whether the crystal unit which is touched is operating at a frequency above or below that of the standard oscillator. The oscillator frequency will be higher or lower than that of the standard according to whether the hand capacitance causes the beat frequency to fall or to rise, respectively, provided that the effective C_0 is actually increased by the touch of the hand, as is invariably assumed. Before this assumption is made with complete assurance, however, the response of the circuit to a grounded holder should be known.

EFFECT OF DISTRIBUTED RESISTANCE

1-189. R_L is assumed to include only the ohmic resistance of the electrical leads and the reflected resistance due to eddy currents in the holder and ground connections. At normal frequencies R_L is quite small, as compared with R_1 ; even the small-sized supporting wires of wire-mounted crystals have r-f resistances that are measurable in tenths of an ohm. As in the case of the other distributed parameters, the effect of R_L upon the equivalent circuit of figure 1-91 becomes more pronounced at the higher frequencies. To a first approximation

R is simply $R_1 + R_L$. However, at frequencies above 10 mc, the r-f resistance of the leads increases directly as the square root of the frequency, so that, in the v-h-f range R_L may be greater than one ohm. R_L will also increase somewhat if the holder is grounded, as the increased eddy-current losses in the shielding will be reflected as additional resistance losses in the crystal circuit. At normal frequencies, however, the effect of R_L is of minor importance; and even at frequencies above 100 mc, its consideration is secondary to the effects of the distributed capacitance.

RULE-OF-THUMB EQUATIONS FOR ESTIMATING PARAMETERS

1-190. The crystal parameters for a given frequency vary rather widely from one crystal unit to the next. Even crystal units of similar dimensions and fabrication made by the same manufacturer may show significant differences between corresponding parameters. These differences arise from the sensitivity of the quartz plate to slight changes in its angle of cut, surface state, electrode area, soldered connections, and the like. The parameter with the greatest percentage variation is R , and it is not uncommon for the larger values of R to be from 300 to 900 percent greater than the minimum values. The most predictable parameter is C_0 , since it is primarily a linear function of the electrode area, the thickness of the quartz dielectric, and the dielectric constant, all of which are reasonably constant for a given fabrication technique, although variations may be expected in crystal units of the same nominal frequency and type of mounting, when made by different manufacturers. For the same manufacturer, nominal frequency, and type of crystal unit, however, C_0 rarely varies by more than $\pm 5\%$ of its nominal value. With a reasonably constant C_0 as a starting point, approximate values for the major parameters L , C , R , and Q may be predicted for the principal types of crystal elements and holders. First, C_0 is computed from the known values of plate area, dielectric thickness, and dielectric constant. Next, C can be found, since it is theoretically equal to C_0 times a constant of proportionality. L can next be computed, since the LC product must conform to the nominal frequency. Next, an approximate range of the values of R may be estimated from the empirical values of the crystal quality factor, Q . Since Q is the ratio X_L/R (or $-X_C/R$), R is thus equal to X_L/Q . Finally, C_0 can be estimated by simply adding to C_0 the approximate total distributed capacitance common to the particular type of holder and mounting.

Estimating C_e , Static Capacitance of Crystal

1-191. Although the dielectric constant of quartz varies somewhat according to the angle of cut, the following formula will be approximately correct for plated electrodes:

$$C_e = 0.402 A/t \mu\mu f \quad 1-191 (1)$$

where A is the effective electrode area in square centimeters, and t is the thickness in centimeters.

1-192. In the case of partially plated A elements, where t is a function of the nominal frequency and the harmonic, equation 1-191 (1) may be expressed as:

$$C_e = 2.42 Af/n \mu\mu f \quad 1-192 (1)$$

where f is the nominal frequency in mc/sec, and n, an odd integer, is the harmonic of the thickness-shear vibration. Although the quartz plates range from 1 to more than 2 sq cm in plate area, the electrode area normally covers only a fraction of the total quartz surface. The RTMA Standards Committee on Quartz Crystals has recommended the following approximate electrode areas for the fundamental frequencies of this type of crystal unit.

Frequency in mc/sec	Electrode Area $\pm 10\%$
(n = 1)	(sq cm)
1 — 2	0.504
2 — 5	0.385
5 — 9	0.283
9 — 15	0.159
15 — 20	0.126

For the overtone modes, where n is greater than 1, the electrode area will be the same as that of the fundamental mode of frequency equal to f/n. The harmonics for various ranges of f are as follows:

- f = 10— 45 mc; n = 3
- f = 45— 75 mc; n = 5
- f = 75—105 mc; n = 7

1-193. In the case of crystals vibrating in a face-shear mode, it is the electrode area A that is a function of the frequency. For fully plated C elements, equation 1-191 (1) may be expressed as:

$$C_e = 0.038/tf^2 \mu\mu f$$

where t has an average value of 0.05 cm, and f (mc/sec) lies between 0.3 and 1 mc/sec.

1-194. For fully plated D elements, equation 1-191 (1) may be expressed as:

$$C_e = 0.0172/tf^2 \mu\mu f$$

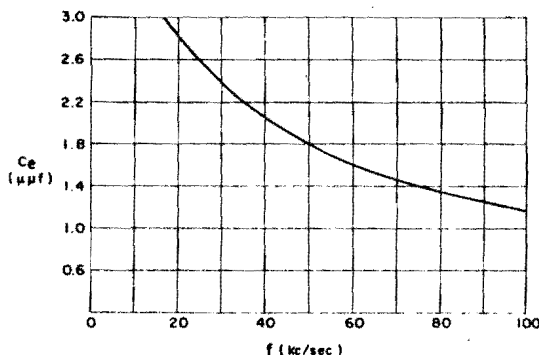

Figure 1-94. C_e versus frequency for typical wire-mounted N elements

where t has an average value of 0.05 cm, and f (mc/sec) lies between 0.2 and 0.5 mc/sec.

1-195. For a typical wire-mounted J element, equation 1-191 (1) may be expressed as:

$$C_e = k/f \mu\mu f$$

- where: k = 38 for f = 1.2 to 2.5 kc/sec
- = 45 = 2.5 to 4.0 kc/sec
- = 58 = 4.0 to 6.6 kc/sec
- = 77 = 6.6 to 10.0 kc/sec

Note that f in this case is to be expressed in kc/sec. 1-196. Typical values of C_e for an N element are shown in figure 1-94.

Estimating C_e , Equivalent Motional-Arm Capacitance

1-197. After C_e is known, an approximate value for C at the fundamental frequency can be readily obtained from the following equation:

$$C = C_e/\Gamma_e \quad 1-197 (1)$$

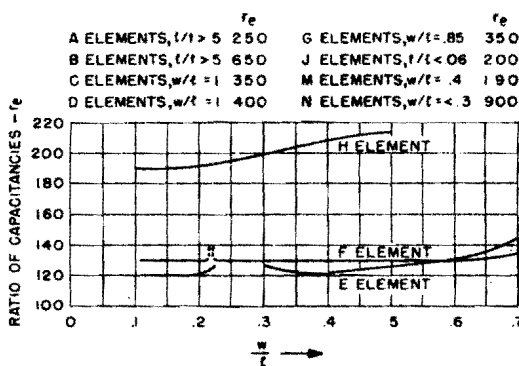

Figure 1-95. Approximate values of the ratio of capacitances, $\Gamma_e = \frac{C_e}{C}$, for various plated crystal elements

Section I

Electrical Parameters of Crystal Units

where r_e is simply the ratio of the electrostatic capacitance C_e to the motional capacitance C , with C_e and C expressed in the same units. The values of r_e for the more important elements are given in figure 1-95. For the odd harmonics (n) of the thickness-shear modes:

$$C = C_e/r_e n^2 \quad 1-197 (2)$$

Estimating L, Equivalent Motional-Arm Inductance

1-198. Since X_L is equal to X_C at the series-resonant frequency of the motional arm, L is found quite simply, once f and c are known. Thus:

$$L = \frac{1}{4\pi^2 f^2 C} \text{ henries} \quad 1-198 (1)$$

Remember, however, that f is expressed in cycles/sec, and C in farads.

Estimating R, Equivalent Motional-Arm Resistance

1-199. A theoretical equation for R would not be practical, since this parameter is much too sensitive to slight variations during the fabrication process and to changes in the crystal drive. An approximate estimate is gained from observations of the value of Q for the various frequency ranges. Thus:

$$R = \frac{2\pi f L}{Q} \text{ ohms} \quad 1-199 (1)$$

where f is in cycles/sec, and L is in henries. The values of Q will range from 10,000 to 200,000, and in exceptional cases will have much higher values. Generally, the higher Q 's are to be found at the higher frequencies. For face-shear elements, the average Q is approximately 30,000, with most values falling between 10,000 and 40,000. Thickness-shear elements will have average Q 's of approximately 75,000, and most of the values will lie between 35,000 and 100,000.

1-200. The Q is not a dependable parameter, and will vary from frequency to frequency, and from manufacturer to manufacturer, for the same type of crystal unit. For example, when expressed as $Q = -X_c/R = \frac{1}{2\pi f C R}$, it can be seen that Q is inversely proportional to C , and thus might be considerably increased by simply reducing the area of the electrodes. On the other hand, the resistance, R , is at least limited in practice by military specifications. For this reason, the typical

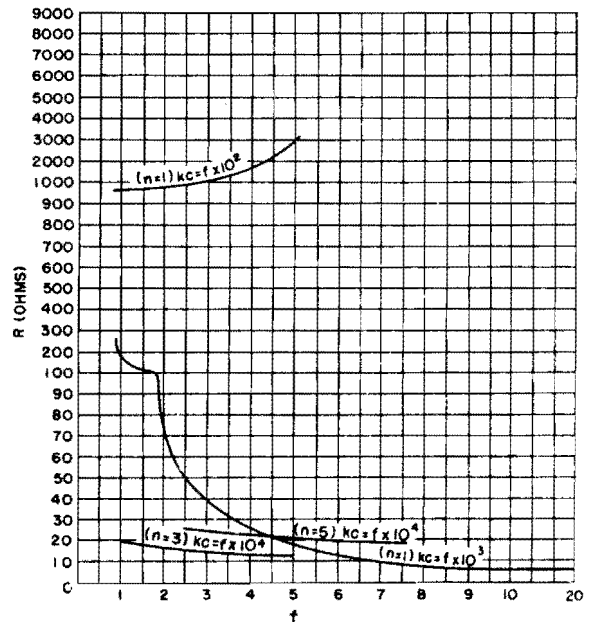

Figure 1-96. Typical curves of the series-arm resistance of plated crystals versus frequency. Actual series-arm resistances will vary between $R/3$ and $3R$, where R is the value shown, except when R is less than 10 ohms, in which case the minimum resistance will be approximately one-half the value indicated. Values indicated are average for fundamental modes and approximately $1/2$ the average for overtone modes

values of R versus f , shown in figure 1-96, are more likely to be found in randomly selected crystal units than is a given value of Q . The values of R indicated in figure 1-96 are merely typical, however, and a small percentage of actual Military Standard crystal units will have series-arm resistances as small as one-third, or as large as three times the amounts shown.

Estimating C_o , Total Static Shunt Capacitance

1-201. The equation for C_o is

$$C_o = C_e + C_d$$

where C_d is the total distributed capacitance of the crystal leads and terminals. Approximate values of C_d for plated crystals in ungrounded holders are given below:

Crystal Holder	C_d ($\mu\mu\text{f}$)
HC-6/U	0.7
HC-10/U	0.3
HC-13/U	1.0
HC-15/U	1.5

**IMPEDANCE CHARACTERISTICS
VERSUS FREQUENCY**

1-202. The superiority of the quartz crystal as a frequency stabilizer lies in the fact that a small change in the frequency will cause a much larger change in the impedance of the equivalent circuit than can be obtained with conventional inductor-capacitor networks. Where an ordinary r-f tank coil would have an inductance measured in microhenries, and an effective Q of 10 to 250, the equivalent circuit in figure 1-91 will have an inductance measured in henries and a Q of 10,000 to 250,000 or more. C, of course, is extremely small, since its reactance must equal X_L at resonance, and is commonly expressed in milli- $\mu\mu\text{f}$ (thousandths of a micromicrofarad). R is expressed in ohms, and although at low frequencies it may have values higher than 3000 ohms, depending upon the particular crystal element and method of mounting, the more common values lie between 10 and 100 ohms. C_0 normally lies between 3.5 and 14 $\mu\mu\text{f}$, although much larger values are encountered where electrodes of large surface area are employed. Among the smaller holders, such as types HC-6/U and HC-10/U, values of 5 to 6 $\mu\mu\text{f}$ are quite common.

1-203. Since $X_L = 2\pi fL$

$$\text{and } X_C = \frac{-1}{2\pi fC}$$

then, the rates at which X_L and X_C change with frequency will be, respectively:

$$\frac{dX_L}{df} = 2\pi L$$

$$\frac{dX_C}{df} = \frac{1}{2\pi f^2 C}$$

Note that both of these derivatives indicate a positive change in reactance with an increase in frequency. However, it should be remembered that X_C is negative, so that a positive change in X_C means that its magnitude becomes smaller as the frequency increases. On the other hand, the reactance of the inductance increases by an amount $2\pi L$ for each additional cycle per second. At the series-resonant frequency of the series arm, the total reactance

$$X_L + X_C = 0$$

or

$$2\pi f_s L = \frac{1}{2\pi f_s C}$$

or

$$2\pi L = \frac{1}{2\pi f_s^2 C}$$

However, note that this last equation not only implies that the two reactances have equal magnitudes at the series-resonant frequency, f_s , but also, that f_s is the one frequency at which both reactances will change with frequency at the same rate. Therefore, for small changes in frequency near series resonance:

$$\Delta X_L = \Delta X_C$$

And since the total change in the reactance of the series arm is

$$\Delta X_s = \Delta X_L + \Delta X_C$$

then

$$\Delta X_s = 2\Delta X_L = 4\pi L \Delta f$$

If f_s is taken as the reference frequency, so that $\Delta f = f - f_s$, then, since $X_s = 0$ at resonance, the total reactance of the series arm, X_s , will be equal to ΔX_s . That is:

$$X_s = 4\pi L \Delta f \quad 1-203 (1)$$

Thus, for all frequencies near f_s , the equivalent circuit of a crystal unit may be represented as shown in figure 1-97, where X_{C_0} and R may be assumed

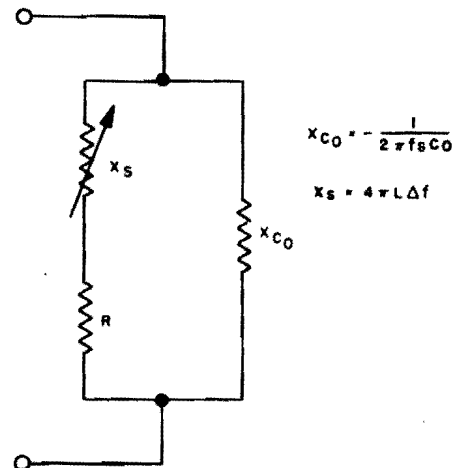

Figure 1-97. Impedance diagram of equivalent circuit of crystal unit

Section I
Electrical Parameters of Crystal Units

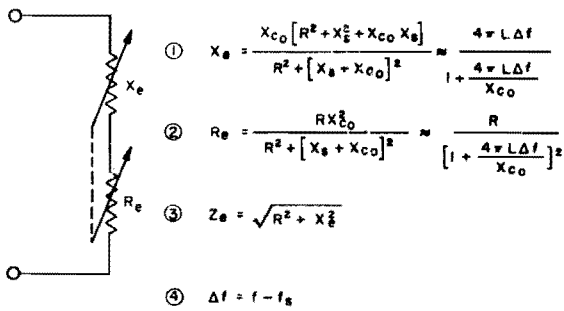

Figure 1-98. Equivalent circuit of crystal unit when represented as an effective reactance in series with an effective resistance. The ganged arrows indicate that X_e and R_e will vary together with changes in the frequency, as indicated by the approximate formulas given as functions of Δf . (X_{c0} is negative.)

to be constant, but with X_e a variable that changes linearly with Δf , and has the same sign as Δf .

1-204. The series-parallel circuit of figure 1-97 may be reduced to an equivalent circuit of X_e and R_e in series, as shown in figure 1-98. It should be remembered, however, that X_{c0} is negative, whereas X_e is either negative or positive, according to the sign of Δf . The values of R_e and X_e , expressed as functions of Δf , are not exact, but are close approximations, well within the accuracy of the normal test procedure, except when the numerators reduce to zero. Note, however, that with $\Delta f = 0$, the approximate expressions equate X_e to 0, and R_e to R . This is equivalent to assuming

that X_{c0} is infinite by comparison with R , so that at series resonance of the motional arm the crystal unit as a whole behaves as a pure resistance equal to R . Although this is a close approximation, it is not exact. For X_e actually to be zero, the term $(R^2 + X_e^2 + X_{c0} X_s)$ must be zero. There are two frequencies at which this will occur. One is called the resonant frequency of the crystal unit, f_r , and the other is called the parallel-resonant, or antiresonant frequency, f_a .

RESONANT FREQUENCY OF CRYSTAL UNIT

1-205. First, it should be remembered that f_r , the resonant frequency of the crystal unit, is almost, but not exactly, identical with f_s , the series-resonant frequency of the motional arm. If there were no shunt capacitance, C_0 , then f_r would indeed be the same as f_s ; but, as it is, C_0 introduces a reactive component to the current which must be cancelled by a reactive component of opposite phase through the motional arm, if the crystal unit is to appear as a pure resistance. These conditions are illustrated (not to scale) in the vector diagram of the currents through the two arms of the crystal unit, shown in figure 1-99. *Note that the frequency at which the crystal unit has the lowest impedance (maximum current) is f_r . Since $X_e = 0$ at this frequency, the equivalent circuit of figure 1-98, according to

* This sentence applies only to the relative impedances suggested by the current vectors in figure 1-99. It can be shown that the true minimum impedance of the crystal unit occurs at a frequency, f_m , that is as far below f_s as f_r is above f_s .

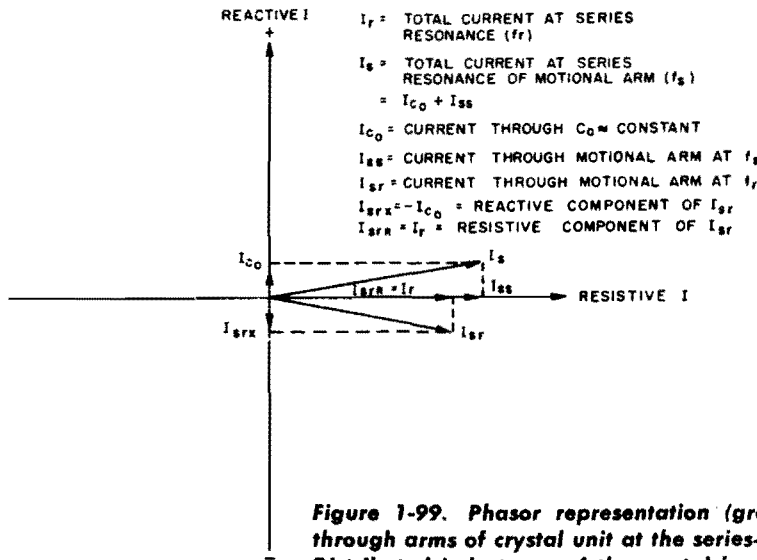

Figure 1-99. Phasor representation (greatly exaggerated) of current through arms of crystal unit at the series-resonant frequencies, f_r , and f_s . Distributed inductance of the crystal leads is assumed to be negligible

equations 1 and 2, becomes

$$X_e = X_{C_0} \left(\frac{R^2}{R^2 + X_{C_0}^2} \right)$$

and

$$R_e = R \left(\frac{X_{C_0}^2}{R^2 + X_{C_0}^2} \right)$$

Except at the very high frequencies, X_{C_0} is much larger than R , so that $R_e \approx R$, and X_e is so small that it may well be more than annulled by the distributed inductance of the external wiring. Even at frequencies in the neighborhood of 100 mc, X_{C_0} will have a magnitude in the vicinity of 400 ohms, or approximately 10 times or more than that of R , so that R_e will equal R within ± 1 percent. The true frequency at which a "series-resonant" crystal circuit is intended to operate, however, is f_r , where all the reactive components of crystal current cancel. Actually, the term "series-resonance" is somewhat misleading, for the conditions of crystal resonance are those of a parallel, and not a series circuit. It should be understood that when we speak of series-mode circuits and oscillators, the operating frequency is generally assumed to be f_r . 1-206. By equation 1, figure 1-98, in order for X_e to be zero, the frequency must be such that:

$$R^2 = - (X_s^2 + X_{C_0} X_s)$$

Since X_{C_0} is negative, this equality can only exist when X_s is positive, i.e., X_s is inductive, and $f > f_s$. At frequencies very close to f_s , $X_{C_0} \gg X_s$, so that X_s^2 may be considered negligible. Thus, f_r will be the frequency at which

$$R^2 = - X_{C_0} X_s = - 4\pi L X_{C_0} \Delta f_r$$

where $\Delta f_r = f_r - f_s$

Since X_{C_0} is negative,

$$\Delta f_r = \frac{-R^2}{4\pi L X_{C_0}} \quad 1-206 (1)$$

1-207. As a concrete example, assume that a partially plated A element, mounted in an HC-6/U holder according to RTMA recommendations, operates at resonance in its fundamental mode at a nominal frequency of 10 mc. Approximately, what value of Δf_r could be expected? Referring to paragraph 1-192, we find that $A = 0.159$ sq cm. On substitution in equation 1—192(1):

$$C_0 = 2.42 \times 0.159 \times 10 = 3.85 \mu\mu f$$

WADC TR 56-156

According to figure 1-95, $r_c = 250$. Thus, by equation 1—197 (1):

$$C = \frac{3.85}{250} = 1.54 \times 10^{-2} \mu\mu f$$

By equation 1—198 (1):

$$L = \frac{10^{14}}{4 \times 3.14^2 \times 10^{14} \times 1.54} \\ = 1.65 \times 10^{-2} \text{ henries}$$

According to paragraph 1-201:

$$C_0 = 3.85 + 0.7 = 4.55 \mu\mu f$$

So that

$$X_{C_0} = \frac{-1}{2\pi f_r C_0} = \frac{-10^{12}}{6.28 \times 10^7 \times 4.55} \\ = -3.5 \times 10^3 \Omega$$

From figure 1-96, a typical value of R is found to be 8 Ω . On substitution of the foregoing values of R , L , and X_{C_0} in equation 1—206(1), we find that:

$$\Delta f_r = \frac{8^2 \times 10^{-1}}{4 \times 3.14 \times 1.65 \times 3.5} \\ = 0.088 \text{ cycle/sec.}$$

With such an extremely small difference between the two resonant frequencies of the crystal unit (less than 1 part of 10^4), for all practical purposes it can be assumed that $f_s = f_r$. Indeed, it would be academic to seek to distinguish between them. Remember, however, that the discussion has only concerned the equivalent circuit, in which the effects of the distributed inductance have been assumed to be reflected in a lower series-arm frequency, and a larger C_0 . If the parameters in the example above are assumed to be the "true" values, so that the inductance of the leads must be represented separately, then a slightly more realistic interpretation will be possible. Assume, for instance, the $L_L = 10^{-8}$ henries. Then

$$X_{L_L} = 2\pi L_L f_s = 0.628$$

In order for X_e to cancel this reactance, then, by equation 1 in figure 1—98:

$$-4\pi L \Delta f_r = 0.628$$

or

$$\Delta f_r = \frac{-0.628}{4\pi \times 1.65 \times 10^{-2}} = 3 \text{ cycles/sec}$$

Section I

Electrical Parameters of Crystal Units

The inductance of the external connections could easily increase this value of Δf , ten-fold, so that for optimum frequency stability, an external series capacitance would be necessary. It is important to note the negligible effect that a small change in R or C_o will have on the frequency of a crystal unit at series resonance. In equation 1-206 (1), as applied to the 10-mc crystal unit, even if R should triple in value, the frequency would not change by more than 1 part in 10^7 . Although the power transferred through the crystal would be diminished, as would the Q, and hence, the effectiveness of the crystal as a frequency stabilizer, a reasonable increase in R will not, in itself, cause the frequency of a series-resonant crystal oscillator to drift.

ANTIRESONANT FREQUENCY OF CRYSTAL UNIT

1-208. Returning again to equation 1 of figure 1-98, it can be seen that the term $(R^2 + X_s^2 + X_{C_o} X_s)$ can also be zero at some higher frequency than f_r , namely, when $X_s = X_{C_o}$ (R^2 being negligible). This would represent the high-impedance, parallel-resonant state of the equivalent circuit in figure 1-97. Letting $\Delta f_a = f_a - f$, then, at f_a , the antiresonant frequency

$$X_{a_s} = 4\pi L\Delta f_a \approx |X_{C_o}|$$

so that

$$\Delta f_a = \frac{|X_{C_o}|}{4\pi L} \quad 1-208 (1)$$

On substitution of the typical values of X_{C_o} and L that were found for the 10-mc crystal unit:

$$\Delta f_a = \frac{3.5 \times 10^3}{4 \times 3.14 \times 1.65 \times 10^{-2}} = 16.9 \text{ kc/sec}$$

For a 10-mc crystal, this value of f_a represents a 0.169 percent frequency range in which the crystal may be used as a frequency-control device. At all frequencies within its range, except at f_r and f_a , the unit will appear to the external circuit as an inductive reactance, X_s , in series with a resistance, R_s . There is a very simple relation between the fractional frequency range, $\frac{\Delta f_a}{f}$, and the ratio of the capacitances, $r = \frac{C_o}{C}$, that can be derived from equation 1. Thus:

$$\Delta f_a = \frac{1}{4\pi L 2\pi f C_o}$$

so

$$\Delta f_a/f = \frac{1}{2\omega^2 LC_o}$$

where $\omega = 2\pi f$. Now,

$$\omega^2 = 1/LC$$

so, on substitution:

$$\Delta f_a/f = C/2C_o = 1/2 r \quad 1-208 (2)$$

In the case of plated crystals, r is usually somewhat less than that predicted by theory. Where it should be slightly greater than the values of r, in figure 1-95, since $C_o > C_s$, it is usually somewhat less. However, as a practical rule-of-thumb, it can be assumed that $r = r_e$, but only in those cases where $C_o \approx C_s$. The ratio of capacitances, r, is quite an important parameter of the crystal unit in its own right, not only as an indication of the maximum percentage width of the frequency band in which a particular crystal element can operate, but, as will be discussed later, as a measure of the electromechanical coupling, and also, because of its relation to the frequency stability.

IMPEDANCE CURVES OF CRYSTAL UNIT

1-209. Figure 1-100 shows the typical characteristics of the equivalent impedance circuit of figure 1-98, but with the frequency scale greatly expanded near the resonance point of the crystal. At frequencies sufficiently removed from resonance, both above and below f_r , where the motional impedance is large compared with X_{C_o} , the X_s curve is essentially the same as the reactance curve of a capacitance equal to C_o . X_s is inductive only between its two zero points, f_r and f_a . Note that R,

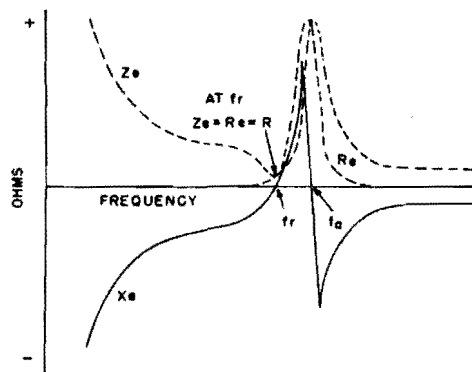

Figure 1-100. Impedance characteristics versus frequency of crystal unit. Neither the frequency nor the impedances are drawn to scale

rises sharply to a maximum at f_a , where it is equal to the parallel-resonant impedance of the equivalent circuit of figure 1-97. Since R is much smaller than X_{Co} , at antiresonance

$$R_e = Z_o = (X_{Co})^2/R$$

In the case of the particular 10-mc crystal unit where $X_{Co} = -3.5 \times 10^3 \Omega$, and $R = 8 \Omega$, R_e at antiresonance will be approximately 1.5 megohms. $Z_e (= \sqrt{R_e^2 + X_e^2})$ at most frequencies is simply equal to X_e . Only in the immediate regions of f_r and f_a , where X_e becomes negligible, is the magnitude of Z_e affected greatly by R_e . The impedances, of course, are not drawn to scale. For example, if Z_e at antiresonance were drawn to the scale used for Z_e at resonance, the curve could extend more than a mile above the horizontal axis.

PARALLEL-RESONANT FREQUENCY, f_p , OF CRYSTAL CIRCUIT

1-210. Although an oscillator may depend upon a crystal operating at its series-resonant frequency, it is not practicable for a crystal unit to control an oscillator at the antiresonant frequency, f_a . The crystal will either be operated to pass a maximum current (series-resonant circuit), or to develop a maximum voltage (parallel-resonant circuit) at some proper phase and frequency. It would seem that these latter conditions could best be met by operating the crystal unit at its antiresonant frequency, for it is in this region that the effective impedance is most sensitive to small changes in the frequency. However, another circuit, such as the input of a vacuum tube, will necessarily be

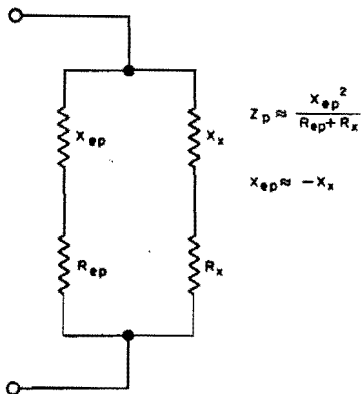

Figure 1-101. Equivalent parallel-resonant circuit of crystal unit (X_{ep} , R_{ep}) shunted by load (X_x , R_x). Normally $f_r < f_p < f_a$, so that X_{ep} is inductive and X_x is capacitive

shunted across the crystal. The shunt, or load circuit into which the crystal operates will have a much lower impedance than that of the crystal at antiresonance, so that the total impedance will be relatively insensitive to small frequency variations in the region of f_a . In determining the actual frequency stability, the entire circuit must be considered as a whole. The operating frequency may be considered as the resonant frequency, f_p , of an equivalent parallel circuit, as shown in figure 1-101. X_{ep} and R_{ep} are simply the reactance and resistance of the equivalent circuit of the crystal unit at f_p , and X_x and R_x are the equivalent shunt reactance and resistance, respectively. Since X_e is more frequency-sensitive above series resonance than below, there is normally no advantage in using a crystal in circuits that require X_e to be capacitive. Thus, in practice, f_p will be some intermediate frequency between f_r and f_a , so that X_{ep} is always inductive and X_x is always capacitive. The distinction made between "parallel resonance" and "antiresonance" in this discussion is somewhat arbitrary, and it is not uncommon to use the term "antiresonant" to describe any parallel-resonant crystal unit.

Effects of Changes in Shunt Capacitance on f_p

1-211. In discussing Δf_r , the difference between the motional and the effective resonant frequency, it was found that

$$\Delta f_r = \left| \frac{R^2}{4\pi L X_{Co}} \right|$$

That this quantity is normally insignificant is fortunate, for it varies directly with the square of R , a parameter quite likely to change during operation. On the other hand, it was later found that

$$\Delta f_a = \left| \frac{X_{Co}}{4\pi L} \right|$$

could amount to more than 0.1 percent difference in frequency. In this case, since Δf_a is relatively large, it is also quite fortunate that, to a first approximation, the antiresonant frequency of a given crystal unit is independent of operational changes in R . However, it is not the antiresonant frequency of the crystal unit itself, but rather, the actual parallel-resonant frequency at which the crystal unit will operate that is of primary interest. Let $f_p - f_r = \Delta f_p$. Now, it can be imagined that Δf_p is simply the Δf_a of a crystal unit whose shunt capacitance C_o has been increased by an

Section I
Electrical Parameters of Crystal Units

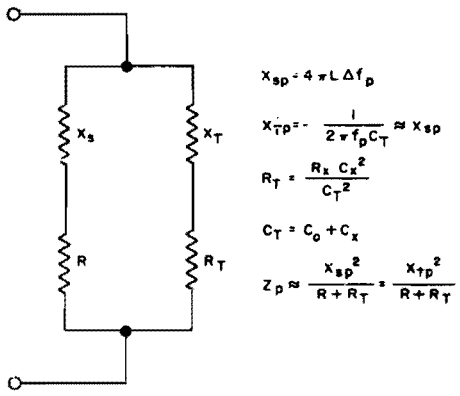

Figure 1-102. Equivalent parallel-resonant tank circuit, in which the motional impedance of the crystal unit is the inductive arm of the tank, and the total shunt impedance is the capacitive arm

amount C_x and which has an effective resistance added to the shunt arm equal to $R_x \left(\frac{C_x}{C_o + C_x} \right)^2$. This last assumption can be made without introducing an appreciable error as long as R_x is small compared with X_x . The multiplying factor is needed, since only a fraction, $\left(\frac{C_x}{C_o + C_x} \right)$, of the total equivalent tank current will flow through R_x . The equivalent tank circuit is shown in figure 1-102, where C_T and R_T are the values of the shunt parameters. Now, since Δf_p is equivalent to the

Δf_a of a crystal unit that has $C_o = C_T$, Δf_p will be expressed by the same general formula that holds for Δf_a . Thus, $\Delta f_p = \left| \frac{X_{Tp}}{4\pi L} \right|$. Also, since $X_T = -1/2\pi f C_T$, it can be seen that Δf_p will be inversely proportional to the total shunt capacitance. Although C_o , itself, is the most stable of all the crystal parameters, the stability of the effective external capacitance C_x will depend upon the over-all design of the oscillator circuit. The crystal unit may be considered a device that determines the limits within which the frequency may be varied; that is, f_p must lie somewhere between f_i and f_a . However, it is primarily the parameters of the external circuit in conjunction with the equivalent L , C , and C_o of the crystal that fix the exact frequency; and although the stability of the crystal parameters is fundamentally a problem for the crystal manufacturer, the stability of the effective C_T is largely the concern of the radio designer.

1-212. Figure 1-103 (A) shows the reactance curve of X_s versus frequency, and figure 1-103 (B) shows the reactance curve of X_T versus C_T . The values of X_s are those of the 10-mc crystal unit which has previously been taken as an example, and where L is assumed to be 1.65×10^{-3} henry. Note that the variations in X_T with frequency have been neglected, and f is simply assumed to equal the nominal frequency of 10 mc, insofar as the capacitive arm is concerned. Since X_s and X_T are drawn to the same scale, a horizontal line drawn through

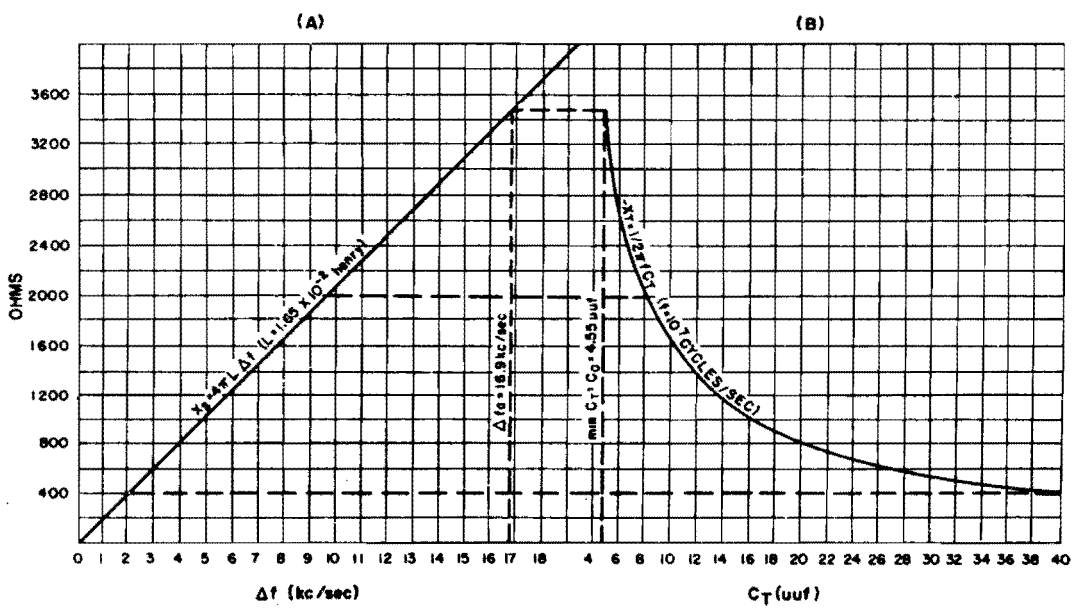

Figure 1-103. Reactance curves of: (A) X_s versus Δf , (B) $-X_T$ versus C_T

both curves will intersect points of equal but opposite reactances. These points of intersection will, in turn, indicate the value of Δf required for a given C_T , if the two arms are to be resonant. For example, at $C_T = 7.69 \mu\mu f$, $X_T = -2000 \Omega$; so that in order for X_s to be 2000Ω , Δf_p must equal 9.65 kc. Likewise, a C_T of $40 \mu\mu f$ will mean approximately a Δf_p of 2 kc. Now it so happens that the part of C_T represented by C_x will have a component that tends to vary with changes in the plate voltage applied to the vacuum tube, changes in the temperature or the tuning, changes in the coupling and neutralizing adjustments, and any changes in the vacuum-tube characteristics or other circuit parameters due to other causes. Such a change in X_x will cause not only a change in the resonant frequency, but also a change in the amplitude of the oscillations. If a given change in C_x is to have a minimum effect upon the frequency and power expenditure of the oscillator, then C_T must be as large as possible without seriously reducing the stabilizing effect of the crystal. In other words, C_T should have a value where the slope of the X_T -vs- C_T curve is not steep. For the 10-mc crystal of figure 1-103, maximum stability would be obtained with C_T between 36 and $40 \mu\mu f$. With C_o equal to $4.55 \mu\mu f$, this would mean a load capacitance, C_x , between 32 and $36 \mu\mu f$. As much of C_x as is possible should be supplied by a fixed or adjustable capacitor connected directly across the crystal unit or in some other part of the circuit, so that its effective capacitance with respect to the crystal terminals will remain constant, and not be affected by changes in the tube characteristics. This would reduce the variable part of C_x to a minimum. C_T , however, should not be made so large that X_T will approach the magnitude of R , otherwise the crystal will not only lose some of its stabilizing effectiveness, but will require an excessive drive level to maintain oscillations.

Stabilizing Effect of Crystal on f_p

1-213. Although C_T plays an important role in the final determination of the frequency, it is the crystal itself that must be primarily responsible for the stability of the frequency—that is, if the use of a crystal is to be justified. For this reason, care should be taken to make certain that the apparent Q_s of the crystal series arm $\left(\frac{X_s}{R}\right)$ is as large as 10, if possible, and preferably much larger during operation. Otherwise, the series-arm impedance will not respond with maximum sensitivity to changes in C_T . However, since X_T , and hence X_s , must be kept small to reduce the effects of a

change in C_T , it might appear at first thought that a conventional coil could serve quite as well as a crystal. The reason why this is not true is that the frequency stability is dependent upon the magnitude of the change in reactance for a given change in frequency, and not primarily upon the total magnitude of the reactance. It will be recalled that, in the conventional L-C circuit, the instantaneous rate of change of X_L with frequency is

$$\frac{dX_L}{df} = 2\pi L$$

and that, at resonance

$$\frac{dX_L}{df} = \frac{dX_C}{df}$$

In the parallel-resonant crystal circuit, however, these equalities do not hold, for $X_s = 4\pi\Delta fL$, and not $2\pi fL$. Thus, $\frac{dX_s}{df} = 4\pi L$, where L of the crystal is greater than L_c of a coil of the same reactance by a factor of $f/2\Delta f$. Since at resonance, the rate of change of X_T would equal that of X_{Lc} , it follows that $4\pi L$, the change in the motional reactance with frequency, will be $f_p/\Delta f_p$ times as great as the change in X_T with frequency. Consequently, the stabilizing effect of the crystal is much greater than that of the shunt reactance, so that, for all practical purposes, the crystal can "automatically" annul the effect of small changes in C_T , but not vice versa. It can be seen that, even with X_s relatively small, the stabilizing effect of the crystal for a fixed change in X_T is not diminished, provided, of course, that X_s is sufficiently large, as compared with R , so that the total impedance of the series arm is essentially equal to, and varies linearly with, X_s . (See paragraphs 1-238 to 1-245.)

Effect on Parallel Crystal Circuit Due to Variations in Resistance

1-214. As long as the apparent Q of the parallel-resonant circuit $\left(\frac{X_s}{R + R_T}\right)$ is at least as great as 10, a change in either R or R_T will not, in itself, have a large effect upon f_p . However, depending upon the design of the particular circuit, a change in the resistance may indirectly affect the frequency by causing a change in C_T , since, to a certain extent, the effective C_T will be a function of the other circuit parameters. The most critical effect due to changes in the resistance parameters is the effect on the power required for excitation of the oscillator in order to obtain a given output. The impedance, Z_p , of the parallel circuit at reso-

Section I

Electrical Parameters of Crystal Units

nance will be approximately $\frac{X_{sp}^2}{R + R_T}$. An increase in the total resistance of 100 percent would thus decrease Z_P by one half. If, for example, the output of the oscillator depended directly upon the r-f voltage across Z_P (i.e., across the crystal), a decrease in Z_P by one half would require twice as much power in the crystal circuit to maintain the output at the same level as before. A part of R_T will be the result of reflected resistance losses in the output circuit. An increase in the load will thus be reflected as an increase in R_T . This is unfortunate, for if the load should increase it would be desirable to have an increase in Z_P , to raise the excitation voltage automatically, or at least to keep it constant. As it is, the effect is to decrease the excitation, unless special circuits, such as the Tri-Tet, are employed to increase the feedback directly. If a principal component of the losses in R_T are due to the losses in the grid circuit, and if the oscillator design is such that the grid current is not linear with the excitation voltage, but rises at a much greater rate, then R_T can rapidly increase or decrease with the excitation voltage, and Z_P will vary inversely. Under these conditions, Z_P will always change in a direction that will tend to annul any change in the excitation voltage. The greater that part of R_T reflecting the grid losses, as compared with that part reflecting the output losses, the greater will be the amplitude stabilizing effect for counteracting changes in the plate voltage or the effective load resistances. Another characteristic of a crystal circuit in which R_T varies automatically is that the effect resulting from a variation in R is minimized. Assume, for example, that the desired output at a constant load will require a certain effective value of Z_P . If, for some reason, R should change, thereby changing the excitation voltage, R_T would tend to change by an equivalent amount in the opposite direction, thus maintaining Z_P , and hence the output, essentially constant. However, a change in R or R_T will almost certainly be accompanied by a change in the crystal power losses, thereby causing a frequency drift if the particular crystal unit is frequency-sensitive to the drive level. At this point, however, the important items to note are: (1) X_{Tp} , and hence X_{sp} , preferably should not be smaller than $10(R + R_T)$, or the maximum stabilizing effect of the crystal will not be realized; (2) the direct effect of a change in $(R + R_T)$ is to change Z_P ; (3) the effects of a change in Z_P primarily will involve changes in the excitation voltage, in the power expended in the crystal circuit, as well as that delivered to the load, and in the equivalent value of

C_T , thereby also changing the frequency; (4) if changes in either R or R_T are such that the power expended in the crystal unit itself is caused to vary, then a significant change in the frequency characteristics of the crystal may result; and (5) for maximum frequency stability, the oscillator should be lightly loaded, and the drive level of the crystal should be as small as is practicable.

Effect on Parallel Crystal Circuits Due to Variations in Motional-Arm C or L

1-215. Crystal circuits operated at the resonant frequency of the crystal units may be only slightly affected by variations in C or L from one crystal unit to the next, or even during the operation of a particular unit, provided that the effective LC product remains constant, so that the frequency does not change. In the parallel-resonant circuit, however, even if f_n is the same, a different C and L means a change in Δf_p . For a given C_T and nominal frequency, X_{Tp} , and hence, X_{sp} , must remain approximately constant, so that Δf_p , equal to $X_{sp}/4\pi L$, will tend to vary inversely with L . The exact value of L for a given crystal unit will depend upon the effective electrode area, the orientation of the cut, the thickness of the crystal, whether twinning is present in the quartz, and the degree to which spurious modes are coupled to the desired mode. Insofar, as the variations in L from one crystal unit to the next are concerned, no problem arises unless it is necessary to adjust f_p to an exact value; in which case the problem of the design engineer is to ensure that C_T will be sufficiently adjustable so that the desired f_p may be obtained with any reasonable value of L . Since such adjustments must be provided for anyway, in order to allow for different values of f_n , no new problems are introduced, except that a greater deviation in Δf_p must be met than otherwise. Unless spurious modes are closely coupled to the desired mode, the variations in L that might occur during the operation of a particular crystal unit will be too small to affect the magnitude of Δf_p , as long as X_{Tp} remains constant. However, the operational variations of L and/or C may be such that f_n will change, in which case f_p will also change. Such a deviation in frequency, i.e., in the equivalent LC product, would occur during changes in temperature or drive level, or because of fatigue or other aging effects. Minimum variations in L and C are obtained by the use of low temperature-coefficient crystals and constant-temperature ovens, and by ensuring that the drive level will remain both low and constant. In any event, a reasonable operational variation in f_p can be compensated for by an adjustment in C_T .

Minimum Value of Δf ,

1-216. Returning to equation 1 in figure 1-98, let it be imagined that X_s represents the effective reactance of the motional arm of a crystal unit in parallel with a total capacitance C_T , instead of simply the C_o of the crystal unit, itself. Furthermore, assume that R_T is negligible. As before, the condition of resonance is that X_s be zero, which will occur only when

$$R^2 + X_s^2 + X_s X_T = 0$$

(Note that X_T now replaces X_{C_o} .) Now $X_s = 4\pi L\Delta f$, and on substitution in the preceding equation and rearranging, it is found that

$$(\Delta f)^2 + \frac{X_T}{4\pi L} \Delta f + \frac{R^2}{16\pi^2 L^2} = 0$$

Note that this is simply a quadratic equation of the type $AX^2 + BX + C = 0$, so by the quadratic formula

$$\Delta f = \frac{-X_T}{4\pi L} \pm \frac{\sqrt{X_T^2 - 4R^2}}{2 \cdot 16\pi^2 L^2}$$

The \pm term indicates that there are two possible solutions for Δf at which resonance will occur. One of these is equivalent to Δf_r (but with C_o replaced by C_T), and the other is equivalent to Δf_p . For these solutions of Δf to be real, X_T^2 must be greater than $4R^2$; otherwise, the expression under the radical sign becomes negative, and Δf will be imaginary. However, in the special case where $X_T^2 - 4R^2 = 0$, there is only one solution for Δf . In other words,

$$\Delta f_r = \Delta f_p = \frac{-X_T}{8\pi L}$$

This represents the minimum value obtainable for Δf_p ; or, from the point of view of series resonance, it may be considered the maximum value obtainable for Δf_r . The important point to note is that neither parallel nor series resonance is possible unless X_T^2 is equal to, or greater than, $4R^2$. At the minimum Δf_p ,

$$X_T^2 = 4R^2$$

or

$$|X_T/R| = X_s/R = 2$$

It should be remembered that all the resistance has been assumed to be in the motional arm, and so

has the effect of limiting the maximum component of lagging current for a given voltage; but parallel resonance could be achieved at any frequency between f_s and f_p if R_T were equal to R . However, since C_o limits the minimum amplitude of leading current, R_T cannot be made equal to R for all values of f_p , and there will still be a minimum f_p greater than f_s . (A minimum which can be shown to be identical with the natural f_r of the crystal unit.) With R_T assumed to be negligible, the ratio of reactance to resistance equal to 2 represents the minimum apparent Q_s of the parallel crystal circuit, if resonance is to be obtained. As stated previously, if the full stabilizing properties of the crystal are to be in use, Q_s should be at least 10. However, if the power delivered to the crystal circuit is sufficient, oscillations can be maintained as long as the apparent Q_s does not fall below 2. This occurs at the frequency at which the amplitude of the lagging component of current through the series arm is the maximum obtainable.

TYPICAL OPERATING CHARACTERISTICS OF CRYSTAL UNIT

1-217. Figure 1-104 shows the effective impedance characteristics of the 10-mc crystal unit which has been assumed to have the following parameters:

$$L = 1.65 \times 10^{-2} \text{ henry}$$

$$C = 1.54 \times 10^{-2} \mu\mu\text{f}$$

$$R = 8 \text{ ohms}$$

$$C_o = 4.55 \mu\mu\text{f}$$

X_s , R_s , and Z_s are given by equations 1, 2, and 3, respectively, in figure 1-98; X_{C_o} is assumed to be equal to -3.5×10^3 ohms for all values of Δf . Note that the normal operating range covers only about one fourth of the total range between f_s and f_p . Of course, if C_o were greater than the value assumed, Δf_s would be smaller and the normal operating range would be a larger percentage of the total. As explained previously, C_T ($= C_o + C_x$) must be relatively large, so that small variations in C_x will not greatly affect the frequency, and it is this consideration that limits the practical operating range to low values of Δf . At parallel resonance, X_s must approximately equal $-X_s$, for the same reason that X_s must equal $-X_T$. Standard military high-frequency crystal units are normally tested with a value of $C_x = 32 \mu\mu\text{f}$. At 10 mc, a capacitance of $32 \mu\mu\text{f}$ will have a reactance of approximately -500Ω , as indicated in figure 1-103 (B). With $C_o = 4.55 \mu\mu\text{f}$, C_T will be $36.55 \mu\mu\text{f}$, which corresponds to a value of $X_T = -440 \Omega$, and a $\Delta f = 2.1 \text{ kc/sec}$. Δf can also be found from the reactance curve of figure 1-104 at the point where

Section I

Electrical Parameters of Crystal Units

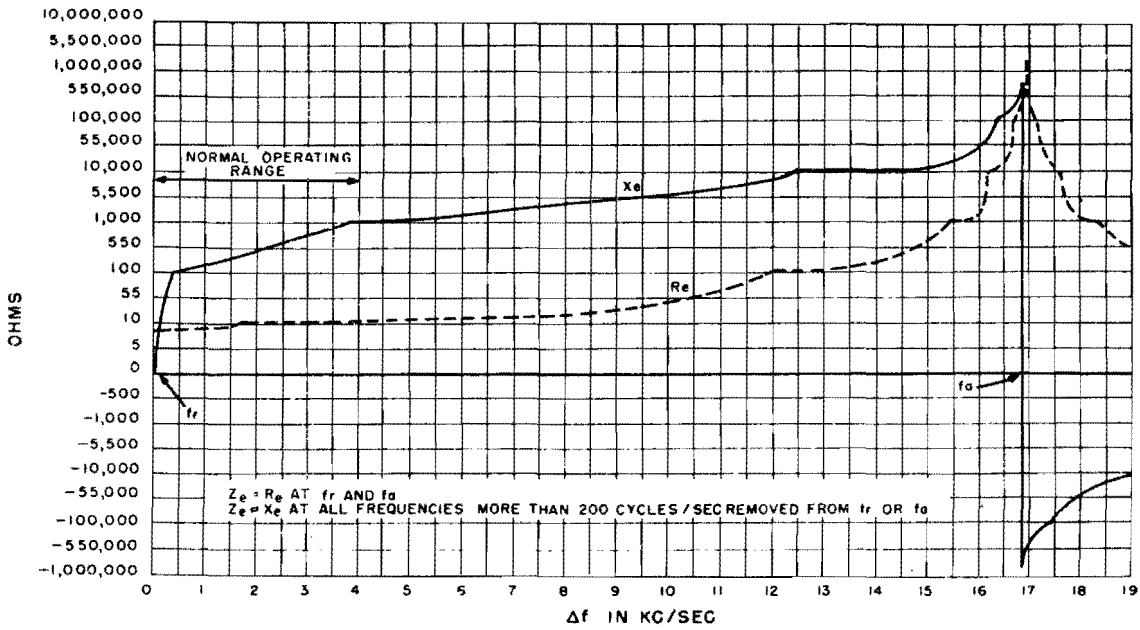

Figure 1-104. Typical characteristic curves for X_e and R_e of 10-mc crystal unit. (Shunt resistance, R_s , across crystal is assumed to be negligible)

$X_e = -X_x = 500 \Omega$. Crystal units are sometimes operated in series with an external capacitor, C_x , as indicated in figure 1-105. Slight variations in the frequency can be compensated for by adjustments of C_x , and resonance will occur at the frequency at which X_x is exactly annulled by X_e . If the ratio of X_e/R_e is sufficiently large, then for all practical purposes the series-resonant frequency, f_{rx} , is the same as the f_p of the crystal unit in parallel with the same C_x . At resonance, the crystal unit and C_x in series have an effective impedance equal to R_e . Although there is an effective maximum $Q_{em} = \frac{X_e}{R_e}$ when $\Delta f = \frac{\Delta f_s}{2}$, it has no special significance directly concerning the frequency sta-

bility of the circuit, but does tend to increase the activity. In general, if a series capacitor is used, its reactance will be small, as compared with X_{Co} . Indeed, it may be used for no other purpose than to annul the self inductance of the crystal leads. It can be seen in figure 1-104 that R_e does not increase nearly as rapidly as does X_e , except in the region of f_s . With $C_x = 32 \mu\mu f$, $\Delta f_{rx} (= f_{rx} - f_s)$ will be 2.1 kc for the crystal unit of figure 1-104, and R_e will be between 11 and 12 ohms.

MEASUREMENT OF CRYSTAL PARAMETERS

1-218. The parameters L , C , R , and C_o of any crystal unit chosen at random are effectively four independent variables, so that a minimum of four measurements are required to determine the values of these variables. Probably the four easiest measurements to make are those for f_p , R , C_o , and f_{rx} . The measurement for the last quantity is made when a known load capacitance C_x is connected in series with the crystal unit. Since f_{rx} , the resonant frequency of the crystal and C_x in series, for all practical purposes will be equal to the f_p of the crystal in parallel with C_x , we shall normally not make a distinction between the two frequencies in the following discussion, but shall use the symbol " f_p " in referring to either.

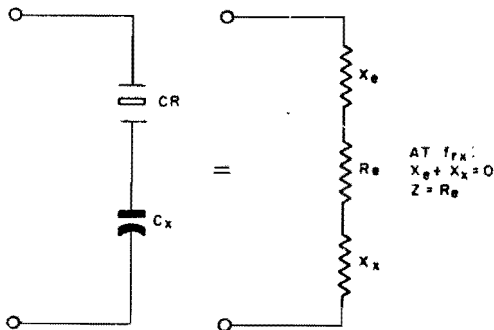

Figure 1-105. Equivalent circuit of crystal unit connected in series with capacitor

Measurement of the Shunt Capacitance, C_0 .

1-219. At all frequencies sufficiently removed from resonance the crystal unit will have the characteristics of a capacitance equal to C_0 . Thus, at these off-resonance frequencies, C_0 can be measured by a conventional Q meter or an r-f bridge. The frequency at which C_0 is to be measured should be lower than, but reasonably close to, the operating frequency, particularly if the crystal unit is to be operated at a high harmonic mode in the v-h-f range. Otherwise, the effect of the distributed inductance of the leads will not be properly taken into account.

Measurement of the Series-Arm Resistance, R

1-220. R is normally measured with the aid of a CI meter (crystal impedance meter). (See also paragraphs 2-60 through 2-65.) There are four standard CI meters with which the crystal units described in Section II of this handbook have been tested:

Crystal Impedance Meter	Frequency Range (kc/sec)
TS-710/TSM	10 to 1100
*TS-537/TSM	75 to 1100
TS-330/TSM	1000 to 15,000
TS-683/TSM	10,000 to 75,000

*(Crystal Impedance Meter TS-537/TSM may soon be replaced entirely by the recently developed

Crystal Impedance Meter TS-710()/TSM.) A CI meter is essentially an r-f oscillator provided with a feedback circuit in which a crystal unit or a resistor, or a crystal unit in series with a calibrated capacitor, can be connected. A simplified schematic diagram of a typical CI meter is shown in figure 1-106. The circuit shown is a modified Colpitts oscillator in which the tank inductor has been effectively divided into two equal sections, L_1 and L_2 , between which a resistor, R_0 , equal to R_c , the effective resistance of the crystal unit, can be connected. The ganged tuning capacitors C_1 and C_2 are at all times equal. C_B is simply a blocking capacitor to isolate the plate voltage from the crystal terminals, and adds only a negligible reactance to the tuned circuit. The potentiometer, P , is used to control the screen grid voltage, and hence the r-f output of the tube and the drive level of the crystal. With S_1 connected as shown, and R_0 adjusted to a value typical of the motional- ϵ - m R for the type of crystal unit being measured, the circuit will oscillate at approximately the resonant frequency of the tank. If C_1 and C_2 are adjusted so that the natural frequency of the oscillator is near the nominal frequency of the crystal, then, on connecting the crystal into the circuit, oscillations will continue, but with the frequency determined

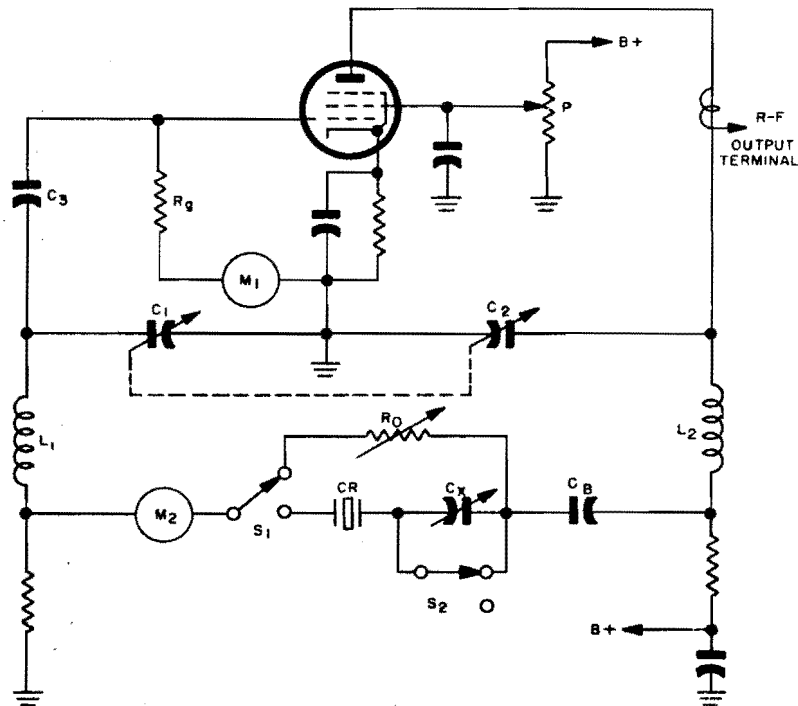

Figure 1-106. Simplified schematic diagram of CI meter

Section I

Electrical Parameters of Crystal Units

by the total reactance of the tank, including X_c of the crystal unit. There is no standard practice as to grounding the crystal holder; but whether grounded or ungrounded, the method of connecting the crystal unit should be noted. The drive is adjusted so that a very small grid current is indicated on M_1 . Under these conditions the control grid is positive with respect to the cathode only at the peaks of the positive swings of the excitation voltage developed across C_1 . Since electrons flow from cathode to grid only at these instants, a small percentage change in the excitation voltage, as illustrated in figure 1-107 can cause a very large percentage change in the cathode-to-grid electron flow. In an actual circuit the idealized constant bias that is indicated in figure 1-107 does not occur because of the gridleak action. However, if the gridleak contribution to the bias is very small compared with that part developed across the cathode resistance, the increase in bias due to an increase in excitation occurs almost entirely across R_g , not across the cathode resistance. Hence, a five or ten per cent increase in the total bias can result from hundred per cent increase in the gridleak IR drop. In this way, the grid current meter is a very sensitive indicator of slight changes in the r-f voltage across C_1 , and hence of any change in the tank current. With S_1 in the crystal position and S_2 closed, as C_1 and C_2 are varied, a peak in the grid-current reading indicates

a maximum current through C_1 . This in turn means that the effective resistance of the crystal unit has reached the minimum value equal to the series-arm R . In other words, the oscillator frequency is coinciding with the resonant frequency, f_r , of the crystal unit. R_o can now replace the crystal in the circuit and be adjusted to give the same meter readings at the same frequency. At this point R_o will equal R , and, since R_o is known, R will have been measured. The crystal current meter, M_2 , is not sufficiently sensitive to permit an accurate observation of the small changes in tank current that occur as the circuit is tuned through f_r . The purpose of the meter is to decrease the possibility of overloading the crystal and to provide a ready means for determining the exact drive level at which the crystal is being tested. Since the crystal parameters may change with the drive, it is necessary to specify the drive level at which the measurements are made. Expressed in milliwatts, the drive level equals $I^2R \times 10^{-3}$, where I (in milliamperes) is the current through M_2 at f_r . If a crystal-current meter is not supplied, two vacuum-tube voltmeters can be used to measure the voltage from each crystal terminal to ground without seriously affecting the circuit. Where E is the difference in potential across the crystal, equal to the difference between the two terminal voltages, the drive level is equal to E^2/R . The temperature at which the measurements are made should also

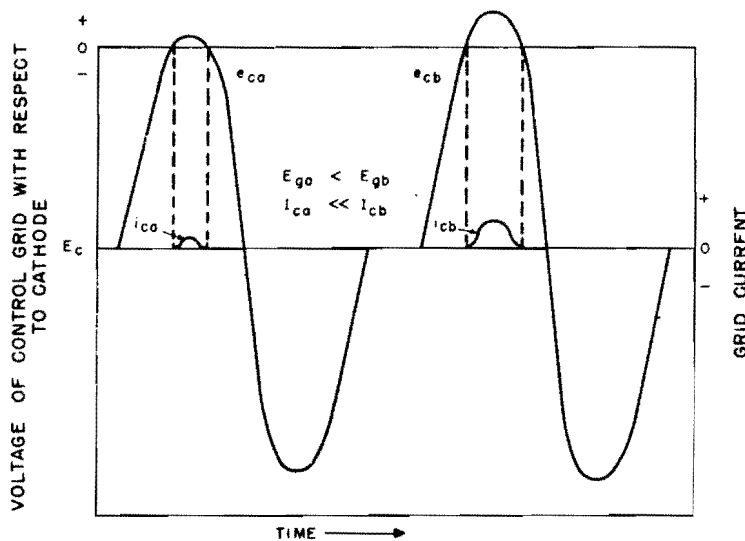

Figure 1-107. How a small percentage change in excitation voltage can cause a large percentage change in grid-leak current of C_1 meter. Bias does not actually remain constant as indicated, but follows the percentage changes of excitation voltage. Nevertheless, the relative percentage variations of grid current and excitation voltage can be approximately as shown when the greater part of the bias is developed across the cathode resistance

be specified, although, in general, the variation of R with ambient temperature is much less than its variation with the amplitude of the crystal vibrations.

Measurement of the Resonance Frequency, f_r .

1-221. To measure f_r , a c-w radio receiver, a radio-frequency standard, a calibrated audio-frequency source (interpolation oscillator), and either a loudspeaker, a pair of ear phones, or an oscilloscope are used in conjunction with the CI meter. With the crystal connected in the CI-meter circuit and the oscillator tuned to series resonance, the r-f output can be loosely coupled through a coaxial cable to the antenna post of the c-w radio receiver. After the receiver is tuned to the frequency of the crystal unit, the CI meter is turned off, and the receiver is connected and tuned to receive the particular harmonic of the frequency standard that is nearest to f_r . The bfo of the receiver is then cut off, and the CI meter is turned on. With both the standard and the CI-meter signals being fed to the receiver input, the output of the receiver will be an audio beat note equal to the difference between the known standard frequency and the unknown crystal frequency. By momentarily switching a fairly large value of C_x in series with the crystal, so that the CI-meter frequency increases slightly, the audio beat frequency will rise or fall according to whether f_r is respectively greater than or less than the standard signal. The audio beat frequency is next mixed with the audio output of the interpolation oscillator, which in turn is adjusted to bring the beat frequency of the two audio signals to zero—the zero beat being observed by phones, loudspeaker, or oscilloscope. At zero beat, the crystal frequency will have been measured to be equal to the selected r-f standard frequency \pm the interpolation oscillator frequency. The accuracy of the measurement depends primarily upon the accuracy of the frequency standard, and secondarily on that of the interpolation oscillator. As in the case of the resistance measurement, both the temperature and the drive level should be specified, and these should be the same as when the measurement of R was made.

Measurement of the Parallel-Resonance Frequency, f_p .

1-222. To measure f_p , it is first necessary to adjust the CI meter to oscillate at f_r , by the same steps employed previously. With the oscillator so adjusted, a known value of C_x is switched in series with the crystal. The new frequency will be approximately equal to f_p . The more common values

of C_x are 32 μmf for high-frequency crystals, and 20 μmf for low-frequency crystals. In testing to determine whether the crystal frequency is above or below the frequency of the test standard, it may be more convenient to add capacitance across the crystal unit than to change the setting of C_x . In this event the CI-meter frequency is decreased rather than increased, so that the effect on the beat note will be the opposite of that previously described. Simply touching the crystal holder with the hand is normally the quickest method of increasing the shunt capacitance; however, care should be taken that the method employed does not effectively decrease the capacitance by grounding the holder.

1-223. Theoretically, the foregoing method of measuring f_p is not exact, for if the LC circuit is correctly tuned when the crystal appears as a pure resistance, the same feed-back phase relations cannot hold at the higher frequency, f_p , unless CR and C_x in series introduce a negative reactance to compensate for the increase in X_{L1} and X_{L2} and the decrease in X_{C1} and X_{C2} . In other words, X_e of the crystal unit is approximately, but not exactly, equal in magnitude to X_x of the load capacitance. Actually, X_e is less than $|X_x|$ by an amount approximately equal to the change in reactance around the LC loop, exclusive of CR and C_x . This change is approximately equal to $4\pi(L_1 + L_2) \Delta f_p$, where Δf_p is the difference between f_p and f_r . At the true f_{rx} , $X_e + X_x = 0$; at the observed f_p ,

$$X_e + X_x + 4\pi(L_1 + L_2) \Delta f_p = 0 \tag{1-223 (1)}$$

Now a small change in $X_e + X_x$, equal to $\Delta X_e + \Delta X_x$, as a result of a small change in frequency, is practically equal to ΔX_e alone. If the frequency is sufficiently close to the resonant point, f_r , we may set $X_e + X_x$ (at observed f_p) = $\Delta(X_e + X_x) \approx \Delta X_e \approx \Delta X_x = 4\pi L \Delta f$, where $\Delta f = \text{observed } f_p - \text{true } f_{rx}$. By substitution in equation (1)

$$\text{True } f_{rx} = \text{Observed } f_p + \left(\frac{L_1 + L_2}{L} \right) \Delta f_p \tag{1-223 (2)}$$

Measurement of the Effective Resistance, R_e , at Parallel Resonance

1-224. In the measurement of f_p , the drive level and the temperature should be the same as in the measurement of R and f_r . To determine the drive level, either the voltage across the crystal unit, or

Section I

Electrical Parameters of Crystal Units

the effective resistance R_e should be known—or both, if a crystal-current meter is not provided. A measurement of R_e is also important for its own sake and as a check to see whether the motional-arm parameters are the same at f_p as at f_r . In the case of a crystal unit which is intended to be operated only at parallel resonance, R_e is generally treated as a primary parameter of more immediate importance than the motional-arm R . R_e is measured in a manner similar to the measurement of R , except that on substituting R_e for the crystal the circuit must be retuned so that oscillations are being maintained at f_p . For a very precise drive-level measurement, additional precautions must be taken if the power dissipation is to be the same in both the series- and parallel-resonant measurements. The best assurance that the f_r and f_p drive levels will not be greatly different is to be had when the crystal current is kept near the minimum necessary to maintain oscillations. Thus, even though the relative differences in drive level may be large, the absolute differences will be small. This is not a completely reliable method, for some crystal units exhibit very sharp increases in resistance when the drive level approaches a minimum.

Computing the Series-Arm C and L from the Measured Parameters

1-225. From the formulas for f_r , X_e , and X_x , it is quite easy to derive the following approximate equations for the series-arm parameters, C and L:

$$C = \frac{2(C_o + C_x)\Delta f_p}{f_r} \quad 1-225 (1)$$

$$L = \frac{1}{(2\pi f_r)^2 C} \quad 1-225 (2)$$

where, C, C_o , and C_x are in farads, L is in henries, and Δf_p and f_r are in cps.

METHODS FOR EXPRESSING THE RELATIVE PERFORMANCE CHARACTERISTICS OF A CRYSTAL UNIT

1-226. If the four equivalent electrical parameters (L, C, R, C_o) are accurately known for a given state of operation, no other independent data concerning a crystal unit can increase the radio engineer's knowledge of how the crystal will perform under the given conditions. However, the radio engineer has been slow in requesting specific information concerning the electrical characteristics of the crystal units available, and as a result the problem of making a given circuit perform correctly

has often in the past effectively become the responsibility of the crystal manufacturer, who, by cut-and-try methods, has been more or less required to design the crystal unit around the particular circuit. Fortunately, progress toward greater standardization of crystal units has been considerably accelerated during recent years because of the increased demands of the military services; but there is still a tendency on the part of the design engineer to regard a crystal unit, as one production engineer has expressed it, as a "mystery box," rather than the equivalent circuit that it is. Contributing to this tendency has been a hesitancy upon the part of the manufacturer to describe his crystal units in terms of the most probable equivalent electrical parameters. At the present state of the art, wide variations from the most probable values can occur, and the manufacturer quite naturally wishes to avoid the chance that typical values of the parameters will be misinterpreted as specified values. For similar reasons, a description of a crystal unit in terms of its most probable parameters is not at present desirable from the point of view of the military services, lest a crystal circuit be designed upon the assumption that the typical crystal parameters will always be available, rather than upon the assumption that the crystal unit cannot be depended upon to meet other than its minimum performance specifications. If the former, rather than the latter assumption were made, a carefully designed circuit might fail to operate properly if used with a borderline crystal unit. Thus, the purpose of the standardization of types—to ensure a complete interchangeability among the crystal units of the same type number and nominal frequency—would be defeated. Nevertheless, the lack of emphasis upon the basic parameters has served to cloak the crystal in an air of mystery, and to instill in the radio engineer an impression that a crystal circuit is possessed of properties that cannot be expressed in the normal idiom of LCR networks. Contributing somewhat to this point of view is the special terminology that has been developed for the purpose of comparing the performance characteristics of one crystal unit with those of another particularly where the definitions of the terms contain certain ambiguities or conditional interpretations, or are presented as mathematical relationships without concrete qualitative meanings. What may be implied as a property of the crystal unit alone, may well be a function of the particular circuit in which the crystal unit is mounted. Much of the difficulty can be avoided if it is kept in mind that a crystal unit has no important circuit performance

qualities that cannot be expressed in the everyday terminology of radio engineering as it might apply if the crystal unit were replaced by an equivalent network of L, C, R, and C_o.

1-227. There are five general categories in which crystal units can be placed for comparison insofar as their relative merits are reflected by their performance in a standard test-oscillator circuit: (1) activity, (2) frequency stabilization, (3) bandwidth, (4) quality factor, and (5) parameter stability. *Activity*, as applied to a crystal, is a general term, rather loosely defined, that refers to the relative ease with which a crystal may be caused to maintain oscillations. The basic parameter most closely associated with the crystal activity is the motional-arm resistance, R. Besides R, or R_e, there are certain performance parameters that can be used as indices of relative activity quality. These are the effective Q (Q_e), the maximum effective Q (Q_{em}), the figure of merit (M), and the performance index (PI). The term, *frequency stabilization*, as used in this context, refers only to the ability of a crystal to minimize any change in the frequency due to variations in the parameters of the external circuit. In this sense, those performance parameters that can be used as indices of the frequency-stabilization quality are the series-arm L/C ratio, the coefficient of frequency stability (F_x), and the capacitance ratios C_T/C and C_T/C_X. The *bandwidth* of a crystal unit refers to the frequency range over which the crystal unit is considered operable. The performance parameters indicating this quality are the capacitance ratio, $r = C_0/C$, and the electromechanical coupling factor, k. The *quality factor* is simply the crystal Q, which is, itself, a major performance parameter, but one that is not exclusively identified with any one of the other four performance categories. The term *parameter stability* is used here to refer to the relative stability of the crystal parameters during changes in the temperature, drive level, tuning adjustments, and the like. The *frequency stability* of the crystal unit, which is included in this category, should not be confused with the function of *frequency stabilization* which is the characteristic we have arbitrarily assigned to the second performance category. The frequency stabilization is dependent upon the *magnitudes* of the equivalent-circuit parameters; whereas, the frequency stability is dependent upon the *stability* of the equivalent-circuit parameters. The stability of a crystal oscillator circuit is dependent upon *both* the crystal stabilization and the parameter stability. Performance indices or terms indicating the relative parameter stabilities are represented by

the temperature coefficients of frequency and resistance, drive-level coefficients of frequency and resistance, frequency tolerance, frequency deviation, resistance deviation, relative freedom from unwanted modes, and general expressions indicating durability and aging characteristics. Since most of the characteristics identified with the five performance categories can be expressed as functions of the same basic equivalent-circuit parameters, a performance parameter in one category quite often serves as an indication of the crystal quality in another. It cannot be said that those properties most closely identified with the activity, for instance, are not also related to the frequency stabilizing effect. Nevertheless, classifying the various methods for rating the performance of a crystal unit is helpful in interpreting the different performance parameters in terms of the basic equivalent-circuit parameters.

Activity Quality of Crystal Unit

1-228. The "activity" of a crystal oscillator is a qualitative expression referring to the amplitude of the oscillations. It is a term that came into use during the early days of crystal resonators, but one that seems never to have been vigorously defined. For example, it is not always certain whether the "activity of an oscillator" is intended to refer to the amplitude of current in the feedback, or in the output circuit, or to the voltage across some particular circuit component, or to the output power, or to the excitation power, or to the ratio of these powers, or simply to the amplitude of the crystal's mechanical vibrations. Were the expression not already so strongly entrenched in the crystal terminology, its use would probably be discouraged. As it is, crystal units are commonly described as having high or low activities, or more specifically, as having high or low potential activities or activity qualities. It will be found that the crystal parameter most directly indicative of the activity quality is the motional-arm conductance, 1/R. In crystal oscillators employing gridleak bias, when one crystal is replaced by another of the same nominal frequency, one of the crystals is usually found to produce stronger excitations and hence a larger grid current under similar operating conditions. Frequently the relative grid currents are defined to be equal to the relative activities of the crystals. With this method of measurement it can be seen that, if a crystal is connected directly across the grid-to-cathode input the excitation, and hence the activity, will depend upon the amplitude of the r-f voltage across the crystal. On the other hand, if the crystal is con-

Section I

Electrical Parameters of Crystal Units

nected in series with the oscillator input, the activity will depend upon the amplitude of the current through the crystal unit. Since, in any event, the grid current depends upon the values of every parameter in the oscillator circuit, such a measurement is ambiguous unless a standard test circuit can be referred to for each frequency. Only in this way can the crystal unit, itself, be considered the only significant variable. Even under the assumption of ideal test conditions, however, the exact mathematical relationship among the crystal parameters, which provides the most direct measure of a crystal unit's inherent activity quality, has been a subject of some controversy. A number of suggestions have been made, but the usefulness of each of these depends considerably upon the method by which the crystal is to be used to control oscillations. As the crystal terminology becomes more rigorously defined we can imagine that the word "activity" will fall into disuse eventually, with "effective resonance resistance" or "conductance" taking its place.

ACTIVITY QUALITY FOR SERIES RESONANCE

1-229. As an example of series-mode operation, we refer to the test circuit in figure 1-106. It can be seen that the grid excitation will be approximately equal to IX_{C_1} , the r-f voltage developed across C_1 . X_{C_1} depends upon the frequency and the value of C_1 , whereas, I , the current through C_1 depends upon the B^+ voltage, the setting of P , the tube characteristics, etc., as well as the tank impedance and hence the resistance of the crystal. With all the circuit parameters constant, the only variable that the crystal introduces at resonance is its resistance R . Rather than specify all the parameters of the test circuit for each nominal frequency, it is clear that the measurements of R provide sufficient indication of the relative activities of different crystal units under any similar conditions of resonance. Since the current and voltage amplitudes vary inversely with R , the series-resonance activity of any crystal unit can be assumed to be directly proportional to $1/R$, the motional-arm conductance.

ACTIVITY QUALITY FOR PARALLEL RESONANCE

1-230. The interpretation of the activity quality of a crystal unit becomes more complicated when the crystal is to be operated at parallel resonance. But even as in the case of series resonance, the inherent property of the crystal unit that most readily indicates the relative activity is the motional-arm

conductance, $1/R$. In a parallel-resonant oscillator circuit, the excitation is normally directly proportional to the voltage developed across the crystal in parallel with its effective load capacitance C_x . This voltage in turn is proportional to $Z_p \approx X_T^2/R$, where Z_p is the parallel-resonance impedance, X_T is the reactance of C_T , the total shunt capacitance, and R is the series-arm resistance. As long as X_T remains constant, the only significant crystal variable that affects the activity is R , or more directly $1/R$. A complication arises from the fact that $C_T = C_o + C_x$, so that if C_x , the effective capacity of the external circuit is to be held constant, then X_T , and hence the activity, changes with C_o . Another complication arises when a measure of crystal quality is desired that will hold between crystals of different nominal frequency. If C_T or C_x is to be held constant, then Z_p tends to vary inversely with the square of the frequency. Finally, the complications are multiplied several fold when one begins to take into account the many ways in which a crystal can be connected to stabilize or to control a parallel-resonant type of circuit. Unless the term "activity" is to refer to some desired and well-defined end result that can be measured quantitatively, the word may have little practical meaning. With this in mind, we note that since the usefulness of the oscillator depends entirely upon its output, the useful oscillator activity can be said to concern only the amplitude of oscillations in the load circuit. Thus, the relative ease with which a crystal unit enables a given output to be achieved under specified conditions can be regarded as the relative activity quality of the crystal unit. From this point of view, the relative activity of a crystal unit can be considered inversely proportional to the driving power that the crystal requires in order to maintain a given output level in a fixed load. Now, there is a special case of parallel-mode operation—where the series arm operates into a constant C_T —for which the activity, as interpreted above, requires only a measurement of R . Assume that a small, variable shunt capacitance, C_v , can be connected directly across each crystal unit whose activity quality is being tested, so that the effective shunt capacitance (eff $C_o = C_o + C_v$) can be adjusted to give the same value for all crystals. With this arrangement, the crystal power dissipation for a given power output will vary positively with the motional-arm resistance, R . In other words, two crystal units of the same series-resonance frequency and the same motional-arm resistance can produce the same oscillator activity at the same parallel-resonance frequency regardless of the particular

values of C_0 , or of the motional-arm C and L , but only if a variable shunt capacitor is provided by which the effective C_0 can be held constant. Thus, for gauging the potential activity of a particular crystal unit to be used in any parallel-mode oscillator circuit having a variable capacitor connected directly across the terminals of the crystal unit, the motional-arm conductance, $1/R$, can usually be considered a sufficient and proper activity parameter.

1-231. Where the load capacitance, C_x , that the entire crystal unit faces (not necessarily $C_T = C_0 + C_x$ that the series arm faces) is to remain constant, the parameter $1/R$ is not a sufficient index of the activity quality. If the proper measure of crystal activity is defined to be the ratio of output power to crystal power, such a definition is general enough to be applicable for any type of crystal oscillator. Certainly, the crystal unit that requires the least expenditure of energy to perform its task should be considered the one of greatest activity. Unfortunately, activity quality, from the point of view of a power ratio, becomes a function of each particular oscillator and load circuit, so that the generalization gained in the definition is completely lost on application, unless a standard test oscillator is available for each type of circuit. Only when the crystal unit is operated at its series-resonant frequency or is connected directly in parallel with a variable capacitor, can the relative activity qualities of two or more crystal units be considered constant and independent of the particular design of the external circuit. In all other cases, C_0 , as well as R , becomes a significant parameter of the activity, and the exact relation of C_0 to the activity will depend upon the circuit design. For a parallel-mode activity parameter to apply in the general case, the oscillator circuit, itself, must be considered from a generalized point of view. By this approach, the effective

$Q \left(Q_0 = \frac{X_c}{R_c} \right)$ is often considered a more reliable activity quality factor, than $1/R$ alone. The reason for this belief is most readily indicated when a generalized crystal oscillator is represented by the negative-resistance method — in particular, by diagrams (A), (B), and (C) in figure 1-108.

Q, AS AN INDEX OF ACTIVITY QUALITY

1-232. If the oscillations of a crystal are to be sustained, energy must be supplied at a rate equal to the power losses in the crystal. This state is indicated in figure 1-108 (A), where the power source is represented as a generator with an emf equal,

but opposite in sign, to the voltage across the effective resistance of the crystal unit. The power input thus is $|EI_c| = I_c^2 R_c$. Furthermore, since the total voltage drop around the circuit must be zero, the external circuit must appear as having a reactance equal, but opposite in sign, to the effective reactance of the crystal. Now, since the current through each component of the equivalent series circuit is the same, the voltage may be represented as being the result of a current flowing through a circuit of zero total impedance, as shown in figure 1-108 (B). Note that the generator is replaced by a negative resistance, ρ_n , numerically equal to R_c . Figure 1-108 (C) shows the same operating conditions, but with X_1 and ρ_n of the external circuit replaced by an equivalent capacitive reactance, X_x , in parallel with a negative resistance, ρ , equal to $-Z_p$, where $Z_p \approx \frac{X_c^2}{R_c} \approx \frac{X_x^2}{R_c}$. At all instants the impedance across the terminals at 1 and 2, whether that of the crystal unit or of the external circuit, is the same for both the (B) and the (C) equivalent circuits. Imagine now that after equilibrium has been reached, R_c suddenly decreases by one half. At this instant the power being supplied, $I_c^2 \rho_n = I^2 \rho$, is greater than that being dissipated in R_c . In (B), the amplitude of oscillations will increase until a new equilibrium is reached, at which time ρ_n will also have decreased by one half and will be once again numerically equal to R_c . In (C), the halving of R_c means that Z_p is approximately doubled. The same increase in current through R_c must be shown to occur in (C) as in (B). Thus, the amplitude of the oscillations must increase until ρ has doubled its value and is again numerically equal to Z_p . (The changes in ρ are caused by the limiting elements in the oscillator. For example, R_p of the vacuum tube will increase with an increase in gridleak bias, and this will be reflected as an increase in ρ .) From the generalized circuit approach, we can reach the general conclusion intuitively that oscillations build up as long as $|\rho_n| > R_c$, or $|\rho| < Z_p$, and that oscillations diminish in amplitude under the reverse conditions. It may not be at once apparent why oscillations should not build up if ρ were numerically larger than Z_p , in the same way that they do when ρ_n is greater numerically than R_c . A rigorous proof can be obtained by a differential equation of the current through the inductance, applying Kirchoff's laws and keeping in mind that resistance, negative or positive, is mathematically an instantaneous rate of change of voltage with current. Qualitatively it can be seen that the amplitude increases or decreases, depending upon

Section I
Electrical Parameters of Crystal Units

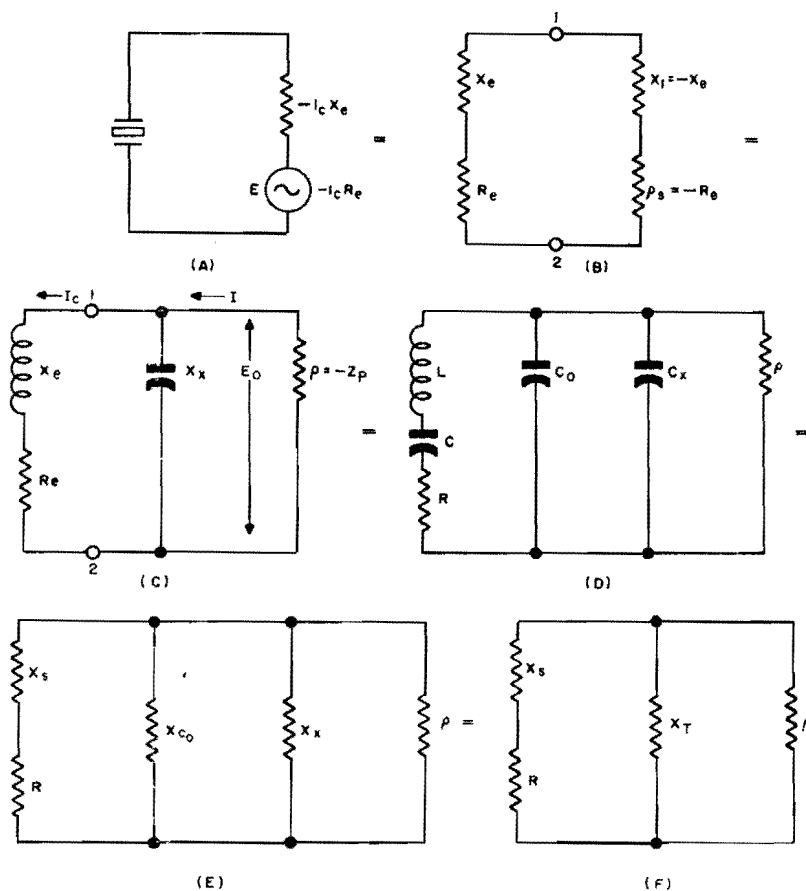

Figure 1-108. Generalized crystal oscillator circuit

whether the ratio of the power input to the power dissipation is, respectively, greater or less than 1. For circuit (B) the current, I_c , is the same for both the crystal unit and ρ_s , so that the power ratio is:

$$\left| \frac{I_c^2 \rho_s}{I_c^2 R_e} \right| = \left| \frac{\rho_s}{R_e} \right| \quad 1-232 (1)$$

Oscillations thus build up as long as ρ_s is greater than R_e . For circuit (C) the voltage, E_o , is the same across the crystal unit as across ρ , so that the power ratio is:

$$\frac{E_o^2 / \rho}{R_e E_o^2 / Z_p^2} \approx \left| \frac{Z_p}{\rho} \right| \quad \text{where } Z_p = \sqrt{R_e^2 + X_e^2} \text{ and } X_e \gg R_e \quad 1-232 (2)$$

Oscillations thus build up as long as ρ is less than Z_p , the equivalent parallel-resonance impedance at

equilibrium. The initial values of ρ_s and ρ for a given frequency can be assumed to be fixed parameters characteristic of the particular oscillator circuit, although the exact magnitudes may be extremely complicated functions involving all the circuit variables. Nevertheless, it is reasonable to assume that the more the negative resistance must change, the greater will be the activity of the oscillator by the time equilibrium is reached. From the point of view of circuit (B), it would seem that with a given initial ρ_s maximum activity is to be obtained with a minimum R_e ; but in circuit (C), on starting with a given value of ρ , maximum activity is to be obtained with a maximum Z_p . Note that these two conditions are not entirely equivalent. For a given crystal unit, Z_p , for instance, can be increased by increasing X_x , which in turn requires that R_e , as well as X_e , become greater. (Since X_e must increase to match the increase in X_x , so must the frequency, and hence also R_e .) Remembering that the activity that is assumed to

be proportional to the change in negative resistance is that in the oscillator output and is not necessarily the current amplitude in the crystal circuit, it can be seen that R_e alone, in spite of the implications to be drawn from figure 1-108 (B), may not be a sufficient parameter to indicate the relative activity quality of a crystal unit in the general case, i.e., X_e must also be considered. For these reasons, the effective Q of the crystal unit, $Q_e = X_e/R_e$, is usually considered the more reliable index of the crystal activity quality for parallel-resonant oscillators. There are exceptions, however, where R_e , or rather $\frac{1}{R_e}$, is the proper activity parameter. These occur when the crystal is actually operated at series resonance with an external capacitance. An example is the CI-meter circuit in figure 1-106, when C_x is connected in series with the crystal. (See paragraph 1-585 for a more detailed analysis of negative-resistance limiting.)

1-233. The crystal Q_e is a more direct index of the potential activity in some oscillator circuits than in others. The first consideration is the effect that a change in Q_e has upon the excitation voltage. Normally, an increase in Q_e means an increase in excitation, but this is not true in every case, even in the conventional parallel-resonant circuits. In these oscillators, the feed-back network may consist of a crystal unit shunted by one capacitance and in series with another. Referring to figure 1-109, assume at first that the capacitance, C_v , shunting the crystal unit in both (A) and (B) is negligible. The generalized circuits are thus equivalent to that of figure 1-108 (B). X_1 of figure 1-108 (B) is represented by $(X_{1a} + X_{1b})$ and by $(X_{1c} + X_{1d})$ in circuits (A) and (B), respectively, of figure 1-109. Referring now to figure 1-109 only, the crystal unit in circuit (A) is connected between the control grid and cathode, so that the principal activity consideration is to obtain the desired excitation voltage across the crystal unit with a minimum power dissipation in the crystal unit. Similarly, in circuit (B), the higher the crystal quality, the less the crystal power that would be required to obtain a desired excitation voltage across X_{1c} . As a first approximation, assume that X_e is much greater than R_e , so that the voltage across the crystal unit can be assumed to equal $I_g X_e$, where I_g is the feed-back current and where $I_g X_e$ is 180° out of phase with the voltage across the series reactance, X_{1a} , or X_{1c} , as the case may be. In circuit (A), the excitation voltage is thus equal to $I_g X_e$, and the crystal power dissipation is $I_g^2 R_e$. If the ratio of the r-f output voltage of the tube to the excitation voltage, E_p/E_g , is assumed

to be k , then the ratio of the output voltage to the crystal power, P_c , is:

$$\frac{E_p}{P_c} = \frac{k I_g X_e}{I_g^2 R_e} = \frac{k Q_e}{I_g} \quad \text{Circuit (A)} \quad \text{(figure 1-109)}$$

The magnitude of the total impedance of the feed-back circuit must be $k Z_g$, where Z_g is the grid-to-cathode impedance. As long as it can be assumed that the impedance of the crystal unit is 180° out of phase with the reactance of the series capacitance, then the magnitude of the plate-to-grid impedance must be approximately $(k + 1) Z_g$. Thus, in circuit (B), $|X_{1c}| \approx \frac{X_e}{k+1}$. Substituting this value of X_{1c} in place of X_e in the equation above:

$$\frac{E_p}{P_c} = \frac{k Q_e}{(k + 1) I_g} \quad \text{Circuit (B)} \quad \text{(figure 1-109)}$$

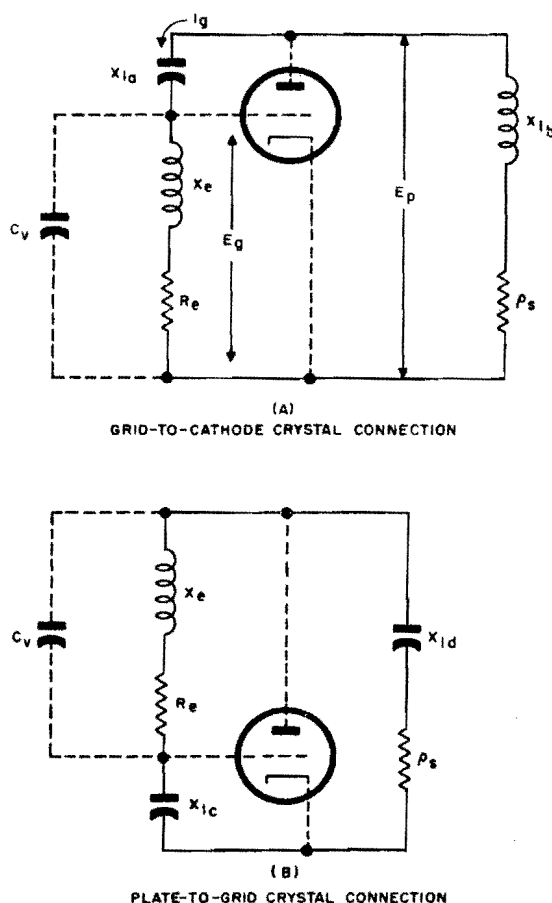

Figure 1-109. Generalized crystal oscillator circuits, showing two conventional methods for connecting crystal unit (X_e , R_e) in feed-back circuit

Section I

Electrical Parameters of Crystal Units

The equations for circuits (A) and (B) show that for a given k and a given crystal current, a maximum ratio of E_p/P_e is to be obtained when Q_e is a maximum. This assumes that the circuit capacitance, C_v , directly shunting the crystal unit is negligible. When this assumption cannot be made, the effective Q of the parallel combination must be substituted for Q_e . The Q of the combination is approximately equal to $Q_e \left(\frac{X_v + X_e}{X_v} \right)$ as long as $(X_v + X_e)$ is numerically large compared with R_e , X_v being the negative reactance of C_v . The larger the magnitude of the ratio X_v/X_e , the more directly does Q_e become the principal activity index. It should be remembered that the direct proportionality between Q_e and the activity in the example above holds only upon the assumption that I_e is to be held constant, regardless of the value of Q_e . Another instance in which the activity of an oscillator is a direct function of Q_e would be the unconventional case of an oscillator so designed that the crystal unit is operated in series resonance with an external capacitance and with the excitation voltage equal to, or directly proportional to, the voltage across either the crystal unit or the series reactance. In such a circuit, use would be made of the resonant rise in voltage that is developed when a component impedance is greater in magnitude than the total impedance. Since the current through the component is the same as that through the total impedance, the step-up voltage ratio is the same as the impedance ratio. At series resonance the total impedance of the crystal circuit would equal R_e (assuming no other resistance in the circuit), so that if Z_e of the crystal unit were approximately equal to X_e , the ratio of the voltage across the crystal unit to the feed-back emf would be $I_e Z_e / I_e R_e = Q_e$. The standard crystal units which are intended for use at parallel resonance are tested for operation with definite values of load capacitance, C_x . Thus, the recommended operating value of X_e may be assumed to be equal to $\frac{1}{\omega C_x} = |X_x|$. The maximum value of R_e that is permissible with this value of X_x is also specified. Hence, in the design of an oscillator that must operate satisfactorily with any randomly selected crystal unit of a given type, allowance must be made in the circuit design to ensure that satisfactory activity is obtained for the minimum

$$Q_e \left(= \frac{1}{\omega C_x R_e (\max)} \right).$$

MAXIMUM EFFECTIVE Q (Q_{em})

1-234. Where it is desirable to have an activity

parameter that is not a function of the particular external load capacitance, the maximum effective Q (Q_{em}) offers a convenient index of the maximum potential activity of a crystal unit which is to be operated in a type of circuit whose activity depends primarily upon Q_e . The maximum effective Q can be expressed solely in terms of the basic crystal parameters, since the maximum occurs midway between f_r and f_s , so that $\Delta f = \frac{\Delta f_s}{2}$. Thus, from equations (1) and (2) of figure 1-98, it can be seen that

$$Q_{em} = \frac{X_e}{R_e} = \frac{2\pi L \Delta f_s}{2R}$$

Since

$$\Delta f_s = \frac{fC}{2C_0} \quad [\text{by equation 1-208 (1)}]$$

Then

$$Q_{em} = \frac{2\pi fLC}{4RC_0} = \frac{\sqrt{LC}}{4RC_0} = \frac{1}{4R\omega C_0} = \left| \frac{X_{C_0}}{4R} \right|$$

1-234 (1)

Q_{em} provides a convenient activity factor combining all the crystal parameters. It is equal to the maximum step-up voltage ratio that can be obtained by operating the crystal in series with a negative reactance. Where another capacitor, C_v , is shunted directly across the crystal unit, the maximum effective Q of the combination becomes

$$\frac{\sqrt{LC}}{4R(C_0 + C_v)}.$$

FIGURE OF MERIT, M

1-235. In paragraph 1-216, it was shown that the minimum f_s obtainable with a crystal unit occurs when the apparent Q_e of the motional arm, $\frac{X_1}{R}$, is equal to 2; that is, unless R_r , the effective resistance in the shunt arm, is significant. Within the frequency range at which the crystal unit appears as a positive reactance, the maximum value of Q_e occurs at the antiresonant upper limit. This maximum theoretical value of Q_e has been selected as a convenient figure of merit to indicate the relative activity quality of a crystal unit, and has been assigned the symbol M . In general, the larger the value of M , the less will be the feed-back energy required to sustain a given activity. If M is less than 2, the crystal unit cannot exhibit a positive reactance, and hence cannot be used in conventional oscillator circuits. To sustain oscillations at

a desired level, an oscillator will require that the crystal exhibit some minimum value of Q_e , equal to 2 or greater, depending upon the oscillator, so that a knowledge of the M of a crystal unit is of value in determining whether or not the crystal can be used. Formulas for M are:

$$M = \left| \frac{X_{Co}}{R} \right| = \frac{X_{ms}}{R} = \frac{4\pi L \Delta f_s}{R} = \frac{2\pi f LC}{RC_o}$$

$$= \frac{Q}{r} = \frac{\sqrt{LC}}{RC_o} = 4 Q_{em} \quad 1-235 (1)$$

where Q is the series-arm Q and $r = C_o/C$. Note that M is equal to four times the maximum Q_e of the crystal unit, so that the measurement of either will indicate approximately the same performance characteristics. Actually, as M approaches 2 the value of Q_{em} as given by equation 1-234 (1) becomes unreliable, because of the approximations made in its derivation. If $M = 2$, Q_{em} is zero, although its approximate formula would indicate a value of 0.5. In practice, however, crystal units with such low values of M are normally far below specified standards, except possibly in the case of v-h-f crystal units operating on harmonics higher than the fifth, so that Q_{em} , which can be measured directly as the maximum step-up voltage ratio obtainable with the crystal unit in series with a capacitor, provides a reasonably accurate indication of $\frac{M}{4}$. M was originally chosen as a figure of merit because it can be shown to be a constant of proportionality in the equation for Q_e , and because it is expressible in terms of the crystal parameters alone. As performance parameters of a crystal unit, M and Q_{em} are practically equivalent, but M is the parameter more commonly encountered in treatises discussing crystal activity.

PERFORMANCE INDEX

1-236. The fact that the Q_e of a crystal unit is the most direct factor influencing the activity first became apparent through consideration of the requirements necessary for oscillations to build up in the generalized oscillator circuit in figure 1-108 (C). When X_e and R_e are assumed to be the reactance and resistance of an actual coil, it can be rigorously shown that oscillations build up as long as $|\omega C_x \rho| < \frac{L_e}{R_e}$. Here, C_x and ρ are both functions of the external circuit, and L_e and R_e can be assumed to be constants of the coil. As the amplitude of oscillations increases, the plate resistance of the tube increases, which in turn causes ρ to increase. (C_x may also vary, but usually to a much smaller

degree.) Multiplying both sides by ω : $|\omega C_x \rho| < \frac{\omega L_e}{R_e}$

or $\frac{\rho}{X_x} < Q_e$. From this point of view it would appear that the change in ρ/X_x which must be undergone before equilibrium is reached, or, equivalently, the rise in amplitude necessary to bring the plate resistance to the equilibrium point, will always increase or decrease with Q_e , and that with a given R_e , the amplitude increases or decreases with X_x . These implications can be misleading. First, with a given X_x , X_e is no longer a significant variable if Q_e is equal to 10 or more, but must remain equal in magnitude to X_x . In this event the only variable of the activity is R_e . Secondly, the rise in amplitude is more accurately a function of the difference between Q_e and the starting value

of $\frac{\rho}{X_x}$ rather than of the magnitude of Q_e alone. Furthermore, Q_e is, itself, a function of X_x , for as C_x is varied from a relatively large value of capacitance and made to approach zero, X_e must increase with X_x . However, Q_e does not increase indefinitely with X_e , but reaches its maximum value, Q_{em} , when $C_x = C_o$ and then steadily decreases as C_x becomes smaller. Yet the difference between Q_e and the starting value of $\frac{\rho}{X_x}$ does continue to increase even though Q_e has passed its maximum, for the change in $\frac{X_e}{R_e}$ is less than the change in the value of $|\rho \omega C_x|$. Now, C_x and even more so, $C_t (= C_o + C_x)$, can be considered reasonably constant parameters as compared with ρ during the build-up of oscillations. Referring to figure 1-108 (F), it can be seen that oscillations build up as long as $\frac{X_e}{R_e} > \frac{\rho}{X_T}$ (for the same reasons that hold in the case of $\frac{X_e}{R_e}$ and ρ/X_x). Since X_T can be assumed to be relatively constant, both sides of the function can be multiplied by X_T , so that it can be said that as long as $\left| \frac{X_e X_T}{R_e} \right| \approx Z_p > |\rho|$, the amplitude of the oscillations continues to increase. Thus, for a given starting value of ρ and with X_T relatively independent of the amplitude, the most direct index of the activity is the equivalent parallel-resonance impedance, Z_p , of the generalized oscillator circuit. For this reason, Z_p is called the Performance Index and has been given the symbol PI. PI, unlike M and Q_{em} , is not a parameter of the crystal unit alone, but of the crystal unit effectively in resonance with some specified load capacitance, C_x . Military Standard crystal units intended to be operated at parallel resonance have a recommended load capacitance

Section I

Electrical Parameters of Crystal Units

specified. PI meters have been developed for measuring the performance index directly, but there are very few such meters available. Where the PI of a crystal unit is desired, it can readily be computed from measurements made with standard CI meters. Various expressions of PI are given below:

$$\text{PI} = \frac{X_T^2}{R} = \frac{1}{\omega^2 (C_o + C_x)^2 R} = \frac{LC}{RC_T^2}$$

$$= \frac{|X_{C_o}|^2}{R \left(1 + \frac{C_x}{C_o}\right)^2} = \frac{|MX_{C_o}|^2}{\left(1 + \frac{C_x}{C_o}\right)^2} \quad 1-236 \quad (1)$$

Note that PI is not a function of the crystal alone, but of C_x as well, and care should be taken that the capacitance ratio of C_x/C_o is not mistaken for $r = C_o/C_x$. It can be seen that the maximum PI occurs at antiresonance, where $C_x = 0$, so that (max) $\text{PI} = |MX_{C_o}|^2$.

1-237. The PI of a crystal unit, or more properly, of a crystal circuit is usually found to be an important parameter entering the equations of an oscillator circuit, particularly when the equations express the conditions required for a given output. As a simple example, consider again the two generalized oscillator circuits in figure 1-109. In paragraph 1-233, it is shown that the ratio of E_p to crystal power, P_c , is equal to kQ_e/I_g for circuit

(A), and equal to $\frac{kQ_e}{(k+1)I_g}$ for circuit (B). As long as I_g is considered predetermined, the voltage-to-power ratio is primarily a function of k and Q_e . Normally, however, it is not I_g that is to be predetermined, but rather the crystal power that must not exceed the maximum value. When $Z_r \approx X_e$, the magnitude of the impedance of the feed-back arm in circuit (A) can be assumed to

be equal to kX_e , and to $\frac{kX_e}{k+1}$ in circuit (B). I_g is thus equal to E_p/kX_e in (A) and to $\frac{E_p(k+1)}{kX_e}$ in (B). On substitution in the E_p/P_c equations:

$$E_p/P_c = \frac{k^2 Q_e X_e}{E_p}$$

$$\text{or} \quad E_p^2/P_c = \frac{k^2 X_e^2}{R_e} = k^2 \text{PI} \quad \text{Circuit (A)}$$

$$\text{Similarly,} \quad \frac{E_p^2}{P_c} = \frac{k^2 \text{PI}}{(k+1)^2} \quad \text{Circuit (B)}$$

Inasmuch as the power output of the oscillator can be assumed to be directly proportional to E_p^2 , then, for a given drive level of the crystal unit, the power output will vary directly with the PI. It

should be noted that the E_p^2/P_c equations above are not affected by the assumption of shunt capacitances, C_v , across the crystal unit. Just as $\text{PI} = \frac{X_e^2}{R_e} = \frac{X_e^2}{R}$, the same value holds even if the shunt capacitance is assumed to be increased by C_v .

Frequency Stabilization Quality of Crystal Unit

1-238. The over-all frequency stability of a crystal oscillator is dependent upon the stability of all the parameters influencing the crystal circuit; these in turn are dependent upon the stability of the power source and the load, as well as the ambient conditions under which the oscillator is required to operate. The over-all stabilizing ability of the crystal is dependent upon both the stability of the crystal parameters when the crystal is exposed to changes in temperature or drive level, and the ability of the crystal to minimize the change in frequency that is necessary when the parameters of the external circuit deviate. It is this latter quality of the crystal that makes the crystal oscillator superior to oscillators that use only coils and condensers to control the frequency, and is the type of frequency stability that concerns us now.

1-239. The frequency stabilizing property of a crystal is normally expressed as the rate at which its reactance changes with frequency. In figure 1-110 are shown the curves of $\frac{dX}{df}$ for the series-arm parameters L and C . Resonance happens to occur at the frequency at which X_C is changing at the same rate as X_L . Since the rate of change of X_L is a constant, at frequencies near resonance it can be said that the total change in reactance with frequency is primarily a function of L , for the absolute rate of this change is the same whether C is large or small. Normally, however, it is not the absolute change in reactance that is important—it is, rather, the change in reactance per percentage change in frequency, or, more usually, the percentage change in reactance per percentage change in frequency. When the frequency stability is expressed in percentage, it is no longer primarily a function of L , but becomes dependent upon the other crystal parameters as well. Only where the major concern is to produce a definite shift in reactance or frequency for a given change in the external circuit does the major attention center upon the parameter L . Just as the relative activity potential of a crystal depends somewhat upon the type of circuit in which it is used, so also does the frequency stabilizing characteristic of a crystal depend upon the external-circuit de-

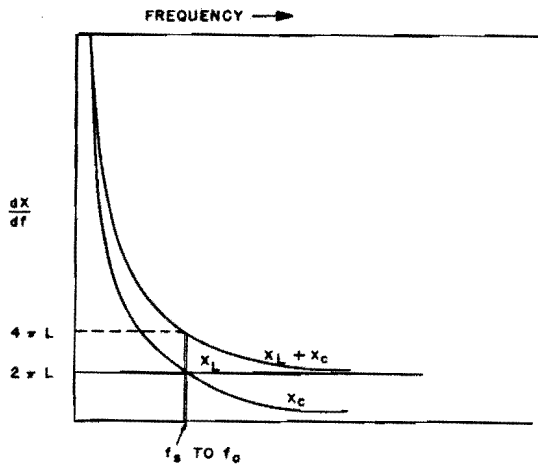

Figure 1-110. Rates of change of reactance of equivalent series-arm parameters, L and C , with frequency

sign. A relative stability index will be discussed briefly for each of three general types of circuits: where the crystal is operated at its normal series-resonant frequency, where it is operated in parallel with a negative reactance, and where it is operated in series with a negative reactance.

FREQUENCY STABILITY AT SERIES RESONANCE

1-240. Since the total series-arm reactance at f_s is equal to zero, it is not convenient to express the relative frequency stability in terms of the percentage rate of change in reactance. Approximately the same considerations apply for the resonance frequency, f_s . Also, the effective stability in a given circuit may well depend more upon the rate of total impedance change or the rate of phase shift with frequency than upon the actual rate at which the reactance changes. Suppose, for example, that the feed-back energy must pass through the crystal unit and return to the oscillator input in a certain phase. If, because of a change in the circuit parameters, the feed-back energy is returned slightly out of phase, the frequency will have to shift away from the normal resonant point exactly enough for the crystal to correct the change in phase. If the change in phase has originally been caused by a change in the reactance of, say, a capacitor connected directly in series with the crystal, it is only necessary for the frequency to shift the amount necessary for the crystal reactance to exactly counteract the change in the series reactance. In this case, the resistance of the crystal circuit is not effective in degrading the stability. It is true that the greater the resistance that the crystal faces, the greater must be the fre-

quency change to produce a given phase shift. But on the other hand, since the series capacitance faces the same resistance, the initial phase shift due to a change in the capacitance is correspondingly reduced. In this case, the frequency stability of one crystal as compared with that of another depends almost entirely upon its relative rate of change of reactance. At series resonance the frequency stability factor can be defined as

$$F_s = \frac{dX_c}{df} f = 2\omega L = 2\sqrt{L/C} \quad 1-240 (1)$$

where F_s is the rate of change of reactance per fractional change in frequency. Thus, in comparing one crystal unit with another, the one with the larger L/C ratio can be assumed to provide the greater frequency stability at series resonance. However, if the change in reactance occurs at a point in the circuit only loosely coupled to the crystal, the resistance of the feed-back circuit is relatively ineffective in reducing the phase shift of the feed-back voltage, but instead, tends to increase the change in frequency necessary for the crystal to correct the phase. In the case of a feed-back network where the crystal must compensate for a change in phase that is relatively independent of the resistance in the crystal circuit, the frequency stability is more directly measured by the rate of change of phase in the crystal circuit as a whole than by the rate of change of reactance alone.

1-241. Figure 1-111 shows that a small phase displacement, $\Delta\theta$, at series resonance is approximately equal to $\Delta X_c/R_c$, where ΔX_c is a small

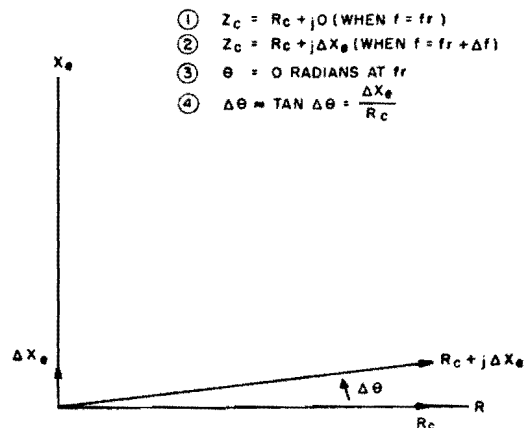

Figure 1-111. Phasor diagram, showing change in reactance, ΔX_c , of series-mode crystal required to produce a small change in phase, $\Delta\theta$, where the resistance of the crystal circuit is equal to R_c .

Section I

Electrical Parameters of Crystal Units

change in the effective reactance of the crystal, and R_c is the total effective resistance in the crystal circuit (equal to R_o of the crystal plus R_x of the external circuit). For convenience, the frequency is usually expressed in terms of angular frequency, $\omega = 2\pi f$ radians per second, instead of cycles per second. In equations (1) and (2) of figure 1-98, it can be seen that for small values of Δf , the denominators of the approximate equations of X_c and R_c are approximately equal to unity, in which case $X_c \approx 2L\Delta\omega$ and $R_c \approx R$. Thus,

$$\Delta\theta = \frac{\Delta X_c}{R_c} = \frac{2L\Delta\omega}{R + R_x}$$

The frequency-stability index can be defined to be

$$\frac{d\theta}{d\omega} = \frac{2L}{R + R_x} \quad 1-241 (1)$$

Expressed as the change in phase angle per percentage change in frequency, equation (1) becomes:

$$\frac{\omega d\theta}{d\omega} = \frac{2\omega L}{100(R + R_x)}$$

or more simply:

$$\frac{\omega d\theta}{d\omega} = \frac{2\omega L}{R_c} = \frac{2X_{L1}}{R_c} = \frac{2}{R_c} \sqrt{L/C} \quad 1-241 (2)$$

The last term on the right shows that where the fractional rate of change is concerned, the frequency stability is directly proportional, not simply to L , but to the square root of the L/C ratio. Equation (2) also shows that the frequency stability is inversely proportional to the crystal circuit resistance. But it must be remembered that this is true only to the extent that the original phase shift of the input to the crystal circuit can be considered independent of R_c .

1-242. As an exaggerated example, we can see that minimum stability is to be expected if the input to a high-resistance, series-resonant, feed-back circuit is supplied through a weak coupling from a plate tank circuit sharply tuned to the resonant frequency but having an impedance small compared with the R_p of the tube. Since a slight change in the parameters of the tank circuit could shift the phase of the feed-back input almost 90 degrees, such an oscillator would obviously be completely unstable, even if it were assumed that oscillations could be maintained.

FREQUENCY STABILITY AT PARALLEL RESONANCE

1-243. When it can be assumed that a crystal unit

is effectively operating in parallel with an external capacitance, C_x , the value of which is relatively independent of small changes in the frequency, the frequency stability can be assumed to be directly proportional to the rate of change in the reactance of the motional arm of the crystal. In this case, it would seem that a frequency-stability factor for parallel resonance

$$F_p = \frac{dX_o}{d\omega} \cdot \omega = 2\sqrt{L/C} = F_s$$

would be appropriate—just as in the case of series resonance—and F_p would be identical with F_s . However, it will be recalled (see figure 1-103) that the higher the reactance, i.e., the smaller the value of C_T , the less stable will the oscillator become. Taking this into account, a more accurate indication of the stabilizing quality of a parallel-resonant crystal is given by what is called the *frequency-stability coefficient*, which is the percentage rate of change in reactance for a percentage change in frequency. Thus,

$$F_{X_s} = \frac{dX_s}{d\omega} \cdot \frac{\omega}{X_s} \cdot \frac{100}{100} = \frac{2\omega L}{X_s} = \frac{f}{\Delta f}$$

This result is quite interesting, for it indicates that for crystal units of the same frequency equal stabilities can be achieved simply by operating the crystal units at the same value of Δf above series resonance. Since the same equation holds for any value of L and C , it is not immediately apparent as to why a crystal is so much more stable than a conventional inductor and capacitor. In paragraph 1-208 it was found that the ratio $\frac{\Delta f_s}{f}$ is equal to $\frac{C}{2C_o}$. If Δf_p is substituted for Δf_s , and C_T is substituted for C_o , then

$$F_{X_s} = \frac{f}{\Delta f_p} = \frac{2C_T}{C}$$

It can be seen that in order for a conventional series-parallel inductor-capacitor network to have the same theoretical stability as a crystal, the shunt capacitance must be thousands of times greater than the series-arm capacitance. The series arm of such a network would require an extremely small L/C ratio. The parallel impedance would be small, and the net series-arm reactance much smaller still. The crystal, on the other hand, has such a small value of C that the reactances are reasonably large even for small values of Δf . Although the equation for the frequency-stability coefficient indicates an unlimited stability if Δf_p is simply made small enough, this would be theo-

retically true only for a circuit resistance equal to zero. In practice, as X_s approaches the motional-arm R in magnitude, a given change in X_T will cause a greater change in the phase of the over-all circuit impedance than will the same change in X_s . Of significance is the fact that the frequency-stability coefficient, F_{X_s} , represents the stabilizing effect of a crystal for the percentage change in the reactance of the total effective shunt capacitance, $C_T (= C_o + C_x)$. With C_o considered constant, a given percentage change in the total capacitance becomes less than the actual percentage change in the variable component, which we can assume to be the equivalent external capacitance, C_x . For a given C_T , the larger the ratio C_o/C_x the smaller will be the percentage change in C_T for a given percentage change in C_x , and the greater will be the oscillator stability in the face of changes in the external circuit. In other words, the effective frequency-stability coefficient of the crystal unit as a whole is greater than that of the motional-arm alone if it can be assumed that the percentage changes in C_o will be negligible compared to those in C_x . When R is small compared with X_s , $X_s \approx X_{C_o}X_s/(X_{C_o} + X_s)$ and the effective frequency-stability coefficient becomes:

$$F_{X_s} = \frac{dX_s}{d\omega} \cdot \frac{\omega}{X_s} = \frac{2LX_{C_o}^2}{(X_{C_o} + X_s)^2} \cdot \frac{\omega(X_{C_o} + X_s)}{X_{C_o} X_s}$$

$$= \frac{2\omega L}{X_s} \cdot \frac{X_{C_o}}{X_{C_o} + X_s} = \frac{fC_T}{\Delta f C_x}$$

Since

$$F_{X_s} = \frac{f}{\Delta f} = \frac{2C_T}{C}$$

then

$$F_{X_s} = F_{X_s} \cdot \frac{C_T}{C_x} = \frac{2C_T^2}{CC_x} \quad 1-243 (1)$$

It should be remembered that equation (1) is based upon the assumption that C_o is constant and that any change in X_s will be due to a change in C_x . If C_o is effectively increased by a fixed capacitance, C_v , directly shunting the crystal unit, the effective variable C_x becomes smaller. The effective C_x , insofar as the frequency stability is concerned, will equal $C_T - (C_o + C_v)$. Substituting this effective value of C_x in equation (1) will provide a more accurate frequency-stability coefficient for a crystal unit directly shunted by a fixed C_v .

FREQUENCY STABILITY AT SERIES RESONANCE WITH EXTERNAL CAPACITANCE

1-244. The effective frequency-stability coefficient, $F_{X_s} = \frac{2C_T^2}{CC_x}$, provides an appropriate index of the frequency-stability quality of a crystal unit operated in series resonance with an external capacitance C_x , for the same reasons that make the coefficient applicable in the case of parallel-resonant circuits. C_T , here, represents the sum of two actual capacitances, $C_o + C_x$, and has a more concrete meaning than simply a generalized parameter. F_{X_s} gives the percentage change in X_s per percentage change in frequency. The reciprocal, $1/F_{X_s}$, can be interpreted as equaling the percentage change in frequency that will occur per percentage change in the negative reactance X_s . In unconventional circuit designs, where a significant phase shift can occur as a result of changes in the impedances in the oscillator output circuit (which is only weakly coupled to the feed-back input), the resistance of the feed-back circuit may need to be taken into account in a manner similar to that discussed in the case of crystal units operating in series resonance.

FREQUENCY STABILITY OF OVER-ALL CIRCUIT

1-245. Although the absolute values of the frequency-stability indices discussed in the foregoing paragraphs depend upon generalized parameters of the external circuit, the values are primarily useful for indicating the relative stabilization quality of one crystal unit as compared with another when operated under similar circuit conditions. The actual frequency drift due to changes in the supply voltages, tube characteristics, circuit impedances, etc., depends upon the particular oscillator design as well as upon the performance characteristics of the circuit components. The percentage variation that can be expected in the generalized parameter, C_x , is of equal importance in gauging the frequency stability of the oscillator as a whole. The crystal-unit frequency-stability coefficients appear as single parameters among others in the frequency-stability equations for each particular type of oscillator circuit. In general, the series-resonant type of oscillator has the greater frequency stability, permitting tolerances from four to twenty times as narrow as those normal for parallel-resonant oscillators. Indeed, in a well-designed series-resonant oscillator where the reactive components are negligible in their effect on the phase of the feed-back voltage, the frequency stabilization of the crystal unit can be very nearly

Section I

Electrical Parameters of Crystal Units

perfect, so that the most significant factor to consider is the stability of the equivalent-circuit parameters of the crystal unit, itself. One source of frequency instability common to both series-resonant and parallel-resonant oscillator circuits is the presence of harmonics in the output. For certain applications, such as in crystal calibrators, these harmonics are desirable, but in most cases it is preferable that they be kept to a minimum. Harmonics are unwanted not only for the sake of a sine-wave output as such, but also because they introduce reactive components in the crystal circuit, thereby increasing the chances of frequency instability. The harmonics can be reduced by designing the oscillator plate circuit to provide a low-impedance bypass path for them, and by using low plate and grid voltages. Unwanted reactive effects in the oscillator circuit also occur as a result of feedback from the amplifier stages following the oscillator. These can be minimized by the use of proper shielding, buffer amplifiers, neutralizing circuits, and by careful attention to the physical layout in designing the equipment, to ensure that all leads are as short as practicable and that the oscillator is electrically isolated from circuits carrying high amplitudes of r-f voltage or current. The effective load capacitance, C_x , with which the crystal unit resonates is usually a function of the vacuum-tube parameters, the load resistance, the effective grid resistance, as well as the reactive impedances in the feed-back and output circuits. All these variables are, in turn, functions of the oscillator output and the grid and plate d-c voltages. Thus, the frequency stability is dependent upon the degree of voltage regulation, the constancy with which the oscillator load is maintained, and in the care taken in the original design to ensure that the circuit components are so proportioned that the effects of variations in the tube parameters are minimized. Silvered mica capacitors normally are to be preferred for fixed capacitances in the tuned circuits. Those capacitors having dielectrics composed of titanium compounds can be used for r-f bypass purposes, but are too variable under changes in temperature and voltage for use as tuning components. Air-dielectric capacitors are almost always adjustable. With the exception of the vacuum-dielectric capacitor, the air-dielectric type is the most stable and is to be preferred for small capacitances and variable tuning elements. As a rule, the improvements in circuit design that permit of greater frequency stability necessitate additional circuit components, additional tuning adjustments, narrower operating frequency ranges, smaller voltage or power outputs, or some combination of the above.

Bandwidth and Selectivity Parameters of Crystal Unit

THE CAPACITANCE RATIO, $r = \frac{C_o}{C}$

1-246. The bandwidth of a crystal unit refers to the particular frequency range over which the crystal unit can be operated in a given oscillator, filter, or transducer circuit. In the case of a conventional oscillator circuit, the applicable frequency range is that in which the crystal can appear as an inductive impedance. In cycles-per-second, this range is $\Delta f_a = f_a - f_r$. Percentage-wise, the bandwidth is $\frac{100\Delta f_a}{f_r}$, which, as shown in paragraph 1-208, is approximately equal to $\frac{100}{2r} = \frac{50C}{C_o}$. Although the practicable operating range does not extend over the entire band, it can be seen that the relative merit of a crystal unit insofar as its range of frequency adjustment is concerned can be indicated inversely by the parameter r , whereas the relative selectivity is indicated directly by r . In figure 1-95, it can be seen that the smallest theoretical values of r (when the distributed capacitance is negligible, so that $r = r_o$) are obtained with the low-frequency, length-extensional-mode elements of the X group. The smallest capacitance ratios are provided by element E, which has values of r as low as 120 to 125. These are equivalent to a resonance-to-antiresonance bandwidth on the order of 0.4 per cent of the nominal frequency. For the high-frequency A and B elements, the bandwidths are approximately 0.2 and 0.083 per cent, respectively.

1-247. Insofar as frequency control is concerned, the resonance-to-antiresonance bandwidth is important primarily as a relative index of the frequency range through which a parallel-resonant oscillator can be made to operate by varying the load capacitance, C_x . For example, the tuning adjustments of an oscillator employing an A element can vary the frequency approximately two-and-a-half times as much as can the same adjustments if the oscillator employs a B element. Although small frequency adjustments are possible, the high selectivity of quartz crystals precludes their use in frequency-modulated oscillators. Eventually, it may be that crystal units mounting high-frequency EDT plates, which have capacitance ratios as low as 20, will find an application in this field, but at the present time EDT crystals are used almost exclusively in filter networks. As a filter element, the capacitance ratio of a crystal is of greater importance than in frequency-control circuits. Filter networks, composed of crystal units alone, can be designed for a

maximum pass band of $\frac{2\Delta f_s}{f_r}$, which in the case of quartz means a maximum pass band of 0.8 per cent. For the low-frequency networks, such as are normal to telephone carrier systems, this is much too selective for passing voice channels. For this reason, quartz crystals employed in 1-f telephone carrier filters must be used in conjunction with inductors and capacitors. The narrow bandwidths of quartz elements used alone are primarily applicable in filters when it is desired to pass a single frequency, such as the pilot signal of a carrier system.

ELECTROMECHANICAL COUPLING FACTOR, k

1-248. To the extent that the equivalent circuit of figure 1-91 is applicable it can be assumed that when a crystal unit is connected across the terminals of a battery the ratio of the energy stored in electrical form to the energy stored in mechanical form is equal to the capacitance ratio $r = C_o/C$. The electrical energy is that stored in the static capacitance, C_o , and is equal to $\frac{1}{2} V^2 C_o$, where V is the applied d-c voltage. The mechanical energy is the energy that is stored because of the piezoelectric strain in the crystal, and is equal to $\frac{1}{2} V^2 C$. In transducer applications, it is useful to rate a crystal according to the ratio of stored mechanical energy to total applied electrical energy under the conditions of d-c or very-low-frequency applied voltages. The parameter for this purpose is the electromechanical coupling factor, k , equal to the square root of the ratio of the stored mechanical to the total input energy. As such, k is an index of the crystal efficiency as a transducer. This factor is given by the formula

$$k = \frac{d}{\sqrt{\frac{\epsilon}{4\pi} s}} \quad 1-248 (1)$$

where ϵ is the dielectric constant, s is the elastic compliance, and d is the piezoelectric constant giving the ratio of strain to field. According to the energy ratio, k^2 should equal $\frac{C}{C_o + C}$, or approximately $\frac{1}{r}$. However, the capacitance ratio, $\frac{C_o}{C}$, at resonance can be shown to be $\frac{\pi^2}{8}$ times as large as the theoretical ratio at zero frequency. Actually, then the ratio is

$$\frac{\text{stored mechanical energy}}{\text{total stored electrical energy}} = k^2 = \frac{\pi^2}{8} \frac{C}{C_o} \quad 1-248 (2)$$

where C and C_o are the equivalent capacitances at resonance. Since the bandwidth is proportional to C/C_o , so also is it proportional to k^2 . In transducer applications, when an inductor is shunted across the crystal to tune out the electrical capacitance, and the crystal is operated near resonance, up to 90 per cent efficiency is possible in the conversion of electrical to mechanical energy. Under these conditions, k is not a direct index of the transducer efficiency, but it does serve as a parameter for estimating the frequency range over which the efficiency is 50 per cent or greater. The ratio of the highest to the lowest frequency for greater than 50 per cent conversion is:

$$\frac{f_H}{f_L} = \sqrt{\frac{1+k}{1-k}} \quad 1-248 (3)$$

Crystal Quality Factor, Q

1-249. The quality factor of a crystal unit is the Q of the motional arm at resonance. Thus,

$$Q = \frac{\omega L}{R} = \frac{1}{\omega CR} = \frac{1}{R} \sqrt{\frac{L}{C}} \quad 1-249 (1)$$

Quartz crystal units are obtained with Q 's ranging in value from 10,000 to more than 1,000,000. The Q is a performance parameter that provides an indication of the ratio of the stored mechanical energy of vibration to the energy dissipated in the crystal unit per cycle at resonance. If I_s is the r-m-s current through the series arm at resonance, then, at the instant the current is a maximum, the equivalent capacitance C can be assumed to be completely discharged and all the vibrational energy, E_v , is at that instant in kinetic form. This energy is equivalent to that stored in motional-arm inductance, L . Therefore,

$$E_v = \frac{(1.414I_s)^2 L}{2} = I_s^2 L \quad 1-249 (1)$$

The energy dissipated per second, P_c , is $I_s^2 R$. Thus, the ratio of the stored mechanical energy to the energy dissipated per second is

$$\frac{E_v}{P_c} = \frac{I_s^2 L}{I_s^2 R} = \frac{L}{R} \quad 1-249 (2)$$

It can be seen that for a given wattage, the greater the L/R ratio the greater will be the amplitude of vibration. Regardless of the wattage, for a given L the amplitude of vibration will vary approximately directly with the current. Theoretically,

Section I

Electrical Parameters of Crystal Units

since there are no Military Standards setting a minimum limit for the series-resonance resistance, a crystal unit can be so excellently mounted that it would be vibrated near its elastic limit if attention were given only to the power dissipation rather than to the current. Such a situation is not likely to arise except possibly in the case of a crystal-controlled power oscillator, where space and cost limitations require a crystal drive level far in excess of the rated level. More important from the point of view of maintaining a sinusoidal wave shape of the excitation voltage and of improving the stability of the oscillator is the ratio of the stored energy to the energy dissipated per cycle, rather than per second. In terms of angular frequency, the dissipation per radian is $I_s^2 R / \omega$, so that

$$\frac{E_v}{P_c / \omega} = \frac{I_s^2 \omega L}{I_s^2 R} = Q \quad 1-249 \quad (3)$$

In an actual series-resonant circuit, it is the Q of the entire circuit rather than of the crystal unit alone that must be considered, so that R should be replaced by the total circuit resistance. If a tuned, class-C-operated circuit is to be effective in maintaining a sinusoidal wave shape and in reducing harmonics, the energy stored in the circuit should be at least twice the amount that is dissipated over the entire cycle. That is,

$$(\text{min}) \frac{E_v}{P_c / f} = \frac{Q}{2\pi} = 2$$

This requirement is met easily in quartz-crystal circuits, but it is an important consideration in the design of plate tank circuits that are to be fed in pulses not smoothed by the action of the crystal. The crystal Q is also an important parameter in crystal filters. In general, the higher the Q the sharper the pass band.

1-250. Since the Q of a crystal is equal to $\frac{1}{R} \sqrt{\frac{L}{C}}$, and since the $\frac{L}{C}$ ratio for a given frequency can

be increased to almost any value desired by decreasing the electrode area and by orienting the crystal in a direction of weak piezoelectric effect, or by using twinned crystal blanks, it might be wondered why much larger values of Q are not in use. The reason is that the L/C ratio and the equivalent series-arm resistance of the crystal are not independent of each other. As $\sqrt{L/C}$ increases, so also does R . This can be intuitively seen if it is kept in mind that fundamentally the Q is the ratio of the energy stored to the energy dissipated

per angular cycle. Suppose that we have two crystal plates, A and B, both of approximately the same size and normal frequency, and both mounted exactly alike in that the frictional losses of one are the same as those of the other for the same energy of vibration. We shall also assume that these mechanical losses account for most of the crystal driving power. In other words, we are assuming that the two crystals have approximately the same quality factor, Q . Now, suppose that crystal A has a much smaller electrode area than does crystal B, or that for some other reason the piezoelectric effect of A is very weak compared with that of B. Under these conditions, crystal A will have a much larger equivalent L/C ratio than does crystal B. But since the Q of A equals the Q of B, it can be seen that the series-arm R of A must be greater than the series-arm R of B in the same proportion as the square roots of the respective L/C ratios. It should be understood that the Q and the L/C ratio are comparatively independent variables as far as R is concerned. Where R could not be estimated without a knowledge of Q and L/C , the latter theoretically could be approximated separately and independently by an examination of the fabrication of a crystal unit. L and C , for example, are approximately predetermined by the electrode area and the type and size of the crystal element. The Q is also to a certain degree a function of the same variables, but for given internal frictional properties, is primarily determined by the quality of the crystal finishing and mounting. Thus it is that the Q is largely determined by the frictional losses and is not subject to control by varying the L/C ratio. Indeed, as the L/C ratio increases, the piezoelectric effect can become so weak and the resistance so high that the crystal cannot be shocked into oscillation unless very high voltages are employed. Once in oscillation, a high L/C crystal unit could presumably operate satisfactorily, except that only very small currents could be withstood without the crystal shattering or arcing. There is a hypothetical case where an exceptionally large L/C ratio could be practical. Such a situation would arise if for any reason the external circuit resistance faced by a crystal could not readily be reduced below some large minimum value. In this event, the use of a crystal unit of normal Q but large L/C ratio would prevent the over-all circuit Q from being excessively degraded by the external resistance. Ordinarily the selection of a crystal unit will be made on the basis of considerations other than the L/C ratio, but where all else is equal, including the average values of Q , it might be assumed that the crystal units having the some-

what higher values of L/C are generally more suitable for those oscillators which do not require a crystal to sustain oscillations, but only to stabilize them. Such a circuit oscillating at or near the crystal frequency can build up the crystal vibrations over a large number of cycles of small amplitude, thereby obviating the need of large voltage surges or abnormally high vacuum-tube amplification.

Stability of Crystal Parameters

1-251. Regardless of how well designed a crystal oscillator may be, or how high the degree to which the crystal stabilizes fluctuations in the external circuit, the over-all performance will depend upon the stability of the crystal parameters, themselves. Changes in the crystal parameters are primarily due to aging, changes in the ambient temperature, spurious modes, and to changes in the drive level. Aging, here, is used in its broadest sense to include practically any nonreversible change in the crystal characteristic from whatever cause. The principal causes and effects of aging are discussed in paragraphs 1-172 through 1-181.

EFFECT OF TEMPERATURE UPON CRYSTAL PARAMETERS

1-252. The temperature-frequency characteristics of quartz plates are covered in the description of the various elements, and will not be repeated here except to note that a change in the frequency means a change in the LC product of the motional arm. To what extent the frequency drift may be due to a change in L and to what extent to a change in C would require very precise measurements of f_1 and f_2 , and the approximate formula in paragraph 1-225 for computing C from the measured parameters would need to be replaced by a more rigorous equation. Although of theoretical value, such small changes in L or C are not, in themselves, of practical importance in circuit design—rather it is the change in the LC product (i.e., in the frequency) which is important, and which must be kept to a minimum. Low-temperature-coefficient crystals have been developed for this purpose, but only the GT, at low frequencies, and the AT, to a lesser extent, at high frequencies provide a near-zero coefficient over a wide temperature range. The more exacting the requirements, the more expensive the crystal unit will be. Fortunately, zero coefficients can be obtained at different temperatures by slight variations in the orientation angle of the cut. By mounting the crystal in an oven thermostatically controlled near the zero-coefficient point of the crystal, the tempera-

ture effected frequency deviation can be kept very small. Indeed, an ideal oven having a zero temperature fluctuation would permit any type of quartz cut to be stable provided the drive level remained constant. Nevertheless, the use of an oven is to be avoided where possible, because of the additional cost, space, weight, and power requirements, and also because the crystal pins of the oven increase the shunt capacitance across the crystal. The additional shunt capacitance proves increasingly objectionable at the higher frequencies, and makes it necessary that either the oven dimensions be as small as possible or that the entire oscillator be mounted within the oven. Either requirement serves to reduce the stability of the oven temperature, particularly if the ambient temperature varies between wide extremes. For ovens of practical size and construction, some frequency deviation is to be expected as a result of temperature changes. If this deviation is to be kept to an absolute minimum, precise temperature-coefficient characteristics must be specified in selecting a crystal unit, or a greater precision in temperature control than is now attainable in the average crystal oven must be sought. An ingenious method of obtaining practically a zero temperature coefficient for A elements over a span of 20°C and more is being developed by the Hunt Corporation. During a luncheon conversation several years ago between E. K. Morse, S. Ryesky, and D. Neidig (the former, a Government representative, the latter two of Hunt) concerning the possibilities of improving the frequency stability of Radio Set AN/ARC-1 in its first modification, the idea originated of operating two temperature-compensating equal-frequency A elements in series. The angles of cutting could be so selected as to provide equal temperature coefficients of opposing polarities which would cancel when both crystals were operating at the same temperature. However, little was attempted in this field until recently. Experimental models show that over room-temperature ranges the frequency deviation can be quite negligible. Aging data is still insufficient, but over a period of six months a stability of about one-half part per million has been achieved, with three-fourths of the drift occurring in the first three months. Probably the most significant recent activity in the development of fabrication processes designed to stabilize the crystal parameters against changes in temperature centers around the current investigations under the direction of Dr. E. A. Gerber of the Signal Corps Engineering Laboratories. As reported by Mr. D. L. Hammond in a modest paper, *Effects of Impurities on the Resonator and Lat-*

Section I

Electrical Parameters of Crystal Units

tice Properties of Quartz, presented at the 1955 Signal Corps Frequency Control Symposium, a systematic exploration is under way to discover and catalog the effects on the parameters of quartz crystals which have been synthetically grown to include controlled percentages of impurities. Impurity elements being experimented with include aluminum, boron, calcium, germanium, lead, selenium, tin, titanium, and zirconium. This work undoubtedly has revolutionary possibilities. The discoveries already made presage the probability that temperature effects, which are now so important a problem, can in the future be largely eliminated by growing crystals, for particular cuts, with controlled impurities of proper quantities and proportions.

1-253. A crystal operated at an overtone mode will have temperature-frequency characteristics different from those exhibited by the same crystal at its fundamental vibration. For the control of very high frequencies the A element is normally preferred to the B element, because of its stronger piezoelectric effect and because of the smaller frequency deviation possible for large variations in temperature. However, an AT cut ideally oriented for operation at the fundamental mode is not usually ideally oriented for the higher modes. A research team at Philco Corporation investigating the characteristics of harmonic-mode crystals found that by far the greatest change in the temperature-frequency characteristics of A elements occurs at the first operable harmonic jump, i.e., between the fundamental and the third harmonic. (See figure 1-112.) Since the subsequent changes at the higher harmonics are relatively small, a

crystal suitably oriented for the fifth harmonic will usually be suitable for operation under the same temperature conditions at all other overtones. The sensitivity of the crystal to slight changes in the orientation angle is acute. Figure 1-113, for example, shows the degree by which the characteristic curve of an 11th-harmonic A element is rotated by successive changes in the orientation angle of only 3 minutes each. If this crystal were to be operated at room temperature, an orientation of approximately $35^{\circ}27'$ would appear to be preferred. For operation under temperature variations of -55° to $+70^{\circ}\text{C}$, an orientation of $35^{\circ}30'$ permits the minimum total frequency deviation from a room-temperature mean. Finally, if the crystal is to be mounted in an 85° crystal oven, an orientation of $35^{\circ}33'$ would be optimum.

EFFECT OF SPURIOUS MODES UPON CRYSTAL PARAMETERS

1-254. Closely allied with the problem of temperature control is the problem of avoiding spurious modes. Spurious modes are most apt to occur in the case of thickness-shear crystals. Among these elements, the AC and BC cuts provide the purest frequency spectrum, but unless crystals of these types are provided with precise temperature control their larger temperature coefficients prevent their being preferred over A and B elements. Cutting the crystal blank to the proper face dimensions is the most important factor in avoiding unwanted modes, but even when due precautions are taken, sudden apparent variations in the motional-arm parameters of individual crystal units

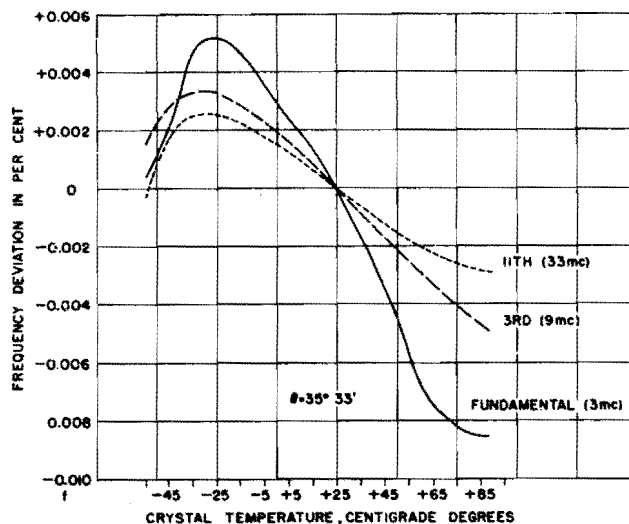

Figure 1-112. Typical variations in frequency-temperature characteristics of A element when operated at different harmonics

are not uncommon. These effects occur most often during variations in temperature, and are due to the fact that the temperature coefficients of nearby modes are quite high. The activity and frequency curves versus temperature of an erratic A element at series resonance in a tuned bridge circuit are shown in figure 1-114. The activity was measured by the grid current. No tuning adjustments were made during the temperature run. Note that the sudden jumps occur at some of the same frequencies, which, at the high-temperature portion of the curve, are apparently of a reasonably pure mode, indicating that the temperature coefficients of the desired and the unwanted modes are different. It can also be seen that the sudden dips in frequency are accompanied by abrupt changes in

activity, the latter probably being due to higher motional resistances for the unwanted modes. Unwanted modes are not always accompanied by changes in the resistance. For example, a sudden jump from one frequency to another, but without the dipping effects shown in figure 1-114, where the temperature-frequency curve is effectively broken into two smooth curves, may have very little effect on the activity. This type of frequency jump, which was quite common in the old Y-cut crystals, seems to be due primarily to small defects in the finishing of the crystal blank. Where only one such jump occurs during the temperature cycle, it can usually be eliminated by a slight re-tuning of the oscillator circuit. However, re-tuning the oscillator circuit, particularly if the crystal is

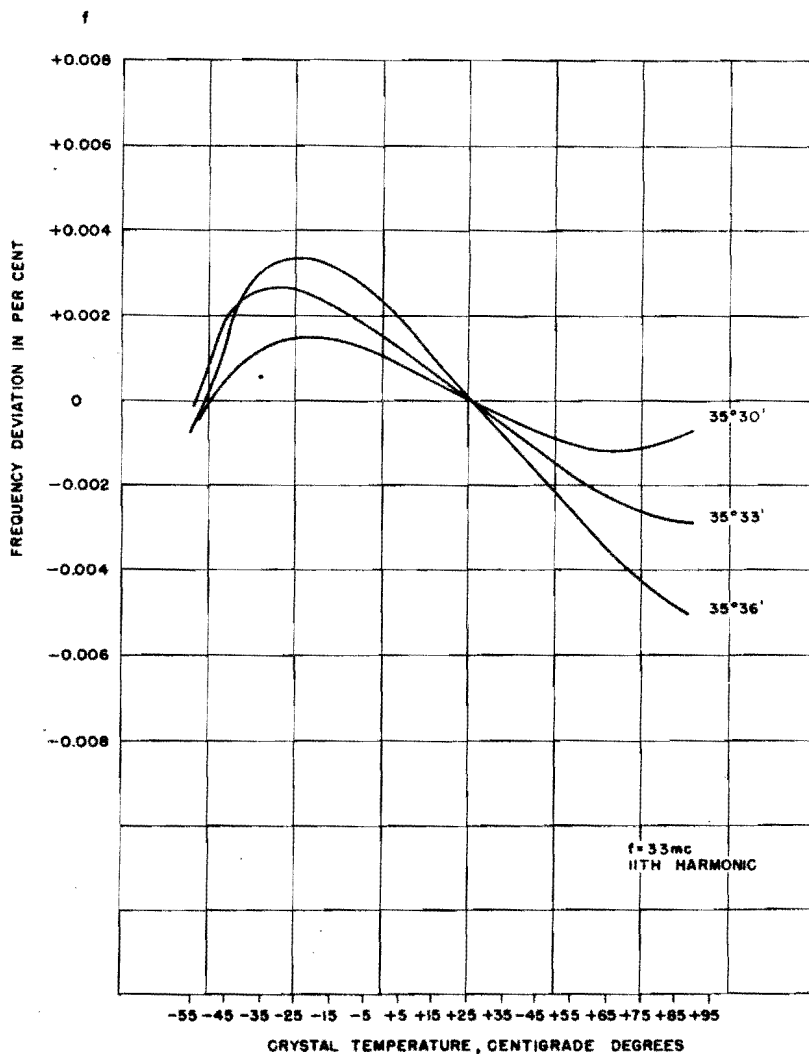

Figure 1-113. Large clockwise angle of rotation of frequency-temperature curve of harmonic-mode A element caused by small increments (3 minutes of arc) in the cutting orientation angle about the X axis

Section I

Electrical Parameters of Crystal Units

being operated near series resonance, will have little effect upon those temperature-frequency characteristics due to unwanted modes that are inherent functions of the major dimensions of the crystal blank. A crystal unit having characteristics similar to those shown in figure 1-114 should not be used where the operating temperature is expected to extend into the erratic region. Unfortunately, the specifications for most of the crystal

units listed in Section II of this handbook are not rigorous enough to provide a guarantee against unwanted modes for every type of unit, if the effects upon the frequency and the effective resistance do not cause over-all deviations beyond the maximum allowed. On the other hand, "jumpy" crystals are the exception rather than the rule, but if particular precautions are necessary where wide temperature variations are to be encountered,

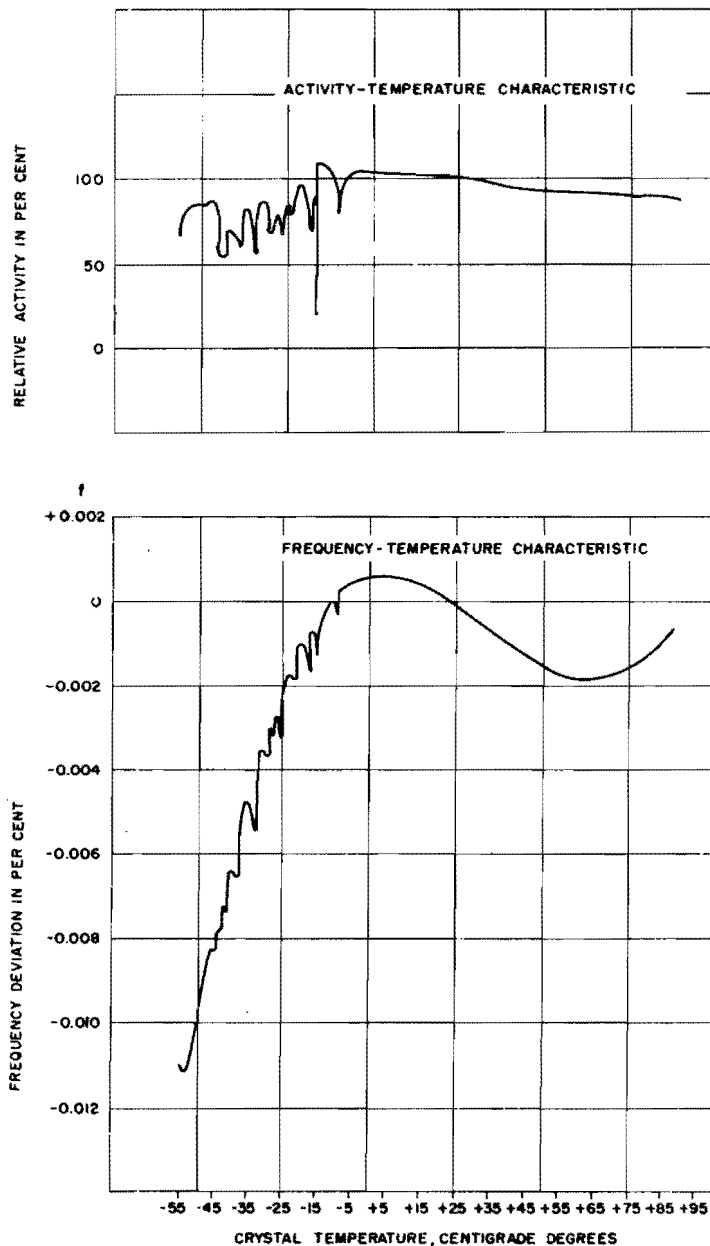

Figure 1-114. Activity-temperature and frequency-temperature characteristics of harmonic-mode A element, showing effects of unwanted modes

only those crystal units should be used which are specified by Military Standards to be free of unwanted modes over the desired temperature range.

1-255. The overtone modes of the thickness-shear elements are more likely to be troubled with spurious frequency dips of the type shown in figure 1-114 than are the fundamental modes, but a crystal that is erratic at its fundamental vibration usually exhibits a pure frequency spectrum at a high harmonic. Indeed, because the frequencies of the unwanted and the desired harmonics do not increase in the same proportion, one method of lessening the probability of interfering modes at the higher harmonics is to deliberately cut the crystal with edge dimensions which favor spurious responses at the fundamental frequency. Nevertheless, the overtone crystals have a tendency to oscillate at two or more thickness-shear frequencies. Usually, this seems to be due to slight differences in the thickness of the crystal from one point to another. For each order of the harmonic, n , the crystal can be imagined to be divided into n layers perpendicular to the thickness, with each layer being a separate crystal vibrating 180° out of phase with the neighboring layers on each side. If n is an even number, the separate sections tend to cancel each other's electrical effects at resonance. For this reason the even harmonics cannot easily be electrically excited. In the case of the odd harmonics, there is always effectively one vibrating layer whose alternating polarity is not neutralized. Most of the activity is more or less centered in one particular region of the crystal plate. If the thickness at an active point differs slightly from the thickness at a neighboring point, there will be a tendency to jump from one activity center to another, and small jumps in the frequency can result. In the case of crystal plates vibrating at high harmonic modes, a small variation in the thickness dimension is generally more likely to produce a sudden frequency jump than if the same crystal were vibrating at its fundamental mode. If there is little difference between the equilibrium conditions of two vibrating stages, the frequency may shift back and forth at an audio rate, thereby effectively modulating the oscillator output with an audio frequency. Such frequency jumps are best avoided by the use of ceramic-button holders, the design of which concentrates the excitation in a small area at the center of the crystal where the most uniform thickness is attainable. Occasionally, it is found that the small frequency jump occurs only at a particular adjustment of the oscillator, and therefore it can be avoided by slight changes in the oscillator tuning. Even so, unless

the temperature is to remain reasonably constant, a crystal unit exhibiting any tuning jump at all should not be used. For although an unwanted mode that occurs during a temperature cycle may never appear during a tuning adjustment, the reverse situation is rarely found—a frequency jump that can be caused by a tuning adjustment is almost certain to appear during a temperature cycle.

EFFECT OF DRIVE LEVEL UPON CRYSTAL PARAMETERS

1-256. There is insufficient data and standardization at the present time to analyze or to predict exactly the effect a change in the drive level will have on a crystal unit of a given type. Not only do crystal units of the same type exhibit various reactions, depending on the nominal frequency, the method of fabrication, and the manufacturer's specifications, but even when all these factors are the same for a sample of crystal units, the individual reactions to changes in drive level are unpredictable. The frequency and series-arm resistance curves versus drive level in figures 1-115 and 1-116 are shown as examples. These curves were prepared from data obtained during a Signal Corps research project at New York University by a research team consisting of Messrs. Don J. R. Stock (Director), L. Silver, E. Strongin, A. Yevlove, and A. Abajian. The curves in both figures were made from the same set of 9-mc crystal units—AT-cut, electrode-plated, wire-mounted types CR-18/U and CR-19/U, all made by the same manufacturer.

FREQUENCY VERSUS DRIVE

1-257. In figure 1-115, note that although the frequency of the average crystal unit tends to increase with drive level, this effect is by no means to be found at all drive levels for all crystal units. Unfortunately, the temperature-frequency curves for these same crystals are not available, so it is not possible to judge how much of the frequency deviation is due simply to the rise in temperature with drive level. However, the frequencies of other A elements have been tested for frequency deviation versus power, and even though the increases of temperature due to drive occur at points of negative slope on the frequency-temperature curve, the actual frequency-drive level curve generally reveals a positive slope. This increase in frequency with drive is apparently due to a relatively large temperature-gradient coefficient. The net effect on the frequency is due to the combined influences of the changes in both the temperature and the temperature gradient, which influences

Section I
Electrical Parameters of Crystal Units

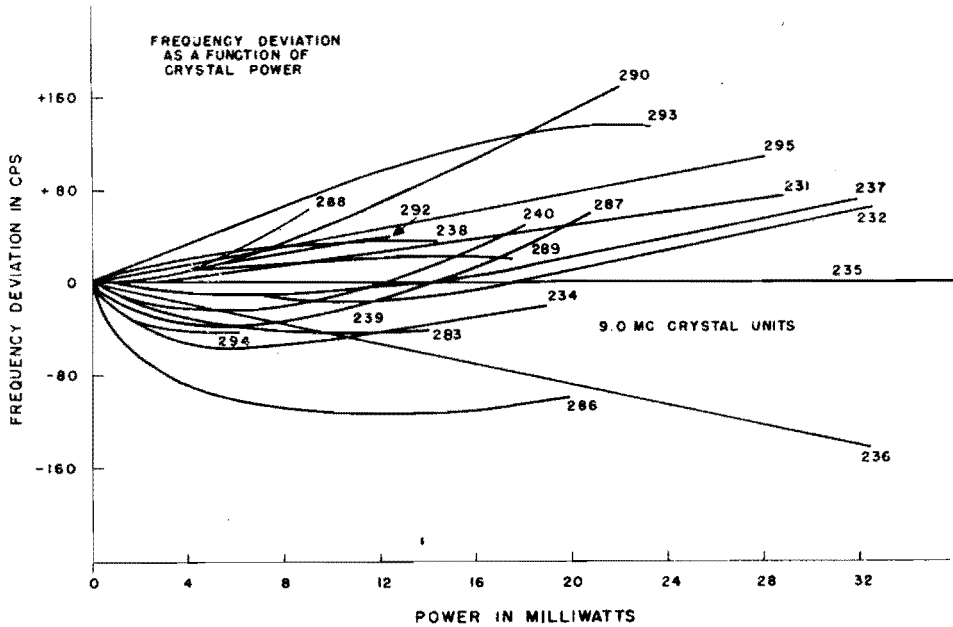

Figure 1-115. Frequency deviation versus drive for a random sample of 9-mc A elements. All crystal units are the products of the same manufacturer and are similarly fabricated and mounted in HC-6/U holders

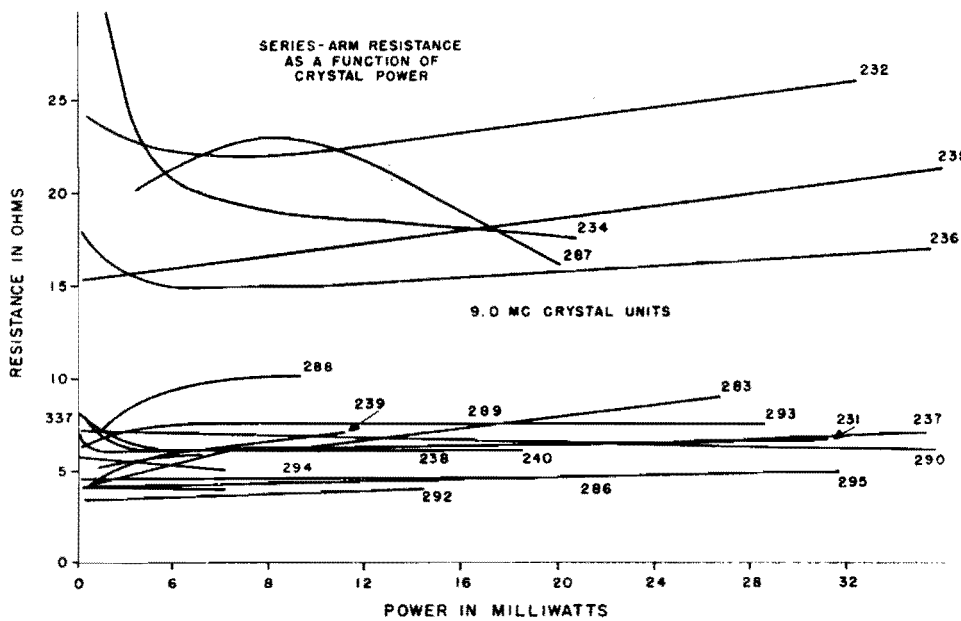

Figure 1-116. Resistance deviation versus drive for a random sample of 9-mc A elements. Curves are for the same sample of crystal units whose frequency-drive characteristics are shown in figure 1-115. Correspondingly numbered curves are those of the same crystal unit

Electrical Parameters of Crystal Units

may or may not be in opposition. From the appearance of the curves in figure 1-115, it is possible that those curves starting with a negative slope may be primarily responding according to the normal temperature coefficient. No data is available concerning the degree by which the orientation of the crystal plate relative to the mounting wires might influence the thermal-gradient effect.

1-258. The rise in temperature per milliwatt of drive varies widely with the types of mounting used and the sizes of the crystal plates. For wire-mounted units, most of the heat generated is due to friction at the points where the crystal is supported. With the heat source thus concentrated in a small region of the crystal surface, steep thermal gradients can be expected. The over-all rise in temperature is also greater in the case of wire-mounted units, since most of the thermal-leakage must be through the air, which, like all gasses, acts as a thermal insulator. If the crystal unit is vacuum-sealed, the temperature change per milliwatt may increase by a factor of from two to ten, depending upon the size of the supporting wires and how much of the crystal surface is metal-plated. With the air evacuated, the heat leakage is primarily through the supports and by radiation. The amount lost by radiation depends largely upon the emissivity of the crystal surface, which is approximately 40 times as great for unplated as for plated areas. If it can be assumed that the heat is evenly distributed over the volume of the crystal, the temperature rise of a one-centimeter-square crystal wire-mounted in an HC-6/U holder (not evacuated) can be expected to be approximately 0.3 to 0.4 centigrade degrees per milliwatt of drive. In practice, however, the temperature of the parts of the crystal where most of the heat is generated may increase as much as 10 times this amount. If high or variable drive levels are to be used, pressure-mounted crystal units should be employed. The relatively large contact area between the crystal and the supporting electrodes permits a more uniform distribution of the heat, thereby reducing the magnitudes of the thermal gradients. The pressure mounts also provide a much higher thermal conductivity away from the crystal, thus enabling a much smaller temperature rise per milliwatt of drive. Finally, the pressure mount provides better mechanical and aging protection for the crystal when operated at high-amplitude vibrations. Regardless of the type of mounting, it is never desirable from the point of view of stability or of long crystal life to use a higher crystal drive than absolutely necessary.

1-259. In tests made with GT-cut crystals, where

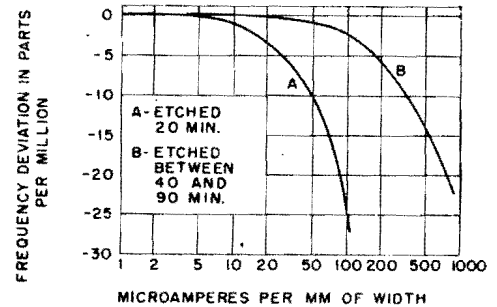

Figure 1-117. Frequency deviation versus crystal current density for two GT-cut crystals which were subjected to different periods of etching*

the frequency deviation with temperature is practically zero over a 100-degree centigrade range, the opportunity has been afforded to study the frequency deviation due to drive alone without the complication of temperature-coefficient effects. Experiments with G elements, as reported by A. R. D'Heedene, reveal a negative frequency deviation with drive, as shown in figure 1-117. Note that the GT plate given a deep etch maintained its stability during much higher drive levels than did the plate etched only 20 minutes. Since the effective resistance of the better finished crystal can be expected to be less than, and to be more stable with increasing drive than, the resistance of crystal A, the changes in frequency with changes in crystal power may have been much closer than the curves in figure 1-117 indicate if it was assumed that the resistances of the two crystals were equal. If the change in frequency is due primarily to changes in the thermal gradients, it is more directly a function of the crystal power. On the other hand, if the frequency deviation is due primarily to mechanical strains resulting from high amplitudes of vibrations, it is more directly a function of the crystal current. Although the evidence now suggests that it is the thermal gradients that are the primary factors, certainly a lowering of the frequency can be expected for any mode if the elastic limit is approached too closely. After crystal units are subjected to high amplitudes of vibration, they do not return immediately to their original frequencies when the drive is reduced to a low level. A period of days or weeks may ensue before the crystal unit regains its former characteristics, during which time the performance resembles that of a crystal rapidly aging.

1-260. Although the frequency-versus-drive characteristics of individual crystal units deviate considerably from the norm, the characteristics are generally similar enough to plot reasonably de-

Section I

Electrical Parameters of Crystal Units

pendable average curves when the fabrication processes and the frequencies are the same. Such curves showing average frequency deviation versus power are illustrated in figure 1-118. Each curve represents the average of several samples from a representative manufacturer for a given frequency. The curves with the same letter correspond to crystal units of the same manufacturer. All the crystals are A elements, metal-plated and wire-mounted in HC-6/U holders. In every case, it can be seen that the average tendency is for the frequency to increase with power.

RESISTANCE VERSUS DRIVE

1-261. The resistance curves shown in figure 1-116 are more or less typical of the wide variations that must be considered in the design of an oscillator.

A minimum performance level must be maintained regardless of the resistance of the crystal unit, as long as the resistance complies with the military specifications. Actually, the average series-arm resistance of the crystal units shown is quite low for 9-mc crystal units. As would be expected, the resistance generally increases as the amplitude of vibration increases. About one crystal unit in eight, however, exhibits a steady decrease in resistance as the drive increases. The initial resistance of such a unit is usually higher than the average. Note in figure 1-116 that a number of the curves have relatively sharp negative slopes at very low power levels. This characteristic is not uncommon, particularly in the case of harmonic-mode elements, where it has become a problem requiring special test procedures. Harmonic-mode

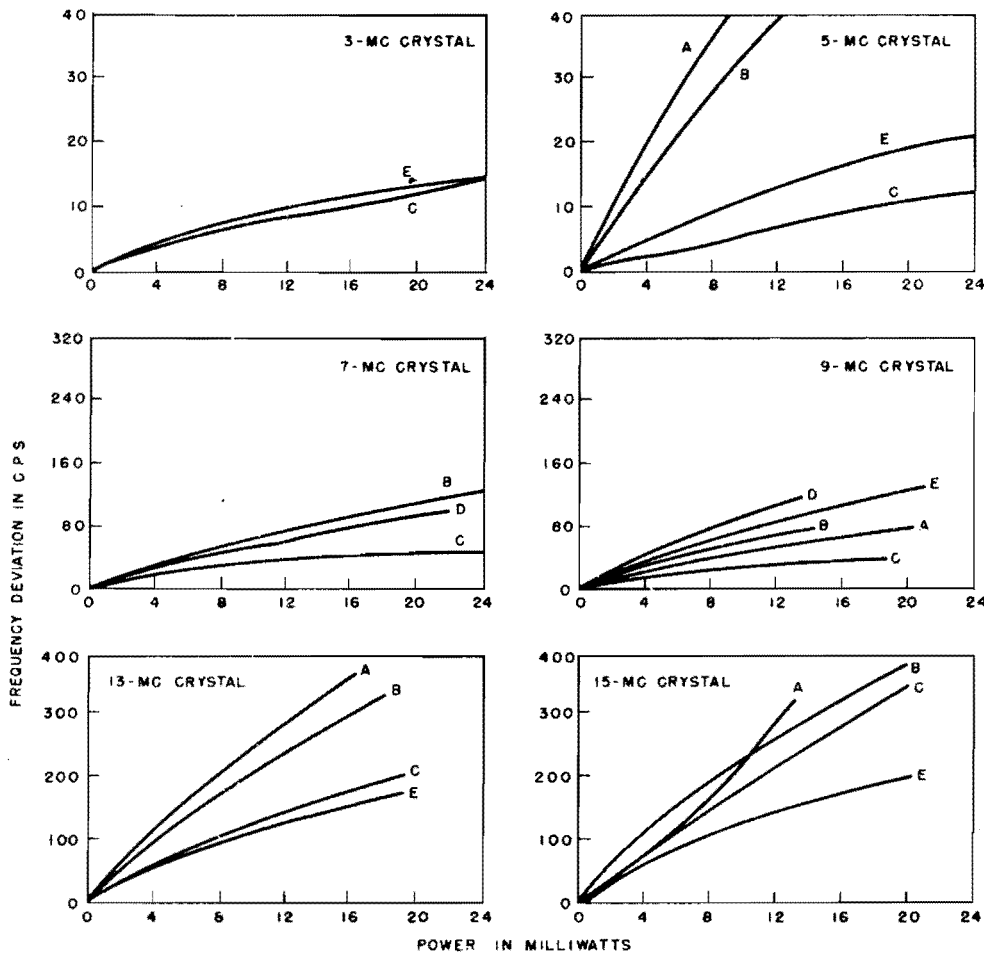

Figure 1-118. Average frequency deviation versus drive. Each curve represents the average of a random sample of several similarly constructed units of one manufacturer. Curves having the same letter represent the characteristics of crystal units of the same manufacturer

crystal units are now required to pass performance tests at two drive levels. The first is at the normal maximum recommended drive level; the second is to ensure that the resistance falls within specifications when the drive is at a minimum. In the case of fundamental thickness-shear elements, sharp negative slopes of the resistance-drive curves at low drive levels are not as common an occurrence percentage-wise as is suggested by the 9-mc samples in figure 1-116. Much more likely to be found are resistance curves with the slopes slightly

more positive at very low drive levels.

1-262. In the design of an oscillator for military equipment a principal consideration is to ensure that the crystal drive does not exceed the recommended maximum when one crystal unit of the same standard type, but of perhaps a greatly different resistance, replaces another. If the drive is not kept to the lowest practicable level, the resistance of a borderline crystal may well be increased beyond the permissible limits, thereby excessively degrading the oscillator stability.

CRYSTAL OSCILLATORS

For a comprehensive cross-index of crystal-oscillator subjects, see end of Section I.

FUNDAMENTAL PRINCIPLES OF OSCILLATORS

1-263. An oscillator can be defined as any physical system having a periodic motion. If the motion is plotted as a function of time, a wave shape or a sequence of wave shapes that fairly accurately repeats itself would be considered the fundamental cycle of a stable oscillator. On the other hand, if there were a continuous change in the wave shape, the oscillator would be classified as being unstable. An oscillator that is unstable in the general sense, may, however, have a stable component of frequency, or amplitude, or some combination thereof. Of course, all oscillating systems are unstable to some degree, so that the terms *stable* and *unstable* define classifications that are somewhat arbitrary though none the less convenient.

1-264. Oscillators may also be classified according to the way in which the oscillations are controlled. A number of classifications are possible, but of those which consider the oscillating system alone, there are three general types: free, forced, and forced-free. Free oscillators are those whose oscillating energy is entirely self-contained in the oscillating state, and whose waveform and frequency are determined entirely by the properties of the system. The solar system, purely from the point of view of the planetary motions, is an example. A quartz crystal vibrating freely in space is another. Forced oscillators are those in which the energy, wave shape, and frequency are under the control of an external power source. An example would be the cone of a loudspeaker, or a quartz filter crystal, where the vibrations are controlled by the signal source. "Forced-free" oscil-

lators can be described as those which are driven by the energy of an external source, but where the frequency is primarily determined by the properties of the system. Crystal oscillator circuits are of the forced-free type. Again, the classification is somewhat arbitrary, for in the final analysis there are no absolutely free nor absolutely forced oscillations, nor can two systems be rigorously considered as distinct when there is an exchange of energy between them. In fact, fourth and fifth categories are possible. In the one, the frequency control and drive are both inherent in the system, yet not in the same sense as that defined for free oscillators. By a stretch of the imagination, a good example is to be found in the hula dancer. In a fifth category, the energy is supplied by the oscillating system, but the frequency is controlled externally. An example is to be found by considering each limb of the hula dancer as a separate oscillating system. Still other categories are possible. Insofar as a crystal oscillator circuit is concerned, as distinct from its power source, we can consider it an independent controlling system in respect to the frequency, but only to the extent that the circuit can predetermine the periodic characteristics of both the input and the output energies.

FUNDAMENTAL REQUIREMENTS OF STABLE FORCED-FREE OSCILLATIONS

1-265. There are two fundamental conditions that are always met when a physical system is being maintained in a *stable* state of forced-free oscillation. First, the primary source of energy, or "prime mover," is supplying energy at the same average rate at which energy is being expended

Section I Crystal Oscillators

by the system. Second, all forces acting on the oscillations are, themselves, stable periodic functions which have frequencies relative to the frequency of the oscillator that can be expressed by rational numbers (e.g., $\frac{f_F}{f_o} = 1, \frac{1}{2}, \frac{8}{7}$, etc). In the practical case, this latter property cannot occur simply by coincidence between independent systems, so that the condition implies that the periods of all forces acting on the stable oscillations are controlled by the oscillator, itself. The most important of these forces are those exerted by the power source in driving the oscillator and those exerted by the output as a result of reaction with the load. The first condition for stable oscillations ensures that the average amplitude of oscillation is stable. The second condition ensures that the fundamental frequency is stable. Together, they ensure that the waveform is stable.

1-266. As a simple example of a forced-free oscillator, consider a system consisting of a swinging pendulum. If the frictional losses per cycle are small relative to the energy stored in the system, and if the amplitude is small, the oscillations are essentially those of simple harmonic motion, with the frequency being determined by the geometry of the system and the gravitational field. Assume that the pendulum, each time it reaches a certain point in its cycle, triggers a latch that releases a spurt of energy from a power source. If each kick received imparts the same amount of energy to the system, an equilibrium of stable oscillations will be reached when the input pulses are being completely transformed into a simple harmonic flow of energy to the surroundings. In order for the power source to transmit energy to the system, it must exert its force while the system is moving in the direction of the force. Otherwise, it will be the "power source," rather than the oscillator, that gains energy. If the system dissipates energy at the exact instantaneous rate at which it is received, the applied force will not, itself, produce momentary accelerations in the pendulum's swing each cycle. However, the losses from the system do not occur at simply a single interval during the cycle, but obey a sine-wave function extending over the entire period. Only at the instants of zero kinetic energy, at the end of each swing, can the instantaneous losses be considered zero. Thus, each pulse of energy must accelerate the pendulum in its direction of motion so that the waveform must deviate somewhat from a pure sine shape. The distortion is a minimum when the ratio of the total stored energy to the energy input per cycle is a

maximum, and when, *during the input interval*, the ratio of the energy dissipated to the energy absorbed is a maximum. In other words, the distortion becomes smaller the higher the "Q" of the pendulum, the longer the interval over which the impulse is spread, and the more the impulse is centered at the middle of the swing where the instantaneous power dissipation is the greatest. Now, even though the impulses distort the waveform, the oscillations are stable if exactly the same pattern is repeated periodically. If instead of swinging back and forth, the pendulum is swinging through a complete circle, it is easier to see that if several impulses are transmitted to the system each cycle, the same pattern will continue to be repeated as long as the frequency, or frequencies, of the impulses are related to the frequency of the pendulum by a ratio of whole numbers. The fundamental of the pendulum cycle need not equal the fundamental of the *stable* wave, but it must be a harmonic thereof. For example, suppose that a pulse of energy is imparted to the system only once every four cycles. Then the fundamental period of the stable waveform is four times the period of the pendulum. If five impulses are delivered for each four cycles of the system before being repeated in the same phase as before, the period of the stable waveform will again equal four pendulum cycles. Only when there are one, two, three, etc, impulses repeated each cycle does the period of the stable wave equal the natural period of the oscillator. In the same way by which the forces exerted by the energy sources distort the sine-waveform, so do the forces exerted by the load into which the pendulum loses its energy. If the impedance during any interval of the swing changes from cycle to cycle without repetition, a stable waveform is not obtainable.

APPLICATION OF FUNDAMENTAL OSCILLATOR PRINCIPLES IN THE DESIGN OF ELECTRONIC OSCILLATORS

1-267. In the application of electronic oscillators, it is not usually a stable over-all waveform that is the first requirement, but a stable fundamental frequency. Practically, however, these two effects are not independent, and the generation of the one involves the generation of the other. The deviation from a pure sine wave in the a-c output of a stable crystal oscillator will be entirely due to the presence of harmonics of the fundamental. Such fractional components as $\frac{5}{4}$ ths of the fundamental or the harmonics thereof do not appear. With the

load impedance constant, the conditions of stability are reached when energy is being supplied at the average rate of dissipation and at the same phase interval of each cycle. In the generalized crystal oscillator circuit of figure 1-108 (B), the first condition is met when ρ_n is equal to $-R_n$. The second condition is met when X_1 is equal to $-X_n$. In application, the two conditions are not independent of each other, for the build up in the energy of oscillation depends upon the power source not exerting its force in phase opposition to the oscillations. Indeed a common approach to the analysis of an oscillator circuit is to establish a single equation that expresses simultaneously the equilibrium requirements of both the rate and the phase of the energy supply. Equation 1-289 (1) for the Pierce and Miller circuits is an example. Since this type of equation, when fully developed, usually becomes quite cumbersome, such an approach is only occasionally followed in this manual, it being more convenient to treat the two basic equilibrium conditions separately. The first condition, that the rates of energy supply and of energy dissipation be equal, can be assumed to be satisfied if the magnitude of the rms voltage between any two points in the circuit is constant. This condition can be expressed by an equation which equates the *loop gain* to unity. By this we mean that, starting with the input circuit, or at any convenient point, the overall voltage gain around the oscillator loop back to the starting point is unity at equilibrium. If the loop gain is greater than unity, oscillations build up, if less than unity, they do not start, or, if already started, they die down. As an example, the loop-gain equation of a simple oscillator of the type shown in figure 1-177 (D), where the feedback energy is transformer-coupled from the plate circuit to the grid circuit, can be expressed as follows:

$$G_1 G_2 G_3 = \frac{E_p}{E_g} \cdot \frac{E_n}{E_p} \cdot \frac{E_g}{E_n} = 1 \quad 1-267 (1)$$

where G_1 is the gain of the vacuum tube, G_2 is the gain of the transformer in the plate circuit, and G_3 is the gain of the feedback from the transformer secondary to the vacuum-tube input. Although the loop-gain equation may at first glance appear trivial since the product of the voltage ratios equals unity regardless of what voltage values are assigned, it should be remembered that a necessary qualitative implication requires that each voltage ratio represent the gain of an actual transfer of energy from one circuit to another. When the voltage ratios are expressed in terms of the circuit parameters an overall network formula is established that will serve to discipline the oscillator

design. In a similar manner, the second condition of equilibrium can be expressed as an equation of the *loop phase rotation*, in which the total phase shift in the voltage around an oscillator loop is equal to zero, or to some integral multiple of 360 degrees. Continuing the example of the transformer-coupled oscillator above:

$$\theta_{pg} + \theta_{np} + \theta_{gn} = 0 \text{ (or } 360^\circ) \quad 1-267 (2)$$

where θ_{pg} is the phase of E_p , with respect to E_g , θ_{np} is the phase of E_n , with respect to E_p , and θ_{gn} is the phase of E_g , with respect to E_n . In most cases approximately ideal conditions can be assumed so that the loop phase requirements need only be analyzed qualitatively. For instance, in the example given of the simple transformer-coupled oscillator, let it be imagined that the plate circuit is to be designed so that the vacuum tube faces a purely resistive load. Thus, θ_{pg} will represent the 180-degree phase reversal introduced by the vacuum tube, θ_{np} will represent a counter 180-degree reversal by the plate transformer, so that the principal phase consideration is to design a grid circuit that will allow E_g to be in phase with E_n at the desired frequency. The loop-phase considerations are much more involved in the case of the conventional one-tube resonator circuit shown in figure 1-119. The loop phase rotation in this general type of circuit applies to such oscillators as the tuned-grid-tuned-plate, the Hartley, the Colpitts, the Pierce, and the Miller. It is discussed in detail in following paragraphs. The loop equations are the guides by which the design engineer approaches the basic oscillator problems of obtaining the desired amplitude, the desired frequency, the desired amplitude stability, and the desired frequency stability. As a general rule, these four fundamental design considerations are handled with the aid of the loop equations in the following ways:

a. An oscillator is designed to provide a certain amplitude of oscillation by ensuring that the parameters that vary with the amplitude (usually the vacuum-tube parameters) reach their limiting values, as defined by the loop-gain equation, when the desired amplitude is reached.

b. An oscillator is designed to oscillate at a given frequency by ensuring that the loop-phase equation holds at, and usually, only at, the desired frequency. Should the loop-phase equation also have a solution at some other frequency (e.g. the loop phase of the transformer-coupled oscillator mentioned above may well equal zero at more than one mode of the crystal's vibration), the design must ensure that the loop gain is less than unity at the unwanted frequency.

Section I
Crystal Oscillators

c. The amplitude stability is improved by counteracting or minimizing variations in those circuit parameters which, as indicated by the loop-gain equation, are most likely to cause changes in the amplitude.

d. The frequency stability is improved by counteracting or minimizing variations in those circuit parameters which, as indicated by the loop-phase equation, are most likely to cause changes in the frequency.

Before proceeding to a discussion of the particular types of oscillators, let us first examine in detail the phase relations of the conventional resonator circuit of figure 1-119(B). If a firm qualitative understanding of the operation of this type of circuit is had, the reader should be greatly aided in interpreting the physical meaning of equations later to be derived.

PHASE ROTATION IN VACUUM-TUBE OSCILLATORS

1-268. The conventional equivalent circuit of a vacuum-tube amplifier is shown in figure 1-119 (A). The equivalent generator voltage is equal to $-\mu E_g$, where μ is the amplification factor of the tube, and E_g is the excitation voltage on the grid. R_p is the plate resistance of the tube, and Z_L is the a-c load impedance. The minus sign of the generator voltage indicates a 180-degree phase difference between the equivalent emf and E_g . For oscillations to build up, energy must be fed back in the proper phase from the plate circuit, or from some circuit in a following stage. The control grid of the vacuum tube is effectively an escapement device for controlling the release of energy from the power source. Since this energy must be re-

leased each cycle so as not to be in phase opposition to the oscillator, the grid voltage alternations must be "timed" by the activity in the rest of the circuit. This means that a sufficient and properly phased part of the energy released by the action of the grid must be fed back from the plate circuit each cycle, or from some other circuit of a following stage, in order to continue the periodic release of energy. The initial rush of plate current is to be sufficient to shock the circuit into oscillation, and the initial alternating voltage fed back to the grid circuit must be sufficient for the vacuum tube to generate more a-c energy than is lost during the first cycle. R_p increases with the amplitude of oscillations until equilibrium is reached.

1-269. The phase relation between the grid and plate voltages of an oscillator vacuum tube at equilibrium is the same as that which would occur if the grid were excited at the same frequency from an external a-c source and the tube were connected as a conventional amplifier, operating into the same equivalent load impedance it faces as an oscillator. However, only a certain impedance relationship among the components of a particular oscillator circuit can provide a feed-back producing the proper input phase. It is this necessary impedance relationship that determines the frequency. In the usual single-tube oscillator, the equivalent vacuum-tube generator, of voltage $-\mu E_g$, must drive a plate-coupled feed-back circuit that causes the voltage appearing across the grid to be rotated 180 degrees ahead of or behind the generator emf. The simplest method of reversing the phase is by transformer coupling. On the other hand, if two tubes are used, the reversal can be accomplished by the second tube alone. Either of these methods can

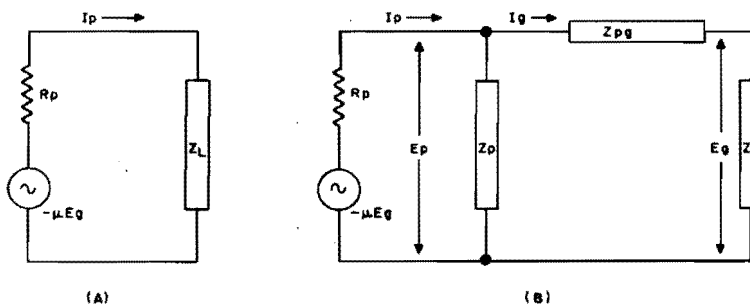

Figure 1-119. (A) Equivalent circuit of vacuum-tube amplifier. (B) Equivalent circuit of crystal oscillators of the Pierce and Miller types

enable a crystal oscillator to work into a more or less resistive load, so that fluctuations in the circuit parameters can have little effect on the feed-back phase, and, hence, upon the frequency. In the conventional parallel-resonant circuits, such as are illustrated in figure 1-109, the phase is rotated as shown in figure 1-119(C). First, assume an ideal case in which the resistive losses in the feed-back arm are zero. In this case, but only in this case, Z_L would need to be resistive. The frequency would be that at which the plate and feed-back arms operate as a parallel-resonant tank. There would be no phase shift in the voltage across Z_L , and E_p would be of the same sign as $-\mu E_g$. Z_p and Z_g , the impedances of the plate circuit from plate to cathode and of the grid circuit from grid to cathode, respectively, are reactive, and must always have the same sign. Z_{pg} , the plate-to-grid impedance is the dominant impedance in the feed-back circuit, and is always opposite in sign to Z_p and Z_g . In the ideal circuit, if Z_p and Z_g are positive, Z_{pg} is negative, so the current, I_g , leads E_p , and therefore $-\mu E_g$, by 90 degrees. If Z_p and Z_g are negative, Z_{pg} is positive, so I_g lags E_p 90 degrees. The voltage across Z_{pg} , of course, would be in phase with E_p in both instances. Since Z_g is opposite in sign to Z_{pg} , E_g thus is opposite in sign to E_p , and the required reversal takes place. Note that I_g is first rotated in phase with respect to E_p ; next E_g is rotated in the same direction with respect to I_g .

1-270. In an actual circuit, the feed-back losses cannot be zero, so that a 180-degree reversal cannot be obtained in the conventional feed-back circuit alone. This means that E_p must first be rotated by an amount exactly sufficient to make up the difference. Assume first that R_p is much greater than Z_L , so that I_p can be assumed to be essentially in phase with the equivalent generator voltage. In

this case, an inductive Z_L causes E_p to lead the emf, whereas a capacitive Z_L causes E_p to lag the emf. Unless the effective Q of the feed-back circuit is very low, Z_L must be very nearly resistive, for the shift in the phase of E_p need not be large. In any event, the rotation of E_p must be in the same direction as that of I_g and E_g . For this to occur, the susceptance of Z_p must be greater in magnitude than the susceptance of $(Z_{pg} + Z_g)$. That is, the reactive component of the current through Z_p must more than cancel the reactive component of I_g . The smaller the value of R_p compared with the value of Z_L , the more nearly will Z_L control the phase of I_p , and the more detuned must the parallel circuit become in order to obtain the necessary rotation of E_p . If practically all the resistance in the feed-back arm is between the grid and the cathode, as is normally the case when E_g is developed directly across the crystal unit, E_p must be rotated through a larger angle than otherwise, thereby requiring the parallel circuit to be detuned to a greater degree. This is because E_p must be rotated by an amount effectively equal to the sum of two angles. One of the angles is the difference between the actual phase of I_g relative to E_p and the ideal phase of ± 90 degrees. The second angle is the difference between the actual phase of Z_g and its ideal phase of ± 90 degrees. If all the resistance is contained in the large impedance Z_{pg} , only the phase deficiency of I_g is reflected in the phase of E_p . On the other hand, if all the resistance is effectively contained in the small impedance Z_g , the effect on the phase of E_p by I_g is normally small by comparison with the effect due to the grid-to-cathode resistance. Expressed in polar form:

$$E_g = I_g Z_g (\theta_{I_g} + \theta_{Z_g}) = I_g Z_g (0^\circ)$$

where θ_{I_g} and θ_{Z_g} , which must be equal in magnitude

CHARACTERISTICS OF EQUIVALENT-CIRCUIT PARAMETERS					PHASE RELATIONS 180° ← 90° 0° → 90° (VOLTAGE AND CURRENT WITH RESPECT TO E_g , IMPEDANCES WITH RESPECT TO CURRENT THROUGH THEM)							
Z_p	Z_g	Z_{pg}	$ R_p/Z_L $	$ Z_p/Z_{pg} $	$-\mu E_g$	Z_L	I_p	E_p	Z_{pg}	I_g	Z_g	E_g
			<OR> 1	≈ 1	←	→	←	←	↓	↓	↓	→
			<OR> 1	≈ 1	←	→	←	←	↓	↓	↓	→
			>> 1	≈ 0.95	←	↘	←	↘	↓	↓	↓	→
			>> 1	≈ 0.99	←	↘	←	↘	↓	↓	↓	→
			≈ 1	< 0.95	←	↘	←	↘	↓	↓	↓	→
			≈ 1	< 0.95	←	↘	←	↘	↓	↓	↓	→

(C)

Figure 1-119. (C) Chart showing ideal and typical phase relations necessary for forced-free oscillations of the circuit shown in (B)

Section I
Crystal Oscillators

but opposite in sign, are the phase angles of I_g with respect to E_g and of Z_g with respect to I_g . Now, letting $\theta_{Z_{pfc}}$ equal the phase of the total feed-back impedance, ($Z_{pg} + Z_g$), with respect to the current through it, and θ_{E_p} equal to the phase of E_p with respect to E_g ,

$$\text{we have } \theta_{E_g} = \theta_{I_g} + \theta_{Z_g} = 0$$

$$\text{and } \theta_{I_p} = \theta_{I_g} + \theta_{Z_{pfc}}$$

$$\text{so that } \theta_{E_p} = \theta_{Z_{pfc}} - \theta_{Z_g} \quad 1-270 (1)$$

Since $\theta_{Z_{pfc}}$ is opposite in sign to θ_{Z_g} , these two phase angles add numerically. If it is assumed that Z_{pfc} is approximately six times the magnitude of Z_g , but that all the feedback-arm resistance is between the grid and cathode, the Q of Z_{pfc} will be approximately five times the Q of Z_g . Under these conditions the rotation of E_p from the ideal value of -180 degrees is approximately 20 per cent greater than the deviation of $-\theta_{Z_g}$ from its ideal value of ± 90 degrees. If Z_g represents the effective impedance of a crystal unit in parallel with the grid-to-cathode capacitance and resistance, the minimum rotation of θ_{E_p} occurs when the effective Q of the crystal and its shunt impedance is a maximum, provided $Z_{pfc} \gg Z_g$. Similarly, if Z_{pg} represents the Z_e of a crystal unit whose effective resistance is much greater than the equivalent series resistance of the grid-to-cathode impedance, the rotation of θ_{E_p} depends primarily upon the crystal unit Q_e , and is a minimum when Q_e is a maximum.

1-271. In a conventional parallel-resonant crystal oscillator having an ideal feed-back arm, the frequency would be determined entirely by the resonance of the tank circuit, so that fluctuations in R_p , although effective in changing the activity, would not affect the frequency. In practice, the equivalent resistance of the crystal unit is a parameter of the feed-back arm, so that the detuning of the tank becomes very nearly a direct function of the effective Q of the crystal and its shunt capacitance. Note that the phase of E_p with respect to E_g and $-\mu E_g$ is determined entirely by the parameters of the feed-back arm. As long as oscillations continue, variations in R_p or Z_p can only change the phase of E_p indirectly, i.e., by causing a change in the Q of the feed-back arm. Since the effective resistance can vary by as much as a factor of 10 between minimum and maximum values for the same standard type of crystal unit, an oscillator cannot be designed too closely upon the assumption that the load impedance Z_L will be essentially the same either in phase or magnitude when one crystal unit

is replaced by another—even if it is of the same type and nominal frequency. This limitation might possibly be minimized by switching the crystal unit from the feed-back circuit to the plate circuit, and replacing it with a high-Q inductor in the feed-back arm. If the grid were operated with bias sufficient to prevent the flow of grid current, a very high and predictable Q could be obtained in the feed-back circuit, and an approximately resistive Z_L could be assumed for the tank regardless of the variations in Z_p due to variations from one crystal unit to the next.

1-272. An oscillator that can be represented by the equivalent circuit shown in figure 1-119 will show the following phase characteristics and related effects.

a. The phase of E_p is entirely determined by the over-all Q of the feed-back circuit and the Q of the grid-to-cathode impedance, Z_g . The phase angle, θ_{E_p} , is given by equation 1-270 (1) as being equal to $(\theta_{Z_{pfc}} - \theta_{Z_g})$. Let us now assume that $(\theta_{Z_{pfc}} - \theta_{Z_g})$ is determined by an imaginary over-all Q of the feed-back circuit. This we define to be

$$\begin{aligned} Q_f &= |\cot \theta_{E_p}| = |\cot (\theta_{Z_{pfc}} - \theta_{Z_g})| \\ &= \left| \frac{\tan \theta_{Z_{pfc}} \tan \theta_{Z_g} + 1}{\tan \theta_{Z_{pfc}} - \tan \theta_{Z_g}} \right| \\ &= \frac{Q_{pfc} Q_g - 1}{Q_{pfc} + Q_g} \approx \frac{Q_{pfc} Q_g}{Q_{pfc} + Q_g} \quad 1-272 (1) \end{aligned}$$

It can be seen that if either Q_{pfc} , the actual effective over-all Q of the feed-back circuit, or if Q_g , the Q of the grid-to-cathode impedance, is very large compared with the other, Q_f is approximately equal to the smaller Q.

b. For a given phase difference between E_p and $-\mu E_g$, the ratio of Z_p to the total feed-back impedance, Z_{pfc} , is less than 1 by an amount which increases as the ratio of R_p/Z_L decreases. In other words, the ratio of the r-f current in the plate circuit to the r-f current in the grid circuit increases as R_p decreases.

c. The value of R_p/Z_L is partly a function of the ratio $\frac{Z_{pfc}}{Z_g} = E_p/E_g$. Assume, for example, that $R_p \gg Z_L$, so that $E_p/\mu E_g \left(= \frac{Z_L}{R_p + Z_L} \right) \approx \frac{Z_L}{R_p}$. Also assume that during oscillations Z_g is decreased, but that Z_{pg} remains essentially constant. The ratio E_p/E_g is thus increased, and likewise the ratio $E_p/\mu E_g \approx \frac{Z_L}{R_p}$. In other words, as E_g becomes a smaller component of the total voltage across the

feed-back circuit, E_p , cannot decrease in the same proportion, else each succeeding cycle would be weaker than the one before; so the ratio R_p/Z_L must decrease. Part of the change is due to the increase in Z_L , and part is due to a decrease in R_p . If it is assumed that a large percentage change in Z_k causes only a small percentage change in Z_{pcc} , then Z_L remains essentially constant in magnitude and R_p becomes the principal variable. In any event, as R_p/Z_L decreases, the effective Q of Z_L , as represented by an equivalent resistance and reactance in series, must increase in order to compensate for the increased phase shift of I_p .

1-273. From the qualitative discussion in the foregoing paragraphs it can be seen that in the conventional parallel-resonant crystal oscillators the state of an oscillator in operation is primarily determined by the impedance relations in the feed-back arm. Since the impedance of a crystal unit changes very rapidly with a small change in frequency, a crystal connected in the feed-back circuit makes the oscillator less critical in design than would otherwise be the case. Where maximum stability is required, the vacuum tube will be operated as nearly class B as possible. Under class-A conditions, R_p and μ are approximately given by the d-c, plate-characteristic data of the tube. In the case of power oscillators, amplifier operation will normally be class C, although class B or even class AB may be employed in particular circuits. In these cases, the effective tube parameters cannot be known beforehand, but reasonably accurate approximations can be made and optimum operating conditions can be reached by more or less trial-and-error final adjustments. The operation of conventional oscillators is made less critical, both in starting oscillations and in maintaining a constant amplitude, by the use of gridleak rather than fixed bias. From the point of view of phase rotation, the conductance of the gridleak somewhat decreases the Q of Z_k , and thereby necessitates increased detuning of the tank. Nevertheless, in low-power oscillations the gridleak losses can normally be considered negligible in comparison with the crystal losses. It is as a limiter and stabilizer of the amplitude that the gridleak bias is most important. Any changes in the circuit that tend to change E_g automatically change the bias in such a direction that R_p and g_m of the tube are readily adjusted to new equilibrium values, so that the tendency is one of immediate opposition to the change in so far as the activity is concerned.

TYPES OF CRYSTAL OSCILLATORS

1-274. Crystal oscillators are frequently classified

as being either *crystal-controlled* or *crystal-stabilized*. A crystal-controlled oscillator is defined as an oscillator that cannot oscillate if the crystal is removed or is defective. A crystal-stabilized oscillator, on the other hand, operates as a "free-running" oscillator if the crystal is removed. When the crystal unit is properly inserted and the "free-running" frequency is made to approach the normal resonance of the crystal, the mechanical vibrations of the crystal sharply increase. At some point the piezoelectric effect will be sufficient to suddenly "capture" the oscillations and thereby synchronize them at the crystal-circuit frequency. Generally, the crystal-controlled oscillator is preferred, since it is not desirable that oscillations continue if the crystal unit suddenly or gradually becomes defective. Also, crystal-controlled oscillators are normally less critical to design and are less likely to jump suddenly from one frequency to another. The crystal-stabilized oscillator does have the possible advantage of being able to operate successfully with very-high- Q crystal units whose piezoelectric coupling, however, would be too weak for the crystal to build up oscillations from a single initial impulse. A number of oscillator circuits appear to be border-line cases, that can only arbitrarily be classified as crystal-controlled or crystal-stabilized. For example, the CI meter circuit shown in figure 1-106, if connected in the crystal position of S_1 , would fail to oscillate if the crystal terminals were open, but not if they were shorted. Most of the oscillator circuits that are discussed in the following paragraphs are classified as crystal-controlled inasmuch as the oscillations do not occur if the crystal units are disconnected.

1-275. A more practical classification from the standpoint of circuit design and of selection of a crystal unit is that of series- and parallel-resonant crystal oscillators. In general, the series-resonant type provides the greater frequency stability and can generate the higher frequencies; whereas the parallel-resonant type is the more economical to construct, can operate over a wider frequency range by the substitution of different crystal units, and can generate the greater power output. There are, nevertheless, a number of exceptions to the general rule.

PARALLEL-RESONANT CRYSTAL OSCILLATORS

1-276. The first quartz oscillators to find general usage as frequency-control devices were of the parallel-resonant type. These oscillators are used primarily with fundamental-mode crystals at fre-

Section I Crystal Oscillators

quencies below 20 mc. In the conventional circuits of this type, the crystal must operate between its resonant and antiresonant frequencies, thereby behaving as an inductor. Under these conditions the circuit does not oscillate if the crystal unit becomes defective. Unless a frequency monitor is to be available, these oscillators should be permitted a tolerance of 0.002 per cent or greater, depending primarily upon the tolerance rating of the crystal unit to be used. Under extreme operating conditions, an oscillator error of approximately twice the crystal unit tolerance should be permitted. The conventional circuits are of the Pierce and Miller types, or their modifications. Maximum stability is achieved with low crystal drive and class-A to class-B operation of the tube. Maximum power efficiency is achieved with class-C operation. Since fundamental-mode crystals become too thin and fragile for operation above 20 mc, overtone crystals are necessary at these higher frequencies. However, the shunt capacitance, C_o , and the series-arm L remain the same whether the thickness-shear crystal is operated at the fundamental or the overtone mode, whereas the series-arm C varies inversely with the square of the harmonic. Thus, the capacitance ratio, C_o/C , increases with the square of the harmonic, so that the electromechanical coupling may be too weak to initiate oscillations at normal voltages if the crystal unit is to be operated at parallel resonance. For this reason and also because C_o , as well as the tube capacitances shunting the crystal, have larger susceptances at the higher frequencies, which greatly reduce the operating range of the crystal unit, the parallel-mode circuits are unsuitable for use at the higher frequencies. If the basic circuits are modified to employ series-mode crystals, or are used in conjunction with frequency-multiplying stages, they can provide stable control of very high frequencies. The introduction of a number of multiplier stages with the attendant problems of preventing unwanted frequencies is usually less to be preferred than the direct generation of the end frequency by the use of overtone-mode crystals in series-resonant circuits. Although frequency multiplication involving more than one multiplier stage is still widely used in conjunction with parallel-resonant master oscillators, this usage is found principally in medium- to high-frequency transmitters where various multiplying combinations can provide the maximum number of channels with a minimum number of crystal units. Control by parallel-mode circuits of frequencies above 30 mc is not very common. One example is to be found in Radio Set AN/ARC-1A. In this

equipment, a fundamental frequency of 8 mc, for instance, would be doubled in the oscillator plate circuit and increased nine times more in the plate circuit of the following stage. Thus, with only two tubes, a parallel-resonant oscillator can control a frequency of 144 mc and higher. In the analysis of the particular oscillators to follow, the Pierce oscillator has been chosen as something of a reference circuit as well as a point of departure in the discussion of many design considerations to be encountered in crystal oscillators. For this reason, the reader will find the treatment of the Pierce circuit, both qualitatively and mathematically, considerably more detailed than that of the other types of circuits. Space forbids as comprehensive a treatment for the other circuits, but the design problems and methods illustrated in the particular case of the Pierce oscillator are applicable in principle to all oscillators.

The Pierce Oscillator

1-277. The Pierce oscillator is fundamentally a Colpitts oscillator in which the plate-to-grid tank inductance has been replaced by a crystal unit, as shown in figure 1-120. The design of the Pierce oscillator is simpler and less critical than that of any other crystal circuit. As long as R_i and R_g are large compared with the capacitive reactances shunting them, the Pierce circuit will oscillate with crystal units covering a wide band of frequencies. The use of load resistance, R_i , in figure 1-120 (A) aids in maintaining a reasonably flat response over a wide frequency range without the necessity of tuning adjustments other than the switching from one crystal unit to the next. Where a broad frequency range is not required, or where greater activity is necessary, an r-f choke should be used in place of R_i ; otherwise, power approximately equal to $I_b^2 R_i$ is simply wasted (I_b = average d-c plate current). But even with this economy, the Pierce oscillator cannot be used to generate as large an output as the Miller circuit. The principal reason is to be found in the fact that the impedance Z_{pg} of the equivalent circuit, which in this case is provided by the crystal unit in parallel with the plate-to-grid capacitance of the tube, must be approximately equal to, or greater than, Z_p and Z_g combined. Since the impedance of the crystal unit is fixed by its frequency and rated load capacitance, larger plate impedances are possible if the specified crystal impedance is Z_g instead of Z_{pg} . Thus, for the same crystal current, larger output voltages can be developed across the tank in the Miller than in the Pierce circuit. On the other hand, the effective feed-back phase Q_r is greater

if the crystal is not connected between the grid and cathode. This permits the tank to appear more nearly resistive to the tube, so that fluctuations in R_p have less influence upon the frequency. Thus, a Pierce oscillator is generally more frequency stable than a Miller oscillator using the same crystal unit. The typical Pierce circuit employs a triode, although screen-grid tubes are usually to be preferred, because the higher R_p and the negligible plate-to-grid capacitance serve to improve the frequency stability. The oscillator is generally used at frequencies above 200 kc and below 15,000 kc. If an overtone mode is to be excited the oscillator must be made frequency-selective, by replacing R_1 with an inductor, L_1 . The inductance of L_1 must be such that the antiresonant frequency of L_1 in parallel with C_1 is lower than the operating frequency of the crystal, in order that Z_p will appear capacitive. The use of the inductor-capacitor combination also reduces the harmonic content of the output waveform. If small L/C ratios are used, the effective plate-to-cathode capacitance will be much greater for the overtones than for the fundamental frequency, so that the former are more readily

bypassed to ground than would be the case if no coil were used. In deciding upon the type of oscillator circuit to use, those rule-of-thumb factors most favorable to the selection of a Pierce circuit are:

- a. The frequency lies between 200 and 15,000 kc.
- b. The permitted frequency error is not less than 0.02 per cent, or 0.015 per cent if a regulated voltage supply is available.
- c. The oscillator is to be capable of untuned operation over a wide frequency range, simply by switching from one crystal unit to another.
- d. Only a small voltage output is required.
- e. The oscillator must be of inexpensive design.
- f. The oscillator must not be critical in operation, but able to oscillate readily with relatively large deviations in the parameters of the external circuit.
- g. Wave shape is not critical.
- h. Same as above, except that the permitted frequency error is 0.01 per cent and thermostatic control of the crystal temperature is feasible.
- i. Same as above, except that the permitted frequency error is 0.005 per cent, thermostatic control of the temperature is feasible, a regulated voltage supply is available, and the oscillator can be designed to operate at one frequency only.

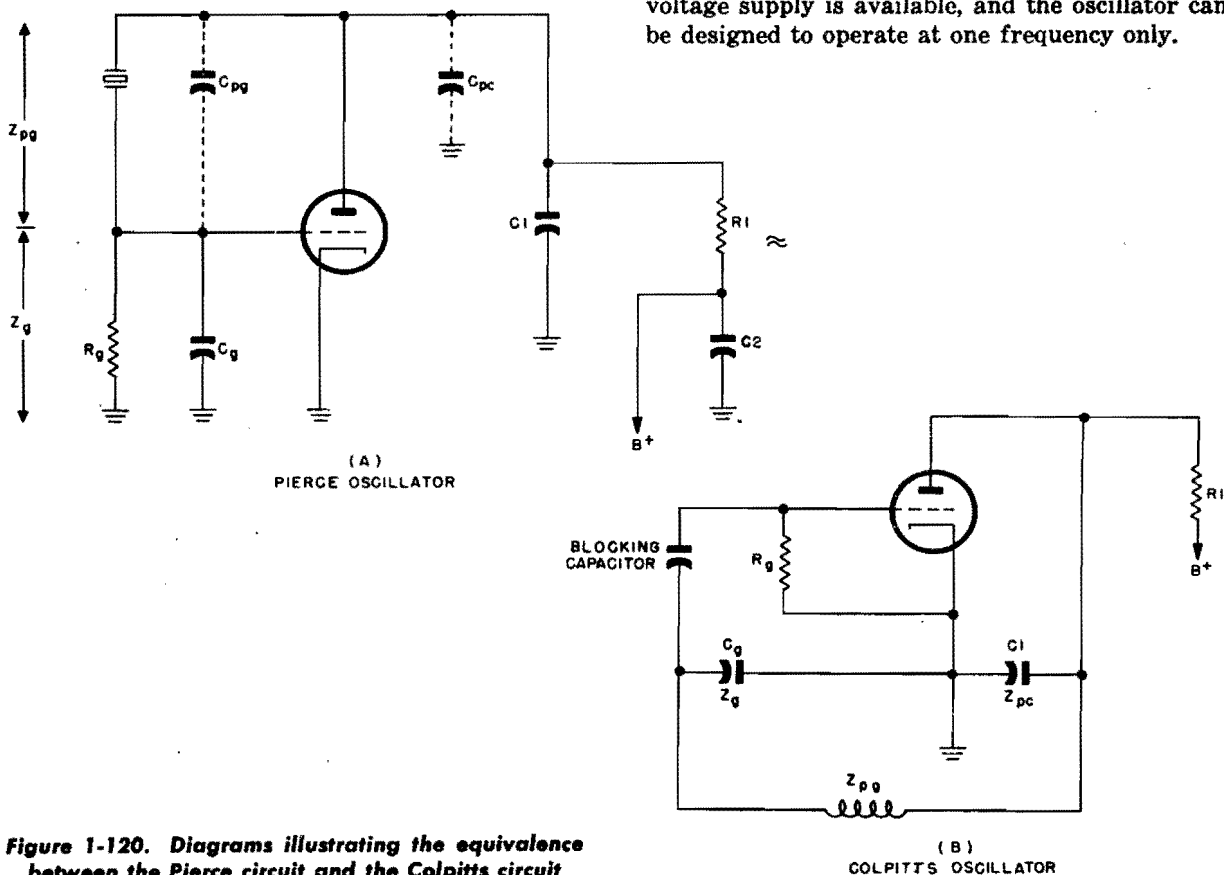

Figure 1-120. Diagrams illustrating the equivalence between the Pierce circuit and the Colpitts circuit

Section I
Crystal Oscillators

**ANALYSIS OF LOAD CAPACITANCE, C_x ,
IN PIERCE CIRCUIT**

1-278. Once that it has been decided to employ a Pierce type oscillator, the standard type of crystal unit is chosen which provides the desired frequency and frequency tolerance and which has been tested according to the Military Standards for parallel-resonance operation. One of the first design considerations is to ensure that the crystal unit will effectively operate into its rated load capacitance, C_x . Such operation is necessary, else there can be no assurance that one crystal unit of the same type can replace another and still fall within the drive-level and effective-resistance specifications. For most parallel-resonance crystal units the value of C_x is $32\mu\mu\text{f}$, although at frequencies under 500 kc, values of $20\mu\mu\text{f}$ are common. In particular instances, still other values of C_x are designated. To a first approximation, referring to figure 1-121 (A), the crystal unit operates into a load capacitance equal to C_{pg} plus the total of C_g in series with the parallel combination of C_1 , C_{pc} , and the effective inductive impedance presented by the vacuum tube. Since the Q of the feed-back arm is not infinite, E_p , it will be recalled, must be rotated slightly away from $-\mu E_g$; the direction is such that for a particular frequency $C_{pc} + C_1$ must be slightly larger than would otherwise be the case.

Even though the actual equivalent tank circuit is slightly detuned, mathematically the crystal unit is to be in resonance with an effective load capacitance C_x . (See figure 1-108 (D).) The vacuum tube appears to the tank circuit as a negative resistance having a positive reactive component sufficient to cancel the excess susceptance of Z_p . At equilibrium, the tube can be represented by an equivalent inductance, L_T , in parallel with a negative resistance, ρ_T , as in figure 1-121 (A). Note that ρ_T is smaller than ρ of figures 1-121 (C) and (D). This is because ρ_T is not connected directly across the crystal, but faces an impedance, approximately Z_L , that is less than the crystal PI. In figure 1-121 (B), L_T has been replaced by an equivalent negative capacitance, C_n . If C_{pg} can be considered negligible, X_e' and R_e' are equal to X_e and R_e , the equivalent parameters of the crystal unit alone; otherwise, the values of X_e' and R_e' are based upon the assumption that the shunt capacitance, C_o , of the crystal has been increased by an amount equal to C_{pg} . In figure 1-121 (C), C_p ($= C_{pc} + C_1$) and C_n are shown combined into a single plate-to-cathode capacitance, C_p' . In figure 1-121 (D), C_p' and C_g are represented by a single load capacitance, C_x . If C_{pg} is negligible, C_x' becomes the equivalent load capacitance, C_x , into which the crystal unit operates, and it should be

$$C_p = C_{pc} + C_1 \quad C_x' = \frac{C_p' C_g}{C_p' + C_g}$$

$$C_n = \frac{1}{\omega^2 L_T} \quad \rho_T = \left(\frac{X_e' + X_{C_g}}{X_e'} \right)^2 \rho$$

$$C_p' = C_p + C_n \quad -\rho = \frac{(X_e')^2}{R_e'} = \frac{X_e^2}{R_e} = PI$$

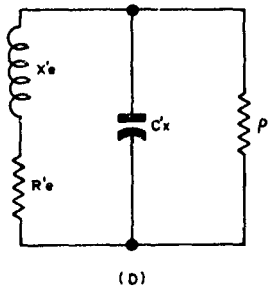
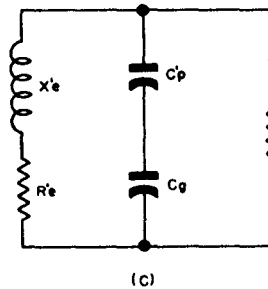
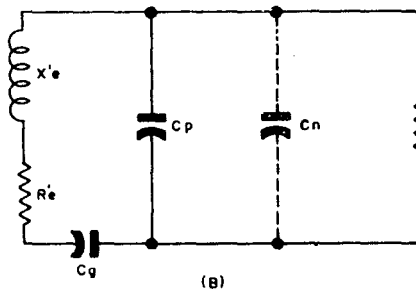
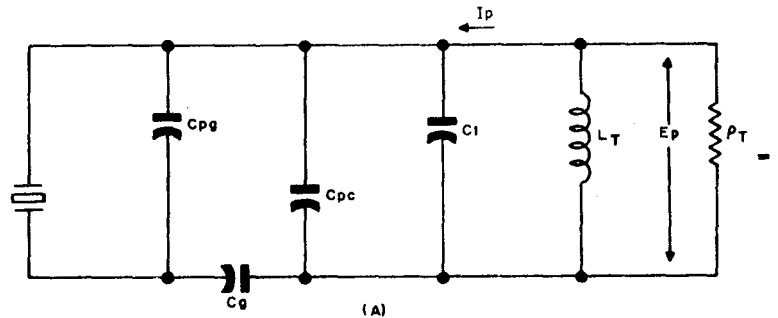

Figure 1-121. Generalized Pierce oscillator. X_e' and R_e' are the effective impedance parameters of the crystal unit based upon the assumption that C_{pg} is a part of C_o . C_x is an equivalent negative capacitance having a positive reactance equal to that of L_T . I_p is the r - f plate current of the vacuum tube.

equal to the value specified for the particular crystal. In any event $(C_x' + C_{pg})$ is the load capacitance that the crystal unit faces, and which should be equal to the rated value, C_x . The value of C_x' includes not only the tuning capacitance in the plate circuit, but also the distributed capacitance of the output leads as well as the effective input capacitance of the next tube. C_g is the input capacitance of the oscillator tube. The losses due to R_g , the effective grid-to-cathode resistance, and to R_L , the effective load resistance, have been assumed to be negligible compared with those in the crystal unit. These assumptions can be made without appreciable error in a low-power Pierce circuit that requires only a minimum of loading. From an inspection of figure 1-121 it can be seen that in order for a crystal unit to operate into its rated load capacitance, the design must be such that

$$C_x = C_{pg} + C_x' = C_{pg} + \frac{C_p' C_g}{C_p' + C_g} \quad 1-278 \quad (1)$$

Effect of C_{pg} in Pierce Circuit

1-279. C_{pg} effectively increases both the reactance, X_c , and the resistance, R_c , of the crystal unit. This does not mean that the true effective X_c and R_c are changed, for these are fixed by the fact that X_c must resonate with the rated load capacitance, C_x . Still, insofar as the impedance from plate-to-grid is concerned, X_c and R_c effectively have increased values which make it appear that the crystal shunt capacitance is increased by an amount equal to C_{pg} . This effect is not desirable, since R_c is effectively increased by a greater percentage than X_c . (See equations (1) and (2) in figure 1-98 for the effect on X_c and R_c if X_c is held constant but X_{Co} is decreased.) Thus, the larger the value of C_{pg} , the smaller the Q of the feed-back arm becomes the more the tank circuit must be detuned, the greater must be the value of the negative capacitance, C_n , and hence the greater the frequency instability due to changes in the tube parameters. The plate-to-grid capacitance needs to be considered only if a triode is used or if the crystal unit is oven-mounted. In the average triode C_{pg} is on the order of 1.5 to 2.5 $\mu\mu\text{f}$, sufficient to increase the effective value of C_x by as much as 50 per cent in some cases. When the second grid of a tube is used as the oscillator anode, as in the case of pentagrid converters, C_{pg} is usually on the order of 1 $\mu\mu\text{f}$. The pin-to-pin capacitance introduced by ovens may be as high as 5 $\mu\mu\text{f}$. The C_{pg} of screen-grid

tubes can all but be neglected, since the increase in capacitance across the crystal is only about one-thousandth of the total. Because of its negligible C_{pg} , a pentode is preferred when the frequency deviation must be kept to a minimum. In the remaining discussion of the Pierce circuit, we shall assume that C_{pg} is negligible, so that X_c' and R_c' will represent the actual effective impedances of the crystal unit, and C_x' will equal the rated capacitance, C_x . Although we shall employ the unprimed symbols X_c and R_c to designate the plate-to-grid impedances, it should be remembered that this is only a convenience, for where X_c is predetermined by the rated load capacitance and the frequency, X_c' necessarily increases or decreases, respectively, with increases and decreases in C_{pg} . Similarly, C_x' varies negatively with C_{pg} , but we shall assume that it is a constant equal to C_x .

Determination of the Effective Negative Capacitance, C_n , Introduced by Vacuum Tube in Pierce Circuit

1-280. First, in order to avoid possible confusion, it should be pointed out that the selected reference or zero phase angle of the equivalent circuit in figure 1-119 is not the same as that implicitly assumed in the negative-resistance circuit of figure 1-121 (A). In figure 1-119, the reference phase has been taken as the phase of E_g , whereas in figure 1-121 (A) it is the phase of the current through the negative resistance ρ_T (not I_p), which in turn is the same as the phase of the r-f plate voltage, E_p . Now, I_p in the negative-resistance circuit, is physically the same as the I_p of the vacuum-tube generator circuit. The equivalent current through ρ_T represents that component of I_p in phase with E_p —not that part of I_p in phase with $-\mu E_g$. The current through the negative resistance is thus smaller in magnitude than the total r-f plate current. The imaginary current through L_T , or C_n , is equal and opposite to that component of I_p which is 90 degrees out of phase with E_p . In the phasor chart in figure 1-119 (C), the bottom line shows the phase relations that are approached in a Pierce circuit if R_p of the tube approaches Z_L in magnitude. Note particularly that E_p and I_p rotate in opposite directions. E_p must lag I_p by an angle whose tangent is at least as great as $\frac{R_c}{X_c + X_{Cg}}$; that is, the tangent of the angle cannot be less than the reciprocal of the Q_T of the feed-back arm. The minimum angle occurs when R_p is very much greater than the load impedance Z_L and the gridleak losses are negligible. On the other hand, the phase difference between E_p

Section I
Crystal Oscillators

and I_p cannot be greater than 90 degrees, for the simple reason that E_p is a counter emf produced by I_p flowing through an equivalent impedance, Z_L , which has no component of negative resistance. There is another limitation in that the rotation of I_p with respect to $-\mu E_g$ cannot exceed 90 degrees minus the necessary rotation of E_p with respect to $-\mu E_g$. Otherwise, the necessary rotation of E_p cannot occur. As this extreme is approached, Z_L approaches a pure reactance approximately equal to X_{Cp} , I_p approaches a 90-degree phase lead over E_p , and the apparent Q of the entire plate circuit

(approximately Z_L/R_p) approaches the Q_t of the feed-back circuit. These maximum and minimum phase angles are summarized in the following table. The phase angles are defined by the absolute values of their tangent expressed in terms of the phase Q of the feed-back arm, Q_t . Also shown are the limiting Q 's of Z_L and $(Z_L + R_p)$; which respectively determine the phases of I_p with respect to E_p and $-\mu E_g$. In the last column are shown the limiting values of C_n which are discussed in the following paragraph.

	With Respect to:		Q of:		C_n (Approx)
	E_p	$-\mu E_g$	Z_L	$R_p + Z_L$	
Angle of E_p at all times	0°	$\tan^{-1}(1/Q_t)$			$-C_p \left(\frac{1}{Q_t^2} + \frac{R_p}{R_p + R_g} \right)$
Minimum angle of I_p	$\tan^{-1}(1/Q_t)$	0°	$1/Q_t$	0	$-C_p/Q_t^2$
Maximum angle of I_p	90°	$\tan^{-1}(Q_t)$	∞	Q_t	$-\frac{C_p R_g}{R_p + R_g}$

1-281. The approximate expressions given in the table above for the limiting values of C_n are derived upon the assumption that the unsigned phase angle between I_p and E_p is given by the equation

$$\tan^{-1} \left(\frac{X_{ZL}}{R_{ZL}} \right) = \tan^{-1} \left(\frac{1}{Q_t} \right) + \tan^{-1} \left(\frac{X_{ZL}}{R_p + R_{ZL}} \right) \quad 1-281 (1)$$

where X_{ZL} and R_{ZL} are the *absolute* values of the equivalent series reactance and resistance whose vector sum is equal to Z_L ; $\tan^{-1} \left(\frac{1}{Q_t} \right)$ is the unsigned phase difference between E_p and $-\mu E_g$, and $\tan^{-1} \left(\frac{X_{ZL}}{R_p + R_{ZL}} \right)$ is the unsigned phase difference in the opposite direction between I_p and $-\mu E_g$. From equation (1) it follows that

$$\frac{X_{ZL}}{R_{ZL}} = \tan \left[\tan^{-1} \left(\frac{1}{Q_t} \right) + \tan^{-1} \left(\frac{X_{ZL}}{R_p + R_{ZL}} \right) \right] \quad 1-281 (2)$$

On applying the general trigonometric equation for the tangent of the sum of two angles

$$\tan (x + y) = \frac{\tan x + \tan y}{1 - \tan x \tan y}$$

Letting $\tan x = 1/Q_t$ and $\tan y = \frac{X_{ZL}}{R_p + R_{ZL}}$, equation (2) becomes

$$\begin{aligned} \frac{X_{ZL}}{R_{ZL}} &= \frac{\frac{1}{Q_t} + \frac{X_{ZL}}{R_p + R_{ZL}}}{1 - \frac{X_{ZL}}{Q_t (R_p + R_{ZL})}} \\ &= \frac{R_p + R_{ZL} + Q_t X_{ZL}}{Q_t R_p + Q_t R_{ZL} - X_{ZL}} \quad 1-281 (3) \end{aligned}$$

On rearranging, equation (3) can be expressed as an equation for R_p :

$$R_p = \frac{R_{ZL}^2 + X_{ZL}^2}{Q_t X_{ZL} - R_{ZL}} = \frac{Z_L^2}{Q_t X_{ZL} - R_{ZL}} \quad 1-281 (4)$$

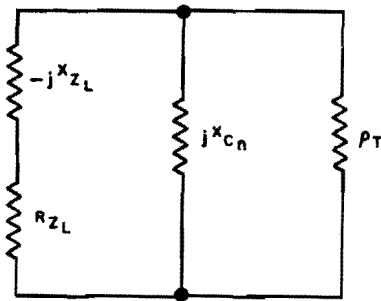

Figure 1-122. Generalized Pierce oscillator. X_{Z_L} and X_{C_n} represent the positive magnitudes of the equivalent reactances of the load and the dynamic effects of the tube, respectively. ρ_T is the same as the ρ_T in Figure 1-121

Note that for oscillations to be maintained, $Q_t X_{Z_L}$ must be greater than R_{Z_L} , else R_p becomes negative. Referring to Figure 1-122, the effective admittance of the Z_L and X_{C_n} branches in parallel is equal to $\frac{1}{R_{Z_L} - jX_{Z_L}} + \frac{1}{jX_{C_n}}$. From this expression it can be shown by straightforward manipulation that if the reactive component of the admittance is to be zero

$$X_{C_n} X_{Z_L} = R_{Z_L}^2 + X_{Z_L}^2 = Z_L^2 \quad 1-281 (5)$$

On substitution of equation (5) in equation (4) and rearranging

$$X_{C_n} = R_p \left(Q_t - \frac{R_{Z_L}}{X_{Z_L}} \right) \quad 1-281 (6)$$

The values of C_n as listed at the end of paragraph 1-280 are obtained from equation (6) by substituting the values of Q_t and R_{Z_L}/X_{Z_L} when these are expressed in terms of the basic circuit parameters. In paragraph 1-289, it is shown that at equilibrium:

$$X_{C_p} + X_{C_g} + X_e + \frac{R_e X_{C_p}}{R_p} = 0 \quad 1-289 (3)$$

The term, $\frac{R_e X_{C_p}}{R_p}$, accounts for that part of the

negative capacitance which is necessary to compensate for the phase shift in I_p , but not for that part which compensates for the phase shift of E_p . For example, if R_p were infinite, the phase shift of I_p , would be zero, and likewise the term, $\frac{R_e X_{C_p}}{R_p}$,

in equation 1-289 (3). Nevertheless, E_p must still be rotated by an angle equal to $\tan^{-1}\left(\frac{1}{Q_t}\right)$, so that the tank cannot actually be parallel-resonant. Some value must be assigned to the negative capacitance, for the apparent resonance to hold in the generalized negative-resistance circuit. Now,

$$Z_L = \frac{Z_p Z_{pgc}}{Z_p + Z_{pgc}}$$

Letting

$$Z_p = jX_{C_p}$$

and

$$\begin{aligned} Z_{pgc} &= R_e + j(X_e + X_{C_g}) \\ &= R_e - j\left(X_{C_p} + \frac{R_e X_{C_p}}{R_p}\right) \end{aligned}$$

we can express Z_L as a complex function equal to $R_{Z_L} - jX_{Z_L}$, where X_{Z_L} is still assumed to be unsigned. Thus,

$$\text{(complex) } Z_L = \frac{jX_{C_p} \left[R_e - jX_{C_p} \left(\frac{R_p + R_e}{R_p} \right) \right]}{R_e - \frac{jX_{C_p} R_e}{R_p}}$$

On multiplying both numerator and denominator by $\left(R_e + \frac{jX_{C_p} R_e}{R_p} \right)$, we find that

$$R_{Z_L} = \frac{X_{C_p}^2}{R_e \left(1 + \frac{X_{C_p}^2}{R_p^2} \right)} = \frac{X_{C_p}^2}{R_e} \quad 1-281 (7)$$

and

$$\begin{aligned} X_{Z_L} &= \frac{|X_{C_p}| \left[R_e + \frac{X_{C_p}^2}{R_p^2} (R_p + R_e) \right]}{R_e \left(1 + \frac{X_{C_p}^2}{R_p^2} \right)} \\ &= \frac{|X_{C_p}| (R_e R_p + X_{C_p}^2)}{R_e R_p} \quad 1-281 (8) \end{aligned}$$

So

$$\begin{aligned} \frac{R_{Z_L}}{X_{Z_L}} &= \frac{|X_{C_p}| R_p^2}{R_e R_p^2 + X_{C_p}^2 (R_p + R_e)} \\ &= \frac{|X_{C_p}| R_p}{R_e R_p + X_{C_p}^2} \quad 1-281 (9) \end{aligned}$$

Also, when assuming that the grid losses are negligible,

$$Q_t = \frac{X_e + X_{C_g}}{R_e} = \frac{|X_{C_p}| (R_p + R_e)}{R_e R_p} \quad 1-281 (10)$$

Section I
Crystal Oscillators

The expression on the right in equation (10) is obtained by substitution from equation 1-289(3). On substituting equations (9) and (10) in equation (6), we have

$$X_{C_n} = |X_{C_p}| \left[\frac{R_p + R_o}{R_e} - \frac{R_p^2}{R_o R_p + X_{C_p}^2 (1 + R_o/R_p)} \right]$$

$$X_{C_n} = |X_{C_p}| \left[\frac{R_p X_{C_p}^2 (1 + R_o/R_p) + R_o^2 R_p + R_o X_{C_p}^2 (1 + R_o/R_p)}{R_o^2 R_p + R_o X_{C_p}^2 (1 + R_o/R_p)} \right]$$

1-281 (11)

Equation (11) is obtained by using the exact values of R_{z_L}/X_{z_L} and Q_t as given by equations (9) and (10). Although the equation for X_{C_n} involves the difference between two nearly equal terms, the error introduced by using the approximate values of Q_t and R_{z_L}/X_{z_L} is negligible for all practical purposes as long as $R_p \gg R_o$.

Now,

$$C_n = - \frac{1}{\omega X_{C_n}}$$

so, on substitution of equation (11),

$$C_n = - C_p \left[\frac{R_o^2 R_p + R_o X_{C_p}^2 (1 + R_o/R_p)}{R_p X_{C_p}^2 (1 + R_o/R_p) + R_o^2 R_p + R_o X_{C_p}^2 (1 + R_o/R_p)} \right]$$

1-281 (12)

In the practical case, R_p is much greater than R_o and $X_{C_p}^2$ is much greater than R_o^2 , so that the approximate equation for C_n becomes

$$C_n = - C_p \left[\frac{R_o^2 R_p + R_o X_{C_p}^2}{R_p (X_{C_p}^2 + R_o^2)} \right]$$

$$= - C_p \left(\frac{1}{Q_t^2} + \frac{R_o}{R_p + R_o} \right)$$

1-281 (13)

The last term on the right inside the parentheses is obtained by assuming that $\frac{X_{C_p}^2}{X_{C_p}^2 + R_o^2}$ is more nearly equal to $\frac{R_p}{R_p + R_o}$ than to 1. We make this assumption arbitrarily for the convenience in remembering the limiting values of C_n . That part of C_n which is necessary so as to compensate for the phase shift of E_p with respect to $-\mu E_g$ is approximately equal to $-C_p/Q_t^2$; whereas the part necessary to compensate for the phase shift of I_p

with respect to $-\mu E_g$ is approximately equal to $\frac{-C_p R_o}{R_p + R_o}$. It is this latter component that is accounted for by the term, $\frac{X_{C_p} R_o}{R_p}$, in equation 1-289 (3). By equation (12), when R_p/Z_L approaches infinity, the limiting value of C_n is found to be

$$C_n = \frac{-C_p R_o^2}{X_{C_p}^2 + R_o^2} \approx \frac{-C_p}{Q_t^2} \quad 1-281 (14)$$

($R_p/Z_L \rightarrow \infty$)

When R_p/Z_L approaches its smallest possible value, the ratio R_{z_L}/X_{z_L} becomes negligible compared with Q_t , so that X_{C_n} by equation (6) is approximately equal to $Q_t R_p$. Substituting equation

(10) for Q_t , we have, when $\left(\frac{X_{z_L}}{R_p + Z_L} \rightarrow Q_t \right)$

$$C_n = \frac{-1}{\omega X_{C_n}} = \frac{-1}{\omega Q_t R_p}$$

$$= - \frac{R_o}{\omega |X_{C_p}| (R_p + R_o)}$$

$$= \frac{-C_p R_o}{R_p + R_o} \quad 1-281 (15)$$

As indicated in figure 1-121, the total effective plate capacitance is

$$C_p' = C_p + C_n = C_p \left(1 - \frac{1}{Q_t^2} - \frac{R_o}{R_p + R_o} \right)$$

1-281 (16)

When $R_p \gg Z_L$, the Q of Z_L approaches $1/Q_t$ in value and

$$C_p' \approx C_p \left(1 - \frac{1}{Q_t^2} \right) \quad 1-281 (17)$$

When R_p is small compared with $X_{C_p}^2/R_o$, then R_{z_L}/X_{z_L} becomes small compared with Q_t and

$$C_p' = \frac{C_p R_p}{R_p + R_o} \quad 1-281 (18)$$

R_p is normally much greater than R_o . Only low-frequency crystals have effective resistances which approach in value the plate resistances of low-power vacuum tubes. For all practical purposes in the average Pierce circuit, C_p' can be assumed to equal C_p , the static plate capacitance, except when considering problems of frequency stability. What is important to note in the limiting equations for C_n is the fact that if the tank is to

be operated well off resonance, R_p becomes quite an important factor in determining the frequency. In this case, because C_n is relatively large, any variation in the tube R_p has a great effect upon the frequency. It should be remembered that the parameter Q_t has been used to account for the required rotation of E_p with respect to $-\mu E_g$. Insofar as the gridleak is effective in increasing the necessary phase shift, $Q_t = \frac{X_e + X_{Cg}}{R_e}$ cannot be assumed, and the complete equation 1-272 (1) must be used.

THE EFFECT OF R_p UPON THE FREQUENCY OF PIERCE CIRCUIT

1-282. It can be seen that for large values of the R_p/Z_L ratio, C_n is small and its percentage variation with changes in R_p is smaller still. C_n is, effectively, a frequency-determining parameter, but more exactly it is a mathematical function that indirectly expresses the effect of R_p and Q_t upon the frequency. The smaller the Q_t and R_p , the larger is C_n ; and the larger C_n , the greater is the effect of R_p . Since R_p is subject to change with changes in the tube voltages, tube aging, and the like, it is important to keep C_n as small as possible. This can be done by designing the circuit to operate with as high of value of tube R_p as is practicable. For a given tube, the higher values of an effective R_p are to be obtained when the tube is conducting during only a small fraction of a cycle. This in turn requires that the oscillator tube be operated class C, so that a larger grid bias than otherwise is required. However, if the crystal drive level is to be kept low and if the gridleak is to have a negligible effect on the effective Q_t , and hence upon C_n , the gridleak resistance must be as large as practicable without running the risk that the tube will block or operate intermittently. The limiting value of R_p occurs when $-\mu E_g$ is just sufficient to maintain oscillations. If the vacuum tube could operate into a pure resistance, I_p would be in phase with $-\mu E_g$, and R_p would be eliminated as a frequency-determining element. In the conventional Pierce circuit this could occur only if Q_t were infinite.

Phase-Stabilized Pierce Circuit

1-283. If an inductor is inserted in the plate circuit of the oscillator, as indicated in figure 1-123, having a reactance equal and opposite to the effective reactance X_{ZL} , then I_p undergoes no phase rotation, and changes in R_p , although affecting the activity, will have little effect upon the frequency. With I_p in phase with $-\mu E_g$, the Q of Z_L must equal $1/Q_t$, and the operation of the tank is the same as it would be if R_p were infinite. If Q_t is reasonably large and is approximately equal to $|X_{Cp}/R_e|$,

$$R_{ZL} = Z_L = X_{Cp}^2/R_e \approx |X_{Cp}/Q_t|$$

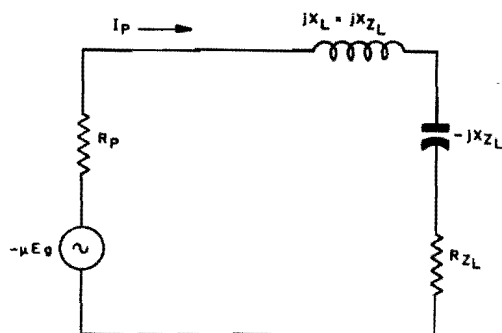

Figure 1-123. Coil inserted in plate circuit of Pierce oscillator to prevent phase of I_p from being influenced by changes in R_p .

Since

$$X_{ZL}/R_{ZL} = 1/Q_t$$

X_{ZL} is approximately equal in magnitude to X_{Cp} . Thus, for the vacuum tube to look into a resistive load, the inductor should have a reactance approximately equal in magnitude to X_{Cp} . This value assumes that the gridleak and output losses are negligible. When such assumptions cannot be made, the value of the series plate reactance becomes a more involved function. Llewellyn analyzed this type of circuit and eliminated R_p from the frequency-determining equation (phase rotation equation) by equating the sum of the factors of R_p to zero. Although the approach is different and the grid losses are assumed to be predominant, Llewellyn's mathematical elimination of the effects of R_p upon the frequency by the introduction of a plate inductor in series with the tank appears to be equivalent to the qualitative condition that I_p must be held in phase with $-\mu E_g$. The experimenter, nevertheless, should be warned that the theory of this type of stabilization has been analyzed above, and also by Llewellyn, only in terms of the phase relations. Difficulty will probably be experienced in obtaining stable oscillations without additional modifications to ensure that the limiting characteristics are changed from a voltage- to a current-controlled nature. This feature of oscillator theory has not been fully explored, but see paragraphs 1-585 to 1-598 for a general discussion, and paragraph 1-323 for a particular example of an attempt, which was not entirely successful, to phase-stabilize a Pierce circuit.

Conditions for Maximum R_p in Pierce Circuit

1-284. Referring to figures 1-119 (A) and (B), we shall begin with the assumption that the tank is operating near resonance so that $Z_L \approx \frac{Z_0^2}{R_e}$, where R_e (not shown) is the effective resistance of the crystal unit whose total impedance is represented by Z_{pe} . Z_L , therefore, is very nearly resistive, and I_p is approximately equal in magnitude to the current through Z_p .

$$\text{Thus, } I_p \approx E_p/Z_p$$

Section I
Crystal Oscillators

$$\text{also, } E_g = I_g Z_g = \frac{E_p Z_g}{Z_p}$$

$$\text{Rearranging, } E_p/E_g = \frac{Z_p}{Z_g} = C_g/C_p$$

In the interest of maximum stability it is desirable for R_p to be a maximum. The problem is to find what capacitance ratio, C_g/C_p , permits the largest possible value of R_p consistent with the rated drive level and load capacitance of the crystal unit. The phase-rotation equations do not enter the problem—only those equations that concern the magnitude of the equilibrium voltages and currents are of concern now. The crystal specifications indirectly set an upper limit for the tank current, I_g . Thus, the output voltage, $E_p \approx I_g Z_p$, also has an upper limit, since $Z_p (= Z_{pg} - Z_g)$ has a theoretical maxi-

mum equal to $\mu Z_{pg} = \frac{\mu Z_{pg}}{\mu + 1} \approx \frac{\mu X_c}{\mu + 1}$, which is ap-

proached as R_p approaches zero. At the other ideal extreme, Z_p and Z_L approach zero and the R_p/Z_L ratio becomes very large. Now, a large R_p/Z_L is desired, but some compromise must be made, since the Q of the feed-back circuit becomes increasingly small as Z_g approaches Z_{pg} in magnitude. A rigorous treatment of the problem to find that relation between R_p/Z_L and Q_f that provides an optimum frequency stability would require that a complete equation of frequency stability be established and that those impedance relations be determined that produce a minimum frequency deviation for small changes in the circuit parameters. Equation (2) in paragraph 1-288, which is a first order expression for the fractional change in frequency for a change in R_p , indicates that the percentage deviation increases directly with the first power of C_p , and inversely with the second power of R_p . This suggests that the stability increases as long as C_p/R_p^2 decreases with an increase in C_p , and is a maximum at the value of C_p , if existent, at which this ratio begins to increase. Such an approach will not be attempted here. Unless all the characteristic curves of a vacuum tube are available, so that either μ , R_p , or g_m can be used as an independent variable to eliminate the other two from the equations, concrete conclusions cannot be reached concerning the optimum design of an oscillator using that particular tube. A more qualitative analysis is presented below, and although the indicated optimum relations cannot be considered conclusive, they can serve as first approximations. All impedance, current, and voltage symbols given below are considered positive and undirected.

$$\text{Now, } E_p = I_p Z_L$$

$$\text{And } I_p = \frac{\mu E_g}{R_p + Z_L} = \frac{\mu E_p Z_g}{Z_p(R_p + Z_L)}$$

$$\text{So } E_p = \frac{\mu E_p Z_g Z_L}{Z_p(R_p + Z_L)}$$

$$\text{or } \mu Z_g Z_L - R_p Z_p = Z_p Z_L$$

On substituting $(R_p g_m)$ for μ , where g_m is the transconductance of the tube,

$$R_p g_m Z_g Z_L - R_p Z_p = Z_p Z_L$$

$$\text{or } R_p = \frac{Z_p Z_L}{g_m Z_g Z_L - Z_p} \quad 1-284 (1)$$

Dividing both sides by Z_L , we have

$$\frac{R_p}{Z_L} = \frac{Z_p}{g_m Z_g Z_L - Z_p} = \frac{1}{\frac{g_m Z_g Z_L}{Z_p} - 1}$$

Our present concern is to seek the largest practical value of R_p/Z_L , so that the phase of I_p will be least affected by small changes in R_p . Now, $Z_g \approx Z_{pg} - Z_p$, where Z_{pg} represents the predetermined crystal impedance, which is approximately equal to X_c . Also, $Z_L \approx Z_p^2/R_c$. On substitution of these values in the equation for R_p/Z_L , it is found that

$$\frac{R_p}{Z_L} = \frac{R_c}{g_m Z_p Z_g - R_c} = \frac{R_c}{g_m (Z_{pg} Z_p - Z_p^2) - R_c} \quad 1-284 (2)$$

It can be seen from equation (2) that for oscillations to be maintained $g_m (Z_{pg} Z_p - Z_p^2)$ must be greater than R_c . A maximum R_p/Z_L ratio is approached as the product $g_m (Z_{pg} Z_p - Z_p^2)$ approaches the value of R_c . Of course, it is impossible for the denominator in equation (2) to be actually equal to zero, for then R_p would be infinite; but it is plausible to assume that a denominator much smaller than the value of R_c can be realized. Thus, we can write

$$\text{(optimum) } g_m \approx \frac{R_c}{Z_{pg} Z_p - Z_p^2} = \frac{R_c}{Z_p Z_g} \quad 1-284 (3)$$

The more nearly this equality is approached, the greater will be the frequency stability. The question arises, is it preferable to seek this equality with a small or a large value of g_m ? Assuming that

$(R_p/Z_L) \gg 1$, the equation, $I_p = \frac{\mu E_g}{R_p + Z_L}$, can be written approximately $I_p = \mu E_g/R_p = g_m E_g$, or $g_m = I_p/E_g$. A large g_m means a large r-f plate current for a given excitation voltage. This would be desirable from the point of view of maximum output, but an examination of the denominator in equation (3) shows that a large transconductance means that the plate impedance, Z_p , or the grid impedance, Z_g , must be made small if the equation is to hold. A small Z_g (large Z_p) means a large Z_L and also a large E_p/E_g ratio. Both consequences are incompatible with a large R_p/Z_L ratio. The former is obviously so, and the latter is implicitly so because the ratio of E_p/E_g times $\frac{R_p + Z_L}{Z_L}$ ($= \frac{\mu E_g}{E_p}$) must equal μ . Every increase in E_p/E_g therefore requires an approximately proportional decrease in the R_p/Z_L ratio, insofar as μ can be assumed to remain constant. On the other hand, a large Z_g and small Z_p permits a large R_p/Z_L ratio and has the additional advantage of permitting a given excitation voltage with a minimum crystal current. It is under these conditions that equation (3) will be most nearly exact. There are serious disadvantages, however, when operating at a maximum R_p/Z_L ratio; the most important of which is that the Q of the feed-back circuit rapidly decreases as Z_g is increased, since $Q_r \approx \frac{Z_{pk} - Z_g}{R_o}$. Also, the voltage output is weak, and has a tendency to instability. This will be discussed more fully later. Since the excitation voltage is stronger for a given crystal current, the grid losses increase proportionately and may no longer be negligible. Furthermore, unless the tube is operated class C, the power efficiency is very low. These last mentioned disadvantages, nevertheless, are minor compared with the effect on Q_r . The minimum effective Q of the average crystal unit when operating into its rated load capacitance is not unduly large. A grid-to-cathode reactance equal in magnitude to three-fourths X_o reduces Q_r to one-fourth Q_o . Since the purpose of a large R_p/Z_L ratio is to permit the entire plate-circuit impedance ($R_p + Z_L$) to appear as nearly resistive as possible, the better stability risk is to operate the parallel-resonant oscillator with small rather than large I_p and g_m . Since we are assuming that $g_m \approx I_p/E_g$, it can be seen that the smaller the value of g_m , the smaller is the r-f plate current for a given excitation voltage, or, for a given plate current, the smaller the value of g_m , the greater the excitation voltage. The problem becomes one of determining what capacitance ratio, C_g/C_p , permits the smallest possible

g_m . By equation (3), g_m is a minimum when the denominator of the right-hand term is a maximum. Since the impedance of the crystal unit, Z_{pk} , is to be held constant, ($Z_p + Z_g$) is also a constant. Thus, the product $Z_p Z_g$ can easily be shown to be a maximum when

$$Z_p = Z_g = Z_{pk}/2 \quad 1-284 (4)$$

A maximum operating R_p and a minimum I_p with a given excitation voltage can thus be obtained when the capacitance and voltage ratios are

$$E_p/E_g = C_g/C_p = 1$$

It is quite fortunate that g_m has a minimum value. At all other operating values a small change in the $\frac{C_g}{C_p}$ ratio causes g_m and R_p , and hence the frequency, to change. At the minimum g_m the rate of change in the tube parameters is necessarily zero, so that the stability in this respect is a maximum. When the more exact equation 1-289 (2) is used instead of equation (1) above, and when μ/R_p is substituted for g_m , it can be shown that

$$R_p = \frac{X_{Cp} X_o + X_{Cp} X_{Cg} + \mu X_{Cp} X_{Cg}}{R_o} \quad 1-284 (5)$$

Note that R_p , as long as μ is constant, is inversely proportional to R_o . Now, approximately

$$X_{Cp} = - (X_o + X_{Cg})$$

Substituting in equation (5), R_p becomes a function of X_o , R_o , μ , and X_{Cg} . Assuming that the first three parameters are constant, it can be shown that R_p is a maximum when

$$X_{Cg} = - \frac{X_o (\mu + 2)}{2 (\mu + 1)} = - \frac{X_o}{2} \left(1 + \frac{1}{\mu + 1} \right) \quad 1-284 (6)$$

If $(\mu + 1) \gg 1$, equation (6) states approximately the same conditions as does equation (4). If μ is small, equation (6) should be accepted as the more accurate in computing the optimum C_g/C_p ratio, since a minimum g_m coincides with a maximum R_p if the d-c plate voltage is kept constant. The capacitance ratio and values corresponding to equation (6) are

$$C_g/C_p = \frac{\mu}{\mu + 2} \quad 1-284 (7)$$

Section I
Crystal Oscillators

or

$$C_g = \frac{2C_x (\mu + 1)}{(\mu + 2)} \quad 1-284 (8)$$

and

$$C_p = \frac{2C_x (\mu + 1)}{\mu} \quad 1-284 (9)$$

Under these conditions the excitation voltage becomes greater than the voltage across the plate load by a factor of $\frac{\mu + 2}{\mu}$, and the following additional relations hold:

$$(\max) R_p = (\mu + 1) Z_L \quad 1-284 (10)$$

$$(\min) g_m = \frac{1}{Z_L} - \frac{1}{R_p} \quad 1-284 (11)$$

As a practical consideration in design as well as for the sake of simplicity in discussion it is convenient to assume that the optimum C_g/C_p ratio is equal to one rather than $\frac{\mu}{\mu + 2}$. However, in interpreting the equations above, a word of caution is necessary. Returning to equation (2), it will be seen that the maximum to be sought for R_p/Z_L is a "practical," not a "mathematical" maximum in the sense that a curve of R_p/Z_L rises to a peak and then decreases. The curve of equation (2) plotted against Z_p passes from positive to negative infinity as the denominator passes through zero and thus is discontinuous at that point. However, for any given value of g_m sufficiently large for R_p/Z_L to be positive, the curve does have a true minimum, not a maximum, at the point where $Z_p Z_g$ is a maximum. To avoid confusion as a result of this apparent contradiction, it is important to recall that the "practical" maximum is to be sought by making equation (3) as nearly true as possible, and not by the process of making $Z_p = Z_g$. This latter consideration is in the interest of over-all stability and maximum activity (if measured by the d-c grid current) for a given d-c plate voltage and load capacitance. Another point that should be well understood is that the minimum g_m , minimum μ , and maximum R_p , are all coincidental. From the point of view of frequency stability the real interest is in the maximum R_p . From equation (10) it can be seen that the magnitude of the maximum R_p will increase with μ ; but remember that this value of μ is the minimum obtainable with a given tube and E_p . As will be discussed more thoroughly in paragraphs 1-294 and 1-295, an oscillator vacuum tube cannot be operated so that μ is the maxi-

imum possible without the risk of amplitude instability. Thus, class-A operation where the tube is operated only along the straight portion of the $E_c I_b$ curve is not feasible in gridleak oscillators. Understand that if equation (7) holds, equations (10) and (11) automatically hold. μ in each equation is the effective μ when equilibrium is reached and is not the starting μ . It is the minimum μ that can be obtained as long as the crystal resistance, R_e , and the total load capacitance, C_x , remain constant. Because R_p , g_m , and μ all pass through extremes at the optimum capacitance ratio, it might be thought that the operating conditions are more ideally unique than they actually are, because the instantaneous rate of change for all the tube parameters with the capacitance ratio is zero under these conditions. Remember, however, that these maximum and minimum values apply only in the event that the total C_x remains constant. An independent variation in C_g or C_p will cause the frequency to change, and the tube parameters will vary. For instance, g_m will tend to vary directly with both C_g or C_p . Only when C_g and C_p are adjusted simultaneously so as always to maintain the same total load capacitance will the instantaneous changes in the tube parameters be zero as the capacitance ratio is varied through its optimum value.

1-285. If equation 1-284 (3) is expressed as a function of Z_{pr} , by substituting from equation 1-284 (4), the minimum value of g_m becomes, approximately,

$$(\min) g_m = \frac{4 R_e}{Z_{pr}^2} \quad 1-285 (1)$$

Since Z_{pr} is the crystal impedance, approximately equal to X_e , the minimum value of g_m can be expressed as

$$(\min) g_m = \frac{4}{PI} \quad 1-285 (2)$$

where PI is the performance index. Using a one-to-one capacitance ratio and a vacuum tube of high R_p , equilibrium will be reached at the value of g_m defined in equation (2). Such operation generally provides the maximum frequency stability in a Pierce oscillator. In estimating the value of PI, X_e is numerically equal to the reactance of the rated load capacitance, and R_e must be assumed to be the maximum permissible effective resistance according to the military specifications of the crystal unit being used.

CAPACITANCE RATIO, C_g/C_p , FOR GREATER OUTPUT IN PIERCE CIRCUIT

1-286. Where a maximum output consistent with the minimum frequency-stability requirements is desired in a Pierce oscillator, the C_g/C_p ratio can be increased and a vacuum tube providing a large transconductance and a large amplification factor should be used. The first consideration is that I_g must not exceed a value that would cause the power dissipation in the crystal unit to exceed the specified drive level. If the output of the oscillator is capacitively coupled to the grid of a buffer amplifier, the output power becomes a minor consideration compared with the output voltage. If this voltage is to be a maximum for a given tank current, the plate impedance Z_p must be a maximum. This means that the capacitance ratio, C_g/C_p , must be as large as practicable. The larger this ratio, however, the smaller will be the excitation voltage for a given I_g . The smaller the excitation voltage, the smaller will be the gridleak bias, and consequently R_p will be less whereas g_m and μ will be greater. An examination of equation 1-284 (3) reveals that the required magnitude of g_m becomes very large as Z_p approaches the value of Z_{pg} of the crystal unit. Where a relatively large frequency deviation can be tolerated a large R_p may not be necessary, so that increased voltage outputs can be obtained with tubes of high transconductance at low d-c plate voltages. In any event the C_g/C_p ratio can never exceed the amplification factor of the tube, nor can the r-f plate voltage be greater than, nor equal to, the voltage across the crystal unit. It should be understood that the higher voltage outputs are only to be had with a large C_g/C_p ratio because of the limitations on the crystal drive level and the load capacitance, C_x , and are not due to the fact that the Pierce or Colpitts type of circuit is inherently more active when the C_g/C_p ratio is a maximum. To the contrary, with a fixed C_x , maximum amplitude of oscillations is to be obtained when $C_p = C_g = 2C_x$. Where a larger than minimum power rather than voltage output is required, this can probably best be achieved when C_g/C_p lies between 1 and 2, and in this case a larger g_m is necessary to maintain oscillations. When a relatively large power output is required, the Pierce circuit should not be used.

HOW TO ESTIMATE THE FREQUENCY VARIATION AND STABILITY OF A PIERCE OSCILLATOR

1-287. In paragraph 1-243 it was shown that the frequency-stability coefficient, F_{X_e} , of the crystal unit is defined as the percentage change in X_e per

percentage change in frequency. By equation 1-243 (1), $F_{X_e} = \frac{2C_p^2}{C C_x}$. The reciprocal, $1/F_{X_e}$, is thus equal to the percentage change in frequency per percentage change in reactance. Since X_e is equal numerically to the reactance of the total load capacitance C_x , the fractional change in the load reactance multiplied by $1/F_{X_e}$ will give the fractional change in frequency. Thus,

$$\frac{df}{f} = \frac{d\omega}{\omega} = \frac{1}{F_{X_e}} \cdot \frac{dX_x}{X_x} = - \frac{1}{F_{X_e}} \cdot \frac{dC_x}{C_x} \quad 1-287 (1)$$

In the Pierce circuit, if it can be assumed that the interelectrode plate-to-grid capacitance and the grid and output losses are negligible, C_x will equal $\frac{C_p' C_g}{C_p' + C_g}$ where $C_p' = C_p + C_n$. (See figure 1-121 (C).) If it is desired to find the fractional change in frequency for a small change in, say C_p' , equation (1) can be used by expressing dC_x as a function of dC_p' , thus: $dC_x = dC_p' \cdot \frac{dC_x}{dC_p'}$

With

$$C_x = \frac{C_p' C_g}{C_p' + C_g}$$

then

$$\frac{dC_x}{dC_p'} = \frac{C_g^2}{(C_p' + C_g)^2}$$

and

$$\begin{aligned} \frac{dC_x}{C_x} &= \frac{C_g^2 dC_p'}{(C_p' + C_g)^2} \bigg/ \frac{C_p' C_g}{C_p' + C_g} \\ &= \frac{C_g dC_p'}{C_p' (C_p' + C_g)} = \frac{C_x}{(C_p')^2} \cdot dC_p' \end{aligned}$$

On substituting in equation (1):

$$\frac{df}{f} = - \frac{1}{F_{X_e}} \cdot \frac{C_x}{(C_p')^2} \cdot dC_p' \quad 1-287 (2)$$

Likewise,

$$\frac{df}{f} = - \frac{1}{F_{X_e}} \cdot \frac{C_x}{C_g^2} \cdot dC_g \quad 1-287 (3)$$

In the event that $C_p' = C_g = 2C_x$ Equations (2) and (3) become

$$\frac{df}{f} = - \frac{dC_p'}{4 F_{X_e}} \quad 1-287 (4)$$

and

$$\frac{df}{f} = \frac{-dC_g}{4F_{X_0}} \quad 1-287 (5)$$

1-288. When a more detailed expression of the frequency deviation is desired C_p' can be replaced by $(C_p + C_n)$, and C_n , in turn, can be expressed as a function of its variables. A rigorous analysis of the effect of each parameter upon the frequency would be quite involved. Probably the simplest approach for determining the frequency deviation due to a change in some particular circuit parameter would be to begin with an appropriate equation in paragraph 1-287, and express the differential element as a function of the differential of the particular circuit parameter. This is the method that was used when dC_x in equation 1-287 (1) was expressed as a function of dC_p' and of dC_g in equations 1-287 (2) and 1-287 (3), respectively. As an additional example, suppose that it is desired to determine approximately the frequency deviation due to a change in R_p of the vacuum tube. Let it be assumed that $C_g = 2C_x$. The most appropriate equation to begin with is 1-287 (4), since dC_p' can be expressed as a function of dR_p . The problem is to determine the function that gives the change in C_p' due to an infinitesimally small change in R_p , and to substitute that function for dC_p' in equation 1-287 (4). Since $dC_p' = \frac{dC_p'}{dR_p} \cdot dR_p$, the first step is to determine dC_p'/dR_p , and then simply to multiply this by dR_p . Now, by equation 1-281 (16),

$$C_p' = C_p - C_p/Q_1^2 - \frac{C_p R_0}{R_p + R_0}$$

so

$$dC_p'/dR_p = C_p R_0 / (R_p + R_0)^2$$

or

$$dC_p' = \frac{C_p R_0}{(R_p + R_0)^2} \cdot dR_p \quad 1-288 (1)$$

Substituting this function for dC_p' in equation 1-287 (4):

$$\frac{df}{f} = - \frac{C_p R_0}{4(R_p + R_0)^2} \cdot \frac{dR_p}{F_{X_0}} \quad 1-288 (2)$$

Note that an increase in R_p causes a decrease in the frequency. It should be well understood that the equations above are only rough approximations. For example, one of the approximations in equation (2) is the assumption that R_p and R_0 are independent variables, which, of course, is not true. However, the direct effect of a change in R_p

upon the frequency can be considered much greater than the indirect effect due to a change in R_0 resulting from the initial change in frequency. The differential element, dR_p , in equation (2) can, in turn, be expressed as a function of an infinitesimal change, dE_b , in the d-c plate voltage. The general equation for this function is $dR_p = \frac{dR_p}{dE_b} \cdot dE_b$. However, the derivative term, dR_p/dE_b , will be quite difficult to determine, except by experiment, since it depends upon both the tube and circuit characteristics at the operating voltages. For its mathematical expression the principal considerations would be the change in R_p with a change in E_b , assuming a constant grid bias, the change in grid bias due to the change in plate voltage, and the change in R_p due to a change in grid bias, assuming a constant plate voltage. In using the equations above it is only necessary to substitute small finite changes in the independent variable for its differential. For example, if the input capacitance were to decrease an amount $\Delta C_g = 1\mu\mu f$, the fractional change in frequency would be given approximately by equation 1-287 (3) if we were to substitute $-1\mu\mu f$ for dC_g .

ENERGY AND FREQUENCY EQUATIONS OF PIERCE CIRCUIT AS COMPLEX FUNCTIONS OF LINEAR PARAMETERS

1-289. It is beyond the scope of this handbook to present the more rigorous analyses of the various oscillator circuits. These can be obtained from the various reference sources listed in the index. Actually, even when following the more explicit equations, so many approximations must be made for the sake of simplicity, and so many unknowns are involved, such as stray circuit capacitance, that the final solutions can rarely be considered more than general indices of the actual circuit conditions. If maximum mathematical exactitude is desired in determining the frequency and activity characteristics of an oscillator, the analysis should be performed by differential equations assuming nonlinear parameters. Such equations are quite involved and are rather difficult to interpret qualitatively. If a moderately rigorous analysis is desired, the equivalent circuit in figure 1-119 (B) may be assumed to have linear parameters, as has been assumed in our previous discussion, but instead of handling the impedances as real numbers, to represent them by complex functions. For the Pierce circuit

$$\begin{aligned} Z_p &= jX_{C_p} \\ Z_g &= jX_{C_g} \\ Z_{p_g} &= R_0 + jX_0 \end{aligned}$$

An equation expressing the conditions for oscillation is derived very similarly to the method followed in paragraph 1-284, except that I_x is expressed by the exact equation

$$I_x = \frac{E_p}{Z_{p\kappa} + Z_x}$$

rather than by the simplifying equation

$$I_x \approx E_p/Z_p$$

For either the Pierce or Miller circuit, the conditions for stable oscillation are expressed by the equation

$$-R_p = \frac{Z_p(Z_{p\kappa} + Z_x)}{g_m Z_p Z_x + Z_x} \quad 1-289 (1)$$

where $Z_x = Z_p + Z_{p\kappa} + Z_x$. Equation (1) is similar to equation 1-284 (1) except that in the derivation of equation (1) I_x is expressed by its exact function and the impedances represent complex quantities. When the impedances are expressed as complex functions, the right-hand side of equation (1) can be reduced to the sum of a real quantity and an imaginary quantity, each with the dimensions of impedance.

Thus, $R_p = R + jX$

However, since R_p is not, itself, reactive, the imaginary term, jX , must equal zero, and the real term, R , must equal R_p . In this manner two equations, $X = 0$ and $R = R_p$, involving the same variables are obtained, both of which must hold if stable oscillations are to be maintained. A minimum of two equations is necessary, since there are two independent functions to perform. One function is to fix the frequency so that the excitation voltage is properly phased, and the other function is to ensure that the feed-back energy per cycle is exactly equal to its dissipation per cycle. If both sides of equation (1) are divided by R_p , the right-hand side again reduces to the sum of real and imaginary parts. The real part must be equal to 1, and the imaginary part must again be zero. It can be shown that the real part becomes, after multiplying through by R_p :

$$R_p = \frac{X_{Cp}(X_o + X_{C\kappa})}{R_o - g_m X_{Cp} X_{C\kappa}} \quad 1-289 (2)$$

This equation, rather than equation (1) is the real equivalent of equation 1-284 (1) and serves the same purpose in that it defines the conditions

necessary for the feed-back energy to be sufficient and stable—in other words, for the loop gain to equal unity. The equation for the imaginary part when made equal to zero can be expressed as:

$$X_{Cp} + X_{C\kappa} + X_e + \frac{R_e X_{Cp}}{R_p} = 0 \quad 1-289 (3)$$

When this equation holds, the loop phase shift is zero. Whereas equation (2) is said to define the feed-back energy requirements, equation (3) is said to define the frequency requirements. Note that in equation (3), the term $\frac{R_e X_{Cp}}{R_p}$ is equivalent to the reactance of a dynamic capacitance

$$C_d = \frac{C_p R_p}{R_e} \quad 1-289 (4)$$

which can be imagined to be in series with C_p . The capacitance of the combination becomes

$$C_p'' = \frac{C_p C_d}{C_p + C_d} = \frac{C_p R_p}{R_p + R_e} \quad 1-289 (5)$$

which is exactly the same as the small- R_p value of C_p' in equation 1-281 (18). C_d is thus a positive series dynamic capacitance equivalent to part of the negative parallel dynamic capacitance C_n . Equation (3) indicates that as R_p increases indefinitely $X_{Cp} + X_{C\kappa} + X_e \rightarrow 0$. This is not to be interpreted as meaning that the tank circuit approaches a parallel-resonant state as a limit or that the total dynamic capacitance approaches zero. Actually, even if the sum of the first three reactances did equal zero, the tank would not be at resonance because of the presence of R_e in the feed-back arm, and a dynamic capacitance would need to be effectively present. What equation (3) does show is that, as R_p increases indefinitely, the frequency becomes entirely determined by the tank-circuit parameters. In the limit, $X_{C\kappa} + X_e = -X_{Cp}$. As this state is approached, the impedance of the feed-back arm can be represented as

$$Z_{p\kappa} = R_e + jX_{p\kappa} = R_e - jX_{Cp}$$

The impedance of the tank circuit is

$$\begin{aligned} Z_L &= \frac{Z_{p\kappa} Z_p}{Z_{p\kappa} + Z_p} = \frac{(R_e - jX_{Cp}) jX_{Cp}}{R_e - jX_{Cp} + jX_{Cp}} \\ &= \frac{X_{Cp}^2}{R_e} + jX_{Cp} \end{aligned}$$

The real component, X_{Cp}^2/R_e , is equivalent to R_{ZL} .

Section I
Crystal Oscillators

and the imaginary component, jX_{Cp} , is equivalent to X_{Zi} . Thus, the tank circuit does not appear as a pure resistance in the limit, but approaches an effective

$$Q = \frac{X_{Zi}}{R_{Zi}} = \frac{|X_{Cp}|}{X_{Cp}^2/R_e} = \frac{R_e}{|X_{Cp}|}$$

$$= \frac{R_e}{|X_e - X_{Cg}|} = \frac{1}{Q_t}$$

This is the same effective Q as was determined qualitatively from the viewpoint of phase angles. The term $R_e X_{Cp}/R_p$ in equation (3) is therefore not to be interpreted rigorously as the total dynamic reactance, but as that part of the dynamic reactance that is a function of the tube parameters. At all times, the total load reactance across the crystal terminals is $X_x = -1/\omega C_x = X_{Cg} + X_{Cp}'$, which is always slightly greater than $(X_{Cg} + X_{Cp})$.

CAPACITIVE ELEMENTS IN DESIGN OF PIERCE OSCILLATOR

1-290. It was declared that equation 1-289 (3) defined the frequency requirements of a Pierce

oscillator. Since the frequency and the value of X_e and X_x are effectively predetermined constants, the primary problem involved in the solution of equation 1-289 (3) lies in determining the values of the lumped capacitances that must be inserted in the circuit to provide the correct value of C_x . In the average Pierce circuit the dynamic capacitance can be considered negligible when compared with the total load capacitance, so that C_x can be assumed to equal C_p and C_g in series to a first approximation. With C_p and C_g decided upon, approximate values of g_m can be had by equating the denominator of equation 1-289 (2) to zero and solving for the transconductance. The maximum and minimum equilibrium values of g_m coincide with the maximum and minimum expected values of R_e , respectively. Next, assuming that $g_m \approx I_p/E_g$, and that $E_g = I_g X_{Cg}$, where I_g is the crystal current, a vacuum-tube and plate voltage are chosen which will provide a maximum R_p , but which will not cause a crystal unit of any expected R_e to be overdriven. To determine the lumped capacitances that must be added to provide the correct values of C_p and C_g , it is first necessary to

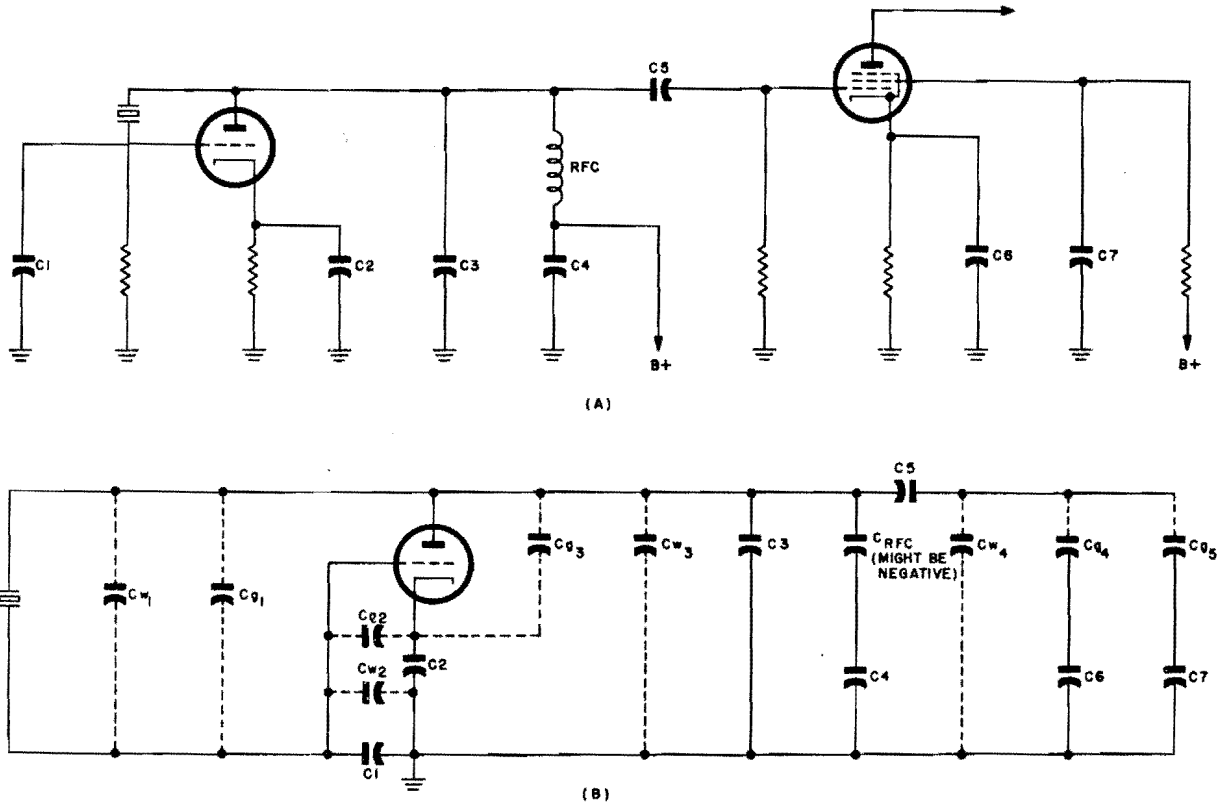

Figure 1-124. (A) Conventional Pierce oscillator and buffer-amplifier circuit. (B) Static capacitances of circuit (A). C_o = interelectrode capacitances. C_w = distributed capacitances of wires

know the values of the stray static capacitances in the circuit. These stray elements effectively create a lower limit to the capacitance across the crystal unit. Obviously, they must not be allowed to exceed the total specified load capacitance. Preferably, they should be as small as possible and not be so distributed that an optimum capacitance ratio, C_g/C_p , cannot be achieved. The static capacitances to be considered in a conventional Pierce oscillator are illustrated in figure 1-124. Before the optimum values of C_1 and C_3 can be determined, an experimental circuit should be constructed with the various leads and circuit components reasonable facsimiles of those intended in the final production models. With C_1 and C_3 omitted, the static capacitances between plate and grid, plate and cathode, and grid and cathode can be measured. C_1 and C_3 can then be computed to provide the total required load capacitance.

1-291. In the early days of crystal oscillators, and even today where the oscillator is not required to meet a frequency tolerance less than 0.02 percent, the choice of grid and plate circuit capacitances was largely a matter of trial and error. Usually,

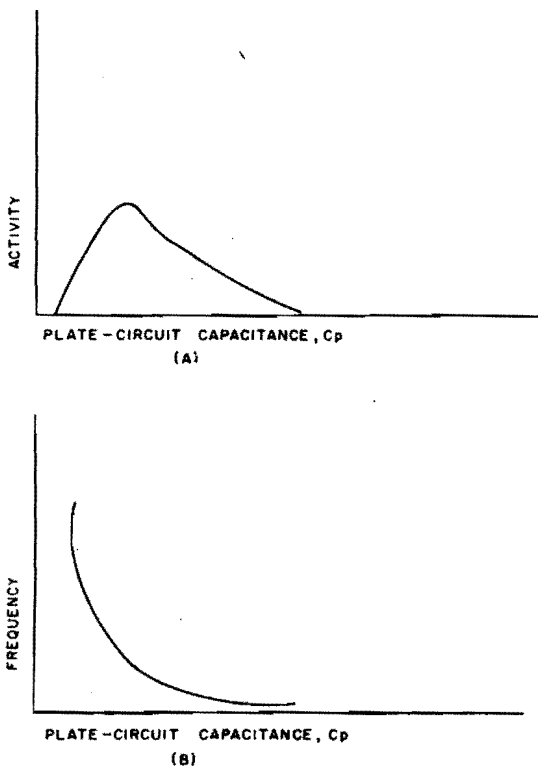

Figure 1-125. Variation of activity and frequency in Pierce oscillator as plate-circuit capacitance is increased

the final choice was based upon the combination that provided the maximum activity for a given d-c plate voltage. For example, if the grid-to-cathode capacitance, C_g , of a Pierce oscillator is held constant while the plate load capacitance is varied from a minimum to a maximum, an activity curve, as measured by the gridleak current, is obtained similar to the one illustrated in figure 1-125 (A). Formerly, it was not unusual for the optimum capacitance to be considered a value slightly greater than that at which the activity is a maximum. In military equipment the principal consideration now is to ensure a given total load capacitance. As shown in figure 1-125 (B), increasing the plate-circuit capacitance causes the frequency to decrease. As the frequency decreases, so does X_e of the crystal unit, and at only one point along the curve will the crystal unit be operating into its rated capacitance. As stated previously, the circuit must provide the specified capacitance if there is to be an assurance that the required frequency tolerance is met when one crystal unit is replaced by another of the same type and nominal frequency. In an exceptional case, the most important consideration may be to maintain a fixed frequency relative to some frequency standard. For this purpose small variations in the load capacitance that can be made manually should be possible, but care should be taken that an operator is not to be able to vary the total more than is just sufficient to allow for a frequency variation equal to the bandwidth of the tolerance range. Otherwise, there can be a risk of overdriving a crystal unit, or of continuing in operation a defective crystal or other circuit component that should be replaced before a complete breakdown is threatened.

Measurement of Stray Capacitances In Pierce Circuit

1-292. In order to measure the stray static capacitances in a circuit such as that shown in figure 1-124, the lumped grid and plate capacitances, C_1 and C_3 , as well as the crystal, should first be removed. The remaining elements can be assumed to form a three-element network as shown in figure 1-126. If an r-f choke is connected in the circuit, the frequency of the Q meter should be approximately the operating frequency of the oscillator. The measurements are made with all vacuum-tube voltages off. The three capacitances in figure 1-126 represent three independent variables, so that a minimum of three measurements is required to determine their values. A fourth measurement is desirable as a check on the accuracy of the first three. Any combination of measurements can be

Section I
Crystal Oscillators

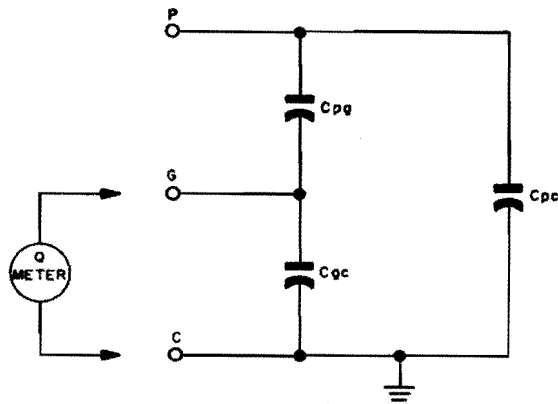

$$\begin{aligned} \textcircled{1} \quad C_{PG} &= C_{pg} + \frac{C_{gc} C_{pc}}{C_{gc} + C_{pc}} & \textcircled{3} \quad C_{PC} &= C_{pc} + \frac{C_{pg} C_{gc}}{C_{pg} + C_{gc}} \\ \textcircled{2} \quad C_{GC} &= C_{gc} + \frac{C_{pg} C_{pc}}{C_{pg} + C_{pc}} & * \textcircled{4-9} \quad C_{XY} &= C_{xy} + (C_{yz} \text{ OR } C_{xz}) \end{aligned}$$

Figure 1-126. Equivalent network formed by the stray static capacitances of a vacuum-tube circuit. A minimum of three different measurements is required. The individual capacitances can be determined by solving simultaneously any three of the nine equations above when the respective terminal capacitances are known

* Generalized equation for a measured terminal capacitance ($C_{XY} = C_{PG}, C_{GC},$ or C_{PC}) when either C_{XY} or C_{yz} , one of the two respective series-branch capacitances, is shorted out.

made, the only restriction is that no two measurements are the same and that each of the capacitances is involved in at least one of the measurements. Three different measurements are possible between any one pair of electrodes. Thus, in measuring the capacitance between grid and cathode, the circuit is unchanged for the first measurement, the plate can be grounded for the second measurement, and shorted to the grid for the third. For the three measurements:

$$\begin{aligned} \text{(1st)} \quad C_{GC} &= C_{gc} + \frac{C_{pg} C_{pc}}{C_{pg} + C_{pc}} \\ \text{(2nd)} \quad C_{GC} &= C_{gc} + C_{pg} \\ \text{(3rd)} \quad C_{GC} &= C_{gc} + C_{pc} \end{aligned}$$

Theoretically, these three measurements could be sufficient, but one or more additional measurements are needed as a check in the event that the Q-meter leads or the shorting wires have significantly affected the readings. With $C_{pg}, C_{pc},$ and C_{gc} determined, the lumped capacitances for both grid and plate circuits can readily be determined.

BIAS VOLTAGE OF PIERCE CIRCUIT

1-293. Oscillator bias voltages are not as critical as are those of other types of vacuum-tube circuits, for usually it is neither wave shape, maximum output, nor maximum power efficiency that is of most importance, but simply a constant fundamental frequency. For this purpose, the Pierce circuit can be designed to obtain a maximum R_p with a minimum drive level, and the optimum bias voltage will be the one that most nearly answers the need. As a general rule, in the case of a vacuum tube that is not being driven to saturation, the effective R_p increases as the bias becomes more negative. If the bias is sufficient for the tube to be operated class B or class C, so that the plate current is cut off for an appreciable part of each cycle, such operation greatly improves the power efficiency. However, a bias developed across a gridleak resistor can never exceed the peak excitation voltage during stable oscillations. The excitation voltage, in turn, is limited by the current I_g , which must not exceed a value that would cause the losses in the crystal to exceed the permissible limit. When I_g is maximum, the limiting crest value of I_g is $I_{gm} = \sqrt{\frac{2P_{cm}}{R_{em}}}$, where P_{cm} is the maximum permissible drive level in watts, and R_{em} is the specified maximum effective resistance when the crystal unit is operating into its rated load capacitance. The maximum grid bias is thus

$$\text{(max)} E_c = -Z_g \sqrt{\frac{2P_{cm}}{R_{em}}} \quad 1-293 \text{ (1)}$$

where $Z_g \left(\approx \frac{1}{\omega C_g} \right)$ is the r-f impedance between grid and cathode. It was found earlier (paragraph 1-284, equation 1-284 (8)) that a maximum R_p is to be had when $C_g = \frac{2C_x(\mu+1)}{\mu+2}$, or approximately when $C_g = C_p \approx 2C_x$. Equation (1) under these conditions becomes

$$\text{(max)} E_c = -\frac{\sqrt{2P_{cm}}}{2\omega C_x \sqrt{R_{cm}}} \quad 1-293 \text{ (2)}$$

Equation (2) is quite important in that it shows that the maximum grid bias obtainable with a maximum R_e is fixed by the crystal specifications. The maximum E_c for any given crystal unit may be obtained from equation (2) by substituting the actual R_e for R_{cm} . The proper anode voltages for a given vacuum tube, or vice versa, to provide a required output are consequently also effectively predetermined by the crystal specifications. For maximum stability with any given vacuum tube in

a conventional Pierce circuit, C_g and C_p should each be made equal to $2C_x$, or if the amplification factor is small, C_g/C_p should be made equal to $\frac{\mu}{\mu + 2}$, with the total capacitance in series made to equal C_x . With the capacitance so determined, the plate and screen voltages can be adjusted to give the desired output and excitation voltages. Since $E_p \approx E_g$, the output voltage is also effectively limited by the crystal specifications. With $C_g = C_p = 2C_x$, $(\max) E_p = .707 (\max) |E_c|$, where $(\max) E_p$ is the maximum r-m-s value of E_p , and $(\max) E_c$ is given by equation (2).

FIXED BIAS FOR PIERCE OSCILLATOR

1-294. It is not conventional to employ a fixed bias in a crystal oscillator, although it can be done—even to advantage in some cases. An r-f choke can be substituted for the gridleak resistance, thereby reducing the grid losses to an absolute minimum as long as the excitation is insufficient to overcome the bias and cause grid current to flow. In order for stable oscillations to be maintained, an increase in excitation must cause a decrease in amplification, and a decrease in excitation must cause an increase in amplification. When using a fixed bias, the choice of operating voltages is much more restricted than when employing gridleak limiting. Because of the more critical operating conditions, the replacement of one crystal unit with another having a different resistance may require additional circuit adjustments. If a fixed, class-B or class-C bias is used, a slight decrease in the amplitude of oscillations normally leads to the oscillations dying out all together. This is because the average amplification of the positive alternation of each cycle increases and decreases directly with the amplitude instead of inversely. For instance, with a class-C fixed bias, a decrease in the amplitude of one cycle would mean that the tube is cut off during a larger fraction of the succeeding cycle, thereby further decreasing the average amplification. On the other hand, if oscillations were once started, the tendency would be for the amplitude to build up until limited by grid and plate saturation. Only if limiting is provided by nonlinear elements, such as thermistors or varistors, in the external circuits is class-B or class-C fixed-bias operation possible if the tube itself is not to provide the limiting action. A fixed bias can be used if the tube is driven to saturation each cycle, but such operation is not practicable unless the utmost power is required from the oscillator, and in any event should not be attempted with the Pierce circuit. The only feasible application of a fixed bias

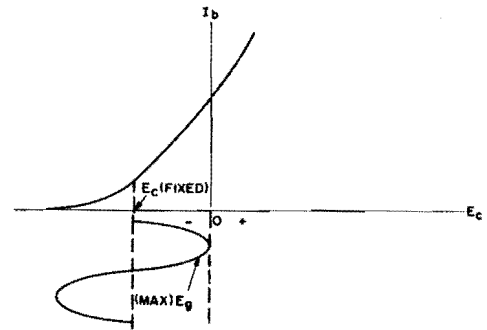

Figure 1-127. Point on E_c, I_b curve at which stable oscillations can be achieved with fixed bias. For minimum grid losses, the peak of the maximum excitation voltage must not exceed the fixed E_c .

in the Pierce oscillator is to operate the tube just above the knee of the E_c, I_b curve (see figure 1-127). (E_c and I_b represent no-signal, d-c values of grid voltage and plate current respectively.) At the indicated operating point a slight decrease in the activity results in the average amplification of the negative alternation of the excitation cycle being greater, whereas the amplification of the positive alternation remains essentially constant. Thus, the over-all amplification of the weaker cycle is greater than that of the stronger, and a stable equilibrium is possible. An r-f choke would normally replace the gridleak resistor. Such operation practically eliminates the grid losses as long as the peak excitation voltage does not exceed the bias. Theoretically, then, the fixed bias permits a maximum Q in the feed-back circuit, and in this respect aids the frequency stability. There are, however, practical difficulties involved. If the C_g/C_p ratio of the external circuit is such that the oscillator is to operate at the minimum g_m , it may be difficult to find a vacuum tube that provides the desired transconductance when operated at suitable voltages just above the knee of the E_c, I_b curve. The low transconductance can readily be achieved by using a remote-cutoff tube, but the amplitude stability will be more critical since the amplification of the positive alternations increases with amplitude, thereby tending to annul the limiting action of the negative alternations. Variations in the circuit capacitances have the following effects, which are essentially the same as those that occur with gridleak bias except that the amplitude variations are more pronounced in the fixed-bias circuit. A small decrease in the capacitance ratio, say by an increase in C_p , would mean that the voltage ratio,

$$E_p/E_g = C_g/C_p = \frac{g_m R_p Z_L}{R_p + Z_L} = g_m Z_L,$$

Section I Crystal Oscillators

must become smaller. Since E_p/E_g varies inversely with C_p , whereas Z_L varies inversely with C_p^2 , an increase in C_p , as long as $R_p \gg Z_L$, requires g_m to increase proportionately in order that equilibrium may be re-established. In other words, an increase in C_p must cause the excitation voltage to decrease. Conversely, a decrease in C_p causes g_m to decrease and the excitation voltage to increase. R_p varies in a direction opposite to that of g_m , but the percentage change in R_p is not as large as the percentage change in g_m . The change in g_m is approximately proportional to the change in C_p . If C_p is constant, but C_r is varied slightly, Z_L will be approximately constant, so that g_m must also vary directly with C_r in order for equilibrium to be maintained. Therefore, the changes in the excitation voltage with changes in C_r are similar to those with changes in C_p . When C_p and C_r are varied independently the total load capacitance C_x changes, and hence the frequency and X_e also change. If, during tuning adjustments, C_p and C_r are varied so that the same total capacitance is always maintained, then, in the region where $C_p \approx C_r$ the change in C_p is approximately equal but opposite to the change in C_r . In this case g_m , which has reached its minimum value, tends to remain constant, as do also the excitation voltage and the plate resistance of the tube. It should be understood that this optimum condition holds only for variations in capacitance that leave the total load capacitance unchanged. With C_x fixed, g_m must increase as the capacitance ratio is varied to either side of its optimum value. When C_r/C_p is made greater than one the change in g_m and the excitation is greater than when C_r/C_p is made less than one by an equivalent proportion. (e.g., Δg_m is greater when C_r/C_p is changed from 1 to 2 than when it is changed from 1 to $1/2$.) An increase in g_m can occur only by virtue of a decrease in excitation voltage. Thus, if the grid impedance, Z_g , is made larger than the plate impedance, Z_p , the crystal current, I_c , must necessarily become smaller. Oscillations can thus be maintained with a smaller drive level. Nevertheless, optimum stability generally requires a maximum R_p , which, in turn, coincides with a maximum excitation voltage and minimum g_m .

1-295. According to equation 1-284(10), the optimum capacitance ratio will automatically cause the oscillator to seek an equilibrium when $R_p = (\mu + 1) Z_L$, or approximately when $R_p = \frac{\mu PI}{4}$, where PI is the performance index. Herein lies the principal limitation of fixed-bias operation of a Pierce circuit. The maximum to minimum values of

the PI of a given type of crystal unit can be as much as 9 to 1 for the same frequency—and greater still if the oscillator is to operate over a wide frequency range. It may be difficult to find a tube to provide equivalent variations in the effective R_p , unless the excitation voltage is to be so large that it drives the grid positive on the positive excitation peaks. In this case, the principal advantage of the fixed-bias—to maintain a maximum Q_r and to minimize the variations in the input impedance—is lost. Since an increase in R_p must be accompanied by an increase in the r-f plate current operating into a proportionally increased load impedance, the tendency will be for the crystal power (approximately equal to $I_p^2 Z_L$) to vary directly with $(PI)^2$ or $\left(\frac{1}{R_c}\right)^2$. Unless there is some guarantee that the maximum R_c is not to be greater than twice the minimum expected value, some additional form of limiting must be used in the fixed-bias circuit, such as connecting a varistor across the r-f load, to ensure that the low-resistance crystal units are not over-driven. The fixed bias should not be less than three times that given by equation 1-293(2). The vacuum tube (preferably a pentode, because of its low plate-to-grid capacitance and high R_p) should be chosen and the anode voltage determined that permits operation at the lower end of the straight portion of the $E_p I_b$ curve. The optimum bias and plate voltages are best established by experiment. The principal problem is to ensure a sufficient output for crystal units of maximum R_c , without overdriving those crystals of minimum R_c . The average crystal unit has an R_c approximately one-third the maximum. An occasional crystal unit may have a value of R_c perhaps as small as one-tenth the maximum. It can be seen that a serious obstacle to the use of a fixed bias is that manual adjustments of the operating voltages are necessary when replacing crystal units, unless the plate circuit is to be rather heavily loaded. The output will tend to vary by a large factor from one crystal unit to the next. The same problem is encountered with the use of a gridleak bias, but voltage adjustments are not absolutely necessary, even under no-load conditions. A familiarity with fixed-bias operation is helpful, however, in that it aids the understanding of gridleak operation.

GRIDLEAK BIAS FOR PIERCE OSCILLATOR

1-296. The importance of having gridleak instead of fixed bias is two-fold: First, it permits a large initial surge of plate current, so that oscillations will build up quickly. If the tube were being operated class B or class C with a fixed bias, the bias

would have to be removed before oscillations could build up at all. Second, it ensures a maximum stability in the output. If for any reason the excitation should increase or decrease, the d-c grid current and hence the bias follows the change, always acting in a direction that tends to annul the original change. When the oscillator is first turned on, the starting bias is zero regardless of the value of the gridleak resistance. Thus, insofar as the initial surge of current is concerned, the value of the gridleak resistance, R_g , is not a first-order factor. However, the value of R_g is significant in its effect upon the total build-up time. This effect is considered in paragraphs 1-304 and 1-305, where the conditions most favorable for oscillator keying are discussed. The present discussion considers only the effects of R_g upon the oscillator stability after the oscillations have reached a maximum amplitude. First, it is desirable that the grid losses be as small as possible, and that they at least can be considered negligible by comparison with the losses in the crystal unit. For a continuous flow of d-c grid current to be maintained, the grid must be positive with respect to the cathode at the positive peak of each excitation cycle. The amount of grid power that is dissipated, the extent to which the grid becomes positive, and the length of the period during which the grid is positive and electrons are flowing from cathode-to-grid depend upon how great a percentage of the total charge escapes through R_g during the remainder of the cycle. This, in turn, depends upon the ratio of the period of one cycle to the RC time constant of the grid circuit.

This ratio, $1/R_g C_g f$, is seen to be equal to $\frac{2\pi |X_{cg}|}{R_g}$. The smaller this ratio can be made, the smaller will be the percentage leakage of charge during one cycle, and the more nearly will the bias remain constant and equal to the peak excitation voltage. At high frequencies, ratios on the order of 1/50 and smaller are quite easily obtained. With the period of one cycle so short compared with the time it would take 63 per cent of the accumulated charge to leak off, it can be assumed that the bias voltage equals the peak excitation voltage in magnitude. Should the excitation voltage increase, the bias also increases. The peak excitation voltage is

$$E_{gm} = I_{gm} Z_g = 1.414 I_g Z_g \approx |E_c| \quad 1-296 (1)$$

where E_c is the grid bias when $R_g C_g \gg 1/f$, and I_{gm} is the peak r-f grid-circuit current. The bias voltage is also given by the equation

$$E_c = I_c R_g \quad 1-296 (2)$$

where I_c is the d-c grid current. If an r-f choke having an impedance that is large compared with R_g is connected in series with R_g , the r-f voltage across R_g becomes small compared with the d-c voltage. With this arrangement it is readily seen that the approximate grid power expenditure is

$$P_g = I_c E_c = E_c^2 / R_g \quad 1-296 (3)$$

If the r-f choke is not present, so that the voltage across R_g varies sinusoidally from a peak of $-2E_{gm}$ to a peak of 0 on the positive alternation, the average squared voltage across R_g , equal to

$$\frac{E_c^2}{2\pi} \int_0^{2\pi} (1 + \sin \omega t)^2 d(\omega t), \text{ is found to be } 1.5 E_c^2.$$

Thus, in the absence of an r-f choke,

$$P_g = 1.5 E_c^2 / R_g \quad 1-296 (4)$$

Clearly, if the grid losses are to be held to a minimum, R_g must be as large as possible. If an examination is made of several representative crystal oscillator circuits in actual production, it will be discovered that very few employ gridleak resistances higher than 100 kilohms, and only an occasional value of R_g is found higher than 0.5 megohms. The answer is principally to be found in the fact that the oscillator design is usually a compromise among several factors: (a) frequency stability, (b) output-voltage stability, (c) output control, (d) operating efficiency, (e) maximum economy in production costs, (f) minimum over-all weight and space requirements, (g) whether or not oscillator is to be keyed, (h) frequency range (i), value of C_g , (j) whether or not circuit is to permit switching from crystal to tuned circuit, and (k) the suppression of parasitic frequencies. Either a high or a low value of R_g can improve the performance in respect to any one of the factors above, depending upon what is required concerning the other factors. For example, a very large R_g can improve the frequency stability by reducing the grid losses, when only a small output is required. On the other hand, the same value of R_g could lead to both frequency and output voltage instability if maximum output or maximum operating efficiency were required. The effects of R_g relative to various factors listed above are discussed briefly in the following paragraphs.

Gridleak Resistance and Frequency Stability of Pierce Oscillator

1-297. The grid R_g can lead to frequency instability in two ways. As R_g is decreased, the grid losses load

Section I
Crystal Oscillators

the feed-back circuit and require that the tank be operated farther away from resonance. R_p of the vacuum tube is reduced and its effect upon the frequency becomes more pronounced. On the other hand, if R_g is increased indefinitely, the oscillator can become self-modulated. This latter effect is more properly classed as a problem of output voltage stability, and is discussed in the paragraph 1-299. The principal frequency-stability importance of R_g is the degree by which it reduces the effective Q_f of the feed-back arm. (Q_f is the feed-back quality factor only from the point of view of phase rotation.) As defined by equation 1-272 (1)

$$Q_f = \frac{Q_{pgc} Q_g}{Q_{pgc} + Q_g}$$

where Q_{pgc} is the actual over-all effective Q of the feed-back arm, and Q_g is the effective Q of the input circuit. In order to analyze the effect of R_g in terms of the equivalent Pierce r-f circuit, we represent Z_g by an equivalent reactance, X_{Cg}' in series with an equivalent resistance, R_g' , as shown in figure 1-128. The problem now is to determine R_g' , such that

$$I_g^2 R_g' = P_g \quad 1-297 (1)$$

where P_g is the power expended in the gridleak resistance. The power expended during the short

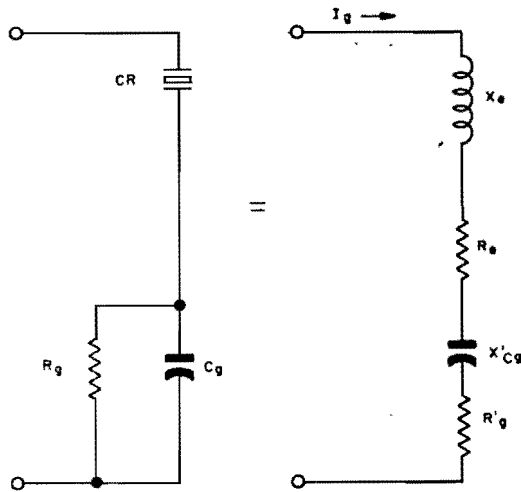

$$\textcircled{1} \quad Q_{pgc} = \frac{X_e + X'_{Cg}}{R_e + R'_{g}} \quad \textcircled{3} \quad Q_f = \frac{Q_{pgc} Q_g - 1}{Q_{pgc} + Q_g}$$

$$\textcircled{2} \quad Q_g = \left| \frac{X'_{Cg}}{R'_{g}} \right| \quad \approx \frac{Q_{pgc} Q_g}{Q_{pgc} + Q_g}$$

Figure 1-128. Equivalent Pierce feed-back circuit

current pulse when the grid is positive with respect to the cathode will be considered negligible compared with the power losses in R_g per cycle. Assuming that no r-f choke is used and that R_g is sufficiently large so that equation 1-296 (4) is approximately correct, equation (1) on substitution and rearrangement becomes

$$R_g' = \frac{1.5 E_c^2}{I_g^2 R_g} \quad 1-297 (2)$$

Since it has been assumed that R_g is large compared with X_{Cg} , then $X_{Cg}' \approx X_{Cg}$ and $E_c^2 \approx E_{gm}^2 = 2(I_g X_{Cg})^2$. On substitution in equation (2),

$$R_g' = \frac{3 X_{Cg}^2}{R_g} \quad 1-297 (3)$$

If an r-f choke were used in series with R_g , the approximate value of R_g' would be

$$R_g' = \frac{2 X_{Cg}^2}{R_g} \quad 1-297 (4)$$

The values of Q_g become

$$\text{(without choke)} \quad Q_g = \left| \frac{X_{Cg}'}{R_g'} \right| \approx \left| \frac{R_g}{3 X_{Cg}} \right| \quad 1-297 (5)$$

$$\text{(with choke)} \quad Q_g = \left| \frac{R_g}{2 X_{Cg}} \right| \quad 1-297 (6)$$

The equations for Q_{pgc} are

$$\text{(without choke)} \quad Q_{pgc} = \frac{(X_e + X_{Cg}) R_g}{R_g R_e + 3 X_{Cg}^2} \quad 1-297 (7)$$

$$\text{(with choke)} \quad Q_{pgc} = \frac{(X_e + X_{Cg}) R_g}{R_g R_e + 2 X_{Cg}^2} \quad 1-297 (8)$$

Assuming that $Q_{pgc} Q_g \gg 1$, Q_f is given by the approximate equations

$$\text{(without choke)} \quad Q_f = \frac{(X_e + X_{Cg})}{R_e - \frac{3 X_e X_{Cg}}{R_g}} \quad 1-297 (9)$$

$$\text{(with choke)} \quad Q_f = \frac{(X_e + X_{Cg})}{R_e - \frac{2 X_e X_{Cg}}{R_g}} \quad 1-297 (10)$$

In the previous discussions it has been supposed that the grid losses are kept negligible compared with the losses in the crystal, so that a Q_r equal to $\frac{X_e + X_{Cg}}{R_e}$ is approximately correct. Where this assumption cannot be made, those equations that define the frequency of the oscillator, such as equation 1-289 (3), can still be used for approximately correct answers if R_e is replaced by the appropriate denominator in equation (9) or (10). Thus, the effective frequency-determining resistance of the feed-back arm, can be defined as

$$R_{fe} = R_e + |3 X_e X_{Cg}/R_g| \quad \text{or} \quad R_e + |2 X_e X_{Cg}/R_g| \quad 1-297 \quad (11)$$

On the other hand, in those equations that concern the equilibrium between the energy input and output of the feed-back arm, such as equation 1-289 (2), the effective feedback-circuit resistance to substitute in the place of R_e is the value

$$R_f = R_e + R_g' \quad 1-297 \quad (12)$$

On multiplying equation (11) by R_g/R_e , it is apparent that if R_g is to have a negligible effect upon the frequency, it must be much greater than $|\frac{3 X_e X_{Cg}}{R_e}|$. Similarly, if R_g is to have a negligible effect on the total feed-back power requirements, according to equations (3) and (12), it must be much greater than $3X_{Cg}^2/R_e$. If the oscillator is to be operated in the region of maximum R_p of the tube, $|X_{Cg}|$ will approximately equal $X_e/2$, and $|\frac{3 X_e X_{Cg}}{R_e}|$ will approximately equal $\frac{3}{2} \text{PI}$. Under these conditions, a good rule of thumb, if the other operating requirements permit, is to employ a grid resistance equal to 15 times the minimum permissible $\text{PI} \left(= \frac{1}{\omega^2 C_x^2 R_{em}} \right)$, or greater, where $R_{em} = (\text{max}) R_e$.

Grid-Resistance Effects and "Class-D" Operation of Pierce Circuit

1-298. Typical curves showing the effect of the grid resistance upon the frequency and the frequency stability of a Pierce oscillator are shown in figure 1-129. The curves in figure 1-129 (A) were obtained for plate voltages (E_p) of 50, 60, and 70 volts under no-load conditions; the curves in figure 1-129 (B) were obtained for plate voltages of 75, 100, and 125 volts when a load resistance of 5000 ohms was connected across the plate circuit. The curves were plotted from measurements of an experimental Pierce oscillator during a USAF re-

search project under the direction of E. Roberts at the Armour Research Foundation, Illinois Institute of Technology. The frequency deviation due to a change in R_p with a change in plate voltage is indicated by the frequency difference between the points on the curves that correspond to the same values of grid resistance. The four sets of curves for each of the two load conditions were obtained by maintaining the grid-to-cathode capacitance constant and varying the plate-to-cathode capacitance. The bottom set of curves in each graph represents the closest approach of the four sets to a C_g/C_p ratio of 1, and the top set represents approximately the largest C_g/C_p ratio (maximum E_p) at which oscillations can be maintained. As is to be expected the frequency deviation due to changes in voltage is greater for the larger than for the smaller values of C_g/C_p . However, part of this greater deviation is due to the fact that in the circuit from which these curves were plotted, the plate capacitance was obtained from a capacitor paralleled by an inductor. At the minimum effective value of C_p , the capacitor and inductor approach a state of parallel resonance, so that the rate of change in the equivalent plate reactance with a change in R_p is larger than would be the case if no inductor were present. Also, the fact that the total load capacitance facing the crystal is smaller at the higher frequencies contributes to the frequency deviation. Partially counteracting this latter condition is the increase in the effective Q_e of the crystal and in the Q_r of the feed-back circuit as a whole because of the rise in frequency. There are three variables influencing the frequency that are affected by a change in the grid resistance. The first of these is the Q_g of the grid-to-cathode impedance. As R_g becomes relatively small, Q_g becomes the dominant factor determining the phase of E_p with respect to E_g . As Q_g decreases, the tank circuit must appear more capacitive. Thus, the reactance of the crystal unit in the feed-back arm, and hence the frequency, must increase. This is indicated by the sharply rising tails of the curves in figure 1-129. The second frequency-determining factor affected by R_g is the effective grid-to-cathode capacitance, C_g . As R_g decreases, C_g effectively increases. That is, if R_g and C_g are represented by an equivalent R_g' and C_g' in series, it can be shown that C_g' increases with a decrease in R_g . As a result of this effect, as R_g becomes small, the frequency tends to decrease; but, as indicated in the upper sets of frequency stability curves of figure 1-129, when C_p is small compared with C_g , changes in C_g have little effect since the total load capacitance is approximately equal to the smaller capacitance. On

Section I
Crystal Oscillators

the other hand, when the C_g/C_p ratio is small, as indicated by the lower-frequency curves in the figure, the changes in the effective C_g have a measurable effect upon the frequency. It can be seen at the low values of grid resistance that the effective increase in capacitance greatly diminishes the rise in frequency that would otherwise occur because of the decrease of the grid-to-cathode, Q_g . Indeed, the bottom curves in figure 1-129 (A) show that for the particular circuit and crystal unit the two opposing frequency effects of R_g apparently cancel each other when R_g is in the neighborhood of 100,000 ohms. This same set of curves indicates that a minimum frequency deviation with plate voltage occurs when the grid resistance is approximately 200,000 ohms. It is with some diffidence that we attempt to explain the reason why this particular

value of R_g should provide a point of maximum frequency stability. Rather than interpret the effect as due to a possible optimum ratio, or as due to a possible variation of R_g with plate voltage that tends to cancel the effect of the variation in R_p , it seems more likely that the optimum results are due to a coincidence between the third frequency factor mentioned above and the characteristics of the tube, a 6C4 (triode), that was used in the test circuit. This third frequency factor is the average grid bias, which tends to increase and decrease with R_g , although the variations are not pronounced when R_g is large. As the bias increases, so also does R_p , which in turn causes the frequency to decrease. This can best be seen from an examination of the curves at the top of figure 1-129, where the effects of R_g on C_g' are negligible as they affect

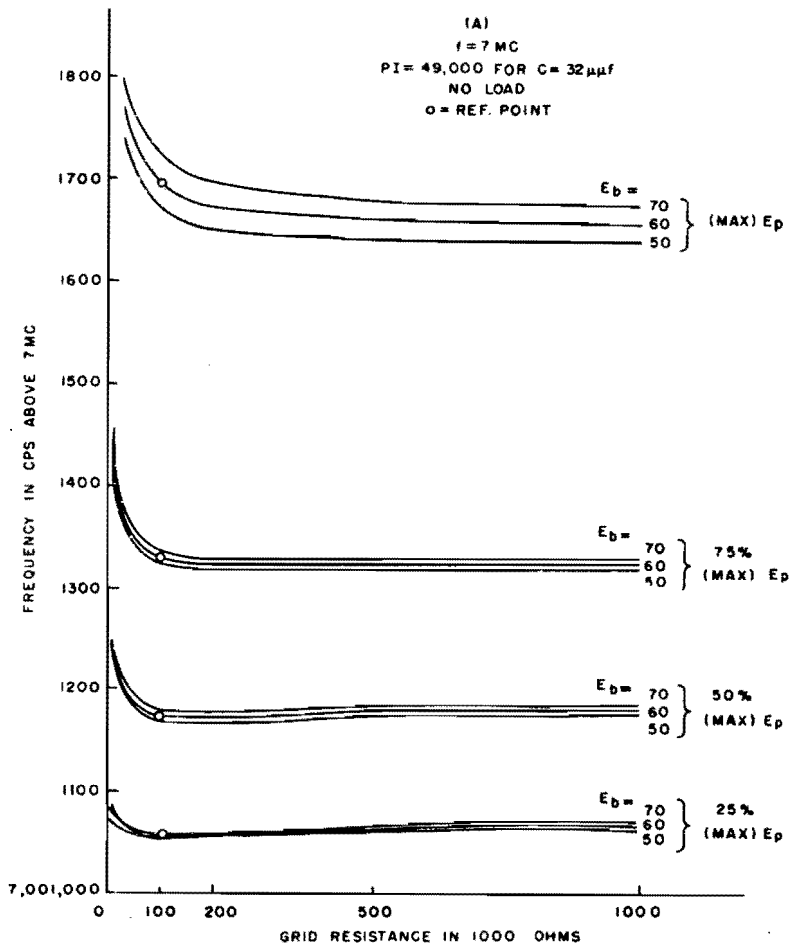

Figure 1-129. Frequency of tuned Pierce oscillator versus plate voltage and grid resistance for various plate-tuned load capacitances. (Max) E_p represents plate tuning adjustment that provided maximum r-f plate voltage when grid resistance and d-c plate voltage were values indicated by zero reference point. A 7-mc CR-18/U crystal unit was used, having a PI of 49,000 ohms when operating into a rated load capacitance of 32 μf

the frequency. As R_p increases, the bias approaches as a limit the magnitude of the peak excitation voltage. Thus, R_p also rises to some limiting value, causing the frequency to level off to some minimum value. If the plate voltage is increased when the tube is biased below the straight portion of the E_b curve, one result is a decrease in R_p , which, in the curves of figure 1-129, clearly causes the frequency to increase. However, an increase in the plate voltage also causes an increase in the excitation voltage, and hence in the grid bias. Thus, it may well be that the point of maximum frequency stability as indicated in the bottom curves of figure 1-129 (A) is the result of an increase in bias with the increase in plate voltage just sufficient to hold R_p constant. A class of operation such that the percentage change in R_p due to a change in E_b is annulled by a percentage change in R_p due to a change in E_c , or vice versa, suggests interesting possibilities in stabilizing the plate resistance by methods other than plate-supply regulation. There is no evidence that this type of operation has been investigated, but on the strength that possibilities exist for practical application in oscillator circuits not employing a fixed bias, the name "class-D"

operation is proposed. Three subclasses are possible: "D₁," where changes in E_b can occur more or less independently and E_c is the dependent variable; "D₂," where E_c can be considered independent and E_b dependent; and "D_{1,2}" where E_b and E_c are mutually dependent. Mathematically, this class of operation can be defined by the following equations:

$$\begin{aligned} \text{(Class D)} \quad \frac{\Delta R_p}{R_p} &= \frac{1}{R_p} \left(\frac{\partial R_p}{\partial E_b} \right)_{E_c = \text{const.}} \Delta E_b \\ &+ \frac{1}{R_p} \left(\frac{\partial R_p}{\partial E_c} \right)_{E_b = \text{const.}} \Delta E_c = 0 \end{aligned} \quad 1-298 (1)$$

$$\begin{aligned} \text{(Class D}_1\text{)} \quad \Delta E_c &= \frac{\partial E_b}{\partial E_c} \Delta E_b \\ &(\Delta E_b \text{ independent}) \end{aligned} \quad 1-298(2)$$

$$\begin{aligned} \text{(Class D}_2\text{)} \quad \Delta E_b &= \frac{\partial E_b}{\partial E_c} \Delta E_c \\ &(\Delta E_c \text{ independent}) \end{aligned} \quad 1-298 (3)$$

(Class D_{1,2}) Equations (2) and (3) both apply.

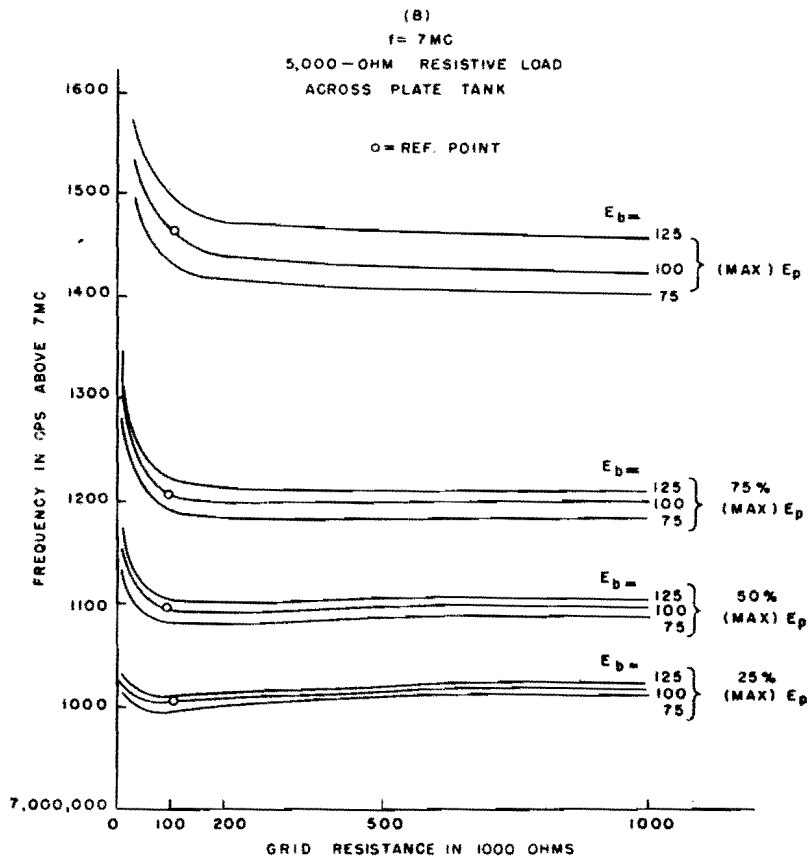

Section I
Crystal Oscillators

Equations (1), (2), and (3) sufficiently define "class-D" operation, but the parameter, R_p , represents a with-signal average plate resistance, and not the instantaneous or static resistances represented by conventional R_p curves; although the static values would apply if the signal amplitude were small relative to the bias, as would be the case if agc were being used. An increase in plate voltage can generally be expected to cause an increase in excitation and grid bias in the conventional oscillator circuits. This action, in turn, can be expected to cause an increase in the average R_p . Thus, if "class D" is to be in effect, it is necessary that an original increase in E_b cause R_p to decrease by the same amount as the change in E_c will cause it to increase. For this to occur, the plate characteristic curves must show positive slopes that increase with plate voltage; that is, the $E_b I_b$ curves must be curving upward in the direction of increasing E_b at the operating voltage, as is quite characteristic of triode curves. Pentodes do not show this characteristic if the screen voltage is held constant, since the plate resistance tends to increase with increasing plate voltage. However, if the screen voltage varies with, and in the same direction as, the plate voltage, as can be the case when the two voltages are obtained from the same source, plate characteristics can be achieved similar to those of triodes, but with the advantages of larger values of R_p and an independent variable (E_{c2}) by which the rate of change of R_p with E_b , ($\partial R_p / \partial E_b$), can be adjusted. Now there is an additional implied condition that must be met if class-D effects are to be achieved in conventional oscillator circuits. This is the requirement that g_m also remain constant. For example, by equation 1-289 (2) which is repeated here

$$R_p = \frac{X_{Cp} (X_c + X_{Cr})}{R_e - g_m X_{Cp} X_{Ck}}$$

it can be seen that feed-back equilibrium in a Pierce circuit requires that as long as R_p and the external circuit parameters remain constant, so also must g_m . An analogy here is to be found in class-A operation, which is defined by the operation of the tube along the straight portion of the $E_c I_b$ curve, i.e., in a region of constant g_m . Since the principal purpose of class-A amplification is a distortionless output, by implication a necessary requirement is that the operation also be in a region of constant R_p . In "class D," on the other hand, a constant effective R_p is the sufficient definitive condition, but in application a constant effective g_m is a necessary implication. If g_m is to remain con-

stant, equations for Δg_m similar to (1), (2), and (3) for ΔR_p must hold simultaneously. This can be achieved in one of two ways, or a combination thereof. Assume that the plate voltage increases. If R_p is sufficiently small for the positive excitation peak to drive the grid reasonably far above the zero point, an increase in excitation, although decreasing the average g_m on the negative alternation, can annul this effect by increasing the average g_m in the region above the zero grid voltage. For this to occur, the tube would have to be operated at plate voltages low enough for the zero grid point to lie well within the bend of the $E_c I_b$ curve. This, indeed, was the state of the 6C4 tube when the curves of figure 1-129 (A) were determined. Presumably, under no-load conditions and a small C_g/C_p ratio, as the grid resistance was decreased, the changes in the positive excitation peaks with changes in plate voltage were just sufficient to maintain g_m approximately constant for values of R_g between 100K and 200K. If R_g is very large, the effect above is negligible, since any increase in the positive excitation above the zero grid voltage point becomes minor compared with the total increase of the negative alternation. For g_m to be stabilized when R_g is large, the change in plate voltage must make a change in the cutoff voltage comparable to the change occurring in the excitation voltage. Plate characteristics most probably favorable to "class-D" operation appear to be had with low plate voltages. Unlike the R_p and g_m in the conventional classes of amplifier operation, where R_p and g_m can be varied independently, this condition cannot exist in class-D operation of conventional oscillators, since R_p and g_m are tied together by the feed-back energy requirements at equilibrium. Any condition that would stabilize the one, would automatically stabilize the other. It is only R_p , however, that directly affects the phase of the feedback. Once R_p becomes large relative to the impedance across the tube, the percentage variations in g_m become very small, so that g_m can be assumed to be a constant for all practical purposes. It is R_p that requires critical attention if it is to be held constant. As discussed in paragraph 1-342, the curves shown in figure 1-146 strongly suggest the possibilities of "class-D" operation in the case of a Miller circuit. The solution of the "class-D" equations for a given vacuum tube and circuit can probably be approximated graphically, using families of R_p curves versus E_b and E_c , or curves of the deviations of the $R_p E_b$ and $R_p E_c$ curves. If rates of change of E_c with E_b can be obtained that provide a solution for equation (1) when the values of E_c and E_b are practicable, the

possibility exists that an oscillator of any type, parallel- or series-resonant, using a gridleak bias (or agc) can be designed so that for all practical purposes it is independent of small fluctuations in the plate-supply voltage. Empirically, "class-D" operation is indicated at the point or points where the frequency deviation curves of an oscillator change in sign, or where frequency curves, such as those in figure 1-129, cross or touch each other. A full analysis of this class of vacuum-tube operation is beyond the scope of this handbook. It is suggested here only as a possible line of inquiry.

Gridleak Resistance and Output Voltage Stability of Pierce Circuit

1-299. The stability of the output voltage depends largely upon how readily the gridleak bias can follow small fluctuations in the excitation voltage. Imagine, for example, that the vacuum tube is being operated class C, and that after equilibrium is reached the positive peak of a certain excitation cycle happens to be slightly higher than the average. The average bias during the succeeding cycle will thus be slightly more negative than is normal, so that during this period the tube is conducting a smaller fraction of the time, and the peak excitation voltage will drive the grid less positive than before. This means that the amplification during this cycle will be less than the amplification during the preceding cycle. If the $R_g C_g$ time constant is extremely large compared with the period of a cycle, the bias remains relatively fixed for the duration of several cycles. In which case the peak of several succeeding cycles must rise to progressively lower points on the $E_g I_g$ curve. The oscillations will continue to decay until a sufficient amount of the bias charge of C_g has leaked through R_g to permit oscillations to again build-up. For this reason R_g cannot be increased indefinitely without the risk of the oscillator becoming self-amplitude-modulated. As R_g is gradually increased, the amplitude sooner or later begins rising and falling at a radio-frequency rate. If R_g is further increased, the modulation of the output can fall within the audio range. Finally, with extremely large values of R_g , the circuit behaves as a damped-wave blocking oscillator. Now, assume that R_g is infinite. As oscillations build up, the bias for each cycle is essentially the same as the peak excitation voltage of the preceding cycle. Eventually a peak excitation voltage is attained which causes the bias for the next cycle to be too great for the circuit to be resupplied with all the energy that will be lost during the period of the cycle. If the peak bias is equal to or greater than the cutoff bias, the oscil-

lations will die out completely, since any decrease in excitation with class-C bias means a decrease in average amplification. To avoid this possibility, it is important that sufficient electrons escape from the grid so that, at the beginning of the cycle immediately following the first peak cycle, the bias will have returned to approximately the same starting point. Expressed in another way, to avoid the intermittent activity, there must be an assurance that the positive peak of every cycle will drive the grid positive. This assurance is to be had for all operating conditions if the bias voltage decreases at a greater rate than would the positive excitation voltage peaks if the tube were cut off for a complete cycle. In practice, the vacuum tube can be conducting in polar opposition to E_p , and hence effectively supplying energy to the circuit during the entire negative alternation of an E_p cycle. Nevertheless, if there is an assurance that the bias voltage drops as fast as the peak excitation voltage when no energy is being supplied to the circuit, the bias reduction is certainly sufficient if the net rate of energy-loss is reduced by virtue of a variable release of energy by the tube throughout a large part of each cycle. The problem, then, becomes one of first determining the percentage change in the peak excitation voltage that would occur during the period of one cycle if the tube were suddenly cut off.

1-300. At the instant that I_g is a maximum, the voltages across the reactances in the tank circuit are zero, and none of the circuit energy is stored in the capacitances. All the stored energy at that instant is in mechanical form, and is equal to the kinetic energy of the crystal as it swings through its position of zero potential energy. As discussed in paragraph 1-249, this stored energy is equal to $I_g^2 L$, where I_g is the series-arm current, and L is the equivalent series-arm inductance. Now, when the crystal appears as an inductance, I_s is approximately equal to I_g plus the current, I_{c_0} , which flows through the shunt capacitance, C_0 , of the crystal unit. (Only the unsigned magnitudes of I_g and I_{c_0} are considered here.) We can say, approximately, that the stored energy is equal to $(I_g + I_{c_0})^2 L$. As is also discussed in paragraph 1-249, the ratio of stored energy to the energy dissipated per radian, is equal to the Q of the circuit, which in

this case is effectively $\frac{\omega L (I_g + I_{c_0})^2}{(R_s + R_g' + R_L') I_g^2}$, or the equivalent value, $\frac{\omega L (I_g + I_{c_0})^2}{R (I_g + I_{c_0})^2 + (R_g' + R_L') I_g^2}$, where R_L' is the equivalent load resistance when represented as in series with the plate-circuit capacitance, and R is the series-arm resistance of

Section I
Crystal Oscillators

the crystal. If R_g' and R_i' can be considered negligible, the circuit Q will be the actual crystal $Q \left(= \frac{\omega L}{R} \right)$. Assume that the plate current is cut off for an entire cycle, which is a period of 2π radians. The fraction of the energy dissipated during this time is approximately equal to $2\pi/Q = R/fL$, if Q is of sufficient magnitude that the percentage decrease in current is not large. Since the energy is proportional to the square of the voltage, the equivalent decay in peak excitation voltage is $E_{em}\sqrt{R/fL} \approx |E_c|\sqrt{R/fL}$. If E_c , the grid bias, whose magnitude only we shall consider, is to decrease at the same rate, the bias charge, equal to $C_g E_c$, must leak through R_g at an average rate of $C_g E_c \sqrt{R/fL}$ during the period of one cycle. Thus

$$(\text{min}) I_c = \frac{E_c}{(\text{max}) R_g} = f C_g E_c \sqrt{R/fL} \quad 1-300 (1)$$

The maximum safe value of R_g for all operating conditions, if R_g' and R_i' are negligible compared with R_g , according to equation (1) is

$$(\text{max}) R_g = \sqrt{L} / C_g \sqrt{fR} \quad 1-300 (2)$$

Since $\sqrt{L} = 1/\omega\sqrt{C}$, where C is the equivalent series-arm capacitance, and since $C \approx \frac{C_o}{r}$, in the case of partially plated elements, where r is approximately equal to the theoretical capacitance ratio, r_o , given in figure 1-95, then, on substitution in equation (2)

$$(\text{max}) R_g = \frac{\sqrt{r}}{\omega C_g \sqrt{fR C_o}} \quad 1-300 (3)$$

In paragraph 1-297 it was shown that when $C_x = 2C_x$, if R_g is to be considered negligible it should be at least 15 times the minimum permissible PI. Assume that $R_g/(\text{min}) PI = k$, (k is not to be interpreted here as a symbol for any quantity other than the ratio defined) and that it is desired that $k = k_m$, its maximum value consistent with equation (3), above. Let it also be assumed that R is approximately equal to R_{em} , the maximum permissible value of R_g , that $C_x = 2C_x$, and that $C_o = C_{om}$, the maximum permissible shunt capacitance specified for the crystal unit. Then,

$$(\text{max}) R_g = k_m (\text{min}) PI = k_m / \omega^2 C_x^2 R_{em}$$

also

$$(\text{max}) R_g = \sqrt{2\pi r} / 2\omega C_x \sqrt{\omega C_{om} R_{em}}$$

Thus,

$$(\text{max}) R_g/(\text{min}) PI = k_m = \frac{\omega C_x \sqrt{2\pi r R_{em}}}{2\sqrt{\omega C_{om}}} \quad 1-300 (4)$$

or

$$k_m^2 = \pi r |(\text{min}) X_{C_o}| / 2 (\text{min}) PI \quad 1-300 (5)$$

It will be found in practice that the limiting values of k_m given by equations (4) and (5) are normally smaller than the minimum desired value of 15. If this should be the case in an actual circuit, the assumption that the power losses in the grid circuit are negligible can no longer be made, and the actual value of k_m would be even less than that given above. The factor $\sqrt{R/fL}$ in equation (1) is derived upon the assumption that only the crystal losses are significant. If this is not to be the case, this factor should be replaced by one equal to $\sqrt{\frac{\text{total energy expended per cycle}}{\text{energy stored}}}$. Now, even though it would seem from equations (4) and (5) that R_g cannot be safely made more than 5 to 10 times larger than the minimum PI, particularly if an AT cut is employed, since it has a value of r of only 250, and since C_x is normally no greater than 4 or 5 times C_{om} , it should be remembered that the value of k_m above is based upon the assumption that no energy is being fed to the circuit during an entire cycle, so that the net loss is equal to the gross loss. This condition is only approached in high-efficiency class-C circuits where the operating bias is several times the cutoff bias. Except in the case of power oscillators, such operation is not feasible because of the high operating voltages that are required. The larger the fraction of the cycle during which the tube is conducting, the larger the ratio of the usable R_g to that given by equation (3). If the tube is conducting one-half the time, class-B operation, the maximum safe R_g is more than twice that given by equation (3). For class-B and class-C operation, the output stability is almost entirely dependent upon the automatic adjustment of the bias, for any decrease in signal strength will mean a decrease in over-all amplification unless the bias can drop immediately to allow more energy to be fed to the circuit. On the other hand, it was found in paragraph 1-294 that if an oscillator tube is operated at a bias immediately above the knee of its $E_c I_b$ curve, the bias can remain fixed and the variations in excitation directly produce a change in amplification that tends to annul the original variation. If the tube

voltages are so selected that a gridleak bias at equilibrium is also at the optimum fixed-bias point, then limiting can be achieved both from the gridleak action and the excitation swings. Under these conditions, R_g can be safely increased to values beyond one megohm, even at high frequencies. As a design consideration, however, the gap between the theoretical and the practical solution can prove quite wide. Among the optimum-bias bugs that resist extermination; there is the difficulty of finding a vacuum tube having the desired operating characteristics, and once found, there is the additional problem of maintaining an optimum operating state with crystal units having different values of effective resistance. These problems are discussed in some detail in succeeding paragraphs. The main problem is to reduce the grid losses to negligible proportions without endangering the output voltage stability. This can normally be done with any parallel-resonant crystal oscillator if the tube is conducting throughout most of each cycle.

Gridleak Resistance and Output Control in Pierce Circuit

1-301. If it is necessary for a Pierce oscillator to provide a higher voltage output than can be obtained under the conditions of maximum frequency stability, the C_g/C_p ratio can be increased. If the total load capacitance is to remain constant, C_g will necessarily be larger, and the excitation voltage smaller, so a smaller value of R_g can be used without the grid losses becoming significant. If the capacitance ratio is to be adjustable in order to permit an operator or technician to control the output voltage, R_g cannot be made larger than that value which would permit a stable output with the largest operable value of C_g at the highest frequency at which the oscillator is to be used. If such an adjustment is to be provided in a Pierce circuit, C_g and C_p should be so ganged as to always provide a constant load capacitance. This problem is discussed in paragraph 1-318. Insofar as the grid-to-cathode resistance is concerned, the maximum safe value of R_g becomes less if C_g is to be variable than otherwise. Without changing the C_g/C_p ratio, larger outputs can be achieved by reducing the value of R_g to a point where the grid leakage is so great that the average bias is considerably smaller than the peak excitation voltage. With this the case, the oscillations must build up to higher amplitude levels before equilibrium can be reached. Although the maximum excitation is still fixed by the rated drive level of the crystal unit, the output can be controlled somewhat within this restriction by a variable R_g . At the higher frequencies, this

method of output adjustment requires such low values of R_g that the grid losses seriously affect the frequency stability. However, at very low frequencies, a variable R_g could be feasible as a means of adjusting the output of a Pierce circuit to a desired level when one crystal unit is replaced by another of different effective resistance. Although such a design feature has no particular recommendation, it could be preferred over those methods of output control that require adjustment of the C_g/C_p ratio, which risk changes being made in the total load capacitance. With grid control, the lowest adjusted value of R_g could be designed to provide the desired output when a crystal unit of maximum effective resistance (minimum PI) is connected in the circuit; whereas the larger values of R_g could ensure the same output with some theoretical minimum value of effective resistance. Since the crystal current, I_c , is practically constant as long as the output voltage E_p is constant, the power losses in the crystal, equal to $I_c^2 R_c$, tend to vary directly with R_c , as long as E_p is held constant by adjustments of R_g . Under those conditions where the capacitance ratio does not change, a maximum crystal drive level is required for the crystal unit of maximum R_c , and a minimum crystal drive level when R_c is a minimum—the reverse of those conditions discussed in paragraph 1-294 when a fixed bias instead of a fixed output is assumed.

1-302. As applied to crystal oscillators in general it cannot be said that a variable gridleak resistance is advisable except for test purposes or unless its purpose is to obtain the minimum possible grid losses when changing from one crystal unit to another. As an output-voltage control device other methods are generally to be preferred. Except at very low frequencies, the resistance values necessary to appreciably lower the average bias are too small to prevent the grid losses from becoming a significant frequency-determining factor. This statement, of course, only expresses a general rule, and in specific instances the inter-relations among the circuit variables may be such as to annul the effects upon the frequency. For example, the bottom set of curves in figure 1-129(A) is to be expected theoretically to indicate a greater frequency stability when R_g is 1 megohm rather than when it is 0.2 megohm, but this effect was not observed. Figure 1-130 shows curves of output voltage obtained from the same experimental oscillator that was used in plotting the curves of figure 1-129. Although the curves are plotted as output-voltage versus crystal driving power, it should be understood that the actual independent variable for each

Section I
Crystal Oscillators

curve is the plate voltage. Each curve represents a particular value of grid resistance. The cross lines intersect the curves at points corresponding to the same values of plate voltage. From figure 1-130 it can be seen that large percentage changes in the grid resistance can cause changes in the output voltage on the order of 30 per cent or so, but which increase sharply as R_g becomes small. 1-303. If an adjustable output voltage is desired, probably the best solution to the problem is to use a screen-grid tube having an r-f-bypassed, variable, voltage-dropping resistor in series with the screen supply voltage. Varying this resistance will control the output of the tube and the crystal driving power. The maximum permissible output voltage must be determined on the assumption that the crystal unit has the maximum permissible R_e .

Since $I_g \approx \frac{E_p}{X_e + X_{Cg}}$ and the maximum permissible $I_g = \sqrt{P_{cm}/R_{em}}$, where P_{cm} and R_{em} are the maximum crystal driving power and effective resistance, respectively, then the maximum permissible constant E_p is

$$(\max) E_p = (X_e + X_{Cg}) \sqrt{P_{cm}/R_{em}} \quad 1-303 (1)$$

If it is assumed that $X_{Cg} \approx X_{Cp} \approx \frac{X_x}{2}$, where $X_x (= -1/\omega C_x)$ is the total load reactance equal and opposite to X_e , equation (1) becomes

$$(\max) E_p = \sqrt{\frac{P_{cm}}{R_{em}}} / 2\omega C_x \quad 1-303 (2)$$

According to equation (2), the maximum permissible constant E_p varies inversely with the crystal frequency. If the oscillator is to be used at more than one frequency, and at the same time is to provide the same output voltage regardless of the frequency, the maximum E_p is that value given by equation (2) for the crystal unit of highest frequency, assuming the crystal specifications are the same for all frequencies. With the ratio of C_g/C_p approximately equal to one, equation (2) also gives the value of E_g , which obviously will also remain constant. R_g can be made quite large, so that $|E_c|$ will approximately equal $E_p\sqrt{2}$. With E_c constant, and with the plate voltage E_b also assumed to be constant, the operating position of the tube on the $E_c I_b$ curve largely becomes the function of the screen voltage. As the screen voltage is increased, g_m increases, which means that the slope of the

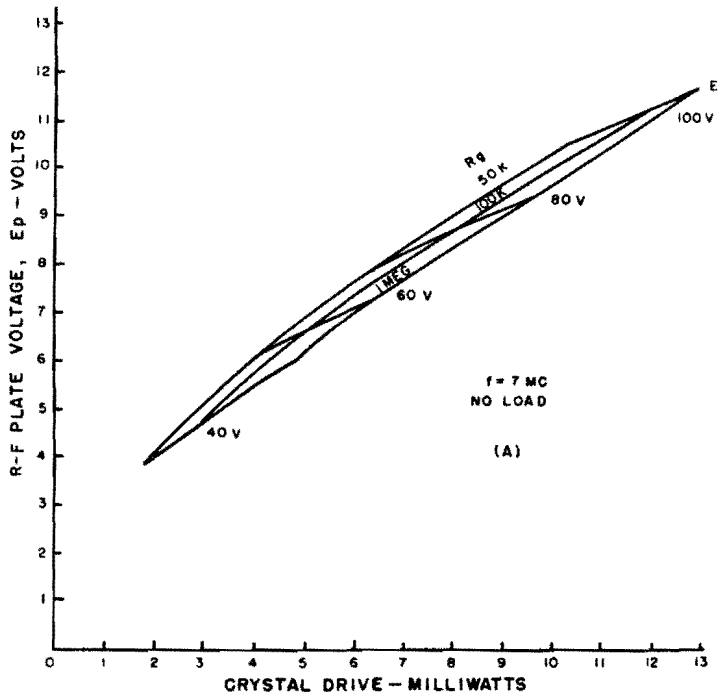

Figure 1-130. Output curves of tuned Pierce oscillator for different values of grid resistance when reactance of tuned plate circuit is adjusted for output voltages equal to 50 percent of the maximum attainable. A 7-mc CR-18/U crystal unit was used, having a PI of 49,000 ohms when operating into its rated load capacitance of 32 $\mu\mu\text{f}$

$E_c I_b$ curve becomes steeper. Also, the cutoff bias is increased. Since E_c is being held constant, the effect is one of shifting the operating bias, percentage-wise, closer to or farther up the straight portion of the $E_c I_b$ curve. From the point of view of using as large a value of R_g as is possible, it is desirable that the operating position be just above the knee of the $E_c I_b$ curve when the screen voltage is to be a maximum, i.e., when R_g of the highest-frequency crystal unit is a maximum.

Gridleak Resistance and Oscillator Keying of Pierce Circuit

1-304. If avoidable, a crystal oscillator should not, itself, be keyed. For one reason, the oscillation build-up time is not negligible if rapid telegraph keying is desired. As the operable speed limit is approached the wave shape becomes distorted and the harmonic output is considerably increased. Even the keying of a crystal oscillator in a push-to-talk voice transmitter is not desirable if frequency stability is important, since on-and-off operation constantly raises and lowers the crystal temperature. Thus, the frequency is kept in a state of constant variation to a degree dependent upon the magnitude of frequency-temperature coefficient of the crystal unit at the average operating temperature. Unless necessary for reasons of economy in space, cost, or the like, the oscillator should be designed for continuous operation and the keying performed in one or more of the succeeding amplifier stages. Usually the keying circuit is designed to remove and apply by one means or another, a cutoff bias in the buffer-amplifier stage. During the time that the buffer amplifier is cut off, the crystal circuit continues to oscillate, but the signal cannot be amplified and applied to the succeeding stages.

1-305. When it is necessary to key the oscillator, itself, the reason is normally that the space and weight requirements are so limited that no more than one or two vacuum-tube stages can be allowed. For this same reason, the oscillator is probably required to develop as much output power as possible, so that a Miller, rather than a Pierce circuit is generally employed if crystal control of the frequency is required. Nevertheless, the factors affecting the build-up time are approximately the same in either circuit. Fundamentally, the reason that a crystal oscillator requires a relatively much longer build-up time than does a conventional inductor-capacitor tuned circuit of the same reso-

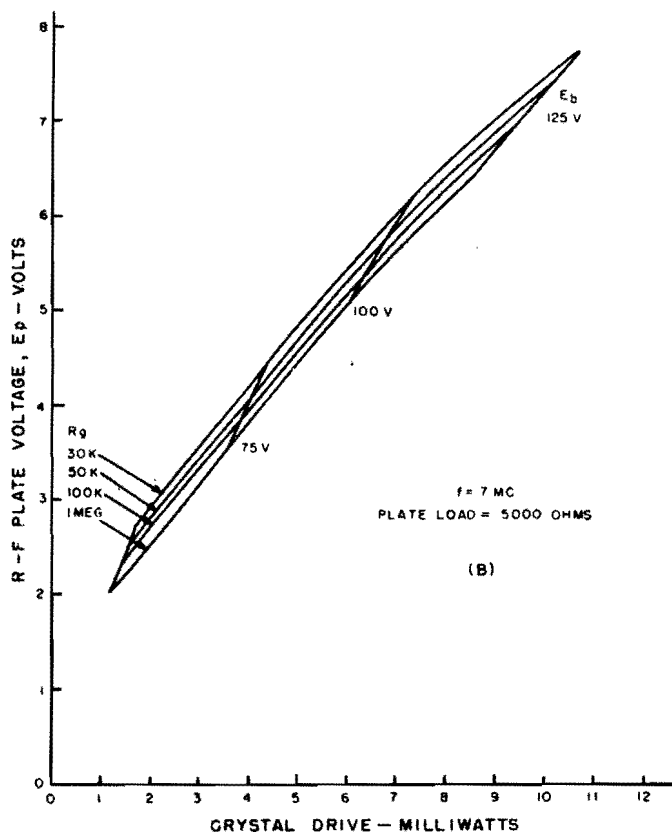

Section I
Crystal Oscillators

nant frequency, is because the energy to be stored in the crystal is much greater than that which would be stored in an inductor-capacitor circuit. For a given tank current, the stored energy is proportional to the inductance, so, to a first approximation, we can suppose that the build-up time of, say, a Pierce oscillator as compared with that of a Colpitts oscillator of the same frequency, is directly proportional to the inductance ratio. On the other hand, it can be imagined that the build-up time tends to vary inversely with the total effective resistance in the tank circuit. The greater this resistance, the more quickly do the losses in the circuit rise to equilibrium with the rate of energy supply. The build-up time also tends to vary inversely with the frequency. Clearly, if the frequency were one cycle per second, equilibrium could not be reached in a shorter period. Finally, the build-up time is a function of the electromechanical coupling of the crystal to the circuit. The larger the C_0/C ratio of the crystal unit, the weaker is the coupling and the longer is the period before equilibrium can be reached. The exact relations of all the circuit variables in an equation expressing the time required for the amplitude to rise to within one per cent or so of its equilibrium limit would, indeed, be quite involved. Insofar as the crystal is concerned, the build-up time can be expected to vary positively if plotted against L , C , C_0 , and $1/R$ of the crystal unit. The percentage variation of the build-up time with a given percentage variation in L can be expected to be greater than with the same percentage variation in C , because of the fact that, say, an increase in C , although increasing the build-up time by lowering the frequency, will also tend to decrease the build-up time by improving the electromechanical ratio. Thus, if the frequency remains constant, a crystal oscillator can be keyed at a faster rate if the L/C ratio is kept to a minimum, provided C_0 is not increased. In other words, a crystal element should be chosen that has as large a piezoelectric effect as possible, provided the frequency-temperature coefficient is small. For example, for high-frequency circuits, an AT-cut crystal which has a capacitance

ratio $\frac{C_0}{C} \approx 250$ is to be expected to provide better

keying characteristics than a BT-cut crystal, which has capacitance ratio of 650. Preferably, from the point of view of a maximum keying speed for a given output voltage, the gridleak resistance should be kept small, not only to load the circuit and to provide quick-action limiting, but also to keep the positive swings of the grid and the transconductance high. The oscillator will almost cer-

tainly be designed for maximum power output, so that the tank circuit will be well loaded, for which reason the grid resistance must be kept relatively small as a safeguard against intermittent oscillations. It is questionable as to just how much the effective tank resistance limits the build-up time. Of course, if the resistance were zero, the oscillations would theoretically continue to rise indefinitely. On the other hand, the time required for the amplitude to reach any given value is least when the energy being lost from the circuit is least. In this respect, the build-up time tends to vary directly, not inversely, with the tank resistance. It would seem, that to obtain a maximum keying speed it might be preferable to use a fixed bias or a cathode bias, instead of the gridleak action. Using a sharp-cutoff tube biased for class-A operation, a grid, plate, or output circuit limiting arrangement could permit the oscillations to build up to a given level under conditions of a maximum ratio of input to dissipated power. Above this amplitude level the ratio would sharply decrease. Such a circuit could raise the permissible keying speed, but since this is accomplished by virtue of sudden changes in the circuit parameters, which changes always accompany to some extent any limiting action, an increased frequency instability and harmonic output are almost certain to result. Although a crystal oscillator should not be designed to be keyed unless absolutely necessary, experimental circuits have obtained keying speeds approaching 400 words per minute. The higher the keying speed, however, the greater must be the frequency tolerance.

Gridleak Resistance When Pierce Circuit Permits Switching from Crystal to Variable LC Control

1-306. It is often necessary to provide a variable-tuned, inductor-capacitor auxiliary circuit to permit emergency operation at frequencies other than those provided by the available crystals, or in the event of crystal failure. For this purpose it is often possible and is usually desirable to use the same vacuum tube that is used during crystal control. For example, a Pierce circuit could be readily converted to a Colpitts circuit simply by switching from the crystal to a tuning inductor, or to an inductor shunted by a variable capacitor. However, when such a conversion is made, the ratio of the stored energy to the power dissipation becomes much smaller than that during crystal control. For this reason, the maximum safe value of gridleak resistance is much smaller than during crystal operation. For output voltages comparable to those obtained with crystal control, the LC circuit em-

employs gridleak resistances ranging from 20,000 to occasionally 100,000 ohms. If the LC circuit is intended to furnish a much greater output than the crystal circuit, lower values of R_g may be necessary. Rather than require the crystal circuit to operate with small values of R_g , it would be preferable to connect an additional shunt resistor in the grid circuit when switching to variable-tuning control.

Gridleak Resistance When Used with Cathode Biasing Resistor in Pierce Circuit

1-307. In addition to the voltage across the gridleak resistance, part of the bias voltage can be furnished by an r-f-bypassed resistance in the cathode circuit. The cathode resistor protects the tube from excessive plate current should oscillations cease, and has the additional advantage of reducing the grid current and, hence, the grid losses. The power expended in the grid circuit will be approximately equal to $E_c I_c$, where E_c is the total bias and I_c is the grid current. Actually, unless an r-f choke is used in the grid circuit, the grid losses will be somewhat greater than $E_c I_c$, because of the a-c component of voltage across R_g . As the cathode component of the bias becomes small, the grid losses approach $1.5 E_c I_c$ as a limit. See paragraph 1-296. The values of the cathode resistance, R_k , usually range from 100 to 1000 ohms. The reactance of the bypass capacitor should be at least as small as $R_k/10$ at the lowest operating frequency. With R_k connected between cathode and ground, the d-c voltage developed equals $(I_b + I_c) R_k$; or approximately, $I_b R_k$. The total bias,

E_c , is still approximately equal to $\sqrt{2} E_g$. The d-c grid current is given by the equation

$$I_c = \frac{|E_c| - E_k}{R_g} \approx \frac{\sqrt{2} E_g - I_b R_k}{R_g} \quad 1-307 (1)$$

where E_k is the voltage across the cathode resistor.

AGC USED WITH PIERCE OSCILLATOR

1-308. Where space and cost permit, optimum output stability can be had when the oscillator bias is provided through an automatic-gain-control circuit. Gridleak action can be effective in initiating oscillations, but the bias furnished through AGC should be of much greater magnitude in order to be of maximum effectiveness. A small increase in output voltage must cause a large increase in bias. The use of AGC reduces the grid losses to a minimum and maintains a constant amplitude of oscillation. It is this latter feature that is, of course, of most importance—particularly so when the same oscillator is to be switched from one crystal unit to another. The voltage requirements for constant output without risking the overdrive of any of the crystals are the same as those that apply in the case of manual adjustment of the output. (See paragraph 1-302.) An A-G-C circuit applicable for use with a Pierce, or Miller, type oscillator, is shown in figure 1-131. The oscillator output is amplified by V_2 . The output of V_2 is then rectified by V_3 . The oscillator bias equals the average rectified voltage across R_3 . C_1 bypasses the r-f component to ground. If R_3 were increased indefinitely the

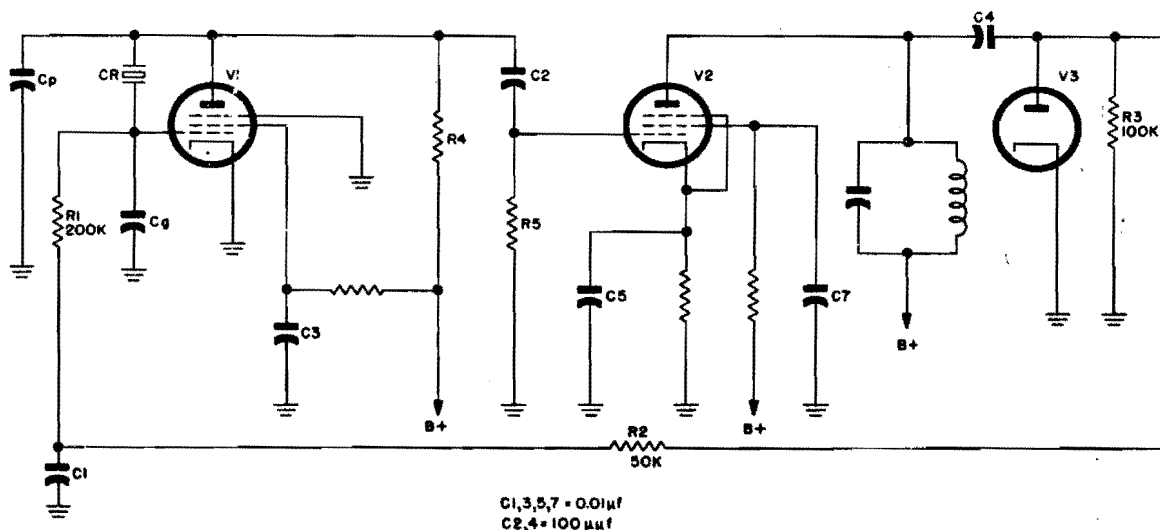

Figure 1-131. Pierce oscillator with automatic gain control

bias voltage would approach in magnitude the peak value of the V_2 output voltage. R_1 , R_2 , and R_3 are not critical—each can be made equal to 50K, if a faster-acting gain control is required. However, R_1 should be kept as large as possible. Assume that the r-f losses in R_1 , R_2 , and R_3 are negligible and that C_p and C_g are approximately equal, so that V_1 is operating into a load impedance approximately equal to $PI/4$. Under these conditions g_m will be the minimum and R_p the maximum possible for sustained oscillations as long as the load capacitance across the crystal unit remains constant. The actual values of g_m and R_p are fixed by the vacuum-tube characteristics. Although the effective parameters of the tube are directly dependent upon the peak-to-peak magnitude of the excitation, as well as indirectly through the bias, it can be said that to a first approximation the equilibrium R_p and g_m are associated with a bias of more or less definite magnitude if the plate voltage is constant, and that approximately the same bias must exist regardless of whether it is developed by gridleak action or by AGC. Thus, the difference between AGC and gridleak control is not primarily in the magnitude of the bias, but in the amplitude of oscillations. Gridleak action requires that the peak excitation voltage of V_1 be slightly greater than the required bias; AGC requires that the peak excitation voltage of V_2 times the voltage amplification of the V_2 stage be slightly greater than the required bias of V_1 . If the peak excitation voltage of V_2 is assumed to equal E_{pm} , which, in turn, is assumed to equal E_{gm} , $\left(\frac{C_g}{C_p} \approx 1\right)$, and k_2 is the effective amplification of the V_2 stage, then

$$|E_c| = k_2 E_{gm} \quad 1-308 (1)$$

or

$$E_{gm} = |E_c/k_2|$$

Since E_c is approximately fixed, it can be seen that the amplitude of oscillations is only $\frac{1}{k_2}$ as large as those that would exist by the gridleak method employing the same plate voltage. This is not a desirable feature where large output is required, but from the point of view of ensuring a low crystal drive and maximum stability, an A-G-C circuit has great advantages. Although the equilibrium amplitude is low, oscillations start as readily as with gridleak bias. AGC permits class-A operation with remote-cutoff tubes, and, since the limiting is very slow-acting, very pure sine-wave outputs and excellent frequency stability as well as amplitude stability is obtainable.

PLATE-SUPPLY CIRCUIT OF PIERCE OSCILLATOR

1-309. For optimum frequency stability it is important that the r-f impedance of the B^+ circuit be as high as possible relative to the impedance of the tank. If $C_g/C_p = 1$, the tank impedance equals $PI/4$. If the oscillator is intended to oscillate at only one frequency, or within a narrow frequency range, it is generally preferable that the B^+ voltage be fed through an r-f choke. This method affords a maximum impedance with minimum loss and minimum voltage at the B^+ source. The inconvenience of an r-f choke is that its impedance changes with frequency, being inductive below its effective parallel-resonant point, and capacitive above. As long as this effect does not change the effective value of C_p by more than ± 10 per cent, the total load capacitance will not change by more than 5 per cent, if $C_g/C_p = 1$. Within these limits the use of a choke is to be preferred. For wide frequency ranges, a resistor should be used in the plate circuit, such as R_4 in figure 1-131. It is desirable for this resistance to be as high as 50K, or higher, from the point of view of frequency stability. On the other hand, the larger the resistance the higher the B^+ voltage source must be to provide a given plate voltage. Plate-supply resistances on the order of 5000 to 10,000 ohms have one other important advantage besides permitting lower B^+ sources. They load the oscillator tank so that differences in the resistance of the crystal from one unit to the next have very little effect upon the output impedance of the tube. Hence, when a change is made from one crystal unit to the next, the output voltage remains approximately the same.

1-310. The proper compromise in selecting a plate-circuit resistance depends upon the frequency-tolerance limits. The plate-circuit resistance does afford a certain frequency-stabilizing effect that is not provided by an r-f choke, particularly so when agc is used. The effect is one of reducing the change in R_p of the vacuum tube caused by a change in grid bias. For example, if the bias becomes more negative R_p increases, and I_b , the average plate current, decreases. There is then less voltage drop across the plate-supply resistor, and the resulting increase in plate voltage tends to decrease R_p , thereby annulling part of the increase in R_p due to the change in bias. The plate-voltage source should be regulated, if good stability is required. Where the frequency deviation must be kept to a minimum, the oscillator may require a separate rectifier unit, filter circuit, and voltage-regulator circuit.

**CHOOSING A VACUUM TUBE FOR
THE PIERCE CIRCUIT**

1-311. It is no problem to find a vacuum tube that will permit a Pierce circuit to oscillate. Indeed, one of the major problems in tube circuit design is to prevent oscillations from occurring. With a crystal connected between the plate and grid of any vacuum-tube amplifier, the stray capacitance in the circuit is usually sufficient to cause oscillations to build up. If the plate voltage is not so high that the crystal is over-driven, the frequency stability of a stray-capacitance circuit may even be satisfactory for general-purpose use. Thus, the problem is not to find a vacuum tube that will work, but one that will be most satisfactory from the point of view of output stability and cost. First, a large tube is not necessary, since the Pierce circuit is not suited for large output. The choice of tube will depend somewhat upon the exact purpose of the oscillator and of the equipment of which it is a component. If the frequency tolerance is to be large, little thought need be given to fine points in the design, for the principal problem will be to keep the production costs to a minimum. A triode would be satisfactory, a 5K to 50K resistance in the plate circuit, a C_r/C_p ratio between 1 and 2, and a plate voltage sufficiently low so that the driving power of the crystal does not exceed the rated level for any effective crystal resistance meeting the specifications. A high- μ triode generally provides the better frequency stability because of its larger effective R_p , but it will have a higher plate dissipation for the same output voltage. Of the high- μ triodes, probably the 6AB4 is to be preferred as a simple unit, and the 12AX7 and the 12AT7 as twin triodes. It is the medium- μ tube that has been the most favored by design engineers when a triode has been chosen. Of these the 6C4, 6J4, and 7A4 single units, and the 6SN7-GTA twin unit are among the more popular. The 6C4 and the 6J4 are to be preferred for high-frequency operation. Since the 7A4 and the 6SN7-GTA have approximately 4 $\mu\mu\text{f}$ capacitance between grid and plate, the 6C4, 6J4, 6J6, or the 12AU7, each with 1.5 $\mu\mu\text{f}$ capacitance grid to plate, should provide the better frequency stability — particularly at high frequencies. The 7A4 and the 6SN7-GTA are generally more satisfactory for use in a Miller circuit. Where greater frequency stability is required, a pentode should be used. A pentode has the advantages of low plate-to-grid capacitance, greater R_p , and a screen grid whose voltage can be adjusted independently of the control-grid bias and plate voltage, thereby permitting a greater range of adjustments in the plate characteristics. Con-

ventional pentodes must be operated at reduced voltages, to avoid overdriving the crystal, unless rather high C_r/C_p ratios are used. Subminiature pentodes have operating characteristics at their normal operating voltages ideally suited for crystal drive levels. The 1U4 is one such type having a sharp cutoff. Among the miniature pentodes having a sharp cutoff, the 6AU6, 6BC5, and 6AH6 are tubes generally recommended for wide-band, h-f circuits. The 6CB6, although designed principally for television use at 40 mc, should also be quite appropriate in crystal oscillator circuits. Remote-cutoff tubes are generally used only in special circuits. For example, if a low harmonic output is required, such tubes could be employed in conjunction with AGC. When the harmonic content is not of first importance, AGC is more effective if used with sharp-cutoff tubes, where a slight change in grid bias can make a much larger change in small-signal outputs than is possible if the slope of the $E_r I_p$ curve changes very gradually. Actually, remote-cutoff tubes, when used, are usually found in doubler circuits, because of the large second-harmonic component that is produced. Although class-B and class-C operation with sharp-cutoff tubes can produce even greater harmonic outputs, there is the problem of ensuring that a crystal of large R_c will not be overdriven if it is to be operated in a class-B or class-C circuit. The output voltages of remote-cutoff tubes tend to vary more with crystals of different resistances than is the case when sharp-cutoff tubes are used. The reason is that in the former case the effective I_p continues to increase as R_c becomes small, since very large excitation voltages are required to override the cutoff point. On the other hand, the effective I_p begins to decrease when class-B operation is approached and such operation can be had with relatively small excitation voltages when sharp-cutoff tubes are used. If a remote-cutoff tube is desired, recommended types are the subminiature 1T4, the miniature 6BA6 and 12BA6, the lock-in 7A7, and the conventional-sized tubes such as the 6SK7 and 12SK7. The mention of particular vacuum tubes here should not be construed as official recommendation; they are named simply because they are the tubes commonly found in new equipment. The design engineer may very well find that the characteristics of other tubes are more appropriate for his needs.

***Pierce-Oscillator Design Considerations When
Vacuum Tube with Very Sharp Cutoff is Used***

1-312. In making a preliminary approximation as to what the performance of a particular tube will

Section I
Crystal Oscillators

be if used in a Pierce circuit, it should first be kept in mind that the ratio

$$E_p/E_g = C_g/C_p = \frac{\mu Z_L}{R_p + Z_L} = \frac{g_m R_p Z_L}{R_p + Z_L} \quad 1-312 (1)$$

is the gain of the tube. If the gain = k , and if

$\frac{R_p}{Z_L}$ is 10 or greater, then

$$g_m = k/Z_L \quad 1-312 (2)$$

or

$$R_p = \mu Z_L/k \quad 1-312 (3)$$

Either equation (2) or (3) can be used to estimate approximately the grid bias for a given plate voltage, and vice versa, that can be expected if a particular tube is used. Assume, for example, that $k = 1$, that gridleak bias is to be used, and that the grid and load losses are negligible compared with the crystal driving power. In this case, the minimum expected Z_L will equal (min) πI_4 , which occurs when a crystal unit has the maximum allowable R_c and is operated at the rated load capacitance, C_x . Under these conditions, the maximum permissible bias, as given by equation 1-293 (2), is

$$(\text{max}) E_c = -\sqrt{2 P_{cm}} / 2\omega C_x \sqrt{R_{cm}}$$

This maximum value of E_c is to be interpreted as a maximum that can be allowed *only* if R_c is a maximum *or* if the output voltage is to be the same magnitude regardless of the value of R_c . In this latter case, P_{cm} and R_{cm} fix the output and bias limits for all crystal units of a given type. The constant output can be obtained in several ways: by the use of an actual or equivalent, parallel, plate load resistance that is small compared with the minimum nonloaded crystal tank impedance; by the use of AGC, by the use of manual voltage adjustments; or by other methods. The present discussion concerns only the noncontrolled nonloaded circuit. If a crystal unit of maximum R_c , being driven at the maximum drive level, is replaced by a crystal unit of smaller R_c , Z_L increases, and E_p and I_g tend to increase proportionately, so that the crystal driving power, equal to $I_g^2 R_c$, is greater than when R_c is a maximum. According to equation (3), insofar as it can be assumed that μ remains approximately constant (in practice, μ decreases somewhat) R_p increases proportionately with Z_L , so that although the equivalent generator voltage, $-\mu E_g$, increases, I_p remains constant. Thus, $I_p \approx g_m E_g \approx k E_g / Z_L \approx \text{constant}$. In an actual circuit

where $R_p \gg Z_L$ and the vacuum tube has a very sharp cutoff, the effective I_p increases up to the point that the tube is cutoff for approximately three-fifths of the negative alternation (three-tenths of the entire cycle). As the excitation voltage increases beyond that point, I_p progressively decreases, although the total power supplied to the tank circuit continues to increase as long as the excitation voltage continues to increase. The conclusions above are derived in the special case of a C_g/C_p ratio of unity, by assuming that for all practical purposes the plate-current pulses are in phase with E_p , and that $E_b \gg E_p$. Figure 1-132 illustrates different states of operation of the same oscillator circuit that can occur if crystal units of the same frequency but different values of R_c are inserted in the circuit. A change from the class-A to the class-C state could readily occur if the crystal R_c were reduced by more than one-half. The effective I_{pm} is defined by the equation

$$P_{Z_L} = I_{pm} E_{pm}/2 \quad 1-312 (4)$$

where P_{Z_L} is the power expended in the tank circuit. Since Z_L is very small compared with R_p , it can be assumed that the sinusoidal component, E_{pm} , of the with-signal d-c plate voltage, e_p , is negligible by comparison with the average value, E_b ; that is, $E_b \pm E_{pm} \approx E_b$. With this assumption we can treat I_{bm} , the value of the with-signal, d-c plate current, at the positive peak of excitation ($e_c \approx 0$) as a constant. The assumptions above also imply that very little grid current exists; otherwise, the larger excitation voltages would drive the grid considerably above zero at the positive peaks. With the peak instantaneous d-c plate current a constant, the *total* energy supplied by the power source progressively decreases as Z_L and the excitation increase, since I_b , the average i_b , becomes progressively smaller, whereas E_b remains constant. (Actually, if the plate current is supplied through a resistor, a decrease in I_b causes E_b to increase somewhat. For the problem at hand, assume that a regulated B^+ is fed through an r-f choke.) Thus, it can be seen that as R_c becomes small the plate efficiency increases considerably. However, the efficiency of a crystal oscillator does not approach the high ratios of input to tank power that are obtained with conventional class-C power amplifiers and oscillators. The latter circuits can operate at efficiencies of 60 to 90 per cent because E_{pm} approaches E_b in magnitude. The instantaneous power being dissipated in the tube is the instantaneous value of $i_b e_b$, and the instantaneous power being delivered to the tank is $i_b e_p$. When i_b is a maximum, $e_b = E_b - E_{pm} \ll e_p =$

E_{pm} , so that most of power goes to the tank circuit. In the conventional Pierce oscillator such high efficiency is not to be approached unless the C_g/C_p ratio is to be made very large and E_b approaches in magnitude the voltage specifications of the crystal unit. Now, to obtain a maximum output without the risk of overdriving a randomly selected crystal unit, it will be useful to derive approximate equations concerning the change in crystal power with a change in R_e . The crystal power, we shall assume to equal the total tank power, P_{ZL} . In short, the problem is to be able to express P_{ZL} as a function of R_e , I_{bm} , E_b , and E_{co} (the cutoff voltage) will be considered constants, and i_p and e_p are to be assumed to be in phase. First, we express the effective I_{pm} for each class of operation in terms of the constants above and the angles ϕ and θ , where appropriate. (See figure 1-132.) As a safeguard against intermittent oscillations, which are most likely to occur when R_e is a maximum, assume that the bias for maximum R_e is to occur on the straight portion of the $E_c I_b$ curve. If the

oscillations are to build up at all, they must continue to do so until the negative excitation peak at least extends into the lower bend of the $E_c I_b$ curve, for it is only beyond the straight portion of the curve that g_m can change in order to seek its equilibrium value—that is, unless R_g is so small that equilibrium is reached by virtue of the increase in grid losses alone. With a large R_g and a reasonably sharp cutoff, it is virtually impossible for oscillations to start if the amplification is not at least sufficient to increase the excitation to where the negative peak is very nearly equal to E_{co} . Assume, then, that with $R_e = R_{em}$, the oscillator is designed to operate approximately as shown in figure 1-132 (A). It can be seen intuitively that

$$\text{(Class A)} \quad I_{pm} \approx I_{bm}/2 \quad 1-312 \text{ (5)}$$

and with $C_g/C_p = 1$, considering only the unsigned magnitudes of the bias voltage,

$$\text{(Class A)} \quad E_{pm} = E_c = E_{co}/2 \quad 1-312 \text{ (6)}$$

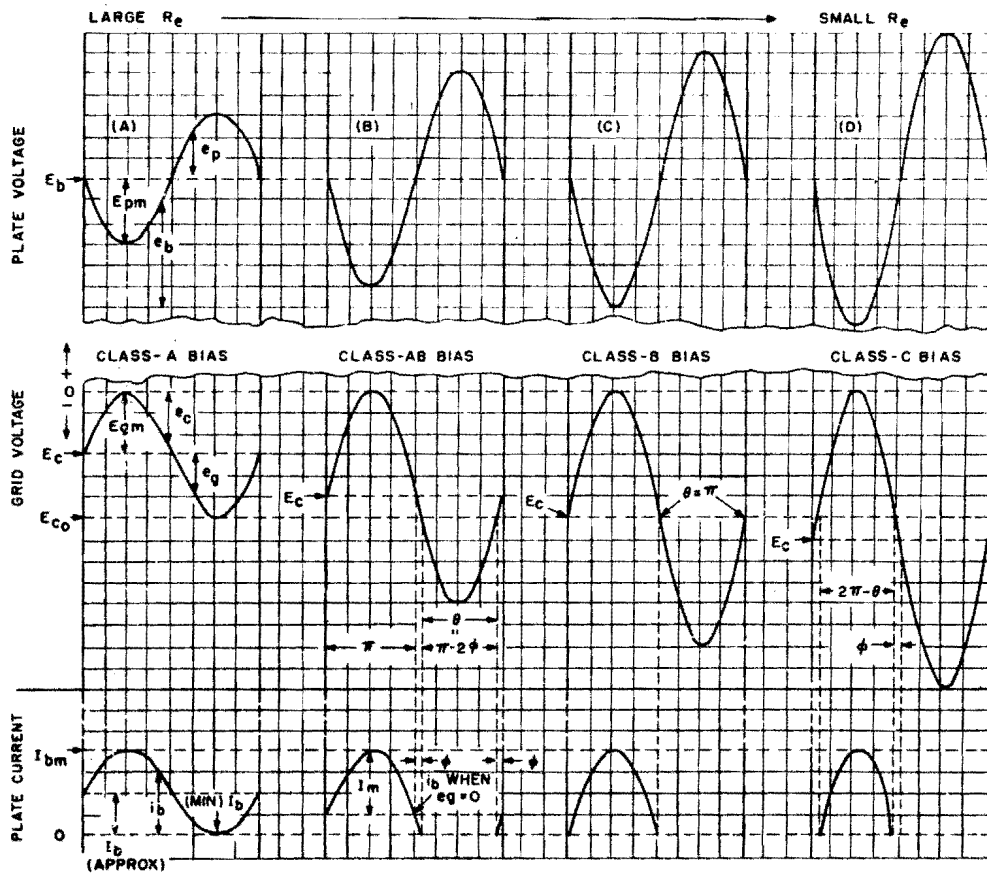

Figure 1-132. Change of state of Pierce oscillator with a C_g/C_p ratio of one, under no-load conditions when E_b is held constant and the effective resistance of the crystal changes

Section 1
Crystal Oscillators

so that

$$\text{(Class A) } P_{zL} = I_{pm} E_{pm}/2 = I_{bm} E_{co}/8 \quad 1-312 (7)$$

Equation (7) represents the maximum possible crystal power if a tube is not to be driven beyond cutoff. Referring now to figure 1-132 (B), we shall assume that a crystal unit with an R_c slightly less than the maximum is connected so that the bias is similar to that under AB operating conditions. I_m represents the *apparent* maximum I_p . It can be seen that except for the angle $(\pi - 2\phi)$, when the tube is cut off,

$$i_b \approx I_m (\sin \omega t + \sin \phi) \quad 1-312 (8)$$

where ϕ can be considered a constant. Now,

$$I_{bm} = I_m (1 + \sin \phi) \quad 1-312 (9)$$

so, on substitution in equation (8),

$$i_b = \frac{I_{bm}}{1 + \sin \phi} (\sin \omega t + \sin \phi) \quad 1-312 (10)$$

Similarly,

$$E_{co} = E_{gm} (1 + \sin \phi) = E_{pm} (1 + \sin \phi) \quad 1-312 (11)$$

so that

$$e_p = E_{pm} \sin \omega t = \frac{E_{co}}{1 + \sin \phi} (\sin \omega t) \quad 1-312 (12)$$

Since no energy is being supplied during the time that the tube is cut off, the energy delivered to the tank per cycle is

$$\int_t^{t+(\pi+\phi)} e_p i_b dt = \frac{1}{\omega} \int_{-\phi}^{\pi+\phi} e_p i_b d\omega t \quad 1-312 (13)$$

where t = time in seconds.

Thus, the energy delivered per second, is

$$P_{zL} = \frac{f}{\omega} \int_{-\phi}^{\pi+\phi} e_p i_b d\omega t = \frac{1}{2\pi} \int_{-\phi}^{\pi+\phi} e_p i_b d\omega t \quad 1-312 (14)$$

On substitution of E_p and I_b from equations (10) and (12),

$$P_{zL} = \frac{E_{co} I_{bm}}{2\pi (1 + \sin \phi)^2} \int_{-\phi}^{\pi+\phi} (\sin^2 \omega t + \sin \phi \sin \omega t) d\omega t \quad 1-312 (15)$$

On integration,

$$\text{(Class AB) } P_{zL} = \frac{E_{co} I_{bm} (\pi + 2\phi + 2 \sin 2\phi)}{4\pi (1 + \sin \phi)^2} \quad 1-312 (16)$$

No maximum exists for equation (16) with values of ϕ between 0 and $\pi/2$. For class-A operation similar to that in figure 1-132 (A), $\phi = \pi/2$, so that equation (16) becomes

$$\text{(Class A) } P_{zL} = E_{co} I_{bm}/8$$

This checks, as is to be expected, with equation (7). For class-B operation, $\phi = 0$, so that equation (16) becomes

$$\text{(Class B) } P_{zL} = E_{co} I_{bm}/4 \quad 1-312 (17)$$

Note that the power expenditure in the crystal unit for class-B operation is exactly twice that found for class-A operation. Since E_{pm} under class-B conditions is equal to E_{co} (see figure 1-132 (C)), or twice the class-A value of E_{pm} , then, because $P_{zL} = I_{pm} E_{pm}/2$, the effective I_{pm} at class B must be equal to the same effective value as at class A. Thus,

$$\text{(Class B) } I_{pm} = I_{bm}/2 \quad 1-312 (18)$$

Also, since $E_{pm} = I_{pm} Z_L$, if E_{pm} has doubled but I_{pm} has not changed it can only mean that Z_L has doubled. In other words, if the oscillator is designed to operate class A when R_c is a maximum, it will operate class B when a crystal unit is inserted that has an effective resistance equal to $R_{cm}/2$. Equation (16) can be generalized to apply for all operating states in which $2E_{pm}$ is equal to or greater than E_{co} . For greater simplicity, ϕ should be replaced by $(\pi - \theta)/2$, where $\theta = \pi - 2\phi$ is the angle during which the tube is cut off. θ is always positive, whereas ϕ would be negative in the case of class-C operation. Thus, equation (16) can be expressed

$$\text{(all classes) } P_{zL} = \frac{E_{co} I_{bm} (2\pi - \theta + \sin \theta)}{4\pi \left(1 + \cos \frac{\theta}{2}\right)^2} \quad 1-312 (19)$$

The slope of this equation is positive for all values of θ less than 2π , so that the power dissipated in a crystal unit always becomes greater as R_e becomes smaller. By substituting $\cos \frac{\theta}{2}$ for $\sin \phi$ in equation (11) and rearranging, we have

$$E_{pm} = E_{co} / \left(1 + \cos \frac{\theta}{2} \right)$$

so that

$$\begin{aligned} I_{pm} &= \frac{2 P_{zL}}{E_{pm}} = 2 P_{zL} \left(1 + \cos \frac{\theta}{2} \right) / E_{co} \\ &= \frac{I_{bm} (2\pi - \theta + \sin \theta)}{2\pi \left(1 + \cos \frac{\theta}{2} \right)} \end{aligned} \quad 1-312 (20)$$

Equation (20), unlike equation (19), has a maximum when θ is approximately $3\pi/5$. That a maximum (or a minimum) occurs between $\theta = 0$ and $\theta = \pi$ is to be expected, since I_{pm} has the same value for each of those values of θ . This maximum is

$$(\max) I_{pm} = 0.54 I_{bm} \quad 1-312 (21)$$

Now,

$$Z_L = 2 P_{zL} / (I_{pm})^2 \quad 1-312 (22)$$

On substituting equations (10) and (20) in (22)

$$Z_L = \frac{2\pi E_{co}}{I_{bm} (2\pi - \theta + \sin \theta)} \quad 1-312 (23)$$

Rearranging and substituting $1/4\omega^2 C_x^2 R_e$ for Z_L , where C_x is the specified load capacitance of the crystal unit,

$$\theta - \sin \theta = 2\pi (1 - 4\omega^2 C_x E_{co} R_e / I_{bm}) \quad 1-312 (24)$$

Equation (24) is quite significant in that it predicts the approximate angle during which a given tube will be cut off for a given value of R_e . A Pierce oscillator designed so that the tube is operating with a class-A bias equal to $E_{co}/2$ when R_e is a maximum will have a value of θ equal to zero. Thus, when $R_e = R_{em}$, each side of equation (24) must vanish. For the right-hand side to equal zero,

$$4\omega^2 C_x E_{co} R_{em} = I_{bm}$$

This is equivalent to saying that

$$\frac{1}{(\min) Z_L} = \frac{4}{(\min) P_L} = \frac{I_{bm}}{E_{co}} = (\text{average}) g_m \quad 1-312 (25)$$

which could have been predicted on the basis of equation (2). Assume that equation (25) holds, what will be the value of θ when a crystal unit having a practical minimum value of R_e equal to $R_{em}/9$ is connected in the circuit? When $R_e = R_{em}$, the negative term within the parentheses of equation (24) is equal to -1 ; with $R_e = R_{em}/9$, the same term is reduced to $-1/9$. Thus, the maximum θ to be expected is defined by:

$$[(\max) \theta \text{ for } (\min) R_e] \text{ when: } \theta - \sin \theta = 16\pi/9 \quad 1-312 (26)$$

Figure 1-133 shows that equation (26) requires that

$$(\max) \theta \approx 16\pi/9 - 1 \quad 1-312 (27)$$

In other words, when a sharp-cutoff tube is used and the oscillator is designed for class-A operation with crystal units of maximum R_e , the oscillator will be operating class C, with the tube cut off approximately three-fourths of the time, when crystal units of minimum values of R_e are connected in the circuit. Equation (24) can be generalized to define θ with reference to any convenient value of R_e , simply by assuming that $\theta = 0$ when $R_e = (\text{ref}) R_e$. Thus,

$$\theta - \sin \theta = 2\pi [1 - R_e / (\text{ref}) R_e] \quad 1-312 (28)$$

or

$$\theta_N - \sin \theta_N = 2\pi (N - 1) / N \quad 1-312 (29)$$

where $N = (\text{ref}) R_e / R_{eN}$, $\theta = 0$ when $R_e = (\text{ref}) R_e$, and θ_N is the value of θ for the particular value of R_e symbolized by R_{eN} . The reference R_e need not be the maximum permissible R_e . For a given oscillator of C_p/C_s ratio equal to 1, $(\text{ref}) R_e$ would be the value of R_e that would cause the peak-to-peak excitation voltage to equal E_{co} in magnitude. Assuming that $(\text{ref}) R_e = R_{em}$, what then will be the ratios of P_{zL} and I_{pm} corresponding to minimum and maximum values of R_e ? When $\theta = \frac{16\pi - 9}{9}$, as given by equation (27), $\cos \theta/2$ is very nearly $-2/3$, so equation (19) becomes

(Class C max) P_{zL}

$$\begin{aligned} &= \frac{E_{co} I_{bm} \left(2\pi - \frac{16\pi}{9} \right)}{4\pi \left(1 - \frac{2}{3} \right)^2} = \frac{E_{co} I_{bm}}{2} \end{aligned} \quad 1-312 (30)$$

On comparison with equations (7) and (17), which give values of P_{zL} of $E_{co} I_{bm} / 8$ and $E_{co} I_{bm} / 4$

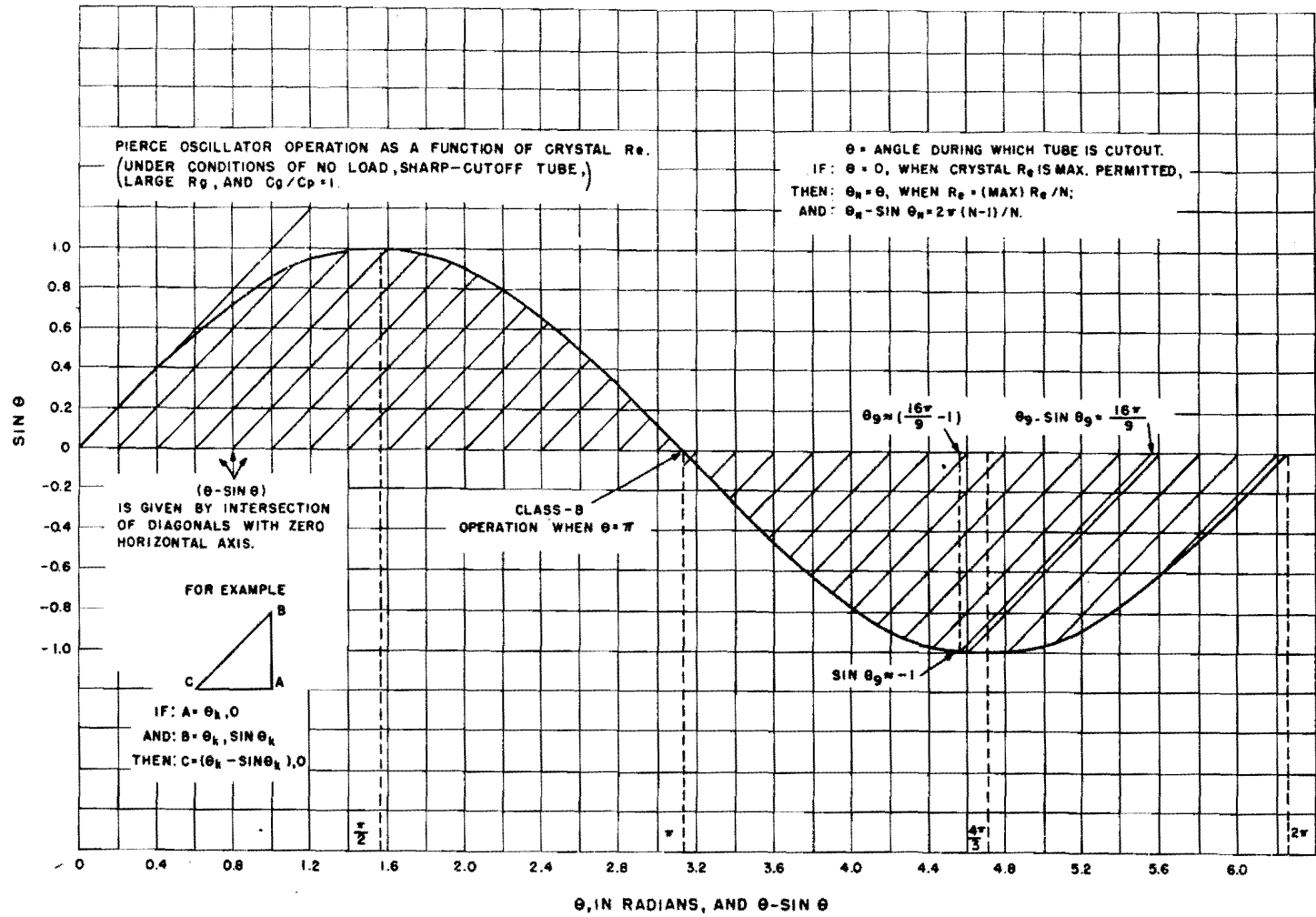

Figure 1-133. Sine curve plotted to same scale as the angle θ . 45-degree diagonal that intercepts $\sin \theta_k$ on curve intercepts $(\theta_k - \sin \theta_k)$ on θ axis

for class-A and class-B operation, respectively, we find that where there is to be no output control, the no-load tube voltage must be so chosen that a crystal unit of maximum R_e is not driven at more than one-fourth the rated drive level, otherwise crystals of small R_e will be overdriven. With a power ratio of 4 when the Z_L ratio is 9, it can be shown quite simply that the I_{pm} ratio is 2/3 and the E_{pm} ratio is 6. Thus,

$$\text{(Class-C min) } I_{pm} = I_{bm}/3 \quad 1-312 \text{ (31)}$$

and

$$\text{(Class-C max) } E_{pm} = 3 E_{co} \quad 1-312 \text{ (32)}$$

The plate dissipation in the tube should be of little concern unless subminiature tubes are used. In any event the plate dissipation is a maximum when R_e is a maximum, so no thought need be taken for other than class-A operation. Approximately,

$$\text{(Class-A) plate power} = E_b I_b = E_b I_{bm}/2 \quad 1-312 \text{ (33)}$$

Finally, the foregoing equations suggest that a Pierce oscillator employing a sharp-cutoff tube be designed for class-A operation on the assumption that R_e will be a maximum and that the maximum permissible drive level is one-fourth its actual rating. Under these assumptions, equation 1-293 (2) should be changed to

$$\text{(max) } E_c =$$

$$-\frac{\sqrt{2 P_{cm}/4}}{2\omega C_x \sqrt{R_{em}}} = -\frac{\sqrt{P_{cm}}}{2\omega C_x \sqrt{2 R_{em}}} \quad 1-312 \text{ (34)}$$

where P_{cm} is the true drive-level rating. Since (max) E_c will also be equal to $E_{co}/2$, approximately, then (no longer continuing to treat E_{co} as a magnitude only)

$$\text{(max) } E_{co} = -\sqrt{P_{cm}} / \omega C_x \sqrt{2 R_{em}} \quad 1-312 \text{ (35)}$$

At the same time, $P_{ZL} \left(= \frac{I_{bm} E_{co}}{8} \right)$ must not exceed $P_{cm}/4$. Consequently,

$$\text{(max) } I_{bm} = \frac{2 P_{cm}}{\text{(max) } |E_{co}|} = 2\omega C_x \sqrt{2 P_{cm} R_{em}} \quad 1-312 \text{ (36)}$$

Equations (35) and (36) define the operating characteristics to be sought if a sharp-cutoff tube is to be used under conditions of maximum output for maximum stability. Remember, that equation (34) actually is an expression of the limitation on I_g , the crystal current, and therefore upon E_p and E_g . As far as the self-excitation voltage of a truly sharp-cutoff tube is concerned, it will be difficult to keep this voltage from building up until it reaches into the bend near the cutoff point. For this reason, the first consideration is that I_{bm} is not exceeded. As a safety measure, I_{bm} should not be greater than the value given by equation (36), even if the actual E_{co} is less than (max) E_{co} . The conclusions reached in the foregoing discussion are summarized in the following table.

PIERCE-CIRCUIT OPERATING LIMITATIONS DUE TO CRYSTAL SPECIFICATIONS OF LOAD CAPACITANCE, C_x , MAXIMUM PERMISSIBLE EFFECTIVE RESISTANCE, R_{em} , AND DRIVE LEVEL, P_{cm}			
Plate Dissipation (max) = $E_b I_{bm}/2$ $E_{co} = -\sqrt{P_{cm}/\omega C_x \sqrt{2 R_{em}}}$ $I_{bm} = 2 P_{cm}/ E_{co} $		Conditions are those for sharp-cutoff tube, negligible load, gridleak bias with large R_g , $C_g/C_p = 1$, $E_b \gg E_p$, $R_p \gg (\text{max}) PI/4 = (\text{max}) Z_L$, Class-A operation when R_e is maximum, and maximum permissible output.	
$R_e =$	R_{em}	$R_{em}/2$	$R_{em}/9$
$E_{pm}, E_{gm}, E_c =$	$ E_{co}/2 $	$ E_{co} $	$3 E_{co} $
$P_c (= P_{ZL}) =$	$P_{cm}/4$	$P_{cm}/2$	P_{cm}
$I_{pm} =$	$I_{bm}/2$	$I_{bm}/2$	$I_{bm}/3$
$Z_L =$	(min) $PI/4$	(min) $PI/2$	9 (min) $PI/4$
$g_m =$	$4/(\text{min}) PI$	$2/(\text{min}) PI$	$4/9$ (min) PI
$\theta =$	0	π	$\frac{16\pi}{9} - 1$
Operation =	Class A	Class B	Class C

Section I
Crystal Oscillators

Pierce-Oscillator Design Considerations When Tube Cutoff Has Below-Average Sharpness

1-313. Unless a vacuum tube has plate characteristics resembling those of subminiature tubes when normal plate voltages are used, or unless by reducing the filament voltage such characteristics can be achieved, a Pierce oscillator tube must be operated at a plate voltage of from one-half to one-fourth normal. In so doing, it is very probable that the lower bend of the $E_c I_b$ curve will become rather extended compared with the straight portion to the left of zero grid volts. In this event, the tube exhibits the characteristics of a remote-cutoff tube, except that the cutoff voltage is one-fifth or less that of a normal remote-cutoff tube operating at an equivalent reduced plate voltage. Where the cutoff is not sharp, it is quite easy for equilibrium to be reached with peak-to-peak excitation voltages much smaller in magnitude than E_{co} , and considerably greater ranges in R_c of the crystal unit can exist before cutoff is reached. Thus, in the more usual case, the assumptions used in paragraph 1-312 cannot be made unless greater care is taken in the oscillator design to ensure a peak-to-peak excitation voltage equal to $|E_{co}|$ when R_c is a maximum—an operating point much more difficult to locate and critical to maintain when a large steady decrease in the effective g_m occurs well before the cutoff point is reached, and which may require very low plate voltages if the maximum- R_c crystal unit is not to be overdriven. As a concrete example, suppose that the oscillator is to employ a 10-mc crystal unit of the CR-18/U type. At this frequency, $P_{cm} = 5$ mw, $R_{em} = 25$ ohms, and $C_x = 32 \mu\mu\text{f}$. On substitution in equation 1-312 (35), we obtain a (max) E_{co} of approximately -5V . By equation 1-312 (36), this value of E_{co} is to be obtained in a tube where the zero-bias, without-signal plate current is $I_{bm} = 2$ ma. Such characteristics are not easily obtained with conventional-sized vacuum tubes. It may be necessary to operate at the given value of I_{bm} , or slightly greater, and a cutoff voltage that is of a smaller magnitude than that indicated for (max) E_{co} in equation 1-312 (35), in which case all crystal units used will drive the tube beyond cutoff. An alternative approach is to operate at a larger than maximum E_{co} , but, if this be done, a safety factor should be allowed by assuming that I_p is to be the same for all values of R_c . Although this will not be strictly true, the assumption is a close approxima-

tion if the change in plate current between the values of $E_c = E_{co}/2$ and E_{co} is very small compared with the change in plate current between $E_c = 0$ and $E_c = E_{co}/2$. It can be seen that insofar as the effective I_p can be assumed to remain constant, E_p , and hence E_g , I_g , E_c , and the crystal driving power, $I_g^2 R_c \approx I_p^2 Z_L$, increase directly with Z_L , or inversely with R_c . The problem is to find the maximum permissible E_c , which, although applying to extended-cutoff operation only when R_c is a maximum, will not lead to a replacement crystal being over-driven if its resistance is less than the maximum. Again we assume a minimum R_c equal to $R_{em}/9$. In a manner similar to the derivation of equation 1-293 (2), we can say (max) E_c (with (min) R_c) =

$$\begin{aligned} \text{(max) } E_c \text{ [for (min) } R_c] &= - \frac{\sqrt{2 P_{cm}}}{2\omega C_x \sqrt{\text{(min) } R_c}} \\ &= - \frac{3\sqrt{P_{cm}}}{\omega C_x \sqrt{2 R_{em}}} \end{aligned} \quad 1-313 (1)$$

Now, if equation (1) gives the bias voltage when a crystal unit of minimum R_c is connected, assuming that I_p is constant, the bias that exists when a crystal unit of maximum R_c ($= 9$ (min) R_c) is substituted will be one-ninth the value above. Thus,

$$\begin{aligned} \text{(extended cutoff max) } E_c \text{ [for } R_c = R_{em}] &= \\ &= - \frac{\sqrt{P_{cm}}}{3\omega C_x \sqrt{2 R_{em}}} \end{aligned} \quad 1-313 (2)$$

If a gridleak Pierce oscillator is not to have a loaded plate circuit, nor an adjustable nor controlled output voltage, nor a sharp cutoff, equation (2) gives the maximum bias that can be safely assumed when R_c is a maximum. The output voltage agreeing with equation (2) is two-thirds that given in paragraph 1-312 for a sharp-cutoff tube. If R_c is not large enough for the average E_c to approximate the peak excitation voltage, a maximum bias less than that given by equation (2) must be assumed. With large values of R_c , $|E_c|$ of equation (2) is the peak of the maximum excitation voltage when R_c is a maximum, and $|E_c|$ of equation (1) is the approximate peak when R_c is a minimum. If a C_g/C_p ratio other than 1 is used, equation (2) can be expressed more exactly

$$\text{(extended cutoff max) } E_c =$$

$$-\sqrt{2 P_{em}} / 3\omega C_x \sqrt{R_{em}} \quad 1-313 (3)$$

It should be understood that although equations (2) and (3) are derived from equation (1), it is wiser to select the vacuum tube and plate voltage upon the assumption that the resistance of the crystal unit is a maximum rather than a minimum. Since the effective amplification factor of the tube cannot be expected to be constant for all values of R_e , equations (1) and (2) will not both hold for the same circuit. If (1) is correct, (2) will indicate a value too low; if (2) is correct, (1) will indicate a value too high. Equation (2) therefore permits a safety factor in the event of an exceptionally low value of R_e . Also, if the oscillator performs properly with R_e a maximum, it will almost certainly operate when R_e is a minimum. The reverse is not necessarily true.

1-314. Equation 1-313(1) is equivalent to a bias and output of the same magnitude as that obtained in paragraph 1-312 for sharp-cutoff conditions and minimum R_e ; but the bias and output of equation 1-312(2) for $R_e = R_{em}$, when E_{co} is assumed to be significantly greater than $2E_c$, are only two-thirds their equivalent sharp-cutoff values. In the case of the 10-mc CR-18/U crystal unit discussed in paragraph 1-313, the (practical max) E_c , as given by equation 1-313(2) is $-\frac{5}{3}V \approx -1.7V$. For the smallest values of R_e , the bias will approach $-15V$. Assuming that $g_m \approx \frac{1}{Z_L}$ (according to equation 1-312(2), when $C_g/C_p = 1$) and that

$$Z_L = \frac{(\text{min}) PI}{4} = \frac{1}{4\omega^2 C_x^2 R_{em}} = \frac{10^{10}}{4 \times 6.28^2 \times 32^2 \times 25} \approx 2500 \text{ ohms}$$

then, $g_m \approx 10^6/2500 = 400 \mu\text{mhos}$ when R_e is a maximum. This is a very small transconductance to be obtained with a bias of approximately -1.7 volts, and usually cannot be obtained at all with normal operating voltages except in the case of the small battery-operated tubes. The 1.7-volt maximum bias represents a peak-to-peak excitation maximum of 3.4 volts. With an average g_m of 400 μmhos , the limiting value of I_{bm} ($\approx 2I_{pm} \approx 2g_m E_{gm}$) becomes 1.4 ma, approximately. Only if agc is used to provide a much larger bias than can be obtained with a peak-to-peak excitation of 3.4 volts will it be possible to have such a small zero-signal plate current without operating conventional tubes at greatly reduced voltages. Generally, it is easier to operate with a small E_{co} and a larger I_{bm} and not

attempt class-A operation. A large percentage of the crystal oscillators now in use drive the crystal units at a considerably higher level than is advantageous from the point of view of stability and long crystal life. Much of the care otherwise taken in the circuit design can be wasted if the first consideration is power output rather than frequency control. Where a vacuum-tube manual recommends a particular voltage of power amplifier for use as a class-C oscillator tube, the typical operating characteristics listed are rarely appropriate for military-standard crystal units, but apply more usually to LC circuits. The plate voltages must be considerably lower than the typical values indicated, in order to reach the small transconductances that must exist at equilibrium without overdriving the crystal unit.

1-315. Assume that a crystal unit is connected in a Pierce circuit using a conventional triode operating at its normal plate voltage, and that the C_g/C_p ratio is near unity. The equilibrium values of g_m and R_p cannot be reached until the amplitude is great enough for the tube to be operating class C, and the crystal unit will almost certainly be overdriven. There are four ways in which the circuit can be adjusted to prevent this overdrive: (a) the plate voltage can be reduced, (b) the filament voltage can be reduced, (c) the C_g/C_p ratio can be increased, or (d) the load losses can be increased. Of these methods, the first, reducing the plate voltage, seems to be the best from the point of view of frequency stability, although a reduction of the filament voltage may be worth consideration. Very possibly, if the filament voltage is decreased sufficiently to lower the zero-bias transconductance to as much as one-fifth its normal value, the operation of the circuit will become unduly sensitive to slight fluctuations in the filament power supply. The only data available at this writing is that reported by Messrs. Roberts, Novak, and Goldsmith of the Armour Research Foundation of Illinois Institute of Technology. Experimenting with a 6C4 tube and a 7- μc Miller circuit, it was found that a 30-percent decrease in filament voltage, which is equivalent to decreasing the filament power by approximately one-half or more, depending upon the temperature coefficient of the filament resistance, caused only a 2.5-cycle rise in frequency. (In a Pierce circuit the frequency would have decreased.) This effect on the frequency is very slight, but the exact decrease in the r-f plate current is not known. Nevertheless, the evidence is sufficient to suggest that if the tube characteristics are made suitable for a crystal circuit by reducing the filament voltage, any instability

Section I
Crystal Oscillators

caused by further fluctuations in the filament voltage would appear primarily as variations in the output voltage, rather than as variations in the frequency. In view of the fact that a reduction in filament current permits a greater saving in power than does a reduction in plate voltage (and lengthens the tube life), this approach to the problem may well be worth experimentation. The conventional approach, however, is to operate with a low plate voltage. If a C_g/C_p ratio on the order of unity is to be used, the average tube will require plate or screen voltages of 40 to 50 volts, or less. The lower the voltage, the nearer class-A operation can be approached at equilibrium. A fair approximation of the operating conditions to be expected can be made from an inspection of a family of plate-characteristic curves. With $C_g/C_p = 1$, the peak-to-peak variations in plate voltage are the same as those of the excitation voltage, so for all practical purposes the plate voltage can be assumed to be constant. Thus, the load line can be assumed to be vertical, and the maximum and minimum amplitudes of I_b for a given plate voltage become the values, respectively, for grid voltages of 0 and $2E_{gm}$, where E_{gm} is the peak excitation voltage. For the 10-mc crystal unit taken as an example above, it was found that the peak-to-peak I_p for a maximum R_e was $2|g_m E_c| = 1.4$ ma. The correct plate voltage for a given tube is thus the value of E_b at which a change of grid voltage from 0 to -3.4 volts causes the plate current to decrease by 1.4 ma. This type of operation—class A to class AB—is generally more feasible when age is used, if it is desired to apply for all values of R_e .

PIERCE-OSCILLATOR DESIGN CONSIDERATIONS FOR C_g/C_p RATIOS OTHER THAN ONE

1-316. When the C_g/C_p ratio is not approximately equal to one but the total load capacitance meets the crystal specifications, g_m is increased, and generally it will be easier to obtain desirable vacuum-tube characteristics at more convenient plate voltages. The first step, as before, is to theoretically limit the peak of the crystal current to $\sqrt{\frac{2P_{cm}}{R_{em}}}$ when R_e is a maximum. The peak excitation voltage, E_{gm} , equals $\frac{1}{\omega C_g} \sqrt{\frac{2P_{cm}}{R_{em}}}$ under these conditions. E_{pm} equals $\frac{1}{\omega C_p} \sqrt{\frac{2P_{cm}}{R_{em}}}$; g_m equals $C_g/C_p Z_L$; I_{pm} equals $g_m E_{gm}$. With these values taken as a start we can retrace the steps taken in paragraphs 1-312 and 1-313, and determine the values of I_{bm} and E_{co} that do not permit the crystal to be overdriven for any value of R_e between R_{em} and $R_{em}/9$.

FINAL WORD ON CORRECT LOAD CAPACITANCE IN THE PIERCE CIRCUIT

1-317. A prime purpose of the military specifications regarding the load capacitance, effective resistance, drive level, and frequency tolerance of the different types of crystal units is to guarantee the replacement of a defective crystal unit in the field without special testing or other complications, and with the same ease that a defective vacuum tube can be replaced with a new tube of the same type. However, a crystal unit is more critical in its performance than a vacuum tube. As a result there can be no replacement guarantee unless the new crystal unit is inserted in a circuit where it will be operated under approximately the same load and drive conditions at which it has been tested. An inspection of the various types of oscillator circuits now in use, such as those illustrated in figures 1-135 to 1-138, most of which have been designed around the older types of crystal units, reveals a much greater versatility in operating conditions than is now desired in the design of new equipment. One of the requirements that is no longer within the jurisdiction of the design engineer is the effective load capacitance into which the crystal unit is to work. This means, that for a given nominal frequency and type of crystal unit, the crystal unit must exhibit a given inductive reactance, X_o , equal numerically to $1/\omega C_x$, where C_x is the rated load capacitance. Furthermore, it means that for each particular crystal unit there is but one frequency at which it is supposed to operate. This does not mean that all crystal units of the same type and nominal frequency have a single common operating frequency, rather that each has its own individual frequency, which, however, will not differ from the nominal frequency by more than the permitted tolerance. It is the effective operating reactance that the crystal units must have in common. Approximately,

$$X_o = \frac{4\pi L \Delta f}{1 + \frac{4\pi L \Delta f}{X_{Co}}} \quad (\text{Equation (1), figure 1-98})$$

Now, $\Delta f = f_p - f_s$, where f_p is the operating parallel-resonant frequency and f_s is the series-resonant frequency of the motional arm. Assume that a 10-mc parallel-resonant crystal unit has a frequency tolerance of ± 0.02 per cent. This is equivalent to an absolute frequency tolerance of ± 2000 cps. Two crystal units at opposite extremes could be within specifications even though their operating frequencies, f_{p1} and f_{p2} , were 4000 cps apart.

If the rated load capacitance were $32 \mu\mu f$ and the crystals were A elements, Δf , itself, for each crystal would be on the order of 2000 cps. If the crystals were B elements of the same shunt capacitance, C_s , Δf for each crystal would be only in the neighborhood of 800 cps, because of the B element's larger series-arm inductance, L. It becomes obvious that there can be no expectation of "pulling" the frequencies together by making slight adjustments in the load capacitance. The lower-frequency crystal could not be raised to zero beat with a frequency 4000 cps higher without reducing C_s several-fold. The higher-frequency crystal could not even be "pulled" to the nominal frequency and oscillations still be maintained. For this reason, the design engineer should generally not attempt to provide an operator with frequency adjustments for the crystal oscillator. The only adjustments needed are those which can be factory preset, in order to compensate for slight differences in stray capacitance. If the frequencies to be generated must be in close agreement with some standard, or with the frequency of some controlling station, the task is to provide oven-controlled crystal units of smaller tolerance. Only when the desired operating tolerance is less than any provided by crystal-unit specifications alone, is it necessary to provide the operator with a frequency adjustment knob. Even then, the adjustment need not provide a tuning range greater than the specified crystal tolerance. Since the smaller tolerances are only 1/10 to 1/20 of the 0.02 per cent in the example above, the total variation in load capacitance may not need to be greater than ± 10 per cent of the specified capacitance.

1-318. It may be desirable to provide an operator with the means of controlling the output voltage

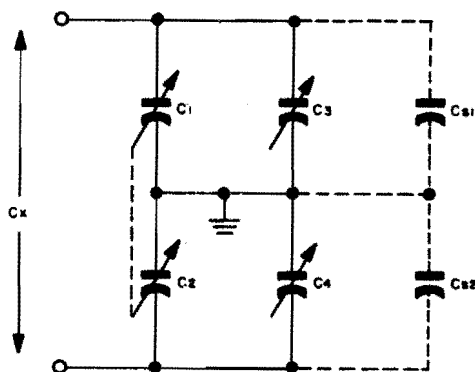

Figure 1-134. Ganged capacitances to enable adjustment of C_g/C_p ratio of Pierce circuit without changing total load capacitance

of a Pierce oscillator by varying the C_g/C_p ratio. In this case, care must be taken to ensure that the total load capacitance remains the same. If C_g and C_p are to be adjusted separately, some type of matching scales should be provided with the two tuning knobs, so that the correct load capacitance can always be had when, say, the two scales give the same reading. It is more desirable to have available ganged capacitors similar to those shown in figure 1-134 for each of the Military Standard capacitance ratings. The capacitors C_1 and C_2 in series are to be designed to always ensure a correct load capacitance when each is shunted by convenient predetermined fixed capacitance. The small variable capacitances C_3 and C_4 are adjusted until the sum of their values and the circuit stray capacitances, C_{s1} and C_{s2} , provide the correct fixed shunts for the ganged elements.

MODIFICATIONS OF PIERCE CIRCUIT

1-319. Figures 1-135, 1-136, 1-137, and 1-138 and their accompanying circuit-data charts reveal a great flexibility in the design of a Pierce oscillator. It would be very convenient to be able to put our finger on a single circuit and say that the design of this circuit is superior to all others. Unfortunately, this is not possible. One would first have to define what is meant by "superior design." The definition, at best would be a complex function of several physical and psychological variables. The very existence of a wide variety of circuit modifications suggests that no one circuit is superior to all others for all given tasks, although much of the variety can be attributed to the desire of the design engineer to create his own circuit and also to avoid the risk of possibly infringing upon the patent rights of another. Our space does not permit a detailed discussion of each of the circuits shown. Only a few of the highlights are to be mentioned. In general, most of the oscillators illustrated employ older-type crystal units; most of the circuits use B+ voltages on the order of 200 volts, and would overdrive the smaller-sized crystals currently recommended; and the load capacitances and the C_g/C_p ratios vary widely from one circuit to another. Those circuits that employ currently recommended Military Standard crystal units (crystal units having nomenclature type numbers, CR-15/U and higher) are designed to operate so that the crystal unit faces its rated parallel-mode load capacitance. In these circuits the plate supply is normally 100 to 120 volts, and the crystal unit of average resistance is operated at 4 to 5 milliwatts.

Section I
Crystal Oscillators

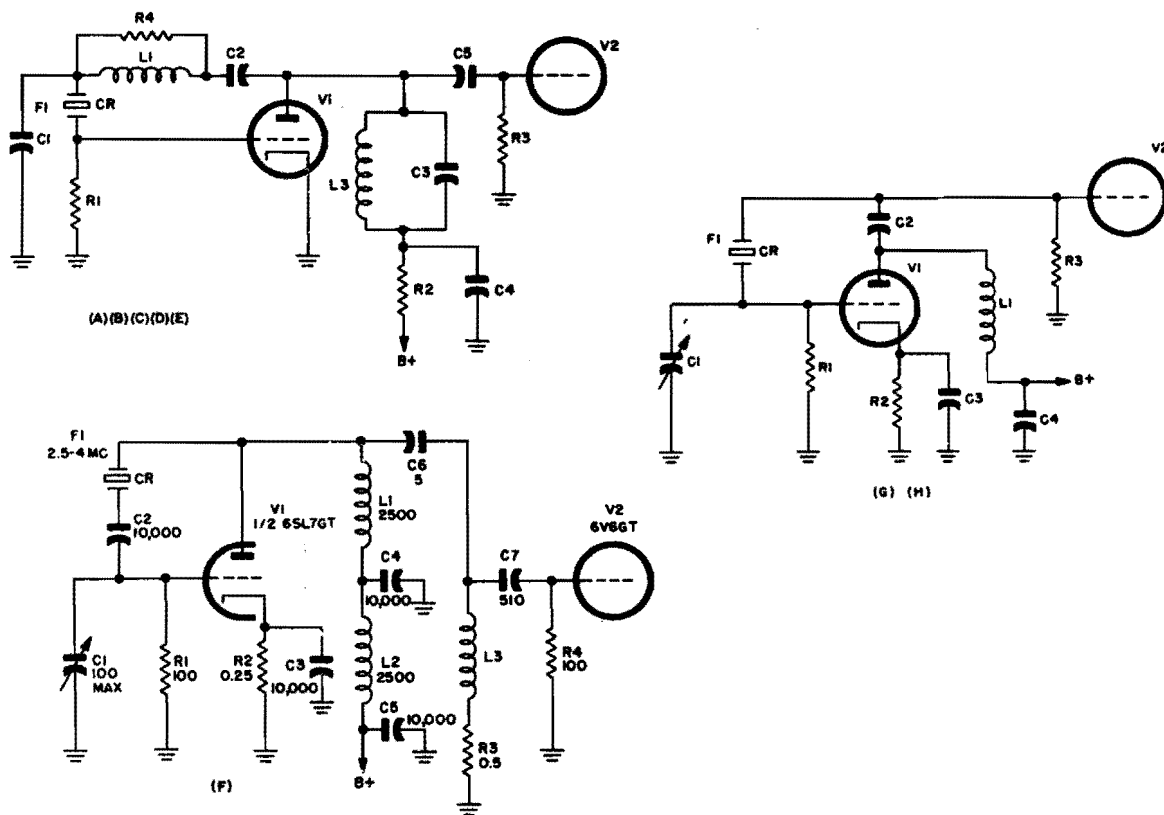

Figure 1-135. Modifications of Pierce oscillator using triodes

Fig.	Equipment	Purpose	F ₁	F ₂	F ₃	CR	R ₁	R ₂	R ₃
(A)	Radio Transmitter T-14(A/B/C)/TRC-1	M.O.	729- 1041			CR-4/U (oven)	350	50	100
(B)	T-14(D/E)/TRC-1	M.O.	729- 1041			CR-4/U (oven)	350	150	100
(C)	T-14H/TRC-1	M.O.	729- 1041			CR-4/U (oven)	350	150	100
(D)	Test Oscillator TS-32(A/B)/TRC-1	Test oscillator	729- 1041			CR-4/U (oven)	350	50	15
(E)	TS-32(C/D)/TRC-1	Test oscillator	729- 1041			CR-4/U (oven)	350	47	15
(F)	Radio Transmitter T-177/FR	M.O.	2500- 4000			FT-164 (oven)	100	0.25	0.5
(G)	Radio Transmitter Assembly OA-60B/ FRT	M.O.	2000- 4000			FT-164 (oven)	100	0.5	25
(H)	Radio Transmitter T-172/FR	M.O.	2000- 4000			FT-164 (oven)	100	0.5	25
(I)	Radio Transmitter T-125A/ARW-34	M.O.	1000 (approx)	Audio for phase mod.		CANC 40138 Otis Elev. Co.	120	22	
(J)	Radio Receiver WE D-99945	2nd beating oscillator	3000			Entire circuit in oven			
(K)	Exciter Unit O-5/FR	M.O.	1800- 5800			FT-249 (oven)	100	0.25	10

Circuit Data for Figure 1-135. F in kc. R in kilohms. C in μf . L in μh .

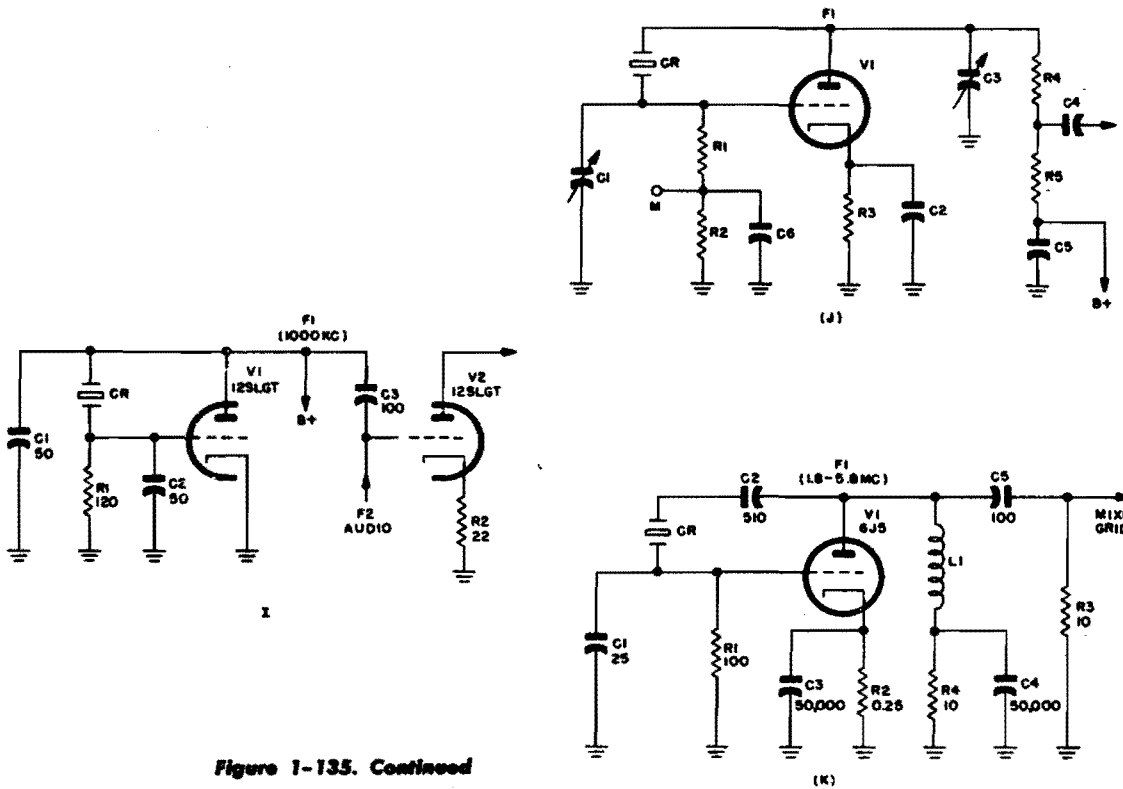
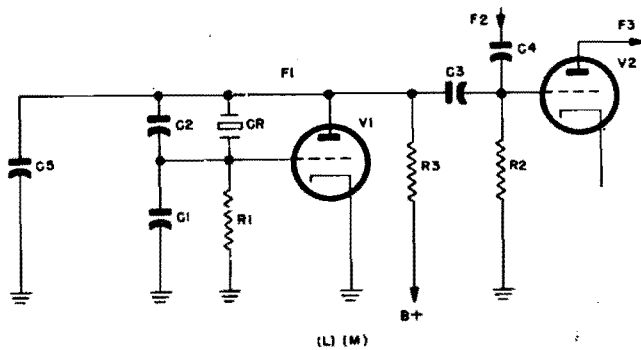

Figure 1-135. Continued

R ₄	R ₅	C ₁	C ₂	C ₃	C ₄	C ₅	C ₆	C ₇	L ₁	L ₂	V ₁	V ₂
∞		40	∞	0	0	100			770	0	1/2 6SN7GT	6AC7
15		22	5000	40	5000	100			770	770	1/2 6SN7GT	6AC7
15		22	4700	39	4700	100			770	770	1/2 6SN7GT	6AC7
∞		40	∞	0	0	100			770	0	1/2 6SN7GT	1/2 6SN7GT
15		22	5100	39	5100	100			770	770	1/2 6SN7GT	1/2 6SN7GT
100		100	10,000	10,000	10,000	10,000	5	510	2500	2500	1/2 6SL7GT	6V6GT
		100	10,000	10,000	10,000				2500 (50Ω)		6J5GT/G	807
		100	10,000	10,000	10,000				2500 (50Ω)		6J5GT/G	807
		50	50	100							1/2 12SL7GT	1/2 12SL7GT
											WE272A	
10		25	510	50,000	50,000	100					6J5	

Section I
Crystal Oscillators



(L) (M)

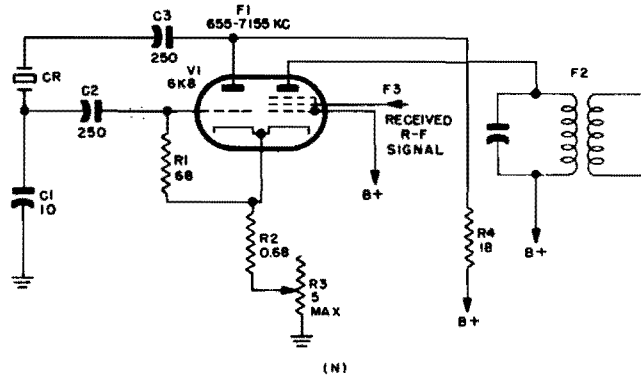

(N)

Figure 1-135. Continued

Fig.	Equipment	Purpose	F ₁	F ₂	F ₃	CR	R ₁	R ₂	R ₃
(L)	Receiver-Transmitter RT-173/ARC-33	"Side-step" injector oscillator	7662.5	104,840-192,280	F ₁ +F ₂	CR-18/U	47	68	68
(M)	Receiver-Transmitter RT-173/ARC-33	Main channel local oscillator	12,517.8	15,325	F ₂ -F ₁	CR-18/U	11	470	33
(N)	Lear Radio Set Model T-30AB-RCBBL-2	Local oscillator	655-7155	455 IF.			68	0.68	5
(O)	Communication Equipment AN/CRC-3	Local oscillator	4755-3845	4300 (1st I.F.)	F ₁ -F ₂ or F ₂ -F ₁ (455 I.F.)	FT-243	0.33	47	150
(P)	Radio Set AN/VRC-2	Local oscillator	4755-3845	4300 (1st I.F.)	F ₁ -F ₂ or F ₂ -F ₁ (455 I.F.)	FT-243	0.33	47	150
(Q)	Radio Receiver R-114/VRC-4	Local oscillator	1175-8175	1700-8700	F ₂ -F ₁ (525 I.F.)	Sig 2Z 3531B	50	0.4	250

Circuit Data for Figure 1-135. F in kc. R in kilohms. C in $\mu\mu\text{f}$. L in μh .

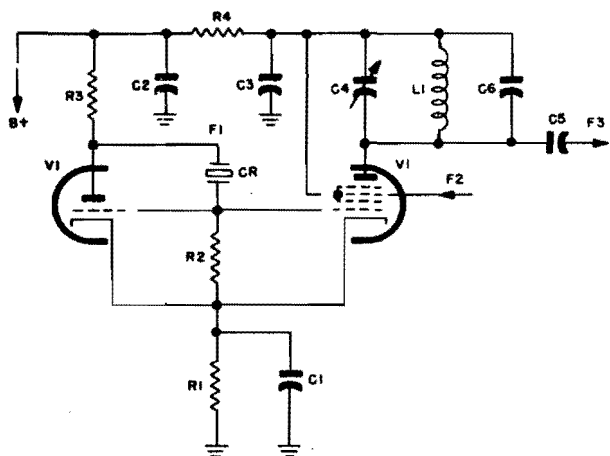

(O) (P)

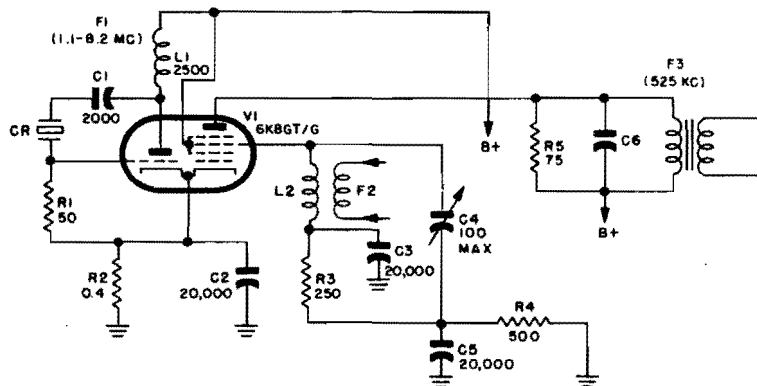

(O)

Figure 1-135. Continued

R ₁	R ₂	C ₁	C ₂	C ₃	C ₄	C ₅	C ₆	C ₇	L ₁	L ₂	V ₁	V ₂
		68	18	5	5	0					6AK5W	
		300	0	10	22	18					6AS6W	
18		10	250	250							6K8	
27		50,000	2,000	50,000	5-44	50	50				6K8GT	
27		50,000	2,000	50,000	5-14	50	50				6K8GT	
500	75	2,000	20,000	20,000	100	20,000			250μ		6K8GT/G	

Section 1
Crystal Oscillators

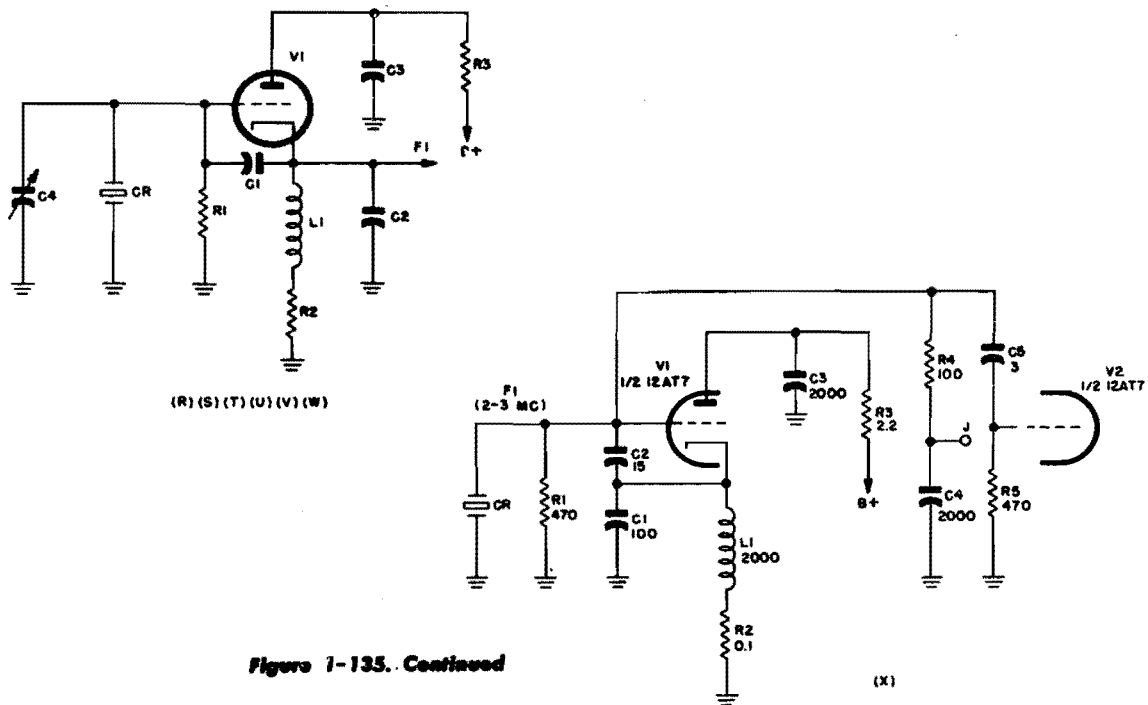
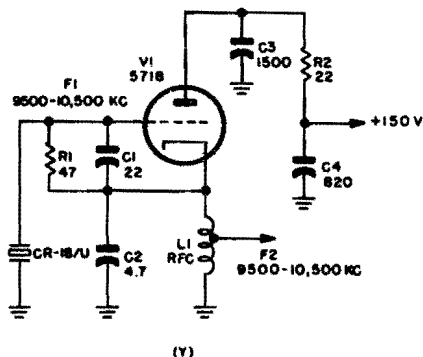

Figure 1-135. Continued

Fig.	Equipment	Purpose	F ₁	F ₂	F ₃	CR	R ₁	R ₂	R ₃
(R)	Receiver-Transmitter RT-178/ARC-27	2nd injector osc (rec guard channel)	15,950			CR-18/U	100	0.12	0.560+
(S)	Receiver-Transmitter RT-173/ARC-33	2nd monitor osc of trans. M.O.	3233.333-3900			CR-27/U	220	0	1
(T)	Receiver-Transmitter RT-173/ARC-33	3rd monitor oscillator of M.O.	3650-3800			CR-27/U	220	0	1
(U)	Receiver-Transmitter RT-173/ARC-33	4th monitor oscillator of M.O.	5172.917-5181.25			CR-27/U	220	0	1
(V)	Receiver-Transmitter RT-178/ARC-27	1st transmitter oscillator	3450			CR-18/U	100	0.56	100
(W)	Receiver-Transmitter RT-178/ARC-27	2nd trans. osc (heterodyned with 1st)	8250-9150			CR-18/U	100	0.56	33
(X)	Transmitter T-217/GR	1st i-f oscillator	1994-2894				470	0.1	2.2
(Y)	Radio Receiver-Transmitter RT-XA-101/ARC-22	Local osc in receiver	9500-10,500	F ₁		CR-18/U	47	22	
(Z)	Signal Generator SG-13/ARN	Fine freq osc for mixing with output of coarse freq osc	Narrow band within 800-15,000 range (10 crystals)	14,400-28,800	F ₂ ± F ₁	CR-18/U	100	0.15	33

Circuit Data for Figure 1-135. F in kc. R in kilohms. C in μmf . L in μh .



(V)

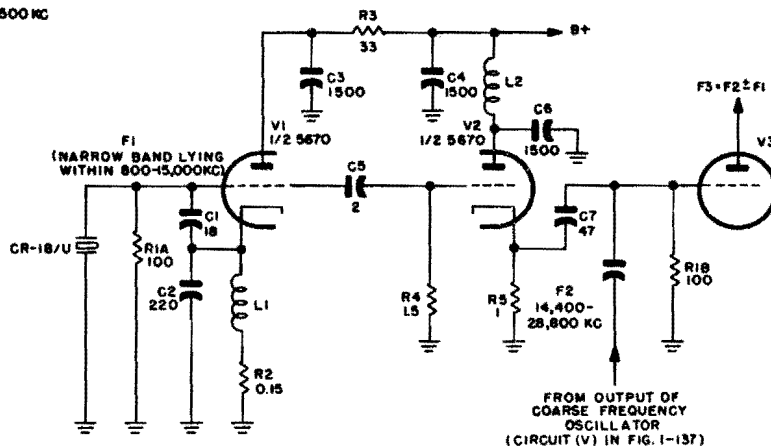

(Z)

Figure 1-135. Continued

R ₁	R ₂	C ₁	C ₂	C ₃	C ₄	C ₅	C ₆	C ₇	L ₁	L ₂	V ₁	V ₂
		24	100	3,000	0.3-3				500		1/2 12AT7	
		30	30	470					2000		1/2 5670	
		15	27	470					2000		1/2 5670	
		27	30	470					2000		1/2 5670	
		20	330	3000	0				500		1/2 12AT7	
		7	32	3000	1-8				500		1/2 12AT7	
100	470	100	15	2000	2000	3			2000		1/2 12AT7	1/2 12AT7
		22	4.7	1500	820				RFC		5718	
1.5	1	18	220	1500	1500	2	1500	47			1/2 5670	1/2 5670

Section 1
Crystal Oscillators

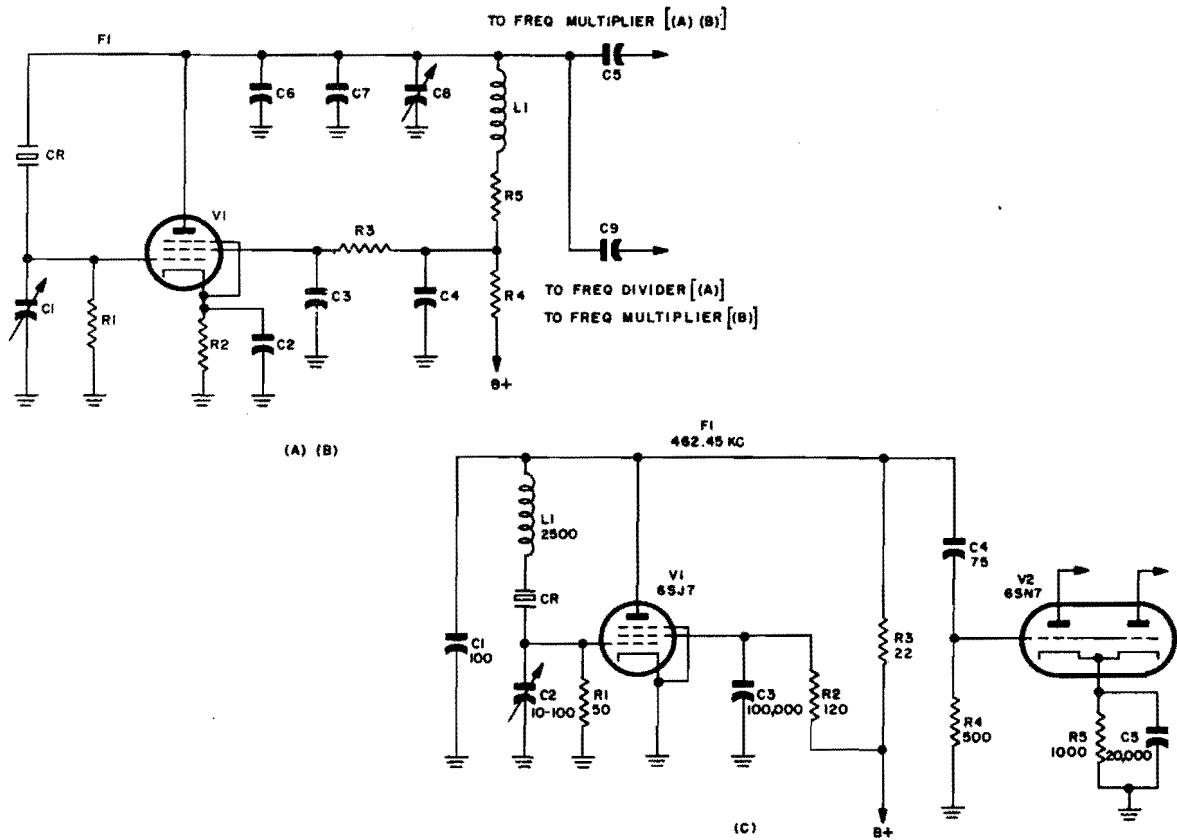
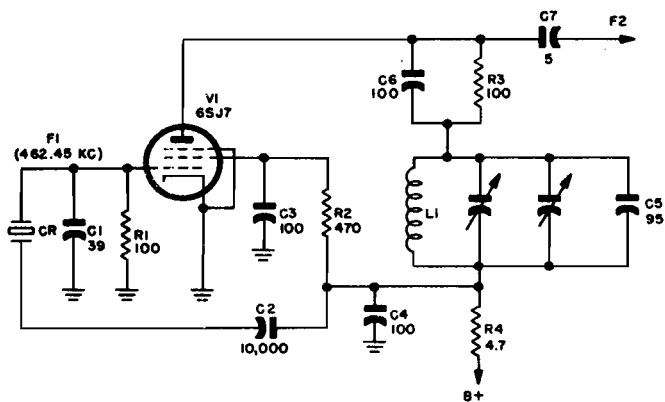

Figure 1-136. Modifications of Pierce oscillator using screen-grid tubes

Fig.	Equipment	Purpose	F ₁	F ₂	CR	R ₁	R ₂	R ₃	R ₄	R ₅	R ₆	R ₇
(A)	Radio Set AN/FRC-10 (WECO Transmitter D-156000)	L-F osc for single-side-band operation	625		WECO 7B	250	1	1	20	0		
(B)	Same as (A)	H-F osc for single-side-band operation	940-5000		WECO 5AA	100	1	10		5		
(C)	Switching Unit SA-107 ()/MRC-4	BFO for two diversity receivers	462.45			50	120	22	500	1000		
(D)	Radio Receiver R-270/FRR	BFO	462.45	F ₁	Bliley SR-901 (FT-241A)	100	470	100	4.7			
(E)	Radio Receiver BC-659-()	Local osc of receiver	5675-8650	4F ₁	FT-243	470	1000	270				

Circuit Data for Figure 1-136. F in kc. R in kilohms. C in μf . L in μh .



(D)

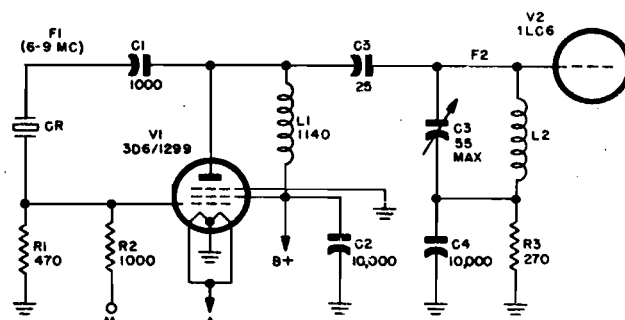

(E)

Figure 1-136. Continued

C ₁	C ₂	C ₃	C ₄	C ₅	C ₆	C ₇	C ₈	C ₉	L ₁	L ₂	V ₁	V ₂
100	10,000	10,000	10,000	1000	250	50	100	10	200		RCA41	
Variable	10,000	10,000	10,000	1000	0	0	0	1000	0		RCA41	
100	10-100	100,000	75	20,000					2500 (25Ω)		6SJ7	6SN7
39	10,000	100	100	95	100	5					6SJ7	
1000	10,000	55	10,000	25					1140	8 turns 5/8-in. dia	3D6/ 1299	1LC6

Section I
Crystal Oscillators

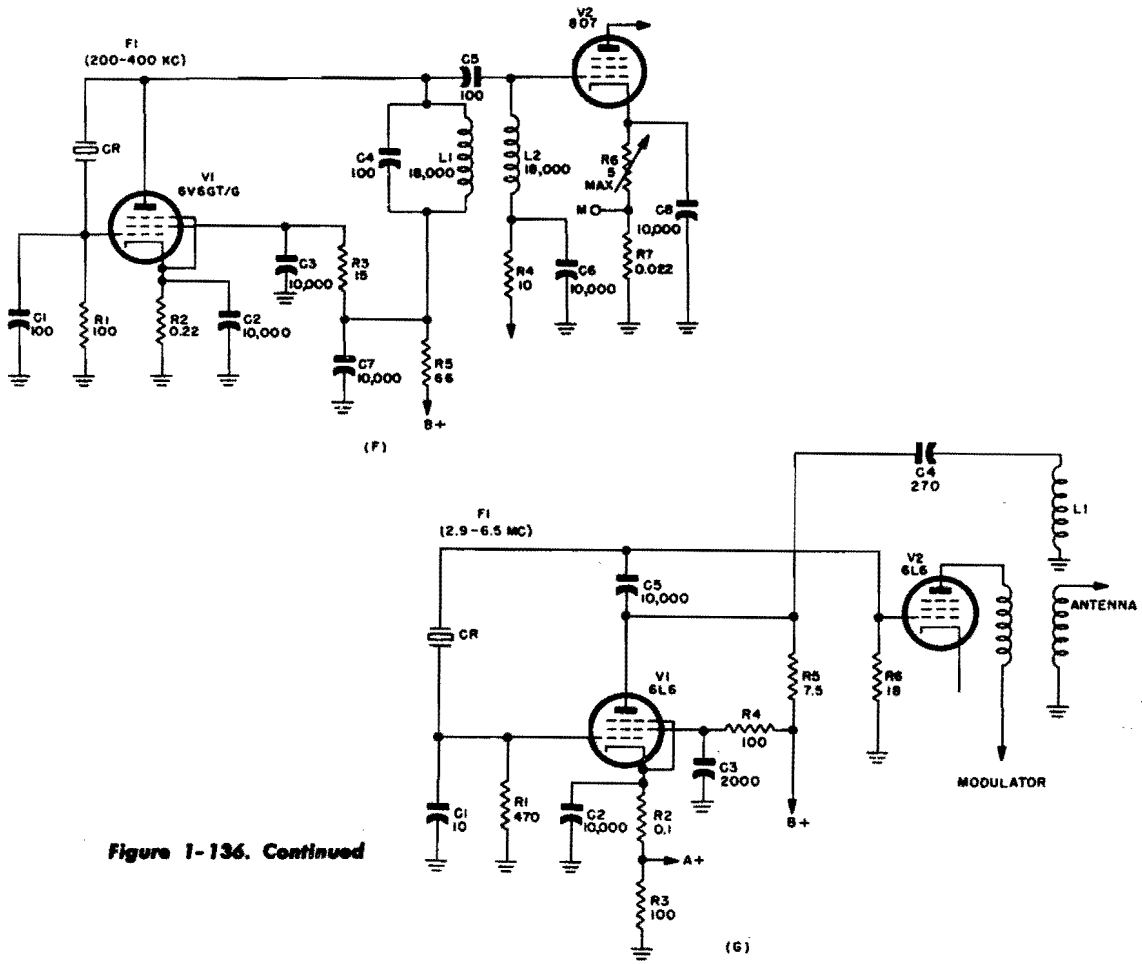

Figure 1-136. Continued

Fig.	Equipment	Purpose	F ₁	F ₂	CR	R ₁	R ₂	R ₃	R ₄	R ₅	R ₆	R ₇
(F)	Radio Transmitter BC-329-N	M.O.	200-400		FT-249	100	0.22	15	10	66	5	0.022
(G)	Lear Radio Set T-30AB-RCBBL-2	M.O.	2900-6500			470	0.1	100	100	7.5	18	
(H)	Modulator-Transmitter T-233/URW-3	M.O. for remote-control transmitter	3966.6-5666.6	2F ₁	CR-1A/AR	47	0.33	6.8	30	27	0.0051	
(I)	Modulator-Transmitter BC-1158	M.O.	3966.6-5666.6	2F ₁	CR-1A/AR	47	0.33	6.8	30	27	0.0051	
(J)	Radio Transmitter 12GLX-2	M.O.	260-1750	F ₁	Holder FT-249	100	0.1	50	385	25		

Circuit Data for Figure 1-136. F in kc. R in kilohms. C in μf . L in μh .

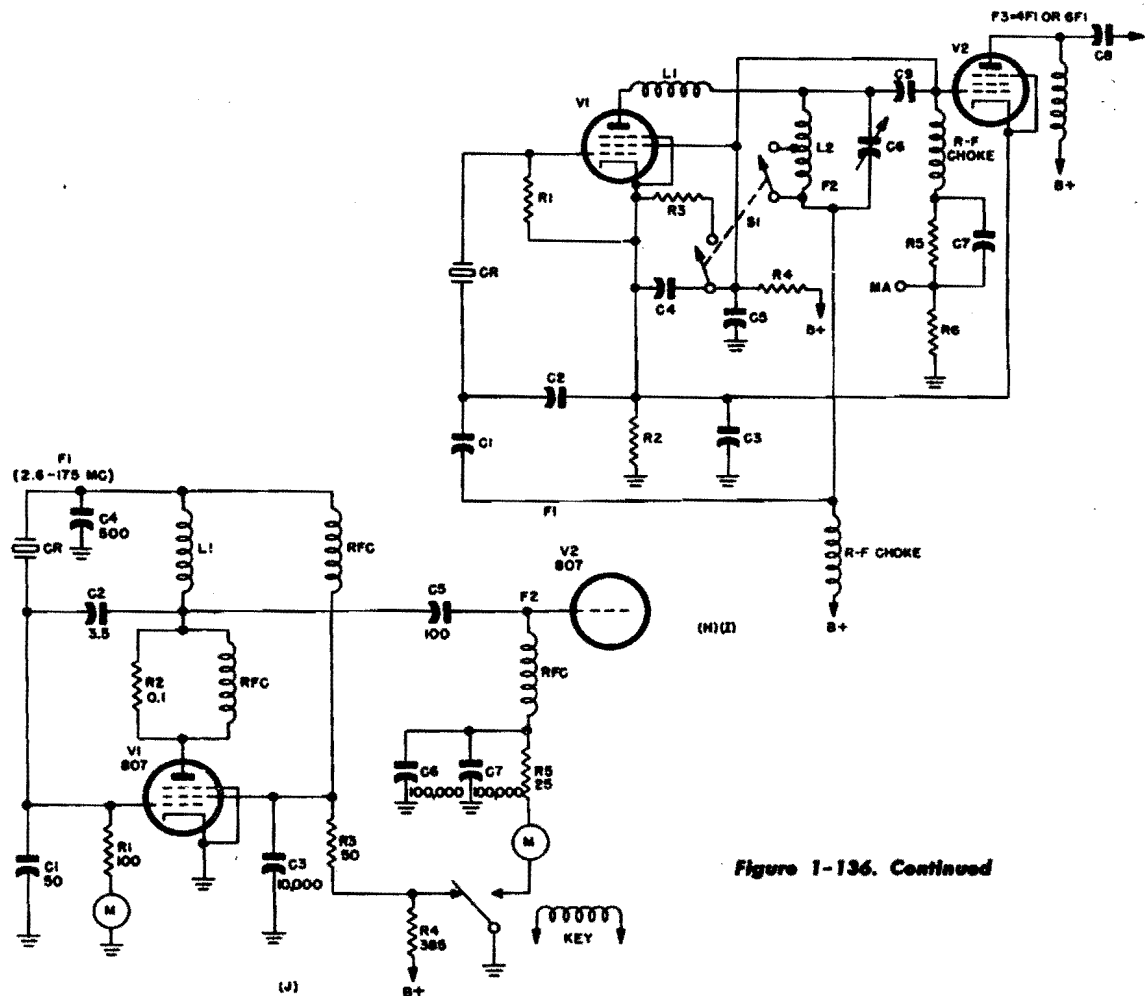

Figure 1-136. Continued

C ₁	C ₂	C ₃	C ₄	C ₅	C ₆	C ₇	C ₈	C ₉	L ₁	L ₂	V ₁	V ₂
100	10,000	10,000	100	100	10,000	10,000	10,000		18,000	18,000	6V6 GT/G	807
10	10,000	2000	270	10,000							6L6	6L6
5100	510	10,000	2400	2400	45	470	470				1/2 815	1/2 815
5100	510	10,000	2400	2400	45	470	470				1/2 815	1/2 815
50	3.5	10,000	500	100	100,000	100,000			Per F ₁		807	807

Section I
Crystal Oscillators

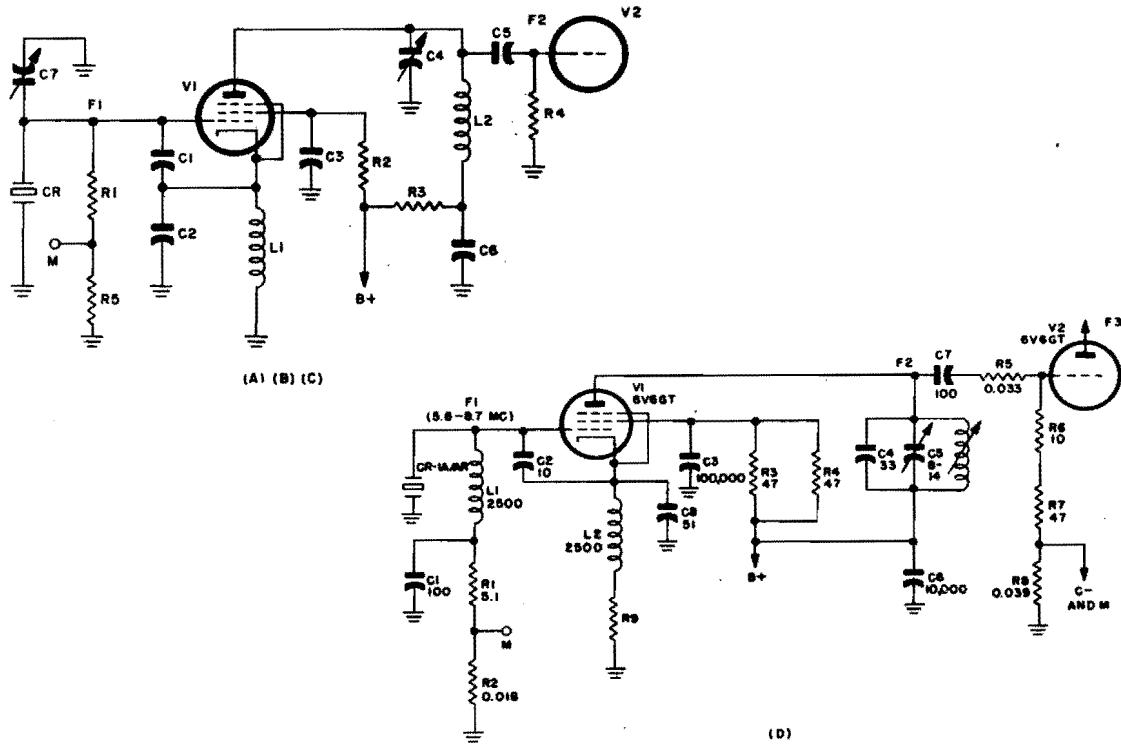

Figure 1-137. Electron-coupled Pierce oscillator modifications. All circuits except circuit (A) provide frequency multiplication

Fig.	Equipment	Purpose	F ₁	F ₂	F ₃	CR	R ₁	R ₂	R ₃	R ₄	R ₅
(A)	Receiver-Transmitter RT-178/ARC-27	Spectrum oscillator	10,000	F ₁		CR-27/U	100	56	12	100	0
(B)	Radio Receiver R-252/ARN-14	2nd monitor osc of receiver vfo	11,275-11,725	F ₁		CR-33/U	8.2	68	0		2.2
(C)	Radio Transmitter BC-400-(B,C,D,E)	M.O. for marker beacon	4166.67	2F ₁		FT-164	200	35	5	20	0
(D)	Radio Transmitter T-67/ARC-33	M.O.	5555-8666	2F ₁	6F ₁	CR-1A/AR	5.1	0.018	47	47	0.088
(E)	Radio Set AN/ARC-1A	Main-channel heterodyne freq osc	5020-8120	2F ₁	18F ₁	CR-1A/AR or CR-18/AR	100	8.2	1	100	
(F)	Frequency Meter TS-186/UP	Crystal calibrator	5000	2F ₁		Navy CG-40210; GE #G31 Thermocell. 6L6 tube envelope; heater; ± 0.002 per cent, -20 to 75°C	1.5	100	100	10	100
(G)	Frequency Meter TS-186(B/C)/UP	Crystal calibrator	5000	2F ₁		CR-18/U (oven, 60°C)	1.5	100	100	10	50

Circuit Data for Figure 1-137. F in kc. R in kilohms. C in μμf. L in μh.

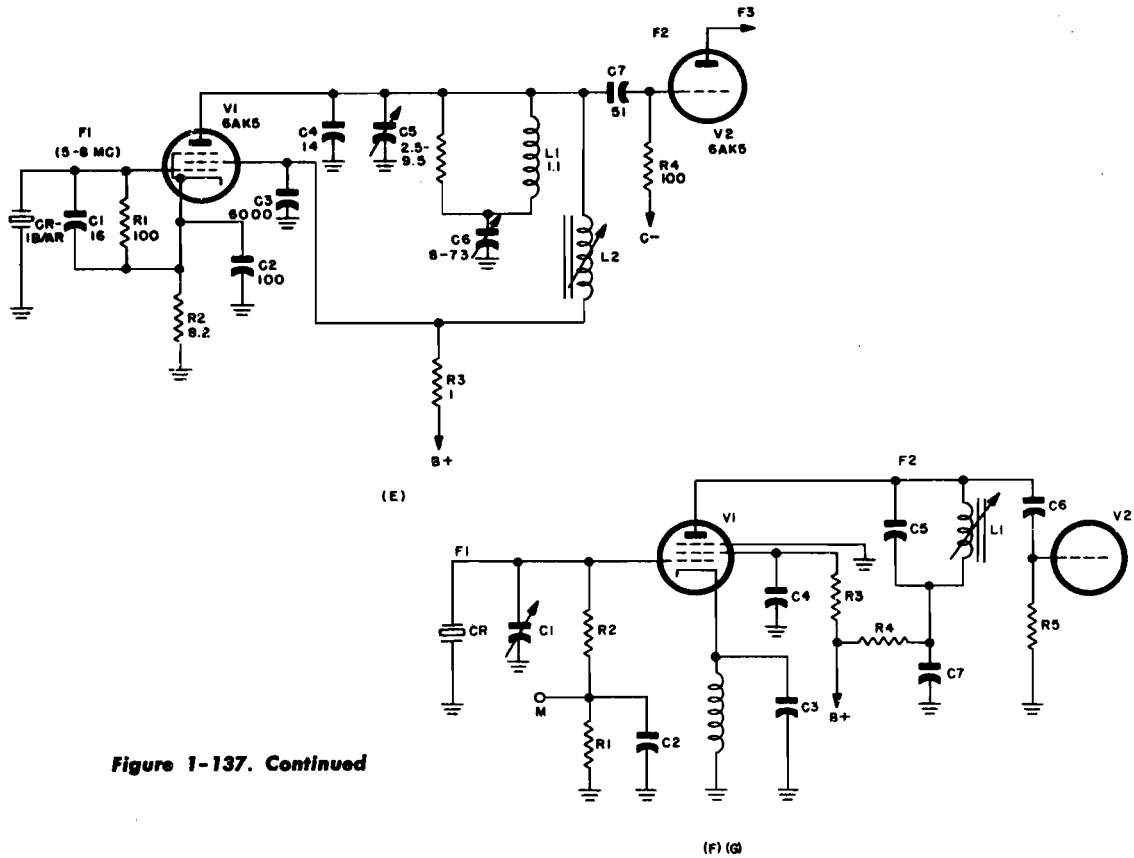

Figure 1-137. Continued

R ₆	R ₇	R ₈	C ₁	C ₂	C ₃	C ₄	C ₅	C ₆	C ₇	C ₈	L ₁	L ₂	V ₁	V ₂
			20	220	2000	0	100	0	1.5-7		500	0	6AG5	6AG5
			22	150	1800	0	470	1800	0				5654/ 6AK5	Discrimin- ator rectifier
			22	100	1500	35	1500	1500	0		1000		6L6	6L6
10	47	0.039	100	10	100,000	33	8-114	10,000	100	51	2500	2500	6V6GT	6V6GT
			16	100	6000	14	2.5- 9.5	8-73	51		1.1	15 turns	6AK5	6AK5
			4-12	470	100	470	22	100	470		4-9	35 (7Ω)	6SJ7	6SJ7
			6-36	470	100	470	22	51			4-9	35 (7Ω)	6SJ7	6SJ7

Section 1
Crystal Oscillators

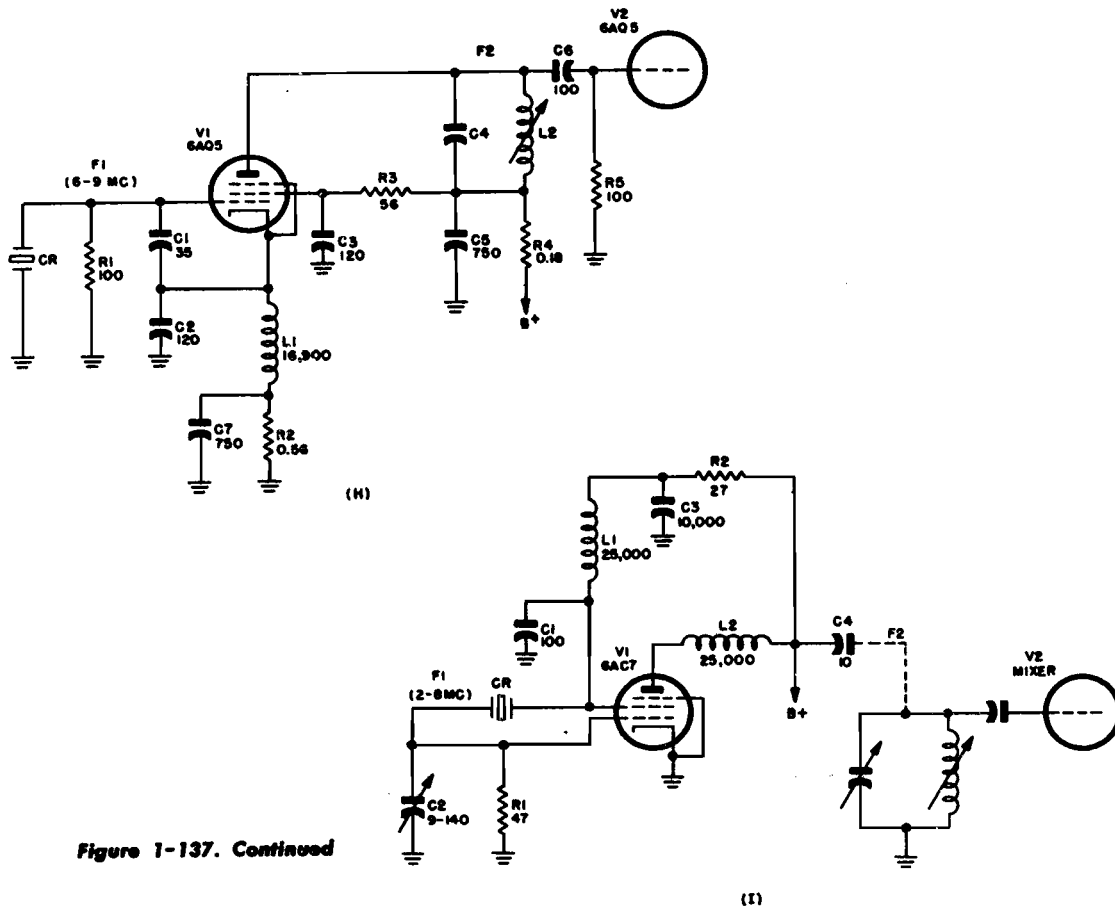
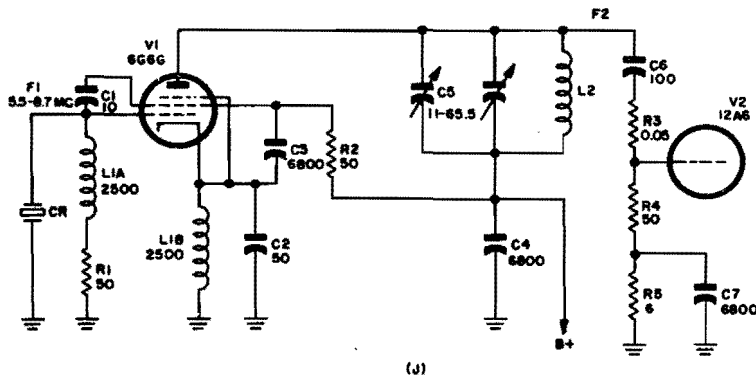

Figure 1-137. Continued

Fig.	Equipment	Purpose	F ₁	F ₂	F ₃	CR	R ₁	R ₂	R ₃	R ₄	R ₅
(H)	Aircraft Radio Corp. Radio Transmitter ARC Types T-13 and T-11A	M.O.	6000-9000	3F ₁		CAATC #1081	100	0.56	56	0.18	100
(I)	Radio Receiver R-270/FRR	Local oscillator	1965-8511.6	F ₁ , 2F ₁ , or 3F ₁		HC-1/U Holder	47	27			
(J)	Radio Transmitter BC-655-A, -AM	M.O.	5560-8660	2F ₁		DC-11(), DC-16, DC-26, or CR-1()/AR	50	50	0.05	50	6
(K)	Radio Transmitter BC-401-B	M.O.	1000-4575	2F ₁			100	0.51			

Circuit Data for Figure 1-137. F in kc. R in kilohms. C in $\mu\mu\text{f}$. L in μh .



(j)

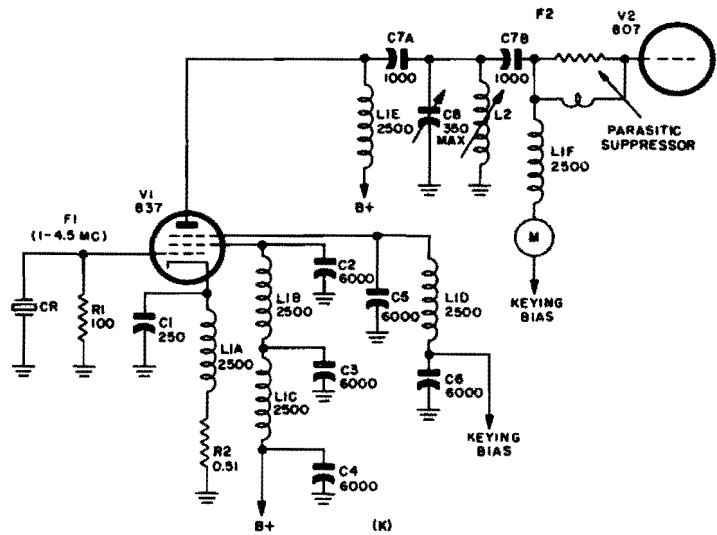

(k)

Figure 1-137. Continued

R ₁	R ₂	R ₃	C ₁	C ₂	C ₃	C ₄	C ₅	C ₆	C ₇	C ₈	L ₁	L ₂	V ₁	V ₂
			85	120	120	40 (T-13) 50 (T-11)	750	100	750		16,900		6A95	6A95
			100	9-140	10,000	10					25,000 (160Ω)	25,000 (160Ω)	6AC7	Mixer
			10	50	6800	6800	11- 65.5	100	6800		2500 (50Ω)	9-1/2 turns	6G6G	12A6
			250	6000	6000	6000	6000	6000	1000	350	2500		837	807

Section 1
Crystal Oscillators

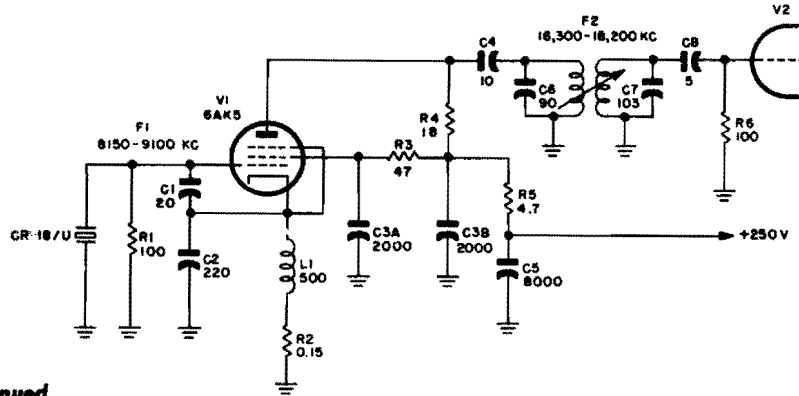
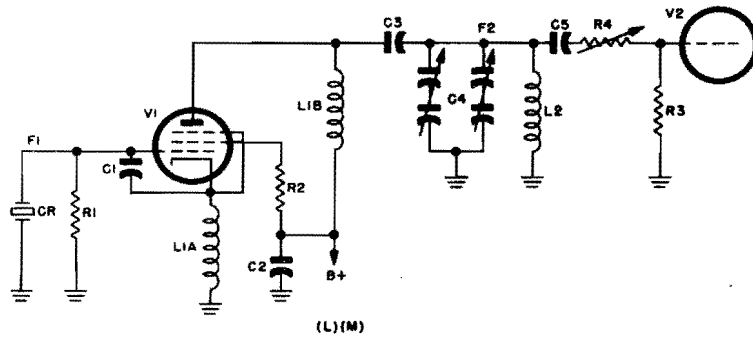
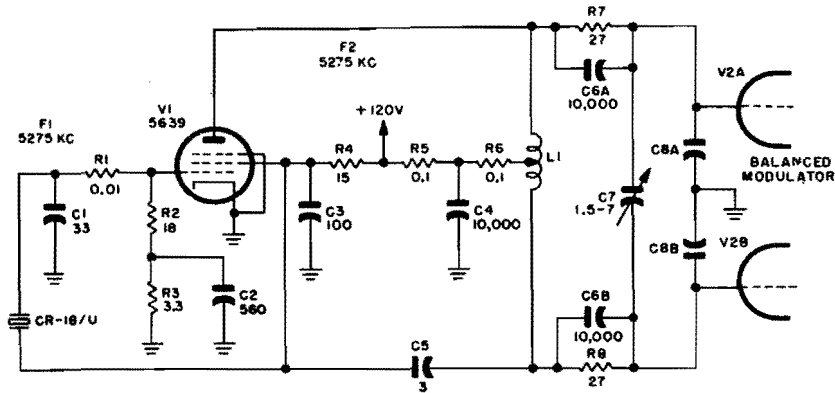

Figure 1-137. Continued

(N)

Fig.	Equipment	Purpose	F ₁	F ₂	F ₃	CR	R ₁	R ₂	R ₃	R ₄	R ₅
(L)	Frequency Meter BC-638-A	M.O. for signal generator	5555 55-8666.6	2F ₁ (?)		Sig 2Z 3501-11A (Bendix)	100	40	150	0-2.2	
(M)	Frequency Meter BC-1420	M.O. for signal generator	5555 55-8666.6	2F ₁ (?)			100	40	150	0-2.2	
(N)	Radio Receiver R-540/ARN-14C	Low freq injection osc	8150-9100 (20 crystals)	2F ₁		CR-18/U	100	0.15	47	18	4.7
(O)	Radio Set AN/ARC-34(XA-1)	Sidestep osc	5275	F ₁		CR-18/U	0.01	18	3.3	15	0.1
(P)	Radio Set AN/ARC-34(XA-1)	1st monitor osc of transmitter M.O.	833.333	F ₁	F ₁	CR-27/U	560	56	10	1000	

Circuit Data for Figure 1-137. F in kc. R in kilohms. C in $\mu\mu\text{f}$. L in μh .



(O)

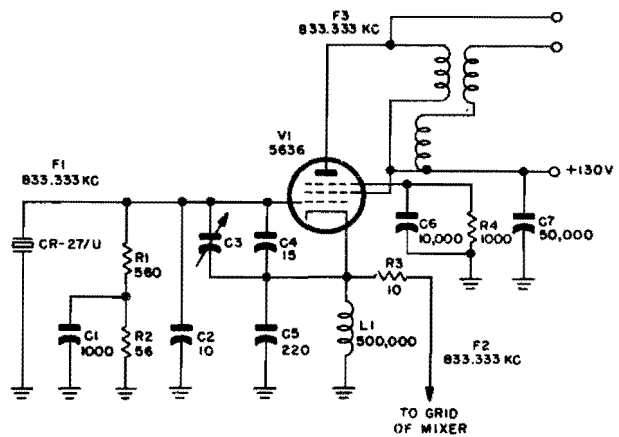

(P)

Figure 1-137. Continued

R ₆	R ₇	R ₈	C ₁	C ₂	C ₃	C ₄	C ₅	C ₆	C ₇	C ₈	L ₁	L ₂	V ₁	V ₂
			25	10,000	3000	6-42 (each section)	1000				1700 (40Ω)	7.5	6SK7	9008
100			25	100	3000	6-42 (each section)	1000				1700 (40Ω)	9.3	6SK7	9008
			20	220	2000	10	8000	90	103	5	500		6AK5	
0.1	27	28	33	560	100	10,000	3	10,000	1.5-7				5639	Balanced modulator
			1000	10		15	220	10,000	50,000		500		5636	

Section I
Crystal Oscillators

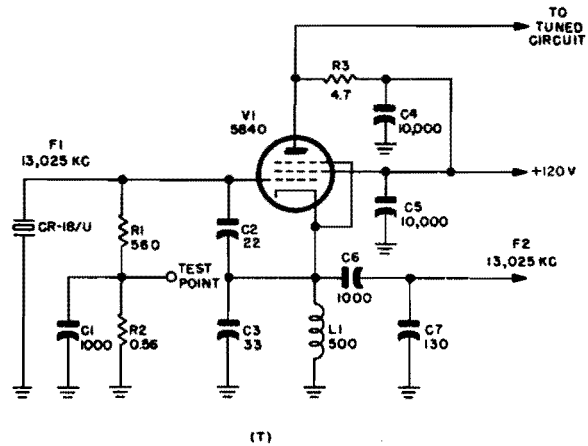
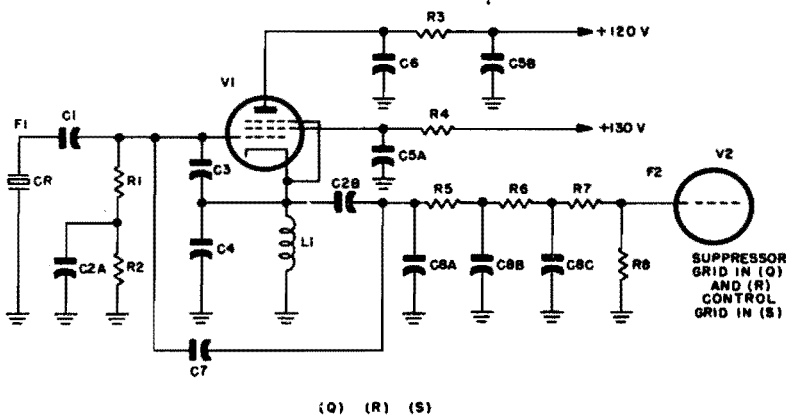

Figure 1-137. Continued

Fig.	Equipment	Purpose	F ₁	F ₂	F ₃	CR	R ₁	R ₂	R ₃	R ₄	R ₅
(Q)	Radio Set AN/ARC-34(XA-1)	2nd monitor osc of transmitter M.O.	3230-3900 (5 crystals)	F ₁		CR-27/U	560	56	4.7	1.8	0.68
(R)	Radio Set AN/ARC-34(XA-1)	3rd monitor osc of transmitter M.O.	3650-3775 (4 crystals)	F ₁		CR-27/U	560	56	4.7	1.8	0
(S)	Radio Set AN/ARC-34(XA-1)	4th monitor osc of transmitter M.O.	5130-5165 (5 crystals)	F ₁		CR-27/U	560	56	4.7	1.8	0
(T)	Radio Set AN/ARC-34(XA-1)	2nd osc for guard channel	13,025	F ₁		CR-18/U	560	0.56	4.7		
(U)	Radio Receiver R-322/ARN-18	Local osc	11,490- 11,700 (20 crystals)	3F ₁		CR-18/U	0.01	100	0.1	16	1.6
(V)	Signal Generator SG-13/ARN	Coarse freq osc for mixing with output of fine freq osc	4800-9600 (28 crystals)	3F ₁		CR-18/U	100	0.15	100	18	

Circuit Data for Figure 1-137. F in kc. R in kilohms. C in μf . L in μh .

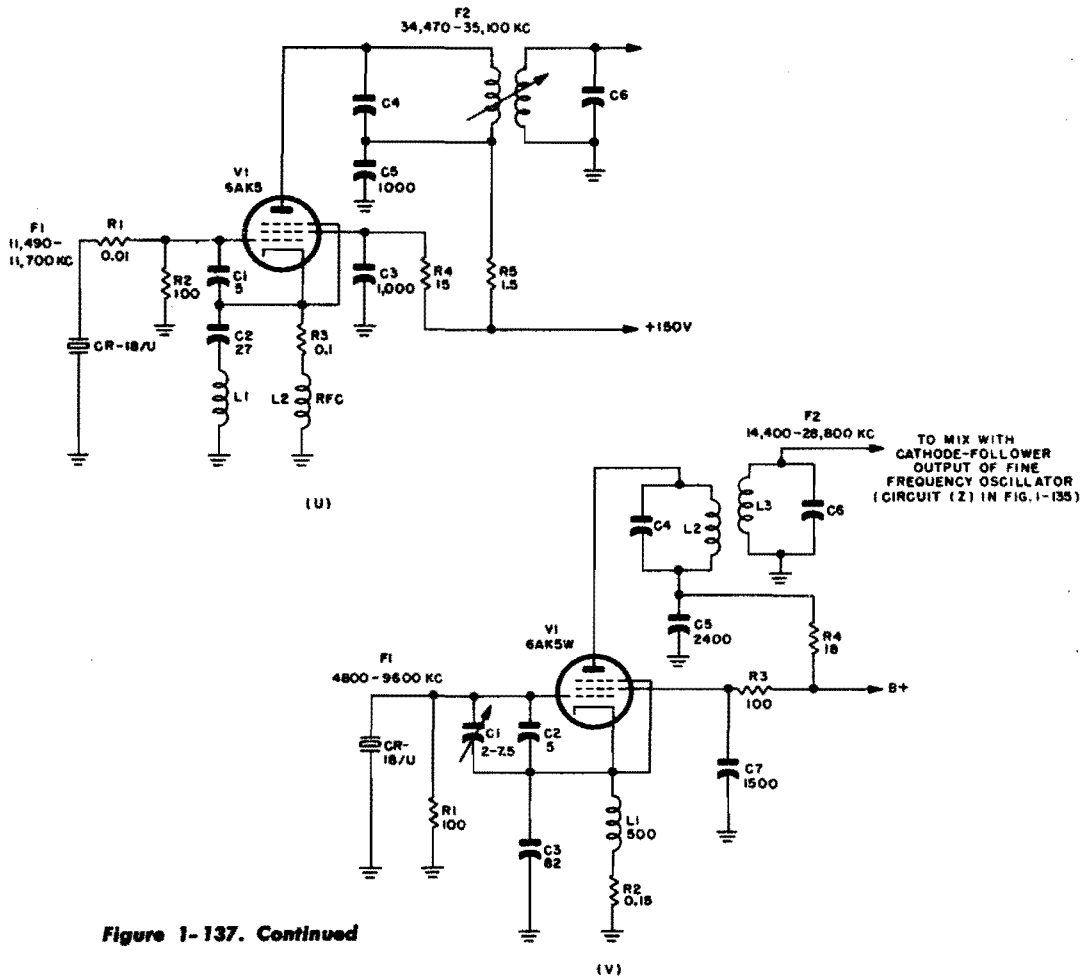

Figure 1-137. Continued

R_6	R_7	R_8	C_1	C_2	C_3	C_4	C_5	C_6	C_7	C_8	L_1	L_2	V_1	V_2
1	0.47	10	47	1000	10	33	10,000	470	0	22	5000		5840	5636
0	0	10	47	1000	10	33	10,000	470	12	0	5000		5840	5636
0	0	2.2	47	1000	10	38	10,000	470	10	0	5000		5840	5840
			1000	22	33	10,000	10,000	1000	130		500		5840	
			5	27	1000		1000					RFC	6AK5	
			2-7.5	5	82		2400		1500		500		6AK5W	

Section I
Crystal Oscillators

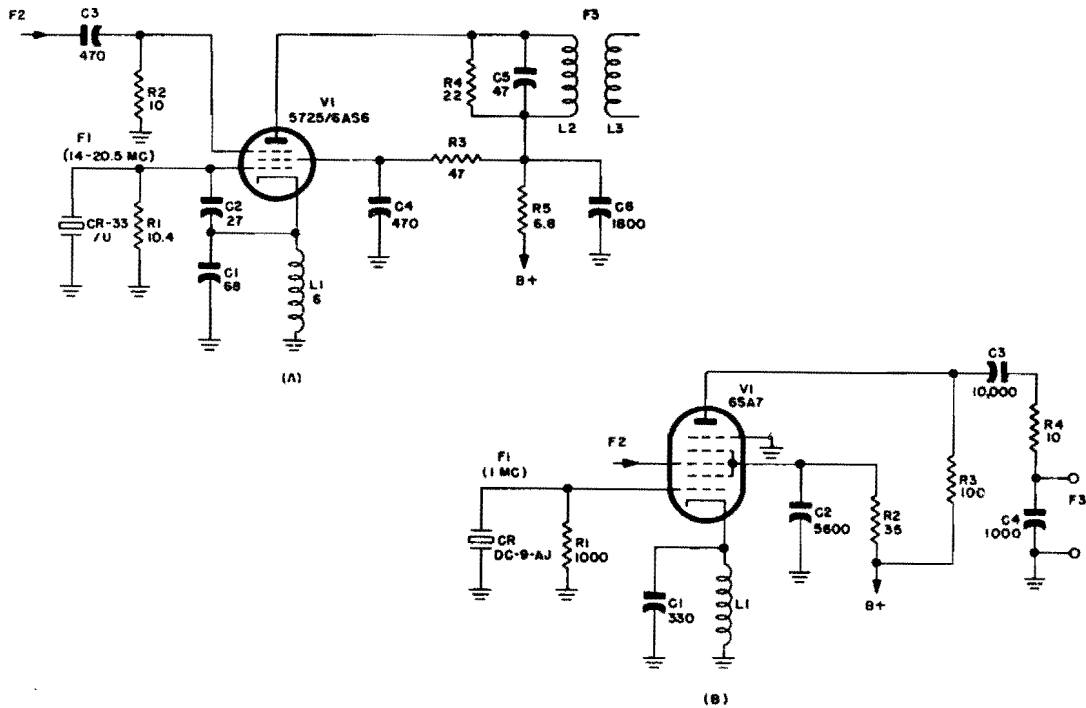

Figure 1-138. Electron-coupled Pierce oscillator modifications for heterodyne circuits

Fig.	Equipment	Purpose	F ₁	F ₂	F ₃	CR	R ₁	R ₂
(A)	Radio Receiver R-252/ARN-14	1st monitor osc of receiver vfo.	14,000-20,500	From isolation amplifier of vfo.	F ₂ -F ₁	CR-33/U	10.4	10
(B)	Signal Generator TS-413/U	Crystal harmonic heterodyne mixer	1000	Variable rf	nF ₁ ± F ₂ (n = 1, 2, . . .)	DC-9-AJ	1000	35
(C)	Radio Receiver R-146A/ARW-35	2nd heterodyne osc	5456	5000	F ₁ -F ₂	FT-243	47	47
(D)	R-F Signal Generator Set AN/URM-25C	Crystal calibrator harmonic generator and mixer	1000	10-50,000 (output from variable osc)	nF ₁ ± F ₂	CR-18/U	1	270
(E)	Radio Receiver R-277 (XA-A)/APN-70	Local osc	400 480 2850 2950 3000 3050	F ₁ -F ₃	300 1100 (1F)	CR-25/U (LF ₁) CR-18/U (HF ₁)	22	0.068

Circuit Data for Figure 1-138. F in kc. R in kilohms. C in μμf. L in μh.

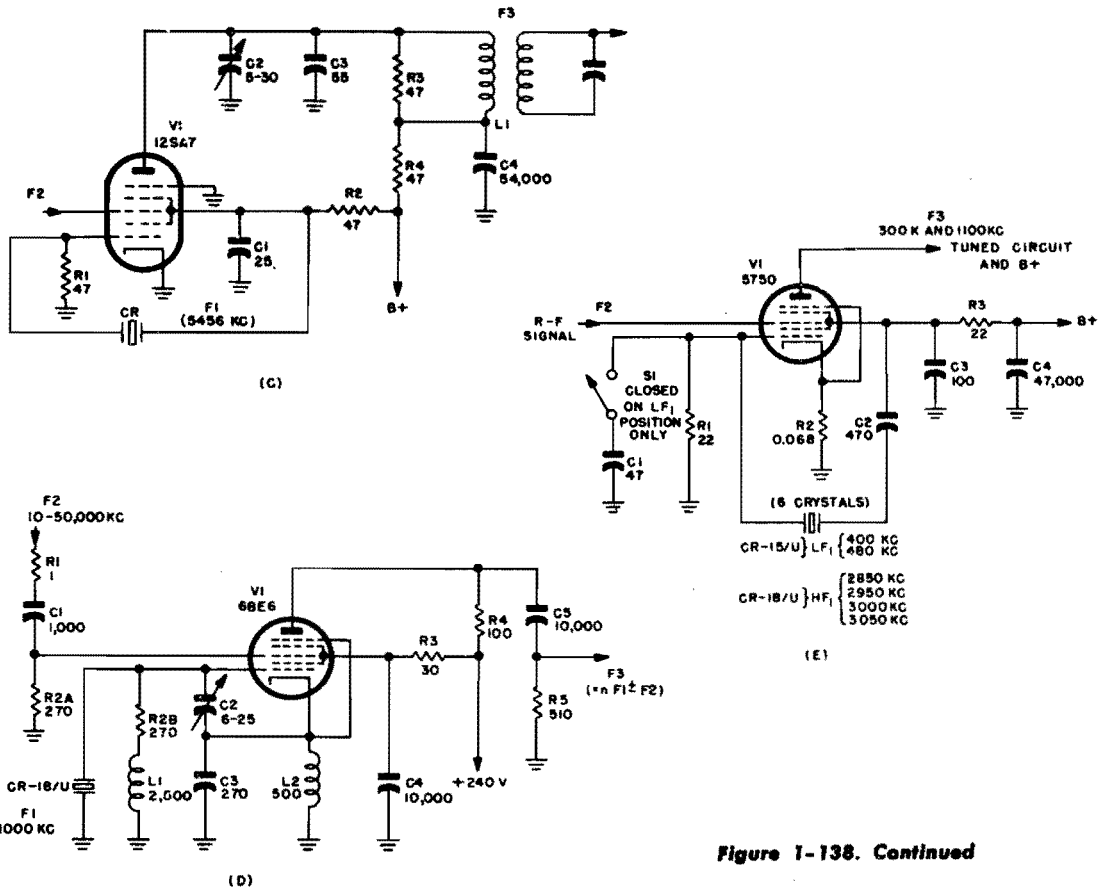

Figure 1-138. Continued

R ₃	R ₄	R ₅	C ₁	C ₂	C ₃	C ₄	C ₅	C ₆	L ₁	L ₂	L ₃	V ₁
47	22	6.8	68	27	470	470	47	1800				5725/ 6AS6
100	10		330	5600	10,000	1000			2500			6SA7
47	47		25	5-30	55	50,000						12SA7
30	100	510	1000	6-25	270	10,000	10,000		2500	500		6BE6
22			47	470	100	47,000						5750

Section I Crystal Oscillators

Preventing B⁺ Voltage from Existing Across Crystal Unit in Pierce Circuit

1-320. There are two commonly used methods for preventing the application of the B⁺ voltage across the crystal unit. One method is to connect a blocking capacitor in series with the crystal unit. The other method is to connect the crystal unit directly to ground, and the plate to ground through an r-f bypass capacitor. With this arrangement, the cathode must be operated above r-f ground. Except for the advantages of electron-coupling to the load to be had in the tri-tet circuit, which uses screen-grid tubes, the r-f-grounded-plate modification is not to be preferred since the plate-to-grid capacitance directly shunting the crystal unit is greatly increased by the addition of the grid-to-ground capacitance. When a capacitor is used to block the B⁺ voltage from the crystal, a number of modifications are possible, three of which are shown in figures 1-135 (F), (G), and (K). In each figure, the blocking capacitor is the one labeled C₂, and has a reactance negligible with respect to that of the crystal unit. The more usual circuit arrangement is that shown in figure 1-135 (K). In figure 1-135 (G), C₂ plays a dual function in blocking the B⁺ voltage from both the crystal and the grid circuit of the succeeding stage. The circuit in figure 1-135 (F), although not effective in blocking the B⁺ voltage from the crystal unit, does, of course, reduce the d-c potential across the crystal equally as well as the other arrangements. It is desirable to keep the d-c potential across the crystal unit low; otherwise the crystal may be heavily strained in one direction, and the chance is increased that the elastic limit of the crystal will be approached on the alternation of the a-c voltage of the same polarity, or, at least, that the effect on the crystal will cause the performance characteristics to deviate from test specifications. Since the crystal unit, itself, is a capacitor of considerably greater dielectric thickness and smaller cross-sectional area than the usual blocking capacitor, it might seem questionable that the d-c voltage across the crystal unit could be expected to be significantly reduced. Certainly in the static state, an air-gap crystal unit should have at least as high a resistance to leakage currents as would the blocking capacitor. However, in the dynamic state some degree of ionization will occur if the voltage is excessive. The consequent leakage tends to charge the blocking capacitor to the full plate-to-grid d-c voltage. An unchecked B⁺ voltage not only can increase the likelihood of corona effects, but also can lead to continuous discharge should corona losses once begin, and to an increase in the effective re-

sistance of the crystal unit, a reduction of the grid bias, and perhaps even to arcing and puncturing of the crystal. A blocking capacitor, if it does not remove the d-c potential completely from across the crystal unit, at least can ensure that the potential is not sufficient to cause ionization. A blocking capacitor is generally more important in high-drive circuits employing air-gap crystal units.

1-321. Figure 1-135 (X) shows one example of a grounded-crystal, grounded-plate Pierce circuit. At first glance such an oscillator might very easily be mistaken for the Miller type. C₃ is a relatively large capacitance that causes the plate to be at r-f ground. C₁ is effectively C_p, the plate-to-cathode capacitance, and C₂ serves as the lumped part of C_g. By interchanging C₁ and C₂ and making the ground connection of the crystal a plate connection, essentially the same oscillator characteristics are obtained except that the B⁺ is across the crystal unit. Note that the circuit is designed for the maximum possible output voltage, in that the output is taken across the crystal unit directly, instead of across C₁, the effective plate capacitance, alone. The fact that the plate is at r-f ground does not remove the grid-to-plate capacitance from shunting the crystal unit, but adds to this the grid-to-ground capacitance. In the circuit of figure 1-135 (R), a small tuning capacitance, C₄, is also shunted across the crystal unit. In addition to this there is the extra shunt capacitance contributed by the oven in which the crystal is mounted. In circuit (R), the C₁/C₂ ratio, which is approximately equal to the C_g/C_p ratio, is on the order of 1/4. The gridleak losses are increased somewhat, since the grid resistance is connected across the crystal instead of across the grid capacitance. All these factors tend to reduce the effective Q_f of the feedback circuit, so it would appear that with crystal units of greater than average resistance the circuit operates with the tank considerably detuned from resonance. The fact is, however, that connecting the grid resistance across the crystal serves to concentrate most of the grid losses in the plate-to-grid circuit and to eliminate them from the grid-to-cathode circuits, and this probably increases the effective feed-back Q_f more than the increased losses diminish it. The circuit in figure 1-135 (X) is similar to that in figure 1-135 (R) except that the tuning capacitance has been eliminated and the output is obtained directly across the crystal unit. It is claimed that this arrangement tends to smooth the output and to reduce the harmonics. What probably is meant is that for a given output voltage the harmonic content is less. This can readily be seen, for the voltage across

the crystal unit is equal to the sum of the voltages across C_1 and C_2 . If the same output is to be taken across either capacitance alone, the excitation must be increased and the circuit will generally be operated beyond tube cutoff a greater fraction of the time, thereby increasing the higher-harmonic content. It should also be noted that the output arm in figure 1-135 (X), since it shunts the crystal, is effectively part of the feed-back circuit. Should the load increase or decrease, so also will the excitation. The circuit is thus a tri-tet modification where the output voltage is somewhat stabilized against changes in the load, but only at the sacrifice of frequency stability. This feature is not important in the particular fixed-load circuit of figure 1-135 (X), since the load in this circuit appears to be reasonably constant.

Electron-Coupled Pierce Oscillator

1-322. The electron-coupled oscillator permits a remarkable freedom from coupling between the plate load circuit and the crystal circuit. Screen-grid tubes are required, with the screen grid serving as the plate of the oscillator circuit. When electron coupling is used in conjunction with Pierce oscillators, the tri-tet arrangement, where the plate load circuit is in series with the oscillator tank, is generally the most advantageous, and is used in all the circuits shown in figure 1-137 except in circuits (I) and (O). With the screen at r-f ground, the vacuum-tube plate circuit performs as a conventional pentode r-f amplifier, with the excitation of the control grid a function of both the screen and plate r-f currents. Variations in the plate impedances have much less effect upon the frequency than do similar variations in the oscillator tank impedances. For this reason, even if the oscillator is to operate over a wide range of crystal frequencies, a tunable coil and capacitor tank can be placed in the plate circuit to obtain a smoother sine-wave output without running the risk of greatly changing the load capacitance of the crystal circuit. In effect, the electron-coupled oscillator reduces by one the number of amplifier stages that are required, and hence is particularly applicable for small portable transmitters where the crystal circuit must perform as nearly as possible the function of a power oscillator. The widest application of the electron-coupled Pierce circuit is for the purpose of frequency multiplication. In figure 1-137 (D), for example, the plate tank circuit is tuned to twice the crystal frequency. The L/C ratio of the plate tank should be as small as practicable, in order to increase the output selectivity and to ensure a low-impedance bypass through the coil for the fundamental frequency and through the ca-

pacitor for all harmonics higher than the second. The larger the angle θ during which the tube is cut off, the larger will be the percentage of the higher-harmonic generation in the output. In general, the lower the order of the harmonic, the greater is its energy content. For optimum output, the tube should not be heavily conducting during a positive alternation of the plate harmonic voltage, E_n . During such intervals the plate tank would be losing energy to the circuit at an instantaneous rate of $i_b e_n$, where i_b is the instantaneous d-c plate current and e_n is the instantaneous harmonic voltage across the plate tank. To meet the requirements above, plate current should be allowed to flow only during the interval of approximately one alternation of a harmonic cycle. Since the tube is to be cut on and off at the fundamental frequency, the plate tank, after receiving a pulse of energy during one alternation of a harmonic cycle, must oscillate freely for the remaining part of the fundamental period. If the frequency is being doubled, plate current should flow approximately one-fourth the time; if the frequency is being tripled, plate current should flow approximately one-sixth of the time. To generalize, if the frequency is to be multiplied n times, optimum n 'th harmonic output is approached if the oscillator is designed so that the tube conducts approximately $1/2n$ of each fundamental cycle. In paragraph 1-312, it was found that for a given peak value of i_b , (I_{bm}), the effective I_p was essentially constant for all bias voltages between class-A and class-B operations, although a small maximum occurred when the tube was cut off during three-fifths of the negative alternation. See equation 1-312 (20). If the plate load is constant, as is the case in the electron-coupled circuit, this point of maximum I_p coincides with the conditions of maximum output. If we assume that approximately the same conditions hold in the case of frequency multiplication, maximum harmonic output is approached if the tube continuously conducts $7/10$ of the period of one harmonic cycle, or $7/10n$ of the period of the fundamental cycle. Since the maximum is not at all sharp, the optimum operating conditions are not critical and can be assumed to extend over a range which permits the tube to conduct from $1/2n$ to $7/10n$ of the time. That is, for optimum output, the oscillator section can be designed so that the crystal unit of average resistance allows the tube to be cut off during a fundamental-cycle angle within the range given by

$$\text{(optimum) } \theta = \frac{\pi(2n - 1)}{n} \text{ to } \frac{\pi(10n - 7)}{5n}$$

1-322 (1)

Section I
Crystal Oscillators

The principal advantage of the tri-tet circuit is that the excitation voltage tends to increase with an increase in load. If the output is to be inductively coupled to the succeeding stage, the tri-tet arrangement tends to stabilize the output voltage when the coefficient of coupling is varied. This feature originally found its greatest popularity among radio amateurs, although it was used principally in conjunction with Miller rather than Pierce oscillators. Figure 1-139 shows the basic tri-tet circuit as applied to Pierce and to Miller oscillators. It is the adaptability to frequency multiplication rather than to variable load conditions, however, that is of greatest importance when considering the tri-tet circuit for use in military equipments. The tri-tet frequency stability is low compared with that of the conventional pentode circuit because of the large stray capacitance (approximately $8 \mu\mu\text{f}$) that directly shunts the crystal unit. About $4 \mu\mu\text{f}$ is the C_{g1g2} of the tube, and the remainder is the capacitance of the grid leads to ground, which otherwise would be part of C_g .

Miscellaneous Pierce Circuit Modifications

1-323. Circuits (A) and (B) in figure 1-135 are of interest because they indicate two stages in the development of a particular modification of the Pierce oscillator. Originally L_s , C_s , C_t , and R_t were not present. Since no grid capacitance is employed other than that of the tube, the C_g/C_p ratio is very small. The tube has approximately $4 \mu\mu\text{f}$ capacitance between plate and grid, and it may be assumed that the crystal oven adds a comparable amount directly across the crystal. In all probability the phase-shifting Q_t of the feed-back circuit is rather low, so that the tank can be expected to be more reactive than resistive. L_t is resonant with C_t at the mid-point of the intended frequency range. If the feed-back circuit is operated with a high effective Q_t , this value of L_t should provide a zero phase shift in I_p . In this event, the tube would operate into a resistive load, and a theoretical independence of the frequency with changes in R_p could be predicted. As it is, the low feed-back Q_t

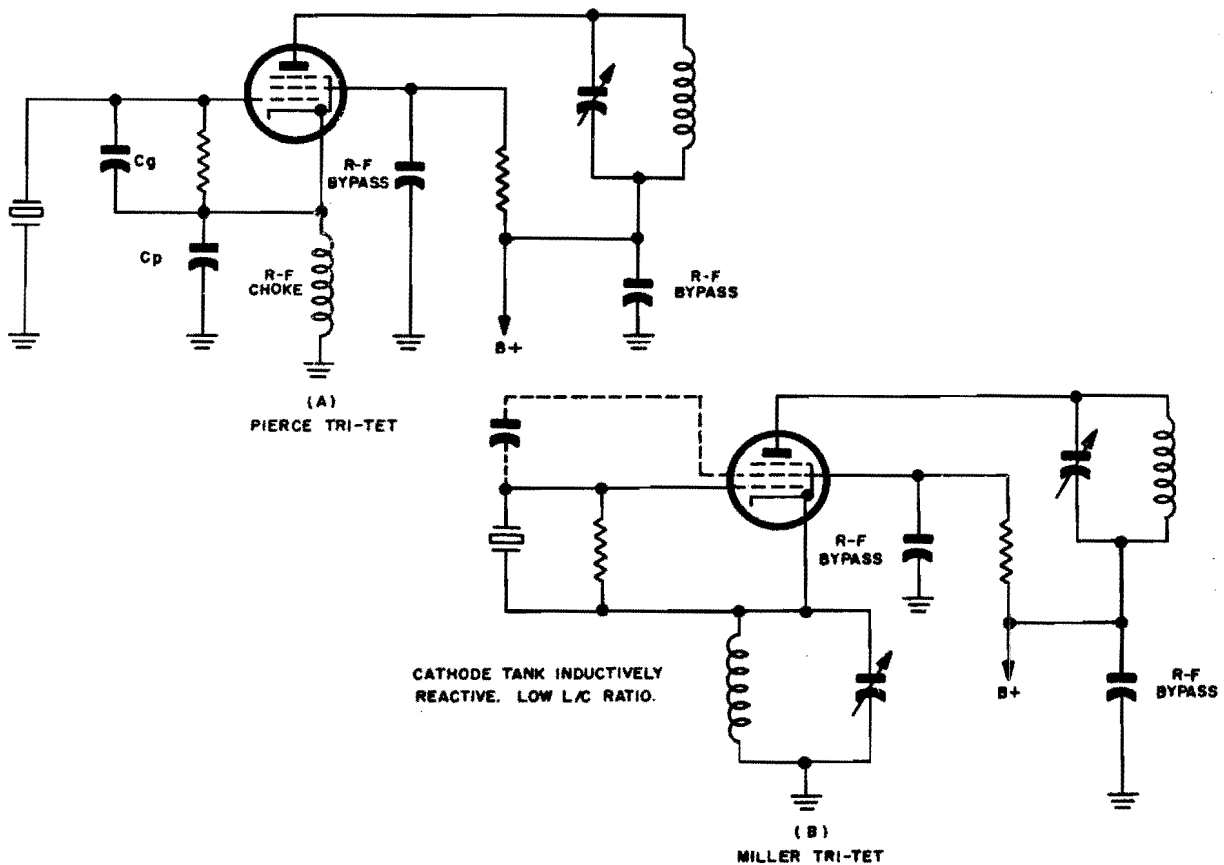

Figure 1-139. Basic tri-tet circuits where excitation voltage is a function of both screen- and plate-circuit r-f currents

probably requires the crystal tank circuit to be detuned to such a point that at equilibrium it appears either as a reactance much greater in magnitude than that of the coil L_1 , or as a reactance approximately equal to that of C_1 , in which case the lagging component of the current through the crystal unit is negligible compared with the current through C_1 . Under these latter conditions, the tube would operate into a low-impedance, series-resonant circuit at the mid-point of the frequency range, where $X_{L1} + X_{C1} = 0$. Nevertheless, it was found that oscillations could not be maintained dependably at the mid-point of the frequency range. It was for this reason that the changes were made in the models represented by circuit (B), as indicated in the data chart for figure 1-135. The tank circuit L_2C_2 is resonant at the mid-point of the frequency range. C_1 has been changed so that the reactance of the coil L_1 is lower than the reactance of the crystal tank at all frequencies. R_1 has been added to dampen the effect of L_1 at the high end of the frequency range. It may be that the dead spot at the mid-point of the frequency range in circuit (A) was due only to transient effects in the crystal units before oscillations could build up, or it may have been due to the fact that the feed-back Q_1 was insufficient to provide the necessary plate impedance to maintain equilibrium even if oscillations were once started.

1-324. An interesting circuit is that shown in figure 1-136 (D). The feed-back voltage is developed across C_4 by the r-f plate current. C_3 , although of the same capacitance as C_4 , maintains the screen at r-f ground, since R_2 is very large. The large value of R_2 keeps the screen voltage, and hence the output, at very low values, so that the crystal is only weakly driven.

1-325. The circuit shown in figure 1-136 (E) is

intended to supply a fourth-harmonic excitation of the V_2 stage. For this purpose the C_2L_2 tank is tuned to $4F_1$. A low L_2/C_2 ratio is provided, to ensure that the fundamental is effectively bypassed. The capacitance C_3 is kept small so as to present a high reactance to the fundamental, else the fundamental would be entirely bypassed around the crystal circuit.

1-326. The circuit shown in figure 1-136 (G) is something of a novelty in that a Pierce instead of a Miller oscillator is employed to directly excite the power amplifier of a small transmitter. The L_1C_4 arm is a neutralizing circuit which prevents the amplitude-modulated output stage from varying the effective impedance of the oscillator load. Normally, neutralizing networks are not necessary for crystal oscillators. Only when the oscillators drive power amplifiers directly is feed-back neutralization advisable. Even then, if the power amplifier is not modulated and performs as a frequency multiplier, neutralization is not necessary.

1-327. The electron-coupled converter circuits shown in figure 1-138 embody more or less the same features previously discussed. The basic methods illustrated for obtaining a heterodyne output are more or less self-explanatory, and will not be elaborated upon here.

The Miller Oscillator

1-328. The Miller oscillator is the crystal equivalent of a Hartley oscillator in which no mutual inductance exists between the plate-to-cathode and grid-to-cathode inductances. (See figure 1-140.) The Miller oscillator has an average frequency deviation of approximately 1.5 times that of the Pierce circuit. The plate circuit must appear inductive in order that the correct phase shift will be produced in E_p , the plate r-f voltage, to compensate for the

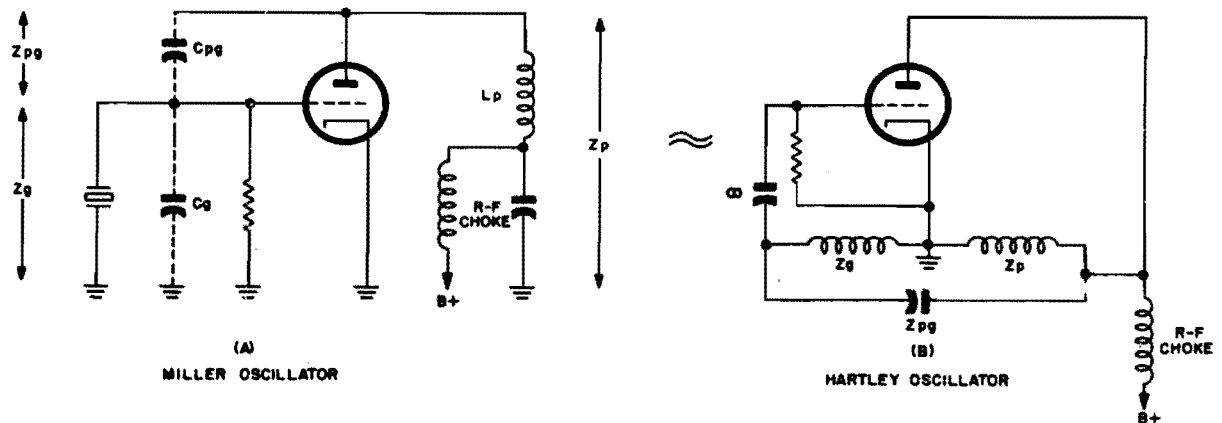

Figure 1-140. Diagrams illustrating the equivalence between the Miller circuit and the Hartley circuit

Section I
Crystal Oscillators

resistance in the feed-back arm, since this resistance prevents the necessary 180-degree phase rotation of the equivalent generator voltage of the amplifier from occurring entirely in the feed-back circuit. The effective load capacitance into which the crystal unit operates is, approximately,

$$C_x = C_g + \frac{1}{\omega} \left(\frac{1}{Z_{pg} - Z_p} \right)$$

$$= C_g + \frac{C_{pg}}{1 - \omega^2 L_p C_{pg}} \quad 1-328 (1)$$

where Z_{pg} and Z_p are both considered as unsigned magnitudes, and the various symbols correspond to those in figure 1-140. Since the load capacitance is a function of the frequency, a Miller oscillator cannot be operated at more than one frequency and still present the same load capacitance to each crystal unit except by providing for an adjustment of the circuit parameters. In spite of its greater frequency instability and lack of circuit simplicity as compared with the Pierce circuit, the Miller design is the one most widely used in crystal oscillators. The reason for this popularity is the greater output that can be obtained for the same crystal drive level. In either the Pierce or the Miller basic circuit, the output cannot exceed the voltage across Z_{pg} , the largest single impedance in the plate tank circuit. In the Pierce circuit, the maximum voltage is thus the maximum permissible across the crystal unit; in the Miller circuit the maximum voltage is $(k + 1)$ times the maximum permissible voltage across the crystal unit, where k is the gain of the stage, equal to E_p/E_g . This gain, theoretically (not practically), can approach the μ of the tube as a limit when the load impedance, Z_L , is large compared with R_p . Thus, the use of a Miller circuit permits a saving of one amplifier stage.

1-329. The feed-back capacitance of the Miller circuit is, normally, simply the plate-to-grid inter-electrode capacitance of the tube. It cannot, of course, be less than this unless an inductive shunt is connected between the plate and grid. When a pentode is used, it is usually necessary to insert a small feed-back capacitance on the order of a few micromicrofarads. The waveform in the output is improved by the use of a tuned tank circuit having a low L/C ratio in place of L_p . The plate tank must be tuned to a frequency above the oscillator frequency, in order that the tank impedance will appear inductive. Such an arrangement also ensures a large effective L_p of high Q . A variable capacitance in the plate tank facilitates adjustments to obtain the correct load capacitance for the crystal unit.

MILLER-OSCILLATOR DESIGN CONSIDERATIONS

1-330. If it is decided to employ a Miller oscillator as a frequency generator, the choice should be dictated by the need of a greater output than can be obtained with a Pierce oscillator. An exception to this rule might be made if a tri-tet circuit is contemplated, in which case, the large capacitance that will directly shunt the Pierce-connected crystal may well prevent the stability from being as high as that of the Miller tri-tet circuit. The Miller circuit is the more critical to design insofar as maintaining the correct load capacitance is concerned, but the basic approach to the problem is the same as that which was followed in analyzing the equilibrium state of the Pierce circuit. Both oscillators are represented by the same basic circuit, shown in figure 1-119. We shall not repeat the steps involved in the derivation of the equilibrium equations in the particular case of the Miller oscillator. The basic equations given in the following paragraphs can be used as points of departure in the design of any Miller circuit. Also, by methods similar to those employed in the analysis of the Pierce circuit, the design limitations of a Miller oscillator in which the crystal unit is to be operated within specifications can be predetermined, approximately.

MILLER-OSCILLATOR EQUATION OF STATE

1-331. As in the case of the Pierce circuit, there are two equations that express the state of oscillation equilibrium in the Miller circuit. Originally derived by Koga, these two equations are the real and the imaginary parts of the general equation:

$$-\frac{\mu Z_p Z_g}{R_p Z_g + Z_p(Z_g + Z_{pg})} = 1 \quad 1-331 (1)$$

where

$$Z_g = Z_g + Z_p + Z_{pg}$$

and

$$Z_g = R_{cg} + jX_g; \quad Z_p = jX_p; \quad Z_{pg} = jX_{pg}$$

R_{cg} is the effective resistance of the grid circuit, accounting for both the crystal and gridleak losses. The losses in the plate circuit are assumed to be negligible. On solving equation (1), the real part can be expressed as

$$-R_p = \frac{X_p [Z_g^2 (\mu + 1) + X_g X_{pg}]}{R_{cg} (X_p + X_{pg})}$$

1-331 (2)

Equation (2) defines the conditions that exist when the feedback power input equals the power dissipated in the grid circuit. The imaginary part of the equation (1) defines the frequency, or, more exactly, the impedance relations that must exist if the feedback is to be of proper phase. This is given as

$$X_x = \frac{X_p X_{pg} - R_{cg} R_p}{R_p Q_g} \quad 1-331 (3)$$

Where Q_g is equal to X_g/R_{cg} , and $X_x = X_p + X_g + X_{pg}$. Equation (1) is the same as equation 1-289 (1) except that the terms are rearranged and μ is substituted for the product $R_p g_m$. Equations (2) and (3) correspond to equations 1-289 (2) and (3), respectively. If it is assumed that $Z_x \approx X_x$ and that $(X_p + X_{pg}) \approx -X_g$, equation (2) above can be simplified, thus:

$$R_p \approx \frac{X_p [X_g (\mu + 1) + X_{pg}]}{R_{cg}} \quad 1-331 (4)$$

Remember that X_p and X_g are positive, and that X_{pg} is negative. When equation (3) is rearranged as follows

$$X_g + X_p + R_{cg}/Q_g - \frac{X_p X_{pg}}{R_p Q_g} = -X_{pg} \quad 1-331 (5)$$

it can be seen that the effect of the tube R_p on the frequency is a function of the term $\left(\frac{X_p X_{pg}}{R_p Q_g}\right)$ only.

LOAD CAPACITANCE OF CRYSTAL UNIT IN MILLER OSCILLATOR

1-332. The load capacitance into which the crystal unit operates in a Miller circuit has been derived by Koga to be

$$C_x = C_g + C_{pg} + C_v \quad 1-332 (1)$$

where C_g and C_{pg} are as represented in figure 1-140, and

$$C_v = \frac{\mu C_{pg}}{1 + R_p^2/X_p^2} \quad 1-332 (2)$$

It appears that equation (2) gives a value to C_v that, for a Miller oscillator operated at the rated load capacitance of the crystal unit, is probably between three and four times too small for the average circuit. Equation (2) is derived from equation 1-331 (1), beginning by expressing the

latter equation in the following form:

$$\frac{1}{Z_x} + \frac{1}{Z_{pg}} + \frac{\mu}{Z_{pg} \left(1 + R_p/Z_p + \frac{R_p}{Z_x + Z_{pg}}\right)} = 0 \quad 1-332 (3)$$

It is next assumed that the term in parentheses

$$1 + R_p/Z_p + \frac{R_p}{Z_x + Z_{pg}} = 1 + R_p/Z_p \quad 1-332 (4)$$

Such an assumption not only implies that the feedback current is negligible compared with the r-f current through the plate coil, L_p , but that the feedback impedance is so high relative to R_p that $R_p/(Z_x + Z_{pg})$ is negligible compared with 1. The former implication requires that Z_L , the effective load impedance across the tube, be approximately equal to jX_p ; the latter implication requires that $|X_{pg}| - |X_g| \gg R_p$. If the effective phase-determining Q_r of the feed-back circuit is 10 or more, as is very likely to be the case when standard crystal units are operating at their rated local load capacitance and C_g is not excessive, then E_p must be very nearly in phase with $-E_g$. Such a condition cannot exist simultaneously with equation (4) unless $R_p \ll X_p$ —an operating state that would be very undesirable from the point of view of frequency stability. If R_p is to have a reasonable value at the rated load capacitance of the crystal unit, the impedance of the feed-back arm cannot be greatly different from that of the plate circuit. Equation (4) would be sufficiently accurate for very low values of Q_g and very large transconductances for the tube; however, it would seem that for crystal units that are to be operated well above series resonance, the approximation of equation (4) should not be made. In this case

$$1 + R_p/Z_p + \frac{R_p}{Z_x + Z_{pg}} = 1 + R_p/Z_L \quad 1-332 (5)$$

and Z_L approaches X_p^2/R_{cg} as R_p and Q_g increase. Since Z_L , as used above, represents an involved complex quantity, an exact expression of equation (2) will not be attempted here. As can be seen from equation 1-331 (5), if $1/Q_g$ and X_p/R_p are each on order of 1/10 or smaller, $X_g + X_p \approx |X_{pg}|$. On the other hand, if X_p/R_p is not small, the variable parameters of the vacuum tube and the variations to be expected in the effective resistance from

Section 1
Crystal Oscillators

one crystal unit to another will have such a large influence upon the effective load capacitance that there can never be an assurance that a crystal chosen at random will be operated according to specifications. In other words, a Miller oscillator cannot be designed to provide approximately a specified load capacitance unless $X_g + X_p \approx |X_{1g}|$. Under these conditions

$$C_x = C_r + \frac{1}{\omega \left(\frac{1}{\omega C_{pr}} - \omega L_p \right)} = C_r + C_{pr} + C_{xp} \quad 1-332 (6)$$

where

$$C_{xp} = C_{pr} \left(\frac{-X_p}{X_{pr} + X_p} \right) \quad 1-332 (7)$$

It must be understood that equations (6) and (7) assume that R_p is large compared with X_p , and that X_r is large compared with R_{gr} . For this latter condition to hold, the grid-to-cathode capacitance, C_{gr} , must be kept as small as possible. If the assumptions above cannot be made, it is not feasible to expect a Miller oscillator to operate at approximately the same load capacitance for all crystal units, nor can good frequency stability be expected. A more comprehensive capacitance equation for the Miller circuit—one that holds approximately for all operating conditions—can be expressed as

$$C_x = C_r + C_{pr} + C_{xp}' \quad 1-332 (8)$$

where C_{xp}' is given by equation (7), except that X_p is replaced by X_p' , where

$$X_p' = X_p + R_{gr}/Q_g - \frac{X_p X_{pr}}{R_p Q_g} \quad 1-332 (9)$$

It will be seen that X_p' has been so chosen that equation 1-331 (5) can be expressed in the form

$$X_g + X_p' + X_{pr} = 0 \quad 1-332 (10)$$

In the event that the plate circuit contains a capacitance shunting the coil, equations (6) and (7) still hold except that X_p refers to the total parallel reactance in the $L_p C_p$ branches.

MAXIMUM R_p OF MILLER OSCILLATOR TUBE UNDER GIVEN LOAD CONDITIONS

1-333. Referring to figure 1-141, R_o and R_{gr} are defined as follows:

$$R_o = E_p^2/P_o \quad 1-333 (1)$$

where P_o is the power dissipated in the output circuit, and

$$R_{gr} = E_g^2/P_g \quad 1-333 (2)$$

where P_g is the power dissipated in the grid circuit. If the gridleak losses are negligible, P_g equals the crystal power and R_{gr} equals the PI of the crystal unit. As can be seen from the equations in figure 1-141, either PI must be small or R_g very large for this assumption to hold. With R_p large compared with Z_{Lp} , I_p is approximately equal to $g_m E_g$. We shall assume that $X_s = X_r + X_p + X_{1g} \approx 0$. Under these conditions it can be shown quite simply that in the circuit of figure 1-141, letting $k = E_p/E_g$,

$$g_m = \frac{k^2 R_{gr} + R_o}{k R_{gr} R_o} \quad 1-333 (3)$$

For a given R_{gr} and R_o , equation (3) has a minimum g_m when

$$k^2 = R_o/R_{gr} \quad 1-333 (4)$$

Since a maximum R_p coincides with a minimum g_m , equation (4) also establishes the conditions for a maximum R_p . Now, R_{gr} is a function of R_e of the crystal unit, so that a circuit design using equation (4) should be based on a most probable value of R_{gr} (i.e., a most probable value of R_e), which will usually correspond to a value of R_e between one-third and one-fourth of the maximum R_e . Equation (4) should not be interpreted to mean that if R_o/R_{gr} is adjusted to equal a fixed value of k^2 , the g_m of the tube will therefore be a minimum relative to its values for other R_o/R_{gr} ratios. Such an interpretation would only hold true if the product $R_o R_{gr}$ were constant. Where equation (4) holds, it can be shown that the ratio of output power to crystal power is

$$P_o/P_g = 1 \quad 1-333 (5)$$

OPTIMUM VALUE OF $k = E_p/E_g$ FOR MILLER OSCILLATOR

1-334. Practical values of k , unless a pentode is used, are limited by the plate-to-grid and grid-to-cathode interelectrode capacitances of the tube and the specified load capacitance of the crystal unit. If $X_s = X_g + X_p + X_{1g} \approx 0$, then

$$X_p = kX_g \quad 1-334 (1)$$

and

$$-X_{pr} = (k + 1) X_g \quad 1-334 (2)$$

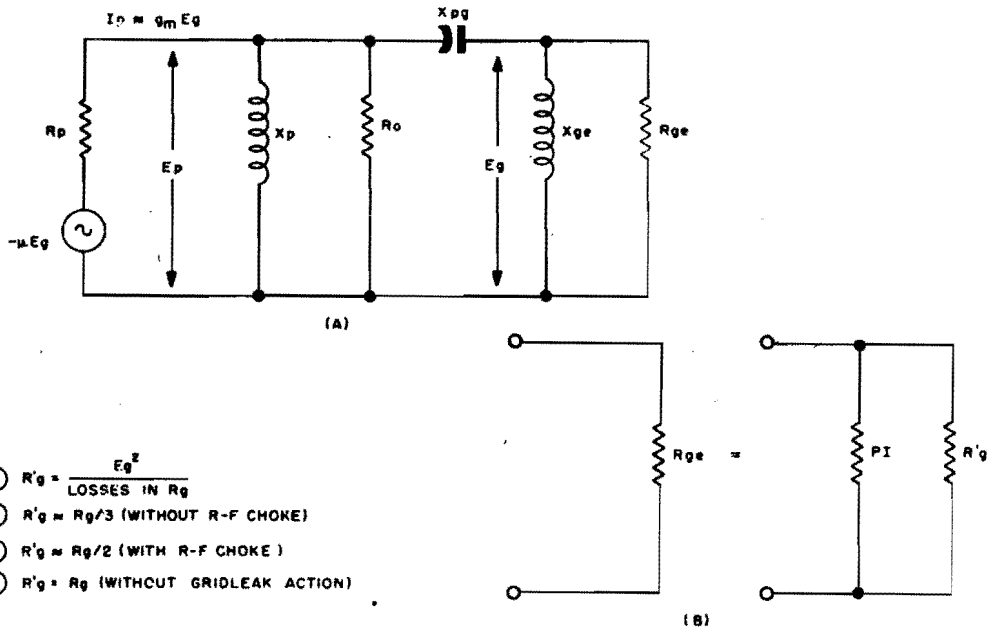

Figure 1-141. Equivalent circuit of Miller oscillator. R_p is assumed to be large compared with the total load impedance. R_o is an equivalent resistance accounting for the output losses. R_{μ} is an equivalent resistance accounting for the crystal and grid losses; it is approximately equal to the resistance of the parallel circuit shown in (B). PI is the performance index of the crystal unit; R'_g is the equivalent grid resistance; and R_g is the actual gridleak resistance

By equation (2)

$$k = \frac{-(X_{pk} + X_g)}{X_k} = \frac{C_x - C_k - C_{pk}}{C_{pk}} \quad 1-334 \quad (3)$$

where

$$X_k = \frac{1}{\omega(C_x - C_g)}, \quad X_{pk} = -1/\omega C_{pk}$$

C_x = rated load capacitance, and C_k = grid-to-cathode capacitance. With triodes, values of k above 4 or 5 are difficult to obtain. If the oscillator is to be designed with no other feedback-circuit capacitances than those provided by the interelectrode capacitances, C_{pk} and C_{μ} , of the tube, it can be assumed that k is a fixed parameter equal to the value given by equation (3). The output arm must thus be designed to provide a reactance, $X_p \approx kX_g$, if the crystal unit is to operate into its rated load capacitance.

1-335. From the point of view of frequency stability it is desired that the term $(X_p X_{pk}/R_p Q_k)$ in equation 1-331 (5) be as small as possible relative to $(X_g + X_p)$, or, equivalently, to $|X_{pk}|$. In other words,

$$X_{pk} / \frac{X_p X_{pk}}{R_p Q_k} = R_p/kR_{ck}$$

should be a maximum. With equation 1-331 (4), it can be shown that

$$R_p/k = Q_k X_k (\mu - 1) \quad 1-335 \quad (1)$$

Equation (1) indicates that as the fraction of the loop reactance (kR_{ck}/R_p) dependent upon R_p becomes smaller, the effective amplification factor of the tube becomes greater. Intuitively from equation (1) it can be seen that with $Q_k X_k$ constant for a given vacuum tube and plate voltage, E_{μ} , R_p must increase as k is made larger, otherwise μ could not decrease. Nevertheless, the larger that k becomes the smaller the value of R_p/k . If $k = 1$, a frequency stability almost approaching that of the Pierce circuit can be achieved, but with twice the output voltage. Lower values of k would soon detune the oscillating tank to a point where the simplifying assumptions made regarding k would no longer hold.

1-336. Since the principal purpose of using a Miller instead of a Pierce circuit is to eliminate an amplifier stage, and since E_k is limited to the maximum voltage that can be placed across the crystal unit, the ratio $E_p/E_k = k$ can be chosen to give a desired gain over that which would be obtained with a Pierce oscillator operating at the same crystal drive level. E_k in the Miller circuit can be assumed to be twice the E_k of a Pierce circuit that

Section I
Crystal Oscillators

has a $k = 1$. If an imaginary gain of 10 is desired, k for the Miller circuit should be equal to 5. For k to be 5, according to equation 1-334 (3)

$$C_{pr} = (C_x - C_r)/6$$

If $C_x = 32 \mu\mu f$ and $C_r = 8 \mu\mu f$, C_{pr} must be $4 \mu\mu f$, which is a value quite representative of the average triode amplifier, or which could be obtained with a pentode by using a small external plate-to-grid capacitance. Equation 1-335 (1) can be rewritten in the form

$$1/R_p = g_m - R_{cr}/kX_r^2 \quad 1-336 (1)$$

For $k = 5$, the value of $1/R_p$, and hence the percentage effect of R_p on the loop reactance, will be a minimum the more nearly that g_m can be made to approach in value $R_{cr}/kX_r^2 = R_{cr}/5X_r^2$. If the effective Q of the crystal unit, $Q_c = \frac{X_r}{R_p}$, is equal to 10 or more and if the gridleak losses are negligible, it can be shown that

$$R_{cg} = \frac{R_c X_{Cr}^2}{(X_e + X_{Cr})^2} \quad 1-336 (2)$$

and that

$$X_r = \frac{X_e X_{Cr}}{X_e + X_{Cr}} \quad 1-336 (3)$$

Thus,

$$Q_c = X_r/R_{cg} = \frac{X_e(X_e + X_{Cr})}{R_c X_{Cr}} \quad 1-336 (4)$$

and

$$X_r^2/R_{cg} = X_e^2/R_c = PI \quad 1-336 (5)$$

where PI is the performance index of the crystal unit. If it is further assumed that the output losses are negligible, the impedance of the crystal tank is

$$Z_L = \frac{X_p^2}{R_{cg}} = \frac{k^2 X_r^2}{R_{cg}} = k^2 PI \quad 1-336 (6)$$

Equation (1) can thus be written

$$\frac{1}{R_p} = g_m - \frac{1}{k PI} = g_m - \frac{k}{Z_L} \quad 1-336 (7)$$

If k is fixed by output considerations, the percentage effect of R_p upon the loop reactance becomes a function of R_p alone, being a minimum when R_p is a maximum. If R_p is increased without limit, g_m approaches k/Z_L as a limit, and the greater the PI , the larger will R_p become. In the case

of the Pierce oscillator, it will be recalled that a maximum R_p was obtained by a proper choice of k . This optimum k was the one that provided the maximum excitation voltage. In the Miller circuit, the excitation is the voltage developed across the crystal unit, and thus is limited by the crystal specifications regardless of the value of k . The smaller that k is made, the smaller will be the effective R_p , but, even so, the percentage effect of R_p upon the effective loop reactance will also be smaller. With k fixed by the requirement to eliminate an amplifier stage, the problem of obtaining a maximum R_p becomes one of keeping the load requirements to a minimum, selecting the vacuum tube, determining the proper operating voltages consistent with the crystal specifications, designing a test model accordingly, and experimenting for optimum results over the resistance range to be expected in the crystal units.

OPERATING CONDITIONS OF MILLER OSCILLATOR PROVIDING MAXIMUM R_p FOR GIVEN g_m .

1-337. If the bias of a tube is supplied by agc , the excitation voltage is small by comparison, so that the operating point of the tube can be theoretically estimated by consulting the R_p and g_m curves plotted against grid voltage. The operating bias for a given plate voltage would approximately be that giving values of R_p and g_m that obey equation 1-336 (7). Unfortunately, there are no curves available that indicate the effective R_p and g_m for large excitation voltages where the tube is cut off a large fraction of each cycle. Nor has a theoretical basis been established for estimating the probable rates of change in R_p and g_m as the excitation is increased under various circuit conditions. If time permits, experiments designed to furnish such data may gain for the engineer a valuable insight into the characteristics of his design models. Most probably the "dynamic" curves of R_p and g_m will correspond closely to the static curves. Yet the possibility exists that significant differences in the rates of change in the tube parameters may be discovered under certain operating conditions. In equation 1-336 (7) it can be seen that for any large value of R_p , g_m very nearly equals k/Z_L . For example, if $R_p = 0.5$ megohm, the difference between g_m and k/Z_L is only 2 micromhos. An R_p of 1 megohm corresponds to practically the same value of g_m , the difference being only on the order of 1 micromho. Thus, when R_p is large, g_m can be considered more or less a circuit constant. During the time that the tube is cut off, R_p is infinite and g_m

is zero. From the point of view of a large effective R_p , it is desirable that the cutoff angle be a maximum. The larger the g_m of the tube above cutoff, the greater can be the cutoff angle. A sharp-cutoff tube would be preferred for this purpose. It is also desirable to have R_p , as high as possible above cutoff. For this purpose, a high- μ tube is to be preferred. A theoretical estimate of the optimum relation between the values of R_p and g_m , for a tube of the same class-A μ , that provides a maximum over-all effective R_p , cannot be attempted here. However, it would seem that the emphasis should be placed upon the larger g_m/R_p ratio. The effective R_p of a pentode can always be increased artificially by inserting a high resistance in the plate circuit in series with the oscillating tank, as illustrated in figure 1-142. In testing a given tube for those bias and excitation conditions which provide a maximum R_p , it may be preferable to control the bias independently of the oscillations, or by using an adjustable, r-f-bypassed cathode resistor. A crystal unit should be employed having parameters known to remain constant over the experimental drive-level range. After the tube has warmed up, if the cathode bias is used, the cathode resistance can be decreased until oscillations begin. The cathode resistance can then be increased until the frequency is a maximum. The maximum frequency would be an indication of an equilibrium point of maximum R_p . In order for oscillations to be maintained in the event that all the bias is developed across the cathode resistance and the excitation is insufficient to drive the grid positive, a

small percentage decrease in the excitation amplitude must cause at least an equal percentage decrease in the average plate current, and hence in the bias. Such operation will require that the tube be cut off for a large fraction of each cycle. An adjustable cathode resistance cannot be considered a particularly practical design feature, but it may prove advantageous in an experimental circuit for finding the operating conditions that provide a maximum R_p for a given g_m .

FREQUENCY-STABILITY EQUATIONS FOR MILLER CIRCUIT

1-338. Regardless of whether the circuit conditions are such that the effective load capacitance of the crystal unit is assumed to be given by equation 1-332 (1), by equation 1-332 (6), or by equation 1-332 (8), the fractional change in frequency for a small change in any one of the equivalent component capacitances is given by the general equation

$$\frac{df}{f} = - \frac{1}{F_{Xc}} \cdot \frac{dC_x}{C_x} \quad 1-338 (1)$$

where dC_x is equal to dC_{cr} , dC_{pr} , dC_v , dC_{Xp} , or dC_{Xp}' , and represents an incremental change in any of the component capacitances, and F_{Xc} is the frequency-stability coefficient of the crystal unit, equal to $2C_T^2/CC_x$. (See equation 1-243 (1).) If a tuning capacitor, C_p , is connected across L_p in the plate circuit, and if equations 1-332 (1) and (2) are assumed approximately correct, it can be shown

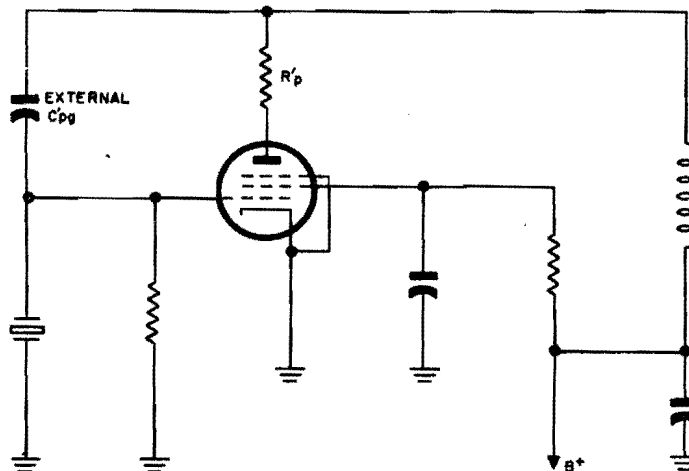

Figure 1-142. The large resistance, R_p' , connected in plate circuit effectively increases R_p of the tube. This method can be used to improve the frequency stability of a Miller oscillator employing a screen-grid tube and an externally connected feed-back capacitance, C_{pg}'

Section I
Crystal Oscillators

that for variations in C_p ,

$$\frac{df}{f} = - \frac{C_{pR}}{C_x} \cdot \frac{2 \mu \omega C_p R_p^2}{F_{Xe} X_p (1 + R_p^2/X_p^2)} \cdot \frac{dC_p}{C_p} \quad 1-338 (2)$$

where ω = angular frequency. If the circuit is operating at maximum activity, in which case $Z_L \approx X_p = R_p$, equation (2) becomes

$$\frac{df}{f} = - \frac{C_{pR}}{C_x} \cdot \frac{\mu R_p \omega C_p}{2 F_{Xe}} \cdot \frac{dC_p}{C_p} \quad 1-338 (3)$$

Where equations 1-332 (6) and (7) can be assumed to be approximately correct, it can be shown that a fractional change in the plate reactance, X_p , causes a fractional frequency deviation of

$$\frac{df}{f} = - \frac{(C_x - C_{pR}) dX_p}{C_{pR} F_{Xe} X_p} \quad 1-338 (4)$$

If no tuning capacitor is provided to shunt the plate coil L_p , equation (4) can be expressed in terms of a fractional change in L_p , thus:

$$\frac{df}{f} = - \frac{(C_x - C_{pR}) dL_p}{C_{pR} F_{Xe} L_p} \quad 1-338 (5)$$

If desired, equations indicating the frequency stability when other parameters are varied can be derived by following a procedure similar to that employed in the analysis of the Pierce circuit.

MILLER CIRCUIT AS A SMALL POWER OSCILLATOR

1-339. The ratio of the output power to the input power is given by the equation

$$P_o/P_i = k^2 R_{re}/R_o$$

where $k = E_p/E_g$, and R_{re} and R_o are the resistances represented in figure 1-141. In practice, ratios of R_{re} to R_o can be obtained on the order of 4 for crystal units of maximum effective resistance. If $k = 5$, this would mean a power ratio of 100. A 10-mw crystal unit could thus be used to develop a 1-watt output. Much higher power outputs, of course, can be obtained with crystal units of small values of R_o or of higher power ratings. It cannot be recommended that a crystal be driven beyond its rated power level, but if an exception should ever arise, the Miller circuit will require the least overdrive. If a larger drive level is necessary than can be obtained with Military Standard crystal units,

the cognizant military agency should first be consulted. It may be that one or more of the crystal manufacturers has available a nonstandard crystal unit with crystal dimensions and mounting sufficient to withstand the required drive—perhaps by operating with an overtone mode—without the risk of significant parameter variations. As a final resort, it will be found that most of the Military Standard crystal units can withstand, without shattering, drive levels from 10 to more than 20 times the rated drive. If need be, power outputs greater than 35 watts can be obtained with the Miller circuit, using a beam power tube or a power pentode. It is much easier to obtain a large output from a high- μ than from a low- μ tube for the same crystal drive. Also, it is easier to obtain a large output from, say, a 50-watt tube operated at low efficiency, than from a smaller tube operated at high efficiency. An r-f choke must be used in the grid circuit if large output is to be developed. Furthermore, fixed bias that is sufficient to prevent the grid from drawing current must be used, so as to reduce the grid losses to a minimum. The voltage gain of the oscillator, $k = E_p/E_g$, should be as high as possible. With proper design, except that the crystal unit is operating at tolerances greater than those specified for low drive levels, the Miller circuit can be made to drive a power amplifier of 300 watts or more. Some crystal units can withstand as much as 120 ma r-f current and still be within the safe-operating range as far as shattering is concerned. A pressure-mounted unit is generally to be preferred at high drive levels, because of the added protection it offers, and because its greater thermal conductivity permits the generated heat to escape more rapidly. For maximum output, the oscillator must operate into an impedance matching the R_p of the tube. If a Miller oscillator is to drive a power amplifier, great care must be taken in neutralizing the feedback from the amplifier, or the crystal may easily be overdriven to the point of shattering—that is, unless the power amplifier is to serve as a multiplier stage, or if a screen-grid tube is used as the amplifier tube. The plate supply voltage for the oscillator can be as high as 350 to 650 volts, and that of the power amplifier, 1500 to 2000 volts. If a low-power (7.5 watts, approximately) oscillator tube is used, a fixed bias of 40 to 60 volts will be required for high efficiency. A 3.5 to 4.5-ampere current in the plate $L_p C_p$ tank can be obtained under these conditions. A fixed bias is usually not necessary when a 50-watt tube operated at low efficiency is used. With the same plate voltage as for the low-power tube, a plate tank current of 4.5 to 7.5 am-

peres can be had. When a fixed bias is used, some arrangement must be provided to cut it in after oscillations build up and the negative peaks of E_p must be sufficient for plate limiting to occur at the positive peaks of E_p . When used as a power oscillator, the Miller circuit is often required to operate as a variable-tuned circuit, with a coil or tank-circuit in place of the crystal, the circuit thereby being converted into a tuned-plate-tuned-grid or a Hartley type oscillator. Because of this, the various tuning adjustments and meters that are needed in the variable circuit are also available in the crystal circuit. In this event, the rated load capacitance of the crystal unit will usually exist more in theory than in application. Since the crystal is intended to be operated at high drive, the risk is greatly increased that a chance adjustment may overload the crystal to the shattering point. This risk can be minimized by the use of an r-f milliammeter in series with the crystal, with the danger zone well marked. Besides excessive plate voltage and stray feedback due to poor shielding or neutralization, a poorly bypassed screen-grid circuit can lead to an overloaded crystal, as also can an excessive control-grid bias. Now, no attempt should be made to design a circuit in which a crystal unit is to be operated above its rated power level unless weight, space, or expense requirements demand the elimination of every possible amplifier stage; unless greater frequency stability is required than can be obtained with a conventional inductor-capacitor network; or unless a long operating lifetime is not a primary consideration. Even so, if a Military Standard unit is operated beyond specifications, it should be well understood that it is no longer effectively a standard type, and no guarantee exists concerning the replacement of one crystal unit by another.

**TYPICAL CHARACTERISTICS OF
MILLER OSCILLATOR**

1-340. Figure 1-143 shows an experimental Miller circuit, the performance characteristics of which were investigated by Messrs. E. A. Roberts, Paul Goldsmith, E. K. Novak, and J. Kurinsky of the Armour Research Foundation at the Illinois Institute of Technology. The crystal units used are of the type CR-18/U. The crystal PI indicated for each of the characteristic curves (figures 1-144 to 1-148) of the oscillator in figure 1-143 is the value observed when the crystal was operating into its rated load capacitance. The PI at the rated load capacitance indicates the relative activity of the crystal unit, but is not intended to imply that the same PI is in effect for all variations of the load capacitance. The curves in figure 1-144 indicate (excitation voltage)² and the output voltage as the plate tuning capacitance is varied. An increase in the plate capacitance means an increase in the effective value of L_p , so that the frequency decreases. Thus, as C_p increases (C_2 in figure 1-144), the reactance, X_c , of the crystal unit decreases. Oscillations cease whenever the Q_c of the grid circuit becomes too small for the proper phase rotation to take place, or the ratio of X_p/X_c becomes too high for the feed-back voltage to be of sufficient amplitude, or the plate tank approaches the parallel-resonant state, so that E_p can no longer assume its proper phase, which requires the plate arm to be an inductive reactance smaller in magnitude than the capacitive-feedback reactance. The percentage points in figure 1-144 refer to percentages of the maximum output voltage that was obtained through variations of the plate tank capacitance alone. The six curves shown represent values for

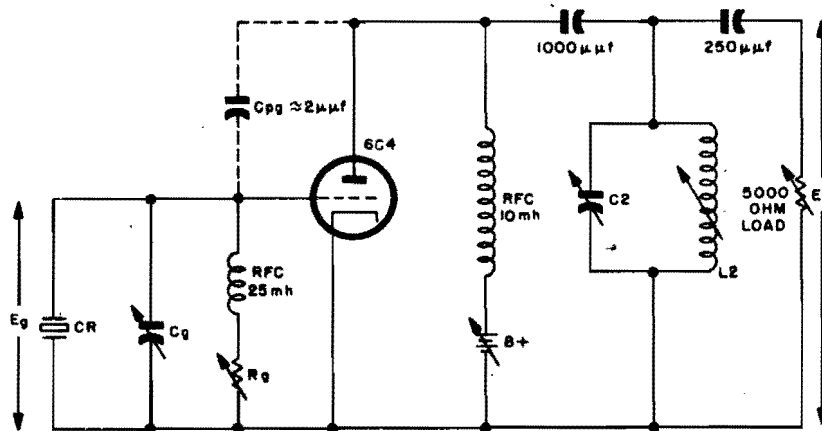

Figure 1-143. Experimental Miller oscillator whose characteristic curves are plotted in figures 1-144 to 1-148

Section I
Crystal Oscillators

an E_b of 200 volts with a full load of 5000 ohms, and for an E_b of 100 volts with full load and with no load. It is interesting to note that in each of the three pairs of curves the maximum grid voltage occurs at a smaller load capacitance than that at which the output voltage is a maximum. For each curve where the plate tuning capacitance is the same, it can be approximately assumed that the load capacitance is the same. Also, between the values of $C_p = 75$ and $C_p = 90 \mu\mu\text{f}$, it can be assumed that the percentage change in C_x is small. Since the PI of the crystal unit is the same where the load capacitance is the same, the excitation-

voltage-squared curves indicate the relative crystal drive for the different E_b and load conditions. Also note that the two pairs of curves representing full-load conditions coincide fairly closely at their points of equal percentages. This is important in interpreting the curves in figure 1-145, each of which represents 50 per cent output, and hence approximately the same load capacitance and frequency. Exceptions are the 10K curves in figure 1-145, as can be checked by figure 1-146. The performances curves in figure 1-145 are the Miller equivalents of the Pierce curves in figure 1-130. It can be seen that the Miller output is much

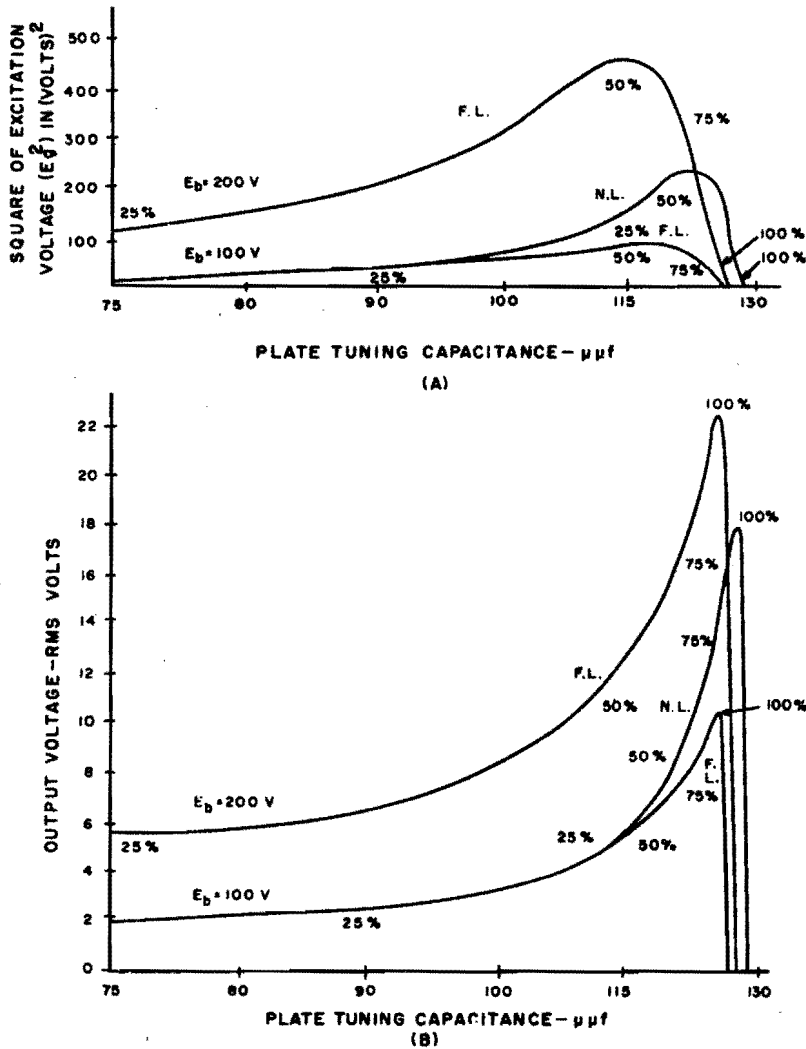

Figure 1-144. (A) Square of excitation voltage and (B) rms value of output voltage versus plate tuning capacitance of experimental Miller oscillator. Frequency = 7 mc; gridleak resistance = 1 megohm; and PI of CR-18/U crystal unit (with load capacitance of $32 \mu\mu\text{f}$) = 49 kilohms. F.L. = full load conditions (5,000 ohms across plate tank) and N.L. = no load conditions. Percentage points refer to percentages of maximum output voltage obtainable under given load and d-c plate voltage conditions

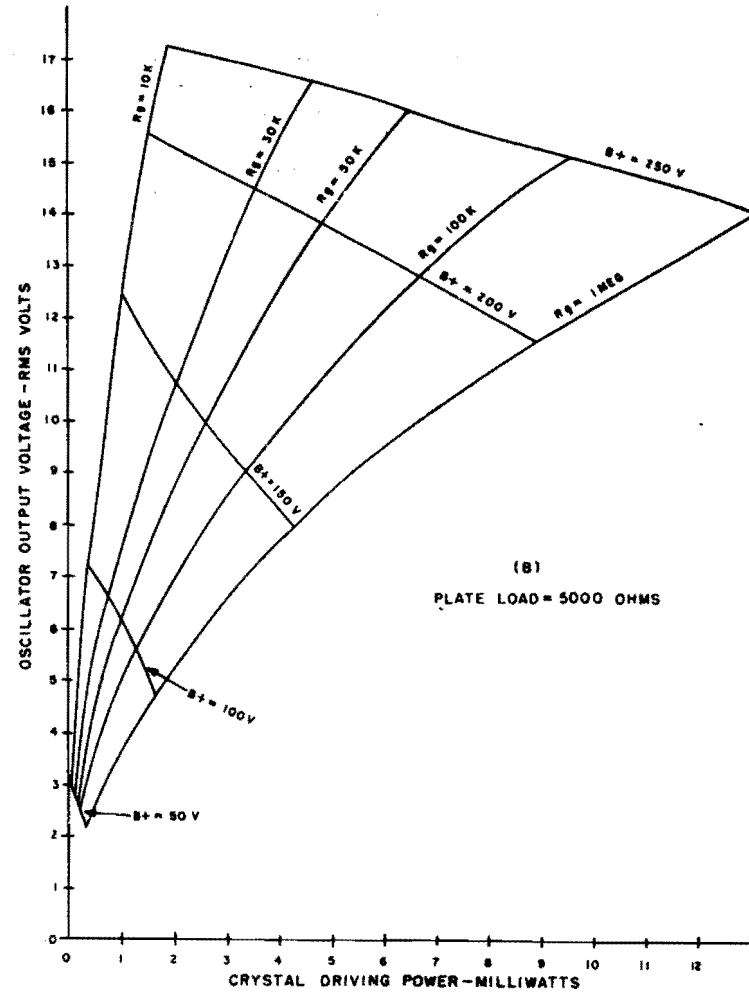
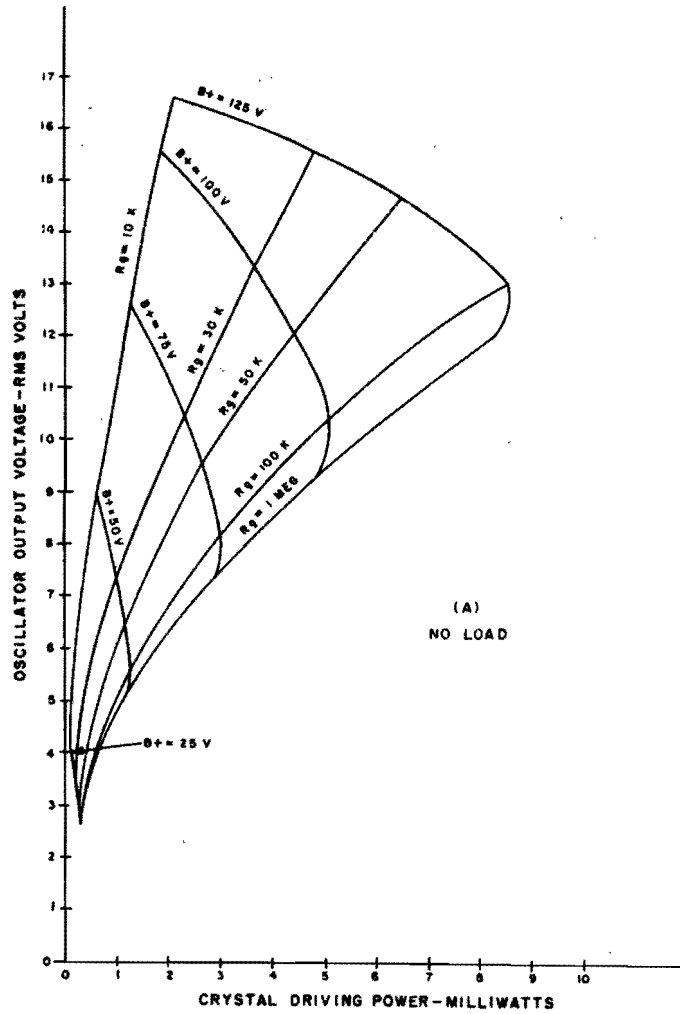

Figure 1-145. Output voltage versus crystal power for various values of gridleak resistance as the d-c plate voltage is varied in experimental Miller oscillator. The circuit is tuned for output voltages 50 percent of the maximum possible by variations in plate tank alone. Frequency = 7 mc; plate tank L/C = 0.04; and PI of CR-18/U crystal unit (with load capacitance of 32 μf) = 49 kilohms

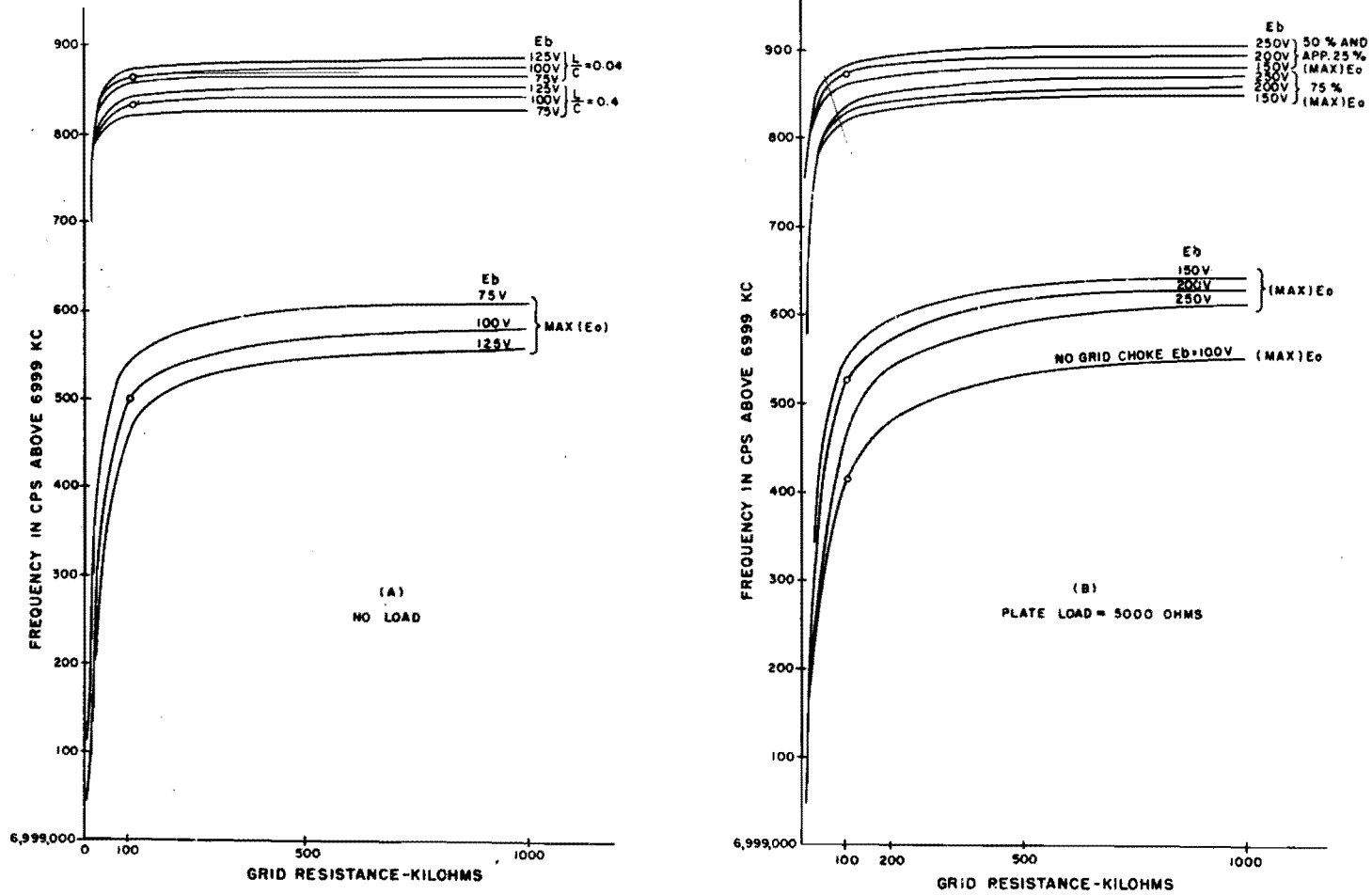

Figure 1-146. Frequency of experimental Miller oscillator versus d-c plate voltage and grid resistance for various plate-tuned load capacitances. (Max) E_o represents the plate tuning adjustment that provided maximum output voltage when grid resistance and d-c plate voltage were values indicated by zero reference point. A 7-mc CR-18/U crystal unit was used, having a PI of 49,000 ohms when operating into a rated load capacitance of 32 μf

more sensitive to changes in the grid resistance. This is to be expected, since the grid-to-cathode r-f impedance and excitation voltage is much greater in the Miller circuit. A crystal r-f voltage of 2 volts represents an excitation of 2 volts in the Miller circuit, but usually of only 1 volt or less in the Pierce circuit. If the curves in figures 1-130 and 1-145 were plotted against excitation voltage instead of crystal driving power they would be much more similar in appearance.

1-341. The frequency curves in figure 1-146 are the Miller equivalents of the Pierce curves in figure 1-129. Note that as R_g is decreased the frequency falls, whereas in the Pierce circuit the frequency increases. This is one reason why the Miller circuit becomes so much more frequency sensitive to changes in R_g when R_g is small. As the Q_g of the grid circuit is decreased because of a decrease in

R_g , the effective Z_L across the tube must appear more inductive in order for E_p to shift in the correct direction to compensate for the decreased phase rotation between grid and cathode. For this to occur, the net capacitive reactance of the feedback arm must increase, which can only come about if the inductive reactance of the crystal unit decreases. Hence, the frequency falls, and in so doing, the Q_g of the crystal and grid circuit becomes smaller still, so that an additional drop in the frequency is necessary to compensate for the decrease in the crystal Q_c . In the meantime, the bias decreases and the grid goes positive a larger fraction of the time. This tends to decrease R_p , which contributes even more to the drop in frequency. With all these effects adding in the same direction, the large frequency sensitivity of the Miller with changes in the grid resistance is ex-

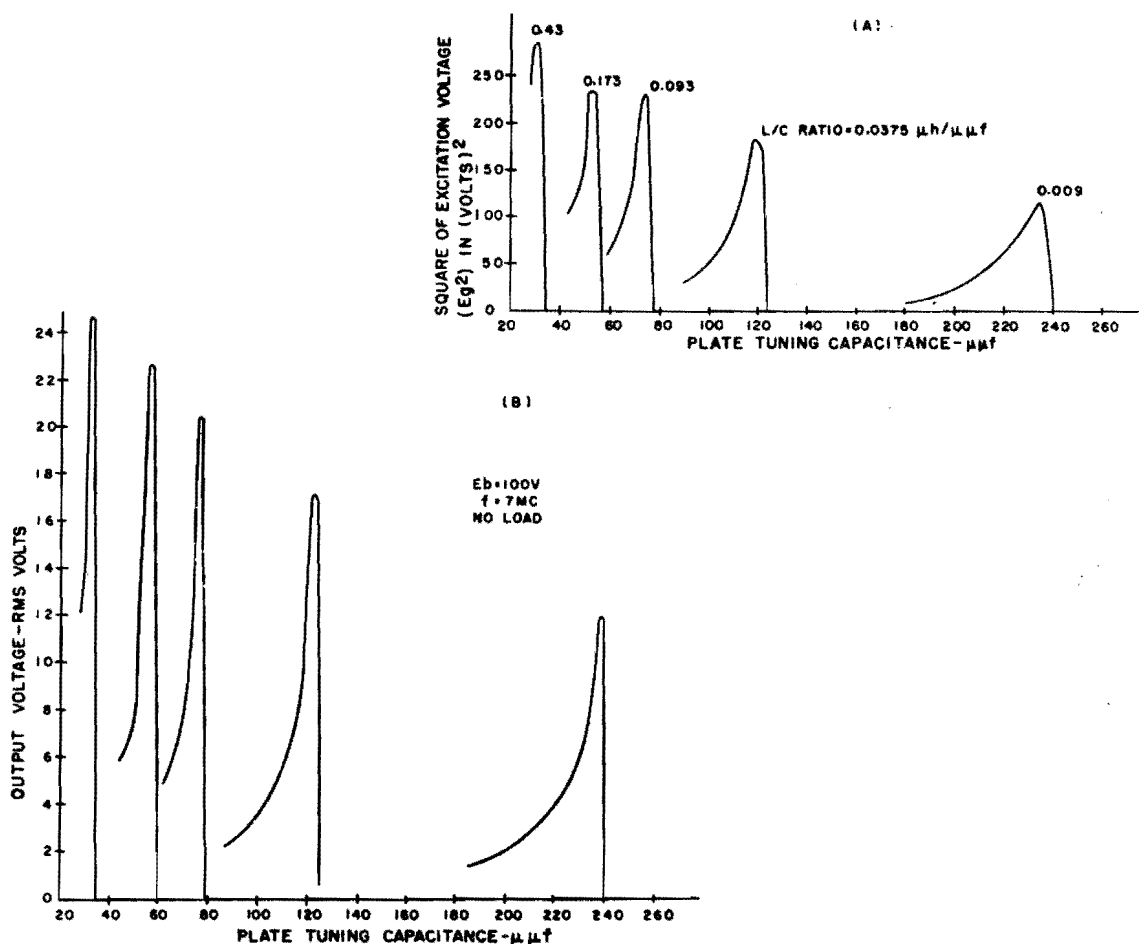

Figure 1-147. (A) Square of excitation voltage and (B) rms value of output voltage of experimental Miller oscillator versus plate tuning capacitance for various L/C ratios of plate tank. Same crystal unit as was used for curves in figure 1-144

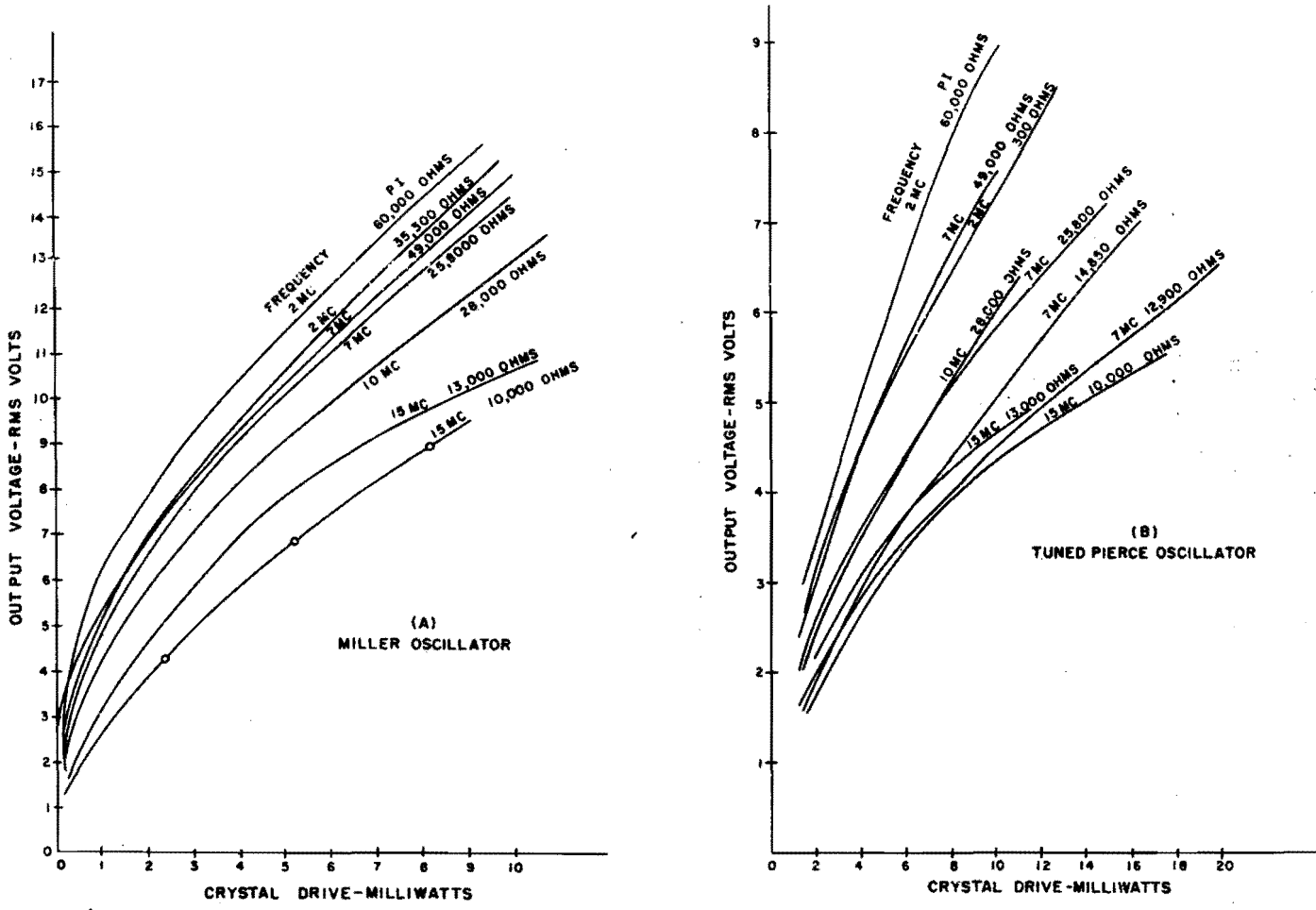

Figure 1-148. Output and crystal drive of experimental Miller and Pierce oscillators as d-c plate voltage is varied for crystal units of various frequencies and PI's. The values of PI assume a rated load capacitance of 32 $\mu\mu\text{f}$. Both oscillators were tuned to provide 50 percent (max) E_c and to operate into a 5000-ohm plate load

plained. The sensitivity is a maximum when L_p is a maximum, for then the frequency is a minimum and the crystal is operating nearest its series-resonant state. This fact makes an exception to the rule that the larger the effective C_x , the greater the stability.

1-342. Of special interest in the curves of figure 1-146 is the fact that those representing the 50-per-cent-maximum-output adjustment show an increase in frequency with an increase in plate voltage, whereas the curves representing a maximum output voltage show a decrease in frequency when the plate voltage is increased, even though the same plate voltages are applied in each case. Now, in the Miller oscillator, the frequency increases and decreases in the same direction with R_p . The plate characteristics of the 6C4 tube, the tube being used when the curves in figure 1-146 were plotted, indicate a decrease in R_p as the plate voltage increases. Thus, we should expect the change in frequency of the (max) E_o curves to be due to the change in R_p caused by the change in plate voltage. On the other hand, the oppositely directed change in frequency of the lower-percentage- E_o curves must be due to an oppositely directed change in R_p brought about by a change in the bias. A re-examination of the crystal voltage curves does indeed show at the 50-per-cent- E_o adjustment that the grid excitation, and hence the bias, is near the maximum. In figure 1-145, it can be seen that for large values of grid resistance the changes in output voltage due to changes in the plate voltage cause a maximum variation in the crystal drive. The evidence is quite strong that there is an operating region between the oppositely changing frequency curves where the changes in R_p due to changes in E_b and E_c will annul each other. From an inspection of the crystal voltage curves in figure 1-144 we would guess that such operating points will lie on both sides of the maximum- E_c region. Such a state of operation would be an example of "class-D" operation described in paragraph 1-298.

1-343. The curves shown in figure 1-147 indicate the effect of variations in the L/C ratio of the plate tank circuit obtained by increasing the value of L_2 in figure 1-148. Increasing L_2 increases the impedance into which the tube operates, and thus increases the r-f plate voltage. This also has the effect of decreasing the frequency and the reactance of the crystal unit. For this reason, the crystal voltage does not increase in the same proportion as the plate voltage. Much greater stability is obtained with low L/C ratios, but much greater values of E_p/E_n , and hence of power gain,

are to be obtained with large L/C ratios. Figure 1-148 compares output-vs-drive curves for several different frequencies and values of PI when the same crystal units are used in both Miller and Pierce oscillators. Note that in the Pierce circuit the slopes of the curves consistently increase with an increase in PI. In the Miller circuit the tendency is for the slopes to increase with decreasing frequency primarily, and secondarily with the PI. This may be due to the fact that the gridleak resistance used in the Miller circuit was smaller than that in the Pierce circuit. In any event, the average bias will tend to be less at the lower frequencies, since the grid charge has more time during a cycle to leak off.

MODIFICATIONS IN DESIGN OF MILLER OSCILLATOR

1-344. A number of Miller oscillators currently being used in military equipment are illustrated in figures 1-149, 1-150, 1-151, 1-152, and 1-153. The values of the circuit parameters, where available, are given in the accompanying circuit-data charts. None of the crystal units employed in these circuits is now recommended for equipments of new design. Nevertheless, all the circuits shown can be modified in one way or another and used with currently recommended crystal units which have been tested for parallel resonance. The necessary modifications would be those that would ensure a correct load capacitance and would not permit a crystal to be overdriven within the expected range of effective resistance. The circuits illustrated suggest the wide adaptability of the Miller oscillator for different output requirements and uses. It is not possible to single out a particular circuit and declare this design to be preferred. The engineer will need to design and test his own circuit for the particular requirements of the equipment in which his oscillator is to be used. Quite often the type of vacuum tube or other circuit components most readily available influence the design. Unlike the Pierce, the Miller circuit must include a means of adjusting the plate impedance to ensure the correct load capacitance for the crystal if the oscillator is to operate to more than one frequency. In the circuits of figures 1-149 to 1-153, the switching arrangements of those circuits designed to operate over a wide frequency range are for the most part omitted. Most often, a separate plate coil is provided for each crystal position. Because of space limitations in the circuit-data charts, occasionally two different components in a circuit having the same value or being of the same type are assigned the same symbol number.

Section I
Crystal Oscillators

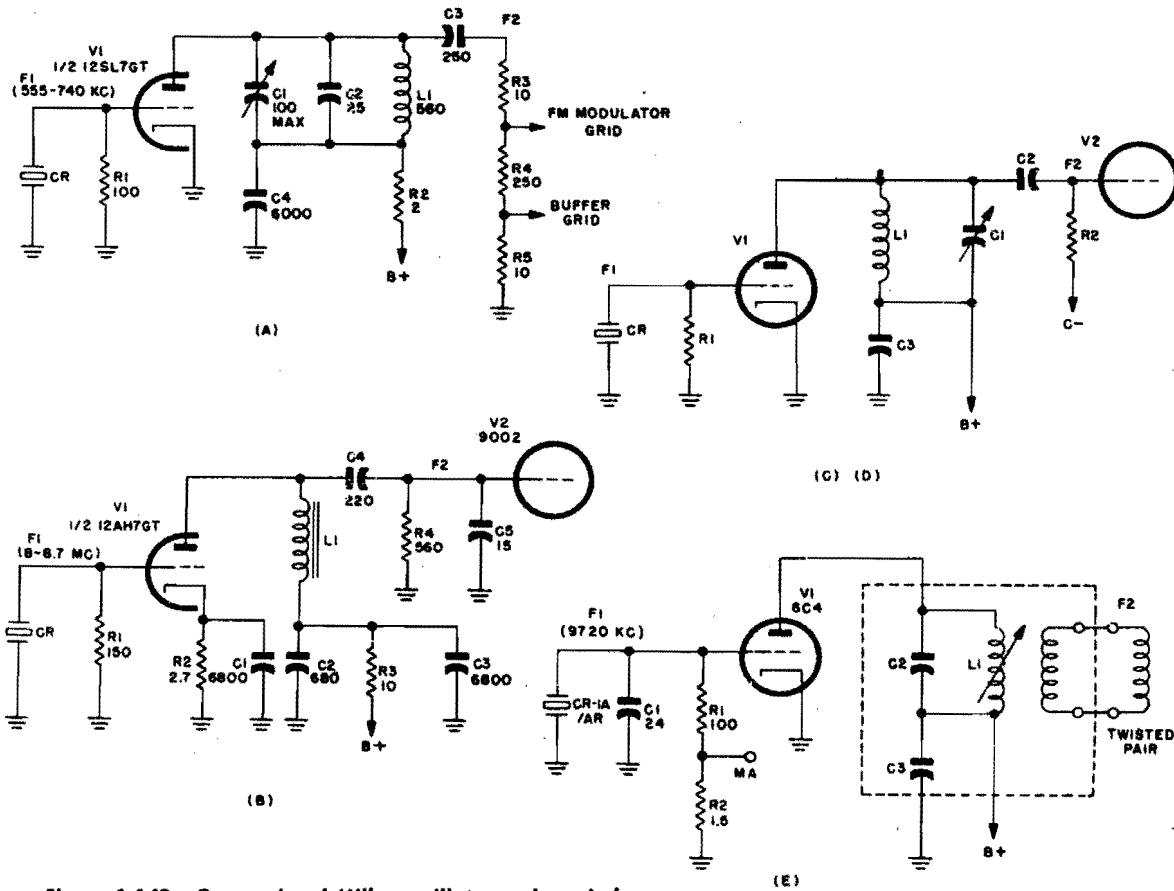

Figure 1-149. Conventional Miller oscillators using triodes

Fig.	Equipment	Purpose	F ₁	F ₂	CR	R ₁	R ₂
(A)	Radio Modulator and Transmitter BC-925	M.O.	555-740	F ₁	Bliley AR-3	100	2
(B)	Radio Receiver BC-624-A,-AM,-C	Local oscillator	8000-8720	F ₁	DC-11-(), DC-16, DC-26, or CR-1()/AR	150	2.7
(C)	Target Control Transmitting Equipment RC-56-A	M.O.	5583-6187	F ₁	CR-1B/AR	100	100
(D)	Test Set TS-67/ARN-5	6.9-mc and 20.7-mc signals for testing receivers in ILS	6900	F ₁	CR-1A/AR	50	70
(E)	Radio Set AN/ARC-1A	Local osc in receiver	9720	F ₁	CR-1A/AR	100	1.5
(F)	Frequency Meter TS-923/UR	Oscillator for heterodyne freq meter and crystal calibrator	1000	nF ₁	Dallon's Laboratories D-1000	100	15
(G)	Signal Generator I-222	Calibration for vfo of signal generator	5000	nF ₁	Holder FT-243	22	22
(H)	Radio Transmitter BC-1332	M.O.	8333.33	F ₁	CR-1A/AR	51	1

Circuit Data for Figure 1-149. F in kc. R in kilohms. C in μ f. L in μ h.

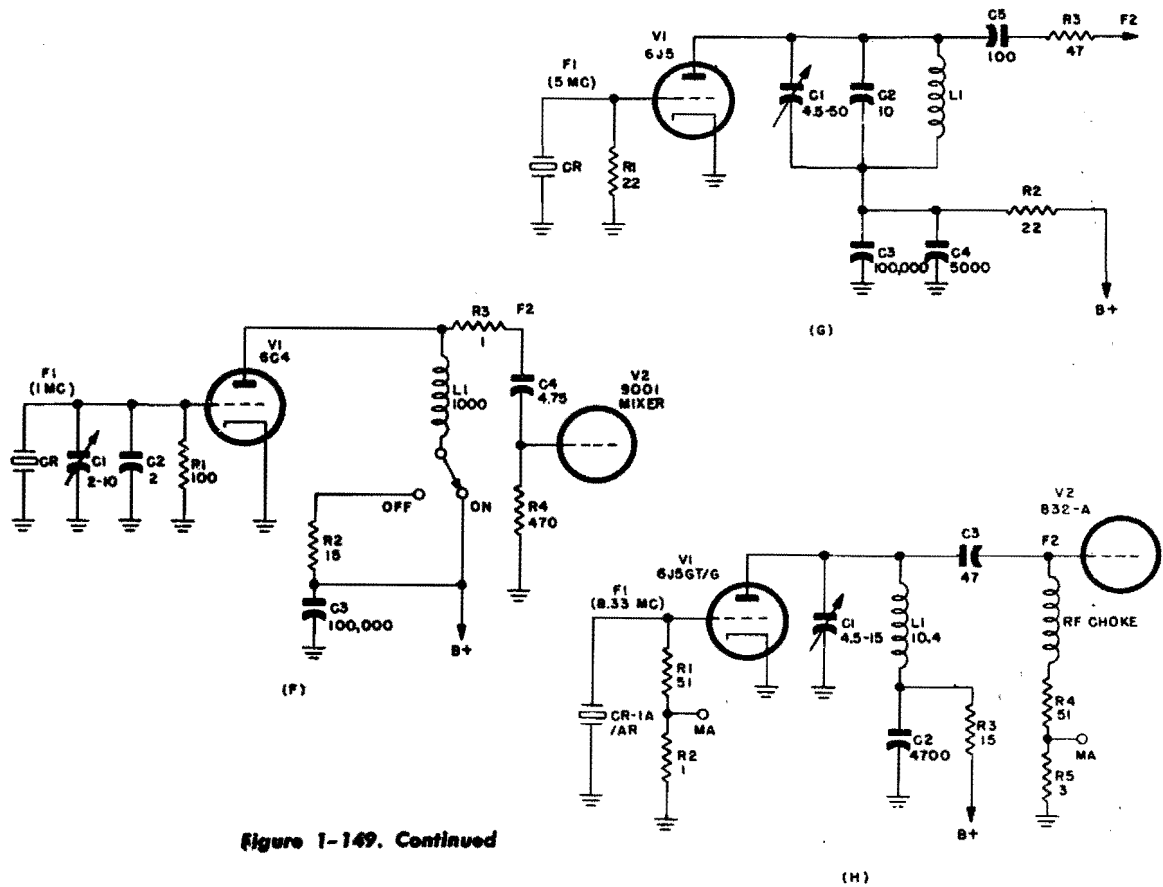

Figure 1-149. Continued

R ₃	R ₄	R ₅	C ₁	C ₂	C ₃	C ₄	C ₅	L ₁	V ₁	V ₂
10	250	10	100	25	250	6000		560	1/2 12SL7GT	
10	560		6800	680	6800	220	15	26 turns	1/2 12AH7GT	9002
			10-100	100	4000				12J5GT	12J5GT
			5-50	50	4000				1/2 6SN7GT	1/2 6SN7GT
			24						6C4	
1	470		2-10	2	100,000	4.75		1000	6C4	9001
4.7			4.5-50	10	100,000	5000	100	44 turns No. 24 AWG; 0.77 x 1.94 in.	6J5	
15	51	3	4.5-15	4700	47			10.4	6J5GT/G	832-A

Section I
Crystal Oscillators

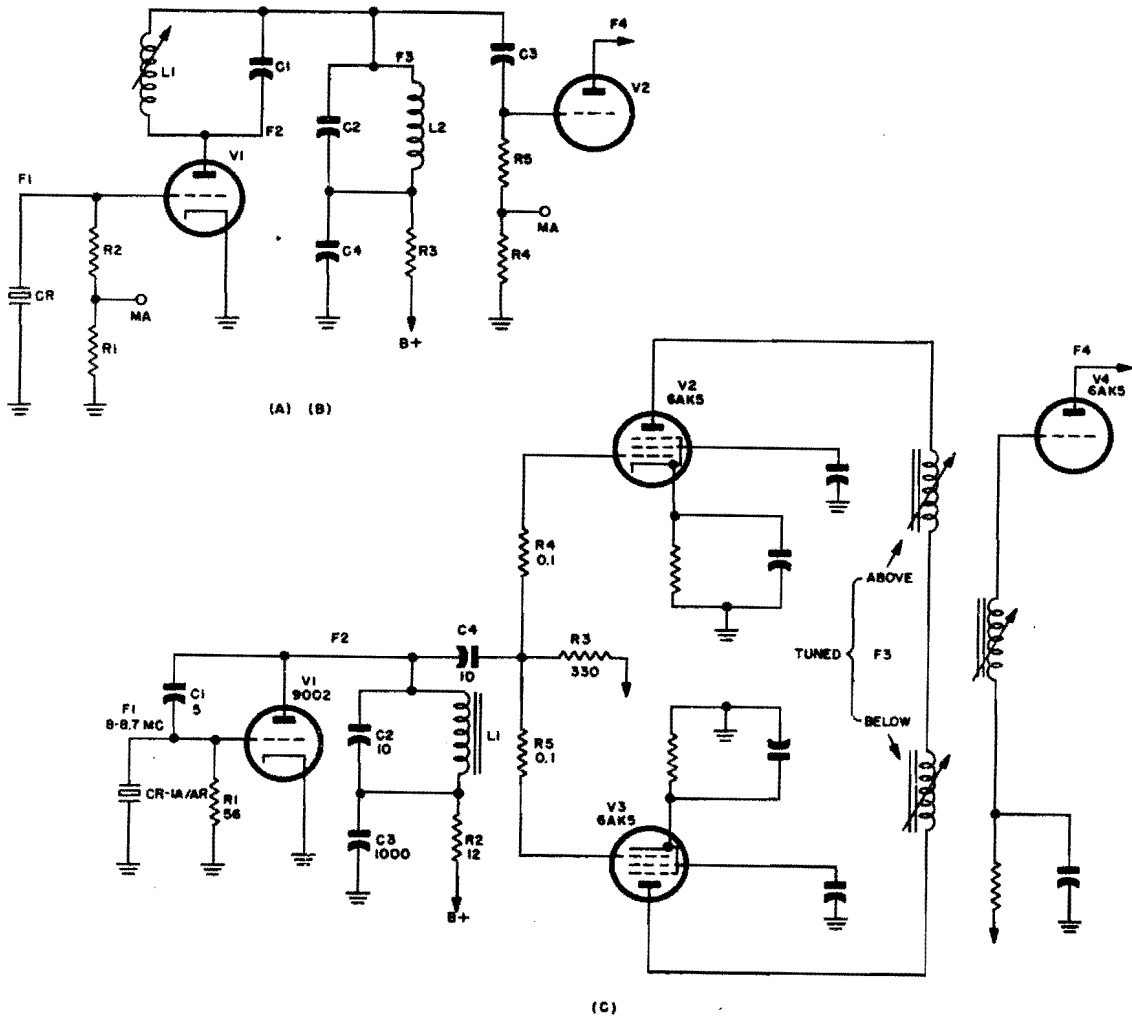

Figure 1-150. Modified Miller oscillators using triodes

Fig.	Equipment	Purpose	F ₁	F ₂	F ₃	F ₄	CR	R ₁	R ₂	R ₃	R ₄	R ₅
(A)	Radio Receiver BC-733-DM	Local oscillator	5633-5745	F ₁	3F ₁	9F ₁	Holder FT-243	1.5	180	8.2	1.5	220
(B)	Radio Receivers R-57/ARN-5 and R-89 ()/ARN-5A	Local oscillator	6498-6548	F ₁	2F ₁	4F ₁	Holder FT-243 (±0.02%)	1.5	8.2		1.5	39
(C)	Radio Receivers R-77/ARC-3 and R-77A/ARC-3	Local oscillator	8000-8727	F ₁	F ₁	11F ₁ -18F ₁	CR-1A/AR	56	12	330	0.1	0.1
(D)	Test Oscilloscope TS-100/AP	Nautical-mile range-synchronizing oscillator	80.86	F ₁	F ₁	F ₁	±25 cps; -30° C to 50° C	2200	5.1	8.2	5.1	50

Circuit Data for Figure 1-150. F in kc. R in kilohms. C in μmf. L in μh.

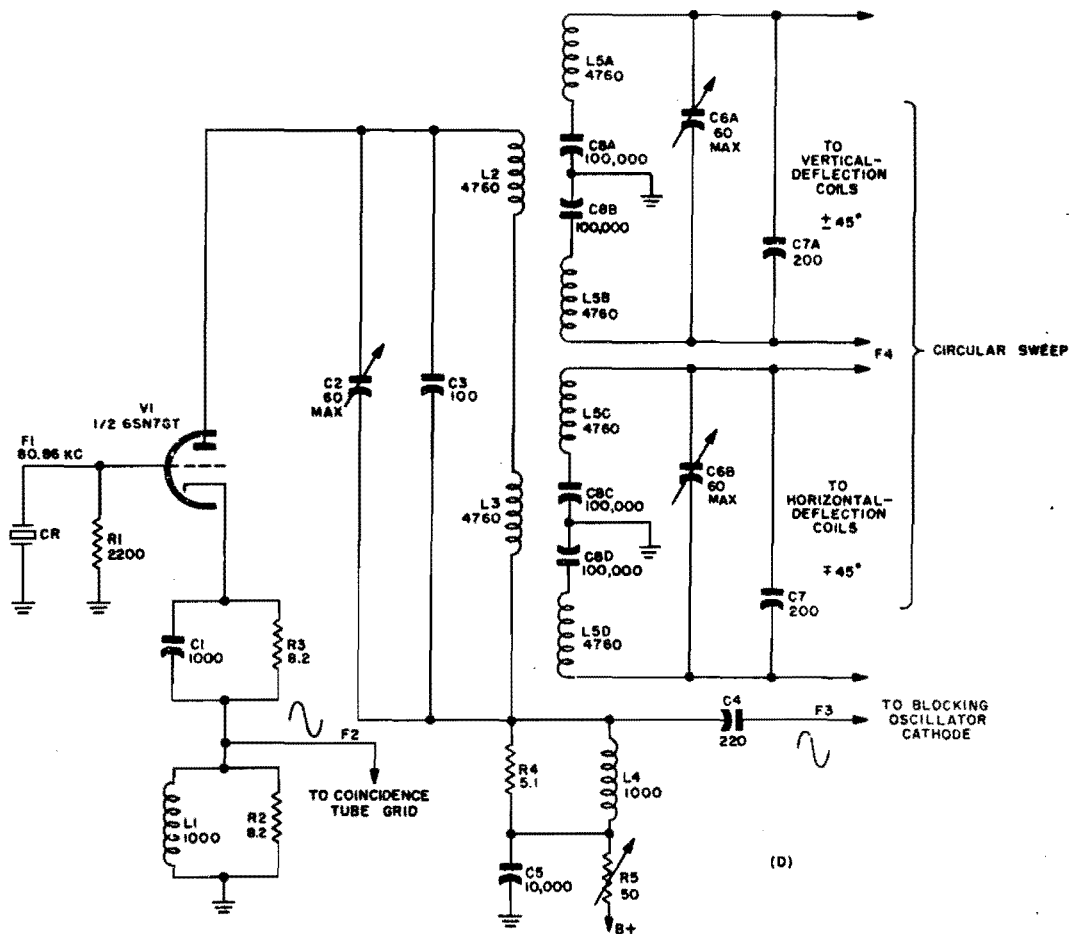

Figure 1-150. Continued

C ₁	C ₂	C ₃	C ₄	C ₅	C ₆	C ₇	C ₈	L ₁	L ₂	L ₃	L ₄	L ₅	V ₁	V ₂	V ₃	V ₄
50	10	100	6000					44 turns, 3/8-in. dia	22 turns, 3/8-in. dia				1/2 12AH7 GT	1/2 12AH7 GT		
30	22	270											1/2 12SN7 GT	1/2 12SN7 GT		
5	10	1000	10					33 turns					9002	6AK5	6AK5	6AK5
1000	60	100	220	10,000	60	200	100,000	1000	4760	4760	1000	4760	1/2 6SN7 GT			

Section I
Crystal Oscillators

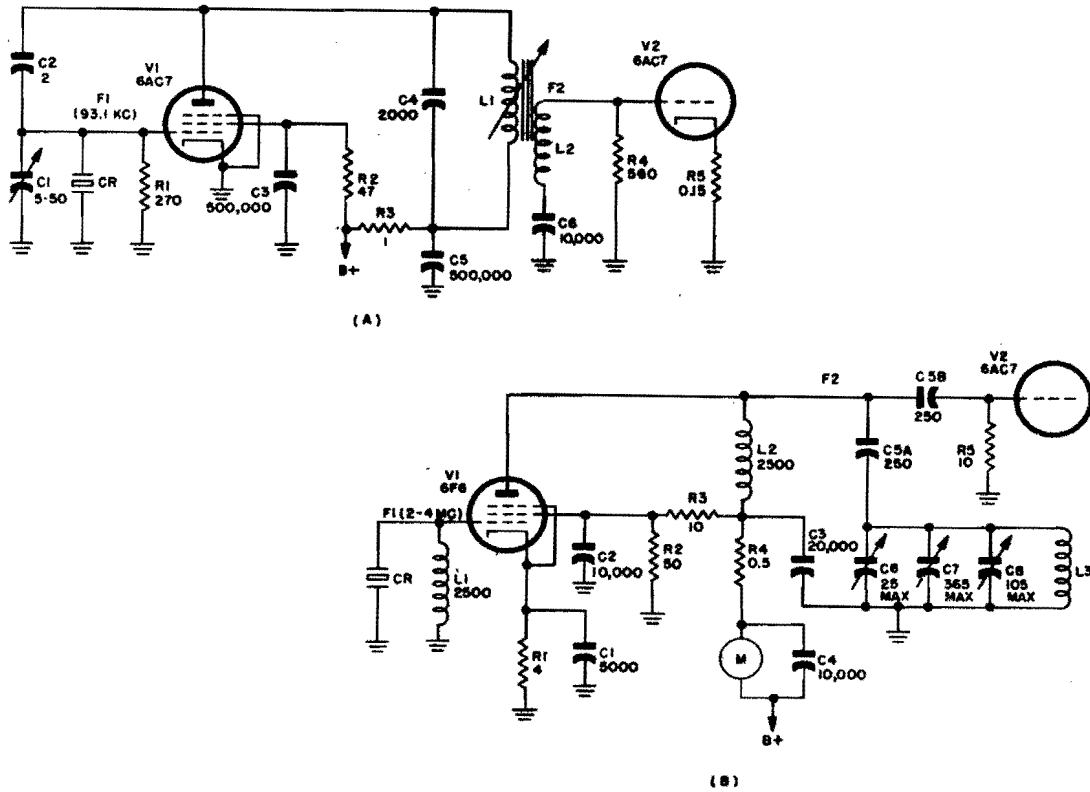
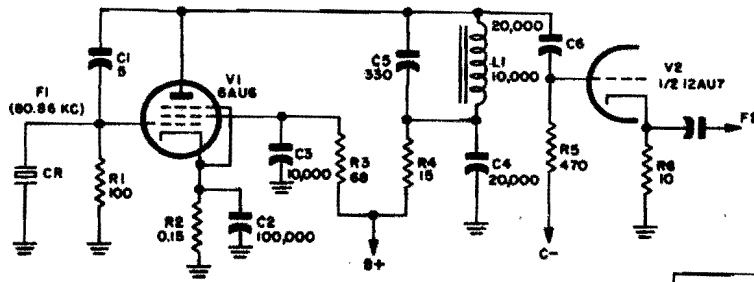

Figure 1-151. Miller oscillators using screen-grid tubes. (Effective suppressor in beam-power tubes is connected to cathode inside tube, although external connection may be indicated in diagram.)

Fig.	Equipment	Purpose	F ₁	F ₂	F ₃	F ₄	CR	R ₁	R ₂	R ₃	R ₄	R ₅	R ₆
(A)	Monitor ID-13/CPN-2	Mile range synchronizing oscillator	93.109	F ₁			75°C oven	270	47	1	560	0.15	
(B)	Radio Transmitters BC-339-E-to-M	M.O.	2000-4000	F ₁			Holder FT-164	4	50	10	0.5	10	
(C)	Range Marker Generator TD-42/FPS-3	Nautical-mile range calibrator osc	80.86	F ₁				100	0.15	68	15	470	10
(D)	Radio Transmitters BC-640-A,-B,-D	M.O.	5555.5-8686.6	F ₁				100	0.05	50	25		
(E)	Radio Transmitter T-171B/FR	M.O.	125-525	F ₁			Holder FT-249	5000	1	100	100		

Circuit Data for Figure 1-151. F in kc. R in kilohms. C in μf . L in μh .



(C)

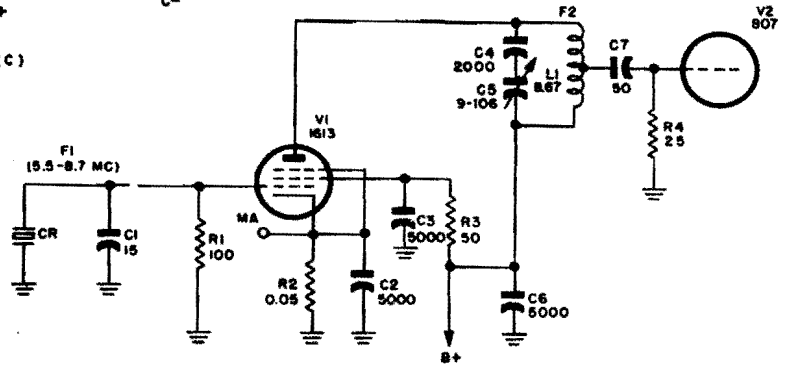

(D)

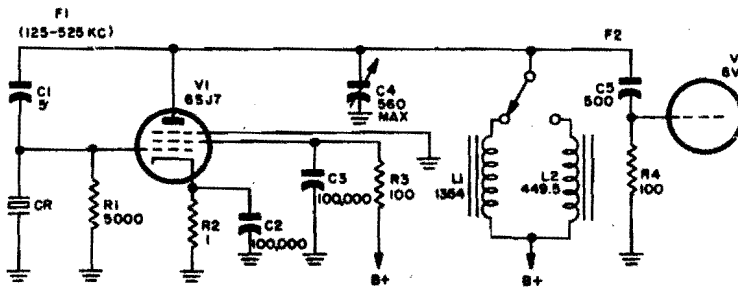

(E)

Figure 1-151. Continued

C ₁	C ₂	C ₃	C ₄	C ₅	C ₆	C ₇	C ₈	L ₁	L ₂	L ₃	L ₄	L ₅	V ₁	V ₂
5-50	2	500,000	2000	500,000	10,000								6AC7	6AC7
5000	10,000	20,000	10,000	250	25	865	105	2500	2500				6F6	837
5	100,000	10,000	20,000	380	20,000			10,000					6AU6	1/2 12AU7
15	5000	5000	2000	9-106	5000	50		8.67					1613	807
5	100,000	100,000	560	500				1354 (7Ω)	449.5 (3.75Ω)				6SJ7	6V6

**Section I
Crystal Oscillators**

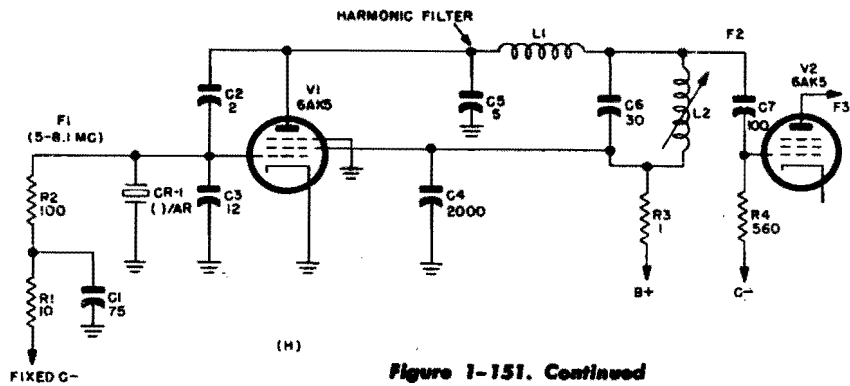
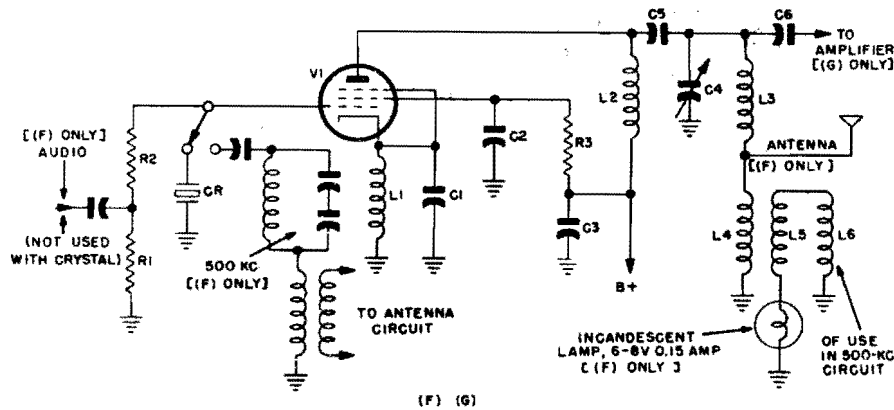
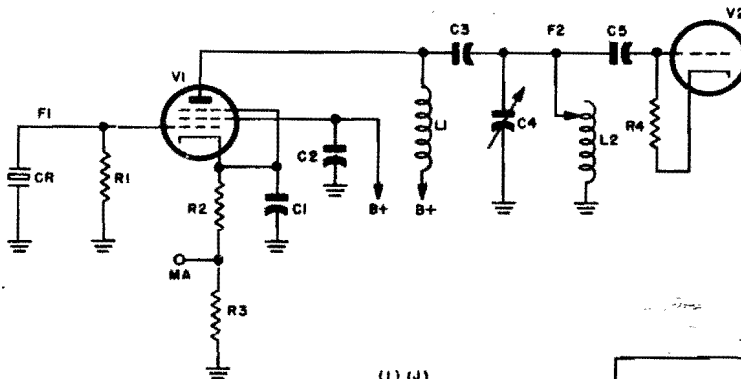

Figure 1-151. Continued

Fig.	Equipment	Purpose	F ₁	F ₂	F ₃	F ₄	CR	R ₁	R ₂	R ₃	R ₄	R ₅	R ₆
(F)	Radio Set AN/CRT-3	"Gibson Girl" power osc	8280	F ₁			CR-1A/AR	33	27	33			
(G)	Radio Transmitter T-91/VRC-4	M.O.	1700-8000	F ₁			Sig Stock #223531B	50	0	50			
(H)	Radio Set AN/ARC-1A	Guard-channel heterodyne freq generator	5020-8120	F ₁	18F ₁		CR-1()/AR	10	100	1	560		
(I)	Radio Transmitter T-4/FRC	M.O.	2000-6000	F ₁			Holder FT-249	100	0.5	0.0238	100		
(J)	Radio Transmitter T-5/FRC	M.O.	150-550	F ₁			Sig Stock #2X41	100	0.5	0.0238	100		
(K)	Radio Transmitter T-10/CRN-5	M.O.	5555.5-8666.6	F ₁	3F ₁	6F ₁	CR-1A/AR or DC-11-()	0.1	100	0.5	0.0008	20	100

Circuit Data for Figure 1-151. F in kc. R in kilohms. C in $\mu\mu\text{f}$. L in μh .



(J)

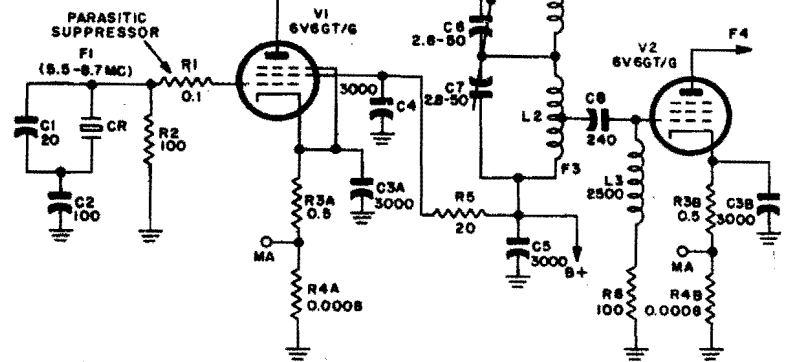

(K)

Figure 1-151. Continued

C ₁	C ₂	C ₃	C ₄	C ₅	C ₆	C ₇	C ₈	L ₁	L ₂	L ₃	L ₄	L ₅	V ₁	V ₂
300	1000	1000	4.5-48.7	1000	0			2350	2500	3-1/2 or 12 turns 1-1/2 in.	3-1/2 or 12 turns 1-1/2 in.	1-1/4 turn, 1-1/2 in.	12A6	
250	10,000		7.2-148.7	100	100			2500	18, 25, 38, 68 turns	18, 25, 38, 68 turns	0	0	6V6 GT	
75	2	12	2000	5	30	100							6AK5	6AK5
10,000	10,000	500	9-150	500				2500					6V6G	807
10,000	10,000	10,000	11-250	10,000				10,000	Pie wound				6V6G	807
20	100	3000	3000	3000	2.8-50	2.8-50	240	37 turns	14 turns	2500			6V6GT/G	6V6GT/G

Section I
Crystal Oscillators

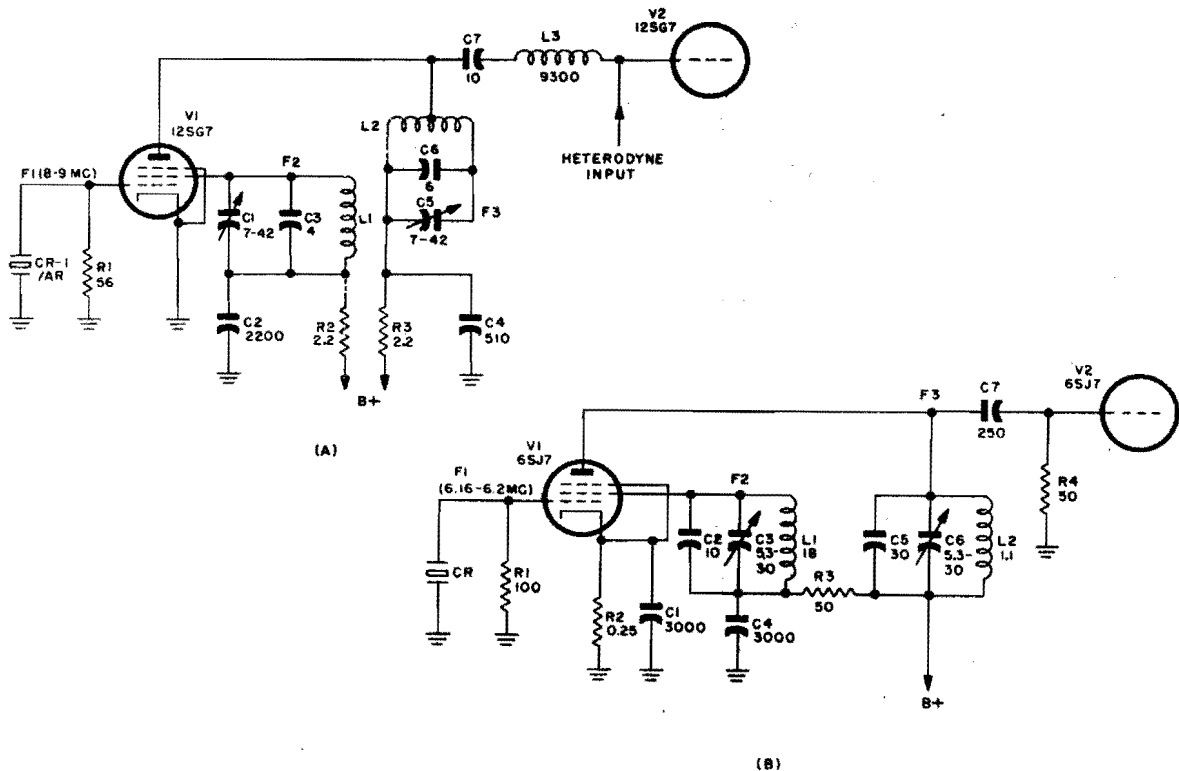

Figure 1-152. Electron-coupled Miller oscillators. All circuits except (A), (B), and (C) are tri-tet modifications

Fig.	Equipment	Purpose	F ₁	F ₂	F ₃	CR	R ₁	R ₂	R ₃	R ₄	R ₅
(A)	Radio Receiver and Selector BC-617-AZ	Heterodyne oscillator	8000-9000	F ₁	4F ₁	CR-1()/AR	56	2.2	2.2		
(B)	Radio Transmitters T-3/CRN-2 and T-3A/CRN-2	M.O. and multiplier	6203.7-6159.26	F ₁	3F ₁	CR-1A/AR or DC-17-B	100	0.25	50	50	
(C)	Radio Transmitter BC-329-J	M.O.	200-410	F ₁		Holder FT-164	1000	1.5	0.001	5	17.5
(D)	Radio Receiver R-146A/ARW-35	1st heterodyne oscillator	7833-10,000	6F ₁	6F ₁ + 5000	Holder FT-243	100	100	4700	0	
(E)	Radio Sets AN/TRC-1, -1A, -1B, -1C	Heterodyne osc in Radio Receiver R-19()/TRC-1	7300-8750	5F ₁ and 6F ₁	NA	CR-6/U	100	100	250	0	
(F)	Radio Sets AN/TRC-1D, -1E	Heterodyne osc in Radio Receiver R-19()/TRC-1	7300-8750	5F ₁ and 6F ₁	NA	CR-6/U	100	100	250	50	
(G)	Radio Receiver R-19H/TRC-1	Heterodyne oscillator	7300-8750	5F ₁ and 6F ₁	NA	CR-6/U	100	100	240	51	

Circuit Data for Figure 1-152. F in kc. R in kilohms. C in μf . L in μh . NA: Not Applicable.

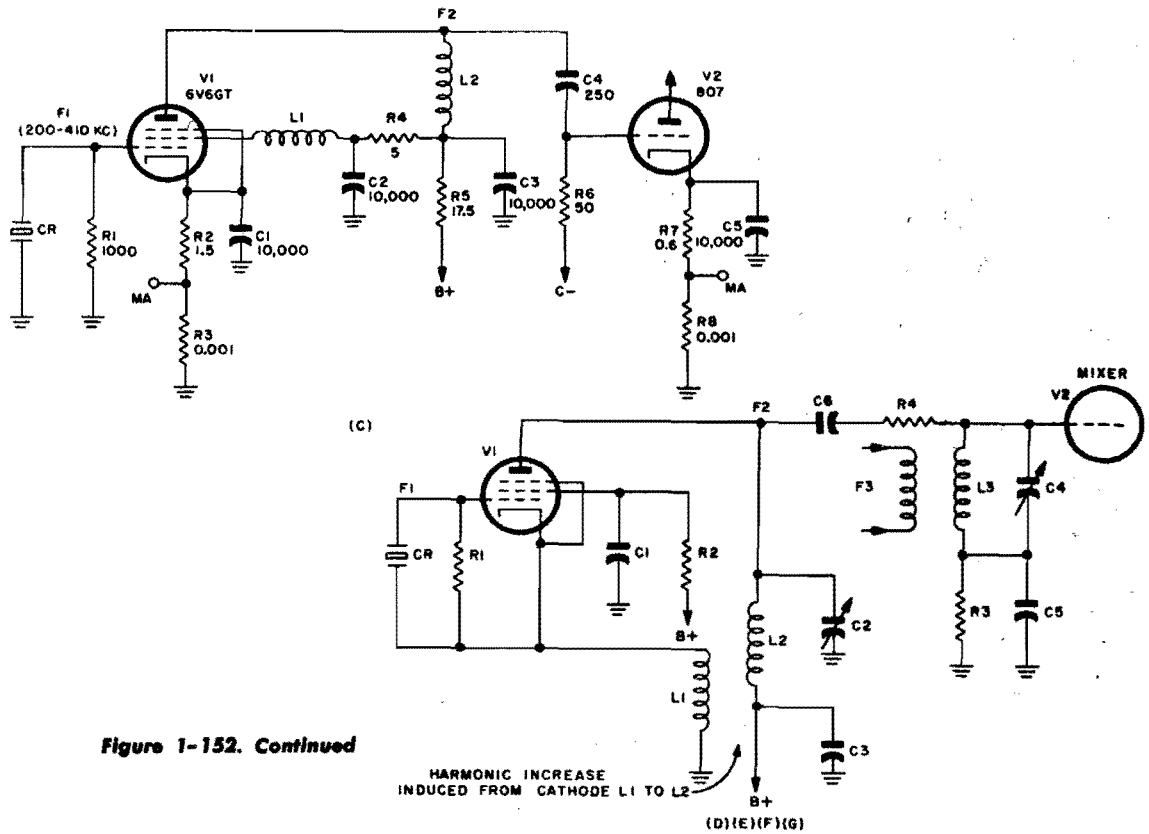

Figure 1-152. Continued

R ₆	R ₇	R ₈	C ₁	C ₂	C ₃	C ₄	C ₅	C ₆	C ₇	L ₁	L ₂	L ₃	V ₁	V ₂
			7-42	2200	4	510	7-42	6	10			9800	12SG7	12SG7
			3000	10	5.8-30	9000	30	5.8-30	250	18	1.1		6SJ7	6SJ7
50	0.6	0.001	10,000	10,000	10,000	250	10,000			2500	2500		6V6GT	807
			2000	3-54	2000	5-30	250	4					12SH7	6AC7
			1500	3-54	1500	0	0	100				0	6SH7	6SH7
			1500	3-54	1500	0	0	100				0	6SH7	6SH7
			1500	3-54	1500	0	0	100				0	6SH7	6SH7

Section 1
Crystal Oscillators

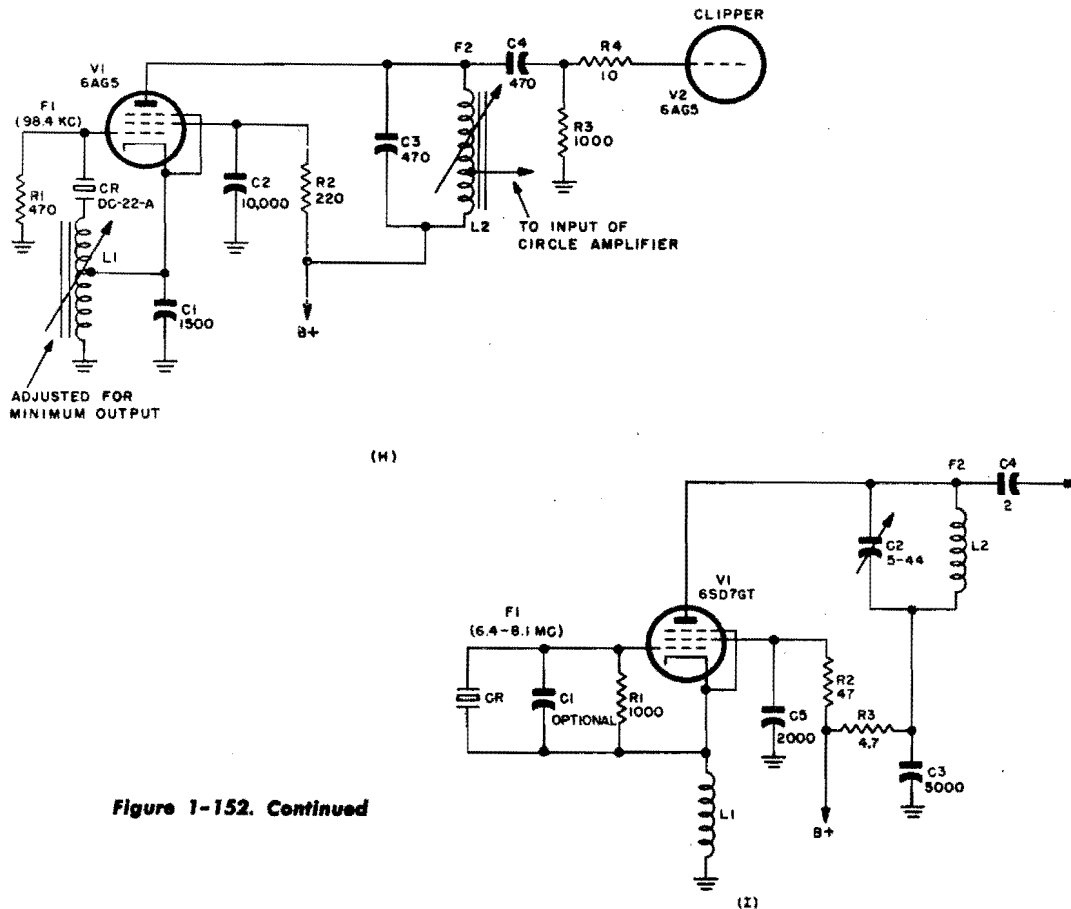

Figure 1-152. Continued

Fig.	Equipment	Purpose	F ₁	F ₂	F ₃	CR	R ₁	R ₂	R ₃	R ₄	R ₅
(H)	Radio Receiver and Transmitter BC-788-A	Timing osc and 5000-ft range control	98.356	F ₁		DC-22-A	470	220	1000	10	
(I)	Galvin Radio Receivers PA-8098 and PA-8245	1st local osc in Communication Equipment AN-CRC-3	6425-8120	4F ₁ and 5F ₁		Holder FT-243	1000	47	4.7		
(J)	Radio Receiver R-368/FRC-6A	Heterodyne oscillator	6425-8425	4F ₁ and 5F ₁	F ₂ + 4.3		1000	47	4.7	47,000	
(K)	Radio Set AN/VRC-2	1st heterodyne osc	6425-8425	4F ₁ and 5F ₁	F ₂ + 4.3		47	47	4.7	47,000	
(L)	Radio Transmitter BC-610-E	M.O.	2000-6000	F ₁		Holder FT-171-B	38	100	15	5.6	

Circuit Data for Figure 1-152. F in kc. R in kilohms. C in μf . L in μh . NA: Not Applicable.

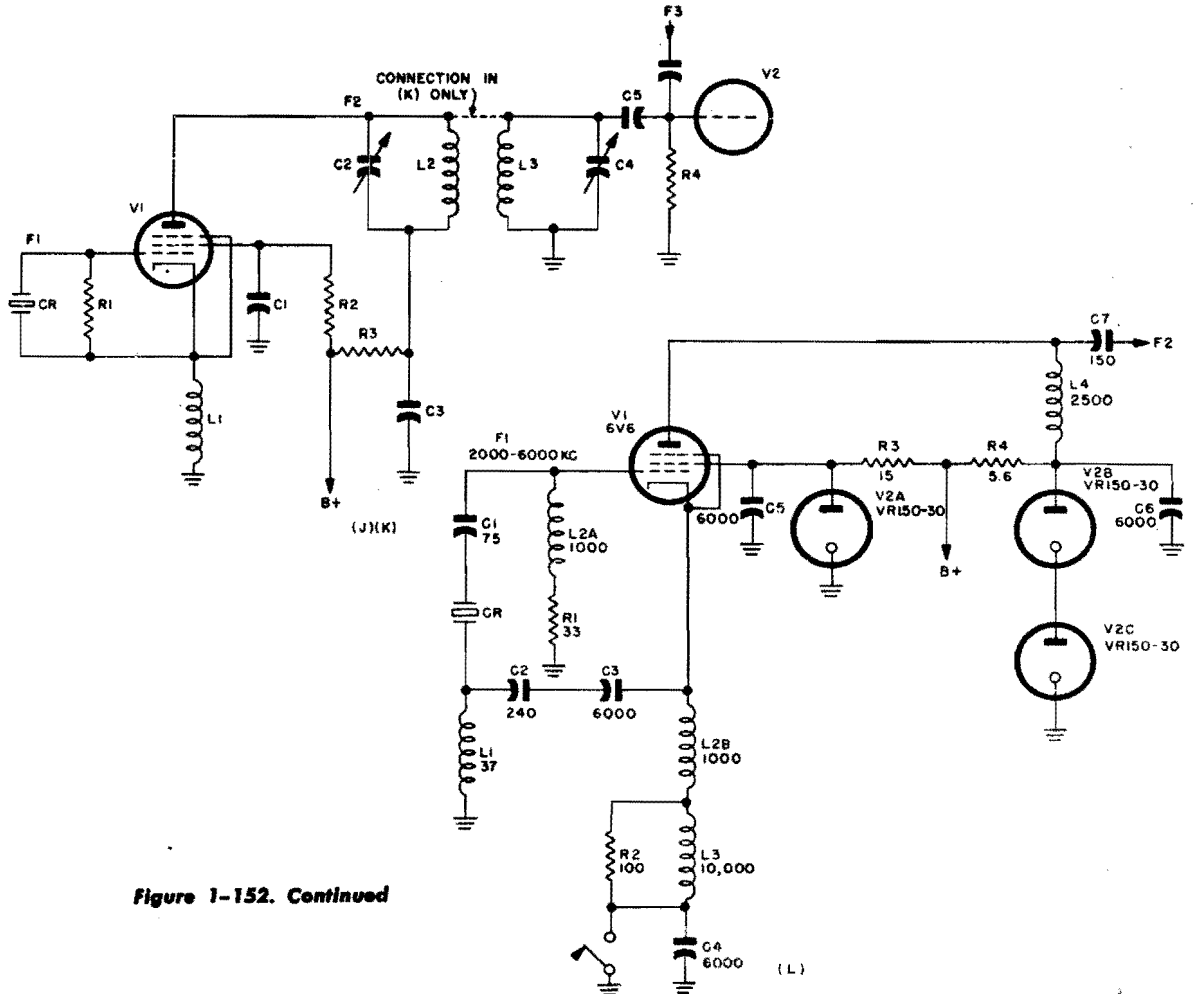

Figure 1-152. Continued

R ₆	R ₇	R ₈	C ₁	C ₂	C ₃	C ₄	C ₅	C ₆	C ₇	L ₁	L ₂	L ₃	V ₁	V ₂
			1500	10,000	470	470				150 and 400 turns	Four 190-turn sections		6AG5	6AG5
			Optional	5-44	5000	2				(0.3Ω)			6SD7 GT	
			5600	6-45	5600	6-45	2						6SG7GT	6SG7GT
			2000	5-44	5000	0	2					∞	6SD7GT	6SD7GT
			75	240	6000	6000	6000	6000	150	37	1000	10,000	6V6	VR150-30

Section I
Crystal Oscillators

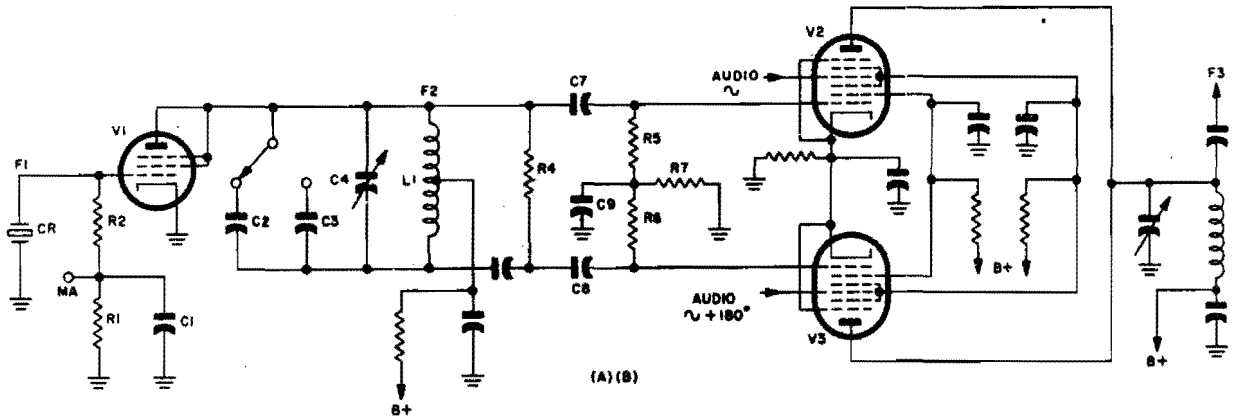
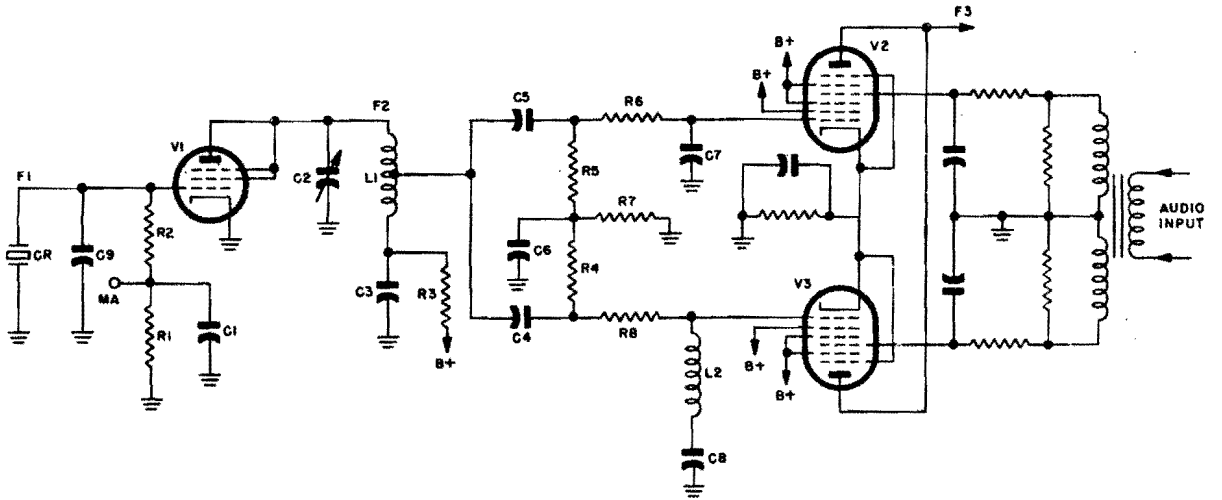

Figure 1-153 Miscellaneous Miller-oscillator modifications

Fig.	Equipment	Purpose	F ₁	F ₂	F ₃	CR	R ₁	R ₂	R ₃	R ₄	R ₅	R ₆	R ₇	R ₈
(A)	Galvin Radio Transmitter PA-8218 P/O AN/CRC-3	M.O. for phase modulator circuit	937.5 1250	F ₁	F ₁ (mod.)	Motorola FMT	1	470	4.7	10	47	47	0.1	
(B)	Radio Transmitter T-264/FRC-6A	M.O. for phase modulator circuit	937.5 1250	F ₁	F ₁ (mod.)		1	470	4.7	10	47	47	0.1	
(C)	Galvin Radio Transmitter PA-8244 P/O AN/CRC-3	M.O. for phase modulator circuit	3750- 5000	F ₁	F ₁ (mod.)	Holder FT-243	1	470	4.7	47	47	4.7	0.1	4.7
(D)	Galvin Radio Transmitter PA-8026 P/O AN/VRC-2	M.O. for phase modulator circuit	3750- 5000	F ₁	F ₁ (mod.)	Holder FT-243	1	470	4.7	47	47	4.7	0.1	4.7

Circuit Data for Figure 1-153. F in kc. R in kilohms. C in μ f. L in μ h, unless otherwise noted.



(C) (D)

Figure 1-153. Continued

R ₀	C ₁	C ₂	C ₃	C ₄	C ₅	C ₆	C ₇	C ₈	C ₉	L ₁	L ₂	L ₃	V ₁	V ₂ V ₃
	5000	25	50	5-44	5000	10	100	100	2000				7C7	7A8
	5600	24	0	6-45	5600	24	100	100	2200				7C7	7A8
	5000	5-44	5000	100	100	2000	5	2000	5		R-F choke		7C7	7A8
	5000	5-44	5000	100	100	2000	5	2000	5		R-F choke		7C7	7A8

Section I
Crystal Oscillators

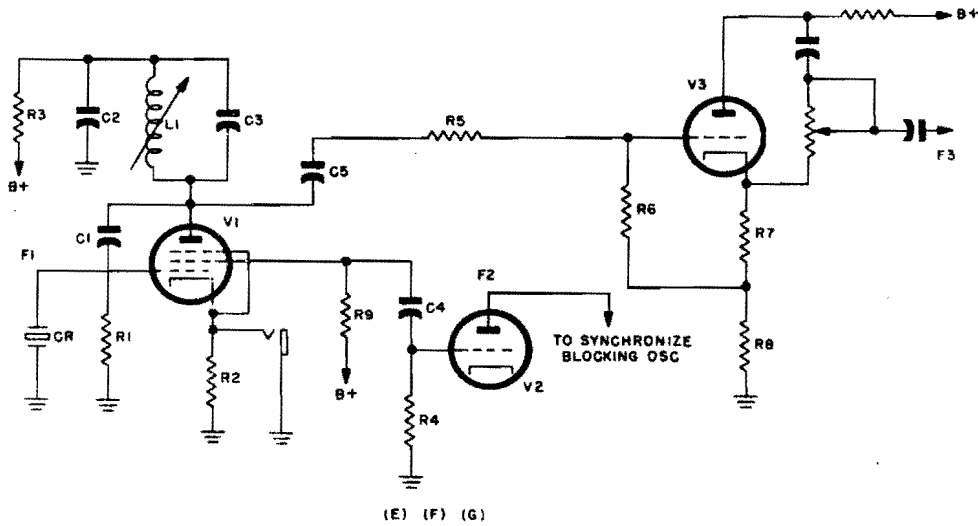

Figure 1-153. Continued

Fig.	Equipment	Purpose	F ₁	F ₂	F ₃	CR	R ₁	R ₂	R ₃	R ₄	R ₅	R ₆	R ₇	R ₈
(E)	Crystal Calibrator TS-177/CPS-1	Calibration of mile range markers	93.12	F ₁	F ₁	GE# 32C401G43	1000	0.012	18	1000	2000	1000	2.2	10
(F)	Crystal Calibrator TS-241/CPS-5	Calibration of mile range markers	93.12	F ₁	F ₁	GE# 32C401G43	1000	0.012	18	1000	2000	1000	2.2	10
(G)	Calibrator-Generator Group OA-96/CPS-6B	Calibration of nautical mile range markers	80.867	F ₁	F ₁		1000	0	15	1000	2200	1000	2.2	10
(H)	Frequency Meter TS-174/U	Crystal calibrator and heterodyne circuit	1000	nF ₁	20,000-250,000	DC-9	1000	8.75	0.075	1000	150	∞		
(I)	Frequency Meter TS-175/U	Crystal calibrator and heterodyne circuit	5600	nF ₁	85,000-1,000,000	CR-1A/AR	1000		0.75	1000	0	100		
(J)	Frequency Meters BC-221-AG,-AK	Crystal calibrator and heterodyne circuit	1000	nF ₁	1000-20,000	DC-9-AD or DC-9-P	1000	10	0.15	500	0	∞		

Circuit Data for Figure 1-153. F in kc. R in kilohms. C in μf . L in μh , unless otherwise noted.

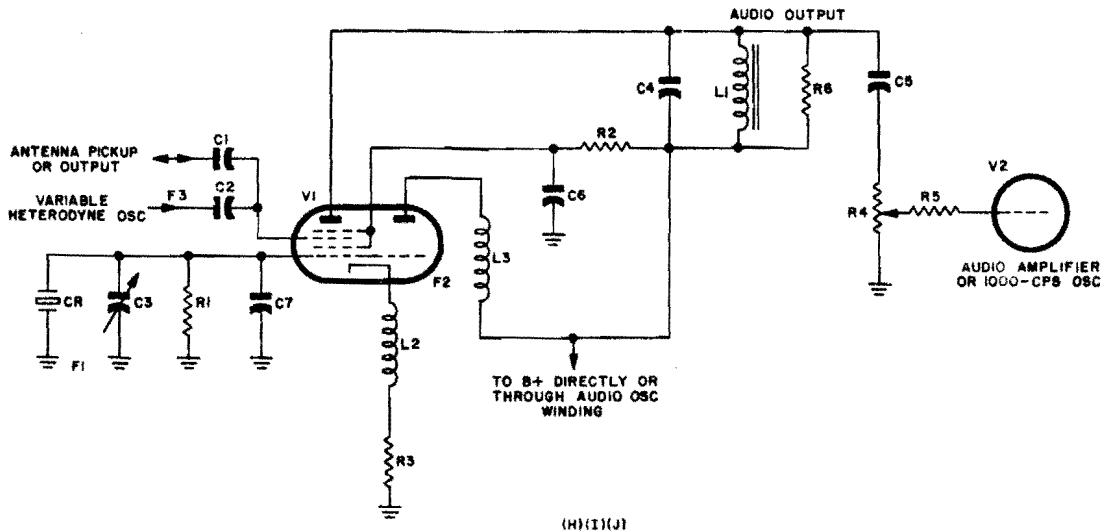

Figure 1-153. Continued

R ₁	C ₁	C ₂	C ₃	C ₄	C ₅	C ₆	C ₇	C ₈	C ₉	L ₁	L ₂	L ₃	V ₁	V ₂ V ₃
100	3.8	500,000	330	51	10,000					8500			6SJ7	1/2 6SN7GT
100	3.8	500,000	330	51	10,000					8500			6SJ7	1/2 6SN7GT
100	5	500,000	470	47	10,000					8500			6SJ7	1/2 6SN7W
	12	12	3-25	1000	50,000	2000	0			80h	0	850	6K8	6SJ7
	2.5	12	3-25	0	6000	2000	0			∞	175	70	6K8	6C8G
	25	50	12	1000	20,000	250,000	6			150h	0	1000	6K8	6SJ7

Section I
Crystal Oscillators

Two-Tube Parallel-Resonant Crystal Oscillators

1-345. Most of the two-tube oscillator circuits are designed so that the crystal is operated at or near its series-resonance frequency. An exception is the multivibrator type of circuit in which the crystal unit is connected between the grid and cathode of one of the tubes. The basic circuit is shown in figure 1-154(A). If there were no capacitive effects to consider, E_{g2} would be 180 degrees out of phase with E_{g1} and the 180-degree feed-back inversion would be accomplished entirely by V_2 . In this case, the input impedance of V_1 would have to be purely resistive—that is, the crystal unit would operate at parallel resonance with the input capacitance. The proper phase of E_{g1} could also be obtained with the crystal unit operating near series resonance, and unless the V_1 input impedance were so reduced that oscillations could not be sustained under such condition there would always be the risk that the oscillator would jump from one equilibrium state to the other. In an actual circuit, the circuit capacitances will prevent V_1 from operating into a purely resistive load, so that E_{p1} slightly lags the equivalent generator voltage $-\mu E_{g1}$. The larger the values of R_a , R_{p1} , R_{g2} , C_1 , and C_{g2} , the nearer will the lag in E_{p1} approach the 90-degree limit. If it is assumed that R_{g2} is very large compared with the reactance of the V_2 input capacitance, C_{g2} , the phase of E_{g2} is approximately the same as the phase of E_{p1} . Also, if the ratio, C_1/C_{g2} , is very large, the magnitudes of E_{g2} and E_{p1} are very nearly equal. As can be seen in figure 1-154(B), the lag in E_{p1} causes the equivalent generator voltage of V_2 , equal to $-\mu E_{g2}$, to lag E_{g1} . The circuit will oscillate at that frequency at which the crystal impedance creates the necessary phase difference between E_{g1} and $-E_{g2}$. Note, that except

for the possible coupling between the output circuits of V_1 and V_2 because of the grid-to-plate capacitance of V_2 (which can be made negligible by the use of screen-grid tubes), the phase of E_{g2} , and hence of $-\mu E_{g2}$, is entirely independent of impedance changes in the V_2 plate circuit. Thus, to predetermine the angle θ in figure 1-154(B), it is only necessary to consider the V_1 stage as a conventional vacuum-tube amplifier circuit. In turn, the V_2 stage can be treated separately as an equivalent circuit driven by a generator of voltage $-\mu E_{g2}$. The design must be such that when the crystal unit is operating at its rated X_c , the voltage across the crystal unit differs from the equivalent generator voltage, $-\mu E_{g2}$, by the desired angle θ . If E_{p1} leads E_{p2} , as indicated in figure 1-154(B), the feed-back current through C_2 will be very nearly in phase with E_{p2} . The input impedance of V_1 will appear somewhat inductive, and close to series resonance with C_2 . The smaller that C_2 is made, the higher will be the frequency. If the plate circuit of V_2 is made inductive, E_{p2} (not by changing θ) can be shifted to be more nearly in phase with E_{g1} ; however, such operation would tend to become unduly critical. For example, assume that E_{p2} were rotated to where it was in phase with E_{g1} . This would mean that the phase of the feed-back current, I_{g1} , with respect to E_{p2} was equal to its phase with respect to E_{p1} , and this in turn would require that the over-all Q of Z_{g1} and C_2 in series be the same as the Q of Z_{g1} alone—an impossibility unless C_2 is infinite. But C_2 cannot be made large without the risk that the circuit will operate as an RC controlled multivibrator. Thus, in the circuit of figure 1-154, E_{p2} must lag E_{g1} if oscillations are to be maintained. The smaller the phase difference between E_{p2} and E_{g1} , the less will be the leading component of I_{g1} with respect to E_{p2} , and

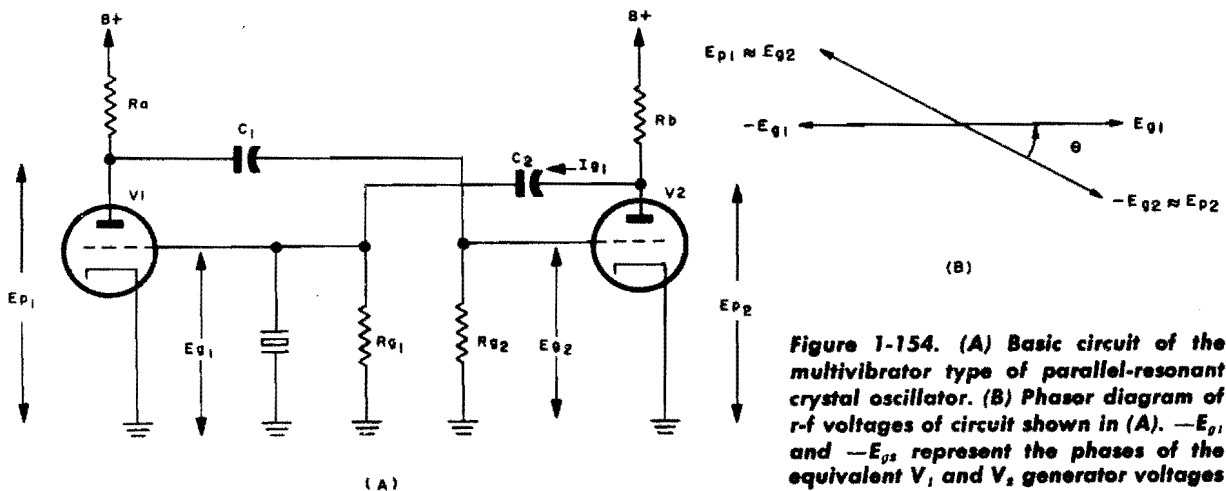

Figure 1-154. (A) Basic circuit of the multivibrator type of parallel-resonant crystal oscillator. (B) Phasor diagram of r-f voltages of circuit shown in (A). $-E_{g1}$ and $-E_{g2}$ represent the phases of the equivalent V_1 and V_2 generator voltages

the less will be the leading (inductive) component of E_{k1} with respect to I_{k1} . Hence, the smaller the angle θ , the more nearly must the crystal approach parallel resonance with the input capacitance of V_1 . Any change in the V_1 plate circuit that tends to decrease θ therefore tends to raise the frequency. C_{k1} can be increased by the insertion of a fixed capacitance to make the total approach the rated load capacitance of the crystal unit.

1-346. Since the crystal unit is effectively a capacitance at all frequencies except those near its points of mechanical resonance, some precaution must be taken in the circuit design to ensure that the crystal maintains control over the frequency and that no danger exists that the two-stage circuit can perform as a free-running multivibrator with the frequency controlled by the RC constants. When C_2 in figure 1-154 is small and C_{k1} is large by comparison, and when the plate impedances R_a and R_b are small by comparison with the R_p of the tube, the feed-back voltage at the low frequencies corresponding to the RC time constants can quite easily be kept below the requirements for sustained oscillations.

1-347. No data is available concerning the relative frequency stability of the parallel-resonant multivibrator type oscillator, but, from qualitative considerations only, it would seem that a performance equal to, and very possibly superior to, that of the average Pierce circuit could be expected, although the operation of the circuit would certainly be much more critical. The V_1 amplifier stage can be designed to operate into a practically purely resistive load, so that fluctuations in the V_1 plate resistance will have little or no effect upon the frequency. On the other hand, under these conditions θ will be slightly negative and $-\mu E_{k2}$ will lead E_{k1} unless a large reactance, or, preferably, a resistance, is connected in series with C_1 . If θ is not critically small, the external circuit of V_2 can also be designed to appear as a pure resistance, and any variations in the plate resistance of the tube will have a negligible effect on frequency. The annulling of the stray-capacitance effects in the output circuits of the two tubes will require the use of coils, which may not be desirable if a wide frequency range is intended. The phase-shifting Q_f of the feed-back circuit is computed in the same manner as in the Pierce and Miller circuits except that the required phase shift is much smaller.

1-348. In the design of such a circuit, the value of θ can be arbitrarily predetermined. Assume that when R_c of the crystal unit is a maximum, the feed-back current, I_{k1} , is to be in phase with $-\mu E_{k2}$.

With R_{k1} assumed to be large compared with the average PI of the crystal unit, estimate the capacitance C_{k1} required across the crystal unit for the Q of Z_{k1} to equal the tangent of θ when the X_c of the crystal unit corresponds to the reactance of the rated load capacitance. Make C_2 such that its reactance at the operating frequency is equal to the reactive component of Z_{k1} computed above. Under these conditions I_{k1} will lag $-\mu E_{k2}$ for all values of R_c less than maximum, since the Q of Z_{k1} would be greater than $\tan \theta$ if the frequency did not increase to bring Z_{k1} nearer its antiresonant value. But the increase in the frequency as a result of a decrease in R_c is less than that which would occur if the circuit were designed so that I_{k1} would lead $-\mu E_{k2}$ for most values of R_c . Also, if the feed-back circuit is designed for series resonance when R_c is a maximum, the values of C_2 should prove more practical, the operation will be less critical, and there is the assurance that all values of R_c will permit oscillation. The plate-circuit impedances of the two tubes are next determined so that the feed-back voltage is sufficient to maintain oscillations when R_c of the crystal unit is a maximum. Generally, neither tube should operate into a load exceeding 5000 ohms. The plate voltages are chosen so that the crystal unit cannot be driven beyond the rated drive level. With the phase characteristics of the circuit determined, more or less by design, to ensure a proper load capacitance for the crystal, it may be that the optimum operating voltage will be more readily determined through experiment. At equilibrium, the total voltage gain of the loop, from E_{k1} to E_{p1} , to E_{k2} to E_{p2} and back to E_{k1} , must be equal to unity. Thus,

$$G_1 G_2 G_3 G_4 = \frac{E_{p2}}{E_{k1}} \cdot \frac{E_{k2}}{E_{p1}} \cdot \frac{E_{p2}}{E_{k2}} \cdot \frac{E_{k1}}{E_{p2}} = 1 \quad 1-348 (1)$$

where, referring to the circuit in figure 1-154,

$$G_1 = E_{p1}/E_{k1} = \frac{\mu_1 Z_{p1}}{R_{p1} + Z_{p1}} \approx g_{m1} R_a \quad 1-348 (2)$$

$$G_2 = E_{k2}/E_{p1} \approx 1 \quad 1-348 (3)$$

$$G_3 = E_{p2}/E_{k2} = \frac{\mu_2 Z_{p2}}{R_{p2} + Z_{p2}} \approx g_{m2} R_b \quad 1-348 (4)$$

$$G_4 = E_{k1}/E_{p2} \approx 1 \quad 1-348 (5)$$

So

$$G_1 G_2 G_3 G_4 = g_{m1} g_{m2} R_a R_b \approx 1 \quad 1-348 (6)$$

Equation (6) is only a first-order approximation in which it is assumed the plate resistances of the tubes are very large compared with the external plate impedances, Z_{p1} and Z_{p2} , which, in turn, are approximately equal to R_a and R_b , respectively. Also, it is assumed that X_{c1} is small compared with Z_{p1} , and that either X_{c2} is small compared with Z_{p2} or the tendency towards a series-resonant rise in voltage across Z_{p1} is sufficient to make equation (5) approximately correct.

1-349. The output is most often taken from across a 500- to 1000-ohm resistance between the cathode of V_2 and ground. In this event, R_{g2} connects directly to the cathode of V_2 —not to ground. The cathode output is quite useful for matching to low-impedance inputs, such as would occur, for example, when feeding a coaxial line. Regardless of where the output is obtained, it can be seen that its amplitude cannot be expected to greatly exceed that of the Pierce circuit. Since two amplifier stages are required and no additional gain is pro-

duced, there can be little advantage in using the multivibrator circuit unless thermostatic control of the temperature is employed and the design is such as to ensure greater frequency stability than can be achieved in the Pierce circuit. The use of a single dual-type tube offers greatest economy. The principal advantages of the circuit are its relative independence of fluctuations in the tube voltage, and its adaptability for impedance-matching to low-impedance output circuits.

1-350. Figure 1-155 illustrates three multivibrator-type crystal oscillators that were designed for use in Diversity Receiving Equipment AN/FRR-3 (). Circuit (A) is a later-model replacement of circuit (B). Very possibly the preference for (A) is at least partly due to a desire to eliminate the variable effects of the inductors in (B) with changes in frequency. From the data available it cannot be said that the crystal in (B) is not actually operating at or very near its series-resonance frequency. The state of operation of the

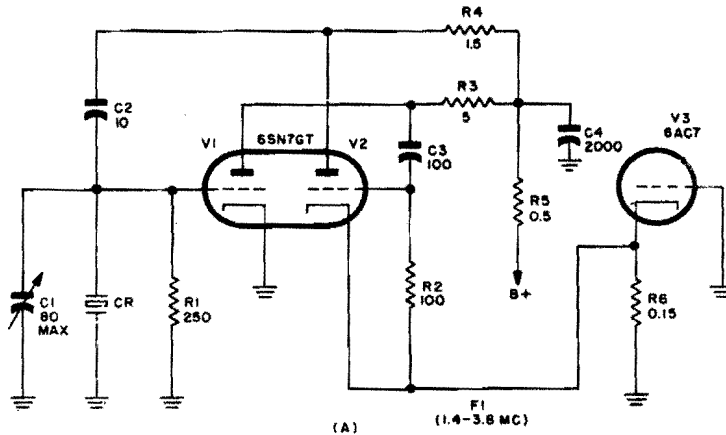

Figure 1-155. Two-stage parallel-resonant oscillators of the multivibrator type.

Fig.	Equipment	Purpose	F_1	CR	R_1	R_2	R_3	R_4	R_5	R_6	R_7	R_8
(A)	Diversity Receiving Equipment AN/FRR-3A	Local oscillator	1400-3800	Holder FT-249	250	100	5	1.5	0.5	0.15		
(B)	Diversity Receiving Equipment AN/FRR-3	Local osc.	1400-3800	Holder FT-249 (Entire circuit in 55° C oven)	250	250	3					
(C)	Diversity Receiving Equipment AN/FRR-3A	BFO with AFC reactance tube, V_1	462.45		50	0.6	10	100	250	250	5	8

Circuit Data for Figure 1-155. F in kc. R in kilohms. C in μf . L in μh .

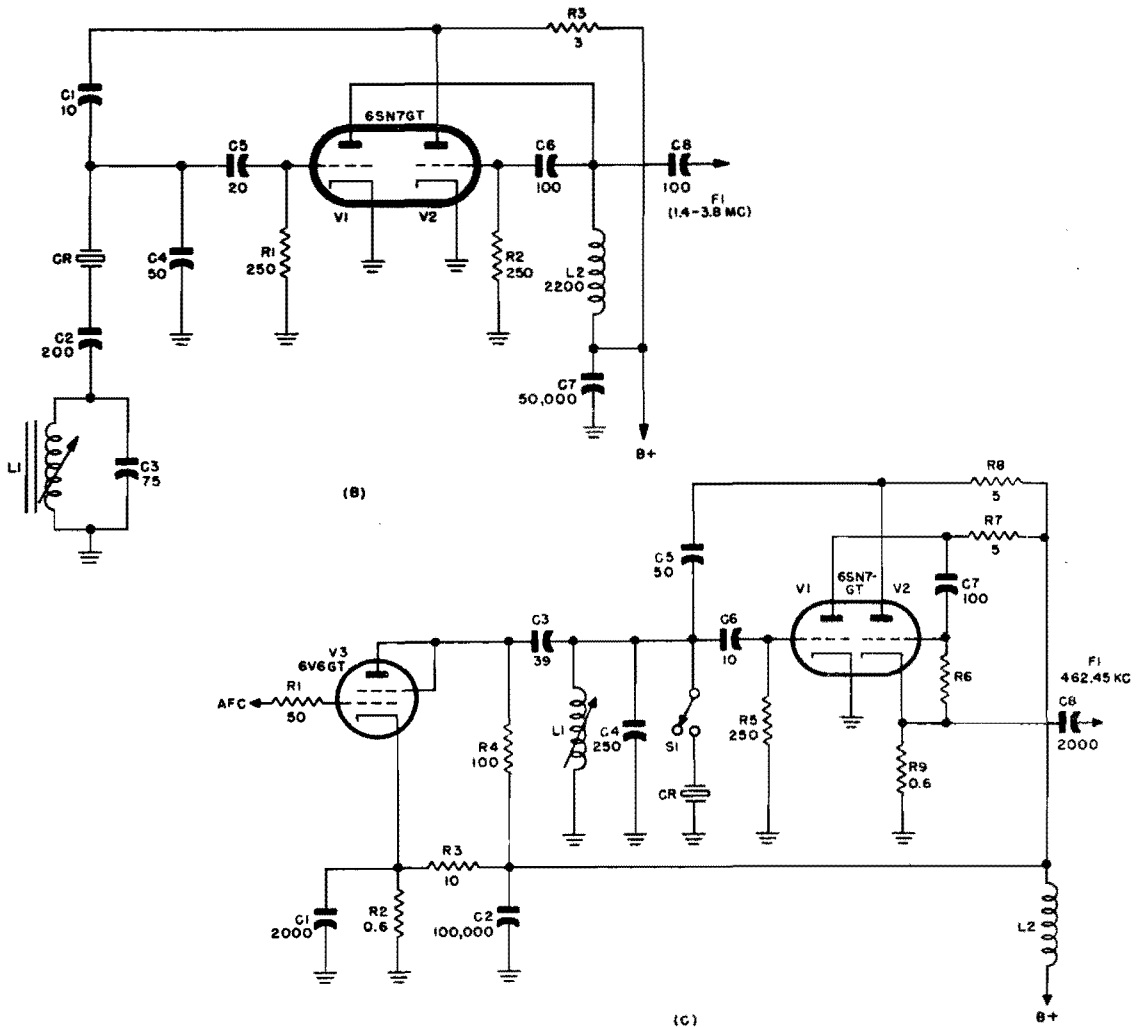

Figure 1-155. Continued

R ₀	C ₁	C ₂	C ₃	C ₄	C ₅	C ₆	C ₇	C ₈	L ₁	L ₂	V ₁ -V ₂	V ₃
	80	10	100	2000							6SN7GT	6AC7
	10	200	75	50	20	100	50,000	100		2200	6SN7GT	
0.6	2000	100,000	39	250	50	10	100	2000		2200	6SN7GT	6V6GT

Section I
Crystal Oscillators

crystal will vary quite widely with changes in the tuning of the L, C , tank. Circuit (C) is a beat-frequency oscillator which is crystal-stabilized when switch S , is in the crystal position, as shown. The triode-connected beam power tube serves as a reactance tube, which effectively shunts the crystal with a capacitance that varies with the bias supplied to the control grid of the tube. The bias, in turn, is controlled by the a-f-c discriminator circuit in a teletype terminal. The purpose of the circuit is to ensure that the beat frequency remains constant even though the frequency of the incoming signal should vary slightly. If the beat frequency tends to drift, the sign and magnitude of the discriminator output causes the bias of the reactance tube to effectively change the load capacitance of the crystal unit in such a direction that the frequency of the oscillator rises or falls by approximately the same number of cycles per second as does the incoming signal.

Oscillators with Crystals Having Two Sets of Electrodes

1-351. The original crystal oscillator devised by Dr. Nicolson, as well as a number of the earlier crystal oscillators tested by Dr. Cady, employed crystals with, effectively, two pairs of electrodes. The basic circuit is shown in figure 1-156. The required phase inversion of the amplifier output voltage is provided by the crystal unit operating at a mode for which the polarities of the plate and grid terminals with respect to ground are 180 degrees out of phase. The circuit shown operates the crystal unit very near its series-resonance frequency. In practice, a capacitor is normally connected between crystal and ground, so that the circuit is more commonly employed for parallel-mode tested crystal units. Still, it is not without some license that we classify this type of oscillator as a parallel-mode type. The crystals most applicable for this class of circuit are the very-low-frequency elements of the X group, which vibrate in lengthwise extensional or flexural modes. The electrode connections that permit the desired phase inversion depend upon the particular crystal element. Assume that electrodes numbers 1 and 3 are on one side of the crystal, and that 2 and 4 are on the opposite side, as indicated in figure 1-156(A). For a flexure element, such as element N, where electrodes 1 and 3 parallel each other down the length of the crystal, as shown in figure 1-156(B), the flexure mode is excited when the potential across 1 and 2 is oppositely polarized to that across 3 and 4. If the same electrode arrangement is to be used to excite an extentional mode

(or the flexural mode of the duplex element J) the polarities of the two sets of electrodes must be in phase. In this case, the connections of one set of electrodes should be reversed in the circuit shown in figure 1-156(A). For example, plates 2 and 3 should be connected to ground and plate 4 should be connected to the grid, if the proper phase inversion is to be obtained. A crystal having the two sets of electrodes at opposite ends of the crystal, as shown in figure 1-156(C), would be driven at the second harmonic of the length extensional mode (or of the flexural mode of a duplex crystal), if connected as shown in figure 1-156(A). Greater stability and a smaller crystal are possible for a given frequency by operating at the fundamental mode. To permit this, if the crystal unit is plated as shown in figure 1-156(C), the connections of one pair of electrodes should be the reverse of those shown in figure 1-156(A). If it can be assumed that the current in the grid circuit is negligible compared with the crystal current between terminals 1 and 2, and if the stray capacitance between the two sets of electrodes is ignored, the equivalent circuit between terminals 1 and 2 will appear approximately as shown in figure 1-156(D). L , C , and C_0 represent the parameters of a fully plated crystal. A more exact analysis of this type of crystal unit can be found in the book "Electromechanical Transducers and Wave Filters" by W. P. Mason, D. Van Nostrand Co.

1-352. Figure 1-157 shows a practical oscillator design employing crystal units having two sets of electrodes. Although the electrode connections shown for CR would indicate that the plate and

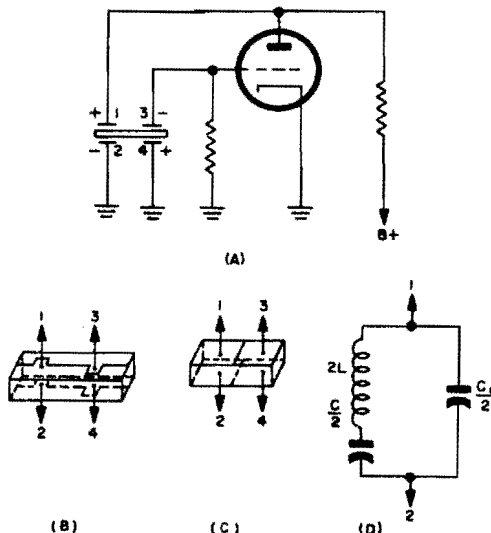

Figure 1-156. Basic circuit of oscillator using crystal with two pairs of electrodes

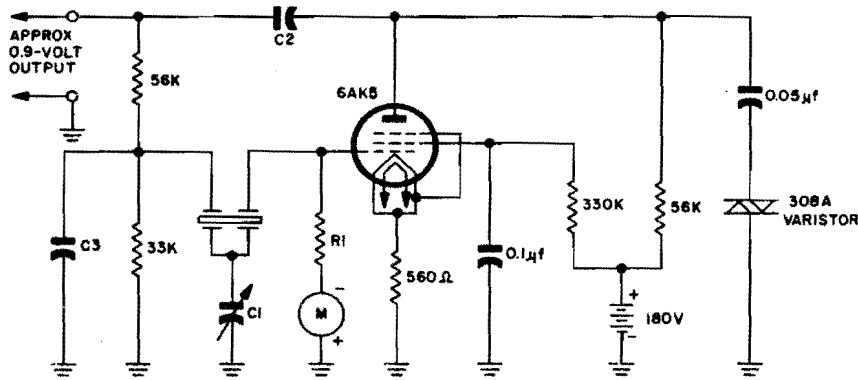

Figure 1-157. Practical crystal-oscillator design employing very-low-frequency crystal unit with two sets of electrodes

grid terminals always connect to the same side of the crystal unit, the actual connections will depend upon the particular element used. The variable capacitor C_1 permits a frequency adjustment of approximately 60 parts per million. To ensure that the crystal unit is operating into its rated load capacitance, the exact frequency of a test crystal should be known when it is at series resonance with its rated capacitance. To a first approximation, the terminal that is to be connected to the grid can be assumed to be open-circuited, so that the resonance to be tested is that between the rated C_x and one half of the crystal. With the test crystal connected in the oscillator circuit, C_1 can be adjusted to provide an output at the previously measured "rated" frequency of the test crystal. This adjustment therefore will provide the rated load capacitance for all crystal units of the same type. The varistor is inserted to protect the crystal unit from overdrive, and to ensure a stable output voltage. As recommended by Bell Telephone Laboratory engineers, the nominal values of R_1 , C_1 , C_2 , and C_3 that provide satisfactory operation in the 1.2- to 10-kc frequency range are given in the following table. The values shown will provide a direct current in M of approximately 12 microamperes.

Frequency Range (kc)	R_1 (kil-ohms)	C_1 ($\mu\mu\text{f}$)	C_2 ($\mu\mu\text{f}$)	C_3 ($\mu\mu\text{f}$)
1.2 — 1.5	100	180	4000	500
1.5 — 2.0	100	180	3000	500
2.0 — 2.5	100	150	2000	500
2.5 — 3.2	100	150	1500	500
3.2 — 4.5	100	120	1000	500

Frequency Range (kc)	R_1 (kil-ohms)	C_1 ($\mu\mu\text{f}$)	C_2 ($\mu\mu\text{f}$)	C_3 ($\mu\mu\text{f}$)
4.5 — 6.7	100	120	700	250
6.7 — 8.0	100	90	500	250
8.0 — 10.0	51	90	1000	0

1-353. Figure 1-158 shows the crystal oscillator in Test Set TS-251/UP, which employs a duplex crystal element. The crystal circuit is used to synchronize the blocking oscillator at a frequency of 1818.18 cps. The output of the blocking oscillator is for counting down to 303.03 pulses per second, which, in turn, are used in checking Loran pulse-repetition rates. A CR-11/U crystal unit is used which has a resonant frequency of 1817.44 ± 0.3 cps at 75° Fahrenheit. The rated maximum effective resistance of the crystal is 30,000 ohms, and its rated maximum permissible current is 0.03 milliamperes. The fixed capacitance paralleling the variable capacitance is used only if necessary. The varistor is rated at 1 ma/14V for temperatures between 75 and 86 degrees Fahrenheit.

Crystal and Magic-Eye Resonance Indicator

1-354. An interesting application of a parallel-resonant crystal circuit is the tuning indicator shown in figure 1-159. When the tuned frequency, F_1 , of a variable oscillator is equal to the antiresonant frequency of the crystal unit in parallel with the input capacitance of V_1 , a magic-eye tube, the excitation of V_1 is a maximum, as is the current through R_1 , and, hence, also the shadow angle of the indicator. The circuit thus provides a constant visual crystal check on the tuned oscillator frequency. Different crystal units can be switched in for different channels.

Section I
Crystal Oscillators

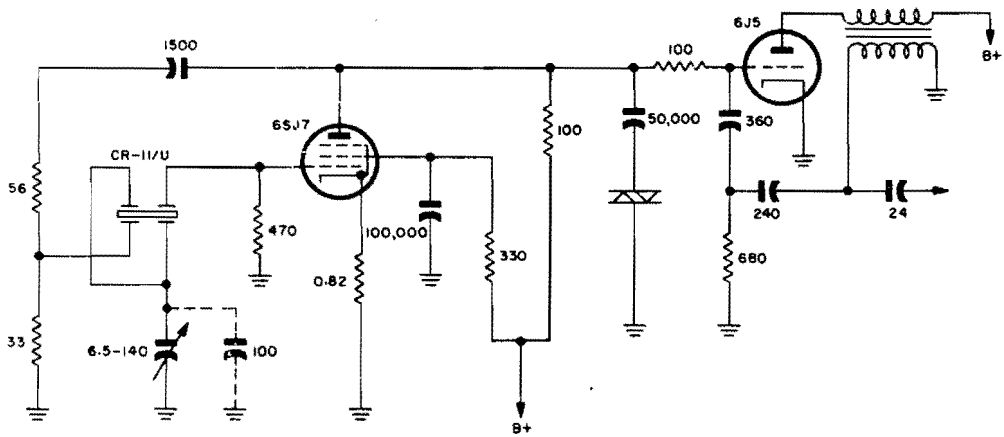

Figure 1-158. Duplex-electrode crystal circuit in Test Set TS-251/UP for synchronizing blocking oscillator at 1818.18 cps. Resistance is given in kilohms, capacitance in micromicrofarads

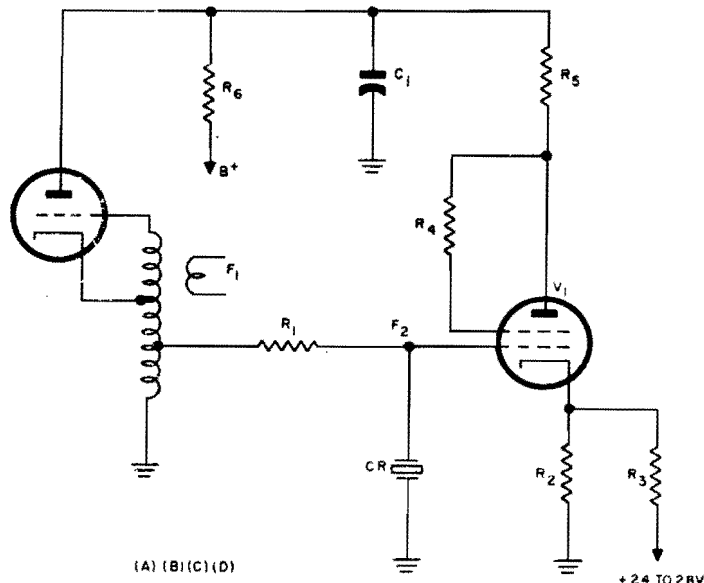

Figure 1-159. Crystal and magic-eye resonance indicator

Fig.	Equipment	F ₁	CR	R ₁	R ₂
(A)	Radio Transmitter BC-696-A	3000-4000	DC-8-C,- D,-K	5.1	0.39
(B)	Radio Transmitter BC-457-A	4000-5300	DC-8-C,- D,-K	10	0.39
(C)	Radio Transmitter BC-458-A	5300-7000	DC-8-C, D,-K	15	0.39
(D)	Radio Transmitter BC-459-A	7000-9100	DC-8-C, D,-K	5.1	0.39

Circuit Data for Figure 1-159. F in kc. R in kilohms. C in $\mu\mu\text{f}$.

SERIES-RESONANT CRYSTAL OSCILLATORS

1-355. For maximum frequency stability it is generally preferable to operate a crystal unit at its series-resonance frequency, but series-mode circuits are most widely used for overtone operation. At series resonance the crystal element appears as a resistance, so that in the normal circuit it can be short-circuited or replaced by a comparable resistance without stopping oscillations. Series-resonant oscillators generally have smaller outputs than do oscillators of the parallel-resonant type. Also, series-resonant oscillators usually require more circuit components, and hence are not often used except in the very-high-frequency range. In general, the operation of the series-mode circuits is less complicated than that of the parallel-mode oscillators. Nevertheless, the circuit design becomes increasingly critical at the higher frequencies and higher overtones. The stray capacitances must be kept to a minimum, and all leads must be as short as possible. It may be necessary to nullify the crystal shunt capacitance, C_0 , by connecting across the crystal unit an inductor that is anti-resonant with C_0 at the operating frequency. It may also be desirable to connect a capacitor in series with the crystal unit, to tune out the stray inductance of the crystal leads. Tuned circuits must be provided if a crystal unit is to be driven at a particular overtone mode. Quite often, satisfactory operation is obtained simply by designing a conventional variable-tuned oscillator to operate at the desired frequency, and then inserting the crystal unit in a plate tank or feed-back circuit. There will be a range of tuning adjustments in

which the crystal can assume control and hold the frequency very nearly constant. As the tuning adjustments are varied beyond this range, the control becomes quite unstable or ceases altogether. Usually, the region of stable control becomes smaller as the overtone order is increased. If broad-band operation is desired with no tuning adjustment other than the selector switch for changing the crystal, additional precautions must be taken to ensure that oscillations cannot be maintained except when the crystal impedance is small—that is, the crystal unit is operating near series resonance. For maximum frequency stability, the effective resistance of the circuit facing the crystal unit should be as small as possible. At the higher frequencies, the stray capacitances limit the impedances obtainable from the tuned circuits, thereby making them more selective and hence more effective in influencing the frequency and in increasing the instability.

1-356. The series-mode oscillators most widely recommended are listed in the following table, and rated according to their relative design and performance characteristics. A rating of 1 represents the top relative superiority in the corresponding characteristic. It should be understood that the ratings are based upon average qualitative results which might well be contradicted by the data of individual investigators. Any one of the series-mode circuits expertly designed could surpass the performance of a poorly designed circuit rated higher in a particular characteristic. The frequency-stability rating assumes average oven and voltage regulation.

R_3	R_4	R_5	R_6	C_1	V_1
1.5	1000	51	0.02	50,000	1629
1.0	1000	51	0.02	50,000	1629
1.0	1000	51	0.02	50,000	1629
1.5	1000	51	0.02	50,000	1629

Section I
Crystal Oscillators

<i>Symbol of Oscillator</i>	A	B	C	D	E	F	G	H	I	J	K	L
<i>Frequency Stability (%)</i>	0.0001	0.002	0.0005	0.0004	0.0004	0.0004	0.0004	0.0002	0.0015	0.002	0.002	0.0015
<i>Power Output</i>	6	5	3	1	3	5	4	4	4	2	1	3
<i>Versatility</i>	4	4	2	1	2	3	2	3	3	3	2	3
<i>Upper Frequency Level</i>	5	1	3	2	2	2	2	3	3	3	4	3
<i>High-Resistance Crystals</i>	2	5	3	4	4	4	2	4	4	4	1	3
<i>Ease of Adjustment</i>	6	7	1	3	2	2	2	5	5	5	4	5
<i>Untuned Bandwidth</i>	5	5	2	2	1	2	1	6	6	6	4	6
<i>Frequency Multiplication</i>	5	5	2	4	4	1	5	5	3	3	5	6
<i>Low Harmonic Output</i>	1	2	2	5	5	5	5	4	4	4	3	2
<i>Circuit Simplicity</i>	4	5	3	2	1	2	2	3	3	3	4	4
<i>Isolation from Load</i>	1	2	3	4	4	2	4	4	4	4	4	4
<i>Low-Frequency Operation</i>	1	6	3	5	5	5	2	4	4	4	1	2

The oscillator symbols in the foregoing table correspond to the respective index letters of the oscillators listed below.

Names of Series-Mode Oscillators

- A. Meacham Bridge
- B. Capacitance Bridge
- C. Butler, or Cathode-Coupled
- D. Grounded-Cathode, Transformer-Coupled Type
- E. Grounded-Grid, Transformer-Coupled Type
- F. Grounded-Plate, Transformer-Coupled Type
- G. Transitron
- H. Impedance-Inverting Transitron
- I. Impedance-Inverting Pierce
- J. Impedance-Inverting Miller
- K. Grounded-Cathode Two-Stage Feedback
- L. Modified Colpitts, C.I. Meter Type

Meacham Bridge Oscillator

1-357. The Meacham bridge oscillator, illustrated in figure 1-160, provides the greatest frequency stability of any vacuum-tube oscillator yet devised, but the region of maximum frequency stability is limited to the lower frequencies because of the increased effect of the stray circuit capacitances when the frequency becomes greater than a few hundred kilocycles per second. The oscillator is of the crystal-stabilized type employing tuned circuits. At frequencies above 1000 kc the effect of the stray capacitance is sufficient to reduce the stability to a point where little is to be gained by the use of the Meacham circuit. The oscillator is principally employed with GT-cut crystals in frequency standards, to generate frequencies of 100 kc. In figure 1-160, it can be seen that if the bridge

were perfectly balanced there would be no excitation voltage. At the start of oscillations, the ratio of R_1 (practically equal to the series-arm R of the crystal unit) to R_2 is smaller than the ratio of the R_3 to R_1 . But R_1 is a thermistor — it is the resistance of a tungsten lamp which sharply increases in value as the temperature rises. (A semiconductor such as carbon, silicon, or germanium can be used, in which case the resistance will decrease with temperature. The negative temperature coefficient of the semiconductor is generally larger than the positive coefficient of tungsten, but the semiconductor thermistor is more expensive and is much more difficult to duplicate because of its great sensitivity to impurities.) As oscillations build up, the current through R_1 increases to a point where the heat generated from the power losses raises the the thermistor temperature, and hence the resistance, to a point where the bridge is almost balanced. Equilibrium is reached when the imbalance of the bridge is just sufficient to supply heat to the thermistor at the same rate at which it escapes. For maximum amplitude stability, the ambient temperature of R_1 should not be permitted to vary over a wide range. Normally, the tungsten lamp will heat to a dull red of approximately 600 degrees centigrade. A variation of over 100 degrees in the ambient temperature could have a significant effect on the equilibrium power losses in the thermistor, if extreme precision were desired. The operating temperature of the lamp is very low compared with the rated temperature, and consequently the lamp can be expected to last indefinitely. The oscillator should be designed and adjusted so that the phase shift occurs entirely in the bridge. That is, the tube should operate into

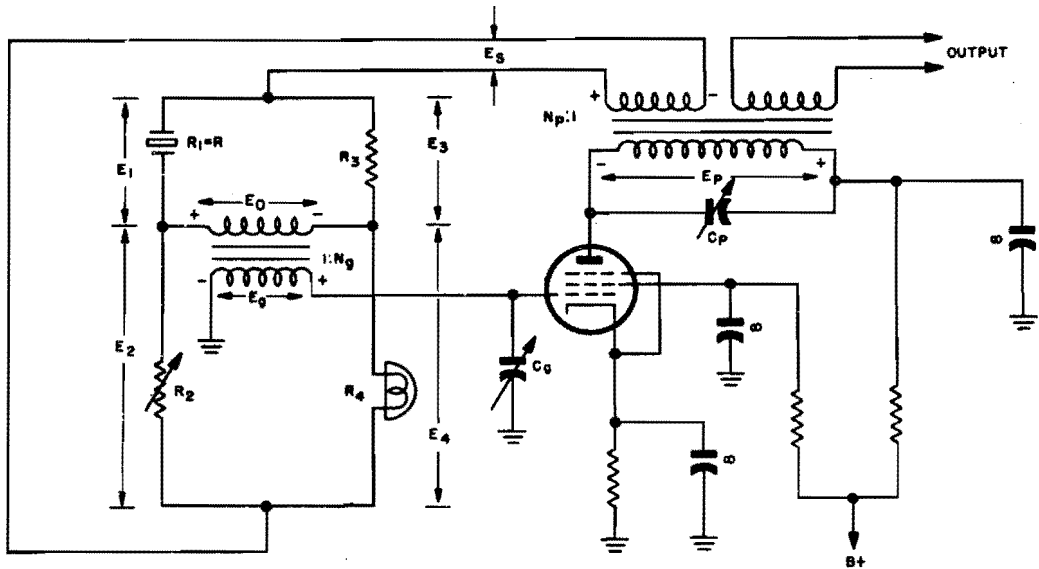

Figure 1-160. Basic circuit of Meacham bridge-stabilized oscillator

a pure resistance, so that the instant the plate current is maximum the peak transformer voltages should occur with polarities as indicated in figure 1-160. Transformers having powdered-iron, toroidal cores can provide a coefficient of coupling very close to unity in the low-frequency range. The following analysis of the frequency stability and the activity stability of the Meacham oscillator, except for minor deviations and extensions, has been guided by the postulates and basic considerations as presented by W. A. Edson.*

FREQUENCY STABILITY OF MEACHAM BRIDGE OSCILLATOR

1-358. First, we shall assume that the vacuum tube in figure 1-160 operates into a purely resistive load, and that the entire phase reversal takes place in the bridge transformer. The phasor diagram in figure 1-161 (A) shows the relation of the voltage E_0 to the other voltages of the bridge network. (Refer to figure 1-160 for voltage symbols.) Next, assume that some change in the capacitance of the circuit requires that E_0 be shifted in phase by a very small angle equal to ϕ , but that the change is so small that the magnitude of all the bridge voltages can be assumed to remain constant. In order to produce the phase shift ϕ , it can be seen that E_s , and hence the current through R_1 , must be rotated by an angle θ . In a triangle with angles A and B opposite to sides a and b, respectively,

$\frac{a}{\sin A} = \frac{b}{\sin B}$ (Law of Sines). Likewise, in the triangle E_0, E_3, E_4 ,

$$E_0/\sin \theta = E_4/\sin \phi$$

or

$$\sin \theta = \frac{E_0}{E_4} \sin \phi \quad 1-358 (1)$$

Since we are assuming that both θ and ϕ are very small, equation (1) can be written, approximately,

$$\theta = \frac{E_0}{E_4} \phi \quad 1-358 (2)$$

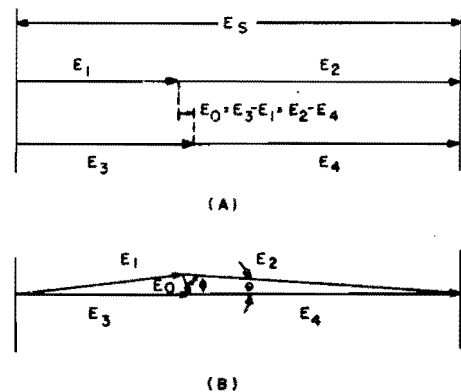

Figure 1-161. Phasor diagrams of bridge voltages in Meacham oscillator. Angles ϕ and θ (greatly magnified) represent small shifts in phase when crystal unit is operating slightly off series resonance

* *Vacuum Tube Oscillators*, John Wiley and Sons, 1958.

Section I
Crystal Oscillators

The current through the input transformer can be assumed to be negligible compared with the total current through the crystal, so the current through R_1 is essentially the same as that through the crystal. Under these conditions, as is shown in paragraph 1-241,

$$\theta = \tan \theta = \frac{X_c}{R_1 + R_2} = \frac{2L\Delta\omega}{R + R_2} \quad 1-358 (3)$$

where L and R are series-arm parameters of the crystal unit. By rearranging equation (3) and dividing by ω , the fractional change in frequency required to produce an angle θ is found to be

$$\frac{\Delta\omega}{\omega} = \frac{\theta (R + R_2)}{2\omega L} = \frac{\theta R_c \sqrt{C}}{2\sqrt{L}} \quad 1-358 (4)$$

where $R_c = R + R_2$ is the total resistance of the crystal side of the bridge, and C is the series-arm capacitance. On substitution of equation (2) in equation (4), it is found that

$$\frac{\Delta\omega}{\omega} = \frac{\phi E_o R_c}{2E_4} \cdot \sqrt{\frac{C}{L}} \quad 1-358 (5)$$

Equation (5) indicates that the more nearly balanced the bridge (the smaller the E_o/E_4 ratio), the greater will be the frequency stability.

Now,

$$E_4 = \frac{R_4 E_o}{R_3 + R_4} \quad 1-358 (6)$$

Letting $(R_3 + R_4)/R_4 = (R_1 + R_2)/R_2 = m$, we see that $E_o/E_4 = \frac{m E_o}{E_o}$.

Also, since

$$\begin{aligned} E_o &= E_o \left(\frac{R_3}{R_3 + R_4} - \frac{R_1}{R_1 + R_2} \right) \\ &= E_o \left(\frac{R_3}{R_T} - \frac{R_1}{R_c} \right) \end{aligned} \quad 1-358 (7)$$

where $R_T = R_3 + R_4$, then

$$E_o/E_4 = m \left(\frac{R_3}{R_T} - \frac{R_1}{R_c} \right) = R_3/R_4 - R_1/R_2$$

On substitution in equation (5), we have

$$\frac{\Delta\omega}{\omega} = \left(\frac{R_2 R_3 - R_1 R_4}{R_2 R_4} \right) \frac{R_c \phi}{2\sqrt{L/C}} \quad 1-358 (8)$$

It now remains to determine the magnitude of ϕ for a small change in the capacitance of the circuit. The most likely changes in capacitance take place in the grid circuit, the average ΔC_g usually being on the order of 10 times the average ΔC_p in the plate circuit. Looking away from the grid, it can be seen that when the bridge is very nearly balanced, the grid faces a resistive impedance

$$R_g = \frac{N_g^2 (R_1 + R_3) (R_2 + R_4)}{R_1 + R_2 + R_3 + R_4} \quad 1-358 (9)$$

The capacitance C_g will have been adjusted to be effectively antiresonant with the leakage inductance of the transformer, which inductance can be imagined to be in parallel with R_g . Still looking away from the grid, we can imagine a generator connected between grid and cathode. If the capacitance should change by a small amount ΔC_g , the ratio of the excess reactive component of current to the resistive component becomes $R_g \omega \Delta C_g$. This will equal the tangent of the phase shift, ϕ , which is sufficiently small for $\tan \phi$ to be assumed to equal ϕ . Thus, with $\phi = R_g \omega \Delta C_g$, on substituting equation (9) for R_g , equation (8) becomes

$$\begin{aligned} \frac{\Delta\omega}{\omega} &= \left(\frac{R_2 R_3 - R_1 R_4}{R_2 R_4} \right) \cdot \frac{(R_1 + R_3) (R_2 + R_4)}{(R_1 + R_2 + R_3 + R_4)} \\ &\quad \cdot \frac{R_c N_g^2 \Delta C_g}{2L} \end{aligned} \quad 1-358 (10)$$

Now, let us assume that R_1 and R_3 remain fixed. As R_2 is varied, R_4 must vary in direct proportion to keep the bridge balanced. If $R_3 = kR_1$, R_4 will always approximately equal kR_2 . Substituting these values of R_3 and R_4 in all terms where the error introduced can be considered negligible, equation (10) becomes

$$\frac{\Delta\omega}{\omega} = \frac{R_1^2 (kR_2 - R_4) (1 + k)}{kR_2} \cdot \frac{N_g^2 \Delta C_g}{2L} \quad 1-358 (11)$$

If R_4 is expressed as being equal to $R_2 (k - i)$, equation (11) becomes

$$\frac{\Delta\omega}{\omega} = \frac{(1 + k) i R_1^2 N_g^2 \Delta C_g}{2kL} \quad 1-358 (12)$$

1-359. Equation 1-358 (12) does not quite indicate the relations among all the circuit parameters that are effective in providing an optimum fre-

quency stability. It is first necessary to determine how i , which is a measure of the imbalance in the circuit, is dependent upon the other parameters. For this purpose, it is necessary to find that value of i which must exist in order for the feed-back voltage to be at equilibrium. It will be assumed that the r-f plate current, I_p , is equal to $g_m E_g$. If this assumption is not warranted, g_m in any of the following equations can be replaced by $\mu/(R_p + Z_p)$. To a first approximation,

$$Z_p = N_p^2 R_c R_T / (R_c + R_T) \quad 1-359 (1)$$

and

$$E_g = E_p / N_p = I_p Z_p / N_p = g_m E_g N_p R_c R_T / (R_c + R_T) \quad 1-359 (2)$$

also, $E_g = N_g E_o$, and E_o is given by equation 1-358(7). On substitution in equation (2)

$$1 = g_m N_p N_g (R_c R_2 - R_1 R_T) / (R_c + R_T) \quad 1-359 (3)$$

Equation (3) is the equilibrium feed-back equation for the Meacham oscillator. On expressing R_2 and R_1 as functions of R_1 and R_2 , it is found that at equilibrium

$$i = \frac{(1+k) R_c}{g_m N_p N_g R_1 R_2} \quad 1-359 (4)$$

Substituting (4) in equation 1-358 (12)

$$\frac{\Delta\omega}{\omega} = \frac{(1+k)^2 R_1 R_c N_g \Delta C_g}{2 k g_m R_2 N_p L} \quad 1-359 (5)$$

In a similar manner, in equating ϕ to $Z_p \omega \Delta C_p$, it can be shown that for small changes in the plate capacitance

$$\frac{\Delta\omega}{\omega} = \frac{R_c^3 N_p \Delta C_p}{2 (1+k) g_m R_2^2 N_g L} \quad 1-359 (6)$$

It can be seen that greater stability is to be had when g_m is a maximum and when the ratio $m = R_c/R_g$ is small. For changes in C_g , the optimum value of k is 1 (when $(1+k)^2/k$ passes through a minimum). For changes in C_p , it would be desirable to have k as large as practicable. A further consideration is to so proportion the parameters that the expected variations in C_g and C_p will have the maximum opportunity to cancel in their effects.

Also, caution must be taken that in improving the stability in one respect, it is not impaired to a greater extent in another. Since the expected ΔC_g is approximately 10 times the expected ΔC_p , the ratio of the right-hand sides of equations (5) and (6) can be equated to 1, with $10 \Delta C_p$ substituted for ΔC_g . On thus dividing (5) by (6)

$$1 = \frac{10 (1+k)^3 R_1 R_2 N_g^2}{k R_c^2 N_p^2}$$

or

$$N_p^2 / N_g^2 = \frac{10 (1+k)^3 R_1}{k m R_c} = \frac{10 (1+k)^3 (m-1)}{k m^2} \quad 1-359 (7)$$

With the oscillator designed according to equation (7), average capacitance variations in the plate and grid circuits will have approximately equal effects upon the frequency. When the square root of equation (7) is combined with equations (5) and (6), and R_c is expressed as $m R_1 / (m-1)$,

$$\frac{\Delta\omega}{\omega} = \frac{\Delta C_g m^2 R_1}{2 L g_m} \sqrt{\frac{1+k}{10 k (m-1)}} \quad 1-359 (8)$$

and

$$\frac{\Delta\omega}{\omega} = \frac{\Delta C_p m^2 R_1}{2 L g_m} \sqrt{\frac{10 (1+k)}{k (m-1)}} \quad 1-359 (9)$$

If the oscillator is to be designed on the basis of equation (7), it can be seen that k should be made as large as is practicable, and m should be such that the factor $m^2/\sqrt{m-1}$ is a minimum. It can be shown that this occurs when

$$m = 4/3 \quad 1-359 (10)$$

Frequency stability, of course, is not the only consideration; there are also the vacuum-tube and thermistor characteristics and the power rating of the crystal unit that must be taken into account in deciding upon the optimum parameter relations. Remember, that in equations (4), (5), and (6), g_m can be replaced by the more exact term $\mu/(R_p + Z_p)$. Certainly, a high- μ tube is to be preferred, and when it is operated class A the second-harmonic output can be expected to be at least 65 db below the fundamental. The screen voltage should be fairly high, in order to increase g_m . Normal operating voltages can be employed, but E_g should not be allowed to drive the grid positive.

Section I
Crystal Oscillators

**ACTIVITY STABILITY OF MEACHAM
BRIDGE OSCILLATOR**

1-360. Starting with E_o , the input to the grid

$$\text{Gain: } G_1 G_2 G_3 G_4 = N_g \times \frac{\mu Z_p}{R_p + Z_p} \times 1/N_p \times \left(\frac{R_3}{R_T} - \frac{R_1}{R_c} \right) = 1$$

$$\text{Voltage: } E_o \xrightarrow{G_1 = E_g/E_o} E_g \xrightarrow{G_2 = E_p/E_g} E_p \xrightarrow{G_3 = E_a/E_p} E_a \xrightarrow{G_4 = E_o/E_a} E_o$$

From equation 1-358(12) it can be seen that in the interest of frequency stability, i , and hence the imbalance of the bridge should be as small as possible. Fortunately, this condition also agrees with the requirements of high activity stability, for the smaller the *difference* of the actual thermistor resistance from a value equal to kR_2 , the larger will be the percentage change in that *difference* for a small change in the thermistor voltage. Equation 1-358(7) can be written

$$E_o = G_4 E_a = i R_1 R_2 E_a / k R_c^2 \quad 1-360 (1)$$

where $i = (kR_2 - R_1)/R_2$ and G_4 is the gain of the stage. In the over-all gain equation, above, G_1 and G_3 can be considered constant, so that G_4 primarily has the function of compensating any changes in G_2 of the vacuum tube. From equation (1), it can be seen that iE_a/E_o can be considered a constant. Or, in the over-all gain equation we see that

$$G_1 G_2 G_3 i R_1 R_2 / k R_c^2 = 1 \quad 1-360 (2)$$

or that

$$G_2 i = k R_c^2 N_p / R_1 R_2 N_g = \text{constant}$$

On differentiating,

$$i dG_2 + G_2 di = 0$$

or

$$\frac{di}{i} = - \frac{dG_2}{G_2} \quad 1-360 (3)$$

Equation (3) shows that for a given percentage change in the gain of the tube, the smaller the value of i , the smaller need be the change in R_1 to restore equilibrium. Since $G_2 \approx g_m Z_p$, we can write

$$di/i = - dg_m/g_m \quad 1-360 (4)$$

On differentiating $iE_a/E_o = C$, where C is a constant, we find that

$$i dE_a + E_a di - C dE_o = 0 \quad 1-360 (5)$$

transformer, we see that at equilibrium the product of the gains of all the stages, from E_o back to E_o , must be equal to 1. Thus,

If the effects on E_o due to the changes in E_a and i exactly cancel so that $dE_o = 0$, then, by equations (3) and (5)

$$- dG_2/G_2 = di/i = - dE_a/E_a$$

Under these circumstances it can be seen that the percentage change in the activity is exactly equal to the change in the gain of the tube. If the thermistor is to be effective in preventing the amplitude of the output from changing significantly with changes in G_2 , clearly an increase in E_a must produce a *decrease* in E_o . We can define the activity sensitivity of the bridge to be

$$s = - E_a di/i dE_a \quad 1-360 (6)$$

The sensitivity is thus defined as the percentage variation in i per percentage variation in the voltage across the bridge. The problem now is to convert equation (6) into a function (equation 14) of the circuit constants so that s can be predetermined by the design engineer. From equations (5) and (6) we find that the percentage change in E_o per percentage change in E_a is

$$- \frac{E_a dE_o}{E_o dE_a} = s - 1 \quad 1-360 (7)$$

In practice, $E_o/E_a (= G_4)$ can be on the order of 0.003 or smaller; so, if the change in E_o is comparable to that of E_a in magnitude, excellent amplitude stability will be achieved. The stability depends first upon the magnitude of i , and secondly, upon the sensitivity of the thermistor. The latter is defined as

$$S = \frac{E_a dR_1}{R_1 dE_a} = \frac{d(\log R_1)}{d(\log E_a)} \quad 1-360 (8)$$

Figure 1-162 shows the resistance-voltage characteristics of a number of tungsten lamps for ambient temperatures at room values. For lower ambient temperatures, the curves would be shifted to the right somewhat, and for higher temperatures, to the left. Since the curves are plotted on log paper, according to equation (8) it can be seen

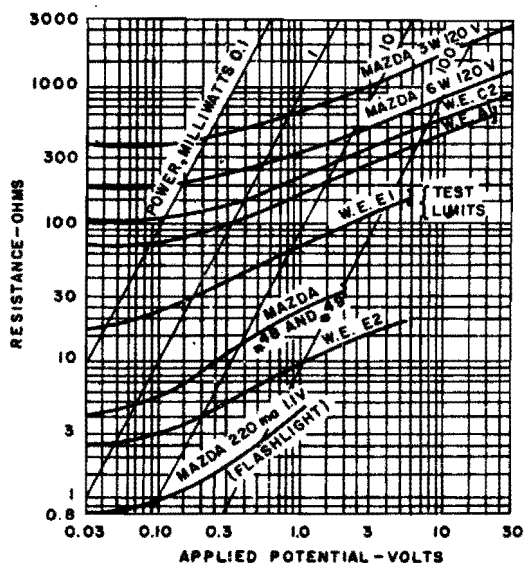

Figure 1-162. Resistance of typical tungsten lamps versus applied voltage and power dissipation when the ambient temperature is 300° Kelvin scale (approximately 27° C)

that the thermistor sensitivity S at a given value of E_4 is the actual slope of a curve at that point. It is important, of course, to operate the thermistor at a voltage where the slope approaches a maximum. It is convenient to express the bridge s as a function of the thermistor S .

Since $i = \frac{k R_2 - R_4}{R_2}$, then

$$di = -\frac{dR_4}{R_2} = -\frac{k dR_4}{R_4} \quad 1-360 (9)$$

or

$$s = -\frac{E_4 di}{i dE_4} = \frac{k E_4 dR_4}{i R_4 dE_4} = \frac{kS}{i} \left(\frac{E_4 dE_4}{E_4 dE_4} \right) \quad 1-360 (10)$$

Now, $E_4 = E_2 - E_0 = E_2$, but $dE_4 (= dE_2 - dE_0)$ is not approximately equal to dE_2 . So $dE_4/E_4 = (dE_2 - dE_0)/E_2 = (dE_2 - mdE_0)/E_2$, where $m = \frac{R_0}{R_2} = \frac{E_0}{E_2}$. On substitution for dE_4/E_4 in equation (10), we find

$$s = \frac{kS}{i} \left(1 - \frac{mdE_0}{dE_2} \right) \quad 1-360 (11)$$

By equation (7) we see that $dE_0/dE_2 = E_0(1-s)/E_2$. On substitution in (11) and after

rearranging, we have

$$s = \frac{kSE_2 - mkSE_0}{iE_2 - mkSE_0} \quad 1-360 (12)$$

The term $mkSE_0$ in the numerator can be considered negligible, and dropped. After expressing E_2 in terms of equation (1) and rearranging, it is found that

$$s = kSR_c/i(R_c - SR_1) \quad 1-360 (13)$$

Finally, on substituting for i its value given by equation 1-359 (4), we are able to express the activity sensitivity entirely in terms of the known circuit parameters. Thus,

$$s = \frac{kSg_m N_p N_g R_1 R_2}{(1+k)(R_c - SR_1)} \quad 1-360 (14)$$

$$s = kSg_m N_p N_g R_1 / (1+k) [m - S(m-1)]$$

The reciprocal of s can be considered the percentage gain in the output voltage (or in E_p or E_s) for a unit percentage change in the gain of the tube, since dG_s/G_s is equal to $-di/i$. In the equation for s , note that if the thermistor sensitivity were equal to R_c/R_1 , the stability mathematically would be infinite. Since R_c/R_1 is greater than 1, a single tungsten lamp could not provide the thermistor sensitivity for the above condition to hold unless special measures were available to reduce the heat leakage from the filament. The effective sensitivity could be increased if R_1 were replaced by another tungsten lamp, and the crystal unit were inserted in the place of R_2 . Theoretically, the sensitivity can be made much larger than unity simply by varying the ambient temperature together with the operating temperature of the filament; for instance, by constructing a thermistor with the filament mounted inside a heater sleeve and controlling the heater current by feedback from a later amplifier stage. If equation (14) is taken apart, it will be found that the denominator term, $(R_c - SR_1)$, originates from that component of dE_4 that is equal to $-dE_0$. When there is an increase in E_0 , the voltage E_4 changes in two ways: one is due to the change in the current through R_1 , and the other is due to the increase in the resistance, itself. It is the latter component that is approximately equal to $-dE_0$. Mathematically, the change in E_4 is expressed by the differential equation

$$dE_4 = d(I_1 R_1) = R_1 dI_1 + I_1 dR_1 \quad 1-360 (15)$$

Section I
Crystal Oscillators

Since dR_4/R_4 is equal to SdE_4/E_4 , on substitution in equation (15) it can be shown that

$$dR_4 = S \left(\frac{R_4 dI_4}{I_4} + dR_4 \right) \quad 1-360 (16)$$

If S is greater than 1, an increase in voltage across R_4 must result in a decrease in current. (Incidentally, since the change in R_4 is actually due to a change in the temperature brought about by an increase in power, a value of S greater than unity implies that the percentage increase in resistance is at least equal to twice the percentage decrease in current.) Now, assuming that the current through the input transformer is negligible, $E_4 = I_4 R_T$, and $dE_4 = I_4 dR_4 + R_T dI_4$, where $dR_4 = dR_T$. If E_4 is to remain constant, that is, if dE_4 is to equal zero for a small change in the gain of the tube, dI_4/I_4 must equal $-\frac{dR_4}{R_T}$. If the latter value is substituted in equation (16), it will be found that for conditions of $s = \infty$:

$$S = \frac{R_T}{R_T - R_4} = \frac{R_T}{R_3} = \frac{R_c}{R_1} \quad 1-360 (17)$$

This is the explanation of the term $(R_c - SR_1)$ in the denominator of equation (14). Other than the assumption that the changes in the current I_4 through the grid transformer can be considered negligible in their effect upon dE_4 , the term is entirely a function of the R_3 and R_4 arms of the bridge, and is not related to the gain characteristics of the rest of the circuit. No experimental data is available concerning the operation of the Meacham bridge oscillator with values of S greater than unity, when R_4 behaves as a negative resistance (an increase in E_4 is accompanied by a decrease in I_4). Theoretically, if S were greater than R_c/R_1 , an increase in the g_m of the tube would ultimately result in a decrease in the output-voltage and in the voltage applied across the bridge. In an actual circuit, whether stable values of R_4 would be maintained under such conditions is open to question. Perhaps the thermal lag of the filament and the extreme sensitivity of E_4 would so influence the operation that R_4 would periodically overshoot its mark and prevent an unmodulated equilibrium from being reached. In practice, the values of S will be on the order 0.5, so such considerations do not arise. For s to be as large as possible, referring to equation (14), it can be seen that $[k/(1+k)]$ should be as large as practicable. This agrees with the equations for frequency stability if the circuit is to be designed according to equation 1-359(7). The term $[k/(1+k)]$ has

no maximum, but approaches unity as k increases indefinitely. Assume that s is equal to 50. This means that a change in the gain of the tube of 1 per cent will cause a change of only one-fiftieth of 1 per cent in the output voltage. Or in terms of db, since

$$s = - \frac{E_4}{dE_4} \cdot \frac{di}{i} = - \frac{\Delta(\log i)}{\Delta(\log E_4)}$$

$$= \frac{\Delta(\log G_2)}{\Delta(\log E_p)} = \frac{\Delta \text{db in tube gain}}{\Delta \text{db in output}} \quad 1-360 (18)$$

an increase of 0.5 db in the gain of the tube will cause only a 0.01-db increase in the output.

CRYSTAL DRIVE LEVEL CONSIDERATIONS IN MEACHAM BRIDGE OSCILLATOR

1-361. A starting consideration in the design of a Meacham bridge oscillator is that the crystal unit is not to be overdriven. If P_1 is the crystal power,

$I_c = \sqrt{P_1/R_1}$ is the crystal current, and

$$E_4 = I_c R_c = \frac{mR_1}{m-1} \sqrt{\frac{P_1}{R_1}} = \frac{m\sqrt{P_1 R_1}}{m-1} \quad 1-361 (1)$$

With R_1 determined by the crystal unit, it is desirable, from the point of view of frequency stability, for m , and hence R_2 to have small optimum values. If S approaches unity, the small R_2 will also be an important consideration in activity stability, but for normal values of S the activity stability is improved slightly if R_2 is large. The term $\left(\frac{R_2}{R_c - SR_1}\right)$ in equation 1-360 (14) has no maximum, but approaches unity as R_2 is increased indefinitely and R_1 and S are held constant. Usually, the requirements of frequency stability are the more important, and R_2 should be kept as small as practical thermistor resistances and values of k permit. At low frequencies, values of R_1 may be in the neighborhood of 1000 ohms or more. The voltage across the thermistor will be

$$E_4 = \frac{E_4}{m} = \frac{I_c R_1}{m-1} = \frac{E_1}{m-1} = \frac{\sqrt{P_1 R_1}}{m-1} \quad 1-361 (2)$$

where E_1 is the voltage across the crystal unit. For convenience, we repeat equation 1-360 (1), but expressed as a function of m and k :

$$E_4 = (m-1) i E_4 / km^2 \quad 1-361 (3)$$

The power dissipation in R_4 is

$$P_4 = E_4 I_4 = E_1 I_c / (m - 1) k = P_1 / (m - 1) k \quad 1-361 (4)$$

The impedance of the bridge in terms of R_1 is

$$Z_s = R_c R_T / (R_c + R_T) = kmR_1 / (1 + k) (m - 1) \quad 1-361 (5)$$

The plate impedance of the tube is

$$Z_p = N_p^2 Z_s = \frac{N_p^2 kmR_1}{(1 + k) (m - 1)} \quad 1-361 (6)$$

The plate voltage is

$$E_p = I_p Z_p = \frac{g_m E_g N_p^2 k m R_1}{(1 + k) (m - 1)} \quad 1-361 (7)$$

Also,

$$E_p = N_p E_s = m N_p \sqrt{P_1 R_1} / (m - 1) \quad 1-361 (8)$$

and

$$E_g = N_g E_o \quad 1-361 (9)$$

Finally, we repeat equation 1-359 (3), the over-all equation for feed-back equilibrium, but expressed in terms of R_1 , m , and k :

$$G_1 G_2 G_3 G_4 = \frac{g_m N_p N_g i R_1}{m (1 + k)} \quad 1-361 (10)$$

R_2 can be adjusted to provide the same value of m for each different crystal unit. Under these circumstances, E_s and E_p will be the same in each oscillator, even though R_1 varies. Two fundamental problems are that the design must ensure that the crystal current does not overdrive the crystal unit when R_1 is small, and that the thermistor current is sufficient for S to be a maximum.

DESIGN PROCEDURE FOR MEACHAM BRIDGE OSCILLATOR

1-362. *The fixed point of reference for estimating the current and voltage at any point in the Meacham circuit is the thermistor voltage E_s . This is the voltage that is required to make $R_s = R_1 / (m - 1)$. If R_s and m are held constant, E_s as well as $E_o (= mE_s)$ and $E_p (= N_p E_s)$ will also be constant. If P_m is the rated crystal power, R_m is the maximum series resistance of the crystal unit, and $\frac{R_m}{N}$ is the minimum expected resistance of the crystal unit, then, by equation 1-361 (2), E_s must not be greater than the value*

$$(\max) E_s = \frac{\sqrt{P_m R_m}}{(m - 1) \sqrt{N}} \quad 1-362 (1)$$

Since the Meacham oscillator is most applicable for use in the low-frequency range where crystal units having resistances in the neighborhood one or more thousand ohms are not uncommon, the risk is greatly increased that an exceptionally well-mounted crystal will have a resistance of as little, as, perhaps, $R_m/25$. Also, since the Meacham circuit is primarily useful as a precision oscillator, an additional safety factor should be allowed to prevent the crystal unit from being driven beyond its test specifications. For these reasons, it is suggested that in the absence of prior experience or manufacturer's recommendations for a given type of crystal unit, the Meacham design for frequencies below 200 kc assume a minimum R of $R_m/25$, rather than $R_m/9$ as was assumed in the case of the parallel-resonant oscillator design. However, it can still be assumed that the most probable crystal unit will have an $R = R_m/3$. If the crystal unit to be used is a precision GT cut, a safety factor as large as $N = 25$ need not be made. In any event, crystal units having resistances less than $R_m/9$ can be expected to be extremely rare, and if $N = 9$ is considered a sufficient safety factor, an output voltage two-thirds greater can be realized than if N is assumed to be 25. A crystal unit having a resistance less than $R_m/9$ would be driven beyond its test level, but far below a level that could damage the crystal. Since the resistance is already low, an increase in resistance with overdrive would do more good than harm. The only concern is that the frequency of a borderline crystal may deviate beyond the tolerance limits. Such a risk could be checked during a production test, but would subtract from the reliability of crystal replacements in the field. In equation 1-361 (10), it can be seen that when k is a minimum (when $R_1 = R_m$), the imbalance, as measured by i , is a minimum. When k is large, the percentage changes in $(k + 1)$ and in R_1 are very nearly equal, so that the imbalance tends to vary as the square of R_1 . k should be chosen for maximum frequency stability under variations of C_o , assuming that the crystal unit resistance is its most probable value (approximately $R_m/3$). According to equation 1-359 (5), with all else fixed, the percentage change in frequency is a minimum when $k = 1$. The most probable optimum value of k , therefore, fixes R_s as equal to $R_m/3$. Thus, for any random value of R_1 ,

$$k = R_m/3R_1 \quad 1-362 (2)$$

Section 1
Crystal Oscillators

Next, a value of m equal to $4/3$ (see equation 1-359 (10)) should be chosen, to provide maximum frequency stability on the assumption that equations 1-359 (8) and (9) are to apply when R_1 is its most probable value. After this is done, a safety factor of N should be selected, and the maximum value of E_1 should be determined by equation (1), such that it will not require a bridge voltage sufficient to overdrive the crystal unit when R_1 is equal to R_m/N . Next, a thermistor is chosen that will provide a value of $R_1 = \frac{R_3}{m-1}$ when E_1 is equal to, or less than, the maximum value determined above. Next, the ratio N_p/N_r can be determined, using equation 1-359 (7) with the assumption that $k = 1$ and $m = 4/3$. This gives a ratio $\frac{N_p}{N_r} = \sqrt{15} \approx 4$, which value thus provides the greatest probability that random changes in C_2 and C_1 can cancel when R_1 is its most probable value. The next step is to select a tube with high

class-A g_m and R_p . A 6AC7 would be very satisfactory. Using equation 1-361 (6), determine N_p on the assumption that $Z_p = \frac{R_p}{10}$ when $R_1 = \frac{R_m}{3}$. Now, N_r can be made equal to $N_p/4$. R_2 , of course, must be variable over a percentage range comparable to that to be expected from the crystal unit. Normal tube voltages are used. The other circuit components can be determined according to the tube specifications for class-A operation and the special output requirements of the oscillator. E_{p1} , E_{r1} , E_o , I_{p1} , I_{r1} , etc can be determined from the equations in paragraph 1-361, the frequency stability from equations 1-359 (5) and (6), and the activity stability from equation 1-360 (14) for maximum, most probable, and minimum values of R_1 .

MODIFICATIONS OF MEACHAM BRIDGE DESIGN

1-363. Two designs of the Meacham bridge stabilized oscillator are shown in figure 1-163. In each

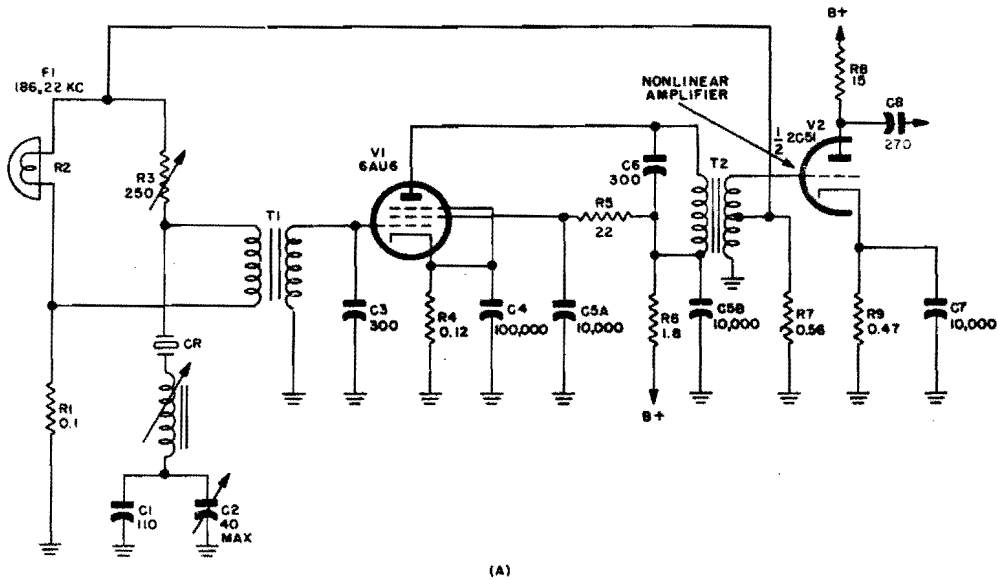

Figure 1-163. Meacham bridge-stabilized oscillators

Fig.	Equipment	Purpose	F ₁	CR	R ₁	R ₂	R ₃	R ₄
(A)	Control-Monitor IP-68/CPN-2A	Timing osc. Controls indicator sweep freq and prr of shoran station	186.22	Oven controlled	0.1	Thermistor	250	0.12
(B)	Radio Set AN/FRC-10	Carrier osc and phase-shift circuit	100	WEC ₀ D-163897 or D-169649	0.1	0.1	0.5	2

Circuit Data for Figure 1-163. F in kc. R in kilohms. C in $\mu\mu\text{f}$. L in μh .

of these circuits inductor-capacitor combination has been connected in series with the crystal unit. Obviously the combination is intended to be resonant at the crystal frequency. The variable arrangement shown in figure 1-163 (A) permits the frequency to be pulled to a more exact value if desired, the crystal unit (if necessary) operating with a reactive component in its impedance. Or, in case the tube operates into a partly reactive load, the tuning elements in the bridge could permit the crystal, itself, to operate at exactly series resonance. The series inductor and capacitor are effective in aiding the initial build up of oscillations and in ensuring that the crystal assumes control at the frequency of the desired mode. It can also be presumed that the LC combination in the bridge improves the waveform somewhat and reduces the small distortion introduced by the tungsten lamp. This distortion is due to the fact that the filament

cools at least to some extent during the time that the current alternates from its effective value in one direction to its effective value in the opposite direction. At frequencies above 100 cycles per second this distortion in the waveform is not serious. At radio frequencies it is normally small compared with the distortion introduced by the tube. The resistance R_1 in figure 1-163 (A) appears to be inserted in order to maintain a constant tube load by minimizing the variations in the bridge impedance due to adjustments and to crystal units having difference resistances. In figure 1-163 (B) note that the crystal unit is grounded. This is the usual arrangement. The parallel primary windings of the grid transformer in the same figure suggest that the arrangement is an adaption of a readily available transformer, very probably of the same construction as the one in the plate circuit. The parallel primary connection is in the direction of phase addition. Because the near-unity coupling between the coils effectively doubles the

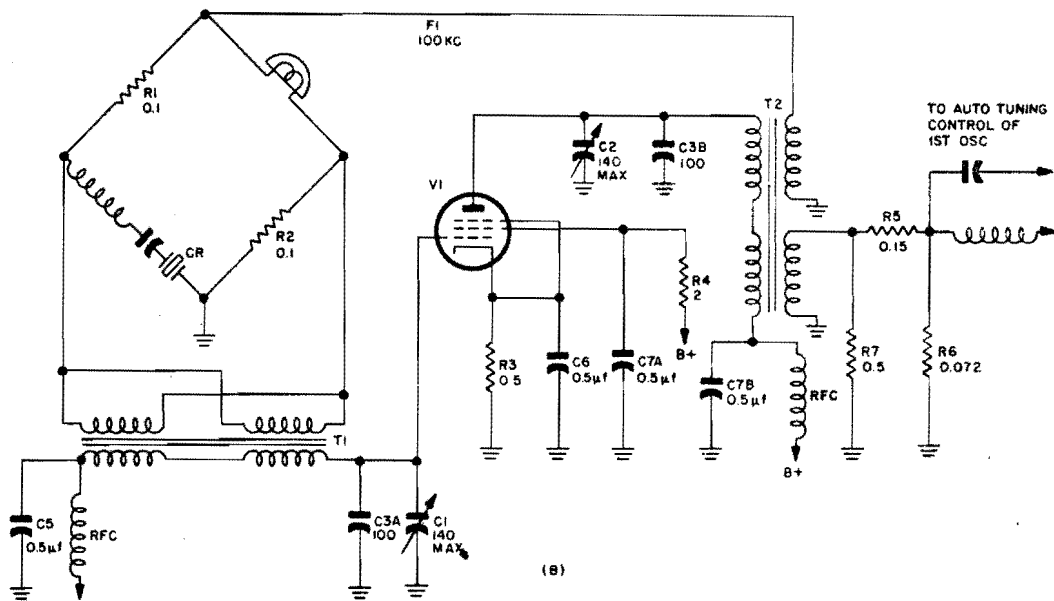

Figure 1-163. Continued

R_5	R_6	R_7	C_1	C_2	C_3	C_4	C_5	C_6	C_7	V_1	V_2
22	1.8	0.56	110	40	300	100,000	10,000	300	10,000	6AU6	$\frac{1}{2}$ 2C51
0.15	0.072	0.5	140	140	100	100	500,000	500,000	500,000	WEC ₀ 337A	

Section I
Crystal Oscillators

inductance of each, the parallel connection provides the same step-up arrangement and primary impedance that would be provided by only one of the coils if used alone, but with a reduction in the leakage inductance. A Meacham bridge-stabilized oscillator can be designed employing two or more tubes. On the average, slightly better frequency stability can be achieved with a two-tube circuit, but only in rare instances are the additional cost, space, and weight requirements worth the small improvement in performance. Perhaps, at frequencies in the neighborhood 1000 kc or higher the two-tube arrangement could be more profitable than the one-tube stage. The design of a multi-stage bridge oscillator can be practically the same as that of the one-stage circuit except that the tube gain, G_{21} , is replaced by $G_{21}G_{22} \dots G_{2n}$, where G_{2k} is the voltage gain of a transformation stage between the output and input of the bridge, and where n is the total number of such transformations. By increasing the number of positive-db stages, the bridge can be made as small as desired, and the frequency and activity stability will be increased in proportion to the gain. It is because the possible gain is unlimited for all practical purposes that the Meacham oscillator represents the ultimate in precision control of the frequency. In the final analysis the limiting condition is the degree to which the crystal parameters, themselves, can be kept constant. Figure 1-164 shows the basic circuit of a two-tube Meacham oscillator that employs no transformers and offers the advantage of only a single tuned stage. Although the design equations are somewhat different from those of the conventional one-tube stage, the same basic approach is to be employed, and the problems to be encountered can be solved similarly to those of the transformer-coupled circuits.

Capacitance-Bridge Oscillators

1-364. Capacitance-bridge oscillators may possibly prove suitable for use in the v-h-f range. Their advantage lies in the fact that a properly balanced capacitance bridge cannot provide sufficient feedback of the proper phase to sustain oscillations at any frequency other than the tuned frequency of the circuit, *provided a crystal unit is connected in the circuit that has a resonant mode of vibration at the tuned frequency*. A properly balanced capacitance-bridge oscillator is thus crystal-controlled, rather than crystal-stabilized. On the other hand, if the bridge is not balanced, the circuit can operate as a free-running oscillator, which may or may not be crystal-stabilized. For the purpose of ensuring operation of crystal units at designated very high harmonic modes, the capacitance bridge, if not the most dependable, is at least as dependable as any other so far tested. The principal disadvantage of this type of circuit is that rather critical tuning adjustments must be made, and one crystal unit cannot replace another unless these adjustments are repeated. Largely on this account the circuit is not to be preferred for frequencies below 50 mc, and perhaps not below 75 mc. Nevertheless, once the bridge is properly adjusted, the operation with a crystal unit free of spurious modes is dependable under any extremes in temperature that can be reasonably expected.

BASIC CIRCUIT OF CAPACITANCE-BRIDGE OSCILLATOR

*1-365. Figure 1-165 illustrates the basic circuit

* The discussion in paragraph 1-365 is based upon the analysis of the basic circuit appearing in the report, *H.F. Harmonic Crystal Investigation*, by S. A. Robinson and F. N. Barry of Philco Corporation, on Army Contract #W33-038 ac-14172, 1947.

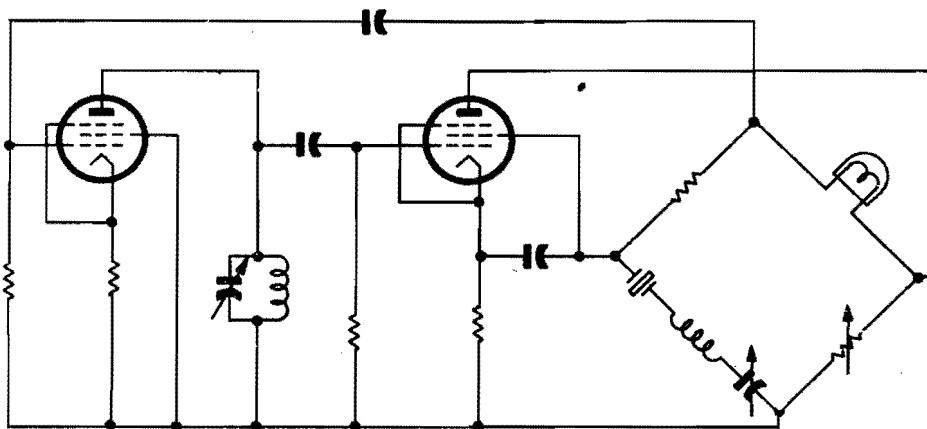

Figure 1-164. Two-stage Meacham bridge-stabilized oscillator

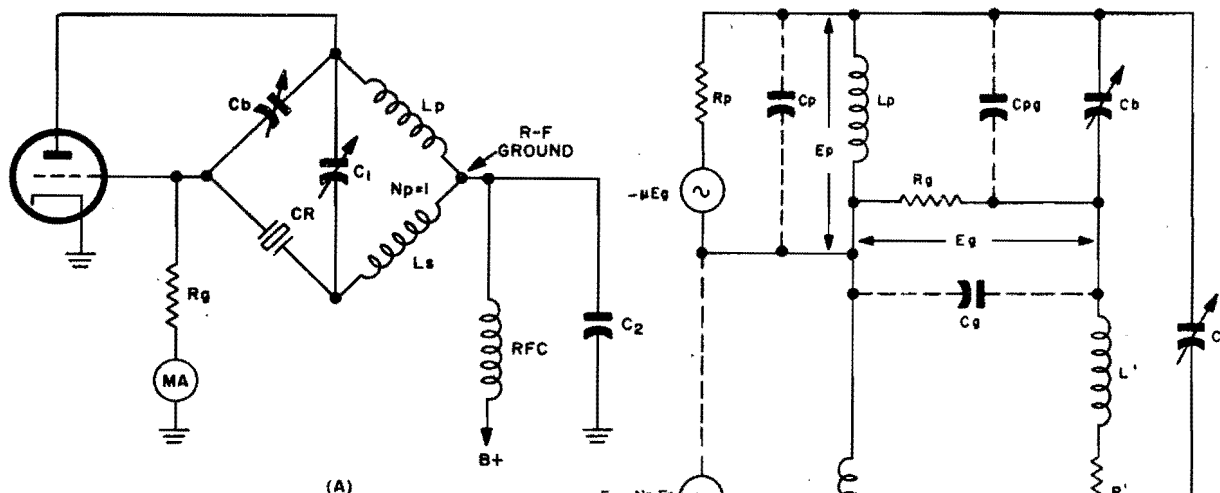

Figure 1-165. (A) Basic circuit of capacitance-bridge oscillator. (B) Equivalent circuit of capacitance-bridge oscillator

of a capacitance-bridge oscillator. The first design consideration in this oscillator, as in all others that are to operate in the v-h-f range, is to keep all the leads as short as possible. Those circuit arrangements and circuit components that provide a minimum of stray inductance and capacitance are to be preferred. In the circuit of figure 1-165 (A), \$L_p\$ and \$L_s\$ are actually a single, tapped inductor with the two sides wound on the same form and tightly coupled together. The induced-voltage effect is equivalent to that of a single generator connected across both coils and driving the bridge with an emf \$(E_p + E_s) \approx E_p(N_p + 1)\$. \$N_p\$, the turns ratio of \$L_p\$ to \$L_s\$, is usually, and most conveniently, equal to 1. In case the shunt capacitance of the crystal unit is greater than \$10 \mu\mu\text{f}\$, it would be desirable to make \$N_p\$ slightly greater than 1. An \$N_p\$ greater than 1 but less than 2 can be expected to provide a higher output, but the operation will tend to be more critical and the frequency less stable. Before the circuit is placed in operation, the bridge must be balanced at an off-resonance frequency, so that no voltage can appear across the grid circuit. At an off-resonance frequency the crystal unit appears as a capacitance \$C_o\$, so that under the conditions of balance

$$\frac{X_{C_b}}{X_{C_o}} = \frac{X_{L_p}}{X_{L_s}} = \frac{C_o}{C_b} = \frac{L_p}{L_s} = N_p^2 \quad 1-365 (1)$$

With \$N_p = 1\$, \$C_b\$ is adjusted to equal \$C_o\$. (\$C_p\$ is here assumed to include \$C_{p0}\$, and \$L_p\$ to account for \$C_p\$. See figure 1-165 (B).) The total capacitance

in the circuit is thus,

$$C_T = C_1 + \frac{C_o}{2} \quad 1-365 (2)$$

Since the distributed inductance of the crystal leads, \$L'\$, tends to increase the effective value of \$C_o\$, the frequency at which the bridge is balanced should not be greatly different from the intended operating frequency. If \$L'\$ is unduly large, a series capacitance should be connected in the crystal arm of the bridge sufficient to annul the stray inductance in the vicinity of the operating frequency. Once the bridge is balanced, \$C_b\$ should not be adjusted again. The initial adjustment is rather critical, requiring an accuracy of a few tenths of a micromicrofarad. \$C_o\$ and \$C_b\$ in the v-h-f range should be as small as possible. The coaxially-mounted crystals, such as those contained in the HC-10/U holder, are to be preferred on this account. Values of \$C_o\$ in the neighborhood of 4 or 5 \$\mu\mu\text{f}\$ are quite feasible. \$C_o\$ can be further reduced by connecting an inductor across the crystal unit to annul part, but not all, of the shunt capacitance; however, this should be avoided, because the presence of the inductor would narrow the frequency

Section I
Crystal Oscillators

range over which the bridge can be considered balanced. C_b must be adjustable over the expected capacitance range of the particular type of crystal unit to be used. C_1 is the tuning capacitance. For crystal-controlled operation, C_1 is adjusted so that the total circuit capacitance C_T is approximately resonant with the total inductance at the operating frequency. To balance the circuit, C_1 is set to a position that tunes the bridge to a frequency well off the resonance frequency of the crystal unit. Referring to figure 1-165 (C), it can be seen that E_g equals $(E_s + E_{CR})$. At the tuned frequency, R can be neglected and the crystal unit considered as a capacitance, C_o . Approximately, E_s and E_{CR} are 180 degrees out of phase, and therefore tend to annul each other. Now, assume that C_b is made to approach zero. I_1 and E_{CR} therefore become negligible, and the circuit behaves as if the crystal side of the bridge were open-circuited at C_b . The remaining circuit would be simply a Hartley oscillator with the crystal unit serving as a blocking capacitor between the inductor and the grid. If C_b is gradually increased, E_{CR} builds up until a point is reached where E_s effectively is canceled and E_g is insufficient to sustain oscillations. C_b should then be increased one more increment beyond the oscillation cutoff. At this setting of C_b , the bridge can be considered properly balanced, but a check should first be made that oscillations do not occur at other settings of C_1 well removed from its value for crystal control. If such oscillations do occur, the adjustment of C_b should be repeated. The free-running oscillations can be distinguished from the crystal-controlled oscillations by the continuous nature of their activity curves as measured by grid current and output meters when C_1 is varied above and below a discontinuous region. A discontinuous point indicates an abrupt

change to crystal control, where the frequency begins to change at a much slower rate with variations in circuit capacitance. However, once the bridge is balanced, no oscillations occur except near the crystal resonance frequency, in which region the bridge balance is upset.

1-366. Referring again to figure 1-165 (C), with the circuit balanced, suppose that C_1 is gradually increased from its minimum value. At some point oscillations suddenly start; as C_1 is further increased, the activity builds up to a maximum and then sharply declines, as is illustrated in figure 1-166. Note also the sharp decrease in frequency when maximum amplitude is approached. Apparently, when oscillations first begin, the crystal appears inductive. E_{CR} therefore has a large component in phase with E_s , and the circuit is essentially a modified Miller oscillator. Also, the ratio of I_1 to I_3 is a maximum, since E_{CR} tends to cancel the voltage across C_b . As C_1 is slowly increased, the frequency and the inductive reactance of the crystal drop. This means that the effective Q of the grid circuit also decreases. Although the presence of the capacitance C_1 modifies the phase relations, the circuit performs fundamentally as a Miller oscillator. L_s can be interpreted as something of a booster inductor to increase the effective inductance of the crystal unit, and I_3 can similarly be viewed as a booster current to boost the voltage across the inductive component in the grid circuit without, at the same time, increasing the voltage across the crystal R_o . That the capacitance-bridge circuit actually has the same characteristics as does the Miller circuit is well illustrated by the similarities between the curves of figure 1-166 and the equivalent curves for the Miller oscillator shown in figure 1-144. Note that for both oscillators, the circuit capacitance for maximum excitation does not coincide with, but is smaller than, the value for maximum output. One significant difference between the two circuits is the fact that the Miller circuit cannot maintain the proper feedback phase if the crystal is operated at series resonance, whereas the capacitance-bridge circuit can, because of the presence of L_s . Where oscillation cutoff for the Miller circuit is above the series-resonance frequency of the crystal, it is below the series-resonance frequency in the capacitance-bridge circuit.

1-367. If the crystal control is to be fully effective, the series-arm resistance must be small compared with the shunt reactance, X_{C_o} . Although this requirement becomes increasingly difficult at the higher harmonics, it can be achieved, even at frequencies well above 100 mc. Assuming that

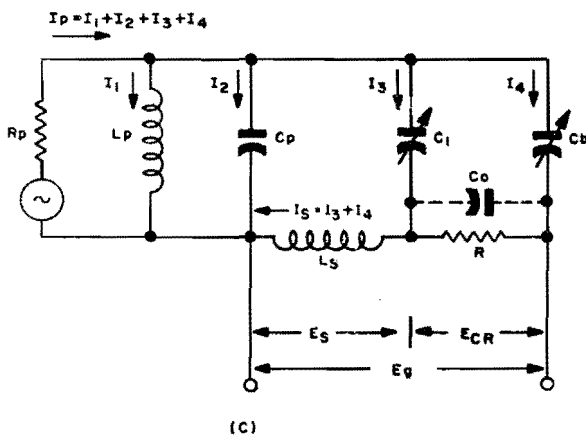

Figure 1-165. (C) Simplified equivalent circuit

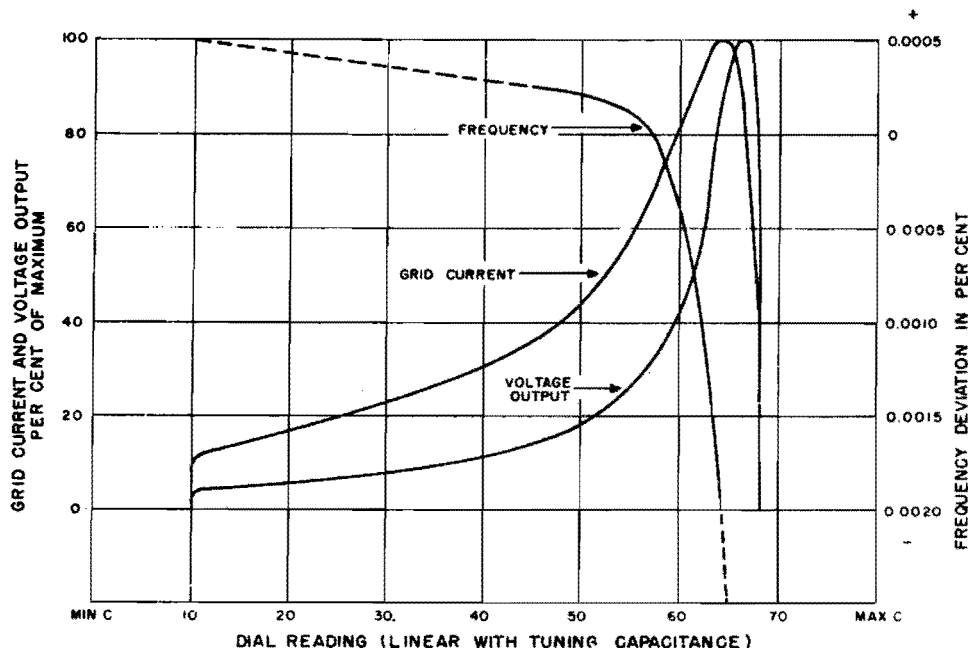

Figure 1-166. Typical performance curves of capacitance-bridge oscillator, showing effects of change in bridge tuning capacitance on voltage output, activity (d-c grid current), and frequency

the series-arm R is not more than one-tenth the magnitude of X_{C_0} , then the approximate equation for the effective crystal reactance, $X_e = X_s X_{C_0} / (X_{C_0} + X_s)$, where $X_s = 4\pi L \Delta f$ series-arm reactance, is sufficiently close for an interpretation of the capacitance-bridge performance. Now, oscillations cannot start unless $|X_{C_b}| > X_e + X_{L_s}$. X_{C_b} we shall assume is equal to X_{C_0} under the conditions of balance. X_e is equal to $|X_{C_b}|$, and hence to $|X_{C_0}|$, when $X_s = -X_{C_0}/2$, that is, when the crystal unit is halfway between series resonance and antiresonance. Thus, when oscillations start, the crystal frequency must be much nearer to the resonant than to the antiresonant state. Also, the plate circuit must appear inductive to the vacuum tube to a degree dependent upon the effective Q of the grid circuit. This means that I_1 must be slightly greater than $(I_2 + I_3 + I_4)$. In figure 1-165 (A), it can be seen that the crystal unit operates into a load reactance approximately equal to the parallel combination of C_1 and the inductor ($L_p + L_s$) in series with C_b . As the reactance of C_1 approaches that of the inductor, the reactance of the parallel combination rises very sharply, and a small change in C_1 can make a large change in the load reactance across the crystal unit. More than any other factor, this is the reason for the sharp dip in the frequency curve as C_1 approaches a maximum. 1-368. It is not possible to tell at which point in

the curve the crystal passes through series resonance. Since at series resonance the reactance of C_1 in parallel with L_p and L_s is equal, approximately, to $-X_{C_b}$, the resonance frequency may well be below the knee of the curve for a crystal having a very small C_0 (conditions for large X_{C_b} and near-parallel resonance of C_1 with the inductor) and above the knee for crystals of larger C_0 . At series resonance, if R is small I_4 approximately equals $I_3 C_b / C_1$. Assuming that $E_s (= I_4 X_{L_s})$ leads $E_{CR} (= I_4 R)$ by 90 degrees, the effective Q of the grid circuit at series resonance is equal to E_s / E_{CR} . When E_s and E_{CR} are expressed as functions of I_s , C_b , C_1 , and X_{L_s} , it can be shown that (series resonance) $Q_g = \frac{E_s}{E_{CR}} = \frac{X_{L_s}(C_1 + C_b)}{RC_b}$. The above equation is only a broad approximation in the v-h-f range, since all the distributed parameters have been ignored, particularly the grid capacitance and the resistance of the inductor. However, it does indicate that the larger the ratio of C_1 to C_b , or, equivalently, X_{C_0} / X_{C_1} , the smaller the inductive phase shift that will be required in E_p , and the more nearly will the bridge tank approach parallel resonance. If R , or rather the total grid losses, should increase or decrease, the frequency will decrease or increase, respectively. It seems safe to assume that crystal units having the larger values of RC_0 products will operate fairly near their

Section I Crystal Oscillators

series-resonant state. This is due partly to the fact that the smaller the X_{C_0}/R ratio, the smaller the frequency range between resonance and antiresonance. Crystal units having the smaller values of RC_0 will perform with greater amplitude and frequency stability if operated above series resonance. Unfortunately, crystal units in the v-h-f range are tested only for series resonance. The greater likelihood of the occurrence of unwanted modes increases the importance of having the circuit designed so that the operation of the crystal unit lies within its tested specifications. While the capacitance bridge is excellent for preventing all modes of oscillation except the one desired, it is not a true series-mode oscillator, although it is so classified because its v-h-f application requires the use of crystals that are only series-tested. Rather, the oscillator is something of a hybrid between a Miller and a stabilized Hartley circuit. In the interest of frequency and amplitude stability, the circuit should be adjusted to operate above the knee of the frequency curve. A setting of the tuning capacitance corresponding to a grid current of 50 per cent of the maximum possible provides, approximately, the optimum output voltage and operating state nearest series resonance that are consistent with the operating region of better stability. The peak of the voltage-output curve in figure 1-166 corresponds closely to the adjustment for maximum tank impedance, which certainly occurs below series resonance where the crystal unit appears as a capacitance. The larger the capacitive reactance that the crystal unit can have and still permit oscillations, the more nearly can series-resonance oscillations fall within the higher stability region. For this purpose, the ratio of L_n to L_p and of C_b to C_0 should be as large as unity, or greater, when the capacitance-bridge oscillator is to be used with series-tested crystal units.

DESIGN MODELS FOR CAPACITANCE-BRIDGE OSCILLATORS

1-369. The circuits shown in figures 1-167 through 1-171 represent five different modifications of the capacitance-bridge oscillator. These circuits were designed and tested by the research team of S. A. Robinson and F. N. Barry of Philco Corporation. No single type of circuit was found to be superior for operation over the entire tested frequency range of 50 to 200 mc, but each circuit has advantages for certain applications. The inductive arms of the bridge can be a single, self-supporting tapped inductor having an inside diameter of one-quarter inch or greater. Silver-plated AWG No. 16

wire can be used. The tuning and balancing capacitances are small air capacitors. The fixed capacitances are, for the most part, the button-mica Erie type. Composition resistances are used, having nominal values of ± 10 per cent. Successful operation of any of the circuits depends largely upon arranging the circuit components to permit the shortest possible leads, and all components should be of small physical size. Silver-plating of the components is desirable, and careful shielding and the use of low-loss insulating materials is necessary. Without good shielding and well-insulated capacitor shafts, it may be impossible to adjust the bridge properly because of the effects of hand capacitance. Transit-time effects become quite significant as the frequency is increased beyond 50 mc. The lag in the response of the plate current with rapid changes in the grid voltages is equivalent to the circuit behavior that would result if an inductance were connected in series with R_p of the tube. The lower the plate voltage, the larger is the apparent inductance and its accompanying tendency to lower the frequency. Usually, this effect makes it easier to operate the crystal unit at series resonance, but the need for careful B^+ regulation becomes all the more important. For normal voltages, transit lag is approximately 0.2 degree per megacycle in v-h-f tubes such as the 6AK5.

SINGLE-TUBE, 50- TO 90-MC CAPACITANCE-BRIDGE OSCILLATOR

1-370. The circuit shown in figure 1-167 has been operated at frequencies as high as 135 mc, but its particular merit lies in its performance at frequencies between 50 and 90 mc. When operated in the high-stability region, output up to 10 volts can be obtained, although care should be taken that the rated drive level of the crystal is not exceeded. Outputs of 2 milliwatts into an inductively coupled 100-ohm resistor can be obtained in the same operating region.

COMPACT, MINIATURE, 50- TO 120-MC CAPACITANCE-BRIDGE OSCILLATOR

1-371. The circuit shown in figure 1-168 is particularly suited for construction as a small, packaged, plug-in oscillator. If desired, several such oscillators of different frequencies can be designed as interchangeable units of the associated equipment. The entire shielded unit need not occupy a space greater than 6 cubic inches. The maximum frequency at which this circuit was found to oscillate was 156 mc, but the activity at that frequency was less than one-tenth that at 50 mc. At 120 mc the activity is approximately one-fourth of that at

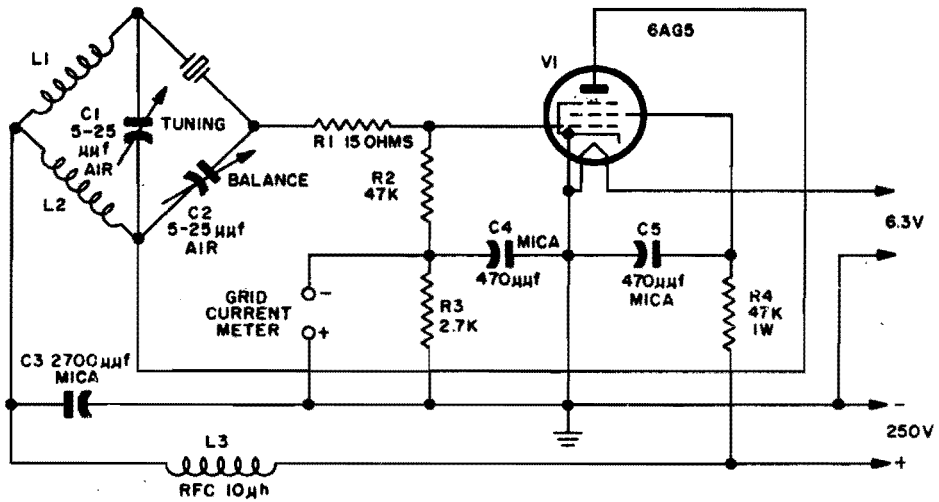

Figure 1-167. A single-tube capacitance-bridge oscillator which is practical for operation in the 50-90-mc frequency range. Resistors not otherwise specified are $\frac{1}{2}$ w. L-1 and L-2 are a single center-tapped coil of suitable inductance

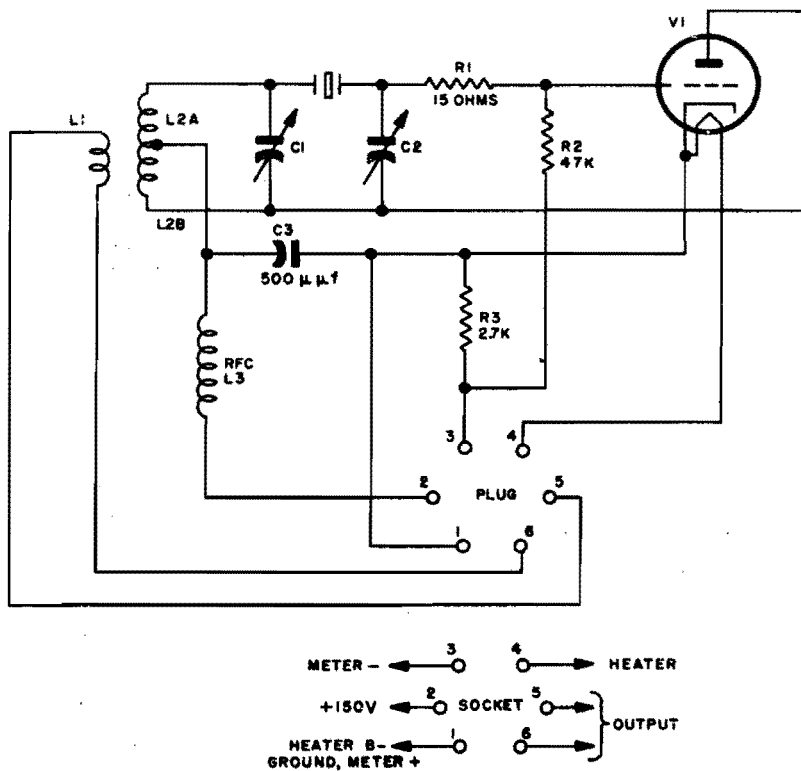

Figure 1-168. A plug-in capacitance-bridge oscillator which is practical for 50-150-mc frequency range

Section I Crystal Oscillators

50 mc, so 120 mc appears to be the most practical upper frequency limit. A subminiature tube having high transconductance is used. Greater output is to be achieved with a triode, but greater frequency stability is to be had with a pentode. With a triode, the comparatively large plate-to-grid capacitance which shunts the balancing condenser may make it difficult to achieve a balancing capacitance as small as that of the crystal unit. This condition requires that the L-2A section of the bridge inductor be somewhat larger than the L-2B section. The possible output is reduced thereby, but the crystal unit will be operated nearer its series-resonance frequency. The output secondary, L_1 , can be a single turn coupled to the plate end of L_2 .

CAPACITANCE-BRIDGE OSCILLATOR FOR GREATER POWER OUTPUT IN THE 50- TO 80-MC RANGE

1-372. The circuit shown in figure 1-169 was designed for the purpose of achieving a maximum power output without regard to the rated drive level of the crystal unit. However, none of the crystals used were fractured during the experiments. The higher-power circuit is essentially the same as that of figure 1-167 except that the N_1 ratio of the bridge inductor is greater, higher voltages are used, and a 6AG7 replaces the 6AG5 tube. Although the 6AG7 has a higher transconductance and power rating than the 6AG5, the interelectrode capacitances are greater, the internal leads are longer, and the base is constructed of higher-loss material. The circuit operated at frequencies as high as 102 mc, but above 80 mc the disadvantages introduced by the vacuum-tube construction make the circuit impractical. Better performance might be expected with a 6AH6. With the tube operated near its maximum rated dissipation, a one-watt inductively coupled output was obtained at 54 mc, and one-third watt at 80 mc. These outputs are representative of the peak obtainable. Much less power is to be had if the oscillator is adjusted for operation in the higher-stability region.

TWO-TUBE, 50- TO 100-MC CAPACITANCE-BRIDGE OSCILLATOR

1-373. The circuit shown in figure 1-170 is similar in operation to the one-tube circuit except that the feedback has an additional amplifier stage to boost the gain. There is a significant difference in that the crystal unit is connected to the plate side of the bridge. Under this arrangement, the excitation voltage of V_1 lags the r-f plate voltage of V_2 , which means that if the plate load is resistive the

r-f plate voltage of V_1 would tend to lag the required excitation voltage of V_2 . For oscillations to occur, the plate tuning tank of V_1 must appear inductive in order to shift the input of V_2 to the proper phase. After equilibrium is reached, a slight increase in the value of C_1 causes the plate impedance of V_1 to become more nearly resistive, and therefore the input of V_2 becomes more nearly 180 degrees out of phase with the input of V_1 . This requires that the frequency drop to a point where the voltage across C_2 is more nearly in phase with the r-f plate voltage for V_2 . For both tubes to operate into resistive loads, the crystal unit must appear as a capacitance. For the crystal unit to operate near series resonance and at the same time maintain the oscillations in the higher-stability region, it would seem that R_1 , the parasitic damping resistor in the input circuit of V_2 can be replaced, if necessary, by a resistance comparable in value to the V_2 input reactance. The effect will be to shift the V_2 input phase in a lagging direction, which would require the V_1 tank to be more detuned, and hence less critically adjusted. This, in turn, will require a comparable shift in the phase of the input to V_1 , which is to be had by a decrease in frequency, thereby permitting the bridge to be less critically tuned in the vicinity of the crystal resonance point. The circuit in figure 1-170 was found quite practical for use as a test oscillator for measuring the relative performance characteristics of harmonic-mode crystal units. During the temperature runs, even though frost had collected on various components, the operation of the circuit was little affected. For duplicate units of this circuit to provide essentially the same meter readings for tests of the same crystal unit, it is necessary that the vacuum tubes used in the twin circuits show the same plate characteristics within ± 5 per cent. A breadboard model of the oscillator having different values of tuning inductances was able to operate at 140 mc. L_1 , in figure 1-170, is a 5-turn coil, approximately one-quarter inch in diameter; L_2 and L_3 are the two halves of a 4-turn, center-tapped coil, approximately one-half inch in diameter.

MULTITUBE CAPACITANCE-BRIDGE OSCILLATOR OPERABLE AT FREQUENCIES UP TO AND ABOVE 200 MC

1-374. The circuit shown in figure 1-171 has been used to generate crystal-controlled frequencies as high as 219 mc, the seventy-third harmonic of a 3-mc crystal. This frequency approaches the ultimate directly obtainable with quartz crystals at the present state of the art. A large part of the

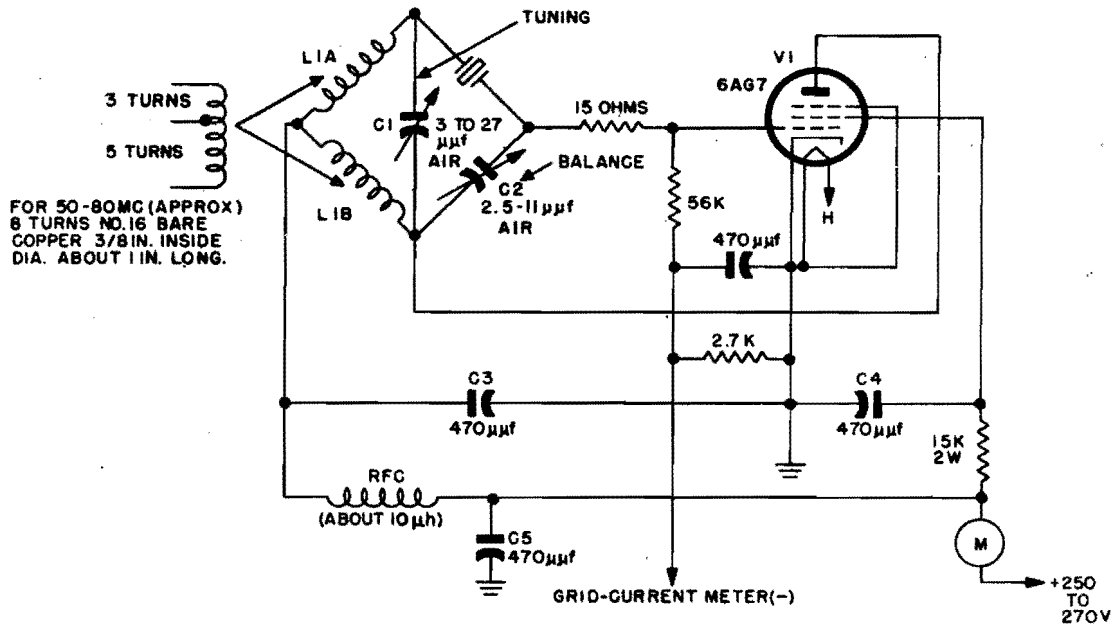

Figure 1-169. A capacitance-bridge oscillator for higher power output which is practical for operation in the 50-80-mc frequency range. Resistors not otherwise specified are 1/2 w. All fixed capacitors have mica dielectrics

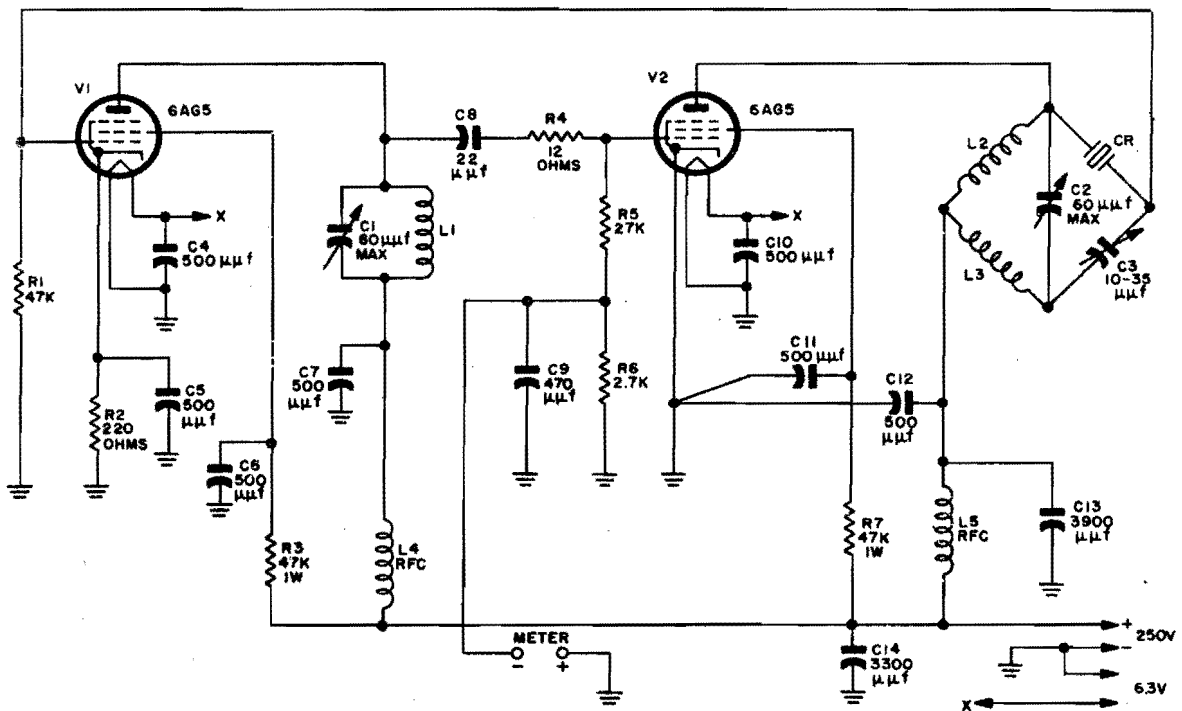

Figure 1-170. A two-tube capacitance-bridge oscillator which is practical for operation in the 50-100-mc frequency range

Section I
Crystal Oscillators

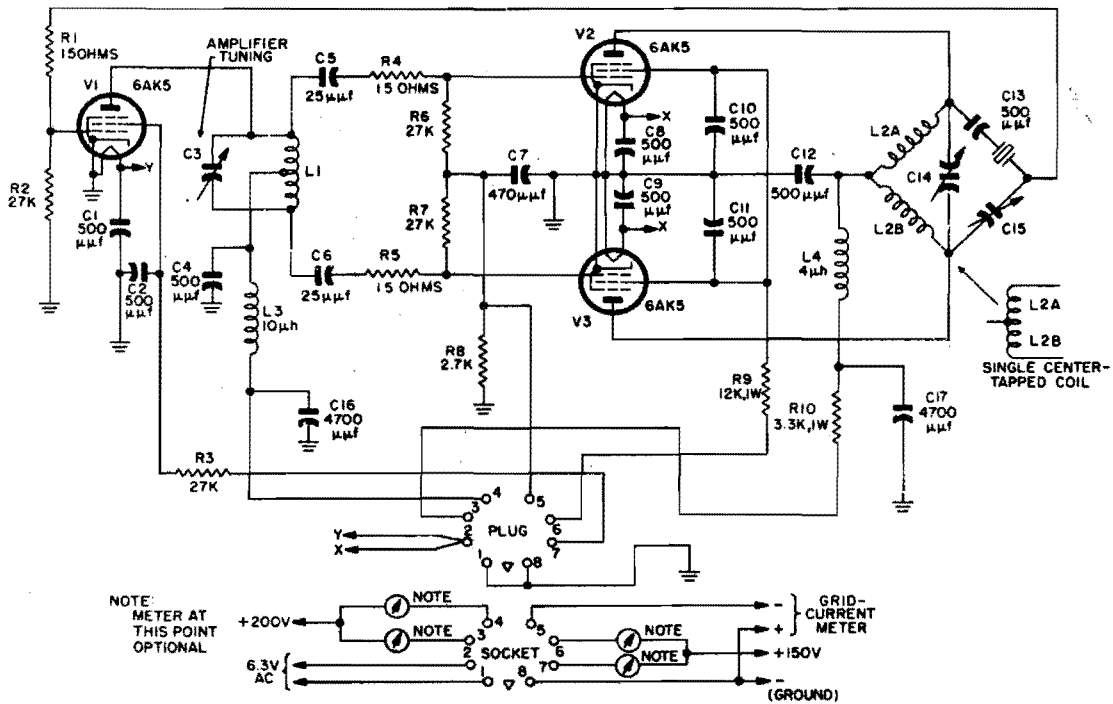

Figure 1-171. A multitube capacitance-bridge oscillator which is practical for operation in the 50–200-mc range. Resistors not otherwise specified are rated at ½ w

success of the oscillator in figure 1-171 is due to the balanced electrical and mechanical nature of the push-pull capacitance-bridge circuit. The operation is very much the same as that of the circuit in figure 1-170 except that the bridge stage is operated in push-pull. With different values of inductance, the circuit provides reliable frequency control anywhere in the v-h-f range, from 200 mc on down. Probably its most practical application is as a harmonic test oscillator. The upper frequency obtainable is not limited by the circuit itself, but by the resistances and shunt capacitances of the crystal units.

OTHER MODIFICATIONS OF THE CAPACITANCE-BRIDGE OSCILLATOR

1-375. A number of capacitance-bridge modifications have been successfully attempted, four of which are illustrated in figure 1-172. The circuits are largely self-explanatory, and will not be discussed here. Probably of most importance is the electron-coupled circuit, since it permits frequency multiplication in the plate circuit. The triode connection of the crystal circuit probably prevents the crystal, itself, from being operated at frequencies above 75 mc.

The Butler Oscillator

1-376. At the present time, probably the most widely used of the series-mode oscillators is the Butler, cathode-coupled, two-stage oscillator. The basic design and equivalent circuits are shown in figure 1-173. Although the single-tube, transformer-coupled type of oscillator will probably outrank the two-tube circuit eventually, the Butler oscillator is the more popular at present because of its simplicity, versatility, frequency stability, and, of most importance, its comparative reliability. With the older types of crystal units, it was generally found that the Butler circuit was the least critical to design and to adjust for operation of the crystal at a given harmonic. The balanced arrangement of the circuit and the fact that twin triodes can be obtained in a single envelope contribute a saving in space and cost, and permit the use of short leads. For greater frequency stability than is normally to be had from parallel-mode oscillations, the cathode-coupled circuit can be used quite satisfactorily at any of the lower frequencies provided the resistance of the crystal unit is not greater than a few hundred ohms. However, the power output is small by comparison

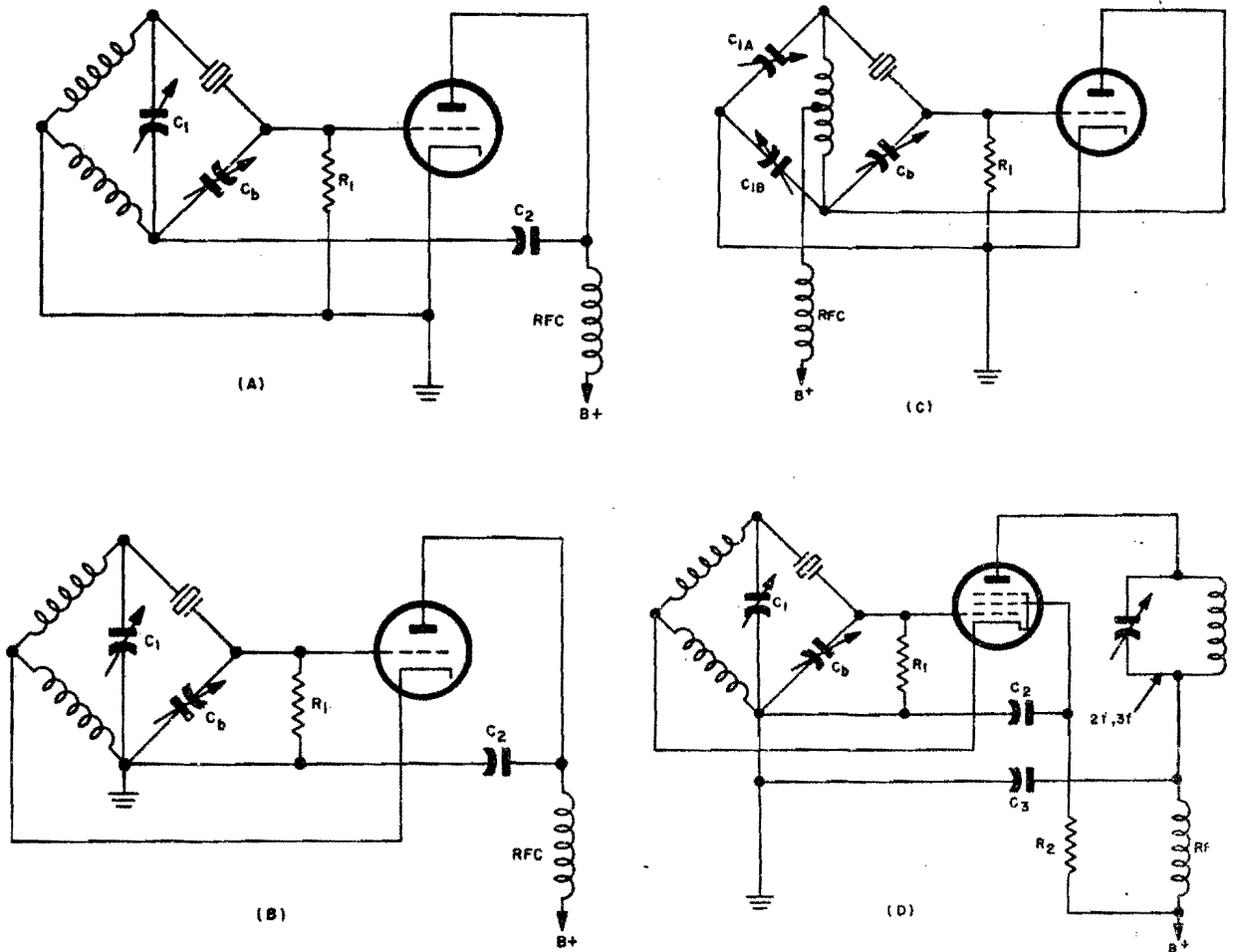
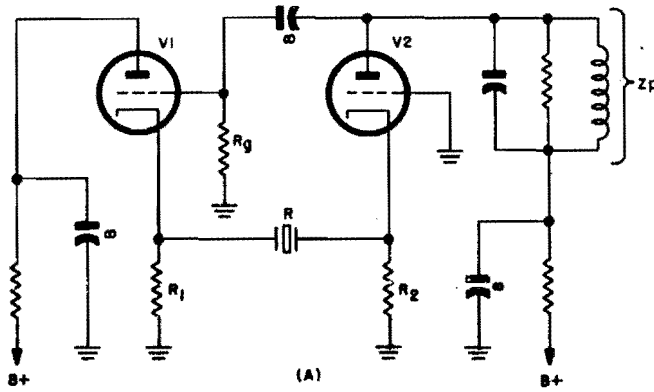

Figure 1-172. Miscellaneous capacitance-bridge oscillators

with that of the Miller circuit for the same crystal power, and the broad bandwidth without plate tuning of the Pierce circuit is not matched. The Butler circuit is usually designed for class-A operation, but class C is possible if greater output and plate efficiency are desired. The output may be taken from almost any part of the circuit—the plate or cathode of either tube. Quite often the cathode follower, V_1 , in figure 1-173, is a pentode, with the screen, control grid, and cathode forming a triode section electron-coupled to a plate circuit that usually is tuned for frequency multiplication, although the electron coupling can be employed simply to obtain greater output amplitude and to isolate the load from the oscillator circuit. At very high frequencies, where the shunt reactance of the crystal unit approaches the magnitude of the series-arm R , the operation is generally improved by shunting the crystal unit with an inductor that

is antiresonant with the shunt capacitance of the crystal at the operating frequency. When properly designed and adjusted, the two tubes operate 180 degrees out of phase into resistive loads, and the crystal unit acts as a pure resistance.

1-377. In figure 1-173, V_1 is connected as a grounded-plate cathode follower. The V_1 output current, I_c , enters the feed-back path through the crystal unit, which is operating at series resonance. The impedance of the crystal unit is thus approximately equal to the equivalent series-arm resistance, V_2 , a grounded-grid amplifier connected in the feed-back circuit, is excited by I_2 , the component of I_c that passes through R_2 . I_{p2} , the remaining component of the feed-back current passes through V_2 . It can be seen that the input voltage of V_1 , E_{k1} , is equal to the output voltage of V_2 if we assume that the coupling capacitance is infinite. The plate circuit of V_2 is broadly tuned to the de-



(A)
↓
EQUALS
+ E_{g1} -

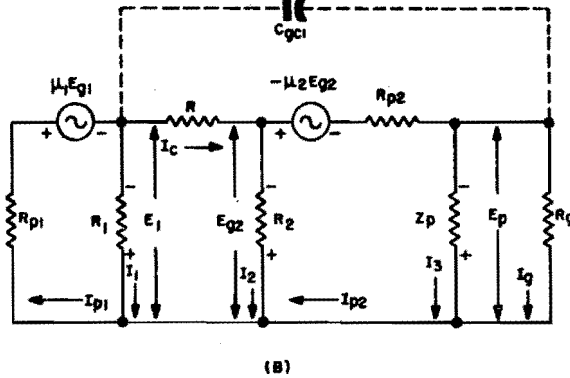

(B)

NOTE:

$$(1) Z_L = \frac{Z_p R_g}{Z_p + R_g}$$

$$(2) \rho = -\frac{\mu_2 E_{g2}}{I_{p2}} = -\frac{\mu_2 (R_{p2} + Z_L)}{\mu_2 + 1}$$

$$(3) Z_1 = \frac{R_{p1}}{\mu_1 + 1}$$

$$(4) Z_2 = \frac{R_{p2} + Z_L}{\mu_2 + 1}$$

$$(5) E_{g1} = E_p - E_1$$

$$(6) Z_{g2} = \frac{R_2 Z_2}{R_2 + Z_2}$$

$$(7) Z_f = R + Z_{g2}$$

$$(8) Z_k = \frac{R_1 Z_f}{R_1 + Z_f}$$

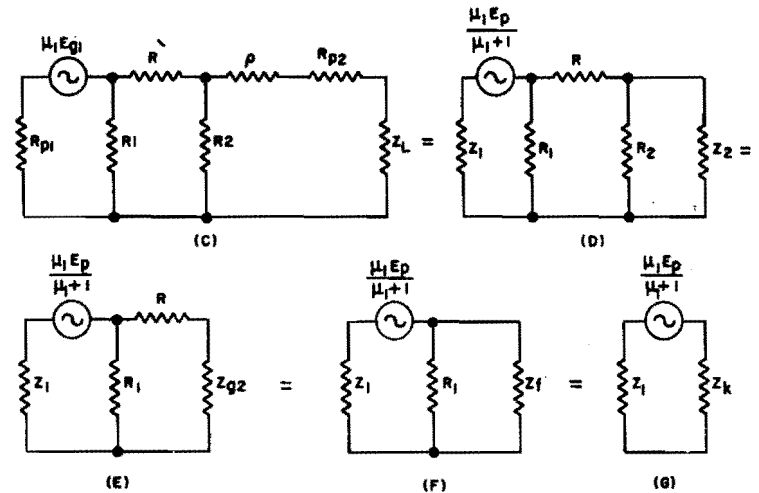

Figure 1-173. (A) Basic diagram of Butler two-stage cathode-coupled oscillator. (B) Equivalent r-f circuit of Butler oscillator. Current arrows indicate instantaneous electron flow when r-f voltages have polarities shown. (C) Simplified equivalent circuit where generator of grounded-grid amplifier is replaced by a negative resistance. (D), (E), (F), and (G) Progressive simplifications of equivalent Butler circuit

sired frequency. If Z_p were simply a resistance, the circuit could still oscillate at the first crystal harmonic. If the crystal unit were shorted out, the circuit could also oscillate, but with the frequency controlled by the tuned plate circuit. R_1 and R_2 are usually equal, having values between 50 and 200 ohms. V_1 and V_2 are also usually of the same tube type. As will be seen, frequency stability is improved with large values of transconductance. Note in figure 1-173(B) that the r-f plate current in V_1 is greater than that in V_2 . As in all other vacuum-tube oscillators, there are two fundamental equilibrium conditions to consider: the over-all gain must equal unity, and the over-all phase shift must equal zero. We shall first consider the factors affecting loop-gain.

LOOP GAIN OF BUTLER CIRCUIT

1-378. At equilibrium we can say that

$$1 = \frac{E_1}{E_p} \cdot \frac{E_{g2}}{E_1} \cdot \frac{E_p}{E_{g2}} = G_1 G_2 G_3 \text{ (respectively)} \quad 1-378 (1)$$

The immediate problem is to find the values of G_k in terms of the circuit parameters. First, referring to figure 1-173 (ignore the capacitance C_{gc1} in circuit (B)), assume that the voltage across R_g is approximately equal to E_p , then

$$E_{g1} = E_p - E_1 \quad 1-378 (2)$$

$$E_1 = I_{p1} Z_k \quad 1-378 (3)$$

and

$$\begin{aligned} I_{p1} &= \frac{\mu_1 E_{g1}}{R_{p1} + Z_k} = \frac{\mu_1 E_p - \mu_1 I_{p1} Z_k}{R_{p1} + Z_k} \\ &= \frac{\mu_1 E_p}{R_{p1} + Z_k (\mu_1 + 1)} \end{aligned} \quad 1-378 (4)$$

On combining equations (3) and (4)

$$E_1 = \frac{\mu_1 E_p Z_k}{R_{p1} + Z_k (\mu_1 + 1)} \quad 1-378 (5)$$

and

$$G_1 = E_1/E_p = \frac{\mu_1 Z_k}{R_{p1} + Z_k (\mu_1 + 1)} = \frac{g_{m1} Z_k}{1 + g_{m1} Z_k} \quad 1-378 (6)$$

The approximation in equation (6) is made on the assumption that $(\mu_1 + 1) \approx \mu_1$. If the numerator and denominator of equation (4) are divided by $(\mu_1 + 1)$, we have

$$I_{p1} = \frac{\frac{\mu_1}{\mu_1 + 1} E_p}{\frac{R_{p1}}{\mu_1 + 1} + Z_k}$$

Note that with Z_k fixed by the external circuit, the plate current is related to the excitation voltage, E_p , in such a way that the tube behaves as if it had an effective amplification factor of $\frac{\mu_1}{\mu_1 + 1}$ and an effective plate resistance equal to $\frac{R_{p1}}{\mu_1 + 1}$. This resistance is given the symbol Z_1 in figure 1-173. If an additional resistance, R_L , were connected between the plate of V_1 and r-f ground, Z_1 would equal $\frac{R_L + R_{p1}}{\mu_1 + 1}$. Now, to find the value of $G_2 = E_{g2}/E_1$, we start with

$$E_{g2} = I_2 R_2 \quad 1-378 (7)$$

$$E_1 = I_c R - \mu_2 E_{g2} + I_{p2} R_{p2} + I_{p2} Z_L \quad 1-378 (8)$$

$$I_c = I_2 + I_{p2} \quad 1-378 (9)$$

and

$$I_{p2} = \frac{E_{g2} + \mu_2 E_{g2}}{R_{p2} + Z_L} = \frac{(\mu_2 + 1) E_{g2}}{R_{p2} + Z_L} \quad 1-378 (10)$$

On rearranging equation (10) to express E_{g2} as a function of I_{p2} , and substituting this function for E_{g2} in equation (8), we have

$$E_1 = I_c R + I_{p2} \left[-\frac{\mu_2 (R_{p2} + Z_L)}{\mu_2 + 1} + R_{p2} + Z_L \right] \quad 1-378 (11)$$

From equation (11) we find that the equivalent generator of V_2 can be represented by an equivalent negative resistance

$$\rho = \frac{-\mu_2 (R_{p2} + Z_L)}{\mu_2 + 1} \quad 1-378 (12)$$

It can be seen that ρ is smaller in magnitude than $(R_{p2} + Z_L)$, so that the total V_2 branch resistance is positive. Defining the V_2 branch impedance to be Z_2 , we have

$$Z_2 = \rho + R_{p2} + Z_L = \frac{R_{p2} + Z_L}{\mu_2 + 1} \quad 1-378 (13)$$

Section I
Crystal Oscillators

On substituting equations (7) and (13) into equation (10), we have

$$I_{p2} = \frac{R_2 I_2}{Z_2} \quad 1-378 (14)$$

so that equation (9) may be written

$$I_c = \left(\frac{Z_2 + R_2}{Z_2} \right) I_2 \quad 1-378 (15)$$

On substituting equations (13), (14), and (15) into (11),

$$\begin{aligned} E_1 &= \frac{I_2 R (Z_2 + R_2)}{Z_2} + \frac{I_2 R_2 Z_2}{Z_2} \\ &= I_2 \left[\frac{R (Z_2 + R_2) + R_2 Z_2}{Z_2} \right] \end{aligned} \quad 1-378 (16)$$

Thus

$$G_2 = \frac{E_{g2}}{E_1} = \frac{R_2 Z_2}{R (Z_2 + R_2) + R_2 Z_2} \quad 1-378 (17)$$

To find $G_3 (= E_p/E_{g2})$, we see that

$$E_p = I_{p2} Z_L \quad 1-378 (18)$$

which, on substituting the value of I_{p2} given in equation (14), becomes

$$E_p = \frac{I_2 R_2 Z_L}{Z_2} \quad 1-378 (19)$$

Dividing by $E_{g2} (= I_2 R_2)$, we have

$$G_3 = \frac{E_p}{E_{g2}} = \frac{Z_L}{Z_2} \quad 1-378 (20)$$

The conditions for equilibrium as expressed by equation (1) are thus found to be

$$\begin{aligned} G_1 G_2 G_3 &= \\ &= \frac{\mu_1 Z_k R_2 Z_L}{[R_{p1} + Z_k (\mu_1 + 1)] [(Z_2 + R_2) R + R_2 Z_2]} = 1 \end{aligned} \quad 1-378 (21)$$

By a slightly different approach, in which the equilibrium is expressed as

$$G_1' G_1'' G_2 G_3 = \frac{E_{g1}}{E_p} \cdot \frac{E_1}{E_{g1}} \cdot \frac{E_{g2}}{E_1} \cdot \frac{E_p}{E_{g2}} = 1$$

where

$$G_1' = \frac{E_{g1}}{E_p} = \frac{R_2 Z_L - (Z_2 + R_2) R - R_2 Z_2}{R_2 Z_L} \quad 1-378 (22)$$

and

$$G_1'' = \frac{E_1}{E_{g1}} = \frac{\mu_1 Z_k}{R_{p1} + Z_k} \quad 1-378 (23)$$

it will be found that

$$\begin{aligned} G_1' G_1'' G_2 G_3 &= G_1 G_2 G_3 = \\ &= \left[\frac{R_2 Z_L}{(Z_2 + R_2) R + R_2 Z_2} - 1 \right] \frac{\mu_1 Z_k}{R_{p1} + Z_k} = 1 \end{aligned} \quad 1-378 (24)$$

Since R_{p1} and $R_2 Z_L$ are very large compared with Z_k and $[(Z_2 + R_2) R + R_2 Z_2]$, respectively, we can simplify equations (21) and (24) by writing

$$\frac{R_2 Z_L Z_k g_{m1}}{(Z_2 + R_2) R + R_2 Z_2} \approx 1 \quad 1-378 (25)$$

On dividing both numerator and denominator by $(Z_2 + R_2)$ and substituting for the values of Z_{g2} and Z_t as defined in equations (6) and (7) of figure 1-173, equation (25) can be simplified somewhat. Thus

$$\frac{Z_{g2} Z_L Z_k g_{m1}}{Z_2 Z_t} = 1 \quad 1-378 (26)$$

1-379. The design of a Butler oscillator must be such that under no-signal conditions the left side of equation 1-378(26) is greater than unity. As oscillations build up, the principal effects will be a decrease in the effective g_{m1} and g_{m2} as the signal swings farther into the lower bend of the $E_c I_b$ curve. How large the equilibrium amplitude will be depends upon how much greater than unity the left side of equation 1-378(26) is at the start. The larger the left-side magnitude, the greater must be the decrease in g_{m1} , and hence the greater the equilibrium activity must be. If the oscillator is to operate class A, as is usual, the gain equilibrium should very nearly hold for no-signal conditions, with due allowance made for a maximum $Z_t (= R + Z_{g2})$ when $R = R_m$, the maximum series resistance permissible for the particular type of crystal unit chosen. With all else constant, maximum activity is to be obtained when g_{m1} and g_{m2} are maximum under no-signal conditions. Assurance that the crystal unit will not be driven beyond its rated power can be approximately predicted from the plate characteristics of the tube to be used. If no grid current is drawn, the bias on V_1 will be

$$E_{c1} = - I_{b1} R_1 \quad 1-379 (1)$$

where I_{b1} is the average d-c plate current of

V_1 . Grid current can be drawn if $[(\max)E_p - (\max)E_1]$ is greater than $I_{b1}R_1$, in which case the bias will be

$$E_{c1} = (\max) E_1 - (\max) E_p \quad 1-379 (2)$$

Greater amplitude stability is achieved if R_1 is sufficiently small for equation (2) to apply. Using the appropriate equations in paragraph 1-378, a maximum value of E_1 can be determined that will not allow the crystal current, I_c , to become greater than $\sqrt{P_{cm}/R}$, where P_{cm} is the maximum recommended power level of the crystal, and R is any crystal resistance between R_m and $R_m/9$. Very possibly, a twin triode may be preferred, or perhaps the choice of tubes will be dictated by the h-f type of tube most readily available. R_1 and R_2 are to be kept as small as possible in the interest of frequency stability. In the final analysis, the plate voltage permitting an optimum output for the average crystal unit, without risking an overdrive for any expected value of crystal R , is most easily checked by experiment.

DESIGN CONSIDERATIONS TO MAXIMIZE THE FREQUENCY STABILITY OF THE BUTLER OSCILLATOR

1-380. If the cathode follower operates into a purely resistive network, as is indicated in the equivalent circuit of figure 1-173(B), maximum stability in the phase characteristics is obtained. As nearly a resistive circuit as possible is desirable, for under these conditions the frequency is independent of the plate resistance of the tubes, and a small increment of reactance requires the least adjustment of the crystal to restore a phase equilibrium. E_1 , the output voltage of the cathode follower, is in phase with the excitation voltage, E_p . In a resistive circuit, E_p will be 180 degrees out of phase with E_{g2} . Thus, E_{g2} must be 180 degrees out of phase with E_1 . Since E_{g2} is the voltage of ground with reference to the cathode of V_2 , and E_1 is the voltage of the cathode of V_1 with reference to ground, I_1 and I_2 must be in phase. For example, imagine that R is zero, then R_1 and R_2 could be assumed to be two halves of a single resistance. In this case E_{g2} would equal $-E_1$, and the proper phase relation would exist.

1-381. To maintain as nearly as possible a resistive circuit, Z_p must tune as broadly as is practicable; the tendency of the input capacitances of V_1 and V_2 to shift the phase must be compensated; the transit time of the vacuum tubes must be minimized; and, if an inductor is connected across the crystal unit to antiresonate with the shunt capaci-

tance, C_o , the resulting parallel-resonant circuit must also tune very broadly. The tuned plate circuit, Z_p , must be sufficiently selective to ensure that the circuit can oscillate only at the desired harmonic of the crystal frequency, but, beyond this, any increase in the tank selectivity only results in a greater phase shift, and consequently a greater frequency shift, for a given percentage change in the plate capacitance. The use of a damping resistance as indicated in figure 1-173(A), or a low-Q coil, will broaden the tuning of the tank. The stray capacitance from the plate of V_2 to ground should be kept to a minimum.

1-382. To annul the input capacitance of V_2 , which is equal to the total capacitance between the cathode of V_2 and ground, we can connect an inductor in series with R_2 , or replace R_2 with a low-Q inductor and employ gridleak bias for V_2 (while keeping the grid at r-f ground by the use of an r-f bypass capacitor), or shunt R_2 with an inductor in series with an r-f bypass capacitor. In any event, the inductor is to be antiresonant with the cathode-to-ground capacitance at the operating frequency. With R_2 acting as a damping resistance, a broad-band response is ensured for the antiresonant combination.

1-383. The grid-to-cathode capacitance and the cathode-to-ground capacitance of V_1 can also be annulled by the use of antiresonant inductors. However, a more effective and economical method is to design the circuit so that the two cathode capacitances of V_1 neutralize each other regardless of the particular frequency. The grid-to-cathode capacitance, C_{gc1} , is illustrated by the dotted-line circuit in figure 1-173(B). The voltage across C_{gc1} is E_{g1} , so that the leading component of current through the grid circuit is

$$I_{gx} = \frac{E_{g1}}{X_{cg1}} \quad 1-383 (1)$$

For convenience, let it be imagined that all of I_{gx} flows through R and R_{p2} in completing its circuit. If it is not to upset the phases of the voltages across these resistances, I_{gx} must be annulled by an equal lagging current through the R - R_{p2} - Z_p circuit. Thus, assuming the transit-time effect is negligible, the plate tank must be slightly inductive if V_2 is to operate into a purely resistive load. This much can be controlled by the adjustment of the V_2 plate circuit. With the circuit properly adjusted, it can now be imagined that I_{gx} is no longer a part of I_c , but circulates directly through Z_L and C_{gc1} in series. The design problem is to ensure that no part of I_{gx} flows through R_1 or V_1 , but returns

Section I
Crystal Oscillators

to Z_L by flowing entirely through the V_1 cathode-to-ground capacitance, C_1 —not shown in figure 1-173. Furthermore, the design should be such that I_{gx} is all the current that flows through C_1 ; otherwise, there will be a net unneutralized leading component upsetting the voltage phases in the rest of the circuit. With proper neutralization, the only reactive current will be confined to a series circuit comprised of C_{gc1} , C_1 , ground, and an effective inductance shunting Z_L . The voltage across each of the reactive impedances due to I_{gx} will be equal in magnitude and phase to the voltages caused by the in-phase currents flowing through the corresponding resistive impedances. Thus, to neutralize the circuit, the leading current, I_{gx} , flowing through C_1 must of itself produce the voltage E_1 . This occurs when

$$E_1 = I_{gx} X_{C1} \quad 1-383 (2)$$

or, using equation (1) to replace I_{gx} ,

$$E_1 = \frac{E_{g1} X_{C1}}{X_{cg1}} \quad 1-383 (3)$$

Now,

$$E_1 = \frac{\mu_1 E_{g1} Z_k}{R_{p1} + Z_k} \approx g_{m1} E_{g1} Z_k \quad 1-383 (4)$$

Using equation (4) to eliminate E_1 in equation (3), we have

$$g_{m1} E_{g1} Z_k = \frac{E_{g1} X_{C1}}{X_{cg1}}$$

or

$$g_{m1} Z_k = \frac{C_{gc1}}{C_1} \quad 1-383 (5)$$

Equation (5) defines the ratio for the V_1 input to output capacitance that should exist for maximum frequency stability.

1-384. To minimize the tendency of the transit time to cause the respective plate currents of V_1 and V_2 to lag the equivalent generator voltages, small-dimensioned h-f tubes should be used, and the plate voltages should be as high as practicable. If the additional expenditure in the design and production of the circuit are warranted, suitable networks can be devised to neutralize the transit effects.

1-385. At the higher frequencies the series resistance of the crystal unit tends to increase, since the lagging component of current through the series arm must increase in order to annul the

increased leading component through the shunt capacitance, C_o . For this to occur, the frequency may need to be increased considerably above the natural resonance of the motional arm, so that the effective series resistance approaches the value of a parallel-resonant impedance. To reduce the resistance to the series-arm value, C_o should be annulled by an antiresonant inductor having an inductance

$$L_o = \frac{1}{\omega^2 C_o} \quad 1-385 (1)$$

To prevent the crystal shunt reactances from being more frequency sensitive than the plate circuit of V_2 , a shunt resistance should also be connected across the crystal unit to dampen the $L_o C_o$ tank. A suitable resistance, R_o , that can interfere very little with the crystal stabilizing effect is

$$R_o = 5 R_m \quad 1-385 (2)$$

where R_m is the rated maximum permissible crystal series resistance.

STABILIZING EFFECT OF CRYSTAL IN BUTLER CIRCUIT

1-386. From equation 1-241(2) we found that for a crystal operating at series resonance the fractional change in frequency required to produce a small change in phase, $d\theta$, is expressed by

$$\frac{d\omega}{\omega d\theta} = \frac{R_c}{2\sqrt{L/C}}$$

where R_c is the total resistance the crystal faces, including the crystal's own resistance, and L and C are the series-arm parameters of the crystal unit. In the Butler circuit (refer to figure 1-173) the crystal operates into a resistance

$$R_o = Z_f + \frac{R_1 Z_1}{R_1 + Z_1} \quad 1-386 (1)$$

where Z_f is the resistance of the feed-back circuit, and $\frac{R_1 Z_1}{R_1 + Z_1}$ is the output resistance of V_1 . On substituting the values for Z_1 and Z_f , we have

$$R_o = R + \frac{R_2 (R_{p2} + Z_L)}{R_2 (\mu_2 + 1) + R_{p2} + Z_L} + \frac{R_1 R_{p1}}{R_1 (\mu_1 + 1) + R_{p1}} \quad 1-386 (2)$$

If we assume that $R_{p1} \approx R_{p2} = R_p \gg Z_L$, and that

$\mu_1 = \mu_2 = \mu \gg 1$, equation (2) becomes

$$R_c = R + \frac{R_2 R_p}{R_2 \mu + R_p} + \frac{R_1 R_p}{R_1 \mu + R_p}$$

or

$$R_c = R + \frac{R_2}{R_2 g_m + 1} + \frac{R_1}{R_1 g_m + 1} \quad 1-386 (3)$$

From equation (3) it is seen that the Q of the crystal circuit, and hence the frequency stability, is to be improved if R_2 and R_1 are kept as small as possible and the transconductance of each tube is high. If R_1 and R_2 are of such values that the denominators in equation (3) are large compared with 1, a limiting value is approached, where

$$(\max) R_c = R + \frac{2}{g_m} \quad 1-386 (4)$$

DESIGN PROCEDURE FOR BUTLER OSCILLATOR

1-387. In considering the use of a Butler oscillator for controlling frequencies below 20 mc, the principal factor to consider is whether the frequency stability required is greater than that which is normally obtained with a Pierce circuit. If not, there is little to gain by using two tubes and a frequency-sensitive tuned circuit, unless it is very important that the waveform in the output be more nearly sinusoidal and less influenced by the variations in the crystal resistance. The frequency stability of an average Butler circuit can be expected to be approximately 0.0005 per cent as compared with a stability of approximately 0.001 to 0.0015 per cent for an average Pierce circuit. Above 20 mc, the principal competitor of the Butler is the transformer-coupled type of oscillator. The chief advantage of the Butler is its relative ease of adjustment and dependability. A borderline replacement crystal unit or an aging crystal unit, as a general rule, is more likely to be operative in the two-stage, cathode-coupled circuit than in any of the other types of v-h-f oscillators. Once the Butler circuit has been selected as the most appropriate to use, a crystal unit that has been series-tested at the intended frequency should be selected. The required minimum frequency tolerance and the operating conditions to be expected determine whether the crystal unit, or perhaps the entire oscillator, is to be oven-controlled. For the next step, it is probably best to select the types of vacuum tubes to use. Insofar as space, weight,

and cost are concerned, a single tube envelope for both amplifier stages is desirable. On the other hand, it may be found that a more balanced arrangement and more direct circuit connections can be had with separate tubes, particularly if the crystal unit is to be oven-mounted. The transconductance and plate resistance of the tubes should both be high, for maximum frequency stability. For the same amplification factor, the tube with the larger g_m is usually to be preferred. For h-f and v-h-f operation miniature tubes are preferable, in order to reduce the transit time and the electrode-to-ground capacitances. For class-A operation, both tubes can be of the same type. For class-C operation, the power rating of the cathode follower should be greater than that of the grounded-grid amplifier. For maximum stability it may be desirable to isolate the load from the rest of the circuit, or to tune the load circuit for frequency multiplication. In this case a pentode can be used for either the cathode follower (usually) or for the grounded-grid amplifier, with the load taken from the electron-coupled plate circuit, and with the screen grid serving as the oscillator plate. Either pentodes or triodes can be used in the basic Butler circuit, as desired. In the v-h-f range, triodes have the advantage of smaller transit-time effects. Assume that it is intended to operate the tubes class A. To reduce the transit time, to increase g_m , and to permit a minimum value of Z_L (low- Q tank), the plate voltages should be as high as practicable. Determine the values of R_1 and R_2 that will provide a normal cathode bias for class-A operation. With all else equal, the feedback transmission losses are a minimum if $R_1 = R_2$. For class-C operation, R_2 should equal approximately $4R_1$. Assume that R of the crystal unit is the maximum permissible value, and that the effective g_m 's of the vacuum tubes are 25 per cent less than their rated values for class-A operation at the selected plate and grid voltages. With these assumptions, determine the value of Z_L that is required to make the gain equation, 1-378 (26), hold. R_p should be large compared with Z_p , so that $Z_L \approx Z_p$. The plate tank represented by Z_p can be designed as a high- Q circuit, antiresonant at the operating frequency, and shunted by a simulated load resistance, R_L , much smaller than the antiresonant impedance of the tank, itself. In this case, $Z_L \approx Z_p \approx R_L$. The approximations above will be sufficient to build an experimental circuit that should oscillate in a free-running state. A variable resistance can be connected to simulate a crystal unit at series resonance. By varying the simulated crystal resistance over the range possible for a ran-

Section I
Crystal Oscillators

dom selection of crystal units, R_L in the plate circuit can be adjusted, if necessary, to ensure that oscillations occur at all possible values of crystal resistance without driving the crystal at a higher than recommended level. The empirical optimum value of R_L can be accepted as the value of Z_L to achieve in the design of the output circuit of the grounded-grid amplifier. The actual design of the output stage depends, of course, upon the type of load into which the oscillator is to operate. The important consideration is that an effective resistance having the value of the experimental R_L is to be introduced in one way or another across the plate tank. The final problem is to neutralize the various circuit capacitances. In neutralizing the V_1 cathode capacitances, the adjustment which permits the feed-back circuit to be purely resistive can be expected to coincide with the conditions for maximum output amplitude and maximum crystal current. The design procedure discussed above should be accepted simply as a suggestion. Individual

engineers may well prefer that primary attention be given to fitting the design to meet special requirements.

MODIFICATIONS OF THE BUTLER OSCILLATOR

1-388. As in the case of other conventional oscillator designs, the number of modifications of the Butler circuit appear to be unlimited. In figure 1-174, the basic electron-coupled circuit is shown in (A), and a circuit employing a common ground return for the two tubes is shown in (B). In the electron-coupled circuit, the load, represented by R_L' , is effectively isolated from the oscillator circuit, in which the screen of V_1 serves as the cathode-follower anode. The plate circuit of V_1 can be tuned to the second or third harmonic of the oscillator frequency, if desired, in which case V_1 should be operated class C. For maximum output voltage, the plate impedance of V_1 should be high. In figure 1-174 (B), the low-Q inductor, L_1 , is

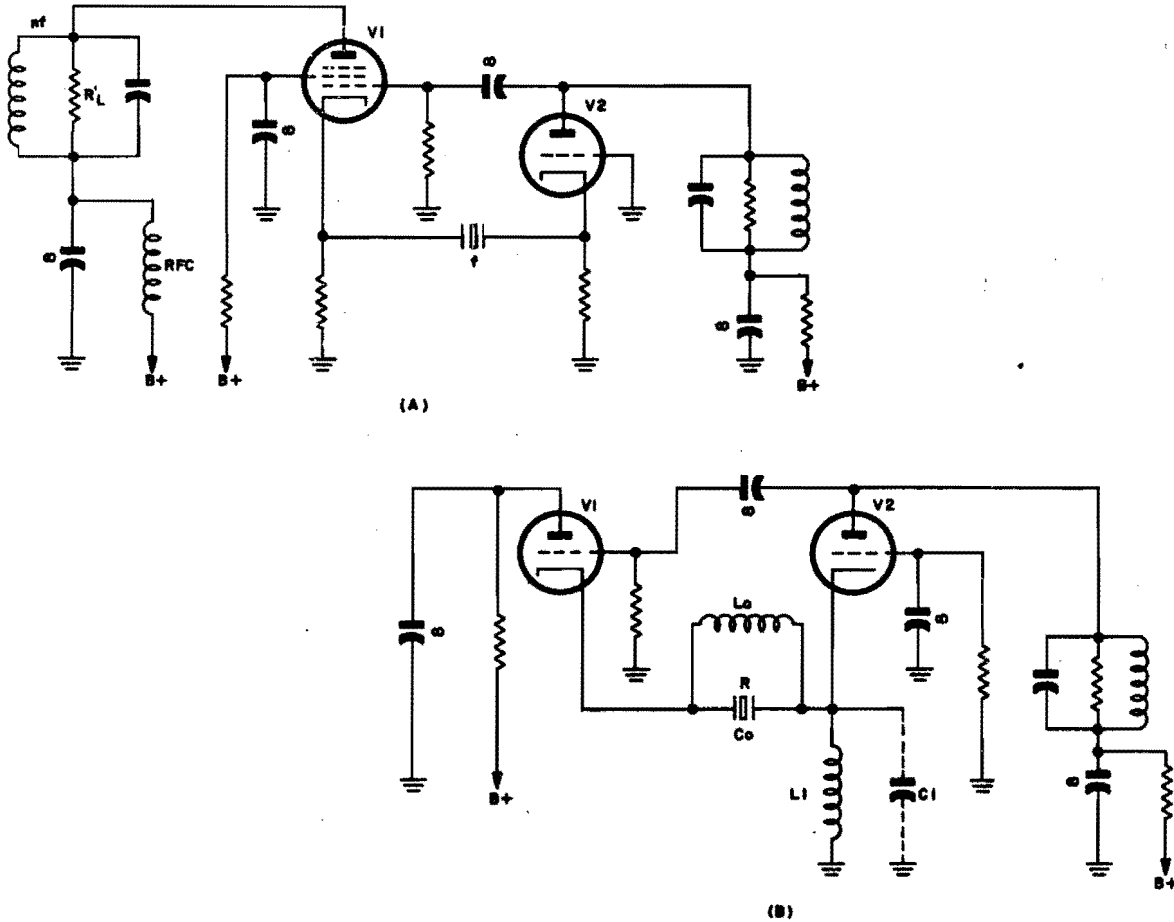

Figure 1-174. (A) Electron-coupled Butler circuit. (B) Butler circuit having common cathode ground return

antiresonant with the distributed capacitance, C_1 , as is L_2 with C_2 . Gridleak bias is employed with both tubes. However, the grid of V_1 is still kept at r-f ground through the bypass capacitance. It can be seen that equation 1-378 (26),

$$\frac{Z_{g2} Z_L Z_k g_{m1}}{Z_2 Z_1} = 1$$

when applied to the common-ground return circuit, becomes

$$\frac{Z_{g2} Z_L g_{m1}}{Z_2} = 1 \quad 1-388 (1)$$

since Z_k is equal to Z_r . Also, since $Z_2 = \frac{R_{p2} + Z_L}{\mu_2 + 1} \approx \frac{1}{g_{m2}}$, since $Z_{g2} = \frac{R_2 Z_2}{R_2 + Z_2}$, where R_2 now represents the antiresonant impedance of the $L_1 C_1$ combination, it can be shown that equation (1) can be expressed as

$$Z_L g_{m1} - \frac{1}{R_2 g_{m2}} = 1 \quad 1-388 (2)$$

If the product $R_2 g_{m2}$ is large compared with 1, at equilibrium g_{m1} must approximately equal $1/Z_L$. 1-389. The schematics of a number of Butler circuits employed by the military services are shown in figure 1-175. Circuit (A) is a receiver heterodyne oscillator that can be switched from crystal to manual operation simply by shorting out the crystal. C_1 is an r-f bypass capacitor that prevents the inductor L_1 from shorting out the cathode bias developed across R_1 . L_1 is designed to be antiresonant with the grounded-grid amplifier cathode-to-ground capacitance. C_2 is inserted to resonate with the distributed inductance of the crystal leads and feed-back circuit. C_3 is a split-stator capacitor which permits the use of a grounded rotor, thereby reducing intersectional capacitances. Since the r-f current through C_3 is small, wiping contacts can be used for grounding without introducing noise. C_4 is simply a trimmer which permits adjustment of the effective inductance of L_2 . The plate side of C_3 effectively has a relatively large fixed component due to the stray plate-to-ground capacitance. To keep the plate tank balanced, an equal amount of fixed capacitance, C_5 , is added to the other side of C_3 . R_2 is added to suppress parasitic oscillations. As can be seen, the output is obtained by split-load operation of the cathode follower. Since the output is delivered to a mixer circuit, where the effective load might be expected to undergo slight

changes, it is probable that the loaded cathode-follower plate circuit is less frequency sensitive than the finely balanced tank in the V_1 plate circuit. Since the balanced tank must be sufficiently selective to stabilize the frequency during manual operation, it cannot be loaded as would normally be done. Although the crystal is not active in the circuit during manual operation, it cannot be removed without resulting in an increase in frequency. This is due to the decrease in the cathode-to-ground capacitance that results when the crystal unit is removed.

1-390. Figure 1-175 (B) (C) (D) (E) (F) is a composite arrangement of five different oscillators, none of which have all the components shown. For example, the B^+ return of V_1 is through R_6 in (B), (E), and possibly (F); it is through R_6 in (C), and also in (D), except that R_2 and R_6 are one and the same in the latter circuit, although the actual circuit is not indicated in the schematic shown. In circuit (E) the F_1 output is cathode-coupled to a mixer tube (6AK5W). An r-f choke is connected between the cathode and ground, not the resistance R_{10} . In circuit (B), C_5 is actually composed of two 1.5- μmf capacitors in series. The F_2 output is developed across a tuned tank inductively coupled to, and also inductively coupled to, the plate tank in the V_1 plate circuit. L_2 in circuit (B) thus serves as a transformer primary. The F_3 output is fed to the grid of one and to the cathode of a second 6AG5 mixer stage. The heterodyned output of the first is 20 to 30 mc, and that of the second is 4.8 to 5.7 mc.

1-391. The circuit shown in figure 1-175 (G) is a carefully designed experimental model that was built and tested during an investigation of h-f and v-h-f oscillators by a research team headed by W. A. Edson at the Georgia Institute of Technology. A breadboard model of this circuit was operative at frequencies as high as 150 mc, with crystal resistances as high as 500 ohms. Circuit (G) was found to have a frequency stability of 0.22 parts per million per volt change in the high-voltage supply. The frequency was controlled at 126 mc, the ninth harmonic of a 14-mc fundamental. The shunt capacitance of the test crystal was 12 μmf , and the series resistance after tuning out the capacitance was 300 ohms. Oscillations could not be sustained at plate voltages below 50 volts, and the frequency instability increased greatly at voltages above 85 volts. Note that circuit (K) in figure 1-175, which has been designed to operate with low- and medium-frequency, fundamental-mode crystal units, is not a true Butler circuit in that neither tube is operated as a cathode follower.

Section I
Crystal Oscillators

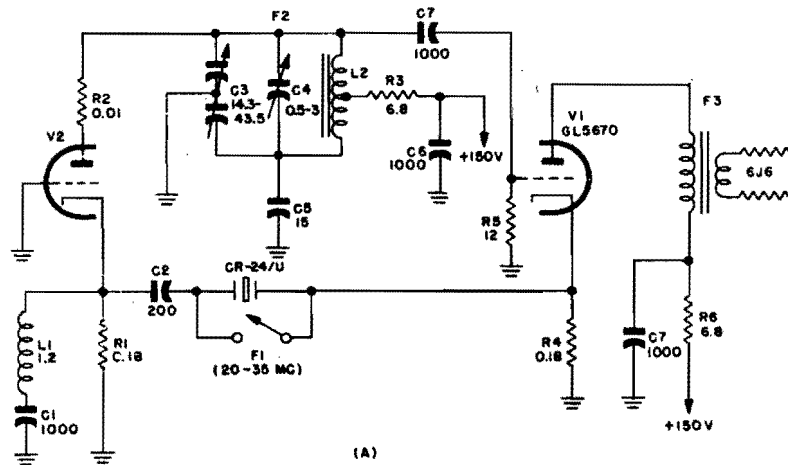

Figure 1-175. Modifications of Butler oscillator. Dotted lines in circuit (G) indicate stray capacitances

Fig.	Equipment	Purpose	F ₁	F ₂	F ₃	F ₄	CR	R ₁	R ₂	R ₃	R ₄	R ₅	R ₆	R ₇	R ₈
(A)	Radio Receiver R-266/URR-13	Heterodyne oscillator	20.3-34.9	2F ₁			CR-24/U (5th mode)	0.18	0.01	6.8	0.18	12	6.8		
(B)	Receiver Transmitter RT-178/ARC-27	3rd transmitter osc or 2nd receiver osc for heterodyning	25.7-34.7	F ₁	?	NA	CR-23/U	0.1	?	100	0	0.15	NA	12	NA
(C)	Receiver-Transmitter RT-178/ARC-27	1st guard receiver local osc	37.266	F ₁	NA	2F ₁	CR-23/U	0.39	0.12	47	0	0.22	0.12	6.8	0
(D)	Receiver-Transmitter RT-173/ARC-33	1st monitor osc of transmitter M.O.	0.8933	F ₁	4F ₁ -18F ₁	F ₁	CR-28/U	8.8	33	100	0	1	Same resistor as R ₂	∞	0.22
(E)	Receiver-Transmitter RT-173/ARC-33	Guard-channel heterodyne oscillator-doubler	55.668-58.169	F ₁	NA	2F ₁ and 4F ₁	CR-32/U	0.12	8.2	33	0	0.33	NA	27	∞
(F)	Radio Receiver R-252A/ARN-14	1st heterodyne oscillator	44.275-57.275	F ₁	NA	2F ₁	CR-23/U		8.2	4.7	0.1		?	∞	?

Circuit Data for Figure 1-175. F in mc. R in kilohms. C in μ f. L in μ h. NA (not applicable) means that no connections of any kind exist between points indicated. Question mark (?) indicates that schematic of the associated part of the circuit is not available.

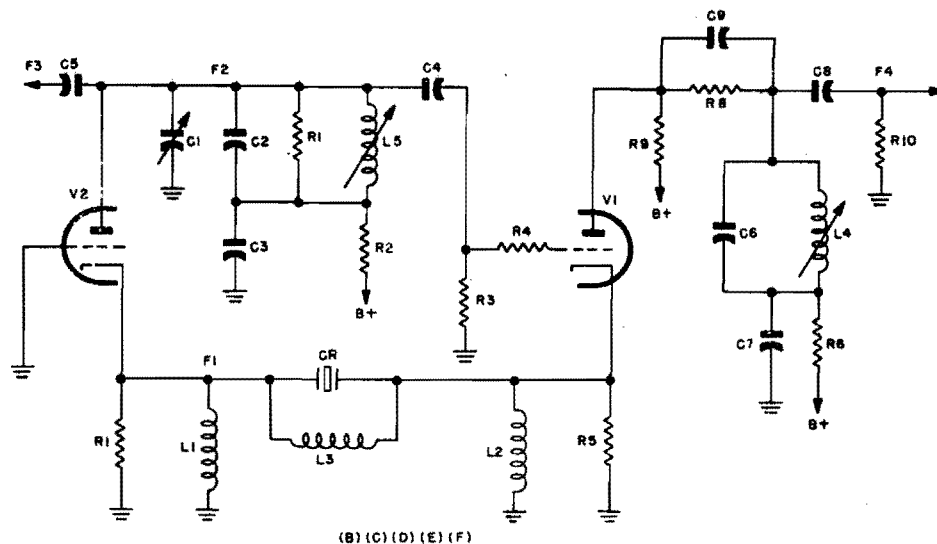

Figure 1-175. Continued

R_0	R_{10}	C_1	C_2	C_3	C_4	C_5	C_6	C_7	C_8	C_9	L_1	L_2	L_3	L_4	L_5	V_1 V_2
		1000	200	14.3-43.5	0.5-3.0	15	1000	1000			1.2					GL5670
1	NA	1-8	7	1500	47	0.75	NA	NA	NA	NA	∞	∞	∞	NA	2-4	12AT7
NA	27	0	20	3000	100	NA	24	500	20	0	∞	∞	∞			12AT7
NA	470	0	104		470	470	100	25,000	170	0	∞	∞	∞			5670
8.2	Cathode of mixer	0	5		10	NA	1.6-5	∞	10	10	∞	∞				5670
?	?	2-7	12	2000	100	NA	?	?	?	?				?		12AT7

Section I
Crystal Oscillators

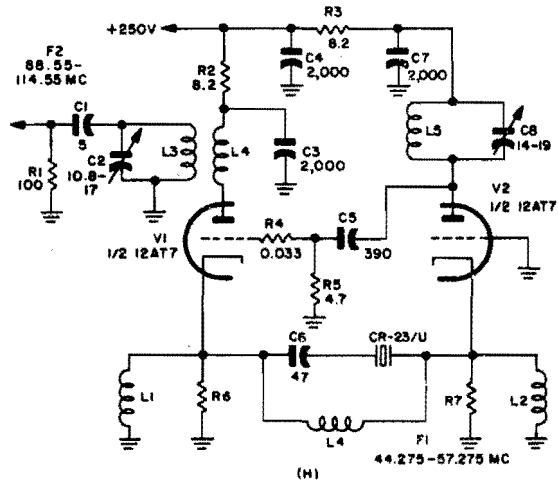
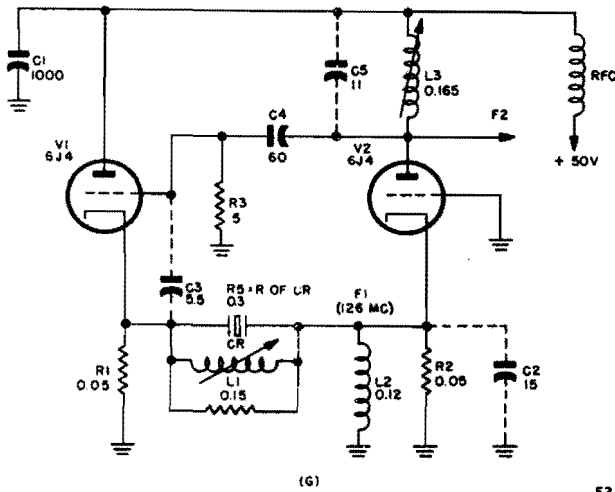

Figure 1-175. Continued

Fig.	Equipment	Purpose	F ₁	F ₂	F ₃	F ₄	CR	R ₁	R ₂	R ₃	R ₄	R ₅	R ₆	R ₇	R ₈
(G)	Experimental osc		126	F ₁			9th harmonic; series resistance equal to R ₅	0.05	0.05	5	1.2	0.3			
(H)	Radio Receiver R-540/ARN-14C	H-F injection osc	44.275-57.275 (14 crystals)	2F ₁			CR-23/U	100	8.2	8.2	0.033	4.7			
(I)	Radio Set AN/ARC-34 (XA-1)	Guard channel injection osc and multiplier	55.67-58.17	2F ₁ and 4F ₁			CR-32/U	0.22	0.56	33	2.7	220	3.3	100	
(J)	Radio Set AN/ARN-21(XN-2)			F ₁			CR-23/U	0.22	0.22	10	1				

Circuit Data for Figure 1-175. F in mc. R in kilohms. C in μmf . L in μh . NA (not applicable) means that no connections of any kind exist between points indicated. Question mark (?) indicates that schematic of the associated part of the circuit is not available.

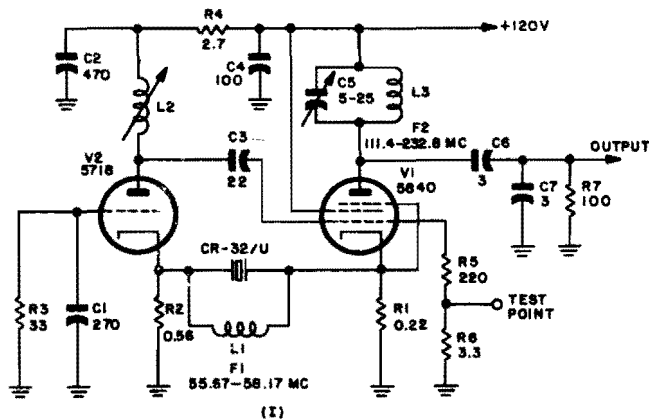
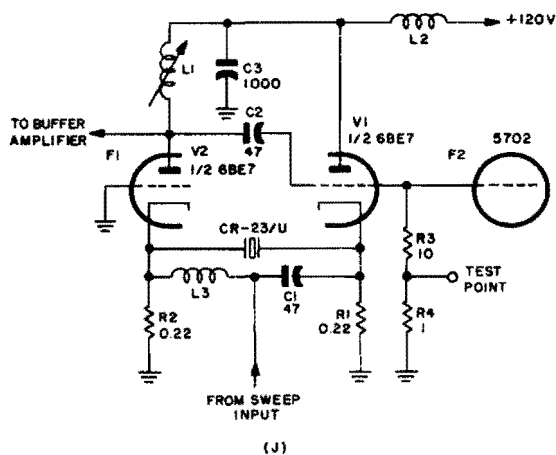

Figure 1-175. Continued



R ₉	R ₁₀	C ₁	C ₂	C ₃	C ₄	C ₅	C ₆	C ₇	C ₈	C ₉	L ₁	L ₂	L ₃	L ₄	L ₅	V ₁ V ₂
		1000	15	5.5	60	11					0.15	0.12	0.165			6J4 each
		5	10.8-17	2000	2000	390	47	2000	14-19							12AT7
		270	470	22	100	5-25	3	3								5840 (V ₁) 5718 (V ₂)
		47	47	1000												6BE7

Section I
Crystal Oscillators

Fig.	Equipment	Purpose	F ₁	F ₂	F ₃	F ₄	CR	R ₁	R ₂	R ₃	R ₄	R ₅	R ₆	R ₇	R ₈
(K)	Signal Generator SG-34(XA)/UP	L-F and m-f osc	0.10 0.18 1.75 1.85 1.90 1.95				CR-16/U (LF ₁) CR-19/U (HF ₁)	10	1.5	0.027	560	39	1000	0.27	
(L)	Signal Generator SG-13/ARN	200-mc generator for mixing with lower freq. signals	50	4F ₁			CR-23/U	56	3.3	0.015	0.01	0.27	0.01	0.27	2.7

Circuit Data for Figure 1—175. F in mc. R in kilohms. C in $\mu\mu\text{f}$. L in μh . NA (not applicable) means that no connections of any kind exist between points indicated. Question mark (?) indicates that schematic of the associated part of the circuit is not available.

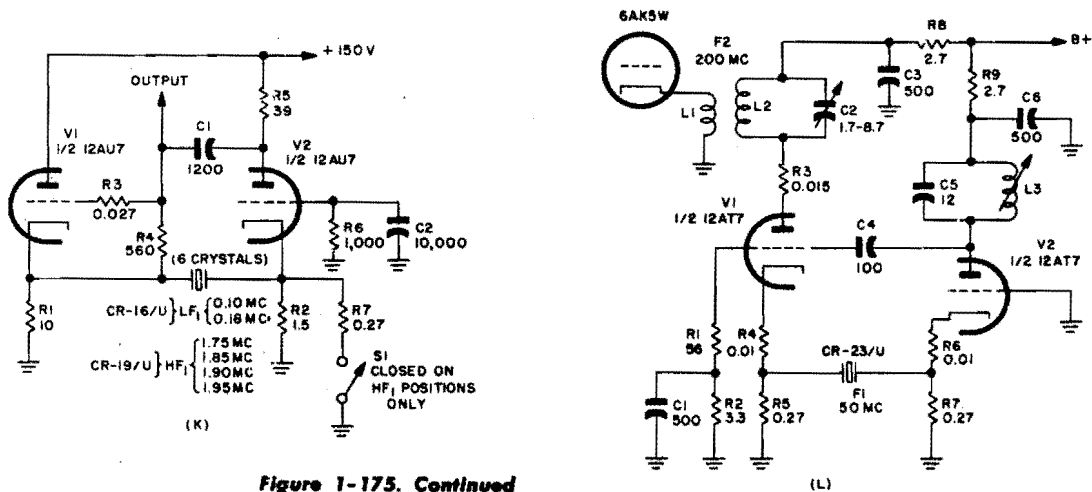

Figure 1-175. Continued

Transformer-Coupled Oscillator

1-392. At the present time, the transformer-coupled crystal oscillator (see figure 1-176) is not being widely used. It was during the v-h-f oscillator investigation at the Georgia Institute of Technology for the Signal Corps in 1950, mentioned in the last paragraph, that the transformer-coupled oscillator appeared to be the most promising for all-around versatility and general-purpose use. First, there is the advantage of a single-tube oscillator. Secondly, for low-power output (about four times the crystal power), the frequency stability has been found to be slightly superior to that of the average Butler circuit. Thirdly, with properly designed phase-compensating networks, an untuned pass band of 10 mc is possible. Finally, with a relatively small sacrifice in frequency stability, the circuit design can be such that the power output is increased several fold without exceeding the recommended maximum drive level of the crystal unit. Although the transformer-coupled oscillator can perform satisfactorily at lower frequencies,

its chief application is for control and generation of harmonic-mode frequencies above 20 mc. The oscillator is generally designed for class-C operation. A significant disadvantage is that the circuit design for optimum performance characteristics—characteristics that can be approximately duplicated from one oscillator to another of similar design—is generally more difficult to achieve than in other oscillator circuits. This is due chiefly to the difficulty in predicting the effective input impedance of tubes operated class C at frequencies where transit-time and stray-capacitance effects become appreciable. As a result, the theoretical and actual equilibrium conditions frequently are found to differ to a greater degree than in the average series-mode oscillator. More cut-and-try experimentation may prove necessary than would otherwise be the case. The operating principle of the grounded-cathode, transformer-coupled oscillator is closely allied to that of the grounded-grid and grounded-plate versions. The discussion and equations for the transformer-coupled oscillators

R _s	R ₁₀	C ₁	C ₂	C ₃	C ₄	C ₅	C ₆	C ₇	C ₈	C ₉	L ₁	L ₂	L ₃	L ₄	L ₅	V ₁ V ₂
		1200	10,000													12AU7
2.7		500	1.7-8.7	500	100	12	500									12AT7

are, for the most part, based upon the analysis by W. A. Edson.

PHASE CONSIDERATIONS OF TRANSFORMER-COUPLED OSCILLATOR

1-393. Referring to figure 1-176, the useful load, represented by R_L, is connected across the secondary of the plate transformer. The chief function of R_L is to improve the frequency stability by lowering the resistance of the crystal circuit, and to improve the amplitude stability by reducing the effect of variations in the input resistance of the tube. The parameter *a* is simply the constant of proportionality relating R_L to R₁. C₁ and C₂ are capacitors for tuning out the leakage inductance of the plate and grid transformers, respectively. The leakage inductance is equal to the high-side inductance multiplied by (1-k²), where k is the coefficient of coupling. It can be directly measured at the low side of the transformer when the high side is shorted. Both transformers can be, simply, tapped coils. The crystal impedance is assumed to be the series-resonance impedance, R. The effective turns ratios, N_p and N_g, can be so chosen that C_{DE} and C_o annul each other's effects. With the

circuit properly designed, the tube operates into a resistive load, C_p being antiresonant with the dampened coil L_p. I_s, I_L, I_c, E_L, and E_o (the voltage across the crystal) are in phase with E_p. The grid transformer thus provides the required 180-degree phase shift between E_p and E_g.

1-394. Where the resistance of the crystal series arm is not small compared with the shunt reactance, X_{C_o}, the effects of C_o can be annulled by the conventional method of connecting an inductor across the crystal unit, by means of mutual inductance between the plate and grid transformers (to be discussed in connection with the grounded-grid oscillator), or by balancing the effects of C_o against those of C_{1p}. When the circuit is properly balanced, the crystal unit operates at the resonant frequency of the series arm. When C_o is balanced against C_{1p}, the leading component, I_s, of the current through the crystal—that part through C_o—passes in its entirety, through C₂ and the primary of the grid transformer. Similarly, the current through C_{1p}, I_{1p}, passes in its entirety, through the secondary of the grid transformer. For this to occur, the voltages induced by the two currents in each section of the grid transformer must exactly

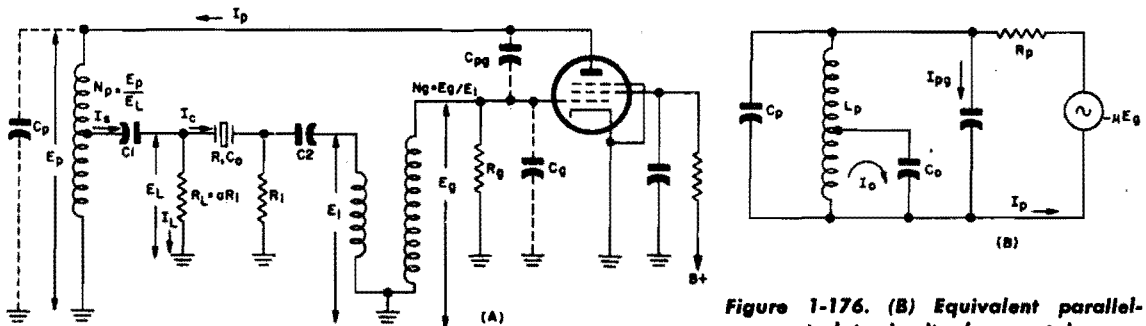

Figure 1-176. (A) Basic circuit of transformer-coupled oscillator

Figure 1-176. (B) Equivalent parallel-resonant plate circuit when crystal capacitance, C_o, is balanced by plate-to-grid capacitance, C_{pg}

Section I
Crystal Oscillators

annul each other. The transformer then appears as a short circuit to both currents. As indicated in figure 1-176 (B), C_o becomes equivalent to a capacitor shunting the ground-connected half of L_p , thereby effectively increasing L_p , and C_{pg} becomes equivalent to an increase in C_p equal to C_{pg} . The balanced state is reached when

$$I_o = N_g I_{pg} \quad 1-394 (1)$$

or

$$\omega C_o E_L = N_g \omega C_{pg} E_p \quad 1-394 (2)$$

or

$$C_{pg} = \frac{C_o}{N_g} \cdot \frac{E_L}{E_p} = \frac{C_o}{N_g N_p} \quad 1-394 (3)$$

Equation (3) can generally be realized with practical values of N_g and N_p if C_{pg} is on the order of 0.05 to 0.1 μmf . Such values of C_{pg} can be obtained with screen-grid tubes but not with triodes unless a d-c blocked inductive arm is connected between plate and grid to annul most of the capacitance.

GAIN REQUIREMENTS OF TRANSFORMER-COUPLED OSCILLATOR

1-395. Referring to figure 1-176 (A), it can be seen that at equilibrium,

$$G_1 G_2 G_3 G_4 = \frac{E_p}{E_g} \cdot \frac{E_L}{E_p} \cdot \frac{E_1}{E_L} \cdot \frac{E_g}{E_1} = 1 \quad 1-395 (1)$$

where

$$G_1 = \frac{E_p}{E_g} = \frac{I_p Z_p}{E_g} = \frac{\mu Z_p}{R_p + Z_p} \approx g_m Z_p \quad 1-395 (2)$$

$$G_2 = \frac{E_L}{E_p} = \frac{1}{N_p} \quad 1-395 (3)$$

$$G_3 = \frac{E_1}{E_L} = \left(\frac{R_1 R_g'}{R_1 + R_g'} \right) \cdot \left(\frac{1}{R + \frac{R_1 R_g'}{R_1 + R_g'}} \right) \\ = \frac{R_1}{R + R_1} \quad 1-395 (4)$$

$$G_4 = N_g \quad 1-395 (5)$$

R_g' in equation (4) is the effective resistance of the grid transformer as it appears in parallel with R_1 . It is equal to E_1^2 divided by the grid losses. Thus,

$$R_g' = \frac{E_1^2}{P_g} = \frac{(\text{eff}) R_g E_1^2}{E_g^2} = \frac{(\text{eff}) R_g}{N_g^2} \quad 1-395 (6)$$

where (eff) R_g is the effective grid resistance which takes into account the gridleak losses and the transit-time loading. For small values of N_g , the R_g' losses can be considered negligible. The plate power can be assumed to be,

$$P_p = I_s E_L \approx \frac{E_L^2 (R_L + R + R_1)}{R_L (R + R_1)} \\ = \frac{E_L^2 (R + R_1 + a R_1)}{a R_1 (R + R_1)} \quad 1-395 (7)$$

and

$$Z_p = \frac{E_p^2}{P_p} = \frac{a N_p^2 R_1 (R + R_1)}{R + R_1 + a R_1} \quad 1-395 (8)$$

on combining equations (2), (3), (4), (5), and (8), we find that at equilibrium

$$G_1 G_2 G_3 G_4 = \frac{g_m a N_p N_g R_1^2}{R + R_1 (1 + a)} = 1 \quad 1-395 (9)$$

Q DEGRADATION IN TRANSFORMER-COUPLED OSCILLATOR

1-396. In Edson's analyses of series-mode oscillators, he employs a useful term which he calls the Q degradation of the crystal unit. It is defined

$$D = \frac{R_c}{R} \quad 1-396 (1)$$

where R_c is the total resistance which the crystal must operate into. In the transformer-coupled oscillator, assuming that the transformer impedances that the crystal faces are large compared with R_L and R_1 of figure 1-176,

$$D = \frac{R + R_1 (1 + a)}{R} \quad 1-396 (2)$$

As discussed in paragraph 1-241, the frequency stability of the series-resonant crystal unit is directly proportional to the Q of the crystal circuit.

It is therefore directly proportional to $\frac{Q}{D}$, where Q is the Q of the crystal, itself. Thus, with a given crystal unit, the frequency stability varies inversely with D. If the minimum Q of a crystal unit is estimated from the maximum permissible C_o , from the frequency, the harmonic, the particular crystal element, and the maximum permissible

series resistance, and if the required frequency stability is known, then the maximum permissible D can be determined from the random phase shifts to be expected during operation. In the average circuit, it is sufficient, simply, to keep D as low as possible consistent with the output desired. When R_1 is expressed as a function of a , R , and D , the loop gain as defined by equation 1-395 (9) becomes

$$G_1 G_2 G_3 G_4 = \frac{g_m a N_p N_g R (D - 1)^2}{D (a + 1)^2} \quad 1-396 (3)$$

LOAD-TO-CRYSTAL POWER RATIO OF TRANSFORMER-COUPLED OSCILLATOR

1-397. The ratio of the load to the crystal power is

$$P_L/P_c = \frac{I_L^2 R_L}{I_c^2 R} = \frac{(D + a)^2}{a (a + 1) (D - 1)} \quad 1-397 (1)$$

It is generally desired to have the power ratio as high as is consistent with satisfactory frequency stability. With a given value of D , the ratio becomes large as a is made small. If the design is based on obtaining a given minimum output with a given value of D when the crystal-unit resistance is a maximum (minimum D), the value of a can be determined by equation (1), and equation 1-396 (3) can be used to determine the value of $N_p N_g$ most likely to produce the required g_m for the crystal to be driven at the desired level.

BROAD-BAND CONSIDERATIONS IN THE TRANSFORMER-COUPLED OSCILLATOR

1-398. For broad-band untuned operation it is important to have Z_p and Z_g (the impedance faced by the grid) and the plate and grid capacitances as small as possible. Assuming that R_g is large compared with the resistance appearing across the secondary of the grid transformer.

$$Z_g = \frac{N_g^2 R_1 (R + a R)}{a R_1 + R_1 + R} \quad 1-398 (1)$$

or

$$Z_g = \frac{N_g (D + 1/a)}{g_m N_p (D - 1)} \quad 1-398 (2)$$

Also, Z_p can be expressed as

$$Z_p = \frac{N_p (D + a)}{g_m N_g (D - 1)} \quad 1-398 (3)$$

To keep Z_p and Z_g low, it is desirable that N_p and

N_g be as small as possible. For a given value of g_m , the product $N_p N_g$ can be a minimum when $\frac{a}{(a + 1)^2}$ (see equation 1-396 (3)) is a maximum. The maximum occurs when $a = 1$. With a , D , and g_m decided upon, equations (2) and (3) give mutually minimum values when $N_p = N_g$. Thus, for broad-band operation, let

$$Z_p = Z_g = \frac{D + 1}{g_m (D - 1)} \quad 1-398 (4)$$

D should be as large as possible consistent with the required frequency stability.

FREQUENCY STABILITY OF THE TRANSFORMER-COUPLED OSCILLATOR

1-399. The frequency-stability equations for the transformer-coupled oscillator are

$$\frac{d\omega}{\omega} = - \frac{\omega Z_p D}{2Q} dC_p \quad 1-399 (1)$$

and

$$\frac{d\omega}{\omega} = - \frac{\omega Z_g D}{2Q} dC_g \quad 1-399 (2)$$

where Q is the Q of the crystal. When equations 1-398 (2) and (3) are multiplied by D , it can be shown the DZ_p is a minimum when

$$D = 1 + \sqrt{1 + a} \quad 1-399 (3)$$

and DZ_g is a minimum when

$$D = 1 + \sqrt{1 + 1/a} \quad 1-399 (4)$$

For both to be a minimum simultaneously, a must be equal to 1, which means that

$$D = 1 + \sqrt{2} = 2.414 \quad 1-399 (5)$$

Under these conditions, the power ratio, as given by equation 1-397 (1), becomes

$$\frac{P_L}{P_c} = 4.12 \quad 1-399 (6)$$

For larger power outputs, the value of a must be decreased and N_p increased. Since the expected variations in the grid capacitance are generally larger than those in the plate capacitance, it is usually desirable to favor the grid circuit insofar as the frequency stability is concerned.

1-400. The greatest probability that the effect of a random variation in the grid capacitance will be

Section I
Crystal Oscillators

canceled by a random variation in the plate capacitance occurs when the fractional change in frequency due to the average ΔC_p is equal to that due to the average ΔC_g . If the average ΔC_g is on the order of 10 times the average ΔC_p , then Z_p should be equal to $10Z_g$. Equations 1-399 (1) and (2) will then represent equal average variations in frequency.

DESIGN PROCEDURE FOR TRANSFORMER-COUPLED OSCILLATOR

1-401. The procedure to follow in designing a transformer-coupled oscillator depends upon the principal objectives to be sought in the design. That is, some fixed requirement serves as a starting point, and the design proceeds from there. One limitation that will be common to all the circuits is that the crystal power rating not be exceeded. This requirement, then, in the general case, can be the initial design consideration. The crystal power is

$$P_c = I_c^2 R = \frac{E_g^2 R}{N_g^2 R_1^2} \quad 1-401 (1)$$

Also

$$P_c = I_c^2 R = \frac{E_L^2 R}{(R_1 + R)^2} = \frac{E_p^2 R}{N_p^2 (R_1 + R)^2}$$

$$= \frac{g_m^2 E_g^2 Z_p^2 R}{N_p^2 (R + R_1)^2}$$

or

$$P_c = \frac{g_m^2 E_g^2 a^2 R_1^2 N_p^2}{R D^2} \quad 1-401 (2)$$

Multiplying equation (1) by equation (2) and taking the square root, we have

$$P_c = \frac{g_m E_g^2 a N_p}{D N_g} \quad 1-401 (3)$$

Now, $(g_m E_g^2)$ is assumed equal to $(I_p E_g)$, which, in turn, is principally a function of the excitation voltage and the plate characteristics of the tube to be used. By equation 1-395 (9) (also by equating equation (1) to equation (2))

$$g_m = \frac{R_c}{a R_1^2 N_p N_g} \quad 1-401 (4)$$

R_c , remember, is equal to RD , the total resistance that the crystal unit operates into. From equation (4) it can be seen that if $R_c (= R + R_1(1 + a))$ is large compared with the maximum $R (= R_m)$, the equilibrium transconductance will be approximately the same for all values of R . On the other

hand, if the minimum D is small, the value of g_m at minimum R may be as much as one-half its value for $R = R_m$. Note that some change must occur in g_m , and hence in E_g , if R varies and the rest of the parameters remain constant. To ensure class-C operation for all values of R , let the class-A value for g_m equal twice the equilibrium g_m according to equation (4), with R_c assumed to be a maximum. With the circuit so designed, the amplitude of the oscillations will build up until the tube is cut off a fair proportion of each cycle. Even if class-A operation is desired, a reasonable difference should be allowed between the rated transconductance of the tube and the estimated equilibrium value when R_c is maximum. This should be sufficient to allow for all expected tolerances in the plate characteristics and in the tuning of the oscillator circuit. The percentage variations in R from one crystal unit to the next is not quite as great in the v-h-f crystals as in the lower-frequency elements, since it is more important that the maximum permissible resistance be kept as small as practicable.

1-402. The ideal design would permit the percentage variations in E_g^2 to exactly equal in magnitude the percentage variations in R . Under these conditions, the crystal power, as indicated in equation 1-401 (1) would be the same for each crystal unit. To approach such a design, g_m , as a function of E_g , would have to be known for the particular tube. Such an analysis is beyond the present discussion, but the method to be used would be quite similar to that employed in the analysis of the effects of different values of crystal resistance for the Pierce circuit. As a rule of thumb, the average crystal R in the v-h-f range can be assumed to equal $\frac{R_m}{2}$. If the transformer-coupled oscillator is designed to drive the crystal unit at 50 per cent of its maximum rated power for the average R , there is little danger that crystal units having other values of resistance will be overdriven. For broadband operation the crystal power will be approximately directly proportional to R . When D is small the crystal power increases as R decreases as long as the percentage increase in E_g^2 is greater than the percentage decrease in R . With $R = \frac{R_m}{2}$ and $P_c = \frac{P_{cm}}{2}$, equation 1-401 (1) gives an assumed value for E_g^2 , thus

$$(ave) E_g^2 = \frac{P_{cm} R_1^2 N_g^2}{R_m}$$

or

$$(ave) E_g = N_g R_1 \sqrt{P_{cm}/R_m} \quad 1-402 (1)$$

Note that equation (1) also gives the value of E_g which would exist if a crystal of maximum resistance were driven at its rated level. However, equation (1) is less important for determining E_g than it is for determining N_g . It is assumed that a class-C value of g_m has been agreed upon. An approximate value of E_g corresponding to the chosen g_m is thus already determined. After the value of R_1 is decided upon, equation (1) can serve to determine N_g .

1-403. The design procedure followed so far can generally be applied to any transformer-coupled oscillator. A v-h-f pentode and a harmonic series-mode crystal unit are selected. Regulated screen and plate voltages for the tube are decided upon. An approximate class-C value of g_m and the corresponding E_g are estimated, and average values of P_c and R are assumed. Once that D and a have been selected according to the particular requirements of the oscillator, the $\frac{N_p}{N_g}$ ratio can be determined from equation 1-401 (3), and N_g from equation 1-402 (1). Or, in case a particular $\frac{N_p}{N_g}$ ratio is to be preferred, a and D can be determined with the aid of equation 1-401 (3). An alternative approach, which is the one to be followed when using the table in paragraph 1-404, is to first determine optimum values for D , a , and N_p/N_g , assume an average crystal $R = \frac{R_m}{2}$ and a crystal

power equal to $\frac{P_{cm}}{2}$, and use equation 1-401 (3) to determine the value of $g_m E_g^2 (= I_p E_g)$. The next problem is to determine what value of E_g will produce the required value of $I_p E_g$ when the tube is operating into a plate impedance that is small relative to the tube R_p . The equations relating I_p to E_g in the analysis of the Pierce circuit, or rather the basic methods used to derive the equations, are applicable here if modified properly. Since some trial-and-error will be required regardless, it may well be preferable to determine the correct E_g empirically. The selected vacuum tube can be driven by an external generator having a variable output at a frequency near the actual frequency for which the oscillator is to be designed. The tube should operate into a small resistive impedance and the gridleak resistance should be the same as that to be used in the final design. E_g should be varied until the measured I_p is such that the product $I_p E_g$ agrees with the value computed from equation 1-401 (3). With E_g approximately known, N_g can be determined by means of equation 1-401 (1). 1-404. The dimensionless equations listed below relate the various parameters. These equations,

some of which have already been given, are also useful in determining the various circuit voltages and currents when E_g is known, or the requirements thereof, and in comparing the characteristics of oscillators of different design.

$$g_m Z_p = \frac{N_p (D + a)}{N_g (D - 1)} \quad 1-404 (1)$$

$$g_m Z_g = \frac{N_g (D + 1/a)}{N_p (D - 1)} \quad 1-404 (2)$$

$$N_p^2 g_m R = \frac{N_p D (a + 1)^2}{N_g a (D - 1)^2} \quad 1-404 (3)$$

$$N_g^2 g_m R = \frac{N_g D (a + 1)^2}{N_p a (D - 1)^2} \quad 1-404 (4)$$

$$R_1/R = \frac{D - 1}{a + 1} \quad 1-404 (5)$$

$$P_L/g_m E_g^2 = \frac{N_p (D + a)^2}{N_g D (D - 1) (a + 1)} \quad 1-404 (6)$$

$$P_L/P_c = \frac{(D + a)^2}{a (a + 1) (D - 1)} \quad 1-404 (7)$$

The following table, prepared by the v-h-f oscillator research team at the Georgia Institute of Technology, lists the quantitative relations that hold for five typical designs of the transformer-coupled oscillator. D , a , and the N_p/N_g ratio are predetermined to provide optimum or practical operating characteristics according to five different objectives.

A. Symmetrical circuit design that yields minimum values of $Z_p D$ and $Z_g D$. By equations 1-399 (1) and (2), this design permits maximum frequency stability if the average variations in C_p and C_g are approximately equal. Low power output. Narrow bandwidth.

B. Nonsymmetrical grid and plate impedances. Designed for optimum frequency stability when (ave) $\Delta C_g = 10$ (ave) ΔC_p . Low power output. Narrow bandwidth.

C. Nonsymmetrical grid and plate impedances. Maximum frequency stability when (ave) $\Delta C_g = 10$ (ave) ΔC_p , and the power output is 10 times that in design B, but the stability is less than that in designs A and B.

D. Symmetrical circuit. Broad-band untuned operation. Provides small values for $Z_p C_p$ and $Z_g C_g$. Tubes require large transconductance and small input and output capacities. Z_p and Z_g are one-half those in design A. Average ΔC_p assumed equal to average ΔC_g . Frequency stability below

Section I
Crystal Oscillators

average. Power output low, but greater than that in designs A and B.

E. Nonsymmetrical design except that $Z_p = Z_g$.

High power output—same as that in design C. Broad-band untuned operation. Frequency stability below average.

TRANSFORMER-COUPLED OSCILLATOR DESIGNS

Parameter	Value of Parameter				
	Design A	Design B	Design C	Design D	Design E
Z_p/Z_g	1	10	10	1	1
a	1	1	0.0985	1	0.24
D	2.414	2.414	2.414	10.65	10.65
N_p/N_g	1	$\sqrt{10}$	7.07	1	1.165
$g_m Z_p$	2.414	7.63	12.55	1.207	1.315
$g_m Z_g$	2.414	0.763	1.255	1.207	1.315
$g_m Z_p D$	5.83	18.4	30.3	12.85	14.10
$g_m Z_g D$	5.83	18.4	30.3	12.85	14.0
$N_p^2 g_m R$	4.828	15.25	104.0	0.457	0.854
$N_g^2 g_m R$	4.828	1.525	2.10	0.457	0.63
P_L/P_C	4.12	4.12	41.2	7.05	41.2
R_i/R	0.707	0.707	1.285	4.825	7.78
$\frac{P_L}{g_m E_g^2}$	1.705	5.4	11.9	0.662	1.08

MODIFICATIONS OF TRANSFORMER-COUPLED OSCILLATOR

1-405. Four modifications of the basic transformer-coupled oscillator are shown in figure 1-177. Circuits (A), (B), and (C) are experimental models that were designed at the Georgia Institute of Technology, but not in accordance with the designs given in paragraph 1-404. Circuit (D) is an oscillator in actual use that has been designed specifically to operate with Crystal Unit CR-24/U without driving the crystal beyond its Military-Standard level. Figure 1-177(A) is a

low-power circuit intended to be operated within a band of ± 2 per cent of 55 mc. When tested with a number of crystal units having overtone frequencies between 50 and 60 mc, the circuit, with L_p and L_g adjusted to be antiresonant with C_p and C_g , respectively, at 55 mc, showed the following operating characteristics. Figure 1-177(D) shows a slug-tuned transformer-coupled oscillator that employs a battery-operated subminiature tube. This oscillator is used in Radio Receiver-Transmitter RT-159A/URC-4.

f (mc)	Harmonic	C_o ($\mu\mu\text{f}$)	R (ohms)	Stability (ppm/volt)	Δf (kc)	P_L (mw)
50	5	5	48	0.6	1.5	100
54	9	5	60	0.18	0.5	80
54.8	7	6	80	0.11	0.0	50
58.3	7	8	82	0.625	1.4	40
60	3	13	25	0.66	1.7	40

Δf is the difference between the operating frequency and the series-resonance frequency of the crystal unit as measured with Crystal Impedance Meter TS-683/TSM. Figure 1-177(B) is a circuit intended for broad-band untuned operation with a center frequency at 63 mc. Satisfactory operation was obtained on a crystal plug-in basis from 53 to 73 mc. The designers recommend that the phase-

compensating network, which was selected with the help of chart I, page 445, "Network Analysis and Feedback Amplifier Design," Bode, be shifted from the grid to the plate circuit. Figure 1-177(C) is a circuit designed to provide an output approaching 1 watt at 50 mc. Due largely to difficulties in predicting the input resistance of the vacuum tube, the differences between the initial

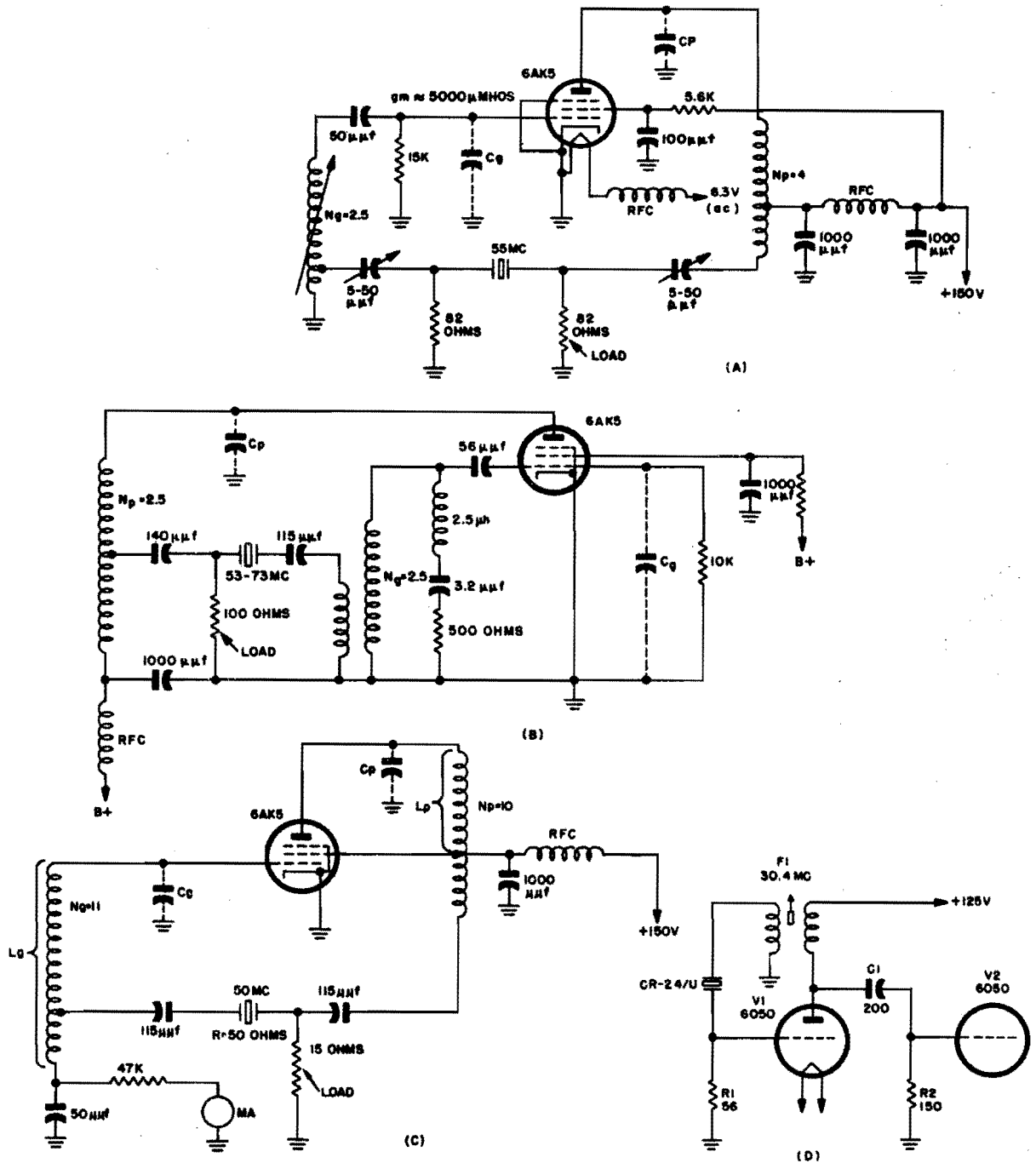

Figure 1-177. Modifications of transformer-coupled oscillator for: (A) High stability. (B) Untuned broad band. (C) Large output. (D) Slug-tuned, narrow band

design and the final adjustments (the latter shown in figure 1-177(C)) were quite large. The operating characteristics of the circuit are given below:

Frequency stability = 0.3 ppm/volt
D-C power input = 1.8 watts

R-F power output = 0.6 watt
Crystal power = 0.02 watt
Efficiency = 33 per cent
 $P_L/P_c = 30$
Grid bias = -19 volts

Section 1
Crystal Oscillators

Grounded-Grid Oscillator

1-406. The grounded-grid oscillator, or single-tube Butler oscillator (see figure 1-178) is very similar in principle to the transformer-coupled oscillator. In fact, it can be described as a transformer-coupled oscillator in which the feedback is cathode-coupled to the input. The cathode coupling eliminates the need for phase reversal in either the plate or input transformer. As indicated in figure 1-178, the input transformer can be reduced to an r-f choke. For the plate circuit, an autotransformer permits a maximum coefficient of coupling. Either a triode or pentode can be used. Although operable at lower frequencies, the oscillator is usually employed in the v-h-f range. The low input impedance reduces the effect of variations in the cathode capacitances. Unless the tube is operated class C, the crystal operates into a relatively low-resistance circuit. The power output is lower than that obtainable with a transformer-coupled oscillator, but for small outputs the frequency stability

is quite high and the load is more readily shielded from the input. This latter feature reduces the possibility that the oscillator will operate at frequencies other than that of the desired mode of the crystal. The shunt capacitance of the crystal unit should be compensated by a broad-band anti-resonant inductor, or by other means. The most dependable method for use over a wide range of frequencies is to introduce mutual inductance between the input transformer or choke and the plate transformer. This can be attained by winding the cathode inductor on the same form as the plate transformer is wound. The correct coefficient of coupling between the input and plate inductors is the one that permits the crystal to vibrate at its true motional-arm resonance. For a theoretical discussion of this mode of capacitance compensation, see Edson et al. The grounded-grid oscillator is most advantageous to use when maximum compactness and simplicity are desired in a low-power, broad-band, untuned v-h-f oscillator. There is the very important additional advantage that the oscil-

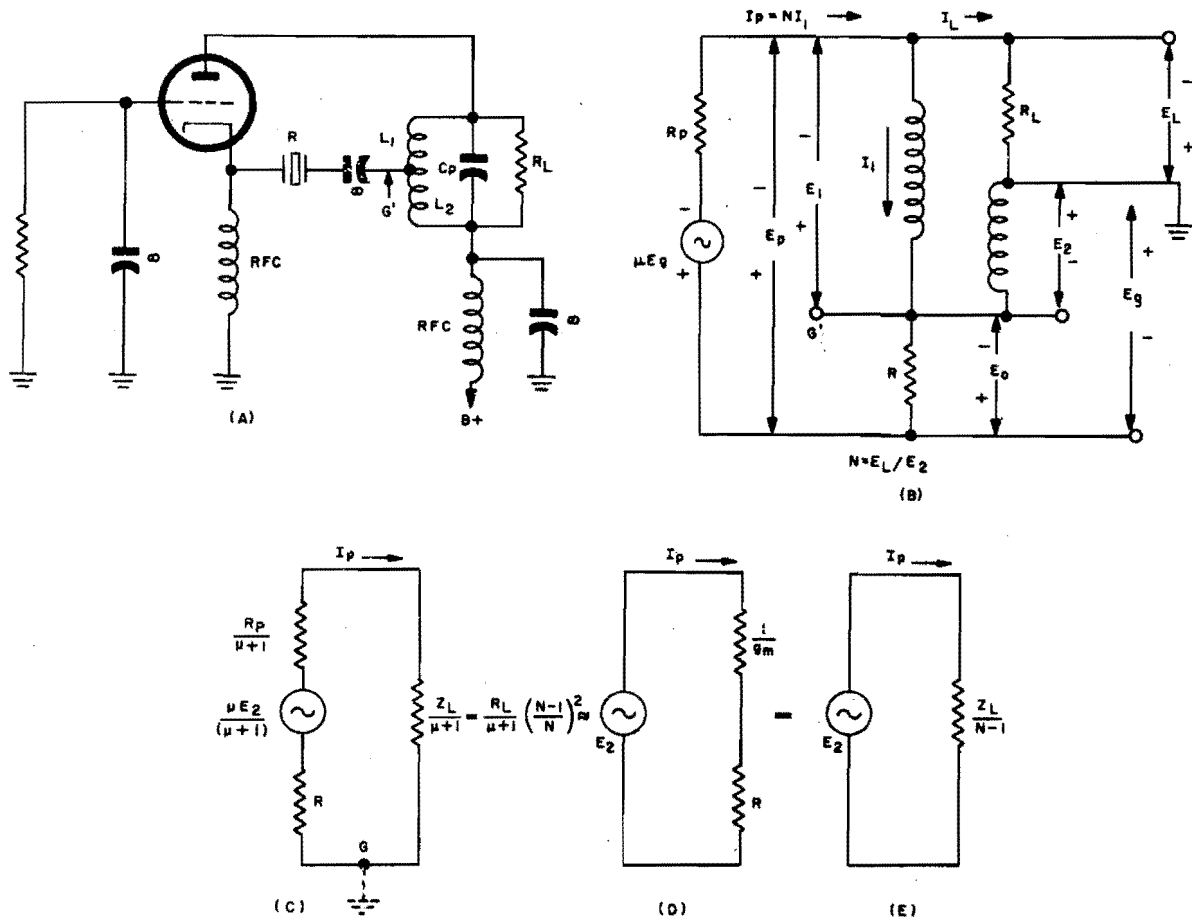

Figure 1-178. Basic grounded-grid oscillator and equivalent circuit progressively simplified

lator can be readily designed so that both the output amplitude and the frequency stability are virtually independent of the crystal resistance.

ANALYSIS OF GROUNDED-GRID OSCILLATOR

1-407. Referring to figure 1-178, it will be assumed that the plate circuit is tuned to the desired harmonic, series-resonance frequency of the crystal, that the resistance in the plate tank is negligible, that the grid current is negligible, that the auto-transformer coefficient of coupling is unity, that the cathode-to-ground capacitance is antiresonant with the cathode choke, and that the r-f current through the choke is negligible. Under these conditions the equivalent r-f circuit of the oscillator is that shown in figure 1-178(B). All voltage symbols are treated as unsigned. The polarities shown correspond to the instantaneous polarities that hold during the positive alternations of the r-f grid voltage, E_g . The current arrows point in the instantaneous direction of the in-phase electron flow. The reactive component of the plate tank current is not represented, although in reality it is primarily the "flywheel" current that produces the voltages E_1 and E_2 . This reactive current in the tank is that which flows through C_p and is equal to $\omega C_p E_L$. If R_L were reduced to zero, there would be no reactive current and the transformer would effectively short-circuit the crystal to the plate. Of course, oscillations could not exist under these conditions, if for no other reason than the fact that E_p would be reduced to zero and E_g , being simply the voltage across the crystal unit, would be displaced 180 degrees from the phase required for oscillations to be maintained. E_2 must be greater than E_1 . The important feature to remember is that insofar as the resistive component of the current is concerned the action of the auto-transformer is the same as that of a conventional transformer when the primary and secondary circuits are connected in parallel as shown in figure 1-178(B). Note, however, that the turns ratio, N , is defined as the ratio of the total turns to the turns comprising L_2 .

1-408. The power fed to the transformer is simply

$$P_L = I_L E_L = I_p E_1 \quad 1-408 (1)$$

Now,

$$E_L = E_1 + E_2 = E_1 + \frac{E_L}{N}$$

or

$$E_L = \frac{NE_1}{N-1} \quad 1-408 (2)$$

So

$$I_L = \frac{I_p E_1}{E_L} = \frac{(N-1) I_p}{N} \quad 1-408 (3)$$

And since

$$I_p = I_L + I_1 \quad 1-408 (4)$$

We have

$$I_p = \frac{(N-1) I_p}{N} + I_1 \quad 1-408 (5)$$

or

$$I_p = NI_1 \quad 1-408 (6)$$

and

$$I_L = I_1 (N-1) \quad 1-408 (7)$$

The ratio of the output to the crystal power is

$$P_L/P_c = I_L^2 R_L / I_p^2 R = \frac{R_L}{R} \left(\frac{N-1}{N} \right)^2 = Z_L/R \quad 1-408 (8)$$

Note that for a given turns ratio, the power ratio is directly proportional to the resistance ratio.

The term $R_L \left(\frac{N-1}{N} \right)^2$ is simply the equivalent load resistance, Z_L , that the transformer presents to I_p . The total impedance across the vacuum tube is thus

$$Z_p = R_L \left(\frac{N-1}{N} \right)^2 + R = Z_L + R \quad 1-408 (9)$$

1-409. It is convenient to imagine that the ground connection is at the point G' in figure 1-178. That is, let G' be our point of reference. Insofar as the r-f circuit is concerned such a supposition requires no alteration in the currents and voltages involved, but it does simplify the visualization of the circuit characteristics. The supposition does not mean that there is no difference in the r-f potential between G' and the actual ground. With G' in figure 1-178 (B) assumed to be the ground connection, it can be seen that the tube is effectively connected as a cathode follower except that no load is taken from the cathode circuit. The crystal R is the cathode resistance, and E_2 is the voltage input to the grid circuit. As discussed in the analysis of the two-tube Butler circuit and as illustrated in figure 1-173, the cathode-follower type of circuit can be represented by an equivalent circuit in which the plate-circuit resistance, exclusive of the cathode resistance, is equal to $\frac{1}{\mu+1}$ times the actual re-

Section 1
Crystal Oscillators

istance. Also, the equivalent generator voltage is $\frac{1}{\mu + 1}$ times the conventional value that would be assumed if the cathode resistance were not present. As applied to the grounded-grid oscillator, the equivalent circuit is that shown in figure 1-178 (C). Care must be taken not to interpret the power supplied to the plate-circuit resistances as being reduced by a factor of $\frac{1}{\mu + 1}$. With μ and R_p assumed large compared with unity and Z_m , respectively, circuit (C) reduces to circuit (D).

LOOP GAIN IN GROUNDED-GRID OSCILLATOR

1-410. At equilibrium

$$G_1 G_2 G_3 G_4 = \frac{E_o}{E_2} \cdot \frac{E_1}{E_o} \cdot \frac{E_L}{E_1} \cdot \frac{E_2}{E_L} = 1 \quad 1-410 (1)$$

where

$$G_1 = \frac{E_o}{E_2} = \frac{\mu R}{R_p + Z_L + R(\mu + 1)} = \frac{R}{\frac{1}{g_m} + R} \quad 1-410 (2)$$

$$G_2 = E_1/E_o = Z_L/R = \frac{R_L(N - 1)^2}{RN^2} \quad 1-410 (3)$$

$$G_3 = E_L/E_1 = N/(N - 1) \quad 1-410 (4)$$

$$G_4 = E_2/E_L = 1/N \quad 1-410 (5)$$

Equation (2) simply represents the gain of a cathode follower. It can be derived from the equivalent circuits in figure 1-178 in a manner similar to the cathode follower gain derivation in the analysis of the two-tube Butler circuit. In combining equations (2), (3), (4), and (5), we have

$$G_1 G_2 G_3 G_4 = \frac{N^2 (R_p + R + \mu R)}{R_L (N - 1) (\mu + 1 - N)} = 1 \quad 1-410 (6)$$

If the approximate value for G_1 can be assumed, the gain equation can be expressed as

$$\frac{1}{g_m} = \frac{R_L (N - 1)}{N^2} - R = \frac{Z_L}{N - 1} - R \quad 1-410 (7)$$

ACTIVITY CONSIDERATIONS IN GROUNDED-GRID OSCILLATOR

1-411. From equation 1-410(7) we can predict

the relative activity to be expected with different load and crystal resistances. When oscillations first start, the term $1/g_m$ is a minimum. The amplitude increases until g_m is reduced by the increase in grid bias to the value that makes equation 1-410 (7) hold. The greater the difference between the initial, zero-bias value of g_m and the equilibrium value, the greater will be the final amplitude. The initial g_m of the tube should therefore be as large as possible if a maximum output is desired. For a given crystal R , the output is increased by increasing R_L and making the ratio $\frac{N - 1}{N^2}$ a maximum, which occurs when $N = 2$. Assuming that $N = 2$, i.e., that the transformer coil is center-tapped at the connection to the crystal, equation 1-410(7) becomes

$$1/g_m = R_L/4 - R = Z_L - R \quad 1-411 (1)$$

In equation 1-408 (8), it was found that the power ratio, to which we shall assign the symbol $r \left(= \frac{P_L}{P_c} \right)$, is equal to Z_L/R . On substituting the value rR for Z_L in equation (1) we find that

$$r = 1 + \frac{1}{g_m R} \quad 1-411 (2)$$

By equations (1) and (2), which hold only when $N = 2$, we see that increasing the amplitude by increasing R_L results in simultaneously increasing the power ratio. Also, note that the minimum power ratio can be predetermined as a function of the class-A value of g_m and the maximum permissible R of the crystal unit. If variations in R from crystal unit to crystal unit are not to have a large effect upon the output amplitude, $Z_L \left(= \frac{R_L}{4} \right)$ must be large compared with the maximum crystal R . In other words, the minimum power ratio should be as large as possible consistent with the requirements of frequency stability.

CRYSTAL DRIVE-LEVEL CONSIDERATIONS IN GROUNDED-GRID OSCILLATOR

1-412. If P_{cm} is the rated maximum power of the crystal unit, the maximum permissible I_p for a given R is

$$(\max) I_p = (\max) E_g g_m = \sqrt{P_{cm}/R} \quad 1-412 (1)$$

Consequently,

$$(\max) E_1 = (\max) I_p Z_L = Z_L \sqrt{P_{cm}/R} \quad 1-412 (2)$$

By equations 1-410 (4) and (5)

$$(\max) E_L = \frac{(\max) E_1 N}{N-1} = \frac{Z_L N \sqrt{P_{cm}/R}}{N-1} \quad 1-412 (3)$$

and

$$(\max) E_2 = (\max) E_L/N = \frac{Z_L \sqrt{P_{cm}/R}}{N-1} \quad 1-412 (4)$$

Assuming that $N = 2$, we have

$$\begin{aligned} \frac{(\max) E_L}{2} &= (\max) E_1 = (\max) E_2 \\ &= \frac{R_L}{4} \sqrt{\frac{P_{cm}}{R}} \end{aligned} \quad 1-412 (5)$$

The maximum permissible excitation voltage of the tube with a center-tapped transformer is

$$\begin{aligned} (\max) E_g &= \frac{(\max) I_p}{g_m} = (\max) E_2 - (\max) E_o \\ &= \left(\frac{R_L}{4} - R \right) \sqrt{\frac{P_{cm}}{R}} \end{aligned} \quad 1-412 (6)$$

Equation (6) is to be interpreted as giving the maximum permissible E_g for a given value of R . The smaller the value of R , the larger will be the permissible value of E_g . For v-h-f crystal units in which the shunt capacitance of the crystal is not compensated the minimum R encountered may be on the order of $R_m/5$, where R_m is the rated maximum. However, with capacitance compensation all values of R will be less than R_m , and the minimum may well be on the order of $R_m/9$ or less. The plate characteristics of the vacuum tube and the electrode voltages must be such that an excitation voltage equal to the maximum permissible E_g , as defined by equation (6), does not cause an effective I_p greater than $\sqrt{P_{cm}/R}$. With a sharp-cutoff, grid-leak-biased tube operating into a plate impedance that is small compared with R_p , the effective I_p remains essentially constant as the peak-to-peak amplitude of E_g is increased from a value equal to $|E_{co}|$ to a value equal to $2|E_{co}|$, where E_{co} is the cutoff bias. As discussed in paragraph 1-312 in connection with the Pierce circuit, the crest amplitude of I_p between the crest values of E_g equal to $\frac{|E_{co}|}{2}$ and $|E_{co}|$ remains approximately equal to $\frac{I_{bm}}{2}$,

where I_{bm} is the zero-bias plate current. There is a small maximum approximately equal to $0.54 I_{bm}$ (see equation 1-312 (21)), but for all practical

purposes it can be assumed that I_p is constant for all values of g_m between class-A and class-B operation. Since the effective g_m is equal to I_p/E_g , the doubling of E_g without changing I_p is equivalent to halving g_m . If oscillations can be maintained at all, the slightest tolerance allowed in g_m ensures that the amplitude will build up until the excitation voltage overlaps the lower bend in the $E_c I_b$ curve. Thus, for a sharp-cutoff tube the minimum equilibrium E_{gm} ($= \sqrt{2} E_g$) will very nearly equal $\frac{|E_{co}|}{2}$. Since $1/g_m = Z_L - R$ when $N = 2$, any value of Z_L greater than $2R_m$ can ensure that the r-f plate current, and hence the output, will be the same for all values of R falling within the crystal specifications. All that need be done is to design the circuit for class-A operation on the assumption that $R = R_m$. This requires the use of a sharp-cutoff vacuum tube with tube voltages such that

$$I_{bm} < 2 \sqrt{\frac{2 P_{cm}}{R_m}} \quad 1-412 (7)$$

and the design of the load and transformer network such that

$$\left| \frac{E_{co}}{I_{bm}} \right| \approx \frac{Z_L}{N-1} - R_m \quad 1-412 (8)$$

Under the conditions defined by equations (7) and (8), a crystal having a maximum R will be driven at or under the rated maximum drive, depending upon whether I_{bm} is equal to, or less than, the value specified in equation (7). If the crystal unit is replaced by another of lower resistance, the crystal current and the output will remain essentially the same. Since E_2 will also be unchanged, the increase in the excitation voltage will be entirely that due to the decrease in the voltage across the crystal. The driving power of the crystal will be directly proportional to the crystal R .

FREQUENCY STABILITY OF GROUNDED-GRID OSCILLATOR

1-413. In the equivalent circuit shown in figure 1-178(D), it can be seen that the effective resistance, R_o , of the crystal circuit is $\left(\frac{1}{g_m} + R \right)$. But,

$$1/g_m = \frac{Z_L}{N-1} - R, \text{ thus}$$

$$R_o = \frac{Z_L}{N-1} - R + R = \frac{Z_L}{N-1} \quad 1-413 (1)$$

If $N = 2$,

$$R_o = Z_L = R_L/4 \quad 1-413 (2)$$

Section I
Crystal Oscillators

Equations (1) and (2) assume that the μ of the tube is large compared with unity, and that $R_p \gg Z_L$. From equation 1-241 (2), the fractional change in frequency required to compensate a small change, $d\theta$, in the feed-back phase is

$$\frac{d\omega}{\omega} = \frac{R_c d\theta}{2\sqrt{L/C}} = \frac{Z_L d\theta}{2(N-1)\sqrt{L/C}} = \frac{R_L d\theta}{8\sqrt{L/C}}$$

1-413 (3)

where L and C are series-arm parameters of the crystal, and equation (2) is assumed to hold. Of significance is the fact that for a given Z_L , the frequency stability is independent of the resistance

of the crystal. However, $\left(\frac{Z_L}{N-1}\right)$ must always be greater than R , else the conditions for oscillation as defined by equation 1-410 (7) cannot hold. Thus, although the frequency stability can be considered independent of R for a given Z_L , the effective Q of the crystal circuit must always be less than the lowest actual Q $\left(= \frac{2\omega L}{R_m}\right)$ of the crystal.

The larger the g_m of the tube, the more nearly can this limiting value for the effective Q be reached,

since the more nearly $\left(\frac{Z_L}{N-1}\right)$ can be made to approach R_m in magnitude. But a large g_m must be accompanied by a low cutoff voltage for the tube, else equations 1-417 (7) and (8) cannot be made to hold and the crystal will be overdriven. Unfortunately — yet not unexpectedly — the requirements for maximum output are the reverse of those for maximum frequency stability. If the only frequency-stability problem were to maintain the circuit Q as high as possible, the output could be increased without decreasing the stability, by making both R_L and N large. This could permit an increase in Z_L , without affecting the value of $\left(\frac{Z_L}{N-1}\right)$. On the other hand, if $d\omega/\omega$ in equation

(3) is to be kept small, not only $\left(\frac{Z_L}{N-1}\right)$ but also $d\theta$ must be kept to a minimum. Because the input impedance of the tube is very low, changes in the cathode capacitance have a negligible effect on the feed-back phase. The principal variations in the phase are due to changes in the plate and load capacitance. To reduce these effects to a minimum, Z_L must be as small as possible. Its smallest permissible value will occur when $\left(\frac{N-1}{N^2}\right)$ is a maximum; that is, when $N = 2$. Letting $N = 2$ and $R_L = 8R_m$, Z_L will equal $R_L/4 = 2R_m$. The crystal-circuit Q for all values of R will then be one-half

the minimum crystal Q to be expected for the particular type of crystal unit. The output will approximately equal $2P_{cm}$ for all values of crystal R . Much larger outputs can be obtained without greatly reducing the frequency stability, by the use of remote-cutoff tubes. With these tubes the r-f plate current can be made to vary inversely with the square root of the crystal resistance. Under these conditions, it would be the crystal power that remains constant and the output power that varies with R . If $P_L = 2P_{cm}$ when $R = R_m$, $P_L = 18P_{cm}$ when $R = R_m/9$.

**DESIGN PROCEDURE FOR
GROUNDED-GRID OSCILLATOR**

1-414. The design procedure depends considerably upon the special requirements to be met by the circuit. As a concrete example assume that a low-power, 50-mc oscillator requiring a minimum of circuit components and an output amplitude that will not be greatly affected by a replacement of the crystal unit with another of the same frequency is desired. The grounded-grid oscillator is probably the best suited for such a purpose. Assume further that a frequency tolerance of ± 0.01 per cent is required without temperature control for all temperatures between -40 and $+90$ degrees centigrade. Crystal Unit CR-24/U with a frequency tolerance of ± 0.005 per cent between -55 and $+90$ degrees centigrade should be able to provide the required stability. So also will Crystal Unit CR-23/U, but the former unit is mounted in the coaxial holder, the HC-10/U, which is generally to be preferred because its lower inherent shunt capacitance should permit a higher average Q . There is no guarantee of this, since the maximum C_o is $7 \mu\text{f}$ in each case; however, the CR-24/U employs the 5th harmonic and the CR-23/U the 3rd harmonic (thinner crystal) for the 50-mc frequency. The greater CR-24/U L/C ratio should more than offset its slightly higher R_m . Nevertheless, a check should be made to see if crystal units of either type having the desired frequency are currently being manufactured or have been manufactured in the past. If not, serious consideration should be given to the possibility of employing a different frequency. The cost of the crystal unit will be less if it is already in production, and the risk that an undue amount of experimentation will be required to produce a crystal unit that meets the military standards at an unexplored frequency can be avoided. If the crystal unit is expected to withstand considerable mechanical shock, the CR-24/U must be used, regardless.

1-415. Assume that a 50-mc CR-24/U crystal unit

has been selected. According to Military Standard MS91380, $R_m = 75$ ohms and $P_{cm} = 2$ mw. By equation 1-412(1)

$$(\text{max}) I_p = 10^3 \sqrt{\frac{0.002}{75}} = 5.2 \text{ ma}$$

According to equation 1-412(7)

$$I_{bm} < 2 \sqrt{2} \times 5.2 = 14.7 \text{ ma}$$

Assume that the most available tube is the 6AU6, sharp-cutoff, miniature pentode. Operated at 250 plate volts, a screen voltage of 140 volts provides a zero-bias plate current of approximately 15 ma. The cutoff bias will be approximately -5 volts. Assuming a value of $N = 2$, by equation 1-412(8)

$$Z_L = 75 + \frac{5}{0.015} = 410 \text{ ohms}$$

and

$$R_L = 4 Z_L = 1640 \text{ ohms}$$

The power ratio when $R = R_m$ will be

$$(\text{min}) r = \frac{Z_L}{R_m} = 5.5$$

The power output for all values of R will be

$$P_L = (\text{min}) r P_{cm} = 11 \text{ mw}$$

The crystal unit will operate into an effective resistance equal to 410 ohms. The effective g_m of the tube will vary from approximately 3000 μmhos , when R is a maximum, to approximately 2500 μmhos , when R is a minimum. If greater frequency stability is required, R_L can be decreased by ap-

proximately three-fourths, so that $Z_L = 300$ ohms. With this value of Z_L , when R is maximum g_m will be 4450 μmhos . By increasing the screen voltage to 150 volts or slightly greater, an r-f plate current very nearly equal to the maximum permissible for R_m can be attained. As R is decreased I_p and P_L increase somewhat, but the crystal unit will not be overdriven.

MODIFICATIONS OF THE GROUNDED-GRID OSCILLATOR

1-416. Figure 1-179 shows four different designs of the grounded-grid oscillator which were built and successfully tested at the Georgia Institute of Technology. Because of the high initial transconductances, 0.011 μmho for the 6J4 and 0.009 for the 6AH6, the oscillation amplitude of these circuits would drive the average Military Standard crystal unit beyond the recommended maximum level. This does not mean that a standard crystal unit will necessarily be in danger of being shattered by the circuits shown, but that the frequency, resistance, and freedom from spurious modes could not be guaranteed by the test standards. To employ the circuits illustrated in figure 1-179, different tubes, or plate-supply voltages may need to be used.

1-417. Figure 1-179(A) is a narrow-band oscillator with the load connected across the secondary of the plate transformer. Except for the fact that the input "transformer" (L_k , having a 1:1 voltage ratio) provides no phase reversal, the circuit is very similar to that of the basic transformer-coupled oscillator. R_L , connected as shown, is equivalent to a load resistance of $N^2 R_L$ connected across L_p . The variable capacitance is for tuning out the transformer leakage inductance. L_k is anti-resonant with the cathode capacitance, and the

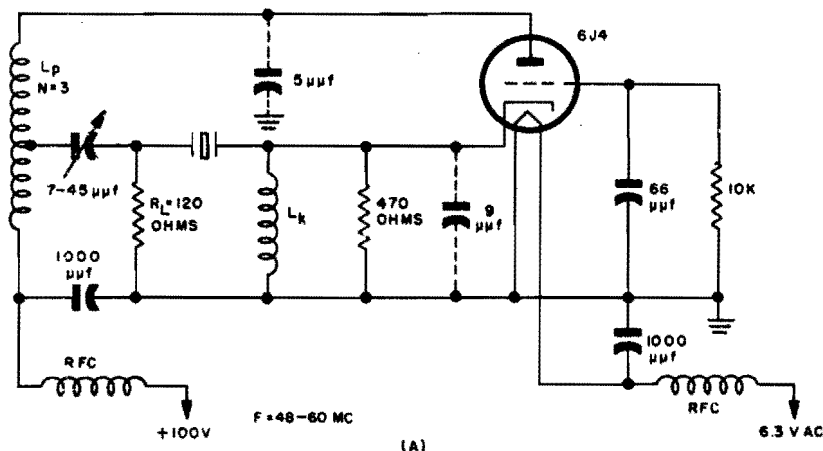

Figure 1-179. Modifications of grounded-grid oscillator. (A) Narrow-band circuit

Section I
Crystal Oscillators

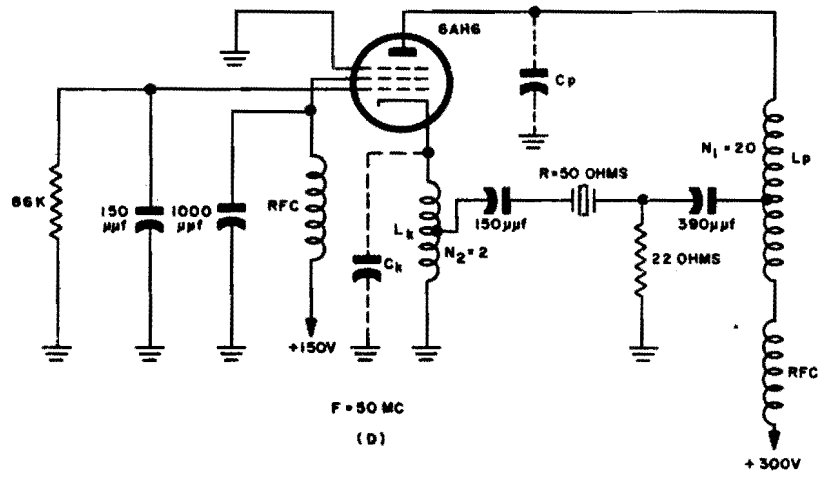
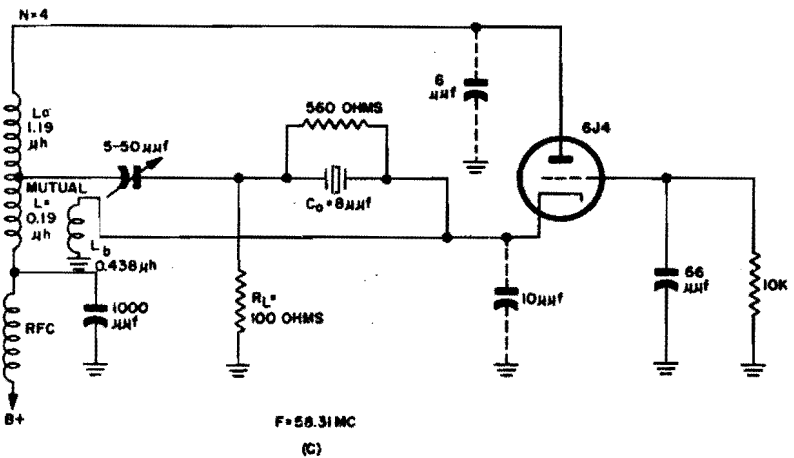
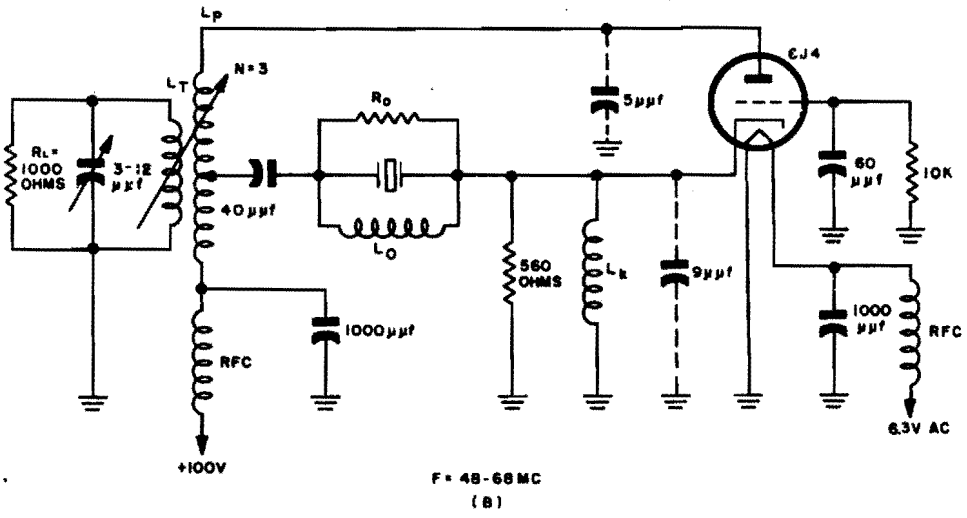

Figure 1-179. Modifications of grounded-grid oscillator. (B) Broad-band circuit. (C) Circuit for compensating crystal capacitance by mutual inductance. (D) High-efficiency class-C circuit

cathode resistance broadens the tuning. The circuit was tuned for operation at a center frequency of 55 mc. The plate transformer consists of 12 turns of AWG No. 26 PE wire wound on a Miller

type 69048 slug-tuned coil form and tapped at 4 turns. The circuit operates class B. The operating data for several different crystal units is given below.

f (mc)	Harmonic	C _o (μμf)	R (ohms)	Stability (ppm/volt)	Δf (kc)	P _L (mw)
48	3	14	45	0.42	3	55
50	3	12.5	35	0.20	1.5	103
54	3	13.5	45	0.11	9	78
58	7	9	32	0.14	0.6	28
60	3	13	25	0.24	1.6	40

The frequency stability is measured in average parts per million per volt when the voltage is changed by 50 volts. Δf gives the deviation observed between the series-resonance frequency, when measured with CI Meter TS-683/TSM, and the actual oscillator frequency. It would seem that the 54-mc crystal, which should show the smallest value of Δf, was influenced by a spurious mode.

1-418. The circuit in figure 1-179 (B) is designed for broad-band untuned operation. L_p consists of 10 turns of No. 30 PE wire, tapped at 3.3 turns

and wound on a 0.4-inch-diameter form. The tertiary winding, L_T, consists of 17 turns on a 0.24-inch form that can be slipped inside the L_p core by a screw adjustment. The circuit is first tuned with a 1000-ohm load connected directly across L_p with L_T open. Next, with the circuit connected as shown, the coupling between L_T and L_p is adjusted until the same grid current as before is obtained. All tuning adjustments were made at 57.5 mc. The performance data of this circuit for several different crystals is given below.

f (mc)	Harmonic	C _o (μμf)	R (ohms)	Grid I _c (μamp)	Stability (ppm/volt)	Δf (kc)	P _L (mw)
48	3	14.5	25	58	0.21	5	41
50	3	11	28	85	0.25	-0.5	45
58.31	7	8	80	60	0.01	0	52
65.31	7	10	80	65	0.15	0.2	46
66.65	5	4	65	90	0.21	2.0	50
67.2	7	14	80	62	0.07	4.0	47

1-419. The circuit in figure 1-179 (C) is designed to compensate the capacitance of the crystal unit by mutual inductance between the plate and cathode inductors instead of by a shunt inductor as in circuit (B). L_a consists of 9 close-wound turns of AWG No. 30 PE wire, tapped at 2.5 turns; L_b consists of 4.5 turns of AWG No. 30 PE wire on a thin spacer. The proper coupling adjustment is obtained by substituting a capacitance equal to C_o in place of the crystal and adjusting the circuit to oscillate at the true series-resonance frequency of the motional arm, but only after L_a and L_b have separately been adjusted to resonate with C_p and C_k, respectively, at their computed resonant frequencies ($\omega_a^2 = \frac{1}{L_a C_p}$, $\omega_b^2 = \frac{1}{L_b C_k}$). It can be shown

that

$$L_a = \frac{L_p N_1^2 L_o}{(1 - M^2) (L_p + N_1^2 L_o)} \quad 1-419 (1)$$

$$L_b = \frac{L_k N_2^2 L_o}{(1 - M^2) (L_k + N_2^2 L_o)} \quad 1-419 (2)$$

and

$$M^2 = \frac{L_p L_k / N_2^2}{(L_p + N_1^2 L_o) (L_o + L_k / N_2^2)} \quad 1-419 (3)$$

where L_p and L_k are the values of the plate-to-ground and cathode-to-ground inductances, respec-

Section I
Crystal Oscillators

tively, that would occur if there were no coupling between them, L_o is the imaginary shunt inductance that would be required to antiresonate C_o , M is the coefficient of coupling between the plate and cathode inductors, and N_1 and N_2 are the plate and cathode turns ratios, respectively. N_2 is simply equal to unity in the circuit shown. The performance data for the circuit is as follows:

- $f = 58.31$ mc
- stability = 0.28 ppm/volt
- $P_L = 90$ mw
- Δf = operating freq minus tested series-resonance freq = -100 cycles
- Δf when C_k increased from 10 to 13 $\mu\mu f$
= -60 cycles
- Δf when C_o increased from 8 to 11 $\mu\mu f$
= -45 cycles
- Δf when C_p increased from 6 to 6.5 $\mu\mu f$
= -90 cycles

1-420. The circuit shown in figure 1-179 (D) is designed for high-efficiency operation as a small class-C power oscillator. L_p consists of 20 turns of AWG No. 28 PE wire wound on a 0.25-inch coil form and tapped at 1 turn. L_s is a 10-turn, 0.25-inch-diameter coil of AWG No. 28 PE wire, tapped at 5 turns. The observed performance data for this circuit is as follows:

- $f = 50$ mc
- load voltage = 9 volts
- grid bias = -10 volts
- load power = 1.9 watts
- crystal power = 0.08 watts
- frequency stability = 0.6 ppm/volt
- plate dissipation = 3 watts
- efficiency = 63 per cent

The Grounded-Plate Oscillator

1-421. The vacuum-tube circuit of the grounded-plate oscillator shown in figure 1-180 is essentially the same as the two-tube Butler oscillator except that a step-up transformer replaces the grounded-grid amplifier of the Butler circuit. The gain of the Butler grounded-grid tube is thus replaced by the gain, N , of the transformer in figure 1-180 (A). The grounded-plate oscillator is most advantageous when used in the electron-coupled form, as shown in figure 1-180 (C), where the plate circuit can be tuned to provide frequency multiplication. Otherwise, the larger output of the basic transformer-coupled circuit or the greater simplicity of the grounded-grid circuit make these oscillators preferable to the grounded-plate design insofar as obtaining the same order of frequency stability is

concerned. The grounded-plate oscillator can be designed for larger outputs by providing a step-up transformer in the cathode circuit and removing the r-f voltage from the gridleak resistor, as is shown in figure 1-180 (B). This permits the cathode-follower to operate into the same output impedance but with a greatly reduced load resistance across the crystal circuit. The output per milliwatt of crystal power is thereby increased. Increasing the power output in this manner makes the oscillator more critical to design and adjust so as to prevent free-running oscillations, particularly if the tube is to be operated class C, where the effective input impedance becomes more or less unpredictable at very high frequencies.

1-422. The over-all gain equation of the oscillator in figure 1-180 (A) is

$$\frac{\mu N R_2 Z_k}{(R + R_2)(R_p + Z_k + \mu Z_k)} = 1 \quad 1-422 (1)$$

where Z_k is the total effective resistance between the cathode and ground. Assuming that the resistance presented by the transformer is equal to R_c/N^2 and is much greater than R_2 , we have

$$Z_k = \frac{R_1 (R + R_2)}{R_1 + R + R_2} \quad 1-422 (2)$$

The effective resistance into which the crystal operates is

$$R_c = Z_k' + R + R_2 \quad 1-422 (3)$$

where Z_k' is the output impedance of the cathode follower as faced by the crystal. If μ is very large compared with unity,

$$Z_k' = \frac{R_1}{1 + g_m R_1} \quad 1-422 (4)$$

For crystal resistances on the order of 75 ohms or smaller, R_1 and R_2 can also be approximately 75 ohms each. Values of $R_1 = 68$ ohms, $R_2 = 100$ ohms, $R_c = 200K$, and $N = 9$ have been recommended for use with a 6J4 triode. The shunt capacitance of the crystal unit, as well as that of the grid and cathode, can be compensated if need be by conventional antiresonant inductors. To be preferred is the method described in the discussion of the two-tube Butler circuit—designing the circuit so that

$$g_m Z_k = \frac{C_{gc}}{C_k} \quad 1-422 (5)$$

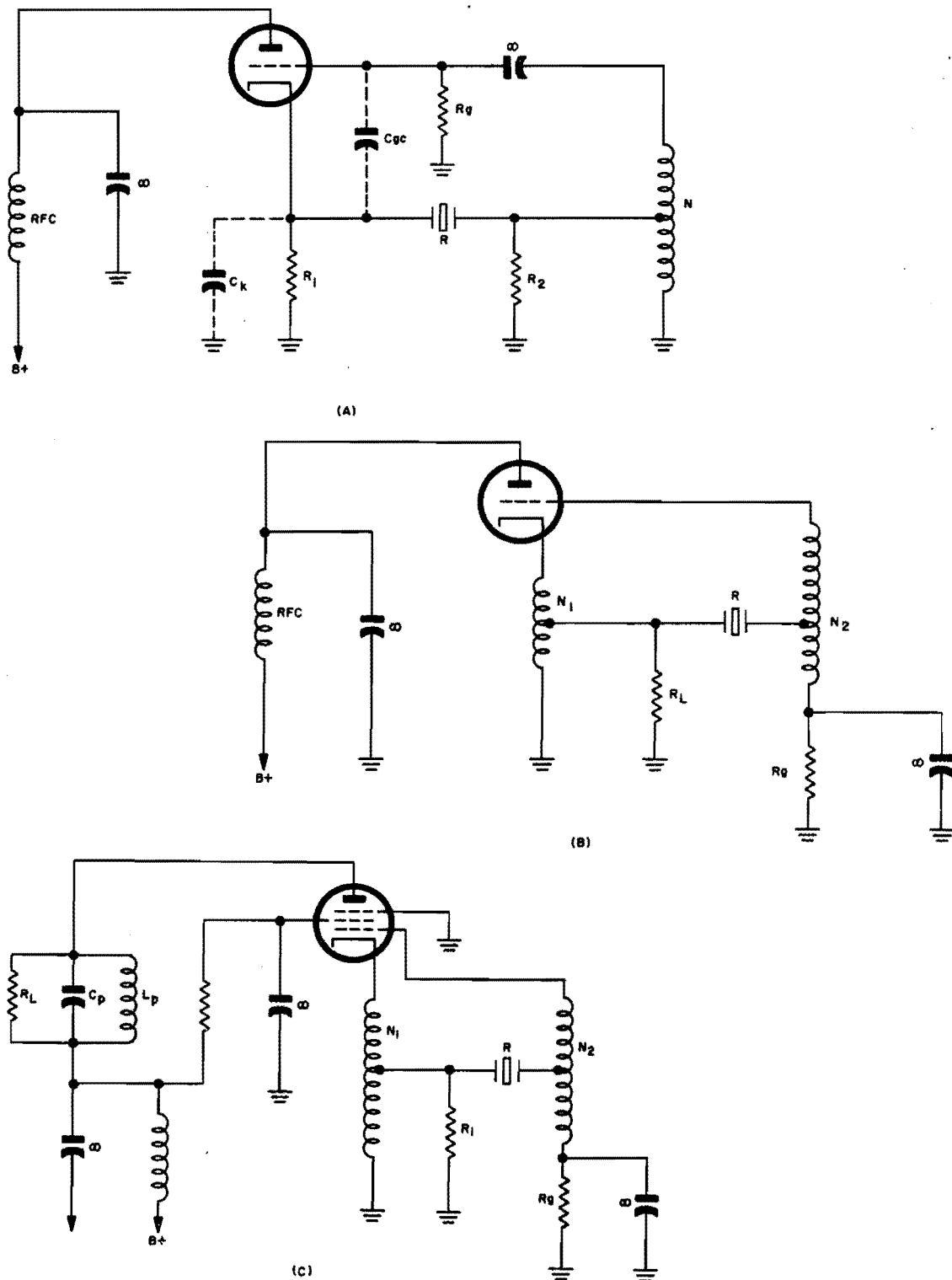

Figure 1-180. Grounded-plate oscillators. (A) Basic circuit. (B) Circuit for increased power output. (C) Electron-coupled circuit

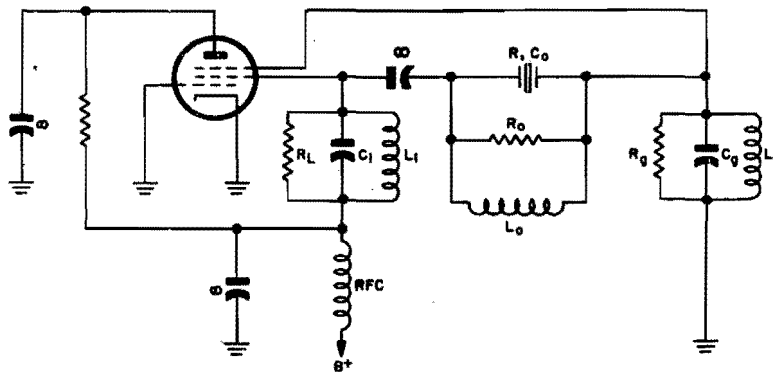

Figure 1-181. Transistron crystal oscillator

Transistron Crystal Oscillator

1-423. The transistron oscillator (see figure 1-181) operates by virtue of the negative transconductance between the suppressor and screen grids of a pentode. The total cathode current of the pentode is little affected by variations in the suppressor voltage, being primarily a function of the potential between the screen and cathode. However, as the suppressor voltage is made more negative, the fraction of the total space current diverted to the screen circuit is increased. The screen voltage therefore tends to follow the suppressor voltage. By connecting a resonant feed-back network between the screen and suppressor, oscillations can be maintained and no phase reversal is necessary. The principal advantage of this circuit is its simplicity and its ability to oscillate with series-mode crystals having comparatively high series resistances. It can be employed in the v-h-f range, but unless the crystal resistances are expected to be abnormally high, the relatively large electrode capacitances and the small transconductance make the performance inferior to that of the transformer-coupled oscillator.

1-424. When the circuit is used with high-resistance crystals it is very important that the crystal shunt capacitance be properly compensated, in order to eliminate the possibility of free-running oscillations. As has been demonstrated by W. A. Edson with the aid of Nyquist diagrams (graphical representations of the over-all loop gain and phase rotation as the frequency is varied from 0 to ∞), the circuit can be designed to permit only one mode of oscillation if, treating g_m as unsigned,

$$\frac{g_m R_L R_g}{R_o + R_L + R_g} < 1 \quad 1-424 (1)$$

and

$$\frac{R_L R_g}{R_o} \left(\frac{C_1 + C_g}{R_o} + \frac{C_1}{R_g} + \frac{C_g}{R_1} \right) < C_o \quad 1-424 (2)$$

The condition implied by equation (1) when g_m is its maximum possible value means that the loop gain is insufficient to start or maintain oscillations at any frequency unless R_o is effectively decreased (such as being bypassed by the series-resonance R of the crystal) so that the left side of the equation is greater than or equal to unity. Equation (2), when satisfied, means that a zero phase shift in the feedback can occur at only one frequency. Thus, if the circuit is tuned for operation at the desired series-mode frequency of the crystal and equations (1) and (2) are satisfied, spurious oscillations will not be possible.

1-425. Note that C_o is effectively increased by the suppressor-to-screen capacitance, so that L_o must be smaller than would otherwise be the case. C_1 and C_g are simply distributed capacitances to ground. Each of the three parallel combinations are antiresonant at the crystal frequency, so $L_1 C_1 = L_o C_o = L_g C_g = \frac{1}{\omega^2}$. Assuming that the antiresonant circuits have impedances R_L , R and R_g , respectively, then if I_{g2} is the r-f screen current, the voltage across the load is

$$E_{g2} = \frac{I_{g2} R_L (R + R_g)}{R_L + R + R_g} \quad 1-425 (1)$$

The r-f suppressor voltage is

$$E_{g3} = \frac{E_{g2} R_g}{R + R_g} = \frac{I_{g2} R_L R_g}{R_L + R + R_g} \quad 1-425 (2)$$

If we assume that E_{g3} is small compared with the

d-c screen voltage, and define the suppressor-to-screen transconductance as the change in screen current per change in suppressor-to-cathode voltage—not per change in the suppressor-to-screen voltage—the gain conditions for equilibrium are, by equation (2),

$$\frac{E_{g2}}{I_{g2}} = \frac{1}{g_m} = \frac{R_L R_g}{R_L + R + R_g} \quad 1-425 \quad (3)$$

Of the vacuum tubes available, the 6AS6, which has a suppressor-to-screen transconductance of 1600 μ mhos, is probably to be preferred. With this tube, oscillations can be maintained with crystal units having series resistances of well over 1000 ohms. Although oscillations can also be maintained with large values of R_L and R_g , these resistances should be kept as small as practicable so as not to unnecessarily degrade the crystal Q and reduce the frequency stability. The transitron oscillator is also quite useful at low frequencies, particularly with high-resistance crystal units. When a fundamental-mode crystal element is employed, the tuned circuits may not be necessary; but to avoid the possibility of free-running oscillations or unwanted crystal modes, at least the screen circuit should be broadly tuned. (See paragraph 1-590 for discussion of negative-resistance limiting of transitron circuit.)

Impedance-Inverting Crystal Oscillators

1-426. Impedance-inverting oscillators employ a network similar to that shown in figure 1-182 (A), to permit conventional lower-frequency oscillators to be operated with crystal control in the v-h-f range. A number of these oscillators were designed and tested at the Georgia Institute of Technology under the direction of Mr. W. A. Edson. The discussion to follow is based on the final report of this research. The impedance-inverting network is designed to behave as a quarter-wave line having a characteristic impedance, $Z_0 = \omega L_1 = \frac{1}{\omega C_n} = \frac{1}{\omega C_o}$. With this design, the network always appears as an inverted Z_s , equal to $Z_n = \frac{Z_o^2}{Z_s}$, where Z_s is the series-arm impedance of the crystal. If $Z_s = 0$, C_o is shorted out and Z_n is infinite. (L_1 is assumed to have a zero loss.) If Z_s is infinite, L_1 is series-resonant with C_o , and $Z_n = 0$. If $Z_s = Z_o$, the network appears as an infinite line with $Z_n = Z_o$. When Z_s is a small inductive reactance, Z_n is a large capacitive reactance, and vice versa. With $Z_o \gg R$ of the crystal, the network

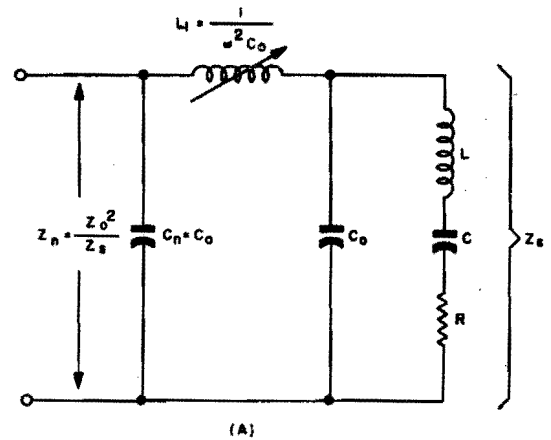

Figure 1-182. Impedance-inverting oscillator circuits.
(A) Basic impedance-inverting network

serves to invert the crystal resistance to a high impedance equal to Z_o^2/R . For a given C_n , maximum frequency stability is to be had under the quarter-wave line conditions ($C_o = C_n$), but, if desired, higher impedances can be had by making C_n less than C_o , or by reducing the effective values of C_n and C_o with the use of shunt inductors. The shunt inductances, however, should be considerably larger than the values required for antiresonance at the crystal frequency. With ω equal to the series-arm resonance frequency, and $L_1 = \frac{1}{\omega^2 C_o} = \frac{1}{\omega^2 C_n}$, Z_n appears as an antiresonant resistance when the series arm of the crystal is resonant and $Z_n = R$. At frequencies well removed from crystal resonance, the crystal behaves simply as a capacitance, C_o , so that the network has a second antiresonant frequency, the square of which is $\omega^2 = \frac{C_n + C_o}{C_n C_o L_1}$. To ensure that this second frequency is damped out, a resistance equal to Z_o can be connected across the crystal unit.

1-427. Even though the equivalent impedance-inverting network is designed to be antiresonant at approximately the crystal frequency, the operating frequency may well require that the crystal network facing the actual terminal connections be reactive if the necessary phase reversal is to be accomplished. For example, it is necessary that the actual plate-to-grid network appear inductive when used in the Pierce circuit. In the Pierce circuit the fundamental modification introduced by the impedance-inverting circuit is simply the addition of an inductor having a reactance $\omega L_1 = \frac{1}{\omega C_o}$ in series with the crystal. It can be imagined that the reactance of the inductor replaces the X_s of a

parallel-resonant crystal unit, and the low series-resonant R of the crystal approximately replaces its parallel-resonant value, R_p . C_n of the network is C_{pk} of the vacuum tube, if we view the circuit literally. By this interpretation, C_n is not antiresonant with the inductive branch, but must offer a higher impedance than does the inductor at the operating frequency. On the other hand, if the entire external circuit is viewed in toto by the negative-resistance method, which is the impedance-inverting interpretation, C_n appears as an equivalent capacitance equal to C_{pk} plus the additional amount required to make the network antiresonant. Since this latter interpretation can be employed to illustrate any oscillator circuit that contains a crystal connected in series with an inductance $L_1 = 1/\omega^2 C_0$, the presence of the series inductance alone could be sufficient to define an impedance-inverting oscillator. The inverted impedance, Z_n , is related to the impedance of the inductor and crystal branch as the PI of a crystal is related to the equivalent impedance of the crystal unit. Although these questions are somewhat academic, for some readers it may be more helpful to interpret the network in figure 1-182(A) as an impedance-converting circuit rather than as an inverting circuit. In the transitron circuit, the network is directly used to invert the crystal R to a higher effective resistance, but in other applications the designer may prefer to treat the actual network as an equivalent X_p and R_p of a parallel-mode crystal unit, transferring the equivalent impedances directly to the equations of the basic parallel-resonant oscillators.

1-428. There are two significant advantages to the impedance-inverting type of design. One is that the conventional parallel-resonant circuits can be operated with excellent frequency stability in the v-h-f range. Another is that by using series-mode crystals at the fundamental frequencies, the design restrictions regarding the parallel-resonant type of crystal unit can be avoided. No data is available, but experimentation may show that even in the fundamental-frequency range larger outputs can be obtained with an inductor and a series-mode crystal without degrading the over-all frequency stability. The chief disadvantage of the impedance-inverting network is that it cannot be used for broad-band untuned operation.

IMPEDANCE-INVERTING TRANSITRON OSCILLATOR

1-429. An experimental 50-mc impedance-inverting transitron oscillator is shown in figure 1-182 (B). In this circuit, the network, consisting pri-

marily of L_1 , C_n , and the crystal, is adjusted to present a resistive impedance between the screen and ground. Since R_1 is very large compared with the crystal R , it can be assumed that R_1 is effectively connected in parallel with the antiresonant network. C_n includes a 3—12 μmf padding capacitor adjusted at 5 μmf , the screen-to-ground capacitance, and the suppressor-to-plate capacitance (the latter is added because the screen is practically bypassed to the suppressor and the plate is at r-f ground). E_{pk} in this circuit can be considered equal to E_{g2} . Thus, the condition required for oscillations to build up is simply that $1/g_m$ be smaller than the actual plate-to-ground resistance. At the plate voltage used, the initial g_m is approximately 1500 μmhos , so $1/g_m = 667$ ohms. Ignoring the suppressor-to-ground resistance, the screen operates into an impedance of $R_L Z_n / (R_L + Z_n) = 1350$ ohms, where $Z_n = X_{C_n}^2 / R$. The margin of gain is therefore on the order of two to one. The power delivered to R_L was observed to be 15 mw. The frequency deviation was measured at 0.1 ppm/volt. When R_1 was replaced by a 40,000-ohm resistor, the frequency deviation was found to be only 0.004 ppm/volt. Although the power output is low, the extraordinary independence of the frequency under variations in the supply voltage marks the impedance-inverting transitron oscillator as the most stable to use in the v-h-f range. One of the chief reasons for this stability is very probably the fact that the r-f screen current need contain no reactive component. The impedance-inverting network, as faced by the screen, can appear as a pure resistance.

IMPEDANCE-INVERTING PIERCE OSCILLATOR

1-430. A 50-mc impedance-inverting Pierce oscillator is shown in figure 1-182(C). This circuit supplied 70 mw to the 1500-ohm load, and had a frequency deviation of 0.6 ppm/volt. Note that the total C_x is equal to the total C_p . The antiresonant C_n for the inductive branch of the impedance-inverting network is thus very nearly $(C_{pk} + C_p/2)$, which in turn is equal to C_0 . This value of C_n neglects the equivalent negative capacitance due to the reactive component of the r-f plate current. Viewed only as an impedance-converting network connected between the plate and grid, $C_n = C_{pk}$, and the network appears as an inductive reactance numerically equal to $2/\omega C_p$ or $2/\omega C_g$. The upper useful limit of this type of circuit is approximately 100 mc.

1-431. Figure 1-182(D) shows an electron-coupled modification of the impedance-inverting Pierce

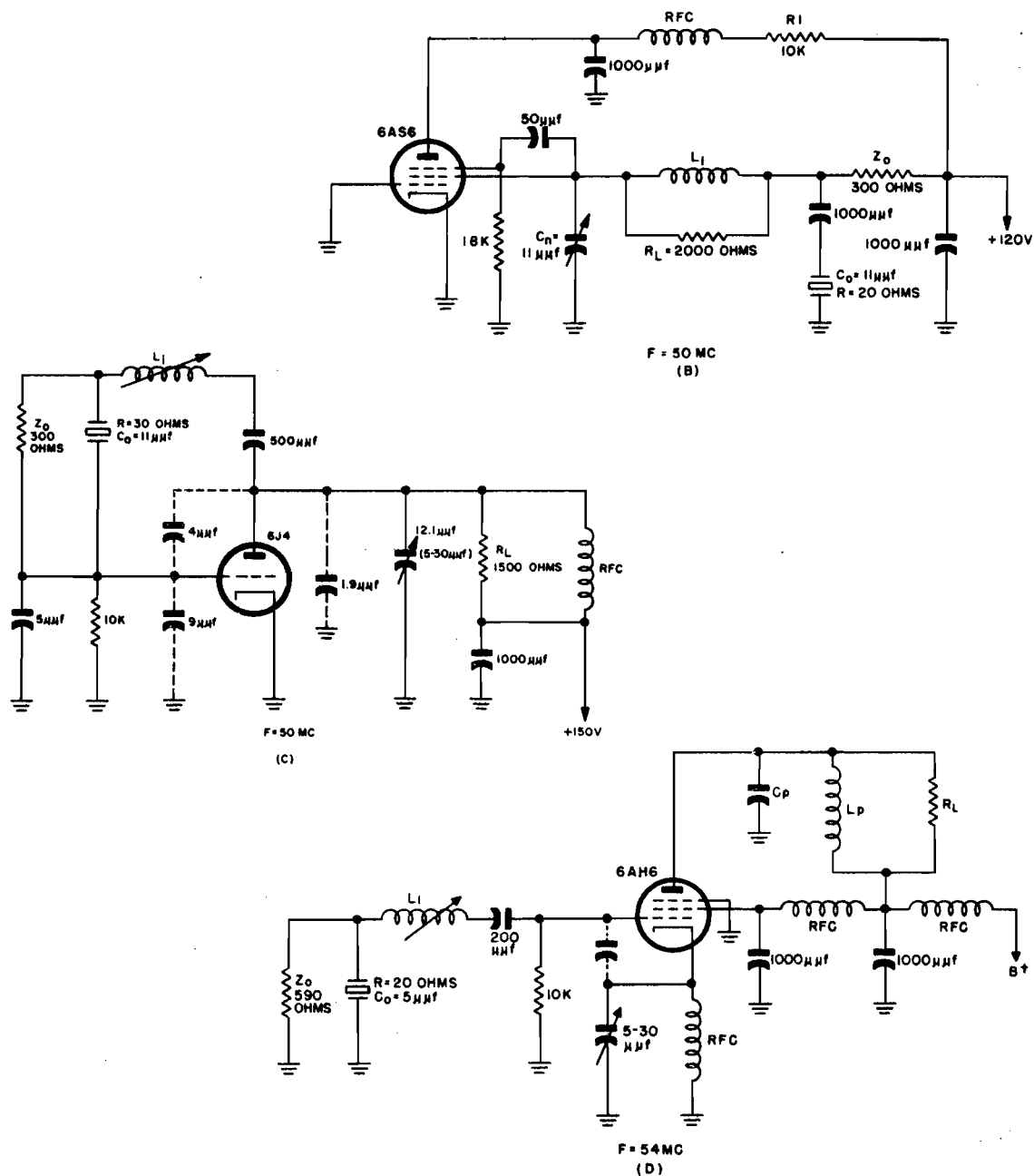

Figure 1-182. Impedance-inverting oscillator circuits. (B) Impedance-inverting transitron oscillator. (C) Impedance-inverting Pierce oscillator. (D) Impedance-inverting electron-coupled Pierce oscillator

oscillator. The frequency of the oscillator circuit is virtually independent of the tuning adjustments in the plate circuit. With the plate circuit tuned to the 1st, 2nd, 3rd, and 4th harmonics successively, the power supplied R_L was found to be 400 mw at 54 mc, 225 mw at 108 mc, 50 mw at 162

mc, and 10 mw at 218 mc. The frequency stability is approximately the same as that of the triode circuit in figure 1-182(C). The upper frequency limit of the grounded-screen circuit in (D) was found to be 70 mc.

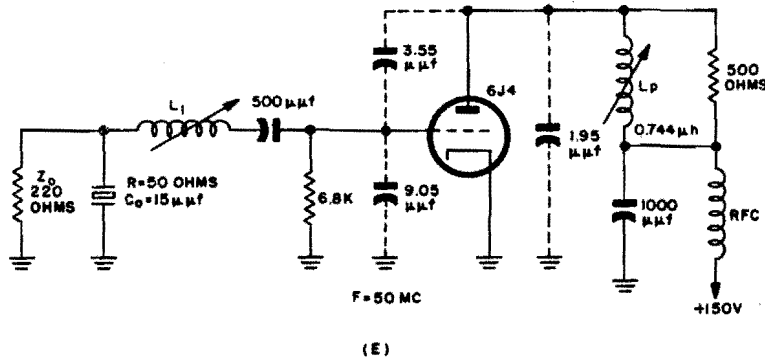

Figure 1-182. Impedance-inverting oscillator circuits. (E) Impedance-inverting Miller oscillator

IMPEDANCE-INVERTING MILLER OSCILLATOR

1-432. Figure 1-182 (E) is an experimental design of a 50-mc, impedance-inverting, Miller oscillator. The oscillator is designed so that the C_n of the equivalent negative resistance circuit is equal to C_o . Assuming that the reactive component of the plate current is negligible, $C_n = C_o = C_g + C_1$, where C_1 is the equivalent capacitance of C_{pg} in series with the parallel combination of C_p and L_p . C_1 is thus given by the equation

$$C_1 = \frac{C_{pg} (1 - \omega^2 L_p C_p)}{1 - \omega^2 L_p (C_p + C_{pg})} \quad 1-432 (1)$$

C_{pg} and C_p are fixed by the tube capacitances, and C_1 is equal to $C_o - C_g$, so the solution of equation (1) requires a definite value of L_p , which in circuit (D) was found to be 0.744 μ h. The circuit supplies R_L with a power output of 0.5 watt for a crystal drive of 0.07 watt. The frequency deviation was found to be 0.6 ppm/volt.

Grounded-Cathode Two-Stage Feed-Back Oscillator

1-433. The two-stage feed-back oscillator (see figure 1-183) is used primarily for high-resistance, series-mode crystals operating at fundamental frequencies not higher than 500 kc and usually below 300 kc. The design is rather straightforward. V_1 and V_2 are tubes of the same type and can be contained in the same envelope. Although pentodes should permit slightly greater frequency stability, triodes are quite satisfactory for most purposes. Since V_2 alone can provide the necessary phase reversal, both tubes can operate into resistive loads. The V_1 plate circuit is thus tuned to the crystal resonance frequency. The proper adjustment of C_p is indicated by a maximum read-

ing on the meter, M . R_2 is connected across the L_p - C_p tank, to broaden the tuning and reduce the frequency effects of variations in the V_1 plate capacitance. The resistance, R_c , of the crystal circuit is approximately $R + 2R_1$. On the assumption that $R = R_m$ (the maximum permissible crystal resistance), R_1 should be made as small as possible consistent with stable oscillations. This is desirable in order for the effective Q of the crystal circuit, and hence the frequency stability, to be maximum.

1-434. The loop-gain requirement for equilibrium is

$$G_1 G_2 G_3 = \frac{E_{p1}}{E_{g1}} \cdot \frac{E_{p2}}{E_{p1}} \cdot \frac{E_{g1}}{E_{p2}} = 1 \quad 1-434 (1)$$

where

$$G_1 = \frac{E_{p1}}{E_{g1}} = g_{m1} R_2 \quad 1-434 (2)$$

$$G_2 = \frac{E_{p2}}{E_{p1}} = \frac{g_{m2} R_1 (R + R_1)}{R + 2R_1} \quad 1-434 (3)$$

and

$$G_3 = \frac{E_{g1}}{E_{p2}} = \frac{R_1}{R + R_1} \quad 1-434 (4)$$

Equations (2), (3), and (4) assume that V_1 and V_2 operate into plate impedances approximately equal to R_c and $\frac{R_1 (R + R_1)}{R + 2R_1}$, respectively, and that these impedances are very small compared with the R_p of the tubes. Combining equations (2), (3), and (4), we find that at equilibrium, the tube transconductances are such that

$$G_1 G_2 G_3 = \frac{g_{m1} g_{m2} R_1^2 R_2}{R + 2R_1} \quad 1-434 (5)$$

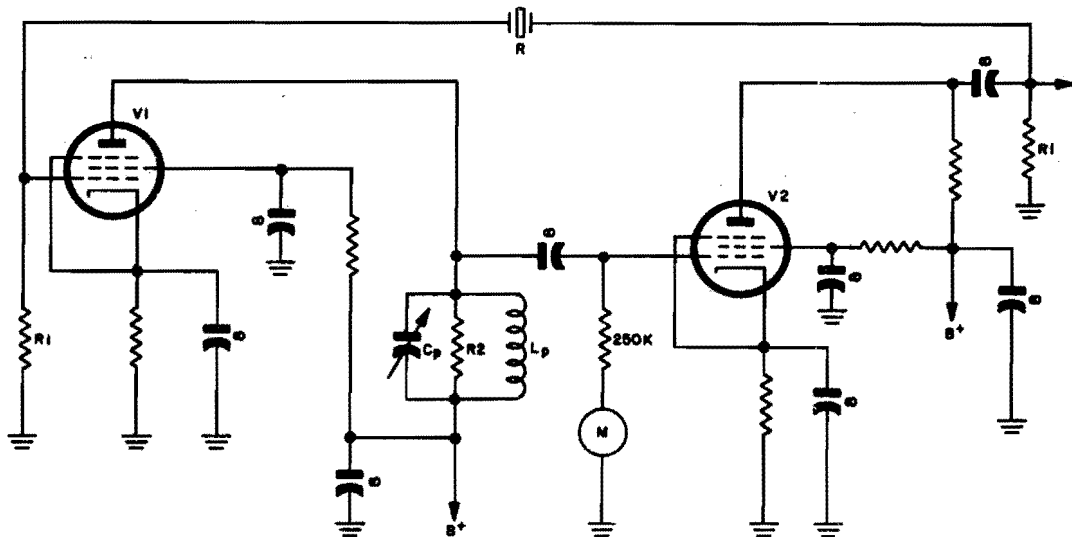

Figure 1-183. Grounded-cathode two-stage feed-back oscillator

Assuming that $g_{m1} g_{m2} = g_m^2$, where g_m is the nominal class-A transconductance of the V_1 and V_2 type of tube, and that $R = R_m$, we can select values of R_1 and R_2 so that equation (5) will equal 1.5. This provides a 3-to-2 margin of gain, which should be sufficient to ensure operation with all but completely defective tubes. The cathode resistors can be selected so that the amplitude of oscillations does not overdrive a crystal of maximum R . An alternative, and possibly a simpler approach, is first to select a cathode resistor for V_1 , with the intention of operating that tube at a fixed class-A bias. The gain of the V_1 stage can then be treated as a predetermined constant and the V_2 stage designed to provide the necessary limiting by gridleak bias. The class-A gain of the V_2 stage must be sufficient to permit oscillations when the crystal unit has a maximum resistance, and the excitation current must not be sufficient to overdrive the crystal unit when the crystal resistance is a minimum. If desired, a parallel-mode crystal unit connected in series with its rated load capacitance can be substituted for a series mode crystal unit. Such operation increases the average effective feedback resistance, but the presence of the capacitor can reduce the tendency of the circuit to oscillate at unwanted frequencies.

MODIFIED TWO-STAGE FEED-BACK OSCILLATOR

1-435. A modification of the two-stage, feed-back oscillator to reduce the higher harmonics and thereby improve the quality of the sine-wave out-

put for sync control is shown in figure 1-184. It can be seen that the tuned tank, undamped, is connected in the plate circuit of V_2 , instead of that of V_1 as is conventionally done. The output, E_o , is taken from a different part of the tank in each of the three circuits represented. The non-bypassed cathode resistors are inserted for their degenerative effect on the higher harmonics and parasitic frequencies. They also reduce the effective input capacitance of the tubes. It would seem that the degradation of the crystal Q is somewhat large. The Miller effect in V_1 is probably significant in determining the impedance that the crystal faces—certainly so in circuit (C), where R_1 is one megohm and C_0 is inserted to increase the plate-to-grid capacitance by 25 $\mu\mu\text{f}$. However, the chief purpose of C_0 is to serve as a neutralizing capacitance for all free-running oscillations where the crystal unit would behave as a capacitance, C_c .

Colpitts Oscillators Modified for Crystal Control

1-436. Figure 1-185 illustrates a number of special-purpose circuits which are basically Colpitts oscillators modified for crystal control. Circuits (A), (B), and (C) are conventional CI-meter oscillators (see paragraph 1-220). The tank inductance, equal to $2L_{11}$, is split into two equal inductances, L_{1A} and L_{1B} . Each of the variable inductors in circuit (A) actually represent seven fixed inductors which can be connected into the circuit by a range switch. The capacitors C_1 (A and B) are continuously variable, and are so ganged that C_{1A} is always equal to C_{1B} . Circuits

Section I
Crystal Oscillators

Fig.	Equipment	Purpose	F ₁	CR	R ₁	R ₂	R ₃	R ₄	R ₅
(A)	Range Calibrators TS-102/AP and TS-102A/AP	Crystal control of 500-yd marker and sync pulses	327.8	Sig C Stock No. 2X62- 327.8; WEC _o No. D-168342	1.8	10	18	1000	1.8
(B)	Calibrator TS-19/APQ-5	Crystal control of 1000-ft marker and sync pulses	491.04	WEC _o No. D-164868	1.8	10	18	1000	1.8
(C)	Range Calibrator TS-293/CPA-5	Osc for radar IFF. P/O Radar Sets AN/CPX-1 and AN/CPX-2	186.3	Belmont Drawing No. A-8K-3577	1.8	10	1000	1000	1.8

Circuit Data for Figure 1-184. F in kc. R in kilohms. C in μ mf. L in μ h.

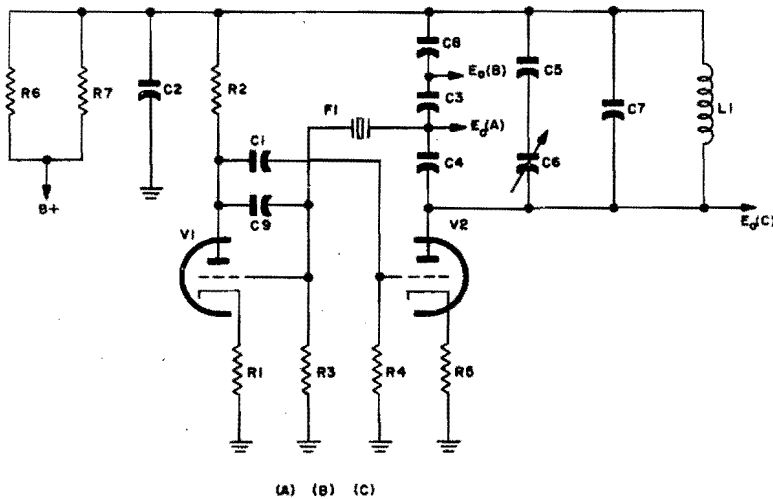

Figure 1-184. Modifications of two-stage feed-back oscillator to improve sine-wave output

Fig.	Equipment	Purpose	F ₁	CR	R ₁	R ₂	R ₃	R ₄	R ₅	R ₆	R ₇	R ₈	R ₉	R ₁₀
(A)	Crystal Impedance Meter TS-330/ TSM	Substitution circuit for measuring parameters of crystal unit	1-15	Military Standard quartz crystal units	2.2 each	22	1	0.27	25					

Circuit Data for Figure 1-185. F in mc. R in kilohms. C in μ mf except where otherwise noted. L in μ h.

R ₆	R ₇	C ₁	C ₂	C ₃	C ₄	C ₅	C ₆	C ₇	C ₈	C ₉	L ₁	V ₁ V ₂
2.2	2.2	3300	100,000	3900	390	10,000	75	20	∞	0	500	6SN7GT
2.2	2.2	3300	100,000	3900	200	10,000	75	10	3900	0	380	6SN7GT
1	∞	6000	50,000	350	75	0	0	25	∞	25	Sig C Stock No. 2C-638- 1C1	6SN7GT

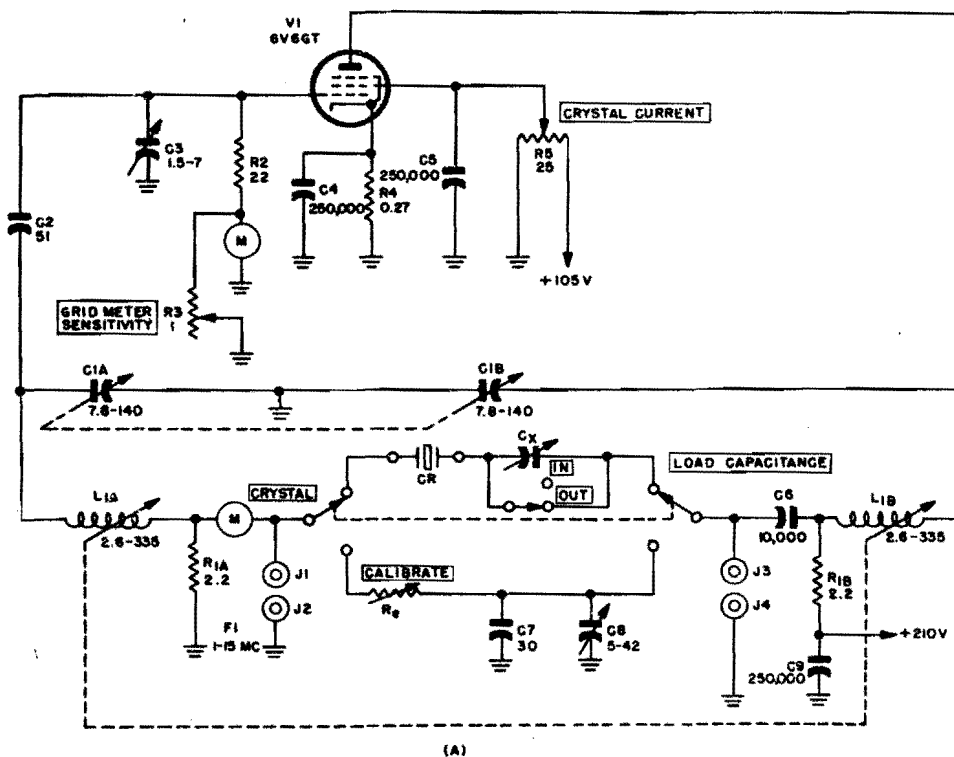

Figure 1-185. Colpitts circuits modified for series-mode crystal control

C ₁	C ₂	C ₃	C ₄	C ₅	C ₆	C ₇	C ₈	C ₉	L ₁	L ₂	L ₃	L ₄	V ₁	V ₂
7.8- 140 each	51	1.5- 7	250,000	250,000	10,000	30	5-42	250,000	2.6- 335 each				6V6GT	

Section I
Crystal Oscillators

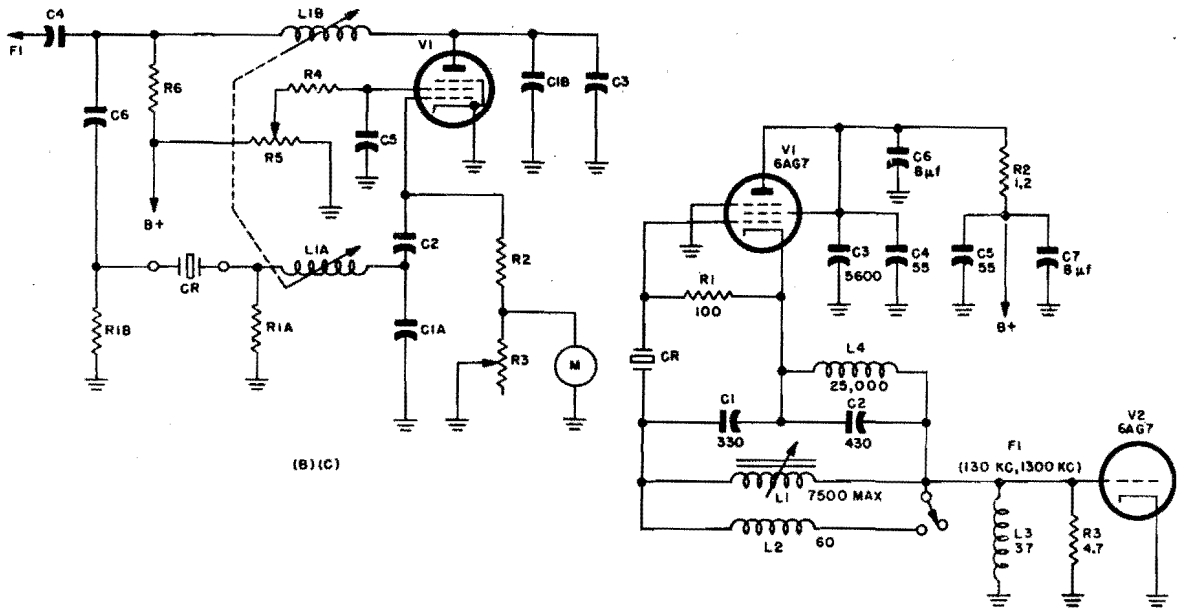

Figure 1-185. Continued

(D)

Fig.	Equipment	Purpose	F ₁	CR	R ₁	R ₂	R ₃	R ₄	R ₅	R ₆	R ₇	R ₈	R ₉	R ₁₀
(B)	Crystal Impedance Meter TS-683/TSM	Substitution circuit for measuring parameters of crystal unit	10-60	Military Standard quartz crystal units	0.1 each	15	1	15	25	4.7				
(C)	Crystal Impedance Meter TS-683/TSM	Substitution circuit for measuring parameters of crystal unit	55-140	Military Standard quartz crystal units	0.056 each	15	1	15	25	2.2				
(D)	Test Set TS-250/APN	Range osc. Output consists of positive range pips	0.13 and 1.3	Bliley No. 122-5006 (octal base)	100	1.2	4.7							
(E)	Diversity Receiving Equipment AN/FRR-3	BFO with afc; manual or crystal operation	0.46245		100	5	1	10	20	2	0.5	0.035	500	1.5

Circuit Data for Figure 1-185. F in kc. R in kilohms. C in $\mu\mu\text{f}$ except where otherwise noted. L in μh .

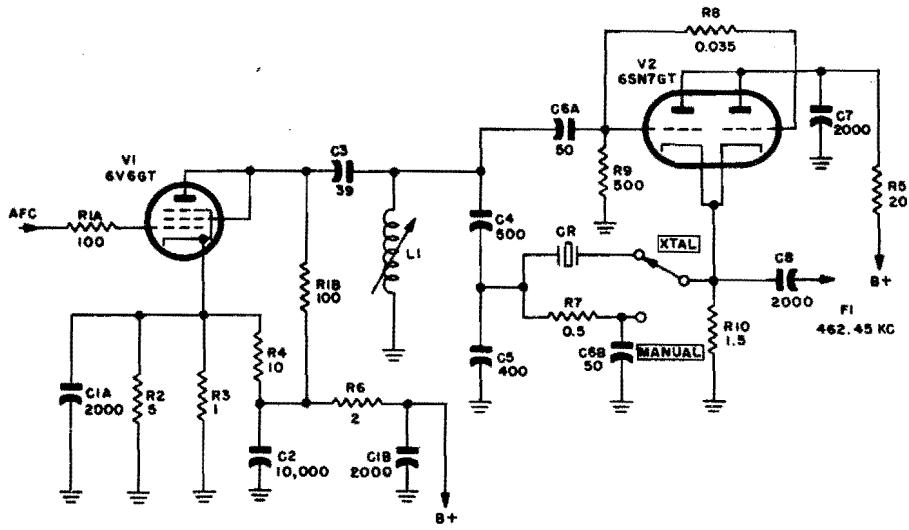

Figure 1-185. Continued

(E)

C ₁	C ₂	C ₃	C ₄	C ₅	C ₆	C ₇	C ₈	C ₉	L ₁	L ₂	L ₃	L ₄	V ₁	V ₂
33 each	22	1	5	470	470				0- 7.35 each				5654	
5 each	12	0	1	470	470				0- 0.987				5654	
330	430	5600	55	55	8 μ f	8 μ f			7500 max	60	37	25,000	6AG7	6AG7
2000	10,000	39	500	400	50	2000	2000						6V6GT	6SN7GT

Section I Crystal Oscillators

(B) and (C) are substantially of the same basic design as circuit (A). Except for resistors R_1 and capacitances C_3 and C_4 , the parameters of circuits (B) and (C) have the same numbers as their functional analogues in circuit (A). Circuits (B) and (C) are not designed for parallel-resonance measurements. For crystal resistance measurements, the calibrating resistor must be substituted externally for the crystal unit. The capacitors C_1 are fixed and the inductors L_1 are continuously variable and are so ganged as always to be equal. In each of the CI-meter circuits shown, it can be seen that if the resistance of the tank, including the crystal, were zero, and if the tank were perfectly balanced, no voltage would exist between the crystal and ground. The voltage across L_{1A} plus that across C_{1A} would equal zero, and no current would flow through the resistors R_{11} , which effectively form a bridge between the inductance arm to the grounded connection of the capacitance arm. In practice, a net voltage does exist across L_{1A} and C_{1A} in series, and this voltage appears across R_{1A} , being measurable at the jacks J1 and J2 in circuit (A). The r-f voltage across R_{1B} is approximately that across J3 and J4, which in turn is equal to the R_{1A} voltage plus that across the crystal resistance. The R_1 resistors are not essential insofar as maintaining oscillations is concerned, but they load the circuit, thereby reducing the effect of the variations in crystal resistance upon the oscillator activity, and they serve to protect the crystal, to balance the circuit to ground, and to facilitate measurements of the crystal voltage ($E_{Rc} = E_{J3} - E_{J1}$) without unduly interfering with the effective circuit parameters. The CI-meter oscillator can be analyzed as a particular type of transformer-coupled oscillator, as an impedance-inverting oscillator, or as an equivalent Pierce oscillator having a crystal $X_c = \omega(L_{1A} + L_{1B})$ and an effective crystal resistance accounting for the losses in the resistances R_1 , as well as in the R_c of the actual crystal.

1-437. Figures 1-185 (D) and (E) are examples of grounded-plate Colpitts circuits which have been modified for series-mode crystal control. Circuit (D) is designed to provide positive range pips to the grid of V_2 . The circuit operates class C at either one of two frequencies, the appropriate crystal being connected between the cathode tank and the grid of V_1 . Circuit (E) is designed for either manual or crystal control. During manual control the resistor R_1 replaces the crystal unit. V_1 is operated as a reactance tube. The a-f-c bias varies in such a way that the b-f-o frequency tends to follow any changes in the frequency of

the teletype signal being received.

CRYSTAL CALIBRATION

1-438. The design of a crystal oscillator to be used for calibrating the frequency of other oscillators generally is directed toward obtaining outputs rich in harmonics. Where tuned-plate circuits are required the L/C ratios should be high, so that high impedances are also presented to the overtone frequencies. The oscillator should be operated class C, and often the gridleak resistance is a megohm, or higher. If the crystal calibrator is to serve as a frequency standard of greater-than-average precision, this precision becomes the principal design problem insofar as the oscillator is concerned; if need be, the required harmonics can be developed in nonlinear amplifier stages that follow the oscillator stage. The higher the overtone, the weaker will be its effective output power, but with proper design useful outputs up to and above the 100th harmonic can be obtained. With the addition of frequency multiplier and/or divider circuits a single crystal can provide a useful calibrator frequency range as broad as desired. For maximum precision, a G element, usually cut for 100 kc, should be used.

1-439. Figure 1-186 illustrates a simply designed crystal calibrator employing an electron-coupled Miller oscillator operating into a resistive plate load. Such a circuit will ensure sufficient frequency stability for most purposes. Harmonic outputs in steps of 100 kc are provided up to frequencies of 10,000 kc. For higher frequencies, the 1000-kc crystal can be used to provide calibration points in multiples of 1000 kc. The variable grid capacitor is employed to ensure that the crystal operates into the correct load capacitance.

Crystal Calibrator Employing Regenerative Frequency Divider

1-440. Figure 1-187 shows the regenerative frequency-divider circuit of the crystal frequency indicator (CFI) used in Radio Transmitting Set AN/ART-13A. This circuit employs a 200-kc crystal to control a rich mixture of harmonics, providing useful check points spaced as close as 25 kc apart. The crystal oscillator, utilizing the triode section, V_1 , seems best described as a modification of an impedance-inverting Pierce circuit. When oscillations first start, the output of the oscillator is fed to grid No. 1 of the pentagrid mixer, V_2 . The 50-kc and 150-kc components of the noise voltages that are mixed with the 200-kc signal are amplified by V_3 and fed to the input of the V_2 triode section. The V_2 plate circuit, which is tuned

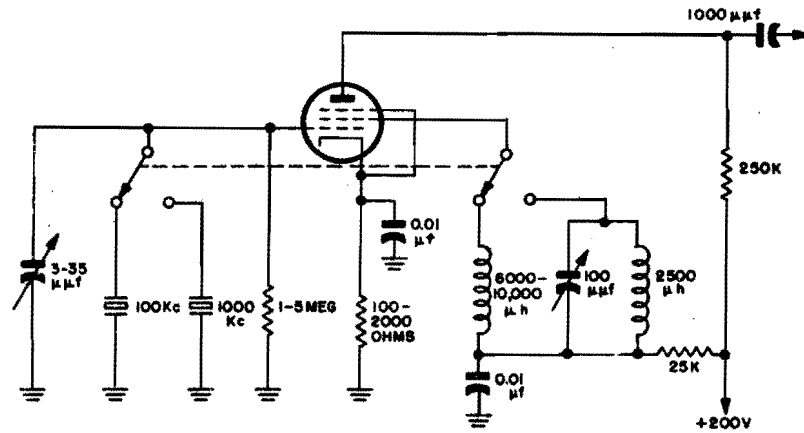

Figure 1-186. Typical design of single-tube general-purpose crystal calibrator circuit

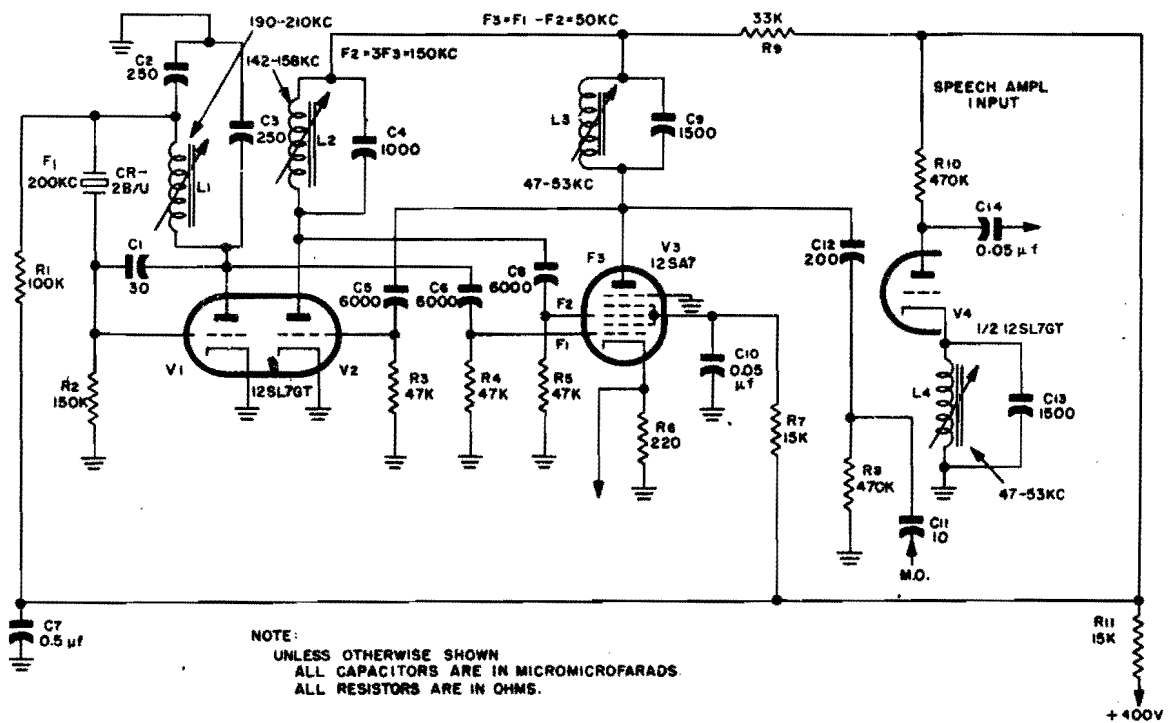

Figure 1-187. CFI regenerative frequency divider in Radio Transmitter T-47A/ART-13 (P/O Radio Transmitting Set AN/ART-13A)

to 150 kc, amplifies the 150-kc noise input and triples the 50-kc input. The 150-kc output of V_2 is then fed back to the pentagrid mixer at grid No. 3. It is again amplified and fed back to V_2 . However, the direct amplification and regeneration of the 150-kc signal alone is not sufficient nor properly phased to maintain oscillations at this frequency. The 150-kc oscillations are sustained principally by tripling the 50-kc feedback, which builds up as the amplified difference frequency of the 200-kc and 150-kc inputs to V_3 . The output of V_3 is effectively a 50-kc fundamental frequency standard of large harmonic content that is fed to the grid of triode section V_4 , where it is mixed with signals from the variable oscillators of the transmitter. The output of V_4 is fed to the input of an audio amplifier, which amplifies the beat note whenever the variable oscillator approaches the frequency of one of the CFI harmonics. In practice, the recommended check-point harmonics are spaced 25 kc apart in the 200—600-kc frequency range, 100 kc apart from 2000 to 3000 kc, 150 kc (3000—4000 kc), 200 kc (4000—6000 kc), 300 kc (6000—9000 kc), 450 kc (9000—12,000 kc), and 600 kc (12,000 to 18,100 kc). The presence of the harmonics of an apparent 25-kc fundamental, which is used in the low-frequency calibrations, is not readily explained on the basis of the foregoing discussion of the circuit. A complete analysis of the nonlinear characteristics of the circuit is not available, but it appears possible that if a 25-kc signal appears at the plate of V_3 , it can conceivably be sustained by being fed to V_2 , mixed with f_2 to form a sum frequency of 175 kc, fed back to V_3 and mixed with the 200-kc injector signal to regenerate a difference frequency of 25 kc. It

should be understood that $f_2 = 3f_3 = \frac{3}{4}f_1$ is a necessary relation, and that f_2 and f_3 are synchronized and controlled by the crystal oscillator. The phase and frequencies of the regenerative circuits automatically follow the phase and frequency of the V_1 output. For a more analytical study of regenerative frequency dividers, see discussions by R. L. Miller, R. L. Fortescue, and W. A. Edson.

SYNTHESIZING CIRCUITS

1-441. Of great promise, particularly for use in airborne radio equipment in the v-h-f range where crystal control is necessary to maintain the required frequency stability, has been the development of synthesizing circuits, in which a very few crystals are able to control a large number of channels. In the discussions to follow we shall use the term *frequency synthesis* very loosely to apply

to any type of frequency-control circuit or system in which a few fixed-frequency oscillators are used to control or to stabilize a large number of radio frequencies. If the term were used rigorously, it would apply only to those cases where an output frequency is produced entirely from heterodyned combinations of internally generated frequencies. Examples of this type are provided by the Plessey frequency generator and by the Collins transmitter frequency-control system employed in Radio Set AN/ARC-27. For our purposes we shall extend the term to cover such systems as the Bendix frequency-control circuit in Radio Set AN/ARC-33, where the output frequency is not actually synthesized but is obtained from a variable-tuned master oscillator that is crystal-stabilized at many frequencies. Also implied by the term will be such systems as the Collins crystal-controlled multichannel receiver circuits. In these latter circuits only one end-product frequency is desired — a fixed superheterodyne intermediate frequency. But the system design is such that with the use of a very few crystals the desired intermediate frequency can be synthesized under crystal control from received signals on any one of hundreds of possible radio channels.†

The Plessey Synthesizing System*

1-442. The first crystal-controlled frequency synthesizer in commercial usage appears to have been

† Not all types of synthesizers in current use are covered in the above discussion. Other recently developed and equally important circuits include:

The General Radio Company synthesizer, developed under Signal Corps Contract No. DA-36-039-sc-15542. The GR synthesizer operates on a principle fundamentally different from those described in this report. In the GR system an oscillator is phase- and frequency-locked through a variable scale-of-N divider. The pulse output of the divider is compared by coincidence methods with a pulse derived from a crystal oscillator. The frequency range of this synthesizer is 0.1 mc to 10 mc.

The Matawan Synthesizer ME-447, of the Lavoie Laboratories Instrument Company. This system generates any multiple of 1 kc within the range of 1.0 mc to 2.0 mc.

The Rohde and Schwarz decade synthesizer and exciter system (Federal Telephone and Radio Company Types HS-431, HS-441, and HS-471), which covers a range of 50 kc to 30 mc.

The Telefunken Precision Frequency Meter. This meter is used in the measurement of frequencies between 1 kc and 300 mc. The circuitry contains a frequency synthesizer capable of generating sine-wave outputs between 1 kc and 30 mc. It is claimed that harmonics and sidebands of the output frequency are at least 80 db below the selected signal, and that the synthesizer accuracy is ± 0.2 cps for frequencies between 1 kc and 3 mc, and ± 2.0 cps between 3 mc and 30 mc.

* Note: The discussion of the Plessey synthesizing system is based primarily upon the report, "The Frequency Synthesizer", by Mr. H. J. Finden of the Plessey Company, Ltd., England, published in the *Journal of the Institution of Electrical Engineers*, Vol. 90, Part III, 1943.

that developed by the Plessey Company, Ltd. of England. This synthesizer has been designed as a frequency generator to be used in making precise radio-frequency measurements. The synthesizing system employed is nevertheless quite applicable for other uses, such as providing multichannel excitation voltages for radio communication equipment. As designed by the Plessey engineers, the synthesizer generates a sequence of harmonic signals of much greater precision and purity than is obtainable with conventional types of frequency generators. The original model permits a direct-reading dial selection of any of the first 10,000 harmonics of 1 kilocycle per second; a later and larger model extends the range to the first 100,000 harmonics, i.e., any harmonic of 1 kc up to 100 mc. All these frequencies are made available singly as pure sine waves (unmixed with other harmonics or frequency products) by a decade system of frequency dividers and multipliers, mixing stages, and filters where all the generated frequencies are under the control of a single 1000-kc precision crystal standard. Theoretically the system could be extended to cover a broader or a different frequency range; or could be changed to permit steps between adjacent frequencies that are smaller or larger than 1 kc. If required, it would be quite practicable for the Plessey generator, itself, to be expanded to cover also the 100-to-1000-mc range in 10-mc steps. In 1955 the Schomandt Company of Munich, Germany placed on the market a similar type of synthesizer frequency generator covering the 0—30-mc range in 1-kc steps. The output of the Schomandt synthesizer is equivalent to that of the Plessey synthesizer in quality, having at least a 60-db attenuation of all unwanted frequencies. It was the demand for such narrowly spaced pure output frequencies for use in making frequency measurements that originally led to the development of the synthesizer circuits.

SYNTHESIZER ADVANTAGES IN RADIO-FREQUENCY MEASUREMENTS

1-443. Prior to the development of the frequency synthesizer there were two conventional methods for measuring radio frequencies—the “interpolation” method and the “successive heterodyning” method.* Briefly, the interpolation method, which is satisfactory where extreme accuracy is not required, consists of mixing the unknown frequency with the two nearest harmonics of a frequency standard, and zero-beating the difference frequencies obtained against the output of a linearly tuned variable oscillator. It is then possible to interpolate the unknown frequency by determin-

ing its relative position between the known harmonics of the standard. In the successive heterodyning method, the unknown frequency is mixed with a known harmonic of a frequency standard; the difference frequency is then heterodyned with a second standard harmonic to obtain a second and lower difference frequency; and the process is repeated, if necessary, until a difference frequency is obtained that lies within an accurately measureable audio range. Although the successive heterodyning method can be quite accurate, occasions arise where the operator cannot be certain without undue checking that the difference frequencies being measured are not the products of unwanted harmonics contained in the heterodyned signals. The use of a frequency synthesizer that permits individual pure sine-wave outputs of a sequence of narrowly spaced frequencies, instead of a simultaneous mixture of many harmonics, can be said to offer a third and greatly superior means of measuring radio frequencies.

1-444. With the use of decade dial control, greater operating simplicity is possible than with the interpolation method; and when the pure sine-wave frequencies are spaced only 1 kc apart, the interpolation accuracy of the successive heterodyning method is maintained, but with the elimination of those chance difference products that can result from harmonic mixtures of multiple stages of heterodyning.

FUNCTIONAL OPERATION OF PLESSEY SYNTHESIZER

1-445. The circuit system by which the Plessey synthesizer produces thousands of frequencies, all controlled by a single 1000-kc crystal standard, is illustrated in figure 1-188. The block diagram shown is that of the original, single-cabinet model that permits the operator a choice of any one of the first 10,000 harmonics of 1 kc. It can be seen that there are three successive stages in which the input frequency is divided by 10, so that the last divider represents an over-all division of the original standard (1000 kc) by 1000. The dividers and the 1000-kc harmonic generator are of the synchronized, free-running, multivibrator type whose outputs are rich in harmonics. Each of these multivibrator circuits forms the first stage of a sequence which can be tuned to pass any one of the first 10 harmonics of its respective multivibrator fundamental. These sequences are labeled A, B, C, and D in figure 1-188. In the synthesis of a frequency, we can say generally that sequence A

* Note: See paragraph 2-66 to 2-151 for detailed descriptions of frequency-measuring systems in current use.

Section I
Crystal Oscillators

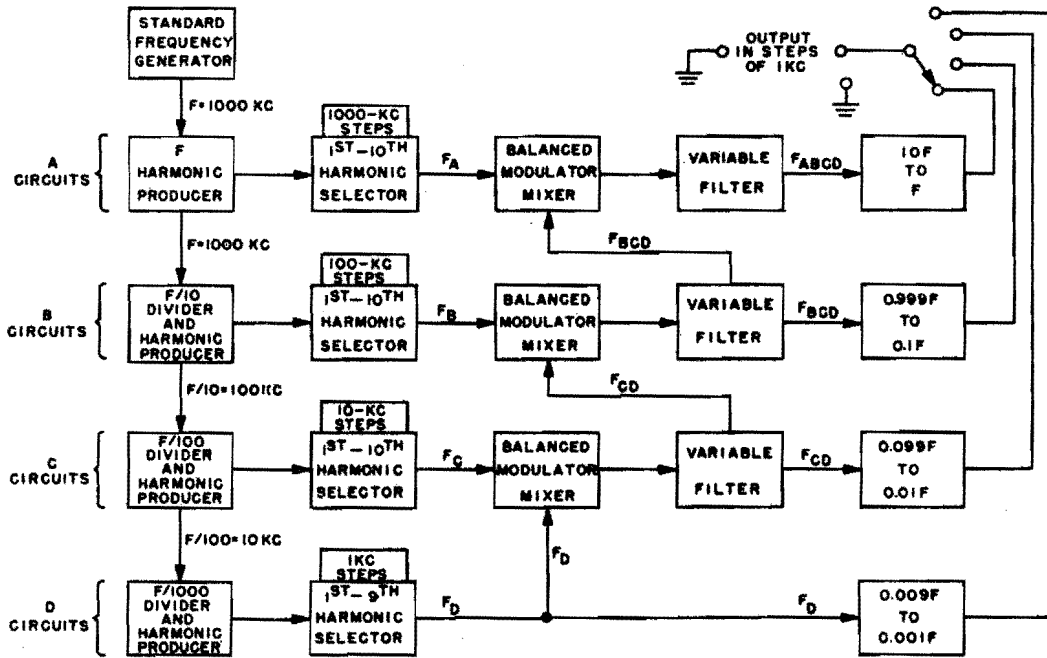

Figure 1-188. Block diagram of a Plessey synthesizer designed to cover the 0—10-mc spectrum in 1-kc steps

supplies that part of the final frequency which is a multiple of 1000 kc, B that part which is a multiple of 100 kc, C that part which is a multiple of 10 kc, and D that part which is a multiple of 1 kc. 1-446. For example, assume that an output frequency of 6789 kc is desired. The A, B, C, and D harmonic selectors, respectively, will be decade-set to pass the 6th, 7th, 8th, and 9th harmonics of their respective input signals from the preceding multivibrator stages. In balanced modulator C, the output of selector D, 9 kc, is mixed with the 80-kc output of selector C. (The signals are heterodyned in a balanced modulator circuit rather than in a more efficient type of mixer in order to eliminate the two input frequencies from the modulator output. In this manner the sum and difference products become the dominant frequencies in the modulator output.) Filter C is dial-set to pass the desired frequency product, 89 kc, which it feeds to balanced modulator B. In modulator B, the 89-kc signal is heterodyned with the 700-kc output of the decade-set harmonic selector B. Filter B is dial-set to pass the sum product, 789 kc, from the B modulator output to the A modulator input, where it is mixed with the 6000-kc output of harmonic selector A. Filter A is dial-set to pass the sum product, 6789 kc, of the mixed signals, which product is then amplified and fed

through a phase inverter to the synthesizer output jack.

1-447. The foregoing example of the operation of the Plessey synthesizer suggests that the sum rather than the difference products of the mixed signals are always selected. In practice this is not the case, even though the decade dialing system is so designed that the operator is always provided a direct reading of the output frequency as if he were only adding the decade units together. In order to sufficiently filter out the unwanted product, it is important that the signals to be mixed are so selected that there is at least a 10 per cent difference in frequency between the sum and difference products. Since the filters must be capable of suppressing all adjacent harmonics of the mixed signals, it can be assumed that they are also capable of suppressing the unwanted heterodyne product if it differs from the desired product by as much as the fundamental harmonic of the modulator input from the harmonic selector. For example, in modulator C, the space between the sum ($f_c + f_n$) and the difference ($f_c - f_n$) frequencies should not be less than 10 kc, the fundamental of the harmonic from selector C. Since

$$(f_c + f_n) - (f_c - f_n) = 2f_n > 10 \text{ kc}$$

then f_n must never be less than 5 kc if it is to be

mixed with f_c . Similarly, f_{CD} must not be less than 50 kc if it is to be mixed with f_B , and f_{BCD} must not be less than 500 kc if it is to be mixed with f_A . 1-448. To illustrate, let us suppose that a frequency of 91 kc is desired. It would not do for f_c and f_D to be 90 kc and 1 kc, respectively, for then the sum product, 91 kc, would be separated from the difference product, 89 kc, by only 2 kc. Rather, 100 kc should be selected as f_c and 9 kc as f_D . The variable filter C would be set to pass the difference product, 91 kc; which product differs from the sum product, 109 kc, by 18 kc, well beyond the minimum permissible limit of 10 kc.

1-449. As a more involved example we shall determine the heterodyne frequencies that would be used in the synthesis of an 8136-kc output. For a mental calculation of the correct frequency combinations the easiest method is to start with the output frequency, f_{ABCD} , and from this determine f_A , f_{BCD} , f_B , f_{CD} , f_C , and f_D in that order, working from the larger units to the smaller. Each of the above six frequencies is determined by remembering that none of the input frequencies to the A, B, and C modulators can be less than 500, 50, and 5 kc, respectively. Thus, we see at once that 8136 kc is not to be the sum product of 8000 kc and 136 kc in the A modulator, since 136 kc is less than 500 kc. So f_A must be 9000 kc and f_{BCD} must be 1000 minus 136 kc, that is, 864 kc; which means that filter A will be adjusted to pass the difference product (9000 kc minus 864 kc). Since 64 kc is greater than 50 kc, the required 864-kc output of modulator B can be obtained as the sum product of 800 kc and 64 kc, f_B and f_{CD} , respectively. Since 4 kc is less than 5 kc, the required 64-kc output of modulator C must be obtained as the difference product of 70 kc and 6 kc, f_C and f_D , respectively. We see that in order to select an output of 8136 kc, the decade dials of the A, B, C, and D harmonic selectors must be set to pass, respectively, the 9th, 8th, 7th, and 6th harmonics. In other words, the output frequency would be a synthetic product of the four frequencies, 9000 kc, 800 kc, 70 kc, and 6 kc. So also would be an output frequency of 9876 kc. Since the decade dials that control the harmonic selectors may be set at the same positions for two or more frequencies, some arrangement must be made so that the decade reading presented to the operator identifies correctly the particular frequency being synthesized. This convenience is accomplished in the Plessey synthesizer by manually operated range adjustments that alter the correspondence of the dial readings with the dial positions. Thus, in the example above, with the proper range settings, decade dial

A in position 9 would give a reading of 8, decade dial B in position 8 would give a reading of 1, decade dial C in position 7 would give a reading of 3, and decade dial D in position 6 would give a reading of 6. The mechanics of exactly how this feature is incorporated in the Plessey synthesizer, although relatively simple in principle, is somewhat beyond the subject matter of our assignment here.

CIRCUIT DESIGN OF PLESSEY SYNTHESIZER

1-450. The general circuit design employed in a Plessey synthesizer is shown in the schematic diagram of figure 1-190. The circuit shown, when synchronized by a 1000-kc standard (whose circuit is not shown), is capable of covering the 0—10-mc range in 1-kc steps. Note that each of the four decade harmonic sequences begins with a multivibrator-type of harmonic generator. Rheostats are furnished for adjusting the natural oscillation period of each multivibrator, in order to allow for aging effects and the like. More elaborate or reliable harmonic-generator circuits are not required since the failure of any of the multivibrators would be immediately apparent by the reading in the output meter. Figure 1-189 shows in detail the circuit parameters of the 100-kc multivibrator, which also acts as the 1st divider. Note that the 1st divider is synchronized by the output of the 1000-kc amplifier and not directly by the frequency standard. The output of the 1st divider in turn is used to synchronize the 2nd divider, and that of the 2nd to synchronize the 3rd.

1-451. In figure 1-190 it can be seen that harmonic selection is achieved by switching to the correct tuning capacitor from a bank of 10. The same inductance is used for each of the harmonics. Since the percentage difference between adjacent harmonics is less as the order of the harmonic becomes higher, it is more difficult to eliminate the 9th and 11th harmonics when selecting the 10th, than it is to eliminate the 1st and 3rd when selecting the 2nd. For this reason, the value of each of the fixed tuning inductors is chosen to provide an optimum Q at the 10th harmonic. This permits a relative magnification of the 10th harmonic over its adjacent harmonics of approximately 200, which is equivalent to a 32-db attenuation of the 9th and 11th harmonics and more than that for all others. The attenuation of adjacent harmonics becomes greater as the selected harmonic becomes lower, so that in any event it is never less than 32 db at each tuned circuit. Two tuned circuits in series provide more than a 60-db attenuation,

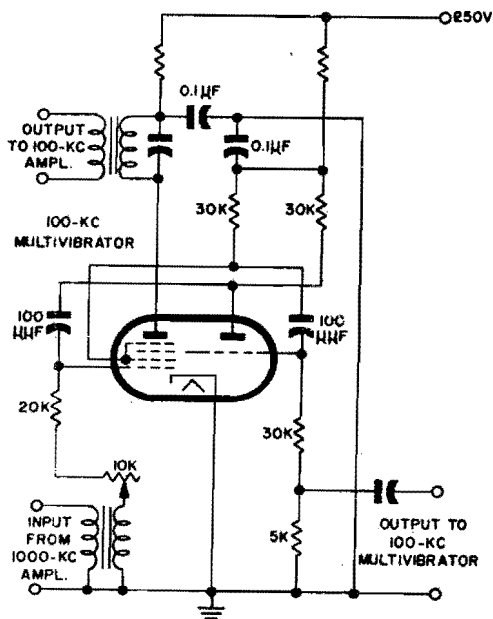

Figure 1-189. Schematic diagram of a Plessey synthesizer designed to cover the 0—10-mc spectrum in 1-kc steps. The circuit of the crystal oscillator standard is not shown

which for all practical purposes is sufficient to consider the selected harmonic a pure sine wave.

1-452. With the use of a balanced modulator it is not necessary to use as many tuned circuits as would otherwise be necessary to eliminate all unwanted harmonics and frequency products. Note in figure 1-190 that the balanced modulator design is such that two matched amplifiers have a common output circuit, but that they are excited by equal signals 180 degrees out of phase, so that the amplified signals cancel each other in the load. Thus, even though the heterodyne efficiency of the balanced modulator is less than that of other types of mixers, the balanced circuit is greatly advantageous in helping to eliminate all the unwanted frequencies, particularly the unwanted harmonics, that originate in the circuits preceding a mixer stage. In the Plessey synthesizer it can be seen that the modulators are provided with a switching arrangement by which one of the tubes of each modulator can be cut out of the circuit by opening its cathode return. One of these switches is opened whenever a modulator stage must pass an un-mixed signal. With one tube removed, the balanced arrangement is destroyed, and since only one input signal is being handled, the vacuum tube still

connected in the circuit will be operated as a conventional amplifier. If, for example, the desired output were a 2000-kc signal, none of the modulators would be in operation except modulator A, which would be unbalanced and operated simply as an amplifier of the 2nd harmonic from the 1000-kc harmonic generator.

1-453. Variable-tuned circuits are provided as bandpass filters. These must be adjusted manually in selecting the proper heterodyne product to be passed. The selectivity is sufficient to provide at least a 30-db attenuation of any unwanted signal that differs as much as 10 per cent from the desired signal.

1-454. The phase inverters are inserted for proper impedance matching. They permit an output at any frequency within the operating range of 100 millivolts across a 75-ohm load. The system as a whole insures at least a 60-db attenuation of all unwanted frequencies.

The Bendix Synthesizing System

1-455. In America, much of the pioneering in the field of frequency synthesis has been done by the research staff of the Bendix Corporation.

The following discussion is based upon the synthesizing circuit originally described by W. R. Hedeman of Bendix in the magazine *Electronics*. Figure 1-191 shows a block diagram of the synthesizer circuit developed at Bendix for use in controlling the frequency of a continuously variable v-h-f receiver heterodyne oscillator. In this circuit, the first crystal oscillator employs but one crystal. The harmonic generator that follows this oscillator produces a rich output of harmonics, the first of which is f_n , the fundamental of the first crystal oscillator. The harmonics selector is composed of a number of band-pass circuits, each circuit designed to pass a particular harmonic of the crystal frequency. The number of frequencies controlled by the synthesizer is directly proportional to the number of harmonic channels in the selector. Let f_n equal the harmonic selected and f_o equal the frequency of the variable oscillator. The value of f_o is always higher than that of f_n . These two frequencies are mixed in the first frequency converter to form the sum-and-difference frequencies, which, in turn, are fed to the input of the first band-pass amplifier. The first band-pass amplifier amplifies and passes only the difference frequency, $f_o - f_n$. This difference frequency is fed to the second frequency converter, where it is mixed with the output, f_n , of the second crystal oscillator. The second crystal oscillator is generally provided with more than one crystal unit, but only the fundamental frequency of the oscillator is used when a

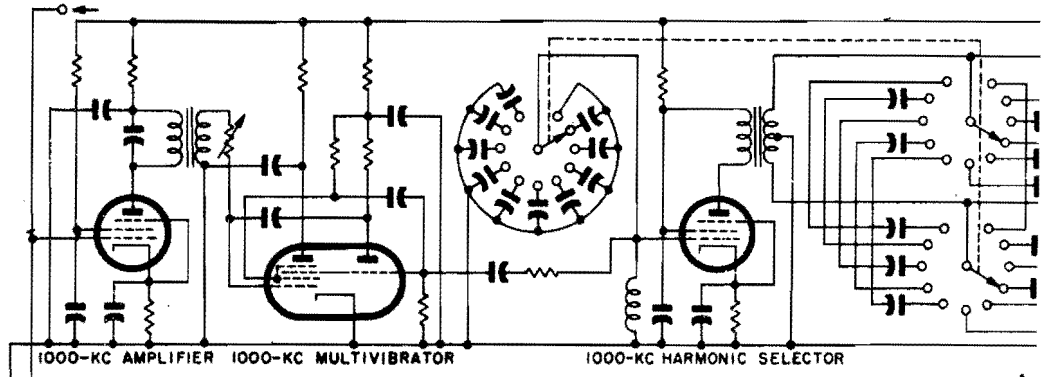

A

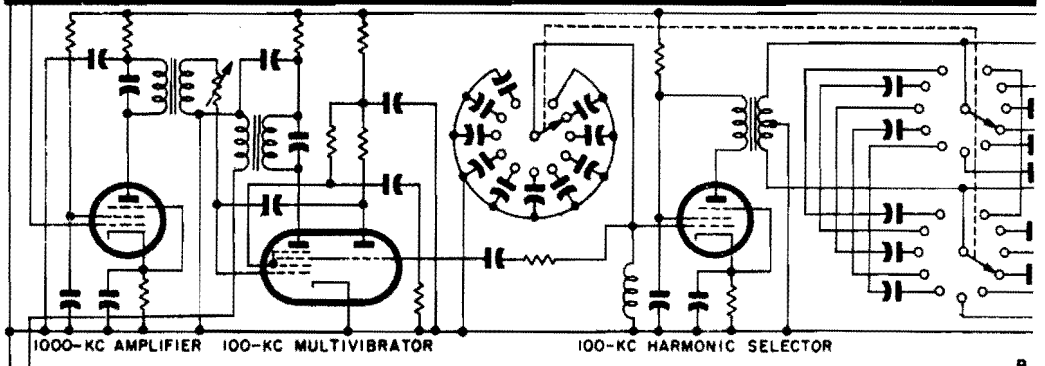

B

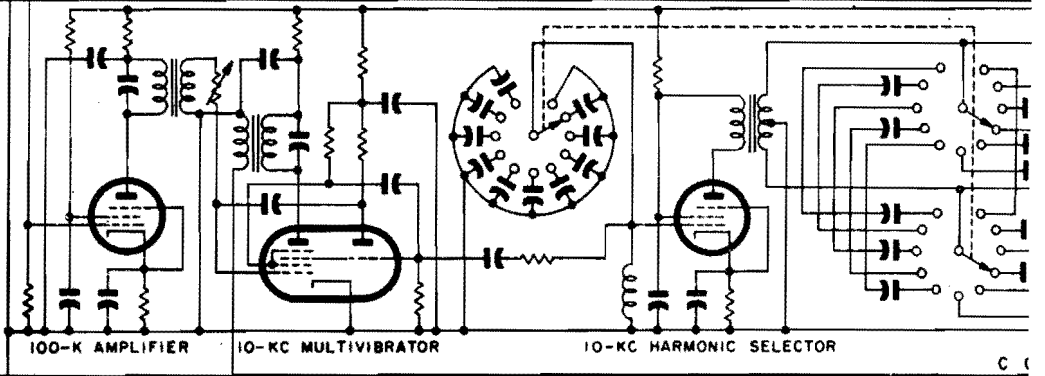

C

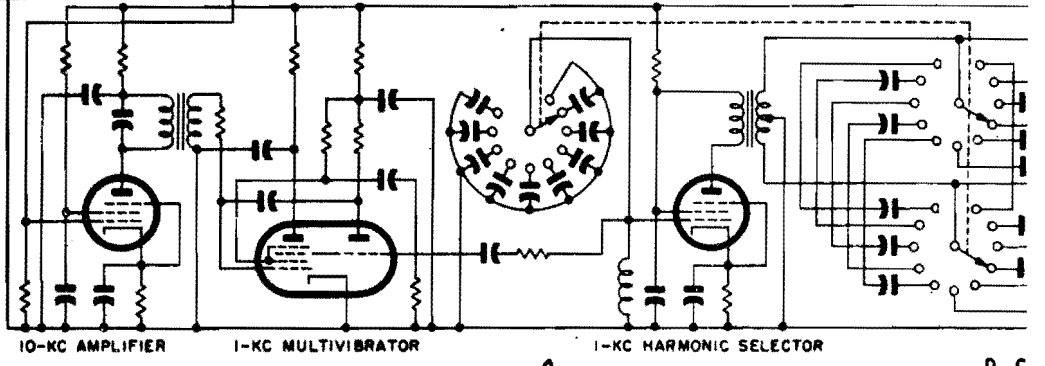

D C

A

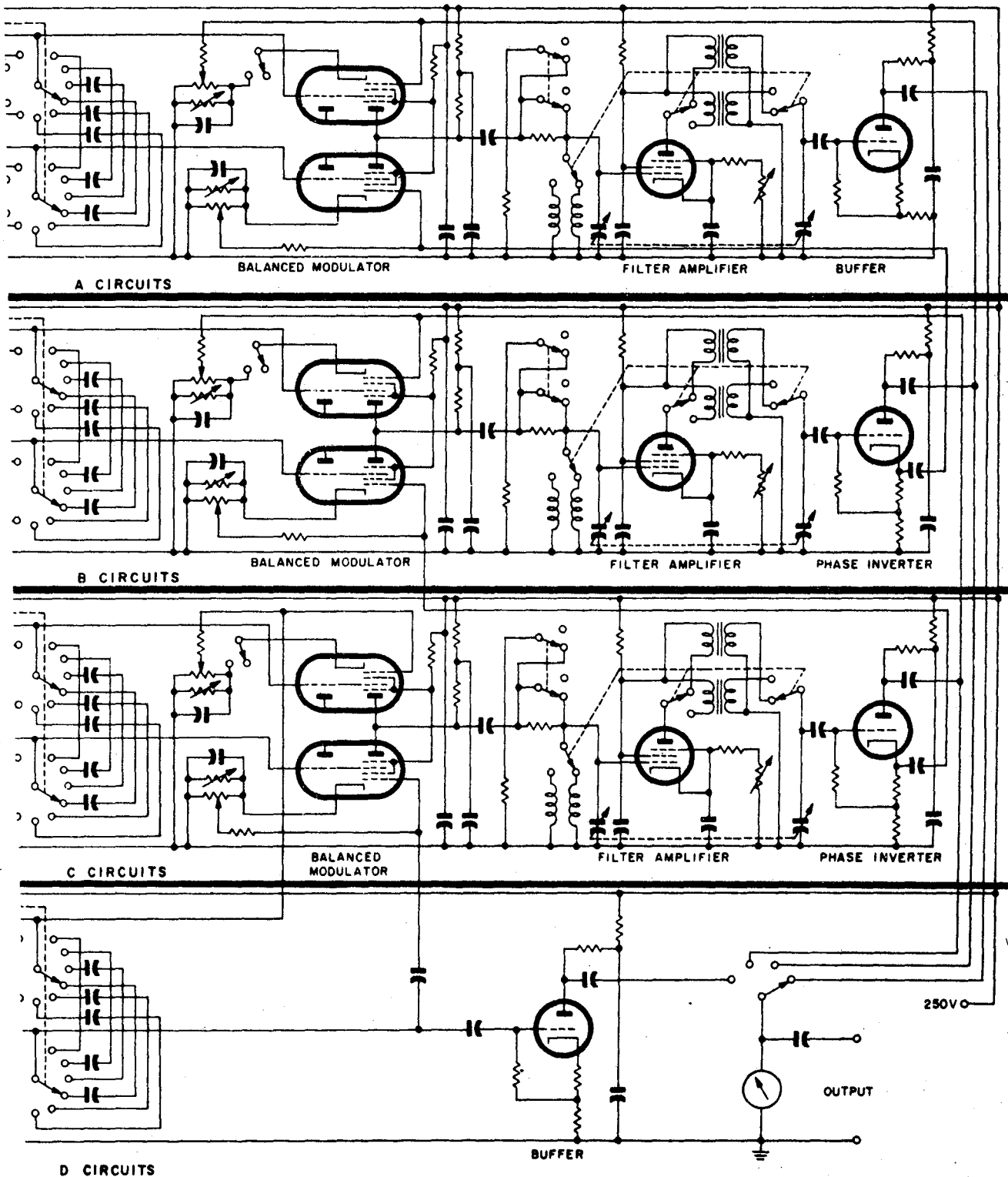

Figure 1-190. Schematic diagram of the 100-kc synchronized multivibrator used in the Plessey synthesizer as a decade divider of a 1000-kc standard and as a 100-kc harmonic generator

B

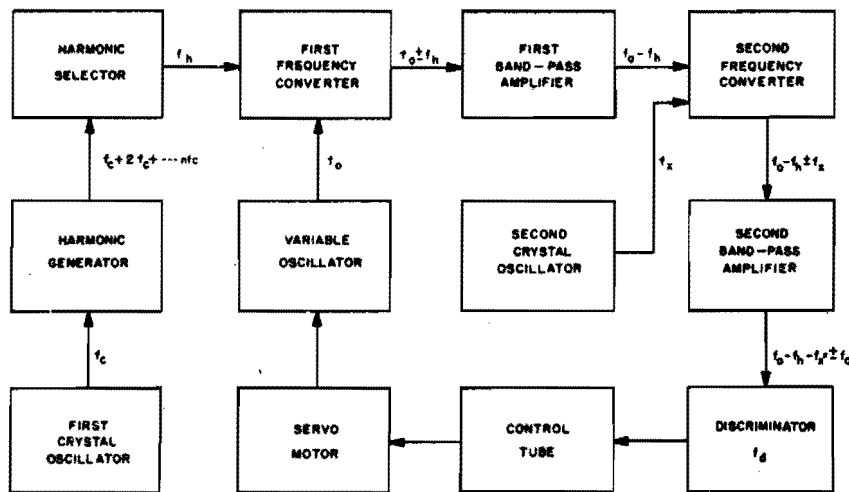

Figure 1-191. Block diagram of frequency-synthesizer circuit

particular crystal is selected. The number of controlled channels is directly proportional to the number of second-oscillator crystals. The sum and difference frequencies of the frequency converter are fed to the second band-pass amplifier, which amplifies and passes only the difference frequency, $(f_o - f_h) - f_x$. This difference frequency is fed to a discriminator. The number of channels controlled is directly proportional to the number of discriminators used. The d-c a-f-c output of the discriminator is used to control the bias of the control tube. The plate current of the control tube determines the rotor position of a servo motor, and the rotor is mechanically coupled to control the tuning elements of the variable oscillator. The servo motor continues to turn and thereby continues to change the frequency, f_o , until the output of the discriminator is zero. This occurs when the output of the second band-pass amplifier is equal to f_d , the frequency of the discriminator circuit. By reversing the polarity of the discriminator output leads, f_o can be made to vary in the opposite direction in order to reach equilibrium. Thus, for each value of f_h , f_x , and f_d , there are two equilibrium values of f_o . These are given by the equation

$$f_o = f_h + f_x \pm f_d \quad 1-455 (1)$$

1-456. Let

- N = Total number of channels, f_o .
- H = Number of harmonics used (1st crystal oscillator).
- X = Number of crystals (2nd crystal oscillator).
- D = Number of discriminators.

It can be seen from equation 1-455 (1) that

$$N = 2HXD \quad 1-456 (1)$$

The factor 2 is introduced by the fact that for each discriminator there are two values of f_o for each combination of f_h and f_x . One value is $f_o = f_h + f_x + f_d$, and the other is $f_o = f_h + f_x - f_d$.

1-457. As a concrete example, let us imagine that it is desired to cover the frequency range between 100 and 156 mc with the channels spaced 200 kc apart. The lowest value of f_o is to be 100.2 mc, and the highest is to be 156 mc. Thus,

$$N = \frac{(\max) f_o - (\min) f_o}{\Delta f_o} + 1 = \frac{156 - 100}{0.2} + 1 = 280 \quad 1-457 (1)$$

By equation 1-456 (1),

$$HXD = \frac{N}{2} = 140 \quad 1-457 (2)$$

The smallest total number of elements occurs when H , X , and D can be made as nearly equal to each other as possible, but in an actual design problem, this may not be the most practical solution. In our particular example let us assume that the first seven harmonics of f_c are to be used.

With $H = 7$, then by equation (2)

$$XD = \frac{140}{7} = 20 \quad 1-457 (3)$$

Section I
Crystal Oscillators

The combinations (X,D) possible are (20,1), (10,2), (5,4), (4,5), (2,10), and (1,20). For our problem we shall suppose that the combination (X = 10, D = 2) proves the most practical. Thus, with the use of 11 crystals in all and 2 discriminators, 280 crystal-controlled channels are to be obtained.

1-458. Let $f_1, f_2, f_3, \dots, f_{280}$ designate the values of f_c from the lowest to the highest, in that order. Let $f_{x1}, f_{x2}, \dots, f_{x10}$ designate the values f_x from the lowest to the highest, in that order. The values of f_h in ascending order are $f_c, 2f_c, \dots, 7f_c$. Finally, let f_{d1} and f_{d2} designate the lower and the higher discriminator frequencies, respectively. To avoid the possibility of spurious conversion frequencies, the highest value of f_h should be less than the minimum associated 1st band-pass amplifier frequency, $f_c - f_h$. Also, the lowest value of f_x should be higher than the highest 2nd band-pass amplifier frequency, which, of course, will equal the highest discriminator frequency, f_d . The order of the variable-oscillator frequencies and the sequence of circuit connections required to provide each frequency is indicated by the following sequence of equations.

$$f_1 = f_c + f_{x1} - f_{d2} = 100.2 \text{ mc}$$

$$f_2 = f_c + f_{x1} - f_{d1} = 100.4 \text{ mc}$$

$$f_3 = f_c + f_{x2} - f_{d2} = 100.6 \text{ mc}$$

$$f_4 = f_c + f_{x2} - f_{d1} = 100.8 \text{ mc}$$

etc

$$f_{20} = f_c + f_{x10} - f_{d1} = 104 \text{ mc}$$

$$f_{21} = f_c + f_{x1} + f_{d1} = 104.2 \text{ mc}$$

$$f_{22} = f_c + f_{x1} + f_{d2} = 104.4 \text{ mc}$$

$$f_{23} = f_c + f_{x2} + f_{d1} = 104.6 \text{ mc}$$

$$f_{24} = f_c + f_{x2} + f_{d2} = 104.8 \text{ mc}$$

etc

$$f_{40} = f_c + f_{x10} + f_{d2} = 108 \text{ mc}$$

$$f_{41} = 2 f_c + f_{x1} - f_{d2} = 108.2 \text{ mc}$$

$$f_{42} = 2 f_c + f_{x1} - f_{d1} = 108.4 \text{ mc}$$

$$f_{43} = 2 f_c + f_{x2} - f_{d2} = 108.6 \text{ mc}$$

etc

$$f_{280} = 7 f_c + f_{x10} + f_{d2} = 156 \text{ mc}$$

1-459. It can be seen from the equation sequence in paragraph 1-458 that the difference between the channel frequencies is equal to the difference

between the discriminator frequencies. Thus,

$$\Delta f_d = f_{d2} - f_{d1} = \Delta f_c = f_2 - f_1 = 0.2 \text{ mc} \quad 1-459 (1)$$

Note in the equation sequence in paragraph 1-458, that for a given harmonic frequency, f_h , all the f_x crystals are used in sequence before the polarity of the discriminator outputs are reversed. In other words, f_{d1} and f_{d2} are first subtracted from all combinations of a particular harmonic with the X-crystal frequencies and then added to the same combinations. This process is repeated with each harmonic. If we subtract the equation for f_1 from the equation for f_3 , we have

$$\Delta f_x = f_{x2} - f_{x1} = f_3 - f_1 = 0.4 \text{ mc} = 2 \Delta f_d \quad 1-459 (2)$$

In the general case,

$$\Delta f_x = D \Delta f_d \quad 1-459 (3)$$

where D is the number of discriminators. The same value of Δf_x also holds between any other two consecutive values of f_x . Thus,

$$f_{x2} = f_{x1} + \Delta f_x$$

$$f_{x3} = f_{x1} + 2 \Delta f_x$$

$$f_{xn} = f_{x1} + (n - 1) \Delta f_x = f_{x1} + (n - 1) D \Delta f_d$$

1-459 (4)

The highest frequency of the second crystal oscillator is given by equation (4) when $n = X =$ the total number of crystals. Thus,

$$(\text{max}) f_x = f_{x1} + (X - 1) D \Delta f_d \quad 1-459 (5)$$

With the use of equation (5) we can find the lowest discriminator frequency, f_{d1} . This is done by subtracting the equation for f_{20} from the equation for f_{21} , which gives

$$f_{21} - f_{20} = f_{x1} - f_{x10} + 2f_{d1} = \Delta f_d = 0.2 \text{ mc} \quad 1-459 (6)$$

Since f_{x10} is a particular case of (max) f_x , we can substitute equation (5) in equation (6) to obtain a general equation. We find

$$f_{x1} - f_{x1} - (X - 1) D \Delta f_d + 2 f_{d1} = \Delta f_d$$

On rearranging after canceling out f_{x1} ,

$$f_{d1} = \Delta f_d \frac{(1 + DX - D)}{2} \quad 1-459 (7)$$

The general equation for any particular discriminator frequency, f_{dn} , is similar to that for f_{xn} given by equation (4). Thus,

$$f_{dn} = f_{d1} + (n - 1) \Delta f_d \quad 1-459 (8)$$

and

$$(\max) f_d = f_{d1} + (D - 1) \Delta f_d \quad 1-459 (9)$$

The next problem is to obtain a general equation for f_c . This can be had by subtracting the equation for f_{d0} from the equation for f_{d1} . The remainder is

$$\Delta f_d = f_c + f_{x1} - f_{x10} - 2 f_{d2}$$

where $f_{x10} = (\max) f_x$ and $f_{d2} = (\max) f_d$. Thus,

$$f_c = 2 f_{d2} - f_{x1} + f_{x1} + (X - 1) D \Delta f_d + \Delta f_d$$

or

$$f_c = 2 f_{d2} + 2 f_{d1} \\ f_c = 2 [(\max) f_d + (\min) f_d] \quad 1-459 (10)$$

Finally, with f_c determined, we can use the equation for f_1 to find f_{x1} .

1-450. We are now in a position to express any of the circuit frequencies in terms of the parameters f_1 , Δf_o , N , H , X , and D . For the n th channel,

$$f_n = f_1 + (n - 1) \Delta f_o \quad 1-460 (1)$$

For the highest channel,

$$(\max) f_o = f_1 + (N - 1) \Delta f_o \quad 1-460 (2)$$

For the lowest discriminator frequency,

$$f_{d1} = \frac{\Delta f_o (1 + DX - D)}{2} \quad 1-460 (3)$$

For the n th discriminator frequency,

$$f_{dn} = \frac{\Delta f_o (DX - D + 2n - 1)}{2} \quad 1-460 (4)$$

For the highest discriminator frequency,

$$(\max) f_d = \frac{\Delta f_o (DX + D - 1)}{2} \quad 1-460 (5)$$

For the fundamental of the 1st crystal oscillator,

$$f_c = 2 \Delta f_o D X = \frac{\Delta f_o N}{H} \quad 1-460 (6)$$

For the n th harmonic frequency,

$$f_{nn} = 2 \Delta f_o D X n \quad 1-460 (7)$$

For the highest harmonic,

$$(\max) f_n = \Delta f_o N \quad 1-460 (8)$$

For the lowest frequency of the 2nd crystal oscillator,

$$f_{x1} = \frac{2 f_1 - \Delta f_o (3 DX - D + 1)}{2} \quad 1-460 (9)$$

For the n th frequency of the 2nd crystal oscillator,

$$f_{xn} = \frac{2 f_1 - \Delta f_o (3 DX + D + 1 - 2 D_n)}{2} \\ 1-460 (10)$$

For the highest frequency of the 2nd crystal oscillator,

$$(\max) f_x = \frac{2 f_1 - \Delta f_o (DX + D + 1)}{2} \\ 1-460 (11)$$

and the difference between the consecutive values of f_x ,

$$\Delta f_x = \Delta f_o D \quad 1-460 (12)$$

1-461. On applying the equations in paragraph 1-460 to the numerical example that has been assumed, where $f_1 = 100.2$ mc, $\Delta f_o = 0.2$ mc, $N = 280$, $H = 7$, $X = 10$, and $D = 2$, we find that

$$f_{d1} = \frac{0.2 (1 + 20 - 2)}{2} = 1.9 \text{ mc}$$

$$f_{d2} = 1.9 + 0.2 = 2.1 \text{ mc}$$

$$f_c = \frac{0.2 \times 280}{7} = 8 \text{ mc}$$

$$f_{n1}, f_{n2}, \text{ etc.} = 8, 16, 24, 32, 40, 48, 56 \text{ mc}$$

$$f_{x1} = \frac{200.4 - 0.2 (60 - 2 + 1)}{2} = 94.3 \text{ mc}$$

$$\Delta f_x = 0.4 \text{ mc}$$

$$f_{x1}, f_{x2}, \text{ etc.} = 94.3, 94.7, 95.1, 95.5, 95.9, 96.3, \\ 96.7, 97.1, 97.5, 97.9 \text{ mc}$$

Section I Crystal Oscillators

Note that the highest harmonic frequency is equal to the bandwidth of the frequency range being covered.

1-462. From the equation, $f_o = f_h + f_x \pm f_n$, it can be seen that the frequency stability will be approximately the stability of the crystal oscillators. This is because f_n is so very much lower than f_h and f_x . Although the discriminators should be designed with low-loss, temperature-compensating materials, even a large percentage variation in f_n would be negligible in its percentage effect upon f_o . Since it is the sum of f_h and f_x that determines f_o , the maximum *percentage* frequency deviation of the total can be no greater than that of the crystal oscillators individually. Without oven control, the channel frequencies can be maintained within a tolerance of ± 0.005 per cent, and better.

RADIO SET AN/ARC-33

1-463. Radio Set AN/ARC-33 is an airborne receiver-transmitter designed to operate in the v-h-f and u-h-f spectrum. This equipment, developed by the Bendix Corporation, employs a modified version of the Bendix frequency-synthesizing system discussed in the foregoing paragraphs. The frequency-control section (see figure 1-192 for block diagram) is designed to permit receive-transmit communication on any one of 1750 channels spaced 100 kc apart in the 225-to-399.9-mc band.

1-464. An important modification in the synthesizing system arises from the fact that the synthesized frequencies are utilized as heterodyne injection signals during reception and as carrier signals during transmission. The tuning controls are such that the receiver and transmitter circuits are always automatically tuned to the same channel, but since the desired receiver injection frequency must differ from the tuned channel frequency by an amount equal to the receiver intermediate frequency, the design engineers had to decide whether to let the variable-frequency oscillator be, in effect, a subharmonic local oscillator for the receiver or a subharmonic master oscillator for the transmitter. They decided in favor of the receiver. Thus, the stabilized output frequency, f_o , of the vfo, after being multiplied 12 times, is used directly as the injection voltage in the 1st mixer stage in the receiver. This provides a fixed intermediate frequency, f_i , of 15.325 mc for each of 1750 channels. Now, the v-f-o output, f_o , is also used in the synthesis of the channel frequency of the transmitter. Since the 12th harmonic of f_o always differs from the channel frequency by an amount equal to f_i , all that needs to be done in principle is to mix $12f_o$ with a fixed oscillator fre-

quency equal to f_i and for the sum product to be isolated and amplified for use as the transmitter carrier. In the ARC-33 transceiver this effect is achieved by mixing the output, f_o , of a crystal-controlled oscillator (called the "sidestep" oscillator) with the 6th harmonic of f_o , then selecting the sum frequency ($6f_o$ plus f_i) and doubling it to form the carrier frequency, f_c , which, after amplification, is fed to the antenna. Summarizing these frequency relations in the form of equations, we have:

$$\text{injection frequency} = 12 f_o$$

$$\text{intermediate frequency} = f_i = f_c - 12f_o$$

$$\begin{aligned} \text{antenna (channel) frequency} &= f_c = 12f_o + f_i \\ &= 2(6f_o + f_i) \end{aligned}$$

$$\text{sidestep frequency} = f_s = f_i/2$$

Note the necessary harmonic relation between the sidestep output and the intermediate frequency. It is also important to note that the principle involved in the use of a sidestep oscillator permits, not only a Bendix synthesizing system, but any synthesizing system to be readily modified for the dual-purpose requirements of transceiver frequency control.

1-465. Comparison of figures 1-191 and 1-192 will reveal that the 2nd crystal oscillator in the basic Bendix synthesizer has been replaced by two crystal oscillators (the 2nd and 3rd in figure 1-192) in Radio Set AN/ARC-33. This has been done to permit a greater number of frequencies with a fewer number of crystals.

1-466. Another significant modification occurs in the ARC-33 discriminator circuit. As is explained in more detail in a subsequent paragraph, the ARC-33 discriminator is not a conventional type that employs a parallel tuned circuit to control the phase differences between the input voltage components. In that type of discriminator the output voltage always has a net d-c component unless the input frequency is equal to the antiresonant frequency of the tuned tank. The polarity of the d-c component is an index of whether the input frequency is higher or lower than that at which the tank is tuned, and the amplitude of the d-c component can be a measure of the amount of difference between the two frequencies. It is this type of discriminator that is assumed in the discussion of the basic Bendix synthesizing system, the d-c output of which is used to control the variable oscillator tuning. In the ARC-33, however, the discriminator does not employ a tuned circuit, but instead is fed a signal that is controlled by the 4th crystal oscillator. The discriminator also receives

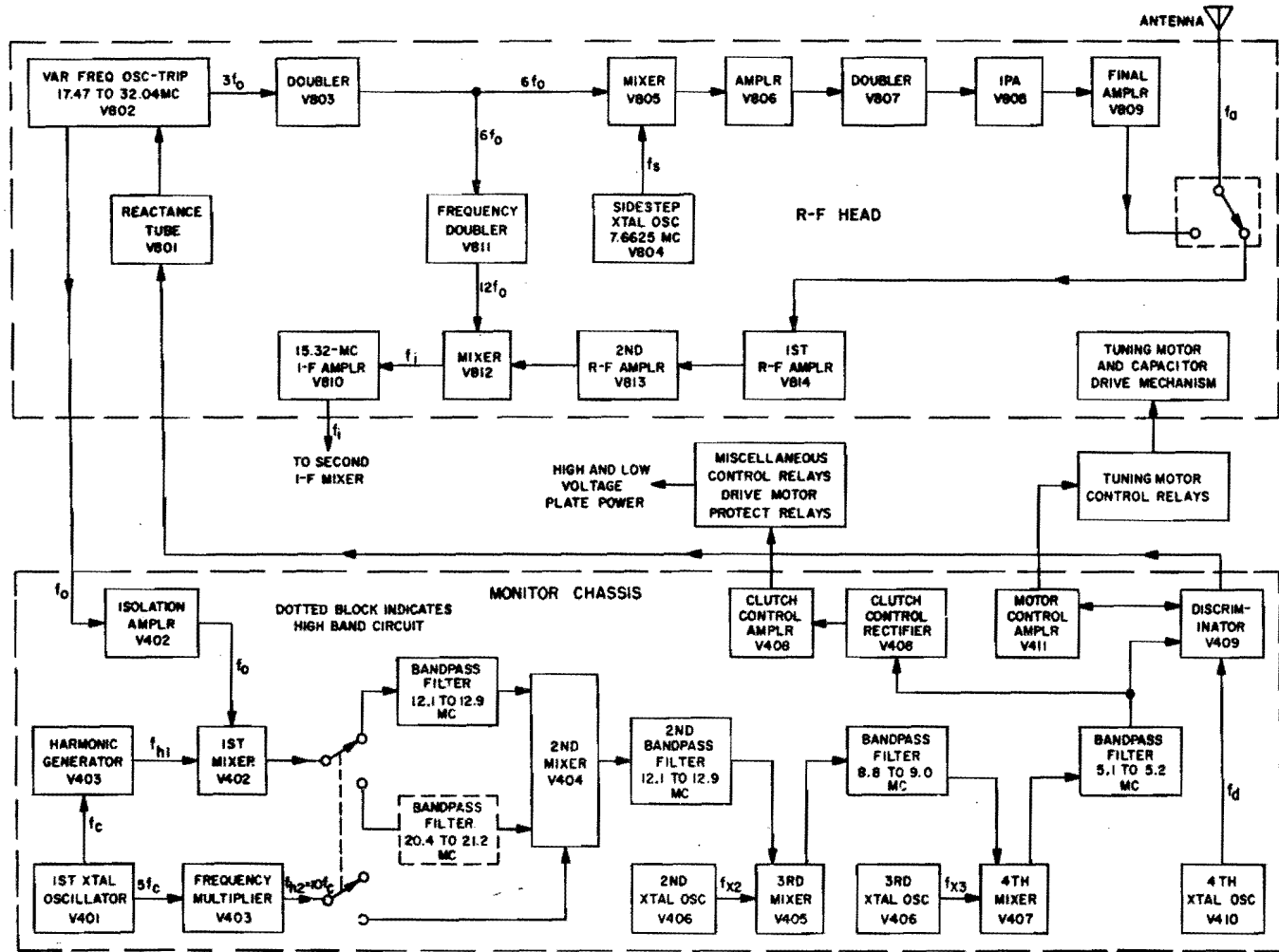

Figure 1-192. Block diagram of frequency control section of Radio Set AN/ARC-33 showing modified version of Bendix synthesizing system

an input signal from the 4th mixer. The two signals combine in the discriminator circuit to provide a net d-c output only when the two signals are of the same frequency. When the frequencies are identical, the behavior of the discriminator is quite similar to the behavior of one that employs a tuned circuit, the d-c output depending upon the differences in phase between the input voltages. Since the 4th oscillator can be controlled by either one of two crystals, this arrangement is equivalent to having two discriminators of the tuned-circuit type.

1-467. In paragraph 1-456 it is explained that for each discriminator, two values of f_o are possible. In Radio Set AN/ARC-33 only one of these values is used for each 4th-oscillator frequency, namely

$$f_o = f_h + f_x + f_d \quad 1-467 (1)$$

In the equation above, f_h is the selected *effective* harmonic of the 1st crystal oscillator, equal to f_{h1} on the low band and to $(f_{h1} + f_{h2})$ on the high band, f_x equals the sum of the frequencies of the 2nd and 3rd crystal oscillators ($f_{x2} + f_{x3}$), and f_d

is the frequency of the 4th crystal oscillator fed to the discriminator.

1-468. Other modifications of the Bendix system as occur in the frequency-control circuits of Radio Set AN/ARC-33 are of an even less radical nature than those described above. There is the division of the 1st bandpass stage into low-band and high-band circuits, and there is the addition of an a-f-c reactance tube, which is actually more of an extension of the modification caused by the use of a crystal-controlled discriminator, but these and other special circuit arrangements are best explained in the more detailed analyses later. At this point it will be helpful to examine briefly the role each of the various oscillator frequencies plays in controlling the final antenna frequency.

1-469. First, we shall examine the simplified block diagram shown in figure 1-193. The frequency-control system indicated represents an imaginary synthesizing circuit that provides the same transmitter output frequencies, f_a , as does Radio Set AN/ARC-33. The principal difference between the

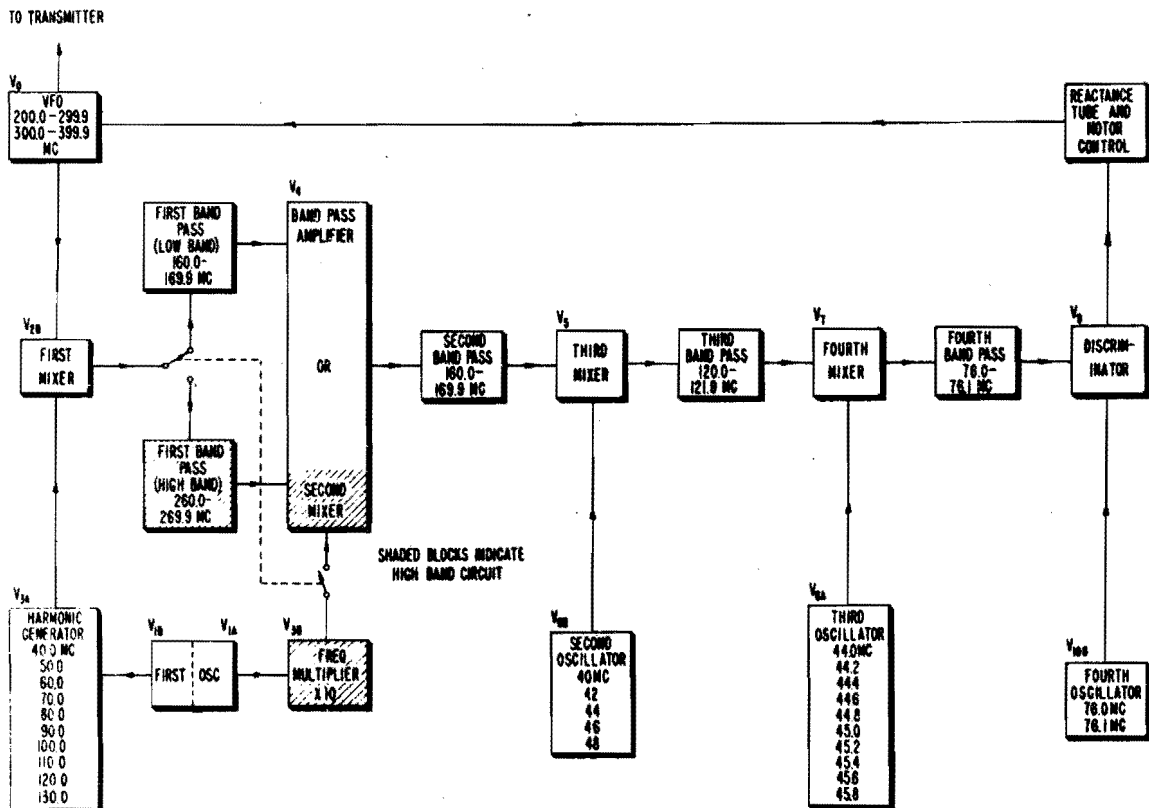

Figure 1-193. Simplified block diagram of the frequency-control section of Radio Set AN/ARC-33 as it would appear if the variable frequency oscillator were the direct generator of the transmitter output frequency without the use of multiplier or side-step circuits

imaginary and the actual systems is that the imaginary system is not required to provide an injection voltage for a receiver heterodyne circuit, nor is it required to employ multiplier stages following the variable oscillator. In other words, f_n can be assumed to equal f_0 . Under these conditions the various crystal and harmonic frequencies would assume the simple values shown in figure 1-193. The actual circuit frequencies are those indicated in the frequency diagram of figure 1-194. A comparison of the frequencies in the two systems will show that the injected frequencies in each mixer stage of the imaginary system vary from one to the next in steps that are 12 times greater than are the corresponding steps in the actual system. This does not mean, except in the case of the 1st crystal oscillator and its harmonics, that the imaginary crystal frequencies are 12 times the actual crystal frequencies; it is only the differences between adjacent frequencies that are related in the proportion of 12 to 1. Since the frequency of the variable frequency oscillator in the actual circuit is eventually multiplied 12 times, it can be seen that the frequency steps in the actual circuit are equivalent to those in the imaginary circuit insofar as they add or subtract in the control of the antenna frequency. Thus, we can say that the antenna frequency is effectively synthesized in 10-mc units by the 1st crystal oscillator and harmonic generator, 2-mc units by the 2nd crystal oscillator, 0.2-mc units by the 3rd crystal oscillator, and finally to the nearest 0.1-mc unit by the discriminator and 4th crystal oscillator.

Detailed Circuit Description

1-470. The principal component of Radio Set AN/ARC-33 is Receiver-Transmitter RT-173/ARC-33. The receiver-transmitter is divided into a number of sectional components, two of which are of importance to us:

a. The *monitor chassis*, which contains all the crystal circuits for controlling the variable-frequency oscillator.

b. The *r-f head*, which contains the variable-frequency oscillator, the multiplier circuits, the 1st i-f mixer, the sidestep oscillator, as well as the r-f amplifiers of the receiver and the power amplifiers of the transmitter. Also of importance to us are the relays which control the tuning motor. These are mounted on the main frame. We shall discuss the monitor circuits first, and then those in the r-f head. Except for occasional insertions and editing, the descriptions to follow are largely extracts from USAF Technical Order No. 12R2-2ARC33-2.

Monitor Chassis

1-471. The monitor chassis in Radio Set AN/ARC-33 concerns only the frequency control of the variable-frequency oscillator and electronic control of the tuning-capacitor drive motor with its clutches. There are no other circuits involved.

The detailed circuit descriptions of the monitor chassis are made with reference to the component symbols employed in the block diagram of figure 1-195 and the schematic diagram of figure 1-196. With the exception of a coaxial connector for the r-f input from the variable-frequency oscillator, all external connections to the unit are made through a single connector, which is so arranged that connection automatically is made when the chassis is inserted in its proper place in the main frame.

1-472. *FIRST CRYSTAL OSCILLATOR*. The 1st crystal oscillator is a single-frequency, fundamental-mode, 833.333-kc oscillator of the cathode-coupled Butler type. A selected harmonic of the oscillator is mixed with the frequency of the variable frequency oscillator in the 1st mixer. A dual triode tube, V401, is employed as the oscillator tube, which has two output connections. Section A is tuned to the 5th harmonic of the crystal and feeds the grid of frequency multiplier V403B. The plate output of the grounded-grid oscillator section B is coupled through capacitor C407 to the harmonic generator grid. The crystal unit, which is of the type CR-28/U, is mounted in a type HD-54/U crystal oven. The oven employs two heaters and thermostats, one heater being used to bring the temperature quickly up to the operating level, whereas the other, which has a lower wattage, is used to maintain constant operating temperature. In order to check the oscillator for proper operation, a test connection for measuring rectified grid current is brought out to test socket X412. The stability of the final transmitter frequency is more dependent upon the stability of this oscillator than upon that of any of the others. The reason is that the 1st crystal oscillator controls a greater percentage of the final frequency, especially in the high band, than do the other oscillators. This can readily be seen if we visualize the final frequency as being synthesized by adding together the crystal-oscillator frequencies in the simplified block diagram of figure 1-193. The key function of this oscillator is the reason why the highly stable Butler circuit is employed.

1-473. *HARMONIC GENERATOR*. The function of harmonic generator V403A is to produce any selected harmonic of the first crystal oscillator

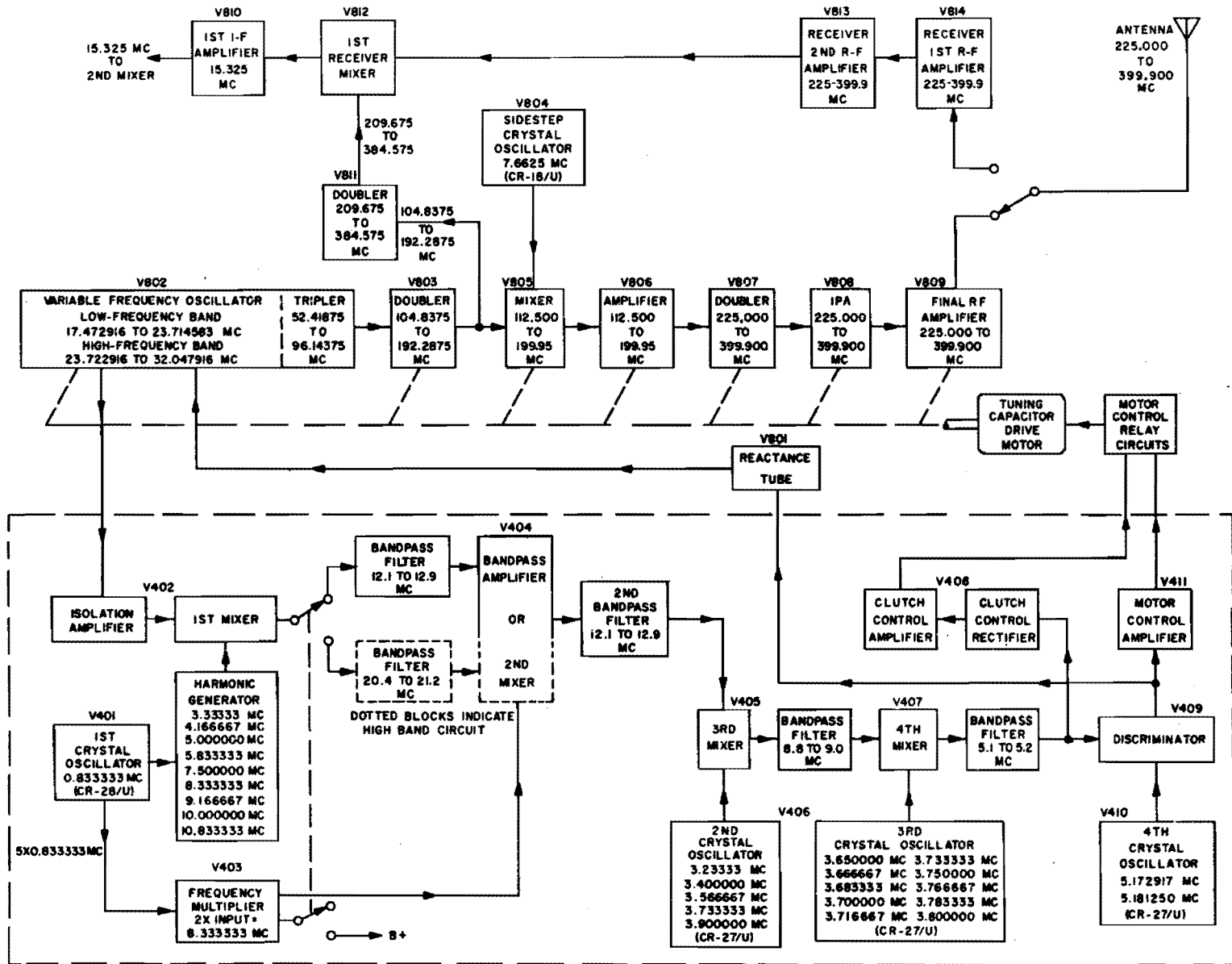

Figure 1-194. Frequency diagram of frequency-control system in Radio Set AN/ARC-33

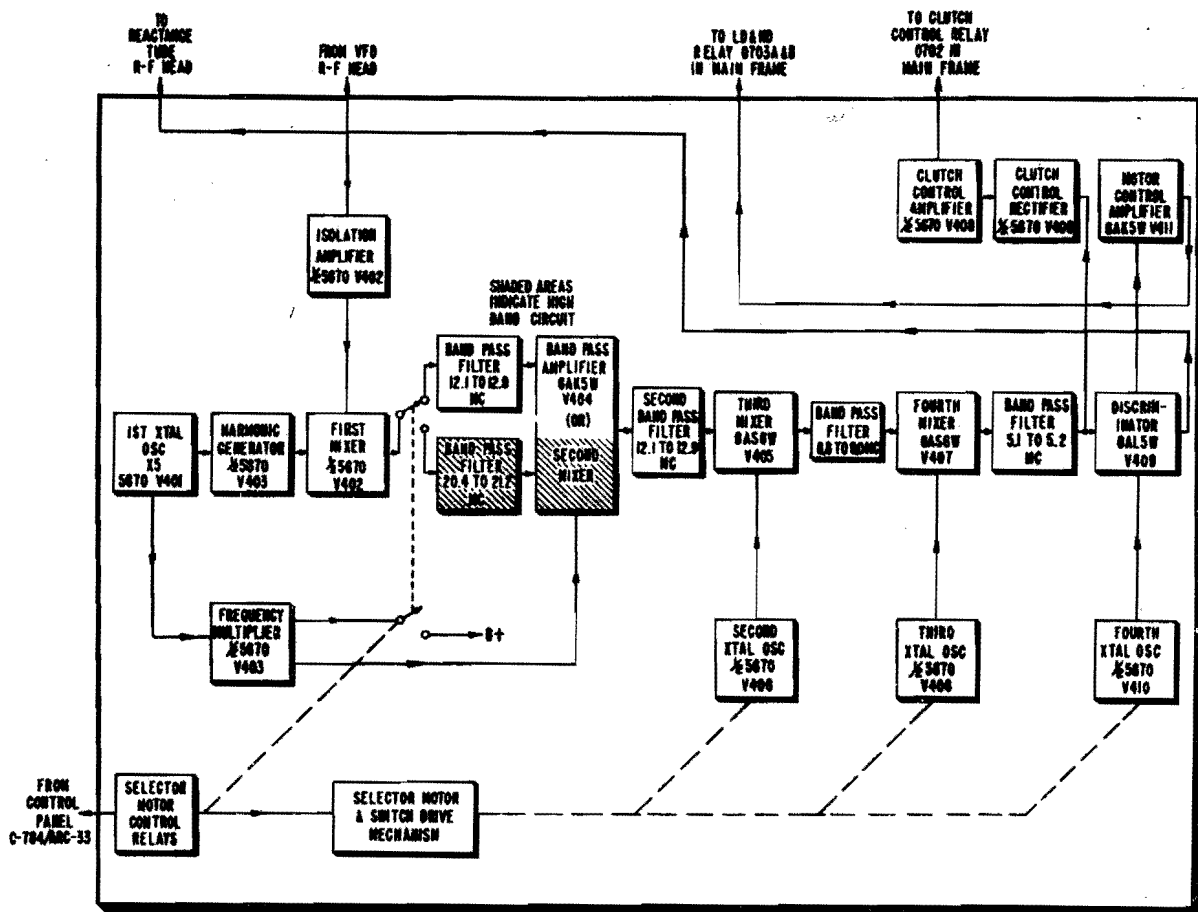

Figure 1-195. Monitor chassis. Block diagram of a-f-c system in Radio Set AN/ARC-33

output from the 4th to the 13th, inclusive. The selected harmonic is fed to the 1st mixer to be heterodyned with the frequency from the variable frequency oscillator. Harmonic selection is achieved by capacitance tuning the primary and secondary of the harmonic generator output transformer T401 to the desired harmonic frequency. The switching is accomplished by 10-position rotary switches S403A and S403B, which are driven by the selector motor through a harmonic generator clutch. These switches merely select the proper fixed capacitors for tuning the primary and secondary winding to the desired harmonic of the 833.333-kc fundamental. 1-474. R-f input from the 1st crystal oscillator is fed to the harmonic generator tube, V403A, through coupling capacitor C407. A grid bias far below cutoff is provided by grid resistor R407 in order to ensure an output rich in harmonics. The primary and secondary windings of transformer

T401 are permeability tuned for alignment at the lowest (4th) harmonic. The highest frequency, which is the 13th harmonic, is determined by capacitors C418 and C419 across the primary and C420 and C421 across the secondary. Capacitors C418 and C421 are trimmers for alignment at the highest frequency. The selection of all harmonics, up to but not including the 13th, is accomplished by switching in the proper fixed capacitor C408 through C417 across the primary of transformer T401, and C222 through C431 across the secondary. For the lowest harmonic, C416 and C417 for the primary and C430 and C431 for the secondary are connected in parallel. For the highest harmonic, no auxiliary capacitor is switched into the circuit. For proper operation of the monitor, it is necessary that the input level of the 1st mixer be approximately the same for each selected harmonic. This is accomplished by selecting a grid bias for the harmonic generator

which causes the output level to vary inversely with frequency under a constant plate load impedance. Then, by maintaining the "Q" of the transformer T401 windings constant at all selected frequencies, the resultant plate load impedance of tube V403 can be made to vary directly with frequency because of the increasing inductance/capacitance ratio. The resultant voltage across the T401 transformer windings, therefore, is essentially constant regardless of the harmonic selected.

1-475. *FIRST MIXER.* The 1st mixer tube, V402, combines the output of the harmonic generator with the output frequency of the variable frequency oscillator (vfo) whose frequency is to be controlled by the monitor circuits. The 1st mixer output consists of the difference frequency between the selected harmonic generator frequency and the v-f-o frequency, the latter frequency always being the higher. Input from the harmonic generator is fed directly to the control grid, whereas the input from the vfo, which enters the monitor chassis through connector J401, is fed from isolation amplifier V402A to the cathode of the 1st mixer through coupling capacitor C432. Output coupling is provided by bandpass coil assembly Z401, which consists of a low-band circuit and a high-band circuit. The bandpass selector relay selects the proper circuit of bandpass coil assembly Z401. The reason for using two bandpass circuits is that the broad frequency range of the radio set makes it necessary to divide the range into two smaller ranges. The band-determining factor is the selection of the 1st digit of the desired channel frequency at the control panel. The control panel switch energizes the band selector relay when the 1st digit is 2; that is, when the antenna frequency is to be less than 300 mc. For antenna frequencies of 300 mc and above, the band relay is unenergized. Coil assembly Z401 is designed to pass a band from approximately 12.1 to 12.9 mc and a band from approximately 20.4 to 21.2 mc. Because of the use of two bandpasses at the 1st mixer output, each of the harmonic generator selected output frequencies is used twice, once in each band.

1-476. *BANDPASS AMPLIFIER.* The bandpass amplifier, V404, is an amplifier for the 1st mixer output on the low-frequency band and is used to improve the bandpass characteristics of the circuit. This stage is unconventional inasmuch as it also functions as a 2nd mixer, the operation of which is described in the following paragraph. The plate load consists of transformer T402, which is tuned to the same frequency band as the

low band of Z401. The bandpass amplifier is capacitance-coupled through capacitor C443 to the number one grid of the 3rd mixer, V405.

1-477. *SECOND MIXER.* The 2nd mixer stage utilizes the same tube elements of V404 as are used when the tube is operated as a bandpass amplifier. However, this dual usage does not occur simultaneously. Tube V404 functions as a 2nd mixer only when the radio set operates in the high band of the frequency range. The 2nd mixer combines the 1st mixer output frequency with the 10th harmonic of the 1st crystal oscillator frequency. The output consists of the difference frequency, where the 10th harmonic frequency is always lower than the output frequency of the 1st mixer. Note that the reduction of the 1st mixer output frequency by an amount equal to the 10th harmonic of the 1st crystal oscillator frequency is equivalent to extending the harmonic generator range from the 13th to the 23rd harmonic and eliminating the high band of bandpass coil assembly Z401. Input to the 2nd mixer from the high-band bandpass filter is fed to the control grid along with the input from frequency multiplier V403B. The plate load consists of transformer T402, which is tuned to pass a band from 12.1 to 12.9 mc. The desired band width for the transformer is obtained through the use of loading resistors R418 and R419. Transformer T402 is the same plate load circuit for the 2nd mixer as is used when the stage operates as a bandpass amplifier.

1-478. *FREQUENCY MULTIPLIER.* The frequency multiplier, V403B, is fed with the 5th harmonic output from the 1st crystal oscillator. The output transformer, T406, is tuned to 8.33333 mc, which is the 2nd harmonic of the multiplier input frequency. Thus, V403B is a frequency doubler and feeds its output, the 10th harmonic of the 1st crystal oscillator frequency, to the control grid of the 2nd mixer, V404. When the radio set is operated in the low band of its frequency range, no output is derived from the frequency multiplier because plate voltage is removed from tube V403B. The application of plate voltage is controlled by the band selector relay. When the band selector relay switches the high bandpass filter into the 1st mixer circuit, it also applies voltage to the plate of the frequency multiplier so that an 8.33333-mc signal is fed to the 2nd mixer. The frequency multiplier is capacitively coupled to the control grid of the 2nd mixer through capacitor C457.

1-479. *SECOND CRYSTAL OSCILLATOR.* The 2nd crystal oscillator provides a selection of any

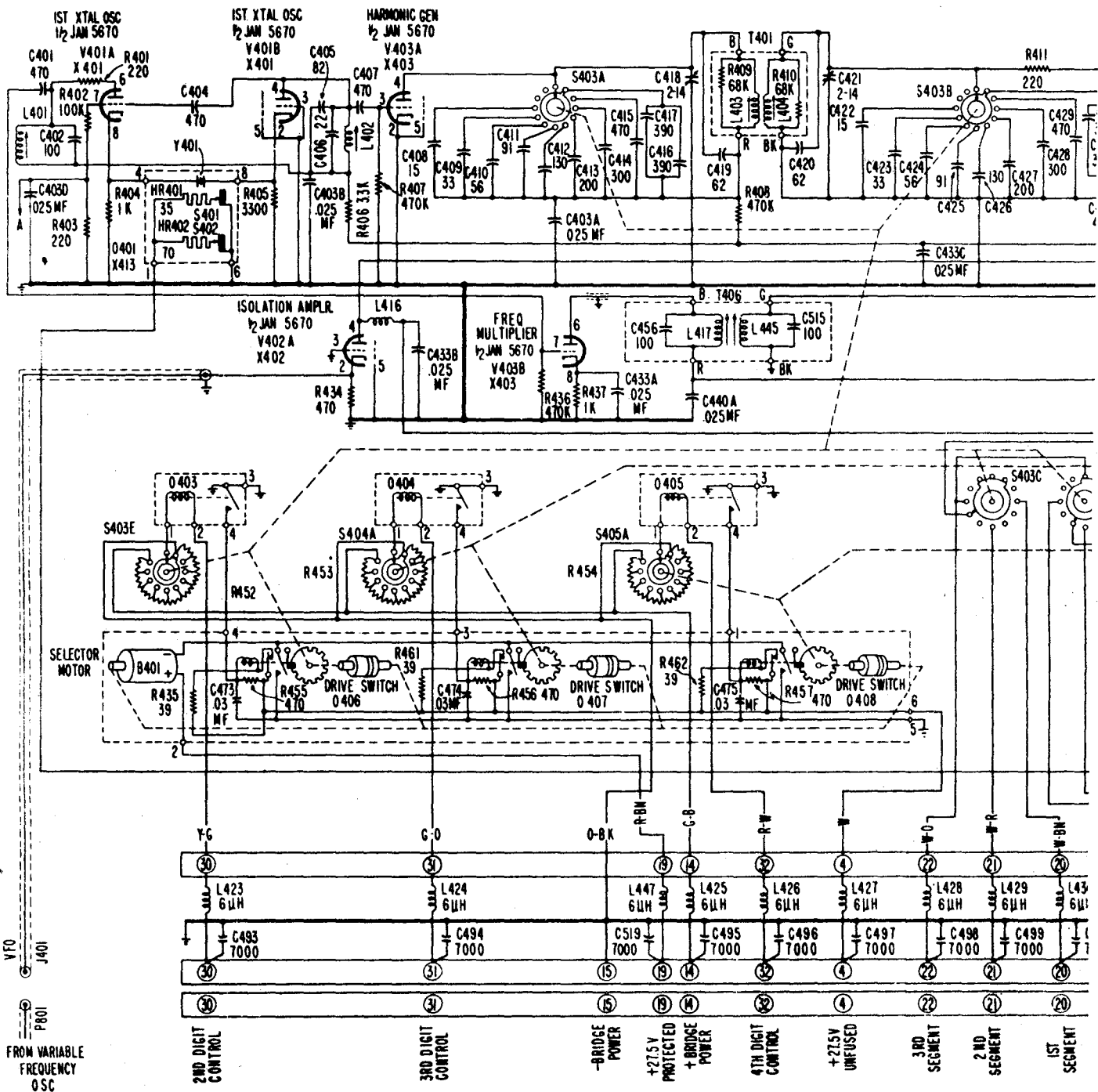

A

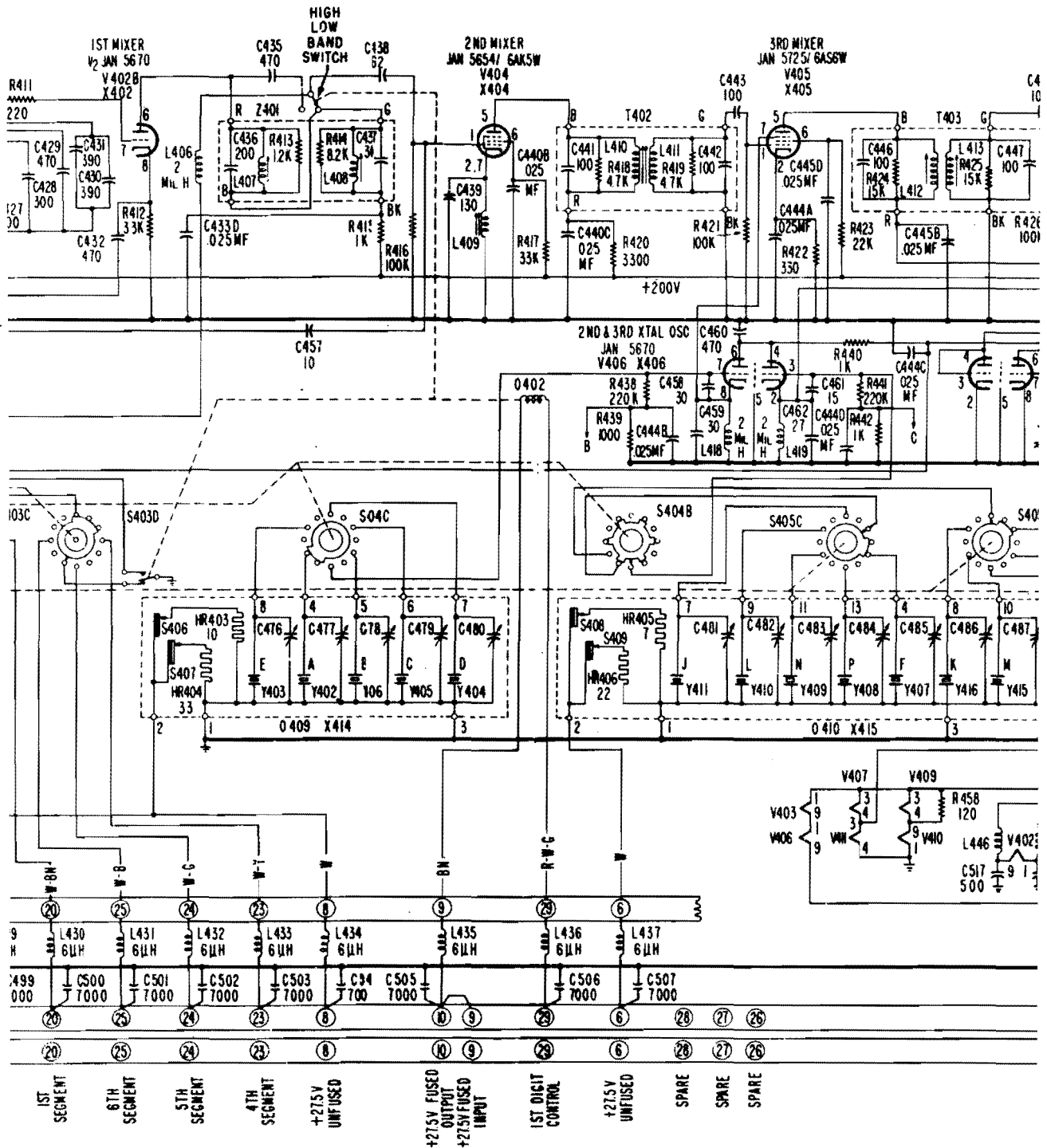

B

- 1ST SEGMENT
- 6TH SEGMENT
- 5TH SEGMENT
- 4TH SEGMENT
- +275V UNFUSED
- +275V FUSED OUTPUT
- +275V FUSED INPUT
- 1ST DIGIT CONTROL
- +275V UNFUSED
- SPARE
- SPARE
- SPARE

Section I
Crystal Oscillators

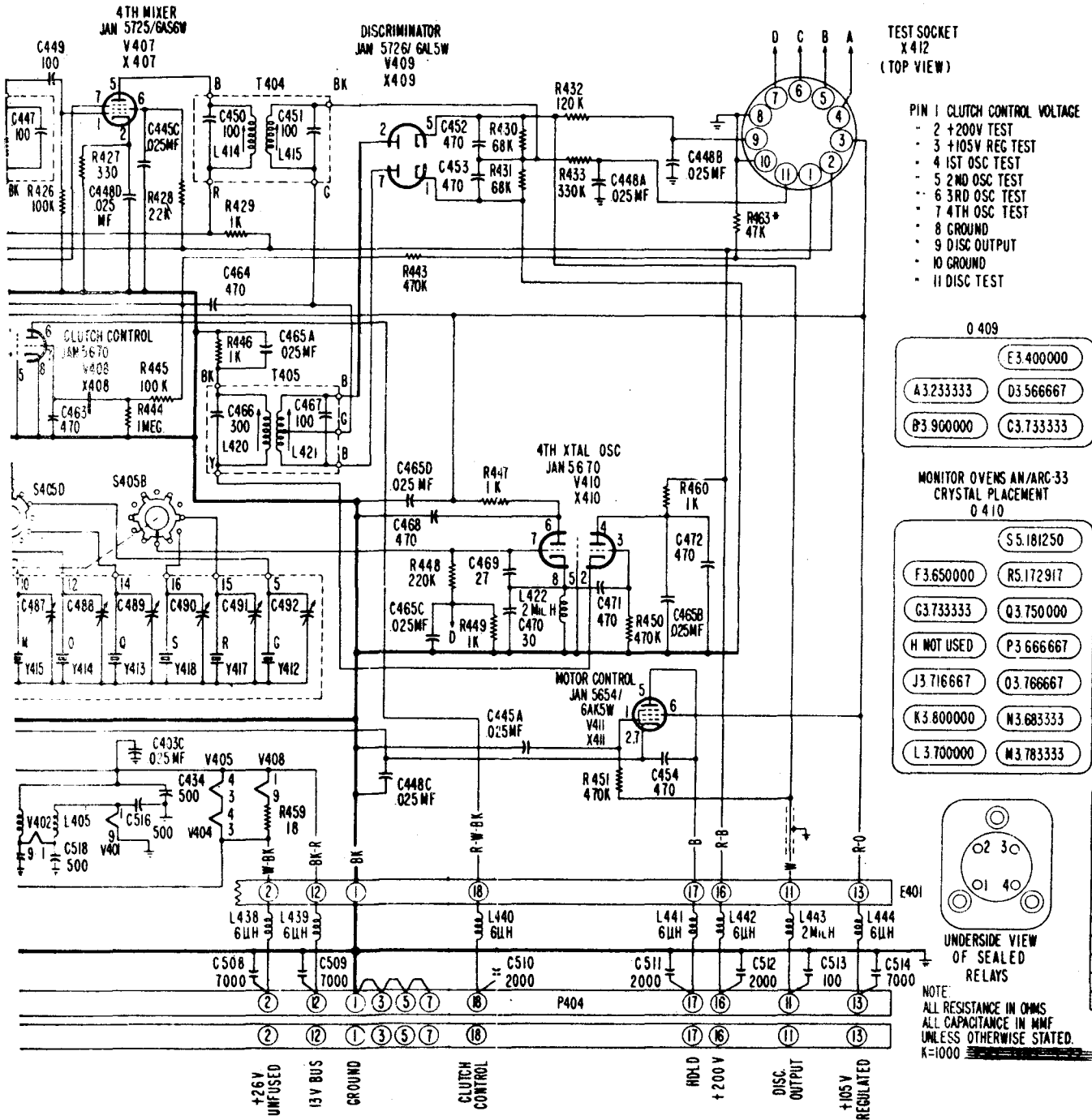

Figure 1-196. Monitor chassis. Schematic diagram of a-f-c system in Radio Set AN/ARC-33

one of five crystal-controlled frequencies by means of crystal switching. The crystal-controlled output frequency is fed to the suppressor grid of the 3rd mixer to be mixed with either the 2nd mixer or the bandpass amplifier output frequency. The oscillator circuit utilizes one half of the duplex triode tube V406 as a grounded-plate Pierce oscillator. R-f output is taken from the cathode. Each of the five crystal units, which are of the CR-27/U type, has a separate trimmer so that each selected 2nd crystal oscillator frequency can be adjusted exactly. All of the crystal units with their trimmers are enclosed in a single oven (Bendix Radio type L205628) which is kept at approximately 75°C (167°F) by a thermostat-controlled heater. A booster heater and thermostat are provided in addition for quick warmup. In order that the oscillator operation may be checked, a test connection from the grid circuit is brought out for checking rectified grid current at test socket X412.

1-480. *THIRD MIXER.* The circuit of the 3rd mixer, V405, is similar to that of the 2nd mixer except that the signal voltage from its heterodyne crystal oscillator is injected at the suppressor grid. The 3rd mixer output circuit is tuned to a center frequency of 8.9 mc and is designed to pass a band approximately from 8.8 to 9.0 mc. The 3rd mixer combines the output frequencies of either the 2nd mixer or bandpass amplifier and the 2nd crystal oscillator, the output frequency of the former two always being the higher. The 3rd mixer output, which is the difference frequency, is fed from the secondary of transformer T403 to the 4th mixer through capacitor C449.

1-481. *THIRD CRYSTAL OSCILLATOR.* The 3rd crystal oscillator, the V406B circuit, is of the same design as the 2nd crystal oscillator except for the operating frequencies. The crystal units, which are of the CR-27/U type, are divided into two groups of five each. All are used throughout the total frequency range of the radio set. The 3rd crystal oscillator employs the second half of the same tube that is used for the 2nd crystal oscillator. The 10 crystal units with their trimmers are housed in a 13-position oven (Bendix Radio type N205651), of which one position is not used. The other two positions are used to mount the two crystals of the 4th crystal oscillator. The oven is thermostatically controlled at 75°C (167°F). A separate booster heater and thermostat are provided for quick warmup.

1-482. *FOURTH MIXER.* The 4th mixer, V407, is identical to the 3rd mixer and operates in the same manner. The 4th mixer output circuit is

designed to pass a band of approximately 5.1 to 5.2 mc. In the 4th mixer are combined the output frequency of the 3rd mixer and that of the 3rd crystal oscillator, the former frequency always being the higher. The difference frequency is selected by the tuned plate transformer and is inductively coupled into the discriminator circuit.

1-483. *DISCRIMINATOR.* The purpose of the discriminator, V409, is to indicate a deviation in phase or frequency between its two inputs. One of these inputs is obtained from the 4th crystal oscillator and is used as the reference signal. The other discriminator input is derived from the 4th mixer output, and it is the deviation in phase of this signal from that of the reference signal that is to be indicated by means of the output voltage across R430 and R431. The magnitude of this discriminator voltage indicates the extent of the deviation, whereas the polarity indicates the direction of the deviation. The circuit design is similar to the type employed for frequency-modulation (FM) receivers, except that in this case the reference voltage is obtained from a separate reference oscillator instead of a parallel resonant tank circuit. The voltages applied to the discriminator are shown in figure 1-197. E_i is the input from the 4th mixer and E_R is the reference voltage from the 4th oscillator. To simplify the discriminator explanation, E_R , insofar as it adds vectorially with E_i to form the r-f voltages across the two diodes, is best interpreted in terms of two equal and separate voltages 180 degrees out of phase. One is E_{2B} , the r-f voltage at pin 2 with respect to point B; the other is E_{7B} , the r-f voltage at pin 7 with respect to point B. Assuming that the bypass capacitors C452 and C453 offer zero impedances to the r-f signals, pins 1 and 5 and point A are all at r-f ground potential. Thus, the r-f voltage (E_2) of plate pin 2 with respect to cathode pin 5 is the same as the voltage of pin 2 with respect to point A. Similarly, E_7 , the r-f plate voltage of the second diode, is equal to the voltage of pin 7 with respect to point A. Now, E_2 and E_7 have one voltage component in common, which is E_i , the voltage of point B with respect to point A. Thus, E_2 and E_7 are equal to the resultants, respectively, obtained by adding vectorially to the common voltage E_i the voltages E_{2B} and E_{7B} . If we assume that C452 charges to the peak of E_2 and that C453 charges to the peak of E_7 , the d-c polarities will be as indicated in figure 1-197 (D), where point A is shown as negative with respect to the two cathodes. The d-c output equals $(E_2 - E_7)$, where both voltage symbols represent the positive peak magnitudes only. The

Section 1
Crystal Oscillators

output is positive or negative according to whether E_2 is greater or less than E_7 , respectively; and this is dependent, respectively, upon whether E_1 lags or leads the zero-output position, which is the 90-degree phase displacement from E_R that is shown in figure 1-197 (A). Upon examination of the discriminator diagram it can be seen that the application of either of the input voltages alone does not develop a discriminator output, since in each case E_2 and E_7 will equal each other, and hence equal currents will flow in opposite directions through the two halves of discriminator load $R430$ and $R431$. Also, it can be seen from the vector diagram (A) that, if the two discriminator input voltages are exactly 90 degrees out of phase, the resultant voltages applied to the diode plates are equal, thus producing

zero discriminator output. If, however, the variable frequency oscillator should vary in phase, the resultant voltages applied to the discriminator plates are unequal, as shown in vector diagrams (B) and (C). This results in a discriminator output voltage whose value and polarity depend upon the magnitude and direction, respectively, of the phase deviation. If there is a frequency deviation, the phase of the 4th mixer output, E_1 , rotates completely around the 4th crystal oscillator output, E_R , with a consequent a-c voltage appearing in the discriminator output. The frequency of this ac is equal to the difference between the two discriminator input frequencies.

1-484. Discriminator output is applied to the tuning-motor-control amplifier and to the reac-

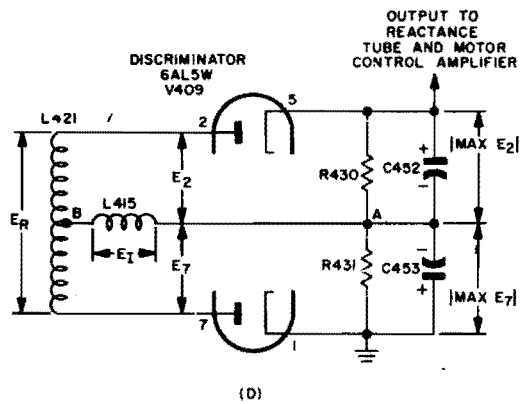
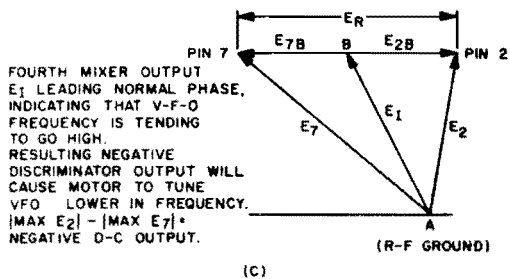
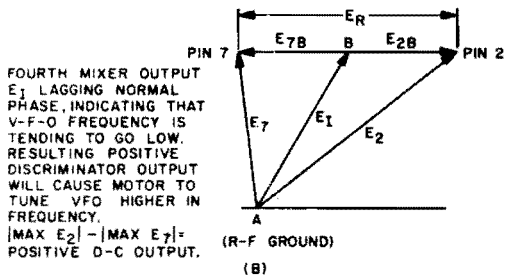
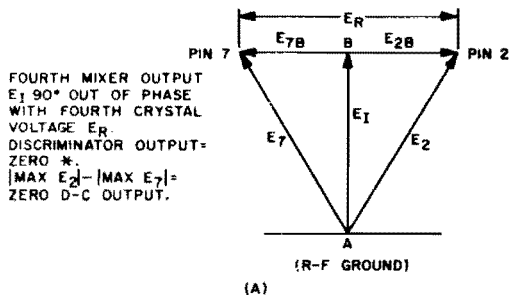

- E_1 - INPUT FROM 4TH MIXER
- E_R - REFERENCE VOLTAGE FROM FOURTH CRYSTAL OSCILLATOR $\pm(E_{2B} + E_{7B}) \pm(E_{2B} - E_{7B})$
- E_2 - RESULTANT VOLTAGE APPLIED TO DIODE PLATE (SOCKET PIN 2)
- E_7 - RESULTANT VOLTAGE APPLIED TO DIODE PLATE (SOCKET PIN 7)

* IN ACTUAL PRACTICE THE V-F-O FREQUENCY CONTROL CIRCUITS ARE SUCH THAT "ON FREQUENCY" DISCRIMINATOR OUTPUT IS APPROX +5 VOLTS. THUS, IN NORMAL OPERATION, VECTOR E_1 WILL BE TILTED SLIGHTLY TO THE RIGHT OF ITS 90° POSITION SHOWN IN FIGURE (A) AT LEFT.

DUE TO THE ACTION OF THE DIODES AND THEIR LOADS, THE DISCRIMINATOR RESULTANT D-C OUTPUT IS EQUAL TO THE DIFFERENCE IN MAGNITUDE BETWEEN E_2 AND E_7 ($|MAX E_2| - |MAX E_7|$).

Figure 1-197. Discriminator operation as a function of the phase difference between the input voltages

tance tube shunted across the variable frequency oscillator. When the variable frequency oscillator approaches the desired operating frequency, a point is reached when the discriminator output frequency becomes equal to or less than the maximum frequency at which the reactance tube can respond. At this point the reactance tube immediately locks the variable frequency oscillator exactly to its correct frequency. When this occurs, the discriminator output is dc and is proportional to the phase difference between its two input voltages, which difference is, in turn, proportional to the amount of "pull" exerted by the reactance tube. This d-c control voltage is fed to the motor-control amplifier, V411, and causes the tuning motor to drive the variable frequency oscillator tuning capacitor to that point which eliminates excessive pull by the reactance tube. The circuit design is such that the equilibrium point corresponds to a discriminator output of approximately 5 volts positive. Normally it would be assumed that the "on-frequency" point would be reached when the discriminator output dropped to zero, which would occur when the two input signals were exactly 90 degrees out of phase. The zero-voltage state is not used, however, in order to avoid ambiguity in identifying the on-frequency condition and to simplify the control circuit by having an equilibrium control voltage of definite magnitude. For example, zero output not only occurs at each of the two (plus and minus) 90-degree phase conditions, but also occurs when the variable frequency oscillator is so far off frequency that there is no input from the 4th mixer, or if one or both of the input voltages fails, or when the two input frequencies are different and the discriminator records the best frequency. Thus, a plus 5-volt reference is used, and the control circuits are so biased that this control level establishes the on-frequency condition. The ac which the discriminator develops before the reactance tube "pull-in" point is reached, is prevented from affecting the motor-control amplifier by the low-pass resistance-capacitance filter, R451 and C445A.

1-485. By employing a phase-sensitive discriminator, it is possible to feed a correction voltage to the control circuits before an actual frequency deviation occurs, since a frequency deviation, unless it is an instantaneous, discontinuous jump, is first indicated as a phase deviation. Therefore, no frequency error occurs except that which may be due to the reference crystals themselves. All small and rapid frequency shifts of the variable frequency oscillator are corrected by the reactance

tube. Larger and slower drifts are corrected by the motor-control amplifier and the tuning motor. An extremely large and sudden frequency jump of the variable frequency oscillator which takes it out of the range of the reactance tube causes the entire tuning sequence to recycle. However, this does not occur during normal operation. To aid in discriminator alignment and test, two test points are brought out to pins of test socket X412. One of these, pin 9, makes it possible to measure the total discriminator output. The other, pin 11, is connected to the load center-tap for checking the discriminator operation.

1-486. *FOURTH CRYSTAL OSCILLATOR.* The 4th crystal oscillator is used to control the operating frequency of the discriminator and thereby has final control of the exact frequency of the variable frequency oscillator. The 4th crystal oscillator can be switched to either one of two type CR-27/U crystal units, whose frequencies are spaced 8.333 kc apart. This spacing is equal to one-twelfth of the channel spacing of 100 kc. Thus, it is the spacing of the 4th crystal oscillator frequencies that determines the channel spacing. For maximum stability the crystal units are mounted in the same crystal oven that houses the crystals of the 3rd crystal oscillator. Crystal selection is controlled by a selector switch on the main control panel. The selection is determined by the choice of the 4th digit of the channel frequency.

1-487. The 4th crystal oscillator circuit employs one half of a duplex triode tube, V410, which is connected as a radio-frequency grounded-plate Pierce oscillator, with the circuit designed in a manner similar to those of the 2nd and 3rd crystal oscillators. The output is taken from the cathode and coupled through C471 to the grid of the other half of tube V410, which is operated as a cathode follower. The output of the cathode follower is inductively coupled into the discriminator circuit through transformer T405. The purpose of the cathode follower is to isolate the loading effects of the discriminator from the 4th crystal oscillator. As a check on the 4th crystal oscillator operation, a test connection for rectified grid current measurement is brought out to test socket X412, pin 7.

1-488. *CLUTCH CONTROL TUBE.* The purpose of the clutch control tube V408, is to shift the r-f head tuning drive from the medium-speed clutch to the low-speed clutch for fine tuning of the exact channel frequency. Whenever the frequency of the variable frequency oscillator, after

being fed through the four mixers, comes within range of the discriminator input tuning at transformer T404, the tuning should be shifted into low speed. Thus, by coupling part of the discriminator input through capacitor C464 to clutch-control rectifier V408A and amplifying the rectifier output through V408B, a control voltage is obtained which is used to operate the clutch-control relay. The clutch-control relay is mounted on the main frame and has its coil connected in series with the plate of clutch-control amplifier V408B. The relay is energized when the tube grid receives no excitation. When a signal is fed to the discriminator from the 4th mixer, a portion of the signal is fed through capacitor C464 and rectified in diode-connected tube V408A. The resulting current flow in resistor R443 causes the ungrounded end to become more negative. This negative voltage is fed to the grid of the clutch-control amplifier through low-pass filter R445 and C463, cutting the tube off. This in turn de-energizes the clutch-control relay and places the low-speed clutch in operation. It should be noted here that the over-all tuning range of the radio set is divided into two nearly equal bands and that while the variable frequency oscillator tuning is being driven through the unused band a spurious frequency may pass through to the discriminator and the clutch-control tube. In this case, however, even though the clutch-control relay is de-energized, the tuning remains in high speed because of a lockup circuit.

1-489. **MOTOR-CONTROL AMPLIFIER.** The motor-control amplifier, V411, is a d-c amplifier whose purpose is the control of a reversible tuning motor in accordance with a d-c control voltage from the discriminator. The discriminator output voltage is fed to the grid through the low-pass resistance-capacitance filter R451 and C445A so that the ac, which appears in the discriminator output as the channel frequency is being tuned, does not influence the operation of the amplifier. As its plate load, the motor-control amplifier works into two relay coils in series. These are called the *high* and *low discriminator relays*. The two relays are mounted on the main frame. The high discriminator relay is designed to "pull in"

at approximately 9 ma and to "drop out" at approximately 6 ma. The low discriminator relay is designed to pull in at approximately 5 ma and to drop out at approximately 3 ma. The plate current of the motor-control amplifier is so adjusted that, with a plus 5-volt "on-frequency" output from the discriminator, approximately 5.5 ma plate current flows. This is sufficient to energize the low discriminator relay but not the high one. The contacts of the low discriminator relay are so connected that when the relay is energized the tuning motor (mounted in the r-f head) is de-energized. If the frequency of the variable frequency oscillator should tend to drift too low, the discriminator voltage controlling the amplifier becomes more positive, increasing the amplifier plate current and thereby energizing both relays. This has the effect of causing the tuning motor to turn in a direction that diminishes the tuning capacitance and hence raises the frequency. If the variable frequency should tend to drift too high, the plate current of the motor-control amplifier decreases to a value below 3 ma and both relays are de-energized. This has the effect of causing the tuning motor to turn in the opposite direction, so that the frequency of the variable frequency oscillator is decreased. Note that in order to keep the motor-control amplifier bias constant, regardless of plate current flow, a positive 6-volt cathode bias is obtained from the d-c drop across the heater, rather than from the drop across a cathode biasing resistor.

R-F Head

1-490. The r-f head contains all the main channel transmitter and receiver r-f circuits including the reactance tube, the tuning capacitor drive mechanism, and certain tuning control circuits. A block diagram is shown in figure 1-198 and a schematic diagram is shown in figure 1-199. Beginning with the variable frequency oscillator, we shall discuss first the transmitter circuits and then the receiver circuits.

1-491. **VARIABLE FREQUENCY OSCILLATOR AND TRIPLER.** The variable frequency oscillator employs an electron-coupled Hartley circuit. The v-f-o frequency is given by the formula:

$$\text{v-f-o frequency} = \frac{\text{transmitter output freq} - \text{receiver 1st intermediate freq}}{12}$$

The screen grid of the v-f-o tube, V802, is the anode of the oscillatory circuit. The plate circuit is tuned to three times the grid frequency, thereby tripling in this tube. Coupling capacitor C907 from grid inductor 1801 feeds a small amount of

r-f energy to the frequency-control circuits in the monitor. A reactance tube is shunted across the oscillator tank for fine frequency control. Oscillator-tripler output is capacitively coupled to the untuned grid of the doubler tube, V803.

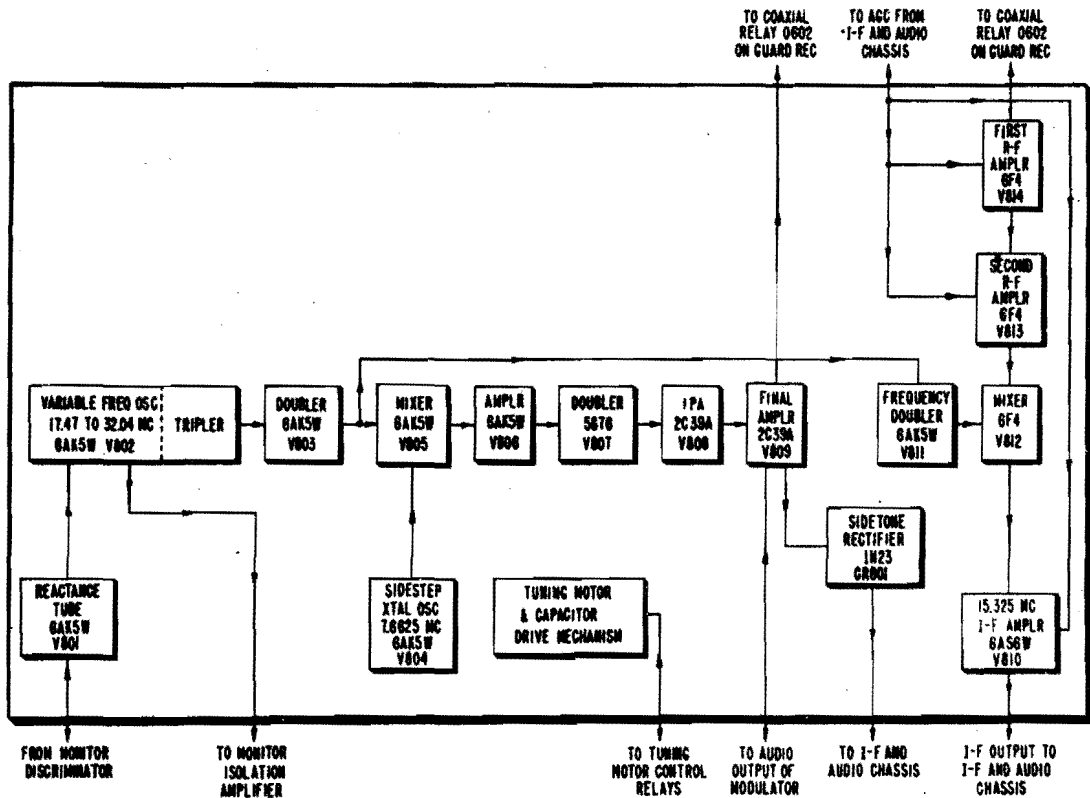

Figure 1-198. R-f head. Block diagram of main channel transmitter and receiver r-f circuits in Radio Set AN/ARC-33

1-492. **REACTANCE TUBE.** The reactance tube, V801, is a device that represents a variable and controllable reactance shunted across the tuned grid circuit of the variable frequency oscillator. Its purpose is to convert d-c control voltage from the monitor into a small frequency variation of the variable frequency oscillator. Radio-frequency voltages from the oscillator are coupled through capacitor C805 to the plate of the reactance tube and directly to a network made up of capacitors C804 and C818, resistors R801 and R804, and the grid-cathode capacitance of the tube, C_g . Capacitor C804 is a blocking capacitor, so that as far as the a-c functioning of the tube is concerned, it need not be considered. Cathode bypass capacitor C803 is sufficiently large for the cathode to be considered at r-f ground potential. Resistor R802, inductor L829, and capacitors C801 and C802 provide a de-coupling network and filter through which the d-c control voltage is applied to the control grid without shunting its r-f input impedance. Resistor R807 is the plate feed component. Resistors R801 and R804 and capacitor C818 in conjunction with the grid-cathode capaci-

tance, C_g , form a phase-shifting network such that the r-f voltage applied to the grid lags the oscillator voltage input to the network by 90 degrees approximately. Since the plate current of reactance tube V801 is in phase with the grid voltage, the plate current flow lags the oscillator r-f voltage applied to the plate by approximately 90 degrees. This appears to the variable frequency oscillator as an inductive reactance since the current in an inductor lags the applied voltage by 90 degrees. By controlling the d-c bias applied to the grid, it is possible to control the amplitude of the current, and thus the magnitude of the effective inductive reactance shunting the oscillator tank. In this way, the frequency of the variable frequency oscillator can be controlled within a narrow range by means of a d-c control voltage. A positive control voltage increases the reactive current in the tube and thereby decreases the effective inductive reactance across the oscillator tank. The effect, therefore, is to cause an increase in the frequency. A negative-going control voltage has the opposite effect. The reactance tube is biased by cathode resistor R805 by an amount

that permits normal "on-frequency" oscillator operation when the control voltage from the monitor is approximately plus 5 volts.

1-493. *FIRST DOUBLER*. The first doubler of the r-f head is a conventional grid-leak-biased frequency multiplier. The stage employs tube V803 with an output circuit tuned to twice the input frequency. The plate circuit consists of two inductors in parallel in order to increase their sizes and make it possible to employ coiled inductors rather than a more space-consuming linear line. The tuning is ganged with the other r-f tuned circuits as shown in the schematic diagram. Radio-frequency energy used for heterodyne oscillator injection into the main channel receiver 1st mixer is taken off at a tap of plate tank L802. The variable frequency oscillator-tripler, the reactance tube, and the doubler are continuously supplied with plate and screen voltages since these circuits are employed in both transmit and receive operation. From the latter stage to the antenna, however, plate and screen voltages are removed from the transmitter tubes during receive operation.

1-494. *TRANSMITTER MIXER*. It is in the mixer that a 7.6625-mc signal from the sidestep oscillator is added to the first doubler output to make the mixer output frequency exactly one half of the transmitting antenna frequency. (Remember that 7.6625 mc is one half of the 1st receiver intermediate frequency of 15.325 mc.) A conventional mixer circuit employing tube V805 is used here, with the side-step oscillator voltage being injected at the control grid through capacitor C821 and with the doubler output being fed to the control grid through capacitor C820. The mixer plate circuit is tuned to the sum frequency by means of a doubler-inductor arrangement. One of the inductors is wound with concentric cable, which allows the tuning capacitor rotor and the cold ends of the inductors to be returned to ground. The center conductor is connected to the plate on the hot end and is bypassed to ground on the cold end by capacitor C825. Plate voltage is supplied to tube V805 through resistor R819.

1-495. *SIDESTEP CRYSTAL OSCILLATOR*. The sidestep crystal oscillator employs pentode V804, connected as a triode and operating on a single frequency of 7.6625 mc. The circuit is arranged as a Pierce oscillator with the crystal connected directly from the plate to the grid of the oscillator tube. A type CR-18/U crystal unit is employed. Since this oscillator controls only a small percentage of the final transmitter frequency, its normal operating stability is sufficient

without the use of thermostatically controlled temperature for the crystal unit. Note that an 18- μmf capacitor is shunted directly across the crystal unit and that no externally connected plate-to-ground capacitor is used. The 18 μmf represents 60 per cent of the required load capacitance for the type CR-18/U crystal unit. With the grid-to-ground capacitance probably 8 or 10 μmf greater than the 68 μmf of the externally connected grid-ground capacitor C822, it appears that the circuit has been designed to provide a maximum output voltage consistent with the drive-level and load-capacitance requirements of the crystal unit, rather than for maximum frequency stability. The oscillator is fed plate voltage through the voltage-dropping resistor R815. The oscillator output is capacitively coupled from the plate of the oscillator tube to the control grid of mixer tube V805 through C821. Plate voltage is derived from the plus 200-volt transmitter supply, so that the tube operates only when the radio set is turned to the transmit position.

1-496. *AMPLIFIER*. This is a conventional grid-leak-biased r-f amplifier employing pentode V806. The circuit acts as a direct amplifier with the output circuit tuned to the same frequency as the input circuit. The input is capacitance-coupled to the preceding mixer stage through capacitor C828 and the output is capacitance-coupled to doubler V807 through capacitor C832. The amplifier tuned output circuit is a double-inductor tank of the same type that is used in the plate circuit of the transmitter mixer.

1-497. *TRANSMITTER DOUBLER*. The doubler, V807, is a grid-leak-biased stage that employs a cavity-tuned plate circuit tuned to twice the input frequency. A pencil triode tube is used because its small size permits superior u-h-f operating characteristics.

1-498. *INTERMEDIATE POWER AMPLIFIER*. The intermediate power amplifier (IPA) employs a lighthouse tube, V808, in a grounded-grid circuit with cavity tuning of the plate. The cavity is tuned to the doubler output frequency, providing an IPA output frequency equal to the transmitter antenna frequency. Radio-frequency input is coupled magnetically from the output of the preceding doubler tube, V807, through coupling loop L809, which applies rf between ground and the IPA cathode through capacitor C838. Concentric inductor L810 is inserted in the heater circuit to make it at the same r-f potential as the cathode. Capacitor C838 also blocks the 12.6-volt d-c filament potential from shorting to ground through the ground coupling loop L809. One heater con-

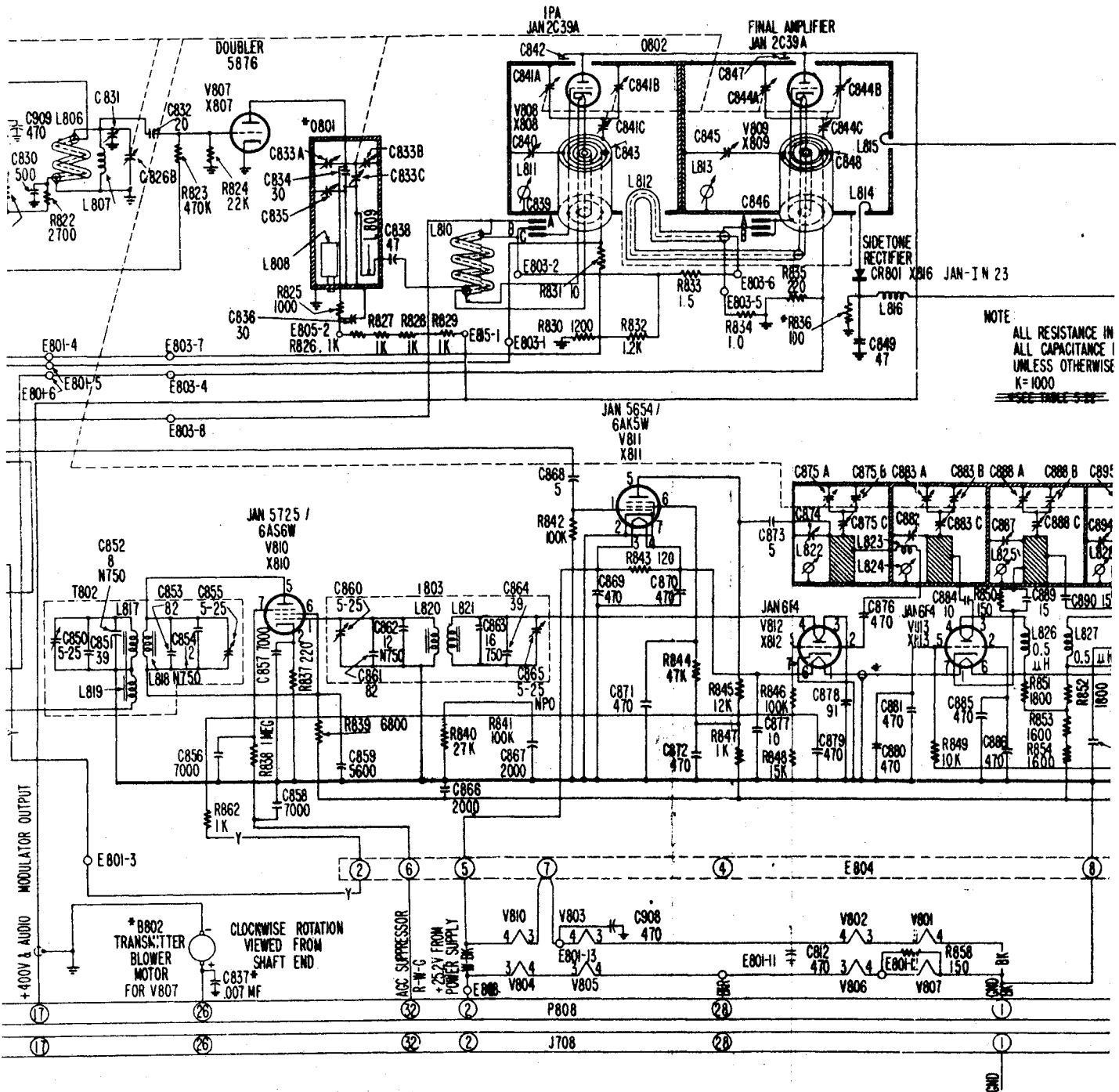

B

Figure 1-199. R-f head. Schem transmitter and receiver r-f circ

C

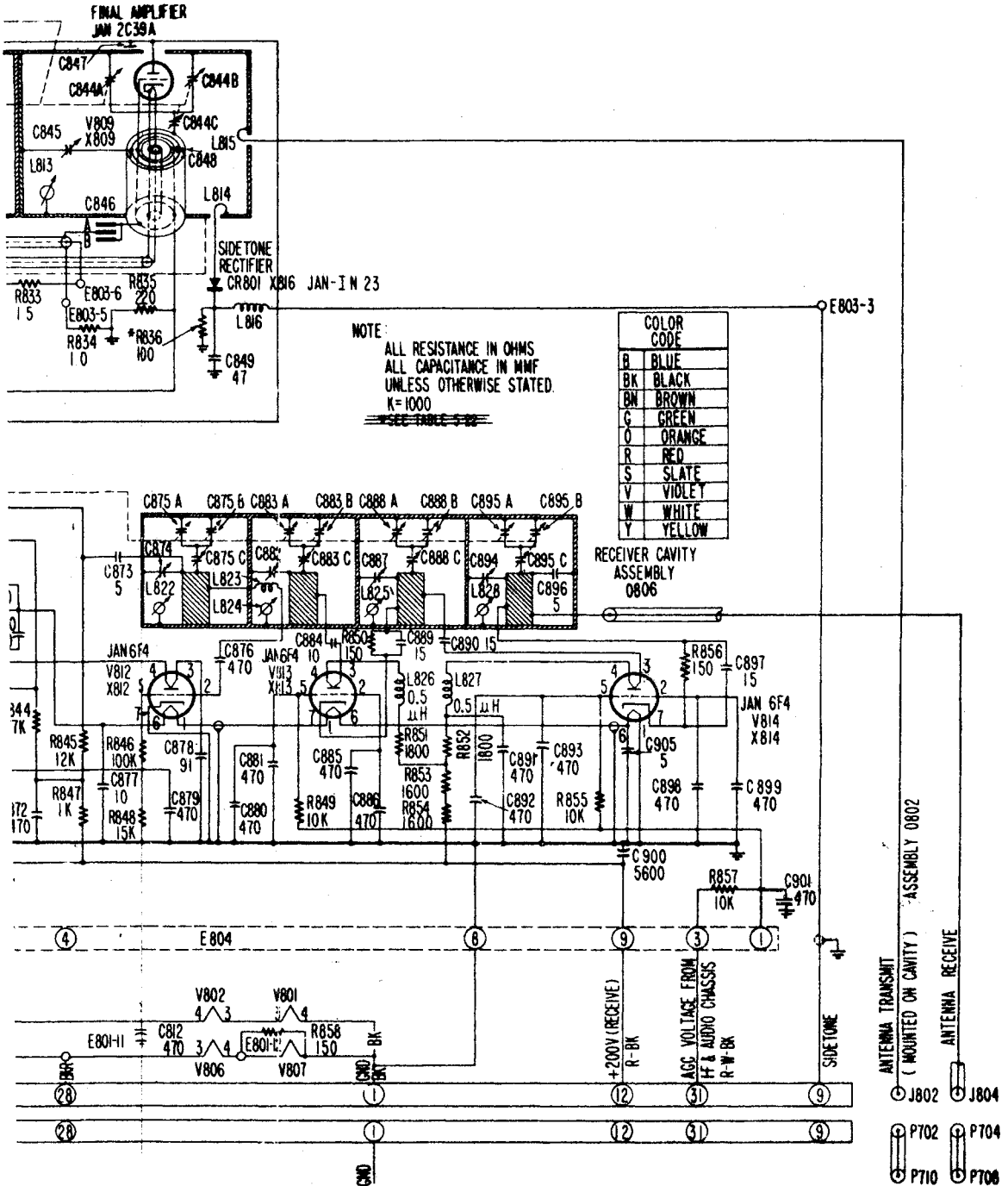

Figure 1-199. R-f head. Schematic diagram of main channel transmitter and receiver r-f circuits in Radio Set AN/ARC-33

C

nection and the cathode connection are common. The heater circuit is wired in series with the heater of the final amplifier so as to provide the required 12.6-volt total drop across the entire circuit after passing through dropping resistor R833. A voltage divider composed of resistors R830 and R832 is connected between one side of the filament and ground. The grid return is connected to the tap to provide the proper negative bias voltage. These resistors are high in value so that they do not influence the heater voltage and current. IPA output is coupled to the final power amplifier input through an inductive coupling loop, L812, in the cavity. Since the final power amplifier is a grounded-grid r-f amplifier, it cannot be plate modulated 100 per cent unless the output of the exciting stage also is modulated. Therefore, to be able to modulate fully the final amplifier output, the plates of doubler V807 and IPA V808 are modulated by the same audio voltage as the power amplifier.

1-499. *FINAL POWER AMPLIFIER.* The final r-f power amplifier, V809, is similar in design and operation to the intermediate power amplifier. Grid bias for the final amplifier is derived from resistor R835. Resistor R834 supplies a cathode bias. Radio-frequency output to the antenna is coupled inductively to the cavity magnetic field by pickup loop L815 and is fed to the antenna receive-transmit changeover relay through a coaxial cable. The coaxial connector is mounted directly on the cavity assembly, O802. To provide a sidetone voltage that is indicative of the transmission quality, the sidetone voltage is obtained from the final r-f output cavity through inductive coupling L814. This r-f voltage is rectified through the sidetone crystal rectifier, CR801, and applied to the i-f and audio chassis to be fed through the receiver audio system to the operator's headset.

1-500. *MAIN CHANNEL RECEIVER R-F CIRCUITS.* The main channel receiver includes two r-f amplifier stages, a mixer, a frequency doubler, and a 15.325-mc i-f amplifier. Both r-f amplifiers and the doubler are cavity-tuned. The doubler is included to multiply the output frequency of the first r-f-head doubler. By employing a heterodyne injection frequency controlled by the same variable frequency oscillator that controls the transmitter frequency, perfect tracking between the transmitter and receiver tuning is possible. The i-f output is fed by coaxial cable to the second mixer and the 2.8-mc intermediate frequency amplifier on the i-f and audio chassis.

1-501. *FIRST R-F AMPLIFIER.* The first r-f amplifier, V814, is a grounded-grid cavity-tuned

amplifier with a shunt-fed plate. The cavity is similar to the cavities used in the transmitter section and operates in exactly the same way except that the amplifier tube is located outside of the cavity. Electrical connections are made through holes in the cavity walls. Tube V814 is tapped down on the cavity center column to prevent loading of the tuned circuit by the tube. The antenna input is also tapped down to match the characteristic impedance of the coaxial line. The grounded-grid circuit is effective in preventing coupling between the input and output circuits, thus preventing oscillations due to feedback through the tube capacitance. Also, the grounded-grid design with the cathode-injection input provides a more constant input impedance over the frequency range. Two plate and two grid connections are provided on the JAN-6F4 tubes to make it possible to use shorter leads and to obtain better bypassing balance, as is illustrated by the V814 grid connections to ground through capacitors C892, C893, C898, and C899. Examination of the tuned-cavity circuits will show that only the first input cavity employs a capacitance connection, represented by C896. Since this cavity is not loaded by the plate capacitance of a vacuum tube, capacitor C896 is added in order for all three cavities to have similar tuning characteristics. Automatic-gain-control voltage, which is obtained from the i-f and audio chassis, is applied to the 1st and 2nd r-f stages and to the 15.325-mc i-f stage.

1-502. *SECOND R-F AMPLIFIER.* The second r-f amplifier, V813, is similar to and operates in the same manner as the first r-f amplifier. Its input is capacitance-coupled from the preceding stage through capacitors C889 and C890. Its output is coupled to the mixer through capacitors C876 and C884 and inductor L823.

1-503. *RECEIVER MIXER.* The mixer, V812, employs the same type of tube as do the r-f amplifiers; however, in this case it is operated as a normal triode mixer with the r-f signal applied to the grid. Heterodyne oscillator injection voltage is coupled from the doubler cavity through capacitor C876 and coupling inductor L823 to the grid, in order to produce the desired 15.325-mc intermediate frequency. The plate circuit is bypassed at the plate connection by a small capacitor, C878, to ensure that no input signal r-f voltage appears in the plate circuit. As regards the much lower intermediate frequency, this capacitor merely forms part of the i-f transformer tuning capacitance. No automatic gain control voltage is applied to the mixer.

1-504. *RECEIVER DOUBLER.* In order to pro-

vide the proper heterodyne injection frequency at the receiver first mixer without frequency multiplication in the mixer, itself, it is necessary to include a doubler, V811, between the r-f head first doubler and the receiver first mixer. The doubler output is cavity-tuned to the received antenna signal frequency minus 15.325 mc, and is ganged to the main channel receiver r-f tuning.

1-505. *I-F AMPLIFIER.* The 15.325-mc i-f amplifier, V810, is conventional in all respects with the possible exception of the suppressor injection of the automatic gain control voltage. By applying automatic gain control voltage to the suppressor grid, it is possible to keep the impedance of the signal grid-return circuit low, thus preventing paralysis of the amplifier on strong noise pulses. The i-f output transformer, T802, is designed to work into the low-impedance (52-ohm) coaxial cable through which the i-f output is carried to the second receiver mixer, located on the i-f and audio chassis.

1-506. *TEST POINTS.* To facilitate testing of the r-f head, an 11-pin test socket is provided. Connections to the socket pins provide for measurement of plate supply voltages, mixer injection voltages, and grid drive.

1-507. *TUNING.* All of the tuned r-f circuits of the transmitter and receiver that must be varied when changing channels, are ganged together and driven by a reversible tuning motor, B801. The drive is through a system of gears and any one of three clutches 0803, 0804, and 0805. A detailed description of the mechanical and switching design of the tuning system is beyond our present assignment.

The Collins Synthesizing System

1-508. An interesting approach to the problem of controlling many r-f channels with the use of only a few crystals is afforded by the frequency-control system employed in a number of the multichannel radio sets developed by the Collins Radio Company. Fundamentally this system is a crystal-controlled multi-conversion superheterodyne circuit when employed in radio receivers, and is equivalent to the same circuit operated in reverse when employed in radio transmitters. The receiver system is quite similar to the Bendix synthesizing system, except that the signal from the variable frequency oscillator is replaced by the antenna signal to which the r-f circuits are tuned and the discriminator is replaced by a final i-f stage. When operated in reverse for transmitter use, the system resembles somewhat the Plessey synthesizing system, except that the frequency dividers and

harmonic selectors of the Plessey system are replaced by crystal oscillators with banks of crystal units. We shall not discuss the Collins system further from a generalized point of view, but shall advance at once to the discussion of its application in two aircraft receiver circuits (Radio Receiver R-252A/ARN-14 and Radio Receiver R-278/GR) and in the aircraft transceiver, Radio Set AN/ARC-27. Since Radio Set AN/ARC-27 performs essentially the same function as does Radio Set AN/ARC-33, described in the foregoing paragraphs, a study of the two circuits provides an interesting comparison of the two systems of frequency control and how they can be applied to achieve the same end.

RADIO RECEIVER R-252A/ARN-14

1-509. Radio Receiver R-252A/ARN-14, a product of the Collins Radio Company, is a component of Radio Receiving Set AN/ARN-14. It is an airborne navigation receiver that provides reception on any one of 280 channels spaced 100 kc apart between 108.0 and 135.9 mc. A crystal-controlled double-conversion superheterodyne circuit is used to "de-synthesize" the incoming signal to a fixed intermediate frequency of 3.15 mc. The 280 channels are obtained from a total of 24 crystal units. Actually, this number of channels can be obtained from a Collins synthesizing system employing a fewer number of crystal units, if a triple- rather than a double-conversion superheterodyne circuit is used. That is, if an additional oscillator, mixer, and i-f amplifier stage is inserted, the required number of crystal units becomes less. In this equipment, however, maximum economy in space, weight, and the over-all number of component parts clearly is achieved by increasing slightly the number of crystal units rather than by the addition of a number of extra vacuum-tube circuits. The functional operation of the frequency-control system is indicated in the block diagram of figure 1-201. Figure 1-200 shows the schematic diagram of the radio-frequency control circuits. With the exception of minor editing changes and technical insertions the circuit descriptions to follow are primarily extracts from USAF Technical Order No. 12R5-2ARN14-12.

R-F Control Circuits

1-510. One stage of tuned r-f amplification is used in Radio Receiver R-252A/ARN-14. The grid and plate tank circuits of the r-f amplifier, V101, pass a 2-mc band of frequencies and cover the entire frequency range 108.0 to 135.9 mc in 14 increments. The output of the r-f amplifier is coupled to the grid of the 1st mixer V102. The 1st mixer receives its injection frequency from a three-stage

108-135.9MC 2MC WIDE
RF AMPLIFIER

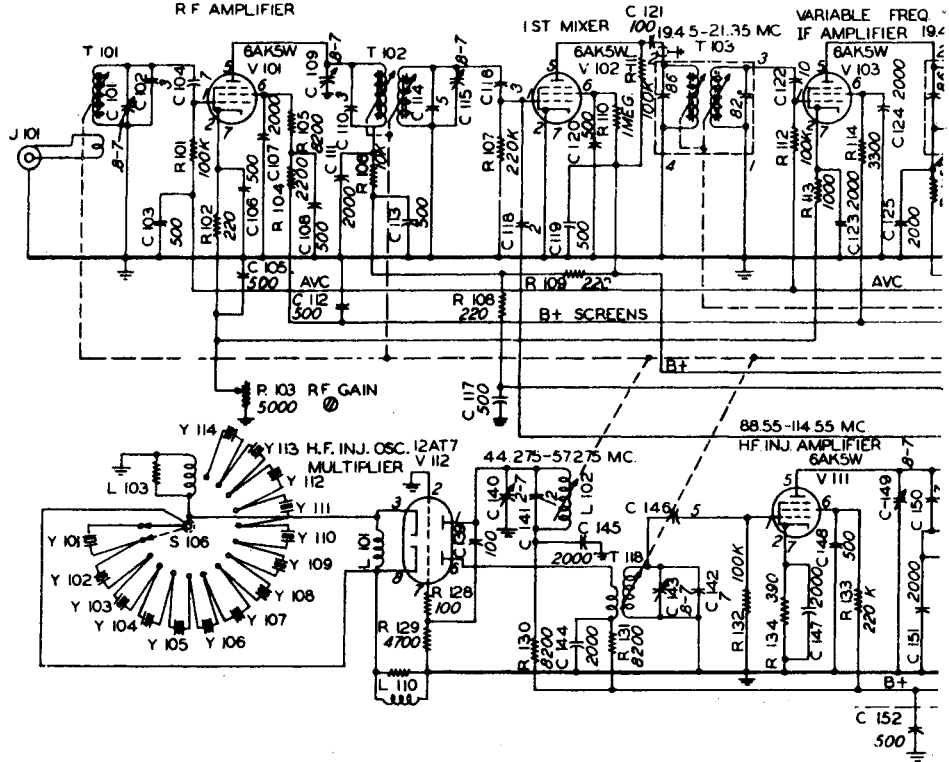

A

Section I
Crystal Oscillators

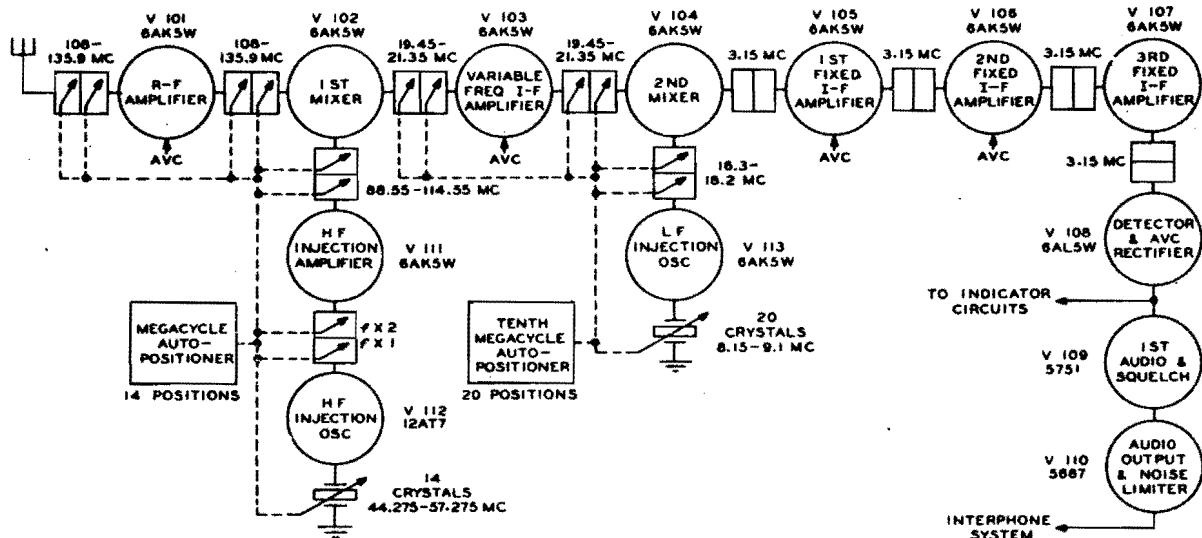

Figure 1-201. Schematic diagram of radio-frequency-control circuits of Radio Receiver R-252A/ARN-14. Only the 1st amplifier of the three-stage fixed (3.15 mc) i-f amplifier circuit is shown. The automatic switching system is not shown

exciter consisting of a crystal-controlled Butler oscillator-multiplier, V112, and an amplifier, V111. The oscillator employs a bank of 14 type CR-23/U crystal units whose frequencies cover the range 44.275 to 57.275 mc in one-megacycle steps. The plate tank of the grounded-grid tube is tuned to the desired crystal frequency. Output from the oscillator is inductively coupled from the plate circuit of the cathode follower to the input tank of amplifier V111. Both the input and output circuits of the amplifier are tuned to twice the oscillator frequency. Thus, the injection frequencies fed to the 1st mixer cover the range of 88.55 to 114.55 mc in 14 two-megacycle steps. These injection frequencies, when mixed with the r-f signals in the range of 108.0 to 135.9 mc, produce an intermediate frequency in the range of 19.45 to 21.35 mc. Note that the function of the 1st injection oscillator and multiplier is to generate 14 very high frequencies spaced 2 mc apart so that by selecting the proper injection frequency, the 280 possible antenna frequencies within a 28-mc range can be reduced to 20 possible intermediate frequencies within a 2-mc range. Each of the 20 i-f channels handles 14 of the r-f channels. The output of the 1st mixer is thus fed to the variable i-f amplifier, and thence to the 2nd mixer. The injection frequency for the 2nd mixer originates in an electron-coupled oscillator-doubler circuit. The oscillator is of the grounded-plate Pierce type and employs a bank of 20 type CR-18/U crystal units spaced 50 kc apart in the 8.15-to-9.10-mc range. The screen grid of tube V113 serves as the oscillator anode. The plate circuit is tuned to twice the oscillator

fundamental, so that the actual injection frequencies for the 2nd mixer are spaced 100 kc apart and cover the range of 16.3 to 18.2 mc. Each of the 2nd injector frequencies can be matched with one of the 20 i-f channels to produce a difference frequency of 3.15 mc. This 3.15-mc frequency is thus used as the fixed intermediate-frequency channel. It passes through three amplifier stages of similar design except that the 3rd 3.15-mc i-f amplifier does not operate with a-v-c grid bias before being fed to the detector.

1-511. The tuning of the r-f and variable i-f circuits, as well as the selecting of the high- and low-frequency crystals, is performed by two Collins "Autopositioners." One Autopositioner controls the tuning in 14 2-mc steps and the other controls the fine tuning in 20 100-kc steps. The tuning elements of the grid and plate tank circuits of the r-f amplifiers and the frequency multiplier, and the high-frequency crystal selector switches are ganged and operated by the megacycle Autopositioner. The 0.1-megacycle Autopositioner tunes the grid and plate circuits of the variable i-f amplifier and the plate circuit of the low-frequency oscillator, and selects the low-frequency crystals. Because the crystal selector switches and tuning elements are ganged, the injection frequencies that result in the fixed intermediate frequency of 3.15 mc are always automatically selected. Table (1) shows the tuning of the double-conversion system for the first 22 channels. By extending the table in the same manner as shown, complete information for the entire range of received frequencies can be obtained.

Section 1
Crystal Oscillators

Channel Selector Position		Frequency of Received Signal	Frequency Band Passed by R-F Amplifier	Frequency of			
Mc	.1 Mc			1st Mixer Inj. Signal	Variable I-F Amplifier	2nd Mixer Inj. Signal	Fixed I-F Amplifier
108	0.0	108.0 mc	108.0 to 110.0	85.55 mc	19.45 mc	16.3 mc	3.15 mc
	0.1	108.1	108.0 to 110.0	85.55	19.55	16.4	3.15
	0.2	108.2	108.0 to 110.0	85.55	19.65	16.5	3.15
	0.3	108.3	108.0 to 110.0	88.55	19.75	16.6	3.15
	0.4	108.4	108.0 to 110.0	88.55	19.85	16.7	3.15
	0.5	108.5	108.0 to 110.0	88.55	19.95	16.8	3.15
	0.6	108.6	108.0 to 110.0	88.55	20.05	16.9	3.15
	0.7	108.7	108.0 to 110.0	88.55	20.15	17.0	3.15
	0.8	108.8	108.0 to 110.0	88.55	20.25	17.1	3.15
	0.9	108.9	108.0 to 110.0	88.55	20.35	17.2	3.15
	1.0	109.0	108.0 to 110.0	88.55	20.45	17.3	3.15
	1.1	109.1	108.0 to 110.0	88.55	20.55	17.4	3.15
	1.2	109.2	108.0 to 110.0	88.55	20.65	17.5	3.15
	1.3	109.3	108.0 to 110.0	88.55	20.75	17.6	3.15
	1.4	109.4	108.0 to 110.0	88.55	20.85	17.7	3.15
	1.5	109.5	108.0 to 110.0	88.55	20.95	17.8	3.15
	1.6	109.6	108.0 to 110.0	88.55	21.05	17.9	3.15
	1.7	109.7	108.0 to 110.0	88.55	21.15	18.0	3.15
	1.8	109.8	108.0 to 110.0	88.55	21.25	18.1	3.15
1.9	109.9	108.0 to 110.0	88.55	21.35	18.2	3.15	
110	0.0	110.0	110.0 to 112.0	90.55	19.45	16.3	3.15
	0.1	110.1	110.0 to 112.0	90.55	19.55	16.4	3.15

Table 1-511(1). Tuning position for first 22 channels of Radio Receiver R-252A/ARN-14. Remaining channels are obtained in similar manner.

RADIO RECEIVER R-278/GR

1-512. Radio Receiver R-278/GR provides a second example of the Collins method of controlling many frequencies with a few crystals. In principle, the frequency-control system is the same type as that described above for Radio Receiver R-252A/ARN-14, except that in the R-278/GR

receiver a triple-conversion superheterodyne circuit is employed instead of a double-conversion circuit. Functionally, the receiver is the same as the AN/ARC-33 receiver circuit in that it provides crystal-controlled reception of 1750 channels spaced 100 kc apart between 225 and 399.9 mc. This task is performed with the use of 38 crystal

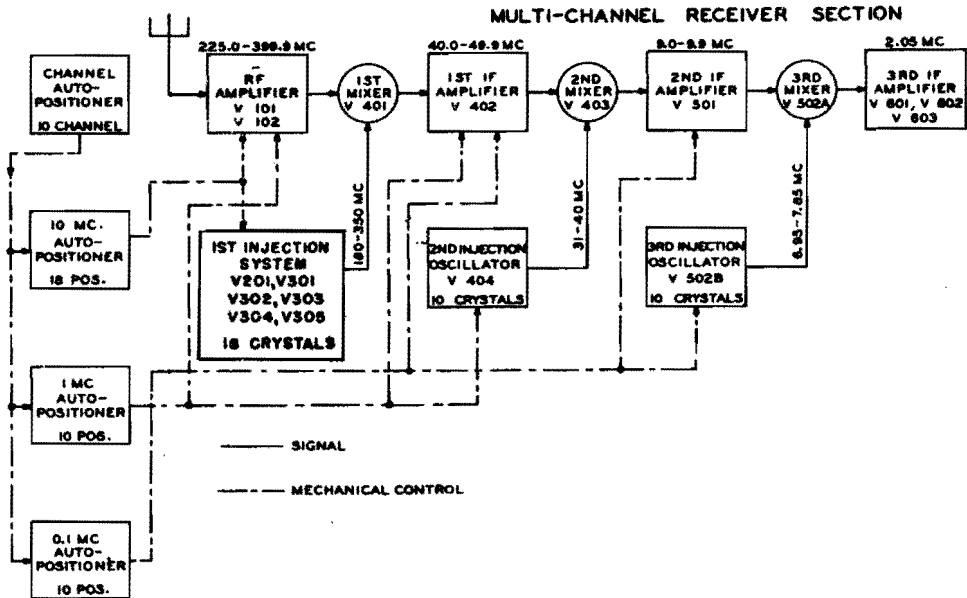

Figure 1-202. Block diagram and frequency chart of Collins frequency-control system as employed in Radio Receiver R-278/GR

<i>10-MC Dial Reading</i>	<i>R-F Band MC</i>	<i>Inj Freq MC</i>	<i>Crystal Freq MC</i>	<i>Mult Factor</i>
22	220.0 - 229.9	180.0	30.0000	6
23	230.0 - 239.9	190.0	31.6667	6
24	240.0 - 249.9	200.0	33.3333	6
25	250.0 - 259.9	210.0	35.0000	6
26	260.0 - 269.9	220.0	36.6667	6
27	270.0 - 279.9	230.0	38.3333	6
28	280.0 - 289.9	240.0	26.6667	9
29	290.0 - 299.9	250.0	27.7777	9
30	300.0 - 309.9	260.0	28.8888	9
31	310.0 - 319.9	270.0	30.0000	9
32	320.0 - 329.9	280.0	31.1111	9
33	330.0 - 339.9	290.0	32.2222	9
34	340.0 - 349.9	300.0	33.3333	9
35	350.0 - 359.9	310.0	34.4444	9
36	360.0 - 369.9	320.0	35.5555	9
37	370.0 - 379.9	330.0	36.6667	9
38	380.0 - 389.9	340.0	37.7778	9
39	390.0 - 399.9	350.0	38.8889	9

<i>1-MC Dial Reading</i>	<i>1st I-F Band MC</i>	<i>Crystal and Inj Freq MC</i>
0	40.0 - 40.9	31.0
1	41.0 - 41.9	32.0
2	42.0 - 42.9	33.0
3	43.0 - 43.9	34.0
4	44.0 - 44.9	35.0
5	45.0 - 45.9	36.0
6	46.0 - 46.9	37.0
7	47.0 - 47.9	38.0
8	48.0 - 48.9	39.0
9	49.0 - 49.9	40.0

<i>0.1-MC Dial Reading</i>	<i>2nd I-F Freq MC</i>	<i>Crystal and Inj Freq MC</i>
.0	9.0	6.95
.1	9.1	7.05
.2	9.2	7.15
.3	9.3	7.25
.4	9.4	7.35
.5	9.5	7.45
.6	9.6	7.55
.7	9.7	7.65
.8	9.8	7.75
.9	9.9	7.85

Frequency Range

R-f amplifier	220.0-399.9 mc*	Tuned in 180 1-mc steps
1st injection	180.0-350.0 mc	Tuned in 18 10-mc steps
1st i-f amplifier	40.0-49.9 mc	Tuned in 100 0.1-mc steps
2nd injection	31.0-40.0 mc	Tuned in 10 1-mc steps
2nd i-f amplifier	9.0-9.9 mc	Tuned in 10 0.1-mc steps
3rd injection	6.95-7.85 mc	Tuned in 10 0.1-mc steps
3rd i-f amplifier	2.05 mc	Fixed tuned

*Note that although the frequency range of the receiver is specified as being from 225.0 to 399.9 mc, the frequency system employed is inherently capable of providing 50 additional frequencies in the range 220.0 to 224.9 mc.

Figure 1-202 (Continued). Frequency chart of Collins frequency-control system

**Section I
Crystal Oscillators**

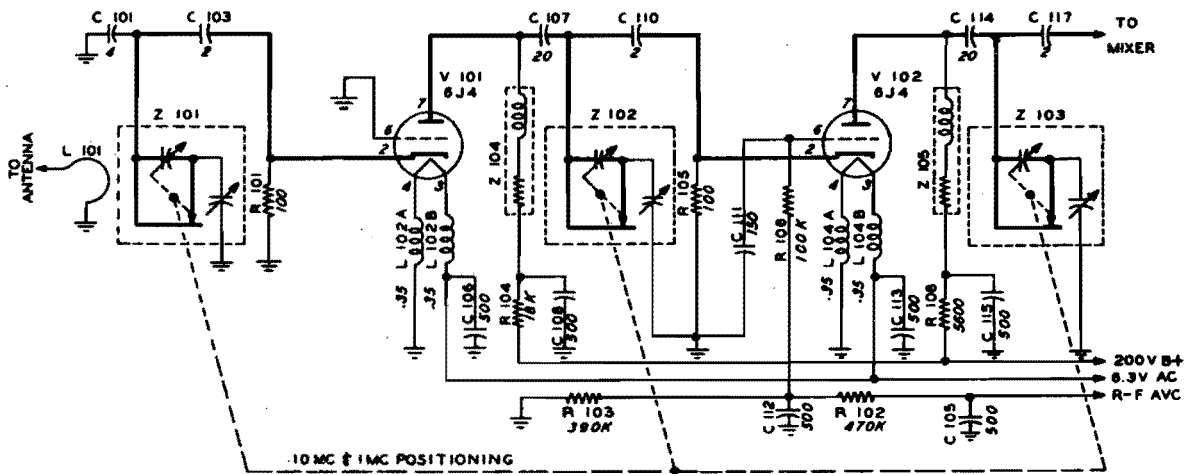

Figure 1-203. Radio-frequency amplifier unit of Radio Receiver R-278/GR. Schematic diagram

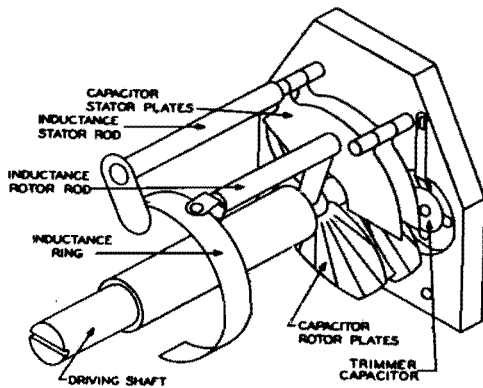

Figure 1-204. Construction of r-f tuner employed in Radio Receiver R-278/GR

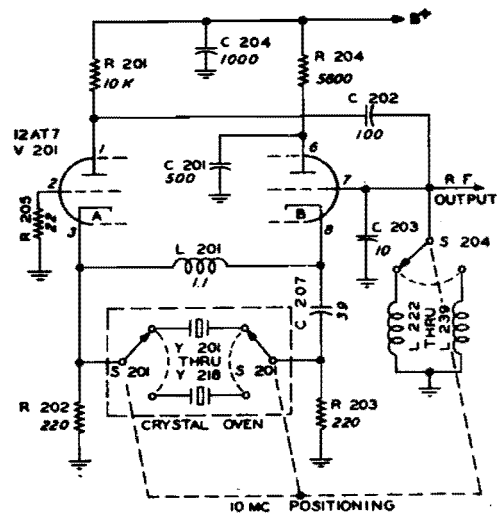

Figure 1-205. Oscillator unit of 1st injection system in Radio Receiver R-278/GR. Schematic diagram

units. For the reader who has followed the discussion of the frequency-control system in Radio Receiver R-252A/ARN-14, the functional operation of the system outlined for Radio Receiver R-278/GR in the frequency diagram of figure 1-202 should be largely self-explanatory.

1-513. Briefly, the r-f amplifier consists of two stages of grounded-grid vacuum-tube amplification, as shown in the schematic diagram of figure 1-203. The r-f amplifier is tuned in 180 one-mc steps covering the range 225 to 399.9 mc. A special type of r-f tuner is used, and is illustrated in figure 1-204. This tuner consists of a variable capacitor and a variable inductor which are rotated simultaneously so that the resonant frequency changes linearly 180 mc in 180 degrees of rotation, or 1 mc per degree. The variable capacitor consists of two stator plates and three rotor

plates, the front and rear of which are radially slotted for the purpose of alignment adjustments. The inductive loop consists of the inductance stator rod, a ring segment, and the inductance rotor rod. The three r-f tuners are geared together and driven through a mechanical differential that combines the rotary motion of an 18-position 10-mc tuning shaft with that of a 10-position 1-mc tuning shaft to permit a total of 180 1-mc steps.

1-514. The 1st injection system consists of the main oscillator unit shown in figure 1-205 followed by the five-stage multiplier-amplifier unit shown in figure 1-206. The oscillator is a Butler

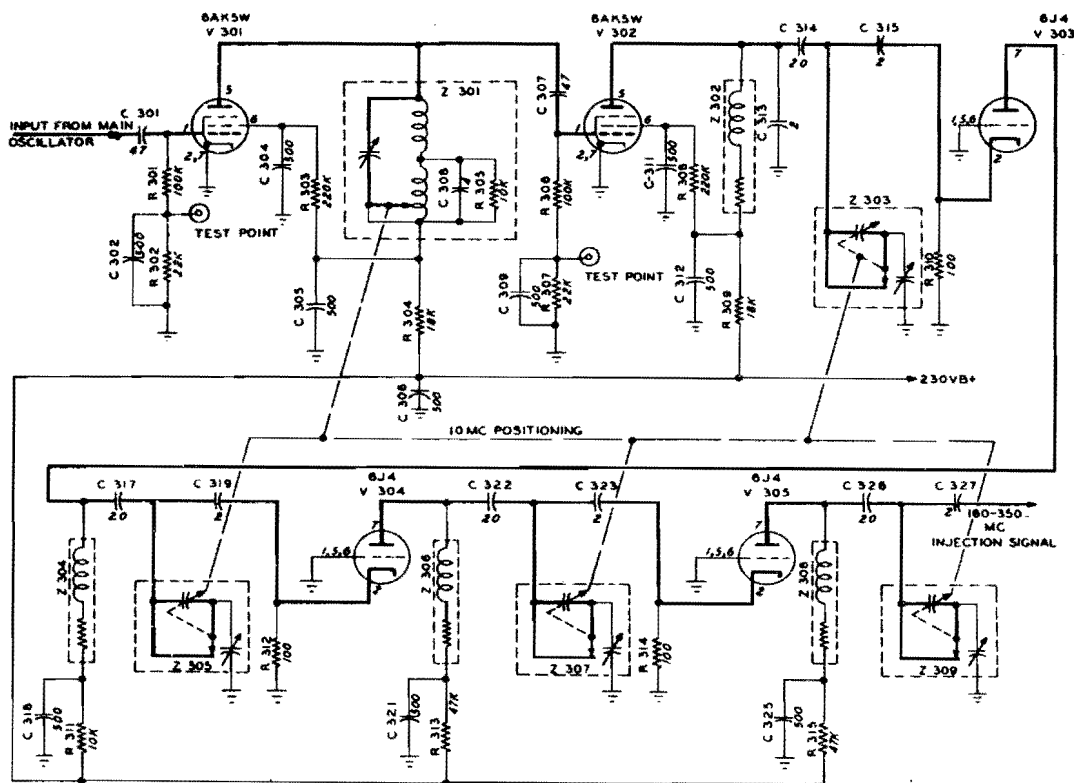

Figure 1-206. Multiplier-amplifier unit of 1st injection system in Radio Receiver R-278/GR. Schematic diagram

circuit employing a temperature-controlled bank of 18 crystal units of the CR-32/U type, and a bank of 18 tuning coils in the plate output circuit of the grounded-grid tube. The first tube, V301, of the multiplier-amplifier unit serves as a doubler for the six lowest injection frequencies (not the six lowest oscillator frequencies) and as a tripler for the 12 highest injection frequencies. The second tube, V302, is tuned to triple all its input frequencies. The next three stages are grounded-grid, shunt-fed amplifiers. The r-f tuners shown in the last four stages of the multiplier-amplifier unit are similar to the r-f tuners described in the foregoing paragraph, but differ in that the frequency range is different. The 1st injection system is tuned in eighteen 10-mc steps by the 10-mc tuning shaft, which also operates the main oscillator crystal selector switch.

1-515. The 1st i-f amplifier unit, see figure 1-207, consists of the 1st mixer, the 1st i-f amplifier, the 2nd oscillator, and the 2nd mixer. The 1st mixer stage reduces the 1750 possible antenna frequencies to 100 possible intermediate frequencies spaced 0.1 mc apart in the 40.0-to-49.9-mc range.

The i-f interstage transformers are therefore tunable in 0.1-mc increments over a 10-mc i-f band. Permeability tuning is employed, with the tuning controlled by a cam-driven tuning rack. The second oscillator is another Butler circuit, this one employing a bank of 10 type CR-23/U crystal units operating at frequencies 1 mc apart from 31 to 40 mc. The 2nd mixer serves to reduce the 100 first i-f channels to 10 second i-f channels spaced 0.1 mc apart in the 9.0-to-9.9-mc range.

1-516. The 2nd i-f amplifier unit, see figure 1-208, consists of the 2nd i-f amplifier, the 3rd injection oscillator, and the 3rd mixer. The 2nd i-f amplifier signal is conducted over a type RG-58/U coaxial line from the plate of the 2nd mixer to the primary of the input transformer, T501, of the 2nd i-f amplifier. The 2nd i-f transformers are permeability-tuned in ten 0.1-mc increments over the range 9.0 to 9.9 mc by a cam-driven tuning rack. The 3rd oscillator, which uses one half of a twin triode tube (12AU7), is a grounded-plate Pierce circuit that uses a bank of 10 type CR-18/U crystal units. The crystal frequencies are spaced 0.1 mc apart in the range 6.95 to 7.85 mc. The 3rd

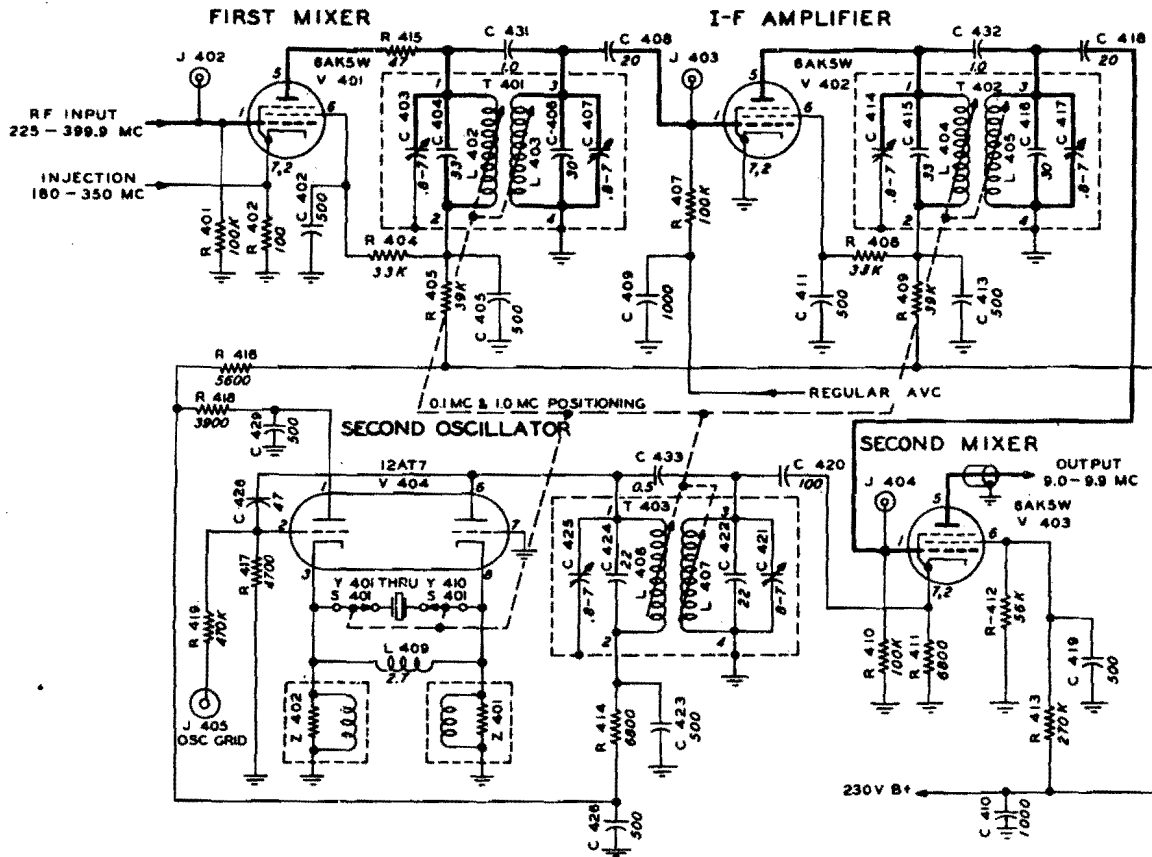

Figure 1-207. First i-f amplifier unit in Radio Receiver R-278/GR. Schematic diagram

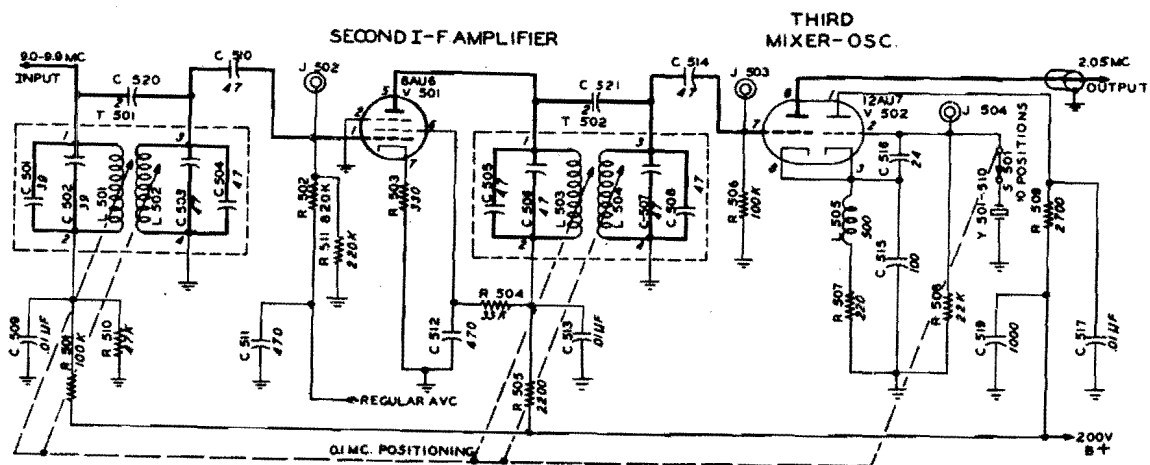

Figure 1-208. Second i-f amplifier unit in Radio Receiver R-278/GR. Schematic diagram

oscillator signal is fed to the cathode of the 3rd mixer, where it is heterodyned with the incoming 2nd i-f signal to form the 3rd and fixed intermediate frequency of 2.05 mc. The 2.05-mc output of the 3rd mixer is carried over a type RG-58/U coaxial line to the input transformer, T601, of the 3rd i-f amplifier, which consists of three fixed-tuned amplifier stages. See figure 1-209.

RADIO SET AN/ARC-27

1-517. Perhaps the most interesting example of the Collins system of frequency synthesis is provided by Radio Set AN/ARC-27. This is a v-h-f and u-h-f airborne transceiver set developed by the Collins Radio Company; it is the functional equivalent of Radio Set AN/ARC-33, described earlier as an example of the Bendix synthesizing method. For transmitter operation of Radio Set AN/ARC-27, four crystal oscillators employing a total of 22 crystal units are interrelated by means of harmonic generators and frequency mixers to cover the range between 225 and 399.9 mc in 0.1-mc increments. The operator thus has a choice of

any one of 1750 crystal-controlled channels of 100-kc width. If transmission were the only function of this radio set, at least one of the four crystal oscillators (the 3.45-mc oscillator) could be eliminated and no doubt much of the remaining network could be simplified. As it is, however, the ARC-27 is also designed to receive the same frequencies that it transmits. The same operation that tunes the receiver to a particular channel automatically tunes the transmitter to the same channel. This is achieved by using many of the same tuned circuits that pass the received signal in one direction during receiver operation, to pass the transmitted signal in the opposite direction during transmitter operation. For example, a transformer primary in the plate circuit of a receiver vacuum tube may become a transformer secondary in the grid circuit of a transmitter tube when the set is switched to transmit operation. The transmitter frequency synthesizer is basically the receiver superheterodyne system operated in reverse. It is the set of modifications imposed upon the frequency synthesizing network by this

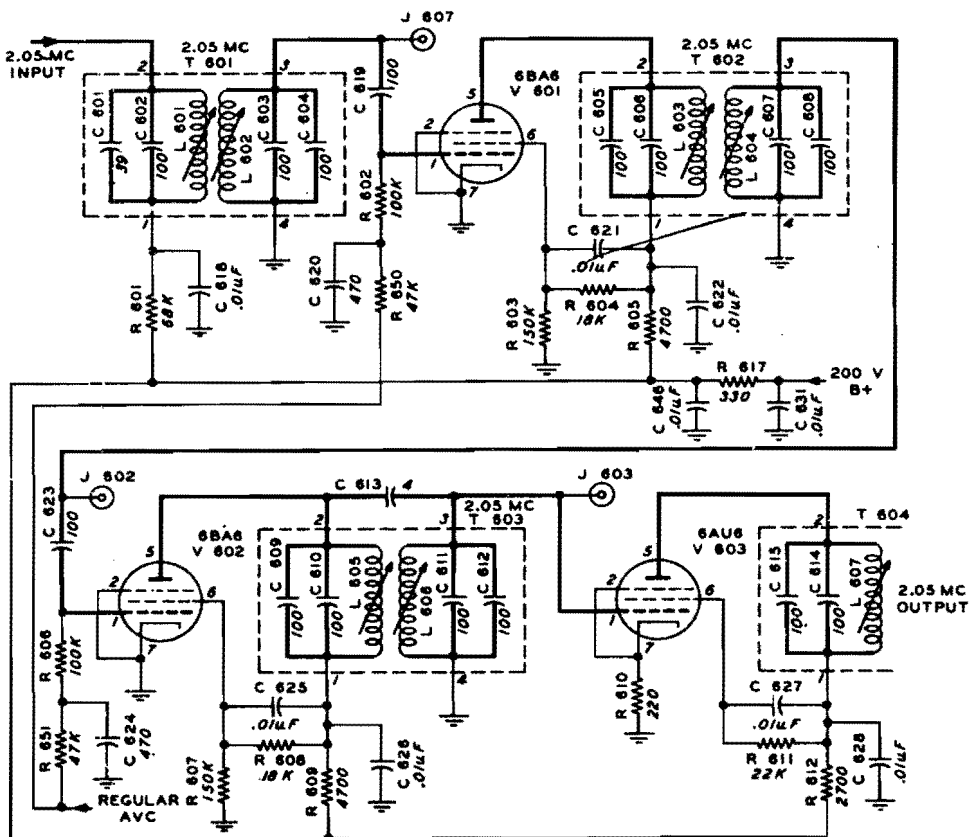

Figure 1-209. Third i-f amplifier in Radio Receiver R-278/GR. Schematic diagram

**Section I
Crystal Oscillators**

bi-directional feature that makes the ARC-27 circuits of special interest.

1-518. The network system incorporated in the design of Receiver-Transmitter RT-178/ARC-27 (the principal unit of Radio Set AN/ARC-27) suggests that, in approaching the problem of frequency control, the designers probably placed first emphasis upon the superheterodyne circuit of the receiver; then, to this basic design introduced the switching arrangements necessary for the same circuit to operate in the opposite direction. Where the receiver reduces all incoming signals to a fixed crystal-controlled intermediate frequency of 3.45 mc, the transmitter starts with a fixed crystal-controlled frequency of 3.45 mc and, by reversing the direction of each of the receiver heterodyne processes, is able to generate for transmission the same channel frequency to which the receiver is tuned. The reversed superheterodyne network thus forms a principal feature of the Collins synthesizing system, a feature uniquely applicable in the design of two-way multichannel radio sets.

1-519. The ARC-27 synthesizing circuit is more readily explained when we examine the network first from the receiver point of view. A block diagram of the receiver circuit is shown in figure 1-210. This circuit operates in exactly the same manner as the triple-conversion superheterodyne

circuit in Radio Receiver R-278/GR discussed previously. The only difference is in the choice of the values of the intermediate frequencies and in the fact that the ARC-27 set employs a fixed-frequency 10-mc crystal oscillator and a spectrum system that permits a selection of any one of eighteen 10-mc harmonics for the 1st injection frequency, whereas the R-278 receiver employs an 18-crystal oscillator and five-stage multiplier-amplifier system for the same purpose, which is to reduce the 1750 antenna channels to 100 first i-f channels. The 2nd and 3rd oscillators of the ARC-27 receiver circuit are of the same design as the 2nd and 3rd oscillators, respectively, of the R-278 receiver except for the actual values of the crystal frequencies. The 1-mc and 0.1-mc spacing of the 2nd and 3rd injection frequencies are, nevertheless, common to both receivers.

1-520. If we now examine the block diagram of the ARC-27 transmitter synthesizer shown in figure 1-211, we see that it essentially is a reversal of what might be described as the "frequency de-synthesizer" network of the ARC-27 receiver. Let f_a , f_b , f_c , and f_d equal the antenna frequency and the 1st, 2nd, and 3rd intermediate frequencies, respectively; and let $f(10)$, $f(1)$, and $f(0.1)$ represent the 10-mc, 1-mc, and 0.1-mc injection frequencies respectively, as indicated in the block

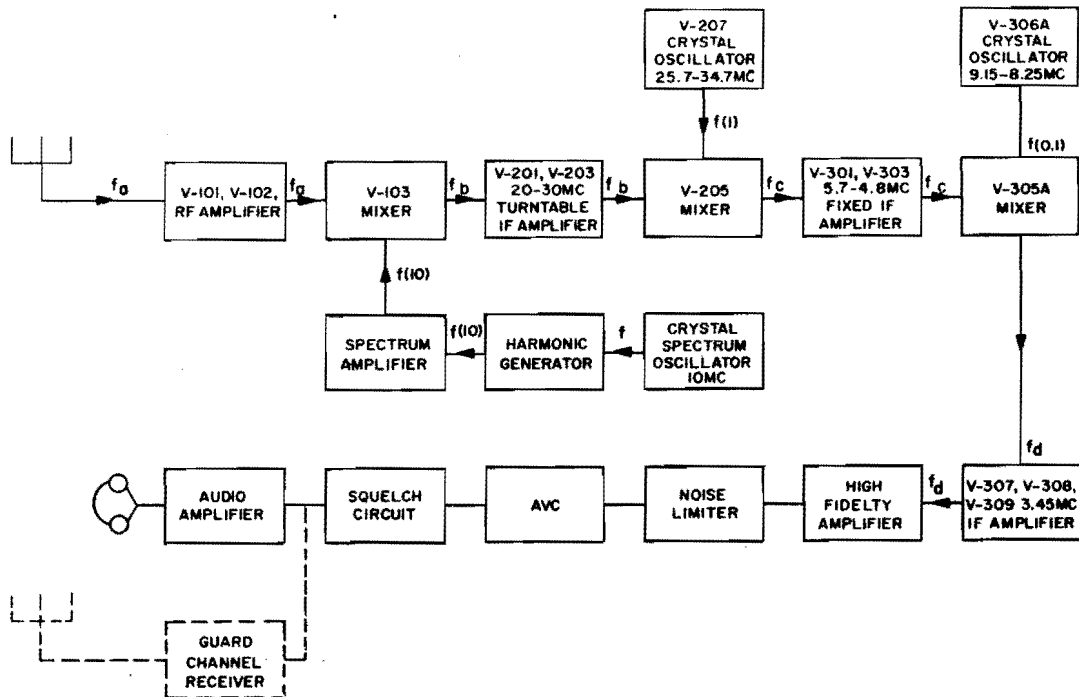

Figure 1-210. Block diagram of main receiver network of Receiver-Transmitter RT-178/ARC-27

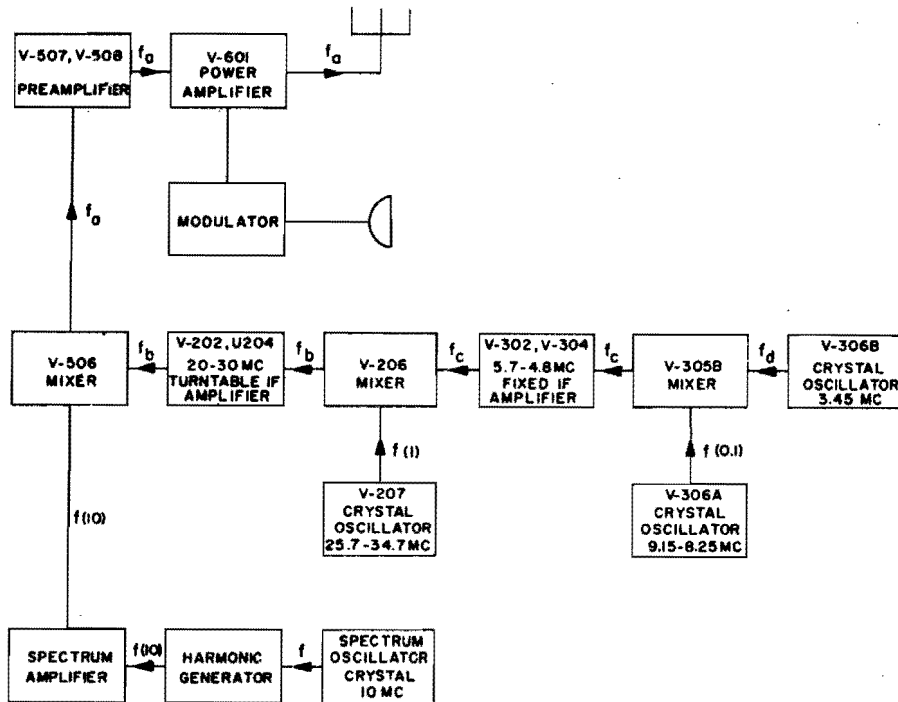

Figure 1-211. Block diagram of transmitter network of Receiver-Transmitter RT-178/ARC-27

diagrams. For both receiver and transmitter operation the frequency of the antenna signal can be expressed by the equation

$$f_a = f(10) + f_b \quad 1-520 \quad (1)$$

where

$$f_b = f(1) - f_c \quad 1-520 \quad (2)$$

and

$$f_c = f(0.1) - f_d \quad 1-520 \quad (3)$$

so by substitution

$$f_a = f(10) + f(1) - f(0.1) + f_d \quad 1-520 \quad (4)$$

Ordinarily for frequency synthesis in a decade system we would suppose that the final frequency would be given by the formula

$$f_a = f(10) \pm f(1) \pm f(0.1) \quad 1-520 \quad (5)$$

where $f(10)$ determines the frequency to the nearest 10-mc unit, $f(1)$ to the nearest 1-mc unit, and $f(0.1)$ to the nearest 0.1-mc unit. Consequently, the employment of a constant frequency, f_d , which in the ARC-27 transmitter is a 3.45-mc oscillator signal, would normally be superfluous. But in the ARC-27 set, the 3.45-mc crystal oscillator is inserted with advantage since it enables the same crystal units that control the injection frequencies in the receiver to control the injection frequencies in the transmitter.

1-521. With the aid of equations 1-520 (1) to (4) and the block diagram in figure 1-211, the frequency synthesizing system employed in the ARC-27 transmitter is largely self-explanatory. The desired transmitter signal is synthesized by heterodyning the 3.45-mc and 4.8–5.7-mc oscillator outputs and selecting their difference product, f_c , for amplification. In turn, f_c is heterodyned with the 25.7–34.7-mc oscillator output and again the difference product, this time f_b , is selected. Next, f_b is amplified and mixed with the $f(10)$ output of the spectrum amplifier. The sum product, f_a , which is the desired final frequency, is selected and amplified for transmission.

1-522. The various injection frequencies used in Radio Set AN/ARC-27 are generated by conventional crystal oscillators, except for the output of the spectrum generator. The function of the spectrum generator is to convert an initial 10-mc output from an electron-coupled Pierce oscillator into any desired harmonic of 10 mc between 200 and 370 mc. Although the function of the spectrum generator is effectively that of a harmonic generator, the output frequency, $f(10)$, is not simply the product of a straightforward sequence of frequency-multiplier and harmonic-selector stages.

Rather, $f(10)$ is a synthesized frequency produced by selecting two appropriate harmonics of the 10-mc fundamental and mixing them to form the desired product. Referring to the block diagram in figure 1-212, it can be seen that the 10-mc oscillator is isolated from the multiplier stages by a buffer amplifier. The output of the buffer amplifier is used to excite two different multiplier circuits. One multiplier is fixed-tuned to select and amplify the 9th harmonic (90 mc); the second multiplier can be switched to select and amplify either the 1st, 2nd, 3rd, or 4th harmonic (10, 20, 30, or 40 mc). The outputs of the two multiplier circuits are then mixed. Selection of the desired frequency product is made by the ganged tuning in 10-mc steps of two selective vacuum-tube amplifier stages. In table (1) below are given the harmonic multiplier combinations by which the desired spectrum frequency, $f(10)$, is obtained. Note that the 90-mc signal is not employed, but only its 2nd, 3rd, and 4th harmonics.

1-523. Figures 1-213 to 1-217 are schematic diagrams of the frequency-control circuits in Receiver-Transmitter RT-178/ARC-27. Minor differences exist among the various models of the transceiver which have been produced since the original. The schematics shown apply to Collins model No. 6 of the RT-178/ARC-27 series. The positions of the different switches and tuning adjustments are controlled automatically by a Collins Autotune system. Any of the 1750 channels can be selected by using the decade frequency selectors on the local control panel. In addition, any one of 18 preset channels or a guard receiver can be selected from both remote and local control panels. When the radio set is being operated in the receive position, plate voltage is automatically removed from those tubes that are used only during transmitter operation; likewise, when the radio set is being operated in the transmit position, plate voltage is removed from those tubes used only during receiver operation. With the aid of the block dia-

$f(10) = m \times 9f \pm nf$	$f(10) = m \times 9f \pm nf$
200 = $2 \times 90 + 20$	290 = $3 \times 90 + 20$
210 = $2 \times 90 + 30$	300 = $3 \times 90 + 30$
220 = $2 \times 90 + 40$	310 = $3 \times 90 + 40$
230 = $3 \times 90 - 40$	320 = $4 \times 90 - 40$
240 = $3 \times 90 - 30$	330 = $4 \times 90 - 30$
250 = $3 \times 90 - 20$	340 = $4 \times 90 - 20$
260 = $3 \times 90 - 10$	350 = $4 \times 90 - 10$
270 = $3 \times 90 + 0$	360 = $4 \times 90 + 0$
280 = $3 \times 90 + 10$	370 = $4 \times 90 + 10$

Table 1-522 (1). Harmonic generator combinations employed in the synthesis of $f(10)$, the output frequency of the spectrum generator in Radio Set AN/ARC-27. All frequencies are in megacycles per second.

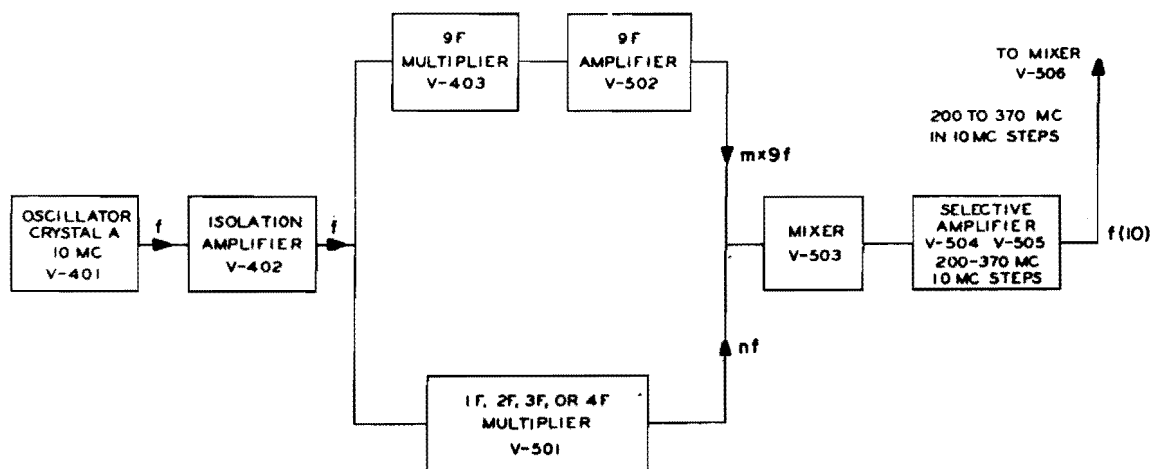

Figure 1-212. Block diagram of spectrum generator system in Radio Set AN/ARC-27

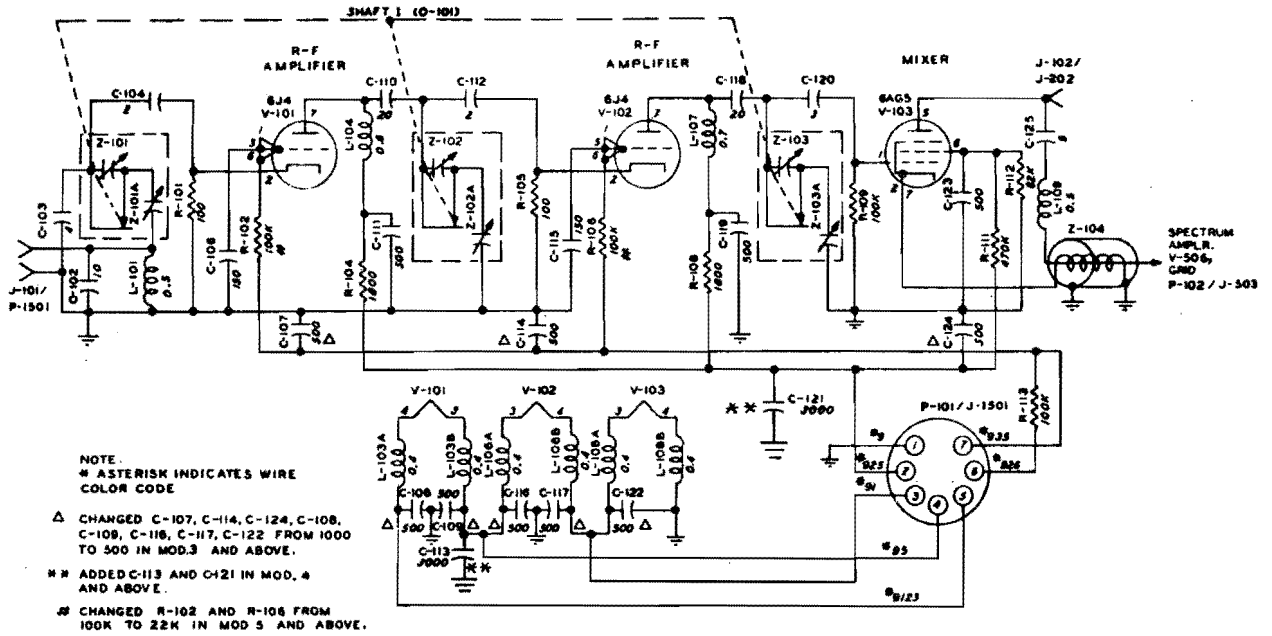

Figure 1-213. Main receiver r-f amplifier subassembly, Receiver-Transmitter RT-178/ARC-27. Includes receiver circuits V101, V102, and V103 (r-f amplifier and 1st mixer stages). See figure 1-210 for relation of the above stages to the rest of the receiver frequency-control system

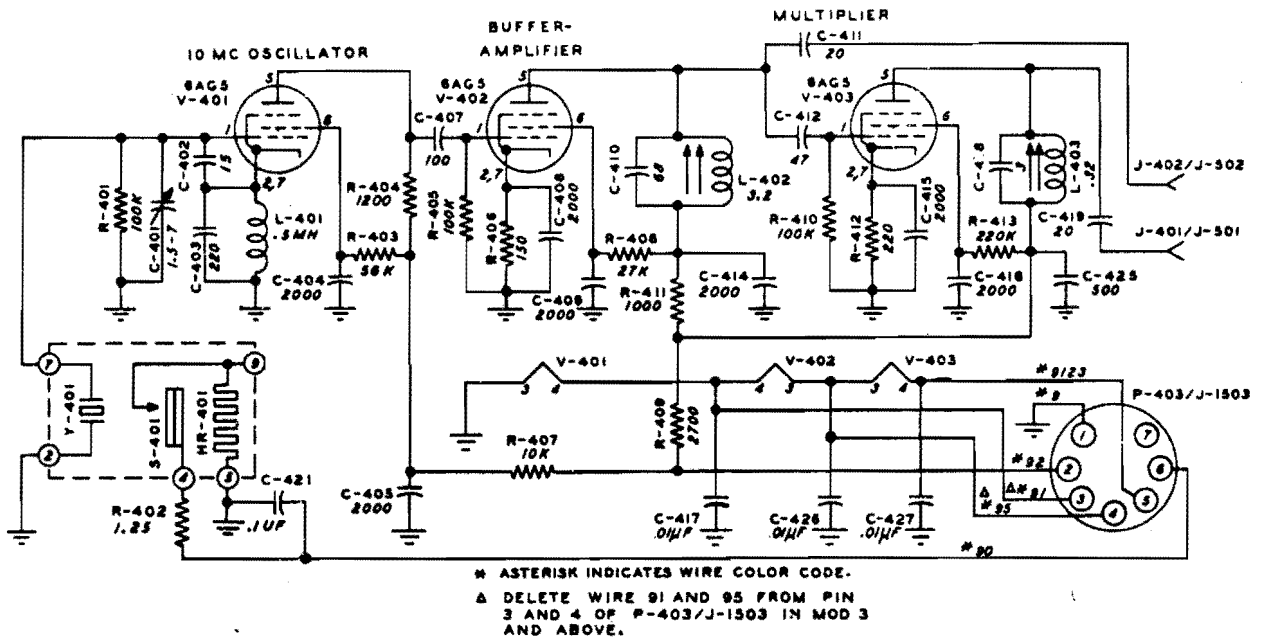

Figure 1-214. 10-mc spectrum oscillator, V401, buffer amplifier, V402, and 90-mc multiplier, V403, of Receiver-Transmitter RT-178/ARC-27. See figure 1-212 for function of the above circuits in the spectrum generator system

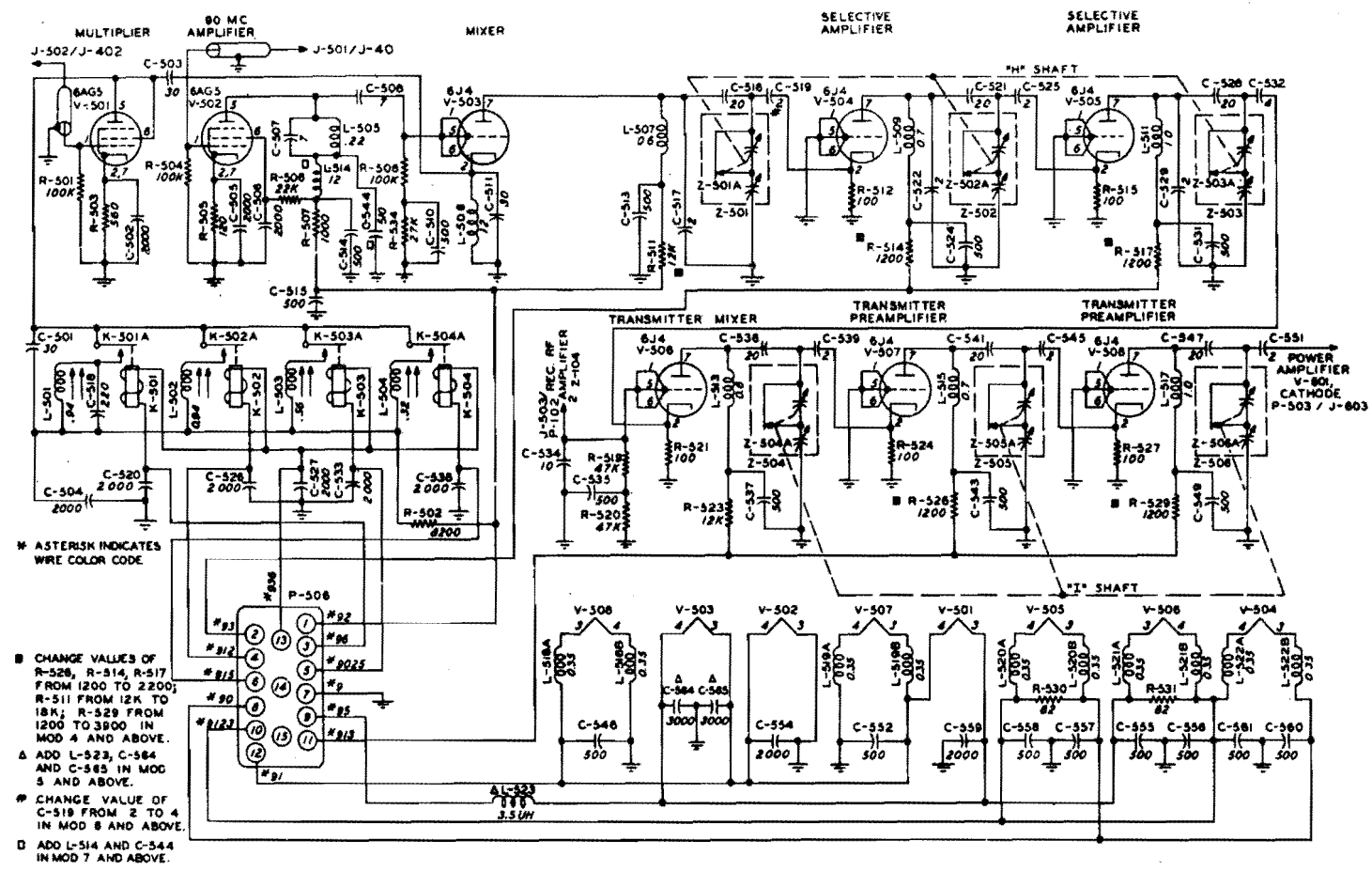
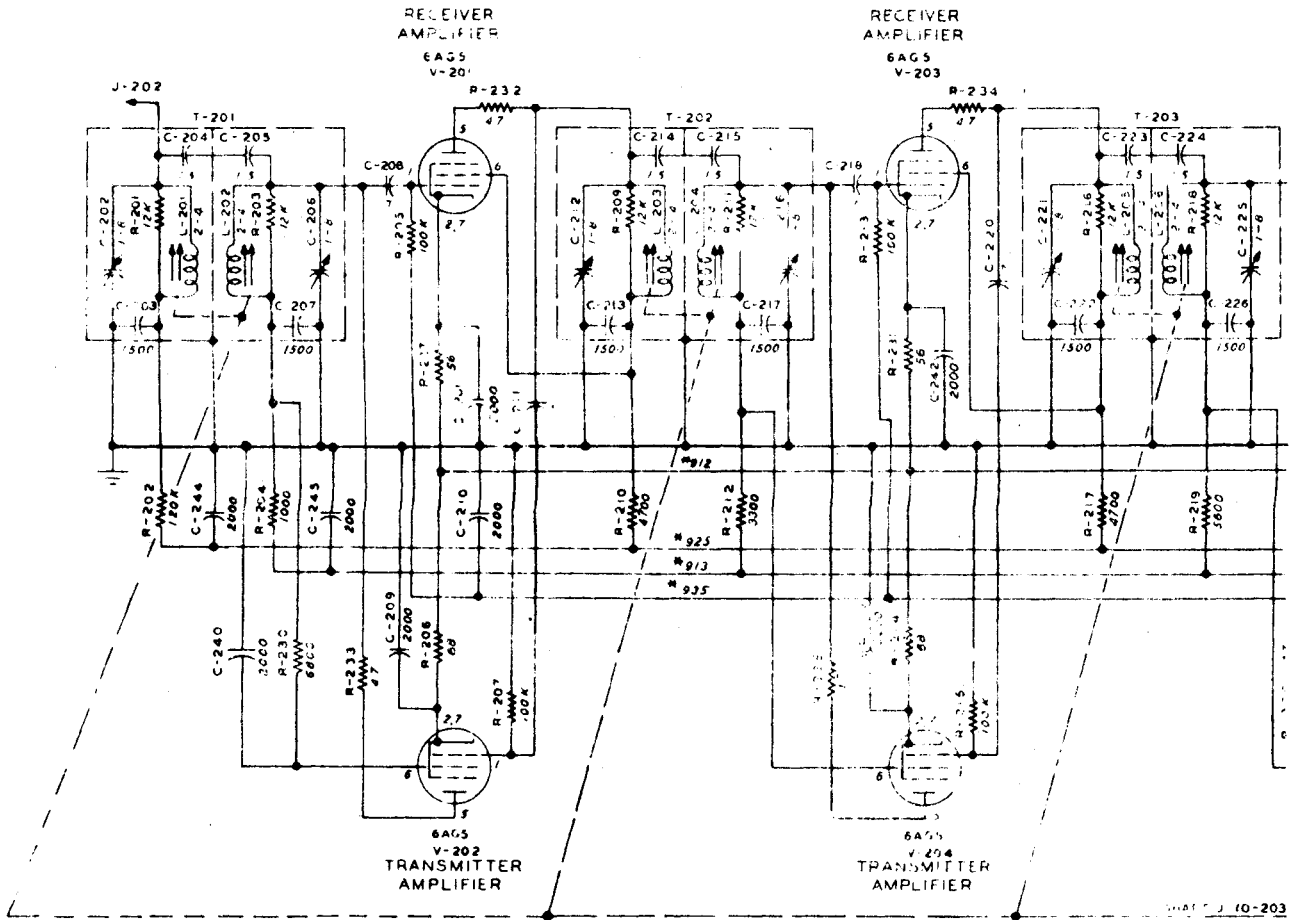

Figure 1-215. Spectrum amplifier and transmitter preamplifier subassembly, Receiver-Transmitter RT-178/ARC-27. See figure 1-212 for functional operation of spectrum generator stages V501, V502, V503, V504, and V505. See figure 1-211 for functional operation of transmitter stages V506, V507, and V508



KEY
 ● FRONT (SIDE MARKED WITH X)
 ○ REAR
 ⊙ FRONT & REAR

NOTE:
 REAR CONTACTS & RINGS ARE SHOWN
 IN DOTTED LINES

* ASTERISK INDICATES WIRING
 COLOR CODE

Δ CHANGED R-224 FROM 100K TO 1MEG
 IN MOD I AND ABOVE.

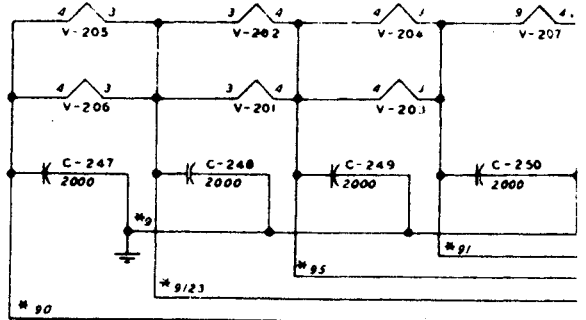

A

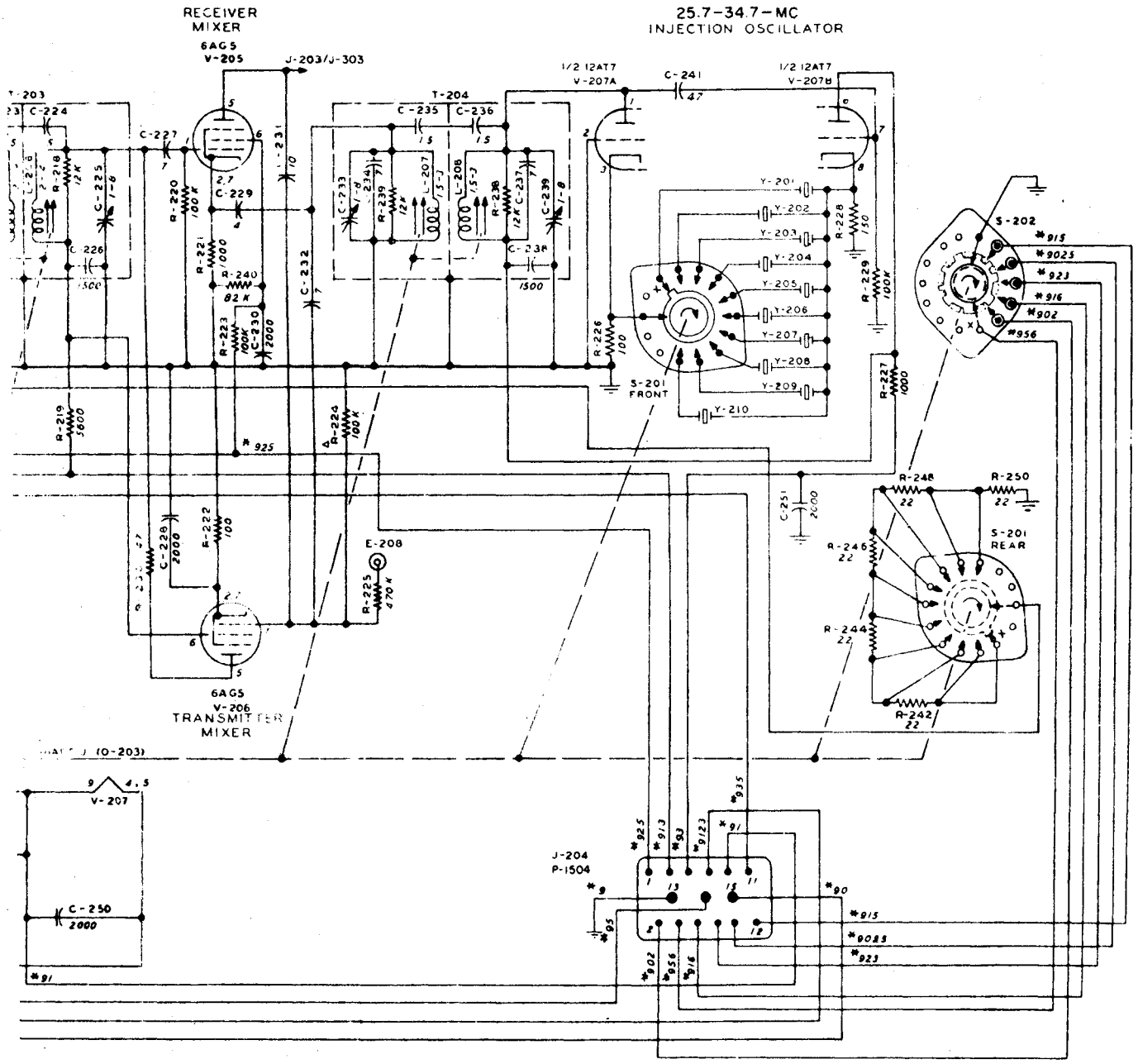
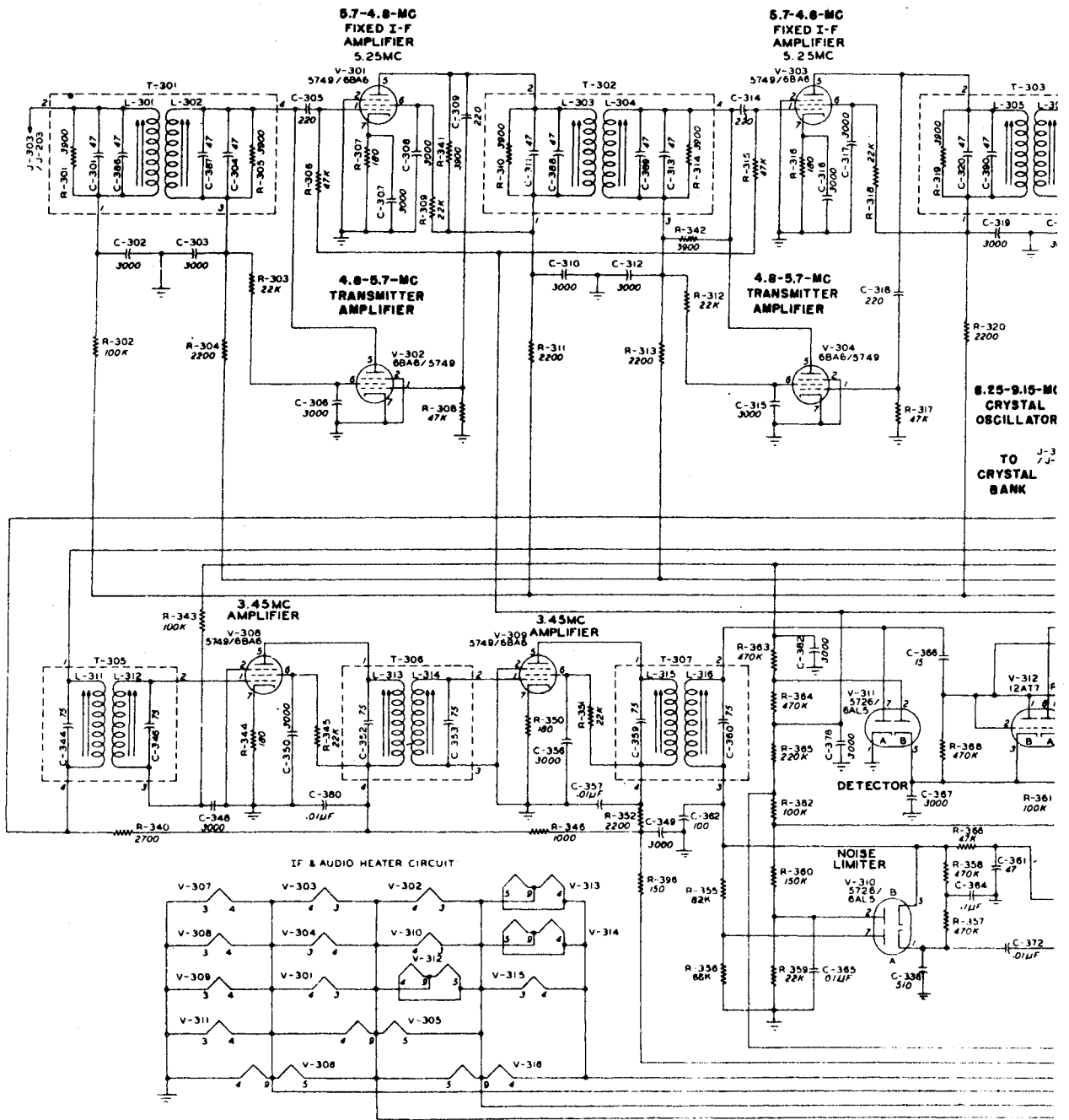

Figure 1-216. 20—30-mc i-f amplifier subassembly, Receiver-Transmitter RT-178/ARC-27. See figure 1-210 for functional operation of receiver circuits V201, V203, V205, and V207. See figure 1-211 for functional operation of transmitter circuits V202, V204, V206, and V207

B



A

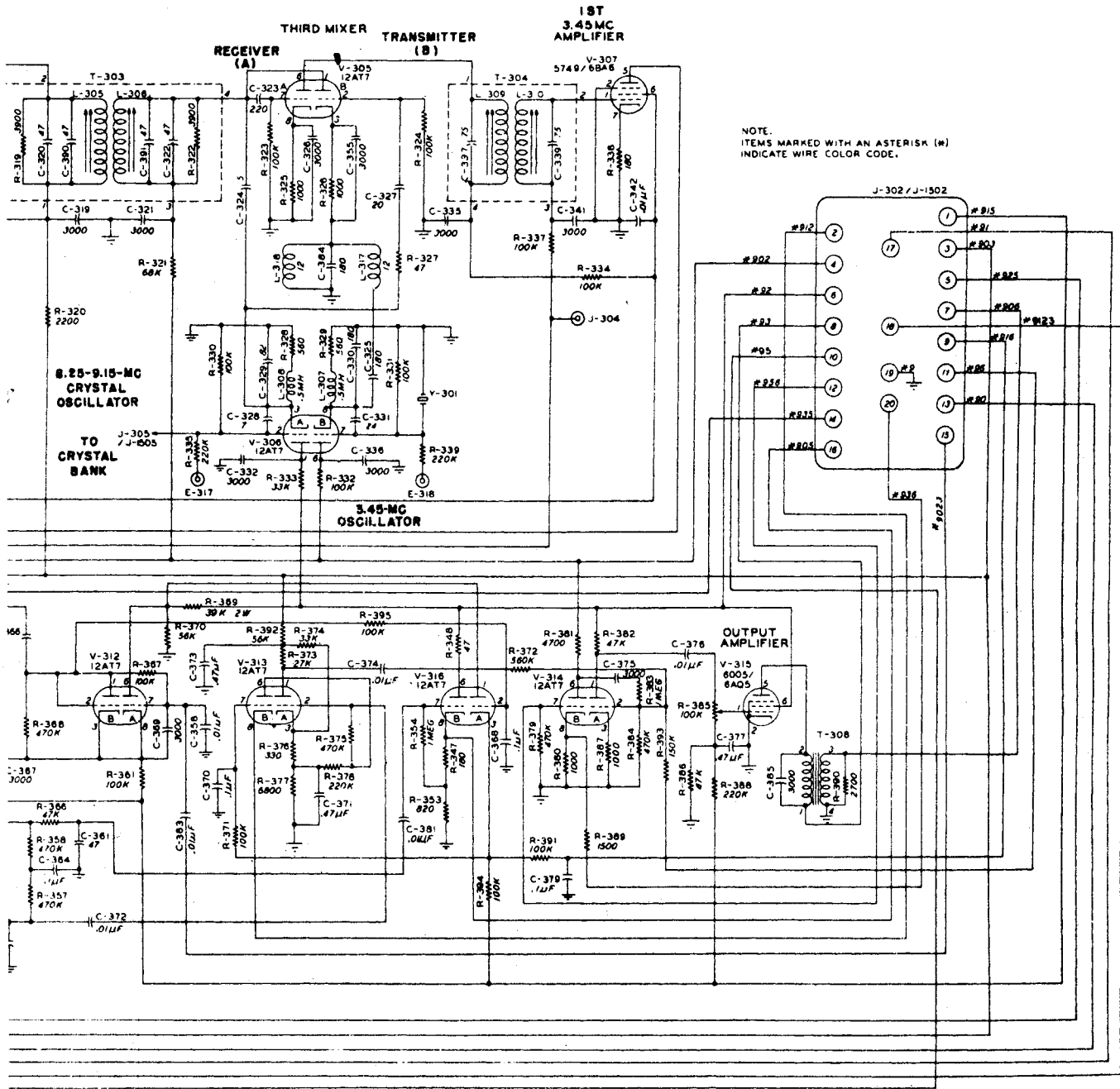

Figure 1-217. Fixed i-f amplifier subassembly, Receiver-Transmitter RT-178/ARC-27. See figure 1-210 for function of receiver circuits V301, V303, V305A, V306A, and V307. (V308 and V309, the 2nd and 3rd 3.45-mc amplifiers, which are similar in design to the V307 stage, are not shown. Also omitted are the vacuum-tube heater circuits.) See figure 1-211 for function of transmitter circuits V302, V304, V305B, V306A, and V306B

B

grams in figures 1-210, 1-211, and 1-212, the functions of the various circuit components shown in the schematic diagrams should be reasonably apparent in most instances. The designs of the individual stages are for the most part conventional. The r-f tuners used in the receiver r-f amplifier, in the spectrum amplifier, and in the transmitter preamplifier are not of a conventional type, but their design has been described in connection with similar circuits in Radio Receiver R-278/GR. See figure 1-204. Also unconventional is the coupling between the 1st mixer in the receiver and the spectrum amplifier. In figure 1-215, note that the V505 output of the spectrum generator is fed to the cathode of the 6J4 transmitter mixer, V506. Capacitor C534, which is connected between the grid of V506 and ground, is large enough to effectively ground the grid at the spectrum generator frequencies, but is small enough to present a fairly high impedance to the input from the 20—30-mc transmitter amplifier, V202. Thus, V506 operates as a grounded-grid circuit insofar as the spectrum injection frequencies are concerned, so that these frequencies tend to be attenuated somewhat in the mixer output. Attenuation of the 20—30-mc signal in the mixer output is less of a problem since the 20—30-mc band is separated by such a large percentage difference from the frequencies at which the transmitter preamplifier circuits are tuned. Although C534 effectively grounds the grid of V506 at the spectrum frequencies during transmitter operation, it does not completely do so. During receiver operation, when plate voltage is removed from V506, the output of the spectrum generator is coupled through the grid-cathode capacitance of the tube to the grid circuit, and the voltage developed across C534 is sufficient for injection excitation of the 1st receiver mixer. This injection voltage for receiver operation is fed through the same cable, Z104 (see figure 1-213), that is used to transmit the 20—30-mc signal to V506 during transmitter operation. The receiver mixer, V103, employs cathode injection by means of capacitance coupling between two wires in the specially constructed cable, Z104. From the schematic it can be seen that the wire that is connected directly to the grid of V506 is connected to the plate of V103 through C125 and L109. L109 is an r-f choke at the spectrum generator frequencies, so that for all practical purposes this circuit can be assumed to be open during receiver operation. For transmitter operation, L109 and C125 in series present a sufficiently low reactance for the 20—30-mc signal from the transmitter amplifier, V202, to be fed to the transmitter mixer, V506.

The reason that the 20—30-mc transmitter signal is fed to the transmitter mixer via the plate circuit of the receiver mixer instead of being fed directly is simply one of economy—to make use of the J102/J202 connection from the plate of the receiver mixer to transformer T201 during transmitter operation as well as during receiver operation. In figure 1-216 it can be seen that during receiver operation, transformer T201 couples the output of receiver mixer V103 to the input of receiver amplifier V201; during transmitter operation, T201 is operated in the reverse direction, coupling the output of V202 to the plate of V103 (which tube is inoperative since its plate voltage is removed) and from there through C125, L109, Z104, and connection P102/J503 to the grid of the transmitter mixer, V506.

1-524. Since the greater part of the final transmitter frequency is controlled by the 10-mc spectrum generator oscillator, it is primarily the stability of this oscillator that determines the stability of the transmitted frequency. The 10-mc oscillator is a grounded-plate (r-f grounded-screen-anode) electron-coupled Pierce circuit that employs an oven-mounted type CR-27/U crystal unit. The remaining oscillators do not employ thermostatically controlled ovens for mounting their respective crystal units, since the normal frequency deviations of these crystals with temperature changes can have but an insignificant percentage effect upon the final frequency. R-f grounded-plate oscillators of the Pierce type employing CR-18/U crystal units are used for the 3.45-mc and the 8.25—9.15-mc oscillators. The 25.7—34.7-mc injection oscillator is of the cathode-coupled Butler type and employs a 10-position bank of type CR-23/U crystal units. For the reader interested in a more detailed discussion of the over-all design of Radio Set AN/ARC-27, reference can be made to USAF Technical Order No. 12R2-2ARC27-2.

Attenuation of Unwanted Products in Frequency Synthesis

(This discussion is primarily an abstract of portions of "Developments in Frequency Synthesis" by Mr. H. J. Finden of the Plessey Company, Ltd., England, a paper delivered before the Conference on High Frequency Measurements, Washington, D.C., 1953 and published in revised form in *Electronic Engineering*, May, 1953.)

1-525. Among the more difficult problems that face the designer of frequency synthesizing circuits are those that concern the elimination of all frequencies except the one desired signal. When two frequencies, f_1 and f_2 , are mixed, it is custom-

ary to regard the output of the mixer stage as being composed of four frequencies, namely, f_1 , f_2 , f_1 plus f_2 , and f_1 minus f_2 . In practice, we know that due to non-linearities of both the input and output stages, higher harmonics of each of the fundamental frequencies are also present, as well as all possible combinations of their sum and difference products. Thus, whenever a particular output frequency is to be selected from a synthesized mixture, especially if a relatively pure sine wave output is desired, many more than the four principal fundamental frequencies must be considered. The conventional method of selecting one frequency from a mixture of several is, of course, to employ filters that readily pass a narrow band of frequencies in the neighborhood of the desired frequency, but greatly attenuate all frequencies above and below the passband. In the special case of where the desired frequency is the lowest frequency present, a low-pass filter can be used to reject all frequencies higher than the one desired. (Where all harmonics are present, high-pass filters are not applicable for the rejection of all but one frequency.) Where a relatively pure output is desired, satisfactory filtering can become quite difficult and expensive to achieve in a frequency synthesizer unless two preventive steps are taken: one step is to ensure that the input frequencies of the mixer are attenuated in the mixer stage itself; a second step is to ensure that none of the significant unwanted frequencies lies close to the desired frequency.

THE BALANCED MODULATOR IN FREQUENCY SYNTHESIS

1-526. When two or more frequencies are to be mixed to obtain a sum or difference product, the normal approach is to employ a mixer stage of maximum efficiency as measured by the ratio of the heterodyne output level to the input signal level. However, where greater-than-normal purity of the desired heterodyne product is the goal, as well may be the requirement of a frequency synthesizer, the more important signal ratio to consider in the mixer is the ratio of the heterodyne output level to the level of the input frequencies as they are measured in the *output*. For this reason the balanced modulator can be used to advantage as a mixer stage in a frequency synthesizer of pure sine waves, even though its conversion efficiency is less than that of other types of mixers. Figure 1-218 illustrates the circuit of a balanced linear modulator of the same design as the mixer stages that are used in the Plessey frequency synthesizer. Note that since the two balanced amplifiers are connected in parallel, but are excited 180

degrees out of phase, the input signals are virtually eliminated in the output. In practice, it is not possible to balance the circuit perfectly. Optimum performance is obtained by adjusting the circuit for maximum attenuation of whichever input frequency differs from the desired heterodyne product by the smallest percentage. Generally, this is the higher of the two input frequencies, except when the desired frequency is the difference product, where the higher of the two input frequencies is not greater than 2.6 (approximately) times the lower.

1-527. Measurements made at the Plessey Company of the relative power levels of the frequencies in the output of an experimental balanced modulator are shown in table (1). For this experiment f_1 equaled 100 kc and f_2 equaled 740 kc. The modulator was balanced for maximum attenuation of f_2 . The output strength of the fundamental difference product, 640 kc, was taken as the zero db reference level. Note that the sum product, 840 kc, was measured at the same level, but that all other frequencies in the output were at negative db levels. The sum and difference products involving the 5th harmonic of f_1 (500 kc) were negligible. Where the strength of the wanted frequency must be made 60 or 70 db greater than that of any other frequency, it can be seen that a mixer stage which does not, itself, attenuate the input frequencies in its output circuit will make the problem of eliminating all the unwanted frequencies by filters and/or selective amplifiers alone much more formidable.

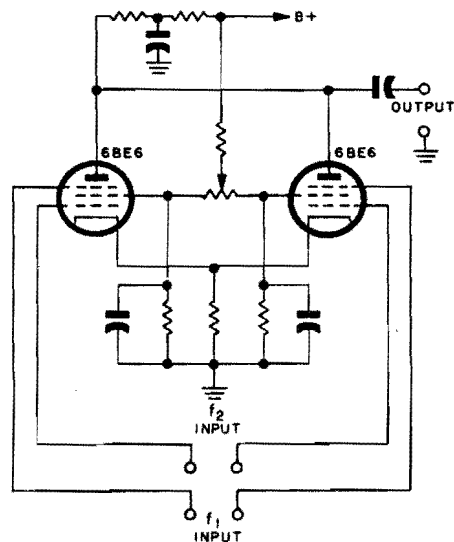

Figure 1-218. Balanced modulator circuit, which is useful as a mixer stage when maximum attenuation of the input frequencies in the output is desired

	$f_2 = 740 \text{ kc}$ — 30 db	$2f_2 = 1480 \text{ kc}$ — 30 db	$3f_2 = 2220 \text{ kc}$ — 33 db	$4f_2 = 2960 \text{ kc}$ — 58 db
$f_1 = 100 \text{ kc}$ — 8 db	$f_2 \pm f_1$	$2f_2 \pm f_1$	$3f_2 \pm f_1$	$4f_2 \pm f_1$
	640 kc 0 db	1380 kc —37 db	2120 kc —49 db	2860 kc —68 db
	840 kc 0 db	1580 kc —37 db	2320 kc —49 db	3060 kc —68 db
$2f_1 = 200 \text{ kc}$ — 35 db	$f_2 \pm 2f_1$	$2f_2 \pm 2f_1$	$3f_2 \pm 2f_1$	$4f_2 \pm 2f_1$
	540 kc —38 db	1280 kc —46 db	2020 kc —69 db	2760 kc —72 db
	940 kc —38 db	1680 kc —47 db	2420 kc —69 db	3160 kc —72 db
$3f_1 = 300 \text{ kc}$ — 42 db	$f_2 \pm 3f_1$	$2f_2 \pm 3f_1$	$3f_2 \pm 3f_1$	$4f_2 \pm 3f_1$
	440 kc —65 db	1180 kc —66 db	1920 kc —73 db	2660 kc —78 db
	1040 kc —63 db	1780 kc —68 db	2520 kc —72 db	3260 kc —79 db
$4f_1 = 400 \text{ kc}$ — 57 db	$f_2 \pm 4f_1$	$2f_2 \pm 4f_1$	$3f_2 \pm 4f_1$	$4f_2 \pm 4f_1$
	340 kc —58 db	1080 kc —70 db	1820 kc —77 db	2560 kc —78 db
	1140 kc —60 db	1880 kc —72 db	2620 kc —77 db	3360 kc —78 db
$5f_1 = 500 \text{ kc}$ — 71 db				

Table 1-527(1). Frequencies present in the output of an experimental balanced modulator when the input fundamental frequencies are 100 kc (f_1) and 740 kc (f_2). All output levels in db are given with respect to a 0-db level assumed for the difference product ($f_2 - f_1$) of 640 kc. The modulator was balanced for maximum attenuation of f_2 .

SELECTION OF INPUT FREQUENCIES FOR SYNTHESIZING STAGE

1-528. Where the output strength of the desired synthesized frequency must be at least 60 db greater than that of any unwanted frequency, it is of utmost importance that none of the unwanted frequencies (that are not already 60 db or more below the desired frequency) in the mixer output approach the frequency of the desired signal. To avoid such a possibility may require a very careful selection of the original frequency elements to be mixed. Assume, for example, that the desired signal is to be the difference product, ($f_2 - f_1$), where f_2 is greater than f_1 , and that no accompanying frequency is to have a filter or selective amplifier output power greater than —70 db relative to that of the desired signal. The question arises: What rules-of-thumb can guide the radio engineer in avoiding unwanted frequencies so close to the wanted frequency that they cannot be easily separated by conventional filter circuits? The answer to this question is to avoid all selections of f_1 and f_2 that cause the ratio $f_2/(f_2 - f_1)$ to approach any of the values shown in table (1).

How these forbidden ratios have been derived is explained in the following paragraph.

Forbidden Values of $f_2/(f_2 - f_1)$	Note: Insofar as a 70-db separation in power levels is concerned, this table applies only to the use of balanced-modulator mixers adjusted for maximum attenuation of f_2 . However, the forbidden values should generally be avoided regardless of the type of mixer circuit.
5	
4	
3	
5/2	
2	
5/3	
3/2	
4/3	
5/4	

Table 1-528(1). Forbidden values of the ratio $f_2/(f_2 - f_1)$, where f_2 is greater than f_1 and the desired frequency, ($f_2 - f_1$), is to be made at least 70 db greater in signal strength than any accompanying frequency.

1-529. The values of the forbidden ratios given in the table of the preceding paragraph were originally derived by H. J. Finden with the aid of the empirical data in table 1-527(1). The assumption was made that this empirical data for f_1 of 100 kc and f_2 of 740 kc could be accepted as generally representative of any values of f_1 and f_2 , where f_2

**Section 1
Crystal Oscillators**

is the higher frequency. The manner of derivation of the forbidden values is as follows:

a. First, let us keep in mind that our principal purpose is to avoid the presence of unwanted frequencies that lie close to the desired frequency, which we here assume to be the difference product, $(f_2 - f_1)$.

b. Let it be assumed that f_2 is greater than f_1 , but that f_1 is large enough that f_2 is at least 5 per cent (or better yet, at least 10 per cent) greater than the difference frequency $(f_2 - f_1)$.

c. With assurances of at least a 5 per cent difference between f_2 and $(f_2 - f_1)$, and with the modulator specifically balanced to eliminate f_2 [note the -30 db level of f_2 in table 1-527(1)], we can assume that the remaining attenuation of f_2 can be achieved by elementary filter design.

d. Likewise we can assume that all overtones of f_2 ($2f_2, 3f_2$, etc) can be eliminated by elementary filter design, as well as all overtones of $(f_2 - f_1)$; i.e. $(2f_2 - 2f_1), (3f_2 - 3f_1)$, etc.

e. Similarly, we can disregard all sum frequencies, $(f_1 + f_2), (2f_1 + f_2), (f_1 + 2f_2)$, etc., since all will be more than 10 per cent greater than the desired frequency, $(f_2 - f_1)$. This group also includes all sums of $(f_2 - f_1)$, or its overtones, with other frequencies. For example, $(f_2 - f_1) + f_2$, which is the same as $(2f_2 - f_1)$.

f. With the above frequencies eliminated from consideration, the remaining frequencies which might prove troublesome, as indicated in table 1-527(1), are generalized below in table 1-529(1).

g. We equate each of these frequencies with the desired frequency, $(f_2 - f_1)$, and solve for f_2 in terms of f_1 . These equations are shown below, with the corresponding solutions for f_2 and for $f_2/(f_2 - f_1)$.

h. Since the numerical values of the ratios derived above correspond to values of f_1 and f_2 that produce harmonic products equal to the desired frequency, it can be seen that any close approach to such ratios should be avoided when selecting the input frequencies to a mixer stage.

f_1	$f_2 - f_1$			
$2f_1$	$f_2 - 2f_1$			
$3f_1$	$f_2 - 3f_1$	$2f_2 - 3f_1$		
$4f_1$	$f_2 - 4f_1$	$2f_2 - 4f_1$	$3f_2 - 4f_1$	

Table 1-529(1). Frequencies present in the output of a mixer that can approach in value the desired difference frequency $(f_2 - f_1)$ and be of a sufficient power level to make elimination by conventional filter circuits difficult.

<i>When</i>	<i>Then</i>	<i>And</i>
$f_2 - f_1 = f_1$	$f_2 = 2f_1$	$f_2/(f_2 - f_1) = 2$
$= 2f_1$	$= 3f_1$	$= 3/2$
$= 3f_1$	$= 4f_1$	$= 4/3$
$= 4f_1$	$= 5f_1$	$= 5/4$
$= 2f_1 - f_2^*$	$= 3/2f_1$	$= 3$
$= 3f_1 - f_2^*$	$= 2f_1$	$= 2$
$= 4f_1 - f_2^*$	$= 5/2f_1$	$= 5/3$
$= 2f_2 - 3f_1$	$= 2f_1$	$= 2$
$= 3f_1 - 2f_2$	$= 4/3f_1$	$= 4$
$= 2f_2 - 4f_1$	$= 3f_1$	$= 3/2$
$= 4f_1 - 2f_2$	$= 5/3f_1$	$= 5/2$
$= 3f_2 - 4f_1$	$= 5/2f_1$	$= 5/3$
$= 4f_1 - 3f_2$	$= 5/4f_1$	$= 5$

* Note that only the equation where f_1 is assumed to be less than the f_1 harmonic is used. Otherwise f_1 would necessarily be zero. For example, if $f_2 - f_1 = f_2 - 2f_1$, then f_1 must be zero. In the last six equations, however, the possibility exists for the f_1 harmonic to be either above or below the f_1 harmonic.

Crystal-Phase-Controlled Harmonic Multipliers

1-530. Of great promise in the field of frequency synthesis is the possible future application of harmonic generators of the crystal-phase-controlled type. With such a generator a single low-, medium-, or high-frequency crystal can be used to control a wide band of radio channels extending well into the u-h-f range. The basic circuitry is quite simple. Where maximum economy in parts is necessary, a single triode stage is capable of producing any one of a sequence of crystal overtone frequencies, with the selected signal being 40 db above the level of the two adjacent harmonics. Such a circuit was demonstrated during the first investigations of phase-controlled multipliers reported in the United States. The basic research, reported by Dr. A. Hahnel*, and a developmental project, reported by L. R. Battersby and E. A. Conover†, were both undertaken at the Signal Corps Engineering Laboratories at Fort Monmouth, N. J.

1-531. The principal operational features of a crystal-phase-controlled harmonic multiplier are illustrated in figure 1-219. As shown in the block diagram of (A), the basic circuit consists of a variable-frequency oscillator arranged to be keyed at a crystal-controlled rate, f_c ; which, of course, should be a much lower frequency than the v-f-o frequency, f_o . If the circuit is properly designed, the variable frequency oscillator, when tuned through its band, will generate a succession of

output frequencies equal to those overtones of the crystal frequency which lie within the v-f-o tuning range. For example, let us suppose that when the variable frequency oscillator is operated in a steady, constant-amplitude state (a steady key-on operation, with the crystal-controlled key shorted across), f_o is found to vary continuously from 9990 kc to 20,000 kc. Then, when crystal-controlled keying is applied, say, at a frequency, f_c equal to 50 kc, it will be found that all the tuned frequencies are suppressed except those that are harmonics of the 50-kc keying voltage. Thus, with the oscillator tuned to its original 9990-kc position, the primary output is no longer 9990 kc, but the nearest 50-kc harmonic, 10,000 kc. As the oscillator is tuned through its natural 10,000-kc position, the output at this frequency reaches a maximum. As the oscillator tuning is varied farther in the high-frequency direction, a 10,050-kc signal begins to increase in amplitude. When the oscillator is tuned to its original 10,025-kc position, the 10,000-kc and the 10,050-kc signals will appear in the output at approximately equal amplitudes. Finally, when the tuning passes through the oscillator 10,050-kc maximum position, the 10,000-kc signal will have dropped to a level 40 db or more below the 10,050-kc output. In such a manner this particular circuit can generate any desired overtone of the crystal frequency between the 200th and 400th harmonics—200 crystal-controlled frequencies in all.

1-532. If all frequencies in the v-f-o output are to be suppressed except the single desired crystal-controlled harmonic, the output waveform, see figure 1-219(B), must meet certain conditions. First, the rise time must be as short as possible.

* Hahnel, Alwin. "Multichannel Crystal Control of VHF and UHF Oscillators," *Proc. I. R. E.*, Vol. 41, Pages 79-81, January 1953. See also Bibliography Nos. 898 to 901.

† Battersby, Lyle R. and Conover, E. A. "A Single Crystal Multi-Channel Oscillator," *Technical Memorandum No. M-1567*, Signal Corps Project No. 132A, March 1954.

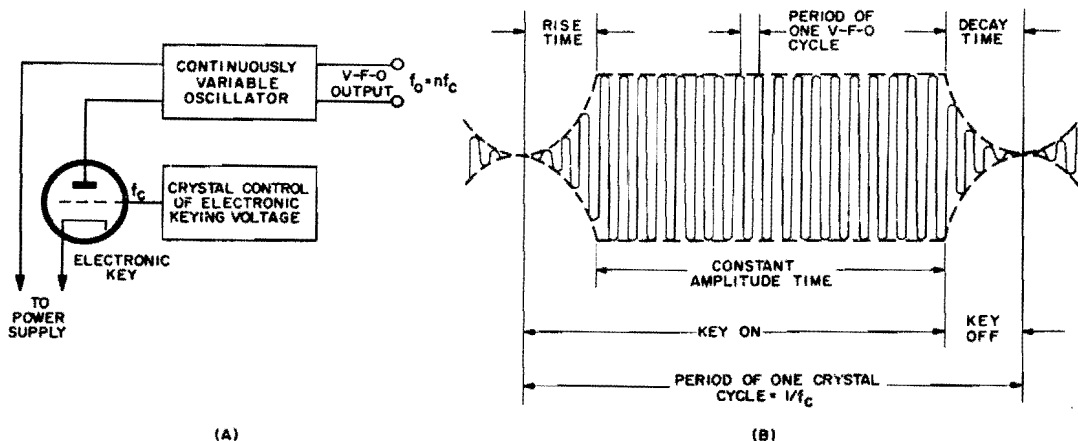

Figure 1-219. Simplified block diagram (A) and output waveform (B) of crystal-phase-controlled harmonic multiplier

Section I Crystal Oscillators

This is the time it takes the v-f oscillations to build up to their equilibrium amplitude. Second, the decay time must also be as short as possible. However, the total key-off period must be extended sufficiently to ensure that the oscillations die down to noise-level proportions. This is necessary in order for oscillations at the beginning of each keying pulse to start in the same phase. Third, as implied by the first two conditions, the constant-amplitude time must be long relative to the rest of the keying cycle — three-fourths or more of the total. If these conditions are not met, the output will always contain a multiplicity of different harmonic frequencies at approximately the same amplitude level.

1-533. That the operational conditions described above are necessary in order to obtain a single-frequency output has been confirmed empirically. Such conditions were originally indicated theoretically when the waveform was subjected to a Fourier analysis. Intuitively, from a qualitative examination of the waveform, it would appear that those conditions of maximum constant-amplitude time, which indicate minimum distortion of the output from a pure unmodulated continuous wave, could be expected to be the conditions approaching most closely single-frequency phase-controlled operation. What may not be qualitatively obvious is why the constant-amplitude portion of the output pulse, which supplies practically all of the output energy, should not cause the dominant frequency to be the actual frequency at which the variable frequency oscillator is tuned to operate. Let us assume that the keying voltage is a square-wave pulse. Since the v-f oscillations must build up from thermal level, we can assume that they contain no "memory" of the preceding keying pulse or of the pulse rate. In other words, once the oscillator is keyed, the buildup waveform and the constant-amplitude frequency are exactly the same whether the keying pulse is to last 1 microsecond or 1 day. So qualitatively we must conclude that the steady-state oscillations have a period and corresponding frequency that are independent of the keying frequency. The steady-state period of a v-f-o cycle during crystal control is thus no different from that of the same tuned circuit without crystal control. How then are we to account for the fact that when crystal control is applied, the measured output frequency immediately shifts from the tuned-circuit resonance value to the nearest harmonic of the crystal frequency? The answer appears to lie in the fact that the generated phase-controlled output physically has the same period and cycle-to-cycle frequency as

the unmodulated tuned oscillator, but because of the periodic phase shift at the crystal frequency, a tuned receiving circuit can indicate a maximum resonance absorption of energy only if it is tuned to a harmonic (approximately) of the periodic phase shift.

1-534. Imagine an ideal phase-controlled waveform in which the build-up time and the decay time are instantaneous, so that the periodic phase shift can also occur instantaneously without the intermission of a key-off interval. In this event, if the v-f-o tuned frequency is exactly equal to a harmonic of the phase-control frequency, no phase adjustment occurs, and the output does not differ in form from a steady-state continuous wave. Now suppose that the v-f-o tuned frequency is not a harmonic of the phase-control frequency, and that we attempt to couple electronically the output to a tuned receiving circuit. With the receiving circuit tuned to the v-f-o frequency, we can imagine that during the first phase cycle the received resonance energy builds up to a certain level. To idealize further, let us also imagine that the resistance of the receiver tuned circuit is effectively zero, so that when the first phase cycle is completed, the energy absorbed during that period continues undiminished as a free-running oscillation without a change in phase. During the succeeding phase period a corresponding component of oscillation of equal amplitude but different phase is fed the receiving circuit. After several such periods, in which the phase of each succeeding oscillation component is rotated in the same direction an equal amount from the phase of the preceding component, it can be assumed that the accumulation of opposite-phased oscillations tend to cancel each other (i.e., the tuned circuit returns energy to its power source as fast as it is supplied). Thus, even if the circuit ohmic resistance is zero, a resonance condition cannot be indicated by a continuous buildup of oscillations. On the other hand, if the receiving circuit is tuned to the near harmonic of the phase cycle, we can imagine that the energy absorbed during each phase period continues as a free-running oscillation at the harmonic frequency, nf . Since there are always exactly n of these cycles during each phase period, the imaginary succession of oscillation components will all have the same phase, and hence will tend to add to each other rather than cancel. Remember that the beginning of each phase cycle does not constitute a phase correction of its harmonic cycle, but of the v-f-o cycles, which we here assume are feeding energy to the semi-free-running harmonic-tuned receiving circuits. Before the phase of the

input cycle can gradually shift to a point where it is in phase opposition to the hypothetical harmonic oscillations, it is abruptly returned to its starting position and a new phase cycle begins. In this way we can see how the phase-controlled v-f-o oscillations are able to continually feed energy to oscillations that are multiples of the phase-control frequency, and yet tend to suppress oscillations that have the same period as the v-f-o steady-state output. Thus, where the frequency-measuring technique involves the absorption of energy in a variable circuit of calibrated tuning range, we would conclude that the output frequency of the phase-controlled vfo is apparently a harmonic of the crystal frequency. Similarly, if the phase-controlled frequency were being tested by matching with the phase of an oscilloscope sweep, the sweep would have to be synchronized by the crystal harmonic frequency to hold the pattern still. If synchronized at the v-f-o tuned frequency, the pattern of a single wave will take a hop in phase at the beginning of each phase correction, and thus appear to move across the screen. When synchronized by a crystal harmonic, the wave may begin a change of phase, but immediately jumps back to its original position at the beginning of each phase correction. Again, the phase-controlled harmonic, nf_c , becomes the measured frequency of the vfo when the measuring technique involves the beat-frequency method, since basically this method measures the unknown frequency by determining the rate at which its phase changes with respect to that of a known standard. Thus, purely from qualitative considerations, we are led to suppose that any conventional frequency-measuring method would indicate that the output of a phase-controlled oscillator has an apparent frequency, f_o , equal, not to the v-f-o tuned operating frequency, but to nf_c .

1-535. The reader should accept the qualitative explanation of the principle of phase-controlled multiplication, as given in the foregoing paragraph, as being somewhat on the speculative side. In the practical oscillator, it may be that sufficient coupling can be expected to exist between the v-f-o oscillator and the crystal oscillator to pull them into a mutual synchronization with each other. Certainly, such synchronization is to be expected when the natural v-f-o frequency approaches very closely a harmonic of the crystal fundamental. Also, the explanation given above implies that a tuned receiving circuit, which, perhaps because of periodic clamping or quenching, lacks a sufficient "memory" to store an oscillation above noise level for the duration of the key-

off interval, could not be used by itself to detect a phase-controlled output. If such a circuit were used as a coupling stage, maximum transfer of energy would occur if the stage were tuned to pass the tuned v-f-o frequency rather than the crystal harmonic. Since the discrimination of an effectively low-Q circuit between nearly equal frequencies is negligible in practical circuits, raising the question at this point is academic, except to remind the reader that our qualitative explanation of the phase-controlled signal implies that the value of f_o is not independent of the detecting system. On the other hand, the Fourier analysis of the output waveform, leads us to consider the crystal-controlled harmonics as being the actual frequencies of the v-f-o output, inherent in the waveform.

HAHNEL SPECTRUM GENERATOR

1-536. Figure 1-220 (A) is the schematic diagram of a one-tube spectrum generator of the phase-controlled v-f-o type developed by Hahnel and associates. Since the v-f-o frequency is several times higher than the crystal frequency, inductors that present very low impedances at the crystal frequency, but high impedances at the v-f-o frequencies, can be used to separate the crystal feedback path from that of the variable oscillator, thus permitting a single triode to serve as amplifier for both oscillators. In figure (B) is shown the equivalent circuit of the crystal oscillator, which we see is more or less a conventional Miller circuit. In figure (C) is shown the equivalent v-f-o circuit, which we see is a Colpitts circuit. This basic spectrum generator is operable at all lower frequencies, but of special interest is the fact that a crystal-controlled output was obtained even in the u-h-f range when an L_4C_4 butterfly circuit tunable from 250 to 900 mc was used.

1-537. As explained earlier, a single-frequency output from the phase-controlled oscillator in figure 1-220 requires that the constant-amplitude interval of the phase cycle be as long as possible consistent with a sufficient decay time. To achieve this R_c must be varied to a value consistent with the resistance of the crystal unit so that the crystal oscillator is biased in the class A region; that is, the tube is cut off (for v-f operation) only a small portion of each crystal cycle. In order to make sure that the decay time is very short, the f_o tuned circuit should be rather heavily damped, and low ratios of L/C should be used in the tuned circuit. Since these design features will tend to keep the energy storage in the v-f-o system low, they will also serve to shorten the buildup time.

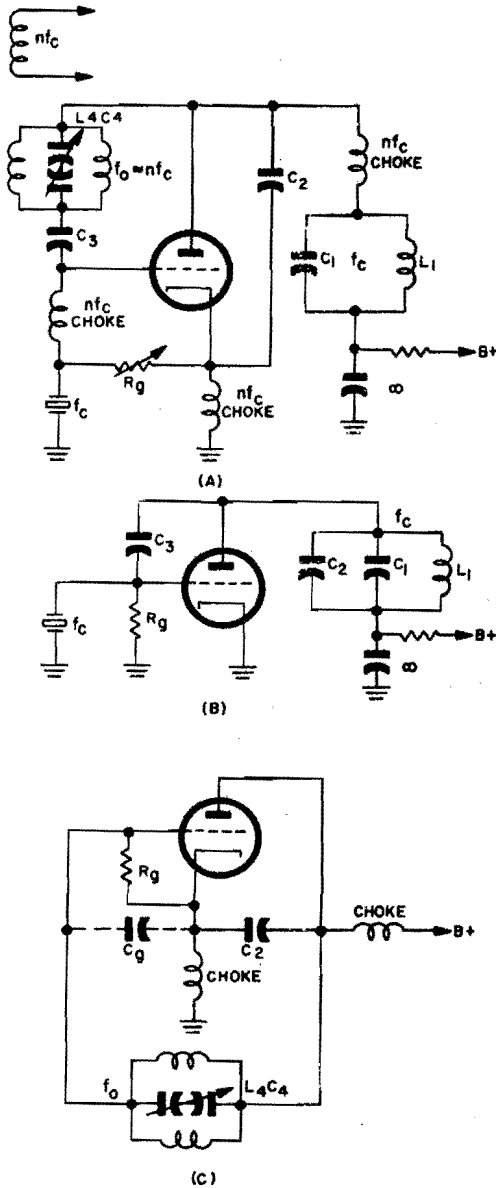

Figure 1-220. (A) Schematic diagram of Hahnel spectrum generator in which two oscillator circuits are combined in one stage; (B) Simplified schematic diagram of the crystal oscillator circuit of the spectrum generator; (C) Simplified schematic diagram of the v-f-o circuit of the spectrum generator

It is also important in this latter respect to use a tube of high transconductance, and to ensure that this transconductance is effective during the constant-amplitude interval. Short rise and decay times also require that the crystal keying voltage is changing at a fast rate at the v-f-o on and off points. For this purpose, the amplitude of crystal

oscillation should be as large as practical. Of course, the gridleak resistance will need to be relatively small in order to keep the bias in the class-A region.

1-538. Figure 1-221 shows the complete schematic of a Hahnel circuit followed by an amplifier. This circuit was developed by Battersby and Conover and designed to cover the frequency range of 20 to 30 mc in 1-mc steps. With the additional amplifier stage, a 50-db selectivity is obtained for the desired harmonic channel relative to the adjacent channels. An output of 3 volts is possible across a 50-ohm load. The oscillator circuit is essentially the same as that in figure 1-220. The amplifier stage is quite conventional. The link coupling to the amplifier is employed to minimize the leakage of the 1-mc signal from the oscillator circuit to the amplifier input. R_g serves to shorten the decay time. Its damping effect also improves the tracking performance of the ganged tuning.

TRANSISTOR OSCILLATORS

Our assignment in transistor oscillators is not to provide detailed mathematical analyses of the various types of circuits, but to describe and discuss semi-quantitatively experimental single-stage circuits that are representative of basic methods for obtaining the loop feedback required to maintain stable oscillations. The basic methods discussed are those that, to obtain feedback, employ series-mode crystal units in the feedback arm, negative-resistance circuitry, and transformer coupling. Modifications of each type of basic circuit are given, but unfortunately the test data available is insufficient to permit definitive comparisons of the characteristics and limitations of the different circuits. The design engineer, of course, would prefer concrete recommendations in choosing a circuit and in guiding its design to provide optimum characteristics for the particular needs at hand. However, crystal oscillators employing transistors in lieu of vacuum-tube amplifiers are at the present writing still more or less in the trial-and-error experimental stage. Although technical information is being accumulated in a number of laboratories, the detailed test data for the most part represent investments in competitive enterprises unavailable at this time for public communication. The reader should understand that the particular circuits described are primarily experimental in nature, being given as illustrations of basic oscillator types and not as endorsements for general use.

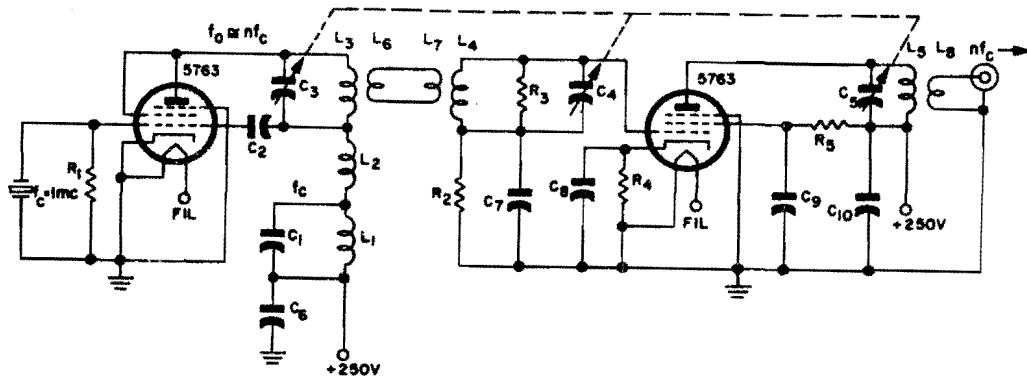

$R_1 = 30,000$ ohms
 $R_2 = 15,000$ ohms
 $R_3 = 2,200$ ohms
 $R_4 = 150$ ohms
 $R_5 = 68,000$ ohms

$C_1 = 112 \mu\mu\text{f}$
 $C_2 = 10 \mu\mu\text{f}$
 $C_3, C_4, C_5 = 6-80 \mu\mu\text{f}$
 $C_6, C_7, C_8, C_9, C_{10} = .01 \mu\text{f}$

$L_1 = 114 \mu\text{h}$
 $L_2 = 37 \mu\text{h}$
 $L_3, L_4, L_5 = 0.8 \mu\text{f}$
 $L_6, L_7 = 0.12 \mu\text{h}$
 $L_8 = 0.17 \mu\text{h}$

$f_c = 1$ mc
 $f_o = 20-30$ mc

Figure 1-221. Schematic diagram 20—30-mc spectrum generator with filter-amplifier stage added for greater adjacent channel selectivity

Transistor Crystal-Feedback Oscillators

POINT-CONTACT TRANSISTOR CRYSTAL-FEEDBACK OSCILLATOR

1-539. The circuit parameters indicated are those of an experimental low-frequency oscillator that was investigated at Bell Telephone Laboratories as a possible future replacement of the present vacuum-tube circuits now used to control telephone carrier frequencies. The information given here is based upon a discussion of the experimental oscillator by R. S. Caruthers.

1-540. A point-contact transistor of the 1729 type was used in the experiments. Superior performance characteristics can be obtained with the more recently developed junction transistor. The extreme simplicity of the basic circuit is possible because the r-f emitter current, I_e , is in phase with the r-f collector current, I_c . All that is necessary for the oscillations to be maintained is that a series resonant circuit, which in this case is the series-mode crystal, feed back a sufficient current to supply I_e . The total feed-back current, however, must be somewhat greater than I_e . Amplitude equilibrium is reached when

$$\alpha = 1 + \frac{R}{R_L} + \frac{R}{r_c} \quad 1-540 (1)$$

where α is the effective r-f current amplification

factor of the transistor, equal to I_c/I_e , R is the crystal resistance, R_L is the load resistance, and r_c is a resistance parameter of the transistor collector circuit, somewhat the analogue of R_p of a vacuum tube. For the point-contact transistor, r_c is generally between 15,000 and 20,000 ohms, so that the term R/r_c is usually quite small compared with the other terms in the equation. For oscillations to build up, the initial value of α must be greater than that given by equation (1). The larger the difference between the initial α and the equilibrium α , the greater is the final activity. In figure 1-223 (A), it can be seen that the values of α are not large, so that R_L cannot be made much smaller than the maximum permissible R of the crystal unit if equation (1) is to hold for all crystal units of a given type. Limiting occurs when the current peaks of I_e extend into the low-amplification regions indicated in figure 1-223 (A). The a-c load line in figure 1-223 (B) indicates the approximate operating region during oscillations. The point Q, which is at the middle of the operating range is predetermined experimentally by adjustments of the d-c supply voltages and the series dropping resistances. Because of the small margin of excess gain in the transistor oscillator, the variations in collector characteristics from one transistor to another result in large percentage variations in oscillator activity. Note the large differences in collector current for the same value of

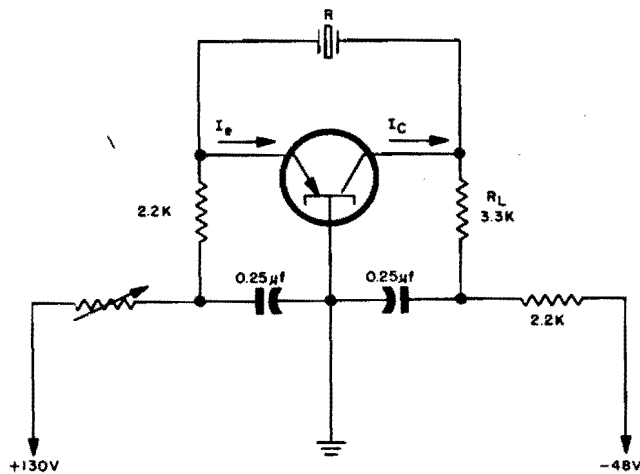

Figure 1-222. Basic circuit for crystal-controlled transistor oscillator

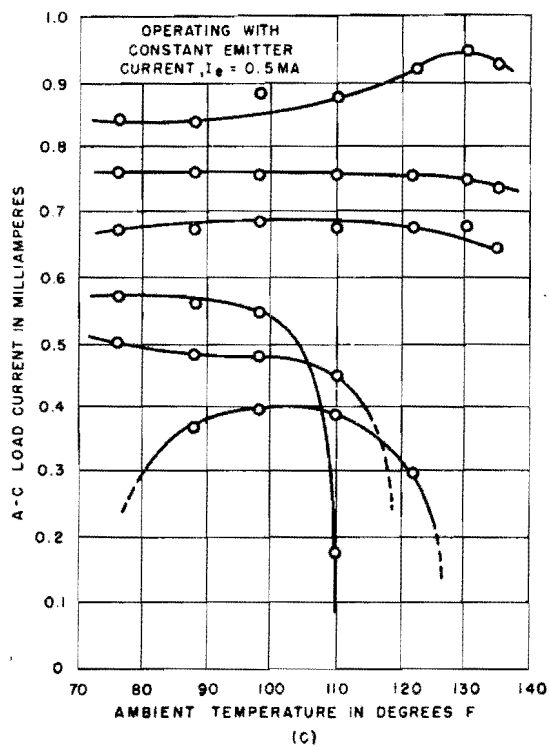
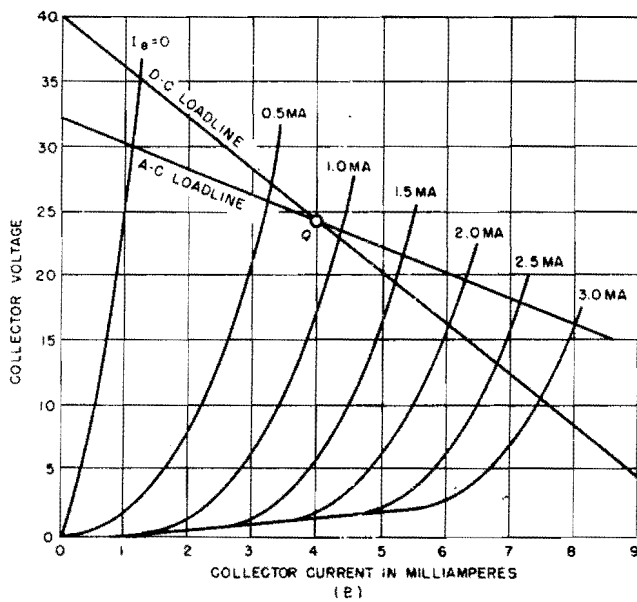
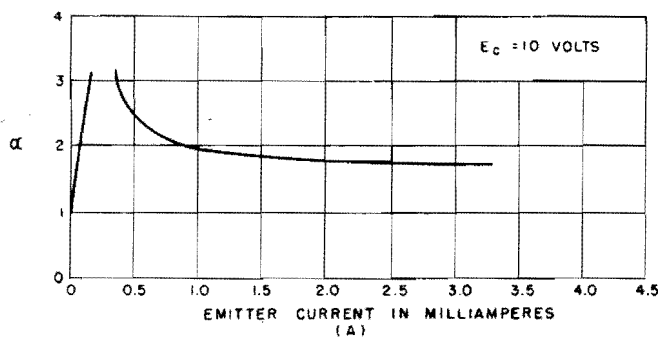

Figure 1-223. (A) Current amplification, α , of point-contact transistor versus emitter current, I_e . (B) Collector characteristics of point-contact transistor. A-C load line indicates approximate operating region during oscillations. (C) Collector current characteristics for different point-contact transistors of type 1729, showing effects of temperature

I_e , when different transistors are used, as shown in figure 1-223 (C). The temperature effects also require consideration. An increase in temperature causes R_e to become lower. In the case of "low-activity" transistors, this effect can easily be sufficient to stop oscillations.

1-541. The frequency stability and sine-wave output of the transistor oscillator can be comparable to that of vacuum-tube oscillators. The oscillator in figure 1-222 was able to supply as much as 30 mw to the load at a frequency of 184 kc. It was found that 0.8 watt less power was required to operate a transistor oscillator and amplifier than is required for an equivalent vacuum-tube circuit, and at least a 50-per cent greater saving should be possible. The consequent reduction in compartment heating, as well as in requirements of weight, space, etc. can be quite advantageous in small, compact units where several power-dissipating elements are packed closely together.

JUNCTION TRANSISTOR CRYSTAL-FEEDBACK OSCILLATOR

1-542. The basic collector-to-emitter crystal feedback circuit shown in figure 1-222 requires a current amplification greater than unity, and therefore is restricted to transistors of the point-contact type and to frequencies generally under 500 kc. When a crystal-feedback oscillator is desired using a junction transistor, or using a point-contact transistor at a frequency too high for alpha to be greater than unity, modifications must be introduced in order to obtain the required current amplification. Perhaps the simplest solution is to employ a voltage-step-down (current-step-up) transformer. However, to simplify the discussion we shall treat the transformer-coupled transistor oscillator in a separate category. A more direct solution, and one that affords a more dependable oscillator insofar as the elimination of free-running oscillations is concerned, is to exploit the current amplifying characteristic of the parallel-tuned circuit. One branch of a tuned tank with a series-mode crystal inserted can be used as a feedback circuit. One such circuit, where the collector output operates into the tuned tank, is shown in figure 1-224. This circuit was designed and tested during a Signal Corps research project* directed by B. J. Dasher at the Georgia Institute of Technology. A simplified schematic illustrating the

* *Transistor Oscillators of Extended Frequency Range*, Quarterly Report No. 5, by B. J. Dasher, D. L. Finn, S. N. Witt, Jr., W. B. Warren, Jr., and T. N. Lowry of the Engineering Experiment Station, Georgia Institute of Technology, Atlanta, Georgia—Department of the Army Contract No. DA-36-039-sc-42712.

necessary loop gain and loop phase conditions for oscillation is shown in figure 1-225. Assuming that the r-f emitter-to-base input impedance of the transistor is small compared with the external 10-kilohm shunting resistance, it can be seen that the feedback current (I_e/θ) through the crystal and the tank tuning capacitor must be approximately equal to I_e , the r-f emitter current, whose phase is taken as the zero reference. The exact phase conditions depend upon the alpha characteristics of the transistor.

1-543. Figure 1-226 shows the alpha characteristics versus frequency of a typical CK-720 junction transistor as measured by Dasher et al at the Georgia Institute of Technology. Note the large lag (ϕ) in the phase of I_e with respect to I_e as the frequency is increased. Alpha is the current gain under external collector-to-base short-circuit conditions. Its value is dependent upon the frequency but is otherwise independent of the particular circuit external to the transistor. The collector circuit shown in figure 1-225 is, of course, not a short circuit, but is assumed to have an impedance very small compared with the internal collector-to-base impedance of the transistor, so that to a first approximation the phase of the operating I_e is equal to the phase, ϕ , of the short-circuit alpha. The phase lag, ϕ , is due to the transit time of the transistor current carriers. It can be seen that if I_e/θ of the feedback arm of the collector tank in figure 1-225 is to have the same phase as I_e/θ° ($\theta = 0$), how nearly the tank is to be tuned to parallel resonance and whether the tuning is above or below resonance depend upon the phase of ϕ , and that this in turn depends upon the frequency. At frequencies in the neighborhood of 400 kc, ϕ has a value of approximately 80° . If it can be assumed that the reactance of the capacitor in the feedback arm is sufficient to cause the feedback current to lead the tank voltage by 80° , then $\theta \approx 0$ when the tank is operated at resonance. At small values of ϕ (at low frequencies), the tank circuit tuning must deviate considerably from the parallel resonant condition in order for θ to equal zero. At very large values of ϕ the loop phase relations approach the 180-degree inversion characteristic of vacuum-tube oscillators, with the circuit in figure 1-224 assuming certain similarities to a Pierce circuit. Since the magnitude of alpha becomes very small as ϕ becomes large, it may be necessary to introduce additional phase-shifting elements in order to ensure that the tank is operated sufficiently close to resonance. (Actually, the practical solution would be to employ a transistor

Section I
Crystal Oscillators

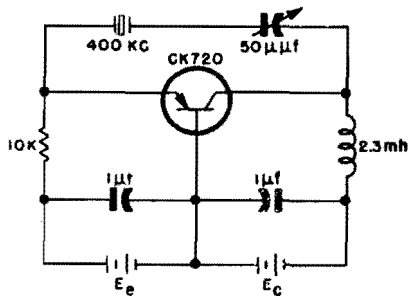

Figure 1-224. Junction transistor crystal-feedback oscillator

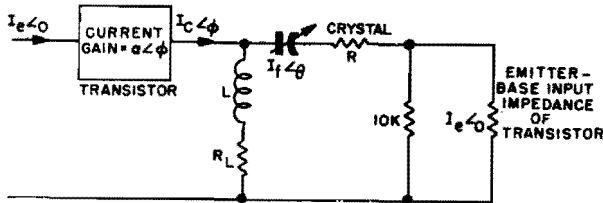

Figure 1-225. Simplified equivalent circuit of junction transistor crystal-feedback oscillator, showing tuned tank in collector circuit for obtaining desired current amplification and loop phase shift for feedback to emitter input. For stable oscillations to be maintained

especially fabricated for use at higher frequencies, as is discussed in the following paragraph.) The value of L in figure 1-224 is purposely made large so that the tank Q is sufficient to permit the necessary current amplification over as wide a tuning range as is possible. With the crystal shorted out, the circuit was found to oscillate in a free-running state at frequencies as high as 2 mc, which is several times the alpha cutoff frequency. (The alpha cut off frequency is that frequency at which the short-circuit current gain is 3 db below the d-c value of alpha.) With a crystal inserted, the upper frequency limit depends upon the crystal's effective resonance resistance. But the upper dependable frequency when employing Military Standard crystal units having element C or D characteristics appears to lie between 300 and 400 kc. Frequency Control Branch engineers of the Fort Monmouth Signal Corps Engineering Laboratories do not recommend this type of oscillator for general use because the operating stability is critically dependent upon the stability of alpha, whose phase and magnitude can be quite difficult to maintain constant under variations of temperature and voltage. Nevertheless, the progressive development of h-f and v-h-f transistors of ever closer tolerances are rapidly

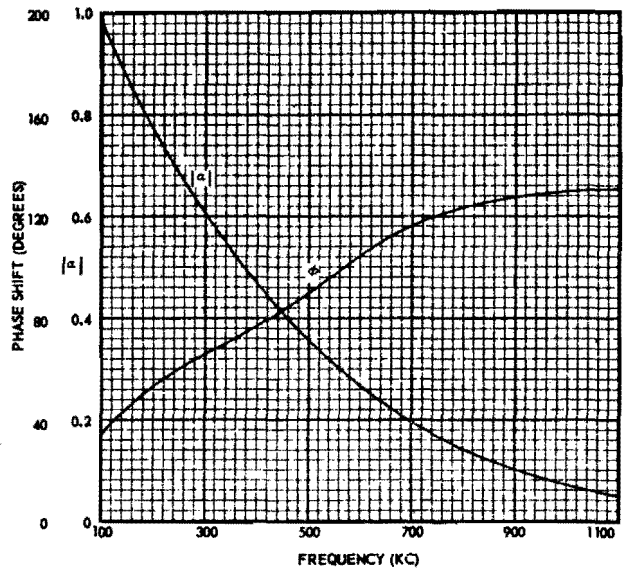

Figure 1-226. Typical alpha characteristics versus frequency of a type CK-720 junction transistor

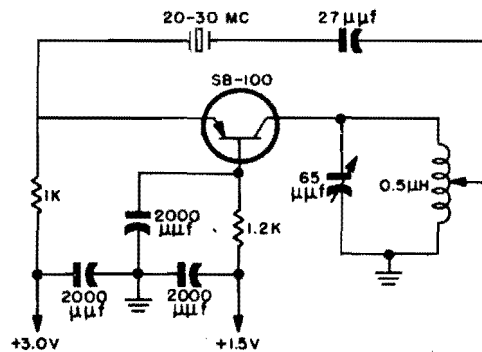

Figure 1-227. High-frequency transistor oscillator

increasing the frequency range over which junction transistor oscillators of all types can be operated below alpha cutoff—in which region unstable transit time effects are less pronounced. For example, a modification of the circuit shown in figure 1-227 (a type that employs a parallel-tuned circuit for amplification of the feedback current), without crystal control, is already in commercial use. For a modified version of the oscillator in figure 1-224 designed to provide maximum frequency stability, see paragraph 1-555.

H-F TRANSISTOR OSCILLATORS

1-544. The comparatively long transit time of the transistor has been a great handicap in applying the semiconductor amplifier in h-f and v-h-f circuits. Although it is quite possible to demonstrate that transistors can operate satisfactorily in h-f

crystal oscillators, it is quite difficult to guarantee that such circuits will operate dependably when the demonstration transistors and crystal units are replaced by others of the same nominal characteristics, unless close tolerances are assured. One of the few types of transistors for h-f and v-h-f application that is commercially available at the time of this writing is the Philco Surface Barrier transistor, SB-100, which is basically a special type of pnp junction transistor designed for low-power, wide-band, h-f applications. Its unique fabrication process permits an above-average degree of uniformity in its low-power, h-f operating characteristics. The maximum dependable oscillation frequency of the SB-100 is rated at 30 mc. This is the highest frequency at which any randomly selected transistor of this type can be expected to show a power gain of at least unity. The highest frequency at which the *average* SB-100 transistor can be expected to show a power gain of unity is 45 mc. With selected SB-100 transistors, oscillators at limit frequencies of 70 mc are possible. If these transistors are to be employed as amplifiers in oscillator circuits at frequencies above 20 mc, the design engineer should specify closer tolerances than those described for randomly selected units. Figure 1-227 shows an oscillator circuit designed for operation in the 20—30-mc range. This oscillator will operate as a free-running circuit at its tuned frequency if the crystal is shorted across. The ratio of the useful oscillator output to the power supplied from the SB-100 collector voltage supply is given by the empirical equation

$$\text{collector efficiency} = 0.8 \log_{10} \frac{f_{\max}}{f} \% \quad 1-544 (1)$$

where f_{\max} is the highest frequency at which the oscillator in figure 1-227 will oscillate (the frequency at which the circuit power gain is unity at starting amplitudes) and f is the operating frequency. Equation (1) assumes that the losses in the crystal unit are negligible; otherwise these losses should be interpreted as part of the "useful" oscillator output.

Negative-Resistance Transistor Oscillators

1-545. Although the driving element of any electronic oscillator can be described as a negative-resistance circuit, it is not customary to classify the oscillator, itself, as being of the negative-resistance type unless the negative resistance is an inherent d-c, as well as an a-c, characteristic of the driving element. Among negative-resistance vacuum-tube oscillators, the transitron circuit is an example. Among transistor oscillators, the series-tuned-emitter circuit, such as that shown in figure 1-228, is an example.

1-546. A negative-resistance characteristic can be obtained between any two terminals of a point-contact transistor by allowing the amplified current to flow through a feedback resistance of such magnitude that the feedback voltage produced is more than sufficient to compensate for any change in the input voltage. Alpha must be greater than one, so that the negative-resistance circuit is not applicable for a single-stage junction type of transistor, nor, for that matter, for a point-contact transistor except at the lower frequencies. The negative-resistance characteristics of the emitter input in a common-base circuit, such as that shown in figure 1-228, is generally superior to a tuned-collector negative-resistance

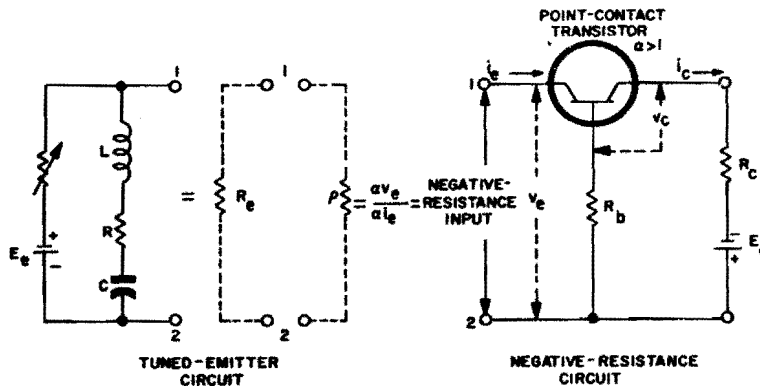

Figure 1-228. Tuned-emitter negative-resistance circuit. Essential features are that alpha be greater than unity, the insertion of an external resistance, R_b , in the common-base circuit to increase the collector-to-emitter energy feedback; and for oscillations to build up, the effective positive resistance, R_e , of the tuned-emitter circuit must be less, numerically, than the negative resistance, at the emitter input

Section I
Crystal Oscillators

mode of operation insofar as oscillator stability is concerned. Figure 1-229 shows a typical emitter-to-base characteristic curve for the circuit in figure 1-228, where the emitter voltage is plotted as a function of emitter current. The slope of this curve equals the dynamic resistance of the input. (By "dynamic resistance" we mean the instantaneous resistance, dv_e/di_e , for an infinitesimal change in voltage and current at any given point on the curve, as opposed to the "static resistance," equal to v_e/i_e , the total voltage divided by the total current at any given point on the curve.) The negative slope between points A and B represents the negative-resistance zone of the emitter circuit. If the tuned circuit shown in figure 1-228 is connected to the emitter input and the rheostat is adjusted so that the transistor is biased to operate at point 0 on the v_e - i_e curve, oscillations at the resonance frequency of the emitter LC circuit will build up provided that the magnitude of the positive resistance, R_e , of the external circuit connected between terminals 1 and 2 is less than that of the negative resistance presented by the transistor at the same terminals. As oscillations about point 0 build up, the positive peaks of I_e swing toward the positive-going slope region at the bend of the curve, so that the effective negative dynamic resistance decreases, and amplitude limiting is achieved. Constant-amplitude oscillations are reached when the effective dynamic impedance looking into the emitter-base terminals is exactly equal and opposite in sign to the impedance of the external

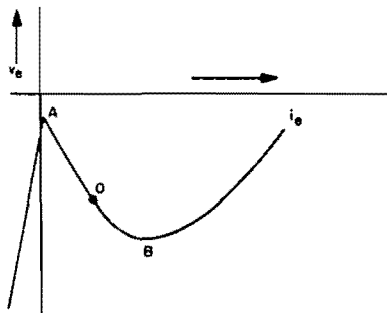
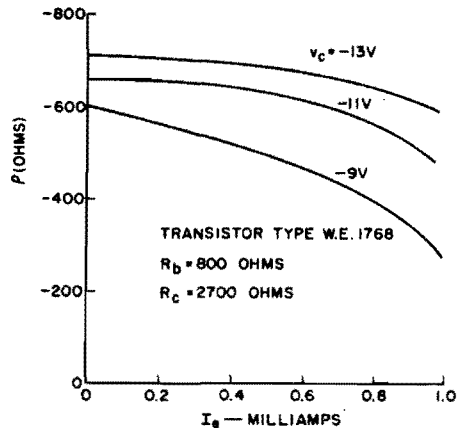

Figure 1-229. Typical point-contact emitter voltage curve plotted as a function of the emitter current when the transistor is common-base connected and the voltage is measured to include the additional feedback voltage developed across an external base resistance, R_b , as indicated in figure 1-228. The current scale is greatly amplified to the left of point A. The slope of the curve equals the dynamic input resistance. The negative-resistance region thus lies along the negative slope between points A and B

emitter-base circuit as faced by the input terminals, 1 and 2. If we assume that the bias-control resistance can be neglected and that the current and voltage at the fundamental frequency are approximately in phase, then we can say that the condition for stable oscillations is that

$$R + \rho \approx R_e + \rho = 0 \quad 1-546 (1)$$

1-547. Figure 1-230 shows the values obtained for ρ for a particular 1768 type transistor when the externally connected resistors R_b and R_c are 800 ohms and 2700 ohms, respectively. The emitter bias current is constant. The horizontal scale represents the rms a-c value of the emitter current. Since the magnitudes of ρ and R_e are equal after oscillation equilibrium is reached, it can be seen that the curves in figure 1-230 can be used to predict the limiting amplitude of oscillation as the external emitter-to-base resistance R_e ($= -\rho$) is varied. The curves indicate that if a low-frequency series-mode crystal is connected across the transistor input, oscillations can be expected to build up as long as the resonance resistance of the crystal unit is not greater than a few hundred ohms. Not many types of low-frequency Military Standard quartz crystal units have such small values of resonance resistance. Exceptions are the precision G-element crystal units CR-39/U and



Note: The Western Electric type transistor shown above and the one following are experimental prototypes whose production has been discontinued. Similar electrical characteristics can be obtained by using Western Electric transistor types 2N21, 2N110, and GA-52837, which are commercially available, but solely for the use of the U.S. Armed Services and their contractors.

Figure 1-230. Negative input resistance of the circuit shown in figure 1-228, plotted as a function of the a-c component of the emitter current for three representative values of collector-to-base d-c voltage. The emitter is biased at approximately point 0 as shown in figure 1-229. Measurements were made by Dasher, Finn, and Jones at the Georgia Institute of Technology

CR-40/U, which have maximum effective resonance resistances of 150 ohms in the 160—250-kc range and of 600 ohms in the 250—330-kc range. The resistance deviations of these crystal units are rated at not greater than 33 per cent of the maximum permissible values—that is, maximum deviations of 50 ohms and 200 ohms, respectively, for the 160—250-kc range and the 250—330-kc range. No data is available concerning their performance in negative-resistance transistor circuits, but from the curves of figure 1-230 wide variations in the amplitude must be expected when replacing one crystal unit with another unless special steps are taken to control the gain of the transistor circuit. Whereas a 33 per cent change in crystal resistance can generally be considered negligible in the average vacuum-tube oscillator, this much resistance deviation in the negative-resistance tuned-emitter oscillator can cause a proportionally much larger percentage change in the output amplitude.

1-548. Figure 1-231 is a schematic diagram of the equivalent a-c circuit of the tuned-emitter circuit. The parameters r_b , r_c , and r_e represent the impedances of the equivalent T network of the transistor at low frequencies and small amplitudes, conditions under which the equivalent impedances can be assumed to be approximately linear and purely resistive. The amplifying properties are represented by the constant-current generator, αI_e . In analyzing this circuit two equations suffice for defining the state of operation at oscillation equilibrium. Following the analysis developed by B. J. Dasher et al in *Transistor Oscillators of Extended Frequency Range*, we find that one equation can equate the over-all voltage drop around the emitter-base loop to zero; the

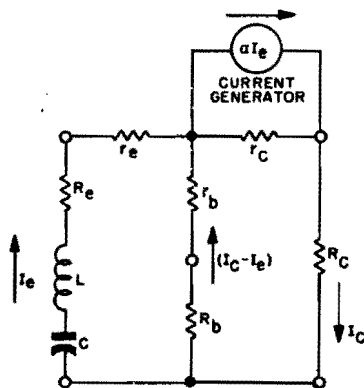

Figure 1-231. Equivalent a-c circuit of tuned-emitter negative-resistance oscillator. For crystal control, L, C, and R_c can be interpreted as being the series-arm parameters of a crystal unit

second equation can equate the over-all voltage drop around the collector-base loop to zero. On combining these equations and separating the real and complex parts, two additional equations are obtained. The complex part gives the loop phase requirement, which serves to determine the frequency:

$$f = \frac{1}{2\pi \sqrt{LC}} \quad 1-548 (1)$$

(That the complex part would reduce to the form shown in equation (1) could virtually have been predicted simply from a qualitative inspection of the circuit.) The real part gives the loop gain requirements and can be expressed as an equilibrium equation for alpha:

$$\alpha = \left(\frac{r_b + R_b + r_e + R_e}{r_b + R_b} \right) \left(\frac{r_c + R_c}{r_c} \right) + \frac{r_e + R_e}{r_c} \quad 1-548 (2)$$

If we assume that r_c is much greater than all of the other resistance parameters, equation (2) can be reduced to the approximate equation

$$\alpha \approx \text{but} > \frac{r_b + R_b + r_e + R_e}{r_b + R_b} \quad 1-548 (3)$$

Note that equation (3) requires that the transistor current gain at equilibrium be slightly greater than the ratio of the total resistance of the emitter-base loop to the total feedback resistance of the base as illustrated in figure 1-231. The reader should not confuse r_e , r_b , or any of the other positive resistance values in figure 1-231 with the effective negative resistance of the input circuit. The equivalent effect of the negative-resistance characteristic is provided by the current generator. 1-549. If desired, the operating voltages of the base-feedback point-contact transistor can be so adjusted that the negative resistance appears in the collector rather than in the emitter circuit, and oscillations can be controlled by connecting a series-mode crystal in the collector circuit. The equivalent tuned-collector circuit is shown in figure 1-232(A). A sample collector-controlled circuit which was tested at 50 kc is shown in figure 1-232(B)*. This circuit, as reported by B. J. Dasher, exhibited a negative resistance sufficient to drive a 40,000-ohm crystal unit. Al-

* To avoid confusing free-running oscillators with their crystal-controlled counterparts, it has been suggested by Frequency Control Branch engineers at SCEL that when a crystal unit replaces a "tuned-emitter" or a "tuned-collector" LC circuit, the oscillator be designated, respectively, as being "emitter-controlled" or "collector-controlled."

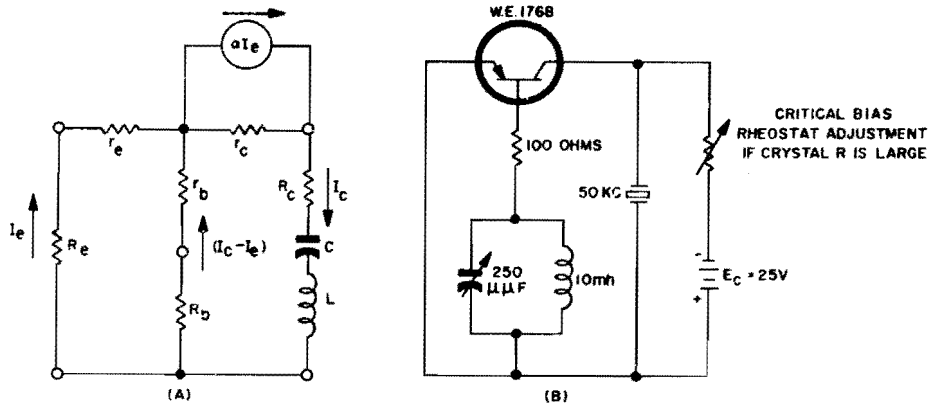

Figure 1-232. (A) Equivalent a-c circuit of tuned-collector negative-resistance oscillator. For crystal control, L , C , and R_c can be interpreted as being the series-arm parameters of a crystal unit; (B) Crystal-controlled tuned-collector negative-resistance oscillator. The parallel tuned tank is inserted in the base circuit in lieu of a resistor in order to obtain negative resistance values in excess of 40,000 ohms

though negative resistance values of 50 kilohms are possible at d-c potentials, these values drop rapidly with increasing frequency, and may be only a few hundred ohms at 100 kc. The tuned-collector (and collector-controlled) circuit is governed by exactly the same loop equations that apply in the case of the tuned-emitter (and emitter-controlled) circuit, which are given in the preceding paragraph (equations 1-548 (1) and (2)). However, the degradation of the crystal Q in the collector-controlled circuit is generally greater than in the emitter-controlled circuit, so that the latter permits the higher frequency stability. Because the tolerances required for good stability are difficult to obtain with point-contact transistors neither circuit, to Signal Corps knowledge, has been developed to the point that it could be recommended for general use.

Transistor Oscillators Using Parallel-Mode or High-Impedance Series-Mode Crystal Units

1-550. Since transistor negative-resistance oscillators require values of alpha greater than unity, they are generally limited to frequencies less than 500 kc. The negative-resistance circuits previously discussed place the crystal directly across the negative-resistance terminals. Yet at low operating frequencies it is difficult to fabricate crystal units having resonance resistances of magnitudes small enough to permit oscillations to start. For this reason, it may be more practical to connect the crystal unit across a high-impedance pair of point-contact transistor terminals and to insert a series-resonant LC circuit, or other low impedance, across the low-impedance negative-

resistance terminals. Such a circuit will not exhibit (to the crystal circuit) the negative-resistance characteristic under d-c conditions—only in the neighborhood of the crystal frequency—and so is not conventionally classified as a negative-resistance oscillator. However, the operating principle is the same. Six oscillators of the high-impedance type are shown in figure 1-233. All the circuits shown (but not including the crystal load capacitances indicated by dotted lines) are the inventions of Everett Eberhard and Richard Endres of RCA, U. S. Patent 2,570,436. A common feature of these oscillators is that the bias currents are so selected that the electrode to which the piezoelectric crystal is connected is made to present a high dynamic impedance, to match the high impedance expected of the crystal unit. A resonant LC circuit is connected to another electrode of the transistor, the tuned LC resonant frequency being approximately equal to the crystal frequency. Each circuit is designed to provide positive feedback sufficient to maintain oscillations. A high impedance can be obtained at the crystal-connected electrode of the transistor by adjustment of the bias current at any one of the three electrodes. Figure 1-233 (G) shows typical curves of the resistance that would be faced by the crystal unit between each terminal and ground as a function of the collector bias current, i_c . In circuits (A), (B), (C), and (D) of figure 1-233, where either the base or the collector impedance must match that of the crystal unit, the transistor is operated near point a on the i_c scale. In circuits (E) and (F) of figure 1-233, where the emitter input

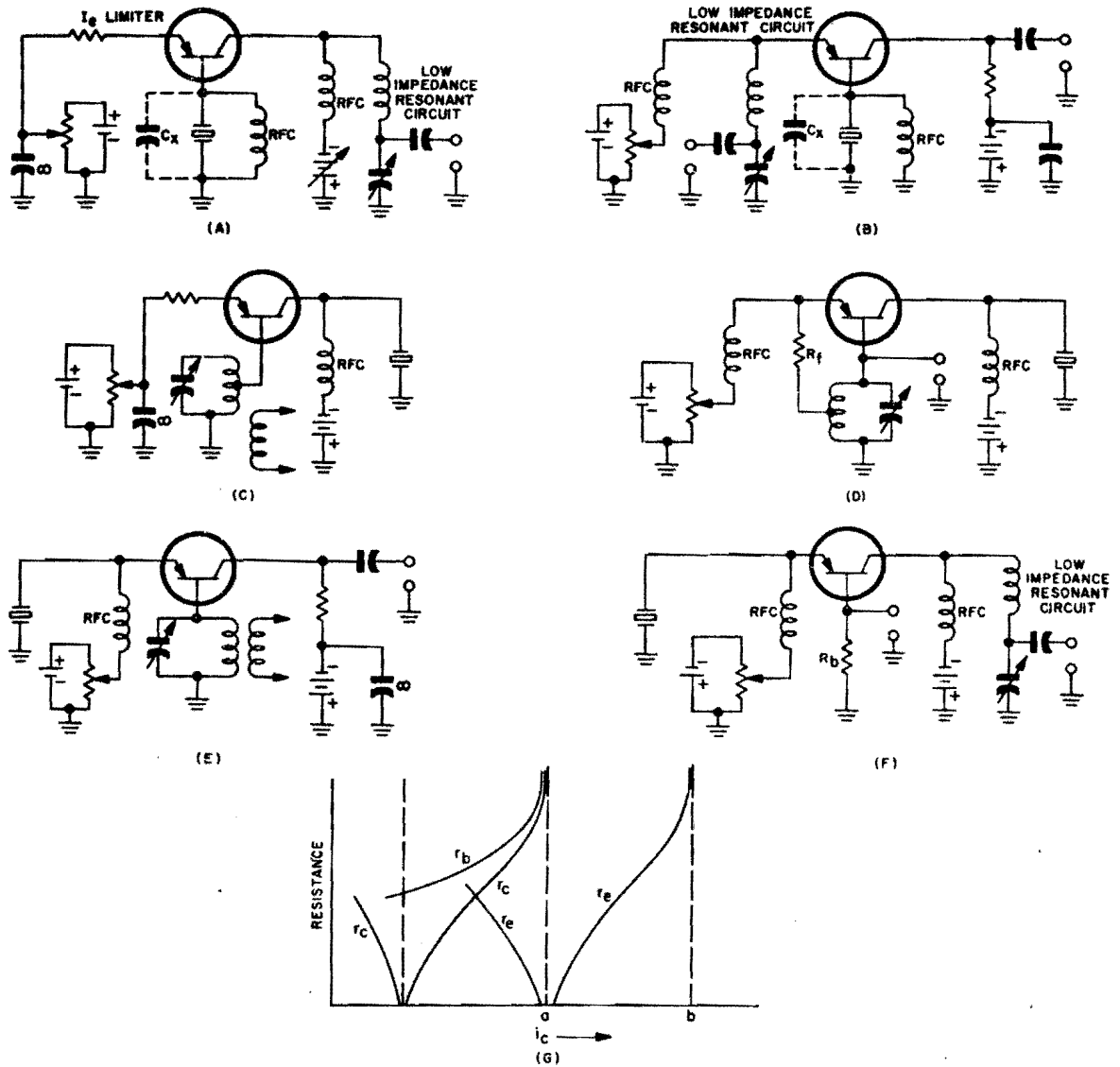

Figure 1-233. (A) to (F) Transistor oscillator circuits designed for high-impedance crystal control; (G) Variation of equivalent network resistances of point-contact transistor as a function of collector current. Point A is the high-impedance region of the base and collector electrodes, and point B that of the emitter electrode, r_b , r_c , and r_e are not drawn to the same scale

impedance must be high, i_c is adjusted to a value near point b in figure 1-233 (G). In all the circuits of figure 1-233, the collector is operated with a relatively large reverse bias, and the emitter with a relatively small forward bias. 1-551. The exact operating point of the crystal unit in the Eberhard-Endres oscillators is not specified in the patent claims. The inference is that the crystal unit is operated near antires-

onance, since it is assumed to be a high-impedance element. However, the resonance resistance of v-l-f crystal units may well be greater than 100,000 ohms, and even the resonance resistance of an m-f crystal may be several kilohms; hence, it appears that at the low frequencies at which the point-contact transistor oscillators normally operate, the crystal units in the circuits of figure 1-233 are not restricted to a particular mode of

resonance, but operate near series resonance as long as they show a sufficiently high impedance. If it can be assumed that the crystal unit and each of the tuned circuits are operating approximately as pure resistances, the gain requirements for sustained oscillations, except in circuit (D) which has an additional feedback element, are the same as those given by equation 1-548 (2) for the negative-resistance oscillators. This can be seen intuitively by noting that all the circuits obtain their necessary positive feedback by virtue of a high-impedance common-base circuit. In circuits (A) and (B) of figure 1-233, the impedance of the crystal unit can be taken as the approximate value of R_b in equation 1-548 (2). Since R_b can assume a resonance or an antiresonance value, either of which could conceivably satisfy the loop gain equation, it would appear that these two circuits might have tendencies to jump frequencies. No experimental evidence is available, but very possibly the dependability of such oscillators could be improved by employing parallel-mode crystal units directly shunted by suitable load capacitances, as indicated by the dotted-line connections. In practice, a proper selection of the reactive elements in each circuit, such as the r-f choke across the crystal unit, may well be entirely sufficient to ensure that a high-impedance crystal will operate at resonance rather than at antiresonance. In circuits (C) to (F) of figure 1-233 maximum feedback occurs when the crystal resistance is a minimum, so that only the series-resonance mode of the crystal unit need be considered. In other words, the loop gain conditions could not be satisfied with practical values of alpha if the extremely high antiresonance impedances of a low-frequency crystal unit were substituted for the values of R_c or R_b in equation 1-548 (2). Nevertheless, it is conceivable that a parallel-mode crystal unit, shunted by its rated load capacitance, could also be applicable in these circuits if desired. *For a given set of operating voltages and circuit parameters, however, only one mode of crystal operation can sustain stable oscillations. Whether the stable mode is series or parallel depends upon whether the limiting action is current- or voltage-controlled, respectively. (See paragraph 1-590.)* An output from any of the circuits in figure 1-233 can be obtained at any of the transistor electrodes. Where maximum sine-wave purity in the output is desired, the circuit parameters should be selected so that the equilibrium value of alpha is only slightly less than the starting value of alpha, so that the amplitude remains as small as possible. Also, the

output harmonic content is greatly reduced if the output is taken from a parallel-tuned circuit having a small L/C ratio, as is done in circuits (C), (D), and (E). In circuit (D), additional feedback is obtained by the insertion of R_t , which may have any value from zero on up. For optimum operation the d-c resistance of the r-f choke in the emitter circuit should be less than R_c . Circuit (D) can be considered a transistor equivalent of a crystal-controlled Hartley oscillator by viewing the emitter, collector, and base as the cathode, plate, and grid, respectively, of the vacuum tube in the Hartley circuit. Note in circuit (F) that the emitter bias battery is shown with its polarity in the reverse direction. This does not mean that the emitter is operated with reverse bias, but simply that the large forward bias provided by the d-c voltage drop across R_b must be partially cancelled to obtain the proper operating bias.

Transformer-Coupled Transistor Oscillators

1-552. Figure 1-234 shows schematic diagrams for three experimental transformer-coupled transistor oscillators designed and tested by Dasher, Jones, and Witt at the Georgia Institute of Technology. The average frequency deviation of each of the three circuits for variations in the power supply is given below in table 1-552 (1).

1-553. An elementary transformer-coupled circuit is shown in figure 1-234 (A). Circuit (B) is a modified version of (A) that was found empirically to provide better frequency stability during changes in the applied voltage. The turns ratio of the transformers in circuits (A) and (B) are not specified, but presumably the ratios are 1:1. The transistor used is a point-contact type with an alpha greater than unity at the operating frequency of 50 kc. Circuit (C) is a 400-kc oscillator

Circuit	Frequency Deviation (Parts Per Million Per 1 Per Cent Change in Voltage)	Bias Variable	Bias Constant
(A)	1.2	E_c	i_o
(A)	0.7	E_c	i_c
(B)	0.25 to 0.8	E_c	
(C)	0.0013*	E_c	

Table 1-552 (1). Frequency stability data for circuits shown in figure 1-234.

* This small frequency deviation is obtainable only when R_b is adjusted for optimum bias compensation. See paragraph 1-555.

that can be adjusted to provide excellent frequency stability against changes in the supply voltage. Also, by the proper adjustment of the variable capacitor C, the current through the shunt capacitance of the crystal unit can be effectively cancelled insofar as the transistor input is concerned. The circuit is effectively a capacitance-bridge oscillator in which all the transformer feedback signals are annulled in the input circuit except those that pass through the series arm of the crystal unit, which of course is effectively an open circuit except at resonance. The

principal adjustment for minimizing the deviation in frequency during fluctuations in the voltage supply is that of the base resistance, R_b . For each crystal unit and transistor a particular value of R_b will provide maximum frequency stability. The reason for this appears to be due to the compensating influences of simultaneous changes in emitter and collector bias currents. See paragraph 1-555 for a more detailed discussion of this bias compensation effect.

1-554. Each of the circuits shown in figure 1-234 exhibits a fair, but not exceptional, frequency stability under changes in temperature, with circuits (B) and (C) being somewhat the superior in this respect. The transformer-coupled transistor oscillators are generally less frequency stable under changes in temperature than are the resistive transistor circuits. An additional disadvantage is that the transformer-coupled circuit has greater-than-average tendencies to break into free-running oscillations, particularly if the shunt capacitance of the crystal unit is large. On the other hand, an important advantage of the transformer coupling is the increase possible in feedback gain. This makes it possible to operate at lower voltages, at higher frequencies, with junction transistors, and generally with smaller values of alpha than otherwise.

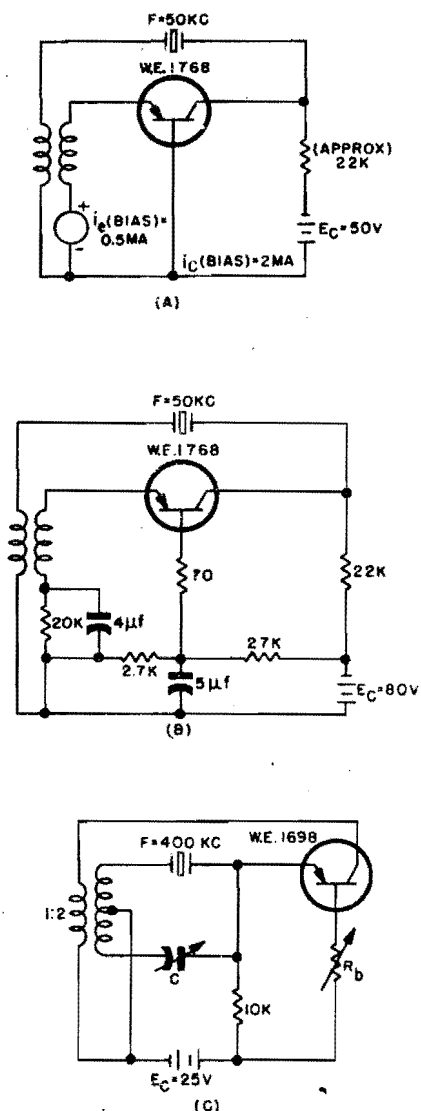

Figure 1-234. Transformer-coupled transistor oscillators

Frequency Stabilization In Transistor Oscillators By Bias Compensation

1-555. Figure 1-235 shows the frequency characteristics of the oscillator in figure 1-224 when the collector and emitter voltages are varied. Note that where an increase in collector voltage causes an increase in frequency, an increase in the emitter voltage causes a decrease in frequency. This property of the circuit suggested to its designers that by a proper choice of emitter and collector voltages the circuit could be frequency-stabilized against fluctuations in the voltage source. From figure 1-235 it can be seen that if the emitter voltage is to vary linearly with the collector voltage, the voltage-compensating circuit must operate in a region where the intersections of the emitter voltage curves with the horizontal constant-frequency lines are evenly spaced. A circuit designed for this mode of operation is shown in figure 1-236. Figure 1-237 shows the frequency-voltage characteristics of the compensated circuit for two values of the resistance R . Note that this mode of operation is a transistor analogue of the "class D" mode of operation described for vacuum-tube oscillators in paragraphs 1-298 and 1-342.

**Section I
Crystal Oscillators**

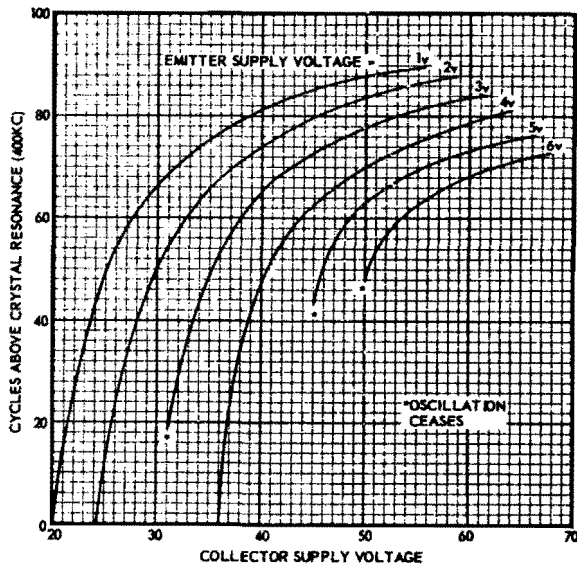

Figure 1-235. Deviation of frequency with the collector supply voltage for various values of emitter supply voltage. Test oscillator circuit is the same as that shown in figure 1-224

1-556. The adjustment of the frequency-stabilized oscillator depends upon the resistance of the crystal unit. A circuit adjusted for maximum stability with one crystal unit may be relatively unstable when a replacement crystal of the same type and nominal frequency, but of different resistance, is inserted. This might be expected, since the resistance of the crystal affects the amplitude of oscillations as well as the phase-shifting Q of the feedback circuit. A complete theoretical analysis of the relations among the stability parameters has not been attempted, and no doubt would prove quite complex. But one of the more important factors affecting the frequency stability is the harmonic content of the oscillations. Any change in the wave distortion, such as would occur with a change in amplitude due to a change in crystal resistance, would be sufficient to shift the fundamental frequency (see paragraph 1-596) to a point where the circuit may no longer be self-compensating.

1-557. Figure 1-238 shows a simple feedback oscillator tested by Dasher and Witt at the Georgia Institute of Technology. The values of the parameters were selected to provide maximum frequency stability for a particular transistor and crystal unit. Figure 1-239 shows how the frequency of this oscillator changed with a 20-volt change in supply voltage. That a number of crystal units having approximately the same resistance caused different effects in the frequency

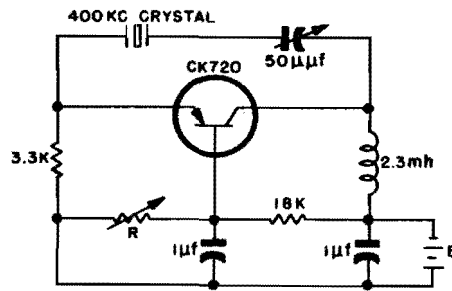

Figure 1-236. Frequency-stabilized circuit for single battery supply

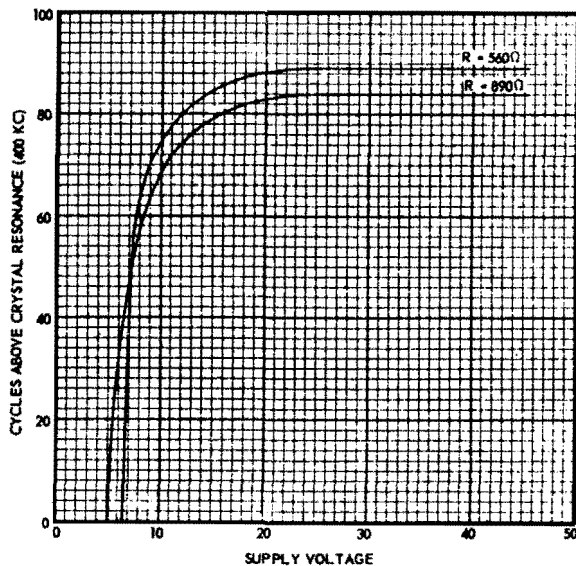

Figure 1-237. Deviation of frequency with changes in supply voltage for two values of R in circuit shown in figure 1-236

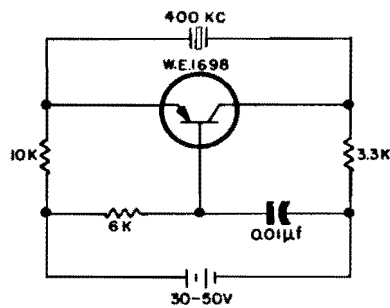

Figure 1-238. Crystal-feedback oscillator in which the resistance parameters have been selected empirically to provide maximum frequency stabilization for the particular 400-kc crystal unit and point-contact transistor being used

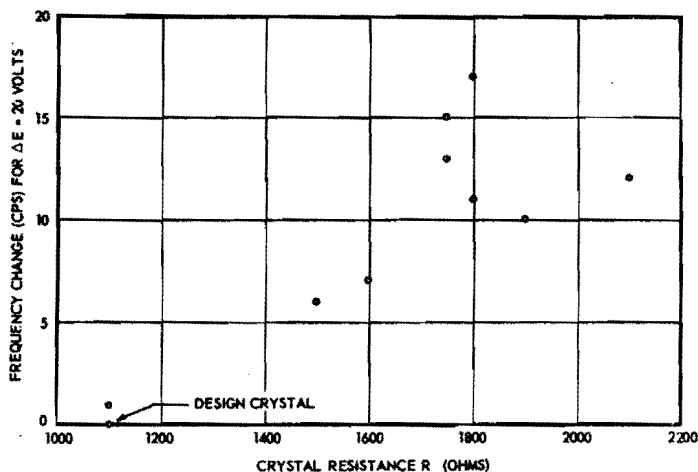

Figure 1-239. Frequency deviation of circuit shown in figure 1-238 for a given change in supply voltage at various values of crystal resistance

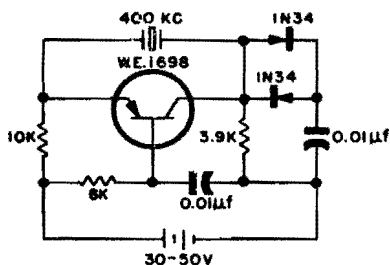

Figure 1-240. Modification of the crystal-feedback oscillator of figure 1-238 to provide greater frequency stability by providing greater amplitude stability with diode clipping

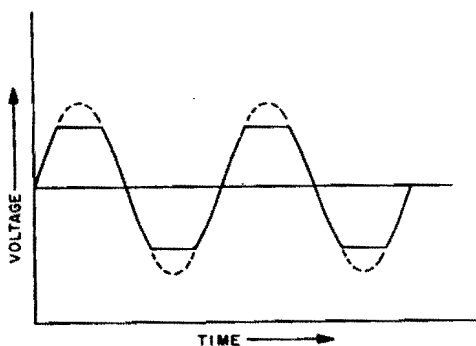

Figure 1-241. Voltage waveform after clipping of both peaks by diode rectifiers

stability apparently is due to differences in crystal resonance frequency, shunt capacitance, and L/C ratios from one crystal to the next. By different adjustments of the circuit resistances, it was nevertheless possible to obtain a maximum-stability point for each crystal.

Transistor Oscillators of Stabilized Harmonic Content

1-558. As explained in paragraphs 1-596 to 1-598, a distorted waveform tends to lower the fundamental frequency of an oscillator. Since the distortion is normally due to the nonlinear amplitude-limiting parameters, any change in the other resistance losses of the circuit will cause the amplitude to change, and hence the amount of distortion to change. For, example, if the resistance of the crystal unit decreases in the oscillator in figure 1-238, the feedback increases and the transistor will be operated farther into the bend of its volt-ampere input curve. This means greater distortion and harmonic content, and hence a shift to a lower fundamental frequency, where the stability characteristics of the circuit will probably be changed. To reduce this change in circuit performance when replacing transistors or crystal units, the double-diode clipping modification shown in figure 1-240 has been designed and tested by Dasher and Witt. The diodes clip both peaks of the oscillator output as indicated in figure 1-241, and thus, as long as the amplitude is sufficiently high, the distortion of the waveform remains relatively constant. The circuit requires an alpha of at least 2 in order to oscillate. Generally, what changes that do occur in the frequency stability are more significant when a crystal unit is replaced than when a transistor is replaced. Although the unadjusted performance of the circuit is inferior to the performance of the circuit in figure 1-238 when the latter is adjusted for a particular transistor and crystal

unit, the diode clipping does provide superior frequency and amplitude stability as compared with the average performance of the unclipped circuit when the latter is adjusted only for optimum performance with an average crystal unit. The measured frequency deviations of the diode-clipped circuit for 10 different crystal units ranged from 0.1 to 0.05 parts per million per 1 per cent change in voltage.

1-559. Where maximum amplitude and frequency stability is desired to be relatively independent of the particular transistor and crystal unit, it may be necessary to operate the transistor on the straight portions of its characteristic curves and to obtain the limiting from slowly responding devices such as thermistors or a-g-c circuits. Such methods permit the oscillator to operate with approximately linear rather than harmonically-varying circuit parameters and do not require distortion for limiting. Nevertheless, these methods involve the introduction of additional components that usually deprive the transistor circuit of its principal advantages of compactness and low power and hence should be avoided if possible.

PACKAGED CRYSTAL OSCILLATORS

1-560. The great strides made in the field of electronics during the past two decades have so rapidly multiplied the diversity and complexity of electronic applications in commercial and military equipments that the problem of adequate maintenance has become a major national concern. One aspect of the problem has been the steadily growing trend to eliminate maintenance on a part-by-part basis; that is, to eliminate the time-consuming type of trouble-shooting that traces a faulty system to the exact defective part, such as to a particular resistor or capacitor. For this purpose it is necessary that electronic equipments be designed as an assemblage of packaged units, in which each unit can be as readily removed, tested, and replaced as is now possible in the case of vacuum tubes. This cannot be achieved unless the circuit being separately packaged actually operates as a functional unit. It is also paramount that the packaged unit be standardized; otherwise, by definition, there can be no standard nor rated tolerances by which the unit can be tested. The standardization is equally important as a means to encourage production of commercially available packaged units of known operational characteristics, so that design engineers can concentrate more of their attention upon new system design and application instead

of repeatedly retracing the basic circuit problems for each new equipment. In the special field of aircraft and guided-missile equipment, an additional requirement of the packaged unit is that, as much as possible, it be miniaturized. As a consequence of these factors, the crystal industry is faced with a growing demand for standardized, miniature packaged crystal oscillators—each of which can be treated simply as a black box, so that when plugged into a circuit connecting to a specified power supply and output impedance, it will supply a radio-frequency signal of a given nominal frequency, purity, and power level within specified tolerances.

1-561. The standardized packaged oscillator is still in the developmental stage. Indeed, it is probably more accurate to say that it is still in the stage of basic research, insofar as the standardization is concerned. Here and there one may find an oscillator fabricated as a packaged unit which has been designed for use in a particular equipment, but with one or two exceptions (see paragraphs 1-571 and 1-572), packaged crystal oscillators are not generally available in the commercial market as standard components for general-purpose applications. Current research in the field of packaged crystal oscillator standardization has primarily been spurred by USAF Wright Air Development Center, in large part due to the urging and initiative of E. H. Borgelt of the Frequency Control Group, and an initial investigatory stage has been centered at the Illinois Institute of Technology Armour Research Foundation. When eventually packaged oscillators are fully available, we can expect that the interests of radio equipment designers will be more attracted to the problems of designing systems around standard crystal oscillator units rather than designing oscillators around standard crystal units.

The Gruen Packet-Oscillator Series

1-562. In 1954-1955 initial steps of a USAF research project were taken at the Armour Research Foundation under the direction of H. E. Gruen* to develop a series of miniature, plug-in, crystal-controlled, vacuum-tube oscillators which could be standardized to cover the frequency range of 0.8 to 75 mc at operating tolerances suitable to meet a majority of the USAF frequency-control requirements. The first phase of

* *Development of Packet Oscillator Series*, H. E. Gruen, Armour Research Foundation of Illinois Institute of Technology, USAF Contract No. AF 33 (616)—2125, 1954-55.

the project was a comprehensive investigation of the frequency-control applications of a large sample of radio sets currently in use by the USAF. It was found that 80 to 90 percent of the frequency-control requirements within the 0.8—75-mc range could be met economically by three conventional circuits, each designed for three bands, or a series of nine standard oscillators in all. It does not require this many separate oscillator circuits simply to cover the necessary frequency range, but it is desirable to have the recommended operating band of each circuit sufficiently narrow so as to avoid having to make critical tuning adjustments. For the same reason the circuits are not designed for specialized optimum operating characteristics within each band, but are intended only to provide a useful output consistent with the minimum requirements of accuracy and stability of the average frequency-control circuit used by the military.

1-563. The primary purpose of the packet-oscillator project has been to develop a sequence of plug-in circuits that can serve as models for establishing an initial set of oscillator Military Standards having the broadest practical tolerances. Once a beginning set of standards is agreed upon, it is to be expected that electronic manufacturers of packaged oscillators will introduce their own design modifications in meeting these standards—modifications which may lead to more rigid standards to supplement the broader standards for special applications. For example, the need may arise for an oscillator having a minimum deviation in frequency with ambient temperature, or with time, or in having a minimum tolerance in output amplitude, or in having a maximum possible output for given load conditions, or in having a minimum harmonic content, and so on ad infinitum with all possible combinations of electronic, physical, and operational special requirements. From a Military Standards point of view it is not the interior design of the oscillator that need or should be officially specified, but only what the unit can do or be or require in relation to the mechanic-thermodynamic-electronic system in which it is to be mounted. In this way a manufacturer is not discouraged from developing an improved packaged oscillator that can do an equivalent job more economically or better than the original standards model.

1-564. On the other hand, from an economically practical point of view, the Gruen packet series can profitably serve as unofficial standards insofar as the designs of the various oscillators are concerned—economical since the circuits used in

these units have known performance characteristics, which, of course, would meet any Military Standards based upon them. The circuits themselves are conventional, designed to be used with Military Standard crystal units. Any standards established for packaged oscillators based upon the Gruen series will, of course, be no more rigorous than those already established for the crystal units being used.

1-565. The Gruen packet series employs three basic oscillator circuits: the grounded-plate Pierce, the electron-coupled grounded-plate Pierce, and the cathode-coupled Butler circuit. The two Pierce-type circuits are both used to cover the same frequency range of 0.8 to 16 mc. The Butler circuit is designed to cover the higher range of 10 to 75 mc. The electron-coupled circuit is recommended as an alternate in the lower frequency range when the input to the following stage is a tuned circuit, or whenever a minimum degree of coupling is desired between the crystal oscillator and the succeeding stage.

GROUNDING-PLATE PIERCE PACKET (0.8 TO 16 MC)

1-566. Figure 1-242 is a picture of the miniature packaged Pierce oscillator designed as a plug-in unit by Gruen to cover the 0.8—16-mc range. This range is covered in three bands. A schematic diagram of the basic circuit and the values of the parameters for each of the three bands is

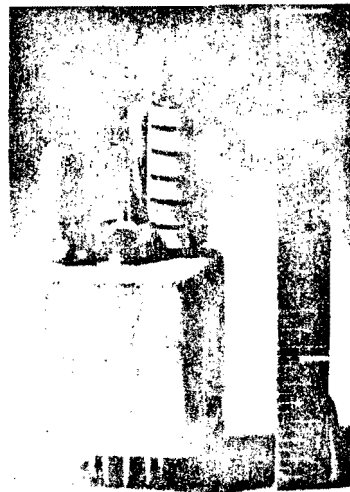
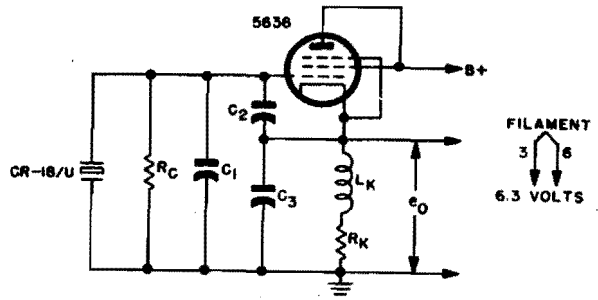

Figure 1-242. Miniature plug-in (standard octal base) Pierce oscillator (0.8 to 16 mc) developed at Armour Research Foundation by H. E. Gruen et al., as an initial basic packaged oscillator unit to be standardized for military use

**Section I
Crystal Oscillators**

shown in figure 1-243. Figure 1-244 shows the output voltage versus frequency for each of the three bands, and figure 1-245 shows the crystal drive in milliwatts versus frequency. These performance charts, prepared by J. S. Kurinsky of Armour Research Foundation, are based upon measurements made under no-load conditions. The range of values at each frequency is representative of the variations in output and crystal drive to be expected due to typical variations in crystal resistance. Thus, the bottom (lowest output and lowest crystal drive) curves of each of



Frequency Band (mc)	R _C (kilohms)	R _K (kilohms)	C ₁ (μμf)	C ₂ (μμf)	C ₃ (μμf)	L _K (mh)	B+ (volts)
0.8 — 5	1000	3.9	15	10	47	7.0	75
3 — 11	100	2.0	15	10	47	0.8	100
5 — 16	47	1.5	15	10	36	0.3	100

Note: The value of C₂ is chosen so that proper operation is obtained when this circuit operates into a load of 15μμf. Wiring capacitance increases the values of C₁, C₂, and C₃ by the following amounts:
 C₁: 5.5 μμf
 C₂: 3.5 μμf
 C₃: 10 μμf

Figure 1-243. Schematic diagram and parameters of the grounded-plate Pierce circuit of Gruen packet series

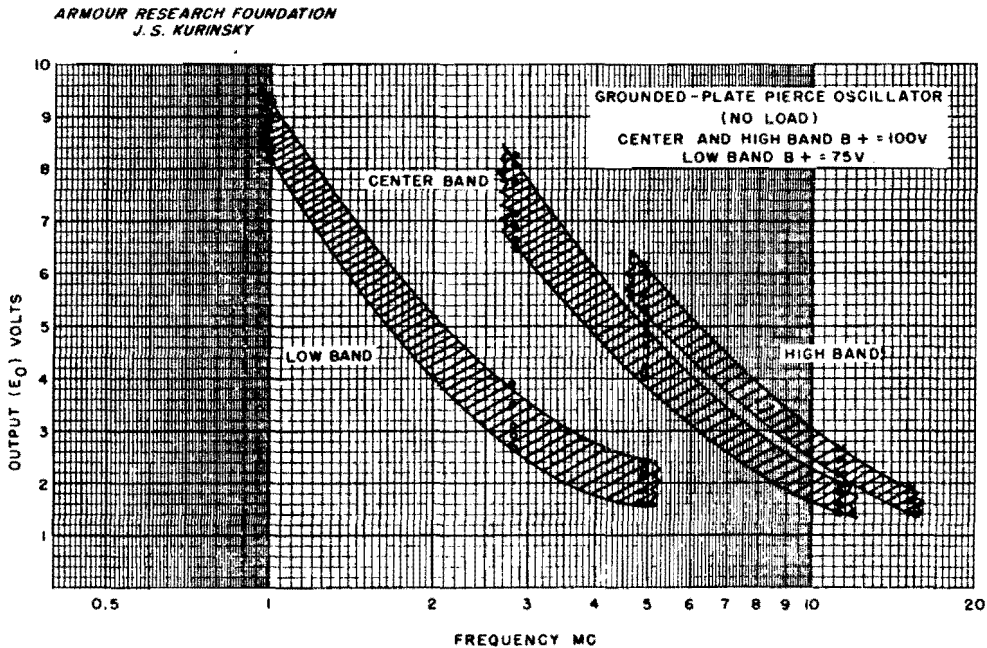

Figure 1-244. Typical output voltage and voltage tolerances of the grounded-plate Pierce circuit of Gruen packet series. These voltages were measured under no load conditions except for the connection of a 15-μμf capacitance across the output to insure a correct effective load capacitance for the crystal unit

ARMOUR RESEARCH FOUNDATION
J. S. KURINSKY

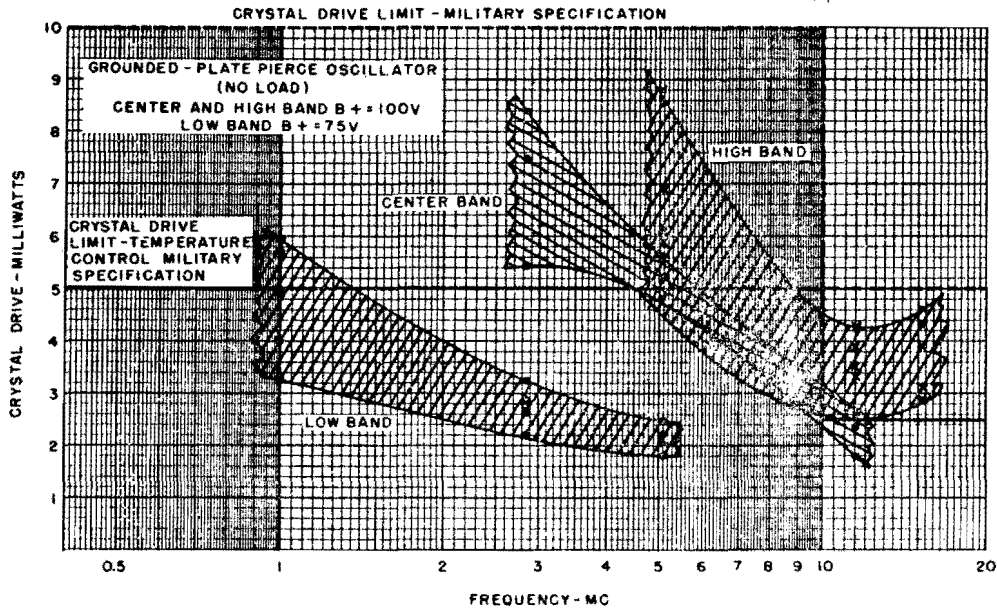

Figure 1-245. Typical drive levels and operating tolerances to be expected for crystal units connected in the grounded-plate Pierce circuit of Gruen packet series. The values shown assume no resistance losses in the output load

the bands should not be interpreted as representing the output and crystal drive when crystal units of maximum permissible resistance are inserted in the circuits. The performance characteristics for maximum-resistance crystals are fairly closely approximated by the bottom curve of the high band; but the highest-resistance crystal units used in the low-band measurements had resistance values only one-half to one-fourth the permissible limits. Note in figure 1-242 that the external mounting of the crystal unit and vacuum tube permits a ready replacement of either without diminishing the advantages of the packaged unit. The metallic clasp appearing to shield or support the vacuum tube is actually inserted as a thermal conductor to prevent overheating. A tuning element, in the form of a screw adjustment for C_3 (in figure 1-243), is provided to ensure that the correct load capacitance ($32 \mu\mu\text{f}$) is across the crystal unit. The parameters indicated for C_3 are based on the assumption that the external load will introduce an additional $15 \mu\mu\text{f}$ in parallel with C_3 . If not, C_3 must be adjusted to give the proper total. C_3 can also be used as a trimmer adjustment in the event of crystal aging. The frequency stability of the Pierce packet as a function of the plate voltage

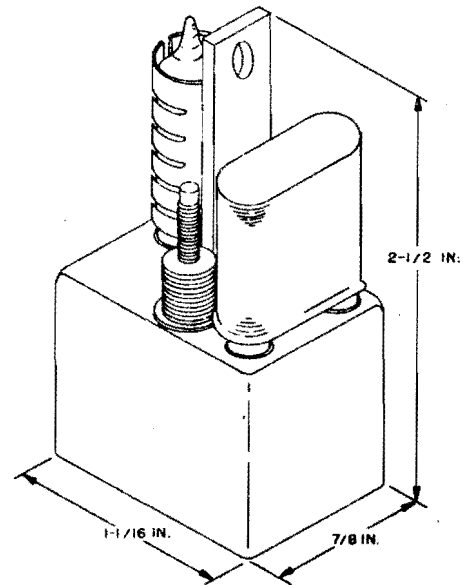
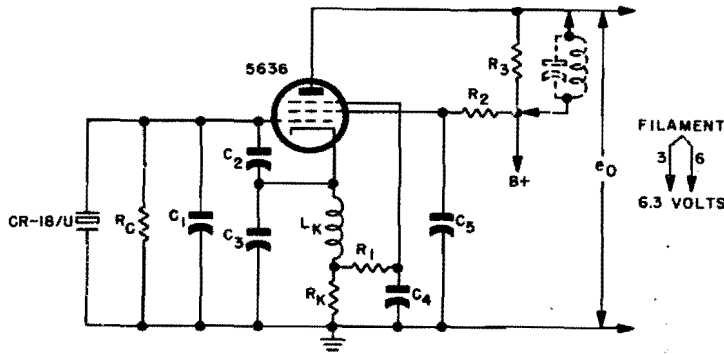

Figure 1-246. Drawing of miniature plug-in (standard octal base) electron-coupled Pierce oscillator (0.8 to 16 mc) developed at Armour Research Foundation by H. E. Gruen et al., as an initial basic packaged oscillator unit to be standardized for military use



Frequency Band (mc)	R_C (kilohms)	R_K (kilohms)	R_1 (kilohms)	R_2 (kilohms)	R_3 (kilohms)	C_1 ($\mu\mu\text{f}$)	C_2 ($\mu\mu\text{f}$)	C_3 ($\mu\mu\text{f}$)	C_4 ($\mu\mu\text{f}$)	C_5 ($\mu\mu\text{f}$)	L_K (mh)	B+ (volts)
0.8 — 5	1000	3.9	100	30	10	15	10	130	1000	1000	7.0	125
3 — 11	100	2.0	100	30	10	15	10	62	1000	1000	0.8	150
5 — 16	47	1.5	100	30	10	15	10	51	1000	1000	0.3	150

Wiring capacitance increases the values of C_1 , C_3 , and C_5 by the following amounts:

- C_1 : 5.5 $\mu\mu\text{f}$
- C_3 : 3.5 $\mu\mu\text{f}$
- C_5 : 10 $\mu\mu\text{f}$

Figure 1-247. Schematic diagram and parameters of the electron-coupled, grounded-plate Pierce circuit of Gruen packet series

supply is rated at 2 to 3 parts per million per 10 per cent voltage change.

ELECTRON-COUPLED PIERCE PACKET (0.8 TO 16 MC)

1-567. Figures 1-246, 1-247 and 1-248, respectively, show a dimensional drawing, the schematic diagram, and the output-voltage characteristics of the electron-coupled packaged unit. The output curves are representative of a typical group of crystal units, the same group that was used in plotting the performance of the Pierce oscillator as shown in figures 1-244 and 1-245, and, hence, are not intended to represent the entire output tolerance to be expected when crystal units of minimum resistance are replaced by those of maximum resistance. The tuned-output curves were obtained by replacing R_3 with a plate tank that was then tuned for maximum output at the fundamental. The fundamental frequency remains stable within 2 to 3 parts per million as the plate circuit is tuned throughout its range. The frequency stability as a function of plate supply voltage is 2 to 3 parts per million

per 10 per cent voltage change. Note in the schematic diagram that the suppressor grid is connected to be operated at the same bias as the cathode, but is r-f bypassed to ground through C_4 . This arrangement permits much greater independence of the frequency-control circuit from the plate load tuning, and therefore, smaller frequency-deviation limits.

CATHODE-COUPLED BUTLER PACKET (10 TO 75 MC)

1-568. Figure 1-249 shows a dimensional drawing of the packet design of a Butler circuit which has been tested in three bands to cover the over-all frequency range of 10 to 75 mc. Figure 1-250 is a schematic diagram of the circuit, with the parameters given for each of the three bands. Figure 1-251 shows the output voltage deviation to be expected from a typical group of crystal units. No data is available at this writing of the exact range of crystal resistance that is represented by the output curves, nor by the crystal-drive curves shown in figure 1-252. Very probably the bottom curves in each of the figures,

ARMOUR RESEARCH FOUNDATION
J. S. KURINSKY

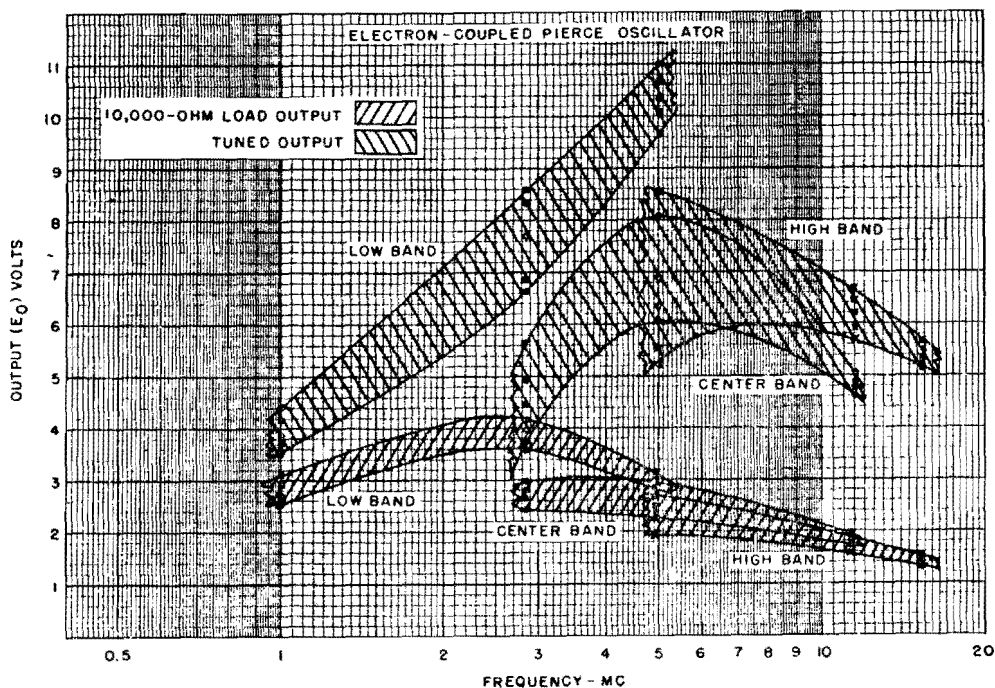

Figure 1-248. Typical output voltage and voltage tolerances of the electron-coupled, grounded-plate Pierce circuit of Gruen packet series

particularly in the high band, are approximately representative of crystal units having the maximum permissible values of resistance. Figure 1-253 shows the difference, in parts per million, between the series-resonance frequency of the crystal unit as measured in a CI meter and the operating frequency of the same crystal unit when connected in the Butler circuit, as measured by different operators at repeated tunings to peak output voltage. This circuit-frequency deviation should be added to the nominal frequency tolerance of the crystal unit in order to evaluate the over-all frequency tolerance of the packaged oscillator. For a 10 per cent change in plate supply voltage the stability of the oscillator unit is within 1 to 2 parts per million in the 10—20-mc range, 3 to 4 parts per million in the 20—40-mc range, and 4 to 5 parts per million in the 40—75-mc range.

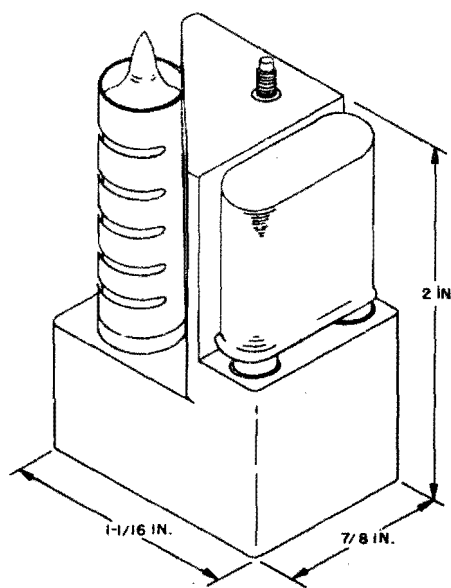
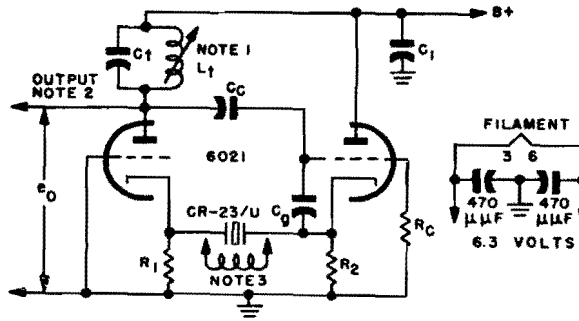

Figure 1-249. Miniature plug-in (standard octal base) cathode-coupled Butler oscillator (10 to 75 mc) developed at Armour Research Foundation by H. E. Gruen et al., as an initial basic packaged oscillator unit to be standardized for military use

**Section I
Crystal Oscillators**



Frequency Range (mc)	R ₁ (ohms)	R ₂ (ohms)	R _C (kilohms)	C ₁ (μμf)	C _O (μμf)	C _E (μμf)	C _i (μμf) Note 4	B+ Volts
10 — 20	1000	1000	10	470	100	4.7	15	100
20 — 40	1000	560	10	470	100	4.7	15	100
40 — 75 Note 3	1000	270	10	470	100	1.5	15	100

- Note 1: Inductance L₁ is tuned to resonate with C₁ at the operating frequency.
- Note 2: All test results were obtained with the oscillator working into a 5000-ohm load.
- Note 3: At frequencies of 40 mc and higher, an inductance which resonates with the static capacitance of the crystal should be used to prevent unwanted oscillation. A low value of Q is desirable; coils wound on 1500-ohm composition resistors perform well.
- Note 4: The value of 15 μμf for C_i includes stray wiring capacitance.

Figure 1-250. Schematic diagram and parameters of the Butler circuit of Gruen packet series

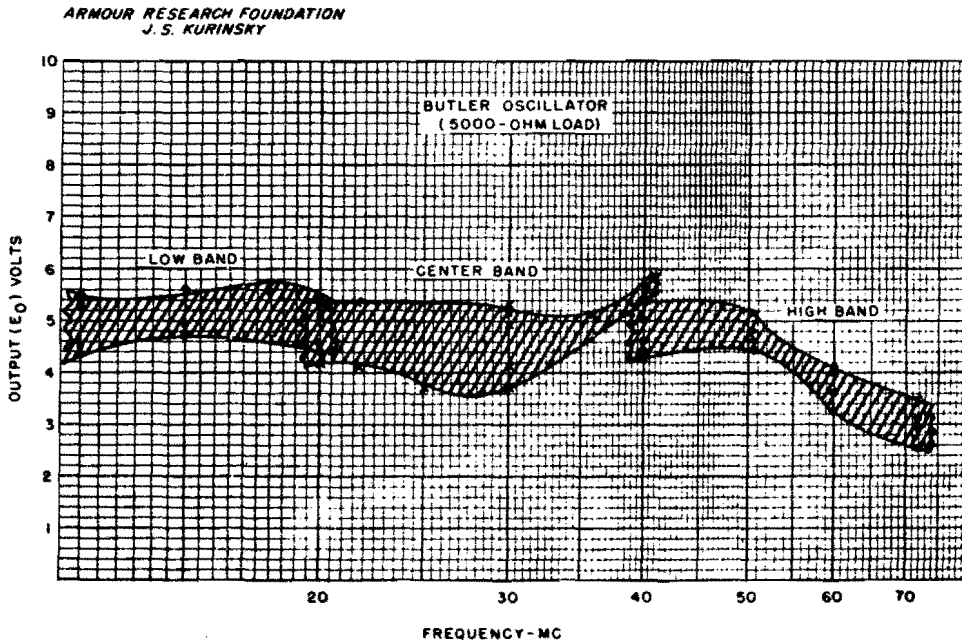

Figure 1-251. Typical output voltage and voltage tolerances of the Butler circuit of Gruen packet series when operating into a 5000-ohm load

ARMOUR RESEARCH FOUNDATION
J. S. KURINSKY

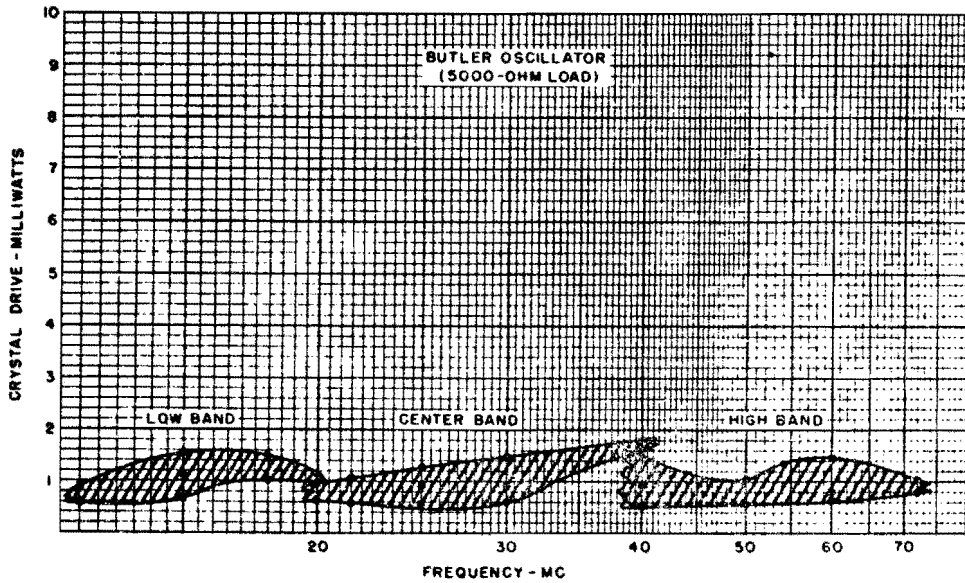

Figure 1-252. Typical drive levels and operating tolerances to be expected for crystal units connected in the Butler circuit of Gruen packet series. The values shown assume a 5000-ohm load resistance

ARMOUR RESEARCH FOUNDATION
J. S. KURINSKY

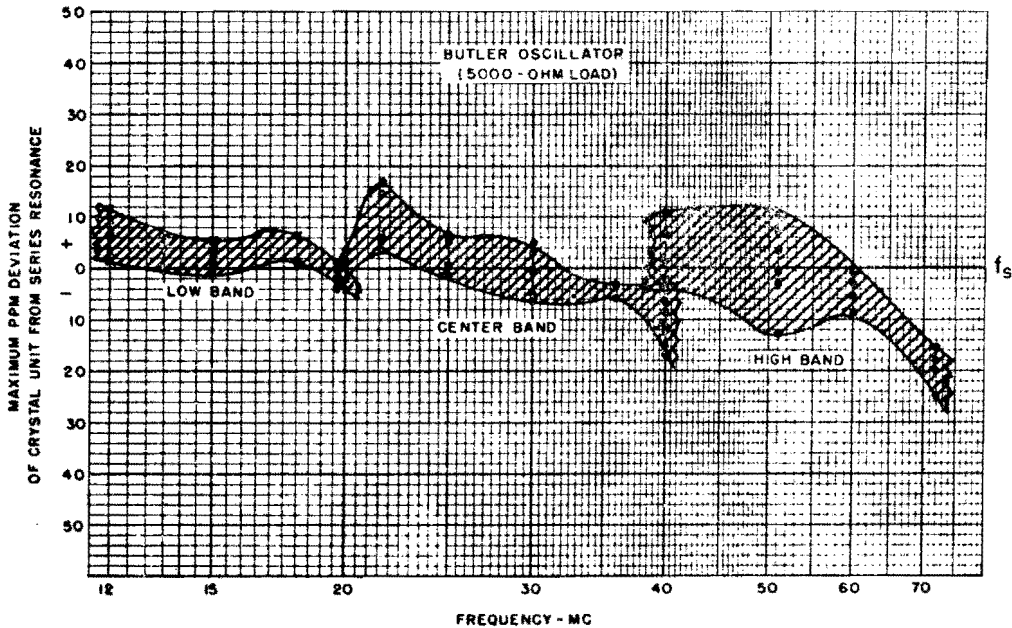

Figure 1-253. Typical frequency tolerances to be expected of crystal units connected in Butler circuit of Gruen packet series. The deviations plotted are deviations of the peak-output operating frequency from the series-resonance frequency of the individual crystal unit as measured with a CI meter, and are not deviations from the rated nominal frequency of the crystal unit. Thus, the overall tolerance to be expected of such an oscillator must be the total of the crystal unit nominal frequency tolerance plus the expected operating resonance tolerance, the latter being indicated by the measured deviation above

Packaged Crystal-Controlled Transistor Oscillators

1-569. Transistor circuits are ideally suited for miniaturized packaged units. Eventually, when transistors, especially those in the h-f range, are being manufactured with closer tolerances, it is to be expected that a majority of the packaged oscillators will be of transistor design. Almost certainly will this be true of those units designed to be temperature controlled since the heat dissipation of the transistor is so much smaller than that of the vacuum tube, and hence less of a factor in causing unwanted temperature gradients in an oven container. Research in the direction of developing standardized transistor packaged oscillators is being initiated by the U. S. Air Force. At the present writing the only information available concerning the development of any type of transistor packaged oscillator is the experimental model developed at the National Bureau of Standards, discussed in the following paragraph, and the temperature-controlled miniature units already being manufactured by the James Knights Company, discussed in paragraphs 1-571 and 1-572.

SULZER MINIATURE PACKAGED TRANSISTOR FREQUENCY STANDARD

1-570. A complete packaged 100-kc frequency standard with a self-contained power supply is shown in figure 1-254. This oscillator unit was developed by Peter G. Sulzer of the National Bureau of Standards. Although the primary purpose of the NBS project was to develop a pocket-

size, self-sufficient frequency standard, the result provides an admirable illustration of the possibilities in packaged design. A G-element is employed for frequency control, and as can be seen, the dimensions of the crystal unit comprise about half of the total volume. Power is supplied from a mercury cell, which, of course, would not be a necessary feature if the oscillator unit were adapted for use as a general-purpose plug-in component for precision frequency control. A grounded-emitter junction transistor is used. Capacitors C_2 and C_3 form a voltage attenuator in the feedback circuit to reduce the voltage applied across the crystal unit. The relatively large values of the capacitors connecting to the terminals of the crystal unit serve to stabilize the feedback phase. All the circuit elements except the crystal unit and the mercury cell are supported in casting resin on a plastic frame. The mercury cell is at the base. The oscillator is packaged in a metal container (not shown), 7 inches by 1 $\frac{3}{4}$ inches. The oscillator has a frequency deviation no greater than 1 part in 10^8 per degree C change in temperature, or 1 part in 10^8 per 0.1 volt change in battery supply.

COMMERCIALLY AVAILABLE PACKAGED CRYSTAL-CONTROLLED TRANSISTOR OSCILLATORS

1-571. A pioneer in the field of miniaturized packaged oscillators has been the James Knights Company. Their research team composed of R. Ives, C. Reynolds, R. Beetham, R. Berge, C. Eickeberge,

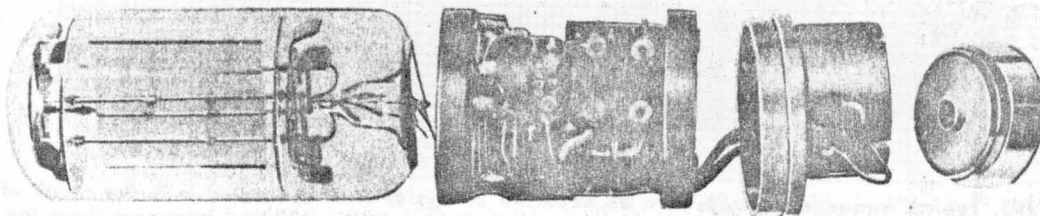
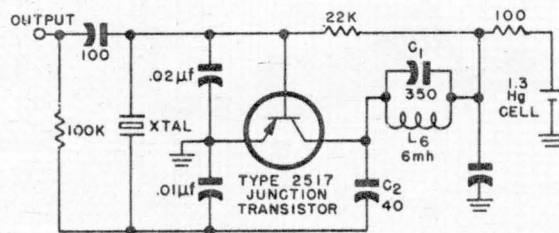

Figure 1-254. Small, portable, packaged transistor crystal oscillator developed by P. G. Sulzer of National Bureau of Standards. Unit is provided with mercury-cell power supply shown at right. Metal container is not shown

11-586

et al appears to have been the first in this country's electronics industry to have developed miniature, temperature-controlled, plug-in crystal oscillators available for general-purpose use.* Three oscillator units have been developed at this date which employ transistor circuits and are designed for mounting within small crystal ovens. One unit is a multichannel h-f oscillator which can be provided with a bank of up to 11 h-f crystal units mounted, together with its oscillator circuit, within a rotary switch. This assembly can plug into a crystal oven, or into an external octal socket, or it can be panel-mounted. When oven-mounted, the entire package occupies a cylindrical volume approximately $3\frac{3}{4}$ inches in diameter and 5 inches high. The crystal units are of a subminiature, evacuated, glass envelope type, which operates at frequencies of 6 mc and higher. Insufficient data

* The Electronic Engineering Company of California has also pioneered a packaging technique finding application in small plug-in oscillator circuits. The EECO Production Company fabricates a plug-in, vacuum-tube, packaged oscillator circuit (see accompanying figure) designed for crystal control in the 90-to-250-kc range. A crystal unit is not supplied as a component part of the packaged unit, nor is temperature control provided. The circuit is a cathode-coupled Butler type. No tuned circuits are employed, so that an externally connected crystal unit will operate at its fundamental mode. The output under no-load conditions is rated at approximately 14 volts rms. The recommended load-impedance range is 100,000 to 250,000 ohms. The power requirements are a plate supply of 200 volts dc between pins 1 and 2 at 3.5 ma., and a

heater supply of 6.3 volts at 300 ma. The d-c potential of the heaters relative to pin 2 must be between plus 90 and minus 70 volts. The circuitry is mounted in the bottom of the unit, the vacuum tube at the top. The weight is approximately 3.25 oz. A standard octal base is provided. A screw cap at the bottom permits the unit to be readily taken apart and assembled. The tube shield is removable to permit easy replacement of the vacuum tube. The finish is grey baked enamel. No information can be given concerning the tolerances and stability of the oscillator since it has not been designed for use with a specific crystal unit. For use with some Military Standard units it might become necessary to reduce the plate supply voltage in order to avoid operating the crystal beyond its rated drive level.

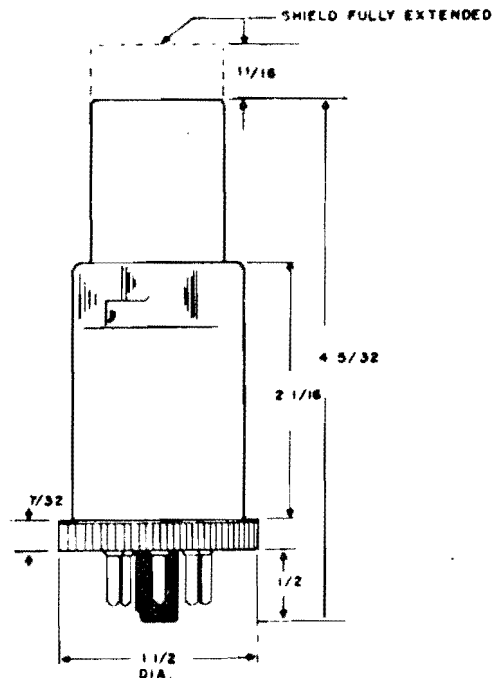
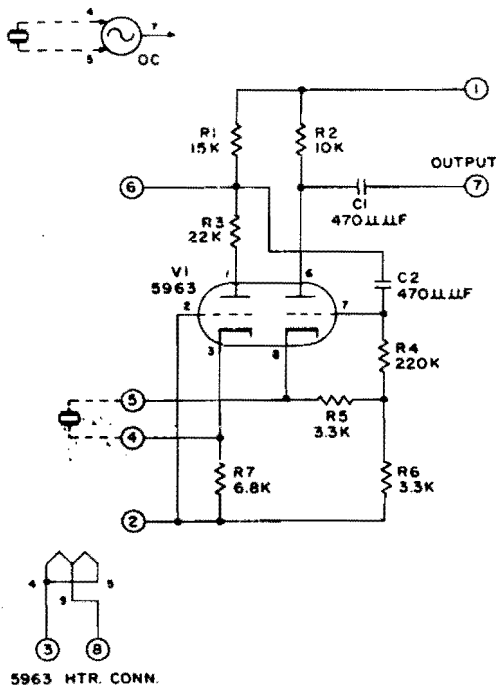

Section I
Crystal Oscillators

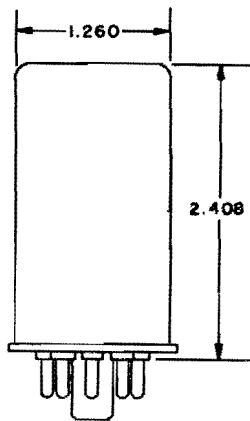

Figure 1-255. Dimensions of miniature, cylindrical, temperature-controlled, transistor plug-in oscillator developed by James Knights Company. Packaged unit is provided with a standard octal base

was 9 cps when the supply voltage was changed from 6 to 4.5 volts. A 2-mc test oscillator has shown an operating stability of 1 ppm over a period of several weeks, but sufficient time has not elapsed for these oscillators, so recently developed, to be tested thoroughly for operating life and aging characteristics. The ovens in which the oscillators are mounted require a maximum of 1.5 amperes at 6.3 volts. The crystal temperature is maintained within plus or minus 1°C over an ambient range of -55° to +70° C. The assembled package is equipped with a standard octal base.

Standards for Packaged Oscillators

Many of the problems associated with the standardization of electronic components appear to defy solutions that satisfy designer, fabricator, distributor, consumer, and repairer alike. As a result, the subject of standardization, itself, is often a controversial issue. After discussing a number of the conflicting points of view with different associates in the crystal industry, it seemed to the writer that perhaps some indirect good might result if these points of view, as applicable in the standardization of packaged oscillators, were assembled on paper where they might more easily be seen in relation to one another. For this reason, the discussion from paragraphs 1-573 to 1-581 detours somewhat from the domain of technical fact into an area more representative of individual opinion. The reader interested only in the technical aspects of packaged oscillators can disregard these paragraphs.

ADVANTAGES OF STANDARDIZATION

1-573. The primary advantages of standardized packaged oscillators, as of other standard pack-

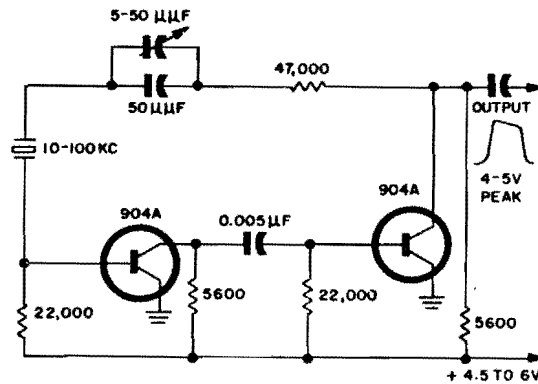

Figure 1-256. Schematic diagram of crystal-controlled transistor circuit employed in James Knights packaged low-frequency (10 to 100 kc) oscillators. Square wave output is rich in harmonics

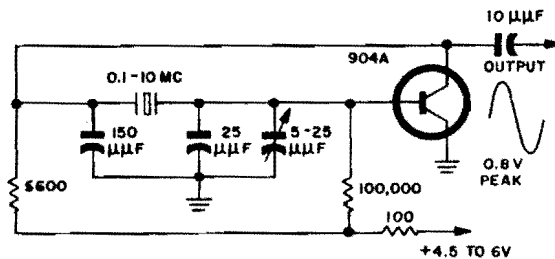

Figure 1-257. Schematic diagram of crystal-controlled transistor circuit employed in James Knights m-f and h-f (0.1 to 10 mc) oscillators. Relatively pure sine-wave output

aged units, can be described as those of economy:

a. It is an economical saving for research and design departments to avoid having continually to assign and train engineers in the special design theory and developmental techniques of oscillator circuits; this saving can be achieved if there are commercially available oscillator units of known operational characteristics capable of meeting all normal frequency-control requirements.

b. It is more economical for equipment manufacturers to assemble a given oscillator circuit in a fixed manner as a separate unit, regardless of the different types of equipment in which it is to be used, than by fabricating the oscillator as an integral part of a much larger network where special production procedures are required to make the electrical and physical connections conform to each different chassis layout.

c. It is more economical for maintenance departments to replace defective oscillators as plug-

in units than to find, educate, break in, and pay highly trained technicians to troubleshoot and repair them; to say nothing of the additional man hours saved by avoiding the necessity of having to store and distribute each oscillator part separately.

d. Consequently, it is an economical saving to the consumer, who ultimately must bear the costs of the research, design, development, fabrication, and maintenance. In addition, the consumer can also profit from the longer life of the oscillator due to the extra protection provided by the package design, particularly if the container is hermetically sealed.

PROBLEMS OF STANDARDIZATION

1-574. Standardization has its dangers as well as its advantages. The dangers arise both from too much standardization, and from not enough standardization—from freezing the design of an item so thoroughly that the development of improved models is discouraged, and from having such ambiguous and unsystematic standards that many of the advantages are lost. Over-standardization is most apt to result from the understandable resistance of maintenance and repair organizations to having endlessly to contend with an ever expanding jumble of different models of every description. Under-standardization is most apt to result from the equally understandable resistance of the manufacturer in committing himself to rigid technical standards that slow his production line, or limit his freedom to experiment with new techniques and designs. Both too much and too little standardization can suffocate technical progress. In the particular case of packaged oscillators, much thought is being given for the establishing of a system of standards that avoids the pitfalls of both extremes.

If Standards Are Too High

1-575. Over-standardization appears to exist at three different levels. When the standards are too high; when they are over-emphasized; and when they are too restrictive. The least offensive are the standards that are too high. Indeed, the effort to meet exceptionally high standards is usually a spur to the development of new inventions and new techniques. Where the product cannot be fabricated with profit, it simply is not produced; so that the problem has a way of working out its own solution.

If Current Standards Are Overemphasized

1-576. Over-emphasis of the importance of keeping the number of available models of a given component to a minimum is probably the most

frustrating bugaboo that a pioneering manufacturer can face when he seeks official acceptance of a new design. It is true that standardization does and should discourage the development of new models that offer no improvement over the currently available standards, since such developments are effectively only a waste of engineering talent. But it should not discourage the development of improved models, which unfortunately does happen when the immediate problems arising from a new adjustment are emphasized ahead of the long-range advantages of a maximum rate of technical progress. It would seem that, if from the beginning, a standards program were planned that would anticipate the systematic development of improved models and higher standards, even to the extent of reserving pigeon holes for its eventual achievement, the advantages of standardization could be increased. For it appears that standardization of engineering products, in essence, is only a means of making known to the engineer *exactly* what is available. If the standards for packaged oscillators can be systematically organized at the start so that the development of new products can readily be placed in their anticipated categories, without disturbing the old standards or changing the cataloging system, then only the duplication of physical and functional characteristics need be discouraged in the development of new models.

If Standards Are Too Restrictive

1-577. Generally it is better to risk too much standardization than not enough, and because of this, probably the most difficult type of over-standardization to pinpoint is that in which too many of a component's characteristics are standardized. The problems that arise become particularly harassing when the committee controlling the standards are under strong pressure to keep the number of standard components to an absolute minimum. Under these conditions every newly developed component is considered primarily as a replacement of an older model, rather than as a new model, to compete with the old *only* for use in equipments of new design. For example, in the matter of standardizing crystal holders, experience has shown that considerable resistance is met when it is desired to gain official acceptance for any new design which in the future could replace an existing standard design, even though the new design is of proven superiority. If a plastic or metal container is standard for a given size of holder, reasons arise for delaying new standards for a superior metal or glass container, respectively. If an odd-shaped base has been standard-

Section I Crystal Oscillators

ized, it is very difficult even to gain acceptance for a standard octal base in an otherwise equivalent holder.

1-578. If a long delay is generally to be expected before new models can be standardized, or if the number of standard items must be kept to an absolute minimum, some of the difficulties facing production engineers are often avoidable when care is taken in establishing only those standards that specify the *function* that a particular item or unit is to perform in relation to any system in which it is to be used—not how the function is to be achieved, unless the manner of achievement in some way affects the design of the external system or the cost of maintenance and repair of the system as a whole. Why, for example, should the manner in which a crystal is mounted inside its holder be standardized, if there is no intention to repair defective units? If a crystal unit can meet all the required physical, electrical, and operational relations to the external system, what difference does it make how this is accomplished?

1-579. In regard to packaged oscillators, it is to be hoped that sufficient performance tests can be devised to eliminate the need for standards governing the internal design of the package. Unless the crystal unit is to be replaceable in the field, or is to have an outside mounting, as in the case of the Gruen package, it should not be necessary to specify the type of crystal unit employed. Indeed, what difference can it make to the user of two packaged units, identical insofar as their external characteristics are concerned, if one contains a crystal-controlled oscillator and the other a little imp turning a crank? As long as either controlling source is confined completely within its container and works dependably within the rated tolerances, the performance standards need not be concerned with whether the control is piezoelectric or metabolic. In the case of the crystal-controlled circuit, if the crystal unit is to be mounted inside the package container, as would be the case in a temperature-controlled unit, a manufacturer should not be required to use a Military Standard crystal unit if he can meet the oscillator requirements more satisfactorily with another type of crystal mounting or holder. (We assume that the oscillator standards will not require that the crystal unit be replaceable in the field. Such a specification for a completely packaged unit would mean that one of the primary advantages of packaging is being wasted—that in the case of breakdown, instead of replacing the packaged unit, the intention is to service it.) Also, it may be preferable to solder the crystal unit in place, than to depend

upon a plug-in connection, since the former method usually permits a more stable circuit. A properly fabricated crystal unit can generally be depended upon to last as long as the useful life of the equipment in which it is to be used, so no objection to the soldered connection should arise except in special applications. For example, the specification for a plug-in crystal unit could be important when mounted outside the package, as in figure 1-242, where it can readily be replaced without disturbing the packaged unit. Such an arrangement should prove desirable if the same oscillator is intended to operate at more than one frequency where space does not permit a switching arrangement capable of mounting and connecting all the required crystals, so that these must be inserted manually in the field as the need arises. Also, the plug-in arrangement becomes important when the operating life of the crystal unit is expected to be much shorter than that of any other part of the packaged unit; or if the operating life of the entire unit is to be of relatively short duration. In any event, it would seem that progress in the development of packaged oscillators will be promoted better if the standards initially established are confined to specifying what the packaged oscillators are to be able to do under specified external conditions and do not tend to limit the ways in which the functional specifications are to be achieved, even if at the time the standards are established there appears to be only one way in which the desired function can be achieved.

Avoidance of Ambiguous Standards

1-580. If too much standardization vexes primarily the manufacturer of the standardized item, too little standardization scatters its headaches chiefly among those that must use the item. Particularly sensitive to the uselessness of ambiguous specifications or generalized advertising claims concerning a component is the design or developmental engineer who wishes to approach his circuit problems scientifically, yet who cannot do so unless he knows quantitatively exactly what he is putting into his circuit. To the engineer, a set of standards sufficiently rigid and dependable for predictable design and replacement purposes is equivalent to a set of rigid production line tests, since a unit cannot be guaranteed to pass certain specifications unless at least a representative sample has been tested to meet the specifications. Furthermore, since the performance of a unit depends upon the conditions under which it is operated, it is often of little help to a design engineer to specify exactly what a unit can do un-

less accompanied by equally exact data concerning the conditions under which the rated performance takes place.

1-581. As applied to packaged oscillator units, it is highly desirable that a systematized set of standard operating conditions be established simultaneously with a systematized set of performance standards. Otherwise, each oscillator may have to be adjusted for optimum performance in the particular equipment in which it is to be used. The ideal standard oscillator need not and should not be adjustable by either the equipment production line technician or by the equipment operator in the field. Too many variables are present. If adjustable, all tolerances must be rated as the maximum to be encountered over the adjustable range. If the equipment in which the unit is used can permit such tolerances, then there is no need to adjust the unit in the first place. A plausible exception would be the case of a small trimmer capacitor to offset the effects of aging in high-precision systems. Another exception would occur if it were practicable to design a unit with marked adjustment points at which the tolerances could be separately specified. For example, one adjustment setting could indicate a point of maximum output amplitude, another a point of maximum amplitude stability, another a point of maximum frequency stability, etc. But to the extent that the adjustments made by the user are not definitely predictable, the advantages of standardization are lost. It would be preferable for the manufacturer of the packaged units to make the adjustments and assign different model numbers where the same circuit had significant performance differences.

PRINCIPAL OSCILLATOR CHARACTERISTICS TO BE STANDARDIZED

1-582. Packaged oscillator characteristics that should be standardized can be grouped in two categories—physical and electrical. The former concerns primarily the mounting requirements and limitations; the latter covers the operating requirements and performance characteristics. Of the physical characteristics the most important are the conventional items such as dimensions, weight, shape, provisions for mounting, ambient temperature range, mechanical ruggedness as measured by well-defined tests, moisture resistance, seal test, operating life of thermostat, if any, and so forth. Of the more important electrical characteristics there are the operating requirements and permissible tolerances of such items as input voltages, currents, and power, the test load impedance, ground connections, and the like; also,

there are the performance characteristics to be specified for the standard test conditions. These performance characteristics include the following: output fundamental frequency; db level of nearest harmonics relative to fundamental; equivalent emf and impedance of oscillator, when viewed as an impedance in series with a generator, at the fundamental frequency and at any useful overtones; output waveform; frequency and amplitude tolerances; frequency and amplitude deviations over input voltage range and over operating temperature range; frequency deviation over permissible load tolerances; and frequency and amplitude deviations permissible after the unit is subjected to the various aging and mechanical tests.

EFFECT OF CRYSTAL RESISTANCE ON PACKAGED OSCILLATOR STANDARDS

1-583. Even in those packaged oscillators in which a Military Standard crystal unit is not to be specified, the most economical fabrication process will probably require the use of such a unit, or at least one that has electrical tolerances equivalent to those of a standard unit, since the oscillator standards will undoubtedly be originally established on the basis of oscillators of known operational characteristics employing Military Standard crystals. In establishing the oscillator standards it is important that account be taken of the full variation in output level and frequency to be expected due to the range of the equivalent resistance of the crystal unit between its maximum permissible and minimum expected values. Likewise, it is important that the developers of the packaged oscillators test their circuits over the expected crystal resistance range to ensure that the oscillator standards are met throughout the range. Generally it is only the maximum resistance conditions that must be specifically tested. If the design engineer does not have maximum-resistance crystal units available, these can be simulated in making the laboratory tests.

Simulating Maximum-Resistance Crystal Units

1-584. First, the equivalent resistance of the crystal unit being used in the test circuit must be measured with the aid of the appropriate CI meter. If the test circuit employs a series-mode crystal unit, simulating a maximum-resistance crystal is readily achieved by connecting in series with the crystal a resistance of such a value that the total resistance is equal to the maximum permissible. If the test circuit employs a parallel-mode crystal unit, the simplest method is to employ a stratagem devised by John W. Sherman, Jr.

Section I
Crystal Oscillators

of General Electric Co.* A high resistance is connected in parallel with the crystal unit. The value of this resistance is chosen so that the power losses of the actual crystal unit and of the resistance in parallel have a combined value equal to the losses that would occur if the crystal unit were of maximum resistance. Assuming that the impedance of the crystal unit is approximately equal to its effective reactance, X_c , which in turn is approximately equal to $\frac{1}{\omega C_x}$, where C_x is the rated load capacitance and ω is the angular frequency, then the current through the crystal unit in both the actual and the maximum-resistance case would be approximately equal to $E_c \omega C_x$, E_c being the voltage across the crystal unit. Letting R_{em} equal the maximum permissible resistance, R_e equal the actual effective resistance of the crystal unit, and R_x equal the value of the shunting resistance, we set the power losses in the hypothetical crystal unit of maximum resistance equal to those due to the actual R_e and R_x :

$$(E_c \omega C_x)^2 R_{em} = (E_c \omega C_x)^2 R_e + E_c^2 / R_x$$

From which the equation for R_x is obtained.

$$R_x = \frac{1}{\omega^2 C_x^2 (R_{em} - R_e)}$$

FACTORS INVOLVED IN OSCILLATOR LIMITING

1-585. The characteristics of any oscillator are dependent to a large extent upon the degree and type of amplitude limiting employed. The factors involved are especially significant in the case of crystal oscillators because the variations in crystal-unit effective resistance tend to introduce wide

* This method for effectively increasing the resistance of a parallel-mode crystal unit, although independently devised and tested successfully over a range of 1.5 to 51 mc by J. W. Sherman for the express purpose of testing the design fitness of particular oscillator circuits, is also reported by engineers of the Signal Corps Engineering Laboratories to have been used in their Frequency Control Branch for several years for measuring crystal activity in various test sets. During World War II a jig was devised that provided the crystal unit with an adapter and a variable shunt resistance. Effectively, the device was a means of readily degrading the activity of a test crystal unit to some predetermined marginal value. For example, by adjusting the shunt resistance, a given effective marginal resistance could be indicated when the drive level of the test circuit reached a certain value. Knowing the total effective resistance, the load reactance, and the shunt resistance, it would be a simple matter to compute the effective resistance of the crystal unit alone. The use of such a jig and test circuit can offer an advantage over the method described above for simulating maximum-resistance crystal units, if the process is to be repeated frequently enough to justify their construction. With the test-circuit activity indicator calibrated in terms of maximum-resistance values, the shunt resistance of the jig can be adjusted immediately to its desired value without computation or having to actually measure the crystal unit resistance.

variations in the amplitude of oscillation when different crystal units of the same type and frequency are substituted in the same circuit. The method of limiting also affects the type of crystal unit to be used, whether it is to be a series- or a parallel-mode unit. Directly dependent upon the limiting method will be the harmonic content in the oscillations. Upon the degree of harmonic distortion will depend the tuning of the circuit, so that any deviations in the limiting characteristics are reflected as instabilities of frequency as well as of the amplitude. In the following paragraphs we shall discuss these factors briefly; but first, the reader may find it helpful to review paragraph 1-232, in which the crystal oscillator, as a generalized negative-resistance circuit, is discussed.

Negative-Resistance Limiting

1-586. In paragraph 1-232 we found that when a crystal oscillator is represented as a series-resonant negative-resistance circuit (figure 1-108 (B)), oscillations continue to build up as long as

the numerical ratio $\left| \frac{\rho_n}{R_c} \right|$ is greater than 1. When

the oscillator is represented as a parallel-resonant negative-resistance circuit (figure 1-108 (C)), oscillations build up as long as the numerical ratio

$\left| \frac{Z_p}{\rho} \right|$ is greater than 1. Now, in figure 1-108, both

the series-resonant and the parallel-resonant negative-resistance circuits are intended to represent the same crystal oscillator, one that employs a parallel-mode crystal unit. Let us modify our interpretation of the series-resonant circuit to let it represent any series-resonant circuit containing a crystal element. That is, we shall treat X_1 as the reactance of any load capacitance actually connected in series with the crystal unit, as is the case, for instance, in a CI-meter circuit connected for parallel-mode crystal control. We shall also be free to assume that X_c and X_1 each equals zero, in which case the circuit is equivalent to a series-mode crystal unit connected across the terminals of a negative resistance equal numerically to the series-resonance resistance of the crystal unit. As far as the parallel-resonant negative-resistance circuits shown in figure 1-108 are concerned, we shall continue to consider them as representing an actual parallel connection of a crystal unit and its load capacitor driven at parallel resonance by a negative resistance, ρ . In other words, we wish simply to make it clear that the generalized series-resonant circuit represents an actual series-resonant circuit, and that the generalized parallel-

resonant circuit represents an actual parallel-resonant circuit.

1-587. In order for oscillations to build up and reach a stable equilibrium in the series circuit, we see that the negative-resistance device must have the property of automatically decreasing its negative resistance as the amplitude of oscillations increases. The negative-resistance device of the parallel circuit must have the opposite property; that is, its negative resistance must increase as the amplitude increases. Literally, these opposing requirements mean that the same device used as a negative resistance in the series circuit cannot be used in the parallel circuit, or at least not with the same operating characteristics, and vice versa. By the term "negative resistance" used in this context, let it be plain that we mean a two-terminal network which, when connected across the crystal circuit, behaves exactly as an automatically variable resistor does, except that the negative resistance supplies energy rather than dissipates it. The act of connecting a negative resistance across a crystal circuit does not in itself generate a voltage and current for driving the circuit. Of course, a signal generator used to force-drive the circuit can be treated as a virtual negative resistance mathematically to simplify a network analysis, but that is not a "passive" type of resistance such as we are concerned with here. The voltage across, or the current through, a passive resistance (negative or positive) is not assumed to be self-generated by that element, but rather is the response of the resistance to the actions in the rest of the circuit. In an oscillator circuit, the initial action is the random thermal motions of the free electrons; the negative resistance reacts to this at the same energy level, the remainder of the circuit reacts to the negative-resistance reaction, the negative resistance reacts, in turn, to this, and so on until the energy builds up. At all times the frequency, amplitude, and phase of the negative-resistance voltages and currents are under the control of the external circuit.

1-588. As long as the oscillations are building up, part of the energy being supplied by the negative resistance is being stored by the circuit. As far as the negative resistance is concerned, the stored energy is equivalent to lost energy, so that process can be represented by the addition of equivalent resistances in the generalized circuits. Figure 1-258 shows the generalized negative-resistance circuits with the equivalent "energy-storing" positive resistances. In the series circuit, the instantaneous value of R_{es} is defined by the equation:

$$R_{es} = |\rho_s| - R_e$$

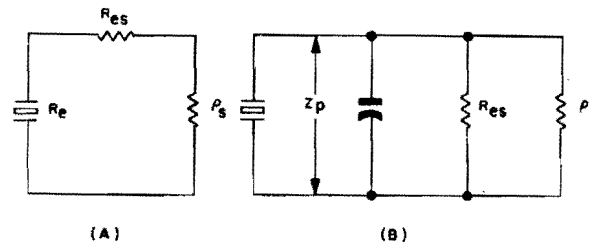

Figure 1-258. Equivalent circuit during build-up period of generalized negative-resistance crystal oscillator. (A) Series-mode circuit (B) Parallel-mode circuit

In the parallel circuit, the instantaneous value of R_{es} is defined by the equation:

$$\frac{1}{R_{es}} = \left| \frac{1}{\rho} \right| - \frac{1}{Z_p}$$

Note that for the oscillations to build up in the series circuit, the total effective positive resistance ($R_e + R_{es}$) must be greater at the start and during the build up than when equilibrium is reached. How much greater, of course, will depend upon the difference at each instant between the negative resistance and the true circuit resistance. For oscillations to build up in the parallel circuit, the

total effective positive conductance $\left(\frac{1}{Z_p} + \frac{1}{R_{es}} \right)$

must be greater at the start and during the build up when the equilibrium is reached. The value of the additional conductance will at each instant equal the difference between the negative conductance and the actual tuned-circuit conductance.

1-589. Clearly, for oscillations to build up in the

two circuits, the respective resistance ratios $\left| \frac{\rho_s}{R_e} \right|$ and $\left| \frac{Z_p}{\rho} \right|$ must be greater than unity at the start

of oscillations. Also apparent should be the fact that these ratios will equal unity when equilibrium is reached. This means that the respective negative-resistance devices must permit ρ_s to decrease and ρ to increase as the amplitude of crystal oscillations increases. But suppose that the devices which produce the negative resistances in the two circuits are switched. What then? If the new

starting ratios, $\left| \frac{\rho}{R_e} \right|$ and $\left| \frac{Z_p}{\rho_s} \right|$ are less than unity,

no oscillations can begin; but if these ratios are equal to or greater than unity, oscillations can start, but they cannot attain a stable equilibrium.

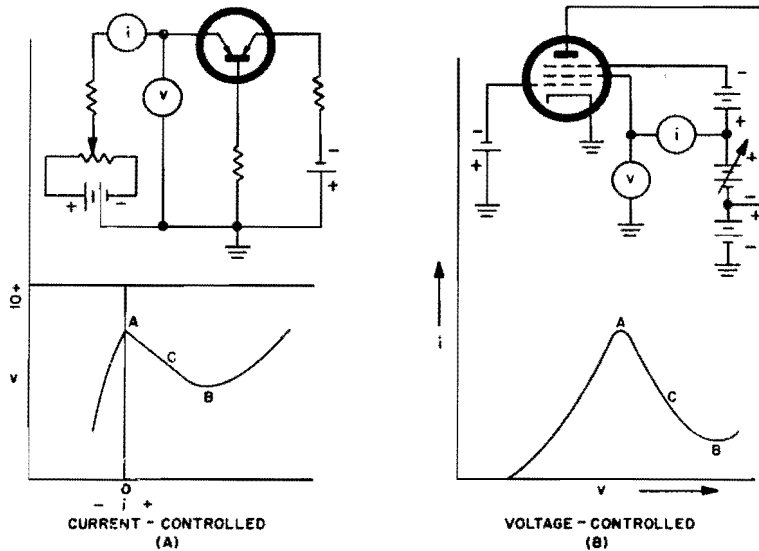

Figure 1-259. Typical negative-resistance devices and characteristics. (A) Transistor emitter current-controlled negative resistance (B) Transitron voltage-controlled negative resistance

Exactly what actions might result from the unstable conditions would depend upon the particular circuit and negative-resistance device.

Current- and Voltage-Controlled Negative-Resistance Characteristics

1-590. Figure 1-259 shows volt-ampere characteristic curves of two representative negative-resistance devices. (A) shows a typical transistor emitter characteristic, whereas (B) shows a typical transitron characteristic. The negative-resistance property is confined to those regions of the curves with a negative slope, as labeled between points A and B. When either of the devices is operated in the negative-slope region, an incremental increase in one of the variables will be accompanied by an incremental decrease in the other variable. Thus, in (A) at a point C between A and B, if the current increases by a very small amount, di , the voltage will decrease by an amount, dv . The ratio, dv/di , is the *dynamic resistance* at the point in question, which in this case is negative since dv and di are opposite in sign. This does not mean that the total resistance, v/i , is necessarily negative, but simply that the resistance to a small variation in current is negative. It is the resistance to be met by a small a-c signal superimposed on the direct current indicated at point C. In curve (A), the slope at each point is equal to the dynamic resistance at that point; in curve (B) the slope is equal to the dynamic conductance at each point.

1-591. Note that for curve (A), one and only one value of voltage corresponds to each value of current. That is, the voltage is a single-valued function of the current. However, note that for a given value of voltage in curve (A), there exist three possible values of current. The current in this case is thus a multivalued function of the voltage. In curve (B), the current is a single-valued function of the voltage, but the voltage is a multivalued function of the current. Where a negative-resistance characteristic is present, at least the voltage or the current must be a multivalued function of the other. Theoretically both can be, but in practical devices one of the parameters will be a single-valued function of the other. That the other must be multivalued is self-evident when we consider that a volt-ampere characteristic having a continuous negative slope would imply an infinite capacity to supply energy. For some value of current and voltage any electronic device can be made to show a positive resistance. But wherever a characteristic curve would show a change from negative to positive resistance, the bend in the curve will require that one of the parameters, v or i , repeat its values as the other continues to increase.

1-592. The characteristic curve, the emitter circuit, and the negative resistance indicated in figure 1-259 (A) are called *current-controlled*, since the voltage is uniquely determined by the current. The transitron circuit and its characteristics in figure 1-259 (B) are called *voltage-controlled*,

since the current is uniquely determined by the voltage.

1-593. Imagine that the devices illustrated in figure 1-259 are to be used in crystal oscillator circuits. The no-signal operating currents and voltages are to be such that each device operates at point C. The initial negative resistance is thus the dynamic resistance at that point. As oscillations build up, the average a-c negative resistance in (A) decreases, that in (B) increases. Thus we see that the current-controlled negative resistance is suitable for use with series-mode oscillator circuits, whereas the voltage-controlled negative resistance is suitable for parallel-mode circuits. On the other hand, if a current-controlled negative resistance were to be used to drive a parallel-mode circuit, the oscillations might build up to a point at which the oscillating circuit would suddenly be shorted out, with the sudden loss of stored energy resembling the action of a relaxation oscillator. Or perhaps the circuit will have a tendency to jump from one mode of operation to another.

1-594. The oscillating current of the parallel-mode circuit is essentially self-contained, the only current required of the external circuit is that necessary to re-supply the energy lost each cycle. This is such a small fraction of the total current in a high-Q circuit, that its wave shape can be quite distorted without significantly affecting the sinusoidal shape of the voltage wave. A momentary variation in the impedance of the energy source can produce a large variation in the current wave through a negative-resistance device but only a small variation in the voltage wave. In other words, the energy stored in an antiresonant circuit is primarily a voltage-controlling source rather than a current-controlling source. If used with a device whose current is a multivalued function of the voltage, instability can be expected to result if the voltage amplitude cannot be limited within a single-valued region of the current. A resonant series-mode circuit, on the other hand, is essentially a current-controlling source. Extremely high voltages would be required to produce a significant distortion of the current wave shape of a high-Q resonant circuit connected in series with a negative resistance device. For stable oscillations to be sustained in a series circuit, it is important not to employ a voltage-controlled negative resistance, since its operating characteristics are not uniquely determined by the current.

1-595. If the limiting action is provided by an external circuit component, such as a thermistor, the fact that the negative-resistance is current-

or voltage-controlled may not be critical, provided the limiter is certain to act before the oscillations enter an unstable region; nevertheless, the oscillating circuit should be matched to an inherently stable negative resistance for the particular resonance mode. The principal advantage of a thermistor-type limiter is that the limiting action is relatively slow, so that once the equilibrium point is reached, the non-linearity introduced by the limiter is relatively insignificant. Under these circumstances all the circuit elements, in particular the negative-resistance source, can be operated as linear parameters, thereby permitting the oscillations (both current and voltage waveforms) to be sinusoidal.

Frequency Deviation Due to Nonlinear Limiting

1-596. As is normally the case, the limiting is provided by the negative-resistance device. The oscillations build up until the amplitude swings into one or both of the bends of the negative-resistance characteristic. The farther that the current or voltage (depending upon whether current- or voltage-controlled, respectively) swings past the straight portion of the negative-resistance curve, the greater the distortion in the respective fundamental wave of the dependent parameter. If the swings are extended sufficiently, a point will be reached at which any further increase in the amplitude of the controlling parameter results in a decrease in the amplitude of the dependent parameter at the fundamental frequency. If the amplitude of the controlling parameter is increased further, the amplitude of the dependent parameter at the fundamental frequency will diminish until it disappears entirely, at that point where the effective negative resistance, itself, disappears. Beyond this critical point the fundamental of the dependent parameter reappears, but with its phase reversed, reflecting the fact that the average a-c resistance at the fundamental frequency has changed from negative to positive. Although the fundamental frequency of the dependent parameter may decrease in amplitude as the fundamental frequency of the controlling parameter increases in amplitude, the higher harmonics of the dependent parameter continue to increase, so that it is quite possible for the overtones to exceed the level of the fundamental in high-amplitude systems. On this account, where the fundamental frequency is of principal concern, it is generally preferable to obtain the output in a way that it depends upon the wave shape of the parameter, voltage or current, that controls the negative resistance. On the other hand, if harmonic outputs are

desired, let them be obtained primarily with the aid of the dependent parameter.

1-597. When harmonics are being generated, the distortion causes the fundamental frequency to assume a slightly different value than would otherwise be the case. This property can be the source of considerable frequency instability in crystal oscillators, since the harmonic content, and hence the fundamental frequency, will vary with the crystal-unit effective resistance, the operating voltages, and the aging and temperature characteristics of the negative-resistance device.

1-598. Briefly, the reason that the fundamental frequency is affected by the presence of harmonics can be explained as follows: First, the mixing of all the harmonics in the nonlinear negative-resistance circuit provides a secondary source of the fundamental frequency, since the fundamental will result as the different frequency between any two successive harmonics. For example,

$$f = 3f - 2f = 4f - 3f, \text{ etc.}$$

Now, if the external crystal circuit is tuned to be approximately resonant at the fundamental frequency, it will generally appear capacitive to the higher harmonic currents. This means that the fundamental frequency obtained from the difference products of the harmonic currents will be displaced approximately 90 degrees in phase from the main fundamental, thereby causing a displacement in the phase of the total fundamental current. Thus, the nonlinear resistance serves to introduce a difference in phase between the current and voltage at the fundamental frequency, and in this manner behaves as if its impedance were

partly reactive. If the negative-resistance device is effectively partly reactive, the external circuit must present an equal and opposite reactance in order for the net impedance around the circuit to be zero. The fact that the harmonic currents pass through the capacitive shunts for the most part means that the external circuit must appear inductive at the operating frequency. For a simple parallel-tuned circuit, this requires that the circuit operate at a frequency below resonance. The frequency displacement to be expected can be approximately obtained from the following equation. The equation was derived by J. Groszkowski.* It is based upon the postulate that a negative-resistance device cannot store energy.

$$\sum_{n=1}^{\infty} n I_n^2 X_n = 0 \quad 1-598 (1)$$

Where:

n = number of harmonic

I_n = current of n th harmonic

X_n = reactance of circuit to n th harmonic

This equation says that the sum of all the products, $nI_n^2X_n$, must equal zero. Since X_n for all values of n greater than 1 can generally be assumed to be negative, the crystal-circuit reactance facing the negative resistance terminals at the fundamental frequency must be positive (inductive) for the equation to hold.

* Note: See Bibliography No. 305. (Also W. A. Edson, No. 211.)

CROSS INDEX OF CRYSTAL OSCILLATOR SUBJECTS

The subjects related to the design of crystal oscillators are separated into five categories for cross-indexing. These categories appear in the following order:

- I. OSCILLATOR FUNDAMENTALS
- II. FUNCTIONAL CHARACTERISTICS OF CRYSTAL OSCILLATORS
(Factors to consider in selection of oscillators—alphabetical listing.)
- III. CIRCUIT ANALYSES OF BASIC CRYSTAL OSCILLATORS
(Quantitative relations which are fundamental as points of departure in attacking particular problems of design.)
- IV. DESIGN OF CRYSTAL OSCILLATORS
- V. CRYSTAL OSCILLATOR DESIGN CONSIDERATIONS
(Alphabetical indexing of principal factors to consider when designing for optimum or special performance characteristics.)

The primary subjects contained in the above categories are listed without line indentation. (Alphabetical listings are followed only in categories II and V above.) Subheads under the primary subjects are indented and preceded by a dot (.). Second order subheads are doubly indented and preceded by two dots (..).

B

	1	2	3	4	5	6	7	8	9	10	11	12	13	14	15	16	17	18	19	20	21	22	23	24	
OSCILLATOR FUNDAMENTALS																									
Classification of oscillators																									
•Stable, unstable	263																								
•Free, forced, forced-free	264																								
•LC-controlled, electromechanically-controlled		6, 7																							
•Crystal-controlled, crystal-stabilized			274																						
•Parallel-mode, series-mode			275																						
Principles of stable forced-free oscillators	265 266	236 267	232 233 236 274 275	232 233 236 274 275	232 233 236 274 275	275 586- 595																			
•Constant-amplitude requirements	265 266	236 267	232 236 267	232 236 267	232 236 267	593 594																			
••Amplitude build-up	266	236 267 268	232 236 267	232 236 267	232 236 267	586 586																			
••Amplitude limiting	266	236 267 268 585- 598	232 236 267	232 236 267	232 236 267	585 585																			
••Loop gain of unity		267	267			267																			
•Constant-frequency requirements	265 266	6 7 267 596	20 238 267																						
••Energy supply, stable	265 266	20 267																							
••Impedances, stable	265 266	20 21 267																							
••Loop phase rotation of zero		267- 273	267- 273	271- 273	267																				
Basic vacuum-tube oscillator circuit		268- 273	268- 273																						
•Loop phase analysis		268- 272	269- 272	271 272 281	267																				
•State of oscillation determined by feedback impedances		20	271 272 273	233 271 272 273																					

	1	2	3	4	5	6	7	8	9	10	11	12	13	14	15	16	17	18	19	20	21	22	23	24
•Generalized crystal circuit			231- 233 236	231- 233 236 586	586																			
Bibliography numbers	211 513 571 598 815	65 69 88 160 211 305 332 466 598	750 806 823																					
FUNCTIONAL CHARACTERISTICS OF CRYSTAL OSCILLATORS (Factors to consider in selection of oscillators.)																								
Activity (See Amplitude.)																								
Advantages and disadvantages		7 322	274 322 560 573- 581	275 276	275 276 355 356	277 322	277 328 330 336 339	347 349	351	356 357 360 363	356 364 369- 374	356 376 387	356 392	356 406	356 421	356 423	356 428 429	356 428 430 431	356 428 432	356 433 435	277 356 436	539 541 544 549 550 554	322 441 442 455	354 356 438
Amplitude		273	300- 303 308 311	275 308	275 355	277 328 291 293- 295 300- 303 312 320- 322	328 330 336 339 340	348 349	352	356 362	356 365 370- 372	356 376 379	356 392 405	356 406 421	356 421	356 429	356 430 431	356 432	356 432	356 435	356 436	540 541 544 554 572	438 538	438
Amplitude build-up time			274 296 299 304 305			296 299 304 305	339		360														532 537	
Amplitude dependence on effective resistance of crystal unit			300- 303 308 309 583	584	584	290 293 295 300- 303 308 309 311- 315 566 567	343		361		379 568	401 402	406 412- 415								436	540 547 558		436
Amplitude dependence on load			300 309 322			286 295 300 309 312 321 322 567	339 340						401	411- 415							436	540 538		436

	1	2	3	4	5	6	7	8	9	10	11	12	13	14	15	16	17	18	19	20	21	22	23	24	
FUNCTIONAL CHARACTERISTICS OF CRYSTAL OSCILLATORS (Continued)																									
Amplitude range		294	300-303 308 311			286 290 291 293-295 300-303 312-316 566 567	336 339	349		361 362	366 370-372	376 379 568	401 402 405	412-415								540	438	438	
Amplitude stability		273 294 306	296 297 299-303 308 322 581 595	322		283 284 294-297 299-303 306 321 322			352	357 360	368	379		412-415								436			436
Amplitude tolerance			308 309 582			290 293 295 303 312-316 566 567	336 343		352	357 360 361		379 568	402	412-415									540		
Availability of required crystal units, vacuum tubes, etc.			294			294 295 300 313-316	339 344		351		368	379		414		425							540 571 572		
Bandwidth (See also Frequency range.)		306	309 311 322 562	275 276	275 355	277 291 295 301 303 309 311 322	328 344	347 350	352	356 357	356 364 366 370-375	356 376 381 387	356 392 405	356 406 417-420	356	356	356 428	356 428	356 428	356 433	356 436 437	539	438-441 442 537 538	436 438-440	
Dependability of starting		268 273 306	294 297 289 300 308	276		277 282 291 294 296 297 299 300 323	339 340	346 348		363	364 374	376 379 387 391		406 414	421	424 425	429			434		540			

	1	2	3	4	5	6	7	8	9	10	11	12	13	14	15	16	17	18	19	20	21	22	23	24	
Ease of adjustment		306	273 294 562 581			277 294 295 306 316- 318	328 329 339 344	347	352	356 361	356 364 365 369 371	356 376 387	356 392	356 418 419	356 421	356	356	356 431	356	356 433	356 436	540 571	439 441 442 445 531	436 439	
Ease of frequency multiplication			322	276		322				356	356 375	356 376 387 388	356	356	356 421	356	356	356 431	356	356	356		438- 442 455 508 530	438- 440	
Economy of manufacture			296 304 308 560 561 564 573	275	275 355	277 296	328 339	349		363		376 379 384 387	392	414									530		
Economy of operation			294 296 304 322			277 294 296 312 322	322 328 339					387										541	442 455 508	570	
Effective resistance of crystal unit			309 563	271		279 290 293 295 301 303 312- 316 566 567	332 336			356 361 362	356 368	356 377 379 568	356 401 402 405	356 406 412- 414	356	356 423 425	356	356	356	356 433	356 436 437	540 550		436	
Equipment employing oscillator		491 531 536	304- 306 311 322			304 305 311 322 479 481 487 495 522 524	305 339 344 536	350	353	357	371 373 374	387 472 514 515		414								436 437	539 541	438 440 530	438 440
Frequency range—operable, practical, optimum (See also Bandwidth.)		306 354	296 305 322 565	275 276	275 276 355	277 290 291 295 296 301 303 566 567	344		351 352	356 357 363	356 364 369- 375	356 376 387 391 568	356 392 405	356 406 414	356 421	356 423 425	356 428 429	356 428 430 431	356 428	356 433	356 436 437	539 543 544 551	438- 442 455 463 530 537 538	354 436 438- 440	

FUNCTIONAL CHARACTERISTICS OF CRYSTAL OSCILLATORS (Continued)																									
	1	2	3	4	5	6	7	8	9	10	11	12	13	14	15	16	17	18	19	20	21	22	23	24	
Frequency stability		354	269 273 274 296- 298 305 309 310 314 315 581	269 273 275	275 355 356	277 279 283 284 296- 298 301 302 309 310 314 315 322 566 567	328 330 332 339 341- 343	269 347 349			356 357 363	356 368	356 376 380 387 391 568	269 356 392 405	356 406 415 417- 420	356 421	356 425	356 428 429	356 428 430 431	356 428 432	269 356	356	541 570 572	438 439 462	438 439 570
Frequency tolerance		354	305 310 317 582	317	355 356	277 291 310 317	328 332 339	347 349			356 357	356 378	356 387 391 568	356 392 405	356 406 414 417- 420	356 421	356 429	356 430 431	356 432	356	356	541 552	438 439 462	438 439	
Harmonic output		596- 598	304 305 308 311 322 582	322		277 304 305 311 321 322	329				356 359	356	356 376 387 388	356	356	356	356	356 431	356	356 435	356 437	541 572	442 530		
Installation (airborne, ship-board, ground, etc)			311 560			311	339								414							541			
Location of load			322	322		277 283 309 321 322 328 566 567	322 328	349			356 363	356 370 371 375 388- 390	356 376	356 392	356 406 407 417- 420	356 421	356 423	356 429	356 430 431	356 432	356 433 435	356 437	540		
Output power		294	294 296 305 322	275	275 355	277 284 286 294- 295 305 311 322 566 567	305 322 328 330 333 339 340 343	349			356	356 370- 372	356 376 568	356 392 404 405	356 406 408 412- 415 417- 420	356 421	356	356 429	356 430 431	356 432	356	356	541 572	438 454 538	438

	1	2	3	4	5	6	7	8	9	10	11	12	13	14	15	16	17	18	19	20	21	22	23	24	
Output voltage		306	294-303-322	275	275-355	277-284-286-293-295-299-303-308-316-318-321-322-566-567	328-336-340-343	349		361-362	366-368-370	379-368-568		420		425						437	572	454-538	
Purpose of oscillator		294	6-294-296-305-311-562-565		355	279-286-291-296-311-320-327	322-336-339-344	349-350	351-353	357-363	364-370-375	376-387-391	392-401-404-405	414-417-420	421	423	426-428	426-428-431	426-428	433-435	436-437	539-541	438-443-455-530	354-438-440	
Simplicity of design			274-311-562	273-275	275-355	277-311	328-330-332		302	356	356-364	356-376-387	269-356-384-392	356-406-414	356-421	356-423	356	356	356	356	356-433	356	540	439-440-531	439-440-570
Space and weight requirements			296-304-305-308-560-582			296-308-311-566-567	339			364	369-371	376-387-568	392	406-414								541-570-572	441	570	
Temperature range requirements			304-582			277		349	353	357	364-373	387		414								540-541-572			
Versatility in application and design		306	294-306-317-562	275	275-355	277-294-295-317-319-327	328-339-344	349-350	353	356-357	356-364-369-375	356-376-387-391	356-392-404-405	356-406-417-420	356-421	356-423-425	356-428-429	356-428-430-431	356-428	356-433-435	356-436-437	539-541	439-440-442-443-455-508-530	439-440-570	
Bibliography numbers		211	10-91-141-147-149-211-212-213-231-289-426-493-494-525-678-697-840	231-781	108-127-128-212-231	91-211-308-533-649-781	91-211-618-649-781		129-496-840	211-231-523	653	128-211-212-212-308-840	211-212-211-212-308	128-212-211-212	211-212	211-212	211-212	211-212	211-212	211-212	211-212	211-840	89	151	329-777-778-779-780-781-840

	1	2	3	4	5	6	7	8	9	10	11	12	13	14	15	16	17	18	19	20	21	22	23	24	
<p>CIRCUIT ANALYSES OF BASIC CRYSTAL OSCILLATORS (Quantitative relations which are fundamental as points of departure in attacking particular problems of design.)</p>																									
Methods of analyzing oscillator circuits																									
•Complex-function, admittance-linear-parameter method <i>(Not used or discussed in this handbook as means of solving over-all circuit, although admittance equations are employed occasionally in restricted problems.)</i>						281																			
••Bibliography numbers	154	149 154 212	149 212	212	149 211 212	211 212 618						211 212													
•Complex-function, impedance-linear-parameter method																									
••Qualitative discussion	267 289	267	289		267 289	267 289	331															458			
••Application illustrated	289		289		281 289	289	331 332 336															458			
••Bibliography numbers	211 466		426		232 426 533	232 426															211 212 697			211 212 697	
•Linear-differential-equation method <i>(Not used or discussed in this handbook as means for solving over-all circuit, although differential equations are employed occasionally in restricted steady-state problems.)</i>	289	203 213 239	243 287 288	240 241	287 288					360															
••Bibliography numbers	211 332	232 750 823	232 750 823		232 823	232 750 823																			
•Loop-gain, loop-phase method <i>(For similar analysis of loop-phase relations, see Phasor method below.)</i>																									
••Qualitative discussion	267	267			280		345 347 348	351	357 360 363	365- 368	377 380	393 394	407 409	422						433		540 542 543			
••Application illustrated		267		267	281		348		360 361		378 383 388	367 394- 395	410	422						434		540 543			

	1	2	3	4	5	6	7	8	9	10	11	12	13	14	15	16	17	18	19	20	21	22	23	24
••Bibliography numbers		211								211		212												
•Negative-resistance method																								
••Qualitative discussion			231- 233 236 267	231- 233 586- 595	586- 595	278- 280										425	429					545 546 549		
••Application illustrated				233		233 278- 282	233					378				425	429					547		
••Bibliography numbers		112 113 114 154 211 271 362 640		232 532													113 554							
•Nonlinear parameter method <i>(Not used or discussed in this handbook.)</i>																								
••Bibliography numbers	428 535	211 466 789	843			843	843																	
•Nyquist-diagram method																								
••Brief mention																424								
••Bibliography numbers		60 211 571 815	212																					
•Phasor (vector) method																								
••Qualitative discussion		267- 273	267- 273	268- 273		280 282 283	330 332	345 347		358														
••Application illustrated		268- 272 281		270 272 281		268- 272 280 281 283 284 312	268- 272 281	345 347		358 359	268- 272							268- 272 281	268- 272 281		268- 272 281			268- 272 281
••Bibliography numbers		332	70 232			70 232	70 232																	
Amplitude considerations																								
•Derivation of loop-gain equation						284 289	289 331 336	348		359 360 363		378 388	395 396	410 411		424 425	425 426	289 426 427	289 331 426 427	434	289 436	548		289 436

		1	2	3	4	5	6	7	8	9	10	11	12	13	14	15	16	17	18	19	20	21	22	23	24	
CIRCUIT ANALYSES OF BASIC CRYSTAL OSCILLATORS (Continued)																										
•Loop-gain equation	267 (1)					284 (1,2, 5) 289 (2)	331 (2,4) 335 (1) 336 (1,7)	348 (1,6)		359 (3,4) 336 (2) 361 (10)			378 (1,21, 24, 25, 26) 388 (1,2)	395 (1,9) 396 (3)	410 (1,6, 7) 411 (1,2)	422 (1)	424 (1) 425 (3)				434 (1,5)		540 (1) 548 (2,3)			
•Interpretation of loop-gain equation and/or discussion of basic requirements for optimum output-to-crystal power consistent with required frequency stability	267					284 286 290 312- 316	331 333- 336 339	348 349	352	361	370- 372	379	395- 402 404	408 411- 413	421 422	424 425	429	430	432	434	436	540 548	438 439	438 439		
•A-C current and voltage limitations due to presence of crystal unit in circuit		294				277 282 284 286 290 293- 295 300 303 312- 316	277 336 339	349		361 362		379 387	402 403	412 415								540				
•Bias voltage limitations due to presence of crystal unit in circuit			245 294 303	271		282 286 293- 295 300 303 312- 315	339			359 362		379	405	412 413 415												
•Fixing electrical characteristics of limiter (vacuum tube, thermistor, etc) from loop-gain equation, crystal-unit limitations, and desired class of operation	267 294	294 300 305 322	273			284- 286 290 293- 295 303 308 312- 316 322	333- 336 339			361 362		379 388	401- 404	411- 413 415	425	429				434		540				
•Output amplitude estimated from equilibrium parameters of limiter	267 294					282 290 293- 295 303 312- 316	336 339			361 362		379	402- 404	412 413 415								540				

	1	2	3	4	5	6	7	8	9	10	11	12	13	14	15	16	17	18	19	20	21	22	23	24	
•Amplitude variation with effective resistance of crystal unit			226-237 294 300 308 309	214 230-237	229	290 293-295 300-303 308 309 312-316	336 343				361 362		379 387	401-403	411-413 415						436	540		436	
•Amplitude variation with frequency			301 303			291 295 301 303	336 340 343					366-368 371 372		405									543 544		
•Amplitude variation with load			294	214		284 286 295 312-316	339 340						387 388	401-403	411-413 415							436	540		436
•Derivation of amplitude-stability equation											360														
•Amplitude-stability equation											360 (6, 10, 11, 12, 13, 14, 18)														
•Interpretation of amplitude-stability equation and/or discussion of basic requirements for optimum amplitude stability		267 294 306	294 296 299 300 306 308	273		284 291 294 296 299 300 308	340 343		352	357 360-363	368 370-372	379	401-403	412 413 415									540		
Frequency considerations																									
•Qualitative analysis and simplification of loop-phase requirements		267-273		269		268-273 280 282 283 289	268-273 328 332	269 345 347	351	357	268-273 365-368	380 383	267 269 393 394	407 409	380 383 421 422	423 424	423 424 429	268-273 427 430 431	268-273 427 432	269 433	268-273 436	540	440	268-273 440	
•Derivation of loop-phase equation		270 272 281		270 272 281		270 272 281 289	270 272 281 289 331					383			383	424	424	270 272 281	270 272 281		270 272 281	548		270 272 281	

	1	2	3	4	5	6	7	8	9	10	11	12	13	14	15	16	17	18	19	20	21	22	23	24	
CIRCUIT ANALYSES OF BASIC CRYSTAL OSCILLATORS (Continued)																									
*Loop-phase equation		267 (2) 270 (1) 281 (1,2, 3,4)		270 (1) 281 (1,2, 3,4)		270 (1) 281 (1,2, 3,4, 6, 11, 12) 289 (3)	331 (3,5)						383 (5)	267 (1)		383 (5) 422 (5)	424 (2)							548 (1)	
*Interpretation of loop-phase equation and/or discussion of basic requirements for optimum frequency, bandwidth, and tolerance		267 270- 273 354	322		355	277 281- 283 289- 291 295 317 322	328 329 331 332	347	351 352	357	368 373	380- 385	393 394 396 398 404	406 413	393 422	424	429	430	432	433 435	436	548	438- 440	354 436 438- 440	
*Derivation of frequency-stability equation				287 288		284 287 288	338			358 359		241 386	399	413											
*Frequency-stability equation				287 (1)		287 (1,2, 3,4, 5) 288 (2)	338 (1,2, 3,4, 5)			358 (4,5, 8, 10, 11, 12) 359 (5,6, 8,9)		241 (2)	399 (1,2)	413 (3)											
*Interpretation of frequency-stability equation and/or discussion of basic requirements for optimum frequency stability		298	245 251- 261 269 298 309 310 593- 598	273 287 288	355	277 279 281 283 284 287 288 298 309 310	332 333 335 336 338 341 342	346 347		357 359 361 363	368 371- 373	379- 386 393	396- 400 404	406 413 415 419		424	426 429	426	426	433 435			438 439	438 439	
Bibliography numbers for amplitude, frequency, and stability analyses		69 154 211 466 571 640 789	212 213 318 872	89 149 232 532	108 127 211 212 233	70 149 211 212 231 232 426 649 533 649 823 843	70 211 212 231 232 426 649 823 843			211 231 523	653	128 211 212	211 212	128 212	212	113 211 212 554	211 212	212	212	211	89 211	151	329	89 211	

DESIGN OF CRYSTAL OSCILLATORS																											
Circuits specifically designed for use with currently recommended Military Standard Crystal Units (Figure numbers)					135 (L,M, R-W, Y,Z) 137 (A,B, E,G, N-V) 138 (A,B, E) 243 247 2-2 2-6 2-18 2-22 2-28 2-32 2-46 2-54 2-56	143 2-44	2-50 2-52																				
Circuits adaptable, but not specifically designed, for use with currently recommended crystal units (Figure numbers)					131 135 (A-K, N-Q, X) 136 137 (C,D, F,H- M) 138 (B,C)	142 149 150 151 152 153 186	155	157 158	163 164	167 168 169 170 171 172	174 175 (G)	177 (A- C)	179	180	161	182 (B)	182 (C, D)	182 (E)	183 184	106 185 (D, E)	222 224 227 232 (B) 233 234 236 238 240 254 256 257	186 187 188 191 220 221	106 159 186 187 254				
Design procedure		267	304 322	317		278 290 291 293 295 303 308 311	332 334 336 337 339	348	352	362	368 369	379 381 387	396- 403	411- 415	422				426 427	426 427	426 427	433 434	436	546	438 443	436 438	
Design procedure illustrated						311- 316	336		352		371		404	414- 420	421 422				429	430	432					439 443 447	439
Bibliography numbers		211 466	108 149 212 213 678 781 840	781	108 212	91 149 211 212 618 533 649	91 211 212 649		840	211 523	653	128 211 212	211 212	211 212	212				113 211 212 554	211 212	212	212	211 840	89 211 840	151	329	89 211 697 840

CRYSTAL OSCILLATOR DESIGN CONSIDERATIONS (Alphabetical indexing of principal factors to consider when designing for optimum or special performance characteristics.)																								
Activity (See also Amplitude.) Definition of			227 228	230 231																				
•Of crystal oscillator			228 294	232 233 232 233 236 237 273 275	254 275 355	277 283 284 286 289 291 293- 295	328 336 338 339		352	360- 362	364- 366 368 370- 372	376 379 387	392 402 403 405	411 412 414- 420	421	423	429	430 431	432	433	436	540 541	438 440	254 438 440
•Of crystal unit (See also Methods of Mounting Crystal Blanks in Crystal Holders—paragraphs 1-132 to 1-170.)			227 228	230- 237	229	312					374	387 388	402 403 405											
Activity quality of crystal unit																								
•Discussion of			227 228	230- 237	229					361														
•Parameters for indicating activity quality			226- 237																					
••Effective Q (Q_e)				231- 234		284																		
••Effective resistance (R_e)			584	232		300 309 312- 316	333 336	348	353	361 362			393 394 401- 403 405	412							436			436
••Equivalent series-arm conductance ($1/R$)			228- 231	230 231	229							379	393 394 401- 403 405	412			426	426	426			540		
••Figure of merit (M)			235																					
••Gridleak current			220 228			284			352		368										220			220
••Maximum effective Q (Q_{em})			234 235																					

	1	2	3	4	5	6	7	8	9	10	11	12	13	14	15	16	17	18	19	20	21	22	23	24	
••Performance index (PI)			427	236 237 584		278 285 295 297 300 312 314	333 336 340 343	348																	
Activity stability (See Ampli- tude stability.)																									
Amplification factor of																									
•Transistor																						540 543			
•Vacuum tube		268	311	273		284 286 295 311- 313	328 335 336	348		359		387		409 413											
Amplification of oscillator signal		268 269	294 299 304 305 308 322			280 282 284 286 294 295 299 308 316 318 322 326	328 331 333- 336 339	345 348		359 360 363	365 373	377- 379 387	395 402	409- 412	421						433 434		540	438 440 442 445 450 473 475 478 480 482 483 487 493 494 522 525- 527 538	438 440
Amplifier following oscillator		21	21 308 322			286 308 322 326	328 339	349		363		387 390									437		438 440 442 445 450 455 473 475 478 480 482 483 487 493 494 522 525 538	438 440	

CRYSTAL OSCILLATOR DESIGN CONSIDERATIONS (Continued)																									
	1	2	3	4	5	6	7	8	9	10	11	12	13	14	15	16	17	18	19	20	21	22	23	24	
Amplitude		268 294 306	249 294 296 304 305 308 311 315 322	275	275 355	277 278 282 284 286 291 293 296 308 318 322 566 567	322 328 333 336 339 340	348 349	352	356 360- 362	356 365- 376 368 370 371	356 376 379 387 388 568	356 392 397 399- 405	356 406 411- 420	356 421	356	356 429	356 430 431	356 432	356 434	356 436	540 541 572	438 454 527	438	
Amplitude range		294	308- 310		355	291 295 308- 310 312 321 566 567	336 339	348 349	352	361 362	366 368 371	376 379 568		411- 413	421			431				540 541	527		
•Expected, due to variation in effective resistance of crystal unit			232 249 300- 303 308 309	233 237		233 237 290 294 295 300- 303 308 309 312- 316	233 237 308 336 343			361 362		379 387	401 402	412- 415							436			436	
•Limitations of, due to specified drive level of crystal unit			258 294 311			277 282 284 286 290 293- 295 301- 303 311- 316	328 336 339 344			361 362	370	379 387	397 401- 404	412 413 415 416						434					
•Of fully loaded circuit			309			286 295 309	339 340	349			370 372	387		417- 420											
•Of nonloaded circuit						278 284 286 293 295 312- 316	336 340			362	366 370 371												438	438	

WADC TR 56-156

391

	1	2	3	4	5	6	7	8	9	10	11	12	13	14	15	16	17	18	19	20	21	22	23	24
•With automatic gain control			308			308 315																		
•With manual gain control			301- 303 311			291 294 295 301- 303 311 318	337 340				366	387												
•With no gain control						286 293 295 312- 315						379 387	402	412 413										
•With overdrive of crystal unit			339				339				372			416										
Amplitude stability	263 265 266	294	294			283 284 294				357 360 361	368		393											
•Under variations of load	265		315 322	212 214		291 312 315 321 322 326	340		352				401 402	411 412										
•With automatic gain control			308 315			308 315	308																	
•With gridleak bias		306	296 297 299- 303			296 297 299- 303						379		412										
•With grid limiting		294	214	273		294																		
•With load electron-coupled			322			322					375													
•With tri-tet operation			214 322			321 322	322																	
•With variation in gain of stage										360	373	379										540		
Bandwidth		354			355	295 566 567	344	347	351 352	356 357 363	356 370- 375	356 376 381 568	356 404- 405	356 406	356	356	356 428	356 428	356 428	356 433	356	539	455 525- 529	220 354
•Broad-band circuit			247 309 310 311 322	275	275 355	277 278 309 310 311 322 323					374	376 377 381- 385 387	392 398 402 404 405	406 418		423 425				433			438- 440	433- 400

CRYSTAL OSCILLATOR DESIGN CONSIDERATIONS (Continued)																								
	1	2	3	4	5	6	7	8	9	10	11	12	13	14	15	16	17	18	19	20	21	22	23	24
•Narrow-band circuit			247 309		355	277 283 308	328 344				365 372 375		404 405	417			428	428	428	435			451- 454	
•Of crystal units (See also Crystal element characteristics.)			139 246- 248	276 317		305 309							405											
•Single-frequency circuit			247 309 322			277 283 291 322		353	357 358 363	364 371			419 420						432	435			451 455	
•With adjustable tuning		306 354	246- 248 322	276 317		291 301 303 317 322	328 329 339 344	350	352	363	364- 368 370- 375	376						431			436		439	220 354 436 439
•With overtone crystal units				276	355	277					364- 366 370- 375	376 387 391	392 402 404 405											
Bandwidth and selectivity parameters of crystal unit			197 246- 248	276							368 374													
Bias		288				288 312	337							411 415								540 549- 553 555		
•Automatic gain control		337	308 310 315			308 315	337																505 510	
•Cathode			307			307	337			359 362		379 382 387									434	220		220
•Class A		298	305 308	273		284 308 312 314 315 322				359 362		376 379 387	401	411 412							434			537
•Class AB				273		312 315 322								412										
•Class B		294	296 300 311	273		293 294 296 311 312 322								412 417										

	1	2	3	4	5	6	7	8	9	10	11	12	13	14	15	16	17	18	19	20	21	22	23	24	
•Class C		294	296 299 300 311	273		282 284 293 294 296 311 312	337 339					376 387 388	392 401- 403	406 420	421						437		438	438	
•"Class D"		298	298			298	342																		
•Effect of crystal resistance				271		297 312- 316															220				
•Effect of gridleak resistance		306	282 296- 298 307 308			282 296- 308 313	341					379													
•Fixed		294	294 296 300 305	271 273		294- 296	339																		
•For frequency multiplication			322			322																		474 537	
•Gridleak		306	296- 308	273		282 286 293 295- 316	339 343		352			379 382 388	405	411 412								220	474 537	220	
•Limitations of, due to speci- fied crystal drive level			294			282 293- 295 303 312- 316	339					379		412 415								220- 224		220- 224	
•Reactance tube (afc)								350														437	484 492		
Build-up of oscillations	266	267 268 294	232 236 275 294 296 299 304 305	232 236 273 276 308 586- 595	355 586- 595	294 296 299 308 315	337 339 340	346		357 363	364- 367	377 379	401	411		425	429				434		540	455 484 489 532- 535 537	
Buffer amplifier			304 305 308			304 305 308 323																		522 538	
Capacitance						290 291						365- 368													

	1	2	3	4	5	6	7	8	9	10	11	12	13	14	15	16	17	18	19	20	21	22	23	24	
CRYSTAL OSCILLATOR DESIGN CONSIDERATIONS (Continued)																									
•Cathode			307			307 566						383 388		407 417 419											
•Dynamic						278- 282 287- 290	332	350										430							
•Grid			296			278 284 287 288 290 291 293 294 296- 298 301 312 322 323	328 334 336	345 348		358 359		381- 383	398- 400 404	406 413				430	432	435				439	354 439
•Load (See Load capacitance of crystal unit.)																									
•Negative (C_n)						278- 282 287- 289												430							
•Optimum grid-to-plate ratio (C_p/C_g) (See also Gain, op- timum.)						284- 286 290 291 293- 295 298 301 303 308- 310 312- 316 318												430							
•Oven			279 4-73			279 321 323																			

WADC TR 56-156

395

	1	2	3	4	5	6	7	8	9	10	11	12	13	14	15	16	17	18	19	20	21	22	23	24		
•Plate (C_p)			309			277 278 280 281 284 287- 290 291 293 294 298 300 309 312	329 332 338 340				358 359		381 389	393 394 398- 400 404	407 413 419				430	432						
•Plate-to-grid (C_{pg})			279 311			277- 279 287 295 311 320- 323	329 332 334 336	345			371		393 394						430	432	435					
•Shunting crystal			182 184 185 187 188 190- 196 201 219 252	208 211 212 230 231 233 243 276	205- 207 355	278 279 287 300 305 320- 323 566	332 334 336	348 350			365 367 368	376 381 385 388 391	393 394 405	406 412 414 417- 419	422	424 425	426	429	430	432 435					354	
•Stray			188 201 311 598	233 276	189 355	278 279 287 289 290 292 311 318 320- 323	332 334 336 339	345 347	351	357	365 372	381 387- 389	392- 394			423 425			429	430						
•Stray, measurement of			292			290 292																			188	
Capacitors						318					369	389													2-90	
•Fixed, r-f bypass			245 303 307 320			303 307 320 321 324			352			382 389													220	
•Fixed, tuning			245		355	290 318	329 336	345- 347	352		369	389	393								432					

CRYSTAL OSCILLATOR DESIGN CONSIDERATIONS (Continued)																									
	1	2	3	4	5	6	7	8	9	10	11	12	13	14	15	16	17	18	19	20	21	22	23	24	
•Variable			245 322 581			291 294 298 301 318 321 322 566	329 338		352	358 363	365- 369	389						429	431		436		439 513	220 436 489	
Cathode bias			305 307			307	337			359		387									434				
Choke, r-f						292								406 407								551			
•To reduce circuit losses		294	296 297 307 309			277 294 296 297 309	339																		
Class A operation		298	305 308	273 276		284 308 312 314 315 322				359 362		376 379 387	401	411 412							434				
Class AB operation				273 276		312 315 322								412 415											
Class B operation		294	296 300 311	273 276		293 294 296 300 311 312 322								412 417											
Class C operation		294	296 299 300 311	273 276		282 284 293 294 296 300 311 312	337 339					376 387 388	392 401- 403	406 420	421						437		438	438	
"Class D" operation		298	298			298	342																553 555		
Coils, inductors										358	365 369														

	1	2	3	4	5	6	7	8	9	10	11	12	13	14	15	16	17	18	19	20	21	22	23	24	
•RFC		294	296 297 307 309			277 292 294 296 297 309	339	350				390		406 407								551			
•To antiresonate with unwanted capacitance			248		355		329	347			365	376 381- 383 385 388 391	394	406 417 418	422	425									248
•Transformer										358 362 363	365- 369 371- 373	390	393 394	406 407 411 417- 420	421							542			
•Tuning		306	322			277 283 298 322 323	328 329 338 340 343 344	350		363	365 367 369 374	389 515	267 393	406 407 417- 420	421	425	426 427	426 427	426 427		436	542	438 513 515 516	220 436	
•V-H-F											365 369 371- 374			417- 420											
Crystal calibration (See also 2-66 to 2-151)										357															438- 440
Crystal calibrator circuits																									
•Figure numbers						135 (D, E, Z) 137 (F, G, L, M, V) 138 (B, D)	149 (D, F, G) 151 (C) 153 (E- J) 186						175 (K, L)					187			184	185 (A- D)		186 187	159 186 187
•Principal requirements of																								438- 440	438- 440
Crystal check points																								439 440	439 440

CRYSTAL OSCILLATOR DESIGN CONSIDERATIONS (Continued)																										
	1	2	3	4	5	6	7	8	9	10	11	12	13	14	15	16	17	18	19	20	21	22	23	24		
Crystal current				216 232 233 594	205 210 249 594	233 237 277 284 286 289 290 293 294 300 301 303 312- 317 323	233 237 332 339	345 348	353	361 362	366- 368	377- 379	393 394	412									540 542 543		188 220 259	
Crystal element characteristics			89- 119 192- 200 246 247 254 256 259- 261 305	208 209 212 217 255 276 317	207 217 253- 255				351	357 358 363	364- 368 374	391	396	413 414				426	426	426					438	
Crystal impedance meters			274																						436	
•Application					229				352					405 417											436	188 220- 225 436
•Design of												373 374													220 436	220 436
•Figure numbers																									106 185 (A- C)	106 185 (A- C)
•Military Standard test sets (See also paragraphs 2-66 to 2-151.)														405 417											436	25 220 236
Crystal oscillators, early devel- opment of			17- 22	276					351																	
Crystal oscillators, types of			274 275 449 560 586	276 345 351 354	345 351 355 356 449																			539		

	1	2	3	4	5	6	7	8	9	10	11	12	13	14	15	16	17	18	19	20	21	22	23	24	
Crystal parameters (See Parameters of crystal unit.)																									
Crystal power			181 186 230 249- 252 256- 261 303	214 215 230- 233 237	249	284 286 293 295 296 301- 303 312- 316 319 324 566 567	333 336 339 340			359 361 362	370 372	379 387 397 399- 404 568	401 402	408 412 413 415 420	421					432	434				220 221 224
Crystal unit, major factors determining selection of (See also Crystal element characteristics.)																									
•Availability							339				374			414											
•Drive level			181 256- 261 311	214 301- 303		277 278 282 284 286 293 311- 316 566 567	333 336 339 340 344		353	359 361 362	370	379 387 568	392 397 399- 404	412 413 415	421					432				540	
•Frequency range		354		276		277 278 295 301- 303	336		351	357	370- 375	376 387	392 402 403	413 414	421			429	430 431	432	433		539		354
•Frequency tolerance		354	215 257- 260	276		277 278 291				357		376 387 568	392 404	413 414	421		429	430 431	432				438	354 438	
•Load capacitance		354		317		278	332	348	352															354	
•Maximum effective resistance			228 261 583	214 230	229	278 293- 295 300 303 312- 316 566 567	333 336 339	348	353	361 362	368	376 377 379 385- 387 568	393 394 396 401- 403	411- 414	421	423 425	429	430 431	432	433		540			
•Maximum shunt capacitance											365	385	394	414 419	422	424	426 429	426 430	426 432						

	1	2	3	4	5	6	7	8	9	10	11	12	13	14	15	16	17	18	19	20	21	22	23	24	
CRYSTAL OSCILLATOR DESIGN CONSIDERATIONS (Continued)																									
•Mode of operation																									
••Fundamental, overtone				276	355	277	339		351		364 365	376 377 387	392 403 405	407 414			428	428	428	433					
••Parallel, series		354	594	214 276		277		350	351			387	393 403 405			425	428 429	428 430 431	428 432	433		550 551			
•Mounting method			24 132- 170 178 258 320 577- 579			320 566 567	339		351		365	381 385 568	393 394	414								570 571 572		570	
•Operating temperature range			22 23 252- 255 304 582			277		349	353		373	387		414									540 541 572		
•Relative performance characteristics			226- 261 305	317		287 288	339 343			357 362	365	386	393 394 396	414										438	438
•Special test specifications			25 317 320 581 582			285 286 295 300 320	332 339 344	351		357 362	365 368			414			426	426	426					438	438
•Type of holder			24 171 320 579			320	339				365	381 385	393 394	414											
•See Section II for full description of Military Standards and Military Test Specifications for recommended crystal units.																									
Crystal voltage																									
•A-C			143 248- 250 320	232- 234		320 324	336 339 340 343	345 348		361 362	365 366 368		393								436			220 436	

	1	2	3	4	5	6	7	8	9	10	11	12	13	14	15	16	17	18	19	20	21	22	23	24	
•D-C (See D-C voltage across crystal unit.)			320			320																			
Damping of tuned circuits			152 309		355	309 311						381 382 385 387 389		406 418		423- 425	426 429	426 430 431	426 432	433					
D-C voltage across crystal unit						320																			
•Effects of			143 320																						
•Methods for reducing or eliminating			143- 152 320 321			320 321																			
•Terminal polarity test																									2-47
Degradation of crystal Q by resistance in external circuit			249 300		240- 242	300						386	396- 399 401- 404	413		425				435			549		
Drive level of crystal			143 149- 153 181 238 249 251 256- 261 311 317	214 215 230- 233 237 276		278 282 284 290 291 293- 295 301- 303 311- 316 324 566 567	333 336 339 340 343 344		353	359 361 362	370 372	379 387 568	392 401- 403	412 413 415 416 420	421					432	434				220- 224
Effective resistance of crystal unit			182- 186 189 199 200 204			280 284	336			358		377	393 394	417 418		423 425	426 427 429	426 427 430 431	426 427 432	433					220 224
•Effect on amplitude			152 228 249 308 309 311 383 586- 589	214 230- 584	229 584	290 293 295 301 303 308 309 311- 316 566 567	336 339			361 362		379 387 568	401- 403	406 411- 415								436	540 543 558		224 436

	1	2	3	4	5	6	7	8	9	10	11	12	13	14	15	16	17	18	19	20	21	22	23	24		
CRYSTAL OSCILLATOR DESIGN CONSIDERATIONS (Continued)																										
•Effect on feedback Q (Q_f)				233 244 270- 273		279 281 289 297 298	332	348																	556	
•Effect on frequency stability			250 597	210- 212 214	206 207 240- 242	279 281	332 333	348		359	368	376	396 399	406 413- 415												
•Expected range of values			199 200 202 205 209 294	217 271		278 290 294 295 300 301 312- 316	332 336 339 343	348		361 362		379 387	401 402	412 414- 416	422	425									549 551	
•Maximum value			216 300 303	271 584	584	278 285 290 293 295 300 303 312- 316	333 339	348	353	362		379 385 387	401- 403	411- 415											433 434	
•Minimum expected value			199 200	271		290 295 301 312- 316				362		379	401	412 415												
•Most probable value			199 200			295	333			362		379	402 403													
•Reducing the effects of changes in			254- 256 261 308 309 595	214 271		278 295 308 309 320	332 333	348		361 362		401 402	412 413 415											436	553 555- 559	436
Efficiency of circuit			248 296	276		284 296 312	339	349				376	405	420											541 544	
Electron-coupled circuits			279 322			279 322 327 567																				

	1	2	3	4	5	6	7	8	9	10	11	12	13	14	15	16	17	18	19	20	21	22	23	24
•Advantages of			320 322	214		320 322 565	322 439				375	387			421			431					439	439
•Design features of			322			322 327 510 567	439				375	388 390			421			431					439	439
•Figure numbers						137 138 139 247 2-2 2-6 2-18 2-22 2-23 2-32 2-54 2-56	139 152 186				172 (C)	174 (A) 175 (I) 2-26 2-66			180 (C)			182 (D)					186 187	186 187
Feedback circuit		267- 273		269- 273		279 281 295 297 324		348		357		377 386	267		421	423							540 542 546	
•Effect on state of oscillation		269- 273 298 306	245 294 298 590- 594	233 237 244 273 291	240- 242	277 278 282 284 289 294 298 321 322	277 328 332 334 336 339 341	345- 347		360	365- 368	386	393 394 402	412 415			429					220 436	540 542	220 436
Feedback Q (Q _r)		271- 273	294	271- 273		277- 284 289 294 295 297 298 321 323	277 332	347															543 556	
Filament voltage			313 315																					
•Effect of variation of			315			315	315																	
First crystal oscillator			17 18						351															

	1	2	3	4	5	6	7	8	9	10	11	12	13	14	15	16	17	18	19	20	21	22	23	24	
Frequency stability	263 265 266	267 269 322 585 597 598	274 294 296- 298 301 302 304 305 309- 311 314 315	273 275 276 287 288 315	207 275 276 287 288 294 296- 298 309- 311 315 322 566 567	277 279- 285 287 288 294 296- 298 309- 311 315 322 566 567	315 328 330 332 335 338 339 341 342	347 349		356- 359 363	356 366 368 371- 373	356 376 380- 387 391 396 404 405	356 392 393 396 400 404 415 417- 420	356 406 421		356 426 428 429	356 426 428 430 431	356 426 428 432	356 433 435	356	541 551- 558 570 572	438 439 462 524	438 440 570		
Frequency stability coefficient (Sec Frequency stability indices.)																									
Frequency stability indices			227 238 239 245	243 244 287 288	240 241 288	287 338						386	396- 401 404												
•Equations of				243 (1)	240 (1) 241 (1,2)								396 (1,2) 399 (3,4, 5)												
•Estimating values of crystal parameters appearing in equations of			184 185 190- 201 207																					187 188 218 225	
Frequency stability equations (See also Frequency stability indices.)		598 (1)		287 (1)	287 (1,2, 3,4, 5) 288 (2)	338 (1,2, 3,4, 5)				358 (4,5, 8,10, 11, 12) 359 (5,6, 8,9)		241 (2)	399 (1,2)	413 (3)											
Frequency stability improved by																									
•Antiresonating shunt react- ances					355			347			365	376 381- 383 385	393 394 407 417 418	406 407 417 418	422	425							551		
•Automatic frequency control								350																455	
•Balanced circuit design			245	210	245						369 374	383 387 389	393 394 404		422							436	558	452 526	436
•Broad-band tuned circuits					242							381 382 385 387		418						433					
•"Class D" operation		298	298			298	342															555			

WADC TR 56-156

406

CRYSTAL OSCILLATOR DESIGN CONSIDERATIONS (Continued)																									
	1	2	3	4	5	6	7	8	9	10	11	12	13	14	15	16	17	18	19	20	21	22	23	24	
•High Q in crystal circuit			186 217 250 274 297	212- 214 216	207 240 241	277 282 297 308					367 368	376 379 381 385 386	393 396- 399 404	413		425				435		549			
•High Q _t		270	294			277 279 282 284 294 295	332																		
•Increasing plate-circuit resistance			310			277 282 284 294 297 298	333 337										429								
•Large gridleak resistance			296- 298			277 282 296- 298	341	348				387	398												
•Low crystal drive			181 252 256- 261 314	276		277 282 284 295 324						379 387	401 402	413											
•Maintaining resistive plate circuit		269 271				277 282- 284 323	332	347 348		357	368	376 377 380- 385 387	393 394												
•Minimizing effects of distributed impedances		269	186- 189 245 252		205 207 217	279	339	347		357 363	365 369 371 372 374	376 380- 385 387- 389	393 394	417- 420	424										219
•Minimizing effects of variations in																									
••Grid capacitance			245			295 298				359	373	381- 383	392 399 400 404	406											
••Load capacitance			245	211- 213 217 243 244		284 295 298 301 318 566	332				368														

Section I
Oscillator Index

WADC TR 56-156

407

	1	2	3	4	5	6	7	8	9	10	11	12	13	14	15	16	17	18	19	20	21	22	23	24	
••Load resistance		21 271 322	245 322	214		322							402												
••Plate capacitance		322	245 322		242	322				359	373	381	399 400 404	413											
••Plate resistance		20 271 298	245 298 310 311			277 282- 284 294 298 310 311 323	332 335 337 342	347 348			368 373	380- 385	402 403												
••Plate voltage		20 298	245 298			277 282- 284 298 323	332 341 342	347			368 369	380- 385	403												
••Temperature (See also Ovens, and Temperature control.)			22 23 252- 261	215		277						387										554			
••Tube gain		298	245			282- 284 294 298	332			363	373	380- 385											474		
•Minimizing harmonics		322 595	245 249 304 305 308 311			277 308 311 321 322	329 343			359 363		387								435		558	438	438	
•Minimizing grid losses		271 294	296- 298 301 306 307 308	273		277 282 284 294- 298 307 308 321	332 336 339 341	348		359		387	392		421										
•Minimizing load						277 278 298 567	336 341					379	392												
•Minimizing transit time											369	381 382 383 387			421										
•Neutralizing circuits			245 326			326	339					383 387 389	392- 394	406 419	422					435					

Section I
Oscillator Index

	1	2	3	4	5	6	7	8	9	10	11	12	13	14	15	16	17	18	19	20	21	22	23	24	
CRYSTAL OSCILLATOR DESIGN CONSIDERATIONS (Continued)																									
•Optimum relations among stability parameters	266	298	302 310 562	210 273	245	285 298 302 310	332 337 342			359 361 362	368	377 379 387	392- 394 396- 404	413 415 419			426 429	426 430 431	426 432			553 555	474		
•Plate phase stabilization		269 530				282 283 323						383	394											530	
•Suppressing parasitic and free-running oscillations			426								365 373 389	381		406	421	424	426	426	426	435		554	458		
Frequency stability versus amplitude stability	263		245 296 297 322 581	214 315		283 284 296 297 315 322	330			360 361	366 368		401	406 415 417- 420											
Frequency stability versus output amplitude		595 596	245 249 294 296 301 302 581	214		277 282 284 286 294 296 330	277 328 330 341			356	356 371 372	356 379	356 392 397 404 405	356 413 417- 420	356 421	356	356 428	356 428	356 428	356	356				
Frequency synthesis				276																			441- 538		
•Estimation of all frequencies involved in synthesizing network																							440 442 445- 449 455- 461 464 519- 522 525- 529		
•Methods of synthesizing frequencies				276																			276 440 442 443 455 463 508 509 512 517 530	440 443 2-124	
•Stability of channel frequencies																							442 458 462		

	1	2	3	4	5	6	7	8	9	10	11	12	13	14	15	16	17	18	19	20	21	22	23	24	
•Total number of channels																							442		
																							455		
																							463		
																							509		
																							512		
																							517		
																							537		
																							538		
Frequency tolerance (See also paragraphs 2-8, 2-18.)	263	354	245 252 304 305 310 317 582	215 276 317	355 356	277 278 310 311 317	328 339	347 349		356 357	356	356 387 568	356 392 404 405	356 406 414	356 421	356	356 429	356 430 431	356 432	356	356	552	438 439 462	354 438 439	
Gain of																									
•Autotransformer											365 368		393- 395 397 398 401- 404	407 408 410- 414 417- 420	421 422										
•Cathode follower												378 383		409 410	378 383 421 422										
•Conventional vacuum-tube amplifier		268 269	233 237			282 284 286 308 311	328 333- 336 339	345 348		360	365		395								434				
•Electron coupling			322	214		322	322																		
•Grounded-grid amplifier												378		409 410										513 523	
•Grounded-plate amplifier			322			321 322						378													
•Thermistor bridge										357 358 360															
Gain control (See also Amplitude range.)				214						360			402 403												
•Automatic			308 310 315	214		308 315	308			360															
•By loading			309			295 309 321			352	363				412 415											
•Gridleak				214 273								379												474	

CRYSTAL OSCILLATOR DESIGN CONSIDERATIONS (Continued)																								
	1	2	3	4	5	6	7	8	9	10	11	12	13	14	15	16	17	18	19	20	21	22	23	24
•Manual			301-303 311			294 295 298 301-303 311 318	340			362	365 366	387									220	540		220
•With load isolated			322			322															220			
Gain, optimum			308 322 562	233 237 273		284 286 290 291 292-293 295 301 303 308 311-316 322	328 333-336 339	348		360-362	368	379 387	392-394 397-399 402-404	411 413 415							434		540	
Grid choke		294	294 297 307			294 297	339																	
Gridleak bias (See Bias.)																								
Gridleak current		294	296 300 307		254	284 294 296 300	339		352	359	365	379		407							220			220 254
Gridleak resistance (R _g)			296-307			296-307		345 348								425								
•Effect on amplitude stability			296-308	273		296-308						379												
•Effect on frequency stability			245 296-298	273		281 282 296-298	341 342																	
•Effect on oscillator keying			296 304 305			296 304 305																		
•Effect on output control		306	296 301-303 305	273		296 301-303 315	340 341																	
•Value of		306	296-308			277 278 282 296-308 311 313	333 341	348	352			387 398		417-420	422								438	438

	1	2	3	4	5	6	7	8	9	10	11	12	13	14	15	16	17	18	19	20	21	22	23	24
Grid losses			296 297 307 308			296 297 308	331																	
•Effect on feedback Q (Q_f)				271 273		281 282 284 297 298 321	332																	
•Effect on grid capacitance		298				298																		
•Effect on oscillator stability			308	214 271 273 296 297		282 284 296 297 300- 303 321	332 341				367 368		392											
•Effect on state of oscillation			305	214 271 273		278 281 282 284 287 321	332 333 339 341				367 368		392 395											
•Input loss of vacuum tube			305			295							392 395		421									
•Minimized by grid choke		294	294 296 297 307			294 296 297	339																	
Grounded-grid circuits												377 378 382		406- 420										523
•Figure numbers												174 175 2-4 2-8 2-10 2-20 2-24 2-26 2-30 2-38 2-40 2-66		179 2-12		181 2-14 2-16 2-48	182 (B)							215
Grounded-plate circuits		322	320 322			320- 322 566 567						377 378			421 422							437		

		1	2	3	4	5	6	7	8	9	10	11	12	13	14	15	16	17	18	19	20	21	22	23	24				
CRYSTAL OSCILLATOR DESIGN CONSIDERATIONS (Continued)																													
•Figure numbers						135 (R-Z) 137 (A-H, J-N, P-V) 138 (A,B, D) 139 243 247 2-6 2-18 2-28 2-32 2-54 2-56	139 151 (F,G) 152 (D- L)						172 (C)	174 175 (G,I, J,K) 2-4 2-8 2-10 2-20 2-24 2-30 2-38 2-40			180	181 2-14 2-16 2-48	182 (B)	182 (D)					185 (D)				
Harmonic of crystal (See also Crystal element characteris- tics.)	75- 86		183 192 197	276	207					351	363	364 365 373 374	376 377 391	403 405	407 414 417 418			428	428	428									
•Overtone versus fundamental			253- 255	276		277	339			351		364	376 377 387	392								433							
Harmonics of oscillator	265 266																												
•Generation of		595- 598	245 304 311 322			311 322 325						375	376 387 388 390					431				437			438- 441 455 464 473 478 519 530	438- 440 2-111			
•In output		595- 598	245 249 304 305 311 322 582			311 322 325				356 359	356	356 388 390	356	356	356	356	356	356	356	356	356	356	356	356	541 551 558 572	438- 440 445 537 538	438- 440		
•Reduction of		595	245 249 308 311 322			277 308 311 321 322	329 343			359		387									435			551 558	452 525- 529				
Heterodyne circuits (See Fre- quency-mixing circuits.)																													
Impedance inversion		426	426- 428																										

WADC TR 56-156

412

	1	2	3	4	5	6	7	8	9	10	11	12	13	14	15	16	17	18	19	20	21	22	23	24		
•Application of			426-432														427 429	427 430 431	427 432		436		440	436 440		
•Analysis of basic circuit for			426 427																							
Impedance of crystal unit			203 204 209 426 427 584	213 214 270 276 317	355 242 254	277 279 284 285 290 317	333 336 240	348	351	357 358	366- 368	377 379 385 391	393 394 401- 403 405	411- 418	422	423- 425	426 427 429	426 427 430 431	426 427 432	433 434	436	540 547 550 555- 559		436		
•Response to changes in frequency			202 203 209 210 217 238 239 245	213 214 243 244 273 287 288 317	240- 242 254	287 288 291 298 317	340	348			366	386	396													
Inductance (See also Coils, inductors.)																										
•Antiresonant			248		355		329	347			365	376 381- 383 385 388	393 394	406 407 417- 420	422	425							542 543			
•Circuit		306 322	305 322 426 427	271		277 283 322 323	328 329 332 338 340 343 344				365- 367 374		393 394	406 407 417- 420	422	425	426 427 429	426 427 432			277 436	542 543 551	438	436 438		
•Distributed			182 186 187 217		205 207 355					358 363	365	389	393	417 418											219	
•Dynamic						278 280					369															
•Leakage													393	417 418												
Interchangeability of crystal units			25 226 254 294 300 308 309 317 579	271 275 317	275	271 277 278 290 291 294 295 300- 303 312- 317	271 328 332 333 336 339 343	348		361 362	271 364 371 374	379 387	401- 403 405	412- 415 417 418	422	425		271	271	434	436 437	543 547 556- 559	439 441 444	436 439		

CRYSTAL OSCILLATOR DESIGN CONSIDERATIONS (Continued)																									
	1	2	3	4	5	6	7	8	9	10	11	12	13	14	15	16	17	18	19	20	21	22	23	24	
Intermittent oscillations			282 297 305	593 594	593 594	282 297		345 346															531		
Keying		531	304 305																					531	
•Of crystal oscillator			149 304 305			304 305	305																		
LC oscillators		7 21 213 267- 273 305 306 314 328										389													
•Crystal stabilized			274		355			350		357 363	364	377 387 389										220 436 437	455 220- 530- 538	224 436	
•Figure numbers (Circuits indicated can operate as free-running oscillators if the crystal unit is shorted out, or else is removed.)							155 (B, C)		163 164	167 168 169 170 171 172	174 175 2-10 2-26 2-38 2-40 2-66	177 2-60 2-68	179 2-12 2-62	180	181 2-14 2-16 2-48	182 (B)	182 (C, D)	182 (E)	184 2-58	106 185		187 219 220 221	106 185 (A- C)		
•Switching from crystal control to		306	396			296 306	339	350				389										220 436 437		220 436	
Leads			182 184 187- 189 201 217 245 579		205 207 355						365 369	376 387 389											523	219 2-122	
Limiting action		585	585	585	585		339					379													
•In generalized oscillator			267 268 596- 598	585- 598	214 232 236 273	586- 595	586- 595																		
•Of plate varistor		294	294 305			294 295			352														558 559		

	1	2	3	4	5	6	7	8	9	10	11	12	13	14	15	16	17	18	19	20	21	22	23	24
•Of thermistor		294 595	294 595							357 360 362												559		
•Of transistor			590- 594																			540		
•Of transitron circuit			590- 594													425	429					546		
•Of vacuum tube with age			308 311			308 311	339																	
•Of vacuum tube with cathode bias		337	305				337				379													
•Of vacuum tube with fixed bias		294	294 300 305			294 295 300	339																	
•Of vacuum tube with grid-leak bias		282 306	296 300 311	214 232 273		282 284 296 300 311 315	339							411										
Load			230																					
•Coupling to		21 322	309 322		242	286 291 309 321 322 566 567	328 339 340	349	352	363	370 371 375	387- 390		406 418							435	437		454 523
•Effect on oscillator performance	265 266	21 269- 272 281 322	238 245 298 305 309 322	214		277 278 280 281 284 286 291 295 298 309 314 322 567	322 332 333 336 339- 343	345 348		363		387 389	392 393 405	406- 408 411- 413 415			429						540	
•Location of						298 321 322 567	328	349		356	356 370 371 375	356 376 387- 390	356 393 405	356 406 407 417- 420	356 421	356	356 429	356 430 431	356 432	356 433 435	356	540		
•Requirements of		281	582			280 281 289 291 322 567	332 333 336 339 344	348				387 388	393 397 404	406 407 412 415			429			433		540		

	1	2	3	4	5	6	7	8	9	10	11	12	13	14	15	16	17	18	19	20	21	22	23	24	
CRYSTAL OSCILLATOR DESIGN CONSIDERATIONS (Continued)																									
Load capacitance of crystal unit (C_L)																									
•Analysis of						278- 282 290 294	328 332																		
•As mathematical abstraction of generalized circuit				210 211 230- 232		233 278 282	233																		
•Dynamic component introduced by vacuum tube						278 280- 282 287 290	332	350																	
•Effect of stray capacitance upon				233		278 279 287 290 311																			
•Ensuring specified value of				217 233 245 317		278 284- 286 289- 291 293 294 301 312 317 318 566	332 334 336 339 344	345 348	352														439	222 439	
•Relation to crystal performance				212 230- 233 236 317		271 285 290 291 317	340- 343				367 368											551			
•Relation to frequency		354	225	210- 217 233 317		290 291 298 317	328 332 340 341	350	352		367 368														218 221 223 354
•Relation to frequency stability		354		210- 217 233 243 244 287 288 317		287 288 298 317	334				367 368											551			354

	1	2	3	4	5	6	7	8	9	10	11	12	13	14	15	16	17	18	19	20	21	22	23	24	
•Value specified by Military Standard (See also Section II.)				217 222 233 236 317		278 279 284- 288 290 291 293 312 316- 319 566	332 336 339- 341 344	345 348	352																218 222
Measurement of																									
•Crystal parameters (See also Parameters of crystal unit, determination of.)							337		352		373 374										436				210- 225 235 236 436
•Frequency (See paragraphs 2-66 to 2-151.)		354	22	222 223	207 221		337		352	357			405 417											438- 440	22 119 218 221- 223 354 357 438- 440
•Oscillator performance characteristics						291 298 302 312 343	337 340- 343					365 366 370- 374	387 391	392 403 405	417- 420			429	430 431	432			541		
•Physical properties of gases, liquids, solids			95 96 110 248																						
•Stray capacitance			188 292			290 292						387									433				
•Temperature (See also Section II, under Requirements and Procedures of Tests, paragraphs 2-21 to 2-50.)			2-81, 89, 104, 105, 145																						110
•Time	2-73		23 119 2-92																						23 119
Meter, CI (See Crystal impedance meters.)																									

	1	2	3	4	5	6	7	8	9	10	11	12	13	14	15	16	17	18	19	20	21	22	23	24	
CRYSTAL OSCILLATOR DESIGN CONSIDERATIONS (Continued)																									
Military Standard crystal units and holders (See Sections II and III, respectively, for complete descriptions of Military Standards for individual types of crystal units and crystal holders.)			25 133 188 200- 202 208 209 226 254 256- 258 260 261	212 217 222- 224 233 236 271	207 220 221	278 279 291 293 295 479 481 486 495 510 516	332 336 339 340		353			472 510 514 515	396 403	414 415										220- 224	
Multiple frequency generation		7 306 596- 598	308 309 322	376		277 301 308 308 309 322	328 344			356	356 371 374 375	356 376 387- 390	356 404 405	356	356 421	356	356	356 431	356	356	220 356 436 437		438- 538 571	220 436 438- 440	
Multistage oscillators		269						345- 350		363	373 374	376- 391 472 510 514 515									433- 435			440	440
Negative capacitance (See Capacitance.)																									
Negative resistance (See Resistance.)																									
Neutralizing circuits			245 326			326	339					383 387 389	392- 394	406 412 419	383 422						435				
Oscillator modifications		283 306	245 301 303- 309 311 428	214 271 273 428	428	271 277 279 282- 286 291 294 305- 309 311 317- 327 566 567	271 329 339	349 350	353	363	369- 375	376 382- 384 388- 391 568	394 404 405 416- 420		421	427				431 436 440		435	436 437	339 440	354 436

	1	2	3	4	5	6	7	8	9	10	11	12	13	14	15	16	17	18	19	20	21	22	23	24	
•Figure numbers		131	131 182	123 131 142		123 131 134 135 136 137 138 139 182 (C, D) 187 243 247	139 142 143 149 150 151 152 153 182 (E) 186 221	155	157 158	163 164	167 168 169 170 171 172	174 175 250	177	179	180	181 182 (B)	182 (B)	106 182 (C, D) 187	182 (E)	183 184	106 182 (C, D) 185	228 232 (B) 233 240 254 256 257	186 187 188 189 192 196 199- 203 205 206 210- 217 219- 221	106 159 185 (A- C) 186 187	
Output control		306 337	214 296 301- 303 308 309 311		428	284 291 293- 296 298 301- 303 308 309 318	337		352	357 360- 363	366	379 387 388	401 402	412 415 417- 420						435	436	540 555- 559	338- 441 448	338- 440 436	
Output power		294 306	214 228 230 294 300 304- 306 322 582	237 275	275 355	277 278 284 286 287 294 305 314 319 322	277 305 322 328 330 333 339 340	349		356	356 370 372	356 376	356 392 397 399 404 405	356 406 408 412- 415 417- 420	356 421	356	356 429	356 430 431	356 432	356	356	541 544	338 454 538	338	
Output-to-crystal-power ratio			228	231 233 237			333 339 340						392 397 399 404	408 411 413 415 420	421				432						
Ovens (See also Section IV.)			22 23 215 252 253 279 317	317		279 317 479 481		349				387 472 514										571 572			
Packaged oscillators			560- 584			566 567					371	568		406								569- 572			570

CRYSTAL OSCILLATOR DESIGN CONSIDERATIONS (Continued)																									
	1	2	3	4	5	6	7	8	9	10	11	12	13	14	15	16	17	18	19	20	21	22	23	24	
Parameters of crystal unit, determination of (See also Crystal element characteristics.)			184 185 188 190- 204 208 209 217 246- 250 584	210- 212 216 230- 237 243 244	205- 207 229 240 241	279- 300 305	337		351	362			396 405								436			218- 225 436	
Plate characteristics, requirements of		272	245 303 305 311	273		280- 282 284- 286 290 293- 295 308 310- 316	332 333 335 336 339 342	348		359 362	371- 373	377 379 386 387	402 404	312- 409 412 413 415		424 425	429			434					
Plate-circuit design		272 306	245 249 308- 310	271 305		278 280 281 283 284 286 289 290 293 294 298 308- 316 318 320- 327 567	328 329 332- 334 336 339 342	345- 348	352	359 362 363	370- 375	376 377 379 381 383 384 387- 391	393 394 398 404 405	407- 409 411 412 415 417- 420	421 422	423- 425	429	430 431	432	433- 435	220 436 437		441- 538	220 436	
Plate d-c voltage			214 245 309 310 311	288		277 284 288 291 311	335					379													
*Magnitude of			245			290 293 298 302 309 310 312- 316 566 567	336 339 340 341	348	352	362	369 372	379 384 387 391 568	403	412 415 417 418 420			429	430	432						

	1	2	3	4	5	6	7	8	9	10	11	12	13	14	15	16	17	18	19	20	21	22	23	24		
•Regulation of		298	245			277 298 309 310					369		403													
Plate resistance of vacuum tube (R _p)		268 270 272	232 311	271 273 288		277 280- 286 288- 290 293- 295 298 311 312 315	331- 333 346 347			362	369	380 387	403								434					
Power delivered to crystal unit (See Crystal drive level, Crystal power, and in Section II, Test Level of Drive, Second Test Level of Drive.)																										
Power oscillators		21 294	149 249 258 294 300 322	273 276		286 300 305 322	300 305 322 339				372			420												
Purpose of oscillator, design factors influenced by		294 296	149 245 247- 250 252 253 258 311 322 562	214 232 273 276	355 356	277 286 291 296 305 306 311 322- 327	322 328 330 336 337 339 344	349 350	353	357 362 363	370- 375	376 387- 391	392 401 415 417- 420	414 421	421		429	431			433 435	220 436 437	539 541	338 443 455 530	338 354 357 570	
Q of crystal unit (effective, as well as actual)			139 186 190 199 200 202 227 249 250 274	213 214 217 231- 237 270		279 284 298 300	336					386	396	413							435					
Q of crystal circuit			300 305 306 584	216 270 283	249	280 283 289 300	331 332 336				367 368	386	396- 399 401- 404	413							433 435		543 549			

	1	2	3	4	5	6	7	8	9	10	11	12	13	14	15	16	17	18	19	20	21	22	23	24	
CRYSTAL OSCILLATOR DESIGN CONSIDERATIONS (Continued)																									
Q _i of feedback circuit		270 272 294	294	271 273 297		277- 284 289 294 295 297 298 321 323	277 332	347																543 556	
Replacement of crystals (See Interchangeability of crystal units.)																									
Resistance							347				369														
•Cathode		337	307			307	337	349	352	362		377 379 386- 388			422						434 435	220			220
•Collector, of transistor (r _c)																						540 548			
•Crystal-circuit			300 426 427 584	214 283 584	240- 242 249 355 584	279 289 297 298 300	331			360	367 368	379 386 387	393 396 401	413 415- 420	422		426 427 429	426 427	426 427	433 435	436			436	
•Damping			426									381 382 385		418		424	426 429	426 430 431	426 432	433	436				436
•Distributed			182 186 189								368														
•Effective, of crystal unit (R _e , R _{em} —also R, R _m for series-mode crystals)			204 205 209 261 311 583 584	217 224 232 241 233 271 427 584	220 229 241 355 584	278- 281 284 285 290 293 295 297 300 301 303 311- 316 320	332 333 336 339		353	357 358 361 362	368	376 379 385 386 387 391	393 394 396 401- 405	406 409 411- 420	422	423- 425		427	427	433 434	436	540		436	

	1	2	3	4	5	6	7	8	9	10	11	12	13	14	15	16	17	18	19	20	21	22	23	24	
•Effective, of grid circuit			308	273		297-300	331-333 336			358	368		393 395 398 404	406 413	421					435					
•Feedback circuit		269 270		271 273 297	240- 242	279- 284 289 297 298	328 332			357 361		379 386	393 395									436	540		436
•Gridleak (See Gridleak resistance.)																									
•Load		269 270 281	245 305 309 310 582	214		277 278 280 281 283 286 289 295 298 300 308- 312 314	331 336 340	348 349		363	370	387 388	393 405	406- 408 411- 413 415 417- 420	422	425	429	430 431	432	433 434	436	540			436
•Negative (ρ)			232 586- 598	232 233 236 586 594	586- 594	278 280						378			590 591				432				545- 547 549 590 591		
•Plate-circuit (See also plate resistance of vacuum tube.)		269		271		277 280- 284 288 311	333	345- 348	352	359 362 363		377 381 387 390	393 395 398 404	408 409 412 413 415		425	429	430 431	432	433 434			339	339	
•Screen-circuit			303			303 324			352			390		417- 420							220				220
•Series-arm, of crystal unit (R, R_m)			182 185 190 199 200 202 204- 207 218 228 261 305	214 216 230 231	205 220 229	300 305				357 358 361 362	367	379 385 386 387 391	393 394 396 401	406 409 411- 420		424 425	426 429	426 430 431	426 432						
•Transistor (r_b, r_c, r_e)																						548			
•Variable (See also Thermistor, Varistor.)		337				301- 303	337		352	357 360- 362		387									220				220

CRYSTAL OSCILLATOR DESIGN CONSIDERATIONS (Continued)																									
	1	2	3	4	5	6	7	8	9	10	11	12	13	14	15	16	17	18	19	20	21	22	23	24	
Resistors								347	352	363	369 373	377 381 385 387 390												2-91	
Resonance indicator		354																						354	
Space requirements			245 296 304 305 311 560			296 311 566 567	339			363	369	376 387 568		406 414									541 570 571 572	530	572
Stability of crystal parameters			251- 261	271			337 339				357 362 363													338	338
Stability of oscillator	263- 266	267 283 294 296 306 354 389 585 595	227 233 236 238 245 252- 273 275 276	211- 217 243 244 275 355	207 240- 242 275 355	277 279- 285 287- 289 291 293 295- 300 308- 311 320- 323 330 566 567	277 328 330 332 335 339 341 342	347 349	351 352	356- 361 363	356 364 366 368 371 372	356 376 379- 387 396- 405	356 392 406 412- 420	356 421	356	356 426 428 429	356 426 428 430 431	356 426 428 432	356 433 435	356 436	540 541 551- 559 570 572	338 339 438	338 339 354 436 570		
Switching from crystal to LC control (See LC oscillators.)																									
Synthesizing circuits (See Frequency synthesis.)																									
Temperature control (See also Section IV.)			22 23 252- 261 317	215 317		277 317		349		357 360		387		414									540 541 571 572		
Thermistors		294 595	294 595			294					357 360- 362												559		

	1	2	3	4	5	6	7	8	9	10	11	12	13	14	15	16	17	18	19	20	21	22	23	24	
Time standard	2-73		23 119 2-92							357															
Tolerance in crystal parameters			25 186 190 226 252- 261 583 597	271 317 584	584	278 300 317 566 567	332 336 337 339			362	365	376 379 568	402 403 405	414								555- 559	338	338	
Transconductance			298 305	273		284- 286 294 298 312- 316	332 333 336 337	348		359 360	371 372	377 379 386- 388	395 397 398 401- 404	410- 413 415 416		423- 425	429			434					
Transducer	17		33 34 95 96 110 248																						
Transformers										357 359 362	365 368 369 371- 373		393 394	406 407 411 417- 420	421							542 552	474 517		
Transit time											369	381- 384 387	395									543			
Tri-tet design			320 322	214		320- 322 330	322 330										431								
Tuned oscillator circuits		272 283 306 354 389 531	274 322	212 271	242 355	277 283 294 298 322 324 325	328 329 332 339 340 344	350		357 358 363	364- 375	376- 391 568	393 394 404 405	407 417 419	421	425	429	430 431	432 433 435	220- 224	436	542 544 549 560	338 440 531	220- 224 338 354 436 440	
Untuned oscillator circuits					355	277 278 323 326 566 567	332	347 350	352			376 377 387	392 398 402 404 405	406 418								539 552 572		354	
Vacuum tubes			300 311			290 293 311	336 344					379													

CRYSTAL OSCILLATOR DESIGN CONSIDERATIONS (Continued)																									
	1	2	3	4	5	6	7	8	9	10	11	12	13	14	15	16	17	18	19	20	21	22	23	24	
•Dual type			311			311		349				376 379 387							433						
•Heterodyne types			279			279 327																			
•Magic-eye			354																						354
•Miniature			311			311					369 387			415											
•Most often recommended			311			277 311	339		352	362	369 371- 373	376 379 384 387	405 417- 420			425					433				
•Plate characteristics of		20 267 268 294 298	232 236 245 294 300 303 305 308 310 311	212 273		280- 286 288 290 293- 295 298 308 310- 316	332 333 336 337 339 341 342	349		359 360 362	369 371- 373	377 379 386- 388	401- 404	312 409 412 413 415 416		423 425 590	429				434				
•Reactance			350					350													437			492	
•Remote-cutoff			308 311			294 308 311 313- 315								413											
•Screen-grid			279 303 311 322			277 279 303 311 322 324- 327	329 334 336 337	345	352	359	371	376 387	394 403	406 416 420		425 590	429	431		433					
•Sharp-cutoff			305 311 322			311 312 322								412 415											532
•Small-power			311 322			311 322	322 339					387													
•Standard-size			311			279 311 316																			

SECTION II—CRYSTAL UNITS

TABLE OF CONTENTS

<i>Subject</i>	<i>Page</i>
INTRODUCTION	
GROUP I—RECOMMENDED MILITARY STANDARD	
CRYSTAL UNITS	
Technical Data Chart.....	432
Crystal Unit CR-15/U.....	434
Crystal Unit CR-16/U.....	436
Crystal Unit CR-18/U.....	438
Crystal Unit CR-19/U.....	440
Crystal Unit CR-23/U.....	442
Crystal Unit CR-24/U.....	444
Crystal Unit CR-25/U.....	416
Crystal Unit CR-26/U.....	448
Crystal Unit CR-27/U.....	450
Crystal Unit CR-28/U.....	452
Crystal Unit CR-29/U.....	454
Crystal Unit CR-30/U.....	456
Crystal Unit CR-32/U.....	458
Crystal Unit CR-33/U.....	460
Crystal Unit CR-35/U.....	462
Crystal Unit CR-36/U.....	464
Crystal Unit CR-37/U.....	456
Crystal Unit CR-38/U.....	468
Crystal Unit CR-39/U.....	470
Crystal Unit CR-40/U.....	472
Crystal Unit CR-42/U.....	474
Crystal Unit CR-43/U.....	476
Crystal Unit CR-44/U.....	478
Crystal Unit CR-45/U.....	480
Crystal Unit CR-46/U.....	482
Crystal Unit CR-47/U.....	484
Crystal Unit CR-48/U.....	486
Crystal Unit CR-49/U.....	488
Crystal Unit CR-50/U.....	490
Crystal Unit CR-51/U.....	492
Crystal Unit CR-52/U.....	494
Crystal Unit CR-53/U.....	496
Crystal Unit CR-54/U.....	498
Crystal Unit CR-55/U.....	500
Crystal Unit CR-56/U.....	502
Crystal Unit CR-57/U.....	504
Crystal Unit CR-58/U.....	506
Crystal Unit CR-59/U.....	508
Crystal Unit CR-60/U.....	510
Crystal Unit CR-61/U.....	512
Crystal Unit CR- /U.....	514
Crystal Unit CR- /U.....	516
Crystal Unit CR- /U.....	518

WADC TR 56-156

A

	1	2	3	4	5	6	7	8	9	10	11	12	13	14	15	16	17	18	19	20	21	22	23	24	
•Subminiature			311			311- 314 566 567					369 371	568													
•Triode			279 311			277 279 311 315 320 321 323	334 336 342	350			371 375	376 379 387	394	406 417- 419				430	432	433					
•V-H-F			311			311					369	379 384 387	403												
Varistors		294	294			294 295			352 353													558			
Weight considerations			296 304 305 560 582			296				363		387										541	530		

427

34	CRYSTAL METERS		
25	MULTIPLE FREQUENCY GENERATORS		
22	<i>Transistor</i>		
21	<i>Modified Colpitts</i>		
20	<i>Grounded Cathode Two-Stage-Feedback</i>		
19	<i>Miller</i>	Impedance-Inverting	
18	<i>Pierce</i>		
17	<i>Transitron</i>		
16	<i>Transitron</i>		
15	<i>Grounded-Plate</i>	Transformer-Coupled	
14	<i>Grounded-Grid</i>		
13	<i>Basic (Grounded-Cathode)</i>		
12	<i>Butler</i>		
11	<i>Capacitance Bridge</i>		
10	<i>Meacham Bridge</i>		
9	<i>Duplex—Electrode</i>		
8	<i>Multivibrator Type</i>		
7	<i>Miller</i>		
6	<i>Pierce</i>		
5	<i>Series Mode</i>		
4	<i>Parallel Mode</i>		
3	<i>Crystal</i>		
2	<i>Electronic</i>		
1	<i>Physical</i>		

Page

.....	432
.....	434
.....	436
.....	438
.....	440
.....	442
.....	444
.....	446
.....	448
.....	450
.....	452
.....	451
.....	456
.....	458
.....	460
.....	462
.....	464
.....	466
.....	468
.....	470
.....	472
.....	474
.....	476
.....	478
.....	480
.....	482
.....	484
.....	486
.....	488
.....	490
.....	492
.....	494
.....	496
.....	498
.....	500
.....	502
.....	504
.....	506
.....	508
.....	510
.....	512
.....	514
.....	516
.....	518

CROSS INDEX OF CRYSTAL-OSCILLATOR SUBJECTS

PARAGRAPH NUMBER BY OSCILLATOR

EQUATION, FIGURE, OR BIBLIOGRAPHY NUMBER WHEN INDICATED
(All except Bibliography numbers apply to Section I unless otherwise shown.)

SUBJECT

B

TABLE OF CONTENTS—Continued

<i>Subject</i>	<i>Page</i>
GROUP II—CRYSTAL UNITS CURRENTLY ON MILITARY SERVICE BUT NOT RECOMMENDED FOR USE IN EQUIPMENTS OF NEW DESIGN	
Technical Data Chart	520
RELATED MILITARY-SPECIFICATION INFORMATION	
Explanation of Military Standard Terms Used in Descriptions of Crystal Units	530
Military Standard Drive Adjustment Procedures for Crystal Units Covered by Military Specification MIL-C-3098 ()	537
Methods for Measuring the Frequency of Military Standard Crystal Units	540

SECTION II—CRYSTAL UNITS

INTRODUCTION

2-1. Section II contains all available descriptions of crystal units now being used in USAF equipments. The crystal units are divided into two groups; as defined in subparagraphs a and b below. Technical data charts present a convenient summary of the crystal units in each group, and following each of the charts are data sheets giving more complete information about the individual units. At the end of Section II is a digest of Military Standard terms, tests, and procedures applicable to crystal units which meet military specifications.

a. Group I includes those Military Standard crystal units that are recommended for use in equipments of new design. These are the crystal units assigned Joint Army-Navy-Air Force type number CR-XX/U, where XX is a two-digit number equal to 15 or higher. Except in the event of unusual or special requirements, the design engi-

neer of crystal-controlled circuits for military equipment should consider only those crystal units in Group I.

b. Group II includes the older types of crystal units which are still widely used in current models of USAF radio equipments, but which are not recommended for use in military equipments of new design. These crystal units are arranged in the order of their USAF stock numbers, which numbers are the same as the Signal Corps stock numbers except for the addition of the prefix "2100-," which serves to identify the item as belonging to the USAF 16-F stock class. The information concerning the Group-II crystal units is included primarily for the benefit of the crystal specialist or field engineer in the military. As a reference source of crystal units and available frequencies, it may also prove helpful to design and research engineers.

GROUP I

RECOMMENDED MILITARY STANDARD CRYSTAL UNITS

The crystal units included in Group I are those conforming to Military Standards and which are recommended for use in armed-services equipment of new design. These units are further classified as belonging to one of two categories and are specified in Military Specification MIL-C-3098() —the latest issue or amendment in effect, as applicable.

Category 1 is composed of those crystal units which are available in production from two or more sources.

Category 2 is composed of those crystal units which are available in limited production and possibly from only one source. The crystal units in this category also may be individual types which are in the process of being replaced by units of new design, or which, at a later date, may be placed in Category 1 by virtue of increased utility and availability.

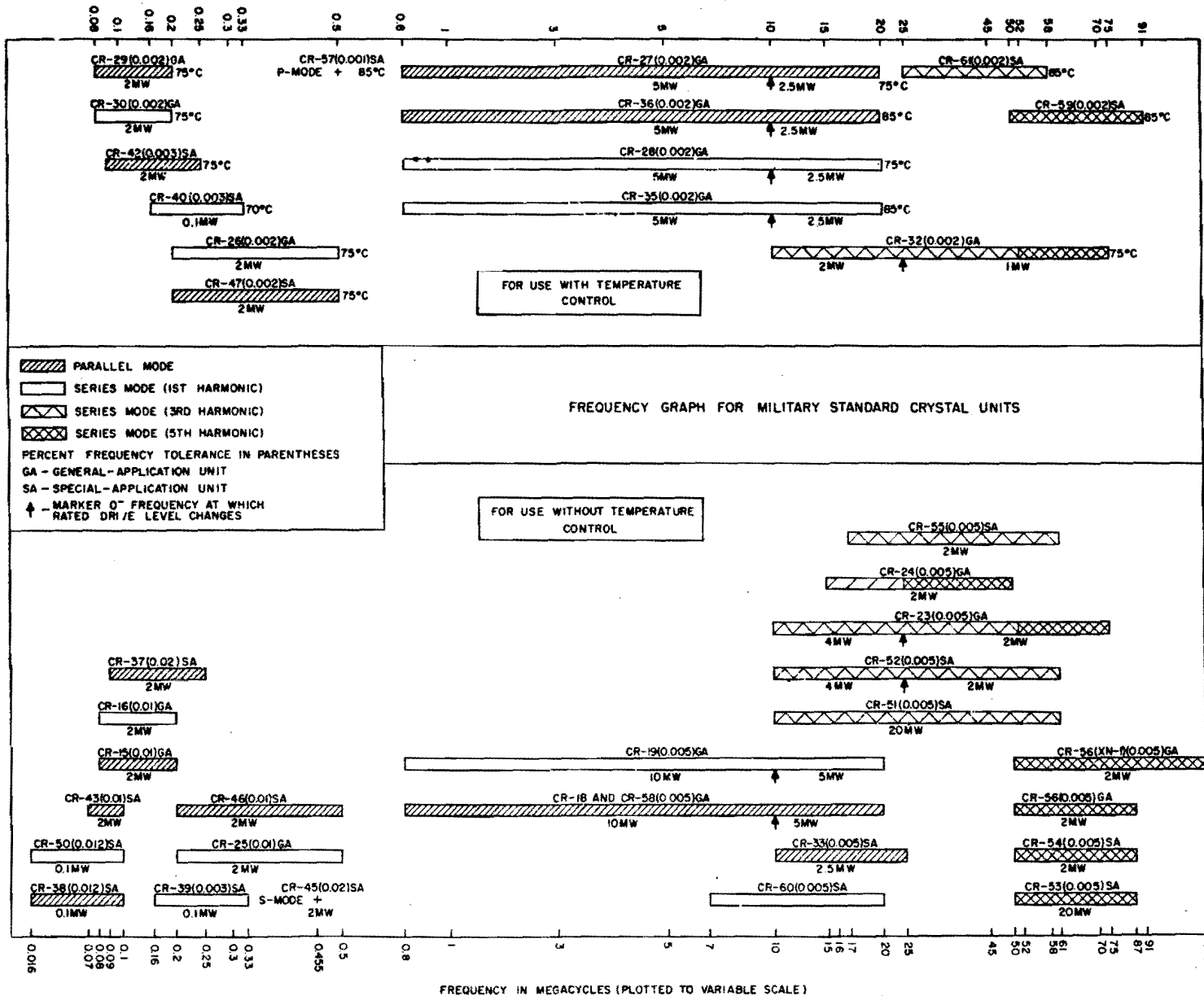

Section II
Crystal Units—Group I

TECHNICAL DATA CHART FOR GROUP-1 MILITARY STANDARD CRYSTAL UNITS

<i>Frequency Range (kc)</i>	<i>Frequency Tolerance (±%)</i>	<i>Operating Temperature Range (°C)</i>	<i>Resonance</i>	<i>Load Capacitance (mmf)</i>	<i>Holder Type</i>	<i>Availability Category*</i>	<i>Crystal Unit Type</i>
16-100	0.012	-40 to +70	parallel	20 ± 0.5	HC-13/U	2	CR-38/U
16-100	0.012	-40 to +70	series	HC-13/U	2	CR-50/U
80.860 (70-100)	0.010	-30 to +75	parallel	45 ± 1.0	HC-16/U	2	CR-43/U
80-200	0.010	-40 to +70	parallel	32 ± 0.5	HC-5/U	1	CR-15/U
80-200	0.010	-40 to +70	series	HC-5/U	1	CR-16/U
80-200	0.002 ^b	75 ± 5	parallel	32 ± 0.5	HC-5/U	1	CR-29/U
80-200	0.002 ^b	75 ± 5	series	HC-5/U	1	CR-30/U
90-250	0.020	-40 to +70	parallel	20 ± 0.5	HC-13/U	2	CR-37/U
90-250	0.003	75 ± 5	parallel	32 ± 0.5	HC-13/U	2	CR-42/U
160-330	0.003	-55 to +75	series	•	HC-15/U	2	CR-39/U
160-330	0.003 ^b	70 ± 5	series	•	HC-15/U	2	CR-40/U
200-500	0.010	-40 to +70	series	HC-6/U	1	CR-25/U
200-500	0.002 ^b	75 ± 5	series	HC-6/U	1	CR-26/U
200-500	0.010	-40 to +70	parallel	20 ± 0.5	HC-6/U	2	CR-46/U
200-500	0.002 ^b	75 ± 5	parallel	20 ± 0.5	HC-6/U	2	CR-47/U
455	0.020	-40 to +70	series	HC-6/U	2	CR-45/U
500	0.001	85 ± 5	parallel	32 ± 0.5	HC-6/U	1	CR-57/U
800-3000	0.0075	-55 to +90	parallel	32 ± 0.5	HC-6/U	2	CR-48/U ^d
800-3000	0.0075	-55 to +90	parallel	32 ± 0.5	HC-6/U	2	CR-49/U ^d
800-15,000	0.002 ^b	75 ± 5	parallel	32 ± 0.5	HC-6/U	1	CR-27/U
800-20,000	0.002 ^b	85 ± 5	parallel	32 ± 0.5	HC-6/U	1	CR-36/U

Section II
Crystal Units—Group I

Frequency Range (kc)	Frequency Tolerance (\pm %)	Operating Temperature Range ($^{\circ}$ C)	Resonance	Load Capacitance (mmf)	Holder Type	Availability Category ^a	Crystal Unit Type
800-20,000	0.005	-55 to +90	parallel	32 \pm 0.5	HC-6/U	1	CR-18/U
800-20,000	0.005	-55 to +90	parallel	32 \pm 0.5	HC-17/U	1	CR-58/U
800-20,000	0.005	-55 to +90	series	HC-6/U	1	CR-19/U
800-20,000	0.002 ^b	75 \pm 5	series	HC-6/U	1	CR-28/U
800-20,000	0.002 ^b	85 \pm 5	series	HC-6/U	1	CR-35/U
7000-20,000	0.005	-55 to +105	series	HC-18/U	1	CR-60/U
10,000-25,000	0.005	-55 to +90	parallel	32 \pm 0.5	HC-6/U	1	CR-33/U
10,000-61,000	0.005	-55 to +90	series	HC-6/U	1	CR-51/U
10,000-61,000	0.005	-55 to +90	series	HC-6/U	1	CR-52/U
10,000-75,000	0.005	-55 to +90	series	HC-6/U	2	CR-23/U ^c
10,000-75,000	0.002 ^b	75 \pm 5	series	HC-6/U	1	CR-32/U
15,000-20,000	0.002 ^b	85 \pm 5	parallel	32 \pm 0.5	HC-6/U	2	CR-44/U ^d
15,000-50,000	0.005	-55 to +90	series	HC-10/U	1	CR-24/U
17,000-61,000	0.005	-55 to +105	series	HC-18/U	1	CR-55/U
25,000-58,000	0.002	85 \pm 5	series	HC-18/U	1	CR-61/U
50,000-87,000	0.005	-55 to +90	series	HC-6/U	1	CR-53/U
50,000-87,000	0.005	-55 to +90	series	HC-6/U	1	CR-54/U
50,000-87,000	0.005	-55 to +105	series	HC-18/U	1	CR-56/U
50,000-91,000	0.002	85 \pm 5	series	HC-18/U	1	CR-59/U

^a See explanation of categories in paragraphs immediately preceding this chart.

^b In addition, the crystal unit shall not deviate more than 0.0005% (0.0003% for CR-57/U) from the frequency value measured at the midpoint of the operating temperature range, when measured over the entire operating temperature range.

^c The permitted value of load capacitance for this crystal unit depends upon the frequency at which the unit is operated.

^d For replacement use CR-18/U.

^e For replacement use CR-52/U or CR-54/U whichever is applicable.

^f For replacement use CR-36/U.

**CRYSTAL UNIT CR-15/U
(LF)**

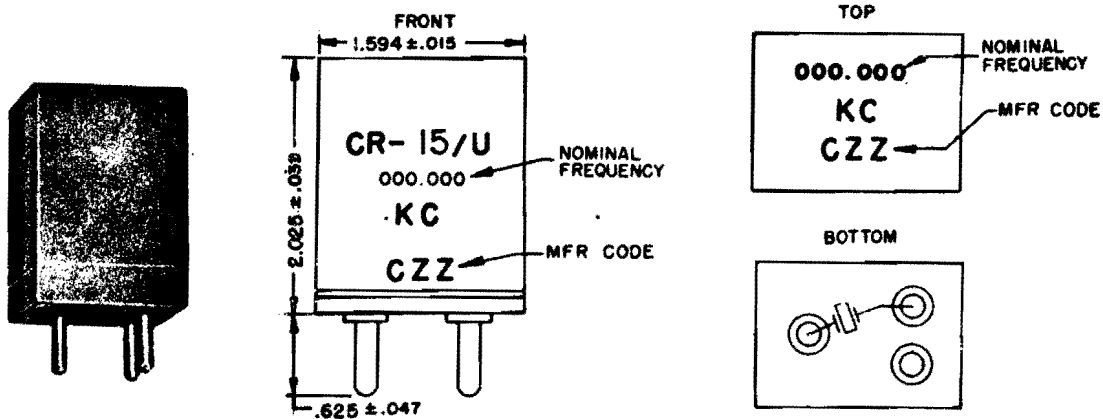

Figure 2-1. Crystal Unit CR-15/U

FUNCTIONAL DESCRIPTION

Metal-plated quartz plate, wire-mounted in a plastic holder and designed to operate on the fundamental frequency of the quartz plate. Used as a low-frequency control element in circuits which must maintain good frequency stability in the absence of oven control, even when exposed to wide variations in temperature. The crystal unit is intended for operation at parallel resonance.

RATED OPERATING CHARACTERISTICS

- Frequency Range: 80 to 199.999 kc
- Nominal Frequency Tolerance: $\pm 0.01\%$ at all temperatures within operating range
- Frequency Deviation with Temperature: Permissible within limits of nominal frequency tolerance
- Operating Temperature Range: -40° to $+70^{\circ}\text{C}$ $\pm 2^{\circ}\text{C}$
- Operable Temperature Range: Not specified beyond operating temperature range
- Resonance: Parallel
- Load Capacitance: $32 \pm 0.5 \mu\text{f}$
- Harmonic of Quartz Vibration: Fundamental
- Maximum Drive Level: 2 mw
- Maximum Pin-to-Pin Capacitance: Not specified
- Maximum Effective Resonance Resistance:

Frequency (kc)	Resistance (ohms)
80 to 119.999.....	10,000
120 to 159.999.....	8000
160 to 199.999.....	6000

**PERFORMANCE CHARACTERISTICS OF
NORMAL CRYSTAL ELEMENT**

See characteristics of element D, paragraph 1-116, figure 1-52.

TYPES OF CIRCUITS USED IN

Two-stage-grounded-cathode, modified transistor, Miller, modified Butler

MOUNTING DATA

- Crystal Holder: HC-5/U or HC-21/U
- Method of Mounting Crystal: Wire-mounted in plastic holder
- Dimensions and Marking: See figure 2-1(B). All dimensions in inches. Unless otherwise specified, tolerances are ± 0.005 in. on decimals.

LOGISTICAL DATA

- USAF Stock No.: 2100-2X515-frequency in kc
- Status: Standard (Category 1)
- Date of Status: 9 October 1950
- Related Specifications, Standards, and Publications: See Appendix IV.
- Commercial Sources: See Appendix III.
- Remarks: Use of this crystal is discouraged by some manufacturers because, in their opinion, the specified holder (HC-5/U) suffers these important disadvantages: The holder is not hermetically sealed (although a metal hermetically-sealed version will be used in procurement of further models); it has poor form factor; and it uses an unorthodox base which requires a special socket.

111 560

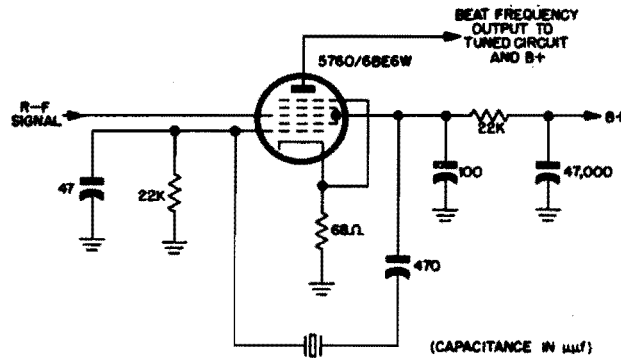

Figure 2-2. Schematic diagram of typical oscillator designed for use with Crystal Unit CR-15/U

Equipment Used In: Radio Receiver R-277/APN-70

MILITARY STANDARD TEST DATA

Authority: Military Specification MIL-C-3098B, approved 9 December 1955

Requirements and Procedures of Tests: See paragraphs 2-21 through 2-50.

Reference Standard Test Set: Crystal Impedance Meter TS-537/TSM

Electrical Connection of Holder: Not applicable

Method of Measuring Frequency and Effective Resonance Resistance: B

Drive Adjustment Procedure: MS91482 (see paragraph 2-61 and MIL-C-3098B)

Shock and Vibration Test:

Permitted change in frequency: $\pm 0.001\%$

Permitted change in effective resonance resistance: $\pm 15\%$

Aging Test: Not required

Tensile Strength Test (Minimum Requirements):

Frequency (kc)	Grams
80 to 119.999.....	1000
120 to 159.999.....	800
160 to 199.999.....	700

**CRYSTAL UNIT CR-16/U
(LF)**

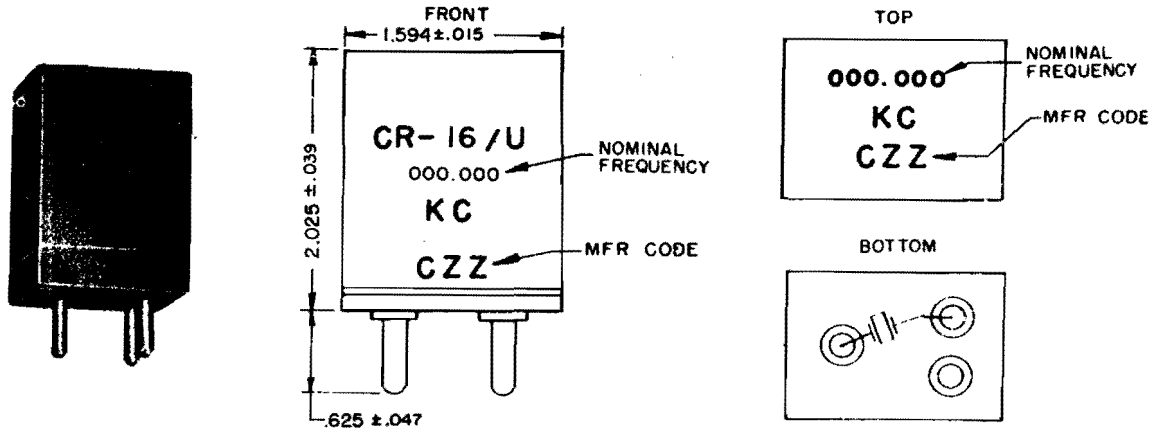

Figure 2-3. Crystal Unit CR-16/U

FUNCTIONAL DESCRIPTION

Metal-plated quartz plate, wire-mounted in a plastic holder and designed to operate on the fundamental frequency of the quartz plate. Used as a low-frequency control element in circuits which must maintain good frequency stability in the absence of oven control, even when exposed to wide variations of temperature. The crystal unit is intended for operation at series resonance.

RATED OPERATING CHARACTERISTICS

- Frequency Range:* 80 to 199,999 kc
- Nominal Frequency Tolerance:* $\pm 0.01\%$ at all temperatures within operating range
- Frequency Deviation with Temperature:* Permissible within limits of nominal frequency tolerance
- Operating Temperature Range:* -40° to $+70^{\circ}\text{C}$ $\pm 2^{\circ}\text{C}$
- Operable Temperature Range:* Not specified beyond operating temperature range
- Resonance:* Series
- Load Capacitance:* Not applicable
- Harmonic of Quartz Vibration:* Fundamental
- Maximum Drive Level:* 2 mw
- Maximum Pin-to-Pin Capacitance:* Not specified
- Maximum Effective Resonance Resistance:* 3000 ohms

**PERFORMANCE CHARACTERISTICS OF
NORMAL CRYSTAL ELEMENT**

See characteristics of element D, paragraph 1-116, figure 1-52.

TYPES OF CIRCUITS USED IN

Two-stage-grounded-cathode, transitron, transformer-coupled, modified Butler, and Meacham-bridge

MOUNTING DATA

- Crystal Holder:* HC-5/U or HC-21/U
- Method of Mounting Crystal:* Wire-mounted in plastic holder
- Dimensions and Marking:* See figure 2-3 (B). All dimensions in inches. Unless otherwise specified, tolerances are ± 0.005 in. on decimals.

LOGISTICAL DATA

- USAF Stock No.:* 2100-2X516-frequency in kc
- Status:* Standard (Category 1)
- Date of Status:* 9 October 1950
- Related Specifications, Standards, and Publications:* See Appendix IV.
- Commercial Sources:* See Appendix III.
- Remarks:* Use of this crystal unit is discouraged by some manufacturers because, in their opinion, the specified holder (HC-5/U) suffers these important disadvantages: The holder is not hermetically sealed (although a metal hermetically-sealed version will be used in procurement of future models); it has a poor form factor; and it uses an unorthodox base which requires a special socket.
- Equipment Used In:* Signal Generator SG-34(XA)/UP—see figure 1-175 (K)

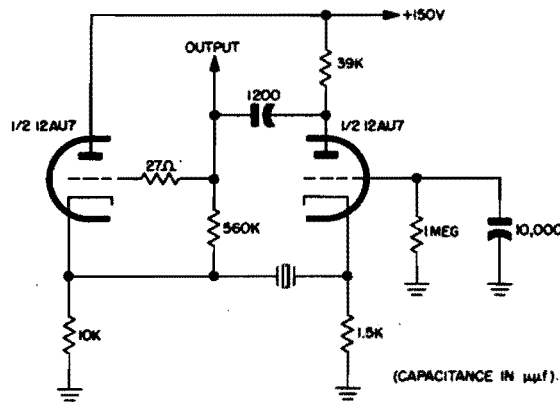

Figure 2-4. Schematic diagram of typical oscillator designed for use with Crystal Unit CR-16/U

Signal Generator SG-34/GPM-15—see figure 1-175 (K)

MILITARY STANDARD TEST DATA

Authority: Military Specification MIL-C-3098B, approved 9 December 1955

Requirements and Procedures of Tests: See paragraphs 2-21 through 2-50.

Reference Standard Test Set: Crystal Impedance Meter TS-537/TSM

Electrical Connection of Holder: Not applicable

Method of Measuring Frequency and Effective Resonance Resistance: B

Drive Adjustment Procedure: MS91482 (see paragraph 2-61 and MIL-C-3098B)

Shock and Vibration Test:

Permitted change in frequency: $\pm 0.001\%$

Permitted change in effective resonance resistance: $\pm 15\%$

Aging Test: Not required

Tensile Strength Test (Minimum Requirements):

Frequency (kc)	Grams
80 to 119.999.....	1000
120 to 159.999.....	800
160 to 199.999.....	700

**CRYSTAL UNIT CR-18/U
(MF—HF)**

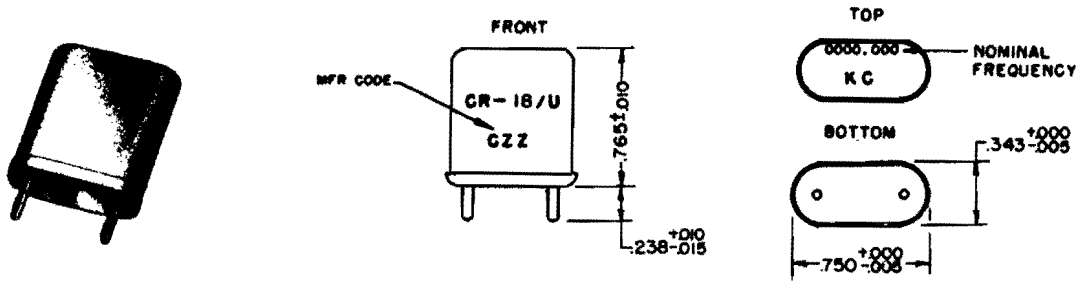

Figure 2-5. Crystal Unit CR-18/U

FUNCTIONAL DESCRIPTION

Metal-plated quartz plate, wire-mounted in a metal holder and designed to operate on the fundamental frequency of the quartz plate. Used as a medium-to-high-frequency control element in circuits which must maintain above-average frequency stability in the absence of oven control, even when exposed to wide variations of temperature. The crystal unit is intended for operation at parallel resonance.

RATED OPERATING CHARACTERISTICS

- Frequency Range:* 800 to 20,000 kc
- Nominal Frequency Tolerance:* $\pm 0.005\%$ at all temperatures within operating range
- Frequency Deviation with Temperature:* Permissible within limits of nominal frequency tolerance
- Operating Temperature Range:* -55° to $+90^{\circ}\text{C}$ $\pm 2^{\circ}\text{C}$
- Operable Temperature Range:* Not specified beyond operating temperature range
- Resonance:* Parallel
- Load Capacitance:* 32 ± 0.5 mmf
- Harmonic of Quartz Vibration:* Fundamental
- Maximum Drive Level:*
 - 800 to 9,999.999 kc—10 mw
 - 10,000 to 20,000 kc—5 mw
- Maximum Pin-to-Pin Capacitance:* 7.0 mmf

Maximum Effective Resonance Resistance:

<i>Frequency (kc)</i>	<i>Resistance (ohms)</i>
800 to 999.999.....	1000
1000 to 1,249.999.....	800
1250 to 1,499.999.....	700
1500 to 1,749.999.....	600
1750 to 1,999.999.....	550
2000 to 2,249.999.....	320
2500 to 2,999.999.....	500
3000 to 3,749.999.....	175
3750 to 4,749.999.....	120
4750 to 5,999.999.....	75
6000 to 7,499.999.....	50
7500 to 9,999.999.....	35
10,000 to 20,000	25

PERFORMANCE CHARACTERISTICS OF NORMAL CRYSTAL ELEMENT

See characteristics of element A, paragraph 1-112, figures 1-49, -118, -115.

TYPES OF CIRCUITS USED IN

Pierce, Miller, multivibrator-type

MOUNTING DATA

- Crystal Holder:* HC-6/U
- Method of Mounting Crystal:* Wire-mounted in metal holder
- Dimensions and Marking:* See figure 2-5(B). All dimensions in inches. Unless otherwise specified, tolerances are ± 0.005 in. on decimals.

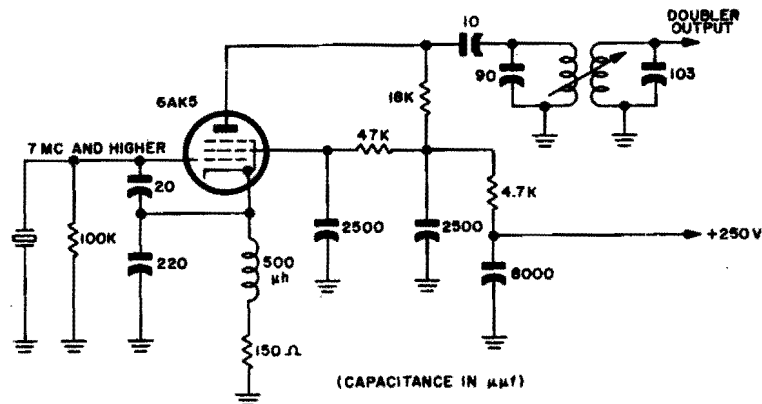

Figure 2-6. Schematic diagram of typical oscillator designed for use with Crystal Unit CR-18/U

LOGISTICAL DATA

USAF Stock No.: 2100-2X518-frequency in kc
 Status: Standard (Category 1)
 Date of Status: 9 October 1950
 Related Specifications, Standards, and Publications: See Appendix IV.
 Commercial Sources: See Appendix III.
 Remarks: Specification requirements become increasingly difficult to meet at the lower frequencies in manufacturing this unit.
 Equipment Used In:
 Receiver-Transmitter RT-173/ARC-33—see figures 1-135 (L), (M)
 Receiver-Transmitter RT-178/ARC-27—see figures 1-135 (R), (V), (W)
 Receiver-Transmitter RT-XA-101/ARC-22—see figure 1-135 (Y)
 Signal Generator SG-13/ARN—see figures 1-135 (Z), -137 (V)
 Frequency Meter TS-186 (B/C)/UP—see figure 1-137 (G)
 Radio Receiver R-540/ARN-14C—see figure 1-137 (N)
 Radio Set AN/ARC-34 (XA-1)—see figures 1-137 (O), (T)
 Radio Receiver R-322/ARN-18—see figure 1-137 (U)
 R-F Signal Generator Set AN/URM-25C—see figure 1-138 (D)
 Radio Receiver R-277 (XA-A)/APN-70—see figure 1-138 (E)
 Radio Receiver R-252()/ARN-14 (14 crystals)
 Signal Generator SG-1/ARN (2 crystals)
 Radio Set AN/ART-13B (20 crystals)
 Radio Receiver R-470/ARN-19 (10 crystals)
 Radio Set AN/ARN-22 (12 crystals)

Radio Set AN/ANT-27
 Radio Set AN/URT-()
 Radio Set AN/MRC-20 (12 crystals)

MILITARY STANDARD TEST DATA

Authority: Military Specification MIL-C-3098B, approved 9 December 1955
 Requirements and Procedures of Tests: See paragraphs 2-21 through 2-50.
 Reference Standard Test Set:
 Crystal Impedance Meter TS-330/TSM—800 to 14,999.999 kc
 Crystal Impedance Meter TS-683/TSM—15,000 to 20,000 kc
 Electrical Connection of Holder:
 Holder grounded
 Method of Measuring Frequency and Effective Resonance Resistance: A.
 Drive Adjustment Procedure:
 800 to 14,999.999 kc: MS90167 (see paragraph 2-60 and MIL-C-3098B)
 15,000 to 20,000 kc: MS90168 (see paragraph 2-62 and MIL-C-3098B)
 Shock and Vibration Test:
 Permitted change in frequency:
 ±0.001% for units below 2000 kc
 ±0.0005% for units of 2000 kc and above
 Permitted change in resonance (effective) resistance: Wire-mounted—±15% or 2 ohms, whichever is greater.
 Aging Test: Not required
 Tensile Strength Test (Minimum Requirements):
 Not required

**CRYSTAL UNIT CR-19/U
(MF—HF)**

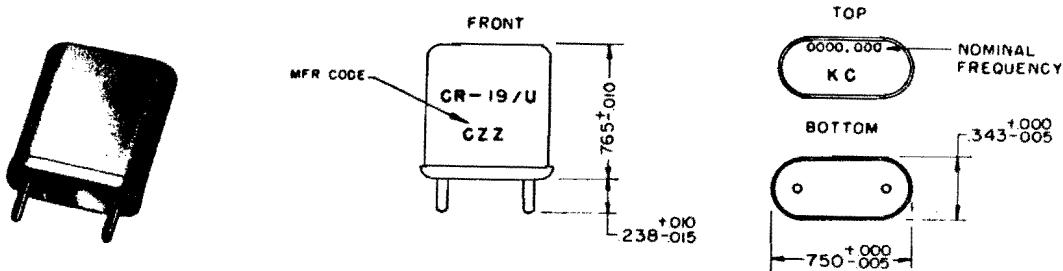

Figure 2-7. Crystal Unit CR-19/U

FUNCTIONAL DESCRIPTION

Metal-plated quartz plate, wire-mounted in a metal holder and designed to operate on the fundamental frequency of the quartz plate. Used as a medium-to-high-frequency control element in circuits which must maintain above average frequency stability in the absence of oven control, even when exposed to wide variation of temperature. The crystal unit is intended for operation at series resonance.

RATED OPERATING CHARACTERISTICS

- Frequency Range:* 800 to 20,000 kc
- Nominal Frequency Tolerance:* $\pm 0.005\%$ at all temperatures within operating range
- Frequency Deviation with Temperature:* Permissible within limits of nominal frequency tolerance
- Operating Temperature Range:* -55° to $+90^{\circ}\text{C}$ $\pm 2^{\circ}\text{C}$
- Operable Temperature Range:* Not specified beyond operating temperature range
- Resonance:* Series
- Load Capacitance:* 7.0 μf
- Harmonic of Quartz Vibration:* Fundamental
- Maximum Drive Level:*
 - 800 to 9,999.999 kc—10 mw
 - 10,000 to 20,000 kc—5 mw
- Maximum Pin-to-Pin Capacitance:* Not specified

Maximum Effective Resonance Resistance:

Frequency (kc)	Resistance (ohms)
800 to 999.999.....	800
1000 to 1,249.999.....	500
1250 to 1,499.999.....	400
1500 to 1,749.999.....	350
1750 to 1,999.999.....	300
2000 to 2,249.999.....	250
2250 to 3,749.999.....	150
3750 to 4,999.999.....	100
5000 to 6,999.999.....	50
7000 to 9,999.999.....	30
10,000 to 20,000.....	25

**PERFORMANCE CHARACTERISTICS OF
NORMAL CRYSTAL ELEMENT**

See characteristics of element A, paragraph 1-49, figures 1-49, -115, -118.

TYPES OF CIRCUITS USED IN

Butler, transformer-coupled, transitron, modified Colpitts

MOUNTING DATA

- Crystal Holder:* HC-6/U
- Method of Mounting Crystal:* Wire-mounted in metal holder
- Dimensions and Marking:* See figure 2-7 (B). All dimensions in inches. Unless otherwise specified, tolerances are ± 0.005 in. on decimals.

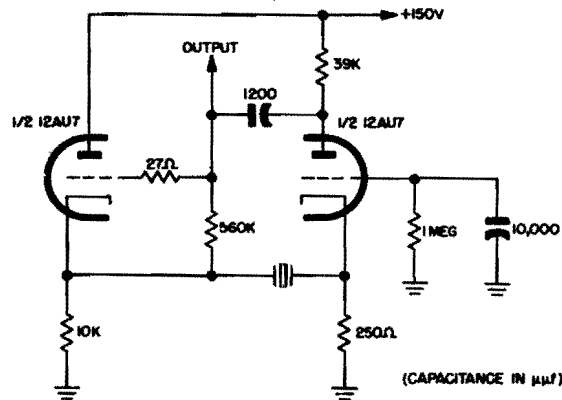

Figure 2-8. Schematic diagram of typical oscillator designed for use with Crystal Unit CR-19/U

LOGISTICAL DATA

USAF Stock No.: 2100-2X519-frequency in kc
 Status: Standard (Category 1)
 Date of Status: 9 October 1950
 Related Specifications, Standards, and Publications: See Appendix IV.
 Commercial Sources: See Appendix III.
 Remarks: None
 Equipment Used In:
 Signal Generator SG-34(XA)/UP—see figure 1-175 (K)
 Signal Generator SG-34/GPM-15—see figure 1-175 (K)
 Radio Receiver R-277/APN-70 (4 crystals)
 Radio Transmitter T-263/MRN-8 (20 crystals)
 Radio Transmitting Set AN/MRN-7 (39 crystals)
 Radio Set AN/MRC-20; Guard Receiver

MILITARY STANDARD TEST DATA

Authority: Military Specification MIL-C-3098B, approved 9 December 1955
 Requirements and Procedures of Tests: See paragraphs 2-21 through 2-50.

Requirements and Procedures of Tests: See paragraphs 2-21 through 2-50

Reference Standard Test Set:

Crystal Impedance Meter TS-330/TSM—800 to 14,999.999 kc

Crystal Impedance Meter TS-683/TSM—15,000 to 20,000 kc

Electrical Connection of Holder:

Holder grounded

Method of Measuring Frequency and Effective Resonance Resistance: A

Drive Adjustment Procedure:

800 to 14,999.999 kc: MS90167 (see paragraph 2-60 and MIL-C-3098B)

15,000 to 20,000 kc: MS90168 (see paragraph 2-62 and MIL-C-3098B)

Shock and Vibration Test:

Permitted change in frequency:

±0.0005% for units of 2000 kc and above

±0.001% for units below 2000 kc

Permitted change in effective resonance resistance: Wire-mounted—±15% or 2 ohms, whichever is greater.

Aging Test: Not required

Tensile Strength Test (Minimum Requirements): Not required

**CRYSTAL UNIT CR-23/U
(HF—VHF)**

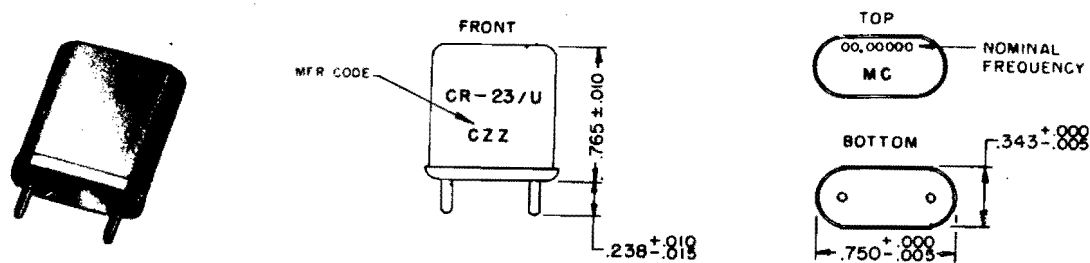

Figure 2-9. Crystal Unit CR-23/U

FUNCTIONAL DESCRIPTION

Metal-plated quartz plate, wire-mounted in a metal holder and designed to operate on the third or fifth mechanical harmonic of the fundamental frequency of the quartz plate. Used as a high-to-very-high-frequency control element in circuits which must maintain above-average frequency stability in the absence of oven control, even when exposed to wide variations of temperature. The crystal unit is intended for operation at series resonance.

RATED OPERATING CHARACTERISTICS

- Frequency Range: 10 to 75 mc
- Nominal Frequency Tolerance: $\pm 0.005\%$ at all temperatures within operating range
- Frequency Deviation with Temperature: Permissible within limits of nominal frequency tolerance
- Operating Temperature Range: -55° to $+90^{\circ}\text{C}$ $\pm 2^{\circ}\text{C}$
- Operable Temperature Range: Not specified beyond operating temperature range
- Resonance: Series
- Load Capacitance: Not applicable
- Harmonic of Quartz Vibration:

Overtone	Frequency (mc)
Third	10 to 52
Fifth	52.000001 to 75

- Maximum Drive Level:
 - 10 to 24.999999 mc (4 mw)
 - 25 to 75 (2 mw)
- Maximum Pin-to-Pin Capacitance: 7.0 μf

Maximum Effective Resonance Resistance:

Frequency (mc)	Resistance (ohms)
10 to 14.99999.....	60
15 to 52.....	40
52.000001 to 75.....	60

**PERFORMANCE CHARACTERISTICS OF
NORMAL CRYSTAL ELEMENT**

See characteristics of element A, paragraph 1-112, figure 1-49, -112, -113, -115, -118.

TYPES OF CIRCUITS USED IN

Butler, transformer-coupled, capacitance-bridge, transitron, impedance-inverted

MOUNTING DATA

- Crystal Holder: HC-6/U
- Method of Mounting Crystal: Wire-mounted in metal holder
- Dimensions and Marking: See figure 2-9 (B). All dimensions in inches. Unless otherwise specified, tolerances are ± 0.005 in. on decimals.

LOGISTICAL DATA

- USAF Stock No.: 2100-2X523-frequency in mc
- Status: Standard (Category 2)
- Date of Status: 9 October 1950
- Related Specifications, Standards, and Publications: See Appendix IV.
- Commercial Sources: See Appendix III.
- Remarks: Difficult to manufacture to all specification requirements over the entire upper and lower range.

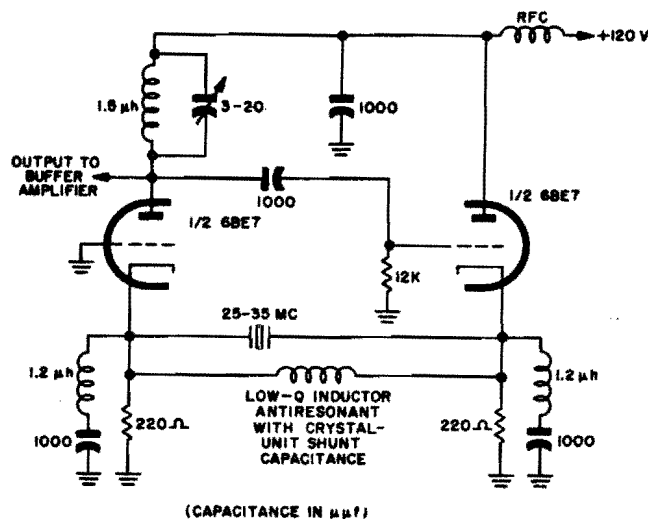

Figure 2-10. Schematic diagram of typical oscillator designed for use with Crystal Unit CR-23/U

Equipment Used In:

- Receiver-Transmitter RT-178/ARC-27—see figures 1-175 (B), (C)
- Radio Receiver R-252A/ARN-14—see figure 1-175 (F)
- Radio Receiver R-540/ARN-14C—see figure 1-175 (H)
- Radio Set AN/ARN-21 (XN-2)—see figure 1-175 (J)
- Signal Generator SG-13/ARN—see figure 1-175 (L)
- Radio Receiver R-470/ARN-19 (14 crystals)
- Radio Set AN/URC-10
- Radio Transmitting Set AN/URT-()
- Radio Set AN/APX-19 (2 crystals)
- Radio Set AN/GRC-30 (3 crystals)
- Radio Set AN/PRC-14 (6 crystals)
- Radio Set AN/MRC-30, Guard Receiver

MILITARY STANDARD TEST DATA

Authority: Military Specification MIL-C-3098B, approved 9 December 1955

Requirements and Procedures of Tests: See paragraphs 2-21 through 2-50.

Reference Standard Test Set: Crystal Impedance Meter TS-683/TSM

Electrical Connection of Holder:
Holder grounded

Method of Measuring Frequency and Effective Resonance Resistance: A

Drive Adjustment Procedure: MS90168 (see paragraph 2-62 and MIL-C-3098B)

Shock and Vibration Test:

Permitted change in frequency:

±0.001% for units below 2000 kc

±0.0005% for units of 2000 kc and above

Permitted change in effective resonance resistance: Wire-mounted—±15% or 2 ohms, whichever is greater.

Aging Test: Not required

Tensile Strength Test (Minimum Requirements):
Not required

**CRYSTAL UNIT CR-24/U
(HF—VHF)**

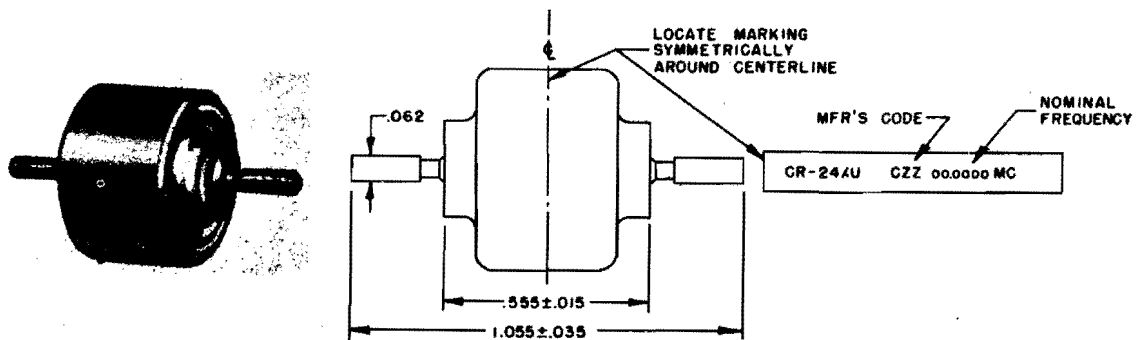

Figure 2-11. Crystal Unit CR-24/U

FUNCTIONAL DESCRIPTION

Pressure-mounted, or metal-plated quartz plate wire-mounted in a metal holder designed to operate on the third or fifth mechanical harmonic of the fundamental frequency of the quartz plate. Used as a high-to-very-high-frequency control element in circuits which must maintain above-average frequency stability in the absence of oven control, even when exposed to wide variation of temperature. The crystal unit is intended for operation at series resonance.

RATED OPERATING CHARACTERISTICS

- Frequency Range: 15 to 50 mc
- Nominal Frequency Tolerance: $\pm 0.005\%$ at all temperatures within operating range.
- Frequency Deviation with Temperature: Permissible within limits of nominal frequency tolerance
- Operating Temperature Range: -55° to $+90^{\circ}\text{C}$ $\pm 2^{\circ}\text{C}$
- Operable Temperature Range: Not specified beyond operating temperature range.
- Resonance: Series
- Load Capacitance: Not applicable
- Harmonic of Quartz Vibration:

Overtone	Frequency (mc)
Third	15 to 24.999999
Fifth	25 to 50

Maximum Drive Level: 2 mw

Maximum Pin-to-Pin Capacitance: 7.0 μf
Maximum Effective Resonance Resistance:

Frequency (mc)	Resistance (ohms)
15 to 24.999999.....	50
25 to 50.....	75

**PERFORMANCE CHARACTERISTICS OF
NORMAL CRYSTAL ELEMENT**

See characteristics of element A, paragraph 1-112, figures 1-49, -112, -113, -116, -118.

TYPES OF CIRCUITS USED IN

Butler, transformer-coupled, capacitance-bridge, transitron, impedance-inverted

MOUNTING DATA

- Crystal Holder: HC-10/U
- Method of Mounting Crystal: Pressure-mounted or wire-mounted in metal holder
- Dimensions and Marking: See figure 2-11 (B). All dimensions in inches. Unless otherwise specified, tolerances are ± 0.005 in. on decimals.

LOGISTICAL DATA

- USAF Stock No.: 2100-2X524-frequency in mc
- Status: Standard (Category 1)
- Date of Status: 9 October 1950
- Related Specifications, Standards, and Publications: See Appendix IV.
- Commercial Sources: See Appendix III.
- Remarks: None

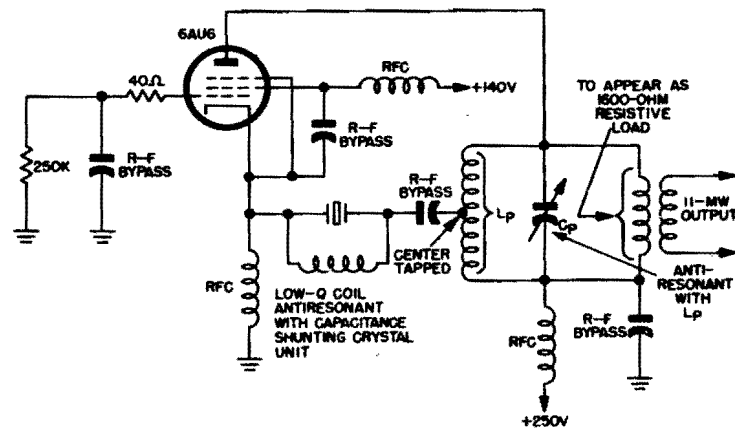

Figure 2-12. Schematic diagram of typical oscillator designed for use with Crystal Unit CR-24/U

Equipment Used In:

- Radio Receiver R-266/URR-13 — see figure 1-175 (A)
- Receiver-Transmitter RT-159A/URC-4—see figure 1-177 (D)
- Radio Receiver R-122/ARN-12
- Marker Beacon Set AN/ARN-32

MILITARY STANDARD TEST DATA

Authority: Military Specification MIL-C-3098B, approved 9 December 1955

Requirements and Procedures of Tests: See paragraphs 2-21 through 2-50.

Reference Standard Test Set: Crystal Impedance Meter TS-683/TSM or ZM-2/U

Electrical Connection of Holder:
Holder grounded

Method of Measuring Frequency and Effective Resonance Resistance: B

Drive Adjustment Procedure: MS90168 (see paragraph 2-62 and MIL-C-3098B)

Shock and Vibration Test:

Permitted change in frequency: $\pm 0.002\%$

Permitted change in effective resonance resistance: Shall not exceed maximum effective resistance

Aging Test: Not required

Tensile Strength Test (Minimum Requirements):
Not required

**CRYSTAL UNIT CR-25/U
(LF—MF)**

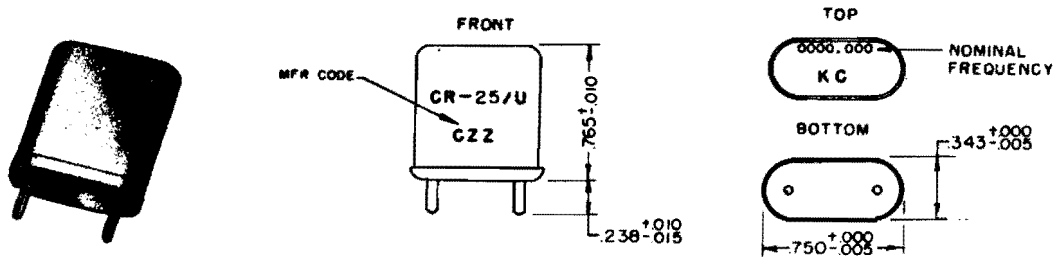

Figure 2-13. Crystal Unit CR-25/U

FUNCTIONAL DESCRIPTION

Metal-plated quartz plate, wire-mounted in a metal holder and designed to operate on the fundamental frequency of the quartz plate. Used as a low-to-medium-frequency control element in circuits which must maintain good frequency stability in the absence of oven control, even when exposed to wide variations of temperature. The crystal unit is intended for operation at series resonance.

RATED OPERATING CHARACTERISTICS

- Frequency Range:* 200 to 500 kc
- Nominal Frequency Tolerance:* $\pm 0.01\%$ at all temperatures within operating range
- Frequency Deviation with Temperature:* Permissible within limits of nominal frequency tolerance
- Operating Temperature Range:* -40° to $+70^{\circ}\text{C}$ $\pm 2^{\circ}\text{C}$
- Operable Temperature Range:* Not specified beyond operating temperature range
- Resonance:* Series
- Load Capacitance:* Not applicable
- Harmonic of Quartz Vibration:* Fundamental
- Maximum Drive Level:* 2 mw
- Maximum Pin-to-Pin Capacitance:* Not specified
- Minimum Effective Resonance Resistance:*

Frequency (kc)	Resistance (ohms)
200 to 249.999	3000
250 to 299.999	4000
300 to 399.999	5000
400 to 449.999	7500
450 to 500	10,000

**PERFORMANCE CHARACTERISTICS OF
NORMAL CRYSTAL ELEMENT**

See characteristics of element D, paragraph 1-116, figure 1-52.

TYPES OF CIRCUITS USED IN

Two-stage-grounded-cathode, transitron, Meacham-bridge, modified Colpitts, modified Butler

MOUNTING DATA

- Crystal Holder:* HC-6/U
- Method of Mounting Crystal:* Wire-mounted in metal holder
- Dimensions and Marking:* See figure 2-13 (B). All dimensions in inches. Unless otherwise specified, tolerances are ± 0.005 in. on decimals.

LOGISTICAL DATA

- USAF Stock No.:* 2100-2X525-frequency in kc
- Status:* Standard (Category 1)
- Date of Status:* 9 October 1950
- Related Specifications, Standards, and Publications:* See Appendix IV.
- Commercial Sources:* See Appendix III.
- Remarks:* Certain waivers from specification are required by some manufacturers before they will produce this unit.
- Equipment Used In:*
Radio Receiver R-277/APN-70 — see figure 1-138(E) (Not a series-mode circuit as shown)

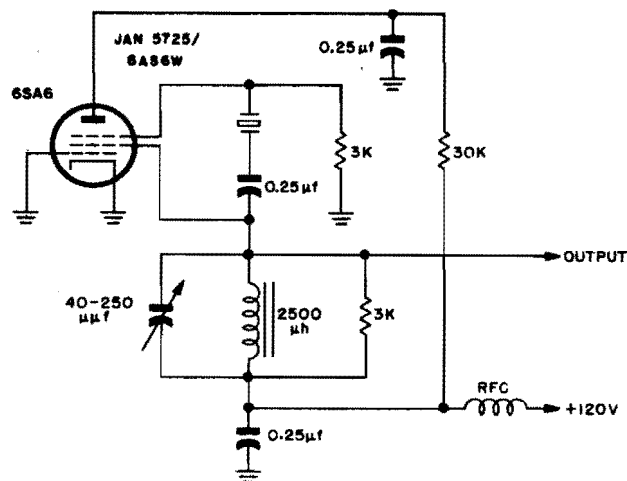

Figure 2-14. Schematic diagram of typical oscillator designed for use with Crystal Unit CR-25/U

MILITARY STANDARD TEST DATA

Authority: Military Specification MIL-C-3098B, approved 9 December 1955

Requirements and Procedures of Tests: See paragraphs 2-21 through 2-50.

Reference Standard Test Set: Crystal Impedance Meter TS-537/TSM

Electrical Connection of Holder:
Holder grounded

Method of Measuring Frequency and Effective Resonance Resistance: A

Drive Adjustment Procedure: MS91482 (see paragraph 2-61 and MIL-C-3098B)

Shock and Vibration Test:

Permitted change in frequency: $\pm 0.001\%$

Permitted change in effective resonance resistance: $\pm 15\%$

Aging Test: Not required

Tensile Strength Test (Minimum Requirements):

Frequency (kc)	Grams
200 to 249.999.....	700
250 to 319.999.....	500
320 to 369.999.....	400
370 to 434.999.....	300
435 to 500.....	250

**CRYSTAL UNIT CR-26/U
(LF—MF)**

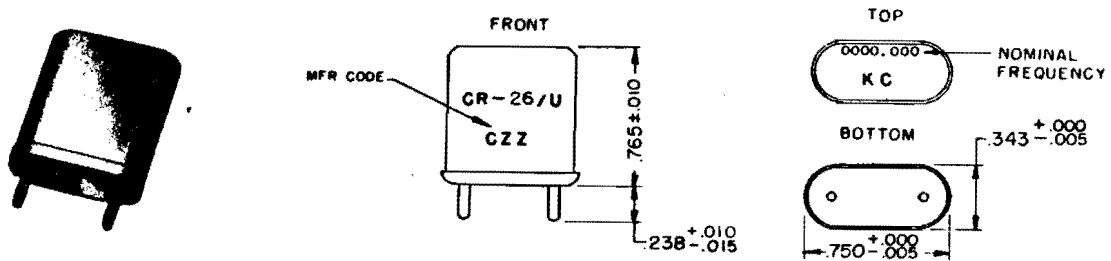

Figure 2-15. Crystal Unit CR-26/U

FUNCTIONAL DESCRIPTION

Metal-plated quartz plate, wire-mounted in a metal holder and designed to operate on the fundamental frequency of the quartz plate. Used as a low-to-medium frequency control in circuits where superior frequency stability is required. This crystal unit is intended to be mounted in a temperature-controlled oven, and operated at series resonance.

RATED OPERATING CHARACTERISTICS

- Frequency Range: 200 to 500 kc
- Nominal Frequency Tolerance: $\pm 0.002\%$ at 75°C
- Frequency Deviation with Temperature: $\pm 0.0005\%$ from frequency measured at 75°C permitted over range of 70° to 80°C
- Operating Temperature Range: $75^\circ \pm 5^\circ\text{C}$
- Operable Temperature Range: -40° to $+80^\circ\text{C}$ $\pm 2^\circ\text{C}$
- Resonance: Series
- Load Capacitance: Not applicable
- Harmonic of Quartz Vibration: Fundamental
- Maximum Drive Level: 2 mw
- Maximum Pin-to-Pin Capacitance: Not specified
- Maximum Effective Resonance Resistance:

Frequency (kc)	Resistance (ohms)
200 to 249.999.....	3000
250 to 299.999.....	4000
300 to 399.999.....	5000
400 to 449.999.....	7500
450 to 500.....	10,000

**PERFORMANCE CHARACTERISTICS OF
NORMAL CRYSTAL ELEMENT**

See characteristics of element D, paragraph 1-116, figure 1-52.

TYPES OF CIRCUITS USED IN

Two-stage-grounded-cathode, transitron, Meacham-bridge, modified Colpitts, modified Butler

MOUNTING DATA

- Crystal Holder: HC-6/U
- Method of Mounting Crystal: Wire-mounted in metal holder
- Dimensions and Marking: See figure 2-15(B). All dimensions in inches. Unless otherwise specified, tolerances are ± 0.005 in. on decimals.

LOGISTICAL DATA

- USAF Stock No.: 2100-2X526-frequency in kc
- Status: Standard (Category 1)
- Date of Status: 9 October 1950
- Related Specifications, Standards, and Publications: See Appendix IV.
- Commercial Sources: See Appendix III.
- Remarks: Certain waivers from specification are required by some manufacturers before they will produce this unit.
- Equipment Used In:

MILITARY STANDARD TEST DATA

Authority: Military Specification MIL-C-3098B, approved 9 December 1955

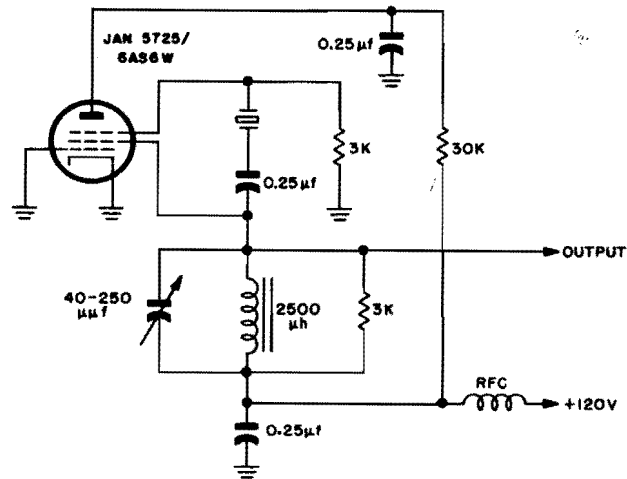

Figure 2-16. Schematic diagram of typical oscillator designed for use with Crystal Unit CR-26/U

Requirements and Procedures of Tests: See paragraphs 2-21 through 2-50.

Reference Standard Test Set: Crystal Impedance Meter TS-537/TSM

Electrical Connection of Holder:

Holder grounded

Method of Measuring Frequency and Effective Resonance Resistance: B

Drive Adjustment Procedure: MS91482 (see paragraph 2-61 and MIL-C-3098B)

Shock and Vibration Test:

Permitted change in frequency: $\pm 0.0005\%$

Permitted change in effective resonance resistance: $\pm 15\%$

Aging Test:

Permitted change in frequency: $\pm 0.001\%$

Tensile Strength Test (Minimum Requirements):

Frequency (kc)	Grams
200 to 249.999	700
250 to 319.999	500
320 to 368.999	400
370 to 434.999	300
435 to 500	250

**CRYSTAL UNIT CR-27/U
(MF—HF)**

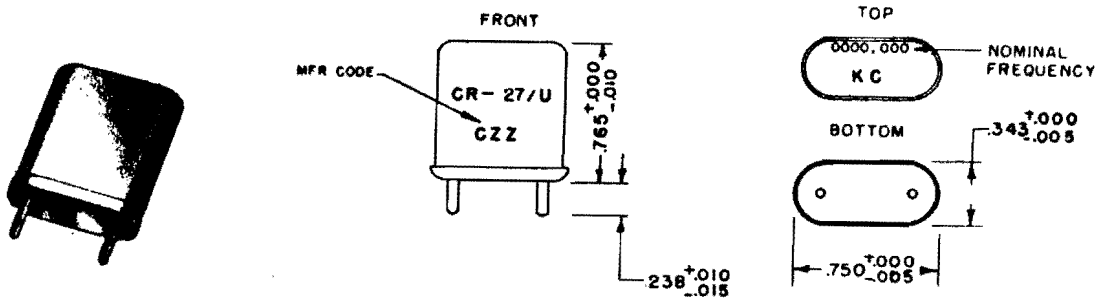

Figure 2-17. Crystal Unit CR-27/U

FUNCTIONAL DESCRIPTION

Metal-plated quartz plate, wire-mounted in a metal holder and designed to operate on the fundamental frequency of the quartz plate. Used as a medium-to-high-frequency control element in circuits where superior frequency stability is required. The crystal unit is intended to be mounted in a temperature-controlled oven and operated at parallel resonance.

RATED OPERATING CHARACTERISTICS

- Frequency Range: 800 to 20,000 kc
- Nominal Frequency Tolerance: $\pm 0.002\%$ at 75°C
- Frequency Deviation with Temperature: $\pm 0.0005\%$ from frequency measured at 75°C permitted over range of 70° to 80°C
- Operating Temperature Range: 75° \pm 5°C
- Operable Temperature Range: -55° to +90°C $\pm 2^\circ\text{C}$

- Resonance: Parallel
- Load Capacitance: 32 \pm 0.5 μf
- Harmonic of Quartz Vibration: Fundamental
- Maximum Drive Level:
 - 800 to 9,999.999 (5 mw)
 - 10,000 to 20,000 (2.5 mw)
- Maximum Pin-to-Pin Capacitance: 7.0 μf
- Maximum Effective Resonance Resistance:

Frequency (kc)	Resistance (ohms)
800 to 999.999	1000
1000 to 1,249.999	800
1250 to 1,499.999	700
1500 to 1,749.999	600

Frequency (kc)	Resistance (ohms)
1750 to 1,999.999	550
2000 to 2,249.999	500
2250 to 2,999.999	320
3000 to 3,749.999	175
3750 to 4,749.999	120
4750 to 5,999.999	75
6000 to 7,499.999	50
7500 to 9,999.999	35
10,000 to 20,000	25

**PERFORMANCE CHARACTERISTICS OF
NORMAL CRYSTAL ELEMENT**

See characteristics of elements A and B, paragraphs 1-112, -114, figures 1-49, -50, -115, -118.

TYPES OF CIRCUITS USED IN

Pierce, Miller, multivibrator-type

MOUNTING DATA

- Crystal Holder: HC-6/U
- Method of Mounting Crystal: Wire-mounted in metal holder
- Dimensions and Marking: See figure 2-17(B). All dimensions in inches. Unless otherwise specified, tolerances are ± 0.005 in. on decimals.

LOGISTICAL DATA

- USAF Stock No.: 2100-2X527-frequency in kc
- Status: Standard (Category 1)
- Date of Status: 9 October 1950
- Related Specifications, Standards, and Publications: See Appendix IV.
- Commercial Sources: See Appendix III.

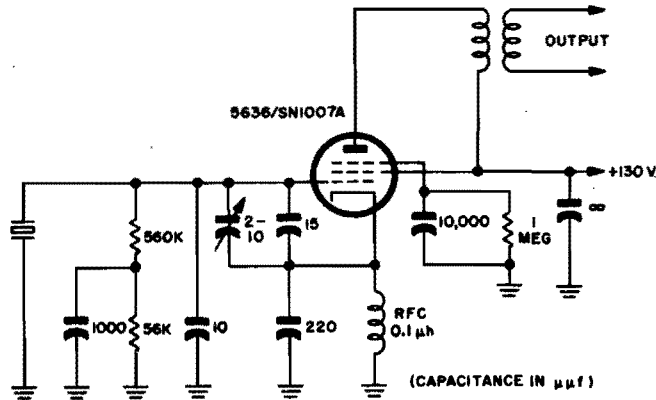

Figure 2-18. Schematic diagram of typical oscillator designed for use with Crystal Unit CR-27/U

Remarks:

Equipment Used In:

- Receiver-Transmitter RT-173/ARC-33 (see figures 1-135(S), (T), (U))
- Receiver-Transmitter RT-178/ARC-27 (see figure 1-137(A))
- Radio Set AN/ARC-34 (XA-1) (see figures 1-137(P), (Q), (R), (S))
- Radio Transmitting Set AN/GRT-3 (1750 crystals)

MILITARY STANDARD TEST DATA

Authority: Military Specification MIL-C-3098B, approved 9 December 1955

Requirements and Procedures of Tests: See paragraphs 2-21 through 2-50.

Reference Standard Test Set:

Crystal Impedance Meter TS-330/TSM (800 to 14,999.999 kc).

Crystal Impedance Meter TS-683/TSM (15,000 to 20,000 kc)

Electrical Connection of Holder:

Holder grounded

Method of Measuring Frequency and Effective Resonance Resistance: B

Drive Adjustment Procedure:

800 to 14,999.999 kc: MS90167 (see paragraph 2-60 and MIL-C-3098B)

15,000 to 20,000 kc: MS90168 (see paragraph 2-62 and MIL-C-3098B)

Shock and Vibration Test:

Permitted change in frequency: $\pm 0.0005\%$

Permitted change in effective resonance resistance: $\pm 15\%$ or 2 ohms, whichever is greater

Aging Test:

Permitted change in frequency: $\pm 0.001\%$

Tensile Strength Test (Minimum Requirements):

Not required

**CRYSTAL UNIT CR-28/U
(MF—HF)**

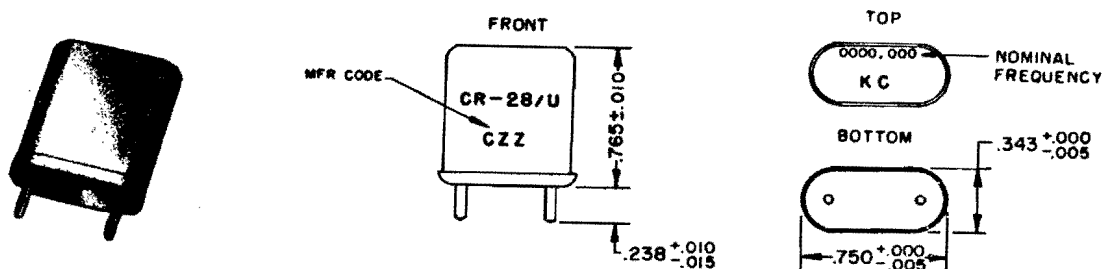

Figure 2-19. Crystal Unit CR-28/U

FUNCTIONAL DESCRIPTION

Metal-plated quartz plate, wire-mounted in a metal holder and designed to operate on the fundamental frequency of the quartz plate. Used as a medium-to-high-frequency control element in circuits where superior frequency stability is required. The crystal unit is intended to be mounted in a temperature-controlled oven, and operated at series resonance.

RATED OPERATING CHARACTERISTICS

- Frequency Range: 800 to 20,000 kc
- Nominal Frequency Tolerance: $\pm 0.002\%$ at 75°C
- Frequency Deviation with Temperature: $\pm 0.0005\%$ from frequency measured at 75°C permitted over range of 70° to 80°C
- Operating Temperature Range: 75° \pm 5°C
- Operable Temperature Range: -55° to +90°C $\pm 2^\circ\text{C}$
- Resonance: Series
- Load Capacitance: Not applicable
- Harmonic of Quartz Vibration: Fundamental
- Maximum Drive Level:
 - 800 to 9,999.999 (5 mw)
 - 10,000 to 20,000 (2.5 mw)
- Maximum Pin-to-Pin Capacitance: 7.0 μf
- Maximum Effective Resonance Resistance:

Frequency (kc)	Resistance (ohms)
800 to 999.999.....	800
1000 to 1,249.999.....	500
1250 to 1,499.999.....	400
1500 to 1,749.999.....	350
1750 to 1,999.999.....	300

Frequency (kc)	Resistance (ohms)
2000 to 2,249.999.....	250
2250 to 3,749.999.....	150
3750 to 4,999.999.....	100
5000 to 6,999.999.....	50
7000 to 9,999.999.....	30
10,000 to 20,000.....	25

PERFORMANCE CHARACTERISTICS OF NORMAL CRYSTAL ELEMENT

See characteristics of elements A and B, paragraphs 1-112, 1-114, figures 1-49, -50, -115, -118.

TYPES OF CIRCUITS USED IN

Butler, transformer-coupled, transitron, modified Colpitts

MOUNTING DATA

- Crystal Holder: HC-6/U
- Method of Mounting Crystal: Wire-mounted in metal holder
- Dimensions and Marking: See figure 2-19(B). All dimensions in inches. Unless otherwise specified, tolerances are ± 0.005 in. on decimals.

LOGISTICAL DATA

- USAF Stock No.: 2100-2X528-frequency in kc
- Status: Standard (Category 1)
- Date of Status: 9 October 1950
- Related Specifications, Standards, and Publications: See Appendix IV.
- Commercial Sources: See Appendix III.
- Remarks: None

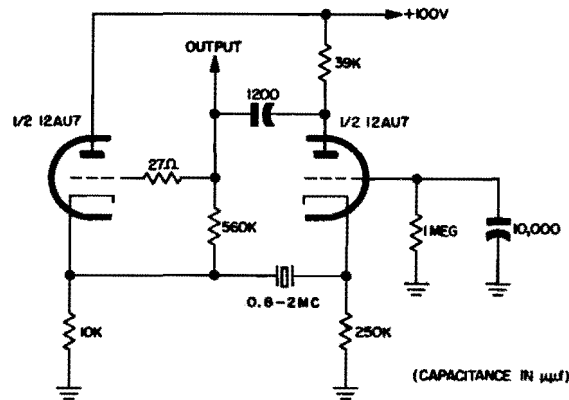

Figure 2-20. Schematic diagram of typical oscillator designed for use with Crystal Unit CR-28/U

Equipment Used In: Receiver-Transmitter RT-173/ARC-33 (see figure 1-175(D))

MILITARY STANDARD TEST DATA

Authority: Military Specification MIL-C-3098B, approved 9 December 1955

Requirements and Procedures of Tests: See paragraphs 2-21 through 2-50.

Reference Standard Test Set:

Crystal Impedance Meter TS-330/TSM (800 to 14,999.999 kc)

Crystal Impedance Meter TS-683/TSM (15,000 to 20,000 kc)

Electrical Connection of Holder:

Holder grounded

Method of Measuring Frequency and Effective Resonance Resistance: B

Drive Adjustment Procedure:

800 to 14,999 kc: MS90167 (see paragraph 2-60 and MIL-C-3098B)

15,000 to 20,000 kc: MS90168 (see paragraph 2-62 and MIL-C-3098B)

Shock and Vibration Test:

Permitted change in frequency: $\pm 0.0005\%$

Permitted change in effective resonance resistance: $\pm 15\%$ or 2 ohms, whichever is greater

Aging Test:

Permitted change in frequency: $\pm 0.001\%$

Tensile Strength Test (Minimum Requirements):

Not required

**CRYSTAL UNIT CR-29/U
(LF)**

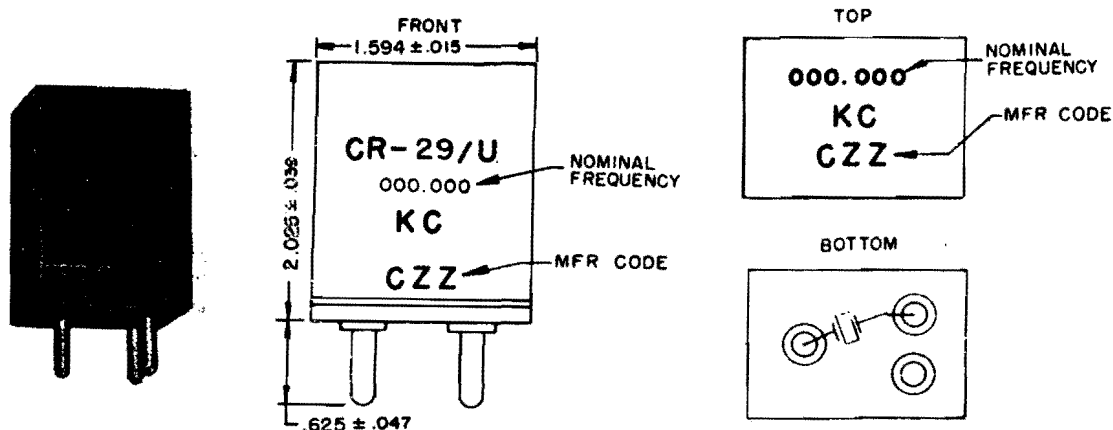

Figure 2-21. Crystal Unit CR-29/U

FUNCTIONAL DESCRIPTION

Metal-plated quartz plate, wire-mounted in a plastic holder and designed to operate on the fundamental frequency of the quartz plate. Used as a low-frequency control element in circuits where superior frequency stability is required. The crystal unit is intended to be mounted in a temperature-controlled oven, and operated at parallel resonance.

RATED OPERATING CHARACTERISTICS

- Frequency Range: 80 to 199.999 kc
- Nominal Frequency Tolerance: $\pm 0.002\%$ at 75°C
- Frequency Deviation with Temperature: $\pm 0.0005\%$ from frequency measured at 75°C permitted over range of 70° to 80°C
- Operating Temperature Range: $75^\circ \pm 5^\circ\text{C}$
- Operable Temperature Range: -40° to $+80^\circ\text{C}$ $\pm 2^\circ\text{C}$
- Resonance: Parallel
- Load Capacitance: $32 \pm 0.5 \mu\text{f}$
- Harmonic of Quartz Vibration: Fundamental
- Maximum Drive Level: 2 mw
- Maximum Pin-to-Pin Capacitance: Not specified
- Maximum Effective Resonance Resistance:

Frequency (kc)	Resistance (ohms)
80 to 119.999.....	10,000
120 to 159.999.....	8000
160 to 199.999.....	6000

**PERFORMANCE CHARACTERISTICS OF
NORMAL CRYSTAL ELEMENT**

See characteristics of element D, paragraph 1-116, figure 1-52.

TYPES OF CIRCUITS USED IN

Two-stage-grounded-cathode, transitron, Miller, modified Butler

MOUNTING DATA

- Crystal Holder: HC-5/U or HC-21/U
- Method of Mounting Crystal: Wire-mounted in plastic holder
- Dimensions and Marking: See figure 2-21 (B). All dimensions in inches. Unless otherwise specified, tolerances are ± 0.005 in. on decimals.

LOGISTICAL DATA

- USAF Stock No.: 2100-2X529-frequency in kc
- Status: Standard (Category 1)
- Date of Status: 9 October 1950
- Related Specifications, Standards, and Publications: See Appendix IV.
- Commercial Sources: See Appendix III.
- Remarks: Use of this crystal unit is discouraged by some manufacturers because, in their opinion, the specified holder (HC-5/U) suffers these important disadvantages: The holder is not hermetically sealed (although a metal hermetically-

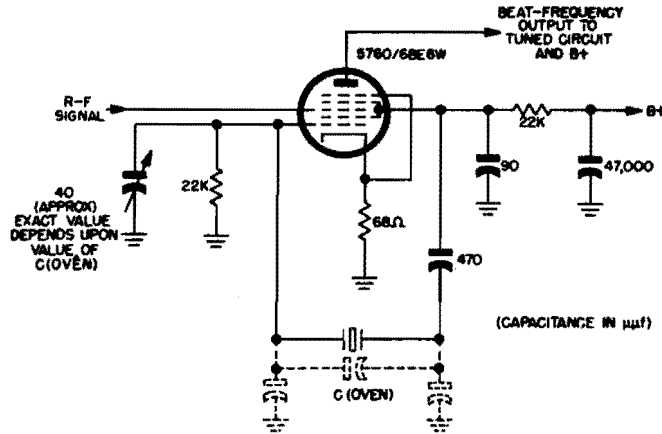

Figure 2-22. Schematic diagram of typical oscillator designed for use with Crystal Unit CR-29/U

sealed version will be used in procurement of future models); it has a poor form factor; and it uses an unorthodox base which requires a special socket. In addition, the phenolic holder is even more detrimental at the 75° operating temperature.

Equipment Used In:

MILITARY STANDARD TEST DATA

Authority: Military Specification MIL-C-3098B, approved 9 December 1955

Requirements and Procedures of Tests: See paragraphs 2-21 through 2-50.

Reference Standard Test Set: Crystal Impedance Meter TS-537/TSM

Electrical Connection of Holder: Not applicable

Method of Measuring Frequency and Effective Resonance Resistance: B

Drive Adjustment Procedure: MS91483 (see paragraph 2-61 and MIL-C-3098B)

Shock and Vibration Test:

Permitted change in frequency: ±0.001%

Permitted change in effective resonance resistance: ±15%

Aging Test:

Permitted change in frequency: ±0.001%

Tensile Strength Test (Minimum Requirements):

Frequency (kc)	Grams
80 to 119.999	1000
120 to 159.999	800
160 to 199.999	700

**CRYSTAL UNIT CR-30/U
(LF)**

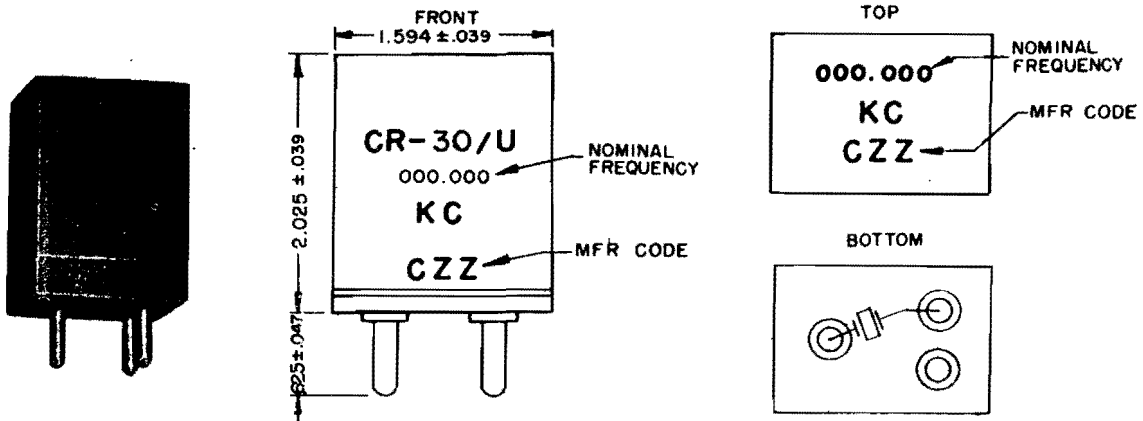

Figure 2-23. Crystal Unit CR-30/U

FUNCTIONAL DESCRIPTION

Metal-plated quartz plate, wire-mounted in a plastic holder and designed to operate on the fundamental frequency of the quartz plate. Used as a low-frequency control element in circuits where superior frequency stability is required. The crystal unit is intended to be mounted in a temperature-controlled oven, and operates at series resonance.

RATED OPERATING CHARACTERISTICS

- Frequency Range: 80 to 199,999 kc
- Nominal Frequency Tolerance: $\pm 0.002\%$ at 75°C
- Frequency Deviation with Temperature: $\pm 0.0005\%$ from frequency measured at 75°C permitted over range of 70° to 80°C
- Operating Temperature Range: $75^{\circ} \pm 5^{\circ}\text{C}$
- Operable Temperature Range: -40° to $+80^{\circ}\text{C}$ $\pm 2^{\circ}\text{C}$
- Resonance: Series
- Load Capacitance: Not applicable
- Harmonic of Quartz Vibration: Fundamental
- Maximum Drive Level: 2 mw
- Maximum Pin-to-Pin Capacitance: Not specified
- Maximum Effective Resonance Resistance: 3000 ohms

**PERFORMANCE CHARACTERISTICS OF
NORMAL CRYSTAL ELEMENT**

See characteristics of element D, paragraph 1-116, figure 1-52.

TYPES OF CIRCUITS USED IN

Meacham-bridge, two-stage-grounded-cathode, transitron, transformer-coupled, modified Butler

MOUNTING DATA

- Crystal Holder: HC-5/U or HC-21/U
- Method of Mounting Crystal: Wire-mounted in plastic holder
- Dimensions and Marking: See figure 2-23 (B). All dimensions in inches. Unless otherwise specified, tolerances are ± 0.005 in. on decimals.

LOGISTICAL DATA

- USAF Stock No.: 2100-2X530-frequency in kc
- Status: Standard (Category 1)
- Date of Status: 9 October 1950
- Related Specifications, Standards, and Publications: See Appendix IV.
- Commercial Sources: See Appendix III.
- Remarks: Use of the crystal unit is discouraged by some manufacturers because, in their opinion, the specified holder (HC-5/U) suffers these important disadvantages: The holder is not hermetically sealed (although a metal hermetically-sealed version will be used in procurement of future models); it has a poor form factor; and it uses an unorthodox base which requires a special socket. In addition, the phenolic holder is even more detrimental at the 75° operating temperature.

Equipment Used In:

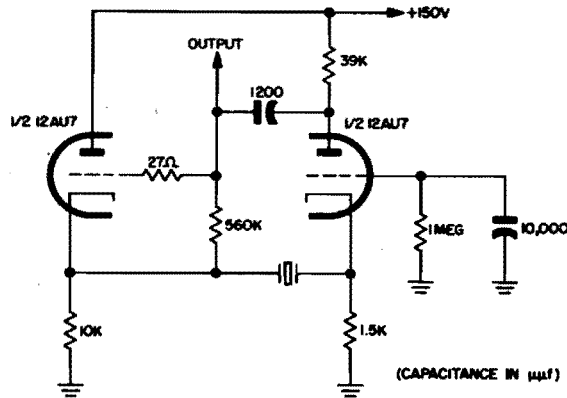

Figure 2-24. Schematic diagram of typical oscillator designed for use with Crystal Unit CR-30/U

MILITARY STANDARD TEST DATA

Authority: Military Specification MIL-C-3098B, approved 9 December 1955

Requirements and Procedures of Tests: See paragraphs 2-21 through 2-50.

Reference Standard Test Set: Crystal Impedance Meter TS-537/TSM

Electrical Connection of Holder: Not applicable

Method of Measuring Frequency and Effective Resonance Resistance: B

Drive Adjustment Procedure: MS91482 (see paragraph 2-61 and MIL-C-3098B)

Shock and Vibration Test:

Permitted change in frequency: $\pm 0.001\%$

Permitted change in effective resonance resistance: $\pm 15\%$

Aging Test:

Permitted change in frequency: $\pm 0.001\%$

Tensile Strength Test (Minimum Requirements):

Not specified

<i>Frequency (kc)</i>	<i>Grams</i>
80 to 119.999.....	1000
120 to 159.999.....	800
160 to 199.999.....	700

**CRYSTAL UNIT CR-32/U
(HF—VHF)**

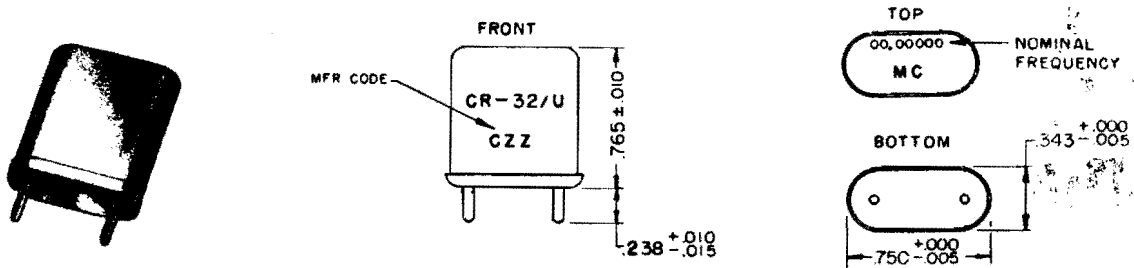

Figure 2-25. Crystal Unit CR-32/U

FUNCTIONAL DESCRIPTION

Metal-plated quartz plate, wire-mounted in a metal holder and designed to operate on the third and fifth mechanical harmonic of the fundamental frequency of the quartz plate. Used as a high-to-very-high-frequency control element in circuits where superior frequency stability is required. The crystal unit is intended to be mounted in a temperature-controlled oven, and operated at series resonance.

RATED OPERATING CHARACTERISTICS

Frequency Range: 10 to 75 mc
Nominal Frequency Tolerance: $\pm 0.002\%$ at 75°C
Frequency Deviation with Temperature:
 $\pm 0.0005\%$ from frequency measured at 75°C permitted over range of 70° to 80°C
Operating Temperature Range: 75° $\pm 5^\circ$ C
Operable Temperature Range: -55° to +90°C $\pm 2^\circ$ C

Resonance: Series
Load Capacitance: Not applicable
Harmonic of Quartz Vibration:
Overtone Frequency (mc)
 Third 10 to 52
 Fifth 52.000001 to 75

Maximum Drive Level:
 10 to 24.999999 (2 mw)
 25 to 75 (1 mw)

Maximum Pin-to-Pin Capacitance: 7.0 μ f
Maximum Effective Resonance Resistance:

Frequency (mc)	Resistance (ohms)
10 to 14.999999.....	60
15 to 52.....	40
52.000001 to 75.....	60

**PERFORMANCE CHARACTERISTICS OF
NORMAL CRYSTAL ELEMENT**

See characteristics of elements A and B, paragraphs 1-112, -114, figures 1-49, -50, -112, -113, -115, -118.

TYPES OF CIRCUITS USED IN

Butler, transformer-coupled, capacitance-bridge, transitron, impedance-inverted

MOUNTING DATA

Crystal Holder: HC-6/U
Method of Mounting Crystal: Wire-mounted in metal holder
Dimensions and Marking: See figure 2-25 (B). All dimensions in inches. Unless otherwise specified, tolerances are ± 0.005 in. on decimals.

LOGISTICAL DATA

USAF Stock No.: 2100-2X532-frequency in mc
Status: Standard (Category 1)
Date of Status: 9 October 1950
Related Specifications, Standards, and Publications: See Appendix IV.
Commercial Sources: See Appendix III.
Remarks: This unit is difficult to manufacture to all specification requirements over the entire upper and lower frequency ranges.
Equipment Used In:
 Receiver-Transmitter RT-173/ARC-33 (see figure 1-175(E))
 Radio Set AN/ARC-34(XA-1) (see figure 1-175(I))
 Radio Set AN/MRC-20 (11 crystals)
 Radio Receiving Set AN/GRR-7 (1750 crystals)

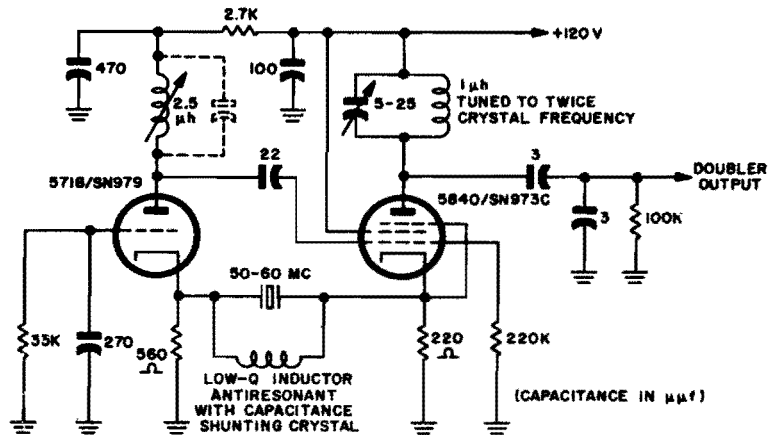

Figure 2-26. Schematic diagram of typical oscillator designed for use with Crystal Unit CR-32/U

MILITARY STANDARD TEST DATA

Authority: Military Specification MIL-C-3098B, approved 9 December 1955

Requirements and Procedures of Tests: See paragraphs 2-21 through 2-50.

Reference Standard Test Set: Crystal Impedance Meter TS-683/TSM

Electrical Connection of Holder:
Holder grounded

Method of Measuring Frequency and Effective Resonance Resistance: B

Drive Adjustment Procedure: MS90168 (see paragraphs 2-62 and 2-64 per MIL-C-3098B)

Shock and Vibration Test:

Permitted change in frequency: $\pm 0.0005\%$

Permitted change in effective resonance resistance: $\pm 15\%$ or 2 ohms, whichever is greater

Aging Test:

Permitted change in frequency: 0.001%

Tensile Strength Test (Minimum Requirements):

Not required

**CRYSTAL UNIT CR-33/U
(HF)**

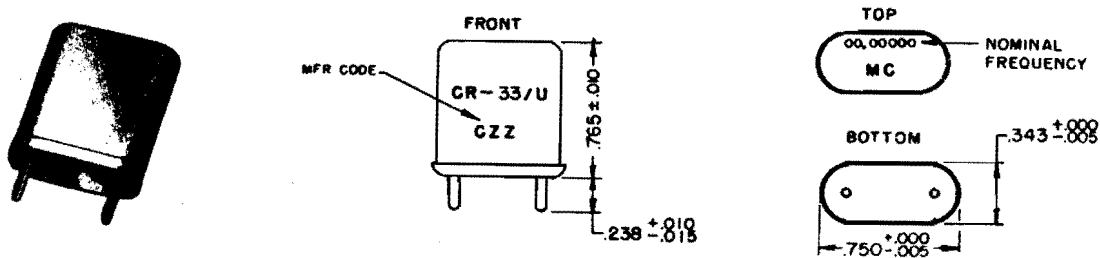

Figure 2-27. Crystal Unit CR-33/U

FUNCTIONAL DESCRIPTION

Metal-plated quartz plate, wire-mounted in metal holder and designed to operate on the third mechanical harmonic of the fundamental frequency of the quartz plate. Used as a high-frequency control element in circuits which must maintain above-average frequency stability in the absence of oven control, even when exposed to wide variations of temperature. The crystal unit is intended for operation at parallel resonance.

RATED OPERATING CHARACTERISTICS

- Frequency Range:* 10 to 25 mc
- Nominal Frequency Tolerance:* $\pm 0.005\%$ at all temperatures within the operating range
- Frequency Deviation with Temperature:* Permissible within limits of nominal frequency tolerance
- Operating Temperature Range:* -55° to $+90^{\circ}\text{C}$ $\pm 2^{\circ}\text{C}$
- Operable Temperature Range:* Not specified beyond operating temperature range
- Resonance:* Parallel
- Load Capacitance:* $32 \pm 0.5 \mu\text{f}$
- Harmonic of Quartz Vibration:* Third overtone
- Maximum Drive Level:* 2.5 mw
- Maximum Pin-to-Pin Capacitance:* $12.0 \mu\text{f}$
- Maximum Effective Resonance Resistance:*

Frequency (kc)	Resistance (ohms)
10 to 10.999999.....	65
11 to 11.999999.....	60
12 to 12.999999.....	55
13 to 13.999999.....	50
14 to 14.999999.....	45

Frequency (kc)	Resistance (ohms)
15 to 15.999999.....	41
16 to 16.999999.....	38
17 to 17.999999.....	36
18 to 18.499999.....	34
18.5 to 18.999999.....	32
19 to 19.499999.....	30
19.5 to 19.999999.....	28
20 to 20.499999.....	26
20.5 to 20.999999.....	25
21 to 21.499999.....	24
21.5 to 21.999999.....	23
22 to 22.499999.....	22
22.5 to 22.999999.....	21
23 to 23.499999.....	20
23.5 to 23.999999.....	19
24 to 24.499999.....	18
24.5 to 25.....	17

**PERFORMANCE CHARACTERISTICS OF
NORMAL CRYSTAL ELEMENT**

See characteristics of element A, paragraph 1-112, figures 1-49, -112, -113, -115, -118.

TYPES OF CIRCUITS USED IN

Tuned-Pierce, tuned-Miller, Butler, modified Colpitts, capacitance-bridge, transformer-coupled, modified transitron

MOUNTING DATA

- Crystal Holder:* HC-6/U
- Method of Mounting Crystal:* Wire-mounted in metal holder
- Dimensions and Marking:* See figure 2-27 (B). All dimensions in inches. Unless otherwise specified, tolerances are ± 0.005 in. on decimals.

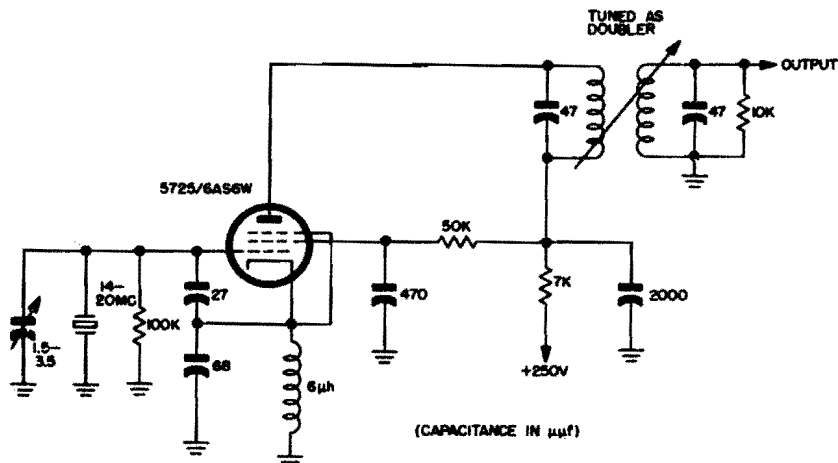

Figure 2-28. Schematic diagram of typical oscillator designed for use with Crystal Unit CR-33/U

LOGISTICAL DATA

USAF Stock No.: 2100-2X533-frequency in mc

Status: Special application (Category 1)

Date of Status: 19 November 1952

Related Specifications, Standards, and Publications: See Appendix IV.

Commercial Sources: See Appendix III.

Remarks: None

Equipment Used In:

Radio Receiver R-252/ARN-14 (see figures 1-137(B), 1-138(A))

Radio Receiver R-252C/ARN-14 (34 crystals)

Radio Receiver R-541/ARN-14D (34 crystals)

MILITARY STANDARD TEST DATA

Authority: Military Specification MIL-C-3098B, approved 9 December 1955

Requirements and Procedures of Tests: See paragraphs 2-21 through 2-50

Reference Standard Test Set: Crystal Impedance Meter TS-683/TSM

Electrical Connection of Holder: Holder grounded

Method of Measuring Frequency and Effective

Resonance Resistance: A

Drive Adjustment Procedure: MS91415 (see paragraph 2-63 and MIL-C-3098B)

Shock and Vibration Test:

Permitted change in frequency:

±0.0005% for units of 2000 kc and above

±0.001% for units below 2000 kc

Permitted change in effective resonance resistance: Wire-mounted — ±15% or 2 ohms, whichever is greater.

Aging Test: Not required

Tensile Strength Test (Minimum Requirements): Not required

**CRYSTAL UNIT CR-35/U
(MF—HF)**

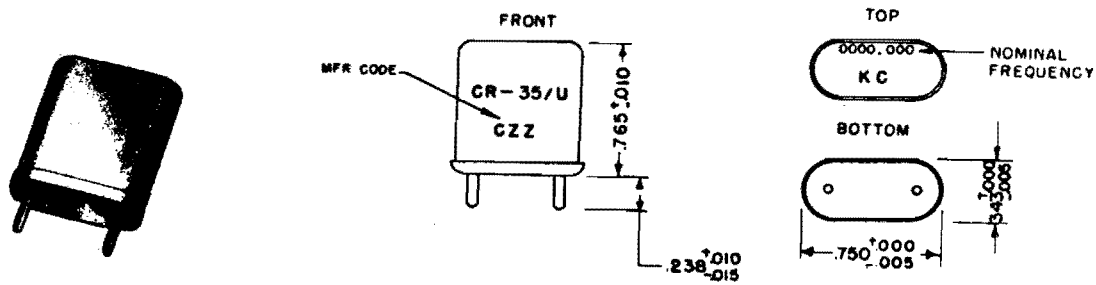

Figure 2-29. Crystal Unit CR-35/U

FUNCTIONAL DESCRIPTION

Metal-plated quartz plate, wire-mounted in a metal holder and designed to operate on the fundamental frequency of the quartz plate. Used as a medium-to-high frequency control element in circuits where superior frequency stability is required. The crystal unit is intended to be mounted in a temperature-controlled oven, and operated at series resonance.

RATED OPERATING CHARACTERISTICS

- Frequency Range: 800 to 20,000 kc
- Nominal Frequency Tolerance: $\pm 0.002\%$ at 85°C
- Frequency Deviation with Temperature: $\pm 0.0005\%$ from frequency measured at 85°C permitted over range of 80° to 90°C
- Operating Temperature Range: $85^\circ \pm 5^\circ\text{C}$
- Operable Temperature Range: -55° to $+90^\circ\text{C}$ $\pm 2^\circ\text{C}$

- Resonance: Series
- Load Capacitance: Not applicable
- Harmonic of Quartz Vibration: Fundamental
- Maximum Drive Level:
 - 800 to 9,999.999 kc (5 mw)
 - 10,000 to 20,000 kc (2.5 mw)
- Maximum Pin-to-Pin Capacitance: $7.0 \mu\text{f}$
- Maximum Effective Resonance Resistance:

Frequency (kc)	Resistance (ohms)
800 to 999.999.....	800
1000 to 1,249.999.....	500
1250 to 1,499.999.....	400
1500 to 1,749.999.....	350
1750 to 1,999.999.....	300
2000 to 2,249.999.....	250

Frequency (kc)	Resistance (ohms)
2250 to 3,749.999.....	150
3750 to 4,999.999.....	100
5000 to 6,999.999.....	50
7000 to 9,999.999.....	30
10,000 to 20,000.....	25

PERFORMANCE CHARACTERISTICS OF NORMAL CRYSTAL ELEMENT

See characteristics of elements A and B, paragraphs 1-112, -114, figures 1-49, -50, -115, -118.

TYPES OF CIRCUITS USED IN

Butler, transformer-coupled, transitron, modified Colpitts

MOUNTING DATA

- Crystal Holder: HC-6/U
- Method of Mounting Crystal: Wire-mounted in metal holder
- Dimensions and Marking: See figure 2-29 (B). All dimensions in inches. Unless otherwise specified, tolerances are ± 0.005 in. on decimals.

LOGISTICAL DATA

- USAF Stock No.: 2100-2X535-frequency in kc
- Status: Standard (Category 1)
- Date of Status: 19 November 1952
- Related Specifications, Standards, and Publications: See Appendix IV.
- Commercial Sources: See Appendix III.
- Remarks: Complete information on long-term performance of crystals operating at the temperature specified for this unit is not yet available.
- Equipment Used In:

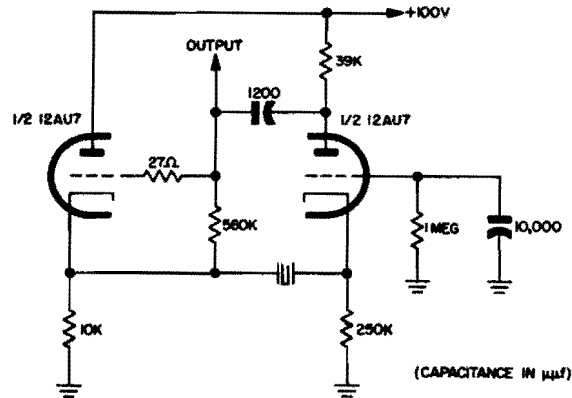

Figure 2-30. Schematic diagram of typical oscillator designed for use with Crystal Unit CR-35/U

MILITARY STANDARD TEST DATA

Authority: Military Specification MIL-C-3098B, approved 9 December 1955

Requirements and Procedures of Tests: See paragraphs 2-21 through 2-50.

Reference Standard Test Set:

Crystal Impedance Meter TS-330/TSM (800 to 14,999.999 kc)

Crystal Impedance Meter TS-683/TSM (15,000 to 20,000 kc)

Electrical Connection of Holder:

Holder grounded

Method of Measuring Frequency and Effective Resonance Resistance: B

Drive Adjustment Procedure:

800 to 14,999.999 kc: MS90167 (see paragraph 2-60 and MIL-C-3098B)

15,000 to 20,000 kc: MS90168 (see paragraph 2-62 and MIL-C-3098B)

Shock and Vibration Test:

Permitted change in frequency: $\pm 0.0005\%$

Permitted change in effective resonance resistance: $\pm 15\%$ or 2 ohms, whichever is greater

Aging Test:

Permitted change in frequency: $\pm 0.001\%$

Tensile Strength Test (Minimum Requirements):

Not required

**CRYSTAL UNIT CR-36/U
(MF—HF)**

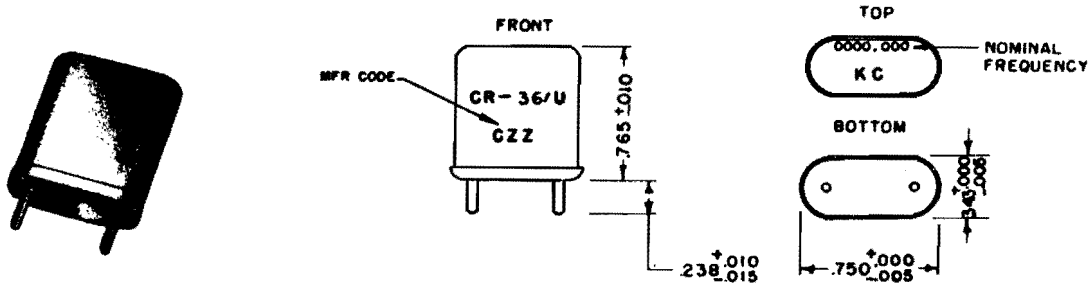

Figure 2-31. Crystal Unit CR-36/U

FUNCTIONAL DESCRIPTION

Metal-plated quartz plate, wire-mounted in a metal holder and designed to operate on the fundamental frequency of the quartz plate. Used as a medium-to-high-frequency control element in circuits where superior frequency stability is required. The crystal unit is intended to be mounted in a temperature-controlled oven, and operated at parallel resonance.

RATED OPERATING CHARACTERISTICS

- Frequency Range: 800 to 20,000 kc
- Nominal Frequency Tolerance: $\pm 0.002\%$ at 85°C
- Frequency Deviation with Temperature: $\pm 0.0005\%$ from frequency measured at 75°C permitted over the range of 80° to 90°C
- Operating Temperature Range: 85° \pm 5°C
- Operable Temperature Range: -55° to +90°C $\pm 2^\circ\text{C}$
- Resonance: Parallel
- Load Capacitance: 32 $\pm 0.5 \mu\text{f}$
- Harmonic of Quartz Vibration: Fundamental
- Maximum Drive Level:
 - 800 to 9,999.999 kc (5 mw)
 - 10,000 to 20,000 kc (2.5 mw)
- Maximum Pin-to-Pin Capacitance: 7.0 μf
- Maximum Effective Resonance Resistance:

Frequency (kc)	Resistance (ohms)
800 to 999.999.....	1000
1000 to 1,249.999.....	800
1250 to 1,499.999.....	700
1500 to 1,749.999.....	600
1750 to 1,999.999.....	550
2000 to 2,249.999.....	500
2250 to 2,999.999.....	320

Frequency (kc)	Resistance (ohms)
3000 to 3,749.999.....	175
3750 to 4,749.999.....	120
4750 to 5,999.999.....	75
6000 to 7,499.999.....	50
7500 to 9,999.999.....	35
10,000 to 20,000.....	25

**PERFORMANCE CHARACTERISTICS OF
NORMAL CRYSTAL ELEMENT**

See characteristics of elements A and B, paragraphs 1-112, -114, figures 1-49, -50, -115, -118.

TYPES OF CIRCUITS USED IN

Pierce, Miller, multivibrator-type

MOUNTING DATA

- Crystal Holder: HC-6/U
- Method of Mounting Crystal: Wire-mounted in metal holder
- Dimensions and Marking: See figure 2-31 (B). All dimensions in inches. Unless otherwise specified, tolerances are ± 0.005 in. on decimals.

LOGISTICAL DATA

- USAF Stock No.: 2100-2X536-frequency in kc
- Status: Standard (Category 1)
- Date of Status: 19 November 1952
- Related Specifications, Standards, and Publications: See Appendix IV.
- Commercial Sources: See Appendix III.
- Remarks: Complete information on long-term performance of crystals operating at the temperature specified for this unit is not yet available.
- Equipment Used In: Radio Set AN/GRC-30 (42 crystals)

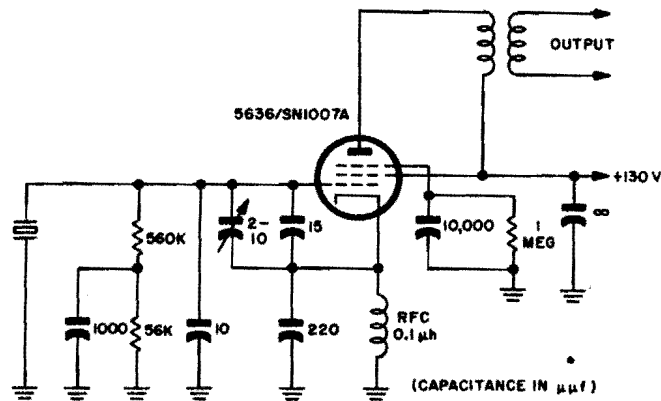

Figure 2-32. Schematic diagram of typical oscillator designed for use with Crystal Unit CR-36/U

MILITARY STANDARD TEST DATA

Authority: Military Specification MIL-C-3098B, approved 9 December 1955

Requirements and Procedures of Tests: See paragraphs 2-21 through 2-50.

Reference Standard Test Set:

Crystal Impedance Meter TS-330/TSM (800 to 14,999.999 kc)

Crystal Impedance Meter TS-683/TSM (15,000 to 20,000 kc)

Electrical Connection of Holder:

Holder grounded

Method of Measuring Frequency and Effective Resonance Resistance: B

Drive Adjustment Procedure:

800 to 14,999.999 kc: MS90167 (see paragraph 2-60 and MIL-C-3098B)

15,000 to 20,000 kc: MS90168 (see paragraph 2-62 and MIL-C-3098B)

Shock and Vibration Test:

Permitted change in frequency: $\pm 0.0005\%$

Permitted change in effective resonance resistance: $\pm 15\%$ or 2 ohms, whichever is greater

Aging Test:

Permitted change in frequency: $\pm 0.001\%$

Tensile Strength Test (Minimum Requirements):

Not specified

**CRYSTAL UNIT CR-37/U
(LF)**

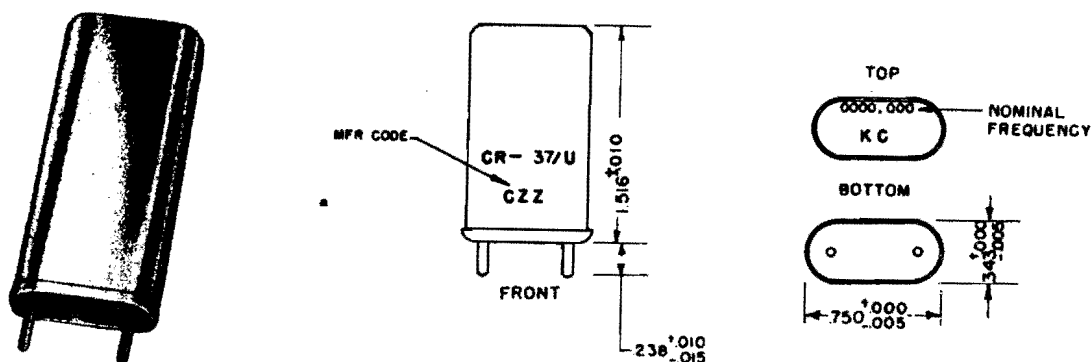

Figure 2-33. Crystal Unit CR-37/U

FUNCTIONAL DESCRIPTION

Metal-plated quartz plate, wire-mounted in a metal holder and designed to operate on the fundamental frequency of the quartz plate. Used as a low-frequency control element in circuits which need only minimum requirements in frequency stability in the absence of oven control under exposure to wide variations of temperature. The crystal unit is intended for operation at parallel resonance.

RATED OPERATING CHARACTERISTICS

- Frequency Range:* 90 to 250 kc
- Nominal Frequency Tolerance:* $\pm 0.02\%$ at all temperatures within the operating range
- Frequency Deviation with Temperature:* Permissible within limits of nominal frequency tolerance
- Operating Temperature Range:* -40° to $+70^{\circ}\text{C}$ $\pm 2^{\circ}\text{C}$
- Operable Temperature Range:* Not specified beyond operating temperature range
- Resonance:* Parallel
- Load Capacitance:* $20 \pm 0.5 \mu\text{f}$
- Harmonic of Quartz Vibration:* Fundamental
- Maximum Drive Level:* 2 mw
- Maximum Pin-to-Pin Capacitance:* See page 467.
- Maximum Effective Resonance Resistance:*

Frequency (kc)	Resistance (ohms)
90 to 169.999.....	5000
170 to 250.....	7000

**PERFORMANCE CHARACTERISTICS OF
NORMAL CRYSTAL ELEMENT**

See characteristics of element E, paragraph 1-199, figures 1-24, -25, -26.

TYPES OF CIRCUITS USED IN

Two-stage-grounded-cathode, modified transistor, Miller, modified Butler

MOUNTING DATA

- Crystal Holder:* HC-13/U
- Method of Mounting Crystal:* Wire-mounted in metal holder
- Dimensions and Marking:* See figure 2-33 (B). All dimensions in inches. Unless otherwise specified, tolerances are ± 0.005 in. on decimals.

LOGISTICAL DATA

- USAF Stock No.:* 2100-2X537-frequency in kc
- Status:* Special application (Category 2)
- Date of Status:* 19 November 1952
- Related Specifications, Standards, and Publications:* See Appendix IV.
- Commercial Sources:* See Appendix III.
- Remarks:* None
- Equipment Used In:* Radio Set AN/ARN-27 (10 crystals)

MILITARY STANDARD TEST DATA

Authority: Military Specification MIL-C-3098B, approved 9 December 1955

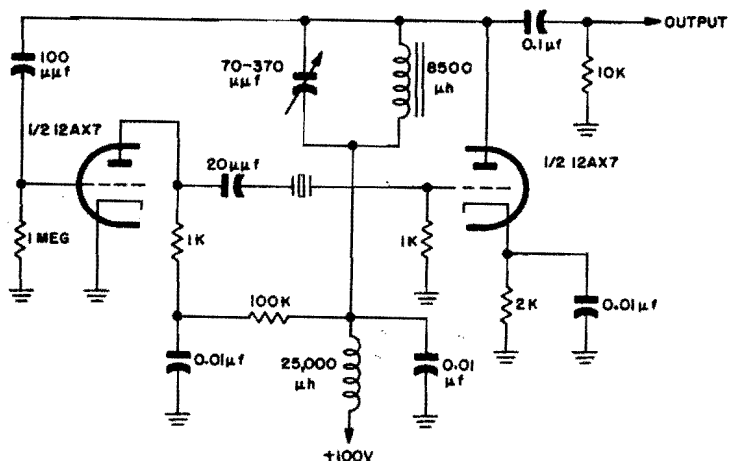

Figure 2-34. Schematic diagram of typical oscillator designed for use with Crystal Unit CR-37/U

Requirements and Procedures of Tests: See paragraphs 2-21 through 2-50.

Reference Standard Test Set: Crystal Impedance Meter TS-537/TSM or TS-710/TSM

Electrical Connection of Holder: Holder grounded

Method of Measuring Frequency and Effective Resonance Resistance: A

Drive Adjustment Procedure: MS91482 (see paragraph 2-61 and MIL-C-3098B) or MS91446 (see paragraph 2-65 and MIL-C-3098B)

Shock and Vibration Test:

Permitted change in frequency: $\pm 0.001\%$

Permitted change in effective resonance resistance: $\pm 15\%$

Aging Test:

Permitted change in frequency: $\pm 0.001\%$

Tensile Strength Test (Minimum Requirements):

Frequency (kc)	Grams
90 to 169.999.....	800
170 to 250.....	700

Capacitance: From pin-to-pin, where f is the specified frequency in kc per second

Frequency (kc) inclusive	Permitted capacitance ($\mu\mu f$)
90.000 to 169.999.....	$\frac{450}{f} + 1.2, \pm 15\%$
170.000 to 250.999.....	$\frac{322}{f} + 1.2, \pm 15\%$

**CRYSTAL UNIT CR-38/U
(VLF—LF)**

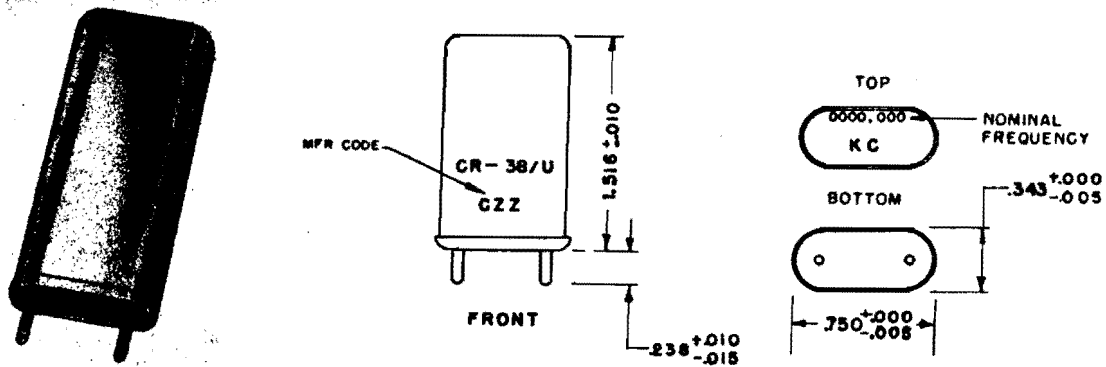

Figure 2-35. Crystal Unit CR-38/U

FUNCTIONAL DESCRIPTION

Metal-plated quartz plate, wire-mounted in a metal holder and designed to operate on the fundamental frequency of the quartz plate. Used as a very-low-to-low-frequency control element which need meet only average requirements in frequency stability in the absence of oven control when exposed to wide variations of temperature. The crystal unit is intended for operation at parallel resonance.

RATED OPERATING CHARACTERISTICS

- Frequency Range:* 16 to 100 kc
- Nominal Frequency Tolerance:* $\pm 0.012\%$ at all temperatures within the operating range
- Frequency Deviation with Temperature:* Permissible within limits of nominal frequency tolerance
- Operating Temperature Range:* -40° to $+70^{\circ}\text{C}$ $\pm 2^{\circ}\text{C}$
- Operable Temperature Range:* Not specified beyond operating temperature range
- Resonance:* Parallel
- Load Capacitance:* $20 \pm 0.5 \mu\mu\text{f}$
- Harmonic of Quartz Vibration:* Fundamental
- Maximum Drive Level:* 0.1 mw
- Maximum Pin-to-Pin Capacitance:* See page 469.
- Maximum Effective Resonance Resistance:* 200,000 ohms

WADC TR 56-156

**PERFORMANCE CHARACTERISTICS OF
NORMAL CRYSTAL ELEMENT**

See characteristics of element N, paragraph 1-104, figures 1-36, -37, -38.

TYPES OF CIRCUITS USED IN

Two-stage-grounded-cathode, modified transistor

MOUNTING DATA

- Crystal Holder:* HC-13/U
- Method of Mounting Crystal:* Wire-mounted in metal holder
- Dimensions and Marking:* See figure 2-35(B). All dimensions in inches. Unless otherwise specified, tolerances are ± 0.005 in. on decimals.

LOGISTICAL DATA

- USAF Stock No.:* 2100-2X538-frequency in kc
- Status:* Special application (Category 2)
- Date of Status:* 19 November 1952
- Related Specifications, Standards, and Publications:* See Appendix IV.
- Commercial Sources:* See Appendix III.
- Remarks:* None
- Equipment Used In:*

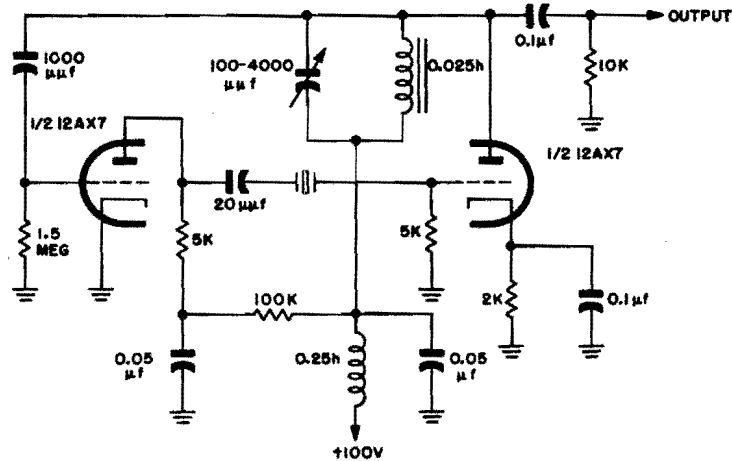

Figure 2-36. Schematic diagram of typical oscillator designed for use with Crystal Unit CR-38/U

MILITARY STANDARD TEST DATA

Authority: Military Specification MIL-C-3098B, approved 9 December 1955

Requirements and Procedures of Tests: See paragraphs 2-21 through 2-50.

Reference Standard Test Set: Crystal Impedance Meter TS-710/TSM

Electrical Connection of Holder:
Holder grounded

Method of Measuring Frequency and Effective Resonance Resistance: A

Drive Adjustment Procedure: MS91446 (see paragraph 2-65 and MIL-C-3098B)

Shock and Vibration Test:

Permitted change in frequency: ±0.001%

Permitted change in effective resonance resistance: ±15%

Aging Test:

Permitted change in frequency: ±0.001%

Tensile Strength Test (Minimum Requirements):

Frequency (kc)	Grams
16 to 59.999.....	800
60 to 100.....	700

Capacitance: From pin-to-pin, where f is the specified frequency in kc per second

Frequency (kc) inclusive	Permitted capacitance ($\mu\mu\text{f}$)
16.000 to 33.999.....	$\frac{24}{\sqrt{f}} + 1.6, \pm 15\%$
34.000 to 53.999.....	$\frac{33}{\sqrt{f}} + 1.6, \pm 15\%$
54.000 to 100.000.....	$\frac{24}{\sqrt{f}} + 1.6, \pm 15\%$

**CRYSTAL UNIT CR-39/U
(LF—MF)**

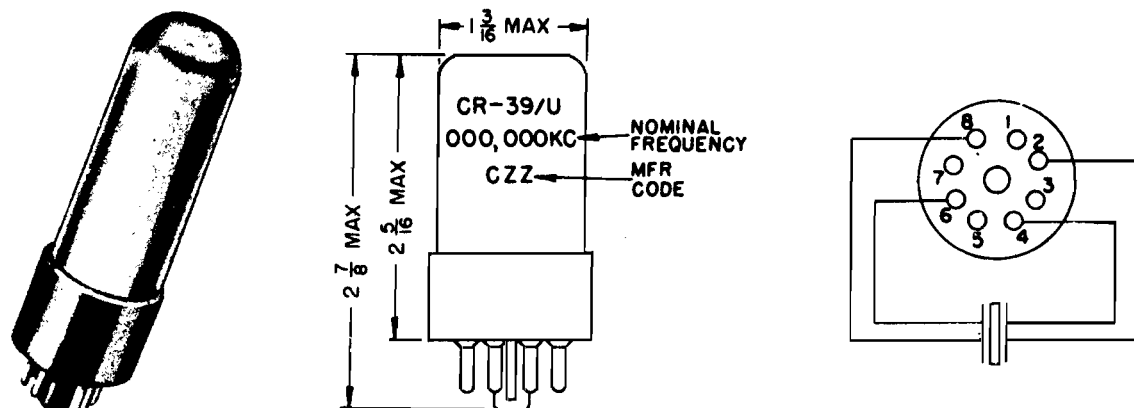

Figure 2-37. Crystal Unit CR-39/U

FUNCTIONAL DESCRIPTION

Metal-plated quartz plate, wire-mounted in an evacuated glass-bulb holder (vacuum-tube type) and designed to operate on the fundamental frequency of the quartz plate. Used as a low-to-medium-frequency control element in circuits which must maintain unusually high frequency stability in the absence of oven control, even when exposed to wide variations of temperature. The crystal unit is intended for operation at series resonance.

RATED OPERATING CHARACTERISTICS

- Frequency Range: 160 to 330 kc
- Nominal Frequency Tolerance: $\pm 0.003\%$ at 25°C
- Frequency Deviation with Temperature: $\pm 0.004\%$ from frequency measured at 25°C over range of -55° to $+75^\circ\text{C} \pm 2^\circ\text{C}$
- Operating Temperature Range: -55° to $+75^\circ\text{C} \pm 2^\circ\text{C}$
- Operable Temperature Range: Not specified beyond operating temperature range
- Resonance: Series
- Load Capacitance: Not applicable
- Harmonic of Quartz Vibration: Fundamental
- Maximum Drive Level: 0.1 mw
- Maximum Pin-to-Pin Capacitance:

Frequency (kc)	Capacitance (μmf)
160 to 249.999.....	$\frac{4320}{\text{Frequency (kc)}} + 2$
250 to 330.....	$\frac{1100}{\text{Frequency (kc)}} + 2$

Maximum Effective Resonance Resistance:

Frequency (kc)	Resistance (ohms)
160 to 249.999.....	150
250 to 330.....	600

Effective Resistance Deviation:

Frequency (kc)	Resistance (ohms)
160 to 249.999.....	50
250 to 330.....	200

**PERFORMANCE CHARACTERISTICS OF
NORMAL CRYSTAL ELEMENT**

See characteristics of element G, paragraph 1-119, figures 1-55, -56, -117.

TYPES OF CIRCUITS USED IN

Meacham-bridge, two-stage-grounded-cathode, transitron, transformer-coupled, Butler, modified Colpitts

MOUNTING DATA

- Crystal Holder: HC-15/U
- Method of Mounting Crystal: Wire-mounted in an evacuated glass-bulb holder
- Dimensions and Marking: See figure 2-37(B). All dimensions in inches. Unless otherwise specified, tolerances are ± 0.005 in. on decimals.

LOGISTICAL DATA

- USAF Stock No.: 2100-
- Status: Special application (Category 2)
- Date of Status: 19 November 1952
- Related Specifications, Standards, and Publications: See Appendix IV.

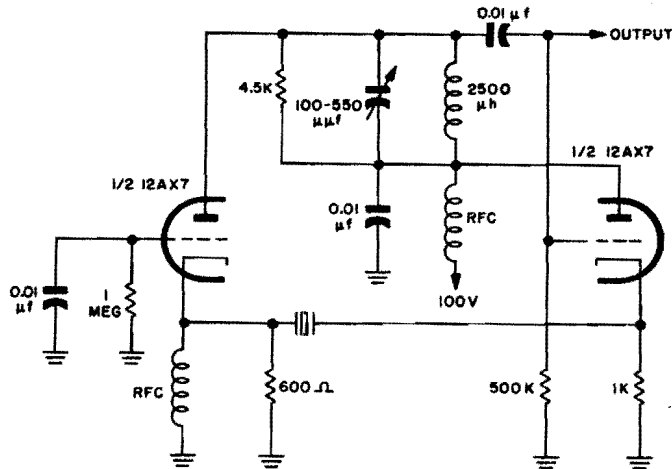

Figure 2-38. Schematic diagram of typical oscillator designed for use with Crystal Unit CR-39/U

Commercial Sources: See Appendix III.

Remarks: Below 180 kc, the shortness of the holder relative to the size of the crystal blank increases the difficulty of obtaining a reliable crystal unit.

Equipment Used In: Radio Set AN/APN-5

MILITARY STANDARD TEST DATA

Authority: Military Specification MIL-C-3098B, approved 9 December 1955

Requirements and Procedures of Tests: See paragraphs 2-21 through 2-50.

Reference Standard Test Set: Crystal Impedance Meter TS-710/TSM

Electrical Connection of Holder: Not applicable

Method of Measuring Frequency and Effective Resonance Resistance: B

Drive Adjustment Procedure: MS91446 (see paragraph 2-65 and MIL-C-3098B)

Shock and Vibration Test:

Permitted change in frequency: $\pm 0.00015\%$

Permitted change in effective resonance resistance: 15%

Aging Test:

Permitted change in frequency: $\pm 0.000075\%$ per week

Tensile Strength Test (Minimum Requirements):

Frequency (kc)	Grams
160 to 249.999.....	1000
250 to 330	800

**CRYSTAL UNIT CR-40/U
(LF—MF)**

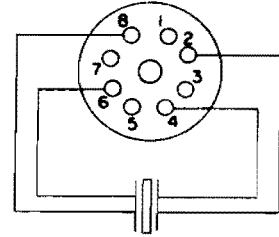
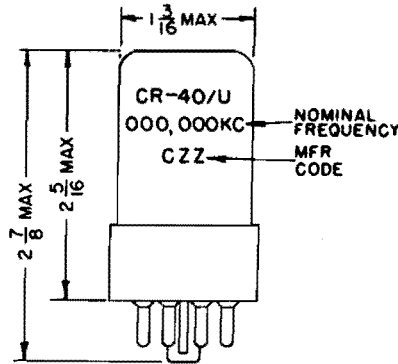
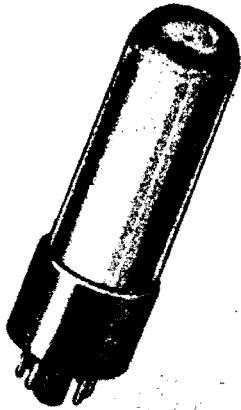

Figure 2-39. Crystal Unit CR-40/U

FUNCTIONAL DESCRIPTION

Metal-plated quartz plate, wire-mounted in an evacuated glass-bulb holder (vacuum-tube type) and designed to operate on the fundamental frequency of the quartz plate. Used as a low-to-medium-frequency control element in circuits where superior frequency stability is required. The crystal unit is intended to be mounted in a temperature-controlled oven and operated at series resonance.

RATED OPERATING CHARACTERISTICS

Frequency Range: 160 to 330 kc
 Nominal Frequency Tolerance: $\pm 0.003\%$ at 70°C
 Frequency Deviation with Temperature:
 $\pm 0.0005\%$ from frequency measured at 70°C
 permitted over range of 65° to 75°C
 Operating Temperature Range: 70° $\pm 5^\circ$ C
 Operable Temperature Range: -55° to +75° $\pm 2^\circ$ C

Resonance: Series
 Load Capacitance: Not applicable
 Harmonic of Quartz Vibration: Fundamental
 Maximum Drive Level: 0.1 mw
 Maximum Pin-to-Pin Capacitance:

Frequency (kc)	Capacitance (μmf)
160 to 249.999.....	$\frac{4320}{\text{Frequency (kc)}} + 2$
250 to 330.....	$\frac{1100}{\text{Frequency (kc)}} + 2$

Maximum Effective Resonance Resistance:

Frequency (kc)	Resistance (ohms)
160 to 249.999.....	150
250 to 330.....	600

Effective Resistance Deviation:

Frequency (kc)	Resistance (ohms)
160 to 249.999.....	50
250 to 330.....	200

**PERFORMANCE CHARACTERISTICS OF
NORMAL CRYSTAL ELEMENT**

See characteristics of element G, paragraph 1-119, figures 1-55, -56, -117.

TYPES OF CIRCUITS USED IN

Meacham-bridge, two-stage-grounded-cathode, transitron, transformer-coupled, Butler, modified Colpitts

MOUNTING DATA

Crystal Holder: HC-15/U
 Method of Mounting Crystal: Wire-mounted in evacuated glass-bulb holder
 Dimensions and Marking: See figure 2-39(B). All dimensions in inches. Unless otherwise specified, tolerances are ± 0.005 in. on decimals.

LOGISTICAL DATA

USAF Stock No.: 2100-2X640
 Status: Special application (Category 2)

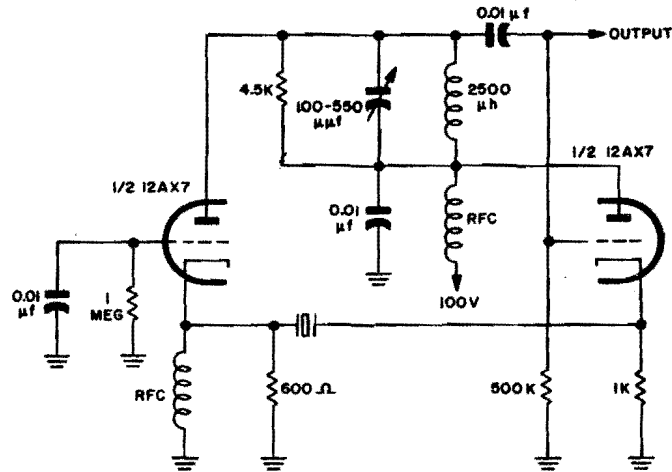

Figure 2-40. Schematic diagram of typical oscillator designed for use with Crystal Unit CR-40/U

Date of Status: 19 November 1952

Related Specifications, Standards, and Publications: See Appendix IV.

Commercial Sources: See Appendix III.

Remarks: Below 180 kc, the shortness of the holder relative to the size of the crystal blank increases the difficulty of obtaining a reliable crystal unit.

Equipment Used In: Radio Set AN/CPN-2A

MILITARY STANDARD TEST DATA

Authority: Military Specification MIL-C-3098B, approved 9 December 1955

Requirements and Procedures of Tests: See paragraphs 2-21 through 2-50.

Reference Standard Test Set: Crystal Impedance Meter TS-537/TSM

Electrical Connection of Holder: Not applicable

Method of Measuring Frequency and Effective

Resonance Resistance: B

Drive Adjustment Procedure: MS91482 (see paragraph 2-61 and MIL-C-3098B)

Shock and Vibration Test:

Permitted change in frequency: $\pm 0.00015\%$

Permitted change in effective resonance resistance: $\pm 10\%$ or 10 ohms, whichever is greater

Aging Test:

Permitted change in frequency: $\pm 0.00005\%$ per week

Tensile Strength Test (Minimum Requirements):

Frequency (kc)	Grams
160 to 249.999	1000
250 to 330	800

**CRYSTAL UNIT CR-42/U
(LF)**

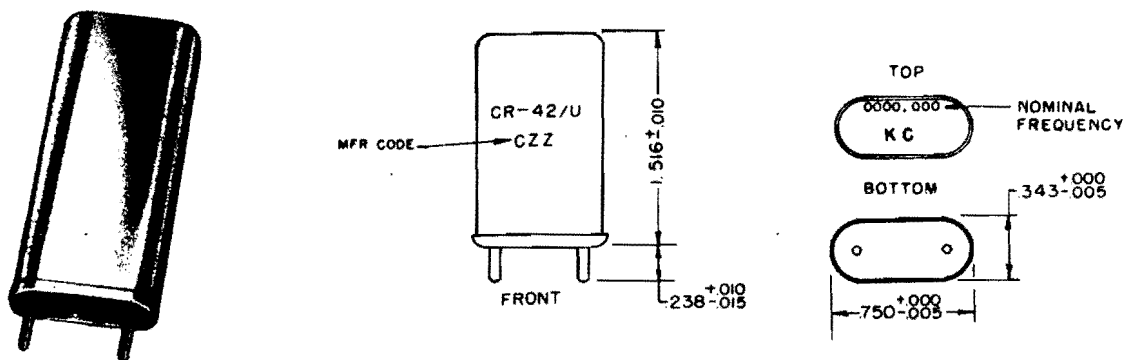

Figure 2-41. Crystal Unit CR-42/U

FUNCTIONAL DESCRIPTION

Metal-plated quartz plate, wire-mounted in an evacuated glass-bulb holder (vacuum-tube type) and designed to operate on the fundamental frequency of the quartz plate. Used as a low-to-medium-frequency control element in circuits where superior frequency stability is required. The crystal unit is intended to be mounted in a temperature-controlled oven, and operated at parallel resonance.

RATED OPERATING CHARACTERISTICS

- Frequency Range: 90 to 250 kc
- Nominal Frequency Tolerance: $\pm 0.003\%$ at 75°C
- Frequency Deviation with Temperature: $\pm 0.002\%$ from frequency measured at 75°C permitted over range of 70° to 80°C
- Operating Temperature Range: $75^\circ \pm 5^\circ\text{C}$
- Operable Temperature Range: -55° to $+85^\circ\text{C}$ $\pm 2^\circ\text{C}$
- Resonance: Parallel
- Load Capacitance: $32 \pm 0.5 \mu\text{f}$
- Harmonic of Quartz Vibration: Fundamental
- Maximum Drive Level: 2 mw
- Maximum Pin-to-Pin Capacitance: Not specified
- Maximum Effective Resonance Resistance:

Frequency (kc)	Resistance (ohms)
90 to 169.999.....	4500
170 to 250	7000

**PERFORMANCE CHARACTERISTICS OF
NORMAL CRYSTAL ELEMENT**

See characteristics of element E, paragraph 1-99, figures 1-24, -25, -28.

TYPES OF CIRCUITS USED IN

Two-stage-grounded-cathode, Miller, modified transitron, modified Butler, Pierce

MOUNTING DATA

- Crystal Holder: HC-13/U
- Method of Mounting Crystal: Wire-mounted in an evacuated glass-bulb holder
- Dimensions and Marking: See figure 2-41 (B). All dimensions in inches. Unless otherwise specified, tolerances are ± 0.005 in. on decimals.

LOGISTICAL DATA

- USAF Stock No.: 2100-2X542
- Status: Special application (Category 2)
- Date of Status: 19 November 1952
- Related Specifications, Standards, and Publications: See Appendix IV.
- Commercial Sources: See Appendix III.
- Remarks: None
- Equipment Used In: Radio Set AN/ARC-21

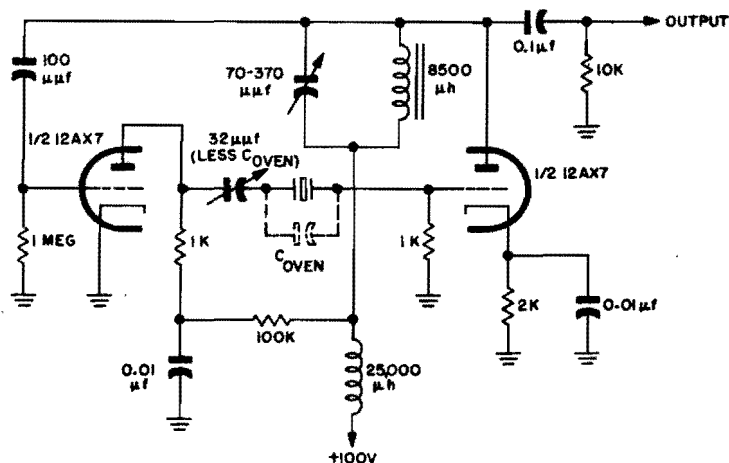

Figure 2-42. Schematic diagram of typical oscillator designed for use with Crystal Unit CR-42/U

MILITARY STANDARD TEST DATA

Authority: Military Specification MIL-C-3098B, approved 9 December 1955

Requirements and Procedures of Tests: See paragraphs 2-21 through 2-50.

Reference Standard Test Set: Crystal Impedance Meter TS-537/TSM or TS-710/TSM

Electrical Connection of Holder: Holder grounded

Method of Measuring Frequency and Effective Resonance Resistance: B

Drive Adjustment Procedure: MS91482 (see paragraph 2-61 and MIL-C-3098B) or MS91446 (see paragraph 2-65 and MIL-C-3098B)

Shock and Vibration Test:

Permitted change in frequency: -0.001 to +0.0005%

Permitted change in effective resonance resistance: ±15%

Aging Test:

Permitted change in frequency: -0.001 to +0.0005%

Tensile Strength Test (Minimum Requirements):

Frequency (kc)	Grams
90 to 169.999.....	800
170 to 250.....	700

**CRYSTAL UNIT CR-43/U
(LF)**

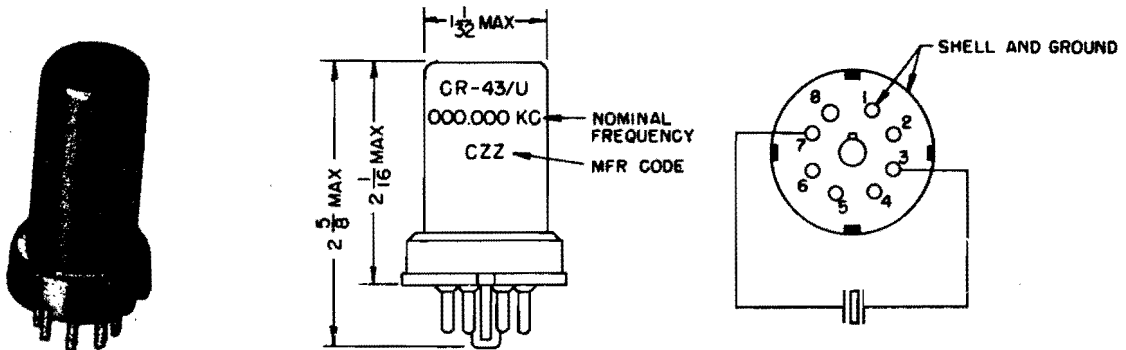

Figure 2-43. Crystal Unit CR-43/U

FUNCTIONAL DESCRIPTION

Metal-plated quartz plate, wire-mounted in an evacuated metal-shell holder (vacuum-tube type) and designed to operate on the fundamental frequency of the quartz plate. Used as a low-frequency control element in circuits which must maintain good frequency stability in the absence of oven control, even when exposed to wide variations of temperature. The crystal unit is intended for operation at parallel resonance.

RATED OPERATING CHARACTERISTICS

Frequency Range: 80.860 kc (can be fabricated within a range of 70 to 100 kc)

Nominal Frequency Tolerance: $\pm 0.01\%$ at 25°C

Frequency Deviation with Temperature:

$\pm 0.0005\%$ from frequency measured at 25°C permitted over range of -30° to +75°C $\pm 2^\circ\text{C}$

Operating Temperature Range: -30° to +75°C $\pm 2^\circ\text{C}$

Operable Temperature Range: Not specified beyond operating temperature range

Resonance: Parallel

Load Capacitance: 45 ± 1.0 μf

Harmonic of Quartz Vibration: Fundamental

Maximum Drive Level: 2 mw

Maximum Pin-to-Pin Capacitance: 45 μf

Maximum Effective Resonance Resistance:

Frequency (kc)	Resistance (ohms)
80.860	3000

**PERFORMANCE CHARACTERISTICS OF
NORMAL CRYSTAL ELEMENT**

See characteristics of element M, paragraph 1-103, figures 1-33, -34, -35. (Optional: element E, paragraph 1-99, figures 1-24, -25, -26.)

TYPES OF CIRCUITS USED IN

Two-stage-grounded-cathode, Miller, modified transitron

MOUNTING DATA

Crystal Holder: HC-16/U

Method of Mounting Crystal: Wire-mounted in evacuated metal-shell holder

Dimensions and Marking: See figure 2-43 (B). All dimensions in inches. Unless otherwise specified, tolerances are ± 0.005 in. on decimals.

LOGISTICAL DATA

USAF Stock No.: 2100-2X543-80.86

Status: Special application (Category 2)

Date of Status: 19 November 1952

Related Specifications, Standards, and Publications: See Appendix IV.

Commercial Sources: See Appendix III.

Remarks: The shortness of the crystal holder relative to the size of the crystal blank increases the difficulty of obtaining a reliable crystal unit. This unit is used in equipment for controlling mile pulses.

Equipment Used In:

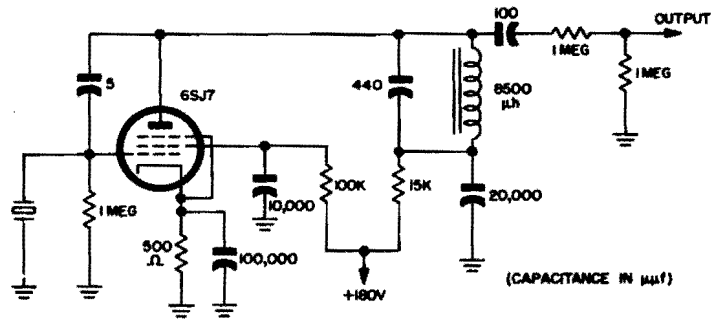

Figure 2-44. Schematic diagram of typical oscillator designed for use with Crystal Unit CR-43/U

MILITARY STANDARD TEST DATA

Authority: Military Specification MIL-C-3098B, approved 9 December 1955
Requirements and Procedures of Tests: See paragraphs 2-21 through 2-50.
Reference Standard Test Set: Crystal Impedance Meter TS-537/TSM
Electrical Connection of Holder: Holder grounded
Method of Measuring Frequency and Effective Resonance Resistance: B
Drive Adjustment Procedure: MS91482 (see paragraph 2-61 and MIL-C-3098B)

Shock and Vibration Test:

Permitted change in frequency: $\pm 0.001\%$
Permitted change in effective resonance resistance: $\pm 15\%$

Aging Test:

Permitted change in frequency: $\pm 0.00075\%$ per week

Tensile Strength Test (Minimum Requirements):

<i>Frequency (kc)</i>	<i>Grams</i>
80.860	1000

CRYSTAL UNIT CR-44/U*
(HF)

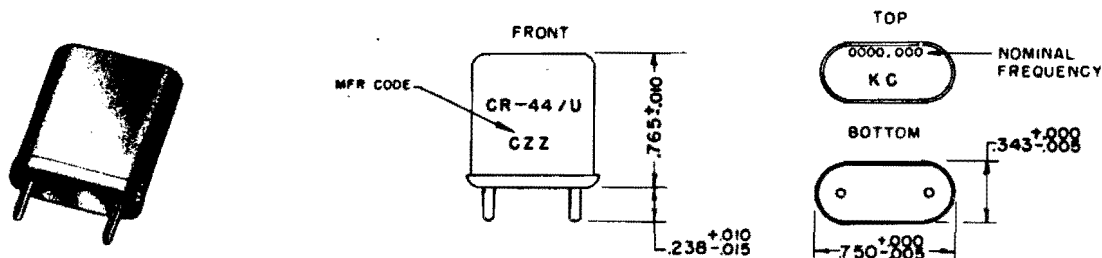

Figure 2-45. Crystal Unit CR-44/U

FUNCTIONAL DESCRIPTION

Metal-plated quartz plate, wire-mounted in a metal holder and designed to operate on the fundamental frequency of the quartz plate. Used as a high-frequency control element in circuits where superior frequency stability is required. The crystal unit is intended to be mounted in a temperature-controlled oven, and operated at parallel resonance.

RATED OPERATING CHARACTERISTICS

- Frequency Range: 15,000 to 20,000 kc
- Nominal Frequency Tolerance: $\pm 0.002\%$ at 85°C
- Frequency Deviation with Temperature: $\pm 0.0005\%$ from frequency measured at 85°C permitted over range of 80° to 90°C
- Operating Temperature Range: 85° \pm 5°C
- Operable Temperature Range: -55° to +90° \pm 2°C
- Resonance: Parallel
- Load Capacitance: 32 \pm 0.5 μ f
- Harmonic of Quartz Vibration: Fundamental
- Maximum Drive Level: 1 mw
- Maximum Pin-to-Pin Capacitance: 7.0 μ f
- Maximum Effective Resonance Resistance: 25 ohms

PERFORMANCE CHARACTERISTICS OF NORMAL CRYSTAL ELEMENT

See characteristics of elements A and B, paragraphs 1-112, -114, figures 1-49, -50, -115, -118.

TYPES OF CIRCUITS USED IN

Pierce, Miller

MOUNTING DATA

- Crystal Holder: HC-6/U
- Method of Mounting Crystal: Wire-mounted in metal holder
- Dimensions and Marking: See figure 2-45 (B). All dimensions in inches. Unless otherwise specified, tolerances are ± 0.005 in. on decimals.

LOGISTICAL DATA

- USAF Stock No.: 2100-
- Status: Special application
- Date of Status: 19 November 1952
- Related Specifications, Standards, and Publications: See Appendix IV.
- Commercial Sources: See Appendix III.
- Remarks: *For replacement only. For new applications specify CR-36/U.

Equipment Used In: Radio Set AN/GRC-30 (42 crystals)

MILITARY STANDARD TEST DATA

- Authority: Military Specification MIL-C-3098B, approved 9 December 1955
- Requirements and Procedures of Tests: See paragraphs 2-21 through 2-50.
- Reference Standard Test Set: Crystal Impedance Meter TS-683/TSM

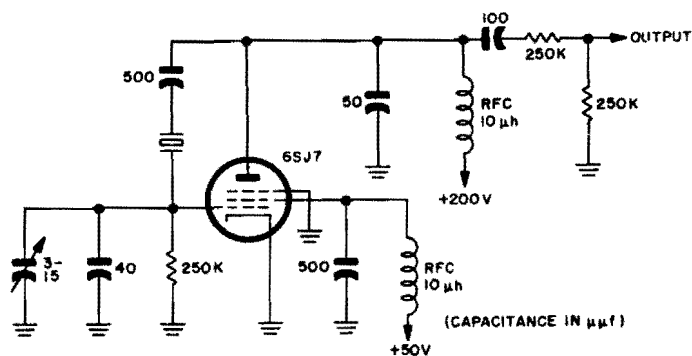

Figure 2-46. Schematic diagram of typical oscillator designed for use with Crystal Unit CR-44/U

Electrical Connection of Holder:

Holder grounded

Method of Measuring Frequency and Effective

Resonance Resistance: B

Drive Adjustment Procedure: MS90168 (see paragraph 2-62 and MIL-C-3098B)

Shock and Vibration Test:

Permitted change in frequency: $\pm 0.0005\%$

Permitted change in effective resonance resistance: $\pm 15\%$ or 2 ohms, whichever is greater

Aging Test: Not required

Tensile Strength Test (Minimum Requirements):

Not required

**CRYSTAL UNIT CR-45/U
(MF)**

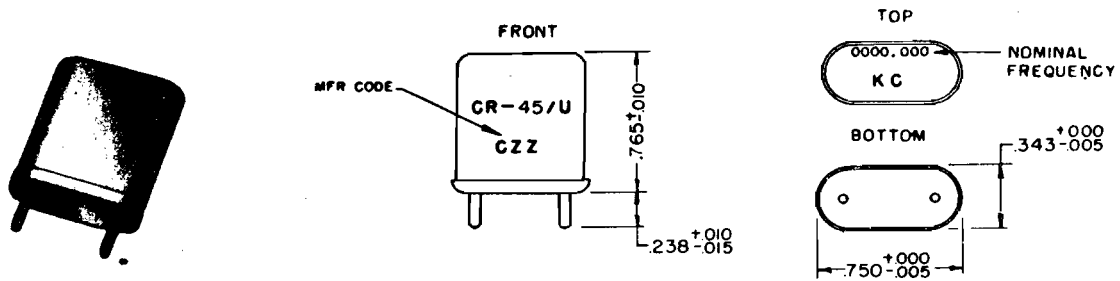

Figure 2-47. Crystal Unit CR-45/U

FUNCTIONAL DESCRIPTION

Metal-plated quartz plate, wire-mounted in a metal holder and designed to operate on the fundamental frequency of the quartz plate. Used as a 455-kc i-f filter element in radio receiver circuits which must provide greater selectivity and i-f stability than can be obtained with conventional L-C bandpass circuits. The crystal unit is intended for operation at series resonance without oven control of the temperature.

RATED OPERATING CHARACTERISTICS

Frequency Range: 455 kc

Nominal Frequency Tolerance: $\pm 0.02\%$ at all temperatures within operating range

Special requirements: (a) The crystal unit shall have a difference in frequency of $+80 \pm 12$ cycles between operating at the series resonant frequency and parallel-resonance of $32 \pm 0.5 \mu\mu\text{f}$. These tests shall be made at room temperature. (b) The crystal unit shall be free of spurious response within 7 kc of the nominal frequency.

Frequency Deviation with Temperature: Permissible within limits of nominal frequency tolerance

Operating Temperature Range: -40° to $+70^\circ \pm 2^\circ\text{C}$

Operable Temperature Range: Not specified beyond operating temperature range

Resonance: Series

Load Capacitance: Not applicable

Harmonic of Quartz Vibration: Fundamental

Maximum Drive Level: 2 mw

Maximum Pin-to-Pin Capacitance: $5 \pm 2.5 \mu\mu\text{f}$

Maximum Effective Resonance Resistance: 3300 ohms

**PERFORMANCE CHARACTERISTICS OF
NORMAL CRYSTAL ELEMENT**

See characteristics of element C, paragraph 1-115, figure 1-51.

TYPES OF CIRCUITS USED IN

Radio receiver i-f bandpass filters, capacitance-bridge

MOUNTING DATA

Crystal Holder: HC-6/U

Method of Mounting Crystal: Wire-mounted in metal holder

Dimensions and Marking: See figure 2-47(B). All dimensions in inches. Unless otherwise specified, tolerances are ± 0.005 in. on decimals.

LOGISTICAL DATA

USAF Stock No.: 2100-

Status: Special application (Category 2)

Date of Status: 19 November 1952

Related Specifications, Standards, and Publications: See Appendix IV.

Commercial Sources: See Appendix III.

Remarks: None

Equipment Used In:

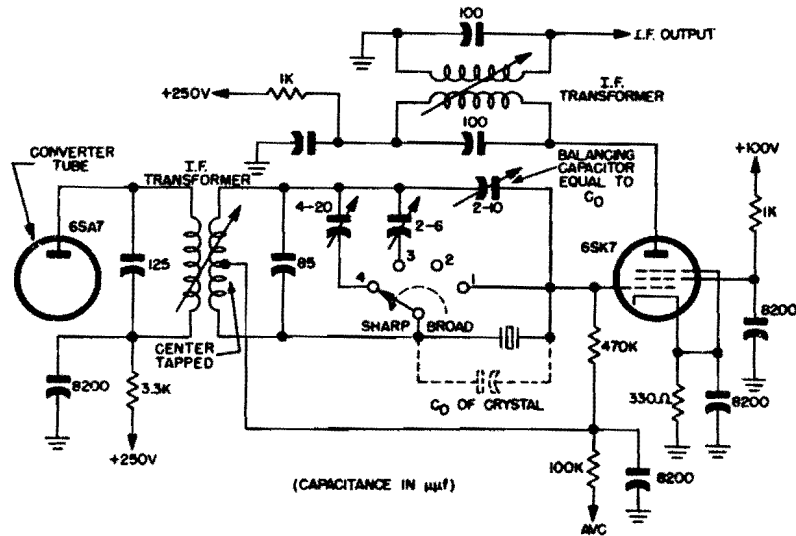

Figure 2-48. Schematic diagram of typical oscillator designed for use with Crystal Unit CR-45/U

MILITARY STANDARD TEST DATA

Authority: Military Specification MIL-C-3098B, approved 9 December 1955

Requirements and Procedures of Tests: See paragraphs 2-21 through 2-50.

Reference Standard Test Set: Crystal Impedance Meter TS-537/TSM

Electrical Connection of Holder:
Holder grounded

Method of Measuring Frequency and Effective Resonance Resistance: A

Drive Adjustment Procedure: MS91482 (see paragraph 2-61 and MIL-C-3098B)

Shock and Vibration Test:

Permitted change in frequency: $\pm 0.003\%$

Permitted change in effective resonance resistance: $\pm 15\%$

Aging Test:

Permitted change in frequency: $\pm 0.001\%$

Tensile Strength Test (Minimum Requirements):
500 grams

**CRYSTAL UNIT CR-46/U
(LF—MF)**

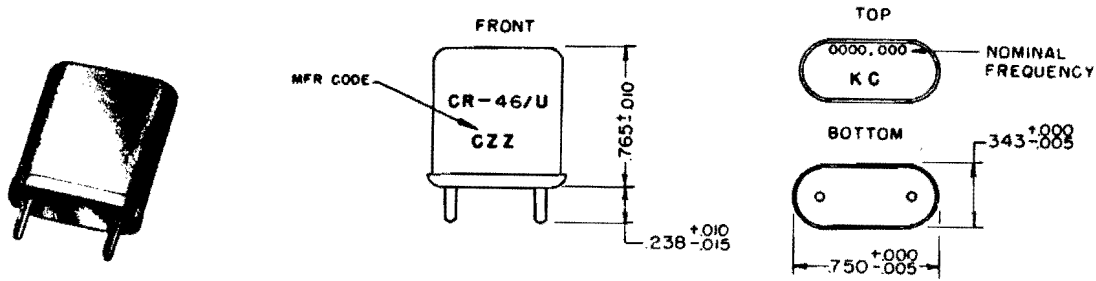

Figure 2-49. Crystal Unit CR-46/U

FUNCTIONAL DESCRIPTION

Metal-plated quartz plate, wire-mounted in a metal holder and designed to operate on the fundamental frequency of the quartz plate. Used as a low-to-medium-frequency control element which must maintain good frequency stability in the absence of oven control, even when exposed to wide variations of temperature. The crystal unit is intended for operation at parallel resonance.

RATED OPERATING CHARACTERISTICS

- Frequency Range: 200 to 500 kc
- Nominal Frequency Tolerance: $\pm 0.01\%$ at all temperatures within the operating range
- Frequency Deviation with Temperature: Permissible within limits of nominal frequency tolerance
- Operating Temperature Range: -40° to $+70^\circ \pm 2^\circ\text{C}$
- Operable Temperature Range: Not specified beyond operating temperature range
- Resonance: Parallel
- Load Capacitance: $20 \pm 0.5 \mu\text{f}$
- Harmonic of Quartz Vibration: Fundamental
- Maximum Drive Level: 2 mw
- Maximum Pin-to-Pin Capacitance: Not specified
- Maximum Effective Resonance Resistance:

Frequency (kc)	Resistance (ohms)
200 to 249.999	6500
250 to 299.999	7000
300 to 399.999	7500
400 to 449.999	10,000
450 to 500	11,000

PERFORMANCE CHARACTERISTICS OF NORMAL CRYSTAL ELEMENT

See characteristics of elements C and D, paragraphs 1-115, -116, figures 1-51, -52.

TYPES OF CIRCUITS USED IN

Miller, Pierce, multivibrator-type, modified transitron, two-stage-grounded-cathode

MOUNTING DATA

- Crystal Holder: HC-6/U
- Method of Mounting Crystal: Wire-mounted in metal holder
- Dimensions and Marking: See figure 2-49 (B). All dimensions in inches. Unless otherwise specified, tolerances are ± 0.005 in. on decimals.

LOGISTICAL DATA

- USAF Stock No.: 2100-
- Status: Special application (Category 2)
- Date of Status: 19 November 1952
- Related Specifications, Standards, and Publications: See Appendix IV.
- Commercial Sources: See Appendix III.
- Remarks: Certain waivers from the specification are required by some manufacturers before going into production.
- Equipment Used In:

MILITARY STANDARD TEST DATA

Authority: Military Specification MIL-C-3098B, approved 9 December 1955

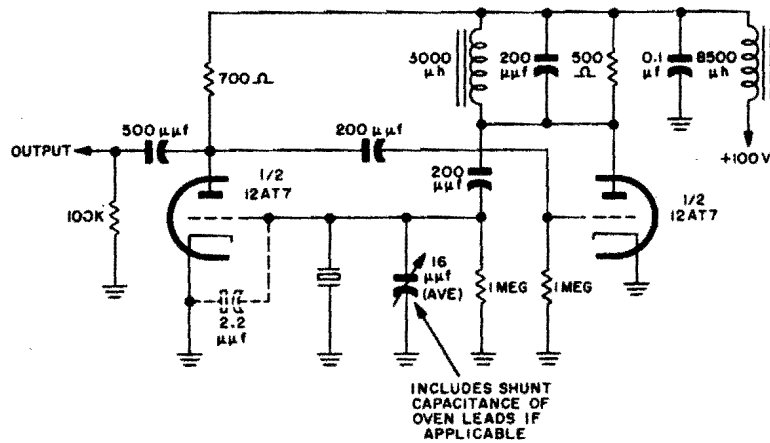

Figure 2-50. Schematic diagram of typical oscillator designed for use with Crystal Unit CR-46/U

Requirements and Procedures of Tests: See paragraphs 2-21 through 2-50.

Reference Standard Test Set: Crystal Impedance Meter TS-537/TSM

Electrical Connection of Holder:
Holder grounded

Method of Measuring Frequency and Effective Resonance Resistance: A

Drive Adjustment Procedure: MS91482 (see paragraph 2-61 and MIL-C-3098B)

Shock and Vibration Test:

Permitted change in frequency: $\pm 0.001\%$

Permitted change in effective resonance resistance: $\pm 15\%$

Aging Test:

Permitted change in frequency: $\pm 0.001\%$

Tensile Strength Test (Minimum Requirements):

Frequency (kc)	Grams
200 to 249.999.....	700
250 to 319.999.....	500
320 to 369.999.....	400
370 to 434.999.....	300
435 to 500.....	250

**CRYSTAL UNIT CR-47/U
(LF—MF)**

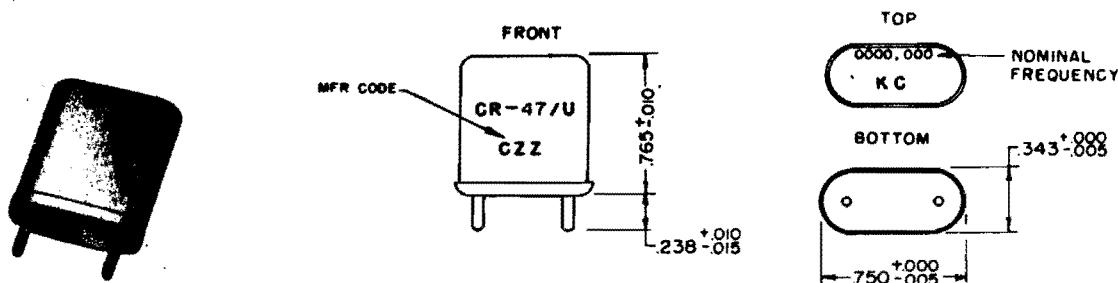

Figure 2-51. Crystal Unit CR-47/U

FUNCTIONAL DESCRIPTION

Metal-plated quartz plate, wire-mounted in a metal holder and designed to operate on the fundamental frequency of the quartz plate. Used as a low-to-medium-frequency control element where superior frequency stability is required. The crystal unit is intended to be mounted in a temperature-controlled oven, and operated at parallel resonance.

RATED OPERATING CHARACTERISTICS

- Frequency Range: 200 to 500 kc
- Nominal Frequency Tolerance: $\pm 0.002\%$ at 75°C
- Frequency Deviation with Temperature: $\pm 0.0005\%$ from frequency measured at 75°C permitted over range of 70° to 80°C
- Operating Temperature Range: $75^\circ \pm 5^\circ\text{C}$
- Operable Temperature Range: -40° to $+80^\circ \pm 2^\circ\text{C}$
- Resonance: Parallel
- Load Capacitance: $20 \pm 0.5 \mu\text{f}$
- Harmonic of Quartz Vibration: Fundamental
- Maximum Drive Level: 2 mw
- Maximum Pin-to-Pin Capacitance: Not specified
- Maximum Effective Resonance Resistance:

Frequency (kc)	Resistance (ohms)
200 to 249.999	6500
250 to 299.999	7000
300 to 399.999	7500
400 to 449.999	10,000
450 to 500	11,000

**PERFORMANCE CHARACTERISTICS OF
NORMAL CRYSTAL ELEMENT**

See characteristics of elements C and D, paragraphs 1-115, -116, figures 1-51, -52.

TYPES OF CIRCUITS USED IN

Pierce, modified transitron, multivibrator-type, Miller, two-stage-grounded-cathode

MOUNTING DATA

- Crystal Holder: HC-6/U
- Method of Mounting Crystal: Wire-mounted in metal holder
- Dimensions and Marking: See figure 2-51 (B). All dimensions in inches. Unless otherwise specified, tolerances are ± 0.005 in. on decimals.

LOGISTICAL DATA

- USAF Stock No.: 2100-
- Status: Special application (Category 2)
- Date of Status: 19 November 1952
- Related Specifications, Standards, and Publications: See Appendix IV.
- Commercial Sources: See Appendix III.
- Remarks:

Equipment Used In:

MILITARY STANDARD TEST DATA

Authority: Military Specification MIL-C-3098B, approved 9 December 1955

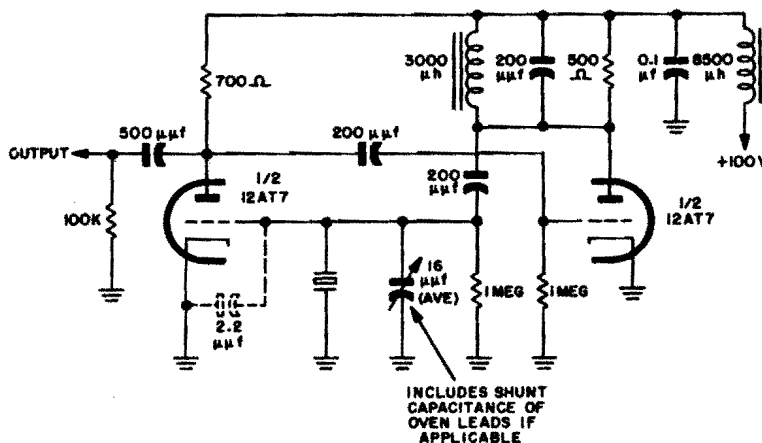

Figure 2-52. Schematic diagram of typical oscillator designed for use with Crystal Unit CR-47/U

Requirements and Procedures of Tests: See paragraphs 2-21 through 2-50.

Reference Standard Test Set: Crystal Impedance Meter TS-537/TSM

Electrical Connection of Holder:
Holder grounded

Method of Measuring Frequency and Effective Resonance Resistance: B

Drive Adjustment Procedure: MS91482 (see paragraph 2-61 and MIL-C-3098B)

Shock and Vibration Test:

Permitted change in frequency: $\pm 0.0005\%$

Permitted change in effective resonance resistance: $\pm 15\%$

Aging Test:

Permitted change in frequency: $\pm 0.001\%$

Tensile Strength Test (Minimum Requirements):

Frequency (kc)	Grams
200 to 249.999.....	700
250 to 319.999.....	500
320 to 369.999.....	400
370 to 434.999.....	300
435 to 500.....	250

**CRYSTAL UNIT CR-48/U *
(MF)**

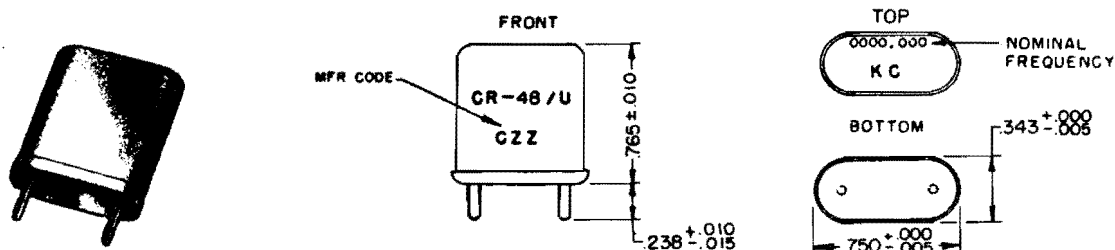

Figure 2-53. Crystal Unit CR-48/U

FUNCTIONAL DESCRIPTION

Metal-plated quartz plate, wire-mounted in a metal holder and designed to operate on the fundamental frequency of the quartz plate. Used as a medium-frequency control element in circuits which must maintain slightly better-than-average frequency stability when exposed to extreme variations of temperature. The crystal unit is intended for operation at parallel resonance.

RATED OPERATING CHARACTERISTICS

- Frequency Range: 800 to 3000 kc
- Nominal Frequency Tolerance: $\pm 0.0075\%$ at all temperatures within the operating range
- Frequency Deviation with Temperature: Permissible within limits of nominal frequency tolerance
- Operating Temperature Range: -55° to $+90^{\circ}\text{C}$ $\pm 2^{\circ}\text{C}$
- Operable Temperature Range: Not specified beyond operating temperature range
- Resonance: Parallel
- Load Capacitance: $32 \pm 0.5 \mu\text{f}$
- Harmonic of Quartz Vibration: Fundamental
- Maximum Drive Level: 10 mw
- Maximum Pin-to-Pin Capacitance: $7.0 \mu\text{f}$
- Maximum Effective Resonance Resistance:

Frequency (kc)	Resistance (ohms)
800 to 999.999.....	1000
1000 to 1,249.999.....	800
1250 to 1,499.999.....	700
1500 to 1,749.999.....	600

Frequency (kc)	Resistance (ohms)
1750 to 1,999.999.....	550
2000 to 2,249.999.....	500
2250 to 3000.....	320

**PERFORMANCE CHARACTERISTICS OF
NORMAL CRYSTAL ELEMENT**

See characteristics of element A, paragraph 1-112, figures 1-49, -115, -118.

TYPES OF CIRCUITS USED IN

Pierce, Miller, multivibrator-type

MOUNTING DATA

- Crystal Holder: HC-6/U
- Method of Mounting Crystal: Wire-mounted in metal holder
- Dimensions and Marking: See figure 2-53 (B). All dimensions in inches. Unless otherwise specified, tolerances are ± 0.005 in. on decimals.

LOGISTICAL DATA

- USAF Stock No.: 2100-
- Status: Special application (Category 2)
- Date of Status: 19 November 1952
- Related Specifications, Standards, and Publications: See Appendix IV.
- Commercial Sources: See Appendix III.
- Remarks: *For replacement only. For new applications specify CR-18/U.
- Equipment Used In:

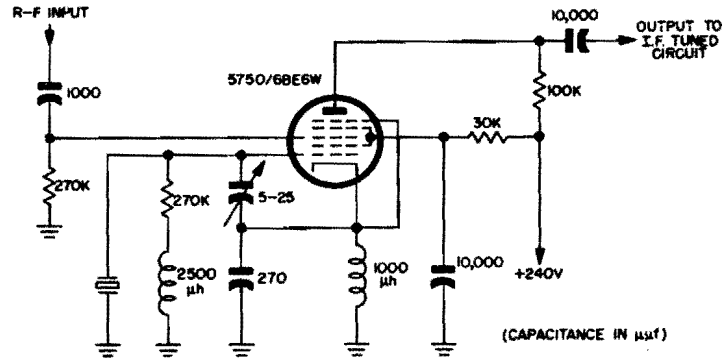

Figure 2-54. Schematic diagram of typical oscillator designed for use with Crystal Unit CR-48/U

MILITARY STANDARD TEST DATA

Authority: Military Specification MIL-C-3098B, approved 9 December 1955

Requirements and Procedures of Tests: See paragraphs 2-21 through 2-50.

Reference Standard Test Set: Crystal Impedance Meter TS-330/TSM

Electrical Connection of Holder:
Holder grounded

Method of Measuring Frequency and Effective Resonance Resistance: A

Drive Adjustment Procedure: MS90167 (see paragraph 2-60 and MIL-C-3098B)

Shock and Vibration Test:

Permitted change in frequency:

±0.001% for units below 2000 kc

±0.0005% for units of 2000 kc and above

Permitted change in effective resonance resistance: ±15%

Aging Test: Not required

Tensile Strength Test (Minimum Requirements):
Not required

CRYSTAL UNIT CR-49/U*
(MF)

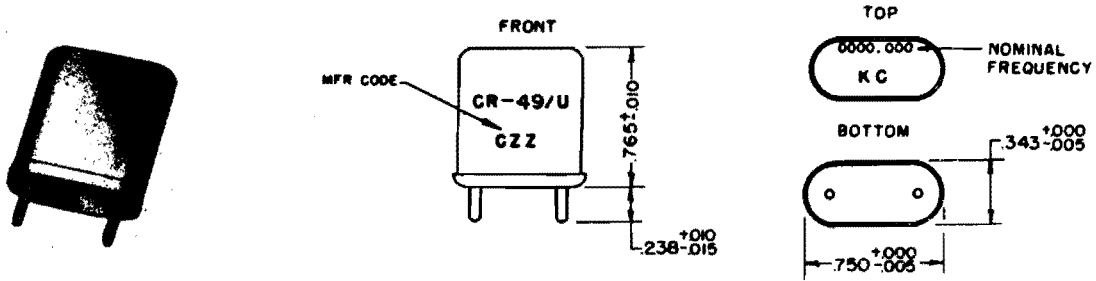

Figure 2-55. Crystal Unit CR-49/U

FUNCTIONAL DESCRIPTION

Spacer-mounted quartz plate in a metal holder designed to operate on the fundamental frequency of the quartz plate. Used as a medium-frequency control element in circuits which must maintain slightly better-than-average frequency stability under exposure to extreme variations in temperature. The crystal unit is intended for operation at parallel resonance.

RATED OPERATING CHARACTERISTICS

- Frequency Range:* 800 to 3000 kc
- Nominal Frequency Tolerance:* $\pm 0.0075\%$ at all temperatures within operating range
- Frequency Deviation with Temperature:* Permissible within limits of nominal frequency tolerance
- Operating Temperature Range:* -55° to $+90^{\circ}\text{C}$ $\pm 2^{\circ}\text{C}$
- Operable Temperature Range:* Not specified beyond operating temperature range
- Resonance:* Parallel
- Load Capacitance:* $32 \pm 0.5 \mu\text{f}$
- Harmonic of Quartz Vibration:* Fundamental
- Maximum Drive Level:* 10 mw
- Maximum Pin-to-Pin Capacitance:* Not specified
- Maximum Effective Resonance Resistance:*

Frequency (kc)	Resistance (ohms)
800 to 999.999.....	1000
1000 to 1,249.999.....	800
1250 to 1,499.999.....	700
1500 to 1,749.999.....	600
1750 to 1,999.999.....	550
2000 to 2,249.999.....	500
2250 to 3000.....	320

PERFORMANCE CHARACTERISTICS OF NORMAL CRYSTAL ELEMENT

See characteristics of element A, paragraph 1-112, figures 1-49, -115, -118.

TYPES OF CIRCUITS USED IN

Pierce, Miller, multivibrator-type

MOUNTING DATA

- Crystal Holder:* HC-6/U
- Method of Mounting Crystal:* Spacer-mounted in metal holder
- Dimensions and Marking:* See figure 2-55(B). All dimensions in inches. Unless otherwise specified, tolerances are ± 0.005 in. on decimals.

LOGISTICAL DATA

- USAF Stock No.:* 2100-
- Status:* Special application (Category 2)
- Date of Status:* 14 January 1954
- Related Specifications, Standards, and Publications:* See Appendix IV.
- Commercial Sources:* See Appendix III.
- Remarks:* *For replacement only. For new applications specify CR-18/U.
- Equipment Used In:*

MILITARY STANDARD TEST DATA

- Authority:* Military Specification MIL-C-3098B, approved 9 December 1955
- Requirements and Procedures of Tests:* See paragraphs 2-21 through 2-50.
- Reference Standard Test Set:* Crystal Impedance Meter TS-330/TSM

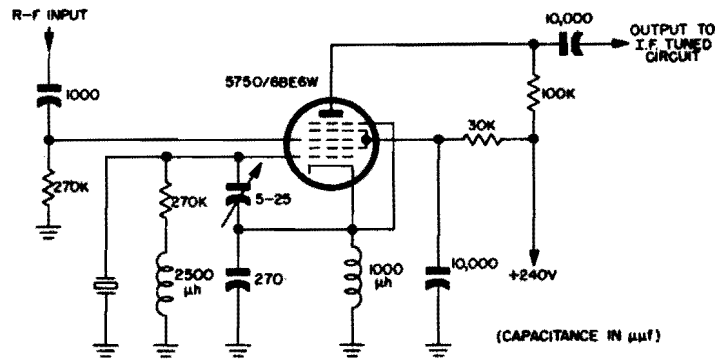

Figure 2-56. Schematic diagram of typical oscillator designed for use with Crystal Unit CR-49/U

Electrical Connection of Holder: Holder grounded

Method of Measuring Frequency and Effective Resonance Resistance: The crystal unit shall be subjected to a temperature run over the operating temperature range specified at any convenient rate of change not to exceed an average rate of 50°C per minute. Observations of frequency and effective resistance shall be made continuously, or intermittently at no greater than 2°C intervals. Values of frequency and effective resistance shall not exceed the prescribed limits over the temperature range.

Drive Adjustment Procedure: MS90167 (see paragraph 2-60 and MIL-C-3098B)

Shock and Vibration Test:

Permitted change in frequency:

±0.002% for units below 2000 kc

±0.0005% for units of 2000 kc and above

Permitted change in effective resonance resistance:

Resistance (ohms)	Permitted change (%)
0 to 10.....	40
10.1 to 50.....	30
50.1 to 100.....	25
above 100.....	20

Aging Test: Not required

Tensile Strength Test (Minimum Requirements):
Not required

CRYSTAL UNIT CR-50/U
(VLF—LF)

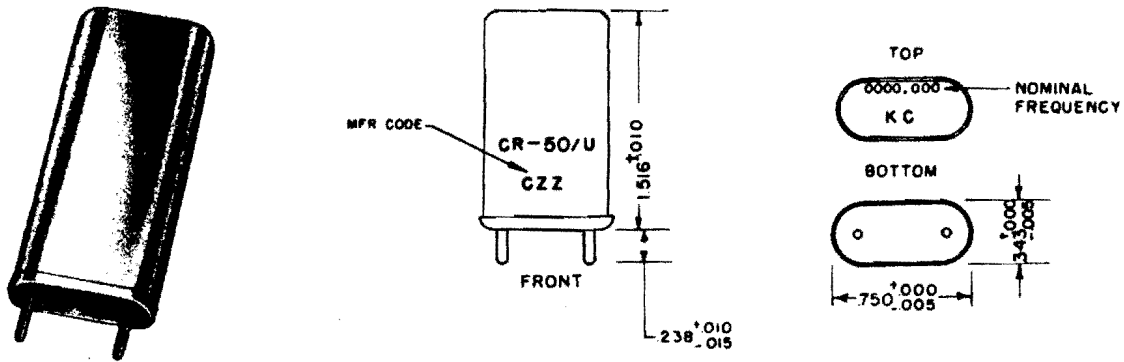

Figure 2-57. Crystal Unit CR-50/U

FUNCTIONAL DESCRIPTION

Metal-plated quartz plate, wire-mounted in a metal holder and designed to operate on the fundamental frequency of the quartz plate. Used as a very-low-to-low-frequency control element which need meet only average requirements in frequency stability in the absence of oven control when exposed to wide variations in temperature. The crystal unit is intended for operation at series resonance.

RATED OPERATING CHARACTERISTICS

- Frequency Range:* 16 to 100 kc
- Nominal Frequency Tolerance:* ±0.012% at all temperatures within the operating range
- Frequency Deviation with Temperature:* Permissible within the limits of nominal frequency tolerance
- Operating Temperature Range:* -40° to +70°C
- Operable Temperature Range:* Not specified beyond operating temperature range
- Resonance:* Series
- Load Capacitance:* Not applicable
- Harmonic of Quartz Vibration:* Fundamental
- Maximum Drive Level:* 0.1 mw
- Maximum Pin-to-Pin Capacitance:*

<i>Frequency (kc)</i>	<i>Capacitance (μpf)</i>
16 to 33.999.....	$\left(\frac{24}{\sqrt{\text{Frequency (kc)}}} + 1.6\right) \pm 15\%$
34 to 53.999.....	$\left(\frac{33}{\sqrt{\text{Frequency (kc)}}} + 1.6\right) \pm 15\%$

<i>Frequency (kc)</i>	<i>Resistance (ohms)</i>
54 to 100.00.....	$\left(\frac{24}{\sqrt{\text{Frequency (kc)}}} + 1.6\right) \pm 15\%$

Maximum Effective Resonance Resistance:
125,000 ohms

PERFORMANCE CHARACTERISTICS OF NORMAL CRYSTAL ELEMENT

See characteristics of element N, paragraph 1-104, figures 1-36, -37, -38.

TYPES OF CIRCUITS USED IN

Two-stage-grounded-cathode, modified transistor

MOUNTING DATA

- Crystal Holder:* HC-13/U
- Method of Mounting Crystal:* Wire-mounted in metal holder
- Dimensions and Marking:* See figure 2-57(B). All dimensions in inches. Unless otherwise specified, tolerances are ±0.005 in. on decimals.

LOGISTICAL DATA

- USAF Stock No.:* 2100-
- Status:* Special application (Category 2)
- Date of Status:* 14 January 1954
- Related Specifications, Standards, and Publications:* See Appendix IV.
- Commercial Sources:* See Appendix III.
- Remarks:* The shunt-capacitance specification is controversial within the industry.
- Equipment Used In:* Radio Set AN/ARN-27 (10 crystals)

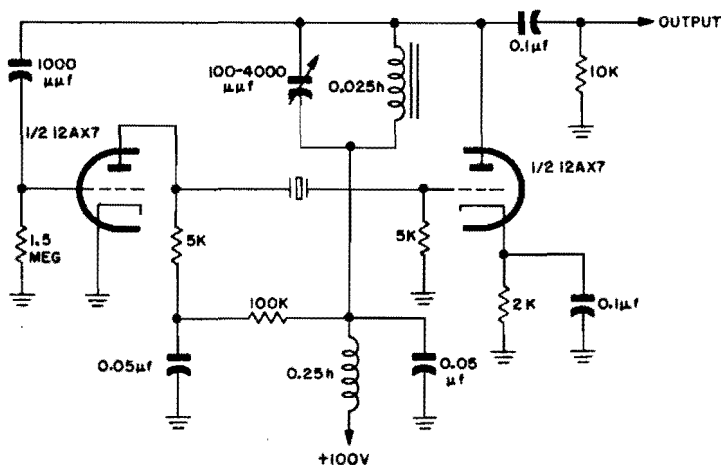

Figure 2-58. Schematic diagram of typical oscillator designed for use with Crystal Unit CR-50/U

MILITARY STANDARD TEST DATA

Authority: Military Specification MIL-C-3098B, approved 9 December 1955

Requirements and Procedures of Tests: See paragraphs 2-21 through 2-50.

Reference Standard Test Set: Crystal Impedance Meter TS-710/TSM

Electrical Connection of Holder: Holder grounded

Method of Measuring Frequency and Effective Resonance Resistance: A

Drive Adjustment Procedure: MS91446 (see paragraph 2-65 and MIL-C-3098B)

Shock and Vibration Test:

Permitted change in frequency: $\pm 0.001\%$

Permitted change in effective resonance resistance: $\pm 15\%$

Aging Test:

Permitted change in frequency: $\pm 0.001\%$

Tensile Strength Test (Minimum Requirements):

Frequency (kc)	Grams
16 to 59.999.....	800
60 to 100.....	700

**CRYSTAL UNIT CR-51/U
(HF—VHF)**

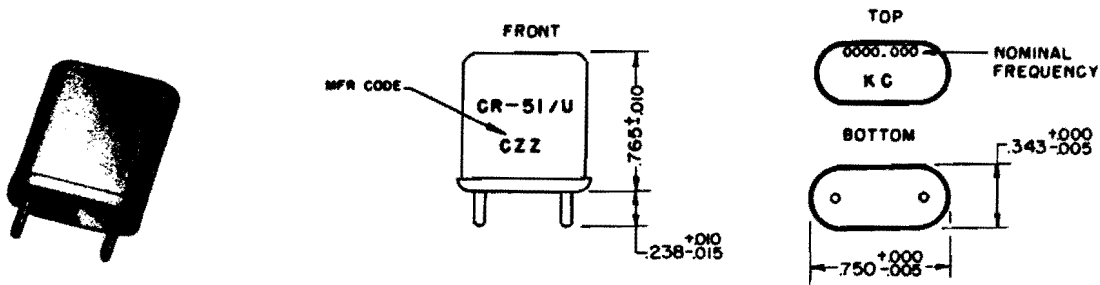

Figure 2-59. Crystal Unit CR-51/U

FUNCTIONAL DESCRIPTION

Pressure-mounted quartz plate in metal holder designed to operate on the third mechanical harmonic of the fundamental frequency of the quartz plate. Used as a high- to very-high-frequency control element in circuits which must maintain above-average frequency stability in the absence of oven control, even when exposed to wide variations in temperature and to relatively high drive levels. The crystal unit is intended for operation at series resonance.

RATED OPERATING CHARACTERISTICS

- Frequency Range:* 10 to 61 mc
- Nominal Frequency Tolerance:* $\pm 0.005\%$ at all temperatures within the operating range
- Frequency Deviation with Temperature:* Permissible within limits of nominal frequency tolerance
- Operating Temperature Range:* -55° to $+90^{\circ}\text{C}$ $\pm 2^{\circ}\text{C}$
- Operable Temperature Range:* Not specified beyond operating temperature range
- Resonance:* Series
- Load Capacitance:* Not applicable
- Harmonic of Quartz Vibration:* Third mechanical harmonic
- Maximum Drive Level:* 20 mw
- Maximum Pin-to-Pin Capacitance:* 7.0 μf
- Maximum Effective Resonance Resistance:*

<i>Frequency (mc)</i>	<i>Resistance (ohms)</i>
10 to 14.999	60
15 to 61	40

**PERFORMANCE CHARACTERISTICS OF
NORMAL CRYSTAL ELEMENT**

See characteristics of element A, paragraph 1-112, figures 1-49, -112, -113, -115, -118.

TYPES OF CIRCUITS USED IN

Butler, transformer-coupled, capacitance-bridge, transitron, impedance-inverted

MOUNTING DATA

- Crystal Holder:* HC-6/U
- Method of Mounting Crystal:* Pressure-mounted in metal holder
- Dimensions and Marking:* See figure 2-59 (B). All dimensions in inches. Unless otherwise specified, tolerances are ± 0.005 in. on decimals.

LOGISTICAL DATA

- USAF Stock No.:* 2100-
- Status:* Special application (Category 1)
- Date of Status:* 14 January 1954
- Related Specifications, Standards, and Publications:* See Appendix IV.
- Commercial Sources:* See Appendix III.
- Remarks:* Difficult to manufacture and meet all specification requirements over entire upper and lower ranges.
- Equipment Used In:*

MILITARY STANDARD TEST DATA

- Authority:* Military Specification MIL-C-3098B, approved 9 December 1955
- Requirements and Procedures of Tests:* See paragraphs 2-21 through 2-50.

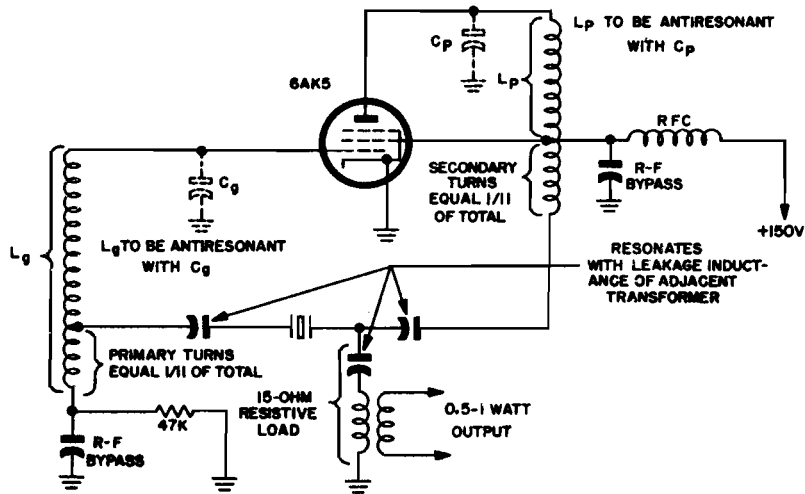

Figure 2-60. Schematic diagram of typical oscillator designed for use with Crystal Unit CR-51/U

Reference Standard Test Set: Crystal Impedance Meter TS-683/TSM

Electrical Connection of Holder: Holder grounded

Method of Measuring Frequency and Effective Resonance Resistance: A or B

Drive Adjustment Procedure: MS90168 (see paragraph 2-62 and MIL-C-3098B), with the exception of the following table of voltage and resistance:

Frequency (mc)	Resistance (ohms)	Volts
10 to 14.999	60	1.1
15 to 61	40	0.9

Shock and Vibration Test:

Permitted change in frequency: $\pm 0.002\%$

Permitted change in effective resonance resistance: Shall not exceed the max effective resistance

Aging Test:

Permitted change in frequency: $\pm 0.001\%$

Tensile Strength Test (Minimum Requirements):

Not required

**CRYSTAL UNIT CR-52/U
(HF—VHF)**

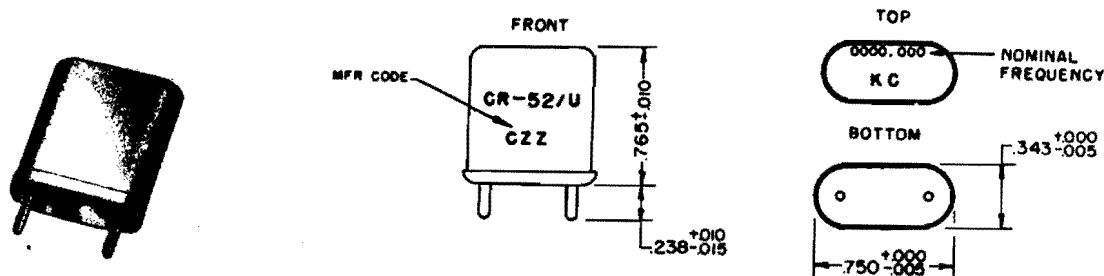

Figure 2-61. Crystal Unit CR-52/U

FUNCTIONAL DESCRIPTION

Metal-plated quartz plate, wire-mounted in a metal holder and designed to operate on the third mechanical harmonic of the fundamental frequency of the quartz plate. Used as a high- to very-high-frequency control element in circuits which must maintain above-average frequency stability in the absence of oven control, even when exposed to wide variations of temperature. The crystal unit is intended for operation at series resonance.

RATED OPERATING CHARACTERISTICS

- Frequency Range:* 10 to 61 mc
- Nominal Frequency Tolerance:* $\pm 0.005\%$ at all temperatures within the operating range
- Frequency Deviation with Temperature:* Permissible within limits of nominal frequency tolerance
- Operating Temperature Range:* -55° to $+90^{\circ}\text{C}$ $\pm 2^{\circ}\text{C}$
- Operable Temperature Range:* Not specified beyond operating temperature range
- Resonance:* Series
- Load Capacitance:* Not applicable
- Harmonic of Quartz Vibration:* Third mechanical harmonic
- Maximum Drive Level:*
 - 10 to 24.999999 mc (4 mw)
 - 25 to 61 mc (2 mw)
- Maximum Pin-to-Pin Capacitance:* 7.0 μf

Maximum Effective Resonance Resistance:

<i>Frequency (mc)</i>	<i>Resistance (ohms)</i>
10 to 14.999999.....	60
15 to 61	40

**PERFORMANCE CHARACTERISTICS OF
NORMAL CRYSTAL ELEMENT**

See characteristics of element A, paragraph 1-112, figures 1-49, -112, -113, -115, -118.

TYPES OF CIRCUITS USED IN

Butler, transformer-coupled, capacitance-bridge, transitron, impedance-inverted

MOUNTING DATA

- Crystal Holder:* HC-6/U
- Method of Mounting Crystal:* Wire-mounted in metal holder
- Dimensions and Marking:* See figure 2-61 (B). All dimensions in inches. Unless otherwise specified, tolerances are ± 0.005 in. on decimals.

LOGISTICAL DATA

- USAF Stock No.:* 2100-
- Status:* Special application (Category 1)
- Date of Status:* 14 January 1954
- Related Specifications, Standards, and Publications:* See Appendix IV.
- Commercial Sources:* See Appendix III.

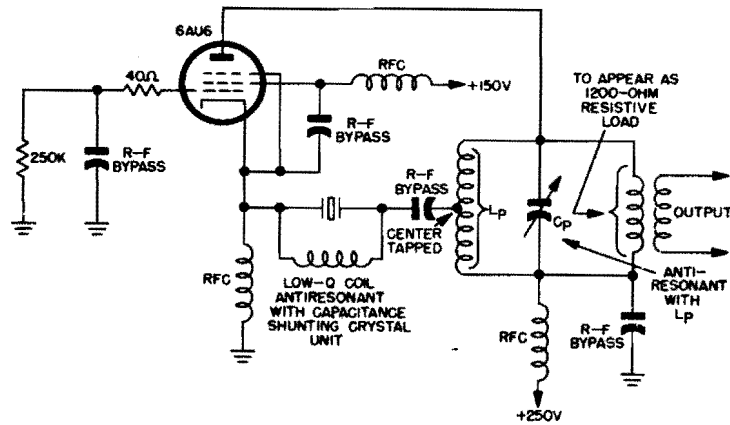

Figure 2-62. Schematic diagram of typical oscillator designed for use with Crystal Unit CR-52/U

Remarks: Difficult to manufacture and meet all specification requirements over entire upper and lower ranges. Same as CR-23/U except designed to operate on 3rd mode only.

Equipment Used In:

MILITARY STANDARD TEST DATA

Authority: Military Specification MIL-C-3098B, approved 9 December 1955

Requirements and Procedures of Tests: See paragraphs 2-21 through 2-50.

Reference Standard Test Set: Crystal Impedance Meter TS-683/TSM

Electrical Connection of Holder: Holder grounded

Method of Measuring Frequency and Effective Resonance Resistance: A

Drive Adjustment Procedure: MS90168 (see paragraphs 2-62 and 2-64 per MIL-C-3098B)

Shock and Vibration Test:

Permitted change in frequency: $\pm 0.005\%$

Permitted change in effective resonance resistance: $\pm 15\%$ or 2 ohms, whichever is greater

Aging Test:

Permitted change in frequency: $\pm 0.001\%$

Tensile Strength Test (Minimum Requirements):

Not required

**CRYSTAL UNIT CR-53/U
(VHF)**

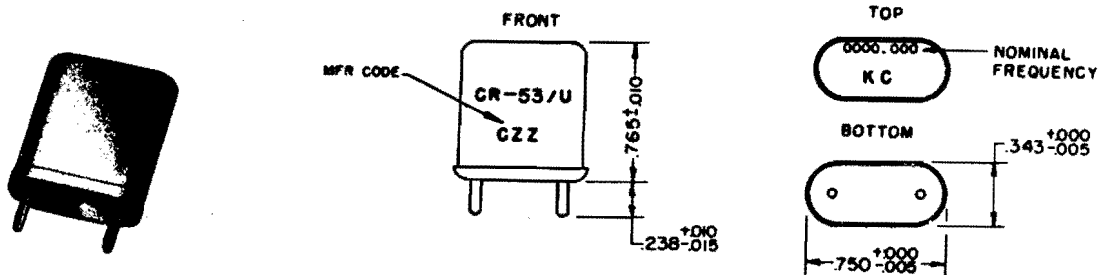

Figure 2-63. Crystal Unit CR-53/U

FUNCTIONAL DESCRIPTION

Pressure-mounted quartz plate in metal holder designed to operate on the fifth mechanical harmonic of the fundamental frequency of the quartz plate. Used as a very-high-frequency control element in circuits which must maintain above-average frequency stability in the absence of oven control, even when exposed to wide variations in temperature and to relatively high drive levels. The crystal unit is intended for operation at series resonance.

RATED OPERATING CHARACTERISTICS

- Frequency Range:* 50 to 87 mc
- Nominal Frequency Tolerance:* $\pm 0.005\%$ at all temperatures within operating range
- Frequency Deviation with Temperature:* Permissible within limits of nominal frequency tolerance
- Operating Temperature Range:* -55° to $+90^{\circ}\text{C}$ $\pm 2^{\circ}\text{C}$
- Operable Temperature Range:* Not specified beyond operating temperature range
- Resonance:* Series
- Load Capacitance:* Not applicable
- Harmonic of Quartz Vibration:* Fifth mechanical harmonic
- Maximum Drive Level:* 20 mw
- Maximum Pin-to-Pin Capacitance:* $7.0 \mu\text{f}$
- Maximum Effective Resonance Resistance:* 60 ohms

**PERFORMANCE CHARACTERISTICS OF
NORMAL CRYSTAL ELEMENT**

See characteristics of element A, paragraph 1-112, figures 1-49, -112, -113, -115, -118.

TYPES OF CIRCUITS USED IN

Butler, transformer-coupled, capacitance-bridge, transitron, impedance-inverted

MOUNTING DATA

- Crystal Holder:* HC-6/U
- Method of Mounting Crystal:* Pressure-mounted in metal holder
- Dimensions and Marking:* See figure 2-63 (B). All dimensions in inches. Unless otherwise specified, tolerances are ± 0.005 in. on decimals.

LOGISTICAL DATA

- USAF Stock No.:* 2100-
- Status:* Special application (Category 1)
- Date of Status:* 14 January 1954
- Related Specifications, Standards, and Publications:* See Appendix IV.
- Commercial Sources:* See Appendix III.
- Remarks:* Some manufacturers cannot produce this unit over the entire upper or lower ranges and meet all requirements of the specification.
- Equipment Used In:*

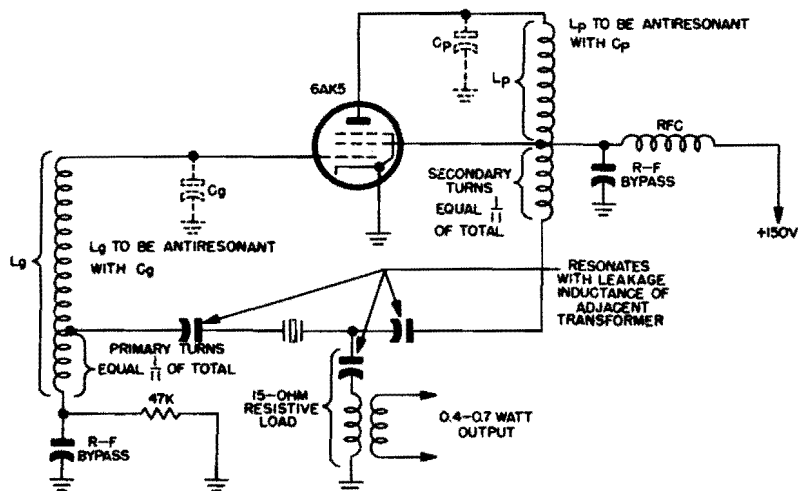

Figure 2-64. Schematic diagram of typical oscillator designed for use with Crystal Unit CR-53/U

MILITARY STANDARD TEST DATA

Authority: Military Specification MIL-C-3098B, approved 9 December 1955

Requirements and Procedures of Tests: See paragraphs 2-21 through 2-50.

Reference Standard Test Set: Crystal Impedance Meter TS-683/TSM

Electrical Connection of Holder: Holder grounded

Method of Measuring Frequency and Effective Resonance Resistance: A or B

Drive Adjustment Procedure: MS90168 (see para-

graph 2-62 and MIL-C-3098B), with the exception that the resistance shall be 60 ohms and voltage shall be 1.1 volts.

Shock and Vibration Test:

Permitted change in frequency: $\pm 0.002\%$

Permitted change in effective resonance resistance: Shall not exceed the max effective resistance

Aging Test: Not required

Tensile Strength Test (Minimum Requirements):
Not required

**CRYSTAL UNIT CR-54/U
(VHF)**

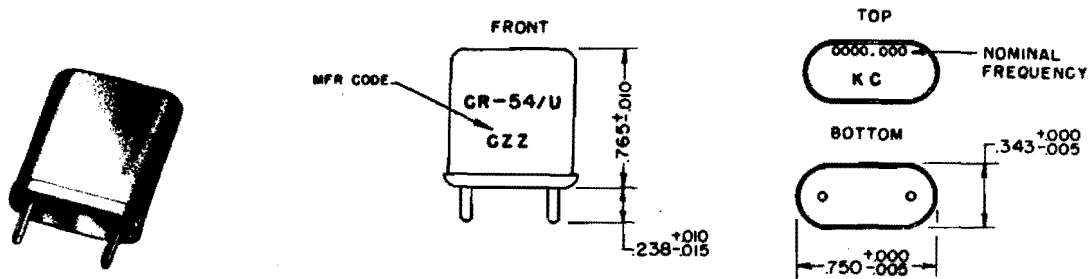

Figure 2-65. Crystal Unit CR-54/U

FUNCTIONAL DESCRIPTION

Metal-plated quartz plate, wire-mounted in a metal holder and designed to operate on the fifth mechanical harmonic of the fundamental frequency of the quartz plate. Used as a very-high-frequency control element in circuits which must maintain above-average frequency stability in the absence of oven control, even when exposed to wide variations in temperature. The crystal unit is intended for operation at series resonance.

RATED OPERATING CHARACTERISTICS

- Frequency Range:* 50 to 87 mc
- Nominal Frequency Tolerance:* $\pm 0.005\%$ at all temperatures within the operating range
- Frequency Deviation with Temperature:* Permissible within limits of nominal frequency tolerance
- Operating Temperature Range:* -55° to $+90^{\circ}\text{C}$ $\pm 2^{\circ}\text{C}$
- Operable Temperature Range:* Not specified beyond operating temperature range
- Resonance:* Series
- Load Capacitance:* Not applicable
- Harmonic of Quartz Vibration:* Fifth mechanical harmonic
- Maximum Drive Level:* 2 mw
- Maximum Pin-to-Pin Capacitance:* 7.0 μf
- Maximum Effective Resonance Resistance:* 60 ohms

**PERFORMANCE CHARACTERISTICS OF
NORMAL CRYSTAL ELEMENT**

See characteristics of element A, paragraph 1-112, figures 1-49, -112, -113, -115, -118.

TYPES OF CIRCUITS USED IN

Butler, transformer-coupled, capacitance-bridge, transitron, impedance-inverted

MOUNTING DATA

- Crystal Holder:* HC-6/U
- Method of Mounting Crystal:* Wire-mounted in metal holder
- Dimensions and Marking:* See figure 2-65 (B). All dimensions in inches. Unless otherwise specified, tolerances are ± 0.005 in. on decimals.

LOGISTICAL DATA

- USAF Stock No.:* 2100-
- Status:* Special application (Category 1)
- Date of Status:* 14 January 1954
- Related Specifications, Standards, and Publications:* See Appendix IV.
- Commercial Sources:* See Appendix III.
- Remarks:* Some manufacturers cannot produce this unit over the entire upper or lower ranges and meet all requirements of the specification. Same as CR-23/U except designed to operate on 5th mode only.
- Equipment Used In:*

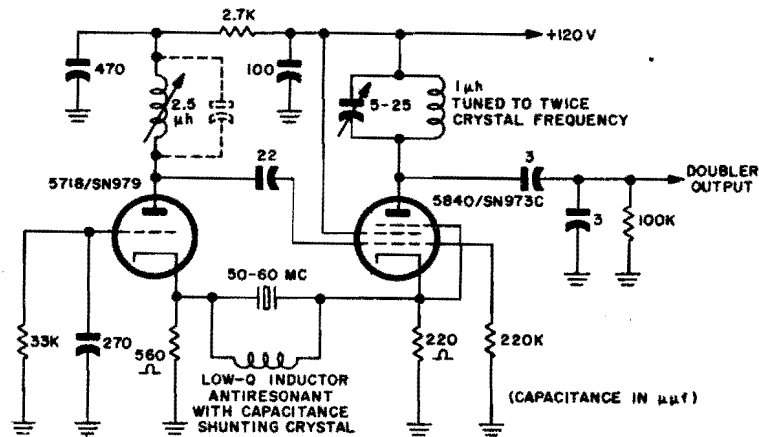

Figure 2-66. Schematic diagram of typical oscillator designed for use with Crystal Unit CR-54/U

MILITARY STANDARD TEST DATA

Authority: Military Specification MIL-C-3098B, approved 9 December 1955

Requirements and Procedures of Tests: See paragraphs 2-21 through 2-50.

Reference Standard Test Set: Crystal Impedance Meter TS-683/TSM

Electrical Connection of Holder: Holder grounded

Method of Measuring Frequency and Effective Resonance Resistance: A

Drive Adjustment Procedure: MS90168 (see paragraphs 2-62 and 2-64 per MIL-C-3098B)

Shock and Vibration Test:

Permitted change in frequency: $\pm 0.0005\%$

Permitted change in effective resonance resistance: $\pm 15\%$ or 2 ohms, whichever is greater

Aging Test:

Permitted change in frequency: $\pm 0.001\%$

Tensile Strength Test (Minimum Requirements):
Not required

**CRYSTAL UNIT CR-55/U
(HF—VHF)**

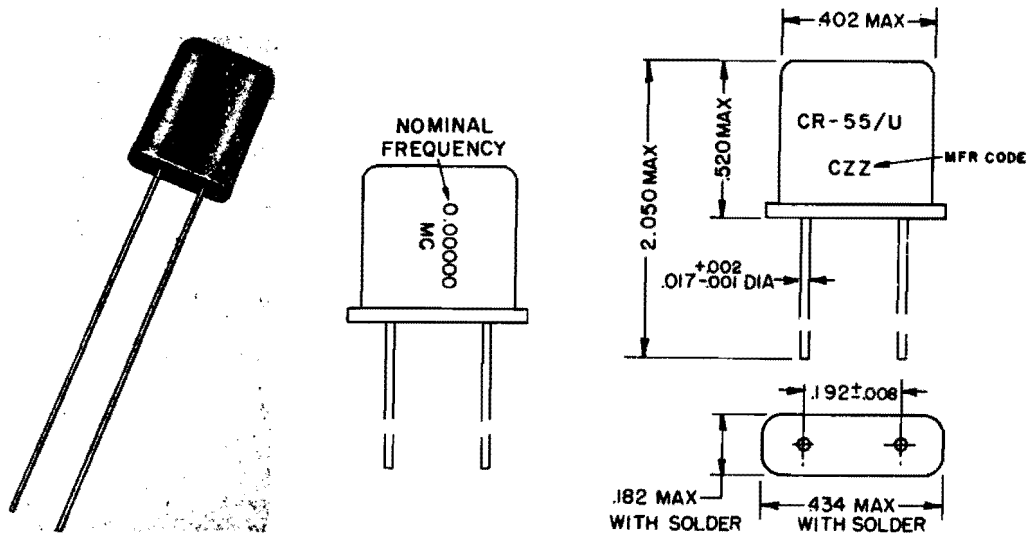

Figure 2-67. Crystal Unit CR-55/U

FUNCTIONAL DESCRIPTION

Metal-plated quartz plate, wire-mounted in a subminiature metal holder and designed to operate on the third mechanical harmonic of the fundamental frequency of the quartz plate. Used as a high- to very-high-frequency control element in transistor-cased or subminiature packaged circuits which must maintain above-average frequency stability in the absence of oven control, even when exposed to extreme variations in temperature. The crystal unit is intended for operation at series resonance.

RATED OPERATING CHARACTERISTICS

Frequency Range: 17 to 61 mc
Nominal Frequency Tolerance: $\pm 0.005\%$ at all temperatures within the operating range
Frequency Deviation with Temperature: Permissible within limits of nominal frequency tolerance
Operating Temperature Range: -55° to $+105^{\circ}\text{C}$
Operable Temperature Range: Not specified beyond operating temperature range
Resonance: Series

WADC TR 56-156

Load Capacitance: Not applicable
Harmonic of Quartz Vibration: Third mechanical harmonic
Maximum Drive Level: 2 mw
Maximum Pin-to-Pin Capacitance: $7.0 \mu\text{f}$
Maximum Effective Resonance Resistance: 40 ohms

PERFORMANCE CHARACTERISTICS OF NORMAL CRYSTAL ELEMENT

See characteristics of element A, paragraph 1-112, figures 1-49, -112, -113, -115, -118.

TYPES OF CIRCUITS USED IN

Transistor, Butler, transformer-coupled, capacitance-bridge, transitron, impedance-inverted

MOUNTING DATA

Crystal Holder: HC-18/U
Method of Mounting Crystal: Wire-mounted in metal holder
Dimensions and Marking: See figure 2-67(B). All dimensions in inches. Unless otherwise specified, tolerances are ± 0.005 in. on decimals.

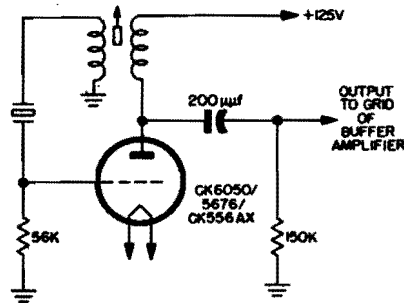

Figure 2-68. Schematic diagram of typical oscillator designed for use with Crystal Unit CR-55/U

LOGISTICAL DATA

USAF Stock No.: 2100-
 Status: Standard (Category 1)
 Date of Status: 9 December 1955
 Related Specifications, Standards, and Publications: See Appendix IV.
 Commercial Sources: See Appendix III.
 Remarks: None
 Equipment Used In:

MILITARY STANDARD TEST DATA

Authority: Military Specification MIL-C-3098B, approved 9 December 1955
 Requirements and Procedures of Tests: See paragraphs 2-21 through 2-50.

Reference Standard Test Set: Crystal Impedance Meter TS-683/TSM
 Electrical Connection of Holder: Holder grounded
 Method of Measuring Frequency and Effective Resonance Resistance: A
 Drive Adjustment Procedure: MS90168 (see paragraphs 2-62 and 2-64 per MIL-C-3098B)
 Shock and Vibration Test:
 Permitted change in frequency: $\pm 0.0005\%$
 Permitted change in effective resonance resistance: $\pm 15\%$ or 2 ohms, whichever is greater
 Aging Test: Not required
 Tensile Strength Test (Minimum Requirements): Not required

CRYSTAL UNIT CR-56/U

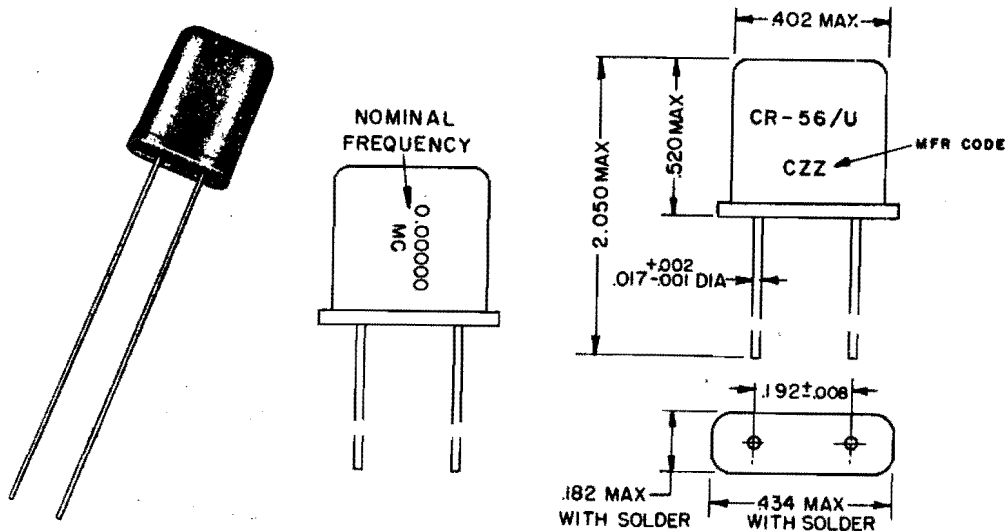

Figure 2-69. Crystal Unit CR-56/U

FUNCTIONAL DESCRIPTION

Metal-plated quartz plate, wire-mounted in a subminiature metal holder and designed to operate on the fifth harmonic of the fundamental frequency of the quartz plate. Used as a very-high-frequency control element in subminiature circuit applications which must maintain above-average frequency stability in the absence of oven control, even when exposed to extreme variations in temperature. The crystal unit is intended for operation at series resonance.

RATED OPERATING CHARACTERISTICS

Frequency Range: 50 to 87 mc (Experimental Crystal Unit CR-56/U (XN-1) extends the frequency range to 121.5 mc)

Nominal Frequency Tolerance: $\pm 0.005\%$ at all temperatures within the operating range

Frequency Deviation with Temperature:

Operating Temperature Range: -55° to $+105^{\circ}\text{C}$

Operable Temperature Range: Not specified beyond operating temperature range

Resonance: Series

Load Capacitance: Not applicable

Harmonic of Quartz Vibration: Fifth harmonic mode

Maximum Drive Level: 2 mw

Maximum Pin-to-Pin Capacitance: $7.0 \mu\text{f}$

Maximum Effective Resonance Resistance: 60 ohms

PERFORMANCE CHARACTERISTICS OF NORMAL CRYSTAL ELEMENT

See characteristics of element A, paragraph 1-112, figures 1-49, -112, -113, -115, -118

TYPES OF CIRCUITS USED IN

Butler, transformer-coupled, capacitance-bridge, transitron, impedance-inverted

MOUNTING DATA

Crystal Holder: HC-18/U

Method of Mounting Crystal: Wire-mounted in metal holder

Dimensions and Marking: See figure 2-69 (B). All dimensions in inches. Unless otherwise specified, tolerances are ± 0.005 in. on decimals.

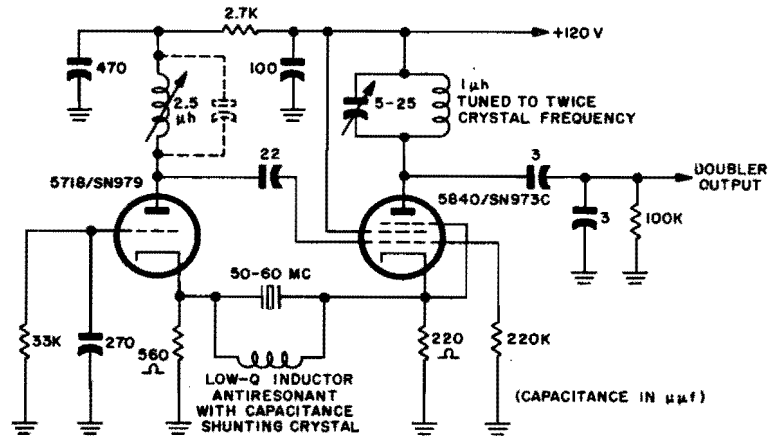

Figure 2-70. Schematic diagram of typical oscillator designed for use with Crystal Unit CR-56/U

LOGISTICAL DATA

USAF Stock No.: 2100-

Status: Standard (Category 1)

Date of Status: 9 December 1955

Related Specifications, Standards, and Publications: See Appendix IV

Commercial Sources: See Appendix III

Remarks:

Equipment Used In:

MILITARY STANDARD TEST DATA

Authority: MIL-C-3098B (Date 9 Dec 1955)

Requirements and Procedures of Tests: See paragraphs 2-21 through 2-50.

Reference Standard Test Set: Crystal Impedance Meter TS-683/TSM

Electrical Connection of Holder: Holder grounded

Method of Measuring Frequency and Effective Resonance Resistance:

Drive Adjustment Procedure: MS90168 (see paragraphs 2-62 and 2-64 per MIL-C-3098B)

Shock and Vibration Test:

Permitted change in frequency: $\pm 0.0005\%$

Permitted change in effective resonance resistance: $\pm 15\%$ or ohms, whichever is greater

Aging Test:

Permitted change in frequency: $\pm 0.001\%$

Tensile Strength Test (Minimum Requirements):

Not required

CRYSTAL UNIT CR-57/U

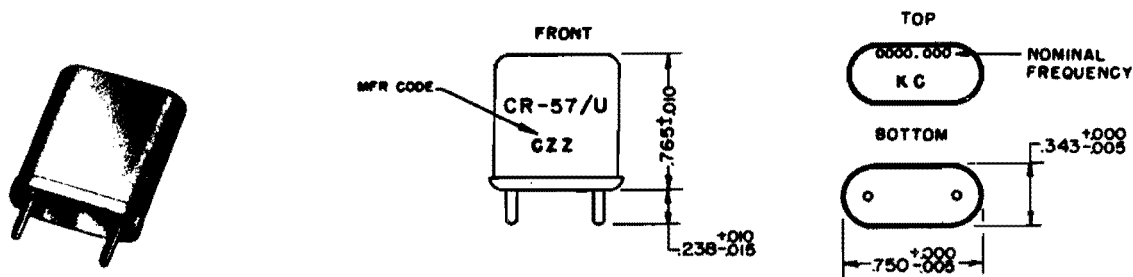

Figure 2-71. Crystal Unit CR-57/U

FUNCTIONAL DESCRIPTION

Metal-plated quartz plate, wire-mounted in a metal holder and designed to operate on the fundamental frequency of the quartz plate. Used as a 500-kc control element in circuits where maximum frequency stability is required. The crystal unit is intended to be mounted in a temperature-controlled oven and operated at parallel resonance.

RATED OPERATING CHARACTERISTICS

- Frequency Range:* 500 kc
- Nominal Frequency Tolerance:* $\pm 0.001\%$ at 85°C, $\pm 1^\circ\text{C}$
- Frequency Deviation with Temperature:*
 $\pm 0.0003\%$ from the measured frequency at 85°C permitted over range of 80°C to 90°C
- Operating Temperature Range:* 85° $\pm 5^\circ\text{C}$
- Operable Temperature Range:* -55° to $+20^\circ \pm 2^\circ\text{C}$, but not necessarily within tolerance on nominal frequency. 0.005% tolerance required from $+20^\circ$ to $+80^\circ\text{C}$
- Resonance:* Parallel
- Load Capacitance:* 32.0 $\pm 0.5 \mu\text{f}$
- Harmonic of Quartz Vibration:* Fundamental
- Maximum Drive Level:* 0.5 mw
- Maximum Pin-to-Pin Capacitance:* 7.0 μf

Maximum Effective Resonance Resistance:

Frequency (kc)	Resistance (ohms)
500	3000

PERFORMANCE CHARACTERISTICS OF NORMAL CRYSTAL ELEMENT

See characteristics of element C, paragraph 1-115, figure 1-51

TYPES OF CIRCUITS USED IN

Pierce, Miller

MOUNTING DATA

- Crystal Holder:* HC-6/U
- Method of Mounting Crystal:* Wire-mounted in metal holder
- Dimensions and Marking:* See figure 2-71 (B). All dimensions in inches. Unless otherwise specified, tolerances are ± 0.005 in. on decimals.

LOGISTICAL DATA

- USAF Stock No.:* 2100-
- Status:* Special Application (Category 1)
- Date of Status:* 5 March 1956
- Related Specifications, Standards, and Publications:* See Appendix IV

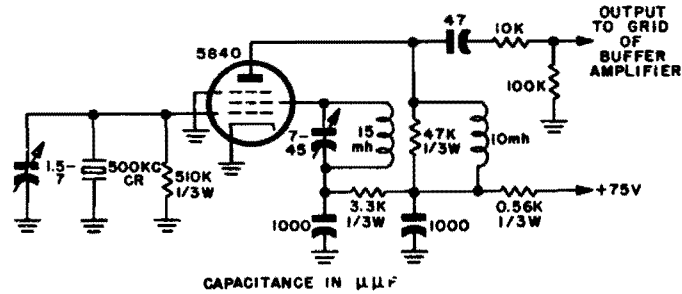

Figure 2-72. Schematic diagram of typical oscillator designed for use with Crystal Unit CR-57/U

Commercial Sources: See Appendix III

Remarks:

Equipment Used In: R.F. Oscillator O-197/U, p/o
Radio Set AN/ARC-21

MILITARY STANDARD TEST DATA

Authority: Military Specification MIL-C-25538
(USAF)

Requirements and Procedures of Tests: See paragraphs 2-21 through 2-50

Reference Standard Test Set: Crystal Impedance
Meter TS-710/TSM

Electrical Connection of Holder: Holder grounded

*Method of Measuring Frequency and Effective
Resonance Resistance:* B

Drive Adjustment Procedure: MS91446 (see para-
graph 2-65 and MIL-C-3098B)

Shock and Vibration Test:

Permitted change in frequency: $\pm 0.0005\%$

*Permitted change in effective resonance resist-
ance:* $\pm 15\%$ or 2 ohms

Aging Test:

Permitted change in frequency: $\pm 0.0005\%$

Tensile Strength Test (Minimum Requirements):
Not required

CRYSTAL UNIT CR-58/U
(MF—HF)

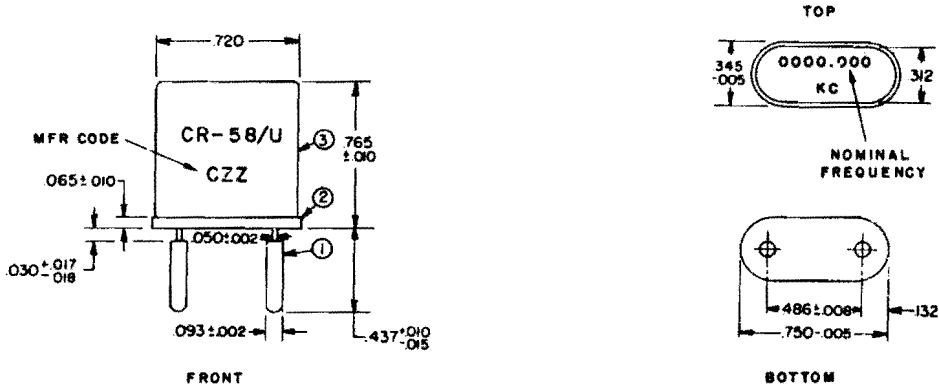

Figure 2-73. Crystal Unit CR-58/U

FUNCTIONAL DESCRIPTION

Metal-plated quartz plate, wire-mounted in a metal holder and designed to operate on the fundamental frequency of the quartz plate. Used as a medium-to-high-frequency control element in circuits which must maintain above-average frequency stability in the absence of oven control, even when exposed to wide variations of temperature. The crystal unit is intended for operation at parallel resonance.

RATED OPERATING CHARACTERISTICS

- Frequency Range:* 800 to 20,000 kc
- Nominal Frequency Tolerance:* ±0.005% at all temperatures within operating range
- Frequency Deviation with Temperature:* Permissible within limits of nominal frequency tolerance
- Operating Temperature Range:* -55° to +90°C ±2°C
- Operable Temperature Range:* Not specified beyond operating temperature range
- Resonance:* Parallel
- Load Capacitance:* 32 ±0.5 mmf
- Harmonic of Quartz Vibration:* Fundamental
- Maximum Drive Level:*
 - 800 to 9,999.999 kc—10 mw
 - 10,000 to 20,000 kc—5 mw

Maximum Pin-to-Pin Capacitance: 7.0 mmf
Maximum Effective Resonance Resistance:

Frequency (kc)	Resistance (ohms)
800 to 999.999.....	1000
1000 to 1,249.999.....	800
1250 to 1,499.999.....	700
1500 to 1,749.999.....	600
1750 to 1,999.999.....	550
2000 to 2,249.999.....	320
3000 to 3,749.999.....	175
3750 to 4,749.999.....	120
4750 to 5,999.999.....	75
6000 to 7,499.999.....	50
7500 to 9,999.999.....	35
10,000 to 20,000	25

PERFORMANCE CHARACTERISTICS OF NORMAL CRYSTAL ELEMENT

See characteristics of element A, paragraph 1-112, figures 1-49, -112, -113, -115, -118

TYPES OF CIRCUITS USED IN

Pierce, Miller, multivibrator-type

MOUNTING DATA

Crystal Holder: HC-17/U
Method of Mounting Crystal: Wire-mounted in metal holder.

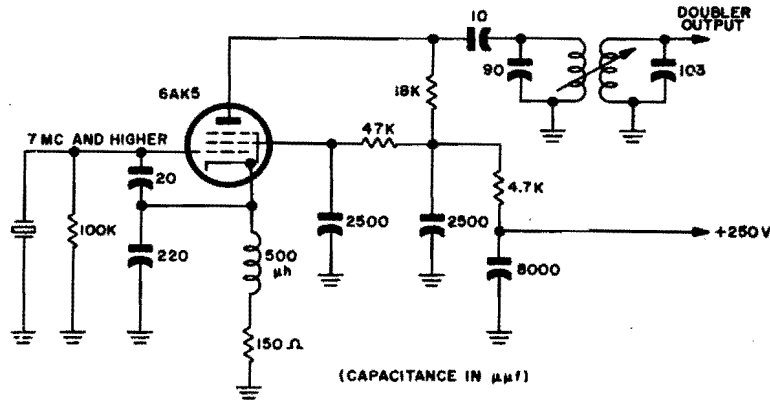

Figure 2-74. Schematic diagram of typical oscillator designed for use with Crystal Unit CR-58/U

Dimensions and Marking: See figure 2-73. All dimensions in inches. Unless otherwise specified, tolerances are ± 0.005 in. on decimals.

LOGISTICAL DATA

USAF Stock No.: 2100-

Status: Special Application (Category 2)

Date of Status: 15 December 1955

Related Specifications, Standards, and Publications: See Appendix IV

Commercial Sources: See Appendix III

Remarks: Identical to CR-18/U except uses Holder HC-17/U (with larger pins) instead of HC-6/U.

Equipment Used In:

MILITARY STANDARD TEST DATA

Authority: Military Specification MIL-C-25498 (USAF)

Requirements and Procedures of Tests: See paragraphs 2-21 through 2-50

Reference Standard Test Set:

Crystal Impedance Meter TS-330/TSM—800 to 14,999.999 kc

Crystal Impedance Meter TS-683/TSM—15,000 to 20,000 kc

Electrical Connection of Holder:
Holder grounded

Method of Measuring Frequency and Effective Resonance Resistance: A

Drive Adjustment Procedure:

800 to 14,999.999 kc: MS90167 (see paragraph 2-60 and MIL-C-3098B)

15,000 to 20,000 kc: MS90168 (see paragraph 2-62 and MIL-C-3098B)

Shock and Vibration Test:

Permitted change in frequency:

$\pm 0.001\%$ for units below 2000 kc

$\pm 0.0005\%$ for units of 2000 kc and above

Permitted change in resonance (effective) resistance: Wire-mounted— $\pm 15\%$ or 2 ohms, whichever is greater.

Aging Test: Not required

Tensile Strength Test (Minimum Requirements):
Not required

CRYSTAL UNIT CR-59/U

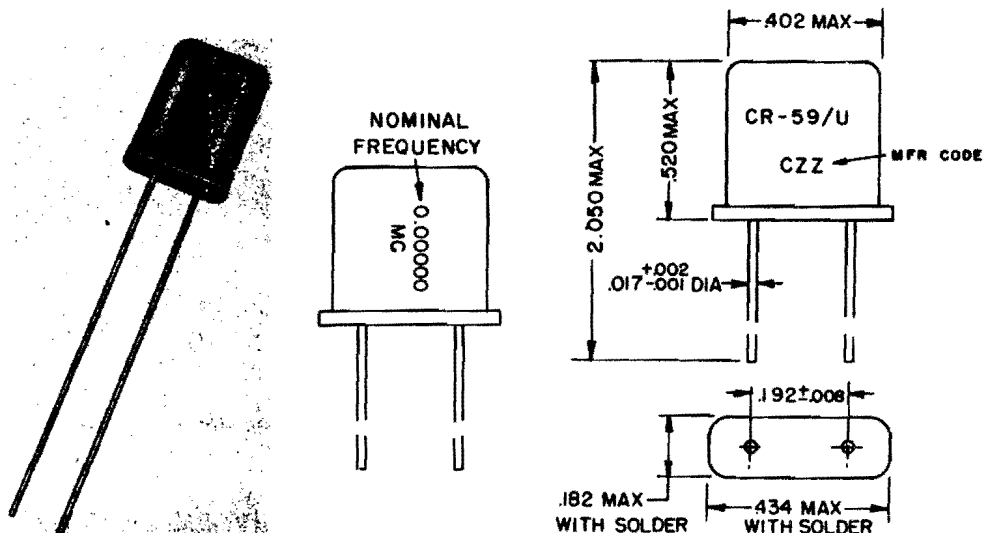

Figure 2-75. Crystal Unit CR-59/U

FUNCTIONAL DESCRIPTION

Metal-plated quartz plate, mounted in a metal holder and designed to operate at series resonance on the fifth harmonic of the fundamental frequency of the quartz plate. The crystal is intended to be mounted in a temperature-controlled oven.

RATED OPERATING CHARACTERISTICS

- Frequency Range: 50.0 to 91.0 mc
- Nominal Frequency Tolerance: $\pm 0.002\%$ at $+85^{\circ}\text{C} \pm 5^{\circ}\text{C}$
- Frequency Deviation with Temperature: $\pm 0.0005\%$ from frequency measured at 85°C permitted over range of 80°C to 90°C
- Operating Temperature Range: $85^{\circ}\text{C} \pm 5^{\circ}\text{C}$
- Operable Temperature Range: -55° to $+90^{\circ}\text{C}$
- Resonance: Series
- Load Capacitance: Not applicable
- Harmonic of Quartz Vibration: Fifth harmonic mode
- Maximum Drive Level: 1.0 mw
- Maximum Pin-to-Pin Capacitance: $7 \mu\text{f}$
- Maximum Effective Resonance Resistance: 60 ohms

PERFORMANCE CHARACTERISTICS OF NORMAL CRYSTAL ELEMENT

See characteristics of element A, paragraph 1-112, figures 1-49, -112, -113, -115, -118

TYPES OF CIRCUITS USED IN

Butler, transformer-coupled, capacitance-bridge, transitron, impedance-inverted

MOUNTING DATA

- Crystal Holder: HC-18/U
- Method of Mounting Crystal: Wire-mounted in metal holder
- Dimensions and Marking: See figure 2-75. All dimensions in inches. Unless otherwise specified, tolerances are ± 0.005 in. on decimals.

LOGISTICAL DATA

- USAF Stock No.: 2100-
- Status: Special Application (Category 1)
- Date of Status:
- Related Specifications, Standards, and Publications: See Appendix IV
- Commercial Sources: See Appendix III
- Remarks:
- Equipment Used In:

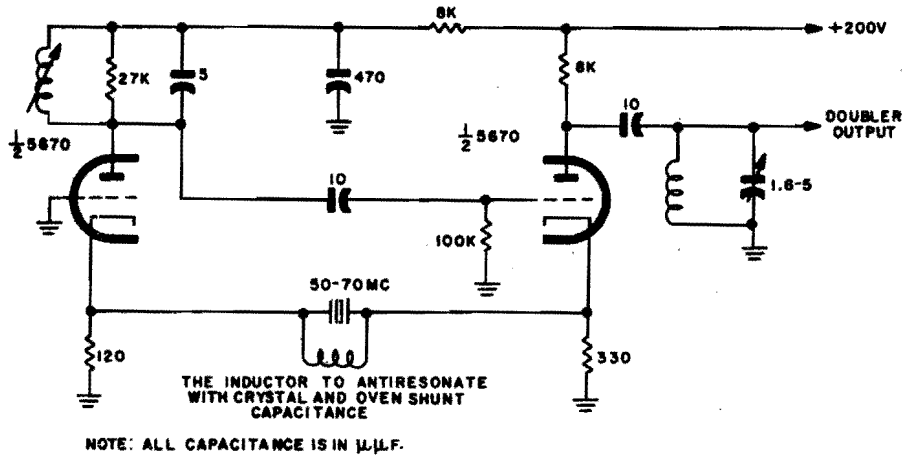

Figure 2-76. Schematic diagram of typical oscillator designed for use with Crystal Unit CR-59/U

MILITARY STANDARD TEST DATA

Authority: Military Specification MIL-C-25709 (USAF)

Requirements and Procedures of Tests: See paragraphs 2-21 through 2-50

Reference Standard Test Set: Crystal Impedance Meter TS-683/TSM

Electrical Connection of Holder: Holder grounded

Method of Measuring Frequency and Effective Resonance Resistance: B

Drive Adjustment Procedure: MS90168 (see paragraph 2-62 and MIL-C-3098B)

Shock and Vibration Test:

Permitted change in frequency: $\pm 0.0005\%$

Permitted change in effective resonance resistance: $\pm 15\%$

Aging Test:

Permitted change in frequency: $\pm 0.001\%$

Tensile Strength Test (Minimum Requirements):
Not required

CRYSTAL UNIT CR-60/U

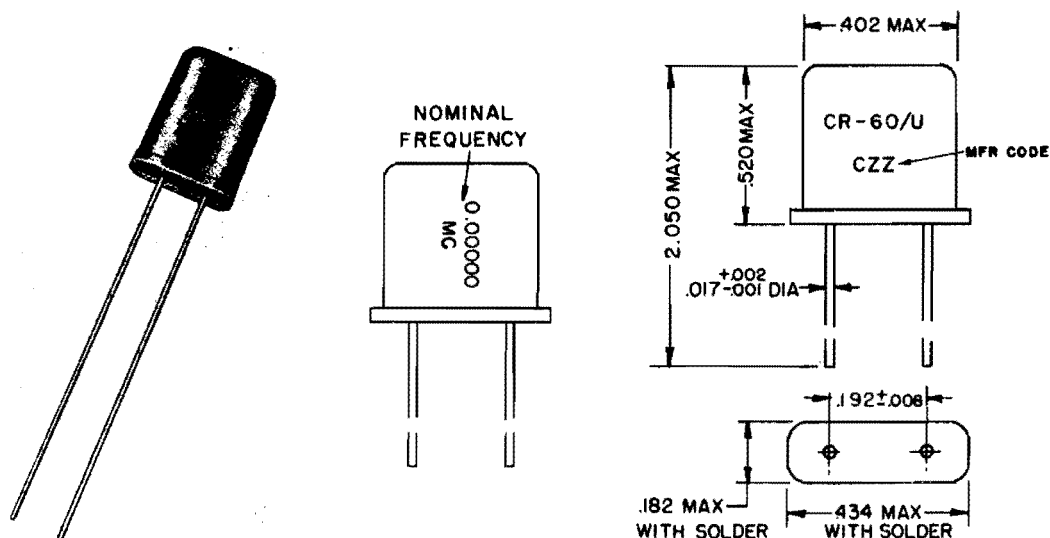

Figure 2-77. Crystal Unit CR-60/U

FUNCTIONAL DESCRIPTION

Metal-plated quartz plate, wire-mounted in a metal holder and designed to operate on the fundamental frequency of the quartz plate. Used as a medium-to-high-frequency control element in circuits which must maintain above average frequency stability in the absence of oven control, even when exposed to wide variation of temperature. The crystal unit is intended for operation at series resonance.

RATED OPERATING CHARACTERISTICS

Frequency Range: 7.0 to 20.0 mc

Nominal Frequency Tolerance: $\pm 0.005\%$ at all temperatures within the operating range

Frequency Deviation with Temperature: Permissible within limits of nominal frequency tolerance

Operating Temperature Range: -55° to $+105^{\circ}\text{C}$

Resonance: Series

Load Capacitance: Not applicable

Harmonic of Quartz Vibration: Fundamental

Maximum Drive Level:

7.0 to 9.999999 mc (10 mw)

10.0 to 20.0 mc (5 mw)

Maximum Pin-to-Pin Capacitance: $7 \mu\text{f}$

Maximum Effective Resonance Resistance:

Frequency (mc)	Resistance (ohms)
7.0 to 9.999	30
10.0 to 20.000	25

PERFORMANCE CHARACTERISTICS OF NORMAL CRYSTAL ELEMENT

See characteristics of element A, paragraph 1-112, figures 1-49, -112, -113, -115, -118

TYPES OF CIRCUITS USED IN

Butler, transformer-coupled, transitron, modified colpitts

MOUNTING DATA

Crystal Holder: HC-18/U

Method of Mounting Crystal: Wire-mounted in metal holder.

Dimensions and Marking: See figure 2-77. All dimensions in inches. Unless otherwise specified, tolerances are ± 0.005 in. on decimals.

LOGISTICAL DATA

USAF Stock No.: 2100-

Status: Special application (Category 1)

Date of Status:

Related Specifications, Standards, and Publications: See Appendix IV

Commercial Sources: See Appendix III

Remarks: Similar to CR-19/U except frequency range and size of holder.

Equipment Used In:

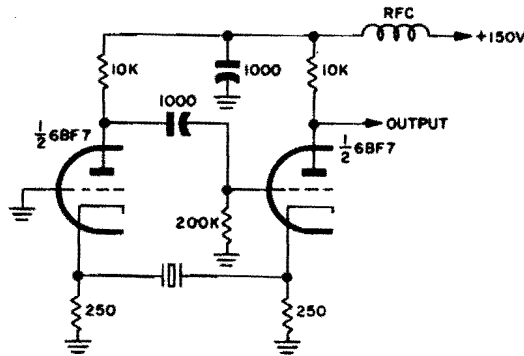

Figure 2-78. Schematic diagram of typical oscillator designed for use with Crystal Unit CR-60/U

MILITARY STANDARD TEST DATA

Authority: Military Specification MIL-C-25710 (USAF)

Requirements and Procedures of Tests: See paragraphs 2-21 through 2-50

Reference Standard Test Set:

Frequency (mc)	Test Set
7.0 to 9.999	TS-330/TSM
10.0 to 20.0	TS-683/TSM

Electrical Connection of Holder: Holder grounded

Method of Measuring Frequency and Effective Resonance Resistance: A

Drive Adjustment Procedure:

7.0 to 9.999 mc: MS90167 (see paragraph 2-60 and MIL-C-3098B)

10.0 to 20.0 mc: MS90168 (see paragraph 2-62 and MIL-C-3098B)

Shock and Vibration Test:

Permitted change in frequency: $\pm 0.0005\%$

Permitted change in effective resonance resistance: $\pm 15\%$

Aging Test: Not specified

Tensile Strength Test (Minimum Requirements):
Not required

CRYSTAL UNIT CR-61/U

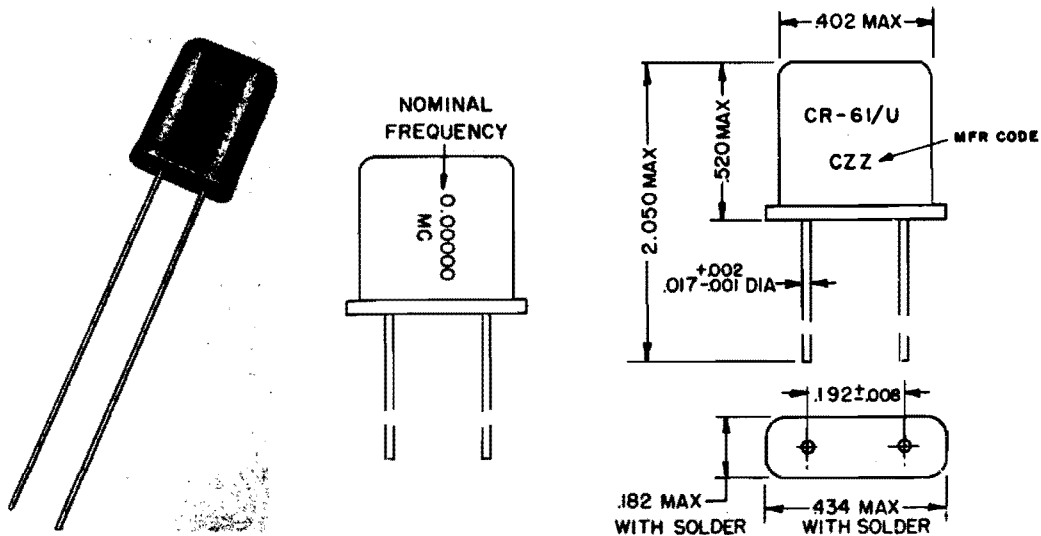

Figure 2-79. Crystal Unit CR-61/U

FUNCTIONAL DESCRIPTION

A metal-plated, quartz plate mounted in a metal holder and designed to operate at series resonance on the third mechanical overtone of the fundamental frequency of the quartz plate. The crystal unit is intended to be operated at a controlled temperature.

RATED OPERATING CHARACTERISTICS

- Frequency Range:* 17.0 to 61.0 mc
- Nominal Frequency Tolerance:* $\pm 0.002\%$ at 85°C
- Frequency Deviation with Temperature:*
 $\pm 0.0005\%$ from frequency measured at 85°C permitted over range of 80° to 90°C
- Operating Temperature Range:* 85°C $\pm 5^\circ$ C
- Operable Temperature Range:* -55° to $+90^\circ$ C
- Resonance:* Series
- Load Capacitance:* Not applicable
- Harmonic of Quartz Vibration:* Third harmonic mode
- Maximum Drive Level:*
17.0 to 24.999 mc (2mw)
25.0 to 61.0 mc (1mw)
- Maximum Pin-to-Pin Capacitance:* 7 μ f
- Maximum Effective Resonance Resistance:* 40 ohms

WADC TR 56-156

PERFORMANCE CHARACTERISTICS OF NORMAL CRYSTAL ELEMENT

See characteristics of element A, paragraph 1-112, figures 1-49, -112, -113, -115, -118

TYPES OF CIRCUITS USED IN

Transistor, Butler, transformer-coupled, capacitance-bridge, transitron, impedance-inverted

MOUNTING DATA

- Crystal Holder:* HC-18/U
- Method of Mounting Crystal:* Wire-mounted in metal holder
- Dimensions and Marking:* See figure 2-79. All dimensions in inches. Unless otherwise specified, tolerances are ± 0.005 in. on decimals.

LOGISTICAL DATA

- USAF Stock No.:* 2100-
- Status:* Special application (Category 1)
- Date of Status:* 13 March 1956
- Related Specifications, Standards, and Publications:* See Appendix IV
- Commercial Sources:* See Appendix III
- Remarks:*
- Equipment Used In:*

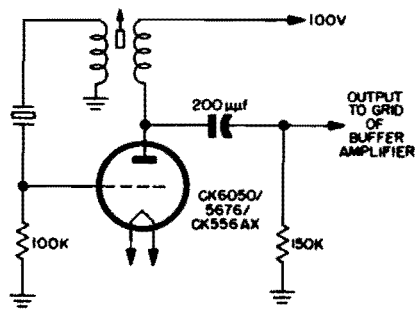

Figure 2-80. Schematic diagram of typical oscillator designed for use with Crystal Unit CR-61/U

MILITARY STANDARD TEST DATA

Authority: Military Specification MIL-C-19374 (SHIPS), approved 13 March 1956

Requirements and Procedures of Tests: See paragraphs 2-21 to 2-50

Reference Standard Test Set: Crystal Impedance Meter TS-683/TSM

Electrical Connection of Holder: Holder grounded

Method of Measuring Frequency and Effective Resonance Resistance: B

Drive Adjustment Procedure: MS90168 (see paragraph 2-62 and MIL-C-3098B)

Shock and Vibration Test:

Permitted change in frequency: $\pm 0.0005\%$

Permitted change in effective resonance resistance: $\pm 15\%$

Aging Test:

Permitted change in frequency: $\pm 0.001\%$

Tensile Strength Test: Not required

CRYSTAL UNIT CR- /U
(For addenda)

Figure 2-81. Crystal Unit CR- /U

FUNCTIONAL DESCRIPTION

Frequency (kc)

Resistance (ohms)

RATED OPERATING CHARACTERISTICS

Frequency Range:

Nominal Frequency Tolerance:

Frequency Deviation with Temperature:

Operating Temperature Range:

Operable Temperature Range:

Resonance:

Load Capacitance:

Harmonic of Quartz Vibration:

Maximum Drive Level:

Maximum Pin-to-Pin Capacitance:

Maximum Effective Resonance Resistance:

WADC TR 56-156

**PERFORMANCE CHARACTERISTICS OF
NORMAL CRYSTAL ELEMENT**

See characteristics of element , paragraph
1- , figure 1-

TYPES OF CIRCUITS USED IN

MOUNTING DATA

Crystal Holder:

Method of Mounting Crystal:

Dimensions and Marking: See figure 2- (B). All
dimensions in inches. Unless otherwise specified,
tolerances are ± 0.005 in. on decimals.

Figure 2-82. Schematic diagram of typical oscillator designed for use with Crystal Unit CR- /U

LOGISTICAL DATA

USAF Stock No.: 2100-

Status:

Date of Status:

Related Specifications, Standards, and Publications: See Appendix IV.

Commercial Sources: See Appendix III.

Remarks:

Equipment Used In:

MILITARY STANDARD TEST DATA

Authority:

Requirements and Procedures of Tests: See paragraphs through

Reference Standard Test Set: Crystal Impedance Meter

Electrical Connection of Holder:

Method of Measuring Frequency and Effective Resonance Resistance:

Drive Adjustment Procedure:

Shock and Vibration Test:

Permitted change in frequency:

Permitted change in effective resonance resistance:

Aging Test:

Permitted change in frequency:

Tensile Strength Test (Minimum Requirements):

Frequency (kc)

Grams

CRYSTAL UNIT CR- /U

(For addenda)

Figure 2-83. Crystal Unit CR- /U

FUNCTIONAL DESCRIPTION

Maximum Effective Resonance Resistance:

Frequency (kc)

Resistance (ohms)

RATED OPERATING CHARACTERISTICS

Frequency Range:

Nominal Frequency Tolerance:

Frequency Deviation with Temperature:

Operating Temperature Range:

Operable Temperature Range:

Resonance:

Load Capacitance:

Harmonic of Quartz Vibration:

Maximum Drive Level:

Maximum Pin-to-Pin Capacitance:

**PERFORMANCE CHARACTERISTICS OF
NORMAL CRYSTAL ELEMENT**

See characteristics of element , paragraph
1- , figure 1-

TYPES OF CIRCUITS USED IN

MOUNTING DATA

Crystal Holder:

Method of Mounting Crystal:

Dimensions and Marking: See figure 2- (B). All
dimensions in inches. Unless otherwise specified,
tolerances are ± 0.005 in. on decimals.

Figure 2-84. Schematic diagram of typical oscillator designed for use with Crystal Unit CR- /U

LOGISTICAL DATA

USAF Stock No.: 2100-

Status:

Date of Status:

Related Specifications, Standards, and Publications: See Appendix IV.

Commercial Sources: See Appendix III.

Remarks:

Equipment Used In:

MILITARY STANDARD TEST DATA

Authority:

Requirements and Procedures of Tests: See paragraphs through

Reference Standard Test Set: Crystal Impedance Meter

Electrical Connection of Holder:

Method of Measuring Frequency and Effective Resonance Resistance:

Drive Adjustment Procedure:

Shock and Vibration Test:

Permitted change in frequency:

Permitted change in effective resonance resistance:

Aging Test:

Permitted change in frequency:

Tensile Strength Test (Minimum Requirements):

Frequency (kc)

Grams

CRYSTAL UNIT CR- /U
(For addenda)

Figure 2-85. Crystal Unit CR- /U

FUNCTIONAL DESCRIPTION

Maximum Effective Resonance Resistance:

Frequency (kc)

Resistance (ohms)

RATED OPERATING CHARACTERISTICS

Frequency Range:

Nominal Frequency Tolerance:

Frequency Deviation with Temperature:

Operating Temperature Range:

Operable Temperature Range:

Resonance:

Load Capacitance:

Harmonic of Quartz Vibration:

Maximum Drive Level:

Maximum Pin-to-Pin Capacitance:

**PERFORMANCE CHARACTERISTICS OF
NORMAL CRYSTAL ELEMENT**

See characteristics of element , paragraph
1- , figure 1-

TYPES OF CIRCUITS USED IN

MOUNTING DATA

Crystal Holder:

Method of Mounting Crystal:

Dimensions and Marking: See figure 2- (B). All
dimensions in inches. Unless otherwise specified,
tolerances are ± 0.005 in. on decimals.

Figure 2-86. Schematic diagram of typical oscillator designed for use with Crystal Unit CR- /U

LOGISTICAL DATA

USAF Stock No.: 2100-

Status:

Date of Status:

Related Specifications, Standards, and Publications: See Appendix IV.

Commercial Sources: See Appendix III.

Remarks:

Equipment Used In:

MILITARY STANDARD TEST DATA

Authority:

Requirements and Procedures of Tests: See paragraphs through

Reference Standard Test Set: Crystal Impedance Meter

Electrical Connection of Holder:

Method of Measuring Frequency and Effective Resonance Resistance:

Drive Adjustment Procedure:

Shock and Vibration Test:

Permitted change in frequency:

Permitted change in effective resonance resistance:

Aging Test:

Permitted change in frequency:

Tensile Strength Test (Minimum Requirements):

Frequency (kc)

Grams

GROUP II

**CRYSTAL UNITS CURRENTLY IN MILITARY SERVICE BUT NOT RECOMMENDED
FOR USE IN EQUIPMENTS OF NEW DESIGN**

The crystal units included in Group II are those currently being used by the United States Air Force, but which are not preferred for use in equipments of new design. Where available, data sheets are included giving the quality control test specifications of the individual units. For illustrations of the principal holders, see Crystal Holders—Group II in Section III.

TECHNICAL DATA CHART FOR GROUP-II CRYSTAL UNITS

USAF Stock Number 2100- ^a	Nomenclature	Crystal Holder	Equipment Used In	Crystal Spec	Holder Spec
2x4-	Crystal Unit CR-1A/AR	CR-1A/AR	AN/ARC-7, AN/ARM-1, BC-517, BC-624, BC-625, BC-640, BC-1158, R-77/ARC-3, R-89 ()/ARN-5A, R-150A/CRW-7	MIL-C-16B	MIL-C-16B
2x5-	Crystal Unit	FT-249			171-148B
2x7-	Crystal Unit CR-6B/U	FT-243	R-19/TRC-1	MIL-C-10405	72-119
2x8-	RCA MI-8412	MI-8412	RCA Model AVT-15, RCA Model AVT-112	MIL-C-10405	
2x10-	Crystal Unit	FT-243	BC-745; SCR-511		72-119
2x11-	Crystal Unit	FT-243	BC-745; SCR-511		72-119
2x12-	Crystal Unit	FT-171-B	BC-610; SCR-299, 399, 499, 699	MIL-C-10405	
2x13-	Crystal Unit CR-4B/U	FT-241-A	AN/TRC-1, -3, -4		
2x14-	Crystal Unit	FT-243			72-119
2x15-5000	Crystal Unit CR-10B/U	FT-243	R-48/TRC-8, I-222-A		72-119
2x16-80.86	Valpey Crystal Part XLST		AN/APS-15 Rec.		
2x17-	Crystal Unit (1st Osc)	FT-171B	FM-1498-1505 (Link)	MIL-C-10405	72-119
2x17-	Crystal Unit (2nd Osc)	FT-243	FM-1498-1505 (Link)	MIL-C-10405	72-119
2x18-	Crystal Unit	FT-171-B/ FT-243	Link Xmtr 1498	MIL-C-10405	72-119
2x20-	Crystal Unit	AVA-10 or 601	RCA Model AVT-15, RCA Model AVT-112	MIL-C-10405	72-119
2x23-	Crystal Unit (Collins 1C)		Collins 32-RA	MIL-C-10405	
2x24-163.94	Crystal Units (Bliley MC-72) (James Knights F)		I-223-A		
2x25-455	Crystal Unit (Bliley CF-6) (Hallicrafters 19A123)		SX-28, R-45/ARR-7		

^a See paragraph 2-59.

Freq Range (mc)	Freq Tolerance ($\pm\%$)	Operating Temperature Range ($^{\circ}\text{C}$)	Base or Terminal Connections	Physical Dimensions (In.)		
				High	Wide	Thick
2.0—15.0	0.02	-55° to +90°	2 pins, $\frac{3}{8}$ in. lg, $\frac{1}{8}$ in. dia, $\frac{1}{2}$ in. c to c	1 $\frac{1}{8}$	1 $\frac{1}{8}$	$\frac{7}{16}$
			3 pins, 0.125 in. dia, $\frac{1}{2}$ in. lg	2 $\frac{1}{16}$	1 $\frac{7}{16}$	1 $\frac{3}{8}$
2.0—10.0	0.02	-40° to +70°	2 pins, 1 $\frac{3}{32}$ in. lg, $\frac{3}{32}$ in. dia, $\frac{1}{2}$ in. c to c	1 $\frac{11}{32}$	1 $\frac{3}{16}$	1 $\frac{1}{32}$
2.0—5.8	0.015	0° to +70°	2 banana pins, 1 $\frac{3}{16}$ in. lg, 0.85 in. c to c	1 $\frac{3}{32}$	1 $\frac{1}{2}$	1 $\frac{3}{16}$
3.0—6.0			Same as 2x7			
3.465 6.455			Same as 2x7			
2.0—6.0	0.02	0° to +70°	2 banana pins, 2 $\frac{3}{32}$ in. lg, 2 $\frac{3}{32}$ in. c to c	2 $\frac{3}{8}$	1 $\frac{1}{2}$	2 $\frac{3}{32}$
70.0—99.9	0.02	-40° to +70°	2 pins, $\frac{7}{16}$ in. lg, $\frac{3}{16}$ in. dia, $\frac{1}{2}$ in. c to c	1 $\frac{1}{2}$	1 $\frac{1}{8}$	$\frac{7}{16}$
2.88—4.3			Same as 2x7			
5.0	250 cps	-40° to +70°	Same as 2x7			
0.08086			NL			
6.25—10.5	0.02	0° to +70°	Same as 2x12			
6.456	0.02	0° to +70°	Same as 2x12			
2.187—2.125	0.02	0° to +70°	Same as 2x12 or 2x7			
1.715—7.5	0.015	0° to +70°	2 banana pins, $\frac{3}{4}$ in. lg, 0.850 in. c to c	2 $\frac{3}{8}$	1 $\frac{1}{2}$	1 $\frac{1}{16}$
1.5—3.75	0.015	0° to +50°	5-pin, $\frac{1}{2}$ in. lg, $\frac{1}{8}$ in. dia	1 $\frac{3}{8}$	1 $\frac{1}{2}$	1 $\frac{1}{8}$
0.16394			2 banana pins, $\frac{1}{2}$ in. lg, $\frac{3}{4}$ in. c to c	1 $\frac{3}{8}$	1 $\frac{3}{8}$	$\frac{9}{16}$
0.455			NL			

Section II
Crystal Units—Group II

TECHNICAL DATA CHART FOR GROUP-II CRYSTAL UNITS—Continued

USAF Stock Number 2100-a	Nomenclature	Crystal Holder	Equipment Used In	Crystal Spec	Holder Spec
2x27-465	Crystal Unit	RCA-MI-19453 Hammarlund SA-178	AN/GRR-2, BC-1004, AN/MRC-3, -4		
2x28-	Crystal Unit	HC-1/U	AN/URC-2, AN/FRC-6	MIL-C-10404	
2x29-	Crystal Unit	FT-249	SCR-281, BC-441	MIL-C-10404	
2x34-455	Crystal Unit (Majestic Dwg 29E6)		BC-969-A, SCR-614-A		
2x35-	Crystal Unit CR-5B/U	FT-243	BC-611, SCR-536	MIL-C-239B	72-119
2x36-	Crystal Unit CR-5B/U	FT-243	BC-1000, SCR-300	MIL-C-239B	72-119
2x37-	Crystal Unit (Bliley AR-3)		RC-65		
2x38-	Crystal Unit	FT-249	BC-1271-A, Wilcox 98A	MIL-C-10405	
2x39-	Crystal Unit	FT-164	RC-52E, BC-797, SCR-641		
2x40-	Crystal Unit (Monitor Piezo 8), (Bendix 3947)	Special	SCR-638, Bendix FC-3006, 3103-24, 3806-24		
2x43-	Crystal Unit (Bliley MO-2)		Hallicrafters HT-4, -9, T-811/VRC-4		
2x48-	Crystal Unit DC-8		BC-225, -338, -352, -353, -457, -458, -459, -695, -696, SCR-240, 261, 264, -274N		
2x50-	Crystal Unit DC-20	FT-243	BC-733, RC-103	MIL-C-10404	72-119
2x53-	Crystal Unit CR-8B/U	FT-243	RT-12/TRC-2, BC-1306, RT-77/GRC-9	MIL-C-10405	72-119
2x54-12500	Crystal Unit (Bliley MO-2)	Bliley MC-5 or -7	BC-376		
2x55-	Crystal Unit CR-10/U	FT-243		MIL-C-10405	72-119
2x58-	Crystal Unit	FT-243	BC-659, SCR-609, -610	MIL-C-10405	72-119
2x60-	Crystal Unit (RCA TMV-129-B)		RCA transmitter 1-K		
2x61-	Crystal Unit	RCA-AVA-53-A	RCA Models AVT-15, -112, ARV-20	MIL-C-10405	
2x62-327.8	Crystal Unit (WECOD-168342)		TS-102/AP		
2x63-	Crystal Unit (WECO5B)		Northern Elec. AT-7		
2x64-1	Crystal Unit				
2x65-	Crystal Unit	FT-243	R-57/ARN-5	MIL-C-16B	72-119
2x66-	Crystal Unit	FT-243	BC-1209, SCR-583 (Xmtr only)		72-119
2x67-	Crystal Unit	FT-243	BC-1209, SCR-583 (Rec only)		72-119
2x68-	Crystal Unit DC-34	FT-171-B	BC-669, SCR-543 (Xmtr only)		

a See paragraph 2-59.

Section II
Crystal Units—Group II

Freq Range (mc)	Freq Tolerance ($\pm\%$)	Operating Temperature Range ($^{\circ}\text{C}$)	Base or Terminal Connections	Physical Dimensions (In.)		
				High	Wide	Thick
0.465			NL			
0.9375—8.2	0.01	-55° to $+90^{\circ}$	2 pins, $\frac{1}{16}$ in. lg, $\frac{1}{8}$ in. dia, $\frac{1}{4}$ in. c to c	$1\frac{1}{32}$	$1\frac{1}{8}$	$1\frac{1}{8}$
1.6—3.0	0.01	0° to $+50^{\circ}$	Same as 2x5			
0.455			NL			
2.0—10.0	0.02	-55° to $+90^{\circ}$	Same as 2x7			
4.3 (Xmtr) 6.815 (Rec)	0.02	-55° to $+90^{\circ}$	Same as 2x7			
30—40			5-pin, $\frac{1}{2}$ in. lg, $\frac{1}{8}$ in. dia	2	$1\frac{1}{16}$	$1\frac{1}{16}$
4.8375 7.458611	0.01	0° to $+70^{\circ}$	Same as 2x5			
1.7—9.0			Term. pin on each side, $\frac{1}{2}$ in. lg, $\frac{1}{16}$ in. dia	$1\frac{1}{16}$	$2\frac{1}{16}$ (dia)	
			Octal	$1\frac{1}{4}$	$1\frac{1}{2}$ (dia)	
1.7—7.5	0.02	0° to $+50^{\circ}$	2 pins, $\frac{1}{16}$ in. lg, $\frac{1}{8}$ in. dia, $\frac{1}{4}$ in. c to c	$1\frac{1}{10}$	$1\frac{3}{8}$ (dia)	
3.0—8.0			Octal	$2\frac{1}{32}$	$1\frac{1}{32}$ (dia)	
5.633— 5.744444	0.02	-40° to $+85^{\circ}$	Same as 2x7			
1.0—10.0	0.02	-40° to $+70^{\circ}$	Same as 2x7			
12.5			Same as 2x43			
5.0	0.005	-40° to $+70^{\circ}$	Same as 2x7			
5.675—8.650	0.02	-40° to $+70^{\circ}$	Same as 2x7			
0.325—3.0	10 cps	$+60^{\circ}$	6-pin, $\frac{1}{4}$ in. lg, $\frac{3}{32}$ in. dia	4	$2\frac{1}{2}$	$1\frac{1}{16}$
1.75—7.5	0.015	-40° to $+55^{\circ}$	2 banana pins, $\frac{1}{4}$ in. lg, 0.85 in. c to c	$1\frac{1}{16}$	$1\frac{1}{4}$	$\frac{1}{16}$
0.3278			NL			
			3-pin, $\frac{37}{64}$ in. lg, $\frac{5}{32}$ in. dia	$2\frac{27}{64}$	$1\frac{11}{32}$	$\frac{3}{16}$
0.375 and 0.5			3-pin, $\frac{1}{16}$ in. lg, $\frac{5}{32}$ in. dia	$1\frac{27}{32}$	$1\frac{11}{32}$	$1\frac{1}{16}$
6.497917 6.547917	0.02	-40° to $+70^{\circ}$	Same as 2x7			
			Same as 2x7			
			Same as 2x7			
			Same as 2x12			

Section II
Crystal Units—Group II

TECHNICAL DATA CHART FOR GROUP-II CRYSTAL UNITS—Continued

USAF Stock Number 2100-A	Nomenclature	Crystal Holder	Equipment Used In	Crystal Spec	Holder Spec
2x69-	Crystal Unit DC-35	FT-171-B	BC-669, SCR-543 (Rec only)		
2x70-	Crystal Unit	FT-164	BC-400-()		
2x70-4166.67	Crystal Unit	FT-164	BC-400-B thru G		
2x73-186.30	Crystal Unit (James Knights Type F)		BC-1267, I-233-A, TS-293/CPA-5, AN/CPX-1, -2		
2x74-	Crystal Unit	FT-241-A	BC-604, SCR-508, -528		
2x75-	Crystal Unit	FT-249	AN/FRR-3		
2x75-462.45	Crystal Unit				
2x76-	Crystal Unit	FT-249	Temco Xmtr 250 GSC		
2x77-	Crystal Unit	FT-171-B	SCR-298, Link FM Model 11-U-F	MIL-C-10405	
2x78-	Crystal Unit	FT-171-B			
2x79-	Crystal Unit	FT-249	BC-329-N	MIL-C-10405	
2x81-	Crystal Unit	FT-171B	R-114/VRC-4		
2x83-81.95	Crystal Unit (GE TYPE 58)		BC-1602, SCR-584		
2x84-	Crystal Unit	FT-171-B	BC-325, SCR-197-F		
2x86-1	Crystal Unit (WECOD-151584)		R-55/ARQ-9		
2x87-	Crystal Unit	FT-164	Fed T & T TLC, TSI		
2x89-100	Crystal Unit (RCA VC-5KS)	RCA VC-5-KL	BC-1184, SCR-722, ID-6/APN-4		
2x90-470	Crystal Unit DC-6		SCR-177, -185, -188, -193, -209, -210, -287		
2x91-	Crystal Unit DC-17A		BC-751, AN/MRN-1		
2x95-245.895	Crystal Unit DC-21				
2x95-	Crystal Unit DC-13 and DC-14		BC-303, SCR-241		
2x96-	Crystal Unit	FT-164	T-65/CRN-11, AN/CRN-20, BC-901, RC-139		
2x98-	Crystal Unit	FT-241-A	BC-684, SCR-608		
2x100-100	Crystal Unit (Bliley SMC-100)		Hallicrafters HT-7		
2x103-93.12	Crystal Unit (GE Dwg K-56J906)		TS-177/CPS-1, TS-241/CPS-5		
2x104-100	Crystal Unit (RCA VC-5-M)		R-65/APN-9		
2x105-200	Crystal Unit CR-2B/U	FT-241/A	AN/ART-18		
2x106-	Crystal Unit	FT-249	BC-401	MIL-C-10405	

* See paragraph 2-59.

Section II
Crystal Units—Group II

Freq Range (mc)	Freq Tolerance ($\pm\%$)	Operating Temperature Range ($^{\circ}\text{C}$)	Base or Terminal Connections	Physical Dimensions (In.)		
				High	Wide	Thick
			Same as 2x12			
4.116 and 4.687	0.01	-15° to $+50^{\circ}$	Same as 2x39			
4.16667	0.01	-15° to $+50^{\circ}$	NL			
0.1863			NL			
			Same as 2x13			
1.4—3.8	0.01	$+45^{\circ}$ to $+55^{\circ}$	Same as 2x5			
			NL			
			Same as 2x5			
3.125—4.395	0.02	0° to $+70^{\circ}$	Same as 2x12			
1.875—2.875	0.02	-40° to $+70^{\circ}$	NL			
0.2—0.4	0.01	-10° to $+50^{\circ}$	Same as 2x5			
1.175—8.175			Same as 2x12			
			Octal, 2-pin, $\frac{35}{64}$ in. lg, $\frac{1}{16}$ in. dia	$3\frac{3}{32}$	$1\frac{1}{16}$ (dia)	
0.75—2.25	0.02	0° to $+70^{\circ}$	Same as 2x12			
5.0 and 5.455				$1\frac{1}{16}$	$1\frac{1}{32}$ (dia)	
0.125—0.195 0.3—0.4			Same as 2x39			
0.100	$+85$ to -35 cps	-40° to $+70^{\circ}$	3-pin, $\frac{1}{2}$ in. lg, $\frac{5}{32}$ in. dia	$2\frac{3}{16}$	$1\frac{1}{16}$	$1\frac{1}{16}$
0.470			NL			
6.016, 6.038, 6.061, 6.083, 6.105, 6.127, 0.245895			Octal	$2\frac{1}{32}$	$1\frac{1}{32}$ (dia)	
0.245895			Same as 2x89-100			
DC-13: 0.201 DC-14: 0.219			Octal	$2\frac{1}{16}$	$1\frac{1}{16}$ (dia)	
0.2—0.4	0.01	-15° to $+50^{\circ}$	Same as 2x39			
			Same as 2x13			
0.100 and 1.000			2 solder lugs	$1\frac{3}{8}$	$1\frac{3}{8}$	$2\frac{3}{32}$
0.09312			Octal	$1\frac{3}{32}$	$1\frac{1}{16}$	$1\frac{1}{16}$
			3-pin, $\frac{39}{64}$ in. lg, 0.156 in. dia	$2\frac{7}{64}$	$1\frac{1}{32}$	$1\frac{1}{16}$
0.2	18 cps	-40° to $+70^{\circ}$	Same as 2x13			
1.0—4.525	0.01	0° to $+50^{\circ}$	Same as 2x5			

Section II
Crystal Units—Group II

TECHNICAL DATA CHART FOR GROUP-II CRYSTAL UNITS—Continued

USAF Stock Number 2100-a	Nomenclature	Crystal Holder	Equipment Used In	Crystal Spec	Holder Spec
2x107-	Crystal Unit	FT-249, AA-9E, MX-9E	Bendix RA-10, RTA-1, AN/ARC-9	MIL-C-10405	
2x111-98.356	Crystal Unit DC-22-A		BC-788, SCR-718		
2x112-100	Crystal Unit (Philco 455-1040) (RCA VC-5-KS)		BC-622		
2x113-13545	Crystal Unit (WECO Dwg D-152497)		R-102/ARQ-9		
2x116-300	Crystal Unit (WECO D-168342)		SCR-545-A		
2x121-	Crystal Unit	FT-164	Fed Tel & Rad CAA 293		
2x122-18.626	Crystal Unit (WECO D-169112)		ID-56/APQ-7		
2x124-	Crystal Unit	Valpey CM.1, Bliley MC-74	Comm. Co. 150C		
2x125-	Crystal Unit	FT-171-B	JT Rad Model 350-A (Rec)		
2x127-	Crystal Unit	FT-171-B	JT Rad Model 350-A (Xmtr)		
2x131-	Crystal Unit	FT-249	T-4/FRC		
2x133-	Crystal Unit	FT-249	Wilcox F3	MIL-C-10405	
2x136-12500	Crystal Unit	FT-243	BC-376-H		72-119
2x137-	Crystal Unit	FT-249, MX-9G, M-9G	Wilcox 96-200		
2x138-100	Crystal Unit (Bliley BC-46RS)		TS-308/U		
2x141-93.109	Crystal Unit (RCA Type VC-5M)	RCA Type VC-5-K	ID-17/APN-3		
2x142-80.86	Crystal Unit (Bliley FM-6)		TS-100/AP		
2x144-	Crystal Unit	FT-249	Navy Model TCS		
2x147R-	Crystal Unit	FT-243	BC-721 (Rec), SCR-585		72-119
2x147T-	Crystal Unit	FT-243	BC-721, SCR-585 (Xmtr)		72-119
2x148-	Crystal Unit	FT-171	Link FMTR-25, -35, UFS-50		
2x149-	Crystal Unit	FT-164	BC-329-A		
2x150-93.109	Crystal Unit (RCA Type TMV-129E)		ID-18/CPN-2		
2x154-300.060	Crystal Unit (WECO 8A)		WECO 23AA, 221B		
2x155-300	Crystal Unit (WECO 8B)				
2x156-300.050	Crystal Unit (WECO 8C)				
2x157-	Crystal Unit	FT-243	TS-233/TPN-2		72-119
2x163-1.81818	Crystal Unit CR-11/U		TS-251/UP		
2x163-1817.44	Crystal Unit CR-11/U		WECO D-170130		
2x167-	Crystal Unit	FT-164	BC-446, BC-467, SCR-277		
2x168-	Crystal Unit	FT-164	BC-447		

* See paragraph 2-59.

Section II
Crystal Units—Group II

Freq Range (mc)	Freq Tolerance (±%)	Operating Temperature Range (°C)	Base or Terminal Connections	Physical Dimensions (In.)		
				High	Wide	Thick
2.5—7.0	0.015	—40° to +55°	Same as 2x5			
0.098356	0.05	—10° to +50°	Same as 2x89-100			
0.1				2 ³ / ₃₂	1 ¹⁰ / ₃₂	1 ³ / ₁₆
13.545			2-pin, 1/2 in. lg, 1/8 in. dia	1 ³ / ₆₄	1/8	7/16
0.3			Octal	3	1/4 (dia)	
0.1—10.0			Same as 2x39			
0.018626			Octal	4	1/4 (dia)	
			NL			
			Same as 2x12			
			Same as 2x12			
2.0—6.0	0.02	0° to +70°	Same as 2x5			
1.0—6.0	0.02	0° to +60°	Same as 2x5			
12.5			Same as 2x7			
0.125—0.525	0.01	0° to +70°	Same as 2x5			
0.100		+50°	5-pin, electrode pin, connection on side	2 ³ / ₁₆	2 ¹ / ₄ (dia)	
0.093109	10 cps	—54° to +70°	3-pin, 3/4 in. lg, 3/32 in. dia	2 ³ / ₈	1 ³ / ₈	1
0.08086			2-pin, 3/4 in. lg, 1/8 in. dia, 3/4 in. c to c	1 ² / ₃₂	1 ³ / ₄ (dia)	
			Same as 2x5			
3.955—6.455			Same as 2x7			
3.5—6.0			Same as 2x7			
0.9375—1.25	0.02	0° to +70°	Same as 2x12			
0.2—0.41	0.02	—15° to +50°	Same as 2x39			
0.093109	0.01	0° to +55°	6-pin, 3/4 in. lg, 3/32 in. dia	4	2 ¹ / ₂	1 ¹ / ₁₆
0.300060			Octal	2 ³ / ₈	1 ¹ / ₄ (dia)	
0.300			Same as 2x154-300.060			
0.300050			Same as 2x154-300.060			
6.6875—7.3125			Same as 2x7			
0.00181818			NL			
1.81744			NL			
0.2—0.4	0.01	—10° to +60°	Same as 2x39			
1.5—5.0			Same as 2x39			

Section II
Crystal Units—Group II

TECHNICAL DATA CHART FOR GROUP-II CRYSTAL UNITS—Continued

USAF Stock Number 2100-a	Nomenclature	Crystal Holder	Equipment Used In	Crystal Spec	Holder Spec
3x172-4495	Crystal Unit DC-10		BC-230, BC-430		
2x173-	Crystal Unit	FT-171-B	Fisher Research Rec		
2x174-	Crystal Unit	FT-171-B	Fisher Research Xmtr TS-25-3	MIL-C-10405	
2x174R-	Crystal Unit	FT-171-B	R-114/VRC-4	MIL-C-10405	
2x175-409.5	Crystal Unit (James Knights Type IF-6Y-101)		TS-126/AP		
2x177-2	Crystal Unit CR-8/U		R-122/APN-12		
2x180-	Crystal Unit	FT-249	Bendix Xmtr TA-6A	MIL-C-10405	
2x181-80.86	Crystal Unit (WECO D-166339)		AN/APQ-13		
2x186R-	Crystal Unit	FT-243	BC-611 (Rec)	MIL-C-239B	72-119
2x186T-	Crystal Unit	FT-243	BC-611 (Xmtr)	MIL-C-239B	72-119
2x187-1.617	Crystal Unit (WECO D-170609)		MD-57/APS-22		
2x188-	Crystal Unit	FT-240	Tempco Xmtr 250-G		
2x191R-	Crystal Unit	Bliley MC-7	BC-348-R		
2x192C-	Crystal Unit CR-3B/U	FT-241-A	BC-506, SCR-508, SCR-528, BC-604, SCR-608	TB SIG 201	
2x204-100	Crystal Unit (RCA-TMV-129G)		AN/CPN-11, -11A, -11B, -12, -12A, -12B		
2x212-80.867	Crystal Unit		AN/CPS-6B		
2x600-	Crystal Unit CR-5/U	FT-243	BC-721	MIL-C-239B	72-119
2x602-	Crystal Unit	FT-249	AN/FRR-3A	MIL-C-10405	
2x602-462.45	Crystal Unit	FT-249	AN/FRR-3A	MIL-C-10405	
2x604-	Crystal Unit	RCA-AVA-53	RCA-AVR-20A		
2x606-	Crystal Unit	AVA-10-D	RCA-AVT-7 (Xmtr)	MIL-C-10405	
2x609-	Crystal Unit	FT-164	BC-330		
2x610-4166.67	Crystal Unit	FT-249	BC-400-H		
2x611-	Crystal Unit	FT-249	BC-460-A thru C, BC-401-()		
2x634-	Improvement Kit MC-531	HC-1/U		MIL-C-10405	
2x635-	Crystal Unit CR-1/AR	FT-249	O-5/FR	MIL-C-10405	1.8
2x680-	Crystal Unit CR-7/U	FT-164	MAR Receiver		
NL-00019	Crystal Unit	FT-164	BC-329-H		

a See paragraph 2-59.

Section II
Crystal Units—Group II

Freq Range (mc)	Freq Tolerance ($\pm\%$)	Operating Temperature Range ($^{\circ}\text{C}$)	Base or Terminal Connections	Physical Dimensions (In.)		
				High	Wide	Thick
4.495			NL			
2.0—8.0			Same as 2x12			
2.0—8.0	0.01	0 $^{\circ}$ to +70 $^{\circ}$	Same as 2x12			
1.175—9.175		0 $^{\circ}$ to +70 $^{\circ}$	Same as 2x12			
0.4095			2 screw-type terminals on each side	1	$\frac{1}{2}$	$1\frac{13}{32}$
15—52			Wire terminals	$1\frac{1}{16}$	$\frac{3}{16}$ (dia)	
2.8—6.0	0.15	-40 $^{\circ}$ to +55 $^{\circ}$	Same as 2x5			
0.08096			Octal	1	$1\frac{1}{8}$ (dia)	
3.5—6.455	0.02	-40 $^{\circ}$ to +70 $^{\circ}$	Same as 2x7			
3.5—6.235	0.02	-40 $^{\circ}$ to +70 $^{\circ}$	Same as 2x7			
0.001617			Octal	$3\frac{7}{8}$	$1\frac{1}{4}$ (dia)	
			Same as 2x5			
			2-pin, $\frac{1}{16}$ in. lg, $\frac{1}{8}$ in. dia, .334 in. c to c	$1\frac{13}{16}$	$1\frac{1}{8}$	$1\frac{19}{32}$
0.3—0.6	0.02	-40 $^{\circ}$ to +70 $^{\circ}$	Same as 2x13			
0.1			6-pin, $\frac{3}{4}$ in. lg, $\frac{3}{32}$ in. dia	4	$2\frac{1}{2}$	$2\frac{1}{2}$
0.080867			Octal	$2\frac{1}{16}$	$3\frac{3}{64}$ (dia)	
2.0—10.0	0.02	-40 $^{\circ}$ to +70 $^{\circ}$	Same as 2x7			
1.4—3.8	0.01	+45 $^{\circ}$ to +55 $^{\circ}$	Same as 2x5			
0.46245	0.01	+45 $^{\circ}$ to +55 $^{\circ}$	Same as 2x5			
2.755—7.155	0.05	-40 $^{\circ}$ to +55 $^{\circ}$	2 banana pins, .85 in. c to c	$1\frac{1}{4}$	$1\frac{1}{16}$	$\frac{9}{16}$
2.5—6.7	0.015	0 $^{\circ}$ to +70 $^{\circ}$	Same as 2x20			
0.19—0.40	0.01	-15 $^{\circ}$ to +50 $^{\circ}$	Same as 2x39			
4.16667	0.01	-15 $^{\circ}$ to +50 $^{\circ}$	Same as 2x5			
1.0—6.0	0.01	0 $^{\circ}$ to +50 $^{\circ}$	Same as 2x5			
1.956—6.830	0.005	0 $^{\circ}$ to +60 $^{\circ}$	NL			
1.8—5.8	0.01	+45 $^{\circ}$ to +60 $^{\circ}$	Same as 2x5			
0.29—0.40	0.02	-15 $^{\circ}$ to +60 $^{\circ}$	Same as 2x39			
0.29—0.40	0.02	-15 $^{\circ}$ to +60 $^{\circ}$	Same as 2x39			

RELATED MILITARY-SPECIFICATION INFORMATION

EXPLANATION OF MILITARY STANDARD TERMS USED IN DESCRIPTIONS OF CRYSTAL UNITS

Aging Test (See paragraph 2-32)

Authority

2-2. Serial numbers and dates of the military publications which prescribe the military specifications and military standards for the crystal unit being described.

Bonding Requirements (See paragraph 2-22)

Corrosion Test (See paragraph 2-33)

Crystal Holder

2-3. All crystal holders specified for Military-Standard crystal units must conform with Military Specification MIL-H-10056 (). A complete description of each standard holder is to be found in Section III of this manual.

Date of Status

2-4. Date of approval of the military status classification by the appropriate authority as prescribed by the applicable regulations of the Army, Navy, and Air Force.

Delivery Requirements (See paragraphs 2-49 and 2-50)

Dimensions and Markings

2-5. Illustrated and largely self-explanatory. Unless otherwise specified, the marking includes only the type number, nominal frequency, and manufacturer's code-designating letters. (See paragraph 2-26 for additional marking requirements.)

Drive Adjustment Procedure

2-6. Method to be used, as prescribed by the applicable Military Standard, in obtaining the correct level of crystal drive when testing the crystal unit with the specified CI meter. See paragraph 2-60.

Drop Test (See paragraph 2-34)

Effective Resistance Test at Second Level of Drive (See paragraph 2-35)

Electrical Connection of Holder

2-7. States whether the cover of a metal crystal holder is to be grounded or not when the crystal unit is connected in its standard test circuit. Not applicable in the case of plastic holders.

Electrical Connection Requirements Inside Holder (See paragraph 2-24)

Etching Requirements (See paragraph 2-25)

Fabrication Requirements (See paragraphs 2-22 through 2-30)

Frequency and Effective Resistance Test (See paragraphs 2-31 and 2-36)

Frequency Deviation with Temperature

2-8. As an additional permissible deviation, distinct from the nominal frequency tolerance, it is applicable in the case of crystal units whose nominal frequency tolerance is specified for a given fixed temperature only, rather than for any temperature within the operating range. The item then specifies the maximum additional variation in frequency that is permissible when the temperature is varied from the fixed reference point to any other temperature in the operating temperature range. Since this method is normally used only when the crystal unit is designed to operate at oven temperatures, where the operating range is narrow and presumably coincides with the zero-temperature-coefficient region of the crystal element, the design engineer is assured that once an oven-mounted crystal unit is in operation, any changes in its frequency due to reasonable changes in the oven temperature will be extremely small even though the overall nominal frequency tolerance from one crystal unit to the next is relatively large.

Frequency Range

2-9. Self-explanatory, except that it should not be assumed that crystal units can always readily be obtained at any desired frequency within the given range. The quickest, most reliable, and least expensive approach is to select a frequency at which the desired type of crystal unit is already available. If this is not possible, the next best approach is to select a frequency at which the crystal unit, although not currently available, has been available in the past. Finally, if it is necessary to fabricate a crystal unit at a heretofore untested frequency, the greatest probability of least delay and expense in the research and developmental stage is to select a frequency as close as possible to other frequencies now available in the desired type of Military Standard crystal unit. Occasionally, it may be found that the fabrication techniques of one manufacturer are more conducive to superior crystal units within one band of the frequency range, whereas another manufacturer fabricates the same type of crystal unit more reliably within another band. In any event, before a

new untested frequency is decided upon, the design engineer should consult one or more of the manufacturers of the crystal unit under consideration.

Frequency Range Abbreviations

- 2-10. VLF (very low frequency) : less than 30 kc.
- LF (low frequency) : 30 to 300 kc.
- MF (medium frequency) : 300 to 3000 kc.
- HF (high frequency) : 3 to 30 mc.
- VHF (very high frequency) : 30 to 300 mc.

Functional Description

2-11. Provides summary of general physical and operational features of crystal unit, such as the type of mounting, operating harmonic, frequency range, frequency tolerance, temperature range, and mode of circuit operation.

Glass Seal Inspection (See paragraph 2-37)

Harmonic of Quartz Vibration

2-12. Mechanical harmonic of crystal element for which the military test specifications are applicable. Where a harmonic mode higher than the fundamental is specified, this should not be construed to mean that the crystal unit is more readily excited at the overtone than at the fundamental frequency, so that the desired harmonic can be obtained in an untuned type of oscillator.

Immersion Test (See paragraph 2-38)

Insulation Resistance Test (See paragraph 2-39)

Internal Inspection (See paragraph 2-40)

Leakage (See paragraph 2-40a)

Load Capacitance (See paragraph 2-56)

Marking Requirements (See paragraph 2-26)

Maximum Capacitance (Pin-to-Pin)

2-13. Maximum permissible electrostatic capacitance across the crystal-unit electrodes, as measured at the pin connections at a frequency lower than the fundamental of the crystal unit, where the unit shows no response other than that of a fixed capacitance.

Maximum Drive Level (See paragraph 2-55)

Maximum Effective Resonance Resistance

2-14. Maximum permissible effective resistance of crystal unit when measured at the specified test resonance and harmonic mode using the specified CI meter and drive adjustment procedure. For series-mode crystal units, the maximum effective resistance is the maximum permissible resonance impedance of the unit and, except at the very highest frequencies, is very nearly equal to an equivalent maximum permissible series-arm resistance. For parallel-mode crystal units, the maximum effective resistance is equal to the maximum permissible resistive component when the crystal

impedance is represented as an equivalent resistance and reactance in series, at the exact frequency at which the reactive component is resonant with the test load capacitance.

Method A (See paragraph 2-36a)

Method B (See paragraph 2-36b)

Method of Measuring Frequency and Effective Resonance Resistance

2-15. The crystal unit is tested for frequency and effective resistance over the operating temperature range in accordance with either method A or method B. In general, method A, which sets minimum and maximum limits for the rate of temperature change, is specified for the smaller rectangular-shaped crystal units that are not intended to be operated in temperature-controlled compartments; otherwise, method B, which sets no limiting rate of temperature change, is specified.

Method of Mounting Crystal

2-16. Only two broad classifications of mounting methods are specified in the Military Standards for quartz crystal units: *pressure mounting* and *metal-plated, wire mounting*. The pressure-mounted method embraces all the sandwich and air-gap mounts except those of the gravity type, and also includes all those mounts having metal-plated crystals held in place purely by the mechanical pressure exerted by pins or knife-edged clamps. The metal-plated, wire-mounted method includes the resonant-wire mounts (not the resonant-pin mounts) and the metal-plated, edge-clamped, cemented-lead mount.

Moisture Resistance Test (See paragraph 2-41)

Nomenclature of Crystal Units

2-17. The Joint Army, Navy, Air Force nomenclature for designating a particular type of crystal unit is as follows:

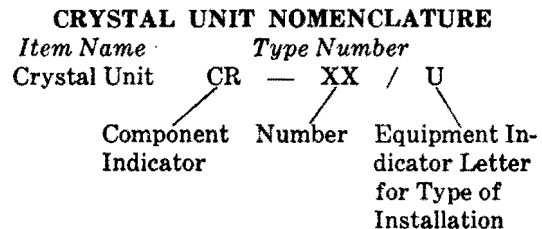

In the type number, the component, which is a crystal mounted in a holder, is identified by the symbol, CR. The component symbol is followed by a hyphen and 2 digits (-XX) which identify the mounted crystal as having been designed according to certain specified electrical and physical characteristics. The letter U, separated from the number by a slant sign, is the equipment indicator

Section II
Military Specifications

symbol for "general utility installation," which means that the crystal unit is intended for use in two or more of the three general installation classes—airborne, shipboard, and ground.

Nominal Frequency Tolerance

2-18. The maximum permissible difference between the rated nominal frequency of the crystal unit and the operating frequency as measured according to the specified test conditions. The tolerance is normally expressed as a given percentage of the nominal frequency and is applicable over the entire operating range unless the crystal unit is intended for oven mounting. In this latter case, the nominal frequency tolerance usually applies only to operation at the midpoint of the operating temperature range. An additional permissible deviation from the measured midpoint frequency is then specified, so that the overall frequency tolerance is equal to the sum of the nominal frequency tolerance and the additional permissible frequency deviation.

Operable Temperature Range

2-19. Temperature range over which the crystal unit has been tested in operation without regard to tolerance limits. Normally, the operable temperature range is specified only for crystal units having a narrow operating temperature range—that is, only for those units standardized for use in temperature-controlled compartments. The specification of an operable temperature range provides assurance of the continued operation of a crystal, although not necessarily within the frequency tolerance limits, during an oven warm-up period, or during the breakdown or absence of temperature control. However, it should be understood that the term "operable" is not rigorously defined. A crystal unit operable in the average test circuit may not be operable in an oscillator that is designed for minimum performance characteristics when the effective resistance is the maximum permissible value.

Operating Temperature Range

2-20. That part of the operable temperature range within which the crystal unit tolerance specifications have been tested and are assumed to hold. Unless the crystal unit is intended to be temperature-controlled, the operating and the operable ranges are identical.

Ordering Requirements (See paragraph 2-49)

Packaging Requirements (See paragraph 2-50)

Pin Alignment Test (See paragraph 2-42)

Plating Adherence Test (See paragraph 2-43)

Reference Standard Test Set (See paragraph 2-58)

Requirements and Procedures of Tests

2-21. See Military Specification MIL-C-3098 () for details of the required inspections, the grouping of tests, and the procedure for sampling. Those tests performed on each individual crystal unit by the manufacturer are the visual and mechanical external inspection, the frequency and effective resistance test, the second level of drive test (for overtone units), and the seal test. Samples of each production lot are subjected to all remaining tests listed herein which are specified as applicable.

FABRICATION REQUIREMENTS

Bonding

2-22. Wire-mounted, metal-plated crystal units are bonded at the point of contact of the suspension wire and the metal plating of the quartz plate. A conductive material of the highest grade commercially available and suitable for the purpose is used. The bond withstands, without electrical or mechanical failure, all tests performed on the crystal unit.

Crystal Holders

2-23. All holders conform to Military Specification MIL-H-10056 ().

Electrical Connections

2-24. When the design of a crystal unit involves the use of a nonferrous metal in direct contact with the metal plating, a tin-lead eutectic solder saturated with the same metal used for plating the quartz surfaces is employed. Saturation of the solder with the plating metal is such that during soldering, or thereafter, migration of the metal from the plated surface of the quartz plate to the solder is effectively checked. Springs are attached to the base pins by using a high-temperature solder or by welding.

Etching

2-25. The quartz plates are finished by etching to the final frequency for pressure-mounted units and to the preplating frequency for metal-plated units. During manufacture, at least one freshly-lapped quartz plate of each type being processed is taken at random from the production line each day for measurement of its frequency under standard test conditions. The quartz plate is then subjected to the etch procedure being used by the manufacturer and tested for compliance with the etching specifications of the Military. AT and BT plates must be subjected to the following minimum etch for fundamental and overtone operations:

<i>Fundamental</i>		<i>Overtone</i>
$\Delta f = 0.6f^2$	(AT Cut)	$\Delta f = 0.3f^2/N$
$\Delta f = 0.4f^2$	(BT Cut)	$\Delta f = 0.2f^2/N$

Where:

- Δf = required frequency increase in kc.
- f = frequency of quartz plate in mc.
- N = harmonic.

The above formulas are based upon the use of 1000-mesh grit abrasive. In the event a manufacturer uses a finer grit abrasive requiring an amount of etch less than that indicated above, he is required to demonstrate to a government inspector that the amount of etch is above the knee of the etch-rate curve, or is a satisfactory equivalent. (The etch-rate curve is the curve produced by plotting frequency change due to etching as the ordinate against time of etch as the abscissa. The knee of the curve is that portion of greatest curvature, which occurs at the beginning of the curve before the rate of frequency change has become a steady slope.) The etching curves (not etch-rate curves) in figure 1-89 are graphical illustrations of the fundamental-frequency formulas above.

Glass Seal (See paragraph 2-37)

Marking

2-26. The type number, the specified nominal frequency, and the code letters designating the manufacturer are permanently and legibly marked on the holder of each crystal unit. Unless otherwise specified by the bureau or service concerned, no other markings are permitted on the holder. The code designating letters are those listed in publication NAVSHIPS 900,152. Each line of characters is symmetrically located with respect to the center axis of the holder. Characters are not less than one-sixteenth inch high and are either metal-stamped, branded, or engraved. The marking is required to withstand all tests specified for the particular crystal unit.

Mounting

2-27. The quartz plate will be either wire- or pressure-mounted.

Solder

2-28. Soft solder is used in accordance with Federal Specification QQ-S-571, and is required to have a minimum tin content of 39.0 per cent by weight, except in the case of the electrical connections to the metal plating on the quartz as described in paragraph 2-24. In the edge-clamped wire mounts, the solder is not used primarily for obtaining mechanical strength, and the electrical connections are mechanically and electrically continuous before and after soldering.

Solder Flux

2-29. Only substantially noncorrosive fluxes are

used unless the corrosive element can be demonstrably removed after soldering.

Workmanship

2-30. All crystal units are required to be manufactured and processed in a careful and workmanlike manner, in accordance with good commercial design and practice. All units are required to be free from any imperfections which may affect their serviceability, and the interiors must be free from flux, loose solder, unapproved or foreign material, dust, or any loose particles at all.

STANDARD TEST CONDITIONS

2-31. Unless otherwise specified, all crystal-unit measurements and tests are made under the prevailing ambient conditions of atmospheric pressure and relative humidity and at a temperature between 20 and 35 degrees centigrade. When measurements of the frequency and/or effective resistance are made both before and after a test, the temperature of the crystal unit for the second measurement is required to be within 2 degrees centigrade of the temperature of the first measurement, and the level of drive for all measurements is to be within 20 per cent of the nominal value specified.

DESCRIPTIONS AND REQUIREMENTS OF TESTS

Aging Test

2-32. The crystal unit is placed in a well-ventilated oven equipped with heating and timing controls that produce the following heat cycle: a "heat-on" period of 2 hours duration with a stabilized temperature of 100 degrees centigrade ($\pm 5^\circ\text{C}$) for at least 30 minutes, followed by a "heat-off" period of sufficient duration to lower the oven to within 15 degrees centigrade of standard test conditions. The crystal unit is subjected to three such continuous cycles and then removed from the oven at the end of the final "heat-off" period, after which the frequency is measured for compliance with the tolerance specifications of the aging test. The specified maximum permissible change in frequency can be assumed to be an approximate gauge of the degree of frequency drift the crystal unit can be expected to undergo due to aging after being in operation a long period of time.

Corrosion Test

2-33. The crystal unit is required to withstand 50 hours of the salt-spray (fog) test specified in Federal Specification QQ-M-151 without evidence of corrosion sufficient to impair the operation of the crystal unit.

Section II
Military Specifications

Drop or Shock Test

2-34. This test is imposed to prove out the mechanical design of the unit to meet normal handling and military environmental conditions. It provides sharp mechanical shock. Method 202 as specified in MIL-STD-202 is recommended for uniformity and duplication of test results. The test is also described as Method A of MIL-C-3098B. The frequency and effective resistance are measured before and after the test. The change in frequency is not to exceed the tolerance specified for the drop test, and the effective resistance is not to exceed the maximum specified for the crystal unit.

Effective Resistance Test at Second Level of Drive for Overtone Crystal Units

2-35. The effective resistance of overtone crystal units is checked at a second and lower level of drive at room temperature to ensure that the specified maximum effective resistance is not exceeded when the amplitude of crystal vibration approaches a practical minimum. The second level of drive is obtained by setting up Crystal Impedance Meter TS-683/TSM in accordance with the applicable instructions contained in Military Specification MIL-C-3098B.

Frequency and Effective Resistance Test Over Operating Temperature Range

2-36. The crystal unit is tested in accordance with method A or B, as specified. Unless otherwise specified, the level of drive during the test is within 20 per cent of the nominal drive level specified for each crystal unit. The reference standard test sets are as specified on the standard sheet in MIL-C-3098B. The drive adjustment procedures for the test set and particular crystal unit are also specified in MIL-C-3098B. The measured crystal frequency is to be within the tolerance specified, and the measured effective resistance is not to exceed the maximum specified.

a. Method A: The crystal unit is subjected to a temperature run over the specified operating temperature range at a minimum rate of change of 3 degrees centigrade per minute. Measurements of frequency and effective resistance are made at intervals no greater than 3 degrees centigrade, except that the portion from -30 to +20 degrees centigrade is completed in a period not exceeding 1 minute, and continuous readings of both frequency and effective resistance are made over the range. The entire temperature range of -55 to +90 degrees centigrade is not to be completed in less than 1 minute.

b. Method B: The crystal unit is subjected to

a temperature run over the specified operating temperature range at any convenient rate of temperature change. Measurements of frequency and effective resistance are made at intervals no greater than 3 degrees centigrade.

Glass Seal Inspection

2-37. Those crystal units with bases having a glass seal are inspected with the aid of a strong light and 10-power magnification. No glass seal is permissible that contains radial or other detrimental cracks.

Immersion Test

2-38. The crystal unit is immersed in water, maintained at 90° to 95°C, for at least 1 hour. Unit is then removed from water, wiped dry, and set aside for one-half hour, after which its insulation resistance, frequency, and effective resistance are measured and compared with those made before the immersion test. Also, markings on the crystal unit must remain legible.

Insulation Resistance Test

2-39. At room temperature, using a test voltage of 50 to 100 volts, the insulation resistance of the crystal unit, as measured between the pins of the unit or between any pin and any other external metal part of the unit, is required to be not less than 500 megohms.

Internal Inspection

2-40. Randomly selected samples of crystal units from an inspection lot are disassembled and the interior of each selected unit is inspected to determine if the material, threaded parts of the holder, and the workmanship comply with military specifications.

Leakage

2-40a. After being held at standard test conditions for a period of at least 24 hours, the sealed crystal unit is immersed in an open container of distilled water. The container is then placed in a sealed chamber which is evacuated to an absolute pressure of 3.0 to 3.4 inches of mercury for a period of not less than 5 minutes. There must be no evidence of leakage of gas or air from inside the unit.

Moisture Resistance Test

2-41. The crystal unit is subjected to a series of thirty 24-hour moisture resistance tests in a humidity test chamber. For the first 16 hours of each test period, the chamber is maintained at 65° ± 2°C, and above 90% relative humidity. For the last 8 hours, the chamber is returned to

normal room temperature. After 4 or more days, and for at least 6 times within the 30-day test period, and at the end, the unit is removed from the chamber and tested for effective resistance, frequency, and insulation resistance.

Pin Alinement Test

2-42. Crystal units having a type HC-6/U, HC-13/U, or HC-14/U holder are tested for correct pin alinement by using a shadowgraph as specified in Military Specification MIL-H-10056(), or by using a test gage as specified in Military Specification MIL-C-3098(). The test gage is equivalent to a 2-hole socket having a depth of 0.238 ± 0.01 inch. The two holes are spaced 0.486 inch center-to-center, and each has a maximum diameter of 0.06 inch. Pins so tested must freely enter the gage until the base of the holder is firmly seated on the gage.

Plating Adherence Test

2-43. The plating adherence test is applicable to all crystal units employing metal-plated crystals. The test is performed by firmly applying a piece of transparent plastic pressure-sensitive tape to the base plating of the quartz crystal, and then removing the tape immediately by lifting one corner and pulling at a slow uniform rate perpendicularly to the plated surface. The above steps are repeated for units that have been plated to the final frequency. After the test there must be no visual evidence (without magnification) of the removal of plating from the quartz surface.

Seal Test

2-44. After being held at standard test conditions for a period of at least 24 hours, the sealed crystal unit is immersed in water having a temperature between 90°C and 95°C for a period of not less than 2 minutes. A seal is considered defective if an escapement of bubbles from the holder is observed, indicating a gas or air leakage from the inside of the crystal unit.

Spurious Frequency Test

2-45. With the reference test set adjusted to provide the specified drive level at standard test conditions, a fixed resistor, whose value is equal to the specified maximum effective series resistance, is substituted for the crystal unit. The output frequency of the test set is then adjusted to both plus and minus 10 per cent of the nominal frequency marked on the crystal unit, and the respective dial settings of the tuning control on the test set are recorded. With the fixed resistor replaced by the crystal unit, the tuning control is varied slowly between the recorded dial settings. The

crystal unit is assumed free of spurious responses if during this tuning variation neither abrupt shifts in frequency nor intermittent oscillations are observed.

Tensile Strength Test

2-46. This is a test of the mechanical strength of the junction of the metal plating and lead wires. This test is generally applied in the case of the lower-frequency wire-mounted units where it is usual for the entire mechanical support of the crystal to depend upon the soldered junctions of the lead wires to the metal plating of the crystal. When the test is applicable, the minimum permissible tensile strength of the junction is specified for each particular type of crystal unit and frequency band. A weight load is gradually applied to the outside ends of both of the lead wires until breakdown occurs at the junction to the metal plating. (Breaking of the quartz plate during the test is not construed as a test failure and another specimen is taken.) A breakdown must not occur at a tensile pull less than that of the minimum weight specified.

Terminal Polarity Test

2-47. The crystal unit is operated in a test set in which the socket is non-polarized, and the frequency, as measured under standard test conditions, must be as specified.

Vibration Test

2-48. Each type of Military Standard crystal unit must undergo the same rigorous test in a vibration machine. The maximum changes in frequency and effective resistance resulting from the test period of vibration that are permissible are specified for each particular type of crystal unit. The crystal unit is rigidly mounted with random orientation on the platform of a vibration machine. A simple harmonic motion having a peak amplitude of 0.015 inch (maximum total excursion of 0.030 inch) is applied to the platform continuously for 2 hours. The frequency of the applied vibration is varied uniformly between the approximate limits of 10 and 55 cycles per second. The entire frequency range from 10 to 55 cps and return is traversed in 1 to 2 minutes. The frequency and effective resistance are measured under standard test conditions before and after the test, and the changes observed in these parameters are not to exceed the tolerances specified.

DELIVERY REQUIREMENTS

Ordering

2-49. According to Military Specification MIL-C-

Section II
Military Specifications

3098B, procurement documents should specify the following:

- a. Title, number, and date of the applicable crystal unit specification (MIL-C-3098B).
- b. Type designation (type number), and the title, number and date of the applicable Military Standard. (Crystal units designated as "special application" shall be purchased and used only with the approval of the bureau or service concerned.)
- c. Nominal frequency required.
- d. Laboratory where preproduction tests are to be conducted. (See MIL-C-3098() for requirements of preproduction tests.)
- e. Whether crystal units are to be packaged individually or in sets.
- f. Whether metal boxes or fiberboard cartons or boxes are to be used for set packaging.
- g. Whether intermediate packages are required, and quantity of individual packages.
- h. Whether packing and marking are for domestic or oversea shipment.
- i. That the contractor shall not substitute for a specified material or fabricated part unless he obtains approval for such substitution from the bureau or service concerned. Evidence to substantiate his claim that such a substitute is suitable shall be submitted with his request. Similar notification and substantiating evidence shall be submitted at any later time if substitution becomes necessary or desirable. At the discretion of the bureau or service concerned, test samples may be required to prove the suitability of the proposed substitute.
- j. Applicable reference standard test set to be furnished by the contracting officer to government inspector at the manufacturer's plant.

Packaging

2-50. When directly purchased by or directly shipped to the Government, Military Standard crystal units must either be packed individually or in sets composed of one crystal unit of each designated frequency. When packed individually, each unit is cushioned and packaged in a folded carton or set-up box conforming to Specification JAN-P-120 or JAN-P-133, respectively. When packaged in sets, each set is contained in a hinged-cover-and-clasp-style enameled or lacquered metal box satisfactory to the bureau or service concerned, or in fiberboard boxes, set-up boxes, or cartons, as specified, with each crystal unit individually wrapped or cushioned. The quantity included in a unit package is 10 or a multiple thereof. Five unit packages or a multiple thereof are further packaged in intermediate containers conforming to Specification JAN-P-120 or JAN-P-133. The

gross weight of the intermediate container is not to exceed 5 pounds. See MIL-C-3098B, Section 5, for detailed packaging and marking instructions. However, it should be understood that the military specifications concerning the packaging, packing, and marking of crystal-unit shipments to the Government are not intended to apply to contracts or orders between the manufacturer and prime contractor.

Resonance (See paragraph 2-57)

Seal Test (See paragraph 2-44)

Second Test Level of Drive

2-51. A very low level of crystal drive used for checking the effective series resistance of overtone crystal units at minimum amplitudes of vibration. This second check is necessary because of the tendency among overtone units to exhibit sharp increases in effective resistance as the crystal drive approaches zero. The procedure for obtaining the second level of drive, which is applicable to the use of Crystal Impedance Meter TS-683/TSM, is specified in Military Specification MIL-C-3098B.

Solder Requirements (See paragraph 2-28)

Solder Flux Requirements (See paragraph 2-29)

Special Application Crystal Units

2-52. Crystal units assigned a status of "special application" are available only in limited production and normally from only one source (availability category 2). Such crystal units are not to be purchased and used without the approval of the service or bureau concerned.

Spurious Frequency Test (See paragraph 2-45)

Standard Crystal Units

2-53. Crystal units assigned a status of "standard" are available from two or more sources (availability category 1) and are recommended for use when applicable without special approval of the service or bureau concerned.

Standard Test Conditions (See paragraph 2-31)

Status

2-54. Type classification of crystal unit, regarding procurement and availability, as assigned by the cognizant Military agency.

Tensile Strength Test (See paragraph 2-46)

Terminal Polarity Test (See paragraph 2-47)

Test Level of Drive

2-55. The power, within ± 20 per cent, usually expressed in milliwatts, that is to be supplied to the crystal unit when the unit is being tested with the specified reference standard test set for frequency and effective resistance. The test level of drive is

also the maximum drive at which the crystal unit can be operated with assurance that the rated tolerances will be met, although the crystal is usually operable at much higher, but nonrecommended levels.

Test Load Capacitance

2-56. Capacitance with which the effective inductance of the crystal unit is resonant during the frequency and effective-resistance test. (Applicable only if the crystal-unit specifications call for parallel-resonance testing.) The circuit in which a parallel-mode crystal unit is intended to operate should be designed and adjusted to provide the unit with a load capacitance equal to the test load capacitance, otherwise no guarantee exists that the specified tolerances in frequency and effective resistance can be met. Since a given effective reactance of a crystal unit will occur at a unique frequency, a circuit can be assumed to be adjusted to present the correct load capacitance if the frequency is exactly the same as that measured when the crystal unit is known to be series-resonant with its test load capacitance under standard test conditions.

Test Resonance

2-57. States whether crystal unit is tested for operation at its resonance frequency (series-mode operation) or at some slightly higher frequency appropriate for parallel-mode operation.

Test Set (Reference Standard Crystal Impedance Meter)

2-58. Reference standard CI meter specified for use in measuring the frequency and effective resistance of the crystal unit.

USAF Stock No.

2-59. Number for identifying item when requisitioning from U. S. Air Force supply depot. The USAF stock numbers of crystal units are the same

as the respective Signal Corps numbers except that the prefix "2100-" is added, which serves to identify the item as belonging to USAF stock class 16-F. The exact frequency is identified by a hyphen-separated suffix equal numerically to the frequency desired in kc.

Vibration Test (See paragraph 2-48)

Workmanship Requirements (See paragraph 2-30)

**MILITARY STANDARD DRIVE ADJUSTMENT
PROCEDURES FOR CRYSTAL UNITS COVERED
BY MILITARY SPECIFICATION MIL-C-3098B**

Crystal Impedance Meter TS-330/TSM

**PROCEDURE FOR OBTAINING TEST
LEVEL OF DRIVE FOR CRYSTAL UNITS
OVER A FREQUENCY RANGE OF 800 TO
15,000 KILOCYCLES PER SECOND**

2-60. The following drive adjustment procedure is specified by Military Specification MIL-C-3098B, Paragraph 4.3.1.1.1:

- a. Set band switch of TS-330/TSM test set to the appropriate frequency.
- b. Set "crystal-calibrate" switch to "calibrate" position.
- c. Determine, from the table below, the value of resistance for the frequency range of the type of crystal unit being tested. Set this value of resistance on the decade resistor in the test set.
- d. Select, from the table below, the value of test frequency shown for the frequency range of the type of crystal unit being tested. Adjust the test set to this frequency by means of the tuning control. (Great precision is not essential in this frequency setting. The adjustment may be accomplished by monitoring the test-set signal by means of a calibrated radio receiver with dial settings comparable in accuracy to that of the National high-frequency receiver type HRO-SP.)
- e. Determine, from the table below, the value

Frequency Range (mc)	Test Frequency (mc)	Non-Temperature-Controlled Units		Oven-Controlled Types	
		Resistance (ohms)	Crystal Current (ma)	Resistance (ohms)	Crystal Current (ma)
0.80— 1.50	1.3	100	10	0	0**
1.51— 2.25	2.0	50	20	90	10
2.26— 3.40	3.0	100	10	50	10
3.41— 5.10	*	45	15	50	10
5.11— 7.50	*	25	20	22	15
7.51—10.00	*	16	25	13	20
10.1 —15.0	*	13	20	11	15

* Set up at frequency of crystal to be tested.
** Set for minimum setting of "crystal current" control.

Section II
Military Specifications

of crystal current for the frequency range of the type of crystal unit being tested. Vary the crystal current control on the test set until the crystal current meter indicates the proper value.

f. The drive in the test set is now properly adjusted for crystal units of the frequency being tested and for crystal units in the frequency range for which the adjustment was made.

Crystal Impedance Meter TS-537/TSM

PROCEDURE FOR OBTAINING TEST LEVEL OF DRIVE FOR CRYSTAL UNITS OVER A FREQUENCY RANGE OF 75 TO 1100 KILOCYCLES PER SECOND

2-61. The following drive adjustment procedure is specified by Military Specification MIL-C-3098B, Paragraph 4.3.1.1.2:

a. With the crystal drive control set for the minimum value at which the crystal will oscillate, measure the effective resistance of the crystal as described in the TS-537/TSM instruction manual.

b. Determine the voltage across the measured value of effective resistance that would provide a 2-milliwatt power dissipation. Use graph in MS-91482, or the following formula:

$$\text{Volts} = \sqrt{0.002 \times \text{Effective Resistance in Ohms}}$$

c. With the test set in the "calibrate" position, and with the decade resistor set for the effective resistance determined in step a, adjust the crystal drive control until the voltage difference obtained in step b appears across the decade resistance. This voltage difference can be measured by obtaining the difference between two vacuum-tube voltmeter readings taken at the voltmeter jacks on the front of the test set. If the drive cannot be decreased sufficiently, set the crystal drive control for minimum drive.

Crystal Impedance Meter TS-683/TSM

PROCEDURE FOR OBTAINING TEST

LEVEL OF DRIVE FOR CRYSTAL UNITS OVER A FREQUENCY RANGE OF 10,000 TO 100,000 KILOCYCLES PER SECOND (10.0 TO 100.0 MEGACYCLES)

2-62. The following drive adjustment procedure is specified by Military Specification MIL-C-3098B, Paragraph 4.3.1.1.3.1:

a. Set band switch of the TS-683/TSM test set to the appropriate frequency.

b. Adjust frequency of the test set to the frequency of the crystal unit by means of the calibrated dial.

c. Determine, from the table below, the value of resistance for the frequency range of the type of crystal unit being tested. Obtain a non-wire-wound type resistor that does not differ from the selected value by more than 2 per cent. (The resistor, for convenience, may be mounted in a type HC-6/U crystal holder.)

d. Insert the resistor in the appropriate socket. It is necessary to fabricate a jig, in which to place the resistor, that will permit the measurement of voltage from both sides of the resistor to ground. This measurement shall be made with a high-frequency probe of the type used in a Model 1800-A General Radio vacuum-tube voltmeter, or equal.

e. Determine, from the table below, the value of resistor voltage drop for the frequency range of the type of crystal unit being tested.

f. By means of the voltmeter specified in step d, measure the voltage from both sides of the resistor to ground and subtract the smaller reading from the larger to determine the resistor voltage drop.

g. Vary the drive control at the rear of the test set and repeat the voltage measurements until the measured resistor voltage drop is equal to that specified in the table.

h. The drive in the test set is now properly adjusted for crystal units of the frequency being tested and for crystal units in the frequency range for which the adjustment was made.

Frequency Range (mc)	Resistance (ohms)	Resistor Voltage Drop (volts)	
		Non-Temperature-Controlled Units	Temperature-Controlled Units
10—24.99999	40	0.40	0.28
25—52.0	40	.28	.20
52.000001—75	60	.35	.24

NOTE: The resistance and voltage values in the table above are not applicable in the case of the 20-milliwatt crystal units, CR-51/U and CR-53/U. See the respec-

tive technical descriptions of these crystal units for the parameters providing the correct test level of drive.

**PROCEDURE FOR OBTAINING TEST
LEVEL OF DRIVE FOR CRYSTAL UNIT
CR-33/U**

2-63. The following drive adjustment procedure is specified by Military Specification MIL-C-3098B, paragraph 4.3.1.1.3.2:

a. Insert a $\frac{1}{8}$ - or $\frac{1}{4}$ -watt carbon resistor having a value of 25 ± 1 ohms, measured on a wheatstone bridge, in the appropriate socket. (The resistor can be mounted on the base of a type HC-6/U crystal holder, with the resistor leads soldered to the mounting pins and kept as short as possible.)

b. Adjust frequency of the test set to the frequency of the crystal unit by means of the calibrated dial.

c. Adjust the screen-grid control knob to present a value of 0.25-volt difference between the voltages when measured from each side of the resistor to ground. This sets up the required level of drive of 2.5 milliwatts.

d. Remove the 25-ohm resistor and insert another carbon resistor having a resistance equal to the maximum effective resistance specified for the crystal unit on Military Standard MS91388.

e. Retune the test set as in step b above.

f. Adjust the knob marked "grid current increase" to read some convenient value of grid current on the microammeter. This value of grid current may then be used to represent the maximum effective resistance. The test set is now adjusted for "Go and No-Go" operation.

g. Remove the resistor and insert the crystal unit with its 32 ± 0.5 microfarad load capacitance in series with one terminal. The test set may now be used to perform the frequency and effective resistance measurements of the crystal unit.

**PROCEDURE FOR OBTAINING SECOND
TEST LEVEL OF DRIVE FOR HARMONIC-
MODE CRYSTAL UNITS UTILIZING
CRYSTAL IMPEDANCE METER
TS-683/TSM**

2-64. The following drive adjustment procedure is specified by Military Standard MS90168 (19 November 1952 revision):

a. With the appropriate calibrating resistor for the frequency involved, the screen voltage control shall be set to a point at which the rectified grid current reading is one-half of one meter division

($2.5 \mu\text{a}$) greater than the non-oscillating reading. This shall be checked by alternately inserting and removing the resistor and observing the meter deflections. Greatest accuracy will be obtained when operating the grid meter shunt control at maximum clockwise position.

b. The tuning control of Crystal Impedance Meter TS-683/TSM shall be adjusted in the usual manner for proper frequency calibration, using the appropriate resistor.

c. The crystal unit shall be inserted in the socket of the test set, and the grid current meter shall show a deflection increase of at least one-half of one meter division ($2.5 \mu\text{a}$). Crystals that do not oscillate or produce readings of less than one-half of one meter division ($2.5 \mu\text{a}$) shall be considered defective. The crystal oscillation frequency can be monitored in the receiver used in calibrating, as an aid to increasing the speed of testing.

Crystal Impedance Meter TS-710/TSM

**PROCEDURE FOR OBTAINING TEST LEVEL
OF DRIVE FOR CRYSTAL UNITS OVER
FREQUENCY RANGE OF 10 TO 1100 KCS**

2-65. The following drive adjustment procedure is specified by Military Specification MIL-C-3098B, paragraph 4.3.1.1.4:

a. Determine the proper power level from the applicable military standard.

b. Compute the required value of substitution resistance by taking 70 percent of the maximum (crystal unit) resistance given on the applicable military standard for the crystal unit under test.

c. Using the data obtained under steps a and b above, determine the crystal unit drive voltage from the formula $E = \sqrt{WR}$

Where

E = drive voltage in volts.

W = specified power level in watts.

R = resistance in ohms found in step b.

d. Insert the correct value of substitution resistance, as obtained in step b above, in the crystal-unit socket; switch the oscillator circuit to series-resonance operation; tune the test set to the frequency of the crystal unit under test; adjust the voltage gain control to obtain the voltage difference required by step c. This voltage difference may also be obtained by measuring the voltage between each terminal of the crystal-unit socket to ground, with the substitution resistor in the socket, and computing the numerical difference.

METHODS FOR MEASURING THE FREQUENCY OF MILITARY STANDARD CRYSTAL UNITS

2-66. The systems employed by manufacturers and laboratories for measuring the frequencies of crystal units vary according to the facilities available, the degree of precision desired, the temperature requirements, the purpose of the particular measurement, and other factors. For example, in a simple room-temperature test of the go, no-go* type, a less elaborate system is required than would be the case if a very precise record of the frequency were desired over an operating temperature range of -55° to 75° C. Again, the measuring systems employed in testing crystal units at points along a production line are arranged to permit simple, repetitive operating techniques that can be readily learned by non-technical personnel. In the research laboratory, on the other hand, the test equipment must be adaptable for a wide variety of measurements over wide frequency ranges and ambient test conditions. Since such tests are to be performed by highly trained technicians, less attention is given to simplified techniques. Normally, the equipment available can be used in a number of different ways to obtain the same measurement, some of the methods being more accurate than the others.

EQUIPMENTS REQUIRED FOR CRYSTAL FREQUENCY TESTS

2-67. In the measurement of crystal frequencies under test conditions corresponding to Military Specifications, the equipments required can be divided into the following categories:

Primary Standards

- a. Primary frequency standard (Station WWV ground-wave signals)
- b. Primary crystal test set standards (Government-furnished CI meters to be used for correlation adjustments) †
- c. Primary load-capacitor standard
- d. Primary calibrated resistor standards
- e. Primary temperature standards (boiling and freezing points of water)

* "Go, no-go" is a technical idiom for the type of test in which a component is tested only for acceptance or rejection; that is, an exact measurement is not necessary. The test need only be sufficient to determine whether or not the specified tolerances are exceeded.

† Government-furnished C. I. meters are not correctly primary standards; officially, they are called "Government Reference Standard Test Sets." See paragraph 2-72 for explanation of terms, "primary standard" and "reference standard" as used in this text.

Reference Standards

- a. Secondary frequency standard (precision crystal-controlled frequency generator)
- b. Audio-frequency reference standard (interpolation oscillator)
- c. Reference crystal test sets (standard CI meters and duplicating circuits used in actual crystal-frequency measurements)
- d. Temperature reference standard (pyrometer)
- e. Reference load capacitors (component parts of reference crystal test sets)
- f. Reference calibrated resistors

Indicating and Recording Instruments

- a. Frequency counter or meter
- b. Frequency-deviation meter
- c. Frequency-deviation-vs-temperature recorder
- d. Oscilloscope (used in exact frequency measurements and in correlation of interpolation oscillator)
- e. Grid-current meter (used in adjustment of reference crystal test set for measuring crystal resistance)
- f. Effective-resistance-vs-temperature recorder
- g. Electronic r-f voltmeter (used in measuring crystal drive level)
- h. Pyrometer (for indicating crystal temperature—same as temperature reference standard, listed above, used in correlating other temperature-measurement controls)
- i. Thermometer (for cold box or multiple-crystal cooling and heating chamber)
- j. Q meter (for calibration of load capacitance)
- k. R-F bridge (for checking calibrated resistors)
- l. Earphones or loudspeaker (for audio zero-beat frequency measurements)

Auxiliary Amplifiers and Frequency Converters

- a. Radio receiver, cw and mcw
- b. Harmonic generators (controlled by frequency standard)
- c. Frequency divider (for dividing frequencies that are too high for receiver)
- d. Variable-frequency oscillator (for rapid frequency checks)
- e. R-f amplifier
- f. D-c amplifier

g. Signal control panel

Auxiliary Devices for Controlling Crystal Unit Test Conditions

- a. Cold box
- b. Cold box thermostat
- c. Heater
- d. Heater thermostat
- e. Variable heater power source (a-c, 0-125-V, 5-watt Powerstat typical)
- f. Timer (for correlation of heater power supply with proper rate of temperature change)
- g. Dummy crystal units (for mounting thermistor or thermocouple temperature sensing element of pyrometer)
- h. Transparent adhesive tape (for binding together dummy crystal units)
- i. Thermocouple wire, AWG #26 or smaller
- j. Vibration machine
- k. Crystal mounting fixture for vibration machine
- l. Shock testing machine
- m. Container for immersion test
- n. Ten-power microscope
- o. Micrometer
- p. Pin-alignment gauges and/or shadowgraph
- q. Socket adapter for Crystal Holder HC-10/U (Crystal Socket Adapter UG-683/U, available from Walter L. Schott Co.)

Test-Plant Fixtures

- a. Primary power source (110 volts, ac)
- b. Secondary regulated power source, if advisable
- c. Mounting facilities (cabinets, shelves, benches, tables, stands, frames, racks, etc)
- d. Cabinet facilities for storing records and expendable supplies
- e. Desk facilities
- f. Vibration-free area of building
- g. Thermostatically controlled room

2-68. Brief functional descriptions of the equipments listed above are given below wherever the exact use of a unit is not self-evident. The descriptions follow the same order as in the outline above. The model mentioned to illustrate each type of equipment is to be interpreted as representative only. Equivalent, and probably improved, models for most of the types of equipment listed are generally available from the same manufacturer as well as from other manufacturers. The examples given as representative are the equipments currently being used by, or in developmen-

tal projects under the technical control of, the Frequency Control Group of the Communications and Navigation Laboratory, Wright Air Development Center.

Primary Standards

2-69. Every arithmetical measurement involves the division of the quantity being measured into countable units. Where the object of the measurement is to make a relatively precise determination of the total number of units contained in the given quantity, it is necessary that *the quantity and the test conditions*, as well as *the measuring unit*, be well defined. For example, if the quantity being measured is the length of an iron bar, a precise measurement requires that the temperature of the bar be specified; otherwise, the particular length being measured, which would be different for each temperature, would not be known. Consequently, a measurement of the length also involves a measurement of the temperature, which, in turn, requires that the unit of temperature also be well defined. In general, the more precise the major measurement, the larger the number of auxiliary minor measurements to be made in order to establish the required test conditions. For each contemplated measurement, major or minor, a standard must be available to ensure the accuracy of the measured units. The accuracy of the measurement, of course, cannot be greater than the accuracy of the standard.

2-70. Before a numerical measurement can be made, a unit of measurement must be decided upon. Most, if not all, types of basic physical quantities now have internationally accepted units. These units, defined as concretely as practicable, are called *absolute units*. Measuring devices, constructed with the greatest possible precision to represent the absolute units, are stored in the chambers of the International Bureau of Weights and Measures in Sèvres, France. These physical objects by common agreement serve as *international standards*. The units which the standards define are called *international units*. Theoretically, the international units are supposed to equal the absolute units, and so they do to the nearest degree attainable at the time the standards are constructed. But improved methods of measurement which permit greater precision are constantly being developed, so it is not unusual for discrepancies to be found between the international and the absolute units. In time, more precise instruments are accepted as international standards in place of the old, but the interval of delay is usually quite extensive. As a result, where measurements of optimum precision are being made, knowledge

Section II Military Specifications

of the exact degree of accuracy obtained is often obscured due to ambiguity regarding the accuracy of the reference units used as standards. Aiding the chance for ambiguity is the fact that each country has its own primary standards for domestic uniformity which may or may not be correlated with the international standards.

2-71. In the United States the national standards are controlled by the National Bureau of Standards, Washington, D. C. The official units of the United States are based on the yard-avoirdupois pound-second system of weights and measures rather than the meter-kilogram-second international system, but are, nevertheless, defined absolutely in terms of the international units. For example, the United States absolute yard is defined as equal to 3600/3937th of the international meter. Presumably the physical primary standard for length at the Bureau of Standards is one that has been carefully correlated with the International Prototype Meter at Sèvres. (The International Prototype Meter is the distance at 0° centigrade between two fine transverse lines engraved on a platinum-iridium bar. This international primary standard was originally intended to represent an absolute unit of one ten-millionth of the distance between the north pole along a meridian to the equator. The absolute meter now is defined to equal 1,533,164.13 wavelengths in air at 760 mm pressure and 15° centigrade of the red line exhibited by cadmium (vapor) during electrical discharge.)

2-72. Within the United States, the *primary standard* for a particular unit is officially the standard maintained by the National Bureau of Standards. Other official measuring devices are called *secondary standards* since they must be correlated with the national primary standards. For some units there have been established hierarchies of standards. Each office has its own standard, which is checked against a local standard, which, in turn, is checked against a regional standard, and so on up to the national primary standard. Such is the system used in meteorological stations in respect to a sequence of correlated barometers of ascending accuracy. A similar system of standards is not readily available for all the types of measurements normally required in the testing of crystal units. The standards available are a mixture of various orders of accuracy and officiality. In the list of equipments in paragraph 2-67 we have arbitrarily classified as *primary standards* those standards of maximum accuracy that are not used in the actual crystal tests, but are employed only by calibrating, adjusting, or in some way correlat-

ing the instruments that are being used as reference standards in making the actual measurements. These latter instruments, whether or not they are periodically checked against another standard, we designate as *reference standards*.

PRIMARY FREQUENCY STANDARD

2-73. To determine the frequency of any periodic event we must measure the number of times the event occurs during a given unit of time, or reciprocally, measure the number of time units contained in the duration of a given number of events. By either method the accuracy of the measurement will depend upon how accurately the unit of time is known. Unfortunately, we cannot freeze an interval of time and preserve it as a standard, so instead we rely upon the conservation of momentum to provide our standard. This is possible since a rotating body, if not acted upon by net external tangential forces, will turn through equal angles in equal intervals of time. The rotating earth is the internationally accepted time standard, there being no specially constructed standard as for the other fundamental units. The international unit, which is also the U. S. standard unit, is the *second*, which is defined to be 1/86400th of a mean solar day. A solar day is the noon-to-noon time between succeeding instances in which the center of the sun crosses the meridian of a fixed earth observer, as distinguished from a sidereal, or star, day. The former is the period of the earth's rotation on its own axis relative to the sun, whereas the latter, a slightly shorter time interval, is the period of the earth's rotation relative to the celestial universe. The sidereal day is essentially the same interval of time throughout the year, but the solar day fluctuates constantly and must be averaged over a long period. Actually, the earth is slowing down perceptibly due to the frictional losses of energy resulting from the tides; but its motions are now so well known and predictable that solar time can be estimated to accuracies on the order of one part in 10⁸.

2-74. In the measurement of time, for each transit of the earth through a mean solar angle of one second, one standard cycle occurs; so that one complete rotation of the earth can be viewed as a sequence of 86400 standard cycles. Now, a radio signal is also a sequence of cycles. Should we call a given sequence a "frequency standard," instead of a "time standard", let it be clear that in changing the name we in no way change the nature of the phenomenon that the name symbolizes. If a radio signal can properly be described as a "frequency", so also might we describe a sequence of inch marks. If our unit of space-length is the

yard, we can describe the *length* of the inch by comparison with the length of the yard by saying that the "frequency" is 36 inches per yard. But note that the number 36 is simply a ratio between two lengths. Where the sequence of marks is something absolute in matter, their frequency is a mental comparison in an observer's mind. Similarly, it can be said that a sequence of radio cycles has an inherent material reality, but that the cycle frequency is only an observed relation of the duration of a cycle compared with that of a standard cycle. Thus, a signal of 100 kc per second means that, if compared with the period of one standard cycle, the period of one radio cycle is one hundred thousandth part. If this signal is defined as a frequency standard, it means that the period of its individual cycles are to be considered standard secondary subunits of the second, in much the same sense that standard inch marks are considered subunits of the yard. For it is as a standard unit of time that a frequency standard is used in the measurement of unknown frequencies. The measurements are made by comparing the periods of unknown duration with the periods of standard duration, and then interpreting the measurements in terms of frequency.

2-75. A standard frequency cannot be assumed to have an *absolute value* of greater precision than either of the two unit cycles of which it is a ratio. That is, the accuracy of the absolute value cannot exceed the stability of the frequency-control device nor the accuracy of the fundamental unit of time. Some oscillators have a short term stability so perfect that over short periods of time unknown frequencies can be measured relative to the frequency standard with much greater precision than the absolute frequencies can be known relative to the international unit of time. If such oscillators could maintain their stability without slow drifts with aging, they could conceivably replace the solar standard in establishing an international prototype unit of time. At the present time such oscillators are not available, but the great stability of atomic and molecular frequencies and the recent developments in the methods of exciting and detecting them, such as the experiments with ammonium clocks at NBS, suggest that eventually perhaps an atomic international time standard will replace the solar standard.*

2-76. The national primary frequency standard is a battery of 100-kc crystal oscillators controlled by G elements at the National Bureau of Standards. Use of this standard is readily available to anyone living in the region immediately surrounding Washington, D. C., since the output of the

standard is used to control the sequence of standard signals continuously broadcast from station WWV. The WWV standard signals (see figure 2-87) are at radio frequencies of 2,500 kc, 5,000 kc, 10,000 kc, 15,000 kc, 20,000 kc, and 25,000 kc and are available by tuning a receiver to any one of these channels. At regular intervals, whose duration serves as a national time standard, the WWV signals are modulated by standard audio frequencies of 440 cps and 600 cps, which can be used in calibrating an interpolation oscillator. For the calibration of r-f standards only the 30-second c-w intervals are employed.

2-77. The national primary standard can be assumed to have a relative stability on the order of 1 part in 10^8 over any 24-hour period, but the absolute frequency, the number of cycles per international unit of time, cannot be guaranteed beyond an accuracy of 1 part in 10^6 . An additional restriction is that this accuracy is only possible if the standard signal is being received as a ground wave. If a sky wave is being received the constantly varying pathlengths due to movements of the ionosphere create doppler effects, so that the received signal is randomly frequency modulated.† Eventually, it is to be hoped that a chain of relay stations can make available WWV ground signals in all parts of the country. At the present time, one slave station, WWVH, is maintained in the Territory of Hawaii. If top precision frequency measurements are to be made in localities remote from both WWV and WWVH, the engineer should have available a high-stability secondary standard which can be periodically brought to Washington and checked against the official primary standard. For the calibration of standards having short-term instabilities greater than 2 or 3 parts per 10^6 , the WWV and WWVH sky

* The most recent definition of the second that has been approved by the International Astronomical Union is contained in the *Excerpts from Meeting of International Astronomical Union, Dublin, Ireland, August 29 to September 5, 1955*. We quote: "The General Assembly of the I. A. U. approves the definition of the second proposed by the Comite International des Poids et Mesures, as follows: The second is the fraction of $1/315,569,259,474$ of the length of the tropical year for 1900." Additional information is contained in the *National Bureau of Standards Report No. 1848* under the title, "Spectral Lines as Frequency Standards."

† If special equipment is available for counting the sky-wave cycles over relatively long intervals of time—1-second intervals, for example—the random frequency variations tend to average out, so that the percentile error introduced by ionospheric deviations can be made relatively negligible. A number of systems for accomplishing this are possible. Essentially the problem is to compare WWV seconds pulses with similar pulses derived from the local secondary standard, adjusting the frequency of the latter until an equality is established. For one solution to the problem see paragraph 2-92.

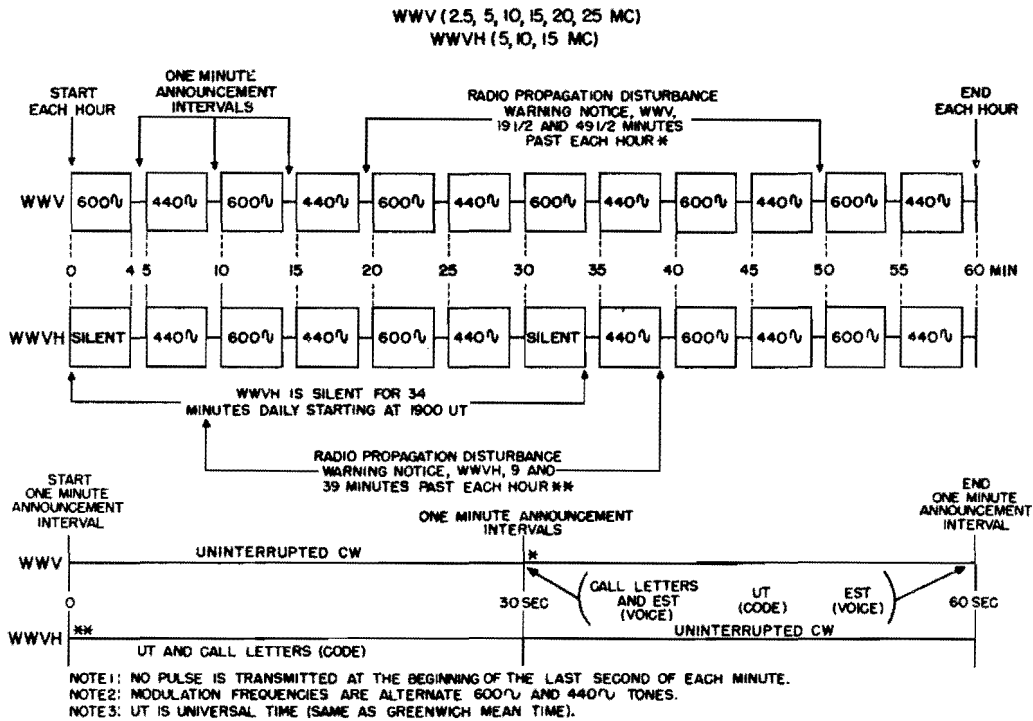

Figure 2-87. Chart showing standard time and frequency signals broadcast by Stations WWV and WWVH (Subject to change)

waves are satisfactory. These can be received on one channel or the other throughout the U. S.

PRIMARY CRYSTAL TEST SET STANDARDS

2-78. The specifications of Military Standard crystal units require that they be tested in standard reference sets. The primary standard test sets are Government-maintained models of the following types of crystal impedance meters:

Crystal Impedance Meter	Frequency Range (kc/sec)
TS-710/TSM	10 to 1100
TS-537/TSM	75 to 1100
TS-330/TSM	1000 to 15,000
TS-683/TSM	10,000 to 75,000

(CI Meter TS-537/TSM listed above is expected eventually to be replaced entirely by TS-710/TSM.) For Government laboratory tests, the primary standard sets are generally used as the actual test reference circuit in which the crystal is inserted. This is not true in the case of production-line and quality-control tests to be made by manufacturers. Here, the Government furnishes

primary standard test sets to a manufacturer only for the purpose of correlating the reference test circuits used by the manufacturer. Even the Government inspection tests of sample lots of crystal units are made with the manufacturer's reference sets and not with the primary standards. When initially obtaining his reference test sets, the manufacturer may build them himself, duplicating the primary-standard circuitry, or he may purchase Military Standard test sets in the commercial market. But the fact that such sets are used for routine tests in production control officially rules out their classification as primary standard sets.

PRIMARY LOAD-CAPACITOR STANDARD

2-79. For routine measurements, the load capacitor contained in each standard CI meter can be considered sufficiently accurate to use without special correlation with a primary standard. However, when precision measurements are required, or when any significant deviation in the calibration of the standard test set should seem to occur, there should be available an external precision standard capacitor with which the test set capacitor can be correlated. A suitable capacitor to serve

as a standard is Precision Capacitor Type 722-D, General Radio Co., or its equivalent.

PRIMARY CALIBRATED-RESISTOR STANDARD

2-80. In order to check the accuracy of the calibrated resistors used in adjusting the crystal test sets, it is desirable that a precision r-f resistance standard be available. The standard should be adaptable for use in a radio-frequency bridge. For this purpose, it is generally convenient to employ a bridge circuit in which a precision resistor standard is incorporated in the design as a component part. See paragraph 2-108.

PRIMARY TEMPERATURE STANDARDS

2-81. The boiling and freezing points of distilled water, with due regard for the atmospheric pressure, permit more than ample precision as a primary standard for routine calibrations of the temperature measuring equipment. Normally, the absolute barometric pressure at the time of testing need not be noted—only the mean pressure for the local elevation above sea level.

Reference Standards

SECONDARY FREQUENCY STANDARD

2-82. In those areas not reached by WWV ground waves, the crystal frequency measuring equipment should include a secondary frequency standard capable of a relative stability of 1 part in 10^8 per day or better. A high-precision secondary standard is also desirable, of course, even when WWV signals are constantly available. But in this case, a standard of less stability, if correlated frequently with WWV, can be as dependable as a maximum-stability unit that is correlated only after long intervals of operation. It is the secondary standard that is used to control the periods of the known cycles against which those of the unknown signal are to be compared.

2-83. A large number of high-precision standards are available on the commercial market. Of these, one that appears the equal, if not the superior of any other in aging stability is the James Knights-Sulzer frequency standard, developed jointly by the James Knights Co. and P. G. Sulzer of the National Bureau of Standards. This standard is used in the development of USAF frequency standards to measure fractional deviations in frequency to an accuracy of 1 part in 10^9 per day. For this degree of precision two Knights-Sulzer standards are used and each, once turned on, are never turned off. The crystal frequency to be measured is checked against each standard and the standards checked against each other. The

high precision obtainable is due in large part to the use of evacuated glass holders in the fabrication of the crystal units employed in the standards, and in the extreme care used in the cleaning stages. The aging data for a 1-mc standard operated continuously from a constant-emf mercury cell at the Knights laboratories showed a net frequency shift from 999,999.5 cps to 999,999.7 cps between November 27, 1953 and March 8, 1955. During this period the frequency fluctuated both above and below the starting frequency by amounts greater than the 2 parts per 10^7 indicated for the total period; so that although a tendency for neither a positive nor a negative aging drift is indicated definitely for long periods of time, the stability over shorter intervals must be assumed to be less than the long-term average. During a 2-month test by the Signal Corps, one crystal unit of the type used in the J.K. frequency standard exhibited a stability of 1 part in 10^8 per week; another unit, 3 parts in 10^8 per week.

2-84. Where reference standards with stabilities on the order of 1 part in 10^8 per day are satisfactory, a representative type is the 100-kc frequency standard, R-F Oscillator O-76/U, of the Western Electric Co. Signal Corps engineers report that the O-76/U oscillator, after aging, can be expected to have a frequency stability on the order of 1 part in 10^9 per day.

AUDIO-FREQUENCY REFERENCE STANDARD

2-85. The a-f reference standard is a variable interpolation oscillator that is used as a difference-frequency reference standard in measuring audio beat frequencies and as a frequency-deviation reference standard for calibrating the frequency-deviation meter and recorder. The conventional method of measuring radio frequencies is to mix the unknown signal with a harmonic (or a subharmonic, or a harmonic of a subharmonic) of the fundamental of the secondary frequency standard. A difference frequency in the audio range is obtained and compared with the output of the variable audio-frequency (interpolation) oscillator. The latter is adjusted until its frequency is equal to the unknown difference frequency. The tuning dial of the variable oscillator will have been calibrated to permit an interpolated reading of the difference frequency, which can then be added to or subtracted from the standard harmonic to give the unknown frequency. The variable oscillator will previously have been correlated with the frequency standard at one or more representative check points, in reference to which the v-f-o tuned frequency can be interpolated.

Section II Military Specifications

2-86. As a frequency-deviation reference standard, these calibrated check points of the interpolation oscillator are used in the correlation of the frequency-deviation meter and the frequency-deviation recorder prior to a temperature-run test.

2-87. The interpolated frequencies, of course, are not as accurate percentagewise as the crystal-oscillator standard; but if the measured difference frequency is an extremely small fraction of the unknown frequency, the error introduced by the interpolation oscillator can be expected to be of much smaller magnitude in terms of cycles per second than the normal deviations of the crystal standard. If precision measurements of the difference frequencies are required, it would be preferable to count the cycles with a frequency counter directly controlled by a crystal standard, or to zero-beat the difference frequency with a vfo that in turn is continuously monitored by a crystal-standardized counter. A representative audio frequency reference standard is the 0-to-5-kc Interpolation Oscillator Type 1107A, General Radio Co.

REFERENCE CRYSTAL TEST SETS

2-88. As explained above in the discussion of the primary standard test sets, crystal manufacturers employ reference standard test sets for production-line and quality-control tests. The reference sets are CI-meter circuits that duplicate those of the primary standards, but which are usually modified somewhat and probably removed from their cabinet to permit convenient installation on or under a testing table in a production line. These reference test sets are correlated periodically with the primary standard test sets by Government inspectors.

TEMPERATURE REFERENCE STANDARD

2-89. Normally a pyrometer is used as a secondary temperature standard for the purpose of correlating the cold box thermometer and other temperature gauges, and the crystal heating controls. The same pyrometer is also generally used as the indicator in measuring the crystal-unit temperature during a temperature-run test. The sensing element of the pyrometer can be a thermocouple or a thermistor, the latter being the more accurate since the temperature reading will be independent of the temperature of a room-temperature junction. Whichever is used, it should be mounted on the quartz plate of a dummy crystal unit in order to simulate as closely as possible the thermal parameters associated with the crystals being tested. The sensing element, being in series with the current windings of the pyrometer, causes the

deflection needle to follow the temperature changes of the dummy crystal plate. A separate dummy crystal unit should be available for each type of crystal holder being used in the tests. Where greater precision is required than is normal for routine tests, the dimensions and mounting of the crystal in the dummy unit should closely simulate the dimensions and mounting of the crystal in the test unit. For this purpose, a dummy crystal unit should be available for each narrow range of frequencies for each type of crystal unit to be tested, instead of simply for each type of crystal holder. The pyrometer scale for each sensing element should be checked and correlated periodically against the primary standard (boiling water and/or ice water). The scale should be calibrated in degrees centigrade. If a thermocouple is used, the current meter should be a microammeter; if a thermistor is used, a 0—1-ma. meter could be used if the power dissipated in the dummy crystal unit does not exceed the drive level of the crystal being tested; but for minimum error, a microammeter is requisite, especially where very thin crystals are to be tested. Preferably the current meter will be a component part of a temperature recorder. A typical thermistor is the Ney Co. model used to measure the dummy crystal temperature in a heater designed by E. L. Minnich as a modification of a USAF-developed model. The thermistor is enclosed at one end of a sealed glass stem. Electrical connection is through two copper-wire leads. Approximately, the resistance varies from 2000 ohms at room temperature to 400 ohms at 90°C. The dummy unit and the test unit are mounted side-by-side in the heater. For greater thermal contact with the dummy crystal blank, and hence for less lag in the temperature readings, the Frequency Control Group at WADC employs a platinum-wire thermistor wrapped around the dummy blank. The WADC heater designed by D. J. Theobald, is 1.5 in. diameter slug, 2.5 in. long which mounts the test crystal unit in one end and the dummy unit in the other.

REFERENCE LOAD CAPACITORS

2-90. The calibrated capacitor used as a standard for simulating the rated load capacitance of a parallel-mode crystal unit will be a component part of the CI meter used as a reference test set. Thus, it does not have to be supplied separately unless the test circuit is being constructed locally. A typical load capacitor is a calibrated, variable, single-section, air-dielectric unit with a range of 5 to 100 μf .

REFERENCE CALIBRATED RESISTORS

2-91. A set of calibrated r-f resistors which covers the effective-resistance range of all Military Standard crystal units to be tested must be available for use with those test sets which are not provided with an internal calibrated resistor set. The calibrated resistors do not have to be precision standards, but they should have short leads and be composition (noninductive) types with tolerances of their nominal values not greater than plus or minus one per cent. The same resistors can be used in both the primary standard test sets and in the manufacturer's reference test sets. For test set adjustments of the drive level for crystal units of maximum effective resistance, it would be convenient to have available a set of maximum-resistance resistors mounted on crystal-holder plug-in bases. The standard Armed Services CI meter, TS-330/TSM, and also the limited-standard model, TS-537/TSM, are internally provided with calibrated decade resistor circuits and appropriate switching controls. External resistors are required for use with the standard CI meters, TS-710/TSM (which is replacing the TS-537/TSM) and TS-683/TSM.

Indicating and Recording Instruments

FREQUENCY COUNTER OR METER

2-92. Certainly, the quickest method for measuring a frequency with reasonably good accuracy is to feed the unknown signal to the input of a frequency counter and read the frequency directly. Representative units used in the crystal industry at the present time are the crystal-controlled counters developed by the Hewlett-Packard Co. Typical models are the 5-digit 522B and the 8-digit 524B. The principle of operation of these counters is essentially the same as that used by a doctor in measuring a pulse rate. It is not the frequency that is counted, but the number of pulses during a given length of time. A crystal oscillator is used as a time standard to measure accurately a given length of time, serving the same purpose as the doctor's watch. (The crystal standard provided with the Hewlett-Packard counter type 524A is reported to have an accuracy of 2 parts in 10^6 per week—for greater accuracy, input controls are incorporated to permit the use of an external frequency standard.) The crystal timing circuit controls a fast-acting flip-flop electronic gate. When the gate is open, the input cycles of the frequency to be measured are passed through to a counting circuit. The gate-controlling circuit can be adjusted to keep the gate open for crystal-controlled intervals of 0.001 second to 10

seconds. If, for instance, the gate is open for one second, the number of input cycles passing through will equal numerically the unknown frequency. It is the problem of the counting circuit to count the cycles accurately. The counting is performed by a sequence of cascaded decade scalars, each of which operates its own indicating system. Each scaler generates one output pulse for every ten input pulses to the circuit. The first scaler divides the input cycles by ten and feeds its output to the second scaler. The second scaler divides by ten again, and passes its output on the third decade scaler. And so on to the last scaler. When the gate is closed, each scaler indicates by a neon lamp a digit representing the number of pulses it has just received from the preceding scaler which have not been passed on to the succeeding scaler. (In the H-P 524B, the first two scalars indicate by meters.) In other words, each scaler effectively counts all the pulses it receives, divides by ten and passes the quotient on to the next scaler to count, and then shows the remainder by lamp light on the front panel. The observer can thus read the frequency directly. A decimal point is automatically positioned to give the reading in kilocycles. Before opening the gate for the next count, the gate flip-flop circuit resets the counting circuit. The counting accuracy is ± 1 count, or a maximum of 1 part in 10^d , where d is equal to the number of digits shown. The frequency range of a single counter, without accessory circuits, is 0 to 10 mc. The addition of plug-in units can extend the range to 220 mc. A plug-in amplifier unit permits an increase in input sensitivity from 1 volt rms, minimum, to 10 millivolts rms, minimum. By using the unknown frequency to control the electronic gate and feeding the frequency standard to the input, the counter can be used to measure the period of the unknown signal in seconds, milliseconds, or microseconds, with the decimal point automatically positioned. A counter also permits a ready method of utilizing WWV sky-wave signals as a primary standard having almost the same dependability as is possible with WWV ground signals. Since the random frequency deviations of the sky wave can be expected to average out over a relatively long period of time—a second is a sufficient interval, except possibly in times of severe ionospheric storms—the WWV sky signals can be received, amplified, and divided (if necessary) for use as a timing standard to control the electronic gate of a counter at intervals of 1 second or greater. With the one-second intervals as measured by the sky wave practically as accurate as those of the ground wave, the counter can thus be

used to give a precision reading of the local secondary standard frequency and permit its correlation with the WWV primary standard. The total accuracy, of course, cannot be greater than the counting accuracy, which, in turn, increases by a factor of 10 for each digit shown. For a counting accuracy between 1 part in 10^8 and 1 part in 10^9 , a minimum of 8 digits must be indicated in the counter reading.

2-93. Other types of frequency meters in widespread use are those of the older heterodyne v-f-o type. The variable-frequency oscillators are periodically calibrated at standard-frequency check points. The unknown signal is mixed with the v-f-o signal, the latter being varied until a zero beat is obtained. The beat note can be indicated either aurally or visually. With precision dialing of the vfo and careful interpolation between the standard harmonic check points, quite high accuracies can be obtained. The closer the check points, the nearer the measuring accuracy approaches the accuracy of the check-point standard. With a visual (oscilloscope) indication of the null heterodyne point this approach can be quite close. The average v-f-o heterodyne frequency meter, nevertheless, is less accurate than those measuring systems that employ the frequency standard, itself, to heterodyne directly with the unknown frequency. Representative heterodyne frequency meters are Frequency Meter FR-4 and Frequency Meter Set SCR-211 ().

2-94. Direct-reading frequency meters employing frequency-divider circuits, which can be calibrated against (but not controlled by) frequency standards, are also in use. The precision of such meters is generally not satisfactory for any but low-frequency crystal measurements. In the audio range such meters are quite useful. (See Frequency-Deviation Meter, paragraph 2-96.)

2-95. As for the use of wavemeters, they are entirely too inaccurate for ordinary crystal measurements. Such meters, being little more than a tuned series circuit with a resonance indicator, are, of course, relatively inexpensive and easy to construct. For very-low-frequency measurements, where broad tolerances are permissible, a wavemeter conceivably could find a useful application if the expense of a more accurate meter is unwarranted.

FREQUENCY-DEVIATION METER

2-96. The frequency-deviation meter is a conventional electronic frequency meter to be correlated with the interpolation oscillator. Its principal purpose is to provide a direct reading of the difference frequency obtained when the frequency of

the crystal under test is mixed with the standard test frequency. Since the difference frequency that would result if the crystal frequency equaled its nominal value is known, the frequency deviation is readily measured as the difference between the actual meter reading and the hypothetical nominal reading. The frequency-deviation meter should also provide an adjustable d-c output for feeding the frequency-deviation recorder.

2-97. The input signal to a typical electronic frequency meter is first amplified to a given level and limited so that each cycle has a predetermined amplitude. A counting circuit follows, which serves to trigger a current pulse of fixed charge that flows through the meter windings. The meter reading will thus be directly proportional to the number of current pulses per second, which in turn will be directly proportional to the number of input cycles per second.

2-98. A representative frequency-deviation meter is the Hewlett-Packard Frequency Meter Type 500A or 500B. The latter has a range of 0 to 100 kc; the former extends only to 50 kc. A phone jack on the panel permits connection to a 1-ma., 1400-ohm frequency-deviation recorder. The input sensitivity is 0.2 volt rms, minimum.

FREQUENCY-DEVIATION RECORDER

2-99. An automatic recorder is required to provide a graphical record of the deviation in frequency as the temperature of the crystal unit being tested is made to vary over the rated operating range. As a strip of graph paper uniformly unwinds, a stylus, or an equivalent device, is actuated by an input from the frequency-deviation meter in such a way that the frequency measurements are continuously recorded on the graph. Additional current pulses at regular temperature intervals from a temperature recorder can serve to calibrate the abscissa of the graph in degrees centigrade. Before testing each type of crystal unit at a given frequency, the recorder must be correlated with the frequency-deviation meter and the temperature recorder. A representative ammeter recorder is the Esterline-Angus Automatic Recorder Model AW, which has a 1-ma. (dc), 1400-ohm (plus or minus 100 ohms) input.

OSCILLOSCOPE

2-100. The oscilloscope is used to provide a visual check when correlating the interpolation oscillator against a crystal standard, and when measuring a difference frequency with the aid of the interpolation oscillator. For either of the above uses, the horizontal plates of the oscilloscope are connected to the output of the interpolation oscillator and the vertical plates are connected to the output

of the receiver. The operator adjusts the interpolation oscillator to obtain a fixed image on the screen, at which point he can either calibrate the interpolation oscillator against a known receiver output, or interpolate an unknown receiver output from the oscillator calibration. A representative oscilloscope is the Dumont Type 241.

GRID-CURRENT METER

2-101. All standard Armed Services CI meters are equipped with a front panel grid-current meter except the TS-710/TSM, which is provided with a vacuum-tube voltmeter. For the reference test sets not provided internally with a grid-current meter, an external meter must be provided. The meter is used principally in correlating the grid excitation of the reference circuit with the effective resistance of the crystal unit. It is then used to correlate the effective-resistance recorder against the reference grid-current levels for maximum specified and minimum expected values of resistance. A representative meter is the JAN type Meter MR26W200DCUA (0 to 200 μ a).

EFFECTIVE-RESISTANCE RECORDER

2-102. A recorder is used in the testing of Military Standard crystal units to automatically plot on graph paper the deviations in crystal resistance as the temperature is varied over the operating range. The recorder stylus is to be actuated by the d-c current in the grid circuit of the reference test set. If the recorder is sufficiently sensitive, the grid current may be used directly; otherwise a d-c amplifier should be employed. The minimum grid current, and hence the minimum excitation of the recorder, occurs when crystal units of maximum resistance are being tested. By previously correlating the recorder with the maximum-resistance grid-current level, the graphical record will indicate whether the resistance of any crystal unit exceeds the rated maximum at any temperature. By also feeding the effective-resistance recorder input pulses from the temperature recorder at regular temperature intervals (every 5 degrees centigrade is normal), the abscissa of the resistance graph will be calibrated in temperature degrees. A recorder of the Esterline-Angus type, described in paragraph 2-99 as representative of the models satisfactory for recording the frequency deviation, is also satisfactory for recording resistance deviation; but a d-c amplifier might be required to provide the necessary sensitivity. A representative recorder sufficiently sensitive to operate at the microampere level is the 0-to-5- μ a Photoelectric Recorder Model 8CEIELIB-1 of the General Electric Co.

ELECTRONIC A-C VOLTMETER

2-103. An a-c voltmeter is required to measure the voltage across the crystal units under test when determinations of the drive level are desired. Care must be taken that the voltmeter causes no significant imbalance or disturbance of the tuned CI-meter circuit. Because of the extreme sensitivity of the test circuits, particularly at the higher frequencies, conventional a-c voltmeters are not satisfactory for such measurements. Only those meters of maximum input impedance and sensitivity should be used. Even then, unless the voltmeter circuit is a differential type, the voltmeter leads should not be connected directly across the crystal unit, as the unmatched impedances to ground of the two leads can cause the test-circuit frequency—and hence the crystal impedance and voltage—to change. The proper method would be to measure the voltage from each crystal-unit terminal to ground separately, making certain that the act of measurement does not in itself change the test frequency of the crystal. The voltage across the crystal unit, of course, is equal to the difference between the two measured voltages. Suitable vacuum-tube voltmeters are the equivalent of Multimeter TS-505/U or the Hewlett-Packard Electronic Voltmeter Model 410B. To be preferred would be a differential vacuum-tube voltmeter such as Voltmeter ME-56 ()/TSM. (The ME-56 ()/TSM should not be used above 60 mc unless special calibration procedures are employed.)

DUMMY-CRYSTAL-UNIT PYROMETER

2-104. This is the same pyrometer that is described above as a secondary reference standard used in the correlation of the other temperature indicators and controlling devices. It is also used during the temperature-run tests as an indirect indicator of the crystal-unit temperature at each instant. The sensing element (thermistor, preferably, or thermocouple) is mounted on the crystal plate in a dummy crystal unit simulating the holder and construction of the crystal unit under test. The heater, which mounts the test crystal during the temperature run, should provide an equivalent mounting position for the dummy unit. The temperature thus indicated by the pyrometer can then be considered a reasonably close approximation to the simultaneous mean temperature of the test crystal.

COLD-BOX THERMOMETER

2-105. Except when mass quantities on a production line are being tested, it is usual for only one crystal unit to be tested during a temperature

run. For this purpose a thermostatically controlled cold box is adequate for cooling the crystal unit to the low-temperature limit. When the temperature run for an individual unit is ready to begin, the unit is removed and mounted in a heater. To make certain that the temperature of the cold box is correct, a thermometer must be provided which has previously been correlated with the pyrometer reference standard. The cold-box thermostat is then adjusted to maintain the correct reading on the thermometer.

2-106. When multiples of perhaps a dozen crystal units are to be given a temperature-run test simultaneously, the cold box and heater are usually replaced by a single chamber which can be cooled and heated as desired by a thermostatically regulated air stream. Even so, a thermometer periodically correlated with the reference pyrometer should be in view to give an accurate indication of the crystal chamber temperature when making thermostatic adjustments and starting a temperature run. Any medium-precision mercury thermometer, such as those used by chemists in measuring reaction temperatures, is satisfactory, provided the calibrated scale covers the necessary temperature range.

Q METER

2-107. A Q meter is required for calibrating the reference test load capacitors against the precision standard. The Q meter should be equipped with a standard inductance coil. A representative model is Q Meter TS-617()/U.

R-F BRIDGE

2-108. An accurate r-f bridge is required in the correlation of the calibrated resistors used as references when measuring the effective resistance of crystal units and when adjusting the test sets to suitable drive levels. The standard resistors, against which the reference resistors are to be checked, are preferably component parts of the r-f bridge. A satisfactory bridge would be the equivalent of R-F Bridge Navy Type No. 60094.

EARPHONES OR LOUDSPEAKER

2-109. Earphones and/or a loudspeaker are desirable as frequency indicators when rapid frequency checks are to be made and neither recordings of temperature runs nor great precision is required. Audio measurements, made by zero-beating the crystal frequency against a known frequency, are particularly suited to certain production-line stages. For example, when plating or etching a crystal to frequency, an audio check is usually the simplest procedure to ensure that the crystal does not overshoot its mark. In laboratory

tests, the radio receiver speaker has many uses, such as providing the aural check when zero-beating the secondary frequency standard against WWV signals.

Auxiliary Amplifiers and Frequency Converters

RADIO RECEIVER

2-110. A cw-mcw receiver is required for the reception of WWV signals and for use as a band-pass amplifier, mixer, detector, and audio amplifier of the various signals used in the measurement of crystal frequencies. Other than its use as an r-f amplifier of the antenna signals received from WWV, the receiver serves chiefly as a mixer-amplifier of the standard frequency and the unknown frequency, and as the detector and amplifier of the resulting audio beat frequency. The r-f tuned circuits, of course, also perform the function of filters in rejecting the amplification of all but the desired band of input frequencies. For fast, approximate checks of frequency adjustments, such as when initially tuning a test set to a given nominal frequency, the receiver can be tuned to the desired frequency, the bfo turned on, the output indicated by an audio or visual indicator, and the oscillating circuit adjusted to a zero beat. For low-frequency measurements, Radio Receiver BC-342() or BC-348() or an equivalent is satisfactory. For higher frequencies, a receiver such as the Hammarlund Model SP-600, with a range from 0.55 to 54 mc, is adequate.

HARMONIC GENERATORS

2-111. Other than a precision secondary frequency standard, a crystal-test laboratory generally has the need for a number of auxiliary frequency generators and harmonic multipliers. For some purposes, these generators, although requiring crystal control, need have only a medium degree of stability—a few parts in 10^6 being sufficient. For example, in correlating a reference load capacitor with the precision standard capacitor, a 400-kc crystal-controlled generator of medium stability is desirable for use with the Q meter. Such a generator could be a Signal Generator TS-497/URR, or its equivalent. Generally, for multi-purpose work, a frequency generator is preferred that can be switched from medium-precision internal control to high-precision external control when harmonics of the precision standard are required. When a harmonic generator is controlled by the principal frequency standard, the output of the harmonic generator in effect becomes the frequency standard with which the measurements of the unknown frequency are to be made. Although it would be desirable to have

selector circuits so that all harmonics are rejected except the particular one selected, such a degree of perfection is not economically practical except where the utmost precision is to be combined with maximum speed of measurement. Nevertheless, harmonic generators of this nature are commercially available. (See the discussion of the Plessey Frequency Synthesizer in Section I.) The harmonic generators most generally found in crystal-test laboratories do not provide sine-wave outputs, but outputs rich in all harmonics simultaneously. Where subharmonics, and harmonics of the subharmonics, of the precision standard are required, the harmonic generator must be designed for frequency division of the controlling standard—that, or else a separate frequency divider must be provided for installation between the standard and the harmonic generator. When the fundamental of the harmonic-generator output is the fundamental of the frequency standard, the generator design need consist of no more than conventional untuned class C amplifiers or multipliers. When the fundamental of the harmonic-generator output is to be a higher multiple of the standard fundamental, tuned amplifier-multiplier stages must precede the final harmonic-generator output amplifier. If the tuned-multiplier circuit is not an inherent part of the harmonic-generator unit design, the circuit must be supplied separately.

2-112. For the calibration of the audio-frequency interpolation oscillator, a 1-kc harmonic generator is desirable but not necessary. A 10-kc harmonic generator can be used for calibrating the a-f oscillator just as easily, and at the same time provide a standard harmonic sequence for measuring low and very low frequencies. For this latter purpose, as an aid in identifying the exact multiple of 10 kc by which a given beat frequency is obtained, it is helpful, but not mandatory, that the same unit be capable of generating harmonics of 9 kc and 11 kc. A harmonic generator providing 9-10-11-kc outputs is the CV-118, developed by the Washington Institute of Technology.

2-113. The principal function of a 10-kc harmonic generator as a frequency standard is to ensure that, on mixing its output with the unknown signal, one of the resulting difference frequencies will be not greater than 5000 cps, and hence can be measured to an accuracy of a cycle per second or better with the aid of an interpolation oscillator and an oscilloscope, and to a somewhat lesser accuracy with a frequency-deviation meter and/or a recorder.

2-114. When frequencies are to be measured that

are higher than the useful harmonic range of the 10-kc generator, they can be reduced to the 10-kc-harmonic range by frequency division, or by heterodyning with a higher-frequency standard to obtain a low difference frequency, which, in turn, can be mixed with the 10-kc harmonics to obtain a difference frequency in the a-f range. The latter method of mixing the unknown frequency first with a high-frequency standard and then with a 10-kc harmonic does not necessarily require two separate mixing stages. The 10-kc harmonics and the higher-frequency harmonics can be mixed simultaneously with the unknown. A receiver is used to detect the audio beat note. It is only necessary that the mixing circuit precede the superheterodyne mixing stage of the receiver; otherwise the beat note will follow all variations of the receiver local oscillator. For example, the standard frequencies should not be used to replace the b-f-o frequency of the receiver, unless the receiver happens to be a tuned r-f type.

2-115. Now, if a given harmonic of 10 kc permits an audio beat frequency of f_1 , an adjacent harmonic will provide another audio beat note equal to 10 kc minus f_1 . The beat note of interest is the one less than 5 kc. To restrict all higher beat frequencies, the receiver should be provided with a low-pass audio filter in the output with a sharp cutoff at 5 kc. In the event that the two lowest beat frequencies are both approximately equal to 5 kc, the 9-kc or 11-kc harmonics should replace the 10-kc standard.

2-116. The principal frequency standard probably will have a fundamental of 50, 100, or 200 kc, with the 100-kc fundamental being the most common. Harmonics of the low-frequency standard can be mixed with the 10-kc harmonics for measurements in the medium-frequency range and in the high-frequency range up to 10 mc, if desired. Generally h-f harmonics will be present in the principal frequency-standard output in sufficient strength that an external multivibrator or other type of harmonic generator, other than the 10-kc unit, is not required. However, if an external harmonic generator is necessary, it may well be that greater equipment efficiency can be attained if a generator fundamental higher than that of the principal frequency standard is employed.

2-117. If a multivibrator is used to generate the 10-kc signal, its useful harmonic range will normally extend as far as the 100th harmonic. Beyond this, unless frequency division of the unknown frequencies is to be used, a 1-mc harmonic generator can be used. The useful harmonic (not frequency) range of the 1-mc generator is gener-

Section II Military Specifications

ally much less than an equivalent 10-kc generator, since the higher harmonics are in the v-h-f spectrum and hence are more rapidly attenuated by distributed circuit losses. Thus, for the measurement of vhf's, if frequency division is not employed, a harmonic generator of 10, 15, 20, or 25 mc should also be available. A representative 1-mc harmonic generator is the JAN type CV-119, or its commercial equivalent, Frequency Generator RA-35134, developed by the Washington Institute of Technology. A representative generator of high frequencies is the 15-20-25-mc frequency generator, JAN type CV-122, manufactured by the Reeves-Hoffman Co.

FREQUENCY DIVIDER

2-118. Where the frequency to be measured is higher than the range of the receiver, one of two means can be employed to lower the frequency of the unknown signal. The first is to heterodyne the unknown frequency with a known standard so that a difference frequency in the radio range of the receiver is produced. The difference frequency can then be measured by conventional methods. The original unknown frequency can thus be computed from the measured difference frequency and the heterodyne standard. The second method is to divide the unknown frequency by a known amount, and then to measure the quotient frequency. Frequency dividers designed as separate units specifically for reducing unknown frequencies to more easily handled lower frequencies do not appear to be readily obtainable at the present time, at least, their availability is not widely advertised. However, there are available counter units, principally of the decade type, which can be used in frequency-measuring systems as frequency dividers. But such dividers are not available in the v-h-f range where they would be of most use. Free-running multivibrators which can be adjusted for synchronization at a subharmonic of the unknown frequency are probably the most effective method of frequency division of very high frequencies. A lock indicator meter should be provided which will show a sharp peak when an appropriate stage is tuned to synchronization with the control frequency. Although measurements of considerable accuracy can be made using frequency division, greater accuracy in the v-h-f range is generally possible if the conversion to a lower frequency is accomplished by the heterodyne method.

VARIABLE-RADIO-FREQUENCY OSCILLATOR

2-119. An r-f oscillator continuously variable over the expected crystal-test range is always useful if

rapid frequency checks are to be made and the accuracy does not have to be of the utmost precision. A vfo is particularly applicable when testing unfinished crystals along a production line. The frequency of the crystal unit under test is mixed directly with the v-f-o output, and one or the other is adjusted until a zero beat is obtained. Some method must be employed to check the accuracy of the known v-f-o frequency against a standard. This can be done periodically by crystal calibration, or continually by employing a crystal-timed counter. The vfo can be any standard signal generator of suitable range, such as Signal Generator TS-497/URR, for example.

R-F AMPLIFIER

2-120. R-f amplifiers are required as separate units wherever the r-f output from one equipment is not sufficient to provide the input level required by succeeding equipment. Such amplifiers are most likely to be required for boosting the inputs to counters, frequency meters, harmonic generators, frequency dividers, and the like, particularly where relatively long cable distances are involved and the frequencies are high.

D-C AMPLIFIER

2-121. A d-c amplifier will be required if the d-c input necessary to properly activate a recorder is greater than that supplied by the respective sensing circuit. Where a d-c amplifier is most likely to be needed is to boost the input to the effective-resistance recorder, which, if not of microampere sensitivity, cannot provide a full-scale recording if activated directly by the grid current of a reference test set.

SIGNAL CONTROL PANEL

2-122. A central switching panel should be available for facilitating the control of all the r-f equipment used in the crystal testing system. Controls should be provided to permit any desired heterodyning and routing of the outputs of the various frequency sources to be used in the tests. Attenuators and a mixer circuit are normally incorporated in the panel design. Such is the design of the CV-120 mixing and switching panel. Switches are provided for selecting the appropriate CI meter, for selecting the signal from the appropriate frequency generator, for selecting attenuators for each signal, and for directing the output of the mixer to the receiver. Great care must be taken in the design of the control panel and the entire r-f signal system to provide adequate shielding of all circuits, and adequate r-f filtering of all power leads. If this is not done, stray frequencies will find their way into the

radio receiver to confuse the measurements. It is also important that the signal levels be of relatively low amplitude. The control panel should be provided with suitable attenuators and amplitude controls.

Auxiliary Test-Control Devices and Test-Plant Fixtures

2-123. In the list given in paragraph 2-67 for equipments used in measuring frequencies, these items classified as *Auxiliary Devices for Controlling Crystal Unit Test Conditions* and as *Test-Plant Fixtures*, if not self-explanatory, are described functionally in the discussions of related test procedures and equipments: and so, will not be discussed additionally at this point.

FREQUENCY-MEASURING SYSTEMS FOR TESTING CRYSTAL UNITS

2-124. Figures 2-88 to 2-94 illustrate by block diagrams a number of frequency-measuring systems commonly used in laboratories and manufacturing plants. For the reader who has followed the foregoing discussion of the equipments used, the illustrations should require only brief explanations.

Heterodyne-Frequency-Meter System

2-125. Figure 2-88 shows the system for measuring crystal frequencies with a heterodyne type of radio-frequency meter and earphones (or speaker). In the decade preceding World War II this method was by far the most commonly used for making relatively precise frequency measurements. The test frequency and the output of the r-f vfo are heterodyned in the r-f mixer. The coupling to the mixer from both frequency sources must be extremely loose so that the act of mixing the frequencies does not significantly affect the tuning of the respective circuits. The precision tuning dial of the vfo is adjusted until an audio beat note is detected and heard in the earphones. The vfo is further adjusted until a zero beat results. The adjustment region of the tuning dial in which no signal can be heard is approximately 40 cps wide, 20 cycles on each side of the true zero beat at the center. The true zero beat, which occurs when the v-f-o frequency exactly equals the unknown frequency, must be interpolated as the halfway point between those dial settings at which the operator can just hear an audible note, which occurs at approximately 20 cps for the average person. By this method, an experienced operator can match the two frequencies to within 1 or 2 cps when no other sound but the beat notes can be detected. However, since

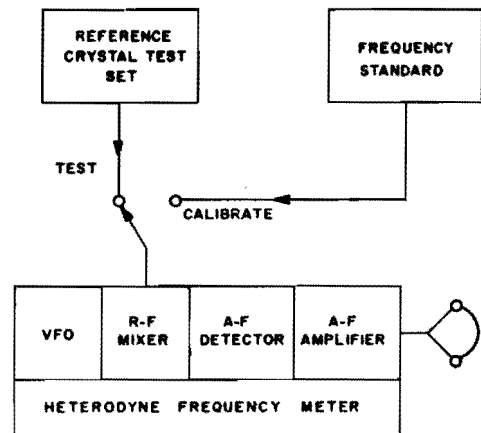

Figure 2-88. System for measuring crystal frequencies aurally with heterodyne frequency meter

there is usually some noise or hum in a heterodyne frequency meter which will wax and wane with a slow beat note, it is often possible to detect directly beat frequencies of less than 1 cycle per second. This is more likely to be possible when detecting a beat note between two audio signals than between two radio signals, since the audio circuits of a radio-frequency vfo are less likely to respond to the extremely low modulation frequencies than are the circuits of an audio-range interpolation oscillator.

2-126. With the use of a tuning fork, resonant, for example, at 256 cps, the vfo can be adjusted to produce 256-cps audio outputs on each side of the null region. That the heterodyne meter is producing exactly 256 cps can be detected by the zero beat between the tuning-fork vibrations and the audio note from the earphones. The use of the tuning fork permits a more precise determination of equal audio frequencies on each side of the r-f-circuit zero beat, the dial point of which will be the exact center between the two 256 cps beat-note settings. The frequency of the vfo at the zero-beat dial setting is to be interpolated from previous calibrations of the vfo.

2-127. The nearest crystal-standard check point on each side of the measured dial setting should be rechecked against the appropriate harmonic from the frequency standard, either immediately before or immediately after the measurement of the unknown frequency is made. The radio frequency corresponding to the measured dial setting is then interpolated between the two adjacent check points by assuming that the differences in frequency are in the same ratio as the differences

Section II
Military Specifications

between the respective dial settings. For example, if the measured dial setting is exactly one-half the distance between the dial settings corresponding to two known harmonics of the standard, then the measured frequency lies halfway between the two harmonics.

2-128. In calibrating the frequency meter against the standard, the output from the standard is coupled to the r-f mixer, the vfo is adjusted for a zero beat, and the dial setting at the center of the null region is determined in exactly the same way as when measuring an unknown frequency. The fact that the frequency in this case is known to equal a standard harmonic permits the measured dial setting to be calibrated as the dial point corresponding to the given frequency. In using the frequency standard in calibrating the heterodyne meter, or in any other frequency-measuring use, care should always be taken that the standard is given sufficient time to reach its equilibrium operating temperature. At least one hour, and preferably two hours, depending upon the precision required, should be allowed for the unit to warm up after a period of inoperation. If frequently used, the standard should be energized continuously throughout its lifetime. The frequency standard used with the heterodyne frequency meter need not be of top precision. A stability of 1 part in 10^7 is sufficient, since greater accuracy than this generally cannot be achieved in correlating and interpolating the radio-frequency dial settings.

Frequency-Reading Counter System

2-129. The system shown in figure 2-89 employing a direct-reading frequency counter is largely self-explanatory. The frequency standard is employed to time the counting intervals. The r-f amplifier may be required, since the input voltage to the counter usually must be on the order of 1 or more volts rms—a voltage level requiring a closer coupling to the CI meter circuit than should be permitted. The accuracy of the counter readings can be no greater than the number of significant digits shown on the counter scale makes possible. If six digits are shown, the maximum theoretical accuracy of 1 part in the 6-digit integer indicated can be assumed if the possible error introduced by the timing frequency standard is very small by comparison and the counting circuit can be depended upon not to skip a count. If the error introduced by the frequency standard is on the same order as the limitations of the counting circuit, the total tolerance for error must be the sum of the tolerances of the two error sources. The use of an r-f amplifier reduces the possibility of

a random counting error, particularly if the amplifier is equipped with an a-g-c circuit to maintain the output amplitude constant against variations in the input amplitude.

VFO-Counter System

2-130. The measuring system shown in figure 2-90 employing a vfo and a counter is particularly useful for individual room-temperature tests of crystal units on a production line. The measuring method is fundamentally similar to the heterodyne-frequency-meter method illustrated in figure 2-88. The principal difference is that the frequency of the vfo is not interpolated from a calibrated crystal-checked scale, but is read directly on the

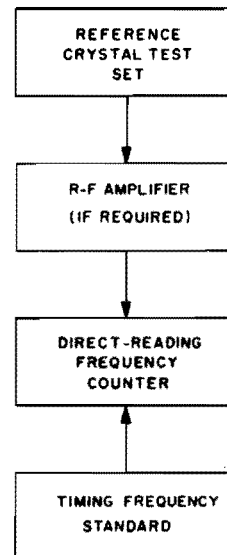

Figure 2-89. System for measuring crystal frequencies visually with a direct-reading electronic counter

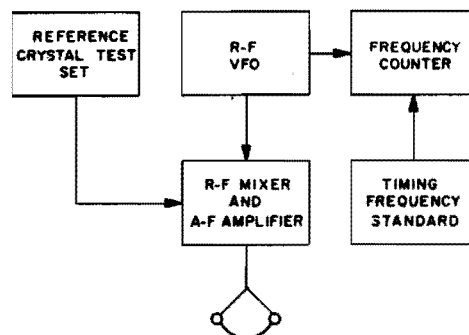

Figure 2-90. System for measuring crystal frequencies aurally with a variable frequency oscillator that is visually monitored by a direct-reading electronic counter

frequency-counter indicator. The system is especially useful when bringing a crystal plate by one process or another to a desired frequency. The vfo is set at the desired frequency and the crystal fabrication process is continued until the crystal can produce a zero beat in the phones or a speaker. When testing odd assortments of crystals which require that the v-f-o frequency be changed and checked often, the use of the frequency counter is a great time-saver over the crystal check-point method. Since a counter reading of the v-f-o frequency can be obtained almost instantly, the same counter can be shared by a large number of crystal testers simultaneously if placed in a position within view of all, and if the proper switching facilities are provided. If necessary, an r-f amplifier can be installed to boost the input to the counter.

Double-Heterodyne System for Precision V-H-F Measurements

2-131. Figure 2-91 illustrates a typical system for obtaining relatively precise measurements in the h-f and v-h-f ranges. Two stages of heterodyning are employed. The first stage converts the unknown crystal frequency into another unknown frequency within the tuning range of the receiver. This second unknown signal, which in the figure is assumed to lie between 5 and 15 mc, is mixed in the second stage with the nearest harmonic combination of 100 kc and 10 kc to produce an unknown difference frequency in the audio range

lying between 0 and 5000 cps. The audio frequency is detected by the receiver (operated mcw) and fed to the vertical plates of an oscilloscope. To the horizontal plates of the oscilloscope is fed the audio output of the interpolation oscillator, whose frequency is adjusted until a reasonably stationary ellipse is obtained on the scope. At this point it can be assumed that the frequency of the interpolation oscillator is equal to the frequency of the receiver output. As the name implies, the interpolation oscillator frequency is determined by interpolation between adjacent calibrated check points. Adjustment of the interpolation oscillator to match the receiver output with the aid of an oscilloscope permits a more accurate measurement than if the measurement is performed aurally with the aid of a loudspeaker or earphones.

2-132. If the unknown frequency in each of the two stages of heterodyning is greater than the respective standard with which it is mixed, the original unknown can be computed as the sum of the mixing standards and the interpolation-oscillator frequency. In general, the unknown input frequency of either stage will be equal to the respective harmonic standard with which it is mixed plus or minus the resulting difference frequency. The initial frequency is computed by starting with the final heterodyne stage in which the difference frequency is directly measured. Because this directly measured frequency is in the low

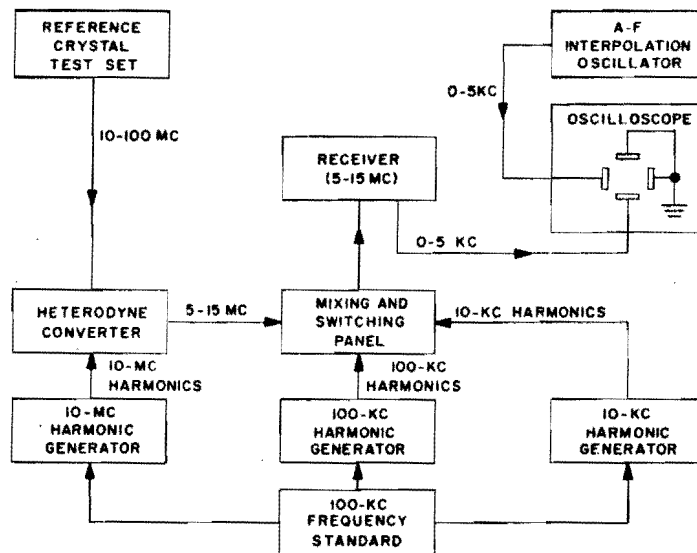

Figure 2-91. System, employing a heterodyne converter, for measuring h-f and v-h-f crystal frequencies visually with an oscilloscope and a-f interpolation oscillator

Section II
Military Specifications

audio range, it represents a very small percentage of the whole, so that the errors made in interpolating its value can usually be considered negligible in estimating the total frequency. The tolerances to be allowed in the measured value of the crystal frequency are essentially the same as those of the 100-kc frequency standard.

Government Inspection System for Room-Temperature Crystal Tests

2-133. Figure 2-92 shows by block diagram a general system for testing crystal frequencies as recommended for U. S. Government inspection tests. The system is essentially the same as that described in the foregoing paragraph and illustrated in figure 2-91. In place of the first heterodyne stage of figure 2-91, figure 2-92 shows a frequency divider. In an actual inspection test, if the frequency under test must be reduced, either a divider or a heterodyne converter can be used, according to the facilities available. The loud-speaker in figure 2-92 is used as an aid in identifying the particular harmonic being mixed with the frequency under test and in correlating the secondary frequency standard against WWV. If the tuning of the crystal test set is adjusted slightly so that the crystal frequency increases, the rise or fall in the pitch of the speaker signal will indicate whether the test frequency is, respectively,

higher or lower than the mixing harmonic. If multivibrator dividers are used, each stage should be tuned separately to lock with the control frequency, as indicated by a sharp peak on the lock indicating meter.

Government Inspection System for Temperature-Run Crystal Tests

2-134. Figure 2-93 shows a generalized block diagram of the system recommended for U. S. Government inspection tests of crystal units when the operating temperature is made to vary over its specified range. Insofar as the instantaneous measurements of the crystal frequency is concerned, using the oscilloscope and interpolation oscillator, the system is exactly the same as that described in the previous paragraph for room-temperature measurements. The additional features are the two recording circuits—one for recording the frequency deviation vs the temperature, the other for recording the effective-resistance deviation vs the temperature. The same audio output from the receiver that can be applied to the oscilloscope is applied to the input of the direct-reading low-frequency meter. The meter converts the audio input into a direct current proportional to the frequency. The d-c control signal, in turn, operates the frequency-deviation indicator of the meter and the stylus of the graphical

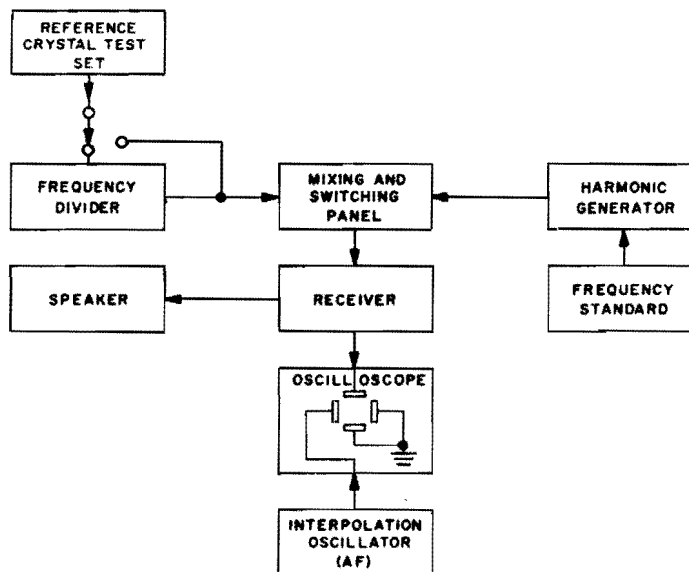

Figure 2-92. System recommended for Government inspection measurements of crystal frequencies at room temperature. The measurements are made visually with the oscilloscope and interpolation oscillator. The speaker is used principally as an aid in determining whether the crystal frequency under test is greater or less than the standard harmonic

recorder. The variations in the control current are thus indicated as deviations in the frequency as the test proceeds through the full temperature run. Similarly, the d-c grid current of the crystal test set is used as a control current to indicate fluctuations in the effective resistance of the test crystal unit. This current directly, or through a d-c amplifier, controls the stylus of the effective-resistance graphical recorder. During the tests, the rate of change in temperature must be under control so that its value at any point in a recording can be interpolated accurately.

Frequency Measuring System at WADC

2-135. Figure 2-94 shows by block diagram the specific system of equipment used at Wright Air Development Center for testing preproduction crystal units. The fundamental system is the same as that shown in figure 2-93. The equipments used are among those mentioned as representative units in the equipment descriptions of paragraphs 2-67 through 2-123.

PROCEDURE FOR CORRELATING TEST EQUIPMENT WITH STANDARDS

2-136. Before the actual testing of a crystal unit begins, the various reference standards must be correlated with the primary standards, and the indicators and recorders must be correlated with

the reference standards. In the *Inspection Manual for Crystal Units, Quartz*, the Armed Services Electro-Standards Agency, Fort Monmouth, N. J., recommends a general correlation procedure to be followed by crystal-unit manufacturers. The measuring system is presumed to include the types of equipment indicated in figures 2-92 and 2-93.

2-137. To illustrate each step, let us suppose that we are a manufacturer with the same test facilities as those used at WADC, shown in figure 2-94. Further, let it be supposed that it is planned to test a 12-mc CR-18/U crystal unit over its operating temperature range. Also, assume that the test location is within ground-wave range of Station WWV and that all other necessary standards and accessories are available. With these suppositions, we shall briefly outline the steps to take in following the ASES recommended correlation procedures.

Correlation of Load-Capacitance Dial

2-138. The calibration of a load-capacitance dial does not require frequent correlation against a standard precision capacitor, but the check is necessary when a CI meter is first installed and whenever precise values of load capacitance are required.

a. If the CI meter is to be used for a wide variety of measurements, it would be advantageous to

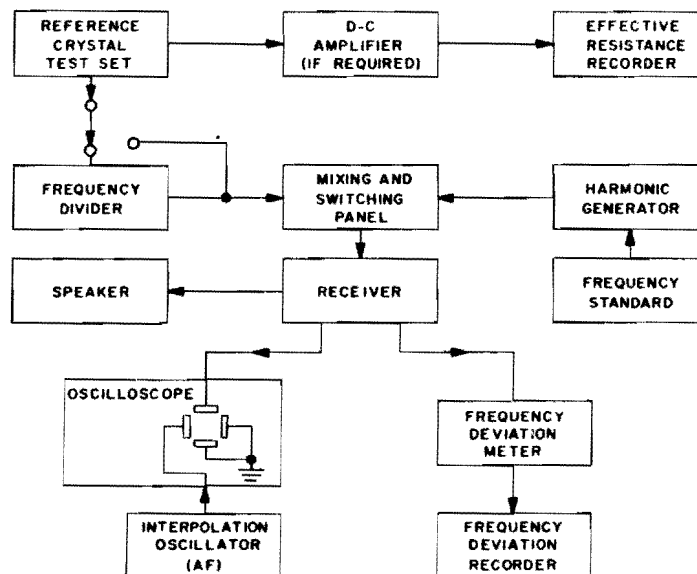

Figure 2-93. System recommended for Government inspection measurements of crystal frequencies over the operating temperature range. The instantaneous frequency-measuring system is the same as that shown in figure 2-80 for room temperature measurements. Added are the frequency-deviation recorder circuit and the effective-resistance recorder circuit

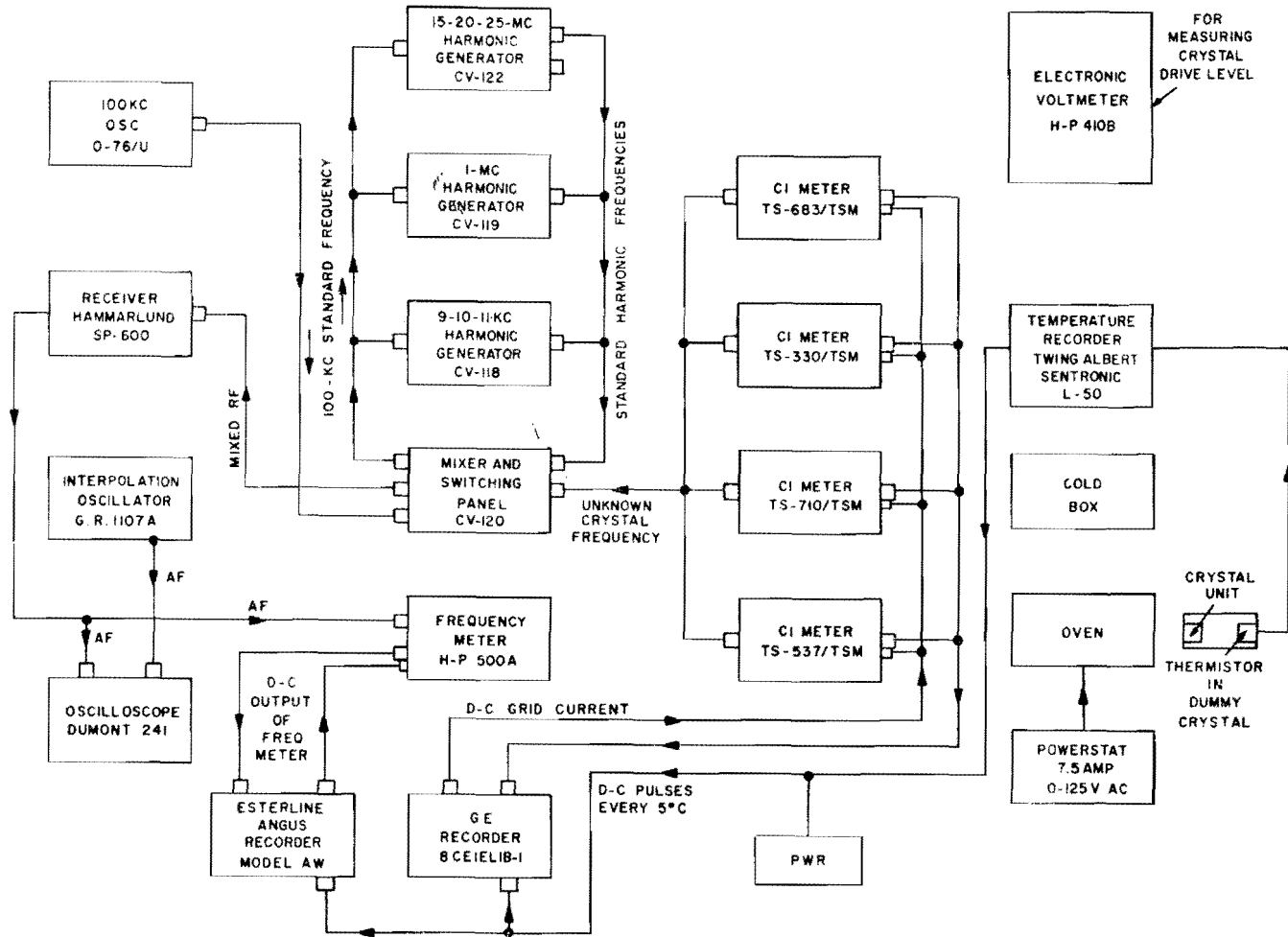

Figure 2-94. System and equipment used at Wright Air Development Center to perform tests on preproduction crystal units

prepare a graphical chart in which the dial settings are plotted against capacitance over the entire adjustable range. If the CI meter is to be used only in measurements of crystal units which, for parallel-mode operation, require no more than one or two standard values of load capacitance, the capacitance dial need be correlated only at the one or two operating positions.

b. For the 12-mc CR-18/U crystal unit we have chosen as an example, the standard reference test set is CI Meter TS-330/TSM. The reference test load capacitance is specified to be $32 \mu\mu\text{f}$. Let it be assumed that the load-capacitance dials of both the primary standard and the reference test sets are to be calibrated at this one position. The procedure to use is the same for each set.

c. Two procedures are possible. If the precision capacitor being used as a primary standard has a value equal to $32 \mu\mu\text{f}$, the correlation can proceed by direct substitution. If the precision capacitor is variable, but all capacitance values are greater than $32 \mu\mu\text{f}$, the correlation depends upon matching the test-set load capacitance with a $32\text{-}\mu\mu\text{f}$ difference between two values of the capacitance standard. The latter method is generally the more accurate, and also faster if a variable capacitor is to be calibrated over its entire range.

d. Direct-Substitution Method. Connect the standard $32\text{-}\mu\mu\text{f}$ capacitor, with leads as short as possible, across the crystal socket in the test set. With the test set tuned to the lowest frequency band and switched to series-resonance operation (internal load capacitor shorted out), turn the set on and, after warm up, check the operating frequency by mixing with crystal-controlled 10-kc harmonics and detecting the audio beat in the receiver speaker. Adjust the tuning capacitor (not the precision capacitor) of the test set until a zero beat is obtained. Remove the precision capacitor and connect a shorting wire across the crystal socket of the test set. Switch the test set to parallel-resonance operation (load capacitor connected into circuit) and adjust the load capacitor until a zero beat is obtained with the same 10-kc harmonic as before. The dial reading of the load capacitor, when adjusted from a clockwise direction, can be recorded as the $32\text{-}\mu\mu\text{f}$ position. Note that once the test-set *tuning* capacitor has been adjusted to a zero beat with the standard capacitor connected in the circuit, its adjustment is not changed while the load capacitor is connected in the circuit. The above test should permit an operating accuracy for the load capacitance within 0.2 or 0.3 $\mu\mu\text{f}$, provided the standard capacitor is, itself, accurate to within 0.1 $\mu\mu\text{f}$. If a more accurate

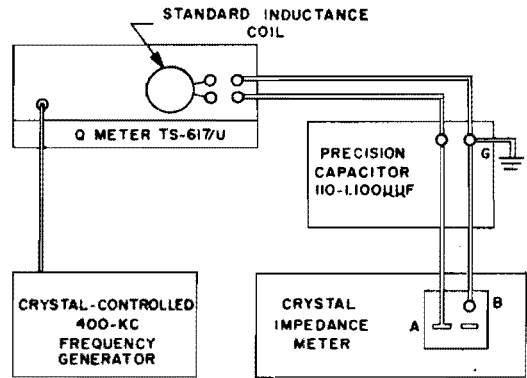

Figure 2-95. Constant parallel-capacitance method for calibration of load capacitance dial

ate measurement is desired, a Q meter should be employed in a manner similar to the test illustrated in figure 2-95, except that in using a $32\text{-}\mu\mu\text{f}$ standard, the capacitors are connected in the Q-meter circuit one at a time, rather than in parallel.

e. Constant Parallel-Capacitance Method. When the lowest value of the precision capacitor is greater than the capacitance to be calibrated, as would be the case if using the G.R. 722-D precision capacitor, a Q meter and a crystal-controlled 400-kc frequency generator can be employed in the manner shown in figure 2-95. Use AWG #12 solid copper wire, supported on 2-inch centers, in connecting the capacitors to the Q meter, keeping leads as short as possible. Lead A connects to the side of the crystal socket making direct electrical contact to one plate of the load capacitor. Lead B connects to the other side of the load capacitor. (Electrical connection to the other plate of the load capacitor can normally be made through one of the rivets that holds the crystal socket in place.) Adjust the precision capacitor to $200 \mu\mu\text{f}$. At the beginning of the test, all leads should be connected except lead A. However, lead A should have the same physical relationship with lead B and with ground as will exist when the load capacitor is connected in the circuit. With the frequency generator driving the circuit, the standard inductance is tuned to resonance with the $200\text{-}\mu\mu\text{f}$ standard capacitance (plus the distributed wiring capacitance), as indicated by the Q meter. With the standard inductance kept constant, the precision capacitance can be reduced $32 \mu\mu\text{f}$ to $168 \mu\mu\text{f}$. Then by connecting lead A, the test-set load capacitor is connected in parallel with the precision capacitor. By adjusting the load-capacitor dial until the Q meter again indicates resonance, it can be assumed that the $32 \mu\mu\text{f}$ subtracted from

Section II
Military Specifications

the circuit has now been restored. Record the load-capacitor dial setting, reached with a clockwise rotation, as the 32- μmf position. The foregoing procedure should permit an operating accuracy of plus or minus 0.1 μmf in the value of the test-set load capacitance.

Correlation of Reference Calibrated Resistors

2-139. The reference calibrated resistors, which are used as substitutes for the effective resistance of crystal units when adjusting the drive level and when measuring crystal resistance, do not require frequent checking, but should be measured with a standard r-f bridge before being used for an extensive series of tests.

a. The measured value of the resistor should equal the calibrated value within plus or minus 1 per cent.

b. In testing the 12-mc CR-18/U taken as an example, a calibrated 25-ohm r-f resistor is required to represent the maximum permissible effective resistance. If a standard CI Meter TS-330/TSM is being used in making the test, a set of calibrated decade resistors with appropriate circuit-control switches is included as a component part of the CI-meter circuit design. When measured with an accurate r-f bridge, such as Navy Type No. 69904, the observed value should lie between 24.75 and 25.25 ohms.

Correlation of Reference Crystal Test Set

2-140. Correlation of a manufacturer's reference test set with the Government standard set is performed by, or under the surveillance of, a Government inspector.

a. At least three crystal units of the type to be tested are selected.

b. The frequency and effective resistance of each crystal unit are measured and recorded under standard test conditions when the crystal unit is connected in the primary test set standard. The same measurements are repeated and recorded with the crystal unit connected in the reference test set.

c. The frequency correlation is satisfactory if the frequency of each crystal unit, as measured in the standard test set, does not differ from the frequency of the same crystal unit, as measured in the reference set, by more than plus or minus 10 per cent of the nominal frequency tolerance. (For the 12-mc CR-18/U, the specified nominal frequency tolerance is plus or minus 0.005 per cent of 12 mc, which is equal to plus or minus 600 cps. 10 per cent of 600 cps requires that the frequency of each 12-mc CR-18/U unit, as measured

with the reference test set, must not differ by more than plus or minus 60 cps from the frequency of the same unit when measured with the primary standard test set.)

d. The effective-resistance correlation is satisfactory if the effective resistance of each crystal unit, as measured in the standard test set, does not differ from the effective resistance of the same crystal unit, as measured in the reference test set, by more than plus or minus 5 per cent of the standard-test-set measured value. (For example, suppose the effective-resistance value of the CR-18/U crystal unit, as measured with the primary standard test set, is 10 ohms. The measurement of the resistance of the same crystal unit in the reference test set must lie between 9.5 and 10.5 ohms, if the correlation is to be assumed satisfactory.)

e. In the event that correlation cannot be achieved, the bureau or service concerned is to be notified.

Correlation of Secondary Frequency Standard

2-141. The secondary standard must be checked against the primary before each series of measurements, and at least three times during any day following a warm-up period.

a. Turn on the standard (O-76/U in our example) and allow to warm up for at least one hour. If the equipment is to be used regularly, the frequency standard should be kept in continuous operation throughout its lifetime.

b. Tune radio receiver to highest usable ground-wave frequency from Station WWV (25, 20, 15, 10, 5, or 2.5 mc), and adjust tuning dial for maximum carrier level.

c. Feed output from standard to receiver antenna input, with receiver adjusted for mcw operation, and audio output applied to speaker.

d. Adjust fine frequency control on standard to center of zero-beat region as heard in speaker during 30-second C-W broadcast intervals of WWV. (If it is possible to detect the zero beat directly by the waxing and waning of interpolation-oscillator noise, the correlation period is not limited to the 30-second C-W intervals. If the noise modulation is not audible and greater accuracy is desired, let interpolation oscillator warm up, then set at a very, very low frequency. Feed output of oscillator to horizontal deflection plates of oscilloscope, and output of receiver to vertical plates. Adjust fine tuning of standard to obtain a stationary elliptical pattern on oscilloscope on both sides of zero beat. Zero beat should coincide with fine tuning point of standard exactly midway between points of stationary patterns.)

Correlation of Interpolation Oscillator

2-142. The interpolation oscillator should be correlated at the beginning of each series of experiments after permitting at least one-half hour warm up.

a. Switch on 10-kc harmonic generator under control of 100-kc standard.

b. Switch receiver to lowest frequency band, new operation.

c. Adjust receiver selectivity to maximum bandwidth reception.

d. Tune receiver to any frequency midway between two adjacent 10-kc harmonics.

e. Feed audio difference frequency, 10 kc, of the two received signals to vertical plates of oscilloscope.

f. After warm up, adjust interpolation-oscillator tuning dial to 5000 cps, and feed output to horizontal deflection plates of oscilloscope.

g. Adjust calibration controls of interpolation oscillator according to instruction manual until a stationary lissajous pattern is obtained on oscilloscope screen. The pattern should indicate two vertical cycles for each horizontal cycle. With the deflection voltages properly phased, this "two-to-one" pattern will resemble a horizontal figure 8.

h. With the position of the calibration control recorded, the interpolation oscillator will be calibrated for 5000 cps.

i. If the interpolation oscillator is tuned to 3333 cps and adjusted for a stationary "three-to-one" pattern, a calibrated check point at this frequency can be recorded. Similarly, stationary patterns in any ratio from 4:1 to 20:1 can provide calibrated check points at the respective frequencies between 2500 cps and 500 cps. At frequencies below 500 cps, the calibration points can be obtained by correlation with the 60-cps line voltage. Federal regulations require that a commercial 60-cps power frequency be accurate within $\pm \frac{1}{2}$ cps. Since the 60-cps reference can be readily obtained by adjustment of the appropriate oscilloscope control, this calibrating method is quite convenient where great accuracy is not essential. Otherwise, the low a-f check points should be obtained by using as standards the 440-cps and 600-cps signals of Station WWV—ground- or sky-wave r-f reception.

j. When using the interpolation oscillator to correlate the frequency-deviation meter, maximum accuracy is ensured if the interpolation oscillator is specifically correlated at the harmonic check point nearest the frequency corresponding to the maximum nominal frequency tolerance of the crystal unit to be tested.

k. In the case of the 12-mc CR-18/U crystal unit, a crystal of exactly the right operating frequency will produce a zero beat when matched against the nearest harmonic of the frequency standard—assuming the test standards as shown in figure 2-82 are available. With a nominal frequency tolerance of plus or minus 600 cps at any temperature in the operating range, a crystal unit at the edge of the tolerance limit will produce a 600-cps receiver output to be fed to the deviation-frequency meter. The two nearest 10-kc check points for the interpolation oscillator are the 16:1 pattern at 625 cps and the 17:1 pattern at 588.2 cps. Each of these points should be calibrated. (Normally, if a precision oscillator, such as the General Radio Interpolation Oscillator, is used, special correlation adjustments for each frequency are not necessary.)

l. An alternative method, ensuring even greater accuracy in this particular example, is to calibrate the 600-cps setting directly against the 600-cps modulation standard of Station WWV.

Correlation of Frequency-Deviation Meter and Recorder

2-143. The frequency-deviation meter and recorder should be correlated at the beginning of each series of tests.

a. Tune interpolation oscillator to the frequency corresponding to the maximum permissible tolerance for the crystal unit being tested. (For the 12-mc CR-18/U, this means tuning the interpolation oscillator to 600 cps. The dial setting can be interpolated between the calibrated points of 588.2 and 625 cps. For this particular frequency, the 10th harmonic of 60 cps, we might be tempted, to check the dial setting against the 60-cps line voltage for a stationary 10:1 pattern. This can readily be done with the normal oscilloscope front-panel controls. But it should be remembered that since the line frequency of 60 cps is not guaranteed beyond $\pm \frac{1}{2}$ cps, a calibration at 600 cps can result in an error of ± 5 cps.)

b. Feed output of interpolation oscillator to input of frequency-deviation meter.

c. With frequency-deviation meter and recorder placed in operation, adjust calibration control of meter until meter indicates same reading as interpolation oscillator. (For the facilities and crystal unit taken as an example, the H-P 500A meter will be switched to the 0-to-1-kc band and the calibration control adjusted so that the meter reads 600 cps.)

d. Adjust sensitivity of frequency-deviation recorder to provide approximately full-scale reading for interpolation oscillator frequency. (For the

Section II Military Specifications

meter d-c output corresponding to a 600-cps input signal, the deflection of the recorder stylus should be adjusted to give a convenient large-amplitude reading calibrated to read 600 cps.)

e. The correlation of the frequency-deviation circuit is completed, so the interpolation-oscillator is disconnected from the frequency meter, and the output circuit of the receiver is connected in its place.

Correlation of Effective-Resistance Recorder

2-144. The stylus of the effective-resistance recorder is to be under the control of the d-c grid current of the reference crystal test set. The grid circuit of the test set must be modified so that the grid current passes through the input circuit of the recorder, or through the input circuit of an intermediary d-c amplifier. The resistance of the input circuit should not increase the total grid-leak resistance by more than 5 per cent. Otherwise, make some compensating change in the original grid resistance. If not already provided by the test set, a grid current meter and a variable resistor in parallel with it should be available to be connected in series with the grid-leak resistance. The variable resistor, normally 0 to 1000 ohms plus or minus 10 per cent, is used to control effectively the sensitivity of the grid meter. Once the grid meter sensitivity has been set, it must not be changed during the remainder of the correlation procedure.

a. If the maximum expected grid current (defined in step i) is insufficient to provide a full-amplitude deflection of the recorder stylus, a d-c amplifier must be inserted to boost the input to the recorder. (To avoid confusion, we shall consider only the recorder input circuit. The correlation procedure is not fundamentally affected if, in practice, a d-c amplifier is employed. The amplifier need only be interpreted as being the input circuit and sensitivity control of the recorder.)

b. If the maximum expected grid current is more than sufficient to provide a full-scale deflection of the recorder arm, the recorder sensitivity control should be adjusted to a lower value. If the sensitivity control is not adjustable to a relatively low level, it can be made so by shunting the recorder input with a suitable variable resistance. Under no circumstances should an attempt be made to match the sensitivity of the recorder by adjustments of the grid current. The grid-leak current is effectively standardized for each value of effective resistance for each Military Standard crystal unit and nominal frequency. This is because a standard reference circuit is employed that is designed with a fixed grid-leak resistance,

and it is operated with a standardized drive adjustment. All of which means that an approximately predetermined grid current will flow for a given frequency and effective resistance. An increase in the grid resistance, for example, would mean, that for the same drive adjustment procedure, the grid bias would be greater, and hence the harmonic distortion in the output would increase, with a consequent increase in the instability. (Where the nomenclature used in the instruction manual and on the front panel of a CI meter designates the sensitivity control of the grid-current meter to be a "grid-current control," the reader should not be misled into thinking that an adjustment of the percentage of grid current flowing through the meter has a significant effect upon the total grid current.)

c. It is to be assumed at this point that the grid circuit is properly connected to the recorder control circuit, that the maximum expected grid current is ample to permit a full scale deflection of the stylus, and that the total grid-leak resistance has not been significantly changed by the insertion of the recorder input resistance.

d. Adjust the reference crystal test circuit that is to be used in testing the crystal unit to the proper drive level, as defined by the applicable Military Standard drive adjustment procedure. (For testing the 12-mc CR-18/U in our example, the reference set will be a CI Meter TS-330/TSM, and the appropriate drive adjustment procedure, defined by *Military Specification MIL-C-3098B*, is described in paragraph 2-60 of this Handbook. In step b of the drive adjustment procedure, the correct decade resistor value is 13 ohms, since the 12-mc CR-18/U is used as a non-temperature controlled unit. In steps c and d of the drive adjustment procedure, the correct test frequency and crystal current, respectively, for the sample CR-18/U are 12 mc and 20 ma.)

e. After the drive adjustment is completed, a calibrated reference resistor is selected whose value is equal to the maximum permissible for the particular crystal unit to be tested. This resistor is to be connected in the test circuit to simulate the resonance impedance of a series-mode crystal unit, or that of a parallel-mode crystal unit in series with its load capacitance. In other words, with the resistor substituted in the circuit in place of the crystal unit, or the crystal-unit-load-capacitor combination, and with the resulting LCR circuit tuned to the nominal operating frequency of the crystal unit, the amplitude of oscillation should approximately equal the amplitude

that would exist if a crystal unit of maximum effective resistance were connected in the circuit. (For example, the maximum permissible resistance of the 12-mc CR-18/U is 25 ohms. The calibrated resistor of this value will be the decade resistance of the TS-330/TSM test circuit. So to perform this step, we need only switch from the 13-ohm resistor used in the drive adjustment to the 25-ohm resistor. The test set remains in the "calibrate" position.)

f. Tune the test set to the nominal frequency of the crystal unit to be tested. (In our particular example, the test set is assumed to have been tuned to the nominal frequency of 12 mc during the drive adjustment procedure. We now make a more exact tuning adjustment by mixing the output of the CI meter with the output of the standard-controlled 1-mc harmonic generator. When the test set is correctly tuned, a zero beat will be obtained in the receiver speaker resulting from the mixture of the 12th harmonic of the generator with the test-set output.)

g. Adjust the grid-current meter sensitivity to give a convenient low-scale reading. Mark the position of the sensitivity control and record the grid current. This represents the minimum permissible grid current for the type of crystal unit and frequency under test, since it corresponds to the maximum permissible effective resistance.

h. Now adjust the recorder and calibrate the graph for a reading of the maximum effective resistance. When correlating the position of the recorder stylus with the effective-resistance scale of the graph, the position of the stylus when the grid current is minimum must be adjusted to give a reading corresponding to the maximum permissible resistance (25 ohms for our sample CR-18/U).

i. The maximum expected grid current can be approximated by replacing the calibrating resistor used in making the maximum-resistance correlation with one having a value representing the minimum expected effective resistance. (In our CR-18/U example, we can assume a minimum effective resistance of 4 ohms.) The resulting grid current we define as the *maximum expected grid current*. This is not the current indicated in the grid-current meter, unless the meter sensitivity is turned to its maximum position; even then the reading is only approximate. There is no need to measure the maximum expected grid current unless the value is required to determine whether the recorder sensitivity will need boosting or attenuating.

j. With the sensitivity control of the grid meter adjusted to its previously marked position, record the current reading. This reading will serve as the meter indication that the maximum expected grid current is flowing. It is valid only for the given adjustment of the meter sensitivity. With the meter indicating the maximum expected grid current, adjust the sensitivity of the stylus deflection for a full amplitude swing. Make this adjustment and calibrate the corresponding reading on the recorder graph, to signify an effective resistance equal to the minimum expected value (4 ohms for our sample CR-18/U).

k. The grid-current meter readings and calibrating adjustments can be recorded and used to speed similar correlation procedures for future crystal tests.

Correlation of Temperature-Measurement Controls (General)

2-145. The details of the procedure for correlating the different reference devices used to control the crystal temperature measurements can be quite varied. In general, four types of measurements or specified test conditions must be correlated with the temperature standards. The crystal unit must start the temperature run at the correct lower temperature limit. Heat must be supplied at a rate sufficient to permit the proper intervals between temperature readings and at a dependable rate so that the length of a temperature run is predictable within plus or minus 5 per cent. The temperature of the crystal unit must be indicated at all times. And finally, the heater must be shut off at the upper temperature limit at the end of the run. The exact methods used to accomplish the above ends vary considerably, depending upon such factors as whether the measurements are for laboratory or production line; whether the measurements are being made for multiple lots or for just one crystal unit at a time; whether a permanent recording of the measurements are being made and, if so, of what type; whether readings are being indicated continuously or only at intervals; whether exact measurements are being made or whether the tests are of the go, no-go type. Even when similar types of tests are being made, the methods vary from laboratory to laboratory and manufacturer to manufacturer, and even from one location to another in the same organization. In spite of the variety encountered in the methods used in measuring and controlling the temperature, the fundamental correlation procedure is applicable generally and should be observed.

Section II
Military Specifications

Correlation of Pyrometer

2-146. The pyrometer is to be correlated at least once each month that it is being used.

a. Correlate at 0°C by immersing sensing element (moisture protected) in ice water, the water having been distilled.

b. Correlate at boiling point of distilled water making allowance for elevation above sea level, or, if available, exact barometric pressure at time of test. Care should be taken that position of pyrometer sensing element is not in temperature gradient near heat source, nor at liquid surface.

c. The temperature measurements are not so critical that both the freezing and boiling temperatures of distilled water need to be correlated, but for accurate measurements both correlations should be made.

d. If a thermocouple sensing element is used, true accuracy requires that the temperature of the constant-temperature junction be maintained at a known value throughout all measurements. In other words, it should be thermostatically controlled. Also, the difference in temperature between the two junctions should be as large as practicable. In practice, the temperature of one junction follows the variations in the temperature of the surrounding air; hence, when the temperature of the sensing junction approaches room values, the corresponding indication of the pyrometer is quite unreliable. However, in a temperature-run test the correlation of the recorders is less dependent upon the absolute indications of the pyrometer in the middle of the run, than upon the more accurate indications at the limits of the range, and upon the constancy at which the rate of temperature change can be maintained.

e. If a thermistor sensing element is used, the temperature correlation can be more dependable, provided the pyrometer voltage source is stable.

Correlation of Cold Box Thermometer

2-147. The cold box thermometer should be correlated with the reference pyrometer once each month.

a. Place dummy crystal unit of pyrometer in cold box in a position simulating that of a normal crystal unit. (In our example, the dummy crystal unit should be contained in an HC-6/U holder, in order to approach as nearly as possible the physical characteristics of the CR-18/U crystal unit.)

b. Adjust temperature of cold box to lower limit of specified temperature range of crystal unit to be tested, measuring the temperature with the pyrometer. (For our test CR-18/U, the lower temperature limit is minus 55° C.)

c. With thermometer inserted in cold box with pyrometer, allow one-half hour for box and temperature instruments to reach thermal equilibrium.

d. Record difference between readings of pyrometer and thermometer, for use in correcting thermometer reading in later measurements of cold box limit temperature.

Correlation of Heater

2-148. Correlate the heater as follows:

a. Cool dummy crystal unit in cold box until it reaches thermal equilibrium at specified low temperature limit for crystal unit to be tested. Temperature is to be read by pyrometer with sensing element attached to crystal plate in dummy unit.

b. Mount dummy crystal unit in heater and begin test temperature run. As read on pyrometer with sensing element attached to quartz plate, carefully measure time required for temperature to reach upper limit. Adjust heater thermostat to cut off power as upper limit is reached (90°C in the case of the CR-18/U example).

c. The heater power is adjusted, if necessary, to ensure that the rate of temperature change meets the specified test conditions. (For the CR-18/U unit in our example, the test conditions specified in Method A must be met. See paragraph 2-36a.)

d. If the periods of three consecutive temperature runs, as specified in steps a and b, meeting the specified test conditions without adjustments of the heater controls, are within plus or minus 10 per cent of each other, the correlation is satisfactory.

Correlation of Recorders with Temperature Range

2-149. The correlation of the recorder with the temperature range will depend upon the facilities available and the degree of accuracy desired.

a. If special facilities are not available, the correlation of the graphical recordings of the frequency and effective resistance with the operating temperature are normally made at only the two temperature limits, which can manually be made to coincide with the starting and stopping of the recorders. If desired, manual calibrations can be obtained at a mid-temperature by observing the pyrometer scale.

b. With special test facilities, such as the modified temperature recorder indicated in figure 2-94, temperature calibrating pulses can be transmitted to the graphical recorders at any desired temperature interval. These pulses are correlated with,

and adjusted for control by, the dummy crystal unit pyrometer circuit. The temperature recorder indicated in figure 2-94 is modified to provide a temperature-indicator pulse to the frequency and resistance recorders at every 5°C change in temperature of the dummy crystal unit.

Correlation of Vibration Machine

2-150. The vibration machine must be correlated for amplitude and frequency at least once each month. With machine in operation, draw lines to indicate amplitude on marking surface held at right angles to direction of vibration. Check amplitude with inch scale at different frequencies to ensure that Military Specifications are met over vibration range. See paragraph 2-48.

MEASURING AND RECORDING FREQUENCY AND EFFECTIVE RESISTANCE

2-151. Assume that the equipment in figure 2-94 is available and that all correlations have been made prerequisite for measuring and recording the frequency and effective resistance of a 12-mc CR-18/U crystal unit over its operating temperature range.

a. Adjust drive of reference crystal test set TS-330/TSM according to correct drive adjustment procedure as specified in paragraph 2-60.

b. Adjust TS-330/TSM for operation of CR-18/U type unit at 12 mc according to instructions in manufacturer's manual, or in USAF Technical Order No. 35TS330-5, or in Signal Corps Technical Manual No. TM 11-5051.

[Briefly, the load capacitance is set at 32 μmf , but is not immediately connected into the circuit. Insert a sample 12-mc CR-18/U crystal unit in the crystal socket. (A sample is inserted since presumably the unit to be tested is being cooled in the cold box.) With the circuit switched for series-mode operation, adjust the tuning capacitor until resonance is indicated by a grid-current peak. We assume that the grid-current meter sensitivity has been adjusted for a suitable reading. Do not change the drive adjustment (the crystal-current control). The Military Standard drive adjustment procedures can be assumed to supersede possible

contrary instructions in operating manuals. Now, switch in the load capacitance, and the circuit is ready for operation.

If desired, since the 12-kc harmonic standard is available to ensure an accurate tuning to the nominal frequency, the circuit could be precisely tuned during the drive adjustment procedure, and the only adjustments necessary would be to disconnect the drive-adjustment resistor from the circuit, switch in the 32-ohm load capacitor, and then insert the crystal unit in its socket when the test is ready to begin.]

c. With sample crystal unit in operation, feed signal from test set through switching panel to receiver input.

d. Feed harmonic output of 1-mc standard-controlled generator to receiver input.

e. Tune receiver, mcw operation, to receive nominal 12-mc signal. Beat note, if fed to speaker, indicates difference between test crystal frequency and 12th harmonic of 1-mc standard-controlled generator.

f. Select range of frequency-deviation meter that corresponds to the maximum permissible frequency deviation for the crystal unit being tested (600 cps in this case, and the proper meter range would be that from 0 to 1000 cps).

g. Feed audio output from receiver to frequency-deviation meter.

h. Feed output of frequency-deviation meter to input of frequency-deviation recorder.

i. Feed grid current from crystal test set to input of effective-resistance recorder.

j. Feed output of temperature recorder to temperature-pulse inputs of frequency-deviation and effective-resistance recorders.

k. From cold box take test crystal unit and dummy crystal unit, both cooled to the low temperature limit and mounted in slug. Insert slug in oven.

l. Insert crystal pins, protruding from oven holder, in crystal socket of test set.

m. Turn on heater power and start temperature run.

SECTION III—CRYSTAL HOLDERS

TABLE OF CONTENTS

<i>Subject</i>	<i>Page</i>
INTRODUCTION	
GROUP I—RECOMMENDED MILITARY STANDARD CRYSTAL HOLDERS.....	569
Technical Data Chart.....	570
Crystal Holder HC-5/U.....	571
Crystal Holder HC-6/U.....	573
Crystal Holder HC-10/U.....	574
Crystal Holder HC-13/U.....	575
Crystal Holder HC-14/U.....	576
Crystal Holder HC-15/U.....	577
Crystal Holder HC-16/U.....	578
Crystal Holder HC-17/U.....	579
Crystal Holder HC-18/U.....	580
Crystal Holder HC-21/U.....	581
Crystal Holder HC- /U.....	582
Crystal Holder HC- /U.....	583
Crystal Holder HC- /U.....	584
Technical Data Chart of Crystal Sockets Suitable for Use With Group-I Crystal Holders.....	586
GROUP II—CRYSTAL HOLDERS CURRENTLY IN MILITARY SERVICE BUT NOT RECOMMENDED FOR USE IN EQUIPMENTS OF NEW DESIGN.....	588
Technical Data Chart.....	588
Crystal Holder Wilcox Type 80D	
Crystal Holder FT-249 (USAF Stock No. 2100-2xH2.1)	
Crystal Holder FT-249 (USAF Stock No. 2100-2xH2.2)	
Crystal Holder FT-249 (USAF Stock No. 2100-2xH2.3)	
Crystal Holder (USAF Stock No. 2100-2xH2.4)	
Crystal Holder Collins Type 1G	
Crystal Holder FT-164 (USAF Stock No. 2100-2xH3.1)	
Crystal Holder FT-164 (USAF Stock No. 2100-2xH3.2)	
Crystal Holder Bendix 3947	
Crystal Holder Bliley MO-2	
Crystal Holder FT-171-B (USAF Stock No. 2xH6.1)	
Crystal Holder FT-171-B (USAF Stock No. 2xH6.2)	
Crystal Holder FT-241-A	
Crystal Holder Collins Type 1C	
Crystal Holder FT-243	
Crystal Holder HC-12/U	

TABLE OF CONTENTS—Continued

<i>Subject</i>	<i>Page</i>
GROUP II (Cont)	588
Technical Data Chart (Cont)	
Crystal Holder CR-1A/AR	
Crystal Holder HC-11/U	
Crystal Holder (USAF Stock No. 2100-2xH15.1)	
Crystal Holder Howard Engineering CM-1	
Crystal Holder WECO Type 5AA	
Crystal Holder Bliley MC-7	
Crystal Holder Aircraft Accessories HN-10	
Crystal Holder Galvin FMT-X5	
Crystal Holder Bliley BC-3	
Crystal Holder Aircraft Accessories 601T	
Crystal Holder RCA AVA-10	
Crystal Holder HFR Type	
Crystal Holder CW Type	
Crystal Holder Bliley LD-2	
Crystal Holder Henry DC34	
Crystal Holder Henry DC35	
Crystal Holder Premier 180GF and 180 GW	
Crystal Holder Bliley C and S	
Crystal Holder Fisher Rad TS25	
Crystal Holder Fisher Rad RS25	
Crystal Holder Aireon AA9E	
Crystal Holder Aircraft Accessories AA9A	
Crystal Holder Aircraft Accessories AA9G	
Crystal Holder Peterson Radio PR	
Crystal Holder RCA AVA-53-A	
Crystal Holder Learadio 3858A	
Crystal Holder WECO DC-20	
Crystal Holder Standard Piezo CS5D	
Crystal Holder Bliley AR8W	
Crystal Holder Howard Type HMC4	
Crystal Holder Collins LD	
Crystal Holder Bliley AR3	
Crystal Holder HC-1/U	
Crystal Holder HC-2/U	
Crystal Holder HC-3/U	
Crystal Holder HC-4/U	
EXPLANATION OF MILITARY STANDARD TERMS USED IN DESCRIPTIONS OF CRYSTAL HOLDERS	595

SECTION III—CRYSTAL HOLDERS

INTRODUCTION

3-1. Section III contains all available descriptions of crystal holders now being used in, or recommended for use in, USAF equipments. The crystal holders described are divided into two groups, as defined in subparagraphs a and b below. Included with the Group-I Crystal Holders and following the technical data chart and description sheets are a table and description sheets giving the types of sockets suitable for use with Group-I Crystal Holders. At the end of Section III is a digest of Military Standard terms, tests, and procedures applicable to crystal holders meeting military specifications.

a. Group I includes those Military Standard crystal holders that are recommended for use in equipments of new design. These are the crystal holders assigned Joint Army-Navy-Air Force type number HC-X/U, where X is either a one-digit

or a two-digit number. Except in the event of unusual or special requirements, the design engineer of crystal-controlled circuits for military equipment should consider only those crystal holders in Group I.

b. Group II includes the older types of crystal holders which are still widely used in current models of USAF radio equipments, but which are not recommended for use in military equipments of new design. These crystal holders are arranged in order of their USAF stock numbers, except for the addition of the prefix "2100-," which serves to identify the item as belonging to the USAF 16-F stock class. The information concerning the Group-II crystal holders is included primarily for the benefit of the crystal specialist or field engineer in the military. As a reference source of crystal holders, it may also prove helpful to design and research engineers.

GROUP I

RECOMMENDED MILITARY STANDARD CRYSTAL HOLDERS

The crystal holders included in Group I are those conforming to Military Specifications and which are recommended for use in armed-services equipments of new design. Also included are descriptions of representative sockets that can be used with the Group-I holders.

Section III
Crystal Holders—Group I

TECHNICAL DATA CHART FOR GROUP-I MILITARY STANDARD CRYSTAL HOLDERS

Type Number	Material	Base or Terminal Connection	Physical Dimensions (In.)			Crystal Units Part of
			High	Wide	Thick	
HC-5/U	plastic holder	3 pins, $\frac{5}{8}$ in. lg, $\frac{5}{32}$ in. dia	$2\frac{21}{32}$	$1\frac{19}{32}$	$1\frac{1}{16}$	CR-15/U, -16/U, -29/U, -30/U
HC-6/U	metallic holder	2 pins, $1\frac{3}{64}$ in. lg, 0.050 in. dia, 0.486 in. c to c	1	$2\frac{3}{32}$	$\frac{5}{16}$	CR-18/U, -19/U, -23/U, -25/U, -26/U, -27/U, -28/U, -32/U, -33/U, -35/U, -36/U, -44/U, -45/U, -46/U, -47/U, -48/U, -49/U, -51/U, -52/U, -53/U, -54/U
HC-10/U	metallic holder	2 sleeves, $\frac{3}{16}$ in. lg, $\frac{1}{16}$ in. dia	$1\frac{1}{16}$	$\frac{9}{16}$	$\frac{9}{16}$	CR-24/U
HC-13/U	metallic holder	2 pins, $1\frac{3}{64}$ in. lg, 0.050 in. dia, 0.486 in. c to c	$1\frac{3}{64}$	$2\frac{3}{32}$	$\frac{5}{16}$	CR-37/U, -38/U, -42/U, -50/U
HC-14/U	metallic holder	2 pins, $1\frac{3}{64}$ in. lg, 0.050 in. dia, 0.486 in. c to c	$1\frac{3}{16}$	$2\frac{3}{32}$	$\frac{5}{16}$	
HC-15/U	electron tube (glass envelope)	std octal	$2\frac{3}{8}$	$1\frac{9}{32}$	$1\frac{1}{32}$	CR-39/U, -40/U
HC-16/U	electron tube (metallic envelope)	std octal	$2\frac{3}{8}$	$1\frac{5}{16}$	$1\frac{3}{16}$	CR-43/U
HC-17/U	metallic holder	2 pins, $7/16$ in. lg, 0.093 in. dia, 0.486 in. c to c	$1\text{-}3/16$	$23/32$	$5/16$	CR-58/U
HC-18/U	metallic holder	2 flexible leads, $1\frac{1}{2}$ in. lg	$33/64^*$	$\frac{3}{8}$	$5/32$	CR-55/U, -56/U, -59/U, -60/U, -61/U
HC-21/U	metallic holder	3 pins, $\frac{5}{8}$ in. lg, 0.156 in. dia	$2\text{-}21/32$	$1\text{-}19/32$	$1\text{-}19/32$	CR-15/U, -16/U, -29/U, -30/U

* Not including flexible leads.

CRYSTAL HOLDER HC-5/U

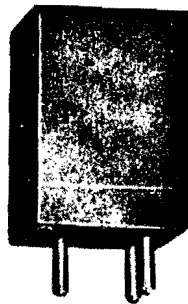
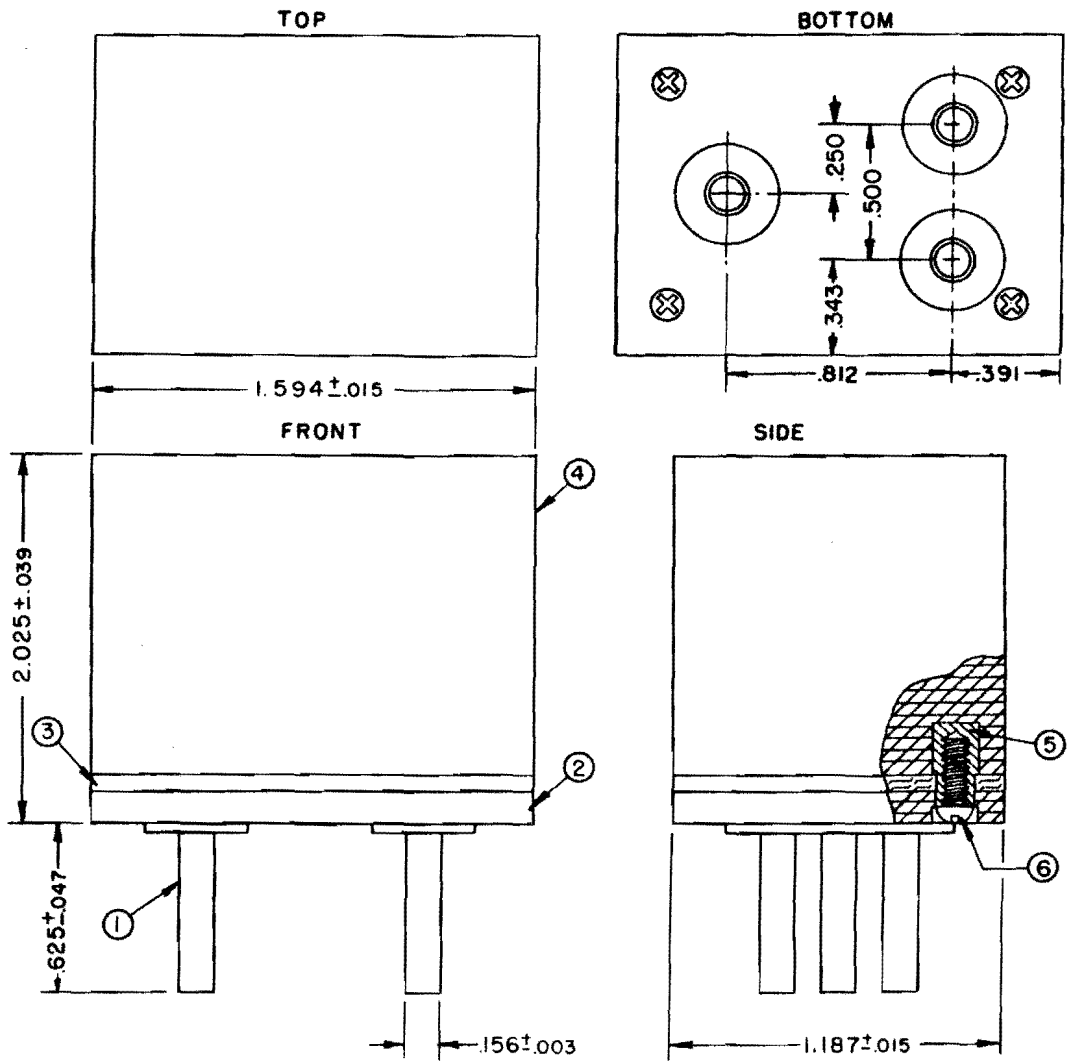

Figure 3-1. Crystal Holder HC-5/U

Section III
Crystal Holders—Group I

FUNCTIONAL DESCRIPTION

A three-pin plastic holder used to mount low-frequency quartz plates. It can be used at temperatures within the range of -40°C to $+75^{\circ}\text{C}$, but since the holder is designed for gasket sealing and has an inferior form factor compared with metal holders, it will operate best in equipments not intended to be subjected to below-freezing or extremely high temperatures, and in areas where the ambient humidity is not at a continuously high level.

EMPLOYMENT OF HOLDER

Crystal Units Employing Holder: CR-15/U, -16/U, -29/U, and -30/U

Sockets Used With Holder: See figure 3-14

MILITARY SPECIFICATIONS

Authority: MIL-H-10056B (16 Jan 53); MIL-H-1056/1 (16 Jan 53)

Dimensions: See figure 3-1. All dimensions in inches. Unless otherwise specified, tolerances are ± 0.005 in. on decimals.

Materials:

<i>Item No. (Fig. 3-1)</i>	<i>Description</i>	<i>Material</i>	<i>Qty</i>
1	Pin	Nickel-silver radio tube pin E.3676, as made by American Brass Co, or equal	3
2	Base	Plastic: Resinox No. 7934, Melmac No. 6105, BM-7156, Durez No. 12708, or equal	1
3	Gasket	Buna S, per Spec MIL-R-3065, 60-75 Shore A Durometer hardness	
4	Cover	Same as for item 2	1
5	Insert	Brass, per Spec QQ-B-611, comp B, $\frac{1}{2}$ hard	4
6	Phillips machine screw No. 2-56 NC-2 x $\frac{1}{2}$ in. lg	Brass	4

Special Requirements: None

LOGISTICAL DATA

USAF Stock No.: 2100-2xH51.1

Status: Standard*

Date of Status:

Commercial Sources: See Appendix III.

Related Specifications, Standards, and Publications: See Appendix IV.

*Note: The proposed revision of Military Specification MIL-H-10056B deletes the plastic holder HC-5/U and substitutes the metal holder HC-21/U.

CRYSTAL HOLDER HC-6/U

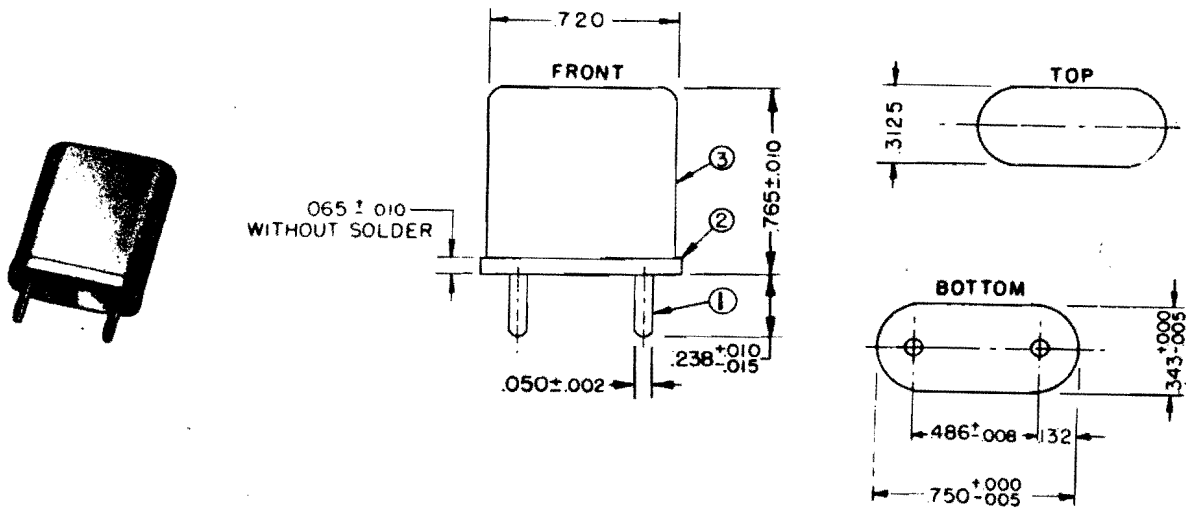

Figure 3-2. Crystal Holder HC-6/U

FUNCTIONAL DESCRIPTION

A lightweight, all-metal unit particularly suitable for use in either mobile or portable equipment and wherever crystal units may be subjected to severe conditions of moisture or mechanical shock. Several types of mounting are possible, but the most satisfactory, generally, is a plated crystal supported by two looped springs. This holder is designed for hermetic sealing and is dependable over a temperature range of -55°C to $+90^{\circ}\text{C}$ and higher.

EMPLOYMENT OF HOLDER

Crystal Units Employing Holder: CR-18/U, -19/U, -23/U, -25/U, -26/U, -27/U, -28/U, -32/U, -33/U, -35/U, -36/U, -44/U, -45/U, -46/U, -47/U, -48/U, -49/U, -51/U, -52/U, -53/U, -54/U, and -57/U

Sockets Used With Holder: See figures 3-15 and 3-16.

MILITARY SPECIFICATIONS

Authority: MIL-H-10056B (16 Jan 53); MIL-H-1056/2 (16 Jan 53)

Dimensions: See figure 3-2. All dimensions in inches. Unless otherwise specified, tolerances are ± 0.005 in. on decimals.

Materials:

Item No. (Fig. 3-2)	Description	Material	Qty
1	Pin	Kovar No. 920050, or equal	2
2	Base	Kovar No. 910010, or equal	1
3	Cover	Nickel silver, per Spec QQ-N-321, type III comp B	1

Special Requirements: (Refer to figure 3-2.)

- Item No. 2 shall be insulated from item No. 1 by glass. Glass shall be Corning Glass Seal No. 705-2, or equal.
- Item No. 2 shall be hot-tin-dipped or electro-tin-plated in accordance with type I finish of Spec 72-53.
- Before forming, item No. 2 shall be 0.010 ± 0.001 inch thick, and item No. 3 shall be 0.010 inch thick.
- Item No. 1 shall project at least 0.040 inch above the inside glass seal.

LOGISTICAL DATA

USAF Stock No.:

Status: Standard

Date of Status:

Commercial Sources: See Appendix III.

Related Specifications, Standards, and Publications: See Appendix IV.

CRYSTAL HOLDER HC-10/U

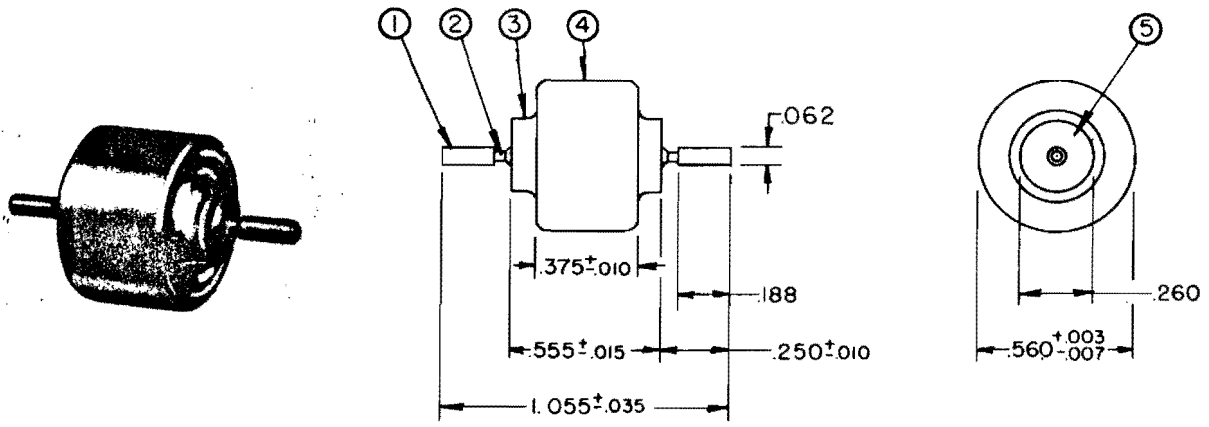

Figure 3-3. Crystal Holder HC-10/U

FUNCTIONAL DESCRIPTION

Compact, miniature, metal holder designed for pressure-mounting thickness-mode circular quartz elements and for hermetic sealing. The coaxial arrangement of the crystal leads introduces a minimum of holder capacitance across the crystal, and hence is particularly suitable for use with v-h-f crystals. Also, the rugged construction and firm support provided the crystal make this holder preferred in mobile or portable equipment that may be subjected to severe conditions of vibrations or shock. The holder is dependable over a temperature range of -55°C to $+90^{\circ}\text{C}$ and higher.

EMPLOYMENT OF HOLDER

Crystal Units Employing Holder: CR-24/U
Sockets Used With Holder: See figure 3-17.

MILITARY SPECIFICATIONS

Authority: MIL-H-10056B (16 Jan 53); MIL-H-1056/3 (16 Jan 53)
Dimensions: See figure 3-3. All dimensions in inches. Unless otherwise specified, tolerances are ± 0.005 in. on decimals.

Materials:

Item No. (Fig. 3-3)	Description	Material	Qty
1	Sleeve	Coil silver	2
2	Pin	Kovar No. 920050, or equal	2
3	End bell	Kovar No. 910010, or equal	2
4	Cover	Nickel silver per Spec QQ-N-321, type III, comp B	1
5	Seal	Corning Glass No. 705-2, or equal	2

Special Requirements: (Refer to figure 3-3.)

- a. Item No. 1 shall be soldered to item No. 2.
- b. Item No. 3 shall be hot-tin-dipped or electro-tin-plated in accordance with type I finish of Spec 72-53.

LOGISTICAL DATA

USAF Stock No.:
Status: Standard
Date of Status:
Commercial Sources: See Appendix III.
Related Specifications, Standards, and Publications: See Appendix IV.

CRYSTAL HOLDER HC-13/U

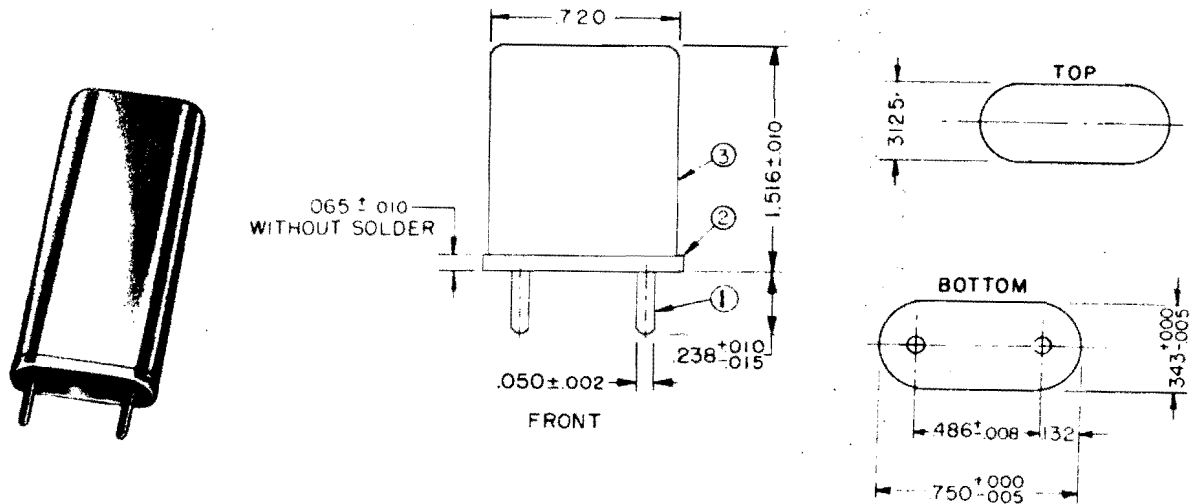

Figure 3-4. Crystal Holder HC-13/U

FUNCTIONAL DESCRIPTION

A lightweight, all-metal unit, similar to Crystal Holder HC-6/U but having a cover of greater length to accommodate a larger quartz plate for lower-frequency use.

EMPLOYMENT OF HOLDER

Crystal Units Employing Holder: CR-37/U, -38/U, -42/U, and -50/U

Sockets Used With Holder: See figures 3-15 and 3-16.

MILITARY SPECIFICATIONS

Authority: MIL-H-10056B (16 Jan 53); MIL-H-1056/4 (16 Jan 53)

Dimensions: See figure 3-4. All dimensions in inches. Unless otherwise specified, tolerances are ± 0.005 in. on decimals.

Materials:

Item No. (Fig. 3-4)	Description	Material	Qty
1	Pin	Kovar No. 920050, or equal	2
2	Base	Kovar No. 910010, or equal	1
3	Cover	Nickel silver, per Spec QQ-N-321, type III, comp B	1

Special Requirements: (Refer to figure 3-4.)

- Item No. 2 shall be insulated from item No. 1 by glass. Glass shall be Corning Glass Seal No. 705-2, or equal.
- Item No. 2 shall be hot-tin-dipped in accordance with type 1 finish of Specification 72-53.
- Before forming, item No. 2 shall be 0.010 ± 0.001 inch thick, and item No. 3 shall be 0.010 inch thick.
- Unless otherwise specified, item No. 1 shall project at least 0.040 inch above the inside glass seal.

LOGISTICAL DATA

USAF Stock No.:

Status:

Date of Status:

Commercial Sources: See Appendix III.

Related Specifications, Standards, and Publications: See Appendix IV.

CRYSTAL HOLDER HC-14/U

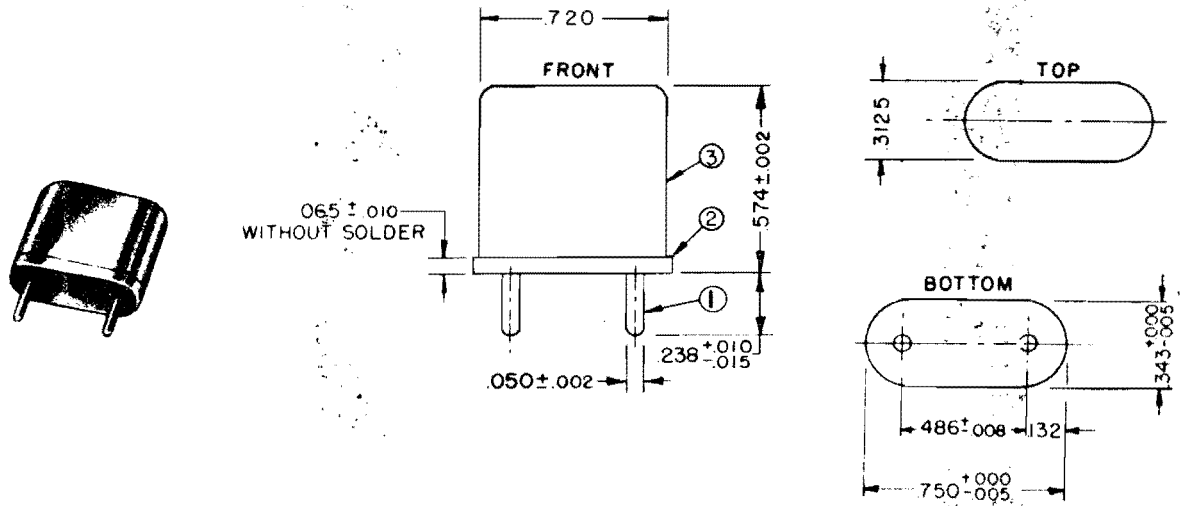

Figure 3-5. Crystal Holder HC-14/U

FUNCTIONAL DESCRIPTION

A miniature, lightweight, all-metal unit. Similar to Crystal Holder HC-6/U but with a shorter cover. It is used to mount quartz plates in the higher-frequency range, where space is at a premium.

EMPLOYMENT OF HOLDER

Crystal Units Employing Holder: CR-7/U

Sockets Used With Holder: See figures 3-15 and 3-16.

MILITARY SPECIFICATIONS

Authority: MIL-H-10056B (16 Jan 53); MIL-H-1056/5 (16 Jan 53)

Dimensions: See figure 3-5. All dimensions in inches. Unless otherwise specified, tolerances are ±0.005 in. on decimals.

Materials:

Item No. (Fig. 3-5)	Description	Material	Qty
1	Pin	Kovar No. 920050, or equal	2
2	Base	Kovar No. 910010, or equal	1
3	Cover	Nickel silver, per Spec QQ-N-321, type III, comp B	

Special Requirements: (Refer to figure 3-5.)

- a. Item No. 2 shall be insulated from item No. 1 by glass. Glass shall be Corning Glass Seal No. 705-2, or equal.
- b. Item No. 2 shall be hot-tin-dipped or electro-tin-plated in accordance with type I finish of Spec 72-53.
- c. Before forming, item No. 2 shall be 0.010 ± 0.001 inch thick, and item No. 3 shall be 0.010 inch thick.
- d. Item No. 1 shall project at least 0.040 inch above the inside glass seal.

LOGISTICAL DATA

USAF Stock No.:

Status:

Date of Status:

Commercial Sources: See Appendix III.

Related Specifications, Standards, and Publications: See Appendix IV.

CRYSTAL HOLDER HC-15/U

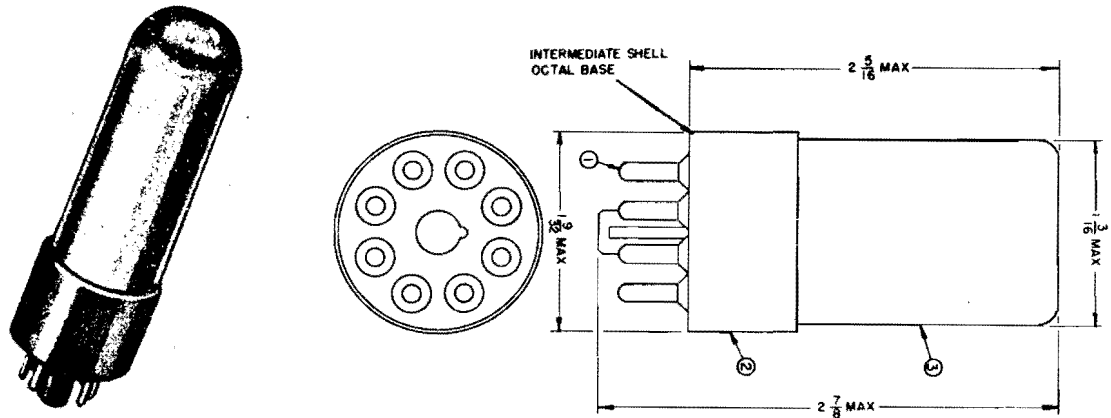

Figure 3-6. Crystal Holder HC-15/U

FUNCTIONAL DESCRIPTION

This glass-envelope crystal holder is similar in size and shape to a 6SC7GT electron tube. It is normally used to mount low-frequency, flexure-mode, quartz plates, where an evacuated container is needed to reduce damping. The holder uses standard vacuum-tube parts and fits in a standard octal socket. The glass envelope is to be preferred to the metal holder when a vacuum seal is required because the elimination of the metal, soldering, etc. minimizes the causes of crystal aging due to gas leakage, electrolysis, and contamination. The holder is dependable within the temperature range of -55°C to $+80^{\circ}\text{C}$.

EMPLOYMENT OF HOLDER

Crystal Units Employing Holder: CR-39/U and -40/U.

Sockets Used With Holder: Standard octal.

MILITARY SPECIFICATIONS

Authority: MIL-II-10056B (16 Jan 53); MIL-H-1056/6 (16 Jan 53)

Dimensions: See figure 3-6. All dimensions in inches. Unless otherwise specified, tolerances are ± 0.005 in. on decimals.

Materials:

<i>Item No. (Fig. 3-6)</i>	<i>Description</i>	<i>Material</i>	<i>Qty</i>
1	Pin	Commercial	8
2	Base	Low-loss phenolic	1
3	T9 envelope	Glass	1

Special Requirements: Except for dimensions, there are none specified.

LOGISTICAL DATA

USAF Stock No.:

Status:

Date of Status:

Commercial Sources: See Appendix III.

Related Specifications, Standards, and Publications: See Appendix IV.

CRYSTAL HOLDER HC-16/U

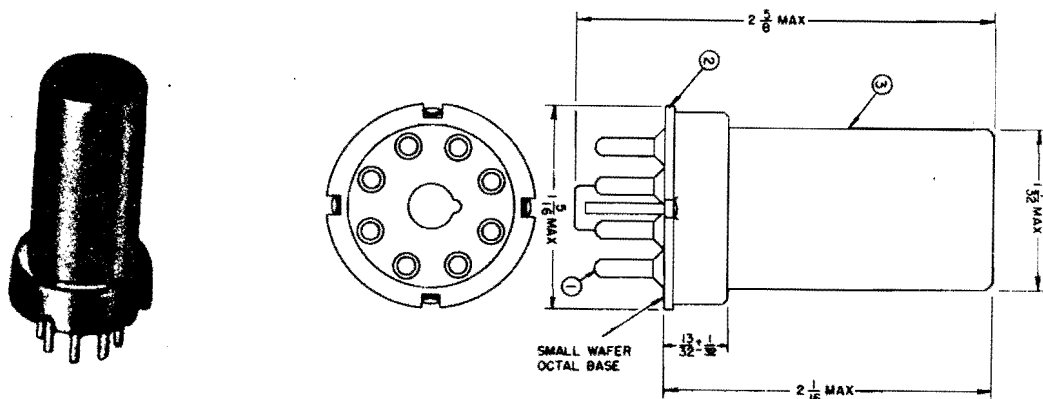

Figure 3-7. Crystal Holder HC-16/U

FUNCTIONAL DESCRIPTION

This crystal holder is similar in size and shape to a metal envelope 6SK7 electron tube. It is a rugged, moisture-proof holder in which quartz plates may either be pressure-, wire-, or fixed-air-gap-mounted. The holder is recommended for calibration, test, and similar purposes. Holder uses standard vacuum-tube parts and fits in a standard octal socket. Although it is used in the 70—100-kc range, the holder is useful for frequencies up to 850 kc. The shortness of the cover relative to the size of crystal blanks of 85 kc and below makes it somewhat difficult to fabricate a dependable crystal unit. The holder can be used at temperatures within the range of -55°C to $+90^{\circ}\text{C}$ and higher.

EMPLOYMENT OF HOLDER

Crystal Units Employing Holder: CR-43/U
Sockets Used With Holder: Standard octal

MILITARY SPECIFICATIONS

Authority: MIL-11-10056B (16 Jan 53); MIL-H-1056/7 (16 Jan 53)

Dimensions: See figure 3-7. All dimensions in inches. Unless otherwise specified, tolerances are ± 0.005 in. on decimals.

Materials:

Item No. (Fig. 3-7)	Description	Material	Qty
1	Pin	Commercial	8
2	Base	Commercial	1
3	MT8 envelope	Commercial	1

Special Requirements: None specified

LOGISTICAL DATA

USAF Stock No.:

Status:

Date of Status:

Commercial Sources: See Appendix III.

Related Specifications, Standards, and Publications: See Appendix IV.

CRYSTAL HOLDER HC-17/U

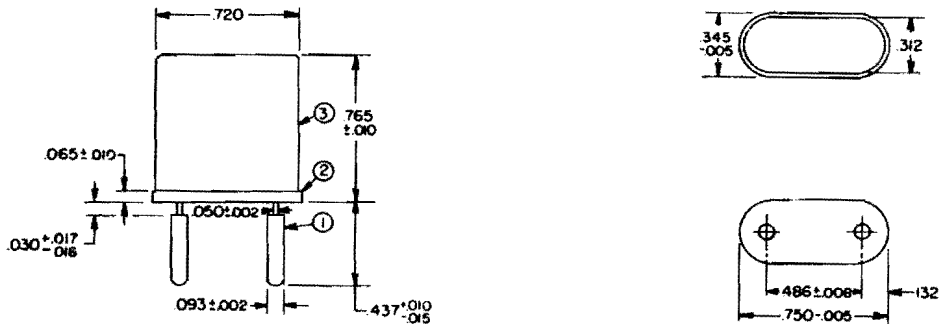

Figure 3-8. Crystal Holder HC-17/U

FUNCTIONAL DESCRIPTION

A lightweight, all-metal unit particularly suitable for use in either mobile or portable equipment and wherever crystal units may be subjected to severe conditions of moisture or mechanical shock. Several types of mounting are possible, but the most satisfactory, generally, is a plated crystal supported by two looped springs. This holder is designed for hermetic sealing and is dependable over a temperature range of -55°C to $+90^{\circ}\text{C}$ and higher. This holder is identical to Holder HC-6/U except for larger dimensions of pins.

EMPLOYMENT OF HOLDER

Crystal Units Employing Holder: CR-58/U

Sockets Used with Holder:

MILITARY SPECIFICATIONS

Authority: MIL-H-10056C (Proposed revision, 4 April 1956)

Dimensions: See figure 3-8. All dimensions in inches. Unless otherwise specified, tolerances are ± 0.005 in. on decimals.

WADC TR 56-156

Materials:

Item No. (Fig. 3-8)	Description	Material	Qty.
1	Pin	50% nickel, 50% iron alloy	2
2	Base	Steel, cold rolled strip condition No. 3, per Specification QQ-S-640	1
3	Cover	Copper, nickel zinc alloy, composition No. 5, annealed soft temper, per Specification QQ-C-585	1

Special Requirements: (Refer to figure 3-8.)

- Item No. 2 shall be insulated from item No. 1 by glass. Glass shall be Corning Glass Seal No. 705-2, or equal.
- Item No. 2 shall be hot-tin-dipped or electro-tin-plated in accordance with type I finish of Specification MIL-F-14072.
- Before forming, item No. 2 shall be 0.010 ± 0.001 inch thick and item No. 3 shall be 0.010 inch thick.
- Item No. 1 shall project at least 0.040 inch above the base.

LOGISTICAL DATA

USAF Stock No.:

Status:

Date of Status:

Commercial Sources: See Appendix III.

Related Specifications, Standards, and Publications: See Appendix IV.

CRYSTAL HOLDER HC-18/U

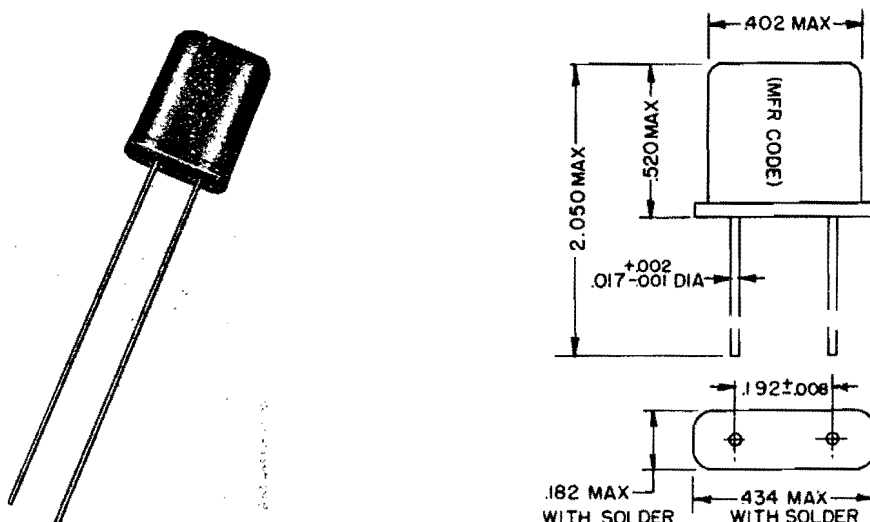

Figure 3-9. Crystal Holder HC-18/U

FUNCTIONAL DESCRIPTION

A lightweight, all-metal holder suitable for use in subminiature circuit applications. Long flexible leads are provided to permit wiring crystal holder directly into the circuit.

EMPLOYMENT OF HOLDER

Crystal Units Employing Holder: CR-55/U, -56/U, -59/U, -60/U, -61/U

Sockets Used with Holder: None

MILITARY SPECIFICATIONS

Authority: MIL-H-10056C (Proposed revision, 4 April 1956)

Dimensions: See figure 3-9. All dimensions are in inches. Unless otherwise specified, tolerances are ± 0.005 in. on decimals.

Materials:

Item No. (Fig. 3-9)	Description	Material	Qty.
1	Pin	Cobalt-nickel-iron alloy (Kovar A)	2
2	Base	Cobalt-nickel-iron alloy (Kovar A)	1
3	Cover	Copper, nickel, zinc alloy, composition No. 5, annealed soft temper, per Specification QQ-C-585	1

Special Requirements: (Refer to figure 3-9.)

- Item No. 2 shall be insulated from item No. 1 by glass. Glass shall be Corning Glass Seal No. 705-2, or equal.
- Item No. 2 shall be hot-tin-dipped or electro-tin-plated in accordance with type I finish of Specification MIL-F-14072.
- Before forming, item No. 2 shall be 0.010 ± 0.001 inch thick and item No. 3 shall be 0.010 ± 0.001 inch thick.
- Item No. 1 shall project at least 0.040 inch above the base.

LOGISTICAL DATA

USAF Stock No.:

Status:

Date of Status:

Commercial Sources: See Appendix III.

Related Specifications, Standards, and Publications: See Appendix IV.

CRYSTAL HOLDER HC-21/U

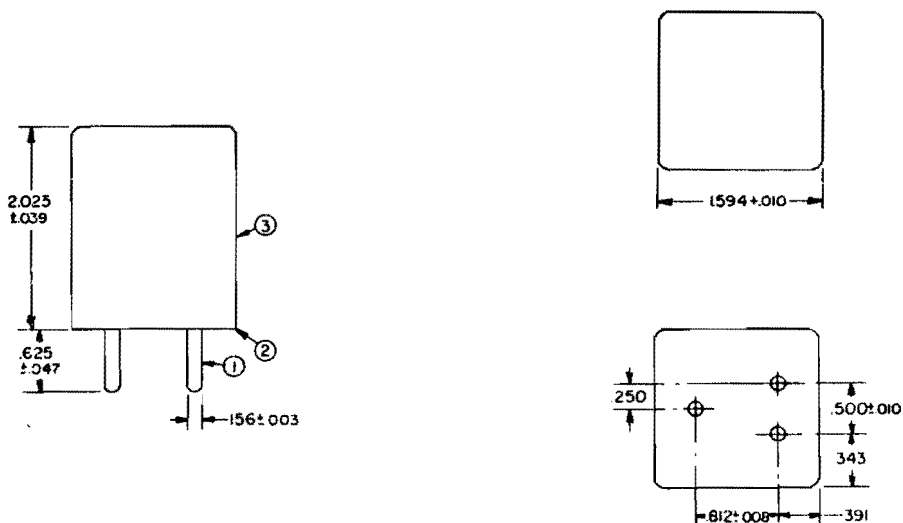

Figure 3-10. Crystal Holder HC-21/U

FUNCTIONAL DESCRIPTION

A three-pin, all-metal holder used to mount low-frequency quartz plates. Dimensions of this holder are identical to those of plastic holder HC-5/U, which it is intended to replace. Holder HC-21/U is designed for hermetic sealing and is dependable over a temperature range of -55°C to $+90^{\circ}\text{C}$ and higher.

EMPLOYMENT OF HOLDER

Crystal Units Employing Holder:

Sockets Used with Holder: See figure 3-14.

MILITARY SPECIFICATIONS

Authority: MIL-H-10056C (Proposed revision, 4 April 1956)

Dimensions: See figure 3-10. All dimensions in inches. Unless otherwise specified, tolerances are ± 0.005 in. on decimals.

Materials:

Item No. (Fig. 3-10)	Description	Material	Qty.
1	Pin	50% nickel, 50% iron	3
2	Base	Cold rolled steel, condition No. 2, dull finish, per Specification QQ-S-636	1
3	Cover	Terneplate type drawing quality, class special coated, grade unassorted, per Specification QQ-T-181	1

Special Requirements: (Refer to figure 3-10.)

- Item No. 2 shall be insulated from item No. 1 by glass. Glass shall be Corning Glass Seal No. 705-2, or equal.
- Item No. 2 shall be hot-tin-dipped or electro-tin-plated in accordance with type I finish of Specification MIL-F-14072.
- Before forming, item No. 2 shall be 0.010 ± 0.001 inch thick and item No. 3 shall be 0.010 ± 0.001 inch thick.
- Item No. 1 shall project at least 0.040 inch above the base.

LOGISTICAL DATA

USAF Stock No.:

Status:

Date of Status:

Commercial Sources: See Appendix III.

Related Specifications, Standards, and Publications: See Appendix IV.

CRYSTAL HOLDER HC- /U
(For addenda)

Figure 3-11. Crystal Holder HC- /U

FUNCTIONAL DESCRIPTION

Materials:

<i>Item No. (Fig. 3-)</i>	<i>Description</i>	<i>Material</i>	<i>Qty</i>

EMPLOYMENT OF HOLDER

Special Requirements:

Crystal Units Employing Holder:

Sockets Used With Holder:

MILITARY SPECIFICATIONS

LOGISTICAL DATA

Authority: MIL-H-10056B (16 Jan 53); MIL-H-1056/

Dimensions: See figure 3-11. All dimensions in inches. Unless otherwise specified, tolerances are ± 0.005 in. on decimals.

USAF Stock No.:

Status:

Date of Status:

Commercial Sources: See Appendix III.

Related Specifications, Standards, and Publications: See Appendix IV.

CRYSTAL HOLDER HC-18/U

(For addenda)

Figure 3-12. Crystal Holder HC- /U

FUNCTIONAL DESCRIPTION

Materials:

<i>Item No. (Fig. 3-)</i>	<i>Description</i>	<i>Material</i>	<i>Qty</i>

EMPLOYMENT OF HOLDER

Special Requirements:

Crystal Units Employing Holder:

Sockets Used With Holder:

MILITARY SPECIFICATIONS

LOGISTICAL DATA

Authority: MIL-H-10056B (16 Jan 53); MIL-H-1056/

USAF Stock No.:

Status:

Date of Status:

Dimensions: See figure 3-12. All dimensions in inches. Unless otherwise specified, tolerances are ± 0.005 in. on decimals.

Commercial Sources: See Appendix III.

Related Specifications, Standards, and Publications: See Appendix IV.

CRYSTAL HOLDER HC- /U
(For addenda)

Figure 3-13. Crystal Holder HC- /U

FUNCTIONAL DESCRIPTION

Materials:

<i>Item No. (Fig. 3-)</i>	<i>Descrip- tion</i>	<i>Material</i>	<i>Qty</i>

EMPLOYMENT OF HOLDER

Special Requirements:

Crystal Units Employing Holder:

Sockets Used With Holder:

MILITARY SPECIFICATIONS

LOGISTICAL DATA

Authority: MIL-H-10056B (16 Jan 53); MIL-H-1056/

Dimensions: See figure 3-13. All dimensions in inches. Unless otherwise specified, tolerances are ± 0.005 in. on decimals.

USAF Stock No.:

Status:

Date of Status:

Commercial Sources: See Appendix III.

Related Specifications, Standards, and Publications: See Appendix IV.

CRYSTAL SOCKETS

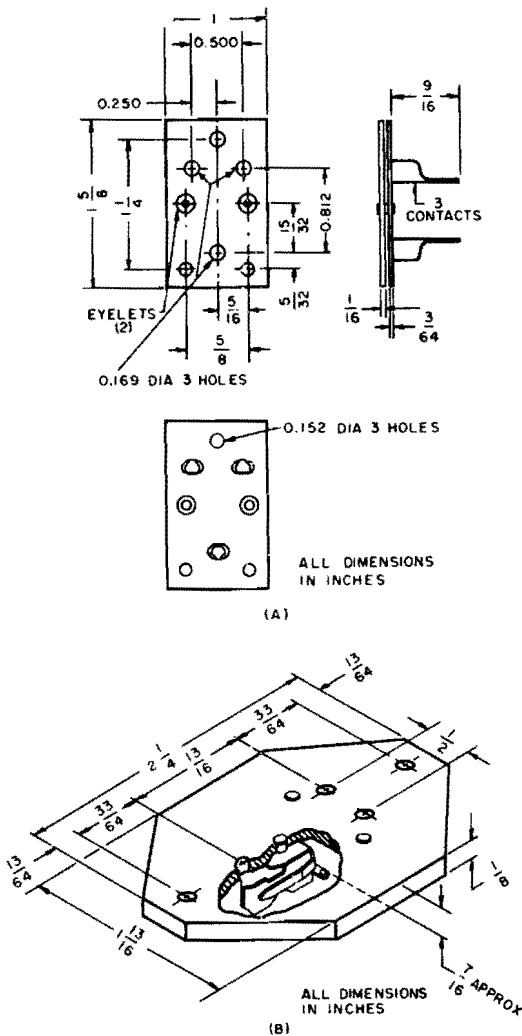

Figure 3-14. Crystal sockets for use with HC-5/U holder

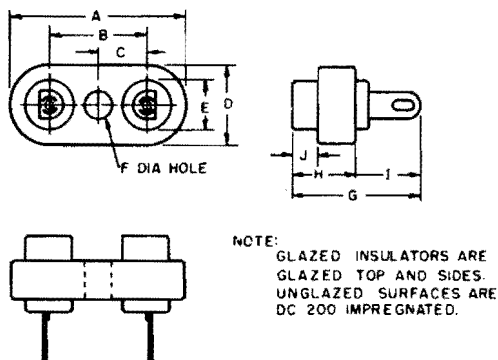

Figure 3-15. Crystal socket for use with HC-6/U, HC-13/U, and HC-14/U holders

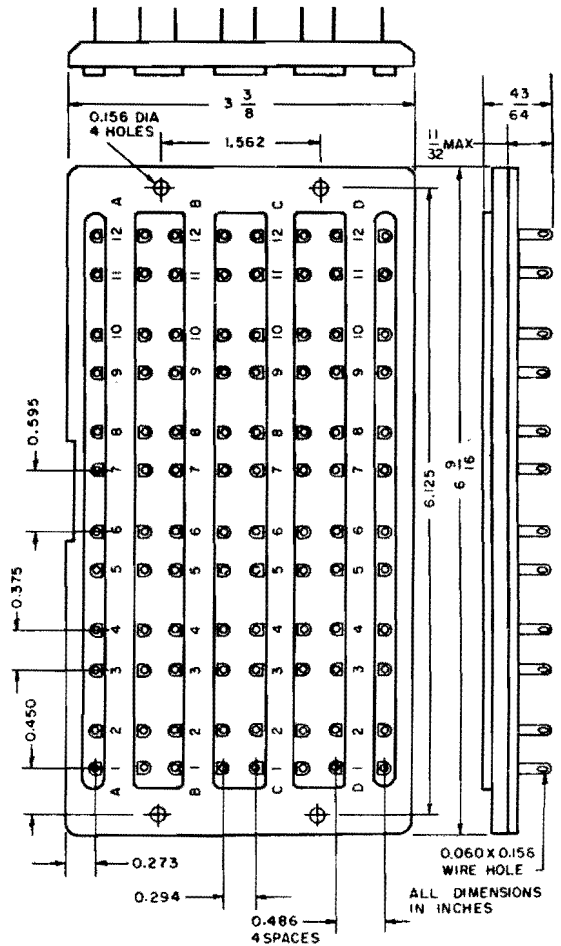

Figure 3-16. Multiple crystal socket for use with HC-6/U, HC-13/U, and HC-14/U holders

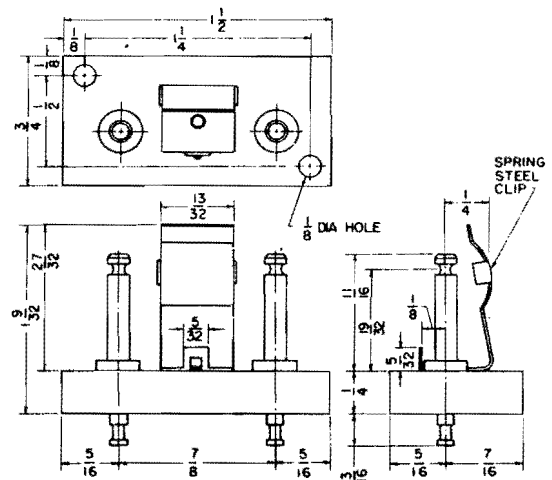

Figure 3-17. Crystal socket for use with HC-10/U holder

Section III
Crystal Sockets

TECHNICAL DATA CHART OF CRYSTAL SOCKETS SUITABLE FOR USE
WITH GROUP-I HOLDERS^b

Type Holder Accommodated	Manufacturer ^a	Model No.	Figure No.	Material of Insulator	Material of Contacts	Additional Stray Cap. Shunted Across Xtal ($\mu\mu f$)
HC-5/U	Cinch	2886	3-14 (A)	NEMA Spec Grade XP laminated phenolic (nat.)	Cinch P27	
	E. F. Johnson	122-223-1	3-14 (B)	Glass-bonded mica or NEMA Spec Grade XXX laminated phenolic	Brass w/steel spring, C _d pl	
		122-223-2		Glass-bonded mica	Phosphor bronze w/beryllium copper springs, silver pl	
HC-6/U, HC-13/U, and HC-14/U	Cinch	54A17358	3-15	Steatite, Grade L5, glazed	Beryllium copper, P31W-3 finish, solder term. hot-tin dipped	
	Elco	430	3-15	Ceramic, Grade 5, glazed	Brass, C _d pl	
		430 U		Ceramic, Grade 5, unglazed		
		430 PH		Ceramic, Grade 5, glazed	Phosphor bronze, C _d pl	
		430 U PH		Ceramic, Grade 5, unglazed		
		430 BC		Ceramic, Grade 5, glazed	Beryllium copper, silver pl	
		430 U BC		Ceramic, Grade 5, unglazed		
	E. F. Johnson	126-105-1	3-15	Steatite, Grade L4 or better, glazed	Beryllium copper, silver pl, solder term., hot-tin dipped	
		126-105-2			Phosphor bronze	
	Methode	SCJ 700-1	3-15	Steatite, Grade L5, glazed	Phosphor bronze, brass, or beryllium copper, as specified; C _d or silver pl; solder term. hot-tin dipped	
		SCJ 700-2				Same as SCJ 700-1 except not DC200 impregnated
Sylvania	G24-666	3-16	Low-loss phenolic	Phosphor bronze C _d pl, hot-tin dipped		
HC-10/U	Eby	8943	3-17	Ceramic	Spring-type body clip; brass, silver pl	
HC-15/U and HC-16/U	These holders are accommodated by standard octal sockets. For technical data and mounting provisions of octal sockets, see National Military Establishment Specification JAN-S-28A					

^a See Appendix III for complete name and address.

^b Crystal Holder HC-18/U is a miniature unit fabricated with wire leads for soldered connections; hence no socket is required.

Mounting Provisions	Dimensions (In.)										Remarks	
	A	B	C	D	E	F	G	H	I	J		
Three 0.152-in. dia holes on $\frac{5}{8}$ x $1\frac{1}{4}$ in. mtg centers					See fig. 3-14 (A)							
Two mtg holes spaced $1\frac{7}{32}$ in. c to c					See fig. 3-14 (B)							
0.115—0.135 in. dia mtg hole	$5\frac{5}{64}$	0.481—0.491	0.243	$\frac{3}{8}$	0.236—0.260	0.115—0.135	$\frac{5}{8}$	$\frac{3}{8}$	$\frac{1}{4}$	$\frac{1}{8}$	Withdrawal force of inserted xtal is $1\frac{1}{2}$ lb \pm 40% direct pull	
0.125-in. dia mtg hole	$5\frac{5}{64}$	0.486	0.243	$\frac{3}{8}$	$\frac{1}{4}$	0.125	$4\frac{3}{64}$	$\frac{3}{8}$	$1\frac{9}{64}$	$\frac{1}{8}$		
0.125-in. dia mtg hole	$5\frac{5}{64}$	0.486		$\frac{3}{8}$			$4\frac{3}{64}$	$\frac{3}{8}$	$1\frac{9}{64}$		Withdrawal force of inserted xtal is $1\frac{1}{2}$ lb \pm 40% direct pull	
0.130-in. dia mtg hole	$5\frac{5}{64}$	0.486		$\frac{3}{8}$	$\frac{1}{4}$	0.130	$3\frac{1}{64}$	$\frac{3}{8}$	$\frac{7}{64}$	$\frac{1}{8}$	Tropicalization treatment optional	
Four 0.156-in. dia holes on $6\frac{1}{8}$ x $\frac{9}{16}$ -in. mtg centers					See fig. 3-16						Accommodates 48 holders	
Two 0.125-in. dia holes on $\frac{1}{2}$ x $1\frac{1}{4}$ -in. mtg centers					See fig. 3-22							

GROUP II

CRYSTAL HOLDERS CURRENTLY IN MILITARY SERVICE BUT NOT RECOMMENDED FOR USE IN EQUIPMENTS OF NEW DESIGN

Group II includes the older types of crystal holders which are still widely used in current models of USAF radio equipments, but which are not recommended for use in military equipments of new design. These crystal holders are arranged in the order of their USAF stock numbers, which numbers are the same as the Signal Corps stock numbers except for the addition of the prefix "2100-," which serves to identify the item as belonging to the USAF 16-F stock class.

TECHNICAL DATA CHART FOR GROUP-II CRYSTAL HOLDERS

<i>USAF Stock Number 2100-</i>	<i>Nomenclature</i>	<i>Holder Spec</i>	<i>Material</i>	<i>Method of Mounting</i>
2xH1.1	Crystal Holder Wilcox Type 80D		Plastic	
2xH2.1	Crystal Holder FT-249		Plastic	
2xH2.2	Crystal Holder FT-249		Plastic	
2xH2.3	Crystal Holder FT-249		Plastic	
2xH2.4	Crystal Holder		Plastic case, metal cover	
2xH2.5	Crystal Holder (Collins Type 1G)		Plastic	
2xH3.1	Crystal Holder FT-164	171-148B	Ceramic	
2xH3.2	Crystal Holder FT-164	171-148B	Ceramic	
2xH4.1	Crystal Holder (Bendix 3947)		Plastic	
2xH5.1	Crystal Holder (Bliley MO-2)		Plastic	
2xH6.1	Crystal Holder FT-171-B	71-975	Plastic	
2xH6.2	Crystal Holder FT-171-B	71-975	Plastic	
2xH7.1	Crystal Holder FT-241-A	71-1696	Plastic	
2xH9.1	Crystal Holder (Collins Type 1C)		Plastic	
2xH10.1	Crystal Holder FT-243	71-1350	Plastic case, metal cover	
2xH14.1	Crystal Holder HC-12/U		Plastic	
2xH14.1-1	Crystal Holder CR-1A/AR		Plastic	
2xH14.2	Crystal Holder HC-11/U		Plastic	
2xH15.1	Crystal Holder	71-1165	Metal	
2xH17.1	Crystal Holder (Howard Engineering CM-1)		Plastic	
2xH18.1	Crystal Holder (WECO Type 5AA)		Plastic	

Base or Terminal Connections	Outside Dimensions (In.)			Electrodes	Remarks
	High	Wide	Thick		
Std 3-pin	1 $\frac{3}{4}$	1 $\frac{5}{16}$	1 $\frac{3}{16}$		
Std 3-pin	1 $\frac{9}{16}$	1 $\frac{3}{16}$	1 $\frac{25}{32}$	2 pr, both 1 x 1 in.	
Std 3-pin	1 $\frac{9}{16}$	1 $\frac{7}{16}$	1 $\frac{25}{32}$	2 pr; 1 pr 1 x 1 in.; 1 pr $\frac{3}{4}$ x $\frac{3}{4}$ in.	
Std 3-pin	1 $\frac{9}{16}$	1 $\frac{3}{16}$	1 $\frac{25}{32}$	2 pr, $\frac{3}{4}$ x $\frac{3}{4}$ in.	
3-pin, $\frac{5}{8}$ in. lg, 0.156 in. dia	2 $\frac{3}{8}$	1 $\frac{9}{16}$	1 $\frac{3}{32}$	1 pr, 1 x 1 in.	
3-pin, $\frac{1}{2}$ in. lg, $\frac{5}{16}$ in. dia	2 $\frac{1}{4}$	1 $\frac{3}{8}$	$\frac{7}{8}$		
	1 $\frac{1}{8}$	2 $\frac{1}{2}$ (dia)		1 pr, brass, nickel-plated	For LF quartz wafer
	1 $\frac{1}{8}$	2 $\frac{1}{4}$ (dia)		1 pr, brass, nickel-plated	For HF quartz wafer
6-pin on std octal base	1 $\frac{3}{16}$	1 $\frac{1}{2}$ (dia)			For 3 quartz plates
2-pin, $\frac{3}{4}$ in. c to c	1 $\frac{3}{16}$	1 $\frac{3}{8}$ (dia)			
2 banana pins, $\frac{7}{16}$ in. lg, $\frac{3}{4}$ in. c to c	1 $\frac{13}{16}$	1 $\frac{1}{2}$	$\frac{3}{4}$	1 pr, 1 x 1 in.	
2 banana pins, $\frac{3}{16}$ in. lg, $\frac{3}{4}$ in. c to c	1 $\frac{13}{16}$	1 $\frac{1}{2}$	$\frac{3}{4}$	1 pr, $\frac{3}{4}$ x $\frac{3}{4}$ in.	
2-pin, $\frac{7}{16}$ in. lg, $\frac{1}{2}$ in. c to c	1 $\frac{1}{16}$	1 $\frac{3}{32}$	$\frac{7}{16}$		
Std 5-pin, $\frac{9}{16}$ in.	1 $\frac{25}{32}$	1 $\frac{9}{16}$	1 $\frac{3}{16}$		
2-pin, 1 $\frac{1}{2}$ in. lg c to c	1 $\frac{1}{8}$	1 $\frac{7}{16}$	0.434		
2-pin, $\frac{5}{8}$ in. lg, $\frac{1}{2}$ c to c	1 $\frac{1}{4}$	1 $\frac{1}{4}$	$\frac{7}{16}$		
2-pin, $\frac{5}{8}$ in. lg, $\frac{1}{2}$ in. c to c	1 $\frac{1}{4}$	1 $\frac{1}{4}$	$\frac{7}{16}$		
2-pin, $\frac{5}{8}$ in. lg, $\frac{1}{2}$ in. c to c	1 $\frac{1}{4}$	1 $\frac{1}{4}$	$\frac{7}{16}$		
Std octal	2 $\frac{13}{32}$	1 $\frac{9}{12}$ (dia)			
2-pin, $\frac{1}{2}$ in. lg, $\frac{3}{4}$ in. c to c	$\frac{5}{8}$	1 $\frac{3}{8}$ (dia)			
Std 3-pin, 1 $\frac{1}{2}$ in. lg	1 $\frac{7}{8}$	1 $\frac{3}{8}$	1 $\frac{1}{8}$		

Section III
Crystal Holders—Group II

TECHNICAL DATA CHART FOR GROUP-II CRYSTAL HOLDERS—Continued

<i>USAF Stock Number 2100-</i>	<i>Nomenclature</i>	<i>Holder Spec</i>	<i>Material</i>	<i>Method of Mounting</i>
2xH24.1	Crystal Holder (Bliley MC-7)		Plastic body, metal front	
2xH25.1	Crystal Holder (Aircraft Accessories HN-10)		Plastic	
2xH26.1	Crystal Holder (Galvin FMT-X5)		Ceramic, with metal front and back	
2xH27.1	Crystal Holder (Bliley BC-3)		Plastic	
2xH28.1	Crystal Holder (Aircraft Accessories 601T)		Ceramic	
2xH29.1	Crystal Holder RCA AVA-10		Ceramic	Pressure-air gap
2xH30.1	Crystal Holder (HFR Type)		Plastic	
2xH31.1	Crystal Holder (CW Type)		Ceramic	
2xH32.1	Crystal Holder (Bliley LD-2)		Plastic	
2xH33.1	Crystal Holder (Henry DC34)		Plastic	
2xH34.1	Crystal Holder (Henry DC35)		Plastic	
2xH35.1	Crystal Holder (Premier 180GF and 180 GW)		Ceramic, with metal front and back	
2xH36.1	Crystal Holder (Bliley C and S)		Plastic	
2xH37.1	Crystal Holder (Fisher Rad TS25)		Plastic	
2xH38.1	Crystal Holder (Fisher Rad RS25)		Plastic	
2xH39.1	Crystal Holder (Aireon AA9E)		Metal	
2xH40.1	Crystal Holder (Aircraft Accessories AA9A)		Metal	
2xH41.1	Crystal Holder (Aircraft Accessories AA9G)		Metal	
2xH42.1	Crystal Holder (Peterson Radio PR)		Ceramic	
2xH43.1	Crystal Holder (RCA AVA-53-A)		Ceramic	Pressure-air gap
2xH44.1	Crystal Holder (Learadio 3858A)		Plastic	
2xH45.1	Crystal Holder (WECO DC-20)		Plastic	
2xH46.1	Crystal Holder (Standard Piezo CS5D)		Plastic	
2xH47.1	Crystal Holder (Bliley AR8W)		Plastic	
2xH48.1	Crystal Holder (Howard Type HMC4)		Ceramic	
2xH49.1	Crystal Holder (Coilins LD)		Plastic	
2xH50.1	Crystal Holder (Bliley AR3)		Plastic	
	Crystal Holder HC-1/U		Plastic	
	Crystal Holder HC-2/U		Plastic	
	Crystal Holder HC-3/U		Plastic	
	Crystal Holder HC-4/U		Plastic	

Base or Terminal Connections	Outside Dimensions (In.)			Electrodes	Remarks
	High	Wide	Thick		
2-pin, 3/4 in. c to c	1 1/8	1 3/8	9/16		
2 banana pins, 0.85 in. c to c	2 7/8	1 1/2	7/8		Plastic model of 601-T holder
2-pin, 7/16 in. lg, 3/4 in. c to c	1 7/8	1 1/2	3/4		
2-pin, 3/4 in. c to c	9/16	1 3/8 (dia)			
2 banana pins, 0.85 in. c to c	2 7/8	1 1/2	7/8		
2 banana pins, 0.85 in. c to c	2 1/8	1 7/32	1 1/16		
2-pin, 3/4 in. c to c	1/2	1 1/8 (dia)			CW Type HFR Model G and R-100
2-pin, 3/4 in. c to c	5/8	1 1/2 (dia)			
2-pin, 3/4 in. c to c					
2-pin, 3/4 in. c to c	2	1 3/8	3/8		
	2	1 3/8	3/8		
3 alined pins	2 5/8	1 1/2	7/8		
2-pin, 3/8 in. c to c	7/8	1 1/2 (dia)			
2-pin		1 1/2 (dia)			
2-pin		1 1/2 (dia)			
Std 3-pin	2 1/4	1 3/8	1 1/2		Same as MX9E
Std 3-pin	2 1/4	1 3/8	1 1/2		Same as MX9A
Std 3-pin	2 1 1/32	1 37/64	1 9/64		
2-pin	3/4	1 3/8 (dia)			
2 banana pins, 0.85 in. c to c	1 3/4	1 7/16	9/16		
2 banana pins	1 5/8	1 3/8	5/8		
2-pin	1 1/4	1 1/8	7/16		
3-pin	2 1/8	1 9/16	1 1/8		
3-pin	1 5/8	1 13/16	1 1/8		Same as AR4W, except freq
5-pin	1 1/2	1 1/8	1 1/16		Interchangeable with Collins 1C holder
Std 3-pin	1 1/2	1 1/8	1 3/8		
Std 5-pin	1 7/8	1 1/2	1 1/2		
2-pin	2 3/64	1 11/64	9/16		
2-pin	2 1/16	1 3/8	1/2		
2-pin	2 1/16	1 3/8	1/2		
2-pin	1 13/32	1 3/16	7/16		

**Section III
Crystal Holders—Group II**

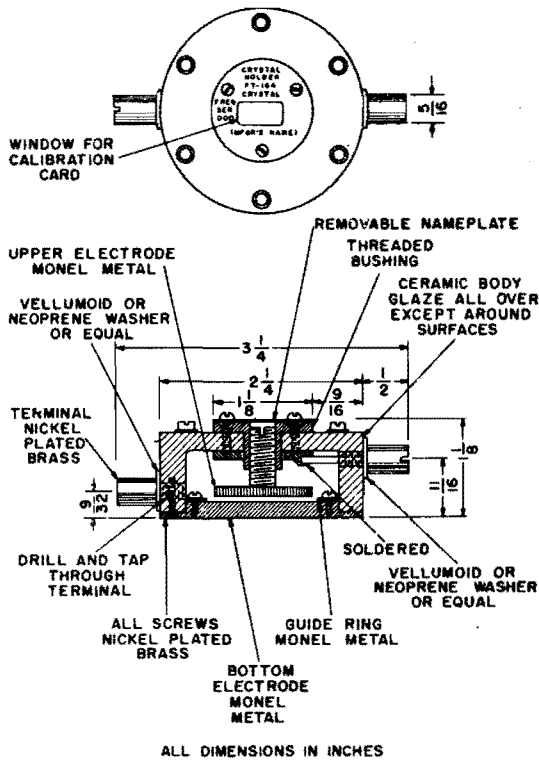

Figure 3-18. Crystal Holder FT-164

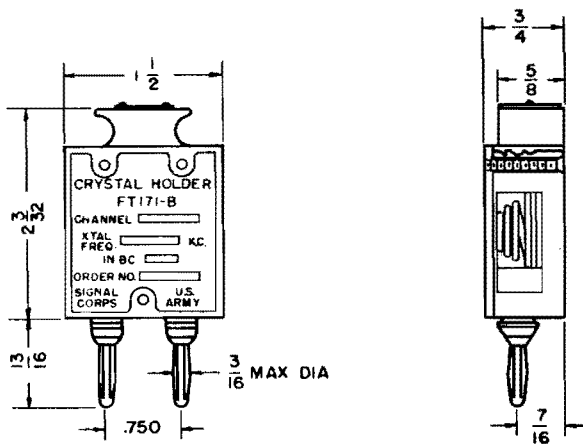
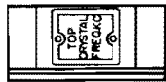

Figure 3-19. Crystal Holder FT-171-B

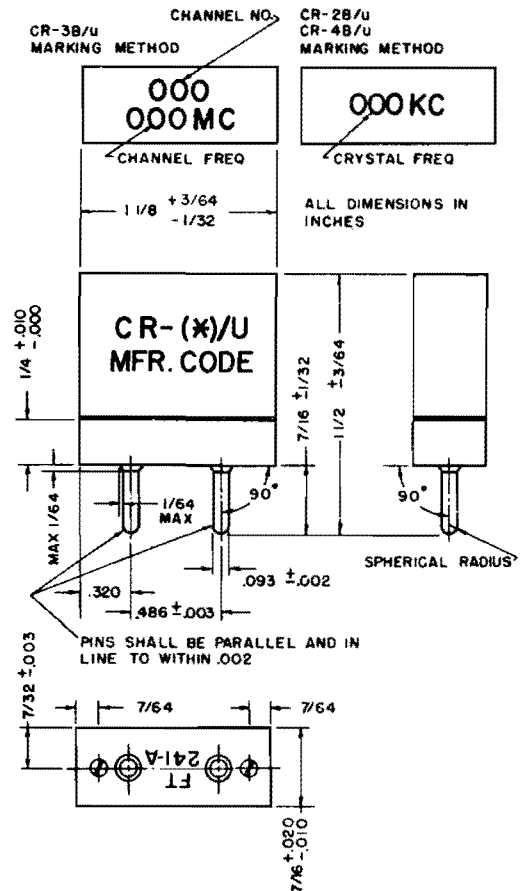

Figure 3-20. Crystal Holder FT-241-A. The markings indicated are applicable for Crystal Units CR-2B/U, CR-3B/U and CR-4B/U

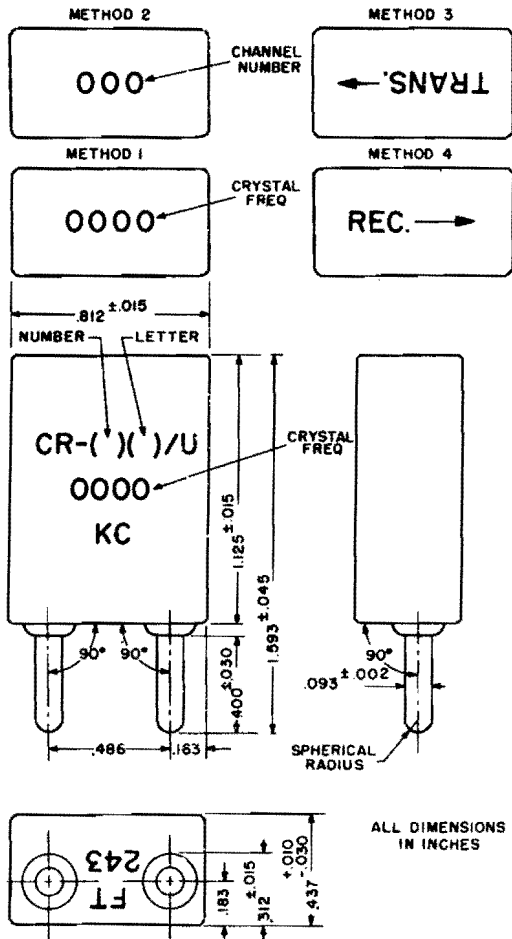

Figure 3-21. Crystal Holder FT-243. The markings indicated are applicable for Crystal Units CR-5B/U, CR-6B/U, CR-7B/U, CR-10B/U, and CR-12A/U. Method 1 is used where the operating frequencies of the using equipment are in terms of frequencies only; or where a single crystal is used to control both a transmitter and a receiver and the channel is expressed in terms of frequency. Method 2 is used where the operating frequencies of the using equipment are designated in terms of channel numbers and frequencies; or where a single crystal is used to control both a transmitter and a receiver and the operating frequency is expressed as a channel number as well as a frequency. Methods 3 and 4 are used respectively where two separate crystal units are employed in a single equipment, each performing a different function, such as one being used for transmitting and the other for receiving. Method 4 is used where the crystal unit is used to control the local oscillator of a receiver. On the back of the receiver crystal holder is marked "RECEIVE ON 0000 KC," where 0000 is the receiver frequency, which is always to be 455 kc below the crystal frequency. For an exploded view of the FT-243 holder, as a part of Crystal Unit CR-8B/U, see figure 1-70.

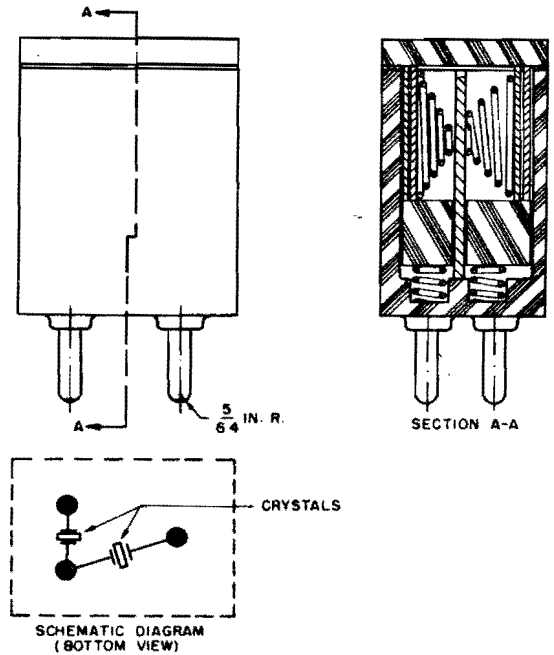

Figure 3-22. Crystal Holder FT-249

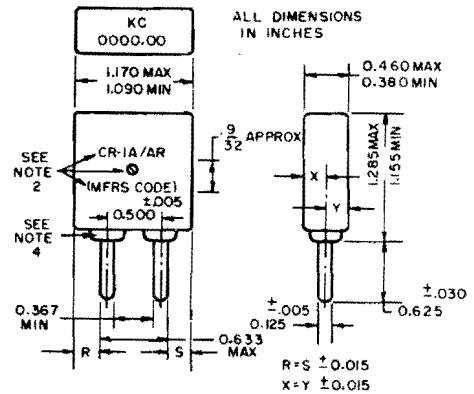

Figure 3-23. Crystal Holder for Crystal Unit CR-1A/AR

Section III
Crystal Holders—Group II

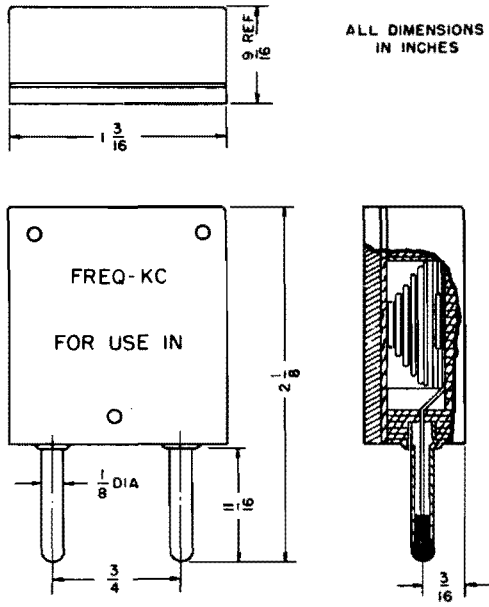

Figure 3-24. Crystal Holder HC-1/U

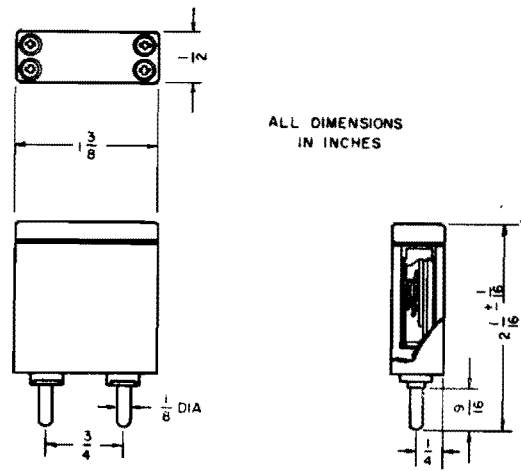

Figure 3-25. Crystal Holder HC-2/U and HC-3/U, except that the latter has pins of $\frac{5}{32}$ -in. diameter

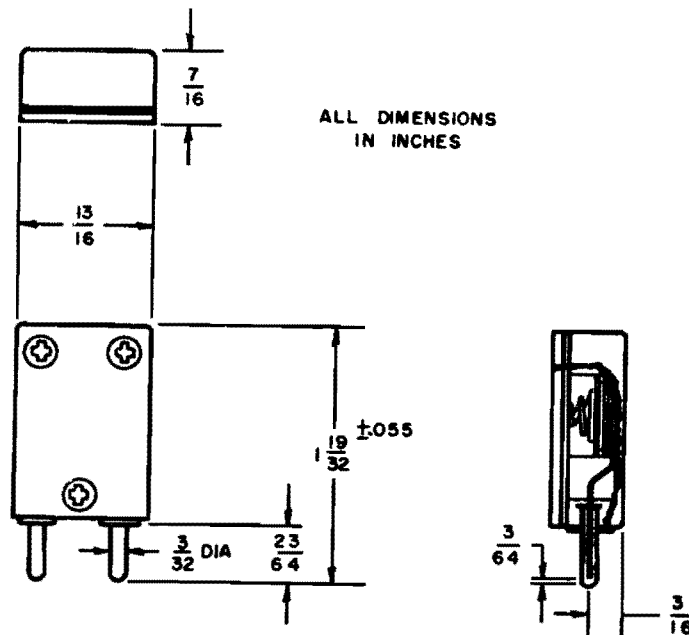

Figure 3-26. Crystal Holder HC-4/U

EXPLANATION OF MILITARY STANDARD TERMS USED IN DESCRIPTION OF CRYSTAL HOLDERS

Applicable Tests

3-2. Tests which have been specified for the particular crystal holder, and which have been performed by the Government or under the supervision of the Government to determine compliance of production and production specimens with the Military Specifications.

Authority

3-3. Serial numbers and dates of the military publications which prescribe the military specifications for the crystal holders being described. All holders described in Group I conform to Military Specification MIL-H-10056().

Condition A—Immersion Test (See paragraph 3-18a)

Condition B—Immersion Test (See paragraph 3-18b)

Corrosion Test (See paragraph 3-16)

Date of Status (See paragraph 2-4)

Delivery Requirements (See paragraphs 3-23 and 3-24)

Dimensions and Markings

3-4. Illustrated and largely self-explanatory. The marking of crystal holders, when required, is to be legible and permanent. See paragraph 2-26 for marking pertaining to crystal unit.

Fabrication Requirements (See paragraphs 3-8 and 3-14)

Functional Description

3-5. Provides summary of the general physical and operational features of the crystal holder.

Glass Seal Inspection (See paragraph 3-17)

Immersion Test (See paragraph 3-18)

Insulation Materials (See paragraph 3-10)

Insulation Resistance (See paragraph 3-18)

Leakage Test (See paragraph 3-19)

Marking (See paragraph 3-4)

Method A—Leakage Test (See paragraph 3-19a)

Method A—Thermal Shock Test (See paragraph 3-22a)

Method B—Leakage Test (See paragraph 3-19b)

Method B—Thermal Shock Test (See paragraph 3-22b)

Nomenclature of Crystal Holders

3-6. The Joint Army, Navy, Air Force nomenclature for designating a particular type of crystal holder is as follows:

CRYSTAL HOLDER NOMENCLATURE

<i>Item Name</i>	<i>Type Number</i>		
Crystal Holder	HC	X	U
	Component	Number	Equipment
	Indicator		Indicator
			Letter for
			Type of
			Installation

In the type number, the component, a crystal holder is identified by the symbol, HC. The component symbol is followed by a hyphen and one or two digits (-X) which identify the crystal holder as having been designed in accordance with a particular set of specifications. The letter, U, separated from the number by a slant sign, is the equipment indicator symbol for "general utility installation," which means that the crystal is intended for use in two or more of the three general installation classes—airborne, shipboard, and ground.

Ordering Requirements (See paragraph 3-23)

Packaging Requirements (See paragraph 3-24)

Pin Alinement Test (See paragraph 3-20)

Requirements and Procedure of Tests

3-7. See Military Specification MIL-H-10056() for details of the required inspections, the grouping of tests, and the procedure for sampling.

FABRICATION REQUIREMENTS

Covers

3-8. Covers are designed to fit the bases in a manner that permits easy assembly and interchangeability of covers and bases of the same type supplied on any one contract or order.

Flux

3-9. Rosin or rosin and alcohol are normally used as flux. If other fluxes are used, conclusive evidence has been presented to the Government that the proposed substitution and technique of application result in a noncorrosive joint. No corrosive compounds are used for soldering or welding.

Section III
Military Specifications

Glass Seal (See paragraph 3-17)

Insulating, Impregnating, and Sealing Compounds
3-10. Insulating, impregnating, and sealing compounds are used only for sealing screws.

Marking (See paragraph 3-4)

Pin Alinement (See paragraph 3-20)

Solder

3-11. Solder is used in accordance with Federal Specification QQ-S-571.

Springs

3-12. Springs, when specified, are attached to the base pins by using a high-temperature solder or by welding.

Threaded Parts

3-13. Screw threads for all screws, nuts, and other threaded parts are in accordance with National Bureau of Standards Handbook H28. All screw-thread assemblies are made resistant to loosening under vibration. When practicable, split-type lock washers are provided under the heads of all screws. When a screw mates with a plastic part, a threaded metal insert is molded therein.

Workmanship

3-14. The crystal holders are required to be manufactured and processed in a careful and workmanlike manner, in accordance with good design and sound practice. The interior surfaces of the holder, its contents and pins, are required to be free from dirt, grease, and any loose or deposited foreign or unapproved material. All burrs must be removed.

STANDARD TEST CONDITIONS

3-15. Unless otherwise specified, all crystal-holder measurements and tests are made under the prevailing ambient conditions of atmospheric pressure and relative humidity and at a temperature between 20 and 35 degrees centigrade.

DESCRIPTION AND REQUIREMENTS OF TESTS

Corrosion Test

3-16. The crystal holder is required to withstand 50 hours of the salt-spray (fog) test specified in Federal Specification QQ-M-151 without evidence of corrosion sufficient to impair the satisfactory operation of the holder.

Glass Seal Inspection

3-17. Those crystal holders with base assemblies having glass seals are inspected with the aid of a strong light and 10-power magnification. No glass seal is permissible that contains bubbles greater in diameter than one-third the distance between

pins and base, or that contains radial or other detrimental cracks, or if there is loosening of pins or glass seal from the base.

Immersion Test

3-18. The base assembly or crystal holder, as applicable, is tested as noted on the individual Specification Sheet in accordance with Condition A or B described below. After all excess moisture is wiped off and the base assembly or crystal holder is allowed to dry at room temperature for 1/2 hour, the insulation resistance between pins, and between each pin and any other external part of the holder, is measured with a low-voltage insulation test, using a test voltage of 50 to 100 volts dc. The insulation resistance must not be less than the value specified below for Condition A or B, whichever is applicable, and there must be no evidence of mechanical damage.

a. Condition A: The base assembly of the holder is immersed in a 10-percent (by weight)-minimum salt-water solution, using common table salt. After the solution is brought to a boil, the base assembly is removed and rinsed in running tap water. After drying, as specified above, the base assembly shall show no mechanical damage, and the insulation must have a resistance not less than 5000 megohms.

b. Condition B: The crystal holder is immersed for one hour in water maintained at a temperature between 90 and 95 degrees centigrade. After drying, as specified above, the insulation must have a resistance not less than 200 megohms.

Leakage Test

3-19. The base assembly or crystal holder, as applicable, is tested as noted on the individual Specification Sheet in accordance with Method A or B described below:

a. Method A: The base assembly is immersed for at least 10 seconds in liquid flux at a temperature not exceeding 25°C, then, abruptly hot-tin-dipped for at least 10 seconds in molten solder at a temperature between 302° to 312°C. The solder is immediately shaken off and the base assembly is plunged back into the liquid flux for at least 10 seconds. A minimum of three such cycles, continuously, is required. The thermal capacities of the flux and solder baths must be sufficient to maintain the specified bath temperature for the quantity of base assemblies being tested at any one time. When the thermal-shock cycles are completed, the insulation resistance must not be less than 5000 megohms when measured with an insulation tester as described in paragraph 3-18, and the glass seal must pass its standard inspection as described in paragraph 3-17.

b. Method B: The glass envelope, but not the base assembly of the holder, is immersed in boiling water for 15 seconds and immediately thereafter immersed in ice water for 5 seconds, the volume of the water being sufficient to maintain constant temperature. The glass envelope must withstand this test without cracking or breaking.

Visual and Mechanical Inspection (See paragraph 3-30)

a. Method A: The base assembly is clamped to a suitable test jig and subjected to a gage pressure of 50 pounds per square inch while immersed in tap water for at least 30 seconds. The base assembly must show no evidence of leakage around the pins, at the seams, or through cracks or porous spots in any of the base material. The continuous formation of bubbles is evidence of leakage.

b. Method B: The crystal holder is clamped to a suitable test jig and the cavity subjected to similar conditions as in Method A. The holder must show no evidence of leakage around the pins, or through cracks or porous spots in the holder material. The continuous formation of bubbles is evidence of leakage.

Pin Alinement Test

3-20. The pins of the crystal holder are required to be so alined that they conform to the mechanical dimensions given in the individual Specification Sheet, when measured by means of a shadowgraph. Refer to paragraph 2-24 for alternate test-gage method.

Tensile Strength Test

3-21. The base assembly of the holder is supported in a way that clears the glass seal. A direct load of 30 pounds is applied along the axis of the pins away from the base for at least 30 seconds, after which, the glass seal must show no evidence of loosening from the pins or base.

Thermal Shock Test

3-22. The base assembly or glass envelope, as applicable, is tested as noted on the individual Specification Sheet in accordance with Method A or B as described below:

a. Method A: The base assembly is immersed for at least 10 seconds in liquid flux at a temperature not exceeding 25°C, then, abruptly hot-tin-dipped for at least 10 seconds in molten solder at a temperature between 302° to 312°C. The solder is immediately shaken off and the base assembly is plunged back into the liquid flux for at least 10 seconds. A minimum of three such cycles, continuously, is required. The thermal capacities of

the flux and solder baths must be sufficient to maintain the specified bath temperatures for the quantity of base assemblies being tested at any one time. When the thermal-shock cycles are completed, the insulation resistance must not be less than 5000 megohms when measured with an insulation tester as described in paragraph 3-18, and the glass seal must pass its standard inspection as described in paragraph 3-17.

b. Method B: The glass envelope, but not the base assembly of the holder, is immersed in boiling water for 15 seconds and immediately thereafter immersed in ice water for 5 seconds, the volume of the water being sufficient to maintain a constant temperature. The glass envelope must withstand this test without cracking or breaking.

DELIVERY REQUIREMENTS

Ordering

3-23. According to Military Specification MIL-H-10056B, procurement documents should specify the following:

a. Title, number, and date of the latest specification (the latest at the present time, being Military Specification: Holders, Crystal, MIL-H-10056B, dated 16 January 1953).

b. Type designation, and the title, number, and date of the applicable individual Specification Sheet (the latest one at the present time for HC-13/U, for example, is MIL-H-10056/4, dated 16 January 1953).

c. Whether springs are required, dimensions, and how they are to be mounted.

d. Length of pin above base. (See note 6 on applicable Specification Sheet for HC-13/U.)

e. The laboratory at which preproduction tests are to be performed. (See MIL-H-10056() for requirements of preproduction tests.)

f. Whether packing and marking are for domestic or overseas shipment.

g. That the contractor shall not substitute for a specified material or fabricated part unless he obtains approval from the bureau or service concerned. Evidence to substantiate his claim that such a substitute is suitable shall be submitted with his request. Similar notification and substantiating evidence shall be submitted at any later time if substitution becomes necessary or desirable. At the discretion of the bureau or service concerned, test samples may be required to prove the suitability of the proposed substitute.

Packaging

3-24. Electron-tube type crystal holders shall be packaged and packed in accordance with packaging group I of Specification MIL-P-75. All other

Section III
Military Specifications

types of crystal holders shall be unit-packages with method III of Specification MIL-P-116. Crystal holders are then placed in containers for either domestic shipment and storage or for overseas shipment described in subparagraphs a. and b. below. In addition to any special marking required by the contract or order, unit packages and exterior shipping containers shall be marked in accordance with Standard MIL-STD-129. These packaging, packing, and marking requirements apply only to direct shipment to the Government and are not intended to apply to contracts or orders between the manufacturer and prime contractors.

a. Packing for Domestic Shipment and Storage: Crystal holders packaged per specification shall be packed in wood-cleated plywood, nailed wood, or corrugated or solid fiber-board boxes conforming to Specification NN-B-601, NN-B-621, LLL-B-631, and LLL-B-636, respectively. Closures shall be made in accordance with the applicable box specification. The gross weight shall not exceed 45 pounds for fiberboard boxes and 150 pounds for plywood or wood boxes. Fiberboard having a minimum dry bursting strength (Mullen test) of less than 200 pounds shall not be used.

b. Packing for Oversea Shipment: Crystal holders packaged per specification shall be packed

in wood-cleated plywood, nailed wood, or fiberboard boxes conforming to Specification JAN-P-105, JAN-P-106, and JAN-P-108, respectively. Plywood shall be type B, condition 1, conforming to Specification JAN-P-139. Each shipping container shall have a case liner conforming to type II, grade A, class 2 of Specification MIL-L-10547. Box closures shall be as specified in the appendix of the applicable specification for fiberboard boxes, and 150 pounds for plywood or wood boxes.

Solder Requirements (*See paragraph 3-11*)

USAF Stock No.

3-29. Number for identifying item when requisitioning from U. S. Air Force supply depot. The USAF stock numbers of crystal holders are the same as the respective Signal Corps numbers except that the prefix, "2100-," is added, which serves to identify the item as belonging to USAF stock class 16-F.

Visual and Mechanical Inspection

3-30. Inspection of crystal holders to determine if material, design, construction, marking, and workmanship comply with applicable specifications. For greater detail, refer to Fabrication Requirements, paragraphs 3-8 to 3-14.

Workmanship Requirements (*See paragraph 3-20*)

SECTION IV—CRYSTAL OVENS

TABLE OF CONTENTS

<i>Subject</i>	<i>Page</i>
INTRODUCTION	
PART I—DESIGN OF CRYSTAL OVENS	
Development of Temperature-Controlled Crystal Ovens.....	601
General Construction Features of Crystal Ovens.....	603
Methods of Thermostatic Heater Control.....	605
Thermal Analogues of Electrical Parameters.....	611
PART II—TECHNICAL DESCRIPTIONS OF CRYSTAL OVENS	
Technical Data Chart of Crystal Ovens for Use with Group I— Military Standard Crystal Units.....	623
Description Sheets	
Crystal Oven HD-54/U.....	624
Bendix Radio Crystal Oven L205628.....	625
Bendix Radio Crystal Oven N205651.....	626

SECTION IV—CRYSTAL OVENS

INTRODUCTION

4-1. Section IV is divided into two main parts. Part I is a discussion of the design of crystal ovens. Part II consists of a series of technical data sheets describing currently available crystal ovens that are suitable for use with the recommended Military Standard crystal units listed in Section II.

4-2. Part I, *Design of Crystal Ovens*, begins with a brief discussion of the development of crystal ovens leading to the present state of the art. Included is a reprint of a Signal Corps Technical Requirements report that outlines the operational and test specifications to be met in the development of new crystal ovens for use by the Armed Services. Following this is a general discussion of the construction features of a representative crystal oven. Next, various types of thermostats and temperature-control circuits are described briefly and illustrated. Finally, the thermal factors involved in maintaining a crystal at a constant

operating temperature are analyzed qualitatively in some detail. As an aid to the radio engineer, the thermal parameters are interpreted in terms of their electrical analogues. Because of the complexity of the many distributed variables, a non-approximating rigorous approach is not practical at the present state of the art. What is attempted is to aid the developmental engineer by making explicit the basic physical problems involved.

4-3. Part II, *Technical Descriptions of Crystal Ovens*, includes descriptions only of crystal ovens meeting military specifications, which have been designed to accommodate Military Standard crystal holders of Group I, Section III. All such ovens, where the information has been available, have been included; but because of unavoidable omissions, the list should be considered representative rather than inclusive. A listing by type and number of crystal holders each oven will accommodate is provided by a technical data chart at the beginning of Part II.

PART I

DESIGN OF CRYSTAL OVENS

DEVELOPMENT OF TEMPERATURE-CONTROLLED CRYSTAL OVENS

Trends in the Demands of Crystal-Oven Performance

4-4. During the early years of crystal oscillators, when the large frequency-temperature-coefficient X and Y cuts were the principal quartz elements, good frequency stability required very accurate control of the crystal temperature. For example, an X-cut element having a temperature coefficient of 20 parts per million per degree C would need to be maintained within $\pm \frac{1}{4}^{\circ}\text{C}$ of its mean temperature if the frequency were not to deviate more than 0.0005 per cent. A Y-cut element having a

temperature coefficient four times as great would need to be limited to an operating temperature range of $\pm \frac{1}{16}^{\circ}\text{C}$ for the same permissible frequency deviation. To control the temperature of relatively large crystal units within such narrow limits required the use of carefully designed, but rather bulky and expensive ovens.

4-5. With the arrival of the zero-temperature-coefficient quartz elements, the demand for precise temperature control greatly decreased. Where an oven formerly was required to maintain an operating temperature within $\pm 0.1^{\circ}\text{C}$, its subsequent functional equivalent was permitted temperature cycles of $\pm 1^{\circ}\text{C}$ and greater. As a result, smaller and cheaper ovens soon became conventional.

Section IV

Crystal Ovens—Design

These consumed less power and employed less sensitive but more rugged thermostats than was originally feasible.

4-6. It has only been in recent years that a strong demand has again arisen for greater care in oven design. This demand has a threefold nature:

a. Better ovens are needed to maintain even the conventional tolerances in operating temperature for the wide variations in ambient temperature now required of military equipment.

b. To relieve the overcrowding of the radio-frequency spectrum, very small percentage deviations in crystal frequency, and hence in oven temperature, are needed to make full use of the v-h-f range.

c. It is important that improved performance be obtained without increasing the size of ovens; indeed, it is highly desirable that the size be further reduced. For the above reasons more than routine attention is now being given to possible improvements in the design of crystal ovens, especially small ovens.

Types of Crystal Ovens

4-7. Ovens used for housing crystal units can be broadly classified into three types: a. Large transmitter ovens. b. Precision laboratory ovens. c. Small ovens.

a. *Large temperature-controlled compartments employed in fixed-plant radio transmitters.* It is not uncommon for these ovens to house the entire oscillator circuit; in which case the crystal unit may be additionally protected from temperature changes by being mounted in a separately-controlled inner chamber. These ovens are normally equipped with thermometers for indicating the compartment temperature on the front panel or through a window. The transmitter, of which the oven is an integral part, is often intended to operate in buildings where the room temperature is not expected to vary by more than $\pm 15^{\circ}\text{C}$. Under such an ambient range, the large transmitter oven can be expected to maintain the crystal temperature within $\pm 1^{\circ}\text{C}$ to $\pm 0.1^{\circ}\text{C}$, depending upon the type of thermostat, the compartment design, and the mounting arrangement of the components within the oven. Monitoring, alarm, and automatic standby thermostatic circuits in case of thermostat failure are occasionally to be found.

b. *Large temperature-controlled boxes for housing crystal units employed in frequency and time standards requiring laboratory precision.* This type of oven most often uses a mercury thermostat. Where extreme precision is required, electronic amplification of a thermistor-bridge

thermostat may be employed. The boxes are constructed with thick walls consisting of heat-distributing and heat-insulating layers interleaved with heater windings. For ambient temperature variations of $\pm 15^{\circ}\text{C}$, temperature-controlled boxes can maintain the temperature at tolerances of $\pm 0.1^{\circ}\text{C}$ to $\pm 0.001^{\circ}\text{C}$. The latter tolerance is sufficient to limit the frequency deviation of an average zero-coefficient quartz element to one part in ten billion, if the operating interval is not too long.

c. *Small crystal ovens equipped with plug-in bases for mounting in standard sockets, or with bases designed for fastening directly to a chassis.* This is the type of crystal oven most commonly encountered and of greatest importance to the design engineer of military radio equipment. It is the only oven type to consider for use in small- and medium-sized equipments. The data sheets in Part II of this section describe several small ovens of this class which are currently available and which have been designed for use with Military Standard crystal units. The average performance of these ovens, although generally satisfactory for normal ranges of room temperature, cannot be said to be entirely satisfactory when subjected to the subfreezing temperatures often required of military equipment. Because of the increased attention being given to the design and development of better small ovens, the radio engineer can reasonably expect a continuous improvement in available models for the next few years. A landmark in the recent trend toward improved oven design was established when Messrs. H. Keen, N. Tetrault, and J. Gilbert of Lavoie Laboratories developed a small oven capable of $\pm 0.15^{\circ}\text{C}$ stability over the ambient range of -40° to $+70^{\circ}\text{C}$. Such a temperature stability is more than adequate for the great majority of purposes. For airborne equipment, until such time that crystal units and/or crystal circuits can be designed to be inherently temperature-compensating, the demand will continue for ever smaller sizes, lighter weights, less power consumptions, as well as greater temperature stabilities, particularly in the case of the multiple-position ovens mounting several crystal units.

Armed Services Technical Requirements for Crystal Ovens of New Design

4-8. The following digest is a reprint of the detailed requirements for the development of crystal ovens to be used by the Armed Services, as established by the Frequency Control Branch, Squier Signal Laboratory, Fort Monmouth, New Jersey,

October 21, 1952, in *Technical Requirements for PR&C 53-ELS/R-3610*:

- a. Temperature, Operating: 75°C and 85°C.
- b. Temperature Setting Tolerance: $\pm 3^\circ\text{C}$.
- c. Temperature Cycling Tolerance: $\pm 1^\circ\text{C}$ over the entire operable temperature range.
- d. Operable Temperature Range: -40 to $+60^\circ\text{C}$ (75° oven), -40 to $+70^\circ\text{C}$ (85° oven).
- e. Storage, Vibration and Shock: After undergoing the following tests, outlined in Specification MIL-T-945A, there shall be no degradation of performance and the oven shall continue to meet all other requirements of the Technical Requirements. The expression "crystal oven" shall be substituted wherever the expression "test set" appears in the referenced specification:
 - Par. 4.4.2—Humidity Test
 - Par. 4.4.4—Temperature and Altitude Test
 - Par. 4.4.5—Vibration Test (omit Test 2)
 - Par. 4.4.6—Shock Test
- f. Aging: Total shift shall not exceed 1°C per month, oven operating, except temperature setting tolerance of sub-panel b shall not be exceeded.
- g. Temperature Retrace: The unit shall be capable of returning to its operating temperature $\pm 1^\circ\text{C}$ during the following temperature-cycling test: unit on 8 hours, off for 16 hours, for a period of 10 cycles.
- h. Stabilizing: Unit should reach thermal equilibrium within 15 minutes at any temperature within the operable range.
- i. Operating Voltage: A-C—6.3 and 12.6 volts $\pm 10\%$ obtained by center-tapping the heater winding; also 26.5 volts $\pm 10\%$.
- j. Temperature Measurement: Method will employ a high drift crystal.
- k. Mounting: Octal base with clamping fixture.
- l. Shape: No factor.
- m. Interchangeability of Components: Desirable for replacement purposes.
- n. Size: Maximum limits: 4 in. high x $1\frac{1}{2}$ in. diameter, or, if rectangular, $1\frac{1}{2}$ in. on a side.
- o. Pin-to-Pin Capacitance: Shunt capacitance across crystal pins (crystal removed) shall not exceed $5 \mu\text{mf}$.
- p. Thermostats: If thermostats are employed they shall be hermetically sealed.
- q. Cavity Size: Shall be capable of housing

Crystal Holder HC-6/U. It is desirable, but not essential, that it shall also accommodate Crystal Holder HC-13/U. Temperature tests which may be conducted employing the latter type of holder will permit a greater tolerance in temperature limits.

- r. Workmanship: Components, subassemblies and parts shall be manufactured and assembled in a thoroughly workmanlike manner.
- s. Materials: All materials shall be entirely suitable for the purpose for which intended.

GENERAL CONSTRUCTION FEATURES OF CRYSTAL OVENS

Provisions for Temperature Control

4-9. Figure 4-1 illustrates by diagram the principal elements to be considered in the construction of a crystal oven. The thermostat contains a temperature-sensitive element, usually one that operates by expanding and contracting as the temperature rises and falls. By one means or an-

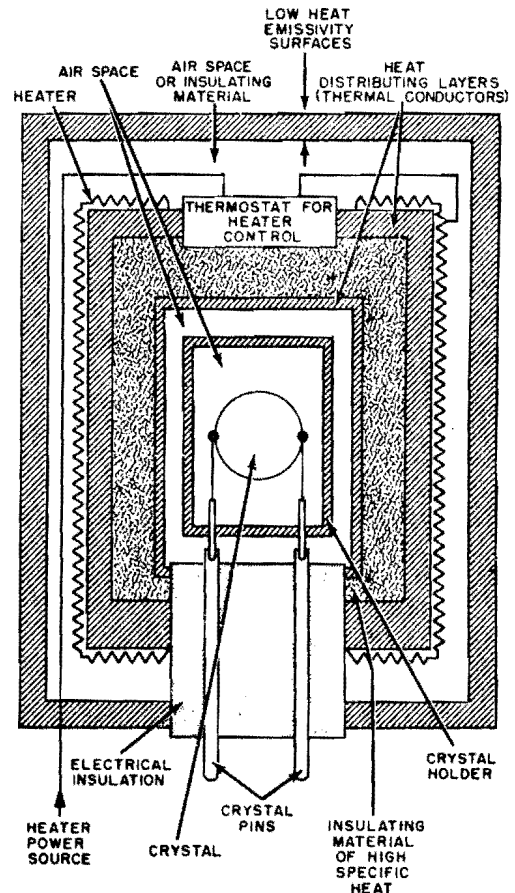

Figure 4-1. General construction features of typical crystal oven

Section IV Crystal Ovens—Design

other, the temperature-varying property of the sensing element is used to control the power to an electrical heater, so that the power increases, or starts, when the temperature of the thermostat falls below the operating level, and decreases, or stops, when the temperature rises above the operating level. The heater power-control mechanism may, or may not, be mounted within the oven proper.

4-10. For minimum temperature deviation at the crystal, the thermostat should be thermally insulated from the crystal chamber but in close thermal contact with the heat-distributing layer adjacent to the heater. This arrangement permits the crystal to be insulated from the temperature variations that must occur at the location of the thermostat in order for the thermostat to operate. The greater the heat capacity and the greater the heat resistance of the intervening layers, the more constant will be the crystal temperature. The inside walls of the crystal chamber should be metallic, that is, should have high thermal conductivity to distribute the heat uniformly around the crystal unit and minimize the temperature gradients within the crystal chamber.

Provisions for Minimizing Power Requirements

4-11. For conservation of operating power, the heater should be as well insulated as is practical against loss of heat to the outside. Ideally, maximum insulation is to be obtained by enclosing the heater and inner compartment within an evacuated container having highly reflective walls—utilizing the same principle as in the Dewar flask and thermos bottle. Practically, the best insulation has been achieved by allowing an air space to separate the heater from the outer walls of the oven. Air, or other gas, is superior as a heat insulator compared with the best of the solid insulators; but this is true only if there is little or no transport of heat by mass movements of the gas from regions of higher to regions of lower temperature. Thus, if the dimensions and temperature gradient of the insulating air space are sufficient for convection currents to circulate around the heater, the space should either be subdivided by horizontal insulating sheets or filled with porous insulating material such as glass wool, Celotex, cotton, hair felt, or balsa wood. Care should also be taken to prevent, or at least retard, convection currents at the outer surface of the oven.

4-12. To reduce to a minimum the heat lost by radiation, the outer case of the oven should be a smooth-surfaced unpainted metal of low emissivity—aluminum, for example. If a plastic case is used, lining the inner and outer surfaces with metal foil

will equally retard heat loss by radiation. Coating a plastic surface with metallic paint can reduce the surface emissivity, and hence the radiation losses, to almost one-half that of the unpainted plastic, but these losses will be ten or more times greater than that of a pure metal surface. Markings on a metallic case should be kept to a minimum. A serial number alone can more than quadruple the radiation losses from that side of the oven. However, these precautions lose much of their importance if it is not practicable to prevent air currents from circulating around the outside of the oven; in which case the heat loss by radiation becomes relatively negligible compared with that by convection and need not be considered a major design consideration.

4-13. The electrical leads from the crystal chamber to the outside should be kept as small in cross-sectional area as possible, since these leads tend to “short-circuit” the crystal chamber thermally to the outside. From the point of view of small temperature tolerances, it would be desirable for these leads to be extended in length and close in thermal contact with the heat-distributing layers of the oven. Unfortunately, the leads must be kept short, well-spaced, and insulated electrically (which is equivalent to being insulated thermally) from metallic parts of the oven. These requirements are necessary in order to minimize the shunt capacitance that the oven adds across the crystal unit, and to a lesser extent, to minimize the distributed resistance and inductance added to the crystal circuit. As a general rule, the major factor limiting the performance of small crystal ovens over wide ambient temperature ranges is the heat leakage through the base; particularly is this true for multiple-position ovens, where a leakage path exists for each individual terminal leading from a crystal socket.

Construction of Typical Small Oven

4-14. Figure 4-2 shows the principal parts of a small commercial crystal oven equivalent to the Military type HD-54/U. The oven is not designed for precision control of the temperature. Because of the heat leakage through the base, it is questionable whether the temperature tolerance is less than $\pm 5^{\circ}\text{C}$ over an ambient range of 100°C . The advantage of this type of oven is its small size, light weight, and inexpensive design, which make it particularly suitable for general-purpose use in airborne installations. The thermal key, which is shown as part of the base assembly, is a metallic heat-distributing layer that makes close thermal contact with the base of the distributing shell around which the heaters are wound. The purpose

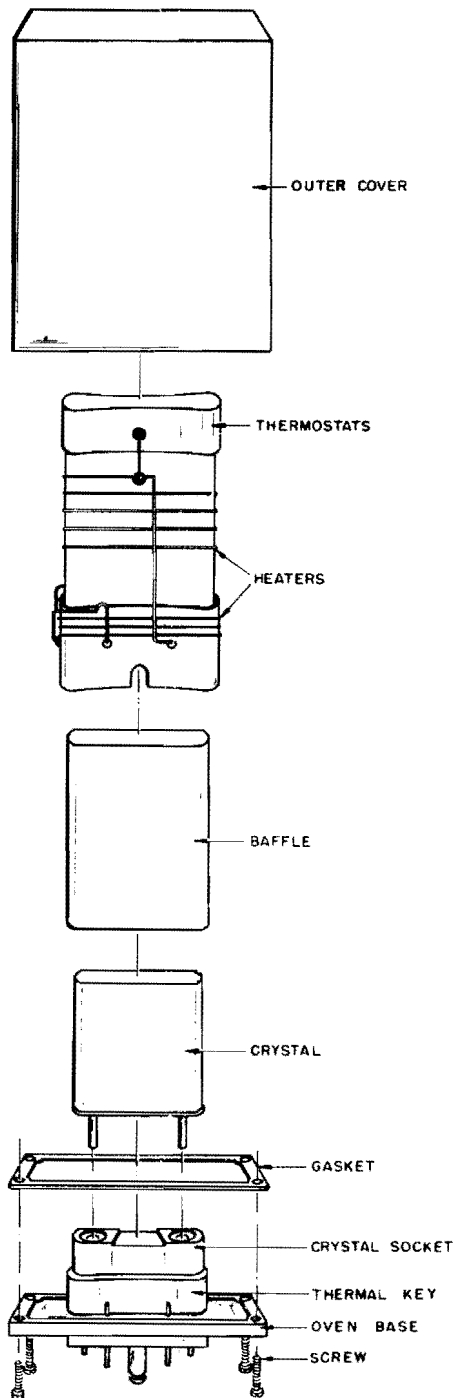

Figure 4-2. Small crystal oven equivalent to Military Type HD-54/U

of the thermal key is to conduct as much heat as possible around the crystal leads before they enter the crystal chamber. The baffle is a plastic cover that forms the walls of the crystal chamber. Its purpose is to provide a heat-storing, as well as a heat-insulating layer between the heater distributing shell and the crystal unit. The metallic case of the crystal holder (type HC-6/U) provides sufficiently uniform heat distribution within the crystal chamber, for the purposes of the oven, so that an additional inner distributing layer is not provided. Two thermostats and two heaters are provided. One thermostat-heater combination is for quick oven warm-up when the oven is first turned on. This thermostat is adjusted to open its associated heater circuit at a temperature slightly below the desired operating temperature. The second thermostat-heater combination determines the actual operating characteristics. The outer cover is plastic and is of sufficient size to provide a small air space around the crystal compartment. The radiation losses are not considered significant compared with the conduction losses through the base and with the expected convection losses around the sides, so that a low-emissivity surface is not provided.

METHODS OF THERMOSTATIC HEATER CONTROL

4-15. There are two general methods of thermostatic heater control: the *on-off* method and the *continuously-variable* method. The latter permits the heater current to be varied gradually with the aid, usually, of vacuum-tube amplifiers until an equilibrium is reached between the heat being supplied and that being lost. This method is used so rarely that it will not be further considered. However, the thermistor-bridge thermostat, which is discussed below as the control element of an on-off vacuum-tube heater circuit, is equally applicable as the control element of a continuously-variable vacuum-tube heater circuit. In the on-off method, the heater circuit is opened and closed periodically. The action of the thermostat varies the ratio of the *on* period to the *off* period until equilibrium is reached at the predetermined operating temperature between the periodic supply of heat and the continuous heat leakage. The on-off thermostat of small ovens is usually connected in series with the heater windings. Where more sensitive thermostats are used, the heater current is controlled indirectly by relay—the thermostat contacts not being required to pass more than a small current sufficient to operate the relay.

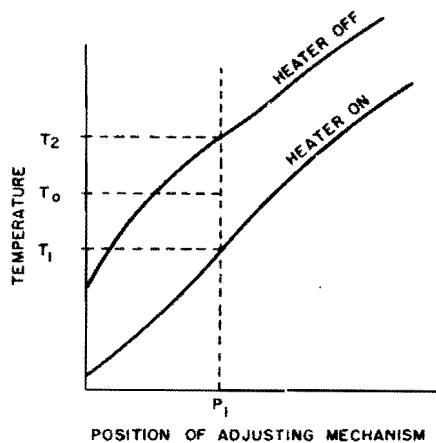

Figure 4-3. Typical differential curves of adjustable thermostat

Temperature Differentials of Thermostats

4-16. Figure 4-3 shows typical on-off curves of an adjustable thermostat. For any given thermostat adjustment, P_1 , the thermostat operating temperature is the temperature, T_0 , midway between the on and off temperatures, T_1 and T_2 , respectively. The total width of the temperature gap, $T_2 - T_1$, is called the *backlash*, and plus or minus one-half the backlash is called the *differential* of the thermostat. In general, the larger the differential, the longer is the operating life of the thermostat, although, of course, the less precise is its temperature-controlling ability.

Thermostats Used for On-Off Heater Control

4-17. Any device that can be used as a thermometer can be modified for use as a thermostat. In practice, the bimetallic thermostat is the type most commonly encountered in crystal ovens, but any corrosion-resistant metal having a large temperature coefficient of expansion can be used as the

sensing element without the bimetallic construction, as long as the associated mechanism provides sufficient sensitivity for opening and closing the thermostat contacts. Where above-average precision is required, a mercury thermometer is usually employed. Thermistors are also occasionally used as the temperature-sensing element, maximum sensitivity being obtained by connecting the thermistor as one arm of a resistance-bridge circuit.

BIMETALLIC THERMOSTATS

4-18. Bimetallic sensing elements are constructed by welding together two thin metallic strips which have widely different temperature coefficients of expansion. Since one of the metals expands and contracts with changes in temperature at a greater rate than the other, the effect of a change in temperature is to cause a straight bimetallic strip to bend. Figure 4-4 illustrates a number of the more common types of bimetallic sensing elements. The deflection of these elements is denoted by the symbol d for linear displacements and by the symbol ϕ for angular displacements. An angular expression of the deflection is more convenient for the helix and spiral elements since the exact linear deflection of a contact will depend upon the length of a contact arm fastened to the moving end of the bimetallic coil. Equations for the deflections indicated in figure 4-4 are given in the table below.

- d = linear displacement in same dimensions as l , t and D
- ϕ = angular displacement in radians
- l = length of strip
- t = overall thickness of strip
- D = diameter of double-helix coil
- ΔT = degrees centigrade change in temperature
- k = k_a , k_b , or k_c = temperature coefficient of deflection in parts per degree centigrade

Bimetallic Strip	Deflection Equation	Representative Values of k
(A) Cantilever	$d = k_a l^2 \Delta T / t$	12 to 20 $\times 10^{-6}$
(B) U-Cantilever	$d = k_b l^2 \Delta T / 2t$	12 to 20 $\times 10^{-6}$
(C) End-Supported	$d = k_c l^2 \Delta T / 4t$	12 to 20 $\times 10^{-6}$
(D) Double-Helix	$d = k_b l D \Delta T / t$	10.5 to 18.5 $\times 10^{-6}$
(E) Helix	$\phi = k_a l \Delta T / t$	1600 to 2500 $\times 10^{-6}$
(F) Spiral	$\phi = k_c l \Delta T / t$	1600 to 2500 $\times 10^{-6}$

Electrical Resistance of Bimetals

4-19. Since the thermostat deflection is used to open and close an electrical circuit, the bimetallic strip, itself, often forms part of the circuit. In this case, with proper design, the additional heat supplied the bimetal due to its electrical resistance can be used to boost the thermostat's temperature response, making it more sensitive, and effectively reducing the operating differential of the surrounding area. In general, the bimetals having the higher deflection coefficients also have the higher electrical resistivities. Per circular mil foot, bimetal resistances range approximately from 20 to 700 ohms.

Adjustment of Bimetallic Thermostat

4-20. Within limits, the operating temperature of a bimetallic thermostat can be adjusted by varying the position of the fixed contact relative to the room-temperature position of the moving contact. The greater the deflection that is required of the moving contact relative to its initial posi-

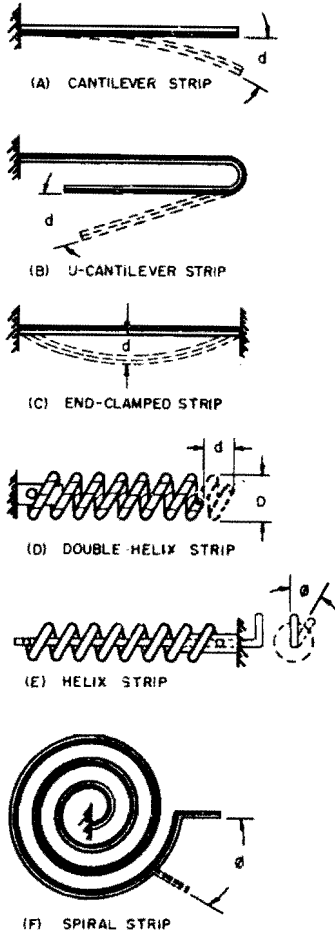

Figure 4-4. Basic types of bimetallic strips

tion, the higher will be the operating temperature.

Creep- and Snap-Action Bimetallic Thermostats

4-21. The deflection of a bimetallic strip can be used to open and close an electrical circuit either slowly, *creep action*, or abruptly, *snap action*. Creep thermostats are the more sensitive, requiring smaller differentials, and are less likely to fail because of fatigue since the bimetallic element is not subjected to vibration or shock. But the contact life is short compared with that of the snap thermostat. This is because of the increased exposure to heating and sparking due to the prolonged periods when the contacts are only barely touching or barely separated. Other limitations of the creep thermostat are its tendency to chatter and the fact that it cannot be used in equipment subjected to vibration. These disadvantages are avoided by the use of a snap thermostat. In fact, the response of the abrupt, positive contact action of the snap thermostat is actually aided by a moderate amount of vibration, requiring slightly smaller temperature differentials than would otherwise be the case. A creep thermostat can be readily converted into a snap type by fastening permanent magnets to the contacts. The contact life of either type is increased by mounting in vacuum, or at least, in a hermetically sealed holder, and by using low a-c voltages in noninductive circuits. Where necessary, additional protection against sparking at the contacts is to be had by shunting the contacts, or inductive parts of the circuit, with a suitable resistance and capacitance in series. This is particularly necessary if the thermostat is used to control the current of an inductive relay, or if voltages higher than 30 volts are employed. The average life of a snap thermostat is on the order of 100,000 actions, although there are a number of significant exceptions to the average. For example, the E-shaped, bimetallic cantilever element, see figure 4-5, is claimed to have a life of a million actions. These elements are available in a number of small sizes that should be sufficiently sensitive for use in crystal heater circuits where the thermostat contacts must pass the entire heater current.

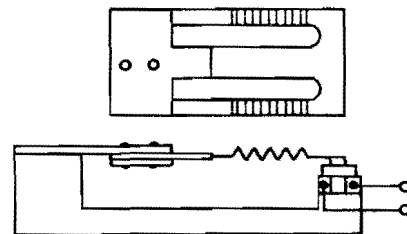

Figure 4-5. E-shaped, bimetallic, snap thermostat

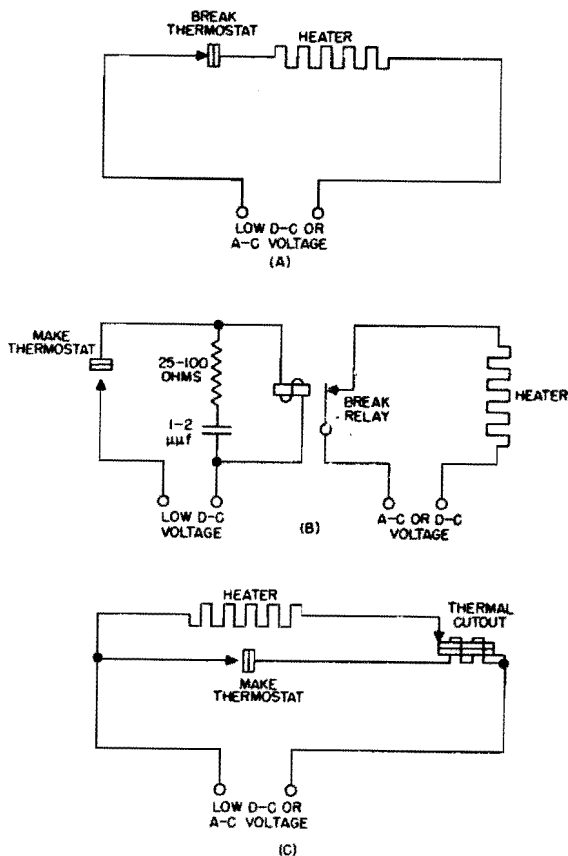

Figure 4-6. Bimetallic thermostat circuits

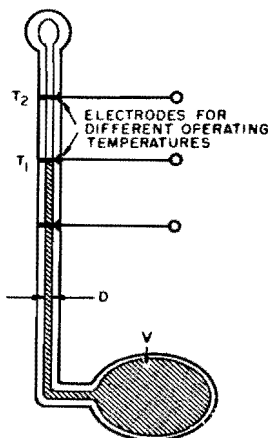

Figure 4-7. Diagram of typical mercury thermostat

Heater Control Circuits Using Bimetallic Thermostats

4-22. Figure 4-6 shows several temperature-controlled heater circuits suitable for use with bimetallic thermostats. Generally, voltages over 30 volts are avoided in the thermostat circuit, 6-volt sources being those most often employed. In circuit 4-6(A), the thermostat contacts must be of sufficient size to pass the full heater current. Differentials as low as $\pm 0.5^\circ\text{C}$ are possible here, but values two and three times this are more common in the average oven. Short cantilever strips mounted in evacuated glass envelopes are the most sensitive per unit length and have comparatively long lifetimes. This type of thermostat is tamper-proof and is the most economical in space and in cost. Its chief disadvantage is that the sealed unit, although permitting a long contact life, prevents the thermostat from being adjustable. Thus, relatively high tolerances in the nominal operating temperature must be allowed the manufacturer.

4-23. Figure 4-6(B) shows a circuit in which a sensitive helix-type bimetallic thermostat can be used to control an electromagnetic relay. The resistance of the relay must be sufficient to limit the current to a value not exceeding the maximum current permissible for the thermostat contacts. In this type of circuit the thermostat current need not exceed 5 or 10 ma, and operating differentials less than $\pm 0.1^\circ\text{C}$ are possible. The resistor-capacitor combination protects the thermostat from high induced voltages when the circuit is opened.

4-24. Figure 4-6(C) is a hot-wire-relay circuit that permits the use of the more sensitive bimetallic thermostats without the disadvantages of highly inductive loads introduced by electromagnetic relays. The hot-wire relay permits thermostat currents as low as 50 ma, and operating differentials as low as $\pm 0.1^\circ\text{C}$.

MERCURY THERMOSTATS

4-25. Mercury thermostats, see figure 4-7, are mercury thermometers constructed with bulb and capillary electrodes which enable the mercury column to close an electrical circuit at a preset temperature. The sensitivity of the average mercury thermostat is on the order of 0.2 in./ $^\circ\text{C}$; but sensitivities 5 times as great are feasible. The sensitivity is directly proportional to the ratio, V/D^3 , where V is the volume of the bulb and D is the diameter of the capillary. Theoretically the sensitivity can be increased indefinitely by increasing the volume of the bulb. Practically this is not possible, because when large bulbs are used ambient effects other than temperature, pressure for example, also become significant factors in deter-

mining the exact height of the mercury column. In addition, the larger the bulb, the greater its thermal inertia, so the slower becomes the response to changes in the temperature of the surroundings. Average operating differentials range from $\pm 0.02^\circ\text{C}$ to $\pm 0.05^\circ\text{C}$. The operating temperature can be adjusted by having separate electrodes in the capillary for each desired temperature, as is indicated in figure 4-7. For a continuous range of operating temperatures, mercury thermostats have been designed with a movable platinum-wire electrode that makes sliding contact with a fixed terminal. The movable electrode is fastened to a small iron rod so that adjustments can be made with the aid of a small permanent magnet. The height of the electrode is varied simply by sliding the magnet up and down the outside of the capillary tube. This type of laboratory thermostat permits excellent frequency precision since the operating temperature of the oven can be adjusted to match exactly the zero-temperature-coefficient point of a crystal.

4-26. Figure 4-8 shows a typical temperature-control circuit employing a mercury thermostat. Note the high resistance in the thermostat circuit. This resistance should be sufficient to limit the current to 1 or 2 microamps or less. At the most, the current should not exceed 5 microamps, otherwise the mercury may become fouled. With negligible currents, the operating life of the thermostat can be quite long. When inoperation does occur it is usually due to capillarity effects. The mercury thermostat, because of its fragility and the size and expense of the associated circuit components is suitable for use only in those large fixed-plant or laboratory crystal ovens that require above-average temperature stability.

Thermistor-Bridge Thermostats

4-27. Thermistor-bridge thermostats have the advantage of requiring no moving parts. Their sensing of temperature changes takes the form of a continuously variable voltage subject to unlimited vacuum-tube amplification, so that theoretically no minimum limit exists for the operating differential. In practice, with the use of high-gain vacuum-tube circuits, the thermistor bridge can be made to respond to temperature differentials as small as $\pm 0.001^\circ\text{C}$. Because of its elaborate circuit requirements the thermistor bridge is not generally practical for temperature control of crystals except when the utmost temperature stability is necessary.

4-28. Figure 4-9(A) is the schematic diagram of a moderately sensitive thermistor circuit which

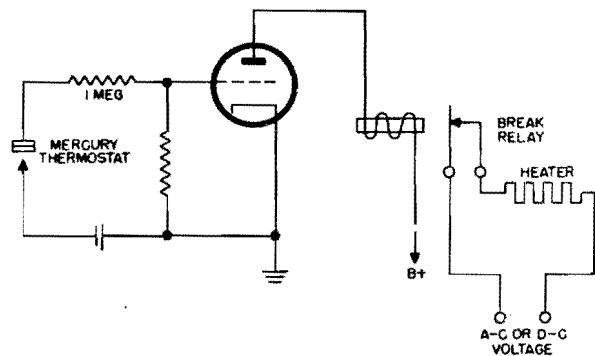
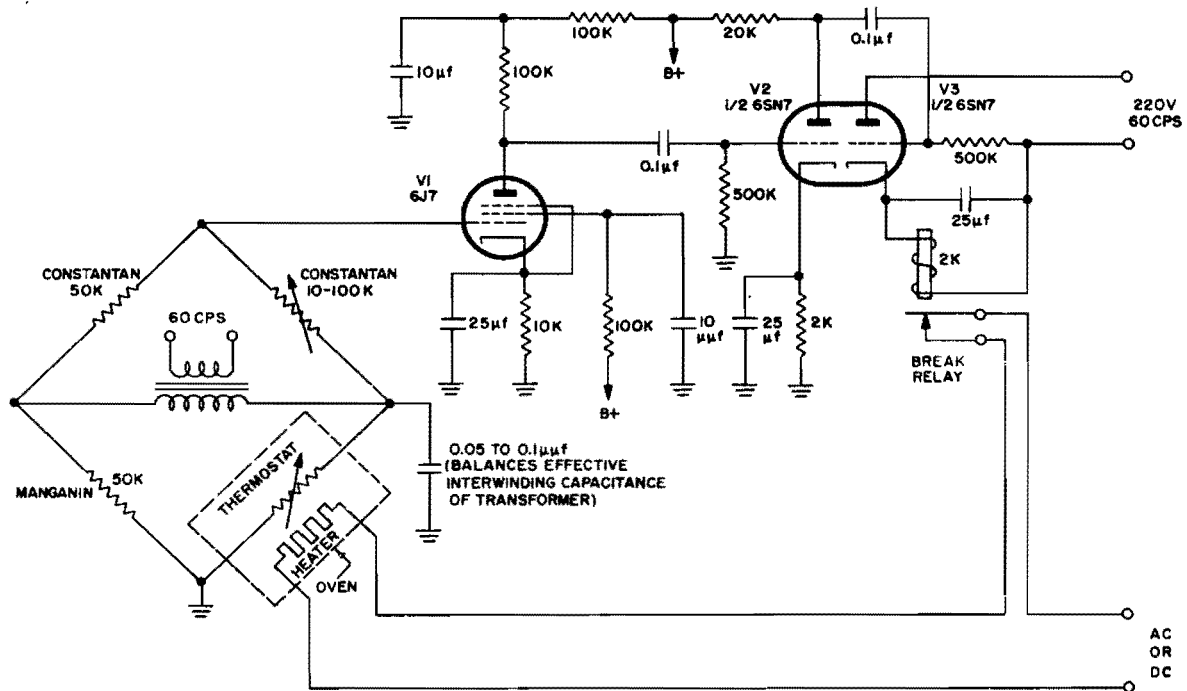

Figure 4-8. Heater control circuit using mercury thermostat

employs a vacuum-tube-operated electromagnetic relay to control the heater current. It can be seen that the input of V_1 is connected across the resistance bridge, which is driven by a 60-cycle signal introduced from the bridge transformer. When the temperature rises to a point where the thermistor resistance balances the bridge, the input signal to V_1 becomes zero. As the temperature continues to rise, the signal again begins to build up, but opposite in phase to its polarity when the temperature was below the balance point. The polarity of the "above-balance" signal is such that the amplified input to V_3 is in phase with the 60-cycle voltage applied to the V_3 plate. Note that V_3 is operated primarily as a half-wave rectifier. The heater relay coil serves as the inductance of the LC filter of the rectified plate voltage, but also as a 2-K cathode-biasing resistance. When the polarities of the V_3 input and plate voltages are in phase, the plate current is sufficient to operate the relay and open the heater circuit. The thermostat circuit that is shown is not sufficiently sensitive to justify its operation for crystal ovens without the addition of at least one more amplifier stage. To be preferred, is a high-gain voltage amplifier used in conjunction with a gas-filled relay tube as shown in figure 4-9(B). If desired, the thermistor can be simply a copper winding. Copper, with a temperature coefficient of resistance of $0.0043/^\circ\text{C}$, will have a resistance variation with temperature 100 or more times that of the manganin bridge arm of equal nominal resistance. Among the metals, the highest temperature coefficients of resistance at normal oven temperatures are those of iron and of nickel, which range between 0.006 and 0.007 parts per $^\circ\text{C}$. The temperature coefficient of tungsten is between 0.0045 and 0.005 part per $^\circ\text{C}$ at oven temperatures.

Thermostat Monitoring

4-29. Where a constant check on the crystal tem-



(A)

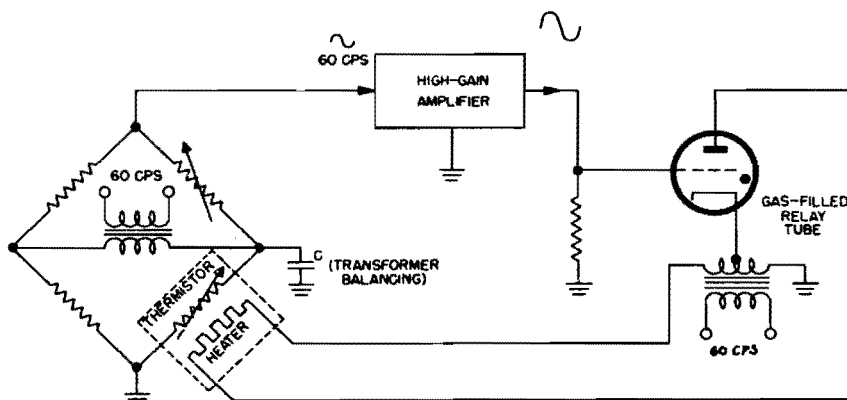

(B)

Figure 4-9. On-off heater control circuits

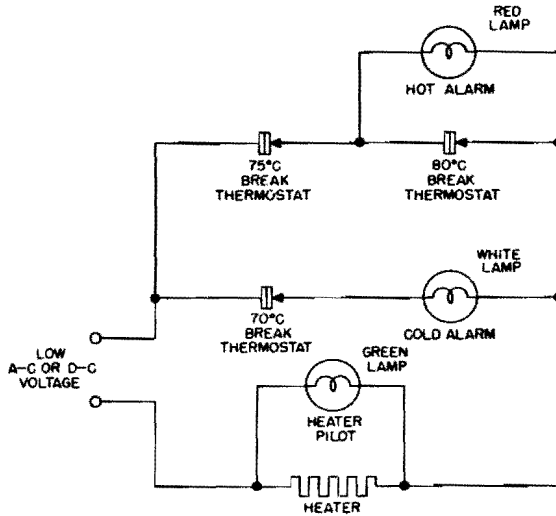

Figure 4-10. Thermostat monitoring and alarm circuit

perature is necessary, additional thermostat circuits can be provided for automatic monitoring. In the event the temperature should fall below or rise above the desired differential range, the thermostat monitoring circuits can be designed to operate alarms or to switch the heater control to a standby thermostat. The possible modifications are quite varied, but relatively easy to design once the basic monitoring requirements of the circuit are agreed upon. Figure 4-10 shows a typical alarm circuit. For simple monitoring, a pilot lamp connected across the heater is sufficient to indicate the on-off operating cycle, and a mercury thermometer is sufficient to indicate the operating temperature.

THERMAL ANALOGUES OF ELECTRICAL PARAMETERS

4-30. The electrical concepts of voltage, current, conductance, and capacitance have their analogues in the thermodynamic laws of heat conduction and storage, where the laws that govern the flow of heat are mathematically equivalent to the laws that govern the flow of electricity. If *difference of temperature* replaces the term *difference of potential*, and *current* is interpreted to mean a net flow of thermal energy past a point per unit time, instead of a net flow of electric charge, then the terms, *thermal conductivity* and *thermal conductance*, and the reciprocals, *thermal resistivity* and *thermal resistance*, are defined by the same relations that define their electrical counterparts.

Thermal Current

4-31. Thermal current, heat/unit time, has the same physical dimensions as power, and, if desired, can be expressed in watts. For example, if a metal rod, well insulated along its length, is heated continuously at one end by an electrical heater imbedded in the rod at that end, the heat will be conducted down the rod at the same rate at which it is produced; so that a proper measure of the thermal current would be the wattage of the heater. Where units of heat capacity are involved, it is common to express heat in units of the gram-, or kilogram-calorie. One gram-calorie is the quantity of heat required to raise the temperature of one gram of water one degree centigrade. One gram-calorie per second equals 4.186 watts. A 1-watt flow of heat is thus equal to a thermal current of approximately 0.25 gram-calories per second.

Thermal Conductivity

4-32. The thermal conductivity, K , of a well-insulated conducting segment of cross-sectional area A and length L is given by the equation

$$K = \frac{I_H L}{\Delta T A} \quad 4-32 (1)$$

where ΔT is the difference in temperature between the two ends of the segment when a steady thermal current, I_H , is caused to flow along the length. If I_H is measured in gram-calories/second, A and L in centimeter units, and ΔT in centigrade degrees, K is expressed in units of gm-cal/sec cm deg C. Approximate values of representative conductivities are given in the following table.

Thermal Conductivity, K (gm-cal/sec cm deg C)	Material
1.0	Copper, Silver
0.5	Aluminum
0.19	Mercury
0.03	Quartz (parallel to Z axis)
0.016	Quartz (perpendicular to Z axis)
0.012	Carbon (graphite)
0.0025	Glass, Porcelain
0.0018	Mica
0.0006	Asbestos paper
0.0004	Rubber, Average Plastic
0.0001	Cork, Glass wool in air
0.00008	Hair felt in air, Rock wool in air
0.000057	Air
0.000052	Nitrogen

Section IV

Crystal Ovens—Design

Thermal Resistance

4-33. The thermal resistance of a conductor of length L , cross sectional area A , and thermal conductivity, K , is defined by the equation

$$R_H = \frac{L}{KA} \quad 4-33 (1)$$

We shall arbitrarily define the unit of thermal resistance to be the resistance of a thermal conductor that requires a difference of temperature of 1°C between the ends of the conductor in order for one calorie per second to flow through it. This unit we shall call a "thermohm."

Thermal Ohm's Law

4-34. When equations 4-32 (1) and 4-33 (1) are combined to cancel the term, L/KA , the following "Ohm's law" for thermal circuits is derived:

$$\Delta T = I_H R_H \quad 4-34 (1)$$

Note that ΔT , the "temperature drop" across the resistance, R_H , of a thermal circuit, is similar to ΔV , the voltage drop across the resistance of an electrical circuit. Where ΔV is a measure of the difference of potential energy per unit charge, ΔT can be shown to be a measure of the difference of kinetic (thermal) energy per unit matter (i.e., per unit particle).

Stefan-Boltzmann Law

4-35. The heat radiation from a surface is not a linear function of the temperature, but obeys a fourth power equation that is known as the Stefan-Boltzmann law:

$$I_R = Ae\sigma T^4 \quad 4-35 (1)$$

where I_R is the total heat radiated per second, A is the area of the radiating surface, e is the *emissivity* of the surface, σ is the Stefan-Boltzmann constant, and T is the temperature in Kelvin (absolute) degrees.

Radiancy

4-36. The radiant energy emitted per second per unit area is called the *radiancy* of a body. Thus,

$$\text{Radiancy} = \frac{I_R}{A} = e\sigma T^4 \quad 4-36 (1)$$

Absorptivity and Emissivity

4-37. An isolated body in thermal equilibrium with its surroundings will necessarily be absorbing and emitting thermal energy at the same rate. A body that absorbs all of the radiation incident to its surface, reflecting none, is called an *ideal black body*. The fraction of the incident radiation absorbed is called the *absorptivity* of the body, which in the case of an ideal black body is equal to 1.

Now, since at thermal equilibrium, the radiancy must equal the rate of absorption per unit area, the radiancy of an ideal black body must equal the radiancy of the empty space surrounding the body. For the same reason, if the absorptivity of a body is small, its radiancy, relative to black body radiancy, must also be small in exactly the same proportion when at thermal equilibrium with its surroundings. The ratio of the radiancy of a body to that of an ideal black body is the *emissivity*, e , of the body. Note that e is also equal numerically to the absorptivity.

Stefan-Boltzmann Constant

4-38. Since e is equal to 1 for an ideal black body, the radiancy of an ideal black body is equal to σT^4 . The constant σ , which equals the radiancy of an ideal black body per (degree)⁴, has been found experimentally to be

$$\sigma = 5.73 \times 10^{-9} \text{ milliwatts/cm}^2 \text{ deg}^4 \text{ K}$$

Expressed in calories,

$$\sigma = 1.37 \times 10^{-12} \text{ cal/sec cm}^2 \text{ deg}^4 \text{ K}$$

Emissivities of Various Substances

4-39. The emissivities of bodies for radiations in the visual range can be judged by the amount of reflection when the body is exposed to white light. Thus, in the case of diffuse reflections, bright white surfaces have low absorptivities, and hence, low emissivities, and dull black surfaces have high emissivities. However, the emissivities of most substances vary considerably with the frequency. A green object, for example, indicates a lower emissivity for the green band of the light spectrum than for the other bands. Asbestos, which is white, has a total emissivity at low temperatures equal to that of lamp black, which is 0.95. Wet ice at 0°C has an emissivity of 0.97, and white hoar frost has an emissivity of 0.985, which is the nearest to ideal black body conditions so far discovered in solids or liquids. The lowest emissivities are to be obtained with polished silver and gold, where at low temperatures values of 0.02 can be realized. Values for the total emissivity of aluminum vary somewhat, ranging from 0.022 to 0.08 at relatively low temperatures. Emissivities of 0.022 and 0.028 appear to be approximately correct for pure aluminum at temperatures of 25°C and 100°C , respectively, whereas the higher emissivities are due to various degrees of oxidation or moisture adsorption at the surface. A completely oxidized aluminum surface, for instance, has an e of 0.11 at 200°C . Surface oxidation usually raises the emissivity of a metal several fold. On oxidation, the emissivity increases from 0.02 to 0.6 for copper,

0.05 to 0.35 for nickel, 0.09 to 0.43 for monel metal, 0.05 to 0.6 for lead, 0.08 to 0.8 for steel, and 0.035 to 0.6 for brass. Quartz, itself, has a relatively high emissivity (approximately 0.9) at low temperatures, so that even if the unplated surface area of a metal-plated crystal is only as much as 1/10 the total area, the total effective emissivity will be several times that of the plated area alone.

Radiant Heat Flow

4-40. Since the absorptivity is equal to the emissivity, the radiant energy being absorbed by a substance is given by the same equation that defines the energy being radiated—that is, by equation 4—35 (1), except that T represents the absolute temperature of the surroundings, rather than of the substance, itself. Thus, the net flow of radiant heat away from a surface, equal to the radiated minus the absorbed energy per second, is given by the equation

$$I_H = I_R - I_A = Ae\sigma (T_o^4 - T_s^4) \quad 4-40 (1)$$

where I_A is the rate of radiant heat being absorbed, T_o is the temperature in Kelvin degrees of the surface, and T_s is the temperature of the surroundings. Now

$$\begin{aligned} T_o^4 - T_s^4 &= (T_o - T_s)(T_o + T_s)(T_o^2 + T_s^2) \\ &= \Delta T(2T_o - \Delta T)(2T_o^2 - 2T_o\Delta T + \Delta T^2) \\ &= \Delta T(4T_o^3 - 6T_o^2\Delta T + 4T_o\Delta T^2 - \Delta T^3) \end{aligned}$$

where $\Delta T = T_o - T_s$. If the difference in the two temperatures is small in comparison with their magnitudes, the percentage error will be negligible for most practical purposes if the higher-power ΔT terms are dropped. Thus, equation (1) can be written approximately

$$I_H \approx 4Ae\sigma T_o^3(T_o - 1.5 \Delta T)\Delta T \quad 4-40 (2)$$

Equivalent Thermal Radiation Resistance

4-41. Technically, thermal conductance and its reciprocal, thermal resistance, are measures of the ability of a substance to transport heat by virtue of molecular impacts alone; but to facilitate the illustration of thermal circuits schematically, we shall represent heat radiation by assuming equivalent conducting paths having appropriate thermal resistances. (Heat transport by air convection shall be treated merely as an increase in air conductance, and not as being due to a separate conducting path.)

4-42. The equivalent radiation resistance indicated by equation 4—40 (2) is

$$R_H = \frac{\Delta T}{I_H} = \frac{1}{4Ae\sigma T_o^3(T_o - 1.5 \Delta T)} \quad 4-42 (1)$$

Equation (1) indicates that for oven surface temperatures between 50° and 85°C (323° and 358°K), the effective radiation resistance approximately doubles as ΔT is varied from 0° to 100°. For example, assuming a T_o of 350°K and an e of 0.08, the effective radiation resistance of 1 sq cm of a partially oxidized aluminum surface will vary approximately from 50,000 to 100,000 thermohms as the ambient temperature increases from 350° to 230°K.

Heat Capacity

4-43. Heat capacity is defined as the thermal energy required to raise the temperature of a substance one degree. The relative capacities of materials for storing thermal energy are more generally described in terms of specific heat. The specific heat of a substance is the heat capacity of one gram of the substance as compared with the heat capacity of one gram of water. Numerically, then, the specific heat is equal to the number of calories required to raise one gram of the substance one degree. The heat capacity of a quantity of matter varies directly with the number of atoms or molecules contained that are free to absorb thermal energy. At the same temperature, the average heavy atom has the same thermal energy per degree of freedom of motion as the average light atom. Thus in solids, where the density of atoms per unit volume does not vary nearly as much as the density of mass per unit volume, the lighter substances generally have the greater specific heats. (For instance, aluminum, which has an atomic weight of 27 and a density of 2.7 gm/cc, has a specific heat of 0.21 cal/gm deg C; whereas lead, with an atomic weight of 207 and a density of 11.3 gm/cc, has a specific heat of 0.03 cal/gm deg C.) If the change in the thermal energy of a system at thermal equilibrium is plotted as the ordinate against the temperature as the abscissa, the slope of the curve at any point is the instantaneous value of the heat capacity at that temperature. At temperatures where there is a change of state, the heat capacity of a substance may rise to a very high value. For example, at 0°C, the instantaneous heat capacity of ice water approaches infinity, since heat can be absorbed without a change in temperature.

Equivalent "Electrical Circuits of Crystal Ovens"

4-44. The relations among the various thermal parameters that affect the performance of a thermostatically-controlled oven can be more readily seen if we represent the equivalent thermal circuit by schematic diagrams, borrowing electrical symbols (see figure 4-11) to represent their thermal

Section IV
Crystal Ovens—Design

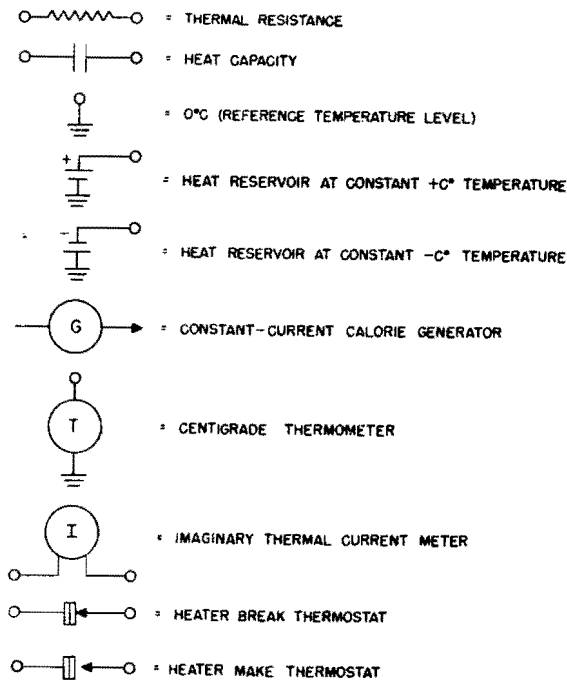

Figure 4-11. Electrical symbols applied to parameters of thermal circuits

analogues. Figure 4-12 is the schematic diagram of the "equivalent electrical circuit" of a representative constant-temperature crystal oven. The actual thermal circuit, of course, consists of continuously distributed heat resistance and capacity. A rigorous quantitative description would require the use of exponential functions and an analysis of the thermal transients. Nevertheless, reasonable approximations can be made and greater simplicity achieved if the circuit is represented by linear, lumped parameters, and steady state conditions assumed, as is done in figure 4-12. The symbols of the circuit parameters indicated in figure 4-12 are defined as follows:

- G_1 = a calorie generator having an output equal to the power losses in the crystal
- G_2 = a calorie generator having an output equal to the wattage of the heater
- T_1 = the temperature, or "difference of potential" between the crystal and "ground" (0°C)
- T_2 = the temperature at the walls of the crystal chamber
- T_3 = the temperature of the heater and thermostat
- T_4 = the ambient temperature, which is represented as determined by the connection of S_1 to the heat-reservoir "battery"
- T_5 = the temperature of the electrical terminals of the crystal unit
- I_1 = current meter reading, which in the steady state equals the output of G_1

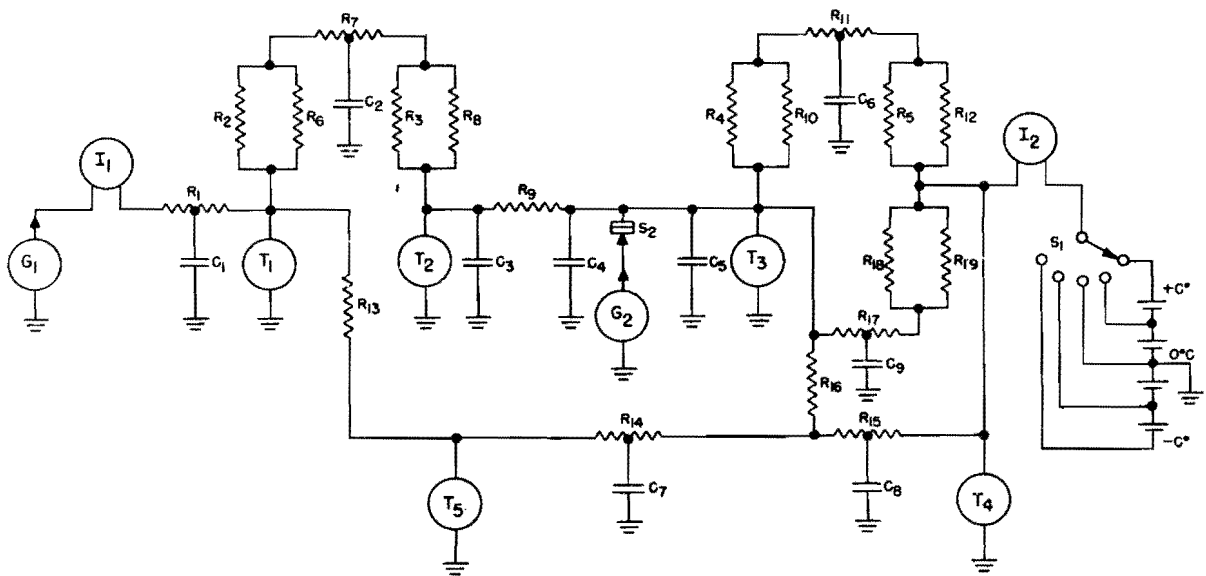

Figure 4-12. Equivalent electrical circuit of crystal oven

- I_2 = average cal/sec passing from the heater and crystal to the outside
- All the resistance values refer to thermal, not electrical resistances.
- R_1 = effective lumped resistance of crystal and electrodes
- R_2 = equivalent resistance to radiation from crystal to walls of holder
- R_3 = equivalent resistance to radiation from holder to walls of inner chamber
- R_4 = equivalent resistance to radiation from heater to outer walls of oven
- R_5 = equivalent resistance to radiation from oven to ambient atmosphere
- R_6 = effective lumped resistance from crystal and electrodes via air to walls of holder
- R_7 = effective lumped resistance of walls of holder
- R_8 = effective lumped resistance of air from holder to walls of inner chamber
- R_9 = effective lumped resistance of walls of inner chamber and of heater surrounding the walls
- R_{10} = effective lumped resistance of air from inner to outer walls
- R_{11} = effective lumped resistance of outer walls
- R_{12} = effective lumped resistance of air surrounding oven (normally reciprocal of equivalent convection conductance)
- R_{13} = effective lumped resistance of wires supporting crystal
- R_{14} = effective lumped resistance of crystal-unit electrical leads and terminals
- R_{15} = effective lumped resistance of external circuit and electrical insulation
- R_{16} = effective lumped resistance between terminal leads and the heat distributing layer of oven chamber
- R_{17} = effective lumped resistance of base, including electrical ground connection
- R_{18} = effective lumped resistance of air and mounting fixtures in contact with base
- R_{19} = equivalent resistance to radiation from base of oven
- C_1 = effective lumped heat capacity of crystal and electrodes
- C_2 = effective lumped heat capacity of holder, except the electrical leads
- C_3 = effective lumped heat capacity of inner walls of oven chamber
- C_4 = effective lumped heat capacity of heater and outer heat-distributing wall of oven chamber
- C_5 = effective lumped heat capacity of thermostat and miscellaneous fixtures in close

- thermal contact with outer heat-distributing wall of oven chamber
- C_6 = effective lumped heat capacity of outer wall
- C_7 = effective lumped heat capacity of electrical leads in crystal holder
- C_8 = effective lumped capacity of external electrical circuit
- C_9 = effective lumped capacity of base
- S_1 = imaginary control varying the ambient temperature
- S_2 = thermostat switch controlling heater

In general, the resistance values close to the crystal are larger than those farther removed because of the much smaller cross sectional area of the conducting path. On the other hand, the capacitance values farther out are much greater than the inner values because of the larger volumes contained. Because it is desired to keep the weight and volume as small as possible, as well as the time required to bring the oven to the operating temperature, those conditions that would tend to increase the heat capacity of all parts except the inner chamber wall (C_3) between the heater and the crystal are generally considered undesirable, and the design engineer is normally more concerned with providing sufficient insulation and a uniform distribution of the heat under steady-state conditions. Under steady-state, or "d-c" conditions the values of the capacities are of no significance, but since the heater is being alternately turned on and off, there is an "a-c" component in the heat flow; in this connection the capacity effects must be considered.

4-45. The principal function of the circuit in figure 4-12 is to maintain the temperature T_1 of the crystal unchanged when the ambient temperature T_2 is varied. To a first approximation, this end is achieved by interposing between the crystal and the outside the constant-temperature heat reservoir, C_1 , which is kept "charged" at the desired operating temperature by the thermostatically controlled constant-current calorie generator, G_2 . The on-off operation of the calorie generator causes the temperature of C_1 to cycle slightly above and below the operating mean; so, to attenuate the a-c component, an RC thermofilter is interposed between the C_1 -reservoir and the crystal.

4-46. The performance of the circuit in figure 4-12 shall be described as dependent primarily upon the individual performances of six overlapping circuits; three of which are d-c circuits, two, a-c, and one is a transient circuit. One of the d-c circuits conducts the crystal power to the outside,

Section IV

Crystal Ovens—Design

the second conducts the heater power to the outside, and the third is the thermal link between the heater and the thermostat. Of the a-c circuits, one is the filter circuit between the heater calorific generator and the crystal—it attenuates the a-c component of the heater temperature; the other is the a-c path from the oven heat reservoir to the outside—it is effective in determining the cycling frequency. The transient circuit is essentially the two a-c circuits combined—it determines the warm-up time. Each of the d-c circuits is discussed separately. The a-c and warm-up circuits, because of their overlapping functions, are discussed jointly.

4-47. The resistive and capacitive parameters can be interpreted as having the effective lumped values that would be measured under steady-state conditions. In the d-c circuits, the heat capacities can be ignored as long as steady-state conditions are assumed. Only when there are fluctuations in the heat flow do the capacity effects need to be considered. For those oven elements that have relatively large ratios of specific heat to resistivity, such as the metallic parts, not too much error is introduced in the a-c circuits by treating the element entirely as a lumped “capacitor,” having an effective heat capacity equal to its actual heat capacity. For those elements that have very small ratios of specific heat to resistivity, such as the air spaces, the error introduced in the a-c circuits by treating the element entirely as a lumped “resistor,” having an effective resistance equal to its actual resistance, can also be considered negligible. Where the greatest tolerances must be allowed the lumped parameters, is in the interpretation of the a-c characteristics of those oven parts that have relatively high specific heats as well as high resistivities, such as plastics and other insulating compounds.

D-C PATH OF CRYSTAL POWER

4-48. Figure 4-13 is a simplified schematic of the equivalent d-c circuit of the crystal unit which conducts the crystal power to the outside of the crystal holder. The external reservoir symbolized by the battery connection can be interpreted as being any constant-temperature heat reservoir of temperature T_3 , without regard to whether the crystal unit is oven mounted or not; otherwise, all symbols are the same as in figure 4-12. The heat from the constant-current generator G_1 , divides between the three resistance paths, that part flowing through each branch being inversely proportional to the respective branch resistance. Note that as long as the heat flow and the resistances

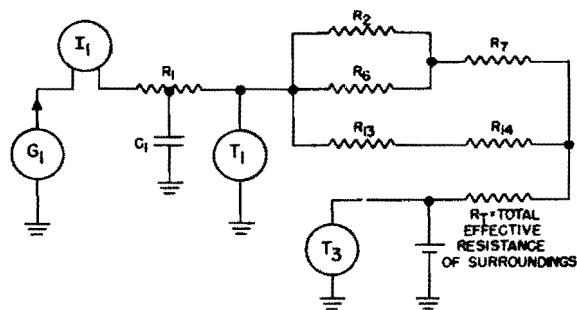

Figure 4-13. Thermal D-C path of crystal power

remain constant, so also does the temperature drop $T_1 - T_3$, so that a given change in the steady-state value of T_3 must cause exactly the same change in T_1 .

4-49. Normally the crystal circuit is designed for a constant drive level, but if, for instance, the crystal is connected in an oscillator stage that is to be keyed by a push-to-talk microphone circuit, there would be little to gain by the use of an oven of high inherent stability. If high temperature stability is desired, a first requirement is that of a crystal circuit providing a constant drive. This, in turn, is best achieved by operating the crystal at the lowest drive level that is practicable. For a small (1-cm diameter) wire-mounted crystal unit, the principal leakage is through R_6 , the air resistance. The temperature drop across R_6 for each milliwatt of drive will be on the order of 0.3°C . Should the drive vary by as much as $\frac{1}{3}$ mw the temperature would vary by 0.1°C . This much variation is ten times more likely at a drive of 5 mw than at one of 0.5 mw. If the same sized crystal unit were evacuated, R_6 would become infinite, and all the leakage would be through R_2 and R_{13} . The total resistance could thereby increase ten-fold, so that a $\frac{1}{3}$ -mw variation in the drive would mean a temperature variation of 1°C . Should a drive of 3 mw for the same crystal be alternately turned off and on, the crystal temperature would vary by approximately 10°C , and a well-designed oven would be practically useless. If fluctuations in the drive are to be anticipated, optimum temperature control is to be had with the use of sandwich-type crystal units, even though these usually require higher drives than do wire-mounted units. Not only is the thermal resistance between the crystal and the holder negligible compared with that of the wire-mounted unit, but the large heat capacity of the sandwich electrodes, as compared with the thin metal films of the plated electrodes of the wire-mounted units, considerably

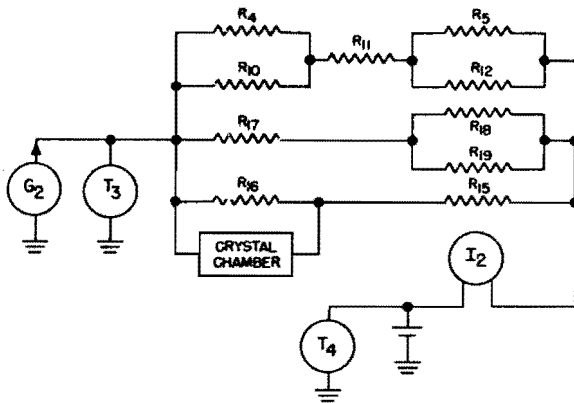

Figure 4-14. Thermal D-C path of heater power

increases the effective heat capacity (C_1 in figure 4-13) of the crystal, and hence can minimize the effects of brief fluctuations in the output of G_1 . In the case of a low-frequency, wire-mounted crystal vibrating in a flexural mode, where it is necessary to evacuate the holder to prevent an excessive damping by the air, it is advantageous if a large area of the crystal is not plated. Otherwise, the low emissivity of the silver, or other metallic film, will cause R_2 to be excessive, thereby raising the temperature of the crystal and increasing its sensitivity to small fluctuations in the drive. For a given drive level, the larger the value of C_1 , the more stable is the temperature of the crystal during brief fluctuations in either the crystal drive or the oven temperature. Also, the larger the magnitudes of R_2 , R_6 , and R_{13} , the less sensitive is the crystal to brief fluctuations in the oven temperature; but, on the other hand, the crystal will be more sensitive to changes in the drive level, whether or not these changes are of brief or long duration.

D-C PATH OF HEATER POWER

4-50. The thermal path by which the heater power escapes to the outside is represented schematically in figure 4-14. The symbols apply to the same parameters as in figure 4-12. The power requirements of the crystal oven equal the average rate of heat flow (I_2) from the heater to the outside. The equation for the leakage current is

$$I_2 = \frac{T_3 - T_4}{R_T} \quad 4-50 \quad (1)$$

where R_T represents the total resistance from T_3 to T_4 . I_1 , the crystal power flow (see figure 4-12), can be considered negligible. A large part of the heat flows through R_{11} , the resistance of the outer walls and top of the oven, although some leakage

is through R_{16} into the electrical circuit, and a large leakage occurs at the base through R_{17} . Because of the large radiation losses if the oven is inclosed in a plastic container, the total resistance through the walls and top can be approximately doubled if the outer walls are composed of polished metal instead of plastic, even though the actual resistance, R_{11} , of the outer oven walls, in itself, becomes negligible. For optimum operation, the oven must be shielded, with baffles if necessary, from forced convection currents in the ambient air; such as might be encountered from blowers, fans, etc. Where the space is available, as in large heavy-duty fixed-plant equipment, the oven should have the protection of two reflective insulating walls separated by a thick air space padded with loose-fill insulation of sufficient density to prevent convection currents between the walls. (Reflective surfaces in series are additive in their insulating effects.)

4-51. In an average aluminum-walled crystal oven, the heat leakage through the base, R_{17} , may well be as great as that through the other five sides of the oven combined. Partly compensating the large conductance of the base is the fact that convection currents in the air are retarded when the heat is escaping *under* horizontal surfaces, since the surface prevents the warmed layers of air from rising. Thus, the effective resistivity of the air beneath a relatively large base may be more than three times that at the top of the oven. Of course, if the air under the crystal oven is circulating due to convection currents initiated in other parts of the equipment in which the oven is used, this advantage will not be in effect. If the oven is a small socket-mounted device, the direct-thermal contact of the base with the socket eliminates most of the air surface, so that the effective conductivity of the base is much greater than if the same oven were mounted on legs, or were otherwise supported so that a large air space exists between the base and the chassis.

4-52. From the point of view of low operating power, it is desirable to keep R_{16} , the leakage path from the inner chamber walls to the electrical circuit, as large as possible. On the other hand, from the point of view of temperature control, as discussed earlier, R_{16} should be as small as possible, so that the temperature of the walls of the inner chamber is readily communicated to the terminals of the crystal unit. This is not easily done since the electrical insulation around the crystal leads also serves as thermal insulation. The problem is analogous to an attempt to maintain some point in an electrical circuit at ground potential, but with

Section IV

Crystal Ovens—Design

no other connection to ground than through the insulation.

4-53. A plastic sheath for a single crystal terminal will have a thermal resistance on the order of 800 thermohms—400 thermohms for each pair of terminals. For an oven that houses four crystal units, even though only one crystal is operating at a time, R_{16} would be on the order of 100 thermohms. This decrease in resistance means only an additional leakage from the heater, and not an increased effectiveness in the control of the temperature of the operating crystal. Insofar as the one crystal in operation is concerned, there is still approximately 800 thermohms between each of its terminals and the constant-temperature reservoir, as compared with perhaps an effective resistance of 400 to as low as 10 thermohms between each terminal and the ambient heat reservoir, depending upon the particular type of connection to the external circuit.

4-54. For a small plastic-enclosed, socket-mounted oven, similar to type HD-54/U, approximately 5 cm high, 3 cm wide, and 2 cm deep, the total resistance of the walls and top—the R_1 , R_3 , R_{10} , R_{11} , R_{12} combination—may be assumed to be on the order of 250 thermohms under ambient conditions of room temperature and no forced convection. The total resistance of the base, R_{17} , including that of the heater terminals, screws, ground terminal, in parallel with the resistance of the plastic material, can be estimated as approximately 100 thermohms; and this can be assumed to be in series with another 100 thermohms where most of the leakage is through direct contact with the socket. Thus, the total base resistance, but not including the leads from the crystal, itself, can be assumed to be 200 thermohms. The third leakage branch, $R_{16} + R_{15}$, can be assumed to total 600 thermohms. Since the only net flow of heat from the crystal chamber will be the power losses of the crystal, a perfectly designed oven would not have a net circulation of heat from the heater into one part of the chamber and out another—i.e. R_{16} would be zero. In the practical case there is a tendency, usually, for the top of the chamber to be warmer than the bottom, so that a net conduction of heat exists from the top to the bottom. Nevertheless, insofar as the heater power is concerned, the crystal-chamber path in parallel with R_{16} can be neglected. Thus, the total thermal resistance, R_T , can be considered to be that of three branches of 250, 200, and 600 thermohms in parallel, or a total of approximately 95 thermohms when no forced convection is present.

4-55. If it is assumed that the oven temperature

is 75°C and that the ambient temperature is 30°C, then

$$I_2 = \frac{75 - 30}{95} = 0.48 \text{ cal/sec}$$

or

$$I_2 = 0.48 \times 4.186 = 2 \text{ watts}$$

Since there is a difference in temperature of 45°, the power consumption under no-convection conditions averages approximately $2/45 = .045$ watt for each degree that the ambient temperature is lower than the oven temperature. With the ambient temperature averaging 30°, a 10-watt heater would be operating one-fifth of the time after the oven had reached equilibrium. Note that this equilibrium condition must hold irrespective of the sensitivity of the thermostat, or the heat capacity of the oven. If the same oven is operated under conditions of moderate forced convection, the total resistance can be more than halved; in which case, the power consumption may increase to as much as a 0.1-watt average for each degree difference between the ambient and oven temperatures. Under these circumstances, the maximum operating range for a 10-watt heater is 100°, which is equivalent to a minimum ambient temperature of -25°C for a 75°C oven. (At the minimum ambient temperature, the heater circuit closes permanently. A further drop in ambient temperature would be accompanied by an approximately equal drop in the oven temperature.) Even where no forced convection is present, the effective total resistance, R_T , of an oven tends to decrease as the difference between the operating and ambient temperatures becomes large. This is because the natural convection around the sides and at the top of the oven becomes greater as the temperature gradient at the outer surface becomes steeper. Partially counteracting the decrease in the equivalent air resistance is the fact that the equivalent radiation resistance tends to increase as the ambient temperature falls.

D-C CIRCUIT BETWEEN THERMOSTAT AND HEATER

4-56. The average crystal oven now in use is built with a hermetically sealed thermostat located either in the crystal chamber, itself (as is generally the case in ovens housing more than one crystal unit), or mounted on top of the chamber in a sealed container that makes good thermal contact with the roof of the chamber. In the former arrangement the temperature deviation can never be reduced below the sensitivity of the thermostat, regardless of how well the rest of the oven is designed, so that high precision in the control

of the temperature cannot be achieved without the use of expensive thermostats. If the temperature deviation is to be reduced to a minimum without excessive cost, the thermostat must be so located that it operates before, rather than after, the temperature in the crystal chamber varies. However, the thermostat cannot be placed between the heater and the outside, for then the heat generator would lie between the crystal and the constant temperature point, A, of the d-c circuit, as illustrated in figure 4-15. The average heater temperature, T_H , and hence, the average crystal temperature, T_C , would vary with the changes in the IR drop across the resistance (R_1) between the heater and the thermostat. Since point A is maintained at a constant average temperature by the thermostat, the current through R_2 varies linearly with the ambient temperature. However, since I_H also flows through R_1 , the heater temperature, T_H ($= T_A + I_H R_1$), must also change linearly with the ambient temperature. Thus, it is necessary that the thermostat either be in nearly direct thermal contact with the heater, or lie between the heater and the crystal. The former arrangement is usually the most to be desired in order to minimize the power requirements as well as the amplitude of the heater temperature cycles.

A-C CIRCUIT OF OVEN THERMOFILTER

4-57. If the temperature cycling amplitude is to be reduced to a minimum before it reaches the crystal, the oven can be designed to make use of a thermofilter. The thermofilter is the analogue of an electrical RC filter that is used to smooth out the ripples of a pulsating d-c voltage. Although a greater percentage of the resistance and capacity of the thermofilter is of a distributed nature than is the case for its electrical analogue, the thermofilter characteristics can be analyzed to a first approximation by assuming that the resistances and capacitances are in a lumped form.

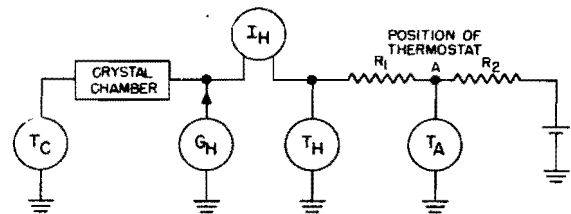

Figure 4-15. Thermal D-C path of heater-to-thermostat when thermostat is outside heater

4-58. Figure 4-16 is a simplified schematic diagram of an oven a-c circuit having a single section thermofilter, where it is assumed that the ambient temperature is at "ground potential" (0°C). R_A is the resistance of the air outside the oven, R_O is the resistance of the oven between the heater and the outside, R is the input resistance of the filter, R_{CC} is the resistance of the crystal chamber, R_{CH} is the resistance of the crystal holder, C_O is the capacity of the walls of the oven, C_H is the capacity of the heater, C_T is the capacity of the thermostat, C is the capacity of the filter, C_{CH} is the capacity of the crystal holder, and C_C is the capacity of the crystal. In general, in going from R_A to C_C , the resistances become progressively larger, and the capacities become smaller, with the exception of C , which should be large. I_G is the instantaneous calorie output per second of the heater when operating; I_H is the average d-c leakage to the outside, and I_{AC} is the peak a-c current through the filter. The component of the a-c current through R_{CC} and R_{CH} can be assumed to be negligible compared with the total I_{AC} . T_H is the temperature of the heater.

4-59. The peak-to-peak amplitude of the a-c component of the temperature T_H is determined by the backlash of the thermostat, and can be assumed to be constant. In the ideal case, the heater and the thermostat should at all times be at the same

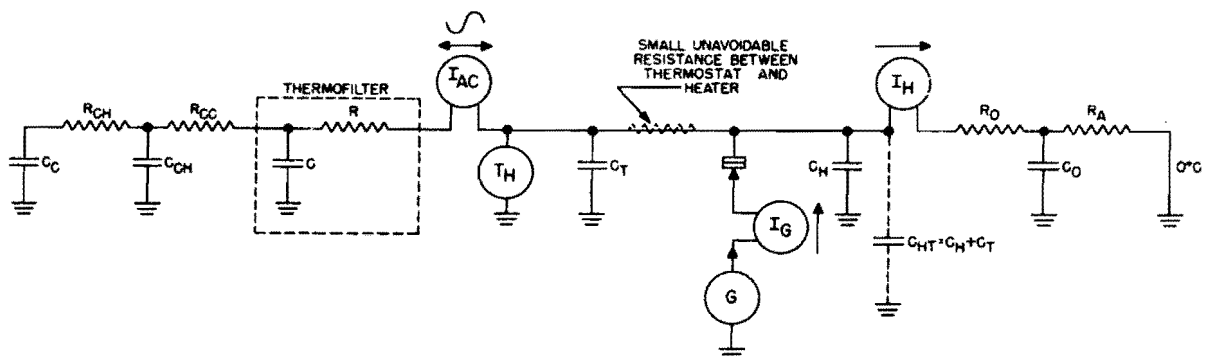

Figure 4-16. Oven thermal A-C circuit

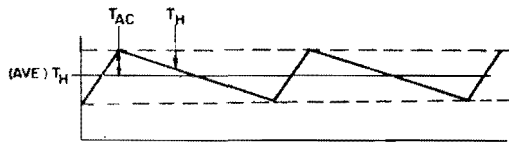

Figure 4-17. A-C component of heater temperature

temperature. In practice, there is always a thermal IR drop between the thermostat and the heater, so that the a-c component in temperature at the heater is always greater than the temperature cycle of the thermostat.

4-60. Referring to figure 4-16, if I_G is large compared with I_H , the rate at which C_{HT} ($= C_H + C_T$) is "charged" can be assumed to be constant, and if the a-c component of the temperature is small compared with the temperature drop between the heater and the outside, the rate at which C_{HT} discharges can be assumed to be constant for a constant ambient temperature (0°C in the diagram). Thus, the a-c component of T_H can be represented by a saw-tooth wave as indicated in figure 4-17. By a Fourier analysis, such a wave is represented as the resultant of a sine wave of the same fundamental frequency, upon which is superimposed an infinite number of harmonics of varying amplitudes. Insofar as the oven filter circuit is concerned, the only component to consider is the fundamental; for if the thermofilter can attenuate the amplitude of the fundamental below the maximum deviation permissible for the crystal, then certainly the higher harmonics will also be sufficiently attenuated.

ATTENUATION FACTOR OF THERMOFILTER

4-61. In figure 4-16, C_{HT} can be assumed to be an alternating temperature generator having a sine-wave output at the fundamental frequency of the thermostat cycling, and a peak amplitude of T_{AC} . The filter circuit presents an impedance to the heat flow of $\sqrt{R^2 + X_C^2}$, where X_C is the thermal "reactance" of C . If R is assumed to be greater than $10X_C$, then I_{AC} can be assumed to approximately equal T_{AC}/R . Note that only the peak values of the a-c current and temperature need be considered. The a-c component of the temperature at C will thus be $I_{AC}X_C = T_{AC}X_C/R$, so that the attenuation factor is X_C/R . Since $X_C = 1/2\pi fC$, where f is the frequency, the attenuation is directly proportional to R , C , and f . Contributing to the attenuation—indeed, effectively forming two additional RC filter sections—are the $R_{CC}C_{CH}$ and the $R_{CH}C_C$ diffusive combinations of the crystal chamber and crystal unit.

THERMOSTAT-HEATER A-C CIRCUIT CHARACTERISTICS AFFECTING FREQUENCY OF TEMPERATURE CYCLE

4-62. The cycling frequency, f , depends upon the rate at which C_{HT} charges and discharges. The charging time is inversely proportional to I_G (I_H and I_{AC} assumed to be small by comparison); the discharging time is inversely proportional to I_H (I_{AC} assumed to be small by comparison); and both the charging and discharging times vary directly with C_{HT} . Since there is always a resistance path between the heater and thermostat and since the thermostat has a heat capacity separate from C_H , the rise in temperature at the thermostat must lag the rise at the heater. Because of this, I_G cannot be made indefinitely large, else the rise in temperature at the heater will far overshoot the thermostat cut-off temperature, and T_{AC} will become excessive. Also, the time gained on the charging half of the cycle could be more than lost because of the additional time required for discharge. Thus, the thermostat-to-heater resistance and capacitance are practical factors that limit the frequency and raise the a-c amplitude of the heater temperature. For a minimum T_{AC} and a maximum frequency, the thermostat must be mounted so that the conductance between it and the heater is a maximum. Another factor limiting the maximum practical cycling frequency is the fact that when a bimetallic thermostat is used, it is desirable that the temperature cycles have as long a period as possible, for, in general, the operating life is rated in the number of open-and-closed cycles that can be made before the thermostat becomes over-fatigued, and is not primarily dependent upon the actual number of hours at which the thermostat can be operated.

4-63. Since the oven is purposely designed to make I_H as small as possible, R_O and R_A cannot be decreased for the sake of increasing the cycling frequency. But if an oven is so constructed that the heat from the heater is evenly distributed on all six sides of the inner chamber, and that a near-perfect conductance exists between the heater and thermostat, the temperature deviation of the crystal at low ambient temperatures can actually be less than that at room ambient temperatures. This is because the consequent increase in f , due to the increase in I_H and decrease in discharge time, permits greater cycling attenuation by the filter. The frequency, however, can only increase as long as I_G remains large compared with I_H . Otherwise, the decrease in the time of discharge would be annulled by the increase in the time of charge.

4-64. More or less predetermined, is the capacity

of the heater and the metallic surfaces that bound it. Although the outer shield can be made as thin as possible, thereby reducing C_H , the inner wall must be of sufficient thickness to provide a low resistance around the crystal chamber. Representative values of C_H for small ovens range from 2.5 to 25 cal/deg, depending principally upon the area of the heater walls, and the thickness of the outer sheath. If I_H is 0.25 cal/sec (approximately 1 watt), and T_{AC} is $\pm 5^\circ\text{C}$, then the time of discharge of a 6-cal/deg C_H (ignoring the thermostat C_T) will be $10 \times 6/0.25 = 240$ sec, or 4 minutes. If I_G is 2.5 cal/sec, the charging time will be $10 \times 6/(2.5 - 0.25)$, or approximately 27 sec. Thus, f will be $1/267$ cycle per second. Obviously with such a very low frequency, and with R of the filter limited to practical values of, at the most, only a hundred or so thermal ohms, an effective filter would require that an extraordinarily large C be contained in the small volume between the heater and the crystal chamber. However, if the thermostat is in excellent thermal contact with the heater, the effective T_{AC} can be made to approach the actual differential of the thermostat; in which case, not only is the cycling temperature reduced at the source, but the attenuation factor of the filter is improved proportionately by the increase in f .

IDEAL THERMOFILTER

4-65. It should be remembered that heat capacity expresses a *change* in heat for a *change* in temperature. In general, the heat capacity of a substance will be different at different temperatures. The *average* heat capacity of a body between two temperatures T_1 and T_2 is $\Delta H/(T_1 - T_2)$, where ΔH is the thermal energy required to raise the temperature of the body from T_2 to T_1 . The *instantaneous* heat capacity at a given temperature is the ratio of an infinitesimal change in thermal energy for an infinitesimal change in temperature, dH/dT . Now, if at a particular temperature the thermal equilibrium of a substance suddenly shifts from a state of low potential energy to a state of high potential energy, the addition of a small quantity of heat will be absorbed in raising molecules from the lower to the higher energy level, so that the added energy is principally an increase in potential, rather than in kinetic energy. However, it is the kinetic energy of the molecules that determines the temperature, so that if a small addition of heat is entirely converted into potential energy, dT will be zero, and the instantaneous heat capacity dH/dT will be infinite.

4-66. In this manner a very large C can be ob-

tained for a thermofilter if a substance is chosen that undergoes a reversible change of state at the operating temperature of the oven. Obviously a non-reversible action would be unsatisfactory, such as the decomposition of a compound, since it is necessary that the same process be repeated during each temperature cycle. Such changes of state as occur at the transition of a crystal from one lattice structure to another, or at the melting and boiling points of substances that do not decompose would permit very high values of C for a small quantity of the material.

4-67. The largest C for a given quantity of substance can be obtained at a boiling point, since the heats of vaporization are generally much greater than the heats of fusion or transition. But the problem of cooling the distillate and returning it to the heated chamber would require an expensive and cumbersome oven. Since heats of fusion are generally much higher than heats of transition, are absorbed during narrower temperature ranges, and are more easily found at a desired operating temperature, a large thermofilter capacity effective at the operating temperature appears to be more readily obtainable by surrounding the crystal chamber with a solid having its melting point within the differential range of the thermostat, but slightly higher than the operating mean. If the melting solid has a very sharp melting point, there is a danger that the mean temperature may rise above the melting point long enough to completely melt the solid, thereby losing the major filtering effect. To remove this danger, the filter can be composed of a mixture of two or more compounds of different melting points, so that, at equilibrium, the densities of the compounds relative to each other will be different in the solid and liquid phases of the partly melted mixture. Although the filtering effect will be diminished, the melting temperature will automatically tend to rise with the mean heater temperature as more of the mixture fuses.

4-68. The substance to use for an ideal heat reservoir, other than one having a melting point at the desired operating temperature, would be a stable electrical insulator having little tendency to react with metal, a low density, a large heat of fusion, a prompt rate of melting and crystallization, a low dielectric constant, a low cost of production, and not be difficult or disagreeable to handle. Recent experiments by C. P. Saylor and R. Alvarez of the National Bureau of Standards indicate the probable suitability of para-dibromobenzene.

4-69. The fact that a number of possible filter elements have a large percentage volumetric ex-

Section IV
Crystal Ovens—Design

pansion on fusion suggests the interesting possibility of employing the expansion to open the heater circuit when the filter material is partially melted. A pure fusing element could thus, theoretically, provide thermostatic action by virtue of a cycling internal-energy differential, rather than a cycling temperature differential. In other words, a change in the temperature of the sensing element of the thermostat would not be an absolute requirement in the ideal case.

4-70. To shorten the warm-up time and to minimize temperature gradients, good thermal conductivity should be maintained within a melting-point thermofilter reservoir; if necessary, by the use of wire mesh or radial fins. However, no through high-conductivity path should be permitted. A relatively high-resistance surface barrier should insulate the inner side of the reservoir from the side nearest the heater.

WARM-UP CIRCUIT OF OVEN

4-71. The warm-up circuit of the oven consists primarily of the thermofilter and thermostat-heater circuit shown in figure 4-16. Arbitrarily, we shall define the warm-up time to be the period required to bring the temperature of the crystal chamber to within 1 per cent of its mean operating value after the heater is first turned on. As a first approximation, this period can be divided into two parts. The first part consists of the time required for the heater, viewed as a constant-current generator, to charge the heater and thermostat capacities, C_H and C_T , to the operating temperature. The second part consists of the additional time required to bring the crystal chamber to within 1 degree of the operating temperature. Normally, a booster heater is provided which permits the first part of the warm-up time to be shortened to as much as one-fourth or more of the time that would otherwise be required. Letting C_{HT} in cal/deg equal the sum of C_H and C_T , I_N in cal/sec equal the average net rate of heat supplied the oven during the initial heating period (this can be assumed to be the total power from the two heaters minus one-half the average operating power after equilibrium has been reached), and ΔT equal the difference between the operating and ambient temperatures, the first part of the warm-up time is approximately

$$t_1 \text{ (in sec)} = C_{HT}\Delta T/I_N \quad 4-71 \text{ (1)}$$

4-72. To the extent that a crystal oven can be represented by the thermofilter circuit in figure 4-16, the second part of the warm-up time can be broadly generalized as the time required for

the capacity, C , to acquire $100(\Delta T - 1^\circ)/\Delta T$ per cent of its warm-up heat. To simplify the problem, we shall assume that no heat flows into C until after the first part of the warm-up period is completed. As in an electrical circuit, the product, RC , is a time constant equal to the time required for the capacity to receive 63 per cent of its equilibrium charge when connected in series with the resistance and a constant potential source. To receive $100(\Delta T - 1^\circ)/\Delta T$ per cent of its equilibrium charge will require a time

$$t_2 \text{ (in sec)} = -RC \log_e \left(\frac{1^\circ}{\Delta T} \right) \quad 4-72 \text{ (2)}$$

Thus, the total warm-up time by rule-of-thumb approximation is

$$t \approx t_1 + t_2 = \frac{C_{HT}\Delta T}{I_N} - RC \log_e \left(\frac{1^\circ}{\Delta T} \right) \quad 4-72 \text{ (3)}$$

Equation 4-72 (3) is only approximate when $t_1 \ll t_2$ and when C is large compared with the distributed capacity of R . If C is attributable entirely to the distributed capacity of an insulating baffle, equation 4-72 (3) is not applicable—unless C and R are prorated from the distributed parameters. If only a general indication of the warm-up time is desired, let R equal the steady-state resistance, and let C equal one-half the actual total capacity of the baffle. The actual warm-up time of the crystal blank itself is a variable that will depend upon the fabrication of the crystal unit and its drive level. For most purposes it can be assumed that, with the aid of the crystal driving power, the temperature of the crystal blank will not significantly lag the rise in temperature of the crystal chamber during the warm-up period. Approximate values of $-\log_e(1^\circ/\Delta T)$ for representative values of ΔT are given in the following table.

ΔT	$-\log_e(1^\circ/\Delta T)$
3	1.0
5	1.6
10	2.3
20	3.0
30	3.4
40	3.7
50	3.9
60	4.1
70	4.3
80	4.4
90	4.5
100	4.6

Pin-to-Pin Electrical Capacitance of Crystal Oven

4-73. It should be remembered that the pin-to-pin capacitance of the oven is not necessarily the capacitance that the oven adds to the shunt capacitance of the crystal unit. For example, in figure 4-18, assume that C_1 and C_2 are both $4\mu\mu\text{f}$ and that C_3 is $2\mu\mu\text{f}$. It can be seen that if neither pin is grounded, the total pin-to-pin capacitance is $4\mu\mu\text{f}$; but if one pin is grounded, the total pin-to-pin capacitance is $6\mu\mu\text{f}$. Also, it can be seen when a crystal unit is inserted in its oven socket, that although the pin-to-pin capacitance of the oven is shunted across the crystal, the crystal shunt capacitance does not increase by that same amount. In effect, since the crystal pins are shielded by the oven receptacles, the oven capacitance substitutes for, rather than adds to the external pin-to-pin capacitance of the crystal unit.

Base Leakage of Small Ovens

4-74. The smaller the crystal oven, the more difficult it becomes to control the chamber temperature, not only because the surrounding heat capacity becomes smaller, but also because the percentage of heat leakage through the base becomes greater, resulting in steeper temperature gradients within the crystal chamber. Improved performance can generally be obtained by concentrating more than an average proportion of the heater windings near the base. An interesting and very successful innovation in this direction occurs in a recent oven design by B. C. Hill, Jr. of HEEMCO. In the Hill oven, the heater windings are extended around the base leads, which therefore are maintained at essentially the heater temperature and so exhibit much less tendency to

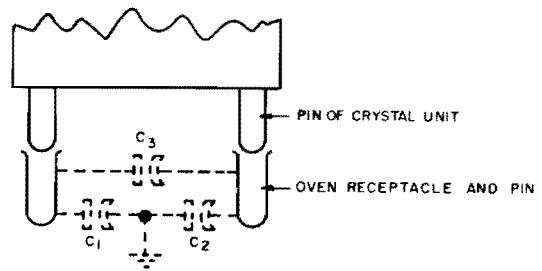

Figure 4-18. Pin-to-pin electrostatic capacitance of crystal oven

follow the changes in the ambient temperature. An entirely different approach, one which ingeniously exploits the fact that the temperature at the base changes more rapidly than at any other part of the oven, has been introduced by R. Beetham of the James Knights Company. The Beetham principle, which has been applied in the design of miniature crystal ovens, is to locate the thermostat at the base and in good thermal contact with it. This arrangement virtually eliminates the existence of steep temperature gradients within the crystal chamber; in addition, because the temperature of the base-mounted thermostat changes relatively rapidly, it permits the cycling frequency to be much higher than otherwise, thereby diminishing the amount of heat capacity required to attenuate the a-c component of temperature at the crystal. Both the base-heater and base-thermostat methods permit cycling temperatures at the crystal to be reduced to a few tenths of a degree C as the ambient temperature varies from -55°C to operating temperatures of 75 or 85°C .

PART II

TECHNICAL DESCRIPTIONS OF CRYSTAL OVENS

**TECHNICAL DATA CHART OF CRYSTAL OVENS FOR USE WITH
GROUP-I MILITARY STANDARD CRYSTAL UNITS**

Mil Std Xtal Holder Accommodated	No. of Holders Accommodated	Military or Commercial Type or Dwg No.	Oven Operating Temperature ($^{\circ}\text{C}$)	Ambient Temp Range ($^{\circ}\text{C}$)	Max Temp Deviation ($^{\circ}\text{C}$)	Heater Voltage (V)	Provisions for Mounting Oven
HC-6/U	1	HD-54/U	75	-55 to $+55$	-7 , $+6$	27.5 dc	Standard lock-in base
	5	Bendix Radio Dwg L205628	75	-55 to $+55$	-10 , $+6$	27.5 dc	Four thd studs on $1\frac{1}{2}$ x $1\frac{3}{8}$ in. mtg centers
	13	Bendix Radio Dwg N205651	75	-55 to $+55$	-10 , $+6$	27.5 dc	Four thd studs on $1\frac{3}{4}$ x $1\frac{1}{8}$ in. mtg centers

CRYSTAL OVEN HD-54/U



Figure 4-19. Crystal Oven HD-54/U

FUNCTIONAL DESCRIPTION

Crystal Oven HD-54/U provides temperature stabilization for a single HC-6/U-mounted crystal unit at a nominal operating temperature of 75°C, over an ambient range of -55°C to +55°C. The oven operates on a heater voltage of 27.5 volts, dc, and mounts in a standard lock-in socket. A booster thermostat with associated heating element is incorporated in the oven to shorten the warm-up period.

OPERATING CHARACTERISTICS

Operating Temperature: 75°C
Temperature Deviation: -7° to +6°C
Ambient Temperature Range: -55° to +55°C
Approximate Warm-Up (stabilization) Time: 6 min
Oven Temperature (inside crystal holder) During Warm-Up Time:

Oven Temp	Warm-up Time
90°C max	0 to 3 min
65° to 85°C	3 to 4 min
68° to 81°C	over 4 min

Power Requirements: 27.5 V, dc; 1.5 amp

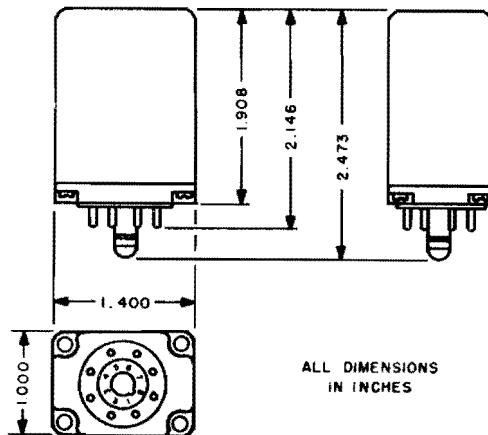

Figure 4-20. Dimensions of Crystal Oven HD-54/U

PHYSICAL CHARACTERISTICS

Net Weight: 2 oz
Thermometer: None
Provisions for Temperature Adjustment: None
Oven Materials: Plastic cover and base
Provisions for Mounting Oven: Standard lock-in base
Oven Will Accommodate: One Crystal Holder HC-6/U

LOGISTICAL DATA

Army-Navy Nomenclature: Crystal Oven HD-54/U
Status:
Date of Status:
Cognizant Agency:
Govt. Specifications:
USAF Stock Class:
USAF Stock No.:
*Source of Supply:** Bendix Radio; Clark (commercial equivalent: Clark CO-10); Downing (commercial equivalent: Downing Single Crystal Unit Oven); Miller Labs (commercial equivalent: Miller Labs BM-100)

* See Appendix III for complete name and address.

BENDIX RADIO CRYSTAL OVEN L205628

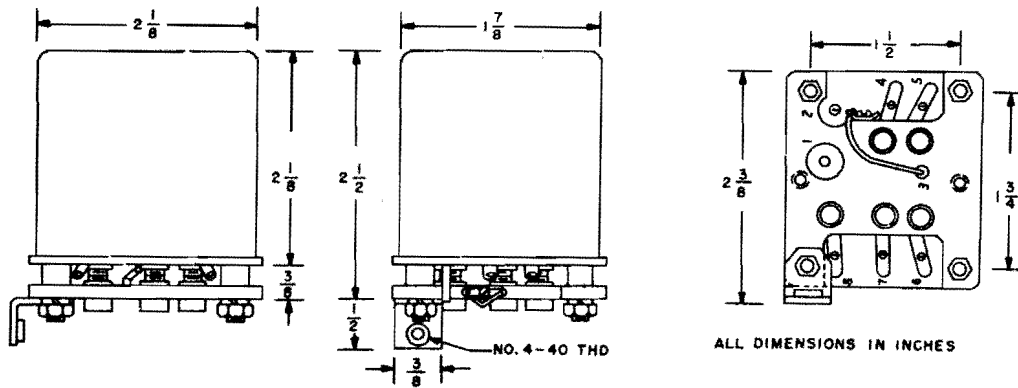

Figure 4-21. Dimensions of Bendix Radio Crystal Oven L205628

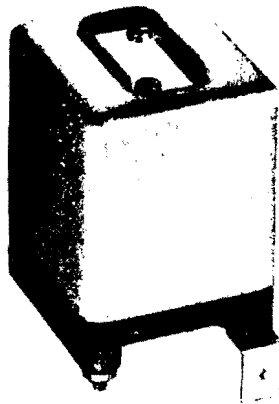

Figure 4-22. Bendix Radio Crystal Oven L205628

FUNCTIONAL DESCRIPTION

The Bendix Radio L205628 Crystal Oven is a multiple oven designed to provide temperature stabilization at 75°C, nominal, over an ambient range of -55°C to +55°C. Up to five HC-6/U-mounted crystal units can be accommodated. The oven operates from a heater voltage of 27.5 volts, dc. It was originally designed for use in Radio Sets AN/ARC-19 and AN/ARC-33.

OPERATING CHARACTERISTICS

Operating Temperature: 75°C
Temperature Deviation: -10° to +6°C

Ambient Temperature Range: -55° to +55°C
Approximate Warm-Up (stabilization) Time: 7 min
Oven Temperature (inside crystal holder) During Warm-Up Time:

Oven Temp	Ambient Temp	Warm-up Time
90°C max	+20° to +55°C	0 to 3 min
60° to 85°C	+20° to +55°C	3 to 4 min
68° to 81°C	+20° to +55°C	over 4 min
90°C max	-55° to +20°C	0 to 3 min
60° to 85°C	-55° to +20°C	3 to 5 min
65° to 81°C	-55° to +20°C	over 5 min

Power Requirements: 27.5 V, dc; 1.5 amp

PHYSICAL CHARACTERISTICS

Net Weight: 7 oz
Thermometer: None
Provisions for Temperature Adjustment: None
Oven Materials: Metallic cover, plastic base
Provisions for Mounting Oven: Four thd studs on 1 1/2 x 1 3/4 in. mtg centers
Oven Will Accommodate: Five Crystal Holders HC-6/U

LOGISTICAL DATA

*Source of Supply:** Bendix Radio (Dwg No. L205628); Downing (commercial equivalent: Downing Five Crystal Unit Oven)
* See Appendix III for complete name and address.

BENDIX RADIO CRYSTAL OVEN N205651

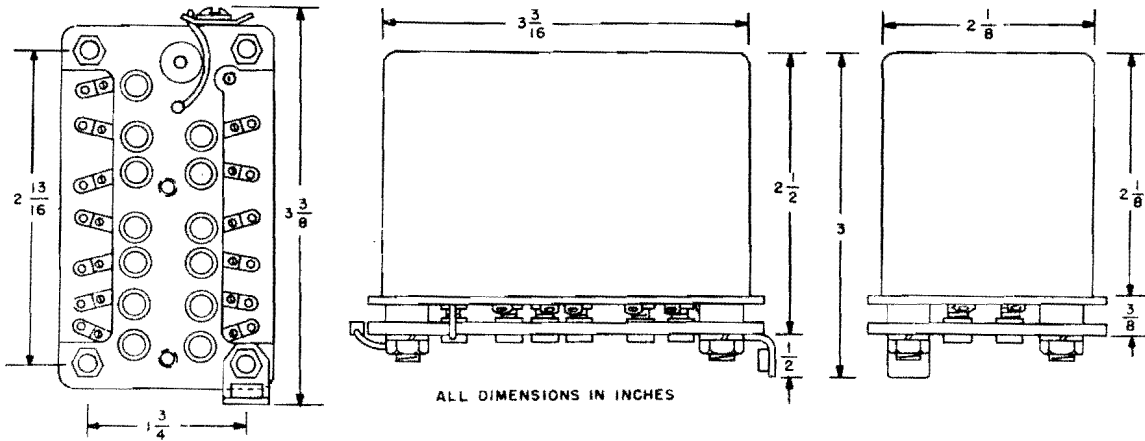

Figure 4-23. Dimensions of Bendix Radio Crystal Oven N205651

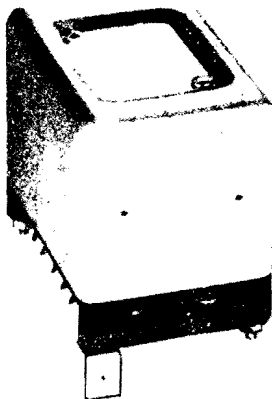

Figure 4-24. Bendix Radio Crystal Oven N205651

FUNCTIONAL DESCRIPTION

The Bendix Radio N205651 Crystal Oven is a multiple oven designed to provide temperature stabilization at 75°C, nominal, for up to thirteen HC-6/U-mounted crystal units in ambient temperatures from -55°C to +55°C. The oven operates from a heater voltage of 27.5 volts, dc. It was originally designed for use in Radio Sets AN/ARC-19 and AN/ARC-33.

OPERATING CHARACTERISTICS

Operating Temperature: 75°C
Temperature Deviation: -10° to +6°C

WADC TR 56-156

Ambient Temperature Range: -55° to +55°C
Approximate Warm-Up (stabilization) Time: 7 min
Oven Temperature (inside crystal holder) During Warm-Up Time:

Oven Temp	Ambient Temp	Warm-up Time
90°C max	+20° to +55°C	0 to 3 min
60° to 85°C	+20° to +55°C	3 to 4 min
68° to 81°C	+20° to +55°C	over 4 min
90°C max	-55° to +20°C	0 to 3 min
60° to 85°C	-55° to +20°C	3 to 5 min
65° to 81°C	-55° to +20°C	over 5 min

Power Requirements: 27.5 V, dc; 1.5 amp

PHYSICAL CHARACTERISTICS

Net Weight: 10 oz
Thermometer: None
Provisions for Temperature Adjustment: None
Oven Materials: Metallic cover, plastic base
Provisions for Mounting Oven: Four thd studs on 1 3/4 x 2 13/16 in. mtg centers
Oven Will Accommodate: Thirteen Crystal Holders HC-6/U

LOGISTICAL DATA

*Source of Supply:** Bendix Radio (Dwg No. N205651); Downing (commercial equivalent: Downing Thirteen Crystal Unit Oven)

* See Appendix III for complete name and address.

11502

APPENDIXES

APPENDIX I—ACKNOWLEDGMENTS

The information contained in this handbook has been gathered from so many diverse sources that it is virtually impossible to give due credit in each particular instance. Especially is this true of the first half of Section I, where much of the information consists of collections of relatively independent facts. In the last half of Section I, it is hoped that specific experimental data, as well as equations and methods of analysis that can be explicitly ascribed to individual authors, have been more adequately acknowledged in the text. The writer wishes to thank the many crystal manufacturers who have cooperated so generously in supplying information and suggestions for inclusion in the Handbook. He is particularly indebted to **Biley Electric Company, HEEMCO, Hunt Corporation, Hupp Electronics Company, McCoy Electronics Company, and Reeves-Hoffman Company** for their contributions and interest and also for the personal courtesies extended the writer during a data-collecting field trip.

At this point, the writer would like to acknowledge those individuals and organizations to whom he is most indebted for the present contents of the Handbook.

Bell Telephone Laboratories.—The greater part of the information on the subject of crystal-unit fabrication contained in the Handbook has, at least partly, had its origin in research projects at Bell Telephone Laboratories. All frequency-constant, temperature-coefficient, and frequency-deviation curves of the various crystal elements developed at Bell Telephone Laboratories have been obtained from graphs made available to the public by the Bell Telephone Company. These illustrations are included below in the individual acknowledgments of published works of Bell scientists.

Bokovoy, S. A.—Most of the descriptive data concerning the V-cut crystal, the single-frequency X-cut crystal, and the dielectric-sandwich type of

crystal mounting have been obtained from U. S. and British patents issued to the inventor, Mr. Bokovoy, of the Radio Corporation of America.

(Mr. P. D. Gerber was coinventor of the dielectric-sandwich mounting—U. S. Patents 2,078,229 and 2,101,893.) Handbook illustrations redrawn from Bokovoy patents are: figure 1-22 (U. S. Patent 2,064,288, May 31, 1934); figures 1-39, 1-40, and 1-41 (British Patent 457,342, November 26, 1936); figures 1-73 to 1-77 (U. S. Patent 2,101,393, December 14, 1937); and figure 1-78 (U. S. Patent 2,078,229, April 27, 1937).

Bond, W. L.—Two treatises by Mr. Bond, "Methods for Specifying Quartz Crystal Orientation and Their Determination by Optical Means" and "Sawing, Grinding, and Lapping" (Chapters II and IX, respectively, *Quartz Crystals for Electrical Circuits*, Heising) have been useful sources of information to the writer. Handbook figure 1-59 has been reprinted from the former article with the permission of the publisher, D. Van Nostrand Co.

Borgelt, E. H.—See Foreword.

Bottom, V. E.—Much of the information contained in "The Mathematics of the Equivalent Electrical Circuit of the Quartz Crystal Unit" by Mr. Bottom (Chapter II, *Fundamental Principles of Crystal Oscillator Design*, Circuit Section, Long Branch Signal Laboratory, Signal Corps, 1945-46) has been incorporated in Section I of the Handbook.

Bower, G. G.—Information obtained from Mr. Bower's treatise, "Crystal-Controlled Electron-Coupled Oscillators" (Chapter V, *Fundamental Principles of Crystal Oscillator Design*, Circuit Section, Long Branch Signal Laboratory, Signal Corps) has been included in the Handbook.

Brown, W. F.—Information contained in "Quartz Crystal Overtone Oscillators," Technical Note No. RAD. 460, by Mr. Brown, Royal Aircraft Establishment, Farnborough, has been of great value to the writer in preparing the discussion of series-mode oscillators.

Cady, W. G.—So much of information contained in the Handbook is indirectly, if not directly, dependent upon the work of Dr. Cady that no attempt

Appendix I
Acknowledgments

can be made to itemize particular instances, other than to acknowledge that figure 1-21 is reprinted from Dr. Cady's textbook, *Piezoelectricity*, McGraw-Hill Book Co., 1946, with the permission of the author and publisher.

Camfield, C. J.—Information obtained from "The Design of Fundamental Mode Quartz Crystal Oscillators," Technical Note No. RAD. 525, by Mr. Camfield, Royal Aircraft Establishment, Farnborough, has been included in the Handbook. Handbook figure 1-131 is based upon the design of an age circuit described in the above treatise.

Capitol Radio Engineering Institute.—The writer is indebted to Capitol Radio Engineering Institute for many valuable items of information scattered throughout the Handbook. Of particular note are the empirical data contained in the discussion of the use of the Miller circuit as a small power oscillator (paragraph 1-339).

Carpantier, V. J.—See Foreword.

Caruthers, R. S.—The writer is indebted to Mr. Caruthers for information contained in paragraphs 1-449 to 1-451, which has been obtained from a treatise on transistor oscillators as published in *The Transistor* by Bell Telephone Laboratories. Handbook figures 1-189 and 1-190 have been copied from this source with the permission of Bell Telephone Laboratories.

Devlin, J. J.—Appreciation is extended Mr. Devlin for valuable assistance in editing parts of Sections II, III, IV, V, and the Appendix.

D'Heedene, A. R.—The treatise, "Effects of Manufacturing Deviations on Crystal Units for Filters" (Chapter XIV, *Quartz Crystals for Electrical Circuits*, Heising), by Mr. D'Heedene, has proven a valuable source of information to the writer. Handbook figure 1-117 has been copied from an illustration contained in the above work with the permission of the publisher, D. Van Nostrand Co.

Drews, W. F. et al.—The treatise by Mr. Drews and coauthor A. E. Swickard, "The Wire Mounted Crystal Unit" (Chapter XVI, *Quartz Crystals for Electric Circuits*, Heising), has been an important source of information for the writer. Handbook figure 1-68 has been drawn from an illustration contained in the above article, with the permission of the publisher, D. Van Nostrand Co.

Edson, W. A. et al.—For that part of Section I covering the theory and application of series-mode quartz crystal oscillators, the writer is heavily indebted to the work of Mr. Edson and those assisting him at the Georgia Institute of Technology

in a Signal Corps research project directed toward the investigation of v-h-f crystal oscillators. Many of the results of this investigation, as described in the 1950 Final Report on Signal Corps Contract W36-039-sc-32100, "High Frequency Crystal-Controlled Oscillator Circuits," prepared by Mr. Edson, W. T. Clary, and J. C. Hogg, Jr., have been included in the discussions of the Butler, transistor, basic transformer-coupled, grounded-grid, grounded-plate, and impedance-inverting oscillators. Also, the circuit equations derived in the h-f oscillator report have provided valuable check points and guides for the circuit analyses and equation derivations of this Handbook. In addition, all equations presented without derivations in the discussion of the above-mentioned oscillators can be assumed to have been taken directly from the above-mentioned h-f oscillator report.

The writer has also been greatly aided by the information contained in the timely book by Mr. Edson, *Vacuum-Tube Oscillators*, copyright 1953, John Wiley and Sons. The analysis of the Meacham bridge oscillator contained therein has served as the principal guide for the slightly modified approach to the same circuit followed in the Handbook. Appreciation is extended to the author and publishers for permission to use the graphical chart shown in the Handbook figure 1-162.

Fair, I. E.—The writer is indebted to the work of Mr. Fair for information concerning the relative performance characteristics of crystal units in parallel-mode oscillator circuits, as described in "Piezoelectric Crystals in Oscillator Circuits" (Chapter XII, *Quartz Crystals for Electrical Circuits*, Heising), and in "Design Data on Crystal Controlled Oscillators" (Appendix II, *Information Bulletin on Quartz Crystal Units*, Armed Services Electro Standards Agency, Fort Monmouth, N. J., August, 1952). Figure 1-164 of the Handbook has been copied from the latter treatise. The crystal performance parameters, M (figure of merit) and PI (performance index), were originally conceived and defined by Mr. Fair.

Goldsmith, P.—Appreciation is extended for the time and assistance generously given the writer in obtaining information relating to the results of experiments conducted at the Armour Research Foundation of Illinois Institute of Technology (USAF Contract No. AF 18(600)-157) on parallel-mode crystal oscillators, in which Mr. Goldsmith had participated as project engineer.

Gordon, S. G. et al.—Information used in the Handbook concerning the preparation of crystal blanks has been obtained from the treatise by Mr. Gordon

and Mr. W. Parrish, entitled "Cutting Schemes for Quartz Crystals" (*American Mineralogist Symposium on Quartz Oscillator Plates*, 1945). Handbook figures 1-60 and 1-62 have been copied from this source.

Greenidge, R. M. C.—"The Mounting and Fabrication of Plated Quartz Crystal Units" (Chapter XIII, *Quartz Crystals of Electrical Circuits*, Heising), by Mr. Greenidge, has proven an important source of information for the writer. Handbook figures 1-80, 1-83, and 1-86 have been drawn from illustrations contained in the above article with the permission of the publisher, D. Van Nostrand Co.

Gruen, H. E.—Of great value to the Handbook has been the circuit data obtained from Mr. Gruen for over thirty oscillators of comparatively recent design which employ currently recommended crystal units. This information was originally catalogued and the circuits tested during a preliminary investigation of the feasibility of standard packaged oscillator designs—a project engineered for the U. S. Air Force by Mr. Gruen at the Armour Research Foundation of Illinois Institute of Technology, with Mr. E. A. Roberts serving as Instrument Supervisor. The writer also wishes to thank Mr. Gruen for giving so generously of his time in helping the writer check test data for inclusion in the Handbook.

Hedeman, W. R.—The method of synthesizing frequencies, as described in paragraphs 1-455 to 1-462, is based upon the Bendix synthesizing method described by Mr. Hedeman in "Few Crystals Control Many Channels," *Electronics* magazine, March, 1948.

Heising, R. A.—The subject matter on the fabrication of quartz crystal units in the Handbook is more dependent upon the information in Mr. Heising's *Quartz Crystals for Electrical Circuits*, D. Van Nostrand Co., copyright 1946, than upon that in any other single publication. Because this collection of articles by members of the technical staffs of Bell Telephone Laboratories and Western Electric Company represents so much of the original discovery, work, and thought that has formed the foundation of the modern quartz-crystal industry in the United States, the book has been invaluable as a reference in the preparation of the Handbook. The many performance curves of the different types of quartz cuts pioneered by Bell Laboratories have proven of particular value. Mr. Heising has also been the source of much of the information concerning the historical development of piezoelectric crystals. The following

figures of the Handbook have been reprinted, copied, drawn, or redrawn—entirely, in part, or in modified form—with the permission of Mr. Heising and D. Van Nostrand Co. from illustrations appearing in the aforesaid publication: 1-5, 1-8, 1-11, 1-12, 1-13, 1-19(G), 1-23, 1-24, 1-25, 1-28, 1-29, 1-33, 1-34, 1-35, 1-38, 1-43, 1-44, 1-53, 1-54, 1-56, 1-58, 1-59, 1-63, 1-65, 1-68, 1-71, 1-80, 1-81, 1-82, 1-83, 1-84, 1-86, 1-87, and 1-117.

Henry, C. W.—See Foreword.

Institute of Radio Engineers.—I.R.E. Standards on Piezoelectric Crystals, as described in the *Proceedings of the I.R.E.*, vol. 37, No. 12, December, 1949, have been followed in the Handbook.

Jakob, M.—*Heat Transfer*, Vol. I, by M. Jakob, copyright 1949, John Wiley and Sons, proved of great value to the writer as a basic reference source during the preparation of the discussion on crystal-oven design in Part I, Section IV of the Handbook.

Jones, M. B.—The writer is indebted to Mr. Jones for many suggestions for improving the usefulness and appearance of the Handbook, and for contributing freely of his time in designing and preparing the layout of the printed manuscript.

Kitter, W. M.—Appreciation is extended Mr. Kitter for valuable assistance in editing and correcting a number of illustrations, data sheets, and tables in Sections II and III.

Koga, I.—The writer has been greatly benefited by a number of equations (acknowledged in the text) derived by Mr. Koga in the treatise "Characteristics of Piezo Electric Quartz Oscillators," *Proceedings of the I.R.E.*, vol. 18, 1930.

Llewellyn, F. B.—Of great aid to the writer has been "Constant-Frequency Oscillators," F. B. Llewellyn, *Proceedings of the I.R.E.*, vol. 19, 1931.

Lobel, A.—The writer is considerably indebted to Mr. Lobel for valuable assistance in preparing, organizing, and editing data sheets and tables appearing in Sections II, III, IV, V, and the Appendixes.

Magie, W. F.—The writer is indebted to Mr. Magie for the translation of the original paper by P. Curie on "Piezoelectricity." The translation contained in the Handbook has been reprinted from *A Source Book in Physics*, W. F. Magie, copyright 1935, McGraw-Hill Book Co., with the permission of the author and publisher.

Mason, W. P.—Much of the descriptive information contained in Section I covering the theory

Appendix I

Acknowledgments

of piezoelectricity and the characteristics of piezoelectric elements is based upon information obtained in the published treatises of Mr. Mason. From *Piezoelectric Crystals and Their Application to Ultrasonics*, copyright 1950, D. Van Nostrand Co., has been obtained most of the information regarding the different types of synthetic piezoelectric crystals as well as a part of the data concerning the X-group of quartz crystals. Figures 1-20, 1-32, and 1-55 of the Handbook have been reprinted entirely or in part from Mr. Mason's book with the permission of the author and the publisher. Equations 1-248 (1) and (2) have also been obtained from this source.

From "Low Temperature Coefficient Quartz Crystals," *Bell System Technical Journal*, January, 1940, permission has been obtained from the author and publisher to use the curves illustrated in Handbook figures 1-45 and 1-46.

The theory of quartz piezoelectric properties, presented in paragraphs 1-69 to 1-74, is based primarily upon Lord Kelvin's model of the quartz molecule, as extended by Mason to illustrate a simplified concept of quartz piezoelectricity in "Quartz Crystal Applications" (Chapter I of *Quartz Crystals for Electrical Circuits*, Heising). From this same article has been obtained much of the general information relating to the various types of quartz cuts, as well as the following Handbook illustrations: figures 1-8, 1-9 (originally from *Collected Works of Lord Kelvin*, Cambridge Press), 1-11, 1-19(G), 1-43, 1-44, 1-53, 1-54, and 1-56.

A large part of the information concerning the characteristics of the X-group of quartz crystals has been obtained from "Low-Frequency Quartz-Crystal Cuts Having Low Temperature Coefficients" (Chapter XVII of *Quartz Crystals for Electrical Circuits*, Heising), of which Mr. Mason is coauthor with Mr. R. A. Sykes. From this source have been obtained figures 1-23, 1-24, 1-25, 1-28, 1-29, 1-33, 1-34, 1-35, 1-38.

Equation 1-82 (1) is a modification of an equation developed by Mr. Mason in "Electrical Wave Filters Employing Quartz Crystals as Elements," *Bell System Technical Journal*, July, 1934.

Miller, C. J., Jr.—The writer has greatly benefited by two treatises by Mr. Miller: "Equivalent Network of a Quartz Crystal Unit and Its Application" and "The Pierce Oscillator," which appear as chapters I and III, respectively, in *Fundamental Principles of Crystal Oscillator Design*, Circuit Section, Long Branch Signal Laboratory, Signal Corps, 1945-46. The approach to the generalized crystal oscillator and the methods discussed for

measuring vacuum-tube-circuit capacitances have proved particularly useful. Figure 1-100 of the Handbook has been traced from one Miller illustration, and figure 1-103 is a modification suggested by another.

Nachman, M. W.—See Foreword.

Philco Corporation.—Regrettably, space simply does not permit acknowledgments of the many personal contributions to the composition of this Handbook that have been made by Philco personnel, but for which the writer nevertheless wishes to express his sincere appreciation. Without the good faith and cooperation of the management and staff of the **Philco Technical Publications Department**, in particular, this Handbook would not have been possible.

Prichard, A. C.—Information obtained from Mr. Prichard's treatise "The Miller Oscillator" (Chapter IV, *Fundamental Principles of Crystal Oscillator Design*, Circuit Section, Long Branch Signal Laboratory, Signal Corps) has been included in the Handbook.

Roberts, E. A. et al.—Appreciation is felt for the assistance and many courtesies extended the writer when collecting data originally obtained in experiments performed under the supervision of Mr. Roberts at the Armour Research Foundation of the Illinois Institute of Technology. Of particular value has been the information concerning the performance of parallel-mode oscillators that is contained in the interim report on USAF research Contract No. AF 18(600)-157, "Investigation of Oscillator Circuits for Proposed Standards," June 22, 1953. Copies of illustrations from this report are shown in figures 1-129, 1-130, 1-143, 1-144, 1-145, 1-146, 1-147, and 1-148. Research engineers contributing materially to the project were E. K. Novak, P. Goldsmith, and J. Kurinsky.

Robinson, S. A. et al.—The discussion of capacitance-bridge oscillators is based primarily upon the final report, "H. F. Harmonic Crystal Investigation," of an Air Force research project undertaken by the Research Division of Philco Corporation in 1947 (AF Contract No. W33-038-ac-14172), with Messrs. Robinson, C. D. O'Neal, and F. N. Barry serving as project engineers. Handbook figures 1-112, 1-113, 1-114, 1-165(A), 1-166, 1-167, 1-168, 1-169, 1-170, 1-171, and 1-172 have been copied from this report.

Ronan, J. A.—Part of the information concerning the plating of crystals has been obtained from Mr. Ronan's technical report, "Fabricating Tech-

niques for Crystal Unit CR-23/U," Signal Corps Engineering Laboratories.

Schnepps, B.—The writer is greatly indebted to the conscientious work of Mr. Schnepps in preparing, organizing, and editing data sheets and tables appearing in Sections II, III, IV, V, and the Appendixes.

Signal Corps.—The writer wishes to thank Mr. W. L. Doxey, Chief, and others of the staff at the Frequency Control Branch, Signal Corps Engineering Laboratories, Fort Monmouth, N. J., for their cooperation in making available a large amount of useful bibliographical material. With their assistance, it has been possible to consult a much broader range of publications, illustrations, and reports than would otherwise have been possible.

It should be mentioned that from the Signal Corps Technical Manual, TM-2540, *Quartz Crystals, Theory, Fabrication and Performance Measurements*, much of the information concerning the fabrication of quartz crystal units has been obtained. The following Handbook illustrations have been obtained from this manual: figures 1-5,* 1-6, 1-10,* 1-42, 1-57,* 1-58,* 1-59,* 1-63,* 1-64, 1-66,* 1-67, and 1-89. Those figures marked with an asterisk have been obtained from negatives made available by the Signal Corps.

Also of great use to the writer has been the *Information Bulletin on Quartz Crystal Units*, Armed Services Electro Standards Agency, Fort Monmouth, N. J. See Fair, I. E. and Sykes, R. A. for illustrations obtained from this source.

In Section III, the illustrations of all Group-II crystal holders have been redrawn from drawings furnished by the Signal Corps.

Finally, the circuit data for a large number of the individual oscillators described have been obtained from Signal Corps technical manuals.

Stock, D. J. R., et al.—Much of the discussion of crystal-unit drive-level characteristics is based upon information contained in the final report, "Investigation, Studies and Evaluation of Performance of Crystal Unit Characteristics," 1952, of a research project (Signal Corps Contract No. DA36-039-sc-5493) undertaken by the Research Division of New York University College of Engineering, Mr. Stock serving as project engineer, with the assistance of L. Silver, E. Strongin, and A. Yevlove. Handbook figures 1-115, 1-116, and 1-118 have been obtained from this report.

Sykes, R. A. (See also Foreword)—The discussions contained in Section I, entitled "Modes of Vibration" and "Rule-of-Thumb Equations for Estimating Parameters," are based upon and fol-

low closely the information contained in the exposition of these subjects by Mr. Sykes in "Design Data on Crystal Units" (Appendix I, *Information Bulletin on Quartz Crystal Units*, Armed Services Electro Standards Agency, Fort Monmouth, N. J., August, 1952). Handbook illustrations obtained from the foregoing treatise are figures 1-26, 1-27, 1-30, 1-31, 1-36, 1-37, 1-49, 1-50, 1-51, 1-52, 1-85, and 1-88(B).

The information contained in the discussion of the modes of vibration of quartz crystals is also dependent upon the more extended treatment of the same subject by Mr. Sykes in "Modes of Motion in Quartz Crystals, the Effects of Coupling and Methods of Design" (Chapter VI, *Quartz Crystals for Electrical Circuits*, Heising). Handbook equations 1-81 (4) and 1-82 (1) have been obtained from this source. Also from this treatise are figures 1-12 and 1-13, which have been copied with the permission of the publisher, D. Van Nostrand Co.

"Principles of Mounting Quartz Plates" (Chapter VIII, *Quartz Crystals for Electrical Circuits*, Heising), by Mr. Sykes, is the source of the information included in the Handbook concerning the cantilever method of crystal mounting, and also of much of the information concerning pressure mounts in general, wire mounts, and air-gap mounts. The equation in paragraph 1-158, and figures 1-71, 1-81, 1-82, 1-84, and 1-87 of the Handbook are taken from this work, with the permission of the publisher, D. Van Nostrand and Co.

For acknowledgments of information obtained from "Low-Frequency Quartz-Crystal Cuts Having Low Temperature Coefficients," coauthored by Mr. Sykes, see Mason, W. P.

Vigoureux, P. et al.—*Quartz Vibration*, by P. Vigoureux and C. F. Booth, H. M. Stationery Office, London, has been a valuable source of reference for the writer. Of special usefulness has been the information on the design of crystal ovens, much of which has not been obtainable elsewhere.

Western Electric Co.—The writer is indebted to the Western Electric Co. for making available the design recommendations of Bell Telephone Laboratories engineers, pertaining to the oscillator circuit illustrated in figure 1-157.

Willard, G. W.—Mr. Willard's treatises, "Raw Quartz, Its Imperfections and Inspection" and "Use of the Etch Technique for Determining Orientation and Twinning in Quartz Crystals" (Chapters IV and V, respectively, *Quartz Crystals for Electrical Circuits*, Heising) have been principal sources of information covering their respective subjects. Handbook figures 1-5, 1-58, 1-63, and

Appendix I

Acknowledgments

1-65 have been obtained from the above sources with the permission of the publisher, D. Van Nostrand Co.

Wojcicki, F. J.—See Foreword.

Wright Air Development Center.—See Foreword.

Addendum

Dasher, B. J. et al.—A large proportion of the data contained in the discussion of junction transistor oscillators has been obtained from the quarterly reports on "Transistor Oscillators of Extended Frequency Range" by Messrs. Dasher, D. L. Finn, S. N. Witt, W. B. Warren, Jr., T. N. Lowry, et al., of the Georgia Institute of Technology, Atlanta, Georgia. (Dept. of the Army Contract No. DA-36-039-sc-42716).

Finden, H. J.—The information on the Plessy synthesizer has been obtained primarily from "The Frequency Synthesizer" by Mr. Finden, *Journal of the Institution of Electrical Engineers*, vol. 90, Part III, 1943.

The information on the attenuation of unwanted frequencies in frequency synthesis is based on "Developments in Frequency Synthesis" by Mr. Finden, *Electronic Engineering*, May 1953.

Gerber, E. A.—The treatise "A Review of Methods for Measuring the Constants of Piezoelectric Vibrators" by Dr. Gerber, *Proceedings of the I.R.E.*, September 1953, has been a valuable source of reference in preparing the discussions on the measurements of crystal oscillators.

The writer also wishes to thank the engineering staff in the charge of Dr. Gerber at the **Frequency Control Branch of the Signal Corps Engineering Laboratories** for the time and effort spent in re-

viewing the Handbook revision material and for the many suggestions and corrections which have helped to improve the usefulness and accuracy of the text.

Gruen, H. E. — The information on the Gruen packet oscillator series was obtained from "Development of Packet Oscillator Series" by Mr. Gruen, a project of the Armour Research Foundation, I.I.T., completed in 1955. (USAF Contract No. AF 33(616)-2125).

Hahnel, A. — The information on crystal-phase-controlled harmonic multipliers is based upon "Multichannel Crystal Control of VHF and UHF Oscillators" by Mr. Hahnel, *Proceedings of the I.R.E.*, January 1953, and upon "A Single Crystal Multi-Channel Oscillator" by Messrs. L. R. Battersby and E. A. Conover (Signal Corps Project No. 132A, March 1954).

Savolainen, U. — The information on bimetallic thermostats in paragraph 4-18 was obtained from "Designing Bimetal Control Devices" by Mr. Savolainen, *Product Engineering*, August 1950.

Sherman, J. W. Jr.—The writer is indebted to Mr. Sherman of the General Electric Company for the method described in paragraph 1-584 for simulating marginal crystal units in parallel-mode circuits.

ACKNOWLEDGMENTS FOR USE OF COPYRIGHTED ILLUSTRATIONS

Figure Number	Courtesy of	Figure Number	Courtesy of
1-2, 1-4, *1-15, 1-16	Institute of Radio Engineers	1-56, 1-58, 1-59, 1-63, 1-65, 1-68, 1-71, 1-80, 1-81, 1-82, 1-83, 1-84, 1-86, 1-87, 1-117	D. Van Nostrand Company
1-5, 1-8, 1-9, 1-11, 1-12, 1-13, 1-19(G), 1-20, 1-23, 1-24, 1-25, 1-28, 1-29, 1-32, 1-33, 1-34, 1-35, 1-38, 1-43, 1-44, 1-53, 1-54, 1-55,	D. Van Nostrand Company	1-21	McGraw-Hill Book Company
		1-45, 1-46	<i>Bell Systems Technical Journal</i>
		1-162	John Wiley and Sons
		1-189, 1-190	Bell Telephone Laboratories

ACKNOWLEDGMENTS FOR USE OF COPYRIGHTED QUOTATIONS

Paragraph Number	Courtesy of
1-57 to 1-68	McGraw-Hill Book Company

APPENDIX II—BIBLIOGRAPHY

1. Adler, R.: "A New System of Frequency Modulation," *Proc. I.R.E.*, vol. 35, pp. 25—31, 1947.
2. Adler, R.: "Locking Phenomena in Oscillators," *Proc. I.R.E.*, vol. 34, pp. 351—357, 1946.
3. Aigrain, P. R., and E. M. Williams: "Theory of Amplitude Stabilized Oscillators," *Proc. I.R.E.*, vol. 36, pp. 16—19, 1948.
4. Aigrain, P. R., and E. M. Williams: "Pseudosynchronization in Amplitude Stabilized Oscillators," *Proc. I.R.E.*, vol. 36, pp. 800—801, 1948.
5. Aldous, D. W.: "A New Temperature-controlled Crystal Cutting-head," *Electronic Eng.*, vol. 14, p. 605, 1942.
6. *American Mineralogist*: Comprehensive series of articles on quartz and quartz-oscillator plates, as well as glossary of terms used in the industry, *A. Min.*, vol. 30, pp. 205—468, May-June 1945.
7. American Radio Relay League: *ARRL Handbook*, West Hartford, Conn., yearly.
8. Ames, M. E.: "Wide Range Deviable Oscillator," *Electronics*, vol. 22, pp. 96—100, May 1949.
9. Anderson, F. E.: "Seven-League Oscillator," *Proc. I.R.E.*, vol. 39, pp. 881—890, 1951.
10. Anderson, J. E.: "Frequency Characteristics of Piezoelectric Oscillators," *Electronics*, vol. 11, pp. 22—24, August 1938.
11. Andrew, V. J.: "The Adjustment of the Multivibrator for Frequency Division," *Proc. I.R.E.*, vol. 19, pp. 1911—1917, 1931.
12. Anon.: "Improved Material for Magnetic Amplifiers," *Electronics*, vol. 21, p. 128, August 1948.
13. Anon.: "Stable Time and Frequency Standard," *Electronics*, vol. 22, pp. 82—84, April 1949.
14. Appleton, E. V.: "The Automatic Synchronization of Triode Oscillators," *Proc. Camb. Phil. Soc.*, vol. 21, pp. 231—248, 1922-1923.
15. Appleton, E. V., and B. van der Pol: "On the Form of Free Triode Vibrations," *Phil. Mag.*, vol. 42, pp. 201—220, 1921.
16. Arguimbau, L. B.: *Vacuum-tube Circuits*, John Wiley, New York, 1948.
17. Arguimbau, L. B.: "An Oscillator Having a Linear Operating Characteristic," *Proc. I.R.E.*, vol. 21, pp. 14—28, 1933.
18. Armed Services Electro Standards Agency: *Information Bulletin on Quartz Crystal Units*, ASES 52-9, Fort Monmouth, N. J., August 1952.
19. Armstrong, E. H.: "Some Recent Developments of Regenerative Circuits," *Proc. I.R.E.*, vol. 10, pp. 244—260, 1922.
20. Arndt, J. P.: *Guard Rings to Prevent Surface Leakage*, Patent 2,289,954.
21. Artz, M.: "Frequency Modulation of Resistance-Capacitance Oscillators," *Proc. I.R.E.*, vol. 32, pp. 409—414, 1944.
22. Atanasoff, J. V., and P. J. Hart: "Dynamical Determination of the Elastic Constants and Their Temperature Coefficients for Quartz," *Phys. Rev.*, vol. 59, pp. 85—96, 1941.
23. Atanasoff, J. V., and E. Kammer: "A Determination of the c_{44} Elastic Constant for Beta-quartz," *Phys. Rev.*, vol. 59, pp. 97—99, 1941.
24. Babat, G., and M. Losinsky: "Power Oscillators," *W. E.*, vol. 17, pp. 16—18, 1940.
25. Balamuth, L.: "A New Method for Measuring Elastic Moduli and the Variation with Temperature of the Principal Young's Modulus of Rocksalt between 78°K and 273°K," *Phys. Rev.*, vol. 45, pp. 715—720, 1934.
26. Baldwin, C. F.: "Quartz Crystals in Radio," *Communications*, vol. 22, pp. 20f., October 1942.
27. Baldwin, C. F.: "Quartz Crystals," *G. E. Rev.*, vol. 43, pp. 188—194, 237—243, 1940.
28. Baldwin, C. F., and S. A. Bokovoy: "Practical Operating Advantages of Low Temperature-Frequency Coefficient Crystals," *QST*, vol. 19, pp. 26, 27, 92, January 1935.
29. Ballantine, S.: "High Quality Radio Broadcast Transmission and Reception (Rochelle salt "sound-cell")," *Proc. I.R.E.*, vol. 22, pp. 564—629, 1934.
30. Ballantine, S.: "A Piezo-electric Loud Speaker for the Higher Audio Frequencies," *Proc. I.R.E.*, vol. 21, pp. 1399—1408, 1933.
31. Ballou, J. W., and S. Silverman: "Young's Modulus of Elasticity of Fibers and Films by Sound Velocity Measurements," *Jour. Acous. Soc. Am.*, vol. 16, pp. 113—119, 1944.
32. Bancroft, D.: "The Velocity of Longitudinal Waves in Cylindrical Bars," *Phys. Rev.*, vol. 59, pp. 588—593, 1941.
33. Bancroft, D.: "The Effect of Hydrostatic Pressure on the Susceptibility of Rochelle Salt," *Phys. Rev.*, vol. 53, pp. 587—590, 1938.
34. Bantle, W., and P. Scherrer: "Anomaly of the Specific Heat of Potassium Dihydrogen Phosphate at the Upper Curie Point," *Nature*, vol. 143, p. 980, 1939.
35. Bardeen, J., and W. H. Brattain: "The Transistor, a Semi-Conductor Triode," *Phys. Rev.*, vol. 74, p. 230, 1948.
36. Barrett, C. S., and C. E. Howe: "X-ray Reflection from Inhomogeneously Strained Quartz," *Phys. Rev.*, vol. 39, pp. 889—897, 1932.
37. Bartelink, E. H. B.: "A Wide-Band Square-Wave Generator," *Trans. A.I.E.E.*, vol. 60, pp. 371—376, 1941.
38. Bartlett, R. M.: "N-Phase Resistance-Capacitance Oscillators," *Proc. I.R.E.*, vol. 33, pp. 541—545, 1945.
39. Barton, Edwin H.: *A Text-Book on Sound*, Macmillan & Co., Ltd., London, 1919, 687 pp.
40. Bass, S. L., and T. A. Kauppi: "Silicones—A New Class of High Polymers of Interest to the Radio Industry," *Proc. I.R.E.*, vol. 33, pp. 441—447, 1945.
41. Batcher, R. R.: "Thermistors in Electronic Circuits," *Electronic Inds.*, vol. 4, pp. 76—80, January 1945.
42. Batcher, R. R.: "Application of Piezoelectric Crystals to Receivers," *Electronics*, vol. 3, pp. 57—58, August 1931.
43. Bauer, B.: "Design Notes on the Resistance-Capacity Oscillator Circuit," *Hewlett-Packard J.*, November and December 1949.
44. Baumgardt, E.: "Velocity of Propagation of Elastic Waves in Piezoelectric Crystals," *C. R.*, vol. 206, pp. 1887—1890, 1938.

Appendix II
Bibliography

45. Baumzweiger, B.: "Application of Piezoelectric Vibration Pick-ups to Measurement of Acceleration, Velocity and Displacement," *Jour. Accus. Soc. Am.*, vol. 11, pp. 303—307, 1940.
46. Baxter, H. W.: "A Recording Instrument for Transient Pressures," *Electrician*, vol. 113, pp. 121—122, 1934.
47. Bazzoni, C. B.: "The Piezo-electric Oscillograph," *Radio News*, vol. 7, pp. 142—143, 233—237, August 1925.
48. Bacon, D.: "Improving Crystal Filter Performance," *QST*, vol. 24, pp. 58f., December 1940.
49. Beck, F. J., and J. M. Kelly: "Magnetization in Perpendicularly Superposed Direct and Alternating Fields," *J. Appl. Ph.*, vol. 19, pp. 551—562, 1948.
50. Becker, J. A., Green, C. B., and G. L. Pearson: "Properties and Uses of Thermistors—Thermally Sensitive Resistors," *Trans. A.I.E.E.*, vol. 65, pp. 711—725, 1946.
51. Bechmann, R.: "The Crystal Control of Transmitters," *W. E.*, vol. 11, pp. 249—253, 1934.
52. Beers, G. L.: "A Frequency-Dividing Locked-in-Oscillator Frequency-Modulation Receiver," *Proc. I.R.E.*, vol. 22, pp. 730—737, 1944.
53. Begun, S. J.: "Some Problems of Disk Recording," *Proc. I.R.E.*, vol. 28, pp. 389—398, 1940; *Jour. Soc. Motion-Picture Eng.*, vol. 36, pp. 666—674, 1941.
54. Benjamin, R.: "Blocking Oscillators," Part IIIA, *J. I.E.E.*, vol. 93, pp. 1159—1175, 1945.
55. Bennett, W. R.: "A General Review of Linear Varying Parameter and Non-linear Circuit Analysis," *Proc. I.R.E.*, vol. 38, pp. 259—263, 1950.
56. Benson, J. E.: "Modes of Vibration and Design of V-cut Quartz Plates for Medium Broadcast Frequencies," *A.W.A. Tech. Rev.*, vol. 6, pp. 78—89, 1943.
57. Benson, J. E.: "A Note on the History of Piezoelectric Crystal Filters," *A.W.A. Tech. Rev.*, vol. 5, pp. 191—192, 1941.
58. Benson, J. E.: "Crystal Control of the Mixer Oscillator in a Superheterodyne Receiver," *A.W.A. Tech. Rev.*, vol. 4, pp. 127—137, 1939; vol. 5, pp. 29—40, 1940.
59. Benson, J. E.: "A Piezoelectric Calibrator," *A.W.A. Tech. Rev.*, vol. 5, pp. 47—50, 1940.
60. Berberich, L. J., Fields, C. V., and R. E. Marbury: "Characteristics of Chlorinated Impregnants in Direct-Current Paper Capacitors," *Proc. I.R.E.*, vol. 33, pp. 389—397, 1945.
61. Bertram, S.: "The Degenerative Positive-Bias Multivibrator," *Proc. I.R.E.*, vol. 36, pp. 277—280, 1948.
62. Bertsch, C. V.: "X-ray Studies of Crystals Vibrating Piezoelectrically," *Phys. Rev.*, vol. 49, pp. 128—132, 1936.
63. Biggs, A. J., and G. M. Wells: "The Measurement of the Activity of Quartz Oscillator Crystals," *J.I.E.E.*, vol. 93, part III, No. 21, January 1946.
64. Bird, J. R.: "Recent Improvements in Crystal Pickup Devices," *Proc. I.R.E.*, vol. 25, p. 660, 1937.
65. Black, H. S.: "Stabilized Feedback Amplifiers," *Bell System T. J.*, vol. 13, pp. 1—18, 1934; also *Elec. Eng.*, vol. 53, p. 114, 1934.
66. Bliley Electric Co.: *Development of Harmonic Mode Crystals*, Signal Corps Contract No. W36-039-sc—32136, February 1949.
67. Bloch, A.: "New Methods for Measuring Mechanical Stresses at Higher Frequencies," *Nature*, vol. 136, pp. 223—224, 1935; see also *Electronics*, vol. 8, pp. 212—213, 1935.
68. Bloomenthal, S.: "The Converse Piezoelectric Effect in Mixed Crystals Isomorphous with Rochelle Salt," *Physics*, vol. 4, pp. 172—177, 1933.
69. Bode, H. W.: *Network Analysis and Feedback Amplifier Design*, D. Van Nostrand, New York, 1945.
70. Boella, M.: "Performance of Piezo-Oscillators and the Influence of the Decrement of the Quartz on the Frequency of Oscillations," *Proc. I.R.E.*, vol. 19, p. 1252, 1931.
71. Bokovoy, S. A.: "Quartz Crystals—Development and Application," *Elec. Comm.*, vol. 21, pp. 233—246, 1944.
72. Bokovoy, S. A.: "Piezoelectric Quartz Element," Patent 2,111,384, filed September 30, 1936, issued March 15, 1938.
73. Bokovoy, S. A.: "Mounting for Piezoelectric Elements," Patent 2,078,229, filed December 31, 1935, issued April 27, 1937.
74. Bokovoy, S. A.: "Quartz Piezo-Electric Element," Patent 2,064,288, filed May 31, 1934, issued December 15, 1936.
75. Bokovoy, S. A., and Baldwin, C. F.: "Improvements in or Relating to Piezo-Electric Crystals," methods of cutting quartz for use as length-and-breadth mode oscillators, British Patent Specification 457,342, filed May 31, 1935, issued November 26, 1936.
76. Booth, C. F.: "The Application and Use of Quartz Crystals in Telecommunications," *J.I.E.E.*, vol. 88, part 3, pp. 97—128, 1941; discussion, pp. 128—144.
77. Booth, C. F., and C. F. Sayers: "The Production of Quartz Resonators for the London-Birmingham Coaxial Cable System," *P.O.E.E.J.*, vol. 32, pp. 7—15, 88—93, 1939.
78. Booth, C. F., and E. J. C. Dixon: "Crystal Oscillators for Radio Transmitters: An Account of Experimental Work Carried Out by the Post Office," *W. E.*, vol. 12, pp. 198—200, 1935; *J.I.E.E.*, vol. 77, pp. 197—236, discussion pp. 237—244, 1935; *Proc. Wireless Sec., I.E.E.*, vol. 10, pp. 129—168, discussion, pp. 169—176, 1935.
79. Bond, W. L.: "Sawing, Grinding and 'Lapping'"; refer to book by Heising, R. A.: *Quartz Crystals for Electrical Circuits*, D. Van Nostrand, New York, pp. 290—316, 1946.
80. Bond, W. L.: "The Ring Eccentricity 'Correction'"; refer to book by Heising, R. A.: *Quartz Crystals for Electrical Circuits*, D. Van Nostrand, New York, pp. 91—94, 1946.
81. Bond, W. L.: "Methods for Specifying Quartz Crystal Orientation and Its Determination by Optical Means," *Bell Syst. T. J.*, vol. 22, pp. 224—262, 1943; also printed in book by Heising, R. A.: *Quartz Crystals for Electrical Circuits*, D. Van Nostrand, New York, pp. 57—91, 1946.
82. Bond, W. L., and E. J. Armstrong: "The Use of X-rays for Determining the Orientation of Quartz Crystals," *Bell Syst. T. J.*, vol. 22, pp. 293—337, 1943; also printed in book by Heising, R. A.: *Quartz Crystals for Electrical Circuits*, D. Van Nostrand, New York, pp. 95—139, 1946.
83. Bond, W. L.: "Processing Quartz," *Bell Labs. Rec.*, vol. 22, pp. 359—361, 1944.
84. Bond, W. L.: "The Mathematics of the Physical Properties of Crystals," *Bell Syst. T. J.*, vol. 22, pp. 1—72, 1943.
85. Bond, W. L.: "A Mineral Survey for Piezoelectric Materials," *Bell Syst. T. J.*, vol. 22, pp. 145—152, 1943.
86. Bond, W. L.: "Division of Metal Plating by Stylus," Patent 2,248,057.
87. Bosch, W. C., and W. G. Allée, Jr.: "Circuit Details for a Small Supersonic Oscillator of the Piezoelectric Type," *Am. Phys. Teacher*, vol. 6, pp. 272—273, 1938.
88. Bothwell, F. E.: "Nyquist Diagrams and the Routh-Hurwitz Stability Criterion," *Proc. I.R.E.*, vol. 38, pp. 1345—1348, 1950.
89. Bottom, V. E., Colorado A. & M. College: *Parameters Which Determine the Performance of Piezoelectric Plate*, Sig. Corps Contract DA36-039-sc—32083, July 1950.

90. Bottom, V. E.: "The Mathematics of the Equivalent Electrical Circuit of the Quartz Crystal Unit," printed in *Fundamental Principles of Crystal Oscillator Design*, U. S. Army Signal Corps, Long Branch Signal Laboratory, pp. 20—35, 1945.
91. Bower G. G.: "Crystal-Controlled Electron-Coupled Oscillator," printed in *Fundamental Principles of Crystal Oscillator Design*, U. S. Army Signal Corps, Long Branch Signal Laboratory, pp. 79—84, 1945.
92. Boyle, R. W., and D. O. Sproule: "Oscillation in Ultrasonic Generators and Velocity of Longitudinal Vibrations in Solids at High Frequencies," *Nature*, vol. 123, p. 13, January 5, 1929.
93. Boyle, R. W.: "Ultrasonics," *Science Progress*, vol. 23, pp. 75—105, 1928.
94. Boyle, R. W., Lehmann, J. F., and S. C. Morgan: "Some Measurements of Ultrasonic Velocities in Liquids," *Trans. Roy. Soc. Can.*, vol. 22, sec. 3, pp. 371—378, 1928.
95. Bradley, A. J., and A. H. Jay: "Quartz as a Standard for Accurate Lattice-spacing Measurements," *Proc. Phys. Soc. (London)*, vol. 45, pp. 507—522, 1933.
96. Bradley, W. E.: "Superregenerative Detection Theory," *Electronics*, vol. 21, pp. 96—98, September 1948.
97. Bradley, W. E.: "Single Stage F-M Detector," *Electronics*, vol. 19, pp. 88—91, October 1946.
98. Bragg, W., and R. E. Gibbs: "The Structure of Alpha and Beta-quartz," *Proc. Roy. Soc.*, vol. 109, pp. 405—427, 1925.
99. Bragg, W. L.: *Atomic Structure of Minerals*, Cornell University Press, Ithaca, New York, 1937, 292 pp.
100. Briggs, H. B.: "A Supersonic Cell Fluorometer," *Jour. Optical Soc. Am.*, vol. 31, pp. 543—549, 1941.
101. Brotherton, M.: *Capacitors*, D. Van Nostrand, New York, 1946.
102. Brown, G. H., Hoyler, C. N., and R. A. Bierwith: *Theory and Application of Radio Frequency Heating*, D. Van Nostrand, New York, 1947.
103. Brown, G. H.: "Efficiency of Induction Heating Coils," *Electronics*, vol. 17, pp. 124—129, August 1944.
104. Brown, H. A.: "Oscilloscope Patterns of Damped Vibrations of Quartz Plates and Q Measurements with Damped Vibrations," *Proc. I.R.E.*, vol. 29, pp. 195—199, 1941.
105. Brown, R. H.: "Harmonic Amplifier Design," *Proc. I.R.E.*, vol. 35, pp. 771—777, 1947.
106. Brown, S. L., and S. Harris: "Measurements of Temperature Coefficient and Pressure Coefficient of Quartz Crystal Oscillators," *R.S.I.*, vol. 2, pp. 180—183, 1931.
107. Brown, W. F., Jr.: "Interpretation of Torsional Frequencies of Crystal Specimens," *Phys. Rev.*, vol. 58, pp. 998—1001, 1940.
108. Brown, W. F.: "Quartz Crystals Overtone Oscillators," Royal Aircraft Establishment, Farnborough, England, Tech. Note: Rad. 460, September 1949.
109. Browne, C. O.: "Demonstration of High-Frequency Fluctuations in the Intensity of a Beam of Light," *Proc. Phys. Soc. (London)*, vol. 40, p. 36, 1927.
110. Bruce, W. A., and G. E. M. Jauncey: "Dependence of Diffuse Scattering of X-rays from Quartz upon the Angle between the Crystal Axis and the Plane of Scattering, (abstract) *Phys. Rev.*, vol. 49, pp. 418—419, 1926.
111. Bruck, G. S.: "Simplified Frequency Modulation," *Proc. I.R.E.*, vol. 34, p. 458, 1946.
112. Brunetti, C., and L. Greenough: "Some Characteristics of a Stable Negative Resistance," *Proc. I.R.E.*, vol. 30, pp. 542—546, 1942.
113. Brunetti, C.: "The Transitron Oscillator," *Proc. I.R.E.*, vol. 27, pp. 88—94, 1939.
114. Brunetti, C.: "The Clarification of Average Negative Resistance with Extension of Its Use," *Proc. I.R.E.*, vol. 25, pp. 1593—1616, 1937.
115. Buckley, O. E.: "The Evolution of the Crystal Wave Filter," *Jour. Applied Phys.*, vol. 8, pp. 40—47, 1937.
116. Buehler, E., and A. C. Walker: "Growing Quartz Crystals," *Sci. Monthly*, vol. 69, pp. 148—155, 1949.
117. Builder, G., and J. E. Benson: "Simple Quartz-crystal Filters of Variable Bandwidth," *A.W.A. Tech. Rev.*, vol. 5, pp. 93—103, 1941; also in *Wireless Eng. Exptl. Wireless (London)*, vol. 20, pp. 183—189, 1943.
118. Builder, G.: "A Stabilized Frequency Divider," *Proc. I.R.E.*, vol. 29, pp. 177—181, 1941.
119. Builder, G., and J. E. Benson: "Contour-mode Vibrations in Y-cut Quartz-crystal Plates," *Proc. I.R.E.*, vol. 29, pp. 182—185, 1941; *A.W.A. Tech. Rev.*, vol. 5, pp. 181—189, 1941.
120. Builder, G.: "A Note on the Determination of the Equivalent Electrical Constants of a Quartz-crystal Resonator," *A.W.A. Tech. Rev.*, vol. 5, pp. 41—45, 1940.
121. Builder, G., and J. E. Benson: "Precision Frequency-control Equipment Using Quartz Crystals," *A.W.A. Tech. Rev.*, vol. 3, pp. 157—214, 1938; *Proc. World Radio Convention*, Sydney, Australia, 1938.
122. Builder, G.: "Resistance-balancing in Wave Filters," *A.W.A. Tech. Rev.*, vol. 3, pp. 83—100, 1938.
123. Builder, G.: "Quartz Crystals for the Control and Measurement of Frequency," *A.W.A. Tech. Rev.*, vol. 2, pp. 104—105, 1936.
124. Burgess, R. E.: "Oscillator Power Relations," *Wireless Eng.*, vol. 23, pp. 237—240, 1946.
125. Burns, G. K.: "Manufacture of Quartz Crystal Filters," *Bell System Tech. Jour.*, vol. 19, pp. 516—532, 1940.
126. Bushby, R. W.: "Thermal Frequency Drift Compensation," *Proc. I.R.E.*, vol. 30, pp. 546—553, 1942.
127. Butler, F.: "Series Resonant Crystal Oscillators," *W. E.*, vol. 23, p. 1, 1946.
128. Butler, F.: "Cathode-Coupled Oscillators," *W. E.*, vol. 21, p. 521, November 1944.
129. Cady, W. G.: *Piezoelectricity*, McGraw-Hill, New York, 1946.
130. Cady, W. G., and K. S. Van Dyke: "Proposed Standard Conventions for Expressing the Elastic and Piezoelectric Properties of Right- and Left-quartz," *Proc. I.R.E.*, vol. 30, pp. 495—499, 1942.
131. Cady, W. G.: "A Survey of Piezoelectricity," *A.P.T.*, vol. 6, pp. 227—242, 1938.
132. Cady, W. G.: "The Longitudinal Piezoelectric Effect in Rochelle Salt Crystals," *Proc. Ph. Soc.*, vol. 49, pp. 646—653, 1937.
133. Cady, W. G.: "The Piezoelectric Resonator and the Effect of Electrode Spacing upon Frequency," *Physics*, vol. 7, pp. 237—259, 1936.
134. Cady, W. G.: "A Quartz Crystal Used as a Selective Filter," Patent 1,994,658, filed June 7, 1927, issued March 19, 1935.
135. Cady, W. G.: "The Potential Distribution Between Parallel Plates and Concentric Cylinders Due to Any Arbitrary Distribution of Space Charge," *Physics*, vol. 6, pp. 10—13, 1935.
136. Cady, W. G.: "The Application of Methods of Geometrical Inversion to the Solution of Certain Problems in Electrical Resonance," *Proc. A.A.A.S.*, vol. 68, pp. 383—409, 1933.
137. Cady, W. G.: "Low Frequency Vibrations in Rochelle Salt and Quartz Plates," (abst.), *Phys. Rev.*, vol. 39, p. 862, 1932.
138. Cady, W. G.: "Piezoelectric Terminology," *Proc. I.R.E.*, vol. 18, pp. 2136—2142, 1930.
139. Cady, W. G.: "Electroelastic and Pyro-electric Phenomena," *Proc. I.R.E.*, vol. 18, pp. 1247—1262, 1930.
140. Cady, W. G.: "Some Electromechanical Properties of Rochelle Salt Crystals," (abst.), *Phys. Rev.*, vol. 33, pp. 278—279, 1929.

Appendix II Bibliography

141. Cady, W. G.: "Bibliography on Piezoelectricity," *Proc. I.R.E.*, vol. 16, pp. 521—535, 1928.
142. Cady, W. G.: "A Shear Mode of Crystal Vibration," (abst.), *Phys. Rev.*, vol. 29, p. 617, 1927.
143. Cady, W. G.: "Piezoelectric Standards of High Frequency," *J.O.S.A.*, vol. 10, pp. 475—489, 1925.
144. Cady, W. G.: "An International Comparison of Radio Wavelength Standards by Means of Piezoelectric Resonators," *Proc. I.R.E.*, vol. 12, pp. 805—816, 1924.
145. Cady, W. G.: "Piezoelectrically Driven Tuning-forks and Rods," *Phys. Rev.*, vol. 21, pp. 371—372, 1923.
146. Cady, W. G.: "A Method of Testing Plates from Piezoelectric Crystals," *J.O.S.A.*, vol. 6, pp. 183—185, 1922.
147. Cady, W. G.: "The Piezoelectric Resonator," *Proc. I.R.E.*, vol. 10, pp. 83—114, 1922.
148. Cady, W. G.: "Theory of Longitudinal Vibrations of Viscous Rods," *Phys. Rev.*, vol. 19, pp. 1—6, 1922.
149. Camfield, G. J.: "The Design of Fundamental Mode Quartz Crystal Oscillators," Royal Aircraft Establishment, Farnborough, England, Tech. Note: Rad. 525, July 1952.
150. Carnahan, C. W., and H. P. Kalmus: "Synchronized Oscillators as F-M Receiver Limiters," *Electronics*, vol. 17, pp. 108—111, August 1944.
151. Carruthers, R. S.: "Some Experimental and Practical Applications of Transistor Oscillators," pp. 397—414 of *The Transistor*, prepared by Bell Telephone Laboratories, Inc., Murray Hill, N. J., November 1951.
152. Chaffee, J. G.: "The Application of Negative Feedback to Frequency-Modulation Systems," *Bell System T. J.*, vol. 18, pp. 404—437, 1939; also *Proc. I.R.E.*, vol. 27, pp. 317—331, 1939.
153. Chaffee, E. L., and C. N. Kimball: "A Method of Determining the Operating Characteristics of a Power Oscillator," *J. Frank Inst.*, vol. 221, p. 237, 1936.
154. Chaffee, E. L.: "Equivalent Circuits of an Electron Triode and the Equivalent Input and Output Admittances," *Proc. I.R.E.*, vol. 17, p. 1633, September 1929.
155. Chance, B., et al.: *Waveforms*, McGraw-Hill, New York, 1949.
156. Chance, B.: "Some Precision Circuit Techniques Used in Wave Form Generation and Time Measurement," *R.S.I.*, vol. 17, pp. 396—415, 1946.
157. Chang, C. K.: "A Frequency-Modulated Resistance-Capacitance Oscillator," *Proc. I.R.E.*, vol. 31, pp. 22—25, 1943.
158. Chang, H., and V. C. Rideout: "The Reactance Tube Oscillator," *Proc. I.R.E.*, vol. 37, pp. 1330—1331, 1949; also p. 1096, 1950.
159. Christopher, A. J., and J. A. Kater: "Mica Capacitors for Carrier Telephone Systems," *Elec. Eng. (Transactions Sect.)*, vol. 65, pp. 670—673, 1946.
160. Chu, E. L.: "Notes on the Stability of Linear Networks," *Proc. I.R.E.*, vol. 32, pp. 630—637, 1944.
161. Clapp, J. K.: "An Inductance-Capacitance Oscillator of Unusual Frequency Stability," *Proc. I.R.E.*, vol. 36, pp. 356—358; also p. 1261, 1948.
162. Clapp, J. K.: "A Bridge Controlled Oscillator," *General Radio Experimenter*, vol. XVIII, No. 11, p. 1, April 1944.
163. Clapp, J. K., and J. D. Crawford: "Frequency Standardization," *QST*, vol. 14, pp. 9—15, March 1930.
164. Clapp, J. K.: "Universal Frequency Standardization from a Single Frequency Standard," *J.O.S.A.*, vol. 15, pp. 25—47, 1927.
165. Close, R. N., and M. T. Lebenbaum: "Design of Phantatron Time-Delay Circuits," *Electronics*, vol. 21, pp. 100—107, April 1948.
166. Cochran, D., and R. W. Samsel: "Ultrasonics—A Method of Determining the Acoustic Properties, Absorption and Velocity, for Materials to be Used as Ultrasonic Windows, Lenses, and Reflectors," *Gen. Elec. Rev.*, vol. 47, pp. 39—41, 1944.
167. Cocking, W. T.: "Linear Saw-Tooth Oscillator," *W. World*, vol. 52, pp. 176—178, June 1946.
168. Colby, M. Y., and S. Harris: "An X-ray Study of a Long X-cut Quartz Crystal Vibrating Under the Transverse Piezoelectric Effect," *Phys. Rev.*, vol. 46, pp. 445—450, 1934.
169. Colby, M. Y., and S. Harris: "Effect of Etching on the Relative Intensities of the Components of Double Laue Spots Obtained from a Quartz Crystal," *Phys. Rev.*, vol. 43, pp. 562—563, 1933.
170. Colebrook, F. M.: "A Theoretical and Experimental Investigation of High Selectivity Tone-corrected Receiving Circuits," *Radio Res. Board, Nat. Phys. Lab., Spec. Rept. 12*, London, 1932.
171. Compton, A. H., and S. K. Allison: *X-rays in Theory and Experiment*, D. Van Nostrand, pp. 340—346, New York, 1935.
172. Cook, R. K.: "Absolute Pressure Calibrations of Microphones" (use of tourmaline disk), *Bur. Standards Jour. Research*, vol. 25, pp. 489—505, 1940.
173. Cooke, W. T.: "The Variation of the Internal Friction and Elastic Constants with Magnetization in Iron, Part I," *Phys. Rev.*, vol. 50, pp. 1158—1164, 1936.
174. Cork, J. M.: Laue Patterns from Thick Crystals at Rest and Oscillating Piezoelectrically," *Phys. Rev.*, vol. 42, pp. 749—752, 1932.
175. Cortez, S. H.: "Interferometer Method for Measuring the Amplitude of Vibration of Quartz Bar Crystals," *J.O.S.A.*, vol. 24, pp. 127—129, 1934; erratum, vol. 24, p. 194, 1934.
176. Coursey, R.: *Electrical Condensers*, Pitman, London, 1927.
177. Crain, H. M.: "Low-Frequency Discriminator," *Electronics*, vol. 22, pp. 96—97, June 1949.
178. Crandall, Irving B.: *Theory of Vibrating Systems and Sound*, D. Van Nostrand, New York, 1926, 272 pp.
179. Creighton, J. L., Lau, H. B., and R. J. Turner: "Crystal Oscillators and Their Application to Radio Transmitters Control," *J.I.E.E.*, vol. 94, part IIIA, No. 12, 1947.
180. Crosby, M. G.: "Communication by Phase Modulation," *Proc. I.R.E.*, vol. 27, pp. 126—136, 1939.
181. Crossley, A.: "Modes of Vibration in Piezoelectric Crystals," *Proc. I.R.E.*, vol. 16, pp. 416—423, 1928.
182. Crossley, A.: "Piezoelectric Crystal-controlled Transmitter," *Proc. I.R.E.*, vol. 15, pp. 9—36, 1927.
183. Dake, H. C., Fleener, F. L., and B. H. Wilson: *Quartz Family Minerals*, Whittlesey House, New York, 1938, 304 pp.
184. Dale, A. B.: *The Form and Properties of Crystals*, University Press, Cambridge, London, 1932, 186 pp.
185. Davey, Wheeler P.: *A Study of Crystal Structure and Its Applications*, McGraw-Hill, New York, 1934, 695 pp.
186. David, E. E., Jr.: "Some Aspects of RF Phase Control in Microwave Oscillators," Technical Report 100, June 11, 1949, Research Laboratory of Electronics, Massachusetts Institute of Technology.
187. David, E. E., Jr.: "Locking Phenomena in Microwave Oscillators," Technical Report 63, April 8, 1948, Research Laboratory of Electronics, Massachusetts Institute of Technology.
188. Davies, R. M.: "On the Determination of Some of the Elastic Constants of Rochelle Salt by a Dynamical Method," *Phil. Mag.*, vol. 16, pp. 97—124, 1933.
189. Davis, K. H.: "Multivibrator Step-Down by Fractional Ratios," *Bell Lab. Record*, vol. 26, p. 114, March 1948.
190. Davy, N., Littlewood, J. H., and M. McCraig: "The Force-Time Law Governing the Impact of a Hammer on a Stretched String," *Phil. Mag.*, vol. 27, pp. 133—143, 1939.

191. Dawson, L. H.: "Piezoelectricity of Crystal Quartz," *Phys. Rev.*, vol. 29, pp. 532—541, 1927.
192. Day, J. R.: "Serrasoid F-M Modulator," *Electronics*, vol. 21, pp. 72—76, October 1948.
193. Debye, P., and F. W. Sears: "Scattering of Light by Supersonic Waves," *Proc. Nat. Acad. Sci.*, vol. 18, pp. 409—414, 1932.
194. Debye, P.: *Polar Molecules*, Chemical Catalog Company, Inc., New York, 1929, 172 pp.
195. De Lange, O. E.: "A Variable Phase-Shift Frequency-Modulated Oscillator," *Proc. I.R.E.*, vol. 37, pp. 1328—1330, 1949.
196. De Laup, S.: "Sine Waves in R-C Oscillators," *Electronics*, vol. 14, pp. 34—36, January 1941.
197. d'Heedene, A. R.: "Effects of Manufacturing Deviations on Crystal Units for Filters," refer to book by Heising, R. A.: *Quartz Crystals for Electrical Circuits*, D. Van Nostrand, New York, pp. 458—492, 1946.
198. Doherty, R. E., and E. G. Keller: *Mathematics of Modern Engineering*, John Wiley, New York, 1936.
199. Doherty, W. H.: "Synchronized FM Transmitter," *F. M. Mag.*, vol. 1, pp. 21—25, December 1940.
200. Donal, J. S., and R. R. Bush: "A Spiral-Beam Method for the Amplitude Modulation of Magnetrons," *Proc. I.R.E.*, vol. 37, pp. 375—382, 1949.
201. Dow, J. B.: "A Recent Development in Vacuum-Tube Oscillator Circuits," *Proc. I.R.E.*, vol. 19, pp. 2095—2108, 1931.
202. Drews, W. F., and A. E. Swickard: "The Wire Mounted Crystal Unit," refer to book by Heising, R. A.: *Quartz Crystals for Electrical Circuits*, D. Van Nostrand, New York, pp. 493—536, 1946.
203. Druesne, M. A. A.: "Quartz Crystals," *Communications*, vol. 23, pp. 46f., September 1943.
204. Dudley, R.: "Introduction to Transients," *Electronics*, vol. 17, p. 132, August 1944.
205. Dye, D. W.: "The Modes of Vibration of Quartz Piezoelectric Plates as Revealed by an Interferometer," *Proc. Roy. Soc.*, vol. 138, pp. 1—16, 1932.
206. Dye, D. W.: "Piezoelectric Quartz Resonator and Equivalent Electrical Circuit," *Proc. Ph. Soc.*, vol. 38, pp. 399—457; discussion, pp. 457—458, 1926.
207. Easton, A.: "Pulse-Modulated Oscillator," *Electronics*, vol. 20, pp. 124—129, March 1947.
208. Eastman, A. V.: *Fundamentals of Vacuum Tubes*.
209. Eccles, W. H., and W. A. Leyshon: "Some New Methods of Linking Mechanical and Electrical Vibrations," *Proc. Ph. Soc.*, vol. 40, pp. 229—232, 1928.
210. Eccles, W. H., and F. W. Jordan: "Trigger Relay," *Radio Rev.*, vol. 1, p. 143, October 1919.
211. Edson, W. A.: *Vacuum-Tube Oscillators*, John Wiley and Sons, New York, 1953, 476 pp.
212. Edson, W. A., et al.: "High Frequency Crystal-Controlled Oscillator Circuits," Final Report on Signal Corps Contract W36-039-sc—36841, Georgia Institute of Technology, State Engineering Experiment Station, Atlanta, Ga., December 1950.
213. Edson, W. A., et al.: "The Keying Properties of Quartz Crystal Oscillators," Final Report on Signal Corps Contract W36-039-sc—32100, Georgia Institute of Technology, State Engineering Experiment Station, Atlanta, Ga., December 1947.
214. Edson, W. A.: "Intermittent Behavior in Oscillators," *Bell Syst. T. J.*, vol. 24, pp. 1—22, 1945.
215. Edwards, C. M.: "A Precision Decade Oscillator for 20 Cycles to 200 Kilocycles," *Proc. I.R.E.*, vol. 39, pp. 277—378, 1951.
216. Ekstein, H.: "Free Vibrations of Anisotropic Bodies," *Phys. Rev.*, vol. 66, pp. 108—118, 1944.
217. Ellis, W. G.: "New Electrophones for High-fidelity Sound Reproduction," *Radio Eng.*, vol. 13, pp. 18f., October 1933.
218. Eltgroth, G. V.: "Frequency Stability of Tuned Circuits," *Electronics*, vol. 17, p. 118, February 1944.
219. Ervin, C. T.: "A Piezoelectric Gauge for Recording the Instantaneous Pressure in Shotguns," *Jour. Franklin Inst.*, vol. 213, pp. 503—514, 1932.
220. Espenschied, L.: "Quartz Crystals Used in Ladder Form Circuits to Obtain Band-pass Filters," Patent 1,795,204, filed January 3, 1927, issued August 8, 1933.
221. Espley, D. C.: "Harmonic Production and Cross Modulation in Thermionic Valves with Resistive Loads," *Proc. I.R.E.*, vol. 22, pp. 781—790, 1934.
222. Essen, L.: "A New Form of Frequency and Time Standard," *Proc. Ph. Soc.*, vol. 50, pp. 413—423; discussion, pp. 423—426, 1938.
223. Essen, L.: "The Dye Quartz Ring Oscillator as a Standard of Frequency and Time," *Proc. Roy. Soc.*, vol. 155, pp. 498—519, 1936.
224. Essen, L.: "International Frequency Comparisons by Means of Standard Radio-frequency Emissions," *Proc. Roy. Soc. (London)*, vol. 149, pp. 506—510, 1935.
225. Essen, L.: "Oscillations of Hollow Quartz Cylinders," *Nature*, vol. 135, p. 1076, 1935.
226. Essen, L.: "Examples of the Electrical Twinning of Quartz," *J. Sci. Instr.*, vol. 12, pp. 256—257, 1935.
227. Essen, L.: "Description of the Quartz Control of a Transmitter at 1785 Kilocycles per Second," *Proc. Wireless Sec. I.E.E.*, vol. 9, pp. 167—169, 1934.
228. Evans, R. C.: "The Dielectric Constant of Mixed Crystals of Sodium Ammonium and Sodium Potassium Tartrates," *Phil. Mag.*, vol. 24, pp. 70—79, 1937.
229. Everitt, W. L.: *Communication Engineering*, McGraw-Hill, New York, 2nd ed., 1937.
230. Everitt, W. L.: "Optimum Operating Conditions for Class C Amplifiers," *Proc. I.R.E.*, vol. 22, pp. 152—176, 1934.
231. Fair, I. E., Bell Telephone Laboratories: "Design Data on Crystal Controlled Oscillators" printed in *Information Bulletin on Quartz Crystal Units*, ASES 52-9, Armed Services Electro Standards Agency, Fort Monmouth, N. J., pp. 1—21, August 1952.
232. Fair, I. E.: "Piezo Electric Crystals in Oscillator Circuits," *Bell System Tech. J.*, vol. 24, pp. 161—216, 1945; also printed in book by Heising, R. A.: *Quartz Crystals for Electrical Circuits*, D. Van Nostrand, New York, pp. 356—411, 1946.
233. Fair, I. E.: "Using High Crystall Harmonics for Oscillator Control," *Bell Labs. Rec.*, vol. 21, pp. 237—242, 1943.
234. Federal Telephone and Radio Corp.: "Reference Data for Radio Engineers," New York, 2nd ed., 1946.
235. Fehr, R. O.: "Quartz-crystal Accelerometer," *Gen. Elec. Rev.*, vol. 45, pp. 269—272, 1942.
236. Feinberg, R.: "Symmetrical and Asymmetrical Multi-vibrators," *W. E.*, vol. 26, pp. 153—158 and 326—330, 1949.
237. Fischer, H. B.: "A Crystal Control Superheterodyne Receiver," *Bell Labs. Record*, vol. 11, pp. 273—278, 1933.
238. Fleming, L.: "Thermistor-Regulated Low-Frequency Oscillator," *Electronics*, vol. 19, pp. 97—99, October 1946.
239. Fleming-Williams, B. C.: "A Single-Valve Time-Base Circuit," *W. E.*, vol. 17, pp. 161—163, 1940.
240. Flint, W. A.: "New Double-crystal Band-pass Filters," *Electronics and Television and Short-wave World*, vol. 13, pp. 552—554, 1940.
241. Floyd, G. H.: "Vacuum Capacitors," *Proc. I.R.E.*, vol. 32, pp. 463—470, 1944.
242. Ford, J. R., and N. I. Korman: "Stability and Frequency Pulling of Loaded Unstabilized Oscillators," *Proc. I.R.E.*, vol. 34, pp. 794—799, 1946.
243. Fortescue, R. L.: "Quasi-Stable Frequency Dividing Circuits," *J.I.E.E.*, vol. 84, pp. 693—698, 1939.

Appendix II Bibliography

244. Foster, D. E., and A. E. Newton: "Measurements of Iron Cores at Radio Frequencies," *Proc. I.R.E.*, vol. 29, pp. 266—276, 1941.
245. Foster, D. E., and S. W. Seeley: "Automatic Tuning, Simplified Circuits and Design Practice," *Proc. I.R.E.*, vol. 25, pp. 289—313, 1937.
246. Foster, R. M.: "A Reactance Theorem," *Bell Syst. T. J.*, vol. 3, pp. 259—269, 1924.
247. Fowler, R. H.: *Statistical Mechanics*, 2nd ed., Cambridge University Press, London, 1936, 864 pp.
248. Fowler, R. H.: "A Theory of the Rotations of Molecules in Solids and of the Dielectric Constants of Solid and Liquids," *Proc. Roy. Soc.*, vol. 149, pp. 1—28, 1935.
249. Fox, F. E., and G. D. Rock: "A Quartz Plate with Coupled Liquid Column as a Variable Resonator," *Proc. I.R.E.*, vol. 30, pp. 29—33, 1942.
250. Fox, F. E., and G. D. Rock: "Ultrasonic Absorption in Water," *Jour. Acous. Soc. Am.*, vol. 12, pp. 505—510, 1941.
251. Fox, F. E., and G. D. Rock: "An Ultrasonic Stroboscope for Measuring Sound Wave-Length in Liquids," *Rev. Sci. Instruments*, vol. 10, pp. 345—348, 1939.
252. Fox, F. E., and G. D. Rock: "An Ultrasonic Source of Improved Design: Optical Studies of Ultrasonic Waves in Liquids," *R.S.I.*, vol. 9, pp. 341—345, 1938.
253. Fox, F. E., and G. D. Rock: "The Ultrasonic Radiation Field of a Quartz Disk Radiating Into Liquid Media," *Phys. Rev.*, vol. 54, pp. 223—228, 1938.
254. Fox, F. E.: "Ultrasonic Interferometry for Liquid Media," *Phys. Rev.*, vol. 52, pp. 973—981, 1937.
255. Fox, G. W., and D. W. Stebbins: "Effect of Quartz Filters on the Distribution of Energy in Laue Patterns," *Phys. Rev.*, vol. 55, pp. 405—408, 1939.
256. Fox, G. W., and J. R. Frederick: "Further Study of X-ray Diffraction in Quartz," *Phys. Rev.*, vol. 53, pp. 135—136, 1938.
257. Fox, G. W., and W. A. Fraser: "X-ray Extinction in Piezoelectrically Oscillating Crystals," *Phys. Rev.*, vol. 47, pp. 899—902, 1935.
258. Fox, G. W., and G. A. Fink: "The Piezoelectric Properties of Quartz and Tourmaline," *Physics*, vol. 5, pp. 302—306, 1934.
259. Fox, G. W., and M. Underwood: "On the Piezoelectric Properties of Tourmaline," *Physics*, vol. 4, pp. 10—13, 1933.
260. Fox, G. W., and W. G. Hutton: "Experimental Study of Parallel-cut Piezoelectric Quartz Plates," *Physics*, vol. 2, pp. 443—447, 1932.
261. Fox, G. W., and P. H. Carr: "The Effect of Piezoelectric Oscillation on the Intensity of X-ray Reflections from Quartz," *Phys. Rev.*, vol. 37, pp. 1622—1625, 1931.
262. Fox, G. W., and J. M. Cork: "Regular Reflection of X-rays from Quartz Crystals Oscillating Piezoelectrically," *Phys. Rev.*, vol. 38, pp. 1420—1423, 1931.
263. Frayne, J. G.: "Reversible Inductivity of Rochelle Salt Crystals," *Phys. Rev.*, vol. 21, pp. 348—359, 1923.
264. Freehafer, J. E.: "Supersonic Vibrations," *Newark Eng. Notes*, vol. 5, no. 1, pp. 18—19, December 1941.
265. Freeman, R. L.: "Improvements in AFC Circuits," *Electronics*, vol. 9, pp. 20—23, November 1936.
266. Frink, F. W.: "The Basic Principles of Superregenerative Reception," *Proc. I.R.E.*, vol. 26, pp. 76—107, 1938.
267. Frommer, J. C.: "A Graphical Method to Find the Optimal Operating Conditions of Triodes as Class C Telegraph Transmitters," *Proc. I.R.E.*, vol. 30, pp. 519—525, 1942.
268. Frondel, C.: "History of the Quartz Oscillator-plate Industry," pp. 205—213, "Final Frequency Adjustment of Quartz Oscillator-plates," pp. 416—431, "Effect of Radiation on the Elasticity of Quartz," pp. 432—446, "Secondary Dauphiné Twinning in Quartz," pp. 447—460, *A. Min.*, vol. 30, May-June 1945.
269. Furst, U. R.: "Harmonic Analysis of Overbiased Amplifiers," *Electronics*, vol. 17, pp. 143—144, March 1944.
270. Fyler, G. W.: "Parasites and Instability in Radio Transmitters," *Proc. I.R.E.*, vol. 23, pp. 985—1012, 1935.
271. Gager, F. M., and J. B. Russell, Jr.: "A Quantitative Study of the Dynatron," *Proc. I.R.E.*, vol. 23, pp. 1536—1566, 1935.
272. Galitzin, B.: "Apparatus for Direct Determination of Accelerations," *Proc. Roy. Soc. (London)*, vol. 95, p. 492, 1919.
273. Gardiner, E. L.: "Crystal Band-pass Filters," *Wireless World and Radio Rev. (London)*, vol. 43, pp. 382—384, 407—408, 447—448, 463—464, 1938; *T. and R. Bull. (London)*, vol. 15, pp. 75—79, 141—144, 178—179, 213—216, 251—253, 1939.
274. Gardner, M. F., and J. L. Barnes: *Transients in Linear Systems*, vol. I, John Wiley, New York, 1942.
275. George, W. D., Selby, M. C., and R. Scolnik: "Precision Measurement of Electrical Characteristics of Quartz-Crystal Units," *Proc. I.R.E.*, vol. 36, pp. 1122—1131, 1948.
276. George, W. D.: "Production of Accurate One-second Time Intervals," *Jour. Research Nat. Bur. Standards*, vol. 21, pp. 367—373, 1938.
277. Gerber, E. A., and H. P. Wasshausen: "High Frequency Crystals for Frequency Control—Lapping and Polishing Methods," Report No. E-1080, Sig. Corps Engineering Laboratories, Fort Monmouth, N. J., September 25, 1951.
278. Gentile AF Depot: "Crystal Handbook for Equipment Using FT-164 Crystal Holder (Unit)," HB-16F-1, April 30, 1953; "Crystal Handbook for Equipments Using AR-3 Crystal Holder (Unit)," HB-16F-2, April 13, 1953; "Crystal Handbook for Equipments Using FT-243 Crystal Holder (Unit)," HB-16F-3, May 22, 1953.
279. Gibbs, R. E., and L. C. Tsien: "The Production of Piezoelectricity by Torsion," *Phil. Mag.*, vol. 22, pp. 311—322, 1936.
280. Gibbs, R. E., and V. N. Thatté: "Temperature Variation of the Frequency of Piezoelectric Oscillations of Quartz," *Phil. Mag.*, vol. 14, pp. 682—694, 1932.
281. Gibbs, R. E.: "Structure of Alpha Quartz," *Proc. Roy. Soc.*, vol. 110, pp. 443—455, 1926.
282. Ginzton, E. L., and L. M. Hollingsworth: "Phase-Shift Oscillators," *Proc. I.R.E.*, vol. 29, pp. 43—49, 1941; also corrections, vol. 32, p. 641, 1944.
283. Gladwin, A. S.: "Oscillation Amplitude in Simple Valve Oscillators," *W. E.*, vol. 26, pp. 159—170 and 201—209, 1949.
284. Glasoe, G. N., and J. V. Lebacqz: *Pulse Generators*. McGraw-Hill, New York, 1948.
285. Glegg, K.: "Cathode-Coupled Multivibrator Operation," *Proc. I.R.E.*, vol. 38, pp. 655—675, 1950.
286. Glucksman, H. A.: "Superregeneration—An Analysis of the Linear Mode," *Proc. I.R.E.*, vol. 37, pp. 500—504, 1949.
287. Golay, M. J. E.: "A Rochelle Salt Electrometer," *R.S.I.*, vol. 8, pp. 228—230, July 1937.
288. Goldsmith, F. H.: "A Noise and Wear Reducing Phonograph Reproducer with Controlled Response," *Jour. Acous. Soc. Am.*, vol. 13, pp. 281—283, 1942.
289. Goldsmith, P., et al., Armour Research Foundation of Illinois Institute of Technology: "Investigation of Oscillator Circuits for AN/ARC-22," Air Force Contract AF 18(600)-157, Final Report, June 22, 1953.
290. Good, W. A.: "Rigidity Modulus of Beta-brass Single Crystals," *Phys. Rev.*, vol. 60, pp. 605—609, 1941.

291. Gordon, J. F.: "A New Angular-Velocity-Modulation System Employing Pulse Techniques," *Proc. I.R.E.*, vol. 34, pp. 328—334, 1946.
292. Gordon, S. G.: "The Inspection and Grading of Quartz," *A. Min.*, vol. 30, pp. 269—290, May-June 1945.
293. Gordon, S. G., and W. Parrish: "Cutting Schemes for Quartz Crystal," *A. Min.*, vol. 30, pp. 347—370, May-June 1945.
294. Goss F. A.: "Division of Metal Plating by Stylus," Patent 2,302,024.
295. Gouriet, G. G.: "High Stability Oscillator," *W. E.*, vol. 27, pp. 105—112, 1950.
296. Grant, K.: "High-frequency Interruption of Light," *Nature*, vol. 120, p. 586, 1927.
298. Gravley, C. K.: "An Instrument for Measuring Surface Roughness," *Electronics*, vol. 15, pp. 70—73, 1942.
299. Greenidge, R. M. C.: "The Mounting and Fabrication of Plated Quartz Crystal Units," *Bell Syst. T. J.*, vol. 23, pp. 234—259, 1944; also printed in book by Heising, R. A.: *Quartz Crystals for Electrical Circuits*, D. Van Nostrand, New York, pp. 412—435, 1946.
300. Griffiths, W. H. F.: "Recent Improvements in Air Cored Inductances," *W. E.*, vol. 19, pp. 8—19 and 56—63, 1942.
301. Griffiths, W. H. F.: "The Temperature Compensation of Condensers," *W. E.*, vol. 19, pp. 101—111 and 148—157, 1942.
302. Grime, G., and J. E. Eaton: "Determination of Young's Modulus by Flexural Vibrations," *Phil. Mag.*, vol. 23, pp. 96—99, 1937.
303. Groszkowski, J.: "The Temperature Coefficient of Inductance," *Proc. I.R.E.*, vol. 25, pp. 448—464, 1937.
304. Groszkowski, J.: "Oscillators with Automatic Control of the Threshold of Regeneration," *Proc. I.R.E.*, vol. 22, pp. 145—151, 1934.
305. Groszkowski, J.: "The Interdependence of Frequency Variation and Harmonic Content, and the Problem of Constant-Frequency Oscillators," *Proc. I.R.E.*, vol. 21, pp. 958—981, 1933.
306. Groszkowski, J.: "Frequency Division," *Proc. I.R.E.*, vol. 18, pp. 1960—1970, 1930.
307. Groth, E. J., and L. N. Liebermann: "Precision Measurement of the Velocity of Sound at Supersonic Frequencies Using a Microphone" (abstr.), *Phys. Rev.*, vol. 65, p. 350, 1944.
308. Gruen, H. E., and E. A. Roberts, Armour Research Foundation of Illinois Institute of Technology: "Feasibility Study for Package Oscillator Design."
309. Guillemin, E. A.: *Communication Networks*, vol. I, John Wiley, New York, 1931.
310. Guillemin, E. A., and P. T. Rumsey: "Frequency Multiplication by Shock Excitation," *Proc. I.R.E.*, vol. 17, pp. 629—651, 1929.
311. Gunn, R.: "A New Frequency-Stabilized Oscillator System," *Proc. I.R.E.*, vol. 18, pp. 1560—1574, 1930.
312. Hall, E. L., Heaton, V. E., and E. G. Lapham: "The National Primary Standard of Radio Frequency," *Jour. Research Nat. Bur. Standards*, vol. 14, pp. 85—98, 1935.
313. Harding, J. W., and F. W. G. White: "On the Modes of Vibration of a Quartz Crystal," *Phil. Mag.*, vol. 8, pp. 169—179, 1929.
314. Harnwell, G. P., and J. B. H. Kuper: "A Laboratory Frequency Standard," *Rev. Sci. Instruments*, vol. 8, pp. 83—86, 1937.
315. Harries, J. H. O.: "Apertures in Cavities," *Electronics*, vol. 19, pp. 132—135, December 1946.
316. Harris, W. A.: "Space-Charge Limited Current Fluctuations in Vacuum-Tube Amplifiers and Input Systems," *R.C.A. Rev.*, vol. 5, pp. 505—524, 1941.
317. Harrison, A. E., and N. W. Mather: "Graphical Analysis of Tuned Coupled Circuits," *Proc. I.R.E.*, vol. 37, pp. 1015—1020, 1949.
318. Harrison, C. W.: "The Measurement of the Performance Index of Quartz Plates," refer to book by Heising, R. A.: *Quartz Crystals for Electrical Circuits*, D. Van Nostrand, New York, pp. 458—492, 1946.
319. Harrison, J. R., and I. P. Hooper: "The Striated Luminous Glow of the Piezoelectric Quartz Resonator at Flexural Vibration Frequencies," *Phys. Rev.*, vol. 55, p. 674, 1939.
320. Harrison, J. R.: "Push-pull Piezoelectric Oscillator Circuits," *Proc. I.R.E.*, vol. 18, pp. 95—100, 1930.
321. Harrison, J. R.: "Piezoelectric Oscillator Circuits with Four-electrode Tubes," *Proc. I.R.E.*, vol. 16, pp. 1455—1467, 1928; discussion, pp. 1467—1470.
322. Harrison, J. R.: "Piezoelectric Resonance and Oscillatory Phenomena with Flexural Vibrations in Quartz Plates," *Proc. I.R.E.*, vol. 15, pp. 1040—1054, 1927.
323. Hartley, J. J., and R. H. Rinaldi: "Demonstration of the Application of Piezoelectric Properties of a Rochelle Salt Crystal and the Three-electrode Valve to the Determination of Impact Stresses in Granular Material," *Proc. Phys. Soc. (London)*, vol. 38, p. 273, 1926.
324. Hartley, R. V. L.: "Oscillations in Systems with Non-linear Reactance," *Bell Syst. T. J.*, vol. 15, pp. 424—440, 1936.
325. Haynes, J. R.: "Apparatus for the Direct Measurement of Force/Displacement Characteristics of Mechanical Systems at Audio-frequencies," *Jour. Acous. Soc. Am.*, vol. 13, p. 332, 1942.
326. Hazeltine, A., Richman, D., and B. D. Laughlin: "Superregenerator Design," *Electronics*, vol. 21, pp. 95—102, September 1948.
327. Healy, C. P., and J. C. Niven: "Mould and Humidity in Radio and Signals Equipment," *Proc. I.R.E.*, vol. 33, pp. 300—306, 1945.
328. Heaton, V. E., and E. G. Lapham: "Quartz Plate Mountings and Temperature Control for Piezo Oscillators," *Proc. I.R.E.*, vol. 20, pp. 261—271, 1932; discussion, p. 1064; *J. Res. N.B.S.*, vol. 7, pp. 683—690, 1931.
329. Hedeman, W. R.: "Few Crystals Control Many Channels," *Electronics*, vol. 21, pp. 118—121, March 1948.
330. Heising, R. A.: *Quartz Crystals for Electric Circuits*, D. Van Nostrand, New York, 1946.
331. Heising, R. A.: "Stability in High Frequency Oscillators," *Proc. I.R.E.*, vol. 31, pp. 595—600, 1943.
332. Heising, R. A.: "The Audion Oscillator," *Phys. Rev.*, vol. 16, pp. 216—237, 1920.
333. Heldt, P. M.: "Piezoelectric Indicators," *Automotive Ind.*, vol. 70, pp. 657—658 and 660, 1934.
334. Henderson, J. T.: "Properties of Tourmaline Crystals Used as Piezoelectric Resonators," *Trans. Roy. Soc. Can.*, vol. 22, pp. 127—131, 1928.
335. Herget, C. M.: "A Constant Path Acoustic Interferometer for Gases at Variable Pressure," *Rev. Sci. Instruments*, vol. 11, pp. 37—39, 1940.
336. Herold, E. W.: "Negative Resistance and Devices for Obtaining It," *Proc. I.R.E.*, vol. 23, pp. 1201—1223, 1935.
337. Hershberger, W. D., and L. E. Norton: "Frequency Stabilization with Microwave Spectral Lines," *R.C.A. Rev.*, vol. 9, pp. 38—49, 1948.
338. Hight, S. C., and G. W. Willard: "A Simplified Circuit for Frequency Sub-standards Employing a New Type of Low-frequency Zero-temperature-coefficient Quartz Crystal," *Proc. I.R.E.*, vol. 25, pp. 549—563, 1937.
339. Hight, S. C.: "Quartz Plates for Frequency Sub-standards," *Bell Labs. Rec.*, vol. 16, pp. 21—25, 1937.
340. Hight, S. C.: "Wind from Quartz Crystals," *Bell Labs. Rec.*, vol. 14, pp. 121—123, 1935.

Appendix II Bibliography

341. Hinton, W. R.: "The Design of R-C Oscillator Phase-Shifting Networks," *Electronic Eng.*, vol. 22, pp. 13—17, 1950.
342. Hitchcock, R. C.: "The Dimensions of Low-frequency Quartz Oscillators," *R.S.I.*, vol. 1, pp. 13—21, 1930.
343. Holden, A. N., and W. P. Mason: "Constants of Heavy-water Rochelle Salt," *Phys. Rev.*, vol. 57, pp. 54—56, 1940.
344. Holton, G. J.: "Rodometric Examination of Quartz Crystals," *Electronics*, vol. 17, pp. 114f., 1944.
345. Holubow, H.: "DC Saturable Reactors for Control Purposes," *Electronic Ind.*, vol. 4, pp. 76—79, March 1943.
346. Honess, A. P.: *The Nature, Origin and Interpretation of the Etch Figures on Crystals*, John Wiley & Sons, Inc., New York 1927, 171 pp.
347. Hopper, A. L., and S. E. Miller: "Considerations in the Design of a Radar Intermediate-Frequency Amplifier," *Proc. I.R.E.*, vol. 35, pp. 1208—1220, 1947.
348. Horton, J. W., and W. A. Marrison: "Precision Determination of Frequency," *Proc. I.R.E.*, vol. 16, pp. 137—154, 1928.
349. Horton, J. W.: "Vacuum-Tube Oscillators," *Bell Syst. T. J.*, vol. 3, pp. 508—524, 1924.
350. Houstoun, R. A.: "The Ultrasonic Diffraction Grating," *Phil. Mag.*, vol. 35, pp. 192—202, March 1944.
351. Houstoun, R. A.: "A New Method of Measuring the Velocity of Light" (Pizeau's method, using quartz crystal), *Nature*, vol. 142, p. 833, 1938; see also *Proc. Roy. Soc. Edinburgh, A*, vol. 61, pp. 102—114, 1941, vol. 62, pp. 58—63, 1943—1944, and *Phil. Mag.*, vol. 35, pp. 192—202, 1944.
352. Hovgaard, O. M.: "Application of Quartz Plates to Radio Transmitters," *Proc. I.R.E.*, vol. 20, pp. 767—782, 1932.
353. Howe, G. W. O.: "Natural and Resonant Frequencies of Coupled Circuits," *W. E.*, vol. 18, pp. 221—223, 1941.
354. Hubbard, J. C.: "Sound Velocity and Absorption by Ultrasonic Interferometry," *Phys. Rev.*, vol. 59, p. 935, 1941.
355. Hubbard, J. C.: "Ultrasonics—A Survey," *Am. Jour. Phys.*, vol. 8, pp. 207—221, 1940.
356. Hubbard, J. C., and I. F. Zartman: "A Fixed Path Acoustic Interferometer for the Study of Matter," *Rev. Sci. Instruments*, vol. 10, pp. 382—386, 1939.
357. Hubbard, J. C.: "The Crevasse Phenomenon in Piezoelectric Quartz and Its Application in Physical Measurements" (ultramicroscope), *Jour. Acous. Soc. Am.*, vol. 10, pp. 87—88, 1938.
358. Hubbard, J. C.: "The Acoustic Resonator Interferometer, I," *Phys. Rev.*, vol. 38, pp. 1011—1019, 1931; II, *Phys. Rev.*, vol. 41, pp. 523—535, 1932; *errata*, vol. 46, p. 525, 1934.
359. Huggins, W. H.: *The Potential Analogue in Network Synthesis and Analysis*, Publication E 5066, Air Force Cambridge Research Laboratories, Cambridge, Mass., March 1951.
360. Huggins, W. H.: "Multifrequency Bunching in Reflex Klystrons," *Proc. I.R.E.*, vol. 35, p. 1518, 1947.
361. Hull, G. F.: "Some Applications of Physics to Ordnance Problems," *Jour. Franklin Inst.*, vol. 192, pp. 327—347, 1921.
362. Hull, A. W.: "The Dynatron, a Vacuum Tube Possessing Negative Resistance," *Proc. I.R.E.*, vol. 6, pp. 5—36, 1918.
363. Hund, A.: "Reactance Tubes in Frequency Modulation Applications," *Electronics*, vol. 15, p. 68, October 1942.
364. Hund, A.: *Frequency Modulation*, McGraw-Hill, New York, 1942.
365. Hund, A.: *High-frequency Measurements*, McGraw-Hill, New York, 1933, 491 pp.
366. Hund, A., and R. B. Wright: "New Piezo-oscillations with Quartz Cylinders Cut Along the Optical Axis," *Proc. I.R.E.*, vol. 18, pp. 741—761, 1930; *J. Res. N.B.S.*, vol. 4, pp. 383—394, 1930.
367. Hund, A.: "Note on a Piezoelectric Generator for Audiofrequencies," *J. Res. N.B.S.*, vol. 2, pp. 355—358, 1929.
368. Hund, A.: "Generator for Audio Currents of Adjustable Frequency with Piezoelectric Stabilization," *Sci. Pap. Bur. St.*, vol. 22, pp. 631—637, 1928 (No. 569).
369. Hund, A.: "Notes on Quartz Plates, Air Gap Effect and Audio-frequency Generation," *Proc. I.R.E.*, vol. 16, pp. 1072—1078, 1928.
370. Hund, A.: "Uses and Possibilities of Piezoelectric Oscillators," *Proc. I.R.E.*, vol. 14, pp. 447—469, 1926.
371. Hunter, L., and S. Siegel: "The Variation with Temperature of the Principal Elastic Moduli of NaCl Near the Melting Point," *Phys. Rev.*, vol. 61, pp. 84—90, 1942.
372. Huntoon, R. D., and A. Weiss: "Synchronization of Oscillators," *Proc. I.R.E.*, vol. 35, pp. 1415—1423, 1947.
373. Hussey, L. W., and L. R. Wrathall: "Oscillations in an Electromechanical System," *Bell Syst. T. J.*, vol. 15, pp. 441—445, 1936.
374. Ide, J. M.: "Some Dynamic Methods for Determination of Young's Modulus," *Rev. Sci. Instruments*, vol. 6, pp. 296—298, 1935.
375. Ide, J. M.: "Magnetostrictive Alloys with Low Temperature Coefficients of Frequency," *Proc. I.R.E.*, vol. 22, pp. 177—190, 1934.
376. "International Critical Tables," vol. 6, pp. 207—212, *Electroelastic and Pyroelectric Phenomena*, McGraw-Hill, New York, 1929.
377. I.R.E.: *Standards on Piezoelectric Crystals, Recommended Terminology*, 1945.
378. I.R.E.: "Proposed Standard Conventions for Expressing the Elastic and Piezoelectric Properties of Right and Left Quartz," *Proc. I.R.E.*, p. 495, November 1942.
379. Iseley, F. C.: "The Relation Between the Mechanical and Piezoelectrical Properties of a Rochelle Salt Crystal," *Phys. Rev.*, vol. 24, pp. 569—574, 1924.
380. Ives, R. L.: "The Relay Oscillator and Related Devices," *J. Frank. Inst.*, vol. 242, pp. 243—277, 1946.
381. Jackson, C. H.: "Development of an Improved Crystal Exciter Unit," *Civil Aeronautics Authority (U.S.A.), Tech., Development Rept.*, 26, pp. 1—14, July 1940.
382. Jacobsen: "Effect of Shear on the Flexure Frequencies of Beams," *Jour. Applied Mechanics*, March 1938.
383. Jaderholm, H. W.: "Iron Powder Cores and Coils," *Proc. I.R.E.*, vol. 33, p. 904, 1945.
384. Jaffee, H.: "Crystalline Transitions and Dielectric Constant" (abst.), *Phys. Rev.*, vol. 53, p. 917, 1938.
385. Jaffee, H.: "Polymorphism of Rochelle Salt," *Phys. Rev.*, vol. 51, pp. 43—47, 1937.
386. Jauncey, G. E. M., and W. A. Bruce: "Diffuse Scattering of X-rays from Piezoelectrically Oscillating Quartz," *Phys. Rev.*, vol. 54, pp. 163—165, 1938.
387. Jefferson, H.: "The Pierce Piezoelectric Oscillator," *W. E.*, vol. 18, pp. 232—237, 1941.
388. Jefferson, H.: "Stabilization of Feedback Oscillators," *W. E.*, vol. 22, pp. 384—389, 1945.
389. Jeffree, J. H.: "The Scopphony Light Control," *Television and Short-wave World*, vol. 9, pp. 260f., 1936; see also Brit. patent 439,236 (1934).
390. Joffé, A. F.: *The Physics of Crystals*, 1st ed., McGraw-Hill, New York, 1928, 198 pp.
391. Johnson, J. B.: "Thermal Agitation of Electricity in Conductors," *Phys. Rev.*, vol. 32, pp. 97—109, 1928.
392. Johnson, K. C.: "Single-Valve Frequency-Modulated Oscillator," *W. E.*, vol. 55, pp. 122—123 and 168—170, 1949.

393. Johnson, R. W.: "Extending the Frequency Range of the Phase-Shift Oscillator," *Proc. I.R.E.*, vol. 33, pp. 597—602, 1945.
394. Johnson, W. C.: *Mathematical and Physical Principles of Engineering Analysis*, McGraw-Hill, New York, 1944.
395. Kakiuchi, Y.: "The Increase of X-ray Reflection from Quartz Due to a Strong Electric Field," *Phys. Rev.*, vol. 54, p. 772, 1938.
396. Kalmus, H. P.: "Some Notes on Superregeneration with Particular Emphasis on Its Possibilities for Frequency Modulation," *Proc. I.R.E.*, vol. 32, pp. 591—600, 1944.
397. Kammer, E. W., and J. V. Atanasoff: "A Determination of the Elastic Constants of Beta-quartz," *Phys. Rev.*, vol. 62, pp. 395—400, 1942.
398. Kantor, M.: "Theory and Design of Progressive and Ordinary Universal Windings," *Proc. I.R.E.*, vol. 35, pp. 1563—1570, 1947.
399. Kao, P. T.: "Relaxation Oscillations Produced by a Quartz Piezoelectric Oscillator," *C. R.*, vol. 191, pp. 932—934, 1930.
400. Karcher, J. C.: "A Piezoelectric Method for the Instantaneous Measurement of High Pressures," *Sci. Pap. Bur. St.*, vol. 18, pp. 257—264, 1922 (No. 445); *J. Frank. Inst.*, vol. 194, pp. 815—816 (abst.), 1922.
401. Keall, O. E.: "Analysis of Bridge Circuit for Piezoelectric Quartz Resonators," *Marconi Rev.*, No. 59, pp. 19—29, March-April 1936.
402. Keithley, J. F.: "Low-Frequency Oscillator," *Electronics*, vol. 21, pp. 108—109, September 1948.
403. Keller, E. G.: "Analytical Methods of Solving Discrete Nonlinear Problems in Electrical Engineering," *Trans. A.I.E.E.*, vol. 60, pp. 1194—1200, 1941.
404. Kellogg, J. B. M., and S. Millman: "Molecular Beam Magnetic Resonance Method," *Rev. Mod. Phys.*, vol. 18, pp. 323—352, 1946.
405. Kelvin, Lord: *Baltimore Lectures*, C. J. Clay & Sons, London, 1904.
406. Kelvin, Lord: "On the Piezoelectric Property of Quartz," *Phil. Mag.*, vol. 36, pp. 331, 342, 384, 453, 1893.
407. Kelvin, Lord: *Mathematical and Physical Papers*, vol. 5, Cambridge University Press, London, 1911; *Phil. Mag.*, vol. 36, pp. 331, 342, 384, 414, 453, 1893.
408. Keys, D. A.: "Adiabatic and Isothermal Piezoelectric Constants of Tourmaline," *Phil. Mag.*, vol. 46, pp. 999—1001, 1923.
409. Keys, D. A.: "Piezoelectric Method of Measuring Explosion Pressures," *Phil. Mag.*, vol. 42, pp. 473—488, 1921.
410. Kiebert, M. V., and A. F. Inglis: "Multivibrator Circuits," *Proc. I.R.E.*, vol. 33, pp. 534—539, 1945.
411. Kilgore, G. R., Shulman, C. I., and J. Kurshan: "A Frequency Modulated Magnetron for Super-High Frequencies," *Proc. I.R.E.*, vol. 35, pp. 657—664, 1947.
412. Kimbark, E. W.: "Electrical Transmission of Power and Signals," John Wiley, New York, 1949.
413. Kingston, R. H.: "Resonant Circuits with Time-Varying Parameters," *Proc. I.R.E.*, vol. 37, pp. 1478—1481, 1949.
414. Kinn, T. P.: "Vacuum-Tube Radio-Frequency-Generator Characteristics and Application to Induction Heating Problems," *Proc. I.R.E.*, vol. 33, pp. 640—657, 1945.
415. Kinzer, J. P., and I. G. Wilson: "Some Results on Cylindrical Cavity Resonators," *Bell Syst. T. J.*, vol. 26, pp. 410—445, 1947.
416. Kirby, T.: "Twin Oscillator," *Electronics*, vol. 22, p. 170, October 1949.
417. Kishpaugh, A. W., and R. E. Coram: "Low Power Radio Transmitters for Broadcast Requirements for 100 to 1000 Watts," *Proc. I.R.E.*, vol. 21, pp. 212—227, 1933.
418. Klingaman, G. W., and G. H. Williams: "Shielding of Dielectric Heating Installations," *Electronics*, vol. 18, pp. 106—109, May 1945.
419. Knox, R. E.: "The Use of Quartz Crystals in Wave Filters," *Electronics*, vol. 13, pp. 78f., November 1940.
420. Koga, I.: "Equivalence of Two Piezoelectric Oscillating Quartz Crystals of Symmetrical Outlines with Respect to a Plane Perpendicular to an Electrical Axis," *Phil. Mag.*, vol. 27, pp. 640—643, 1939.
421. Koga, I.: "Young's Modulus of a Crystal in Any Direction," *Proc. I.R.E.*, vol. 24, pp. 532—533, 1936.
422. Koga, I.: "Notes on Piezoelectric Quartz Crystals," *Proc. I.R.E.*, vol. 24, pp. 510—531, 1936.
423. Koga, I.: "Thermal Characteristics of Piezoelectric Oscillating Quartz Plates," *U.R.S.I. Gen. Assembly, Document 33, Comm. I*, London, 1934.
424. Koga, I.: "Vibration of Piezoelectric Oscillating Crystal," *Phil. Mag.*, vol. 16, pp. 275—283, 1933.
425. Koga, I.: "Note on the Piezoelectric Quartz Oscillating Crystal Regarded from the Principle of Similitude," *Proc. I.R.E.*, vol. 19, pp. 1022—1023, 1931.
426. Koga, I.: "Characteristics of Piezo-Electric Quartz Oscillators," *Proc. I.R.E.*, vol. 18, pp. 1935—1959, 1930.
428. Kryloff, N., and N. Bogoliuboff: *Introduction to Non-Linear Mechanics*, Princeton University Press, 1943.
429. Kunz, K. S.: "Bilinear Transformations Applied to the Tuning of the Output Network of a Transmitter," *Proc. I.R.E.*, vol. 37, pp. 1211—1217, 1949.
430. Kurtz, E. B., and G. F. Corcoran: *Introduction to Electric Transients*, John Wiley, New York, 1935.
431. Kusunose, Y., and S. Ishikawa: "Frequency Stabilization of Radio Transmitters," *Proc. I.R.E.*, vol. 20, pp. 310—339, 1932.
432. Labaw, L. W.: "Wave Front Determination in a Supersonic Beam" (abst.), *Phys. Rev.*, vol. 66, p. 354, 1944.
433. Lack, F. R., Willard, G. W., and I. E. Fair: "Some Improvements in Quartz Crystal Circuit Elements," *Bell Syst. T. J.*, vol. 13, pp. 453—463, 1934.
434. Lack, F. R.: "Observations on Modes of Vibration and Temperature-coefficients of Quartz Crystal Plates," *Proc. I.R.E.*, vol. 17, pp. 1123—1141, 1929; *Bell Syst. T. J.*, vol. 8, pp. 515—535, 1929.
435. Ladner, A. W., and C. R. Stoner: *Short-Wave Wireless Communication*, John Wiley, New York, 5th ed., 1950.
436. Lamb, Horace: *The Dynamical Theory of Sound*, Edward Arnold & Co., London, 1910, 303 pp.
437. Lampkin, G. F.: "An Improvement in Constant Frequency Oscillators," *Proc. I.R.E.*, vol. 27, pp. 199—201, 1939.
439. Lamb, J. J.: "A New I.F. Coupling System for Superhet Receivers," *QST*, vol. 21, pp. 28—30, April 1937.
440. Lamb, J. J.: "A Practical Survey of Pentode and Beam Tube Crystal Oscillators for Fundamental and Second Harmonic Output," *QST*, vol. 21, pp. 31—38, pp. 106, 107, April 1937.
441. Lamb, J. J.: "Receiver Selectivity Characteristics," *QST*, vol. 19, pp. 37—41, May 1935.
442. Lamb, J. J.: "Tritet Multi-band Crystal Control," *QST*, vol. 17, pp. 9—15, October 1933.
443. Lamb, J. J.: "A More Stable Crystal Oscillator of High Harmonic Output," *QST*, vol. 17, pp. 30—32, June 1933.
444. Lamb, J. J.: "Developments in Crystal Filters for S-S Superhets," *QST*, vol. 17, pp. 21—24, November 1933.
445. Lamb, J. J.: "Short-wave Receiver Selectivity to Match Present Conditions," *QST*, vol. 16, pp. 9—20, 90, August 1932.

Appendix II Bibliography

446. Lane, C. E.: "Duplex Crystals," *Bell Lab. Record*, vol. 24, pp. 59—62, 1946.
447. Lane, C. E.: "Crystal Channel Filters for Carrier Cable Systems," *Bell Syst. T. J.*, vol. XVII, p. 125.
448. Lane, C. E.: "Limitations in Band Filter Design," *Bell Labs. Record*, vol. 16, pp. 56—61, October 1937.
449. Lane, C. T.: "Magnetic Properties of Rochelle Salt," *Phys. Rev.*, vol. 45, p. 66, 1934.
450. Langer, R. M.: "Passage of X-rays through Oscillating Crystals," *Phys. Rev. (abstract)*, vol. 49, p. 206, 1936.
451. Langer, R. M.: "X-ray Reflections from Oscillating Crystals," *Phys. Rev.*, vol. 38, pp. 573—574, 1931.
452. Larmor, J.: "Electro-crystalline Properties as Conditioned by Atomic Lattices," *Proc. Roy. Soc.*, vol. 99, pp. 1—10, 1921.
453. Last, E.: "Blocking Oscillator," *Electronics*, vol. 18, p. 184, October 1945.
454. Law, H. B., and F. J. M. Laver: "Measurements of the Dependence of the Frequencies of Some 100 Kc/s Quartz Crystal Units on Their Amplitude of Vibration," *P.O.E.D.*, Radio Report No. 1830, December 1948.
455. Lawson, H. W.: "Precision Tuning Fork with Vacuum-Tube Drive," *Gen. Radio Expt.*, vol. 20, pp. 1—5, September 1945.
456. Lawson, A. W., and P. H. Miller, Jr.: "Piezometer for Transient Pressures (crystals of tartaric acid, tourmaline, and sucrose)," *Rev. Sci. Instruments*, vol. 13, pp. 297—298, 1942.
457. Lawson, A. W.: "The Vibration of Piezoelectric Plates," *Phys. Rev.*, vol. 62, pp. 71—76, 1942.
458. Lawson, A. W.: "A Determination of the Elastic Modulus s_{11} of Beta-quartz," *Phys. Rev.*, vol. 59, pp. 608—612, 1941.
459. Lawson, A. W.: "Comment on the Elastic Constants of Alpha-quartz," *Phys. Rev.*, vol. 59, p. 838, 1941.
460. Lawson, A. W.: "The Piezoelectricity of Beta-quartz," *Science*, vol. 92, p. 419, 1940.
461. Lea, N.: "Notes on Stability of L-C Oscillators," *J.I.E.E.*, vol. 92, pp. 261—274, 1945.
462. le Corbeiller, Ph.: "The Nonlinear Theory of the Maintenance of Oscillations," *J.I.E.E.*, vol. 79, pp. 361—368, 1936.
463. Lee, R.: "Radio Telegraph Keying Transients," *Proc. I.R.E.*, vol. 22, pp. 213—215, 1934.
464. Leonard, S. C.: "Measurement of Minute Changes of Capacitance and Inductance," *Electronics*, vol. 11, p. 18, March 1938.
465. Linder, E. G.: "Attenuation of Electromagnetic Fields in Pipes Smaller Than the Critical Size," *Proc. I.R.E.*, vol. 30, pp. 554—556, 1942.
466. Llewellyn, F. B.: "Constant Frequency Oscillators," *Bell Syst. T. J.*, vol. 11, pp. 67—100, 1932; *Proc. I.R.E.*, vol. 19, pp. 2063—2094, 1931.
467. Llewellyn, F. B.: "A Study of Noise in Vacuum Tubes and Attached Circuits," *Proc. I.R.E.*, vol. 18, pp. 243—265, 1930.
468. Loomis, A. L., and W. A. Marrison: "Modern Developments in Precision Timekeepers," *Electrical Engineering*, vol. 51, pp. 542—549, 1932.
469. Loomis, A. L.: "Precise Measurement of Time," *Monthly Notices Roy. Astron. Soc.*, vol. 91, pp. 569—575, 1931.
470. Love, A. E. H.: *A Treatise on the Mathematical Theory of Elasticity*, 4th ed., Cambridge University Press, London, 1934, 643 pp.
471. Lucas, H. J.: "Some Developments of the Piezoelectric Crystal as a Frequency Standard," *J.I.E.E. (London)*, vol. 68, pp. 855—872, 1930; reprinted in *Wireless Section*, vol. 5, pp. 151—163, 1930; discussion, pp. 163—168.
472. Ludloff, H. F.: "Ultrasonics and Elasticity," *Jour. Acous. Soc. Am.*, vol. 12, pp. 193—197, 1940.
473. Lukesh, J. S.: "The Effect of Imperfections on the Usability of Quartz for Oscillator-plates," *A. Min.*, vol. 30, pp. 291—295, May-June 1945.
474. Lynch, T. E., and S. J. Begun: "General Considerations of the Crystal Cutter," *Communications*, vol. 20, pp. 9f., December 1940.
475. Lynn, J. G., Zwemer, R. L., and A. J. Chick: "The Biological Application of Focused Ultrasonic Waves," *Science*, vol. 96, pp. 119—120, July 1942; see also *Sci. American*, vol. 168, p. 115, March 1943, and *Jour. Gen. Physiol.*, vol. 24, pp. 179—193, 1942.
476. Lythall, W. B.: "Frequency Instability of Pulsed Transmitters with Long Wave Guides," *J.I.E.E.*, vol. 93 (part IIIA), pp. 1081—1089, 1946.
477. Lyons, H.: "Microwave Frequency Dividers," *J. Appl. Phys.*, vol. 21, pp. 59—60, 1950.
478. Maa, D. Y.: "A General Reactance Theorem for Electrical, Mechanical, and Acoustical Systems," *Proc. I.R.E.*, vol. 31, pp. 365—371, 1943.
479. MacKinnon, K. A.: "Crystal Control Applied to the Dynatron Oscillator," *Proc. I.R.E.*, vol. 20, pp. 1689—1714, 1932.
480. Mallett, E.: "Frequency Stabilization of Valve Oscillators," *J.I.E.E.*, vol. 68, pp. 2063—2094, 1930; also *Wireless Sect.*, vol. 5, p. 124, 1930.
481. Mallett, E., and V. J. Terry: "The Quartz Oscillator," *W. World*, vol. 16, pp. 630—636, 1925.
482. Malling, L. M.: "Triode Linear Saw-tooth-Current Oscillator," *Proc. I.R.E.*, vol. 32, pp. 753—757, 1944.
483. Maloff, I. G., and D. W. Epstein: *Electron Optics in Television*, McGraw-Hill, New York, 1938.
484. Mandell, W.: "Resonance in Crystal Beams of Sodium-ammonium Seignette Salt," *Proc. Roy. Soc.*, vol. 165, pp. 414—431, 1938.
485. Mandell, W.: "The Determination of the Piezoelectric Moduli of Ammonium Seignette Salt," *Proc. Roy. Soc.*, vol. 121, pp. 130—140, 1928.
486. Mandell, W.: "The Change in Elastic Properties on Replacing the Potassium Atom of Rochelle Salt by the Ammonium Group," *Proc. Roy. Soc.*, vol. 121, pp. 122—130, 1928.
487. Mandell, W.: "The Determination of the Elastic Moduli of the Piezoelectric Crystal Rochelle Salt by a Static Method," *Proc. Roy. Soc.*, vol. 116, pp. 623—636, 1927.
488. Marks, B. H.: "Ceramic Dielectric Materials," *Electronics*, vol. 21, pp. 116—120, August 1948.
489. Marcum, J., and T. P. Kinn: "Heating with Microwaves," *Electronics*, vol. 20, pp. 82—85, March 1947.
490. Marrison, W. A.: "The Crystal Clock," *Proc. Nat. Acad. Sci.*, vol. 16, pp. 496—507, 1930.
491. Marrison, W. A.: "A High Precision Standard of Frequency," *Proc. I.R.E.*, vol. 17, pp. 1103—1122, 1929; *Bell Syst. T. J.*, vol. 8, pp. 493—514, 1929.
492. Mason, C. A., and B. B. Ray: "Piezoelectric Vibration Meter: Its Use for the Detection of Bearing Vibrations," *Electrician*, vol. 117, pp. 565—567, 1936.
493. Mason, W. P.: *Piezoelectric Crystals and Their Application to Ultrasonics*, D. Van Nostrand, New York, 1950, 508 pp.
494. Mason, W. P.: "Quartz Crystal Applications," *Bell Syst. T. J.*, vol. 22, pp. 178—223, 1943; also printed in book by Heising, R. A.: *Quartz Crystals for Electrical Circuits*, D. Van Nostrand, New York, pp. 11—33, 1946.
495. Mason, W. P.: "Voigt's Elastic and Piezoelectric Relations and Their Application to the Determination of Low Temperature Coefficient Crystals," refer to book by Heising, R. A.: *Quartz Crystals for Electrical Circuits*, D. Van Nostrand, New York, pp. 31—56, 1946.

496. Mason, W. P., and R. A. Sykes: "Low Frequency Quartz-crystal Cuts Having Low Temperature Coefficients," *Proc. I.R.E.*, vol. 32, pp. 208—215, 1944; also printed in book by Heising, R. A.: *Quartz Crystals for Electrical Circuits*, D. Van Nostrand, New York, pp. 537—554, 1946.
497. Mason, W. P., and I. E. Fair: "A New Direct Crystal-Controlled Oscillator for Ultra-Short Wave Frequencies," *Proc. I.R.E.*, vol. 30, pp. 464—472, 1942.
498. Mason, W. P.: *Electromechanical Transducers and Wave Filters*, D. Van Nostrand, New York, 1942, 333 pp.
500. Mason, W. P.: "Electrical and Mechanical Analogies," *Bell Syst. T. J.*, vol. 20, pp. 405—414, 1941.
501. Mason, W. P., and R. A. Sykes: "Electrical Wave Filters Employing Crystals with Normal and Divided Electrodes," *Bell Syst. T. J.*, vol. 19, pp. 221—248, 1940.
502. Mason, W. P.: "The Location of Hysteresis Phenomena in Rochelle Salt Crystals," *Phys. Rev.*, vol. 58, pp. 744—756, 1940.
503. Mason, W. P.: "Low Temperature Coefficient Quartz Crystals," *Bell Syst. T. J.*, vol. 19, pp. 74—93, 1940.
504. Mason, W. P.: "A New Quartz-crystal Plate, Designated the GT, Which Produces a Very Constant Frequency Over a Wide Temperature Range," *Proc. I.R.E.*, vol. 28, pp. 220—223, May 1940.
505. Mason, W. P.: "A Dynamic Measurement of the Elastic, Electric and Piezoelectric Constants of Rochelle Salt," *Phys. Rev.*, vol. 55, pp. 775—789, 1939.
506. Mason, W. P.: "Resistance Compensated Band-pass Crystal Filters for Use in Unbalanced Circuits," *Bell System Tech. Jour.*, vol. 16, pp. 423—436, 1937.
507. Mason, W. P.: "Quartz Crystal Filters," *Bell Labs. Record*, vol. 13, pp. 305—311, 1935.
508. Mason, W. P.: "The Motion of a Bar Vibrating in Flexure, Including the Effects of Rotary and Lateral Inertia," *J.A.S.A.*, vol. 6, pp. 246—249, 1935.
509. Mason, W. P.: "An Electromechanical Representation of a Piezoelectric Crystal Used as a Transducer," *Proc. I.R.E.*, vol. 23, pp. 1252—1263, 1935; *Bell Syst. T. J.*, vol. 14, pp. 718—723, 1935.
510. Mason, W. P.: "Electrical Wave Filters Employing Quartz Crystals as Elements," *Bell Syst. T. J.*, vol. 13, pp. 405—452, 1934, or patent 2,173,589.
511. Mather, N. W.: "Multivibrator Circuits," *Electronics*, vol. 19, pp. 136—138, October 1946.
512. Matsumura, S., and S. Kanzaki: "Quartz Plates with a Very Small Temperature-coefficient of Oscillation Frequency," *U.R.S.I. Gen. Assembly, Document 34, Comm. I*, London, 1934.
513. Maxwell, J. C.: "On Governors," *Proc. Roy. Soc.*, vol. 16, pp. 270—283, 1868.
514. Mayberry, W.: "Supersonics," *Electronics*, vol. 10, pp. 7—9, July 1937.
515. McCrath, J. W., and A. R. Kurtz: "Isolation of an Ultrasonic Crystal Radiator from Conducting Liquids," *Rev. Sci. Instruments*, vol. 13, p. 128, 1942.
516. McCreary, H. J.: "The Magnetic Cross Valve and Its Application to Sub-frequency Power Generation," *Proc. Natl. Elec. Conf.*, vol. 5, pp. 450—466, 1949.
517. McDade, J. R.: "The Phantastron Control Circuit," *Elec. Eng.*, vol. 67, pp. 974—977, 1948.
518. McGaughan, H. S., and C. B. Leslie: "A Resistance-Tuned Frequency-Modulated Oscillator for Audio Frequency Applications," *Proc. I.R.E.*, vol. 35, pp. 974—978, 1947.
519. McKinley, D. W. R.: "Measurement of Small Optical Activities with the Quartz Crystal Light Modulator," *Can. Jour. Research*, vol. 17, pp. 202—207, October 1939.
520. McKinley, D. W. R.: "Application of Quartz Crystals to the Modulation of Light," *Can. Jour. Research*, sec. A, vol. 16, pp. 77—81, 1938.
521. McSkimin, H. J.: "Theoretical Analysis of Modes of Vibration for Isotropic Rectangular Plates Having All Surfaces Free," *Bell Syst. T. J.*, vol. 23, pp. 151—177, 1944; also printed in book by Heising, R. A.: *Quartz Crystals for Electrical Circuits*, D. Van Nostrand, New York, pp. 249—275, 1946.
522. McSkimin, H. J.: *The Distribution of Stress and Strain for Rectangular Isotropic Plates Vibrating in Normal Modes of Flexures*, Thesis, New York University, June 1940.
523. Meacham, L. A.: "The Bridge-stabilized Oscillator," *Proc. I.R.E.*, vol. 26, pp. 1278—1294, 1938; *Bell Syst. T. J.*, vol. 17, pp. 574—591, 1938; short account in *Bell Labs. Rec.*, suppl. to vol. 18, January 1940.
524. Meacham, L. A.: "High-precision Frequency Comparisons," *Bridge of Eta Kappa Nu*, vol. 36, pp. 5—8, February-March 1940.
525. Meahl, H. R.: "Quartz Crystal Controlled Oscillator Circuits," *Proc. I.R.E.*, vol. 22, pp. 732—737, 1934.
526. Meissner, A.: "Piezoelectric Crystals at Radio Frequencies," *Proc. I.R.E.*, vol. 15, pp. 281—296, 1927.
527. Mendelssohn, J., and K. Mendelssohn: "Specific Heat of a Substance Showing Spontaneous Electric Polarization," *Nature*, vol. 144, p. 595, 1939.
528. Meyer, O., and S. L. Penfield: "Results Obtained by Etching a Sphere and Crystals of Quartz with Hydrofluoric Acid," *Trans. Conn. Acad. Sci.*, vol. 8, pp. 158—165, 1889.
529. Mickey, L., and A. D. Martin: "Development of Standard Frequency Transmitting Sets," *Jour. Research Nat. Bur. Standards*, vol. 12, pp. 1—12, 1934.
530. Millen, J., and D. Bacon: "Modern Design of High-frequency Stages for the Amateur Superhet," *QST*, vol. 19, pp. 13f., January 1935.
531. Miller, J. M.: "Quartz Crystal Oscillators," *U. S. Navy Radio Sound Rept.*, issue of April 1, May 1, June 1, 1925, pp. 53—64.
532. Miller, C. J., Jr., Capt.: "The Equivalent Network of a Quartz Crystal Unit and Its Application," printed in *Fundamental Principles of Crystal Oscillator Design*, U. S. Army Signal Corps, Long Branch Signal Laboratory, pp. 1—18, 1945.
533. Miller, C. J., Jr., Capt.: "The Pierce Oscillator," printed in *Fundamental Principles of Crystal Oscillator Design*, U. S. Army Signal Corps, Long Branch Signal Laboratory, pp. 37—64, 1945.
534. Miller, R. L.: "Fractional-Frequency Generators Utilizing Regenerative Modulation," *Proc. I.R.E.*, vol. 27, pp. 446—456, 1939.
535. Minorsky, N.: *Introduction to Nonlinear Mechanics*, J. W. Edwards, Ann Arbor, Mich., 1947.
536. Mittelman, E.: "Load Matching in Electronic Heating," *Electronics*, vol. 18, pp. 110—115, February 1945.
537. Modrak, P.: "Quartz and Tourmaline," *W. E.*, vol. 14, pp. 127—134 and 175—183, 1937.
538. Modrak, P.: "Small Temperature Coefficient of Frequency Quartz Plates," *W. E.*, vol. 16, pp. 6—15, 1939.
539. Mögel, H.: "Monitoring the Operation of Short-wave Transmitters," *Proc. I.R.E.*, vol. 19, pp. 214—232, 1931.
540. Montgomery, B. E.: "An Inductively Coupled Frequency Modulator," *Proc. I.R.E.*, vol. 29, pp. 559—563, 1941.
541. Moore, J. B.: "Design of Stable Heterodyne Oscillators," *Electronics*, vol. 18, pp. 116—118, October 1945.
542. Morrison, H.: "Ten-frequency Receiver," *Bell Labs. Record*, vol. 19, pp. 307—309, 1941.
544. Morrison, J. T.: "A New Broadcast Transmitter Circuit Design for Frequency Modulation," *Proc. I.R.E.*, vol. 28, pp. 444—449, 1940.

Appendix II
Bibliography

545. Moullin, E. B.: *The Theory and Practice of Radio Frequency Measurements*, 2nd ed., Charles Griffin & Company, Ltd., London, 1931, 487 pp.
546. Moullin, E. B.: "Spontaneous Fluctuations of Voltage," Oxford, London, 1938.
547. Moullin, E. B.: "Effect of Curvature of the Characteristic on Frequency of Dynatron Generators," *J.I.E.E.*, vol. 73, p. 186, 1933.
548. Mueller, H.: "The Dielectric Anomalies of Rochelle Salt," *Ann. N. Y. Acad. Sci.*, vol. 40, pp. 321—356, 1940.
549. Mueller, H.: "Properties of Rochelle Salt, IV," *Phys. Rev.*, vol. 58, pp. 805—811, 1940.
550. Mueller, H.: "Properties of Rochelle Salt, III," *Phys. Rev.*, vol. 58, pp. 565—573, 1940.
551. Mueller, H.: "Properties of Rochelle Salt, II," *Phys. Rev.*, vol. 57, pp. 829—839, 1940.
552. Mueller, H.: "Properties of Rochelle Salt, I," *Phys. Rev.*, vol. 47, pp. 175—191, 1935.
553. Mueller, H.: "Influence of Electrostatic Fields on the Elastic Properties of Rochelle Salt," *Phys. Rev.*, vol. 57, pp. 842—843, 1940.
554. Muller, W.: "Transitron Oscillator for High Stability," *Electronic Inds.*, vol. 4, p. 110, December 1945.
555. Murphy, E. J., and S. O. Morgan: "The Dielectric Properties of Insulating Materials," *Bell Syst. T. J.*, vol. 16, pp. 493—512, 1937, vol. 17, pp. 640—669, 1938.
556. Myers, L. M.: *Television Optics: An Introduction*, Pitman Publishing Corporation, New York, 1936, 338 pp.
557. Myers, L. M.: "Application of the Electrometer Triode to the Determination of Piezoelectric Constants," *Brit. Rad. Ann.*, pp. 15—20, 1934-5.
558. Myers, L. M.: "A Piezoelectric Peak Voltmeter," *Marcconi Rev.*, 1934, pp. 4—8, November-December.
559. Nelson, E. L.: "Radio Broadcasting Transmitters and Related Transmission Phenomena," *Bell Syst. T. J.*, vol. 9, pp. 121—140, 1930.
560. Newitt, J. H.: "R-C Oscillator Performance," *Electronics*, vol. 17, p. 126, March 1944.
561. Nicolson, A. M.: "The Piezoelectric Effect in the Composite Rochelle Salt Crystal," *Trans. A.I.E.E.*, vol. 38, pp. 1467—1485, 1919; *Proc. A.I.E.E.*, vol. 38, pp. 1315—1333, 1919; *Electrician (London)*, vol. 83, pp. 32f., 1919; Patent 2,212,845, filed April 10, 1918, issued August 27, 1940.
562. Nishikawa, S., Sakisaka, Y., and I. Sumoto: "X-ray Investigation of the Mode of Vibration of Piezoelectric Quartz Plates," *Phys. Rev.*, vol. 38, pp. 1078—1079, 1931, and vol. 43, pp. 363—364, 1933.
563. Nolle, A. W.: "Adjustment Speed of Automatic Control Systems," *Proc. I.R.E.*, vol. 36, pp. 911—916, 1948.
564. Norgorden, O.: "The Inverse Piezoelectric Properties of Rochelle Salt at Audio Frequencies," *Phys. Rev.*, vol. 49, pp. 820—828, 1936.
565. Norgorden, O.: "The Piezoelectric Properties of Rochelle Salt," *Phys. Rev.*, vol. 50, p. 782, 1936 (letter to the editor).
566. Norrman, E.: "The Inductance-Capacitance Oscillator as a Frequency Divider," *Proc. I.R.E.*, vol. 34, pp. 799—803, 1946.
567. Norrman, E.: "Tuning Fork Stabilization," *Electronics*, vol. 13, pp. 15—17, January 1940.
568. Norrman, E.: "A Precision Tuning Fork Frequency Standard," *Proc. I.R.E.*, vol. 20, pp. 1715—1731, 1932.
569. North, H. Q.: "Properties of Welded Contact Germanium Rectifiers," *J. Appl. Ph.*, vol. 17, pp. 912—923, 1946.
570. Norton, R. L.: "Crystal Controlled Diathermy," *Electronics*, vol. 19, pp. 113—115, October 1946.
571. Nyquist, H.: "Regeneration Theory," *Bell Syst. T. J.*, vol. 11, pp. 126—147, 1932.
572. Nyquist, H.: "Thermal Agitation of Electric Charge in Conductors," *Phys. Rev.*, vol. 32, pp. 110—113, 1928.
573. O'Brien, E. J.: "A Coupled-Circuit Frequency Modulator," *Proc. I.R.E.*, vol. 32, pp. 348—350, 1944.
574. Offner, F. F.: "The Effect of Q on Power-Amplifier Efficiency," *Proc. I.R.E.*, vol. 34, pp. 896—897, 1946.
575. Offner, F.: "Recorder for Electrical Potentials. Damping of Piezo-electric Systems," *Jour. Applied Phys.*, vol. 11, pp. 347—352, 1940.
576. Okolicsanyi, F.: "The Wave-slot, an Optical Television System," *Wireless Eng. Exptl. Wireless (London)*, vol. 14, pp. 527—536, October 1937.
577. Oliver, M. H., and S. J. Fry: "A Method of Measuring the Impedance of Quartz Crystals at Series Resonance," *T.R.E. Tech. Note No. 26*.
578. Oram, D. K.: "Full-range Selectivity with 455-kc. Quartz Crystal Filters," *QST*, vol. 22, pp. 33f., December 1938.
579. Osborn, P. H.: "A Study of Class B and Class C Amplifier Tank Circuits," *Proc. I.R.E.*, vol. 20, pp. 813—834, 1932.
580. Osterberg, H., and J. W. Cookson: "An Interference Method for Measuring the Piezoelectric Moduli of Alpha-quartz: The Moduli," *R.S.I.*, vol. 6, pp. 347—356, 1935.
581. Osterberg, H., and J. W. Cookson: "Longitudinal, Shear, and Transverse Modes of Vibration in Quartz and Tourmaline," *Physics*, vol. 6, pp. 246—256, 1935.
582. Osterberg, H., and J. W. Cookson: "A Theory of Two-dimensional Longitudinal and Flexural Vibrations in Rectangular Isotropic Plates," *Physics*, vol. 6, pp. 234—246, 1935.
583. Osterberg, H., and J. W. Cookson: "Some Piezoelectric and Elastic Properties of β -quartz," *J. Frank. Inst.*, vol. 220, pp. 361—371, 1935.
584. Osterberg, H., and J. W. Cookson: "Piezoelectric Stabilization of High Frequencies," *R.S.I.*, vol. 5, pp. 281—286, 1934.
585. Osterberg, H.: "A Refracting Interferometer for Examining Modes of Vibration in Quartz Plates," *R.S.I.*, vol. 5, pp. 183—186, 1934.
586. Osterberg, H.: "A Multiple Interferometer for Analyzing the Vibrations of a Quartz Plate," *Phys. Rev.*, vol. 43, pp. 819—829, 1933.
587. Osterberg, H.: "A Triple Interferometer for Distinguishing Flexural and Longitudinal Vibrations in Quartz," *J.O.S.A.*, vol. 23, pp. 30—34, 1933.
588. Osterberg, H.: "An Interferometer Method of Studying the Vibrations of an Oscillating Quartz Plate," *J.O.S.A.*, vol. 22, pp. 19—35, 1932.
589. Osterberg, H.: "An Interferometer Method of Observing the Vibrations of an Oscillating Quartz Plate," *Proc. Nat. Acad. Sci.*, vol. 15, pp. 892—896, 1929.
590. Ostlund, E. M., Vallerino, A. R., and M. Silver: "Center-Frequency-Stabilized Frequency Modulation Systems," *Proc. I.R.E.*, vol. 35, pp. 1144—1147, 1947.
591. Page, R. M., and W. E. Curtis: "The van der Pol Four-Electrode Relaxation Oscillator," *Proc. I.R.E.*, vol. 18, pp. 1921—1929, 1930.
592. Page, R. M.: "An Investigation of the Phenomena of Frequency Multiplication, as Used in Tube Transmitters," *Proc. I.R.E.*, vol. 17, pp. 1619—1655, 1929.
593. Parrish, W.: "Methods and Equipment for Sawing Quartz Crystals," pp. 371—388, "Machine Lapping of Quartz Oscillator-plates," pp. 416—431, *A. Min.*, vol. 30, May-June 1945.
594. Parrish, W., and S. G. Gordon: "Orientation Techniques for the Manufacture of Quartz Oscillator-plates," pp. 296—325, "Precise Angular Control of Quartz-cutting by X-rays," pp. 326—346, *A. Min.*, vol. 30, May-June 1945.
595. Pauling, L.: *The Nature of the Chemical Bond*, Cornell University Press, Ithaca, N. Y., 1939.
596. Peirce, B. O.: *A Short Table of Integrals*, Ginn & Co., Boston, 2nd rev. ed., 1910.

597. Peterson, E., Manley, J. M., and L. R. Wrathall: "Magnetic Generation of a Group of Harmonics," *Bell Syst. T. J.*, vol. 16, pp. 436—455, 1937.
598. Peterson, E., Kreer, J. G., and L. A. Ware: "Regeneration Theory and Experiment," *Proc. I.R.E.*, vol. 22, pp. 1191—1210, 1934.
599. Peterson, E.: "Impedance of a Non-Linear Circuit Element," *Trans. A.I.E.E.*, vol. 46, p. 528, 1923.
600. Pielemeier, W. H., Saxton, H. L., and D. Telfair: "Supersonic Effects of Water Vapor in CO₂ and Their Relation to Molecular Vibrations," *Jour. Chem. Phys.*, vol. 8, pp. 106—115, 1940.
601. Pielemeier, W. H.: "Acoustical Detection of Electrically Weak Vibrations in Quartz Plates," *J.A.S.A.*, vol. 9, pp. 212—216, 1938.
602. Pierce, J. R.: "Noise in Resistances and Electron Streams," *Bell Syst. T. J.*, vol. 27, pp. 158—174, 1948.
603. Pierce, J. R., and W. G. Shepherd: "Reflex Oscillators," *Bell Syst. T. J.*, vol. 26, pp. 460—681, 1947.
604. Pierce, G. W.: "The Songs of Insects," *Jour. Franklin Inst.*, vol. 236, pp. 141—146, 1943 (see also *Radio Rev. Australia*, vol. 5, p. 303, 1937).
605. Pierce, G. W.: "Magnetrostriction Oscillators," *Proc. I.R.E.*, vol. 17, pp. 42—88, 1929.
606. Pierce, G. W.: "Piezoelectric Crystal Oscillators Applied to the Precision Measurement of the Velocity of Sound in Air and Carbon Dioxide at High Frequencies," *Proc. A.A.A.S.*, vol. 60, pp. 277—302, 1925.
607. Pierce, G. W.: "Piezoelectric Crystal Resonators and Crystal Oscillators Applied to the Precision Calibration of Wavemeters," *Proc. A.A.A.S.*, vol. 59, pp. 81—106, 1923.
608. Pitt, A., and D. W. R. McKinley: "Variation with Temperature of the Piezoelectric Effect in Quartz," *Can. J. Res., A*, vol. 14, pp. 57—65, 1936.
609. Pitt, A., and W. J. Jackson: "Measurement of the Velocity of Sound in Low Temperature Liquids at Ultrasonic Frequencies," *Can. Jour. Research*, vol. 12, pp. 686—689, 1935.
610. Plasencia, H. T.: "Spanish Standard for the Roentgen (piezoelectric device for standard charge)," *Radiology*, vol. 34, pp. 82—94, January 1940.
611. Poppele, J. R., Cunningham, F. W., and A. W. Kishpaugh: "Design and Equipment of a Fifty-kilowatt Broadcast Station for WOR," *Proc. I.R.E.*, vol. 24, pp. 1063—1081, 1936.
612. Porter, B. H.: "The Supersonic Oscillator," *Ind. Eng. Chem.*, vol. 12, pp. 748—749, 1940.
613. Post, E. J., and H. F. Pit: "Alternate Ways in the Analysis of a Feedback Oscillator and Its Applications," *Proc. I.R.E.*, vol. 39, pp. 169—174, 1951.
614. Pound, R. V.: "Frequency Stabilization of Microwave Oscillators," *Proc. I.R.E.*, vol. 35, pp. 1405—1415, 1947.
615. Powers, W. F.: "Temperature Coefficient of Frequency of Quartz Resonators" (abst.), *Phys. Rev.*, vol. 23, p. 783, 1924.
616. Poynting, J. H., and J. J. Thomson: *A Text-book of Physics*, vol. 4, "Electricity and Magnetism," part 1; "Pyroelectricity and Piezoelectricity," pp. 148—163, London, 1920.
617. Prichard, A. C., Druesne, M. A. A., and D. G. McCaa: "Increase in Q Value and Reduction in Aging of Quartz Crystal Blanks," *Proc. I.R.E.*, vol. 38, p. 314, 1950.
618. Prichard, A. C.: "The Miller Oscillator," printed in *Fundamental Principles of Crystal Oscillator Design*, U. S. Army Signal Corps, Long Branch Signal Laboratory, pp. 65—77, 1945.
619. Prince, D. C.: "Vacuum Tubes as Power Oscillators," *Proc. I.R.E.*, vol. 11, pp. 275—315, 405—435, and 527—550, 1923.
620. Proshauer, R., and H. E. Smith: "Fungus and Moisture Protection," *Electronics*, vol. 18, pp. 119—123, May 1945.
621. Puckie, O. S.: "A Time Base Employing Hard Valves," *J. Television Soc. (London)*, vol. 2, p. 147, 1936.
622. Puckie, O. S.: *Time Bases*, John Wiley, New York, 2nd ed., 1951.
623. Pullen, K. A.: "The Cathode-Coupled Amplifier," *Proc. I.R.E.*, vol. 24, pp. 402—405, 1946.
624. Quimby, S. L., and S. Siegel: "The Variation of the Elastic Constants of Crystalline Sodium with Temperature between 80°K and 210°K," *Phys. Rev.*, vol. 54, pp. 293—299, 1938.
625. Quimby, S. L.: "New Experimental Methods in Ferromagnetism" (abstr.), *Phys. Rev.*, vol. 39, pp. 345—353, 1932.
626. Quimby, S. L.: "On the Experimental Determination of the Viscosity of Vibrating Solids," *Phys. Rev.*, vol. 25, p. 558, 1925.
627. Radio News Staff: "Ultra-selectivity with Crystal Filters," *Radio News*, vol. 15, pp. 477f., 1934; vol. 16, pp. 603f., 1935.
628. Rambo, S. I.: "AFC for RF Heating," *Electronics*, vol. 19, pp. 120—122, April 1946.
629. Rayleigh, Lord: *The Theory of Sound*, Macmillan & Company, Ltd., London, 1926, vol. 1, 480 pp.; vol. 2, 504 pp.
630. Rayner, E. H.: "The Researches of the Late Dr. D. W. Dye on the Vibrations of Quartz," *J.I.E.E. (London)*, vol. 72, pp. 519—527, 1933; *Proc. Wireless Sec., I.E.E.*, vol. 8, pp. 99—107, 1933.
631. R.C.A.: "Low-frequency Crystal Units (80 kc to 250 kc)," Bureau of Ships Contract Nobsr-42409, December 1950.
632. R.C.A.: "Mechanical Overtone Crystal Units, 50 mc to 150 mc or Higher," Signal Corps Contract W36-039-sc-38265, October 1950.
633. R.C.A.: "Low-frequency AT Cut Crystal Plates (500 kc to 1,000 kc)," Signal Corps Contract W36-039-sc-5460, January 14, 1952.
634. Read, T. A.: "The Internal Friction of Single Metal Crystals," *Phys. Rev.*, vol. 58, pp. 371—380, 1940.
635. Record, F. A., and J. L. Stiles: "An Analytical Demonstration of Hartley Oscillator Action," *Proc. I.R.E.*, vol. 31, pp. 281—287, 1943.
636. Reddick, H. W., and F. H. Miller: *Advanced Mathematics for Engineers*, John Wiley, New York, 2nd ed., 1947.
637. Regener, V. H.: "Decade Counting Circuits," *R.S.I.*, vol. 17, pp. 185—189, 1946.
638. Regener, V. H.: "Reversible Decade Counting Circuits," *R.S.I.*, vol. 17, 375—376, 1946.
639. Reich, H. J.: "The Use of Vacuum Tubes as Variable Impedance Elements," *Proc. I.R.E.*, vol. 30, pp. 288—293, 1942.
640. Reich, H. J.: *Theory and Applications of Electron Tubes*, McGraw-Hill, New York, 1939.
641. Reich, H. J.: "Trigger Circuits," *Electronics*, vol. 12, pp. 14—17, August 1939.
642. Rice, S. O.: "Mathematical Analysis of Random Noise," *Bell Syst. T. J.*, vol. 23, pp. 282—332, 1944, and vol. 24, pp. 46—156, 1945.
643. Richards, W. T.: "Supersonic Phenomena," *Rev. Modern Phys.*, vol. 11, pp. 36—64, 1939.
644. Richards, W. T.: "Recent Progress in Supersonics," *Jour. Applied Phys.*, vol. 9, pp. 298—306, 1938.
645. Ridenour, L. N.: *Radar System Engineering*, McGraw-Hill, New York, 1947.
646. Riebmman, Leon: "Theory of the Superregenerative Amplifier," *Proc. I.R.E.*, vol. 37, pp. 29—33, 1949.
647. Rideout, V. C.: "Automatic Frequency Control of Microwave Oscillators," *Proc. I.R.E.*, vol. 35, pp. 767—771, 1947.

Appendix II Bibliography

648. Rinehart, J. S.: "Temperature Dependence of Young's Modulus and Internal Friction of Lucite and Karolith," *Jour. Applied Phys.*, vol. 12, pp. 811—816, 1941.
649. Roberts, E. A., Goldsmith, P., Kurinsky, J., and E. K. Novak, Armour Research Foundation of Illinois Institute of Technology: "Investigation of Oscillator Circuits for Proposed Standards," Air Force Contract AF 18(600)—157, June 22, 1953.
650. Roberts, S.: "Dielectric and Piezoelectric Properties of Barium Titanate," *Phys. Rev.*, vol. 71, 2nd ser., p. 890, 1947.
651. Robinson, D. M.: "The Supersonic Light Control and Its Application to Television with Special Reference to the Scopony Television Receiver," *Proc. I.R.E.*, vol. 27, pp. 483—486, 1939; also papers by J. Sieger (pp. 487—492), G. Wikkenhauser (pp. 492—496), and H. W. Lee (pp. 496—500).
652. Robinson, J.: "The Stenode Radiostat," *Radio News*, vol. 12, pp. 590f., 1931. More on this device will be found in *Electronics*, *Radio News*, *Wireless Eng. Exptl. Wireless*, and *Wireless World* from 1931 on.
653. Robinson, S. A., and F. N. Barry, Philco Corporation: "H.F. Harmonic Crystal Investigation," Air Force Contract W33-038-ac—14172, April 1947.
654. Rogers, Austin F., and Paul F. Kerr: *Optical Mineralogy*, McGraw-Hill, New York, 1942, 390 pp.
655. Ronan, J. M.: "Fabricating Techniques for Crystal Unit CR-23/U (49.9 to 51.1 Mc)," Engineering Report No. E-1108, Sig. C. Proj. No. 4302E, Signal Corps Engineering Laboratories, Fort Monmouth, N. J., February 2, 1953.
656. Rose, F. C.: "The Variation of the Adiabatic Elastic Moduli of Rocksalt with Temperature between 80°K and 270°K," *Phys. Rev.*, vol. 49, pp. 50—54, 1936.
657. Rosenthal, A. H.: "Storage in Television Reception," *Electronics*, vol. 14, pp. 46f., October 1941; also *Electronic Eng. (British)*, pp. 578f, January 1942.
658. Rosenthal, L., et al., Rutgers University: "Research Measurements of Power Dissipation Temperature Rise Characteristics of Crystal Units," Signal Corps Contract W36-039-sc—32081, August 1947.
659. Sabaroff, S.: "A Voltage Stabilized High-frequency Crystal Oscillator Circuit," *Proc. I.R.E.*, vol. 25, pp. 623—629, 1937.
660. Salisbury, W. W., and C. W. Porter: "An Efficient Piezoelectric Oscillator," *R.S.I.*, vol. 10, pp. 269—270, 1939.
661. Sanders, E. W.: "Wave Propagation in Shearing Quartz Oscillators of High Frequency," *J. Appl. Ph.*, vol. 11, pp. 299—300, 1940.
662. Sanders, E. W.: "Modes of Fracture in Piezoelectric Crystals," *QST*, vol. 21, pp. 17—18, 84, 1937.
663. Sarbacher, R. I., and W. A. Edson: *Hyper and Ultra-High Frequency Engineering*, John Wiley, New York, 1943.
664. Sarbacher, R. I.: "Power-Tube Performance in Class C Amplifiers and Frequency Multipliers as Influenced by Harmonic Voltage," *Proc. I.R.E.*, vol. 31, pp. 607—625, 1943.
665. Sarbacher, R. I.: "Graphical Determination of Power Amplifier Performance," *Electronics*, vol. 15, p. 52, December 1942.
666. Sawdey, R. S., Jr.: "Piezoelectric Surface Analyzer," *Radio*, pp. 20—23, March 1943.
667. Sawdey, R. S., Jr.: "Bimorph Rochelle Salt Crystals and Their Applications," *Radio*, pp. 23f., September 1943.
668. Sawyer, C. B.: "The Use of Rochelle Salt Crystals for Electrical Reproducers and Microphones," *Proc. I.R.E.*, vol. 19, pp. 2020—2029, 1931.
670. Sawyer, C. B., and C. H. Tower: "Rochelle Salt as a Dielectric," *Phys. Rev.*, vol. 35, pp. 269—273, 1930.
671. Schaffner, H.: *Range of Synchronization of Subharmonic External Resonance*, Report from E. E. Research Laboratory, University of Illinois, 1949.
672. Schelkunoff, S. A.: "Representation of Impedance Functions in Terms of Resonant Frequencies," *Proc. I.R.E.*, vol. 32, pp. 83—90, 1944.
673. Schlesinger, Kurt: "Cathode-Follower Circuits," *Proc. I.R.E.*, vol. 26, p. 1278, October 1938.
674. Schmidt, C. R.: "Frequency Division with Phase-Shift Oscillators," *Electronics*, vol. 23, pp. 111—113, June 1950.
675. Scott, H. H.: "A General Purpose Vibration Meter," *Jour. Acous. Soc. Am.*, vol. 13, pp. 46—50, 1941.
676. Scott, H. J.: "A Precise Radio-frequency Generator," *Bell Labs. Record*, vol. 11, pp. 102—108, 1932.
677. Scroggie, M. G.: "Applications of the Dynatron," *W. E.*, vol. 10, pp. 527—540, 1933.
678. Searles, C. E.: "Discussion of Crystal Units and Oscillators," ASES 340, June 1, 1952, and printed in "Information Bulletin on Quartz Crystal Units," ASES 52-9, Armed Services Electro Standards Agency, Fort Monmouth, N. J., pp. 1—13, August 1952.
679. Searles, C. E., and D. A. Venn: "Theory and Description of Radio Frequency Ohmmeter ZM-2/U," *Tele-Tech*, March 1950.
680. Seddon, J. C.: "Square Wave Keying of Oscillators," *Electronics*, vol. 23, p. 162, February 1950.
681. Seeley, S. W., and J. Avins: "The Ratio Detector," *R.C.A. Rev.*, vol. 8, pp. 201—236, 1947.
682. Seeley, S. W., and E. I. Anderson: "U-H-F Oscillator Frequency-Stability Considerations," *R.C.A. Rev.*, vol. 5, pp. 77—88, 1940.
683. Selgin, P. J.: *Electrical Transmission in the Steady State*, McGraw-Hill, New York, 1946.
684. Shannon, C. E.: "Communication in the Presence of Noise," *Proc. I.R.E.*, vol. 37, pp. 10—21, 1949.
685. Sharpless, T. K.: "High Speed N-Scale Counters," *Electronics*, vol. 21, pp. 122—125, March 1948.
686. Shaw, H. S.: "Oscillating Crystals," *QST*, vol. 7, pp. 30f., July 1924.
687. Shea, T. E.: "Transmission Networks and Wave Filters," D. Van Nostrand, New York, 1929.
688. Shear, S. K., and A. B. Focke: "The Dispersion of Supersonic Waves in Cylindrical Rods of Polycrystalline Silver, Nickel and Magnesium," *Phys. Rev.*, vol. 57, pp. 532—537, 1940.
689. Shenk, E. R.: "The Multivibrator, Applied Theory and Design," *Electronics*, vol. 17, pp. 136—141, 140—145, 138—142, January, February, March 1944.
690. Shepherd, W. G., and R. O. Wise: "Variable-Frequency Bridge-Type Frequency-Stabilized Oscillators," *Proc. I.R.E.*, vol. 31, pp. 256—269, 1943.
691. Shore, S. X.: A series of articles on the grading and orientation of quartz crystals and the sawing, lapping, finishing, and testing of quartz plates, *Communications*, vol. 23, October-December 1943, vol. 24, January, February 1944.
692. Shulvas-Sorokina, R. D.: "Is It Possible to Determine the Piezoelectric Constant at High Temperature by the Statistical Method?" *Phys. Rev.*, vol. 34, pp. 1448—1450, 1929.
693. Shulvas-Sorokina, R. D., and M. V. Poshnov: "The Time of Relaxation in Crystals of Rochelle Salt," *Phys. Rev.*, vol. 47, pp. 166—174, 1935.
694. Siegel, S.: "Review of Supersonic Methods for Measuring Elastic and Dissipative Properties of Solids," *Jour. Acous. Soc. Am.*, vol. 6, pp. 26—30, 1944.
695. Siegel, S., and S. L. Quimby: "The Variation of Young's Modulus with Magnetization and Temperature in Nickel," *Phys. Rev.*, vol. 49, pp. 663—670, 1936.
696. Signal Corps Engineering Laboratories: "Crystal Data Sheets," vol. 1, Project 44221, Fort Monmouth, N. J., March 1, 1951.

697. Silver, L., Strongin, E., and A. Yevlove: "Investigation, Studies and Evaluation of Performance of Crystal Unit Characteristics," N. Y. University, Research Division, Fourth Quarterly Progress Report, 1952, prepared for U. S. Signal Corps, Contract No. DA36-039-sc-5493.
698. Simon, A. W.: "On the Theory of the Progressive Universal Winding," *Proc. I.R.E.*, vol. 33, pp. 868-871, 1945.
699. Sing, C.: "Series Sawtooth Oscillator," *Electronics*, vol. 23, p. 178, August 1950.
700. Sivian, L. J.: "Absolute Sound Pressure Measurements with Tourmaline" (abst.), *Jour. Acous. Soc. Am.*, vol. 92, p. 462, 1941.
701. Skellett, A. M.: "Modes of Vibration of a Round Plate Cut from a Quartz Crystal," *J.O.S.A.*, vol. 20, pp. 293-302, 1930.
702. Skellett, A. M.: "A Visual Method for Studying Modes of Vibration of Quartz Plates," *J.O.S.A.*, vol. 17, pp. 308-317, 1928.
703. Skinner, L. V.: *Criteria for Stability in Circuits Containing Non-Linear Resistance*, Doctor's Thesis, University of Illinois, 1948.
704. Slater, J. C.: "Microwave Electronics," *Rev. Mod. Phys.*, vol. 18, pp. 441-512, 1946.
705. Slater, J. C.: "Theory of Transition in KH_2PO_4 ," *Jour. Chem. Phys.*, vol. 9, pp. 16-33, 1941.
706. Sloane, R. W., and E. G. James: "Transit Time Effects in Diodes in Pictorial Form," *J.I.E.E.*, vol. 79, pp. 291-296, 1936.
707. Slonzewski, T.: "High-Accuracy Heterodyne Oscillators," *Bell Syst. T. J.*, vol. 19, p. 407, 1940.
708. Smith, A. W., and L. M. Ewing: "The Diffraction of Light by Supersonic Waves in Liquids; Apparatus for Demonstration and for an Intermediate Laboratory Experiment," *Am. Jour. Phys.*, vol. 8, pp. 57-59, 1940.
709. Smith, P. H.: "Optimum Coax Diameters," *Electronics*, vol. 23, p. 111, February 1950.
710. Smith, W. V., de Guevedo, J. L. G., Carter, R. L., and W. S. Bennett: "Frequency Stabilization of Microwave Oscillators by Spectrum Lines," *J. Appl. Ph.*, vol. 18, p. 1112, 1947, and vol. 19, p. 831, 1948.
711. Sokolnikoff, I. S., and E. S.: *Higher Mathematics for Engineers and Physicists*, McGraw-Hill, New York, 1948.
712. Sosman, R. B.: *The Properties of Silica*, Chemical Catalog Company, Inc., New York, 1927, 856 pp.
713. Soucy, C. I.: "Temperature Coefficients in Electronic Circuits," *Electronics*, vol. 21, pp. 117-121, January 1948.
714. Speight, J. W.: "The Electrodynamic Characteristics of the Quartz Piezoelectric Oscillator," *Can. J. Res.*, vol. 12, pp. 812-819, 1935.
715. Spitzer, C. F.: "Sustained Subharmonic Response of Non-Linear Series Circuits," *J. Appl. Ph.*, vol. 16, pp. 105-110, 1945.
716. Spring, W. S.: "Characteristics of Deltamax," *Electronics*, vol. 22, p. 152, June 1949.
717. Stamford, N. C.: "The Production of Rochelle Salt Piezoelectric Resonators Having a Pure Longitudinal Mode of Vibration," *Proc. I.R.E.*, vol. 25, pp. 465-471, 1937.
718. Stanesby, H.: "A Simple Narrow-band Crystal Filter," *Post Office Elec. Eng. Jour.*, vol. 35, pp. 4-7, April 1942.
719. Stanesby, H., and E. R. Broad: "A Narrow Band Filter Using Crystal Resonators," *Post Office Elec. Eng. Jour.*, vol. 33, pp. 176-182, 1941.
720. Stansel, F. R.: "A Secondary Frequency Standard Using Regenerative Frequency-Dividing Circuits," *Proc. I.R.E.*, vol. 30, pp. 157-162, 1942.
721. Starr, A. T.: "Electro-acoustic Reactions," *W. E.*, vol. 17, pp. 247-256, 303-309, 1940.
722. Stephenson, C. C., and A. C. Zettlemoyer: "The Heat Capacity of Ammonium Dihydrogen Phosphate from 15° to 300°K. The Anomaly at the Curie Temperature," *J. Am. Chem. Soc.*, vol. 66, pp. 1405-1408, 1944.
723. Stephenson, C. C., and A. C. Zettlemoyer: "The Heat Capacity of Potassium Dihydrogen Arsenate from 15° to 300°K. The Anomaly at the Curie Temperature," *J. Am. Chem. Soc.*, vol. 66, pp. 1402-1405, 1944.
724. Stephenson, C. C., and J. G. Hooley: "The Heat Capacity of Potassium Dihydrogen Phosphate from 15° to 300°K. The Anomaly at the Curie Temperature," *J. Am. Chem. Soc.*, vol. 66, pp. 1397-1401, 1944.
725. Stephenson, C. C., and H. E. Adams: "The Heat Capacity of Ammonium Dihydrogen Arsenate from 15° to 300°K. The Anomaly at the Curie Temperature," *J. Am. Chem. Soc.*, vol. 66, pp. 1409-1412, 1944.
726. Sterky, H.: "Frequency Multiplication and Division," *Proc. I.R.E.*, vol. 25, pp. 1153-1174, 1937.
727. Stevens, H. C., and J. M. Snodgrass: "A Piezoelectric Myograph" (for measurement of contracting muscle), *Proc. Soc. Exptl. Biol. Med.*, vol. 30, pp. 939-943, 1933.
728. Stockman, H.: "Superregenerative Circuit Applications," *Electronics*, vol. 21, pp. 1153-1174, 1937.
729. Stoiber, R. E., Tolman, C., and R. D. Butler: "Geology of Quartz Crystal Deposits," *A. Min.*, vol. 30, pp. 245-268, May-June 1945.
730. Stone, J. E.: "An Ultra-Low Frequency Oscillator," *Electronics*, vol. 23, pp. 94-95, January 1950.
731. Strong, J. A.: "New Method of Investigating the Modes of Vibration of Quartz Crystals," *Nature*, vol. 129, p. 59, 1932.
732. Sturley, K. R.: "The Phase Discriminator," *W. E.*, vol. 21, pp. 72-78, 1944.
733. Sturtevant, M.: "A Voltage Controlled Multivibrator," *Electronics*, vol. 22, p. 144, October 1949.
734. Sulzer, P. G.: "The Tapered Phase-Shift Oscillator," *Proc. I.R.E.*, vol. 36, pp. 1302-1305, 1948.
735. Summerhayes, H. R.: "A 260 to 350 Megacycle Converter Unit," *Proc. I.R.E.*, vol. 31, p. 252, 1943.
736. Swan, A. G.: "Radiation from R-F Heating Generators," *Electronics*, vol. 19, p. 162, May 1946.
737. Sykes, R. A., Bell Telephone Laboratories: "Design Data on Crystal Units," printed in *Information Bulletin on Quartz Crystal Units*, ASES 52-9, Armed Services Electro Standards Agency, Fort Monmouth, N. J., pp. 1-16, August 1952.
738. Sykes, R. A.: *Equations of Elastic and Piezoelectric Constants for Rotation of Axes About the X Axis*, refer to book by Heising, R. A.: *Quartz Crystals for Electrical Circuits*, D. Van Nostrand, New York, pp. 247-248, 1946.
739. Sykes, R. A.: *Location of Mass on Supporting Wire*, refer to book by Heising, R. A.: *Quartz Crystals for Electrical Circuits*, D. Van Nostrand, New York, pp. 287-289, 1946.
740. Sykes, R. A.: "Modes of Motion in Quartz Crystals, the Effects of Coupling and Methods of Design," *Bell Syst. T. J.*, vol. 23, pp. 52-96, 1944; also printed in book by Heising, R. A.: *Quartz Crystals for Electrical Circuits*, D. Van Nostrand, New York, pp. 205-246, 1946.
741. Sykes, R. A.: "Principles of Mounting Quartz Plates," *Bell Syst. T. J.*, vol. 23, pp. 178-189, 1944; also printed in book by Heising, R. A.: *Quartz Crystals for Electrical Circuits*, D. Van Nostrand, New York, pp. 276-286, 1946.
742. Synge, E. H.: "Application of Piezoelectricity to Microscopy," *Phil. Mag.*, vol. 13, pp. 297-300, 1932.

743. Taschek, R., and H. Osterberg: "Crystalline Symmetry and Shear Constants of Rochelle Salt," *Phys. Rev.*, vol. 50, p. 572, 1936.
744. Teare, B. R., Jr., and E. R. Schatz: "Copper-Covered Steel Wire at Radio Frequencies," *Proc. I.R.E.*, vol. 32, pp. 397—403, 1944.
745. Telfair, D., and W. H. Pielemeier: "An Improved Apparatus for Supersonic Velocity and Absorption Measurements," *Rev. Sci. Instruments*, vol. 13, pp. 122—126, 1942.
746. Terman, F. E.: *Radio Engineers Handbook*, McGraw-Hill, New York, 1943.
747. Terman, F. E., and W. C. Roake: "Calculation and Design of Class C Amplifiers," *Proc. I.R.E.*, vol. 24, p. 620, April 1936.
748. Terman, F. E.: "Resonant Lines in Radio Circuits," *Elec. Eng.*, vol. 53, p. 1046, 1934.
749. Terman, F. E.: "Resistance Stabilized Oscillators," *Electronics*, vol. 6, p. 190, July 1933.
750. Terry, E. M.: "The Dependence of the Frequency of Quartz Piezo-Electric Oscillators Upon Circuit Constants," *Proc. I.R.E.*, vol. 16, p. 1486, 1928.
751. Thomas, H. A.: *Theory and Design of Valve Oscillators*, Chapman & Hall, London, 2nd ed., 1951.
752. Thomas, H. A.: "The Dependence on Frequency of the Temperature Coefficient of Inductance of Coils," *J.I.E.E.*, vol. 84, pp. 101—112, 1939.
753. Thompson, B. J., North, D. O., and W. A. Harris: "Fluctuations in Space-Charge-Limited Currents at Moderately High Frequencies," *R.C.A. Rev.*, vol. 6, pp. 114—124, 1941.
754. Thomas, H. P., and R. H. Williamson: "A Commercial 50-kilowatt Frequency-Modulation Broadcast Transmitting Station," *Proc. I.R.E.*, vol. 29, pp. 537—545, 1941.
755. Thomson, J. J.: "Piezoelectricity and Its Applications" (quartz and tourmaline for explosion pressures), *Engineering*, vol. 107, pp. 543—544, 1919.
756. Thompson, L.: "Shock Waves in Air and Characteristics of Instruments for Their Measurement" (discharge of heavy artillery, use of quartz, Rochelle salt, and tourmaline), *Jour. Acous. Soc. Am.*, vol. 12, pp. 198—204, 1940.
757. Thomson, W. T.: "Effect of Rotary and Lateral Inertia on Flexural Vibration of Prismatic Bars," *J.A.S.A.*, vol. 11, pp. 198—204, 1939.
758. Thurston, G. M.: "Adjusting to Frequency," refer to book by Heising, R. A.: *Quartz Crystals for Electrical Circuits*, D. Van Nostrand, New York, pp. 317—332, 1946.
759. Thurston, G. M.: "A Crystal Test Set," *Bell Labs. Rec.*, vol. 22, pp. 477—480, 1944.
760. Thurston, G. M.: "Flatness and Parallelism in Quartz Plates," *Bell Labs. Rec.*, vol. 22, pp. 435—439, 1944.
761. Tibbetts, R. W.: "Rochelle Salt Crystal Devices of Low Impedance" (loud-speaker and oscilloscope), *Electronics*, vol. 16, pp. 88f., April 1943.
762. Tillyer, E. D., American Optical Co.: "Y Cut Crystal Vibrating in a Shear Mode," Patent 1,907,613, issued May 9, 1933.
763. Titchmarsh, E. C.: *Theory of Functions*, Oxford, pp. 191—192, 1932.
764. Tolansky, S.: "Topography of a Quartz Crystal Face," *Nature*, vol. 153, pp. 195—196, 1944.
765. Tomlinson, G. A.: "Recent Developments in Precision Time-keeping," *Observatory*, vol. 57, pp. 189—195, 1934.
766. Tournier, M.: "History and Applications of Piezoelectricity," *Elec. Comm.*, vol. 15, pp. 312—327, 1937; *ENT*, vol. 15, pp. 320—334, 1937.
767. Travis, C.: "Automatic Frequency Control," *Proc. I.R.E.*, vol. 23, pp. 1125—1141, 1935.
768. Tschappat, W. H.: "New Instruments for Physical Measurements" (pressure gauge for interior ballistics), *Mech. Eng.*, vol. 45, pp. 673—678, 1923; see also vol. 48, pp. 821—825, 1926.
769. Tsi-Ze, Ny, Ling-Chao Tsien, and Fang Sun-Hung: "Oscillations of Hollow Quartz Cylinders Cut Along the Optic Axis," *Proc. I.R.E.*, vol. 24, pp. 1484—1494, 1936.
770. Tucker, D. G.: "Forced Oscillations in Oscillator Circuits and the Synchronization of Oscillators," *J.I.E.E.*, vol. 92, pp. 226—233, Part III, 1945.
771. Tucker, D. G.: "The Synchronization of Oscillators," *Electronic Eng.*, vol. 15, pp. 412—418 and 457—461, 1943; also vol. 16, pp. 26—30 and 114—117, 1944.
772. Tucker, D. G.: "The Generation of Groups of Harmonics," *Electronic Eng.*, vol. 15, pp. 232—237, 1942.
773. Tuller, W. G., Galloway, W. C., and F. P. Zaffarano: "Recent Developments in Frequency Stabilization of Microwave Oscillators," *Proc. I.R.E.*, vol. 36, pp. 794—800, 1948.
774. Tutton, A. E. H.: *Crystallography and Practical Crystal Measurement*, 2nd ed., Macmillan & Company, Ltd., London, 1922, 2 vols., 746 and 699 pp.
775. Tyrrell, W. A.: "Hybrid Circuits for Microwaves," *Proc. I.R.E.*, vol. 35, pp. 1294—1306, 1947.
776. U. S. Air Force, Air Material Command, Wright-Patterson Air Force Base, Civilian Personnel Division in Conjunction with Gentile Air Force Specialized Depot: "Quartz Crystal Fabrication Assignments," April 1952.
777. U. S. Air Force Technical Order, T.O. No. 16-35TS330-5, and U. S. Army Technical Manual, TM 11-5051: "Crystal Impedance Meter TS-330/TSM," April 1951, U. S. Government Printing Office, Washington, D. C., 64 pp.
778. U. S. Air Force Technical Order, T.O. No. 16-35TS537-5, and U. S. Army Technical Manual, TM 11-5052: "Crystal Impedance Meter TS-537/TSM," U. S. Government Printing Office, Washington, D. C.
779. U. S. Air Force Technical Order, T.O. No. 16-35TS683-5, and U. S. Army Technical Manual (TM 11-2652 cancelled), or Radio Frequency Laboratories, Inc., Instruction Book: "Crystal Impedance Meter TS-683/TSM," 54 pp., December 10, 1951.
780. U. S. Air Force Technical Order, T.O. No. 16-35TS710-(), and U. S. Army Technical Manual: "Crystal Impedance Meter TS-710/TSM," U. S. Government Printing Office, Washington, D. C., when printed.
781. U. S. Army Signal Corps, Long Branch Signal Laboratory, Circuit Section: "Fundamental Principles of Crystal Oscillator Design," 84 pp., 1945.
782. U. S. Army Technical Manual: "Quartz Crystals Theory, Fabrication and Performance Measurements," TM 11-2540, December 1950, U. S. Government Printing Office, Washington, D. C., 130 pp.
783. Valasek, J.: "Infrared Absorption by Rochelle Salt Crystals," *Phys. Rev.*, vol. 45, pp. 654—655, 1934.
784. Valasek, J.: "Note on the Piezoelectric Effect in Rochelle Salt Crystals," *Science*, vol. 65, pp. 235—236, 1927.
785. Valasek, J.: "Dielectric Anomalies in Rochelle Salt Crystals," *Phys. Rev.*, vol. 24, pp. 560—568, 1924.
786. Valasek, J.: "Properties of Rochelle Salt Related to the Piezoelectric Effect," *Phys. Rev.*, vol. 20, pp. 639—664, 1922.
787. Valasek, J.: "Piezoelectric Activity of Rochelle Salt Under Various Conditions," *Phys. Rev.*, vol. 19, pp. 478—491, 1922.
788. Valasek, J.: "Piezoelectricity and Allied Phenomena in Rochelle Salt," *Phys. Rev.*, vol. 17, pp. 475—481, 1921.

789. van der Pol, B.: "The Nonlinear Theory of Electric Oscillations," *Proc. I.R.E.*, vol. 22, pp. 1051—1086, 1934.
790. van der Pol, B., and M. J. O. Strutt: "On the Stability of the Solutions of Mathieu's Equation," *Phil. Mag.*, vol. 5, pp. 18—38, 1928.
791. van der Pol, B.: "On Relaxation Oscillations," *Phil. Mag.*, vol. 2, pp. 978—992, 1926.
792. van der Pol, B.: "On Oscillation Hysteresis in a Triode Generator with Two Degrees of Freedom," *Phil. Mag.*, vol. 43, pp. 700—719, 1922.
793. van der Ziel, A.: "On the Mixing Properties of Non-linear Condensers," *J. Appl. Ph.*, vol. 19, pp. 999—1006, 1948.
794. Van Dyke, K. S.: "The Standardization of Quartz Crystal Units," *Proc. I.R.E.*, vol. 33, pp. 15—20, 1945.
795. Van Dyke, K. S.: "The Piezoelectric Quartz Resonator," *A. Min.*, vol. 30, pp. 214—244, May-June 1945.
796. Van Dyke, K. S., and A. M. Thorndike: "The Three-crystal Method of Quartz Resonator Measurement" (abst.), *Phys. Rev.*, vol. 57, p. 560, 1940.
797. Van Dyke, K. S.: "On the Right- and Left-handedness of Quartz and Its Relation to Elastic and Other Properties," *Proc. I.R.E.*, vol. 28, pp. 399—406, 1940.
798. Van Dyke, K. S.: "Vibration Modes of Low Decrement for a Quartz Ring" (abst.), *Phys. Rev.*, vol. 53, p. 945, 1938.
799. Van Dyke, K. S.: "Some Unusual Demonstrations with Piezoelectric Resonators" (abst.), *Phys. Rev.*, vol. 53, p. 686, 1938.
800. Van Dyke, K. S.: "Note on a Peculiar Case of Fracture of a Quartz Resonator," *A. Appl. Ph.*, vol. 8, pp. 567—568, 1937.
802. Van Dyke, K. S.: "A Determination of Some of the Properties of the Piezoelectric Quartz Resonator," *Proc. I.R.E.*, vol. 23, pp. 386—392, 1935; *Document AG, No. 24, Comm. I., U.R.S.I. Gen. Assem.*, 1934.
803. Van Dyke, K. S.: "Temperature Variation of Viscosity and of the Piezoelectric Constant of Quartz" (abst.), *Phys. Rev.*, vol. 42, p. 587, 1932.
804. Van Dyke, K. S.: "The Electric Network Equivalent of a Piezoelectric Resonator" (abst.), *Phys. Rev.*, vol. 40, p. 1026, 1932.
805. Van Dyke, K. S.: "The Measurement of the Decrement of Piezoelectric Resonators" (abst.), *Proc. I.R.E.*, vol. 18, p. 1989, 1930.
806. Van Dyke, K. S.: "The Piezoelectric Resonator and Its Equivalent Network," *Proc. I.R.E.*, vol. 16, pp. 742—764, 1928.
807. Van Dyke, K. S.: "Some Experiments with Vibrating Quartz Spheres" (abst.), *Proc. I.R.E.*, vol. 16, pp. 706—707, 1928; *Phys. Rev.*, vol. 31, pp. 1113, 1133, 1928 (absts.).
808. Van Dyke, K. S.: "The Use of the Cathode Ray Oscillograph in the Study of Resonance Phenomena in Piezoelectric Crystals" (abst.), *Phys. Rev.*, vol. 31, p. 303, 1928.
809. Van Dyke, K. S.: "The Electric Network Equivalent of a Piezoelectric Resonator" (abst.), *Phys. Rev.*, vol. 25, p. 895, 1925.
811. van Slooten, J.: "Stability and Instability in Triode Oscillators," *Philips Tech. Rev.*, vol. 7, pp. 40—45 and 171—177, 1942.
812. van Slooten, J.: "The Stability of a Triode Oscillator with Grid-Condenser and Leak," *W. E.*, vol. 16, pp. 16—19, 1939.
813. Van Vleck, J. H.: *The Theory of Electric and Magnetic Susceptibilities*, Oxford, Clarendon Press, New York, 1932, 384 pp.
814. Vaughan, W. C.: "Phase Shift Oscillator," *W. E.*, vol. 26, pp. 391—399, 1949.
815. Vazsonyi, A.: "A Generalization of Nyquist's Stability Criteria," *J. Appl. Ph.*, vol. 20, pp. 863—867, 1949.
816. Vecchiacchi, F.: "Oscillations in the Circuit of a Strongly Damped Triode," *Proc. I.R.E.*, vol. 19, pp. 856—872, 1931.
817. Verman, L. C.: "Negative Circuit Constants," *Proc. I.R.E.*, vol. 19, pp. 676—681, 1931.
818. Vigness, I.: "Dilatations in Rochelle Salt," *Phys. Rev.*, vol. 48, pp. 198—202, 1935.
819. Vigness, I.: "Inverse Piezoelectric Properties of Rochelle Salt," *Phys. Rev.*, vol. 46, pp. 255—257, 1934.
820. Vigoureux, J. E. P., and H. E. Stoakes: "All-electric Clock," *Proc. Phys. Soc. (London)*, vol. 52, pp. 353—357, 1940 (discussion pp. 357—358).
821. Vigoureux, J. E. P.: "Development of Formulas for the Constants of the Equivalent Electrical Circuit of a Quartz Resonator in Terms of Elastic and Piezoelectric Constants," *Phil. Mag.*, vol. 6, pp. 1140—1153, 1928.
822. Vigoureux, J. E. P.: "The Valve-maintained Quartz Oscillator," *J.I.E.E. (London)*, vol. 68, pp. 265—295, 1930; discussion, pp. 867—872; *Proc. Wireless Section, I.E.E.*, vol. 5, pp. 41—71, 1930; discussion, pp. 163—168.
823. Vigoureux, J. E. P.: *Quartz Resonators and Oscillators*, H. M. Stationary Office, Adastral House, Kingsway, London, W. C. 2, 1931, 217 pp.
824. Vigoureux, J. E. P., and C. F. Booth: *Quartz Vibrators and Their Application*, His Majesty's Stationary Office, Adastral House, Kingsway, London, W. C. 2.
826. Vigoureux, J. E. P.: *Quartz Oscillators and Their Applications*, His Majesty's Stationary Office, London, 1939, 131 pp.
827. Voigt, W.: *Lehrbuch der Kristallphysik*, B. G. Teubner, Leipzig, 1st ed., 1910, 964 pp.; 2nd ed., 1928, 978 pp., identical with the first except for the addition of an appendix on secondary effects in the flexure and torsion of circular cylinders, based on refs. 583 and 576.
828. von Ardenne, M.: "Distortion of Saw-Tooth Wave Forms," *Electronics*, vol. 10, pp. 36—38, November 1937.
829. von Hippel, A., Breckenridge, R. G., Chesley, R. G., and L. Tiza, *Ind. and Eng. Chem.*, vol. 38, p. 1097, 1946.
830. Wallace, R. L., and W. J. Pietenpol: "Some Properties and Applications of $n-p-n$ Transistors," *Proc. I.R.E.*, vol. 39, pp. 753—767, 1951.
831. Waltz, W. W.: "Crystal Filter Design," *Radio Engineering*, vol. 16, pp. 7—10 (January), 14—17 (February), 16—17 (March), 12—14 (April), 1936.
832. Warren, B. E., and H. M. Krutter: "X-ray Study of Crystal Structure of Rochelle Salt and Effect of Temperature" (abst.), *Phys. Rev.*, vol. 43, p. 500, 1933.
833. Watanabe, Y.: "The Piezoelectric Resonator in High-Frequency Oscillation Circuits," *Proc. I.R.E.*, vol. 18, pp. 695—717 and 862—893, 1930.
834. Watson, H. G. I., and D. A. Keys: "A Piezoelectric Method of Measuring the Pressure Variations in Internal Combustion Engines," *Can. Jour. Research*, vol. 6, pp. 322—331, 1932.
835. Webb, H. W., and G. E. Becker: "Theory of the Multi-vibrator," *J. Appl. Ph.*, vol. 15, pp. 825—834, 1944.
836. Webster, R. A.: "Piezoelectric Gauge and Amplifier" (pile of 21 quartz plates, for pressures up to 30,000 lb./in.²), *Jour. Franklin Inst.*, vol. 211, pp. 607—615, 1931.
837. Webster, R. A.: "Piezoelectric versus Mechanical Spring Pressure Gauge," *Jour. Applied Phys.*, vol. 10, pp. 890—891, 1939.
838. Weinhart, H. W., and H. G. Weke: "Metal Electrodes Deposited on Quartz Crystals by the Evaporation Process," refer to book by Heising, R. A.: *Quartz Crystals for Electrical Circuits*, D. Van Nostrand, New York, pp. 333—355, 1946.

Appendix II
Bibliography

839. Wesleyan University: "Piezoelectric Crystal Studies and Measurements," Signal Corps Contract DA36-039-sc-73, July 31, 1948.
840. Western Electric Co.: *Quartz Crystal Units*, General Bulletin.
841. Whale, H. A.: "Optimum Conditions for an R-C Oscillator," *Electronics*, vol. 21, p. 178, February 1948.
842. Wheeler, H. A.: "Formulas for the Skin Effect," *Proc. I.R.E.*, vol. 30, pp. 412-424, 1942.
843. Wheeler, L. P.: "An Analysis of a Piezoelectric Oscillator Circuit," *Proc. I.R.E.*, vol. 19, pp. 627-646, 1931.
844. Wheeler, L. P., and W. E. Bower: "A New Type of Standard Frequency Piezoelectric Oscillator," *Proc. I.R.E.*, vol. 16, pp. 1035-1044, 1928.
845. Wheeler, M. S.: "Frequency Contours for Microwave Oscillator with Resonant Load," *Proc. I.R.E.*, vol. 37, pp. 1332-1336, 1949.
846. White, G. J.: "Crystal I.F. Coupling and Filters," *Proc. I.R.E. Australia*, vol. 1, pp. 50-56, 1938.
847. Whinnery, J. R.: "Skin Effect Charts and Formulas," *Electronics*, vol. 15, pp. 44-48, February 1942.
848. Wing, A. H.: "On the Theory of Tubes with Two Control Grids," *Proc. I.R.E.*, vol. 29, pp. 121-136, 1941.
849. Winlund, E. S.: "Electronic Heating in the Furniture Industry," *Electronics*, vol. 19, pp. 108-113, May 1946.
850. Wilson, A. J. C.: "The Heat Capacity of Rochelle Salt Between -30° and $+30^{\circ}\text{C}$," *Phys. Rev.*, vol. 54, pp. 1103-1109, 1938.
851. Wilson, J. E.: "The Crystal Filter Treated as an Impedance Bridge Circuit," *Communications*, vol. 21, pp. 18, 20, April 1941.
852. Wilson, I. G., Schramm, C. W., and J. P. Kinzer: "High-Q Resonant Cavities for Microwave Testing," *Bell Syst. T. J.*, vol. 25, pp. 408-434, 1946.
853. Willoner, G., and F. Tihelka: "A Phase-Shift Oscillator with Wide-Range Tuning," *Proc. I.R.E.*, vol. 36, pp. 1096-1100, 1948.
854. Willis, E. S.: "Channel Crystal Filters for Broadband Carrier Systems," *Bell Labs. Record*, vol. 17, pp. 62-65, 1938.
855. Williams, A. L., and J. P. Arndt: "Crystal Microphone Design for Single-direction Pickup," *Electronics*, vol. 8, pp. 242-243, August 1935.
856. Williams, A. L.: "Piezo-electric Loudspeakers and Microphones," *Electronics*, vol. 4, pp. 166-167, May 1932; see also *Jour. Soc. Motion-picture Eng.*, vol. 25, pp. 196f., 1934, and *Proc. I.R.E.*, vol. 23, pp. 1420-1421, 1935.
857. Williams, E.: "A Valve Oscillator Theorem," *W. E.*, vol. 20, pp. 489-491, 1943.
858. Williams, E. K., and A. W. Marsh: "Harmonic Mode Crystals and Oscillator Circuits for the 40-50 Mc/s Range," *T.R.E. Tech. Note No. 99*, January 1951.
859. Williams, N. H.: "Modes of Vibration of Piezoelectric Crystals," *Proc. I.R.E.*, vol. 21, pp. 990-995, 1933.
860. Williams, S. R.: *Magnetic Phenomena*, McGraw-Hill, New York, 1931.
861. Willard, G. W.: "Inspecting and Determining the Axis Orientation of Quartz Crystals," *Bell Labs. Rec.*, vol. 22, pp. 320-326, 1944.
862. Willard, G. W.: "Raw Quartz, Its Imperfections and Inspection," *Bell Syst. T. J.*, vol. 22, pp. 338-361, 1943; also printed in book by Heising, R. A.: *Quartz Crystals for Electrical Circuits*, D. Van Nostrand, New York, pp. 164-204, 1946.
863. Willard, G. W.: "Ultrasonic Absorption and Velocity Measurements in Numerous Liquids," *Jour. Acous. Soc. Am.*, vol. 12, pp. 438-449, 1941.
864. Willard, G. W.: "Use of the Etch Technique for Determining Orientation and Twinning in Quartz Crystals," *Bell Syst. T. J.*, vol. 23, pp. 11-51, 1944; also printed in book by Heising, R. A.: *Quartz Crystals for Electrical Circuits*, D. Van Nostrand, New York, pp. 164-204, 1946.
865. Wood, A. B.: "The Piezoelectric Oscillograph," *Phil. Mag.*, vol. 50, pp. 631-637, 1925.
866. Wood, A. B., Tomlinson, G. A., and L. Essen: "The Effect of the Fitzgerald-Lorentz Contraction on the Frequency of Longitudinal Vibration of a Rod" (two quartz oscillators, one stationary and one rotating), *Proc. Roy. Soc. (London) A*, vol. 158, pp. 606-633, 1937.
867. Wood, H. O.: "On a Piezoelectric Accelerograph," *Bull. Seismol. Soc. Am.*, vol. 11, pp. 15-57, 1921.
868. Wood, R. G., and C. H. McCale: "Simple Apparatus for Detecting the Pyroelectric Effect in Crystals," *J. Sci. Instr.*, vol. 17, pp. 225-226, 1940.
869. Wood, R. W.: *Supersonics, the Science of Inaudible Sounds*, Charles K. Colver Lectures, 1937, Brown University, Providence, R. I., 1939, 158 pp.
870. Woodyard, J. R.: "Application of the Auto-Synchronized Oscillator to Frequency Demodulation," *Proc. I.R.E.*, vol. 25, pp. 610-619, 1937.
871. Wooster, W. A.: *A Text-book on Crystal Physics*, Cambridge University Press, London, 1938, 295 pp.
872. Wright, J. W.: "The Piezoelectric Crystal Oscillator," *Proc. I.R.E.*, vol. 17, pp. 127-142, 1929.
873. Wright, R. B., and D. M. Stuart: "Some Experimental Studies of the Vibrations of Quartz Plates," *J. Res. N.B.S.*, vol. 7, pp. 519-553, 1931.
874. Wyckoff, R. W. G.: *The Structure of Crystals*, The Chemical Catalogue Co., 1931.
875. Wyckoff, R. W. G.: *The Analytical Expression of the Results of the Theory of Space-groups*, Carnegie Institute of Washington, 1922, 180 pp.; 2nd edition, 1930, 180 pp.
876. Wynn-Williams, C. E.: "A Piezoelectric Oscillograph," *Phil. Mag.*, vol. 49, pp. 289-313, 1925.
877. Young, C. H.: "A Precise Decade Oscillator," *Bell Labs. Record*, vol. 28, pp. 487-489, 1950.
878. Young, J. D., and H. M. Beck: "Design Equations for Reactance Tube Circuits," *Proc. I.R.E.*, vol. 37, pp. 1078-1082, 1949.
879. Zacek, A., and V. Petrzilka: "Radial and Torsional Vibrations of Annular Quartz Plates," *Phil. Mag.*, vol. 25, pp. 164-175, 1938.
880. Zacharias, J.: "The Temperature Dependence of Young's Modulus for Nickel," *Phys. Rev.*, vol. 44, pp. 116-122, 1933.
881. Ziegler, A. W.: "Channel Crystal Filters for Broadband Carrier Systems: Physical Features," *Bell Labs. Record*, vol. 17, pp. 66-70, 1938.
882. Zeigler, A. W.: "Wire Mounts," Patent 2,275,122, issued March 3, 1942.
883. Zeleny, A., and J. Valasek: "Variation of the Dielectric Constant of Rochelle Salt Crystals with Frequency and Applied Field Strength," *Phys. Rev.*, vol. 46, pp. 450-453, 1934.

884. Bagley, A., and D. Hartke: "Measurement of the Carrier Frequency of RF Pulses," paper presented at 4th Conference on High Frequency Measurement, Washington, D. C., January 1955; also circular of Hewlett-Packard Co.
885. Bagley, A., D. Hartke, and W. D. Myers: "Frequency and Time Measurements with the New H-P High Speed Counter," *Hewlett-Packard Jour.*, vol. 5, March-April 1954.
886. Battersby, L. R., and E. A. Conover: "A Single Crystal Multi-Channel Oscillator," *Technical Memorandum No. M-1567*, Signal Corps Project No. 132A, March 1954.
887. Bechmann, R., and D. R. Hale: "Electronic Grade Synthetic Quartz," *Brush Strokes* (Brush Electronics Co.), vol. 4, pp. 1-7, September 1955.
888. Bechmann, R.: "The Frequency-Temperature Behavior of Piezoelectric Resonators Made of Natural and Synthetic Quartz," *I. R. E. Convention Record*, vol. 3, part 9 (Ultrasonics, Medical and Industrial Electronics), pp. 56-61, 1955.
889. Bechmann, R.: "On Circuits for Piezoelectric Quartz Oscillators and Resonators for Frequency Stabilization and Filters," *Telefunken-Hansmitteilungen*, No. 78, March 1938.
890. Dasher, B. J., et al.: "Transistor Oscillators of Extended Frequency Range," Reports on Department of the Army Contract No. DA-36-039-sc-42712, Georgia Institute of Technology, State Engineering Experiment Station, Atlanta, Ga., 1954.
891. Eberhard, E., and R. Endres: Descriptions of several transistor oscillators using high-impedance crystal units, U. S. Patent 2,570,436.
892. Finden, H. J.: "Developments in Frequency Synthesis," paper presented at Conference on High Frequency Measurements, Washington, D. C., 1953; also, in revised form, *Electronic Eng.*, May 1953.
893. Finden, H. J.: "The Frequency Synthesizer," *J.I.E.E.*, vol. 90, part III, 1943.
894. Gerber, E. A.: "A Review of Methods for Measuring the Constants of Piezoelectric Vibrators," *Proc. I.R.E.*, vol. 41, pp. 1103-1112, September 1953.
895. Gerber, E. A.: "Quartz-Crystal Measurement at 10 to 180 Megacycles," *Proc. I.R.E.*, vol. 40, pp. 36-40, January 1952.
896. Gerber, E. A.: "Amplitude of Vibration in Piezoelectric Crystals," *Electronics*, vol. 24, pp. 142, 204-218, April 1951, and p. 236, September 1951.
897. Gruen, H. E.: "Development of Packet Oscillator Series," Reports on U. S. Air Force Contract No. AF 33(616)-2125, Armour Research Foundation of Illinois Institute of Technology, 1954-55.
898. Hahnel, A.: "A Multichannel Crystal Oscillator," *I.R.E. Transactions on Vehicular Communications*, June 1955.
899. Hahnel, A.: "Phase Controlled Multichannel Oscillator," *Electronics*, pp. 164-165, April 1955.
900. Hahnel, A., and L. Battersby: "A Single Tube Spectrum Generator for High Order Harmonics," *Technical Memorandum No. M-1558*, Signal Corps Project No. 132A, January 1954.
901. Hahnel, A.: "A Multichannel UHF Crystal Oscillator," *Technical Memorandum No. M-1548*, Signal Corps Project No. 132A, December 1953.
902. Hahnel, A.: "Multichannel Crystal Control of VHF and UHF Oscillators," *Proc. I. R. E.*, vol. 41, pp. 79-81, January 1953.
903. Hale, D. R.: "The Properties of Synthetic Quartz Crystals and their Growing Techniques," *Brush Strokes* (Brush Electronics Co.), vol. 1, pp. 1-6, December 1952.
904. Hale, D. R.: "The Laboratory Growing of Quartz," *Science*, vol. 107, pp. 393-394, 1948.
905. Hammond, D. L.: "Effects of Impurities on the Resonator and Lattice Properties of Quartz," paper presented at 9th annual Frequency Control Symposium, Frequency Control Branch, Signal Corps Engineering Laboratories, Ft. Monmouth, N. J., May 1955.
906. Hok, G.: "Response of Linear Resonant Systems to Excitation of a Frequency Varying Linearly with Time," *Jour. Appl. Phys.*, vol. 19, no. 3, pp. 242-250, 1948.
907. James Knights Co.: *Crystal Handbook*, 1953.
908. Kerr, P. F., and E. Armstrong, "Recorded Experiments in the Production of Quartz," *Bull. Geol. Soc. Am.*, vol. 54, suppl. 1, pp. 1-43, 1943.
909. Koerner, L. F.: "Progress in Development of Test Oscillators for Crystal Units," *Proc. I. R. E.*, vol. 39, pp. 16-26, January 1951.
910. Lauer, F. J. M.: "Crystal Resonators as Frequency Substandards," *Proc. IEE* (London), vol. 97, part III, pp. 93-99, March 1950.
911. Lynch, A. C.: "Measurement of the Equivalent Electrical Circuit of a Piezoelectric Crystal," *Proc. Phys. Soc.* (London), vol. 63, sec. B, pp. 323-331, May 1950.
912. Mendousse, J. S., P. D. Goodman, and W. G. Cady: "A Capacitance Bridge for High Frequencies," *Rev. Sci. Instr.*, vol. 21, pp. 1002-1009, December 1950.
913. National Bureau of Standards: "High-Stability One-Megacycle Frequency Standard," *NBS Tech. News Bull.*, November 1954.
914. Prichard, A. C., and M. Bernstein: "Crystal Impedance Meters Replace Test Sets," *Electronics*, vol. 26, pp. 176-180, May 1953.
915. Rosenthal, L. A., and T. A. Peterson, Jr.: "Measurement of the Series Resonant Resistance of a Quartz Crystal," *Rev. Sci. Instr.*, vol. 20, pp. 426-429, June 1949.
916. Rothange, C. H., and F. Hamburger: "Measurement of the Electrical Characteristics of Quartz Crystal Units by Use of a Bridged T-Network," *Proc. I. R. E.*, vol. 38, pp. 1213-1216, October 1950.
917. Schure, A.: *Crystal Oscillators*, John F. Rider, New York, 1955.
918. Srivastava, K. G.: "A New and Quick Method for Detection of Piezoelectricity and Measurement of the Piezoelectric Constants," *Indian Jour. Phys.*, vol. 25, pp. 33-34, January 1951.
919. U. S. Air Force Technical Order, T. O. No. 12R2-2ARC27-2, *Radio Set AN/ARC-27*.
920. U. S. Air Force Technical Order, T. O. No. 12R2-2ARC33-2, *Radio Set AN/ARC-33*.
921. U. S. Air Force Technical Order, T. O. No. 12R5-2ARN14-12, *Radio Receiving Set AN/ARN-14*.
922. U. S. Air Force Technical Order, T. O. No. 31R2-2GRC27-12, *Radio Receiver R-278/GR*.
923. Van Dyke, K. S., and E. C. Crume, Jr.: "Bibliography of Piezoelectricity," Reports on Department of the Army Contract No. DA 36-039-sc-42587, Wesleyan University, 1953.
924. Venn, D. A.: "Measuring VHF Impedance of Piezoelectric Crystals at Resonance," *Tel-Tech.*, pp. 44-46, March 1950.
925. Walker, A. C.: "Hydrothermal Growth of Quartz Crystals as Related to Phase Considerations," *Ind. and Eng. Chem.*, vol. 46, pp. 1670-1676, 1954.
926. Wolfskill, J. M.: Production techniques for etching crystal blanks, U. S. Patent 2,481,806, 1949, and U. S. Patent 2,364,501, 1944.
927. Wolfskill, J. M.: "Resonant Pin" crystal mount, U. S. Patent 2,240,453, 1941.
928. Woodward, G.: "A Precision Transistor Oscillator," *Philco TechRep Div. Bull.*, vol. 3, pp. 12-13, March 1953.

APPENDIX III—LIST OF MANUFACTURERS

Manufacturers of crystals, crystal products, and crystal accessories are listed alphabetically by company name followed by letter symbols representing the product or products available from stock, presently in manufacture, or capable of being produced within a reasonable time. The products enumerated beside a firm name are those represented as being available at the time of preparation of this handbook. In the first column are listed the Standard Codes of Manufacturers' Names.

The list represents a cross-section of the crystal industry; it is presented for reference purposes only and is not intended as an exclusive directory of recommended commercial sources. Manufacturers desiring to be included in this list should contact Communications and Navigation Laboratory, Attention WCLNE-1, Wright Air Development Center, Wright-Patterson Air Force Base, Ohio. A tabulation of the crystal products manufactured and comments on their availability should be submitted, along with the full company name and address.

Mfrs Code	Manufacturer	Product*	Mfrs Code	Manufacturer	Product*
	Aeronautical Electronics, Inc. Raleigh-Durham Airport P.O. Box 6043 Raleigh, N. C.	B, C		Breon Laboratories 1520 Evergreen Rd. Williamsport, Pa.	A, B, C
CYA	Alden Products Co. 112 N. Main St. Brockton 64, Mass.	G, H	CBD	Brush Electronics Co. 3405 Perkins Ave. Cleveland 14, Ohio	A, B, E, F
CAS	American Lava Corp. Chattanooga 5, Tenn.	E, G	CBVZ	Bulova Watch Co. Quartz Crystal Div. 62-10 Woodside Ave. Woodside, Long Island	B, C, H, I, J
CAHZ	Bassett, Rex, Inc. 1314 N.E. 17th Court Fort Lauderdale, Fla.	C		Caribe Aircraft Radio Corp. Coamo, Puerto Rico	I
CRR	Bendix Radio Div. Bendix Aviation Corp. Baltimore 4, Md.	I	CBN	Centralab Div. of Globe-Union, Inc. 914Y E. Keefe Ave. Milwaukee 1, Wis.	E, G
CQB	Bliley Electric Co. Union Station Bldg. Erie, Pa.	C, G, I, J	CMG	Cinch Mfg. Co. 1026 S. Homan Ave. Chicago 24, Ill.	H
	Bodnar Industries, Inc. 19 Railroad Ave. New Rochelle, N. Y.	B	CBQR	Clark Crystal Co. 2 Farm Road Marlboro, Mass.	B, C, D
	Bram Chemical Co. 820 65th Ave. Philadelphia 26, Pa.	A, B, C, D	CBPR	Constantin, L. L., & Co. Lodi, N. J.	G

***PRODUCT SYMBOLS**

A—CRYSTALS—RAW
B—CRYSTALS—UNFINISHED
C—CRYSTAL UNITS—QUARTZ
D—CRYSTAL UNITS—TOURMALINE
E—CRYSTAL TRANSDUCERS—BARIUM TITANATE

F—CRYSTAL TRANSDUCERS—ROCHELLE SALTS
G—CRYSTAL HOLDERS
H—CRYSTAL SOCKETS
I—CRYSTAL OVENS
J—PACKAGED OSCILLATORS

Mfrs Code	Manufacturer	Product*	Mfrs Code	Manufacturer	Product*
CBYB	Cryco, Inc. 1138 Mission St. South Pasadena, Calif.	C	GWM	Frequency Control Branch Components Department Signal Corps Engineering Laboratories Fort Monmouth, N. J.	C
	Crystals, Inc. Odell, Ill.	C	CDP	General Ceramics & Steatite G Corp. Keasbey, N. J.	G
CJL	Daltron Corp. 5066 Santa Monica Blvd. Los Angeles 29, Calif.	C		General Crystal Co. P.O. Box 9 Burlington, Wis.	C
	Diamond Drill Carbon Co. 244 Madison Ave. New York 16, N. Y.	A	CG	General Electric Co. Semi-Conductor Section Electronics Park Syracuse, N. Y.	C
DABS	Downing Crystal Co. 191 Shaffer Ave. Westminster, Md.	A, B, C, I	CBGY	Gombos Co., John, Inc. 107 Montgomery Ave. Irvington 11, N. J.	G
CAZQ	DX Radio Products Co., Inc. 2300 W. Armitage Ave. Chicago 47, Ill.	C		Gulton Mfg. Co. Metuchen, N. J.	E
CEB	Eby, Hugh H., Inc. 4700 Stenton Ave. Philadelphia 40, Pa.	H		Hermetic Seal Products Co. 29-37 S. 6th St. Newark 7, N. J.	G
CBEK	Edo Corp. College Point, N. Y.	E, F		HEEMCO (Hill Electronic Engineering & Manufacturing Co.) New Kingstown, Pa.	C, I, J
	Eidson Electronic Co. 1902 N. Third St. Temple, Texas	B, C	CACG	Hoffman Co., P. R. 321 Cherry St. Carlisle, Pa.	B, C
	Elco Corp. "M" St. below Erie Ave. Philadelphia 24, Pa.	H	CAAN	Hunt Corp., The 453 Lincoln St. Carlisle, Pa.	B, C, I
	Elgin National Watch Co. Electronics Division 2435 N. Naomi Street Burbank, Calif.	H	CKZ	Hupp Electronics Co. (Formerly Standard Piezo Co.) Carlisle, Pa.	C, I
CBEF	Electrical Industries, Inc. 44 Summer Ave. Newark 4, N. J.	G		Ingram Labs, Inc. Griffin, Ga.	C
	Electro-Voice, Inc. Buchanan, Mich.	E, F		International Crystal Mfg. Co. 18½ N. Lee Ave. Oklahoma City 1, Okla.	C, H, J
CER	Erie Resistor Corp. 644 W. 12th St. Erie, Pa.	E	CEJ	Johnson Co., E. F. Waseca, Minn.	H

*PRODUCT SYMBOLS

A-CRYSTALS-RAW
B-CRYSTALS-UNFINISHED
C-CRYSTAL UNITS-QUARTZ
D-CRYSTAL UNITS-TOURMALINE
E-CRYSTAL TRANSDUCERS-BARIUM TITANATE

G-CRYSTAL HOLDERS
H-CRYSTAL SOCKETS
F-CRYSTAL TRANSDUCERS-ROCHELLE SALTS
I-CRYSTAL OVENS
J-PACKAGED OSCILLATORS

**Appendix III
List of Manufacturers**

<i>Mfrs Code</i>	<i>Manufacturer</i>	<i>Product*</i>	<i>Mfrs Code</i>	<i>Manufacturer</i>	<i>Product*</i>
CAK	Kaar Engineering Co. 2995 Middlefield Rd. P.O. Box 1320 Palo Alto, Calif.	C	CKM	Miller Laboratories, August E. 9226 Hudson Blvd. North Bergen, N. J.	B, C, D, H, I, J
CBSS	Keystone Electronics Co. 114 Manhattan St. Stamford, Conn.	C	CZN	Monitor Products Co. 815 Fremont Ave. South Pasadena, Calif.	B, C, G, I, J
	King Laboratory, Inc. 2645 South Second West Salt Lake City, Utah	A	CGG	Motorola, Inc. 4545 West August Blvd. Chicago 51, Ill.	C
CADI	Knights Co., James, The 131 S. Wells St. Sandwich, Ill.	B, C, G, I, J		Murray American Corp. 15 Commerce St. Chatham, N. J.	A
CAJR	Lavoie Laboratories Morganville, N. J.	I	CNA	National Co., Inc. 61 Sherman St. Malden 48, Mass.	H, J
CBVS	Lewis Co., Inc. E. B. 11 Bragg St. East Hartford 8, Conn.	B, C		National Electronic Mfg. Corp. 186 Granite St. Manchester, N. H.	G
CLF	Littelfuse, Inc. 4757 N. Ravenswood Ave. Chicago 40, Ill.	H	REN	Nebel Lab., R. E. 1624 E. 12th St. Brooklyn 29, N. Y.	B, C, G
	L. & O. Research & Development Corp. 134 North Wayne Ave. Wayne, Pa.	I		Northern Engineering Laboratories C 434 Wilmont Ave. Burlington, Wisconsin	
	Maryland Lava Co. Bel Air, Md.	A, E, G		Pan American Trade Development Corp. 2 Park Ave. New York 16, N. Y.	A
CBXK	McCoy Electronics Co. Chestnut & Watt Sts. Mt. Holly Springs, Pa.	B, C, I	CAIJ	Pan-Electronics Corp. P.O. Box 584 Griffin, Ga.	B, C
	Meridian Laboratory Lake Geneva, Wis.	C, I	CAMG	Petersen Radio Co., Inc. 2800 W. Broadway Council Bluffs, Iowa	C
	Method Mfg. Corp. 2021 W. Churchill St. Chicago 47, Ill.	H		Piezo Products Co. Whitney St. Sherborn, Mass.	C
CZX	Midland Mfg. Co., Inc. 3155 Fiberglas Rd Kansas City 15, Kansas	B, C, I	CBWN	Precision Crystal Laboratory 2223 Warwick Ave. Santa Monica, Calif.	B, C, I, J
CJA	Millen Mfg. Co., James, Inc. 150 Exchange St. Malden, Mass.	H			

***PRODUCT SYMBOLS**

A- CRYSTALS—RAW
B- CRYSTALS—UNFINISHED
C- CRYSTAL UNITS—QUARTZ
D- CRYSTAL UNITS—TOURMALINE
E- CRYSTAL TRANSDUCERS—BARIUM TITANATE

F- CRYSTAL TRANSDUCERS—ROCHELLE SALTS
G- CRYSTAL HOLDERS
H- CRYSTAL SOCKETS
I- CRYSTAL OVENS
J- PACKAGED OSCILLATORS

<i>Mfrs Code</i>	<i>Manufacturer</i>	<i>Product*</i>	<i>Mfrs Code</i>	<i>Manufacturer</i>	<i>Product*</i>
	Precision Piezo Service 427 Mayflower St. Baton Rouge, La.	B, C	CSJ	Stupakoff Ceramic & Mfg. Co. Latrobe, Pa.	E, G
CL	Premier Research Laboratories, Inc. 79-89 Seventh Ave. New York 11, N. Y.	B, C, D, G, J	CHS	Sylvania Electric Products, Inc. 12 Second Ave. Warren, Pa.	H
CBPN	Radiation Counter Laboratories, Inc. 5121 W. Grove St. Skokie, Ill.	I	CAYM	Tedford Crystal Labs. 4126 Colerain Ave. Cincinnati 23, Ohio	C
CRV	Radio Corporation of America Commercial Electronics Products Camden 2, N. J.	C		United States Gasket Co. Fluorocarbon Products Div. P.O. Box 648 Camden, N. J.	H
CUR	Reeves-Hoffman Corp. Cherry and North Sts. Carlisle, Pa.	B, C	CAMU	Valpey Crystal Corp. 1244 Highland St. Holliston, Mass.	B, C, D, I
	Scientific Electronic Labs., Inc. 866 Bergen St. Newark 8, N. J.	G	CAND	V Precision Instrument Co. 57-02 Hoffman Drive Elmhurst, N. Y.	C
CADG	Scientific Radio Products, Inc. 215 S. Eleventh St. Omaha 8, Neb.	B, C, I, J	CW	Western Electric Co. Radio Div., Electronic Products Sales Dept. 120 Broadway New York 5, N. Y.	C
	Sealtron Co. Reading Rd. at Amity Cincinnati 15, Ohio	G	CBVJ	Wright Electronics Inc. 1519 McGee St. Kansas City 8, Mo.	B, C, D, I
CBXR	Sherold Crystals, Inc. 1510 McGee St. Kansas City 15, Kansas	C, D		X-tron Electronics 890 71st Ave. Oakland 21, Calif.	A, B, C
CBZA	Standard Crystal Co. 1714 Locust St. Kansas City 8, Mo.	B, C, I		Young Brothers Co. 1829 Columbus Rd. Cleveland, Ohio	I

*PRODUCT SYMBOLS

A - CRYSTALS--RAW
 B - CRYSTALS--UNFINISHED
 C - CRYSTAL UNITS - QUARTZ
 D - CRYSTAL UNITS - TOURMALINE
 E - CRYSTAL TRANSDUCERS--BARIUM TITANATE

F - CRYSTAL TRANSDUCERS-- ROCHELLE SALTS
 G - CRYSTAL HOLDERS
 H - CRYSTAL SOCKETS
 I - CRYSTAL OVENS
 J - PACKAGED OSCILLATORS

APPENDIX IV—RELATED SPECIFICATIONS, STANDARDS, PUBLICATIONS, AND DRAWINGS

ORDERING INFORMATION

D-1. Copies of specifications, standards, publications, and drawings required by contractors in connection with specific procurement functions should be obtained from the procurement agency or as directed by the contracting officer.

D-2. The following may be obtained from the Commanding General, Air Materiel Command, Wright-Patterson Air Force Base, Dayton, Ohio:

- a. U. S. Air Force Specifications and Drawings.
- b. Federal Specifications.
- c. Military Specifications and Standards.

D-3. The following may be obtained from the Commanding Officer, Signal Corps Procurement Agency, 2800 South 20th Street, Philadelphia 45, Pennsylvania:

- a. U. S. Army Specifications.
- b. National Military Establishment and Joint Army-Navy Specifications.
- c. Signal Corps Drawings and Marking Instructions.

D-4. The following may be obtained from the Bureau of Supplies and Accounts, Navy Department, Washington 25, D. C. (activities of the Armed Forces should make application to the Commanding Officer, Naval Supply Center, Norfolk 11, Va.):

- a. Navy Department Specifications.
- b. Federal Specifications.
- c. Military Specifications.

D-5. The following may be obtained from the Superintendent of Documents, Government Printing Office, Washington 25, D. C.:

- a. Department of Commerce Publications.
- b. Federal Specifications.

D-6. Both the title and identifying number or symbol should be stipulated when requesting copies of specifications, standards, publications, and drawings.

SPECIFICATIONS

	U. S. AIR FORCE	NN-B-621	Boxes, Wood, Nailed and Lock-Corner.
AN-P-13	Preservation and Packaging Parts and Equipment (General Specification for) (<i>Note:</i> This is an Air Force-Navy Aeronautical specification applicable only to Air Force purchases).	QQ-A-318	Aluminum-Alloy (AL-52) (Aluminum-Magnesium-Chromium); Plate and Sheet.
40985	Marking of Interior Packages (for Communications Equipment).	QQ-B-611	Brass, Commercial; Bars, Plates, Rods, Shapes, Sheets, and Strips.
	AIR FORCE-NAVY AERONAUTICAL	QQ-B-746	Bronze, Phosphor; Bars, Plates, Rods, Shapes, Sheets, and Strips.
AN-P-34	Plating Nickel.	QQ-M-151	Metals; General Specification for Inspection of.
	FEDERAL	QQ-N-321	Nickel-Silver (German Silver); Bars, Plates, Rods, Shapes, Sheets, and Strips.
NN-B-601	Boxes, Wood-Cleated Plywood, for Domestic Shipment.		

Ordering Information—Specifications

QQ-S-571	Solder; Soft (Tin, Tin-Lead, and Lead-Silver).	JAN-P-105	Packaging and Packing for Overseas Shipment—Boxes; Wood, Cleated, Plywood.
QQ-S-636	Steel; Carbon (Low Carbon), Sheets and Strips.	JAN-P-106	Packaging and Packing for Overseas Shipment—Boxes; Wood, Nailed.
QQ-S-763	Steel, Corrosion-Resisting; Bars and Forging (Except for Re-forging).	JAN-P-108	Packaging and Packing for Overseas Shipment—Boxes, Fiberboard (V-Board and W-Board), Exterior and Interior.
LLL-B-631	Boxes; Fiber Corrugated (for Domestic Shipment).	JAN-P-120	Packaging and Packing for Overseas Shipment—Cartons, Folding, Paperboard.
LLL-B-636	Boxes; Fiber, Solid (for Domestic Shipment).	JAN-P-125	Packaging and Packing for Overseas Shipment—Barrier Materials, Waterproof, Flexible.
MILITARY			
MIL-C-16B	Crystal Unit, Quartz (CR-1A/AR, Pressure, Mounted).	JAN-P-133	Packaging and Packing for Overseas Shipment—Boxes, Set-up, Paperboard.
MIL-C-239B	Crystal Unit, Quartz (CR-5/U).	JAN-P-139	Packaging and Packing for Overseas Shipment—Plywood, Container Grade.
MIL-C-3098B	Crystal Units, Quartz.	JAN-P-140	Packaging and Packing for Overseas Shipment—Adhesives, Water-Resistant, Case-Liner.
MIL-C-10405 (Sig C)	Crystal Units, Quartz, Pressure and Spacer Mounted.	JAN-S-28A	Sockets, Electron Tube, and Accessories.
MIL-H-10056B	Holdings, Crystal.		
MIL-L-10547	Liners, Case, Waterproof.		
MIL-P-14	Plastic-Materials, Molding, and Plastic Parts, Molded; Thermosetting.		
MIL-P-116	Packaging and Packing for Overseas Shipment—Preservation, Methods of.	72-53	U. S. ARMY Finishes (For Ground Signal Equipments).
MIL-R-3065	Rubber and Synthetic Rubber Compounds, General Purpose (Except Tires, Inner-Tubes, Sponge Rubber, and Hard Rubber).	72-119-A	72-119-A 94-40645 Holders for Quartz Crystals.
MIL-T-945A	Test-Equipment, for Use with Electronic Equipment: General Specification.	100-2	100-2 Standard Specification for Marking Shipments by Contractors.
JAN-C-173	Coating Materials, Moisture- and Fungus-Resistant, for the Treatment of Communications, Electronic, and Associated Electrical Equipment.	726-15	SIGNAL CORPS INSTRUCTIONS 726-15 Marking of Interior Containers (For Signal Corps Equipment).
JAN-P-13	Plastic-Materials, Laminated, Thermosetting; Sheets and Plates.	22W13	NAVY General Specification for Inspection of Material (applicable only to Navy purchases). 22W13 Wire, Steel, Corrosion-Resisting.
JAN-P-14	Plastic-Materials, Molded, Thermosetting.	46N7	46N7 Nickel-Copper-Silicon-Alloy: Castings.

STANDARDS

MILITARY

(Military Standards for individual Crystal Units and for drive adjustment procedures for the standard crystal impedance meters are contained in Military Specification MIL-C-3098B.)

MIL-STD-105	Sampling Procedures and Tables for Inspection by Attributes.
MIL-STD-129	Marking of Shipments.
JAN-STD-15	Electrical and Electronic Symbols.

PUBLICATIONS

U. S. AIR FORCE

HB-16F-1	Gentile AF Depot—Crystal Handbook for Equipments FT-164 Crystal Holder (Unit).
HB-16F-2	Gentile AF Depot—Crystal Handbook for Equipments Using AR-3 Crystal Holder (Unit).
HB-16F-3	Gentile AF Depot—Crystal Handbook for Equipments Using FT-243 Crystal Holder (Unit).
S-16-F	USAF Supply Catalog, Class 16-F, Code 2100, Radio Crystals.

SIGNAL CORPS

Project 4422D†	Crystal Data Sheets (technical requirements for fabrication of crystal units contained in various equipments).
----------------	--

NAVY

NAVSHIPS 900,152	Manufacturer's Designating Symbols.
	Navy Shipment Marking Handbook.

DEPARTMENT OF COMMERCE

National Bureau of Standards Handbook H28	Screw-Thread Standards for Federal Services.
---	--

AMERICAN IRON AND STEEL INSTITUTE

Steel Products Manual (Stainless and Heat-Resisting Steels).††

† Direct requests for this publication to: Commanding General, Signal Corps Engineering Laboratories, SCCSCL-PMM-3, Fort Monmouth, N. J.

†† Direct requests for this publication to: American Iron and Steel Institute, 350 Fifth Avenue, New York 1, New York.

DRAWINGS

	U. S. AIR FORCE	SC-D-17316	Crystal Impedance Meter TS-330/TSM, Circuit Diagram.
52B13216	Crystal Holder HC-()/U, Assembly (Crystal Holders HC-11/U and HC-12/U).	SC-D-17499	Crystal Holder FT-243, Marking for Standard Units.
	SIGNAL CORPS	SC-D-20032	Crystal Holder HC-4/U, Assembly.
SC-A-200	Crystal Holder FT-164.	SC-D-20035	Crystal Holder HC-3/U, Assembly.
SC-D-247	Crystal Holder FT-249, Outline Dimensions and Marking Information.	SC-D-20036	Crystal Holder HC-2/U, Assembly.
SC-D-5213	Crystal Holder FT-171-B, Drawing List.	SC-D-20724	Crystal Holder HC-5/U, Assembly.
SC-D-6306	Crystal Holder FT-243.	SC-D-20877	Crystal Holder HC-1/U, Assembly.
SC-D-7627	Crystal Units DC-34 and DC-35, Outline Dimensions.	SC-D-22892	Crystal Holder FT-171-B, Assembly.
SC-D-9553	Crystal Holder FT-241-A, Critical Dimensions.	SC-D-25222	Crystal Impedance Meter TS-537/TSM, Circuit Diagram.
SC-D-14444	Standard Oscillator TS-39/TSM-1, Circuit Diagram.	SC-D-26189	Crystal Holder FT-249, Case Assembly.
SC-D-14445	Standard Oscillator TS-39/TSM-1, Calibration and Operation.		

APPENDIX V—DEFINITIONS OF ABBREVIATIONS AND SYMBOLS

ABBREVIATIONS

ac (a-c)	alternating current	ma	milliampere (s)
ADP	ammonium dihydrogen phosphate	max	maximum
afc (a-f-c)	automatic frequency control	mc	megacycle (s)
AGC	automatic gain control	mf (m-f)	medium frequency
amp	ampere (s)	mfr	manufacturer
approx	approximately	Mil	Military
AWG	American Wire Gauge	min	minimum, minute (s)
bfo	beat-frequency oscillator	mm	millimeter (s)
C	centigrade	mmf, $\mu\mu\text{f}$	micromicrofarad (s)
cal	calorie (s)	mtg	mounting
cap.	capacitance	mw	milliwatt (s)
cc	cubic centimeter (s)	NA	not applicable
CFI	crystal frequency indicator	nat	natural
CI	crystal impedance (meter)	NL	not listed
cm	centimeter (s)	no.	number (s)
Co	Company	osc	oscillator
cont	continued	oz	ounce (s)
cos	cosine	PE	paper, enamel (wire insulation per JAN-W-583)
cot	cotangent	PI	performance index
cps	cycles per second	pl	plate (d)
c to c	center to center	ppm	parts per million
cw (c-w)	continuous wave	pr	pair (s)
db	decibels	qty	quantity
dc (d-c)	direct current	rec	receiver
deg	degrees	ref	reference
dia	diameter	rf (r-f)	radio frequency
DKT	dipotassium tartrate	rms	root mean square
EDT	ethylene diamine tartrate	RTMA	Radio and Television Manufacturer's Association
eff	effective	sec	second (s)
emf	electromotive force	/sec	per second
etc.	et cetera	sin	sine
F	Fahrenheit	soc. min. de	
f	farad (s)	France	societe mineralogique de France
fig.	figure	spec	specification (s)
freq	frequency	sq	square
ft	foot (feet)	std	standard
gm	gram (s)	tan	tangent
gnd	ground	temp	temperature
h	henry (s)	term.	terminal
hf (h-f)	high frequency	thd	thread (ed)
if (i-f)	intermediate frequency	T.O.	(Air Force) Technical Order
in.	inch (es)	USAF	United States Air Force
ins	insulat (ion) (ed)	V	volt (s)
I.R.E.	Institute of Radio Engineers	vhf (v-h-f)	very high frequency
K	Kelvin	vlf (v-l-f)	very low frequency
kc	kilocycle (s)	w/	with
lb	pound (s)	xmtr	transmitter
lf (l-f)	low frequency	xtal	crystal
lg	long, length		
μa	microampere (s)		

SYMBOLS

Definitions are given for all usages of symbols appearing in this manual. For each usage, the first paragraph wherein the symbol appears is listed. For a complete definition, in most instances, it is necessary to examine the symbol in context by referring to the cited paragraph.

Symbol	Paragraph
A.....	(1) quartz element 1-90
	(2) effective electrode area 1-191
	(3) constant-transconductance mode of vacuum-tube operation 1-273
	(4) cross-sectional area 4-32
	(5) area of radiating surface..... 4-35
AB.....	mode of vacuum-tube operation where control grid is biased on bend of $E_c I_b$ curve between cutoff point and constant- g_m region..... 1-273
AC.....	quartz cut 1-23
AT.....	quartz cut 1-23
a.....	proportionality constant relating load resistance to the effective input resistance of transformer-coupled oscillator 1-395
a_1	(1) empirical proportionality constant for length harmonic in quartz thickness-shear frequency equation 1-81
	(2) empirical proportionality constant for width harmonic in quartz face-shear frequency mode 1-82
a_2	empirical proportionality constant for width harmonic in quartz thickness-shear frequency equation 1-81
B.....	(1) quartz element 1-90
	(2) cutoff-bias mode of vacuum-tube operation..... 1-273
BC.....	quartz cut 1-23
BT.....	quartz cut 1-23
C.....	(1) Carbon 1-29
	(2) quartz element 1-90
	(3) motional-arm (or series-arm) capacitance of crystal equivalent circuit..... 1-183
	(4) greater-than-cutoff-bias mode of vacuum-tube operation 1-273
	(5) heat capacity of thermofilter..... 4-58
C_A	air-gap capacitance between crystal and electrode 1-183
C_B	blocking capacitor 1-220
C_C	adjustable capacitance, connected as one arm of capacitance-bridge circuit in series with crystal unit; used to balance bridge at off-resonance frequency when crystal unit appears as a capacitance, so that bridge is only unbalanced near resonance of crystal 1-365
C_D	heat capacity of crystal in crystal-oven circuit 4-58
C_{DH}	heat capacity of crystal holder in crystal-oven circuit 4-58

<i>Symbol</i>	<i>Paragraph</i>
C_d	(1) total distributed capacitance across leads and terminals of crystal unit..... 1-201
	(2) dynamic positive capacitance effectively in series with vacuum-tube plate-to-cathode capacitance 1-289
	(3) Cadmium Sect. III
C_e	electrostatic capacitance across quartz-plate dielectric 1-183
C_g	(1) total effective grid-to-cathode capacitance of vacuum-tube circuit 1-278
	(2) suppressor grid-to-ground capacitance of transitron crystal-oscillator circuit..... 1-425
C_g'	equivalent grid-circuit capacitance when grid impedance is represented as equivalent resistance in series with equivalent capacitive reactance 1-298
C_{g1}	grid-to-cathode capacitance of first vacuum tube in two-tube crystal-oscillator circuit..... 1-383
C_{g2}	grid-to-cathode capacitance of second vacuum tube in two-tube crystal-oscillator circuit..... 1-383
C_{g1}	input capacitance of first tube in two-tube parallel-resonant crystal oscillator..... 1-345
C_{g1g2}	excitation-grid-to-screen-grid capacitance of vacuum tube 1-322
C_{g2}	input capacitance of second tube in two-tube parallel-resonant crystal oscillator..... 1-345
C_{H1}	heat capacity of crystal-oven heater and adjacent thermal distributing layers..... 4-58
C_{HT}	sum of heat capacities of heater and thermostat in crystal oven ($C_{H1} + C_T$)..... 4-59
C_{H11}	distributed capacitance of crystal unit between crystal holder and one electrode-terminal side of crystal (capacitance on side of crystal opposite to C_{H12})..... 1-183
C_{H12}	distributed capacitance of crystal unit between crystal holder and one electrode-terminal side of crystal (capacitance on side of crystal opposite to C_{H11})..... 1-183
C_k	distributed cathode-to-ground capacitance in modified grounded-grid oscillator..... 1-419
C_l	distributed capacitance of leads and terminals of crystal unit..... 1-182
C_n	(1) dynamic negative plate-to-cathode capacitance effectively introduced by vacuum tube in Pierce crystal oscillator..... 1-278
	(2) capacitance in impedance-inverting network of impedance-inverting crystal oscillator equal to electrostatic shunt capacitance of crystal unit 1-426
C_o	heat capacity of crystal-oven walls..... 4-58
C_o	total electrostatic shunt capacitance of crystal-unit equivalent circuit..... 1-184

<i>Symbol</i>	<i>Paragraph</i>
(eff) C_o	effective electrostatic shunt capacitance of crystal unit (equal to C_o plus any circuit capacitance directly shunted across unit terminals) 1-230
C_p	total effective electrostatic plate-to-cathode capacitance of vacuum-tube plate circuit..... 1-278
C_p'	total effective plate-to-cathode capacitance of generalized oscillator taking into account dynamic effects of vacuum tube..... 1-278
C_{pc}	plate-to-cathode capacitance of vacuum-tube circuit 1-278
C_{pg}	plate-to-grid capacitance of vacuum-tube circuit; normally represents only stray capacitance 1-278
C_T	(1) total capacitance ($C_o + C_x$) shunting series arm of generalized crystal-oscillator circuit..... 1-211
	(2) total capacitance of capacitance-bridge oscillator circuit 1-365
	(3) effective heat capacity of thermostat in crystal oven 4-58
C_e	external capacitance directly shunting crystal unit; considered as circuit variable..... 1-230
C_x	equivalent load capacitance shunting parallel-mode crystal unit..... 1-211
C_{x_p}	component of load capacitance of crystal unit in Miller oscillator due to inductive plate circuit (applicable when effect of grid-circuit losses on frequency can be considered negligible) 1-332
C_{x_p}'	component of load capacitance of crystal unit in Miller oscillator due to inductive plate circuit 1-332
CT.....	quartz cut 1-23
C_1	equivalent series-arm capacitance of desired-frequency mode of crystal unit..... 1-183
$C_1, C_2, \text{etc.}$	capacitances in schematic diagram..... 1-220
$C_2, C_3, \dots C_k$	equivalent series-arm capacitance of unwanted-frequency modes of crystal unit..... 1-183
$C_6H_{14}N_2O_6$	ethylene diamine tartrate..... 1-36
c	stiffness factor 1-78
D	(1) quartz element 1-90
	(2) Q degradation of crystal unit; equal to ratio of total effective resistance into which crystal must operate to crystal resonance resistance $\left(\frac{R_c}{R}\right)$ 1-396
	(3) number of discriminators in synthesizer circuit 1-456
	(4) diameter 4-18
$D, D_1, D_2, D_{1,s}$	plate-stabilized modes of vacuum-tube operation 1-298
DT.....	quartz cut 1-23

Appendix V
Symbols

<i>Symbol</i>	<i>Paragraph</i>
d.....	(1) distance between parallel atomic planes..... 1-127
	(2) diameter of pin or wire..... 1-158
	(3) differential sign..... 1-203
	(4) piezoelectric constant giving ratio of strain to field..... 1-248
	(5) linear displacement of bimetallic sensing element..... 4-18
E.....	quartz element..... 1-90
E _b	d-c plate voltage of vacuum tube..... 1-288
E _c	(1) d-c bias voltage of excitation grid of vacuum tube..... 1-293
	(2) rms r-f voltage across crystal unit..... 1-312
E _{co}	cut-off voltage of vacuum tube..... 1-312
E _{cr}	rms r-f voltage across crystal unit in capacitance-bridge oscillator circuit..... 1-365
E _{c1}	d-c bias voltage of excitation grid of first vacuum tube in two-tube crystal-oscillator circuit..... 1-378
E _{c2}	(1) d-c voltage of screen grid..... 1-298
	(2) d-c bias voltage of excitation grid of second vacuum tube in two-tube crystal oscillator..... 1-378
E _g	grid-to-cathode excitation voltage (rms) of vacuum tube..... 1-233
E _{gm}	peak amplitude of vacuum-tube excitation voltage..... 1-296
E _{g1}	grid-to-cathode excitation voltage (rms) of first vacuum tube in two-tube crystal-oscillator circuit..... 1-345
E _{g2}	(1) grid-to-cathode excitation voltage (rms) of second vacuum tube in two-tube crystal-oscillator circuit..... 1-345
	(2) screen-grid rms voltage of vacuum tube..... 1-425
E _{g3}	suppressor-grid rms voltage of vacuum tube..... 1-425
E _h	harmonic plate voltage of vacuum tube..... 1-322
E _L	rms voltage across load resistor in transformer-coupled oscillator..... 1-393
E _o	(1) rms voltage across equivalent parallel-resonant crystal-oscillator circuit (same as r-f voltage, E _c , across crystal unit)..... 1-232
	(2) rms voltage output from oscillator circuit..... 1-342
	(3) rms voltage across center leg of bridge in Meacham-bridge oscillator..... 1-358
E _p	r-f plate voltage (rms) of vacuum tube..... 1-233
E _{pm}	maximum value of a-c component of vacuum-tube plate voltage..... 1-312
E _{p1}	r-f plate voltage (rms) of first vacuum tube in two-tube crystal-oscillator circuit..... 1-345
E _{p2}	r-f plate voltage (rms) of second vacuum tube in two-tube crystal-oscillator circuit..... 1-345
E _{R_e}	rms voltage across crystal unit (or equivalent resonance resistance in CI meter)..... 1-436
E _s	rms voltage across secondary of plate transformer..... 1-358

<i>Symbol</i>	<i>Paragraph</i>
E_v	mechanical vibrational energy of crystal..... 1-249
E_t	rms voltage across thermistor in bridge circuit of Meacham-bridge oscillator..... 1-358
ET.....	quartz cut..... 1-23
e	emissivity..... 4-35
e_b	instantaneous value of vacuum-tube plate voltage..... 1-312
e_c	instantaneous value of vacuum-tube grid voltage..... 1-312
e_h	instantaneous harmonic voltage across vacuum-tube plate tank circuit..... 1-322
e_p	instantaneous value of a-c component of vacuum-tube plate voltage..... 1-312
F.....	quartz element..... 1-90
F_p	frequency-stability factor for parallel-mode crystal-oscillator circuit; equal to rate of change in crystal-unit reactance per fractional change in frequency..... 1-243
F_s	frequency-stability factor for series-mode crystal-oscillator circuit; equal to rate of change in crystal-unit reactance per fractional change in frequency..... 1-240
F_x	coefficient of frequency stability; equal to percentage change in reactance of stabilizing element per percentage change in frequency..... 1-227
F_{x_c}	frequency-stability coefficient; equal to percentage rate of change in overall effective reactance (X_c) of crystal unit for a percentage change in frequency; a measure of the stabilizing effect of crystal unit against percentage change in reactance of load capacitance, C_x 1-243
F_{x_s}	frequency-stability coefficient: equal to percentage rate of change in series-arm reactance (X_s) of crystal unit for a percentage change in frequency; a measure of the stabilizing effect of crystal unit against percentage change in reactance of total effective shunt capacitance, C_T 1-243
FT.....	quartz cut..... 1-23
f	(1) frequency..... 1-78
	(2) farad..... 1-188
	(3) nominal frequency at which crystal unit is assumed to operate..... 1-208
	(4) fundamental frequency of crystal-oven temperature cycles..... 4-60
f_a	antiresonant frequency of crystal unit..... 1-204
f_c	fundamental frequency of first crystal oscillator in synthesizer circuit..... 1-455
f_d	frequency of discriminator in synthesizer circuit..... 1-455
f_F	frequency of force acting on oscillator..... 1-265
f_H	highest frequency..... 1-248

Appendix V
Symbols

<i>Symbol</i>	<i>Paragraph</i>
f_b	any particular harmonic of fundamental crystal-oscillator frequency passed by harmonic selector in synthesizer circuit 1-455
f_L	lowest frequency 1-248
f_o	(1) frequency of oscillator 1-265
	(2) frequency of variable oscillator in synthesizer circuit 1-455
f_p	parallel-resonant frequency of equivalent crystal-oscillator circuit 1-210
f_{p1}	operating parallel-resonant frequency of first crystal unit 1-317
f_{p2}	operating parallel-resonant frequency of second crystal unit 1-317
f_r	resonant frequency of crystal unit 1-204
f_{rx}	frequency at which an external reactance, X_x , is series-resonant with the equivalent reactance, X_e , of a crystal unit 1-217
f_s	series-resonant frequency of series arm 1-203
f_x	output frequency of second crystal oscillator in synthesizer circuit 1-455
$F_1, F_2, \text{ etc}$	dominant frequencies in various parts of frequency-control circuits as indicated in schematic diagrams 1-319
G	quartz element 1-90
$G_1, G_2, \text{ etc}$	voltage gains of coupling stages around oscillator loop 1-267
G_1'	voltage gain of the first part of G_1 , which in turn is the overall gain of a coupling stage that can be subdivided into two or more steps of gains $G_1', G_1'', \text{ etc}$ 1-378
G_1''	voltage gain of the second part of G_1 , which in turn is the overall gain of a coupling stage that can be subdivided into two or more steps of gains $G_1', G_1'', \text{ etc}$ 1-378
GT	quartz cut 1-23
g_m	transconductance of vacuum tube 1-273
g_{m1}	transconductance of first vacuum tube in two-tube crystal-oscillator circuit 1-348
g_{m2}	transconductance of second tube in two-tube crystal-oscillator circuit 1-348
H	(1) Hydrogen 1-29
	(2) quartz element 1-90
	(3) crystal holder 1-183
	(4) number of first-crystal-oscillator harmonics utilized in synthesizer circuit 1-456
I_A	rate of absorption of radiant heat 4-40
I_{Ac}	peak a-c thermal current through thermofilter 4-58
I_b	average value of d-c plate current of vacuum tube 1-277
I_{bm}	maximum d-c value of vacuum-tube plate current (plate current at peak of positive excitation alternation) 1-312
I_{b1}	average value of d-c plate current of first vacuum tube in two-tube crystal-oscillator circuit 1-378

<i>Symbol</i>	<i>Paragraph</i>
I_{b2}	average value of d-c plate current of second vacuum tube in two-tube crystal-oscillator circuit 1-378
I_c	(1) total r-f current through crystal unit (rms) .. 1-232
	(2) average d-c vacuum-tube grid current 1-296
	(3) r-f collector current in transistor oscillator 1-540
I_{c_0}	a-c current through electrostatic shunt capacitance of crystal unit 1-300
I_e	r-f emitter current in transistor oscillator 1-540
I_Q	instantaneous calorie output per second of crystal-oven heater when operating (equivalent to wattage of heater) 4-58
I_g	r-f grid current (rms) of vacuum tube 1-233
I_{gm}	peak amplitude of r-f current 1-293
I_{g1}	reactive component of rms grid current due to grid-to-cathode capacitance of vacuum tube .. 1-383
I_{g1}	that part of r-f plate current of second tube that is fed back to grid of first tube in two-tube parallel-resonant crystal oscillator 1-345
I_{g2}	that part of r-f plate current of first tube that is fed to grid of second tube in two-tube parallel-resonant crystal oscillator 1-345
I_H	(1) thermal current 4-32
	(2) average rate of heat leakage to the outside in crystal-oven heater (equal to average power consumption of oven) 4-58
I_m	apparent maximum a-c component of vacuum-tube plate current 1-312
I_N	average net rate of heat supplied to crystal oven during initial heating period 4-71
I_o	portion of total r-f current through crystal unit that flows through electrostatic shunt capacitance 1-394
I_p	a-c component of vacuum-tube plate current (rms) 1-270
I_{pm}	maximum (peak) amplitude of a-c component of vacuum-tube plate current 1-312
I_{p1}	a-c component of plate current of first vacuum tube in two-tube crystal-oscillator circuit..... 1-377
I_{p2}	a-c component of plate current of second vacuum tube in two-tube crystal-oscillator circuit 1-377
I_R	total heat radiated per second 4-35
I_s	(1) equivalent r-f current through series arm..... 1-249
	(2) portion of total rms plate current flowing through inductance of secondary in plate transformer of capacitance-bridge oscillator 1-366
I_2	portion of total rms plate current flowing through the effective electrostatic plate-to-cathode capacitance of capacitance-bridge oscillator circuit 1-367
I_3	portion of total rms plate current flowing through center leg of bridge circuit in capacitance-bridge oscillator 1-366

Appendix V
Symbols

<i>Symbol</i>	<i>Paragraph</i>
I_1	(1) rms current through thermistor in bridge circuit in Meacham-bridge oscillator 1-360
	(2) portion of total rms plate current flowing through plate-to-grid leg of bridge circuit in capacitance-bridge oscillator 1-366
i	measure of imbalance in Meacham-bridge oscillator 1-359
i_b	instantaneous value of total vacuum-tube d-c plate current 1-312
i_p	instantaneous value of a-c component of vacuum-tube plate current 1-312
J	quartz element 1-90
j	complex-number operator; equal to $\sqrt{-1}$ 1-281
$J_1, J_2, \text{ etc.}$	jacks in schematic diagrams 1-436
K	(1) Potassium 1-29
	(2) thermal conductivity 4-32
$K_2C_4H_4O_6 \cdot \frac{1}{2}H_2O$	dipotassium tartrate 1-38
k	(1) frequency constant 1-79
	(2) electromechanical coupling factor 1-227
	(3) gain of vacuum tube; equal to ratio of r-f plate voltage to r-f grid voltage 1-233
	(4) ratio of grid-leak resistance to minimum permissible performance index of Military Standard crystal unit 1-300
	(5) proportionality constant relating value of fixed resistance in Meacham bridge to crystal resistance 1-358
	(6) coefficient of transformer coupling 1-393
	(7) temperature coefficient of thermostat deflection in parts per degree centigrade, equal to $k_a, k_b, \text{ or } k_c$ 4-18
k_{mi}	maximum practical ratio of grid-leak resistance to minimum performance index of Military Standard crystal unit 1-300
k_1	frequency constant for length- or width-extensional mode 1-79
k_2	frequency constant for thickness-extensional mode 1-80
k_3	frequency constant for thickness-shear mode 1-81
k_4	frequency constant for face-shear mode of square plates 1-82
k_4'	frequency constant for face-shear mode 1-82
k_5	frequency constant for length-width-flexural mode 1-83
k_6	frequency constant for length-thickness-flexural mode 1-84
L	(1) motional-arm (or series-arm) inductance of crystal-unit equivalent circuit 1-183
	(2) length of thermal conductor 4-32
L_a	inductance of plate transformer in modified grounded-grid oscillator 1-419
L_b	cathode-to-ground inductance in modified grounded-grid oscillator 1-419

<i>Symbol</i>	<i>Paragraph</i>
L_c	equivalent, or effective, inductance of crystal unit when unit is viewed as an equivalent resistance and reactance in series 1-236
L_k	suppressor-grid circuit tank inductance in transitron crystal-oscillator circuit 1-425
L_k	cathode-to-ground inductance in modified grounded-grid oscillator 1-417
L_l	distributed inductance of leads and terminals of crystal unit 1-183
L_o	external inductance connected across crystal unit to antiresonate with electrostatic shunt capacitance of the unit 1-385
L_p	(1) inductance of plate circuit 1-328
	(2) inductance of primary in plate transformer of capacitance-bridge oscillator 1-365
	(3) inductance of plate-to-ground transformer in modified grounded-grid oscillator 1-417
L_s	inductance of secondary in plate transformer of capacitance-bridge oscillator 1-365
L_T	dynamic inductance between plate and cathode effectively introduced by vacuum tube 1-278
L_1	equivalent series-arm inductance of desired-frequency mode of crystal unit 1-183
$L_1, L_2, \text{ etc}$	inductances in schematic diagrams 1-220
$L_2, L_3, \dots L_k$	equivalent series-arm inductance of unwanted-frequency modes of crystal unit 1-183
l	length 1-79
l_1	mechanical one-quarter wavelength of wire.... 1-165
l_2	mechanical three-quarter wavelength of wire 1-165
l/t	ratio of length to thickness 1-141
M	(1) quartz element 1-90
	(2) figure of merit 1-227
	(3) coefficient of inductive coupling 1-419
$M, M_1, M_2, \dots M_k$	meter 1-188
MT	quartz cut 1-23
m	(1) quartz face 1-42
	(2) harmonic integer 1-81
	(3) constant for mode of vibration in frequency equation of clamp-free rod in flexural vibration 1-158
	(4) proportionality constant relating total resistance on crystal side of Meacham bridge to the value of the resistance of the variable arm alone 1-358
N	(1) nitrogen 1-29
	(2) quartz element 1-90
	(3) ratio of a conveniently assumed reference value of R_o to any particular value of R_o ($= R_{oN}$); thus $N = (\text{ref}) R_o / R_{oN}$ 1-312
	(4) same as in definition (3), but in the particular case where (ref) R_o is the maximum permissible resonance resistance of a Military Standard crystal unit and R_{oN} is the minimum expected resonance resistance 1-362

<i>Symbol</i>	<i>Paragraph</i>
(5) turns ratio of autotransformer in grounded-grid oscillator (equal to ratio of total turns to turns of secondary).....	1-407
(6) total number of frequency channels in synthesizer circuit	1-442
Na.....	Sodium 1-29
$\text{NaKC}_4\text{H}_4\text{O}_6 \cdot 4\text{H}_2\text{O}$	Rochelle salt 1-29
N_g	turns ratio of grid transformer in vacuum-tube circuit 1-358
N_p	turns ratio of plate transformer in vacuum-tube circuit 1-359
$\text{NH}_4\text{H}_2\text{PO}_4$	ammonium dihydrogen phosphate 1-29
NT.....	quartz cut 1-23
n.....	(1) integer; equal to harmonic of oscillation..... 1-79
	(2) a positive integer; equal to the sequence number of any given frequency in a set of frequencies (e.g. in an ascending sequence of evenly-spaced crystal frequencies numbered 1, 2, . . . etc., $n = 1$ for the No. 1 crystal, $n = 2$ for the No. 2 crystal, etc.)..... 1-445
O.....	Oxygen 1-29
P.....	Phosphorus 1-29
P_c	power dissipated in crystal unit 1-233
P_{cm}	maximum power dissipation recommended for Military Standard crystal unit..... 1-293
P_g	power dissipated in vacuum-tube grid circuit 1-296
P_L	power dissipated in crystal-oscillator load..... 1-397
P_o	power dissipated in output circuit..... 1-333
P_p	power dissipated in plate circuit of transformer-coupled oscillator 1-395
P_{zL}	power dissipated in oscillator tank circuit..... 1-312
P_1	(1) power dissipated by R_1 (crystal-unit) arm in Meacham-bridge oscillator 1-361
	(2) position of any given adjustment of adjustable thermostat 4-16
p.....	harmonic integer 1-81
Q.....	quality factor 1-36
Q_e	effective quality factor of crystal unit equal to X_c/R_c 1-227
Q_{em}	maximum possible effective quality factor of a given crystal unit..... 1-217
Q_t	imaginary effective overall phase-rotating quality factor of an oscillator feedback circuit 1-272
Q_g	quality factor of vacuum-tube input impedance 1-272
Q_{ngc}	overall quality factor of a-c impedance of oscillator feedback circuit from plate to grid to cathode 1-272
Q_s	effective quality factor of series arm of crystal unit (equal to X_s/R)..... 1-213
R.....	(1) motional-arm (or series-arm) resistance of crystal-unit equivalent circuit..... 1-183

<i>Symbol</i>	<i>Paragraph</i>
	(2) effective lumped thermal resistance of thermo- filter in crystal oven..... 4-58
R_A	thermal resistance of air outside crystal oven 4-58
R_p	plate load resistance of first vacuum tube in two-tube parallel-resonant crystal oscillator... 1-345
	(1) plate load resistance of second vacuum tube in two-tube parallel-resonant crystal oscillator... 1-345
	(2) external resistance in base circuit of tran- sistor 1-548
R_{cc}	effective thermal resistance of crystal cham- ber in crystal oven..... 4-58
R_{CH}	effective thermal resistance of crystal holder 4-58
R_c	(1) total effective resistance faced by crystal unit (normally useful only when unit is assumed to operate at resonant frequency)..... 1-241
	(2) collector resistance of transistor..... 1-540
	(3) external resistance in collector circuit of tran- sistor 1-548
R_{cg}	effective grid resistance in oscillator circuit 1-331
R_e	(1) equivalent, or effective, resistance of crystal unit when unit is viewed as an equivalent re- sistance and reactance in series 1-204
	(2) external resistance in emitter circuit of tran- sistor 1-546
R_e'	effective resistance, R_e , of crystal unit when assuming stray shunt capacitance introduced by circuit is part of total electrostatic shunt capacitance of crystal unit..... 1-278
R_{em}	specified maximum effective resistance of parallel-mode, Military Standard crystal unit 1-293
R_{eN}	any particular value of R_e whose ratio to a conveniently assumed reference value, (ref) R_{e0} , is equal to N..... 1-312
R_{ep}	equivalent, or effective, resistance (R_e) of crystal unit when operating at parallel-reso- nance frequency, f_p , of equivalent crystal- oscillator circuit 1-210
R_f	total resistance of feedback circuit..... 1-297
R_{fe}	effective resistance of feedback circuit insofar as it affects oscillator frequency..... 1-297
R_g	grid-leak resistance 1-277
R_g'	resistive component of grid impedance when latter is represented as equivalent resistance in series with equivalent reactance 1-297
R_{ge}	effective grid resistance in equivalent oscil- lator circuit 1-333
R_{g1}	grid-leak resistance of first vacuum tube in two-tube crystal-oscillator circuit 1-345
R_{g2}	grid-leak resistance of second vacuum tube in two-tube crystal-oscillator circuit 1-345
R_H	thermal resistance 4-33
R_t	terminal-to-terminal r-f insulation resistance of crystal unit 1-183
R_k	cathode biasing resistance 1-307

<i>Symbol</i>	<i>Paragraph</i>
R_L	(1) distributed resistance of leads and terminals of crystal unit 1-183
	(2) equivalent, or effective, load resistance of oscillator tube 1-278
	(3) load resistance of transistor oscillator circuit 1-450
R_L'	equivalent load resistance of vacuum-tube plate-circuit impedance when represented as in series with reactive component..... 1-300
R_m	maximum permissible resonance resistance of series-mode Military Standard crystal unit.... 1-362
R_o	effective thermal resistance of crystal oven between heater and the outside..... 4-58
R_o	equivalent output resistance connected across vacuum-tube plate circuit having such a value that its losses equal the power output for a given r-f plate voltage..... 1-333
R_p	plate resistance of vacuum tube..... 1-268
R_{p1}	plate resistance of first vacuum tube in two-tube crystal-oscillator circuit 1-378
R_{p2}	plate resistance of second vacuum tube in two-tube crystal-oscillator circuit 1-378
R_T	(1) total load resistance in series with total reactance, X_T , shunting series arm of equivalent crystal-oscillator circuit 1-211
	(2) sum of fixed resistance and resistance of indicator lamp in bridge circuit of Meacham-bridge oscillator 1-358
R_x	equivalent load resistance in series with reactance, X_x , shunting crystal unit in equivalent parallel-resonant crystal circuit..... 1-210
R_{zL}	resistive component of load impedance..... 1-281
R_1	equivalent series-arm resistance of desired-frequency mode of crystal unit..... 1-183
$R_1, R_2, \text{ etc}$	resistances in schematic diagram..... 1-277
$R_2, R_3, \dots R_k$	equivalent series-arm resistance of unwanted-frequency modes of crystal unit..... 1-183
r	(1) quartz face 1-42
	(2) ratio of total electrostatic shunt capacitance, C_o , to motional-arm capacitance, C , of crystal equivalent circuit 1-208
	(3) power ratio in grounded-grid oscillator, equal to P_L/P_c 1-411
r_b	effective internal, small-signal, linear, base resistance of transistor when transistor represented by equivalent T network 1-548
r_c	effective internal, small-signal, linear, collector resistance of transistor when transistor is represented by equivalent T network..... 1-540
r_e	(1) ratio of electrostatic capacitance, C_e , across quartz-plate dielectric, to motional-arm capacitance, C , of crystal-unit equivalent circuit 1-197
	(2) effective internal, small-signal, linear, collector resistance of transistor when transistor is represented by equivalent T network 1-548

<i>Symbol</i>	<i>Paragraph</i>
S	thermistor sensitivity in Meacham-bridge oscillator 1-360
S, S ₁ , S ₂ , etc	switches in schematic diagram 1-188
Si	Silicon 1-40
SiO ₂	silicon dioxide 1-40
s	(1) quartz face 1-43
	(2) elastic compliance factor 1-78
	(3) activity sensitivity of bridge circuit in Meacham-bridge oscillator 1-360
T	temperature 4-35
T _{AC}	peak amplitude of temperature cycles 4-61
T _C	average crystal temperature 4-56
T _H	average heater temperature 4-56
T _o	operating temperature of oven and/or thermostat 4-16
T _s	absolute temperature of surroundings of radiating surface 4-40
t	(1) thickness 1-80
	(2) time (in seconds) 1-296
t/l	ratio of thickness to length 1-101
tan ⁻¹	arctangent (an angle whose tangent is) 1-280
V	(1) quartz cut 1-23
	(2) applied d-c voltage 1-248
	(3) volume 4-25
V ₁ , V ₂ , etc	vacuum tubes in schematic diagram 1-309
v	velocity 1-78
w	width 1-79
w/l	ratio of width to length 1-79
X	(1) quartz cut 1-23
	(2) crystal axis 1-23
	(3) number of crystals for second crystal oscillator in synthesizer circuit 1-442
X'	directional axis of the crystal dimension that initially coincided with a true X axis before rotation Fig. 1-17
X _C	(1) capacitive reactance 1-187
	(2) motional-arm capacitive reactance of crystal-unit equivalent circuit 1-190
	(3) thermal reactance of thermofilter capacity 4-61
X _{C_b}	capacitive reactance of balancing capacitance of capacitance-bridge circuit 1-365
X _{C_g}	reactance of effective grid-to-cathode capacitance of vacuum-tube circuit 1-280
X _{C_{g1}}	reactance of effective grid-to-cathode capacitance of first vacuum tube in two-tube crystal oscillator circuit 1-383
X _{C_g'}	capacitive reactive component of grid impedance when latter is represented as equivalent capacitance in series with equivalent resistance 1-297

<i>Symbol</i>	<i>Paragraph</i>
X_{C_n}	(1) equivalent positive reactance of dynamic negative plate-to-cathode capacitance effectively introduced by vacuum tube in Pierce crystal oscillator 1-281
	(2) reactance of C_n in impedance-inverting crystal oscillator 1-426
X_{C_o}	shunt capacitive reactance of crystal-unit equivalent circuit 1-187
X_{C_p}	reactance of total effective electrostatic plate-to-cathode capacitance of vacuum-tube plate circuit 1-281
X_e	equivalent, or effective, reactance of crystal unit when unit is viewed as an equivalent resistance and reactance in series..... 1-204
X_e'	effective reactance, X_e , of crystal unit when assuming stray shunt capacitance introduced by circuit is part of total electrostatic shunt capacitance of crystal unit..... 1-278
X_{ep}	effective reactance, X_e , of crystal unit when operating at parallel-resonance frequency, f_p , of generalized crystal-oscillator circuit..... 1-210
X_g	generalized reactive component of grid impedance in oscillator circuit..... 1-331
X_L	(1) inductive reactance 1-187
	(2) motional-arm inductive reactance of crystal-unit equivalent circuit..... 1-190
X_{LL}	reactance of distributed inductance of leads and terminals of crystal unit..... 1-187
X_{L_s}	inductive reactance of secondary of plate transformer in capacitance-bridge oscillator 1-365
X_p	reactive component of plate impedance in oscillator circuit 1-331
X_p'	reactive component of plate impedance in Miller oscillator when expressed as a combined function of plate and grid circuit 1-332
X_{pg}	plate-to-grid reactance in vacuum-tube circuit 1-331
X_s	total series-arm reactance of crystal-unit equivalent circuit 1-203
X_{s_a}	total series-arm reactance, X_s , of crystal-unit equivalent circuit at antiresonance..... 1-208
X_{s_p}	total series-arm reactance, X_s , of crystal-unit equivalent circuit when operating at parallel resonance with total effective load capacitance, C_T , of generalized oscillator circuit (employed only when convenient to distinguish between X_s used in the general sense and X_s when used in the particular case of the equivalent parallel-resonant crystal-oscillator circuit) 1-214
X_T	total reactance in series with total load resistance, R_T , shunting series arm of equivalent crystal-oscillator circuit 1-211

<i>Symbol</i>	<i>Paragraph</i>
X_{TP}	total reactance in series with total load resistance, R_T , shunting series arm of equivalent parallel-resonant crystal-oscillator circuit (employed only when convenient to distinguish between X_T used in the general sense and when used in the particular case of the equivalent parallel-resonant crystal-oscillator circuit) 1-211
X_x	reactance in series with load resistance, R_x , shunting crystal unit in equivalent parallel-resonant crystal circuit..... 1-210
X_{zL}	reactive component of load impedance..... 1-281
x	(1) quartz face 1-43
	(2) dimension of crystal blank in X-axis direction 1-51
Y	(1) quartz cut 1-23
	(2) crystal axis 1-23
Y'	directional axis of the crystal dimension that initially coincided with a true Y axis before rotation Fig. 1-17
YT	quartz cut 1-90
y	dimension of crystal blank in Y-axis direction 1-51
Z	(1) quartz axis 1-51
	(2) impedance 1-188
Z'	directional axis of the crystal dimension that initially coincided with a true Z axis before rotation Fig. 1-17
Z''	directional axis of the crystal dimension that initially coincided with the Z' axis before rotation Fig. 1-17
Z_e	equivalent, or effective, impedance of crystal unit 1-209
Z_f	impedance of feedback circuit..... 1-378
Z_g	(1) grid-to-cathode impedance as viewed by the excitation source 1-233
	(2) impedance of excitation source as viewed by grid of vacuum tube..... 1-398
Z_{e1}	input impedance of first tube in two-tube parallel-resonant crystal oscillator 1-345
Z_{e2}	input impedance of second tube in two-tube parallel-resonant crystal oscillator..... 1-345
Z_k	vacuum-tube a-c plate-circuit impedance between cathode and ground (in the Butler oscillator, Z_k is the output impedance of the cathode follower) 1-378
Z_k'	output impedance of cathode follower as viewed by the crystal in grounded-plate oscillator 1-422
Z_L	a-c load impedance 1-268
Z_n	input impedance of impedance-inverting network 1-426
Z_o	characteristic impedance of impedance-inverting network 1-426
Z_p	(1) impedance of an equivalent parallel-resonant crystal circuit; antiresonant impedance of

Appendix V
Symbols

<i>Symbol</i>	<i>Paragraph</i>
Z_p (Cont)	crystal unit in parallel with equivalent load capacitance, C_x (equal to the performance index of a crystal unit having a rated load capacitance, C_x)
	1-214
(2)	a-c impedance of vacuum-tube plate circuit
	1-269
Z_{pg}	a-c impedance between plate and excitation grid of vacuum tube
	1-269
Z_{pec}	total a-c impedance of oscillator feedback circuit from plate to grid to cathode
	1-270
Z_{p1}	external plate impedance of first tube in two-tube crystal oscillator
	1-348
Z_{p2}	external plate impedance of second tube in two-tube crystal oscillator
	1-348
Z_s	series-arm impedance of crystal-unit equivalent circuit
	1-426
Z_1	effective plate impedance of cathode follower in two-tube Butler circuit as faced by cathode-to-ground output circuit
	1-378
Z_2	effective plate impedance of grounded-grid vacuum tube in two-tube Butler circuit as faced by cathode-to-ground input circuit
	1-378
z	(1) quartz face
	1-42
	(2) dimension of crystal blank in Z-axis direction
	1-51
0	zero quantity; used only in data charts of composite schematic diagrams that represent more than one circuit. Equivalent to short circuit when used to designate value of resistance or inductance; equivalent to open circuit when used to designate value of capacitance
	Fig. 1-135
$5^\circ X$	quartz cut
	1-90
$-18^\circ X$	quartz cut
	1-90
μ	current amplification factor of transistor
	1-450
Δ	any small difference or incremental change
	1-203
Δf	any small change in frequency, but usually the difference between crystal-unit operating frequency, f , and series-resonance frequency, f_s
	1-203
Δf_a	difference between antiresonant frequency, f_a , and series-resonance frequency, f_s , of crystal unit
	1-208
Δf_o	any small change in frequency of variable oscillator in synthesizer circuit
	1-461
Δf_p	difference between parallel-resonance frequency, f_p , of crystal circuit and series-resonance frequency, f_s , of crystal unit
	1-211
Δf_r	difference between resonance frequency, f_r , and series-resonance frequency, f_s , of crystal unit
	1-206
Δf_{rx}	difference between the frequency, f_{rx} , at which the crystal unit is series-resonant with an external load capacitance, C_x , and the series-resonance frequency, f_s , of the crystal unit itself
	1-217
ΔH	a change in thermal energy
	4-65

<i>Symbol</i>	<i>Paragraph</i>
ΔT	a change or difference in temperature; a "temperature drop" along a heat-conducting path 4-18
ΔV	a difference of potential; a voltage drop 4-34
ΔX_e	any small change in the effective reactance, X_e , of a crystal unit, where the unit impedance is viewed as an effective resistance and reactance in series 1-223
∂	partial differential of 1-298
ϵ	dielectric constant 1-248
θ	(1) second angle of rotation, used in defining orientation of crystal cut 1-88
	(2) angle of incidence of X-rays with atomic plane 1-127
	(3) impedance phase angle of crystal-oscillator circuit 1-240
	(4) that angle of vacuum-tube excitation-voltage excursion during which no plate current flows 1-312
	(5) angle indicating small phase shift in variable-leg voltage of Meacham-bridge oscillator 1-358
θ_{R_g}	phase angle of vacuum-tube grid-to-cathode excitation voltage with respect to a designated reference 1-270
θ_{R_p}	phase angle of vacuum-tube r-f plate voltage with respect to a designated reference 1-270
θ_{I_g}	phase angle of vacuum-tube r-f grid current with respect to a designated reference 1-270
θ_N	that angle of vacuum-tube excitation-voltage excursion during which no plate current flows for the case when R_e equals a particular value, R_{e_N} 1-312
θ_{Z_C}	phase angle of the a-c voltage across the grid-to-cathode impedance with respect to the a-c current through the impedance 1-270
$\theta_{Z_{PEC}}$	phase angle of the voltage across the impedance of the oscillator feedback circuit with respect to the current through the impedance 1-270
λ	wavelength 1-78
μ	(1) micro 1-191
	(2) amplification factor of vacuum tube 1-268
μ_1	amplification factor of first vacuum tube in two-tube crystal-oscillator circuit 1-378
μ_2	amplification factor of second vacuum tube in two-tube crystal-oscillator circuit 1-378
π	pi (approximately equal to 3.14) 1-158
ρ	(1) density 1-78
	(2) negative resistance 1-232
ρ_s	negative resistance of generalized crystal oscillator when circuit is represented as series-connected 1-232
ρ_T	equivalent negative resistance of vacuum tube when tube is represented by an equivalent reactance and negative resistance in parallel 1-278

<i>Symbol</i>	<i>Paragraph</i>
$\sum_{n=1}^{\infty}$	algebraic sum of the indicated quantities corresponding to all <i>integral</i> values of n from 1 to ∞ 1-598
σ	the Stefan-Boltzmann constant, equal to the radiancy of an ideal black body per (degree) ⁴ 4-35
ϕ	(1) first angle of rotation, used in defining orientation of crystal cut 1-88
	(2) angle indicating small phase shift of center-leg voltage in Meacham-bridge oscillator 1-358
	(3) angular displacement in radians of bimetallic element 4-18
ψ	third angle of rotation, used in defining orientation of crystal cut 1-88
Ω	ohm(s) 1-207
ω	nominal angular frequency at which crystal unit is assumed to operate 1-208
=	is equal to 1-78
\approx	is approximately equal to 1-82
>	is greater than 1-206
>>	is much greater than 1-206
<	is less than 1-232
<<	is much less than 1-106
\rightarrow	as one quantity approaches another in value 1-281
\pm	plus or minus 1-88
.....	the absolute or unsigned value of any quantity contained within the verticals 1-208
∞	infinite quantity; equivalent to an open circuit when used to designate the value of a resistance or an inductance, and equivalent to a short circuit (d-c as well as a-c) when used to designate a capacitance in the data charts of those figures showing composite schematic diagrams that represent more than one circuit. Equivalent to an r-f bypass value when used to designate the value of a capacitance in a single-circuit drawing 1-280
%	per cent 1-104
$^{\circ}$	(1) degree(s), temperature 1-29
	(2) degree(s), orientation angle 1-88
	angular minute(s) 1-90

Fraction of Unit	Lowest Integral Part Per Power of 10	Decimal Part Per Unit	Decimal Part Per 100 (Per Cent)	Miscellaneous Fractional Expressions
1/1000	1 PP 10 ³	0.001	0.1 %	1000 p/p/million
2/10,000	2 PP 10 ⁴	0.0002	0.02	200 p/p/million
12/100,000	12 PP 10 ⁵	0.00012	0.012	120 p/p/million
1/10,000	1 PP 10 ⁴	0.0001	0.01	100 p/p/million
75/1,000,000	75 PP 10 ⁶	0.000075	0.0075	75 p/p/million
5/100,000	5 PP 10 ⁵	0.00005	0.005	50 p/p/million
3/100,000	3 PP 10 ⁵	0.00003	0.003	30 p/p/million
2/100,000	2 PP 10 ⁵	0.00002	0.002	20 p/p/million
1/100,000	1 PP 10 ⁵	0.00001	0.001	10 p/p/million
5/1,000,000	5 PP 10 ⁶	0.000005	0.0005	5 p/p/million
1/1,000,000	1 PP 10 ⁶	0.000001	0.0001	1 p/p/million
1/10,000,000	1 PP 10 ⁷	0.0000001	0.00001	1 p/p/10 million
1/100,000,000	1 PP 10 ⁸	0.00000001	0.000001	1 p/p/100 million
1/1,000,000,000	1 PP 10 ⁹	0.000000001	0.0000001	1 p/p/billion
1/10,000,000,000	1 PP 10 ¹⁰	0.0000000001	0.00000001	1 p/p/10 billion

Conversion Table for Commonly Encountered Fractional Parts

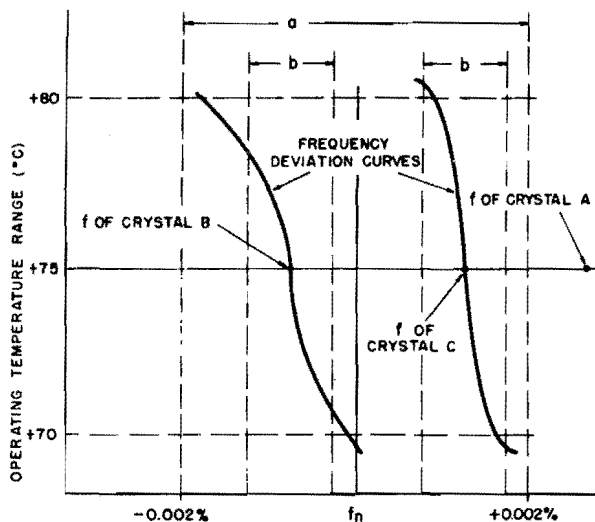

FREQUENCY
 f_n = NOMINAL FREQUENCY OF CRYSTAL (AS MARKED ON CRYSTAL UNIT)
 f = ACTUAL FREQUENCY MEASURED AT MIDPOINT (75°C) OF OPERATING TEMPERATURE RANGE
 a = NOMINAL FREQUENCY TOLERANCE ($\pm 0.002\%$ OF f_n) SPECIFIED AT MIDPOINT (75°C) OF OPERATING TEMPERATURE RANGE OF CRYSTALS UNDER TEST.
 b = MAXIMUM FREQUENCY DEVIATION ALLOWED ($\pm 0.0005\%$ OF f) WITHIN OPERATING TEMPERATURE RANGE (+70°C TO +80°C)

RESULTS OF TESTS
 CRYSTAL-A REJECTED: NOMINAL FREQUENCY TOLERANCE NOT WITHIN $\pm 0.002\%$ OF f_n
 CRYSTAL-B REJECTED: FREQUENCY DEVIATION NOT WITHIN $\pm 0.0005\%$ OF f
 CRYSTAL-C ACCEPTED: NOMINAL FREQUENCY TOLERANCE AND FREQUENCY DEVIATION WITHIN SPECIFIED LIMITS

Diagram illustrating distinction between nominal frequency tolerance and frequency deviation with temperature of crystal units

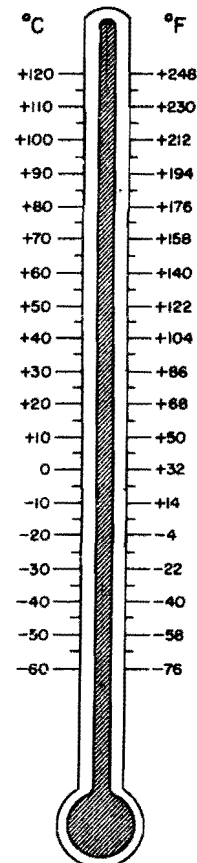

Temperature conversion chart: degrees centigrade to degrees fahrenheit

INDEX

(See also Cross Index of Crystal Oscillator Subjects)

A

- A element
 - calculation of series resonance of, 1-207
 - change in temperature-frequency characteristics of, 1-253
 - characteristics of, 1-112
 - frequency vs. drive, 1-260
 - static capacitance of, 1-192
- Abbreviations (*see* Appendix V)
- AC cut, characteristics of, in thickness-shear mode, 1-111
- Acknowledgments (*see* Appendix I)
- Activity quality, 1-227, -228
 - for parallel resonance, 1-230, -231
 - for series resonance, 1-229
 - in grounded-grid oscillator, 1-411
 - in Meacham-bridge oscillator, 1-360
 - μ as an index of, 1-235
 - PI as an index of, 1-236, -237
 - Q_c as an index of, 1-232, -233
 - Q_{vm} as an index of, 1-234
- ADP crystals, physical characteristics of, 1-34, -35
- Aging of crystal units, 1-173, -174
 - reduction of, 1-175—1-181
 - cleanliness, 1-177
 - etching, 1-176
 - heat cycling, 1-179
 - lapping, 1-175
 - low drive level, 1-181
 - low relative humidity, 1-180
 - mounting, 1-178
- Antiresonant frequency
 - see also* Parallel-resonant frequency
 - of crystal unit, 1-208
 - effects of changes in shunt capacitance on, 1-211, -212
 - measurement of, 1-222, -223
 - measurement of effective resistance at, 1-224
- Asymmetrical displacement of charge, 1-69
- Automatic gain control (*see* Pierce oscillator)
- Axes of quartz, 1-50—1-55
 - asymmetrical displacement of charge, 1-70
 - conventions, 1-87
 - rotational symbols, 1-88
 - X axis (*see* X axis)
 - Y axis, 1-53
 - Z axis (*see* Z axis)

B

- B element, characteristics of, 1-114
- Bandwidth and selectivity parameter, 1-227, -246
 - the capacitance ratio, 1-247
 - electromechanical coupling factor, 1-248
- BC cut, characteristics of, in thickness-shear mode, 1-113
- Bias (*see* Pierce oscillator)
- Bibliography (*see* Appendix II)
- Bragg's law, 1-127
- BT cut, 1-23
 - with B element, 1-114
 - mounting for, 1-140
- Butler oscillator, 1-376, -377
 - see also* Cross Index of Crystal-Oscillator Subjects, Sect. I
 - design procedures, 1-387
 - frequency stability considerations, 1-380—1-385
 - frequency stability, 1-380—1-385
 - effect of crystal, 1-386
 - loop gain of, 1-378, -379
 - modifications, 1-386—1-391

C

- C element
 - characteristics of, 1-115
 - dielectric constant for, 1-193
- Calibration (*see* Crystal calibrators)
- Capacitance
 - distributed, effect on crystal-unit parameters, 1-188
 - in Miller circuit, 1-332
 - in Pierce circuit, 1-279—1-281, 1-290—1-292
 - ratio, 1-247, -286
 - series-arm
 - computing value from measured parameters, 1-225
 - effect on parallel crystal circuit due to variations in, 1-215
 - equivalent, estimating, 1-197
 - shunt
 - effects of changes in, 1-211, -212
 - measurement of, 1-219
 - static
 - of crystal, rule-of-thumb for estimating, 1-191
 - total shunt, estimating, 1-201

- Capacitance-bridge oscillators, 1-364
see also Cross Index of Crystal Oscillator Subjects, Sect. I
 basic circuits, 1-365—1-368
 compared with Miller oscillator, 1-366
 design model for, 1-369
 for greater power output in 50- to 80-mc range, 1-372
 miniature, 50- to 120-mc, 1-371
 modifications, 1-315
 multitube, operable up to and above 200 mc, 1-374
 single-tube, 50- to 90-mc, 1-370
 two-tube, 50- to 100-mc, 1-373
- CI (crystal impedance) meter, 1-220, 2-60—2-65
- Colpitts oscillators, modified for crystal control, 1-227, -436, -437
see also Cross Index of Crystal-Oscillator Subjects, Sect. I
- Conductance (*see* Activity quality)
- Conoscope, use for determining optical axis, 1-124
- Control of radio frequency, 1-6, -7
- Cracks, in quartz crystals, 1-47, -175
- Crystal blanks
 cleaning, 1-177
 effect of twinning on, 1-178
 lapping, 1-175
 mounting of
see also Crystal holders
 button mounts, 1-153
 cantilever clamp, 1-158, -159
 corner-clamped, air-gap mounting, 1-140, -141
 dielectric sandwich, 1-143—1-149
 edge-clamped mounts, 1-170
 gravity air-gap mounting, 1-138, -139
 gravity sandwich, 1-134, -135
 headed-wire support, 1-168, -169
 knife-edged clamp, 1-160, -161
 nodal-clamped, air-gap mounting, 1-142
 plated crystals, 1-154, -155
 plated-dielectric sandwich, 1-150—1-152
 pressure-pin mounting, 1-156, -157
 pressure sandwich, 1-136, -137
 to reduce aging, 1-178
 solder-cone wire support, 1-164—1-167
 wire mounting, 1-162, -163
 preparation of, 1-131
- Crystal calibrators, 1-438, -439
 employing frequency regenerative divider, 1-440
- Crystal filters
 pass band of, 1-247
 quartz elements and cuts used as, 1-36, -38, -96, -97, 1-99—1-104, -107, -115
- Crystal holders
see also Crystal blanks
- Crystal holders—(Cont)
see also Military specifications
 definition of, 1-132
 development of, 1-24
 Military Standard types, Sect. III
- Crystal oscillators
see also Cross Index of Crystal-Oscillator Subjects, Sect. I
see also Packaged crystal oscillators
 circuit analysis of (*see* Cross Index)
 design of (*see* Cross Index)
 functional characteristics of (*see* Cross Index)
 fundamentals (*see* Cross Index)
 phase rotation in vacuum-tube oscillators, 1-268—1-273
 principles, 1-263, -264
 requirements of stable forced-free oscillations, 1-265—1-267
 types, 1-274—1-276, 1-355, -356
 Butler (*see* Butler oscillator)
 capacitance-bridge (*see* Capacitance-bridge oscillator)
 Colpitts modified for crystal control, 1-436, -437
 crystal and magic-eye resonance indicator, 1-354
 grounded-cathode two-stage feedback, 1-433—1-435
 grounded-grid (*see* Grounded-grid oscillator)
 grounded-plate, 1-421, -422
 impedance-inverting, 1-426
 Miller, 1-432
 Pierce, 1-430, -431
 transitron, 1-429
 Meacham-bridge (*see* Meacham-bridge oscillator)
 Miller (*see* Miller oscillator)
 oscillators with crystals having two sets of electrodes, 1-351—1-353
 Pierce (*see* Pierce oscillator)
 transformer-coupled (*see* Transformer-coupled oscillator)
 transitron, 1-423—1-425
 two-tube parallel-resonant, 1-345—1-350
- Crystal ovens
 construction of typical small oven, 4-14
 Military Standard types, Sect. IV
 provisions for minimizing power requirements, 4-11—4-13
 provisions for temperature control, 4-9, -10
 technical requirements, 4-8
 thermal analogues (*see* Thermal analogues of crystal-oven electrical parameters)
 thermostatic heater control (*see* Thermostats)
 types of, 4-7

- Crystal units
see also Military specifications
aging of (*see* Aging of crystal units)
air-gap, equivalent circuit of, 1-185
definition of, 1-132
electrical parameters of (*see* Parameters of crystal units)
equivalent circuit of, 1-182—1-184
fabrication of (*see* Fabrication)
housing of, 1-171, -172
see also Crystal blanks
impedance curves of, 1-209
methods of expressing relative performance characteristics of (*see* Performance characteristics of crystal units)
Military Standard types, Sect. II
production of, 1-25
typical operating characteristics of, 1-217
- Crystals
ADP, 1-34, -35
blanks (*see* Crystal blanks)
DKT, 1-38, -39
EDT (*see* EDT crystals)
elements (*see* Quartz elements)
physical characteristics of, 1-26—1-54
plating of, 1-154, -155
Q of (*see* Q)
quartz (*see* Quartz crystals)
raw quartz (*see* Raw quartz)
Rochelle salt (*see* Rochelle salt crystals)
tourmaline, 1-29—1-31
- Crystal and magic-eye resonance indicator, 1-354
see also Cross Index of Crystal-Oscillator Subjects, Sect. I
- CT cut, 1-23
in C element, 1-115
- Cuts, crystal (*see* Quartz crystals)
- Cutting quartz crystals
direct wafering, 1-125
preparation of crystal blanks, 1-131
preparation of wafers, 1-130
X block, 1-125, -128
Z section Y bar, 1-125
- D**
- D element
characteristics of, 1-116
dielectric constant for, 1-194
- Dielectric
constant, formula for, 1-191
material, 1-143
- Distributed capacitance (*see* Capacitance)
Distributed inductance (*see* Inductance)
Distributed resistance (*see* Resistance)
DKT crystals, physical characteristics of, 1-38, -39
- Drive level
effect on crystal parameters, 1-256
vs. frequency, 1-257—1-260
in grounded-grid oscillator, 1-412
in Meacham oscillator, 1-361
vs. resistance, 1-261
- DT cut, 1-23
in D element, 1-116
- Duplex crystals, 1-351
- E**
- E element
capacitance ratio of, 1-246
characteristics of, 1-99
- EDT crystals
physical characteristics of, 1-36, -37
use in frequency-modulated oscillators, 1-247
- Effective resonance resistance (*see* Activity quality)
- Electrodes, types used in mounting crystal blanks, 1-134—1-169
- Electrostriction, definition of, 1-13
- Elements (*see* Quartz elements)
- Etching, 1-176
- ET cut, 1-23
characteristics of, in combination mode, 1-117
- F**
- F element, characteristics of, 1-102
- Fabrication
of crystal holders
covers, 3-8
insulating, impregnating, and sealing compounds, 3-10
solder, 3-11
solder flux, 3-9
springs, 3-12
threaded parts, 3-13
workmanship, 3-14
- of crystal units
aging of crystal units (*see* Aging of crystal units)
bonding, 2-22
crystal holders, 2-23
cutting X block, 1-128
electrical connections, 2-24, -27
etching, 2-25
glass seal inspection, 2-37
housing of crystal units, 1-171, -172
marking, 2-26
methods of mounting crystal blanks in crystal holders (*see* Crystal blanks)
mounting, 2-27
preparation of crystal blanks, 1-131
preparation of wafers, 1-130

Index

Fabrication—(Cont)

- of crystal units—(Cont)
 - sectioning the stone, 1-125
 - solder, 2-28
 - solder flux, 2-29
 - workmanship, 2-30

Figure of merit of crystal activity, 1-235

Filters, crystal (*see* Crystal filters)

5° X cut, 1-93, -98

- characteristics of
 - in E element, 1-99
 - in F element, 1-102
 - in H element, 1-100
 - in J element, 1-101
 - in M element, 1-103
 - in N element, 1-104

Frequency

- deviation of Military Standard crystal units, 2-8
- vs. drive, 1-257—1-260
- vs. impedance characteristics, 1-202
- multiplication, 1-276
- parallel-resonant (*see* Parallel-resonant frequency and Antiresonant frequency)
- vs. power, 1-260
- vs. quality factor (Q), 1-199
- range of Military Standard crystal units, 2-9
- range of normal modes, 1-85
- series-resonant (*see* Resonant frequency)
- vs. temperature, 1-254, -255

Frequency stability

- in Butler oscillator, 1-380—1-386
- coefficient, 1-243
- in grounded-grid oscillator, 1-413
- in Meacham oscillator, 1-358, -359
- in Miller oscillator, 1-338
- of overall circuit, 1-245
- at parallel resonance, 1-243
- in Pierce oscillator, 1-287, -288
- at series resonance, 1-240—1-242
- at series resonance with external capacitance, 1-244
- in transformer-coupled oscillator, 1-399, -400

Frequency stabilization quality, 1-227, -238, -239

see also Frequency stability

FT cut, 1-23

- characteristics of, in combination mode, 1-118

G

G element

- characteristics of, 1-119
- frequency deviation of, 1-259

Grounded-cathode two-stage feedback oscillator, 1-433, -434

see also Cross Index of Crystal-Oscillator Subjects, Sect. I

- modified two-stage feedback oscillator, 1-435

Grounded-grid oscillators (single-tube Butler), 1-406

see also Cross Index of Crystal-Oscillator Subjects, Sect. I

- activity of, 1-411
- analysis of, 1-407—1-409
- designs of, 1-414, -415
- drive level in, 1-412
- frequency stability of, 1-413
- loop gain in, 1-410
- modifications of, 1-416—1-420

Grounded-plate oscillators, 1-421, -422

see also Cross Index of Crystal-Oscillator Subjects, Sect. I

GT cut, 1-23

- in G element, 1-119
- stability vs. drive, 1-259
- temperature coefficient of, 1-252
- use in Meacham-bridge oscillator, 1-357

H

H element, characteristics of, 1-100

Harmonic mode crystals, 1-253

Harmonics, 1-76, -255

reduction of, 1-245

Hartley oscillator, 1-328

Holders, crystal (*see* Crystal holders)

I

Impedance

- characteristics vs. frequency, 1-202
- curves of crystal unit, 1-209

Impedance-inverting crystal oscillators, 1-426—1-428

see also Cross Index of Crystal-Oscillator Subjects, Sect. I

Miller oscillator, 1-432

Pierce oscillator, 1-430, -431

transitron oscillator, 1-429

Imperfections in quartz crystals, 1-47—1-50

Inclusions, 1-48

Inductance

- distributed, effect on crystal-unit parameters, 1-187

series-arm

- computing value from measured parameters, 1-225
- effect on parallel crystal circuit due to variations in, 1-215
- estimating equivalent, 1-198

Inspection

of crystal holders

- glass seal, 3-17
- visual and mechanical, 3-30

of crystal units

- glass seal, 2-37
- internal, 2-40

- Inspection—(Cont)
of raw quartz
determination of twinning, 1-129
determination of X axis, 1-126, -127
initial inspection, 1-121, -122
inspection for optical axis and optical twinning, 1-123
use of conoscope for exact determination of optic axis, 1-124
Inspectoscope, 1-121—1-123
- J**
- J element
characteristics of, 1-101
dielectric constant for, 1-195
- L**
- Lapping, 1-175
Leakage resistance, r-f (*see* Resistance)
Limiting of oscillation amplitude, 1-232, -585, -598
see also Cross Index of Crystal-Oscillator Subjects, Sect. I
current- and voltage-controlled characteristics, 1-590, -595
frequency deviation due to, 1-596, -598
negative-resistance limiting, 1-586, -589
- M**
- M element, characteristics of, 1-103
Manufacturers (*see* Appendix III)
Meacham bridge oscillator, 1-357
see also Cross Index of Crystal-Oscillator Subjects, Sect. I
activity stability of, 1-360
crystal drive level, 1-361
design of, 1-362
frequency stability of, 1-358, -359
modifications of, 1-363
thermistor in, 1-357, -360, -363
Measurement of crystal parameters, 1-218
computing series-arm C and L from the measured parameters, 1-225
effective resistance, 1-224
parallel-resonant frequency, 1-222, -223
resonant frequency, 1-221
series-arm resistance, 1-220
shunt capacitance, 1-219
Measuring frequency and effective-resistance of Military Standard crystal units, 2-66, -151
equipments required, 2-67, -123
auxiliary amplifiers and frequency converters, 2-110, -122
amplifier, d-c, 2-121
amplifier, r-f, 2-120
frequency divider, 2-118
harmonic generators, 2-111, 1-117
Measuring frequency and effective resistance of Military Standard crystal units—(Cont)
equipments required—(Cont)
auxiliary amplifiers and frequency converters—(Cont)
radio receiver, 2-110
signal control panel, 2-122
variable r-f oscillator, 2-119
auxiliary test-control devices, 2-123
indicating and recording instruments, 2-92, -109
earphones, speaker, 2-109
effective-resistance recorder, 2-102
frequency counter, or meter, 2-92, -95
frequency-deviation meter, 2-96, -98
frequency-deviation recorder, 2-99
grid-current meter, 2-101
oscilloscope, 2-100
pyrometer, dummy-crystal-unit, 2-104
Q meter, 2-107
r-f bridge, 2-108
thermometer, cold-box, 2-105
voltmeter, electronic a-c, 2-103
primary standards, 2-69, -81
crystal test set, 2-78
frequency, 2-73, -77
load capacitor, 2-79
resistors, 2-80
temperature, 2-81
time, 2-73, -77
reference standards, 2-82, -91
crystal test set, 2-88
frequency, a-f, 2-85, -87
frequency, r-f, 2-82, -83
load capacitor, 2-90
resistors, 2-91
temperature, 2-89
time, 2-92
frequency-measuring systems, 2-124, -135
double-heterodyne for vhf, 2-131
frequency-reading counter, 2-129
Government inspection
room-temperature tests, 2-133
temperature-run tests, 2-134
heterodyne-frequency meter, 2-125, -128
vfo-counter, 2-130
WADC, 2-135
procedure for correlating test equipment with standards, 2-136, -150
correlation of
calibrated resistors, 2-139
cold-box thermometer, 2-147
crystal test set, 2-140
effective-resistance recorder, 2-144
frequency-deviation meter and recorder, 2-143

- Measuring frequency and effective resistance of
 Military Standard crystal units—(Cont)
 procedure for correlating test equipment with standards—(Cont)
 correlation of—(Cont)
 frequency standard, 2-141
 heater, 2-148
 interpolation oscillator, 2-142
 load-capacitance dial, 2-138
 pyrometer, 2-146
 recorders with temperature range, 2-149
 temperature-measurement controls (general), 2-145
 vibration machine, 2-150
 procedure for making measurements and recordings, 2-151
- Military specifications
 of crystal holders
 authority, 3-3
 date of status, 2-4
 delivery requirements, 3-23, -24
 fabrication (*see* Fabrication)
 functional description, 3-5
 inspection (*see* Inspection)
 nomenclature, 3-6
 status, 2-54
 tests (*see* Tests)
 USAF stock numbers, 3-29
 of crystal units
 authority, 2-2
 crystal holder, 2-3
 date of status, 2-4
 delivery requirements, 2-49, -50
 drive adjustment procedures, 2-6, 2-60—2-65
 fabrication (*see* Fabrication)
 frequency deviation of temperature, 2-8
 frequency range, 2-9
 frequency range abbreviations, 2-10
 functional description, 2-11
 harmonic of quartz vibration, 2-12
 inspection (*see* Inspection)
 maximum effective resonance resistance, 2-14
 method of measuring frequency and resonance resistance, 2-15
 nomenclature of crystal units, 2-17
 nominal frequency tolerance, 2-18
 operable temperature range, 2-19
 operating temperature range, 2-20
 pin-to-pin capacitance, 2-13
 second test level of drive, 2-51
 standard, 2-53
 status, 2-54
 test level of drive, 2-55
 test load capacitance, 2-56
 test set (*see* Crystal Impedance meter)
- Military specifications—(Cont)
 of crystal units—(Cont)
 tests (*see* Tests)
 USAF stock number 2-59
- Military Standard
 crystal holders (*see* Crystal holders)
 crystal ovens (*see* Crystal ovens)
 crystal units (*see* Crystal units)
- Miller oscillator
see also Cross Index of Crystal-Oscillator Subjects, Sect. I
see also Pierce oscillator
 compared with capacitance-bridge oscillator, 1-366
 design considerations, 1-330
 equation of state, 1-331
 frequency stability equations, 1-338
 load capacitance of crystal unit, 1-332
 maximum R_p , 1-333
 modifications, 1-344
 operating conditions, 1-337
 optimum value of $K = E_p/E_g$, 1-334—1-336
 as a small power oscillator, 1-339
 typical characteristics of, 1-340—1-343
- Miniature capacitance-bridge oscillators
see Capacitance-bridge oscillators
see also Cross Index of Crystal-Oscillator Subjects, Sect. I
- Modes of vibration, 1-75—1-86, -90
 face-shear, 1-82
 frequency of, 1-78
 frequency range of, 1-85, -86, -90
 length- (or width-) extensional, 1-79
 length-width-flexural, 1-83
 length-thickness-flexural, 1-84
 thickness-extensional, 1-80
 thickness-shear, 1-81
- Motional arm (*see* Series arm)
- Mounting crystal blanks
see Crystal blanks
see also Crystal holders
- MT cut, 1-23
 in M element, 1-103
- Multi-tube capacitance-bridge oscillators
see Capacitance-bridge oscillators
see also Cross Index of Crystal-Oscillator Subjects, Sect. I
- Multivibrator circuit, 1-345
- N**
- N element
 characteristics of, 1-104
 dielectric constant for, 1-196
- Nodes, 1-75

- NT cut, 1-23
in N element, 1-104
-
- Oriascope, 1-126
- Orientation of crystal cuts
right-handed coordinate system, 1-87
rotation symbols, 1-88, -90
X-ray determination of, 1-127
- Oscillations, stable forced-free, 1-265—1-267
- Oscillators, crystal (*see* Crystal oscillators)
- Oscillators with crystals having two sets of electrodes, 1-351—1-353
see also Cross Index of Crystal-Oscillator Subjects, Sect. I
- Ovens, crystal (*see* Crystal ovens)
- P
- Packaged crystal oscillators, 1-560, -584
problems of standardization, 1-573, -584
transistor
Sulzer miniature frequency standard, 1-570
commercially available temperature-controlled units, 1-571, -572
vacuum-tube (Grüen series) 1-562, -568
- Parallel crystal circuit
effect of variations in resistance, 1-214
effect of variations in series-arm C or L, 1-215
- Parallel-resonant frequency
see also Antiresonant frequency
see also Parallel crystal circuit
activity quality for, 1-230, -231
of crystal circuit, 1-210
frequency stability at, 1-243
minimum value of Δf_p , 1-216
stabilizing effect of crystal on, 1-213
- Parameter stability, 1-227
effect of drive level on, 1-256
effect of spurious modes on, 1-254, -255
effect of temperature on, 1-252, -253
frequency vs. drive, 1-257—1-260
resistance vs. drive, 1-261
- Parameters of crystal units, 1-182—1-262
antiresonant frequency, 1-208
bandwidth and selectivity, 1-246
computing series-arm C and L from the measured parameters, 1-225
effect of distributed capacitance on, 1-188
effect of distributed inductance on, 1-187
effect of r-f leakage resistance on, 1-186
effect of distributed resistance on, 1-189
equivalent circuit of crystal unit, 1-182—1-184
impedance characteristics vs. frequency, 1-202—1-205
- Parameters of crystal units—(Cont)
measurement of (*see* Measurement of crystal parameters)
methods of expressing relative performance characteristics (*see* Performance characteristics)
parallel-resonant frequency of crystal circuit (*see* Parallel-resonant frequency)
resonant frequency, 1-205—1-207
rule-of-thumb equations for estimating, 1-190—1-201
simplified equivalent circuit of air-gap crystal unit, 1-185
typical operating characteristics, 1-217
- Performance characteristics of crystal units, 1-226
activity quality (*see* Activity quality)
bandwidth (*see* Bandwidth and selectivity parameter)
frequency stabilization quality (*see* Frequency stabilization quality)
parameter stability (*see* Parameter stability)
quality factor (*see* Q)
- Performance index (PI), 1-236, -237
- Phase
relation, 1-269
rotation, 1-268
-stabilized Pierce circuit, 1-283
- Pierce oscillator
see also Cross Index of Crystal-Oscillator Subjects, Sect. I
AGC, 1-308
analysis of load capacitance, 1-278—1-285, 1-317—1-327
bias voltage, 1-293
capacitance ratio for greater output, 1-286
capacitive elements in design, 1-290—1-292
choosing a vacuum tube for, 1-311—1-315
design considerations, 1-316—1-318
energy and frequency equations as complex functions of linear parameters, 1-289
fixed bias, 1-294, -295
frequency variation and stability, 1-287, -288
gridleak bias, 1-296—1-307
modifications of, 1-319—1-323
plate-supply circuit, 1-309, -310
- Piezoelectric devices
development of, 1-14—1-25
early applications, 1-17—1-25
transducers, 1-17
- Piezoelectric effect
definition and history of, 1-8—1-13
report on discovery of, 1-56—1-68
- Piezoelectricity, theory of (*see* Theory of piezoelectricity)
- Plate resistance (*see* Resistance)

Index

- Plating, method of
 - electroplating, 1-154, -155
 - spraying and baking, 1-154, -155
 - sputtering, 1-154, -155
- Pyroelectricity, defined, 1-29, -57

Q

- Q (quality factor)
 - of EDT crystals, 1-37
 - effect of r-f leakage resistance on, 1-186
 - vs. frequency, 1-199
 - maximum effective (Q_{em}), 1-234
 - as a performance characteristic, 1-227, -249, -250
 - of recommended crystal units in metal or glass holders, 1-186
- Q meter, 1-292
- Quartz crystals
 - atomic lattice, 1-69
 - axes of, 1-51—1-55
 - early applications of, 1-20—1-23
 - elements (*see* Quartz elements)
 - imperfections in, 1-44—1-50
 - modes of vibration (*see* Modes of vibration)
 - orientation of cuts (*see* Orientation of crystal cuts)
 - raw (*see* Raw quartz)
 - types of cuts, 1-91—1-119
- Quartz elements, 1-99—1-119
 - characteristics of (*see specific element*)
 - table of, 1-90

R

- Raw quartz
 - alpha and beta, 1-40
 - axes of, 1-51—1-55
 - imperfections in, 1-44—1-50
 - preparation of, for fabrication of crystal units (*see* Fabrication and Inspection)
 - physical characteristics of, 1-40—1-43
- Resistance
 - distributed, effect of, on crystal-unit parameters, 1-189
 - vs. drive, 1-261
 - effect on parallel crystal circuit due to variations in, 1-214
 - equivalent series-arm, estimating, 1-199
 - grid, in Pierce oscillator, 1-298
 - gridleak, in Pierce oscillator, 1-297, 1-299—1-307
 - plate, in Miller circuit, 1-333
 - plate, in Pierce circuit, 1-282, -284, -285
 - r-f leakage, effect on crystal-unit parameters, 1-186
 - series-arm, measurement of, 1-220
 - thermal (*see* Thermal analogues of electrical parameters)

- Resonant frequency
 - activity quality for, 1-229
 - of crystal unit, 1-205—1-207
 - frequency stability at, 1-240—1-242
 - with external capacitance, 1-244
 - measurement of, 1-221
- Rochelle salt crystals
 - development of devices, 1-17
 - physical characteristics of, 1-32, -33
 - as transducers, 1-32
- RTMA Standards Committee on Quartz Crystals
 - recommended electrode areas, 1-192

S

- Sectioning (*see* Cutting quartz crystals)
- Selectivity (*see* Bandwidth and selectivity parameters)
- Series-arm
 - capacitance (*see* Capacitance)
 - definition of, 1-182
 - inductance (*see* Inductance)
 - resistance (*see* Resistance)
- Series resonance (*see* Resonant frequency)
- Single-tube capacitance-bridge oscillators
 - see* Capacitance-bridge oscillators
 - see also* Cross Index of Crystal-Oscillator Subject, Sect. I
- Solder, used with solder-cone wire support, 1-167
- Spurious modes, effect on crystal parameters, 1-254, -255
- Symbols
 - definition of, Appendix V
 - element, 1-89
 - rotation, 1-88, -90
- Synthesizing circuits, 1-441—1-448
- Synthesizing systems, 1-441—1-538
 - attenuation of unwanted products in, 1-525—1-529
 - balanced modulator in frequency synthesis, 1-526, -527
 - selection of heterodyne input frequencies, 1-528, -529
 - Bendix synthesizing system, 1-455—1-507
 - Radio Set AN/ARC-33, 1-463—1-507
 - Collins synthesizing system, 1-508—1-524
 - Radio Receiver R-252A/ARN-14, 1-509—1-511
 - Radio Receiver R-278/GR, 1-512—1-516
 - Radio Set AN/ARC-27, 1-517—1-529
 - crystal-phase-controlled harmonic multipliers, 1-530—1-538
 - Hahnel spectrum generator, 1-536—1-538
 - Plessey synthesizing system, 1-442—1-454
 - advantages in r-f measurements, 1-443, -444
 - circuit design, 1-450—1-454
 - functional operation, 1-445—1-449

T

Temperature

- coefficient of
 - ADP, 1-34
 - DKT, 1-38
 - EDT, 1-36
 - quartz, 1-40
 - Rochelle salt, 1-32
 - tourmaline, 1-30
- effect on crystal parameters, 1-252, -253
- thermistor, 1-357

Tests

- of crystal holders
 - corrosion, 3-16
 - immersion, 3-18
 - inspection (*see* Inspection)
 - leakage, 3-19
 - pin alinement, 3-20
 - standard conditions, 3-15
 - tensile strength, 3-21
 - thermal shock, 3-22
- of crystal units
 - aging, 2-32
 - corrosion, 2-33
 - drop, 2-34
 - frequency and effective resistance, 2-35, -36
 - immersion, 2-38
 - inspection (*see* Inspection)
 - insulation resistance, 2-39
 - moisture resistance, 2-41
 - pin alinement, 2-42
 - plating adherence, 2-43
 - requirements and procedures, 2-21
 - seal, 2-44
 - spurious frequency, 2-45
 - standard conditions, 2-31
 - tensile strength, 2-46
 - terminal polarity, 2-47
 - vibration, 2-48

Theory of piezoelectricity, 1-56—1-74

see also Piezoelectric effect

see also Modes of vibration

asymmetrical displacement of charge, 1-69—1-74

Thermal analogues of crystal-oven electrical parameters, 4-30

- absorptivity and emissivity, 4-37
- conductivity, 4-32
- current, 4-31
- emissivity of various substances, 4-39
- equivalent "electrical circuit of crystal ovens," 4-44—4-72
- equivalent thermal radiation resistance, 4-41, -42
- heat capacity, 4-43

Thermal analogues of crystal-oven electrical parameters—(Cont)

- Ohm's law, 4-34
- pin-to-pin electrical capacitance, 4-73
- radiancy, 4-36
- radiant heat flow, 4-40
- resistance, 4-33
- Stefan-Boltzmann constant, 4-38
- Stefan-Boltzmann law, 4-35
- Thermistor, in Meacham-bridge oscillator, 1-357, -360, -363

Thermostats

- bimetallic, 4-18—4-24
- mercury, 4-25, -26
- methods of heater control, 4-15—4-17
- monitoring, 4-29
- thermistor-bridge, 4-27, -28

Tourmaline crystals, physical characteristics of, 1-29—1-31

Transducers

- electromechanical coupling factor of, 1-248
- use of piezoelectric crystal as, 1-17

Transformer-coupled oscillators, 1-392

see also Cross Index of Crystal-Oscillator Subjects, Sect. I

- broad-band considerations in, 1-398
- design procedure for, 1-401—1-404
- frequency stability of, 1-399, -400
- gain requirements of, 1-395
- lead-to-crystal power ratio in, 1-397
- modifications of, 1-405
- phase considerations of, 1-393, -394
- Q degradation in, 1-396

Transistor oscillators, 1-539—1-559

see also Cross Index of Crystal Oscillator Subjects, Sect. I

- crystal-feedback types, 1-539—1-543
 - junction transistor, 1-542, -543
 - point-contact transistor, 1-539—1-541
- h-f types, 1-544
- high-impedance types, 1-550—1-551
- negative-resistance types, 1-545—1-549
- stabilized design, 1-555—1-559
 - amplitude and harmonic stabilization, 1-558, -559
 - frequency stabilization, 1-555—1-557
 - transformer-coupled types, 1-552—1-554

Transitron crystal oscillators, 1-423—1-425

see also Cross Index of Crystal-Oscillator Subjects, Sect. I

Tri-tet oscillator, 1-322

see also Cross Index of Crystal-Oscillator Subjects, Sect. I

Twinning, 1-49, -50

determination of, 1-129

Index

Twining—(Cont)

- effects on electrical characteristics of crystal element, 1-178
- inspection of raw quartz for, 1-123
- Two-tube capacitance-bridge oscillators
 - see* Capacitance-bridge oscillators
 - see also* Cross Index of Crystal-Oscillator Subject, Sect. I
- Two-tube parallel-resonant crystal oscillators, 1-345—1-350
 - see also* Cross Index of Crystal-Oscillator Subjects, Sect. I

U

- Units, crystal (*see* Crystal units)

V

- Vacuum-tube oscillators
 - see* Crystal oscillators
 - see also* Cross Index of Crystal-Oscillator Subjects, Sect. I
- V cut, 1-93, -95
 - characteristics in thickness-shear mode, 1-106
 - characteristics in face-shear mode, 1-107
- Vibration (*see* Modes of vibration)

W

- Wafers, preparation of, 1-130

X

- X axis (electrical)
 - see also* Axes of quartz
 - characteristics of, 1-54, -55
 - determination of 1-126, -127
- X cut, 1-93
 - see also* Cutting quartz crystals
 - characteristics of,
 - in length-extensional mode, 1-96
 - in thickness-extensional mode, 1-95
 - in width-extensional mode, 1-97

Y

- Y axis (mechanical), characteristics of, 1-53
 - see also* Axes of quartz
- Y cut, 1-108, -109
 - see also* Cutting quartz crystals
 - characteristics in thickness-shear mode, 1-110
- YT cut, 1-89
 - see also* Cutting quartz crystals

Z

- Z axis (optical)
 - see also* Axes of quartz
 - characteristics of, 1-52
 - inspection for, 1-123
 - use of conoscope for exact determination of, 1-124
- Z cut, 1-92
 - see also* Cutting quartz crystals