

HANDBOOK
ON
Radio **F**requency **I**nterference

VOLUME 2
ELECTROMAGNETIC INTERFERENCE
PREDICTION AND MEASUREMENT

PREFACE

This is the second in a series of four Volumes comprising the Handbook on Radio Frequency Interference. Each of the Volumes covers an important area of the subject of RFI. In this Volume we discuss prediction and measurement of interference.

Problems of prediction and measurement are basic to all aspects of science and engineering. The degree to which we can utilize the resources of nature is dependent on our ability to forecast or predict conditions and/or to measure these conditions. As our measurement techniques improve, so, too, do we improve our prediction capabilities and, therefore, our degree of resources utilization.

In our use of the radio frequency spectrum, many aspects of the prediction/measurement process have been neglected, and it is only in fairly recent years that there has been a general recognition of the need for increased effort in this area.

Important factors in prediction/measurement are (1) the cost of measuring devices and (2) techniques for handling data resulting from measurements. When the instrumentation can be simple and relatively inexpensive, and the data rate is low, prediction capability becomes high due to the small amount of effort necessary to obtain all of the necessary data. On the other hand, where instrumentation must be complex and costly, and/or the data rate is high, prediction capability will be dependent on (1) funds available to develop and manufacture instruments with necessary characteristics and (2) availability of manpower or equipment to record and process the data.

The RFI prediction, measurement process has suffered in the past from a relatively low scale of funding and effort. Instrumentation to make measurements across the radio spectrum from, say, 60 cps to 40 gcs is very costly, and the data rate will be very high. We should be able to quickly and conveniently make the measurements and obtain the data if we are to make best use of the spectrum. Due to lack of development funds, the state of the art in RFI measurements and prediction has not advanced as fast as might be desirable for optimum radio spectrum utilization. Only today are we on the threshold of the introduction of automatic spectrum scanning field intensity meters, automatic recording of interference data, and computer processing of this data.

In this Volume, we have attempted to bring together information concerning measurement and prediction principles, as well as information concerning equipment and techniques in current use or under development.

The material presented is based largely on experience gained by the Frederick Research Corporation in the past ten years in performing tests, measurements and predictions in system design, equipment development, and spectrum signature projects. In making this information and data available to others we hope that we can contribute to a better understanding of RFI measurements and to more effective measurement procedures.

There are a number of references to theoretical material developed in Volume I. In some instances, where there is a close relationship to such material, important parts are repeated in Volume II.

For furnishing data and pictures on instruments and equipment, I am grateful to Stoddart Aircraft Radio Co., Inc., Polarad Electronics Corporation, Empire Devices, Inc., Shielding, Inc., and Ace Engineering and Machine Co., Inc.

I wish to express my appreciation to A. H. Sullivan, Jr., our Director of Advanced Systems Development, who has acted as Editor and Coordinator of the Handbook project, to H. D. Zink, Jr., our Director of Research, who has prepared most of the material on signal acceptability criteria, and who has also provided technical review of material throughout the volume, to D. Sabalos and R. E. Hannah for the material on RFI prediction, to T. H. Miller, our Director of Engineering, for the material on screen rooms, to T. H. Miller, L. Q. Fleenor, and J. A. Hopkins, for Chapter IV on test instruments, to R. E. Hannah for the material on radiation hazards; to Messrs. Sabalos, Steinebach, Shaver and Lightner for the material on spectrum signature measurements and test locations, and to Harry Petrey for propagation considerations which account for the presence of the earth and for details in preparing ROLS maps.

Messrs. Agee and Humbertson have done an excellent job in guiding and dealing with the multitudinous complexities of production. Robert Frederick has been responsible for art work. Also my thanks to Marjorie Brown, Roma Taylor, Mary Schmidt, Frances Zello, Billie Harrison and others for their strenuous efforts in typing the copy and to Messrs. Roger Claxton, Daniel Barnes and Marvin Tilly for production work.

Carl L. Frederick, Sr.
Wheaton, Maryland
20 March 1962



HANDBOOK
ON
RADIO FREQUENCY INTERFERENCE

- VOLUME I Fundamentals of Electromagnetic Interference
- VOLUME II Electromagnetic Interference Prediction and Measurement
- VOLUME III Methods of Electromagnetic Interference-Free Design and Interference Suppression
- VOLUME IV Utilization of the Electromagnetic Spectrum



VOLUME 2
ELECTROMAGNETIC INTERFERENCE
PREDICTION AND MEASUREMENT

TABLE OF CONTENTS

	<u>Page</u>
INTRODUCTION	1
CHAPTER 1 SIGNAL ACCEPTABILITY CRITERIA	1-1
1. INTRODUCTION	1-1
1.1 GENERAL CONSIDERATIONS	1-2
2. SYSTEMS INVOLVING HUMAN ASSIMILATION OF THE FINAL DATA	1-3
2.1 GENERAL	1-3
2.2 AURAL EFFECTS OF INTERFERENCE	1-4
2.2.1 Effects of Interference on the Ear	1-4
2.2.2 Auditory Masking	1-6
2.2.3 Discussion of a Practical Case	1-8
2.2.4 Aural Acceptability Criteria	1-8
2.3 VISUAL EFFECTS OF INTERFERENCE	1-12
2.3.1 Effects of Interference on the Eye	1-13
2.3.2 Visual Interference Characteristics	1-14
2.3.3 Visual Acceptability Criteria	1-15
3. SYSTEMS INVOLVING MACHINE PROCESSING OF THE FINAL DATA	1-20
3.1 GENERAL	1-20

TABLE OF CONTENTS (Continued)

	<u>Page</u>
3.2 INTERFERENCE TO DIGITAL DATA COMMUNICATIONS SYSTEMS	1-21
3.2.1 Use of Frequency Modulation for Digital Data	1-22
3.2.2 Digital Errors Due to Interference	1-22
3.3 ACCEPTABILITY CRITERIA FOR AUTOMATIC SYSTEMS	1-24
3.3.1 Digital Systems	1-24
3.3.2 Teletype Systems	1-25
3.3.3 Facsimile Systems	1-25

CHAPTER 2 RFI PREDICTION

1. INTRODUCTION

1.1 GENERAL	2-1
1.2 SELECTION OF CULPRIT TRANSMITTERS	2-3

2. DETERMINING POWER WITHIN RECEIVER BANDWIDTH

2.1 GENERAL	2-4
2.2 FUNDAMENTAL COCHANNEL INTERFERING POWER	2-8
2.3 HARMONIC COCHANNEL	2-10
2.4 ADJACENT CHANNEL INTERFERING POWER	2-12
2.5 TRANSMITTER SPURIOUS EMISSIONS	2-21

3. ANTENNA CONSIDERATIONS AND LINE LOSSES

3.1 ANTENNA GAIN	2-21
3.1.1 Introduction	2-21
3.1.2 Approximate Methods for Calculating Antenna Gain	2-21
3.1.3 Antenna Gain at Harmonic Frequencies	2-23

iii



TABLE OF CONTENTS (Continued)

	<u>Page</u>
3.2 POLARIZATION	2-24
3.3 ANTENNA OFF-AXIS POINTING	2-25
3.4 TRANSMISSION LINE LOSSES	2-26
4. PROPAGATION CONSIDERATIONS WHICH ACCOUNT FOR THE PRESENCE OF THE EARTH	2-33
4.1 GENERAL	2-33
4.2 360° RADIO LINE OF SIGHT (RLOS) MAPS	2-33
4.2.1 Material and Data Required	2-33
4.2.2 Preparing the Map	2-34
4.3 RADIO LINE OF SIGHT (RLOS) PROFILES	2-34
4.3.1 Required Materials and Data	2-35
4.3.2 Preparing the Profile	2-35
5. PREDICTION MODEL	2-36
5.1 GENERAL	2-36
5.2 RADAR INTERFERENCE AGAINST MICROWAVE RECEIVERS	2-37
5.3 PREDICTION FORM	2-38
5.4 PROCEDURE FOR MAKING ENTRIES	2-38
5.4.1 Entry A	2-38
5.4.2 Entry B	2-38
5.4.3 Entry C	2-39
5.4.4 Entries 1a and 1b	2-39
5.4.5 Entry 2	2-42
5.4.6 Entry 3	2-42
5.4.7 Entry 4	2-42

TABLE OF CONTENTS (Continued)

	<u>Page</u>
5. 4. 8 Entry 5	2-42
5. 4. 9 Entry 6	2-43
5. 4. 10 Entries 7 and 8	2-47
5. 4. 11 Entry 9	2-47
5. 4. 12 Entry 10	2-47
5. 4. 13 Entry 11	2-47
5. 4. 14 Entry 12	2-47
CHAPTER 3 INTERFERENCE MEASUREMENTS	3-1
1. THE MEASUREMENT OF INTERFERENCE SIGNALS	3-1
2. CATEGORIES OF MEASUREMENTS	3-2
2.1 MEASUREMENTS OF INTERFERENCE OUTPUT AND SUSCEPTIBILITY POTENTIAL	3-3
2.2 MEASUREMENTS OF INTERFERENCE FIELD CHARACTERISTICS	3-3
3. INSTRUMENTS AND TECHNIQUES	3-3
3.1 ESTABLISHING A MEASUREMENT CAPABILITY	3-4
3.1.1 General	3-4
3.1.2 Measurement Personnel	3-5
3.2 A TYPICAL LABORATORY	3-5
3.2.1 General Laboratory Considerations	3-6
3.2.2 Basic Equipment	3-6
3.2.3 Equipment Details	3-7
3.2.4 Equipment Layout	3-15
	v

TABLE OF CONTENTS (Continued)

	<u>Page</u>
3.2.5 Method of Mounting	3-17
3.2.6 Antennae	3-17
3.2.7 Control Panel and Switching Arrangement	3-19
3.2.8 Power Supply	3-20
3.2.9 Personnel Comfort	3-22
3.2.10 Housekeeping Provisions	3-22
3.2.11 Instruction Book	3-22
3.3 OTHER MOBILE LABORATORIES	3-23
3.3.1 A Heavy Duty Laboratory	3-23
3.3.2 Laboratories for Specialized Purposes	3-23
4. TYPICAL INTERFERENCE TESTS	3-31
4.1 MEASUREMENT OF THE RADIATION PATTERN OF A HIGH GAIN HF ANTENNA	3-31
4.1.1 Airborne Instrumentation	3-32
4.1.2 Space Position Determination	3-35
4.1.3 Receiving and Recording Equipments	3-35
4.1.4 Flight Patterns	3-37
4.1.5 Data Reduction and Error Analysis	3-39
4.1.6 An Alternate Procedure	3-40
4.2 INTERFERENCE TEST OF A RECEIVER TO DETERMINE CONFORMANCE TO A MILITARY SPECIFICATION (MIL-1-16910)	3-43
4.2.1 General Information	3-43
4.2.2 Summary of the Test	3-44
4.2.3 RFI Fixes Employed in Model X Radio Receiver	3-44
4.2.4 Test Equipment Description	3-45
4.2.5 Test Procedure	3-47

TABLE OF CONTENTS (Continued)

	<u>Page</u>
4. 2. 6 General Test Conditions	3-47
4. 2. 7 Report Terms	3-48
4. 2. 8 Sample Calculations	3-49
4. 2. 9 Power Line Conducted RFI Test	3-50
4. 2. 10 External Systems Connections Conducted RFI Test 21.4 mc IF Output Jack	3-53
4. 2. 11 External Systems Connections Conducted RFI Test 1 mc Output Jack	3-53
4. 2. 12 External Systems Connections Conducted RFI Test Video Output Jack	3-56
4. 2. 13 External Systems Connections Conducted RFI Test Audio Output Jack	3-60
4. 2. 14 Receiver Oscillator Interference Test	3-63
4. 2. 15 Undesired Radiation Test	3-66
4. 2. 16 Equipment Radiated RFI Test	3-68
4. 2. 17 Equipment Spectrum Signature Radiated	3-70
4. 2. 18 Equipment Spectrum Signature Susceptibility	3-72
4. 3 TESTS TO DETERMINE METHODS OF GROUNDING CABLE SHIELDS FOR SUPPRESSING RADIATION AND MINIMIZING SUSCEPTIBILITY	3-77
4. 3. 1 Description of Test Apparatus	3-77
4. 3. 2 Test Conditions	3-77
4. 3. 3 Test Results	3-79
4. 4 TESTS TO DETERMINE RELATIVE EFFECTIVENESS OF SUPPRESSION MEASURES IN A RELAY-MICROSWITCH CIRCUIT	3-97
4. 4. 1 General	3-97
4. 4. 2 Summary of Test	3-97
4. 4. 3 Test Procedure	3-98
4. 4. 4 Test Results	3-100



TABLE OF CONTENTS (Continued)

	<u>Page</u>
4.4.5 Suppression Techniques	3-106
4.4.6 Parts List	3-107
4.5 TESTS TO DETERMINE METHODS OF SUPPRESSING INTERFERENCE FROM A TRANSISTOR SWITCHING CIRCUIT	3-108
4.5.1 General	3-108
4.5.2 Test Procedure	3-108
4.5.3 Test Results	3-113
4.5.4 Suppression Techniques	3-114
4.6 CONCLUSION	3-117

CHAPTER 4 DESIGN FEATURES, USE, AND CALIBRATION OF TEST INSTRUMENTS 4-1

1. INTRODUCTION	4-1
2. RADIO INTERFERENCE MEASURING EQUIPMENT	4-1
2.1 GENERAL FEATURES AND USE	4-1
2.1.1 Impedance-Matching Networks	4-4
2.1.2 Radio Frequency Amplifier Stage	4-5
2.1.3 Calibrator	4-6
2.1.4 Mixer and Local Oscillator	4-8
2.1.5 Intermediate Frequency Amplifier Stages	4-8
2.1.6 Detector and Weighting Circuits	4-9
2.1.7 Audio Amplifier Stages	4-9
2.1.8 Output Indicating Devices	4-9
2.2 DESCRIPTION OF INTERFERENCE METERS	4-12



TABLE OF CONTENTS (Continued)

2.2.1	Radio Interference Measuring Set AN/URM-41	4-14
2.2.2	Radio Test Set AN/URM-6 and AN/URM-6B	4-15
2.2.3	Radio Test Set AN/PRM-1 and AN/PRM-1A	4-15
2.2.4	Radio Interference Test Set AN/URM-3	4-18
2.2.5	Noise and Field Intensity Meter Empire NF-105	4-17
2.2.6	Noise and Field Intensity Meter Empire NF-205	4-18
2.2.7	Noise-Field Intensity Meter TS-587/U and TS-587A/U	4-19
2.2.8	Radio Interference Measuring Set AN/URM-7	4-20
2.2.9	Radio Interference Measuring Set AN/URM-47	4-21
2.2.10	Radio Interference Measuring Set AN/TRM-4	4-22
2.2.11	Radio Test Set AN/URM-17 and AN/URM-17A	4-23
2.2.12	Radio Frequency Measuring Set AN/URM-42	4-23
2.2.13	Radio Interference Measuring Set AN/TRM-6	4-23
2.2.14	Radio Interference Measuring Set AN/URM-138	4-25
2.3	SUMMARY OF INTERFERENCE MEASURING EQUIPMENT	4-27
3.	SPECTRUM ANALYZERS AND PANORAMIC ADAPTERS	4-29
3.1	GENERAL FEATURES AND USE	4-30
3.1.1	Resolution	4-30
3.1.2	Bandwidth	4-31
3.1.3	Sweep Width	4-31
3.1.4	Sweep Frequency	4-32
3.1.5	Sweep Rate	4-32
3.1.6	Calibration	4-32
3.1.7	Frequency Marker	4-33
3.1.8	Sensitivity	4-33

.x



TABLE OF CONTENTS (Continued)

4. PICKUP DEVICES	4-33
5. SIGNAL GENERATORS	4-36
6. FREQUENCY METERS	4-17
7. CALIBRATION	4-38
7.1 INTRODUCTION	4-38
7.2 GENERAL	4-38
7.3 CALIBRATION OF INSTRUMENTS	4-38
 CHAPTER 5 SHIELDED ROOMS	 5-1
1. GENERAL	5-1
2. CONSTRUCTION DETAILS	5-5
2.1 MAINTENANCE	5-8
 CHAPTER 6 RADIATION HAZARD PREDICTION AND MEASUREMENT	 6-1
1. INTRODUCTION	6-1
2. HAZARDS TO PERSONNEL	6-1
3. HAZARDS TO ORDNANCE	6-2
4. HAZARDS TO FLAMMABLE FUELS	6-3
5. MEASUREMENT AND PREDICTION OF RADIATION HAZARDS	6-4
5.1 CALCULATION OF POWER DENSITY IN THE FRESNEL REGION	6-5

TABLE OF CONTENTS (Continued)

	<u>Page</u>
5.2 EED CIRCUITRY AS AN ANTENNA	6-12
6. INSTRUMENTATION CONSIDERATIONS	6-15
6.1 RF POWER DENSITY METER FOR DETERMINATION OF HAZARDS TO PERSONNEL	6-15
6.2 INSTRUMENTATION FOR MEASUREMENT OF HAZARD TO ORDNANCE	6-16
CHAPTER 7 SPECTRUM SIGNATURE MEASUREMENT TECHNIQUES	7-1
1. INTRODUCTION	7-1
1.1 MEASUREMENT TECHNIQUES	7-3
1.2 MEASURING AND TEST EQUIPMENTS	7-3
1.3 CALIBRATION TECHNIQUES	7-4
1.4 ENVIRONMENTAL DATA	7-4
1.4.1 Ambient Signal Level	7-4
1.4.2 Physical Environments	7-4
2. TRANSMITTER MEASUREMENTS	7-9
2.1 POWER OUTPUT	7-9
2.1.1 General	7-9
2.1.2 Measurement Setup	7-11
2.1.3 Measurement Procedure	7-11
2.2 SPURIOUS EMISSIONS	7-11
2.2.1 General	7-13
	x1



TABLE OF CONTENTS (Continued)

	<u>Page</u>
2.2.2 Measurement Setup	7-16
2.2.3 Measurement Procedure	7-19
2.3 EMISSION SPECTRA	7-20
2.3.1 General	7-20
2.3.2 Measurement Setup	7-22
2.3.3 Measurement Procedure	7-22
2.4 MODULATION CHARACTERISTICS	7-27
2.4.1 General	7-27
2.4.2 Measurement Setup	7-27
2.4.3 Measurement Procedure	7-30
2.5 CARRIER FREQUENCY STABILITY TEST	7-30
2.5.1 General	7-30
2.5.2 Measurement Setup	7-30
2.5.3 Measurement Procedure	7-30
2.6 INDIRECT APPROACH	7-32
2.6.1 Signal Sampling Concept	7-32
2.6.2 Signal Substitution Measurement Concept	7-32
2.6.3 Signal Sampling Technique (Modal Determination)	7-35
3. RADAR RECEIVER MEASUREMENTS	7-39
3.1 RECEIVER SENSITIVITY	7-41
3.1.1 General	7-41
3.1.2 Test Procedure for Sensitivity Tests	7-41

TABLE OF CONTENTS (Continued)

	<u>Page</u>
3.1.3 Special Considerations in Making Sensitivity Tests	7-43
3.2 SELECTIVITY TESTS	7-44
3.2.1 General	7-44
3.2.2 Test Procedure	7-45
3.2.3 Special Considerations	7-47
3.3 SPURIOUS RESPONSE AND OVERALL SUSCEPTIBILITY TESTS	7-47
3.3.1 General	7-47
3.3.2 Measurement Setup	7-49
3.3.3 Measurement Procedure and Data Collection	7-52
3.4 OVERALL SUSCEPTIBILITY TESTS	7-52
3.4.1 General Discussion	7-52
3.4.2 Measurement Procedure	7-53
3.5 INTERMODULATION TESTS	7-55
3.5.1 General	7-55
3.6 ADJACENT CHANNEL TESTS	7-57
3.6.1 General	7-57
3.6.2 Adjacent Channel Test Procedure	7-57
3.6.3 Special Considerations	7-59
3.7 PULSE DESENSITIZATION	7-61
3.7.1 General	7-61
3.7.2 Measurement Procedure	7-61



TABLE OF CONTENTS (Continued)

	<u>Page</u>
3.7.3 Special Considerations	7-63
3.8 CW DESENSITIZATION	7-63
3.8.1 General	7-63
3.8.2 Measurement Procedure	7-63
3.9 DYNAMIC RANGE	7-66
3.9.1 General	7-66
3.9.2 Measurement Procedure	7-66
3.10 OSCILLATOR RADIATION TEST	7-68
3.10.2 General	7-68
3.10.2 Measurement Setup and Procedure	7-70
4. ANTENNA MEASUREMENTS	7-70
4.1 ABSOLUTE ANTENNA GAIN	7-71
4.2 RELATIVE ANTENNA PATTERNS	7-73
4.2.1 General	7-73
4.2.2 Rotatable Antennas	7-74
4.2.3 Non-Rotatable Antennas	7-75
4.3 DATA PRESENTATION	7-77
4.4 FRESNEL REGION CONSIDERATIONS	7-78
5. FUNCTIONAL APPROACH TO THE PERFORMANCE OF A TYPICAL TASK	7-79
5.1 PREPARATION OF TEST PLAN	7-79
5.2 IMPLEMENTATION OF PLAN	7-81

TABLE OF CONTENTS (Continued)

	<u>Page</u>
5.3 PREPARATION AT THE SITE	7-R1
5.4 MAKING MEASUREMENTS AND GATHERING DATA	7-R2
5.5 DATA REDUCTION	7-R2
6. THEORETICAL AND PRACTICAL PROBLEMS IN OBTAINING SPECTRUM SIGNATURES	7-R2
6.1 CATEGORIES OF PROBLEMS	7-R2
6.2 AN EXAMPLE OF MEASUREMENT TECHNIQUE PROBLEMS - ANTENNA PATTERNS	7-R3
6.3 DATA RECORDING AND REDUCTION	7-R4
6.4 UTILIZATION OF TEST EQUIPMENT	7-R6
6.5 CALIBRATION OF TEST EQUIPMENT	7-R6
6.6 LOGISTICS PROBLEMS	7-R6
6.7 FAMILIARIZATION WITH EQUIPMENT TO BE MEASURED	7-R7
6.8 RADIATION HAZARDS	7-R7
6.9 FUTURE TECHNIQUES	7-R8
CHAPTER 8 TEST LOCATIONS AND ENVIRONMENTAL ELECTRONIC DATA	8-1
1. GENERAL	8-1
2. SURROUNDING OBJECTS	8-1
3. SPECTRUM SEARCH	8-2

TABLE OF CONTENTS (Continued)

3.1	USE OF A SPECTRUM SEARCH	8-2
3.1.1	Determining an RF Ambient Environment	8-3
3.1.2	Priorities and Types of Measurements	8-6

APPENDICES AND INDEX

APPENDIX I	MEASUREMENT OF INSERTION LOSS OF FILTERS	I-1
APPENDIX II	MEASURING THE RADIO- FREQUENCY IMPEDANCE OF BONDS	II-1
APPENDIX III	DESCRIPTIVE DATA SHEETS OF INTERFERENCE TEST SETS	III-1
APPENDIX IV	DECIBEL EQUIVALENTS TO CURRENT, VOLTAGE, AND POWER RATIOS	IV-1
INDEX		V-1

INTRODUCTION

The prediction and measurement of electromagnetic interference has long been an area of minor concern in communication-electronic system development. However, with the rapidly increasing use of the spectrum, the higher output powers of transmitters, the vastly improved receiver sensitivities, and, last but not least, the development of satellite communication systems, there has been a growing concern about the possibilities of important system degradations due to interference. These degradations in many cases must be considered as catastrophic in nature since they may result in loss of control of aerospace vehicles, premature destruction of guided missiles, loss of command in fluid combat situations, and economic or even personnel loss where high data rates are interrupted in logistics communication networks.

As a consequence of considerations of system degradation possibilities, more emphasis is now being placed on the requirements and means for predicting and measuring interference as it relates to system performance. "Spectrum signature" programs have been established to measure equipment characteristics and other programs exist to collate and evaluate the "spectrum signature" information in terms of radio spectrum utilization. Increasing effort is being placed on theoretical studies of propagation and on measurements of antenna patterns. Design groups are putting more effort into the measurement and elimination of interference in components and circuitry in the early stages of development. All of these activities are indications of the increased importance of measuring and forecasting interference before it becomes a major problem.

Chapter I of this Volume contains a discussion of the criteria and requirements of signals by the user. In the following chapters there are discussions of prediction, instruments, and measurement techniques. The appendices contain associated material which will be found useful in measurement and prediction work and, in particular, Appendix III contains descriptive data sheets on standard RFI test sets.

In Volumes III and IV to follow, design considerations, RFI specifications, and radio spectrum utilization will be discussed in detail.

1. INTRODUCTION

The detailed analysis of signal acceptability criteria is a subject which has been studied for specific systems under the exact circumstances for which the system was intended to be used, but very little work has been done in making a compilation and correlation of the subject which ties together the results of these studies and extended them to cover the general problem. Two expressions are in common use which denote the degree of interference which a system can tolerate and still be considered fully operational. The first term is "threshold signal-to-interference ratio" sometimes abbreviated TSI ratio.¹ The second term which is sometimes used is "acceptance ratio." They may be used interchangeably and because the term "acceptance ratio" seems to have a better connotation, it will be used here.

The term "acceptance ratio" is defined as the ratio of the desired signal strength to the undesired signal strength which will just permit acceptable performance of a communications-electronics or radar system. Naturally, most systems must normally be operated with a signal strength considerably in excess of this value.

Whether this ratio is expressed in terms of carrier values or modulation ratios or otherwise, and whether it is in terms of peak, rms, average or some other measure, depends upon the nature of both the desired and the undesired signal. It should be recognized that the term "acceptable performance" lacks precision and must be defined in a particular way for every system which is examined for interference effects.

Because of the great number of variables involved and the subjective nature of the output in many systems, it is impossible to give tolerable values of output signal-to-interference ratios that will fit all cases. In calculating acceptance ratios, it is necessary to: (1) understand how a specified interference signal will be manifested in the output or affect performance; (2) estimate the signal-to-interference ratio which can be tolerated in the output; and (3) use items (1) and (2) to work back to the input terminals through the receiver transfer function to find the acceptance ratio. In this chapter only those signals which do not sufficiently overload the receiver so as to cause desensitization and other severe non-linear effects will be discussed as these subjects are covered

elsewhere in these volumes (see Volume 1, Chapter 2). This limitation is necessary to keep the present discussion within reasonable bounds.

The calculation of an acceptance ratio must take into account the type of message to be conveyed, the modulation employed on the desired signal and on the interfering signal, and the various parameters of the signals and system concerned (including the bandwidth, depth of modulation, frequency deviation, and miscellaneous other factors).

It will be assumed that, in the case of mutual interference, the cochannel interference problem will be largely mitigated by system design requirements. Thus, all signals present at the receiver in sufficient power to cause interference to desired signals will be in a carrier frequency of slightly or greatly different frequency from that of the desired signal. In some cases, the effect of cochannel interference will be discussed however, since not all systems are so allocated as to prevent it.

1.1 GENERAL CONSIDERATIONS

A communications system can be described in simplified fashion as a source, a coder and transmitter, a communication medium or channel, a receiver and decoder, and a display.² All communications channels known possess some degree of noise or interference to the desired signal which has the effects of: (1) reducing the amount of information that can be transmitted through the channel; (2) rendering difficult decoding of the desired information at the receiver and degrading the performance of the receiver information display. These displays permit coupling of electronic communication equipment to their human operators who are, in most cases (except when automatic data processing equipment is involved), the final recipients of the communication.

Among the processes whereby an interfering signal may adversely affect a given system are the following: (1) demodulation of the intelligence contained in the interfering signal and superposition of that intelligence on the desired intelligence; (2) substitution of the interfering signal for the desired one, as in the case of the capture effect in FM transmissions; (3) creation of a beat note between the wanted and unwanted carriers and superposition of this on the desired intelligence; (4) creation of intermodulation, cross-modulation and harmonic distortion terms from either or both signals and superposition of these terms on the desired in-



telligence; (5) exceeding a certain recognition level in the case of certain pulse systems, and (6) breaking of synchronism in automatic systems which require it.

The interference to the signal may be of many forms, CW, AM, SSB, FM, Pulse and others. All these signals affect varied equipments such as PPI scopes, facsimile, teletype and other systems, but the end effect is to cause an erroneous display of information. The human operator or the automatic processing equipment has two prime functions in the presence of interference to the desired signal; (1) the detection, and (2) the correction of errors in the information. The success with which this can be done depends, to a large extent, on the coding and structure of the transmitted information. "Structure" here refers to the restriction on the freedom of choice in the source of information due to certain defined rules for message assembly. "Structure" implies redundancy and depends on the statistical dependence between symbols or the interrelationship of information given by each symbol to the other symbols.

2. SYSTEMS INVOLVING HUMAN ASSIMILATION OF THE FINAL DATA

2.1 GENERAL

The output displays of systems which use the human as the final interpreter of the information couple the information from the electronic communication equipment to the human operators who are the receivers of communications. The visual and aural capability of the human operator to perceive and analyze the displayed information becomes the ultimate limitation on the performance of the system. Just as all electronic receivers have a threshold sensitivity, so do human operators, and it is the change in sensitivity of the operator to the desired signal in the presence of noise and interference that determines the extent to which the information will be correctly received by the operator.

Human responses are, in general, not continuous,² but are intermittent, even in response to continuous stimuli, due to the intermittent characteristic of the sensory apparatus. For example, current theory holds that the eye sees events in a series of 0.1 sec snapshots, sending pulse modulated information to the brain at a rate of 10 cps, which seems to be related to the normal 10 cps alpha rhythm or scan rate of the brain. This is also the normal modulation rate of the vocal apparatus; that is, the speed of movement of the tongue, lips and cheeks. Auditory acuity under optimum conditions is so sensitive that the thermal agitation and rush of blood in the vessels of the ear are almost audible. It is not clear, at present, whether the ear also sends messages to the cortex in

pulse modulated fashion, but some relation to the 10 cps alpha rate is suspected.

Concerning both the auditory and visual "threshold detection of signals" such as perceiving a voice through noise or a target on a noise-cluttered PPI scope, it can be stated that any given signal detection device strikes an arbitrary balance between the detection of signals and the calling of "false alarms." The more signals the device (which, in this case, is the ear or the eye of the observer) detects, the lower must be the perception threshold, which will result in an increase in the number of false alarms caused by random noise and interference fluctuations. Thus, an increase in the channel noise will cause the observer to raise his perception threshold to keep the false alarm rate from increasing too rapidly, which will result in a lowering of signal detectability and, therefore, a loss of transmitted intelligence.

2.2 AURAL EFFECTS OF INTERFERENCE²

Speech structure has a redundancy and depends on the statistical dependence between symbols or the other interrelationship of information given by each symbol to the other symbols. In voice communications, for example, it is dependent on the structure of the words, the grammatical structure of sentences, and the idea structure of related or associated thoughts in a message. As Figure 1-1 shows, for 80% of the words to be correctly received, approximately 16 db more noise can be tolerated for words in a contextual framework, as compared with the same words spoken singly, or as stated in information theory, intelligibility (the number of items correctly received) increases with increasing redundancy and decreases with increasing entropy; that is, outcome uncertainty. It has been estimated that the redundancy of ordinary conversational English is 60 to 75%, while experimental study has established an increase in redundancy to a total of 80 to 96% under the effects of military situational context, procedural knowledge, and linguistic constraints. It is obvious that speech, which requires a minimum bandwidth of approximately 3000 cps for 90% intelligibility, is inefficient for the transmission of information when compared with a more highly coded single frequency transmission of which Morse Code, requiring a bandwidth of only 100 cps, is an example.

2.2.1 EFFECTS OF INTERFERENCE ON THE EAR

The ear is perceptive to signals of extremely small duration and experiments utilizing signals as brief as 0.1 milliseconds have elicited a corresponding cortical response.³ However, for impulsive sounds, the apparent loudness is the integrated effect over a period of 1

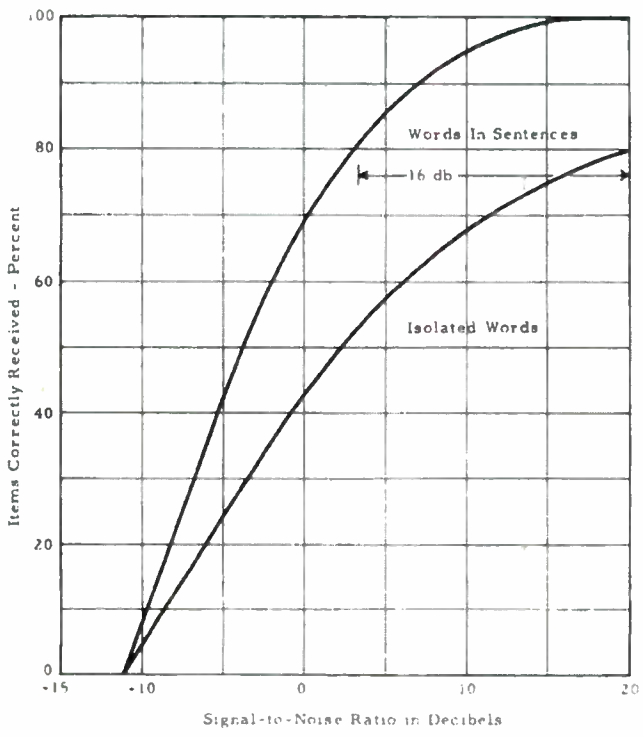

Figure 1-1. Intelligibility of Words and Sentences as a Function of Signal-to Noise Ratio

millisecond. The intensity required for response is inversely proportional to the duration, for the sensitivity falls off rapidly below durations of 0.2 sec. As the signal duration is increased, the ear's sensitivity also proportionately increases up to durations of 0.2 sec., until durations of 0.5 sec., the ear is at maximum sensitivity. For judging the effect of a sound, the ear plus the brain seems to act in the manner of an integrator with a charging time constant of 10 milliseconds and a discharging time constant of 500 milliseconds.

The ear's cochlear mechanism is unable to analyze into their component frequencies two sounds which stimulate overlapping segments of the basilar membrane. Thus, two tones differing in frequency by less than 6 cps are heard as one intertone of varying loudness, which takes on a throbbing quality when the frequency difference is 6-7 cps. When this frequency differential increases to 25 cps, the throb disappears and the intertone becomes faint, taking on a rough burring quality. With greater frequency differentials, the two original tones become more predominant.

As previously discussed, the readiness or speed with which any word will be identified is a function of the word's relation to other words in the listener's experience. The more frequently a word is used in conversation, the better are its chances of evoking a correct listener response, even though the word may be mutilated in transmission reception. The probability of correctly reconstructing a mutilated word will vary inversely with the number of other words in the listener's experience and the contextual vocabulary that the desired word resembles. Apperceptive variables are of importance, such as the listener's dialect, educational level, and knowledge of the desired message content.

2.2.2 AUDITORY MASKING

In the presence of interfering signals, a voice message either becomes masked by the intensity of the noise or is distorted by intermodulation products. From the point of view of communications in the presence of noise, the most important characteristic of the human ear is its analytical ability to respond selectively to certain components of the total acoustic spectrum presented to it and to ignore others. However, the ear is not an ideal analyzer and perception of some signals is obscured by others, the extent to which this obscuration occurs is called masking. It is defined as the shift in auditory threshold for a desired signal which is produced by the introduction of extraneous interference, and is usually measured by the amount the desired signal must be increased in intensity to become audible.

There are three arbitrarily chosen thresholds with respect to the identification of speech sounds, detectability, perceptibility and intelligibility. The first is the threshold when the sound can just be detected but not identified and corresponds to a signal-to-noise ratio of -18 db when white noise is used as a masking signal on AM reception. Perceptibility refers to understanding, with effort, the overall context of a connected discourse and, in general, requires a signal-to-noise ratio of zero to +5 db. Intelligibility threshold is that point when the listener is able to understand almost each word in discourse and requires signal-to-noise ratios taken under the above conditions of from +10 to +15 db.

The masking efficiency of a pure tone or a band of noise is greatest for frequencies near and above the tone, or in and above the bandwidth of the noise. The efficiency increases with the intensity of the masking signal. For maximum masking of speech communications, the interfering signal must produce in the listener's ear an interference spectrum continuous both in time and frequency throughout the transmitted speech range. Single tones are then not as disabling as random noise because it extends over a spectrum of frequencies. The result of mixing several sinusoidal tones together, approaches the masking effect of noise as a limit. Low frequency tones of high intensity in the 400 to 1000 cps region are the most disabling ones because they cause possible overloading and non-linear distortion within the listener's auditory mechanism.

Since the interfering signal must be continuous in time for maximum effectiveness, the masking effect of interrupted signals is less than for continuous. The masking effect of interrupted noise varies as the rate of interruption increases because the listener detects parts of speech during the intervals. However, if the rate of interruption to a speech signal is sufficiently high, say several thousand interruptions per second, then the intelligibility is good even when the speech is present only 15% of the time. The table in Figure 1-2 summarizes the pertinent data relating to the rate of speech cut-off and intelligibility:

Percent of Time Speech Is Present	Rate of Cut-Off	Percent Intelligibility
50% on - 50% off	2000/sec	95
50% on - 50% off	100 sec	75
50% on - 50% off	10 sec	85
50% on - 50% off	1 sec	40

Figure 1-2. Intelligibility Table
(Percent of Message Correctly Received)



2.2.3 DISCUSSION OF A PRACTICAL CASE

A short time spent with an amateur radio operator or listening to the communications between airport control towers and the pilots would lead one to believe that, at least for voice signals, the human brain can be trained to correctly recognize signals in the presence of unbelievable amounts of interference having characteristics similar to the desired signal. The average person upon first hearing either of the above-mentioned systems in operation will be almost completely unable to understand any of the transmissions. After several hours (or days) of intense listening, however, the observer will begin to develop a facility which will enable him to understand a very high percentage of the transmissions.

In many cases, these transmissions are highly redundant because the recipient is anticipating the content of the bulk of the message and is concentrating on receiving only certain specific new information. Apparently, once the observer recognizes the content of the redundant message, then, he too, can concentrate on the new information. Since the phrasing of the redundant words is almost always the same, the listener is given a further clue by knowing very nearly the time in the message when the new information will be transmitted. If the listener is part of the communications system and the interfering signals are such as to blot out the new information, he may then ask for a repeat with the great likelihood that the interference will not be so great at the precise instant when the new information is transmitted. The casual observer, of course, is not in such a position and loses intelligence if he has a similar experience. It should be noted that in the above cases that the observer need not receive very much of the redundant portion of the message if the word phrasing used is standard, since he can tell by the rhythm when the new information will arrive.

It has been stated by some observers that a fatigue factor sets in which decreases the ability of the human to detect the signal correctly after a period, when communications must be carried out in an environment having high interference. This is probably true for control tower operators but it may not apply for all other cases.

2.2.4 AURAL ACCEPTABILITY CRITERIA

A survey of experimental values for determining just tolerable interference shows that the range from zero to +10 db includes the range of output signal-to-noise ratios most frequently postulated as criteria. It is obvious that, depending on the type of desired and interfering signal and the degrees of modulations used, the input signal-to-interference

ratio will vary widely for a given desired output signal-to-noise ratio or percentage intelligibility.

The various characteristics of the receiver in use determine, to a great extent, the input acceptance ratio. Thus, the degree of non-linearity, selectivity, and RF amplification will markedly affect the resistance of the receiver to interfering or jamming signals. The receiver possessing a minimum of non-linearity and RF amplification and a high degree of sharp selectivity will be much more tolerant of interfering signals than those not possessing these characteristics.

2.2.4.1 CW Receiver

For the case of CW communications, when the interfering signal is exactly frequency coincident with the desired signal, equality of signal strength produces masking of the desired information. Mutual interference signals are not likely to be of exact frequency coincidence, thus lessening the probability of effective masking. Therefore, the desired information can almost always be distinguished even though heavily masked by noise or other interfering signals.

2.2.4.2 Conventional AM Receiver

Conventional AM communications receivers have been the subject of a great deal of experimental testing, both in the laboratory and the field, leading to the setting of a fairly reliable figure as a tolerable interference criterion. This criterion depends however, on the degree of co-channelarity of the interfering signal and the desired signal. If the carriers are exactly coincident in frequency, the resulting masking will be due only to the superposition of the interfering modulation on the desired signal modulation. This represents less masking of the desired intelligence than does the case where the two carriers differ in frequency, thereby producing an intelligence masking beat-note product. The signal-to-interference ratio covers a range of some 15 db for the extremes of this situation, making an accurate choice of an acceptance ratio highly difficult.

In an AM receiver a peak linear detector is used for demodulation and reproduces the envelope of the impressed modulation waveform. Theoretical analysis of the waveforms applied to such a detector establishes that intermodulation products between a desired and an interfering signal are relatively negligible in relation to the masking effect of the beat frequency of heterodyning CW carriers. Thus, when signals are isochronous, the chief masking agent will be the demodulated intelligence

of the interfering signal, but when the signals are non-isochronous, the beat-note product of the two carriers will be the principal agent in masking the desired intelligence. Inasmuch as exact frequency coincidence and isochronism are extremely unlikely to occur in practice, a beat note will almost always be present, usually slowly varying in pitch. The masking effect of such a note or tone can add 5 db to the previously required signal-to-interference ratio needed for satisfactory intelligibility.

The diode detector plays a significant role in determining the true selectivity characteristics of a receiver. A review of the basic equations relating to envelope detection shows that the carrier-to-interference ratio is a significant parameter in the determination of adjacent channel interference effects. It is known that when the carrier-to-interference ratio is large, additional selectivity is obtained by the capture effect. Under impulse-noise or other interference conditions, where the carrier-to-interference ratio is less than one, the diode detection process is captured by the noise or interference and the desired signal is significantly degraded well beyond the effects indicated by the usual RF and IF selectivity response.

When an FM interfering signal enters an AM receiver, a conversion of FM to AM takes place, due to the slope of the selectivity curve. This causes generation of second harmonics of the intelligence frequencies in the interfering signal, which, in turn, will cause garbling of the desired intelligence. The smaller the frequency deviation of an FM signal, the stronger must be the desired signal to maintain a constant signal-to-interference ratio. The point of maximum interference will be where the frequency deviation of the interfering FM signal is just sufficient to fill the acceptance band of the receiver.

When a single sideband suppressed carrier signal is received by an AM receiver, the effect is that of a continuous wave detuned from the carrier with resulting strong beat-note products which are the primary source of masking.

2. 2. 4. 3 Single Sideband Receivers

The reception of an undesired single sideband suppressed carrier by another single sideband receiver can result either in cross modulation of the desired signal, if the carriers are coincident, or in beat notes between the single sideband spectrum and the injected carrier of the receiver if the carriers are not identical. This is similar to the AM case. If the received signal does not utilize suppressed carrier, then obviously, there will be a strong beat note produced between the detuned carriers. It

should also be pointed out that the frequency difference between the locally inserted and reference carrier must be kept below 50 cps to prevent severe distortion of the desired information.

Single sideband receivers can be considered as less susceptible to interfering signals than AM or FM since there is a greater concentration of intelligence on the RF carrier in relation to the bandwidth of the receiver. Thus, an SSB receiver can successfully operate with desired signals of less magnitude than the channel noise.

2.2.4.4 FM Receivers

In an FM receiver the instantaneous frequency deviations are detected by the discriminator, and as long as any signal is above the level of circuit sensitivity, the discriminator will not respond to amplitude variations of the waveform envelope. However, while frequency modulation systems contain inherent interference reducing characteristics, certain types of interfering signals combine with these inherent characteristics to make the receiver quite vulnerable in some cases. The capture effect, wherein the receiver limiter responds to the stronger of two signals and blocks the receiver to the weaker signal, is an illustration of such vulnerability. This capture will occur, for most FM receivers, when the power of one signal is 1.26 times that of the other. This corresponds to a signal-to-interference ratio of -1 db; that is, the undesired signal must be 1 db greater than the desired signal for complete capture to occur. This is not to imply that interference will not be appreciable when the undesired signal is lower than this level but that this level is that which will essentially blot out the desired signal. In general, for the undesired signal to be completely suppressed, it must be 6 db below the desired signal. This is not a hard and fast figure and will depend on the design of the particular FM receiver.

2.2.4.5 Other Systems

The channel grabbing characteristics of certain interfering signals can produce highly annoying effects which require an increase in signal-to-interference ratio to overcome. Frequency Shift Keying (FSK) and interrupted CW are two examples of such signals that can cause the receiver either to shift between two or more competing signals or to be quieted by a strong, recurring, interfering signal. Therefore, the acceptance ratios for such signals are higher by 2 db than those for AM or FM modulated carriers.

2.3 VISUAL EFFECTS OF INTERFERENCE

Almost without exception, receiving devices which are used for visual presentation of the output information consist of a system employing one or more cathode ray tubes (CRT) for the display. Prominent examples are: (1) television picture tubes (which are used for many display purposes in addition to the conventional one); and (2) radar video devices such as PPI scopes, A scopes, J scopes, and others. These two examples constitute the large majority of cases where visual signal acceptability criteria must be formulated. Extensive studies for use in channel allocation have been conducted to determine acceptable signal-to-interference ratios for conventional television systems when subjected to a limited class of interference, but many of the possible interfering signals were not considered. Little has been published concerning criteria for other TV type displays (such as might be used in air traffic control systems). Most radar studies have been directed towards the effects of intentional jamming and multiple target confusion factors and while these results are not directly addressed to the signal acceptability problem, the results could be reinterpreted to apply. Unfortunately, much of the most valuable information is classified and so cannot be discussed here.

Other visual displays consist of output information presented on an X-Y plot by the use of a recording pen or stylus and data shown by dial positions, counter readings or neon or incandescent alphanumeric display devices. It would appear that no formal study has been made which would apply specifically to these devices.

In the radar and television cases, the eye has a decoding problem similar to the ear under interference conditions. The interference and noise is usually present so as to cause distracting stimuli to be received from large areas of the visual field. The task of concentrating on a particular area is required as well as separating the signal from the interference in that area.

For the X-Y plot and the alphanumeric displays, if the information is useable at all, the distracting effect of noise is not usually as great as in the CRT cases, and it is somewhat easier to mentally integrate the signal and thereby read through the interference.

Strictly speaking teletype and facsimile are visual presentations. However, the effects of interference are not dynamic ones when the visual display is presented to the human observer and therefore, the factors

that are discussed in this section do not apply. If the information has been degraded and must be mentally reconstructed, the redundancy and structure of the message or picture is more significant than the visual effects involved. Because of these facts, the above systems are discussed as ones which use machine decoding.

2.3.1 EFFECTS OF INTERFERENCE ON THE EYE

The brightness sensation resulting from a single short flash of light is a function of the duration of the flash as well as its intensity.³ For low intensity flashes near the threshold of vision, stimuli of shorter duration than about $1/5$ sec are not seen at their full intensity. Their apparent intensities are very nearly proportional to the effective pulse length of the flash. With increasing intensity of the flash, the time necessary for the resulting sensation to reach its maximum becomes shorter and shorter. A flash of 5 millilamberts reaches its maximum apparent intensity in about $1/10$ sec, while a flash of 1000 millilamberts reaches it in less than $1/20$ sec. Also, for the higher intensities there is a brightness overshooting effect and for a stimulus time longer than that necessary to have the maximum effect, the apparent brightness of the flash is decreased. A 1000 millilambert flash of $1/20$ sec will appear to be almost twice as bright as a flash of the same intensity which continues for $1/5$ sec.

Intermittent excitations at low frequencies are seen as successive individual light flashes. With an increase in frequency, the flashes appear to merge into one another giving a coarse pulsating flicker effect. Further increases in frequency result in finer and finer pulsations until, at a sufficiently high frequency, the flicker effect disappears. The lowest frequency at which flicker is not seen is called the critical fusion frequency or simply critical frequency. Over a wide range of stimuli luminosities, the critical fusion frequency is a logarithmic function of the luminance. It may vary from about 16 cps to over 50 cps.

Interaction between widely separated areas of the visual field appears to be essential to many perceptual processes.⁴ When a spatially periodic stimuli (such as the parallel lines which occur on a television screen in the presence of offset carrier, or channel television interference) is superimposed on a display containing random visual noise or brief flashes of illumination, sometimes a dynamic form of interaction sets in that generates in the brain of the viewer an additional pattern which is not present in the display. This pattern manifests itself as a vigorously moving transient complementary after image suggestive of standing wave patterns of activity in the stimulated area. A variety of



evidence suggests that this effect is not entirely retinal in origin, since stabilization of the retinal image and the use of flash illumination have shown it to be quite distinct from effects due to eye movement.

2. 3. 2 VISUAL INTERFERENCE CHARACTERISTICS

Visual interference can be classified into three general types: (1) interference having characteristics similar to random noise; (2) coherent interference, and (3) impulsive interference.³ The origin and nature of random noise is well known, thus interfering signals having characteristics similar to random noise can be treated as though it were present instead of the actual interfering signal. Random noise has characteristics on video displays similar to those in audio systems. It appears on the output of a CRT video display as random variations in amplitude deflections or luminescence. As the effective amplitudes are greatest for the highest frequencies, the variations tend to be greatest for the smallest elemental areas reproduced on the CRT. The eye does not fully resolve these small area differences, and so those which are resolved appear to have a lower brightness or amplitude than the actual luminescence or amplitude differences that exist. The net visual effects of random noise are therefore, brightness fluctuations which appear most conspicuously as small flickering areas in rapid motion. These fluctuations are called snow on intensity modulated displays and grass on deflection modulated displays.

Coherent noise arises as the result of RFI from undesired signals and miscellaneous types of electrical equipment such as fluorescent or incandescent lamps. Alternating current interference in the system also falls into this classification. Coherent interference differs from random noise in having a characteristic pattern which may be either stationary or in motion.

Impulsive interference results from rapid intermittent induced voltages. Sources of such voltage include faulty equipment, components or connections, automobile ignition systems, electrical motors, natural electrical discharges and strong radar interference. For intensity modulated displays, the visual effects are usually small light and dark areas or streaks of random position. Usually, the entire display is not affected. The disturbances are usually of short duration, but if continued they appear at irregular intervals unless they are the result of radar interference, in which case a regular pattern may be formed.

2.3.3 VISUAL ACCEPTABILITY CRITERIA

With the exception of radar systems, a learning effect in regard to interpreting degraded visual displays does not seem to occur to any great extent. As was discussed above, extended exposure to a degraded audio signal seems to aid in information recovery, but in general, most observers will be able to recover about all the information obtainable from a degraded visual display after only a short period of exposure. This is probably because most observers have been required to train themselves in precision viewing but not in precision listening. This faculty enables them to perceive information in degraded visual displays much easier than in degraded audio presentations. By the same token, however, the eye is more critical of degradation than is the ear. An example is a group of untrained observers viewing a television picture. They will, if asked, easily point out most of the defects in the picture. Some training in understanding what phenomena are considered defects will enable the same group to score even higher. Each individual's subjective evaluation of whether the defect is objectionable will vary quite widely but generally there will be little disagreement as to what picture information has been degraded. This is contrary to the audio case where it seems that long training enables a person to gather more information from the sound as well as to recognize more defects.

In the radar case the operator is not required to accept the display as he initially observes it, but instead, the characteristics of the radar system can be changed in many ways to affect the information content of the CRT. This is probably the primary reason that a pronounced learning effect is noted for radar operators.

2.3.3.1 Acceptability Criteria for Television Type Displays

A study of the viewer reaction to the effects of several interfering signals on video displays was conducted by the Television Allocations Study Organization (TASO).⁵⁶ Observers assessed the quality of a standard stationary scene which was subjected to interference at various levels of signal-to-interference ratio. The interfering signals used were: (1) upper adjacent channel signals; (2) lower adjacent channel signals; (3) cochannel signals; and (4) random noise. These were impressed separately onto the desired signal in varying degrees to determine the levels of interference that the observer would rate as excellent, fine, passable, marginal, inferior and unusable. These tests resulted in a great deal of information which cannot easily be summarized. They are best reported by giving values which represent the concurrence of 75% of the viewers.



For upper adjacent channel interference the signal-to-interference ratio, which 75% of the viewers considered to give a just passable picture, was -22 db. In other words, the interference had to be 22 db above the desired signal to degrade it to the passable level. The same figures were found to apply to the lower adjacent channel case.

A number of tests were conducted for the cochannel signal case. Six different carrier off-set frequencies were used; 604, 9985, and 19,995 cps, which had previously been found to give very detrimental results, and 360, 10,010 and 20,020 cps which had been found to be more acceptable.

The picture was judged passable by 75% of the viewers when the interfering signal was 24.5 db below the desired signal for 360 cps offset, 47 db below for 604 cps offset, 26 db below for 9985 cps offset, 19.5 db below for 10,010 cps offset, 28 db below for 19,995 cps offset, and 20 db below for 20,020 cps offset.

When random noise was used as the undesired signal, 75% of the viewers rated the picture as passable when the noise was 30 db below the desired signal.

These results were conducted under situations especially applicable to a broadcast television situation and therefore the figures cannot be blindly applied to situations that are not similar. There should be, however, many cases in which they can be used as a guide.

2.3.3.2 Acceptability Criteria for Radar Type Displays

In discussing signal acceptability criteria for radars, it should be noted that this section is concerned only with cases where a human operator is required to detect signals in the presence of interference and noise.^{7,8} It is becoming increasingly common for the actual detection and tracking of radar targets to be accomplished by automatic data processing systems so that human criteria no longer apply. When this is the case, the criteria discussed in Section 3 of this Chapter should be used. The primary present-day use of a human in radar operations is in accomplishing the initial detection of a target on a PPI display from a search radar and following the target until an automatic tracking radar locks on to it or some other appropriate action is taken. For air traffic control or GCA the lock-on step is not presently taken and the operator is required to follow the target as long as required.

When used for initial target detection, the search radar must display the target on its PPI at the maximum detection range and with a min-

imum false alarm probability. In target tracking with a search radar, the flight path of the target is plotted or recorded at frequent intervals. In both cases the target to be detected or tracked consists of a spot, blip, or dot on the PPI.

Interference to a search radar from another pulsed RF system such as a second search radar is displayed as dots on the PPI with one dot for each interference pulse. These interference dots are, in general, very similar, both in size and shape, to the echoes from aircraft and hence, can cause considerable degradation of performance of the radar system by increasing the time needed for initial target detection or making target tracking more difficult.

The relative pulse repetition frequencies of the two radars affect the pattern of the received PPI display. This pattern can vary from circles and spirals to straight lines and dots uniformly distributed over the PPI. They can vary from stationary patterns to patterns which rotate in a clockwise or counterclockwise direction on the PPI. Drawings showing typical patterns caused by interference between radars are shown in Figures 1-3 and 1-4.

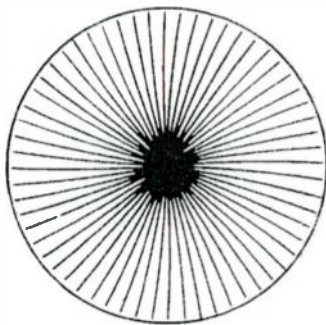

Figure 1-3. PPI Presentation Showing Typical Pattern Caused By Interference Between Radars



Figure 1-4 PPI Presentation Showing Another Typical Pattern Caused By Interference Between Radars

Detectability is that property of a target on a radar indicator which enables it to be seen by an operator.⁷ It is a function not only of the signal-to-noise or interference ratio at the input to the radar, but also the following factors:

- a. Video gain of the PPI system.
- b. Bias of the signal grid of the CRT.
- c. Use of video signal clipping.
- d. Type of viewing screen.
- e. Target position on the viewing screen.
- f. Pulse repetition frequency.
- g. Sweep length.
- h. Pulse length.
- i. Antenna rotation rate.

From this list, it can be seen that the detectability of targets on a given radar will be a very marked function of the skill and experience of the operator. He must learn, from experience, the proper adjustments required to maintain adequate detectability in the presence of interference and noise. The quality of the operator is probably more important in the radar case than in any other system discussed in this chapter. It is because of this fact, and also because the target echoes vary widely in

strength for a given range, that it is very difficult to formulate appropriate acceptability criteria for radar signals.

In general, the operator must adjust the video gain and the bias of the signal grid (these affect the contrast and brightness of the display, respectively) for the best target visibility under interference conditions. In some cases, it will be possible to make adjustments which will greatly reduce the effects of some types of interference, but in others, no combination of the controls will be particularly helpful.

It has been found that detectability is a maximum in the area midway between the center and edge of the screen (middle annulus). If the interference clutters the edge of the screen more than the middle annulus, then its effect on detectability will be higher than would be expected from other considerations.

Fundamental or harmonic adjacent channel interference from another radar presents an effect of randomly varying dashes of light which dance over the face of a PPI. These dashes are commonly called rabbits. Most good operators can read through this effect unless it becomes very bad, in which case, they may attempt to readjust various parameters of the radar system to reduce it. In making these adjustments, it is likely that the sensitivity of the radar will be inadvertently reduced and, therefore, detectability will be reduced.

Criteria which have been used in the past for radar performance, but which are known to have many shortcomings, are the following:

$$\frac{S}{N+I} > +5 \text{ db then RFI is improbable} \quad (1-1)$$

$$-5 \text{ db} \leq \frac{S}{N+I} \leq +5 \text{ db then RFI is marginal} \quad (1-2)$$

$$\frac{S}{N+I} < -5 \text{ db then RFI is probable} \quad (1-3)$$

where:

- S = target signal
- N = radar system noise
- I = external interference

Unfortunately, because of the factors previously discussed and the security classification of pertinent studies, the above criteria is the only one presently used.

3. SYSTEMS INVOLVING MACHINE PROCESSING OF THE FINAL DATA

As mentioned above, the determination of signal acceptability criteria for data that is processed by a machine is considerably different from the criteria used when the data is processed by a human receptor. In most cases, the human is superior to the machine in making decisions regarding information that has been degraded by interference. This is because of the ability of a properly trained person to interpolate and extrapolate when data is missing. While this is generally true, in cases where high speed data processing systems of either the analog or digital type are used, the machine may be considerably superior to the human because data is transferred at too rapid a rate to be comprehended and acted upon by a human receptor. This applies especially if autocorrelation, crosscorrelation or error detecting and correcting techniques are employed since certain machines can perform these operations at a far greater rate than could a human. Another example where the machine is superior to a human, involves the extensive processing of the received data after the event under consideration has taken place; that is, where processes equivalent to long integration times are used. Under these conditions, the machine can process and reprocess the data and detect information so far below the noise level that it could never be detected by a human. A classic example is in connection with the first radar contact with Venus in which the returned signal was processed a year before it could definitely be stated that the contact had been made. Human observation of the returned signal revealed only noise, regardless of the conditions of observation.

3.1 GENERAL

In almost all systems involving machine processing of the final data, it is in digital rather than analog form. It is not impossible that analog information could be machine processed but, generally, digital techniques are used. What might be considered an exception to this statement is in facsimile transmission where the picture information is transmitted by an amplitude modulated 400 cps pulse train. Even here, these pulses might be considered digital in nature for the purpose of interference considerations.

With very few exceptions, machine data processing is based on a fixed threshold for activation; that is, the voltage level required to activate the device is unchanged with time and signal level. In many

cases, an automatic gain control is incorporated to insure that, within reasonable limits, the signal level into the threshold device will be constant but aside from this no provision is built in to take into account noise or interference. Since this type of system is the one in use, at present, it will be discussed in detail below.

Another type of machine processor is possible and much attention is being given to designs which would allow it to be implemented. This system would have an adaptive threshold so that in the event of moderate interference, its threshold could be increased and the effect of the interference reduced. Some systems in use today might be said to be approaching this type of performance, but the generalized adaptive machine has not yet been fully developed. If such a device or one approaching its characteristics should be encountered, then the signal acceptability criteria for it would have to be specially measured. It would be expected that, in some respects, this machine would operate similar to a human.

3.2 INTERFERENCE TO DIGITAL DATA COMMUNICATIONS SYSTEMS

One of the more important forms of communications systems, especially as regards future applications, is that involving the transmission of digital data over radio links. Interference problems must be considered very carefully in this case if large transmission errors are not to result. As with other forms of communications, the basic problem in digital communication is that of carrying information from one point to another. In this case, however, the information is of a special sort in that only certain discrete forms of the various possible messages are used. Such messages are made up of collections of symbols each one of which is selected from a finite alphabet of symbols. Since such a message would seem to be simpler to discern at the receiver than one which could assume infinitely many values, digital communication would appear to be simpler than say, voice or television transmission. To a certain extent this is true; however, certain complicating factors arise in practice.

First, the usual speech or television signals are already highly redundant by the time that they are presented to the communication channel. This means that some of the difficulties of transmission can be ignored because the person listening to the speech or watching the television picture can take over the task of interpolating whenever the system falters or is interfered with momentarily. On the other hand, with digital messages, it is often found that this inherent redundancy is missing. The message frequently does not represent the normally redundant speech found on voice connections, but rather some seemingly random collection

of symbols. This fact makes it necessary to provide some other way of dealing with transmission difficulties and interference problems.

Second, largely because of the redundancy present in most non-digital material, the actual ratio of information transfer attempted is not such as to push the capacity of the communication channel. On the other hand since digital material is often not so redundant, the channel is stretched considerably further. As an illustration of this, it has been estimated that the information rate used in voice transmission does not exceed fifty bits per second. In comparison, a digital data transmission rate of a thousand bits per second in the same channel is common and this has been pushed to much higher rates in special cases.

A third complication, somewhat related to the first one, is that no reasonable counterpart of the human receiver is present in many data cases. Thus, whatever cleverness may be necessary to obtain a reasonable copy of the received message must be provided in the form of hardware. For all but the simplest cases, the provision of such built-in ingenuity is quite complex and consequently costly.

3.2.1 USE OF FREQUENCY MODULATION FOR DIGITAL DATA

A system which yields nearly the simplest modulation and demodulation equipment is frequency modulation. In this case, the two binary states are represented by two different frequencies. Binary signals represented in this way are usually detected by using two frequency tuned sections, one tuned to each of the two bit frequencies. The demodulated signals are then averaged over the duration of a bit and the results compared in order to decide which binary state is present. Such a system is somewhat less sensitive to most of the interference forms which exist than are other systems.

3.2.2 DIGITAL ERRORS DUE TO INTERFERENCE

As has been previously mentioned, digital communications must be more carefully protected from error than must some other forms of communication. Therefore, more careful consideration is generally given to the subject of accuracy than is the case with other systems. Of prime importance in any discussion about error control is the form of the interfering signal which may cause the errors. Generally speaking, noise in the digital communication field is divided into two categories; (1) white noise, and (2) impulse noise. Of course, both of these are band limited in real channels. White noise is characterized by a flat frequency spectrum with equal contributions from all frequencies and with vari-

ous components having random phases. For calculation purposes, it is generally sufficient to know only its average power and that the noise is "white." In this discussion, it is assumed that the proper system design techniques have been used in laying out the system and that the presence of system noise has been reduced to the point where it will not contribute any errors. However, there are many cases where the interference caused by an undesired signal can be assumed to be very closely approximated by assuming that its effect is the same as white noise and calculations can be made on this basis.

The term impulse noise is not nearly so definite. Conceptually, impulse noise is made up of a collection of randomly sized impulses; however, by convention, impulse noise has come to mean the noise which reaches the receiver as a result of the presence of various short disturbances in the communication path. (The effect of several radar signals of various strengths interfering with a microwave digital link would be an example of impulse noise.)

Since the approximate statistical form of interference which can be approximated by white noise is known, its ideal effect on digital communications is fairly simple to compute. On the other hand, a similarly accurate description of impulse interference is not yet available. This is partially because not as much data have been taken on it but it is probably more attributable to the way most interference is categorized. The result of this is that accurate statistical descriptions of impulse interference are not available and even when they become so, they will be difficult to use.

Even though accurate descriptions are not available, a number of interesting and useful facts are known about impulse interference bursts. In the first place, they have very low average power on the whole. Second, the interference will be correlated with itself over a time, at least on the order of the reciprocal of the bandwidth, and often for considerably longer than this. Finally, and most important in regard to radar interference in microwave digital links, the peak interference will often have very large values when it occurs so that errors are very likely to appear at that time, no matter how good the filtering and detection process.

One of the more standard methods of protecting a digital information channel against errors caused by interfering signals involves the insertion of redundant digits. These digits are added with certain constraints placed on the possible sequences which may appear in the encoded message. Since these constraints are known at the receiver, it is possible

to determine there whether a certain class of errors has occurred in transmission. This class of errors may be made as broad as desired, provided a suitable encoding scheme is used. In practice, of course, an attempt is made to make this class similar to that which is caused by the interference in the channel. By suitably designing a detecting scheme, it is possible not only to detect an error but to correct it. Such processes require more and more additional redundant digits as the scope of the check improves. Error detection and correction systems, in general, are obtained only for an exorbitant investment in circuit complexity. Error correction systems are often completely out of the question because of the presence of long bursts of errors. Thus, there is a tendency in the digital communication field to provide error detection of a very high order and to correct the errors by retransmission of the message. The implication that can be drawn from this philosophy is that impulsive interference which can be very damaging to a digital transmission will be costly from the standpoint of the operator of the communication system since revenue will be lost for all the time that the system was being interfered with.

3.3 ACCEPTABILITY CRITERIA FOR AUTOMATIC SYSTEMS

For coded transmission such as telegraph, teletype, facsimile, digital data and other such systems, the criterion for acceptable performance is that the interference should not be greater than a certain recognition level which is set by the nature of the system. In manually operated systems, the signal must at least equal or exceed the noise on a peak basis, but for automatic systems, the signal must usually be somewhat higher.

3.3.1 DIGITAL SYSTEMS

The nature of the output must be considered in detail to obtain an acceptance ratio for a digital data transmission system. The data output usually consists of sharp changes from one level to another level. One of these levels often is zero. The responder must decide at any given moment which of these two levels is present and then act in a way predetermined for this level. Anything that confuses the clear-cut decision of the device can cause an error. Recognition level is defined as that level above which the responder acts as though the higher level were present and below which the response characteristic of the lower level is obtained. This recognition level may differ for different types of equipment, consequently, it is not wise to arbitrarily assign a value to it. Nevertheless, in order to get some figures, the relative value of one-half shall be assigned to it. This implies that anything that produces an average output level of over

one-half of what the normal high level signal would produce will actuate the responder in the same way that a high level signal would. Conversely, anything which produces an output level which averages below one-half of this reference level will cause the responder to act as though zero level were applied to it. Though it has not been explicitly stated, the averaging time is about the length of the period of the usual digital pulse. In most practical systems the device which provides the recognition level will have some hysteresis associated with it and, therefore, if an input has a value of exactly one-half the output of the device will depend on the previous characters. From this, it can be seen that the acceptance ratio must be greater than one-half by the amount of the hysteresis and that the signal-to-interference ratio selected must use the peak interference value when the acceptance ratio is computed. For reliable commercial operation, a signal about 10 db above the acceptance ratio should be the minimum allowed.

3.3.2 TELETYPE SYSTEMS

When synchronization is involved, as in automatic teletype systems, it is necessary for the signal to be well above the noise; loss of a character may result in loss of synchronization with consequent loss of many additional characters before synchronization is restored. A conservative value of 10 db on a peak basis has been chosen for a tolerable output signal-to-interference ratio. It is recognized that this will not necessarily hold for all systems and that it is well below what is aimed for commercially.

3.3.3 FACSIMILE SYSTEMS

In facsimile transmission, the dual requirements of no significant loss of either detail or synchronization demands a high output signal-to-interference level. A value which has been chosen somewhat arbitrarily is 10 db on an rms basis. Commercial standards usually require even higher ratios than this.

References

1. Schwartz, R. F.: Signal Acceptability Criteria, IRE Transactions Professional Group on RFI, May 1961, p 11.
2. Pearlston: Interference Acceptance Ratios in Electronic Communication Equipments, Fourth Conference on Radio Interference Reduction, Armour Research Foundation, Illinois Institute of Technology, Chicago, Illinois, 1958



3. Fink, D.: Television Engineering Handbook, First Edition, McGraw-Hill Book Co., Inc., 1957, pp. 3-16, 3-17.
4. Rosenblith, W. A.: Sensory Communication, MIT Press and John Wiley & Sons, Inc., Interactive Processes in Visual Perception, by D. M. MacKay, p. 339.
5. Frendendall: Picture Quality - Procedures for Evaluating Subjective Effects of Interference, Proceedings of the IRE, June 1960, p. 1030.
6. Dean: Measurements of the Subjective Effects of Interference in TV Reception, Proceedings of the IRE, June 1960, p. 1035.
7. Garner, W. R. and Hamberger, F.: Detectability and Discriminability of Targets on a Remote Projection Plan-Position Indicator, Proceedings of the IRE, Nov. 1947, p. 1221.
8. Haeff, A. V.: Minimum Detectable Radar Signal and Its Dependence Upon Parameters of Radar Systems, Proceedings of the IRE, Nov. 1946, p. 857.
9. Wier: Digital Data Communication Techniques, Proceedings of the IRE, Jan. 1961, p. 196.



1. INTRODUCTION

1.1 GENERAL

This chapter deals with a technique for the prediction of radio frequency interference (RFI) between a transmitter-receiver (TX-RX) pair. In any method used to predict RFI, there are certain basic variables whose related contributions must be determined and their use defined. A graphical illustration of the parameters involved are shown in Figure 2-1.

Figure 2-1 shows the basic parameters involved in RFI prediction which indicates the gain and attenuation that a desired and undesired signal undergo in reaching the input of a receiver. In essence, Figure 2-1 is a presentation of the one-way transmission equation (for frequencies above 30 mc) where the signal at the receiver, whether it be desired or undesired, is given by the following expression:

$$I \text{ or } S = \frac{P_{TR} G_T G_R}{(4\pi d)^2 L_T L_R p A} \quad (2-1)$$

where.

P_{TR} = power within the RX bandwidth

G_T = gain of TX antenna

G_R = gain of RX antenna

λ = wavelength

d = distance between TX and RX

L_T = TX line loss

L_R = RX line loss

A = propagation factor for other than free space line-of-sight

p = loss due to polarization mismatch

In the prediction process the ratio of signal to interference (S/I) must be determined so that it can be compared to some signal acceptability criteria peculiar to the receiver. Figure 2-2 represents a typical

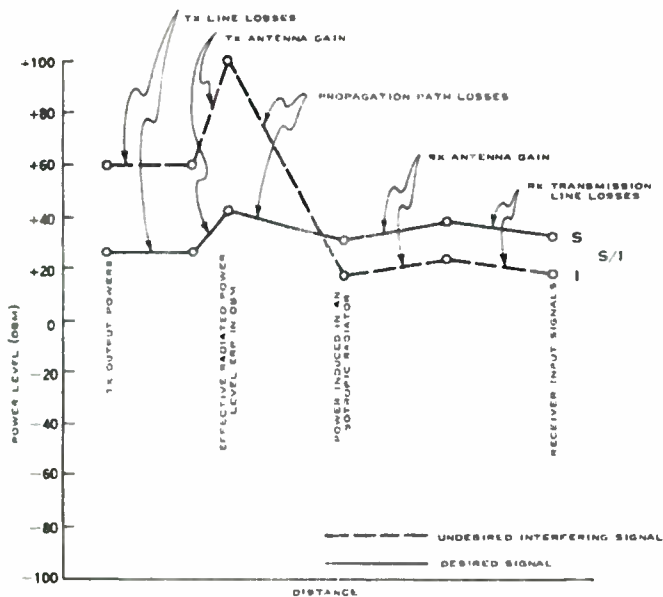

Figure 2-1. Graphical Illustration of Basic Interference Parameters

physical case of a desired microwave link TX₁-RX and a possible interfering transmitter TX₂. In this case, the desired signal level at the receiver is easily computed or measured since all parameters are known. Power output of the transmitter TX₁, gain of the TX₁ and RX antennas are known, polarization is established, propagation path is optimized for free space and line-of-sight, line losses are negligible, and separation distance between TX₁ and RX is set so that the signal level "S" is such that a satisfactory level is achieved in terms of signal acceptability. It is, therefore, the interference signal "I" that must be predicted and compared to the signal at the receiver.

A discussion is provided in Sections 2, 3, 4, and 5 of this chapter, of the various parameters involved in RFI prediction. Section 2 discusses the various "types" of interfering power; fundamental and harmonic cochannel as well as fundamental and harmonic adjacent channel. Section 3 discusses antenna characteristics including gain, patterns, polarization, off-axis pointing, and line losses. Section 4 provides a discussion on various propagation situations including free space radio line-of-sight, diffraction, reflection, beyond radio horizon, and terrain effects for use in the prediction. Finally, in Section 5, a prediction model is discussed indicating the step by step procedure for predicting interference.

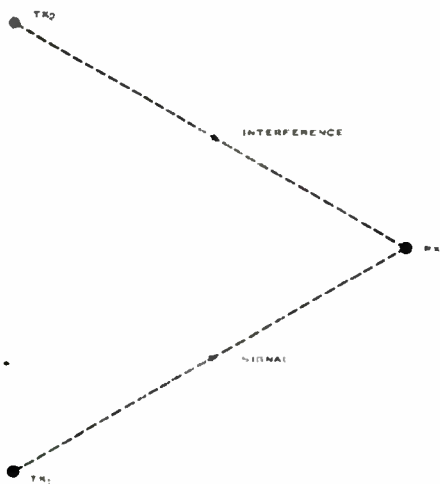

Figure 2-6. A Typical Interfering Situation

1.2 SELECTION OF CULPRIT TRANSMITTERS

Sections 2, 3, 4, and 5 concern themselves with the treatment of RFI prediction. However, prior to this effort it is necessary to decide which types of transmitter equipments represent culprit interference

situations. For example, if one is interested in computing interference to a microwave receiver operating in the common carrier band 3700 - 4200 mc, a decision must be made as to what equipments operating in the vicinity of the receiver are to be included for RFI prediction. Obviously, one would consider all transmitters operating in the band, as would be the case of other microwave systems and possibly some radars. In addition, radars with high peak powers, although not in the band of interest, could have harmonic or sideband components which would cause interference. Therefore, radars operating in the following ranges would certainly be of interest since they are harmonically related to the band of interest:

500 - 600 mc	925 - 1050 mc
600 - 700 mc	1233 - 1400 mc
740 - 840 mc	1850 - 2100 mc

With this information as a background, a "census" of equipments can now be made (Section 6.2 of Chapter 2, Volume I provides details on the procedures for conducting such a census.) The data necessary for an RFI prediction is then collected in some standard format peculiar to the interference situation being examined. Figure 2-3 represents a typical form that might be used in collecting information which pertains to the location and operating characteristics of a possible interfering transmitter. Figure 2-4 shows a more detailed form that could be used if measured data were available, and it would be used to supplement the local characteristic data shown in Figure 2-3.

2. DETERMINING POWER WITHIN RECEIVER BANDWIDTH

2.1 GENERAL

The prediction process requires considerable knowledge of the nature and level of the power normally associated with various types of emitters. Communication transmitters normally provide fundamental power outputs in the range of 100 mw to 50 kw, radars are normally found with power outputs of 100 kw to 10 megawatts or higher, and microwave relay transmitters are usually low power emitters of 10 mw to 10 watts. Therefore, as a whole, the RFI prediction engineer must deal with emitted fundamental power levels of 0 to 100 dbm. This represents the range of fundamental power levels for which fundamental cochannel interference would need to be computed. Cochannel interference is only one of many types of interference that must be considered and is defined as being the case in which the power of a transmitter is centered about the tuned frequency of the receiver. Another type of interference of significance is

Nomenclature: _____

Using Agency: _____

Site: _____

Equipment Location: _____ Lat.: _____ Long.: _____

Antenna Elevation Above MSL: _____

Equipment Status: _____

Functions: _____

Time on the Air: _____

Frequency Band: _____

Assigned Radio Frequency(s): _____

Antenna Orientation: _____ °Azimuth _____ ° Elevation _____

Scan Sector Scanned: _____ °to _____ °

Scan Rate: _____ °to _____ °

Polarization Used: _____ Antenna Gain: _____ db

Operational Peak Power: _____

Pulse Width: _____

PRF: _____

Distance From Radar to _____ Site: _____ miles.

Remarks:

Figure 2-3. Radar Local Operating Characteristics

1. Transmitter

a. Type Antenna _____ Feed System _____

b. Antenna Dimensions: Height _____ ft. Width _____ ft. Focal Length _____ ft.

c. Number of Beams _____ Beam Displacement _____ ΔZ _____ ΔE _____

d. Antenna Characteristics _____

Harmonic Number	Ant. Gain (db)	Horiz. BW (deg)	Vert. BW (deg)	Side Lobes (db down)	Back Lobes (db down)	Cross Polaris. (db below nom.)
Fundamental						
Second						
Third						
Fourth						
Fifth						
Sixth						
Seventh						
Eighth						
Other						

e. Types of Scan NA OMNI

f. Scan Rates: Horizontal _____ SPM over _____ degrees.
Vertical _____ SPM over _____ degrees.

g. Polarization _____ Alternate _____ Pol. Diversity: Yes, No.

h. Freq. Range _____ mc to _____ mc. FD: Yes, No.

i. Shift Rate _____ mc in _____ sec.

j. BF Stability _____ mc/_____ MTI Yes, No. AFC Yes, No.

k. Peak Power _____ w. PPF(%) _____ Duty _____ Cycle(s)

l. Other Pk. Power _____ w. _____ Duty _____ Cycle(s)

b. Radiated Power ERP Power at Input to Antenna

Harmonic Number	Avg. Power (watts)	db	Per Sid Dev (or ct)	Center BF (mc)	3 db BW (lic)	20 db BW (lic)	60 db BW (lic)
Fundamental							
Second							
Third							
Fourth							
Fifth							
Sixth							
Seventh							
Eighth							
Other							

l. Pulse Rise Time _____ μ sec. Pulse Decay Time _____ μ sec. K Factor _____

m. Modulation and Coding _____ Type Emission _____

Figure 2-4a. Communication-Electronic Detailed Characteristics Sheet

2. Receiver

a. Type Antenna _____

b. Selectivity: 3 db _____ mc. 20 db _____ mc. 60 db _____ mc. Noise Fig _____ db.

c. Sensitivity _____ dbm. Signal Output visual, aural, digital, Other

d. Multiplexed Channels Yes, No No. of Channels _____

3 db Bandwidth _____ mc.

e. Multiplexed Channel Sensitivity _____ dbm; visual aural digital

f. Submultiplexed Channels Yes, No No. of Subchan. _____ 3 db BW _____ kc.

g. Submultiplexed Chan. Sensitivity _____ dbm, visual aural digital

h. Image or signal rejection expressed in sensitivity:

Fundamental	= _____ dbm at _____ mc.	Other Spurious Responses
2nd Harm.	= _____ dbm at _____ mc.	_____
3rd Harm.	= _____ dbm at _____ mc.	_____
4th Harm.	= _____ dbm at _____ mc.	_____
5th Harm.	= _____ dbm at _____ mc.	_____
6th Harm.	= _____ dbm at _____ mc.	_____

i. IF _____ mc. LO above or below signal

j. RFI/AJ Circuitry or Modes: SEC, ITC, AGC

AVNL, CFAR, SCV db, other _____

k. RF Preselector Yes, No. AFC Yes, No AGC Yes, No

3. Remarks

FREDERICK RESEARCH CORPORATION FORM NO. 20118, NC, 1 APRIL 1960

NOTE-Abbreviations

AFC-Automatic Frequency Control	LO-Local oscillator
AGC-Automatic Gain Control	MTI-Moving target indicator
Ant.-Antenna	PD-Pulse duration in microseconds
AZ-Azimuth	PRF-Pulse repetition frequency in
bw-Bandwidth	pulses per second; cps
BW-Bandwidth	RFI/AJ-Radio frequency interference,
dbm-No. of decibels referred to one milliwatt	anti-jamming, spec. a. circuits for
EL-Elevation	SPM-Scans per minute
ERP-Effective radiated power	σ-Standard deviation
IF-Intermediate Frequency	
K factor-Twice the rise time divided by pulse duration	

Figure 2-4b. Reverse Side of Communication-Electronic Detailed Characteristics Sheet



adjacent channel interference caused by the fundamental sideband power overlapping the receiver response. Additional cases of cochannel and adjacent channel interference can result from the generation of harmonic frequencies of the transmitter. Finally, another source of interfering power may occur as the result of spurious frequencies, other than harmonics, peculiar to a particular transmitter or family of transmitters. These spurious emissions may produce cochannel or adjacent channel frequency components in the passband of the receiver in question. The following sections will further elaborate on the various types of interfering power which may exist.

2.2 FUNDAMENTAL COCHANNEL INTERFERING POWER

As previously pointed out, cochannel interference occurs when an undesired carrier falls in any portion of the channel required for reception of the desired signal. Figure 2-5 represents the cochannel interfering situation. It is important to note, at this time, that the interfering power is a function of receiver bandwidth B_r as well as spectral power associated with the interfering transmitter. In the radar situation, for example, approximately ninety percent of the transmitter power is located within the first frequency zero crossings of the power spectrum. The first zero crossing of a pulsed radar transmitter occurs at $f_c \pm 1/\tau$; therefore, ninety percent of the power is concentrated within a transmitter

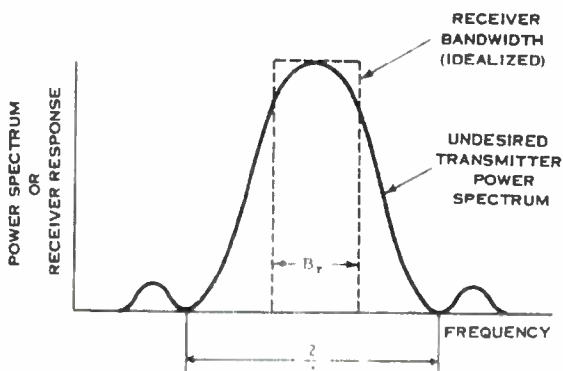

Figure 2-5. Cochannel Diagram For FTR

bandwidth defined by $2/\tau$. The term τ represents pulse width and f_c is the center frequency of the interfering radar transmitter. Figure 2-6 is representative of the power spectra for a pulsed radar. Therefore, when the receiver bandwidth $B_r \geq 2/\tau$, it can be assumed that all the available transmitter power falls within the receiver bandwidth. Available interfering transmitter power is expressed as $10 \log_{10} P_T$, where P_T is the peak power of the interfering radar transmitter. In some instances, the bandwidth of the receiver may be less than $2/\tau$. The amount of power entering the cochannel receiver is now a function of both the transmitter and receiver bandwidths; therefore, the available interfering power entering the receiver P_{TR} is a function of the ratio of the transmitter to receiver bandwidth such that:

$$P_{TR} = P_T \cdot \left[\frac{B_r}{2/\tau} \right] < .5 \tau B_r P_T \quad (2-2a)$$

$$10 \log_{10} P_{TR} = 10 \log_{10} (P_T B_r \tau / 2) \quad (2-2b)$$

$$= 10 \log_{10} P_T + 10 \log_{10} (0.5 \tau B_r)$$

$$\therefore 10 \log_{10} P_{TR} < 10 \log_{10} P_T \quad (2-3)$$

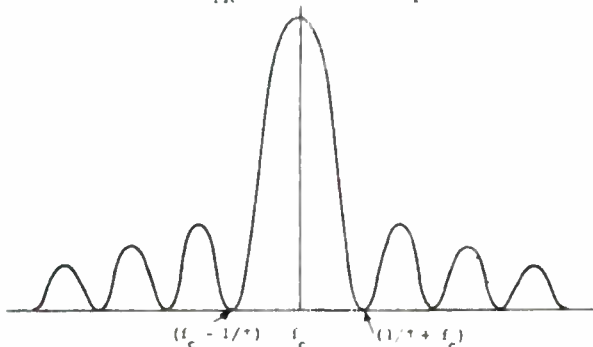

Figure 2-6. Power Spectra for a Pulsed Radar

It should be pointed out that receiver susceptibility characteristics determine the interfering frequencies for which RFI predictions should be made, particularly when one is dealing with the full power of an interfering transmitter. It is not enough to consider only the tuning band of the receiver

but also the image response as well as any other spurious responses outside the tuning band. This data is usually not available and must be obtained by direct measurements.

2.3 HARMONIC COCHANNEL INTERFERING POWER

The case of fundamental cochannel interference is easily and accurately predictable. Unfortunately, transmitters do yield spurious outputs of which harmonics represent one group of major interference culprits. This is particularly true of radar transmitters having high peak powers. These frequently give rise to harmonic levels of sufficient magnitude to cause serious interference situations, particularly to microwave communications systems. In general, the case of harmonic cochannel interference is of considerably greater interest and concern than the fundamental cochannel situation, since various controls and regulations exist to protect against fundamental cochannel operation, while regulations for the suppression of harmonics do not exist.

The generation of harmonic frequencies is usually attributed to non-linearities in the power amplifying sections of a transmitter and particularly the final stage. Measured data of the true harmonic level is generally not available. The DOD spectrum signature program has as one of its objectives the gathering of data on harmonic levels. Whenever measured data is available, it should be used, since it is in the form of effective radiated power (ERP) which accounts for the effect of the antenna gain which is not usually predictable at harmonic frequencies. Unfortunately, since this data is not available, some empirical means must be used in calculating the harmonic levels. Some work performed by a variety of researchers indicates that a conservative calculation on harmonic levels can be computed using the following expression:

$$10 \text{ Log}_{10} P_{TN} = 10 \text{ Log}_{10} P_T - [50 + 6N] \quad (2-4)$$

where:

- P_{TN} = power at th harmonic
- P_T = peak fundamental power
- N = harmonic number
- $50 + 6N$ = harmonic loss

For example, the third harmonic power level would be 52 db down from the peak fundamental power level. In the case of a 1 megawatt transmitter, the peak power level delivered to the antenna is 90 dbm. Considering the third harmonic as being 52 db down, the harmonic power delivered to the antenna is 38 dbm, a rather appreciable power level to deal with in RFI prediction.

When considering the harmonic output of a transmitter, Equation 2-4 holds when the bandwidth of the receiver $B_r > 2/\tau$. When the bandwidth of the receiver $B_r < 2/\tau$, then the received power is a function of the ratio of the transmitter bandwidth to receiver bandwidth. Therefore, the power within the receiver bandwidth P_{TR} is given by the following expression:

$$10 \text{ Log}_{10} P_{TR} = 10 \text{ Log}_{10} P_T - [50 + 6N] + 10 \text{ Log}_{10} (0.5N \tau B_r) \quad (2-5)$$

when $B_r < \frac{2}{\tau}$

So far, no mention has been made of the use of low pass filters for harmonic suppression. In general, most transmitters employ filtering either directly or indirectly. Indirect filtering may be likened to the case where impedance mismatch between transmitter and antenna is such that harmonics can not be supported. Direct filtering is, as in the case of radars, provided by output low pass filters between the transmitter and the antenna. In the past, harmonic filters capable of handling large peak powers were only effective to a limited extent, but recent advances in filter design provide considerably more effective filtering with relatively high insertion loss at harmonics on the newer radars. It is important to recognize that the characteristics of these filters are usually good to the fourth harmonic but beyond that they may be relatively poor. Therefore, it is not uncommon to find second, third, and fourth harmonic levels lower than the fifth, sixth, or even the seventh harmonic. Where filter data is available, it should be used. Equation 2-4, when filter data is available, can then be expressed as follows:

$$10 \text{ Log}_{10} P_{TN} = 10 \text{ Log}_{10} P_T - [50 + 6N] - L_p \quad (2-6)$$

where: L_p insertion loss of the filter in db at the frequency of interest

Similarly, Equation 2-5 would be modified by the term L_p .

2.4 ADJACENT CHANNEL INTERFERING POWER

This section provides a discussion of the spectral content of certain signals important from an interference point of view. Pulsed carriers such as those used in radar systems are particularly important for two basic reasons. First, the spectral composition of the signal is broadband in nature due to the rather abrupt changes in power level inherent in a pulsed system. Second, the peak power of the system is very high and the sideband components, even at a large frequency separation from the carrier, still contain an appreciable amount of energy and are thus possible interference sources.

The term adjacent channel interference is used to describe the situation where the modulation sideband power of a signal falls within the receiver bandwidth and creates interference. The modulation sideband may be centered around the fundamental or any of the harmonics. Fundamental adjacent channel interference may be very serious; however, harmonic adjacent channel interference is generally of insufficient level to be of concern.

The technique used to determine the power falling within the receiver bandwidth is to integrate the spectral power density over the bandwidth of the receiver. This yields the total interference power received from that source. An adjacent channel interference situation is illustrated in Figure 2-7. The power falling within the receiver passband is thus given by:

$$P_{TR} = \int_{-\infty}^{\infty} P(f) A(f) df \quad (2-7)$$

where:

$P(f)$ = power spectral density

$A(f)$ = receiver response function

For most receivers and a reasonably large frequency difference, $f_T - f_C$, between the transmitter carrier f_C , and the receiver center frequency, f_T , the above expression may be approximated by:

$$P_{TR} = P(f_T) \cdot B_r \quad (2-8)$$

where: $P(f_T)$ = spectral power density at f_T

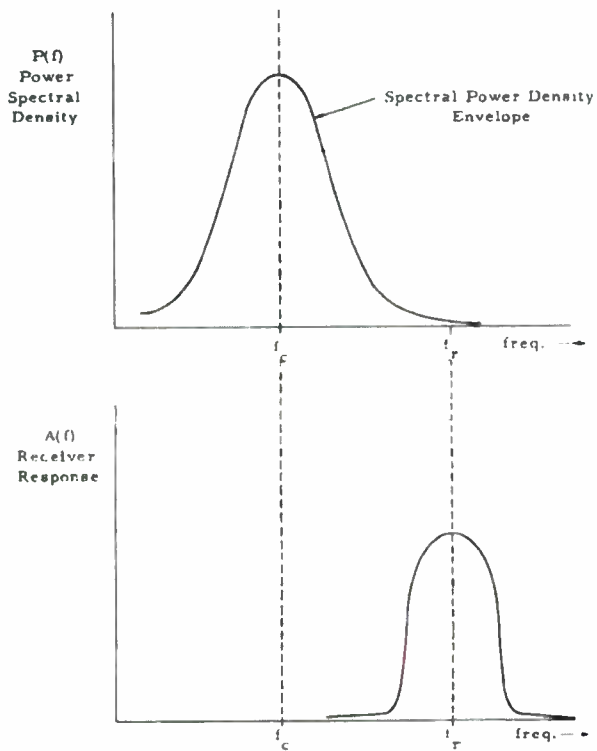

Figure 2-7. Adjacent Channel Interference

The calculation of the adjacent channel interference is thus approximated by the simple product. The receiver bandwidth, B_r , is generally known. The same technique may also be used for receiver image responses and other receiver spurious responses. The determination of $P(f_p)$, the spectral power density of the pulsed signal is not so simple and will be discussed in the following paragraphs.

The spectral power density of a particular radar pulse may best be determined experimentally. In most cases, it is desirable to have available some technique for estimating it. The power spectrum of a pulse may be determined mathematically from its time function $v(t)$. The time function to be considered here is shown in Figure 2-8. τ is defined as the pulse width at the 50% points. t_r is the 0-100% rise time and is also the 100-0% fall time. K is a convenient parameter defined as the ratio of t_r to τ . It is useful to note that as K approaches 0, the pulse shape becomes rectangular, and as K approaches 1, the pulse becomes cosine squared in shape. These special cases are shown in Figure 2-9.

For $\left(-\frac{\tau}{2} - \frac{t_r}{2}\right) < t < \left(\frac{\tau}{2} + \frac{t_r}{2}\right)$ then the curve is described by:

$$\text{Voltage as a function of time} = v(t) = \frac{v_m}{2} \left[1 + \cos \frac{\pi}{K\tau} \left[t - \frac{\tau}{2} (1 - K) \right] \right]$$

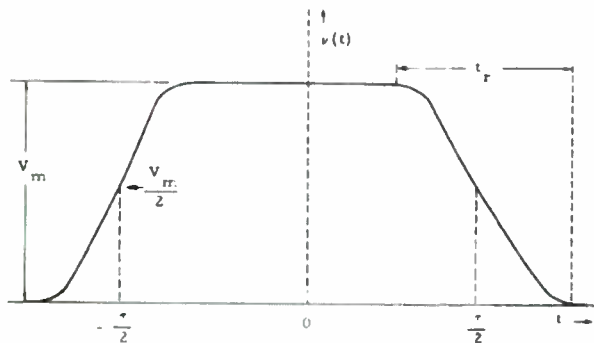

Figure 2-8 Idealized Pulse Shape



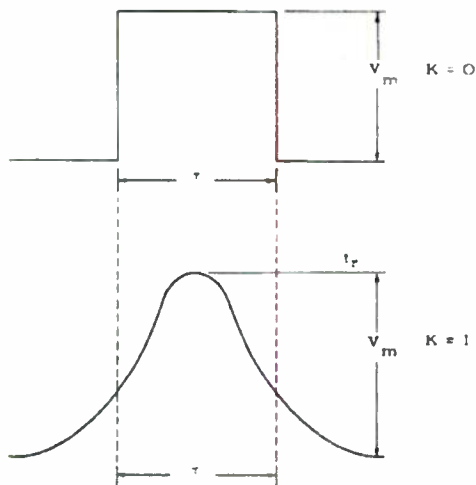

Figure 2-9. Special Pulse Shapes

The Fourier Transform of the voltage pulse is

$$V(\omega) = 2 \int_0^{\tau} v(t) \cos \omega t \, dt \quad (2-9)$$

$$= 2 \int_0^{\tau/2} \frac{(1-K)}{V_m} \cos \omega t \, dt +$$

$$2 \int_{\tau/2}^{\tau} \frac{(1+K)}{V_m/2} \left[1 + \cos \frac{\pi}{K\tau} (t - \tau/2(1-K)) \right] \cos \omega t \, dt \quad (2-10)$$

$$V(\omega) = \omega^{-2} V_m \left[\frac{\sin(\omega\tau/2)(1+K) + \sin(\omega\tau/2)(1-K)}{\omega^2 - (K\tau\omega)^2} \right] \quad (2-11)$$

or, in terms of frequency,

$$V(f) = \frac{\tau V_m}{2} \left[\frac{\sin \pi \tau f (1+K) + \sin \pi \tau f (1-K)}{\pi \tau f [1 - (2K \tau f)^2]} \right] \text{ volts/mc} \quad (2-12)$$

The energy distribution of the pulse is proportional to the square of the absolute value of the voltage distribution; i. e., from equation 2-12

$$\begin{aligned} CW(f) &= |V(f)|^2 \\ &= \left[\frac{\tau V_m}{2} \right]^2 \left[\frac{\sin \pi \tau f (1+K) + \sin \pi \tau f (1-K)}{\pi \tau f [1 - (2K \tau f)^2]} \right]^2 \frac{\text{watt-sec}}{\text{mc}} \end{aligned} \quad (2-13)$$

where C is an arbitrary constant yet to be determined. The total energy within the pulse must be the same in both the frequency domain and the time domain. Thus,

$$\int_{-\infty}^{\infty} |V(f)|^2 df = \int_{-\infty}^{\infty} [v(t)]^2 dt = CW_t \quad (2-14)$$

where W_t is the total energy within the pulse. Carrying out the second integration in Equation 2-14 gives

$$CW_t = \frac{\tau V_m^2}{4} (1 - K) \quad (2-15)$$

The average power during the pulse is equal to the total energy of the pulse divided by the total pulse duration $(\tau + \tau_r)$. Then

$$P_{\text{avg}} = \frac{W_t}{\tau + \tau_r} = \frac{W_t}{\tau(1+K)} = \frac{V_m^2}{4C} \cdot \frac{(1-K)}{(1+K)} \quad (2-16)$$

In the case of the rectangular pulse, the average power during the pulse is equal to the peak pulse power P_T . Inserting $K=0$ into Equation 2-16 gives

$$P_T = \frac{V_m^2}{C} \quad (2-17)$$

Substituting this value of V_m into Equation 2-13 gives the energy distribution in terms of peak power, P_T

$$W(f) = \frac{\tau^2 P_T}{4} \left[\frac{\sin \pi \tau f (1+K) + \sin \pi \tau f (1-K)}{\pi \tau f [1 - (2K \tau f)^2]} \right]^2 \frac{\text{watt-sec}}{\text{mc}} \quad (2-18)$$

The spectral response of the average power during the pulse is equal to the spectral response of the energy contained within the pulse divided by the total pulse duration $\tau + t_r$, or

$$P(f) = \frac{W(f)}{\tau + t_r} = \frac{W(f)}{\tau(1+K)} \quad \text{watts/mc} \quad (2-19)$$

Then from Equation 2-18

$$P(f) = \frac{\tau P_T}{4(1+K)} \left[\frac{\sin \pi \tau f (1+K) + \sin \pi \tau f (1-K)}{\pi \tau f [1 - (2K \tau f)^2]} \right]^2 \frac{\text{watts}}{\text{mc}} \quad (2-20)$$

For the case where the voltage pulse is used to modulate a carrier of frequency f_c , the entire spectrum is shifted so that it is centered about the carrier frequency. Thus, Equation 2-20 may be rewritten as

$$P(f) = \frac{\tau P_T}{4(1+K)} \left[\frac{\sin \pi \tau \Delta f (1+K) + \sin \pi \tau \Delta f (1-K)}{\pi \tau \Delta f [1 - (2K \tau \Delta f)^2]} \right]^2 \frac{\text{watts}}{\text{mc}} \quad (2-21)$$

where $\Delta f = f - f_c$

The average power during the pulse contained within a bandwidth B_T centered at a frequency f_T is

$$P_{TR} = \int_{f_T - B_T/2}^{f_T + B_T/2} P(f) df = \int_{f_T - B_T/2}^{f_T + B_T/2} \frac{\tau P_T}{4(1+K)} \left[\frac{\sin \pi \tau \Delta f \cos \pi \tau K \Delta f}{\pi \tau \Delta f [1 - (2K \tau \Delta f)^2]} \right]^2 df \quad (2-22)$$

A simpler and more useful expression for RFI purposes is obtained by taking the envelope of the integrand in Equation 2-16. This envelope may be approximated as follows:

$$\text{for } K \cdot \Delta f \ll 1, P(f) \cong \frac{\tau P_T}{1+K} \cdot \frac{\sin^2 \pi \tau \Delta f}{(\pi \tau \Delta f)^2} \quad (2-23)$$

$$\text{for } K \cdot \Delta f \gg 1, P(f) \cong \frac{\tau P_T}{1+K} \left[\frac{1}{(16 \pi^2 K^4 \tau^2 \Delta f^2)} \right] \quad (2-24)$$

The case where $K \cdot \Delta f \ll 1$ is of little interest here because it is the co-channel rather than the adjacent channel case and is discussed in Section 2.4. The second case, i. e., for $K \tau \Delta f \gg 1$, is of prime importance for the adjacent channel interference situation and must be considered further. Considering only the envelope of the spectral power density, Equation 2-22 becomes:

$$P_{TR} = \frac{\tau P_T}{1+K} \int_{f_r - B_r/2}^{f_r + B_r/2} \frac{1}{(16 \pi^2 K^4 \tau^2) (f - f_c)^2} df \quad (2-25)$$

If the term Δf_r is defined as $(f_r - f_c)$, Equation 2-17 becomes

$$P_{TR} = \left[\frac{\tau P_T}{(1+K)(16 \pi^2 K^4 \tau^2)} \right] \cdot \left[\frac{1}{5 (\Delta f_r)^2} \right] \cdot \left[\frac{\left[1 + \frac{B_r}{2 \Delta f_r} \right]^2 - \left[1 - \frac{B_r}{2 \Delta f_r} \right]^2}{\left[1 - \left[\frac{B_r}{2 \Delta f_r} \right]^2 \right]^2} \right] \quad (2-26)$$

If the terms in the right-hand bracket are now expanded and terms such as $(B_r/2\Delta f_r)^2$, $(B_r/2\Delta f_r)^3$, and higher order terms are considered negligible compared to 1, the expression becomes:

$$P_{TR} = \frac{\tau P_T}{(1+K)(16 \pi^2 K^4 \tau^2 \Delta f_r^2)} \left(\frac{B_r}{\Delta f_r} \right) \quad (2-27)$$

This then verifies and establishes the conditions under which the approximation given in Equation 2-8 is valid. Equation 2-27 may be put into a

slightly different form and plotted for different values of K to simplify the computation. This form is given in Equation 2-28 and is plotted in Figure 2-10.

$$10 \text{ Log}_{10} \left(\frac{P_{TR}}{P_T} \right) = 10 \text{ Log}_{10} (B_r) - 10 \text{ Log}_{10} \left[16^{-n^2} K^4 \tau^6 \Delta f_r^6 (1+K) \right] \quad (2-28)$$

In this expression τ has the units of μsec and both B_r and Δf_r have the units of mc. For an actual calculation of the effective transmitted power level in the receiver bandwidth in dbm (db relative to 1 milliwatt), Equation 2-29 may be used for the fundamental adjacent case.

$$10 \text{ Log}_{10} (P_{TR}) = 10 \text{ Log}_{10} (\tau P_T) + 10 \text{ Log}_{10} (B_r) - 10 \text{ Log}_{10} \left[16^{-n^2} K^4 \tau^6 \Delta f_r^6 (1+K) \right] \quad (2-29)$$

where:

- P_{TR} is in milliwatts
- τ is in μsec
- P_T is in milliwatts
- B_r is in mc
- Δf_r is in mc

The left side of the equation is in dbm. The last log expression on the right side is from Figure 2-10.

It was mentioned earlier in this section that harmonic adjacent channel interference is rarely of sufficient level to be of concern. It is, in addition, very difficult to calculate the shape of the spectrum because, in general, the nature of the non-linearity creating the harmonic is not known. In the absence of other data, the effective transmitted power level in the receiver bandwidth for the nth harmonic is given by:

$$10 \text{ Log}_{10} (P_{RN}) = -40 - 4N + 10 \text{ Log}_{10} (\tau P_T) + 10 \text{ Log}_{10} (B_r) - 10 \text{ Log}_{10} \left[16^{-n^2} K^4 (\tau \Delta f_r)^6 (1+K) \right] \quad (2-30)$$

The last term in Equation 2-30 may be determined from the graph (Figure 2-10).

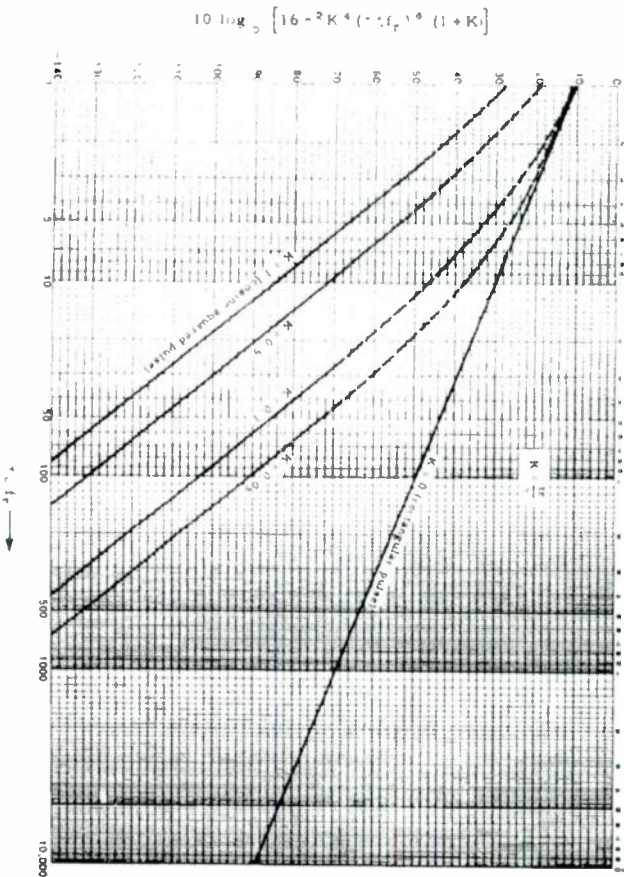

Figure 2-10 Graph for Determining Last Log Expression in Equations 2-29 and 2-30

In Figure 2-19, a form is provided to facilitate the actual computation required in both Equation 2-29 and Equation 2-30.

2.5 TRANSMITTER SPURIOUS EMISSIONS

The previous discussions concerned types of interfering power which are easily predictable or can be empirically determined (harmonics). Another type of interfering power is that of spurious emissions (other than harmonics) occurring at the receiver tuned frequency which would also cause interference. Consideration of this type of power in RFI prediction will require measured data. The DOD spectrum signature program is accumulating such data at the Electronic Compatibility and Analysis Center (ECAC) at Annapolis, Maryland.

3. ANTENNA CONSIDERATIONS AND LINE LOSSES

3.1 ANTENNA GAIN

3.1.1 INTRODUCTION

Antenna gain of transmitters and receivers represent parameters of considerable importance in the RFI prediction process. In the case of radar and microwave applications, it is not uncommon to have antennas with gains as high as 45 db. For example, in situations where predictions of interference from radars to microwave receivers are made and there is no off-axis pointing (both antennas looking at each other), a total gain of 70-90 db is possible, which tends to offset free-space propagation loss and enhance the potential RFI situation. It is, therefore, of particular interest to discuss antenna gain and its calculation by a variety of methods so that the RFI prediction engineer can select a means for computing gain in the absence of measured data. Sections 3.1.2 and 3.1.3 discuss antenna gain at design frequency and at harmonics.

3.1.2 APPROXIMATE METHODS FOR CALCULATING ANTENNA GAIN

A great many methods of approximating antenna gain are to be found in the literature, a few of which are presented here. The particular method chosen will depend upon available information concerning the antenna under consideration.

For large aperture type antennas, such as horn fed reflectors, the gain is given approximately by



$$G \approx \frac{4\pi A_p F_h F_v k}{\lambda^2} \quad (2-31)$$

- where:
- A_p = physical area of the aperture or reflector
 - F_h = correction factor depending on the type of illumination in the horizontal direction
 - F_v = correction factor depending on the type of illumination in the vertical direction
 - λ = wavelength
 - k = correction factor which takes into account spillover, imperfections in the reflector surface, etc., and is usually taken to be about 0.55.

The correction factors, F_h and F_v , are shown below:

Type of Illumination	Correction Factor
Uniform	1.000
Cosine	0.810
Cosine Squared	0.667
Cosine Cubed	0.575
Cosine Fourth	0.515

Although uniform illumination gives the highest antenna gain, tapered illumination is often used in practice for the purposes of side lobe level reduction.

A second approximation for antennas with unidirectional patterns is

$$G \approx \frac{4\pi}{\theta_1 \theta_2} \frac{k}{B} \quad (2-32)$$

where: θ_1, θ_2 = horizontal and vertical beam widths in radians at the half-power points

B = beam area in (radians)² at the half-power points

k = correction factor, usually taken to be between 0.5 and 1.0, depending on the type of antenna.

The constant k arises because the power contained within the side lobes has been neglected. For antennas with appreciable side lobe levels, the smaller values of k should be used. For radars, a value of $k = 0.6$ to 0.65 gives results generally accurate within two or three db.

An approximation which gives fairly reliable results for those antennas with "do-nut" patterns, such as dipoles, loops, or broadside arrays, is

$$G \approx \frac{1}{\sin^2\left(\frac{\theta_1}{2}\right)} \quad (2-33)$$

where θ_1 is the beam width in degrees at the half-power points. As an example, consider a half-wave dipole with a beam width of 78°. The above formula yields a gain of 1.59, as compared to the true value of 1.64.

3.1.3 ANTENNA GAIN AT HARMONIC FREQUENCIES

Antenna gains at spurious frequencies above the fundamental is an area in which reliable information is almost totally absent. Neither experimental nor analytical data has been compiled to any great extent. There are, however, several schools of thought on the matter, and these are discussed below.

Measurements have been performed on a standard horn antenna at frequencies above the design value.* It was found that the gain remained fairly constant up through the 3rd harmonic. Beyond this point, a sharp drop in gain was observed. Thus, on the basis of this information, one might assume constant gain up through the 3rd harmonic and unity gain thereafter for aperture type antennas.

A second approximation for horn-fed reflectors is obtained from the gain-effective area relationship,

*From a paper by E. Jacobs and O. M. Salati presented at the Fifth Conference on Radio Interference Reduction and Electronic Compatibility.



$$G = \frac{4\pi A_{eff}}{\lambda^2} \quad (2-34)$$

where A_{eff} = the effective area of horn fed reflectors

Assuming the area illuminated by the horn to remain constant, the gain varies as the square of the ratio of the frequencies; i. e.,

$$G = \left[\frac{f}{f_0} \right]^2 G_0 \quad (2-35)$$

where f and G pertain to the frequency of interest and f_0 and G_0 are the operating frequency and gain. Thus, at the second harmonic, $G = 4G_0$, or the gain at the second harmonic is approximately 6 db greater than at the fundamental.

It will be noted that the above theory yields unusually high gains at the higher harmonics. A more commonly accepted theory is that the gain remains essentially constant at the higher frequencies, the decreased wavelength being offset (at least qualitatively) by a decrease in the reflector area illuminated. This assumption falls more into line with the observations made by Jacobs and Salati on the horn antenna.

Additional support for the assumption of unity gain above the third harmonic is found in the case of large radar reflectors. Because of weight and wind resistance considerations, these reflectors are meshed rather than solid. At frequencies considerably above the fundamental, the wavelength approaches the dimensions of the mesh openings. In this situation, much of the power radiated by the feed system penetrates the reflector, adding to the back lobe level. This, together with other scattering phenomena, make the assumption of unity gain at these frequencies not unreasonable.

In summary, until reliable measured data is available, the safest course in assigning antenna gain at spurious frequencies is the following: for frequencies up to and including the third harmonic, the antenna gain remains constant, while above this point unity gain is assumed.

3.2 POLARIZATION

The loss of power between two antennas that are polarized differently may be termed the loss factor due to transmitter-receiver polarization alignment. The fact that there exists such a loss is frequently used

to advantage in the reduction of interference. A table indicating the loss factor for various combinations of polarization is given as Figure 2-20 of this chapter. This table is valuable in the absence of measured data. The data given in the table is not appropriate for off-axis pointing (discussed in the following paragraphs). For off-axis pointing, it is more realistic, on the basis of typical data, to assume no polarization isolation, i. e., a 0 db loss factor, in the absence of other data.

3.3 ANTENNA OFF-AXIS POINTING

Another important consideration in the prediction of interference is that of off-axis pointing of the antennas, i. e., the fact that the azimuth and elevation angles between the two antennas may be such that one or both of the antennas are not in the main beam of the second antenna. In the prediction technique used in Section 5, the full gain of both the antennas is used and a correction factor is applied to correct for both antennas' off-axis pointing. The correction factor is termed loss due to off-axis pointing and is normally expressed in terms of db relative to the maximum gain. The geometry of an off-axis pointing situation is shown in Figure 2-11 for the two dimensional case. The composite antenna gain for the situation depicted in Figure 2-11 is $G_c(\theta_x = \theta_{12}) G_2(\theta_y = \theta_{21})$. For the sake of convenience in the following discussion the composite antenna gain will be designated G_c , with its maximum value, $G_c(\max)$. Consider now the more general case of the three-dimensional problem. Using the coordinate system established in Figure 2-12, the composite gain for the two sites, x and y, is:

$$G_c = G_x(\theta_{xy}, \phi_{xy}) G_y(\theta_{yx}, \phi_{yx}) \quad (2-36)$$

$$= G_x(\max) \left[\frac{G_x(\theta_{xy}, \phi_{xy})}{G_x(\max)} \right] G_y(\max) \left[\frac{G_y(\theta_{yx}, \phi_{yx})}{G_y(\max)} \right] \quad (2-37)$$

In logarithmic form this becomes

$$\begin{aligned} 10 \text{ Log}_{10} G_c &= 10 \text{ Log}_{10} [G_x(\max)] + 10 \text{ Log}_{10} [G_y(\max)] \\ &+ 10 \text{ Log}_{10} \left[\frac{G_x(\theta_{xy}, \phi_{xy})}{G_x(\max)} \right] + 10 \text{ Log}_{10} \left[\frac{G_y(\theta_{yx}, \phi_{yx})}{G_y(\max)} \right] \end{aligned} \quad (2-38)$$

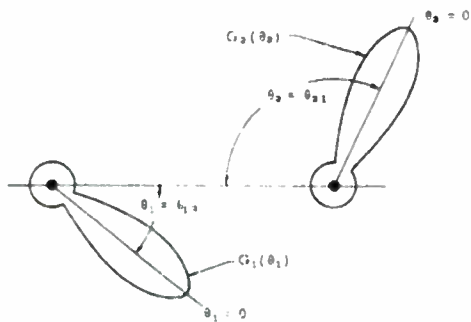

Figure 2-11. Off-Axis Pointing Geometry for Two Dimensional Case

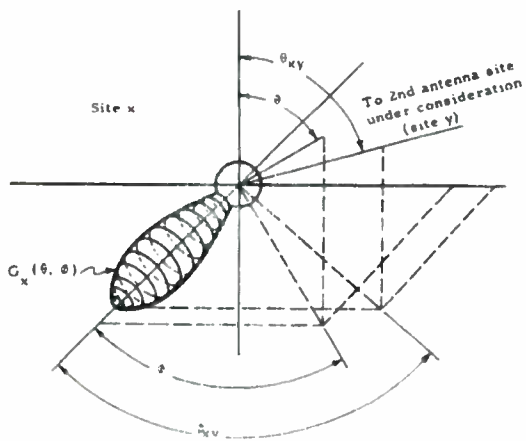

Figure 2-12. Three Dimensional Antenna Pattern Considerations

The first two terms in Equation 2-38 are the maximum gains of the two antennas expressed in db. The second two terms are defined as the off-axis pointing losses for the antennas at sites x and y, respectively. A closer examination of this loss for site x shows that it is simply the antenna gain for antenna x in a direction from site x to site y, relative to its maximum gain.

If antenna data is available, the calculation of this loss is relatively simple. However, generally data of sufficient detail is not available and it is necessary to estimate the loss. In Chapter 4, Section 1.1.5 of Volume I, some typical data for various types of antennas is given. For a parabolic reflector illuminated by a point source feed, the two dimensional pattern may be approximated as indicated in Figure 2-13.

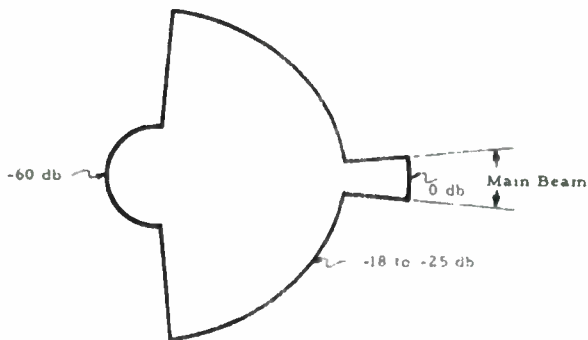

Figure 2-13. Parabolic Antenna Pattern Considerations

3.4 TRANSMISSION LINE LOSSES

In the typical RFI prediction situation, transmission line losses contribute very little to the outcome and may be neglected in many instances. There are cases, however, where these losses may become significant, as in some microwave applications where fifty or one hundred feet of coaxial cable might be employed between antenna and receiver. In this case while coax losses may be negligible at the design frequency, they could become appreciable at the higher harmonics. In systems employing waveguide, such as radar, the attenuation below the cut-off frequency of the guide is such that spurious emissions in this region may, in most instances, be neglected entirely.

In performing an RFI prediction, the line losses of both the transmitter and receiver should be known experimentally. If this data is not available, however, the following theoretical calculations will suffice (only coaxial cable and rectangular waveguide are considered here).

Coaxial Cable (See Figure 2-14)

The attenuation in db per foot of cable length is

$$L = (9 \times 10^4) \frac{1}{\sqrt{f}} \frac{(1/a + 1/b)}{\text{Log}_{10}(b/a)} \text{ db/ft} \quad (2-39)$$

$$\text{where: } \alpha_0 = 1/2 (\mu_2 \epsilon_1^{-1} + \sigma_2 \mu_1)^{1/2} \quad (2-40)$$

$$\epsilon_1 = C, \epsilon_0 = C_1 \cdot 8.854 \times 10^{-12} \text{ (farad per meter)}$$

$$\mu_1 = m_1 \mu_0 = m_1 \cdot 1.257 \times 10^{-6} \text{ (henry per meter)}$$

$$\mu_2 = m_2 \mu_0 = m_2 \cdot 1.257 \times 10^{-6} \text{ (henry per meter)}$$

σ_2 = conductivity of the waveguide or cable metal (mhos per meter)

C_1 = relative dielectric constant of insulator in waveguide or cable

m_1 = relative permeability of insulator in waveguide or cable

m_2 = relative permeability of metal in waveguide or cable

f = frequency in megacycles

a, b are measured in inches

See Figure 2-16a and 2-16b for typical attenuation values of coaxial cable.

Rectangular Waveguide (See Figure 2-15)

The attenuation in db per foot of guide at frequencies above cut-off is

$$L = \frac{0.416 \times 10^6}{a} \gamma_0 \sqrt{\frac{f}{1 - (fc/f)^2}} \left(\frac{a}{2b} + \frac{fc^2}{f^2} \right) \quad dn/ft \quad (2-41)$$

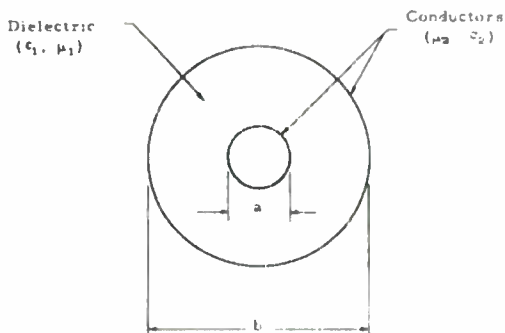

Figure 2-14. Coaxial Cable Parameters

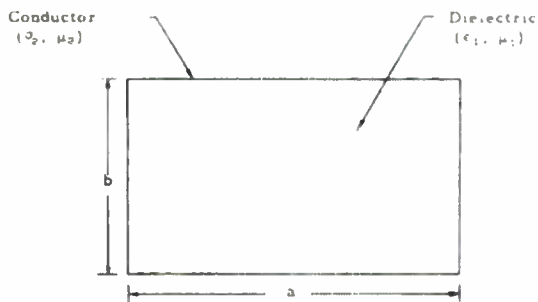

Figure 2-15. Waveguide Parameters



where: $\alpha_0 = 1/2(\mu_0 \epsilon_0 / c_0 \mu_1)^{1/2}$ (MKS units) (2-42)

See page 2-28 for definition of symbols.

f_c = cut-off frequency in megacycles

f = operating frequency in megacycles

a, b are measured in inches

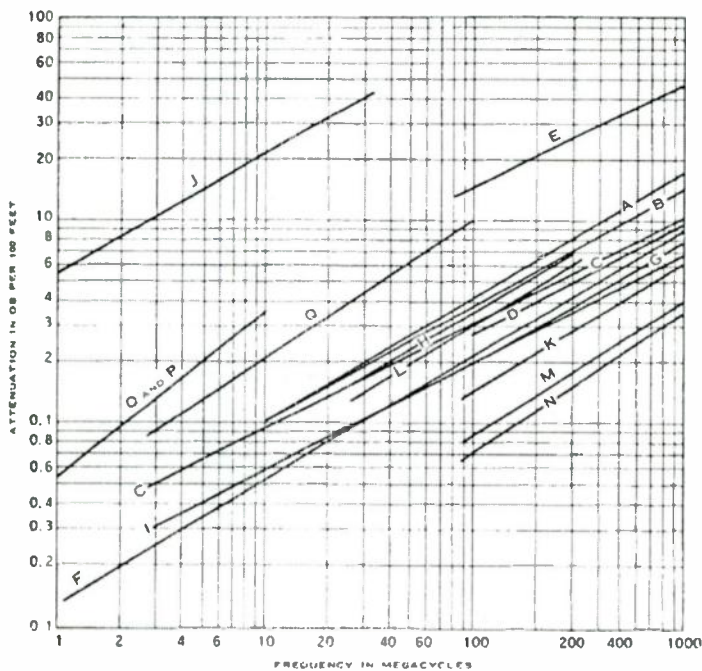

Figure 2-16a. Attenuation of Standard RF Cables vs. Frequency
(See Figure 2-16b for identification of curves)

The attenuation below cut-off is

$$L = 0.0554 f_c \left[1 - \left[\frac{f}{f_c} \right]^2 \right]^{\frac{3}{2}} \text{ db/ft} \quad (2-43)$$

Notice that as f becomes appreciably less than f_c , the attenuation approaches a constant value of

$$L \cong 0.0554 f_c \text{ db/ft} \quad (2-44)$$

See Figure 2-17 for a table of typical waveguide attenuation.

See Figure 7-26, Chapter 7 this Volume, for measured data on RG-51/U waveguide near cutoff.

CURVE	RG -() /U	CURVE	RG -() /U
A	55	I	63
A	58	J	65
B	59	K	14
C	62	K	74
C	71	L	57
D	5	M	17
D	6	M	18
E	21	N	19
F	8	N	20
F	9	O	25
F	10	O	26
G	11	O	64
G	12	P	27
G	13	P	28
H	22	Q	4

Figure 2-16b. Identification of Curves in Figure 2-16a

FREQUENCY (GHz) TF ₁₀ MODE	EIA DESIGNATION WR()	THEORETICAL ATTENUATION, LOWEST TO HIGHEST FREQUENCY (dB/100 ft.)		
		BRASS	ALUMINUM	SILVER
320 - 490	2300		0.039 - 0.027	
350 - 530	2100		0.046 - 0.031	
410 - 625	1800		0.056 - 0.038	
490 - 750	1500		0.067 - 0.050	
640 - 960	1150		0.128 - 0.075	
750 - 1120	975		0.137 - 0.095	
950 - 1500	700		0.201 - 0.136	
1120 - 1700	650	0.424 - 0.283	0.269 - 0.178	
1450 - 2200	510	0.606 - 0.398	0.488 - 0.257	
1700 - 2600	310	0.788 - 0.516	0.501 - 0.330	
2200 - 3300	310	1.046 - 0.728	0.669 - 0.466	
2600 - 3950	2P4	1.478 - 1.008	0.940 - 0.641	
3100 - 4900	223	1.862 - 1.320	1.192 - 0.815	
3950 - 5850	187	2.79 - 1.93	1.77 - 1.22	
4900 - 7050	134	2.89 - 2.24	1.83 - 1.42	
5850 - 8200	137	3.85 - 3.08	2.45 - 1.94	
7050 - 10000	112	5.51 - 4.11	3.50 - 2.74	
8200 - 12400	90	8.64 - 6.02	5.49 - 3.83	
10000 - 15000	75	10.07 - 7.03	6.45 - 4.40	
12400 - 18000	62	12.76 - 11.15	8.13 - 7.10	6.14 - 5.36
15000 - 22000	51	17.3 - 12.6	11.05 - 8.05	8.37 - 6.10
18000 - 26500	42	27.7 - 19.8	17.6 - 12.6	13.3 - 9.5
22000 - 33000	34	33.3 - 23.1	21.3 - 14.8	16.1 - 11.2
26500 - 40000	28			21.9 - 15.0
33000 - 50000	22			31.0 - 20.9
40000 - 60000	19			38.8 - 27.2
50000 - 75000	15			52.9 - 39.1
60000 - 90000	12			93.3 - 52.2
75000 - 110000	10			100 - 70.4
90000 - 140000	138			152 - 99
110000 - 170000	136			163 - 137
140000 - 220000	135			308 - 193
170000 - 260000	137			384 - 254
220000 - 325000	139			512 - 348

* Jan Type RG-()/U

Figure 2-17. Normal Waveguide Loss

GC - G.gacycles = Kmc

4. PROPAGATION CONSIDERATIONS WHICH ACCOUNT FOR THE PRESENCE OF THE EARTH

4.1 GENERAL

It is occasionally necessary to account for the presence of the earth in RFI predictions. This has been discussed in Chapter II, Section 6.2 of Volume I and methods for doing so are discussed in Chapter IV of Volume I. Where smooth terrain exists, the methods given there can be used successfully and are appropriate for use in filling in the forms in Section 5 of this chapter.

In mountainous terrain, the exact application of the methods which are useful for smooth earth regions cannot be applied directly without preliminary investigations. This section will discuss the necessary data which must be acquired and computed in order to determine which method of propagation calculation is applicable.

4.2 360° RADIO LINE OF SIGHT (RLOS) MAPS

Radio Line of Sight maps are prepared for a given transmitter "TX" site or receiver "RX" site to show the areas which the TX will illuminate or from which the RX could be illuminated. To conduct a prediction study, additional transmitters or receivers which could cause interference or be interfered with are plotted on the RLOS map. Those that are well beyond line of sight are then easily noted and are removed from further consideration. RLOS maps are a useful tool in rapidly reducing the number of TX RX pairs to be critically analyzed in detail.

4.2.1 MATERIAL AND DATA REQUIRED

The following information and material is required to construct a 360° RLOS map:

- a. The accurate location in latitude and longitude and elevation in feet of the TX or RX antenna for which the RLOS map is to be prepared.
- b. Topographic maps of the area around the site for a radius of approximately 100 miles, depending on the height of the site being investigated. The area required varies considerably with the elevation of the antenna and the terrain. These maps are available from the U. S. Geological Survey, Denver, Colorado. The 1:250,000 scale maps are recommended for the RLOS map.

4.2.2 PREPARING THE MAP

The 1:250,000 maps obtained from an appropriate source are assembled into a single map by trimming one map and gluing it to the next one so that the lines of latitude and longitude are perfectly registered. The site for which the map is being prepared is then plotted and appropriately marked. A pencil line is drawn on the map approximately true north from the site, and an RLOS profile is made for this line. The preparation of RLOS profile graphs is discussed below.

Additional profiles are prepared for other radials until the entire 360° sector has been covered. The spacing in degrees between profiles is a matter of judgment which depends on the terrain.

After plotting a profile, a straight line is drawn from the antenna to the ridge which first touches a line which is depressed from the horizontal. The procedure is repeated for all the radials. This readily shows the areas illuminated and those optically shadowed. The plan view map is marked to show the points where the shadow region begins and ends for all the profiles.

If adjacent points of different radial lines are on the same ridge, these points may be connected by a line drawn between them. If the points are on the side of a mountain or hill, the terrain between the two radial lines must be examined more closely to determine if more radials should be drawn. If terrain is quite uniform, the points can be connected by a line roughly parallel to the contour lines, if terrain is very irregular one or more intermediate profiles must be plotted.

The RLOS boundary lines are then drawn in by connecting the points and shading the areas in the shadow regions to facilitate reading the map. For ease in using the plot, the lines of latitude and longitude should be marked at 30 minute intervals and a graphic scale and north arrow should be placed on the map. The map may then be photographed and reduced to a more convenient size.

4.3 RADIO LINE OF SIGHT (RLOS) PROFILES

Radio Line of Sight Profiles are prepared from a transmitter site (TX) to a receiver site (RX) to determine if the earth's surface comes near the path of the wave which is propagated between the sites. They are used to prepare an RLOS map as discussed above.

4.3.1 REQUIRED MATERIALS AND DATA

The following information is required to construct an RLOS profile:

- a. The accurate location in latitude and longitude and elevation in feet of the TX and RX antennas
- b. Topographic maps of the route between the TX and RX. These maps are available from the U. S. Geological Survey, Denver, Colorado or Washington 25, D. C. Local map stores often have a supply of these maps. It is recommended that 1:62,500 scale maps be obtained. These maps usually have contours at 50 feet intervals or less.
- c. Four thirds earth radius profile paper. If the profile paper is not available, it can be constructed from the equation: $h = D^2/2$, in which, h is the departure in feet from a level tangent $D^2 =$ distance from origin in miles.

4.3.2 PREPARING THE PROFILE

The maps are assembled into a single strip map of the route between the TX and RX. This is done by trimming one map and gluing it to the next so that the lines of latitude and longitude are registered. This process is continued until the strip map is completed. A straight line is then drawn on the plan view map, connecting the TX and RX. The mid-point of this line is determined and distances are marked at 4 or 5 miles intervals each way from the center point to aid in scaling the map.

Next, the scales to be used for the profile are selected. The scale is determined by both the horizontal distance between the TX and RX and range of elevations to be covered. In flat country, the horizontal scale normally controls the scaling while in mountainous terrain the vertical scale will be controlling. Any scale change on a given profile paper must be in accordance with the equation $h = D^2/2$. For example, if the horizontal scale is doubled, the vertical scale must be multiplied by four.

The following example illustrates the method for determining the scale factors:

(Example) Horizontal distance between TX and RX = 30 miles
 Range of elevation 200' to 5800'
 Original scale 0 to 30 miles (1 mile/division)
 0 to 1,000 feet elevation (20 ft/division)
 Scales to use 0 to 75 miles (2.5 miles/division)
 0 to 6,250 feet (125 ft/division)
 (Horizontal scales increased by 2.5, therefore,
 vertical scale by 2.5^2 .)
 A sample $4/3$ radius graph is shown in Figure 2.22

It should be noted that if the elevation range was from 2,000 to 5,800 feet for the 30 miles distance rather than 200 to 5,800 feet, the best scale to use would be:

Horizontal: 0 to 60 miles (2 miles per division)
 Vertical: 2,000 to 6,000 feet (80 feet per division)
 (The 2,000 foot mark would be at the original scale zero.)

Scales should always be selected so that the profile will be as large as possible consistent with reasonable units per division for ease in plotting.

The TX and RX should be plotted an equal distance from the vertical centerline of the graph for maximum accuracy since the graph equation is a parabolic function. First, the elevation value on the centerline is plotted. Then, scaling each way from the mid-point, points at 4 to 5 mile intervals maximum are plotted being sure that the highest and lowest points crossed are accurately plotted. A straight line connecting the TX and RX antennas is drawn on the profile. Maps should be double checked at points where the profile indicates that the ground is near the straight line joining the TX and RX.

5. PREDICTION MODEL

5.1 GENERAL

The discussions in the previous section have described the various parameters involved in computing radio frequency interference. This section outlines a step-by-step procedure for rapidly and efficiently placing the data in a form convenient for entry. The form used carries the prediction process to the point of computing signal to interference S/I. Interpretation

process to the point of computing signal to interference S/I. Interpretation of results or scoring methods are discussed in Chapter I of this Volume.

5.2 RADAR INTERFERENCE AGAINST MICROWAVE RECEIVERS

The operation of microwave equipment in the common carrier bands 3700-4200 mc, and 5925-6425 mc, for example, poses a problem of insuring interference-free operation from radars which may be operating cochannel, harmonically related, or adjacent to these bands. The prediction process, therefore, provides a vehicle for computing S/I and relegates actual measurements to a corroborative role. Prediction computations, in essence, direct the efforts of the RFI engineer to the problem area by excluding situations that are by analysis positive non-interfering situations. Measurements can then be accomplished on an "as required" basis, and in the direction of looking for culprit radars.

The basic transmission equation (Equation 2-1) that must be solved for the interfering signal I at the receiver when expressed in Log form (db) is:

$$I_{\text{dbm}} = 10 \text{ Log}_{10} P_{\text{TR}} + 30 \text{ db} + G_{\text{T}} + G_{\text{R}} + 20 \text{ Log}_{10} (\lambda - 4\pi d) - L_{\text{R}} - L_{\text{T}} - A - p \quad (2-45)$$

where:

I_{dbm} = interfering signal power in db below 1 milliwatt*

P_{TR} = interfering transmitter power in watts at the receiver frequency and within the receiver bandwidth.

G_{T} = gain of the TX antennas in db

G_{R} = gain of the RX antennas in db

p = polarization mismatch in db

λ = wavelength in miles

d = distance between RX and TX in miles

* I would be in db referred to 1 watt except for the +30 db term which converts it to dbm.

A = correction factor for other than free-space and line-of-sight conditions

L_R = RX line losses in db

L_T = TX line losses in db

The previous sections of this Handbook and Volume I (Fundamentals of RFI) have discussed, in considerable detail, the parameters of equation (2-45) and their effects on RFI prediction.

5.3 PREDICTION FORM

To present the data in computing S/I in a convenient form, an RFI prediction form is shown in Figure 2-18. The form includes all the parameters, from Equation 2-45, necessary in making a prediction analysis with each of the variables made as an entry. Each of the entries in columns A and B, therefore, represents an operational condition associated with the potentially interfering transmitter-receiver pair being analyzed.

5.4 PROCEDURE FOR MAKING ENTRIES

The following paragraphs provide a step-by-step (cook book) approach to the manner in which each parameter is computed and entered into the RFI prediction form.

5.4.1 ENTRY A

Obviously, the first step is to identify the TX-RX pair for which a prediction is to be made. The TX and RX are first identified by their nomenclature (i. e., AN FPS-x or WLD-6, etc.) and by the site identification (location). The TX and RX frequencies are identified as well as the separation distance between the pair of interest.

5.4.2 ENTRY B

Entry B provides information which identifies whether the RFI case to be considered is fundamental or harmonic cochannel or adjacent channel. For example, if the TX is operating at 3600 mc and receiver 3700 mc, then $\Delta F = 100$ mc and indicates that the RFI prediction is to be made for a fundamental adjacent case. For harmonic situations, provisions are made on the form to include which harmonic is of interest and

any difference frequency between the harmonic output of the transmitter and receiver tuned frequency.

In addition, provisions are made on the form to include polarization of the transmitting as well as receiving antennas.

5.4.3 ENTRY C

This entry provides for the inclusion of operational field data obtained from an equipment census identifying TX and RX antennas orientation with respect to each other for both azimuth and elevation. This data is pertinent to the computation of off-axis pointing and its effects on the level of interfering signal at the receiver input.

5.4.4 ENTRY 1A AND B

Entry 1a represents the power in dbm of the transmitter signal existing at the tuned frequency of the receiver as contained in the 3 db bandwidth of the receiver. The three basic sources of RFI considered are: (a) cochannel interference, (b) adjacent channel interference, and (c) cochannel and adjacent channel interference at harmonic frequencies of the transmitter.

The computation for transmitter power within the RX bandwidth are made on a separate form as shown in Figure 2-19, where six different cases are presented. Care should be exercised in selecting the proper case. The derivations and discussion pertinent to the entry on the form on Figure 2-19 are given in Section 2 of this chapter.

Entry 1b is a special case where measured ERP data is available and should be used in preference to a computed value. Normally, however, this data is not available.

Entries 1.3 and 1.6 may give rise to some confusion concerning units. The term $10 \text{ Log}_{10} P_t$ is in spectrum power units or dbm/mc. The term δf describes the spectral power at some frequency δf from the transmitter frequency and this difference in spectral power is in units of db. Having arrived at the power spectral level in dbm/mc at δf , it now remains to determine total power within the receiver bandwidth B_r . This is accomplished by the term $10 \text{ Log}_{10} B_r$, which now converts spectral power dbm/mc into total power at the receiver in dbm.

RF PREDICTION FORMAT

A TRANSMITTER (TX) _____ TX SITE _____ TX FREQUENCY USED _____ MC SEPARATION DISTANCE BETWEEN TX AND RX _____ MILES	RECEIVER (RX) _____ RX SITE _____ RX FREQUENCY USED _____ MC TX ANTENNA POL _____ RX ANTENNA POL _____
B TX-RX FUNDAMENTAL OF _____ MC HARMONIC OF _____ MC	TX ANTENNA ORIENTATION WITH RESPECT TO RX _____ Azimuth Off-Axis _____ Elevation Off-Axis Antenna Height Above MSL _____ ft
C TX ANTENNA ORIENTATION WITH RESPECT TO TX _____ Azimuth Off-Axis _____ Elevation Off-Axis Antenna Height Above MSL _____ ft	RX ANTENNA ORIENTATION WITH RESPECT TO TX _____ Azimuth Off-Axis _____ Elevation Off-Axis Antenna Height Above MSL _____ ft

ENTRY NO.	TYPE ENTRY	A + DB	B - DB
1 a	TX POWER WITHIN RX BANDWIDTH PTR (dbm) <small>(See Line 1.7 of Figure 2-19 for this value)</small>		
b	<small>(NOTE: If ERP data is available enter here.)</small> PTR measured		
2 a	TX ANTENNA GAIN G_T (db)		
b	<small>(NOTE: When 1, b is filled leave 2a blank.)</small> LOSS DUE TO OFF-AXIS POINTING AT TX (db)		
3 a	RX ANTENNA GAIN G_R (db)		
b	LOSS DUE TO OFF-AXIS POINTING AT RX (db)		
4	LOSS DUE TO POLARIZATION MISMATCH (db) <small>(Use Polarisation Table Figure 2-20)</small>		
5	FREE-SPACE PROPAGATION LOSS (db) <small>(Use Nomograph Figure 2-21)</small>		
6	CORRECTION FACTOR FOR OTHER THAN FREE-SPACE AND LINE-OF-SIGHT CONDITIONS		
7	TX TRANSMISSION LINE LOSS (db)		
8	RX TRANSMISSION LINE LOSS (db)		
9	SUBTOTALS OF COLUMNS A AND B		
10	INTERFERENCE LEVEL, I, AT RX (dbm) = A + B		
11	SIGNAL LEVEL, S, AT RX (dbm)		
12	$S/I_{db} = S_{dbm} - I_{dbm}$		

Figure 2-18. Format for RF Prediction Data

FORMAT			
TRANSMITTER POWER WITHIN RECEIVER BANDWIDTH			
ENTRY NO	TYPE ENTRY (Choose the appropriate TX-TX situation below)	+ DB	- DB
1	FUNDAMENTAL COCHANNEL $B_R < 2f_c$		
1.1	$10 \log_{10} P_T$ in dbm		
1.2	FUNDAMENTAL COCHANNEL $B_R < 2f_c$		
1.2.1	$10 \log_{10} P_T$ in dbm		
1.2.2	$10 \log_{10} (10^{-5} B_R)$ db		
1.2.3	Subtotal of 1.2.1 and 1.2.2		
1.3	FUNDAMENTAL ADJACENT CHANNEL		
1.3.1	$10 \log_{10} P_T$ _____ dbm/mc		
1.3.2	For Δf see Figure 2-10 (obtain no. of db's below level of 1.3.1) _____ db		
1.3.3	$10 \log_{10} B_R$ _____ mc		
1.3.4	Subtotal of 1.3.1, 1.3.2, and 1.3.3 in dbm		
1.4	HARMONIC COCHANNEL $B_R > 2f_c$		
1.4.1	$10 \log_{10} P_T$ in dbm		
1.4.2	db down from fundamental: If unknown use - [50 + 6N] db		
1.4.3	Subtotal of 1.4.1 and 1.4.2		
1.5	HARMONIC COCHANNEL $B_R < 2f_c$		
1.5.1	$10 \log_{10} P_T$ in dbm		
1.5.2	db down from fundamental: If unknown use - [50 + 6N] db		
1.5.3	$10 \log_{10} (10^{-5} B_R)$ db		
1.5.4	Subtotal of 1.5.1, 1.5.2, and 1.5.3		
1.6	HARMONIC ADJACENT CHANNEL		
1.6.1	$10 \log_{10} P_T$ _____ dbm/mc		
1.6.2	db down from fundamental: If unknown use - [50 + 6N] db		
1.6.3	For Δf see Figure 2-10 (obtain no. of db's below spectral level 1.6.1) _____ db		
1.6.4	$10 \log_{10} B_R$ _____ mc		
1.6.5	Subtotal of 1.6.1, 1.6.2, 1.6.3, and 1.6.4		
1.7	ENTER HERE THE APPLICABLE SUBTOTAL (either 1.1, 1.2.3, 1.3.4, 1.4.3, 1.5.4, or 1.6.5)		

Figure 2-19. Transmitter Power Within Receiver Bandwidth

5. 4. 5 ENTRY 2

Entry 2 represents the gain of the transmitter antenna over an isotropic radiator in db. Where gain in db is not available, it can be computed knowing the effective aperture of the antenna and frequency. Normally, the gain of antennas at the fundamental are known; however, at harmonics this data is generally not available and certain assumptions must be made. (See Section 3 of this Chapter).

Included in this entry are the effects of off-axis pointing which, in many instances, can yield considerable reduction in the level of the interfering signal at the receiver. Off-axis pointing can take place in two dimensions, azimuth and elevation. Other parameters pertinent to off-axis pointing are the beamwidths of the TX antenna in azimuth and elevation, distance between TX-RX, and heights above mean sea level (MSL). See Section 3 of this Chapter for computing off-axis pointing. Having determined off-axis pointing in degrees, then refer to antenna pattern data to ascertain the level below the main beam in db and insert this in line 2b. If antenna pattern data is not available, refer to Chapter IV of Volume I (Fundamentals of Radio Frequency Interference) on antenna sidelobe considerations for estimating the correction for off-axis pointing.

It is noted that when measured ERP data on a TX is known, the gain of the antenna is also included. Measured data should be used in preference to calculated data. Therefore, when measured ERP data is included in lb, then entry 2a will be zero; however, item 2b must be evaluated.

5. 4. 6 ENTRY 3

Entry 3 represents the gain of the receiver antenna in db over an isotropic radiator. The discussion of 5. 4. 5 on the transmitter antenna applies here as well.

5. 4. 7 ENTRY 4

This entry represents the measured loss due to polarization difference between the receiving antenna and the arriving wave. Where measured data is not available, Figure 2-20, Transmitter-Receiver Alignment Factors for Inserting Losses Due to Polarization Mismatch, should be used. For harmonic radiations from the transmitter, a 10 db loss should be considered for cross-polarized conditions.

TRANSMITTER-RECEIVER POLARIZATION ALIGNMENT FACTORS* (Expressed in Units of DB Loss)					
	Horizontal	Vertical	Diagonal (45°)	Circular RH	Circular LH
Horizontal	0	20	3	3	3
Vertical	20	0	3	3	3
Diagonal (45°)	3	3	0-20	3	3
Circular RH	3	3	3	0	25
Circular LH	3	3	3	25	0

* For harmonic radiations from the transmitter, use 10 db for cross-polarized conditions.

Figure 2-20. Transmitter-Receiver Alignment Factors

5.4.8 ENTRY 5

Up to this point no consideration has been given to the propagation path and whether the situation is one of radio line-of-sight, diffraction, beyond radio line-of-sight, reflection, etc. Radio line-of-sight between receiving and transmitting antennas, for smooth earth, can be determined from the nomograph shown in Figure 2-21 when the antenna heights are known with respect to mean sea level. In irregular terrains (mountains, in particular), it may also be necessary to make a profile between the transmitter-receiver to determine whether any intervening terrain masks the propagation path between transmitter and receiver. Figure 2-22 is a $4/3$ earth profile on which the earth profile characteristics can be included. Should the results indicate radio line-of-sight with no obscured, diffraction, or reflection zones, then the free-space transmission loss can be computed. For the purpose of conserving computational time nomographs for free-space transmission loss can be used as shown in Figure 2-23. Given the frequency at which an RFI prediction is to be made and the distance between TX-RX, the free-space transmission loss in db is obtained and inserted in Entry 5.

5.4.9 ENTRY 6

In some instances prediction between a TX-RX will not involve a free-space transmission but may involve propagation beyond radio line-of-sight diffraction, reflection, and terrain effects. Chapter IV of Volume I describes the procedures to be used in providing correction factors for other than free-space radio line-of-sight.

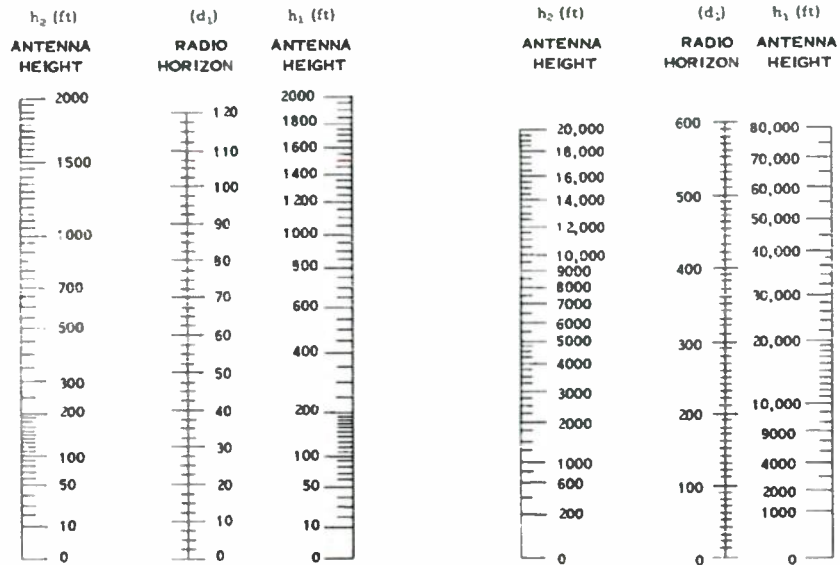

Figure 2-21. Nomographs Giving Radio Horizon Distance

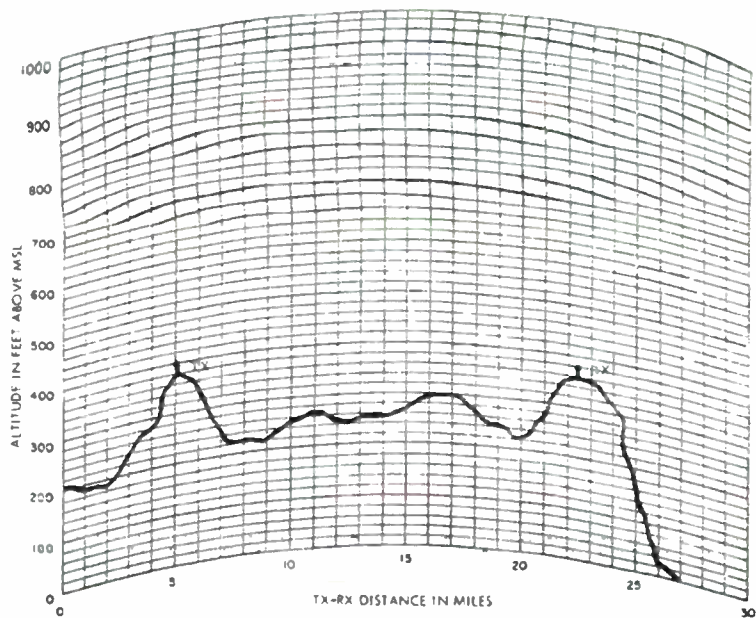
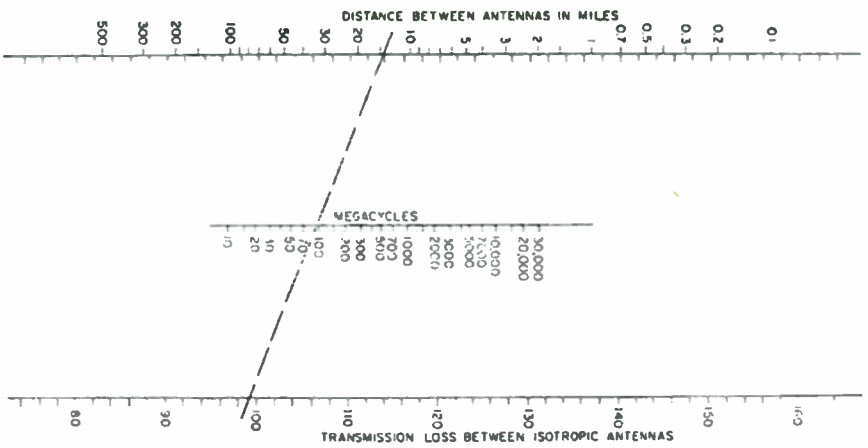

Figure 2-22. $4/3$ Earth Profile Drawing Between Transmitter and Receiver



2-46

Figure 2-23. Free Space Transmission Loss

5.4.10 ENTRIES 7 AND 8

These entries represent transmitter and receiver transmission line losses. This data may be obtainable from pertinent equipment operating characteristics and should be used. If not available, then it may be estimated or calculated. Section 3.4 of this chapter provides some discussion concerning line losses.

Include in this entry any filter insertion losses which are applicable to the transmitter or receiver of interest.

5.4.11 ENTRY 9

Entry 9 represents the sum of the various contributing Column A and attenuating Column B factors affecting the final value of the interference level.

5.4.12 ENTRY 10

Entry 10 is the sum of Columns A and B and represents the interference level in dbm at the receiver input.

5.4.13 ENTRY 11

This is the desired signal expected at the receiver for a given power output of the desired transmitter, antenna gains, and propagation losses.

5.4.14 ENTRY 12

This entry represents the signal to interference ratio $S/I_{db} = S(\text{dbm}) - I(\text{dbm})$ which forms the basis for scoring the degree of interference.

1. THE MEASUREMENT OF INTERFERENCE SIGNALS

It is obvious that in order to design equipment that is neither a source of, nor susceptible to, radio interference, there must be available adequate means of measuring both the amount of interference generated by, and the degree of susceptibility of, a component, equipment, or complete installation. "Adequate means" here refers not only to the necessary test equipment but also standardized test procedures and a set of meaningful limits in terms of easily measured quantities.

As was explained in Section 1 of Chapter 1, Volume 1, the nature of interfering signals, in general, is such that no single quantity can be used for its adequate description. A complete description could be given only in the form of one of two equivalent curves, either a plot of amplitude as a function of time, or a plot of amplitude (or energy) as a function of frequency. The first is called the wave form, the second the frequency distribution. Neither of these is suitable for quick and easy determination, each requiring a very large number (theoretically an infinite number) of individual measurements.

If the interfering signal consists of a single transient, there is, indeed, no simple method available of obtaining significant information about it by means of a single or a very small number of measurements. But most interfering signals encountered in practice are either periodic, or such that the small differences between samples of the signal taken at different times are not significant. In either case, information about the signal at all times is not required, and attention may be focused on just a short space of time, either a cycle or an arbitrary interval. Furthermore, properties may be defined which can be measured by means of a single measurement, and these properties may be used to characterize the signal. The properties most commonly used are the true average (rarely used because it is usually zero), the half-cycle average, usually simply called "average"; the root-mean-square, and the peak values of the interfering current or voltage taken either over a period or over an arbitrary time interval.

All interfering signals consist, or may be considered to consist, of a series of pulses. In practice, most such signals may be classified as one of two types: the impulsive type, in which the individual pulses are very short as compared to the average repetition rate, so that a comparatively long period of silence exists between successive pulses,

and the random type, often called "white noise," in which the pulses follow one another so closely that the character of the individual pulses is completely lost. There is no sharp boundary between the two, and all intermediate stages are possible. Yet it seems that most interfering signals encountered in practice can definitely be placed in one group or the other.

Interference of the impulsive type will show very high peak values and very low average or root-mean-square values. In fact, on some type of meters reading average or root-mean-square values, an impulsive type of interference may indicate nothing despite having a high nuisance value. Random interference, on the other hand, is best measured by its average or root-mean-square value, while its peak value, which may be only slightly larger than the average and may be subject to considerable random variation, is of no great significance. Thus it is seen that a meter, or its mode of operation, must be chosen intelligently according to the type of interference to be measured.

Just as the type of meter to be used in measuring generated interference must be chosen according to the type of interference to be measured, so the generator used in susceptibility tests must be chosen according to the type of response of the receiver. Since any type of interference may be present, the susceptibility of a receiver should be tested with a signal of the type which causes the greatest response.

Inasmuch as all "receiver" (as defined in the Introduction to Volume I) must terminate in some kind of indicator or other device capable of responding to the interference, the simplest and most direct check on the presence of interference is by routine use of the equipment already installed as a functional part of a communication-electronic system. If all electrical components are of proper design and have been correctly installed, and no external interference is entering the equipment, no interference will be indicated by headsets, radar-scopes, or other output devices. If, on the other hand, interference is found in the system, test instruments must be employed to measure the interference and determine the source. In this chapter we discuss interference measurements and techniques in general. Further information on instruments and procedures is contained in succeeding chapters and appendices of this Volume.

2. CATEGORIES OF MEASUREMENTS

In general, interference measurements may be categorized in one of two ways:

a. Measurements to determine interference output and susceptibility potential of components, equipments, and systems

b. Measurements to determine characteristics, amounts, sources, and paths of interference signals

2.1 MEASUREMENTS OF INTERFERENCE OUTPUT AND SUSCEPTIBILITY POTENTIAL

Measurements to determine interference output and susceptibility potential are made in order to determine whether a system, equipment, or component will cause interference or is susceptible to interference. "Spectrum signature" measurements fall in this category and are fully discussed in Chapter 7 of this Volume. Similar measurements are also made to determine whether a system, equipment, or component will meet interference specifications such as those of the Army, Navy, or Air Force, Federal Communications Commission, or specialized procurement specifications (as for guided missiles or satellite systems). The measurements may be made in the laboratory or in the field, and may be made during equipment development, during prototype testing, or during production. A basic requirement of this type of measurement is a signal source to simulate an interfering signal in determining receiver susceptibility.

2.2 MEASUREMENTS OF INTERFERENCE FIELD CHARACTERISTICS

The elimination or suppression of existing interference depends upon accurate determination of the source, path, characteristics, and amount. This determination may require an investigation of the interference conditions within a circuit or it may require study of the electronic environment in the neighborhood of the equipment which is affected. Electronic environmental studies are discussed in Chapter 8 of this Volume.

In general, the techniques for measuring existing interference are similar to techniques for measuring potential interference. However, since characteristics of existing signals are being measured, signal sources are not necessary (except as comparison standards to determine the relative magnitude of interfering signals).

3. INSTRUMENTS AND TECHNIQUES

To determine potential or actual interference, measurements must be made of characteristics pertaining to transmitters, receivers, and antennas and propagation. Each of these three elements of a

communication-electronic system requires special techniques for measurement depending on the type of equipment, power, location, frequency, size, and circuitry. In general, these measurements are made with instruments and techniques as prescribed in technical specifications and standards. Major specifications currently in use are reprinted in Appendix V of Volume IV.

3.1 ESTABLISHING A MEASUREMENT CAPABILITY

3.1.1 GENERAL

The establishment of an RFI measurement capability is a complex and costly operation. Unless a small, specialized program is being considered, the establishment of anything short of broadband coverage is not recommended. Near-field measurements for specification compliance or for certification of shielded enclosures may require a frequency coverage from about 10 kc to 40 kmc. In terms of field intensity measuring receivers and signal generators, this represents many pieces of equipment. In fact, the upper portions of the frequency range can be covered only with custom-built units. In addition to the basic measuring equipments, the documentation of absolute value measurements requires a considerable quantity of calibration and auxiliary units, including antennas, connectors, matching devices, cables, and miscellaneous hardware. The establishment of a fixed facility generally involves the purchase and erection or construction of a screen room or microwave darkroom. The latter is preferable because of the additional attenuation afforded by sheet metal construction. Far-field measurements require a mobile, self-contained laboratory, preferably including an all weather capability. Because of the terrain often encountered, a separate four-wheel drive vehicle should be included. The need for on-site mobility may also necessitate an additional vehicle for personnel. Ample power should be provided for the mobile laboratory. The electronic equipment, heaters, air-conditioning, and lights will require some 5 to 10 kva.

Many of the test equipments are bulky and heavy and, at the same time, extremely delicate. Broad frequency coverage is frequently provided in several units by interchangeable RF tuning heads that have to be rotated often during spectrum search type programs.

If standard field intensity meters are used, the measured signal values can be obtained in $\mu\text{v}/\text{m}/\text{kc}$ or mV of bandwidth by applying the published attenuator, antenna, and calibration factors. The limiting factor on determining signal intensities is the sensitivity of the measuring receiver.

The antennas to be used in spectrum search applications should be chosen so as to use as few as feasible. Broadband antennas should be used whenever practical. One method for eliminating the need for changing antennas and their polarizations is to mount the antenna on a circular disc. The disc may be rotated in either the horizontal or vertical plane by gear trains with operating controls located in the mobile laboratory. The antennas may be connected to the measuring instruments by coaxial cable and flexible waveguide through appropriate rotary joints. This type of an antenna arrangement would enable spectrum search measurements to be conducted under all environmental considerations.

Data requirements may justify the use of automatic recording techniques for obtaining signal densities of a predetermined area. However, this technique may not enable the user to obtain information on all types of signals received in the search. The recorder trace, if made, must be correlated in time and frequency to obtain an accurate indication of the signals in a given time frame. The time limit would be governed by the response time of an associated recorder.

Many military specifications and contracts include the requirement for calibration of measurement instruments to be performed at regular intervals. In any case, recalibration will be necessary whenever repairs are made, or tubes or components are replaced.

3.1.2 MEASUREMENT PERSONNEL

Naturally the ability of a laboratory to properly function is dependent entirely on the competence of its staff. Personnel must receive special training for the jobs they are to perform, be intimately familiar with the equipment they use, and be able to properly interpret the data being processed. Many of the measuring equipment manufacturers provide courses to acquaint technical personnel with their equipment and how best it may be used.

3.2 A TYPICAL LABORATORY

Laboratories for conducting interference measurements may be either mobile or fixed. Since mobile laboratories are frequently used to simplify problems of access to equipment, such a laboratory will be

described here. Equipment for a fixed laboratory might be similar but arranged differently.

3.2.1 GENERAL LABORATORY CONSIDERATIONS

The operational capability requirements of a mobile laboratory are dictated by the user requirements. The general requirements for a mobile laboratory are: (1) the laboratory must be shielded and grounded (2) the power supply should be remote from the laboratory and grounded, and (3) the laboratory must be capable of operating under all environmental conditions that are likely to be encountered.

The laboratory should be equipped with standard radio frequency interference instrumentation to cover the spectrum 15 kcs to 10 gcs. A compact mobile vehicle should be used to provide maximum operational capability. The combination of mechanical and electrical requirements necessitates the application of a completely integrated approach to the design. The mobile unit not only must fully satisfy the electronic and instrumentation requirements, but also must provide maximum operating efficiency and personnel comfort. Thus, the design criteria for the mobile unit fall into two general categories: (a) human engineering considerations and (b) technical or equipment considerations.

From the human engineering standpoint, such factors as personnel comfort, ease of equipment operation and maintenance, efficiency of system layout, proper lighting, and other similar factors must be considered as an integral part of the overall design approach. Although human engineering principles are generally conceded to be important, they are frequently overlooked. Mobile units have been built which completely fulfill the technical requirements but which afford less than ideal operational flexibility and efficiency because the human factor has either been overlooked or given minimum attention. For example, equipment which is required to be operational continuously for long periods of time may inadvertently be mounted at a height which requires the operator to stand. In addition, equipment may not be grouped in such a way that multi-frequency operation can be carried out from one operating station.

3.2.2 BASIC EQUIPMENT

A satisfactory vehicle for a mobile laboratory for light field duty is described below, utilizing a Panel Truck with an air cooled engine. Such an engine requires no radiator fluid, antifreeze, or ra-

diator maintenance. A four-speed transmission is desirable. Side loading double doors, heavy duty absorbers, and overload springs should be provided.

In addition to the interference measurement equipments described below, sufficient tools and spare parts should be included to perform minor repairs and some calibration in the field.

4.2.3 EQUIPMENT DETAILS

Technical data pertaining to the equipments selected for the laboratory are shown in the following paragraphs. This data is included here in considerable detail for the specific purpose of aiding the engineer-reader with suggestions which may prove helpful in preparing specifications for the construction of a light duty mobile laboratory to fit his own needs.

4.2.3.1 Stoddart Field Intensity Meter NM-20H

Frequency Range: 150 kc to 25 mc in 6 bands

Sensitivity: $(S/N \geq 1)$

Narrow Band (CW) Measurements

Loop Antenna Input		Rod Antenna Input
Small Loop $\mu\text{v}/\text{meter}$	Large Loop $\mu\text{v}/\text{meter}$	$\mu\text{v}/\text{meter}$
10 to 30	2 to 6	2 to 5

Voltage Measurement Range: A measurement range of 40 db in each attenuator position is provided on a 2 decade meter scale. Attenuation in 20 db steps (0-20-40-60-80 db).

Detector functions may be selected for measuring FI, quasi-peak and peak.

Rejection: Image rejection is ≥ 50 db. LF rejection is ≥ 50 db.

Signal Overload Capacity: 16 db

Power input requirements are: (a) 105 to 125 or 210 to 250 volts ac, single phase, 50 to 1600 cps, consumes 25 watts and has an 87% power factor, and (b) bias batteries required (used for both ac and battery operation): 9 volts (2 Burgess No. 5360) plus 1.5 volts (2 Burgess No. 2)

Heat Dissipation. 85.3 BTU/hr

Physical Size:

FIM 7-9/16" x 14" x 16-7/16" or	1.01 cu. ft.
Power Supply 8-5/8" x 10-1/2" x 7-17/32" or	0.38 cu. ft.
Total space required	1.39 cu. ft.

Weight: FIM 37 lbs, Power Supply 18 lbs.

Component Parts Required.

<u>Component</u>	<u>Part No.</u>
NM-20B FIM	NM-20B
Power Supplies, AC	90780-2
Rod Antenna	90291-2
Loop Antenna, Small	90298-2
Loop Antenna, Large	91077-2
Matching Impedance	90305-4
Matching Impedance	90305-7
Remote Meter	90078-4
AC Power Cable	91258-1
Power Supply Cable	91487-1
Remote Meter Cable	90075-2
Loop Cable	90048-2
Oscilloscope Cable	90071-1
Headphone Extension Cable	90074-1
Headphones 300-7000 cps	10796
Loop Calibration Network	91160-1
Low Pass Filter	11148
Instruction Book	

Spare Tubes, Fuses, and Lamps.

<u>No. Spares Required</u>	<u>Type</u>
8	1T4 Tube
2	1R5 Tube
8	1R5 Tube
8	3V4 Tube
2	2A20 Tube
2	0A3-VK75 Tube
2	5/8A 5AG Fuse

3 2 3.2 Stoddart Field Intensity Meter NM-30A

Frequency Range. 20 to 400 mc in 6 bands



Sensitivity: $(S/N \geq 1)$

Narrow Band (CW) Measurements

Tuned Dipole Input	
Frequency (mc)	μ v Meter
20 to 145	0.6 to 4
145 to 240	8 to 13.6
240 to 400	40 to 60

Voltage Measurement Range: A measurement range of 40 db in any attenuator position is provided on a 2 decade meter scale. Attenuation in 20 db steps (0-20-40-60-80 db).

Detector functions may be selected for measuring FI, quasi-peak and peak.

Rejection: Spurious response rejection is ≥ 40 db. IF rejection is ≥ 60 db.

Signal Overload Capacity: 20 db \pm 2 db

Power input requirements are: 105 to 125 or 210 to 250 volts, ac, single-phase 50 to 60 cps and 400 cps, 120 watts at 115 volts, ac, 60 cps

Heat Dissipation: 409 B BTU/hr

Physical Size:

FIM 10-3/8" x 19-11/16" x 7-5/8"	or	0.9 cu. ft.
Power Supply 8-3/8" x 10-1/2" x 7-17/32"	or	0.38 cu. ft.
Total Space Required		1.28 cu. ft.

Weight: FIM 29 lbs, Power Supply 16 lbs.

Component Parts Required:

Component	Part No.
NM-30A FIM	NM-30A
Power Supply	91226-1
Dipole Antenna	90833-2
Head Assembly, High Frequency	
Dipole Antenna	90832-2
Head Assembly, Low Frequency	
Vertical Antenna Ground Plane	90429-2

Loop Antenna	90799-2
Frequency Measuring Tape	10645
R-F Transmission Line	
20 ft.	90933-1
AC Power Cable	91258-1
Oscilloscope Cable	90071-1
Remote Meter Cable	90075
Power Cable	91487-1
Loop Antenna	90995-2
Base Assembly	
Instruction Book	

Spare Tubes, Fuses and Lamps:

No. Spares Required	Type
8	5840
2	5718
12	6BH6
2	6005
2	5726
8	6135
2	6AU6
2	5814
2	OA2
2	OB2
2	2 amp 3AG Fuze
4	Lamp GE No. 47
2	Lamp NE-48

3.2.3.3 Stoddart Field Intensity Meter NM-52

Frequency Range: 375 to 1000 mc in 1 band

Sensitivity: $(S/N \geq 1)$

Narrow Band (CW) Measurements

Tuned Dipole Input

35 to 165 $\mu\text{v}/\text{meter}$

Voltage Measurement Range: A measurement range of 40 db in any attenuator position is provided on a 2 decade meter scale. Attenuation in 20 db steps (0-20-40-60-80-100 db).

Detector functions may be selected for measuring FI, quasi-peak and peak

Rejection: Image and spurious response rejection is ≥ 40 db. IF rejection is ≥ 60 db.

Signal Overload Capacity: 20 db

Power input requirements are: 105 to 125 or 210 to 250 volts, ac, 50 to 1600 cps, single-phase, 110 watts, 0.935 power factor.

Heat Dissipation: 375.6 BTU/hr

Physical Size:

FIM 10-3/8" x 19-13/16" x 9-3/16" or	1.09 cu. ft.
Power Supply 8-3/8" x 10-1/2" x 7-17/32" or	0.38 cu. ft.
Total Space Required	1.47 cu. ft.

Weight: FIM 30 lbs; Power Supply 16 lbs.

Component Parts Required:

<u>Component</u>	<u>Part No.</u>
NM-52A	NM-52A
Power Supply, AC	90329-4
Power Cable, AC	91258-1
Power Supply Cable	91487-1
Dipole Antenna	90330-3
RF Transmission Line	90933-8
Instruction Book	

Spare Tubes, Fuzes, and Lamps

<u>No. Spares Required</u>	<u>Type</u>
2	9005
4	6F4
16	6BH6
2	6AR5
4	6AL5
4	6C4
2	12AU7
2	6AS7
2	NE32
4	GE-47 Lamp
4	2 Amp, 250 volts Fuze AGC2

3. 2. 3. 4 Stoddart Field Intensity Meter NM-62A

Frequency Range. 1 to 10 gcs

Frequency Scanning. Controlled through variable speed motor drive.

Voltage Measurement Range: A measurement range of 40 db is provided on a 2 decade scale. Recorder output for plotting amplitude vs frequency.

Attenuation: 60 db RF and 20 db IF; instantaneous band switching

3. 2. 3. 5 Polarad Synchroscope-Spectrum Analyzer Model TSA-S

Frequency Range 910 to 22,000 megacycles in 4 bands

Tuning Units: STU-2A 910 to 4560 mc in 2 bands; STU-3A 4570 to 22,000 mc in 2 bands

Frequency Dial Accuracy: $\pm 1\%$

Power Requirements: 115/230 volts, ac, 50 to 60 cps, 400 watts

Heat Dissipation: 1366 BTU/hr

Physical Size:

Display Unit 17-1/8" x 19-1/2" x 23-1/8" or 4.08 cu. ft.

Tuning Unit 14.7" x 10.6" x 8.7" (approx) or 0.78 cu. ft.

Weight: 140 lbs. for display unit and one tuning unit.

3. 2. 3. 6 Frequency Meter, Gertsch FM-6

Weight: 45 lbs.

Size: 19-1/4" x 9 3/4" x 13-1/4"

Volume: 1.44 cu ft

Power Requirements. 115 or 230 volts, ac, 50 to 60 cps, 75 volt amps.

3. 2. 3. 7 Gonnet 3139 GA Transceiver

Weight: 35 lbs

Size: 10-3/4" x 10" x 8-1/4"

3. 2. 3. 8 Panoramic Panadapter SA-8B

Dimensions 12 1/8" x 22-1/2" x 20-1/4" or 3.23 cu ft

Power Supply Dimensions. 8-3/4" x 16-1/4" x 11-1/8" or 0.02 cu. ft.

Power Requirements: 115 volts, ac, 60 cps single-phase, approximately 50 watts

3. 2. 3. 9 Talk-A-Phone Intercom System

Type System: One master and two substations

Power Requirements: 115 volts, ac, 60 cps

Type Circuit: Transistor, 3 audio stages, push-pull output

Dimensions:

Master Station 15-1/2" x 6" x 4" or 0.215 cu. ft.

Substations 3-5/8" x 5-5/8" x 2" or 0.02 cu. ft.

Junction Box 1-1/4" x 8-3/4" x 8-3/4" or 0.05 cu. ft.

Power Supply 3" x 5" x 2" or 0.02 cu. ft.

Total Weight: 18-1/2 lbs

3. 2. 3. 10 Stromberg-Carlson Mobile Audio Amplifier SAM-88

Power Supply: 12 vdc, current drain 0.15 amp on standby,
0.3 amp speech, 0.5 amp music

Power leads: 3 ft. with fuse in positive lead

Power Output: 8 watts, less than 5% distortion

Response: 100 cps to 10,000 cps \pm 3 db

Inputs: 1 microphone, medium impedance (150-600 ohms),
phono, high impedance (0.5 megohms)

Gain: 97 db

Noise Level: 65 db below rated output

Controls: ON-OFF switch, microphone-phono selector switch,
gain control

Output Impedance: 4, 8, 16 ohms

Power leads: 3FY, identified for polarity

Transistors: 1 2N214, 2 2N226, 2 2N257

Mounting: "L" brackets furnished for mounting to bulbheads

Weight: 3 lbs.

Dimensions: 6-5/8" x 4-1/8" x 3-1/8" or 0.65 cu. ft

- 3.2.3.11 Recorder, Esterline Angus Model AW
 Range: 0 to 1 ma dc signal recording with events marker
 Accuracy: $\pm 1\%$ of full scale
 Dimensions: 8-9/16" x 14-1/2" x 8-3/4"
 Volume: 0.63 cu. ft.
 Power Requirements: 115 volts, ac, 60 cps, single-phase,
 5 to 6 watts
 Weight: 34 lbs
- 3.2.3.12 Polarad Broadband Antenna Model CA-B
 Frequency Range: 1 to 10 gcs
 Gain: 3 to 10 db
- 3.2.3.13 Stoddart Broadband Rod Discone
 Frequency Range: 20 mc to 900 mc
- 3.2.3.14 General Communication Position Remote RF Switch (1 required)
 Power Required: 115 volts, ac, 60 cycles
 Impedance: 51.5 Ω
 Switching: 6 Position rotary activated by remote selector switch
- 3.2.3.15 Bird Electronic Corporation CoaxSwitch Model 74 (6 required)
 Switching: 8 position manual coax selector switch, pull to rotate
 push to contact
 Impedance: 51.5 Ω
- 3.2.3.16 Bird Electronic Corporation Model 72R (1 required); 2 position
 coaxial circuit reversing switch
 Impedance: 51.5 Ω
- 3.2.3.17 Auxiliary Mast
 Mounting: Mounts in roof of van on bearing, rotates through
 370° in azimuth
 Fittings: Provides bracket on which any loop, dipole or rod
 antenna may be mounted. Provides facility for passage of
 single RF cable through roof. Interior bushing mounts a
 movable relative bearing scale

3.2.3.18 Modified Polarad CA-T Tripod

Azimuth Scale. Calibrated 0 to 90, 90 to 0, 0 to 90 and 90 to 0 degrees

Azimuth and Elevation Angle: Manual adjustment and lock

Level: Built-in bubble type

Collapsed Height: 36-1/2"

Extended Height: 60"

Modification: To include a calibrated scale for vertical elevation indications

3.2.3.19 Permanent Mast for Mounting all Antennas From 1 to 10 gcs

Mounting: Mounts permanently in roof of van on a bearing, rotates 370° in azimuth.

Fittings: Provides bracket on which Polarad CA-B omni-antenna is permanently mounted. Interior bushing mounts a movable, relative bearing scale. Provides mounting for remote RF coax switch. Contains controlled movable arm which rotates 90° off the horizontal for mounting L, S, M, and X Band horns.

3.2.3.20 Rotary Switch, 2 section, 2 pole, 6 position, 2 required

Type: Centralab Type 1009

3.2.3.21 Rotary Switch, 1 section, 1 pole, 6 position, 1 required

Type: Centralab Type 1001

3.2.3.22 Dial Plate, Mallory Type 376, 3 required

3.2.4 EQUIPMENT LAYOUT

Equipment should be arranged within the van for maximum operator convenience permitted by the limitations of the vehicle. All frequently used equipment should be located to permit operation without moving from a central control position. From past experience with the FRC mobile laboratories, it appears that frequency of equipment use is in the descending order below:

- a. Field Intensity Meters, antennas, and switching panel
- b. Recorder
- c. Spectrum analyzer
- d. Frequency meter

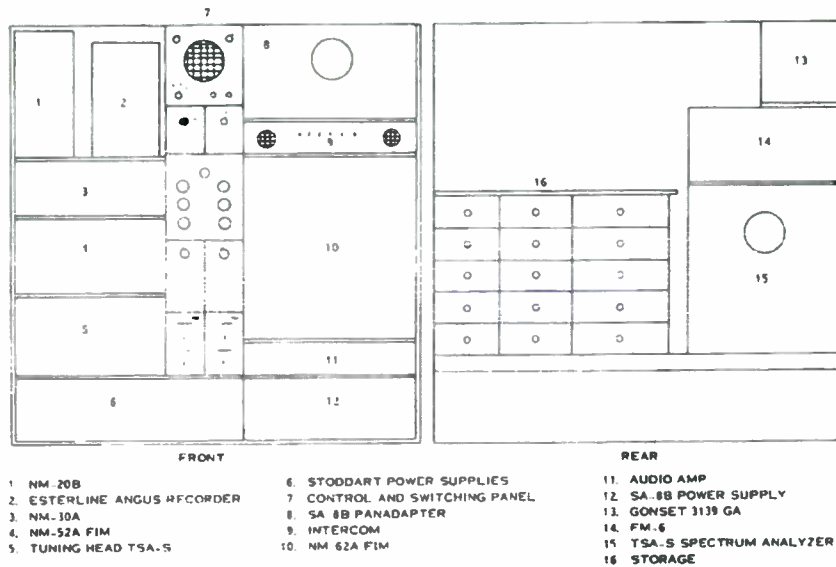

Figure 3-1. Layout of Van Interior

Roughly 90% of the time is spent in operating the category a equipment. It is desirable, therefore, to situate the control position in such a manner that all this equipment can be operated from a sitting position without the necessity of standing or moving. It is also desirable to provide writing facilities which do not interfere with operation but which are readily accessible. Category b, c, and d equipment can be located so as to allow either simultaneous operation by a second operator from another control position, or by the first operator with a minimum of movement.

Figure 3-1 shows the layout for a vehicle containing all of the required equipment. With this layout, field intensity measurements, spectrum searching, recording, and direction finding can be carried out from the forward operator's position. A rear operator's position allows the auxiliary functions, such as spectrum analysis and frequency measuring, to be carried on by a second operator, or by the first with a minimum of movement.

Certain features of the van are not evident in the figure but should be mentioned. These are:

a. All antennas can be simultaneously mounted on top of the van and controlled in azimuth and polarization from the operator's position. This eliminates the need for frequent climbing, a serious drawback in some laboratory designs.

b. A convenience box is located on top of the van. This is a weather-proof unit containing an intercom, 115 vac receptacle, remote FIM meter receptacle, and RF receptacle.

3.2.5 METHOD OF MOUNTING

Polyurethane sheets are used for shock mounting. The superior effectiveness of this method as compared to individual mounts is attested to by the fact that mobile laboratories using this mounting have covered thousands of miles over all types of terrain with no equipment failures directly traceable to shock. In addition, less space is required than conventional mounts. Quick release tie-down straps are used to hold the equipments in place. The use of the polyurethane sheets and tie-down straps has been of considerable value in preventing damage to equipment even when a large mobile laboratory overturned.

3.2.6 ANTENNAS

One of the more difficult tasks in outfitting a mobile laboratory is

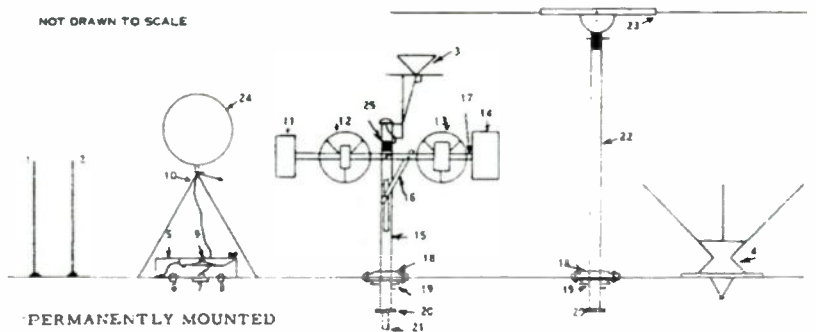

- | | |
|--|--|
| *1. TRANCEIVER ANTENNA | *13 M BAND HORN AND REFLECTOR |
| *2. ROD ANTENNA 150 KC TO 20 MC | *14 S-BAND HORN |
| *3. POLARAD CA-B OMNI ANTENNA 1 TO 10 GC | *15 ROTABLE ANTENNA MAST |
| *4. STODART DISCONE 20 TO 900 MC | *16 HORN ANTENNA ARM ACTIVATING LEVER |
| *5. CONVENIENCE BOX | *17 HORN ANTENNA MOUNTING ARM |
| *6. 110 VAC OUTLET | *18 BEARING |
| *7. RF JACK | *19. ADJUSTABLE AZIMUTH INDICATOR |
| *8. REMOTE METER JACK | *20. SLEWING KNOB |
| *9. INTERCOM OUTDOOR SPEAKER | *21 POLARIZATION CONTROL ROD |
| *10 MODIFIED POLARAD TRIPOD | *22. AUXILIARY ANTENNA MAST |
| *11. L-BAND HORN | *23. ANY DIPOLE, LOOP OR ROD ANTENNA |
| *12 X-BAND HORN AND REFLECTOR | *24 ANY DIPOLE, LOOP OR ROD ANTENNA |
| | *25 SIX POSITION RF SWITCH-REMOTELY CONTROLLED |

Figure 3-2. Mobile Laboratory Roof Antenna Arrangement

the selection of suitable antennas and the means for mounting them. The problem resolves itself into two parts:

- a. permanent installation of a set of omni-directional antennas to enable a spectrum search function to be accomplished over the desired frequency range.
- b. provisions for quickly mounting and dismounting directional antennas required for direction-finding functions.

Part 'a' is solved by utilizing a series of ferrite or rod and disc cone antennas permanently mounted atop the vans and connected to the receivers through a co-axial RF switching arrangement. It is realized that such antennas are subject to cross-polarization limitations, however, these limitations can be eliminated by suitable polarization and azimuth shifting devices. For example, consider the case of a horizontally polarized antenna at 2000 kc. A quick-turn 360° azimuth and 90° zenith control permits rapid determination of signal strength vs polarization during search.

Part 'b' is resolved by providing a series of height-staggered directional antennas installed only during direction-finding operations. Loop and sense antennas are utilized at the lower frequencies. Yagis are utilized at the intermediate frequencies, and horns at the higher frequencies. These antennas are on turnstile-type mounts to provide full-spectrum coverage without changing antennas. Azimuth and zenith angle indicators are provided inside the vans to give directional information. Manual drives are provided for the azimuth functions. To allow measurement of signal strengths, where desired, a plot of effective aperture (A_e) vs frequency is used with each antenna.

The antenna system allows both the search and the direction-finding functions to be accomplished with a minimum of effort on the part of the operators. Figure 3-2 shows the antenna arrangement.

3. 2. 7 CONTROL PANEL AND SWITCHING ARRANGEMENT

It is desirable that all switching functions required in the operation of vans be readily accomplished from the operating position. Thus, a central control and switching panel is used for all power, RF, IF, video, audio, and recording functions. This panel is logically arranged and so located as to allow the equipment operator to switch the various circuits as desired without leaving the operating position.



All RF energy is transferred from the antennas to the receivers by means of co-axial cables. While this entails some losses at the higher frequencies, these losses are offset by the convenience of co-axial switching as opposed to waveguide switching. The only difficulty in the RF switching is that involved in the frequency meter take-off. Incoming signals are too weak in many cases to actuate the meter, and it is then necessary to resort to the substitution method of measurement using a standard signal generator.

In the case of IF switching to the panoramic adaptors, it is necessary to provide an IF mixer and beat oscillator to insure system frequency compatibility. This is accomplished by switching the beat oscillator in conjunction with the IF switching to insure that the proper frequencies are always fed to the panadaptors.

The remainder of the control and switching functions involving power, video, audio, and recorder frequencies are straightforward and require no special discussion. Standard components are used throughout, and extra switching positions are provided to allow future expansion of the system.

3.2.8 POWER SUPPLY

3.2.8.1 General

The 115 volts, ac, 60 cps power can be furnished by a gasoline motor driven generator. An inverter will supply the 115 volts, ac, 400 cps from the 60 cps source.

Since heat, space, noise, interference, and weight distribution considerations limit the installation of power equipment within the limits of the van, a trailer should be used as a power supply vehicle.

Specifications of the generator, inverter, and trailer are listed below.

3.2.8.2 Power Plant:

Onan Model 5ccK-IR

Electrical Capacity: 5KVA

Type Engine: 4 cycle, 1800 rpm, gasoline driven

Type Starter: Self starting, 12 volt system, push button remote start

Dimensions: 29-7/8' x 20-3/4' x 21-1/8"; 7.55 cu. ft.

Output: 115 volts, 60 cycle, single-phase

Weight: 325 lbs.

Accessories: Vacuum flow cool

Gasoline Pump Capability: 4 ft. vertical lift

Fuel Consumption: approx. 3/4 gal./hr.

3.2.8.3 Inverter:

Georator Corp. Type 30-002

Output: 115 volts, ac, 408 to 420 cps, single-phase

Input: 115 volts, ac, 60 cps

Dimensions: 6" x 9 1/4" x 11"

Weight: 50 lbs.

3.2.8.4 Trailer:

Type: 2 wheel, rectangular with tail gate

Weight: 580 lbs.

Type Hitch: Ball

Tires: 640 x 15

Mount: Trailer mounted on springs

Dimension (Body): 72" x 48" x 18"

Dimension (Overall): 106" x 7" x 36"

3.2.8.5 Fuel Storage:

Capacity: 25 gal

Installation: Mounted on brackets in trailer

3.2.8.6 Alternate Power Plant

Onan Model 5ccK3R

Output: 115 and/or 230 volts ac, 60 cps

(other characteristics similar to Onan Model 5ccK-1R)

3.2.9 PERSONNEL COMFORT

To maintain maximum operator efficiency throughout the year, a combination heating and cooling system is desired. The most efficient method of obtaining this is to use a reverse cycle air conditioning system. Specifications for such a system are included below.

Type: Fedders 15FS3E

Cooling and Heating Capacity: 12,000 BTU/Hr.

Supplemental Electric Heating: 1800 watts

Cooling Capacity: 340 cu. ft. per minute

Power Supply: 220 volt, ac, 60 cps, 8.7 amps running

Dimensions: 16-1/4" x 27" x 19-1/2"

Type Intake: Fresh Air

Defrost Cycle: Automatic

3.2.10 HOUSEKEEPING PROVISIONS

Storage within the laboratory van is provided for antennas, maintenance parts and cables. In addition, a combination workbench and writing desk is provided. Each horn and omnidirectional antenna is stored and secured in an individual cushioned antenna bin. The antenna bin is constructed in such a manner as to be accessible from both front and rear directions, and is located in the rear of the truck. The antennas are secured in the bins by fasteners which will provide a quick dismount for the antenna. Dipole antennas and their associated masts are mounted by spring-clip fasteners to a board. The board is mounted on the side panel of the laboratory van. Cables, such as the RG-9/U for connecting the test equipment to its associated antenna, is stored on top of the motor cover. Drawers are available for the storage of maintenance parts and tools. The drawers are secured to prevent opening during on-the-road travel. The drop-leaf combination workbench and writing desk is large enough for minor repairs and adjustment of the equipment.

3.2.11 INSTRUCTION BOOK

An operating instruction book should be a part of the mobile van equipment, and should contain general instructions on the use of the mobile van, plan layouts, diagrams, and other graphic presentations, as may be needed, to facilitate operator familiarization with the units.

3.3 OTHER MOBILE LABORATORIES

The laboratory described in Section 3.1 above is well-equipped for interference testing under most conditions. However, for heavier duty work requiring more complete capabilities, a larger laboratory may be desirable. Other types of laboratories may be required for specialized work.

3.3.1 A HEAVY DUTY LABORATORY

A large heavy duty laboratory designed and built by Frederick Research Corporation consists of three elements:

a. An interference laboratory is mounted on a 27-foot truck chassis (see Figure 3-3). The laboratory is completely equipped with the most modern instrumentation for the performance of measurements from near zero to 44,000 mc. Working space and storage facilities are provided and the unit is completely air-conditioned and heated for personnel comfort. The test instruments and equipment are listed in Figure 3-5a and b. Each laboratory is screened and all equipment is shock-mounted and tied down with quick release straps. This allows individual items of equipment to be easily removed from the laboratory for remote measurements. Figure 3-4 shows a block diagram of major items in the heavy duty laboratory.

b. An FC-190 Jeep truck is used for two functions. A 10 kva gasoline driven engine generator is mounted on the truck bed and supplies the power necessary for operation. The truck is also used to tow the trailer for the 150-foot telescoping tower.

c. A 150-foot telescoping tower is included as part of the laboratory equipment to provide means of raising a test antenna to a sufficient height to get it into the main beam of radar antennas or similar radiators. In the telescoped carrying position, the tower is approximately 40 feet long. A gin-pole, winches, cables and pulleys are all included to provide means of erection.

3.3.2 LABORATORIES FOR SPECIALIZED PURPOSES

Laboratories for specialized purposes are shown in Figures 3-7, 3-8, and 3-9. The size and type of laboratory vary and the type of equipment in each case depends upon the tests to be made as well as the conditions of operation and the cost considerations. In general, the greater the quantity of data desired, and the wider the frequency range, the larger the laboratory will be and the more equipment will be required.

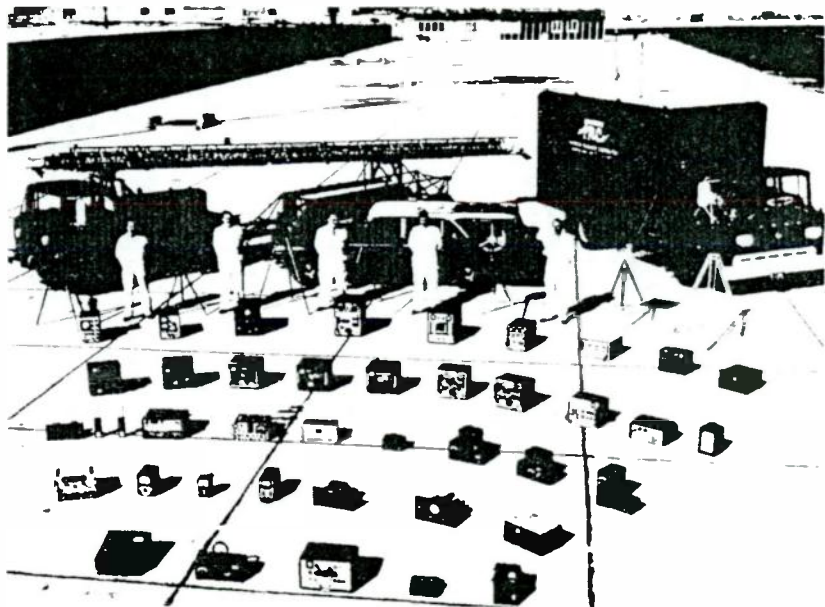
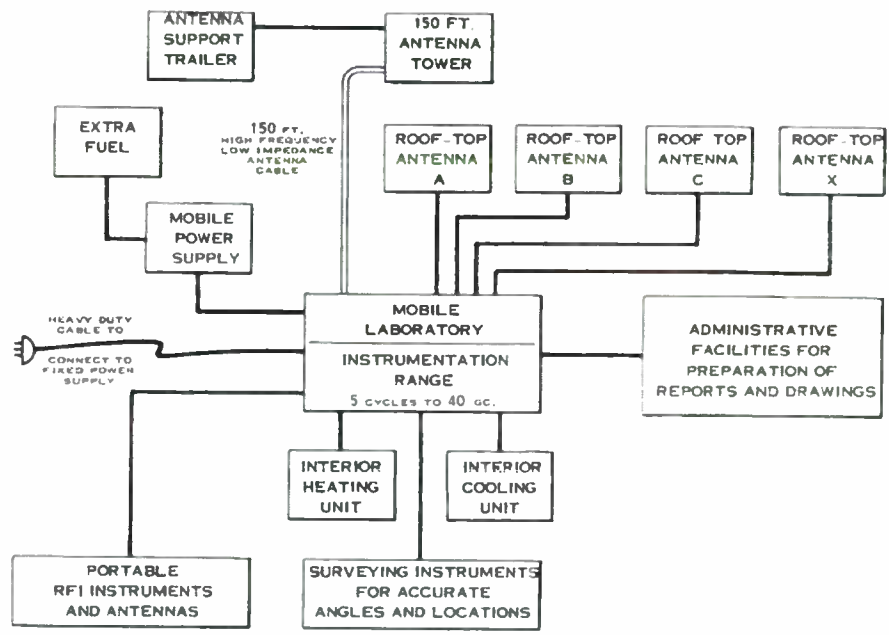

Figure 3-3. Heavy Duty Mobile Laboratory
(One of four owned and operated by Frederick Research Corporation)

3-24



3-25

Figure 3-4. Block Diagram of Major Items in Mobile RF Laboratory

EQUIPMENT	MODEL	FREQUENCY RANGE	REMARKS
SIGNAL GENERATORS			
GENERAL RADIO	1G1 A	5 mc - 30 mc	
HEWLETT PACKARD	808 F	10 - 400 mc	VHF
HEWLETT PACKARD	812 A	850 - 2,250 mc	UHF
POLARAD	MSC	950 - 2,400 mc	
POLARAD	MSL-2A	2,000 - 4,500 mc	
FIELD INTENSITY METERS			
STODDART	NM 45A	10 - 15 -	PORTABLE
STODDART	NM 10A	14 - 250 -	PORTABLE
STODDART	NM 25B	150 - 25 -	PORTABLE
STODDART	NM 50A	70 - 400 -	PORTABLE
STODDART	NM 50A	175 - 1,000 -	PORTABLE
STODDART	BATTERY BOX		PORTABLE
POLARAD	FIM B	1,000 - 16,000 -	BASIC UNIT
POLARAD	FIM P		POWER UNIT
POLARAD	FIM L	1,000 - 7,240 -	TUNING HEAD
POLARAD	FIM S	2,180 - 4,180 -	TUNING HEAD
POLARAD	FIM M	4,200 - 7,240 -	TUNING HEAD
POLARAD	FIM S	7,180 - 11,000 -	TUNING HEAD
RECEIVERS			
NATIONAL	HRC 604	30 - 30 -	WITH A B C D F G H AND J COIL SETS AND 60 RS SPEAKER WITH PSU-100B
HEMS CLARKE	'801	10 - 90 -	
PANADAPTOPS			
PANORAMIC	SA 882 '700	SAME AS NATIONAL	WITH POWER SUPPLY PS 88
PANORAMIC	SA 1 T124AC	SAME AS HEMS CLARKE RECEIVER	WITH POWER SUPPLY PS 88
SPECTRUM ANALYZER			
POLARAD	SA 88		10 - 400 -
POWER METER			
HEWLETT PACKARD	430C		
POLARAD	P-3		
COAX THERMISTOR MOUNT	4-1-8	10 - 1,000 -	
COAX THERMISTOR MOUNT	FM-1	10 - 10,000 -	
WAVEGUIDE THERMISTOR	K487B	3,700 - 12,800 -	
WAVEGUIDE THERMISTOR	PARTR	12,400 - 8,000 -	
WAVEGUIDE THERMISTOR	K487B	18,000 - 24,000 -	
FREQUENCY METER			
LAVOIE	LA-75A	1 - 1,700 -	
HARDA	RL-8	1,250 - 10,500 -	
HEWLETT PACKARD	8532A	8.75 - 12.800 -	DIRECT READ WAVE GUIDE FREQUENCY METER
HEWLETT PACKARD	87-72A	12.45 - 8,000 -	DIRECT READ WAVE GUIDE FREQUENCY METER
HEWLETT PACKARD	85-72A	8.75 - 12,800 -	

Figure 3-5a. List of Test and Measuring Equipment used in Frederick Research Corporation's Heavy Duty Mobile Laboratories

EQUIPMENT	MODEL	EFFICIENCY RANGE	REMARKS
ANTENNAS			
STOODART	ROD AND LOOPS	10 dBS - 1,000 W	
STOODART	DISCONE	20 W - 1,200 W	
POLARAD	CA L	1,000 W - 2,340 W	
POLARAD	CA-B	1,000 W - 10,000 W	
POLARAD	CA-S	2,740 W - 6,340 W	
POLARAD	CA-M	4,180 W - 7,240 W	
POLARAD	CA-R	18,000 W	
POLARAD	CA-X	7,160 W - 10,000 W	
POLARAD	MU	17,400 W - 18,000 W	
POLARAD	R	18,000 W - 26,500 W	
WAVEGUIDES			
POLARAD	WRU	17,400 W - 18,000 W	FLEXIBLE WAVEGUIDE
POLARAD	WR	18,000 W - 27,500 W	FLEXIBLE WAVEGUIDE
FILTERS			
MICROPHASE	LP1000	1,000 W	
MICROPHASE	LP1400	1,400 W	
MICROPHASE	LP1000	1,000 W	
MICROPHASE	LP1000	7,000 W	
MICROPHASE	HP1000	2,000 W	
MICROPHASE	LY1000	4,000 W	
MICROPHASE	LY1000	4,000 W	
MICROPHASE	LY1000	12,000 W	
MICROPHASE	HP1000	12,000 W	
ATTENUATORS			
WEINSCHTEL	210-A	1-10 W	
WEINSCHTEL	210-10	1-10 W	
WEINSCHTEL	210-20	2-10 W	
OTHER ACCESSORY EQUIPMENT			
SWEEP GENERATOR (RAY)	170A	50 W - 1,000 W	MEGA SWEEP
OSCILLOSCOPE (TELEVISION)	345A		WITH PRE-AMP CA
TUBE TESTER (MICRON)	938B		
MULTIMETER (SIMPSON)	24		
VTVM (HEWLETT PACKARD)	602H		
OSCILLOSCOPE CAMERA			
DUMONT:	172		
WALKIE TALKIE (NMF)	810J	CITIZEN'S BAND	TYPE 2414
TRIPOD (DAVID WHITE)	810P		
TRIPOD (DAVID WHITE)	9010		
LEVELING ROD (DIETZGEN)	6510		
RECORDER (ESTERLINE ANGLIS)	4MILLIAMMETER		
RECORDER (SANTORN)	151-170A		
Voice Audio Pre Amp (SANTORN)	151-1600		
COAX CABLE	RG-18A (1)		
COAX CABLE	RG-9		
ANTENNA ROTOR AND INDICATOR			10 W
POWER GENERATOR (ONAN)			
ANTENNA TOWERS			
C-2 WAY	15V - TELESCOPING		
	5C - PORTABLE		

Figure 3-5b. Test and Measuring Equipment
(Continued)



Figure 3-6. Inside Views of an FRC Heavy Duty Mobile Laboratory



Figure 3-7. A Light Duty Mobile Laboratory Constructed By Frederick Research Corporation for a Special RFI Survey

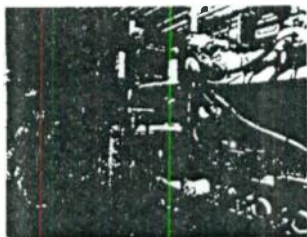

Figure 3-8. Interior Views of the Light Duty FRC Mobile Laboratory

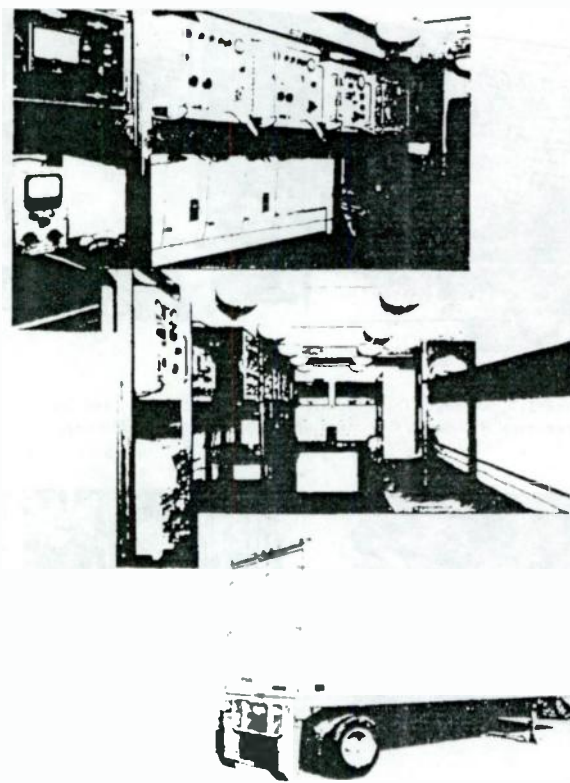

Figure 3-9. A Large Trailer Type Laboratory Designed and Constructed by Frederick Research Corporation for a Special Army Project

4. TYPICAL INTERFERENCE TESTS

Interference measurements may be made either inside the laboratory or under actual environmental conditions. The principal advantage of a laboratory measurement is that the test can be accomplished under known and standardized conditions. This fact makes the determination of the radiation, conduction, and transmission of energy by components or equipment units particularly amenable to laboratory techniques. On the other hand, field tests provide information on the characteristics of an equipment in its actual operating environment. These results, because of the reflection, refraction, and absorption effects of environmental objects, may differ considerably from those obtained in the laboratory.

In this section we will discuss typical tests on various types of equipment and components. (Details of measurements necessary to obtain spectrum signatures are presented in Chapter 7).

4.1 MEASUREMENT OF THE RADIATION PATTERN OF A HIGH GAIN HF ANTENNA

In order to maximize both the transmitted power efficiency and the received signal effectiveness in the high frequency region of the radio spectrum, emphasis is placed on the design and testing of large, high gain antennas. The concept of high main lobe gain connotes considerable directionality. In addition, the problem of unintentional interference from off-axis radiations has led to the reduction of side-lobe levels through the use of designs such as the Tapered Aperture Horn and multiple rhombic antennas with gains of 20 to 25 db, sidelobe suppressions of 15 to 20 db and dynamic ranges in the order of 50 to 60 db overall. The testing of these antennas is normally accomplished in the laboratory by making pattern measurements on scale models at UHF wavelengths, but because of the variations in radiation patterns caused by the operational environment, it is often highly desirable to perform field measurements.

With a large, fixed installation, such as an HF rhombic antenna, the measurement of three-dimensional patterns require airborne as well as ground-based equipment. The aircraft may be either fixed or rotary wing. Helicopters offer the advantages of landing area versatility, maneuverability, and low forward speed. Fixed wing aircraft are more stable at high elevations, offer more load carrying ability, and have far less vibration. Let us assume the use of a helicopter. Because of vibration, it is desirable to carry the signal source and transmitting antenna aboard the aircraft and connect the antenna under test to the receiving equipment. Regardless of the type of pattern being measured, the elevation-azimuth position of the source relative to the antenna under test must be known at all times. Since three-dimensional tracking radar is generally not available, and farfield distance is not excessive at these frequencies, an optical tracker has proven satisfactory. Range is computed from altitude and elevation angles. After any necessary corrections have been made to equate received signal strengths to a constant radius from the receiving antenna, these signal levels are converted to db below peak amplitude and plotted against the azimuth-elevation position of the source to provide the desired patterns.

4 1 1 AIRBORNE INSTRUMENTATION

Since a majority of the HF antennas are broadband, most measurement programs will involve several frequencies. Optimum use of the available flying time requires a multichannel signal source and a broadband transmitting antenna, such as is illustrated by block diagram in Section A of Figure 3-10. It is desirable that the radiated power be high enough to permit operation of the receiver(s) with considerable input attenuation. This insures ample dynamic range and allows measurement at levels well above the ambient noise or interference. Radiation of about 5 watts on an assigned channel should be ample at tracking ranges of two to three miles. The transmitting antenna can be of several designs. The simplest consists of an end-fed monopole trailed 100 to 120 feet behind the aircraft. The monopole should be less than one-quarter wavelength at the highest frequency used. Of prime importance is the transmission of a broad, single lobe pattern so that slight variations between the axis of the antenna and a tangent drawn to the flight path circle will not adversely affect the power level radiated toward the antenna under test. Several other antennas which could be trailed from the helicopter include a center-fed broadband dipole composed of radiating elements separated by tuned circuits which alter the electrical length with frequency. Another antenna, although not as practical, is a standard dipole which can be reeled back



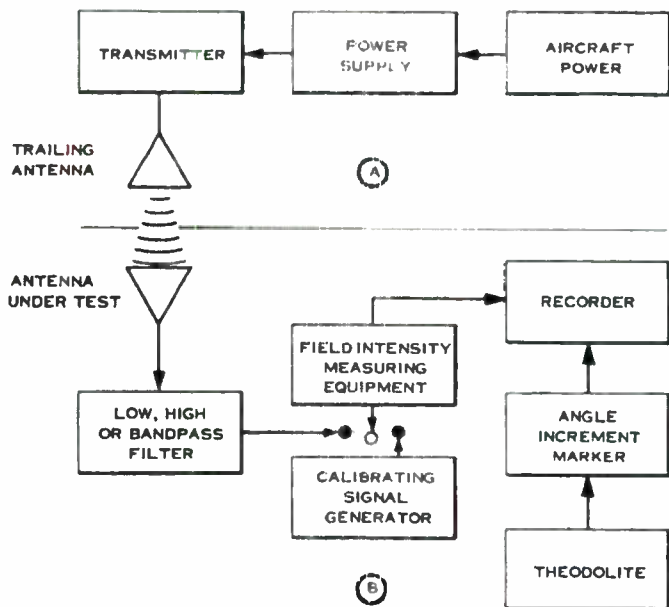

Figure 3-10. Block Diagram of Test Configuration

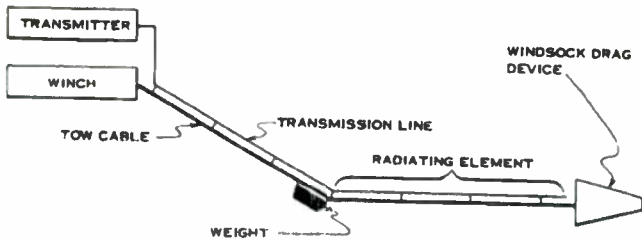

Figure 3-11. Horizontal Polarization

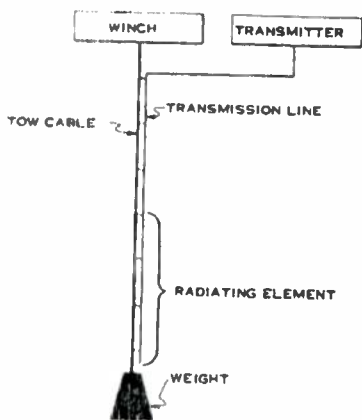

Figure 3-12. Vertical Polarization



into the helicopter and physically shortened as the frequency increases. The principal disadvantage of this type antenna, aside from having to return it to the aircraft often, is the requirement that all patterns at the same frequency be completed before the antenna is modified. In order to keep the antenna well below the plane of the helicopter rotor blade(s) and to lessen the possibility of reflection and modulation from the rotor blades, it is best to trail the antenna with weights and drag devices some 100 to 150 feet behind and below the aircraft. By proper choice of aircraft speed, weight, and windsock drag, any desired transmission line droop angle can be achieved. Arrangements which have been successfully used are shown in Figures 3-11 a and b.

4.1.2 SPACE POSITION DETERMINATION

One satisfactory method of tracking involves a theodolite, manually operated, with an angle increment output connected to the events marker of a strip chart recorder. Such a theodolite could consist of a high resolution, high magnification alidade mounted on a heavy azimuth plate. The azimuth plate attaches to a standard surveyor's tripod for ease of leveling and mobility. The vertical plane arc is unlimited. The azimuth plate contains small protrusions every 10 degrees of arc which are used to trip a microswitch suspended below the plate. This switch, connected in series with a battery and the recorder events marker, causes a pulse to appear on the trace every 10 degrees. A parallel circuit is used to mark the trace when the transmitting antenna is at a point whose azimuth relation to the characteristic axis of the antenna is known. This mark is used to correlate the flight path and the signal strength recording. Increments less than 10 degrees are plotted by assuming a constant aircraft speed over any 10 degrees increment and making a linear division of the space between the leading edges of successive pulses. There is provision on the tracker for driving a multi-turn linear potentiometer from the azimuth plate. The angular position of the tracker can then be determined by comparing a trace of the potentiometer voltage output against a laboratory trace calibrated in voltage output and rotation angle. A similar arrangement utilizing a single turn potentiometer is included for the determination of elevation angle.

4.1.3 RECEIVING AND RECORDING EQUIPMENTS

4.1.3.1 Instrumentation

The instrumentation for receiving and recording should include:

- a. A field intensity meter covering the desired frequency range. It would be most desirable to have a dynamic range comparable to that of the recorders.
- b. An accurate signal generator covering the same frequency range.
- c. A strip chart recorder with events markers and a wide dynamic range. In measurement of high gain HF antennas, a dynamic range of about 40 db should suffice.

Figure 3-10b shows the basic setup for receiving and recording equipments. The block labeled filter is indicative of the fact that the field intensity meter should be properly filtered to eliminate the possibilities of adjacent channel interference.

4.1.3.2 Theory of Operation

The detected output of the field intensity meter will follow the variations of received signal strength in accordance with the directional characteristics of the antenna under test. This detected output is coupled to the strip chart recorder, whose deflection mechanism follows and records the same variations.

The strip chart recorder events markers are coupled to the tracking device. One marker is pulsed at intervals corresponding to a 10 degree change in azimuthal bearing. The strip chart recorder, therefore, records a rectangular plot of received signal strength vs the azimuthal bearing of the signal source. The other events marker is synchronized to pulse at azimuthal reference points, e. g., the antenna's physical boresight location, back boresight, etc. The main lobe axis can be referenced to a compass direction by using a standard surveyor's transit.

4.1.3.3 Calibration

The test set-up is calibrated by means of the signal substitution method as follows:

- a. The signal generator is coupled to the RF input of the field intensity meter.
- b. The output of the signal generator is varied in increments of approximately 2 db and the corresponding deflection noted on the strip chart recorder.



This procedure is carried throughout the field intensity meter input attenuator ranges used during the antenna pattern measurements and at the specific frequencies

4.3.4 FLIGHT PATTERNS

The flight patterns chosen for making measurements can vary widely. It is desired that the final results should present a vertical plane picture of the main lobe and a polar coordinate display a 360 degree azimuthal pattern taken at the elevation angle which passes through the peak power point of the main lobe. The method described in this section places no restriction on polarization used. Either vertical or horizontal polarization may be used equally well. Vertical patterns are measured by flying a serpentine pattern back and forth between ground reference points on either side of the antenna axis, as illustrated by Figure 3-12.

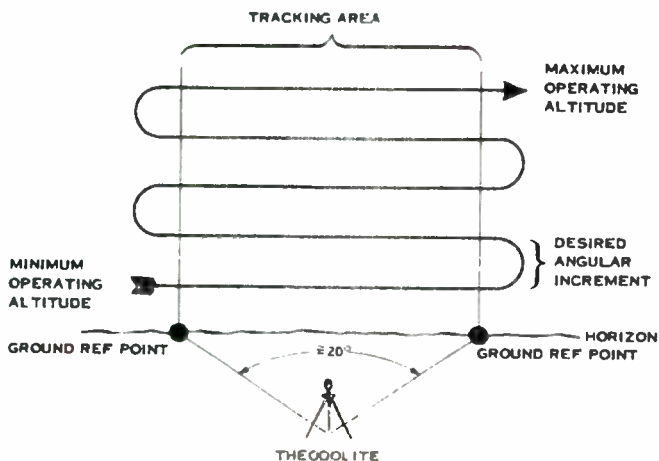

Figure 3-12. Serpentine Flight Path for Obtaining Vertical Radiation Pattern



Each segment of the serpentine flight path is a constant altitude run followed by an ascending or descending 180 degree turn to reverse direction. The altitude changes between each segment can be adjusted to yield any desired incremental definition. The angular coverage of the main beam is only limited by the minimum and maximum operating altitudes of the aircraft. By providing a certain minimum horizontal coverage during vertical pattern measurements, any azimuthal variations in the peak power point can be noted. During a vertical pattern measurement, a selected altitude can be rerun at intervals to determine any drift in the system power transfer. Azimuthal patterns are accomplished by flying the aircraft in a constant-radius circle around the tracker while maintaining a constant indicated altitude, as shown in Figure 3-13. The system drift

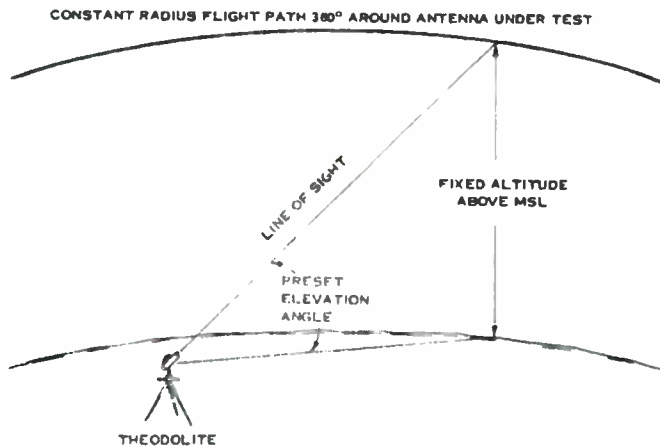

Figure 3-13 Azimuthal Flight Path for Obtaining Horizontal Radiation Pattern

is checked on these patterns by overlapping some selected azimuth at the end of the run. By pre-calculating the track elevation angle for many indicated altitudes, it is possible to preset the proper angle into the tracker and maintain the aircraft within the field of view by voice commands over a ground-to-air communications link. This plan is valid only when the field of view of the tracker represents an angular variation which, when converted to a constant altitude "drift in" or "drift out" error, causes received power variations within acceptable limits.

4.1.5 DATA REDUCTION AND ERROR ANALYSIS

Due to the fact that only relative signal strength measurements are desirable for antenna pattern display, the problem of data reduction is quite simple and straightforward. The maximum received signal strength, for a particular pattern, is equated to zero db and all other values are expressed in terms of db below peak antenna gain.

The signal substitution method, employing a precision signal generator, field intensity meter, and chart recorder, should be used for calibrating equipment. For relative signal strength measurements, this procedure should yield an uncertainty in patterns of approximately ± 1 db.

To eliminate parallax corrections the tracking device should be placed along the antenna boresight and in the apparent center of the antenna. Due to many factors, this will not always be practicable or possible. Therefore, corrections must be made to the instantaneous angle tracked to arrive at the azimuthal bearing of the signal source relative to the apparent center of the antenna.

For obvious reasons, the flight path is held at a constant radius from the tracker. It follows, therefore, that the signal source will not always be the equidistant from the apparent center of the antenna. Corrections for the path loss should be applied in these cases.

Referring to Figure 3-13, it may readily be seen that the line-of-sight distance will be increasingly greater as the signal source altitude (therefore, elevation angle) is increased. As in the previous case, path loss corrections should again be taken into account.

As discussed previously in Section 4.1.4, flying check altitudes and overlapping boresight measurements should eliminate the uncertainty of receiver drift and/or changes in transmitter radiated power.

4.1.5.1 Data Presentation

The measured data should be presented in a format designed to project the more useful information and attempts should be made to render quick access to such data. Figures 3-14 and 3-15 show vertical and horizontal patterns respectively measured recently by Frederick Research Corporation in the field. Although the desired information for antenna patterns is contained in the figures, additional data may be used in other presentations. Some examples are:

- a. A plot of beamwidth at the half power points in the horizontal plane vs frequency.
- b. Beamwidth at the half power points in the vertical plane vs frequency.
- c. Elevation angle of main lobe axis vs frequency (vertical plane)
- d. Principal sidelobe and backlobe levels may be tabulated vs frequency.
- e. If the design or model data is made accessible to the measurement contractor, it may be desirable to also make comparative plots of model to measured data.

4.1.6 AN ALTERNATE PROCEDURE

The procedures described in the previous paragraphs are designed to yield vertical patterns through the main lobe at either polarization, and azimuthal patterns through the peak power point of the main lobe. Regardless of the number of frequencies or polarizations chosen, the main beam vertical plane definition may be selected by the choice of run separation for the serpentine path. There is no data gathered on the vertical patterns of the secondary lobes.

As an alternate procedure, it is possible to obtain multiple azimuthal patterns at the same frequency and polarization. The vertical plane radiation is then roughly determined for all of the lobes by plotting the relative field intensities from each pattern for a selected azimuth. One drawback, however, is encountered where there is a significant difference

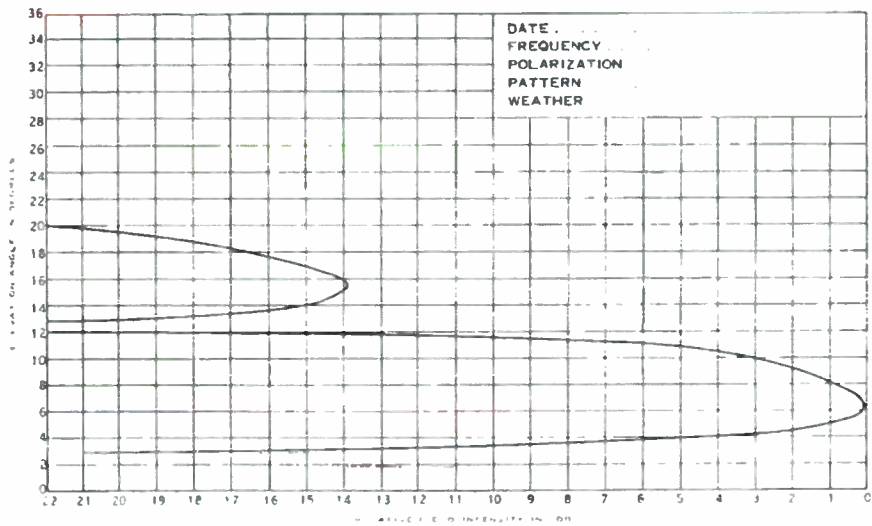

Figure 3-14. Vertical Radiation Pattern

3-41

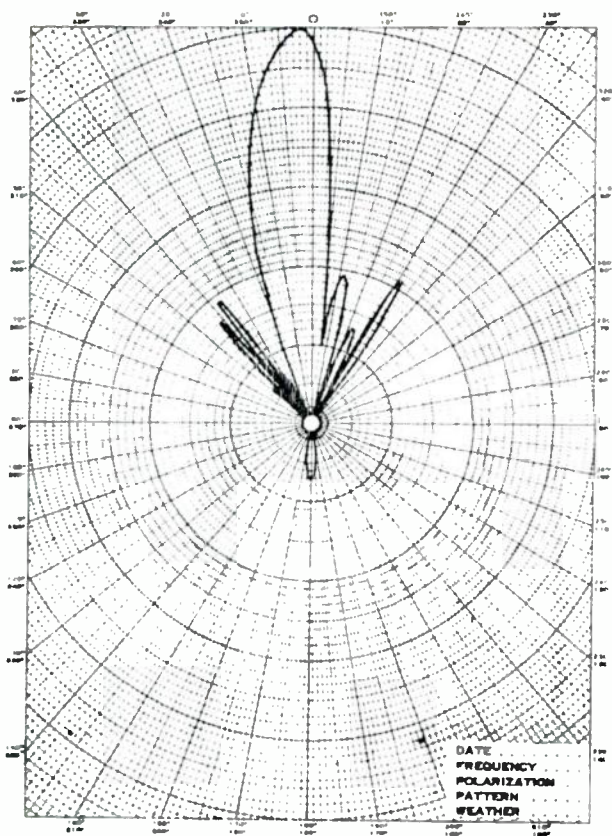

Figure 3-15 Horizontal Radiation Pattern

in the take-off angles of the secondary lobes. There is the possibility of obtaining little or no coverage, depending upon the disparity of take-off angle. There is, of course, the same problem existing for the main lobe unless preliminary data is available showing a probable vertical distribution.

4.2 INTERFERENCE TEST OF A RECEIVER TO DETERMINE CONFORMANCE TO A MILITARY SPECIFICATION (MIL-I-16910A)

The tests described in this section are typical of military specification certification tests on radio receivers. For the purposes of the description we will consider Radio Receiver Model X, having a frequency range of 30 to 260 mc, manufactured by Smith and Brown, Inc. (fictitious name). Audio, Video and IF outputs are provided. Video bandwidth is variable from 1 to 300 kc. Three IF channels or modes are available: Audio Gain, IF Gain, BFO On-Off, BFO Pitch, Squelch and AGC-Manual. The set operates from 115 volts ac and has provisions for a 50 Ω antenna input to each band. The receiver employs double IF conversion when operating in the 10 kc AM IF mode. A 1 mc IF output is available at the rear of the chassis for this mode of operation. In the 300 kc AM and FM modes, an IF output of 21.4 mc is provided.

4.2.1 GENERAL INFORMATION

Purpose of Test:

Evaluation of the degree of conformance of Radio Receiver Model X to Specification MIL-I-16910A(SHIPS) including Amendment 2.

Manufacturer:

Smith and Brown, Inc.

Manufacturer's Type or Model No.:

Model X, Serial No. XN-1.

Drawing, Specification or Exhibit:

MIL-I-16910A(SHIPS) and MIL-I-16910A(SHIPS) Amendment 2

Quantity of Items Tested:

One.

Security Classification of Items.

Unclassified.

Date Test Completed:

15 January 1962

Test Conducted By:

L. Q. Fleenor, J. A. Hopkins, and J. D. Powers.

Disposition of Specimens:

Returned to Smith and Brown, Inc.

4.2.2 SUMMARY OF THE TEST

The Model X Radio Receiver was tested over the frequency range of 0.014 mc to 10 kmc to ascertain the degree of conformity to MIL-1-16910A(SHIPS) and MIL-1-16910A(SHIPS) Amendment 2. Tests were performed for conducted and radiated interference and data was obtained for the equipment spectrum signature.

The equipment was checked for both narrow and broadband interference. Gross deviations from the specification were noted in a pre-check of the test sample. RFI fixes were then employed to eliminate or reduce interference below specification limits. All data recorded in this report was obtained after implementation of the RFI fixes.

The only deviation from the specifications noted after implementation of the RFI fixes was line radiation of the 6th harmonic of the 21.4 mc BFO at 128 mc. Investigation showed that the power line was cut to 1/2 wavelength of 128 mc during this test. When the line length was changed to a non-harmonic length, this harmonic did not appear above specification limits.

4.2.3 RFI FIXES EMPLOYED IN MODEL X RADIO RECEIVER

4.2.3.1 Line Conducted (Power Line)

- a. Add line filter in shielded box
- b. Add bypass capacitors on power transformer high voltage secondary (for low frequency hash)

4. 2. 3. 2 IF Chassis

- a. Add L matching network to 1 mc IF output.
- b. Add shield around both IF outputs.
- c. Add choke in 22.4 oscillator B+ lead and bypass capacitor.
- d. Add .22 μ f to B+ lead of 1 mc BFO.
- e. Add bypass (.0047) to 10 kc B+ lead
- f. Change ground point of existing bypass (away from 22.4 mc oscillator).

4. 2. 3. 3 High Band Tuner (55-260 mc)

- a. Add 6.8 μ h choke in 150 volt B+ lead to local oscillator

4. 2. 4 TEST EQUIPMENT DESCRIPTION

4. 2. 4. 1 Test Apparatus Used

In accordance with Table 1 of MIL-I-16910A, the following Class 1 interference measuring instruments were utilized during the tests:

a. Interference Measuring Instruments

Frequency Range	Model No.	Serial No.	Calibration Date
0.014 - 0.15 mc	Stoddart NM-10A	239-35	9-26-61
0.15 - 25 mc	Stoddart NM-20B	251-20	9-18-61
20 - 400 mc	Stoddart NM-30A	248-3	9-25-61
375 - 1000 mc	Stoddart NM-50A	249-24	9-1-61
1000 - 2240 mc	Polarad FIM-L	147	10-4-61
2140 - 4340 mc	Polarad FIM-S	131	10-3-61
4200 - 7740 mc	Polarad FIM-M	138	10-3-61
7360 - 10,000 mc	Polarad FIM-X	138	9-30-61

b. Signal Generators

Frequency Range	Model No.	Serial No.	Calibration Date
5 kc - 50 mc	General Radio 1601-A	3653	9-9-61
10 mc - 480 mc	Hewlett-Packard 608C	369-02403	9-13-61
400 - 1230 mc	Hewlett-Packard 612A	279-C1690	9-12-61
950 - 2400 mc	Polarad MSG-1	353	9-15-61
2150 - 4600 mc	Polarad MSG-2	261	9-14-61
54 - 216 mc	Boonton 202E	5019	10-19-61

c. Vacuum Tube Voltmeter

Frequency Range	Model No.	Serial No.	Calibration Date
10 cps - 4 mc	Hewlett-Packard 400H	7854	9-19-61

d. Polarad Field Intensity Measuring Equipment Specifications

Frequency Range. 1000 to 10,000 mc in 4 bands.

Tuning Unit FIM-L: 1000 to 2240 mc.

Tuning Unit FIM-S: 2140 to 4340 mc.

Tuning Unit FIM-M: 4200 to 7740 mc.

Tuning Unit FIM-X: 7360 to 10,000 mc.

Frequency Calibration Accuracy. Better than $\pm 2\%$.

Input Sensitivity: Better than -85 dbm.

Input Impedance: 50 ohms nominal.

Bandwidth: 5 mc 6 db down, 3 mc 3 db down.

Image and Spurious Response Rejection. Better than 60 db.

Signal Attenuation: 80 db maximum.

RF: 0 to 60 db in 20 db steps.

IF: 20 db.

Intermediate Frequencies

First: 260 mc

Second: 140 mc

Third: 40 mc.

Calibration Signal: 0.2 v rms to 5 microvolts.

Power Supply: 115 v ac, $\pm 10\%$, 50 cps, single-phase.

e. Antennas and impedance matching devices used during the tests were those specified by the equipment manufacturer or by Specification MIL-I-16910A.

4.2.5 TEST PROCEDURE

The test procedures were identical to those described in the following sections of the Specifications* MIL-I-16910A(SHIPS) and MIL-I-16910A (SHIPS) Amendment 2:

3.8.2	4.4	4.5.1.4.4
3.8.3	4.4.1	4.5.1.4.5
3.8.4.1	4.4.2	4.5.1.4.6
3.8.4.2	4.4.3	4.5.1.4.7
3.8.4.3	4.5.1.3.1.2	4.5.1.4.11
3.8.4.4	4.5.1.3.1.3	
3.8.4.5	4.5.1.4.3	

These sections are referenced in lieu of reporting them herein.

Specific test procedures preface each report of test data.

4.2.6 GENERAL TEST CONDITIONS

The test conditions outlined in MIL-I-16910A were followed as near as practicable. Equipment configurations for the various test setups are shown in Figures 3-16, 3-17, 3-18, and 3-19.

Radiation from the line and test sample from 25 mc to 1000 mc was measured in "open space" as defined by the specification. Radiation from the line and test sample from 0.014 mc to 25 mc was measured inside the Frederick Research Corporation shielded mobile laboratory at the "open space" site in Spencerville, Maryland. All other measurements were made inside the mobile laboratory at Smith and Brown, Inc.

* Copies of Military Specifications on Interference are contained in Volume 4, Appendix V of this Handbook.

Power was supplied to the mobile laboratory by a 10 kw Onan generator mounted on a Jeep truck. Line voltage was 117 volts $\pm 3\%$ for all tests.

The test sample operated normally throughout the tests.

Specific test conditions preface each report of the data collected.

4.2.7 REPORT TERMS

Results of the tests specified in MIL-I-16910A were reported in standard units as follows:

a. Radiated

(1) Broadband RFI in microvolts per meter per kilocycle bandwidth.

(2) CW type RFI in microvolts per meter.

b. Conducted

(1) Broadband RFI in microvolts per kilocycle bandwidth.

(2) CW type RFI in microvolts.

The spurious response and noise limits are given in the equipment specification in terms of db below the required response. Therefore, the results of tests required by the equipment specification were reported in the following terms:

c. Conducted

(1) Broadband RFI in db above one microvolt per kilocycle bandwidth.

(2) CW RFI in db above one microvolt.

These terms may be converted to the standard units by the application of the following formula:

$$E_{\text{(in microvolts)}} = \text{Anti Log } \frac{\text{db (above 1 } \mu\text{v)}}{20}$$



4.2.8 SAMPLE CALCULATIONS

a. Equipment: NM-20B

Frequency of broadband conducted measurements: 0.15 mc

Meter reading: 20 μ v

Attenuator: X10

Correction factor: 1

Random noise bandwidth: 2.26 kc

Microvolts per kc (μ v/kc)

$$\begin{aligned}\mu\text{v/kc} &= \frac{(\text{meter reading}) (\text{attenuator}) (\text{correction factor})}{2.26} \\ &= \frac{(20) (10) (1)}{2.26} = 88.6 \mu\text{v/kc}\end{aligned}$$

db above 1 microvolt/kc (db, μ v/kc)

$$= 20 \log 88.6 = 39 \text{ db above } 1 \mu\text{v/kc}$$

b. Equipment: NM-50A

Frequency of broadband radiated measurements: 750 mc

Meter reading: 18 μ v

Attenuation: X10

Correction factor: 0.65

Random noise bandwidth = Impulse bandwidth \times 0.74

$$\text{at } 750 \text{ mc} = (500 \text{ kc}) (0.74) = 370 \text{ kc}$$

$$\mu\text{v/kc} = \frac{(18) (10) (0.65)}{370} = 0.315 \mu\text{v/kc}$$

$$\text{db}/\mu\text{v/kc} = 20 \log 0.315 = -10 \text{ db}/\mu\text{v/kc}$$

No correction factor for cable length vs frequency was used in the calculations since all Frederick Research measuring equipment is calibrated using a 20'0" length of RG-9 coaxial cable which is employed in the tests.

4.2.9 POWER LINE CONDUCTED RFI TEST

4.2.9.1 Specific Test Conditions

A non-shielded 3-lead power line cut as short as practicable was connected to the line impedance stabilization networks. The third lead was connected to ground. No RF input was provided. (See Figures 3-16 and 3-17).

4.2.9.2 Specific Test Procedure

The tuning dial was set to 45 mc on band 1 and 160 mc on band 2 (mid-points). Scans were made in each position of the IF channel selector. Measurements were made after all operating controls were maximized for interference. Measurements were made as specified over the frequency range of 0.15 mc to 160 mc on each phase of both bands. The results are tabulated in the following pages.

4.2.9.3 Test Results (Table 3-A)

No RFI was observed that exceeded specifications.



Figure 3-16 Line Impedance Stabilization Networks
Mounting and Connection Detail

TABLE 3-A. POWER LINE CONDUCTED RFI TEST FROM 0.15 TO 10 MC.

Frequency (Meters)	Type	Band 1		Band 2	Latus
		Line 1	Line 2		
15	MB	11.7	14.4	0.7	10.9
14.75	DB	5	8.8	1.4	5.6
14	DB	1.5	15.3	2.5	15.6
13	DB	1.6	0.7	1.6	7.1
12	DB	2.9	0.1	1.6	15.8
11	DB	2.9	0.1	1.6	15.8
10	DB	4.7	1.1	1.6	16.6
9	DB	1.9	1.1	1.6	13.5
8	DB	1.1	1.1	1.1	12.8
7	DB	2.6	2.6	2.6	7.8
6	DB	2.6	2.6	2.6	7.8
5	DB	2.6	2.6	2.6	7.8
4	DB	2.6	2.6	2.6	7.8
3	DB	2.6	2.6	2.6	7.8
2	DB	2.6	2.6	2.6	7.8
1	DB	2.6	2.6	2.6	7.8
15	MB	11.7	14.4	0.7	10.9
14.75	DB	5	8.8	1.4	5.6
14	DB	1.5	15.3	2.5	15.6
13	DB	1.6	0.7	1.6	7.1
12	DB	2.9	0.1	1.6	15.8
11	DB	2.9	0.1	1.6	15.8
10	DB	4.7	1.1	1.6	16.6
9	DB	1.9	1.1	1.6	13.5
8	DB	1.1	1.1	1.1	12.8
7	DB	2.6	2.6	2.6	7.8
6	DB	2.6	2.6	2.6	7.8
5	DB	2.6	2.6	2.6	7.8
4	DB	2.6	2.6	2.6	7.8
3	DB	2.6	2.6	2.6	7.8
2	DB	2.6	2.6	2.6	7.8
1	DB	2.6	2.6	2.6	7.8
15	MB	11.7	14.4	0.7	10.9
14.75	DB	5	8.8	1.4	5.6
14	DB	1.5	15.3	2.5	15.6
13	DB	1.6	0.7	1.6	7.1
12	DB	2.9	0.1	1.6	15.8
11	DB	2.9	0.1	1.6	15.8
10	DB	4.7	1.1	1.6	16.6
9	DB	1.9	1.1	1.6	13.5
8	DB	1.1	1.1	1.1	12.8
7	DB	2.6	2.6	2.6	7.8
6	DB	2.6	2.6	2.6	7.8
5	DB	2.6	2.6	2.6	7.8
4	DB	2.6	2.6	2.6	7.8
3	DB	2.6	2.6	2.6	7.8
2	DB	2.6	2.6	2.6	7.8
1	DB	2.6	2.6	2.6	7.8

F ₁ (MHz)	Type	S ₁		S ₂		S ₃	S ₄	S ₅	S ₆	S ₇	S ₈	S ₉	S ₁₀
		dBm	dB	dBm	dB								
44.8	CA												
49.1	AM					1.2							
51.2	C		1.2										
63.5	CW					1.8							
64	CA		6		6								
76.9	CA	1.7	1.6	1.5	1.4								
153	CA	2.1	2.2	2.2	2								

The above table is a summary of the results of the tests conducted on the test sample. The test results are given in dBm and dB. The test results are given in dBm and dB. The test results are given in dBm and dB.

TABLE 3-A (Continued). POWER LINE CONDUCTED RFI TEST FROM 0.15 TO 100 MC.

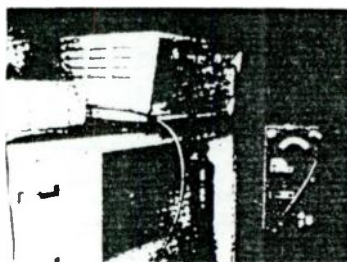

Figure 3-17. Equipment Arrangement of Test Sample (Model X Receiver), Line Impedance Stabilization Networks, Ground Plane and Stoccard NM-26B

4. 2. 10 EXTERNAL SYSTEMS CONNECTIONS CONDUCTED RFI TEST
21.4 mc IF OUTPUT JACK

4. 2. 10. 1 Specific Test Conditions

A 10 μ v, 45 mc signal was fed into the RF jack of Band 1 and a 10 μ v, 160 mc signal was fed into the RF jack of Band 2.

4. 2. 10. 2 Specific Test Procedure

The tuning dials were set to the test signal for each band. A measurement was made of the desired response (21.4 mc). Both bands were then scanned in each position of the IF channel selector from 0.15 mc to 100 mc for spurious responses and RFI. The results are tabulated in the following pages.

4. 2. 10. 3 Requirement

The test sample equipment specification requires all spurious responses arising from the equipment itself to be 40 db below the desired response to a 10 μ v signal.

4. 2. 10. 4 Desired Response

111.5 db at 21.4 mc - Band 1

111 db at 21.4 mc - Band 2

4. 2. 10. 5 Spurious Limit

111.5 db - 40 db = 71.5 db - Band 1

111 db - 40 db = 71 db - Band 2

4. 2. 10. 6 Test Result (Table 3-B)

No response was observed in excess of specifications.

4. 2. 11 EXTERNAL SYSTEMS CONNECTIONS CONDUCTED RFI TEST
1 mc IF OUTPUT JACK

4. 2. 11. 1 Specific Test Condition

A 10 μ v, 45 mc signal was fed into the RF jack of Band 1 and a 10 μ v, 160 mc signal was fed into the RF jack of Band 2.

FREQUENCY TEST RANGE 0-15 MC 150 MC

Spurious Limit

Band 1- 71.5 db above a microvolt

Band 2- 71 db above a microvolt

Broadband measurements are in db above a microvolt per Kc of

bandwidth, continuous wave measurements are in db above a microvolt

Frequency (Megacycles)	Type Interference	Band 1 30 - 60 mc	Band 2 55 - 260 mc
15	RF	13.8	14.3
22.5	DF	19.4	17.9
3	RF	17.8	16.1
4	DF	17.4	25.4
5	RF	21.6	16.6
6	RF	11.6	7.6
7.5	BF		3
8	CW	12	
9.9	CW		24
9.95	CW	13	
1.2	CW	10.5	9.5
1.6	CW	10	9.5
1.98	CW		32
2.0	CW	6.5	
2.03	CW	10.1	
2.4	CW	12.5	12
2.97	CW		31.5

Frequency (Megacycles)	Type Interference	Band 1 30 - 60 mc	Band 2 55 - 260 mc
3.7	CW	1	10
3.92	CW		1.2
1.48	CA		21.1
6.7	CA		
4.02	CA	24	
4.1	CA	17	1
6.24	CA		14
5.32	CA		6.5
7.41	CA		17.2
8.2	CA		11
6.54	CA		12
6.1	CA		4
6.21	CA		24
7.25	CA		
9.2	CA		16
8.04	CA		1
8.9	CA		12.1
9.45	CW		11
9.6	CA		11
9.8	CA		16
12.0	CW		19.5
12.8	CA		8.8
13.0	CA		13

TABLE 3-B. EXTERNAL SYSTEMS CONNECTIONS CONDUCTED RFI TEST
21.4 MC IF OUTPUT JACK

FREQUENCY TEST RANGE: 0.15 mc - 100 mc

Frequency (Megacycles)	Type Interference	Band 1 10 - 60 mc	Band 2 60 - 260 mc
15.0	CW	1.5	
16.0	CW	6.0	11
19.2	CW	8.5	8
19.85	CW	9	
21.5	CW	11.5*	11*
22.1	CW		28.3
22.4	CW	31.5	
22.6	CW	29.5	29.8
22.8	CW	8	
24.7	CW	46.5	15.2
32	CW	0.5	1
38.4	CW		1.2
40.0	CW	13.3	
42.8	CW	62.0	71
44.8	CW	26	26.1
51.2	CW		10
53.1	CW	4.5	
64.2	CW		69.5
64.3	CW	69.8	
67.2	CW		15.8
67.3	CW	18.1	
76.8	CW	4	1
85.6	CW	88	15.3
88.8	CW	12.8	
89.6	CW		0.2
100	CW	5.5	5

* Desired response

TABLE 3-B (Continued). EXTERNAL SYSTEMS CONNECTIONS
CONDUCTED RFI TEST 21.4 MC IF OUTPUT JACK

4.2.11.2 Specific Test Procedure

The tuning dials were set to the test signals for each band. A measurement was made of the desired response (1 mc). Both bands were then scanned in each position of the IF channel selector from 0.15 mc to 100 mc for spurious responses and RFI. The results are tabulated in the following pages.

4.2.11.3 Requirement

The test sample equipment specification requires all spurious responses arising from the equipment itself to be 40 db below the desired response to a 10 μ v signal.

4.2.11.4 Desired Response

111.2 db at 1 mc for Band 1

110.5 db at 1 mc for Band 2

4.2.11.5 Spurious Limit

111.2 db - 40 db = 71.2 db for Band 1

110.5 db - 40 db = 70.5 db for Band 2

4.2.11.6 Test Result (Table 3-G)

No response was observed in excess of specifications.

4.2.12 EXTERNAL SYSTEMS CONNECTIONS CONDUCTED RFI TEST VIDEO OUTPUT JACK

4.2.12.1 Specific Test Condition

The following signals were fed into the RF input of each band.

Band 1 - 10 μ v, 45 mc, modulated 50% with 1 kc for 300 and 10 kc test.

Band 1 - 10 μ v, 55 mc, 100 kc deviation, 1 kc modulation for FM test.

Band 2 - 10 μ v, 160 mc, modulated 50% with 1 kc for 300 and 10 kc test.

FREQUENCY TEST RANGE 0.15 - 100 MC

Sporadic Limit

Band 1 71.2 db above a microvolt

Band 2 72.5 db above a microvolt

Broadband interference in 40 dB above a microvolt per Kc at band-width

Continuous wave interference in db above a microvolt

Frequency (Megacycles)	Type Interference	Band 1 0.15 - 60 mc	Band 2 55 - 200 mc
15	BB	5.2	
15	CW		6.5
22.5	BB	7.4	
22.5	CW		7.5
3	BB	7.1	
3	CW		
4	BB	7.2	
4	CW		10
5	BB	7.1	
5	CW		10
6	BB	7.2	
6	CW		10
8	BB	6.2	
8	CW		10
9.5	CW		11.0

Frequency (Megacycles)	Type Interference	Band 1 0.15 - 60 mc	Band 2 55 - 200 mc
1.0	CW	11.2	
1.2	CW	11.2	9.2
1.6	CW	10	9.5
1.34	CW		6.1
2	CW	6.1	
2.4	BB	2.9	4.4
3.2	CW	51.0	53.2
3.2	BB		1.4
3.2	CW	9	
4.1	CW	44.8	46.2
4.4	BB		1.1
4.4	CW	4.6	
5	CW	10	40.2
5	BB	36	24.2
7.4	BB		1.1
7	CW	15.4	16
8	CW	14	16.2
8.1	CW	7	
8.1	CW	11	
9.4	BB		7.4
9.6	CW	7	
9.5	CW		27.1

TABLE 3-C. EXTERNAL SYSTEMS CONNECTIONS CONDUCTED RFI TEST
1 MC IF OUTPUT JACK

FREQUENCY TEST RANGE 0.15 - 100 MC

Frequency (Megacycles)	Type Interference	Band 1 10 - 60 mc	Band 2 55 - 260 mc	Frequency (Megacycles)	Type Interference	Band 1 10 - 60 mc	Band 2 55 - 260 mc
9	CW	26.2		21.4	CW	56.2	
10.9	CW		24.1	21.5	CW		64
1.0	CW	21.6		22.25	CW	10	11.4
9	CW		25.6	22.5	CW	13.8	20.8
2.0	CW	24.6		23.2	CW		16.5
2.6	BB		25.1	23.25	CW	14.3	
2.8	BB	2.5		24.2	CW		11.4
2.84	CW		25	24.25	CW		
3.0	CW	23.3		31.2	CW		5.5
3.9	CW		19	32.0	CW	1.4	
4.0	CW	18		33.2	CW		7.5
14.4	CW		23	33.0	CW		5
15.0	CW	20		34	CW		5
6.0	CW	20.6	22.3	35	CW		2.2
17.0	CW		18.7	36	CW		6
17.2	CW	17.2		38.4	CW		4
9.0	CW		13	40.0	CW		
19	CW		18	42.8	CW	53.6	52.7
19.2	BB	1.4		44.8	CW	12	11.2
19.2	CW		16.6	51.2	CW	2.6	0.2
20.25	CW	16.5	18.5	64.2	CW	48.7	49.2
21.25	CW	11	21	67.2	CW	9.2	8

TABLE 3-C (Continued). EXTERNAL SYSTEMS CONNECTIONS CONDUCTED
RFI TEST 1 MC IF OUTPUT JACK

FREQUENCY TEST SIGNALS

Frequency (MHz)	IF	Band	Modulation	Modulation Frequency (kHz)
10.0	0.5	Band 1	AM	10
10.0	0.5	Band 1	FM	10
10.0	0.5	Band 1	FM	100
10.0	0.5	Band 1	FM	1000
10.0	0.5	Band 1	FM	10000
10.0	0.5	Band 1	FM	100000
10.0	0.5	Band 1	FM	1000000

Desired response

**TABLE 3-C (Continued). EXTERNAL SYSTEMS CONNECTIONS
CONDUCTED RFI TEST 1 MC IF OUTPUT JACK**

Band 2 - 10 μ v, 160 mc, 100 kc deviation, 1 kc modulation for FM test.

4. 2. 12. 2 Specific Test Procedure

The tuning dials were set to the test signals for the respective band and IF channel. A measurement was made of the desired response. Each IF channel was scanned on both bands over the frequency range of 0.15 mc to 100 mc for spurious responses and RFI. The results are tabulated in the following pages.

4. 2. 12. 3 Requirement

The test sample equipment specification requires all spurious responses arising from the equipment itself to be 40 db below the desired response to a 10 μ v signal.

The equipment specification gives the minimum allowable signal-to-noise ratio permitted for a given input. Measurements made with the specific inputs in each case showed that the noise limit was above the spurious limit. Therefore, the more restrictive spurious limit was cited on the data sheets.

4. 2. 12. 4 Desired Response

IF Position	Band 1 db above 1 μ v	Band 2 db above 1 μ v
300 kc	143.3	142.8
10 kc	129.5	129.0
FM	136.8	136.7

4. 2. 12. 5 Spurious Limit

IF Position	Band 1 db above 1 μ v	Band 2 db above 1 μ v
300 kc	103.3	102.8
10 kc	89.5	79.0
FM	96.8	96.7

4. 2. 12. 6 Test Result (Table 3-D)

No RFI was observed that exceeded specifications.

4. 2. 13 EXTERNAL SYSTEMS CONNECTIONS CONDUCTED RFI TEST AUDIO OUTPUT JACK

4. 2. 13. 1 Specific Test Condition

The following signals were fed into the RF input of each band.

Band 1 - 10 μ v, 45 mc, modulated 50% with 1 kc for 300 and 10 kc test.

Band 1 - 10 μ v, 55 mc, 160 kc deviation, 1 kc modulation for FM test.

Band 2 - 10 μ v, 100 mc, modulated 50% with 1 kc for 300 and 10 kc test.

Band 2 - 10 μ v, 160 mc, 100 kc deviation, 1 kc modulation for FM test.

Spectrum Limit

FREQUENCY TEST RANGE (15 - 10 MHz)

Band 1: 1.390 - 1.310 MHz, 34.5 - 37.5 MHz

Band 2: 37.50 - 102.0 MHz, 49 - 57.5 MHz

Broadband interference is displayed as measured per 100 kHz bandwidth

Continuous wave interference and spurious emissions								Frequency (MHz)	Type of Interference	Band 1 (1.390-1.310 MHz)			Band 2 (37.50-102.0 MHz)		
Frequency (MHz)	Type of Interference	1.390	1.380	1.370	1.360	1.350	1.340			37.50	49.0	57.5			
1	DR	98.8	5.5	14.1	83.1	2.6	85.1	4.8	DR	26.7	3.2	7.2	19.3	6.4	15.7
26.5	DR	44.9	6.9	81.4	8.3	81.9	6	6	DR	14.2	0.2	11.2	11.7		
27.5	CA		14					6	CA		26.1		27		
3	RR	79.8	5.7	0.6	9.1	8.1	26.1	8	DR	5.6		4	3.2		
4	RR	74.4	5.2	19.8	7.6	7.9	77.4	8	CA		18.5		17.2		
5	DR	72	3.8	2.4	2.3	1.6	1.4	9	RR		1.2				
6	DR	55.1		2.5	83.1		86.4	9.6	RR	1.4			2		
6	CA							9.6	CA				17		
7	DR	50.2		1.2	7.6		7.6	10	CA				16.4		
8	CA							10	DR						
1	DR	64.8	3.5					17.8	DR	11.5	5.3				
1	RR	27.1		13.5	1.1		1.1	17.9	CA						
2	CA							18	DR				1.6		
1.6	RR	17.3	7.2	16.8	11.4	8	7.1	18	CA				1.6		
1.9	RR	43.6	7	9.4		1.1	1.1	19.7	CA				1.4		
2.4	DR	17.1	4	4.9	3.4	4	77.4	19.2	CA	11.2					
3.3	DR							21	DR				3.4		1.1
3.3	CA							21.6	CA				6.2		
3.4	CA							21.7	DR						
3.2	CA							22	CA				26.4		6.6
4.8	DR	1.26	14.7	1.2	7.7	3.6	27.4	23	DR				7.2		

TABLE 3-D. EXTERNAL SYSTEMS CONNECTIONS CONDUCTED RFI TEST VIDEO OUTPUT JACK

FREQUENCY RESPONSE

Frequency (mc)	Response (dB)	Response (dB)	Response (dB)	Response (dB)	Response (dB)
0.15	20	20	20	20	20
0.2	20	20	20	20	20
0.3	20	20	20	20	20
0.5	20	20	20	20	20
1.0	20	20	20	20	20
2.0	20	20	20	20	20
3.0	20	20	20	20	20
5.0	20	20	20	20	20
10.0	20	20	20	20	20
20.0	20	20	20	20	20
30.0	20	20	20	20	20
50.0	20	20	20	20	20
100.0	20	20	20	20	20
200.0	20	20	20	20	20
300.0	20	20	20	20	20
500.0	20	20	20	20	20
1000.0	20	20	20	20	20

TABLE 3-D (Continued). EXTERNAL SYSTEMS CONNECTIONS
CONDUCTED RFI TEST VIDEO OUTPUT JACK

4. 2. 13. 2 Specific Test Procedure

The tuning dials were set to the test signals for respective band and IF channel. A measurement was made of the desired response. Each IF channel was scanned on both bands over the frequency range of 0. 15 mc to 1000 mc for spurious responses and RFI. The results are tabulated in the following pages.

4. 2. 13. 3 Requirement

The test sample equipment specification requires all spurious responses arising from the equipment itself to be 40 db below the desired response to a 10 μ v signal.

The equipment specification gives the minimum allowable signal-to-noise ratio permitted for a given input. Measurements made with the specific inputs in each case showed that the noise limit was above the spurious limit. Therefore, the more restrictive spurious limit was cited on the data sheets.



4.2.13.4 Desired Response

IF Position	Band 1 db above 1 μ v	Band 2 db above 1 μ v
300 kc	141.5	140.0
10 kc	138.7	139.4
FM	140.0	140.5

4.2.13.5 Spurious Limit

IF Position	Band 1 db above 1 μ v	Band 2 db above 1 μ v
300 kc	101.5	100.0
10 kc	98.7	99.4
FM	100.0	100.5

4.2.13.6 Test Result (Table 3-E)

No RFI was observed that exceeded specifications.

4.2.14 RECEIVER OSCILLATOR INTERFERENCE TEST

4.2.14.1 Specific Test Condition

The test sample receiver RF input was connected to the 50 Ω FIM input using RG-9A/U cable.

4.2.14.2 Specific Procedure

The FIM was tuned to the test sample oscillator frequencies and all receiver operating controls were tuned for maximum response on the FIM.

4.2.14.3 Requirement

Receiver oscillator interference shall not exceed 400 μ watts.

4.2.14.4 Test Result (Table 3-F)

No interference from the receiver oscillator was observed to exceed 400 μ watts.



EFFICIENCY TEST DATA

Operating Parameters

Bandband interference in dB above a microvolt per Hz of bandwidth

Continuous wave interference in dB above a microvolt

Frequency Megacycles per sec.	Type Interference	Band 1, 30-60 mc.			Band 2, 65-765 mc.		
		5-7 Mc.	100-150 Mc.	400-500 Mc.	1-2 Mc.	3-5 Mc.	15-20 Mc.
15	BB	8	4.8	53.2	59.6	6.4	62.4
22.5	BB	4.9	5.9	62	60.4	6.2	66.7
3	BB	30.2	4.1	41.3	34.4	5.5	83.4
9	BB	20	4.6	23.4	47.4	4.2	31.6
9	BB	23.2	23.2	19.2	15.6	3.2	34.4
9	BB	19.2		4.4	6.52	1.4	27.2
6	CB						
8	BB	5.1		9	5	6	21.2
8	CB						
14	BB	7.1	0	2.24	0		12.6
17	CB						
8	BB	3		0	0		12.6
8	CB					4.5	
7	BB	3		0	0		9.2

Bandwidth (Megacycles)	Type Interference	Band 1, 30-60 mc.		Band 2, 65-765 mc.		Total
		5-7 Mc.	100-150 Mc.	1-2 Mc.	3-5 Mc.	
2	CW					
4	BB	3.5				
2.4	CB					
3						
3.2	BB	1.96				
3.2	CB					
4	BB					
4	CB					
4	BB	11		3.2		
4.8	BB					
4.8	CB	12				
6	BB					
6	CB	10.5	10.4	5		
8	BB				2.24	
8	CB	10				
9.6	BB	0	1.2			
9.6	CB					
10.6	BB	9.4	1			
12.4	CB					
11	BB	0				
10	CB			4.5		
15.2	BB	0	3.1			

TABLE 3-E. EXTERNAL SYSTEMS CONNECTIONS CONDUCTED RFI TEST AUDIO JACK

FREQUENCY TEST RANGE 0 15-100 mc

Frequency (Megacycles)	Type Interference	Band 1 10-60 mc			Band 55-260 Mc		
		30 Kc	10 Kc	FM	300 Kc	10 Kc	FM
19.2	CW			10			
21.4	CW	47.8		50	23.8		
21.4	CW						48.5
22.4	CW		20.0				
22.5	CW					27	
25	WB	-92	-2.6		-4	-3.1	-1.1
25	CW			9			
32	BB	-14	-10.4	-0.4	-12.0	-14.9	-5.5
40	BB	10.4	-6.8	-12	7.32	-9.2	5.34
42.9	CW	47.8		47.2	43.5		45.8
44.8	CW		46.1		42.1		
51.2	BB		-9.12	-3.8	-7.8	-6.24	7.8
51.2	CW	35.6					
64.2	CW				42.2		
64.3	CW	43.9					
64.4	CA			4.4			4.7
50.2	BB		-9.36				
76.4	BB	-15.4	-14.1	-11.1	-17.7	-15.7	-12.6
95.0	CW	34.3					34.3
96.8	CW			33	35.5		
100	WB	-20.9	-17.4	-14.7	-14.4	0	-14.7

TABLE 3-E (Continued). EXTERNAL SYSTEMS CONNECTIONS CONDUCTED RFI TEST AUDIO JACK

Continuous wave measurements indicated in this table.
Limit: 400 microns per volt (1.6:4uV into 50Ω)

Oscillator Frequency (Megacycles)	Receiver Dist. Freq Megacycles	Type Interference	Band 2 55-100 mc
51.4	50	CA	2.1
61.6	4	CA	7.7
71.4	5	CA	1.8
80.4	54	CA	4
81.4	6	CA	6.1
101.4	80	CA	15.4
121.4	150	CW	3
141.4	12	CW	14.5
182	150	CW	8
221.3	190	CW	19.2
261.3	24	CA	8.7
282.5	261	CA	14.4

TABLE 3-F. RECEIVER OSCILLATOR INTERFERENCE TEST

4.2.15 UNDESIRED RADIATION TEST

4.2.15.1 Specific Test Condition

The test sample receiver RF input was connected to a non-inductive dummy load of arbitrary value (5, 4, 20, 36, 54, 66, and 94 Ω s). (See Figure 3-18). The dummy load was connected to a series decoupling resistor having approximately ten times the resistance of the dummy load. The decoupler was connected to the FIM with an RG-9A/Y cable.

4.2.15.2 Specific Procedure

The FIM was tuned to the oscillator frequency of the receiver. All operating controls of the test sample were adjusted for maximum response on the FIM and the response level noted. The decoupler resistor and RG-9A/U cable were then connected to a signal generator. The signal generator was then tuned to give maximum response on the FIM. Its output level was adjusted to the same reference noted above.

4.2.15.3 Requirement

Receiver oscillator radiation not to exceed 400 μ watts.

4.2.15.4 Test Result (Table 3-G)

No oscillator radiations were observed to exceed 400 μ watts with any load.



Figure 3-18. Connection of Dummy Loads

UNDESIRABLE RADIATION TEST																			
Band 1																			
Test Unit	Freq Dev	% Crn Output	Power ear	Lead 1 dbms	1/2 Crn Output	Power ear	Lead 1 dbms	7/8 Crn Output	Power ear	Lead 1 dbms	5/8 Crn Output	Power ear	Lead 1 dbms	3/8 Crn Output	Power ear	Lead 1 dbms	1/8 Crn Output	Power ear	Lead 1 dbms
1	11.4	0.5	0.05	5.4	0.5	132	15	0.5	0.05	136	15	0.5	114	54	ND	00	ND	00	ND
10	11.4	ND		5.4	0.5	318	20	ND		36	ND		54	ND	88	ND			84
15	11.4	ND		5.4	ND		70	ND		54	ND		54	ND	86	ND			84
1	11.4	ND		5.4	ND		22	ND		36	ND		54	ND	86	ND			84
Band 2																			
10	14.4	15	18.52	5.4	23	26.4	20	17	23.24	36	20	15.57	54	12	15.5	88	14	12.3	84
1	12.1	1.3	817	5.4	5.0	1.25	20	5.4	8.1	36	7.1	316	54	0.5	1.042	88	11.3	1.16	84
2	21.2	1.7	515	5.4	4.0	600	20	4.3	5.4	36	5.5	40	54	0.3	.603	88	7.0	.497	84
1	14.0	1.0	1.076	5.4	4.4	368	20	5.5	5.5	36	5.4	101	54	4.0	370	88	7.0	.321	84
10	142.0	2.84	1.15	5.4	2.3	255	20	2.5	1.4	36	3.4	267	54	4.2	.208	88	0.5	.452	84
1	125.4	1.0	1.076	5.4	4.0	1.2	24	8.7	1.0	36	0.0	1.15	36	10.2	1.375	88	12.0	1.072	84
10	200.4	2.0	.87	5.4	4.2	1.2	7	3.4	14	10	5.0	661	54	1.0	1.05	88	5.5	3.21	84
10	42.2	2.0	844	5.4	4.2	1.55	20	1.7	1.48	36	0.6	104	54	0.4	1.71	88	12.0	1.312	84

TABLE 3-G UNDESIRABLE RADIATION TEST

4.2.16 EQUIPMENT RADIATED RF TEST

4.2.16.1 Specific Test Conditions

Radiated test from 25 mc to 1000 mc were conducted in "open space" as shown in Figure 3-19. Due to the high RF ambient level below 25 mc the portion of the test from 0.014 mc to 25 mc was conducted inside the FRC shielded mobile laboratory at the "open space" site. Power lead length was limited to 2 feet in both tests. A ground plane with an earth ground was employed in the "open space" test for operating convenience and personnel safety.

4.2.16.2 Specific Procedures

Each band was scanned in each IF position and maximized readings were taken on each band at specified intervals.

4.2.16.3 Test Results (Table 3-II)

Radiation at 128.8 mc was observed to be $2.2\mu\text{v}$ above the specified limit of $14\ \mu\text{v}$. Investigation of the circuitry indicated that the power line lead length (2 feet specified outside equipment cover plus two feet inside cover to allow for normal installation) was one-half wavelength at 128 mc. The signal observed was the 6th harmonic of the 21.4 mc BFO. Since this condition will normally exist only under the prescribed test conditions and will not occur when the power line is of random length, it is recommended that an exception to the specification be allowed.



Figure 3-19. "Open Space" Test Set-up

Broadband interference measurements in microvolts per meter
per Kc of bandwidth.

014Kc 20-100 mc

Continuous wave measurements in microvolts per meter

Frequency (Megacycles)	Type Interference	Band 1 30-60 mc	Band 2 55-250 mc	Limits	Frequency (Megacycles)	Type Interference	Band 1 30-60 mc	Band 2 55-250 mc	Limits
014	BB	11 9	11 9	100	1 8	CW	1 8	1 8	5
019	BB	8 84	8 84	78	2 4	BB	1 87	2 57	2 8
024	BB	17 36	17 36	62	3 6	BB	2 37	2 32	2 5
028	BB	8 24	8 24	52	3 6	CW	3 2	3 7	5
037	BB	2 46	2 66	40	4 4	CW	4	4	5
044	CW	0 2	0 2	10	6 0	CW	1 8	1 4	5
048	CW	0 1	0 1	10	7 2	CW	1 2	1 2	5
046	CW	0 2	0 2	10	8 6	CW	4 7	4 2	5
046	CW	0 2	0 2	10	12 0	CW	1 8	1 8	5
12	CW	0 1	0 1	10	14 4	CW	1 8	1 8	5
50	CW	0 15	0 15	5	19 2	CW	4 1	4 1	5
57	CW	0 1	0 1	5	24	CW	1 8	1 8	5
224	CW	0 1	0 1	5	28 4	CW	1 8	1 36	5
289	BB	4 34	4 34	7	38 4	CW	6	1 8	5
371	BB	3 64	3 44	6 2	48 0	CW	1 25	1 25	5
41	BB	3 66	3 66	6	57 5	CW	1 4	1 64	5
6	BB	2 66	2 66	5 2	76	CW	4 17	4 7	5
71	BB	2 36	2 36	4 7	92	CW	1 4	1 31	5
9	CW	4 8	4 8	5	115 2	CW	1 4	1 4	5
12	CW	4 4	4 4	5	124 4	CW	1 27	1 2	2
15	BB	2	2	3 4	131 6	BB	1 11	1 11	1 4
					185	BB	1 11	1 11	1 5

TABLE 3-H. EQUIPMENT RADIATED RFI TEST

914Mc TO 1060 mc

Frequency (Megacycles)	Type Interference	Band 1 10 - 50 mc	Band 2 55 - 250 mc	Limits
210.4	BB	117	117	1.35
407.4	BB	165	765	6.1
494	BB	268	766	1.7
424	C-A	73.5	73.5	170
511	C-A	99	29	240
674	C-A	145	145	450
867	C-A	220	775	700
907	C-A	546	546	136.2

TABLE 3-H (Continued) EQUIPMENT RADIATED RFI TEST

4.2.17 EQUIPMENT: SPECTRUM SIGNATURE RADIATED

4.2.17.1 Specific Test Conditions

A nominal 50 ohm load was connected to the input of the receiver under test. The field intensity measuring equipment was connected to the load by a coaxial cable.

4.2.17.2 Test Procedure

The field intensity measuring equipment was tuned to the oscillator frequencies of the receiver under test, its harmonics and other areas of interest. A further check for spurious emissions was made by scanning the frequency spectrum from 14 Kc to 1000 mc.

4.2.17.3 Test Results

Signals in the frequency spectrum from 21.4 to 990 mc were observed during the spectrum scan. These signals are plotted in dbm as a function of frequency (See Figures 3-20, 3-21, and 3-22).



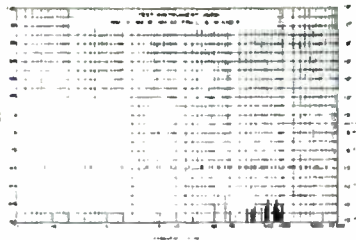

Figure 3-20. Equipment Spectrum Signature (.01-10,000 mc)

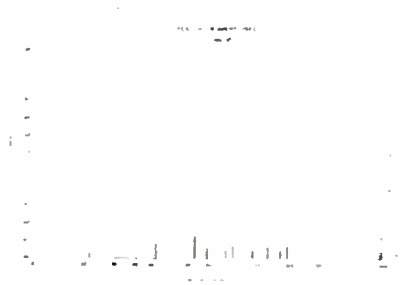

Figure 3-21. Equipment Spectrum Signature (10-1000 mc)

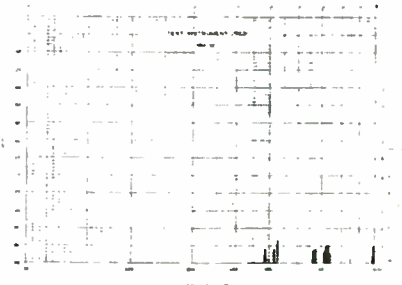

Figure 3-22. Equipment Spectrum Signature (100-1000 mc)

3-21

4.2.18 EQUIPMENT SPECTRUM SIGNATURE SUSCEPTIBILITY

4.2.18.1 Specific Test Conditions

A signal generator was connected to the RF input of the receiver under test by means of a coaxial cable to determine the minimum perceptible level of the receiver.

4.2.18.2 Test Procedure

The receiver under test and the signal generator were adjusted to identical frequencies and the receiver was adjusted to maximum sensitivity. The output of the signal generator was reduced to the minimum perceptible level of the receiver under test and the results recorded. This test was performed at three discrete frequencies per octave over the tuning range of the receiver.

Signal generators covering the frequency range from 14 kc to 10 mc were used to furnish a minimum input level to the antenna terminals of the receiver of 86 db above the minimum perceptible level of the receiver.

4.2.18.3 Test Results

Minimum perceptible signal levels of the receiver under test are shown in Table 3-1. An overall graph of susceptibility is shown in Figure 3-23. Figures 3-24, 3-25, 3-26, 3-27, 3-28, and 3-29 show the susceptibility to the individual test frequencies.

TEST REPORT SIGNATURES

This is to certify that to the best of my knowledge the attached report correctly represents the results of the test performed upon the Model X Radio Receiver for Smith-Brown, Incorporated.

This data is warranted only for the configurations utilized during the test and only if all RFI fixes, as listed in this report, are employed.

ATTEST:

J. D. Powers
Electronics Engineer
Frederick Research Corporation



BAND 1			
Dial Freq	IF CHANNELS		
Mr	TR	FM	SR
30	-127*	-127*	-127*
40	-127*	-127*	-126
50	127*	-127*	-127*
60	127*	127*	-127*

BAND 2			
80	-127*	-125	-127*
90	-127*	-125	-127*
100	-127*	-125	-124
110	-127*	-119	-125
140	-127*	-124	124
200	-127*	-115	-124
240	127*	-120	-123
260	-127*	-122	-123

*MPS was less than -127

The spectrum range was scanned using signal generators furnishing a minimum input level, to the receiver antenna terminals of 80 db above the receiver minimum perceptible level stated above.

TABLE 3-1. SUSCEPTIBILITY TEST

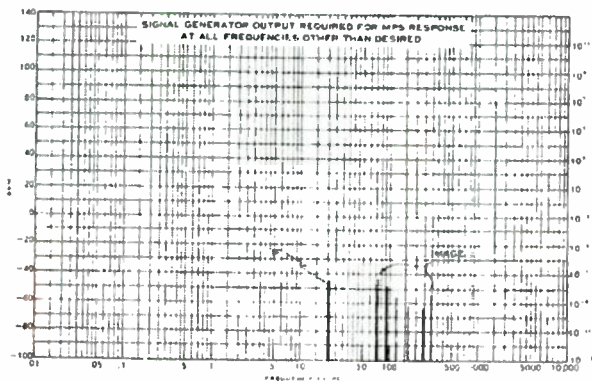

Figure 3-23. Susceptibility Test (All Test Frequencies)

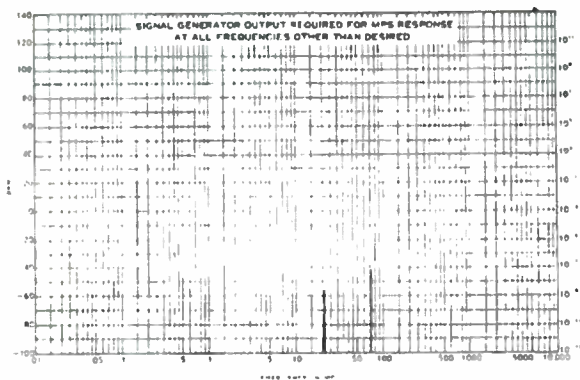

Figure 3-24. Susceptibility Test (30 mc)

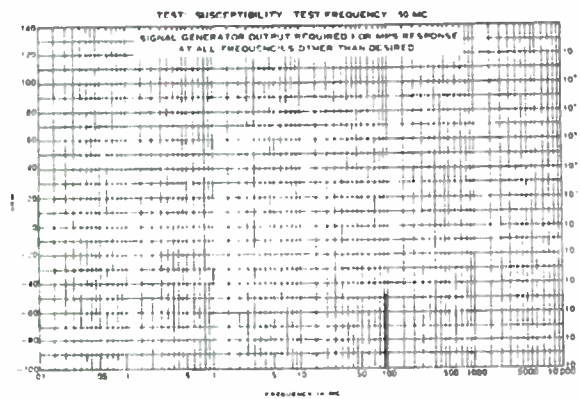

Figure 3-25. Susceptibility Test (50 mc)



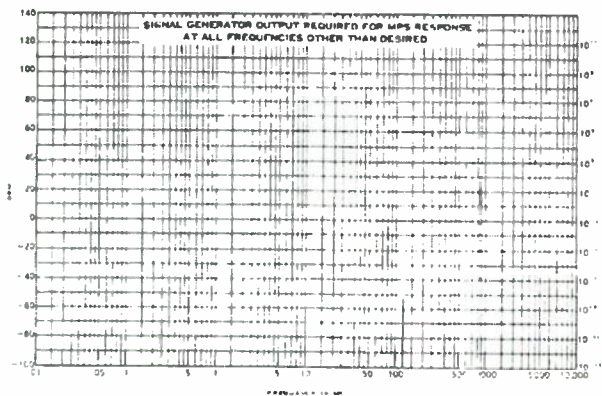

Figure 3-26. Susceptibility Test (80 mc)

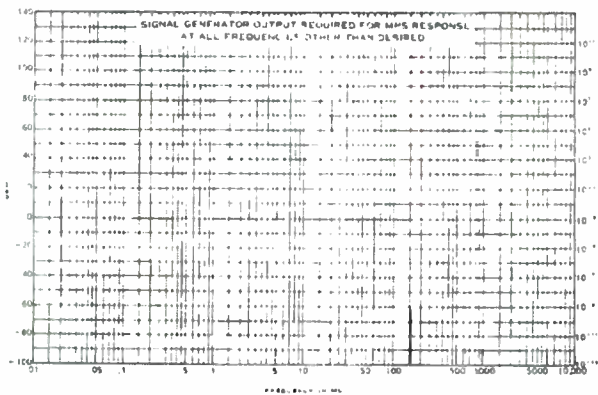

Figure 3-27. Susceptibility Test (120 mc)

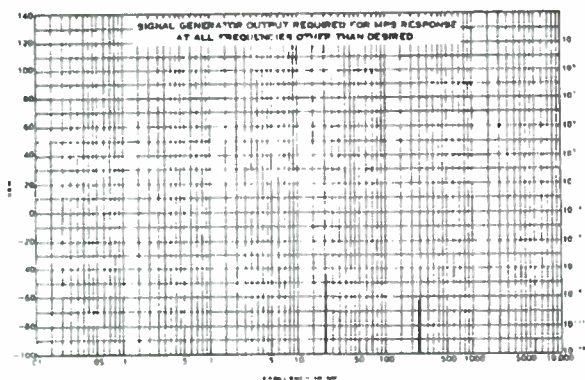

Figure 3-28. Susceptibility Test (200 mc)

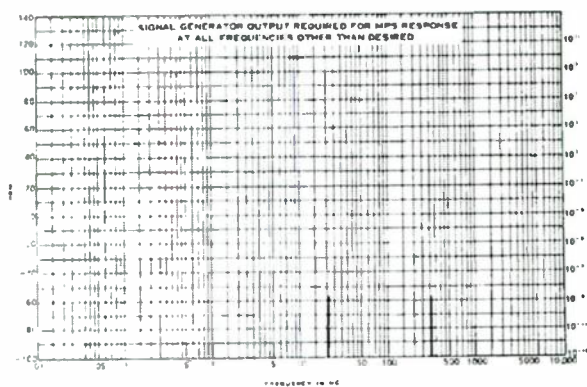

Figure 3-29. Susceptibility Test (260 mc)



4.3 TESTS TO DETERMINE METHODS OF GROUNDING CABLE SHIELDS FOR SUPPRESSING RADIATION AND MINIMIZING SUSCEPTIBILITY

In this section tests are described which were made on various cable grounding configurations to determine relative effectiveness from the standpoint of suppressing radiation from the cables and of minimizing the susceptibility of the cable load. Each configuration was checked over a frequency range of 0.015 to 4200 megacycles. The total cable length was 160 cm and was placed 4 cm above the ground plane. In general, grounding of the shield at the generator end for radiation suppression and at the receiver end for minimizing susceptibility proved to be the best compromise method for all cable configurations. The test set-ups were made in general accordance with Military Specification MIL-1-26600, 2 June 1958, and Amendment 2, 9 May 1960 (which superseded Amendment 1, 17 June 1959).

4.3.1 DESCRIPTION OF TEST APPARATUS

The test equipment used is listed below. Each piece meets the requirements for approved interference measuring instruments as set forth in Table 1, page 43, of MIL-1-26600.

<u>Frequency Range</u>	<u>Model No</u>	<u>Manufacturer</u>
0.014 - 0.25 mc	NM-10A	Stoddart
0.015 - 25 mc	NM-20B	Stoddart
20 - 400 mc	NM-30A	Stoddart
375 - 1000 mc	NM-50A	Stoddart
1000 - 10,000 mc	FIM	Polarad

The following signal generators were used as signal sources.

<u>Frequency Range</u>	<u>Model No</u>	<u>Manufacturer</u>
0.15 - 10 mc	1001-A	General Radio
10 - 480 mc	606C	Hewlett-Packard
950 - 2400 mc	MSG-1	Polarad
2000 - 4600 mc	MSG-2A	Polarad
4600 - 10,000 mc	FIM	Polarad

4.3.2 TEST CONDITIONS

The cable sample was mounted on a ground plane (3 ft x 8 ft) and was positioned in accordance with MIL-1-26600. All antennas and

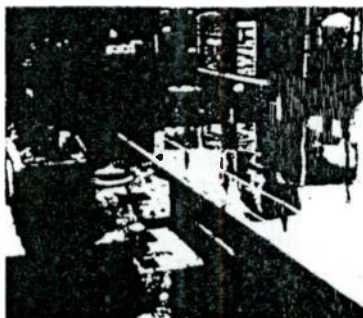

Figure 3-30.
Use of Loop Antenna

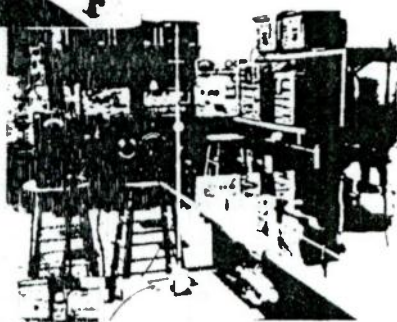

Figure 3-31.
Use of Vertical Rod Antenna

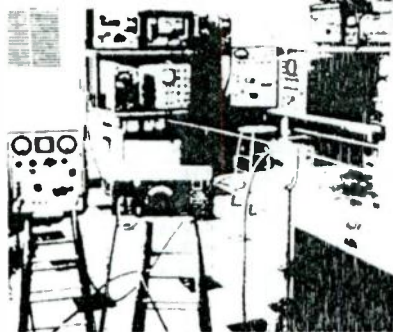

Figure 3-32. Use of Horizontal Dipole Antenna

(PHOTOS TAKEN IN LABORATORY
OF FREDERICK RESEARCH COM-
PANY ON WHEELTON, MARYLAND)

measuring equipment were positioned in accordance with the requirements of MIL-1-26600. Figures 3-30 through 3-32 show typical test set-ups.

The tests for each of the configurations were made identical with respect to generator, receiver, load and total cable length, thus permitting a direct comparison of the various results. Each configuration was tested at three different frequencies, within the range of 150 kilocycles to 1000 megacycles, which were selected as follows:

- a. Frequency 1 was selected such that the total test cable length was equal to $1/4$ wave length of the transmitted frequency.
- b. Frequency 2 was selected such that the total test cable length was equal to $1/2$ wave length of the transmitted frequency.
- c. Frequency 3 was selected such that the total test cable length was less than 0.05 wave length of the transmitted frequency.

The length (L) of the bonding jumpers was ± 4 cm and $L/40$ where L was the total length of the test cable.

A total cable length of 160 cm was selected as a length which would be compatible with the size of the ground plane. Thus, the length of bonding jumpers was 4 cm and the test frequencies were 47 mc, 94 mc, and 9.4 mc.

4.3.3 TEST RESULTS

The following pages contain plots of the data obtained from radiation and susceptibility measurements made on the various cable configurations. Schematic diagrams of the configurations appear at the top of the respective data sheets. Two facts common to all plots are:

- a. The reference point (0 db) was established by the indicated meter level with the shield ungrounded for each cable configuration at each frequency. The amount of radiation or susceptibility suppression was then determined by subtracting the grounded level from the ungrounded level and then plotting this difference relative to 0 db.

- b. This symbol $\cdot\cdot\cdot\cdot\cdot\cdot$ between data points, indicates that the level as read from the meter was the noise meter level, therefore, the actual suppression level could not be obtained but was at least equal to this level.

4.3.3.1 Plain Shielded Cable - Radiation Test (Figure 3-33)

Seven grounding configurations were tested and the measurements are plotted in Figures 3-34a and 3-34b. These configurations were:

- a. Ground generator end only
- b. Ground load end only
- c. Ground center only
- d. Ground generator and load ends
- e. Ground generator end and center
- f. Ground load end and center
- g. Ground generator end, load end, and center

In order of their relative effectiveness, the three best overall grounding methods were:

- a. Generator end, load end, cable center
- b. Generator end and cable center
- c. Generator end only

There was some degree of peaking and nulling at multiples and sub-multiples of the cable wavelength, dependent on the particular ground method as shown by the curves. For example, curve nulls occurred at $1/4\lambda$, peaks at 1λ and then nulls at 2λ for the configurations where the generator end, load end, and cable center were grounded.

The best method of grounding was not the same at all frequency ranges. For example, between 0.015 and 0.125 mc., grounding at the generator end, load end, and cable center was best; from 1 mc to 47 mc ($1/4\lambda$), grounding generator end, load end, and cable center was equally as good as grounding generator end and center; and from 47 mc to 10 kmc., any one of the three above was almost equally good.

4.3.3.2 Plain Shielded Cable - Susceptibility Test (Figure 3-35)

The same grounding configurations were tested for susceptibility as were for radiation from a plain shielded cable. The results are plotted in Figures 3-36a and 3-36b.

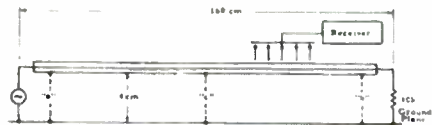

Freq	Ungnd	Grd A	Diff ⁽¹⁾	Grd B	Diff ⁽²⁾	Grd C	Diff ⁽³⁾	Grd D	Diff ⁽⁴⁾
150	16	31	1	21	1	20	1	20	10
50	14	23	1	13	1	13	1	10	10
100	1	11	1	10	1	10	1	11	20
150	18	1	1	18	1	18	1	11	23
SEC	1	1	1	1	1	1	1	1	16
100	1	1	1	1	1	1	1	1	16
50	1	1	1	1	1	1	1	1	16
150	1	1	1	1	1	1	1	1	16
100	1	1	1	1	1	1	1	1	16
50	1	1	1	1	1	1	1	1	16
150	1	1	1	1	1	1	1	1	16
100	1	1	1	1	1	1	1	1	16
50	1	1	1	1	1	1	1	1	16
150	1	1	1	1	1	1	1	1	16
100	1	1	1	1	1	1	1	1	16
50	1	1	1	1	1	1	1	1	16
150	1	1	1	1	1	1	1	1	16
100	1	1	1	1	1	1	1	1	16
50	1	1	1	1	1	1	1	1	16
150	1	1	1	1	1	1	1	1	16
100	1	1	1	1	1	1	1	1	16
50	1	1	1	1	1	1	1	1	16

NOTE: A - levels in db as read from meter
 B - values in db as read from meter
 Difference (1) - ungrounded cable minus ground "A" level
 Difference (2) - ungrounded cable minus ground "B" level
 Difference (3) - ungrounded cable minus ground "C" level
 Difference (4) - ungrounded cable minus ground "D" level

Freq	Ungnd	Grd A	Diff ⁽¹⁾	Grd B	Diff ⁽²⁾	Grd C	Diff ⁽³⁾	Grd D	Diff ⁽⁴⁾
150	16	21	5	1	1	1	1	1	10
50	14	20	6	1	1	1	1	1	10
100	1	17	16	1	1	1	1	1	20
150	18	1	1	1	1	1	1	1	23
SEC	1	1	1	1	1	1	1	1	16
100	1	1	1	1	1	1	1	1	16
50	1	1	1	1	1	1	1	1	16
150	1	1	1	1	1	1	1	1	16
100	1	1	1	1	1	1	1	1	16
50	1	1	1	1	1	1	1	1	16
150	1	1	1	1	1	1	1	1	16
100	1	1	1	1	1	1	1	1	16
50	1	1	1	1	1	1	1	1	16
150	1	1	1	1	1	1	1	1	16
100	1	1	1	1	1	1	1	1	16
50	1	1	1	1	1	1	1	1	16
150	1	1	1	1	1	1	1	1	16
100	1	1	1	1	1	1	1	1	16
50	1	1	1	1	1	1	1	1	16
150	1	1	1	1	1	1	1	1	16
100	1	1	1	1	1	1	1	1	16
50	1	1	1	1	1	1	1	1	16

NOTE: All levels in db as read from meter
 A - values in db as read from meter
 Difference (1) - ungrounded cable minus ground "A" level
 Difference (2) - ungrounded cable minus ground "B" level
 Difference (3) - ungrounded cable minus ground "C" level
 Difference (4) - ungrounded cable minus ground "D" level

Figure 3-33. Test of Cable Shield Grounding for Radiation Suppression (Cable Only)

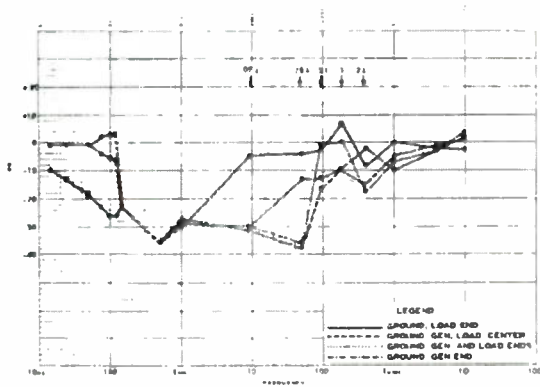

Figure 3-34a. Plain Shielded Cable Radiation

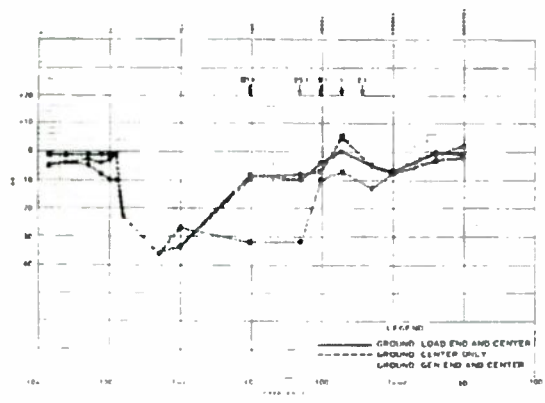
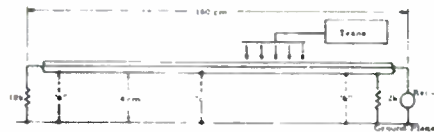

Figure 3-34b. Plain Shielded Cable Radiation



Freq	Ungrd	Grd "a"	Diff ⁽¹⁾	Grd "b"	Diff ⁽²⁾	Grd "c"	Diff ⁽³⁾	Grd "a & b"	Diff ⁽⁴⁾
150	60	19NL	72	19NL	22	19NL	22	19NL	22
45	68	19NL	50	19NL	10	19NL	30	19NL	30
100	64	19NL	60	19NL	10	19NL	60	19NL	60
300	72	19NL	16	19NL	16	19NL	16	19NL	16
1000	54	19NL	37	19NL	17	19NL	17	19NL	17
1.4	66	62	2	20	24	66	0	20	26
47	66	46	10	46	10	57	10	57	29
12	72	67	5	16	2	67	5	67	6
11	62	57	5	4	24	32	10	38	7
430	73	72	1	7	63	17	63	17	22
1000	71	70	1	14	2	67	1	66	2
4	73	73	0	22	66	0	67	67	14

NOTE: All levels are as read from meter.
 "NL" refers to noise level of field set. Meter.
 Difference (1) - grounded case minus ground "a" level.
 Difference (2) - grounded case minus ground "b" level.
 Difference (3) - grounded case minus ground "c" level.
 Difference (4) - grounded case minus ground "a & b" level.

Freq	Ungrd	Grd "a & b"	Diff ⁽¹⁾	Grd "c"	Diff ⁽²⁾	Grd "a & b & c"	Diff ⁽³⁾
150	67	19	22	19NL	22	19NL	22
45	66	19NL	19	19NL	12	19NL	10
100	64	19NL	60	19NL	43	19NL	60
300	72	19NL	16	19NL	16	19NL	16
1000	54	19NL	37	19NL	17	19NL	17
1.4	66	66	0	71	73	71	21
47	66	5	13	61	24	61	29
12	72	65	7	6	67	65	2
11	62	5	2	6	30	6	2
430	73	72	1	63	17	63	10
1000	71	70	1	67	1	66	2
4	73	67	6	63	3	64	10

NOTE: All levels are as read from meter.
 "NL" refers to noise level of field set. Meter.
 Difference (1) - grounded case minus ground "a & b" level.
 Difference (2) - grounded case minus ground "a & b & c" level.
 Difference (3) - grounded case minus ground "a & b & c" level.

Figure 3-35. Test of Cable Shield Grounding for Minimizing Susceptibility (Cable Only)

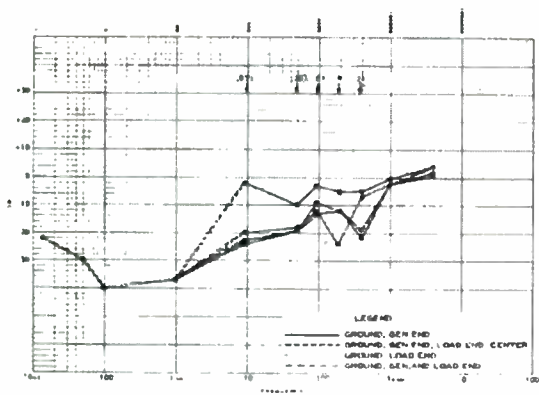

Figure 3-36a. Plain Shielded Cable Susceptibility

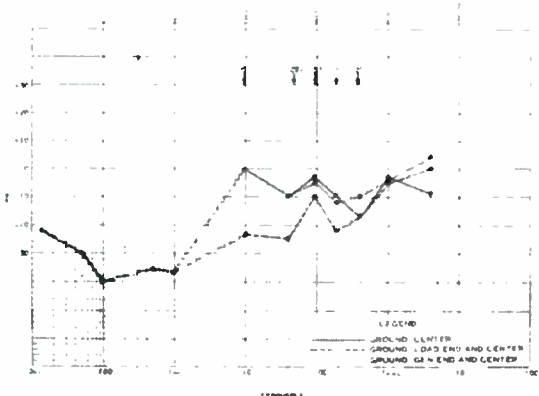

Figure 3-36b. Plain Shielded Cable Susceptibility

Referring to the figures, it can be seen that any grounding method provided in the order of at least 30 to 40 db suppression of susceptibility below a frequency of 9.4 mc. Throughout the frequency range investigated, there were four methods almost equally effective:

- a. Generator end and load end
- b. Generator end, load end, and cable center
- c. Load (Receiver) end only
- d. Load end and cable center

As with the radiation measurements, there was peaking and nulling associated with the susceptibility measurements which, again, was dependent upon the grounding method as can be seen from the curves.

4. 3. 3. 3 Connector in Shielded Cable - Radiation Test (Figs. 3-37, 3-39, 3-40)

Three grounding configurations were tested with the connector in the center of the cable. The connector shield was not grounded. The grounding configurations were:

- a. Shield carried through connector, ground at load
- b. Shield carried through connector, ground at load and at connector on the generator side
- c. Shield split at connector, ground at load and at connector on the generator side

The results plotted in Figure 3-38 showed that any grounding was so ineffective that it was decided to repeat the tests and compare cable with a connector to a cable with a varying gap cut in its shield. Figures 3-41a and 3-41b show this comparison. For the measurements shown in Figures 3-41a and 3-41b, the connector was mounted in an aluminum bracket which was firmly bolted to the ground plane. Comparing Figures 3-41a and 3-41b with Figure 3-38, it appears that the solid grounding of the connector body resulted in some improvement of the radiation suppression.

The results of increasing the gap length seem to follow the expected pattern; i. e., the radiation and susceptibility increased as the gap length increased from 1/8 to 2 inches. However, the curve for the connector did not fall into the expected position somewhere between a gap length of 1 to 2 inches. This was probably due to the fact that the connector was firmly bonded to the ground plane.

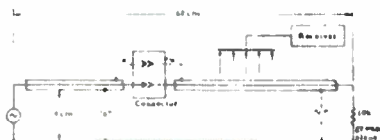

FREQ	TX SWR		CONTR		RX SWR		DIFF
	dB	%	dB	%	dB	%	
100	6.7	57	0	54	1	57	1
110	6.2	52	0	55	5	61	15
120	6.7	56	0	55	11	58	7
130	6.1	51	0	54	16	64	13
140	6.1	51	0	54	16	64	13
150	5.5	47	0	49	14	57	10
160	5	44	0	45	12	57	13
170	5.1	45	0	46	10	55	9
180	5.1	45	0	46	10	55	9
190	4.5	41	0	43	8	51	10
200	4.1	38	0	40	6	46	8
210	4.1	38	0	40	6	46	8
220	4.1	38	0	40	6	46	8
230	4.1	38	0	40	6	46	8
240	4.1	38	0	40	6	46	8
250	4.1	38	0	40	6	46	8
260	4.1	38	0	40	6	46	8
270	4.1	38	0	40	6	46	8
280	4.1	38	0	40	6	46	8
290	4.1	38	0	40	6	46	8
300	4.1	38	0	40	6	46	8

NOTE: All levels are in dB as read from meter.
 "TX" refers to noise level of Field test meter.
 Difference (1) - ungrounded level minus a. alignment "TX" level.
 Difference (2) - ungrounded level minus a. multiple level "TX" level.
 Difference (3) - ungrounded level minus a. multiple level "TX" level.

Figure 3-37. Test of Cable Shield Grounding for Radiation Suppression (Cable with Connector)

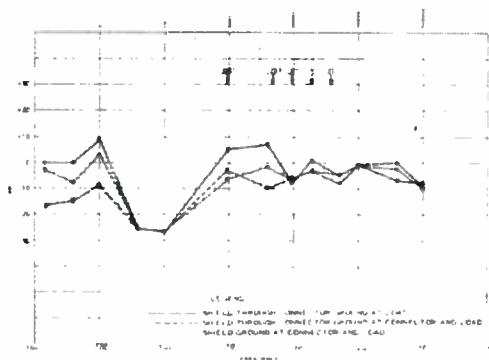
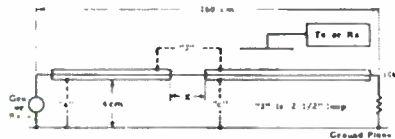

Figure 3-38. Connector in Cable Radiation



Freq	100 cm		a=0		Diff (1)		a=1.5"		Diff (2)	
	Rad	Sw	Rad	Sw	Rad	Sw	Rad	Sw	Rad	Sw
10	10	10	70	10	0	20	10	10	1	2
50	10	67	70	10	1	35	10	10	2	15
100	10	66	60	10	2	63	60	10	3	62
150	10	63	50	10	61	63	10	10	61	62
200	67	67	23	10	64	65	21	10	64	65
250	73	73	20	10	61	60	10	10	60	61
300	65	67	27	17	62	64	15	12	16	66
400	64	66	27	17	61	61	6	10	10	11
500	64	67	67	67	22	31	65	64	34	36
600	67	66	51	5	22	11	64	62	61	2
750	55	55	64	66	6	6	60	60	5	15
1000	70	72	67	67	5	5	62	64	6	6
1500	65	66	55	59	10	7	66	69	63	64

NOTE: All levels in db are read from meter.
 "Rad" refers to meter level of Field Int. Meter.
 Difference (1) ungrounded level minus ground "a"
 Difference (2) unground level minus ground "2" in Grid "a" = 1.5"

Freq	100 cm		a=1.5"		Diff (3)		a=2"		Diff (4)	
	Rad	Sw	Rad	Sw	Rad	Sw	Rad	Sw	Rad	Sw
100	10	66	70	10	10	3	21	10	6	7
50	10	67	70	10	10	1	10	10	10	6
100	71	66	70	10	10	1	65	66	20	6
150	60	60	10	10	61	61	21	6	11	11
200	67	67	25	24	62	61	11	12	13	15
250	71	73	24	37	66	16	30	19	41	35
300	58	61	51	52	6	6	60	27	16	16
400	61	64	74	74	17	20	64	66	1	6
500	64	66	60	60	21	16	6	11	11	11
600	61	66	63	64	3	1	64	64	11	11
750	55	55	54	54	1	2	63	63	6	6
1000	70	72	59	59	11	11	66	66	6	6
1500	65	66	66	66	7	5	65	64	1	2

NOTE: Difference (3) unground level minus ground "2" in Grid "a" = 1.5"
 Difference (4) unground level minus ground "2" in Grid "a" = 2"

Figure 3-39a. Test of Cable Shield Grounding for Radiation Suppression and Minimizing Susceptibility (Cable with Shield Cap)

FREQ	Shield	Cap	Shield	Cap	Shield	Cap	Shield	Cap	Shield	Cap
150	18	36	72							
ND	19	67	73							
100	71	88	85							
150	63	80								
200	51	67	74							
250	41	54	64							
300	31	44	54							
350	21	34	44							
400	11	24	34							
450	1	14	24							
500	1	14	24							
550	1	14	24							
600	1	14	24							
650	1	14	24							
700	1	14	24							
750	1	14	24							
800	1	14	24							
850	1	14	24							
900	1	14	24							
950	1	14	24							
1000	1	14	24							

NOTE: Difference in % between Shield and Cap is shown in the shaded area. The shaded area is the difference between the Shield and Cap values.

FREQ	Shield	Cap	Shield	Cap	Shield	Cap	Shield	Cap	Shield	Cap
150	18	36	72							
ND	19	67	73							
100	71	88	85							
150	63	80								
200	51	67	74							
250	41	54	64							
300	31	44	54							
350	21	34	44							
400	11	24	34							
450	1	14	24							
500	1	14	24							
550	1	14	24							
600	1	14	24							
650	1	14	24							
700	1	14	24							
750	1	14	24							
800	1	14	24							
850	1	14	24							
900	1	14	24							
950	1	14	24							
1000	1	14	24							

NOTE: Difference in % between Shield and Cap is shown in the shaded area. The shaded area is the difference between the Shield and Cap values.

Figure 3-59b. Test of Cable Shield Grounding for Radiation Suppression and Minimizing Susceptibility (Cable with Shield Cap)

Freq.	Ungrd.		Config. "a" & "b"		Difr. ⁽¹⁾		
	Rad	Sue	Rad	Sue	Rad	Sue	
	* - 2"						
15kc	9	10	7	1	NL	7	25
50	11	47	12	16		7	31
100	11	44	64	14			31
150	62	60	34	16	25	24	
100	67	67	44	46	22	21	
1mc	73	73	47	52	26	21	
9.4	48	51	56	55	1	6	
47	41	44	74	77	16	17	
92	14	78	12	12		6	
190	63	54	63	63	7	1	
176	14	15	17	17	42	42	
1mc	70	72	72	74	42	42	
4.2	64	56	56	57	9	9	

NOTE: Difference (1) ungrounded level minus 1" from Grid "a" & "b" * - 2"

Figure 3-39c. Test of Cable Shield Grounding for Radiation Suppression and Minimizing Susceptibility (Cable with Shield Cap)

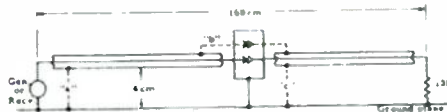

Freq.	Ungrd.		Config. "a" & "b"		Difr. ⁽¹⁾		Ungrd.		Config. "a" & "c"		Difr. ⁽²⁾	
	Rad	Sue	Rad	Sue	Rad	Sue	Rad	Sue	Rad	Sue	Rad	Sue
	* - 2"											
.5kc	44	14 _{NL}	14	14 _{NL}	410	0	50	14 _{NL}	50	14 _{NL}	0	0
10	44	13	61	14 _{NL}	1	23	69	10	58	7 _{NL}	4	21
100	59	37	58	14 _{NL}	1	35	55	14	55	2 _{NL}	0	34
150	61	61	27 _{NL}	28	14	13	58	19	25	25	33	34
500	74	73	32	32	42	40	71	73	31	32	40	19
1mc	76	77	26	40	50	27	75	75	36	46	39	29
9.4	54	66	19	27	27	27	63	61	58	52	3	9
47	80	80	14	14	14	14	94	99	76	77	16	3
92	81	80	19	19	22	23	79	79	73	71	6	6
100	55	54	67	67	412	11	62	66	68	67	16	1
176	55	54	55	54	0	0	50	50	55	56	4	1
1mc	64	64	64	64	0	0	66	66	63	62	5	4
4.2	54	54	54	54	0	0	60	60	56	56	6	4

NOTE: All levels in db μ o read from meter
 "NL" refers to noise level of 3 db.
 Difference (1) ungrounded level minus configuration "a" & "b"
 Difference (2) ungrounded level minus configuration "a" & "c"

Figure 3-40. Test of Cable Shield Grounding for Radiation Suppression and Minimizing Susceptibility (Cable with Connector)

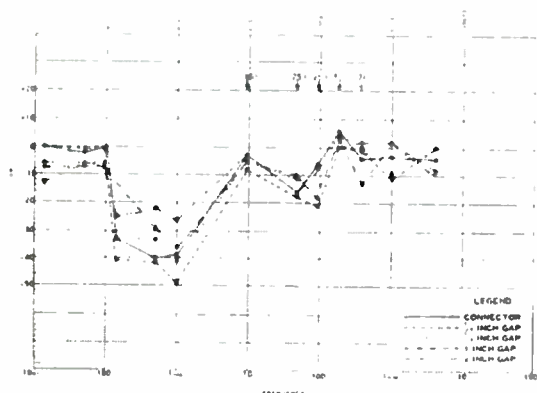

Figure 3-41a. Comparison of Connector and Gap Radiation (No Shield Jumper, Ground at Generator and Load Side of Gap)

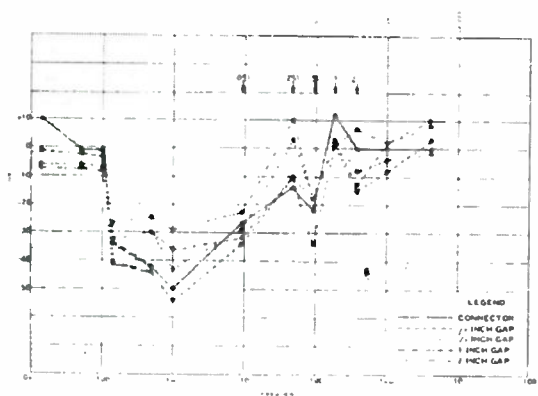

Figure 3-41b. Comparison of Connector and Gap Radiation (Shield Jumper, Ground at Generator)

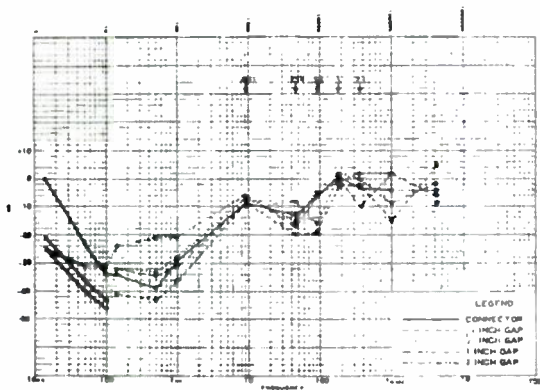

Figure 3-41c. Comparison of Connector and Gap Susceptibility (No Shield Jumper, Ground at Generator and Load Side of Gap)

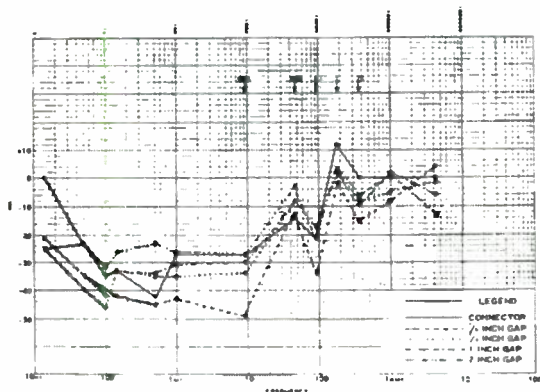

Figure 3-41d. Comparison of Connector and Gap Susceptibility (Shield Jumper, Ground at Generator)

There was definite peaking and nulling associated with all configurations. When the shield was carried through the connector or a jumper was placed across the gap, peaks existed at $1/4\lambda$ and 1λ and a null at $1/2\lambda$. When the jumper was off or the shield not carried through the connector, peaks were at $.05\lambda$ and 1λ and nulls at $1/4\lambda$ and 2λ .

In general, the best suppression resulted from grounding the shield at the generator end and on the load side of the connector and not carrying the shield through the connector.

4.3.3.4 Connector in Shielded Cable - Susceptibility Test (Figs. 3-37, 3-39, 3-40)

The same remarks can be made for the susceptibility measurements as were made for the radiation measurements if one substitutes receiver for generator.

The best method to minimize susceptibility was to be the grounding of the shield at the receiver and on the load or source side of the connector and not carrying the shield through the connector.

4.3.3.5 Shielded Twisted Pair versus Two Shielded Wires - Radiation Test (Figures 3-42 and 3-43)

Figures 3-44a through 3-44c show the relative effectiveness of each configuration to suppress radiation. In all cases, the two shielded wires were found to be more effective and the best method was the grounding of the shield at the generator end.

4.3.3.6 Shielded Twisted Pair versus Two Shielded Wires - Susceptibility Test (Figures 3-42 and 3-43)

As with the radiation measurements, the two shielded wires were more effective and the best method of grounding was, as before, the grounding of the shield at the receiver end. (See Figures 3-44d through 3-44f)

4.3.3.7 Summary

From the results of all tests, the following two rules could be applied in most cases.

4. For radiation suppression, grounding of the shield at the generator or source end of the cable, in general, gave the best results.

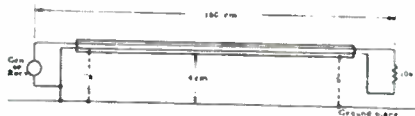

Freq	Grnd		Grnd		Dist ⁽¹⁾		Grnd		Dist ⁽²⁾		Dist ⁽³⁾	
	Red	Blue	Red	Blue	Red	Blue	Red	Blue	Red	Blue	Red	Blue
100	31	21	21	31	0	21	21	0	21	21	0	0
150	31	21	21	31	0	21	21	0	21	21	0	0
200	31	21	21	31	0	21	21	0	21	21	0	0
250	31	21	21	31	0	21	21	0	21	21	0	0
300	31	21	21	31	0	21	21	0	21	21	0	0
350	31	21	21	31	0	21	21	0	21	21	0	0
400	31	21	21	31	0	21	21	0	21	21	0	0
450	31	21	21	31	0	21	21	0	21	21	0	0
500	31	21	21	31	0	21	21	0	21	21	0	0
550	31	21	21	31	0	21	21	0	21	21	0	0
600	31	21	21	31	0	21	21	0	21	21	0	0
650	31	21	21	31	0	21	21	0	21	21	0	0
700	31	21	21	31	0	21	21	0	21	21	0	0
750	31	21	21	31	0	21	21	0	21	21	0	0
800	31	21	21	31	0	21	21	0	21	21	0	0
850	31	21	21	31	0	21	21	0	21	21	0	0
900	31	21	21	31	0	21	21	0	21	21	0	0
950	31	21	21	31	0	21	21	0	21	21	0	0
1000	31	21	21	31	0	21	21	0	21	21	0	0

NOTE: All levels in dB, as read from meter.
 (1) refers to noise in one of the lead wires.
 Difference = (1) - ungrounded level in one configuration.
 Difference = (2) - ungrounded level in one configuration.
 Difference = (3) - ungrounded level in one configuration.

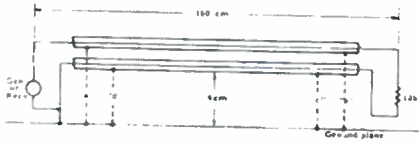

Freq	Grnd		Dist ⁽¹⁾		Grnd		Dist ⁽²⁾		Grnd		Dist ⁽³⁾	
	Red	Blue	Red	Blue	Red	Blue	Red	Blue	Red	Blue	Red	Blue
100	31	21	21	31	0	21	21	0	21	21	0	0
150	31	21	21	31	0	21	21	0	21	21	0	0
200	31	21	21	31	0	21	21	0	21	21	0	0
250	31	21	21	31	0	21	21	0	21	21	0	0
300	31	21	21	31	0	21	21	0	21	21	0	0
350	31	21	21	31	0	21	21	0	21	21	0	0
400	31	21	21	31	0	21	21	0	21	21	0	0
450	31	21	21	31	0	21	21	0	21	21	0	0
500	31	21	21	31	0	21	21	0	21	21	0	0
550	31	21	21	31	0	21	21	0	21	21	0	0
600	31	21	21	31	0	21	21	0	21	21	0	0
650	31	21	21	31	0	21	21	0	21	21	0	0
700	31	21	21	31	0	21	21	0	21	21	0	0
750	31	21	21	31	0	21	21	0	21	21	0	0
800	31	21	21	31	0	21	21	0	21	21	0	0
850	31	21	21	31	0	21	21	0	21	21	0	0
900	31	21	21	31	0	21	21	0	21	21	0	0
950	31	21	21	31	0	21	21	0	21	21	0	0
1000	31	21	21	31	0	21	21	0	21	21	0	0

Figure 3-43. Test of Cable Shield Grounding for Radiation Suppression and Minimizing Susceptibility (Two Separate Shielded Wires)

Figure 3-42. Test for Radiation Suppression and Minimizing Susceptibility (Shielded Twisted Pair)

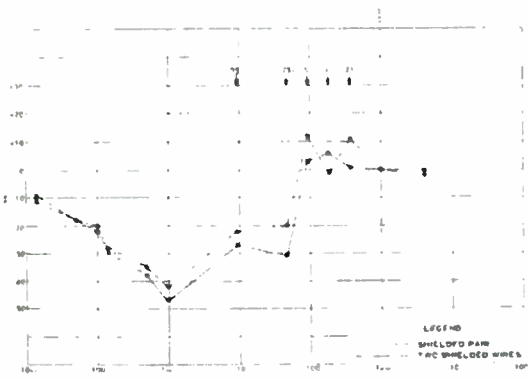

Figure 3-44a. Shielded Twisted Pair vs Two Shielded Wires Radiation (Ground at Generator and Load)

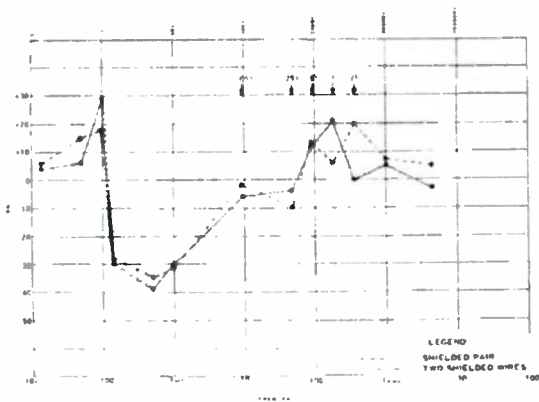

Figure 3-44b. Shielded Twisted Pair vs Two Shielded Wires Radiation (Ground at Load)

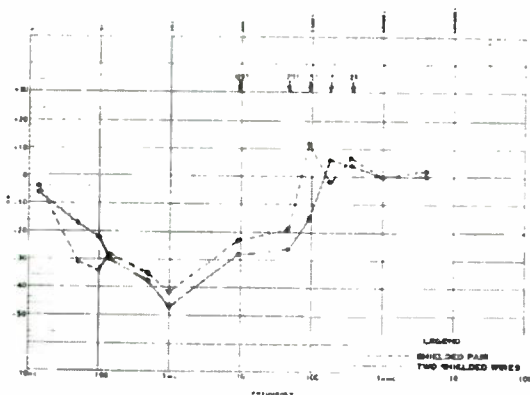

Figure 3-44c. Shielded Twisted Pair vs Two Shielded Wires Radiation (Ground at Generator)

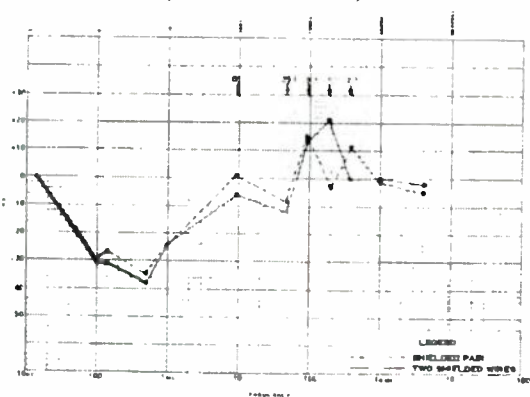

Figure 3-44d. Shielded Twisted Pair vs Two Shielded Wires Susceptibility (Ground at Generator and Load)

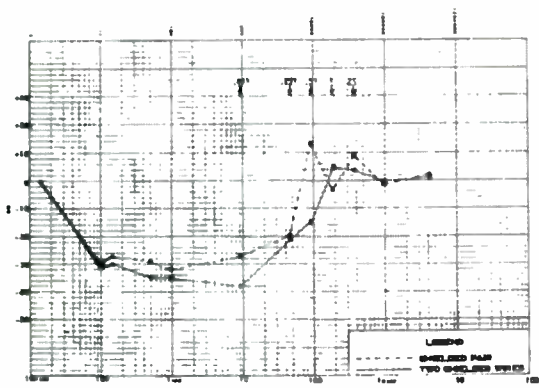

Figure 3-44e. Shielded Twisted Pair vs Two Shielded Wires Susceptibility (Ground at Load)

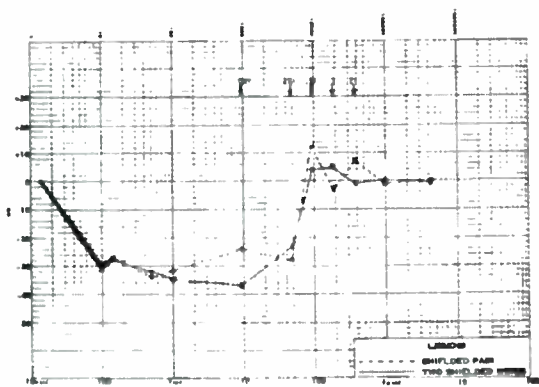

Figure 3-44f. Shielded Twisted Pair vs Two Shielded Wires Susceptibility (Ground at Generator)

- b. For minimum susceptibility, grounding of the shield at the receiver end of the cable, in general, gave the best results.

It should be kept in mind that the preceding tests were on single wires of definite length with no other wires in the cable or running through the connector. It shall be noted that this may not be the case in a complete electronics system and different radiation and susceptibility conditions may be found when multiple wire cables are used.

4.4 TESTS TO DETERMINE RELATIVE EFFECTIVENESS OF SUPPRESSION MEASURES IN A RELAY-MICROSWITCH CIRCUIT

4.4.1 GENERAL

Tests were conducted on various suppression schemes to determine their relative effectiveness on both conducted and radiated interference from a relay-microswitch circuit. A suppression scheme was determined which gave results within the limits defined by Military Specification MIL-I-26600, 2 June 1958, and Amendment 2, 9 May 1960, for Class 1b equipment.

It was found necessary to shield the microswitch, filter the leads to the microswitch, and suppress the inductive current of the relay to meet the specification.

The cable length between the power source and the relay was 24 inches. In the test, the microswitch was arbitrarily located midway between the relay and power source. Each configuration was checked over a frequency range of .150 mc to 400 mc for radiated interference and .150 mc to 25 mc for conducted interference, in accordance with MIL-I-26600.

4.4.2 SUMMARY OF TEST

4.4.2.1 Radiated Interference

From the results of the tests, the radiated energy was apparently generated by two sources. The first and most pronounced was the transient caused by the closing of the switch where energy was radiated by both the arc between the contacts and by circuit leads. The second was the dissipation of the energy stored in the inductance of the relay coil upon opening of the switch contacts.

The radiation from the switch was suppressed by bypassing the leads close to the terminals and shielding the switch and associated components. The energy in the relay coil was dissipated in the near proximity of the relay with a diode and capacitor. The function of the capacitor was to control the change in potential across the relay coil until the diode assumed conduction.

The successful suppression scheme described above caused the radiated interference level to fall within the limits of MIL-I-26600. Mounting the relay suppressing elements on the cable a distance of 6 inches from the relay caused a small increase in radiated interference which did not exceed the specification limits.

4.4.2.2 Conducted Interference

The conducted interference fell below the specification limits without need of suppression, although the techniques used lowered the value below the ambient noise level.

Comparison of the various schemes tested can be seen in Figures 3-45 and 3-46.

4.4.3 TEST PROCEDURE

4.4.3.1 Test Apparatus

The test apparatus used is listed below. These instruments meet the requirements set forth for Category A as shown in Table I, page 43, of Military Specification MIL-I-26600 for the measurement of radio frequency interference.

<u>Frequency Range</u>	<u>Model No.</u>	<u>Serial No.</u>	<u>Manufacturer</u>
150 to 25 mc	NM20B	251-19	Stoddart
20 to 400 mc	NM30A	248-3	Stoddart

4.4.3.2 Test Conditions

The microswitch, relay, and connecting cable were mounted on a 3' x 8' ground plane in accordance with the typical test set-ups of MIL-I-26600. All tests were performed in accordance with the procedures in MIL-I-26600.

Radiated and conducted interference tests were performed with five circuit configurations, as follows.

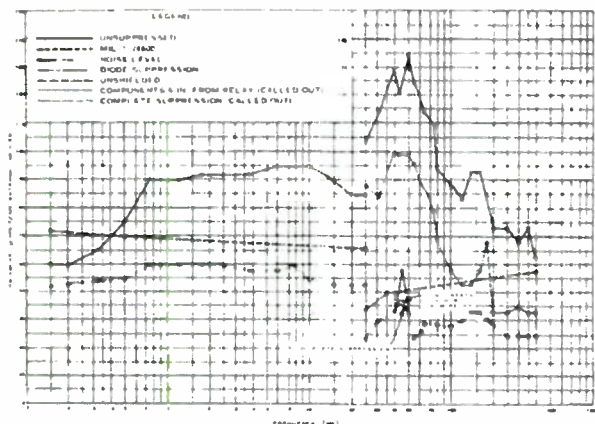

Figure 3-45. Relay Coil - Microswitch Radiation Interference

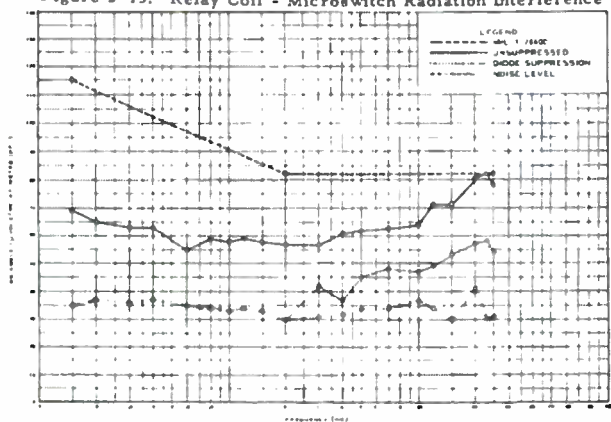

Figure 3-46. Relay Coil - Microswitch Conducted Interference

Test 1 - Complete Suppression. The circuit contained all of the suppression elements and the microswitch was shielded. The diode and capacitor were mounted at the relay. See Figure 3-47.

Test 2 - Unshielded. The cover was removed from the box used to shield the microswitch and associated suppression components. The circuit components were identical with Test No. 1. See Figure 3-48.

Test 3 - Same as Test No. 1, with the exception that the diode and capacitor were mounted 6 inches from the relay. See Figure 3-49.

Test 4 - Diode Suppression. The only suppression component used was a diode. See Figure 3-50.

Test 5 - Unsuppressed. No suppression components used. See Figure 3-51.

The cable length was held constant at 24 inches throughout the tests. The microswitch was arbitrarily positioned midway between the power source and the relay. The microswitch and associated suppression components were shielded by an aluminum box 1-1/2" x 3-1/4" x 2" bonded to the ground plane. During the radiation tests, the negative side of the 30 volt supply was grounded at the zero potential point and the positive side of the supply was bypassed with a .1µfd capacitor to the zero potential point. During the conducted interference tests, a line stabilization network was introduced into the cable at the zero potential point. See Figures 3-52a through 3-52d for illustrations of both conducted and radiated test set-ups.

The entire frequency spectrum from .150 mc to 400 mc was checked for the radiated measurements, and peaks were chosen for the data points where definite peaks were observed. Other data points were taken to complete the curve.

The same procedure was used in taking the conducted interference measurements except the maximum frequency checked was 25 mc.

4.4.4 TEST RESULTS

Figures 3-45 and 3-46 are curves plotted from data taken in each configuration. At many points the lowest level was determined by ambient noise. The curve for each test is shown only where it could be detected above the noise level and is at least as low as the noise level at all other points.

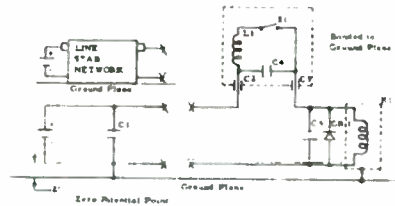

RADIATED							
Freq	Level	Freq	Level	Freq	Level	Freq	Level
15mc	12NL	10mc	18NL	11mc	10NL	6 mc	10NL
20	11NL	15	18NL	12	10NL	100mc	15NL
25	11NL	20	18NL	15	10NL	200	15NL
30	11NL	25	18NL	20	10NL	250	15NL
35	11NL	30	18NL	25	10NL	300	15NL
40	11NL	35	18NL	30	10NL	350	15NL
45	11NL	40	18NL	35	10NL	400	15NL
50	11NL	45	18NL	40	10NL	450	15NL
55	11NL	50	18NL	45	10NL	500	15NL
60	11NL	55	18NL	50	10NL	550	15NL
65	11NL	60	18NL	55	10NL	600	15NL
70	11NL	65	18NL	60	10NL	650	15NL
75	11NL	70	18NL	65	10NL	700	15NL
80	11NL	75	18NL	70	10NL	750	15NL
85	11NL	80	18NL	75	10NL	800	15NL
90	11NL	85	18NL	80	10NL	850	15NL
95	11NL	90	18NL	85	10NL	900	15NL
100	11NL	95	18NL	90	10NL	950	15NL
105	11NL	100	18NL	95	10NL	1000	15NL

CONDUCTED							
Freq	Level	Freq	Level	Freq	Level	Freq	Level
15mc	11NL	10mc	17NL	11mc	9NL	6 mc	9NL
20	11NL	15	17NL	12	9NL	100mc	14NL
25	11NL	20	17NL	15	9NL	200	14NL
30	11NL	25	17NL	20	9NL	250	14NL
35	11NL	30	17NL	25	9NL	300	14NL
40	11NL	35	17NL	30	9NL	350	14NL
45	11NL	40	17NL	35	9NL	400	14NL
50	11NL	45	17NL	40	9NL	450	14NL
55	11NL	50	17NL	45	9NL	500	14NL
60	11NL	55	17NL	50	9NL	550	14NL
65	11NL	60	17NL	55	9NL	600	14NL
70	11NL	65	17NL	60	9NL	650	14NL
75	11NL	70	17NL	65	9NL	700	14NL
80	11NL	75	17NL	70	9NL	750	14NL
85	11NL	80	17NL	75	9NL	800	14NL
90	11NL	85	17NL	80	9NL	850	14NL
95	11NL	90	17NL	85	9NL	900	14NL
100	11NL	95	17NL	90	9NL	950	14NL
105	11NL	100	17NL	95	9NL	1000	14NL

NOTE: NL refers to ambient noise level.
 Conducted level is to db above 1u volt/mv at meter input.
 Radiated level is to db above 1u volt/mv antenna induced.

Figure 3-47. Test No. 1
 Complete Suppression

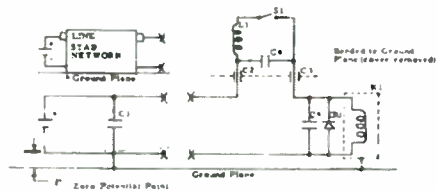

RADIATED							
Freq	Level	Freq	Level	Freq	Level	Freq	Level
15mc	12NL	10mc	18NL	11mc	10NL	6 mc	10NL
20	12NL	15	18NL	12	10NL	100mc	15NL
25	12NL	20	18NL	15	10NL	200	15NL
30	12NL	25	18NL	20	10NL	250	15NL
35	12NL	30	18NL	25	10NL	300	15NL
40	12NL	35	18NL	30	10NL	350	15NL
45	12NL	40	18NL	35	10NL	400	15NL
50	12NL	45	18NL	40	10NL	450	15NL
55	12NL	50	18NL	45	10NL	500	15NL
60	12NL	55	18NL	50	10NL	550	15NL
65	12NL	60	18NL	55	10NL	600	15NL
70	12NL	65	18NL	60	10NL	650	15NL
75	12NL	70	18NL	65	10NL	700	15NL
80	12NL	75	18NL	70	10NL	750	15NL
85	12NL	80	18NL	75	10NL	800	15NL
90	12NL	85	18NL	80	10NL	850	15NL
95	12NL	90	18NL	85	10NL	900	15NL
100	12NL	95	18NL	90	10NL	950	15NL
105	12NL	100	18NL	95	10NL	1000	15NL

CONDUCTED							
Freq	Level	Freq	Level	Freq	Level	Freq	Level
15mc	11NL	10mc	17NL	11mc	9NL	6 mc	9NL
20	11NL	15	17NL	12	9NL	100mc	14NL
25	11NL	20	17NL	15	9NL	200	14NL
30	11NL	25	17NL	20	9NL	250	14NL
35	11NL	30	17NL	25	9NL	300	14NL
40	11NL	35	17NL	30	9NL	350	14NL
45	11NL	40	17NL	35	9NL	400	14NL
50	11NL	45	17NL	40	9NL	450	14NL
55	11NL	50	17NL	45	9NL	500	14NL
60	11NL	55	17NL	50	9NL	550	14NL
65	11NL	60	17NL	55	9NL	600	14NL
70	11NL	65	17NL	60	9NL	650	14NL
75	11NL	70	17NL	65	9NL	700	14NL
80	11NL	75	17NL	70	9NL	750	14NL
85	11NL	80	17NL	75	9NL	800	14NL
90	11NL	85	17NL	80	9NL	850	14NL
95	11NL	90	17NL	85	9NL	900	14NL
100	11NL	95	17NL	90	9NL	950	14NL
105	11NL	100	17NL	95	9NL	1000	14NL

NOTE: NL refers to ambient noise level.
 Conducted level is to db above 1u volt/mv at meter input.
 Radiated level is to db above 1u volt/mv antenna induced.

Figure 3-48. Test No. 2
 Unshielded

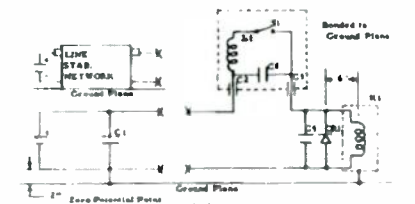

RADIATED							
Freq.	Level	Freq.	Level	Freq.	Level	Freq.	Level
15mc	52ML	5.0mc	56ML	31mc	69ML	65mc	160mc
20	47ML	6.0	46ML	46	65	100	60ML
25	38ML	8.0	42ML	61	70	150	59ML
30	34ML	10	37ML	67	67	175	56ML
35	30ML	12.5	31ML	71	61	200	51ML
40	26ML	15	27ML	75	55	225	47ML
45	22ML	17.5	23ML	79	49	250	43ML
50	18ML	20	19ML	83	43	275	39ML
55	14ML	22.5	15ML	87	37	300	35ML
60	10ML	25	11ML	91	31	325	31ML
65	6ML	27.5	7ML	95	25	350	27ML
70	2ML	30	3ML	99	19	375	23ML
75	0ML	32.5	0ML	103	13	400	19ML
80	0ML	35	0ML	107	7	425	15ML
85	0ML	37.5	0ML	111	1	450	11ML
90	0ML	40	0ML	115	0ML	475	7ML

CONDUCTED							
Freq.	Level	Freq.	Level	Freq.	Level	Freq.	Level
15mc	55ML	5.0mc	58ML	31mc	71ML	65mc	160mc
20	50ML	6.0	48ML	46	70	100	61ML
25	42ML	8.0	40ML	61	70	150	58ML
30	34ML	10	32ML	67	65	175	55ML
35	26ML	12.5	24ML	71	59	200	51ML
40	18ML	15	16ML	75	53	225	47ML
45	10ML	17.5	8ML	79	47	250	43ML
50	6ML	20	4ML	83	41	275	39ML
55	2ML	22.5	0ML	87	35	300	35ML
60	0ML	25	0ML	91	29	325	31ML
65	0ML	27.5	0ML	95	23	350	27ML
70	0ML	30	0ML	99	17	375	23ML
75	0ML	32.5	0ML	103	11	400	19ML
80	0ML	35	0ML	107	5	425	15ML
85	0ML	37.5	0ML	111	0ML	450	11ML
90	0ML	40	0ML	115	0ML	475	7ML

NOTE: ML refers to ambient noise level.
 Conducted level to be 40 above 1μvolt/mc. at meter input.
 Radiated level to be 40 above 1μvolt/mc. antenna output.

Figure 3-49. Test No. 3

Similar to Test No. 1 but
 diode and capacitor mounted
 6 inches from relay

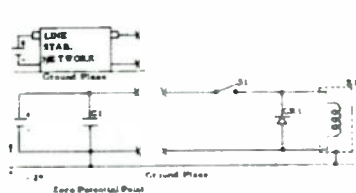

RADIATED							
Freq.	Level	Freq.	Level	Freq.	Level	Freq.	Level
15mc	52ML	5.0mc	56ML	31mc	69ML	65mc	160mc
20	47ML	6.0	46ML	46	65	100	60ML
25	38ML	8.0	42ML	61	70	150	59ML
30	34ML	10	37ML	67	67	175	56ML
35	30ML	12.5	31ML	71	61	200	51ML
40	26ML	15	27ML	75	55	225	47ML
45	22ML	17.5	23ML	79	49	250	43ML
50	18ML	20	19ML	83	43	275	39ML
55	14ML	22.5	15ML	87	37	300	35ML
60	10ML	25	11ML	91	31	325	31ML
65	6ML	27.5	7ML	95	25	350	27ML
70	2ML	30	3ML	99	19	375	23ML
75	0ML	32.5	0ML	103	13	400	19ML
80	0ML	35	0ML	107	7	425	15ML
85	0ML	37.5	0ML	111	1	450	11ML
90	0ML	40	0ML	115	0ML	475	7ML

CONDUCTED							
Freq.	Level	Freq.	Level	Freq.	Level	Freq.	Level
15mc	55ML	5.0mc	58ML	31mc	71ML	65mc	160mc
20	50ML	6.0	48ML	46	70	100	61ML
25	42ML	8.0	40ML	61	70	150	58ML
30	34ML	10	32ML	67	65	175	55ML
35	26ML	12.5	24ML	71	59	200	51ML
40	18ML	15	16ML	75	53	225	47ML
45	10ML	17.5	8ML	79	47	250	43ML
50	6ML	20	4ML	83	41	275	39ML
55	2ML	22.5	0ML	87	35	300	35ML
60	0ML	25	0ML	91	29	325	31ML
65	0ML	27.5	0ML	95	23	350	27ML
70	0ML	30	0ML	99	17	375	23ML
75	0ML	32.5	0ML	103	11	400	19ML
80	0ML	35	0ML	107	5	425	15ML
85	0ML	37.5	0ML	111	0ML	450	11ML
90	0ML	40	0ML	115	0ML	475	7ML

NOTE: ML refers to ambient noise level.
 Conducted level to be 40 above 1μvolt/mc. at meter input.
 Radiated level to be 40 above 1μvolt/mc. antenna output.

Figure 3-50. Test No. 4

Diode Suppression Only

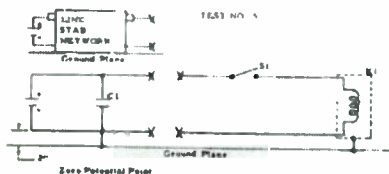

RADIATED

Freq. Level	Freq. Level	Freq. Level	Freq. Level	Freq. Level
15mc 00	1 0mc 92	31mc 114	100mc 88	400mc 81
20 00	6 3 94	40 115	120 81	
42 65	8 0 95	63 121	140 83	
62 74	10 95	80 124	160 83	
74 80	15 90	95 124	200 83	
1 2 90	20 85	65 118	210 71	
1 15 92	25 85	74 109	100 80	
2 4 92	24 104	80 96	150 73	

CONDUCTED

Freq. Level	Freq. Level	Freq. Level	Freq. Level	Freq. Level
15mc 60	60mc 54	1 5 58	5 0 62	15 71
20 64	80 44	2 0 57	7 0 63	20 80
30 63	1 0 58	1 0 57	10 68	21 82
40 63	1 2 50	4 0 61	12 71	24 78

NOTE: Conducted level is in db above 1u volt/mc at meter input.
 Radiated level is in db above 1u volt/mc distance indicated.

Figure 3-51. Test No. 5
Unsuppressed

Figures 3-47 through 3-51 show the test configurations along with the data obtained.

Test 1 - Complete Suppression with the Diode and Capacitor Mounted at the Relay. This system meets MIL-I-26600 at all frequencies. At its closest point, it is 4.5 db below the specification in the frequency range of 40 to 50 mc. At all other points, it falls below the ambient noise level.

Test 2 - Unshielded. This configuration did not meet MIL-I-26600 specifications between 40 and 50 mc. It was 7.5 db high which was attributed to radiation from the microswitch contacts.

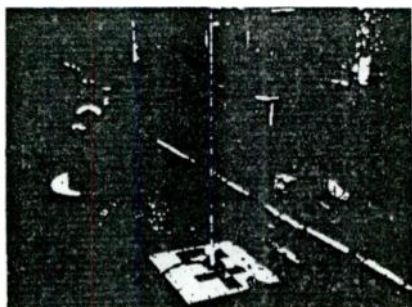

Figure 3-52a. Low Frequency Radiation Measurement

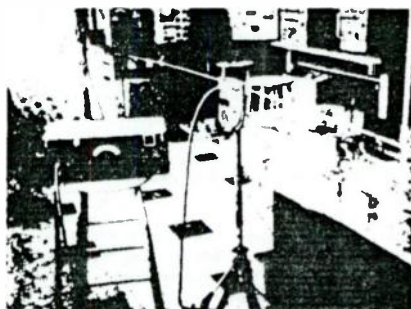

Figure 3-52b. High Frequency Radiation Measurement

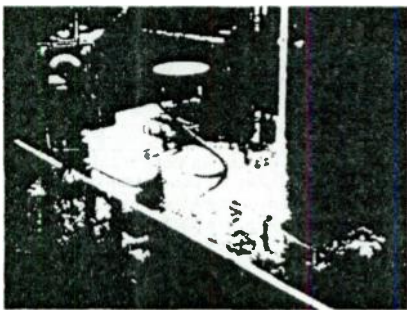

Figure 3-52c. Conducted Interference Measurement

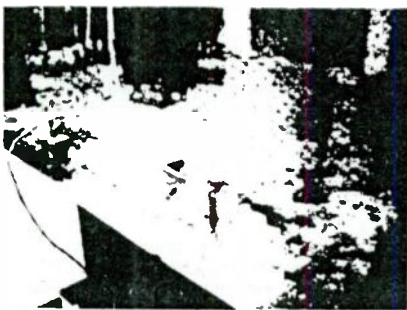

Figure 3-52d. Detail of Suppression Scheme

Test 3 - Complete Suppression with the Relay Suppression Components Mounted 6 Inches from the Relay. This configuration meets MIL-I-26600 specifications at all frequencies and differs from Test No. 1 by 1 db at its highest point in radiation and is identical to Test No. 1 in conduction, which is below the noise level at every point.

Test 4 - Diode Suppression Only. This configuration was out of specification limits at all points from 25 mc to 400 mc in the radiation tests and, although it was within the specification limits on conduction, it was much higher than the noise level from 2 mc to 25 mc.

Test 5 - Unsuppressed. This configuration was above the specification on radiation through almost the entire spectrum measured, reaching a maximum of about 80 db high.

4.4.5 SUPPRESSION TECHNIQUES

Upon closing the microswitch a transient is generated and energy is radiated from the cable as well as from the arc present between the switch contacts. The switch itself can be considered as a broadband interference generator.

The signal generated at the switch can be suppressed by three means: First, by introducing sufficient inductance into the circuit to cause the initial current to be extremely low, second, by providing a low impedance path around the switch thereby short-circuiting the signal, and third, by shielding the configuration to prevent direct radiation. The first method requires the inductor to have a high reactance over a large frequency range in addition to presenting the problem of dissipating the stored energy when the switch contacts are opened.

A combination of the second and third suppression methods seemed to be the most practical and therefore it was used. The microswitch was mounted in a shielded enclosure and the connecting leads were brought into the enclosure through two .001 μ d feed-through capacitors. Inside the enclosure, the two feed-through points were connected together by a .05 μ d capacitor to provide the low impedance path across the switch. The principal current loop is around the switch and not to ground, therefore, small value feed-through capacitors were used to minimize the physical size of the circuit. A 7.5 henry choke was placed in series with the switch and incoming leads to limit the high frequency current. See Figure 3-53.



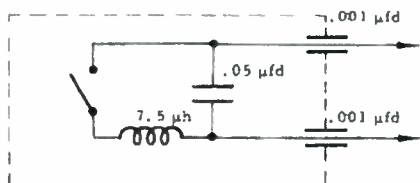

Figure 3-53. Suppression Circuit

When the switch is opened, the energy contained in the relay coil must be dissipated at a low rate to minimize radiated interference. Since the potential developed by the relay coil when the switch is opened is opposite in polarity to the previously applied potential, a properly polarized diode is the appropriate dissipation device. Before the diode can begin to conduct, the potential across the relay coil must decrease to zero and build up in the opposite direction. A small capacitor (see Figure 3-54 Parts List) placed in parallel with the diode limits the rate of potential change during the transition period. The size of the capacitor is a compromise between controlling the above-mentioned transition period and minimizing the initial current when the switch is closed.

The conducted interference fell below MIL-I-26600 specifications without need of suppression and the radiation suppression components lowered the conducted level below the ambient noise level.

4.4.6 PARTS LIST

C1	1 mfd capacitor
C2, C3	.001 mfd feed-through capacitor
C4	.05 mfd disc ceramic capacitor
C5	.01 mfd disc ceramic capacitor
CR1	1N649 general purpose silicon diode, Texas Instrument, Inc.
K1	P/N G26A1OP6AS, Filters, Inc
L1	7.5 microhenry high frequency choke
S1	Microswitch, 115M1-T

Figure 3-54. Parts List - Relay-Microswitch Suppression Circuit

4.5 TESTS TO DETERMINE METHODS OF SUPPRESSING INTERFERENCE FROM A TRANSISTOR SWITCHING CIRCUIT

4.5.1 GENERAL

Radiated and conducted RFI tests were performed on a transistor switching circuit with a tape cable load. The tests were conducted in accordance with Military Specification MIL-1-26600, 2 June 1958, and Amendment 2, 9 May 1961, for Class 1b equipment. No radiated RFI was observed, although several load configurations were used. Conducted RFI exceeded specifications by more than 20 db. The installation of a .047 Voltain Q capacitor between the collector and emitter of the transistor reduced the RFI to within specification limits. Grounding of the dc return wire to the ground plane at the line impedance stabilization network decreased the RFI on the +28 volt line by an additional 3 to 5 db.

4.5.2 TEST PROCEDURE

A transistor switching circuit and its cable load were mounted on a 3' x 8' copper ground plane in accordance with the typical test setups of MIL-1-26600. All tests were performed in accordance with the procedures in MIL-1-26600.

The 28 volt power leads were 24 inches in length throughout the tests. The cable load was placed 4" from the edge of the ground plane, and test antenna placements were measured from the center of the cable. The transistor chassis was placed 5 inches away from the cable at its mid-point (directly in line with all test antennas).

An RFI shielded microswitch (Figure 3-53) was used in place of the thermostat to increase the circuit cycling speed. This facilitated rapid detection of RFI peaks while frequency scanning. After the spectrum was scanned, using the microswitch to trigger the circuit, the thermostat was put into the circuit and measurements were made at the test frequencies of highest interference level. The thermostat was activated by alternately heating and cooling.

The following tests were performed:

Test 1 - Conducted RFI on the +28V and return lines over the frequency range of .15 to 25 mc using the shielded microswitch as a circuit triggering device. Figure 3-55 shows a schematic drawing of the test set-up.

Test 2 - Conducted RFI on the +28V and return lines at the test frequencies recorded in Test No. 1 using heat cycling of the thermostat as a circuit triggering device. Figure 3-56 is a photograph of the test set-up.

Test 3 - Radiated RFI over the frequency range of 0.15 mc to 10 gc with the tape cable load flat on the horizontal ground plane and using the shielded microswitch as a circuit triggering device. Figures 3-57 and 3-58 are photographs of the test set-up.

Test 4 - Radiated RFI under the same conditions as Test 3 but using heat cycling of the thermostat as a circuit triggering device.

Test 5 - Radiated RFI over the frequency range of .15 mc to 10 gc with the tape cable load mounted 4 cm above the horizontal ground plane or insulators and using the shielded microswitch as the circuit triggering device. Figure 3-59 shows a photograph of the test set-up.

Test 6 - Radiated RFI over the frequency range of 0.15 to 25 mc with 1/2 of the tape cable load flat on the horizontal ground plane and the other half flat on the vertical ground plane. The shielded microswitch was used to trigger the circuit. Figure 3-60 shows a photograph of the test set-up.

Test 7 - Conducted RFI on the +28V and return lines using the test frequencies employed in Test 1 with the thermostat as a circuit triggering device and with a 0.047 mfd capacitor installed between the emitter and collector of the transistor.

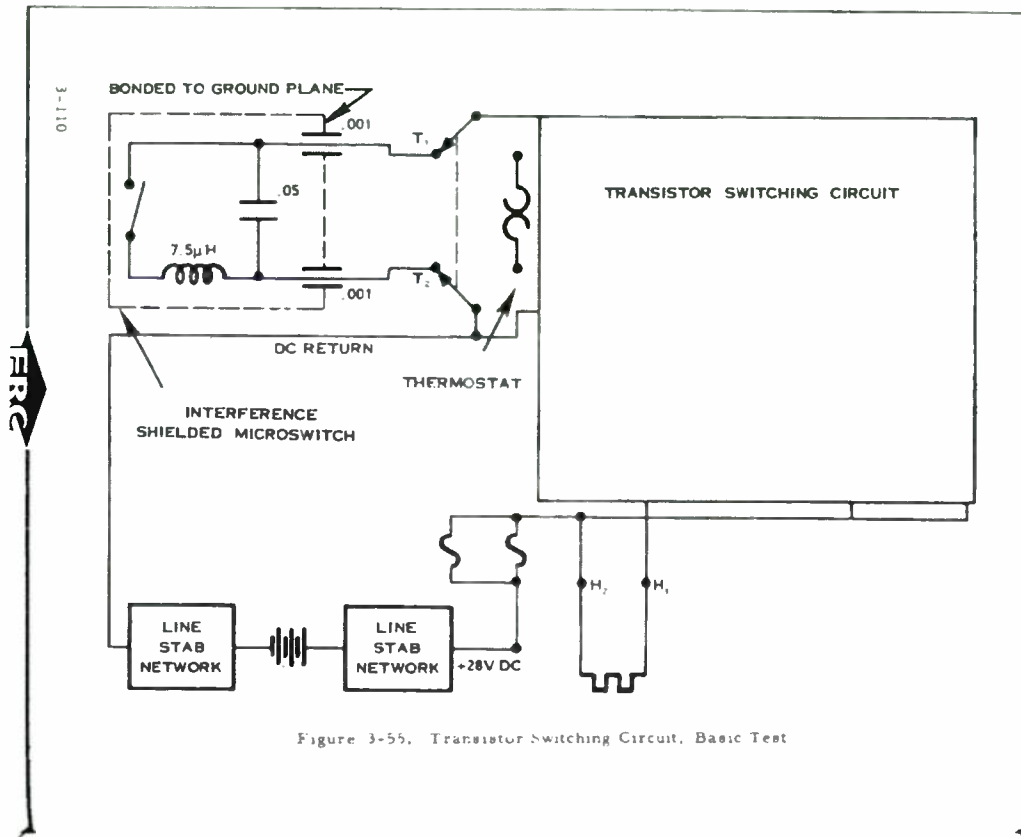

Figure 3-55. Transistor Switching Circuit, Basic Test

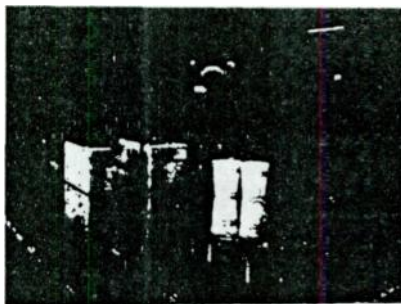

Figure 3-56. Conducted Interference Measurement with Heat Cycling

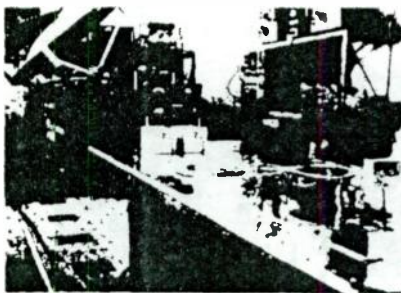

Figure 3-57. High Frequency Radiation Measurement with Load Cable Resting on Ground Plane

(PHOTOS TAKEN IN LABORATORY
OF FREDRICH RESEARCH COR-
PORATION, WHEATON, MARYLAND)

3-111





Figure 3-58. Low Frequency Radiation Measurement with Load Cable Resting on Ground Plane

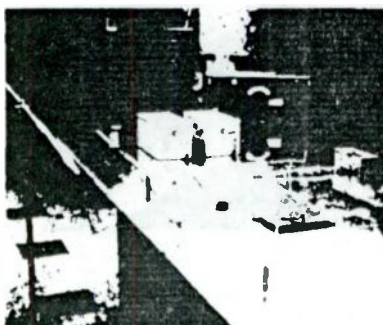

Figure 3-59. Radiation Measurement with Load Cable Elevated 4 cm Above Ground Plane

(PHOTO TAKEN IN "AERIALS"
OF FREDRICK RESEARCH COR-
PORATION WHEATON, MARYLAND)

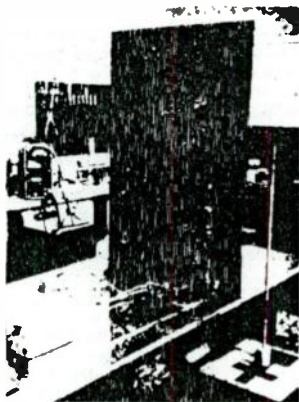

Figure 3-60. Radiation Measurement with Load Cable Taped to Horizontal and to Vertical Ground Plane

Test 8 - Conducted RFI on the +28V and return lines using the test frequencies employed in Test 1 with the thermostat as a circuit triggering device and with a .022 mfd capacitor installed between the emitter and collector of the transistor.

4.5.3 TEST RESULTS

The curves of Figures 3-61 and 3-62 show the conducted RFI for both microswitch and thermostat triggering devices with the tape cable load flat on the horizontal ground plane. Comparison of the plotted data shows that the interference was approximately equal on both the +28V and return power leads.

Figure 3-65 shows the RF ambient levels measured when checking the test sample for radiated interference. No RFI was observed above the ambient noise level. Ambient RF levels varied somewhat during the various tests, but in all cases were within specification limits.

Figure 3-64 shows the conducted RFI on the +28V and return power leads after the installation of a 0.047 mfd capacitor between the collector and emitter of the transistor. The thermostat was heat cycled to trigger the circuit for these measurements.

The results indicate that the installation of the 0.047 mfd capacitor is the only RFI fix required to reduce interference to within specification limits.

Figure 3-65 shows the conducted RFI on the +28V and return power leads after the installation of a .022 mfd capacitor between the collector and emitter of the transistor. The thermostat was heat cycled to trigger the circuit for these measurements.

4 5.4 SUPPRESSION TECHNIQUES

Upon the opening or closing of the thermostat, a switching transient is generated and RF energy emanates from the thermostat and is conducted into the circuit via the leads. Due to the small current (about 650 μ A) normally flowing through the thermostat, the transient produced upon "make" or "break" is relatively small. The radiated energy is therefore limited and produces no RFI above the specification limits.

Conducted RFI, during the "make" and "break" of the thermostat, appears across the base-emitter circuit of the 2N1893 and is amplified while the transistor is in the switching state. The amplified output is developed across the 2700 Ω collector resistor.

There are several methods of reducing the switching transient by the application of suppression techniques to the thermostat. The simplest and most effective solution is to employ a 0.047 mfd Vitamin Q capacitor between the collector and emitter of the transistor, thereby inducing degeneration of the RFI while the transistor and thermostat are in the switching conditions. Switching time is lengthened slightly.

By-pass capacitors were tried across all other components and combinations of components without positive results. A by-pass capacitor across the 2700 Ω collector resistor raises the level of conducted RFI considerably.

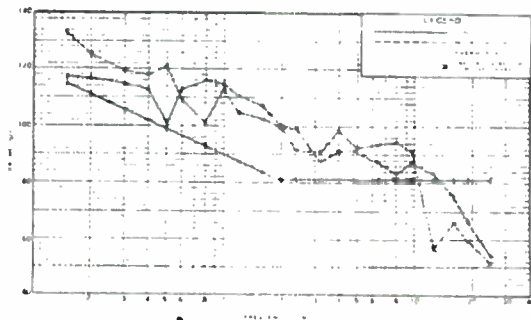

Figure 3-61. Broadband Conducted Interference Test - 2A Volt Lead

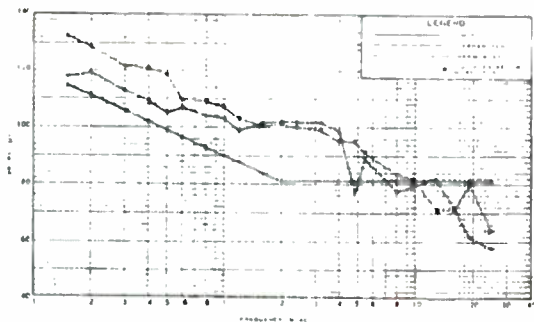

Figure 3-62. Broadband Conducted Interference Test +28 Volt Lead

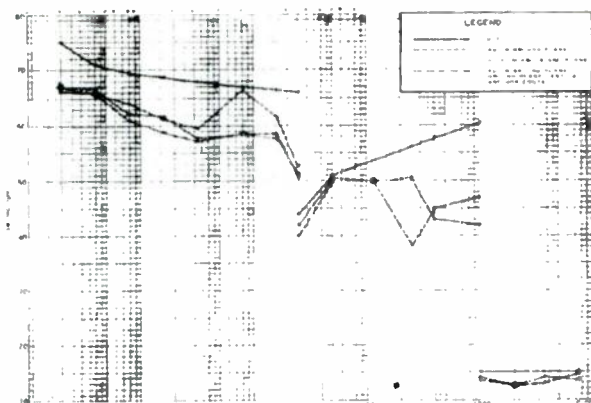

Figure 3-63. Broadband Radiated Interference Test

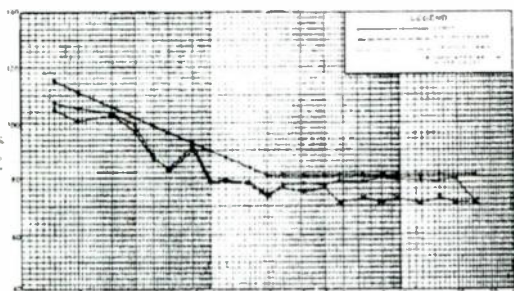

Figure 3-64. Broadband Conducted Interference Test +28 Volt and -28 Volt Lead Using Thermostat as Circuit Trigger After Installation of .047 μ f Capacitor Between Collector and Emitters of the 2N1893 Transistor

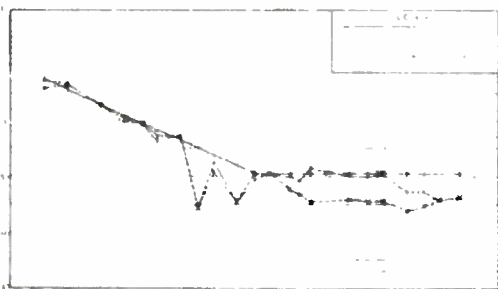

Figure 3-65. Broadband Conducted Interference Test
 +28 Volt and -28 Volt Leads Using Thermostat
 as Circuit Trigger After Installation of
 .022 μ Capacitor Between Collector and
 Emitter of the 2N1893 Transistor

4.6 CONCLUSION

The tests which have been discussed in this section are typical of situations encountered in designing equipments which are compatible with their electronic environments. No component, however small, can be overlooked. Nor is the fact that a component is accepted as a standard or qualified part any guarantee that it will not produce interference in a given circuit. Detailed analysis and test is the only sure way to ascertain that a 25 cent component will not degrade a \$25,000,000 system by means of radio interference.

Tests covering a broad frequency spectrum and several possible configurations of components and equipment may require an extended period of time as well as a large number of man-hours to complete. In addition, a wide range of special test instruments and laboratory facilities may be necessary. Previous sections of this Chapter have discussed such facilities. Chapter 4 discusses test instruments in detail and Appendix III presents their characteristics and data.



DESIGN FEATURES, USE, AND CALIBRATION OF TEST INSTRUMENTS

CHAPTER 4

1. INTRODUCTION

Five basic types of equipment are required in the performance of electromagnetic interference measurements; radio interference field intensity meters, spectrum analyzers, pickup devices, signal generators, and frequency meters. In addition, accessory equipments such as vacuum tube voltmeters (VTVM's), oscilloscopes, oscilloscope cameras, power meters, attenuators, and filters are required. Design features of each of the five basic types of equipment mentioned above are discussed in this chapter, and information is provided on their utilization and calibration.

2. RADIO INTERFERENCE MEASURING EQUIPMENT

Equipments presently available for conducting field intensity measurements are discussed in the succeeding paragraphs. It should be noted that new instruments are being developed to keep pace with the demand for measurements, particularly at frequencies above 10 mc, and to meet requirements for increased accuracy, portability, and reliability. The user should investigate the possible availability of newer types whenever the instruments described do not satisfy the measurement requirements.

2.1 GENERAL FEATURES AND USE

From the discussion in Section 1 of Chapter 1, Volume 1 and from what has been said in Section 1, Chapter 1 of this Volume, it is obvious that the nature of radio interference prohibits its adequate description by any single measurement. Presently available measuring instruments are usually calibrated to read the peak, quasi-peak, effective, or average values of the interference. However, since the electrical disturbances causing interference are complex waves varying greatly in amplitude, phase, and frequency distribution, a single type of measurement can be no more than an arbitrary established standard. The measurement of several associated parameters are required to adequately describe the interference.

A radio frequency type of interference meter measures the RF amplitude of radio interference in much the same manner as a "conventional" field strength meter. It is complete within itself, consisting of a specially designed and constructed radio receiver, and an indicating meter which is connected into the receiver by means of a special circuit. Attention is drawn to the fact that the conventional type field

strength meters are useful only for measuring sinusoidal waves, that is, they do not have the dynamic characteristics necessary for measuring the many types of wave shapes which, as stated above, constitute radio interference. For this reason, any attempt to "fix" or modify a radio receiver in such a way as to make it satisfactory as a general-purpose radio interference meter will be unlikely to succeed.

A meter which responds to audio signals is used to indicate and measure the effect of radio interference. It is essentially an output meter, provided with special circuits to give quasi-peak, peak, and average readings on a meter which may be calibrated in volts, milliwatts, or decibels. Meters of this type may be used to measure radio frequency interference currents and voltages if they are used in conjunction with a calibrated receiver. It is helpful to record, along with the values read on the meter, a qualitative description of the interfering signal obtained by monitoring by ear or eye with headphones and/or an oscilloscope.

The ideal meter for making interference tests should be capable of admitting signals at a very low energy level, amplify them with high fidelity and by known amounts, and present them to a calibrated output meter for measurement. Because of the selectivity and stability of the superheterodyne receiver circuit, it has been used largely as the foundation for all radio frequency meters of recent design. Attempts to modify regular service receivers to make them function as interference meters have met with only partial success because of inherent limitations. The functions of the essential parts of typical interference meters are shown in the block diagram of Figure 4-1.

The selection of interference detecting and measuring equipment to be utilized in measurement procedures should include but not be confined to a consideration of the following operating characteristics:

- a. Capable of detecting and measuring various types of emission.
- b. Capable of tuning the required frequency range.
- c. Adequate frequency stability together with accurate dial calibration for resetability. For most purposes over the range of frequencies involved, a frequency stability of 0.005% of the received frequency after one-hour warm-up is satisfactory.
- d. Suitable IF bandwidth to provide both control over rejection of undesired signals and maintain undistorted output indications for emissions of various modulations, e. g., pulsed RF.

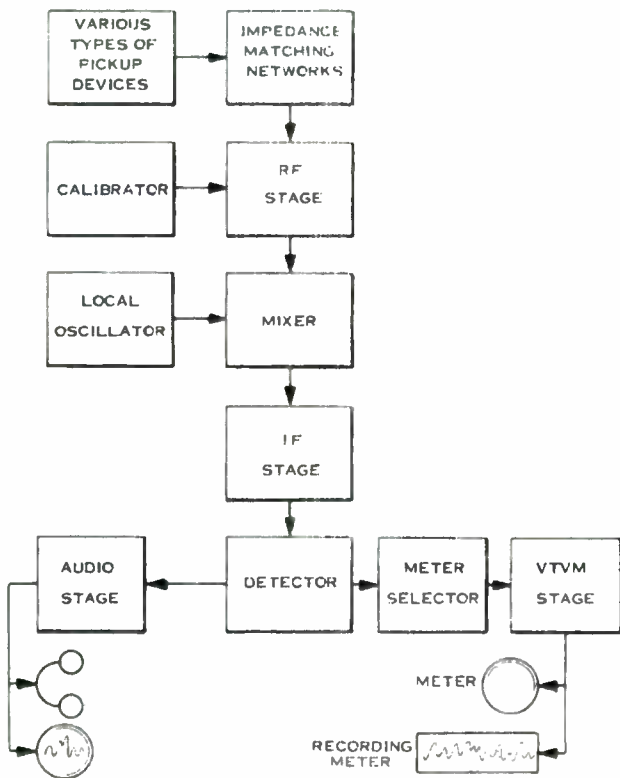

Figure 4-1. Block Diagram of a typical Radio Interference Meter

e. RF selectivity to reduce susceptibility to spurious response (a minimum of two RF stages preceding the first mixer is recommended).

f. High sensitivity to insure detection of weak interference signals. In most cases two RF amplifier stages will provide sensitivity in the order of one microvolt (-107 dbm, assuming a receiver input impedance of 50 ohms) in the HF range and five microvolts (-93 dbm) in the VHF-UHF range to produce a detectable receiver output.

g. Adequate shielding to prevent high level undesired signals from penetrating the case.

h. Adequate suppression of spurious receiver radiation to minimize the interference potential to other receivers.

i. Suitable output indicators and provisions for connection of external monitors such as headphones, oscilloscopes, and recorders.

j. Rapid means of changing frequency bands.

k. Rapid and accurate means of instrument calibration.

In the following paragraphs, each stage is briefly discussed with respect to its function in a radio interference measuring set. Special emphasis is given to the features which distinguish a radio interference measuring set from an ordinary receiver: the calibrating device (see Paragraph 2.1.3), the detector with its weighting circuits (see Paragraph 2.1.6), and other output indicating devices (see Paragraph 2.1.8).

2.1.1 IMPEDANCE-MATCHING NETWORKS

Because of the necessity for matching impedances, networks must be provided to match the various types of antennas and probes to the input of the meter. In addition, for the measurement of signals of high energy, an attenuator must be provided in order to avoid overloading of the final circuits. The functions of impedance matching and attenuation may be conveniently combined in the same network. The impedance-matching network must be suitable for all antennas provided with the meter, and should include provision for a 50 ohm connection for calibration purposes. The attenuation ratios normally provided are 1:1, 10:1, 100:1, 1000:1, and 10,000:1. Instead of providing the attenuation before the first radio frequency stage by placing the attenuator in the impedance-matching network, a separate attenuator is sometimes placed before the mixer or IF stages.

2.1.2 RADIO FREQUENCY AMPLIFIER STAGE

As in all superheterodyne receivers, the radio frequency stage consists of a highly selective amplifier with a good gain ratio (see section 2.1f). When an instrument is designed to cover a wide range of frequencies, for example, 38 mc to 1000 mc in 3 to 4 bands, the tuning condensers must be provided with proper band switches which allow a minimum overlap of 5% between bands. A 2% accuracy on frequency indicated requires high grade parts and careful calibration.

While commercial practice in the design of broadcast receivers employs one multipurpose tube as RF amplifier and local oscillator, the rigid requirements of measuring instruments requires better performance obtained by using a separate tube in the local oscillator position. One of the advantages is a greater IF rejection ratio and a higher image rejection ratio, both of which are of the order of 60 db.

The major difference between the radio frequency stage of a normal receiver for amplitude modulated signals and that of a radio interference meter lies in the effective bandwidth of that stage. For the reception of radio signals amplitude modulated with audio signals, a bandwidth of from 10 to 20 kc is adequate at all frequencies. For a radio frequency meter, there are two requirements: First, the bandwidth should not exceed a certain fraction of the operating frequency in order to allow the determination of that frequency with fair accuracy. Second, the bandwidth should be large enough to allow interference pulses of short duration to pass through the stage without appreciable lengthening and peak depression. These requirements mean that, at the higher frequencies, the bandwidth must be considerably larger than 20 kc. Specification MIL-I-16910A requires meters to have an effective bandwidth (defined as the frequency span between half voltage points, or between points 6 decibels down from maximum response) of 100 kc for the frequency range from 20 to 1000 mc, and in addition an adjustment for a bandwidth of one megacycle for the frequency range from 200 to 1000 mc. For measurements of narrow pulse radar signals, bandwidths as high as 5 mc may be required; however, for measurements of CW type signals much narrower bandwidths are desirable due to the resultant increase in receiver sensitivity. However, it is more important for making accurate measurements that the bandwidth be accurately known and compared to the needs of the user than have a specific predetermined value. Charts giving the exact bandwidth as a function of frequency should be supplied with each meter.

2.1.3 CALIBRATOR

Calibration of a radio interference measuring instrument may be made either with an external signal generator or with a built-in internal source. The source, whether external or internal, may be either a generator of sinusoidal signals or a source of random noise. Any set may be calibrated by means of an external source of either kind provided the proper connectors are available for the proper impedance match and provided the external source furnishes a signal of known magnitude and character.

Whether the calibration is to be made with a sinusoidal signal or with a random signal depends on the type of interference to be measured. For accurate results, the signal produced by the calibrating source should resemble the interfering signals as closely as possible. When this is not possible, a certain inaccuracy is necessarily introduced. When a meter has an internal calibrator, considerations of space, weight, and simplicity demand that one or the other type be chosen. About as many sets use random interference sources as use sinusoidal ones. When a sinusoidal oscillator is used, it may either be tunable so that calibration can be made at the test frequency (this is preferable), or it may have a fixed frequency, usually near the middle of the range of the meter. A random interference source need not be tuned since a single source is usually sufficient to cover the entire range of the set.

Calibration is accomplished by applying the known output voltage of the calibrator to the input terminals of the test set, and then adjusting the gain of the set until the correct output indication is obtained. A convenient source of random voltage is found in the thermal agitation currents in the first tuned circuit of the test set. This voltage has many characteristics that are desirable in a calibration source and it has been used as such in some instances. One important advantage of this source is that it covers the entire radio frequency spectrum almost uniformly and thus requires no tuning. Another advantage is that the magnitude of the voltage generated depends only upon such relatively constant quantities as the impedance, bandwidth, and temperature so that it does not need to be measured. Furthermore, its use involves no extra tubes, parts, or circuit complications. Unfortunately, the magnitude of the voltages obtainable in this way is too low for real usefulness as a calibrator.

A more efficient source of random voltages for calibration purposes is the so called "shot noise" arising in the plate circuit of a vacuum tube. "Shot noise" is a result of random variation in the number of electrons emitted from the filament of a thermionic tube. Like thermal

agitation, "shot noise" is uniformly distributed over the entire radio frequency spectrum, and since its magnitude can be much greater than that of thermal agitation, it is a much more useful calibrating source. Vacuum diodes are used most frequently for this purpose, but gas diodes, such as neon tubes, may also be used, particularly at the lower frequency ranges.

When the "shot noise" in a diode is used, the space charge in the tube must be eliminated. Space charge acts as a buffer, smoothing out to some extent the fluctuations which generate the "shot noise". Since it is desirable to have the fluctuations as strong as possible, space charge is detrimental in this application. It can be eliminated by lowering the filament temperature and at the same time keeping the plate voltage at a high value, so that all electrons emitted are immediately attracted by the plate and the plate current is limited only by the number of electrons emitted by the cathode. The operation of the tube is then said to be "temperature limited." Under these conditions, there is a simple and definite relationship between the "shot noise" voltage generated and the direct plate current, which can be read conveniently on a direct current milliammeter. This type of calibrator is used most frequently for random interference calibration. It is simple, inexpensive, reliable, and convenient to use, and it has proved to be capable of sufficient accuracy for most measurement work.

Calibration by means of an external standard signal generator, while capable of greater accuracy, requires more equipment and is not as convenient so that its usefulness lies in those cases where the greatest possible accuracy is required. The output of the "shot noise" diode is not inherently any less definite or stable than that of a signal generator, but there are some differences in the manner of utilization which account for the greater accuracy of the signal generator in practice. These differences are the following:

A. Standard signal generators are normally equipped with dummy antennas (antenna simulators) to provide impedance matching between the signal generator and receiver input circuits. When the signal generator is used with a dummy antenna of the correct impedance in the circuit, any variations in the antenna circuit (step-up or step-down impedance ratios) are taken into account. When an internal calibrator is used, a dummy antenna is not usually used and the output of the internal source is connected directly across the first radio frequency stage. Variations in the antenna input circuit cannot therefore be compensated for in the calibration process, and a variation in the antenna circuit trimming may result in an error of measurement.

b. The output of the "shot noise" diode is of the order of from 5 to 50 microvolts. "Noise" contributions of the test receiver itself can effect the resulting output considerably, particularly at the lower frequencies where circuit impedances are large. The superiority of the external signal generator lies in the fact that it can be used at higher voltage levels, and thus the inherent receiver "noise" may be made negligible by comparison.

c. The output indication produced by a given "shot noise" input depends on the bandwidth of the receiver, so that changes of bandwidth affect the calibration. This last point makes the sinusoidal generator more advantageous only when sinusoidal measurements are to be made. For measurements of common interference signals, the advantage is actually with the "random noise" calibrator since variations in the bandwidth affect the calibration and the actual measurement in the same way. Thus, these variations are compensated for by this manner of calibration. As was said before, greatest accuracy is achieved when the calibrating signal is most nearly like the signal to be measured.

2.1.4 MIXER AND LOCAL OSCILLATOR

The mixer and local oscillator stages are substantially the same as found in any good superheterodyne receiver. Though some radio interference measuring sets utilize the same tube both as mixer and as local oscillator, for the stable operation and high grade performance required, separate tubes for the two functions are preferable. This procedure also decreases oscillator radiation and improves the image and intermediate frequency rejection ratio.

2.1.5 INTERMEDIATE FREQUENCY AMPLIFIER STAGES

Special considerations for the intermediate frequency amplifier stages include the large bandwidth and the wide frequency range covered by some radio interference measuring sets. Since the gain of a single stage is roughly inversely proportional to its bandwidth, the number of intermediate frequency stages must be larger than in an ordinary receiver. At least three, and in some cases as many as six, are used in currently available instruments. In order to cover a very wide frequency range, more than one intermediate frequency may have to be used. This also has the advantage that no hiatus need be left for frequencies near the intermediate frequency. For example, a meter covering the range from 150 kc to 20 mc and using an intermediate frequency of 455 kc cannot cover the range from about 400 to 500 kc because these frequencies would require excessively low oscillator frequencies. If the same meter employs two intermediate frequencies, say 455 kc for the low band

and 1600 kc for the high band, then special provisions can be made to allow utilization of the second intermediate frequency of 1600 kc for the range from 400 to 500 kc, and thus the entire range may be covered.

Commonly used intermediate frequencies are 12.5 kc, 455 kc, 1600 kc, 12 mc, 33 mc, 60 mc, 160 mc, and 260 mc.

2 1 6 DETECTOR AND WEIGHTING CIRCUITS

As in any receiver, the detector functions as a rectifier which demodulates the intermediate-frequency signal and converts it into a pulsating, unidirectional current. However, the weighting circuits associated with the detector are the very heart of the radio interference measuring set. They determine which feature of the interference shall be indicated by the output meter.

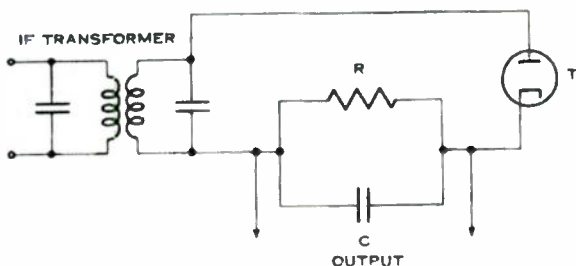

Figure 4-2. Basic Detector Circuit

The basic circuit of a diode detector is shown in Figure 4-2. The parallel combination of R and C, across which the output is taken, is called the weighting circuit. When the signal developed in the intermediate frequency transformer makes the plate of the diode positive with respect to its cathode, a current will flow charging the capacitor. To a first approximation, the presence of the resistor R may be neglected during this charging process, and the voltage appearing on the capacitor is mainly determined by the time constant of the series circuit formed by the plate resistance of the diode and the capacitance C. When the polarity of the voltage reverses, no current can flow through the tube, and the capacitor discharges through the resistance R. The rate of discharge

now depends on the time constant of the loop containing C and R. Thus, by proper choice of R and C, the time constants for charge and discharge may be of any desired value.

If both the charging and the discharging time constants are made comparatively long, the detector circuit is unable to follow any fast variations of the input voltage, such as may be caused by interference pulses, or even a sinusoidal audio modulation. It will produce an indication that is essentially proportional to the carrier strength. When this kind of weighting circuit is used, the output indication is usually labeled "Field Intensity."

When the charging time constant is made much smaller than the discharging time constant—say one milliser and charge and 600 milliseconds discharge, the voltage across the capacitor reaches a value near the peak of the applied voltage and remains at or near this value as long as the peak reoccurs frequently enough to prevent the voltage from decreasing. When the signal is modulated 100 per cent at an audio frequency of 500 cycles per second or higher, this circuit will produce a reading almost twice as high as the "Field Intensity" circuit. The proper name for a circuit of this type is "Quasi-Peak," meaning "almost like peak."

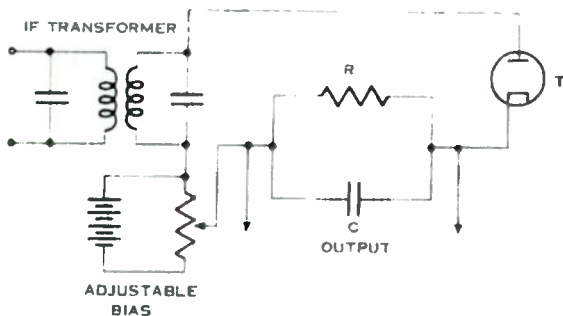

Figure 4-3. Detector With Adjustable Bias

It is practically impossible to obtain a true peak reading for all kinds of pulses by adjusting the parameters of the weighting circuits. To obtain a true peak reading, a so called "slide back" circuit is made use of. This consists of an adjustable bias on the detector diode as shown in Figure 4-3. This circuit makes the plate of the diode negative with respect to the cathode when no signal is applied. Even with a signal applied, no current can flow, and therefore no output voltage can appear, until the signal produces a voltage large enough to overcome the bias. The procedure is to adjust the bias manually until the aural output indication just disappears, using the highest possible gain of the output stages. At this point the bias is just equal to the peak value of the applied signal. The time constants for this case are usually chosen about the same as for the "Field Intensity" position.

It should be emphasized that the weighting circuits can give information only about the signal as it is presented to them. Since the weighting circuits are placed at the second detector, the carrier strength, quasi-peak, or peak voltage indicated by them refer to the signal after it has passed the radio frequency and intermediate frequency amplifier stages. If there is any distortion, pulse lengthening, or peak depression in these stages, the output indication does not give correct information about the input signal to the instrument.

2.1.7 AUDIO AMPLIFIER STAGES

The audio signal, passed by the detector and blocking condenser, is boosted by one or two stages of audio frequency amplification which terminate in a telephone jack through impedances matched with regulation 600 ohm telephone headsets. For purposes of visual study of the signal, terminals for the connection of an oscilloscope are usually provided. These may come directly from the detector or from the output of the first audio amplifier. The amplifier within the oscilloscope is depended upon for obtaining deflections of sufficient amplitude to study wave-form characteristics and to differentiate between audio frequency modulation and interference.

2.1.8 OUTPUT INDICATING DEVICES

To make the maximum use of the potentialities of a radio interference measuring instrument, the output should be monitored aurally and visually as well as by an indicating meter. Provisions should therefore be made for connecting headphones and cathode ray oscilloscopes

The output meter is the final terminal of the amplifiers and metering circuits. It usually consists of a dc milliammeter. Provisions are usually made for a jack into which an outside meter can be plugged, and for another jack to accommodate a recording meter. Since these additional meters are connected in series with the one which is an integral part of the instrument, the jacks contain a matching impedance that is normally in series but is shorted out when replaced by that of the external meter. The service meter may also be provided with multipliers for checking portable batteries used for power supply.

For field intensity work where it becomes important to have a permanent record of the interference pattern around a specified area, or a record of the results obtained from extensive rework of troublesome interference sources, a recording meter may be used. The Army-Navy standard type milliammeter-recorder has a range of 0-1 ma and a resistance of 1400 ohms so that it will readily fit into the circuits already described. Its use is limited, however, by the fact that the recording paper is pulled through by a 60 cycles, 115 volts, synchronous motor and can be used only where such a power supply is available. It has changeable gears to provide for different speeds of recording.

2.2 DESCRIPTION OF INTERFERENCE METERS

Continued effort has been made in recent years to develop for military services interference meters which will give dependable service and comply with the specifications which may be demanded of them. The Navy specification MIL-1-16910A details the characteristics of acceptable instruments and classifies them into four principal classes. Briefly, Class 1 includes those meters which have been designed to meet the standards established and approved by the Armed Services. Class 2 instruments are special purpose and as such do not conform to overall specifications. Class 3 meters have not yet been finally approved by the Armed Services, and Class 4 are those in general use, but do not meet most approved standards. Instruments which are in the development stages but not yet ready for production are called "Experimental."

Classification of interference measuring test instruments by Military Specifications MIL-1-0181D and MIL-1-26600 is divided into four principal categories. Basically, Category A equipments are those instruments which adequately measure the interference parameters as required by these specifications. Category B equipments are those existing instruments which are in use but do not adequately measure the parameters of interference signals as required by these specifications. Category C-1 equipments are those instruments which have recently been developed but

FREQUENCY RANGE AND STATUS OF INTERFERENCE MEASURING EQUIPMENT
ACCEPTABLE FOR TESTING IN ACCORDANCE WITH MILITARY SPECIFICATIONS
18 JANUARY 1962

MILITARY SERIAL NUMBER	COMMERCIAL MODEL	COMPLIANCE C	DESCRIPTION				FREQ. RANGE	1500	1500-5	5-10	10-15	15-20	20-30	30-40	40-50	50-60	60-70	70-80
			MIL. SPEC. CATEGORY	NO. 1	NO. 2	NO. 3												
AN 10M 47	NM 12A STODDART	N				1500 TO 1500												
AN 10M 48	NM 12A STODDART	N				1500 TO 1500												
AN 10M 13	NM 12B STODDART	N	A			1500 TO 1500												
AN 10M 3		SC				1500 TO 1500												
AN 10M 81		SC				1500 TO 1500												
	NM 5 EMPIRE	AF	A			1500 TO 1500												
	LF 11 NEW	LF				1500 TO 1500												
	AF 10 M 14					1500 TO 1500												
	EMPIRE					1500 TO 1500												
	AF 10 EMPIRE	AF	A			1500 TO 1500												
15 10 M	NM 1 STODDART	N				1500 TO 1500												
AN 10M 7		NC				1500 TO 1500												
AN 10M 27	NM 12A STODDART	N	A			1500 TO 1500												
AN 10M 8		AF				1500 TO 1500												
	NM 3 A STODDART	N	A			1500 TO 1500												
AN 10M 17A	NM 12A STODDART	N	A			1500 TO 1500												
AN 10M 21	NM 614 STODDART	N				1500 TO 1500												
AN 10M 2	200 A 8 WY ARAD	AF	A			1500 TO 1500												
AN 10M 10	NM 1 A STODDART	N				1500 TO 1500												
	AF 12 EMPIRE	AF	A			1500 TO 1500												
	SPECIAL TUBES					1500 TO 1500												

COMPLIANCE KEY

N NAVY

AF AIR FORCE

SC ARMY SIGNAL CORPS

SEE APPENDIX I
DESCRIPTIVE DATA SHEETS
WHICH LIST THE
EQUIPMENT'S

Figure 4-4. Status Chart of Interference Measuring Equipment Acceptable for Testing in Accordance With Military Specifications

have not been evaluated by the procuring activity. Category C-2 equipments are those instruments which have recently been developed but do not meet Category A requirements, and which presumably can be modified by the manufacturer to meet Category A requirements.

U. S. Army Signal Corps Specification MIL-I-11748B does not classify into groups but lists as "acceptable" the instruments which adequately meet the requirements of the specification. To assist the reader, the frequency range and status of interference measuring equipments as of January 1962 are shown in Figure 4-4. More complete information on interference measuring test equipment is contained in Appendix III or further extended by other applicable specifications.

4.2.1 RADIO INTERFERENCE MEASURING SET AN/URM-41

Radio Interference Measuring Set AN/URM-41, similar to commercial model NM-40A manufactured by Stoddart Radio Aircraft Company, is an equipment developed by the Bureau of Ships for use in interference or field strength surveys to determine the source and magnitude of conducted and radiated signals within its operating frequency range of 30 to 15,000 cps.

The equipment consists of two fundamentally different types of receivers having certain common circuits and metering contained within one case. These two receivers are designated "Selective Operation" and "Wideband Operation."

In selective operation the equipment functions as a superheterodyne receiver with an untuned front end. A preamplifier, a low pass filter, a mixer stage, and an adjustable bandwidth intermediate frequency amplifier are included in the selective operation channel. From the IF amplifier the signal is amplified logarithmically. Automatic gain control for logarithmic amplification is obtained from a detector diode output. The output of the logarithmic amplifier is fed by way of a driver circuit to a half wave detector. Any modulation superimposed on the input signal and passed by the receiver bandwidth is available for monitoring at both the phone and oscilloscope jacks. A beat frequency oscillator supplies an audible beat with an incoming signal and permits coded (CW) signals to be read. During selective operation the detector function is calibrated in terms of the RMS value of a steady unmodulated carrier signal.

The selective operation meter scale is calibrated in two decades logarithmically and 40 decibels linearly. A neon lamp energizes to indicate mixer overloading during the measurement of weak harmonics

When in wideband operation the equipment operates as an untuned amplifier and uses the same preamplifier, detector driver, and detector circuitry as in selective operation. Additionally, wideband operation includes a quasi-peak circuit for measurement of the effective peak value of an input waveform, a polarity turnover switch for difference measurements in peak amplitudes between the negative and positive excursions of the input signal, and a peak slide-back detector for measurements of peak values. The automatic gain control and logarithmic amplifier are switched out of the circuit during wideband operation. Signals from the detector driver circuits are available at the phone and oscilloscope jacks for presentation of the input waveform. The wideband operation meter scale is linear single decade with a logarithmic 20 decibel scale and a suppressed zero. An internal source of 400 cps is provided by a tuning fork circuit for calibration purposes.

The equipment operates on an input voltage of 105 to 125 volts, AC, 50 to 60 cps, single-phase.

Two pickup devices are supplied, a 50 inch 11 turn loop for magnetic field measurements, and a capacitive probe for electric field measurements.

2.2.2 RADIO TEST SET AN/URM-6 AND AN/URM-6B

This meter has been approved for general use by the Military Services and is similar to commercial model Stoddard NM-10A. It was developed under Navy cognizance and covers a frequency range from 14 to 250 kilocycles. It has attenuator settings corresponding to 0, 20, 40, 50, 60, and 80 db. The calibrator circuit consists of a neon bulb and an amplifier tube together with the necessary tuned circuits. The local oscillator is separate from the mixer, and a very stable beat frequency oscillator is connected into the grid of the third IF tube. The BFO is used for identification of signals only and must be off while tuning for. The power input goes through an isolation transformer with filters to keep extraneous powerline noises out of the instrument. It is designed to operate from an AC power source of 105-125 volts, or 210-250 volts, and on frequencies from 50 to 1600 cycles per second.

2.2.3 RADIO TEST SET AN/PRM-1 AND AN/PRM-1A

Made to Navy specifications, this meter (see Figure 4-5) is on the Air Force approved list and is similar to commercial model Stoddard NM-20B. It covers the range from 150 kilocycles to 25 megacycles in seven bands: 150 kc-320 kc, 320 kc-750 kc, 750 kc-1750 kc; 1.75 mc-3.8 mc; 3.8 mc-8 mc, 8 mc-15 mc, 15 mc-25 mc. Intermediate



Figure 4-5. Radio Test Set AN/PRM-1A
(Similar to Stoddart NM-20B)

frequencies of 455 kc are used in bands 1, 3, and 4, and 1600 kc in the other four bands. Attenuator settings of $X10$, $X10^2$, $X10^3$, and $X10^4$ are built into the RF and IF amplifiers. The indicating meter has a two decade logarithmic scale of 1 to 100 microvolts and an approximately linear scale which runs from 0-40 db. The calibration frequency is fed into the first RF amplifier. The mixer consists of two tuned stages, the mixer and the amplifier, and the local oscillator. Four IF amplifier stages and two stages of AF amplification are used. A balanced bridge circuit with two pentodes forms the VTVM circuit, the unbalance being created by potentials from the receiver and AGC outputs. The power requirements for this meter are 1.1 volts at 0.86 amperes for the "A" battery and 75 volts, 30 milliamperes for the "B" battery, all of which can be provided by means of regulation type dry cells. The meter is also equipped for obtaining power from 115 or 230 volts AC, 50 to 1600 cycles per second. For 115 volts, 60 cycles power supply constant voltage is maintained through a regulating transformer with two secondaries. One has high leakage-reactance; and the other, shunted by a condenser, is a resonant loop. The 1.1 volt filament supply is obtained through a step-down transformer and a bridge connected selenium rectifier with filter. The 75 volt plate potential comes directly from the secondary of the regulating transformer, before rectification. The rectifier is a selenium bridge and close regulation is obtained by means of an OA-3/VR 75 tube. For frequencies other

than 50 cycles per second where the resonant loop cannot be used without modification, thermo regulator tube serves as a voltage regulator. An autotransformer makes provision for power supplies of 230 volts. The AN/PRM-1A includes the addition of a beat frequency oscillator (BFO) circuit.

2.2.4 RADIO INTERFERENCE TEST SET AN/URM-3

Radio Interference Measuring Set AN/URM-3, covering the frequency ranges of 0.15 to 0.4 mc, and 1.6 to 40 mc, was designed and developed by the Signal Corps Engineering Laboratories primarily for the measurement of "broadband" interference and represents a new concept in the measurement of broadband interference. It is approved and in use by the Army for interference measurements. The equipment consists basically of a superheterodyne receiver and a calibrated impulse noise generator generating pulses exhibiting a stable and uniform spectrum up to 40 mc, the peak value of which is adjustable to known values.

2.2.5 NOISE AND FIELD INTENSITY METER EMPIRE NF-105

Noise and Field Intensity Meter Empire NF-105 is produced by Empire Devices Products Corporation of Amsterdam, New York. The equipment is designed for use over a frequency range of 150 kc to 1000 mc. Basically, the equipment consists of a receiver, calibrating circuits, indicators, and pickup devices.

Components which are common to all frequency ranges are enclosed in the basic measuring unit. They include the peak and average reading vacuum tube voltmeter, the calibration standards, attenuators, detectors, the audio amplifier, and the power supplies.

The RF and IF circuits are housed in four interchangeable plug-in tuning units. The first unit tunes from 150 kc to 30 mc in six bands and incorporates a 455 kc and a 1600 kc IF strip. The second unit tunes from 20 mc to 200 mc in 2 bands and incorporates a 10.7 mc IF strip. The third unit is continuous tuning from 200 to 400 mc and incorporates a 30 mc IF strip. The fourth unit uses two bands to tune from 400 mc to 1000 mc and incorporates a 42 mc IF strip. The instrument has input attenuator settings corresponding to 0, 20, 40, 60, and 80 db.

Two types of calibration standards are housed in the basic unit. One standard, a sine wave generator, is used in the frequency ranges 20 to 200 mc and 200 to 400 mc and permits spot frequency calibration. The other standard is a broadband impulse noise generator which produces a

spectrum flat within $\pm 1/2$ db over the entire frequency range of the equipment. The amplitude of the noise generator is variable from 37 to 97 db above 1 microvolt per megacycle bandwidth.

Carrier or peak measurements of CW signals are indicated on a meter in microvolts, and db above 1 microvolt. Peak measurements of broadband signals are achieved by direct meter reading or by an aural slide-back method. Broadband interference is indicated directly in microvolts per megacycle or per kilocycle of bandwidth.

The equipment's power supply provides regulation for both plate and filament voltages. Input power to the equipment may be 115 volts AC, 50 to 400 cps or 12 or 24 volts DC. An inverter is used for DC operation.

A 12 inch loop antenna or a vertical pickup rod is supplied for measurements from 150 kc to 30 mc. For measurements from 20 mc to 1000 mc dipole antennas are supplied. These antennas include balun transformers which match the balanced output of the antennas to the unbalanced input to the receiver. A 50 or 500 ohm line probe or a clamp-on probe is available for conductive measurements.

2.2.6 NOISE AND FIELD INTENSITY METER EMPIRE NF-205

The Noise and Field Intensity Meter Empire NF-205 (see Figure 4-6) is similar to the Empire NF-105 in frequency range and other parameters. However, it is noted that the NF-205 has an improved mercury type impulse generator with a peak amplitude variable from -10 to +81 db above 1 microvolt per megacycle bandwidth.

Interference measurements are made in terms of the output of the calibrated impulse noise generator by aural comparison at threshold level with the "unknown" interference. This method provides an accurate measurement of the peak value of the impulse interference in terms of microvolts per unit bandwidth and is independent of the gain and bandwidth of the measurement receiver. The method of injecting the output of the calibrated impulse generator into the receiver input is such that interference measurement is independent of antenna impedance.

A nine-foot rod antenna is provided for radiation measurements for increased sensitivity. It is not calibrated for effective height because of the manner in which it is used for interference measurements (in close proximity to the equipment being tested and in a non-uniform

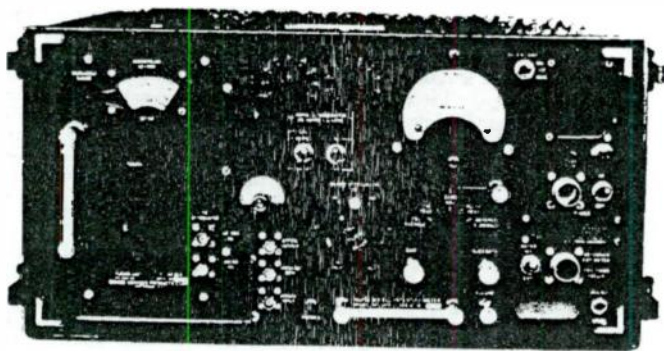

Figure 4-6. Noise and Field Intensity Meter EMPIRE NF 205

field over its length). In measurements under these conditions such a calibration indicating the term "per meter" would be invalid.

Accessories include magnetic and electric field probes for exploration purposes, and matching and coupling networks for use of the test set as a two-terminal RF microvoltmeter. Plug-in power supplies are provided for 115 volt AC and 12 and 24 volt DC operation.

2.2.7 NOISE-FIELD INTENSITY METER TS-587/U AND TS-587A/U

Noise-Field Intensity Meter TS-587 U or TS-587A/U is also listed as NMA-5. It is acceptable only until a replacement is available. This meter operates from 15 mc to 400 mc in four bands. There are three low frequency bands: 15 mc-31 mc, 29 mc-64 mc, 60 mc-125 mc and one high frequency band: 100 mc-400 mc. The intermediate frequency employed for the three lower ranges is 42 mc and 30 mc is used for the upper band. Its construction is unique in that the IF amplifiers for the two intermediate frequencies are completely independent of each other as to tube complements and transformers. This improves the tuning, selectivity and stability of the circuits but adds to the weight and complexity of the instrument by requiring more tubes and parts. The attenuator has values of $\times 1$, $\times 10$, $\times 10^2$, $\times 10^3$. When set at $\times 1$ the output meter has a range of

0-100 microvolts. A decibel scale is also provided. Another feature of the TS-587/U meter which adds to stability is the use of a grounded-grid push-pull amplifier in the 100-400 mc RF stage. This instrument employs four stages of IF amplification in each channel and two AF stages beyond the detector. The metering circuit for the VTVM contains two amplifier tubes in a balanced circuit with the indicating meter connected between the plates. The control grid of one tube is connected to ground, unbalance being produced by the output of the detector fed into the grid of the other tube. The 60 cycle, 115 volt power input contains a line filter but has no voltage regulation in the input. The rectifier and filter for +B supply is conventional with electronic voltage regulation added. A separate rectifier, through an RC network, provides 45 volts DC for the plates of the balanced tubes in the metering circuit.

2.2.8 RADIO INTERFERENCE MEASURING SET AN/URM-7

Radio Interference Measuring Set AN/URM-7 is a radio interference and field intensity meter developed by the Signal Corps as an engineering instrument primarily for the measurement of broadband interference, although incorporating facilities for CW interference and field intensity measurements. Inasmuch as broadband interference has spectrum properties, the Radio Interference Measuring Set is designed to measure the peak value of such interference in terms of microvolts per megacycle bandwidth over the range 20 to 400 megacycles. To accomplish this type of measurement, the instrument incorporates a noise reference standard, the output of which is calibrated in terms of microvolts per unit bandwidth.

The noise reference standard is an impulse generator which generates impulses of the order of 5×10^{-10} seconds in duration and as a result these impulses exhibit uniform stable spectra out to at least 400 megacycles which is the highest frequency to which the Test Set can be tuned. The impulse generator output is injected into the input circuit of the tuner portion of the Test Set in such a manner as to permit measurement of open-circuited antenna terminal voltage on a per megacycle basis.

The tuner portion of the Test Set utilizes a superheterodyne circuit. The frequency range 20 to 400 megacycles is covered by means of two plug-in type RF heads, the first of which tunes from 20 to 200 mc in two bands and incorporates a 10.7 megacycle IF strip, and the second head tunes continuously from 200 to 400 megacycles and incorporates a 30 megacycle IF strip. The visual output indicator is a peak reading vacuum tube voltmeter with a logarithmic scale calibrated in microvolts

and a linear decibel scale calibrated in terms of decibels above one microvolt per megacycle. The logarithmic scale characteristic is achieved through tapered pole pieces in the indicating movement, which eliminates the necessity of using automatic gain control with its inherent undesirable effects on noise measurement. The VTVM time constants are such as to permit peak measurement, within 10 percent, at repetition rates down to ten pulses per second. The Test Set can be operated directly from 110 volt AC power and is equipped with a converter unit to permit 24 volt DC operation.

The Test Set is to be equipped with two antennas, a dipole type which can be resonated at each test frequency, and a broadband antenna which requires less frequent adjustment. The dipole antenna is used for field intensity measuring applications where the effective height must be known. The broadband antenna is used in suppression test applications where the antenna must be placed close to the source of interference, e. g., testing an automotive vehicle for interference emanation. The Test Set is equipped with probes for conducting exploratory interference tests and coupling networks to permit use of the instrument as a two terminal noise microvoltmeter.

2.2.9 RADIO INTERFERENCE MEASURING SET AN/URM-47

Radio Interference Measuring Set AN/URM-47 is an equipment developed by the Navy to locate and measure radio interference and field intensities. It is similar to commercial model Stoddart NM-30A (see Figure 4-7). The equipment covers the frequency spectrum of 20 to 400 megacycles per second in six bands. A low-pass filter located at the input to the receiver provides attenuation for frequencies above the tuning range of the receiver. The RC time constant peculiar to the detector and AGC circuits permit measurements in terms of the average, quasi-peak, or peak value of the input signal. To accomplish these measurements the instrument incorporates a comparison (calibrating) voltage source.

The calibrating voltage source contains an impulse type calibrator which is driven by a free running multivibrator operating from approximately 8 to 20 cps. The output of the impulse calibrator is applied to the input of the receiver to provide means of adjusting the gain of the IF strip for a standard value of signal input to the metering circuits. Switching circuits then permits this source to be disconnected and the signal to be measured to be applied to the test set. Field intensity measurements in microvolt per meter are then a product of the meter reading times the attenuator setting times the antenna factor.



Figure 4-7. Radio Interference Field Intensity Meter Stoddart NM-30A
(Similar to AN/URM-47)

Circuits closely resembling conventional superheterodyne circuits are used in the RF, IF, and AF stages of the test set. These circuits differ from conventional receiver circuits mainly in their provisions for RF attenuation and detector output measurement. A turret type attenuator provides RF attenuator settings corresponding to 0, 20, 40, 60, and 80 db. The local oscillator utilizes a triode, transformer, and a tuning and trimming capacitor arranged in a modified colpitts circuit. The circuit is designed so that the local oscillator frequency is always 15 megacycles higher than the signal frequency. Signals from the RF and local oscillator are fed to a mixer which provides an IF frequency of 15 megacycles. The indicating meter has a two decade logarithmic scale calibrated from its 100 microvolts and an approximately linear scale calibrated from 0 to 40 db. The test set can be operated from voltages of 105 to 125 or 210 to 250 volts AC at frequencies of 50 to 60 or 400 cycles per second, single-phase.

2 2 10 RADIO INTERFERENCE MEASURING SET AN/TRM-4

Radio Interference Measuring Set AN/TRM-4 is designed to cover the frequency range of 150 to 1000 megacycles in 3 bands. The equipment has not passed evaluation by the military and therefore has been assigned a Class 3 by MIL-STD-10A.

2. 2. 11 RADIO TEST SET AN/URM-17 AND AN/URM-17A

Radio Test Set AN/URM-17 is a portable, single band, super-heterodyne type radio interference and field intensity meter. A similar commercial equipment NM-50A is manufactured by Stoddart Aircraft Company. It may be used to measure radiated or conducted radio interference in the frequency range of 375 to 1000 megacycles. As a radio frequency voltmeter it will measure voltages from 10 microvolts to 10 volts. As a field intensity meter it will measure from 100 microvolts per meter to 100 volts per meter. The intermediate frequency is 60 megacycles. The effective bandwidth varies from 1.8 megacycles at a signal frequency of 1000 megacycles to 1.0 megacycles at 470 megacycles signal frequency. Charts are provided with the equipment showing effective bandwidth as a function of frequency of the measured signal. The attenuator control, graduated in X10 steps provides for attenuation from X10 to X100,000. It is designed to operate from an AC power source of 105 to 125 volts, or 210 to 230 volts, between 50 and 1600 cycles per second. This set is designated as Class I by MIL-I-16910A.

2. 2. 12 RADIO FREQUENCY MEASURING SET AN/URM-42

Radio Frequency Measuring Set AN/URM-42, similar to Stoddart's commercial model NM-60A, is an equipment used for detecting and measuring the intensity of radiated and conducted interference. In addition, the instrument is also used for field intensity measurements in the frequency range from 1 kc to 10.7 mc. The frequency range of the equipment is divided into 4 bands.

Basically, the unit comprises a double superheterodyne receiver incorporating an AN/APK-9 tuner. Intermediate frequencies of 60 and 160 mc are employed. Time constants of the detector weighing circuits permit average, quasi-peak, or peak analysis of the received signal. Gain is standardized by use of an impulse generator. Input voltage is 105 to 125 volts, AC, 50 to 400 cps, single-phase.

A small disc-type antenna is supplied for omnidirectional measurements over the entire frequency range of the equipment. Directional horn antennas are supplied for each tuning range.

2. 2. 13 RADIO INTERFERENCE MEASURING SET AN/TRM-6

Radio Interference Measuring Set AN/TRM-6, similar to Polarad Electronics Company commercial model FIM A, B (see Figure 4-8),

is a triple conversion superheterodyne receiver developed by the Air Force for radio frequency interference and field intensity measurements. The equipment operates over the frequency range between 1 and 10 gc.

In order to cover the wide frequency range, four RF tuning units are employed. Each tuning unit contains a preselector, a first crystal mixer, a local oscillator, a calibrated signal generator, and an associated mechanical drive system. The calibrated signal generator derives its power from a klystron located within a coaxial cavity resonator. A temperature compensated thermistor bridge and metering circuit permits direct reading in microvolts or -dbm of signal generator output.

The output of the signal generator or the input RF signal may be applied to an RF step attenuator which has a range of 0 to 60 db in 20 db steps. The attenuator control also inserts a 0 to 20 db attenuation pad in 1 db steps, in series with the 140 mc IF output of the preamplifier.

The output of the klystron local oscillator is tracked with the preselector through a mechanical drive system. The system is so designed that the frequency of the local oscillator when heterodyned with the signal from the preselector produces an IF frequency of 260 mc (first IF).

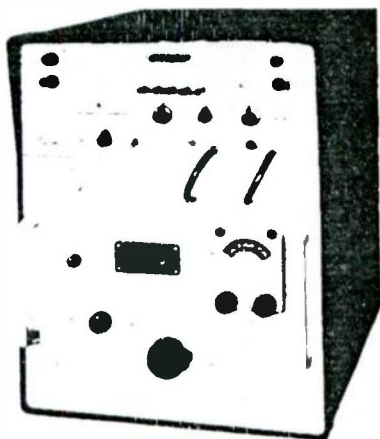

Figure 4-8. Radio Interference Measuring Set AN TRM-6
(Similar to Polarad FIM A)

Crystal controlled local oscillator outputs of 120 and 180 mc are mixed with the first IF frequency to obtain IF frequencies of 140 mc (second IF) and a 40 mc (third IF). The third IF signal is applied to the signal detector, the meter detector, and the AFC circuit.

The signal detector recovers the modulation of the 40 mc IF signal and applies it via a cathode follower to a video output jack. The meter detector drives the output meter in accordance with the position of the output meter function selector switch. The function selector switch provides for the measurement of the average, quasi-peak, or peak value of the input signal. A recorder output jack, connected in parallel with the meter permits continuous recording of the meter reading. A 1000 cps audio oscillator and amplifier can be used to amplitude modulate the output of the crystal controlled local oscillator as an aid in detecting unmodulated input signals.

The power supply for the equipment is contained in a separate unit. The unit includes meters and switches circuits for monitoring the bias, low voltage, repeller, beam supply output voltages, and the cathode currents of the local oscillator and signal calibrator klystrons. Power requirements for the power unit are 115 or 230 volts AC, $\pm 10\%$, 50 to 450 cps, single-phase.

One omnidirectional and four directional antennas are supplied with the equipment. The conical omnidirectional (discone) antenna covers the entire frequency range of the equipment and may be operated with vertical or horizontal polarization. Two of the directional antennas are waveguide horn antennas with coaxial inputs while the other two are of the horn fed parabolic type also with coaxial inputs. The directional antennas may also be operated with either vertical or horizontal polarization. The antennas are equipped with mounting plates for attachment to a tripod.

2.2.14 RADIO INTERFERENCE MEASURING SET AN/URM-138

Radio Interference Measuring Set AN/URM-138 (see Figure 4-9) is one of the more recent equipments developed by the Bureau of Ships for interference and field intensity measurements. The equipment is designed to operate over the frequency range between 1 and 10 gc. Similar commercial equipment is manufactured by Stoddart as Model NM 62-A.

The frequency range of the equipment is covered by four integral radio frequency tuners. The tuners are connected to a motor drive system which permits the frequency range of the equipment to be scanned automatically. An internal impulse generator is used as the reference

standard to calibrate the gain of the equipment. The equipment has attenuator settings corresponding to 0, 20, 40, 60, and 80 db. Jacks and connectors on the front panel provide a stretched video output for connection to an oscilloscope, a 60 mc intermediate frequency output for connection to a panadapter, a DC output for connection to a rectilinear plotter, and an audio output for connection to a headset. An internal speaker is also incorporated to monitor the audio signal. Transistors are used in the power supply circuits. Power required for operation of the equipment is 115 or 230 volts, AC, 50 to 60 or 400 cps, single-phase.

An omnidirectional broadband disc antenna is provided to cover the entire frequency range of the equipment. A separate directive antenna is provided for each of the four radio frequency tuners. The antennas for Bands 1 and 2 are of the horn type; the antennas for use with Bands 3 and 4 are horn fed parabolic assemblies. The antennas are equipped with mounting plates for attachment to a tripod.



Figure 4-7. Radio Interference Measuring Set AN URM-158
(Type 127-1, General Model 12M-62A)

2.3 SUMMARY OF INTERFERENCE MEASURING EQUIPMENT

For comparison purposes the currently available interference and field intensity instruments can be divided into the following seven family groups according to their frequency ranges.

- a. Very low frequency meters (30 cps to 15 kc) Only the AN/URM-41 is discussed in this group.
- b. Low frequency meters (14 kc to 210 kc) Only the AN/URM-6 is discussed in this group.
- c. Medium and high frequency meters (150 kc to 20 mc and 150 kc to 40 mc). The AN/PRM-1A and the AN/URM-3 are discussed in this group.
- d. Very high frequency meters (15 mc to 400 mc and 20 mc to 400 mc). The TS-587/U, the AN/URM-7, and the AN/URM-47 are discussed in this group.
- e. Ultra high frequency meters (150 mc to 1000 mc and 400 mc to 1000 mc). The AN/TRM-4 and the AN/URM-17A are discussed in this group.
- f. Meters covering the low frequency through the ultra high frequency spectrum (150 kc to 1000 mc) The AN/URM-85, the NF-105, and the NF-205 are discussed in this group.
- g. Super high frequency meters (1 gc to 10 gc and 1 gc to 10.7 gc). The AN/TRM-6, the AN/URM-13R, and the AN/URM-42 are discussed in this group.

In the very low frequency range the AN/URM-41 is one of the more recently developed general purpose interference measuring instruments. Available military specifications do not dictate a requirement for the low frequency range covered by this instrument. However, it is felt that one of the military specifications such as MIL-I-10910A (Ships) may at a later date issue an amendment for broader frequency coverage and therefore incorporate the requirements for this equipment. The equipment is unique in its method of measurement but takes considerable training in its use.

For low frequency coverage the AN/URM-6B is used and is the latest model in the AN/URM-6 series. The instrument is accepted for

use in MIL-I-11748B and designated as Class I by MIL-I-16910A. The equipment has satisfactory bandwidth and sensitivity and provides the proper detector functions.

In the medium and high frequency range the AN/PRM-1A is designated Category A by MIL-I-6181D and MIL-I-26600 and as Class I by MIL-I-16910A. The instrument is truly a field equipment incorporating its own battery pack or will operate from a power line source as well. The equipment has satisfactory bandwidth and sensitivity together with the proper detector functions for interference measurement requirements. The AN/URM-3 is designated as acceptable by MIL-I-11748B and as Class II by MIL-I-16910A. The instrument is a special purpose equipment developed by the Signal Corps for measurements of impulse type interference. The equipment incorporates a standard pulse generator with a variable pulse repetition rate for calibration purposes. The pulse generator permits calibration of the meter with a signal nearly identical with the signal being measured and therefore eliminates the need for weighting circuits. The equipment is limited however to measurement of broadband signals.

In the very high frequency range, the TS-587/U is designated as Class IV by MIL-I-16910A; the AN/URM-7 is designated as Category A by MIL-I-6181D, acceptable by MIL-I-11748B and as Class II by MIL-I-16910B, the AN/URM-47 is designated as Category A by both MIL-I-6181D and MIL-I-26600, acceptable by MIL-I-11748B, and Class I by MIL-I-16910A. The TS-587/U is the military designation for the Stoddart NM-5A. The company has replaced the NM-5A with the NM-30A (AN/URM-47) which covers the same frequency range and incorporates both physical design and circuit modifications. The AN/URM-7 was developed by the Army Signal Corps for open field testing. Actually, the equipment is similar to Empire Devices NF-105 incorporating the 20 to 200 mc and the 200 to 400 mc tuning units. The instrument does not provide for measurement of the "Quasi-Peak" value of a signal. The AN/URM-47 has satisfactory sensitivity and bandwidth and has three types of weighting circuits properly identified as "Field Intensity," "Quasi-Peak," and "Peak" for across the board approval.

In the ultra high frequency range the AN/URM-17A has been designated Category A by MIL-I-6181D and MIL-I-26600; acceptable by MIL-I-11748B and Class I by MIL-I-16910A. The instrument complements the Stoddart line of equipment and is equivalent to the NM-50A. The equipment has satisfactory sensitivity and bandwidth characteristic in addition to properly labeled detector functions.

For frequency coverage from 150 kc to 1000 mc three equipments are available: the AN/URM-85 and Empire models NF-105 and NF-205. The AN/URM-85 was developed by the Army Signal Corps and available information indicates that it is not commercially available. The equipment is designated as Category A by MIL-I-6181D and as acceptable by MIL-I-11748B. Both the Empire model NF-105 and NF-205 cover identical frequency ranges by the use of four RF tuning units. MIL-I-11748B which lists both instruments as acceptable actually states that the NF-205 is preferred for accuracy, reliability, ease of operation, and maintenance. Neither instrument provides for the measurement of the "Quasi-Peak" value of a signal. Air Force Specifications MIL-I-6181D and MIL-I-26600 designate the NF-105 as Category A. MIL-I-6181D designates the NF-205 as Category C-1.

Super high frequency range coverage includes the AN/URM-42, AN/TRM-6 and the AN/URM-138. The AN/URM-42 has been designated acceptable by MIL-I-11748B and is equivalent to the Stoddart NM-60A. This unit requires the use of an AN/APR-9 Tuning Unit. The AN/TRM-6 has been designated Category A by MIL-I-6181D and MIL-I-26600 and acceptable by MIL-I-11748B. The instrument utilizes four tuning units for coverage of the frequency range. The AN/URM-138 is a newly designed instrument for the Navy and is under evaluation. The three above equipments have adequate sensitivity and bandwidth characteristics and incorporate circuits to permit "Field Intensity," "Quasi-Peak" and "Peak" radio interference examinations.

3. SPECTRUM ANALYZERS AND PANORAMIC ADAPTERS

Spectrum analyzers and panoramic adapters are devices used to provide a panoramic display of radio frequency signal distribution in a selected portion of the radio frequency spectrum. The display represents a plot of signal amplitude versus frequency, usually on a cathode-ray oscilloscope. A panoramic adapter is a visual display unit used in conjunction with a suitable receiver which provides the required preselection of the desired signal as well as audible indications. The spectrum analyzer is a self-contained unit which includes both the receiver and the display unit. For many purposes, measurements utilizing spectrum analyzer techniques have distinct advantages over the use of interference meters which indicate rms values, weighted circuits which indicate quasi-peak levels and slide back techniques which indicate peak levels. Useful information such as the presence, or absence, of signals of interest, their frequencies, frequency differences, relative amplitudes, type of modulation, sideband structure, and relative amplitudes may be determined.

Figure 4-10 is a simplified block diagram of a spectrum analyzer. Data on 17 spectrum analyzers can be found in Volume 3 of Frederick Research Corporation's Test Equipment Data Handbook.

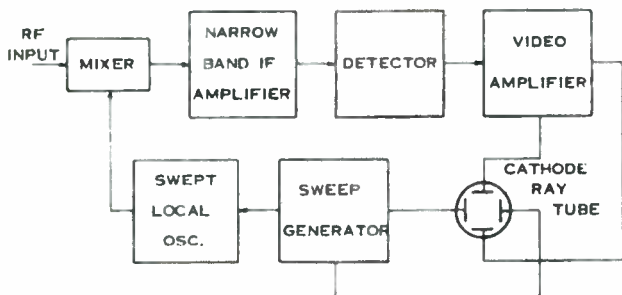

Figure 4-10. Simplified Block Diagram of a Spectrum Analyzer

3.1 GENERAL FEATURES AND USE

3.1.1 RESOLUTION

Resolution may be interpreted as the apparent bandwidth of a spectrum analyzer while sweeping. Resolution is dependent upon the IF bandwidth and sweep rate. Excessive sweep rate will reduce the resolution. Most spectrum analyzers and panoramic adapters presently available do not provide sweep rates sufficiently high to produce a serious loss of resolution. However, there are some special types which do provide high sweep rates capable of producing excessive loss of resolution. For example, with a 25-mc sweep width, 30 cps sweep frequency, and a 25 kc IF bandwidth, there would be a loss in resolution of approximately 13%. A loss of resolution up to 20% is tolerable. In the selection of spectrum analyzers and panoramic adapters, the sharpest resolution is determined by the IF bandwidth while the effective resolution is dependent upon the sweep rate. The resolution is expressed in terms of frequency as the width while sweeping of the spectrum display of a continuous wave signal between the 3 db down points. A spectrum analyzer which presents a CW signal 10 mc wide at the 3 db points has a resolving power of 10 mc. Thus, the spectrum of any signal located within 10 mc of each other would not be resolved by the spectrum analyzer and would appear as one signal. Sharp selectivity is required in low frequency spectrum analyzers or panoramic adapters to provide sufficient resolution. In the case where two or three CW signals are spaced only 1 kc apart, they would appear as one signal if the resolution were 10 kc. However, with a resolution of 100 cycles,

each would appear as separate signals. For the usual type of emission which is encountered below 400 mc, a resolution of 100 cycles is usually adequate. In the case of pulsed signals, however, the condition of sharp resolution is not satisfactory since pulses require a wider bandpass to be effectively amplified. Since pulsed signals are usually encountered at frequencies above 400 mc, spectrum analyzers for use with pulsed signals usually have lower resolution and broader bandwidths. In general, the resolving power for pulsed signals should be smaller than one-tenth the reciprocal of the pulse length. This means that a spectrum analyzer with a resolution of 25 kc would resolve the envelope of a spectra of pulses up to 4 microseconds in time duration, which is adequate for radar.

3.1.2 BANDWIDTH

Bandwidth is generally defined as the spectral width in cycles per second of the frequency response curve of a receiver stage between frequencies where the response is down 3 db from the maximum value. At microwave and radar frequencies, the proper choice of IF bandwidth for a spectrum analyzer is determined by the pulse duration. The longest pulse length to be used determines the maximum value of the bandwidth of the IF amplifier in order that the spectrum seen on the spectrum analyzer screen will be a true reproduction of the power spectrum. However, the shortest pulse length determines the intermediate frequency. When RF preselection is not employed, a high intermediate frequency in the order of four times the reciprocal of the shortest pulse duration should be used to avoid appreciable overlapping of image frequency signals. Since the pulse length determines the limits of the IF bandwidth and the intermediate frequency, the range of pulse lengths will determine jointly the maximum IF bandwidth and the minimum intermediate frequency. The video amplifier bandwidth should be approximately equal to IF bandwidth to amplify a signal without excessive loss. Due to the congestion at communication frequencies, a much sharper resolution is required to provide a means of discriminating against frequencies on or near the same frequency. For the purpose of observing interfering signals, a 100 cycle bandwidth will provide sufficient distinction between frequencies that are on or near each other. In general, resolution much less than 100 cycles will result in too great a loss of sensitivity.

3.1.3 SWEEP WIDTH

This is the maximum frequency spectrum width which the spectrum analyzer will accept and present as a visual display. The sweep

width is determined by the emission type to be observed. In most cases, a 25 mc sweep width is adequate above 500 mc and a 100 kc sweep width is adequate below 500 mc.

3.1.4 SWEEP FREQUENCY

The sweep frequency is the number of times per second the displayed width of a frequency spectrum is scanned. The amount of envelope detail in the spectrum depends upon the relationship between the pulse repetition frequency and the sweep frequency. The definition of a pulse spectrum will be adequate if the sweep frequency is no greater than one-fiftieth of the pulse repetition frequency of the input signal. The effect of different sweep frequencies on the same RF pulse spectrum is shown in Figure 4-11. The lower limit of sweep frequency depends upon the persistency of an indicator screen, since objectionable flicker will result from a 20 cycle sweep frequency using a short persistence screen. With a long persistence screen (such as P7) a sweep frequency of 1 cycle is usable. A loss of sensitivity and resolution will result if the sweep frequency is too high. A 10 cycle sweep frequency, 25 kc IF bandwidth, and a 25 mc sweep width will result in approximately a 6 percent loss of sensitivity. Generally, this loss is not considered excessive for normal spectrum analyzer applications.

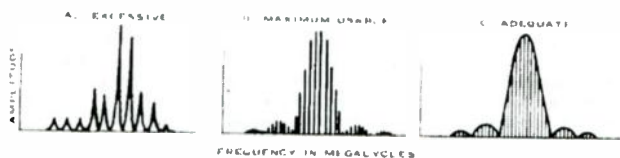

Figure 4-11. Effect of Sweep Frequency on RF Pulse Spectrum

3.1.5 SWEEP RATE

The sweep rate is the product of the sweep width in cycles per second times the sweep frequency in cycles per second. The product is expressed in cycles per second per second.

3.1.6 CALIBRATION

Accurate frequency calibration is desirable in both spectrum analyzers and panoramic adapters. The frequency calibration is only desired to measure frequency differences, while the absolute frequency measurements should be made with a frequency meter.

3.1.7 FREQUENCY MARKER

A frequency marker is a marker that enables the operator to measure the frequency difference in the visual display. The marker should contain an on-off switch and controls for varying the marker amplitude and position.

3.1.8 SENSITIVITY

For use with a measuring antenna, a spectrum analyzer should have high sensitivity. A minimum discernible CW signal indication should be obtained with an output of -85 dbm or less in the frequency range of 400 mc to 10,000 mc. The sensitivity requirement may be reduced in the order of 30 db when the spectrum analyzer is directly coupled to a transmitter output by means of an attenuator or directional coupler. In the frequency range 50 kc to 500 mc a much higher sensitivity is desirable. A communication receiver adapted for use with a panoramic adapter should provide a minimum discernible CW signal indication with an input of one microvolt or less. This level of sensitivity may be achieved with a communication receiver with two or more RF amplifier stages. A normal overall RF selectivity curve of a receiver will appear as shown in Figure 4-12A. A panoramic adapter normally employs an overcoupled input stage which produces a selectivity curve as shown in Figure 4-12B. The resulting overall selectivity curve at the output of the first amplifier in the panoramic adapter will then appear approximately as shown in Figure 4-12C. The purpose of this overcoupled amplifier stage is to insure uniform sensitivity throughout the visual display.

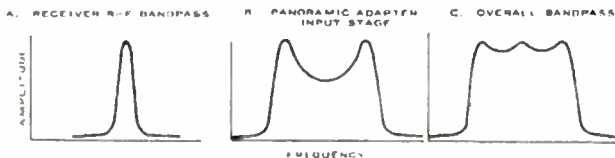

Figure 4-12. Selectivity Curves

4. PICKUP DEVICES

The pickup devices used for radio interference measurements are either a two terminal probe, which is used for making measurements of conducted interference, or an antenna, which is used for making meas-

urements of radiated interference in the sense of the interpretation of MIL-1-16181D (see Paragraph 2.1.1 of Section 2).

For any kind of pickup device, the first question to be asked is whether it is desired to obtain the maximum indication of the output meter, or whether the most important consideration is to keep the measured circuit undisturbed. In the first case, the pickup device should be designed for an impedance match so that maximum power transfer may take place. In the second case the input impedance of the pickup device should be as high as possible. Since radio interference measuring sets should give indications of the worst possible conditions, the pickup devices are usually designed for a good impedance match. The measurement of conducted interference is achieved by means of the impedance stabilizing network specified in MIL-1-16910A the main purpose of which is standardization, and minor mismatches are of little consequence. For the measurement of radiated interference, the antenna may be thought of as a device that matches the input impedance of the meter to the impedance of the wave that is being picked up. If the antenna is placed close to the source, which is the condition usually found in radio interference work, then the difference between the conditions of maximum power transfer and minimum effect on the source still exists. But if the antenna is placed far away from the source (i.e. in the true radiation field as defined in Paragraph 2.2 of Volume 1), then the difference disappears since the antenna will not react back on the source regardless of its impedance.

The position of the transmitting antenna in space with respect to earth determines the polarization of the emitted wave. A vertical antenna radiates a wave consisting of a vertical electric field vector and a horizontal magnetic field vector. A horizontal antenna radiates a horizontally polarized wave consisting of a horizontal electric field and a vertical magnetic field. A radiated field intercepted by an antenna sets electrons in motion in the antenna. This electron flow constitutes a current that varies in accordance with the variations of the field. The voltage which is effective in producing a response in the receiver is equal to an effective height times the electric intensity of the field. The effective height of an antenna can be described as the calculated true electrical length, corresponding to a perfect antenna that will produce the same field strength.

When a loop antenna is used, the magnetic component of the radiated field induces a voltage in the loop. The loop output voltage is a function of its area, number of turns, and frequency of excitation.

Field intensity is the value of the electric field at a given point and is measured in terms of volts-per-meter. One volt-per-meter is equivalent to a potential of one volt induced in a vertical rod antenna having an effective electrical length of one meter.

For plane waves three types of antennas are used for measurement of field intensity: rod, dipole, and loop. However, for fields other than the plane wave type, these three types of antennas yield different quantitative results when measurements are made near a noise source. This is due to the predominance of the electric or magnetic field. Rod and dipole antennas are more sensitive to electric fields, whereas loop antennas are more sensitive to magnetic fields. Loop antennas have very low impedances and are therefore more sensitive in the vicinity of sources which produce small electric fields compared to the magnetic field. The impedance of a loop antenna may be decreased further by surrounding the loop with an electrostatic shield, broken in the middle, which decreases the sensitivity to electric fields. This feature is sometimes valuable when high electric and magnetic fields are present simultaneously and the antenna is to discriminate against the first. It is obvious that in a field whose nature is unknown, measurements must be made both with a rod and with a loop antenna in order to determine the worst possible conditions.

Both directional and omnidirectional antennas are required. A directional antenna will have maximum gain in the direction for which it is designed while omnidirectional antennas have uniform gain in a particular plane. Before an antenna is chosen, the desired polarization should be considered. The polarization of a half-wave dipole is the same as the direction of its axis. The direction of the electric component of the field is the same as the direction of the antenna wire. The polarization of antennas composed of a number of half-wave elements arranged so that their axes lie in the same direction will be the same as that of any one of the elements. However, if both horizontal and vertical elements are used, the polarization will be the resultant of the contributions made by each set of elements to the total electromagnetic field. A vertical whip antenna is omnidirectional in the horizontal plane.

Loop antennas have the property of being strongly directional. The received signal is a maximum if the source lies in the plane of the loop and a minimum if the plane of the loop is perpendicular to the line from the antenna to the source. This property is of great value in locating an unknown source. The directional pattern results from opposite sides of a loop acting as a pair of spaced antennas carrying currents of opposite polarity. Energy is not radiated in a direction perpendicular to the plane



of the loop because the radiation in this direction is always cancelled by radiation from a corresponding element on the opposite side of the loop that is carrying current in the opposite direction. The directional pattern is independent of the exact shape of the loop, provided the loop is small compared with a wavelength. Special loop antennas with comparatively high impedances are available so that their directional effects may be utilized also for high impedance fields.

With most radio interference measuring sets, regulation equipment consists of two vertical rod antennas and several loop antennas of different sizes. The rod antennas have effective electrical heights of one-half and one meter, respectively. They are built in three or four sections which telescope to save space in packing, and have adapter connectors at the base for attachment to the meter input. The telescoping rods may be conveniently calibrated for lengths corresponding to different input frequencies. Connectors are provided for attaching horizontal wire antennas and for coupling with impedance matching networks. The loop antennas may be round or rectangular and vary in size from one-half inch to 30 inch diameter or more. The larger loop antennas can be mounted on tripods so that they can be rotated in any direction. Shielded cables are provided to connect these antennas to the meter.

Although the basic principles of antennas are essentially the same for all communication frequencies, certain factors at VHF and UHF frequencies require changes in antenna techniques. Antenna systems at VHF and UHF frequencies are required to cover a wider frequency range than antennas at the lower frequencies. Usually there is no marked difference in effective working radius with either vertical or horizontal polarized antennas, although horizontal polarization may provide better signal levels over irregular terrain. The following antennas may be used in the VHF and UHF range: dipole, Yagi, conical, discone, and vertical antennas. Antennas used in the microwave region are usually of the broadband type. Conical and discone antennas are satisfactory for microwave reception because they are capable of covering a wide range of frequencies in the order of 10 to 1 and their physical size is small. A horn-type antenna is capable of providing directivity in most cases where a directional antenna is required.

Data on 33 pickup devices can be found in Volume IV of Frederick Research Corporation's Test Equipment Data Handbook.

5. SIGNAL GENERATORS

The strength of an interfering signal may be accurately measured by comparison with a signal from a calibrated signal generator used in

conjunction with a suitable indicator such as the spectrum analyzer described above (signal substitution method). Calibrated signal generators may be used to provide an approximate frequency check, however, in most cases they are not accurate enough for absolute frequency checks. The following specifications should be considered for each signal generator available before the final selections are made: (a) capable of tuning the required frequency range, (b) capable of 1-mw output, (c) attenuation from 0 to -120 dbm, and (d) low harmonic and spurious output. Data on 165 signal generators can be found in Volume 4 of Fredrick Research Corporation's Test Equipment Data Handbook.

6. FREQUENCY METERS

Heterodyne frequency meters are needed to provide sufficient accuracy for frequency measurements in interference studies. A signal from a heterodyne frequency meter can be beat with an unknown signal to obtain its frequency by adjusting for an audible zero beat between the two signals. The zero beat point may be more accurately obtained by using an electron ray tube (magic eye). The following specifications should be considered in the selection of frequency meters. Values given are only typical of these for a precise instrument and not intended as standard or minimum requirements.

- a. Frequency Calibration Accuracy. The accuracy should remain constant over wide temperature variations (+25° to +125°F).
- b. Frequency Stability. The frequency meter should maintain the selected frequency without drift after a warmup period (1 part in 10 million).
- c. Resetability. It should be possible to recalibrate the frequency meter with ease and accuracy (± 5 cps).
- d. Frequency Indicators. The indicating devices should be either direct reading or suitable for simple interpolating.
- e. Fundamental and Harmonic Signal Amplitude. The frequency meter should provide adequate signal levels at the fundamental and harmonic frequencies. A heterodyne frequency meter is useful over any frequency range that it will produce harmonics of sufficient amplitude to obtain a distinguishable zero beat with a signal being measured. When used as a mixer

Data on 136 frequency meters can be found in Volume 2 of Fredrick Research Corporation's Test Equipment Data Handbook.



or receiver, the frequency meter's range is determined by its highest useful harmonic and its sensitivity. When used as a generator, as often required in receiver measurements, the usefulness of a frequency meter is determined by its harmonic level and the sensitivity of the equipment under test.

7. CALIBRATION

7.1 INTRODUCTION

Calibration is defined as the comparison between two instruments, one being a standard of known accuracy, to detect and correlate, or to adjust any variation in the accuracy of the instrument being compared.

All military specifications on interference measurements require the measuring equipment to be periodically calibrated or after the occurrence of any event which might affect the validity of the last periodic calibration. For example, MIL-I-16910A requires a time interval of not more than 6 months between calibrations, whereas MIL-I-26600 merely states periodic calibrations must be made.

7.2 GENERAL

A system, including procedures, records, and certificates should be established which provides the selection of proper measuring and testing equipment and the schedule of periodic calibration thereby assuring the interference measuring equipment to be of continued known accuracy. Equipment should be calibrated with measurement standards, the calibration of which is traceable to the National Bureau of Standards. The equipment should be marked to indicate the date of the last calibration and the date the next calibration is due. Certificates indicating the source and traceability of calibration, the date of last calibration, and by whom certified should be maintained for all standards.

7.3 CALIBRATION OF INSTRUMENTS

Interference or field intensity measuring equipment is generally calibrated by signal substitution, that is, substituting a signal of known intensity for the signal to be measured. An example of such a procedure is typified by the Stoddart field intensity meters which have internal calibrators such as a noise, impulse, or signal generator. In this case, the instrument is calibrated so that its indicating meter reads directly the unknown signal intensity.

An alternate procedure is that of substituting an external radio frequency signal generator for the unknown signal and merely adjusting its output to produce the same indication on the intensity indicator. This procedure implies that the signal generator has been previously calibrated thereby assuring its output to be of known accuracy.

Three aspects of signal generators must be calibrated. They are frequency, power, and attenuator linearity. The calibration requires the use of a standard frequency meter, power meter, and a series of standard attenuators.

In any interference-free design program, particularly when such a program must meet military specifications, it is important that there be early recognition of the cost and effort required to calibrate RFI test equipment. The unique characteristics of the equipment require a specialized technical knowledge if the calibration is to be accomplished in a minimum of time. In addition, calibration technicians require a broad background in test instrument work since a large variety of instruments must be used in calibration work.

Because of the importance of correct calibration procedures in interference-free design and suppression engineering work, a complete discussion of these procedures has been prepared. This discussion is presented in Appendix V of Volume 3 of this Handbook. The discussion includes step-by-step methods of calibrating and shows in detail exactly how each type of calibration should be accomplished.



1. GENERAL

The object of a shielded room is to provide a space which is free from electromagnetic fields originating outside the intended protected space, or, conversely, to confine any electromagnetic fields originating inside the shielded room to that space. The shielding of one area from another is normally obtained by placing a physical barrier between the two regions. The best method for accomplishing this objective is to enclose the desired space in a material which has very high conductivity, such as copper. The shielding action, produced by a metal enclosure, is the result of two effects, reflection of the field from the metal and attenuation of the field in passing through the metal. Each effect is independent of the other. Chapter 6 of Volume III contains a detailed analysis of the total shielding effect resulting from both of these phenomena.

The effectiveness of a shielded room is expressed as the ratio between the intensities of an electromagnetic field outside the room and that of the residual field inside the room or the converse. The ratio may be expressed directly, but is usually given in db of attenuation as calculated from

$$\text{Attenuation (db)} = 20 \log \frac{E_2}{E_1}$$

where: E_2 is the field intensity before passing through the shield, and E_1 is the field intensity after passing through the shield.

Both field intensities must, of course, be expressed in the same units, such as microvolts/meter. (MIL-STD-245 contains shielded room attenuation measurement standards. For discussion and copy of this standard, see Volume IV of this Handbook, Chapter 6 and Appendix V.)

It is not sufficient to discuss the attenuation provided by a shielded room without referencing this attenuation to the type of field. Electromagnetic fields consist of two components termed the electrical component and the magnetic component. Both are always present in an electromagnetic field, but the relative intensity of each may vary greatly. In free space, at a long distance (compared to wavelength) from a source of energy, the two components contain equal energy. This condition defines what is commonly termed a "radiation field" or the Plane Wave. At short distances from the source of energy, the relative energy may vary decidedly from the free space condition. Since the electrical component of the field corresponds to voltage on the conductor and the magnetic



component corresponds to current, a field with most of the energy in the electrical component is termed a high impedance field (such as produced by a rod antenna at a distance much less than one wavelength/ 2π). Similarly, a field having most of the energy in the magnetic component is termed a low impedance field (such as produced by a loop antenna at a distance much less than one wavelength/ 2π).

In general, it can be said that shielded enclosures offer higher attenuation to high impedance and plane wave sources than to low impedance or magnetic fields. The reason for this is that attenuation is a function of wall impedance. The greater the difference between the shielded enclosure wall impedance and the radiated wave impedance, the more the energy of the field will be attenuated. It is necessary, of course, that the wall have a lower impedance than the radiation field, implying thereby a high conductivity. It is more difficult to achieve as great an impedance differential between a low impedance field and a low impedance metallic barrier than can be achieved between a high impedance field and a low impedance barrier; therefore, attenuation of low impedance (magnetic) fields by a barrier cannot be as effective as the attenuation of high impedance fields when a barrier using only high conductivity material is employed. Figure 5-1 is a typical shielded enclosure attenuation curve, which illustrates this characteristic.

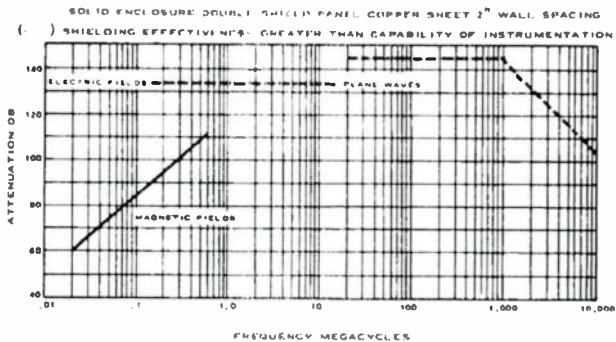

Figure 5-1. Attenuation Curve of Typical Shielded Enclosure

(AFTER SHIELDING, INC., RIVINGTON N. J.)

In the normal laboratory environment, the probability of encountering a high energy magnetic field is very small. Unless the shielded enclosure is located very close to a loop antenna which is radiating radio frequency energy in the Low Frequency band (less than 30 kc), it is highly improbable that any special consideration need be given to the design and construction of the enclosure to increase its effectiveness against magnetic fields.

Shielding effectiveness can be expressed by the general equation

$$S = R + A + B$$

where: S = Shielding effectiveness in db,
R = Total reflection loss in db from both surfaces of the shield,
A = Penetration or absorption loss in db inside the barrier,
B = A positive or negative correction term which need not be taken into account when A is more than 15 db. It is caused by the reflecting waves inside the shielding barrier and is calculated in db. When a metallic barrier has an A of less than 15 db, it is defined as "electrically thin."

All of the terms in the previous shielding effectiveness equation may be expressed as functions of the metal conductivity (g) and permeability (μ), relative to copper, and the frequency (f) in cps, as well as the physical relations that exist. The reflection loss R depends upon the electrical nature of the source (i.e., low impedance, high impedance, or plane wave) and upon the distance r , in inches, of the shield from the source. The penetration loss A depends not only upon μ , f and g , but also upon the thickness d , in inches, of the shielding material.

$$A(\text{db}) = 3.54 \mu f g d$$

Reflection loss is normally neglected in shielding design. Since its effect is always added to the attenuation of the field through the shield, its neglect provides a safety factor. Reflection loss is inversely proportional to frequency. Although this loss is a significant number of decibels at all frequencies, at Very High Frequency this loss relative to the penetration loss is nearly negligible.

The effectiveness of the metal enclosure as a shield depends on the absence of any discontinuities in the metal. Discontinuities may occur at necessary openings such as access doors or ventilating ducts or at joints between the metal sheets due to defective construction. Such



defects will always reduce the attenuation of the field through the metal enclosure but will have little effect on the reflection.

Another form of defect in construction which reduces shielding effectiveness appreciably, occurs when a conductor passes through the metal shield of an enclosure, but is not connected to the shield through a circuit of approximately zero impedance. A nail driven through the shield, but not soldered to the shield, is an example of this fault. An improperly installed water or steam pipe is also an example. The voltage induced by the external field on the portion of the conductor outside the shield is conducted inside the enclosure and establishes a field by re-radiation. The coupling between external and internal space probably increases with frequency since the conductor becomes longer compared to wavelength and, therefore, becomes a more efficient receiving and transmitting antenna.

It is necessary to have power available inside a shielded room to operate test equipment. One method of obtaining power inside the room is by means of batteries or an alternator. However, the most practical way to get power into the room is to bring it in on well-filtered power lines. The power line filter is the most critical component in the shielded room

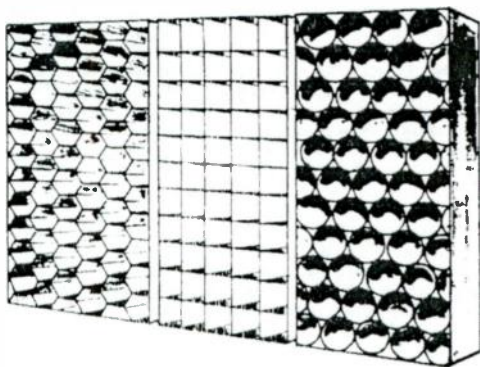

Figure 5-2 Waveguide-Below-Cut Off Type of Ventilation Grids for Shielded Enclosures (SHIELDING IN RIVINGTON N. J.)



Usually, the overall shielding characteristics of a room are the same as those of the filters. Except at very low frequency, the reduction in intensity in a field by the shield is usually much greater than the maximum possible attenuation through the filters. Obviously, every effort should be exerted to obtain the maximum attenuation possible in the line filters.

The ventilation of shielded rooms is often a problem. Rooms made of screen mesh can be ventilated by forcing air through the walls. Air can be introduced into the solid-wall rooms by means of a honeycomb grid arrangement that acts as a waveguide below cut-off to very high frequency radio waves. One easy way to obtain the honeycomb grid is to use an automobile radiator. Figure 5-2 shows samples of grid types in general use.

Lighting for shielded rooms should be obtained by means of incandescent lamps operating from the room's power supply; fluorescent lamps are not recommended because they have a high interference power output throughout the radio frequency spectrum.

2. CONSTRUCTION DETAILS

The most important factor in the fabrication of a shielded enclosure site is that of construction. Results anticipated by adhering to detailed design considerations and specifications will be effectively reduced by inferior workmanship. Generally, most construction contractors are unfamiliar with RF shielding techniques and consider that adequate shielding will result from a mechanically sound construction

Post-construction corrective measures are usually very costly and in several cases have approached the original installation costs, a high price to pay for experience. Case histories indicate that it becomes economically feasible for inexperienced contractors to engage the services of a consultant or provide supervisory personnel with a basic course in the field of practical shielding techniques and requirements.

RF shielding, or attenuation is a function of wall impedance which, in turn, is a function of joint technique, contact pressure, and contact area. It follows then that the ideal RF joint is a clean metal-to-metal contact under pressure. The pressure of mounting bolts compressing the shielding panels together, provides the necessary electrical and mechanical bond between each panel. The greater the pressure and more evenly it is distributed over the entire contact area, the greater

will be the attenuation characteristics afforded by the enclosure. Contact pressure plates used in conjunction with large diameter bolts, spaced not more than 12 inches on-center, is a recommended practice. All bolts must be pulled up evenly to a minimum torque of 140 inch/pounds. Nails, screwdriver-head bolts, or small diameter bolts can not be tightened sufficiently to provide pressure required for an adequate bond.

Shielded enclosure attenuation problems generally lie within the areas of paneling, service entries, and doors. Loosened or untightened bolts, skips in welded or soldered seams, and corroded or cold solder joints are among leading contributors in RF shielding inadequacy. The type of paneling used will present its own peculiar problem. Attenuation characteristics are difficult to maintain in enclosures incorporating wood frames, for example, as wood can warp and shrink, and bolts eventually work loose seriously degrading the shielding effectiveness. Effective bonding of interlocking panels is dependent upon properly tightened U or Hat channels to the supporting members. Improperly tightened bolts may result in a permanently damaged panel. Figure 5-3 shows one manufacturer's solution to this problem of achieving and maintaining high pressure joint construction, providing mechanical strength and rigidity as well as excellent electrical bonding between shielding panels.

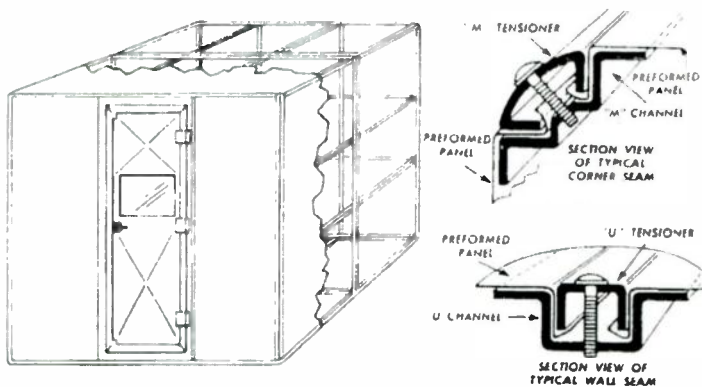

Figure 5-3 Construction Details of Shielded Enclosures Showing Features Desirable for Low Impedance Connection of Adjoining Surfaces
(ACE ENGINEERING CO.)

Installation of corner pieces are particular sources of trouble. The pieces are more difficult to tighten sufficiently and because of the various directions of stresses applied to these panels during tightening, poor integral bonding and damage may result. No attempt at installation of these pieces should be considered without the aid of a torque wrench. Enclosures utilizing inside bolting assure access to bolts for tightening should the construction be erected against building walls or other obstructions. Figure 5-4 illustrates an effective method for joining panels of a double shielded enclosure to obtain high shielding integrity at corner joints and wall seams.

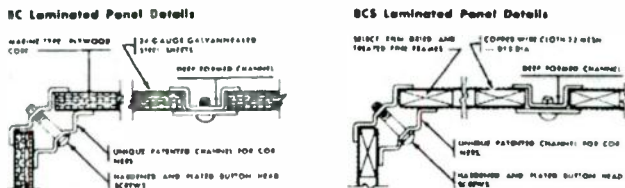

Figure 5-4. Effective Method for Joining Panels of A Double Shielded Enclosure
(ACF ENGINEERING CO.)

Bonding the seams of panels used in large enclosures is normally accomplished by welding. To be effective, the welding must be of good quality and all seams must be electrically joined along their horizontal and vertical lengths. Stringent visual inspections of seam welds by personnel acquainted with RF shielding practices and techniques will greatly reduce requirements for post-construction corrective measures. Obstructions often impose space limitation problems that prohibit welding, in which case, the obstruction must be removed or other modifications entailed to permit completion of the bond. Studies of detailed site drawings prior to assembly will prevent this problem by permitting the welding of seams, which may later be inaccessible, or by permitting other modifications required prior to installations. Undue welding skips in seams cannot be tolerated.

All shielded enclosures must have service entries for electrical power, air conditioning, heating, and perhaps water or similar services. Adequate shielding effectiveness of air conditioning and heating ducts is satisfactorily accomplished by the use of waveguide type louvers or filters having attenuation characteristics greater than that for the entire

room. (See Figure 5-2) Conduits carrying unfiltered signal cables through the shield walls must be provided with a good electrical bond to the enclosure walls by either brazing or mechanical coupling. All power leads into the enclosure must pass through a power line filter mounted on the external wall of the enclosure. Maintaining adequate RF shielding at the access door is often the most difficult provision to achieve. The door, when closed, must have just as low an RF impedance as the remainder of the structure. Proper alignment of the door is essential and the door must be sufficiently braced to prevent sagging which will ruin the RF seal. This also applies to the door jamb. Most shielded enclosure manufacturers utilize a series of phosphor-bronze contact fingers around the entire periphery of the door to provide the RF seal. The better arrangements use two sets of fingers set at right angles to each other. One set wipes the other, and is compressed when the door is fully closed. The wiping action of the finger stock alone cannot be relied upon to provide results for extended periods. The use of pressure contact is necessary. Extreme care must be exercised before, during and after installation to protect the relatively delicate finger stock from damage.

A three point, wedge-type locking system within the door helps to assure sufficient even pressure on the contact fingers. The system can be operated by means of a single handle. If the door is designed to be opened from either side, it is mandatory that the handle be thoroughly bonded at its point of entry through the frame to prevent its acting as an antenna at certain frequencies.

2.1 MAINTENANCE

Maintenance of enclosures is usually ignored completely and seldom considered anything but secondary. Unlike the majority of equipment used in the electronics field, deterioration in performance of shielded enclosures is normally a gradual unapparent degradation in effectiveness. Monthly preventive maintenance procedures will provide some insurance against general uncontrolled degradation. These monthly checks should include testing assembly bolts with a torque wrench, inspecting the finger stock of doors for broken or missing fingers, dirt, and corrosion, examining the door locking mechanism to ensure proper pressure for satisfactory bonding and checking for damage to shielding panels, both inside and outside. Personnel working in the enclosure will likely make minor modifications to suit their needs, including such things as driving nails or screws through the shield panels, punching holes for antennas, telephone lines, or signal cables, and the like. These modifications can reduce the enclosure's effective attenuation by 20 to 40 db

A tight control must be maintained in such instances to assure that only necessary modifications are made and that the shielding integrity of the enclosure is not destroyed.

Military Specification MIL-E-4957A (ASC) sets forth construction details and performance criteria for the copper mesh, double-walled, cell-type, shielded enclosure. This type of enclosure has been considered the standard for many years by electronics industry for research and industrial laboratories. The prefabricated interchangeable, modular panel type of construction, described in this specification, utilizes 40-inch panel increments in 8 and 10 foot lengths. The two layers of screening material are separated from each other by the panel frame (approximately 1 inch) and are bonded together along the periphery of each panel. Cell-type construction is the only type covered by current military specifications on screen rooms. Figure 5-5 shows a completely assembled cell type enclosure. Installation procedures are illustrated in Figure 5-6.

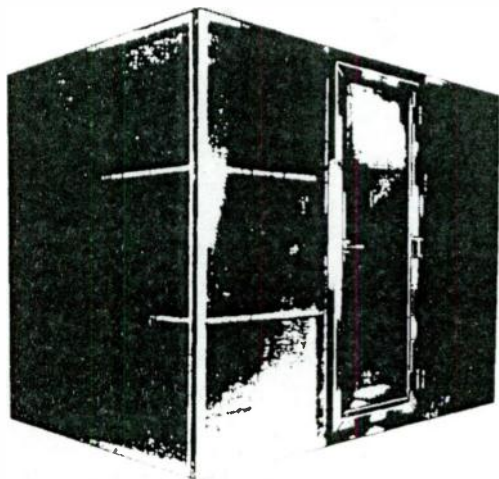
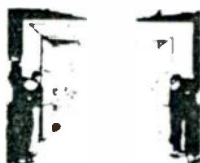

Figure 5-5. Cell-Type Shielded Enclosure Completely Assembled.
(ACE ENGINEERING CO.)



STARTING SECTION
Floor panel is placed in position. Two wall panels are positioned to form a corner. Additional wall panels are added to complete section.

INSTALLING CEILING PANELS After walls are secured ceiling is lifted up and bolted in position.



ADDING PANEL SECTIONS Additional sections are added as required to increase room to proper length.

Figure 5-6 Assembly of a Fabricated Cell-Type Shielded Enclosure
(AFCE ENGINEERING CO.)

In addition to the cell-type construction, there are two other basic types in general use, namely, the Single Shield and the Double Shield Isolated Wall. Single shielded enclosures are often quite adequate in areas where the radio frequency environment is known to be rather limited. The maximum attenuation to be expected is approximately 70 db. In addition to the lower cost of construction, single shielded enclosures have the advantages of less weight, ease of ventilation, simplification of bonding interconnecting surfaces, and simplification of connections through the walls of water lines, cable conduits, and other service items which may be required. The Double Shield Isolated Wall-type construction, on the other hand, presents some rather complex disadvantages in comparison with both the Cell-Type and the Single Shield-Type. The Double Shield enclosure is basically a shield within a shield, and theoretically offers the highest attenuation. The inner and outer shields are isolated from each other except at one point - the point where power service is brought into the enclosure. Maintaining this isolation of the two shields creates many difficulties in construction as well as in providing other services to the room such as ventilation and water. The slight increase in attenuation provided by this type construction, as compared with the double wall cell type, is greatly overshadowed by the increased cost of construction and maintenance and, therefore, is seldom used.

RADIATION HAZARD PREDICTION AND MEASUREMENT

CHAPTER 6

1. INTRODUCTION

Significant advances over the last few years in power handling capabilities at UHF frequencies have opened new vistas in the communications field. At the same time, however, the high intensity electromagnetic fields thus made available have created a variety of problems in the form of radiation hazards to personnel and ordnance.

The many aspects of radiation hazard (RAD HAZ) may be classified into three groups: (1) hazards to personnel; (2) hazards to electro-explosive devices; and (3) hazards to flammable or volatile liquids such as aircraft fuel. Each of these groups is examined in the following sections. The mechanism whereby the hazardous situation is created will be discussed, and consideration will be given the instrumentation and techniques available in the prediction and measurement of RAD HAZ situations.

Methods for eliminating radiation hazard have been for the most part limited to the restriction of personnel or ordnance from those areas where high level power densities are known to exist; or conversely, restricting high power transmitters from illuminating those areas where personnel or ordnance are located. Additionally, shielding or screening methods have been utilized in an effort to reduce the radiation levels at a particular point, but the reflected energy often creates or contributes to a hazardous situation at another point. The use of materials which absorb a large percentage of the energy incident upon them has been investigated¹ and, although such materials are generally effective only at the higher frequencies (their absorption characteristics being dependent upon their physical thickness relative to the wavelength of the incident field), they may be of considerable value in reducing those hazardous situations attributed to a relatively few known emitters.

2. HAZARDS TO PERSONNEL

Extensive experimentation has been conducted in an effort to determine the harmful effects produced in living tissue as a result of exposure to high level electromagnetic radiation. The results of such experiments on animals, together with the knowledge of circumstances surrounding human mishaps, have provided considerable insight into the matter, although complete understanding of cause and effect is still lacking.

The principal manifestation of an overexposure to high intensity radiation is a significant increase in body temperature.⁹ The degree to which the body may be exposed to such radiations without suffering severe after-effects is dependent upon its ability to reject the absorbed heat through normal bodily processes such as perspiration and blood circulation. Because of the heating effect, the average power per unit area to which the body is subjected becomes a parameter of importance in defining a potentially hazardous situation. The presently accepted maximum safe level, which is held in general agreement by all branches of the Armed Forces, is 10 milliwatts per cm^2 for incidental or occasional exposure, and somewhat less than this value for continuous exposure. Any value of power density greater than 10 mwatts/ cm^2 average power then defines a radiation hazard to personnel (although no conclusive evidence has been obtained, there are indications that portions of the body react to peak power as well as average power, thus indicating a susceptibility to other than thermal effects).

Frequency, as well as power density, is a parameter of interest from the RAD HAZ standpoint.¹ Because of the penetration characteristics of RF energy (the lower frequencies penetrate more deeply than do the higher frequencies), the portions of the body affected by electromagnetic radiations vary with frequency. Since the sensory elements are located primarily in the skin, exposure to deep heating, or low frequency radiation (<1000 mc), may go unnoticed until the damage is done. High frequency radiation, (>3000 mc), on the other hand, acts in much the same way as infrared or sunburn, and the body should receive sufficient warning of exposure to this type of radiation. The range of 1000 mc to 3000 mc is often considered to be the most dangerous, since the body coefficient of absorption may approach 100% at these frequencies (as compared to about 40% above and below this range). The overall frequency range of interest has been established roughly as being between 200 mc and 10,000 mc. It is important to remember that individual power density contributions at various frequencies add directly to yield the total power density level.

3. HAZARDS TO ORDNANCE

The dangers of premature detonation of electroexplosive devices (EEDs) caused by the pick-up of stray RF energy need not be elaborated. Although the causes of many such accidents are readily traced, cases have been reported in which the suspected origins of the interfering electromagnetic radiations defy reason. This fact, together with the almost endless array of complex manners in which energy may be coupled into the EED circuitry, makes the prediction of radiation hazards to ordnance a difficult task.



Electroexplosive devices, such as the squibs used extensively in virtually every type of aerospace vehicle are, by definition, electrically actuated devices which, when initiated, result in an explosive system.⁴ The most common EED is the wire bridge type, consisting of a fine wire bridge, a primary charge, and the main charge. Upon application of the input signal, the bridge wire heats rapidly, leading to the initiation of the chemical reaction in the primary charge which, in turn, detonates the main charge. Because of heat losses in the bridge wire, the total energy required for initiation is less if applied "all at once" than if applied over a longer period of time, allowing compensation through heat loss. For this reason, peak values of field intensity are of primary importance in evaluating the potential radiation hazard of a particular electromagnetic environment.

A second type of EED which has recently received a great deal of attention is the exploding bridge wire type, or EBW. In this system, the main charge is actuated directly thus eliminating the need for the sensitive primary charge. The input signal to the EBW triggers a standard capacitor discharge, usually of the order of a thousand volts or greater, to the terminals of the bridge wire which promptly "explodes" with sufficient heat intensity so as to initiate the main charge. Although these types of EED are relatively new and much remains to be learned of them, they are considered by many to maintain a better functioning reliability, as well as reducing somewhat the danger of premature detonation.

Most electroexplosive devices are shielded to prevent misfiring due to irradiation by undesired electromagnetic fields. Also, trigger coding methods are often used to reduce the radiation hazard to these devices. The prediction engineer is, however, still confronted with the often complex problem of conducted RF energy and the multitude of paths which it may assume in coupling from the electromagnetic environment into the EED circuitry.

4. HAZARDS TO FLAMMABLE FUELS

Any metallic body may act as an antenna for receiving or radiating RF energy at a specific frequency if its size is such as to make it resonant at that frequency. Thus, it is possible for such an object, when located in an electromagnetic field of the proper frequency, to develop a high potential with respect to ground. A situation of this nature, under the proper conditions, could well lead to a spark discharge between one metallic body and another. If such a discharge takes place in the vicinity of a highly flammable liquid, such as aircraft fuel, and the energy con-

tained within the discharge is comparable to the minimum ignition energy of the fuel, an explosion may result. Further studies into the relationship between field intensity and ignition energy are necessary before any comprehensive conclusions can be made as to maximum safe radiation levels, although safe distance tables are presently in existence¹ which denote the minimum safe separation between RF transmitters and fuels and fueling operations. (A power density of 5 watts/cm² has been considered by some as the maximum safe level in the vicinity of volatile fuels.)

5. MEASUREMENT AND PREDICTION OF RADIATION HAZARDS

The susceptibility of both personnel and ordnance to high intensity electromagnetic fields, and the adverse effects brought about by prolonged exposure to these fields, have been discussed in the previous sections. Attention is now diverted to methods whereby the existence of a hazardous electronic environment may be predicted so that steps toward its suppression may be taken.

The accurate prediction of radiation hazards, as with any radio frequency interference situation, can become a formidable task, even in the seemingly straight-forward cases. The problem of calculating the power density in the near field of a transmitting antenna (which is not an easy matter) is, in a majority of instances, rapidly compounded by a multitude of possible reflection paths from surrounding buildings or terrain, or by the shielding action of other objects. When several potentially hazardous transmitters are operating simultaneously in close proximity as, for example, aboard ship, the prediction problem is further complicated. It would then seem that the quickest and safest method of approaching the problem lies with actual measurements. However, while measurements should be undertaken whenever a RAD HAZ situation is suspected, they should be accomplished with thought toward the evolution of reliable theoretical prediction techniques, thus aiding in the prevention of hazards through systems planning and design.

The measurement of radiation hazard to personnel or flammable fuels is basically one of power density over a broad band of frequencies. In some cases, it may be desired merely to check one or two areas for potential hazards, while in other situations, it may be desired to "map" the power density over an entire facility or installation. As an example of the former situation, it is often desirable, when installing a new radar in close proximity to existing operational radars, to determine the power densities at various elevations on the proposed antenna tower with

regard to the safety of construction workers. The results of such tests may indicate the need for sector blanking of present equipments to prevent irradiation of potentially hazardous areas. In any event, the RAD HAZ measurement technique must be both rapid and accurate, since consideration must be given the safety of personnel performing the measurements.

The determination of radiation hazards to electroexplosive devices is somewhat more complicated than merely performing field intensity or power density measurements. A multitude of paths, both radiated and conducted, exist whereby energy from an external electromagnetic field may find its way to the EED circuitry. Thus, if any useful results are to be obtained from the tests, the device should be installed in the missile or aerospace vehicle under fully operational conditions save for the final arming of the device itself. The measurement then consists of establishing a known electromagnetic environment to which the missile is subjected, and then measuring the resulting energy in the EED bridge wire. The tests must be repeated over a broad range of frequencies and for a large number of devices usually present in the more complex aerospace vehicle. An alternate method makes use of the reciprocity theorem, i. e., a known source is applied at the EED terminals and the external fields determined.

Because of the complexities touched on above, prediction of radiation hazard is not easily standardized. Each situation, in general, involves a new set of variables demanding a new approach. However, several calculations prove invaluable in RAD HAZ predictions, some of which are included below.

5.1 CALCULATION OF POWER DENSITY IN THE FRESNEL REGION

Because of the power densities involved, the minimum safe distances for many high power radars employing aperture type antennas occur in the Fresnel Regions. Thus, the calculation of Fresnel Region power density becomes an extremely useful tool in the prediction of radiation hazard.

The energy radiated from aperture type antennas is confined essentially to three regions:

a. Near Zone Region — This region includes points in the immediate vicinity of the aperture. In general, any mathematical representation of the fields in the near zone becomes far too complicated for

practical use, and since this zone extends only a few wavelengths from the aperture, it will be neglected here.

b. **Fresnel Region** - The fields of the Fresnel Region, to which our attention is restricted here, are substantially confined within a cylindrical pattern. A commonly accepted limit for this region is taken to be

$$R_1 = \frac{A}{2\lambda} \quad (6-1)$$

where: A is the aperture area, and
 λ is the wavelength

c. **Fraunhofer Region** - The Radiation in the Fraunhofer, or far field, region is essentially confined within a conical pattern, the power density falling off inversely with the square of the distance from the aperture. The region of transition from the Fresnel Region to the far field may be quite broad, such that the formula given in Equation (6-1) above for the boundary between the two is at best a rough approximation.

Two types of aperture will be discussed; the circular aperture and the rectangular aperture.

a. **Circular Aperture**

Figure 6-1 illustrates the geometry to be considered in calculating the Fresnel Region fields of a circular aperture.

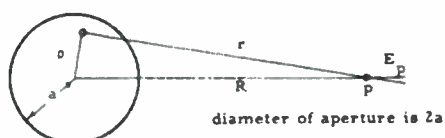

Figure 6-1. Geometry for Calculating the Fresnel Region Fields of a Circular Aperture

The differential electric field at point "p" is given by

$$dE_p = E_0 \frac{j\epsilon}{\lambda r} e^{-j\beta r} F(\rho) dA \quad (6-2)$$



where: E_0 = maximum field intensity at the aperture
 λ = wavelength
 $F(\rho)$ = function describing the field distribution over the aperture surface
 dA = elemental aperture area

In polar coordinates,

$$r = \left[R^2 + \rho^2 \right]^{\frac{1}{2}} \quad (6-3)$$

If we assume $R \gg \rho$, we may replace this by the approximation

$$r \approx R + \frac{\rho^2}{2R} \quad (6-4)$$

Then the differential field becomes

$$dE_p = \frac{jE_0}{\lambda R} e^{-j\beta r} F(\rho) e^{-j\beta \rho^2 / 2R} dA \quad (6-5)$$

Notice that insofar as the amplitude is concerned, r may be replaced by R , but that the ρ must be retained in the exponent to account for phase distribution.

The total field at point "p" is found by integrating the above expression over the entire aperture, or

$$\begin{aligned} E_p &= \frac{jE_0}{\lambda R} e^{-j\beta R} \int_A F(\rho) e^{-j\beta \rho^2 / 2R} dA \\ &= \frac{jE_0}{\lambda R} e^{-j\beta R} \int_0^{2\pi} \int_0^a F(\rho) e^{-j\beta \rho^2 / 2R} \rho d\rho d\phi \quad (6-6) \\ &= \frac{jE_0}{R} e^{-j\beta R} \int_0^a F(\rho) e^{-j\beta \rho^2 / 2R} \rho d\rho \end{aligned}$$

where: $E = \frac{jE_0}{\lambda}$

If we now assume uniform illumination of the aperture, $F(\rho) = 1$ and Equation (6-6) reduces to

$$E_p = j2E_0 \epsilon^{-j\beta(R + a^2/4R)} \sin\left(\frac{\beta a^2}{4R}\right)$$

The absolute value

$$\begin{aligned} |E_p| &= 2E_0 \sin\left(\frac{\beta a^2}{4R}\right) \\ &= 2E_0 \sin\left(\frac{A}{2\lambda R}\right) \end{aligned} \quad (6-7)$$

where: $A = \pi a^2 =$ aperture area.

Assuming plane waves, the power density at point "p" becomes

$$W_p = \frac{|E_p|^2}{\eta} = \frac{4E_0^2}{\eta} \sin^2\left(\frac{A}{2\lambda R}\right) \quad (6-8)$$

where: $\eta =$ the intrinsic impedance of the medium.

The term E_0^2/η represents the power density at the aperture, or

$$\frac{E_0^2}{\eta} = W_0 = \frac{P}{A}$$

where: $P =$ the total power radiated.

Substituting into Equation (6-8) gives

$$W_p = \frac{4P}{A} \sin^2\left(\frac{A}{2\lambda R}\right) \quad (6-9)$$

or

$$\frac{W_p}{W_0} = 4 \sin^2\left(\frac{A}{2\lambda R}\right) \quad (6-10)$$

Figure 6-2 is a plot of Equation (6-10). The locus of the maxima is

$$\frac{W_p}{W_0} = 4 = 6 \text{ db}$$

$$\text{or} \quad W_p = 4W_0 = \frac{4P}{A} \quad (6-11)$$

where: P is total power radiated, W_0 is power density at the aperture, W_p is power density at point "p" in Fresnel region, and A is aperture area.

Equation (6-11) then gives the maximum power density in the Fresnel region in terms of the total radiated power and the aperture area. Notice that this equation is independent of distance, R , the result of the essentially cylindrical pattern. It should be noted that the derivations thus far have assumed free-space transmission; ground reflections could double the electric field or quadruple the power density. Thus, a more pessimistic result (always to be used where radiation hazards are concerned)

18

$$W_p = \frac{16P}{A} \quad (6-12)$$

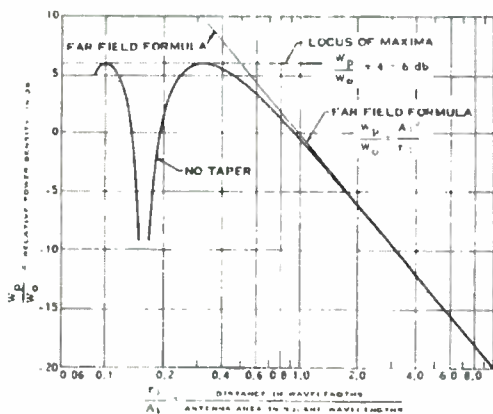

Figure 6-2. Power Density vs Distance for Uniformly Illuminated Round Aperture

Although uniform illumination of the aperture has been assumed, Equation (6-11) is found to conform well when linear or square law taper of the field distribution is used.

b. Rectangular Aperture

Figure 6-3 shows the geometry of the rectangular aperture. By methods similar to those used for the circular aperture, the Fresnel region fields may be shown to be

$$E_p = \frac{jE_0}{1R} e^{-j\beta R} \int_0^a \int_0^b F(x, y) e^{-j\beta x^2/2R} e^{-j\beta y^2/2R} dx dy$$

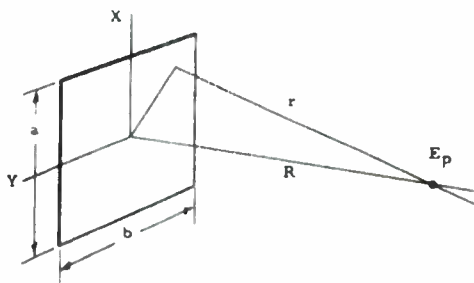

Figure 6-3. Geometry for Calculating the Fresnel Region Fields of a Rectangular Aperture

Again, assuming uniform illumination ($F(x, y) = 1$), the above equation reduces to

$$E_p = \frac{jE_0}{1R} e^{-j\beta R} \left[\int_0^a e^{-j\beta x^2/2R} dx \right] \left[\int_0^b e^{-j\beta y^2/2R} dy \right] \quad (6-13)$$

The integrals in Equation (6-13) are of the form

$$\sqrt{\frac{2R}{j\beta}} \int_0^a \sqrt{\frac{j\beta}{2R}} e^{-\eta^2} d\eta = \sqrt{\frac{2R}{j\beta}} \int_0^a \sqrt{\frac{j\beta}{2R}} (1 - \eta^2 + \frac{\eta^4}{2} - \dots) d\eta$$

where:

$$z = \sqrt{\frac{j\beta}{2R}} x$$

and

$$\sqrt{\frac{2R}{j\beta}} \int_0^b \sqrt{\frac{j\beta}{2R}} e^{-y^2} dy = \sqrt{\frac{2R}{j\beta}} \int_0^b \sqrt{\frac{j\beta}{2R}} (1 - y^2 + \frac{y^4}{2} - \dots) dy$$

where:

$$y = \sqrt{\frac{j\beta}{2R}} y$$

If we may now make the assumptions that

$$a^2, b^2 \ll 1,$$

corresponding to the conditions

$$\frac{x^2}{\lambda R} \ll \frac{y^2}{\lambda R} \ll 1,$$

these integrals, when all but the first term in the series is neglected, reduce to a and b respectively, the dimensions of the aperture. Thus, the approximate Fresnel region field of the rectangular aperture for uniform illumination is

$$\begin{aligned} E_p &= \frac{jE_0}{\lambda R} e^{-j\beta R} ab \\ &= \frac{jE_0 A}{\lambda R} e^{-j\beta R} \end{aligned}$$

where $A = ab =$ area of the aperture. The absolute value

$$|E_p| = E_0 \frac{A}{\lambda R}$$

or

$$\frac{W_p}{W_0} = \left(\frac{A}{\lambda R} \right)^2 \quad (6-14)$$

This equation may be expressed in terms of the total radiated power P as

$$W_p = \frac{AP}{(\lambda R)^2}$$

or, assuming 100% ground reflection,

$$W_p = \frac{4AP}{(\lambda R)^2} \quad (6-15)$$

5.2 EED CIRCUITRY AS AN ANTENNA

Under optimum conditions the firing circuitry of an EED may act as a thin linear antenna capable of receiving RF energy and conducting it to the bridge wire. If the impinging electromagnetic field is sufficiently strong, and the device is poorly shielded, enough energy may be induced in the squib circuitry to cause detonation. It is, therefore, often useful to treat the bridge wire leads as a linear antenna and determine the induced voltage under the assumption of ideal conditions. In an actual situation, severe impedance mismatches at RF frequencies and the shielding effect of the missile in which the EED is mounted, serve to render the results of such a calculation quite pessimistic in a majority of cases. When, however, more is known about the individual case under study, these effects can be accounted for in arriving at a more realistic result.

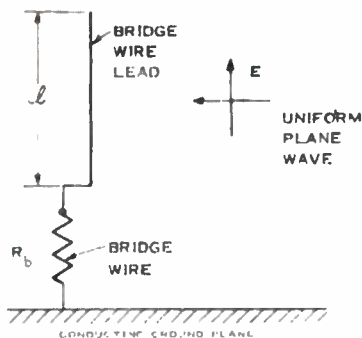

Figure 6-4. EED Circuitry Acting as an Antenna

Consider the configuration shown in Figure 6-4 with the EED bridge wire lead normal to a large conducting ground plane and with the incident electric field parallel to it.

The bridge wire lead acts as a thin linear antenna. The open circuit voltage induced at the bridge wire terminals is

$$V_{oc} = E\ell$$

where ℓ = length of bridge wire lead. The equivalent circuit for the configuration is shown in Figure 6-5.

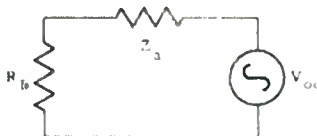

Figure 6-5. The equivalent circuit for the configuration shown in Figure 6-4.

where Z_a = antenna impedance.

The current flowing in the bridge wire is

$$I = \frac{V_{oc}}{Z_a + R_b} = \frac{E\ell}{Z_a + R_b}$$

where R_b = bridge wire resistance. The maximum safe field strength E_{max} may be found by letting the bridge wire current equal the maximum "no-fire" value, I_{nf} . Thus

$$E_{max} = \frac{I_{nf}}{\ell} (Z_a + R_b) \quad (6-16)$$

The maximum allowable power density at the EED circuitry is (assuming plane waves)

$$W_{max} = \frac{|E_{max}|^2}{120\pi}$$

where 120π = impedance of free space. Then from Equation (6-16),

$$W_{\max} = \frac{1}{120\pi} \left| \frac{I_{nf}}{l} (Z_a + R_b) \right|^2 \quad (6-17)$$

As an example, assume the bridge wire lead to be a quarter wavelength long. Then

$$l = \frac{\lambda}{4}$$

$$Z_a = 36.5 + j21 \text{ ohms}$$

Typical values of no-fire current and bridge wire resistance are

$$I_{nf} = 1 \text{ amp}$$

$$R_b = 1 \text{ ohm}$$

Inserting these values into Equation (6-17) gives

$$W_{\max} = \frac{1}{120\pi} \left| \frac{(1 \text{ amp})}{(\lambda/4)} (37.5 + j21) \text{ ohms} \right|^2$$

$$\approx \frac{79}{\lambda^2} \text{ watts/cm}^2$$

where λ is in centimeters. At a frequency of 1000 mc, $\lambda = 30$ cm and the critical power density becomes approximately

$$W_{\max} = 88 \text{ mwatts/cm}^2$$

It is noted that the critical power density decreases inversely with the square of the wavelength. Thus, at 500 mc, W_{\max} is only 22 mwatts/cm², while at 250 mc, corresponding to a wavelength of 120 cm or a lead length of 30 cm, only about 5 mwatts/cm² of power is required to produce a hazardous situation. (The above values assume no shielding effects which, in a practical situation, will substantially increase the amount of energy necessary to cause detonation.)

The above discussion outlines only one method whereby RF energy may be transmitted to the bridge wire circuitry of an electro-

explosive device. Inductive or capacitive coupling from active circuits in close proximity to the squib leads, or the conduction of surface currents induced in the missile skin itself, represent other possibilities. At certain frequencies, cables and wires protruding from the missile in which the device is mounted, may act as resonant antennas capable of coupling energy into the EED circuitry. Similarly, open vents or ports may appear as aperture antennas at the correct frequencies. To discuss, or even to foresee, the multitude of phenomena associated with the prediction of radiation hazards to ordnance devices is a formidable task. Although much of the related material mentioned above may be found elsewhere within these volumes in connection with other RFI considerations, the complexity of the problem forces the analysis of each individual situation as it arises, rather than permitting a standardized prediction procedure.

6. INSTRUMENTATION CONSIDERATIONS

6.1 RF POWER DENSITY METER FOR DETERMINATION OF HAZARDS TO PERSONNEL

From the foregoing brief discussion, in which the various parameters of interest from a RAD HAZ standpoint have been outlined, it is possible to determine the desired test equipment characteristics for their measurement. Abstracting from Reference 5, the following features define a power meter capable of meeting the requirements for quickly determining radiation hazards to personnel.

- a. The equipment should be battery operated and highly portable.
- b. The equipment should give direct reading of time average power density in milliwatts per cm^2 , with a minimum of calibration per reading.
- c. The basic unit should be broadband (200 mc to 10 kmc).
- d. Sufficient dynamic range should be available for measurements of power densities substantially above and below the 10 mwatt/ cm^2 value.
- e. Accuracies within one or two db should be achieved (the unit should be shielded for increased accuracy).

One such instrument meeting these specifications has been designed by Knapp and Lambdin.⁵ The basic instrument is a balanced bridge

type with temperature compensation to minimize drift due to changes in ambient temperature. A dynamic range of from 0.1 mwatt/cm² to 2000 mwatt/cm² is afforded. To achieve direct reading of power density, the effective area of the probe, including cable losses, is maintained at a constant one cm² throughout the frequency range of 200 mc to 10 kmc.

In the 200-800 mc range a tuned half-wave dipole is used as the probe. Because the effective area of this antenna is much greater than the desired one cm², variable attenuation is obtained by inserting a section of two-inch cylindrical waveguide into the line. This waveguide, being below cutoff, provides an attenuation of approximately 1 db per 1/16 inch. The position of the pickup loop in the waveguide is variable relative to the insertion loop and is calibrated so that it may be adjusted for the correct attenuation (about 35 db is necessary at 200 mc) prior to measurement.

Two conical horns are employed in the frequency range above 800 mc (800-4000 mc and 4000-10,000 mc). The desired effective area of 1 cm² is obtained by varying the position of the coaxial pickup within the horn. Calibration curves are supplied with the equipment to insure proper settings.

6.2 INSTRUMENTATION FOR MEASUREMENT OF HAZARD TO ORDNANCE

Because peak values of field intensity are of concern in the determination of potential hazards to electroexplosive devices, the average reading power meter described in Section 5.1 finds limited use in this application. Also, in many instances, the electromagnetic fields of interest are of sufficiently low level so as to necessitate the sacrifice of broadband characteristics for greatly increased sensitivity. These needs, therefore, dictate the use of a heterodyne type field intensity meter as one of the basic instrumentation requirements. The frequency range to be considered extends from about 200 kc, below which the physical dimensions of the ordnance device or vehicle in which it is mounted become negligibly small compared to the wavelength, to 10 kmc, above which, at the present time, the power capabilities of communications-electronics equipments are small. Since a large number of satisfactory meters are available and their characteristics well known, they will not be discussed further here.

The amount of energy coupled into the EED circuitry from an external field is often difficult to measure. The parameter of prime importance is the current in the bridge wire, but because of the low bridge-

wire resistance (usually in the order of one ohm) and the stray capacitance and inductance found at high RF frequencies, great care must be exercised to insure that the electrical properties of the EED are not appreciably altered by the measurement device.

Although the "all-fire" condition of the electroexplosive device is ordinarily expressed in terms of the bridge wire current, the amount of heat generated ultimately determines the point of detonation. Thus, one possible measurement technique involves the use of heat sensing elements such as thermocouples or thermistors. In addition to almost complete isolation from the EED circuitry, these sensors offer the additional features of broadband capability, small size to allow easy access, and relative insensitivity to electromagnetic radiation.

References

1. Midwest Research Institute, Summary Report: Survey of Radio Frequency Radiation Hazards, 14 June 1960.
2. W. W. Mumford: Some Technical Aspects of Microwave Radiation Hazards, Proc. IRE, Vol. 49, p. 427, February 1961.
3. H. P. Schwan and K. Li: Hazards Due to Total Body Irradiation by Radar, Proc. IRE, Vol. 44, p. 1572, 1956.
4. B. Weinbawn: Susceptibility of Pyrotechnic Devices to Electromagnetic Energy, Fifth Conference on RFI Reduction and Electromagnetic Compatibility (Proceedings), October 1959, p. 43.
5. K. W. Knapp and W. S. Lambdin: An Instrument for Measurement of High RF Power Density, Sixth Conference on RFI Reduction and Electromagnetic Compatibility (Proceedings), October 1960, p. 406.

SPECTRUM SIGNATURE

MEASUREMENT TECHNIQUES

CHAPTER 7

1. INTRODUCTION

In order to make accurate predictions of communication-electronic system compatibility, it is necessary to know the radio frequency characteristics of transmitters, receivers, antennas, and other parts of the system. This material is frequently referred to as "spectrum signature" data.

The importance of planning communication-electronic system compatibility has been widely recognized and, in 1960, the Department of Defense established a Radio Frequency Compatibility Program (RFCP) to "insure to the maximum practicable extent that military electronic systems will not suffer degradation due to the effects of mutual interference." To centralize the DOD analysis activities under the plan, the DOD Electronic Compatibility Analysis Center (ECAC) was established with the U. S. Air Force acting as executive agent for the Department of Defense. A Military Collection Plan for Spectrum Signatures was established to provide data for the RFCP and the ECAC.

The Collection Plan for Spectrum Signatures defines a spectrum signature as "the package of data which describes the electromagnetic radiating and receiving characteristics of equipment." Spectrum signature measurements, therefore, must include all RF radiating and receiving characteristics of an equipment. The radiating and receiving characteristics can be estimated fairly well. However, as with other design parameters such as reliability, maintainability, and human engineering, actual data must be obtained under operating conditions if the true characteristics of the equipment are to be known.

It is frequently found, in fact, that the radiating and receiving characteristics under operating conditions may differ from design characteristics in one of two ways.

a. The quantitative amount of some of the characteristics may differ, e.g., the power output at the second harmonic might be an actual 100 watts by measurement, instead of 50 watts as estimated.

b. It may be found that some undesirable characteristics



exist which were not considered in the design, e.g., by measurement 500 watts might be found to be radiated at a non-harmonic spurious frequency.

Only by taking the actual spectrum signature can any assurance be had as to the true operating characteristics of an equipment. Although spectrum signature programs are relatively new, it is expected that they will provide empirical data upon which may be based general procedures for future performance prediction that is more closely related to actual equipment performance than previously.

In order to standardize spectrum signature requirements, the DOD Spectrum Signature Collection Plan sets forth the method of obtaining the signatures and establishes specific requirements such as number of points for antenna pattern data, dynamic range of measurements, accuracy of frequency measurements, and format for data. Such standardization is essential since the large quantities of data make necessary the manipulation of data by standardized manual procedures or by computers.

For example, the SSC Plan specifies, in Section 1.2, that Standard Test Frequencies are "that group of frequencies to which transmitters or receivers are tuned during the test procedure. Three such frequencies exist in each equipment tuning band located at approximately the 5%, 50%, and 95% points in each band."

Spurious Emissions are defined as "emissions on a frequency or frequencies which are outside the necessary bandwidth, and the level of which may be reduced without affecting the corresponding transmission of intelligence. Spurious emissions include harmonics, parasitic emissions, and intermodulation products, but exclude unnecessary modulation sidebands of the fundamental frequency."

Other specifications include antenna "far-field distance" as being at least D^2/λ (where D is the largest linear dimension of the antenna) but not less than 3λ ; frequency accuracy as 1 part in 1000; and antenna pattern dynamic ranges of 60 db at the fundamental and 40 db at other frequencies. Antenna patterns must be obtained at the midband transmitter standard test frequency and all its harmonics up to 12 kmc.

The present DOD Spectrum Signature requirements, although more standardized than previously, are but an initial attempt at solution of the spectrum signature collection problem. Future revisions of the plan will probably include requirements for information which takes into account anti-jamming features, MFI modes of operation, range gates,

and similar features.

In addition to the spectrum signature requirements as called out by the Spectrum Signature Collection Plan, other similar requirements are contained in Military Specifications such as MIL-I-26600, MIL-I-16910, and MIL-I-6181. These specifications spell out, in detail, the measurement techniques, instruments, and data required to determine RFI compatibility. These specifications are discussed in Volume IV of this Handbook and copies of the specifications are included as Appendices in Volume IV.

In this chapter, a brief discussion is presented of the techniques, equipments, calibration, theory, and environmental considerations applicable in performing spectrum signature measurements on a complete radar system, followed by a discussion of the same factors as they apply to the subsystem. The operations involved in the performance of a typical task are briefly discussed. In addition, a portion of the section is devoted to a discussion on the theoretical and practical problems that may be encountered in obtaining spectrum signatures.

1.1 MEASUREMENT TECHNIQUES

In a typical plan for obtaining spectrum signatures, requirements are often stated which necessitate consideration of special techniques to comply with the stated objectives. These techniques, including alternate procedures, are developed in the following sections. The problems and theory associated with the measurements include impedance matching considerations, existence of numerous TE and TM modes at higher frequencies other than at the fundamental tuning band, site consideration, power and sensitivity requirements of the test equipment; and similar factors. These are discussed, as applicable, under the receiver, transmitter, and antenna measurement sections.

1.2 MEASURING AND TEST EQUIPMENTS

In the succeeding sections the particular test equipments and interconnections necessary to conduct the field measurements for each of the subsystems tests are described relative to the test procedure for receivers, transmitters, and antennas. The data formats also provide for sketches to be made by test personnel documenting the exact configuration of the test equipment, cables, couplers, attenuators, and other items. Thus, results can be compared to calibration charts and characteristics prepared prior to field tests.

1.3 CALIBRATION TECHNIQUES

All signal generators, field intensity meters, and other measuring equipment utilized must be calibrated in accordance with standard and accepted procedures. All antennas, cables, attenuators, couplers, waveguides, etc., used in conjunction with these equipments must also be calibrated. Calibration charts displaying attenuation losses as a function of frequency must be obtained for each component employed in the measurement program. Frequency meters used must have accuracies of better than one part in a million to meet many of the required accuracies. A continuous maintenance and calibration procedure assures that the accuracy of measurements will be uniform throughout the program.

1.4 ENVIRONMENTAL DATA

In addition to the spectrum signature characteristics, it may also be necessary to determine the environmental conditions associated with the measurements. Two types of environmental data are important: the ambient signal level where the measurements are to be made, and the identification of objects in the measurement area. The following is a brief discussion on the acquisition of this data.

1.4.1 AMBIENT SIGNAL LEVEL

To accomplish controlled measurements, it is first necessary to identify the ambient signal levels prevailing in the measurement area to permit identification of results with the equipment under test and not some other equipment located in the area. This is done prior to the performance of spectrum signature measurements. The search must be made at selected hours of the day or night to cover desired traffic densities. The information is then collected and recorded in the field on a typical spectrum search data sheet. (See Chapter VIII for detailed information on spectrum search techniques.)

1.4.2 PHYSICAL ENVIRONMENTS

In addition to the ambient signal data needed to establish signal density levels over the spectrum 10 kc to 12 gc, the surrounding terrain, buildings, or more important, the physical factors of an area such as distances between equipments, altitude above mean sea level (MSL), antenna heights, etc., may be required. Figures 7-1 through 7-4 are examples of a plan view of a typical site, profile showing propagation paths and distance, census of installations existing within radio line-of-sight (RLOS) of a radar, and propagation profile between radars.



Figure 7-1. Plan View of a Typical Site

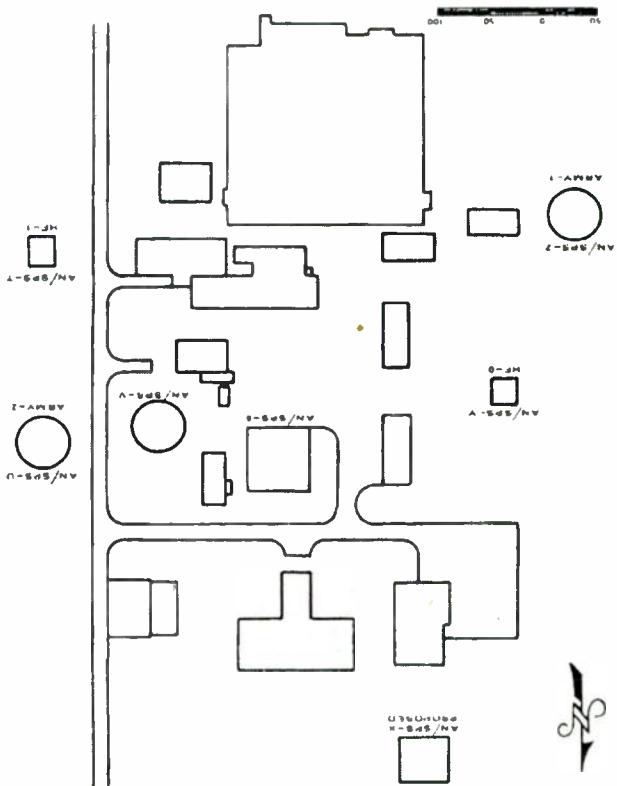

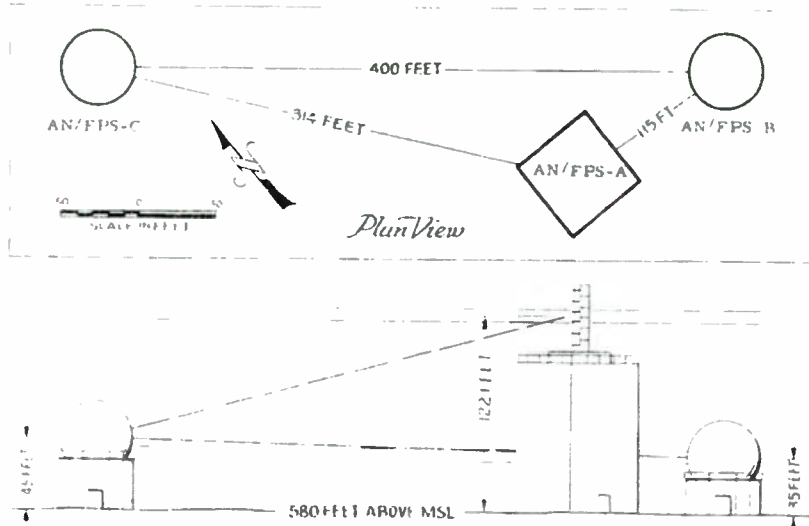

Figure 7-2. Profile Showing Propagation Path Between the Three Radars

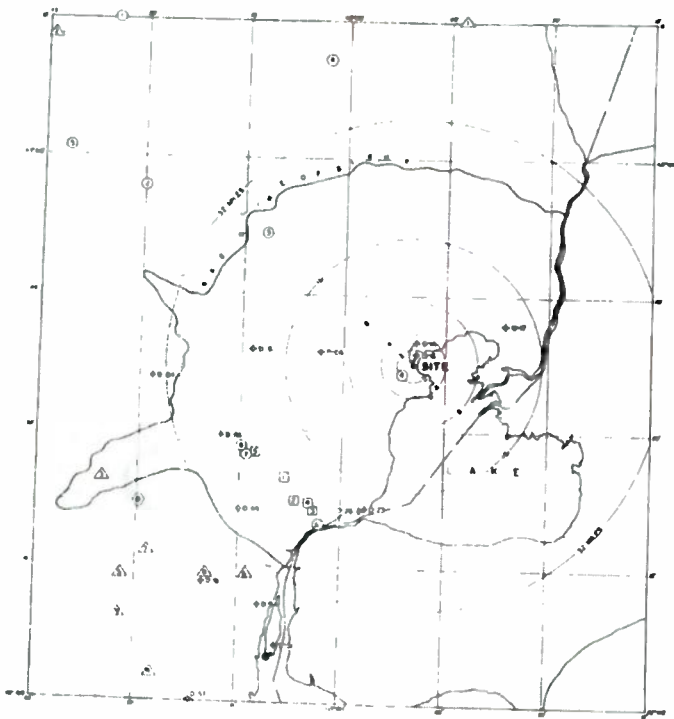

Figure 7-3. C.E. Census of Installations Existing Within Radio Line-of-Sight of An Electronic Site.

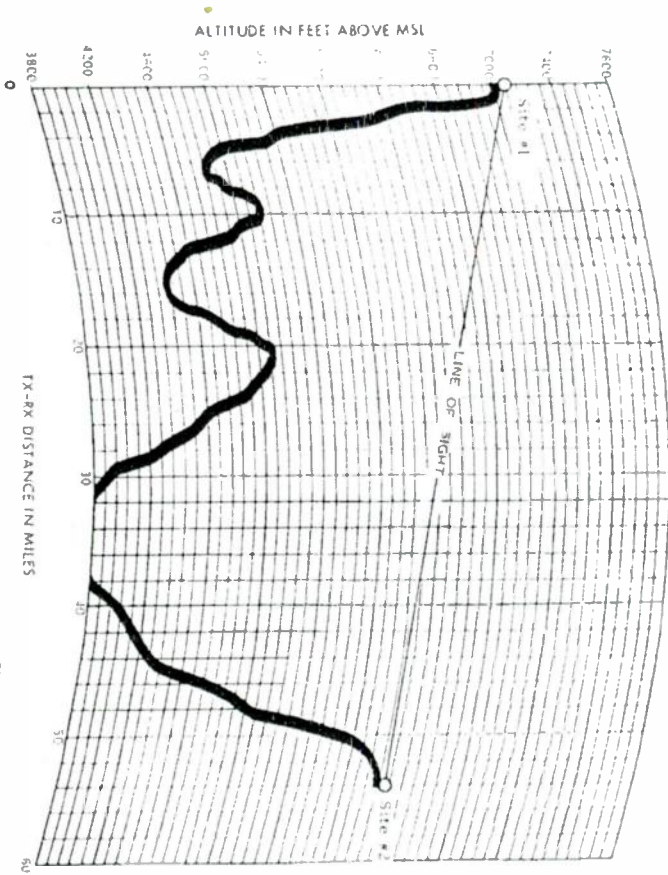

Figure 7-4. Propagation Profile Between Two Sites.

2. TRANSMITTER MEASUREMENTS

A transmitter is a system specifically designed to generate and emit radio frequency energy. It is desired that the system emit only those frequencies in a necessary bandwidth. Necessary bandwidth is defined as that minimum bandwidth necessary to sufficiently insure the transmission of intelligence at the rate and with the quality required for the system employed. Since most transmitters generate frequencies outside of their necessary bandwidths, it is important to establish the mutual interference capabilities of these out-of-band emissions.

The specifications on uniform measurement techniques require the following measurements to be performed on all pulsed radar transmitters:

- a. Power Output
- b. Spurious Emission
- c. Emission Spectra
- d. Modulation Characteristics
- e. Carrier Frequency Stability

A transmitter identification format is shown in Figure 7-5.

Since an absolute system of measurement is used in these transmitter tests, the uniform unit for power is dbm and all power ratios and/or transfer functions are reported in db. During the tests, the transmitter power output is monitored and the variations recorded.

The above five tests should be performed under conditions of minimum and maximum duty cycle at each standard test frequency. The same tests are performed with the mean duty cycle at the center standard test frequency of the tuning band.

A detailed discussion is presented of the open field method for the performance of direct power density measurements in the far field.

2.1 POWER OUTPUT

2.1.1 GENERAL

In an ideal pulse transmission, a major portion of the emitted energy is contained in the necessary bandwidth. A reference for the power monitor tests is established by making a fundamental power measurement in the transmission line.

TRANSMITTER IDENTIFICATION FORMAT

PULSED, W/ANTENNA

1. Equipment Nomenclature
Alphanumeric _____ Serial Number: _____

2. Frequency Band: Initial _____ mc. Final _____ mc.

3. Source: _____

4. Function: _____

5. Other Operation Characteristics: _____

6. Emission Type and Bandwidth: _____

7. Pulse Repetition Rate _____ pps. Pulse Widths _____

8. Power: Nominal Peak _____ kw. Nominal Average _____ kw.

9. Main Antenna Beamwidth: Vertical _____ Horizontal _____

10. Polarization _____ Normal Scan: _____

11. Remarks: _____

_____ Date _____ Observer _____

Figure 7-5. Transmitter Identification Format
Pulsed, W/Antenna

The signal sampling device is generally supplied with radar transmitters. A response curve as a function of frequency shall be to ± 1 db at each measurement frequency.

The fundamental power output is measured at all three standard test frequencies in each tuning band. Peak and average power measurements are made at all test frequencies and their appropriate duty cycles. The duty cycle will be measured in each case.

2.1.2 MEASUREMENT SETUP

The setup for the radar transmitter power output measurement is shown in block diagram form in Figure 7-6.

The field measuring equipments are placed in a screened area or in areas sufficiently free from interference and reflections. Because of the high level signal from the signal sampling network, the variable attenuator is placed outside the screen room area to decrease possible interference to test equipment.

The coaxial cabling from the sampling network to and from the variable attenuator to the coaxial switch is as short as possible and adequately shielded to minimize unwanted pickup from the high power transmitter signals. The variable attenuator is substantially shielded such that little or no interference is coupled into the test equipment.

The calibrated oscilloscope is used for accurate time information on the various duty cycles.

The frequency meter, or counter, is connected to the output of the signal generator only when taking a frequency measurement for the required accuracies after each power measurement.

2.1.3 MEASUREMENT PROCEDURE

a. The test equipment and the radar are allowed sufficient time for warmup. The radar transmitter is turned on and tuned to the medium standard test frequency (50%) in the tuning band at the mean duty cycle according to operational manual instructions for optimum efficiency.

b. Reading the peak function, the frequency-selective voltmeter is tuned to the transmitter-output frequency with the coaxial switch in position No. 1. At the tuned frequency a maximum reading at mid-



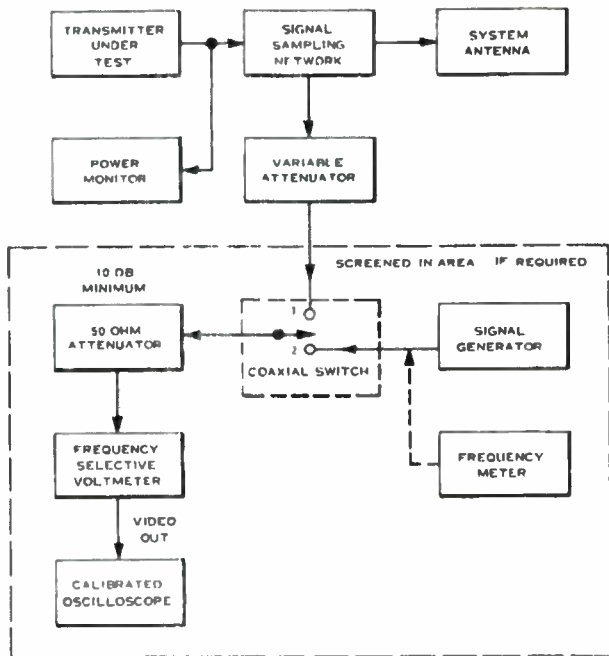

Figure 7-6. Transmitter Power Output Measurement Setup

scale is obtained by adjusting the variable attenuator and/or the field-intensity-meter controls.

c. The coaxial switch is turned to position No. 2, and with the field-intensity-meter controls at the same positions, the signal generator frequency control is tuned for a maximum CW signal indication on the meter. The output attenuator control on the signal generator is adjusted for the same mid-scale reading obtained for the transmitter output.

d. The frequency meter, or counter, is inserted at the output of the signal generator to determine the exact tuned frequency with the required accuracy.

e. The signal generator output level in dbm plus the sum of insertion losses in db at the test frequency for the signal sampling network, the coaxial cabling, the variable attenuator, and the coaxial switch are recorded as the power output in dbm at the standard test frequency.

f. The above five steps are repeated for the remaining two standard test frequencies in the band (1% and 95%) and the minimum and maximum duty cycle. The whole procedure is repeated for each applicable tuning band. The data obtained is recorded on a data form such as shown in Figure 7-7.

2.2 SPURIOUS EMISSIONS

2.2.1 GENERAL

The purpose of the spurious emission test is to scan the spectrum and to measure and record all spurious outputs of the transmitter under test. Since this example is a pulsed radar transmitter, the measurements are made in the far field. The advantage of making the measurements in the far field are that the absolute fundamental and spurious densities can be determined directly, and the possible problem created by the existence of more than one mode of propagation in the line that feeds the antenna is overcome.

However, there are distinct disadvantages that should be mentioned also. First, the emission frequencies have to be located and the test and radar antennas positioned for maximum interception. Generally, this may be accomplished by maximizing signal strength received with respect to the radar antenna azimuth and elevation. The measurement must be referenced to the radar antenna azimuth and elevation at the fundamental and at each spurious frequency. Secondly, the maximum

Transmitter Power Output Test Data Format

- I. Radar Type: _____ Transmitter Serial No. : _____
- II. Equipment Setup: Draw block diagram of the test setup on the reverse side of this sheet. Identify by model and serial numbers of all test equipment and interconnections (cable types, cable lengths, connectors, attenuators, etc.) Indicate control and dial settings where necessary.
- III. Test Data.
 Transmitter Time On _____, Time Off _____.
 Tuning Band: _____, Tuned Frequency _____ mc.

Frequency (mcs)	Power Output (dbm)	Remarks

Figure 7-7. Transmitter Power Output Test Data Format

field strength at a given distance will vary with the location at the site (i. e., reflection of energy for objects). Depending upon the desired results, the measurements may be made at a number of locations at the site, or attempts may be made to reduce the effects of reflections. One method that may be used to reduce the effects of reflections in most cases is to elevate a pickup antenna to a position such that when the signal strength is maximized, the foreground is not appreciably illuminated by the radar antenna.

Another disadvantage to the open-field technique is that it requires very accurate calibration of certain components since an absolute measurement is specified. Calibrated pickup antennas, cabling and filters, and attenuators, where applicable, must be used such that the power level measured may be accurately related to field strength at the pickup antenna aperture. The calibration problem is decreased by using the signal substitution method with a calibrated signal generator through a portion of the same signal path as the unknown signal.

The high pulse power at the tuned frequency necessitates some rejection of that frequency when harmonics or spurious emissions are being measured. The rejection will be provided by a low pass filter at frequencies below the tuned frequency. At frequencies above the tuned frequency, several different antennas are used, and a length of waveguide between the test antenna and the receiver will provide adequate rejection below the cutoff frequency, f_c , of the waveguide. The loss in db, L , at a frequency, f , below the cutoff frequency, f_c , and for a length, d , of waveguide is given by the following equation:

$$L = 54.5 \frac{d}{\lambda_c} \left[1 - \left(\frac{f}{f_c} \right)^2 \right]^2 \quad (7-1)$$

where: λ_c = cutoff wavelength of the waveguide. Note d and λ_c are in the same dimensions.

The frequency-selective voltmeter and receiving system used should have a calibrated sensitivity greater than:

- a. -90 dbm, m^2 at frequencies below 300 mc
- b. -80 dbm, m^2 above 300 to 1000 mc
- c. -70 dbm, m^2 above 1000 to 3000 mc
- d. -60 dbm, m^2 above 3000 to 10,000 mc
- e. -50 dbm, m^2 above 10,000 m.

The power density, P_{dn} , at a distance, d , from the transmitting antenna and at the frequency, f_n , may be written as

$$P_{dn}(d) = \frac{P_{tn} G_n}{4\pi(d)^2} \quad (7-2)$$

where: P_{tn} = the transmitted power at the frequency, f_n .
 G_n = the transmitter gain at the frequency, f_n .

The distance, d , will be known and the antenna gain is obtained from the antenna characteristics; thus the actual transmitted power at a given frequency can be determined.

A typical L-Band radar transmitter spectral signature, measured by this contractor in the field, is shown in Figure 7-8.

2.2.2 MEASUREMENT SETUP

The setup for the radar transmitter to be used for open-field spurious emission measurements is shown in block diagram form in Figure 7-9.

The test antennas are placed at a known distance in the far field of the test transmitter fundamental frequency. The far field distance is approximately D^2/λ_f and the separation between test antenna and transmitting antenna is at least $3\lambda_f$ where D is the maximum dimension on the largest antenna aperture and λ_f is the wavelength of the fundamental test frequency.

The field measuring equipment is placed in the screened area or in areas sufficiently free from interference to decrease the effects of undesired pickup due to radiation of equipment.

Each test antenna should have coaxial cabling, a coupling network, attenuators and waveguide, plus necessary shielding for detection of spurious responses in certain frequency ranges. Each antenna and its accessories to the coaxial switch should have a calibrated frequency response curve such that the absolute field strength can be determined from the signal substitution measurement on the field-intensity meter.

The power monitoring equipment is connected to the signal sampling network in the transmission line at the radar site and variations in the fundamental power are recorded during spurious emission tests.



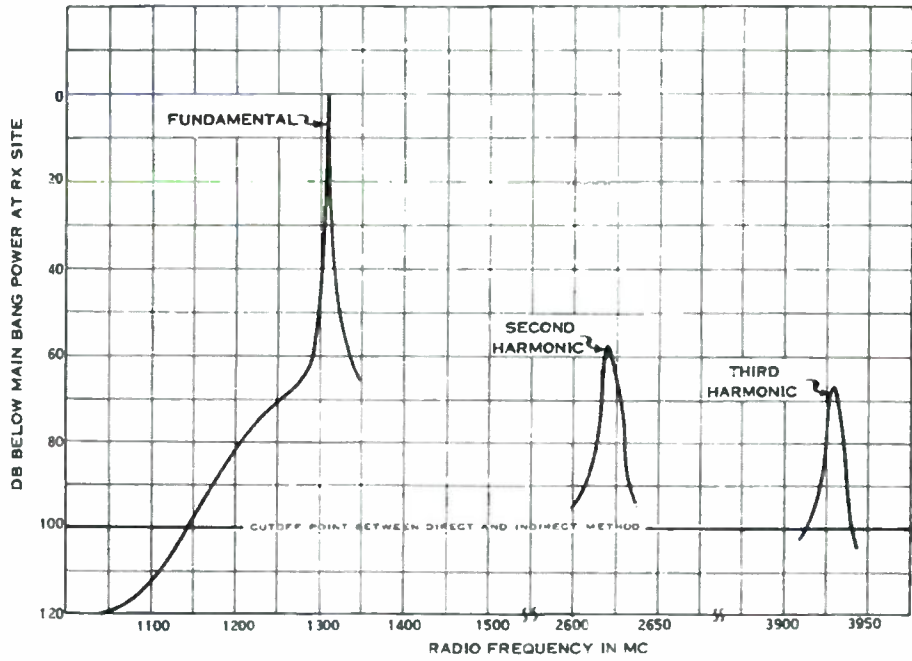

Figure 7-8. Sample L-Band Radar Transmitter Spectral Signature. Measured in Far Field

7-17

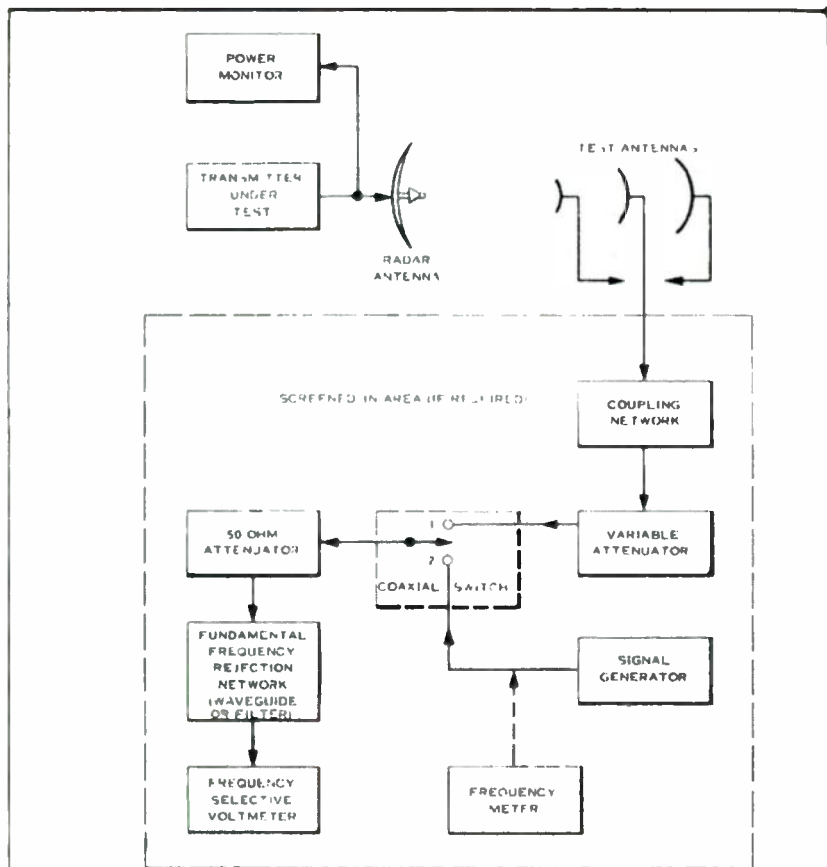

Figure 7-9. Transmitter Open Field Spurious Emission Measurement Setup

The frequency meter, or counter, is connected to the output of the signal generator only when taking a frequency measurement of the required accuracy at each spurious emission detected, and then disconnected for the power level measurement.

2.2.3 MEASUREMENT PROCEDURE

a. The radar transmitter is turned on and tuned to one of the standard test frequencies in the tuning band. It should already be tuned to the 5%, 50%, or 95% standard frequency from the previous power output test. Again, the tuning is done according to operational manual instructions for optimum efficiency.

b. The coaxial switch is turned to position No. 1 with the fundamental frequency rejection network bypassed. The field-intensity meter is tuned to the standard test frequency of the radar transmitter. In case the pickup antenna is in a null of the transmitter antenna pattern, the antenna position may be adjusted as stated below.

c. The transmitter and test antennas are oriented in the following sequence:

(1) If the radar system is a scanning type, the radar antenna is positioned such that the maximum radiated energy is as close to the geometric axis of the test antenna as is practical.

(2) If the transmitter antenna has both azimuth and elevation control, it is positioned such that maximum signal is received at each spurious frequency. If the transmitter antenna cannot be controlled in either azimuth or elevation, the test antenna is positioned for the maximum signal at each spurious frequency.

(3) At each detected spurious emission, the test antenna is rotated in polarization for the maximum signal. Both radar antenna and test antenna positioning information is recorded for analysis.

d. The variable attenuator and frequency-selective voltmeter attenuation controls are adjusted for the maximum reading at mid-scale on the test receiver. The coaxial switch is turned to position No. 2, and the signal generator frequency control is tuned for maximum on the field-intensity meter. The signal generator output attenuator control is adjusted to give the same mid-scale reading obtained for the transmitter signal.



e. The frequency meter is inserted at the output of the signal generator to determine the frequency with the required accuracy for the signal being measured.

f. The signal generator output level in dbm, plus the sum of the insertion losses in db at the signal frequency for the coupling network, variable attenuator and associated cabling, minus the test antenna gain are recorded as the power level at the antenna aperture. The power density of this signal is determined in accordance with the procedures of the field-intensity meter instruction manual, and recorded with the antenna positioning information and frequency.

g. With the fundamental frequency rejection network (waveguide or filter) selected to pass certain frequencies and reject the fundamental, the above six steps are repeated by tuning through the spectrum to find all spurious responses. Care is taken that spurious emission responses will not be due to the test equipment. Only transmitter spurious output and antenna position are recorded. Other responses are discarded.

h. The above seven steps are repeated for the remaining two standard test frequencies in the band. If applicable, the whole procedure is repeated again for the standard test frequencies in each of the remaining tuning bands. All of the tests are performed under conditions of minimum and maximum duty cycle at each standard test frequency. The power density data obtained is recorded in dbm/m² as a function of response frequency on a data form similar to that shown in Figure 7-10.

2.3 EMISSION SPECTRA

2.3.1 GENERAL

A large amount of interference information on a specific radar transmitter is obtained from a spectral analysis of the transmitter's power output. A radar transmitter is modulated by short, high powered pulses normally at some constant pulse width and pulse repetition rate. The ideal spectrum for a rectangular pulse has two distinct characteristics. The first is the separation between spectral lines equal to the PRF. The other is the envelope of the spectral lines which is determined by the pulse width. Since the carrier frequency (the standard test frequency) has harmonics, the spectral distribution is a function of the carrier frequency, its harmonics, and other spurious emissions. Variations in these parameters, such as shifting of carrier frequency, non-rectangular pulse shape and any deviation in PRF, produce spectrum distortion from

Transmitter Spurious Emission Test Data Format			
I. Radar Type _____ Transmitter Serial No. _____			
II. Equipment Setup. Draw block diagram of the test setup on the reverse side of this sheet. Identify by model and serial numbers of all test equipment and interconnections (cable types, cable lengths, connectors, attenuators, etc.). Indicate control knob/dial settings where necessary.			
III. Test Data			
Transmitter Time On _____ Time Off _____			
Tuning Band _____ Tuned Frequency _____ mcs			
Measurement Distance _____ meters			
Frequency (mcs)	Origin	Power Density (dbm/m ²)	Remarks
*Report power density as "peak" or "average." If peak give bandwidth of measuring equipment under "Remarks"			

Figure 7-10. Transmitter Spurious Emission Test Data Format



the ideal. Figures 7-11 through 7-13 are typical spectral photographs of the fundamental, second, and third harmonics of an L-Band radar.

The purpose of this test is to determine the spectrum of a pulsed carrier. The emission spectra will be the power versus frequency distribution about some nominal frequency. The nominal frequencies are the fundamental and spurious frequencies of the transmitter found in the previous "spurious emission" test. For this reason, the two tests are normally run at the same time. When a spurious emission power density is determined with the frequency-selective voltmeter, the voltmeter is disconnected, and a spectrum analyzer is used as the receiver.

2.3.2 MEASUREMENT SETUP

The power versus frequency distribution test setup for the spectrum of a pulse signal is shown in block diagram form in Figure 7-14.

The setup is the same as that for the open-field spurious emission test. The sequence for aligning the radar antenna and the test antenna is the same as in Section 2.2.3(1). Since the two tests are run together, this alignment is accomplished at the same time. Again, care is taken not to include signals due to test equipment or its setup. This means spurious emissions of the signal generator must be suppressed with a low pass filter at the output of the signal generator.

2.3.3 MEASUREMENT PROCEDURE

a. The test equipment and the radar are allowed sufficient time for warmup. The radar transmitter is turned on and tuned to the 5%, 50%, or 95% standard frequency (whichever standard frequency is being used in the spurious emission test).

b. The coaxial switch is turned to position No. 1 with the fundamental frequency-rejection network bypassed. The spectrum analyzer is tuned to the standard test frequency of the radar transmitter. The signal coupling network, variable attenuator, and spectrum analyzer input attenuator are adjusted for a convenient amplitude reference on the scope face making sure no overloading distortions exist.

c. The spectrum analyzer is fine tuned so that the nominal frequency appears in the mid-position of the scope face. The sweep width is adjusted to contain sidelobe peaks down to a -80 db level from the nominal frequency amplitude or to the system sensitivity equivalent level of -80 dbm/kc/m^2 .

SECURITY CLASSIFICATION _____

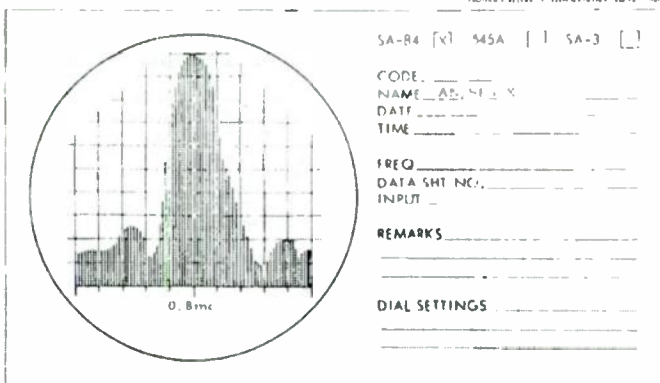

Figure _____ Title _____

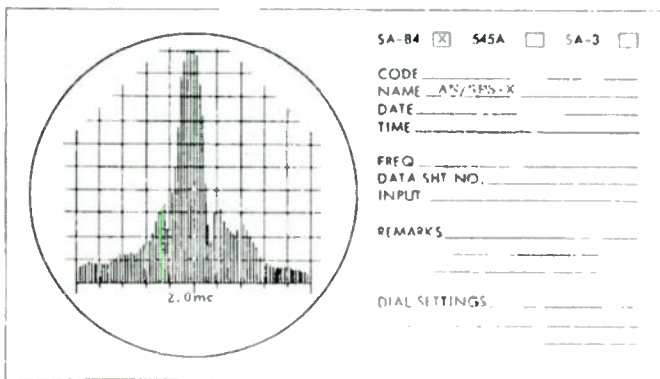

Figure _____ Title _____

Figure 7-11. Transmitter Spectrum Signature of an L-Band Radar Set at Fundamental Frequency

SECURITY CLASSIFICATION _____

FBI/DOJ IDENTIFICATION NUMBER: 100

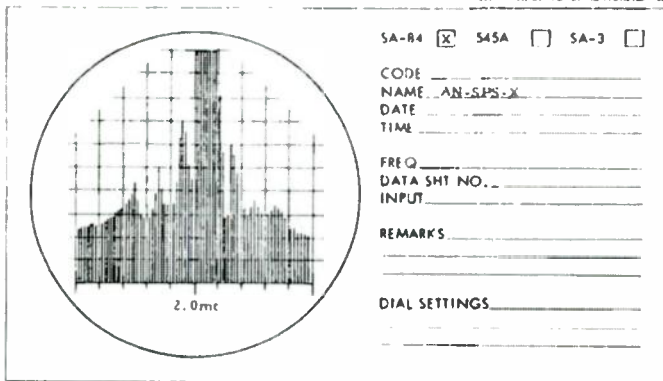

Figure _____ Title _____

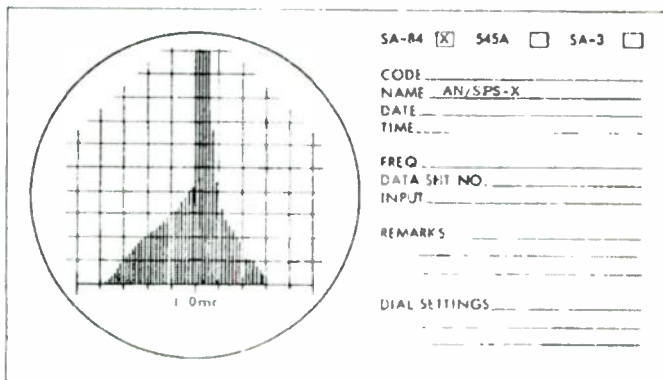

Figure _____ Title _____

Figure 7-12. Transmitter Spectrum Signature of an L-Band Radar Set at Second Harmonic Frequency

SECURITY CLASSIFICATION

FORMER SECURITY CLASSIFICATION

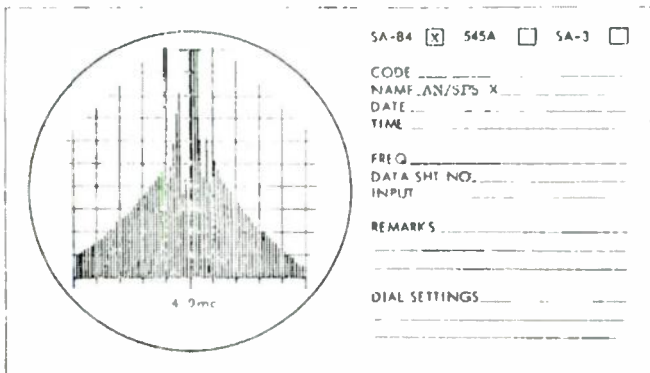

Figure _____ Title _____

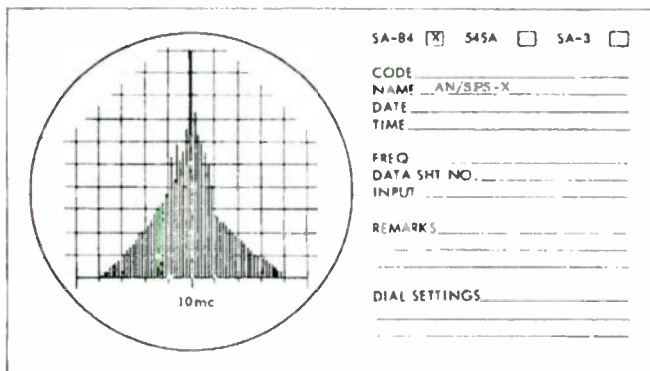

Figure _____ Title _____

Figure 7-13. Received Spectrum Signature of an L-Band Radar Set at Third Harmonic Frequency



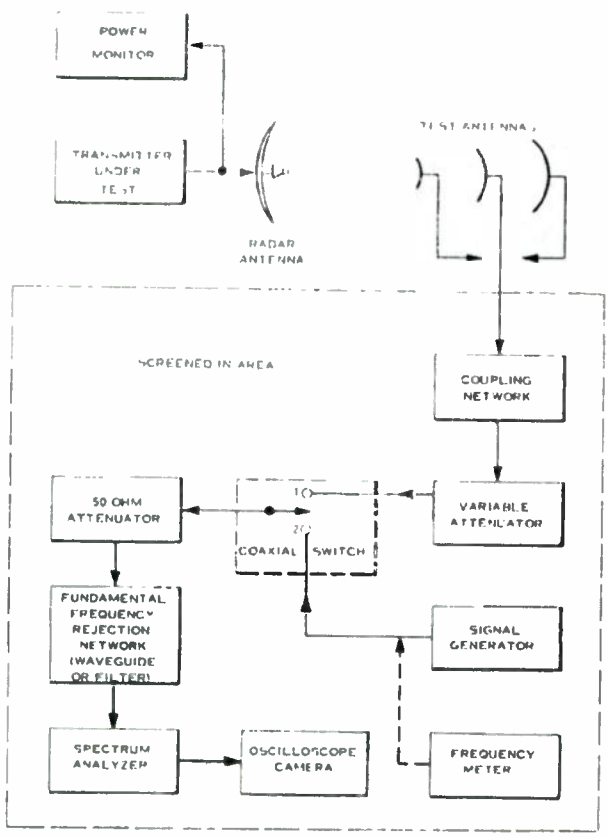

Figure 7-14. Transmitter Open-Field Emission Spectra Measurement Setup

d. The scope presentation is photographed to record the display, and the scope face is calibrated and marked to adequately represent the spectral envelope at sufficient frequency increments.

e. The coaxial switch is turned to position No. 2, and the signal generator is tuned to give a CW signal at mid-position on the spectrum analyzer scope face. The output level is adjusted so that the peak CW is equivalent to the peak amplitude of the nominal frequency on the spectrum envelope. This establishes the level reference of the spurious emission power density.

f. The signal generator is then retuned up or down in frequency to the points recorded on the scope face for the spectral envelope power levels for each frequency increment desired. The frequency meter is connected at each increment for the required frequency accuracy.

g. The spectral power density is computed and expressed in $\text{dbm}/\text{kr m}^2$ at the distance from radar antenna to test antenna, with the peak fundamental power density found in the spurious emission test as the reference. Transmitter spectral data can be documented in Figure 7-15. Each spectral display photograph should be calibrated in amplitude and frequency as shown in Figures 7-11 through 7-13.

h. The above steps are repeated at all spurious emissions at the standard test frequencies and their associated duty cycles in all tuning bands.

2.4 MODULATION CHARACTERISTICS

2.4.1 GENERAL

In the discussion of spectrum distortion, it is pointed out that pulse width, pulse shape, pulse repetition rate, and pulse amplitude all affect the spectrum. This may place more transmitter power in the side-band lobes, thus increasing the transmitter's interference capabilities. It is the purpose of this test to display the amplitude versus time information of the envelope of the transmitted energy.

2.4.2 MEASUREMENT SETUP

The setup for the radar transmitter modulation characteristics measurement is shown in block diagram form in Figure 7-16. An oscilloscope is placed at the output of the second detector of the frequency-selective voltmeter for displaying amplitude versus time characteristics.

Transmitter Emission Spectra Test Data Format			
I Radar Type _____		Transmitter Serial No. _____	
II Equipment Setup Draw a block diagram of the test setup on the reverse side of this sheet. Identify by model and serial number all test equipment and interconnections (cable types, cable lengths, connectors, attenuators, etc.). Show receiver input and output points. Indicate control and dial settings where necessary.			
III Test Data.			
Transmitter Time On _____		Time Off _____	
Tuning Band _____		Fundamental Frequency _____ mc	
Frequency Increment ΔF	Above or Below or	Spectral Power Density (dbm/ke /m ²)	Remarks

Figure 7-15. Transmitter Emission Spectra Test Data Format



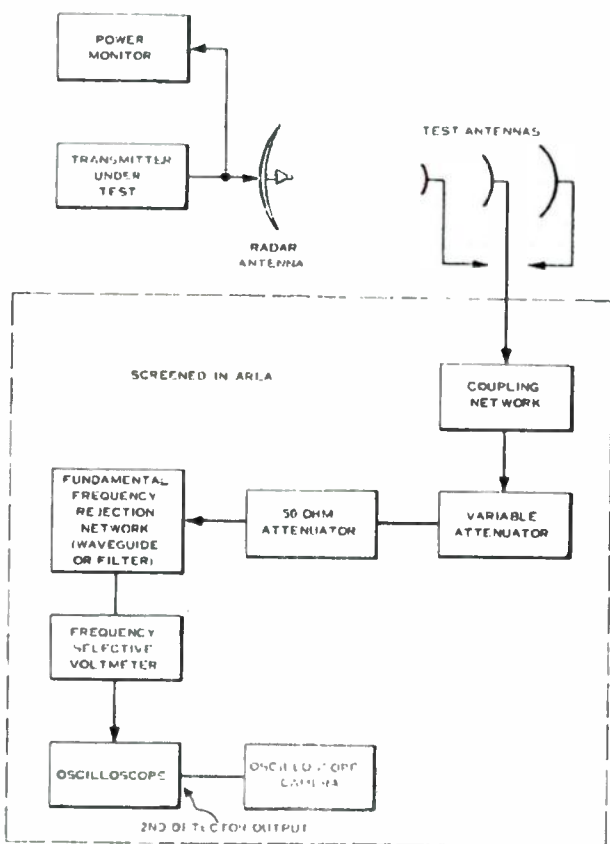

Figure 7-16. Transmitter Open-Field Modulation Characteristics Measurement Setup

The scope camera is used to record the oscilloscope displays. The signal generator and frequency meter are not required for this test.

2.4.3 MEASUREMENT PROCEDURE

The modulation characteristic measurement is conducted at each spurious signal recorded, and the modulation information is taken from the frequency-selective voltmeter used in the spurious emission test. The PRF is measured at this time, but usually only at the fundamental frequency. The scope trace is adjusted to permit display of the complete pulse. The face is calibrated and the calibration settings are recorded on the data sheets or on the scope face itself. The display is photographed for every spurious emission at all the standard test frequencies.

2.5 CARRIER FREQUENCY STABILITY TEST

2.5.1 GENERAL

The purpose of this test is to determine the stability of the tuned frequency. The test should establish trends in the tuned frequency. The frequency measuring device has an accuracy of at least one part per million.

2.5.2 MEASUREMENT SETUP

The setup for the radar transmitter carrier frequency stability test measurement is shown in block diagram form in Figure 7-17. The coupling device is the directional coupler usually supplied with the radar equipment, and the load is the system antenna. The sampled signal may have to be attenuated before connecting to the input of the frequency meter or counter.

2.5.3 MEASUREMENT PROCEDURE

a. The test equipment and the radar are allowed sufficient time for warmup. The radar transmitter is turned on and tuned to a mean standard test frequency in the lowest tuning band.

b. After the transmitter has been on for 15 minutes, a frequency reading is taken, and thereafter up to 4 hours, frequency readings are taken every 15 minutes until a frequency trend is established.

c. The above two steps are repeated for all tuning bands and all data is recorded on the format shown in Figure 7-18.

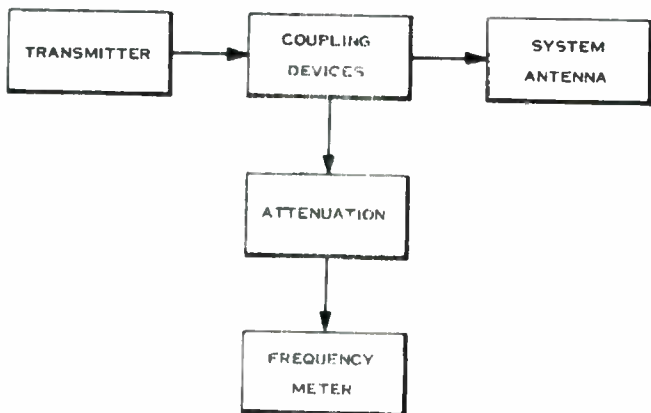

Figure 7-17. Carrier Frequency Stability Test Setup

Carrier Frequency Stability Test Data Format		
Transmitter Time _____, Tune Off _____		
Tuning Band _____, Tuned Frequency _____ mcs.		
Frequency (mcs)	ΔF (mcs)	Time (minutes)

Figure 7-18. Carrier Frequency Stability Test Data Format

2.6 INDIRECT APPROACH

Two approaches may be used for the determination of transmitter characteristics. The discussion in the preceding sections has dealt with the direct or open-field approach. In this section, the techniques directly applicable to closed-system measurements are discussed. The closed-system approach consists of (1) determining the power fed to the antenna at the plane of reference, and (2) determining the gain of the antenna. Antenna measurements are discussed in Section 4. In the following paragraphs, descriptions are presented of signal sampling methods and a signal substitution method for determining the power at the plane of reference. These methods are directly applicable to closed-system measurements, however, they will give an indication of the spurious emissions that can be expected when going to an open-field test.

2.6.1 SIGNAL SAMPLING CONCEPT

The following cases may represent possible techniques which could be used if the proper requirements are met in a given radar system.

If a directional coupler is built into the radar system, it may be possible to measure over the frequency range of interest. The directional coupler must be of a type that provides an output upon which a frequency analysis can be made, rather than one that provides an output proportional to total power. In addition, a directional coupler when inserted into the line must not establish an abnormal condition on the line at any frequency of interest. If these conditions can be reasonably met, then perhaps the use of a directional coupler will provide the best measurement technique. However, in many measurement problems, the conditions may not be met in an efficient manner, and the substitution method described in the following paragraph will provide the best solution to the problems.

2.6.2 SIGNAL SUBSTITUTION MEASUREMENT CONCEPT

For the indirect method of measurement, the main problem is to determine the power fed to the antenna at each of several spurious frequencies. To identify these frequencies, antennas covering various frequency ranges are placed in the near field of the radar antenna as illustrated in Figure 7-19. Once the physical setup is established, none of the antennas including the radar antenna will be moved. A field-intensity meter connected to one of the test antennas will yield a power level, P_{RN} , at the frequency, f_n , as received from the radar transmitter. The radar transmitter may now be disconnected from its antenna and a calibrated

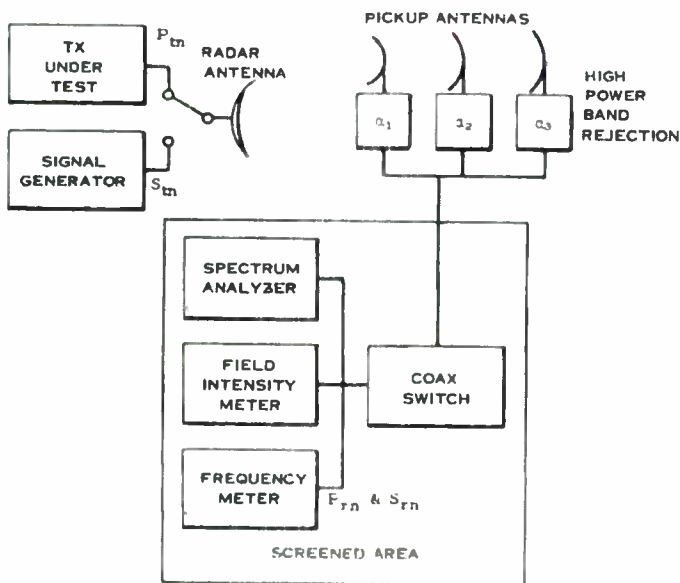

Figure 7-19. Radar 1 transmitter Signal Substitution Measurement Test Setup

signal generator connected. The signal generator is tuned to the frequency, f_n , and a known power, S_{TN} , is fed to the antenna. Generally, it will be necessary to use an attenuator following the signal generator such that it is loaded properly. Since the power fed to the antenna will not be accurately indicated unless the signal generator and antenna are properly matched, the VSWR should be known so that S_{TN} may be calculated. Care must be taken to insert the signal into the line at a point where only one mode of propagation can exist. The power level, S_{RN} , now received through the same test antenna is recorded. At the frequency, f_n , the power loss in both cases is identical and the following relationship holds.

$$P_{TN} - P_{RN} = S_{TN} - S_{RN} \quad (7-3)$$

P_{TN} is the actual power fed to the radar antenna from the transmitter, and all of the powers in the equation are expressed in dbm. P_{TN} is the desired parameter and may be computed as follows:

$$P_{TN} = S_{TN} - S_{RN} + P_{RN} \quad (7-4)$$

When applicable, this is the basic substitution technique used to determine the power fed to the radar antenna from the transmitter at each particular frequency, f_n . At all of the frequencies where emission is detected, the technique just described can be used.

The high pulse power at the tuned frequency necessitates some rejection of that frequency when harmonics or spurious emissions are being measured. The rejection should be provided by a low pass filter at frequencies below the tuned frequency. At frequencies above the tuned frequency, several different antennas are used and a length of waveguide between the test antenna and the receiver will provide adequate rejection below the cutoff frequency, f_c , of the waveguide. The loss in db, L , at a frequency, f , below the cutoff frequency, f_c , and for a length, d , of waveguide is given by the following equation:

$$L = 54.5 \frac{a}{\lambda_c} \left[1 - \left(\frac{f}{f_c} \right)^2 \right]^{\frac{1}{2}} \quad (7-5)$$

where: λ_c = cutoff wavelength of the waveguide. Note: d and λ_c are in the same dimensions.

The measurements described will provide the spurious emission frequencies (and their spectral power levels) in the line to the antenna. The antenna gain at each of these frequencies can then be determined when the antenna measurements are made. The actual peak envelope power densities and spectral power densities at the far field distance can be calculated.

The measurement concept described in the preceding paragraphs provides an indirect means of determining the actual power fed to the antenna at each of the spurious frequencies. As opposed to techniques which insert a signal sampling device in the line, this technique allows the accomplishment of the measurement with no disturbance to actual operating conditions. For this reason it is felt that the technique described exhibits the promise of more reliable results for situations in which an indirect tech-

nique may be used. However, as a general technique for use on any system, there is an important problem which must be considered. The problem is the existence of more than one mode of propagation at some frequency above the design frequency in the transmission line that feeds the antenna. The additional modes will create an antenna pattern which is different than that created with the presence of a single mode, and the equation given above will not hold if the modes of propagation in the line are different at the antenna terminals when the signal generator is applied. As mentioned in a preceding paragraph, if the signal is inserted at a point where only one mode of propagation can exist or where additional modes exist but are sufficiently suppressed before arriving at the antenna terminals, then the technique is valid. Since at a particular frequency the degree of coupling is dependent upon the mode of propagation, the use of a conventional directional coupler as a signal sampling device does not alleviate this problem. The following section describes a signal sampling technique for modal determination. Measurements made by the indirect method will provide the data which will be independent of site conditions and may be applied to any antenna measurements taken at various positions around the site.

2.6.3 SIGNAL SAMPLING TECHNIQUE (MODAL DETERMINATION)

One of the vexing problems in the spectrum signature program is the various modes of propagation associated with spurious response frequencies that are capable of being propagated in a transmission line. The following procedure is one developed by Mr. Vernon G. Price of Electromagnetic Technology Corporation, Palo Alto, California.

The spectrum of the transmitters specified in various specifications are required to be scanned from 10 kc to 10 or 12 gc, and any spurious outputs are to be measured and recorded. Although open-field measurements are usually required, closed-system tests provide a desirable supplement to the open-field tests because they yield additional information constituting an effective check of other measurement results. Assuming that the radar being tested has a low fundamental frequency, a complete closed-system test of the system is a formidable undertaking. However, performing a closed-system test on a radar operating at a higher fundamental frequency is entirely practicable. By confirming open-system tests on the one radar, such a test serves to support corresponding measurements on the other radar. In brief a relatively small incremental effort will provide closed-system measurements which add substantially to the credibility of the overall measurement program. Closed-system tests at frequencies where multimodal propagation may



occur require the use of an appropriate signal sampling network which can respond to power in each mode in the line. A network suitable for that task is described below.

a. Technical Aspects

Any measurement of power in transmission lines must take into account the mode of propagation of the energy within the line. This fact is often lost sight of because most transmission lines propagate only one mode at the fundamental frequency. For example, coaxial lines commonly employ the TEM mode, and rectangular waveguides make use of the TE₁₀ mode since it is in this dominant mode that the principal wave in the line propagates. Spurious signals, however, may be of a considerably higher frequency which can propagate in higher order modes. Therefore, a more sophisticated approach is required to measure their level. Assuming the radar transmitter uses WR-187 waveguide, the following modal cutoff frequencies are obtained:

Mode	Cutoff Frequency
TE ₁₀	3155 mc
TE ₂₀	6310 mc
TE ₀₁	6773 mc
TM ₁₁ - TE ₁₁	7471 mc
TM ₂₁ - TE ₂₁	9255 mc
TE ₃₀	9465 mc
TM ₂₂ - TE ₂₂	11641 mc
TE ₄₀	12620 mc

Signals at the second harmonic frequency of the radar may propagate in as many as 10 modes, while harmonic spurious signals lying between the fundamental and the second harmonic may propagate in only 3 or 4 modes. No signals may propagate in the transmission line at frequencies much below 3155 mc; therefore, no measurements need be made in this frequency range. Signals having frequencies between 3155 mc and 6310 mc propagate in only one mode. Hence, their measurement is straightforward, using the proposed signal sampling network.

To obtain valid measurements of signals having frequencies above 6310 mc, it is necessary to separate and collect all the power in each mode or else to carry out a properly weighed sampling. The signal sampling network performs this function.

Four distinctly different methods for the measurement of harmonic power in transmission lines have been described. Lewis has described a selective mode sampler method, Forrer and Tomiyasu have described an electric probe analysis method, and Price has described a calorimeter method. More recently, Sharp has tested a measurement device which samples harmonic power by means of a number of slot-coupled secondary waveguides (forming Tee-junctions) located at appropriate positions on the broad and narrow walls of the main waveguide.

The choice of a measurement method depends upon the particular application and specification. In the present situation the following aspects weigh heavily in the choice of method:

- (1) Frequency Identification
- (2) Speed of Measurements
- (3) Accuracy of Measurement

Another method called the field amplitude analysis is discussed below. This method, which does not identify the power in each individual mode, is not as accurate as the multimodal probe analysis method. However, it is simpler to employ and has adequate accuracy for field use. The recommended amplitude analysis method of measurement utilizes probes just as does the multimodal method, but no phase data is taken and the results can be readily interpreted.

In the multimodal analysis method described by Forrer and Tomiyasu, the relative phase and power level of signals sampled at dozens of precisely located points is determined. The raw data so obtained is then reduced by use of a digital computer, programmed to perform numerical Fourier analyses and to invert the matrices used in solving the set of linear equations resulting in the analysis. This method has been shown to be rigorously correct in principle and to give quite accurate results in practice. However, it is relatively difficult to apply.

The accuracy of the recommended field amplitude analysis method has been established by comparison with the results of over one hundred multimodal analysis tests including the second, third, and fourth harmonics. Assuming that the multimodal analysis method yielded perfect results, it was found that the 85% of the power levels determined by the two methods agreed within ± 3 db and that distribution was almost Gaussian. Higher accuracy can be obtained if one makes use of redundant samples. This was not possible in the above comparison since only the minimum number of samples were used.

b. Design of Signal Sampling Network

The general physical arrangement of the signal sampler is given in Figure 7-20 as was suggested and worked out by Electromagnetic Technology Corporation, Palo Alto, California. The basic waveguide section has the proper dimensions to substitute directly for one of the waveguide sections in the transmitter. Holes located precisely on the broad and narrow walls are used to permit insertion of a calibrated probe to sample the electric fields with the guide. Approximately 20 probe locations are used to give the desired accuracy. An absorptive filter of the leaky-wall type is provided to avoid any measurement errors which might be caused by reflections of spurious signals from irregularities in the transmission line terminating the network.

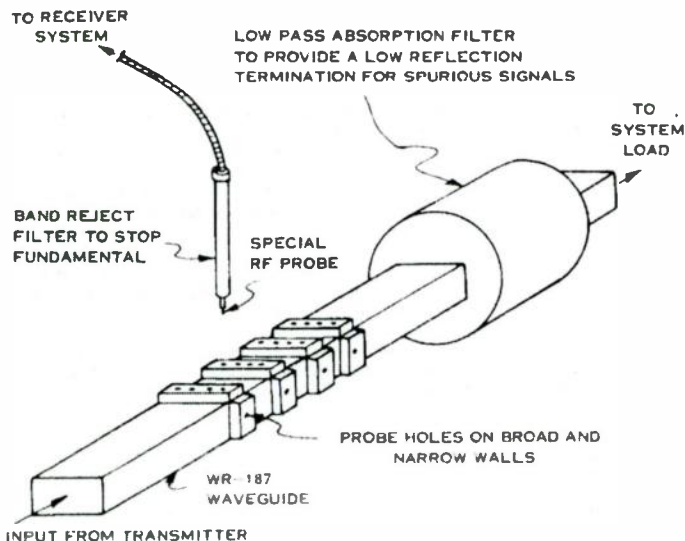

Figure 7-20. Signal Sampling Network

The signal sampling network described herein is not designed to operate under pressurized conditions. If it is necessary to operate the radar under pressure, then an alternate design using fixed probes in conjunction with a multiple position coaxial switch can be utilized.

A band-reject filter is included with the sampling probe to insure that no fundamental-frequency power is coupled out of the transmission line. To obtain data, the probe is inserted at a particular location. A receiver run is then made across the frequency range, and the probe is moved to the next position. Initial calibration of the probe section will be accomplished by launching test signals of known power level into the sampling network. These test signals will be made to have either a known modal characteristic or a random one by the use of special mode launchers. The probe will be dimensionally stable in design and fabrication so that only routine recalibration tests need be made.

3. RADAR RECEIVER MEASUREMENTS

The following are ten types of receiver tests required in obtaining a spectrum signature: (a) Sensitivity, (b) Selectivity, (c) Spurious Response, (d) Overall Susceptibility, (e) Intermodulation, (f) Adjacent Channel Interference, (g) Pulse Desensitization, (h) CW Desensitization, (i) Dynamic Range, and (j) Oscillator Radiation.

The procedures for conducting each of these tests, including block diagrams, specific test equipment, test techniques, and sample data formats proposed for use in the collection and recording of data are described in the following paragraphs.

The equipment to be measured should be set up so that it closely approximates the intended operating conditions and physical configuration of the radar. The primary power supply voltages should be maintained and monitored to assure that they remain within 5% of the mean of the rated operating voltage of the equipment being tested.

Wherever practicable, all measurements should be conducted at time periods, in areas of minimum interference and reflections, and under environmental conditions which will not adversely affect the results.

Prior to any measurements, it is necessary to determine that the equipment is in proper operating condition as described by the appropriate operating and maintenance technical orders or manuals, and corrections made to correct any operating discrepancies. Alignments, as

defined in the operating instructions, should be made to insure that, insofar as possible, the equipment is performing under normal operating conditions. The equipment under test will not be optimized with regard to alignment at test frequencies, so that readings will represent operational field conditions. Receiver characteristics should be recorded on the receiver data form, Figure 7-21.

Receiver Data Form	
1. Equipment nomenclature:	_____
2. Frequency band: initial: _____, final: _____ (a) IF Frequencies _____, (b) LO Frequencies _____	
3. Signal type: AM, FM, CW, SSB, Pulse: _____, (circle one)	
4. Function: _____ (a) Other Operational Characteristics _____	
5. Nominal sensitivity: _____	
6. Type receiver: Crystal video, TRF, Single superheterodyne, double superheterodyne, _____	
7. Bandwidth: _____, Antenna nominal gain: _____	
8. Main antenna beamwidth, vertical: _____, horizontal: _____	
9. Number of beams: _____, Description: _____	
10. Polarization: _____, Nominal s an. _____	
11. Serial numbers tested: _____	
12. Source: _____	
_____ Date	_____ Observer

Figure 7-21. Receiver Data Form



3.1 RECEIVER SENSITIVITY

3.1.1 GENERAL

The sensitivity of the radar receiver should be measured at enough points to identify every two to one change in power sensitivity of the receiver for the standard test frequencies in each tuning band.

Tests of receiver sensitivity can be accomplished by having the transmitter "on" or "off." However, damage to the signal generator may occur, and the tests should be performed with the transmitter off. The block diagram for making the tests is shown in Figure 7-22.

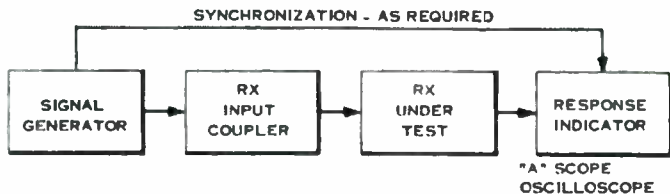

Figure 7-22. Test Setup for Radar Receiver Sensitivity Tests

3.1.2 TEST PROCEDURE FOR SENSITIVITY TESTS

- a. The positive "Sync-out" jack of the signal generator is connected to the radar indicator ("A" scope) or an oscilloscope Ext trigger jack.
- b. The sync selector on the signal generator is set to internal.
- c. The pulse width is set to correspond to the radar's pulse width.
- d. The pulse delay is set to approximately one-half of the radar sweep-length or to 300 μ sec if the sweep-length is greater than 50 nautical miles and the PRF control will be set to the same PRF as the radar.

$$\text{sweep-length} = \text{range in nautical miles} \times 12.2$$

Receiver Sensitivity Data Format

- I. Radar Type: _____ Receiver Serial No. _____
- II. Equipment Set-Up Draw a block diagram of the test set-up on the reverse side of this sheet. Identify by model and serial no. all test equipment and interconnections (cable types, cable lengths, connectors, attenuators, etc.). Show receiver input and output points. Indicate control and dial settings where necessary.
- III. Test Data:

Receiver Tuned Freq. mcs	MDS power input dbm	Notes

Figure 7-73 Receiver Sensitivity Data Format

- e. The gain of the radar receiver is set so that a 50% grass level appears (normally 1/8 inch).
- f. All receiver special circuits such as IAGC, STC, FTC, etc., should be turned off.
- g. The radar receiver is tuned to the low end of the tuning band (5% point).
- h. The signal generator frequency is adjusted until a pulse appears on the "A" scope or oscilloscope. About -60 dbm plus any necessary external attenuators should be sufficient power output.
- i. The signal generator output level is then adjusted until the pulse drops below the saturation level.
- j. The frequency is then adjusted for maximum amplitude of the pulse.
- k. This procedure is continued until the mid-pulse is barely visible in the grass. The MPMVS (mid-pulse minimum visible signal) sensitivity of the receiver is then equal to the signal generator output level, minus the sum of any external attenuators including cabling. It should be noted that radar sensitivities typically run -90 to -112 db.
- l. The above tests are repeated for all receiver frequencies where the sensitivity varies by two to one (i. e., where there is a 3 db power change). These points are determined by tuning the receiver and signal generator through the tuning range of the radar noting the 3 db variations. Tests should also be conducted at the 50% and 95% points of the tuning band.
- m. Data obtained from the above tests should be recorded on the form (Figure 7-23) shown above.

3.1.3 SPECIAL CONSIDERATIONS IN MAKING SENSITIVITY TESTS

The point where the carrier level indication is made should be carefully selected to represent normal operation and preclude the effects on signal level of special circuitry. Care should be taken that the FTC (Fast Time Constant), STC (Sensitivity Time Control), and AVNL (Automatic Video Noise Limiting) circuits are in the "off" position for the normal receiver.



Impedance mismatch between the signal generator and receiver must be considered and corrected. Where necessary and as required VSWR measurements are made to determine impedance levels so that appropriate matching couplers can be used.

Calibrated cables, connectors, couplers, etc., are used so that corrections can easily be made to the indicated signal generator to output level.

3.2 SELECTIVITY TESTS

3.2.1 GENERAL

Selectivity tests should be made to determine the bandpass characteristics of the radar receiver, using the test setup shown in Figure 7-24. Relative receiver response is measured at frequencies slightly removed from the tuned frequency. In most radar receivers, this characteristic is determined by the intermediate frequency (IF) amplifier circuits, and should be fairly symmetrical about the center frequency. Thus, selectivity is a measure of the ability of the receiver to reject slightly off-frequency signals.

Unless the receiver has a tunable RF stage preceding the IF amplifiers, the measurement need only be made at the 50% frequency of the range. The test procedure is similar to that required for sensitivity measurements, with standard response defined as a mid-pulse minimum visible signal at radar receiver output or as indicated on an "A" scope or oscilloscope.

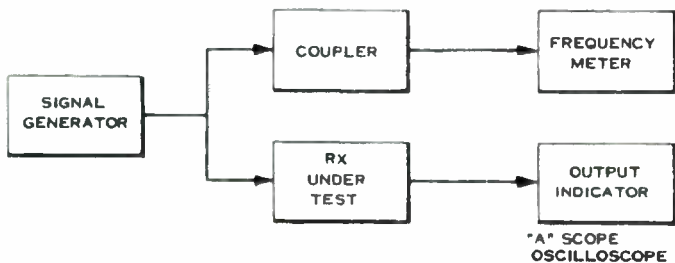

Figure 7-24. Selectivity Measurement Test Setup



The signal input is pulse modulated at a PRF which is the same as that of the operating radar. The pulse width, however, will be of sufficient duration so that an effective CW signal is synthesized. The spectral distribution looks more and more like a CW spike as the pulse width increases. Care will be taken that the pulse width is not so long as to lead to a CW desensitization test due to bias enhancements in the receiver's gain control circuits. Also, the pulse will not be so short that the receiver bandwidth is comparable to the bandwidth necessary to pass the complete pulse.

3.2.2 TEST PROCEDURE

a. With the equipment setup, as shown in Figure 7-24, the receiver is tuned to the center of the operating band. Using normal operating manual procedures of the receiver under test, the receiver gain is adjusted to produce the maximum usable sensitivity. Special purpose circuits such as IAGC, STC, and AVC should be turned off. If the receiver has a manual selectivity control, the selectivity measurement is made for both maximum and minimum settings.

b. The signal generator is set for a standard response (minimum discernible signal) at the receiver tuned frequency. The input power is increased to 3 db above the standard response reference input. The generator is then tuned to a frequency above the receiver frequency until the output is returned to the standard response level, with signal generator power output held constant. The change in signal generator frequency ($\pm\Delta f$) is recorded. Next the signal generator is tuned to a frequency below the receiver frequency to again obtain standard response. This difference between generator frequency and receiver frequency is recorded as $(-\Delta f)$.

c. The frequency is measured with the frequency meter with an accuracy better than one part in 10^6 and the signal generator switched from Int Pulse to CW modulation for this purpose.

d. This measurement procedure is repeated with the signal generator power set at 6, 20, 40, and 60 db above the standard response reference input. A measurement may be taken for power 3 db above reference if necessary for a smooth curve.

e. Data obtained from these tests is recorded on a form similar to Figure 7-25.



Selectivity Data Format

- I. Radar Type: _____ Receiver Serial No.: _____
- II. Equipment Set-Up: Draw a block diagram of the test set-up on the reverse side of this sheet. Identify by model and serial no. all test equipment and interconnections (cable types, cable lengths, connectors, attenuators, etc). Show receiver input and output points. Indicate control and dial settings where necessary.
- III. Test Data:
 Manual Selectivity Control _____
 Receiver Tuned Frequency _____ mcs
 Receiver Sensitivity at Tuned Freq. _____ dbm

Relative Response db	- Δf kcs	+ Δf kcs	Bandwidth kcs	Notes
3				
6				
20				
40				
60				

Special Remarks:

Figure 7-25. Selectivity Data Format

3.2.3 SPECIAL CONSIDERATIONS

The frequency meter must be excluded or isolated from the test equipment setup, while the MPMVS measurements are being made, since the frequency meter having active circuits may provide false receiver responses. After the MPMVS measurement is made, then the frequency meter may be used to measure $\pm f$.

3.3 SPURIOUS RESPONSE AND OVERALL SUSCEPTIBILITY TESTS

3.3.1 GENERAL

Spurious response tests are performed on the receiver to measure the receiver's susceptibility to all radio frequency emissions not intended for the reception of intelligence. Spurious responses occur when the receiver reacts to off-frequency signals by the combination of the incoming signal (or its harmonics) with the local oscillator (LO) frequency (or its harmonics) to produce an IF signal capable of being passed. These mix products are identified in most cases by the following expression:

$$F_{sp} = \frac{p(F_{LO}) \pm F_{if}}{q} \quad (7-6)$$

where: F_{sp} = spurious response frequency
 F_{LO} = local oscillator frequency
 F_{if} = intermediate frequency
 p = multiple positive integer of the LO frequency
 q = positive integer to identify harmonic order of the input signal

Therefore, it is both possible and practical not merely to scan the spectrum from 10 kc to 12 gc, but to use the above expression in predicting where the spurious responses are likely to occur. Nomographs of the above expression are available to assist and aid field measurement personnel.

Since signal generators do generate harmonics of the tuned frequency, low and bandpass filters of known insertion loss should be used to isolate unwanted signals during these tests. At signal generator frequencies below the receiver tuned frequency, low pass filters must be used to insure that harmonics at the receiver tuned frequency do not cause a response.

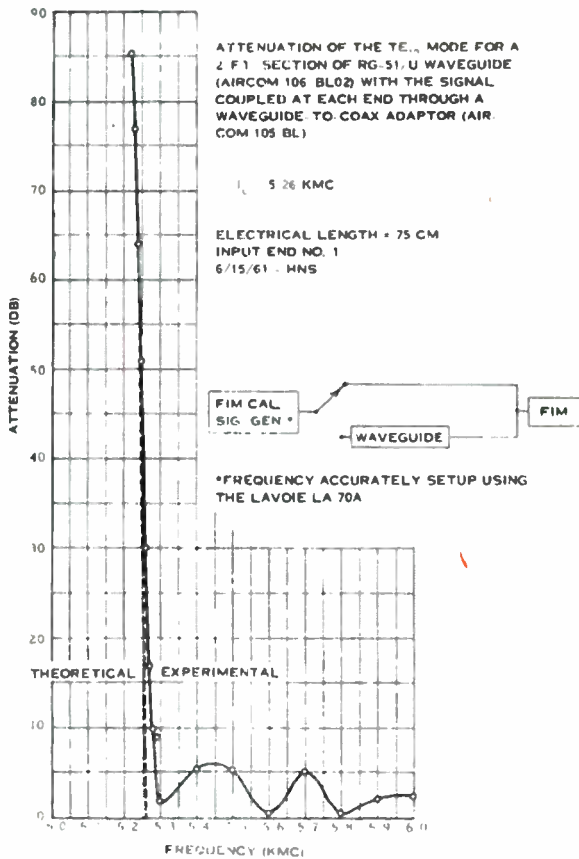

Figure 7-26. Frequency Cut-off Characteristics for a Two-foot Section of RG-51 U Waveguide

In systems employing waveguide components, the waveguide itself acts as a high pass filter with a sharp cutoff frequency. This determines the lower frequency limit for the spurious response tests. The loss in db, L ; at a frequency, f ; below the cutoff frequency, f_c , and for a length, d , is given by the expression below:

$$L = 54.5 \frac{d}{\lambda_c} \left[1 - \left(\frac{f}{f_c} \right)^2 \right]^{-\frac{1}{2}} \quad (7-5)$$

where: λ_c = cutoff wavelength

Figure 7-26 is a plot of the attenuation of the TE_{10} mode for a two-foot section of RG-51/U waveguide (AIRCOR 106-BLD 2) with the signal coupled at each end through a waveguide-to-coax adaptor. This data is the result of continuous instrumentation tests performed at Frederick Research Corporation laboratories. The cutoff frequency is $f_c = 5.26$ kmc with an attenuation of approximately 85 db.

At signal frequencies above the receiver-tuned frequency measurement, operational procedures will be established to insure that the receiver is responding at the signal frequency and not some harmonic of the signal frequency. The use of low or bandpass filters will obviate such situations.

3.3.2 MEASUREMENT SETUP

In the performance of the spurious response tests, it is required that the VSWR be less than 1.3 between the signal generator and coupler, and less than 1.5 between the coupler and receiver. This may be accomplished by measuring the VSWR between the coupler and the receiver. Figure 7-27 represents a block diagram of the instrumentation required to perform these tests.

These conditions are necessary so that the signal generator available power read on the dial represents the real power delivered to the receiver input, and to insure a reasonably high power input to the receiver. Between the receiver coupler and the receiver input, serious mismatch will occur as the signal generator frequency is tuned out of the passband. Therefore, a coaxial slotted line should be used to monitor the VSWR so that it remains less than 1.5. To adjust for the mismatch, a tuner may be employed. Stub-type tuners in the coaxial line where only one mode of propagation can exist should be used. The tapered transition section

provides the vehicle for coupling X-, S-, C-, and L-band signals to the receiver input. All components used must have the insertion losses measured to correct the power readings of the signal generator.

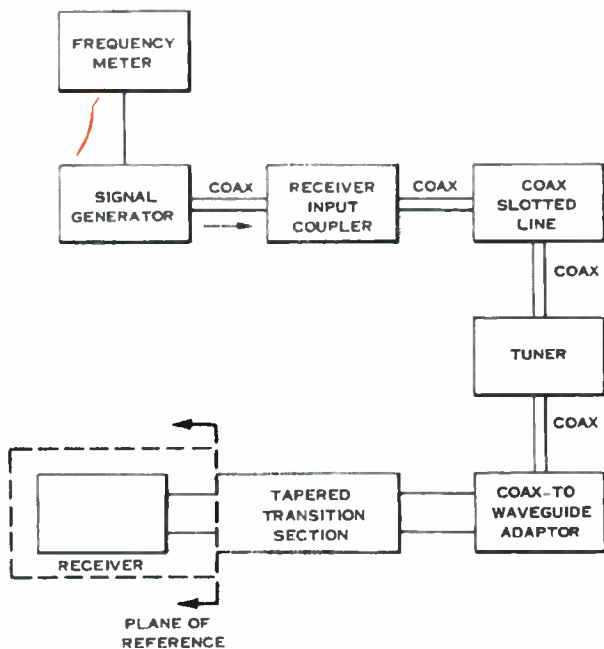

Figure 7-27. Test Setup For Spurious Response Tests



Spurious Response Data Format

I. Radar Type _____ Receiver Serial No. _____

II. Equipment Set-Up: Draw a block diagram of the test set-up on the reverse side of this sheet. Identify by model and serial no. all test equipment and interconnections (cable types, cable lengths, connectors, attenuators, etc.) Show receiver input and output points. Indicate control and dial settings where necessary.

III. Test Data:

Maximum Permissible Receiver Input Power _____ dbm

Frequency Range Covered _____ mcs

Note: spurious response frequency = $\frac{p(\text{LO freq}) \pm (q \text{ IF freq})}{q}$ in most cases.

Signal Freq mcs	Identification			Power Input dbm	Notes (Identification)
	"a"	"b"	sign		
5% Receiver Freq _____ mcs					
50% Receiver Freq _____ mcs					
95% Receiver Freq _____ mcs					

Figure 7-28. Spurious Response Data Format

3.3.3 MEASUREMENT PROCEDURE AND DATA COLLECTION

Since the test procedure is essentially that which can be found in many sources, the details will not be repeated. Signal generators should be employed that have a capability of 0 dbm output. Past experience with many signal generators indicates that they have a capability of delivering power from +7 to +22 dbm which is higher than the advertised capability by the test equipment manufacturers. Where maximum permissible receiver input power is less than the 0 dbm requirement, it should be used to preclude damage to the receiver.

The accuracy of the signal power measurements should be ± 2 db and frequency measured to an accuracy better than one part in 10^6 .

Figure 7-28 is a typical spurious response data format that may be used for data collection and tabulation. On the reverse side (not shown) of the data format, all cables, connectors, attenuators, slotted lines, waveguide sections, etc., should be identified by model and serial number so that results can be identified with particular equipment and component usage.

3.4 OVERALL SUSCEPTIBILITY TESTS

3.4.1 GENERAL DISCUSSION

The overall susceptibility tests provide a receiver system test which includes the receiver and antenna, as well as the transmission line components. This represents a system check on the spurious response and antenna gain tests previously outlined, as well as including the effects of multiple mode propagation.

The power density in dbm/m^2 is given by the following expression:

$$P_D = \frac{P_t G_t}{4\pi D^2} \quad (7-7)$$

where: P_D = power density at distance D from transmitter
 P_t = transmitter power
 G_t = antenna gain at frequency
 D = distance in meters

The transmitter and antenna in these tests are the signal generator and test antennas. The signal generators should be capable of a 0 dbm output.

and the test antennas may have gains varying from 6 to 30 db. For example, assume that the test antenna gain is approximately 15 db at 5.4 mc. For a distance D of 1000 meters, the power density at the receiving antenna is shown below:

$$P_D = 10 \text{ Log}_{10} 10^{-3} + G_t - 10 \text{ Log}_{10} 4\pi D^2$$

$$P_D = 0 \text{ dbm} + 15 \text{ db} - 71 = -56 \text{ dbm/m}^2$$

The effective aperture of the antenna can be then computed from the antenna gain measurements made in the far field with the signal generator input at the plane of reference. The expression for antenna aperture is the following:

$$A_A = \frac{G_R \lambda^2}{4\pi} \quad (7-8)$$

where: A_A = antenna effective aperture
 G_R = receiver antenna gain
 λ = wavelength

The power received can then be computed from the following expression:

$$P_R = \frac{P_t G_t G_R \lambda^2}{(4\pi D)^2} \quad (7-9)$$

3.4.2 Measurement Procedure

From the spurious response tests, antenna gain measurements and computations presented in the general discussion judicious selection of the spurious frequencies can be made for performing the far field susceptibility tests.

Prior to the conduct of these tests, it will be necessary to first establish the placement and orientation of the test antenna with the maximum gain direction of the receiver antenna. This data will be provided by the antenna pattern and gain measurements which will be performed before the susceptibility tests. An analysis will reveal the variations in antenna patterns and gains and a determination made as to the desirability of additional patterns at the spurious frequencies to insure direction of maximum gain for the receiver.

Having selected the spurious frequencies and position of the test antenna, tests should be performed to determine the signal generator output level necessary to produce a receiver response mid-pulse minimum visible signal (MPMVS). Figure 7-29 is a typical type of data sheet that can be used in the collection of this data.

Overall Susceptibility Data Format			
I. Radar Type: _____ Receiver Serial No.: _____ II. Equipment Setup: Draw a block diagram of the test setup on the reverse side of this sheet. Identify by model and serial number all test equipment and interconnections (cable types, cable lengths, connectors, attenuators, etc.). Indicate control and dial settings where necessary. III. Test Data Band _____ Receiver Tuned Frequency (mc) _____ Measurement Distance (meters) _____			
Spurious Frequency (mc)	Signal Generator Power Output (dbm)	Test Antenna Gain (db)	Power Density at System Antenna dbm/m ²

Figure 7-29. Overall Susceptibility Data Format

3.5 INTERMODULATION TESTS

3.5.1 GENERAL

Intermodulation type of interference can occur in a receiver system as a result of the simultaneous reception of two or more signals if they combine to produce the frequency to which a receiver is tuned, or a spurious response frequency. Typical types of mixes which can occur are the following:

$$f_o = f_A - f_B \text{ (primary mix)} \quad (7-10)$$

$$f_o = 2f_A - f_B \text{ (3rd order mix)}$$

$$f_o = 3f_A - 2f_B \text{ (5th order mix)}$$

$$f_o = 4f_A - 3f_B \text{ (etc.)}$$

where: f_o = receiver tuned frequency

f_A & f_B = interfering signal frequencies

Note: The tests should be performed for all measurable orders of products.

For the pulse systems one of the input signals should be unmodulated, and the other should be a pulse signal having a pulse width and PRF equal to the nominal characteristics of the system under test. This then results in intermodulation products that exhibit the modulation characteristics of the receiver and avoiding random phasing if both input signals were modulated.

Another problem associated with this test is the determination of the real power delivered to the receiver, since there will be variations in receiver input impedance as a function of signal generator frequencies. Figure 7-30 depicts the generalized testing procedure.

The two matching couplers provide a match to the 50 ohm input impedance of the signal generators. Corrections should be made to determine the real power delivered to the receiver through the use of a slotted line which will be used to make VSWR measurements between the receiver and the signal generators. Any one of the established procedures for conducting intermodulation tests may be followed. Presentation of the data is shown in Figure 7-31 and represents a typical format.

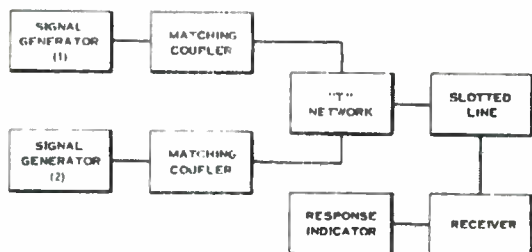

Figure 7-30. Intermodulation Test Setup

Intermodulation Data Format				
I Radar Type: _____ Receiver Serial No.: _____				
II Equipment Setup: Draw a block diagram of the test setup on the reverse side of this sheet. Identify by model and serial number all test equipment and interconnections (cable types, cable lengths, connectors, attenuators, etc.). Indicate control and dial settings where necessary.				
III. Test Data				
Band _____				
Receiver Tuned Frequency (mc) _____				
Intermodulation Order	f_A	f_B	Δf	Power Input dbm

Figure 7-31. Intermodulation Data Format

3.6 ADJACENT CHANNEL TESTS

3.6.1 GENERAL

These tests are performed to determine a receiver's response to weak and strong desired signals in the presence of weak and strong off-channel interfering signals. The off-channel interfering signals are due to the emissions of a transmitter which is operating at a frequency outside the bandpass of the receiver in question, but whose modulation sidebands fall within the receiver's bandpass and may cause interference. Figure 7-32 typifies the type of interference possible under these conditions. It is essential, therefore, to measure a receiver's response to this situation so that radio frequency interference predictions between a receiver and other transmitter(s) is possible.

3.6.2 ADJACENT CHANNEL TEST PROCEDURE

Figure 7-33 depicts the test setup required to perform adjacent channel tests.

A desired signal from the signal generator (1) will be adjusted to an output level which will yield a MPMVS output on the output indicator ("A" scope) exhibiting the modulation characteristics of the receiver.

The interfering signal from the signal generator (2) should be unmodulated and set to a standard level of 0 dbm when tuned to the receiver frequency and held to this level for the remainder of this portion of the test.

The interfering signal will be changed enough in frequency so that the interference effects disappear, then adjusted back toward the tuned frequency. When one of the types of interference becomes evident, the desired signal should be increased to restore the MPMVS. The level of desired signal, P_D , should be recorded, and also the difference between the desired and undesired frequency, Δf . This process of tuning the interfering signal toward the receiver frequency to obtain greater interference levels will be continued to measure a sufficient number of points to define the shape of a curve, until the difference between the interfering signal frequency and the tuned frequency is 10 kc, or the closest point at which the 6 db ratio still is obtainable. This process should then be repeated to obtain measurements at frequencies on the other side of the receiver tuned frequency.

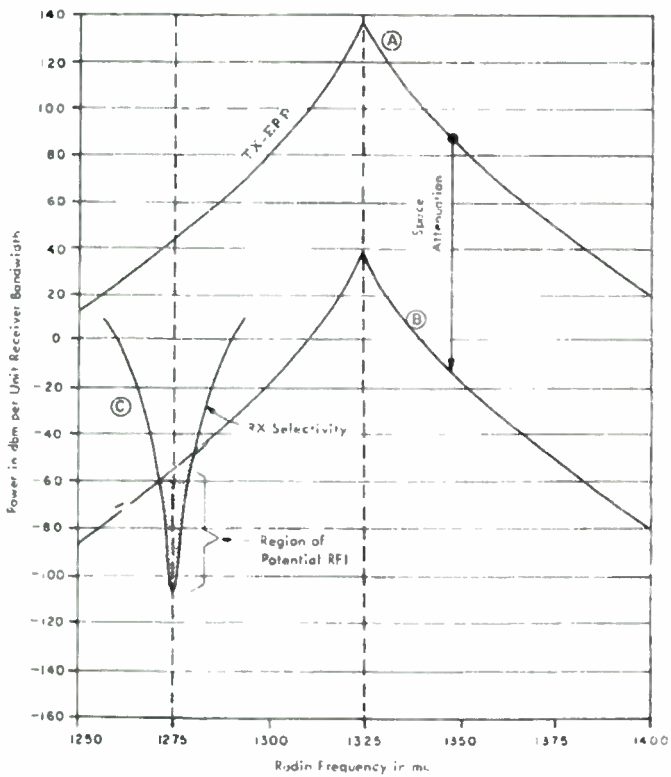

Figure 7-32. Typical RFI Situation (Adjacent Channel Interference Shown)

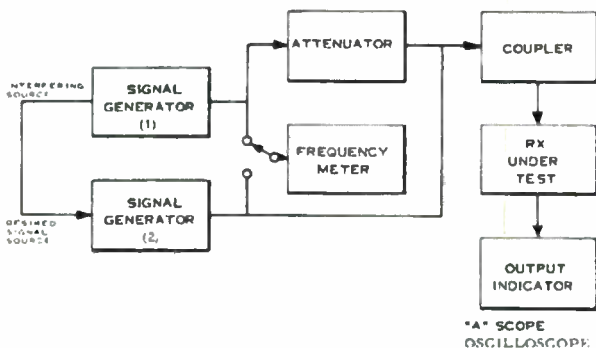

Figure 7-33. Test Setup for Adjacent Channel Tests

This test should be performed at the mean frequency in each receiver band and for interfering signal levels of 0, -6, -13, and -30 dbm at the input to the receiver.

Data from these tests can be recorded on the form displayed in Figure 7-34.

3.6.3 SPECIAL CONSIDERATIONS

In performing these tests, it is essential that the frequency meter be excluded from the circuit while the MPMVS is being restored, otherwise, the frequency meter having active circuits may provide false information. After the restoration of MPMVS, the frequency meter may be used to measure $\pm 1f$.

In the measurement and data collection process, it is required to know the impedance mismatch that will occur between the signal generators and receiver input. For example, the signal generators have a nominal 50 ohm output impedance and the paralleling of the two results in an overall source impedance of 25 ohms. VSWR measurements between the signal generators and receiver will be required so that the proper coupling devices can be used to assure a 0 dbm interfering signal and that the dial readings on the signal generators can be corrected for impedance mismatch.

Adjacent Channel Test Data Format

I Radar Type: _____ Receiver Serial No: _____

II Equipment Setup: Draw a block diagram of the test setup on the reverse side of this sheet. Identify by model and serial no. all test equipment and interconnections (cable types, cable lengths, connectors, attenuators, etc.) Show receiver input and output points. Indicate control and dial settings where necessary.

III Test Data:
 Band _____
 Receiver Tuned Frequency (mc) _____

Interference Power -- dbm	Δf	Desired Sig Power to restore MDS dbm
0		
-6		
-13		
-20		

Figure 7-34. Adjacent Channel Test Data Format



3.7 PULSE DESENSITIZATION

3.7.1 GENERAL

Desensitization is a loss in sensitivity to the desired signal in the presence of a strong undesired signal. Pulse delays of appreciable duration provide a test of the effects on the mixer or clipping circuits, whereas pulse delays of short duration represent a test of the time constants associated with the receiver circuitry such as receiver recovery times. Figure 7-35 represents the test equipment configurations required to perform these tests.

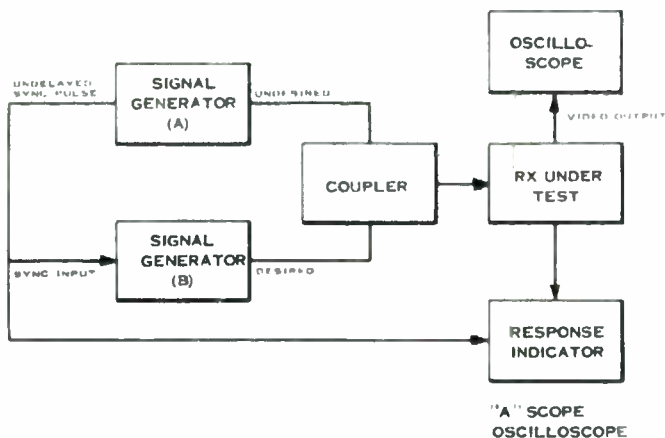

Figure 7-35. Test Equipment Utilized for Radar Receiver Desensitization Measurements

3.7.2 MEASUREMENT PROCEDURE

Two signal generators A and B will be used as signal sources for these tests. A is the undesired pulse and B the desired pulse. The undelayed sync pulse from A is applied to the sync input of B. The pulse characteristics of A and B are the same as the equipment under test.

Receiver Desensitization Data Format

- I. Radar Type: _____ Receiver Serial No.: _____
- II. Equipment Setup: Draw a block diagram of the test setup on the reverse side of this sheet. Identify by model and serial no. all test equipment and interconnections (cable types, cable lengths, connectors, attenuators, etc.). Show receiver input and output points. Indicate control and dial settings where necessary.
- III Test Data:
 Band _____
 Receiver Tuned Frequency (mc) _____
 Maximum Permissible Receiver Input Power _____ dbm

Desired Pulse Delay (mc)	Desired Signal Power (0 dbm)	Remarks

Figure 7-36. Receiver Desensitization Data Format

The output of the undesired pulse is set to 0 dbm and the pulse initially delayed for a period equal to $1/2$ the PRF. An oscilloscope is used to note all PRF, PW, and pulse delays.

With these inputs, the receiver sensitivity measurements to the desired signal are made as previously described under sensitivity tests. This is continued for a number of reduced delay times to define a change in sensitivity as a function of pulse delay.

These tests are conducted at the mean or 50% frequency in each tuning band. Figure 7-36 illustrates a typical data format.

3.7.3 SPECIAL CONSIDERATIONS

As discussed in previous sections, impedance matching and an appropriate coupling is determined to insure that the signal generator power output reads true, or appropriate corrections are made for mismatch conditions.

3.8 CW DESENSITIZATION

3.8.1 GENERAL

CW desensitization is a test used to measure any adverse changes in the bias levels of the receiver's amplifier stages and a resultant deleterious effect on receiver sensitivity.

3.8.2 MEASUREMENT PROCEDURE

Figure 7-37 depicts the test setup recommended to be used in conducting these tests.

The frequencies of signal generator 1 and 2 should be set at the mean frequency of the receiver's operating band and measured by a frequency meter. Signal generator No. 2 (desired signal) has a modulated output consisting of the PRF and pulse width normally associated with receiver. An oscilloscope may be used to determine these settings.

The undesired CW signal generator is set to 0 dbm (or within receiver input power limitations) and the desired signal output adjusted to produce a MPMVS. Then the undesired signal power output is reduced in steps and receiver sensitivity checked for each point. This process is continued until no further change in receiver sensitivity is noted. A curve of CW interfering signal versus receiver sensitivity can then be plotted.



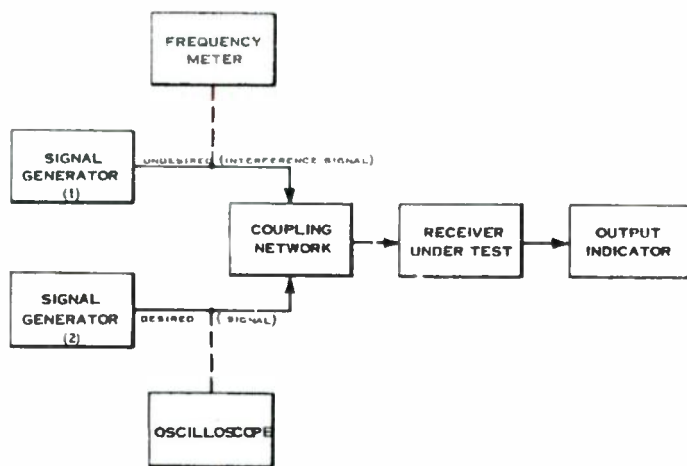

Figure 7-37. Test Setup for Measurement of CW Desensitization

As previously discussed, the coupling network will provide the impedance coupling necessary to insure that the power output dial readings on the signal generators can be read directly or appropriate corrections made.

Data may be recorded on a data sheet similar to that shown in Figure 7-38 (CW Desensitization Data Format).

C.W. Desensitization Data Format		
I Radar Type: _____ Receiver Serial No. _____		
II Equipment Setup: Draw a block diagram of the test setup on the reverse side of this sheet. Identify by model and serial number all test equipment and interconnections (cable type, cable lengths, connectors, attenuators, etc.). Show receiver input and output points. Indicate control and dial settings where necessary.		
III. Test Data Band _____ Receiver Tuned Frequency (mc) _____ Maximum Permissible Receiver Input Power (dbm) _____		
Interfering C.W. Signal Power (dbm)	Desired Signal Power (dbm)	Remarks

Figure 7-38. C.W. Desensitization Data Format

3.9 DYNAMIC RANGE

3.9.1 GENERAL

This test provides information pertinent to the effectiveness of the AVC or AGC circuits common to many receivers and, therefore, is a description of receiver linearity over a wide range of input power to the receiver.

3.9.2 MEASUREMENT PROCEDURE

Figure 7-37 represents the test configuration necessary for conducting this test.

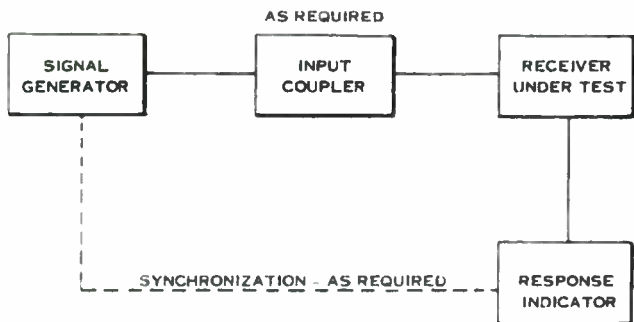

Figure 7-37. Dynamic Range Test Setup

The signal generator is tuned to the mean frequency in the receiver band, and the power output adjusted so that a MPMVS is obtained. Next, the power output should be adjusted ± 6 db, and the peak receiver output voltage measured. A calibrated oscilloscope provides an accurate means for measuring peak voltage (the video output of the receiver may be used for this purpose). The signal generator power output is then adjusted in ± 6 db incremental steps until the output voltage is constant (saturation). The range between MPMVS and saturation represents the dynamic range of the receiver in terms of input power and output volts.

The input coupler is used, as required, to match the output impedance of the signal generator and input impedance of the receiver under test.

Figure 7-40 is the Dynamic Range Data Format.

Dynamic Range Data Format		
I. Radar Type: _____ Receiver Serial No.: _____ II. Equipment Setup. Draw a block diagram of the test setup on the reverse side of this sheet. Identify by model and serial number all test equipment and interconnections (cable types, cable lengths, connectors, attenuators, etc.). Show receiver input and output points. Indicate control and dial settings where necessary. III. Test Data Band _____ Receiver Tuned Frequency (mc) _____		
Power Input (dbm)	Peak Output (volts)	Remarks

Figure 7-40. Dynamic Range Data Format

3.10 OSCILLATOR RADIATION TEST

3.10.1 GENERAL

The receiver contains oscillators and other internal generators that are possible interference sources. These signals can emanate most easily from the receiver via the transmission line to the antenna. This is especially true of the local oscillator frequency, since it is in the band for which the line is designed. Because the signal levels involved are quite small, attenuators and signal sampling devices are not used, but matching and coupling networks may be required.

It is assumed that the nominal input impedance of the receiver under test will not match the nominal input impedance of the frequency-selective voltmeter over a frequency range from 10 kc to 12 mc. Therefore, matching techniques such as those discussed in the receiver spurious response measurement may be necessary to measure the true power delivered to the frequency-selective voltmeter. This represents the worst situation of receiver oscillator output, since it maximizes, or matches, the signal to the point of reference in the transmission line where under normal operation with the antenna loading the receiver, true match may not occur at out-of-band frequencies. Those frequencies in the transmission line that are above the minimum sensitivity level required of the frequency-selective voltmeter should be further analyzed with antenna characteristics.

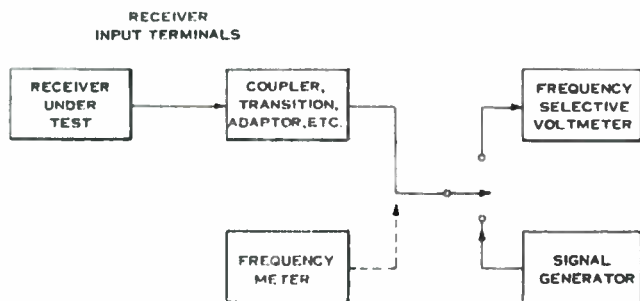

Figure 7-41. Receiving Radiation-Measurement Block Diagram

Oscillator Radiation Data Format			
<p>I Radar Type: _____ Receiver Serial No. _____</p> <p>II Equipment Setup. Draw a block diagram of the test setup on the reverse side of this sheet. Identify by model and serial number all test equipment and interconnections (cable types, cable lengths, connectors, attenuators, etc.) Indicate control and dial settings where necessary.</p> <p>III. Test Data: Band _____ Receiver Tuned Frequency (mc) _____</p>			
Frequency (mcs)	Identification	Power Output	Remarks

Figure 7-42. Oscillator Radiation Data Format

3. 10.2 MEASUREMENT SETUP AND PROCEDURE

The setup for the radar receiver oscillator radiation test is shown in block diagram form in Figure 7-41. The coupling network from the receiver to the frequency-selective voltmeter is a pad, transition piece, slotted line tuner, and adaptors as required for measuring true power delivered to the voltmeter. The frequency meter is connected only when measuring a detected emission to the required frequency accuracies.

The receiver is treated as a transmitter and the frequency spectrum is scanned from 10 kc to 12 kmc, unless otherwise specified. The lower limit can be set to some higher value for given tests when the type of transmission line is known due to the high pass characteristics of typical waveguides.

The test data may be presented in tabular form as shown in Figure 7-42.

4. ANTENNA MEASUREMENTS

The purpose of these measurements is to measure the spatial distribution of power radiated by the antenna or, similarly, the effective spatial distribution of power seen by the antenna as it absorbs power. It is necessary to have this information for each frequency where (a) either the transmitter emits significant energy through the antenna, or (b) there is sufficient energy received through the antenna to cause a significant response in the receiver. The characteristic data that yields this information is a set of absolute antenna pattern measurements at each of the required frequencies. The measurement of this data is conveniently achieved through two characteristic measurements - one of absolute antenna gain, and one of the relative antenna pattern.

Generally, it is desirable to obtain this data for two conditions: first, with as little site effect as possible, and second, including the effects of the site. For all mobile and semiportable equipment, it is especially important to obtain characteristic data with as little site effect as possible. For large fixed installations, it will probably be necessary to consider the site as part of the radiating or receiving system, and thus the characteristic data will include the effects of the site.

Because it is physically impossible to attach measuring gear directly to the antenna terminals, it is necessary to arbitrarily establish a "plane of reference" in the feed complex which connects to the antenna. The parameters measured are then all referred to this reference point.

and it is considered as the antenna terminals. This "antenna" may include transmission lines, rotary joints, and other components, in addition to the physical antenna structure.

The choice of the "plane of reference" should be based upon three important considerations: (a) the functional or operational parameters of the particular transmitter, receiver, and antenna; (b) the minimization or reduction of the number of measurements to be performed, and (c) the avoidance or compensation for the multiple mode problem.

Gain and pattern measurements should be made in the far field, that is, at a distance greater than or equal to D^2/λ where D is the maximum dimension on the aperture of the largest antenna, and λ is wavelength at the fundamental operating frequency of the system under test. In no measurements, however, should the distance be less than 3λ .

Antenna gain and pattern measurements should be made for both horizontal and vertical polarization at each of the measurement frequencies.

4.1 ABSOLUTE ANTENNA GAIN

The absolute antenna gain should be measured at the fundamental frequency, at each harmonic frequency, and at other frequencies, as required. If possible, the measurement of gain should be made at the peak of the main lobe. Otherwise the deviation from the electrical axis and/or the mechanical axis must be noted.

A calibrated source, either pulsed or CW depending upon the frequency, must be used in the measurement of antenna gain and pattern. This source (or field intensity meter since reciprocity is valid) should be inserted in the line at the same point at which the line was broken for the receiver measurements; i. e., at the "plane of reference." The method of coupling between the signal source and the antenna is very important and is dependent upon several factors. The method is dependent upon the frequency at which it is desired to make the measurement and the type of transmission line (waveguide, coaxial cable, etc.) available at the "plane of reference." As an example, Figure 7-43 shows a proposed technique for coupling an X-Band signal from a signal generator that has a coaxial output into an S-Band waveguide.

The VSWR at the output of the signal generator is measured through the use of the coaxial slotted line and the VSWR indicator. The VSWR at this

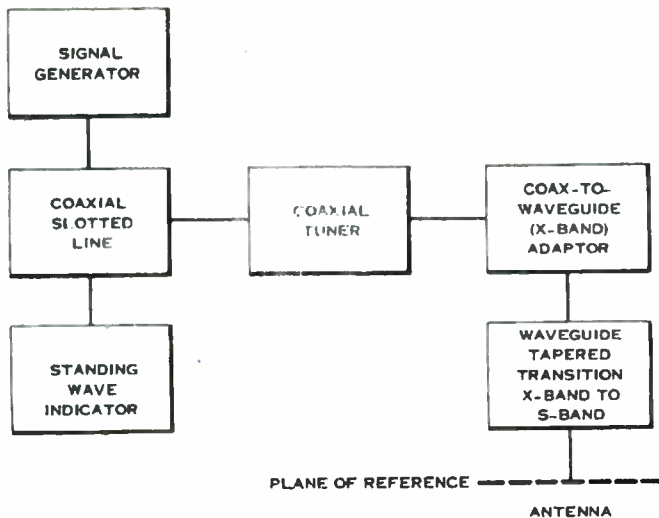

Figure 7-43. Technique for Coupling X-Band Signal into S-Band Waveguide

point is minimized by means of the coaxial tuner, so that the signal generator is not presented with a high VSWR. It is desired to inject a reasonably high level signal (perhaps 0 dbm) into the "antenna" without a large mismatch loss. Since the tuner will not generally tune the higher order modes that could exist at the higher frequencies, it is better to match at the antenna. However, this is not usually practicable. Since each waveguide propagation mode may exhibit a different VSWR, a similar problem arises in the measurement of VSWR with a slotted line. Thus, the VSWR should be measured and the tuning accomplished at a point in the line where only one mode can exist.

A coax-to-waveguide adaptor of a specific size is connected following the tuner so that only one mode can exist (X-Band in this example).

The waveguide is then slowly transformed into S-Band guide through a long tapered transition. A smooth transition is accomplished to prevent (insofar as possible) the excitation of higher order modes.

A test antenna is set up in the far field ($D \geq \lambda$) and connected as in the transmitter measurements to a frequency-selective voltmeter. The entire field test setup should be calibrated and actual power densities are calculated from the voltmeter measurements. The actual power gain can be calculated using the following relationship:

$$G = \frac{4\pi d^2 P_D}{P_t} \quad (7-11)$$

where: G = antenna gain

P_D = power density measured at a distance D from the system antenna

P_t = power fed to the antenna from the calibrated signal generator

Where possible, the measurement is made at the azimuth and elevation of maximum gain. Measurements are made with both vertical and horizontal polarization of the test antenna.

The test antennas used for these measurements should meet the following requirements above 1000 mc: the half-power beamwidth shall not exceed 10 degrees, and the sidelobe suppression shall be at least 16 db unless otherwise specified. This beamwidth requirement can be achieved by the use of a parabolic reflector, with diameter of approximately 8 feet (assuming a frequency of 1000 mc and a factor of 1.4 to account for the tapered illumination of the reflector). It is very desirable to use such a test antenna for these measurements to minimize the effect of site reflections on the measurements, and to increase the measuring system sensitivity. In situations where the site effect must be included, an omnidirectional antenna is required to receive all the reflections.

4.2 RELATIVE ANTENNA PATTERNS

4.2.1 GENERAL

As in the gain measurements described in Section 4.1, it is necessary to make antenna pattern measurements at the midband fundamental frequency, at all of the harmonics of this frequency up to a fre-



quency of 12 kmc. and at frequencies of other spurious emissions and responses when specifically requested. The basic test setup is identical to that described in Section 4.1 for the measurement of absolute antenna gain. However, the position of the test antenna will vary with the requirements for the specific type of antenna under test. Insofar as possible, the measurements should be made in an area unobstructed by buildings and trees, and the test antennas are placed to minimize unusual ground reflections. In this manner, an attempt will be made to approach free space conditions. The test antennas used for these measurements should be placed in the far field. These should be the same antennas that were used for the far field transmitter measurements and the antenna gain measurements. Patterns should be made for both horizontal and vertical polarization.

The calibrated sensitivities of the required measurements are:

- a. -90 dbm/m² at frequencies up to 300 mc
- b. -80 dbm/m² from 300 to 1000 mc
- c. -70 dbm/m² from 1 to 3 kmc
- d. -60 dbm/m² from 3 to 10 kmc
- e. -50 dbm/m² above 10 kmc

In addition, the dynamic range of the antenna pattern measurements should be at least 60 db for the fundamental frequency and at least 40 db for all other frequencies. Assuming the smallest probable antenna gain of the radars to be investigated is 20 db relative to an isotropic antenna, patterns should be made 40 db below isotropic to satisfy a -60 db pattern requirement of the fundamental. Therefore, assuming a field intensity meter sensitivity of -85 dbm, the ERP of the test antenna and transmitter must be 46 dbm. Since additional losses, i. e., SWR loss and line attenuation do exist, it will be assumed that the line loss is 4 db and the increase in these losses as a function of frequency is offset by the antenna gain dependence on frequency. Therefore, a tabulation of necessary power and antenna gain is:

<u>Transmitter Power</u>	<u>Antenna Gain</u>
100 Mw	30 db
1 watt	20 db
10 watts	10 db

The power versus antenna type now becomes:

Transmitter Power

Antenna Types

100 Mw

15' Parabolic Reflector

1 watt

6' Parabolic Reflector

10 watts

Waveguide Horn.

The 8-foot parabolic reflector needed to achieve the narrow beamwidth above 1000 mc (discussed in Section 4.1) would require a power somewhat less than 1 watt.

The procedure used for pattern measurements will vary with antenna type. A primary classification of antenna type will be rotatable and non-rotatable.

4.2.2 ROTATABLE ANTENNAS

The rotatable classification applies to antennas which can be rotated through 360°. Patterns may be taken by using a recorder with a very fast response time. An azimuthal pattern should be recorded with the electrical centers of the antenna under test and the probe antenna at the same height. In addition, if it is possible, another pattern is recorded with the probe antenna at the peak of the main lobe. These patterns are made at each of three measurement locations for the fundamental frequency and at the best available location for the other frequencies. The angular separation of these locations will be a minimum of 45° and preferably greater than 90°. The choice of the "best" available location should be made such that unusual reflections are minimized. If the antenna can be readily elevated, additional azimuthal patterns should be recorded. The probe antenna height is maintained at the same height as the system antenna. The elevation angles for these additional patterns should be (a) the maximum angle, and (b) a minimum of four other elevation angles at which peaks of elevation lobes are observed. The same will apply to semielevatable antennas except that patterns need not be recorded for intervals less than 5°. For antennas that are elevatable only in steps, an azimuthal pattern should be recorded at each step with the total not to exceed six patterns.

4.2.3 NON-ROTATABLE ANTENNAS

For non-rotatable antennas it is necessary to select eight test positions equally spaced around the system antenna. At least one of these should be located on the electromagnetic axis of the main beam, or beams, if the antenna is directional. If the antenna is not elevatable,

ANTENNA IDENTIFICATION

1. Equipment nomenclature _____
2. Frequency range _____
3. Antenna polarization _____
4. Nominal gain (dB) _____
5. Scan characteristics
 - Ratting rates _____ Nudging rate _____
 - Scan limitations _____
 - Sector scan details _____
 - _____
 - Conical scan details _____
 - _____
 - Rotating scan details _____
 - _____
 - Other _____
 - _____
6. Beam characteristics
 - Number of beams _____
 - Beam nomenclature _____
 - Tilt angle _____
 - 3 db beamwidth _____
 - Frequency range _____

Figure 7-44. Antenna Identification

then these are the only measurements required. If the antenna is elevatable, measurements should be made at a minimum of six elevation angles, preferably at the peaks of any lobes at each of the eight azimuthal test positions. However, measurements are not made for elevation changes of less than 5° for semielevatable antennas. For antennas with fixed incremental elevation steps, measurements should be made at incremental steps not exceeding a total of six.

4.3 DATA PRESENTATION

The general data necessary to describe the system and the overall test setup has been discussed in the section on general system considerations. The data directly applicable to the antenna system is documented in a manner similar to the one described in the following paragraphs. The identification format for antennas is shown in Figure 7-44.

ANTENNA PATTERN DATA

1. Equipment nomenclature _____ Serial number _____
2. Frequency _____
3. Test antenna polarization _____
4. Distance at which antenna pattern data is taken _____
5. Cut -- azimuth _____ degrees
 elevation _____ degrees
6.

Angle (degrees)	Relative Amplitude (db)

Figure 7-45. Antenna Pattern Data

The antenna pattern data is presented in two forms - analog and digital. The analog pattern is in the form of a rectangular graph of gain versus azimuth or elevation angle in degrees. The gain scale is linear in db. Irregularities in the pattern that may be attributed to reflections, transients, instrumentation and other factors are identified. In addition to the analog presentation, a digital tabulation of the relative antenna pattern is made. The tabulation is made in 2.5 degree increments referenced to the center of the main beam at the fundamental operating frequency. In the vicinity of the main beam, a sufficient number of more closely spaced increments are included to characterize the main beam. The amplitude is recorded relative to the amplitude maximum at the frequency of measurement. Azimuthal and elevation beamwidths for both horizontally and vertically polarized signals are tabulated at 3 db points. A form that may be used for this purpose is shown in Figure 7-45.

4.4 FRESNEL REGION CONSIDERATIONS

Far field antenna measurements have been discussed in the previous sections. The Fresnel measurements are occasionally required because of collocation problems that may exist. For Fresnel measurements, patterns must be obtained within the D^2/λ distance. The following paragraphs provide a brief discussion of a testing procedure that might be used for Fresnel measurements.

Theoretical corrections for Fresnel region patterns have been discussed in articles by researchers such as Benjamin Lindeman¹ at RADC, Jacobs², and Mumford³. Because of mathematical necessity, field distribution at the aperture must be assumed, thus limiting the application of theoretical synthesis. The difficulty is especially pronounced when Fresnel patterns are required at harmonic frequencies or frequencies considerably above design frequency, since antenna tolerances and dominant mode operation are considered for the design frequency. The synthesis of far field measurements to yield Fresnel region patterns would be erroneous unless true free space patterns can be obtained. For this reason, it is essential that in a task with such a requirement, Fresnel patterns be obtained by measurement techniques.

When a test probe is placed in close proximity to a large illuminated aperture, the phases viewed by the test probe from contributing incremental areas at the aperture will vary greatly. Therefore, as the test probe is moved away from the aperture, the intensity received will gyrate about an average level due to phase additions and cancellations. When the phase difference from the various contributing areas becomes essentially constant, the test probe is in the far field. This extremely simplified ex-

planation of Fresnel region behavior has been added simply to indicate that in the Fresnel field the radiated pattern is a function of distance and in addition the effective area of a test probe used in the measurement of the Fresnel pattern must be extremely small.

The distance between maxima and minima in the cyclic variations expected in field intensity along a radial line from the antenna aperture is on the order of

$$L = \frac{4x^2}{D^2} \quad (7-12)$$

where: x = distance along the line
 λ = wavelength
 D = maximum antenna dimension
 L = space between maxima and minima

To completely define the Fresnel rings, it is necessary to make measurements at a separation less than L . However, when the distance from the aperture is small and the wavelength small, L becomes so small that the quantity of measurements necessary to define the Fresnel rings is too great to be practical. For this reason, a minimum collocation distance must be assumed. Not only does this reduce the requirements on the number of measurements but also requirements on the pickup antenna. The measurement procedure that can be employed consists of taking reference measurements near the far field transition point. Fresnel patterns can be taken along radial lines at points sufficient to describe the cyclic variation. As indicated by the preceding expression, the number of test setups is determined by the frequency under investigation. Measurements must be taken along enough radial lines to define the Fresnel pattern.

5. FUNCTIONAL APPROACH TO THE PERFORMANCE OF A TYPICAL TASK

The operations involved in the performance of a typical task are shown in the Flow Chart of Figure 7-46. The process begins with the assignment of the task.

5.1 PREPARATION OF TEST PLAN

Upon receipt of the task assignment, a specific, comprehensive, and detailed test plan must be prepared. Such a test plan would comply with the general requirements set forth in the task and would follow the

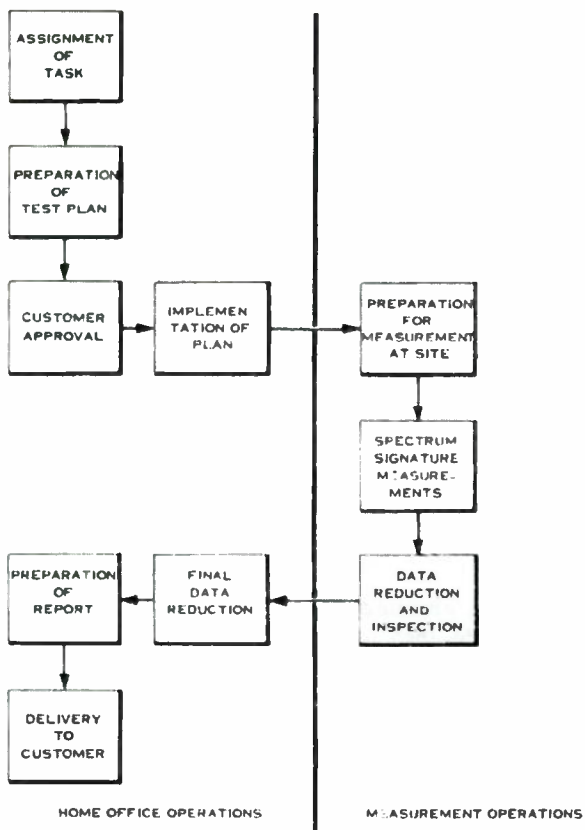

Figure 7-46. Typical Task Performance Flow Chart

procedures outlined in the preceding sections. This is obviously one of the most critical phases in the overall process and it is felt that much can be done in the way of foretelling possible difficulties and problem areas through competence and thoroughness in the preparation of the test plan. Thorough researching of all available data on the equipment being tested on the site (whether at Government facility or at contractor test location) will facilitate this phase of the program by lending an insight as to measurement problems and which of these problems will be most critical. It is realized that the same general measurements are required to satisfy the spectrum signature requirements no matter what the task, but it is also apparent that where particular equipments are concerned, certain of the measurements will assume more significance than others. In some instances the test plan will identify areas requiring specialized engineering consideration prior to testing as well as peculiar operational and logistic considerations. The test plan that is prepared must also include provisions for the collection of certain environmental data. Such data represents an important input in the analysis and use of the spectrum signature data.

5.2 IMPLEMENTATION OF PLAN

The next operation, as shown in the Task Performance Flow Chart, is the implementation of actual work in obtaining the spectrum signature and environmental data. This operation is envisioned as a "clearing the way" process. If the work is to be done at a government facility, contact must be made and liaison set up with the government unit where the measurements are to be made. The establishment of security clearances, obtaining passes to the base for members of the field crew, and similar tasks must be accomplished.

The scheduling of personnel, the readiness of equipment, and the "logistics" of insuring that both are available at the site at the right time must be carefully coordinated.

For work to be performed at the Contractor's facility, necessary logistic arrangements must be made for security, emplacement, and operation of the equipment.

5.3 PREPARATION AT THE SITE

At the site, the first order of business would be the performance for such test and check-out procedures as are necessary to determine that the equipment is operating properly. In making field strength measurements, the field intensity instruments must be calibrated as each measurement is made. In addition, it is also necessary, at this stage, to perform tests on the measuring equipment to insure that it is operating "up to specs."

5.4 MAKING MEASUREMENTS AND GATHERING DATA

As dictated by the requirements of each specific task, the engineers and technicians on the measurement team will make those field strength measurements necessary to determine antenna patterns at the fundamental and spurious frequencies, measurements to determine receiver response, and measurements of the susceptibility of electronic components. As shown on the Flow Chart, the technicians of the field crew would perform data reduction and make preliminary analysis of measured levels. This is done at the site in order that measurements may be repeated if, upon inspection, the raw data appears to be unreliable or questionable on the basis of sound engineering judgments. Preliminary field evaluation of each set of measurements should be made to insure that meaningful results are carried back to the home office for processing into finished form. Such field evaluations may involve the plotting of field intensity levels in graphic form for comparison against specification or rated limits. The measurement analysis should be sufficient to assure the validity of the measured raw data.

5.5 DATA REDUCTION

Engineers at the contractor's home office, assisted by technicians as required, would perform necessary data reduction and processing into final form and in compliance with DOD requirements. Plots of field intensity versus frequency would be prepared for all of the various equipments upon which measurements were made. Likewise, antenna patterns would be plotted. Curves would also be prepared showing graphically in terms of magnitude, frequency, phase shift, etc., the response (or susceptibility) of the specific receivers encountered. Oscilloscope photographs would be presented showing pulse trains, output wave shapes, receiver response, pass bands, tuned high, low or bandpass filters, or the characteristics of any other equipment for which photographic evidence of behavior has been obtained.

6. THEORETICAL AND PRACTICAL PROBLEMS IN OBTAINING SPECTRUM SIGNATURES

6.1 CATEGORIES OF PROBLEMS

The problems of obtaining spectrum signature measurements may be divided into several categories:



- a. Problems in measurement techniques
- b. Data handling and recording problems
- c. Problems in test equipment utilization
- d. Logistics problems
- e. Radiation hazard problems

6.2 AN EXAMPLE OF MEASUREMENT TECHNIQUE PROBLEMS - ANTENNA PATTERNS

Problems encountered in measurements techniques may vary from simple difficulties in impedance matching to the much more complex problems of antenna pattern determination. Of particular significance is the problem of placing a test antenna in a specific part of the propagation field of the radiating equipment under test. For example, taking a measurement in the main beam of a radar may involve positioning a test antenna 50 to 100 feet above the ground. In other cases, where a radar is located on a hill or mountain, a measurement in the far field of the antenna may not be possible unless the test antenna can be placed several hundred feet above the ground. An economical solution to this problem requires consideration of the use of nearby high structures, the use of aircraft, helicopters, and balloons, or the erection of temporary test antenna towers. This implies the use of a transmission line and attenuators of appropriate power and attenuation ratings. In some cases, where an extremely long transmission line would provide too much attenuation, consideration must be given to passive reflectors or to antenna mounted mixers and preamplifiers.

Another aspect of the antenna pattern measurement problem is the general requirement for measurements at a number of points in the antenna field. For the horizontal pattern, this can be accomplished either by rotating the transmitter antenna, or by moving the test antenna horizontally. For the vertical pattern, the test antenna must be raised and lowered. The transmitter antenna may be tilted under some circumstances but, in many cases, it may be impossible or impractical to do this. Reflections from the surrounding terrain normally affect the transmitter antenna pattern to some extent and tilting the antenna may provide antenna pattern data which is not a true representation of the normal site pattern. This problem of obtaining three dimensional antenna pattern data is one which is difficult of solution from the standpoint of technique.

cost, and time. Much additional study and development work will be required if we are to obtain entirely satisfactory methods for determining antenna patterns for rotating narrow-beam antennas, as well as many other antenna types.

In many cases the antenna patterns of radars must be obtained without interfering with the operational use of the prime equipment. For example, in the case where a radar is a part of the national defense system, an absolute minimum of down time is allowed. It is thus apparent that methods must be used to take antenna patterns "on the fly" - that is, with the prime equipment in normal operation.

For example, suppose the equipment on hand covering the frequency range required for the fundamental and harmonic patterns of the transmitter antenna include a Polarad Field Intensity Measurement Receiver, a Stoddart NM-50A, an Esterline-Angus recorder, a Sanborn recorder with preamp and driver, a Tektronix 545A scope, and suitable test antennas. A pattern having at least a 60 db dynamic range is necessary, and it is desired to obtain a test pattern while the prime equipment antenna is rotating.

Certain types of test equipment sometimes fail to produce satisfactory patterns. Investigation may show that the fine lobe structure is being lost because of the long AGC time constants of both the FIM and NM-50A receivers. The problem can be resolved by incorporating Instantaneous Automatic Gain Control into the receivers. This may result in excellent patterns using the Sanborn recorder. Since the receivers have only a 40 db dynamic range, the required 60 db may be obtained by recording the pattern in three parts. A total dynamic range of 80 db has been obtained.

6.3 DATA RECORDING AND REDUCTION

The output signal for recording is usually taken from the audio or video jacks of the test receivers, and this introduces another problem, that of calibrating the recordings. It is sometimes necessary to run the receiver gain so high that the signal to noise ratio of the lower level lobes is quite low. When a calibrated signal generator is substituted for the signal, the recorder stylus fluctuations, due to noise, make calibration

impossible at the lower levels. This problem may be solved by running the varying dc output of the test receiver through a 1000 cycle chopper to the recorder. The final result then is a recording technique which provides easily calibrated, low-level patterns which are achieved without special equipment. Figure 7-47 shows a typical recorded pattern.

Another recording technique may be of some interest because of the extremely fine lobe structure obtained; in fact, it results in an instantaneous plot of a radar antenna pattern and has no recorder speed limitations. Briefly, a slow sweep oscilloscope (545A, in this case) is adjusted so that one sweep corresponds in time to slightly more than one antenna revolution. The vertical amplifiers of the scope are driven by the video output of a receiver modified for IAGC. A Polaroid scope camera is set up and the shutter left open during one sweep. From the positive print obtained, a negative is made and projected upon a screen. The result is an instantaneous plot of any desired size.

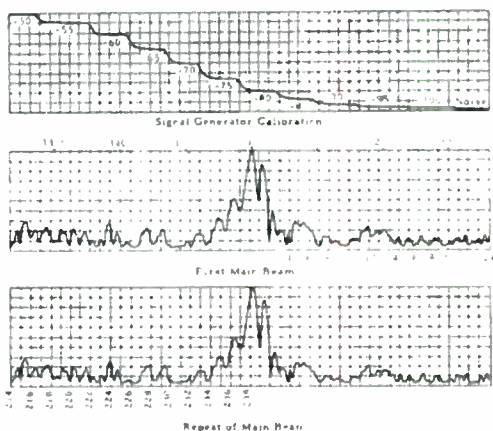

Figure 7-47. Radar Antenna Harmonic Pattern Showing Repeatability of Data and Fine Lobe Structure Obtained With Equipment Described

It is important that all items of data concerning each test be recorded thoroughly and accurately. Such items as VSWR, time of day, test equipment readings, and similar data must be a part of the data record to avoid errors in the data reduction.

Reduction of data can be done by the field team at the site or done at the home office, as preferred. However, reduction should be done as quickly as possible after each test, in order that errors may be discovered and re-runs made, if necessary. Careful checking and double-checking is imperative since the correction of test procedure errors after the field team has left the site would be an expensive and difficult undertaking.

6.4 UTILIZATION OF TEST EQUIPMENT

To perform spectrum signature measurements over the range of 10 kc/s to 12 kmcs requires a large amount of expensive, specialized equipment. To keep expenditures for equipment to a minimum, it is necessary to critically review the capabilities of test equipment on hand and attempt to improve these capabilities by combination, modification, and experimentation. For example, at frequencies above 4.2 kmcs, experimentation showed that the gate output of a synchroscope on hand could be used to pulse modulate the CW signal generator built into the Polarad FIM equipment. This provides all of the versatility of standard signal generators and thereby avoids additional expenditures.

6.5 CALIBRATION OF TEST EQUIPMENT

An important detail in spectrum signature work is calibration of test equipment. The large amount of equipment involved requires an extensive calibration effort before spectrum signature test work begins. Without this calibration, all or part of the test data may be found to be inaccurate and unusable. Details of calibration procedures are presented in Volume III, Appendix V.

6.6 LOGISTICS PROBLEMS

The logistics problems in spectrum signature measurements involve personnel, equipment, geography, weather, and, in the case of Department of Defense installations, the security of classified equipment and information. Selection of a test site is a critical aspect of any measurements program since poor site location may result in excessive expenditure of man-hours and time in making antenna pattern measurements. Poor weather, particularly freezing, snowy, or rainy weather, will make it difficult for test personnel to function efficiently. It is obviously not possible to make a selection if the characteristics of a specific site must

be investigated or if the prime equipment is permanently installed and is one of a kind. However, where possible, all of the factors mentioned above should be considered before a test site is decided upon.

At almost all test sites, special circumstances exist requiring coordination with other groups. In general, the spectrum signature test group will find that they must coordinate with great care with other groups who are involved in operation or maintenance of the system being tested. Only by such careful coordination can the spectrum signature project schedule be maintained without unnecessary lag time.

6.7 FAMILIARIZATION WITH EQUIPMENT TO BE MEASURED

Spectrum signature test personnel should become familiar with the physical layout of the system to be tested. The time spent in this endeavor will be repaid by a reduction of the setup and measurement time required for the spectrum signature tests. There will also be a reduction in the possibility of erroneous measurements. Some of the more sophisticated electronics systems occupy large buildings. Test points are located throughout the system and related parts under test are often on different floors. Thus, it is desirable that the cooperation of the operating and maintenance personnel be secured for the tests. The successful establishment of a close working relationship with site personnel may mean the difference between success and failure in the undertaking. All of the personnel participating in these measurements should be thoroughly trained and familiar with the equipment.

6.8 RADIATION HAZARDS

The Army, Navy, and Air Force have chosen 10 milliwatts per square centimeter as the time average power intensity not to be exceeded in the exposure of personnel to radio frequency energy. Radiation hazards are becoming of greater significance, particularly in the case of the new, very high power radars with very narrow, concentrated antenna beams. As a matter of routine, radiation hazard measurements should be made before conducting tests. In particular, such measurements should be made when testing is being done near antennas or in the immediate vicinity of high-power RF generators, waveguides, and couplers. X-rays emitted from high-power RF generators have also been found to be specific hazards to personnel. It may be necessary, under some circumstances, to establish special test setups to protect personnel. (See Volume I, Chapter 5, and Volume II, Chapter 6.)

6.9 FUTURE TECHNIQUES

As the spectrum signature programs gain more impetus, it is inevitable that additional problems will be found even while we develop better solutions to old problems. Much work remains to be done in equipment development as in test procedures. In particular, the data recording and reducing aspect needs additional attention. The large amount of data required for each spectrum signature, when multiplied by the total number of systems, means that improved data handling procedures are desirable to reduce cost and time factors. As technical personnel become more experienced, such procedures are certain to evolve.

References

1. Benjamin Lindeman, "Interference Aspects of Fresnel Region Phenomena." RADC-TN-60-214, Dec. 1960.
2. E. Jacobs, "Fresnel Region Patterns and Gain Corrections of Large Rectangular Antennas." Unclassified Proceeding of the Fifth Conference on Radio Interference Reduction and Electronic Compatibility, Oct. 1959.
3. W. W. Mumford, "Some Technical Aspects of Microwave Radiation Hazards." Proceeding of the IRE, p. 427, Vol. 49, No. 2, Feb. 1961.

TEST LOCATIONS AND ENVIRONMENTAL ELECTRONIC DATA CHAPTER 8

1. GENERAL

Interference measurements conducted under ideal conditions should be performed in a shielded room to insure that the ambient electronic environment does not affect the measurements. Although shielded room measurements are realistic for components and small assemblies or sub-assemblies, measurements are frequently required on systems that cannot be put into a small shielded enclosure due to size limitations. In addition, measurements may be required in the far field of the equipment being tested. Thus, many measurements may be necessary at outdoor locations, and it is then essential to consider the effect of the surrounding objects and signals emanating from other equipments in the area. This chapter presents information concerning selection and characteristics of test locations and discusses acquisition of environmental electronic data.

2. SURROUNDING OBJECTS

The electromagnetic field intensity at a specified location due to a particular emitter is a function of the radiated power, the frequency of the received signal, the distance from the transmitter, the attenuation over the path between the transmitter and receiver; reflections and reradiations from nearby conductors such as power lines, wire fences and steel structures, absorption by trees and other vegetation, and various effects produced by the local terrain, both natural and man made. Thus, the selection of a site for the performance of PEI measurements should be made only after a thorough investigation into each of the above considerations.

The ideal site would be on open, flat terrain at a considerable distance (1000 feet or more) from buildings, electric lines, fences and hills. Even buried cables can cause serious effects at low frequencies since the lower the frequency, the greater the depth of ground penetration. Ideal sites are rare in the more populated sections of the country. It is, therefore, good practice to check a proposed location by taking measurements on the desired signal at several points in the vicinity. If the same value of field intensity is obtained at each of the points, any one may be considered satisfactory. If it is necessary to use an unsatisfactory site, a series of readings should be recorded at a number of different points in the neighborhood of the selected site. In any case, descriptive notes on the site conditions should be appended to the recorded data.



There are no fixed rules to govern the minimum distance between the field intensity measuring equipment and the nearest extraneous objects since some possible effects are unpredictable. Some sites have been found to be satisfactory for low-frequency measurements where this distance was as small as 100 feet. A check of the location should always be made if any doubts exist. Consideration must necessarily be given in site selections to the possible presence of local electrical interference sources which may make field intensity measurements difficult.

3. SPECTRUM SEARCH

In addition to determining the physical layout of the area surrounding a site, the electromagnetic environment must be known to distinguish between signals originating from the equipment under test and spurious signals originating from other equipment. A practical and effective method for determining the electromagnetic environment is to conduct a detailed spectrum search. A spectrum search is defined as a scan of the applicable frequency spectrum to determine the magnitude, frequency, and source and/or location (if possible) of signals capable of being received at the test site. The following paragraphs discuss the various aspects of spectrum searches.

3.1 USE OF A SPECTRUM SEARCH

Information obtained from a spectrum search is useful in the following applications.

- a. Providing Data Necessary for Site Selection
- b. Supplementing Communication-Electronic Census Surveys
- c. Locating an Unknown Transmitter
- d. Documenting and Describing the Electromagnetic Ambient

RF ambient measurements complement a combined C-E population census and tabulation of manufacturer's nominal equipment characteristics. The nominal equipment characteristics are determined by visits to various equipment sites, and reference to equipment characteristic files and other information. Together, both nominal and empirical data make it possible to determine a more comprehensive picture of the C-E electromagnetic environment.

Although a comprehensive C-E population census may be conducted, additional and previously unknown transmitters will probably be revealed in the spectrum search. These transmitters may be mobile, and thus it is very unlikely that any additional C-E census will reveal their

accurate locations. However, a well equipped mobile laboratory capable of obtaining fixes using direction finding equipment and techniques can accurately locate the source of such transmissions.

The information obtained through a spectrum search is also useful in documenting and describing the electromagnetic ambient environment. Although the detail of documenting an ambient environment varies with the user's requirements, a minimum number of measurements must be made to determine the overall ambient environment. For example, users that must operate in low "noise" areas must have the site ambient documented at least to the extent of detailing the sources that contribute to the ambient level. This will enable the user to suppress, eliminate, or control those sources that add to the ambient level, e.g., powerline, ignition, machinery, medical, instrumentation, etc.

3.1.1 DETERMINING AN RF AMBIENT ENVIRONMENT

The factors, which will describe the RF ambient environment desired, must be delineated before a measurement program schedule and data gathering/reduction procedures can be formulated. Basically, a four-dimensional model of a C-E environment is needed, i.e., power density vs radio frequency vs spatial location vs time. This requirement sets the stage for all subsequent effort in this area.

During a spectrum search, measurements should be made at predetermined frequencies and time intervals to determine the broadband ambient level at the measurement site.

Figure 8-1 is a data sheet of a hypothetical spectrum search completed in a two-hour search of the frequency range 100 to 10,000 mc. Similar data would be gathered in each two-hour time period of a spectrum search. If the primary emphasis is on broadband interference instead of narrowband signals, the receivers would be tuned off all signals and the ambient level would be recorded. The remarks column would be used to distinguish the type of ambient noise, e.g., ignition, powerline, machinery, etc.

Figure 8-2 is a hypothetical power spectral density vs radio frequency plot for one particular time increment as existing at a particular intercept site. The lower line sloping up to the right corresponds to a hypothetical measurement receiver sensitivity of -80 dbm for a 1 mc bandwidth receiver and an omnidirectional antenna. Similar plots should be prepared for each spectrum search conducted.

SECURITY CLASSIFICATION None
SPECTRUM SEARCH DATA SHEET

Date: 21 May 64
Location: Ft. Belvoir, AR
Operator: [Name]
Receiver: [Name]

Receiver Used: AN AM-2 and AN ACD-2
Antenna Used: [Type]
Antenna Element: [Type]
Antenna Polarization: [Type]
Antenna Orientation: [Type]

Temperature: [Value]
Humidity: [Value]
Barometer: [Value]
Wind: [Value]

No.	Time Reading	Azimuth	Elevation	Frequency (MHz)	Bandwidth (MHz)	Modulation	Pulse Rate (pps)	Pulse Width (μs)	Pulse Shape	Sweep Rate (Hz/sec)	Sweep Type	Sweep Range (MHz)	Sweep Rate (Hz/sec)	Sweep Type	Sweep Range (MHz)	Remarks
1																
2																
3																
4																
5																
6																
7																
8																
9																
10																
11																
12																
13																
14																
15																
16																
17																
18																
19																
20																
21																
22																
23																
24																
25																
26																
27																
28																
29																
30																
31																
32																
33																
34																
35																
36																
37																
38																
39																
40																
41																
42																
43																
44																
45																
46																
47																
48																
49																
50																

FREDERICK RESEARCH CORPORATION FORM NO. 1004

Figure 8-1. Typical Spectrum Search Conducted During A 2-Hour Period

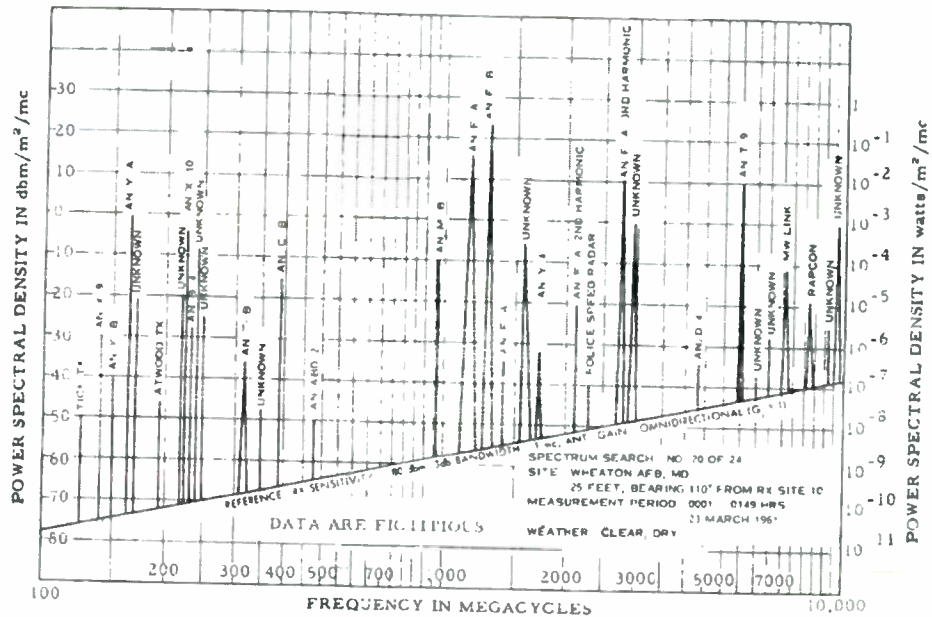

Figure 8-2. Typical Example of Data Resulting From A 2-Hour Spectrum Search

3.1.2 PRIORITIES AND TYPES OF MEASUREMENTS

It would be desirable to document thousands of instantaneous views of all signals in a spectrum as a function of time and frequency in order to obtain a complete and valid statistical model. This, of course, is impossible to do for a number of reasons: (1) time required to search the spectrum and to document the pertinent data, (2) time required to reduce data and plot results, (3) cost and logistic factors, and (4) time scheduling and priorities. Like all real problems, a trade-off and point-of-no-return must be determined. Thus, a minimal effort program can be defined as documenting the RF electromagnetic environment and identifying, to the extent practical, each emitter for:

a. At least one site as near to the equipment or equipments as practical and at a measurement antenna height as near as practicable to the centerline of the antenna associated with the equipment(s).

b. A single 45 degree diagonal polarization of the measurement antenna in order to be receptive to nearly all polarizations.

c. In the case of scanning radars, the associated intercept should correspond to the condition of the nearest approach of the radar antenna beam direction to the measurement antenna in any 30-second search interval.

d. The time interval to measure and record the data should not exceed two hours per decade. Twelve approximately equal time interval samples should be made over each 24-hour period. These measurements should be conducted during both the midweek and the weekends.

The above will result in at least 24 spectrum plots (assuming one search on a weekday and one on a weekend). This statistical sampling can then be summed up and molded into a graph that contains the mean value, standard deviation, and the upper and lower values obtained for each emitter. The probability that emitter R is on the air may be expressed by $P_R = N/24$ where N is the number of times that the signal was received in the 24 spectrum searches.

The probability of each equipment being on the air in any given 24-hour period should be plotted. From this information, a determination can be made concerning the amount of interference to be expected from a given transmitter. For example, if an emitter is rarely on the air, it can rarely cause interference, if at all. Figure 8-3 illustrates a typical procedure for performing a 24-hour spectrum search. The preferred equipments

for use in performing a spectrum search are field intensity meters and their associated equipments. Discussion of measurement techniques and instruments is contained in Chapters 3 and 4 of this Volume.

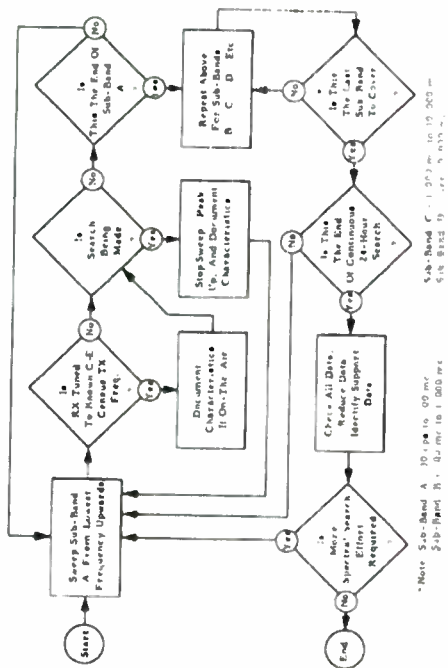

Figure 8-3. Typical Procedure For Performing A 24-Hour Spectrum Search

MEASUREMENT OF INSERTION

LOSS OF FILTERS

APPENDIX I

This appendix covers technique and procedure for measuring the insertion loss of filters designed to operate in the frequency range of 10 to 1000 megacycles. Insertion loss is defined as the number of decibels, or nepers, by which the current on the load side of a network has been changed by the insertion of the filter. Since the current through the load is reduced by the insertion of a shunt path, load voltage is proportionately reduced, assuming a constant load. The ratio of output current with a shunt path to the output current without a shunt path is equivalent to the ratio of voltage across the load with and without the shunt path. Therefore, insertion loss is measured more conveniently by the expression $20 \text{ Log } E_2/E_1$.

Accurate insertion loss measurement requires that the filter under test be inserted between source and load impedances which remain constant and are known throughout the entire frequency range of measurement. Isolation pads or attenuators are required to provide sufficient isolation between the filter under test and the signal generator, as well as the signal detector on the output side. This provides a constant and specific impedance to the filter at all frequencies. A 50 ohm resistive network has been adopted for convenience, since 50 ohm cable and connectors are standard items.

Figure I-1 illustrates two arrangements for measuring insertion loss. The alternate method given in (b) is useful for obtaining measurements up to 400 megacycles. The basic circuit, in (a), consists of a calibrated RF sine wave voltage source which supplies a signal through a coaxial transmission line and attenuator to the filter under test, then to another attenuator, receiver, with the final output registered on the output meter. In the process of obtaining data for measurement, as a first step, adjust the receiver gain for a convenient output indication of receiver fluctuation interference. Then apply power to the signal generator, and adjust the output indication 1 decibel above the interference level. This will give the output voltage, E_1 , for the filter-out condition. After inserting the filter for measurement, first retune the receiver to resonance, and again adjust the output of the signal generator for the same receiver output level as indicated on the output meter. This output of the signal generator yields the value of E_2 , and the insertion loss of the filter at the frequency of measurement will be given by the expression $20 \text{ Log } E_2/E_1$.

The accuracy of measurement will be affected by several factors. Error is commonly introduced by the variation of impedance with frequency

between the attenuators and filter under test. This is probably due to a slight mismatch between attenuator impedance and line impedance, and an impedance variation will occur at the points where the line connects to the filter unit. Maximum variation would occur at the frequency for which the electrical line length is $1/4$ of a wavelength or any odd multiple thereof. The attenuator may well have a frequency characteristic causing its impedance to vary with frequency, so that the impedance variation at the cable end will combine the two effects. The overall impedance variation, up to 1000 megacycles, can be held to 20 percent of the low frequency value, allowing error of 1.6 db. Up to 400 megacycles, these effects combine to produce an error less than 0.2 db.

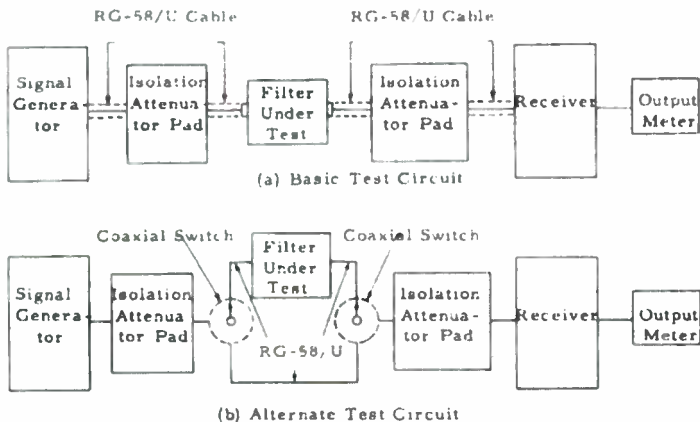

Figure I-1. Circuit for Measuring Insertion Loss of Filters

Some leakage from the signal generator, from poor cable, or from connectors may be picked up by direct radiation or by some unintentional coupling to the receiver antenna circuit. Properly shielded and filtered instruments are the best possible solution to this problem. In the case of undesirable coupling occurring with a given test set-up, receiver and signal generator must be separated as far as possible. To obtain good results,



make sure that all radio frequency connectors are tight, all cables are well shielded, and then operate at a signal level and sensitivity which reduces any possible extraneous coupling to a minimum.

Where multiple-filter circuits are to be measured, the procedure is to measure one section leaving all others open. Then measure the same section short circuiting all others. The short circuit connections shall be as short and direct as possible. The lesser of the two measurements will be considered the insertion loss of the circuit at the test frequency.

MEASURING THE RADIO-FREQUENCY IMPEDANCE OF BONDS

APPENDIX II

Insertion-loss measurements, which indirectly supply information from which the impedance may be computed, are made in preference to the direct measurement of radio frequency impedances because of the many difficulties encountered in the latter. The insertion-loss ratio is defined as the ratio of voltages existing across a load impedance before and after connecting the two-terminal test impedances in parallel with it. The insertion-loss ratio of any specimen under test is given by the expression.

$$\text{Insertion Loss Ratio} = \left| 1 + \frac{Z Z_R}{Z(Z_S + Z_R)} \right| \quad (1)$$

The quantity Z represents the impedance of the specimen under test, Z_S and Z_R represent the source and load impedances respectively, as shown in Figure II-1.

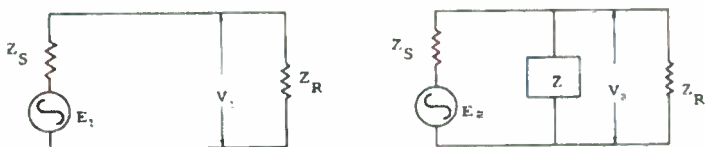

Figure II-1. Equivalent Circuits Used In the Derivation of the Insertion-Loss Ratio

The derivation of this expression can be obtained as follows. Let V_2 and V_1 represent the voltage drops across the load impedance with and without the specimen under test connected, and E_2 and E_1 represent the generator voltages in each case. Then:

$$V_1 = \frac{E_1 Z_R}{Z_S + Z_R} \quad (2)$$

$$V_2 = \frac{E_2 Z Z_R}{Z(Z_0 + Z_R) + Z_0 Z_R} \quad (3)$$

$$\frac{V_1 E_2}{V_2 E_1} = 1 + \frac{Z_0 Z_R}{Z(Z_0 + Z_R)} \quad (4)$$

When $E_2 = E_1$, i. e., generator voltage constant, the insertion loss is as defined above. It is seen that the same expression is obtained when the load voltage is kept constant, i. e., $V_1 = V_2$, and the generator voltage is adjusted accordingly. This second method is used in practical measurements.

In test set-ups for measuring insertion loss, the source and load impedances are usually made resistive and equal to one another by means of isolation network pads. This simplifies the expression for the insertion-loss ratio which is now given as:

$$\text{Insertion Loss Ratio} = \left| 1 + \frac{R}{2Z} \right| \quad (5)$$

where R represents the equal resistive values. Furthermore, the resistive values are often arbitrarily fixed at 50 ohms which changes the expression to:

$$\text{Insertion Loss Ratio} = \left| 1 + \frac{25}{Z} \right| \quad (6)$$

It must be recognized that the insertion-loss ratio as measured between 50 ohm resistors will not represent the actual insertion loss of the impedance under test when used between the wide range of impedances encountered in practice. However, as long as some standard for source and load impedances is accepted and consistently used, test results are significant and comparison of data is valid since there is a direct correlation between insertion loss and impedance.

It is often convenient to use the insertion loss, measured in decibels, rather than the insertion-loss ratio.

$$\text{Insertion Loss} = 20 \log_{10} \left| 1 + \frac{R}{2Z} \right| \quad (7)$$



A circuit for measuring insertion loss is shown schematically in Figure II-2.

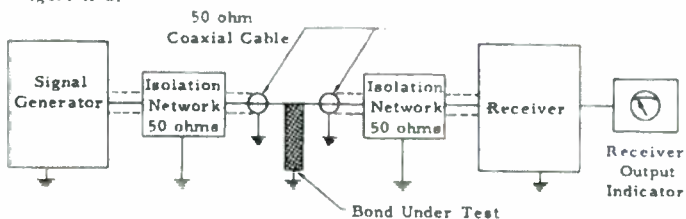

Figure II-2. Schematic Diagram for Measuring Insertion Loss

To make a measurement at any frequency the bonding jumper under test is removed from the circuit, a signal is introduced and the receiver output is recorded. The bonding jumper is then inserted into the circuit, and the signal generator output is raised until the same receiver output is obtained. The ratio of the second generator output reading to the first is the insertion-loss ratio.

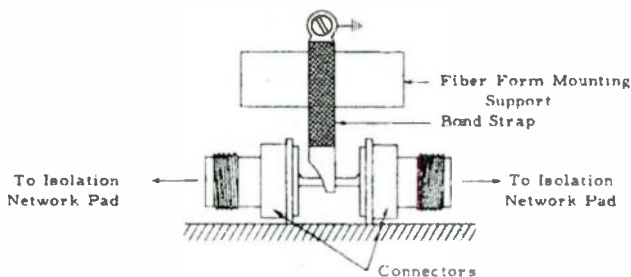

Figure II-3. Method of Connecting Bonding Jumper to Studs

Several precautions must be taken in order to obtain accurate results. The length of the open line between the extremities of the coaxial cables must be minimized to prevent the introduction of an appreciable

value of inductance in series with the source and load impedances. This is conveniently accomplished by connecting the extremity of each coaxial cable to a connector. Each of the two connectors is equipped with a stud no longer than 1/4 inch. These studs are connected directly when a measurement in the absence of a jumper is made. When a measurement is made with a bonding jumper present, they are firmly connected to the lug at the extremity of the jumper as shown in Figure II-3.

The lug at the jumper's other extremity is securely bolted to the ground plate. A fixed orientation with respect to ground for all test samples must be ensured. This may be accomplished by securing the bonding jumper to a cylindrical, fiber mounting form as shown in Figure II-4.

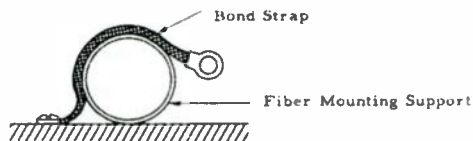

Figure II-4. Method of Connecting Bonding Jumper to Ground

Difficulties due to the impedance of the ground path at high frequencies can be avoided by mounting the signal generator, the isolation network pad on the source side of the circuit, and the specimen under test on a fiber plate. This isolates the source side from the receiver side and prevents the ground-path impedance from affecting the results. The return current path is, of course, through the outer conductor of the coaxial cable. In order to prevent a high capacity to ground, which results in a low impedance by-pass, the fiber plate must not be less than 1/4 inch thick.

**DESCRIPTIVE DATA SHEETS OF
INTERFERENCE TEST SETS**

APPENDIX III

The following test equipments are described in this appendix:

<u>EQUIPMENT TYPE</u>	<u>MILITARY DESIGNATION</u>	<u>COMMERCIAL DESIGNATION</u>
Field Intensity Meter	TS-318/UP	None
Noise-Field Strength Meter	TS-432 U	None
Field Strength Meter	TS-579 U	None
Noise-Field Intensity Meter	TS-587 A/U	Stoddart NMA-5A
Test Set	I-149	None
RF Indicator-Probe	ID-263/U	None
Radio Frequency Indicator	TS-446 U	None
Field Strength Meter	TS-509/UR	None
Radio Test Set	AN PRM-1A	Stoddart NM-20B
Radio Interference Measuring Set	AN/URM-3	None
Radio Test Set	AN/URM-6	Stoddart NM-20A
Radio Interference Measuring Set	AN/URM-7	None
Radio Test Set	AN/URM-17	Stoddart NM-50A
Field Intensity Meter	AN/URM-41	Stoddart NM-40A
Radio Interference Measuring Set	AN/URM-47	Stoddart NM-30A
Noise and Field Intensity Meter	None	Empire NF-105
Field Intensity Meter	None	Empire NF-112
Field Intensity Meter	AN TRM-6	Polarad FIM

III-1



<u>EQUIPMENT TYPE</u>	<u>MILITARY DESIGNATION</u>	<u>COMMERCIAL DESIGNATION</u>
Radio Frequency Measuring Set	AN/URM-42	Stoddart NM-60A
Radio Interference Measuring Set	AN/URM-138	Stoddart NM-62A
Pickup Assembly	TS-131/AP	None
Fluxmeter	TS-15/AP	None
Fluxmeter	TS-15A/AP	None
Fluxmeter	TS-15B/AP	Marion MFM-2
Fluxmeter	TS-15C/AP	TLG S-01
Gaussmeter	None	Dyna-Labs D-79
Audio Level Meter	AN/URM-38	Hickok 900-079

**FIELD INTENSITY METER TS-318/UP
(METER, FIELD STRENGTH TS-318/UP)**

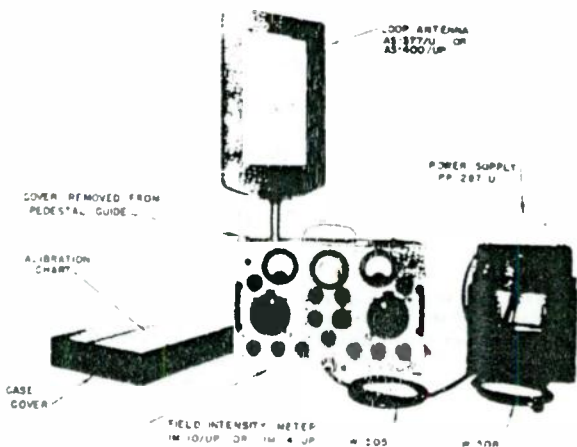

FUNCTIONAL DESCRIPTION

A portable instrument used to measure field intensity and pulse repetition rate of Loran signals and field intensity of continuous waves. It compares the incoming signal against a measured pulse signal generated in the field intensity meter. The comparison is made by superimposing both signals on the vertical deflecting plates of the cathode ray tube (visible on the front panel), adjusting the sweep rate so that the pulses remain stationary on the screen and adjusting the height of the calibrating pulse to the same height as the incoming signal. By use of field intensity graphs the intensity of this signal is obtained from the vacuum tube voltmeter reading. The pulse recurrence rate is obtained from the reading of the sweep frequency dials.

The field intensity of continuous wave signals may be determined by measuring the amount of internally generated constant voltage necessary to give the same deflection as the received signal.

All controls and indicators are located on the operating (front) panel.

	AIR FORCE	NAVY	ARMY
TYPE CLASS.	Standard		
STOCK NOS.	7CAC-526245	F17-M-23328-6346	3F4325-318
PROCUREMENT INFO.:	BuShips Spec No. RE13A1031A		
PROCUREMENT COG.:	Navy	DESIGN COG.:	Navy, BuShips
F.I.I.N.:	FUNCTIONAL CLASS. NO.: 5.1.:		
	- Electronics Test Equipment -		TS-318/UP

This project was supported by the USAF on Contract AF 33(600)18276 and sponsored by RADC, ARDC - Carl L. Frazee-146, Bethesda, Md. - Multiplied in U.S.A.

**FIELD INTENSITY METER TS-318/UP
(METER, FIELD STRENGTH, TS-318/UP)**

RELATIONSHIP TO OTHER EQUIPMENT.

Similar to TS-635/UP except for frequency range.

Equipment required but not supplied: One vertical antenna, 10 to 60 feet high.

ELECTROMECHANICAL DESCRIPTION:

Circuit Information: Consists of a cathode ray indicator unit, a sweep generator unit, a signal generator unit and a receiver.

The sweep generator unit supplies voltages for the horizontal deflection plates and for synchronization of the calibrating pulses from the signal generator. A vacuum tube voltmeter indicates the radio frequency level of the signal generator section output. This output passes through an attenuator to the antenna where it is fed into the receiver section along with the incoming section picked up by the antenna.

Power Supply: 115 volts AC, single phase, 60 cycles per second or 6 volts DC (internal or external battery) or Power Supply Unit PP-287/U.

Frequency Range: 1550 to 2500 kilocycles per second.

Field Intensity Range: 50 microvolts per meter to 15 volts per meter with loop antenna, 1 microvolt per meter minimum with 60-foot vertical antenna.

Pulse Repetition Rates: 49,300 to 50,000 microseconds S (slow).

39,300 to 40,000 microseconds L (low).

29,300 to 30,000 microseconds H (high).

Type of Reception: Continuous Wave, Pulsed.

Receiver: Superheterodyne, 455 kilocycles per second, intermediate frequency.

Output Indicators: Two-inch cathode ray tube for Loran or pulse, 0 to 1 milliamperes DC meter for continuous wave

MANUFACTURERS' OR CONTRACTORS' DATA:

Washington Institute of Technology, Inc., 4810 Calvert Road, College Park, Maryland; Contract No. NXs-88850, 5 February 1945; Contract No. NObs-39362, 26 June 1947.

TUBE COMPLEMENT:

1 JAN-2AP1A, 1 JAN-6X5GT/G, 2 JAN-6AK5, 1 JAN-6AL5, 3 JAN-6AS6, 1 JAN-6AQ6, 1 JAN-6SA7, 1 JAN-OA3/VR-75, 1 JAN-OD3/VR-150, 1 JAN-8016, 2 JAN-9002, 3 JAN-9003.

REFERENCE DATA AND LITERATURE:

NavShips 91089 (Instruction Book).

TO 16-35TS318-5 (Instruction Book).

SHIPPING DATA:

No. of Boxes	Contents & Identification	Volume (Cu. Ft.)	Over-all Dimensions (inches)			Weight Packed (Lbs.)
			H	W	D	
1	Field Intensity Meter, TS-318/UP	5.2	18-1/4	26-5/8	18-1/4	104
1	Power Supply	4.2	16-1/8	27-1/4	16-1/8	90
1	Storage Battery	1.1	13	14-1/2	9-1/2	60
1	Spare Parts	2.9	14-3/4	24-1/4	14	80

TS-318/UP

- Electronics Test Equipment -

FIELD INTENSITY METER TS-318/UP
(METER, FIELD STRENGTH, TS-318/UP)

EQUIPMENT SUPPLIED:

Quant. Per Eq'pt	Name and Nomenclature	Case Mat'l	Stock (USAF) Numbers (Navy) (Army)	Over-all Dimensions (inches)			Weight (Lbs.)
				H	W	D	
1	Field Intensity Meter, TS-318/UP Including:		7CAC-526245 F17-M-23328-6346 3F4325-318				
1	Field Intensity Meter, IM-10/UP	Alum- inum		14-27/32	19-15/16	11-1/8	50.9
1	Antenna As- sembly, AS-377/U			28-1/4	12	1-3/16	5.5
1	Antenna Coupler CU-142/U			4-3/4	3-15/16	1-11/16	0.7
1	Power Supply Less Battery PP-287/U			11-7/8	20-9/16	11-1/16	37.0
1	Storage Battery 6VSBM-50AH			9-1/2	10	7-1/4	40.0
1	Adapter Signal Generator Output CWI-62408						
1	Power Cable As- sembly CWI-62407 (inter unit)			78 long			
1	Power Cable Assembly						
1	Video Output Cable Assembly						
1	External Synchronizing Cable Assembly						
1	Eye Shield						
1	Battery Cable(+)						
1	Battery Cable(-)						
1	Set Calibration Charts						
2	Instruction Book						
1	Spare Parts			12	18-1/16	12	45.0

- Electronic Test Equipment -

TS-318/UP

NOISE-FIELD STRENGTH METER TS-432/U
(METER, FIELD STRENGTH, TS-432/U)

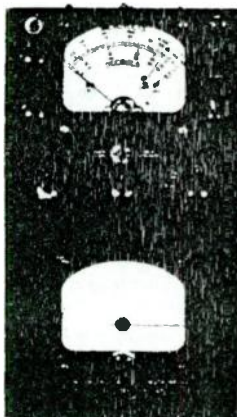

FUNCTIONAL DESCRIPTION:

A portable, general purpose, field and depot radio interference and field strength meter, used for measurements of carrier voltages and fields, interference voltages and fields, signal-to-noise ratio, voltages on lines and conductors, antenna field patterns, filter characteristics, localization of noise sources and interference reduction means, and all kinds of radio interference fields.

The tuning dial is graduated in megacycles, while the output meter scale reads directly in microvolts the value of the voltage applied to the input.

RELATIONSHIP TO OTHER EQUIPMENT:

Similar to Ferris Model 32-A Radio Noise and Field Strength Meter.

ELECTROMECHANICAL DESCRIPTION:

Circuit Information: A single radio frequency stage feeds into a combination mixer

(Continued)

	AIR FORCE	NAVY	ARMY
TYPE CLASS.			
STOCK NOS.	1600-326196000	F17-M-25304-5347	3F2728-1
PROCUREMENT INFO.:	Navy Specs. RE13A678 and RE13A678B.		
PROCUREMENT COG.:	Navy	DESIGN COG.:	Navy, BuShips
F.I.I.N.:	FUNCTIONAL CLASS. NO. . 5. 1. 1		
- Electronics Test Equipment -			TS-432/U

This project was supported by the USAF on Contract AF 31(600)10276 and monitored by, ADC, ARDC, Cecil L. Frederick, Bethesda, Md. - Multiplied in U.S.A.

NOISE-FIELD STRENGTH METER TS-432/U
(METER, FIELD STRENGTH, TS-432/U)

ELECTROMECHANICAL DESCRIPTION: (Continued)

and oscillator. This is followed by two intermediate frequency stages and a detector. There is no audio frequency stage. The circuits are designed for compactness and simplicity of operation.

Power Supply: Normally supplied with small dry battery pack (32-BPI). Large battery pack, AC power pack, or 115 volt, 60 cycles per second, rectifier packs may be obtained by special order.

Frequency Range: 150 to 350 kilocycles per second and 550 to 20,000 kilocycles per second in five bands: 150 to 350, 550 to 1550, 1550 to 4000, 4000 to 10,000, 10,000 to 20,000. The gap is for the intermediate frequency of 455 kilocycles per second.

Voltage Range: 1 to 1000 microvolts and 100 to 100,000 microvolts.

Field Intensity Range: 2 to 200,000 microvolts (with standard antenna).

Standard Time Constants: Charge 10 milliseconds, discharge 600 milliseconds.

Sensitivity: 1 microvolt.

Calibrating Source: Internal shot noise diode oscillator (calibration curves are supplied).

MANUFACTURERS' OR CONTRACTORS' DATA:

Ferris Instrument Company, Boonton, New Jersey; Approximate Cost per Unit, \$500.00

TUBE COMPLEMENT:

3 RETMA-D5GP, 1 RETMA-H6G, 1 JAN-5Y3GT, 1 RETMA-C7G, 1 RETMA-H4G, 1 JAN-6SJ7, 1 RETMA-B1, 1 JAN-6L6, 1 JAN-991.

REFERENCE DATA AND LITERATURE:

SHIPPING DATA:

No. of Boxes	Contents & Identification	Volume (Cu. Ft.)	Overall Dimensions (inches)			Weight Packed (Lbs.)
			H	W	D	
1	Noise-Field Strength Meter TS-432/U					28

EQUIPMENT SUPPLIED:

Quant. Per Eq'pt	Name and Nomenclature	Case Mat'l	Stock Numbers (USAF) (Navy) (Army)	Overall Dimensions (inches)			Weight (Lbs.)
				H	W	D	
1	Noise-Field Strength Meter TS-432/U		1600-326196000 F17M-23304-5347 3F2728 1	13-1/4	7	12	22
1	Telescoping Rod Antenna			41 long			

TS-432/U

- Electronics Test Equipment -

FIELD STRENGTH METER TS-579/U

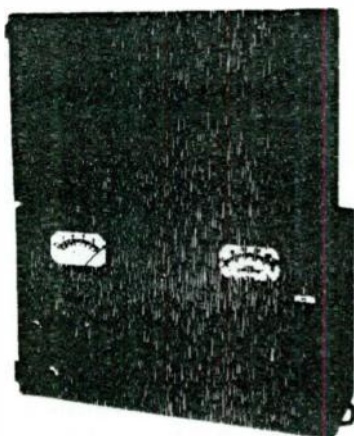

FUNCTIONAL DESCRIPTION:

A portable, general purpose, field intensity meter, designed for measuring field intensities of radio transmitters operating in the HF and VHF spectra for the purpose of checking antenna efficiency, coverage, service area, and also for carrying out research work or propagation studies. The instrument may be used in conjunction with a standard recording meter for making records of the variation in signal intensity and may also be employed with a noise meter attachment for indicating the noise level on any particular radio frequency channel. The instrument is designed to provide either linear or logarithmic output to facilitate recording. It has been designed particularly for field use and is arranged for convenient operation and for carrying from one location to another. The instrument requires the use of calibration curves, which are supplied for converting readings into field intensity values.

RELATIONSHIP TO OTHER EQUIPMENT:

This instrument is similar to RCA Type 301-B Field Intensity Meter.

	AIR FORCE	NAVY	ARMY
TYPE CLASS.	Standard		
STOCK NOS.	7CAC-526225		3F3309-1
PROCUREMENT INFO.:			
PROCUREMENT COG.:	Army	DESIGN COG.:	Army, CSL
F.I.I.N.:	FUNCTIONAL CLASS. NO.:		5.1.1
- Electronics Test Equipment -			TS-579/U

FIELD STRENGTH METER TS-579/U

ELECTROMECHANICAL DESCRIPTION:

Circuit Information: A local oscillator provides a calibrating voltage source. Its voltage is put across the transmission line coming from the doublet. A super-heterodyne receiver unit is used. Automatic volume control is used on the three stage IF amplifier to obtain a logarithmic output characteristic. The diode second detector output is amplified by a triode DC amplifier which drives the output meter.

Power Supply: Vibrator and Battery, 6 volts, DC, at 4 amperes load.

Frequency Range: 18 to 125 megacycles per second in 3 bands. Tuning dial ratios of 30 to 1 and 5 to 1.

Type of Reception: Continuous Wave, Modulated Continuous Wave.

Field Intensity Range: 10 to 500,000 microvolts per meter and 50 to 2,500,000 microvolts per meter.

Output Scale:

Linear: 10 to 1 or 20 decibels.

Logarithmic: 100 to 1 or 40 decibels.

Output:

Audio: Operates phones or noise meter.

Recorder: Operates any recorder of 5 milliamperes and 560 ohms maximum resistance.

Antenna: Doublet in 6 sections, 4 fixed and 2 variable sections of stainless steel.

Variable sections cover frequency range down to 37.5 megacycles per second.

Antenna Support: Bakelite tripod adjustable to 137 inches.

RF Transmission Line: Length 30 feet, 2 wire shielded, rubber covered line.

Accuracy: $\pm 10\%$ of indicated field intensity.

MANUFACTURERS' OR CONTRACTORS' DATA:

Radio Corporation of America, Camden, New Jersey.

TUBE COMPLEMENT:

2 JAN-955, 3 JAN-6K7, 1 JAN-0D3, 1 JAN-954, 1 JAN-6R7.

REFERENCE DATA AND LITERATURE:

TO 16-35TS579-3 (Field Strength Meter).

SHIPPING DATA:

No. of Boxes	Contents & Identification	Volume (Cu. Ft.)	Over-all Dimensions (inches)			Weight Packed (Lbs.)
			H	W	D	
TS-579/U			Electronics Test Equipment			

NOISE-FIELD INTENSITY METER TS-587A/U



FUNCTIONAL DESCRIPTION:

A field and depot equipment used to locate and measure RF interference and to make field strength measurements. It can be used as a two terminal sensitive voltmeter. A tripod is furnished for mounting the antennas. Signal monitoring provisions are available from the phone jacks. Measurements can be made with the receiver in terms of the peak value of the interference (the PEAK function), in terms of a weighted value (the QUASI-PEAK function), or in terms of the average value (the FIELD INTENSITY function). The measurements are made using the panel-mounted meter or the remote meter jacks. The meter scale is directly calibrated in microvolts, decibels, and arbitrary units of "shot noise". Arbitrary units of "shot noise" are used only in the calibration procedures of the equipment. By use of correction curve furnished with the equipment, the meter readings can be converted to microvolts per meter.

RELATIONSHIP TO OTHER EQUIPMENT:

Similar to the Stoddart Model NMA-5A.

	AIR FORCE	NAVY	ARMY
TYPE CLASS.			
STOCK NOS.		F16-T-20141-9606	
PROCUREMENT INFO.			
PROCUREMENT COG.:	Navy	DESIGN COG.:	Navy, BuShips
F.I.I.N.:		FUNCTIONAL CLASS NO.:	
		5 1.1	
- Electronics Test Equipment -			TS-587A/U

NOISE-FIELD INTENSITY METER TS-587A/U

ELECTROMECHANICAL DESCRIPTION:

Circuit Information: It is a high-sensitivity HF and VHF superheterodyne radio receiver which contains internal means for calibrating its VTVM section. Four decade steps of attenuation are inserted between the antenna input and the RF head. The output signal of the attenuator is fed to the RF head, where it is amplified and mixed with the local oscillator frequency, producing the intermediate frequency. The IF signal is amplified in four IF stages and demodulated in the detector stage. The demodulated signal is acted upon by the meter detector weighting circuits and applied to the VTVM stage, thus actuating the meter. The audio components are subsequently amplified and delivered to the headphone jacks.

Power Supply: 115 volts, $\pm 10\%$, AC, single phase, 60 cycles per second, 0.96 amperes at 92% power factor.

Frequency Range: 15 to 400 megacycles per second in four bands.

LF Head: 15 to 31, 29 to 64, 60 to 125 megacycles per second.

HF Head: 100 to 400 megacycles per second.

Intermediate Frequency: LF Head: 12 megacycles per second.

HF Head: 30 megacycles per second.

Voltage Scale: 0 to 100 microvolts.

-6 to 40 decibels.

0 to 8 arbitrary units of shot noise.

Input Voltage Range: 2 to 100,000 microvolts. Balance resistance attenuator with steps of: X1, X10, X10², and X10³.

Receiver Output: 200 milliwatts maximum.

Input Impedance: 95 ohms, balanced to ground.

Output Impedance: 300 or 4000 ohms, for headphone.

Sensitivity: Two-terminal Voltmeter: LF Head: 2 microvolts.

HF Head: 5 microvolts.

Field Intensity Meter: LF Head: 20 microvolts per meter.

HF Head: 5 microvolts per meter.

Bandwidth: LF Head: 150 kilocycles per second at 6 decibels down.

HF Head: 210 kilocycles per second at 6 decibels down.

MANUFACTURERS' OR CONTRACTORS' DATA:

Stoddart Aircraft Radio Company, 6644 Santa Monica Boulevard, Hollywood 38, California, Contract No. NObsr-30088, dated 15 June 1946, Contract No. NObsr-30140, dated 21 June 1946, Contract No. NObsr-30200, dated 26 June 1946, Contract No. 39272, dated 27 June 1947.

TUBE COMPLEMENT:

RF-36/U: 2 JAN-6AK5, 2 JAN-6C4.

RF-37/U: 2 JAN-6J4, 1 JAN-6J6, 1 JAN-9002.

AM-194/U: 1 JAN-6AL5, 1 JAN-6AQ6, 4 JAN-6BA6.

AM-195/U: 1 JAN-6AL5, 1 JAN-6AQ6, 4 JAN-6SG7.

PP-267/U: 1 JAN-OD3/VR-150, 1 JAN-5Y3GT/G, 1 JAN-6H6, 1 JAN-6J 5GT/G,
1 JAN-6L6GA, 1 JAN-6SJ7, 2 JAN-6V6 or 6V6GT/G.

TS-587A/U

- Electronics Test Equipment -

NOISE-FIELD INTENSITY METER TS-587A/U

REFERENCE DATA AND LITERATURE:

Navships 900, 990 (Instruction Book).

SHIPPING DATA:

No. of Boxes	Contents & Identification	Volume (Cu. Ft.)	Overall Dimensions (inches)			Weight Packed (Lbs.)
			H	W	D	
1	Noise-Field Intensity Meter TS-587A/U	3.53	36	47	36	330

EQUIPMENT SUPPLIED:

Quant. Per Eq'pt	Name and Nomenclature	Case Mat'l	Stock Numbers (USAF) (Navy) (Army)	Overall Dimensions (inches)			Weight (Lbs.)
				H	W	D	
1	Noise-Field Intensity Meter TS-587A/U		F16-T-20141-9606	15-3/16	21-1/2	29-1/2	64
1	Canvas Cover						2
1	Equipment Case CY-606/U Containing:		16-C-170001-254	15	40	9	53 (w/contents)
1	Radio Frequency Head RF-36/U		15-G-12161-100	6-1/2	17-1/2	14	
1	Intermediate Frequency Amplifier AM-194/U		16-A-32246-2934	4-1/2	13-1/2	5	
1	Dipole Antenna AS-385/U		16-A-45177-9701	60 long			
2	Dipole Mast Section for AS-385/U			33 long			
1	Loop Probe MX-822/U		16-A-45883-2134		8-3/4 dia.		
1	Measuring Tape CADV-10671		16-T-19041-1001	2	1-3/4	3/4	
							(Continued)
- Electronics Test Equipment -							TS-587A/U

NOISE-FIELD INTENSITY METER TS-587A/U

EQUIPMENT SUPPLIED: (Continued)

Quant. Per Eq'pt	Name and Nomenclature	Case Mat'l	Stock (USAF) Numbers (Navy) (Army)	Over-all Dimensions (inches)			Weight (Lbs.)
				H	W	D	
2	Instruction Book Navships 900, 990						
1	Accessory Case CY-607/U Containing:		16-C-170001-255	15	40	9	40 (w/con- tents)
1	Dipole Antenna CADV-66151-A			44 long			
2	Dipole Mast Section for CADV-66151-A						
1	Loop Probe MX-821/U		16-A-45902-1134	5-1/2	1-17/32 dia.		
1	Line Probe CADV-491087		16-P-87007-1041	5-3/8	2-1/4 dia.		
1	Antenna Tripod CADV-10545		16-T-802001-107	37-1/2	3-13/16 dia.		
1	Matching Impedance CADV-471228		16-A-22081-1007	2-5/8	1-23/32 dia.		
1	Input Cable CG-444/U		16-C-12400-4616	72 long			
1	Power Cable						
							Total: 159.0

TS-587A/U

- Electronics Test Equipment -

TEST SET 1-149
(MIXER STAGE 1-149)



FUNCTIONAL DESCRIPTION:

A portable, general purpose, field strength meter used to measure relative transmitted field strength of radio and radar sets within its frequency range. Indication is on a meter dial in microamperes. This meter is used in organizational and field maintenance.

RELATIONSHIP TO OTHER EQUIPMENT:

ELECTROMECHANICAL DESCRIPTION

Circuit Information: Essentially this instrument is a half-wave diode rectifier which rectifies pulse voltage and indicates the rectified voltage on a DC microammeter.

This value is proportional to the strength of the electric field at the receiving point.

(Continued)

	AIR FORCE	NAVY	ARMY
TYPE CLASS.			
STOCK NOS.	7CAC-526231		3E4149
PROCUREMENT INFO.:	Army Dwg. FS-D-11147		
PROCUREMENT COG.:	USAF	DESIGN COG.:	USAF, Rome
FUNCTION:	FUNCTIONAL CLASS. NO.: 5.1.2		
	- Electronics Test Equipment -		
			1-149

This project was supported by the USAF on Contract AF 33 (60)1227 and monitored by WADC, ARDC, Capt. E. Frederic, Bethesda, Md. Multi-View - 1-5

TEST SET I-149
(MIXER STAGE I-149)

ELECTROMECHANICAL DESCRIPTION: (Continued)

Power Supply: One internal Battery BA-65 (6.3 volts, DC).

Frequency Range: 100 to 112 megacycles per second.

Current Range: 0 to 200 microamperes, DC; 0 to 600 microamperes, AC.

Field Intensity Range: Relative.

MANUFACTURERS' OR CONTRACTORS' DATA:

Esey Manufacturing Company, Inc., 528 East 72nd Street, New York 21, New York; Order No. 995-SCRL-42.

Viewtone Company, Inc., New York, New York; Order No. 103-MPD-44; Approximate Cost per Unit, \$125.00.

TUBE COMPLEMENT:

1 JAN-1N5GT/G.

REFERENCE DATA AND LITERATURE:

TO 16-40RC70-2 (Operating Instructions for Test Equipment RC-70-A).

SHIPPING DATA:

No. of Boxes	Contents & Identification	Volume (Cu. Ft.)	Overall Dimensions (inches)			Weight Packed (Lbs.)
			H	W	D	
1	Test Set I-149 (Shelf Package)	0.19	8	8	5	5.9

EQUIPMENT SUPPLIED:

Quant. Per Eq't	Name and Nomenclature	Case Mat'l	Stock Numbers (USAF) (Navy) (Army)	Overall Dimensions (inches)			Weight (Lbs.)
				H	W	D	
1	Test Set I-149	Sheet-iron	7CAC-526231 3F4149	6	6	2-3/4	3.0

I-149

- Electronics Test Equipment -

RF INDICATOR-PROBE ID-263/U



FUNCTIONAL DESCRIPTION:

A general purpose probe used to indicate the presence of RF fields of relatively large magnitude such as exist around transmitters. An extension rod which slips onto the tip of the probe is provided in order to reach into a deep chassis or into high voltage areas. When the extension rod is used, it normally increases the sensitivity of the unit.

RELATIONSHIP TO OTHER EQUIPMENT:

ELECTROMECHANICAL DESCRIPTION:

Circuit Information: When the unit is placed in an RF field, dielectric or capacity currents flow through the coupling capacitor. On the positive half cycle the capacity current flows through a germanium diode to the instrument frame, and then through the operator's hand capacity to the operator, and back into the field. This prevents the coupling capacitors from assuming a DC charge. On the negative

(Continued)

	AIR FORCE	NAVY	ARMY
TYPE CLASS.	Standard		
STOCK NOS.	7CAC-657535	F17-P-84881-7676	3F3711-263
PROCUREMENT INFO.:	Navy Spec. CS-818		
PROCUREMENT COG.:	Navy	DESIGN COG.:	Navy, BuShips
F.I.I.N.:	FUNCTIONAL CLASS. NO.:		5.1.2
	- Electronics Test Equipment -		ID-263/U

This project was supported by the USAF as Contract AF 33(600)18276 and monitored by WADC, ARDC - Carl L. Frederick, Bethesda, Md. - Modified in U.S.A.

RF INDICATOR-PROBE ID-263/U

ELECTROMECHANICAL DESCRIPTION: (Continued)

half cycle the current flows through a second diode and DC meter which indicates the magnitude of this current.

Power Supply: None.

Frequency Range: 100 kilocycles per second to 400 megacycles per second.

Sensitivity: 25% full scale for one volt per meter of RF field applied to tip of probe at 3.5 megacycles; 5 volts per meter for 25% full scale at 30 megacycles with extension rod in RF field; 200 microamperes full scale for meter.

RF Signal: 10 volts maximum across crystal diode.

Meter Range: 0 to 100 (arbitrary scale); 10 scale divisions.

MANUFACTURERS' OR CONTRACTORS' DATA:

Radio Frequency Laboratories, Inc., Boonton, New Jersey; Type H-2360; Navy Contract NObsr-42100 dated 17 February 1948, and Navy Contract NObar-49181 dated 1 June 1950.

TUBE COMPLEMENT:

2 JAN-IN34 (Crystal Rectifier).

REFERENCE DATA AND LITERATURE:

NAVSHIPS 91146 (Instruction Book for AN/USM-3).

SHIPPING DATA:

No. of Boxes	Contents & Identification	Volume (Cu. Ft.)	Overall Dimensions (inches)			Weight Packed (Lbs.)
			H	W	D	
1	RF Indicator-Probe ID-263/U	0.028	8	3-1/2	1-3/4	0.375

EQUIPMENT SUPPLIED:

Quant. Per Eq'pt	Name and Nomenclature	Case Mat'l	Stock Numbers (USAF) (Navy) (Army)	Overall Dimensions (inches)			Weight (Lbs.)
				H	W	D	
1	RF Indicator-Probe ID-263/U	Plastic	7CAC-657535 F17-P-84881-7676 3F3711-263	6	1 dia.		0.156
1	Extension Rod O-904			5 long			0.031

ID-263/U

- Electronics Test Equipment -

RADIO FREQUENCY INDICATOR TS-446/U
 (INDICATOR, ELECTRICAL, POTENTIAL, TS-446/U)



FUNCTIONAL DESCRIPTION:

A pocket size, pencil type indicator consisting of a neon bulb enclosed in a lucite tube designed to indicate the presence of stray radio frequency fields from all types of radio and radar transmitters. May also be used to provide a high voltage check on Power Transformers, etc., without the danger of shock.

RELATIONSHIP TO OTHER EQUIPMENT:

ELECTROMECHANICAL DESCRIPTION:

Nominal Watts: 1/4 (NE-2) watts.

MANUFACTURERS' OR CONTRACTORS' DATA:

Star Measurements Company, 442 East 166th Street, New York 56, New York;
 Order No. 48-3138; Approximate Cost per Unit, \$.10.

(Continued)

	AIR FORCE	NAVY	ARMY
TYPE CLASS.	Standard		
STOCK NOS.	7CAC-439725		3F4325-446
PROCUREMENT INFO.: USAF Dwg. Nos X45H40679 & 45A40680			
PROCUREMENT COG.: USAF		DESIGN COG.: USAF, ARL	
F.I.I.N.:		FUNCTIONAL CLASS. NO.: 5.1.2	
- Electronics Test Equipment -			TS-446/U

RADIO FREQUENCY INDICATOR TS-446/U
(INDICATOR, ELECTRICAL, POTENTIAL, TS-446/U)

MANUFACTURERS' OR CONTRACTORS' DATA: (Continued)
Bell Sound Systems Incorporated, 1190 Essex Avenue, Columbus 27, Ohio; Contract No. AF 33(038)25693.

TUBE COMPLEMENT:
None.

REFERENCE DATA AND LITERATURE:

SHIPPING DATA:

No. of Boxes	Contents & Identification	Volume (Cu. Ft.)	Overall Dimensions (inches)			Weight Packed (Lbs.)
			H	W	D	
1	Radio Frequency Indicator TS-446/U (Domestic Packed)	.000725	5	1/2	1/2	0.5

EQUIPMENT SUPPLIED:

Quant. Per Eq't	Name and Nomenclature	Case Mat'l	Stock Numbers (USAF) (Navy) (Army)	Overall Dimensions (inches)			Weight (Lbs.)
				H	W	D	
1	Radio Frequency Indicator TS-446/U (Complete)	Lu- cite	7CAC-439725 3F4325-446	4-5/8 long	1/2 dia.		0.5 oz.
1	Neon Bulb G. E. Bulb T-2						
1	Probe				5/8 dia.		
1	Pencil Type Pocket Clip						
TS-446/U				- Electronics Test Equipment -			

FIELD STRENGTH METER TS-509/UR

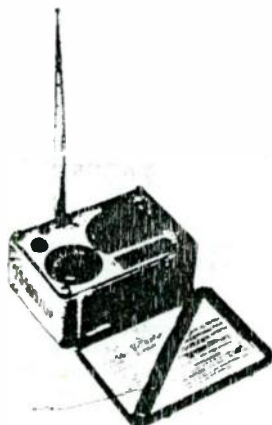

FUNCTIONAL DESCRIPTION:

A portable, general purpose, self-contained unit housed in its own watertight carrying case. This instrument provides an indication of the relative field strength and approximate frequency of RF energy emitted by a transmitter within its frequency range. No tubes, batteries, or power supply are needed. A six section telescoping antenna plugs into a receptacle on the control panel. This antenna has a 90° joint at its base so it can be extended either horizontally or vertically. Also, the case can be placed either on its bottom or side, whichever position is best suited for given operating conditions. An extra jack is provided for direct input connection of very weak signals. Tuning is controlled by a knob on the panel, which is attached to a pointer and dial system. The pointer indicates the resonant frequency of the tuned circuit on the dial. A microammeter dial also on the panel indicates relative field strength. A sensitivity control protects the microammeter from damage due to reception of signals whose strength would otherwise cause it to go off scale or burn out.

	AIR FORCE	NAVY	ARMY
TYPE CLASS.			
STOCK NOS.	7CAC-526230	F17-M-23375-1681	
PROCUREMENT INFO.:	Spec EP-387(Aer), Spec. 16M21(Aer)		
PROCUREMENT COG.:	Navy	DESIGN COG.:	Navy, BuAer
F.I.I.N.:	FUNCTIONAL CLASS. NO.		5.1.2
	- Electronics Test Equipment -		TS-509/UR

This project was supported by the USAF on Contract AF 33(6)90128176 and monitored by WADC, ARDC - Cor. L. Frederick Bethesda, Md. - Manufactured in U.S.A.

FIELD STRENGTH METER TS-509/UR

RELATIONSHIP TO OTHER EQUIPMENT:

ELECTROMECHANICAL DESCRIPTION:

Circuit Information: The tubular antenna is adjustable to a quarter wavelength of the transmitted signal. It is loosely coupled to a butterfly L-C resonating circuit. When the butterfly circuit is tuned to resonance, a voltage builds up across it. This voltage is applied through a coupling capacitor to a crystal rectifier. The rectified signal is directed through two RF chokes to the microammeter. The microammeter is shunted by a variable resistor which acts as a sensitivity control.

Power Supply: None required.

Frequency Range: 100 to 400 megacycles per second.

Type of Reception: Continuous Wave, Interrupted Continuous Wave.

Distance Range: 0 to 75 feet.

RF Power Input Rating: Up to 40 watts.

Basic Meter Range: 0 to 50 microamperes, DC.

Accuracy: (Basic Meter) $\pm 2\%$ of full scale reading.

$\pm 5\%$ or better of indicated frequency.

MANUFACTURERS' OR CONTRACTORS' DATA:

Harvey-Wells Electronics, Inc., Southbridge, Massachusetts; Navy Contract No. NOa(s)-10404.

TUBE COMPLEMENT:

1 JAN-1N21B (Rectifier).

REFERENCE DATA AND LITERATURE:

TO 16-35TS509-3 (Maintenance Instructions).

SHIPPING DATA:

No. of Boxes	Contents & Identification	Volume (Cu. Ft.)	Over-all Dimensions (inches)			Weight Packed (Lbs.)
			H	W	D	
TS-509/UR - Electronics Test Equipment -						

FIELD STRENGTH METER TS-509/UR

EQUIPMENT SUPPLIED:

Quant. Per Eq't	Name and Nomenclature	Case Mat'l	Stock (USAF) Numbers (Navy) (Army)	Over-all Dimensions (inches)			Weight (Lbs.)
				H	W	D	
1	Field Strength Meter TS-509/UR Including:	Alum- inum	7CAC-526430 F17-M-23375-1681	4-15/16	7-11/16	6	8
1	Rod Antenna			Extended and Straight 32-1/2	9/16	7/16	0.3
				Col- lapsed and Bent 90° 6-5/8	1-7/16	9/16	
- Electronics Test Equipment -							TS-509/UR

RADIO TEST SET AN/PRM-1A

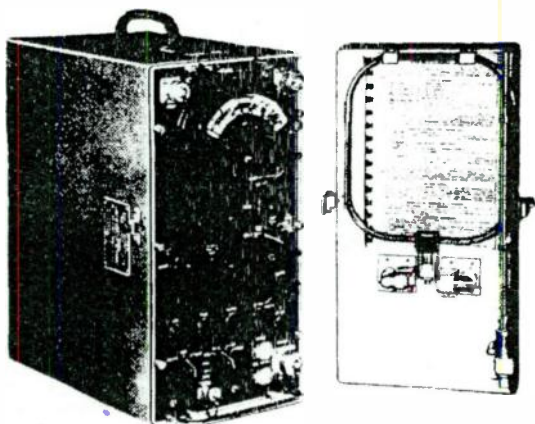

FUNCTIONAL DESCRIPTION:

A portable, general purpose radio interference and field intensity measuring equipment used for radio interference surveys to determine the source of radiated or conducted interference from any source within its frequency range. The test set may also be used as a selective two-terminal voltmeter to measure the gain of a radio frequency stage, to measure conducted interference on power and transmission lines and to provide null indications when used in conjunction with a radio frequency bridge. Measurements can be made with the equipment in terms of the peak value of the interference (the PEAK function), in terms of a weighted value (the QUASI-PEAK function), or in terms of the average value (the FIELD INTENSITY function). Results are indicated on a dial calibrated in frequency and on a meter calibrated in both microvolts and decibels. Charts provide calibration settings for the input device in use, the effective bandwidth of the equipment for any given frequency and determining sine wave signal strength in the presence of ambient interference of random nature. Provision is made for the monitoring of the received signal by means of a headset, an external oscilloscope or an external meter.

	AIR FORCE	NAVY	ARMY
TYPE CLASS.		Standard	
STOCK NOS.			
PROCUREMENT INFO.:	Spec MIL-T-16205		
PROCUREMENT COG.:	Navy	DESIGN COG.:	Navy, BuShips
F.I.L.N.:	FUNCTIONAL CLASS. NO.:		5.1.3
- Electronics Test Equipment -			AN/PRM-1A

RADIO TEST SET AN/PRM-1A

RELATIONSHIP TO OTHER EQUIPMENT.

Similar to Radio Interference Field Intensity Meter Stoddart NM-20B

ELECTROMECHANICAL DESCRIPTION:

Circuit Information: The equipment is essentially a seven band superheterodyne receiver provided with input attenuation and metering circuits for the measurement of detector output. The radio frequency signal received by the antenna or probe is delivered through a coaxial cable to the radio frequency input connector located on the front panel of the equipment. The radio frequency signal is amplified in the radio frequency stage and heterodyned with the local oscillator frequency in the mixer stage to produce an intermediate frequency. The intermediate frequency is amplified in four intermediate frequency stages and demodulated in the detector stage. The demodulated signal is acted upon by the meter detecting weighing circuits and applied to the vacuum tube voltmeter. The audio components are subsequently amplified and delivered to the headphone jacks.

Power Supply: 115 or 230 volts, AC $\pm 10\%$, 50 to 1600 cycles per second, single-phase, 25 watts, 87% power factor. Nine volts supplied by 2 Batteries Burgess 5360 (4.5 volts) and 1.5 volt supplied by 2 Batteries Burgess 2 (1.5 volt). Batteries required when AC is not available are 90 volts supplied by 2 Batteries Burgess 5308 (45 volts), and 1.5 volt supplied by 2 Batteries Burgess 4FII (1.5 volt).

Frequency Range: 0.15 to 25 megacycles per second in the following seven bands: 0.15 to 0.32, 0.32 to 0.75, 0.75 to 1.75, 1.75 to 3.8, 3.8 to 8, 8 to 15 and 15 to 25 megacycles per second.

Intermediate Frequency: 455 kilocycles per second for bands 1, 3 and 4; 1600 kilocycles per second for bands 2, 5, 6, and 7.

Image and Intermediate Frequency Rejection: 50 decibels minimum.

Meter Scale: 0 to 100 microvolts, 0 to 40 decibels.

Overall Effective Noise Bandwidth: 2 to 5 kilocycles per second.

Sensitivity:

As a Two Terminal Voltmeter: 1 microvolt at frequencies above 2 megacycles per second.

As a Field Intensity Meter: 2 microvolts per meter at frequencies above 2 megacycles per second using rod antenna.

Overload Capacity: 16 decibels.

Audio Output: 100 milliwatts

Audio Output Impedance: 600 ohms.

MANUFACTURERS' OR CONTRACTORS' DATA:

Stoddart Aircraft Rad. Co. Company, Inc. 6644 Santa Monica Boulevard, Hollywood 38, California

AN/PRM-1A

- Electronic Test Equipment -

RADIO TEST SET AN/PRM-1A

TUBE COMPLEMENT:

Radio Test Set: 3 1T4, 1 1R5, 4 3V4, 4 3A5, 1 1U5.

Power Supply: 1 2A20, 1 0A3/VR75.

REFERENCE DATA AND LITERATURE:

Instruction Book for NM-20B.

SHIPPING DATA:

No. of Boxes	Contents & Identification	Volume (Cu. Ft.)	Overall Dimensions (inches)			Weight Packed (Lbs.)
			H	W	D	
	Radio Test Set AN/PRM-1A					
- Electronic Test Equipment -						

EQUIPMENT SUPPLIED:

Quant. Per Eq'pt	Name and Nomenclature	Case Mat'l	Stock Numbers (USAF) (Navv) (Army)	Overall Dimensions (inches)			Weight (Lbs.)
				H	W	D	
1	Radio Test Set AN/PRM-1A	metal		14	7-9/16	16-7/16	37
1	Power Supply PP-472B/PRM-1	metal		7-17/32	10-1/2	8-3/8	18
1	Rod Antenna AT-213/PRM-1			41 long			
1	Loop Antenna AT-212/PRM-1				8-1/4 dia.		
1	Loop Probe AT-211/PRM-1				1/2 dia.		
1	Line Probe MX-980/PRM-1						
1	Impedance Matching Network CU-195/PRM-1						
1	Impedance Matching Network, 50 Ohms CU-197/PRM-1						
(Continued)							
- Electronics Test Equipment - AN/PRM-1A							

RADIO TEST SET AN/PRM-1A

EQUIPMENT SUPPLIED:

Quant. Per Eq'pt	Name and Nomenclature	Case Mat'l	Stock Numbers (USAF) (Navy) (Army)	Overall Dimensions (inches)			Weight (Lbs.)
				H	W	D	
1	AC Power Cable			72 long			
1	Power Supply Cable			120 long			
1	Antenna Cable			240 long			
1	Instruction Manual						

AN/PRM-1A

- Electronics Test Equipment -

RADIO INTERFERENCE MEASURING SET AN/URM-3

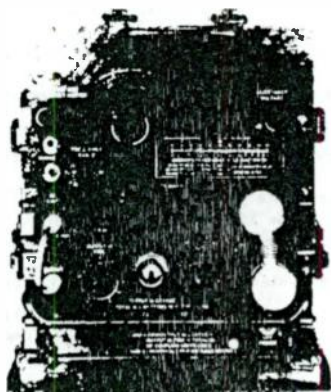

FUNCTIONAL DESCRIPTION:

A general purpose, field, and depot maintenance equipment used for detecting and measuring the intensity of radiated and conducted radio interference. Probes are provided for conducting exploratory interference tests, and matching and coupling networks are used to permit it to be used as a two-terminal RF microvoltmeter.

RELATIONSHIP TO OTHER EQUIPMENT:

ELECTROMECHANICAL DESCRIPTION:

Circuit Information: Consists basically of a superheterodyne receiver and a calibrated impulse noise generator which generates pulses exhibiting a stable and uniform spectrum throughout the range of the receiver, the peak value of which is adjustable to known values. The receiver is a six-band receiver with two tuned RF stages, a mixer, local oscillator, two IF stages, second detector, first audio
(Continued)

	AIR FORCE	NAVY	ARMY
TYPE CLASS.			
STOCK NOS.			
PROCUREMENT INFO.:	Spec MIL-T-10645(SigC) and Amendment 1		
PROCUREMENT COG.:	Army	DESIGN COG.: Army, CSL	
F.I.I.N.:	FUNCTIONAL CLASS. NO.: 513		
	- Electronics Test Equipment -		AN/URM-3

This project was supported by the USAF on Contract AF 33(600)29276 and monitored by WADC ABDC Cecil L. Frederick, Bethesda, Md. - Manufactured in U.S.A.

RADIO INTERFERENCE MEASURING SET AN/URM-3

ELECTROMECHANICAL DESCRIPTION: (Continued)

and output stages. The output of the impulse generator is injected into the receiver antenna input circuit in such a manner that interference measurement is independent of antenna impedance.

Power Supply: 115 volts, $\pm 10\%$, AC, single phase, 60 cycles per second; or 24 volts DC; or 12 volts DC.

Frequency Range: 0.15 to 0.4 and 1.6 to 40 megacycles per second in six bands. The ranges are 0.15 to 0.4, 1.6 to 3.0, 3.0 to 5.8, 5.8 to 11.0, 11.0 to 21.0, and 21.0 to 40.0 megacycles per second.

Voltage Range: 10 microvolts per megacycle to 31600 microvolts per megacycle.

Radio Noise Generator:

Pulse Duration: Approximately 0.01 microsecond.

Pulse Repetition Rate: 10 to 1000 pulses per second.

Pulse Amplitude: 0 to 90 decibels above one microvolt per megacycle or kilocycle bandwidth.

Spectrum: Flat to 40 megacycles per second within ± 3 decibels.

MANUFACTURERS' OR CONTRACTORS' DATA:

Designed by the Signal Corps Engineering Laboratories, Fort Monmouth, New Jersey.

TUBE COMPLEMENT:

R-178/URM-3: 1 JAN-OB2, 1 JAN-OA3/VR-75, 1 JAN-OC3/VR-105, 1 JAN-6AC7W, 1 JAN-6H6, 2 JAN-6SA7Y, 1 JAN-6SG7Y, 2 JAN-6SK7W, 1 JAN-6SQ7, 1 JAN-6V6GT.

TS-496/URM-3: 2 JAN-OA2, 1 JAN-OB3, 1 JAN-6J6, 1 JAN-5696.

REFERENCE DATA AND LITERATURE:

Preliminary Instruction Manual, 1 September 1950, Signal Corps Engineering Laboratories, Fort Monmouth, New Jersey.

SHIPPING DATA:

No. of Boxes	Contents & Identification	Volume (Cu. Ft.)	Over-all Dimensions (inches)			Weight Packed (Lbs.)
			H	W	D	
AN/URM-3 - Electronics Test Equipment -						

RADIO INTERFERENCE MEASURING SET AN/URM-3

EQUIPMENT SUPPLIED:

Quant. Per Eq'pt	Name and Nomenclature	Case Mat'l	Stock Numbers (USAF) (Navy) (Army)	Over-all Dimensions (inches)			Weight (Lbs.)
				H	W	D	
1	Test Set AN/URM-3			24-1/2	12	14-1/2	110
1	Mast Base AB-15/GR						
1	Antenna Bracket MT-195/URM-3						
1	Cable Assembly RG-55/U		3300-132335652	180 long			
1	Cable Assembly RG-55/U		3300-132335652	60 long			
1	Adapter UG-273/U		8850-102000				
1	Headset H-16/U						
1	Cord (Headset) CD-307						
1	Probe, Electric Field MX-839/URM-3						
1	Probe, Magnetic Field MX-838/URM-3						
1	Mast Section MS-116						
1	Mast Section MS-117						
1	Mast Section MS-118						
1	Cord (DC Power) CX-1063/URM-3						
1	Cord (AC Power) CX-1062/URM-3						
- Electronics Test Equipment -							AN/URM-3

RADIO TEST SET AN/URM-6

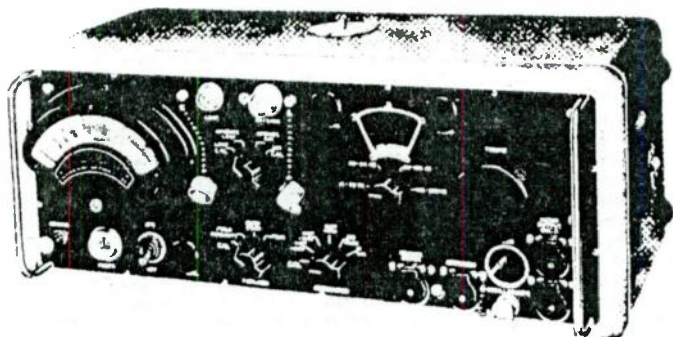

FUNCTIONAL DESCRIPTION:

A field and depot equipment used to measure the field intensity of a given radio transmission, to measure the intensity of radiated or conducted radio interference, or as a sensitive RF microvoltmeter within its frequency range. Two tripods are provided for mounting the large loop antenna and the superheterodyne receiver. Mounting provisions have been made on the receiver for either of two rod antennas and a small loop antenna. Signal monitoring provisions are available from panel-mounted headphones, oscilloscope, recorder, and remote meter jacks. Measurements are made using the panel-mounted meter or the remote meter and graphic recordings are made using the milliammeter-recorder. A calibration chart is furnished with the equipment.

RELATIONSHIP TO OTHER EQUIPMENT:

Similar to Stoddart Model NM-10A.

ELECTROMECHANICAL DESCRIPTION:

Circuit Information: The power input goes through an isolation transformer with filters to keep extraneous power-line noises out of the instrument. Input devices include rod antennas, loop antennas, a line probe, and impedance matching networks. Meter indications must be modified by the pick-up factor of the antenna

(Continued)

	AIR FORCE	NAVY	ARMY
TYPE CLASS.	Standard		
STOCK NOS.	7CAC 801319-26325		
PROCUREMENT INFO.:	Spec. MIL-T-16202 (Ships) dated 1 April 1951		
PROCUREMENT COG.:	Navy	DESIGN COG.:	Navy, BuShips
F.I.I.N.:	FUNCTIONAL CLASS. NO.:		5.1.3
	- Electronics Test Equipment -		AN/URM-6

This project was supported by the USAF Procurement Contract AF 33(600)22276 and monitored by WADC, ARDC, Carl L. Fredricks, Bethesda, Md. - Multilithed in U.S.A.

RADIO TEST SET AN/URM-6

ELECTROMECHANICAL DESCRIPTION: (Continued)

used. The receiver is a highly sensitive low frequency radio receiver which contains internal means for calibrating or standardizing its RF gain, thus permitting direct readings in indicated microvolts or microvolts per meter. Measurements can be made with the receiver in terms of the peak value of the signal or interference (the PEAK function), in terms of a weighted value (the QUASI-PEAK function), or in terms of the average value (the FIELD INTENSITY function).

The signal channel of the receiver resembles a conventional superheterodyne receiver in its RF, IF, and AF portions, but differs in its provision for attenuation and measurement of detector output. The RF signal is amplified in the RF stage and mixed with the local oscillator frequency in the mixer stage to produce an intermediate frequency. The IF signal is amplified in three IF stages and demodulated in the detector stage. The demodulated signal is acted upon by the meter detector weighting circuits and applied to the VTVM stage. The audio components are subsequently amplified and delivered to the headphone jacks.

Attenuator step ratio settings are built in the inputs of the RF, mixer, and IF stages.

Power Supply: 115 volts, $\pm 10\%$, or 230 volts, $\pm 10\%$, AC, single phase, 50 to 1600 cycles per second except for Milliammeter - Recorder which utilizes 60 cycles per second, 100 watts at 115 volts, 60 cycles. 3.0 volts, DC, supplied by two Battery, BA-30, for the Observer-Compass, Mark 1, Model O. A suitable battery pack can be used in place of the separate power supply, however, the Milliammeter-Recorder cannot be used.

Frequency Range: 14 to 250 kilocycles per second.

Intermediate Frequency: 12.5 kilocycles per second.

Audio Output: 100 milliwatts.

Audio Impedance: 600 ohms (headset).

Attenuator Setting: 0, 20, 40, 60, and 80 decibels.

Receiver Meter Scale: 0 to 100 microvolts, 0 to 40 decibels.

Voltage Range: 1 microvolt to 1 volt.

Field Intensity Range: 1 microvolt per meter to more than 1 volt per meter, depending on the antenna used.

Effective Bandwidth: 100 to 600 cycles per second at 6 decibels down, 2000 cycles per second at 60 decibels down.

Image Rejection: -50 decibels or better from signal level.

Intermediate Frequency Rejection: 60 decibels or better.

Signal-to-Noise Ratio: Unity or better.

Dynamic Range: 20 decibels at full scale.

Accuracy: Field Intensity Measurements, $\pm 10\%$ 10 microvolts per meter to 1 volt per meter.

MANUFACTURERS' OR CONTRACTORS' DATA:

Stoddart Aircraft Radio Company, 8644-C Santa Monica Boulevard, Hollywood 38, California; Contract No. NObsr-39263, 27 June 1947; Approximate Cost per Unit, \$4800.00.

TUBE COMPLEMENT:

1M-36/URM-6: 1 JAN-6AL5, 1 JAN-6AT6, 6 JAN-6AU6, 1 JAN-6BE6, 3 JAN-6C4, 1 JAN-6E5, 1 JAN-6J6, 1 JAN-6X4, 1 JAN-NE2.

PP-449/URM-6: 1 JAN-5Y3GT, 1 JAN-NE32, 2 JAN-OC3/VR-105.

AN/URM-6

- Electronics Test Equipment -

RADIO TEST SET AN/URM-6

REFERENCE DATA AND LITERATURE:

Navships 91196 (Instruction Book).

SHIPPING DATA:

No. of Boxes	Contents & Identification	Volume (Cu. Ft.)	Overall Dimensions (inches)			Weight Packed (Lbs.)
			H	W	D	
1	Radio Test Set AN/URM-6	26.2	25-1/2	37-1/2	47-1/2	297

EQUIPMENT SUPPLIED:

Quant. Per Eq'pt	Name and Nomenclature	Case Mat'l	Stock Numbers (USAF) (Navy) (Army)	Overall Dimensions (inches)			Weight (Lbs.)
				H	W	D	
1	Radio Test Set AN/URM-6		KAC-801319-26325				
1	Radio Interference Field Intensity Meter IM-36/URM-6			8	19-13/16	10-3/8	26.00
1	Transit Case CY-706/URM-6	Ply-wood		14-1/2	10-7/8	34-1/2	30.00
1	Power Supply PP-449/URM-6			7-31/32	9-29/32	19-3/4	24.75
1	Antenna AT-203/URM-6			51 long			
1	Antenna AT-204/URM-6			84 long			
1	Antenna AT-205/URM-6				5 dia.		
1	Adapter UG-537/U		1800-298292755				
1	RF Cable Assembly CG-577/URM-6						
1	Power Cable Assembly CADV-62480			72 long			
1	Special Purpose Cable Assembly CADV-62481			120 long			
1	Chart PT-107/URM-6						

(Continued)
AN/URM-6

- Electronics Test Equipment -

RADIO TEST SET AN/URM-6

EQUIPMENT SUPPLIED: (Continued)

Quant. Per Eq'pt	Name and Nomenclature	Case Mat'l	Stock Numbers (USAF) (Navy) (Army)	Over-all Dimensions (inches)			Weight (Lbs.)
				H	W	D	
1	Clipboard						
2	Instruction Book Navships 91196						
1	Headphone CW-49509						
1	Accessory Case CY-707/URM-6	Ply-wood		21-1/8	6-3/4	27-3/4	24.00
1	Observer-Compass with case Mark I, Model O			4-3/4	10-7/8	4-7/8	4.75
1	Ammeter ME-31/U						
1	Antenna AT-207/URM-6						
1	RF Probe MX-951/URM-6						
1	Impedance Matching Network CU-184/URM-6						
1	Impedance Matching Network CU-185/URM-6						
1	Impedance Matching Network CU-186/URM-6						
1	Cord CG-444/U			240 long			
1	Special Purpose Cable Assembly CG-571/U			240 long			
1	Special Purpose Cable Assembly CG-572/U			240 long			
							(Continued)
AN/URM-6		- Electronics Test Equipment -					

RADIO TEST SET AN/URM-6

R-1

EQUIPMENT SUPPLIED: (Continued)

Quant. Per Eq'pt	Name and Nomenclature	Case Mat'l	Stock Numbers (USAF) (Navy) (Army)	Over-all Dimensions (inches)			Weight (Lbs.)
				H	W	D	
1	Special Purpose Cable Assembly CG-571/U			72 long			
1	Special Purpose Cable Assembly CADV-62482			24 long			
1	Special Purpose Cable Assembly CG-573/U			36 long			
1	Case (Recorder) CY-708/URM-6	Ply- wood		18	14	11	15.00
1	Millimeter- Recorder with inking kit RD-59/U			13-1/4	8-9/16	8-3/4	
1	Power Cable Assembly CADV-62480			72 long			
1	Shoulder Strap						
1	Tripod Case CY-709/URM-6	Can- vas		41-1/2	9-1/4 dia.		5.00
2	Tripod MT-674/U						
1	Loop Case CY-710/URM-6	Ply- wood		33-3/4	5	33-7/8	36.00
1	Antenna AT-206/URM-6				30 dia.		
1	Shoulder Strap						
						Total:	222.00

- Electronics Test Equipment -

AN/URM-6

RADIO INTERFERENCE MEASURING SET AN/URM-7

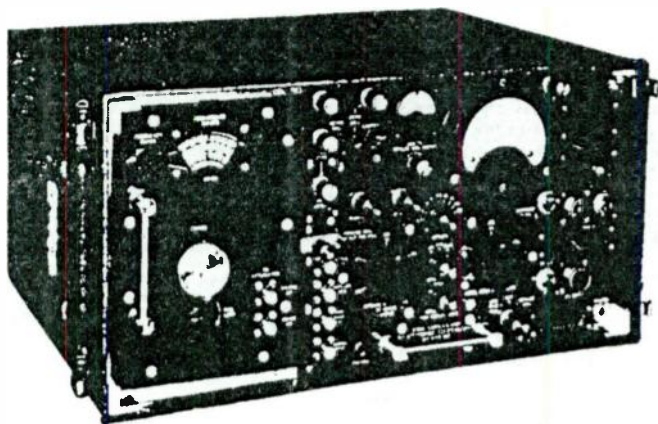

FUNCTIONAL DESCRIPTION:

A general purpose, field radio interference and field intensity meter designed primarily for the measurement of broadband interference although it incorporates facilities for CW interference and field intensity measurement. Test set incorporates an impulse generator used as a noise reference standard, whose output is calibrated in terms of microvolts per unit bandwidth. The visual output indicator is a peak reading vacuum tube voltmeter with a logarithmic scale calibrated in microvolts and a linear decibel scale calibrated in terms of decibels above one microvolt per megacycle. Probes are provided for conducting exploratory interference tests, and coupling networks are used to permit the test set to be used as a two-terminal noise-microvoltmeter.

RELATIONSHIP TO OTHER EQUIPMENT:

AN/URM-7 is similar to Empire Devices, Inc. Commercial Model NF-105.

	AIR FORCE	NAVY	ARMY
TYPE CLASS.			
STOCK NOS.			
PROCUREMENT INFO.:	Army Spec. SCL-1170		
PROCUREMENT COG.:	Army	DESIGN COG.:	Army, CSL
F.I.I.N.:	FUNCTIONAL CLASS. NO.: 5. 1. 3		
- Electronics Test Equipment -			AN/URM-7

This project was supported by the USAF on Contract AF 33(600)12076 and monitored by WADC, ARDC, Carl L. Friedrich, Bethesda, Md. - Multiplied in U.S.A.

RADIO INTERFERENCE MEASURING SET AN/URM-7

ELECTROMECHANICAL DESCRIPTION:

Circuit Information: The impulse generator output is injected into the input circuit of the tuner in such a manner as to permit measurement of open circuited antenna terminal voltage on a per megacycle basis. The tuner utilizes a superheterodyne circuit. The frequency range is covered by means of two plug-in type RF heads. The logarithmic scale characteristic of the output indicator is achieved through tapered pole-pieces in the indicating meter movement, which eliminates the necessity of using automatic gain control. The dipole antenna, used for field intensity measurement applications, can be resonated at each test frequency. The broadband antenna is used in suppression test applications where the antenna must be placed close to the source of interference.

Power Supply: 115 volts $\pm 10\%$, AC, single phase, 50 to 400 cycles, 100-volt-amperes; or 24 volts, DC; or 12 volts, DC.

Frequency Range: 20 to 200 megacycles, 200 to 400 megacycles.

Intermediate Frequency Range: 10.7 megacycles, 30 megacycles.

Voltage Range: 12 microvolts per megacycle to 1, 200, 000 microvolts per megacycle (for 20 to 200 megacycles)
6 microvolts per megacycle to 5, 000, 000 microvolts per megacycle (for 200 to 400 megacycles).

Indicating Meter Scale: 0.5 to 10 microvolts

-6 to +20 decibels (10 decibel scale expansion; ± 4 provided for scale overlap).

Calibration Standards:

(a) Spot frequency sine wave generator.

(b) Broadband impulse noise generator (output externally available)

Pulse duration: 5×10^{-4} microseconds.

Pulse Repetition Rate: 2.5 to 2500 pulses per second.

Pulse Amplitude: 47 to 97 decibels above one microvolt per megacycle bandwidth.

Spectrum: Flat to 100 megacycles within $\pm 1/2$ decibels.

Accuracy: $\pm 10\%$, voltage.

MANUFACTURERS' OR CONTRACTORS' DATA:

Empire Devices, Inc., 38-25 Bell Boulevard, Bayside, New York, Contract No. W36-039-sc-38120; Approximate Cost per Unit, \$4650.00, 1953.

TUBE COMPLEMENT:

8 JAN-6BJ6, 4 JAN-12AT7, 3 JAN-12AU7, 5 JAN-6X4, 1 JAN-OA2, 5 JAN-6AK5,
1 JAN-6AL5, 1 JAN-6AB4, 1 JAN-6J6, 1 JAN-6F4, 1 JAN-5876, 1 JAN-1N21B
(Crystal), 1 JAN-1N34 (Crystal).

REFERENCE DATA AND LITERATURE.

AN/URM-7 - Electronics Test Equipment -

RADIO INTERFERENCE MEASURING SET AN/URM-7

SHIPPING DATA:

No. of Boxes	Contents & Identification	Volume (Cu. Ft.)	Over-all Dimensions (inches)			Weight Packed (Lbs.)
			H	W	D	

EQUIPMENT SUPPLIED:

Quant. Per Eq't	Name and Nomenclature	Case Mat'l	Stock Numbers (USAF) (Navy) (Army)	Over-all Dimensions (inches)			Weight (Lbs.)
				H	W	D	
1	Radio Interference Measuring Set, AN/URM-7			9-1/2	18-3/4	14-5/8	65
1	Carrying Case (Spare)						
1	Accessory Carrying Case						
1	Dipole Antenna Set						
1	Tripod						
1	Line Probe (50 ohms)						
1	Magnetic-Field Probe						
1	Electric-Field Probe						
1	Balanced Injection Block						
1	Unbalanced Injection Block						
2	RF Cable			360 long			
1	Power Line Cord						
1	Earphones						
1	Alignment Harness						
1	Operation Manual						
- Electronics Test Equipment -							AN/URM-7

RADIO TEST SET AN/URM-17

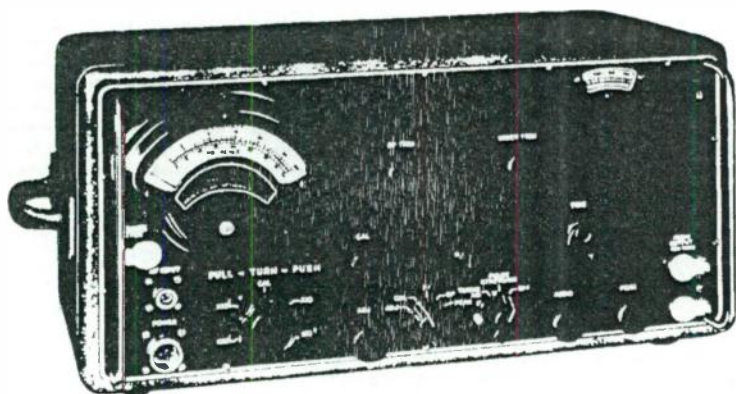

FUNCTIONAL DESCRIPTION:

A field and depot equipment used for intensity measurements of all types of radio-frequency energy in the radio frequency spectrum. It contains internal means for calibrating or standardizing its gain. Measurements can be made with the receiver in terms of the peak value of the interference (the PEAK function), in terms of a weighted value (the QUASI-PEAK function), or in terms of the average value (the FIELD INTENSITY function). The indicating meter scale on the panel is directly calibrated for a two decade, approximately logarithmic range of 1 to 100 microvolts, and an approximately linear 0 to 40 decibel range. Charts provided with the equipment show actual effective bandwidth versus frequency.

RELATIONSHIP TO OTHER EQUIPMENT:

Similar to Stoddart Model NM-50A

	AIR FORCE	NAVY	ARMY
TYPE CLASS.	Standard		
STOCK NOS.	7CAC-801319-254145		
PROCUREMENT INFO.:	Spec MIL-T-16870 (Ships) dated 6 December 1951.		
PROCUREMENT COG.:	Navy	DESIGN COG.:	Navy, BuShips
F.I.I.N.:	FUNCTIONAL CLASS. NO. 5.1.3		
	- Electronics Test Equipment -		AN/URM-17

This project was supported by the USAF on Contract AF 53(60R)28276 and monitored by WJ-DC, PRDC - Cor: L. Frederick, Bethesda, Md - Multiplied in U.S.A.

RADIO TEST SET AN/URM-17

ELECTROMECHANICAL DESCRIPTION:

Circuit Information: The signal channel closely resembles a superheterodyne receiver in its RF, IF, and AF portions, but differs from most superheterodyne receivers in its provision for attenuation and measurement of detector output.

The RF signal as picked up by the antenna or probe is delivered to the RF input receptacle and passes through the RF stage. It is then mixed with the local oscillator frequency in the mixer stage, to produce the intermediate frequency. The IF signal is amplified in six IF stages and demodulated in the detector stage. The demodulated signal is acted upon by the meter detector weighing circuits and applied to the VTVM stage, thus actuating the meter. The audio components are subsequently amplified and delivered to the headphone jacks.

Power Supply: 115 volts, $\pm 10\%$, AC, or 230 volts, $\pm 10\%$, AC, single phase, 50 to 1600 cycles per second, 110 watts at 115 volts or a suitable battery pack used in place of the separate power supply.

Frequency Range: 375 to 1000 megacycles per second.

Intermediate Frequency: 60 megacycles per second.

Input Impedance: 50 ohms.

Attenuator Steps: 60 decibels to 140 decibels.

Effective Bandwidth: Approximately 1.8 megacycles at signal of 1000 megacycles to 1.0 megacycles at signal of 370 megacycles.

Image Rejection: 40 decibels or better.

Spurious Response Rejection: 40 decibels or better.

Intermediate Frequency Rejection: Better than 60 decibels.

Voltage Range: 100 microvolts to 10 volts.

Field Intensity Range: 100 microvolts per meter to 100 volts per meter.

Signal-to-Noise Ratio: Unity or better based on an equipment sensitivity of 10 microvolts as a two-terminal voltmeter.

Audio Output: 100 milliwatts or better.

Audio Output Impedance: 600 ohms.

Dynamic Range: 20 decibels.

MANUFACTURERS' OR CONTRACTORS' DATA:

Stoddart Aircraft Radio Company, 6644 Santa Monica Boulevard, Hollywood 38, California; Contract No. NObSr-42430; 30 June 1948.

TUBE COMPLEMENT:

IM-52/URM-17: 2 JAN-6AL5, 1 JAN-6AR5, 7 JAN-6BH6, 2 JAN-6C4, 2 JAN-6F4, 1 JAN-9005, 1 JAN-12AU7, 1 JAN-1N21B (Crysta! Rectifier).

PP-530/URM-17: 1 JAN-6AS7G, 1 JAN-6BH6, 1 JAN-NE-32.

REFERENCE DATA AND LITERATURE:

Navships 91388 (Instruction Book).

RADIO TEST SET AN/URM-17

SHIPPING DATA:

No. of Boxes	Contents & Identification	Volume (Cu. Ft.)	Overall Dimensions (inches)			Weight Packed (Lbs.)
			H	W	D	
1	Radio Test Set, AN/URM-17	8.3	18-1/4	43-1/2	19	170

EQUIPMENT SUPPLIED:

Quant. Per Eq'pt	Name and Nomenclature	Case Mat'l	Stock Numbers (USAF) (Navy) (Army)	Overall Dimensions (inches)			Weight (Lbs.)
				H	W	D	
1	Radio Test Set AN/URM-17 Including:		7CAG-801319-254145				
1	Radio Interference Field Intensity Meter IM-52/URM-17			9-3/16	19-3/16	10-3/8	30
1	Transit Case CY-866/URM-17	Ply-wood		16-1/4	23-3/4	10-7/8	25
1	Chart Set PT-210/URM-17						
2	Instruction Book Navships 91388						
1	Accessory Case CY-865/URM-17	Ply-wood		14-5/8	15-1/2	10-1/8	17
1	Power Supply PP-530/URM-17			7-31/32	9-29/32	19-3/4	16
1	Antenna AT-255/URM-17	Brass	F16-A45194-7901	5-1/2 (extends to 16)			
1	RF Probe DT-56/URM-17		N16-P-87008-4021	2-31/32 long	9/16 OD		
1	Impedance Matching Network CU-227/URM-17		N16-N-30826-1073	2-31/32 long	9/16 OD		

(Continued)
AN/URM-17

- Electronics Test Equipment -

RADIO TEST SET AN/URM-17

EQUIPMENT SUPPLIED: (Continued)

Quant. Per Eq't	Name and Nomenclature	Case Mat'l	Stock Numbers (USAF) (Navy) (Army)	Over-all Dimensions (inches)			Weight (Lbs.)
				H	W	D	
1	Power Cable Assembly CADV-62480			72 long			
1	Special Purpose Cable Assembly CADV-62481		NI7-C-48703-5521	120 long			
1	RF Cable CG-678/U		NI6-C-11957-3021	240 long			
1	Glow Lamp JAN-NE-32 (Spare)		2Z5809-8				
1	Ballast Lamp (Spare)		NI6-B-85001-1511				
1	Cable Connector (20 ohms)			1-11/16 long	53/64 OD		
1	Tripod Bag CW-218/URM-17	Can- vas		39-3/4 high	6-1/4 dia.		3.25
1	Tripod Navy Type- 10545	Wood	NI6-T-802001 107	37-1/2 (extends to 60)			
1	Antenna Mast Section AB-189/URM-17			36-1/8 long	1 dia.		
1	Azimuth Dial Assembly	Alum- inum	NI6-I-21801-1045	3 long	2-1/4 dia.		
1	Azimuth Dial Pointer		NI6-K-701645-401	3/4 long	2 dia.		
						Total:	109.25
AN/URM-17 - Electronics Test Equipment -							

FIELD INTENSITY METER AN/URM-41

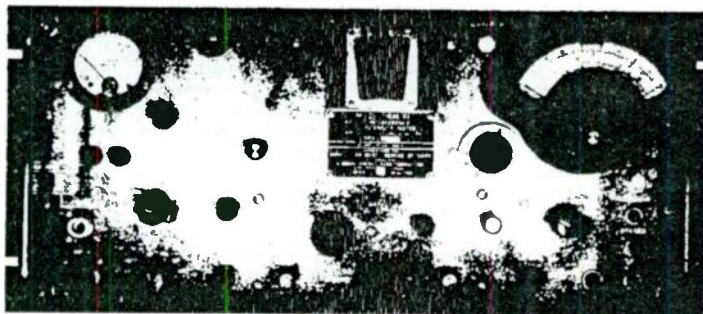

FUNCTIONAL DESCRIPTION.

A portable, general purpose, very low frequency radio interference and field intensity measuring instrument designed for use during interference or field strength surveys to determine the source and magnitude of radiated or conducted signals. Separate analysis of magnetic and electric fields may be made. The instrument may also be used as an ultra-sensitive audio frequency microvoltmeter. Signals may be measured in quasi-peak, average, or true peak values.

RELATIONSHIP TO OTHER EQUIPMENT:

The AN/URM-41 is the military equivalent of the Stoddart Radio Interference Field Intensity Meter NM-40A.

ELECTROMECHANICAL DESCRIPTION.

Circuit Information: The field intensity meter consists fundamentally of two types

(Continued)

	AIR FORCE	NAVY	ARMY
TYPE CLASS.			
STOCK NOS.			
PROCUREMENT INFO.:	Contract NOsr-71168		
PROCUREMENT COG.:	Navy	DESIGN COG.:	Navy, BuShips
F.I.L.N.:	FUNCTIONAL CLASS. NO.:		5.1.3
	- Electronics Test Equipment -		AN/URM-41

FIELD INTENSITY METER AN/URM-41

ELECTROMECHANICAL DESCRIPTION:

of receivers, one selective and the other wideband. In selective operation the set functions as a tunable superhetrodyne receiver. The set incorporates an untuned radio frequency amplifier, a low-pass filter, an intermediate frequency amplifier having an adjustable bandwidth, an amplifier employing an automatic gain control to obtain logarithmic action, and detector and indicating circuits. The detector circuit time constant provides RMS indication of the signal. When the test set is used as a wideband receiver the same radio frequency amplifier is used to feed signals through wideband amplifiers to the detector and metering circuits. In wideband operation the signal bypasses the selective intermediate frequency amplifiers. The detector circuits are weighted to provide average, quasi-peak or peak analysis of signals. Audio and video outputs are obtained from jacks located on the front panel.

Power Supply: 105 to 125 volts, AC, single-phase, 50 to 60 cycles per second, 250 volt-amperes.

Selective Frequency Range: 30 cycles per second to 15 kilocycles per second.

Wideband Frequency Range: Output flat from 100 cycles per second to 15 kilocycles per second. Output 6 decibels down at approximately 150 kilocycles per second. Correction curve supplied for frequencies 30 to 200 cycles per second.

Input Impedance: 50, 600, 10,000 and 100,000 ohms.

Intermediate Frequency: 25 kilocycles per second.

Selectivity: Effective noise bandwidth 9.0 to 60 cycles per second, 6 decibel bandwidth 13 to 90 cycles per second, 40 decibel bandwidth 60 to 500 cycles per second.

Image Rejection: 60 decibels or greater.

Spurious Response Rejection: 55 decibels or better.

Intermediate Frequency Rejection: 60 decibels or better.

Selective Sensitivity: (As an asymmetric voltmeter, narrowest bandwidth, detector in average function, and 10,000 ohm input impedance).

Frequency Range

Signal Measurable for a 20 decibel Signal/Noise Ratio

30 to 300 cycles per second

10 microvolts

300 to 1000 cycles per second

2.5 microvolts

1000 to 15,000 cycles per second

1.5 microvolts

Full Scale Sensitivity: 10 microvolts, attenuated.

Wideband Sensitivity: 100 microvolts full scale deflection with no attenuation and 100,000 ohm input impedance, detector in average function, 150 microvolts for a 20 decibel signal to noise ratio, maximum.

Selective Meter Indication: Two decade logarithmic calibrated 0.1 to 10.0 microvolts.

Wideband Operation Meter Indication: Single decade linear scale, suppressed zero.

FIELD INTENSITY METER AN/URM-41

ELECTROMECHANICAL DESCRIPTION: (Continued)

Attenuation: 100 decibels in 5 decades.

Audio Output: 100 milliwatts minimum into 600 ohms with full scale signal and BFO on.

Wideband Dynamic Range: Approximately 28 decibels above full scale deflection for quasi-peak operation.

Loop Sensitivity: 10 microvolts meter indication for an equivalent radiated field of 400 microvolts per meter at 1000 cycles per second. Frequency/amplitude response is proportional to frequency.

Probe Sensitivity: Voltage reading of 10 microvolts for an electric field of 200 microvolts per meter. Response flat with frequency.

Calibrator:

Type: 400 cycle per second tuning fork.

Stability: $\pm 0.2\%$ total deviation for a temperature change of -15° C to $+50^{\circ}$ C

MANUFACTURERS' OR CONTRACTORS' DATA:

Stoddart Aircraft Radio Company, Incorporated, 6644 Santa Monica Boulevard, Hollywood 38, California; Contract No. NObser-71168.

TUBE COMPLEMENT:

3 5751, 3 5814, 3 5879, 2 5726, 6 6A6, 2 6AQ5W, 4 6X25, 3 6X7Z, 3 6C4W, 1 5R4WGA, 1 6080, 1 56F1, 2 12AT7WA.

REFERENCE DATA AND LITERATURE:

Technical Manual for Radio Interference-Field Intensity Meter AN/URM-41
NavShips 92739

SHIPPING DATA:

No. of Boxes	Contents & Identification	Volume (Cu. Ft.)	Overall Dimensions (inches)			Weight Packed (Lbs.)
			H	W	D	
- Electronic Test Equipment - AN/URM-41						

FIELD INTENSITY METER AN/URM-41

EQUIPMENT SUPPLIED:

Quant. Per Eq'pt	Name and Nomenclature	Case Mat'l	Stock Numbers	Overall Dimensions (inches)			Weight (Lbs.)
				(USAF)	(Navy)	(Army)	
1	Field Intensity Meter AN/URM- 41						
1	Including: IM-121/URM-41 Radio Interfer- ence Measuring Set						
1	Power Supply 91182-2						
1	Cable Assembly Power, Electri- cal 91258-1						
1	Cable Assembly Power, Electri- cal 91186-2						
1	Capacitive Probe 91183-2						
1	Support. Test Prod. (Capaci- tive Probe Moun- ting Assembly) 90689-2						
1	Cable Assembly, Capacitive Probe 91185-2						
1	Loop Antenna 90117-2						
1	Loop Cable Ass- embly 90048-2						
							(Continued)
AN/URM-41			- Electronics Test Equipment -				

FIELD INTENSITY METER AN/URM-41

EQUIPMENT SUPPLIED: (Continued)

Quant. Per Eq'pt	Name and Nomenclature	Case Mat'l	Stock Numbers	Overall Dimensions (inches)			Weight (Lbs.)
				(USAF)	(Navy)	(Army)	
1	Tripod 90095-2						
1	Coupler, Antenna 91184-2						
1	Case, Radio In- terference Measuring Set 91187-2						
1	Antenna (for use with capacitive probe) 91299-2						
1	Case, Power Supply 91188-2						
1	Radio Frequency Cable Assembly 90757-2						
1	Headphones, Crystal 91384-2						
1	Headphones, 600 ohms 10796						
1	Remote Meter						
1	Special Purpose Cable Assembly (for remote meter) 90075-2						
1	Chart Set 91140-2						
1	Tripod Bag 90186-2						

- Electronics Test Equipment -

(Continued)
AN/URM-41

FIELD INTENSITY METER AN, URM-41

EQUIPMENT SUPPLIED: (Continued)

Quant. Per Eq'pt	Name and Nomenclature	Case Mat'l	Stock Numbers (USAF); (Navy) (Army)	Overall Dimensions (inches)			Weight (Lbs.)
				H	W	D	
1	Special Purpose Cable Assembly (Headphone ex- tension) 90074-1						
1	Millimeter- Recorder 90097-2						
1	Special Purpose Cable Assembly Recorder Cable 90075-1						
1	Special Purpose Cable Assembly (use with Oscil- loscope) 90075-1						
1	Lead, Test (Cap- acitive probe calibration cable, two conductors, 18 inches) 91248-1						
1	Lead, Test (Cap- acitive probe calibration cable, one conductor; 18 inches) 91247-1						
1	Case, Access- ories (Loop case) 91144-2						
2	Instruction Book NavShips 92739						
AN/URM-41		- Electronics Test Equipment -					

RADIO INTERFERENCE MEASURING SET AN/URM-47

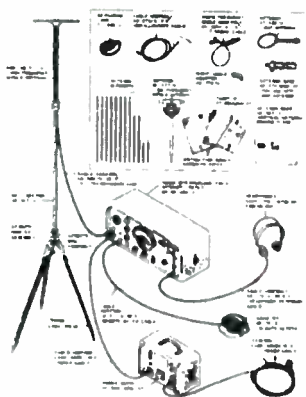

FUNCTIONAL DESCRIPTION:

A general purpose, highly sensitive, HF and VHF, superheterodyne receiver used to locate and measure radio interference and field intensities. In addition, it is used to adjust directive antennas and to explore radiation patterns, where the field intensity may vary over a wide range of values. The main component of the set is a selective, two-terminal voltmeter designed to measure RF interference or the intensity of radiated or conducted RF signals. The equipment also contains a power supply and antennas for signal pickup.

RELATIONSHIP TO OTHER EQUIPMENT:

ELECTROMECHANICAL DESCRIPTION:

Circuit Information: A calibrated meter, a function switch, and dipole antennas make it possible to make qualitative measurements of the intensity of radio

(Continued)

	AIR FORCE	NAVY	ARMY
TYPE CLASS.		Standard	
STOCK NOS.			
PROCUREMENT INFO.: Spec. MIL-STD-125			
PROCUREMENT COG.: Navy		DESIGN COG.: Navy, BuShips	
F.I.I.N.:		FUNCTIONAL CLASS. NO.: 5 1 3	
- Electronics Test Equipment -			AN/URM-47

RADIO INTERFERENCE MEASURING SET AN/URM-47

ELECTROMECHANICAL DESCRIPTION: (Continued)

signals and interference. By proper adjustment of the function switch, the meter will record the peak, weighted, or average value of the signal picked up by the antennas. A beat frequency oscillator facilitates the accurate tuning of weak signals. By observing the zero beat note or audio null of the oscillator, the strength of the weak signal can be accurately measured.

Power Supply: 105 to 125 volts or 210 to 250 volts, AC, 50 to 1000 cycles per second, single phase.

Frequency Range: 20 to 400 megacycles per second.

Frequency Calibration Accuracy: $\pm 2\%$

Meter Calibrations: 1 to 100 microvolts; 0 to 40 decibels.

Meter Accuracy: $\pm 1\%$.

Input Impedance: 50 ohms.

Type of Receiver: Superheterodyne.

Sensitivity: 1 to 60 microvolts per meter.

Spurious Response Rejection: Greater than 40 decibels.

IR Rejection: Greater than 60 decibels.

Audio Output: 100 millivolts into 600 ohm, noninductive load.

Oscilloscope Output: Frequency response flat within 3 decibels from 20 to 100,000 cycles per second depending upon scope loading.

MANUFACTURERS' OR CONTRACTORS' DATA:

Stoddart Aircraft Radio Company, Hollywood 38, California; Navy Contract NObsr-52301, 26 March 1951.

TUBE COMPLEMENT:

1 JAN-OA2, 1 JAN-OB2, 1 JAN-1N63, 1 JAN-5R4GY, 1 JAN-5651, 1 JAN-5718, 1 JAN-5726, 2 JAN-5814, 4 JAN-5840, 2 JAN-6AU6WA, 6 JAN-6BH6, 1 JAN-6AQ5, 1 JAN-6080, 4 JAN-6135.

REFERENCE DATA AND LITERATURE:

NAVSHIPS Instruction Book 92147.

SHIPPING DATA:

No. of Boxes	Contents & Identification	Volume (Cu. Ft.)	Over-all Dimensions (inches)			Weight Packed (Lbs.)
			H	W	D	
1	Radio Interference Measuring Set AN/URM-47	13.9	18-7/8	48-3/4	26-1/4	212
AN/URM-47 - Electronics Test Equipment -						

RADIO INTERFERENCE MEASURING SET AN/URM-47

EQUIPMENT SUPPLIED:

Quant. Per Eq'pt	Name and Nomenclature	Case Mat'l	Stock Numbers (USAF) (Navy) (Army)	Over-all Dimensions (inches)			Weight (Lbs.)
				H	W	D	
1	Radio Interference Measuring Set AN/URM-47						
	Consisting of:						
1	Test Case CY-1527/URM-47			13-1/2	23-3/4	11-5/16	50
	Containing:						
1	RI-FI Meter IM-88/URM-47			7-5/8	19-13/16	10-3/8	
1	Headphone (GFE) Navy Type 49753						
2	Chart Set PT-188/URM-47						
2	Instruction Book NavShips 92147			11	8-1/2		
1	Accessories Case CY-1525/ URM-47			16-1/8	15-1/2	10-5/8	46
	Containing:						
1	Power Supply FP-906/URM-47			7-17/32	10-1/2	8-3/8	
1	Ammeter ME-76/U						
1	Antenna Base AB-364/U						
1	RF Cable Assy. CG-1064/U						
1	Assembly CADV-62480						
1	Combination Cable Assembly						
1	Antenna Case CY-1526/URM-47						
	Containing:						
							(Continued)
- Electronics Test Equipment -							AN/URM-47

RADIO INTERFERENCE MEASURING SET AN/URM-47

EQUIPMENT SUPPLIED: (Continued)

Quant. Per Eq'pt	Name and Nomenclature	Case Mat'l	Stock Numbers (USAF) (Navy) (Army)	Over-all Dimensions (inches)			Weight (Lbs.)
				H	W	D	
1	Mast AB-371/U						
1	Antenna AT-477/U						
2	Mast Section AB-363/U						
1	Tripod CADV-10545						
1	Antenna AT-426/U						
1	Antenna Base AB-374/URM-47						
1	Measuring Tape TL-635/U						
1	Rt. Angle Adapter UG-27B/U		8850-108716				
1	Azimuth Dial Assembly						
1	Azimuth Pointer Assembly						
1	Antenna Elements Set						
						Total:	132
AN/URM-47 - Electronics Test Equipment -							

NOISE AND FIELD INTENSITY METER
MODEL NF-105
(Empire Devices Products Corporation)

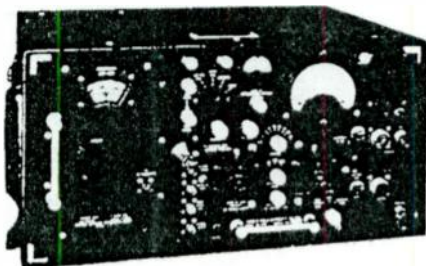

FUNCTIONAL DESCRIPTION.

A general purpose equipment used to detect and measure the intensity of radio frequency signals. The instrument is used for field intensity measurements, radio frequency interference measurements, antenna pattern measurements, and determining the harmonic output of oscillators used in transmitters and receivers. Carrier or peak measurements of continuous wave signals are indicated on a meter calibrated in microvolts and decibels above a microvolt. Peak indication of broadband signals is achieved by direct indication or by the aural slide-back method. Broadband interference is indicated in microvolts per megacycle (or per kilocycle) of bandwidth.

RELATIONSHIP TO OTHER EQUIPMENT.

(Continued)

	AIR FORCE	NAVY	ARMY
TYPE CLASS.			
STOCK NOS.			
PROCUREMENT INFO.:			
PROCUREMENT COG.:	DESIGN COG.: Commercial		
F. I. L. N.:	FUNCTIONAL CLASS. NO.: 5, 1, 3		
- Electronics Test Equipment - Empire NF-105			

NOISE AND FIELD INTENSITY METER
MODEL NF-105
(Empire Devices Products Corporation)

ELECTROMECHANICAL DESCRIPTION:

Circuit Information: The instrument consists of a basic measuring unit and four interchangeable plug-in tuning units. The basic measuring unit contains the circuits which are common to all frequency ranges of the equipment. These include the vacuum tube voltmeter, sine-wave calibrator, impulse generator, audio amplifier, power supplies and attenuators. The radio frequency and the intermediate frequency circuits are contained in the tuning units. A 12 inch loop antenna or vertical pickup rod is used for measurements in the 150 kilocycles per second to 30 megacycles per second range. A broadband antenna or dipole antennas with matching balun transformers are used for measurements in the range from 20 to 1000 megacycles per second. A clamp-on probe or a 50- or 500- ohm line probe is used for conducted measurements.

Power Supply: 115 volts, AC, 50 to 400 cycles per second, 100 volt-amperes.

Tuning Unit A:

Frequency Range: 150 kilocycles per second to 30 megacycles per second in 6 bands

Intermediate Frequency: 455 and 1600 kilocycles per second.

Full Scale Sensitivity: 1 microvolt maximum

Noise Bandwidth: 10 kilocycles per second

Tuning Unit 1:

Frequency Range: 20 to 200 megacycles per second in 2 bands.

Intermediate Frequency: 10.7 megacycles per second.

Full Scale Sensitivity: 10 microvolts maximum.

Noise Bandwidth: 100 kilocycles per second.

Tuning Unit 2:

Frequency Range: 200 to 400 megacycles per second continuous.

Intermediate Frequency: 30 megacycles per second.

Full Scale Sensitivity: 10 microvolts maximum.

Noise Bandwidth: 200 kilocycles per second

Tuning Unit 3:

Frequency Range: 400 to 1000 megacycles per second in 2 bands.

Intermediate Frequency: 300 kilocycles per second.

Full Scale Sensitivity: 10 microvolts maximum.

Noise Bandwidth: 300 kilocycles per second.

Narrow Band Voltage Measurement Range: 1 to 100,000 microvolts.

Broadband Voltage Measurement Range: 1 microvolt divided by the bandwidth in megacycles per second to 100,000 microvolts divided by the bandwidth in megacycles per second (microvolts per megacycle).

Input Impedance: 50 ohms.

Impulse Noise Generator:

Frequency: Flat to 1000 megacycles per second, 40.5 decibel.

**NOISE AND FIELD INTENSITY METER
MODEL NF-105**

(Empire Devices Products Corporation)

ELECTROMECHANICAL DESCRIPTION: (Continued)

Pulse Repetition Rate: 2.5 to 2500 pulses per second.

Peak Output: Variable 37 to 97 decibels above 1 microvolt per megacycle bandwidth.

Meter Calibration: 0.5 to 10 microvolts, -6 to +20 decibels.

MANUFACTURERS' OR CONTRACTORS' DATA:

Empire Devices Products Corporation, Amsterdam, New York, Approximate Cost per Unit, \$9100.00

TUBE COMPLEMENT:

REFERENCE DATA AND LITERATURE:

Manufacturer's Catalog.

SHIPPING DATA:

No. of Boxes	Contents & Identification	Volume (Cu. Ft.)	Overall Dimensions (inches)			Weight Packed (Lbs.)
			H	W	D	
	Noise and Field Intensity Meter Empire NF-105					
- Electronic Test Equipment -						Empire NF-105

NOISE AND FIELD INTENSITY METER
MODEL NF-105
(Empire Devices Products Corporation)

EQUIPMENT SUPPLIED:

Quant. Per Eq'pt	Name and Nomenclature	Case Mat'l	Stock Numbers	Overall Dimensions (inches)			Weight (Lbs.)	
				(USAF) (Navy) (Army)	H	W		D
1	Noise and Field Intensity Meter Empire NF-105				9-1/2	18-3/4	14-5/8	
1	Basic Measuring Unit, Empire BA-105							
1	Tuning Unit, Empire T-A/NF- 105							
1	Tuning Unit, Empire T-1/NF- 105							
1	Tuning Unit, Empire T-2/NF- 105							
1	Tuning Unit, Empire T-3/NF- 105							
1	Standard Acces- sory Kit, Empire KT-105-D							
Empire NF-105 - Electronics Test Equipment -								

FIELD INTENSITY METER
 MODEL NE-112
 (Empire Devices Products Corporation)

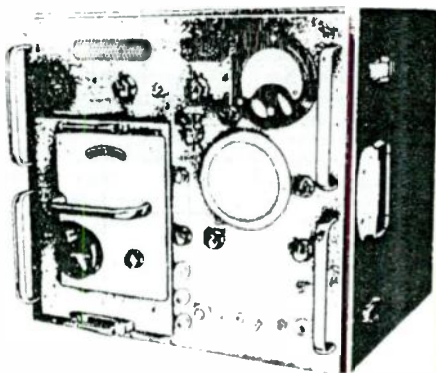

FUNCTIONAL DESCRIPTION

A portable, general purpose instrument designed for field intensity and RF interference measurements in the frequency range of 10 to 100 kilomegacycles. The instrument may also be used for antenna pattern analysis, determination of harmonic or spurious frequency output of transmitters, receiver local oscillator radiation measurements, determination of shielding effectiveness, and may be used as a tunable sensitive null detector or sensitive RF vacuum tube voltmeter. Test results are indicated on a meter located on the front panel of the instrument. Carrier or peak measurements of CW signals are indicated in microvolts, and decibels above 1 microvolt. Broadband interference is indicated directly in microvolts per megacycle bandwidth. Peak indication of broadband signals is achieved by direct meter reading or by the aural slide-back method.

RELATIONSHIP TO OTHER EQUIPMENT

	AIR FORCE	NAVY	ARMY
TYPE CLASS.			
STOCK NOS.			
PROCUREMENT INFO.:			
PROCUREMENT COG.:		DESIGN COG.: Commercial	
E.I.N.:		FUNCTIONAL CLASS. NO.: 5.1.1	
	- Electronics Test Equipment -		Empire NE-112

FIELD INTENSITY METER
MODEL NF-112
 (Empire Devices Products Corporation)

ELECTROMECHANICAL DESCRIPTION.

Circuit Information: The equipment consists basically of a superhetrodyne receiver, calibrating circuits, and indicators. The unit covers the frequency range by means of four plug-in RF tuners. The circuits common to all frequency ranges (i.e., intermediate amplifiers, vacuum tube voltmeter, impulse generator, detectors, audio amplifiers, and power supply), are housed in the basic measuring unit. An impulse generator producing a flat spectrum throughout the frequency range of the instrument serves as the calibrator. A single multiposition coaxial resistive step attenuator provides RF and IF attenuation. The instrument incorporates double tuned cavities preceding the first mixer, thus, reducing the possibility of pulse overload and cross modulation.

Power Supply: 115 volts, AC, 50 to 450 cycles per second.

Frequency Range: 1.0 to 10.0 kilomegacycles in four bands

Voltage Range:

Carrier Intensity: 10.0 microvolts to 10.0 volts.

Effective Noise Bandwidth: 1.0 and 5.0 megacycles per second.

Input Impedance: 50 ohms.

Impulse Noise Generator:

Frequency: Flat to 10.0 kilomegacycles within ± 0.5 decibel.

Pulse Repetition Rate: 1000 cycles per second.

Peak Output: 73 decibels above 1.0 microvolt per megacycle bandwidth.

Indicating Meter: 4.5-inch logarithmic movement calibrated 5 to 100 microvolts and ± 14 to 40 decibels.

MANUFACTURERS' OF CONTRACTORS' DATA:

Empire Devices Products Corporation, Amsterdam, New York

TUBE COMPLEMENT:

REFERENCE DATA AND LITERATURE:

Manufacturer's Catalog No. F-958

SHIPPING DATA:

No. of Boxes	Contents & Identification	Volume (Cu. Ft.)	Overall Dimensions (inches)			Weight Packed (lbs.)
			H	W	D	
Empire NF-112 - Electronic Test Equipment -						

**FIELD INTENSITY METER
MODEL NF-112
(Empire Devices Products Corporation)**

EQUIPMENT SUPPLIED:

Quant. Per Eq'pt	Name and Nomenclature	Case Mat'l	Stock Numbers (USAF) (Navy) (Army)	Overall Dimensions (inches)			Weight (Lbs.)
				H	W	D	
1	Basic Measuring Unit BA-112			15	19	15	120
1	Tuning Unit No. 1, 1.0 to 2.0 kmc T-1/NF-112						
1	Tuning Unit No. 2, 2.0 to 4.0 kmc T-2/NF-112						
1	Tuning Unit No. 3, 4.0 to 7.0 kmc T-3/NF-112						
1	Tuning Unit No. 4, 7.0 to 10.0 kmc T-4/NF-112						
- Electronics Test Equipment -				Empire NF-112			

FIELD INTENSITY METER
MODEL FIM
(Polarad Electronics Corporation)

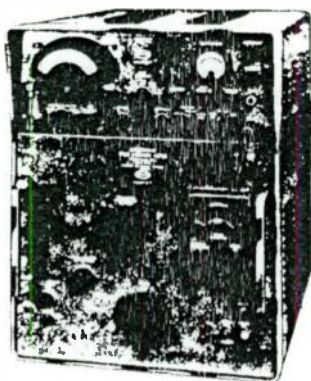

FUNCTIONAL DESCRIPTION:

A portable, general purpose, field intensity meter designed for locating and measuring radio frequency interference and making field intensity measurements in the frequency range of 1.0 kilomegacycles to 10.0 kilomegacycles. The FIM can be used to determine the source and magnitude of radiated or conducted interference. The equipment can also be used for adjusting directive antennas, exploring radiation patterns, intermediate frequency attenuator measurements, standing wave ratio measurements, insertion losses where field intensity may vary over a wide range of values. Measurements can be made in terms of average, quasi-peak, or peak value of the signal. In addition to providing circuitry for calibrating or standardizing its gain for precalibrated measurements, the test set also provides a means of accurately measuring the average value of a signal by the direct signal substitution method. Detection of an unmodulated signal is aided by the use of an audio frequency oscillator modulating the incoming signal. Detected signals are audibly monitored by the use of headphones.

	AIR FORCE	NAVY	ARMY
TYPE CLASS.			
STOCK NOS.			
PROCUREMENT INFO.:			
PROCUREMENT COG.:	DESIGN COG.: - Commercial -		
F.L.L.N.:	FUNCTIONAL CLASS. NO.: 5.1.3		
	- Electronics Test Equipment -		Polarad FIM

**FIELD INTENSITY METER
MODEL FIM
(Polarad Electronics Corporation)**

RELATIONSHIP TO OTHER EQUIPMENT:

ELECTROMECHANICAL DESCRIPTION.

Circuit Information: The test set is basically a frequency-selective voltmeter employing a triple conversion superhetrodyne receiver. The equipment consists of three major units, a monitor unit (FIM-B), four plug-in tuning units (FIM-L-S-M and -X); and a power unit (FIM-P). The monitor unit consists of the control and monitoring portion of the FIM. The lower section of the monitor unit is designed to accept any of the four tuning units. The four tuning units cover the entire frequency range of the receiver and provide single-dial, direct-reading, continuous frequency tuning with automatically tracked repeller voltages. The power unit contains the high- and low-voltage supplies necessary for operation of the equipment.

Power Supply: 115 volts $\pm 10\%$, AC, 50 to 450 cycles per second, single-phase, 700 watts.

Frequency Range: Band 1: 1.00 to 2.24 kilomegacycles per second. Band 2: 2.14 to 4.34 kilomegacycles per second. Band 3: 4.20 to 7.74 kilomegacycles per second. Band 4: 7.36 to 10.00 kilomegacycles per second.

Frequency Calibration Accuracy: Better than $\pm 1.0\%$

Input RF Voltage Range: 20 microvolts to 3 volts

Input Impedance: 50 ohms nominal

Bandwidth: 5.0 ± 0.5 megacycles per second at -6 decibels.

Impulse Bandwidth: 5.0 megacycles per second

Image and Spurious Response Rejection: Better than 60 decibels.

Signal Attenuation Range: 0 to 80 decibels in 20 decibel steps, 60 decibels RF, 20 decibels IF.

Intermediate Frequencies: First, 260 megacycles per second, second, 140 megacycles per second, third, 40 megacycles per second.

Weighting Circuit Time Constants:

Average and Peak Measurements: 0.1 ± 0.05 microsecond, charge.

0.3 ± 0.03 microsecond, discharge

Quasi-peak Measurements: 50 ± 10 microseconds, charge.

500 ± 100 milliseconds, discharge

Audio Output: 100 milliwatts minimum into 600 ohms

Video Output: 0.5 volt minimum across 2 megohms

Recorder Output: 0 to 1 milliampere, 1500 ohms

Calibration Signal (CW): 0.2 volt to 5 microvolts, rms, 0 to -95 decibels below a milliwatt

MANUFACTURERS' OR CONTRACTORS' DATA:

Polarad Electronics Corporation, 1-20 34th Street, Long Island City 1, New York, Approximate Cost per Unit, \$19,464.00

Polarad FIM - Electronic Test Equipment -

**FIELD INTENSITY METER
MODEL FIM
(Polarad Electronics Corporation)**

TUBE COMPONENT:

1 OA2, 3 OB2 6 5R4WGA, 1 6AN5, 10 6AU6, 9 6X4, 3 12AT7, 1 5814, 4 OA3/
VR75, 12 6AK5, 4 5721 or 6390, 1 5722, 1 6AL5, 2 5751, 2 5836, 2 5837, 2 5876,
1 5933, 3 6AQ5, 2 6080, 2 6J6, 2 1N23C, 2 1N86 or D979, 1 1N28A, 2 1N69,
1 1N198.

REFERENCE DATA AND LITERATURE:

Microwave, Field Intensity Meter, Model FIM, Preliminary Handbook of In-
structions (Serial Nos. 13) and up).

SHIPPING DATA:

No. of Boxes	Contents & Identification	Volume (Cu. Ft.)	Overall Dimensions (inches)			Weight Packed (Lbs.)
			H	W	D	
- Electronic Test Equipment -						Polarad FIM

FIELD INTENSITY METER
 MODEL FIM
 (Polarad Electronics Corporation)

EQUIPMENT SUPPLIED:

Quant. Per Eq'pt	Name and Nomenclature	Case Mat'l	Stock Numbers (USAF) (Navy) (Army)	Overall Dimensions (inches)			Weight (Lbs.)
				H	W	D	
1	Monitor Unit Model FIM-B			17 - 13/16	23 - 1/2	21 - 1/2	70
1	Band 1 Tuning Unit Model FIM-L			17 - 3/8	16	14 - 1/2	50
1	Band 2 Tuning Unit Model FIM-S			17 - 3/8	16	14 - 1/2	50
1	Band 3 Tuning Unit Model FIM-M			17 - 3/8	16	14 - 1/2	50
1	Band 4 Tuning Unit Model FIM-X			17 - 3/8	16	14 - 1/2	50
1	Power Unit Model FIM-P			16 - 5/32	19 - 13/16	25 - 1/2	115
1	Omnidirectional Antenna Model CA-B			9 - 3/16	9 - 3/16	10 - 9/32	2.5
1	Band 1 Direc- tive Antenna Model CA-L			9 - 7/16	13 - 3/4	8	2
1	Band 2 Direc- tive Antenna Model CA-S			10 - 1/2	13 - 29/32	17 - 11/16	3.5
1	Band 3 Feed Horn Model CA-M			2 - 1/4	1 - 15/16	3 - 1/4	0.5
1	Band 4 Feed Horn Model CA-X			1 - 15/32	1 - 5/8	3 - 1/8	0.5

(Continued)

Polarad FIM - Electronics Test Equipment -

FIELD INTENSITY METER
 MODEL FIM
 (Polarad Electronics Corporation)

EQUIPMENT SUPPLIED: (Continued)

Quant. Per Eq'pt	Name and Nomenclature	Case Mat'l	Stock Numbers (USAF) (Navy) (Army)	Overall Dimensions (inches)			Weight (Lbs.)
				H	W	D	
1	Antenna Reflec- tor, Model CA-R			19 - 15/16	20 - 13/16	13 - 3/16	2
1	Tripod Model CA-T			5	36 - 1/2	5	5
1	RF Cable			6 ft. long			1
1	Interconnecting Cable No. 1			8 ft. long			2.5
1	Interconnecting Cable No. 2			4 - 3/4 long			0.25
1	Interconnecting Cable No. 3			8 long			0.3
1	Power Cable			10 ft. long			1.5
1	Wrench Set						
- Electronics Test Equipment -							
Polarad FIM							

RADIO FREQUENCY MEASURING SET
MODEL NM-60A
(Stoddart Aircraft Radio Company, Incorporated)

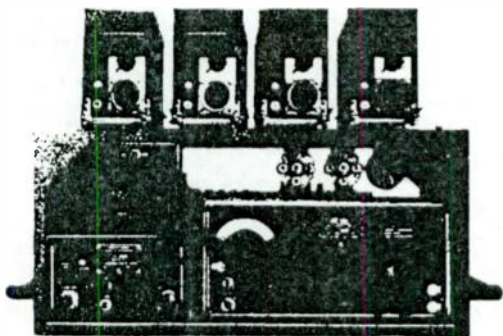

FUNCTIONAL DESCRIPTION

A portable, general purpose radio interference measuring set used for detecting and measuring the intensity of radiated and conducted radio interference in the S, L, and X portions of the frequency spectrum. The instrument may also be used for field intensity measurements in the frequency range from 1000 megacycles per second to 10,700 megacycles per second.

RELATIONSHIP TO OTHER EQUIPMENT

An AN/APR-9 RF tuner is required but not supplied. The Stoddart NM-60A is the modified commercial equivalent of the AN/URM-42.

ELECTROMECHANICAL DESCRIPTION:

Circuit Information The unit consists basically of a double superhetrodyne receiver incorporating an AN/APR-9 tuner. Test results are indicated by means of a calibrated meter located on the front panel. Three detector weighting circuit functions permit average, quasi-peak or peak analysis of the signal being

(Continued)

	AIR FORCE	NAVY	ARMY
TYPE CLASS.			
STOCK NOS.			
PROCUREMENT INFO.:			
PROCUREMENT COG.:	DESIGN COG.: Commercial		
E. L. L. N.:	FUNCTIONAL CLASS. NO.: 5.1.3		
	- Electronics Test Equipment - Stoddart NM-60A		

**RADIO FREQUENCY MEASURING SET
MODEL NM-60A**
(Stoddart Aircraft Radio Company, Incorporated)

ELECTROMECHANICAL DESCRIPTION (Continued)

measured. An impulse calibration method is employed to standardize the receiver gain for direct meter readings over the entire frequency range.

Power Supply: 105 to 125 volts, AC, 50 to 400 cycles per second, single-phase, 375 watts

Frequency Range: 1500 to 10,000 megacycles per second in four bands

Intermediate Frequencies: 160 and 60 megacycles per second.

Selectivity: 1.5 megacycles per second bandwidth at the 6 decibel points.

Image Rejection: 60 decibels or better.

Intermediate Frequency Rejection: 60 decibels or better.

Sensitivity as a Two Terminal Voltmeter: 5 to 15 microvolts

Sensitivity as a Field Intensity Meter:

Broadband Conical Antenna With 6-Foot Cable: 48 to 58 decibels above 1.0 microvolt per meter, 44 to 64 decibels above 1.0 microvolt per meter per megacycle.

Directional Horn Antennas With 6-Foot RF Cable: 44 to 48 decibels above 1.0 microvolt per meter, 40 to 44 decibels above 1.0 microvolt per meter per megacycle.

Signal to Noise Ratio: Unity or better, based on stated sensitivity.

Audio Output: 100 milliwatts into 600 ohms, based on 1000 cycles per second, 50% modulation, and output indication of 10 microvolts.

Dynamic Range: 20 decibels.

MANUFACTURERS' OR CONTRACTORS' DATA:

Stoddart Aircraft Radio Company, Incorporated, 5644 Santa Monica Boulevard, Hollywood 38, California. Approximate Cost per Unit, \$7,664.00; approved for use with Specifications MIL-I-11748B (Signal Corps), MIL-I-16910A (SHIFS), and MIL-I-26600 (U. S. Air Force).

TUBE COMPLEMENT:

REFERENCE DATA AND LITERATURE:

Manufacturer's Catalog.

PACKAGING DATA:

No. of Boxes	Contents & Identification	Volume (Cu. Ft.)	Overall Dimensions (inches)			Weight Packed (Lbs.)
			H	W	D	

Stoddart NM-60A - Electronic Test Equipment -

RADIO FREQUENCY MEASURING SET
MODEL NM-60A
(Stoddart Aircraft Radio Company, Incorporated)

EQUIPMENT SUPPLIED:

Quant. Per Eq'pt	Name and Nomenclature	Case Mat'l	Stock Numbers (USAF) (Navy) (Army)	Overall Dimensions (inches)			Weight (Lbs.)
				H	W	D	
1	Meter, Radio- Interference- Field Intensity						
4	RF Tuners with Shock Trays and Power Plugs (Customer furnished)						
1	RF Tuner Power Supply						
1	RI-FI Meter Power Supply						
1	Power Supply 24 vdc						
1	Impulse Calibrator						
1	Control Panel						
1	Turrent Attenuator						
1	Junction Box						
3	Electrical Co- axial Switches						
1	Set Inter-connect- ing Cables						
1	Antenna (Small) Discone 1 0- 10.7 kmc						
1	Antenna, Band 1 1 0-2.5 kmc						

(Continued)

- Electronics Test Equipment -

Stoddart NM-60A

RADIO FREQUENCY MEASURING SET
 MODEL NM-60A
 (Stoddart Aircraft Radio Company, Incorporated)

EQUIPMENT SUPPLIED:

Quant. Per Eq'pt	Name and Nomenclature	Case Mat'l	Stock Numbers	(USAF) (Navy) (Army)	Overall Dimensions (inches)			Weight (Lbs.)
					H	W	D	
1	Antenna, Band 2 2.5-4.4kmc							
1	Antenna, Band 3* 4.4-7.0kmc							
1	Antenna, Band 4 7.0-10.7kmc							
1	Antenna Reflector							
1	Tripod							
1	Tripod Index Head							
1	Remote Meter							
1	Remote Meter Cable							
1	Headset Exten- sion Cable							
Stoddart NM-60A - Electronics Test Equipment -								

RADIO INTERFERENCE MEASURING SET
MODEL NM-62A
(Stoddart Aircraft Radio Company, Incorporated)

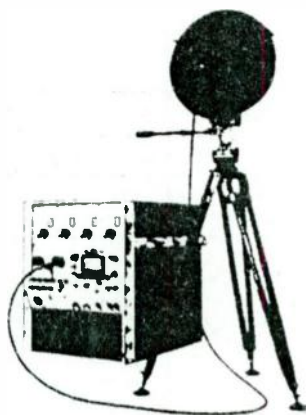

FUNCTIONAL DESCRIPTION

A general purpose microwave superheterodyne receiver designed for detecting and measuring radio frequency interference and making field intensity measurements. The equipment may also be used as a selective two-terminal voltmeter for conducted interference measurements. Quantitative frequency and field intensity measurements can be made in terms of average, quasi-peak direct-reading peak, or slideback peak detector functions. A meter on the front panel has an approximately logarithmic 2 decade scale calibrated in microvolts and an approximately linear scale calibrated in decibels. Calibration charts are provided with the equipment.

RELATIONSHIP TO OTHER EQUIPMENT

Commercial equivalent to Radio Interference Measuring Set AN/URM-138.

ELECTROMECHANICAL DESCRIPTION

Circuit Information The frequency range of the equipment is covered by means

(Continued)

	AIR FORCE	NAVY	ARMY
TYPE CLASS.			
STOCK NOS.			
PROCUREMENT INFO.:			
PROCUREMENT COG.: Navy		DESIGN COG.: Navy, BuShips	
F.I.L.N.:		FUNCTIONAL CLASS. NO.: 5.1.3	
- Electronics Test Equipment - Stoddart NM-62A			

RADIO INTERFERENCE MEASURING SET
MODEL NM-62A
(Stoddart Aircraft Radio Company, Incorporated)

ELECTROMECHANICAL DESCRIPTION: (Continued)
of four integral radio frequency tuners. A motor drive system is connected to the tuners and provides for automatic scanning over the frequency range of the equipment. An internal impulse generator is used as the reference standard to calibrate the gain of the equipment. An automatic frequency control circuit is provided to compensate for any long period frequency drift in the incoming signal. A turret attenuator provides for attenuation of received signals. Jacks and connectors on the front panel provide a stretched video output for connection to an oscilloscope, an intermediate frequency output for connection to a panadapter, a DC output for connection to a rectilinear plotter, and an audio output for connection of a headset. An internal speaker is also provided for monitoring the audio signal. An omnidirectional broadband disccone antenna is provided to cover the entire frequency range of the equipment. The disccone antenna is used primarily as a vertically polarized pickup device. A separate directive antenna is provided for each of the four radio frequency tuners. The antennas for bands 1 and 2 are of the horn type, the antennas for use with bands 3 and 4 are horn-fed parabolic assemblies. The antennas are equipped with mounting plates for attachment to a tripod. The power supply is transformerized. Power Supply: 115 or 230 volts, AC, 50 to 60 cycles per second or 400 cycles per second, single-phase, 450 watts.

Frequency Range: 1 to 10 gigacycles (kilomegacycles) per second in four bands.
Narrow Band Sensitivity (Signal-to-Noise Ratio of Unity):

500 Kilocycle Per Second Bandwidth:

Two Terminal 50 Ohm Input: 2 to 4 microvolts, 6 to 12 decibels above 1 microvolt, -101 to -95 decibels referred to 1 milliwatt.

Horn Antennas: 20 to 40 microvolts per meter, 26 to 32 decibels above 1 microvolt per meter.

Disccone Antenna: 80 to 640 microvolts per meter, 38 to 56 decibels above 1 microvolt per meter.

5 Megacycle Per Second Bandwidth:

Two Terminal 50 Ohm Input: 6 to 12 microvolts, 16 to 22 decibels above 1 microvolt, -91 to -85 decibels referred to 1 milliwatt.

Horn Antennas: 60 to 120 microvolts per meter, 36 to 43 decibels above 1 microvolt per meter.

Disccone Antenna: 240 to 1920 microvolts per meter, 48 to 66 decibels above 1 microvolt per meter.

RADIO INTERFERENCE MEASURING SET
MODEL NM-62A
(Stoddart Aircraft Radio Company Incorporated)

ELECTROMECHANICAL DESCRIPTION - (Continued)
Broadband Sensitivity (Signal-to-Noise Ratio of Unity):

500 Kilocycle Per Second Bandwidth:

Two Terminal 50 Ohm Input: 13 to 26 microvolts per megacycle per second.
22 to 28 decibels above 1 microvolt per megacycle per second.

Horn Antennas: 130 to 260 microvolts per meter per megacycle per second.
42 to 48 decibels above 1 microvolt per meter per megacycle per second.
Disccone Antenna: 520 to 4160 microvolts per meter per megacycle per second.
54 to 72 decibels above 1 microvolt per meter per megacycle.

5 Megacycle Per Second Bandwidth:

Two Terminal 50 Ohm Input: 4 to 8 microvolts per megacycle per second.
12 to 18 decibels above 1 microvolt per megacycle per second.

Horn Antennas: 40 to 80 microvolts per meter per megacycle per second.
32 to 38 decibels above 1 microvolt per meter per megacycle per second.
Disccone Antenna: 160 to 1280 microvolts per meter per megacycle per second.
44 to 62 decibels above 1 microvolt per meter per megacycle per second.

Voltage Measurement Range: 120 decibels greater than rated sensitivity, 40 decibels in lowest attenuator position. Additional 80 decibels of attenuation in 20 decibel steps.

Input Impedance: 50 ohms with less than 1.5 to 1 voltage standing-wave ratio.
Intermediate Frequency Output: 60 megacycles per second, 10 millivolts across 50 ohms.

Video Output: Bandwidth 2.5 megacycles per second; Output impedance 300 ohms.
Analog Output:

X Axis: 0 to 10 volts DC, voltage proportional to frequency.

Y Axis: 3.3 volts DC across 100,000 ohm load at full scale meter deflection.

Internal Speaker Output: 1 watt, maximum.

Audio Output: 100 milliwatts into 600 ohms, maximum.

Impulse Generator Accuracy: ± 1 decibel over entire frequency range.

Spurious Response Rejection, Image: 60 decibels minimum; all others, 80 decibels minimum.

Case Shielding Effectiveness: 90 decibels.

Local Oscillator Radiation: Less than 200 microwatts.

Meter Range: 0 to 100 microvolts, 0 to 40 decibels.

Meter Overload Capacity: 20 decibels past full scale deflection.

Stretched Video Pulse Width: 0, 33, 160 or 800 microseconds.

RADIO INTERFERENCE MEASURING SET
MODEL NM-62A
 (Stoddart Aircraft Radio Company, Incorporated)

ELECTROMECHANICAL DESCRIPTION: (Continued)

Horn, Band 1:

Frequency Range: 1 to 2.3 gigacycles per second.

Power Gain: 8 decibels at 1 gigacycle, 16 decibels at 2.3 gigacycles per second.

Antenna Factor: 20.5 decibels at 1 gigacycle per second, 22 decibels at 2.3 gigacycles per second.

Horn, Band 2:

Frequency Range: 2.3 to 4.4 gigacycles per second.

Power Gain: 16 decibels at 2.2 gigacycles per second, 22 decibels at 4.4 gigacycles per second.

Antenna Factor: 20 decibels at 2.3 gigacycles per second, 21 decibels at 4.4 gigacycles per second.

Horn with Reflector, Band 3:

Frequency Range: 4.4 to 7.3 gigacycles per second.

Power Gain: 23 decibels at 4.3 gigacycles per second, 28 decibels at 7.3 gigacycles per second.

Antenna Factor: 18 decibels at 4.3 and 7.3 gigacycles per second.

Horn with Reflector, Band 4:

Frequency Range: 7.3 to 10 gigacycles per second.

Power Gain: 28 decibels at 7.3 gigacycles per second, 31 decibels at 10 gigacycles per second.

Antenna Factor: 18.5 decibels at 7.3 and at 10 gigacycles per second.

Reflector Characteristics: 18 inch solid parabola with 7 inch focal length.

VSWR of Horn and Discone Antennas: Less than 2 to 1.

MANUFACTURERS' OR CONTRACTORS' DATA:

Stoddart Aircraft Radio Company, Incorporated, 6644 Santa Monica Boulevard, Hollywood 38, California; Approximate Cost per Unit, \$18,000.00.

TUBE COMPLEMENT:

REFERENCE DATA AND LITERATURE:

Manufacturer's Brochure.

SHIPPING DATA:

No. of Boxes	Contents & Identification	Volume (Cu. Ft.)	Overall Dimensions (inches)		Weight Packed (Lbs.)
			W	D	
	Radio Interference Measuring Set, Stoddart NM-62A				
Stoddart NM-62A - Electronic Test Equipment -					

**RADIO INTERFERENCE MEASURING SET
MODEL NM-62A**
(Stoddart Aircraft Radio Company, Incorporated)

EQUIPMENT SUPPLIED:

Quant. Per Eq'pt	Name and Nomenclature	Case Mat'l	Stock Numbers	Overall Dimensions (inches)			Weight (Lbs.)	
				(USAF) (Navy) (Army)	H	W		D
1	Radio Interference Measuring Set NM-62A	Metal			28	24	22	280
1	Horn Antenna Stoddart 91888-1				13-3/8	7-1/8	19-3/8	
1	Horn Antenna Stoddart 91889-1				13-9/16	10-1/4	23-5/8	
1	Horn Antenna Stoddart 91890-1							
1	Horn Antenna Stoddart 91891-1							
1	Antenna Mount- ing Base Stoddart 92341-1							
1	Antenna Reflec- tor, Stoddart 91892-1				19-1/4	18-5/8	13-1/4	
1	Disc Antenna, Stoddart 90794-2							
1	Antenna Tripod Stoddart 92245-1							
1	RF Cable Stoddart 92477-1				72 long			
1	AC Power Cable, Stoddart 92342-1				72 long			
- Electronics Test Equipment - Stoddart NM-62A								

PICKUP ASSEMBLY TS-131/AP
(METER, FIELD STRENGTH, TS-131/AP)



1. Adapter M-359
2. Case CY-108/AP
3. Cord CX-149/AP
4. Pickup Unit
5. Control Box C-111/AP



FUNCTIONAL DESCRIPTION:

A special purpose test antenna assembly used to indicate the relative output of a transmitting antenna installed on an airplane. The equipment is not designed for permanent installation and is used for test purposes only on Transmitting Equipment such as AN/APT-1, Radar Set AN/APT-2, etc.

RELATIONSHIP TO OTHER EQUIPMENT:

TS-131A/AP is an improved model.

Equipment required but not supplied: Test Set I-139-A (0-1 milliamper, DC, milliammeter with cord and plug). Since some transmitter adjustments also require the use of I-139-A, it is advantageous to use two I-139-A.

ELECTROMECHANICAL DESCRIPTION:

Circuit Information: The short antenna rod which is included in the Pickup Assembly TS-131/AP is mounted near the transmitting antenna on the exterior of the

(Continued)

	AIR FORCE	NAVY	ARMY
TYPE CLASS.	Standard		
STOCK NOS.	7CAC-526237		3F4325-131
PROCUREMENT INFO.:	USAF Spec. No. 71-5051		
PROCUREMENT COG.:	USAF	DESIGN COG.	USAF, ARL
F.I.I.N.:	FUNCTIONAL CLASS. NO.: 5.2		
	- Electronics Test Equipment -		TS-131/AP

PICKUP ASSEMBLY TS-131/AP
(METER, FIELD STRENGTH, TS-131/AP)

ELECTROMECHANICAL DESCRIPTION: (Continued)

aircraft for testing purposes. This antenna picks up a small portion of the radiation. The signal is rectified by a crystal connected between the antenna rod and ground and is then fed through a radio frequency choke into a shielded cable. The radio frequency choke is provided to prevent the cable capacity from short circuiting the crystal at high frequencies.

After passing through the shielded cable, the rectified signal is fed to a rheostat which is in series with DC milliammeter (Test Set I-139-A). The rheostat provides control over the current through the I-139-A so that the equipment may be used over a wide range of input signal strengths.

Power Supply: No power source is required for operation of the pickup assembly
Frequency Range: 20 to 1000 megacycles per second approximately.

MANUFACTURERS' OR CONTRACTORS' DATA:

Cover Dual Company, 5215 Ravenwood Avenue, Chicago, Illinois; Order No 659-DAY-44; Approximate Cost per Unit, \$49.13, Order No. 649-44, 22 February 1944; Approximate Cost per Unit, \$23.31, Order No. 985-44, 18 September 1944. Approximate Cost per Unit, \$20.95.

TUBE COMPLEMENT:

1 JAN-1N21B (Crystal Rectifier)

REFERENCE DATA AND LITERATURE:

TO 16-35TS131-2 (Maintenance Instructions).
TO 16-55-80 (Spare Parts List).

SHIPPING DATA:

No. of Boxes	Contents & Identification	Volume (Cu. Ft.)	Over-all Dimensions (inches)			Weight Packed (Lbs.)
			H	W	D	
1	Pickup Assembly, TS-131/AP, with accessories. (Shelf package - water resistant carton)	.50	12	8	9	9.5

TS-131/AP

- Electronics Test Equipment -

PICKUP ASSEMBLY TS-131/AP
(METER, FIELD STRENGTH, TS-131/AP)

EQUIPMENT SUPPLIED:

Quant. Per Eq'pt	Name and Nomenclature	Case Mat'l	Stock Numbers (USAF (Navy) (Army)	Over-all Dimensions (inches)			Weight (Lbs.)
				H	W	D	
1	Pickup Assem- bly TS-131/AP less accessories		7CAC-526237 3F4325-131	6-1/2	1	4	0.3
1	Control Box C-111/AP		1690-325938400 3F1795-111	1-31/32	2-11/32	1-27/32	0.4
1	Cord CX-149/AP		1690-322849979 3E6000-149	420 long			0.8
1	Adapter M-359		8850-107500 22299-359				0.1
1	Case CY-108/AP	Wood	1690-326125585 3F2529-108	9-7/8	5-11/16	6-5/16	
4	Snap Slide Stud		1690-295757257 2Z8634-3				
3	Spare Crystal 1N21B		3300-234137010 2J1N21B				
						Total:	1.6
- Electronics Test Equipment -							TS-131/AP

FLUXMETER TS-15/AP



FUNCTIONAL DESCRIPTION:

A portable meter used to provide qualitative measurements of the flux densities between the pole faces of magnets employed in oscillatory circuits of x-band and s-band transmitters. The meter is calibrated directly in Gauss units of flux density. All controls and indicators are located on the front panel.

RELATIONSHIP TO OTHER EQUIPMENT:

Similar to TS-15A/AP and TS-15B/AP except for certain modifications made in the later models to facilitate operation and insure greater accuracy of measurements, and for additional equipment supplied with TS-15A/AP and TS-15B/AP.

ELECTROMECHANICAL DESCRIPTION:

Circuit Information: Consists of two milliammeters in series, a group meter, and a probe meter, a rheostat and associated shunts. When taking measurements,

(Continued)

	AIR FORCE	NAVY	ARMY
TYPE CLASS.			
STOCK NOS.	7CAC-312150	SNSNF-17-M-23912-2401	3F4325-15
PROCUREMENT INFO.:	USAF Spec. No. 7425		
PROCUREMENT COG.:	Army	DESIGN COG.:	Army, ESL
F.I.I.N.:	FUNCTIONAL CLASS. NO.:		5.3
	- Electronics Test Equipment -		TS-15/AP

This project was supported by the USAF on Contract AF 33(600)28276 and monitored by WADC, ARDC - Carl L. Fredericks, Bethesda, Md. - Multilithed in U.S.A.

FLUXMETER TS-15/AP

ELECTROMECHANICAL DESCRIPTION: (Continued)

the probe meter is inserted between the poles of the magnet under test and the indications are read on the Gauss meter. The probe meter uses the field of the magnet under test to produce a deflection when a current is passed through its coil. The indication on the probe meter is always adjusted to the same point by varying the current. The current required to produce this reading is then a measure of flux density.

Power Supply: 1.5 volts supplied by 1 Battery, BA-30 (1.5 volts).

Flux Density Range: 1200 to 2300 Gauss "A" scale.

1700 to 3200 Gauss "B" scale.

2400 to 4500 Gauss "C" scale.

Accuracy: ±2% between limits of 1200 to 1700 Gauss on "A" scale, 1700 to 2400 Gauss on "B" scale, and 2400 to 3000 on "C" scale.

MANUFACTURERS' OR CONTRACTORS' DATA:

Marion Electrical Instrument Company, 407 Canal Street, Manchester, New Hampshire; Approximate Cost per Unit, \$150.00.

TUBE COMPLEMENT:

None.

REFERENCE DATA AND LITERATURE:

TM 11-1088 (Instruction Book).

TM 11-2559 (Instruction Book).

TO 16-35TS15-3 (Maintenance Instructions).

TO 16-35TS15-5

TO 16-35TS15-6

SHIPPING DATA:

No. of Boxes	Contents & Identification	Volume (Cu. Ft.)	Overall Dimensions (inches)			Weight Packed (Lbs.)
			H	W	D	
1	Fluxmeter, TS-15/AP (Shelf Package, Water Resistant Carton)	0.47	13	9	7	9

EQUIPMENT SUPPLIED:

Quant. Per Eq't	Name and Nomenclature	Case Mat'l	Stock Numbers (USAF) (Navy) (Army)	Overall Dimensions (inches)			Weight (Lbs.)
				H	W	D	
1	Fluxmeter TS-15/AP Including:	Wood	7CAC-312150 F-17-M-23912-2401 3F4125-15	10	6	4-1/2	6.5
1	Yoke Assembly		1690-328572000 3F53400	1-13/16	1-1/2	2-3/16	
TS-15/AP - Electronics Test Equipment -							

FLUXMETER TS-15A/AP



FUNCTIONAL DESCRIPTION:

A portable meter used to provide qualitative measurements of the flux densities between the pole faces of magnets employed in oscillatory circuits of x-band and s-band transmitters. The meter is calibrated directly in Gauss units of flux density. All controls and indicators are located on the front panel.

RELATIONSHIP TO OTHER EQUIPMENT:

Similar to TS-15B/AP except that TS-15B/AP is not supplied with handle for holding probe and an additional yoke.

TS-15A/AP and TS-15B/AP are similar to TS-15/AP except for certain modifications made to facilitate operation and insure greater accuracy of measurements.

ELECTROMECHANICAL DESCRIPTION:

Circuit Information: Consists of two milliammeters in series, a group meter, and a probe meter, a rheostat and associated shunts. When taking measurements, the probe meter is inserted between the poles of the magnet under test and the indications are read on the Gauss meter. The probe meter uses the field of the magnet under test to produce a deflection when a current is passed through its coil. The indication on the probe meter is always adjusted to the same point by

(Continued)

	AIR FORCE	NAVY	ARMY
TYPE CLASS.			
STOCK NOS.	7CAC-312140	ASO BU-1-A-N-TS-15A/AP	3F4325-15A
PROCUREMENT INFO.:			
PROCUREMENT COG.:	Army	DESIGN COG.:	Army, ESL
F.I.I.N.:	FUNCTIONAL CLASS. NO.:		5.3
- Electronics Test Equipment -			TS-15A/AP

This project was supported by the USAF on Contract AF 33(609)2067 and monitored by W-137 - RDC - Carl L. Fredericks, Bethesda, Md - Multiplied in U.S.A.

FLUXMETER TS-15A/AP

ELECTROMECHANICAL DESCRIPTION: (Continued)
varying the current. The current required to produce this reading is then a measure of flux density.

Power Supply: 1.5 volts supplied by 1 Battery, BA-30 (1.5 volts).

Flux Density Range: 1200 to 2400 Gauss.
2400 to 4800 Gauss.
4800 to 9600 Gauss.

Gap Size: 0.6" - 0.7"
1.3" - 1.5"

Pole Face Diameter: 0.67" - 1.12"
1.5" - 2.0"

Accuracy: ±2%.

MANUFACTURERS' OR CONTRACTORS' DATA:

Marion Electrical Instrument Company, 407 Canal Street, Manchester, New Hampshire. Navy Contract No. NXss-21899; Approximate Cost per Unit, \$150.00.

TUBE COMPLEMENT:

None.

REFERENCE DATA AND LITERATURE:

TM 11-1088 (Instruction Book).

TO 16-35TS15-5

TM 11-2559 (Instruction Book).

TO 16-35TS15-6

TO 16-35TS15-3 (Maintenance Instructions).

TO 16-55-454 (Spare Parts List).

SHIPPING DATA:

No. of Boxes	Contents & Identification	Volume (Cu. Ft.)	Overall Dimensions (inches)			Weight Packed (Lbs.)
			H	W	D	
1	Fluxmeter, TS-15A/AP (Shelf Package, Water Resistant Carton)	0.47	13	9	7	9

EQUIPMENT SUPPLIED:

Quant. Per Eq'pt	Name and Nomenclature	Case Mat'l	Stock Numbers (USAF) (Navy) (Army)	Overall Dimensions (inches)			Weight (Lbs.)
				H	W	D	
1	Fluxmeter TS-15A/AP	Wood	7CAC-312140 R16-TAN-TS-15A/AP 3F4325-15A	10	6	4-1/2	6.5
1	Yoke Assembly		1670-328572001 3F53400-1	1-11/16	1	1-1/16	
1	Yoke Assembly		1670-328572000 3F53400	2-3/16	1-1/2	1-13/16	

TS-15A/AP

- Electronics Test Equipment -

FLUXMETER TS 15B/AP

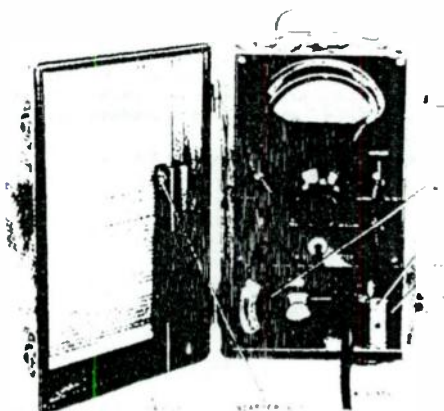

FUNCTIONAL DESCRIPTION:

A portable meter used to provide qualitative measurements of the flux densities between the pole faces of magnets employed in oscillatory circuits of x-band and s-band transmitters. The meter is calibrated directly in Gauss units of flux density. All controls and indicators are located on the front panel.

RELATIONSHIP TO OTHER EQUIPMENT:

Similar to Fluxmeter TS-15A/AP except as follows: Supplied with handle for holding probe, and an additional yoke.

TS-15A/AP and TS-15B/AP are similar to TS 15/AP except for certain modifications made to facilitate operation and insure greater accuracy of measurements.

ELECTROMECHANICAL DESCRIPTION:

Circuit Information: Consists of two milliammeters in series, a Gauss meter, and

(Continued)

	AIR FORCE	NAVY	ARMY
TYPE CLASS.	Limited Standard		
STOCK NOS.	7CAC-312130	F17-M-23912-2401	3F4325-15B
PROCUREMENT INFO.:			
PROCUREMENT COG.:	Army	DESIGN COG.:	Army, ESL
F.I.I.N.:	FUNCTIONAL CLASS. NO.: 5.3		
	- Electronics Test Equipment -		TS-15B/AP

This document was prepared by the USA For Contract AF 17(60)7237A and was based on WADC ARDC Form 1, Frederick, Bethesda, Md. - Multilithed in U.S.A.

FLUXMETER TS-15B/AP

ELECTROMECHANICAL DESCRIPTION: (Continued)

a probe meter, a rheostat and associated shunts. When taking measurements, the probe meter is inserted between the poles of the magnet under test and the indications are read on the Gauss meter. The probe meter uses the field of the magnet under test to produce a deflection when a current is passed through its coil. The indication on the probe meter is always adjusted to the same point by varying the current. The current required to produce this reading is then a measure of flux density.

Power Supply: 1.5 volts supplied by 1 Battery BA-30.

Flux Density Range: 1200 to 2400 Gauss
2400 to 4800 Gauss
4800 to 9600 Gauss.

Gap Size: 0.5" - 0.75"
1.30" - 1.51"
2.0" - (B model)

Pole Face Diameter: 0.75"
1.625"
2.0" (B model)

Accuracy: ±2%.

MANUFACTURERS' OR CONTRACTORS' DATA:

Marion Electrical Instrument Company, 407 Canal Street, Manchester, New Hampshire; Approximate Cost per Unit, \$150.00.

TUBE COMPLEMENT:

None.

REFERENCE DATA AND LITERATURE:

TM 11-1088 (Instruction Book)
TM 11-2559 (Instruction Book)
TO 16-35TS15-3 (Maintenance Instructions).
TO 16-35TS15-5
TO 16-35TS15-6
TO 16-55-454 (Spare Parts List).

SHIPPING DATA:

No. of Boxes	Contents & Identification	Volume (Cu. Ft.)	Over-all Dimensions (inches)			Weight Packed (Lbs.)
			H	W	D	
1	Fluxmeter, TS-15B/AP (Shelf Package, Water Resistant Carton)	0.47	13	9	7	9
TS-15B/AP - Electronics Test Equipment -						

FLUXMETER TS-15B/AP

EQUIPMENT SUPPLIED:

Quant. Per Eq'pt	Name and Nomenclature	Case Mat'l	Stock (USAF) Numbers (Navy) (Army)	Over-all Dimensions (inches)			Weight (Lbs.)
				H	W	D	
1	Fluxmeter TS-15B/AP Including:	Wood	7CAC-312130 F17-M-23912-2401 3F4325-15B	10	6	4-1/2	
1	Yoke Assembly		1690-328572001 3F53400.1	1-1/16	1-11/16	1	
1	Yoke Assembly		1690-328572000 3F53400	1-13/16	1-1/2	2-3/16	
1	Handle		3F4890-1	5-3/4	3/4		
1	Adapter Nut		1690-286054116 2Z306-17	5/8	3/8		
						Total:	6-1/2

- Electronics Test Equipment -

TS-15B/AP

FLUXMETER TS-15C/AP

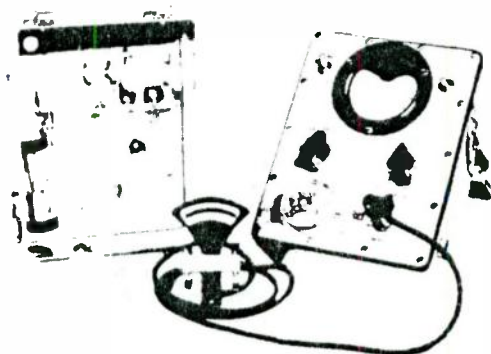

FUNCTIONAL DESCRIPTION:

A portable meter used to provide qualitative measurements of the flux densities between the pole faces of magnets employed in oscillatory circuits of x-band and s-band transmitters. The meter is calibrated directly in gauss units of flux density. All controls and indicators are located on the front panel.

RELATIONSHIP TO OTHER EQUIPMENT:

Similar to Fluxmeter TS-15B/AP except as follows: External dimensions and weight altered, metal case instead of wood case, four probe meter adapters instead of two.

ELECTROMECHANICAL DESCRIPTION:

Circuit information: The circuit consists of two milliammeters in series, a gauss meter, a probe meter, a rheostat, and associated shunts. When taking measurements, the probe meter is inserted between the poles of the magnet under test and the indications are read on the gauss meter. The probe meter uses the field of the magnet under test to produce a deflection when a current is passed through its coil. The indication of the probe meter is always adjusted to the same point by varying the current. The current required to produce this reading is then a

(Continued)

	AIR FORCE	NAVY	ARMY
TYPE CLASS.	Standard		
STOCK NOS.	7CAC-312175		
PROCUREMENT INFO.: Spec. Mil-F-11543			
PROCUREMENT COG.: USA		DESIGN COG.: USA, SCEL, ESL	
F. I. I. N.:		FUNCTIONAL CLASS. NO.: 5.3	
- Electronics Test Equipment -			TS-15C/AP

This document is controlled by the 1965 U.S. Government and its use is limited to the specific conditions of the contract under which it was prepared. It is not to be distributed outside the organization to which it was prepared.

FLUXMETER TS-15C/AP

ELECTROMECHANICAL DESCRIPTION: (Continued)
measure of flux density.

Power Supply: 1.5 volts supplied by 1 Battery BA-30.

Flux Density Range: 1200 to 2400 gaussess.
2400 to 4800 gaussess.
4800 to 9600 gaussess.

Gap Size: 0.6 inch to 4.44 inches (using probe meter adapters).

4.44 inches and wider (using probe meter handle).

Pole Face Diameter: 0.87 inch to 2 inches.

Accuracy: ±2%.

MANUFACTURERS' OR CONTRACTORS' DATA:

T. L. G. Electric Corporation, 31 West 27th Street, New York 1, New York; Order No. 3364-Phila-52, 9 March 1954; Approximate Cost per Unit, \$250.00.

TUBE COMPLEMENT: None.

REFERENCE DATA AND LITERATURE:

T. L. G. Electric Corporation, "Instruction Book for Fluxmeter TS-15C/AP."

SHIPPING DATA:

No. of Boxes	Contents & Identification	Volume (Cu. Ft.)	Overall Dimensions (inches)			Weight Packed (Lbs.)
			H	W	D	
1	Fluxmeter TS-15C/AP (including adapters and probe meter)	1/2	8-1/2	10-1/2	9	9-1/2

EQUIPMENT SUPPLIED:

Quant. Per Eq'pt	Name and Nomenclature	Case Mat'l	Stock Numbers (USAF) (Navy) (Army)	Overall Dimensions (inches)			Weight (Lbs.)
				H	W	D	
1	Fluxmeter TS-15C/AP	Aluminum	7CAC-312175	6	8-1/2	6-1/2	6
1	Adapter	Polyethylene			4-7/16	1-1/8 dia.	
1	Adapter	Brass		2	1-7/8	1-1/2	
1	Adapter	Brass		1-11/16	1-3/32	1	
1	Adapter	Brass		2	1-13/16	1-1/2	
1	Handle	Aluminum			5-1/4	3/4	
1	Probe Meter	Bakelite		1-5/8	2-5/8	1-3/4	
TS-15C/AP - Electronics Test Equipment -							

GAUSSMETER
MODEL D-79
(Dyna-Labs, Incorporated)



FUNCTIONAL DESCRIPTION:

A portable, general purpose instrument used to measure the magnitude and direction of flux density. The unit may also be used to determine flux paths and to locate leakage fields. Test results are indicated on a calibrated meter located on the front panel of the equipment.

RELATIONSHIP TO OTHER EQUIPMENT:

ELECTROMECHANICAL DESCRIPTION

Circuit Information. The meter operates on the principle of the "Hall effect" (the development of a transverse, electric potential-gradient in a current-carrying conductor). A non-magnetic probe is used as the current-carrying conductor and constitutes one arm of a bridge circuit. When the probe is inserted in a magnetic field, the bridge becomes unbalanced in proportion to the strength of the magnetic field. A highly sensitive probe is provided for measurement of low density fields and a linear probe is provided for measurement of high density

(Continued)

	AIR FORCE	NAVY	ARMY
TYPE CLASS.		Substitute Standard	
STOCK NOS.			
PROCUREMENT INFO.:			
PROCUREMENT COG.:	Navy	DESIGN COG.: Commercial	
E.I.L.N.:		FUNCTIONAL CLASS. NO.: 5.3	
	- Electronics Test Equipment -		Dyna-Labs D-79

GAUSSMETER
MODEL D-79
(Dyna-Labs, Incorporated)

ELECTROMECHANICAL DESCRIPTION: (Continued)

fields. The probes are constructed of a noncorrosive, rust proof material. When performing measurements above the normal ambient temperature and humidity range, the instrument should be compared to a standard magnetic field and readjusted for a true meter reading.

Power Supply: 105 to 125 volts, AC, 50 to 60 cycles per second, single-phase, 75 watts.

Meter Range: 10 to 30 000 gauss AC (rms) or DC in four ranges

Frequency Response: Flat to 400 cycles per second, comparative readings to 1000 cycles per second.

Meter Accuracy: $\pm 2.5\%$ over the entire range.

Calibrated Magnetic Air Gap Accuracy: $\pm 1\%$ of value indicated.

MANUFACTURERS' OR CONTRACTORS' DATA:

Dyna-Labs, Incorporated, 1075 Stewart Avenue, Garden City, Long Island, New York. Approximate Cost per Unit, \$350.00.

TUBE COMPLEMENT:

1 6X4, 1 6AL5, 1 12AU7, 4 6AU6

REFERENCE DATA AND LITERATURE:

Manufacturer's Catalog.

EQUIPMENT SUPPLIED:

Quant. Per Eq't	Name and Nomenclature	Case Mat'l	Stock Numbers (USAF) (Navy) (Army)	Overall Dimensions (inches)			Weight (Lbs.)
				H	W	D	
1	Gaussmeter Dyna-Labs D-79	Metal		13	6 - 3/4	10 - 1/2	10.5
7	Probes			0.25	0.200	1 - 3/4	
1	Cable			48 long			

SHIPPING DATA:

No. of Boxes	Contents & Identification	Volume (Cu. Ft.)	Overall Dimensions (inches)			Weight Packed (Lbs.)
			H	W	D	
	Gaussmeter Dyna-Labs D-79					
Dyna-Labs D-79 - Electronic Test Equipment -						

AUDIO LEVEL METER AN/URM-38



FUNCTIONAL DESCRIPTION:

A portable, general purpose equipment used to measure the intensity of audio signals. Test results are indicated by a hermetically sealed meter calibrated in decibels.

RELATIONSHIP TO OTHER EQUIPMENT

The AN/URM-38 is the overall nomenclature for Audio Level Meter ME-49/U. The AN/URM-38 is similar to Audio Level Meter Hickok 900-079.

ELECTROMECHANICAL DESCRIPTION

Circuit Information: The instrument is a nonelectronic device which utilizes a copper oxide rectifier to convert the input audio signals to DC for energizing the meter movement.

Power Supply: None

Frequency Range: 60 to 10,000 cycles per second

Decibel Range: -20 to +2 decibels; +2 to +16 decibels; -16 to +30 decibels.

(Continued)

	AIR FORCE	NAVY	ARMY
TYPE CLASS.		Standard	
STOCK NOS.		E16-Q-123752-0100	
PROCUREMENT INFO.: Spec MIL-M-131			
PROCUREMENT COG.:		DESIGN COG.: Navy	
E. I. L. N.: 6625-352-0019		FUNCTIONAL CLASS. NO.: 5.5	
- Electronics Test Equipment -		AN/URM-38	

AUDIO LEVEL METER AN/URM-38

ELECTROMECHANICAL DESCRIPTION (Continued)

Meter Movement: 217 microamps for full scale deflection.

Meter Accuracy: $\pm 2\%$ of full scale.

Input Impedance: 600 ohms.

MANUFACTURERS' OR CONTRACTORS' DATA:

Hickock Electrical Instrument Company, 10514 Dupont Avenue, Cleveland, Ohio;

Contract No. NObar-49136.

TUBE COMPLEMENT:

None.

REFERENCE DATA AND LITERATURE.

NavShips 91470.

EQUIPMENT SUPPLIED:

Quant. Per Eq'pt	Name and Nomenclature	Case Mat'l	Stock Numbers (USAF) (Navy) (Army)	Overall Dimensions (inches)			Weight (Lbs.)
				H	W	D	
1	Audio Level Meter AN/URM- 38	Alumi- num	F16-Q-123752- 0100	5-5/8	5-1/2	7-5/32	
	Including:						
1	Audio Level Meter ME-49/U						
1	Transit Case			6-3/8	8-1/2	4-3/8	
2	Test Lead			46 long			

SHIPPING DATA:

No. of Boxes	Contents & Identification	Volume (Cu. Ft.)	Overall Dimensions (inches)			Weight Packed (Lbs.)
			H	W	D	
AN/URM-38 - Electronic Test Equipment -						

DECIBEL EQUIVALENTS TO CURRENT, VOLTAGE, AND POWER RATIOS

APPENDIX IV

The word Decibel is frequently used to express the ratio of any two dimensionally equivalent quantities in convenient numerical terms. It is simply a logarithm of a ratio to the base ten. In practice, the engineer often refers to a quantity as so many decibels "up" or "down" with respect to another quantity. This means that, if quantity a is "up" a given number of decibels on quantity b, the ratio of a/b is greater than unity, or if the a is "down" on b, the ratio a/b is less than unity. Sometimes +db is used to express the fact that the ratio is greater than one and -db for ratios less than one. Since the engineer always can use the reciprocal of any ratio to obtain the same result when expressed in decibels, it is never necessary to use a conversion table showing ratios less than unity.

The number of decibels, N_{db} , corresponding to a power ratio P_1/P_2 or P_2/P_1 is defined as:

$$\pm N_{db} = 10 \text{ Log}_{10} (P_1/P_2) \text{ or } 10 \text{ Log}_{10} (P_2/P_1) \quad (1)$$

If $P_1/P_2 > 1$, P_1 is up on (larger than) P_2 and the sign of N_{db} may be taken as +. However, if $P_1/P_2 < 1$, that is $P_2/P_1 > 1$, P_1 is down on (less than) P_2 and the sign is -.

In the case of direct currents, power is the product of the current I and the voltage E, that is $P = IE$. Since the resistance R is defined as E/I , the power may be taken as $P = E^2/R$ or $P = I^2R$. Thus $P_1/P_2 = (E_1/E_2)^2 \times (R_2/R_1)$ or $P_1/P_2 = (I_1/I_2)^2 \times (R_1/R_2)$. This means that provided the currents I_1 and I_2 are flowing into the same resistance ($R_1 = R_2$) the power ratio may be expressed as:

$$\pm N_{db} = 10 \text{ Log}_{10} (I_1/I_2)^2 \quad (2)$$

$$= 20 \text{ Log}_{10} (I_1/I_2) \quad (3)$$

or also as
$$\pm N_{db} = 20 \text{ Log}_{10} (E_1/E_2) \quad (4)$$

In the case of alternating currents, the product IE must be multiplied by the power factor in order to obtain the power. But if now the currents I_1 and I_2 are flowing into the same impedance ($Z_1 = Z_2$), the power



factor will cancel when the ratio P_1/P_2 is formed, and the expressions given above remain correct provided that I_1 , I_2 , E_1 , and E_2 are interpreted as the absolute values of these quantities. It should be noted that the first expression, involving the currents, remains correct even for different impedances provided only that the resistances are equal. But the second expression, involving the voltages, is correct only if both the resistances and the reactances are equal.

In case the designer desires to obtain the current, voltage, or power ratio when the number of decibels is known, the relations are:

$$\left| I_1/I_2 \right| = 10^{+N_{db}/20} \quad (5)$$

$$\left| V_1/V_2 \right| = 10^{+N_{db}/20} \quad (6)$$

or

$$P_1/P_2 = 10^{+N_{db}/10} \quad (7)$$

keeping in mind, as before, that the number of decibels corresponding to any value of the ratios is the same as that for the reciprocal, but the sign is different.

The table given in this appendix, Figure IV-2, may be entered to obtain the ratios of currents, voltages, and power corresponding to decibel numbers from 0.1 to 20.0. This range of decibels covers ratios of current and voltage from 1.012 to 10.00 and ratios of power from 1.023 to 100.

The designer of radio interference suppression equipment will not frequently have occasion to deal with ratios or decibel values smaller than those shown in the table, Figure IV-2. In those cases, however, the designer may easily compute any of the values lying below the range of the table from the equations given above or the approximate formula, $N_{db} = 8.5 (\left| I_1/I_2 \right| - 1)$, with an error less than 0.001 db.

Usually radio interference problems demand consideration of larger values of attenuation. Figure IV-1 is helpful in determining the ratios for larger values of decibels in 10 db steps from 10 to 160 db and may be used in conjunction with Figure IV-2 to quickly obtain intermediate values as in the following examples:

- (a) To determine current ratio corresponding to 43.6 db, enter



Figure IV-1 and note that 40 db is equivalent to a current ratio of 100. Entering Figure IV-2 shows that 3.6 db is equivalent to a ratio of 1.514. Then to obtain the ratio for 43.6 db, multiply 1.514 x 100 which gives 151.4.

- (b) To find the voltage ratio for 56.7 db, enter Figure IV-1 and find 3.162×10^2 opposite 50 db, multiply this by 2.163 from Figure IV-2 opposite 6.7 db and obtain 683.9. Or to find the corresponding power ratio enter the same tables in the power column and get $100,000 \times 4.677$ or 467,700.
- (c) Conversely, to find the number of decibels corresponding to a current ratio of 2427 divide by 1000 = 10^3 , enter Figure IV-2 opposite 2.427 and find 7.7 decibels, enter Figure IV-1 opposite 10^3 , and find 60 decibels opposite 10^3 , then add to obtain 67.7 db.

Decibels	Current of Voltage Ratio $ I_1/I_2 $ or $ E_1/E_2 $	Power Ratio P_1/P_2
10	3.162	10
20	10.000	10^2
30	3.162×10	10^3
40	10^2	10^4
50	3.162×10^2	10^5
60	10^3	10^6
70	3.162×10^3	10^7
80	10^4	10^8
90	3.162×10^4	10^9
100	10^5	10^{10}
110	3.162×10^5	10^{11}
120	10^6	10^{12}
130	3.162×10^6	10^{13}
140	10^7	10^{14}
150	3.162×10^7	10^{15}
160	10^8	10^{16}

Figure IV-1. Decibel Values Corresponding to Power Ratios and Absolute Values of Current or Voltage Ratios. (For reciprocal ratios use negative sign for decibels. For negative decibel values take reciprocal ratios.)

Decib. Ratio	[E ₁ /E ₂]		P ₁ /P ₂	Decib. Ratio	[I ₁ /I ₂]		P ₁ /P ₂	Decib. Ratio	[V ₁ /V ₂]		P ₁ /P ₂
	E ₁	E ₂			I ₁	I ₂			V ₁	V ₂	
0.1	1.014	0.986	1.000	0.0	1.000	1.000	1.000	0.0	1.000	1.000	1.000
0.2	1.028	0.972	1.000	0.0	1.000	1.000	1.000	0.0	1.000	1.000	1.000
0.3	1.043	0.957	1.000	0.0	1.000	1.000	1.000	0.0	1.000	1.000	1.000
0.4	1.059	0.943	1.000	0.0	1.000	1.000	1.000	0.0	1.000	1.000	1.000
0.5	1.075	0.929	1.000	0.0	1.000	1.000	1.000	0.0	1.000	1.000	1.000
0.6	1.092	0.916	1.000	0.0	1.000	1.000	1.000	0.0	1.000	1.000	1.000
0.7	1.109	0.904	1.000	0.0	1.000	1.000	1.000	0.0	1.000	1.000	1.000
0.8	1.127	0.892	1.000	0.0	1.000	1.000	1.000	0.0	1.000	1.000	1.000
0.9	1.146	0.881	1.000	0.0	1.000	1.000	1.000	0.0	1.000	1.000	1.000
1.0	1.165	0.870	1.000	0.0	1.000	1.000	1.000	0.0	1.000	1.000	1.000
1.1	1.185	0.860	1.000	0.0	1.000	1.000	1.000	0.0	1.000	1.000	1.000
1.2	1.205	0.850	1.000	0.0	1.000	1.000	1.000	0.0	1.000	1.000	1.000
1.3	1.226	0.841	1.000	0.0	1.000	1.000	1.000	0.0	1.000	1.000	1.000
1.4	1.247	0.832	1.000	0.0	1.000	1.000	1.000	0.0	1.000	1.000	1.000
1.5	1.269	0.824	1.000	0.0	1.000	1.000	1.000	0.0	1.000	1.000	1.000
1.6	1.291	0.816	1.000	0.0	1.000	1.000	1.000	0.0	1.000	1.000	1.000
1.7	1.314	0.808	1.000	0.0	1.000	1.000	1.000	0.0	1.000	1.000	1.000
1.8	1.337	0.801	1.000	0.0	1.000	1.000	1.000	0.0	1.000	1.000	1.000
1.9	1.361	0.794	1.000	0.0	1.000	1.000	1.000	0.0	1.000	1.000	1.000
2.0	1.385	0.787	1.000	0.0	1.000	1.000	1.000	0.0	1.000	1.000	1.000
2.1	1.410	0.781	1.000	0.0	1.000	1.000	1.000	0.0	1.000	1.000	1.000
2.2	1.435	0.775	1.000	0.0	1.000	1.000	1.000	0.0	1.000	1.000	1.000
2.3	1.461	0.769	1.000	0.0	1.000	1.000	1.000	0.0	1.000	1.000	1.000
2.4	1.487	0.764	1.000	0.0	1.000	1.000	1.000	0.0	1.000	1.000	1.000
2.5	1.514	0.759	1.000	0.0	1.000	1.000	1.000	0.0	1.000	1.000	1.000
2.6	1.541	0.754	1.000	0.0	1.000	1.000	1.000	0.0	1.000	1.000	1.000
2.7	1.569	0.749	1.000	0.0	1.000	1.000	1.000	0.0	1.000	1.000	1.000
2.8	1.597	0.745	1.000	0.0	1.000	1.000	1.000	0.0	1.000	1.000	1.000
2.9	1.626	0.741	1.000	0.0	1.000	1.000	1.000	0.0	1.000	1.000	1.000
3.0	1.655	0.737	1.000	0.0	1.000	1.000	1.000	0.0	1.000	1.000	1.000
3.1	1.685	0.733	1.000	0.0	1.000	1.000	1.000	0.0	1.000	1.000	1.000
3.2	1.715	0.729	1.000	0.0	1.000	1.000	1.000	0.0	1.000	1.000	1.000
3.3	1.746	0.725	1.000	0.0	1.000	1.000	1.000	0.0	1.000	1.000	1.000
3.4	1.777	0.721	1.000	0.0	1.000	1.000	1.000	0.0	1.000	1.000	1.000
3.5	1.809	0.717	1.000	0.0	1.000	1.000	1.000	0.0	1.000	1.000	1.000
3.6	1.841	0.713	1.000	0.0	1.000	1.000	1.000	0.0	1.000	1.000	1.000
3.7	1.874	0.709	1.000	0.0	1.000	1.000	1.000	0.0	1.000	1.000	1.000
3.8	1.907	0.705	1.000	0.0	1.000	1.000	1.000	0.0	1.000	1.000	1.000
3.9	1.941	0.701	1.000	0.0	1.000	1.000	1.000	0.0	1.000	1.000	1.000
4.0	1.975	0.697	1.000	0.0	1.000	1.000	1.000	0.0	1.000	1.000	1.000
4.1	2.010	0.693	1.000	0.0	1.000	1.000	1.000	0.0	1.000	1.000	1.000
4.2	2.045	0.689	1.000	0.0	1.000	1.000	1.000	0.0	1.000	1.000	1.000
4.3	2.081	0.685	1.000	0.0	1.000	1.000	1.000	0.0	1.000	1.000	1.000
4.4	2.117	0.681	1.000	0.0	1.000	1.000	1.000	0.0	1.000	1.000	1.000
4.5	2.154	0.677	1.000	0.0	1.000	1.000	1.000	0.0	1.000	1.000	1.000
4.6	2.191	0.673	1.000	0.0	1.000	1.000	1.000	0.0	1.000	1.000	1.000
4.7	2.229	0.669	1.000	0.0	1.000	1.000	1.000	0.0	1.000	1.000	1.000
4.8	2.267	0.665	1.000	0.0	1.000	1.000	1.000	0.0	1.000	1.000	1.000
4.9	2.306	0.661	1.000	0.0	1.000	1.000	1.000	0.0	1.000	1.000	1.000
5.0	2.345	0.657	1.000	0.0	1.000	1.000	1.000	0.0	1.000	1.000	1.000

Fig. IV-2. Decibel Values Corresponding to Power Ratios and Absolute Value of Current and Voltage Ratios (Use negative db values for reciprocal ratios or reciprocal ratios for negative db values.)

INDEX

- Acceptance ratio
calculating, 1-1, 1-2
definition of, 1-1
digital systems, 1-24
input, 1-9
receiver characteristics for,
1-9, 1-10, 1-11
- Acceptable performance, 1-1
see acceptability criteria
- Acceptability criteria
for digital systems, 1-24, 1-25
for facsimile systems, 1-25
for radar, 1-16 to 1-20
for receivers, 1-8 to 1-11
for teletype systems, 1-25
for television, 1-15
- Acoustic spectrum, 1-6
- Aerospace vehicle, 6-3
- Air conditioning, 3-22
- Air traffic control, 1-16
- Alidade, 3-35
- Alpha rhythm, 1-3, 1-4
- Ambient signal level, 7-4
- Antenna
absolute antenna gain, 7-71
to 7-73
broadband antenna Polarad
CA-B, 3-14
broadband rod disccone Stoddart,
3-14
calculating, gain of, 2-21 to 2-23
correction factors, 2-22
electroexplosive device circuitry
as an, 6-12 to 6-15
gain at harmonic frequencies,
2-23 to 2-24
loss due to off axis pointing,
2-25 to 2-27
loss due to polarization, 2-24
measurement of radiation pat-
tern, 3-31 through 3-42
non-rotatable, 7-75, 7-77
pattern considerations, 2-26, 2-27
relative antenna patterns, 7-73
to 7-75
rotatable, 7-75
selecting and mounting, 3-19
used in spectrum search
applications, 3-5
- Aperature
circular, 6-6 to 6-10
rectangular, 6-10 to 6-12
- Apperceptive variables, 1-6
- Arranging mobile laboratory
equipment, 3-15, 3-17
- Arscope, 1-12, 7-43
- Attenuation, (db), 5-1
- Audio amplifier, 4-11
- Audio frequency meter, 4-2
- Auditory circuitry, 1-3
- Automatic data processing
equipment, 1-2, 1-3
- Automatic gain control, 1-21
- Average, 3-2
- AVNL (automatic video noise
limiting), 7-43
- Azimuthal reference points, 3-36
- Bandpass filters, 7-47, 7-49
- Bandwidth, 1-2, 1-4, 1-7, 1-11,
4-31, 7-9
- Basic transmission
equation, 2-37
- Basilar membrane, 1-6
- Beacon tracker, 3-32
- Beat frequency, 1-9
- Beat note, 1-2, 1-10
- Bonding, 5-7
- Cable gap length, effects of, 3-85
- Cable grounding configuration,
3-77, 3-79, 3-80
- Calculation on harmonic levels,
2-10
- Calibration, 4-6, 4-8, 4-38,
4-32, 7-4

INDEX (Continued)

- Calibrator, interference measuring instrument, 4-6
Capture effect, 1-2, 1-10, 1-11
Carrier frequency, 1-2
Carrier to interference ratio, 1-10
Cathode-ray tube, 1-12
Census, 2-7
Channel allocation, 1-12
Choosing an interference meter, 3-2
Circular aperture, 6-6
Closed system test, 7-35
Coaxial reversing switch, Bird 72R, 3-14
Coaxial switch, 7-11, 7-13, 7-16, 7-19, 7-22, 7-27
Coaxial switch, Bird 74, 3-14
Cockle mechanism, 1-6
Coherent interference, 1-14
Conductivity, 5-1, 5-2
Conical antenna, 4-36
Contact area, 5-5
Contact pressure, 5-5, 5-6
Control panel, 3-19
Cortex, 1-3
Critical fusion frequency, 1-15
Critical response, 1-4
Cross modulation, 1-2, 1-10
Decibel equivalents to current, voltage, and power ratios, IV-1 to IV-4
Depth of modulation, 1-2
Desensitization, 1-1, 7-61, 7-63
Desired information for antenna patterns, 3-42
Detectability, 1-7, 1-18, 1-19
Detector and weighing circuits, 4-9
Dial plate, Mallory, 3-70
Different frequency, 1-2
Diffraction, 2-3
Digital data transmission rate, 1-22
Diode detector, 1-10
Directional antenna, 4-35
Discone antenna, 4-36
Discriminator, 1-11
Displayed information, 1-3
DOD spectrum signature program, 2-10, 2-21
Dynamic range, 6-16, 7-2, 7-66 to 7-68, 7-74
Effective aperture of the antenna, 7-53
Effective radiated power, 2-10, 7-74
Electroexplosive devices, 6-2, 6-3, 6-5, 6-12, 6-14, 6-16, 6-17
Electromagnetic field, 5-1
Electromagnetic Technology Corporation, 7-35
Electronic compatibility analysis center, 2-21, 7-1
Electronic environmental studies, 3-3
Emission spectra, 7-22
Equipment categories, 4-12, 4-14
Establishing a measurement capability requirements for measurements, 3-4
user requirements, 3-5
Exploding bridge wire, 6-3, 6-5
Facsimile, 1-3, 1-12, 1-24
Facsimile transmission, 1-20
Far field distance, 7-1, 7-2, 7-16, 7-71
Far field measurement, requirement for, 3-4
Fatigue factor, 1-8

INDEX (Continued)

- Field intensity meter calibration, 3-36
- Field intensity meter Stoddart NM-20B
characteristics of, 3-7
component parts required, 3-8
spare parts required, 3-8
- Field intensity meter Stoddart NM-30A
characteristics of, 3-8, 3-9
component parts required, 3-9
spare parts required, 3-10
- Field intensity meter Stoddart NM-52
characteristics of, 3-10, 3-11
component parts required, 3-11
spare parts required, 3-11
- Field intensity meter Stoddart NM-62A
characteristics of, 3-12
- Field strength meter, 4-1, 4-2
- Filter data, expressed as, 2-11
- Fixed wing aircraft, 3-32
- Flight patterns
azimuthal, 3-38, 3-42
vertical, 3-37, 3-42
- FM receiver, 1-11
- Forrer, 7-37
- Four-thirds earth radius profile paper, 2-35
- Fraunhofer region, 6-6
- Frederick Research Corporation, 3-42, 3-47, 3-50, 7-49
- Free space propagation loss, 2-21
- Frequency coincident, 1-9, 1-10
- Frequency, critical fusion, 1-13
- Frequency deviation, 1-11
- Frequency differential, 1-11
- Frequency marker, 4-33
- Frequency meter, 4-37, 7-11, 7-13, 7-45, 7-47, 7-59
- Frequency meter Gertsch FM-6, 3-12
- Frequency modulation, 1-11
- Frequency selective voltmeter, 7-15, 7-19, 7-30, 7-70
- Frequency shift keying, 1-11
- Fresnel region, 6-6, 7-78 to 7-80
- FTC (fast time constant), 7-43
- Fuel storage, 3-21
- Generator for susceptibility tests, 3-2
- Half power beamwidth, 7-73
- Half wave dipole, 4-35, 6-16
- Harmonic distortion, 1-2
- Hat channels, 5-6
- Helicopter, 3-32, 3-35
- Heterodyne field intensity meter, 6-16
- Heterodyning CW carriers, 1-9
- High impedance field, 5-2
- Horizontal antenna, 4-34
- Horn antenna, 4-36
- Human responses, 1-3
- Hysteresis, 1-25
- Identification of speech sounds, 1-7
- Impedance matching networks, 3-47, 4-4, 4-5
- Impedance mismatch, 2-11
- Impulse interference bursts, 1-23
- Impulsive interference, results from, 1-14
- Indicating devices, 4-11, 4-12
- Information theory, 1-4
- Insertion loss, 1-1, 1-3, II-1, II-2, II-3
- Instrumentation for receiving and recording, 3-35
- Intelligence, 1-3, 1-7, 1-10
- Intelligence masking beat note product, 1-9

INDEX (Continued)

- Intelligibility
 see intelligence
- Intercom system Talk A Phone
 3-13
- Interference
 adjacent channel, 1-19, 2-12 to
 2-14
 affects to a given system, 1-2
 categories of measurement, 3-7
 cochannel, 1-2
 digital errors due to, 1-22 to 1-24
 effects on the ear, 1-4, 1-6
 effects to a desired signal, 1-2
 equivalent curves, 3-1
 forms of, 1-3, 3-1
 fundamental cochannel, 2-8 to
 2-10
 harmonic cochannel, 2-10 to
 2-12
 human responses to, 1-3
 impulsive, 1-14, 1-23, 1-24,
 3-1, 3-2
 measurement of, 3-1, 3-2, 8-1
 meter reading of impulsive, 3-2
 meter reading of random, 3-2
 mutual, 1-1, 1-9
 periodic interfering signal, 3-1
 prediction, 2-38 to 2-47
 properties used to characterize,
 3-1
 random, 3-2
 reasons for measurement, 3-3
 signal consisting of a single
 transient, 3-1
 spectrum, 1-7
 spurious emissions, 2-21, 7-2,
 7-19
 suppression techniques, 3-44,
 3-45, 3-106, 3-107
 to digital data communication
 systems, 1-21
 types of, 2-7, 2-8, 3-1
 typical tests of, 3-31
 visual characteristics of, 1-14
 visual effects of, 1-12, 1-13
- Interference test sets, III-1, III-2
- Intermediate frequency amplifier,
 4-8
- Interference meters, 3-7 to 3-12,
 4-1, 4-12 to 4-29
- Intermodulation, 1-2
- Intermodulation products, 1-9
- Inverter, Generator Corp., 3-21
- Isochronous, signals, 1-9
- Jacobs, 7-78, 7-88
- J-scope, 1-12
- Knapp, K. W., 6-15
- Lambdin, W. S., 6-15
- Lewis, 7-37
- Lindeman, Benjamin, 7-78, 7-88
- Loop antenna, 4-34, 4-35, 4-36
- Low impedance field, 5-2
- Low pass filters, 2-11, 7-15, 7-31,
 7-47, 7-49
- Magnetic field, 5-2
- Masking, 1-6, 1-7
- Masking, auditory, 1-6
- Masking, effect, 1-10
- Masking, efficiency, 1-7
- Mast, auxiliary, 3-14
- Mast, permanent, 3-15
- Measurement on pulsed radar
 transmitters, 7-9
- Measurement personnel, 3-5
- Measuring the insertion loss of
 filters, I-1 to I-3
- Measuring the radio frequency im-
 pedance of bonds, II-1 to II-4
- MIL-E-4957A(ASG), 5-9
- MIL-I-6181D, 4-12, 4-28, 4-29,
 7-3
- MIL-I-11748B, 4-14, 4-28, 4-29
- MIL-I-16910A, 3-43, 3-44, 3-45,
 3-47, 3-48, 4-5, 4-12, 4-22,
 4-27, 4-28, 4-29, 4-34, 7-1

INDEX (Continued)

- MIL-1-26600, 3-77, 3-79, 3-91,
3-98, 3-107, 3-108, 4-12, 4-29,
7-3
- Milliamperes, 1-13
- Mixer and local oscillator, 4-8
- Mobile audio amplifier, Stromberg
Carlson, SAM-88, 3-13
- Mobile laboratory
basic considerations for, 3-6
equipment required, 3-6, 3-7
heavy duty, 3-28
human engineering considerations,
3-6
specialized, 3-28
technical or equipment consid-
erations for, 3-6
- Modal cutoff frequencies, 7-36
- Mounting mobile laboratory equip-
ment, 3-17
- Morse Code, 1-4
- Multiple azimuthal patterns, 3-42
- Mumford, 7-78, 7-88
- Near field measurements, 3-4
- Near zone region, 6-5
- Noise
channel, 1-4
coherent, 1-14
impulse, 1-23
inherent receiver, 4-8
random, 1-4, 1-7, 1-14, 1-16
shot, 4-7
white, 1-22, 1-23, 3-1, 3-2
- Noise in the digital communica-
tions field, 1-22
- Non-isochronous signal, 1-10
- Non-linear effects, 1-2, 1-9
- Nuisance value, 3-2
- Omnidirectional antenna, 4-35,
7-73, 8-3
- One way transmission equation,
2-1
- Open field test, 7-35
- Optical tracker, 3-32
- Over exposure to high intensity
radiation, 6-2
- Panadapter Panoramic SA-8B, 3-12
- Panoramic adapter, 4-29, 4-30,
4-32, 4-33
- Parallax corrections, 3-39
- Parameters involved in RFI pre-
diction, 2-1, 2-2
- Pattern caused by interference be-
tween radars, 1-17
- Peak linear detector, 1-9
- Perceptibility, 1-7
- Perception threshold, 1-4
- Phosphor bronze contact fingers,
5-8
- Pickup devices
loop antennas, 4-35, 4-36
rod antennas, 4-35, 4-36
- Plane of reference, 7-70, 7-71
- Plane wave, 5-1
- Polar coordinate display, 3-37
- Polarization, 2-2
- Power density, 6-2, 6-4, 6-5, 6-9,
6-14, 7-9, 7-16, 7-20, 7-27,
7-52, 7-73
- Power plant, Onan 5ccK-1R
characteristics of, 3-20, 3-21
- Power plant, Onan 5ccK3R, 3-21
- Power within receiver bandwidth,
2-11
- Power falling within the receiver
passband, 2-12
- PPI scope, 1-3, 1-4, 1-16, 1-17
- Price, Vernon G., 7-35, 7-37
- Propagation path, 2-2
- Protecting a digital information
channel, 1-23
- Pulse modulated, 1-3, 1-4
- Pulse power spectrum, 2-14
through 2-20
- Pulse repetition frequency, 1-17

INDEX (Continued)

- Pulse system, 1-3
Pulsed carriers, spectral composition, 2-12
Rabbits, 1-19
Radar contact with Venus, 1-20
Radar performance criteria, 1-19
Radar receiver measurements
 adjacent channel, 7-57 to 7-60
 dynamic range, 7-66 to 7-68
 intermodulation, 7-55
 oscillator radiation, 7-68 to 7-70
 pulse desensitization, 7-61 to 7-66
 selectivity, 7-44 to 7-47
 sensitivity, 7-41 to 7-44
 spurious response, 7-47 to 7-52
 susceptibility, 7-52 to 7-54
Radiation hazards
 calculation of 6-5 to 6-12
 measurement and prediction 6-4 to 6-5
 test equipment considerations, 6-15 to 6-16
 test equipment for measurement of, 6-16 to 6-17
 to flammable fuels, 6-3
 to ordnance, 6-2
 to personnel, 6-1
Radio frequency amplifier, 4-5
Radio Frequency Compatibility Program, 7-1
Radio line of sight maps, 2-33 to 2-34
Radio line of sight profiles, 2-34 to 2-36
Rate of interruption, 1-7
Receiver bandwidth, 2-11
Receiver RFI fixes, 3-44
Receiver special purpose circuits, 7-45
Receiver tests to MIL-1-15910A conditions for, 3-17
 conducted report terms for, 3-48
 equipment radiated, 3-68, 3-69
 equipment required for, 3-45, 3-46
 equipment spectrum signature radiated, 3-70
 equipment spectrum signature susceptibility, 3-72
 external systems connections conducted, 3-53 to 3-63
 power line conducted, 3-50 to 3-52
 procedure for, 3-47
 radiated report terms for, 3-46
 receiver oscillator interference, 3-63 to 3-65
 results of, 3-72
 sample calculations of, 3-49, 3-50
 undesired radiation, 3-65 to 3-67
Recognition level, 1-3, 1-24
Recorder Esterline Angus AW, 1-14
Recorder events marker, 3-35
Rectangular aperture, 6-10
Reflection loss, 5-3
Reflection path, 6-4
Remote rf switch, General Communications, 3-14
RF amplification, 1-9
RF energy, penetration characteristics, 6-2
RF shielding techniques, 5-5, 5-7, 5-8
RFI suppression techniques, to receiver, 3-44, 3-45
RFI suppression techniques, to microswitch, 3-106, 3-107
RFI suppression techniques, to a transistor switching circuit, 3-114
Rhombic antenna, gain of, 3-31
Rod antenna, 4-35, 4-36

V-6

ERIC

INDEX (Continued)

- Root mean square, 3-2
- Rotary switch
 - Centralab 1001, 3-5
 - Centralab 1004, 3-5
- Scan rate, 1-3
- Seam welds, 5-7
- Sector blanking, 6-5
- Selectivity, 1-9, 1-10
- Sensitivity, 4-33
- Sensory apparatus, 1-3
- Serpentine flight path, 3-37, 3-38
- Sharp, 7-37
- Shielded enclosure
 - attenuation curve, 5-2
 - cell type, 5-9
 - double shield isolated wall, 5-10
 - single shield isolated wall, 5-10
- Shielding effectiveness, 5-1, 5-3
- Signal acceptability criteria for radars, 1-16
- Signal detectability, 1-4
- Signal generator, 4-36, 7-13, 7-19, 7-20, 7-27, 7-41, 7-43, 7-44, 7-45, 7-52, 7-57, 7-63, 7-66, 7-71
- Signal sampler, 7-36
 - design of, 7-38
- Signal substitution, 3-37, 3-39, 7-32 to 7-35
- Signal to interference ratio, 1-8, 1-10, 1-11, 1-12, 1-15, 1-18, 1-24, 2-1
- Signal to noise ratio, 1-7, 1-8, 1-18, 7-85
- Single side band receivers, 1-10, 1-11
- Single side band suppressed carrier signal, 1-10
- Slide back circuit, 4-11
- Space charge, 4-7
- Spark discharge, 6-3
- Spatially periodic stimuli, 1-13
- Spectrum analyzer
 - bandwidth, 4-31
 - calibration, 4-32
 - frequency marker, 4-33
 - resolution, 4-10
 - sensitivity, 4-33
 - sweep frequency, 4-32
 - sweep rate, 4-32
 - sweep width, 4-31, 4-32
- Spectrum distortion, 7-20
- Spectrum search, 8-2, 8-3
- Spectrum signature, 3-3, 3-31, 3-44, 3-70, 7-1, 7-2, 7-3, 7-87
- Spectrum signature collection plan, 7-2
- Speech cutoff, 1-7
- Squib, 6-3
- Standard test frequencies, 7-2, 7-20
- STC (sensitivity time control), 7-43
- Storage, 3-22
- Stub-type tuners, 7-49
- Superposition, 1-2
- Sweep frequency, 4-32
- Sweep rate, 4-32
- Sweep width, 4-31, 4-32
- Switching arrangement, 3-19
- Synchronism, 1-3
- Synchroscope-spectrum analyzer, Polarad TSA-S, 3-12
- Tapered aperture horn, gain of, 3-31
- Teletype, 1-3, 1-12, 1-25
- Television Allocations Study Organization, 1-12, 1-15
- Temperature limited, 4-7
- Tests to determine methods of grounding cable shield
 - conditions for, 3-77, 3-79
 - equipment for, 3-77
 - radiation test, plain shielded cable, 3-80

INDEX (Continued)

- Tests to determine methods of grounding cable shield results of, 3-79
- susceptibility test connector in shielded cable, 3-92, 3-97
- susceptibility test plain shielded cable, 3-80, 3-85
- Tests to determine methods of suppressing interference from a transistor switching circuit procedure for, 3-108
- results of, 3-113
- tests performed, 3-108 to 3-113
- suppression techniques, 3-114
- Tests to determine relative effectiveness of suppression measures in a relay micro-switch circuit
- conducted interference, 3-96
- conductions for, 3-98, 3-100
- radiated interference, 3-97, 3-98
- results of, 3-100, 3-103, 3-106
- suppression techniques, 3-106, 3-107
- test equipment, 3-98
- Test report signatures, 3-72
- Theodolite, 3-35
- Thermal agitation, 1-3, 4-6
- Three dimensional pattern antenna design for, 3-32, 3-35
- measurement of, 3-32
- power output requirements for, 3-32
- Three point, wedge type locking system, 5-8
- Threshold detection of signals auditory, 1-4
- speech detectability, 1-7
- speech intelligibility, 1-7
- speech perceptibility, 1-7
- visual, 1-4
- Threshold of vision, 1-13
- Threshold sensitivity, 1-3
- Threshold signal to interference ratio definition, 1-1
- Tolerable interference, 1-8
- Tolerable interference criterion, 1-9
- Tōmiyaan, 7-37
- Topographic maps, 2-33, 2-35
- Trailer, 3-21
- Transceiver Gonset, 3139 GA, 3-12
- Transmission line loss of coaxial cable, 2-28
- of rectangular waveguide, 2-28
- Transmitter measurements carrier frequency stability, 7-30
- emission spectra, 7-20 to 7-27
- modulation characteristics, 7-27 to 7-30
- power output, 7-9
- spurious emissions, 7-13 to 7-20
- Tripod, 3-35
- Tripod, modified Polarad CA-7 characteristics of, 3-15
- U channels, 5-6
- Vertical antenna, 4-34, 4-36
- Vertical plane picture, 3-37
- Visual effects of random noise, 1-14
- Visual interference, 1-14
- Vocal apparatus, 1-3
- Voice communications, 1-4
- Voice transmission rate, 1-22
- Voltage standing wave ratio, 7-33, 7-44, 7-49, 7-55, 7-59, 7-71, 7-72, 7-85
- Wall impedance, 5-2, 5-5
- Weighting circuits, 4-9, 4-10, 4-11
- Yagi antenna, 4-36

V-8



