

# PRINCIPLES OF TELEVISION ENGINEERING

BY

DONALD G. FINK

*Editor, "Electronics"; Author, "Engineering Electronics"  
"Radar Engineering"; Editor, "Television  
Standards and Practice"*

FIRST EDITION  
ELEVENTH IMPRESSION

REVISED PRINTING TO CONFORM TO 525-LINE  
STANDARD, ISSUED JULY, 1947

McGRAW-HILL BOOK COMPANY, INC.  
NEW YORK AND LONDON  
1940

COPYRIGHT, 1940, BY THE  
MCGRAW-HILL BOOK COMPANY, INC.

---

PRINTED IN THE UNITED STATES OF AMERICA

*All rights reserved. This book, or  
parts thereof, may not be reproduced  
in any form without permission of  
the publishers.*

THE MAPLE PRESS COMPANY, YORK, PA.

**PRINCIPLES  
OF  
TELEVISION ENGINEERING**

*The quality of the materials used in  
the manufacture of this book is gov-  
erned by continued postwar shortages.*





*To*  
MY MOTHER AND FATHER



## PREFACE

The adoption of television standards and the establishment of public programs have set the stage for a great expansion of the radio industry. With it comes the need for much new information, for new approaches to old problems, and for coordination of work reported by many engineers in widely scattered periodical literature. This book has been written to bring together conveniently the basic principles upon which television engineering rests and to illustrate the application of these principles in practical equipment now in use in the field. More specifically, the book has been written to perform a definite function: to enable the technical worker to make the transition from familiarity with radio engineering to familiarity with television engineering.

It has been assumed that the reader is acquainted with the general principles of radio engineering as they apply to vacuum tubes and circuits and to the practice of amplification, modulation, carrier transmission, and demodulation. Those aspects of the subject not generally found in the radio engineer's background, such as scanning, illumination, camera tubes, picture tubes, waveform analysis, and the like, are treated in detail.

The author has been confronted by the choice of transmission standards to use as a basis for concrete illustrations. The standards of the Radio Manufacturers Association Committee on Television have been adopted for this purpose. In a revised printing, first issued in July, 1947, the text has been altered to conform with the Federal Communications Commission standard of 525 lines per frame. In all other respects, the scanning standards given in the text are substantially the same as the F.C.C. standards, which have governed American stations since 1941.

The author is indebted to the many technical workers in the television field on whom he has drawn for information and assistance. In particular thanks are due to Beverly Dudley for his careful reading of the manuscript, to R. E. Shelby and other members of the staff of the National Broadcasting Com-

pany's television department for information and suggestions, to Major Lenox Lohr for permission to use illustrations from his forthcoming book "Television Broadcasting," to Arthur Van Dyck for permission to use material published in the reports of the RCA License Laboratory, and to George Fyler, H. J. Heindel, and Kenneth Chittick for information on receiver designs and testing methods. Credit for various illustrations is gratefully acknowledged to the following: Bell Telephone Laboratories, Fig. 140; Columbia Broadcasting System, Figs. 157 and 273; Beverly Dudley, Figs. 26 and 85; Farnsworth Television and Radio Co., Fig. 48; General Electric Company, Figs. 260, 272, 284-287; National Broadcasting Company, Figs. 4, 6, 7, 13, 25, 46*B*, 50, 169, 240, 264, 275; Philco Radio and Television Corp., Fig. 200; RCA Institutes, Inc., Fig. 295; RCA License Laboratory, Figs. 242, 244, 251, 254, 255; RCA Manufacturing Co., Inc., Figs. 8, 10, 27, 41, 49, 58, 110, 119, 226-238, 279-282, 288, 289, 301; Wilhelm Schrage, Figs. 5 and 46*A*; F. W. Sickles Co., Figs. 299 and 300; Weston Electrical Instrument Corp., Fig. 306. Thanks are also due to Robert Fink who prepared the index.

DONALD G. FINK.

ENGLEWOOD, N. J.,  
*January, 1940.*

# CONTENTS

PREFACE . . . . .	PAGE vii
-------------------	-------------

## CHAPTER I

TELEVISION METHODS AND EQUIPMENT . . . . .	1
Basic Factors in Direct Vision—Methods of Visual Representation—Electrical Transmission of Visual Information—Scanning and Picture Repetition—Sequence of Transmitting Picture Elements—Standards of Transmission in the United States—Equipment Used in a Typical Television System—Technical and Economic Limitations of the Television System.	

## CHAPTER II

IMAGE ANALYSIS . . . . .	25
Factors Influencing the Number of Lines in the Scanning Pattern—The Number of Picture Elements along Each Line—The Acuity of the Eye—Critical Viewing Distance and Number of Picture Elements—Proportions of the Picture Area—The Geometry of Scanning Patterns—Progressive (Noninterlaced) Pattern—Detailed Analysis of the Progressive Pattern—Number of Active Scanning Lines—The Thickness of Each Scanning Line—Requirements for Picture Repetition in Progressive Scanning—Details of the Geometry of Interlaced Patterns—Summary—Factors Influencing the Picture-repetition Rate—Rate of Transmission of Picture Elements—Defects of Image Analysis—Linear Displacement—Nonlinearity—Defects Involving the Scanning Pattern as a Whole—Charts for Testing Image Characteristics.	

## CHAPTER III

FUNDAMENTALS OF TELEVISION CAMERA ACTION . . . . .	63
Elements of Illumination Theory—Calculating Illumination and Brightness—Illumination of the Camera Plate—Light Flux Contained in a Picture Element—Contrast and Tonal Range in Optical Images—Photoelectric Surfaces—Luminous Sensitivity of Photoelectric Surfaces—Output Current from a Surface—Collection and Utilization of the Photoelectric Current—Application of Scanning Technique of Phototubes and Amplifier Circuits—Rotating Disk Scanning—Light Source (Flying Spot) Scanning—Instantaneous Electronic Scanning—The Image-dissector Tube—Storage Electronic Scanning—The Iconoscope—Structure of the Iconoscope Mosaic—Electrical Action of the Iconoscope—Analysis	

of Output Current—Transient Response—Factors Reducing Iconoscope Efficiency—The Image Iconoscope—The Orthiconoscope—Static-image Signal-generating Tubes.

## CHAPTER IV

## FORMATION, DEFLECTION, AND SYNCHRONIZATION OF SCANNING BEAMS 118

Basic Requirements for Scanning Beams—Formation and Electrostatic Focusing of Electron Beams—Electron Guns—Effect of Control Grid on Power Density and Focus—Distribution of Energy in Beam Cross Section—Magnetic Focusing of Electron Beams—Deflection of Focused Electron Beams—Dynamic Action of Deflecting Force—Electric Deflecting Force—Magnetic Deflecting Force—Defects of Electric and Magnetic Deflection—Defocusing of the Beam—Formation of the Ion Spot—Saw-tooth Waveforms—Other Defects of Deflection—Scanning Generators—Methods of Producing Saw-tooth Waves of Voltage—Methods of Producing Saw-tooth Waves of Current—Amplification of Saw-tooth Voltage Waveforms—Amplification of Waveforms for Magnetic Deflection—Impulse Generators for Controlling Discharge Tubes—Synchronization of Scanning Generators—The Form of the Synchronization Impulses—Amplitude Separation—Waveform Separation.

## CHAPTER V

## THE VIDEO SIGNAL . . . . . 166

General Description of the Video Signal—The Video Signal during Frame Retrace—Analysis of the Camera Signal—The D-c Component—The A-c Component—Fourier Analysis of Waveforms—Examples of Fourier Series Analysis—The Square Wave—The Maximum Frequency in the Video Range—The Ideal Saw-tooth Wave—The Nonideal Saw-tooth Wave—Distortions of the Picture Signal Due to Nonideal Phase and Amplitude Characteristics—Influence of Masking Voltages on the Video Signal—Intentional Distortions of the Video Signal.

## CHAPTER VI

## VIDEO AMPLIFICATION. . . . . 207

Fundamental Analysis of a Single Amplifier Stage—The Form of the Output Impedance  $Z_o$ —Low-frequency Response of  $RC$  Coupled Amplifiers—Compensation Applied to a Single Amplifier Stage—High-frequency Compensation—Shunt Peaking—Other Methods of High-frequency Compensation—Series Peaking—Filter Coupling—Combination of Shunt and Series Peaking—Comparison of High-frequency Compensation Methods—Low-frequency Compensation in a Single Amplifier Stage—Effect of Cathode-bias Filter on Low-frequency Response—Compensation in Multistage Amplifiers—Figure of Merit for Video Amplifier Tubes—Video Amplifiers for Special Output Conditions—High-

## CONTENTS

xi

PAGE

Voltage Output—Low Output Impedance—The Cathode-coupled Stage—Low-noise Considerations—Logarithmic Response—Transient Response of Video Amplifiers—Coaxial Cable Parameters—Measurement of Video Frequency Characteristics—Amplitude-frequency Response—Phase-frequency Response—Low-frequency Response Tests—Measurements for Design Purposes.

### CHAPTER VII

CARRIER TRANSMISSION OF VIDEO SIGNALS. . . . . 261

Carrier Frequencies Employed in Television Transmission—Carrier Assignments Set Up by the F.C.C.—The Structure of a Television Channel—Selective Sideband Transmission—Characteristics of Ultra-high-frequency Waves—Maximum Unobstructed Line-of-Sight Distance—Distance to Horizon over Flat Earth—Combination of Direct and Reflected Rays—Signal Strength within Horizon Distance—Signal Strength beyond the Horizon Distance—Effect of Band Width on Signal Strength—Television Transmitters—Generation of the Carrier Frequency—Modulation of Television Transmitters—Establishing D-c Levels in Modulation—Sideband Suppression in Television Modulation—Amplification of Modulated Carrier Signals—Radiation of Modulated Carrier Signals—Television Receiving Antennas—Termination of the Antenna at the Receiver—R-f Circuits in Television Receivers—Signal-to-mask Ratio in the R-f Input Circuits—Oscillator and Converter Circuits—Types of Frequency-converter Circuits—Oscillator Considerations—Picture Intermediate-frequency Amplification—Components for Picture I-f Amplification—Compensation of Mid-band Response—Phase Response of Picture I-f Amplifiers—Demodulation of Video Carrier Signals—Detector Coupling Circuits—Video Detection—Influence of Detector Polarity on Succeeding Circuits—Synchronizing and Automatic Circuit Functions.

### CHAPTER VIII

IMAGE REPRODUCTION. . . . . 328

General Theory of Brightness Transfer in Image Reproduction—Desirable Values of Over-all Gamma—Electronic vs. Mechanical Methods of Image Reproduction—The Cathode-ray Image-reproducing Tube—Fluorescence Applied to Image Reproduction—Preparation and Application of Phosphors—Signal-to-light Relationship—Auxiliary Circuits for Cathode-ray Tubes—High-voltage Rectifier Circuits—Filtering of High-voltage Supply—The Bleeder Circuit—Safety Consideration in High-voltage Power Supplies—The Picture Signal Circuit—Gain in the Signal Circuit—Scanning and Synchronization Circuits—Separation of Vertical from Horizontal Pulses—Automatic-gain-control Circuits—Defects in Image Reproduction.

## CHAPTER IX

## TELEVISION BROADCASTING PRACTICE. . . . . 388

Studio Facilities for Television Broadcasting—Camera and Pre-amplifier—Iconoscope-preamplifier Design—Control (Mixing and Blanking) Amplifier—Synchronization Signal Generator—Timing Unit—The Shaping Unit—Horizontal Shaping Action—Vertical Blanking and Keying Action—Shading Correction Generator—Television Transmission of Motion-picture Film—Continuous Projection Method—Intermittent Storage System of Film Scanning—Modulation Methods and Practice—Reinserting and Preserving the D-c Component—Removal of the Undesired Sideband—Carrier Generation and Radiation.

## CHAPTER X

## TELEVISION RECEIVER PRACTICE . . . . . 441

General Factors Relating to Choice of Tubes and Circuits—Wide-band Amplifier Tubes—High-voltage Rectifier Tubes—Converters and Oscillators—Video Detectors—Choice of Circuit Constants and Frequencies—Typical Receiver Design for a 5-in. Picture Tube—Typical Receiver Design for a 12-in. Picture Tube—A Scanning and Deflection Chassis—Testing High-voltage Supply Systems—Nonimage Methods of Testing—Testing Scanning Performance—Nonimage Methods of Testing Video Amplifier Response—Methods of Testing Picture I-f and Detector Characteristics—R-f and Oscillator Testing—A Simple Image-signal Generator—Procedure in Using Image-signal Generator—Applying the Image-signal Generator to Carrier Testing—Projection of Fluorescent Television Images—The Scophony System of Projecting Television Images.

## APPENDIX

## TRANSMISSION STANDARDS, RECOMMENDED PRACTICES, DEFINITIONS, AND NAMES OF CONTROLS ADOPTED BY THE RADIO MANUFACTURERS ASSOCIATION . . . . . 517

Television Transmission Standards—Recommended Practice on Polarization and Intermediate Frequencies—Receiver and Transmitter Definitions—Names of Controls of Television Receivers.

## INDEX. . . . . 523



# PRINCIPLES OF TELEVISION ENGINEERING

## CHAPTER I

### TELEVISION METHODS AND EQUIPMENT

Whenever the techniques of electrical communication are employed to extend natural sense perceptions, the specifications of the communication system must be determined by studying the sense organs involved. In the case of telephony, for example, the ranges of pitch and loudness to which the human ear responds have been measured and the corresponding frequency and energy limits in the electrical system have been established. Sound-transmission devices, developed with these limits in mind, can reproduce adequately the entire ranges of pitch and loudness to which the ear naturally responds. The result is that sounds may be transmitted electrically with any desired degree of realism, subject only to the economic resources at the command of the engineer.

In television, an analogous development is now in progress. The ranges of brightness, detail, contrast, and color to which the eye normally responds have been measured, and the corresponding photoelectrical and frequency-response characteristics have been established. But the development of sight-transmission devices, capable of responding adequately throughout the response ranges of the eye, is as yet incomplete. It is not possible to transmit television images with any desired degree of realism, because the economic and technical limitations of present equipment prevent it. In its present state of development, therefore, television engineering is a science of compromises. On the one hand, the natural requirements of the sense of sight are well known. On the other, the practical limitations of television equipment are inescapable, at least for the present.

Despite these limitations, a technically adequate television system has been devised, capable of reproducing all manner of subjects and scenes with sufficient realism to hold the attention and interest of critical observers. This achievement has been won, in spite of the severe handicaps that are imposed by the sense of sight itself (1) by determining the effects of compromises on the apparent realism of the reproduction and (2) by expending time and effort on those problems which admit of the least compromise. Color has been dispensed with, for example, because the eye does not insist on reproduction in natural colors. On the other hand, great effort has been directed toward reproducing a maximum amount of pictorial detail, since detail is one of the primary attributes of a satisfactory pictorial reproduction. No attempt need be made to reproduce the absolute ranges of brightness in the scene, since the effect of brightness contrasts can be achieved within a restricted range of brightness if the system takes into account the logarithmic response of the eye. These compromises are treated at greater length in the following chapters. Here they serve to illustrate the basic principle that the compromises adopted in the design of a television system must be acceptable to the eye. Accordingly it is necessary, in studying the television system, to examine the functions of the unaided sense of sight.

**1. Basic Factors in Direct Vision.**—When the eye views a scene directly, the intelligence conveyed from the scene to the mind of the observer is based on four factors: (1) distribution of light and shade, (2) motion, (3) color distribution, and (4) stereoscopy or “three-dimensional perspective.” These factors have been listed in order of importance. No visual intelligence is possible without distribution of light and shade, but this one factor alone suffices to represent a static scene, as in photographic prints and printed half-tone engravings. When the scene is dynamic, that is, when it depicts a connected series of events, motion is an essential part of the vision process. The representation of half-tone distributions in motion has been achieved in black-and-white motion pictures. Experience in this method of presentation has shown that a surprising degree of realism can be achieved, provided that the missing elements of color and stereoscopy are in part restored by the careful use of lighting, depth of focus, and camera action.

The four factors involved in direct vision are based on corresponding functions of the human eye. The structure of the eye, with the scientific names of its various parts, is shown in Fig. 1. Essentially, the eye consists of a lens system of adjustable focus, which receives light from the scene before it and focuses the light on the light-sensitive retina. The retina is composed of about 18,000,000 light-sensitive elements, called "rods and cones." Many of these rods and cones are capable of acting independently of each other and are connected to separate fibers in the optic nerve. In this arrangement rest the flexibility of the sense of sight and, incidentally, the difficulty of devising an electrical system that will perform the functions of seeing.

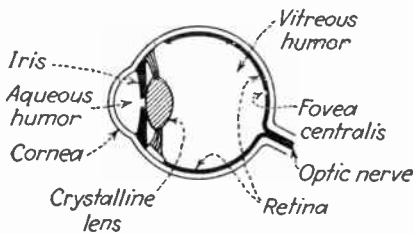

FIG. 1.—The human eye.

The rods and cones of the retina have extraordinary powers, the most important of which are as follows:

1. The ability to distinguish between degrees of light and darkness, that is, to evaluate the brightness of the light received.
2. The ability to distinguish between colors, that is, to distinguish between light rays of different wavelength (primarily a function of the cones in the foveal region, shown in Fig. 1).
3. The ability to transmit sensation, of both color and brightness, to the optic nerve some time after the light stimulus is removed, the so-called "persistence of vision."

In addition to these functions of the rods and cones, several other important functions of the eye are made possible by the two-dimensional arrangement of the many rods and cones in the retinal layer:

4. The ability to perceive the geometrical arrangement of the various parts of the image that is focused on the retina, through the simultaneous excitation of many rods and cones. The geometry reveals the width and height of objects directly and their depth indirectly by perspective.

5. The ability to distinguish motion in the image, as the geometry of the image changes and as a given part of the image illuminates several rods and cones in sequence.

6. The ability to distinguish detail in the image, each small detail being perceived by an individual cone or by small groups of them, in the foveal region.

The focusing action of the lens system makes possible

7. The ability to distinguish far objects from near objects by the relative sharpness of the details contained in their images.

Finally, the possession of two eyes provides

8. The ability to infer the relative distance and position of several objects by perception of the effects of the angle between the lines of sight from the eyes to the objects in question (so-called "stereoscopic perspective").

In view of these eight important aspects of vision, we may define the word "scene" as follows: A scene is an illuminated two-dimensional area or three-dimensional space, the contents of which are perceived by the eye as a distribution of small lighted areas, differing in color and degree of brightness, the areas being so perceived that the two dimensions at right angles to the line of sight are directly apparent and the third dimension is inferred by perspective. This rather laborious definition has been stated because it illustrates precisely the items that must be dealt with in a television system, namely, an arrangement of small lighted and colored areas, which, incidentally, are usually in motion. By such a definition, we reduce our direct experience with the process of vision to an objective statement of its essential elements.

Ideally a television system should have all eight of the primary abilities of the eye listed above. Actually all of them can be achieved, at least to some degree, by a television system that employs six complete picture-transmission circuits at once. Such a system can transmit a pair of images in each of the three primary colors, the pairs being arranged, stereoscope fashion, to give the illusion of depth. But if we confine ourselves to one picture-transmission channel as the limit now practically available for any one program, then color and stereoscopic perspective (the second and eighth items in the foregoing list) cannot be transmitted. By utilizing the remaining six factors, it is possible to reproduce a black-and-white (monochrome) image in motion.

**2. Methods of Visual Representation.**—Before considering the manner in which a scene is transmitted by television, we discuss the familiar methods of visual representation by photography and photoengraving. These methods differ considerably from those employed in television, but they serve to introduce the



FIG. 2A.—A simple still picture reproduced in a 120-line half-tone engraving. The picture elements (half-tone dots) cannot be discerned except on close inspection.

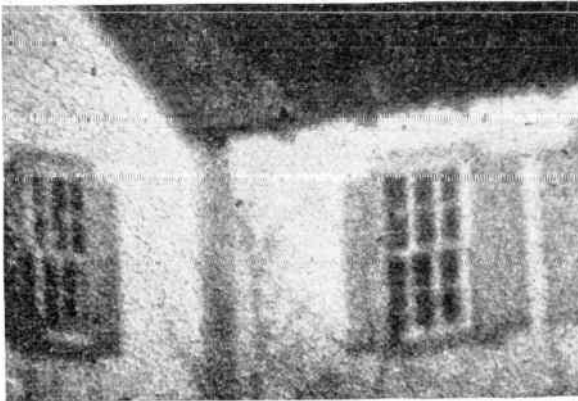

FIG. 2B.—A portion of the picture in Fig. 2A, enlarged to show the grain structure of the original photograph.

important ideas of *picture element* and *image repetition* which are essentials in the television process.

The simplest form of photography, the black-and-white still picture, is an example of the first essentials of vision since it is a geometrical arrangement of small areas of light and shade. If

we examine a photographic print under the microscope, we find that it is composed of fine grains of silver (see Fig. 2B). The silver grains are distributed throughout the picture area so as to represent the differences in light and shade present in the scene. Similarly a printed picture, reproduced from a photoengraving, is composed (see Fig. 3) of many fine printed dots, the dots being small in diameter or missing altogether in the highlights and of large diameter in the shadows. The silver grains and printed dots are examples of *picture elements*. A picture element is a small area of light or shade which constitutes the basic structure of the image.

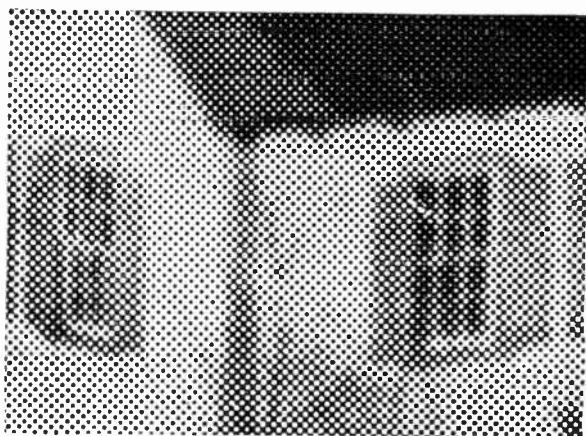

FIG. 3.—Enlargement of the half-tone dots of a portion of the engraving in Fig. 2A. Compare the same details in Fig. 2B with the coarse dot-structure above.

Upon the size of the picture elements depends the satisfaction that a picture can give the eye, when viewed at a stated distance. If the picture elements are small and numerous, fine detail is possible, and the picture may be examined closely without the individual picture elements themselves being evident. On the other hand if the picture elements are large, as they are for example in the ordinary 60-line half-tone engravings employed in newspaper printing, on close inspection the dots become evident. Such a coarse-grained picture is acceptable only if viewed at a distance of a foot or two, and the picture elements are not separately discernible at all if the picture is viewed from a distance of 4 or 5 ft. The size of the picture elements required



to portray a given subject depends, therefore, equally as much on the distance at which the picture is to be viewed as on the number of details to be represented in the picture.

The next type of photography, in order of complexity, is the black-and-white motion picture, which has all the properties of the still photograph and, in addition, is capable of reproducing motion in the image.

A motion-picture film, as shown in Fig. 4, contains a great many still pictures each of which differs slightly from the preceding and following pictures. As the film runs through the projector, each picture or "frame" is held stationary before the projecting lens for a brief time, then the picture is cut off by a shutter and the next frame is moved into place before the lens. The shutter then opens and reveals the second picture while it is stationary. The shutter then closes again, the next picture moves into place, remains stationary while the shutter opens, and so on. Since each picture is stationary when exposed to the screen, there is no blurring, and the only changes noticed by the eye are the differences between the successive pictures. If the stationary pictures are presented rapidly enough, the image formed in the eye by one picture *persists* during the succeeding dark interval and the eye is not aware that the light has been cut off between pictures. Consequently the screen, on which the picture is projected, appears as if it were continuously illuminated, and at the same time any motion in the image appears smooth and continuous.



FIG. 4.—Typical motion-picture film (35-mm.).

The rate at which the still pictures must be presented depends on two factors, the apparent rate of motion of the objects in the

image, and the time during which each still picture persists in the mind of the observer. The former factor, rate of motion in the image, can ordinarily be satisfied by a picture-repetition rate faster than 15 per second. The rate of persistence of vision is less easy to satisfy. When the illumination level is high, a picture rate of 15 per second is not rapid enough to ensure smooth blending of one image into the next and objectionable flicker results.

In standard motion-picture practice, the picture-repetition rate has been set at 24 pictures per second. At this rate, and at the illumination levels commonly employed in theater projection, the eye can detect a definite flicker. To avoid the difficulty, the projection of each still picture is broken up into two periods of equal length, by the action of a shutter which in effect shows each picture twice, making 48 separate projection periods from the 24 separate pictures in each second of the performance. By thus increasing the effective picture-repetition rate, the flicker is made undetectable under ordinary conditions.

**3. Electrical Transmission of Visual Information—Scanning and Picture Repetition.**—The transmission of visual information by electricity is severely limited by the fact that a single electrical-transmission circuit can carry but one item of information at a time. In general, these items of information are conveyed by current impulses that are caused to flow through the circuit by corresponding voltage impulses generated by the transmitting equipment. If several such voltage impulses are applied simultaneously to the circuit, the corresponding current impulses lose their separate identities in the circuit and cannot be separated at the receiving end of the line. Consequently the impulses must be conveyed “in single file” rather than “many abreast.”

With this limitation of transmission circuits in mind, we recall that a scene consists of a great many picture elements, which are perceived simultaneously by the eye. The many picture elements cannot be conveyed simultaneously by a single electrical communication channel. Hence it would seem necessary to provide a separate communication channel for each picture element and cause each channel to respond only to the changes of its particular picture element. This has been called the “parallel” method of transmitting visual information. It has been experimented with, but it has proved practical only when the



number of picture elements in the picture is small and when the distance of transmission is short enough to make feasible the great number of separate circuits required. The animated electric sign in which bulbs are used for picture elements, each wired to a separate circuit, is to date the only practical application of the parallel method of transmission. For pictures containing 100,000 picture elements or more (typical of modern television work), it is obviously impractical to provide the necessary number of individual circuits for parallel transmission.

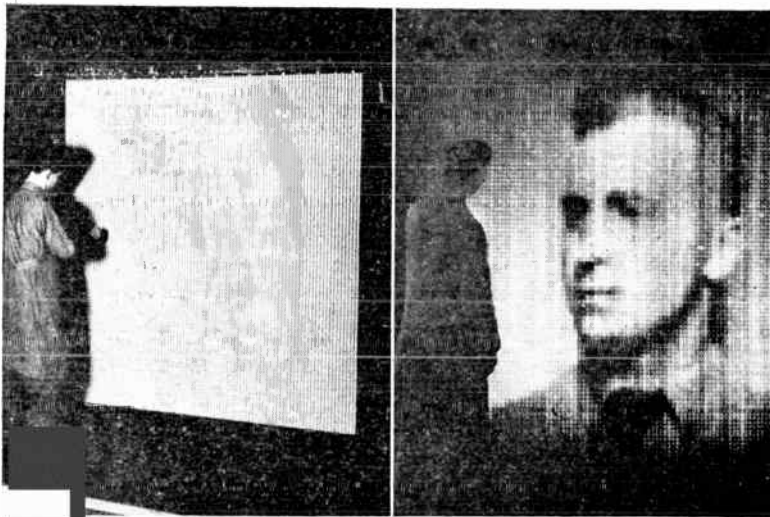

FIG. 5.—Parallel transmission of picture elements. Some 9000 separate lamps and circuits are required to reproduce the crude picture shown.

The alternative is to employ *one* communication channel and to send the picture-element impulses *one after the other* in orderly sequence at a very rapid rate. This is the so-called “successive” method of transmission. It is used universally in television and in the simpler processes of still-picture transmission by the wire-photo and radiophoto systems.

The effectiveness of the successive method of transmission rests on a very fortunate property of the eye, persistence of vision. If the eye were instantaneous in its action, the successive method would fail, since the eye at the receiver would then see each picture element individually and separately. It is fortunate, therefore, that the impression made by any one pic-

ture element persists in the eye for a small fraction of a second. During the interval of persistence of this one element, all the other elements are presented successively to the eye in their proper positions. In effect, the eye acts as though it were seeing all the elements at once, and the simultaneous aspect of direct vision is recreated artificially.

The persistence of vision is a complicated phenomenon. Its duration depends on the brightness of the light employed. The persistence of the sensation of light is very definite and marked for a short period after the light stimulus is removed, after which the sensation gradually dies away. In view of these complications, it is difficult to state definitely what fraction of a second is occupied by the persistence effect. Experience with motion pictures has revealed that the projected image appears continuously illuminated if the individual light impulses from the projector are presented to the eye at a rate of about 50 per second, which would indicate an effective persistence of about  $\frac{1}{50}$  sec. If the light impulses are presented to the eye at a slower rate, the sensation decays to a low level between the light impulses and flicker is apparent. The flicker is less noticeable if the light is not very bright, but it is readily apparent, even at reduced brightness, when the repetition rate falls below 30 per second.

Taking  $\frac{1}{30}$  sec., for convenience, as a measure of the persistence effect, it follows that in the successive method of visual transmission all the picture elements must be sent, one after the other, within the duration of  $\frac{1}{30}$  sec. if the eye is to see them all at once. Since there is a large number of picture elements in each picture, they must be sent very rapidly. Typical images in television reception contain a maximum of 100,000 to 200,000 elements. When these elements are sent successively in  $\frac{1}{30}$  sec., it follows that 3,000,000 to 6,000,000 elements must be sent in a second. The problem of dissecting pictures and reassembling them at this extraordinary rate has been solved by the development of "cathode-ray" devices which employ streams of free electrons capable of moving with the required agility.

**4. Scanning, an Orderly Sequence of Transmitting Picture Elements.**—No mention has been made thus far of the geometrical sequence in which the picture elements are selected from the body of the picture for transmission in the successive method. Any convenient method of selection may be used so long as the

same sequence is followed in transmitter and receiver. A great variety of selection methods have been proposed and many of them tried. The one universally adopted in television is known as "linear scanning."

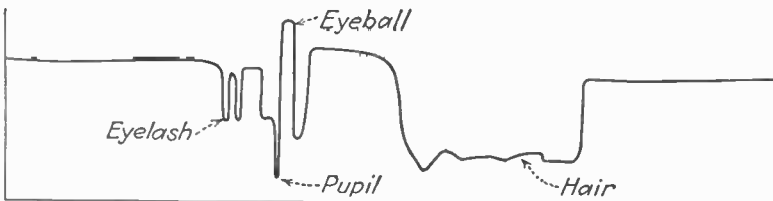

FIG. 6A.—The scanning technique. The image is divided into a number of parallel horizontal lines, each of which is explored in succession for the information it contains. The diagram shows the values of brightness (measured with a densitometer) at corresponding points along the line which passes directly through the pupil of the left eye. This "waveform" represents the information contained in that particular scanning line.

The word "scanning" arises from its similarity to the manner in which a reader scans a page of printed type. The eye begins at the upper left-hand corner of the page, travels along the first line of type until it reaches the right-hand edge of the page.

There the eye quickly reverses its motion and returns rapidly to the beginning of the next line where it resumes its slower left-to-right motion, traveling to the end of the line, then back, and so on.

A very similar motion is employed in television scanning. The picture elements, distributed over the picture area, are considered to lie in parallel horizontal rows, much the same as the letters of print are arranged on a page. When the transmission of the picture begins, all the picture elements present in the topmost row are selected, one after the other from left to right, and converted into corresponding electric pulses which are sent successively over the communication channel. When the first row has been scanned, the picture elements in the second row (which lies adjacent to and just below the first row) are selected in the same fashion, followed by the elements in the third row, and so on, until the bottom row of the picture is reached. In this manner, the whole area of the picture is systematically explored for the information it contains. At the receiver, the electric impulses are translated back again to light impulses and these impulses are assembled before the eye in the same scanning sequence.

The scanning process must proceed at a very rapid pace, of course. If the eye is to see the whole picture at once, it is necessary that the last picture element in the last row in the array be presented to the eye while the impression from the first element in the first row still persists in the eye, that is, within  $\frac{1}{30}$  sec. or less. Within this short time it is necessary, in other words, that all the elements of the picture be so presented that the eye sees the picture "all at once."

The entire process is then immediately repeated, and a new picture, differing somewhat from the first, is sent in the same fashion. At the end of 1 sec., 30 complete pictures have been sent. Any motion which occurs in the scene during that time is thereby divided into 30 smaller motions which, viewed by the eye, appear to blend smoothly and continuously one into the next.

The fundamental picture-repetition rate in television has been set in accordance with the frequency of the power-supply system to which the receiver and transmitter are connected. Since 60-c.p.s. areas predominate in this country, the picture-repetition

rate has been set at 30 per second. (The reasons for the connection between repetition rate and power-supply frequency are discussed in Chap. II.)

At this rate of repetition, flicker is quite evident even at the low illumination levels that may be used in the home. To reduce the flicker, a method somewhat similar to that used in motion pictures is employed, that is, the duration of each picture is divided into two intervals. In television, however,



FIG. 6B.—Televised reproduction of the subject in Fig. 6A.

it is not sufficient to interrupt the picture with a shutter, since the shutter would merely obscure some of the rows of picture elements in the image. Instead, *every other row* in the pattern is scanned during the first scanning period. In the following scanning period, the rows that were omitted from the first scanning are scanned. At the conclusion of the second scanning period, each point of the image has been scanned only once, but the eye has received two light impressions from the picture area. The picture-repetition rate is thus effectively doubled, and the

picture information remains unchanged. This method of scanning is known as *interlaced scanning*. Interlaced scanning is now universally employed in the television systems standardized throughout the world, because it has proved to be highly effective in reducing flicker to the point where it is undetectable under all ordinary conditions.

The interlacing technique introduces important problems in the scanning process, the most important of which is the necessity of causing one set of lines to fall accurately into the blank spaces left between the lines of the preceding set. A detailed account of interlacing methods is given in the following chapter.

*Standards of Transmission in the United States.*—With this brief account of the methods of picture analysis used in television transmission in mind, we can summarize by stating the situation as it applies to present practice in the United States, according to the standards of the Radio Manufacturer's Association Committee on Television.

Each picture is scanned into a total of 525 rows or "lines," of which about 470 are active in presenting the picture. Each line contains a maximum of 400 to 500 picture elements, depending on the capabilities of the transmission system. In transmitting the picture elements, the odd-numbered lines (first, third, fifth, seventh, etc.) are sent first, the even-numbered lines being omitted. Consequently after one-half the lines have been sent ( $262\frac{1}{2}$  lines), the end of the first "field" (set of alternate lines) is reached. The scanning process then begins again, and the even-numbered lines (second, fourth, sixth, etc.) are sent. These lines fall into the spaces between the odd-numbered lines previously sent. The entire process of transmitting both odd-numbered and even-numbered lines occupies a time of  $\frac{1}{30}$  sec., and consequently 30 complete pictures are sent each second.

In addition to the signals representing the picture elements, special signals are sent out by the transmitter between successive lines and between successive fields. These latter signals are employed to keep the receiver and transmitting scanning motions in step and hence are called "synchronizing signals." Those at the beginning of each line are called *horizontal synchronization signals*, and those at the beginning of each field are termed *vertical synchronization signals*.

It is instructive to consider the tremendous rate of speed at which the scanning process proceeds in the system just outlined. The complete picture of 525 lines is sent in  $\frac{1}{30}$  sec., consequently  $30 \times 525 = 15,750$  lines are sent each second. If the picture is 7 in. wide, this means that  $7 \times 15,750 = 110,250$  in. are covered in the entire scanning process every second. This is a rate in excess of a mile a second. It is obvious that highly specialized equipment must be used to perform the scanning process at the transmitter and to reproduce the image lines in the receiver.

Still more astonishing is the number of picture elements scanned in a second. In the next chapter, it is shown that if the picture is to have the same degree of resolution in the horizontal direction as in the vertical direction, then each line in the image must be capable of division into about 450 picture elements. Since 15,750 lines are sent in each second, this means  $15,750 \times 450 = 7,100,000$  picture elements per second. If more picture elements are to be accommodated in each line, the rate is proportionately increased. Rates as high as 8,000,000 picture elements per second are used in practice.

**5. Equipment Used in a Typical Television System.**—The following rapid survey of equipment used in a typical television system is presented to introduce briefly the manner in which the principles of scanning and picture repetition are carried out in practice.

The conversion of the scene from light to electricity occurs in a *camera tube*, which performs the two important functions of converting the optical image into the corresponding electrical image and selecting the picture elements in the proper sequence of alternate rows required for interlaced transmission. The type of camera tube described here is a "storage" type known as an *iconoscope*.

The essential element in the iconoscope tube is a flat plate of mica on which are deposited several million separately insulated hemispheres or globules of silver. These silver globules are treated with a surface layer of cesium oxide and are thereby endowed with the property of releasing negative electric charge when illuminated. The scene to be transmitted is focused, through a lens, on this plate in much the same fashion as if the plate were the film in an ordinary photographic camera. The light on the plate releases negative charge from the silver-cesium

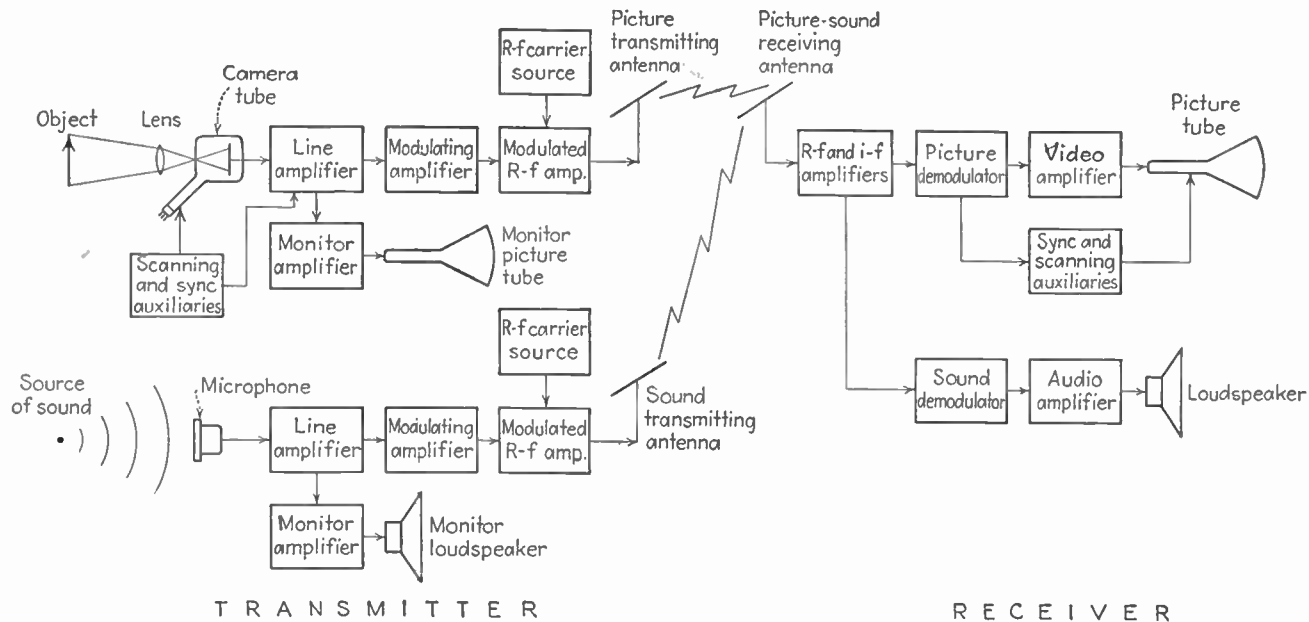

FIG. 7.—Elements of a typical television system.



globules in proportion to the illumination falling on them. As a result, the plate assumes an electrical charge deficiency the distribution of which is the same as that of the light in the optical image. In this way, the fundamental action of photoelectrical translation is performed, and the optical image is translated into an electrical image.

It then remains to dissect the electrical image in an orderly series of horizontal lines. This is done by directing, from a side

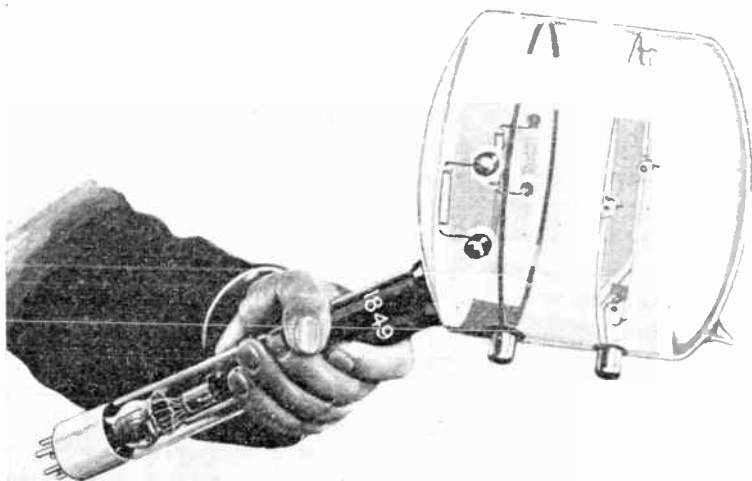

FIG. 8.—A typical television camera tube, the type 1849 iconoscope, now widely used in television broadcasting.

arm in the tube, a stream of electrons at the image plate. This stream of electrons is of very narrow cross section, and it can be aimed accurately at any point on the plate by two pairs of electromagnetic “deflection” coils placed externally to the tube.

The electron beam is aimed initially at the extreme upper left-hand corner of the image (as viewed upright) and is then moved horizontally across the upper edge of the picture, thus tracing out the first scanning line. In passing over the silver globules in this line of the image, the stream of electrons restores to equilibrium the charge previously lost by each globule. With each restoration of charge, the electrical potential of the image plate changes, and as a result the potential of the plate assumes

a rapid succession of different values, each depending upon the amount of charge restored at that particular instant. In other words, the successive values of the image-plate potential are measures of the brightness of the successive picture elements contained in the first scanning line.

At the end of its motion across the first scanning line, the electron beam is returned to the left-hand edge of the picture. During the forward and return motions, the beam is moved, comparatively slowly, vertically downward, so that by the time it reaches the left-hand edge of the picture, its position is somewhat below its initial position. The beam is then caused to travel again from left to right, tracing out another line in the image, parallel to the first, but separated from it by the width of one

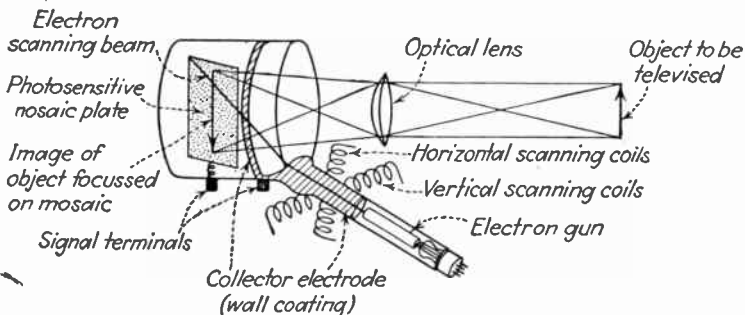

FIG. 9.—Diagrammatic view of the operation of the iconoscope camera tube.

line. The empty space between lines is later filled in by the second interlaced field. In this way, the area of the optical image is covered by the beam in a succession of alternate lines, each line being separated from the next by the width of one line.

When the beam reaches the bottom of the picture, the slow vertical motion is then stopped, the beam is extinguished and returned while extinguished to the top of the picture. Here it begins its scanning motion again, but this time the beam is positioned so as to traverse the spaces between the lines just scanned, thereby filling in the gaps. When the beam reaches the bottom of the picture, it has then covered every point in the area, in two series of alternate lines. During this entire process, the potential of the image plate continually changes, in such a way that the change in its potential at any instant is proportional to the change in the brightness between

the adjacent picture elements being scanned by the beam at that instant.

In transmitting the television program, two separate transmitters are employed, one for the sound transmissions, the other for the picture transmissions. The electrical signal from the camera tube, with synchronizing impulses superimposed, is impressed on a carrier current and is then radiated from the antenna.

At the receiver, the voltages induced in the receiving antenna by the sound- and picture-carrier signal waves are conducted to the receiver proper. There the picture-carrier frequency is

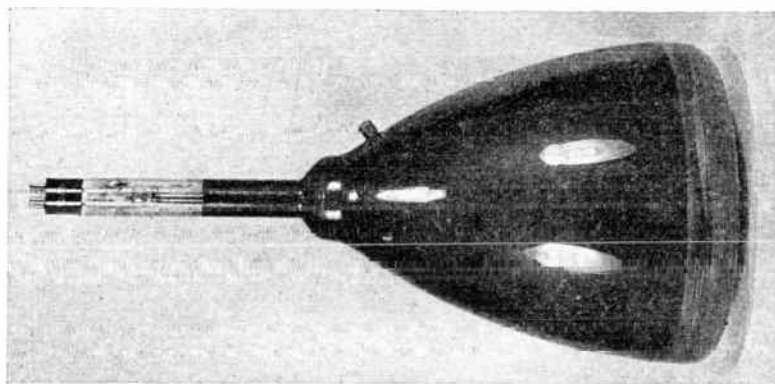

FIG. 10.—A typical television picture tube, capable of reproducing a picture 8 by 10 in. in size (screen diameter 12 in.).

separated from the sound-carrier frequency by a superheterodyne conversion process, and thereafter the two signals are amplified separately. The sound carrier is demodulated to restore the sound frequencies, which after amplification are applied directly to the loudspeaker. The picture carrier is similarly demodulated to obtain the picture frequencies. After amplification, the picture frequencies are used to control the image-reproducing tube.

The image-reproducing tube ("picture" tube), a typical example of which is shown in Fig. 10, is a funnel-shaped glass structure in the narrow end of which is contained an electrode structure capable of producing a narrow beam of electrons. This beam is directed toward the wide end of the tube, where it encounters a screen of luminescent material. Where the beam

hits the screen, it causes a small spot of light to appear on the luminescent material.

The electron beam in the picture tube is caused to move in the same manner as, and synchronously with, the beam of electrons in the camera tube in the transmitting studio. In the picture tube, as in the camera tube, the direction of the beam is controlled by two pairs of control coils (or by deflecting plates), one of which causes the beam to move horizontally, whereas the other causes it to move comparatively slowly in a vertical direction. The currents in the coils which cause these motions are controlled by the synchronizing signals, which are separated

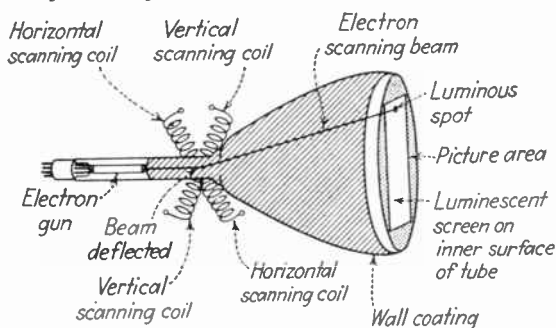

FIG. 11.—Diagrammatic view of the operation of a television picture tube. The scanning beam moves synchronously with the scanning beam in the camera tube and reproduces the image point by point.

from the picture signal. As a consequence of this control, the electron beam moves across the luminescent screen in a series of alternate horizontal lines, forming one interlaced field immediately followed by a second field which falls into the empty spaces of the first. The spot of light, produced on the screen by the impact of the electron beam, traces out the beam motion. Thereby all the points in a rectangular area on the screen are illuminated, one after the other. The process of successive illumination of these points is so rapid that the effect on the eye is of simultaneous and uniform illumination over the rectangular area. Close examination of the screen shows it to be illuminated in a series of parallel, adjacent, horizontal lines.

The reproduction of the picture is accomplished by changing the brilliance of the spot of light as it moves across the lines of the scanning pattern. This change of brilliance is obtained by changing the potential applied to a control electrode in the beam-

forming electrode structure. This control potential is derived from the picture signal itself, which in turn is derived from the camera tube. Consequently as the beam moves across each line in the pattern, the brilliance of the spot is controlled in direct accordance with the corresponding changes in image-plate potential in the transmitting camera tube. The image-recreating tube thus performs the process of assembling the picture elements with the correct values of light and shade in the correct order of interlaced lines. The image is thereby reproduced. The process repeats itself at a rate of 30 complete pictures per second.

**6. Technical and Economic Limitations of the Television System.**—In the present state of the art, television suffers from several limitations which restrict the service in four respects:

1. The detail of the received image is limited to approximately 200,000 picture elements, regardless of its over-all dimensions. This compares poorly with the best half-tone engravings, which contain as many as 4,000,000 picture elements in a picture comparable in size with the largest unprojected television pictures (8 by 10 in.). A fine "contact" photographic print of the same dimensions contains as many as 50,000,000 picture elements.

2. The reliable range of television transmission is less than 100 miles, with 50 miles as the useful limit in any but the most favorable receiving locations.

3. The number of television transmitters that can be accommodated in the currently useful portion of the ether spectrum is limited to seven in any area of less than 100 miles radius.

4. At present, transmitting stations cannot be linked together in networks for the simultaneous transmission of the same program, except at prohibitive cost and only with the installation of large amounts of equipment not now available.

The fundamental cause of these limitations is the rate of speed at which the television system must be operated. The upper limit of transmitting speed at present is less than 8,000,000 picture elements per second in any system involving radio waves as part of the transmission circuit. If 30 pictures are to be sent per second, this limits the number of picture elements per picture to about 260,000, of which less than 200,000 are available for actively reproducing the picture.

One of the reasons for the limitation of transmitting rate to 8,000,000 picture elements per second has to do with the physical

ability of apparatus, particularly amplifiers and transmission circuits, to respond to voltage variations any more rapid than this. Progress has been made in this respect by the development of new types of vacuum-tube structures and by the use of refined techniques of constructing and arranging the circuit parts. There seems to be no discernible restriction to the ability of the amplifiers and circuits to go beyond these limits. It is not impossible to conceive of a system capable of transmitting 100,000,000 picture elements per second, if present advances are pressed to completion.

But when the transmission circuit involves radio waves, the limitation is not only one of apparatus: it is one involving the available space in the ether spectrum. The ether spectrum at present open to, and reserved for, television use includes waves in the range from 40,000,000 to 100,000,000 per second (40 to 100 Mc. per second). Another range from 100,000,000 to 300,000,000 per second (100 to 300 Mc.) is available but is not economically suitable for use with present equipment.

The standard television channel, including the sound system, is 6,000,000 c.p.s. (6 Mc.) in width. In the ether range between 40,000,000 and 100,000,000 c.p.s., there is room, accordingly, for 10 stations each occupying a band of 6,000,000 c.p.s. The valid requirements of other services, notably those of the government and of amateur operators, reduce the total to seven stations.

The radius over which each of these stations is capable of causing interference with other stations is about 100 miles. Hence the seven frequency assignments may be duplicated in different geographical localities, provided that no two stations operating on the same frequency are nearer to each other than 200 miles. In the densely populated regions such as the New England and Middle Atlantic states, the frequency assignments cannot be duplicated for each city, and many of the smaller cities must therefore be satisfied with transmissions originating in the larger cities.

The limitation of reception to comparatively short distances from the transmitter is occasioned by the fact that radio waves in the range from 40,000,000 per second to the upper limit of the spectrum do not follow the curvature of the earth. On reaching the horizon, or thereabouts, the waves glance off the surface of the earth, tangentially, and are lost in the space beyond. By

raising the transmitting antennas 1000 ft. or more above the ground, the horizon may be pushed back to about 45 or 50 miles. A slight bending effect, subject to considerable variation, does occur and accounts for reception up to several hundred miles. Beyond this limit, reception is possible only when the atmospheric conditions are exceptional, and then only when very elaborate receiving antennas are employed.

The fourth named limitation, the difficulty of linking stations for simultaneous broadcasting of the same program, is dictated by the fact that telephone facilities are limited to a slow rate of handling information, much slower than is required for handling modern television images. An experimental "coaxial" telephone cable between New York and Philadelphia has been demonstrated operating at about 2,000,000 picture elements per second and has been rebuilt to convey about 4,000,000 per second. This is satisfactory performance for television transmission, but the installation of the cable generally must wait for an economic justification. Such a telephone cable will carry about 480 simultaneous telephone conversations and could be released for television use only if additional facilities were available for handling the telephone toll traffic.

Another proposal for linking television stations is that of operating radio-repeater stations between the broadcast stations. This seems to be feasible in the r-f range between 100,000,000 and 300,000,000 c.p.s., since no frequency assignments for them would be ordinarily available in the range between 40,000,000 to 100,000,000 c.p.s. In any event, such repeater stations would involve such an expense for installation and operation that they could be installed only in response to a very evident demand on the part of the public. Short of the appearance of this demand, it seems likely that television transmissions will continue to be available only on the basis of isolated stations serving urban and suburban areas.

#### Bibliography

##### *Vision*

HARDY and PERRIN: "Principles of Optics," Chap. X, p. 185, McGraw-Hill Book Company, Inc., New York, 1932.

HELMHOLTZ, H. v.: "Physiological Optics" (English translation, Optical Society of America, 1924).

- MONK, G. S.: "Light: Principles and Experiments," Chap. XVII, p. 323, McGraw-Hill Book Company, Inc., New York, 1937.
- MOON, PARRY: "The Scientific Basis of Illumination Engineering," Chap. XII, p. 396, McGraw-Hill Book Company, Inc., New York, 1936.
- PARSONS, SIR J. H.: "An Introduction to the Study of Colour Vision," The Macmillan Company, New York, 1924.
- Report of Standards Committee on Visual Sensitometry, *Jour. Optical Soc. Am.*, **4**, 55 (1920).
- Television Principles*
- ASHBRIDGE, N.: Television in Great Britain, *Proc. I.R.E.*, **25**, 708 (June, 1937).
- BEAL, R. R.: Equipment Used in the Current RCA Television Field Tests, *RCA Rev.*, **1** (3), 36 (January, 1937).
- BEERS, ENGSTROM, and MALOFF: Some Television Problems from the Motion Picture Viewpoint, *Jour. Soc. Motion Picture Eng.*, **32**, 18, (January, 1939).
- BROLLY, A. H.: Television by Electronic Methods, *Trans. A.I.E.E.*, **53**, 1153 (August, 1934).
- ENGSTROM, KELL, BEDFORD, TRAINER, HOLMES, CARLSON, and TOLSON: An Experimental Television System, *Proc. I.R.E.*, **22**, 1241, 1246, 1266 (November, 1934).
- GANNETT and GREEN: Wire Transmission System for Television, *Bell Sys. Tech. Jour.*, **6**, 616 (October, 1927).
- GOLDSMITH, A. N.: Image Transmission by Radio Waves, *Proc. I.R.E.*, **17**, 1536 (September, 1929).
- GRAY, HORTON, and MATHES: The Production and Utilization of Television Signals, *Bell Sys. Tech. Jour.*, **6**, 560 (October, 1927).
- HORTON, J. W.: The Electrical Transmission of Pictures and Images, *Proc. I.R.E.*, **17**, 1540 (September, 1929).
- IVES, H. E.: Television, *Bell Sys. Tech. Jour.*, **6**, 551 (October, 1927).
- JENKINS, C. F.: Radio Vision, *Proc. I.R.E.*, **15**, 958 (November, 1927).
- NELSON, E. L.: Radio Transmission System for Television, *Bell Sys. Tech. Jour.*, **6**, 633 (October, 1927).
- STOLLER and MORTON: Synchronization of Television, *Bell Sys. Tech. Jour.*, **6**, 604 (October, 1927).
- STRIEBY, M. E.: Coaxial Cable System for Television Transmission, *Bell Sys. Tech. Jour.*, **17**, 438 (July, 1938).
- WEINBERGER, SMITH, and RODWIN: The Selection of Standards for Commercial Radio Television, *Proc. I.R.E.*, **17**, 1584 (September, 1929).
- WILSON, J. C.: Trichromatic Reproduction in Television, *Jour. Roy. Soc. Arts*, **82**, 841 (July, 1934).
- WILSON, J. C.: "Television Engineering," Pitman Publishing Corporation, New York, 1937.
- ZWORYKIN, V. K.: The Iconoscope, a Modern Version of the Electric Eye, *Proc. I.R.E.*, **22**, 16 (January, 1934).
- ZWORYKIN, V. K.: Television, *Jour. Franklin Inst.*, **217**, 1 (January, 1934).



## CHAPTER II

### IMAGE ANALYSIS

The transmission of television images, as we have seen in the foregoing chapter, is accomplished by analyzing the scene into its picture elements, which are selected from the picture area in the orderly sequence of scanning and transmitted one after the other. Since the scanning and picture-repetition processes are essentially artificial ones, we can choose arbitrarily the total number of scanning lines, the number of picture elements in each line, the sequence of transmission of the lines, the width of the scanning pattern relative to its height, and the rate of picture repetition.

When only one transmitter and one receiver are involved, these items can be decided upon without reference to the choices of other workers. But in television broadcasting, in which many transmitters and an even greater number of receivers are involved, it is necessary that the scanning process be identical in all transmitters and all receivers, since any receiver may be called upon to receive images from any transmitter within range.

Consequently there exists the need for standards of image analysis that will satisfy all workers as the best compromise among their differing ideas and that may be used, without major changes, for a long period of time. It is clear that such standards cannot be decided upon without careful study of the requirements of the eye on the one hand and the technical means for satisfying these requirements on the other. Such a study has been undertaken by qualified groups of engineers in every country where television systems are now under development.<sup>1</sup>

<sup>1</sup>The full text of the R.M.A. Television Transmission Standards is printed in the Appendix, p. 517. For information relating to television standards development in this country, see:

LEWIS, H. M., Standards in Television, *Electronics*, 10, (7), 10 (July, 1937).

MURRAY, A. F., R.M.A. Television Standards, *R.M.A. Eng.*, 1 (2) (November, 1936).

MURRAY, A. F., R.M.A. Completes Television Standards, *Electronics*, 11,

In this country, the standards relating to the scanning pattern are as follows: the total number of scanning lines in the picture, whether actively employed or not, has been set at 525. In practice, about 470 of these lines are active in the received image. The number of picture elements in each line, determined by the frequency-response limits of the system, usually has a value of about 400 to 500. Fewer picture elements may be transmitted, of course, if the subject matter of the transmission does not contain fine detail or if the performance of the transmitter or receiver is defective.

The sequence of transmission of the lines, as described in Chap. I, follows the order of interlacing, the picture being divided into two groups of alternate lines. The scanning pattern is so proportioned that the active illuminated area of the received picture is a rectangle having a width four-thirds times as great as its height. The rate of picture repetition is 30 per second, interlaced in 60 fields per second.

**7. Factors Influencing the Number of Lines in the Scanning Pattern.**—We consider first the basic factors underlying the choice of 525 lines as the standard number of lines in the scanning pattern. The discussion must be divided into two parts: (1) the reasons for choosing a number in the vicinity of 500 and (2) those for choosing the exact figure, 525.

It is clear, in the first place, that the number of scanning lines determines the number of details that can be accommodated along any vertical line in the image, since each of the scanning lines can represent *at best* but one detail on any such vertical line. In the worst case, however, the scanning lines may represent no vertical detail at all. To illustrate the two cases, consider Fig. 12. The objects to be televised are two vertical bars, each containing a number of alternate black and white segments the heights of which are equal to the width of the scanning lines.

If the image of the bar is so positioned that the scanning beam passes directly over a white segment, as in the bar at *A*, the corresponding voltage pulse is transmitted and reproduced in the receiver as a white spot of light. This is the best possible case;

---

(7) 28 (July, 1938).

WEINBERGER, SMITH, and RODWIN, The Selection of Standards for Commercial Radio Television, *Proc. I.R.E.*, **17**, 1584 (September, 1929).

the received image  $A'$  corresponds exactly with the original image  $A$ .

But if the segments in the image are so placed with respect to the scanning beam that the scanning beam passes directly over the boundary between a black and a white segment, as in the bar at  $B$ , then the *average brightness* perceived by the system is a *gray* intermediate between black and white. The corresponding voltage pulse produces an intermediate gray spot of light in the

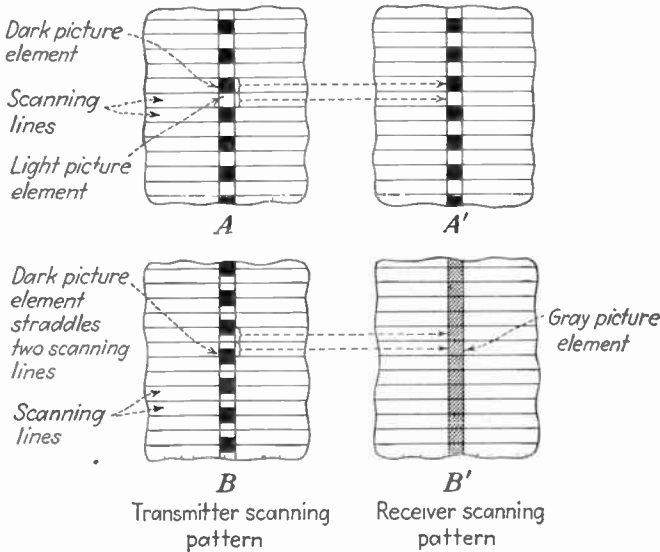

FIG. 12.—Relationship of scanning lines to picture elements. If the scanning lines pass directly over the picture elements, the reproduction  $A'$  is like the original  $A$ . If, however, the scanning lines "straddle" the picture elements, the detail may be wholly lost in the reproduction (cf.  $B'$  with  $B$ ).

receiver. On the next scanning line, the beam again passes over the boundary between a black and a white segment; the next spot of light produced on the receiver is of a gray tone indistinguishable from the preceding gray spot. Consequently it is impossible to distinguish between the two spots, and the detail is entirely lost. The received image  $B'$ , instead of being a vertical bar marked with equally spaced black and white segments, becomes a vertical bar uniformly gray in color.

It is evident, therefore, that the number of picture elements that can be reproduced on a vertical line depends largely on the position of the elements with respect to the scanning lines in the

camera-scanning pattern. If the position of an element is such that it is passed over completely by the scanning beam, then that element can be reproduced, but if its position is such that it "straddles" two scanning lines, then the detail may be partially, or even wholly, lost.

In practice, of course, the subjects transmitted are not segmented vertical bars but whole pictures containing a scattered arrangement of picture elements, some of which fall directly on a scanning line, others of which straddle two lines. The question then arises, How many picture elements, *on the average*, can be represented along a vertical line by a given number of scanning lines?

Suppose, for example, that the scanning pattern contains 470 active lines and that, as might be expected, half of the 470 picture elements on a given vertical line straddle the scanning lines and are thereby lost or merged with other elements. Then only the remaining 235 picture elements will be reproduced accurately in the received image. Whether this half-and-half division of the elements is actually representative of the practical case can be determined only by careful testing of different types of subject matter.

Such tests have been made, both experimentally and theoretically. Engstrom and his coworkers,<sup>1</sup> on the basis of a large practical experience, came to the conclusion that about 64 per cent of the picture elements are, on the average, correctly reproduced in the scanning process and that the remaining 36 per cent are lost or distorted. According to this figure, 470 active scanning lines are capable of reproducing, on the average, about  $470 \times 0.64 = 300$  picture elements on a vertical line.

Wheeler and Loughren<sup>2</sup> undertook to study the problem from a theoretical approach. They chose as their transmitted object a nearly horizontal black line on a white background, so positioned that the bar crossed several scanning lines, as shown in Fig. 13. Where this bar coincides with a scanning line, its width is repro-

<sup>1</sup> ENGSTROM, E. W., A Study of Television Image Characteristics, *Proc. I.R.E.*, Part I, **21**, 1631 (December, 1933); Part II, **23**, 295 (April, 1935).

<sup>2</sup> WHEELER and LOUGHREN, The Fine Structure of Television Images, *Proc. I.R.E.*, **26**, 540 (May, 1938).

See also: JESTY and WINCH, Television Images—Analysis of Their Essential Qualities, *Jour. Telev. Soc.*, **2**, 316 (December, 1937).

duced by the full width of the receiver scanning line. Where it crosses the boundary between two scanning lines, on the other hand, it is not reproduced at all. Consequently the reproduced image of the bar has the irregular shape shown at the right in the figure. Wheeler and Loughren calculated the average width of this bar by assuming a distribution of light in each line that occurs in practice. The calculation shows that the average width of the bar is 1.41 times that of each scanning line. With 470 scanning lines available, therefore, only  $470/1.41 = 333$  horizontal bars can be accommodated on the pattern. Since each of these 333 bars represents a picture element along a

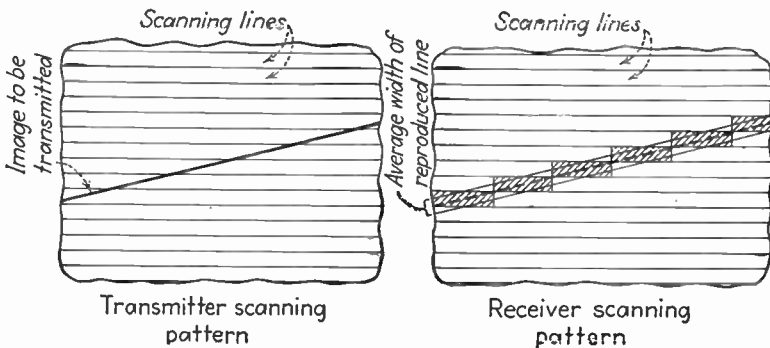

FIG. 13.—Wheeler and Loughren's method of determining the vertical resolution possible from a given number of scanning lines.

vertical line, it follows that the percentage of the scanning lines representing picture elements is  $333/470 = 71$  per cent. This is in remarkably close agreement with the experimental determination of Engstrom. Practical experience indicates, however, that slightly better resolution may be obtained. In practice, 350 to 400 elements, on a vertical line, may be represented by 470 active scanning lines. The conclusion is that a scanning pattern containing 470 active lines is capable of reproducing accurately an image that contains from 300 to 400 picture elements measured in the vertical direction.

**The Number of Picture Elements along Each Line.**—The number of picture elements measured in the *horizontal* direction, that is, the number of picture elements contained in each line, is not limited by the scanning pattern at all but rather by the ability of the transmitting- and receiving-system equipment to generate, convey, and reproduce rapid changes of voltage and current.

At one time, it was commonly assumed that the spacing of the reproduced picture elements should be the same in the horizontal direction as in the vertical direction. Under this assumption (since the picture width is  $\frac{4}{3}$  times its height),  $\frac{4}{3}$  as many picture elements is required in each line as is accommodated in the vertical direction, as shown in Fig. 14. If a scanning pattern of 470 lines can represent 350 picture elements vertically, then to fulfill this condition will require  $\frac{4}{3} \times 350 = 465$  picture elements in each line. The total number of picture elements in

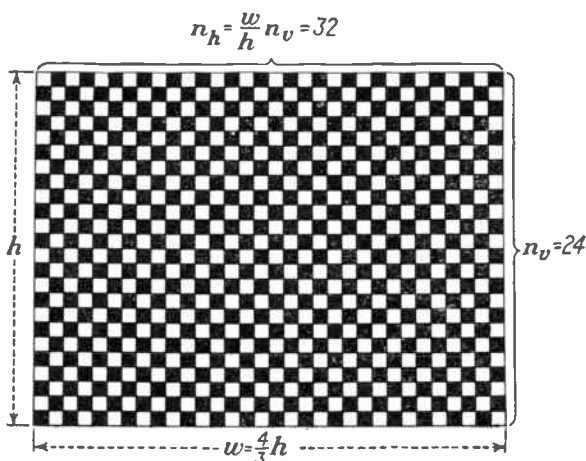

FIG. 14.—Relationship between vertical and horizontal resolution when picture-element spacing is equal in the two dimensions. The total number of picture elements is then  $\frac{4}{3} \times n_r^2$ , where  $n_r$  is the number in the vertical dimension and  $\frac{4}{3}$  is the ratio of the picture's width to its height.

the picture area is then  $350 \times 465 = 163,000$ . Later experience has shown, however, that more elements may be crowded into each line, over 500 in some cases, with resulting improvement of the picture. Accordingly, as many as 200,000 picture elements may be accommodated in the picture area.

As a first approximation, then, we can say that a picture containing 525 lines, 470 of which are active, having a width  $\frac{4}{3}$  times its height, can accommodate 100,000 to 200,000 picture elements. This number of picture elements is the "figure of merit" of the scanning pattern and may be compared with other methods of visual representation. A single frame of 35-mm. motion-picture film contains about 500,000 effective picture

elements when exposed, developed and projected in the usual fashion. The smaller 16-mm. motion-picture frames contain about one-fourth as many, or 125,000.

The question remains, Under what conditions can a television image of, say, 150,000 picture elements give satisfaction to the eye? If such an image is viewed closely, the lines in the image and the gradations of shading along each line are very evident. As the image is viewed at greater and greater distances, the structural detail becomes less and less evident, until at a certain limiting distance, the structure of the picture becomes indiscernible and the picture elements blend uniformly one into the other.

To investigate more fully the desirable viewing distance of a 470-line image, we must examine the fundamental ability of the human eye to perceive details in the objects before it.

**The Acuity of the Eye.**<sup>1</sup>—The term *visual acuity* has to do with the ability of the eye to distinguish the details of the scene it observes. The explanation of this ability of the eye, as we have seen, lies in the fact that the lens system of the eye focuses the image of the scene on the separate rods and cones of the retina. In the most acute portion of the retina (the fovea), each cone is connected to a separate fiber in the optic nerve and hence is capable of registering sensation independently of its neighbors. Each detail in the scene is registered by one cone, or by a small group of them.

When a scene made up of picture elements is viewed by the eye, the separate picture elements can be distinguished from one another if they fall on separate cones. Thus, when an object is viewed closely, the image on the retina is large, and when each picture element occupies one or more of the separately sensitive cones, the structure of the picture is evident. However, if the scene is viewed at a greater distance, its image on the retina becomes smaller, and the picture elements may then be so small that two or more picture elements are focused on but one cone. These picture elements register in the brain not as separate elements but as one element, since only one nerve fiber is involved. The discernible detail in the scene is thereby decreased. The critical viewing distance is that at which this reduction in detail just becomes evident.

<sup>1</sup> See the bibliography of references on "Vision," end of Chap. I, p. 23.

To express the acuity of the eye in a quantitative fashion, it is customary to express the angle subtended, at the eye, by two picture elements that can just be distinguished from one another. The situation is shown in Fig. 15. Two small dots, separated from each other by a distance of  $s$  inches, are viewed on a screen, and the distance  $d$  from the screen to the eye is increased until the dots are just distinguishable from one another. The angle  $\alpha$  subtended at the eye by the dots is then measured. When the observer possesses a normal eye, the angle is found to have a value of approximately 1 min. of arc. Persons of very acute vision may be able to distinguish the dots when the angle is as small as  $\frac{1}{4}$  min., whereas persons of defective vision may not be able to resolve the dots when the angle is 5 min. or more.

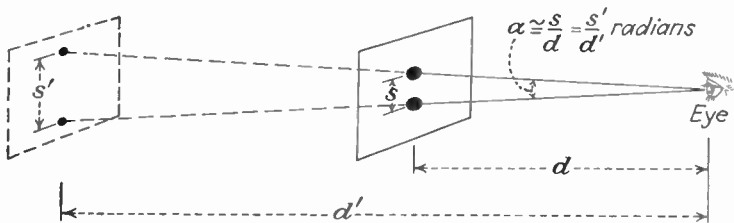

FIG. 15.—Quantitative measurement of visual acuity. The ability of the eye to distinguish detail is measured by the angle at which the two dots are separately visible.

The value of 1 min. is taken simply as a convenient basis for the average case.

We may derive a simple equation relating the separation between the dots or picture elements and the viewing distance  $d_c$  at which the normal eye can just resolve the dots. The angle  $\alpha$ , as shown in Fig. 15, is that subtended by the centers of the two dots. This separation is  $s$  cm., and the distance of viewing is  $d$  cms. The ratio  $s/d$  is approximately equal to the angle, in radians, subtended by the dots at the eye. This angle, at the viewing distance  $d_c$ , has a value of 1 min., or  $\frac{1}{3438}$  radian. Accordingly

$$\alpha = \frac{1}{3438} = \frac{s}{d_c} \text{ radians}$$

and

$$d_c = 3438s \quad (1)$$



Equation (1) states that two picture elements may just be distinguished from one another by the average eye when the viewing distance is roughly 3500 times the distance between the centers of the picture elements.

The application of Eq. (1) to the scanning pattern in television is evident from the following reasoning: We have seen that the number of picture elements that can be accommodated in the vertical height of a scanning pattern of 400 active lines is about 300 elements. These elements will have, in general, various degrees of light or shade, but for convenience, we can consider the case of 150 black elements and 150 white elements, arranged alternately on a vertical line. When the elements are so arranged, two white elements are separated by a single black element, and

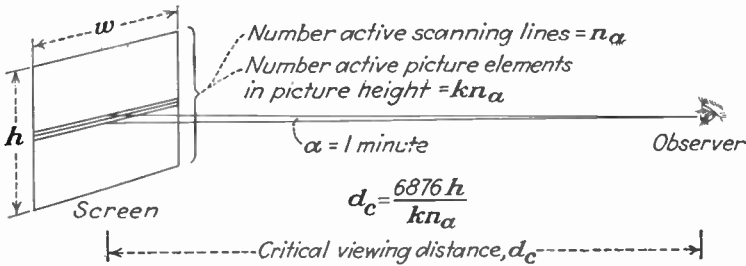

FIG. 16.—Application of the acuity angle to the scanning pattern in television images.

the question is, At what distance can these two white elements just be distinguished from each other by the eye? The general expression is derived as follows:

With reference to Fig. 16, the height of the picture area,  $h$  inches, contains  $n_a$  active scanning lines. The number of picture elements  $n_v$  that can be accommodated on a vertical line is  $k n_a$  where  $k$  is the *utilization ratio*, a number less than one, a factor that represents the fact that some of the picture elements straddle the scanning lines and are lost or distorted. The values of  $k$ , determined by theory and experiment, run from 0.6 to 0.95. The value 0.75 is adopted here as a convenient basis for calculations.

We now assume that half the picture elements, or  $k n_a / 2$ , are black and the remainder are white. The separation between the centers of two white elements is the height of the picture divided by the number of white elements, or  $2h / k n_a$ . This is

the separation corresponding to  $s$  in Eq. (1); hence we may substitute it and find the corresponding distance  $d_c$  at which the two white elements may be resolved:

$$d_c = 3438s = \frac{6876h}{kn_a} \quad (1a)$$

At this distance, the elements are resolved. At a greater distance, they appear to merge into a single element. At a smaller distance, no further detail is observed, and the picture structure becomes evident. Hence  $d_c$  may be considered as a "critical" viewing distance. This equation states that the critical viewing distance increases with the size of the picture but decreases as the number of active scanning lines and the utilization ratio are increased. For example, with a picture 8 in. high, composed of 470 active scanning lines that reproduce 75 per cent of the picture elements adequately ( $h = 8$ ,  $n_a = 470$ , and  $k = 0.75$ ), the critical viewing distance becomes 155 in., or nearly 13 ft. If the picture height were doubled, the critical viewing distance would likewise be doubled.

The direct dependence of critical viewing distance on picture height suggests an important ratio  $d_c/h$ , which is the ratio of the critical viewing distance to the picture height. From Eq. (1a), this becomes

$$\frac{d_c}{h} = \frac{6876}{kn_a} \quad (2)$$

By assuming, as before, that  $k = 0.75$  and  $n_a = 470$ , the ratio becomes  $\frac{6876}{350} = 20$  times. Thus it appears that if the eye is to be just able to distinguish two white elements separated by a black element, the picture must be viewed from a distance twenty times as great as that of the picture height. Under such conditions, the picture area occupies a very small field of view ( $2.5^\circ$  measured in a vertical plane), and it would appear that little enjoyment could be derived from viewing the picture at so great a distance.

Practical experience with television images has shown that the foregoing critical ratio of twenty-three times between viewing distance and picture height is far too rigorous. Actually, viewing ratios as low as 5 to 1 or 4 to 1 are habitually employed by television audiences. Under such conditions, the structural detail

of the image should be very evident, and to persons of acute vision under certain circumstances, the structure of the picture is in fact quite evident. But the picture structure rarely if ever interferes with the enjoyment of the picture, even at viewing distances as short as four times the picture height. This is a sharp contradiction of the ratio of twenty times predicted by the use of the visual-acuity value of 1 min. of arc.

Some of the reasons for this contradiction are readily apparent when certain characteristics of television images are considered. In the first place, the value of 1 min. for visual acuity applies when the elements to be resolved by the eye are sharply defined and stationary. In television images, the limitations of the image-reproducing apparatus preclude completely sharp definition at the edges of the picture elements. Along each line of the image, in fact, the gradations of shading that constitute the picture elements are always more or less gradual, because the signal causing the variations in light cannot jump instantaneously from one value to another and also because there is a certain amount of light spreading (halation) along the line. Sharp distinctions in light between adjacent lines are similarly inhibited by halation and by the fact that the distribution of light across the width of the scanning line is not uniform. Hence the edges of the picture elements are not sharply defined, and this circumstance reduces the ability of the eye to distinguish between them. In contrast, the edges of the printed dots in a half-tone engraving (see Fig. 3) are very sharp, and the detailed structure of such pictures is correspondingly more evident under a given ratio of viewing distance to picture height.

In the second place, the picture elements in a television image are rarely completely stationary. When the image is moving, the ability of the eye to resolve the picture elements is very seriously impaired, perhaps by a factor of 5 to 1. This would account for a reduction in the desirable viewing distance by the same ratio, or from 20 to 1 to about 5 to 1. Even during the rare occasions in which the image is completely stationary, a secondary effect comes into play that impairs the acuity of the eye to a lesser extent. This effect arises from small casual motions of the scanning lines upward or downward from their normal positions, because of small irregularities in the generation and synchronization of the scanning motion. Ordinarily this

motion is no more than one-fifth to one-tenth of the line width, but it is sufficient to account for a perceptible blurring of the picture elements, making it correspondingly difficult for the eye to resolve them.

These image defects (lack of sharp definition and motion of the scanning lines) actually represent a degradation of the detail in the image, but their principal effect is in making the image appear much smoother in texture than it would be were the picture elements sharp and stationary. The result is that the picture can be viewed closely without the picture elements themselves being individually apparent.

Disregarding the structure of the picture elements, then, we may consider the question of the scanning lines themselves. As the picture is viewed increasingly closely, a point will be reached where the scanning lines themselves become evident. If the scanning lines were uniformly bright across their width and if they were perfectly adjacent, then the scanning pattern would provide a perfectly uniform field of light, the lines would not be separately discernible, and the only structure visible would be that of the picture elements previously considered. This is, in all probability, a highly desirable condition. However, the limitations of television picture tubes prevent the formation of such a uniform field of light, and it is found desirable to operate the tubes so that they produce narrow lines between which a very slight dark region is visible. Under such conditions, the lines may be resolved by the eye if the image is viewed closely enough.

The distance at which the lines are resolved is computed as follows: Since there are  $n_a$  active lines, in a picture  $h$  in. high the separation between the centers of adjacent lines is  $h/n_a$  in., and the viewing distance  $d_c$  at which they are resolved is, by Eq. (1),

$$d_c = \frac{3438h}{n_a} \quad (1b)$$

For a picture containing 470 active lines, the ratio of viewing distance to picture height under these circumstances  $d_c/h = 7.3$  times. If the edges of the lines were perfectly sharp and if the lines themselves were perfectly stationary, a ratio of this order of magnitude would probably apply. In practice, the lines ordinarily cannot be resolved until the viewing distance is reduced to

about four times the picture height, because of the effects of motion and lack of sharpness just considered. Viewing distances as short as two or three times the picture height, sometimes used in practice, permit the lines to be seen individually under ideal conditions, but when the image is in motion, the eye cannot resolve them and at the same time follow the motion. Hence the fact that a television image viewed at a ratio of 4 to 1 is usually satisfactory to most observers.

It should be pointed out that the television image is satisfactory at such short viewing distances only because it is imperfect. When picture tubes and other technical elements in the system are improved to provide sharper detail and more stationary scanning lines, even though the number of active lines remains at 470, the desirable viewing distance may thereby be increased somewhat.

Before leaving the subject of viewing distance and its relation to the picture height, it should be pointed out that too small a viewing distance is undesirable, even if there is sufficient detail in the picture to warrant it, because at short viewing distances, the field of view is so large that the eye must move excessively to cover the picture area. It must be remembered that the field of sharp definition of the eye, corresponding to the foveal area of the retina, is very much restricted and that the eye is constantly shifting position to follow the movements in the scene before it. When the viewing ratio becomes smaller than 3 to 1, therefore, the observer is likely to suffer from fatigue of the eye muscles unless the interest of the program is confined to the center of the picture area. Such muscular fatigue has been experienced by those who have observed a motion-picture performance from the front seats of the theater (where the viewing ratio may be 2 to 1 or less). This fact indicates that the optimum viewing ratio is somewhere in the neighborhood of 4 to 1, and this conclusion is in agreement with the observed preferences of audiences in viewing both theater and television programs.

The matter of the required number of scanning lines has been put to direct test by Engstrom and his associates.<sup>1</sup> In this work, an ingenious arrangement was set up for projecting motion-picture film through a multiple-lens system of embossed

<sup>1</sup> Engstrom, E. W., *Proc. I.R.E.*, **23**, 295 (April, 1935). See reference, p. 28.

celluloid in such a way that the images appeared to have a line structure similar to that of television images. The conclusions reached were that images of 400 to 500 lines are required for a viewing ratio of 5 to 1 and that images so viewed are capable of giving substantially the same satisfaction as the original film projected directly. The lower curve in Fig. 17 summarizes these experimental conclusions; the upper curve indicates the ratios at which adjacent picture elements can just be distinguished separately, *i.e.* the critical viewing distance is one-half that determined

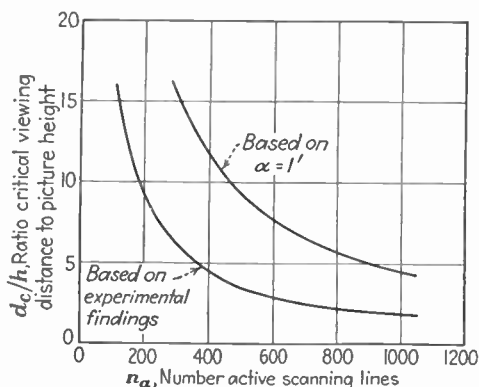

FIG. 17.—Relationship of viewing conditions to the number of active scanning lines in the pattern. With 470 active lines, the critical viewing distance is 4 times the picture height according to Engstrom's findings (lower curve) although predictions based on the visual acuity angle indicate a value of 10 times the picture height for resolving adjacent picture elements (upper curve). If non-adjacent elements are considered, the detail may be resolved at a distance of 20 times the picture height. The difference between theory and experiment is explained by the effects of motion and lack of sharpness in the picture elements.

for resolving two white elements separated by a black element. On the basis of these and similar findings, the N.T.S.C. Committee decided upon a number of scanning lines intermediate between 500 and 550.

The exact number of 525 lines between the beginning of one picture and the beginning of the next is based on the facts (1) that an odd number of lines is required for odd-line interlacing (see Sec. 9, page 49) and (2) that the number is made up of simple odd factors ( $525 = 3 \times 5 \times 5 \times 7$ ) which make for simplicity in generating the synchronizing signals and coordinating them with the power-supply system. The details of the synchronizing-signal generation system are given in Chap. IX.

**Total Number of Picture Elements in the Pattern.**—The total number of picture elements that can be accommodated in the scanning pattern depends not only on the number of active lines but also on the number of picture elements contained in each line. Thus, if 350 picture elements are accommodated vertically by the 470 active scanning lines and if each scanning line contains, say, 465 picture elements, then the total number of picture elements in the pattern is  $350 \times 465 = 163,000$ . In this case, there are four-thirds as many elements horizontally as vertically, a condition in agreement with the fact that the picture is four-thirds as wide as it is high. In other words, under this condition the spacing of the picture elements horizontally (the horizontal resolution) is equal to the spacing vertically (the vertical resolution). It was once thought that this equality of vertical and horizontal resolutions was the optimum condition, since, it was argued, the satisfaction derived by the eye would be limited by the poorer resolution and hence the excess resolution in the other dimension would be wasted. Experience has indicated that this is not actually the case. Within limits, the resolution in one dimension may be considerably greater than that in the other, without waste of the picture information. Thus, as the number of picture elements in each line is increased above 465 (the number required for equal vertical and horizontal resolution), the quality of the picture improves until perhaps 600 elements are included in each line. This fact has permitted the employment of higher definition in the horizontal direction (which is not limited by the number of lines) at the same time that the vertical resolution is allowed to be limited by the number of scanning lines. With 350 picture elements vertically and 600 in each line, the total number of elements becomes  $350 \times 600 = 210,000$ . The figure of 200,000 elements, which has been used in Chap. I, represents approximately the upper limit of which the standard 470-line scanning pattern is capable, without waste of picture information. Pictures employing more than 200,000 elements have better resolution (smaller spacing) horizontally than vertically.

A general expression for the number of picture elements that can be accommodated in the scanning pattern may be derived as follows. The number of picture elements in the vertical dimension has previously been defined as  $kn_v$ . For equal resolutions in both dimensions, the number in the horizontal

dimension should be  $(w/h)(kn_a)$ . If the horizontal resolution exceeds the vertical resolution by a factor  $m$ , then the number of elements in the horizontal direction is  $(w/h)mkn_a$ . The product of the vertical and horizontal numbers of elements (the total number  $N$  of picture elements in the pattern) is then

$$N = \frac{w}{h}mk^2n_a^2 \quad (3)$$

On the assumption that  $n_a$  is 470, that  $k = 0.75$ , that  $m = 1.0$ , and by using the standard value of  $w/h = \frac{4}{3}$ ,  $N$  becomes 165,000. For  $N = 200,000$ ,  $m$  is 1.21, that is, the horizontal resolution is 1.21 times that of the vertical resolution. In practice, of course, other values of the utilization ratio  $k$  may apply, and the ability of the system to convey the detail in each line may be considerably poorer than the ideal case just considered. At present, it is safe to say that a pattern containing 200,000 elements represents the system at its best operation.

*The Proportions of the Picture Area.*—The ratio of the width to the height of the picture (aspect ratio) has been set at 4 to 3, to conform with the existing standard employed by motion pictures. The advantage of choosing this value is that it permits the televising of standard motion-picture film without waste of any of the area of the scanning pattern.

**8. The Geometry of Scanning Patterns.**<sup>1</sup>—Thus far we have discussed only the number of lines in the pattern, without inquiring how the lines are laid down in practice. We consider next, therefore, the geometrical form taken by scanning patterns. First, we may state briefly the requirements to be met by the pattern. It must be composed of two sets of alternate lines, each set composed of an equal number of horizontal lines spaced

<sup>1</sup> For more detailed treatments of scanning theory and practice, see:

KELL, BEDFORD, and TRAINER, Scanning Sequence and Repetition Rate of Television Images, *Proc. I.R.E.*, **24**, 559 (April, 1936).

MERTZ and GRAY, Theory of Scanning and Its Relation to the Transmitted Signal in Telephotography and Television, *Bell Sys. Tech. Jour.*, **13**, 464 (July, 1934).

SOMERS, F. J., Scanning in Television Receivers, *Electronics*, **10**, (10), 18 (October, 1937).

WILSON, J. C., "Television Engineering," Pitman and Son, Ltd., Chap. III, p. 46, and Chap. IV, p. 73, London, 1937; also extensive bibliography to periodicals and patents.



by the width of one line. The speed of the scanning motion must be constant along each scanning line, in order that the equipment shall be capable of producing the same resolution of picture elements at any point. Finally, the scanned area must have a width-to-height or aspect ratio of 4 to 3, and the total number of lines, both active and inactive, must be 525.

*Progressive (Noninterlaced) Pattern.*—In the interests of simplicity, we consider first a noninterlaced or “progressive” pattern, formed of a single set of adjacent, parallel lines. The pattern is shown in Fig. 18. The scanned area has the standard aspect ratio of 4 to 3, and the scanning spot is located initially in the upper left-hand corner of the area, at point *A*. When the

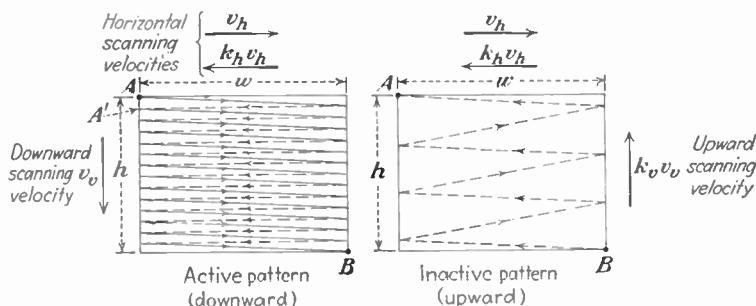

FIG. 18.—Geometry of the progressive (noninterlaced) scanning pattern. Left, the active (downward) scanning interval; right, the inactive (upward) period. The arrows indicate the direction of motion of the scanning spot.

scanning motion begins, the spot moves at constant speed along the first *active* line (shown solid) until it reaches the right-hand edge of the pattern. At the end of this line, the spot motion is suddenly reversed, and the spot moves as quickly as possible to the left-hand edge. During this retrace motion, the spot is inactive. This inactive motion (shown in dashed line) must be as rapid as possible, since it consumes time that could be otherwise used for transmitting the picture-element signals.

When the spot reaches the left-hand edge of the picture area, it is ready to trace out the second active line. In the noninterlaced pattern under discussion, this second line lies parallel and adjacent to the first active line. Consequently the spot, at the beginning of the second active line, must lie just below its initial position, at *A'* as shown in the figure.

This position can be reached by a vertically downward motion of the spot. The downward motion might be given to the spot suddenly, just before the beginning of the second active line, but such a sudden motion is very difficult to produce and to control in practice. Instead the downward motion is given to the spot continuously, throughout the duration of the active line and the inactive retrace. Consequently, as shown, the active line is inclined slightly downward to the right, whereas the inactive retrace is inclined, to a still less degree, downward to the left. As a consequence, when the first active line and retrace are completed, the spot occupies the position  $A'$  in the diagram, and the second active line begins. Since the downward motion persists at constant speed, the second active line lies parallel to the first line, and the second retrace lies parallel to the first retrace.

The sequence of active and inactive motions is repeated until approximately 470 active lines have been scanned. By this time, the vertical motion has moved the spot downward a distance equal to three-fourths the length of one active line (to satisfy the 4 to 3 aspect ratio).

At the end of the 470th line, at point  $B$ , the downward motion is suddenly reversed, and the spot is caused to move upward as rapidly as possible. The upward motion, although fast compared with the downward motion, is in practice slow if compared with the scanning speed along each active line. The result is that during the upward motion the spot executes several back-and-forth motions (as shown to the right in Fig. 18), all of which are *inactive*. These upward back-and-forth motions constitute the difference between the 470 active lines and the 525 lines in the entire pattern.

At the conclusion of the upward motion, the scanning spot must be in readiness to scan the next picture or "frame" and must therefore occupy its initial position  $A$  in the diagram. The spot will occupy this position if it has executed a whole number of back-and-forth motions while executing one up-and-down motion. The standard value of this "whole number" is 525. In other words, the total number of scanning motions, from the beginning of one frame to the beginning of the next, is 525.

The number of inactive lines, which must be kept to a minimum, is determined by the upward speed relative to the down-

ward speed. If the upward speed is rapid, the number of inactive lines is small. In practice, the number of inactive "upward" lines is restricted to 55 or less, leaving 470 or more active lines.

*Detailed Analysis of the Progressive Pattern.*—To analyze the relationships in the progressive pattern more completely, refer to Fig. 18. The scanned area has a width of  $w$  in. and a height of  $h$  in. The spot moves horizontally to the right, during the scanning of each active line, at a velocity of  $v_h$  in. per second. It returns to the left, during the inactive retrace, at a velocity  $k_h$  times as fast, that is, at  $k_h v_h$  in. per second. The spot moves vertically downward during the active scanning of the frame at a rate  $v_v$  in. per second and vertically upward  $k_v$  times as fast, or at  $k_v v_v$  in. per second. The total number of lines scanned from the beginning of one pattern to the beginning of the next, that is, all active as well as inactive lines, is  $n$  lines. The patterns are scanned at a rate of  $f$  frames per second; so the time between the beginning of one frame and the beginning of the next is  $1/f$  sec.

Of the preceding factors, the following are definitely standardized:  $n = 525$ ,  $w/h = 4\frac{2}{3}$ , and  $f = 30$ . The ratio  $k_h$  between the retrace and forward speeds in the horizontal direction is limited in practice to between seven and ten times, whereas the corresponding ratio  $k_v$  between the upward and downward speeds falls between the limits of 10 and 15. In addition, for any particular case, the width and height of the picture are specified. With these factors given, we can calculate the scanning speeds  $v_h$  and  $v_v$  required to fulfill the given conditions, as follows:

The time consumed in each left-to-right motion is the width of the area divided by the speed of motion, that is,  $w/v_h$ . Likewise the time consumed in each right-to-left (retrace) motion is  $w/k_h v_h$ . Since there are  $n$  of each of these motions in the complete pattern, the time consumed for the entire pattern is

$$n \left( \frac{w}{v_h} + \frac{w}{k_h v_h} \right)$$

But this time is also  $1/f$  sec. Hence

$$\frac{1}{f} = n \left( \frac{w}{v_h} + \frac{w}{k_h v_h} \right) \quad (4)$$

from which we obtain the horizontal scanning velocity

$$v_h = fnw \left( 1 + \frac{1}{k_h} \right) \quad (5)$$

To obtain the vertical scanning velocity  $v_v$ , we proceed similarly. The time required for a downward motion is  $h/v_v$  sec. and for the upward motion  $h/k_v v_v$ . The sum of these times must equal the complete frame time, or  $1/f$ . Hence

$$\frac{1}{f} = \frac{h}{v_v} + \frac{h}{k_v v_v} \quad (6)$$

and

$$v_v = fh \left( 1 + \frac{1}{k_v} \right) \quad (7)$$

From Eqs. (5) and (7), we can compute the required ratio of  $v_h$  to  $v_v$  as

$$\frac{v_h}{v_v} = \frac{nw}{h} \left( \frac{1 + \frac{1}{k_h}}{1 + \frac{1}{k_v}} \right) \quad (8)$$

Substituting the standard values of  $n = 441$  and  $w/h = \frac{4}{3}$  and the practical values of  $k_h = 7$  and  $k_v = 12$  in Eq. (8), we obtain

$$\frac{v_h}{v_v} = 525 \times \frac{4}{3} \times \frac{1.14}{1.08} = 740$$

The horizontal scanning velocity must be, under these conditions, 740 times as fast as the vertical scanning velocity.

If the picture is 6 in. high ( $h$ ) and 8 in. wide ( $w$ ), substituting in Eq. (7), we obtain

$$v_v = 30 \times 6 \times 1.08 = 194 \text{ in. per second}$$

for the downward velocity. The upward velocity is

$$k_v h v_v = 12 \times 194 = 2330 \text{ in. per second.}$$

The left-to-right velocity  $v_h$  is 740 times as great as  $v_v$ , or  $194 \times 740 = 144,000$  in. per second, and the right-to-left (retrace) velocity is  $k_h v_h = 7 \times 144,000 = 1,000,000$  in. per second.

This latter speed is about 18 miles per second. It is evident, therefore, that to lay down a scanning pattern of standard dimensions it is necessary to employ scanning agents capable of very rapid motion.

*The Number of Active Scanning Lines.*—The preceding sections have shown that the number of picture elements accommodated vertically in a pattern depends on the number of active lines  $n_a$ , which in general are fewer than the total of 525. The ratio of the number of active lines  $n_a$  to the number of inactive lines  $n_i$  is the same as the ratio of the upward velocity to the downward velocity, which is  $k_v$ . Hence

$$\frac{n_a}{n_i} = k_v \quad (9)$$

Also the sum of the active and inactive lines is the total  $n$ , that is,

$$n_a + n_i = n \quad (10)$$

Eliminating  $n_i$  from these two equations, we obtain

$$n_a + \frac{n_a}{k_v} = n \quad (11)$$

and finally

$$n_a = n \left( \frac{1}{1 + \frac{1}{k_v}} \right) \quad (12)$$

Using the value of  $k_v = 12$ , the last factor is  $1/1.08$ , or 92.5 per cent. In the 441-line picture, therefore,  $0.925 \times 525 = 485$  lines are active. For  $k_v = 10$ , the number of active lines is approximately 470, the figure used in the preceding discussions.

*The Thickness of Each Scanning Line.*—In order to fill the scanning area uniformly with light, it is necessary that the lines be just thick enough to be adjacent. In this case, the thickness of the lines must equal the distance between the centers of adjacent lines, which is equal to the height of the picture  $h$  divided by the number of active lines  $n_a$  present in the pattern. Hence the line thickness  $t$  is

$$t = \frac{h}{n_a} \quad (13)$$

For a height of 6 in. and a pattern of 470 active lines, the line width must be  $\frac{6}{470} = 0.013$  in.

This calculation is based on a line that is uniformly bright throughout its thickness. In practice, the lines produced by the electron beam in the image-reproducing tube are considerably brighter at the center than at the edges. To obtain uniform brightness under these conditions, it is sometimes desirable although seldom practiced to overlap adjacent lines somewhat. In this case, the line thickness may be about 50 per cent greater than that indicated by Eq. (13). Picture tubes currently used have scanning spots small enough to meet the condition of Eq. (13) and are customarily used so that the scanning lines do not overlap.

*Requirements for Picture Repetition in Progressive Scanning.*— Thus far we have considered only one individual scanning sequence or *frame*. In practice, the frames follow one another in succession, and the lines in one frame fall directly over the positions of the lines in the previous frame. It is obvious that successive frames must lie in this relationship if there is to be no blurring of picture elements that remain stationary between successive frame-scanning periods. Referring to Fig. 18, we see that the first frame begins with the spot in position *A* and follows the successive lines to the bottom of the pattern, at *B*, whereupon it returns to the top of the pattern. When the downward motion recommences and the second frame starts, the spot must again occupy the position at point *A*. This requirement is met (1) by causing the spot to execute a whole number of left-and-right motions, while one up-and-down motion is being executed. (2) It is necessary that the distance of travel be precisely the same in every left-and-right motion as well as in every up-and-down motion. When these two requirements are met, one set of scanned lines will fall exactly on the positions held by the preceding set of lines. To maintain an exact whole number of lines scanned during one up-and-down motion, it is necessary that the two motions be synchronized with each other, and this is usually done by deriving both motions ultimately from a common timing source. The details of synchronizing methods are treated in Chap. IX.

**9. Details of the Geometry of Interlaced Patterns.**—With the previous description of the progressive scanning pattern for

reference, we can now turn our attention to the type of scanning pattern actually used in practice, that is, the interlaced type of pattern that consists of two sets of alternate lines. The requirements for the interlaced pattern are two: (1) the lines must be spaced from each other by the width of one line and (2) the lines of one set must fall accurately into the spaces between the lines of the preceding set. The word *field* has been chosen to designate a scanning pattern composed of half the total number of lines with blank spaces between them.

The first requirement, empty spaces between the lines, is met very simply, by employing a downward scanning velocity twice as great as would be employed in progressive scanning. The time available for covering the picture area is thus reduced from  $\frac{1}{30}$  to  $\frac{1}{60}$  sec., and the spacing between the centers of the active lines is doubled. Consequently between each pair of lines, there is an empty space the thickness of which is equal to the thickness of the lines on either side. The expression for the downward velocity  $v_v'$  in interlaced scanning is accordingly  $2v_v$ , or twice that given in Eq. (7). Also, the *frame* repetition rate  $f$  of 30 frames per second has been replaced by the *field* repetition rate  $f'$  of 60 per second.

It must be understood that increasing the downward (and upward) velocities to twice the values they would have in progressive scanning does not mean that any more lines are scanned in the complete pattern. The number of lines per complete frame remains at 525, and the number of active lines remains at approximately 470. These groups are divided into two groups of  $262\frac{1}{2}$  lines and approximately 235 lines each, respectively, which are sent successively. Essentially the only difference between progressive and interlaced scanning is the *order of sequence* in which the lines are scanned. In progressive scanning, the order is 1, 2, 3, 4, etc. In interlaced scanning, the order is 1, 3, 5, 7, etc., followed by 2, 4, 6, 8, etc.

The second requirement of interlaced scanning, that the lines of one field fall accurately into the blank spaces between the lines of the preceding field, is met in a manner very similar to that employed in causing the successive frames to fall on top of each other in progressive scanning. The situation in interlaced scanning is shown in Fig. 19. The spot begins at point *A* and scans half the lines in reaching the bottom of the area and return-

ing to the top. On commencing the second field scanning, the spot must not again fall on point *A* but on point *C*, which lies in the middle of the blank space below point *A*. Moving from point *C*, the spot then traces out a pattern exactly similar to the preceding pattern but displaced vertically downward by the thickness of one line.

The basis of the interlacing action is this vertical displacement. The vertical displacement can be obtained in several ways, of which two have been employed in television development. These two methods go by the names of *even-line interlacing* and *odd-line interlacing*.

In the even-line system, now superseded in favor of the odd-line method, the total number of lines in the pattern (active as

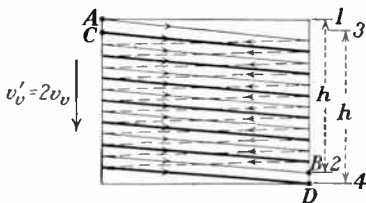

FIG. 19.—Even-line method of interlaced scanning. The successive fields (light and heavy lines) are displaced vertically by upward and downward scanning motions of unequal length.

well as inactive) is an even number, say 530. The number of lines in each field is then half as many, or 265. Since the total number is an *even* number, the number of lines in each field is always a *whole* number. The spot starts at point *A* (Fig. 19) and moves through a whole number of lines in reaching the bottom and returning to the top of the area. At the beginning of the second field, the spot then must necessarily lie at the left-hand edge of the pattern. The spot will lie directly on point *A* if the upward motion of the spot is the same length as the downward motion. Since the spot must occupy point *C* at that instant, the upward motion is made shorter by the thickness of one line. The spot thereby attains the level at point *C* and then covers the second field. In so doing, the spot fills in the gaps of the first field. On reaching the bottom of the pattern, at point *D*, the spot then moves up by a distance *greater* than its downward motion by the thickness of a line and in consequence the spot falls at the end of the field on point *A*, ready to lay down the third field exactly over the first. The sequence then follows with the fourth field falling over the second, and so on. The difficulty with the even-line system lies in the necessity of forming up-and-down motions of unequal lengths and of doing



so accurately in the required succession. Although not impractical, the system is not so reliable as the fundamentally simpler odd-line system.

In odd-line interlacing, the total number of lines (active as well as inactive) is an odd number, e.g., 525. One-half of such an odd number is necessarily a whole number plus one-half. Consequently each field contains a *nonintegral* number of lines, e.g.,  $262\frac{1}{2}$ . The spot starts from A (Fig. 20) and scans  $262\frac{1}{2}$  lines in traveling to the bottom of the pattern and back to the top. On arriving at the top, ready to start the second field, the spot occupies the spot C, which is one-half a line to the right of

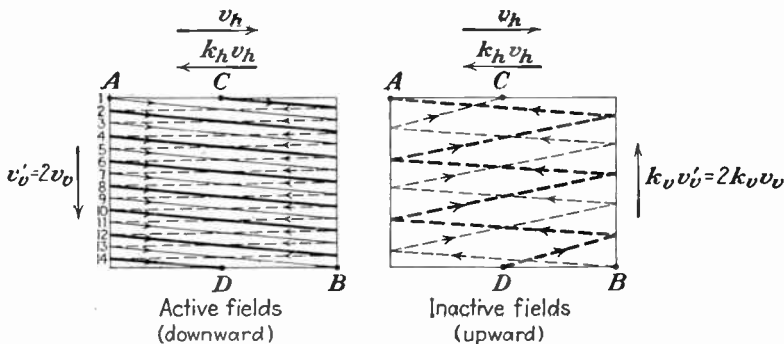

FIG. 20.—The odd-line method of interlaced scanning, now standard in the United States. The upward and downward scanning motions are of equal length (cf. Fig. 19) and the number of lines in each field is a whole number plus one-half ( $262\frac{1}{2}$  lines for a 525-line pattern).

point A. Now if the spot is exactly on the same level with the spot A, as shown in the figure, the spot must lie above the first line in the first field by the thickness of one line. From this position, it is then ready to scan out an additional  $262\frac{1}{2}$  lines in reaching the bottom of the area and returning to the top. At the conclusion of this motion, it has scanned a whole number (525) of lines and in consequence returns to point A, ready for the third field, which will then fall directly over the first field, as it should.

To preserve the interlaced relationship in this method of scanning, it is necessary that every up-and-down motion be of precisely the same length. This condition is easier to achieve in practice than the unequal lengths required in even-line scanning. A further requirement is that the timing of the beginning of

each field be accurate. In beginning a field, the spot must lie exactly on the same level with, and one-half a line distant from, the beginning of the previous field; otherwise the two sets of lines, as shown in Fig. 24, will partially overlap at one side, and a gap in the pattern will be left at the opposite side. The result is known as "pairing" of the lines.

*Summary.*—To summarize the fundamental relationships in the odd-line interlaced pattern, we may state the following definitions and equations: The total number of lines  $n$  in each frame is 525. The total number of lines  $n'$  in each field is  $n/2$ , or  $262\frac{1}{2}$ . The aspect ratio of the active pattern is  $w/h = \frac{4}{3}$ . The frame-repetition rate  $f$  is 30 per second. The field-repetition rate  $f'$  is 60 per second. The retrace scanning velocity is  $k_h$  times as rapid as the active-line scanning velocity; the practical values of  $k_h$  lie between seven and ten times. The upward velocity is  $k_v$  times as rapid as that of the downward velocity; the practical values of  $k_v$  lie between 10 and 15.

The active-line scanning velocity  $v_h$  is the same as in progressive scanning

$$v_h = fnw \left( 1 + \frac{1}{k_h} \right) \quad (5)$$

The vertical (downward) frame scanning velocity is

$$v_v' = f'h \left( 1 + \frac{1}{k_v} \right) \quad (14)$$

which is twice as rapid as that in progressive scanning.

The thickness of the active scanning lines is the same as in progressive scanning

$$t = \frac{h}{n_a} \quad (13)$$

where  $n_a$  is the total number of active lines in each frame, equal to twice the number of active lines in each field. The number of active lines in each field  $n_a'$  is

$$n_a' = \frac{1}{2}n_a = \frac{1}{2}n \left( \frac{1}{1 + \frac{1}{k_v}} \right) \quad (15)$$

**10. Factors Influencing the Picture-repetition Rate.**<sup>1</sup>—In the preceding discussion, we have concerned ourselves principally with the description of single frames or fields. We must now consider the rates of repetition of the fields and frames as well as the rates at which the scanning lines and picture elements must be produced by the system.

The number of complete pictures or frames sent per second has been standardized by the R.M.A. Television Committee at the value of 30 per second. In choosing this value, the committee was forced to choose between a lower value, which would entail the problems of flicker and improper representation of motion in the image, and a higher value, which would make necessary a correspondingly higher rate of transmitting the picture elements.

A picture-repetition rate of 24 per second was seriously considered at first because this rate coincides with the previously established standard in motion pictures. However, a more important consideration was found in the effect of the power-supply frequency. The majority of receivers in this country must be operated on 60-c.p.s. power systems. Since the rectifier and filter circuits employed to convert the alternating current to direct current are never complete in their action, there is always a small residual 60- or 120-c.p.s. a-c ripple in the voltage supply that operates the scanning and synchronizing circuits in the receiver. If the rate were 24 per second, the field-repetition rate in the interlaced fields would be 48 per second. The 120-c.p.s. ripple would interfere with the 48-c.p.s. field-repetition rate, since the cycles would coincide only once in every  $\frac{1}{24}$  sec., being to some degree opposed at all other times. Although this opposition could be reduced to a negligibly small degree by adequate filtering in the rectifier circuits, this procedure involves additional costs. If on the other hand, the picture-frame-repetition rate were set at 30 per second, the field-repetition rate would be 60 per second. The power-supply ripple would then coincide with the 60-c.p.s. synchronizing signals at every cycle. In practice, this reasoning is borne out by the fact that the maintenance of proper synchronism with a repetition rate of 30 is far more reliable than with a rate of 24 per second, when the power supply is 60-c.p.s. Accordingly the value of 30 frames per

<sup>1</sup>Kell, Bedford, and Trainer. See reference, p. 40.

second has been standardized. In areas served by 25-c.p.s. power systems, the standard is open to question. In this case, since the repetition rate is set at 30 per second, adequate filtering must be provided to avoid interaction between power-supply and synchronizing signals.

The standard picture-repetition rate of 30 per second is the basis of the rate at which the entire transmission system operates. Since the 525 lines must be sent in the frame-repetition interval of  $\frac{1}{30}$  sec., it follows that  $30 \times 525 = 15,750$  complete lines and retraces must be formed each second. In the interlaced patterns, the field-repetition rate is 60 per second, but since each field contains  $262\frac{1}{2}$  lines, the product is  $60 \times 262\frac{1}{2} = 15,750$ , the same value in progressive scanning. It follows that in deflecting the scanning beam horizontally, the currents that flow through the magnetic deflecting coils (or the voltages applied to the deflecting plates, if these are used see page 132) must oscillate at a rate of 15,750 c.p.s. For the vertical motion, a rate of 60 c.p.s. is required for the interlaced field-repetition rate of 60 per second.

**11. The Rate of Transmission of Picture Elements.**—We consider now the central factor in the operation of a television system, the maximum rate at which the picture elements must be transmitted. To calculate this figure, we must return to the number of active lines in the pattern and the number of picture elements in each.

The general expression for the rate at which the picture elements are transmitted is derived as follows: First we obtain the maximum number of elements per line. This number of picture elements  $n_h$  must equal the number of picture elements vertically  $kn_a$  times the aspect ratio  $w/h$ , times  $m$ , the ratio of horizontal resolution to vertical resolution. That is,

$$n_h = \frac{w}{h} m k n_a \quad (16)$$

where  $k$  is the utilization ratio and  $n_a$  is the number of active scanning lines. But by Eq. (12), the number of active lines  $n_a$  is

$$n_a = n \left( \frac{1}{1 + \frac{1}{k_v}} \right) \quad (12)$$

Hence, substituting,

$$n_h = \frac{w}{h} m k n \left( 1 + \frac{1}{k_v} \right) \quad (17)$$

Next we must find the time consumed in transmitting these  $n_h$  picture elements. This time  $t_h$  is equal to the width of the picture  $w$  divided by the horizontal scanning velocity  $v_h$ , that is,

$$t_h = \frac{w}{v_h} \quad (18)$$

But by Eq. (5), which applies to interlaced scanning,  $v_h$  is

$$v_h = f n w \left( 1 + \frac{1}{k_h} \right) \quad (5)$$

Hence substituting,

$$t_h = \frac{1}{f n \left( 1 + \frac{1}{k_h} \right)} \quad (19)$$

The maximum rate  $R$  at which the picture elements are sent is the maximum number of picture elements per line divided by the time in which the line is scanned, that is,  $n_h/t_h$ . Hence

$$R = \frac{n_h}{t_h} = \frac{w}{h} m k f n^2 \left( \frac{1 + \frac{1}{k_h}}{1 + \frac{1}{k_v}} \right) \quad (20)$$

For the values  $(w/h) = \frac{4}{3}$ ,  $m = 1$ ,  $k = 0.75$ ,  $f = 30$ ,  $n = 525$ ,  $k_h = 7$ , and  $k_v = 12$ ,  $R$  becomes 8,700,000 elements per second. In other words, the entire television system from camera to picture-reproducing tube must be capable of generating, conveying, and reproducing voltage and current variations at a rate faster than 8,000,000 per second.

The expression for  $R$  commonly used is

$$R = \frac{w}{h} k m f n^2 \quad (21)$$

which omits the last factor in Eq. (20). It will be noticed that this latter expression assumes equal values of  $k_h$  and  $k_v$ , since the last factor in Eq. (20) becomes unity in this case.

**12. Defects of Image Analysis.**—It is obvious that there are many opportunities in the scanning process for defects to appear in the received image. Such defects have to do either with the relative brightness of the different picture elements or with their positions. The relative intensity of the picture elements is determined almost entirely by the electrical performance of the transmitting and receiving equipment and is consequently discussed in Chap. V. The position of the picture elements is controlled, on the other hand, entirely by the scanning processes at the transmitter and receiver.

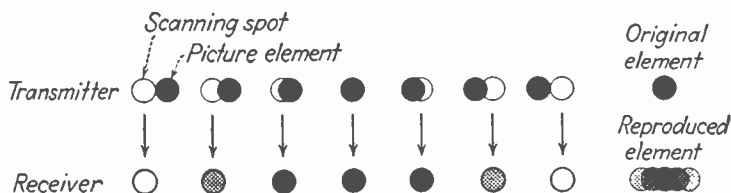

FIG. 21.—Aperture distortion in scanning. As the scanning spot passes over the picture element, the scanning spot in the receiver gradually changes from white to black, and the reproduced element (lower right) is broadened and indefinitely outlined.

In discussing errors of the position of the picture elements, we treat first the errors that may occur in connection with a single line of the image. These may be classed as errors due to *aperture distortion*, *linear displacement*, and *nonlinearity* of scanning.

Aperture distortion results from the fact that the scanning spot in the transmitter is an area of appreciable width. Figure 21 shows such a spot crossing a solid black picture element in the image to be transmitted, the picture element being of the same size as the scanning spot. When the spot reaches the edge of the picture element, the change in image-plate potential begins. Thereafter the change in potential increases until the picture element lies wholly within the scanning spot. The potential then decreases until the spot has moved wholly from the picture element.

At the receiver, when the change in image potential is converted into a corresponding change in brilliance on the receiving-tube

screen, the received picture element will be broader than the original element. This broadness is caused by the fact that the width of the transmitting scanning spot is of the same dimension as the width of the original picture element. This form of distortion is minimized by the use of a very narrow scanning beam, one whose width is considerably smaller than that of the picture elements which the scanning pattern is capable of handling. The effect may also be minimized by electrical means, in circuits that emphasize the change from black to white.

*Linear displacement* occurs when one whole line in the image is displaced bodily with respect to the rest of the pattern. All the picture elements contained in this line are then out of position by the amount of the displacement. If the displacement is small, the effect may be noticeable only as an indefinite loss of detail, but if it is greater than the width of one or two picture elements, and especially if it occurs in several lines in the image, the effect can be definitely identified. Linear displacement may be controlled by proper design and adjustment of the circuits that produce the current or voltage used for deflecting the electron beams in transmitter and receiver. It is necessary that the maximum amplitude of each cycle in the deflecting voltage or current be the same and, further, that the duration and timing of each successive cycle be accurately the same as those preceding it. It is this latter requirement that brings with it the need for accurate synchronizing signals at the beginning of each line. These matters are discussed more fully in Chap. IV.

*Nonlinearity of scanning* arises from an inconstant speed of the scanning spot as it moves across each line. It is necessary that the scanning spots in transmitter and receiver move simultaneously across each line in the image so that their positions in the line always correspond. If the transmitter scanning spot moves faster than the receiving scanning spot, then the picture elements in the received image will be "bunched," as shown in Fig. 22, whereas if the receiver spot is faster, the elements will be "spread," as shown. To avoid both effects, the motion is made uniform throughout each line, in both transmitter and receiver. If either transmitter or receiver or both get out of adjustment, so that the scanning rate is not uniform, bunching or spreading will occur. Usually the effect is such that the bunching occurs at one side of the received image, and the spreading occurs at the

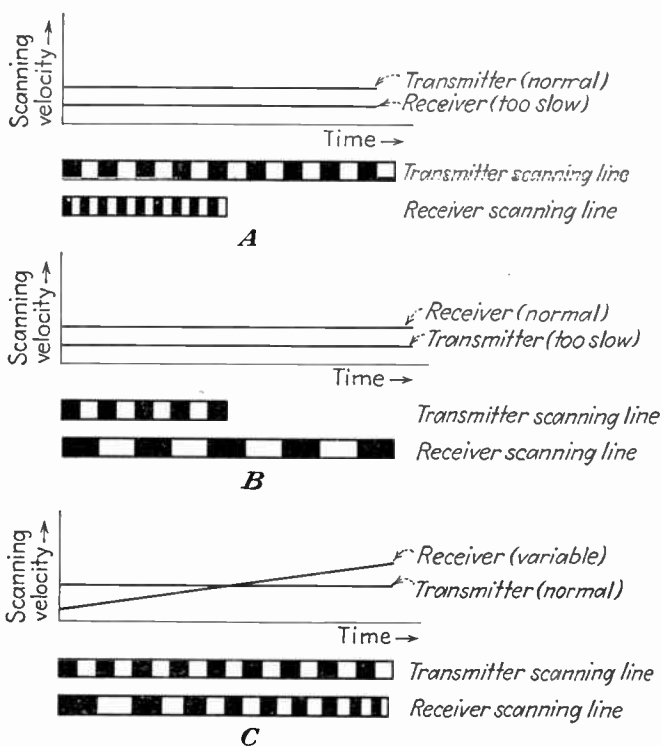

FIG. 22.—Bunching and spreading of picture elements, the result of disparity between the scanning velocities in transmitter and receiver.

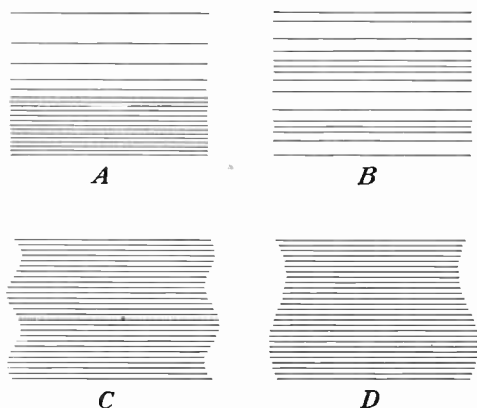

FIG. 23.—Scanning defects characteristic of the pattern as a whole. *A* and *B* result from nonlinear vertical scanning, *C* from linear displacement, and *D* from variations in the horizontal scanning amplitude.



other side. Control of this defect is obtained through the design and adjustment of the deflecting current or voltage generators.

*Defects Involving the Scanning Pattern as a Whole.*—Errors in the positions of picture elements that involve more than one line are usually characteristic of the pattern as a whole. Several of the common defects in progressive scanning are illustrated in Fig. 23. In Fig. 23A, nonlinearity of the downward motion of the scanning spot causes the upper lines to be spread apart farther than the lower lines. In Fig. 23B, a different type of nonlinearity causes an alternate bunching and spreading of the lines. This defect arises from 120-cycle power-supply ripple voltage superimposed

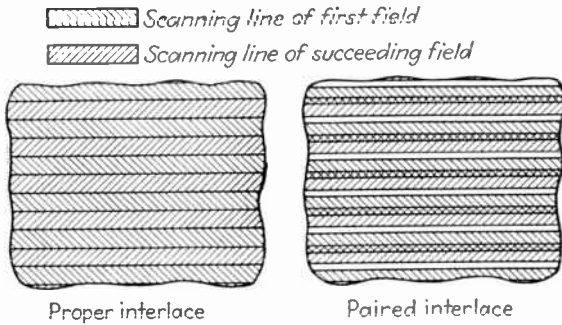

FIG. 24.—Pairing of the lines in successive interlaced fields which results from improper timing of the vertical scanning motions, or from irregularity in the vertical scanning amplitude.

on the vertical deflecting voltage or current. The defect in Fig. 23C is due to a similarly superimposed ripple on the horizontal scanning voltage or current, causing a regular displacement of lines. Another somewhat similar form of distortion, but not a true displacement, is shown in Fig. 23D, a distortion due to regular changes in the amplitude of the horizontal scanning motion.

In interlaced patterns, all the defects shown in Fig. 23 may apply separately to each individual field. In interlacing, moreover, a very important and difficult-to-correct defect is that called "pairing," shown in Fig. 24. As previously stated, this defect occurs if one field does not fall accurately in the spaces left in the previous field. It is possible, in an extreme case, that each successive field may fall in the same position. This is complete pairing of the lines, and the effective scanning pattern

is one-half the total number of lines. Partial pairing is more common. In odd-line interlacing, partial pairing results usually from inaccurate timing in the successive fields. If the beginning of the downward motion in a given field is delayed by a very small fraction of the line-scanning time, the spot will start scanning, not midway between two of the previously scanned lines, but nearer to one of these lines than the other. This causes a vertical displacement of one field relative to the preceding one, and the

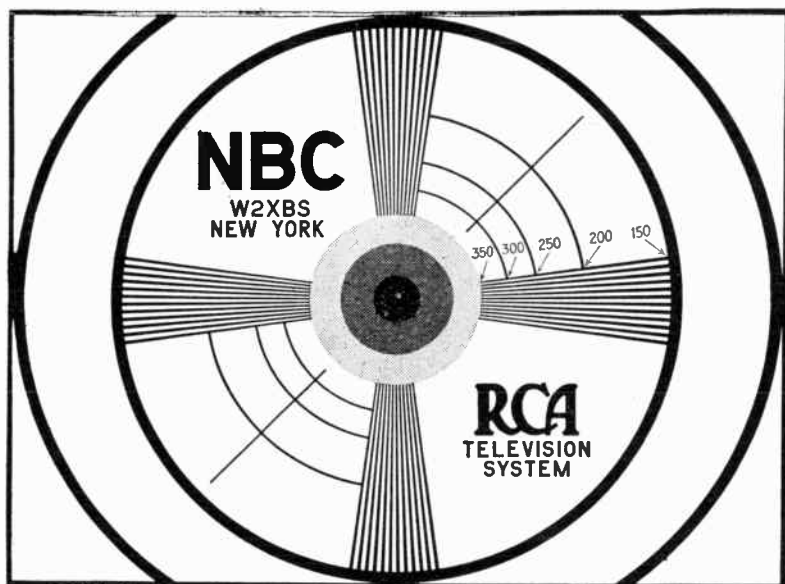

FIG. 25A.—Test chart employed by station W2XBS, the NBC transmitter in New York City. The chart reveals imperfections in scanning amplitudes or linearity, in the degrees of vertical or horizontal resolution, and in the rendition of tonal values. The numbers have been added to show the values of resolution on the wedges of converging lines.

displacement is carried out through the whole of the field. The lines in the two fields, instead of sharing the scanned area equally, overlap to some extent and leave blank, to the same degree, the spaces between lines.

**13. Charts for Testing Image Characteristics.**<sup>1</sup>—It is difficult to determine the cause of imperfect reproduction of scanned images if the image is moving rapidly and is not familiar to the

<sup>1</sup> BEDFORD, A. V., Figure of Merit for Television Performance, *R.M.A. Eng.*, 2 (1), 5 (November, 1937); also *RCA Rev.*, 3, (1), 36 (July, 1938).

viewer. Accordingly, several forms of static test charts have been devised for use in testing the resolution and geometrical form of the received image. One of the simplest patterns is shown in Fig. 25. It consists of two large concentric circles (the upper and lower parts of the outer circle are missing). The radius of the outer circle measures the width of the picture, that of the inner circle, the height. The ratio of the radii of

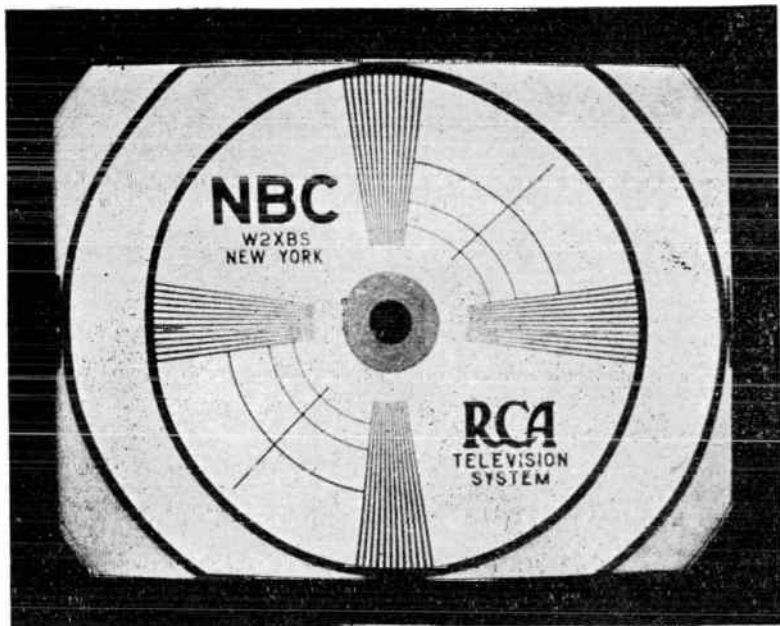

FIG. 25B.—Televised reproduction of the chart in Fig. 25A, photographed from the monitor picture tube in the NBC studios. The resolution of the wedges is substantially complete, representing "350-line" performance. Note, however, the indefiniteness of the inner portions of the horizontal wedges, indicating that 400 active scanning lines are just barely able to reproduce 350 picture elements in the vertical direction.

the circles is equal to the standard aspect ratio of 4 to 3. If the scanning patterns are adjusted at transmitter and receiver so that these circles have a true circular form, then it follows that the aspect ratio of the received image is correct. If the circles have an elliptical shape, the pattern is too wide when the main axis of the ellipse is horizontal, too narrow when the axis is vertical. If the circles have an egg-shaped outline, then the rate of scanning is nonlinear, in the vertical direction

when the axis of symmetry of the "egg" is vertical and in the horizontal direction when the axis is horizontal.

Within the outer circles are three smaller concentric shaded areas, the density of shading of which is divided in three shades. If the system is adjusted so that the apparent difference in brightness between each shade is the same, then the relative brightness of the image elements is in proper proportion from the shadows to the high lights.

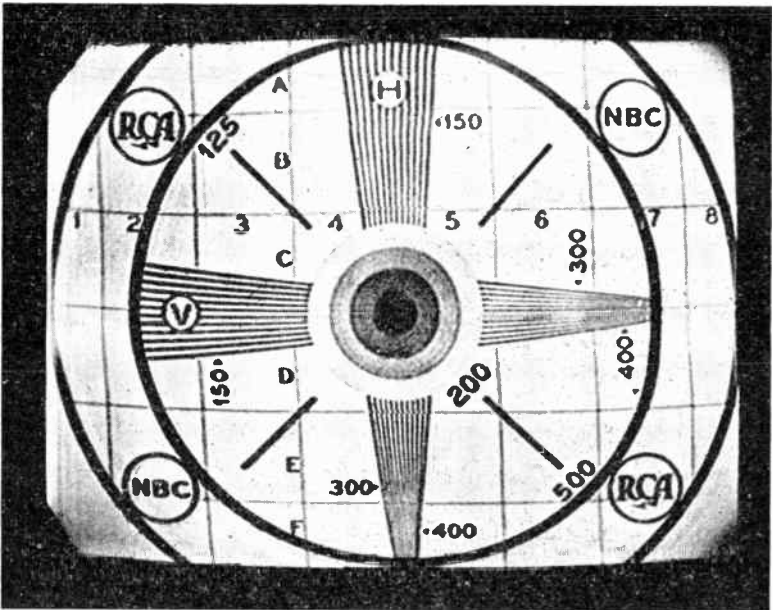

FIG. 26.—Televised reproduction of an early form of test chart. The vertical resolution (horizontal wedge) is slightly better than 300 lines, whereas the horizontal resolution (vertical wedge) cuts off rather sharply at 300 lines.

Above and below the innermost circles are two "wedges" composed of black and white lines, the purpose of which is the testing of the horizontal resolution of the picture elements in the pattern. The lines are spaced so that the width of each line corresponds to a definite fraction of the picture height. The denominator of this fraction is known as the resolution in "lines." If the wedges are completely resolved on the received image, the inference is that the horizontal resolution exceeds 350 lines (that is, a line  $1/350$ th as high as the picture is resolved). If only

the outer portions of the wedges are resolved, then the resolution is less than the maximum, as indicated by the numbers on the figure. If the left and right wedges are resolved, in similar fashion, then the vertical resolution has the value indicated.

A somewhat similar chart, much used in early work, is shown in Fig. 26. Here the outer circles have the same significance as in Fig. 25. The vertical and horizontal wedges of converging lines indicate the degrees of resolution. To test the vertical

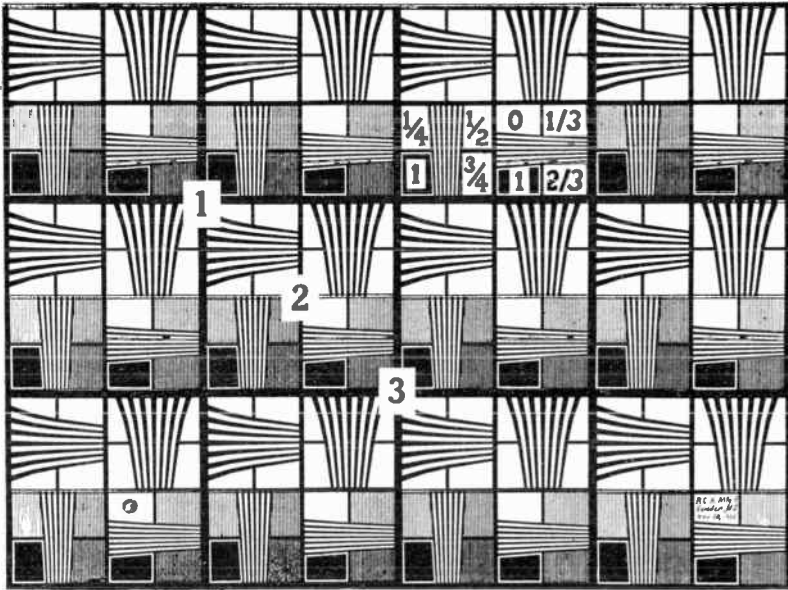

FIG. 27.—The "12-square" test chart used in production testing of camera tubes, picture tubes, and overall system performance. The fractions indicate the degree of shading, while the numbers 1, 2, and 3, indicate resolutions of 100, 200, and 300 lines in the wedges.

resolution, the observer sights along the horizontal wedge until the lines are no longer separated. At this point, the degree of resolution is indicated by a corresponding number, which gives the separation of the converging lines at that point in the wedge. The same procedure is used with the vertical wedge to determine the horizontal resolution.

Figure 27 shows a more comprehensive type of chart used in developing camera tubes and image tubes as well as in testing system operation. The chart consists of 12 large squares, each

of which is divided into 4 smaller squares. Each of the 12 large squares is identical with all the others. Consequently 12 equal portions of the scanned area are examined independently, and the detection of defects is correspondingly localized. Each major square contains four wedges of converging lines, two vertical and two horizontal. The most open part of the larger wedges has a resolution of 100 picture elements per picture height. The narrow edges of the same wedges have a resolution of 200 elements, as do the wide edges of the smaller wedges. The narrow edges of the smaller wedges have a resolution of 300 elements. The chart indicates relative half-tone intensity as the small shaded areas surrounding each small wedge. The degree of shading, relative to black as 1, are  $\frac{1}{4}$ ,  $\frac{1}{2}$ , and  $\frac{3}{4}$  around the vertical small wedges, and 0,  $\frac{1}{3}$  and  $\frac{2}{3}$  around the horizontal small wedges. The geometrical properties of the image are indicated by the shape of each of the main and subordinate squares. The aspect ratio is indicated by the fact that there are four squares across the image, three in its height. Consequently if each of the squares has equal sides, the aspect ratio of the reproduction is correct. Nonlinearity in either direction is indicated by a gradual change in shape of the squares. The orthogonal character of the pattern is indicated by the shape of lines bounding each square.

In all the patterns shown, the phenomenon of pairing in interlaced patterns is shown on the wedges indicating vertical resolution, as an uneven appearance of the line widths near the region of maximum resolution.



## CHAPTER III

### FUNDAMENTALS OF TELEVISION-CAMERA ACTION

The television camera, through which the television program begins its journey from studio to audience, has three important functions: (1) It must be a viewing device, capable of forming an image of the scene before it. (2) It must be an image analyzer, capable of dissecting the image into picture elements. (3) It must be a photoelectrical conversion device, capable of generating a chain of electrical impulses that correspond to the picture elements.

We begin with the optical aspects of television-camera action. These optical aspects include the source of light, the objects to be televised, and the optical viewing system of the camera. The relationships among these elements may be treated by the elementary illumination theory discussed below.

**14. Elements of Illumination Theory.**<sup>1</sup>—The important quantities describing a source of light are its *candle power* and the *color composition*. The color aspect is most conveniently treated in connection with the color response of the camera. Consequently we defer any statement of the color relationships and consider first the candle power of the source.<sup>2</sup> The candle power of the source is a numerical measure of the rate at which the source produces *visible* energy. It must be remembered that all incandescent sources, including the sun and filament lamps, radiate a great deal of energy that is not visible to the eye. The candle power is concerned only with that part which produces the sensation of light in the mind of the observer.

<sup>1</sup> An excellent treatment of practical illumination engineering is to be found in Parry Moon, "The Scientific Basis of Illumination Engineering," McGraw-Hill Book Company, Inc., New York, 1936.

<sup>2</sup> The candle power depends upon the color composition, of course, so that the two concepts cannot properly be separated, except for convenience in exposition. The term candle power, as ordinarily used, relates to a visual comparison between the given source and a standard source, that is, to a simple photometric balance between sources of nearly the same color composition.

The unit of candle power is the *standard candle*, which is a specified fraction of the visible power radiated by a group of 45 carbon-filament lamps preserved in the U. S. Bureau of Standards, when the lamps are operated at a specified voltage. Originally, the standard candle was the amount of light power radiated by a tallow candle of specified composition and shape. A unit intimately related to the standard candle, and widely employed in practice, is the *lumen*. The lumen is the amount of luminous flux radiated within a unit solid angle (one steradian) from a source of one candle. In accordance with this definition, a source of one candle radiates a luminous flux of  $4\pi = 12.57$

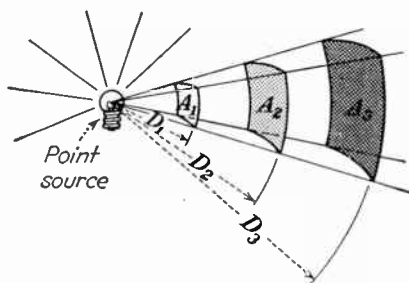

FIG. 28.—Light flux radiating from a point source. As the illuminated areas  $A_1$ ,  $A_2$ , and  $A_3$  are removed from the source, the light flux available in the given solid angle is spread over larger and larger areas, with resulting decrease in illumination.

lumens. It is customary to rate light sources in lumens, as well as in candles.

Of equal importance with the rate at which a source emits visible energy are the directions that the light flux takes as it flows away from the source. As the light flux travels away from the source, the rays of light may diverge, converge, or remain parallel, depending on the nature of the source and the shape of the lenses or reflectors, if such are employed to direct the light.

One simple type of source commonly used as a basis for calculations is the "point" source, the dimensions of which are small if compared with the distance at which it is viewed. If such a point source exists in free space (see Fig. 28), the light flux flows away from it equally in all directions, spreading out into larger and larger volumes of space as it flows away from the source. In consequence of this spreading action, the energy



density in the light beam decreases as the square of the distance from the source. If such a concentrated source is fitted with a reflector, on the other hand, the rays are confined along a narrower path, as for example in the ordinary automobile head lamp. Depending upon the nature of the reflector and lens system, the rays in the beam can be made to diverge, converge, or remain parallel. If they diverge, the energy density in the light beam decreases as the light flows away from the source; if they remain parallel, the energy density remains constant except for the energy absorption in the transmission medium.

The ability of a light beam to illuminate an object is in direct proportion to the flux density of the beam as it falls on the object. Consequently it is of importance to be able to determine the flux density in the beam. This determination is conveniently carried out by computing or measuring the number of lumens that fall on the illuminated object and dividing by the area that is illuminated. Illumination is thus measured in the unit *lumens per square foot*, the common name of which is the *foot-candle*.

Objects so illuminated may reflect, transmit, or absorb the light that falls upon them. If they reflect or transmit any light, they become light sources in themselves. The candle power of such "secondary" sources is usually measured in *candles per square foot* (or in millilamberts = 3.38 candles per square foot) and is referred to as the *surface brightness* of the object in question. The total number of lumens emanating from the secondary source may be computed and employed in further calculations in the same manner as if the source were a primary source of light.

The symbols commonly employed for these quantities are as follows:

Candle power (or intensity)  $I$  candles

Illumination  $E$  lumens per square foot or foot-candles

Light flux  $F$  lumens

Brightness  $B$  candles per square foot

The basic relationships are as follows: If a point source has a candle power of  $I$  candles, it radiates a flux  $F$  of

$$F = 4\pi I \text{ lumens} \quad (22)$$

If  $F$  lumens of light flux fall uniformly on an object the area of which, when projected in the direction of the source, is  $A$  sq. ft.,

the illumination  $E$  of the object is

$$E = \frac{F}{A} \text{ lumens per square foot or foot-candles} \quad (23)$$

If the object so illuminated reflects light, the amount of light reflected is measured by the reflection coefficient  $R$  of the object. Colored objects reflect certain colors better than others, that is, the reflection coefficient varies with the color of the light. In computing the amount of reflected light, it is necessary, therefore, to use the value of  $R$  that applies to the particular color or combination of colors present in the illumination.<sup>1</sup>

Two types of reflection are of interest. The first, *specular reflection*, occurs from mirror surfaces and obeys the law that the angle of the reflected rays with respect to the surface is the same as the angle of the incident rays. In this case, the surface brightness  $B$  is

$$B = RE \text{ candles per square foot} \quad (24)$$

where  $R$  is the reflection coefficient (applicable to the color composition) of the illumination  $E$  (in foot-candles). This value of the surface brightness applies, of course, only in the path of the normally reflected beam.

The second type of reflection, of much more general occurrence in studio practice, is *diffuse reflection*, in which the incident rays are scattered by the reflecting object. In this case, the reflected light may be seen from any angle, and the apparent brightness depends only on the illumination, regardless of the direction from which it is viewed. Under these conditions, the surface brightness of the object is

$$B = \frac{RE}{\pi} \text{ candles per square foot} \quad (25)$$

Here the factor  $\pi$  takes into account the diffuse nature of the

<sup>1</sup> In some cases, the reflection coefficient is plotted as a curve against the wavelength (color) of the incident light. When such a curve is available, the over-all reflection coefficient relative to a given source of illumination may be arrived at by multiplying the coefficient curve by the curve representing the color content of the source. The "over-all" reflection coefficient may be taken as the average ordinate of this product curve divided by the average ordinate of the color content curve. The multiplication of color-response curves is discussed more fully on p. 77.

reflected light. This relationship is approximate only, since in most practical cases the reflection coefficient varies with the angle of incidence, but it may be used for many of the conditions commonly encountered in studios.

Similarly, if an illuminated object transmits light, the brightness of the object is measured by the transmission coefficient  $T$  as

$$B = TE \text{ candles per square foot} \quad (26)$$

If the transmission diffuses the light, the brightness is

$$B = \frac{TE}{\pi} \text{ candles per square foot} \quad (27)$$

**Calculating Illumination and Brightness.**—In performing calculations based on the preceding relationships, the initial problem is that of computing the number of lumens which fall upon the illuminated object. This computation is based on the candle power of the source, on the divergence or convergence of the rays in the beam, together with the absorption properties of the transmission medium.

For example, consider a point source the dimensions of which are small when compared with the distance to the illuminated object (Fig. 28). In this case, the rays diverge equally in all directions, and it is simple to calculate the number of lumens intercepted by the projected area of any object in the path of the light. If the source has a power  $I$  candles and is located a distance  $D$  ft. from an object the projected area of which is  $A$  sq. ft., then the number of lumens intercepted by the object is

$$F = \frac{IA}{D^2} \text{ lumens} \quad (28)$$

and the illumination is

$$E = \frac{I}{D^2} \text{ foot-candles} \quad (29)$$

If the source is not a point source, the divergence or convergence of the rays depends upon the extent of the source and the geometry of its luminous surface. Exact calculations in this case are difficult, so it is usual to treat most basic sources of light as point sources, subject to the rule that the distance between

source and the illuminated object shall be at least five times that of the greatest dimension of the source.

The use of reflectors and lenses, to confine the output of a source to the direction of greatest use, introduces additional geometrical computations in determining the number of lumens intercepted by an object. Usually it is possible to determine the number of lumens of light flux which are reflected by the reflector, or transmitted by the lens, and which form the total content of the beam. Then the area of the object illuminated, projected in the direction of the source, is compared with the whole area of the beam, measured at the plane of the projected area. The number of lumens intercepted by the object  $F_o$

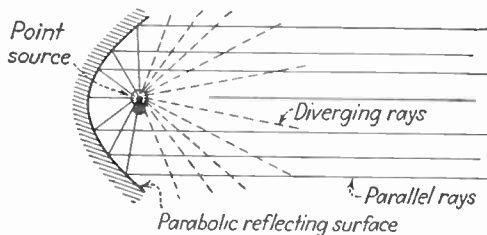

FIG. 29.—Action of a parabolic reflector. The rays to the right of source diverge, whereas those to the left are reflected in a parallel beam. The illumination caused by the parallel beam is independent of the distance from the source (except for absorption in the transmission medium).

is to the total number of lumens  $F_t$  in the beam as the projected object area  $A_o$  is to the beam area  $A_t$ , that is,

$$\frac{F_o}{F_t} = \frac{A_o}{A_t} \quad (30)$$

This assumes, of course, that the light is uniformly distributed throughout the beam. If this assumption is not justified, then the calculations are so involved that they are seldom attempted, and direct measurements must be made.

To illustrate these relationships, consider a source of 1000 candles (12,570 lumens) mounted in a reflector that reflects all the light uniformly in a conical beam the solid angle (as measured on a bisecting plane) of which is  $45^\circ$ , as shown in Fig. 30. The object illuminated is a perfectly diffusing white placard the reflection coefficient  $R$  of which (specified for the color composition of the source) is 0.8. The placard is placed a dis-

tance  $D$  15 ft. from the source and so oriented that its projected area in the direction of the source is 1 sq. ft. We are to find the illumination of the placard and its brightness.

The 12,570 lumens are distributed uniformly over the  $45^\circ$  solid angle. In the plane of the projected area of the object, this solid angle includes an area of about 100 sq. ft. (This area is that subtended by the  $45^\circ$  solid angle at a distance of 15 ft.) The object (area 1 sq. ft.) thus intercepts  $\frac{1}{100}$  of the total number of lumens, hence  $F_o = 126$  lumens. The area in the direction of the source is 1 sq. ft., consequently the illumination  $E$

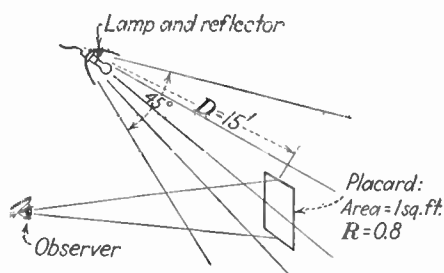

FIG. 30.—Illumination of a reflecting placard. The observed brightness depends on the distance  $D$  from the light source, and on the reflecting coefficient  $R$ , as well as on the geometry of the reflecting system

of the object is 126 lumens per square foot. The brightness of the object is then

$$B = \frac{ER}{\pi} = \frac{126 \times 0.8}{3.14} = 32 \text{ candles per square foot}$$

It should be noted that this simple solution depends upon perfectly diffuse reflection from the object. In usual studio practice, of course, conditions are not so idealized, and the computations are often dispensed with in favor of measuring the surface brightness in the desired direction by means of a photoelectric exposure meter. The preceding example serves to illustrate the factors that must be controlled if unsatisfactory lighting conditions prevail.

**Illumination of Camera Plate.**—The surface brightness of the object has been emphasized in the preceding paragraphs because it is the quantity that determines the illumination received by the photosensitive plate in the television camera. It can be shown that the illumination of this plate depends upon four

factors (see Fig. 31): the surface brightness of the object, the size of the lens opening, the transmission coefficient of the lens, and the angle the rays make with the optical axis of the lens. The complete relationship among these quantities can be stated as follows:

$$E_p = \frac{0.785BT \cos^4 \theta}{f^2} \text{ foot-candles} \quad (31)$$

where  $E_p$  is the illumination of the plate, in foot-candles, produced by an object of surface brightness  $B$  in candles per square foot, through a lens system of transmission coefficient  $T$ , when the aperture (stop opening) of the lens is  $f$  and  $\theta$  is the angle

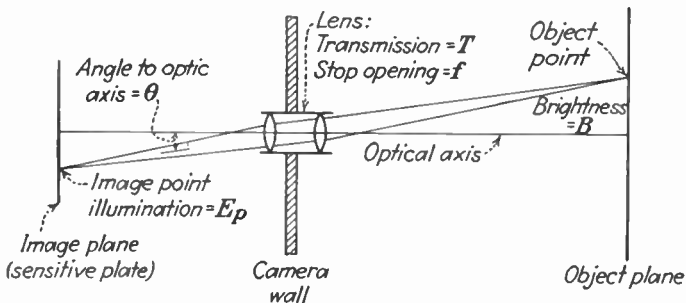

FIG. 31.—Illumination of a camera plate. When the brightness of the object is known (cf. Fig. 30), the illumination of the plate can be calculated from the lens stop opening and its transmission.

between the light rays in question and the optical axis of the system. Since this equation is too complicated to be used in practice, it is useful to average the effect over angles ( $\theta$ ) up to, say,  $15^\circ$  and to insert a representative value of transmission coefficient  $T$  (say 0.75). In this case, the relation becomes

$$E_p = \frac{0.5B}{f^2} \text{ foot-candles} \quad (32)$$

The  $f/$  number is familiar to all photographers; it is the ratio of the principal focal length of the lens to the diameter of the lens opening. Its values range from 1.5 to 64 or higher in photographic work. Values from 2 to 10 are usual in television.

To return to the foregoing example, in which the surface brightness of the object in the direction of the observer was

found to be 32 candles per square foot, it follows that if this object is viewed by a camera employing an aperture of  $f/4.5$ , the illumination on the plate would be  $0.5 \times 32/(4.5)^2$ , or roughly 0.75 foot-candle.<sup>1</sup>

*Light Flux Contained in a Picture Element.*—The remaining question is to determine the number of lumens falling on a single picture element on the camera plate. This is an important quantity because the amount of current available from the picture element (that is, the amplitude of the current impulse corresponding to the picture element) depends on the number of lumens contained in the element.

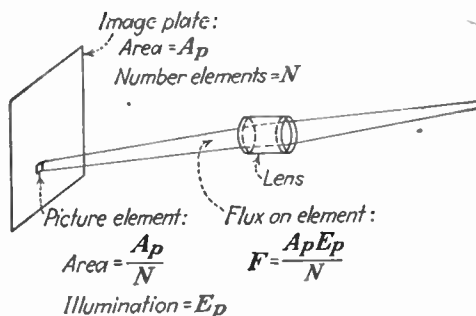

FIG. 32.—Light flux contained in a single picture element, computed from the illumination and the area of the element.

To determine the lumens from the illumination falling on a picture element, we use Eq. (23) as follows (see Fig. 32):

$$F = \frac{A_p E_p}{N} \quad (33)$$

where  $F$  is the number of lumens falling on a picture element illuminated by  $E_p$  foot-candles,  $N$  is the total number of picture elements, and  $A_p$  is the plate area in square feet. Suppose, for example, that the number of picture elements is 150,000, that the plate area is 12 sq. inches, and that the illumination of the

<sup>1</sup> The plate illumination decreases with the magnification of the image. The decrease in illumination is important if the magnification is greater than one-tenth (that is, if the size of the image on the plate is greater than one-tenth the actual size of the object). Magnifications greater than this are sometimes encountered in close-up work. In this case, the plate illumination is divided by the factor  $(m + 1)^2$  where  $m$  is the magnification expressed as a fraction. For most purposes, however, Eq. (32) may be used directly.

camera plate (see calculation, page 71) is 0.75 foot-candle. Then the light flux falling on a single picture element is [by Eq. (33)] about 0.0000004 lumen. This is an exceedingly small amount of light flux, and the amount of photoelectric current produced by it is correspondingly small. The question of adequate sensitivity in the television camera is thus a very urgent one.

*Contrast and Tonal Range in Optical Images.*—Thus far we have considered only the absolute brightness of any one picture element and the luminous flux associated with it. The visual intelligence in a scene, we recall from Chap. I, is conveyed by *differences* in brightness between adjacent picture elements. Consequently we must examine not only the average brightness of the scene, but also the departures from the average which contain the visual intelligence.

We consider first the maximum and minimum brightnesses present. The ratio of these brightnesses, known as the *brightness contrast* of the scene, varies widely according to subject matter and illumination. A bright sunlight scene in the out-of-doors may display a brightness contrast of 10,000 to 1 between the sky and the deep shadows. On a cloudy day, the contrast decreases considerably. Values as low as 2 to 1 may be encountered in ordinary subjects. It follows that if a television system is to imitate nature exactly, it must display a dynamic range of 2 to 1 or lower in certain cases and 10,000 to 1 in others. The latter case is, of course, the most difficult since the camera would then be required to generate a minimum current 1/10,000th as strong as its maximum current. The maximum current is limited by the saturation of photoelectric emission, hence the minimum current is small and may be masked by the random currents produced in the amplifier circuit. Even if a dynamic range of 10,000 to 1 were possible in the camera tube and transmission circuit, the image-reproducing tube, in its present state of development, could not make use of this wide range because the brightness contrast is limited by halation and saturation of the luminescent screen and by the defocusing effect ("blooming") associated with the electron gun when large signals are impressed on it. Consequently it has been necessary to restrict the dynamic range of the television system to not more than 100 to 1, and even this range cannot readily be reproduced in image-reproducing tubes, up to the present time.



The question then arises whether such a restricted brightness range is capable of reproducing adequately the ranges of brightness present in the subject matter being televised. Fortunately such is the case. Owing to the logarithmic response of the eye (the sensation of light is approximately proportional to the logarithm of the brightness producing the sensation, as discussed in Chap. VIII), a reproduced picture may be given the appearance of high contrast even though the absolute range of brightnesses employed is restricted. For this reason, a brightness-contrast range of 100 to 1 is considered fully adequate for

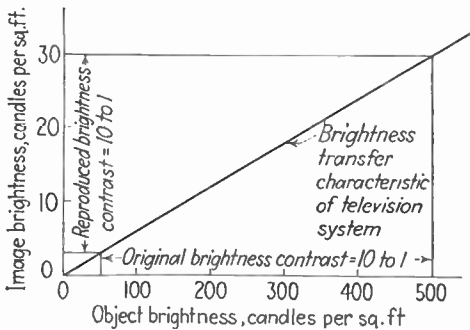

FIG. 33.—Contrast and tonal range. A brightness contrast of 10 to 1 in the object may be reproduced accurately in the image, although the absolute brightness of the image is reduced (cf. Fig. 197, page 336).

pictorial reproductions. Present attainment in this respect falls somewhat short of this ideal. A brightness contrast of 50 to 1 is the limit in most present-day image-reproducing tubes, and between closely adjacent picture elements the maximum contrast may fall as low as 10 to 1. This limitation of the picture tubes will no doubt be removed as improved forms of electron guns and luminescent screens are developed. Hence it is desirable to design the remainder of the system with a wider range of brightnesses in mind. A contrast of 1000 to 1 (60 db) would permit the proper reproduction of almost any type of subject matter, but in practice no more than 100 to 1 is ordinarily used as the available range for cameras and transmitting equipment.

It may be assumed that the least change in light to be reproduced is 1/100th as great as the maximum brightness which may be accommodated by the system. The corresponding minimum change in photoelectric current is accordingly 1/100th

as great as that of the maximum photoelectric current. It should be remembered that the absolute value of this change in photoelectric current depends on the absolute values of illumination and luminous sensitivity employed. Thus if the maximum illumination in the scene is  $E_{\max}$  foot-candles, the least perceptible difference in illumination  $dE$  is limited, so far as the television system is concerned, to

$$dE = 0.01E_{\max} \quad (34)$$

The corresponding difference in luminous flux  $dF$  between adjacent picture elements is

$$dF = 0.01E_{\max}A \quad (35)$$

where  $A$  is the area of a picture element. Finally, the difference in photoelectric current arising from this difference in flux is

$$dI = 0.01E_{\max}AS \quad (36)$$

where  $S$  is the luminous sensitivity of the camera plate (see page 76).

This difference in current constitutes the peak-to-peak value of the a-c component of the camera output current for the least perceptible change in light in the image. If this peak-to-peak value of current is larger than the random currents generated in the camera amplifier, then the signal may be amplified properly. However if the maximum illumination  $E_{\max}$  is small, the change in current is correspondingly small, and it may be less than the random currents. In this case, the random currents mask the least perceptible change in the signal. When this occurs, the least perceptible change in brightness (properly transmitted through the system) is greater than 1/100th the maximum illumination. It follows that to obtain adequate transmission of tones in the system, adequate illumination must be available to overcome the masking effect of the random currents. This requirement is established in more detail later in the chapter (page 85).

**15. Photoelectric Surfaces.**<sup>1</sup>—We now consider the mechanism of the transfer from light to electricity. When light falls on the surface of matter, its effect is to render the space near

<sup>1</sup> For a more detailed treatment of photoelectricity see:

HUGHES and DUBRIDGE, "Photoelectric Phenomena," McGraw-Hill Book

the surface slightly more conducting to electricity than it is when the surface is not illuminated. This phenomenon, the *photoelectric effect*, was discovered in 1887 by Hertz, who found that a spark could be made to jump between two terminals more readily if the negative terminal was illuminated with ultraviolet radiation. Later Hallwachs subjected the photoelectric effect to systematic study and found that the increase in conductivity is proportional to the light flux falling on the surface and that the degree of conductivity varies greatly in illuminated surfaces of different physical and chemical composition. Hallwachs came to the conclusion that the conductivity arises from the presence of invisible electrified particles that are freed from the surface by the action of light. In 1897, Sir J. J. Thomson established the truth of this conclusion and showed that the electrified particles are *electrons*, that is, negative charges of about  $4.80 \times 10^{-10}$  electrostatic unit (e.s.u.).

In 1905, Einstein enunciated the theory of the photoelectric effect which has remained essentially without change to the present. According to this theory, the energy present in a light ray is collected into very small discrete bundles, called *quanta*. The energy present in each quantum maintains its individuality, so that when a quantum penetrates a solid surface, it is capable of transferring its energy to an electron within the surface. The electron, if invigorated by a sufficient amount of this transferred energy, is capable of freeing itself from the surface and so becoming a free electron in the space just outside the surface. Ordinarily the electron does not remain in this free condition but returns at once to the surface. However, if the space outside the surface is electrified by the application of a positive electric field, the electron moves away from the surface under the influence of the electric field. In this way, the electron may become permanently disengaged from the surface, and it may move to a near-by collecting electrode. The motion of the electron from the illuminated surface to the collector constitutes an electric current. This current, under certain conditions, can be made

---

Company, Inc., New York, 1932.

KOLLER, L. R., "The Physics of Electron Tubes," McGraw-Hill Book Company, Inc., New York, 1937.

ZWORYKIN and WILSON, "Photocells and Their Application," John Wiley & Sons, Inc., New York, 1934.

proportional to the light flux falling on the surface. This is the fundamental action by which the optical image in the television camera is converted into a corresponding electrical image.

The following attributes of the photoelectric effect are of importance in the action of television cameras:

1. The action of the photoelectric effect is practically instantaneous. The time lapse between the illumination of the surface and the appearance of the current of free electrons is of the order of hundredths of millionths of a second.

2. The efficiency of conversion of the energy from light to electricity is extremely poor. Even the most highly photosensitive surfaces are capable of producing only a few hundred millionths of an ampere from 1 lumen of light flux.

3. The amount of current available from the surface depends to a very large degree on the chemical composition and physical state of the surface in question. Slight chemical or physical changes in the surface may cause the current to become immeasurably small, whereas special treatment may increase the current many times.

4. The amount of current derived from the surface depends not only on the amount of illumination it receives, but also on the color of the illumination. If we increase the light flux without changing its color composition, the current increases in proportion to the illumination. However, if the color composition of the light is changed, the corresponding changes in current are difficult to predict. It is usual to plot the relationship between color and photoelectrical current in a curve derived from measurements (see Fig. 35).

5. The current available from the surface is proportional to the illumination only if there are no appreciable numbers of other free particles, such as gas molecules, present. Consequently it is necessary to enclose the photosensitive surface in an envelope or "tube" from which the gas is exhausted. A collecting electrode is also included in the envelope to collect the electrons and thus to establish the current through the tube.

*Luminous Sensitivity of Photosensitive Surfaces.*—It follows from Einstein's theory of the photoelectric effect that the number of free electrons released is proportional to the amount of light energy received by the surface. Hence the rate at which the electrons are released (that is, the electric current) is proportional to the rate at which light energy is received, which is measured by the number of lumens of light flux. Consequently the ratio between current and light flux or *luminous sensitivity* is expressed in microamperes per lumen.

In employing the luminous sensitivity of a surface, we can use a simple ratio of microamperes per lumen only if that ratio has been

evaluated for the particular color composition actually in use. Usually the luminous sensitivity is measured and rated by using the standard condition of a tungsten lamp operated at  $2870^{\circ}\text{K}$ . The color composition of such a lamp is shown plotted in the curve of Fig. 34. The height of the curve at any point represents

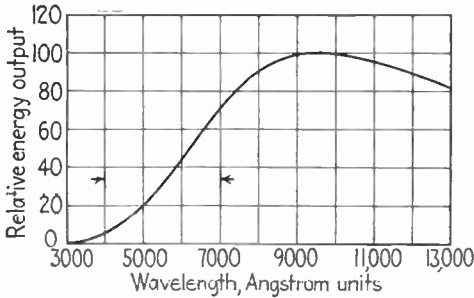

FIG. 34.—Spectral distribution of a standard tungsten incandescent lamp operated at  $2870^{\circ}\text{K}$ . The arrows mark the approximate limits of the visible region of the spectrum (violet, 4000 Angstroms, to red, 7000 Angstroms).

the relative amount of the energy output of the lamp at the color corresponding to that point. It will be noticed that a large percentage of the radiated energy falls outside the visible region.

In Fig. 35 is shown the color response of a typical photosensitive surface. This curve shows, at any point, the number of

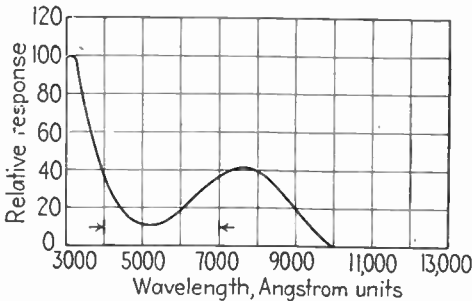

FIG. 35.—Spectral response of a typical cesium-oxide-silver photoelectric surface, including the filter action of the glass envelope.

microamperes of current obtainable from 1 microwatt of light power of the color corresponding to that point. Suppose that the light represented in Fig. 34 falls on the sensitive surface represented in Fig. 35. Then the resultant response of the surface is represented by the *product* of the two curves, shown in

Fig. 36, which is obtained by multiplying the corresponding values of energy output and sensitivity at each point on the two curves.

For comparison, consider the visibility curve of the eye in Fig. 37 which shows the relative response of the eye to the

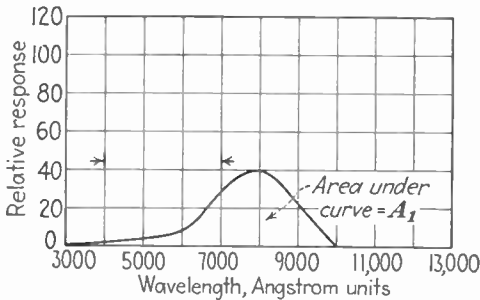

FIG. 36.—Response of the photoelectric surface of Fig. 35 to the spectral distribution of Fig. 34, that is, the product of the two curves. Note that the response in the visible region (between the arrows) is very low, compared with that in the infra-red region above 7000 Angstroms.

different colors in the spectrum. The tungsten-source light output (Fig. 34) applied to the eye evokes the response represented by the product of the two corresponding curves, shown in Fig. 38. The difference between the response of the eye and the response of the phototube is very marked, as shown by

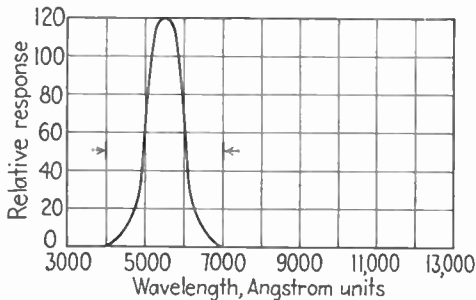

FIG. 37.—Standard visibility curve of the human eye. Compare with the response curve of the photoelectric surface, in Fig. 35.

comparing Fig. 38 with Fig. 36. It follows that a television camera employing such a sensitive surface may see the objects before it quite differently from an eye viewing the same objects.

*The Output Current from a Photosensitive Surface.*—Turning to the important practical problem of computing the photo-

electrical current produced by a given amount of light flux, we can state an example as follows: Given a photosensitive surface in a television camera the sensitivity of which to the light from a standard tungsten source operated at  $2870^{\circ}$  is  $50 \mu\text{a}$  per lumen.

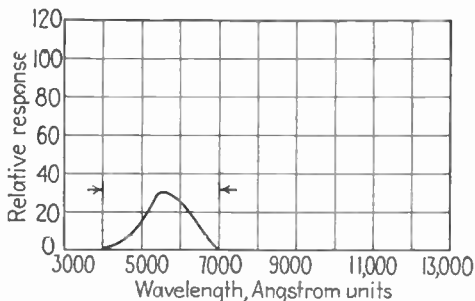

FIG. 38.—Response of the human eye to the standard tungsten light source of Fig. 34, determined by multiplying the curves in Figs. 34 and 37.

Suppose that light from such a standard tungsten source is focused on the surface in such a way that the light flux falling on one picture element (computed by methods of the preceding section) is  $0.000001$  lumen. Then the current impulse corresponding to this picture element is  $50 \times 0.000001 = 0.00005 \mu\text{a}$ .

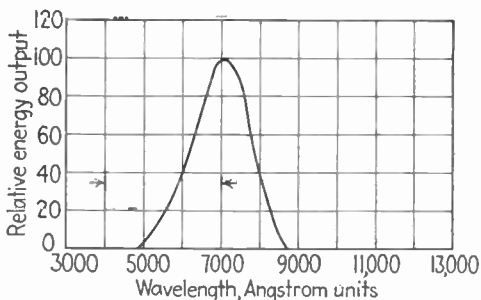

FIG. 39.—Spectral distribution of a typical "nonstandard" light source, for which the photoelectric response is to be computed.

In general terms, the equation for the current from one picture element may be expressed as

$$I_{\text{instantaneous}} = \frac{SE_p A_p}{N} \mu\text{a} \quad (37)$$

where  $S$  is the luminous sensitivity in microamperes per lumen,  $E_p$  the illumination in foot-candles falling on the picture element

in question,  $A_p$  the area on the camera plate in square feet, and  $N$  the total number of picture elements.

If the color composition is not "standard," we can predict the current only by a series of conversions to find the proper value of  $S$ . Suppose that the nonstandard color composition is that given by Fig. 39, resulting from the predominance of red color in the televised object. The sensitivity figure of  $50 \mu\text{a}$  per lumen no longer applies, but it is possible to compute the value that does apply by the following procedure:

First multiply the standard tungsten-source curve (Fig. 34) by the spectral-response curve of the photosensitive surface (Fig. 35). This product (Fig. 36) is the response of the surface to the

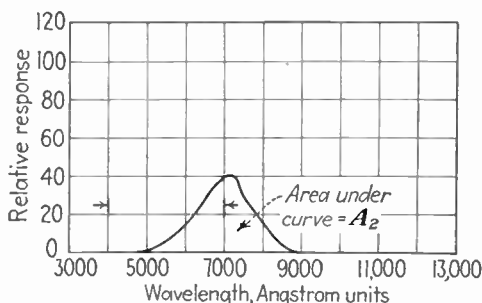

FIG. 40.—Response of the photoelectric surface to the spectral distribution of Fig. 39, determined by multiplying the curves in Figs. 35 and 39. The area under this curve,  $A_2$ , is compared with the area  $A_1$  under the curve in Fig. 36 to obtain the value of luminous sensitivity to the nonstandard light source.

standard source. Then perform a similar multiplication of the curve for the nonstandard color composition by the response curve of the surface and thus obtain the response to the nonstandard color composition (Fig. 40). The areas under the two product curves represent the relative currents available from the two light sources. By taking  $A_1$  as the area under the standard product curve and  $A_2$  as the area under the nonstandard product curve, the ratio  $A_2/A_1$  may be formed. This ratio, multiplied by the standard sensitivity value of  $50 \mu\text{a}$  per lumen, gives the value of luminous sensitivity applicable to the nonstandard source.<sup>1</sup>

<sup>1</sup> It should be mentioned that the sensitivity ratio expressed in microamperes per lumen is a misleading one, since the word lumen applies only to the visible effect of the light, whereas the ratio expresses the electrical response of the surface to all radiation, whether visible or not. The stand-



It is obvious that such an involved computation cannot be employed for every color composition encountered in studio practice. Instead, the surface brightness may be measured directly (in the direction of the camera) by a photoelectric exposure meter the color response of which is the same as that of the sensitive surface in the camera. The luminous flux in each element is then computed on the basis of the measured surface brightness by using Eqs. (32) and (33).

**16. Collection and Utilization of the Photoelectric Current.**—No mention has yet been made of the manner in which the photoelectrically emitted electrons are collected and used. In Fig. 41 is shown a typical phototube, at one time used in television transmission. When light falls on the cathode surface, the photoelectric current produced is forced to flow from the cathode to the anode and through the external circuit to the battery. Because the photoelectric current is so small that it is incapable of being utilized at once, it must be amplified.

The effect of the amplification is computed as follows: The anode circuit contains the anode battery and the resistance  $R_L$

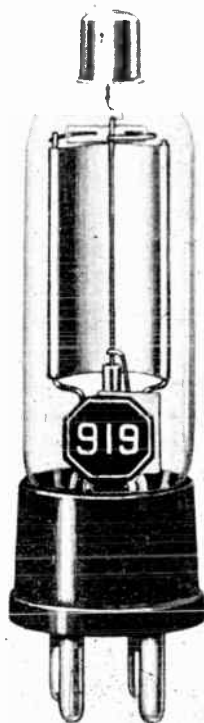

FIG. 41.—Typical commercial phototube. The hemicylindrical cathode, when illuminated, releases electrons which are collected by the central wire anode.

and value of luminous sensitivity in microamperes per lumen is arrived at by multiplying the standard tungsten-source curve by the visibility curve of the eye and taking the area under the resultant product curve as representative of the candle-power output of the source. The observed current obtainable from 1 lumen of flux from such a lamp is then taken as the value of the luminous sensitivity.

In the foregoing procedure conversion, the visibility factor may be ignored, since it serves only to fix the absolute value of the sensitivity, whereas we are concerned in the conversion process with relative values only.

which serves to receive the amplified current from the tube. The grid circuit contains a grid-bias battery, which maintains the grid at a negative potential with respect to the cathode, and a grid resistance  $R_g$  through which is passed the photoelectric current to be amplified. The amplifier tube itself is characterized by two operating characteristics, its amplification factor  $\mu$  and its transconductance  $g_m$ . When a small change in voltage  $\Delta e_g$  is applied across the grid resistor  $R_g$ , an amplified change in voltage  $\Delta e_L$  appears across the anode resistor  $R_L$  such that

$$\Delta e_L = \Delta e_g \left( \frac{\mu R_L}{R_L + \mu/g_m} \right) \quad (38)$$

For example, consider the phototube circuit and light source of Fig. 42 connected through a resistance of 1,000,000 ohms to an

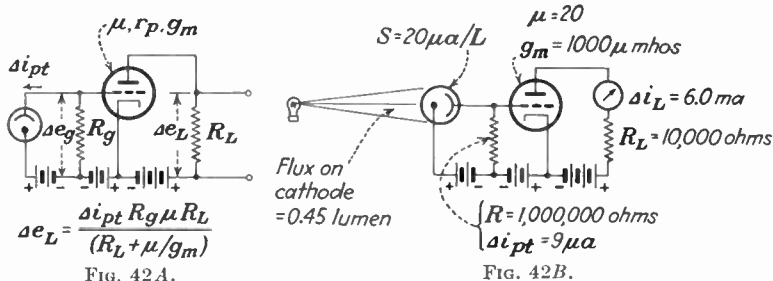

FIG. 42A.—Basic phototube amplifier circuit. The photoelectric current  $\Delta i_{pt}$  passes through the grid resistor  $R_g$ , producing a voltage  $\Delta e_g$  which is amplified to the value  $\Delta e_L$ .

FIG. 42B.—Example of phototube amplification, calculated in the text. An incident light of 0.45 lumen is converted to an amplified voltage change of 60 volts.

amplifier tube the  $\mu$  value of which is 20 and the  $g_m$  value of which is 1000  $\mu$ a per volt. The load resistance  $R_L$  is 10,000 ohms. The photoelectric current, calculated by multiplying the incident light flux by the luminous sensitivity, is 9  $\mu$ a. Hence the voltage change is  $0.000009 \times 1,000,000 = 9$  volts. Substituting this value and the other given data in Eq. (38), we obtain

$$\Delta e_L = 9 \left( \frac{20 \times 10,000}{10,000 + 20,000} \right) = 60 \text{ volts}$$

The current in the anode resistance is 60 volts divided by its resistance value 10,000 ohms, or  $60/10,000 = 6.0$  ma. The

current has thus been amplified from  $9 \mu\text{a}$  as it left the phototube to 6 ma. in the anode circuit, a current amplification of about 660 times.

**Application of Scanning Technique of Phototubes and Amplifier Circuits.**—In television applications, the cathode surface of a phototube must be illuminated by a scene in such a way that it can produce current variations that correspond successively to the scanning of the picture elements contained in the scene. In this process, a scanning device is required which presents to the cathode surface a series of illuminations corresponding to the succession of picture elements.

Scanning devices may be classed in two groups: those which utilize some rotating or reciprocating mechanical system for analyzing the picture into its elements, and those which convert the picture into a distribution of electric charge and then scan the charge image electronically. An example of the second group, the iconoscope, has been briefly described in Chap. I.

The first group, the so-called mechanical scanners, may be used in connection with the phototube and amplifier circuits just described.<sup>1</sup> The patent literature in television contains hundreds of forms of mechanical-scanning devices, most of which are now in the discard owing to some basic limitation. Mechanical scanning is of importance because it illustrates the difficulties that led to the development of the electronic-scanning devices and also because mechanical-scanning systems have been developed which are of use in the transmission of motion-picture film and the projection of received images.

**17. Rotating-disk Scanning.**—In Fig. 43 are shown the essential elements of one of the simplest mechanical-scanning systems, the rotating disk. The scene to be transmitted, represented by the cross-shaped area, is focused by a lens on the surface of the scanning disk. The scanning disk rotates about a horizontal axis. The disk is opaque except for a series of apertures, each the size of the picture element to be produced, through which light is admitted to the phototube. The apertures are arranged around the edge of the disk at different distances from the center of the disk, as shown in the figure.

<sup>1</sup> See WILSON, J. C., "Television Engineering," Chap. III, Pitman & Sons, Ltd., London, 1938, for a full account of rotating and reciprocating scanning devices.

The action of the disk in scanning the scene is as follows: Consider the disk in the position shown in the figure, with the outermost scanning aperture in the position at the edge of the image. As the disk rotates, this aperture passes across the image and allows light to pass from the lens to the cathode of the phototube. As the disk rotates, the light that passes consists only of those rays which make up the uppermost edge of the image, *i.e.*, the first scanning line. When the disk has rotated far enough to bring the outermost aperture to the right-hand edge of the scene, the next aperture has reached the left-hand edge, and as the first

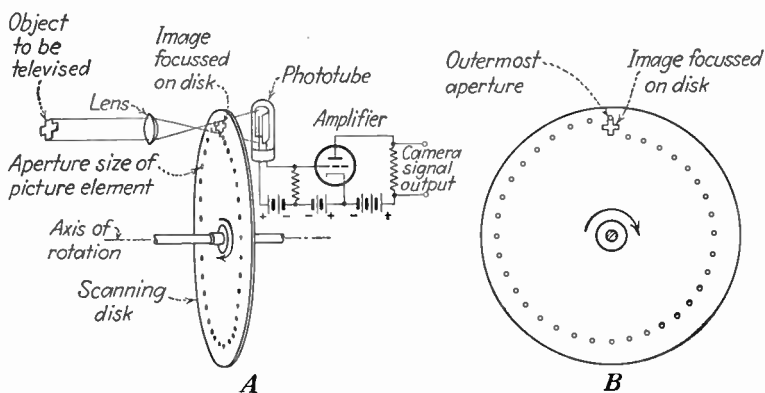

FIG. 43.—Elementary rotating-disk scanning. The 36 apertures, arranged in a spiral, scan the image in a succession of 36 lines, passing the light to the phototube. This method is limited by the small amount of light contained in each scanning aperture.

aperture passes out of the frame, the second aperture passes into it. The second aperture scans the second line. When the second aperture has passed over the scene, the third enters the frame and scans the third line, and so on.

Throughout these successive motions of the scanning apertures, the cathode of the phototube receives, at any instant of time, only the light contributed by one picture element of the scene. In this way, the light received by the phototube is caused to be representative of a succession of picture elements, the elements being arranged one after the other in a succession of lines corresponding to the paths taken by the apertures. As the light on the cathode changes in response to the successive illuminations, the photoelectric current changes correspondingly. The varying

current, passing through a resistor, gives rise to a varying voltage of the same form, and this voltage is amplified.

This system, although simple and direct, suffers from several drawbacks. In the first place, the equipment involves moving parts with their accompanying mechanical problems. In the second place, the device is cumbersome, because a disk of large diameter is required to minimize the curvature of the scanning lines and to make the speed of the motion across the frame approximately the same for all the scanning apertures.

These mechanical limitations, although troublesome, are far less serious than the electro-optical limitations. Suppose that the region of maximum brightness in the object produces a light flux on a single picture element of 0.000001 lumen (a typical case, see page 72). The minimum perceptible flux difference, defined by Eq. (35), is 1/100th of this maximum flux, or 0.0000001 lumen. This difference, translated into current at 50  $\mu$ a per lumen, becomes 0.0000005  $\mu$ a. If this current is passed through a coupling resistor of 300,000 ohms (a representative value) to the following amplifier, the corresponding voltage difference is 0.15 microvolt.

In practice, it is impossible to amplify a voltage as small as this, owing to the presence of small random voltages that are generated spontaneously by thermal effects in the coupling resistor. These random voltages go by the name of "noise" in sound-transmission systems and might be called "masking voltages" in the corresponding visual system. The amplitude of the masking voltage is given by

$$E_n = \sqrt{KfR} \quad (39)$$

where  $K$  is a constant  $1.6 \times 10^{-20}$ ,  $f$  is the highest a-c frequency involved in the transmission (about 3,000,000 cycles per second, for example), and  $R$  is the resistance value in ohms, 300,000 ohms in this case. The voltage in this case is about 120 microvolts. Obviously the signal voltage of 0.15 microvolt is completely lost in the interference caused by the 120-microvolt "mask."

If the number of picture elements per picture (assumed to be 150,000 in the preceding case, corresponding to a flux of 0.000001 lumen) is reduced to 1500 (reduction by a factor of 100), the signal becomes 100 times as strong, or 15 microvolts. The highest

frequency  $f$  is reduced by a factor of 100 also, becoming 30,000 c.p.s., and the masking voltage thereby becomes 12 microvolts. In this case, the signal overcomes the mask. For high definition, however, higher levels of illumination in the studio or larger lens apertures must be used. Consequently simple disk scanning can be used only for images of low definition and only when very high illumination is available.

*Light-source (Flying-spot) Scanning.*—Some of the difficulties of the simple disk system described above may be avoided by employing a very small light source, called a “flying spot,” which in itself acts as the scanning agent. Such a system is shown in Fig. 44. The light source is a very bright and highly

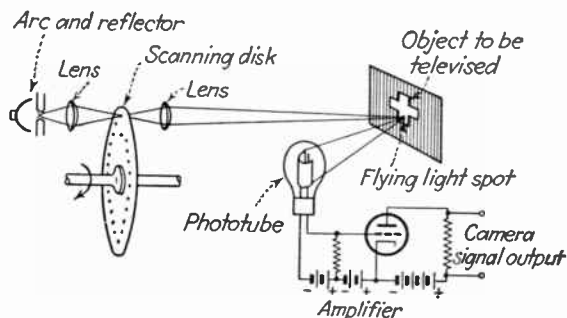

FIG. 44.—Light-source (“flying spot”) scanning. Here all the light from the source is directed to the object, and the optical efficiency is higher than in the system shown in Fig. 43. However, the phototube picks up only a small part of the light reflected from the object, and the object cannot be otherwise illuminated.

concentrated one, such as a carbon arc. The light from this source is focused on the scene through the scanning apertures in a disk having the same shape as in the system just described. The intrinsic brilliance of the spot of light thereby projected on the scene is very great, much greater than would be possible with uniform illumination. Several phototubes are used to intercept the light reflected from the scene. The intense spot of light is caused to move over the scene in a series of adjacent lines as the scanning disk rotates. By employing several phototubes the cathodes of which have a large area, a photoelectric current may be developed which is several hundred times stronger than that available from simple disk scanning. This current may then be amplified without interference from the

masking voltage previously mentioned, provided that the number of scanning lines in the image is not too great.

The scanning-light-source (flying-spot) method is practical in high-definition work only if the scene to be transmitted is small in area. Such is the case in motion-picture-film transmission. A typical mechanical-scanning system devised for use with motion-picture film is illustrated in Fig. 45. The light source is focused through the scanning apertures onto the surface of the film. The film moves past the disk at a constant rate of speed. The apertures are arranged on a circle, *i.e.*, all the apertures are at the same distance from the center of the disk.

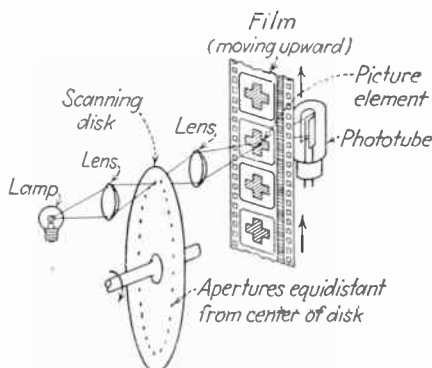

FIG. 45.—Light-source scanning of motion-picture film. In this arrangement, all the light is directed to each successive picture element, and subsequently collected by the phototube. When a multiplier phototube is used this method is capable of high-definition transmission with adequate signal-to-mask ratio.

The rapid rotation of the disk then supplies the horizontal scanning motion, whereas the slower motion of the film supplies the vertical scanning motion. As an additional aid to sensitivity, the "electron-multiplier" type of phototube is usually employed in such film scanners. This type of phototube operates with greater freedom from the interference of masking currents than does the conventional phototube. In such equipment, the output current of the electron-multiplier phototube may be several microamperes. A further refinement is the use of lenses in place of simple apertures in the scanning disk. The lenses have greater area than the apertures and consequently make much more efficient use of the light source, while focusing on the film a spot of light no larger than the desired area of each





FIG. 46A.—Typical high-speed mechanical scanning drum. The scanning apertures are fitted with lenses to improve the optical efficiency.

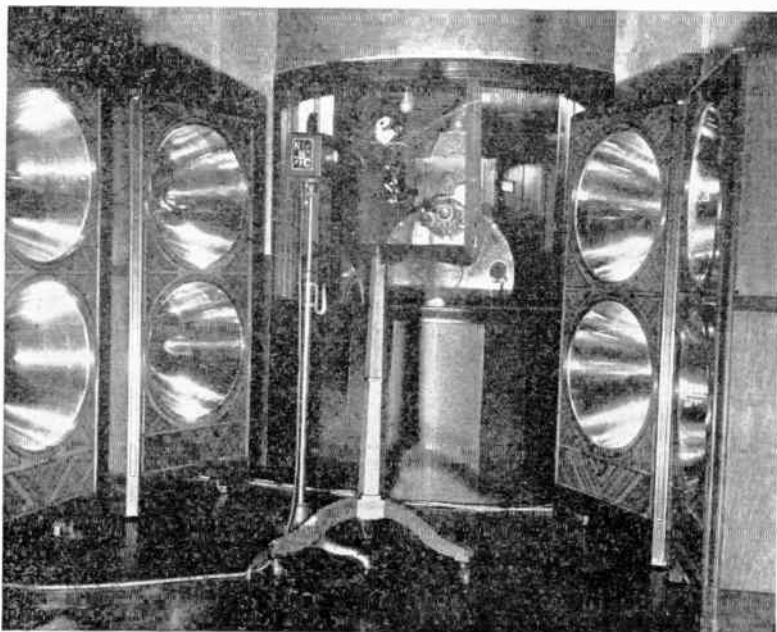

FIG. 46B.—Early NBC television pickup equipment, which made use of the flying-spot method of mechanical scanning. Eight phototubes and reflectors were used to gather the light reflected from the object being televised. The scanning disk and lens system are visible in the booth at the rear.



picture element. The disk may also be replaced by a drum containing lenses set in its surface as shown in Fig. 46A.

It should be noted that the scanning-light-source method, as applied to subjects other than motion film, is limited greatly by the inability of the phototubes to collect sufficient light from any but near-by objects. Further, the scheme is practical only if the spot is in itself the main source of illumination present. Any general lighting of the scene must be kept to a minimum, otherwise its effect masks that of the scanning spot of light. As a consequence, the system is unsuited to outdoor subjects or any subject located at a great distance from the camera.

The difficulties encountered in mechanical scanning are rooted not only in the optical problem of obtaining sufficient light in each scanning aperture, but also in the mechanism of the rotating scanner itself. One such mechanical problem is raised by the required speed of scanning motion. In a 525-line picture, sent 30 times per second, 15,750 lines are scanned each second. If the picture width at the plane of the scanning aperture is 2 in., the scanning apertures must move 31,500 in. per second. If the rotating disk or drum is 3 ft. in diameter, such a scanning speed can be obtained only at a rotation of about 16,500 r.p.m. This is a high rate of rotation and necessitates careful dynamic balancing to prevent mechanical distortions which would displace the scanning apertures. In fact, accurate alignment of 525 scanning apertures in a space of 2 in. is difficult enough when the disk is stationary, to say nothing of the problem when the rotation speed is 16,500 r.p.m. For this reason, mechanical scanners, even for low-definition pictures containing 300 or fewer lines, are expensive to construct, cumbersome to operate, and difficult to maintain in adjustment. The appreciation of these limitations of mechanical scanners has led to the development of several forms of *electronic scanners* that employ the motion of electrons as the scanning agent.

**18. Instantaneous Electronic Scanning.**—Of the two forms of electronic scanning, we discuss first the *instantaneous* type. In this type of scanning device, the light used is that present on the picture element at the instant it is scanned.

The advantage of electronic scanning lies in the use of the motion of electrons, rather than of mechanical parts, to scan the scene to be transmitted. Electron motion is suited to the

purpose primarily because the electron possesses an extremely small mass and hence may be accelerated to very high speeds by the use of moderate amounts of energy. For example, an electron initially at rest, situated between two plates that are separated 1 cm., and connected to a 300-volt battery will attain a speed of a billion centimeters per second in traveling from one plate to the other.

One of the simplest methods of instantaneous electronic scanning is shown in Fig. 47. The light source is the luminescent screen of a conventional cathode-ray image-reproducing tube, such as has been described in Chap. I (page 19). Two sets of control coils apply horizontal and vertical magnetic deflecting

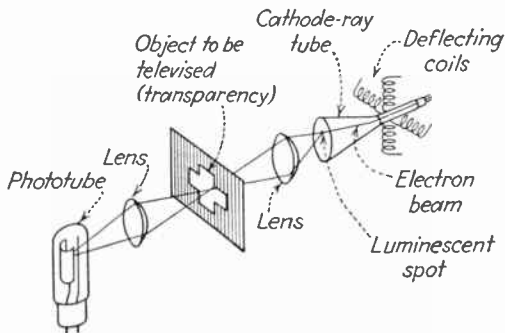

FIG. 47.—A simple method of electronic scanning, employing a cathode-ray tube as the light source. The lack of moving parts is an advantage but the available light is limited and the scanned area must be small.

forces to the beam of electrons in the tube in such a way that the beam moves across the luminescent screen in the conventional progressive scanning pattern, forming, say, 30 complete patterns per second each containing 525 lines. As the beam moves through each scanning line, it produces a spot of light the brilliance of which does not change but remains at a value as bright as can be obtained without injury to the screen. The scene to be transmitted takes the form of a transparent film located directly in front of the luminescent screen. The light from the scanning spot, passing through the film, is collected by a lens that focuses it on the cathode of a phototube. The current in the phototube then varies in accordance with the light transmitted from the scanning spot through the film. The advantage of the system is that any required scanning speed may

be readily obtained. The disadvantages lie in the optical limitations. The light available from a luminescent screen is small and must be carefully conserved in its passage to the phototube cathode. For this reason, the system is limited to the use of film images. A second difficulty is that of maintaining a fine spot of light. If high illumination is obtained by the use of a dense beam of electrons, the spot of light produced tends to "spread" over the screen, and in so doing it exceeds the maximum allowable size of the picture elements. There are also optical distortions made necessary by the curved shape of the screen (used to withstand the air pressure on the glass bulb) and other optical defects caused by reflection inside the bulb walls. This

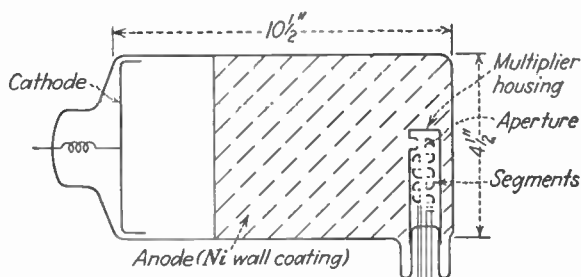

FIG. 48A.—The Farnsworth image dissector, a practical television camera tube which employs instantaneous electronic scanning. An electron image, formed at the cathode by the optical image, is conveyed down the tube and moved bodily past a small aperture. The electrons entering the aperture, after multiplication, constitute the output signal of the tube.

method of electronic scanning, although of interest as an example of the method, has not achieved commercial use.

**The Image-dissector Tube.**<sup>1</sup>—The most successful of the instantaneous electronic scanners is the image-dissector device invented by P. T. Farnsworth. This device employs what is known as a "photocathode," that is, a flat photosensitive surface on which the scene is focused at the transmitter. The arrangement of a typical image dissector is shown in Fig. 48. The cylindrical glass envelope is highly evacuated and contains the photocathode at one end, facing a flat glass plate that forms the opposite face of the tube. A lens exterior to this glass face

<sup>1</sup> FARNSWORTH, P. T., Television by Electron Image Scanning, *Jour. Franklin Inst.*, 218, 411 (October, 1934).

LARSON and GARDNER, The Image-dissector, *Electronics*, 12 (10), 24 (October, 1939).

focuses the scene to be transmitted on the photocathode. The resulting illumination of the photocathode frees electrons from its surface. The current released from any point on the surface is proportional to the strength of the illumination at that point. The electrons emitted from the photocathode thereby are given a distribution that corresponds, point for point, with the distribution of light and shade in the optical image.

By means of a field supplied by an electrode at the opposite end of the tube, this distribution of electrons, called an "electron image," is caused to move down the length of the tube. The mutual repulsions among the electrons tend to scatter the image as it moves, but this scattering effect is counterbalanced by magnetic forces supplied by a focusing coil. Consequently the electron image arrives in focus at a multiplier structure containing a small aperture at its center, as shown in the diagram. Any electrons that pass through this aperture impinge on a surface that has the property of emitting electrons in the ratio of 5 to 10 electrons for every electron that impinges on it. This "multiplication" of electrons is repeated several times within the structure, until finally the multiplied stream of electrons is collected and removed from the tube in the form of a current impulse.

In this device, the scanning aperture cannot be moved. Consequently when the electron image arrives in focus in the plane of the aperture, it is necessary to move the *image* bodily past the aperture in such a way that the electrons passing through the aperture are taken from the electron image in a succession of scanning lines. This motion of the electron image past the aperture is accomplished by the action of currents in external control coils, one set of which moves the image horizontally at a rate of, say, 15,750 back-and-forth motions per second, whereas the other set of coils moves the image up and down at a rate of 60 per second. As a consequence of this motion, the electrons entering the aperture correspond to the picture elements in a succession of 525-line pictures, each picture being divided into two interlaced fields at a picture-repetition rate of 30 per second. The electrons received by the aperture are then "multiplied" by a factor of several thousand times as they pass through the multiplier structure. Emerging from the multiplier, the electron current is passed through a resistor, and the voltage varia-

tions thereby produced are amplified in an electronic voltage amplifier.

The image dissector has the virtue of high scanning speed, but it suffers from the optical difficulties incident to the use of instantaneous scanning. The electrons actually employed in generating the picture signal are those which enter the scanning aperture, that is, those corresponding to a single picture element. All the remaining electrons in the electron image, at that instant, do not enter the multiplier and hence are of no use.

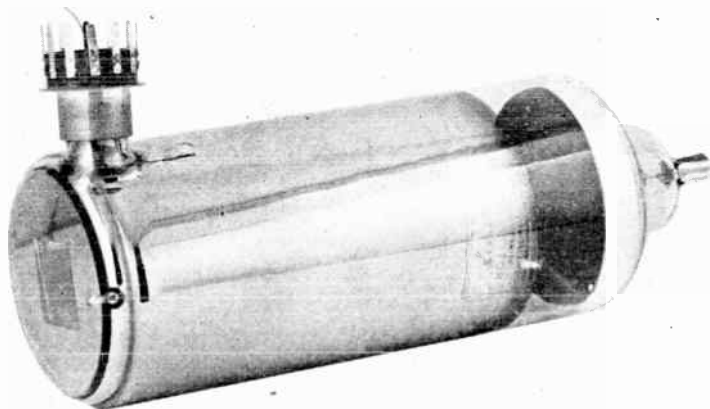

FIG. 48*B*.—Physical appearance of a modern image dissector, designed especially for the transmission of motion-picture film images. The terminals at the top lead to the electrodes in the electron-multiplier structure.

Two measures are taken to make the best use of the light available. First a lens system of large area is used, which collects a large percentage of the light radiated from the scene. The second is the electron-multiplier structure, which increases the number of electrons obtainable from each picture element, and which does so with a high degree of freedom from the masking currents previously mentioned. A useful signal output can be obtained from such an image-dissector tube from an average studio scene illuminated to a level of 1000 foot-candles. The tube is also useful for scanning motion-picture film and outdoor scenes, provided that sufficient light is available. Otherwise the signal falls to a level comparable to that of the ever-present masking currents, and the picture information is interfered with.

When the light is strong, on the other hand, a picture of exceptional contrast, detail, and evenness of shading can be transmitted from it.

**19. Storage Electronic Scanning.** *The Iconoscope.*—In all the scanning systems thus far described, both mechanical and electronic, a very large amount of light is wasted. In the rotating scanning disk (Fig. 43), only that light which passes through the active scanning aperture is used; all the other light from the scene is intercepted by the disk. In the image dissector, light from the entire scene illuminates the photosensitive surface, but the light effectively used is confined to that producing the electrons which enter the aperture in the electron multiplier; all the light producing other electrons, at the same instant, is wasted since these electrons do not enter the aperture.

It is possible to avoid wasting light by utilizing some means of light storage. Such a storage process was proposed very early in the art (by Rosing and by Campbell-Swinton), but no practical means of achieving it was forthcoming until 1925, when V. K. Zworykin filed his patent (issued in 1928, U. S. No. 1691324) on the iconoscope.

The principle of light storage employed in the iconoscope has already been briefly mentioned in Chap. I. Essentially, the method involves setting up a flat plate ("image plate" or "mosaic")<sup>1</sup> the surface of which is illuminated, through a lens, by the scene to be transmitted, and which possesses the characteristics of photosensitivity and electrical insulation.

The photosensitivity characteristic is employed to release electrons from the surface in the form of an electron image in very much the same manner as in the image-dissector tube. The electron image is not utilized directly as in the dissector but is allowed to dissipate itself within the tube, the electrons being collected by an electrode and removed from the tube without further use.

<sup>1</sup> Published papers on the iconoscope include the following:

ZWORYKIN, V. K., *The Iconoscope, a New Version of the Electric Eye*, *Proc. I.R.E.*, **22**, 16 (January, 1934).

ZWORYKIN, V. K., *Iconoscopes and Kinescopes in Television*, *RCA Rev.*, **1** (1), 60 (July, 1936).

ZWORYKIN, MORTON, and FLORY, *Theory and Performance of the Iconoscope*, *Proc. I.R.E.*, **25**, 1071 (August, 1937).

The transverse insulation characteristic of the surface (provided by the mica) is employed to preserve the configuration of the charge deficiency on the plate. This conservation of charge continues for as long as is required, and the value of the charge deficiency at any point on the surface continues to increase the longer the light is allowed to fall upon it. Consequently the light is effectively "stored" in the form of stored charge, the distribution of which corresponds to that of the light in the scene to be transmitted.

When the scanning agent (a narrow beam of electrons) passes over a picture element, it makes use not only of the light which illuminates that element at that instant, but also of the light which has fallen on that element since the previous passage of the scanning beam. In a scene transmitted at a rate of 30 pictures per second, the scanning agent passes over a given picture element once and then does not pass over that same element until the next complete picture is transmitted, or  $\frac{1}{30}$  sec. later. During this  $\frac{1}{30}$  sec., the light falling on the picture element is stored in the form of a continually increasing charge deficiency. Therefore, the number of electrons, available for producing a signal corresponding to that picture element, is equal not to the electrons released by the light at the instant of scanning, but to the number of electrons released during the entire frame-scanning interval. It is thus clear that an enormous difference in sensitivity between instantaneous and storage scanning is made available through the storage principle. In a typical 525-line 30-frame picture, with 170,000 effective picture elements, a gain in sensitivity of about 10,000 times is obtainable.

*Structure of the Iconoscope Mosaic.*—A wide variety of constructions and materials can be employed to fulfill the conditions of photosensitivity and insulation required of the iconoscope image plate. In early work, a very thin coating of cesium was deposited on a thin plate of mica. In depositing, the cesium breaks up into small local "islands," leaving the insulating mica between. The insulation of the mica provides the transverse insulation required to preserve the charge deficiency on each cesium island independently of the deficiency on the other droplets. Mica is used as the insulation because of its high electrical insulation, good surface, and uniform thickness (the

last characteristic being necessary for uniformity in transferring effect of the charge deficiency to the external circuit).

The form of surface currently adopted for practical use is formed in the following manner: A mica plate of uniform thickness (about 0.001 in. thick) is coated with a thin, finely sifted coating of silver oxide powder and is then baked in an oven. The heat reduces the silver oxide to pure silver, and the silver congeals in the form of extremely minute globules. The surface so formed

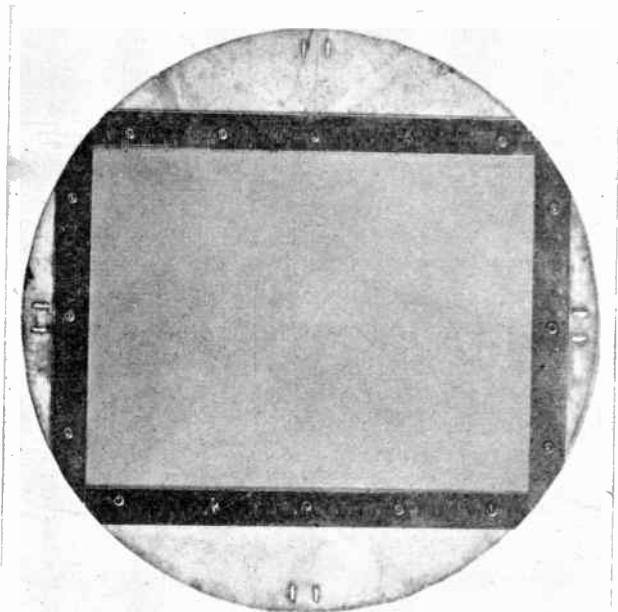

FIG. 49A.—A typical iconoscope mosaic, mounted on a circular mica plate, as it is when contained in the glass envelope (see also Fig. 8, page 17).

is known as the "mosaic." A highly magnified view of the mica surface containing the silver globules is shown in Fig. 49B. Each globule is less than 0.001 in. in diameter, is separated from its neighbors, and is insulated from them by the mica. The distribution of the globules can be made uniform over an area 4 by 6 in. by careful treatment in manufacture. Although there are local irregularities in the surface, the globules are so small compared with the area of the scanning beam (*i.e.*, the area of the picture element) that the distribution of globules in each picture element may be considered the same all over the plate.



The silver globules are made photosensitive by admitting cesium vapor to the tube and by passing a glow discharge through the tube in an atmosphere of oxygen. A surface of silver oxide, cesium oxide, and some pure cesium is thereby formed on the silver globules, rendering them photosensitive. Care must be taken to avoid depositing too much cesium, since it may enter the insulating regions between globules and thus destroying the transverse insulation required to preserve the charge configuration.

This type of plate has high sensitivity, but it shows a preference for the red and infrared regions of the spectrum, so that



FIG. 49B.—Surface of the iconoscope mosaic, magnified 250 diameters. The square (0.008 inch on a side) is roughly the size of a single picture element.

the picture it sees has color values at variance with those perceived by the eye. A technique known as "silver sensitizing" has been developed which corrects the red emphasis in the spectral response and at the same time increases the sensitivity of the iconoscope. In this process, after the cesium oxide surface is formed, a small amount of silver is vaporized within the tube by heating a piece of silver in a tungsten filament. The silver vapor is allowed to deposit on the image plate.

The reverse side of the mosaic plate is coated, before insertion in the tube, with a thin "signal coat" of colloidal graphite which serves as the electrode through which the signal is transferred, during scanning, to the external circuit. The details of the

electrical action of this coating are given in the following paragraph.

*The Electrical Action of the Iconoscope.*—In the electrical operation of the iconoscope, each globule in the mosaic surface is a miniature phototube cathode. Each cathode is coupled to the external circuit through the electrical capacitance between the globule and the signal coat on the reverse side of the mica. The capacitance becomes charged when the globule loses electrons under the influence of the illumination on it. As the illumination persists, the charge on the capacitance increases.

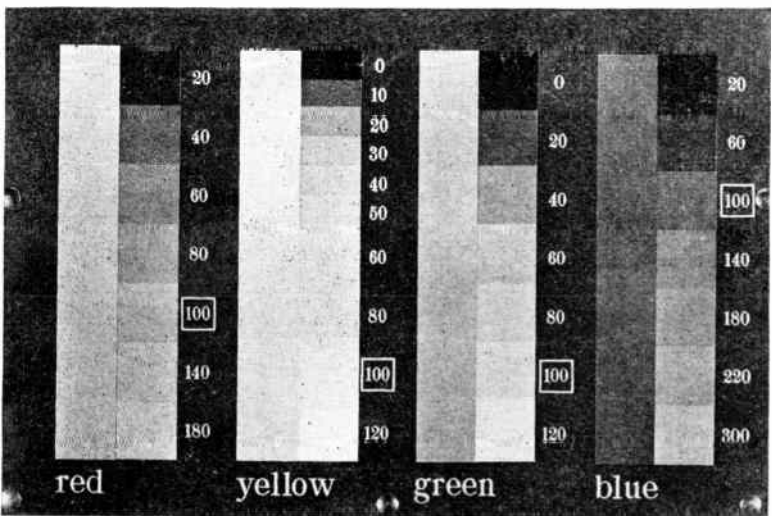

FIG. 50A.—The Agfa color chart photographed with panchromatic film, for comparison with the color response of the iconoscope (Fig. 50B).

Scanning is accomplished by the use of a narrow beam of electrons (formed in the gun) that is directed over the surface of the mosaic in the pattern of scanning lines. A simple (but not too rigorous) explanation of the action of the scanning beam is that the beam suddenly replaces the lost charge on each globule and the capacitance thereby becomes discharged at a much more rapid rate than that at which it was charged. The sudden discharge, acting through the capacitance to the signal coating, appears as a current impulse in the signal circuit connected to the signal coating. Therefore, as the scanning beam moves across each line, the current impulses generated correspond

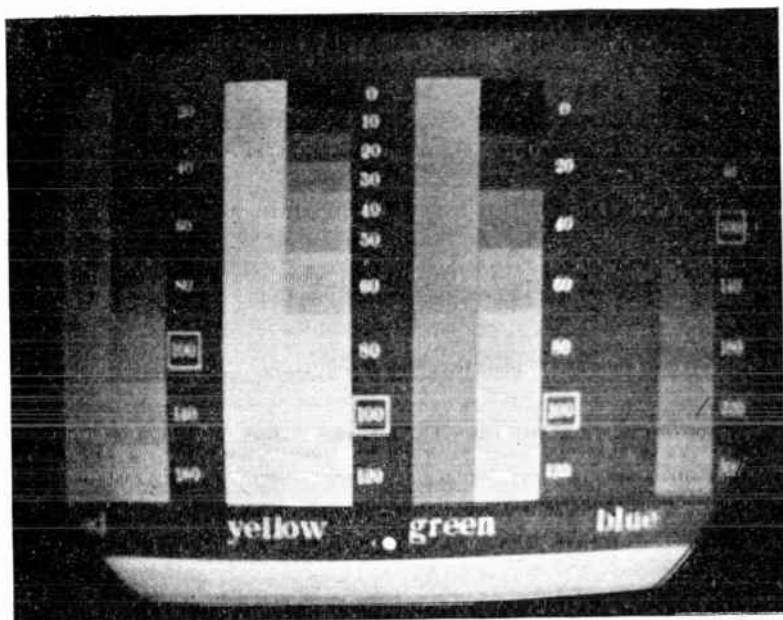

FIG. 50B.—Televised reproduction of the Agfa color chart transmitted from a typical iconoscope camera. Compared with the original photographed with panchromatic film (Fig. 50A) the iconoscope camera color response is excellent except in the red and blue extremes of the spectrum. The technique of silver-sensitizing the mosaic has greatly improved the over-all color response of the iconoscope in recent years. (Photograph from Lohr, "Television Broadcasting.")

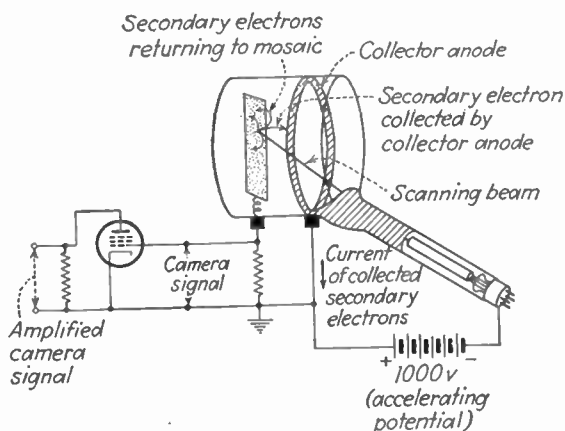

FIG. 51.—Electrical connections of the signal circuit of an iconoscope tube. The series connection between mosaic and collector is completed by the passage of secondary electrons, which constitute the output signal current of the tube. (For the optical action of the iconoscope, see Fig. 9 page 18.)

in magnitude with the magnitude of the illumination present on the globules scanned. This elementary theory of iconoscope operation suffices to introduce the subject and has accordingly been used in Chap. I. But extensive experiments with the iconoscope have indicated that the operation is far more complex than this simple explanation suggests.

If the scanning beam acts directly to produce the signal, it would be necessary that the sudden change of the capacitance between globules and signal plate occur in series with the scanning beam itself. In other words, the scanning beam would act as

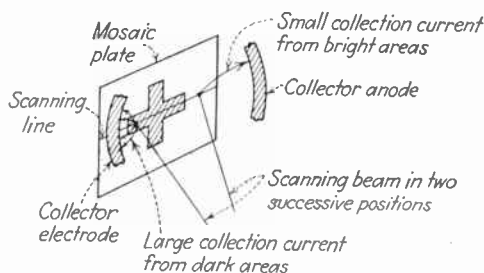

FIG. 52.—Difference in collection current between dark and bright areas on the mosaic. The photoelectric emission from the dark areas is small, hence the retarding field is small and the secondary emission (induced by the scanning beam) is large. In bright areas the reverse condition exists, and the collection current is small. Hence the output current is "negative" relative to the brightness differences.

the return conductor between the globules and the signal plate. But experiments show that the electrical resistance of the scanning beam is substantially infinite and hence that no signal current can flow along it. Consequently it is necessary to look elsewhere within the tube for a return path between the globules and the signal coating.

The required path is found by taking into account the generation of *secondary electrons* that are freed from the mosaic by the action of the scanning beam (see Fig. 52). These secondary electrons are found to be of the great importance, also, in explaining the limitations of the iconoscope sensitivity and in accounting for the generation of a spurious signal, which has the effect of causing an unevenness of background illumination in the reproduced image.

Consider first the mosaic surface unilluminated but scanned in the usual fashion by the scanning beam. Under such condi-

tions, it might be assumed that no charge deficiency is present on the mosaic and that no signal would appear in the signal lead. It is found, however, that a signal (see Fig. 54) does appear. This signal reflects the fact that certain parts of the mosaic have become charged at the expense of other parts. The unequal distribution of charge is explained by the fact that the scanning beam, impinging on the globules of the mosaic, frees secondary electrons from them by the force of the impact. These secondary electrons are in part collected by the near-by collector anode (see Fig. 52) which is maintained at a positive potential. How-

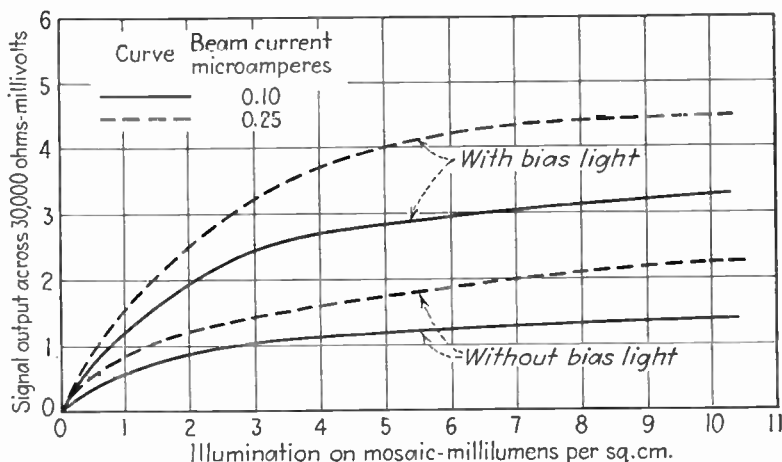

FIG. 53.—Typical iconoscope curves relating signal output to mosaic illumination, showing effect of beam current and bias lighting. (After Janes and Hickok.)

ever, since the mosaic is insulated, no more electrons can leave the plate than reach it, and in consequence the secondary electrons not collected find themselves attracted back toward the image plate. The secondary electrons, in falling back on the mosaic, do so in a more or less evenly distributed "shower." If the shower were perfectly uniform, the distribution of charge would not change. The shower is not uniform, however, owing to local irregularities in the secondary-emission ratio of the surface and differences in the collecting field. Consequently the secondary electron shower deposits itself on the mosaic in an irregular distribution. The scanning beam, in scanning this irregular distribution of charge, produces the spurious signal that

in turn produces an uneven shading in the reproduced image at the receiver.\*

Now consider that the mosaic is illuminated by the scene to be transmitted. The illumination produces an additional loss of charge from the photosensitive globules. This *regular* charge distribution is superimposed on the *irregular* distribution discussed above. The regular charge distribution, that correspond-



FIG. 54.—Television image showing improper background shading due to the spurious signal generated by redistribution of secondary electrons in the iconoscope. To avoid this defect, a compensating signal must be added (see Fig. 256, page 414).

ing to the picture, modifies the electric field just exterior to the plate. At a point where the plate is strongly illuminated, the field just adjacent to that point is strongly negative and thereby impedes the release of secondary electrons when the scanning beam passes over that point. A *smaller* secondary electron current is thereby induced by the illumination. It is this decrease in the secondary-emission current that acts through the capacitance to the signal coating and creates a corresponding current pulse in the external circuit.



*Analysis of the Output Current of the Iconoscope.*—The following reasoning indicates the manner in which the output signal (current and voltage impulses corresponding to picture elements) from an iconoscope can be computed in terms of the optical and electric characteristics of the system. First consider the object to be televised. Its surface brightness may be computed by Eq. (25). Assume then that the illumination falling on a certain picture element on the mosaic is found to be  $E_p$  foot-candles. The area of the picture element is  $A_p/N$  where  $A_p$  is the picture area (square feet) on the mosaic and  $N$  is the number of picture elements in the whole picture. The light flux on the element is then  $E_p A_p/N$ . The luminous sensitivity of the surface (to the color distribution used) is  $S \mu\text{a}$  per lumen, consequently the instantaneous current available from the picture element is

$$I_{\text{instantaneous}} = \frac{SE_p A_p}{N} \quad (37)$$

This current is available from the surface at all times regardless of the storage action. The equation indicates the output current of any instantaneous system such as the image dissector or a mechanical scanner.

The output current of the iconoscope is increased greatly by the storage action. The current indicated in Eq. (37) flows from the picture element during the entire frame-scanning interval, or  $1/f$  sec., and is stored for this time. When the scanning beam passes over the element, the stored charge deficiency is suddenly released, while the beam is on that particular element. Since the beam covers the total number of elements  $N$  in  $1/f$  sec., it must cover one element in  $1/Nf$  sec. Consequently, the charge deficiency stored in  $1/f$  sec. is released in  $1/Nf$  sec., or  $N$  times as fast as it is stored. Consequently the current impulse corresponding to the picture element is  $N$  times as great as the instantaneous current of Eq. (37). The current output of the iconoscope is, in other words,

$$I_{\text{storage}} = SE_p A_p \quad (40)$$

If this output current passes to the following amplifier through a coupling resistor of  $R$  ohms, the output voltage  $V_o$  developed across this resistor is

$$V_o = SE_p A_p R \quad (41)$$

It will be noticed that the sensitivity of the storage type of device is theoretically  $N$  times as great as that of an instantaneous device. In a picture having 150,000 picture elements, therefore, the advantage of the storage principle might give an increase of 150,000 times in output voltage. Actually, as noted below, the efficiency of the conventional iconoscope is about 5 to 10 per cent,



FIG. 55.—Appearance of televised image when subject is insufficiently illuminated.

so the increase in sensitivity is 7,500 to 15,000 times for a picture having 150,000 picture elements.

In practical cases, the value of  $S$  is about  $7 \mu\text{a}$  per lumen,  $A_p$  is about 20 sq. in. or 0.14 sq. ft., and  $R$  is 10,000 ohms.<sup>1</sup> Therefore, the output voltage, assuming 5 per cent efficiency, is

$$V_o = 0.05 \times 7 \times 0.14 \times 10,000 E_p = 490 E_p \text{ microvolts} \quad (41a)$$

<sup>1</sup> This value has been used in obtaining several published curves [Zworykin, Morton, Flory, *Proc. I.R.E.*, 25 (8), 1080 (August, 1937)] but a better signal-to-mask ratio has been obtained with  $R = 100,000$  ohms or higher.



In other words, the over-all sensitivity is about 500 microvolts per foot-candle of illumination falling on the mosaic.

It is interesting to compare the masking voltage encountered under these circumstances. By using Eq. (39) with a coupling



FIG. 56.—Appearance of television image when subject is adequately illuminated and when shading-correction signal has been added to remove effects of spurious shading signal. (Figs. 54, 55, and 56 from Lohr, "Television Broadcasting.")

resistor  $R$  of 10,000 ohms and a maximum signal frequency  $f$  of 3,000,000 c.p.s., the masking voltage is

$$E_m = \sqrt{1.6 \times 10^{-20} \times 3 \times 10^6 \times 10^4} = 22 \text{ microvolts}$$

An acceptable image may be obtained if the signal is twenty times as great as this masking voltage. The required signal is then 440 microvolts, relative to the 22-microvolt masking voltage. The 440-microvolt signal can be obtained, according to Eq. (41a), with a mosaic illumination of somewhat less than one foot-candle.

*Transient Response.*—It has been stated, in the derivation of iconoscope sensitivity, that the discharge of the stored charge must occur while the beam is passing over the picture element, that is, within  $1/fN$  sec. Otherwise less than the full signal is realized. To show the conditions under which this requirement may be met, consider the diagram in Fig. 57. The picture element falls on a collection of photosensitive globules that reside within an area equal to the area of the scanning beam. These globules, taken together, constitute the cathode of a phototube. When light falls on the cathode, the capacitor  $C$ , which is the

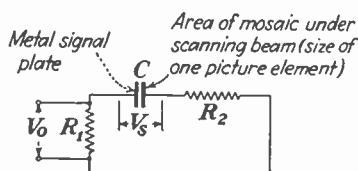

FIG. 57.—Equivalent signal circuit of iconoscope, on which the transient analysis is based.  $C$  is the capacitance between globules under a picture element and the signal plate.  $R_1$  is the coupling resistor and  $R_2$  is the ohmic resistance of the secondary emission path from mosaic to collector electrode.

capacitance existing between the globule group and the signal plate, is discharged through the two resistances  $R_1$  the coupling resistor and  $R_2$  the resistance of the secondary emission path created by the bombardment. The equation for the transient discharge is

$$V_o = \frac{R_1 V_s}{R_1 + R_2} \epsilon^{-t/[C(R_1 + R_2)]} \quad (42)$$

where  $V_o$  is the transient output voltage across  $R_1$ ,  $V_s$  is the voltage stored across the capacitance  $C$  at the beginning of the discharge,  $R_2$  is the secondary emission path resistance, and  $t$  is the time measured from the start of the discharge. The exponent of  $\epsilon$  shows that the discharge is completed in a time approximately equal to the time constant of the circuit  $C(R_1 + R_2)$ . But this time must be less than the time  $1/fN$  during which the scanning beam is on the picture element, that is,

$$C(R_1 + R_2) < \frac{1}{fN} \quad (43)$$

If the frame-repetition interval  $1/f$  is  $\frac{1}{30}$  sec. and the number of picture elements  $N$  is 150,000, the available time  $1/fN$  is  $1/4,500,000$  sec. In the conventional iconoscope, the value of  $C$  is about  $100 \mu\mu\text{f}$  per square centimeter. The resistance  $R_2$  depends on the beam current that produces the secondary emission path. With a typical value of beam current,  $0.5 \mu\text{a}$ , the

product  $C(R_1 + R_2)$  is about  $1/10,000,000$ . Consequently the discharge occurs well within the available time.

*Factors Reducing the Efficiency of Iconoscope Action.*—Mention has been made of the fact that the iconoscope displays an overall efficiency of about 5 to 10 per cent. The low efficiency is due (1) to the fact that not all the stored charge passes through the coupling resistor  $R_1$  and (2) to the fact that the photoelectrical emission of charge is limited by the low value of the electric field at the surface of the mosaic.

The first factor, loss of stored charge, results from the distribution of secondary electrons that are released under the impact of the scanning beam. These secondary electrons may follow any one of three possible paths: they may be collected by the collector anode and thus constitute a picture signal; they may return directly to the globules from which they are released; or they may return to other parts of the mosaic, there causing a charge distribution that gives rise to the spurious signal previously referred to. Calculations indicate that only about 25 per cent of the secondary electrons are collected by the anode and thus enter the signal circuit. Of this theoretical 25 per cent efficiency, only 5 or 10 per cent is actually realized owing to the low value of electric field available for drawing off the photoelectrically emitted electrons.

It has been found that the sensitivity of the standard iconoscope can be considerably increased if a technique known as "bias lighting" is employed. As the name suggests, this technique consists in illuminating the iconoscope from the rear in such a way that the glass walls and rear surface of the mosaic receive light from the back-lighting source, whereas the mosaic surface itself receives light only from the image focused on it. The back lighting is provided, in the usual case, by small flashlight lamps set in openings in the shield that surrounds the back of the iconoscope proper. The theoretical cause of the increased sensitivity has been studied, but no completely satisfactory explanation has been evolved. One effect of the back lighting is the excitation of photoelectric emission of electrons from the glass walls of the iconoscope envelope. These walls become coated with a thin coating of cesium during the manufacture of the tube and are thus rendered photosensitive. The illumination of the walls may thus be used as a means of freeing charges

trapped on the walls and elsewhere in the tube. The effect of removing these trapped charges is to increase the net electric field available for collecting the photoelectrons from the mosaic and so to increase the efficiency of the storage action.

*Summary of Electrical Action.*—The mosaic of the iconoscope may be considered as a surface having very high insulation transversely (along its face) but having conductivity perpendicular to the surface. The latter conductivity may be excited in two ways: by illumination, which induces photoelectric emission of electrons, and by bombardment, which induces emission of secondary electrons. When the surface is illuminated, the photoelectric emission gives rise to a distribution of electric potential over the surface of the mosaic, the form of which is the same as that of the illumination. When this potential distribution is scanned, the scanning beam produces secondary emission the amount of which is controlled by the potential distribution. Part of this secondary emission is collected by the collecting anode, and so enters the signal circuit. The variations in current in the signal circuit are caused by the variations in the collected secondary electrons, which in turn are caused by the variations in the potential of the surface induced by photoelectric emission.

**20. The Image Iconoscope.**<sup>1</sup>—The image iconoscope (iconotron) is a type of camera tube developed to improve the sensitivity of the fundamental iconoscope action. Although the necessity for improvement may seem to be slight, in view of the high sensitivity of the iconoscope itself, additional sensitivity can always be used.

The foregoing discussion has shown that a usable television signal may be obtained with the conventional iconoscope with 1 or 2 foot-candles of illumination on the mosaic plate. This 1 foot-candle of mosaic illumination can be obtained through the best obtainable lenses only with illuminations of the subject of the order of several hundred foot-candles, and then only when the lens aperture is at its maximum. When the lens is used “wide

<sup>1</sup> IAMS, MORTON, and ZWORYKIN, The Image Iconoscope (presented before the Annual I.R.E. Convention, June 17, 1938). Described briefly in *Electronics*, 11 (7), 12 (July, 1938).

IAMS, MORTON, and ZWORYKIN, The Image Iconoscope, *Proc. I.R.E.*, 27, 541 (September, 1939).

open," the depth of focus of the system is severely restricted, with the result that near-by and far objects cannot be focused upon simultaneously. This is a serious restriction in any but the simplest studio presentations. Were greater sensitivity available, the lens aperture could be reduced and greater depth of focus obtained.

An additional gain of sensitivity of about ten times is available in the image iconoscope, which combines the action of the image-dissector tube and the conventional iconoscope. A diagram of the image iconoscope is shown in Fig. 58.A. The televised object is focused by the lens system on the *photocathode*, a transparent glass plate on which has been sputtered a photosensitive silver

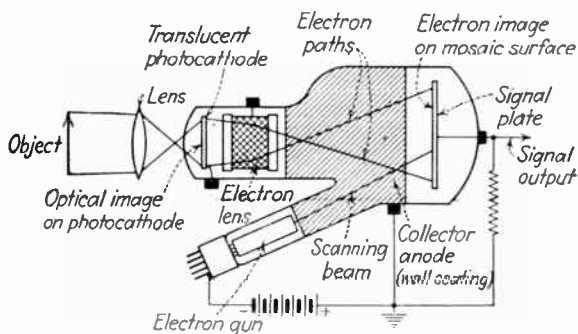

FIG. 58.A.—Element structure and signal circuit of the image iconoscope, which employs electron multiplication to obtain increased sensitivity.

cesium layer. This layer is located on the opposite side of the plate, so that the light passes through the plate and then excites photoelectric emission of electrons from the sensitive surface. The electrons are emitted in the form of an electron image, which is drawn down the length of the tube to the mosaic surface located directly opposite. This mosaic is not photoelectrically sensitive but is capable of emitting secondary electrons. A series of ringlike electrodes is used to bring the electron image into focus in the plane of the mosaic.

When the electron image (in which the density of the electrons at any point corresponds to the brightness of the corresponding optical image at that point) impinges on the mosaic, it releases secondary electrons and so forms a charge deficiency on the mosaic. The insulating character of the mosaic preserves the charge-deficiency configuration between successive scannings.

The scanning beam then scans the mosaic and releases from it additional secondary electrons. The number of electrons released by the scanning beam is controlled by the potential of the mosaic just under the beam, and this potential is determined by the previous emission of secondary electrons. The electrons released by the scanning beam are collected by the collector anode, and thus enter the signal circuit, recharging the mosaic with respect to the signal plate. This current, as in the conventional iconoscope, constitutes the signal output of the tube.

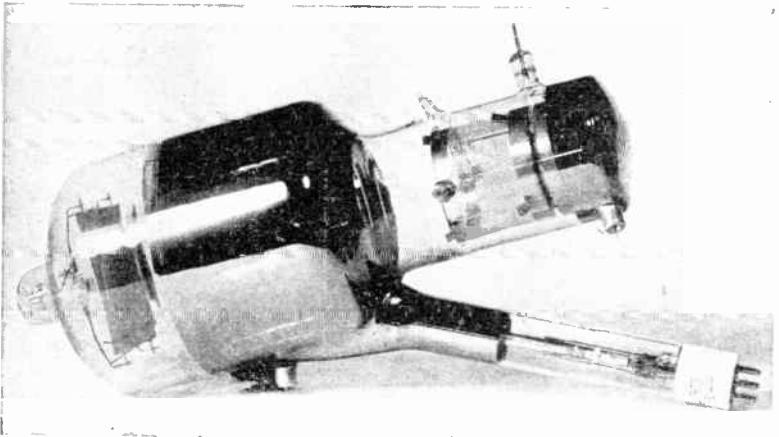

FIG. 58B.—Typical developmental form of the image iconoscope. The optical image is focused on the photocathode at the right, and is scanned at the multiplier mosaic at the left.

The advantages of the image iconoscope reside, first, in the fact that the original photoelectrically emitted electrons are drawn from the photocathode by an appreciable electric field, whereas in the conventional iconoscope the available electric field is very small. Secondly, an important advantage is gained when the photoelectrically emitted electron image impinges on the mosaic. The mosaic has a high secondary-emission ratio, that is, it may release five or more electrons under the impact of one impinging electron. The stored charge on the mosaic is thus increased by a factor of five or more. This increase and the effect of the electric field at the photocathode result in an effective gain in sensitivity of about ten times, so that a current of

roughly 5000  $\mu\text{v}$  per foot-candle is available under the conditions previously cited (page 105).

An important optical advantage is the fact that the photocathode can be located close to the wall of the envelope, and hence a lens of short focal length can be employed to focus the image. Such a lens is considerably less expensive than one of longer focal length of the same  $f/\text{number}$ .

The net improvement of using the image iconoscope is that a usable signal may be obtained with smaller illumination or that greater depth of focus (smaller lens aperture) may be utilized with a given amount of illumination than with the conventional iconoscope.

The mosaic employed in the image iconoscope is in reality not a mosaic at all. It is simply a uniform flat insulating surface that is capable of a high degree of secondary emission. Ordinary mica or a flat metal plate coated with china clay may be used. The charge image is stored on such a surface just as readily as if small metal globules were provided, and the signal is readily transferred to the external signal circuit if a capacitance exists between the surface and the metallic signal coating on the reverse side.

**21. The Orthiconoscope.**<sup>1</sup>—Early in 1939, Iams and Rose announced the development of a new storage-type pickup tube known as the orthiconoscope (orthicon for short). The name derives from the fact the tube is a form of iconoscope and from the fact that the curve relating its output current to the mosaic illumination is a straight line (ortho = "straight"). The tube shows great promise of removing the principal restrictions now facing the iconoscope. The storage efficiency of the iconoscope is, as previously noted, 5 to 10 per cent. The efficiency of the orthiconoscope, on the other hand, is inherently 100 per cent. Accordingly, the sensitivity of the new tube is potentially ten to twenty times as great. The orthiconoscope displays no spurious

<sup>1</sup> IAMS and ROSE, A New Television Pick-up Tube (presented before the New York Section, I.R.E. June 7, 1939). Described in *Electronics*, "The Orthicon," 12 (7), 11 (July, 1939).

IAMS and ROSE, Television Pickup Tubes Using Low-velocity Electron Beam Scanning, *Proc. I.R.E.*, 27, 547 (September, 1939).

ROSE and IAMS, The Orthicon, Television Pickup Tube, *ICA Rev.*, 4 (2), 186 (October, 1939).



signal, and there is accordingly no background shading defect to be compensated. Since the light output-current curve is linear, the orthiconoscope is a gamma-unity device (see page 335) and hence capable of reproducing a picture with greater contrast than is the iconoscope, the gamma of which is in the neighborhood of 0.7.

The principle on which the orthiconoscope depends is the use of a beam of *low-velocity* electrons for scanning the mosaic. In the iconoscope, the beam has a high velocity (about 1000 equivalent volts), and it is this high velocity that excites secondary emission on the mosaic surface. These secondary electrons, as we have seen, have two important functions, one desirable, the other undesirable. In the first place, the variations in the secondary emission which is collected from the mosaic constitute the video-signal current. In the second place, the secondary emission not collected from the mosaic falls back on the mosaic and there produces a charge distribution that gives rise to the spurious shading signal. In the new tube, in which low-velocity electrons are used for scanning, no observable secondary emission occurs. Consequently, no spurious signal is generated, but at the same time no secondary electrons are collected and no video signal can arise from this source. In their place, however, the scanning electrons themselves can be collected, and it is the variations in this collection current that constitute the useful output of the tube. The maximum signal output current from the tube is accordingly the maximum beam current in the tube, which in present forms of the tube is of the order of  $1 \mu\text{a}$ . Since there is no secondary emission, there is no loss of stored charge and hence no loss of efficiency from this cause. Moreover, the field available for collecting the photoelectrons is sufficient to remove all the electrons actually released from the mosaic. These two effects give rise to the 100 per cent photoelectric storage efficiency of the tube.

The principal difficulty associated with scanning the mosaic by low-velocity electrons lies in the difficulty of producing and deflecting such a low-velocity beam without distortions and defocusing of the scanning pattern. A low-velocity beam is subject to serious disturbances from stray electric and magnetic fields, but these may be avoided by adequate shielding, etc. By far the most serious effect is defocusing, which occurs if the



scanning beam does not hit the mosaic perpendicularly. Special means are taken to deflect the scanning beam in "temporary" fashion, so that it hits the mosaic perpendicularly at all points in the scanning pattern.

The defocusing effect may be examined more in detail as follows: Consider a beam of electrons starting from the cathode of the electron gun and arriving ultimately at the mosaic, which is maintained automatically in the new tube at cathode potential. The electrons on reaching the mosaic are turned back (it being assumed they left the cathode with zero velocity). If their

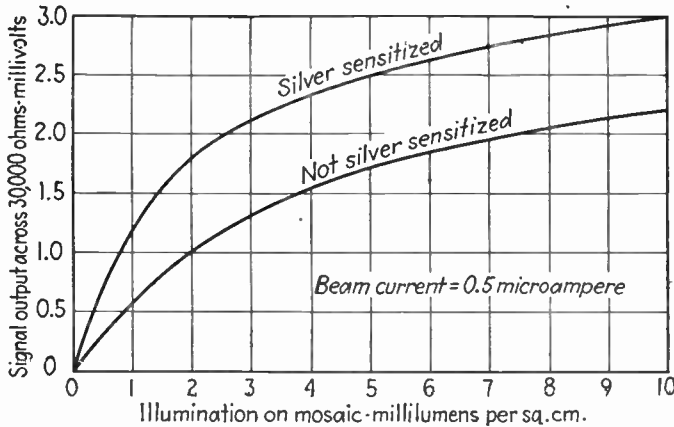

FIG. 59.—Iconoscope output vs. illumination curves showing increased sensitivity due to silver sensitizing. The silver-sensitizing technique also improves the color response of the camera tube.

path is perpendicular to the mosaic, they return directly on the path by which they reached the mosaic. On the other hand if the beam approaches the mosaic at an oblique angle (as it would at the edges of the scanning pattern in the conventional iconoscope), the electrons are reflected from the mosaic at an angle equal to their angle of incidence. At their region of contact with the mosaic, the electrons glide along the mosaic surface tangentially for a short distance before leaving the mosaic surface. In consequence, the point of contact of the electron beam with the mosaic surface is ill-defined, or in other words, the beam is poorly focused.

Several evolutionary methods were used by Rose and Iams to secure perpendicular scanning at all points of the mosaic before the orthiconoscope itself was developed. In its present form,

shown in Fig. 60, the horizontal deflection is obtained with a combination of magnetic and electric fields. The magnetic field is an axial one, supplied by a coil surrounding the tube. This axial field tends to guide the electrons from the electron gun to the mosaic at the opposite end of the tube. Superimposed in the axial magnetic field is a transverse electric field produced between two deflecting plates. An electron, on entering the region between these plates, is urged to travel toward the positive plate. In so moving, however, it crosses the axial lines of magnetic force and is constrained thereby to execute a cycloidal motion which deflects the electron *sidewise* (at right angles to the original line of motion and parallel to the planes of the deflecting plates). The combination of sidewise and forward motions causes the beam to be deflected, and the deflection continues so long as the electrons are within the deflecting plates. However, on emerging from the plates, the electron loses the sidewise component of motion and resumes its forward course, parallel to the axial lines of the magnetic field. Thereafter the beam hits the mosaic at right angles, no matter at what position on the plate.

The cycloidal motion is somewhat difficult to control, so a smoother sidewise motion is secured by introducing the beam to the electric field gradually (by employing a fringing field produced by curving the deflection plates at their edges). This sidewise motion can be made to occur at right angles to the forward motion, and its amplitude can be made proportional to the field existing between the deflecting plates. In consequence, conventional scanning generators may be used to produce the horizontal deflection.

The vertical deflection is obtained by using a coil that sets up a transverse magnetic field, as shown in Fig. 60. The combination of this transverse field with the axial field tends to set up helical motions in the beam electron, but the helices are so small that they do not interfere with the accuracy of the scanning motion. The result is that a standard scanning pattern may be set up within the tube, the scanning beam impinging on the mosaic perpendicularly at all points. Hence no defocusing of the beam occurs.

In operation, the image to be televised is focused on a translucent mosaic and there sets up an image in stored charge. The charge distribution is returned to equilibrium by the scanning

electrons which impinge on the reverse side of the mosaic. The scanning beam hits, at a given instant, a particular point of the mosaic. If that point on the mosaic has previously lost charge (due to illumination by the image), the scanning electron will be collected. The number of electrons so collected at that point depends on the magnitude of the charge photoelectrically emitted from the point, that is, on the amount of illumination at that point. In this way, each point in the mosaic is restored to equilibrium according to its needs, and the variations in mosaic potential are conveyed in the usual manner to the signal circuit.

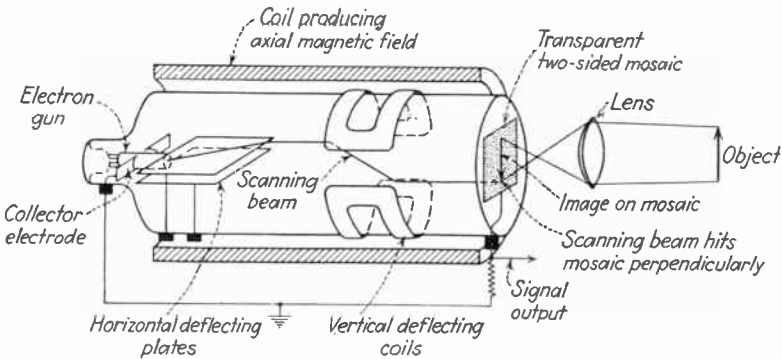

FIG. 60.—Diagrammatic view of a developmental form of the orthiconoscope ("orthicon") which employs low-velocity electrons for scanning and thereby avoids the spurious signal generated by redistribution of secondary electrons.

The specifications of current models of the orthicon are of interest. The device itself is about 20 in. long and 4 in. in diameter, a convenient size for inclusion in a camera. The mosaic itself measures 2 by  $2\frac{1}{2}$  in. and is placed close to one end of the tube. In consequence, a lens of small diameter and short focal length can be used to focus the image upon the mosaic. The picture resolution obtainable within this small mosaic area varies from 400 to 700 lines, but in any event it exceeds the requirements set by a scanning pattern of 200,000 picture elements and is capable of further refinement. The maximum signal-to-noise ratio in the tube (when the full beam current is drawn to the signal circuit) is about 500 times. At a brightness-contrast ratio of 100 to 1, therefore, the weakest signal is still five times as strong as the noise. This represents very adequate performance with respect to noise (superior to other forms of

pickup tube). The sensitivity of current models of the orthicon is superior to that of the iconoscope by a factor of several times, but the full increase in sensitivity of twenty times has not as yet been realized.

At the time of writing, no practical experience with the image iconoscope or the orthicon has been obtained in broadcasting practice, but it seems likely that either or both of these tubes will be introduced commercially in the near future.

**22. Static-image Signal-generating Tubes.**—The actions of the iconoscope and the image iconoscope depend on the variations in the emission of secondary electrons at the point of bombardment of the scanning beam. It follows that a picture signal may be generated using any surface from which such variations in secondary emission may be obtained. Such variations in secondary emission may be obtained readily from differences in the physical or chemical nature of the surface.

This effect has been put to use in tubes somewhat resembling the iconoscope in physical form, but intended to produce a signal from a fixed image. Such tubes (variously called monoscopes, phasmajectors, monotrons, etc.) are used as sources of signals for testing purposes. They are not camera tubes in the strict sense, because they are restricted to producing a signal from a static image which is printed on the signal plate within the tube.

One such tube (the monoscope<sup>1</sup>) contains a flat plate of aluminum, about 0.004 in. thick, on which is printed with ordinary printer's ink the image to be reproduced, using a half-tone engraving or line engraving as the printing agent. In the process of heating the tube, during manufacture, the ink on the surface is reduced to practically pure carbon. The ratio of secondary emission for the carbon is about 3 electrons per incident electron, whereas for the aluminum the ratio is about 7 to 1. Consequently as the scanned beam travels over the printed surface, it excites more electron emission from the unprinted portions than from the printed portions. The variations in the secondary emission are collected by the collector anode and are conducted to the signal circuit.

The static image tube does not depend upon photoelectric emission or upon storage, but simply on the difference in second-

<sup>1</sup> BURNETT, C. E., *The Monoscope*, *RCA Rev.*, 2 (4), 414 (April, 1938).

ary-emission ratio. Consequently the efficiency is high, and a signal output of 3 to 4 millivolts is obtainable across a 10,000-ohm output resistor.

The detail of the image depends upon the cross-sectional area of the scanning beam and on the detail inherent in the printed image itself. By using a 133-line half-tone screen, with a 4-in. plate, about 500 half-tone dots are printed in the height of the picture, which is slightly better than the number of active lines in the screening pattern. Consequently the detail is limited only by the scanning beam.

The tube is used primarily in testing equipment. For this purpose, it excels the iconoscope for the following reasons: The tube itself is inexpensive to manufacture and requires no auxiliary source of lighting or object to be televised. The signal is exceptionally strong, equal to ten times that obtained by a conventional iconoscope with 1 foot-candle of plate illumination. There is no spurious signal generated, and the contrast of the image is consequently very high. But perhaps its most important advantage, for testing purposes, is the fact that the signal is exactly reproducible and produces an image with which the tester soon becomes familiar, whereas if an iconoscope were used, variations in illumination, spurious signal, etc., would make comparisons of performance less exact.

#### Bibliography

- FARNSWORTH, P. T.: Image Amplifier Pick-up Tubes (delivered before the Rochester section, I.R.E., Nov. 14, 1938). Described briefly in *Electronics*, **11** (12), 8-9 (December, 1938).
- FINKE, H. A.: A Television Pick-up Tube, *Proc. I.R.E.*, **27**, 144 (February, 1939).
- JAMS, JANES, and HICKOK: The Brightness of Outdoor Scenes and Its Relation to Television Transmission, *Proc. I.R.E.*, **25**, 1034 (August, 1937).
- JAMS and ROSE: Television Pick-up Tubes Employing Cathode-ray Beam Scanning, *Proc. I.R.E.*, **25**, 1048 (August, 1937).
- JANES and HICKOK, Recent Improvements in the Design and Characteristics of the Iconoscope, *Proc. I.R.E.*, **27**, 535 (September, 1939).
- MALOFF, I. G.: Gamma and Range in Television, *RCA Rev.*, **3** (4), 409 (April, 1939).
- McILWAIN, KNOX: Survey of Television Pick-up Devices, *Jour. App. Physics*, **10**, 432 (July, 1939).

## CHAPTER IV

### FORMATION, DEFLECTION, AND SYNCHRONIZATION OF SCANNING BEAMS

In the discussion of television camera action in the preceding chapter, our attention has been confined to the photoelectric and secondary-emission phenomena that underlie the production of the picture signal. It is now necessary to extend our investigation to the scanning beam within the camera tube. In so doing it is convenient to discuss scanning beams in general, not only those in camera tubes but those in image-reproducing tubes as well. In principle, the transmitting and receiving scanning beams are identical. They are formed and put into motion in the same way. Furthermore, the transmitting and receiving beams must be considered together for another important reason, the necessity of maintaining synchronism between their scanning motions. Consequently in the present chapter, we consider the means whereby beams of electrons are formed, deflected, and synchronized whether for the purpose of analyzing an image at the camera or synthesizing it at the receiver.

**23. Basic Requirements of Scanning Beams.**—In considering the requirements to be met by the scanning beam, the first question is the diameter of the cross section of the beam, as it hits the scanned surface. The beam diameter determines the size of the picture element. The area of the picture element  $A_e$  is the area of the active scanning pattern  $A_p$  divided by the total number of picture elements  $N$

$$A_e = \frac{A_p}{N} \quad (44)$$

Since the shape of the picture element is ordinarily circular, the diameter of the picture element  $d_e$  is

$$d_e = 2\sqrt{\frac{A_e}{\pi}} = 2\sqrt{\frac{A_p}{\pi N}} \quad (45)$$

As a first approximation, we can state that the beam diameter  $d_b$  should be equal to the picture-element diameter. Hence

$$d_b = 2\sqrt{\frac{A_p}{\pi N}} \quad (46)$$

Here  $A_p$  refers to the total area of the scanning pattern.

By assuming 150,000 picture elements and a pattern area of 20 sq. in. at the camera tube, according to Eq. (46), the diameter of the transmitting beam must be roughly 0.013 inch. At the receiver, with a pattern area of 50 sq. in. (8- by 6-in. picture), the spot diameter is about 0.02 in. This indicates that the requirements for forming the beam in a camera tube are considerably more strict than those in the receiving picture tube.

In addition to the diameter of the spot, two other important quantities in the scanning beam are the number and energy of the electrons contained in it. This factor is measured by the *power density* of the beam, that is, the number of microamperes per square centimeter of cross-sectional area in the beam multiplied by the voltage drop through which the beam passes. The power density is measured in watts per square centimeter. When the power density is high, the effect of the scanning beam when it impinges on the scanned surface (image plate or luminescent screen) is correspondingly vigorous.

Here an important difference between transmitting and receiving scanning beams arises. The transmitting beam is intended to produce secondary electrons and thereby to discharge the mosaic in the camera tube. An optimum value of secondary emission exists at which the highest ratio between signal and spurious signal is obtained. Under typical conditions of illumination, this optimum value is found at a beam current of about  $0.5 \mu\text{a}$  and a voltage drop of about 1000 volts. If a beam cross-sectional area of 0.00004 sq. in. is assumed, the power density is then

$$W_b = \frac{I \times E}{A} = \frac{0.0000005 \times 1000}{0.00004} = 12.5 \text{ watts per square inch}$$

or roughly 2 watts per square centimeter.

In the receiving tube, on the other hand, the power in the beam is used directly to produce light from the luminescent material on the screen. Here a higher power density is required. The

beam current may be several hundred microamperes, the voltage drop as high as 10,000 volts, and the beam power density as high as 1000 watts per square centimeter. The actual power delivered to the screen area is spread by the scanning motion over the whole pattern area of, say, 50 sq. in., or roughly 300 sq. cm., so that the continuous power input to the screen is in the latter case  $1000/300$ , or 3 watts per square centimeter. Values of 1 watt per square centimeter are commonly used. The effect of the power input on screen brilliance is discussed in Chap. VIII.

**24. Formation and Focusing of Electron Beams.**<sup>1</sup>—Electron beams are formed in structures known as *electron guns*. The

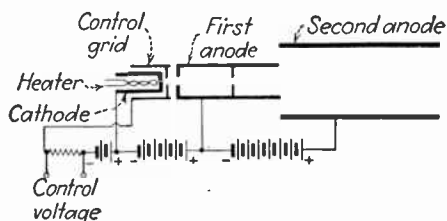

FIG. 61.—Elements of a typical electrostatic electron gun which employs two electron lenses for focusing the electron beam, and a control grid for varying its power density.

electron gun is a device used to form a beam of electrons and to focus the beam on the scanned surface. Two types of gun structures are employed, one employing electrostatic forces, the other magnetostatic forces. The electrostatic type is more widely employed at present in this country and hence is considered first.

A typical example of an electrostatic electron gun is shown in Fig. 61. At the extreme left in the diagram is the *cathode*, a nickel cap fitted over a nickel sleeve. Within the sleeve is the *heater*, an insulated tungsten wire through which sufficient current is passed to bring the cathode surface to its operating temperature of about 1100°K. The cathode cap is covered with a mixture of barium and strontium oxides, which at operating temperature is capable of emitting electrons to the extent of about 1 ma. of current per square millimeter of surface.

Directly to the right of the cathode surface is the *control grid* consisting of a nickel sleeve and a cap that contains a small

<sup>1</sup> A general treatment of the electron optics of television tubes is given in Maloff and Epstein, "Electron Optics in Television," Chaps. VI, VIII, IX, X, McGraw-Hill Book Company, Inc., New York, 1938.



aperture. Any electrons traveling through the grid must pass through this aperture, and hence they are confined to a comparatively narrow angle.

To the right of the control grid and insulated from it is the *first anode*, a cylindrical sleeve containing several apertures spaced at intervals on the axis of the system. These apertures serve to confine the beam further. The first anode is maintained at a positive potential, relative to the cathode, and thereby attracts electrons from the cathode through the several apertures.

Beyond the first anode is the *second anode*, which usually takes the form of a conducting coating on the inside of the glass

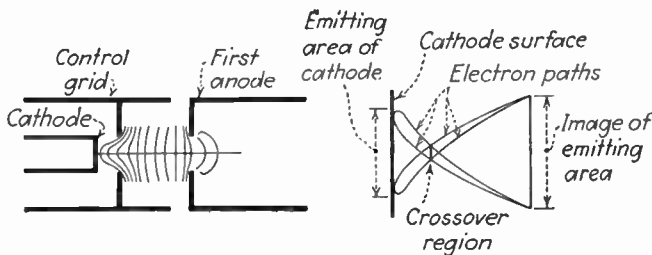

FIG. 62.—Equipotential contours and electron trajectories of the first (“immersion”) electron lens of the gun shown in Fig. 61. Left, the lens system and the electric field lines, across which the electrons move. Right, paths taken by electrons as they leave the cathode surface. The crossover region is focused on the scanned surface by means of the second electron lens.

envelope surrounding the gun. The second anode has a larger diameter than the first anode and is placed so that its edge just overlaps the edge of the first anode. The second anode is maintained at a considerably higher positive potential, with respect to the cathode, than is the first anode.

The beam is formed by the attraction of the electrons from the cathode and by the restriction of the electron path imposed by the apertures. However, the beam so formed tends to spread into a broad angle, after emerging from the last aperture, unless special means are taken to focus the beam on the scanned surface. The term “focus” is used from analogy with the optical action of a lens in focusing a beam of light. Likewise the focusing electrodes in the electron gun are termed “electron lenses.”

The electron gun in Fig. 61 contains two electron lenses. The first is the system comprising the cathode surface, the control-grid

aperture, and the first aperture in the first anode. The dimensions of this electrode system, and the electrical potentials applied to it, are chosen to cause the electrons traveling from the cathode to converge to a small region located on the axis of the system and slightly in front of the cathode surface. This is the electron "crossover" point, which has a diameter considerably smaller than the area of the cathode from which the electrons were emitted. This crossover may be viewed as a source of electrons in itself, and the electrons emerging from it may be focused, by another lens system, on the scanned surface at the other end of the tube. The advantage of focusing the electrons from the crossover rather than from the cathode surface directly is that the crossover has a considerably smaller diameter than the cathode-emitting area.

The second electron lens in the gun system is the region where the edges of the first and second anodes meet, as shown in Fig. 63. This region, by virtue of the difference in potential on the two anodes, acts to deflect the electrons toward the axis of the system. When the ratio of the voltages on the two anodes is properly chosen with respect to the length of the tube, the electrons will be so directed that they meet the axis at its intersection with the plane of the scanned surface. Consequently there exists at the scanned surface another electron-crossover region, which is the electron-optical image of the first crossover. The diameter of this second crossover region is what is referred to in the term "beam diameter" used in the preceding section.

The action of the two electron lenses in focusing the beam can be explained most easily in terms of the equipotential contours that exist between the various electrodes involved. These contours are surfaces in the plane of which an electron experiences no urge to move. Perpendicularly to the contours, however, the electron experiences a forward-urging force. Typical equipotential contours in the first and second electron lenses are shown in Figs. 62 and 63. The shape of the contours depends on the geometry of the electrode system but not on the ratio of the potentials applied to it.

So far as the *focusing action* of the second electron lens is concerned, the important factors are two ratios, the ratio of the diameters of the cylindrical electrodes and the ratio of the potentials (with respect to the cathode) applied to these electrodes.

The former ratio is controlled by the manufacturer of the tube, but the latter is under the control of the user of the tube and hence is of importance in the design of the associated electric circuits. It is customary to provide means for varying the voltage applied to the first anode, while that applied to the second anode remains fixed. By adjusting the first-anode voltage, the ratio of voltages is changed until the beam is brought into focus. Ordinarily the ratio of voltages applied to second and first anode is about 5 to 1.

The question still remains as to what absolute values these voltages should have. In the case of the iconoscope, as already

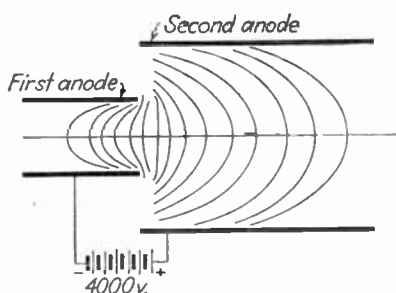

FIG. 63.—Equipotential contours of the second electron lens of the gun shown in Fig. 61. Any electrode system having cylindrical symmetry about the gun axis can serve as a lens, but the particular form shown has gained the widest acceptance in commercial tubes.

noted, the second-anode voltage is 1000, and that on the first anode is about 200 volts. In image-reproducing tubes, the second-anode voltages run from 2000 to 7000 volts, whereas the first-anode values range from 400 to 1400 volts. Lower values of voltage, which would be desirable in view of the expense of high-voltage power supplies, are equally as capable of providing a properly focused beam as are high voltages, but the power density produced by lower voltages would be insufficient to produce the required effect on the scanned surface.

*The Effect of the Control Grid on Power Density and Focus.*—The purpose of the control grid in the first lens of the gun structure is to vary the current in the beam and, consequently, the power density of the beam. In so controlling the beam current, the control grid also changes to a limited extent the focal length of the first lens, thus changing the size of the focused image on the scanned surface. The two effects, acting together, produce a

change in the power per unit area conveyed by the beam to the scanned surface.

The control grid obtains its control over the electron beam by changes in electric potential applied between the control grid and the cathode. The effect of such changes are shown in Fig. 64, which shows typical equipotential contours in the first lens for two values of voltage between the grid and cathode. When the potential is the same as that of the cathode, the contours have

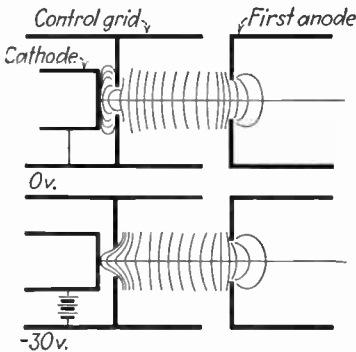

FIG. 64.—Variations in contours with control-grid potential. Top, with cathode and grid at same potential, the field at the cathode surface is strong and widespread. Bottom, with the control grid 30 volts negative, the field is weaker and covers a smaller area of the cathode. (After Maloff and Epstein.)

the shape shown at the top. The contours make contact with a large area of the cathode surface. When the grid is 30 volts negative with respect to the cathode, on the other hand, the contours have the shape shown at the bottom. In the latter case, the contours make contact at a small area of the cathode surface, consequently few electrons are emitted by the surface. Furthermore the separation between the contours (the potential gradient) is much less when the control grid is negative. The forces urging electrons to leave the cathode surface are thus reduced, and the electrons acquire lower velocity in leaving the cathode surface. Consequently the number and energy of the electrons in the beam are reduced as the control grid assumes a more negative voltage with respect to the cathode. A plot of the relationship between beam current and control-grid voltage, illustrating the net result, is indicated in Fig. 65.

The changes in the contours shown in Fig. 64 have the further effect of changing the focus of the system. In general, as the control grid becomes more negative, the crossover point is removed farther from the second lens. This effect, together with the fact that a small area of the cathode is in use, makes the diameter of the beam, in the plane of the scanned surface, smaller the more negative the control-grid voltage. This

change is not ordinarily great enough to affect the beam focus but produces a noticeable change in beam diameter.

The use of the control grid in the iconoscope is comparatively simple; it is used to fix the value of the beam current at the value that produces an optimum ratio of signal to spurious signal under the given conditions of illumination.

In the receiving tube, on the other hand, the control grid receives the signal that controls the brilliance of the successive picture elements. The elements, we remember, are laid down at a rate approximating 6,000,000 per second, and the range of brightness included in them may be as high as 100 to 1. It is obvious that in this case the control grid must perform a very exacting service. In particular, it is necessary that the control grid be capable of receiving and utilizing voltage variations as rapid as, say, 6,000,000 per second, corresponding roughly to an a-c frequency of 3,000,000 c.p.s. Secondly the power density in the beam (from which the light is produced) should vary in proportion to the control-grid voltage. Finally, the range of voltage corresponding to the range between full power density and zero must be such that it can be supplied by the circuit without undue complications. A detailed treatment of these requirements is given in Chap. VIII.

*Distribution of Energy in the Cross Section of the Beam.*—As might be supposed from the properties of the lens system, not all electrons are treated exactly alike. The "axial" electrons, originating at the cathode on the axis of the system, suffer but little change in direction. The "paraxial" electrons which

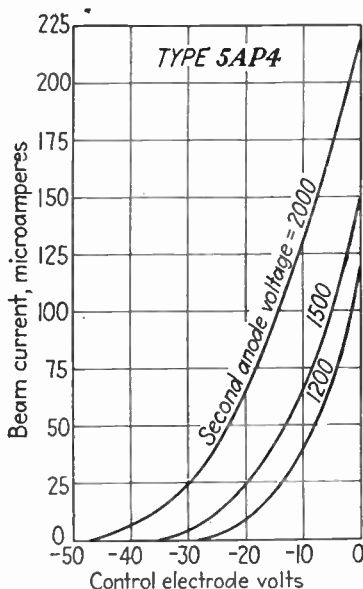

FIG. 65.—Typical control characteristic of an electrostatic gun. Note that the relationship between control voltage and beam current is not linear, particularly so in the operating region from  $-15$  to  $-40$  volts.

originate near, but travel at a small angle to, the axis are brought into nearly exact focus by the system. But those at the edge of the beam, or those taking a path at a large angle to the axis, the "nonparaxial" electrons, are subject to less perfect focusing action and, in consequence, meet the scanned surface somewhat removed from the axis of the system. The result is that the cross section of the beam, at the scanned surface, contains a dense distribution of electrons on the axis, which gradually "thins out" as the distance from the axis increases. The corresponding power density associated with the electrons has the shape shown in Fig. 66. Most of the power is delivered at or

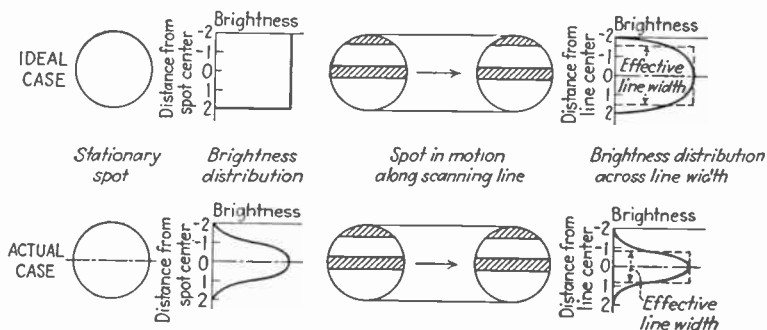

FIG. 66.—Distribution of brightness in scanning spot compared with that of scanning line. Top, the ideal case in which the spot area is uniformly bright produces a nonuniform distribution when the spot is spread out into a line because the upper and lower regions of the spot cover the line area with less light than do the central regions. In the practical case (bottom) of a nonuniform spot of light, the nonuniformity of the line is emphasized.

very near the axis, but a considerable portion of it falls symmetrically about the axis. The *effective width* of the beam may be defined as the distance between the dotted lines, which represents the width of a rectangle having the same area as that under the curve of the actual distribution of power in the beam. It must be remembered that the curve is representative only. Changes of focusing voltage ratio (ratio of second-anode voltage to first-anode voltage) and control-grid voltage produce distributions which may be very different from that shown.

*Magnetic Focusing of Electron Beams.*—The electrostatic forces considered in the electron gun may be replaced by corresponding magnetostatic forces. The magnetic forces are set up by passing current through a coil of wire the axis of which corresponds with

the axis of the focusing system. The coil may be extended so that it covers the whole length of the electron beam, or it may be concentrated in a smaller coil. The extended coil is employed to focus the electron image in the Farnsworth image dissector, whereas the concentrated "short-coil" system is employed in magnetically focused image-reproducing tubes.

The principle underlying magnetic focusing may be examined in terms of the magnetic lines of force set up by the coil. Consider the system shown in Fig. 67. Here the cathode surface is set up directly opposite the scanned surface, which is here con-

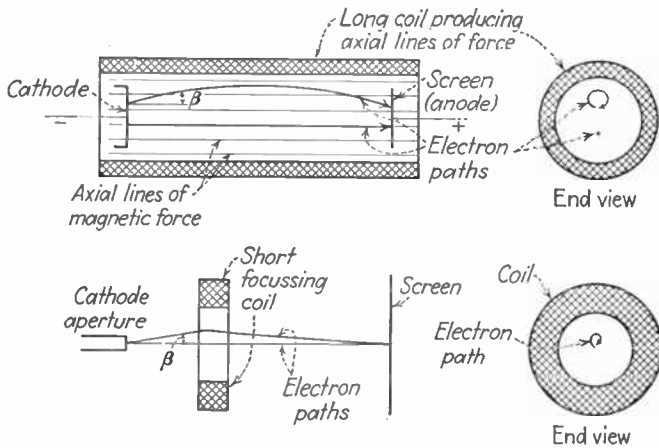

FIG. 67.—Magnetic focusing of an electron beam. With a long focusing coil (top) the electron path is a true spiral. With a short coil (bottom) the twisting motion is active only while the electron is within the magnetic field of the coil.

sidered to be an anode that attracts electrons from the cathode. Surrounding the tube is a focusing coil. The lines of magnetic force produced by the coil are uniformly distributed and extend the length of the tube, parallel to the direction of the electron motion.

The electrons experience a force from the magnetic field only if their motion is at an angle to the lines of magnetic force. If the line of motion and magnetic lines of force are parallel, the electron is urged to move only by the attractive force from the anode. However, if the electron leaves the cathode at a slight angle to the axis of the system, then a force is exerted on it by the magnetic field. The direction of this force is at right angles both to the direction of the motion and to the magnetic lines of force.

The force thus acts, in the case shown in Fig. 67, into the plane of the paper, and the electron travels in a spiral path, urged forward by the anode and to the side by the magnetic force. The path of the electron, projected on the anode surface, is a circle. If this circle is completed by the time the electron reaches the anode (scanned surface), the electron lies on the axis of the tube just opposite the point from which it was emitted at the cathode. All other electrons emerging from the same point on the cathode are brought to the same point on the scanned surface, hence the electrons are focused on the scanned surface.

In practice, the electrons leave the cathode at different initial speeds and at varying angles to the axis of the tube. But the time required for any electron to complete the circle in its spiral flight depends only on the strength of the magnetic field and on the charge to mass ratio of the electrons, which is the same for all electrons. Hence any electron from the cathode completes the circle in the same time, provided only that the magnetic field is uniform.

The strength of the magnetic field is controlled by the amount of current passing through the coil and by the number of turns in the coil. For a given coil, the magnetic field strength may be varied by varying the current until the electrons are properly focused on the scanned surface.

If the focusing coil does not cover the whole length of the electron path (Fig. 67), the lines of force are not parallel to the axis of tube throughout its length. In this case, the twisting action of the magnetic force is confined to a small region in the electron path. The axial electrons as before suffer no deflection of any kind. The paraxial electrons receive a suddenly applied twisting force. This force does not act continuously, so the electron may not complete the circular projection of the spiral path. If the circle is nearly completed, however, the electron is given a component of motion toward the axis of the system, and this component, persisting after the electron has passed through the magnetic field, is sufficient to bring the electron to the axis of the system in the plane of the scanned surface. The current in such a short coil, as in the extended coil, is adjusted until the best degree of focus is obtained. Usually the coil system is supplied with an iron core that concentrates the field within the coil and reduces the number of stray lines of force which



would produce a defocusing action. Computations of performance of the short coil are possible, but difficult, so it is usual to determine the requirements by experiment. In magnetic focusing, it is necessary to maintain the current in the coil constant, of course, to avoid defocusing. It is possible to employ permanent magnets as the source of the focusing field.

**25. Deflection of Focused Electron Beams.**—When the electron beam has been formed and focused, it is then necessary to *deflect* it (that is, to change its position) continuously so that it travels over the scanned area in the standard sequence of scanning lines.

To produce the scanning motions, it is necessary to set up *fields of force*, either electric or magnetic, that will force the electrons in the beam from their original lines of motion. In practice, the force is ordinarily applied to the electrons during but a small period in their forward motion. In consequence, the beam changes its direction of motion through an angle, the size of the angle being dependent on the amount and the duration of the applied force. The change in direction of the beam produces a corresponding displacement of the end of the beam where it impinges on the scanned surface.

Since the beam must move continuously and at constant speed across each scanned line, the force must change continuously, producing a larger and larger deflection until the end of the line is reached. Then the force must suddenly reverse its direction and cause the beam to retrace, at much higher speed, to the beginning of the next line. The applied electric or magnetic field must therefore increase at a constant rate, reverse and decrease at a much higher rate to its initial value, then start again to increase at the original rate. Two such reversing fields are required, one for the vertical (frame) motion and the other for the horizontal (line) motion.

The field of force producing the horizontal scanning motion for the standard scanning pattern must trace and retrace itself  $n$  ( $= 525$ ) times in  $1/f$  ( $= 1/30$ ) sec., or  $nf$  ( $= 15,750$ ) times per second. The vertical deflecting field must trace and retrace itself  $f'$  ( $= 60$ ) times per second for interlaced scanning. The forces must increase linearly with respect to time, since the speed of the scanning spot across each active line and downward in each field or frame must be constant. Finally, the deflecting

forces must produce a large enough deflection to cover the desired picture area.

*The Dynamic Action of the Deflecting Force.*—Before describing the technical means employed to set up the deflecting forces, we must consider the dynamic relationships between the strength of the deflecting force, the velocity of the electrons in the beam, and the resulting displacement of the end of the electron beam. The general rule is: The higher the velocity of the electrons in the beam, the more deflecting force is required to produce a given deflection.

Since the deflection depends upon the velocity of the electrons in the beam, we consider first the factors influencing this velocity.

Consider an electron starting from rest at a point on plate *A* (Fig. 68) and passing to the positively charged plate *B* opposite. The electron motion is the result of the attractive force exerted by the positive charge on the plate *B*, maintained by the battery of *E* volts connected between the plates. The distance between the plates is *L* cm. The electric field existing between the plates is  $E/(300L)$  c.s.u. The force acting on the electron is the electric field multiplied by the charge *e* on the electron, that is,  $eE/(300L)$ . The electron, urged by this force, travels a distance *L* cm and in so doing derives an amount of energy from the field equal to the force times the distance traveled, that is,  $Ee/(300L) \times L = Ee/300$ .

FIG. 68.—Acceleration of an electron in a uniform electric field. The expression for velocity neglects the change of mass which occurs at high velocities [cf. Eq. (51)].

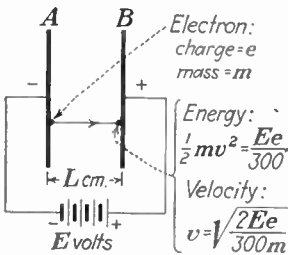

When the electron reaches the plate *B*, its kinetic energy  $\frac{1}{2}mv^2$  must equal the energy derived from the field, that is,

$$\frac{1}{2}mv^2 = \frac{Ee}{300} \tag{47}$$

Solving for the velocity *v*, we obtain

$$v = \sqrt{\frac{2Ee}{300m}} \tag{48}$$

The ratio  $e/m$  is a known physical constant,  $5.3 \times 10^{17}$  c.s.u. per gram. When this value is substituted in (48), we obtain

$$v = 5.94 \times 10^7 \sqrt{E} \text{ cm. per second} \quad (49)$$

Equation (49) shows that the velocity acquired by an electron is proportional to the square root of the voltage difference through which it passes. This relationship assumes that the mass  $m$  remains constant.

In image-reproducing tubes, the voltage  $E$  may be taken as the voltage difference between the cathode and the second anode, which ranges from 2000 to 10,000 volts. At the high velocities produced by such high values of voltage, the electron displays an apparent change in mass, and the expression becomes much more complicated. The velocity in this case is the velocity  $v$  in

$$\frac{Ee}{300} = mc^2 \left[ \frac{1}{\left( \sqrt{1 - \frac{v^2}{c^2}} \right)} - 1 \right] \quad (50)$$

Solving for  $v$ , we obtain

$$v = c \sqrt{1 - \left( \frac{1}{\frac{Ee}{300mc^2} + 1} \right)^2} \quad (51)$$

where  $c$  is a constant  $3 \times 10^{10}$  cm. per second. Table I shows the values of  $v$  calculated from Eq. (51) for voltages from 1000 to 100,000 volts, a range that includes the values of voltage currently employed in television equipment.

TABLE I.—ELECTRON VELOCITIES  
[Computed by Eq. (51)]

Accelerating voltage, volts	Velocity, cm. per second	Accelerating voltage, volts	Velocity, cm. per second
1000	$1.88 \times 10^9$	10,000	$5.86 \times 10^9$
1500	$2.30 \times 10^9$	20,000	$8.11 \times 10^9$
2000	$2.66 \times 10^9$	30,000	$9.86 \times 10^9$
3000	$3.29 \times 10^9$	40,000	$1.12 \times 10^{10}$
5000	$4.03 \times 10^9$	50,000	$1.24 \times 10^{10}$
7000	$4.93 \times 10^9$	100,000	$1.65 \times 10^{10}$

*Electric Deflecting Force.*—A simple electric deflecting system is that shown in Fig. 69. The beam of electrons, traveling forward at a velocity  $v_f$  cm. per second [calculated by Eq. (51)],

passes between two parallel flat deflecting plates, each  $l$  cm. long and separated  $s$  cm. A voltage of  $V$  volts is applied between the plates, and the upper plate is charged positively. As the beam passes between the plates, the electrons in it are attracted upward by a force of  $Ve/(300s)$  dynes. The force produces an upward acceleration  $a$  cm. per second equal to the force applied divided by the mass  $m$  of the electron (here the mass of the elec-

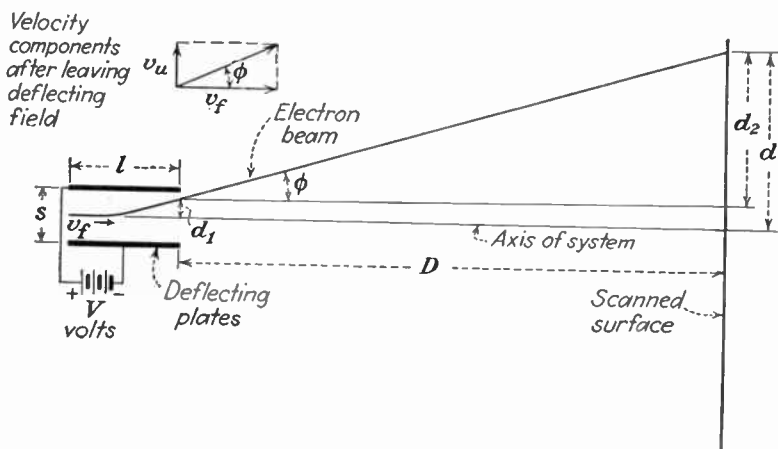

FIG. 69.—Electric deflection of an electron beam. The upward component of velocity, imparted while the electron is between the deflecting plates, persists for the remainder of the motion, producing the upward deflection  $d_2$ .

tron may be considered to be independent of the velocity). Hence the acceleration is

$$a = \frac{Ve}{300sm} \quad (52)$$

The electrons, in moving between the plates, maintain their forward velocity  $v_f$  cm. per second and hence pass through the plates in  $l/v_f$  sec. In this time, the upward velocity  $v_u$  has achieved a value equal to the upward acceleration  $a$  times the time  $l/v_f$ . Then  $v_u$  is

$$v_u = \frac{Vel}{300smv_f} \quad (53)$$

The ratio of the upward velocity to the forward velocity is then

$$\frac{v_u}{v_f} = \frac{Vel}{300smv_f^2} \quad (54)$$

This is the ratio of the velocities at the time the electron leaves the space between the plates. Thereafter the electron retains these velocities and travels in a direction shown by the angle  $\phi$  in Fig. 69. The tangent of this angle is the ratio of the upward to the forward velocities, that is,

$$\tan \phi = \frac{v_u}{v_f} \quad (55)$$

To determine the actual displacement of the beam on the scanned surface, we determine (1) the sidewise displacement within the deflecting plates and (2) the displacement due to the change in direction measured by the angle  $\phi$ . The first displacement  $d_1$  is equal to  $\frac{1}{2}at^2$  where  $a$  is given in Eq. (52) and  $t$  is the time  $l/v_f$ . Hence

$$d_1 = \frac{\frac{1}{2}Vel^2}{300smv_f^2} \quad (56)$$

The second displacement  $d_2$  is equal to the distance  $D$  (cm.) from the deflecting plates to the screen multiplied by the ratio of the upward to the forward velocities given in Eq. (54)

$$d_2 = D \frac{v_u}{v_f} = \frac{VelD}{300smv_f^2} \quad (57)$$

The total displacement  $d$  relative to the axis of the electron gun is then

$$d = d_1 + d_2 = \frac{Vel}{300smv_f^2} \left( D + \frac{1}{2}l \right) \quad (58)$$

where  $e/m = 5.7 \times 10^{17}$  e.s.u. per gram.

This expression states that the displacement of the beam is (1) directly proportional to the voltage  $V$  applied to the deflecting plates, (2) inversely proportional to the separation  $s$  between the deflecting plates, and (3) inversely proportional to the forward velocity squared  $v_f^2$  of the electron beam. It follows also, since the forward velocity squared  $v_f^2$  depends approximately upon the first power of the second-anode voltage  $E$  that (4) the displacement is inversely proportional to the second-anode voltage [see also Eq. (67) page 149].

In any given deflection system, in a camera or image-reproducing tube, the dimensions of the deflecting system are fixed. Therefore, there are only two factors that are available for

control, the deflecting voltage  $V$  and the second-anode voltage  $E$ . For a given deflection, the ratio of these two quantities is a constant, that is, the effect of doubling one voltage may be counterbalanced by doubling the other.

In practice, the deflection system is characterized by a *deflection coefficient*, expressed in millimeters of deflection on the scanned surface, per volt applied to the deflecting plates. The deflection coefficient, of course, is specified at some particular second-anode voltage, usually at the value corresponding to the maximum rating of the tube.

The parallel deflecting plates considered in the previous discussion are the simplest to analyze, but they have the disadvantage that they may interfere with the beam itself when the deflection angle is large. Thus, in Fig. 69 we see that if the upward deflection is increased much beyond the amount shown, the beam will be intercepted by the deflection plate and prevented from reaching the scanned surface. For this reason it is customary in commercial tubes to employ deflecting plates which are not parallel but which are inclined at an angle to the axis of the tube, so that the separation at the outer edges of the plates (nearest the scanned surface) is considerably greater than the separation at the opposite edges of the plates. This produces a funnel-shaped region through which the beam may be deflected over a wide angle without encountering the plates. On the assumption that the field at each point between the plates is proportional to the distance between the plates at each point, the expression for the deflecting field may be found in terms of the length of the plates and their separation at the inner and outer edges of the system. The net result is that a wider deflection may be obtained with a given deflection voltage than if parallel plates were used.

In addition, various secondary departures from the parallel-plate case may be used to increase the deflection sensitivity or to preserve the uniformity of the deflecting field. A typical example of a commercial electron-gun and deflecting-plate system is shown in Fig. 199*B*. In this case the outer edges of the deflection plates nearest the scanned surface are "flared out" to avoid intercepting the beam.

*Magnetic Deflecting Force.*—When magnetic forces are used for deflection, the magnetic field is set up by passing current through

a coil or coils situated so that the axis of the coils intersects the axis of the electron beam at right angles, as shown in Fig. 70. The lines of magnetic force thus produced are at right angles to the direction of the electron motion. Under these circumstances, the electrons experience a force, due to the magnetic field, that urges them to move at right angles to both the magnetic lines of force and their direction of motion. The deflecting force is shown in Fig. 70 as upward, to correspond with the electric case previously considered.

The magnetic field continues to move the electron at right angles to the line of motion as long as the electron is in the field.

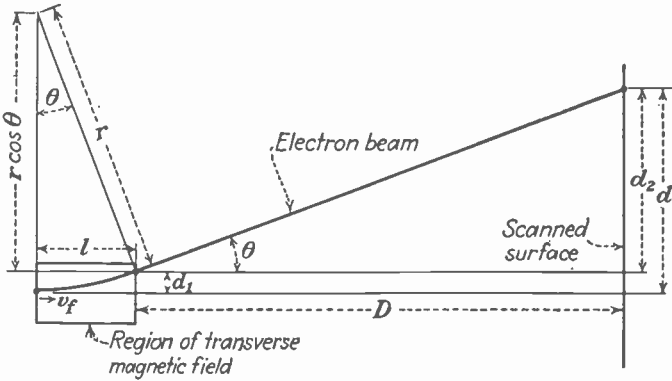

FIG. 70.—Magnetic deflection of an electron beam. No change in velocity occurs, but the direction is changed by the twisting motion of the magnetic field.

Therefore, the path of the electron, after entering the deflecting magnetic field, is a circle. The radius  $r$  of this circle depends on the forward velocity of the electron  $v_f$  and on the strength of the magnetic flux  $B$ . The relationship may be derived as follows:

The centrifugal force of the electron moving in a circle of radius  $r$  cm. is  $mv^2/r$  where  $m$  is the mass of the electron in grams and  $v$  is its velocity in centimeters per second (in this case  $v = v_f$ ). The force exerted on the electron by the magnetic field is  $Bev \sin \phi$ , where  $B$  is the strength of the magnetic flux in gauss,  $e$  is the charge on the electron in electromagnetic units,  $v$  is the velocity of the electron in centimeters per second, and  $\phi$  is the angle between the lines of magnetic force and the line of motion of the electron. In the case under consideration, the lines of

magnetic force are at right angles to the line of motion of the electron, consequently  $\phi = 90^\circ$  and  $\sin \phi = 1$ . Hence, equating the centrifugal force to the centripetal force

$$Bev_f = \frac{mv_f^2}{r} \quad (59)$$

and the radius  $r$  is

$$r = \frac{mv_f}{eB} \quad (60)$$

The electron continues to travel in an arc of a circle until it emerges from the magnetic field. Thereafter it travels in a straight line. Thus we have here, as in the case of the electric deflection, two displacements:  $d_1$  within the magnetic deflecting field and  $d_2$  external to it.

The displacement  $d_1$  is calculated as follows: The angular change in direction between the entering beam and the outgoing beam is  $\theta$ . The sine of this angle is the ratio of the length of the magnetic field  $l$  to the radius of the circular motion  $r$ , that is,  $\sin \theta = l/r$ . The displacement  $d_1$  is less than the radius  $r$  by the amount  $r \cos \theta$ , as Fig. 70 shows. But the  $\cos \theta$  is

$$\sqrt{1 - \sin^2 \theta} = \sqrt{1 - \frac{l^2}{r^2}}$$

Hence the displacement within the field is

$$d_1 = r - r \cos \theta = r - r \sqrt{1 - \frac{l^2}{r^2}} \quad (61)$$

The displacement  $d_2$  is the distance  $D$  from the edge of the magnetic field to the scanned surface, multiplied by  $\tan \theta$ . But since  $\sin \theta = l/r$ ,  $\tan \theta = l/\sqrt{r^2 - l^2}$ . Hence  $d_2$  is

$$d_2 = \frac{Dl}{\sqrt{r^2 - l^2}} \quad (62)$$

The total deflection  $d$  is

$$d = d_1 + d_2 = r - r \sqrt{1 - \frac{l^2}{r^2}} + \frac{Dl}{\sqrt{(r^2 - l^2)}} \quad (63)$$

This is not a simple relationship. If it is assumed that  $l$  is small when compared with  $r$ , however, then the expression becomes



$$d = \frac{Dl}{r} \quad (64)$$

This expression states that the displacement is inversely proportional to the radius  $r$  through which the electron travels. But this radius has been shown to be, by Eq. (60),  $r = mv_f/eB$ . Hence

$$d = \frac{DleB}{mv_f} \quad (65)$$

This expression states that the deflection is (1) directly proportional to the strength of the applied magnetic flux  $B$ ; (2) inversely proportional to the velocity  $v_f$  of the electrons, that is, inversely proportional (approximately) to the *square root* of the second-anode voltage; (3) directly proportional to the length of the magnetic field  $l$ ; and (4) directly proportional to the field-to-screen distance  $D$ . The ratio  $e/m$  appears as a ratio numerically equal to  $1.8 \times 10^7$  e.m.u. per gram.

*Defects of Electric and Magnetic Deflection. Defocusing of the Beam.*—It is necessary, of course, that the size of the scanning spot remain the same, within narrow limits, regardless of its position on the scanned surface. When an electron beam is deflected, either electrically or magnetically, the motion of the beam may interfere with the focusing action of the electron gun. Such defocusing of the beam, as it is deflected, can arise from several causes. The most obvious cause is the difference in distance from the electron gun to the various parts of the scanned surface. If the beam is in focus on the axis of the system, it may be out of focus at the edges of the pattern, simply because the distance from the electron gun to the scanned area is greater at the edges. In image-reproducing tubes, this problem is not serious, since the scanned surface (luminescent screen) may be curved so that the distance from gun to screen is the same at all points. In the iconoscope, the scanned surface is a plane surface. Here it is necessary to employ a gun that produces a long, narrow beam of electrons near the scanned surface. Hence the beam cross section is constant for several inches at the end of the beam, and the change in distance produces little defocusing action.

A more serious cause of defocusing is nonuniformity of the electric or magnetic fields used for deflection. Suppose that the beam passes through a nonuniform field in such a way that

the upper portion of the beam (Fig. 72) passes through a region of strong field, while the lower portion passes a region of comparatively weak field. Then the upper part of the beam suffers a greater deflection than the lower, and the result is that the beam is spread out in the vertical direction. Its cross section is

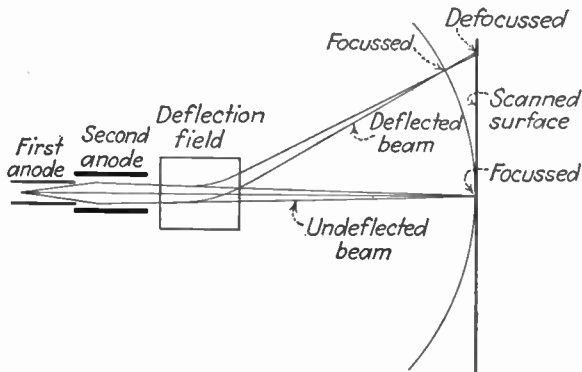

FIG. 71.—Geometrical cause of defocusing at the edges of a flat scanned surface.

thereby distorted from the proper circular shape into an ellipse. The effect can arise from any nonuniform field whether electric or magnetic. In consequence, it is necessary that the deflecting plates or coils be so arranged and connected that as uniform as possible a deflecting field is produced.

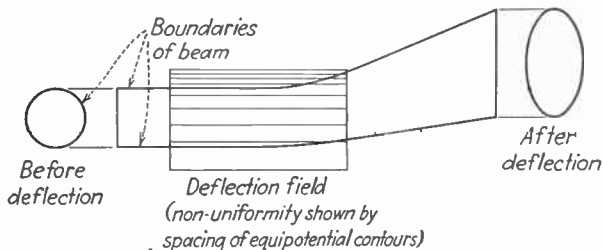

FIG. 72.—Defocusing of a beam deflected in a nonuniform electric field.

Still another cause of defocusing is the variations of electron velocity in the beam. The electrons emitted from the cathode in the electron gun leave the cathode at different velocities, and these differences in velocity are preserved as the electrons pass through the gun. Since the amount of deflection depends on the velocity of the electrons, it follows that a beam composed of

electrons having a range of velocities will suffer a corresponding range of deflections. The beam is thereby spread out into an elliptical cross section, with the long axis in the direction of the deflection. Since electric deflection depends on the square of the electron velocity, whereas magnetic deflection depends only on the first power, this source of defocusing is more serious when electric deflection is employed.

*The Ion Spot in Magnetic Deflection.*<sup>1</sup>—A defect of deflection peculiar to the magnetic method is the formation of the so-called *ion spot*, which registers itself as a stationary dark spot in the center of the scanned area. The spot is the result of a beam of negative ions, that is, electric charges of the same charge (or some multiple of it) as the electron but of considerably greater mass. These ions form a beam and are focused in the same manner as the electrons. When electric deflection is employed, these ions are deflected through the same angle as the electrons, and in consequence they are indistinguishable from the electrons. When magnetic deflection is employed, however, the ions are deflected to a very small degree compared with the electrons, and as a result the scanning pattern of the ions is contained in a very small region near the center of the scanned area. The continual bombardment of this small area by the ions renders it insensitive to the electron bombardment. In the image-reproducing tube, the ion bombardment acts to disintegrate the luminescent coating, rendering it incapable of producing light under the influence of the electron bombardment. The effect is that the center of the reproduced picture contains a dark spot on the axis of the focusing system. When sulphide luminescent screens are employed, the spot is definitely dark in color, but in the silicate screens the spot is of a lighter, usually yellow, color and is not so noticeable. The absence of the ion spot is an argument frequently advanced in favor of electric, as against magnetic, deflection.

The theoretical basis for the small deflection of the ions in a magnetic deflecting system may be found readily by comparing the equations for total deflection in the electric vs. the magnetic system. In electric deflection, the expression is

<sup>1</sup> For a chemical analysis of the ionic components in cathode-ray beams see, Bachman and Carnahan, Negative Ion Components in the Cathode Ray Beam, *Proc. I.R.E.*, 26, 529 (May, 1938).

$$d = \frac{Vcl}{300smv_f^2} \left( D + \frac{1}{2}l \right) \quad (58)$$

By Eq. (48),  $v_f^2$  is proportional to  $(e/m)$ . Hence in Eq. (58), the  $v_f^2$  factor cancels the factors  $e$  and  $m$ , except for a factor of proportionality. The total electric deflection is, in other words, independent of the charge and the mass of the particles in the beam, and the ions receive the same treatment as the electrons. In magnetic deflection, on the other hand, the total deflection is

$$d = \frac{DleB}{mv_f} \quad (65)$$

Here the factor  $v_f$  occurs in the first power and is proportional to

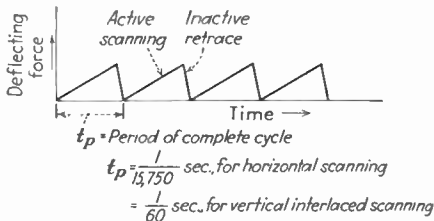

FIG. 73.—Saw-tooth waveform of deflecting force, required to produce a scanning pattern of uniform horizontal and vertical scanning velocities.

$\sqrt{e/m}$ . When  $v_f$  is divided into the  $e$  and  $m$  factors, therefore, the result is

$$d = \frac{DLB\sqrt{e/m}}{K} \quad (65a)$$

where  $K$  is the factor of proportionality between  $v_f$  and  $\sqrt{e/m}$ . The expression shows that the deflection is inversely proportional to the square root of the mass of the particles. The ions have masses from 2000 to 500,000 times the electron mass, depending on their chemical nature, and suffer correspondingly smaller deflections.

**Saw-tooth Waveforms.**—In scanning, it is necessary that the deflection increase linearly with time. Since the deflection is proportional to the deflecting force, linear deflection is obtained by applying a deflecting voltage or current that increases linearly with time. When the end of the scanning motion is reached,

the deflecting force must then reverse itself and decrease rapidly to its initial value. The deflecting forces must, in other words, have the shape shown in Fig. 73, when plotted against time. The appearance of the wave is the reason for its name, "saw-tooth" wave.

The deflection system of an electrically deflected tube consists of two sets of deflecting plates, one pair arranged to deflect the beam horizontally, the other pair for vertical motion. The horizontal plates are connected to a scanning generator that produces saw-tooth waves of *voltage* that recur  $nf$  ( $= 15,750$ ) times per second, whereas the vertical plates are fed saw-tooth waves  $f'$  ( $= 60$ ) times per second. In consequence of these two deflections, the end of the scanning beam travels over the scanned surface in the interlaced pattern shown in Fig. 20, page 49.

In magnetic scanning, the variation in the deflecting force is obtained by varying the magnetic flux  $B$ . This field is directly proportional to the current flowing in the deflecting coils. Consequently in this case a saw-tooth wave of *current* is required. In practice, two sets of deflecting coils are required: One pair, arranged on a horizontal axis, produces the vertical motion and is fed with 60 c.p.s. saw-tooth current; the other, arranged on a vertical axis, is fed 15,750 c.p.s. saw-tooth current waves and produces the horizontal deflection. Note that in magnetic deflection the *current* must have a saw-tooth shape; the voltage applied across the coils will have, in general, a considerably different (non-saw-tooth) shape, to overcome the tendency of the electrical inductance present in the deflecting coils to inhibit rapid changes in current.

*Other Defects of Deflection.*—The deflecting system may suffer from defects inherent in the scanning generators that produce the electric or magnetic deflecting fields. The principal defects are nonlinearity of scanning and unequal amplitudes of scanning. The saw-tooth waves shown in Fig. 74 illustrate the causes of these defects. The methods of controlling the waveform to avoid these defects are discussed in Sec. 26. One form of scanning-amplitude distortion of interest occurs in the iconoscope tube. In this tube, the plane of the image plate is inclined to the scanning beam at an angle of about  $30^\circ$ . If the horizontal amplitude of deflection is kept constant for all lines in the pattern, the distance scanned at the bottom of the plate is much

smaller than that scanned at the top, owing simply to the difference in the distance between the gun and the plate. The shape of the scanning pattern on the image plate under these conditions is shown in Fig. 75. When such a scanned image is reproduced

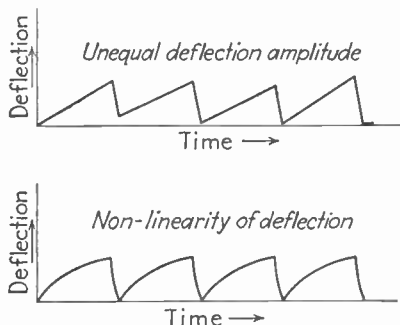

FIG. 74.—Typical defects of scanning waveforms. Top, unequal amplitudes of successive cycles. Bottom, nonlinearity.

in the receiver, all the picture elements in the lower lines are spread out too far relative to those in the top line. This is the so-called *keystone effect*. It is corrected by the use of a horizontal scanning generator which produces a larger deflecting force at

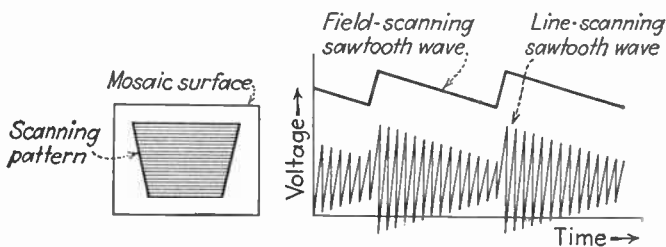

FIG. 75.—Trapezoidal distortion ("keystoning") of scanning pattern in the iconoscope, caused by difference in the distances from electron gun to top and bottom of mosaic plate. A keystone-correction scanning wave (right) is produced by modulating the line-scanning waveform with the field-scanning waveform, which causes the beam to scan over a wider angle at the bottom of the pattern than at the top.

the base of the pattern than at the top, thus nullifying electrically the geometrical distortion of the pattern.

**26. Scanning Generators.**—Scanning generators are intended to produce saw-tooth waves of voltage or current, depending upon whether electric or magnetic deflection is used. The saw-tooth waves must have the standard rate of repetition of  $f'$  ( $= 60$ ) per

second for the vertical frame motion and  $nf$  ( $= 15,750$ ) per second for the horizontal line motion. The motion during the active scanning periods must be linear with respect to time. The velocity of the retrace motion must be fast compared with that of the active motion. The amplitude of the current or voltage must be sufficient to produce deflection of the full width or height of the scanning pattern. Finally, the initiation of each saw-tooth wave must be under the control of a synchronizing signal received from the synchronizing source of the system.

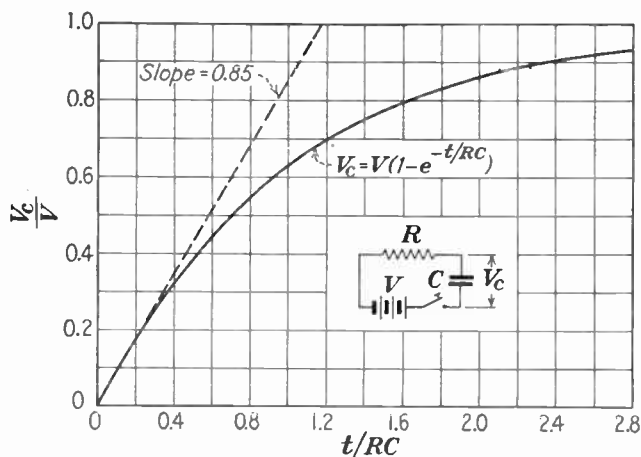

FIG. 76.—Capacitance charge-vs.-time curve (solid line) in the series resistance-capacitance circuit shown in the inset. The dashed line represents a linear relation (slope 0.85) somewhat below the initial slope of the charge curve (cf. Fig. 77).

In the following paragraphs, the operation of equipment that fulfills these requirements is discussed.

*Methods of Producing Saw-tooth Waves of Voltage.*—The method of producing saw-tooth waves of voltage universally employed in television is based on the gradual accumulation of charge on a capacitor, followed by its rapid discharge. Since the voltage across a capacitor is directly proportional to the charge on it, it follows that the slow charge and rapid discharge are accompanied by a slow rise of the voltage across the capacitor terminals, followed by a rapid fall.

The capacitor may be charged in several ways. The simplest is that shown in Fig. 76. The capacitor has a capacitance of  $C$  farads and is charged from a battery of  $V$  volts through a resist-

ance of  $R$  ohms. The switch is closed, with the capacitor initially discharged, at a time  $t = 0$ . At any later time  $t$ , the voltage  $V_c$  across the condenser is

$$V_c = V(1 - e^{-t/RC}) \quad (66)$$

where  $e = 2.718+$  is the base of the natural system of logarithms. A plot Eq. (66) is shown in Fig. 76. The plot shows that the voltage rises at a rapid rate just after the switch is closed, but the rate progressively falls off to lower values as the time of charge increases. At the end of  $t = RC$  sec., the voltage  $V_c$  is approximately 63 per cent as great as  $V$ , as substitution in Eq. (66) shows.

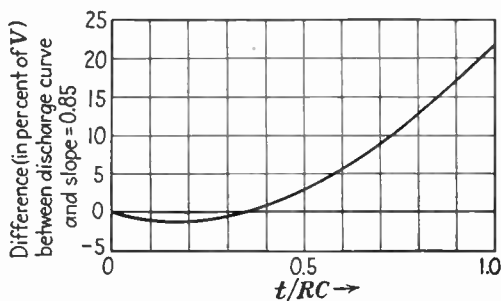

FIG. 77.—Difference between charge-time curve and linear slope ( $= 0.85$ ). A nonlinearity of  $\pm 1$  per cent can be achieved if the charging time is restricted to  $0.4RC$  or less, but the nonlinearity increases to  $\pm 5$  per cent if the charge is allowed to continue for  $t = 0.7RC$  seconds.

The rise in voltage across the capacitor can be used as the forward portion of a saw-tooth wave, provided that the portion used is sufficiently linear with respect to time. The linear relation is shown by the dashed line in Fig. 76. The difference between the charge curve and the linear line, measured vertically may be determined for different values of time, measured in multiples of the time  $t = RC$  sec. Such a determination is shown in Fig. 77.

The second method of charging the condenser employs a constant-current device in series with the condenser. The constant current, entering the capacitor, produces a uniform accumulation of charge, with a resulting linear relation between the capacitor voltage and time. Two forms of constant-current tubes have been used for the purpose: the saturated diode and the pentode. The current-voltage relation of the pentode is shown in Fig. 78.



Capacitor-charging circuits employing these tubes are more complicated than the simple resistance connection, but they have the advantage of inherent linearity and higher effective utilization of the charging voltage. In most modern scanning generators, the constant-current system has been superseded by the simpler resistance circuit, which can be made to perform with sufficient linearity (or can be compensated) for the purpose.

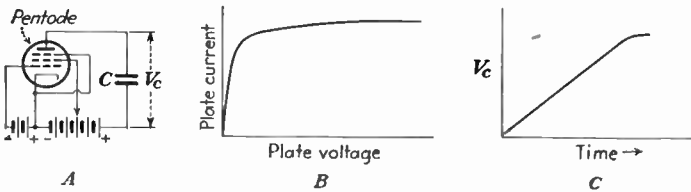

FIG. 78.—Current-limiting action of the pentode tube, useful for obtaining a linear charge-vs.-time relationship, but seldom used in television scanning circuits.

The capacitor, once charged, must be discharged at the end of the active portion of the charge curve. The discharge must be as rapid as possible, since the ratio of forward to retrace scanning velocities is determined directly by the ratio of charge time to discharge time. To perform the discharge, an auxiliary discharge device is connected across the capacitor at the proper time. The discharge path must possess a low resistance when

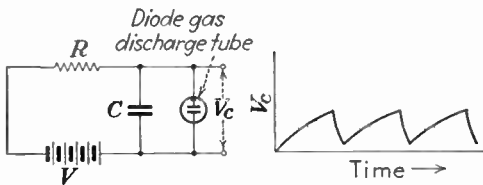

FIG. 79.—Simple saw-tooth-generating circuit employing a gaseous discharge tube. Cannot be accurately synchronized, hence of little value for television purposes.

compared with the charging path. One of the simplest discharge devices, not much used in television equipment at present, is the two-element gas-discharge tube. Such a tube contains two electrodes immersed in a gas at low pressure and connected directly across the terminals of the capacitor as shown in Fig. 79. As the voltage across the capacitor increases, the gas-discharge tube remains nonconducting until a critical value of voltage is reached. Thereupon the tube suddenly becomes conducting

and quickly discharges the capacitor. The capacitor voltage falls to a low value of voltage (not zero, but usually not more than 10 or 20 volts) before the tube again becomes nonconducting. Thereupon the capacitor charge begins again and the process is repeated. The resulting voltage wave across the capacitor has the shape of a saw tooth, shown in Fig. 79.

The simple two-terminal gas-discharge device suffers from the limitation that the time of discharge cannot be accurately controlled.

A three-element gas-discharge tube (thyatron) may be employed as shown in Fig. 80. The grid of the thyatron receives the synchronizing impulses and initiates the discharge at the proper time. The thyatron discharge circuit has been employed in television equipment in British practice, but in America it has not been used to any extent. One of the difficulties is the variation in the characteristics of the thyatron tube, which change with temperature and with the

age of the tube. Furthermore, the time required for the gas to become noneconducting at the end of the discharge tube (*deionization time*) is rather long, comparable with the scanning interval of 1/15,750 sec. for horizontal deflection. The deionization time is subject to erratic changes that make for faulty synchronization of the lines in the pattern, with resulting linear displacement of the corresponding picture elements.

The discharge device most in favor is a conventional three-element (triode) vacuum tube. Such tubes are free from temperature effect and display no deionization delay. Their disadvantage is that the conducting path they provide for the condenser discharge is of high resistance unless a very large and sharp control impulse is applied to the grid of the tube. These control impulses are produced in impulse-generating circuits, several forms of which are described below.

The discharge device most in favor is a conventional three-element (triode) vacuum tube. Such tubes are free from temperature effect and display no deionization delay. Their disadvantage is that the conducting path they provide for the condenser discharge is of high resistance unless a very large and sharp control impulse is applied to the grid of the tube. These control impulses are produced in impulse-generating circuits, several forms of which are described below.

*Methods of Producing Saw-tooth Waves of Current.*<sup>1</sup>—The saw-tooth wave of voltage available from the condenser charge and

<sup>1</sup> HOLMES, CARLSON, and TOLSON, Experimental Television System, *Proc. I.R.E.*, 22, 1266 (November, 1934).

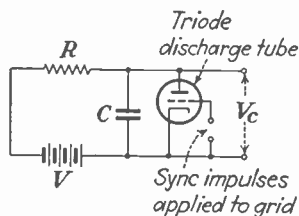

Furthermore, the time required for the gas to become noneconducting at the end of the discharge tube (*deionization time*) is rather long, comparable with the scanning interval of 1/15,750 sec. for horizontal deflection. The deionization time is subject to erratic changes that make for faulty synchronization of the lines in the pattern, with resulting linear displacement of the corresponding picture elements.

discharge cannot ordinarily be used as a source of saw-tooth waves of current required for magnetic deflection. The reason is that the deflecting coils in the magnetic system have the property of electrical inductance, combined in greater or less degree with resistance. When a periodic voltage wave is applied to such a resistance-inductance combination, the corresponding periodic current does not have the same wave shape, except in the two cases of the sine waveform and the exponential transient, neither of which is of interest in television scanning since they are nonlinear with respect to time.

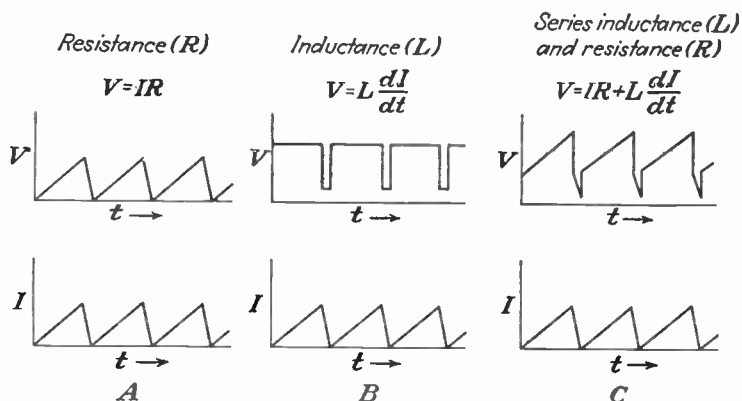

FIG. 81.—Saw-tooth waves of current produced by voltage waves in a resistive circuit (A), an inductive circuit (B), and a combination resistive-inductive circuit (C). The voltage waveform (C) is that commonly applied to the deflecting coils in magnetic deflection systems.

It is necessary to determine, therefore, what form of voltage wave must be applied to a resistance-inductance combination to produce a saw-tooth wave of current. This may be done by considering first an ideal deflecting coil composed of inductance only. Analysis of this case, by the methods of operational calculus, reveals that the current in the inductance can be made to change linearly with time, only if an instantaneous change in voltage is applied across the inductance. The corresponding voltage waveform is shown in Fig. 81B. The voltage wave consists of sharp, instantaneous impulses, the height of which corresponds to the desired rate of change of current in the inductance. When the coil contains resistance also, as do all practical coils, then the required waveform is modified further, as shown in Fig. 81C. Here the instantaneous voltage changes occur

between gradual changes in voltage. Actually this curve is the sum of an instantaneous pulse waveform and a saw-tooth waveform, the first forcing a saw-tooth current through the inductive part of the circuit, the second a saw-tooth current through the resistive part.

The combination of impulse and saw-tooth voltages shown in Fig. 81C must be produced by the scanning generator. The manner in which this voltage wave is produced is illustrated in Fig. 82. Here  $C$  is the capacitor charged through the two resistors  $R_1$  and  $R_2$  from the voltage source  $V$ . The tube is

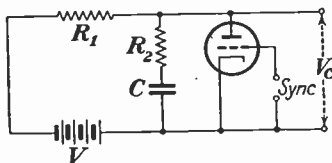

FIG. 82.—Peaking circuit used to produce the voltage waveform of Fig. 81C. The combination of  $R_2$  and  $C$  acts to produce a voltage wave, part impulse, part saw-tooth, necessary to produce a saw-tooth of current in an inductive-resistive circuit.

the discharge tube to the grid of which the control impulses are applied. The output-voltage waveform is taken across the capacitor and the peaking resistor  $R_2$ . The part of the voltage appearing across the capacitor is a saw-tooth wave, in no way different from that produced in the simple electric deflecting circuit. The voltage appearing

across the resistor  $R_2$  must be considered in two categories. When the condenser is charging, the voltage across the resistors  $R_1$  and  $R_2$  is the reverse of that appearing across the condenser (since the sum of the two voltages must equal the constant voltage  $V$ ). When the discharge of the condenser is begun by the discharge tube, however, the voltage across  $C$  and  $R_2$  is suddenly shunted by the low resistance of the discharge tube. The voltage across the capacitor cannot change suddenly; hence the difference in voltage must appear suddenly across the peaking resistor  $R_2$ . After the initial change of voltage, the condenser discharges until the discharge tube again suddenly becomes nonconducting. Then the voltage in the circuit suddenly rises to the battery voltage  $V$ . The capacitor voltage cannot change instantaneously, so the voltage across  $R_2$  changes suddenly, and thereafter the capacitor charges at the rate determined by  $R_1$  and  $R_2$  in series. The sequence of sudden changes in voltage across  $R_2$  and the capacitor results in the combination waveform, part impulse, part saw tooth, shown in Fig. 81. Such a voltage wave, passed through deflecting

coils, will produce a saw-tooth wave of current. By adjusting the relative values of  $C$  and  $R_2$ , the amount of peaking impulse, relative to the saw-tooth amplitude, may be given any desired value to match any given combination of resistance and inductance in the deflecting coils. Usually the adjustment is made by varying the resistance  $R_2$ , while observing the scanning pattern, until the proper degree of linearity is obtained.

*Amplification of Voltage Waveforms.*—Before application of the voltage waveform to the deflection plates or coils, it is usually necessary to amplify the waveform to the amplitude required for full deflection. The waveform must not be distorted in the amplification process. This requirement is met if the amplifier is capable of reproducing without discrimination sine-wave components of all frequencies up to and including a frequency approximately ten times as great as the scanning frequency, that is, up to  $60 \times 10 = 600$  c.p.s. in the case of the vertical scanning amplifier and up to  $15,750 \times 10 = 157,500$  c.p.s. in the horizontal scanning amplifier. In addition, the angular phase displacement of the sine-wave components must be proportional to the frequency. The significance of these requirements is explained in detail in the chapter on the video signal (Chap. V).

The remaining requirement is that the amplitude of the voltage or current output from the amplifier be sufficient to produce the required deflection. Consider first the case of electric deflection: Equation (58) can be rewritten to give the deflection in terms of the scanning voltage  $V$ , the dimensions of the tube, and the second-anode voltage  $E$  as follows:

$$d = \frac{1}{2} \frac{Vl}{Es} \left( D + \frac{1}{2l} \right) \quad (67)$$

For a tube having  $l = 3$  cm., a second voltage  $E$  of 6000 volts, a gun-to-screen distance  $D$  of 25 cm., and a plate separation  $s$  of 0.5 cm., a deflection of about 0.013 cm. is obtained for every volt applied to the deflecting plates. Accordingly for a deflection of 8 in. (20 cm.), a peak-to-peak voltage of approximately 1560 volts is required. This voltage is rather high for production by conventional receiver tubes. At lower values of second-anode voltage, the required deflection voltage is proportionately lower.

The manner of application of the voltage to the deflecting plates is a matter of considerable importance. In one method, not suitable for television scanning, one deflection plate is connected directly to the second anode. As shown in Fig. 83, the resulting electric field between the plates is nonuniform and the

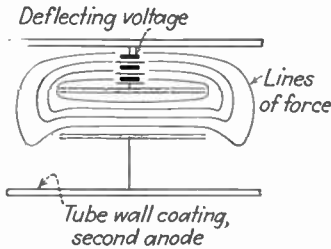

FIG. 83.—Nonuniform electric deflecting field caused by connecting one deflecting plate directly to the second anode. Defocusing at one side of the pattern and trapezoidal distortion result.

scanning spot is badly defocused at one side of the pattern. A preferable method, now universally used in electric deflection, is a symmetrical circuit, in which the two deflecting plates are connected by a high resistance, the center point of which is returned to the second anode. Both plates are then symmetrically disposed, electrically, with respect to the second-anode potential, and the field within the plates is as uniform as

the plate system itself allows. A push-pull electric-deflection amplifier of this type is shown in Fig. 84.

If the voltage output from the amplifier tube is not sufficient, it is possible to employ a step-up transformer, provided that its windings are symmetrically disposed about the center point and also that the frequency and phase response of the transformer meet the fundamental amplifier requirements stated above.

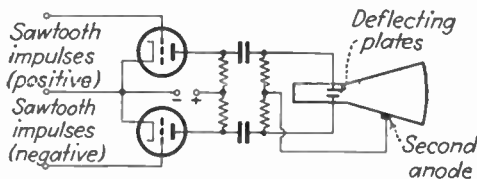

FIG. 84.—Symmetrical deflecting circuit with second anode connected to midpoint of deflecting system, which avoids the defects noted in Fig. 83.

*Amplification of Waveforms for Magnetic Deflection.*—The same frequency and phase-response requirements apply to amplification of waveforms intended for magnetic deflection. In general, magnetic-deflection amplifiers are very similar to electric-deflection amplifiers, except that the magnetic form must be capable of a high current output, rather than high voltage. Usually

the tube cannot supply sufficient current directly, so a step-down transformer is employed.

The magnitude of the current required for magnetic deflection may be deduced from Eq. (65). In the case of the tube previously mentioned ( $D = 25$  cm.,  $d = 20$  cm.,  $E = 6000$  volts, and  $l = 10$  cm., where  $l$  is the length of the magnetic field), the deflection is about 0.9 cm. per gauss of magnetic flux  $B$ . The magnetic field, produced by the scanning coils, is proportional to the product of the number of turns in the coils times the cur-



FIG. 85.—Typical magnetically-deflected picture tube. The scanning yoke (cylindrical structure) contains two sets of coils which produce horizontal and vertical deflecting fields at right angles to the axis of the tube.

rent flowing in them, that is, to the ampere turns. The amount of current required in the coils thus depends directly on the number of turns in the coils. In typical cases, the current required for full horizontal deflection is about 400 ma., and that for full vertical deflection is about 20 ma.

An important factor to be considered in the design of amplifiers for horizontal deflection is the presence of high peak voltages, which are generated in the inductance of coils when the rate of change current through them changes suddenly from positive to negative. In typical cases, the peak voltage across the terminals of the horizontal deflecting coil may reach values as high as 1000 volts, and this voltage, transformed by the output

transformer, appears as a voltage of about 5000 volts across the amplifier tube. The insulation in the tube and the associated circuits must be capable of withstanding these surges.

The scanning coils have associated with them also a definite distributed capacitance which, acting with the inductance, forms a resonant circuit. At the peak of each saw tooth, the sudden

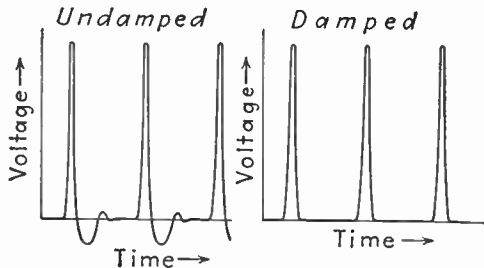

FIG. 86.—Resonance oscillations (left) at base of scanning waveform caused by reaction of deflection coil inductance and distributed capacitance. A damping circuit removes the oscillations, as shown at the right.

shock applied by the impulse in the voltage waveform tends to set this resonant circuit into oscillation, and the result is a waveform similar to that shown in Fig. 86. The undesired oscillations in the voltage waveform produce corresponding irregularities in the current waveform, which are reproduced in the scanning

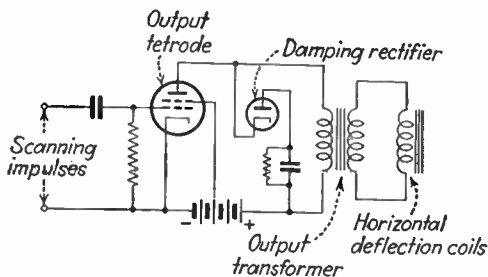

FIG. 87.—Typical output circuit of magnetic deflecting system, with damping rectifier and absorption circuit to remove oscillations shown in Fig. 86.

motion. The undesired oscillation may be eliminated by the use of a damping circuit, a rectifier tube in series with a shunt capacitance-resistance combination, the whole circuit being shunted across the primary (or secondary) of the output transformer. The rectifier has very low impedance to the portions of the oscillation that make its anode positive, and the energy



in these portions is absorbed in the tube. The capacitance charges during the negative portions and thus removes the remainder of the oscillation. The voltage waveform is thereby damped, so far as the high-frequency oscillations are concerned, and the current has the required linear form. A typical amplifier for magnetic deflection, including the damping circuit, is shown in Fig. 87.

*Impulse Generators for Controlling Discharge Tubes.*—An important part of any saw-tooth wave generator is the discharge tube which suddenly removes the charge from the capacitor across which the saw-tooth voltage wave is built up. This discharge tube must act suddenly and accurately—suddenly to produce a rapid retrace and accurately to ensure proper synchronization.

The discharge tube is caused to act by the application of a sudden positive voltage pulse to its grid. If this pulse is very sharp, that is, of large amplitude and short duration, the discharge tube will assume a correspondingly low impedance for a correspondingly short time. The problem, then, is to generate extremely sharp impulses of voltage, which can be applied to the discharge tube. Such impulses are produced in *impulse generators*, of which there are three important types: the dynatron,<sup>1</sup> the multivibrator,<sup>2</sup> and the blocking oscillator.<sup>3</sup>

The connection diagram of a dynatron impulse generator is shown in Fig. 88. Essentially the circuit consists of a tetrode tube operated with its screen at a higher positive potential than its plate. Under such conditions, the secondary emission generated at the plate is collected by the screen in such a way that the path between cathode and anode displays negative resistance. When such a negative resistance path is connected in series with a tuned circuit, the positive resistance of the tuned circuit may be neutralized, and self-sustained oscillations are maintained. If the tuned circuit has a high inductance-to-capacitance ratio (for example, a large inductance coil shunted only by its distributed capacitance), then the oscillations are of the relaxation variety. In this case, energy is stored slowly in the magnetic field of the inductance and then suddenly dis-

<sup>1</sup> HULL, A. W., The Dynatron, *Proc. I.R.E.*, 6, 5 (February, 1918).

<sup>2</sup> ABRAHAM AND BLOCH, *Ann. phys.*, 12, 237, (1919). See also CLAPP, J. K., *J. Optical Soc. Am.*, 15, 25 (July, 1927).

<sup>3</sup> HOLMES, CARLSON, and TOLSON, see reference p. 146.

charged. The complete analysis of the circuit action is complicated, but for our purposes only the end result is of interest. The output voltage wave across the inductance has the shape as shown in Fig. 88. When this voltage wave is passed through a capacitor, the lower frequency components in it are removed and two impulses appear, one above the time axis, the other

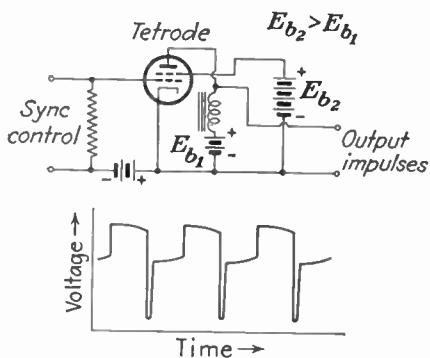

FIG. 88.—Dynatron oscillator circuit, a form of impulse generator used to initiate the discharge of the capacitor in the scanning voltage circuit.

below. Either of these impulses may be used to initiate the conduction of the discharge tube, provided only that the polarity of the pulse used is such that it makes the grid of the discharge tube positive.

A typical form of multivibrator impulse generator is shown in Fig. 89. Here two tubes are connected in a circuit very similar

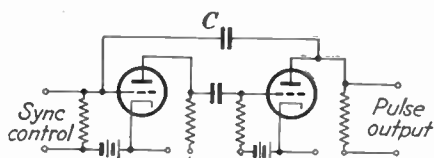

FIG. 89.—Multivibrator circuit, another form of impulse generator widely used in television receiver practice.

to that of the ordinary resistance-capacitance coupled amplifier, except that the grid of the first tube is connected to the output of the second tube. As a consequence of this connection, the circuit oscillates, slowly charging the condenser  $C$  and then suddenly discharging. In the unsymmetrical type of circuit shown, the waveform of the output has sharp peaks on one side of the axis with longer flatter waves on the other. The sharp

peaks, properly poled, are used to initiate the conduction of the discharge tube. The multivibrator circuit requires two triodes (which are customarily included in a single envelope), but it is easy to synchronize and has enjoyed considerable popularity in television equipment.

The blocking oscillator, shown in Fig. 90, is a somewhat later development and has enjoyed popularity because of its reliability and ease of adjustment and because it does not depend critically upon the characteristics of the tube used, as do the other circuits. The action of the blocking oscillator is as follows: When the anode voltage is applied to the tube, the circuit begins to oscillate by virtue of the coupling connection between grid and anode circuits through the oscillation transformer. Consider that the

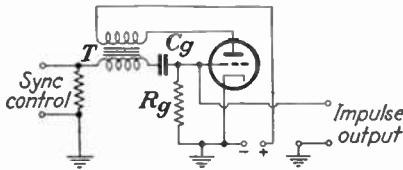

FIG. 90.—The blocking-oscillator impulse generator, which is less dependent on tube characteristics than are the dynatron and multivibrator circuits, and hence enjoys wide popularity in television receiver designs.

oscillation starts with the grid at its most negative point. Thereafter the grid rapidly becomes more positive, as the oscillation starts, and the plate current increases. The increase in plate current, transferred back to the grid circuit through the transformer, drives the grid still more positive. When the grid potential becomes more positive than the cathode, grid current begins to flow from cathode to grid. This grid current quickly charges the condenser  $C_g$  in the grid circuit, and the grid thereby finds itself with a growing negative charge. This negative charge is accumulated very quickly, once the grid potential becomes more positive than the cathode, and as a result the grid cuts off the plate current. The charge on the grid capacitor  $C_g$  is thereupon slowly discharged by the resistor  $R_g$ . When the capacitor has been sufficiently discharged to allow the grid to resume control of the plate current, the oscillation begins again, only to be cut off once more. The result is a succession of sharp pulses in the plate circuit. Each pulse of plate current gives rise to the pulse of voltage that controls the discharge tube.

It is necessary that the oscillating circuit be highly damped, otherwise the oscillation will not cease quickly enough when the grid becomes negatively charged. Also, the frequency of oscillation must be high enough so that the duration of each voltage pulse is short when compared with the scanning interval. Finally, the amplitude of the output voltage pulse must be great enough to drive the discharge tube rapidly into full conduction.

The frequency at which the pulses are generated in the blocking oscillator depends primarily on the capacitance and resistance  $C_o$  and  $R_o$  in the grid circuit. As  $R_o$  is made smaller, the capacitance  $C_o$  discharges faster and the blocking action repeats itself at a higher rate.  $R_o$  and  $C_o$  have comparatively high values in the vertical deflecting circuit, smaller values in the horizontal deflecting circuit.

**27. Synchronization of Scanning Generators.**<sup>1</sup>—Each of the impulse-generating circuits described above is provided with a terminal, usually in the grid circuit, for synchronization control. Between this terminal and ground is applied the synchronizing signal that initiates the impulse generator. The impulse in turn brings the discharge tube suddenly to the discharge point, and the scanning-voltage capacitor is thereby discharged. This sequence of events must occur with a minimum of delay and more important, whatever delay exists must be exactly the same at each cycle. If the timing of each scanning cycle is not exactly the same in each scanning motion, the picture elements are displaced in the reproduced picture. If the horizontal scanning synchronization is faulty, the picture elements in one line are displaced relative to those in the other lines in the pattern. If the vertical scanning synchronization is not accurate, on the other hand, the lines in one interlaced field will not fall accurately in between the blank spaces of the preceding field. In the horizontal case, the line synchronization must be accurate to within  $\frac{1}{5}$  per cent of the line-scanning interval to avoid a displacement any greater than the width of one picture element in a 500-picture-element line. In the vertical case, the situation is much more critical. Here the synchronization must be

<sup>1</sup> KELL, BEDFORD, and TRAINER, Scanning Sequence and Repetition Rate of Television Images, *Proc. I.R.E.*, **24**, 559 (April, 1936).

BINGLEY, F. J., The Problem of Synchronization in Cathode-ray Television, *Proc. I.R.E.*, **26**, 1327 (November, 1938).

accurate to within about 0.05 per cent of the frame-scanning interval if pairing of the lines is to be avoided.

There are two frequencies of importance in synchronizing action: one is the *free frequency* of the impulse generator, determined by the resistance and capacitance values, tube constants, oscillation-transformer characteristics, etc. This is the frequency at which impulses are generated if the generator is left to its own devices. The second frequency is the *synchronizing frequency*

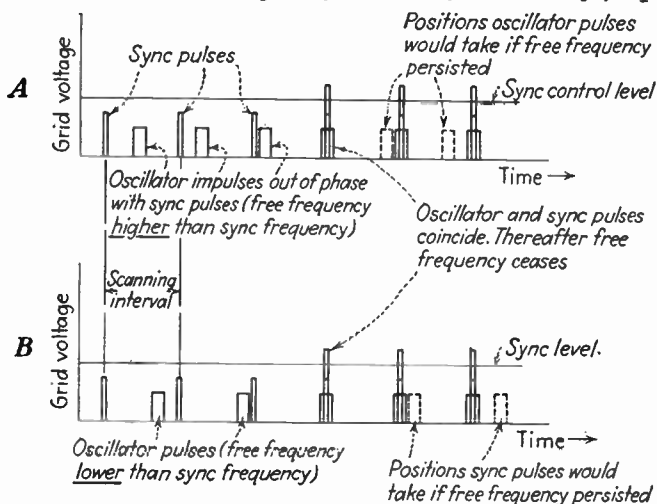

FIG. 91.—Two forms of synchronization between sync impulses and pulse generator impulses. In A the free generator frequency is higher than the sync frequency, and the sync impulses occur *during* the active scanning interval. Consequently the picture is divided in two by the blanking interval. This situation is avoided in B by making the free frequency lower than the sync frequency, so that the sync impulses and blanking occur at the end of the active scanning interval.

itself, that is, the rate of synchronizing impulses applied to the control terminal of the impulse generator. When the synchronizing frequency is approximately the same as the free frequency, then the impulse generator may be made to “fall in step” with the synchronizing frequency. The impulse generator then no longer operates at its free frequency but at a forced frequency equal to the synchronizing frequency. It is in this condition that the impulse generator must operate whenever an image is to be reproduced.

In practice, it is not desirable (even if it were possible) to maintain the free frequency exactly equal to the synchronizing

frequency. In that case, if the free frequency varies (from such causes as changes in tube voltage or characteristics), it may become higher or lower than the synchronizing frequency. The synchronizing action is very different in these two cases. If the synchronizing frequency is lower than the free frequency, the situation shown in Fig. 91A obtains. Here the small pulses show the grid impulses operating at free frequency in a blocking-oscillator impulse generator. The narrow impulses are the synchronizing impulses applied to the control terminals of the blocking oscillator. Since the synchronizing frequency is lower than the free frequency, the spacing between the former impulses is greater than that between the grid impulses. When the action of the circuit starts, the grid impulses and the synchronizing impulses do not correspond, but after several cycles have passed the synchronization (sync) impulses catch up with the grid pulses. When the two coincide, as shown in the diagram, the impulse generator "locks in" with the sync impulses and the generator frequency suddenly changes from the free frequency to the forced frequency. The generator grid pulses thereafter keep in step with the sync impulses. In this case, the period between impulses is *lengthened* by the synchronizing action and the sync pulses occur *during* the scanning motion.

If on the other hand the free frequency is lower than the synchronizing frequency (Fig. 91B), then the period between grid impulses is *shortened* by the synchronizing action. The tendency of the oscillator is to get ahead of the sync pulses, but the sync pulses continually hold the oscillator back. This is the desirable type of action, because the sync pulses then always occur at the end of the scanning motion.

The rule is, then, that the free frequency of the oscillator should be set below the sync frequency by an amount large enough to ensure that the free frequency will not become equal to the sync frequency, but not by such a large amount that the sync circuit loses control. When the sync frequency is applied it assumes control, holding the image in synchronism.

**The Form of the Synchronizing Impulses.**—The synchronizing signals are sharp pulses of voltage applied to the control terminals of the impulse generator in the proper polarity so that it may initiate the generation of each impulse. Ideally the synchronizing impulses (plotted against time) should have a rectangular

shape, that is, they should assume the required level of control voltage instantaneously. Actually, of course, such impulses cannot be generated. The impulse is trapezoidal in shape, that is, the rise in voltage level is more or less gradual. When the voltage rises to the control level, the sync action occurs. It is necessary that the rate of rise of the sync impulse be exactly the same in each pulse, so that it will reach the control value at the same instant of time in each cycle.

In practice, the synchronization impulses are generated in a synchronizing generator located at the transmitter. The pulses are used to initiate the vertical and horizontal scanning motions in the camera tube, and the same pulses are sent over the communication circuit to the receiver, where they initiate the corresponding scanning motions at the receiver. An important question is how to transmit the synchronizing pulses over the communication circuit so they will have the desired accuracy of control over the receiving equipment.

The simplest method of transmitting the sync impulses is to utilize entirely separate circuits for them.<sup>1</sup> One pair of wires (or one carrier frequency if radio is used) may be used for the vertical sync impulses and another for the horizontal sync pulses.

There is considerable difficulty involved in such a system, since the two circuits must be maintained and kept separate from each other, and from the picture and sound signals, throughout the transmission process. The method recommended by the R.M.A. Committee in this country, and by similar bodies abroad, involves the use of but one communication channel for all synchronizing functions, and this channel is combined with the picture-signal channel in such a way that part of the amplitude of the picture signal is devoted to sync impulses, the remainder to the picture signal. The details of this arrangement are described in the next chapter. For the present purposes, we

<sup>1</sup> A system employing separate channels for the synchronizing function has been developed by DuMont and Goldsmith. In this system, the scanning waveforms of the transmitter are transmitted directly to the receiver where, after amplification, they control the image-reproducing tube directly. See Television without Sync Signals, *Electronics*, 11 (3), 33 (March, 1938); also T. T. Goldsmith, The DuMont Television System, *Communications*, 14 (2), 38 (February, 1939).

need to consider only the portion of the signal (the "sync region") on which both vertical and horizontal impulses are imposed.

The obvious problem in this case is the separation of the impulses at the receiving end of the system. It is necessary that the horizontal sync impulses have no effect on the vertical generator and the vertical impulses no effect on the horizontal generator. Consequently, whatever method is adopted, it must be such that the two sets of impulses may be completely separated

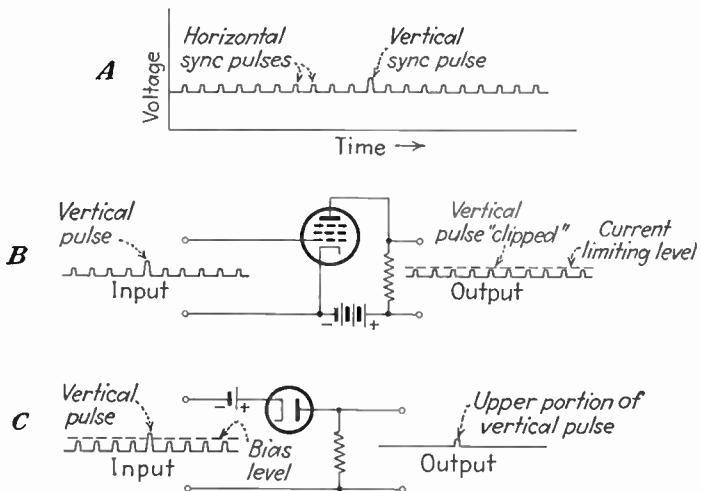

FIG. 92.—The "narrow" vertical sync-impulse system, widely used in television development but now superseded by the waveform system. A, the form of the sync signal; B, separation of horizontal sync pulses in a current-limiter tube; and C, separation of the vertical pulse in a biased diode tube.

at the receiver, and precautions must be taken to keep them separate.

*Amplitude Separation.*—The form of composite sync-pulse signal (containing both vertical and horizontal pulses) employed depends upon the method of separation employed at the receiver. Two separation methods have been widely experimented with: amplitude separation and waveform separation. The waveform system has been adopted in preference in this country and abroad. However, the amplitude method is simpler in principle and will be described first.

A composite sync-impulse signal intended for amplitude separation is shown in Fig. 92. The horizontal sync impulses occur regularly at the line-scanning frequency  $nf$  ( $= 15,750$ )



c.p.s., and the maximum amplitude they reach is that shown in Fig. 92A. The vertical sync impulses, on the other hand, occur at the field frequency  $f'$  ( $= 60$ ) c.p.s., that is, one vertical impulse occurs for every  $262\frac{1}{2}$  horizontal impulses. The vertical impulses attain a height about 20 per cent greater than that of the horizontal impulses shown by the dotted line C. The difference between the two sets of impulses is one of amplitude only, and they may be placed anywhere on the time axis without mutual interference. At the receiver, the composite sync signal is applied to an amplitude separator, such as a biased diode tube. In the output of this tube, only the high-amplitude vertical signals appear. The composite signal is also applied

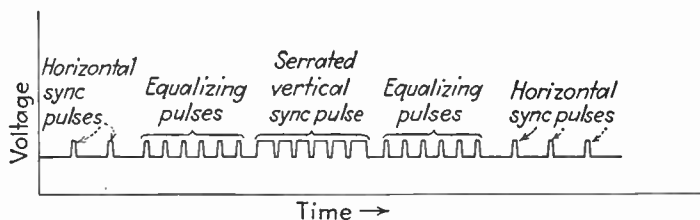

FIG. 93.—The serrated type of vertical sync pulse (with equalizing pulses). In this system, the energy contained in the serrated pulse is integrated to distinguish it from the smaller energy present in the horizontal pulses. The equalizing pulses produce equal energy integrations during successive blanking periods between the interlaced fields.

to a current-limiting tube, such as a pentode. The limiting action of this tube removes the high-amplitude vertical sync signals, and only the low-amplitude horizontal signals appear in the output of this tube. In this manner, the two sets of signals are separated in a very direct manner. The advantage of the system lies principally in the great accuracy with which the vertical sync impulses may be timed.

*Waveform Separation.*—The waveform method of separating sync signals is illustrated in Fig. 93. Here the horizontal signals, as before, are sharp, nearly rectangular pulses occurring 15,750 times per second. For every  $262\frac{1}{2}$  of these pulses, there must be one vertical impulse. The vertical impulse in this case has the same amplitude as the horizontal pulses. The difference is that the vertical impulse is prolonged, enduring through some 3 or 4 horizontal pulses. It might appear that the vertical pulse must obliterate these horizontal pulses, but if this were allowed to happen the horizontal generator would slip out of synchronism

while the vertical pulse persists. Therefore, it is essential that the horizontal pulses persist during the vertical pulse. Accordingly, the prolonged vertical pulse is broken up into smaller intervals, each of which serves as a horizontal pulse. The continuity of the horizontal pulses is thereby preserved. In addition to the horizontal pulses, a series of *equalizing pulses*, having twice the line-scanning frequency, is inserted before each vertical impulse. The purpose of these equalizing pulses is to make the effective shape of every vertical impulse the same, after separation, as explained below. The vertical impulse, with horizontal impulses interspersed in it, is known as the *serrated* type of vertical sync impulse.

The separation of the horizontal from the vertical pulses cannot be carried out by amplitude separation since both sets of pulses

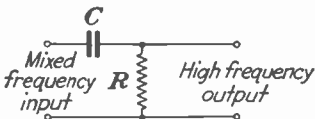

FIG. 94.—Differentiation circuit, which delivers high-frequency impulses from a mixed-frequency input.

have the same amplitude. Instead, circuits must be used that respond to the difference in the duration of the two sets of pulses. These circuits are capable of distinguishing differences in waveform and are commonly known as *differentiation* and *integration* circuits.

A typical differentiation circuit is shown in Fig. 94. It consists of a capacitance and resistance combination, the capacitance being in series with the signal input, the resistance in shunt across the output. The reactive impedance of the capacitor, relative to the resistance of the resistor, is small at the horizontal line-scanning frequency of 15,750 c.p.s. Consequently, the horizontal impulses are passed by the capacitor and develop a correspondingly large signal voltage across the resistor. The reactive impedance of the capacitor to the lower field-scanning frequency of 60 c.p.s. is  $262\frac{1}{2}$  times higher than it is for the 15,750 line-scanning frequency. Consequently, most of the frame-scanning signal appears across the capacitor and very little of it across the resistor. This circuit thus tends to separate the line-scanning pulses from the frame-scanning impulses.

The integration type of circuit is exactly the reverse of the differentiation circuit. As shown in Fig. 95, it consists of a series resistance and a shunt capacitance, the capacitance being large enough to offer very low impedance to the line-scanning frequency

but comparatively high impedance to the field-scanning frequency. When the composite signal is applied to this combination, most of the frame-scanning frequency appears across the capacitor and most of the line-scanning frequency appears across the resistance. In consequence, the output contains a high percentage of frame-scanning frequency and a low percentage of field-scanning frequency—just the reverse of the output of the differentiation circuit. Combinations of differentiation and integration circuits may be used in conjunction with amplifier tubes to secure substantially complete separation of the two sets of signals. A typical separation circuit containing two triodes is shown in Fig. 96.

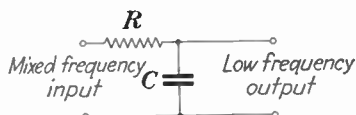

FIG. 95.—The integrator circuit, the reverse of the differentiator, which delivers low-frequency impulses from a mixed-frequency input. Several integrators or differentiators may be used in cascade to provide sharper separation of the two sets of impulses.

It must be remembered that the operation of these circuits depends strictly on the waveform involved. It is this fact that leads to the necessity for equalizing impulses. Suppose that, as shown in Fig. 97, no equalization signals are present. Then

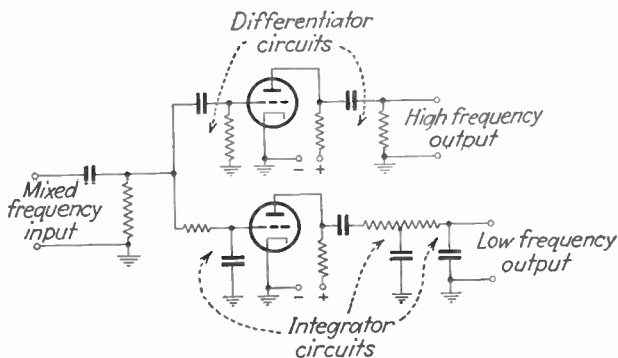

FIG. 96.—Typical waveform separator circuit, employing integrators and differentiators in the grid and plate circuits of two triode tubes.

at the beginning of the first field, the last horizontal impulse is separated from the vertical pulse by the distance *A*. At the beginning of the next field, that is,  $262\frac{1}{2}$  horizontal pulses later, the corresponding horizontal pulse is separated a distance *B*, which is greater than the distance

A by the duration of half a line. The two cases, applied to an integrating circuit, give the effects shown in the figure. The output of the integrating circuit is not exactly the same in the two cases, and the differences are sufficient to throw the vertical synchronization timing off by more than the allowable limit. If, however, equalization pulses are inserted midway between the horizontal pulses, the period immediately preceding the vertical impulses is substantially the same, and the effect on the

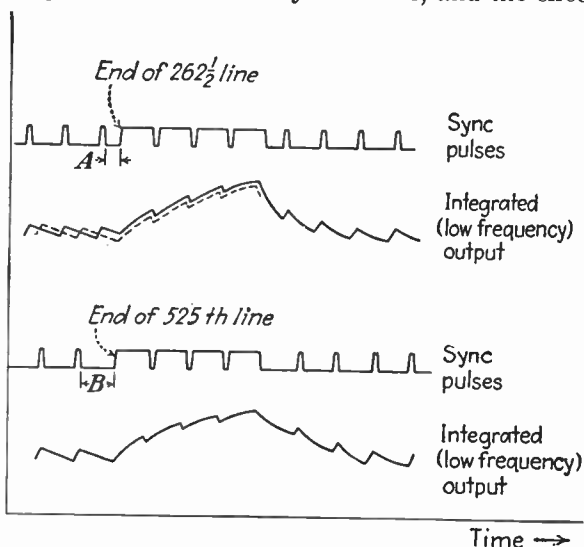

FIG. 97.—Effect of half-line difference in successive fields on integrated vertical sync pulse. The dashed line in the upper figure is the lower figure superimposed. The difference between the two integrated pulses is made negligibly small by the insertion of equalizing pulses (*cf.* Fig. 93).

integrating circuit is nearly enough identical for each field so that no serious asynchronism occurs in the deflecting circuit. The equalization pulses have no effect on the horizontal synchronization, since they occur midway between the horizontal impulses, that is, when the impulse generator is not in a position to react to a synchronizing pulse.

The serrated type of vertical pulse, with equalization signals, is a complex type of signal to generate, but once generated it gives very positive sync performance and is economical of the amplitude of the signal devoted to synchronization functions. This latter fact is the principal reason why it has been adopted in preference to the amplitude-separation system.

**Bibliography**

- EPSTEIN, Electron Optical System of Two Cylinders as Applied to Cathode-ray Tubes, *Proc. I.R.E.*, **24**, 1095 (August, 1936).
- IAMS, H.: A Fixed Focus Electron Gun for Cathode-ray Tubes, *Proc. I.R.E.*, **27**, 103 (February, 1939).
- JOHNSON, J. B.: The Cathode-ray Oscillograph, *Bell Sys. Tech. Jour.*, **11**, 1 (January, 1932).
- LANGMUIR, D. B.: Theoretical Limitations of Cathode-ray Tubes, *Proc. I.R.E.*, **25**, 977 (August, 1937).
- MALOFF and EPSTEIN: Theory of the Electron Gun, *Proc. I.R.E.*, **22**, 1386 (December, 1934)
- MALOFF and EPSTEIN, "Electron Optics in Television," McGraw-Hill Book Company, Inc., New York, 1938.
- WILSON, J. C.: "Television Engineering," Chap. VIII, Pitman and Sons, Ltd., London, 1937.
- ZWORYKIN, V. K.: Iconoscopes and Kinescopes in Television, *RCA Rev.*, **1** (1), 60 (July, 1936).

## CHAPTER V

### THE VIDEO SIGNAL

In the four preceding chapters, we have been considering primarily the transmitting terminal equipment of a television system, that is, the camera with its associated scanning and synchronization-impulse generators. This terminal equipment produces a succession of electrical impulses that correspond to the optical information of the scene in the studio (or film) together with the auxiliary signals that establish and maintain the timing of the scanning process. The two sets of signals, the camera impulses and the synchronization impulses, are combined so that they may be transmitted over one communication channel. The combined signal is known as the "composite video signal," or simply the "video signal."<sup>1</sup>

It is the task of the transmission equipment in the system to convey the video signal from the transmitter-terminal equipment to the receiver-terminal equipment, and to do so with a minimum amount of distortion and interference from masking currents. In fulfilling this task, the transmission equipment must meet definite specifications that relate to the amplitude, frequency, and phase aspects of the video signal. In the present

<sup>1</sup> The word *video* (Latin, "I see") is employed to denote in the television system the same sense of meaning as the word *audio* (Latin, "I hear") denotes in a sound-transmission system. Strictly speaking, the term *video* should be applied to a signal only when the signal contains a-c frequencies from which visual intelligence can be derived directly by application to an image-reproducing tube. In practice, the video signal exists from its source in the television camera and synchronization equipment, through the following amplifiers, and up to the terminals of the modulating equipment (if carrier transmission is employed). The video signal reappears in the output of the second detector in the receiver and persists through the succeeding amplifiers to the control grid of the image-reproducing tube. The intermediate signal, between the transmitter modulator and the receiver second detector, contains the carrier frequency and sideband components, which cannot be used directly to reproduce the scene, and hence cannot be called a video signal. The broader terms "television signal" or "picture signal" apply to the carrier and sideband components.

chapter we examine in detail these aspects of the composite video signal.

**28. General Description of the Video Signal.**—In Fig. 98 is shown a plot of a portion of the standard video signal according to the R.M.A. standards.<sup>1</sup> The plot represents successive values of voltage or current amplitude, plotted vertically, at corresponding values of time, plotted horizontally. The diagram shown represents the voltage or current amplitudes generated during the scanning of three lines in the image, together with the interim periods during which the synchronization and blanking signals are transmitted. The current or voltage amplitude is divided into two sections. The upper section (20 to 25 per cent of the total amplitude) is devoted to synchronization and the remaining lower section to the picture signals.

The polarity of the current or voltage is purposely chosen so that as the amplitude of the video signal increases the corresponding brilliance in the reproduced picture decreases. This is "negative transmission." It is obvious that this polarity must be standardized, since it determines the sense of the tone values in the picture. If a receiver designed for positive transmission is used to view images from a negative-polarity transmission, the picture would have the appearance of a photographic negative, that is, all the tones in the picture would be reversed. Positive-polarity transmission serves equally well as a basis of transmission (as it does in England), but the negative polarity has been established in this country.

The relative merits of negative transmissions as opposed to positive have been argued for some time, but experience seems to have shown that the negative system is preferable. In the negative system, any increase in the signal level, such as might be caused by interference from automobile ignition systems, makes the signal go farther into the black region, and the result is that such interference simply cuts into the image in a series of black dots or lines, which are not very conspicuous. In the positive polarity of transmission, on the other hand, an increase in the signal level produces an increase in brightness, so that interference shows up as a series of bright spots or lines which are

<sup>1</sup> For a discussion of the significance of the standard R.M.A. signal see: Murray, A. F., *The R.M.A. Television Synchronizing Standard—A Semi-technical Explanation*, *R.M.A. Eng.*, 3 (1), 22 (November, 1938).

much more conspicuous than the black regions produced in negative modulation. The effect of a decrease in the signal level, which might also be caused by interference, if the interference were in the proper instantaneous phase relative to the signal, would produce the opposite effect; but experience shows that interference increases the signal level much more often than it decreases it. Accordingly, negative transmission is to be preferred from the standpoint of interference effects. An argument on the other side of the question urges that the synchronizing signal region in negative transmission should be much more vulnerable to interference than it would be in the positive

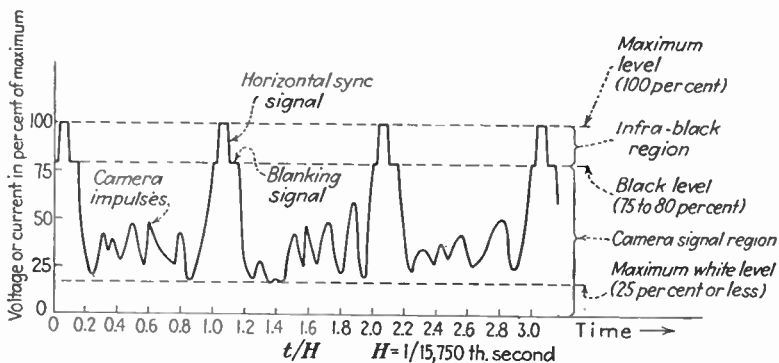

FIG. 98.—Three lines and blanking periods of the N.T.S.C. Standard Video Signal.

method, but there seems to be no great difference in the sync performance of the two polarities, at least not a sufficient difference to balance the advantage of the negative polarity in respect to the visible effects of interference.

It follows from this definition of the polarity that white tones in the picture are produced by low amplitudes in the picture signal. Successively deeper grays are represented by higher amplitudes, until at the level shown in the diagram, the amplitude represents a total absence of light. This is the so-called "black level." The black level is a fixed amplitude in the video signal. This level has been fixed at a value of 75 to 80 per cent of the maximum amplitude in the signal. During transmission, this level, relative to the maximum level of the signal, is maintained constant.

The remaining 20 to 25 per cent of the signal amplitude is devoted to synchronization. Any portion of the signal in this region lies above the black level and hence cannot produce light



in the received image. This region of amplitude is known as the "blacker than black" or "infra-black" region.

Figure 98 shows the video signal resulting from the scanning of the first three lines of the image. Wherever the picture is bright, the amplitude is low, and conversely, wherever the picture is dark, the amplitude is high. The variations in voltage are produced by the camera tube as it scans the lines in the image. At the conclusion of the first line, the camera becomes inactive, while the scanning beam is retracing to the beginning of the next line. During this inactive period, a *blanking amplifier* imposes on the signal circuit a voltage the amplitude of which corresponds to black (or slightly "blacker than black"). During the retrace interval, therefore, no picture information is transmitted. At the receiver, during this interval, the scanning beam is retracing and is maintained at the black level (that is, the signal on the control grid holds the beam current so low that no luminescence is excited on the screen).

Immediately after the beginning of the blanking period, the signal amplitude is caused to rise momentarily still farther into the "infra-black" region by an impulse superimposed on the signal circuit by the synchronizing signal generator. This impulse, the *horizontal-synchronization impulse*, initiates the action of the horizontal scanning generator at the receiver.

After the horizontal-synchronization impulse is completed, the signal level drops again to the black level until the blanking interval is concluded. At the end of the blanking interval, the beam in the camera tube has reached the beginning of the next line, which it proceeds to scan. Simultaneously, the blanking amplifier removes the blanking voltage level and the camera resumes control over the signal. Thereafter, the signal level is representative of the brightness of the successive picture elements in the second line. At the conclusion of the second line, the blanking amplifier again comes into play, followed immediately by the synchronization-impulse generator, and the blanking and synchronizing interval is repeated. Thereafter the camera resumes control, scans the third line, and so on. This sequence is repeated until  $262\frac{1}{2}$  lines have been completed, and by that time the complete field has been scanned, from top to bottom of the picture. Then the second field is scanned in similar fashion, and so on.

The dimensions of the picture, blanking, and synchronization signals, as defined in the N.T.S.C. Standard, are shown in Fig. 99. The interval between the beginning of one scanning line and the beginning of the next (the line-scanning interval) is labeled  $H$ . This time, as shown in the preceding chapter, must equal  $1/nf$  sec., that is,  $H = 1/15,750$  sec. The blanking period occupies 15 per cent of  $H$ . The horizontal-synchronization impulse begins after 1 per cent of the line-scanning interval  $H$  has passed. The synchronization impulse must reach its maximum within  $\frac{1}{2}$  per cent of the line-scanning interval or less. The signal maintains its maximum for 7 per cent of  $H$  and returns to the blanking

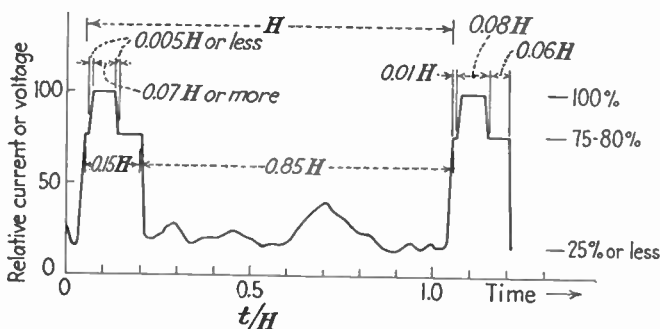

FIG. 99.—Dimensions of the blanking and synchronizing signals (N.T.S.C. Standard) in terms of the line-scanning interval  $H$  ( $= 1/15,750$ th sec.).

level in  $\frac{1}{2}$  per cent or less. Thus 8 per cent of the line-scanning interval is taken by the horizontal-synchronization impulse. This impulse is included in the blanking interval which is 15 per cent. The remaining 85 per cent of the line-scanning interval is occupied with the transmission of the picture information in that line.

It will be noted that the ratio of active line-scanning time to inactive blanking time is  $85/15 = 5.67$  times. If the retrace of the scanning beam takes the entire blanking time, then the ratio of retrace velocity to scanning velocity ( $k_r$ ) is the same, that is, about 6 to 1. The ratio has been taken as 7 to 1 in the discussion of scanning action in Chap. II, representing a retrace that completes itself in somewhat less time than the blanking interval. The result is that part of the forward scanning motion occurs while the signal is blank, but this has no effect other than to decrease the width of the picture somewhat, an effect easily

overcome by increasing the amplitude of the horizontal-scanning current or voltage.

It may be wondered why such a long blanking interval has been established as standard, since this is precious time during which picture information might otherwise be sent. The reason lies principally in the fact that scanning generators having retrace ratios higher than 6 to 1 are difficult to manufacture in production. By allowing some tolerance in this portion of the signal,

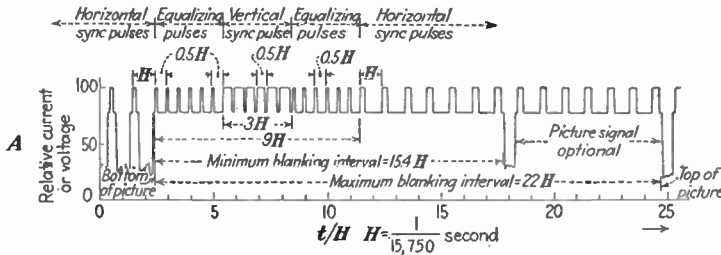

FIG. 100A.—The N.T.S.C. Standard Video Signal during the vertical blanking (field retrace) period, representing the beginning of the first field.

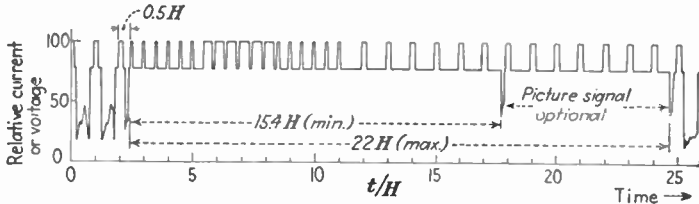

FIG. 100B.—Same, at beginning of next successive field. Note that the blanking period begins in this case after the scanning of one-half a line, whereas in Fig. 100A the last scanned line was completed.

much more reliable horizontal-scanning performance may be obtained, and the necessity for adjustment of the scanning circuits by the operator of the receiver is largely eliminated.

*The Video Signal during Frame Retrace.*—When the bottom line of the field has been reached, it is necessary to bring the signal once more to the blanking level and to maintain this level while the scanning spot moves to the top of the pattern. During this interval, the *vertical synchronizing impulse* which initiates the action of the vertical scanning generator must also be sent. The waveform method of separating the vertical from the horizontal impulses has been adopted in the N.T.S.C. Standard Signal. Accordingly, the serrated type of sync pulse, with

equalizing pulses, must be imposed on the blanking level during the frame-retrace interval.

A plot of the video signal from the end of one field to the beginning of the next field is shown in Fig. 100B. At the left are shown two scanned lines with horizontal blanking and horizontal sync impulses between them. We assume that the field scanned is one that ends at the end of the 262½ line. Consequently, the last line is only half completed when the blanking level is reached. There follows a series of six equalizing pulses, spaced at intervals equal to 50 per cent of the line-scanning interval, with durations equal to 4 per cent of this interval, and having as steep sides as possible (durations of ½ per cent of  $H$  or less).

Following the six equalizing pulses come six broad-topped serrated pulses (which are integrated at the receiver to produce the vertical-synchronization impulse). The separation between corresponding edges of these pulses is 50 per cent of the line-scanning interval. Their duration is 43 per cent, the rise and fall ½ per cent or less, and the interval between pulses endures for 7 per cent. When six of these broad pulses have been sent, six more equalizing pulses are sent. After the sixth equalization pulse, there follows a number of ordinary horizontal sync pulses. At some point thereafter, the blanking signal is removed and the line scanning begins again at the top of the second field. The only restriction is that the total vertical-blanking period shall be not less than 7 per cent and not more than 10 per cent of the vertical field-scanning interval. This latter interval, symbolized in the figure by  $V$ , is  $1/f'$  or  $1/60$  sec. According to these limits, the vertical-blanking impulse ends, at the earliest, after 8 ordinary horizontal sync impulses have been sent, and at the latest, after 13 such pulses have been sent. These limits are shown in the figure.

The succeeding field is then scanned. This field ends, not on a half line, but on a whole line, since at the end of this field 525 complete lines (active and inactive) have been covered. Consequently the beginning of the frame blanking period in this case is somewhat different, as shown in Fig. 100A. Here the equalizing pulses begin immediately at the end of the last complete line. Six pulses are sent as before, followed by 6 serrated broad-top pulses, followed by 6 equalizing pulses, followed by from 7 to

12 ordinary horizontal sync impulses, whereupon the next field begins. It will be noticed that the two vertical-blanking intervals, shown in Figs. 100A and 100B, do not contain identical signals; hence there is a chance for a slight irregularity in the integrated signal which initiates the vertical scanning generator at the receiver. However, the parts of the blanking interval immediately preceding and following the serrated vertical sync pulse are very similar, owing to the presence of the equalizing impulses. The residual irregularity is so slight that substantially identical integrated vertical pulses are produced at the end of every field, and no loss of synchronism is suffered. A somewhat expanded detail of the serrated impulse and the preceding equalizing impulse is shown in Fig. 100C.

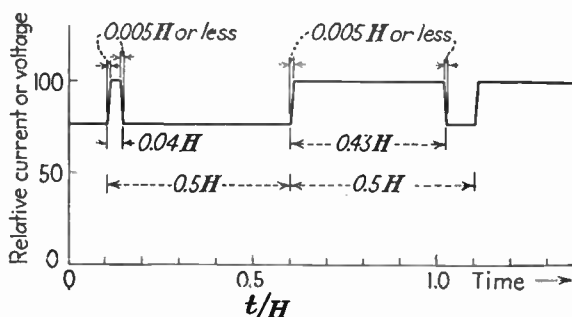

FIG. 100C.—Dimensions of the equalizing and serrated vertical pulses, in terms of the line-scanning interval  $H$ . (R.M.A. Standard Video Signal.)

It will be noted that the synchronizing signals shown in Fig. 100 are substantially the same as those discussed in the preceding chapter and that they have been placed on the signal in such a position that they cannot have any influence on the reproduction of picture elements (in the infra-black region). Furthermore in confirmation of the discussion in Chap. IV, the slopes of each sync impulse are made to be as sharp as possible (full sync amplitude level must be reached in  $\frac{1}{2}$  per cent of the line-scanning time). It is clear that the generation of such highly specialized and accurately timed sync impulses requires extensive equipment. Some of the details of the sync-impulse generators and the associated blanking amplifiers are given in Chap. IX.

**29. Analysis of the Camera Signal.**—In this section, we confine our attention to that part of the video signal which exists during the active scanning of each line, that is, the electrical impulses

generated by the camera which correspond to the details in the picture. For convenience, we shall refer to this part of the signal merely as the "camera signal." This signal is obviously the heart of the television system; upon its characteristics (amplitude, frequency, and phase) depends the design of all the transmission equipment.

What information must be conveyed by the camera signal? The signal must (1) have at any instant an amplitude that corresponds to the brightness of the picture element scanned at that instant. This is the instantaneous aspect of the signal. (2) The signal must have an average value that corresponds to the average illumination of the scene (the average is taken over all the lines in the image). This is the steady-state aspect of the camera signal, usually referred to as the "d-c component." The instantaneous (a-c) and steady-state (d-c) aspects of the signal may be varied independently of one another. The first contains the *detailed* information, corresponding to the departure in brightness of each picture element from the average. The second contains the *background* information, which may be equally important. A given scene superimposed on a bright background gives the impression of sunlight, brightness, warmth, color. The same detail superimposed on dark background may convey the impression of moonlight, darkness, cold—exactly the opposite context, although the detail remains the same.

*The D-c Component.*—The d-c component of the camera signal lends itself to the simplest analysis, hence we consider it first. The d-c component is the average value of the camera signal, averaged over the whole frame-scanning interval. Consider Fig. 101, which shows one line of the camera signal, the average of which is represented by the solid line. Suppose we wish the a-c component to remain unchanged, but we wish to make the scene appear brighter in the reproduced image. Then we subtract a direct current or voltage from the signal, represented by the dotted line. This subtraction raises the average brightness (since we are considering negative transmission) by the amount of the subtracted d-c amplitude. The a-c component remains the same but is displaced downward. The reproduced scene is thereby made to appear brighter. If no further change is made, the scene may appear "thin" since the ratio of brightnesses between the high lights and shadows is decreased by adding

the d-c component, *i.e.*, the apparent brightness contrast of the reproduced image is reduced. Conversely if we add a direct current or voltage to the camera signal, the average brightness decreases and the apparent brightness contrast increases.

In practice, the d-c component may be increased or decreased in a variety of ways. It may be changed arbitrarily by adding a voltage to the transmission circuit from a manually controlled source of direct voltage. Certain camera tubes, notably the nonstorage Farnsworth image dissector, produce automatically a direct current in their output which is representative of the average brightness of the scene. The iconoscope, however is

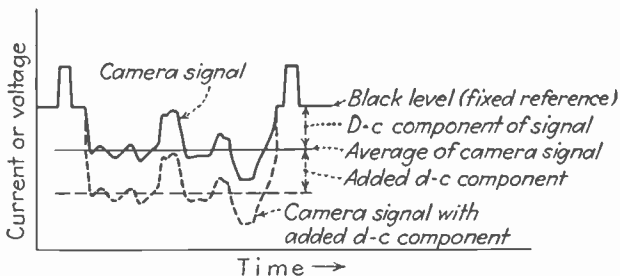

FIG. 101.—The d-c component of the video signal. The waveform retains its shape, but is displaced upward or downward as the picture becomes darker or brighter, respectively.

not a direct-coupled device, since the mosaic capacitance is in series with the signal circuit. Consequently its output consists of an a-c component referred to some arbitrary axis. To determine the average brightness of the scene in this case, an auxiliary phototube is sometimes employed to view the scene, and the output current of the phototube, after suitable amplification, is used to control the average level of the picture signal. Whenever the signal passes through a capacitance-coupled amplifier (nearly all video amplifiers are of this type), the d-c component is removed and an arbitrary level introduced. To correct this loss, the d-c level must be evaluated in the last amplifier (or other transducer) in the transmission circuit. This latter process is known as "reinsertion of the d-c component." It is discussed at greater length in Chaps. IX and X.

The insertion of the d-c component in reality refers to establishing a given voltage level of the video signal as a fixed reference and ensuring that this reference does not change as the waveform

of the camera signal changes. When a video signal is passed through a capacitor, the level of the signal which remains fixed is the average of the entire waveform, which remains at zero potential (since no direct voltage is passed by the capacitor). Consequently, the reference potential (zero in this case) varies with the waveform. To avoid this problem in television transmissions, the blanking level is taken as a fixed reference, and caused to have a constant value in the envelope of the modulated carrier. Another level which remains fixed is that corresponding to the tips of the sync pulses, since the height of the sync pulses above the blanking level is constant.

The establishment of the blanking level (or, alternatively, of the tips of the sync pulses) as a fixed voltage is performed by passing the video signal through a rectifier and load circuit, which develop a voltage equal to the peak value of the wave. This voltage is then used as the d-c portion of the signal. The rectification is commonly used in two places in the system: first, directly before modulation (in the grid circuit of the modulating amplifier), and second, directly before the control of the picture tube (in the grid circuit of the final video amplifier, or even in an auxiliary rectifier in the grid circuit of the picture tube itself). The first rectification, before the modulator, ensures that the blanking and sync-tip levels will remain constant in the carrier envelope, and the second rectification ensures that the bias on the picture-tube control circuit will remain fixed at a corresponding level. Any variation of the average of the waveform away from or toward the d-c level thus established causes a brightening or darkening of the picture. Hence, such variations of the waveform average are used to establish the desired picture brightness and to produce the desired changes in it.

*The A-c Component.*—The a-c component consists of departures from the average d-c value. Since the a-c and d-c components are independent in the transmission process we can devote our attention to the a-c component relative to any arbitrary amplitude level we choose. Usually it is convenient to establish the level of zero amplitude as the maximum brightness and some higher level as black. Intermediate levels correspond to intermediate gray tones, and levels above black are in the infra-black (sync signal) region. The camera signal resides in the amplitude region between zero level and the black level.



The a-c component of the signal is made up of more or less rapid changes in voltage or current, which correspond to the changes in brightness between adjacent picture elements as the scanning agent passes over them. *The requirement for perfect transmission of the a-c component is that the changes in voltage be conveyed without change in waveform from the camera tube to the image-reproducing tube.*

In addition to the preservation of waveform, the signal must possess at the end of the transmitting circuit a zero level which will produce the desired maximum brightness and a black level which will produce an absence of light on the image-reproducing tube screen. The latter requirement is met (1) by adjusting the d-c component fed to the control grid of the tube and (2) by adjusting the over-all amplification of the signal, so that the minimum and maximum values of the a-c component cover the desired range from white to black. The insertion of the d-c component and the adjustment of amplifier gain are readily performed and offer no theoretical problem.

The preservation of waveform, on the other hand, is a matter of the gravest importance, both theoretically and practically. Every item of equipment in the transmission system conspires to distort the waveform of the signal sent through it, and this tendency must be arrested or compensated at every point in the system where waveform degradation may occur. It is important, therefore, to know exactly the requirements for the preservation of waveform.

The ability of an electrical system to convey a current or voltage waveform without impairment is measured in terms of three response characteristics: its amplitude response, frequency response, and phase (time-delay) response. Usually these responses are measured and plotted as two functions of frequency, (1) amplitude of response vs. frequency and (2) time delay vs. frequency. The ideal characteristics are horizontal straight lines of indefinite length, that is, the system should pass all frequencies without amplitude discrimination and without time-delay discrimination.

Practical operating characteristics fall far short of these ideals. The amplitude-frequency-response curve is made as nearly flat and horizontal as possible, but only over the frequency range required for the desired amount of detail in the reproduced image.

The time-delay characteristic is made as flat as possible over the same range of frequency.

Although the concepts of frequency, phase, and amplitude are familiar to electrical engineers and the use of frequency characteristics to communications engineers, their relation to waveform transmission is not so generally understood. Accordingly, we review briefly the elements of Fourier analysis on which the frequency analysis of waveforms is based.

**30. Fourier Analysis of Waveforms.**<sup>1</sup>—The basis of Fourier analysis, as applied to electrical problems, is the sinusoidal or cosinusoidal wave on which all a-c theory is based. The sinusoidal form is given by the relation

$$e = E \sin 2\pi ft \quad (68)$$

and the cosine form by

$$e = E \cos 2\pi ft \quad (69)$$

where  $e$  is the instantaneous voltage amplitude at a time  $t$  sec. of a voltage the amplitude of which is  $E$  volts and the frequency of which is  $f$  c.p.s.

The impedances of simple electrical circuit elements, when subjected to such voltages, are given by the familiar relations

$$Z = R \quad (70)$$

$$Z = j2\pi fL \quad (71)$$

and

$$Z = \frac{-j}{2\pi fC} \quad (72)$$

respectively, for the case of resistance  $R$  ohms, inductance  $L$  henries, and capacitance  $C$  farads. Any transmission system, consisting of a combination of  $R$ ,  $L$ , and  $C$  elements, will allow current to flow in an amount determined by the impedances of the elements and their manner of connection. Since inductance and capacitance display impedances that vary with frequency, the amplitude of the current flow through such a combination

<sup>1</sup> For a more extended treatment of Fourier analysis see:

PHILLIPS, H., "Differential Equations," John Wiley & Sons, Inc., New York, 1934.

SOKOLNIKOFF, I. S., and E. S. SOKOLNIKOFF, "Higher Mathematics for Engineers and Physicists," Chap. VI, McGraw-Hill Book Company, Inc., New York, 1936.

of elements in general depends upon the frequency, or frequencies, involved. When the complex impedance (amplitude and phase) at each significant frequency is evaluated, then the current amplitude may be determined in terms of the applied voltage. It follows that the amplitude response of the transmission system is conveniently analyzed in terms of the frequencies of the voltages applied to it. This is the reason why the response characteristics of the system are plotted as functions of frequency.

In television, we do not apply a-c frequencies, as such, to the transmission system. Rather we apply a voltage waveform that we desire to deliver unimpaired to the receiver. The preceding discussion indicates that the waveform must be analyzed into a combination of frequency components, to each of which the transmission system displays a calculable response.

The analysis of a waveform into its component frequencies is carried out by Fourier analysis. We begin with the Fourier series theorem which applies only to functions within a restricted interval, or to functions that repeat themselves at regular intervals (periodic functions). In general, a television picture signal is not a periodic function unless the scene is completely static, but the periodic analysis serves nevertheless to point out the requirements for the nonperiodic functions encountered in the video signal.

The Fourier theorem states that any continuous function (say the function between current or voltage amplitude and time, represented by the picture signal) may be represented by a sum of cosine and sine terms with appropriate coefficients and arguments. We choose the argument of the sine and cosine terms in the form  $(2\pi nft)$  to correspond with the basic voltage form given by Eqs. (68) and (69). Let the picture signal be represented by the function  $E(t)$ , such as is shown in Fig. 102. Then we may write, following the Fourier theorem,

$$E(t) = \frac{a_0}{2} + a_1 \sin 2\pi ft + a_2 \sin 2\pi 2ft + a_3 \sin 2\pi 3ft + \dots \\ + a_n \sin 2\pi nft + b_1 \cos 2\pi ft + b_2 \cos 2\pi 2ft + \\ b_3 \cos 2\pi 3ft + \dots b_n \cos 2\pi nft \quad (73)$$

To choose a concrete example, let  $E(t)$  be the given function of voltage against time, produced by the camera tube during the scanning of a line. The term  $a_0/2$  represents the d-c component

of the signal. The sine terms represent alternating voltages of frequency  $f$ ,  $2f$ ,  $3f$ , etc., and of corresponding amplitudes  $a_1$ ,  $a_2$ ,  $a_3$ , etc. An indefinite number of such sine terms is taken, depending on how closely it is desired that the sum of terms shall equal  $E(t)$ . The final sine term is indicated by the subscript  $n$ . Similarly, the cosine terms have frequencies that are multiples of  $f$  and amplitudes given by  $b_1$ ,  $b_2$ ,  $b_3$ , and so on to  $b_n$ . The equation states that the given function  $E(t)$  may be considered to be equal to the sum of a number of alternating components having frequencies that are multiples of a basic frequency  $f$  and the

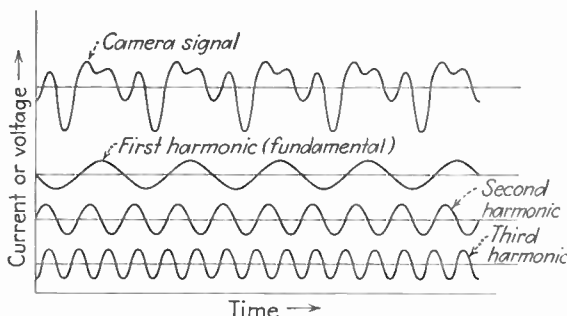

FIG. 102.—Analysis of a complex waveform (top) into three harmonic components. The upper waveform is the algebraic sum of the three harmonics, point by point along the time axis.

amplitudes of which are as yet undetermined. The determination of the frequency  $f$  and the amplitudes depends, evidently, on the function  $E(t)$  that the sum represents.

The importance of phase is not at once evident in this series of terms. The concept of phase is introduced by adding the sine and cosine terms of the same frequency, say  $a_1 \sin 2\pi ft$  and  $b_1 \cos 2\pi ft$ . The sum is

$$a_1 \sin 2\pi ft + b_1 \cos 2\pi ft = \sqrt{a_1^2 + b_1^2} \sin \left( 2\pi ft + \tan^{-1} \frac{b_1}{a_1} \right) \quad (74)$$

The term  $\tan^{-1} \frac{b_1}{a_1}$  is the phase angle of the term of frequency  $f$ . It simply states that at time  $t = 0$  the amplitude of this alternating component is not zero but has a value produced by a shift of the time coordinates equal to angle  $\tan^{-1} \frac{b_1}{a_1}$  radians. This displacement of the time coordinate is known as the “phase

“shift,” relative to the origin at  $t = 0$ , of the component of frequency  $f$ . The amplitude of this component is  $\sqrt{a_1^2 + b_1^2}$ .

Similarly, we may add the two terms of frequency  $2f$  and obtain a phase shift of  $\tan^{-1} \frac{b_2}{a_2}$  the amplitude of which is  $\sqrt{a_2^2 + b_2^2}$ , and so on, for all the terms up to the frequency  $nf$ . It is true therefore that when the amplitudes  $a_1, a_2, a_3 \dots a_n$ , and  $b_1, b_2, b_3 \dots b_n$  are determined, together with the basic frequency  $f$ , the amplitude of every frequency component in the sum is uniquely determined, and the phase is determined likewise,

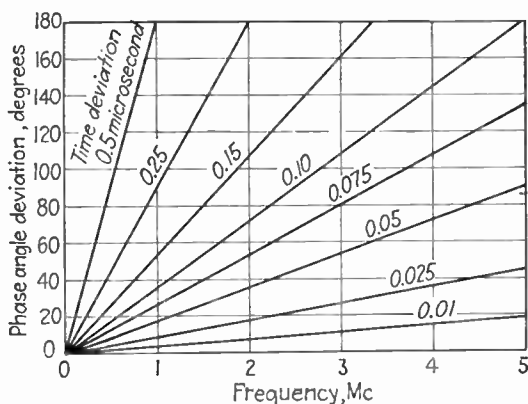

FIG. 103.—Relationship between angular phase measure and the equivalent time delay. The phase angle corresponding to a given fixed time delay becomes larger as the frequency increases.

but not uniquely. The phase angle  $\tan^{-1} \frac{b_n}{a_n}$  gives an angle  $\phi_n$  and also any other angle  $\phi_n + 2\pi a$  radians, where  $a$  is any integer. Hence the phase need be specified no closer than any multiple of  $2\pi$  radians.

The phase characteristic of a transmission system may be represented in either of two ways. If phase delay is measured in time (microseconds), the ideal phase characteristic is a straight horizontal line extending over the required frequency range, representing a time delay independent of frequency. However, the delay is usually expressed in terms of a phase angle (degrees or radians). In this case, the ideal phase characteristic is a straight line inclined at an angle to the frequency axis, indicating an *angular* phase delay proportional to frequency. The two ideal characteristics are exactly equivalent, since the angular

phase displacement representing a given time delay is proportional to the frequency under consideration. Thus a phase delay of 10 microseconds is  $36^\circ$  at 10,000 c.p.s.,  $360^\circ$  at 100,000 c.p.s.,  $3600^\circ$  at 1,000,000 c.p.s., etc. Accordingly, the usual phase characteristic is an oblique line, more or less linear, depending on the uniformity of the phase response.

It remains to show how the coefficients  $a_1, a_2, a_3$ , etc., and  $b_1, b_2, b_3$ , etc., may be obtained. The mathematical method is to solve the following integrals:

$$a_n = 2f \int_{t=-\frac{1}{2f}}^{t=\frac{1}{2f}} E(t) \sin (2\pi nft) dt \quad (75)$$

and

$$b_n = 2f \int_{t=-\frac{1}{2f}}^{t=\frac{1}{2f}} E(t) \cos (2\pi nft) dt \quad (76)$$

Here  $-1/2f$  is the time at the beginning and  $1/2f$  is the time at end of the interval over which the analysis is performed.

The integrals in Eqs. (75) and (76) are incapable of analytical solution unless the function  $E(t)$  is a simple one, or unless it is expressed in terms of a power series, in which case the integration must be performed term by term. In all but the simplest cases, therefore, calculation based on these integrals is not attempted. Instead, general rules are derived from inspection of the integrals.

Experimentally, of course, it is possible to measure the amplitudes  $\sqrt{a_1^2 + b_1^2}$ ,  $\sqrt{a_2^2 + b_2^2}$ , etc., in a wave analyzer, and the phase shifts in a Lissajous-figure system employing a two-dimensional oscillograph. But usually it is not necessary to measure the individual amplitudes and phases of the harmonic components, so long as generalizations may be made in terms of the character of the signal itself.

In deriving these generalizations, the first is obtained by noting from the integrals in Eqs. (75) and (76) that the frequency  $f$  is determined by the interval of time  $1/f$  over which the analysis is performed. Suppose that the analysis is performed over the line-scanning interval that occupies a time of  $1/13,230$  sec. The corresponding basic frequency is then 15,750 c.p.s. The other components in the picture signal contain frequencies of 31,500, 47,250, 63,000, 78,750, 94,500 c.p.s., etc., up to an

undetermined upper limit. The phase of each of these frequency components, as well as their relative amplitudes, depends on the waveform of the picture signal during the scanning of the line in question. *Moreover, if the phases and amplitudes are preserved by the transmission system, the waveform is preserved.* The generalization is, therefore, that the relative amplitudes and phases of all the frequency components are to be preserved. In this case, the lowest frequency of consequence is 15,750 c.p.s. and the uppermost frequency has not as yet been determined.

Suppose now that we extend the analysis to cover the whole frame-scanning interval, which consumes a time of  $\frac{1}{30}$  sec. The basic frequency is then 30 c.p.s., and the harmonic frequency

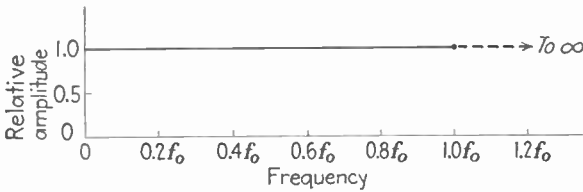

FIG. 104.—Ideal amplitude-frequency response characteristic, which displays no discrimination in its response to any frequency from zero to infinite frequency.

components are 60, 90, 120 c.p.s., etc., up to an undetermined upper limit. This shows that to transmit the whole picture, as against a single line, much lower frequencies must be considered. If the analysis is taken over a still longer time, say 10 frames, the frequencies of importance go as low as 3 c.p.s. It follows that the longer the time that a significant change in light takes to complete itself, the lower the frequency which must be included in the signal to convey that change in light.

In all the foregoing discussion, no limit has been placed on the undetermined upper frequency represented by the subscript  $n$ . One method of approach is to perform our waveform analysis over smaller and smaller intervals of time until some "logical" limit has been reached and to specify the uppermost frequency as the inverse of this smallest significant time interval. We have already taken the duration of one scanning line as an interval. Suppose we now restrict the interval of analysis to the duration of one picture element. The picture elements are sent at a rate, calculated by Eq. (20), of about 8,000,000 per second. Actually, as we shall see in considering the square wave, a single

cycle of the basic frequency can accommodate two picture elements of different brightness. It follows that picture elements may be represented by an alternating current the basic frequency of which is equal to one-half the rate at which the picture elements must be transmitted, that is, 4,000,000 c.p.s. for 8,000,000 picture elements per second. In present practice, the upper limit employed is about 4,000,000 c.p.s.

We come to the conclusion, as a result of this rather roundabout procedure, that the important frequency components in preserving the picture-signal waveforms are those lying between 30 and 4,000,000 c.p.s. (or higher). The lower limit suffices to handle changes in light that occur between successive frames. The upper limit suffices to handle changes that occur between succes-

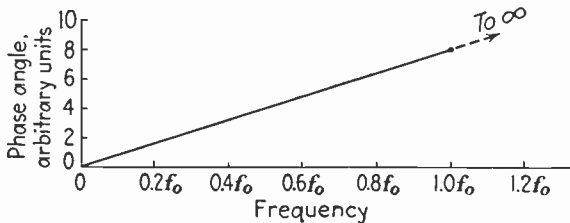

FIG. 105.—Ideal phase-angle-frequency response characteristic, showing phase angle proportional to frequency (fixed time delay) for all components up to infinite frequency.

sive picture elements. Any intermediate degree of detail can be handled by frequency components intermediate between 30 and 4,000,000. Since such intermediate degree of detail may be present in any given scene, it follows that all frequencies in the range between 30 and 4,000,000 c.p.s. may be present, at some time or other, in the picture signal. *In consequence, the transmission system must be set up to transmit any and all frequencies within this range, without amplitude discrimination and with an angular phase shift proportional to the frequency involved.* On this frequency-range requirement rests the technical design of all the transmission equipment in the television system. When the requirement is met the signal waveform is transmitted adequately.

**The Maximum Frequency in the Video Range.**—The foregoing discussion has established the basic reasoning behind the frequency range of the video signal but has not given any quantitative measure of the frequencies involved in terms of the



dimensions of the scanning process. We proceed, therefore, to the derivation of an expression for the maximum frequency in the video range.

It is clear that the high-frequency limit is produced from the scanning of the finest detail in the image, that is, from the scanning of successive picture elements. Let us return, therefore, to the basic scanning pattern of  $n$  total lines, approximately  $n_a$  active lines, in which the horizontal resolution is  $m$  times as great as the vertical resolution. In such a pattern, according to Eq. (3), there are  $N = (w/h)mk^2n_a^2$  picture elements, and the number of picture elements in each line is  $n_h = (w/h)mkn_a$ . When the pictures are sent at a rate of  $f$  ( $=30$ ) frames per second and the retrace ratios are  $k_h$  ( $=7$ ) and  $k_v$  ( $=12$ ), these  $n_h$  picture elements are sent at a rate of

$$R = \frac{w}{h}kmfn^2 \left( \frac{1 + \frac{1}{k_h}}{1 + \frac{1}{k_v}} \right) \quad (20)$$

The maximum frequency in the video range is directly related to this rate of scanning picture elements, but the connection between the two quantities depends on the particular waveform under consideration.

It is customary to base the analysis on a checkerboard image composed of black and white squares of the size of picture elements (see Fig. 14). When a single line of such an image is scanned by an ideal scanning agent, the result is a video signal of square waveform, as shown in Fig. 107. The frequency content of such a square wave contains theoretically an infinite number of frequency components, and hence, the frequency range required to reproduce the picture elements is of infinite extent. If, however, only the first harmonic (fundamental) of the square-wave signal is transmitted, the video signal after transmission is no longer a square wave but a sine wave of the same frequency, as shown at the bottom of Fig. 107. This sine wave when applied to a picture tube, is not capable of reproducing the original black and white squares, but it is capable of reproducing variations of brightness of the same general character as the squares. The reproduced picture elements are not perfectly black and perfectly white squares, but are rather

gradually shaded areas merging from black to white and having no definite outline. Although a reproduced line composed of such indefinite squares is a poor approximation of the original line in the checkerboard, it nevertheless establishes the basic structure of the reproduced picture. Accordingly, it is usually assumed that the picture elements are adequately reproduced by a sine wave of the same frequency as the square wave which would result from scanning the checkerboard pattern.

On this assumption, it is necessary to determine the frequency of the square wave. The square waves are scanned at a rate of  $R$  elements per second, given by Eq. (20) above. Each square wave accommodates *two* adjacent picture elements of different brightness, as shown in Fig. 107. Hence, the frequency of the square wave is

$$f_s = \frac{R}{2} \text{ c.p.s.} \quad (77)$$

This frequency is the fundamental frequency of the square wave and is equal to the maximum frequency in the video range. Thus, substituting in Eq. (77) the expression for  $R$  in Eq. (20), we obtain for the maximum frequency  $f_{\max.}$ :

$$f_{\max.} = \frac{w}{h} kmfn^2 \left( \frac{1 + \frac{1}{k_h}}{1 + \frac{1}{k_v}} \right) \text{ c.p.s.} \quad (78)$$

where  $w/h$  is the aspect ratio of the picture,  $k$  the utilization ratio,  $m$  the ratio of horizontal resolution to vertical resolution,  $f$  the frame-repetition rate,  $n$  the total number of lines in the scanning pattern,  $k_h$  the horizontal retrace ratio, and  $k_v$  the vertical retrace ratio. In practice  $w/h$ ,  $f$ , and  $n$  are fixed by the transmission standards,  $k$  by the nature of the scanning pattern, and  $k_h$  and  $k_v$  by the performance of the scanning equipment (these latter quantities are also fixed within limits by the transmission standards). Hence, the two quantities capable of variation are the resolution ratio  $m$  and the maximum frequency video frequency  $f_{\max.}$ .

The interdependence between  $f_{\max.}$  and  $m$  operates in two distinct ways. When the video signal is generated in the television camera, the ratio  $m$  is determined by the size of the scan-

ning spot (or by the structure of the mosaic, which, however, is usually much finer than the diameter of the scanning spot). Hence, the maximum frequency of the video signal generated by the camera depends fundamentally upon the resolution of the scanning agent. Then, when the maximum video frequency is thus established, it remains to be seen whether this frequency is transmitted through the system without attenuation. If attenuation occurs to any extent, then the maximum frequency in the video range is lower than the  $f_{\max}$ , generated by the camera tube. Then the dependency between  $f_{\max}$  and  $m$  works in reverse order, in the receiver, and the degree of horizontal resolution in the reproduced image (relative to the vertical resolution) depends on the maximum video frequency actually received.

As an example, we may cite current practice in television studio equipment. The studio circuits are almost always built for a maximum video frequency of 5 Mc. or higher. A good iconoscope tube is capable of giving a horizontal resolution fine enough to generate a frequency as high as 5 Mc. Accordingly, when the image is viewed on the monitor equipment, with 5 Mc. still effective in the signal, the horizontal definition of the image is correspondingly high. This fact is borne out by the appearance of the standard test chart on the monitor screens, which universally displays a higher resolution in the horizontal direction than in the vertical direction. However, when the video signal passes through the transmitter, the sideband is restricted so that usually no higher frequencies than 4 Mc. can be transmitted. In the receiver, if we assume ideal circuits, the 4 Mc. is still the limit; in most practical cases the receiver inserts additional attenuation, so that a maximum video frequency of 3.5 Mc. is usual when the video signal finally arrives at the control electrode of the picture tube. With a maximum video frequency of 3.5 Mc., the horizontal definition is correspondingly reduced, relative to the 5-Mc. limit in the original camera signal. The result is that  $m$  in the reproduced picture depends on the upper frequency limit of the video signal actually imposed on the tube. If the luminescent spot on the picture-tube screen is not fine enough to reproduce the picture elements, then the resolution in both horizontal and vertical directions is reduced in proportion.

Table II gives the maximum video frequencies, according to Eq. (78), for various scanning patterns that have been used in

the past, for the present standard pattern, and for one possible case in the future (1029 lines, 30 frames per second). Two cases are given: one in which the resolution ratio  $m$  is 1.00 and another in which it is 1.33. It will be noted that the latter ratio produces a maximum video frequency with the R.M.A. standard pattern of 4.08 Mc., which is approximately the limit of which the present standard television channel is capable. The fact that the horizontal resolution then exceeds the vertical resolution is clearly evident from the wedges of test charts reproduced under these conditions (see Fig. 25B).

Another matter of considerable interest in connection with the maximum video frequency is the ability of the television system to reproduce the edges of extended objects in the image. Suppose the image to be reproduced is a checkerboard composed of squares whose size is not that of a single picture element, but, say, 10 times as large in linear dimensions. Then the number of black and white segments along each line is not  $n_h$  but  $n_h/10$ , and the rate of transmitting the segments is not  $R$  per second, but  $R/10$  per second. The corresponding sine-wave fundamental frequency is not  $R/2$  but  $R/20$ , and the maximum video frequency is  $f_{\max.}/10$ . But the maximum attainable video frequency still remains at the value  $f_{\max.}$ , which is determined by the transmitting equipment. Consequently, in this case it is possible to transmit not only the fundamental of the square wave, but 10 harmonics of the fundamental as well. When 10 harmonics can be transmitted (see Fig. 106), the square wave can be approximated tolerably well. In particular, if more than 10 harmonics can be transmitted, the edge of the square wave is very nearly vertical, and the edge of the reproduced square is correspondingly sharply defined. If the squares scanned are larger than 10 times the size of a picture element, then a correspondingly larger number of harmonics may be accommodated in the available video-frequency range, and the sharper will be the edge of the reproduction. Furthermore, as the number of harmonics transmitted is increased, the flatter becomes the top of the reproduced square wave and the more uniform the tone of the black and white squares. Hence, it may be stated as a theorem that the higher the maximum frequency in the video range, the finer the degree of detail that may be reproduced, the sharper the edges of extended regions, and the more uniform the tone of

such extended regions. All three effects are of importance in the apparent quality of the reproduced image, depending on the subject matter being televised.

Although the foregoing analysis has been based on the scanning of a checkerboard pattern, the same reasoning applies to any scanned image. If the image has fine detail in certain portions, the detail can be reproduced only if the maximum video frequency can accommodate it. If the image has larger extended regions in other portions, the edges of these regions can be reproduced sharply, and the tone within them can be reproduced uniformly only if a high maximum video frequency is available. Furthermore, since the images to be televised will generally contain both fine detail and extended objects, all frequencies in the video range, including the maximum, must be transmitted equally well. In practice, as previously noted, the limits are about 30 per second at the low end and 4,000,000 per second at the high end. Brightness changes that occur at a slower rate than 30 per second (*i.e.*, changes in brightness which take longer than the frame-scanning time to complete themselves) can ordinarily be accommodated by changes in the d-c component of the signal.

TABLE II.—MAXIMUM VIDEO FREQUENCIES FOR DIFFERENT SCANNING PATTERNS

Number of scanning lines ( $n$ )	Number of frames per second ( $f$ )	Maximum video frequency for equal vertical and horizontal resolution ( $m = 1.00$ ), c.p.s.	Maximum video frequency for horizontal resolution = $0.925 \times$ vertical resolution ( $m = 0.925$ ), c.p.s.
20	16	3360	3100
60	16	30,200	27,900
120	24	181,500	168,000
180	24	410,000	380,000
240	24	727,000	675,000
343 ( $7 \times 7 \times 7$ )	30	1,860,000	1,720,000
525 ( $3 \times 5 \times 5 \times 7$ )	30	4,330,000	4,000,000
1029 ( $3 \times 7 \times 7 \times 7$ )	30	16,650,000	15,400,000

Note: Calculation based on  $w/h = 4/3$ ,  $k_h = 7$ ,  $k_v = 12$ ,  $k = 0.75$ .

**31. Examples of Fourier Analysis Applied to Simple Wave-forms (Square Wave and Saw-tooth Waves).—**To illustrate

the processes of Fourier analysis, we proceed now to determine the series of sine and cosine terms that represent certain simple waveforms of basic importance in television work.

In the following examples, it will be noted that the origin of the coordinates is placed so that the waveform is symmetrically

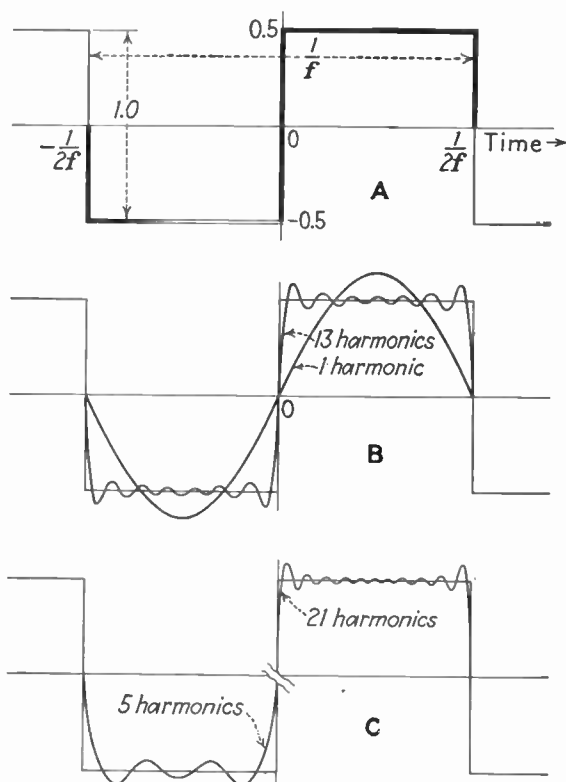

FIG. 106.—The square wave. A, the basic wave on which Eq. (80) is based; B, wave computed from Eq. (80) using one harmonic and 13 harmonics (one term and seven terms, respectively); C, same for 5 harmonics (lower portion) and 21 harmonics (upper portion).

(precisely, skew symmetrically) disposed about the origin. This arrangement permits considerable simplification of the series. If the waveform can be so placed that  $E(t) = -E(-t)$ , then the function is an *odd function*, the coefficients of all the cosine terms become zero, and the series contains only sine terms. Similarly if  $E(t) = E(-t)$ , the function is an *even function* and the series contains only cosine terms.

We consider first the square waveform shown in Fig. 106. The over-all amplitude of the wave is assumed to be unity and its total duration  $1/f$  sec. ( $f$  is the fundamental frequency of the series). The origin is placed in the center of the wave. Hence in the interval of time from  $t = -1/2f$  to  $t = 0$ ,  $E(t) = -0.5$ , and from  $t = 0$  to  $t = +1/2f$ ,  $E(t) = +0.5$ . The function in this case is an odd function, so only sine terms are present. Consequently we confine our calculations to the integral in Eq. (75) that gives the coefficients of the sine terms

$$\begin{aligned}
 a_n &= 2f \int_{-\frac{1}{2f}}^{\frac{1}{2f}} E(t) \sin(2\pi nft) dt & (75) \\
 &= 2f \int_{-\frac{1}{2f}}^0 -0.5 \sin(2\pi nft) dt + 2f \int_0^{\frac{1}{2f}} +0.5 \sin(2\pi nft) dt \\
 &= -f \left( -\frac{1}{2\pi n f} \cos 2\pi nft \right)_{-\frac{1}{2f}}^0 + f \left( -\frac{1}{2\pi n f} \cos 2\pi nft \right)_{0}^{\frac{1}{2f}} \\
 &= \frac{1}{2\pi n} [1 - \cos(-n\pi)] - \frac{1}{2\pi n} [\cos(n\pi) - 1] \\
 &= \frac{1}{\pi n} [1 - \cos(n\pi)] & (79)
 \end{aligned}$$

For  $n = 2, 4, 6$ , etc.,  $\cos n\pi = +1$ , hence  $a_2, a_4, a_6$ , etc.,  $= 0$ . For  $n = 1, 3, 5$ , etc.,  $\cos n\pi = -1$ , hence  $a_n = 2/\pi n$ . The waveform, as arranged, has no d-c component, hence  $a_0 = 0$ . The series is then

$$E(t) = \frac{2}{\pi} \left( \frac{\sin 2\pi ft}{1} + \frac{\sin 2\pi 3ft}{3} + \frac{\sin 2\pi 5ft}{5} + \dots + \frac{\sin 2\pi nft}{n} \right) \quad (80)$$

The series contains components of fundamental frequency, third harmonic, fifth harmonic, seventh harmonic, etc. The amplitude of each harmonic is inversely proportional to its frequency. At the twenty-first harmonic, for example, the amplitude is one twenty-first of the amplitude of the fundamental. It is usually considered sufficient to include harmonics up to the tenth to obtain an approximation to the square wave close enough for television work. Figure 106 shows the degrees of approximation for 5, 13, and 21 harmonics.

The square wave is useful in considering the transmission of the synchronizing pulses. In the case of the horizontal sync

pulses, the duration is about 9 per cent of the line-scanning interval, or roughly  $1/174,000$  sec. The fundamental frequency is then 174,000 c.p.s., and the tenth harmonic is 1,740,000 c.p.s. This frequency range is accommodated by the transmission system, whose frequency limits are roughly 30 to 4,000,000 c.p.s.

The square wave is based on a waveform the maximum and minimum amplitudes of which endure for equal lengths of time. The sync pulse does not meet this specification, since the intervals between pulses are long when compared with the duration

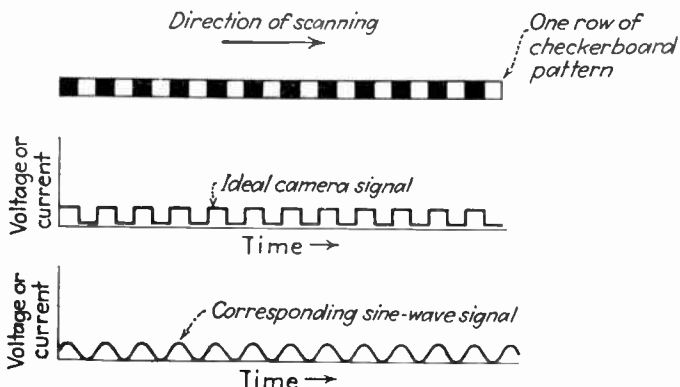

FIG. 107.—The square wave as a result of scanning a “checkerboard” image. If a large number of harmonics can be transmitted, the signal waveform approaches the ideal square wave. This can occur only if the squares are large relative to the area of the scanning pattern. If the squares are the size of picture elements, then only the fundamental frequency can be transmitted (lower curve) and the sharp demarcation of the squares is lost in the reproduction.

of the pulses themselves. The series in Eq. (78) does not describe the sync impulse exactly, therefore, but the conclusions drawn from the square-wave analysis may be applied to the sync impulse. The square wave may also be used as the ideal signal form for a “checkerboard” pattern shown in Fig. 107. When perfectly black and perfectly white squares in the pattern are assumed, the waveform resulting from an ideal scanning process will be a square wave of the shape shown in Fig. 106.

*Ideal Saw-tooth Waveform.*—Another waveform of interest in television work is the ideal saw-tooth wave shown in Fig. 108. The wave is so arranged on the coordinates that the function is odd, and only sine terms need be considered. As in the case of



the square wave, we assume that the over-all amplitude is unity and the duration  $1/f$  sec. The expression for  $E(t)$  is

$$E(t) = ft \quad (81)$$

as may be shown by substituting the values of time at the beginning and end of the wave,  $-1/2f$  and  $+1/2f$ , respectively.

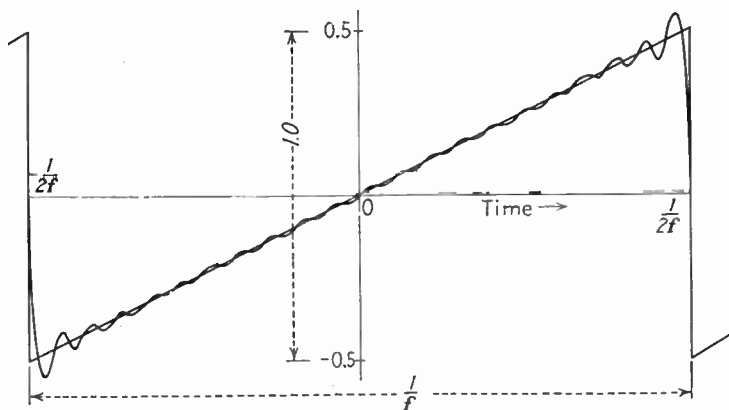

FIG. 108.—The ideal saw-tooth wave, represented by Eq. (83). The wavy line shows the approximation to the original wave obtained when twenty harmonics are included in the sum of the series.

Substituting in the integral for the sine-term coefficients,

$$\begin{aligned} a_n &= 2f \int_{-1/2f}^{1/2f} ft \sin(2\pi nft) dt \quad (75) \\ &= 2f^2 \left[ \frac{1}{(2\pi nf)^2} \sin 2\pi nft - \frac{1}{2\pi nf} t \cos 2\pi nft \right]_{-1/2f}^{1/2f} \\ &= 2f^2 \left[ -\frac{1}{2\pi nf} \frac{1}{2f} \cos(n\pi) - \frac{1}{2\pi nf} \frac{1}{2f} \cos(-n\pi) \right] \\ &= -2f^2 \left[ \frac{1}{2\pi nf^2} \cos(n\pi) \right] \\ &= -\frac{1}{n\pi} \cos(n\pi) \quad (82) \end{aligned}$$

For  $n = 1, 2, 3$ , etc.,  $\cos(n\pi) = -1$ . For  $n = 2, 4, 6$ , etc.,  $\cos(n\pi) = +1$ . There is no d-c component, hence  $a_0 = 0$ . Accordingly the series is

$$E(t) = \frac{1}{\pi} \left( \frac{\sin 2\pi ft}{1} - \frac{\sin 2\pi 2ft}{2} + \frac{\sin 2\pi 3ft}{3} - \frac{\sin 2\pi 4ft}{4} + \dots \right. \\ \left. - \cos(n\pi) \frac{\sin 2\pi nft}{n} \right) \quad (83)$$

In this case, the fundamental frequency and all harmonics are included, with amplitudes inversely proportional to frequency and with alternate reversals of phase between the harmonics.

The saw tooth discussed above is the ideal case of the saw tooth deflecting voltage or current employed in scanning generators.

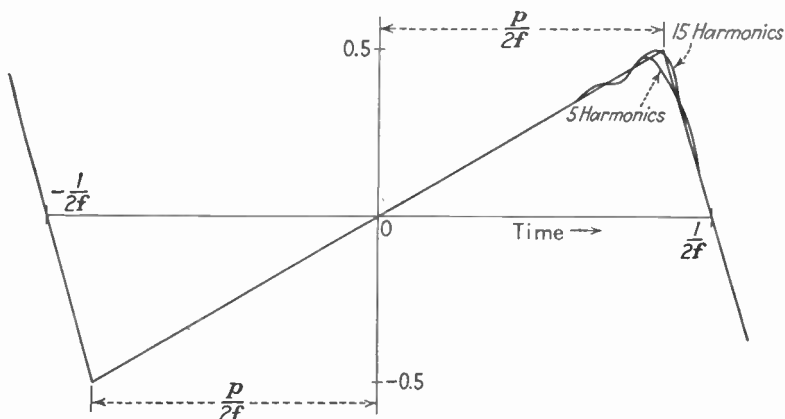

FIG. 109.—Nonideal saw-tooth wave, such as appears in horizontal and vertical scanning generators. This wave is much easier to approximate with a small number of harmonics than the ideal wave in Fig. 108. The approximations for 5 and 15 harmonics coincide with the original wave except at the apex, as shown above.

In the ideal case, the retrace occurs instantaneously and the entire scanning interval is devoted to active scanning. This requirement cannot be satisfied in practice, and a very large number of harmonic components are required to satisfy it even approximately. Figure 108 shows the degree of approximation for 20 harmonics.

The nonideal saw-tooth wave,<sup>1</sup> with noninstantaneous retrace, is shown in Fig. 109. The over-all amplitude is unity, and

<sup>1</sup> SOMERS, F. J., Scanning in Television Receivers, *Electronics*, 10 (10), 18 (October, 1937).

VON ARDENNE, M., Distortion of Saw-tooth Waveforms, *Electronics*, 10 (11), 36 (November, 1937).

the over-all duration is  $1/f$  sec. Of the total scanning time, the forward trace occupies a fraction  $p$  of the total time; hence the duration of the active portion of the wave is  $p/f$  sec. For convenience in computation, the wave is disposed in odd-function fashion and is divided into three intervals. The first interval, from  $-1/2f$  to  $-p/2f$ , covers a portion of the retrace. The function  $E(t)$  in this interval is

$$E(t) = \frac{-f}{(1-p)} \left( \frac{1}{2f} + t \right) \quad (84)$$

In the active interval from  $-p/2f$  to  $+p/2f$ , the function is

$$E(t) = \left( \frac{f}{p} \right) t \quad (85)$$

Finally, in the retrace interval  $p/2f$  to  $1/2f$ , the function is

$$E(t) = \frac{f}{1-p} \left( \frac{1}{2f} - t \right) \quad (86)$$

The validity of these equations may be tested by substituting the values of  $t$  at the ends of the intervals stated and by noting that each is a linear function of  $t$ .

The sine-term coefficients are calculated by the integral

$$a_n = 2f \left[ \int_{-\frac{1}{2f}}^{-\frac{p}{2f}} \frac{-f}{(1-p)} \left( \frac{1}{2f} + t \right) \sin 2\pi n f t \, dt + \int_{-\frac{p}{2f}}^{+\frac{p}{2f}} f t \sin 2\pi n f t \, dt + \int_{\frac{p}{2f}}^{\frac{1}{2f}} \frac{f}{(1-p)} \left( \frac{1}{2f} - t \right) \sin 2\pi n f t \, dt \right] \quad (87)$$

The evaluation of this integral is straightforward and leads to the following result:

$$a_n = \frac{1}{p-p^2} \frac{(\sin \pi n p)}{n^2 \pi^2} \quad (88)$$

The series is

$$E(t) = \frac{1}{\pi^2(p-p^2)} \left( \frac{\sin \pi p}{1} \sin 2\pi f t + \frac{\sin 2\pi p}{4} \sin 2\pi 2f t + \frac{\sin 3\pi p}{9} \sin 2\pi 3f t + \dots + \frac{\sin n\pi p}{n^2} \sin 2\pi n f t \right) \quad (89)$$

Note that the amplitude of the harmonics decreases with the *square* of the order of the harmonic.

Figure 109 shows the approximation obtained in this case with 5 and 15 harmonics with a value of  $p = 85$  per cent (roughly  $k_h = 6$ ). The approximation is much closer in this case than in the ideal saw-tooth wave previously considered.

The series in this case gives the frequency and amplitude considerations underlying the design of amplifiers for saw-tooth voltage waves. Amplifiers intended to produce saw-tooth waves of current for magnetic deflection must meet different requirements since the voltage waveform is not then a saw tooth, nor is it any simple analytic function. It is found that magnetic deflection amplifiers give satisfactory performance when the fifteenth harmonic is transmitted and may serve adequately when only the tenth harmonic is included.

**32. Distortions of the Picture Signal.**—We have now set up the ideal forms that the amplitude-frequency characteristic and the phase-frequency characteristics of a television system must approach to preserve the picture-signal waveform. We have, in addition, indicated some of the waveforms that arise from scanning lines of different degrees of detail and related the frequency range required to the rate at which the frames and the picture elements are transmitted.

When an attempt is made to put these ideal requirements into practice, distortions from them inevitably occur. In the remainder of this chapter, we consider some of the major defects that arise in the transmission of the video signal. We shall consider the distortions in three categories: (1) the distortions that arise from nonideal amplitude- and phase-response characteristics; (2) the limitations on the waveform imposed by the presence of masking voltages (noise); and (3) the advantages of certain distortions that may be purposely introduced into the picture signal to compensate shortcomings of other equipment or to enhance the realism of the reproduced picture.

*Distortions Due to Nonideal Phase and Amplitude Characteristics.*—In the preceding section, we have seen the degrees of approximation with which certain waveforms may be reproduced, when the transmission system includes up to the twentieth harmonic. These cases have been computed by adding the amplitudes of the several harmonics at several values of time

within the function interval. This addition process rests on the assumption that the harmonics considered are transmitted without amplitude discrimination and with no relative time delay (phase angle proportional to frequency). If we wish to investigate the effects of nonideal characteristics, the harmonic amplitudes are added at such amplitudes and displaced at such intervals of time as are produced by the nonideal transmission characteristics. Such an investigation is very laborious and out of the question as a practical procedure except for purposes of illustration. It is more useful to draw general conclusions from the effects of nonideal characteristics.

Two general conclusions may be simply stated: If the amplitude-frequency characteristic is not ideal, that is, if certain harmonic amplitudes are emphasized relative to the others, then the waveform is distorted *symmetrically*. If the phase characteristic is not ideal, that is, if certain harmonics are delayed by longer or shorter times than others, then the waveform is distorted *asymmetrically*.

To understand the meaning of symmetrical and asymmetrical distortion, we consider the transmission of a "unit pulse," that is, a nonperiodic waveform containing but one pulse, of unit area, and having an amplitude very great when compared with its duration. Such a unit pulse is shown in Fig. 110. Since the waveform is nonperiodic, it cannot be represented by a Fourier series of discrete frequency components, but it may be analyzed, by means of the Fourier integral, into a *continuous spectrum* of frequency components, all frequencies within the given range being considered. The Fourier integral analysis of the unit pulse shows it to be composed of an infinite number of harmonic components, all of equal amplitude. The frequency spectrum in this case is shown in Fig. 110. To transmit a unit pulse, the transmission equipment must convey all frequencies from zero c.p.s. to infinity without discrimination. In practice, of course, the range of frequencies transmitted is not infinite, nor are all transmitted frequencies transmitted with equal amplitudes. Consequently, the unit pulse is more or less distorted in the transmission process.

Consider for example the nonideal transmission characteristic given by the function of frequency  $F(f)$  shown in Fig. 110. If it is desired to determine the reproduced form  $E(t)$  of the unit

pulse, when passed through equipment having this characteristic, we must evaluate the integral

$$E(t) = 2 \int_0^{\infty} F(f) \cos 2\pi ft \, df \quad (90)$$

This form of the Fourier integral assumes that there is no phase delay in the system.<sup>1</sup> The result of evaluating the integral is

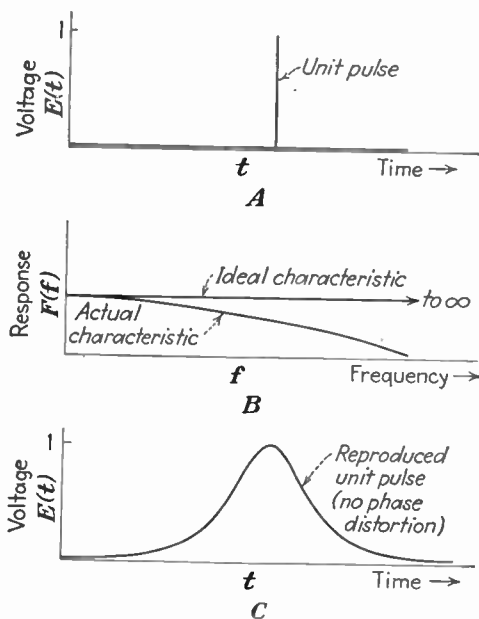

FIG. 110.—Response to a unit pulse of a transmission system having amplitude distortion but no phase distortion: A, the applied pulse, of unit area; B, the ideal amplitude-response characteristic required to reproduce the pulse exactly and a typical actual characteristic; and C, the pulse reproduced by the system displaying the nonideal characteristic, in the absence of phase distortion.

shown in Fig. 110. It will be seen that the unit pulse has become a broad “hump” with sloping sides. The distortion manifests itself as a broadening of the pulse, accompanied by variations in tone. The distortion is symmetrical about the maximum

<sup>1</sup> Conversely if we know the reproduced form  $E(t)$  of the unit pulse and desire to determine the amplitude characteristic  $F(f)$ , we may employ the symmetrical form of the integral

$$F(f) = 2 \int_0^{\infty} E(t) \cos 2\pi ft \, dt \quad (91)$$

amplitude. This is characteristic of amplitude distortion, when phase distortion is absent.

Suppose now that we introduce phase distortion to the case discussed above. Wheeler<sup>1</sup> has shown that the effect of a small amount of phase distortion may be represented by the addition

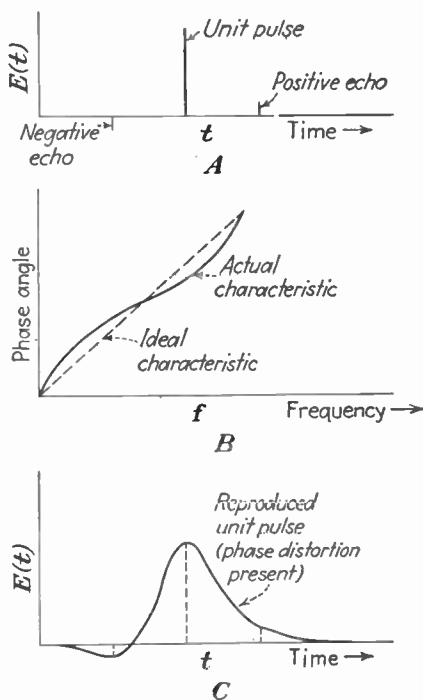

FIG. 111.—The "paired echo" method of analyzing the effects of phase distortion, due to Wheeler. The presence of a nonideal phase characteristic may be represented by two small echo signals each of which gives rise to a response similar to that of Fig. 110. Note that the reproduced pulse, C, is not symmetrical.

of two additional signals to the unit pulse. The additional signals have the form of "echoes," that is, they are signals like the unit pulse in shape but smaller in amplitude and spaced from it on the time axis, as shown in Fig. 111. One of the echoes is above the time axis, the other below it. The echoes indicated

<sup>1</sup> WHEELER, R. A., The Interpretation of Amplitude and Phase Distortion in Terms of Paired Echoes, *Proc. I.R.E.*, **27**, 359 (June, 1939).

See also: SHIFFENBAUER, R. G., Phase Distortion in Television, *Wireless Eng.*, **13**, 21 (January, 1936).

result from a distortion of the phase characteristic shown in Fig. 111. To evaluate the effect of the phase distortion, we erect on each echo signal and on the main signal a pulse of the type that is reproduced in the absence of phase distortion, shown in Fig. 110. The three reproduced pulses are added together, as shown, and produce a resultant pulse shown by the heavy line in *C*. This is the reproduced form of the unit pulse, when both phase and amplitude distortion are present. We note that the reproduced pulse is asymmetrical about the maximum amplitude. This is typical of the effects of phase distortion. In television images, it often results in the appearance of a white margin at one edge on all black objects, but not on the opposite edge. The reproduced pulse shown in Fig. 111 would display the white edge of the leading (earliest produced) edge of each black object.

The detailed treatment of phase and amplitude distortion, although of the greatest importance, is a highly complicated subject for any but the simple cases considered here. For a more detailed treatment, the reader may consult the references listed.

**The Influence of Masking Voltages on the Video Signal.**—Brief mention has been made in connection with the discussion of television-camera action of the effect of masking voltages (“noise”) in degrading the quality of picture signals. Several categories of masking voltage are of importance. Among the most important are those arising from thermal agitation in resistors, from shot effect in electron emission, and from natural atmospheric disturbances. In addition to these natural disturbances, there is a variety of man-made sources of interference, especially that arising from electrical contacts and automobile ignition systems, and interference from high-frequency generators, especially those used for therapeutic treatments. All these disturbances, except thermal agitation and shot effect, make their effect known in conjunction with the carrier transmission of the video signal. Thermal- and shot-effect noise, on the other hand, arise in the sources of the video signal and in video-frequency transmission equipment. Accordingly we consider briefly here the effect of thermal-agitation and shot-effect masks on the video signal.

Thermal-agitation masking voltages arise from the random motions of the electrons in conductors. The square of the voltage



generated depends on the resistance or impedance of the conductor, on its temperature, and on the range of a-c frequencies to which the circuit is responsive. The expression is

$$e_{r.m.s.} = 7.4 \times 10^{-12} \sqrt{TZ(f_1 - f_2)} \text{ r-m-s volts} \quad (92)$$

where  $e_{r.m.s.}$  is the root-mean-square value of the thermally generated masking voltage,  $T$  is the absolute temperature of the conductor ( $273 + ^\circ\text{C}.$ ),  $Z$  the conductor impedance, and  $f_1$  and  $f_2$  the limits of the significant frequency range. At room temperature,  $T$  is about  $300^\circ$ , and in television work, the limits of fre-

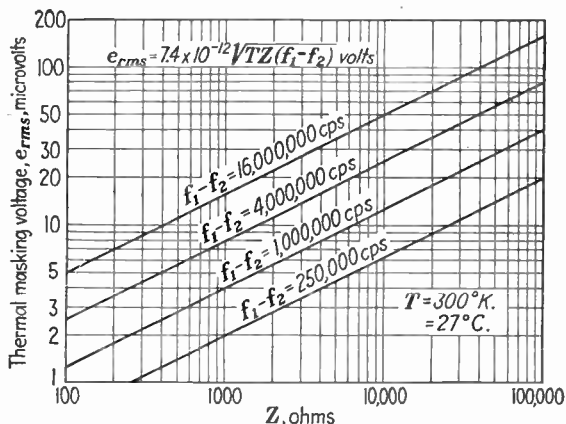

FIG. 112.—Thermal masking voltage (noise) as a function of circuit impedance and frequency range.

quency band (as we have just seen) are roughly 30 and 4,000,000 c.p.s. The graph in Fig. 112 shows the relationship between  $e_{r.m.s.}$  and  $Z$  for these assumed values of  $T$  and  $f_1 - f_2$ . It will be noted that the voltage produced is ordinarily of the order of 2 to 100 microvolts (corresponding to  $Z$  values of 100 and 100,000 ohms, respectively).

The other source of random masking voltage is the shot effect, which may be of considerable importance when compared with thermal agitation. Shot-effect voltage arises from the incremental nature of electron emission. It is found that the electrons emitted from cathodes leave in groups that represent small pulses of current. These pulses excite the transmission circuit over the entire frequency spectrum to which it is responsive. The magnitude of the effect thus depends upon  $f_1 - f_2$ , as in

the case of thermal agitation. The other significant factors are the value of the emission current and the coupling impedance across which the current pulses give rise to the shot-effect masking voltage. The expression is

$$e_{r.m.s.} = 5.64 \times 10^{-10} Z \sqrt{I(f_1 - f_2)} \quad (93)$$

where  $e_{r.m.s.}$  is the root-mean-square value of the shot-effect masking voltage,  $I$  the value of the emission current in amperes,  $Z$  the coupling impedance in ohms, and  $f_1 - f_2$  the significant frequency range in the transmission circuit. For equal values of frequency range and coupling resistor, shot-effect voltage may be large compared with thermal agitation although it is not amplified in the stage under consideration. The curve in Fig. 113 shows the relationship between  $e_{r.m.s.}$  and  $Z$ , for assumed values of  $I$  and  $(f_1 - f_2) = 4,000,000$  c.p.s.

The type of noise which predominates in the video signal depends on the circuit constants and the plate current employed. In typical pre-amplifier circuits (see page 392), the input coupling resistor and its shunt capacitance are so chosen that the effective high frequency range extends upward only to the region of one megacycle or less. This means that the thermal agitation noise generated in this circuit is low, much lower than if the circuit were designed for the full useful bandwidth of 5 Mc. In a later stage of the preamplifier, high frequency compensation is introduced to raise the effective high frequency limit. The thermal noise is, in that stage, no longer a factor. Shot-effect noise, on the other hand, is introduced across the load resistor of the first amplifier stage, which is compensated to pass the full video range up to 5 Mc. Accordingly a much higher value of shot effect noise, relative to thermal noise, is present in this load circuit. The high frequency compensation thereafter introduced increases the high frequency content of the shot noise further. The net result is that shot-effect noise is usually predominant in practical camera preamplifier circuits.

In any event the effect of the noise, whatever its source, is to limit the lower level of illumination at which the camera may be operated. The masking voltages remain constant, for a given tube and circuits, whereas the desired camera signal decreases as the illumination decreases. Hence it is found that at low light levels, the reproduced picture shows definite evidence of "noise,"

that is, the image displays a shimmering mottled appearance. If the peak value of the camera signal voltage is 20 times that of the noise, satisfactory images result, that is, they may be said to have entertainment value. A ratio of 40 to 1 is usually necessary, however, before all traces of the noise are absent. On the other end of the scale ratios as low as 2 to 1, or even 1 to 1, may exist before the intelligibility of the picture is lost.

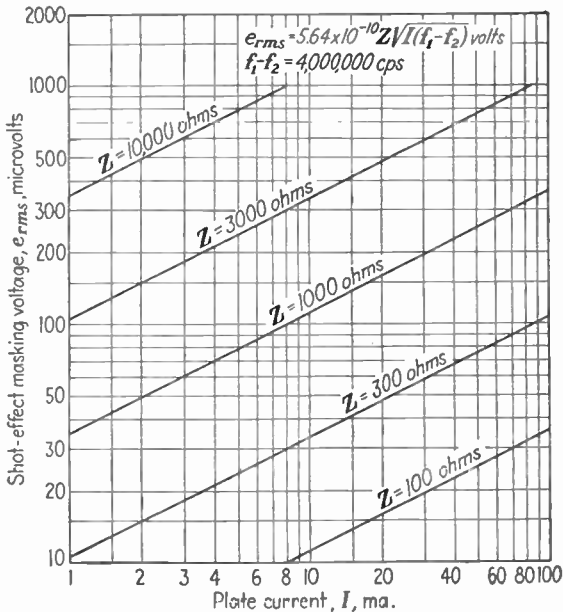

FIG. 113.—Shot-effect masking voltage (noise) as a function of plate circuit impedance and current. While of larger magnitude than the thermal voltage (Fig. 112), shot-effect voltage is not so serious because it is not multiplied by the gain of the first amplifier tube.

Shot-effect noise arising within the camera is usually not important in storage type tubes, since the emission current is very small (of the order of microamperes or less). In non-storage pick-up tubes the small value of desired signal makes the noise problem particularly serious, and has led to the use of electron multiplier structures (in the case of the Farnsworth image dissector) to obtain the highest possible signal-to-mask ratio.

Both these sources of noise increase with the square root of the band of frequencies employed in the transmission system. It follows that the circuits should be responsive to a range no wider

than is actually needed to convey the information in the picture signal, and it also follows that the more information is transmitted (the larger the number of picture elements), the more serious the noise problem becomes.

*Intentional Distortions of the Picture Signal.*<sup>1</sup>—We consider, finally, certain types of waveform distortion that may be applied to the picture signal for the purposes of enhancing the apparent

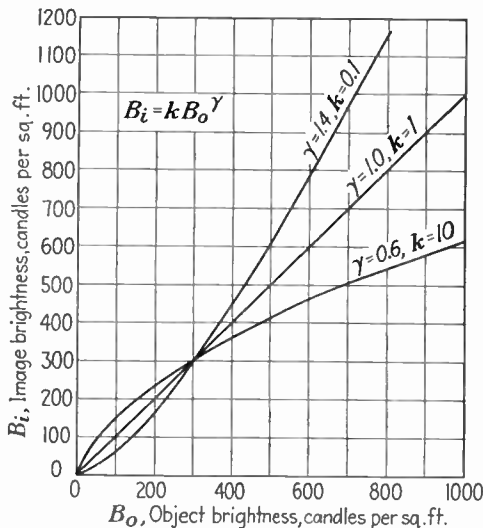

FIG. 114.—Relationships between object brightness (in studio) and image brightness (at receiver) which satisfy the condition that the sensation in the minds of the receiver audience shall be proportional to the sensation in the minds of the studio audience. Based on the Weber-Feehner law which states that sensation is proportional to the logarithm of brightness (cf. Figs. 194 to 198).

realism of the reproduction or for compensating for the limitations of camera tubes and image-reproducing tubes.

The picture signal, we recall, has an amplitude that varies with the illumination of the subject in the studio or film being televised. If the picture signal is generated and transmitted without waveform distortion, and if the brightness produced on the receiving screen is directly proportional to the picture signal applied to the tube, the brightness in the reproduction will be in direct proportion to the brightness of the subject. We can then say that the subject brightness bears a linear relationship to the

<sup>1</sup> For the significance of intentional distortion see: Maloff, I. G., Gamma and Range in Television, *RCA Rev.*, 3 (4), 409 (April, 1939).

reproduction brightness. This linear relationship might seem to be an essential to the faithful reproduction of the subject. But there are also other relationships, not linear in form, that can give a realistic reproduction.

The type of nonlinear relationship between subject brightness and reproduction brightness of greatest significance is that described by a logarithmic curve. The value of the logarithmic curve lies in the fact that the sensation of light in the mind of the observer varies logarithmically with changes in brightness

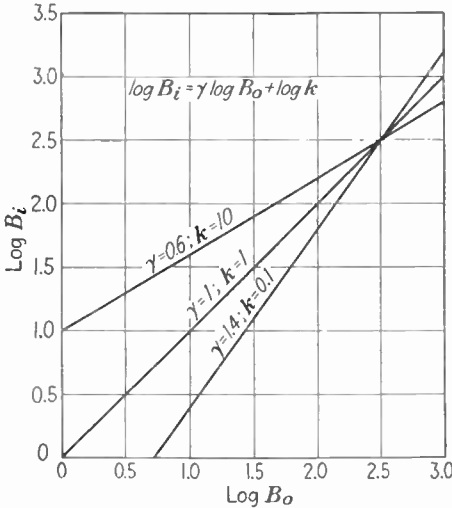

FIG. 115.—Logarithmic plots of the curves in Fig. 114, showing the linear relationship between the logarithms of brightness.

(the Weber-Fechner law). Thus if we plot the logarithm of subject brightness against the logarithm of reproduction brightness, we in effect plot the relation between the sensation in the minds of the studio audience and the sensations in the minds of the television audience. If these two sensations are in one-to-one correspondence, then the reproduction may be said to be satisfactory from a sensation point of view.

In Fig. 114 are shown typical relations between subject brightness and reproduction brightness that have this logarithmic form, together with the curves (Fig. 115) between the logarithms of the same quantities. The curves in the first case are plots of

$$B_i = k B_o^\gamma \tag{94}$$

and in the second case

$$\log B_i = \gamma \log B_o + \log k \qquad (95)$$

where  $B_i$  is the brightness of a given area of the reproduction,  $k$  a proportionality factor,  $B_o$  the brightness of the corresponding area in the subject, and  $\gamma$  (gamma) the exponent that relates the two brightnesses exponentially.

The nonlinear characteristics shown in Fig. 114 are often present inherently in certain pieces of equipment, such as camera and reproduction tubes. Of equal significance from the engineering standpoint is the fact that they may be purposely introduced into the transmission equipment (especially in video amplifiers), and hence may be used to compensate defects in other elements of the system. If the gamma of the transmitter is to have a value of unity, the low-gamma characteristics of the camera tube may be compensated by choosing an appropriate gamma in the amplifier circuits. Practically, the compensation may be most economically introduced at the transmitter, where its effect applies equally to all receivers. The effect of the various transmission elements on the over-all gamma of the system is treated at length in Chap. VIII.

## CHAPTER VI

### VIDEO AMPLIFICATION

The basic requirements to be met in transmitting the video signal have been developed in the preceding chapter. Briefly they are as follows: The transmitting equipment must respond to a-c frequencies lying within an extended range, from a lower limit approximately equal to the frame-repetition frequency to an upper limit at least one-half as great as the rate of transmitting picture elements. In practice, these limits are 30 c.p.s. and 3,000,000 to 4,000,000 c.p.s. The transmitting equipment must pass components within this frequency range with a minimum of amplitude discrimination and with a minimum of time-delay discrimination. The latter requirement is satisfied if the phase angle introduced by the transmitting equipment is proportional to the frequency involved. In addition to these amplitude and phase characteristics, video amplifiers must be designed to fulfill requirements set by the minimum permissible signal-to-mask ratio, the necessary output voltage or power level, the terminal impedances presented to the amplifier, and the permissible or desired amount of nonlinear amplitude distortion. In the present chapter, we examine the methods by which these transmission characteristics may be met in amplifiers that operate at video frequencies.

**33. Fundamental Analysis of a Single Amplifier Stage.**<sup>1</sup>—To introduce the subject of video amplification, we recall the conventional treatment of a single stage of amplification, illustrated in Fig. 116. An input signal of sinusoidal form and amplitude  $e_i$  is applied between the grid and cathode of the amplifier tube (triode, tetrode, or pentode). The grid is maintained at a negative potential by the presence of the bias battery.

<sup>1</sup> For a full treatment of the uncompensated *RC* coupled amplifier see: TERMAN, F. E., "Radio Engineering," 2d ed., McGraw-Hill Book Company, Inc., New York, 1938.

SEELEY and KIMBALL, Analysis and Design of Video Amplifiers, *RCA Rev.*, 2 (2), 171 (October, 1937); and 3 (3), 290 (January, 1939).

The signal voltage  $e_i$  introduces a change in the space potential between cathode and anode, thereby producing a change in plate current, which flows through the output impedance  $Z_o$  and develops an output voltage of amplitude  $e_o$ . Since the signal input is sinusoidal, the output signal will be sinusoidal also, provided that the circuit operates over a linear region of its dynamic characteristic.

The gain  $G$  of the amplifier is defined as

$$G = \frac{e_o}{e_i} \quad (96)$$

and the phase shift  $\phi$  introduced by the amplifier is defined as the angle between  $e_o$  and  $e_i$ . The amplifier inherently introduces

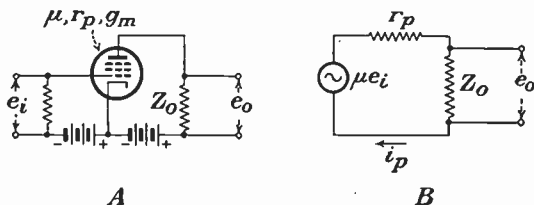

FIG. 116.—Basic amplifier circuit on which gain and phase-angle equations are based.

a phase shift of  $180^\circ$  (since the upper end of the load impedance becomes less positive as the grid becomes more positive). The additional phase shift  $\phi_a$ , introduced by the amplifier in addition to the  $180^\circ$  shift, is defined as

$$\phi_a = \phi - 180^\circ \quad (97)$$

To determine  $G$  and  $\phi_a$  in terms of the tube parameters and circuit constants, we must employ the concepts of amplification factor  $\mu$ , dynamic plate resistance  $r_p$ , and grid-plate transconductance  $g_m$ , all of which are descriptive of the tube employed. The amplification factor  $\mu$  is the ratio of a small change in plate voltage to the small change of grid voltage that produces an equal and opposite effect on the plate current. The dynamic plate resistance  $r_p$  is the ratio of a small change in plate voltage to the corresponding change in plate current, and the transconductance  $g_m$  is the ratio of a small change in plate current to the small change in grid voltage producing it. It follows that  $\mu/r_p = g_m$ . During all the changes referred to, all other voltages and currents in the tube are maintained constant.



In consequence of the definitions of these parameters, the amplifier circuit shown in Fig. 116*A* may be replaced by the equivalent circuit in Fig. 116*B*. The result is a single series circuit containing a generator of  $\mu e_i$  volts and two impedances in series,  $r_p$  the tube plate resistance and  $Z_o$  the output impedance. The current flow in the circuit is

$$i_p = \frac{\mu e_i}{r_p + Z_o} \quad (98)$$

and the output signal  $e_o$  is  $i_p Z_o$  or

$$e_o = \frac{\mu e_i Z_o}{r_p + Z_o} \quad (99)$$

Finally, the gain of the amplifier  $G = e_o/e_i$  is

$$G = \frac{\mu Z_o}{r_p + Z_o} \quad (100)$$

The added phase shift  $\phi_a$  is

$$\phi_a = \tan^{-1} \frac{X_o r_p}{R_o^2 + R_o r_p + X_o^2} \quad (101)$$

where  $R_o$  and  $X_o$  are the equivalent series resistance and series reactance of  $Z_o$ , respectively.

In video amplifiers employing pentode tubes,  $r_p$  is large if compared with  $Z_o$ . In that event, we may neglect  $Z_o$  in comparison with  $r_p$  and the gain [Eq. (100)] becomes

$$G = \frac{\mu Z_o}{r_p} = g_m Z_o \quad (102)$$

and the added phase angle becomes

$$\phi_a = \tan^{-1} \frac{X_o}{R_o} \quad (103)$$

Equations (102) and (103) serve as a convenient basis for investigating pentode video amplifier characteristics. The first equation shows that the gain is directly proportional to the grid-plate transconductance of the tube, which is independent of frequency. Therefore if the gain (amplitude characteristic) is to remain constant over a given frequency range,  $Z_o$  must not vary with frequency over the same range. This is a rather strict requirement, since the output impedance  $Z_o$  is in general com-

posed of  $R$ ,  $L$ , and  $C$  components, the latter two of which vary with frequency. Means must be found to minimize this variation by choosing the proper proportions of  $R$ ,  $L$ , and  $C$ .

The added phase shift, in Eq. (103), must be as closely proportional to frequency as possible. The means of satisfying this requirement are not obvious from inspection. However, if we restrict the discussion to small angles, the tangent may be replaced by its angle and

$$\phi_a = \frac{X_o}{R_o} \quad (104)$$

Now if  $X_o$  is a series inductive reactance (such as would arise from a shunt capacitive reactance), its value is directly proportional to frequency, and the added phase angle is proportional to frequency.

It should be remarked that the preceding discussion is based on the approximate Eqs. (102) and (103) which hold only if the dynamic plate resistance  $r_p$  is large when compared with the output impedance  $Z_o$ . If this does not hold (as for example in certain output stages employing beam-power tetrodes or output-type pentodes), then a more complicated analysis must be undertaken. An example is given later in this chapter.

*The Form of the Output Impedance  $Z_o$  in the Uncompensated Amplifier.*—It is clear that no further general conclusions can be drawn until the form of  $Z_o$  is specified. In video amplifier practice,  $Z_o$  is usually a relatively simple combination of  $R$ ,  $L$ , and  $C$  components and may be treated either from the standpoint of the ordinary impedance equations or by employing the concepts of filter theory.

We consider first the "uncompensated" resistance-capacitance coupled amplifier shown in Fig. 117. The impedance  $Z_o$  in this case consists of the output capacitance  $C_o$  of the amplifier tube and wiring, the plate-circuit resistor  $R_o$ , the coupling capacitance  $C_c$ , and the input capacitance  $C_i$  of the following tube, including wiring, and the input resistor  $R_i$  of the following stage. No inductive elements are present (those present in the wiring are so small as to have no appreciable effect throughout the frequency range considered).

It is possible to express  $Z_o$  explicitly in terms of all the  $R$  and  $C$  elements shown and to determine the gain and added phase

shift by substitution. But it is much more convenient to consider the response of the circuit to the lowest frequencies and to the highest frequencies in the range. If satisfactory performance is obtained at these limits, it usually follows that satisfactory performance is also obtained in the intermediate range of frequencies.

Accordingly, we consider first the high-frequency response of the circuit. In this case, the coupling capacitor  $C$  displays so small a reactance that it may be replaced by a short circuit.

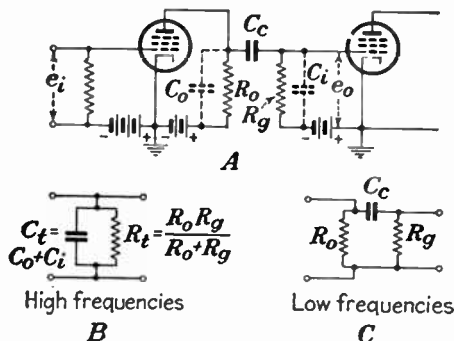

FIG. 117.—Uncompensated amplifier coupling connection (A), with equivalent circuits at high (B) and low (C) frequencies.

Then the input and output capacitances add to form the total circuit capacitance  $C_t$ :

$$C_t = C_o + C_i \quad (105)$$

and the plate resistor and grid resistor combine in an equivalent load resistance  $R_t$  such that

$$R_t = \frac{R_o R_g}{R_o + R_g} \quad (106)$$

The load impedance  $Z_o$  consists of  $C_t$  and  $R_t$  in parallel, that is,

$$\frac{1}{Z_o} = \frac{1}{R_t} - \frac{1}{jX_t} \quad (107)$$

where  $X_t$ , the reactance of the capacitance  $C_t$  at the operating frequency  $f$ , is equal to

$$X_t = \frac{1}{2\pi f C_t} \quad (108)$$

Solving Eq. (107) for  $Z_o$ , we obtain

$$Z_o = \frac{-jR_t X_t}{R_t - jX_t} \quad (109)$$

Dividing numerator and denominator by  $-jX_t$ ,

$$Z_o = \frac{R_t}{1 + \frac{jR_t}{X_t}} \quad (110)$$

The amplitude of  $Z_o$  is

$$Z_o = \frac{R_t}{\sqrt{1 + \frac{R_t^2}{X_t^2}}} \quad (111)$$

$$= \frac{R_t}{\sqrt{1 + 4\pi^2 f^2 R_t^2 C_t^2}} \quad (112)$$

It is convenient to define a frequency  $f_o$  such that

$$f_o = \frac{1}{2\pi R_t C_t} \quad (113)$$

Then, substituting  $f_o$  in Eq. (112), we obtain

$$Z_o = \frac{R_t}{\sqrt{1 + \frac{f^2}{f_o^2}}} \quad (114)$$

and the gain  $G$  is, by Eq. (102),

$$G = g_m Z_o = \frac{g_m R_t}{\sqrt{1 + \frac{f^2}{f_o^2}}} \quad (115)$$

Equation (115) may be plotted in terms of the ratio  $f/f_o$ , as shown in Fig. 118. Since  $f_o$  is a constant defined by the  $R_t$  and  $C_t$  values, the  $f/f_o$  scale is proportional to frequency  $f$ .

It will be noted that when  $f/f_o = 1$ , that is, when the frequency of operation equals  $f_o$ , the gain is about 71 per cent of its value at the low frequencies. Hence we find that  $f_o$  is the frequency at which occurs a loss of gain of roughly 29 per cent when compared with the low-frequency response. When the  $R_t$  and  $C_t$  values are known, it is simple then to compute the frequency

at which this 29 per cent loss occurs, by Eq. (113). Figure 119 shows the frequency  $f_o$  in terms of different  $R_t$  and  $C_t$  values.

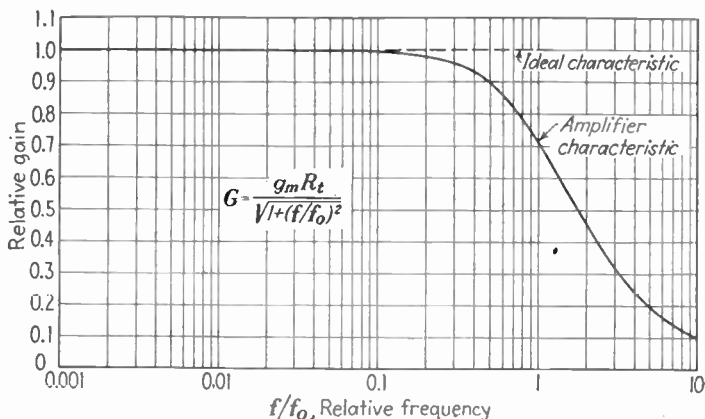

FIG. 118.—High-frequency amplitude-response characteristic of the uncompensated amplifier (Fig. 117) plotted in terms of the reference frequency  $f_o$  determined by the values of shunt resistance and capacitance in the coupling circuit.

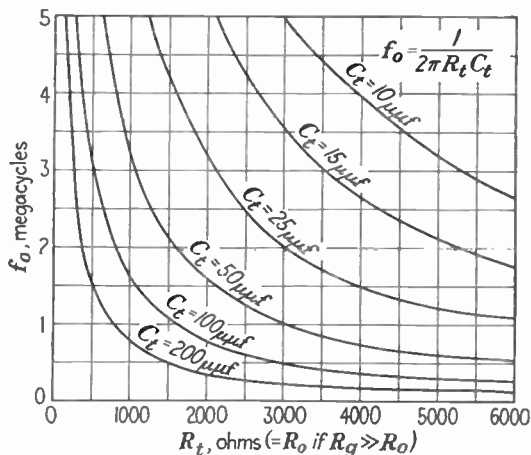

FIG. 119.—The reference frequency  $f_o$  in terms of the shunt capacitance  $C_t$  and resistance  $R_t$ .

The added phase shift (in addition to the  $180^\circ$  phase reversal) of the circuit discussed above is simply the phase angle of  $Z_o$ , that is,

$$\phi_a = \tan^{-1} \frac{X_o}{R_o} \tag{103}$$

To find  $X_o$  and  $R_o$ , we must rationalize Eq. (109) as follows:

$$Z_o = \frac{R_t X_t^2 - j X_t R_t^2}{R_t^2 + X_t^2} \quad (116)$$

from which

$$R_o = \frac{R_t X_t^2}{R_t^2 + X_t^2} \quad (117)$$

and

$$X_o = \frac{-X_t R_t^2}{R_t^2 + X_t^2} \quad (118)$$

whence

$$\frac{X_o}{R_o} = -\frac{R_t}{X_t} \quad (119)$$

Then, Eq. (103) becomes

$$\phi_a = \tan^{-1} -\frac{R_t}{X_t} = \tan^{-1} - 2\pi f R_t C_t \quad (120)$$

and finally

$$\phi_a = \tan^{-1} -\frac{f}{f_o} \quad (121)$$

Equation (120) may be plotted as a function of  $f/f_o$  as shown in Fig. 120. It will be noted that  $\phi_a$  is proportional to the frequency  $f$  at low values of frequency, but that it departs from the ideal by about  $15^\circ$  at  $f = f_o$ .

Figures 118 and 120 show that the performance of the circuit may be generalized in terms of the frequency  $f_o$  defined by Eq. (113). In other words, the upper frequency performance of the amplifier is limited by  $f_o$ , that is, by the  $R_t$  and  $C_t$  values present. The larger the values of  $R_t$  and  $C_t$ , the lower the upper frequency limit.

By making  $R_t$  small when compared with  $C_t$ ,  $f_o$  and hence the upper frequency limit may be extended indefinitely. But as  $R_t$  becomes smaller, the gain [Eq. (115)] is reduced proportionately. At the point where  $R_t = 1/g_m$ , the gain of the amplifier is equal to or less than unity (that is, the output voltage is less than the input voltage). It follows that *for maximum gain and a high frequency limit,  $g_m$  must be great and  $C_t$  must be small.*

It appears, therefore, that a basic limiting factor to good high-frequency response is the capacitance  $C_t$ . This capacitance

is composed of four elements: the total capacitance to ground  $C_s$  of wiring and coupling elements (stray capacitance); the out-

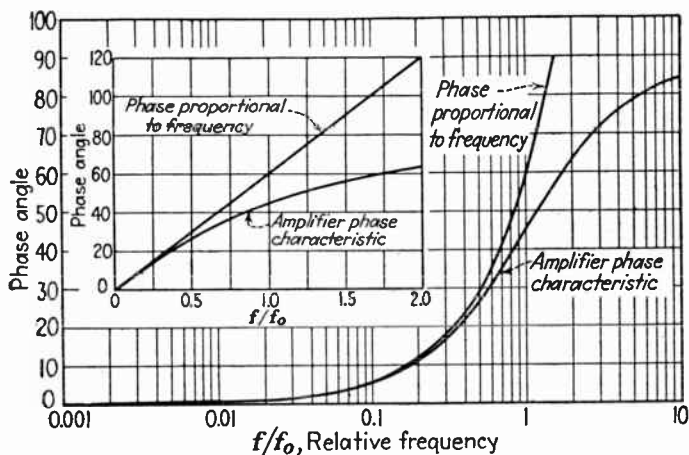

FIG. 120.—Phase-response characteristic of the uncompensated amplifier at high frequencies, compared with the linear (ideal) characteristic. Plotted in linear coordinates in inset, in logarithmic frequency coordinates in the larger diagram.

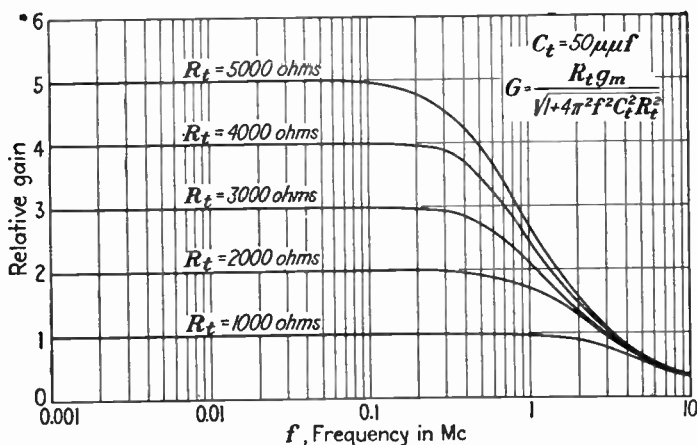

FIG. 121.—Effect on high-frequency response (uncompensated amplifier) of increasing the shunt resistance  $R_t$ . While higher gain may be obtained thereby at low frequencies, the presence of the shunt capacitance places an upper limit on the gain at high frequencies.

put capacitance  $C_{pk}$  of the preceding tube; the input capacitance of the following tube  $C_{\mu k}$ ; and the grid-plate capacitance  $C_{op}$

of the following tube, multiplied by the gain of the following stage plus one. That is,

$$C_i = C_s + C_{gk} + C_{pk} + C_{gp}(1 + G) \quad (122)$$

An effect of interest is the change of the input capacitance  $C_{gk}$  as the plate current of the tube varies, an effect especially prominent in tubes whose  $g_m$  value is high. As the gain and plate current are varied by the amplifier gain control, the value of  $C_i$  may change appreciably, and with it the amplitude and phase response at the high frequencies will vary.

*The Low-frequency Response of RC Coupled Amplifiers.*—At the

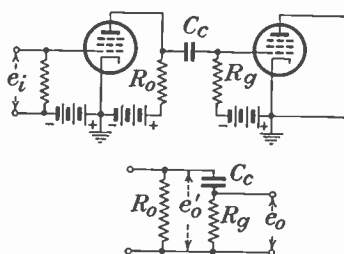

FIG. 122.—Uncompensated amplifier with equivalent low-frequency circuit.

low-frequency end of the video range, a different type of analysis applies. At low frequencies, the shunt capacitance  $C_i$  has such a high reactance that it may be neglected. On the other hand, the coupling capacitance  $C_c$  also has a high reactance so it can no longer be replaced by a short circuit. At low frequencies, therefore, the output impedance has the form shown in Fig. 122, that is, it consists of the output resistor  $R_o$  shunted by the series combination of the coupling capacitance  $C_c$  and the grid resistor  $R_g$ . The output voltage is taken from the terminals of the resistor  $R_g$ . The equivalent circuit, shown in Fig. 122, consists of the output resistor  $R_o$  across which a gain of

$$G = g_m R_o \quad (123)$$

is available. Of this available gain, only a part is passed on to the next stage, since  $C_c$  and  $R_g$  (the latter assumed to have negligible shunting effect) act as a voltage divider. The fraction of the voltage passed on is

$$\frac{R_g}{R_o - jX_c} \quad (124)$$

where  $X_c$  is the reactance of the coupling capacitor and is equal to

$$X_c = \frac{1}{2\pi f C_c} \quad (124a)$$



The gain of the entire stage, including the coupling circuit is, then,

$$G = g_m R_o \left( \frac{R_g}{R_g - jX_c} \right) \quad (125)$$

$$= \frac{g_m R_o R_g}{X_c} \left( \frac{1}{\frac{R_g}{X_c} - j} \right) \quad (126)$$

$$= \frac{g_m R_o R_g 2\pi f C_c}{\sqrt{1 + (2\pi f C_c R_g)^2}} \quad (127)$$

Again, as in the high-frequency case, it is convenient to define a frequency  $f_c$  such that

$$f_c = \frac{1}{2\pi R_g C_c} \quad (128)$$

Substituting  $f_c$  in Eq. (127), we obtain

$$G = \frac{g_m R_o (f/f_c)}{\sqrt{1 + (f/f_c)^2}} \quad (129)$$

A plot of this equation in terms of  $f/f_c$  is shown in Fig. 123. It will be noted that at the frequency  $f = f_c$  ( $f/f_c = 1$ ) the gain is 29 per cent lower than its value at higher frequencies. Hence to obtain good performance at low frequencies, as small a value of  $f_c$  as possible is desirable. A low value of  $f_c$  is obtained by employing large values of  $R_g$  and  $C_c$ . These large values have a negligible effect on the high-frequency performance of the circuit, since at high frequencies  $C_c$  is a short circuit and  $R_g$  is a high resistance in shunt with the low resistance  $R_o$ .

Too large values of  $C_c$  and  $R_g$  cannot be employed for several practical reasons. One is the large size attained by the capacitor and consequent high stray capacitance ( $C_s$ ) to ground, which degrades the high-frequency response. Another is the effect of grid (gas) current on the grid-bias voltage of the following tube if  $R_g$  is too large. Still another is the tendency of the amplifier to "motor-boat," that is, to oscillate in relaxation fashion owing to coupling between stages in the impedance of the power supply. For these reasons, it is desirable to employ values of  $C_c$  and  $R_g$  small enough to avoid these troubles. Compensation elsewhere in the circuit may be employed to correct the low-frequency amplitude and phase responses, if necessary.

The phase response of the amplifier at low frequencies is especially troublesome. The reason is that a very small phase shift, measured in degrees, is a very large time delay, in seconds, when the frequency is low. One effect of excessive low-frequency phase shift is a gradual change in shading from top to bottom of the picture.

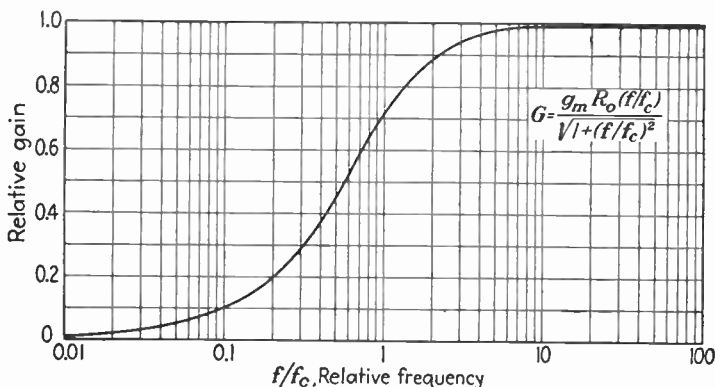

FIG. 123.—Amplitude-frequency response curve of uncompensated amplifier at low frequencies, in terms of the reference frequency  $f_c$  determined by the coupling capacitor and grid resistor.

The phase shift produced by the circuit in Fig. 122 may be computed by rationalizing Eq. (126)

$$G = \frac{g_m R_o R_g \left( \frac{R_g}{X_c} + j \right)}{(R_g/X_c)^2 + 1} \quad (130)$$

The ratio  $X_o/R_o$  then becomes

$$\frac{X_o}{R_o} = \frac{X_c}{R_g} \quad (131)$$

and the added phase shift  $\phi_a$  is

$$\phi_a = \tan^{-1} \frac{X_c}{R_g} \quad (132)$$

$$= \cot^{-1} 2\pi f C_c R_g \quad (133)$$

$$= \cot^{-1} \frac{f}{f_c} \quad (134)$$

A plot of Eq. (134) is shown in Fig. 124. The departures from linearity are minimized by employing as low a value of  $f_c$  as possi-

ble, which means employing as large values of  $R_o$  and  $C_c$  as are practicable.

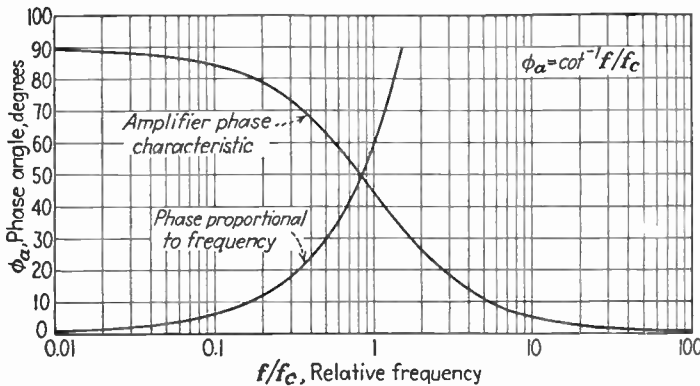

FIG. 124.—Phase-frequency characteristic of the uncompensated amplifier.

**34. Compensation Applied to a Single Amplifier Stage.<sup>1</sup> a. High-frequency Compensation.**—The principal cause of loss of

gain at the high frequencies, as shown in the preceding section, is the shunting effect of the capacitance  $C_t$ , composed of tube and stray capacitances. It is possible to compensate for the effect of this capacitance in several ways. One of the simplest is the use of a small inductance  $L_o$  in series with the output resistor  $R_o$ . The load impedance  $Z_o$  then becomes the combination shown in Fig. 125.

The analysis of  $Z_o$  in terms of its  $L$ ,  $R$ , and  $C$  values is carried out for the high frequencies as follows:  $R_o$  is the output resistance,  $C_t$  the total shunt capacitance, and  $L_o$  the output inductance. The coupling

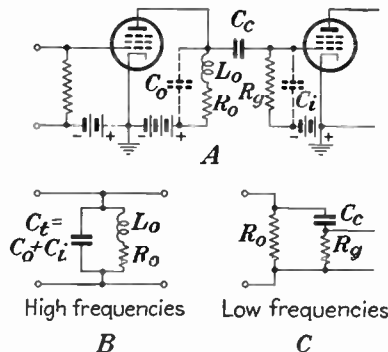

FIG. 125.—The "shunt-peaking" system of compensating high-frequency response by the insertion of the coil  $L_o$  in shunt across the amplifier output (and in series with the load resistor).  $B$  and  $C$  give the equivalent circuit at high and low frequencies.

<sup>1</sup> High-frequency compensation as well as other aspects of video amplification are treated at length in:

BARBER, A. W., Video Amplifier Design, *Communications*. 18 (6), 13

capacitance  $C_c$  is replaced by a short circuit, allowing  $C_o$  and  $C_i$  to be represented by a single combined value  $C_t$ .  $R_o$  is considered so large (it must be large for proper low-frequency response) that its shunting effect may be neglected. We have then for  $Z_o$

$$\frac{1}{Z_o} = \frac{1}{-jX_c} + \frac{1}{R_o + jX_L} \quad (135)$$

where  $X_c$  is the reactance of  $C_t$  and  $X_L$  is the reactance of  $L_o$ , equal to

$$X_L = 2\pi fL_o \quad (136)$$

Solving Eq. (135) for  $Z_o$ , we obtain

$$Z_o = \frac{(R_o + jX_L)(-jX_c)}{[R_o + j(X_L - X_c)]} \quad (137)$$

Since the explicit solution of this equation is rather complicated, it is desirable to undertake an investigation originally suggested by Robinson. The impedance  $Z_o$  consists of two branches, one capacitive, the other resistive-inductive. Suppose

(June, 1938).

BUILDER, G., The Amplification of Transients, *Wireless Eng. Exp. Wireless*, 246 (May, 1935).

EVEREST, E. A., Wideband Television Amplifiers, *Electronics*, 11 (1), 16 (January, 1938); 11 (5), 24 (May, 1938).

FREEMAN and SCHANTZ, Video Amplifier Design, *Electronics*, 10 (8), 22 (August, 1937).

HEROLD, E. W., High-frequency Correction in Resistance-coupled Amplifiers, *Communications*, 18 (8), 11 (August, 1938).

KEALL, O. E., Correction Circuits for Amplifiers, *Marconi Rev.*, 54, 15 (May, 1935).

NAGY, P., The Design of Vision-frequency Amplifiers, *Television*, 10, 160, 220, 279 (March, April, May, 1937).

Oakey, C. W., Distortionless Amplification of Electrical Transients, *Wireless Eng. Exp. Wireless*, 245 (May, 1931).

PREISMAN, A., Some Notes on Video Amplifier Design, *RCA Rev.*, 2 (4), 421 (April, 1938).

ROBINSON, G. D., Theoretical Notes of Certain Features of Television Receiving Circuits, *Proc. I.R.E.*, 21, 833 (June, 1933).

SEELEY and KIMBALL, Analysis and Design of Video Amplifiers, *RCA Rev.*, 2 (2), 171 (October, 1937); 3 (3), 290 (January, 1939).

WHEELER, H. A., Wideband Amplifiers for Television, *Proc. I.R.E.*, 27, 429 (July, 1939).

WILSON, J. C., "Television Engineering," Chap. VI, Pitman and Sons, Ltd., London, 1937.

we equate the susceptance of one branch to the susceptance of the other. This will ensure that, at the frequency for which the two susceptances are equal, the impedance  $Z_o$  will be nonreactive. The susceptance of the  $C_t$  branch is

$$B_C = 2\pi f C_t \quad (138)$$

That of the resistive-inductive branch is

$$B_{RL} = \frac{2\pi f L_o}{R_o^2 + (2\pi f L_o)^2} \quad (139)$$

We now suppose that  $L_o$  is small and that  $(2\pi f L_o)^2$  may be neglected (this assumption is usually met in practice). Equating  $B_C$  and  $B_{RL}$ , we obtain the result

$$2\pi f C_t = \frac{2\pi f L_o}{R_o^2} \quad (140)$$

We may cancel  $2\pi f$ , showing that  $B_C$  and  $B_{RL}$  are equal, *regardless of the frequency*, so long as  $(2\pi f L_o)^2$  can be neglected. The condition then expressed in Eq. (140) is

$$L_o = C_t R_o^2 \quad (141)$$

This equation shows that if  $C_t$  and  $R_o$  are given, a value of  $L_o$  can be found that will make  $Z_o$  nonreactive for all frequencies, up to the frequency at which  $(2\pi f L_o)^2$  can no longer be neglected.

Figure 126 shows the value of  $G_o$  plotted against  $f/f_o$ , where  $f_o$ , as in the previous discussion, is

$$f_o = \frac{1}{2\pi R_o C_t} \quad (113)$$

In the figure, the curves have been plotted for several values of  $L_o$ , including  $L_o = 0$  which corresponds to the uncompensated case treated in the previous section. It is clear that by increasing the value of  $L_o$  the high-frequency response of the circuit is improved, so far as amplitude is concerned. In particular when  $L_o$  is half the value indicated in Eq. (141), that is,  $L_o = \frac{1}{2} C_t R_o^2$ , the gain is maintained constant up to the frequency  $f = f_o$  ( $f/f_o = 1$ ). This is the condition on which many practical designs are based.

In practice, the design procedure is as follows: The frequency  $f_o$ , up to which uniform gain is required, is decided upon and the

given value of  $C_t$  measured or computed. From  $f_o$  and  $C_t$ , it is possible to compute the required value of  $R_o$  by Eq. (113), rearranged as

$$R_o = \frac{1}{2\pi f_o C_t} \quad (142)$$

Finally  $L_o$  is computed from the values of  $C_t$ ,  $R_o$ , and  $f_o$

$$L_o = \frac{1}{2} C_t R_o^2 = \frac{0.5 R_o}{2\pi f_o} \quad (143)$$

The action of the compensation inductance may be explained readily in terms of the shunt resonant circuit which  $C_t$  and  $L_o$

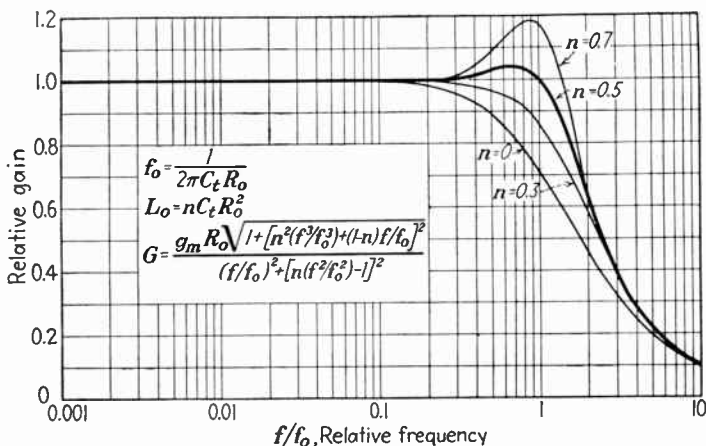

FIG. 126.—Amplitude-frequency response characteristics of the shunt-peaking compensated amplifier, for different values of the compensating inductance  $L_o$ . The case for  $n = 0$  is the uncompensated case, whereas that for  $n = 0.5$  is that usually adopted in practice. Plotted as the magnitude of Eq. (147).

form. The shunt resonance raises the impedance in the region of the resonant frequency of this combination. Under the frequency conditions specified in Eqs. (142) and (143), the resonant frequency is 1.41 times as great as the highest frequency ( $f_o$ ) to be amplified in the video range. As shown later, other values of  $R_o$  and  $L_o$  than those shown in Eqs. (142) and (143) may be used, but the values given represent a good compromise between linearity of amplitude and phase response on the one hand and available gain on the other.

The exact expressions for gain and added phase response for the conditions outlined above may be deduced as follows: The expression for  $Z_o$  [Eq. (137)] is first rearranged by dividing numerator and denominator by  $X_c$

$$Z_o = \frac{-j(R_o + jX_L)}{\frac{R_o}{X_c} + j\left(\frac{X_L}{X_c} - 1\right)} \quad (144)$$

Then the equation is rationalized

$$Z_o = \frac{-j(R_o + jX_L) \left[ \frac{R_o}{X_c} - j\left(\frac{X_L}{X_c} - 1\right) \right]}{\left(\frac{R_o}{X_c}\right)^2 + \left(\frac{X_L}{X_c} - 1\right)^2} \quad (145)$$

$$= \frac{R_o + j\left(X_L - \frac{X_L^2}{X_c} - \frac{R_o^2}{X_c}\right)}{\left(\frac{R_o}{X_c}\right)^2 + \left(\frac{X_L}{X_c} - 1\right)^2} \quad (146)$$

Now recalling that  $X_c = 1/(2\pi f C_t)$ , that  $X_L = 2\pi f L_o$ , that  $R_o = 1/(2\pi f_o C_t)$ , and assuming that  $L_o = nR_o/(2\pi f_o)$ , we obtain for  $Z_o$

$$Z_o = \frac{R_o(1 - j[n^2(f/f_o)^3 + (1 - n)(f/f_o)])}{(f/f_o)^2 + [n(f/f_o)^2 - 1]^2} \quad (147)$$

The plots in Fig. 126 represent Eq. (147) for several values of  $n$ . The gain is found by multiplying Eq. (147) by the  $g_m$  of the tube involved.

The added phase shift  $\phi_a$  is an angle the tangent of which is the ratio of the imaginary to the real parts of Eq. (147), that is,

$$\phi_a = \tan^{-1} \left[ n^2 \left( \frac{f}{f_o} \right)^3 + (1 - n) \frac{f}{f_o} \right] \quad (148)$$

The plots in Fig. 127, showing the phase shift in terms of  $f/f_o$ , are obtained from this equation.

In general, there are two ratios of importance in the circuit, the ratio  $m$  of the resistance  $R_o$  to the reactance of  $C_t$  at  $f_o$

$$m = 2\pi f_o C_t R_o \quad (149a)$$

and the ratio  $n$  of the reactance of  $L_o$  to the reactance of  $C_t$  at  $f_o$

$$n = (2\pi f_o)^2 L_o C_t \quad (149b)$$

In the previous discussion,  $m$  has been made equal to 1, and  $n$  to 0.5. Freeman and Schantz<sup>1</sup> have shown that if  $m = 0.85$  and  $n = 0.3$ , the amplitude and phase responses are almost perfectly linear up to  $f_0$  and somewhat beyond, but the stage gain is decreased by 15 per cent (since  $m = 0.85$  rather than 1.0) at all frequencies. Values of  $m = 0.9$  and  $n = 0.5$  may be used to obtain slightly higher gain at the high-frequency limit relative to that at low frequencies, and this procedure is sometimes

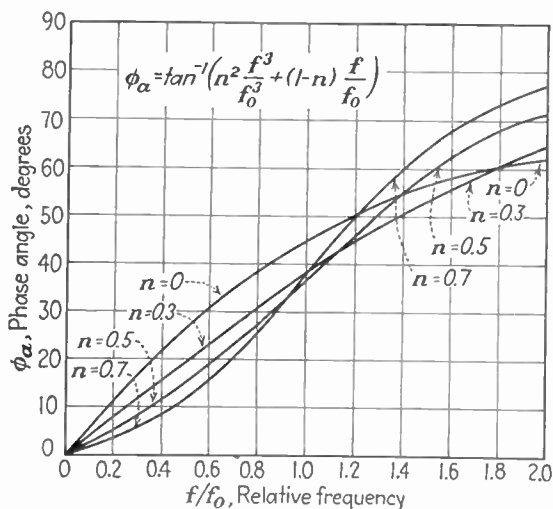

FIG. 127.—Phase-frequency response characteristics corresponding to the curves in Fig. 126. Note that the compensating inductance not only improves the amplitude response but straightens out the phase response as well.

desirable for compensating deficiencies of other elements in the video transmission system. Priesman<sup>1</sup> has urged that  $m = 0.853$  and  $n = 0.42$  are especially suitable for use in compensating the separate stages of a multistage amplifier.

In general  $L_o$ ,  $R_o$ , and  $C_t$  may be varied independently of one another with widely varying results on the high-frequency amplitude and phase responses. For practical purposes, it is possible to arrive at the approximate values from Eqs. (142) and (143), with the results shown in Figs. 126 and 127. If different amplitude and phase responses are necessary, small variations from the computed values may be made experimentally and the results

<sup>1</sup> See references, p. 220.



observed by the measurement techniques described later in this chapter.

*Other Methods of High-frequency Compensation.*—The simple method of compensation described above, employing a single shunt inductance or “peaking coil,” serves well for most cases, if the maximum frequency limit is not too high and the number of

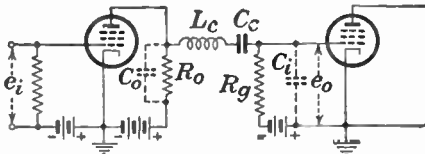

FIG. 128.—The “series-peaking” method of high-frequency compensation, which results in higher gain and more linear phase response than the shunt-peaking method. The series coil  $L_c$  isolates the two capacitances  $C_o$  and  $C_i$ .

stages is few. For stricter requirements, a desirable method of compensation is that known as “series peaking,” which gives higher gain and more linear phase response. A typical example of this method of coupling is shown in Fig. 128. The filter elements consist of the output capacitance  $C_o$ , the following input impedance  $C_i$ , and the coupling inductance  $L_c$  which isolates  $C_o$  from  $C_i$ . The filter is terminated at the entering end by the impedance  $R_o$  and at the far end by the resistor  $R_g$ . The effect

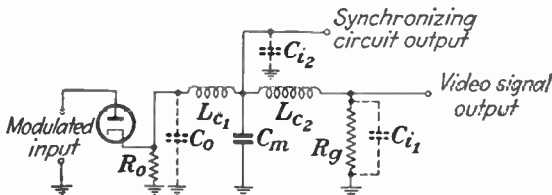

FIG. 129.—Filter coupling (two series-peaking coils in cascade) applied to a detector load circuit. Two sources of the signal are made available without loading the circuit with additional capacitance.

of the blocking capacitor  $C_c$  may be neglected since it is effectively a short circuit at high frequencies.

Several filter sections may be employed in cascade to improve the band-pass characteristics and to provide additional terminals from which signal energy may be derived. In Fig. 129, for example, a two-section filter is used, the middle point of which serves as the source of signal energy for synchronization.

The value of this connection lies in the fact that the center capacitance of the filter  $C_m$  is twice as large as  $C_o$  or  $C_i$ . The capacitance loading (causing loss of high-frequency response) of the following stage is thus much less when applied at the mid-point than if applied to the end termination. In this circuit, two connections are made to the filter as shown in Fig. 129, one for the picture-signal circuit, the other for controlling the synchronizing system. The two connections placed separately on the filter introduce less loading effect than if they were applied together at one point.

*Compensation by Series Peaking (Filter Coupling).*—The advantage of series-peaking compensation, as noted above, lies in the isolation of the capacitance  $C_o$  from  $C_i$ . The load impedance may accordingly be chosen by reference to  $C_o$  only, and since  $C_o$  is smaller than  $C_i$ , the value of  $R_o$  may be proportionately larger and the gain of the stage increased without impairing the high-frequency response. The output voltage  $e_o$  across  $R_o$  can be shown by the methods applied to shunt peaking to be

$$e_o = \frac{e_i g_m R_o}{1 + (2\pi f_o C_o R_o)^2} \quad (150)$$

This voltage is applied across the coupling connection  $L_c$  in series with  $R_o$  and  $C_i$  in shunt. The useful voltage (passed on to the next stage) is that developed across  $R_o$  and  $C_i$ . Since  $R_o$  is large, it is sufficient to consider  $C_i$  and  $L_c$  as a reactive voltage divider.

The resonance frequency of  $C_i$  and  $L_c$  is chosen above the upper limit of the desired video range; hence the voltage developed across  $C_i$  tends to rise with frequency at the upper limit, and this rise counteracts the loss in the uncompensated output circuit  $R_o$ - $C_i$  of the preceding tube.

In this circuit, an important ratio is that between the second capacitance  $C_i$  and the first  $C_o$ . Priesman shows that  $C_i/C_o$  should be approximately two, and this condition is often met in practice or may be brought about by the use of lumped capacitance where needed.

The design procedure for this type of compensation is similar to that in shunt peaking: the upper limit of the video range  $f_o$  is determined, and the capacitances  $C_o$  and  $C_i$  are measured. Then  $L_c$  is determined from  $f_o$  and  $C_o$  as follows:

$$L_c = \frac{1}{8\pi^2 f_o^2 C_o} \quad (151a)$$

This equation derives from the fact that the resonant frequency of  $L_c$  and  $C_o$  is chosen 1.41 times as great as that of  $f_o$ .

The resistance  $R_o$  is chosen to have a value

$$R_o = \frac{1.5}{2\pi f_o C_i} \quad (151b)$$

where  $C_i = C_o + C_i$ .

By comparing Eq. (151b) with Eq. (142) and by noting that for a given stage  $C_i$  is the same whether shunt or series peaking is employed, it will be noted that the series-peaking case (filter coupling) offers a gain approximately 50 per cent greater than that of the shunt-peaking case. On this account alone, series peaking has been incorporated in many commercial television receivers where video amplification up to 4 Mc. is required.

It should be noted that the filter-coupling network may be turned end for end (that is, the input connected to the output terminals and the output to the input terminals) without changing the characteristics of the stage. This procedure is sometimes indicated if the capacitance  $C_i$  is smaller than  $C_o$ . If this is true, the ratio  $C_i/C_o$  is given a value of about one-half, and the load and terminating resistances ( $R_o$  and  $R_o$ , respectively) exchange places in the network.

The phase delay is a rather complicated function in the series-peaking circuit, but in general, as Seeley and Kimball have shown, the time delay (in seconds) up to the frequency  $f_o$  is constant within a variation of  $0.0113/f_o$   $\mu$ sec. This is roughly one-half the variation in phase delay experienced with shunt peaking.

*Combination of Shunt and Series Peaking.*—As might be expected from the foregoing discussion, the advantages of shunt and series peaking are complementary, and an advantage is to be obtained, therefore, by combining both forms in the coupling network. Herold<sup>1</sup> has examined this circuit (Fig. 130) in detail. Under specified conditions (commonly met in practice), the gain of the combined shunt-series peaking stage is 80 per cent greater than that of the simple shunt-peaking system. The conditions under which this is true are  $C_i/C_o = 2$ ,  $R_o = 1.8/[2\pi f_o(C_i + C_o)]$ ,

<sup>1</sup> See reference, p. 220.

$L_o = 0.12(C_o + C_i)R_o^2$ , and  $L_c = 0.52(C_o + C_i)R_o^2$ . The design procedure is as follows: decide upon  $f_o$ ; measure  $C_o$  and  $C_i$ , and make  $C_i/C_o = 2$ ; determine  $R_o$  by the preceding relation; then determine  $L_o$  and  $L_c$  from the foregoing equations. The variation in phase delay associated with combined shunt-series coupling is about the same as that in the series-peaking circuit.

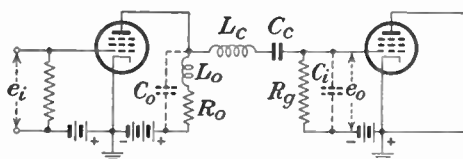

FIG. 130.—The shunt-series peaking system which combines the advantages of the shunt- and series-peaking coils.

*Comparison of High-frequency Compensation Methods.*—Table III gives the essential design data for high-frequency compensation by the three methods just outlined, shunt, series, and shunt-series peaking, when compared with the uncompensated case. The relative time-delay figures are taken from Seeley and Kimball.

TABLE III.—HIGH-FREQUENCY COMPENSATION SYSTEMS

Type	$R_o$	$L_o$	$L_c$	Relative gain at $f_o$	Variation in time delay, sec. up to $f_o$ c.p.s.
Uncompensated . . . . .	$1/2\pi f_o C_t$	.....	.....	0.707	$0.035/f_o$
Shunt . . . . .	$1/2\pi f_o C_t$	$0.5C_t R_o^2$	.....	1.0	$0.023/f_o$
Series ( $C_i/C_o = 2$ ) . . . . .	$1.5/2\pi f_o C_t$	.....	$0.67C_t R_o^2$	1.5	$0.0113/f_o$
Shunt-series ( $C_i/C_o = 2$ ) . . . . .	$1.8/2\pi f_o C_t$	$0.12C_t R_o^2$	$0.52C_t R_o^2$	1.8	$0.015/f_o$

**b. Low-frequency Compensation in a Single Amplifier Stage.<sup>1</sup>**

The amplitude and phase characteristics in an uncompensated amplifier (Figs. 123 and 124) at low frequencies show that impractically large values of coupling capacitance and grid resistance are required for proper performance at frequencies as low as the

<sup>1</sup> See Preisman (reference p. 220).

frame-repetition rate of 30 c.p.s. If large values are employed, the high-frequency response may suffer from the high value of shunt capacitance to ground introduced by the coupling capacitor, and furthermore, the tendency of the amplifier to set up relaxation oscillators is augmented. The compromise usually adopted is to employ a low-frequency compensation circuit in series with the output resistor  $R_o$ . The compensation circuit consists of two elements, a filter capacitor  $C_F$  and a filter resistor  $R_F$ .

The purpose of the filter  $R_F C_F$  is twofold. (1) It introduces a phase shift that compensates for the phase shift in the coupling

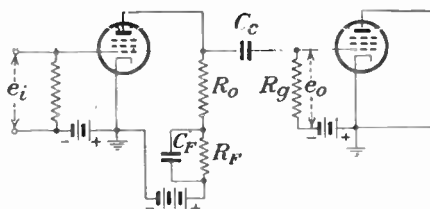

FIG. 131.—Compensation filter ( $R_F C_F$ ) applied to improve the amplitude and phase responses at low frequencies.

circuit  $R_o C_c$ . (2) By virtue of the decoupling action of  $R_F$  and  $C_F$ , it prevents the amplified signal voltage from developing across the impedance of the power supply and thus it inhibits feedback and relaxation oscillations.

The analysis of the coupling circuit, including the compensation filter, is carried out as follows: The tube is considered to be a constant-current generator, which delivers a current

$$i_p = e_i g_m \quad (152)$$

The constant-current condition holds so long as  $R_o$  and  $R_F$  are small when compared with the dynamic resistance of the tube, as is assumed in this and the previous derivations.

The constant current produced by the tube divides into the two branches of the output impedance  $Z_o$  (see Fig. 131). In practice,  $R_g$  is very large if compared with  $R_o$  and  $R_F$ ; hence we may consider that the shunting effect of the  $C_g$ - $R_g$  branch is negligible and derive the gain  $G'$  which is available across the  $R_o$ - $R_F$ - $C_F$  branch. Writing  $1/(j\omega C_F)$  as the impedance of  $C_F$  where  $\omega = 2\pi f$ , we obtain for the impedance  $Z_p$  of the  $R_o$ - $R_F$ - $C_F$  branch

$$Z_p = R_o + \frac{R_F}{j\omega C_F} \frac{1}{R_F + \frac{1}{j\omega C_F}} \quad (153)$$

Rearranging, we obtain

$$Z_p = R_o + \frac{R_F}{1 + j\omega R_F C_F} \quad (154)$$

The gain developed across  $Z_p$  is

$$G' = g_m Z_p = g_m \left( R_o + \frac{R_F}{1 + j\omega R_F C_F} \right) \quad (155)$$

Of this gain, only a fraction is delivered to the output, because of the voltage dividing action of  $C_c$  and  $R_o$ . The over-all gain  $G$  is

$$G = G' \left( \frac{R_o}{R_o + \frac{1}{j\omega C_c}} \right) \quad (156)$$

Multiplying through  $j\omega C_c$ , we obtain

$$G = j\omega C_c G' \left( \frac{R_o}{1 + j\omega R_o C_c} \right) \quad (157)$$

Substituting  $G'$  from Eq. (155),

$$G = g_m R_o j\omega C_c \left( R_o + \frac{R_F}{1 + j\omega R_F C_F} \right) \left( \frac{1}{1 + j\omega R_o C_c} \right) \quad (158)$$

Expanding the first parenthesis,

$$G = g_m R_o j\omega C_c \frac{(R_o + R_F + j\omega R_o R_F C_F)}{(1 + j\omega R_F C_F)(1 + j\omega R_o C_c)} \quad (159)$$

This equation is greatly simplified if  $R_p$  is introduced for  $R_o R_F / (R_o + R_F)$  and if the  $RC$  product is written in the denominator of each  $j$  term.

$$G = \frac{g_m R_o j\omega C_c \left( \omega - \frac{j}{C_F R_p} \right)}{\left( \omega - \frac{j}{C_F R_F} \right) \left( \omega - \frac{j}{C_c R_o} \right)} \cdot \frac{R_o + R_F}{j C_F R_F} \cdot \frac{j R_o R_F}{R_o + R_F} \cdot \frac{C_F}{j C_c R_o}$$

hence

$$G = \frac{g_m R_o \omega \left( \omega - \frac{j}{C_F R_p} \right)}{\left( \omega - \frac{j}{R_F C_F} \right) \left( \omega - \frac{j}{R_o C_c} \right)} \quad (160)$$

This equation shows that there are three important time constants  $R_F C_F$ ,  $C_c R_o$ , and  $\frac{C_F R_o R_F}{(R_o + R_F)}$  that determine the gain and its phase angle, but it gives no explicit information on the manner in which these quantities vary with frequency.

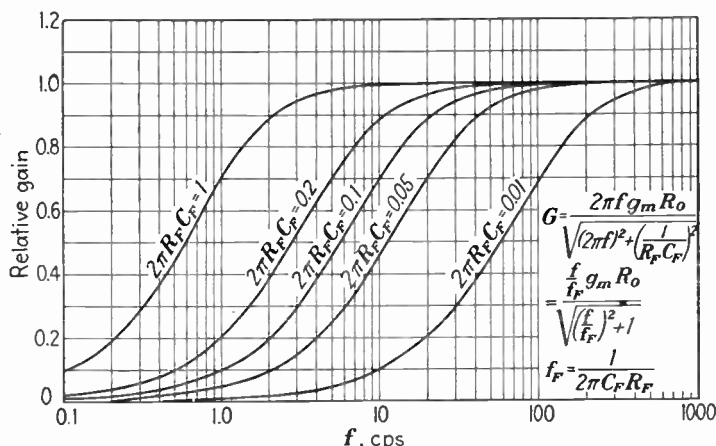

FIG. 132A.—Low frequency gain-frequency response curves of amplifier compensated with  $R_F C_F$  filter. The higher the  $RC$  product, the better the gain at low frequencies.

The equation, cast in this form, shows that the term

$$\left( \omega - \frac{j}{C_F R_p} \right)$$

in the numerator may be canceled by either of the terms in the denominator  $[\omega - (j/R_F C_F)]$  or  $[\omega - (j/R_o C_c)]$ . In other words, one time constant may be compensated by the other. For example,  $C_F R_p$  may be made equal to  $C_c R_o$ . Then the gain is

$$G = \frac{\omega g_m R_o}{\omega - \frac{j}{R_F C_F}} \quad (161)$$

This relationship may be plotted, in amplitude and phase, for given values of  $g_m$ ,  $R_o$ ,  $R_F$ , and  $C_F$ , as shown in Fig. 132. The higher the value of  $R_F C_F$ , the more uniform the gain and the smaller the phase shift. In practice,  $R_F$  cannot be made too large, since the d-c plate voltage applied to the amplifier tube is thereby decreased, but it is given as large a value as is economical. A comparison of the curves for the uncompensated case (Figs. 123 and 124) with those for the compensated case (Fig. 132) shows the improvement made possible by the presence of  $R_F C_F$ .

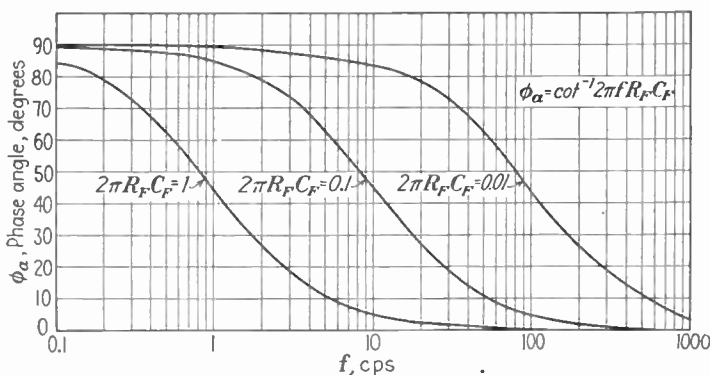

FIG. 132B.—Phase-frequency response of the low-frequency compensated amplifier. The higher the value of  $R_F C_F$ , the lower the point of zero phase shift.

Thus far no statement of the desirable values of  $R_p C_F = R_p C_o$  is forthcoming from the analysis, other than the general rule that the time constant should be as large as possible, short of introducing capacitance to ground and relaxation oscillations. Experimenters are in some disagreement about the maximum permissible value of the  $RC$  product. Keall<sup>1</sup> states that a value higher than  $R_o C_o = 0.01$  is apt to produce instability, and this is especially true if the number of stages is large. In simple amplifiers, however, it seems that values as high as 0.1 or even 0.5 may be employed safely, with resultant improvement in the phase and amplitude responses at the lowest frequencies.

The entire response curve of a typical single-stage video amplifier, compensated for high-frequency as well as low-frequency response, is shown in Fig. 133. It will be noted that the phase

<sup>1</sup> KEALL, O. E., Correction Circuits for Amplifiers, *Marconi Rev.*, 54, 15 (May, June, 1935).



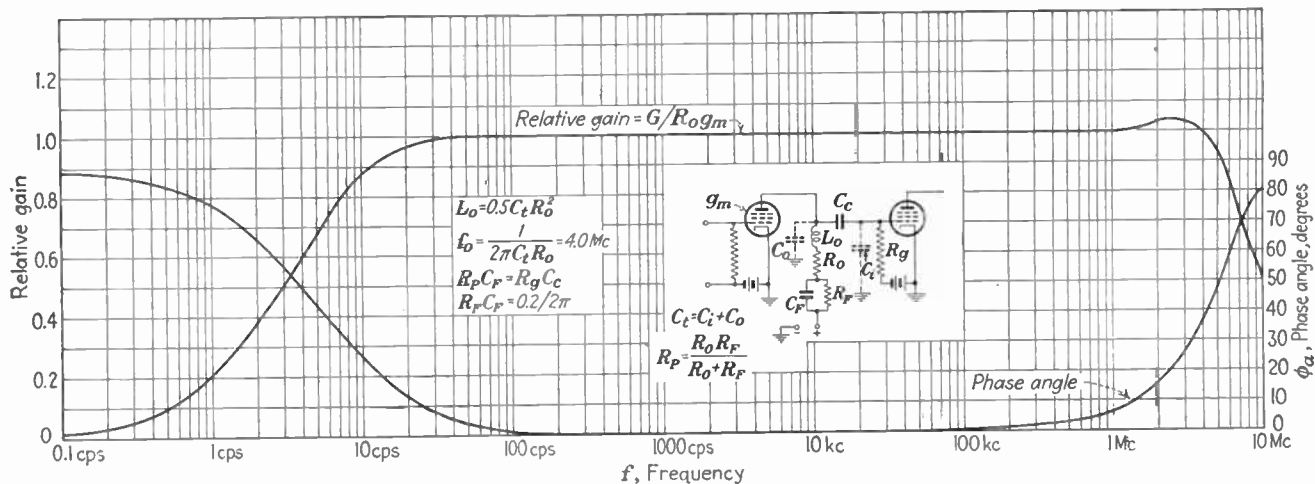

FIG. 1:3.—Circuit (inset) of complete video amplifier with high-frequency and low-frequency compensation, and its theoretical response curves over a frequency range of 100,000 to 1. The design relationships assume  $f_o = 4.0$  Mc.,  $n = 0.5$ , and  $R_P C_F = 0.2/2\pi$ . Otherwise the curves are general for any values of  $C_i$ ,  $C_o$ ,  $R_o$ , and  $g_m$ . For convenience all values of the phase angle have been plotted as positive. Actually the high-frequency phase angle has the reverse sign relative to the low-frequency angle [cf. Eqs. (148) and (151)].

shift is proportional to frequency in the intermediate- and high-frequency ranges. At a value of frequency in the upper part of the low-frequency range, the phase shift reaches a minimum, approximately  $0^\circ$ . At lower frequencies, however, the phase shift becomes inversely proportional to frequency and the phase shift rises (with reversed sign relative to the high-frequency angle) as the frequency approaches zero. It is important that the frequency of minimum phase shift occur at as low a frequency as possible.

*Effect of the Cathode-bias Filter on Low-frequency Response.*—To obtain negative bias voltage on the grid of an amplifier tube, it is usual to include a resistor  $R_k$  and a capacitance  $C_k$  in series with the cathode and ground. The capacitance  $C_k$  is usually made

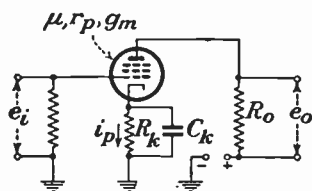

FIG. 134.—Amplifier circuit with grid-bias filter  $R_k C_k$ , used to derive Eq. (167).

large enough so that its reactance at the lowest frequency under consideration is not greater than one-tenth the value of  $R_k$ . In practice, the capacitance  $C_k$  may reach values in the hundreds of microfarads, especially if  $R_k$  has a low value. The significance of the bias filter  $R_k C_k$  on the low-frequency response arises from the fact that the lower the frequency, the higher the reactance of  $C_k$ , and the less its shunting effect on  $R_k$ . At a value of frequency low enough to make the reactance of the same order as  $R_k$ , the resistor  $R_k$  becomes important in the signal action of the circuit. The plate-current signal, passing through the cathode resistor, applies a signal to the grid circuit in reverse phase to the input signal and thereby reduces the amplification. The result is an amplitude attenuation of the low frequencies. The effect of  $R_k$  may be computed from the circuit diagram in Fig. 134. The input signal  $e_i$  is reduced by the signal developed across the cathode resistor  $i_p R_k$ . Thus the generator voltage is

$$e = \mu(e_i - i_p R_k) \quad (162)$$

Furthermore, the total resistance in the plate circuit has become  $r_p + R_o + R_k$ . The plate current then is

$$i_p = \frac{\mu(e_i - i_p R_k)}{r_p + R_o + R_k} \quad (163)$$

which solved for  $i_p$  becomes

$$i_p = \frac{\mu e_i}{r_p + R_o + R_k(1 + \mu)} \quad (164)$$

The output signal is  $e_o = i_p R_o$ , and the gain  $G$  is  $e_o/e_i$ . Hence for the gain we have

$$G = \frac{\mu R_o}{r_p + R_o + R_k(1 + \mu)} \quad (165)$$

If we compare the gain  $G$  in this case with the gain  $G_o$  produced with no  $R_k$  in the circuit [Eq. (100)], we find the gains to be the ratio

$$\frac{G}{G_o} = \frac{r_p + R_o}{r_p + R_o + R_k(1 + \mu)} \quad (166)$$

Since the  $\mu$  value of pentode amplifier tubes is often very great, the loss of gain is appreciable unless  $R_k$  is very small. Accordingly, values of capacitance  $C_k$  large enough to remove the signal components from  $R_k$  are required.

When the effect of  $C_k$  is taken into account, the value of the gain of the stage is

$$G = \frac{\mu R_o}{R_o + r_p + (1 + \mu) \left( \frac{R_k}{1 + j\omega C_k R_k} \right)} \quad (167)$$

The phase shift and amplitude attenuation introduced by the cathode-bias filter may be compensated by the  $R_F C_F$  filter in the plate circuit of the tube in much the same manner as previously described for the compensation of  $R_o C_o$ . The complete analysis of the circuit including the four time constants ( $R_p C_F$ ,  $R_F C_F$ ,  $R_o C_o$ , and  $R_k C_k$ ) is so complicated that it is usually attacked experimentally.

The compensation of the time constant  $R_k C_k$  is carried out in a filter  $R_F C_F$  having the same time constant, that is,

$$R_F C_F = R_k C_k \quad (168)$$

Furthermore,

$$R_F = R_k (g_m R_o) \quad (169)$$

and

$$C_F = \frac{C_k}{g_m R_o} \quad (170)$$

It should be noted that the filter designed to compensate  $R_k C_k$  cannot in general compensate also for the time constant  $R_o C_o$ . In practice, it is customary to compensate for  $R_k C_k$  only and to employ a larger value of  $R_o$  than might otherwise be used. The large value of  $R_o$  makes the time constant  $R_o C_o$  large and hence reduces the need for compensation at this point. The large  $R_o$  may be used by virtue of the fact that cathode-biased amplifiers, in general, may have much larger values of  $R_o$  than those applicable to fixed-biased stages.

*Compensation in Multistage Amplifiers.*<sup>1</sup>—The discussion thus far has been limited to the compensation of a single stage of amplification. In all but the simplest applications, more than one stage is usually used; hence it is necessary to consider some of the cumulative effects that arise when amplifiers are connected in cascade.

The first statement is simple: The over-all amplitude-frequency characteristic of a multistage amplifier is equal to the product of the amplitude-frequency characteristics of the individual stages. This follows from the fact that the gain action of a single stage is a simple multiplication of the input signal. Suppose a single amplifier stage of gain  $G$  emphasizes the amplitude of one frequency relative to another by a factor  $n$  and that the relative discrimination between the same two frequencies in another stage of gain  $G'$  is  $n'$ . If the two frequencies are applied at unity amplitude to the input of the first amplifier, their amplitudes are  $G$  and  $Gn$  at the input to the second amplifier and  $GG'$  and  $GG'nn'$  at the output of the second amplifier. The ratio of their amplitudes is then  $nn'$ , which is the product of the discriminations of the two stages.

Similarly, the over-all time-delay-frequency characteristic of a multistage amplifier is equal to the sum of the time-delay-frequency characteristics of the separate stages. This follows from the fact that the time delay introduced by one stage establishes the time reference for the time delay of the succeeding stage. The same statement applies to phase-shift curves, since at any given frequency the phase shift is proportional to time delay. It follows that the phase-shift characteristics are additive in multistage amplifiers.

<sup>1</sup> See Preisman, also Seeley and Kimball (references on p. 220).

When compensation is applied to a multistage amplifier, it is theoretically possible to compensate for the over-all amplitude and phase distortion by one corrective network for low frequencies and by one network for high frequencies. If the compensations were exact, this procedure would have no disadvantages and might have advantages from the economic point of view. Unfortunately the compensations are not exact, and it often happens that the cumulative phase and amplitude distortion cannot be compensated in a single stage because the range of the compensating circuit is insufficient for the purpose. Conse-

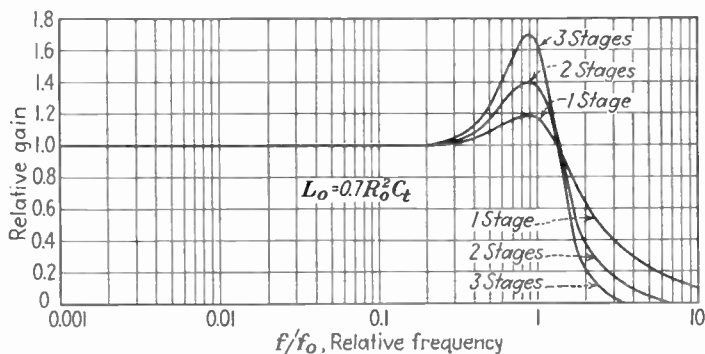

FIG. 135.—Cumulative effect of improper compensation when applied to a 3-stage amplifier.

quently, it is usually considered good practice to compensate each stage individually.

When individually compensated stages are connected in cascade, it sometimes happens that the secondary effects of the compensation, unnoticed in a single stage, become serious in the over-all response. Thus for example, in high-frequency compensation, if  $L_0$  is chosen greater than 50 per cent of  $C_t R_0^2$ , the compensated amplitude characteristic has a rise in voltage at or near the frequency  $f_0$ . This rise may cause no trouble in a single stage. But if the rise occurs in the same region of frequency in each of a succession of stages, the over-all effect may be a serious overemphasis of frequencies in the upper region. When this effect is present, the multistage amplifier is apt to display unwanted transient responses to frequencies in this range.

The problem of multistage amplification is most serious in studio and broadcast-transmitter installations, where as many

as 20 or 30 video amplifiers may intervene between the camera and the modulated amplifier of the transmitter. In such cases, each stage must be very carefully designed and compensated if the over-all response is to meet (preferably to surpass) that possible in the one or two video stages present in the receiver. Here the problem is best attacked by arbitrarily assuming a much wider band width, say 10 to 6,000,000 c.p.s., and compensating to obtain uniform gain and phase shift throughout this region. In general, the gain in each stage will be much lower than if the design were based on 3,000,000 c.p.s., and this loss must be made up by including more stages. If the system aims at good performance over this wide range, its performance over the practically useful range up to 4,000,000 c.p.s. will be correspondingly satisfactory.

**35. Figure of Merit for Video Amplifier Tubes.**<sup>1</sup>—All the expressions for amplifier gain, at high as well as at low frequencies, thus far derived have contained the factor  $g_m$  in the numerator. The gain is proportional, in other words, to the grid-plate transconductance of the tube, which should accordingly have as high a value as possible. Tubes having high values of  $g_m$  have been developed especially for television service. Typical high- $g_m$  tubes have very small spacing between control grid and cathode and a fine winding pitch in the grid.

So far as low-frequency response is concerned, the only tube characteristic of importance is the  $g_m$  value. At the high frequencies, on the other hand, the input and output capacitances, as well as the variations in the apparent input capacitance with gain and plate current, have a very important bearing on the response and the amount of compensation required. In our derivations of high-frequency response, the frequency  $f_o$  (the highest frequency at which uniform gain is required) varies inversely with the total shunt capacitance  $C_t$ . According to Eq. (122), a goodly portion (in practice, roughly one-quarter to one-half) of the  $C_t$  arises in the  $C_{\nu k}$  and  $C_{pk}$  values of the tube. It follows that the lower the values of tube capacitance, the better suited the tube to amplifier service in the high-frequency ranges.

The necessity of high  $g_m$  and low-input and -output capacitances are unfortunately fundamentally opposed to one another. The

<sup>1</sup> See POLLACK, DALE, Choice of Tubes for Wide-band Amplifiers, *Electronics*, 12 (3), 38 (April, 1939).

small grid-cathode spacing and fine winding pitch of high- $g_m$  tubes make for high values of input capacitance. However, it is possible usually to gain more by high- $g_m$  construction than is lost in tube capacitances, especially since the effects of the latter may be compensated.

In view of the foregoing discussion, an acceptable figure of merit  $N$  applying to video amplifier tubes is the ratio of the  $g_m$  to the sum of the input and output capacitances of the tube. Table VII, on page 443, gives the values of the figure of merit

$$N = \frac{g_m}{C_{gk} + C_{pk} + C_{p0}(1 + G)} \quad (171)$$

of tubes that are available for the purpose.

**36. Video Amplifiers Designed for Special Output Conditions (High-power, Low-impedance, Low Signal-to-noise Ratio), Logarithmic Response, Etc.**—The amplifiers heretofore considered are “general-purpose” amplifiers, intended for voltage amplification at moderate levels and to work into circuits of impedances of 10,000 ohms or higher. For special purposes, departures from this basic design are often required. The present section treats briefly a few of the more important aspects of these specialized amplifiers.

*Amplifiers for High-voltage Output.*—In certain transmission amplifiers (especially in modulators), and in output amplifiers intended to control the image-reproducing tube, high output voltage is required. Suppose an r-m-s voltage output of 100 volts is to be developed across a load resistor  $R_o$  of the order of 2000 ohms (usual practice for 3,000,000 c.p.s. frequency limit), then the power expended in the resistance is 5 watts. Ordinary voltage-amplifier pentodes cannot supply such a power output without serious waveform distortions arising from nonlinear dynamic characteristics. In such cases, it is customary to employ a power-output tube to supply the power losses in the output resistor. Such power tubes are ordinarily of the “beam-power tetrode” type and may be treated in the same fashion as voltage-amplifier pentodes, with the important exception that the dynamic plate resistance  $r_p$  of such tubes is low enough relative to the output resistor to effect the gain. The basic equation for gain in this case is not  $G = g_m Z_o$ , but rather

$$G = \frac{\mu Z_o}{r_p + Z_o} \quad (100)$$

Since  $\mu = r_p g_m$ , the gain in this case may be written

$$G = g_m Z_o \left( \frac{r_p}{r_p + Z_o} \right) \quad (172)$$

The factor in parentheses represents the correction factor that may be applied to the gain, calculated by the simple formula  $G = g_m Z_o$ . Ordinarily it is permissible to replace  $Z_o$  by  $R_o$ , in which case the correction factor becomes a simple numeric ratio, readily calculated.

It must be remembered that the presence of  $r_p$  in the calculations introduces changes in the compensation action of the circuit, but ordinarily this effect is of small importance at the high-frequency end of the range. In the low-frequency compensation circuits,  $r_p$  is an important factor but may be readily compensated.

The same remarks apply to the use of triodes as video amplifiers, since the dynamic plate resistance is of even lower value than that of the tetrode tubes just considered. In triode amplifiers, another effect of importance lies in the appreciably high values of plate-to-grid capacitance  $C_{gp}$ . According to Eq. (122), this capacitance enters into the shunt capacitance, multiplied by a factor equal to the stage gain plus one. If triode amplifiers have a stage gain of, say, 5 and a  $C_{gp}$  value of 5  $\mu\mu\text{f}$ , the added capacitance from this source is 25  $\mu\mu\text{f}$ , or roughly half the contribution to be expected from all other sources. It follows that the triode tube is not well suited to the problem when compared with voltage-amplifier pentodes, power pentodes, or power tetrodes.

*Amplifiers for Low Output Impedance.*<sup>1</sup>—When video signals are to be sent over low-impedance circuits (such as coaxial cables, see Sec. 38), it is desirable that the amplifier impedance match the circuit impedance. Impedance matching serves two purposes: maximum energy transfer and freedom from reflections.

Several methods of reducing the output impedance are available. The simplest method is to employ a low value of load resistance  $R_o$ , such that  $R_o$  is approximately equal to the imped-

<sup>1</sup> For treatment of the cathode-coupled stage, see Preisman (reference, p. 220).



ance to be matched. This method is useful when the impedance level is of the order of 500 to 2000 ohms. The stage gain is lowered by the low  $R_o$  value, but the high-frequency compensation and low-frequency compensation are not adversely affected. If the  $R_o$  value is less than  $1/g_m$  ohms, where  $g_m$  is the transconductance of the tube, then the stage gain is less than unity.

When it is desired to obtain low output impedance without sacrificing gain, it is possible to employ several tubes in parallel in one stage. The figure of merit of such a combination of tubes is not materially worse than that of a single tube, since the  $g_m$  and capacitance values of the combination are equal to the sum of the  $g_m$  and tube capacitances of the individual tubes. However, larger values of stray capacitance due to wiring, etc., are encountered. The output impedance of a stage containing  $n$  tubes connected in parallel is  $1/n$ th of the load impedance ordinarily connected to one tube. Consequently the load resistance employed may have a value of  $R_o/n$  where  $R_o$  is the load resistance for a single tube.

A type of low-impedance stage that has won wide acceptance because of its stability and freedom from distortion is the

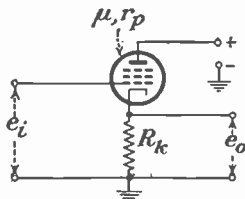

FIG. 136A.—Elements of the cathode-coupled stage (cathode-follower) used for obtaining low output impedance.

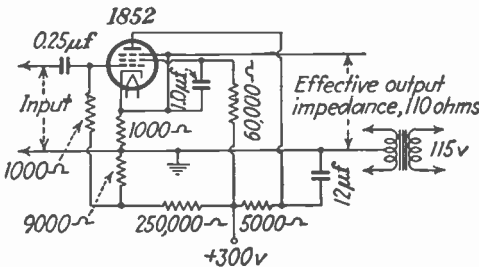

FIG. 136B.—Practical arrangement of a cathode-coupled stage displaying an output impedance of 110 ohms.

cathode-coupled stage, sometimes called “cathode-follower” stage. A typical stage of this type employing a pentode and the corresponding equivalent stage employing a triode are shown in Fig. 136. The analysis based on the triode applies equally well to the pentode. We note, first, that the cathode-coupled stage is the same as that shown in Fig. 134 for the cathode-biased

stage, except that  $R_o$  is identically the same as  $R_k$  and there is no capacitor  $C_k$ . By following through the derivation of Eqs. (162) to (166) with  $R_o = R_k$ , we obtain for the gain of the cathode-coupled stage

$$G = \frac{\mu R_k}{r_p + R_k(\mu + 1)} \quad (173)$$

The presence of the  $(\mu + 1)$  factor in the denominator assures that the gain of the stage can never be greater than one. The circuit is, in other words, a deamplifier. However, usually the loss of gain may readily be made up in other circuits.

The value of the circuit in producing low output impedance may be seen by writing Eq. (173) as follows:

$$G = \frac{\mu}{\mu + 1} \frac{R_k}{\frac{r_p}{(\mu + 1)} + R_k} \quad (174)$$

This shows that the stage acts like an ordinary plate-coupled stage containing a tube the dynamic plate resistance of which is  $1/(\mu + 1)$  of the actual value and the gain of which is  $\mu/(\mu + 1)$ . In pentodes,  $\mu$  has a very large value (1000 is typical); hence the apparent dynamic plate resistance is reduced by a large factor. Furthermore, the effective dynamic plate resistance acts in shunt with the cathode-coupling resistance. Hence the apparent output impedance  $Z_o'$  is

$$Z_o' = \frac{R_k r_p / (\mu + 1)}{R_k + \frac{r_p}{(\mu + 1)}} \quad (175)$$

The result is that effective output impedances as low as 50 or 100 ohms may readily be obtained at a gain that is very close to unity.

The cathode-coupled circuit may be employed to great advantage to couple to grounded-sheath coaxial cable circuits, since one end of the output impedance is at ground potential and no blocking capacitor is needed at the other end. Moreover, the input impedance between grid and cathode is increased by a factor  $1/(1 - G)$  where  $G$  is the gain (less than unity) of the circuit. Low values of  $R_o$  and high values of  $C_c$  may be employed therefore without detrimental effect on the high-frequency response. Still further advantages are obtained from the fact

that the circuit is inherently an inverse-feedback arrangement, since the output voltage is applied in reverse phase to the grid. This effect accounts for the lowered apparent values of input impedance and also adds greatly to the freedom of the amplifier from instability resulting from tube-constant and line-voltage changes, as well as reducing the harmonic distortion.

*Low-noise Considerations.*—The description of masking voltages in shot-effect and thermal agitation (page 200) has shown that low fluctuation-voltage levels are maintained by employing low values of coupling resistor and low values of plate current. Ordinarily these precautions need apply only to the first stage in the chain, but they must be observed in any stage where the signal level is low (less than 10 millivolts). The coupling resistor between two stages is ordinarily given such a low value (by the necessity of maintaining good high-frequency response) that thermal noise from this source can be minimized only by a reduction in gain, which lowers the signal input relative to the masking voltage introduced in the next tube. By employing tubes the plate current of which is small, and by operating them at rated values or less, shot effect may be controlled without serious detrimental effects. Low plate current is associated with low  $g_m$ , however, and the gain of the first stage may be seriously lowered if too small a value of plate current is employed.

In designing low-noise amplifiers, it is important to note that the thermal noise increases with the square root of the width of the frequency band employed as well as with the square root of the coupling impedance. The signal-frequency range is determined by the detail of the image and by the resolution of the picture-tube scanning system. Once this frequency has been established, little can be done to cut it down without loss of detail, *provided* that the successive elements in the transmission system are capable of handling the full frequency range of the original signal. However, if succeeding amplifiers, etc., have a narrower range than the initial amplifier, it may be well to limit the frequency range in the first place to a width not too much greater than the limits passed by the rest of the system. The reason for this is that cross modulation of the noise components in the extended frequency range may result in the noise being effective in the lower frequencies passed by the remaining transmission equipment, whereas if the noise

voltage had not been allowed to develop in the first place, the cross modulation would not have occurred.

Another effect of interest is the fact that the signal increases in direct proportion (assuming a constant-current source) to the load impedance in the grid of the amplifier stage, whereas the noise voltage developed in this impedance increases only as the square root of the impedance value. An improvement in signal-to-noise ratio is therefore to be obtained by using as large a value of coupling impedance as possible. In practice too large a value of coupling impedance cannot be used. There are two reasons for this: First, the gas current in the amplifier tube

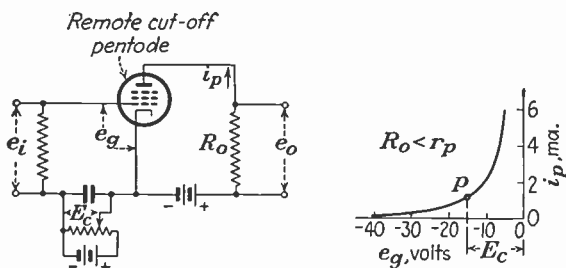

FIG. 137.—Typical distorting amplifier circuit used for obtained nonlinear reproduction ("gamma-control" amplifier). By adjusting the bias voltage  $E_c$  different portions of the  $i_p$ - $e_g$  operating characteristic may be chosen.

will lead to erratic variations in the grid bias of the tube; and second, the generator (camera tube) is never a truly constant-current device. Coupling impedances of the order of 100,000 ohms may be used (see Fig. 242). Such a high value of coupling impedance lowers the relative response at high frequencies (see Fig. 121), but this may be compensated in a later stage where noise is no longer a factor.

*Logarithmic Response.*—When it is desired to introduce changes to the over-all gamma (see page 204) of the television system, it is possible to do so by employing an amplifier the output voltage of which is a nonlinear function of its input voltage (so-called distorting amplifier). The circuit of such an amplifier is shown in Fig. 137. The control of the nonlinear response is obtained by selecting different ranges on the dynamic characteristic of the circuit. To date, such nonlinear amplifiers have not found much use in television work, but it seems likely that they will be employed to improve the apparent contrast range of the repro-

duction as soon as this factor becomes the limiting item in the enjoyment of the results. At present, other questions, notably maintaining detail, the picture background level, and evenness of shading, are the principal technical problems.

**37. Transient Response of Video Amplifiers.**—Thus far, in this and the preceding chapters, the treatment of video amplification has been based on the two criteria of uniform amplitude-frequency response and phase response proportional to frequency. The characteristics of a video amplifier are determined by measuring the amplitude and phase characteristics as functions of frequency, and these measurements are performed with sine-wave signals of steady amplitude. This is the simple steady-state analysis, and within limits it serves to predict the performance of the amplifier when a picture signal is applied to it.

A more advanced type of analysis, the transient solution of a video amplifier response, takes into account the fact that most picture signals are not repetitive, that is, they do not attain a steady-state. Rather they consist of rapid nonrepeated variations. This type of signal is usually called a "transient signal." If the amplifier response to a generalized transient signal is determined, the performance of the amplifier for video amplification is more fully known than if reliance is placed simply on steady-state responses.

The generalized transient signal employed for this purpose is the unit pulse of voltage, sometimes called the "Heaviside unit voltage." This voltage is zero until at a time  $t$  it suddenly attains unity amplitude, thereafter remaining at this amplitude indefinitely. If such a unit pulse of voltage is applied to a video transmission system, it can be reproduced accurately only if the phase and amplitude responses are uniform from zero to infinite frequency. If the frequency responses are restricted (as in all practical cases), the unit pulse is distorted. The problem of the transient analysis is to show the extent of the distortion introduced by the use of amplitude and phase characteristics extending over a specified range and displaying specified irregularities within that range. Several workers<sup>1</sup> have addressed themselves

<sup>1</sup> BEDFORD and FREDENHALL, Transient Response of Multistage Video Amplifiers, *Proc. I.R.E.*, **27**, 277 (April, 1939).

CARNAHAN, C. W., The Steady-state Response of a Network to a Periodic Driving Force of Arbitrary Shape, and Its Applications to Television

to this problem and have obtained solutions based on typical amplifier circuits.

Three methods have been used to determine transient response. The methods of operational calculus have been applied by Lane to uncompensated stages and by McLachlan to the shunt-compensated stage. The latter result is as follows (symbols as in Fig. 125):

$$e(t) = g_m R_o \left[ 1 - \frac{e^{-\pi f_r K t}}{K \sqrt{1 - \frac{K^2}{4}}} \sin (M t + \theta) \right] \quad (176)$$

where  $e(t)$  is the output voltage as a function of time with unit pulse applied,  $f_r$  is the resonant frequency of  $L_o$  and  $C_t$ ,  $K$  is the ratio of  $R_o$  to the reactance of  $C_t$  at  $f_r$ ,  $M$  is the quantity

$$M = 2\pi f_r \sqrt{1 - \frac{K^2}{4}} \quad (177)$$

and  $\theta$  is the angle

$$\theta = \tan^{-1} \frac{K \sqrt{1 - \frac{K^2}{4}}}{\frac{K^2}{2} - 1} \quad (178)$$

This analysis applies to only one stage, and it can be applied only when lumped constants are effective.

When measured amplitude and phase-response curves are available, the more general treatment employs the Fourier integral

$$e(t) = \frac{r_{d.c.}}{2} + \frac{1}{\pi} \int_{-\infty}^{\infty} \frac{r_f \sin \omega(t - p_f)}{\omega} d\omega \quad (179)$$

where  $e(t)$  is the response to a unit applied voltage,  $r_{d.c.}$  is the d-c response of the amplifier,  $r_f$  is the amplitude-frequency

Circuits, *Proc. I.R.E.*, **23**, 1393 (November, 1935).

LANE, H. M., Resistance-capacitance Amplifier in Television, *Proc. I.R.E.*, **20**, 722 (April, 1932).

MCLACHLAN, H. W., Reproduction of Transients by Television Amplifiers, *Wireless Eng.*, **13**, 519 (October, 1936).

PUCKLE, O. S., Transient Aspect of Wideband Amplifiers, *Wireless Eng.*, **12**, 251 (May, 1935).

response function,  $\omega$  is the angular frequency ( $2\pi f$ ), and  $p_f$  is the phase-frequency (time-delay) response function. Since the curves representing  $r_f$  and  $p_f$  are in practice not analytic functions, it is usual to evaluate the integral in Eq. (177) graphically, and this is a very tedious process.

The third method of analyzing transient response, described by Bedford and Fredenhall, is simpler and more generally applicable than the other two. It consists of a Fourier series of terms, rather than the Fourier integral of Eq. (179), and as such is more readily evaluated numerically. However, the Fourier series can be used only with repetitive (periodic) functions, and hence the Heaviside unit voltage cannot be used directly. Instead of a unit pulse, therefore, a square wave is used as the applied voltage. The analysis is performed over a very short interval of time, over the interval during which the amplifier output voltage rises from zero response to unit response. This interval is the interval during which the distortion introduced by the amplifier appears and hence is the region of interest in the analysis.

The justification for replacing the unit voltage pulse by a unit square wave may be established from Fig. 138. The unit pulse applied to the amplifier produces a response which is delayed in time and which does not follow the sharp edge of the pulse exactly, but has the more gradual rise indicated. The characteristics of this rise in the response curve are determined almost wholly by the high-frequency amplitude and phase responses of the amplifier. After the initial rise, the output curve remains constant, but after a very long time (much longer than indicated in the figure) the level decreases from causes associated with the low-frequency amplitude and phase responses.

Now if the unit pulse is replaced by a square wave, the response is essentially the same during the sharp rise at the beginning (and sharp fall at the end) of each pulse, but the gradual diminution of the level due to the low-frequency responses has no opportunity to appear. By using the square wave, therefore, we eliminate the low-frequency aspect from the analysis but otherwise no harm is done, since the low-frequency analysis can conveniently be carried out separately.

The method of analysis for the square wave is simple. The series for the square wave [Eq. (78)] is applied term by term to the Fourier integral of Eq. (179), and the following series results:

$$e(t) = \frac{1}{2} + \lim_{f \rightarrow 0} \frac{2}{\pi} [r_1 \sin 2\pi f(t - p_1) + r_3 \sin 2\pi 3f(t - p_3) + r_5 \sin 2\pi 5f(t - p_5) + \dots] \quad (180)$$

where  $e(t)$  is the response to the square wave, the  $r_1, r_3, r_5, \dots$ , coefficients are the numerical heights of the amplitude-response curves at frequency  $f, 3f, 5f, \dots$ , and the  $p_1, p_3, p_5, \dots$ , are the values of time delay (seconds) at the same frequencies.

The series of Eq. (180) gives a rigorous result only in the limit when  $f$  approaches zero. However, by choosing a frequency the

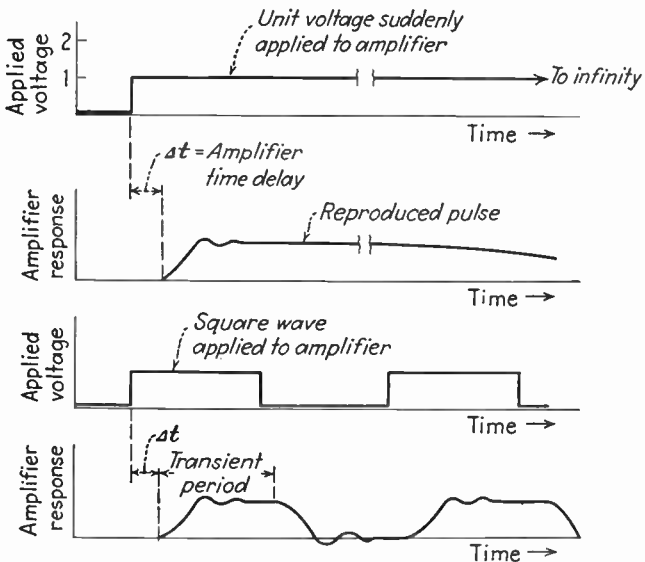

FIG. 138.—Amplifier response to a Heaviside unit voltage (above) and square-wave approximation (below) suggested by Bedford and Fredenhall for analyzing transient response of video amplifiers.

period of which is the time interval during which the significant distortion occurs, highly accurate results may be obtained. Bedford and Fredenhall show comparisons between the rigorous McLachlan solution in Eq. (176) and the series solution Eq. (180) that indicate accuracy to 1 per cent or better in nearly all cases, the more serious discrepancies occurring in the neighborhood of the discontinuities of the applied square wave. In this work, the authors used a square wave of a period equal to twice the time from the application of the square wave to the time the



amplifier response reached unity amplitude (the time is indicated in Fig. 138).

The series method of transient analysis may be applied readily both to single stages and multistage amplifiers. In the single-stage case, by assuming simple shunt peaking, the amplitude response is given in Eq. (147) multiplied by the  $g_m$  of the tube used and the phase response (converted to time delay) is given in

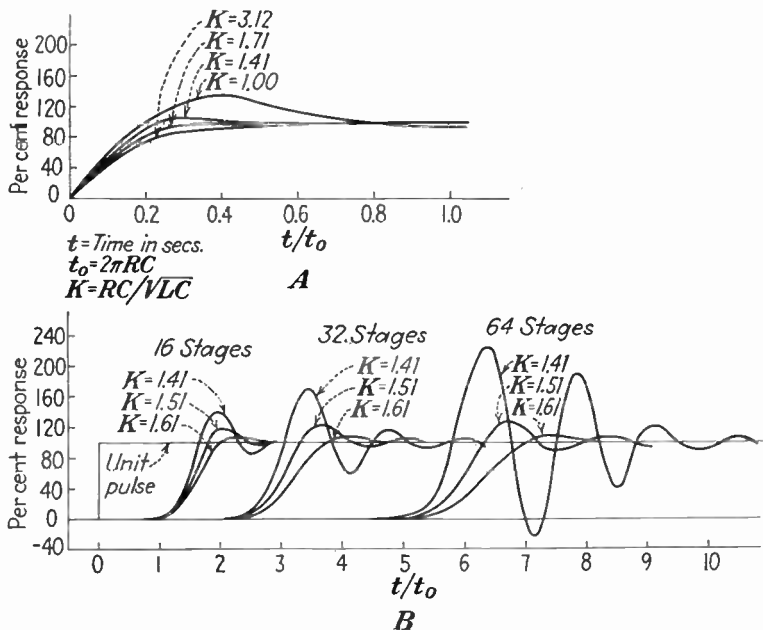

FIG. 139.—Transient analysis of video amplifiers computed by Bedford and Fredenhall using the square-wave approximation. A, for a single stage; B, for multistage amplifier.

Eq. (148). The plots of these equations over the video frequency range are used to obtain the values of  $r$  and  $p$  in Eq. (178) and the series is summed for different values of time. The response to a unit pulse (or leading edge of a square wave) of a single-stage amplifier is shown in Fig. 139A. The values of  $K$  [defined in connection with Eq. (176) as the ratio of the resistance  $R_o$  to the reactance of  $C_i$  at the frequency where  $C_i$  and  $L_o$  are resonant] are shown to have marked effect on the steepness of rise of the voltage response and on the amount by which it overshoots the unity level. In all preceding discussions,  $K$  has

been given a value of 1.41 (corresponding to a resonant frequency 1.41 times as great as the frequency  $f_0$  at which  $R_0$  and the reactance of  $C_t$  are equal). It will be noted that other values of  $K$  give approximately the same result.

The importance of multistage transient analysis is indicated by the fact that most television programs are amplified in some 20 to 30 stages before being reproduced. Accordingly, Bedford and Fredenhall have used the series method to compute the response of amplifiers of 16, 32, and 64 stages, as shown in Fig. 139B. It will be noted that the value  $K = 1.51$  seems to be better adapted to good transient response than the more usual  $K = 1.41$  and that in each case there is a compromise between the steepness of rise of the response and the amplitude of the oscillatory overshoot. The curves shown in Fig. 139B were obtained by raising the amplitude responses from Eq. (147) to the  $n$ th power and multiplying the phase delays from Eq. (148) by  $n$  where  $n$  is the number of stages. The resulting multistage values of  $r$  and  $p$  were then inserted in the series and the summation performed at different values of time.

**38. Coaxial Cable Parameters.**<sup>1</sup>—In considering video amplification equipment, account must be taken of the circuits that are employed to connect two amplifiers separated some distance from one another. The type of connecting circuit almost universally used for this purpose is the coaxial cable, shown in Fig. 140, which consists of a central conductor running through the center of a cylindrical sheath. The center conductor acts as one conductor, the sheath as the other.

The important quantities describing a coaxial circuit are (1) the surge (or "characteristic") impedance offered by the line to voltages applied to it, (2) the attenuation (amplitude-frequency

<sup>1</sup> Ives, H. E., Transmission of Motion Pictures over a Coaxial Cable, *Jour. Soc. Motion Picture Eng.*, **31**, 256 (September, 1938).

JARVIS and FOGG, Formulæ for Calculation of Theoretical Characteristics and Design of Coaxial Cables, *Jour. Post Office Elec. Eng.*, **30**, 138 (July, 1937).

SCHELKUNOFF, S. H., Coaxial Communication Transmission Lines, *Elec. Eng.*, **53**, 1592 (December, 1934).

SEELEY and KIMBALL, Transmission Lines as Coupling Elements in Television Equipment, *RCA Rev.*, **3** (4), 418 (April, 1939).

STRIEBY, M. E., Television Transmission by Coaxial Cable, *Bell Sys. Tech. Jour.*, **17**, 438 (July, 1938).

response) of the signal introduced by the losses in the conductors and insulation, (3) the time delay (phase-frequency response) produced by reactive effects.

The parameters on which these values depend are four: the inductance  $L$ , capacitance  $C$ , resistance  $R$  (sum of inner and

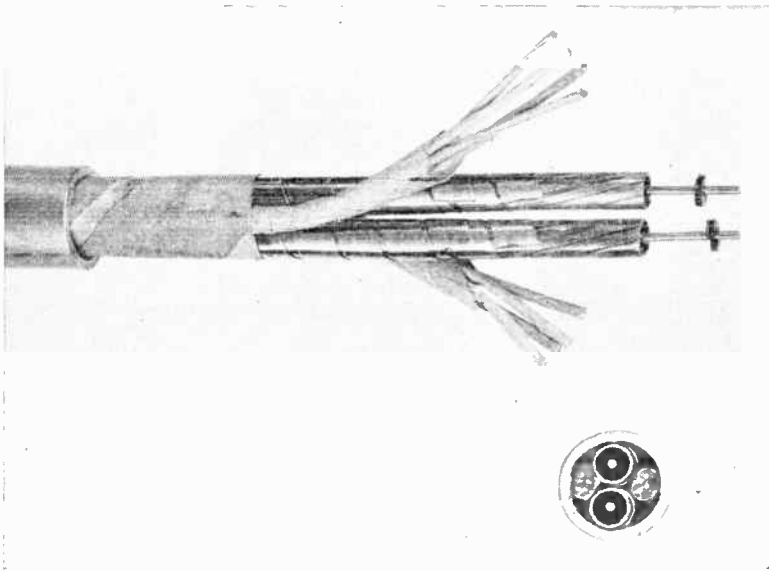

FIG. 140.—Typical coaxial cable, including two channels and auxiliary wire circuits, used in the Philadelphia-New York installation of the Bell System.

outer conductor), and conductance  $G$ , all per foot (or per meter) of cable. In terms of these quantities, the surge impedance  $Z_o$  is

$$Z_o = \sqrt{\frac{R + j\omega L}{G + j\omega C}} \text{ ohms} \tag{181}$$

If  $R$  and  $G$  are neglected, as being small when compared with  $j\omega L$  and  $j\omega C$ , respectively,

$$Z_o = \sqrt{\frac{L}{C}} \text{ ohms} \tag{182}$$

$Z_o$  may also be computed from the dimensions of the cable

$$Z_o = 138.5 \log_{10} \frac{d_o}{d_i} \text{ ohms} \tag{183}$$

where  $d_o$  is the inside diameter of the outer conductor and  $d_i$  is the diameter of the inner conductor.

The attenuation, measured in decibels per unit length, is

$$A = 4.346 R \sqrt{\frac{C}{L}} \text{ db per unit length} \quad (184)$$

or

$$= \frac{0.031R}{\log_{10} (d_o/d_i)} \quad (185)$$

where  $R$  is the sum of the resistances of the two conductors, per unit length. If  $G$  is appreciable, the attenuation is much higher than that indicated in Eq. (185).

The time delay, measured in seconds, is

$$t = \sqrt{LC} \text{ sec. per unit length} \quad (186)$$

where  $L$  is measured in henries and  $C$  in farads. This is the time required to transmit energy from one end of the line to the other. The time delay is, within wide limits, independent of frequency. This makes the coaxial line ideally suited to the propagation of video signals.

Measured in degrees, the phase delay is

$$\phi = 2\pi f \sqrt{LC} \quad (187)$$

At the low frequencies,  $R$  and  $G$  may be large when compared with  $j\omega L$ , and  $j\omega C$ , and in the limit of zero frequency, the surge impedance is  $\sqrt{R/G}$ . This value of impedance is usually very different from that at the higher frequencies, but fortunately at the lower frequencies the length of the cable is short when compared with the wavelength of the propagated signal. Consequently no adverse effects arise.

Reflections occur at the termination of a transmission line, if the line is terminated in an impedance not equal to the surge impedance, and these reflections are of importance if the length of the line is an appreciable fraction of a wavelength. Such reflected signals may make themselves apparent as ghost images. At the upper end of the video frequency range (say 3,000,000 c.p.s.), the wavelength is only 100 meters, and a 25-meter length constitutes a quarter-wavelength section. At the lower frequency region, however, the wavelength is so long (5,000,000

meters at 60 c.p.s.) that the reflections do not give rise to echo signals and have very small effect on the amplitude of the signal actually delivered to the far end of the line.

**39. Measurement of Video Frequency Characteristics.**<sup>1</sup> *a. Amplitude-frequency Response.*—In measuring the amplitude response of a video amplifier, two pieces of equipment are necessary: (1) a signal source (signal generator) having a frequency range from, say, 20 to 6,000,000 c.p.s. at a voltage output of, say

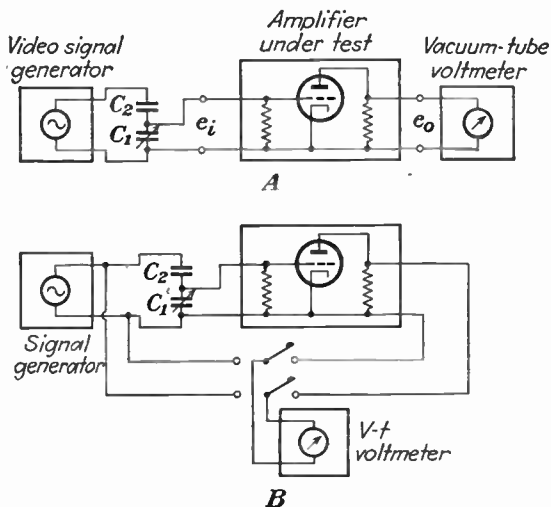

FIG. 141.—Methods of measuring amplifier gain: *A*, when the video signal generator is calibrated; *B*, substitution method for uncalibrated signal source.

10 volts r-m-s and (2) a measuring device such as a direct-coupled cathode-ray oscilloscope or vacuum-tube voltmeter. The connections are as shown in Fig. 141. The capacitance voltage divider should be of such proportions that

$$\frac{C_1 + C_2}{C_1} = G \quad (188)$$

where  $G$  is the gain of the stage.  $C_1$  should be large when compared with the input capacitance of the amplifier. If the output of the signal source is calibrated, the circuit in Fig. 141A may be used. Otherwise the ratio of input to output voltages is determined by applying the vacuum-tube voltmeter (or cathode-

<sup>1</sup> SEELEY and KIMBALL (see reference, p. 220).

ray oscilloscope) first to the input and then to the output, as indicated in Fig. 141B.

A simple substitution method is employed to measure the gain. First the vacuum-tube voltmeter is connected across the signal source, which is set at some desired frequency, and the reading recorded. Then the voltmeter is placed across the output terminals of the amplifier and the capacitance  $C_1$  adjusted until the same reading is obtained. The gain of the amplifier at the frequency used is then given by Eq. (188) above. The procedure is then repeated for as many different frequencies as are required to cover the full range of the amplifier. The only requirement is that the signal generator have sufficient output to produce an easily read deflection on the voltmeter or oscilloscope when the full generator output is applied to it. If the generator does not fill the requirement, then an auxiliary amplifier is interposed. This auxiliary amplifier need not have any specified characteristics except that it supply sufficient output for useful deflection of the voltmeter or oscilloscope throughout the video frequency range.

The capacitance voltage divider is used because it is free from errors due to stray parameters. If a resistance voltage divider is employed, the capacitances associated with it will come into play at the high frequencies, and the voltage ratio is then not strictly proportional to the resistance ratio.

This method of measurement omits any consideration of harmonic distortion that may be generated in the amplifier. However, if an oscilloscope is used and if a linear sweep voltage is applied to the horizontal deflection system plates while the output signal is applied to the vertical plates, then waveform distortion may be detected by inspection of the waveform of the output relative to the waveform of the input. The latter should be sinusoidal for frequencies above 100 c.p.s.

At lower frequencies, sine waves may be employed, but a better check on the amplitude response is a square wave. A special square-wave generator is required for this purpose. A square-wave check at 60 c.p.s. is usually sufficient to judge the low-frequency performance of the amplifier, since this is the lowest frequency having to do with the background illumination level of each scanned field. The utility of square-wave testing is described in connection with the measurement of low-frequency phase response.

In the method just outlined, the cathode-ray deflection is obtained directly from the signal circuits, without any intervening amplifiers. Such amplifiers, usually provided with oscilloscope equipment, may be used provided that the amplifier has amplifying properties throughout the video frequency band. Most ordinary oscilloscope amplifiers have useful ranges only up to 50,000 or 100,000 c.p.s. and hence are not suited to video response measurements.

Since the method described is a substitution method, the accuracy of measurement depends only on the accuracy with which the capacitances  $C_1$  and  $C_2$  may be determined and is

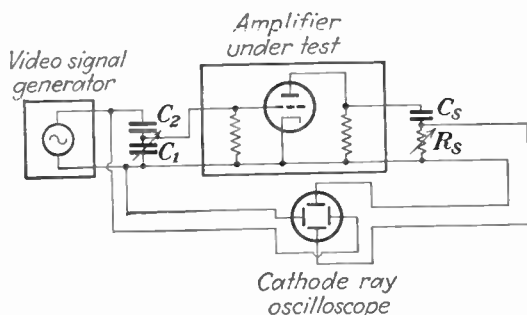

FIG. 142.—Method of forming Lissajous figures for determining the phase-frequency characteristic of a video amplifier.

independent of the oscilloscope calibration. If many measurements are in prospect, it is wise to calibrate a voltage divider especially for the purpose or to employ calibrated capacitors. Otherwise  $C_1$  and  $C_2$  may be measured on a capacitance bridge.

*b. Phase-frequency Response.*<sup>1</sup>—The measurement of phase-frequency response may be best carried out by forming Lissajous figures on the screen of a cathode-ray oscilloscope. The circuit is shown in Fig. 142. The arrangement is very similar to that employed in measuring amplitude response, except that the two sets of deflecting plates are connected simultaneously and an additional phase shift is added by the presence of  $R_s$  and  $C_s$  in the output. These values of resistance and capacitance are made adjustable.

<sup>1</sup> BARCO, A. A., Measurement of Phase Shift in Television Amplifiers, *RCA Rev.*, 3 (4), 411 (April, 1939).

SWIFT, G., Amplifier Testing by Means of Square Waves, *Communications*, 14 (2), 22 (February, 1939).

The input and output voltages are of approximately the same amplitude and are displaced in phase by an amount equal to the phase shift in the amplifier plus the phase shift in the  $R_s C_s$  combination. The latter shift is opposed to the phase shift in the amplifier. Consequently by adjusting  $R_s$  and  $C_s$ , the net phase shift may be made equal to  $0^\circ$ ,  $180^\circ$ , or some multiple  $n$  of these values. When the phase relation between input and output voltage has this  $0^\circ$  (or  $n \times 180^\circ$ ) relationship, the trace of the Lissajous figure on the cathode-ray screen is a straight line.

In making the measurement, the frequency is increased in steps from a low value upward through the video frequency range and  $R_s$  or  $C_s$  adjusted so that at the frequency  $f$  the Lissajous figure is a straight line. The phase added by  $R_s C_s$  is

$$\theta = \tan^{-1} \frac{1}{2\pi f R_s C_s} \quad (189)$$

The added phase shift in the amplifier (exclusive of the normal  $180^\circ$  shift) is then

$$\phi_a = 90^\circ - \theta \quad (190)$$

In a single-stage amplifier, the phase shift is limited to  $90^\circ$  or less and the foregoing procedure offers but little difficulty. A multistage amplifier may have phase shifts considerably larger than  $90^\circ$ , and in this case it may be difficult to determine the multiple of  $180^\circ$  at which the measurement is made. In this case, the procedure is essentially the same except that the measurement is begun at a low value of frequency, somewhere between 5000 and 25,000 c.p.s., where the added phase shift  $\phi_a$  is zero. The frequency is then increased until the Lissajous figure becomes elliptical and then circular ( $R_s$  and  $C_s$  remaining unchanged). At this point, the added phase shift is  $90^\circ$ . As the frequency is increased, the figure will again become elliptical and finally assume a straight line, showing  $180^\circ$  shift. Thereafter another circle indicates  $270^\circ$ , another straight line  $360^\circ$ , and so on. By counting the number of circles and straight lines already passed through at any given frequency, the added phase shift may be found in multiples of  $90^\circ$ . The additional amount, less than  $90^\circ$ , after the last found line or circle is then indicated by small changes in  $R_s$  and  $C_s$ , as indicated in the preceding paragraph.



If oscilloscope amplifiers are used between the signal circuits and the deflecting plates, they may have any amplitude or phase characteristics provided only that the horizontal amplifier is identical with the vertical amplifier.

In the amplitude and phase-characteristic measurements just described, the signal source should have a good sine-wave output, the frequency calibration should be accurate and should cover the desired range of frequencies. Beat-frequency oscillators are now available that have been especially designed for the purpose. It is also possible to employ two more usual items of laboratory equipment, a beat-frequency oscillator for the range from, say 20 to 20,000 c.p.s. and a standard signal generator from 20,000 to 6,000,000 c.p.s. (20 kc. to 6 Me.). If the standard signal gen-

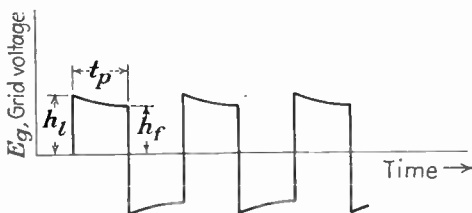

FIG. 143.—Typical distorted reproduction of a low-frequency square wave due to improper phase response (cf. Fig. 294).

erator frequency range does not extend downward to 20,000 c.p.s., it is usually not a serious omission to omit measurements from 20,000 to 100,000 c.p.s., since the phase and amplitude characteristics of even a poor video amplifier are usually linear within this range.

*c. Low-frequency Response Tests.*—Although amplitude and phase-shift tests may be performed to any low value of frequency described by the methods just outlined, the results at the lowest frequencies, below 100 c.p.s., are not indicative of the performance of the amplifier in reproducing the television image. Rather, as already stated, a square wave is best suited to low-frequency testing, since it reveals very quickly the presence of improper time constants in the coupling and low-frequency-compensation circuits. A square-wave generator is described in connection with the description of sync-signal generators in Chap. IX (Fig. 295). When the output wave from the video amplifier is viewed on a cathode-ray oscilloscope, the distortions are

readily apparent, and it is not difficult to determine whether they arise from amplitude or phase discrimination.

The amount of "tilt" in the wave top of the output wave (see Fig. 143) may be taken as an indication of the effective time constant of the coupling circuit in a single stage. The coupling circuit is shown in Fig. 144, consisting of the source of signal (preceding tube), the coupling capacitor  $C_c$ , and the grid resistor  $R_g$ . The square-wave generator applies a sudden rise of voltage  $E$  across the  $RC$  combination, and the voltage  $E_c$  and  $C_c$  is then given by

$$E_c = E(1 - e^{-t/R_g C_c}) \quad (191)$$

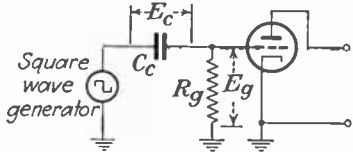

FIG. 144.—Circuit analysis for square-wave generator testing of low-frequency response.

If the time constant  $R_g C_c$  is long when compared with the period of the wave (as is the case in video amplifiers), then the following may be written

$$\frac{E_c}{E} = \frac{t}{R_g C_c} \quad (192)$$

where  $t$  is the duration in seconds of the pulse.

The ratio  $E_c/E$  may readily be measured at any point in the reproduced square wave, but usually for convenience the measurement is made by comparing the heights of the leading and following edges of the reproduced wave ( $h_l$  and  $h_f$ , respectively). Taking  $t = t_p$  as the corresponding interval of time equal to the duration of the pulse ( $1/20$  sec. in a 60-c.p.s. wave), then

$$R_g C_c = t_p \frac{h_l}{(h_l - h_f)} \quad (193)$$

If the test pulse is a 60-c.p.s. wave, the reproduced signal represents the background illumination of each successive field (approximately only, since the separation between field scanings is short when compared with their duration). The ratio  $(h_l - h_f)/h_l$  represents the fractional change in background level between the top and bottom of each field. Usually a 5 or 10 per cent change is tolerable, if the field also contains other contrasts and detail in motion. But when representing a uniform blank space, the variations in brightness must be kept within narrower limits, perhaps not more than 2 or 3 per cent, if the variation in background level is to be imperceptible.

*d. Measurements for Design Purposes.*—The ordinary methods of audio amplifier and radio practice are sufficient to determine most of the constants on which the design of a video amplifier is based, such as the  $g_m$  and  $r_p$  values of the tubes (usually taken directly from the manufacturer's ratings) and the resistance and capacitance values. But one item of design information that presents some difficulty is the measurement of the total shunt capacitance  $C_t$ , on which depend the values of  $R_o$  and  $L_o$ , used for high-frequency compensation. Seeley and Kimball have outlined a very simple method of measuring  $C_t$  under the actual conditions present in the amplifier. The method depends on the fact that in an uncompensated amplifier the gain drops to 71 per cent of its maximum (mid-range frequency) value at a frequency equal to  $f_o = 1/(2\pi C_t R_o)$ . To measure  $C_t$ , insert a known value of  $R_o$  in the amplifier (not necessarily the value required for correct compensation), and apply a source of high-frequency signal to the input of the amplifier. Then increase the frequency until the gain, measured by the methods outlined in the first part of this section, is 71 per cent of its mid-range value. Then by applying the relationship given immediately above [see also Eq. (113)],  $C_t$  is determined.

When  $C_t$  is known,  $f_o$  (the highest frequency at which uniform gain is to be maintained) is decided upon and  $R_o$  calculated from Eq. (142). Then the value of the compensation inductance  $L_o$  is determined from Eq. (143). The design of the inductance to meet the required value of  $L_o$  is then performed by using one of the well-known inductance formulas. Checks of the inductance values may be made on an inductance bridge.

*e. Measurement of Constants of Coaxial Lines.*—The  $L$ ,  $C$ ,  $R$ , and  $G$  values associated with coaxial transmission lines may be simply measured by the use of an ordinary 1000-cycle inductance-capacitance bridge. The  $L$  value is measured with the far end of the cable short-circuited. The inductance per foot is then equal to the measured value divided by the length of the cable in feet. The capacitance is similarly measured with the far end of the line open-circuited and the measured value divided by the length of the cable in feet.

The attenuation of the cable may be measured exactly as the gain of an amplifier is measured, as shown in Fig. 145, provided that the two ends of the cable can be brought to the test equip-

ment. Otherwise, the attenuation may be measured in terms of a short piece of cable, cut to a length equal to one-quarter wavelength at the frequency used for the measurement. The input resistance  $R_i$ , with the far end open, is then measured by noting the effect of the line on the  $X/R$  ratio of a tuned circuit. The attenuation in this length of line is then approximately

$$A' = \frac{8.69R_i}{Z_o} \text{ db.} \quad (194)$$

where  $Z_o$  is the surge impedance of the line. The attenuation  $A'$  is for a quarter wavelength of line. The attenuation per foot  $A$  is

$$A = \frac{A'}{\lambda/4} \text{ db. per ft.} \quad (195)$$

where  $\lambda$  is the wavelength in feet. Since the attenuation increases with the frequency, it is desirable to make this measure-

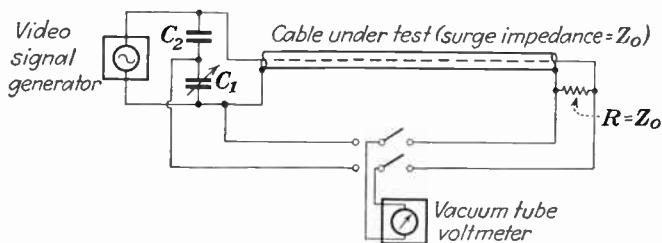

FIG. 145.—Measurement of attenuation in coaxial cable.

ment at several different frequencies, although the quarter wavelength sections become unmanageably long at frequencies below 1,000,000 c.p.s.

Methods of measuring transmission-line constants by the impression of rectangular pulses of high frequency depend upon the fact that if a line is terminated in any resistance other than one equal to the surge impedance, reflections occur. If a good oscilloscope is connected at the transmitting end of a transmission line, with a variable resistance at the other, the presence of reflections may be noted in the oscillograph waveform and the resistance varied until the reflection disappears. The value of resistance is then equal to the surge impedance  $Z_o$ .

## CHAPTER VII

### CARRIER TRANSMISSION OF VIDEO SIGNALS

In transmitting a television image, video amplification suffices only when the entire transmission process occurs at video frequencies, and this is possible only when coaxial cable or some similar transmission line is used as the transmitting medium. In television broadcasting, the transmitting medium is an electromagnetic field in space, and the methods of carrier transmission must be employed to generate and to modulate this electromagnetic field.

The methods employed in carrier transmission in television are basically the same as those employed in telephonic broadcasting. The essential processes are the generation of a carrier frequency, modulation of the carrier frequency by the video frequencies, radiation of the modulated carrier into space, propagation of the carrier wave, its absorption by a receiving antenna, and subsequent demodulation of the modulated carrier signal. By this series of steps, the video signal is converted at the transmitter to frequencies suitable for radio transmission and then reconverted at the receiver to the original video frequencies. At several points in the system, amplification of the carrier is necessary, and in addition a submodulation (frequency conversion) may be used, as in the case of superheterodyne receivers.

The design of equipment for performing these functions is determined (1) by the value of the carrier frequency and (2) by the range of the video frequencies imposed on the carrier. We proceed now to the first of these questions, the selection of carrier frequencies for television service.

**40. Carrier Frequencies Employed in Television Transmission.**<sup>1</sup>—We recall that when a carrier signal is amplitude modulated, the amplitude of the carrier signal is caused to vary at a rate corresponding to the frequency of the modulating signal. When a carrier signal of varying amplitude is analyzed,

<sup>1</sup> ENGSTROM and BURRILL, Frequency Assignments for Television, *RCA Rev.*, 1 (3), 88 (January, 1937).

it is found that the effect of modulation is to generate additional signals having frequencies clustered about the carrier frequency. The additional signals, known as "sideband frequencies," are so disposed that the frequency separation between a sideband component and the carrier is numerically equal to the frequency of the modulating signal producing that component. Unless special precautions are taken, two sets of sideband components are generated, which are disposed symmetrically about the carrier frequency. If  $f_c$  is the carrier frequency and  $f_m$  is the modulating frequency, then the sideband components are  $f_c + f_m$  and  $f_c - f_m$ .

The lower sideband frequency  $f_c - f_m$  can exist only if the modulating frequency is lower than (or equal to) the carrier frequency. As a guide to the selection of a carrier frequency, we note first that the carrier frequency must be higher, preferably much higher, than the modulating frequency.

In television, the highest modulating frequencies, corresponding to the finest detail in the image, range up to 4,000,000 c.p.s. It follows that the carrier frequency employed must be at least 4 Mc. (4,000,000 c.p.s.), and preferably it should be much higher than this. The higher the carrier frequency, relative to the modulating frequency, the narrower the range of sideband components in percentage of the carrier frequency, and the easier it is to secure linear amplitude and phase responses in the transmission system. In practice, carrier frequencies as low as 10 Mc. may be employed, as for example in the i-f stages of a superheterodyne receiver. But the carrier frequencies employed for radiating the signal into space are 40 Mc. or higher. Under this condition, the modulating frequency range is 10 per cent or less of the carrier frequency, and excellent responses may be obtained.

There are additional reasons for employing carrier frequencies as high as 40 Mc. One is the fact that the region of the r-f spectrum from 40 Mc. to the upper limit of the spectrum is not at present actively employed by other services, whereas carrier frequencies lower than 40 Mc. are already occupied by many thousands of stations.

A second reason is the fact that there is not sufficient space, in the region lower in frequency than 40 Mc., for the simultaneous operation of several television transmitters in the same locality. The space occupied by one television station, as shown later, is

a region 6 Mc. wide. In the region between 40 and 10 Mc., there would be room therefore for only five television channels. On the other hand, in the region from 40 to 200 Mc. space has been found for 19 television station channels, and there is room for many other services in the same region.

The third factor in favor of frequencies above 40 Mc. is the fact that they possess certain desirable natural characteristics. The waves in the region above 40 Mc. are free of natural atmospheric disturbances. Within the service range, they display virtually no fading. The waves are not reflected by the ionized layers in the upper atmosphere. Such reflections would cause "ghost" images at a distance from the transmitter.

On the debit side of the ledger are the facts that man-made disturbances are unusually severe in the ultra-high-frequency region (40 Mc. and higher) and the signal reflections from vertical structures (such as buildings) may cause serious "ghosts" or impairment of image detail. The fact that the waves are not reflected by the ionosphere limits the reliable service range of the transmitter to the horizon, as viewed from the transmitting radiator, but in certain respects this is an advantage in that it prevents natural signal reflections (as noted above) and permits the same carrier frequencies to be employed by many stations simultaneously, provided that the geographical separation between the transmitters is such that their interference areas do not overlap.

These considerations have resulted in a universal agreement that the carrier signals employed for radiation of high-definition television signals should have frequencies higher than 40 Mc.

*Carrier Assignments for Television Stations Set up by the F.C.C.*<sup>1</sup> The Federal Communications Commission in 1937 set up a frequency allocation for services in the ultra-high-frequency region from 30,000 to 300,000 kc. The principal features of this allocation are shown in Fig. 146. It will be noted that there are 19 television channels in all. The channels should be considered in two groups. The first seven (44 to 50 Mc., 50 to 56 Mc., 66 to 72 Mc., 78 to 84 Mc., 84 to 90 Mc., 96 to 102 Mc., and 102 to 108 Mc.) are channels that form the basis of the public television service and hence are of major interest. The remaining

<sup>1</sup> Revised Ultra-high-frequency Allocations, *Electronics*, 12 (3), 34 (April, 1939).

12 channels will eventually find use in home television receivers, but at present it is difficult to build sensitive and efficient circuits for these frequencies without undue expense. At present the frequencies from 156 to 192 Mc. have been applied for by broadcast stations, for portable and point-to-point relay work only, that is, for carrying programs from studio to transmitter, mobile truck to transmitter, or transmitter to transmitter. The frequencies from 192 to 294 Mc. have not yet found any commercial use in television.

The utility of the higher carrier frequencies (100 Mc., and above) for the future can hardly be doubted. As transmitters of higher efficiency and receivers of higher sensitivity are designed, these higher frequencies will find increased use, especially for

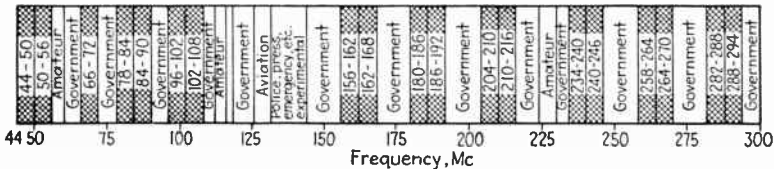

FIG. 146.—Principal features of frequency allocations made by the Federal Communications Commission in 1937, for frequencies from 44 to 300 Mc. A recent F.C.C. revision (June, 1940) has allocated the 44-50 Mc. channel to frequency modulation and the 60-66 Mc. channel to television.

service near cities of small population where the short distances to be covered and the lack of obstructions make feasible the use of very high frequencies. Furthermore, it seems inevitable that scanning patterns of larger numbers of lines, perhaps 1000 to 1500 per frame, will eventually be demanded to make possible a higher quality of reproduction. Inasmuch as the maximum video frequently increases with the square of the number of scanning lines, the use of such scanning patterns would require television channels four to nine times as wide as the present widths. The problem of finding room for such extensive channels (and the accompanying engineering problem of securing uniform amplitude and phase responses over the width of the channel) can be solved much more readily if the highest possible carrier frequencies are employed. Recent developments of transmitting tubes capable of generating hundreds of watts at frequencies as high as 1000 Mc. and of very sensitive receiving devices for the same frequencies point directly



toward the ultimate utilization of carrier frequencies much higher than those currently used.

**41. The Structure of a Television Channel.**—Each of the channels considered above consists of a band of frequencies 6 Mc. in width. Within the limits of this 6-Mc. region are contained all the carrier and sideband components for one complete television system, including sound as well as picture signals. The disposition of the picture- and sound-carrier signals and their respective sideband components must, of course, be standardized, so that all transmitters will emit signals which may be received on any receiver. In particular, the frequency separation between the sound- and picture-carrier signals must be fixed, so that the

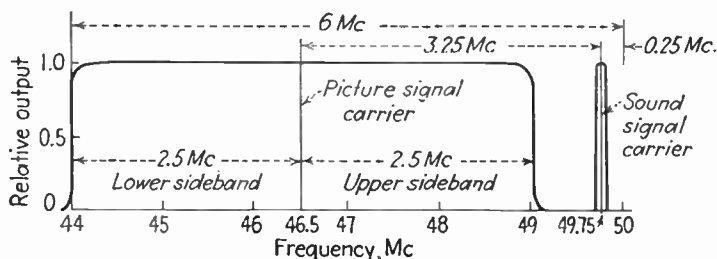

FIG. 147.—Double sideband television channel, now superseded by the vestigial system in the United States.

tuned circuits of the receiver may be tuned or switched for both signals at once.

The standardization of the television channel<sup>1</sup> has been undertaken in the United States by the R.M.A. Committee on Television Standards. When this committee first attacked the problem, so-called *double sideband transmission* was the only practical method of transmission. In this system, two identical sets of sideband components are disposed symmetrically about the carrier frequency. With this type of transmission in view, the channel was arranged by the committee as shown in Fig. 147. The picture carrier (modulated by video frequencies) was placed 2.5 Mc. above the lower frequency limit of the channel, and the audio carrier 0.25 Mc. below the upper frequency limit. The picture sideband components extended symmetrically 2.5 Mc. each side of the picture carrier. The channel thus restricted the highest video frequency to 2,500,000 c.p.s. The sound

<sup>1</sup> See Appendix, p. 517.

sidebands extended roughly 0.020 Mc. each side of the sound carrier, and the region between the adjacent sideband components of the picture and sound signals was reserved as a "guard band" to prevent the sound signals from interfering with the picture, and vice versa. The separation between carriers was 3.25 Mc.

The double sideband system is a wasteful method of transmission, since the signal components in the two sidebands contain

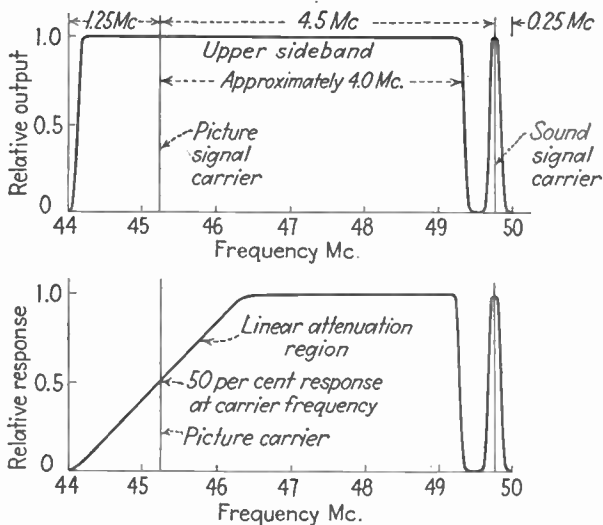

FIG. 148.—The vestigial sideband television channel standardized by the R.M.A. Television Committee and now used as the basis of transmissions in the United States. The upper diagram is the transmitter output curve, the lower the receiver response curve which equalizes the percentage modulation of sideband components near the carrier to that of components far removed.

identical information. If only one sideband is transmitted, on the other hand, maximum use is made of the channel width in transmitting picture detail. Unfortunately, the production of a single sideband is a difficult problem, technically. Conventional amplitude-modulation circuits produce two sidebands inherently, and it is necessary to remove the unwanted sideband subsequent to the modulation process. The removal is accomplished by a band-elimination filter, but since such filters do not have ideal cutoff characteristics, it is not possible to remove all the components of the undesired sideband without introducing undesirable phase shifts. In practice, a compromise has

been adopted known as "quasi-single-sideband" or "vestigial sideband" operation.<sup>1</sup> In this system, the unwanted sideband components are removed completely only at a sufficient frequency separation from the carrier to avoid the phase-shift difficulties. The unwanted components near the carrier frequency are not removed, and the carrier itself is not attenuated.

The television channel based on the vestigial sideband method, as recommended by the R.M.A. Standards Committee, is shown in Fig. 148. The sound carrier remains at a position 0.25 Mc. below the upper frequency limit of the channel. The picture carrier is removed to the opposite edge of the channel at a position 1.25 Mc. above the lower frequency limit. The frequency separation between the carriers is accordingly 4.5 Mc., as against 3.25 Mc. in the double-sideband case. The desired picture sideband components are distributed upward in frequency from the carrier, covering a region roughly 4 Mc. wide. The highest frequency in the modulating video signal is accordingly 4,000,000 c.p.s., compared with 2,500,000 c.p.s. in the double sideband case. A correspondingly higher degree of picture detail may be conveyed in the selective sideband system. The region between the picture carrier and the lower frequency limit of the channel is occupied by portions of the undesired sideband. The home television receivers at present manufactured in the United States are based on the channel composition indicated in Fig. 148.

**42. Characteristics of Ultra-high-frequency Waves.**<sup>2</sup>—In recent years, many experimental and theoretical investigations

<sup>1</sup> GOLDMAN, STANFORD, Television Detail and Selective Sideband Transmission, *Proc. I.R.E.*, **27**, 725 (November, 1939).

HOLLYWOOD, J. M., Single Sideband Filter Theory with Television Applications, *Proc. I.R.E.*, **27**, 457 (July, 1939).

NERGAARD, L. S., A Theoretical Analysis of Single Sideband Operation of Television Transmitters, *Proc. I.R.E.*, **27**, 666 (October, 1939).

<sup>2</sup> For detailed treatments of ultra-high-frequency propagation, see:

BEVERAGE, H. H., Some Notes on Ultra-high Frequency Propagation, *RCA Rev.*, **1** (3), 76 (January, 1937).

BURROWS, DECINO, and HUNT, Ultra-short Wave Propagation over Land, *Proc. I.R.E.*, **23**, 1507 (December, 1935).

CARTER and WICKIZER, Ultra-high-frequency Transmission between the RCA Building and the Empire State Building in New York City, *Proc. I.R.E.*, **24**, 1082 (August, 1936).

COLWELL and FRIEND, Ultra-high-frequency Wave Propagation over

have been undertaken to explain the propagation characteristics of waves the frequencies of which are higher than 30 Mc. Here we must limit ourselves to a brief survey of those aspects which bear particularly on the special problems of television transmission and reception.

The ultra-high-frequency waves are distinguished by the fact that the ionized layers of the upper atmosphere ordinarily have a negligibly small refraction effect upon them, whereas the lower frequency waves (20 Mc. and lower) are often totally reflected by refraction in these layers. In consequence, the propagation of the ultra-high-frequency radiation is explained in terms of the so-called "ground-wave" effects, as distinguished from the "sky-wave" effects prominent in the lower frequencies.

The field strength associated with the ground wave depends on four effects: direct transmission of the energy through space; reflection of energy from the surface of the earth or from other obstructions; diffraction of the waves by obstacles, including the earth itself; and refraction of the waves in the lower layers

---

Plane Earth and Fresh Water, *Proc. I.R.E.*, **25**, 32 (January, 1937).

CONKLIN, E. H., 56-Megacycle Reception via Sporadic-E-layer Reflections, *Proc. I.R.E.*, **27**, 36 (January, 1939).

GEORGE, R. W., A Study of Ultra-high-frequency Wide-band Propagation Characteristics, *Proc. I.R.E.*, **27**, 28 (January, 1939).

GEORGE, R. W., Field Strength Measuring Equipment for Wide-band Ultra-high Frequency Transmission, *RCA Rev.*, **3** (4), 431 (April, 1939).

GODDARD, D. R., Observations on Sky-wave Transmission on Frequencies above 40 Mc. *RCA Rev.*, **3** (3), 309 (January, 1939). Also *Proc. I.R.E.*, **27** (12), (January, 1939).

GODDARD, D. R., Transatlantic Reception of Television Images, *Proc. I.R.E.*, **27**, 692 (November, 1939).

HOLMES and TURNER, An Urban Field Strength Survey at Thirty and One Hundred Megacycles, *Proc. I.R.E.*, **24**, 755 (May, 1936).

JONES, L. F., A Study of the Propagation of Wavelengths between Three and Eight Meters, *Proc. I.R.E.*, **21**, 349 (March, 1933).

PETERSON, H. O., Ultra-High Frequency Propagation Formulas, *RCA Rev.*, **4** (2), 162 (October, 1939).

PETERSON and GODDARD, Field Strength Observations of Transatlantic Signals 40 to 45 Mc., *Proc. I.R.E.*, **25**, 1291 (October, 1937).

SHELLENG, BURROWS, and FERRELL, Ultra-short Wave Propagation, *Proc. I.R.E.*, **21**, 427 (March, 1933).

TREVOR and CARTER, Notes on Propagation of Waves below Ten Meters in Length, *Proc. I.R.E.*, **21**, 387 (March, 1933).

VON HANDEL and PFISTER, Ultra-short-wave Propagation along the Curved Earth's Surface, *Proc. I.R.E.*, **25**, 346 (March, 1937).

of the atmosphere (not ionized). The combined effect of these four phenomena may be calculated only under ideal conditions. In practice, the random geometry of the earth's surface and the structures on it, together with the variable and uncertain electrical characteristics of the earth's crust, make exact predictions difficult.

It is possible, nevertheless, to explain the observed strength of the electromagnetic field fairly well in terms of simple concepts. The analysis is simplified considerably if the effects are divided into two divisions, those occurring within the horizon distance (the distance to the horizon as viewed from the transmitting antenna) and those occurring beyond the horizon. Within the horizon distance, the directly propagated energy and the reflected energy are the principal components of the radiation. Beyond the horizon, diffraction and refraction play the predominant parts.

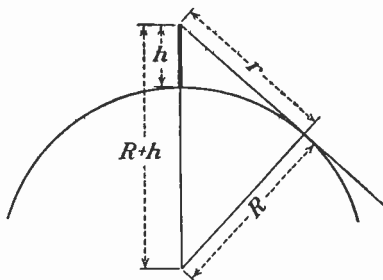

FIG. 149.—Geometrical relationship of antenna height to the horizon distance.

*Distance to the Horizon over Flat Earth.*—Since the distance to the horizon is an important figure, we introduce first a derivation of the distance to the horizon over a flat region of the earth, such as a plain or the surface of the sea. In Fig. 149,  $h$  is the height of the transmitting antenna,  $R$  is the radius of the earth,  $r$  is the distance from the top of the antenna to the horizon (precisely,  $r$  is the distance along a tangent to the earth surface, measuring from the top of the antenna to the point of tangency). The lines  $r$ ,  $R$ , and  $(R + h)$  form the sides of a right triangle. Accordingly

$$R^2 + r^2 = (R + h)^2 = R^2 + 2Rh + h^2 \quad (196)$$

Since  $h$  is very small when compared with  $R$ , we may neglect the  $h^2$  term and obtain

$$r^2 = 2Rh \quad (197)$$

from which

$$r = 1.23\sqrt{h} \quad (198)$$

where  $h$  is in feet and  $r$  is in miles. A plot of this relationship is shown in Fig. 150.

*Maximum Unobstructed Line-of-sight Distance between Two Antennas.*—By a similar line of reasoning, we may determine the maximum distance separating two antennas when the line of sight between them is unobstructed by the horizon. Suppose  $h$  is the height of the transmitting antenna and  $a$  the height of the receiving antenna. Then the distances to the horizon, viewed from these antennas, are  $1.23\sqrt{h}$  and  $1.23\sqrt{a}$ , respectively. The maximum unobstructed line of sight occurs when the two antennas view the same point on the horizon. Consequently,

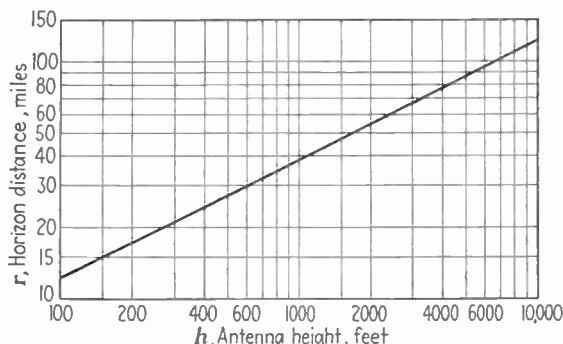

FIG. 150.—Plot of Eq. (198), showing relation between horizon distance and antenna height, assuming no obstructions on the earth's surface.

the maximum unobstructed line of sight  $d_{\max.}$  is the sum of the distances to the horizon, or

$$d_{\max.} = 1.23(\sqrt{h} + \sqrt{a}) \quad (199)$$

where  $d_{\max.}$  is in miles and  $a$  and  $h$  are in feet. Within the distance  $d_{\max.}$ , direct transmission of energy from one antenna to the other is possible. Beyond this limit, energy may be absorbed by the receiving antenna only if diffraction or refraction, or both, come into play.

*Combination of Direct and Reflected Rays.*—Within the horizon distance, the field strength at any point is the vector sum of the field strengths due to the direct ray and the ray reflected from the ground. The direct ray is the energy that would be transmitted by an antenna in free space. The field strength in this ray falls off as the first power of the distance from the point of

observation to the transmitting antenna and is proportional to the square root of the power radiated from the antenna. In the case of a half-wave dipole (straight wire or rod, the length of which is one-half the length of the wave, and which is fed energy at the center), the field strength  $E_d$  due to the direct wave is

$$E_d = \frac{7\sqrt{W}}{r} \text{ volts per meter} \quad (200)$$

where  $W$  is the power in watts radiated by the antenna and  $r$  the distance in meters from the antenna to the point of observation. This field strength applies only to points on the plane that bisects the dipole perpendicularly. At other points, the field strength is multiplied by the cosine of the angle between the perpendicular bisector of the dipole and the line from the point of observation to the dipole. This expresses the fact that the simple dipole is a directional antenna that radiates no energy in the direction of its length, although radiating a maximum at right angles to its length.

To the direct wave considered above, we must add vectorially the wave that is reflected from the surface of the earth. Here the complications enter. In general, the wave suffers a change in phase at the point of reflection and a loss of energy due to absorption in the ground. The magnitude of these effects depends on the direction of polarization of the wave, that is, the direction of the electric field relative to the earth's surface. Two cases are of interest: vertical and horizontal polarization. The direction of polarization is primarily determined by the orientation of the transmitting antenna, a vertical wire or rod producing vertically polarized waves, a horizontal antenna, horizontally polarized waves. In England, vertical polarization is in favor, whereas in this country horizontal polarization is the rule for television transmissions. If the wave is vertically polarized, the degree of energy absorption at reflection depends greatly on the conductivity of the surface at which the reflection occurs.

Since we are usually interested in cases where the antenna height is small when compared with the transmission distance, we can restrict our discussion to "grazing angles" of reflection, that is, to rays that just graze the surface of the reflecting surface. Under these conditions, the reflected wave suffers a reversal in phase, that is, changes in phase by  $180^\circ$ , whether the

wave is vertically or horizontally polarized. The wave is also absorbed to some degree by the earth, to a degree determined by the conductivity of the surface. If the conductivity is high, as when the reflecting surface is sea water, the wave undergoes a high degree of absorption if it is vertically polarized, otherwise the absorption is usually small enough to be neglected. For horizontal polarization, the wave suffers a small attenuation of energy and a 180° phase reversal occurring at the point of reflection. If no other phase change occurred, it would follow that the reflected wave would very nearly cancel the direct wave and very weak signals would result.

Fortunately there is an additional phase change occasioned

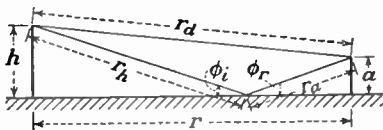

FIG. 151.—Geometrical relationship of direct and reflected waves, showing dependence on transmitting and receiving antenna heights.

by the difference in length of the direct path when compared with that of the reflected path. In Fig. 151, the direct ray is of length  $r_d$ , the transmitting antenna height  $h$ , the receiving antenna height  $a$ , the horizontal

distance between them  $r$ . The reflected path is composed of two straight lines  $r_a$  and  $r_h$  so arranged that the angle of reflection is equal to the angle of incidence ( $\phi_i = \phi_r$ ), which is a necessary condition of the reflection. It follows then, that

$$\frac{r_h}{h} = \frac{r_a}{a} \tag{201}$$

that

$$r_d^2 = (h - a)^2 + r^2 \tag{202}$$

and that

$$r = \sqrt{r_h^2 - h^2} + \sqrt{r_a^2 - a^2} \tag{203}$$

On the assumption that  $r$  is large when compared with  $a$  and  $h$ , it can be shown from the preceding equations that

$$r_d + \frac{2ah}{r} = r_a + r_h \tag{204}$$

Consequently the difference  $d$  in the length of the direct path  $r_d$  and the reflected path  $r_a + r_h$  is



$$d = \frac{2ah}{r} \tag{205}$$

This path difference may be expressed in terms of the wavelength  $\lambda$  of the radiation as a phase angle  $\psi$

$$\psi = \frac{2\pi d}{\lambda} = \frac{4\pi ah}{\lambda r} \tag{206}$$

The total phase shift between direct and reflected rays is then the sum of  $\psi$  and the  $180^\circ$  ( $\pi$  radians) shift that occurs at the

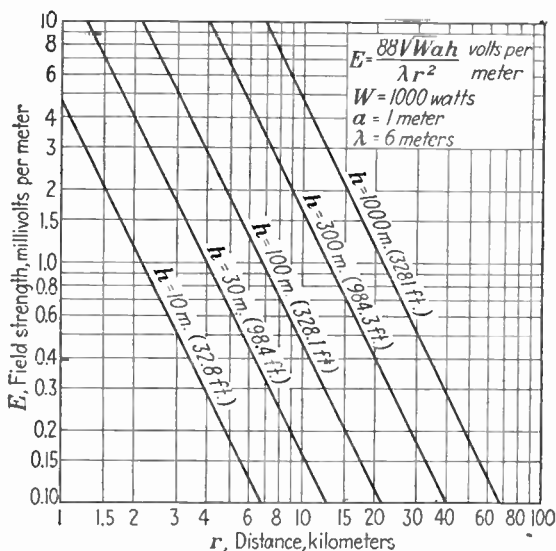

FIG. 152.—Signal field strength against distance and transmitting antenna height, for given values of power, receiving antenna height and operating wavelength, computed by Eq. (207).

point of reflection. If  $\psi$  is zero, the direct and reflected waves tend to cancel each other. In general  $\psi$  is not zero but is a small quantity, since  $a$  and  $h$  are small when compared with  $r$ . Since  $\psi$  is small, we may employ it directly (replacing  $\sin \psi$  by  $\psi$ ) as a coefficient that multiplies the direct field strength to obtain the resultant field strength  $E$ .

$$E = \frac{7\sqrt{W}}{r} \frac{4\pi ah}{\lambda r} = \frac{88\sqrt{Wah}}{\lambda r^2} \text{ volts per meter} \tag{207}$$

where  $a$ ,  $h$ , and  $r$  are measured in the same units (*e.g.*, meters) and  $\lambda$  is in meters. This relationship shows that the field strength increases with the heights of the transmitting and receiving antennas, and with the square root of the power, and that of the field decreases as the square of the distance between transmitter and receiver. It also states that the field becomes stronger as the wavelength decreases, but this may be relied on only for wavelengths longer than 4 meters (frequencies lower than 75 Mc.). A plot of the relationship is given in Fig. 152, showing field strength against distance and transmitting antenna height, for assumed values of  $W = 1000$  watts,  $a = 1$  meter, and  $\lambda = 6$  meters (50 Mc.). Conversions to other given values of  $W$ ,  $a$ , and  $\lambda$  may be made readily by multiplying the ratios of square root of power, receiving antenna height, or wavelength which apply.

The preceding derivation is based on a flat earth between receiving and transmitting antennas. To take the curvature of the earth into account, as shown by Trevor and Carter,<sup>1</sup> it is simply necessary to replace  $a$  by  $a'$  and  $h$  by  $h'$  as follows:

$$h' = h - \frac{r^2(h)^2}{2R(a+h)^2} \quad (208)$$

$$a' = a - \frac{r^2(a)^2}{2R(a+h)^2} \quad (209)$$

where  $R$  is the radius of the earth (6,370,000 meters).

The relationship shown in Eq. (207) has been subjected to a wide series of tests and has been found to hold with fair accuracy up to and including the horizon distance. Within the horizon distance, the values predicted by the equation are the maximum observed values, found only under favorable conditions, such as complete freedom from obstructions. When buildings or other obstructions (such as hills or cliffs) are present in the transmission path, these obstructions introduce attenuation, even though they are below the line of sight. When such obstructions are present, the observed signal strength is usually about 20 to 50 per cent of the theoretical value indicated by the Eq. (207).

When the transmission path is over sea water, vertical polarization offers much stronger signal strengths than the predicted values, owing to the absorption of the reflected wave in the

<sup>1</sup> See reference, p. 268.

highly conducting reflecting medium. But over ordinary settled terrain, there seems to be little preference between vertical and horizontal polarization. Tests as high as 100 Mc. (approximately the upper limit of frequency in the seven television channels most useful for broadcasting) show that the signal strength drops off as the square of the transmission distance, within the horizon distance, and that Eq. (207) may be used less 50 to 80 per cent due to obstructions mentioned above.

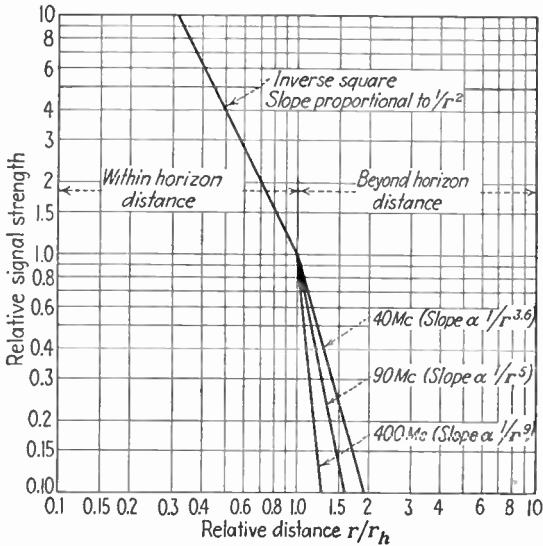

FIG. 153.—Empirical values of field strength within and beyond the horizon distance,  $r_h$ .

*Signal Strengths beyond the Horizon Distance.*—Ordinarily the horizon distance is taken as the limit of the reliable service area of a television station, even if the power of the station is measured in tens of kilowatts. But this rule must not be taken too seriously. Instances of consistently satisfactory reception up to twice the horizon distance have been reported both here and abroad, with transmitters of 10-kw. power. These reports show definitely that optical “line-of-sight” paths are not absolutely required.

The presence of any signal beyond the horizon must be explained either by penetration of the signal through the earth or by a bending or reflection of the waves around the “bulge”

of the earth. The penetration theory is insupportable in view of the known values of absorption of the waves by the earth. Reflection by ionized layers occurs but very rarely and only when the meteorological conditions are exceptional. The only remaining sources of bending are refraction by the (un-ionized) atmosphere and diffraction by the surface of the earth at the horizon. Both effects have been investigated. Beverage<sup>1</sup> comes to the conclusion that the net signal strength beyond the horizon

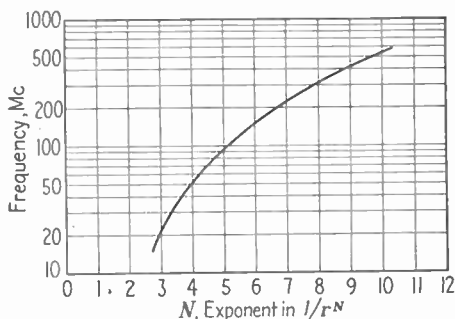

FIG. 154.—Variation in the exponent governing field strength beyond the horizon, as a function of frequency. (After Beverage.)

varies inversely as the 3.6 power of the distance, for frequencies near 40 Mc. (wavelength of 7 meters). The relationship then is

$$E = E_h \left( \frac{r_h}{r} \right)^{3.6} \quad (210)$$

where  $E$  is the signal strength at a distance  $r$  meters from the transmitter (greater than the horizon distance  $r_h$ ) and  $E_h$  is the signal strength at the horizon predicated by Eq. (207). Other data show the exponent to be about 5 at 90 Mc. and 9 at 411 Mc. The conclusion is that the attenuation of signals beyond the horizon is very rapid and increases as the frequency increases.

The theory of diffraction and refraction is complicated inherently, and their effects are very difficult to measure independently. Schelleng, Burrows, and Ferrell<sup>1</sup> have supposed that refraction occurs owing to a changing of the dielectric constant of the atmosphere with height and have suggested that the effects of refraction alone may be taken into account by supposing the earth to have a radius roughly 33 per cent larger than its

<sup>1</sup> See reference, p. 268.

actual radius. The diffraction effects cannot be dealt with so readily. Diffraction depends on the form of the obstruction and its dimensions relative to the wavelength of the radiation. Methods of calculating diffraction have been advanced by Handel and Pfister.<sup>1</sup> Their results show that diffraction effects usually are independent of the season and time of day, although the effects of refraction are more pronounced in summer than in winter. The late Ross Hull has made interesting correlations between refraction and the presence of masses of polar air above warmer layers. But at the present state of the investigations, the best indices to beyond-the-horizon performance are the empirically measured values previously cited.

*Effect of Band Width on Signal Strength.*—Thus far the only indication of the effect of frequency and wavelength on signal strength is given in Eq. (207) which states that the field varies inversely with the wavelength or directly with the frequency. In selective sideband transmission, the band occupied by the television signal is roughly 4 Mc. wide, or roughly 10 per cent of the carrier frequency in the case of a 40-Mc. carrier. It follows that the several frequencies present in the sideband region are transmitted with a 10 per cent differential of signal strength, the highest frequency sideband components being 10 per cent stronger than the lowest. At the high carrier frequencies near 100 Mc., the differential reduces to 4 per cent.

This effect is a small one, when compared with other differentials arising from the character of the transmitting radiator itself and from the effect of reflections other than the "mirror" reflection from the ground. In any event, the differential due to propagation effects may be compensated in the transmitting or receiving circuits.

**43. Television Transmitters.**<sup>2</sup> *a. Generation of the Carrier Frequency.*—In the present section, we review briefly the four aspects of carrier transmission that are included in the operation of a television transmitter: (1) generation of the carrier frequency

<sup>1</sup> See reference, p. 268.

<sup>2</sup> CONKLIN and GIBRING, Television Transmitters Operating at High Powers and Ultra-high Frequencies, *RCA Rev.*, 2 (1), 30 (July, 1937).

Television Transmitters, *Electronics*, 12 (3), 26 (March, 1939).

GOLDMARK, P. C., Problems of Television Transmission, *Jour. App. Physics*, 10, 447 (July, 1939).

(including amplification prior to modulation), (2) modulation, (3) amplification subsequent to modulation, and (4) radiation.

The carrier generator of the transmitter must meet certain specifications, particularly the frequency value and the constancy of frequency prescribed by the transmitting license, and the desired power level, for which the modulation equipment must be designed.

The principal problem in generating the carrier at low-power levels is maintaining the required constancy of frequency. Crystal control is usually employed. In crystal-controlled transmitters, several frequency-multiplying and isolating stages are used, since it is impractical to grind quartz crystals for frequencies higher than 30 Mc. It is common to employ a crystal frequency of the order of 5 Mc., to obtain the advantages of stability that the higher frequency crystals lack. The crystal directly controls the frequency of a low-power (5 to 10 watt) oscillator, which may also serve as a frequency doubler or tripler. Thereafter the signal frequency is doubled or tripled in as many stages as are needed to produce the required carrier frequency. Usually the frequency-multiplying stages are of the pentode type (since they required no neutralizing). The final carrier frequency is usually obtained in the stage just preceding the final output amplifier, which acts simply as a linear (non-multiplying) amplifier. This method of operation minimizes the tendency of the transmitter to radiate at subharmonic or harmonic frequencies.

The final stage, operating at high-power levels at ultra high frequencies, presents several problems not met in lower frequency practice. The principal difficulties arise from the fact that the wavelength of the oscillating current is of the same order of magnitude as the dimensions of the tube elements and the leads to the elements. If large water-cooled tubes are used, the leads may be long enough to permit standing waves to set up voltage maxima within the envelope of the tube itself. One of the results is the difficulty of neutralizing the plate-to-grid capacitance necessary to prevent self-oscillation of the amplifier. Furthermore, the ground potential of the amplifier is not established simply by connecting the element in question to a grounded conductor. If the filament connections, for example, are long enough to constitute a fraction of a wavelength, the inductance

of the leads may act to transfer energy from the plate circuit to the grid circuit, and self-sustained oscillations may be set up. One method of grounding filament connections consists of connecting half-wavelength leads between ground and the filament terminals. Zero potential is thereby maintained at both ends of the leads. To overcome these problems, careful engineering

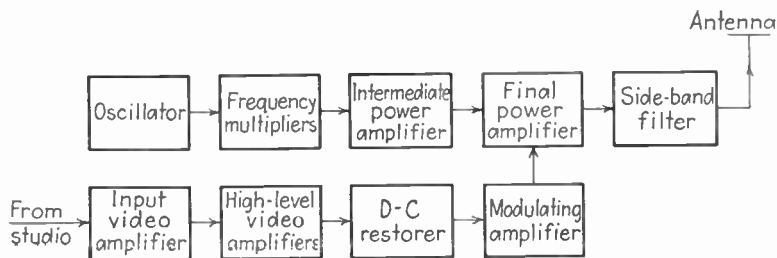

FIG. 155.—Essential elements of a television transmitter employing high-level modulation.

is necessary. Water-cooled tubes of small dimensions have been especially designed for ultra-high-frequency work and are essential for transmitters of over 2-kw. power at frequencies higher than 70 Mc.

The tuned circuits employed are usually of the transmission-line variety, that is, they consist of parallel or concentrically-spaced conductors the distributed capacitance and inductance

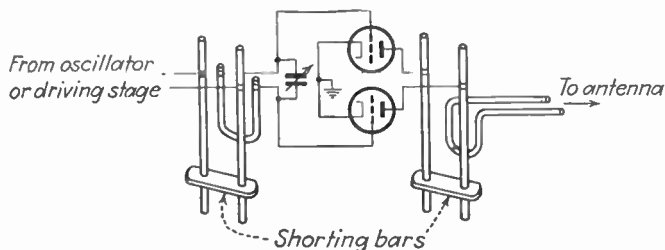

FIG. 156.—Typical push-pull r-f amplifier stage employing transmission-line segments as tuned circuits.

of which form the reactive elements of the circuit. The length of the section employed is commonly a quarter wavelength. Such sections display widely varying characteristics, depending upon their termination. If the quarter-wave section is open-circuited at the far end, it displays practically zero impedance at the near end. If short-circuited at the far end, the near-end

impedance is very high, theoretically infinite. Such sections may accordingly be used as "insulators" of the high-frequency current, while allowing free passage of direct current. If the quarter-wave section is terminated in its surge impedance [see Eq. (182)], the section acts as an infinitely long line and will offer no reflection to the input signal energy. On the other hand, if the line is one-half wavelength long, the impedance looking into the near end is equal to the terminating impedance at the far end, regardless of the surge impedance of the line. Quarter-wave sections may be employed also as impedance transformers, that is, to match a circuit of one impedance to another of higher or lower impedance. If  $Z_1$  and  $Z_2$  are the two impedances to be matched, the surge impedance of the matching quarter-wave section is given in the value  $\sqrt{Z_1 Z_2}$ , resulting in a correct impedance match at both terminations. Impedance matching lines having gradually changing or "tapered" shape may also be employed to match two circuits of different impedance.

The concentric transmission-line section is very useful as a frequency-determining source. If the section is so constructed that changes in its dimensions due to heating are automatically compensated by other changes in the tuned elements, it is possible to devise oscillator circuits of very high stability that operate at high power. One such oscillator, operating at 50 Mc., is capable of delivering 2 kw. of power from a single tube at a frequency stability of 0.1 per cent. The mechanical convenience, circuit simplicity, and economy of tubes of this arrangement have much to recommend it in preference to the crystal-controlled oscillator-and-amplifier system. Several television transmitters now in operation employ coaxial circuits as the frequency-determining source, but they are usually followed by at least one stage of power amplification.

Power amplifiers of the water-cooled type employ triode tubes and hence must be neutralized to operate at maximum efficiency. The problem is simplified (with respect to both neutralizing and obtaining a common r-f ground) if push-pull amplification is employed in the final stage. Transmission-line circuits with small air condensers for neutralizing are employed with each tube. Early forms of coaxial circuits were composed principally of copper, but it has been found cheaper and more



efficient electrically to form the circuits of steel plated with silver. Skin effect confines the current flow within the few thousandths of an inch thickness of the silver coating, which offers very small resistance (less than copper), and the steel gives mechanical strength without undue weight.

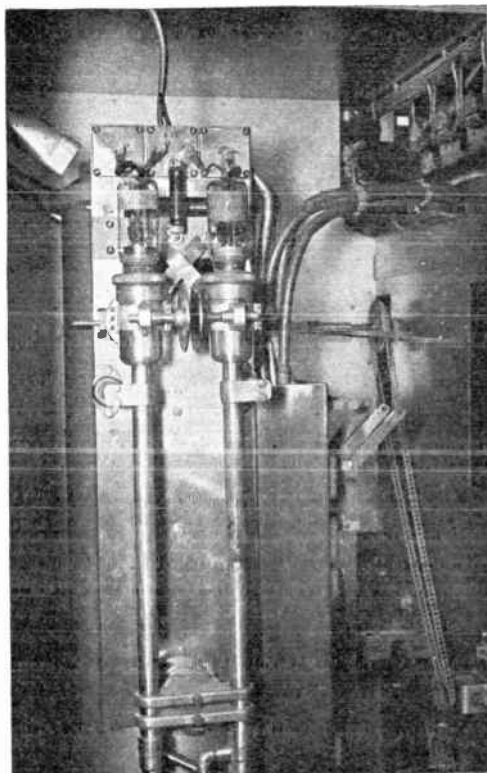

FIG. 157.—Transmission-line controlled oscillator of station W2XAB, New York. Note that the anodes of the tubes are enclosed in the transmission-line conductors, which serve to conduct the cooling water to them.

Despite the improvements noted in the tuned-circuit design, the efficiency of modulated power amplifiers at the ultra-high frequencies remains very low. If the power amplifier is used to pass the broad band of frequencies that are present after modulation, the plate-circuit efficiency may drop as low as 15 per cent, even at the comparatively low frequency of 50 Mc. This means 100 kw. of input power for 15 kw. of useful output—with 85 kw.

of heat that must be dissipated. New tube structures now in development may materially improve the efficiency of the final stages, but until these tubes are available, it seems certain that television-transmitter powers will be limited to carrier levels of 10 kw., with peak levels less than 40 kw.

In this connection, Kaar<sup>1</sup> has calculated the theoretical power required of a transmitter to produce a 1-millivolt (1000 microvolt) signal at the horizon distance, basing his computation on Eq. (207), assuming an effective receiving antenna height of  $\lambda/\pi$  meters and an actual receiving antenna height of 4 meters. The result is 12.9 kw. carrier power (51.6 kw., peak) which is

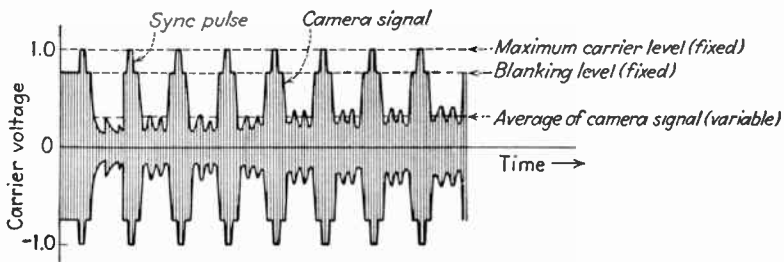

FIG. 158.—Modulated television carrier signal. The blanking level and maximum level are fixed amplitudes, whereas the average of the camera signal varies in accordance with the background brightness of the televised scene.

somewhat more power than can be generated at present at frequencies higher than 40 Mc. This value of 12.9 kw. has some absolute significance, since it applies regardless of the transmitting antenna height, the increase in field strength due to increased antenna height just compensating for the increased distance to the horizon.

*b. Modulation of Television Transmitters.*—The modulation of a television transmitter is made difficult by the range of modulating frequencies (from 30 to 4,000,000 c.p.s.) in the modulating video signal and by the necessity of maintaining a fixed reference level in the modulation envelope. This reference level corresponds to black in the reproduced picture and is the level of the envelope that divides the picture-signal amplitudes from the synchronizing signal amplitudes. In addition, the average level of the picture signal in the carrier envelope must be made

<sup>1</sup> KAAR, I. J., *The Road Ahead for Television*, *Jour. Soc. Motion Picture Eng.*, **32**, 18 (January, 1939).

to correspond to the d-c component of the video signal, so that the background illumination of the picture may be transmitted (see page 174). Finally, since selective sideband transmission is used, means must be provided for removing the undesired sideband components.

Modulation may occur in the low- or high-level stages of the transmitter, and the question of which method to use depends primarily on the economics of the situation. If low-level modulation is used, the necessary modulating voltage can be supplied by video amplifiers of small power output and consequently of inexpensive construction. However, in low-level modulation the stages following the modulated amplifier must be capable

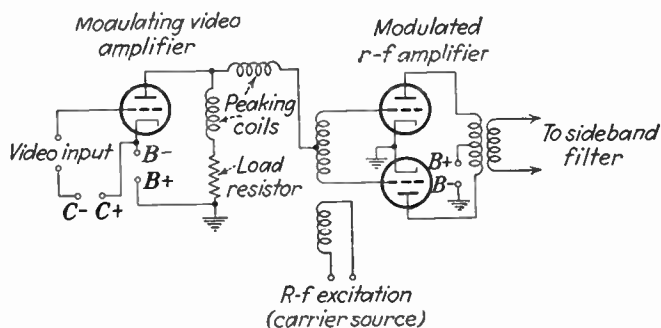

FIG. 159.—Method of conductive coupling between modulating video amplifier and modulated r-f amplifier. The plate of the video amplifier operates at the bias potential of the r-f amplifier, hence the cathode of the video amplifier must be maintained at a high negative potential.

of passing the full frequency width of the sideband regions. This lowers the efficiency of the amplifier, and a considerable increase in tube and power-supply capacity is thereby required, the cost of which may overbalance the saving in the modulating video amplifier. Moreover, in selective sideband transmission the r-f amplifier stages must be highly linear to avoid reinsertion of the attenuated sideband components. High-level modulation is accordingly more popular with designers at present. Modulation occurs either in the final amplifier or in the stage preceding the final.

Three methods of modulation are available: plate-circuit modulation, grid-circuit modulation, and absorption modulation. Plate modulation, desirable from the standpoint of minimizing distortion, is practically eliminated in high-level stages by the

fact that it is practically impossible to build video amplifiers (of adequate phase and amplitude response) that can deliver the several thousand volts of signal required. If grid-circuit modulation is used, the modulating voltage requirements are reduced, approximately, by a factor equal to the amplification factor of the modulated amplifier tube. In practice, this means that hundreds, rather than thousands, of volts of video modulating voltage will suffice. The plate circuit of the grid-modulated amplifier must have a frequency response wide enough to pass the sidebands, and consequently the plate-circuit efficiency is much lower than it would be with plate-circuit modulation. The grid-circuit modulation system is the only practical one at present for transmitter powers of 5 kw. carrier power or higher.

For lower power transmitters, several absorption-modulation schemes have proved practical. One of these, described by Parker,<sup>1</sup> employs a quarter-wavelength transmission line between the modulating voltage source and the output of the final amplifier (*i.e.*, in the transmission line to the antenna). The method has been analyzed by Roder,<sup>2</sup> who terms it "load-impedance" modulation. The impedance-inverting properties of a quarter-wave line are employed to reflect a varying load to the output of the final amplifier and thereby to vary the amplitude of the output. Since the modulation occurs in the antenna circuit, no special precautions regarding the width of the frequency response are necessary, except in the antenna itself. The efficiency of the power amplifier is also considerably improved since there is no steady-state damping in the output tuned circuit. Modulating frequency band widths equal to 10 per cent of the carrier frequency are readily obtained. Figure 160 shows a typical arrangement of the Parker system. The oscillator is a push-pull coaxial-line-controlled self-excited unit. The modulator consists of two tubes the plates of which are fed from the oscillator power supply. The video signal is applied to the grids of the modulators. When the grid voltage increases (becomes less negative), the plate resistance of the modulator tubes decreases. The impedance at the junction point *J* (see Fig. 160)

<sup>1</sup> PARKER, W. N., A Unique Method of Modulation for High-fidelity Television Transmitters, *Proc. I.R.E.*, **26**, 946 (August, 1938).

<sup>2</sup> RODER, HANS, Analysis of Load-impedance Modulation, *Proc. I.R.E.*, **27**, 386 (June, 1939).

is thereby caused to increase. The carrier generator acting through a quarter-wavelength line to the junction point produces a constant current at the junction point. Consequently as the impedance at the junction rises, the output power increases. In other words, increasing the plate current in the modulator tubes results in an increase in power output, and in this sense the modulation is positive. This is in contrast to conventional absorption methods of modulation, in which the amplitude of the output is always decreased below its carrier value as the modulating current increases.

*Establishing D-c Levels in Modulation.*—The “black” reference level in the amplitude of the modulated envelope is established by the d-c bias applied to the grids of the modulating amplifier

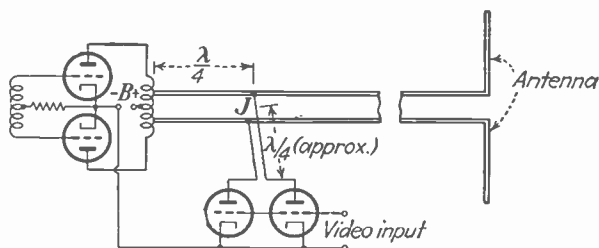

FIG. 160.—The Parker method of “load-impedance” modulation for television transmitters, which employs the impedance-inverting property of a quarter-wave transmission line.

tubes, and this reference level must remain fixed throughout the transmission. Furthermore, the values of signal above the bias value correspond to the sync-signal region, those below it to the picture signal. Hence the proper polarity of these portions of the signal, relative to the bias value, must be maintained. Finally, the average of the picture-signal content must correspond to the background illumination of the scene.

The manner in which the d-c levels are maintained and established is described in Chap. V, page 176. Here we repeat briefly the principle on which the methods rest. When the composite video signal is generated, the blanking level, which separates the camera-signal amplitudes from the sync-impulse amplitudes, is a fixed level. Relative to this level, the average picture brightness must be established by the insertion of a d-c component. At present in studio presentations, the d-c level is established manually and the correct value is obtained by view-

ing the image in a monitor picture tube until a satisfactory appearance is obtained. In motion-picture film presentations, on the other hand, the changes in background brightness are apt to be abrupt and numerous, and in this case it is convenient to adjust the d-c component relative to the blanking level automatically. For this purpose, a phototube is used to integrate light passed through the film from a lamp, and the integrated output current for the phototube is passed through a resistor. The voltage across this resistor, with proper polarity, is inserted in the camera-control amplifier at the proper point to establish the d-c component of the picture relative to the blanking level.

Once the average of the picture signal (d-c component) has been set relative to the blanking level, the proper proportions are maintained between these levels through the rest of the system, since the waveform of the composite video signal is preserved in all the succeeding amplifiers and other items of transmission equipment. However, the absolute value of the blanking level is replaced by arbitrary bias level whenever the composite video signal is passed through a capacitively coupled stage. Furthermore, when capacitive coupling intervenes, the average ordinate of the composite signal varies with the wave shape of the picture-signal content of the signal, that is, the blanking level changes as the detail of the picture changes. Since the average brightness must be independent of the picture detail, it is necessary to reestablish a constant d-c level in the composite video signal before transmitting or reproducing the picture. The d-c level that is actually restored and maintained constant is the peak value of the video signal (the tips of the sync pulses). If this level is held at a fixed value, the blanking level is also held fixed and the average of the camera-signal components depends only on the average background brightness of the scene.

In practice, it is customary to restore the d-c component in the modulating amplifier, as shown in Fig. 262, page 426, by means of a diode rectifier. The load circuit of the diode rectifier is proportioned so that the d-c component developed across it is approximately equal to the peak signal level. The d-c component across the diode load resistor is used to determine the bias of the modulating amplifier tube, and the output of this tube is conductively coupled to the modulated r-f stage, so that the

blanking level in the modulated envelope remains fixed. Any variations in the average of the modulation envelope then correspond directly to changes in the d-c background brightness of the transmitted picture.

At the receiver, another peak-signal diode is used to establish the blanking level, and the output of this diode is used (either directly or after conductive coupling) as part of the bias of the image-reproducing tube. The latter bias is adjusted so that the blanking level in fact produces an absence of light on the luminescent screen. The average of the camera-signal components, relative to the fixed blanking level, then produce an average light on the screen that corresponds to the average light in the studio scene or motion-picture film being transmitted.

*Sideband Suppression in Television Modulation.*<sup>1</sup>—

Another highly important aspect of modulation in television work not typical of other forms of radio communication is the removal of part of one of the sidebands generated in the modulation process. The reasons for the removal of this

signal energy have been discussed on page 266. The practical problem of carrying out the removal rests on the design of filter structures that will pass the desired sideband regions and attenuate the undesired region, without introducing undesirable phase distortions.

The form of the output signal of the television transmitter as standardized by the R.M.A. Committee is shown in Fig. 162. The higher frequency sideband is transmitted without attenuation. Likewise the carrier is transmitted unattenuated. The

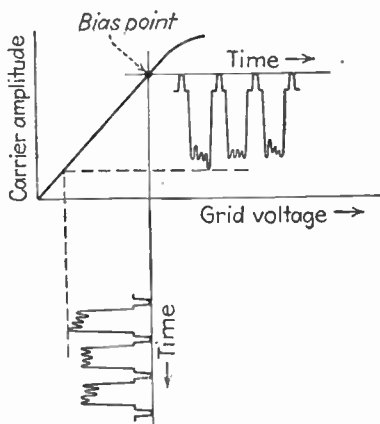

FIG. 161.—Modulating characteristic of grid-modulated r-f amplifier. The fixed bias point corresponds to the tips of the sync pulses.

<sup>1</sup> HOLLYWOOD, J. M., Single Sideband Filter Theory with Television Applications, *Proc. I.R.E.*, 27, 457 (July, 1939).

POCH and EPSTEIN, Partial Suppression of One Sideband in Television Reception, *RCA Rev.*, 1 (3), 19 (July, 1937).

lower frequency sideband is completely attenuated at frequencies far below the carrier, but at frequencies just below the carrier it is not attenuated. This region, extending roughly 0.75 Mc. lower in frequency than the carrier frequency, is transmitted to avoid introducing phase distortions. Beyond the 0.75-Mc. limit, the sideband is attenuated as rapidly as possible, and at the edge of the channel (1.25 Mc. lower in frequency than the carrier), the sideband energy must be attenuated substantially to zero.

It should be noted that this method of transmission gives double-sideband treatment to the sideband components clustering about the carrier (corresponding to the low and intermediate

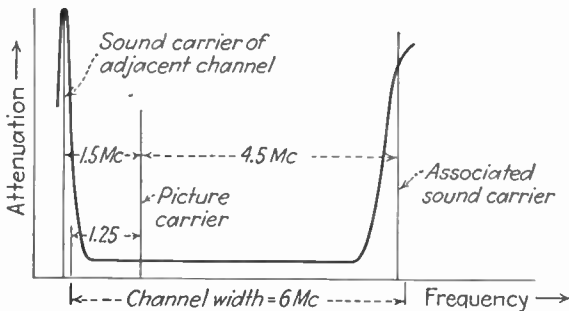

FIG. 162.—Attenuation characteristic required to transmit the vestigial sideband carrier signal according to the R.M.A. transmission standards.

frequencies in the video range), whereas at the far-removed sideband components (high video frequencies) the transmission is single sideband in character. In the latter case, the percentage modulation is only 50, in the conventional sense. Restoration of the 100 per cent modulation is accomplished at the receiver by placing the carrier on the edge of the receiver band-pass curve, at the 50 per cent voltage level.

At the transmitter, the principal problem of vestigial sideband transmission (as the above-described system is called) is the design of a filter having the pass characteristics shown in Fig. 162. Such a filter structure, in idealized form, is shown in Fig. 163. It consists of two branches. The upper branch leads to the antenna and transmits the desired (high-frequency) sideband through a capacitance. The other branch transmits the undesired (low-frequency) sideband through an inductance to a resistance that



absorbs the energy. In each branch, a series-tuned trap circuit is used to aid in obtaining the flat-topped sharp-edged pass band, and in addition an extra "notching" filter (not shown) is used to give further attenuation at the low-frequency edge of the channel to avoid interference with the sound carrier of the adjacent channel.

*c. Amplification of Modulated Carrier Signals.*—Whenever it is necessary to amplify the television carrier after the video modulation has been imposed upon it, the amplifier must be capable of passing, without attenuation, all frequencies lying within the sideband regions. Such amplifiers employ tuned circuits loaded with resistance to permit them to respond to the range of sideband frequencies. The effective impedance of such loaded circuits and the resulting gain of the amplifier are low. The analysis of the loaded tuned circuit which follows applies equally well to a power amplifier following the modulator in a transmitter or to r-f amplifiers that follow the antenna in a receiver.

Consider the tuned circuit of Fig. 164, consisting of an ideal capacitance  $C$ , and ideal inductance  $L$ , and an ideal resistance  $R$ , all in parallel. At the resonant frequency  $f_r$ ,

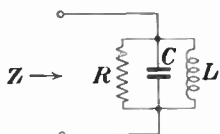

FIG. 164.—Elementary tuned circuit with shunt loading resistance, on which Eq. (220) is based.

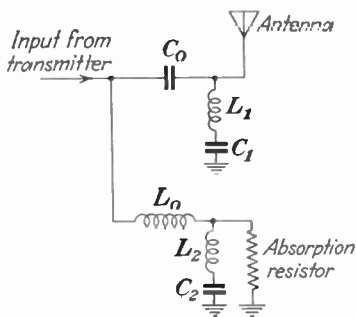

FIG. 163.—Vestigial sideband filter, shown with lumped constant elements. In practice the elements are usually segments of coaxial transmission lines (cf. Figs. 266 and 267).

$$f_r = \frac{1}{2\pi\sqrt{LC}} \tag{211}$$

the inductive reactance  $X_L = 2\pi fL$ , and the capacitive reactance  $X_C = 1/(2\pi fC)$  are equal and opposite. Consequently at the frequency  $f_r$ , the impedance of the circuit is simply the resistance value  $R$ . At any other frequency, the impedance is lower, owing to the fact that the reactances  $X_L$  and  $X_C$  do not cancel each other. The combined effect of the two reactances may be taken into account in terms of the total susceptance  $B$  of the circuit

$$B = \frac{1}{X_C} - \frac{1}{X_L} \quad (212)$$

The impedance of the circuit is

$$Z = \frac{1}{\sqrt{(1/R)^2 + B^2}} \quad (213)$$

Now  $B$  changes with frequency, and at a certain frequency  $f_o$  the value of  $1/B$  is equal to  $R$ . Then, substituting in Eq. (213),

$$Z = \frac{1}{\sqrt{2(1/R)^2}} = 0.707R \quad (214)$$

In other words, at the frequency  $f_o$ , the impedance drops to 71 per cent of its value at the resonant frequency. Actually,

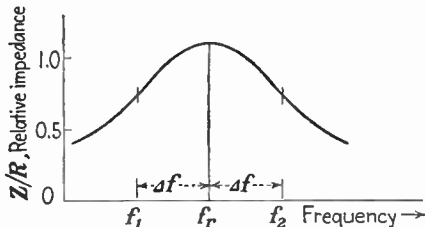

FIG. 165.—Impedance-frequency characteristic of shunt-loaded tuned circuit. A variation of 0.707 occurs between the frequency limits  $f_1$  and  $f_2$ .

there are two values of  $f_o$  that satisfy the relationship  $B = 1/R$  since the equation<sup>1</sup> is a quadratic in  $f_o$ . These two values of  $f_o$  are the frequency limits over which the circuit will display an impedance  $Z$  the amplitude of which lies between  $R$  and 71 per cent of  $R$ .

In practice, the problem usually resolves itself to determining the value of  $R$  required to broaden the circuit response to meet given upper and lower frequency limits. Let the lower frequency limit be  $f_1$  and the upper limit be  $f_2$ . The resonant frequency  $f_r$  is chosen approximately midway between  $f_1$  and  $f_2$ . The frequency range  $\Delta f$  each side of the resonant frequency is then

<sup>1</sup> The equation for  $f_o$  is

$$f_o = \frac{1}{4\pi RC} \pm \sqrt{\frac{1}{16\pi^2 R^2 C^2} + \frac{1}{4\pi^2 LC}} \quad (215)$$

For given values of  $R$ ,  $C$ , and  $L$ , two values of  $f_o$  may be found.

approximately

$$\Delta f \doteq \frac{f_1 + f_2}{2} \quad (216)$$

the upper frequency limit is  $f_r + \Delta f$ , and the lower frequency limit  $f_r - \Delta f$ . We recall that at the frequency  $f_r$ , the inductive reactance  $X_L$  is equal and opposite to the capacitive reactance  $X_C$ , and hence that the susceptance  $B = 0$ . But at the limiting values of frequency  $f_r \pm \Delta f$ , the susceptance has the values

$$B = \frac{1}{X_r} \left( \frac{f_r \pm \Delta f}{f_r} - \frac{f_r}{f_r \pm \Delta f} \right) \quad (217)$$

where  $X_r$  is the value of the capacitive and inductive reactances at the resonant frequency (the factor in brackets expresses the change in the inductive and capacitive branches as the frequency changes). At the limiting values of frequency  $f_1$  and  $f_2$ ,  $R = 1/B$ , which by substitution in Eq. (217) becomes

$$R = \frac{1}{B} = X_r \left[ \frac{f_r(f_r \pm \Delta f)}{\Delta f^2 \pm 2\Delta f f_r} \right] \quad (218)$$

$$= \frac{X_r f_r}{\Delta f} \left( \frac{f_r \pm \Delta f}{2f_r \pm \Delta f} \right) \quad (219)$$

In practice,  $\Delta f$  is 5 per cent or less of the resonant frequency  $f_r$ , consequently we may neglect  $\Delta f$  in comparison with  $f_r$  to obtain the approximate expression

$$R = X_r \frac{f_r}{2\Delta f} \quad (220)$$

In other words, the resistance value  $R$  required to load a tuned circuit is equal to the reactance  $X_r$  of the inductive or capacitive elements at the resonant frequency, multiplied by the ratio of the resonant frequency  $f_r$  to the total width of the required band  $2\Delta f$ .

The value of  $R$  thus computed is the maximum impedance that the tuned circuit can show under any condition. Hence to obtain high gain from the amplifier, as high a value of  $R$  must be employed as possible. With a given ratio of  $f_r$  to  $2\Delta f$ , the higher the value of  $X_r$ , the higher the value of  $R$ . High values of  $X_r$  are obtained from large values of  $L$  and small values of  $C$

in the tuned circuit. In other words, for the highest impedance in a loaded tuned circuit, consistent with a specified band width, the inductance of the tuned circuit should be high and the capacitance low. The higher the  $L/C$  ratio, the better.

In practice, the lower limit of capacitance is the stray capacitance of the wiring in parallel with the tube capacitance. These residual capacitances are usually the only capacitance employed in the circuit. The inductance  $L$  is chosen to resonate with the residual capacitance at the desired frequency  $f_r$ . The reactance of the inductance at the frequency  $f_r$  is the basis of the value of

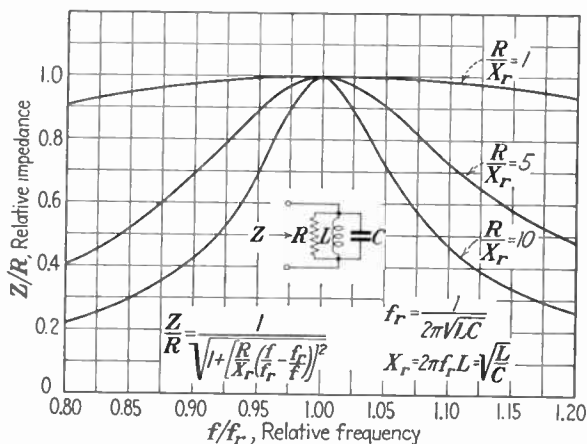

Fig. 166.—General impedance-frequency curves of the loaded tuned circuit. In r-f practice, the useful range usually extends from 0.95 to 1.05  $f_r$ .

the load resistor, by Eq. (220). The resistor ensures response uniform within 29 per cent over the frequency range

$$2\Delta f = f_r \left( \frac{X_r}{R} \right)$$

In selective sideband transmission, the highest video frequency is approximately  $2\Delta f$ .

It should be noted that a single tuned circuit, no matter how loaded, cannot produce perfectly uniform response over a frequency range that includes the resonant frequency. The sloping response either side of the resonant frequency, apparent in the generalized curves of Fig. 166, cannot be avoided. However, if two tuned circuits are coupled closely together either capaci-

tively or inductively, it is possible to produce a response that is higher at frequencies off resonance than at resonance (the so-called "double-hump" resonance curve). The response of such an overcoupled stage can be made to compensate for the loss of response of a single tuned-circuit stage by operating the two stages in cascade. This is common practice in receivers and to a lesser extent is employed in transmitters.

The phase response of the single-loaded tuned circuit may be most conveniently formulated in terms of the conductance

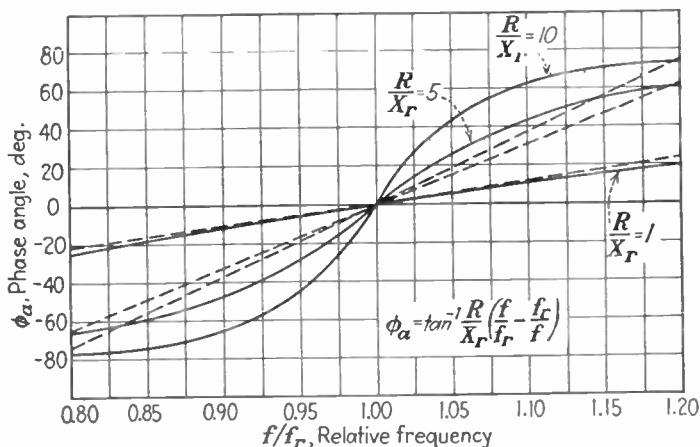

FIG. 167.—Phase angle vs. frequency of the shunt-loaded tuned circuit corresponding to the amplitude responses shown in Fig. 166.

$G = 1/R$  and the susceptance  $B = \frac{1}{X_C} - \frac{1}{X_L}$  of the circuit. The phase angle of the impedance is

$$\phi_\alpha = \tan^{-1} \frac{B}{G} = \tan^{-1} - \frac{R}{X_C} + \frac{R}{X_L} \quad (221)$$

The phase response indicated by this equation has been plotted in Fig. 167 in terms of the ratio  $R/X_r$  ( $X_r$  is the reactance  $X_C = X_L$  at the resonant frequency  $f_r$ ) and the ratio of the frequency of operation  $f$  to the resonant frequency  $f_r$ . It will be noted that substantially linear phase response is obtained through the region  $2\Delta f$  (the range of operating frequencies, 10 per cent of the resonant frequency or less). It should be noted that the total range of phase angle is from  $-90^\circ$  to  $+90^\circ$

( $-\pi/2$  to  $+\pi/2$ ) since the resonant frequency is included in the range. In the simple video amplifier (in which the resonant frequency is above the operating range), only  $90^\circ$  of high-frequency phase shift can occur in a single stage.

The effect of phase shift of the carrier and sideband signals on fidelity of reproduction is not so obvious as in the case of the original video components. But it can be shown that if the relative phase shift suffered by one sideband component relative to another is in direct proportion to the frequencies of the components, then after demodulation the components in the resultant video signal will suffer phase delays in proportion to the video frequency. This is the criterion for equal time delay of the component video frequencies. It follows that a linear phase response serves the same purpose in the amplification of a modulated carrier signal as in the amplification of a video signal.

*d. Radiation of Modulated Carrier Signals.*—Several of the factors influencing the radiation of television signals have already been discussed in connection with the propagation of ultra-high-frequency signals, indicating that the transmitting radiator should be as high and as free from obstructions as possible. Two other important considerations depend on the construction of the radiator. These are the impedance of the radiator in the range of frequencies within the transmitted band and the concentration of the radiated energy in the directions of maximum utility. The latter problem involves two aspects: directing the energy to a center of population and preventing radiation in the direction of the sky, where it serves no purpose. If vertical polarization is used, a single dipole has desirable properties in that it radiates no energy vertically upward, and a maximum of energy in the direction of the horizon. On the other hand, horizontally polarized antennas radiate no energy in the horizontal line that coincides with the length of the dipole, but a maximum of energy at right angles to that line, both vertically upward and horizontally. When horizontal polarization is used, therefore, it is desirable to employ a multielement radiator to suppress radiation to the sky and to concentrate it within the solid angle subtended by the horizon and the base of the antenna.

The problem of providing a constant impedance (amplitude and phase) over the sideband range of 4 or 5 Mc. (6 Mc. if both

sight and sound carriers are radiated from a single radiator) is a much more serious one than that of directivity. The simple dipole antenna must be very heavily loaded to respond equally to all frequencies within this range, and until recently the amplitude discrimination has constituted the final limitation to the transmission of a 4- or 5-Mc. sideband. Recently, however, Lindenblad<sup>1</sup> has undertaken a new approach to the problem and has evolved a design that consists of two horizontal half-wave dipoles of unusual ovoid shape.

The theory of the antenna structure is based on the fact that the impedance of a series inductance-capacitance combination

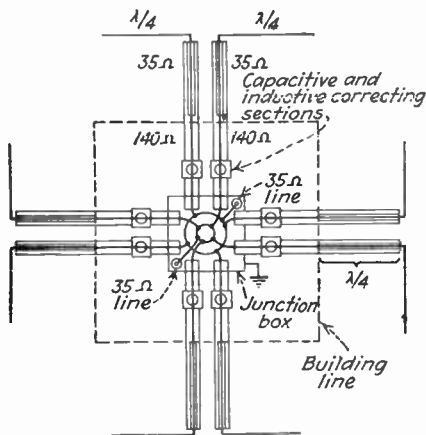

FIG. 168.—Arrangement of transmission lines and crossed dipoles in the radiator array used at station W2XAX, the Columbia Broadcasting System's transmitter in New York City.

is independent of frequency if the inductance and capacitance are loaded with equal resistors the value of which is the square root of the inductance-capacitance ratio. An antenna structure having an impedance independent of frequency may then be built if the antenna is composed of two colinear coaxial segments, one capacitive and the other inductive, so proportioned that they divide the radiation resistance between them and that the radiation resistance is equal to the square root of the inductance-capacitance ratio. Since coaxial conductors and radiators possess distributed inductance and capacitance, which are not in

<sup>1</sup>LINDENBLAD, N., Television Transmitting Antenna for Empire State Building, *RCA Rev.*, 3 (4), 387 (April, 1939).

themselves independent of frequency, the problem is somewhat complicated, but it can be solved approximately by employed coaxial members of unusual shape. The optimum shape was determined by experiment, and it was found that the outer element of the coaxial radiator should have the form of a curved

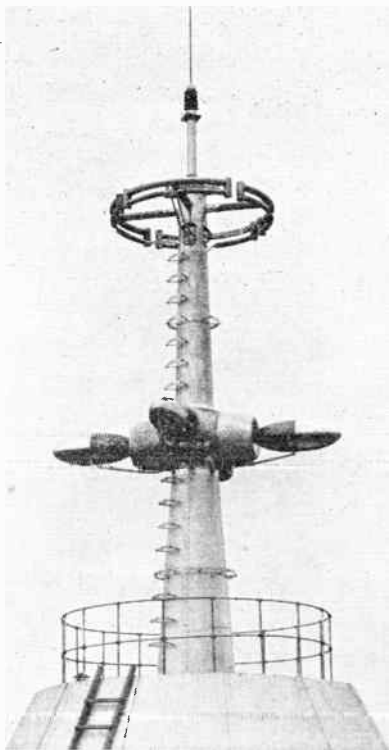

FIG. 169.—Radiator system designed by Lindenblad for station W2XBS, the National Broadcasting Company's transmitter atop the Empire State Building in New York City. The top structure is the folded dipole used for sound transmission, the lower the constant-impedance turnstile structure for the picture signal.

collar from which protrudes the inner conductor which has an ellipsoidal shape. Such a combination displays but very small differences in impedance over a range of frequencies equal to 20 per cent of the mid-frequency (over a range of 10 Mc. in 50 Mc. or more than is required for a station radiating signals within a 6-Mc. channel).



To obtain horizontal polarization, four collar-ellipsoid combinations are arranged in the form of a turnstile antenna and fed in phase quadrature. The sound antenna is of the folded-dipole type which has a much narrower impedance characteristic and which displays virtually zero mutual impedance with the collar-ellipsoid structure. Consequently no energy is transferred from the vision radiator to the sound radiator, or vice versa.

**44. Television Receiving Antennas.**<sup>1</sup>—Receiving antennas for television signals are far more critical than those for ordinary sound broadcasting. The principal problem lies in avoiding reflected signals either from near-by structures or within the antenna system itself.

If the reflected signal is separated from the main signal by a sufficient time delay, a double image results. If the reflection arrives nearly coincidentally with the main signal, no double image is visible, but the fine detail of the image is impaired, and the image has a blurred, indistinct appearance. The degradation of picture detail from this cause is fully as serious as that resulting from inadequate high-frequency response in the video amplification system.

The magnitudes of the effects of signal reflections can be deduced readily by considering the speed of the scanning spot across the image-reproducing screen. According to Eq. (5) (see pages 44 and 45), the active scanning velocity  $v_h$  in each line is roughly 120,000 in. per second (or 300,000 cm. per second) for a picture 7 in. wide, 525 lines, 30 frames per second. Since the speed of propagation of radio waves is  $3 \times 10^{10}$  cm. per second, the scanning beam moves 1 cm. while the radio wave travels 100,000 cm. In other words, while the scanning beam moves over one picture element (0.02 in. wide), the radio wave travels 2000 in., or 170 ft. If the reflected signal travels over a path that is 170 ft. longer than the direct wave, two picture

<sup>1</sup> SEELEY and BARDEN, A Discussion of Television Receiving Antennas, Report LB-423 RCA License Laboratory. Information made available by special permission.

SEELEY, Effect of Receiving Antenna on Television Reception Fidelity, *RCA Rev.*, 2 (4), 433 (April, 1938).

CORK and PAWSEY, Aerial Feeders for Television, *Television*, 12, 282 (May, 1939).

CARTER, P. S., Simple Television Antennas, *RCA Rev.*, 4 (2), 168 (October, 1939).

elements are produced side by side, and a blurred image results. If the reflected wave has a shorter path difference than 170 ft., the image is not double, but the reproduced picture element is broadened, and in general if the path difference is greater than 50 ft., degradation of the picture detail results.

This fact makes the conventional wire-and-lead-in type of receiving antenna unsatisfactory unless specifically designed for a particular transmission. The antenna and lead-in are often sufficiently long to allow reflections whose path differences are much longer than the 50 ft. minimum. Reflections may be prevented, of course, by proper design and by loading the antenna. But if the antenna is to be used for reception from a number of channels, it is impractical to prevent reflections on any but one of these channels.

In consequence, television-receiving antennas are usually of the short-dipole (either single- or multi-element types) variety, and the lead-in takes the form of a transmission line that has no signal pickup. The signal absorption is thereby restricted to the dipole element, within which significant signal reflections do not occur. Reflections may occur in the transmission line, but these may be damped out or eliminated by terminating the line in its surge impedance. The dipole has another advantage in its directive characteristics. By changing the orientation of the dipole element, relative to the line of signal propagation, it is possible to discriminate against signal reflections that arrive from near-by obstructions. In cities, reflections from vertical objects (buildings, etc.) are apt to be troublesome, but it is usually possible to orient the dipole so that one signal predominates over the others sufficiently to provide an image free from reflections. It should be noted that in such cases the orientation of the antenna applies only to transmissions from one station. If programs are desired from any of several stations in the neighborhood, a compromise adjustment must be found or else a separate antenna employed for each station. In suburban areas, reflection difficulties are usually much less serious, especially if the antenna can be mounted high and clear of near-by obstructions.

Three types of transmission lines are commonly employed: the parallel-wire type, the coaxial type, and the twisted pair. The parallel-wire type usually has a higher surge impedance and is

more difficult to balance against signal pickup than the others. The attenuation is in the order of 0.1 db per wavelength. The twisted pair is perhaps most widely used. Its surge impedance is usually 50 to 150 ohms, and the attenuation about 1 to 2 db per wavelength. This high value of attenuation is useful in suppressing reflections in the line if the line is improperly terminated, but if the line is long, the attenuation represents a serious loss of signal strength. For installations requiring more than 50 ft. of transmission line, the coaxial form is suitable. This form has extremely low attenuation and is insensitive to signal pickup. The low attenuation (0.01 to 0.05 db per wavelength) makes it necessary to eliminate reflections in the line by proper termination, since reflections may persist five to ten times before being attenuated beyond recognition.

The problem of impedance matching involves the method of connection of the transmission line to the antenna at one end and to the antenna coupling coil of the receiver at the other. At the antenna, the average resonant impedance at the center of a dipole varies from 72 (for  $\frac{1}{2}$  wavelength) to 125 ohms (for 7 half wavelengths). If a transmission line of 50 to 150 ohms is connected at the center of a dipole of these or any intermediate lengths, the mismatch will not introduce a serious loss of signal.

The length of the dipole employed depends greatly on the type of directivity desired and on the number and frequencies of the several stations the signals of which are to be picked up. An antenna the length of which is  $\frac{1}{2}$  wavelength at 40 Mc. is a full wavelength long at 80 Mc., and  $1\frac{1}{2}$  wavelengths long at 120 Mc. It is obvious that the performance of the antenna varies widely over the full range of the television channels from 44 to 108 Mc. In practice, if it is necessary to cover the whole range, it is usual to design the antenna to be  $\frac{1}{2}$  wavelength long at the geometric center of the range ( $\sqrt{44 \times 108} = 70$  Mc.) The wavelength corresponding to 70 Mc. is 4.3 meters, in free space. The velocity of propagation in the antenna conductor is roughly 90 per cent of that in free space, so the corresponding wavelength in the antenna is about 3.9 meters. One-half wavelength is 1.95 meters, or 6 ft. 6 in. Each element of the dipole is accordingly 3 ft., 3 in. long.

The directivity patterns of dipoles of several lengths are shown in Fig. 170. These patterns have been drawn to scale

and show that an antenna several wavelengths long has much stronger pickup in the major lobes than the shorter antennas. Ordinarily long antennas are used only when the extra pickup is

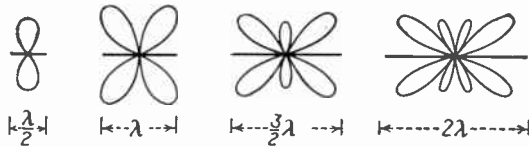

FIG. 170.—Radiation patterns (in a horizontal plane) of horizontal dipoles of various lengths. The patterns also represent the directional sensitivities of the dipoles when used for reception.

essential, usually at the boundaries of the service area. One difficulty is the fact that the transient response of a long antenna is poor, that is, a sudden increase in the amplitude of modulation is not immediately transferred to the transmission line, but requires some time for “accumulation” in the long antenna.

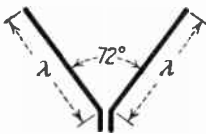

FIG. 171.—V antenna, consisting of two full wave sections, which displays maximum sensitivity along the bisector of the angle between the elements.

When the sensitivity of the antenna is the limiting factor, it is usually wise to employ some form of directive antenna, made of several short ( $\frac{1}{2}$  or 1 wavelength long) elements. The V antenna shown in Fig. 171, composed of two full-wavelength sections at a  $72^\circ$  angle, gives a maximum response along the bisector of the angle but no response at right angles. The rhombic (“diamond”) antenna (Fig. 172) consists of two V’s with a terminating resistor of 400 to 800 ohms. The termination of the closed

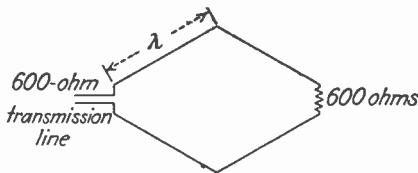

FIG. 172.—The rhombic antenna, consisting of two V antennas combined. This structure, besides having highly directional sensitivity, is effective over a wide range of operating frequencies.

V effectively prevents reflections to the transmission line. The rhombic antenna is especially suitable for covering a wide range of frequencies. If designed for 70 Mc., this form of antenna will give acceptable performance throughout the range

from 40 to 100 Mc. A third type of directive antenna is the double doublet, shown in Fig. 173. The two colinear elements form one doublet having a full wavelength at the center of the desired frequency range (70 Mc.), whereas the shorter lengths make a doublet of approximately half wavelength at the same frequency. A transmission line of about 150 ohms surge impedance is connected as shown. The directional response of the antenna is a combination of the double-lobe and four-lobe patterns shown in Fig. 170.

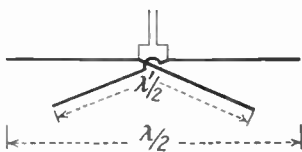

FIG. 173.—Double doublet, designed for two operating wavelengths,  $\lambda$  and  $\lambda'$ , which displays good response within those limits.

*Termination of the Antenna at the Receiver.*<sup>1</sup>—The input circuit of the receiver consists usually of an antenna-coupling transformer. The primary of this transformer is connected to the transmission line, and the transmission-line surge impedance acts as the loading. The impedance of the primary coil must match the transmission-line impedance, at least approximately, to prevent reflections, and further it must be balanced with respect to ground when connected to a balanced transmission line (such as the twisted-pair or open-wire line). The need for balance rises from the fact that the conductors in the transmission

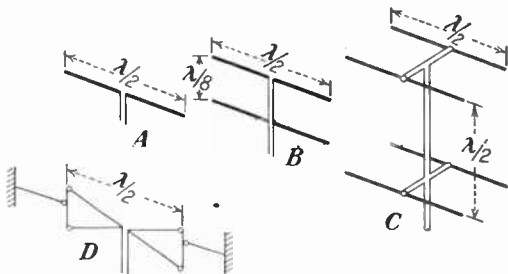

FIG. 174.—Elementary forms of television antennas available commercially: A, the simple dipole; B, the stacked double dipole; C, stacked dipoles with reflectors; D, double-V dipole.

line act as antennas, picking up signals of like magnitude and phase. If the line is properly balanced, these signals cancel each other. Otherwise they combine with the signal pickup of the antenna proper, and time-delay difficulties may arise. When

<sup>1</sup> BENHAM, W. E., Aerial Coupling System for Television, *Wireless Eng.*, 16, 555 (October, 1938).

the coaxial type of line is used, the line itself is unbalanced (the sheath of the line is grounded) and hence may be connected to an unbalanced primary in the input transformer.

**45. Radio-frequency Circuits in Television Receivers.**<sup>1</sup>—Next in logical order are the amplifier circuits that follow the antenna input in a television receiver. Two types of receiver must be considered: the t-r-f receiver, in which all amplification prior to demodulation occurs at the original carrier frequency, and the superheterodyne type, in which a frequency conversion is introduced either directly at the antenna or after one stage of carrier-frequency amplification. In the superheterodyne, most of the gain in the receiver is obtained in i-f amplifiers.

Radio-frequency amplifier circuits are essentially the same in both types of receiver. The acceptance frequency band of the amplifier must be wide enough at least to accept the carrier and video sideband components (4 Mc. band width). If the audio carrier signal is accepted in the same circuit, the desired band width is about 5.5 Mc., nearly the whole channel width of 6 Mc.

It is common practice in superheterodynes to accept both picture and sound carriers in the same circuit, since the loss in gain that accompanies the wider band width is not serious, not enough to justify the duplication of tubes that is necessary if the two carriers are amplified separately. The necessary selectivity between channels and between the picture and sound carriers is obtained in the i-f stages.

The calculation of the gain of an r-f amplifier employing loaded tuned circuits is carried out essentially in the manner outlined for carrier amplification in transmitters (subsequent to modulation), discussed on page 289. Since pentode tubes are universally employed, the load impedance  $Z_o$  is small when compared with the tube plate resistance, and the gain is given by Eq. (102).

$$G = g_m Z_o \quad (102)$$

the value of  $Z_o$  is obtained by the analysis of Eqs. (211) to (220).

<sup>1</sup> LYMAN, H. T., Television Radio Frequency Input Circuits, *R.M.A. Eng.*, **3** (1), 3 (November, 1938).

STRUTT, M. J. O., High Frequency Mixing and Detector Stages in Television Receivers, *Wireless Eng.*, **16**, 174 (April, 1939).

MOUNTJOY, GARRARD, Television Signal-Frequency Circuit Considerations, *RCA Rev.*, **4** (2), 204 (October, 1939).

The basic capacitance  $C$  is the stray capacitance and tube capacitance. The inductance  $L$  is chosen to resonate with this capacitance at the frequency of the center of the channel. The reactance  $X_r$  of  $L$  at the resonant frequency is computed. The whole circuit is then loaded with a resistance  $R$  such that

$$R = X_r \frac{f_r}{2\Delta f} \tag{220}$$

where  $2\Delta f$  is the desired band width and  $f_r$  is the resonant frequency. The impedance  $Z_o$  of the circuit is then equal to  $R$ , at resonance, and to  $0.707R$  at the upper and lower edges of the

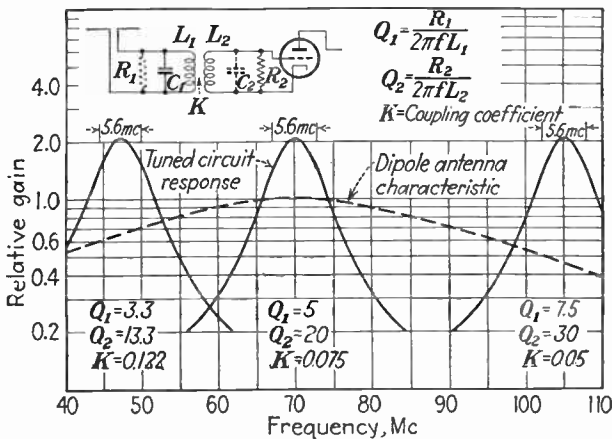

FIG. 175.—Response of r-f stage to three channels, computed by Lyman.

desired band. The gain is  $g_m R$  at resonance and  $0.707g_m R$  at the band edges. This analysis applies, of course, only if the load impedance is a single-loaded tuned circuit, and in this case the amplification of the desired band of frequencies is not uniform.

The single-tuned circuit, even if employed in several stages, is undesirable because it is not sharply selective, and because the circuit itself has no inherent gain. This latter defect is especially important in the antenna circuit, since the signal-to-mask ratio of the receiver is established by the ratio of the signal (applied by the antenna-coupling transformer to the first tube) to the masking voltages generated in the coupling circuit and in the first tube.

In order to preserve the highest possible  $L/C$  ratio in the tuned circuits, it is common practice to employ inductive tuning. The

stations are selected by switching to taps on the coil, or to separate coils, rather than by variable capacitance.

The need for high selectivity and gain has led to the use of coupled circuits, that is, two tuned circuits coupled inductively. The  $L/C$  ratio in each tuned circuit is kept high, and loading is determined by Eq. (220). The coefficient of coupling  $K$  between the two coils is determined by the desired band width relative to the carrier frequency. Lyman<sup>1</sup> has given the expression for the coupling coefficient as

$$K = \sqrt{\frac{4d^2}{A^2 - 1} \left[ \sqrt{A^2 + \frac{n(A^2 - 1)}{4d^2}} - 1 \right] - \frac{1}{Q_1 Q_2}} \quad (222)$$

where  $d$  is  $\Delta f/f_r$  (half-width divided by resonant frequency),  $A$  is the attenuation at the edges of the pass band,  $Q_1$  is  $R_1/X_1$  (resistance over inductive reactance at resonance, of primary circuit),  $Q_2$  is  $R_2/X_2$  (of the secondary), and  $n$  is  $\frac{1}{Q_1} + \frac{1}{Q_2}$ . Figure 175 (due to Lyman) shows the calculated responses of the given input circuit for three channels, together with the attenuation (dotted line) due to a half-wave dipole tuned to 70 Mc. The band width is taken as 5.6 Mc., sufficient to accept both sound and picture carriers simultaneously.

The stage gain  $G$  corresponding to this value of  $K$  is

$$G = \frac{2\pi f_r K \sqrt{L_1 L_2}}{\left( \frac{1}{Q_1 Q_2} + K^2 \right)} \quad (223)$$

where  $L_1$  and  $L_2$  are the self-inductances of the coil between which the coupling coefficient  $K$  exists and the other symbols are as in Eq. (222).

*Signal-to-mask Ratio of the R-f Input Circuit.*—A vital consideration in the input circuit of a television receiver is the signal-to-mask ratio made possible by the tube and circuit arrangement. Experience has shown that the ratio of the r-m-s signal voltage to the r-m-s mask voltage should be at least 20 to 1 (26 db) for acceptable performance, and preferably 50 to 1 (34 db) or higher.

The least signal necessary for satisfactory performance is calculated in terms of the masking voltage generated prior to

<sup>1</sup> See reference, p. 302.



and in the first stage. The masking voltage has two components, thermal and shot effect, which are calculable by Eqs. (92) and (93). The thermal noise, assuming a temperature of 300°K. (27°C.), a grid-load impedance of 1500 ohms, and a frequency band of 4 Mc., is found by Eq. (92) to be 10 microvolts. By assuming a stage gain of 5, this grid-circuit masking voltage becomes 50 microvolts in the plate circuit of the tube.

The shot-effect noise, assuming a plate current of 10 ma., a plate-load impedance of 1200 ohms, and a frequency band of 4 Mc., is calculated by Eq. (93) to be 135 microvolts. The total mask voltage is the square root of the sum of the two mask voltages squared, or  $\sqrt{(50)^2 + (135)^2} = 144$  microvolts, in the plate circuit of the first tube. At a signal-to-mask ratio of 20 to 1, the r-m-s signal voltage required in the plate circuit is then  $20 \times 144 = 2880$  microvolts.

Knowing the required signal in the plate circuit, we may work backward to determine the field strength required at the antenna. The gain between the antenna and the plate circuit of the first tube is composed of the following elements: the inverse of the transmission-line attenuation, the gain of the antenna-coupling transformer, and the gain of the first stage itself. Improving the first two elements improves the signal-to-mask ratio, improving the stage gain improves the ratio only with respect to the shot-effect noise. In typical cases, the transmission-line attenuation is 6 db (gain of  $\frac{1}{2}$ ), the transformer gain is 2, and the stage gain, as previously assumed, is 5. The total gain from antenna to plate circuit of the first tube is then  $\frac{1}{2} \times 2 \times 5 = 5$ . The required 2880 microvolts of signal in the plate circuit is produced by an antenna voltage of  $\frac{2880}{5} = 576$  microvolts.

The field strength required to produce this antenna voltage depends on the effective height of the antenna. By assuming 2 meters as typical of antenna heights, the required field strength for a 20 to 1 signal-to-mask ratio, under the assumed conditions, is 288 microvolts per meter. This is the minimum. For good results, a signal-to-mask ratio of 50 to 1 is desirable, requiring a field strength of 720 microvolts per meter. The figure commonly accepted is 1000 microvolts per meter.

This analysis of the masking-voltage problem has to do only with the irreducible noises generated in the tube and circuit of the first amplifier stage. Masking effects due to man-made

interference (ignition systems, diathermy equipment, etc.) have an equally serious effect on the picture (in many respects, they have a worse effect, since the effect on the picture is often localized, whereas the shot-effect and thermal noises are evenly distributed as a mask over the picture). To maintain the desired signal-to-noise ratio as low as 50 to 1, the man-made interference should have a field strength lower than 20 microvolts per meter in the presence of a 1000-microvolt-per-meter signal. Unfortunately in many locations, higher interfering field strengths occur, and it is necessary to obtain high signals by careful antenna placement, use of directional antenna arrays, etc. It should be noted that improvements in the transmission-line attenuation and antenna-coupling-transformer gain are effective against shot-effect and thermal masking voltage only—not against interference picked up by the antenna proper.

**46. Oscillator and Converter Circuits.**—In superheterodyne television receivers, the frequency converter (first detector) is universally employed to change the frequency of the picture as well as the sound carriers, simultaneously. The input signals to the converter consist of these carriers (derived either from the preceding r-f stage or directly from the antenna) and a locally generated oscillation signal. The difference between the picture-carrier frequency and the oscillator frequency is the intermediate frequency for the picture channel, whereas the frequency difference between the sound carrier and the oscillator constitutes the sound intermediate frequency. Since the same oscillator frequency is used in both cases, it follows that the frequency separation between the two intermediate frequencies is the same as the frequency difference between the carriers. The latter separation has been standardized, in this country, at 4.5 Mc. Furthermore, most manufacturers have adopted a sound i-f value of 8.25 Mc., which puts the picture intermediate frequency at 12.75 Mc. These two frequencies are not absolute standards, since other values may be produced from the standard carrier frequencies by employing a different oscillator frequency. But experience has shown that these values are suitable for the design of the i-f channels.

The reason for choosing a picture intermediate frequency higher than the sound intermediate frequency follows from the fact that it is easier to design amplifier circuits for the wide range of video

sideband components when the intermediate frequency is high (since the percentage band width  $2\Delta f/f$ , is then a smaller quantity, the necessary load resistor has a higher value and the gain per stage is higher). On the other hand, it is equally desirable to have the radiated picture carrier *lower* in frequency than the sound carrier, since the lower frequencies are more readily generated and radiated in the region above 40 Mc.

Accordingly, the picture carriers assigned by the F.C.C. are lower in frequency than the sound carriers, although the picture intermediate frequency is higher than the sound intermediate frequency. The result is that the oscillator frequencies employed must be higher in frequency than the carrier frequencies. In the 44- to 50-Mc. channel, for example, the two carriers are 45.25 Mc. (picture) and 49.75 Mc. (sound). When an oscillator frequency of  $49.75 + 8.25 = 58$  Mc. is employed, the corresponding intermediate frequencies are 8.25 Mc. (sound) and 12.75 Mc. (picture) as required by the suggested standards. The fact that a high-frequency oscillator must be used (the oscillator frequency is 116 Mc. for the 102- to 108-Mc. channel) has some disadvantages, since the higher the frequency, the lower the power output, and the poorer the frequency stability of the oscillator. But these disadvantages are outweighed by the i-f and carrier considerations stated above.

*Types of Frequency-converter Circuits.*—When the receiver is to be designed for reception of seven channels, it is virtually necessary to employ separate converter and oscillator tubes, but a combined oscillator-converter tube can be used (at some loss in efficiency) if reception is confined to carriers lower than 72 Mc. One type of combined tube (the 6K8) is particularly serviceable in the latter case, largely because of the high  $\mu$  and transconductance in the oscillator section. The accepted practice is to employ two tubes. Accordingly we may discuss the converter separately from the oscillator.

If the converter is the first tube in the set (r-f stage omitted), then the converter tube sets the signal-to-mask voltage ratio for the receiver. The computation is somewhat similar to that used above for computing this ratio in the r-f stage. The principal difference is the fact that the conversion conductance  $s_c$  of the converter tube is smaller than the mutual conductance of the amplifier, and the signal gain is cut down proportionately.

The signal is thereby made weaker relative to the shot-effect noise present in the plate circuit of the converter tube. In the presence of weak signals, therefore, an r-f stage is to be desired. Ultimately the decision is based on the expected signal strengths and on economic factors. The r-f stage serves also, of course, to prevent radiation of the oscillator frequency from the antenna and improves the image-response ratio.

The figure of merit for the converter tube itself is very similar to that of a tube intended for video amplification, that is, it is the ratio of the conversion transconductance to the sum of the input and output capacitances

$$\text{Figure of merit} = \frac{s_c}{C_{gk} + C_{pk}} \quad (224)$$

Usually the high-transconductance tubes employed for video amplification serve equally well for converter service. The principal circuit difference is the fact that a higher grid-bias voltage is sometimes employed for conversion than for amplification and that the impedances in the grid and plate circuits are resonated at carrier and intermediate frequencies, respectively.

*Oscillator Considerations.*—The oscillator tube must supply sufficient signal voltage to the converter tube to produce a strong i-f output, and in addition, the oscillating circuit should be as stable as possible with respect to supply-voltage changes and temperature changes. In general, the merit of the tube is determined by the ratio of its mutual conductance to its capacitance sum. Since the value of  $C_{gp}$  need not be considered, the triode type of tube usually exhibits the best figures in this respect.

Equally important with the tube used is the type of oscillator circuit. Two circuits seem to show the highest degree of freedom from frequency instability (with respect to supply-voltage changes): the modified Hartley ("floating-cathode") circuit and the tuned-plate circuit, shown in Fig. 176. Tuned grid circuits are avoided because of frequency instability. In designing the oscillator circuit for the highest channel (above 100 Mc.), the greatest care must be exercised to obtain high circuit  $Q$  values (high reactance-resistance ratios) in the tuned circuits and the feed-back paths. In contrast with video work, good results are obtained when large values of capacitance are used.

The oscillator tuning is one of the most critical adjustments in the entire receiver, since the audio i-f frequency must be made to fall accurately in the center of the pass band of the audio i-f

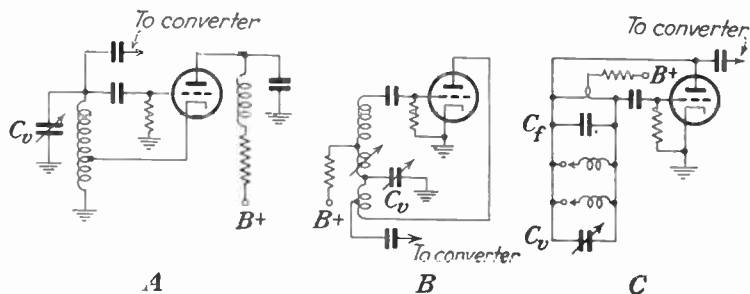

FIG. 176.—Oscillator circuits suitable for television superheterodynes: A, the floating-cathode circuit; B, center-tuned; C, shunt-inductance tuned. All are variations of the Hartley circuit. The capacitor  $C_v$  in each case is used as a trimmer.

channel, and since the signal carriers must fall accurately on the rejection frequency of the various traps used. Ordinarily, the sound channel is designed to accept any signal within a band of 50 to 100 kc. This allows a drift of 0.05 to 0.1 Mc. in 116

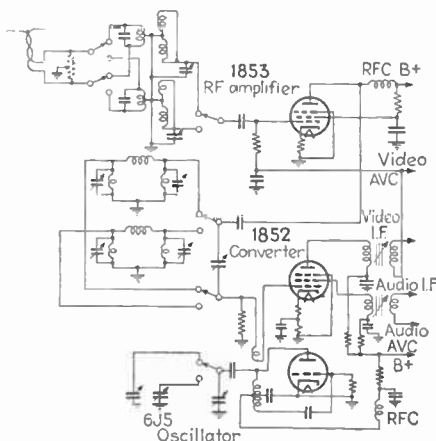

FIG. 177.—Input, r-f, converter and oscillator circuit of a typical television receiver, described by Lyman.

Mc. at the highest oscillator frequency, or roughly 0.05 to 0.1 per cent. Since adjustment of the oscillator to this degree of precision is in itself difficult, it is customary to employ capacitance

tuning (or the equally sensitive inductance tuning, using adjustable iron cores).

Figure 177 shows a typical converter-oscillator section (one channel only), employing complete switching of circuits in the converter input and capacitance tuning in the oscillator. The injection of the oscillator signal is made at the grid of the converter tube, since this arrangement gives the highest sensitivity. The method shown is a combination of capacitance coupling and magnetic coupling, making use of a single-turn coil in close proximity to the plate end of the oscillator coil. Simple capacitance coupling may also be used.

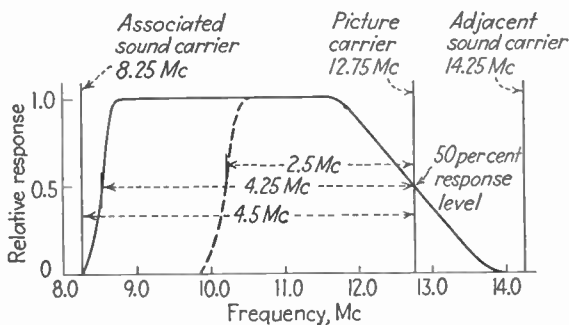

FIG. 178.—Response curve of a television i-f amplifier. The solid line has the maximum width practical within the channel limits, whereas the dotted line shows response limited to 2.5 Mc. to allow greater gain per stage and better signal-to-mask ratio, at the expense of picture detail.

**47. Picture I-f Amplification.**<sup>1</sup>—The picture i-f amplifier stages that follow the frequency converter in a television superheterodyne receiver must perform two functions: amplification of the desired picture signal and rejection of the undesired sound carriers. Two sound carriers must be considered: that accompanying the picture signal in the same channel, and that in the adjacent channel. These requirements are met by amplitude-frequency characteristics having uniform response in the desired picture-signal band and sharp attenuation at the edges of this band. Figure 178 shows the ideal form of the response of a pic-

<sup>1</sup> SEELEY and BARDEN, Video I-f System Considerations, Report LB-417 RCA License Laboratory. Information made available by special permission.

COCKING, W. T., Television I-f Amplifiers, *Wireless Eng.*, **15**, 358 (July, 1938).

ture i-f amplifier for selective sideband reception and intermediate frequencies of 8.25 Mc. (sound) and 12.75 Mc. (picture).

The number of i-f stages required depends, of course, on the desired sensitivity of the receiver. The minimum signal at the input to the receiver is determined by the signal-to-mask ratio. On the basis of the case previously calculated (ratio 20 to 1), the signal in the plate circuit of the r-f stage, required to overcome the mask voltages at that point in the circuit, is roughly 3000 microvolts. If no r-f stage is employed, roughly the same signal (or somewhat larger) is required in the plate circuit of the converter, but the gain is decreased by a factor equal to the gain of the r-f stage. For design purposes, it may be considered that the output of the converter tube will contain a signal of 2500 microvolts or greater, peak. The second detector requires a voltage of roughly 5 volts peak for optimum action. Consequently the i-f gain must be at least 2000 times. For receiving weak signals, the picture i-f amplifier gain must be much higher, say 10,000 times.

The number of stages required to produce this gain is determined, of course, by the gain per stage. Stage gains of 15 are possible, covering a 4-Mc. band width. But it is usual to base the design on stage gains of no more than 10 to obtain the most uniform band-pass response characteristic. On this basis, four stages are required to produce a gain of  $10^4 = 10,000$ . Three stages, at a gain of 17 per stage, will produce the same effect. Present receiver designs are based on three stages for the lower-priced sets and four or five stages for the more expensive receivers.

*Components for Picture I-f Amplification.*—A stage of picture i-f amplification consists essentially of two units, the amplifier tube and the coupling circuit. The requirements for the tube are the same as those for tubes employed in wide-band r-f amplification, *i.e.*, high mutual conductance and low input and output capacitances. The figure of merit is accordingly the same as that

given in Eq. (171): Figure of merit =  $\frac{g_m}{C_{pk} + C_{pk}}$ . Usually the same tubes are employed for picture i-f amplification as for wide-band r-f amplification and for video amplification.

The coupling circuit employed in i-f amplifiers must be very carefully designed if the dual requirements of picture i-f amplification and sound i-f rejection are to be satisfied. If the rejection

problem were not present, comparatively simple coupling arrangements could be employed, such as simple loaded tuned circuits, one in the plate circuit and the other in the grid circuit of the following tube. But the selectivity question cannot be solved by such simple circuits. Rather it has become the usual practice to design i-f coupling circuits in terms of band-pass filter theory, employing as many as 3 tuned circuits in the coupling circuit, one in the plate circuit, one in the grid circuit of the following tube, and a third in the coupling connection between the two others. The last circuit serves not only as a part of the filter design, but also isolates the tube capacitances (in the same manner as in

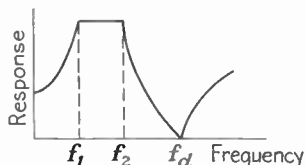
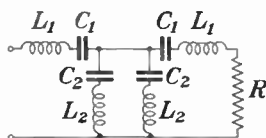

FIG. 179.—Elementary band-pass filter ( $m$ -derived) and idealized response characteristic.

filter coupling of video amplifier stages, see page 226). An elementary statement of band-pass filter design accordingly serves as a convenient point of departure. A simple band-pass filter is shown in Fig. 179. The filter consists of four tuned circuits and a terminating resistor. The  $L$  and  $C$  values of each tuned circuit are determined by the value of the terminating resistor and by the frequency limits of the pass band, as well as by a frequency outside the pass band at which very great attenuation is desired. This latter frequency is ordinarily chosen at the frequency corresponding to one of the undesired audio carriers, either that accompanying the video signal or that in the adjacent channel.

The relationships determined by the  $L$ ,  $C$ , and  $R$  values are based on the lower frequency limit of the pass band  $f_1$ , the upper frequency limit  $f_2$ , and the rejection frequency  $f_d$ . First two ratios are derived from these frequencies

$$m_1 = \sqrt{\frac{1 - (f_2/f_d)^2}{1 - (f_1/f_d)^2}} \quad (225)$$

$$m_2 = m_1 \left( \frac{f_1}{f_2} \right) \quad (226)$$

The inductance  $L_1$  and the capacitance  $C_1$  (the same values in both series tuned circuits) are given by the following:



$$L_1 = \frac{Rm_1}{\pi(f_2 - f_1)} \tag{227}$$

$$C_1 = \frac{(f_2 - f_1)}{2\pi Rf_1f_2m_2} \tag{228}$$

and 
$$L_2 = \frac{(1 - m_1^2)L_1}{4m_1^2} \tag{229}$$

$$C_2 = \frac{4m_2^2C_1}{(1 - m_2^2)} \tag{230}$$

These relationships apply equally well at any frequency and may be useful in designing circuits for r-f amplification as well as for i-f amplification.

The circuits shown in Fig. 179 are assumed to have no coupling, inductive or capacitive, between the filter elements. Another

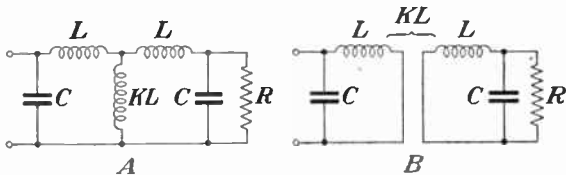

FIG. 180.—Inductively coupled band-pass circuits: A, self-inductance coupling; B, mutual inductance coupling.

type of band-pass filter that has considerable merit in picture i-f circuits is the coupled filter, consisting of two tuned circuits which are coupled beyond critical coupling, and which thereby are caused to display two frequencies of maximum response, as shown in Fig. 181. In some designs, mutual inductance is employed, but mutual inductance is a difficult quantity to control in production, and if uniform amplification over a band width of 4 Mc. is required, it is usually considered more expedient to employ a separate inductor or capacitor as the coupling agent. Two such circuits are shown in Fig. 180. In both cases, the filter is terminated at the far (grid) end by a shunt resistor. Series damping may be employed rather than shunt, but this usually produces a higher amplification at one edge of the pass band than at the other. In the case of inductive coupling, the input and output capacitances  $C$  are assumed equal, the series coupling inductors  $L$  are equal, and the shunt coupling inductor has a value  $KL$ . The lower frequency limit of the pass band is  $f_1$  and the upper limit  $f_2$ . The lowest possible (tube and stray) values of  $C$  are chosen (if

the two capacitances are not equal, a small trimmer capacitance may be added to the smaller one to make them equal). The inductance  $L$  is found in terms of  $C$  as follows:

$$L = \frac{1}{(2\pi f_2)^2 C} \quad (231)$$

The value of  $K$  chosen depends on the band width and on the tolerable deviations from uniform response over the pass band. Usually a value of  $K$  somewhere between 0.2 and 0.6 is chosen. The terminating resistor  $R$  has the value

$$R = PX \quad (232)$$

where  $P$  has a value somewhere between 5 and 20 and  $X$  is the reactance of  $L$  at the frequency  $f_2$ . The stage gain  $G$  at any

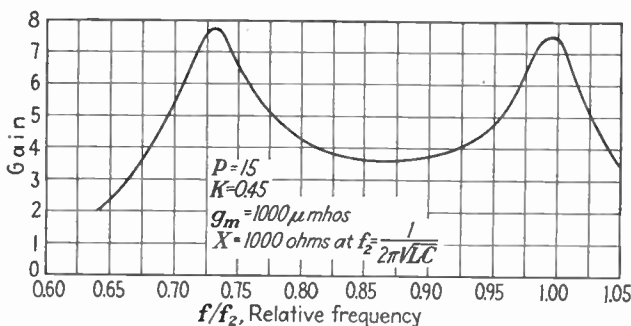

FIG. 181.—Band-pass response curve of circuit shown in Fig. 180A. The gain is directly proportional to the  $g_m$  of the tube and the value of  $X$  (after Seeley and Barden).

frequency  $f$  depends on the frequency  $f_2$  and the values of  $K$ ,  $P$ , and  $X$ :

$$G = \frac{g_m K P X f / f_2}{[(1 + K)(f/f_2) - (1 + 2K)(f/f_2)^3 + \frac{jP[-1 + 2(1 + K)(f/f_2)^2 - (1 + 2K)(f/f_2)^4]}{2}]} \quad (233)$$

A plot of Eq. (233) for  $K = 0.45$  and  $P = 15$  is given in Fig. 181 in terms of the ratio  $f/f_2$ . The range covered by the pass band is from  $0.73f/f_2$  to  $0.99f/f_2$ . Substituting for  $f_2$  the picture i-f carrier frequency of 12.75 Mc., it follows that the pass band is 3.3 Mc., extending from 12.75 to 9.45 Mc. The gain per stage,

averaged over the pass band, is roughly 18 for a tube of  $g_m = 5000$  micromhos and an  $X$  value of 600 ohms.

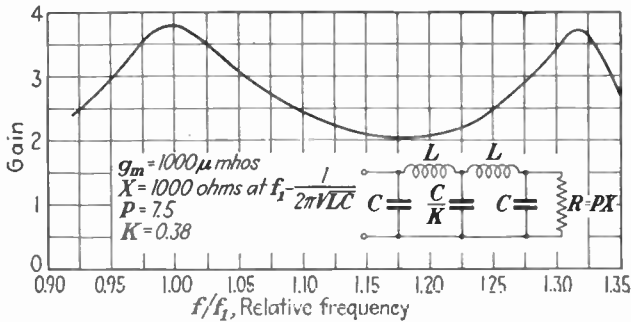

FIG. 182.—Response curve of the capacitively coupled band-pass circuit shown in the inset (after Seeley and Barden).

If the inductance  $KL$  is replaced by a capacitance  $C/K$  (as shown in Fig. 182), the expression for the gain becomes

$$G = \frac{g_m K P X (f_1/f)}{2 \left[ \left( \frac{K f_1}{f} \right) - (1 + 2K) \left( \frac{f}{f_1} \right) + \left( \frac{f}{f_1} \right)^3 \right] + j \left[ P(1 + 2K) + \left( \frac{2K}{P} \right) - \left( 2KP + 2P + \frac{1}{P} \right) \left( \frac{f}{f_1} \right)^2 + P \left( \frac{f}{f_1} \right)^4 \right]} \quad (234)$$

Figure 182 shows the curve for  $G$  vs.  $f/f_1$  for  $P = 7.5$ ,  $K = 0.38$ .

If a combination of capacitive and tuned-circuit coupling, shown in Fig. 183, is used, it is possible to employ the inductance and capacitance of the coupling to reject the audio carrier. The inductance  $L_1$  and capacitance  $C_o$  are chosen so that their resonant frequency is equal to the sound intermediate frequency to be rejected. Series resonance then exists across the shunt (coupling) connection, and there is no coupling of the audio carrier except that due to the resistive component of the coil  $L_1$ . To ensure optimum rejection, the ratio of reactance to resistance ( $Q$  value) in this coil should accordingly be kept as high as possible. The capacitance  $NC_o$  in shunt across the inductance  $L_1$  is usually chosen about ten times as

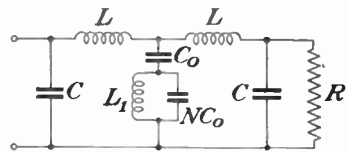

Fig. 183.—Band-pass circuit with series trap ( $L_1 C_o$ ) which may be tuned to eliminate response at the sound carrier frequency.

great as  $C_o$ , so the resonant frequency is about one-third that of the rejected audio carrier. At frequencies higher than the rejected audio carrier, the net reactance across the coupling branch is capacitive.

*Compensation of the Mid-band Response.*—All the coupled circuits just described display considerably less amplification in the middle of the pass band than at the edges. It is possible to compensate for this loss by employing one or more stages coupled with single tuned circuits, loaded with shunt resistance. This type of coupling has already been discussed (page 289). The frequency resonant to the  $L$  and  $C$  values (Fig. 166) is chosen in

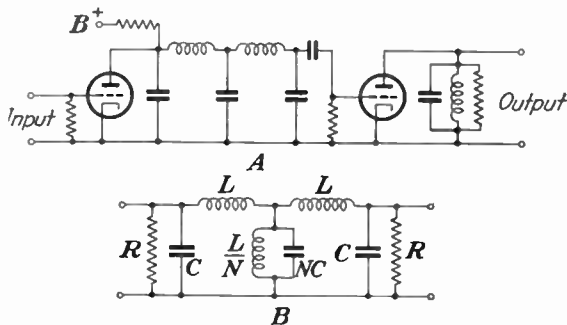

FIG. 184.—Top, capacitively coupled band-pass circuit and simple loaded circuit in cascade for compensating mid-band response. Bottom, combination circuit for developing similar compensation.

the middle of desired pass band. The value of the shunt resistor is  $R = PX$  where  $X$  is the reactance of  $L$  at resonance. In our previous discussions,  $P$  has been given the value  $f_r/2\Delta f$ , producing a response of 71 per cent of the resonant response, at the limiting frequencies  $f_r + \Delta f$  and  $f_r - \Delta f$ . Other values of  $P$  may be desirable for compensatory purposes. The stage gain  $G$  for any values of  $P$  and  $X$  is given by

$$G = \frac{g_m P X f / f_r}{(f/f_r) + jP[-1 + (f/f_r)^2]} \quad (235)$$

By placing the resonant frequency  $f_r$  at or near the middle of the range from  $f_1$  to  $f_2$ , it is possible to obtain very nearly uniform response over the entire range from  $f_1$  to  $f_2$ , as shown in the typical response curve of two stages, one compensating the other, in Fig. 185.

*Phase Response of Picture I-f Amplifiers.*—The expressions for stage gain given above have denominators expressed in complex form. The phase relationship implied is an angle the tangent of which is the quadrature ( $j$ ) term of the denominator divided by the real term of the denominator. In all but the simplest cases, the phase angles thus expressed are very complicated functions of the frequency and of the  $P$  and  $K$  values employed. Usually the phase delay, expressed as an angle, increases more or less regularly as the frequency departs from the carrier value, but the increase is not exactly proportional to frequency. The deviation from linear response, expressed in degrees, is usually greatest

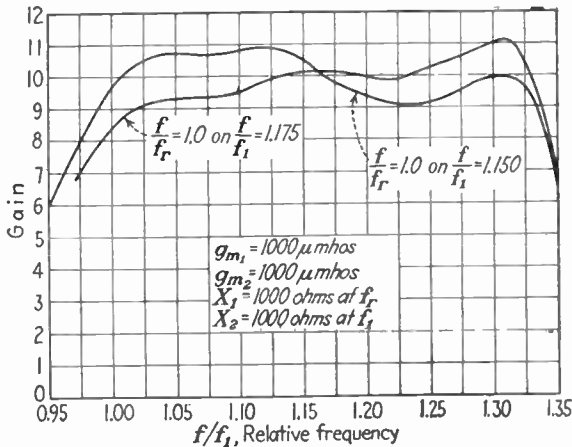

FIG. 185.—Examples of mid-band compensation obtained from the curves in Figs. 182 and 166.

at the frequencies farthest from the picture i-f carrier, that is, at the highest modulating signals. These deviations represent correspondingly small delays, measured in time, and the over-all time-delay characteristic, although not horizontal, usually does not deviate from the average by more than a few tenths of a microsecond.

Calculation of phase response of picture i-f amplifiers is laborious, but its measurement may be made comparatively simple. The diagram shown in Fig. 186 illustrates the method. At the input to the i-f amplifier, a converter (mixer) tube is employed to mix a source of modulating voltage covering, say, 30 to 4,000,000 c.p.s. and a source of carrier voltage of the video i-f carrier fre-

quency (12.75 Mc.). The output of the amplifier is demodulated in a detector tube to restore the modulating frequencies. The comparison between the phase of the input modulating frequency and the output demodulated frequency is then made by applying the voltages through amplifiers to the plates of a cathode-ray

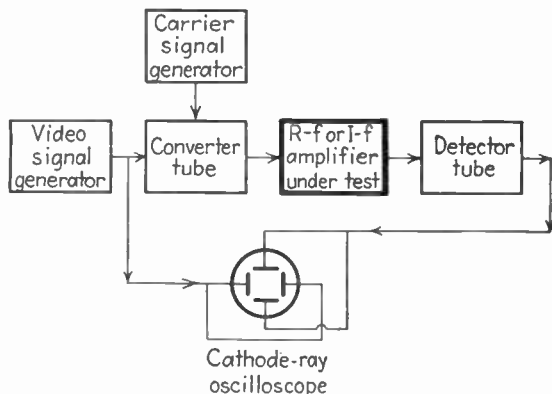

FIG. 186.—Method of investigating phase response of r-f or i-f amplifiers.

oscilloscope in essentially the same manner as is used in measuring the phase response of a video amplifier (see page 255).

If the picture i-f amplifier contains many stages, the phase angle introduced especially at the higher modulating frequencies will be many hundreds of degrees. For each time an increment

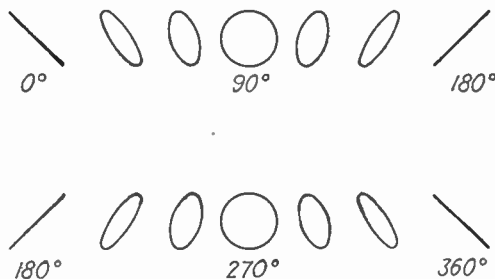

FIG. 187.—Lissajous figures formed on cathode-ray oscilloscope screen for various phase displacements between voltages of equal amplitude and frequency.

in phase angle of  $90^\circ$  is introduced by the amplifier, the pattern on the cathode-ray tube will change from a circular to a straight line, or vice versa. The appearance of the cathode-ray patterns at different phase shifts, from 0 to  $180^\circ$ , equal amplitudes of voltage at input and output being assumed, is shown in Fig. 187.

As the modulating frequency is increased from less than 100 cycles, the number of changes from circle to line (or vice versa) is counted and  $90^\circ$  phase shift recorded for each change. Between 1000 and 100,000 c.p.s., the phase shift will be very small. As the frequency is increased, at some point, usually around 5000 c.p.s., the first straight-line pattern will be observed. This point represents zero phase shift and establishes the base of the phase scale. At frequencies below this level, the phase shift is negative (this does not mean a negative time delay, however). A typical phase characteristic of a video i-f amplifier is shown in Fig. 188.

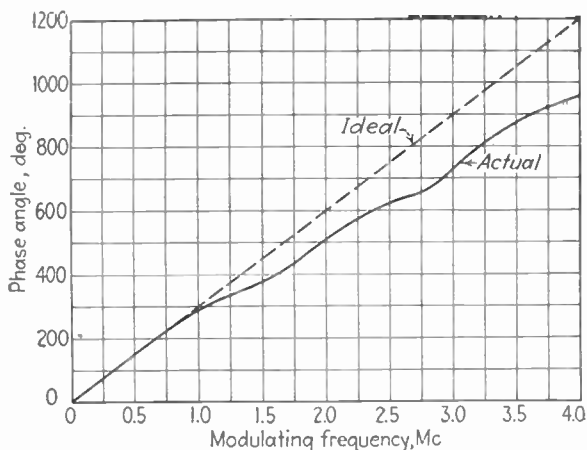

FIG. 188.—Typical phase response curve of an i-f amplifier. Note that the angle is measured in hundreds of degrees, representing the cumulative effects of several stages.

The same phase-measuring technique may be employed in the entire receiver from antenna to detector output simply by utilizing a carrier generator of frequency equal to the u-h-f picture carrier frequency and proceeding in the manner just outlined.

**48. Demodulation of Picture Carrier Signals.**—The demodulator (second detector) in a television receiver serves to convert the carrier (either r-f or i-f depending on whether r-f or superheterodyne reception is considered) and its sideband components to the video frequency range. The output of the detector tube is, in other words, intended to be substantially the same as the input to the modulator of the transmitter. The detector output contains the picture-signal components as well as the sync-signal

components. Also (unless balanced push-pull detection is used) the detector output contains components of the carrier and side-band frequencies that are undesired and must be eliminated before the signal is passed on to the video amplifier. The detector thus serves the purpose of developing the video signal and passing it on to the video amplifier with a minimum of amplitude and phase discrimination, and at the same time, it must serve to hinder the passage of the carrier frequencies.

*Detector Coupling Circuits.*<sup>1</sup>—To perform these functions, it is usual to employ a coupling circuit between detector and video amplifier which has a very much lower impedance (and consequently lower developed signal) at carrier frequencies than at video frequencies. One of the simplest circuits for the purpose is the compensated circuit similar to that used in the plate circuit

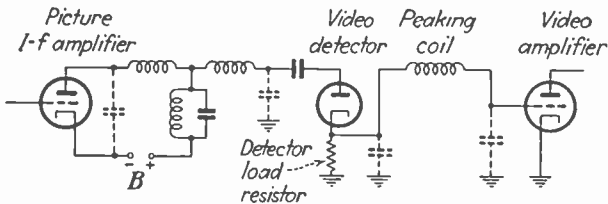

FIG. 189.—Typical video detector circuit.

of a compensated video amplifier. When used for a detector load circuit, the design of the  $R$ ,  $L$ , and  $C$  values is the same as in the case of the video amplifier and is carried out in terms of the Eqs. (142) and (143), page 222. In consequence, the lower the value of the wiring capacitance and the capacitances of the tube, the higher the value of  $R$  and the higher the developed voltage available for a given video-band width.

Since the detector load circuit must display very low impedance to the carrier frequencies, it is of interest to determine the impedance of the compensated circuit at carrier frequencies. In the superheterodyne receiver, the carrier frequency is 12.75 Mc., and the band width is 4 Mc. The ratio of highest modulating frequency (4 Mc.) to carrier frequency is then roughly 1 to 3, and the impedance ratio (depending primarily on the capacitive reactance of the circuit) at the two frequencies is in approximately the inverse ratio. This may not be sufficient

<sup>1</sup> BARDEN, W. S., A Discussion on Video Modulation Detection, presented before Annual Convention, I.R.E., New York, June 18, 1938.



discrimination, and for i-f detection it is necessary to employ more involved coupling circuits, having more pronounced band-pass characteristics. When r-f amplification only is used, the ratio of highest modulating frequency to carrier frequency is 1 to 10 or lower and the discrimination of the simple tuned circuit is usually sufficient.

In detectors that follow i-f amplifiers, it is usual to employ a filter circuit to couple the detector output to the video amplifier. Such a circuit is shown in Fig. 190. This is a typical low-pass filter section designed for a cutoff frequency  $f_c$  that is approxi-

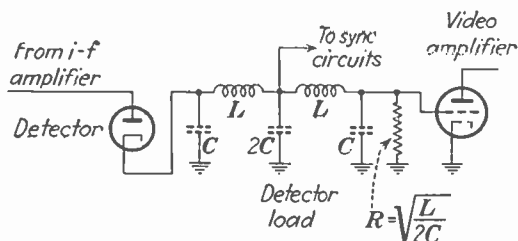

FIG. 190.—Filter coupling in video detector load circuit, useful for obtained two sources of video signal.

mately twice the highest video frequency. The cutoff frequency is

$$f_c = \frac{1}{\pi\sqrt{2LC}} \quad (236)$$

The surge impedance  $R$  of the filter section is

$$R = \sqrt{\frac{L}{2C}} \quad (237)$$

The filter is terminated in this resistance. The capacitance  $C$ , as usual, is chosen as small as possible and the inductance  $L$  chosen to cut off at twice the value of the highest modulating frequency. Since the carrier frequency is three times as great as the highest modulating frequency, the carrier falls well outside the pass band of the filter and is highly attenuated.

One striking aspect of the filter connection shown in Fig. 190 is the fact that the midshunt capacitance is twice as great as the terminating capacitances. Stated differently, the filter may be loaded with twice the capacitance at its center as it can at the ends, and this makes the center of the filter a particularly advan-

tageous point for deriving the output voltage. In typical receivers, the detector output is used for three functions: for feeding the video amplifier, to supply signal to the sync-separator circuits, and to control the automatic gain control. Assuming equal input capacitances to each of these three circuits, it is possible to connect one circuit to the output of the filter and the remaining two circuits to the center. In a receiver employing separate automatic gain control, the picture- and sync-signal circuits are commonly connected to the center of the filter, and the far end of the filter is simply terminated in the resistance  $R$ . If more than three circuits must be connected, then it is quite feasible to employ a recurrent filter having three or more sections.

*Video Detection.*—The action of video detectors is considerably more complicated than that of audio detectors (which itself is an abstruse subject if pursued rigorously). The video detector covers a very large range of modulating frequencies relative to the carrier. The sideband components are disposed asymmetrically about the carrier, since the input signal is selective-sideband in character, and since the pass band of the i-f amplifiers is disposed to cover only one of the sidebands. If the selective sideband is present in any other form but the ideal one shown in Fig. 178, the low modulating frequencies nearest the carrier may display a double sideband character, whereas the higher frequencies far from the carrier are of single-sideband form. The requirements for distortionless detection of these types are not the same. Fortunately, however, the distortion introduced by the detector does not have so adverse an effect on the reproduction as it does in the case of sound reception. Ordinarily the detector distortion serves simply to emphasize the amplitude of the high-amplitude regions of the signal.

Two forms of detector are of interest, plate-circuit detection and diode detection. The remaining type used in receivers, grid-leak detection, can be conveniently treated as a combination of diode detection and video amplification, the grid and cathode serving as the diode elements, and the grid-cathode and plate serving to amplify the demodulated voltage developed across the grid leak.

Diode detection, most widely used at present for picture-modulated signals, is treated in much the same manner as for

audio-modulated signals, with the exception that the diode load circuit must necessarily display a much lower impedance than would be used for audio detection. As a result, the detected voltage is low, and the amount of distortion introduced, even for high-level signals, is higher than usual in audio "linear" detectors. Fortunately, as previously noted, this type of distortion does not produce objectionable visual effects in the reproduced image.

The two major design aspects of the video detector are the loading of detector circuit on the r-f or i-f circuit that precedes the detector and the amplitude discrimination displayed by the circuit with respect to the demodulated output frequencies. The phase discrimination is also of interest, but is limited to 90°

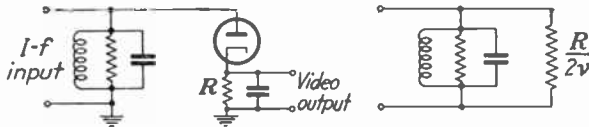

FIG. 191.—Actual and equivalent circuits of the video detector, from i-f input to video output.

in any event, and hence is small when compared with the phase delay of the r-f, i-f, and video amplifiers.

The loading of the detector circuit is given in terms of the detector efficiency  $\nu$  and the actual resistance  $R$  present in the load circuit of the diode, illustrated in Fig. 191. As in the case of audio detection, the effective input resistance  $R_e$  displayed by the diode and load is

$$R_e = \frac{R}{2\nu} \tag{238}$$

This value of loading resistance is used in determining the band-pass characteristics of the circuit preceding the detector. The detected voltage depends on the ratio of the load resistance  $R$  to the diode plate resistance  $r_p$ . Since  $R$  is limited by the design of the load circuit to 2500 to 5000 ohms and since the plate resistance of the diode is usually 3000 ohms or higher, the ratio  $R/r_p$  is usually no greater than 2 to 1, in contrast to values of 20 to 1 to 100 to 1 in audio practice.

The amplitude-vs.-frequency discrimination of the detector circuit is expressed in terms of the ratio  $Z/R$  where  $Z$  is the

magnitude of the impedance of the load circuit to the video frequency considered and  $R$  is the resistance of the load circuit to direct current.

If the load circuit is a compensated circuit, such as shown in Fig. 190, the impedance of the load circuit remains essentially constant up to the frequency at which the shunt capacitive reactance equals the resistance value. The shunt capacitance must include the capacitance to ground of the diode, and account should also be taken of the fact that the diode plate resistance is shunted by the cathode-to-plate resistance of the diode. If the values  $R$  and  $Z$  are calculated, they may be applied in an expression that gives the effective degree of modulation  $m_e$  in terms of the actual degree of modulation  $m$ , as follows:

$$m_e = m \frac{Z \left( Z_{ic} + \frac{R}{2\nu} \right)}{R \left( Z_{is} + \frac{Z}{2\nu} \right)} \quad (239)$$

where  $Z_{ic}$  is the impedance of the input circuit at carrier frequency and  $Z_{is}$  is the same impedance to the sideband frequency corresponding to the video frequency for which  $Z$  is computed. The tendency of the circuit is to produce lower effective modulation at the higher modulating frequencies. For selective sideband detection, however, the input carrier does not correspond with the resonant frequency of the input circuit, and the result is that the middle-range frequencies are apt to be emphasized relative to the low- and high-modulating frequencies. Slight overcompensation at the extremes of the range, introduced in the video amplifier, may be employed to correct this tendency.

Grid-leak detection for video demodulation follows the basic considerations for diodes. The grid-leak circuit, which acts as the load impedance for the grid-cathode diode elements, may be compensated by series inductance. The demodulated voltage across the grid-leak circuit is amplified by direct coupling in the three elements of the tube. The main difference between grid-leak detection and a diode followed by a separate amplifier is the direct-coupling connection in the grid-leak detector. In consequence of this connection, the amplifier amplifies the d-c as well as the a-c components of the detected signal and is there-

fore somewhat more subject to overload if the input is of high level. However, where sensitivity is needed, and where the d-c component must be amplified for automatic background control, the grid-leak detector is a useful device.

Plate-circuit detection has not been widely used for video demodulation, because it offers no advantage over the diode system except sensitivity, a quantity usually best obtained in video practice by amplifiers especially designed for the purpose, rather than in dual-function circuits. The diode has the advantage of operating over a wide range of input voltage and of providing a d-c output current of the proper polarity for automatic-circuit functions.

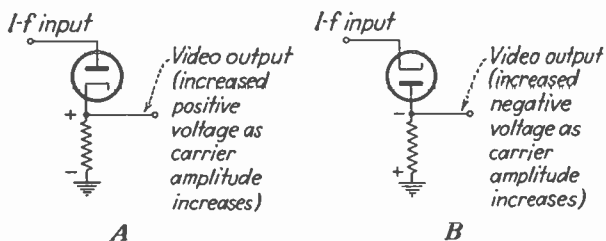

FIG. 192.—Video detector polarities: A, the cathode-above-ground connection which produces a positively poled output (output signal more positive as carrier amplitude increases). The anode is returned to ground through the i-f circuit; B, the anode above ground (cathode grounded through i-f) which produces a negatively poled output.

*Influence of Detector Polarity on Succeeding Circuits.*—When a diode tube is used for detection, two polarities are possible: with the cathode above ground or with the plate above ground (at the upper end of the load resistor) as shown in Fig. 192. The anode-above-ground connection is preferable, since the output capacitance to ground is lower in this connection. With the anode above ground, and with negative transmission, the detector-output voltage becomes more negative as the brightness of the scene decreases. This is the proper phase relation for reproducing the picture, when the signal is applied to the control grid of the picture-reproducing tube. It follows that an even number of video amplifier stages must be interposed between the detector output and the cathode-ray tube, since an even number of stages does not reverse the phase of the signal. Usually two stages are employed in this case.

On the other hand, if the cathode of the diode is connected to the upper end of the load resistor, the detector-output voltage becomes more positive as the brightness of the scene decreases. The phase is thus reversed, and an odd number of stages must be employed in the video amplifier. Usually but one stage is used in this case. Since only one video stage is necessary to develop the necessary signal voltage, economy is best served by the cathode-above-ground connection, despite the higher output capacitance associated with this connection.

*Synchronizing and Automatic-circuit Functions.*—Strictly speaking, the carrier communication of the video signal ends with the second detector, hence discussion of the functions subsequent to

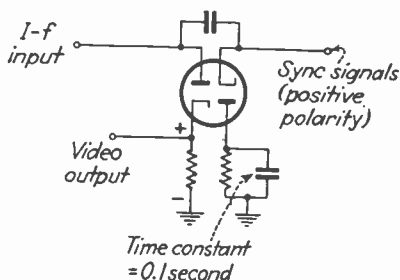

FIG. 193.—Double-diode circuit for video detection and amplitude separation of sync signals. The  $RC$  circuit in the right-hand section develops the cutoff bias.

detection are treated in other chapters. However, it should be pointed out here that the detector polarity has an influence not only on the stages used for video amplification, but also for vertical and horizontal synchronization of the scanning generators, and for the automatic control of the background level and contrast of the picture. In the commonly used cathode-above-ground diode detector, the sync-signal amplitude becomes more positive as the carrier level goes farther into the sync-signal (infra-black amplitude) region. In consequence, the polarity of the sync signals is positive against ground. The scanning generators are synchronized, at least in the multivibrator or blocking oscillator types, by positive signals. In consequence, an even number of stages are required between the detector output and the scanning generator sync terminals. Usually two stages are employed.

For automatic contrast control, the gain of the receiver is varied in terms of the peak output of the detector, that is, in terms of the tips of the sync signals. As the signal loses strength, for any cause, the peak level becomes less positive. Consequently, the d-c output of the detector tube must be applied in reverse polarity to control the bias voltages applied to the r-f and i-f amplifier stages, to increase the gain and thus compensate for the loss in signal strength.

## CHAPTER VIII

### IMAGE REPRODUCTION

#### Picture Tubes and Auxiliary Circuits

The foregoing chapters have been concerned with the generation and transmission of the video signal. These processes are intended ultimately for one purpose, to control the image-reproducing device that presents the image to the eye of the observer. In the present chapter, we present the fundamentals of the electrophotographic process of converting the picture signal into variations in light.

The image-reproduction process implies the use of a device that performs four processes: (1) the formation of a spot of light corresponding to the basic picture elements; (2) the displacement of this spot along a series of lines, forming the scanning pattern, (3) the synchronization of the scanning motion with that which occurs at the transmitter, and (4) the modulation of the light spot so that its brightness at any point in the scanning pattern corresponds to the brightness of the corresponding point of the scanned image in the television camera tube. Essentially the image reproducer is a television camera working in reverse, but the problems associated with it are not simply the reverse of those in the camera tube. So far as the scanning and synchronization motions are concerned, the camera and the image reproducer are very similar. But here the resemblance ends. The performance of the reproducer follows laws dependent on the light-producing medium employed and on the characteristics of the eye that views the image. These laws are in many respects different from the laws affecting the photosensitive plate in the camera.

**49. General Theory of Brightness Transfer in Image Reproduction.**—Before discussing the technical means employed in reproducing television images, it is advisable to examine some of the basic ideas involved in the reproduction of visual intelligence and define some of the terms, such as “contrast” and



“gamma,” which are frequently used in discussing television reproduction.<sup>1</sup>

The transmission of any pictorial image involves three steps: perception, transfer, and reproduction. The perceiving device, the camera, must transfer variations in light intensity and in color into some other quantity capable of storage or of transmission, depending on whether the pictorial system is intended to preserve the picture (as in photography) or to transmit it to some distant place (as in television). The transfer device must carry the stored or transmitted quantity to the reproduction device, where the image is converted from its intermediate form to the form of light variations (with or without color variations) which affect the eye of the observer. The entire process is linked on the one hand to the intensity and color of the light on the subject, and on the other to the light and color (if color is reproduced) of the reproduced image. The effectiveness of the pictorial system may be gauged in terms of a relationship between these two sets of quantities.

The foregoing paragraph applies generally to any picture-reproducing system. To be more explicit, we may define an over-all “transfer characteristic” which describes, at least in part, the effectiveness of a television system. For convenience, we restrict our attention to a subject of the monochrome type, that is, possessing variations in light of but one color or white light. Such a subject would be presented by a frame of black-and-white motion-picture film or by a studio presentation in which no appreciable color contrasts are present. The visual content of the subject is then represented by changes in light intensity only, that is, by variations in *object brightness*. When these variations in object brightness are impressed on the photosensitive plate of the television camera, they produce corresponding changes in the photoelectric current issuing from the camera. This photoelectric current, passing through the load resistor in the camera circuit, produces variations in the output voltage of the camera. So far as the camera is concerned, the significant transfer is from variations in *object brightness* to variations in *output voltage*. The relationship between these two quantities,

<sup>1</sup> For a more extended treatment of the effect of transmission characteristics on realism of reproduction, see: Maloff, I. G., Gamma and Range in Television, *RCA Rev.*, 3 (4), 409 (April, 1939).

the camera transfer characteristic, may be measured experimentally and plotted as a curve. Convenient units for the object brightness are millilumens per square centimeter and for the output voltage, millivolts. A typical example of such a transfer characteristic is shown in Fig. 194 (see also Fig. 53, page 101). This particular curve applies, of course, only to one particular color composition in the subject. Similar curves for any given color combination may be prepared for the technique of multiplying and averaging spectral response curves as outlined on page 80.

The output voltage of the camera is applied to a video amplifier. The variations in voltage applied to the amplifier input

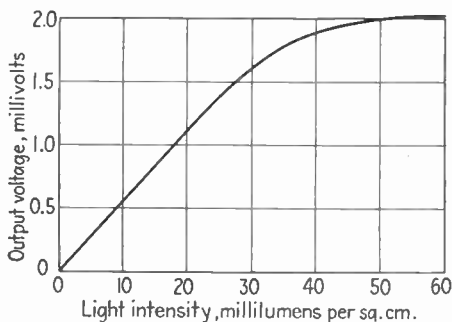

FIG. 194.—Typical transfer characteristic, relating the light input and the voltage output of an iconoscope camera tube.

become amplified variations in voltage appearing across the output impedance of the amplifier. The transfer characteristic of the amplifier is accordingly a simple input-voltage vs. output-voltage curve, which may be plotted from measurements made on the amplifier in question. For each succeeding amplifier in the transmission chain, a similar transfer characteristic relating the input and output voltages may be specified. In each amplifier-transfer characteristic, the origin is taken at the point that represents the black level.

When the amplified video signal is imposed on the modulated amplifier, another type of transfer characteristic occurs. Here the input is a video voltage, and the output is the amplitude of the carrier envelope, measured against the black reference level. In the r-f amplifiers that follow the modulator (in the transmitter and the receiver), the transfer characteristic is that portion of

the voltage-amplification curve (output volts vs. input volts) over which the carrier amplitude varies, with the black level as origin. In the demodulator at the receiver, the transfer characteristic is the curve relating carrier amplitude to video voltage, both taken over the ranges of these quantities that correspond to the picture signal. The video amplifiers that follow the detector have the same transfer characteristics as the video amplifiers that follow the camera, namely, a curve relating input volts to output volts, measured from an origin at the black level.

Finally, the transfer characteristic of the image-reproduction tube is the curve relating the control voltage (*i.e.* the control-grid voltage applied to the electron gun) to the brightness of the reproduced picture element. This final brightness, the *image brightness*, is the quantity corresponding to the object brightness which constitutes the input to the television camera.

The important relationship, so far as the system as a whole is concerned, is the *over-all brightness-transfer characteristic*, that is, the *curve relating object brightness to image brightness*. This over-all relationship is descriptive of the ability of the television system to reproduce changes in brightness.

The characteristic is, of course, not a complete criterion of the system performance, for it is necessary not only to reproduce changes in brightness, but also to reproduce changes in position of the subject, as well as to reproduce changes in position and brightness with great rapidity without impairing the fine structure of the image. But the over-all brightness-transfer characteristic, as defined above, does have the virtue of specifying more or less completely the nondynamic performance of the system. If the amplitude and phase responses vs. frequency are adequate and if the synchronizing and scanning functions are adequate, the only information then required to characterize the system is the brightness-transfer characteristic. Since the frequency responses and scanning techniques have been covered in the preceding chapters, it remains to determine how the brightness characteristic is influenced by the equipment in the system and how changes in the brightness characteristic affect the sensation in the mind of the observer.

We return to the transfer characteristics of the camera, video amplifier, modulator, r-f amplifier, demodulator, and image-

reproducing tube, as defined in preceding paragraphs and as illustrated in Fig. 195. We may connect the object brightness  $B_o$  to the image brightness  $B_i$  in terms of the subsidiary transfer characteristics, as follows: Using the symbol  $\alpha$  to denote "varies with," we write

$$B_o \propto E_{co} = E_{ai} \propto E_{ao} = E_{mi} \propto E_{mo} = E_{ri} \propto E_{ro} = E_{di} \propto E_{do} = E_{ai} \propto E_{ao} = E_{ti} \propto B_i \quad (240)$$

where (as indicated in Fig. 195) the subscripts  $i$  and  $o$  refer to input and output (except in  $B_i$  and  $B_o$ ),  $c$  to camera,  $a$  to video amplifier,  $m$  to modulator,  $r$  to r-f amplifier,  $d$  to demodulator, and  $t$  to image-reproducing tube.

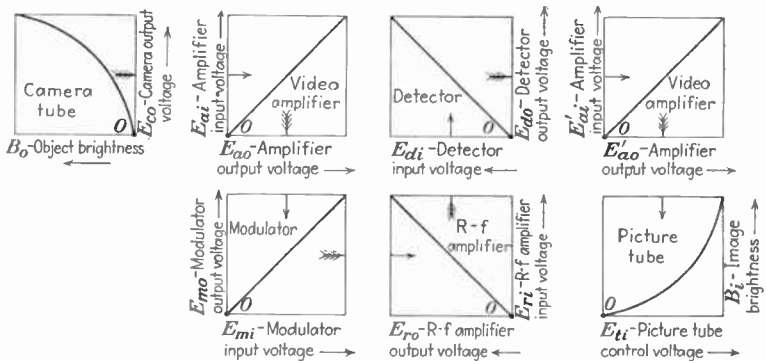

FIG. 195.—Transfer characteristics of the television system, so arranged that the output of one device coincides with the input of the following device. By following the arrows, the brightness of the object may be traced through the subsidiary signal voltages to the brightness of the received image. The relationship between these two brightnesses, the over-all brightness-transfer characteristic, is determined by the curvature of the subsidiary characteristics.

The relationship in Eq. (240) traces the causal connection between object brightness  $B_o$  and image brightness  $B_i$  in terms of the general connective  $\alpha$ . The relationships expressed by  $\propto$  are the transfer characteristic curves themselves. Consequently if we combine the curves shown in Fig. 195, point by point, employing voltage scales in volts throughout, the combined curve relates object brightness in millilumens per square centimeter to image brightness in millilumens per square centimeter. This curve is, by definition, the over-all characteristic. The general theorem is: The over-all transfer characteristic curve is found by a point-by-point combination of all the subsidiary transfer characteristic curves in the system.

The combination of the transfer curves is a tedious process, but no simpler method is available so long as the curves themselves are not expressible in simple analytical form. Actually the shapes of the transfer curves depend upon such a multitude of factors that the only general method of predicting the brightness transfer in terms of the equipment in the transmission system is measurement of the curves and the combination of the curves. (In a self-contained system, of course, it is possible to measure the over-all brightness transfer directly with a photometer, placed first in the studio and then in front of the reproduced image, but this measurement is of little consequence so far as a

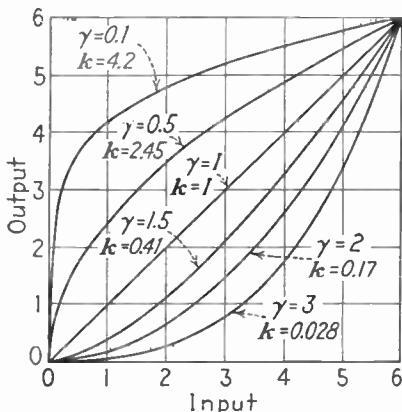

FIG. 196.—Various logarithmic transfer characteristics plotted for various values of gamma, with the proportionality constants chosen to give a total range of 0 to 6 in output and input (cf. Figs. 114 and 115, pages 204 and 205).

knowledge of the faults or virtues of the parts of the system is concerned.)

Although the transfer characteristics are in general not simple analytical functions, it is possible to approximate many of the curves actually met in practice by logarithmic curves of the form

$$\text{Output} = K(\text{Input})^\gamma \quad (241)$$

where the exponent  $\gamma$  is the so-called gamma of the transfer (by analogy to a similar exponent used in photography and designated by this symbol) and  $K$  is a proportionality factor. The form of the curve indicated by Eq. (241) may have a wide variety of shapes, depending on the value of  $\gamma$ , as shown in Fig. 196.

In order to proceed from curve to curve logically, a common origin must be established. Each transfer characteristic is plotted so that the origin corresponds to the maximum (or minimum) values of input and output over which the transfer device actually operates. Since the output of one transfer device corresponds with the input of the succeeding transfer device, it follows that the same origin (namely, that corresponding to the maximum or minimum point of the operating curves) is carried throughout the succession of transfer operations. When the origin in each curve is so placed, it is then necessary to determine values of  $\gamma$  and  $K$  that most nearly fit the empirical curves. When these values of  $\gamma$  and  $K$  have been found, it is possible to write the general relationship in (240) as a series of explicit equations each of which is related to the preceding and following equation, as follows [the symbols and subscripts are the same as in (240) and in Fig. 195]:

$$E_{co} = K_c(B_o)^{\gamma_c} = E_{ai} \text{ (camera output)} \quad (242)$$

$$E_{ao} = K_a(E_{ai})^{\gamma_a} = E_{mi} \text{ (video amplifier output)} \quad (243)$$

$$E_{mo} = K_m(E_{mi})^{\gamma_m} = E_{ri} \text{ (modulator output)} \quad (244)$$

$$E_{ro} = K_r(E_{ri})^{\gamma_r} = E_{di} \text{ (r-f amplifier output)} \quad (245)$$

$$E_{do} = K_d(E_{di})^{\gamma_d} = E_{ai}' \text{ (demodulator output)} \quad (246)$$

$$E_{ao} = K_a'(E_{ai}')^{\gamma_a'} = E_{ti} \text{ (receiver video amplifier output)} \quad (247)$$

$$B_i = K_t(E_{ti})^{\gamma_t} \text{ (image-reproducer output)} \quad (248)$$

If we work upward in this series of equations, substituting from one equation to the next lower equation, we obtain

$$\begin{aligned} B_i &= K_t K_a'^{\gamma_t} K_d^{\gamma_d} \gamma_a'^{\gamma_t} K_r^{\gamma_r} \gamma_d^{\gamma_a' \gamma_t} K_m^{\gamma_m} \gamma_r \gamma_d^{\gamma_a' \gamma_t} K_a^{\gamma_a} \gamma_m \gamma_r \gamma_d^{\gamma_a' \gamma_t} K_c^{\gamma_c} \gamma_a \gamma_m \gamma_r \gamma_d^{\gamma_a' \gamma_t} \\ &= K_o (B_o)^{\gamma_o} \end{aligned} \quad (249)$$

where  $K_o$  is the over-all proportionality factor and  $\gamma_o$  is the over-all gamma of the system. A plot of Eq. (249) is the over-all brightness-transfer characteristic of the system since it relates the image brightness directly to the object brightness.

Equation (249) shows that the over-all proportionality factor  $K_o$  (which sets the scale of the screen brightness relative to that of the studio brightness) is a complicated function of the proportionality factors and the gamma values associated with the subsidiary equipment in the system. This factor serves only to set the scale of the curves. The over-all gamma  $\gamma_o$  on the

other hand is a relatively simple function of the subsidiary gammas, namely, the product of them all. This gamma value  $\gamma_o$  is of great interest for it determines the *shape* of the over-all transfer characteristic. Furthermore, the fact that the over-all gamma is equal to the product of the subsidiary gammas indicates that changes in the shape of the over-all curve may be brought about very simply by changes in the gammas of the subsidiary curves.

*Desirable Values of Over-all Gamma.*—We may now consider the desirable values of the over-all gamma (and of the corresponding shape of the over-all transfer curve). It might appear without further investigation that a linear relationship between object brightness and image brightness would be desirable, since this type of curve would ensure proportional changes in brightness in subject and image. A straight line is obtained from Eq. (249) when  $\gamma_o = 1$ , and this condition is accordingly referred to as the “gamma-unity” case. If the transfer of brightness were the sole criterion of the system, gamma unity would undoubtedly be the desirable condition. But in a television system, brightness is merely a means to an end. The final end of the system is the *sensation* produced in the mind of the observer. This sensation depends on the brightness but is not directly proportional to it. It is obvious, therefore, that before deciding on a desirable value of gamma, it is necessary to relate the brightness of the reproduced image to the sensation produced in the observer’s mind.

This relationship has received the attention of the students of physiological optics for many years. It is a difficult subject of study, since visual sensation is not a directly measurable quantity, but depends on the interpretation of the observer and is influenced by his physiological state, especially by the degree of fatigue of the sense of sight and by the environment under which the measurements are made. One of the first statements of the relationship was made by Weber, and later extended by Fechner. The Weber-Fechner law states that the sensation produced in the mind of the observer varies logarithmically with the brightness of the object viewed. It is now well established that this law is an approximation only and that it holds with accuracy under a certain range of brightnesses, under specified conditions of measurement. Observers are not agreed on the form that the

law should take, but it appears that it is not expressible in simple analytic form.

Nevertheless, conclusions regarding the desirable relation between the brightness in a reproduction and the corresponding brightnesses of the object are usually based on the logarithmic law, and it is customary in most photographic work, and in television, to refer to the logarithm of brightness as the basic psychological quantity.

Assuming, therefore, that the Weber-Fechner law holds with sufficient accuracy for the purpose, we can relate our previous discussion of subject brightness and image brightness to the corresponding sensations. Object sensation (the sensation

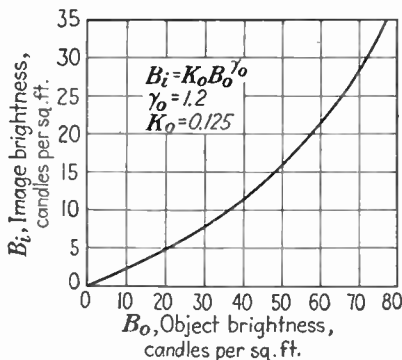

FIG. 197.—Empirical over-all brightness-transfer characteristic. The values of gamma and the proportionality constant are obtained by plotting the curve in logarithmic coordinates (Fig. 198).

produced in the mind of an observer in the studio) is taken as proportional to the logarithm of the object brightness, and image sensation (the sensation produced in the mind of an observer viewing the reproduced image) as proportional to the logarithm of the image brightness. We may then replot the general transfer characteristics of Fig. 114 in terms of log brightness, with the result shown in Fig. 115. The curves so plotted become straight lines, regardless of the value of gamma, and the slope of the lines varies in direct proportion to the gamma value.

The desirable relationship between object and image in a pictorial reproduction system is that the image sensation shall be directly proportional to the object sensation. Figure 115 shows that this requirement is fulfilled regardless of the value of



the over-all gamma, so long as the over-all transfer characteristic (Fig. 114) is a curve of logarithmic form. Theoretically any value of gamma may be used without violating the rule, but practically speaking, values in the neighborhood of unity (between 0.5 and 2.0) are obtained in practice.

The value of gamma has an important bearing on the apparent contrast of the reproduced image. If high values of gamma are used, the slope of the curve between object sensation and image sensation is steep. That is, a comparatively small change in the sensation received by an observer in the studio corresponds to a comparatively large change in the sensation received by the observer of the reproduced image. Consequently if the effect of high contrast is required, it may be obtained by the use of a

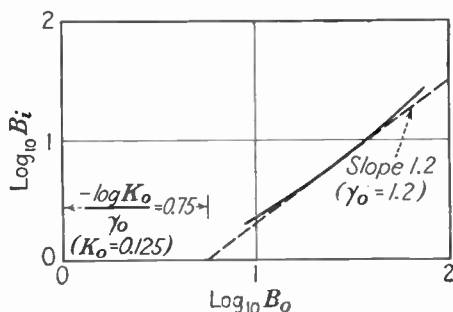

FIG. 198.—Transfer characteristic of Fig. 197 plotted in logarithmic coordinates. The gamma is the slope of the straight line (dashed) which most nearly fits the actual curve. The proportionality constant is determined from the intercept of the straight line with the  $\log_{10} B_o$  axis.

high value of gamma, even though the absolute range of brightness obtained from the image reproducer's screen is not thereby extended.

A very similar situation exists in motion-picture photography, in which the transfer characteristics are those between object brightness and the opacity of the silver deposit on the negative, and between the opacity of the positive print and the resulting brightness of the projection screen. An over-all value of gamma of between 1.2 and 1.7 is used in commercial motion pictures, the high values compensating for the lack of color in the reproduced picture. Maloff has suggested that similar values of gamma should serve equally well for television work.

If the individual transfer characteristics of camera, amplifier, modulator, etc., shown in Fig. 195 are replotted in terms of the

logarithms of brightness, it is found that the gamma of most camera tubes is less than one, that of amplifiers and other transmission equipment very nearly unity, and that of the image-reproducing tube considerably greater than one. The product of these values thus tends to produce an over-all gamma not far from the unity value. To obtain higher values of gamma, a logarithmic amplifier may be employed anywhere in the system, preferably in the transmitter since it is then under the control of the production staff. In any event, the over-all gamma of the average receiver (product of its subsidiary gammas in amplifiers, demodulator, and image tube) should be known to the broadcaster, so that the over-all effect of the system may be predictable and changes made according to program requirements. In this connection, it is important to note the effect of d-c vs. a-c signal gain on high-light detail vs. shadow detail. This subject is treated in Sec. 53, page 368.

**50. Electronic vs. Mechanical Methods of Image Reproduction.**—In television image-reproduction devices, as in television cameras, two alternative scanning methods are of importance. The earlier historically is the mechanical method<sup>1</sup> in which a rotating scanning disk is used. The disk may have any of the forms used in the corresponding forms of television camera (see page 84), and the same limitations apply, namely, the low optical efficiency and the cumbersome mechanical apparatus required for high-speed, high-definition reproduction of a large number of scanning lines. The scanning-disk motion is synchronized with that of the disk at the transmitter. The light source used is one the intensity of which may be varied electrically; two common forms are the gas-discharge lamp and an incandescent or arc lamp fitted with a Kerr-cell light valve.<sup>2</sup> The modulated light from the source is passed through the apertures in the scanning disk and is directed to the eye of the observer directly, or to a viewing screen. The principal electrical difficulty lies in controlling the light source at a rate of 6,000,000 light variations per second, required for a high-definition image.

<sup>1</sup> For detailed discussion of mechanical image reproduction see: Wilson, J. C., "Television Engineering," Chaps. III and IV, Pitman & Sons, Ltd., London, 1937.

<sup>2</sup> LEVIN, N., The Kerr Cell and Its Application to Television, *Marconi Rev.*, 44, 13 (September–October, 1933).

The optical difficulty arises from the fact that the total light available is that passing through each scanning aperture and that this light is spread (so far as its effect on the eye is concerned) over the entire area of the reproduced picture. The apparent brightness of the source must be  $N$  times that of the desired brightness of the image, where  $N$  is the number of picture elements. It is obvious that very intense sources must be used for pictures containing 200,000 elements. In practice, only the arc lamp (either exposed or enclosed in a glass tube) has proved practical for high-definition work.

At present, one form of mechanical picture reproduction seems to have promise, the system developed by Scophony in England. This system employs an arc lamp as the light source and separate revolving optical systems for the horizontal and vertical scanning motions. The light control is a type of diffraction cell in which supersonic (10-megacycle) vibrations are set up by the motion of a vibrating quartz crystal. The stress waves resulting from the vibrations have the property of storing the changes in optical transmission imposed on the cell by the video signal. The storage action<sup>1</sup> permits many picture elements to be reproduced simultaneously, and the optical efficiency of the device is thereby greatly increased, to the point in fact where an acceptably bright image may be produced, containing 200,000 picture elements and covering a screen area of several square feet. The Scophony receiver requires a highly stabilized form of synchronizing signal, but otherwise is capable of operating on the standard forms of video signal used here and abroad. The system is expensive and seems at present to be limited to uses where a picture considerably larger than 12 in. across is mandatory, as for example in theaters. A diagram of the Scophony mechanical method is shown in Figs. 310 and 311.

The poor optical efficiency and other limitations of mechanical image-reproducing systems have given an outstanding advantage to the electronic method, *i.e.*, the use of a cathode-ray tube incorporating an electron beam and a fluorescent screen. Cathode-ray image reproduction is, in fact, the only method employed at present throughout the world (with the exception of the Scophony equipment just mentioned) for high-definition work.

<sup>1</sup> See also VON ARDENNE, M., Storage Methods in Television Reception, *Television*, 12, 68 (February, 1939).

**51. The Cathode-ray Image-reproducing Tube (Picture Tube, Kinescope, Oscillight, Etc.).**<sup>1</sup>—The typical form of a television image-reproducing tube (Fig. 199) is a funnelshaped structure at the narrow end of which is contained an electron gun (see Chap. IV, pages 120 to 129). The gun serves to produce and direct a narrow pencil of electrons (cathode ray) which travels down the length of the tube to the enclosed wide end (face or screen). The inner surface of the face of the tube is coated with a luminescent material which produces light under the impact of the electrons. The luminescent material must have sufficient luminous efficiency to produce a highly brilliant spot of light, since the apparent average brightness of the picture is  $1/N$ th that of the average brightness of the spot ( $N$  is the number of picture elements). The effective size of the spot of light must approximate that of the desired picture elements. In practice, it is roughly  $\frac{1}{50}$  in. in diameter.

At the neck of the tube, a deflection system (Chap. IV, pages 132–137) is provided to direct the electron beam over the surface of the luminescent screen. Electric deflection, magnetic deflection, or a combination of the two may be used. In this country, magnetic deflection is favored for tubes the screens of which are 9 in. in diameter or larger, electric deflection for the smaller sizes.

The appearance of the ion spot and its dependence on the deflection in the tubes have already been stated in Chap. IV, they are repeated here for convenience. If electrostatic focusing of the electron beam is used, an ion spot will form on the fluores-

<sup>1</sup> See also:

BURNAP, R. S., Television Cathode-ray Tubes for the Amateur, *RCA Rev.*, 2 (3), 297 (January, 1938).

BURNETT, C. E., A Circuit for Studying Kinescope Resolution, *Proc. I.R.E.*, 25, 992 (August, 1937).

MALOFF, I. G., The Cathode-ray Tube in Television Reception, "Television," Vol. I, p. 337, RCA Institutes Technical Press, New York, 1936.

MALOFF, I. G., Direct-viewing Type Cathode-ray Tube for Large Television Images, *RCA Rev.*, 2 (3), 289 (January, 1938).

MALOFF and EPSTEIN, "Electron Optics in Television," Chap. XII, McGraw-Hill Book Company, Inc., New York, 1938.

McGEE and LUBSZYNSKI, E. M. I., Cathode-ray Television Tubes, *Television*, 12, 78 (February, 1939).

WALLER, L. C., Kinescopes for Television Receivers, *Communications*, 14 (4), 20 (April, 1939).

cent material unless electric deflection is used. Electric deflection has its faults, however, especially regarding the uniformity of focus at all points of the screen. On the other hand, if magnetostatic focusing is used, the ion spot is spread over a much larger area (often the full area of the screen) and is much less troublesome, whether electric or magnetic deflection is used. The

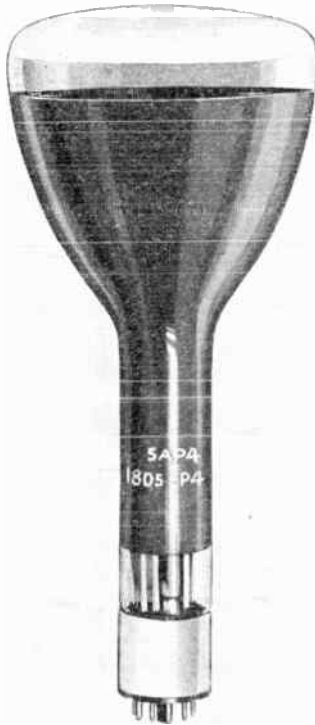

FIG. 199A.—Typical image-reproducing tube (picture tube), the type 5AP4.

combination of magnetostatic focusing and electric deflection gives virtually complete freedom from ion-spot trouble, if the tube is otherwise satisfactory, but the electric method does not give as even focusing. Probably the most satisfactory combination from the standpoint of the perfection of the reproduced image is magnetostatic focusing and magnetic deflection. Improvements in the processing of the tubes and in the types of fluorescent

material have minimized the ion spot in the electric-focusing magnetic-deflection type.

The ion spot may also be eliminated by an ingenious construction in the electron gun known as an "ion trap." The electrons and negative ions are caused to leave the cathode at an angle to the axis of the tube and are subjected to a fixed transverse

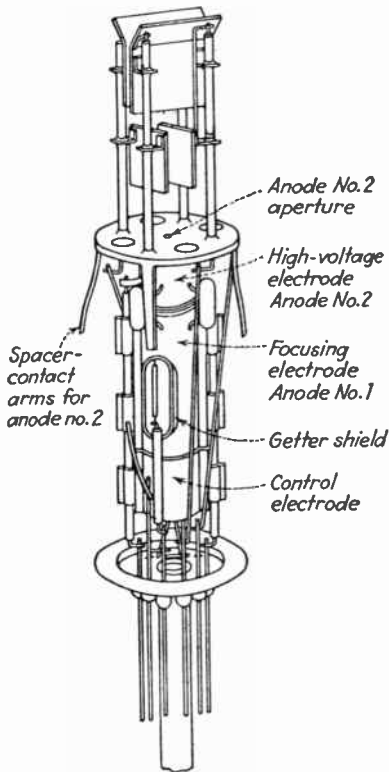

FIG. 199B.—Electron gun and deflecting structure of the 5AP4 picture tube.

use of glass approximately 0.6 in. thick, which is strong enough to withstand the atmospheric pressure on the face of the tube. The luminescent screen, coated on the inside of the glass, displays a picture free from the geometrical distortions due to the bulb curvature of conventional tubes, but at the same time, the scanning system for such flat-screen tubes must be properly designed to avoid nonlinearity of

magnetic field (which may be produced by a permanent magnet or by a coil through which a steady current flows). The magnetic field deflects the electrons but has substantially no effect on the ions. An obstacle, in the form of a metal disk with a small aperture in it, is placed so that the undeflected ions impinge on the disk, whereas the deflected electrons fall on the aperture and pass through it. The ions are thereby trapped and cannot reach the luminescent screen beyond the obstacle. The aperture through which the electrons pass is used as a virtual cathode, acted upon by a conventional electrostatic electron gun, which brings the electrons to focus at the other end of the tube.

Another unusual construction in picture tubes is the flat screen, made possible by the

scanning, defocusing at the edges of the pattern, and pin-cushion shape of the scanning pattern, all of which may arise from the fact that all points of the flat surface are not equidistant from the electron gun.

Control of the brilliance of the luminescent spot is derived from the control-grid structure in the electron gun (page 124, Chap. IV). Most practical control structures require a signal voltage, peak to peak, of at least 35 volts to create optimum contrast in the reproduced picture, when the second-anode voltage is 5000 to 8000 volts. The relation between spot brilliance and control-grid voltage, as shown in Sec. 54, is not strictly linear. Over the operating range of the tube, the transfer characteristic is characterized by a gamma value greater than one, which tends to enhance the apparent contrast of the picture.

The cathode-ray tube must be operated or controlled by several auxiliary circuits. A high-voltage power supply is required for the first-anode and second-anode voltages. Heater current must be supplied to the electron gun to secure the electron emission from which the beam is formed. The deflection system consists of the scanning generators and their associated synchronizing signal amplifiers and separators. The signal circuit should have two distinct parts, an a-c circuit which produces the variation in the picture detail, and a d-c circuit which produces an average brightness corresponding to the average brightness in the studio at the transmitter. Finally, adjustments must be provided for focusing the electron beam to its optimum size and for setting the average brightness and contrast at levels that are suitable for viewing in the ambient illumination. It is clear, therefore, that

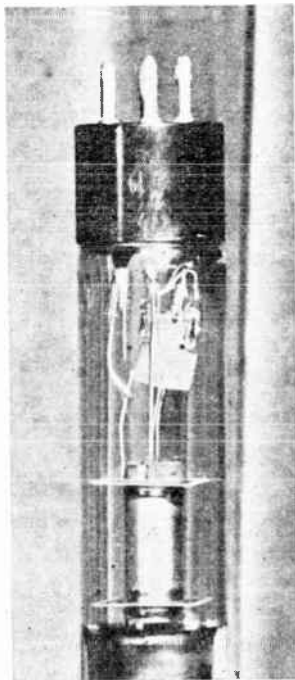

FIG. 200A.—Ion trap used to eliminate ion spot in electrostatically focused, magnetically deflected tube. The cathode (top) is inclined to the axis of the tube.

the processes involved in cathode-ray image reproduction are diverse and that they must be properly correlated if the resulting picture is to be steady, sufficiently bright, and of sufficient contrast.

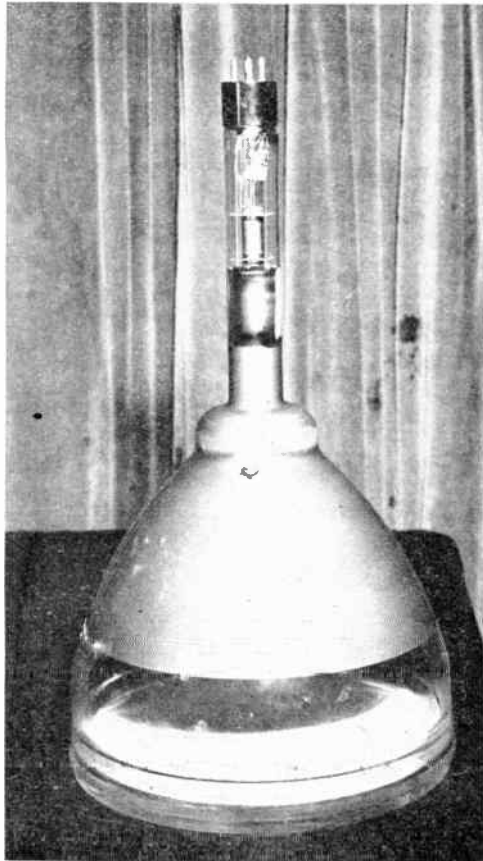

FIG. 200B.—Flat-faced picture tube, with glass face 0.6 in. thick to withstand external atmospheric pressure.

## 52. Fluorescence (Cathodo-luminescence) as Applied to Image Reproduction.<sup>1</sup>—The materials used in the luminescent

<sup>1</sup> Characteristics of Phosphors for Cathode-ray Tubes, *Electronics*, **11** (12), 31 (December, 1938).

LEVERENZ and SEITZ, Luminescent Materials, *J. App. Physics*, **10**, 479 (July, 1939).

LEVY and WEST, Fluorescent Screens for Cathode-ray Tubes for Tele-



materials of cathode-ray tubes, known as phosphors, are usually compounds of the light metals, such as zinc, cadmium, and calcium, with nonmetals such as silicon, or sulphur, and oxygen. Zinc silicate, cadmium tungstate, and zinc sulphide are out-

TABLE IV.—PROPERTIES OF PHOSPHORS

Material	Color	Spectral maximum, angstroms	Efficiency,* candle-power per watt	Persistence time to 1 per cent of initial value, sec.
Zinc sulphide (ZnS).....	Light blue	4700	1 to 3	$10^{-3}$
Zinc sulphide-silver (ZnS-Ag).....	Blue violet	4500 to 4700	1 to 3	$10^{-3}$
Zinc sulphide-copper (ZnS-Cu).....	Blue green	4700 to 5250	0.5 to 5	$5 \times 10^{-2}$
Zinc cadmium sulphide-silver (ZnS, CdS-Ag)....	Blue to red	4600 to 7500	1 to 5	$10^{-3}$
Zinc silicate-manganese (ZnO + SiO <sub>2</sub> -Mn).....	Green	5230	1 to 3	$5 \times 10^{-2}$
Zinc beryllium silicate-manganese (ZnO + BeO + SiO <sub>2</sub> -Mn).	Green to orange	5250 to 6000	0.5 to 3	$5 \times 10^{-2}$
Cadmium tungstate (CdWO <sub>4</sub> ).	Blue white	4900	Less than 1.0	$10^{-5}$

\* Efficiency of beam current of  $1 \mu$  per square centimeter and with accelerating voltages from 1000 to 6000 volts.

standing examples. Cadmium sulphide and calcium tungstate are also used, especially in mixtures. Zinc-beryllium orthosilicate is widely used, and its color may be controlled over wide limits. These compounds are only a few of several thousand organic and

vision and Other Purposes, *Jour. Inst. Elec. Eng.*, **79**, 11 (July, 1936).

LEVY and WEST, Luminescence and Its Application to Television, *Jour. Telev. Soc.*, **2**, 337 (March, 1938).

MALOFF and EPSTEIN, Luminescent Screens for Cathode-ray Tubes, *Electronics*, **10** (11), 31 (November, 1937).

NOTTINGHAM, W. B., Electrical and Luminescent Properties of Willemite under Electron Bombardment, *Jour. App. Physics*, **8**, 762 (November, 1937).

SCHMIDLING, G. T., Fluorescent Materials for Television Tubes, *Communications*, **14** (4), 30 (April, 1939).

inorganic compounds that display some degree of fluorescence when excited by cathode rays, but they are the principal ones that display sufficient stability and luminous efficiency to warrant commercial use. The efficiency and stability, as well as the color produced, depend very greatly on the degree of purity of the compounds. In most cases, a small amount of a specified foreign substance in the phosphor is necessary to obtain high luminous efficiency. The foreign substance is known as the

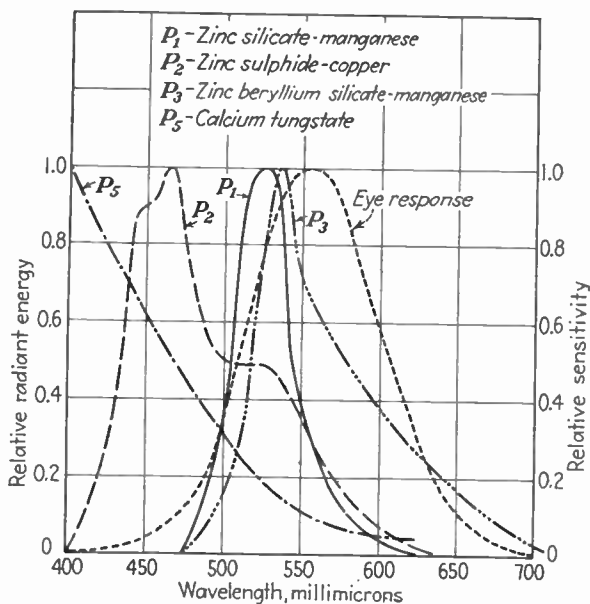

FIG. 201.—Spectral distribution of radiation from various phosphors under electronic excitation.

activator of the compound and usually takes the form of a very faint trace of some metal. Silver and copper are commonly used to activate zinc sulphide, and manganese is used with zinc orthosilicate.

The color of the light produced depends greatly on the chemical composition of the compounds, the activator used, and the processing to which it is subjected in the manufacture of the tube. The measured spectral-distribution curves of several standardized phosphors manufactured by the RCA Manufacturing Company are shown in Fig. 201. On this graph is also

shown the spectral response of the eye. The phosphors, the curves of which show a pronounced peak within the range of visibility, are of distinct color. For example, zinc silicate with manganese activator is green, zinc-beryllium silicate with manganese, yellow green, zinc sulphide with copper activator blue green. The curve for cadmium tungstate, on the other hand, has no pronounced peak in the visible region, and consequently its appearance is white, usually with a bluish tinge. Another compound useful for white light is zinc-cadmium sulphide activated with silver. Depending on the processing of this latter compound, it may assume almost any color from red to blue.

The theory of the mechanism of fluorescence induced by electron bombardment is very imperfectly developed. Ordinary fluorescence excited by exposure to light exhibits light the wavelength of which is longer than that of the light which causes the excitation. This implies that the quanta of the exciting light undergo a transformation within the fluorescent material, emerging with less energy and consequently longer wavelength. With electronic excitation, the light quanta radiated by the phosphor have less energy than the bombarding electrons, which indicates that a similar energy-loss transformation occurs.

In the absence of a satisfactory mechanistic explanation of the fluorescent effect, investigators have contented themselves with an empirical study of the relation between light output and energy of excitation. One of the earliest statements of this kind, originally proposed by Lenard, states that the total output candle power  $C$  from a fluorescent substance is proportional to the current density  $I$  in the beam and to the voltage  $V$  drop through which the electrons have passed, less a fixed "dead" voltage  $V_0$  characteristic of the phosphor. The relationship is

$$C = KI(V - V_0) \quad (250)$$

where  $K$  is a proportionality factor characteristic of the phosphor. Most of the present treatments are based on this relationship, but recent investigations by Nottingham have indicated another relationship

$$C = f(I)(V - V_0)^n \quad (251)$$

where the exponent  $n$  has a value of 2 in most cases and the dead voltage  $V_0$  is usually very small, if not zero. The  $V$  in this case

corresponds to the potential of the fluorescent screen when under bombardment, which is usually within a few hundred volts of the actual voltage difference applied between cathode of the electron gun and the second anode of the electron gun. Nottingham's results also show that the light output in lumens per square centimeter of phosphor surface is directly proportional to the current density in amperes per square centimeter cross section of the beam, until the current density reaches high values, at which point the light increases less than proportionately to the current density in the beam. The results varied widely, depending on the particular type of phosphor used.

The *luminous efficiency* of the phosphor is usually expressed in candle power per watt. The values of useful phosphors range from less than 1 candle per watt to 5 candles per watt. These figures compare with values of roughly 1 candle per watt for incandescent lamps and 5 candles per watt for the sodium lamp, the most efficient artificial illuminant used commercially. The fluorescent surface thus compares favorably with other sources of artificial illumination.

The luminous efficiency varies to some degree with the applied voltage. This is to be expected from the Nottingham relationship. Assuming zero dead voltage and  $n = 2$ , the luminous efficiency (ratio of candle power to bombarding power)  $C/VI$  is, by Eq. (251),

$$\text{Luminous efficiency} = \frac{KIV^2}{VI} = KV \quad (252)$$

Most measurements before Nottingham's do not indicate so rapid an increase in luminous efficiency with voltage, but some increase has been noted especially when the anode voltage has values around 2000 to 4000 volts. Figure 202 shows measurements of luminous output based on results shown by Maloff and Epstein and by Nottingham. Both show that anode voltages of at least 5000 volts must be used to obtain acceptable values of luminous output, and the higher the voltage, up to say 8000 volts, the more light is obtained for a given product of beam current and anode voltage. This fact accounts for the very high anode voltage commonly used in image-reproducing cathode-ray tubes when compared with those used in other electron-beam devices, such as the iconoscope.

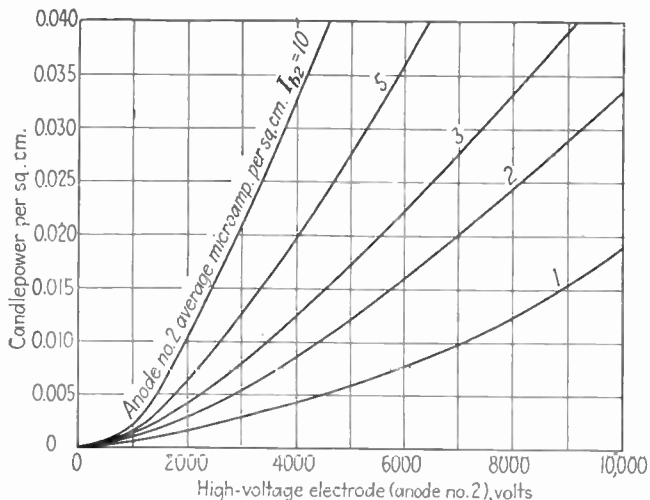

FIG. 202A.—Relationship of output brightness to accelerating voltage for various values of beam current (white-light phosphor, type P4).

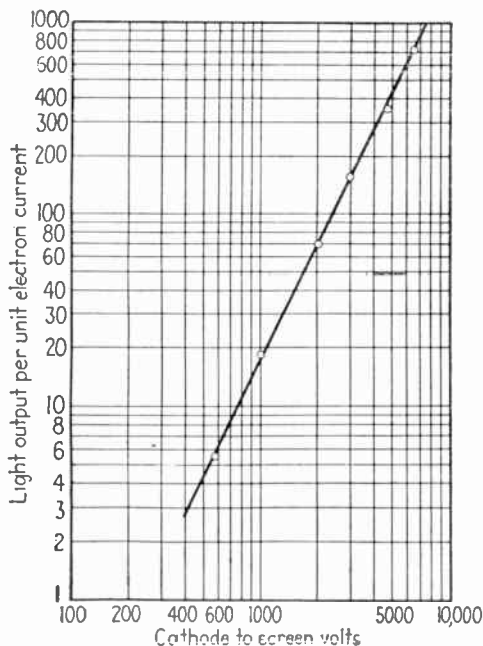

FIG. 202B.—Light output vs. screen potential, according to Nottingham's findings, which indicate the relationship in Eq. (251).

In the operation of the cathode-ray picture tube, the anode voltage must remain constant to preserve the focus of the spot, hence changes in anode voltage are not used to modulate the light output (and would not be in any event since the second-anode voltage is so high that appreciable variations in it could not be produced at video frequencies). Rather the control grid in the electron gun is used to vary the beam current. The modulation characteristic of the phosphor light output with respect to beam current is thus a very important operating criterion of the

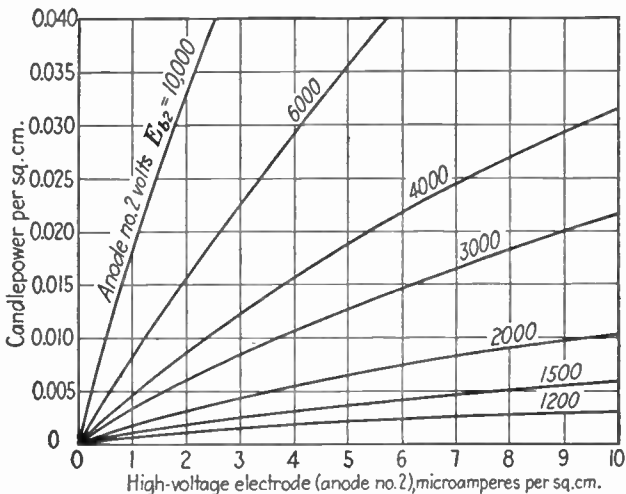

FIG. 203.—Light output vs. beam current for various values of second-anode voltage (white-light phosphor type P4).

material. Figure 203 shows some examples, plotted in candle power against beam current, for a typical phosphor commonly used in television tubes. These curves are descriptive of the phosphor alone. In any particular tube, the important operating curve is the candle power per unit area plotted in terms of the control-grid voltage (see Fig. 205). Such curves are treated in Sec. 53.

An important operating characteristic of a phosphor is its *persistence characteristic*. When the excitation is removed from a phosphor, the radiated light does not immediately disappear, but decays according to an exponential law. If the rate of decay is very rapid, so that the effect on the eye is substantially instantaneous, the phosphor is known as *fluorescent*. If the

decay is slow enough to show a perceptible persistence after the excitation is removed, the phosphor is known as *phosphorescent*.

If the radiation were to cease instantaneously when the spot is removed, the effect of the spot on the eye is limited to the time the spot is present on each picture element, that is, about  $1/6,000,000$  sec. for a 400 (active) line 30-frame picture. On the other hand, phosphorescent persistence increases the apparent brightness of the image by increasing the duration of the luminous effect of each picture element. If the duration of the persistence approaches the duration of the frame interval, then the apparent flicker in the image may be reduced, but at the same time, it is likely that rapidly moving objects in the image will be blurred by the persistence of one frame of the image into the succeeding frame. It is desirable therefore that the time of the persistence effect be limited to less than  $1/30$  sec., and this condition is fulfilled by all phosphors used for television cathode-ray tubes.

Since the decay of the radiation is exponential in form, it is customary to express the persistence effect in terms of the number of seconds required for the luminosity to decay to a definite percentage of its "initial" value just before the excitation is removed. Nearly all phosphors in current use, except the zinc sulphide with copper and zinc orthosilicate with manganese, have very short persistence times, *i.e.*, the light decays to less than 1 per cent of its initial value in  $1/1000$  sec. or less. The zinc silicate compounds retain 10 per cent of their initial luminosity for as long as  $1/50$  sec., a value approaching the duration of frame interval.

Phosphors intended to produce white light are usually formed by combining several compounds the individual spectral outputs of which have maximum energies in several different sections of the spectrum. In such combined phosphors, it is desirable to employ compounds of short persistence, or to match the persistence characteristics of the several components. Otherwise the component of longest persistence will predominate over the others, and rapidly moving objects may show "tails" of a color corresponding to the light produced by that component.

*Preparation and Application of Phosphors.*<sup>1</sup>—The electrical and optical characteristics of a phosphor depend not only on its

<sup>1</sup> LEVERENZ, H. W., Problems concerning the Production of Cathode-ray Screens, *Jour. Optical Soc. Am.*, 27, 25 (January, 1937).

chemical composition, but also to a considerable extent upon the methods used in preparing the compounds and in applying them to the face of the cathode-ray tube. The physical size of the particles of the phosphor also has its effect on the output light. After fusing, the material is ground in a ball mill until very fine particles of uniform size are obtained. The grinding process may consume several hundred hours in some cases. The material is applied to the glass face of the tube by spraying, settling from a solution, or dusting. Spraying is a rapid and economical method. The spraying liquid is formed in water or in an organic binder which is removed by the subsequent heating of the tube when the air is exhausted from it. The thickness of the coating must be carefully controlled to obtain maximum luminous efficiency. Zinc silicate screens having a thickness (measured by the weight of material per unit area) of 0.7 mg. per square centimeter have a light output approximately 50 per cent greater than the same material in a thickness of 0.4 mg. per square centimeter.

The useful life of a phosphor screen varies with its preparation, with the voltage and beam current at which it is operated, and with the degree of ionic bombardment. Zinc silicate screens usually have a life of 500 to 2000 hr., under ordinary scanning conditions, if care is taken to obtain a high vacuum in the tube and if the beam current is limited to an average value not greater than 500  $\mu$ a. The sulphide screens and the "nonsulphide" white screens (cadmium-zinc silicate) have a somewhat shorter life, other factors being equal. The end of the useful life of a fluorescent screen is usually determined by discoloration due to ion bombardment and by a gradual decrease in the luminous efficiency.

The degree of vacuum necessary within the tube is very high, judged by the standards ordinarily employed in vacuum-tube manufacture. Pressures of  $5 \times 10^{-7}$  mm. (0.0005 micron) of mercury are customarily reached before the tube is removed from the exhaust pump.

**53. Signal-to-light Relationship.**—It has been pointed out in the previous section that the important operating characteristic of a cathode-ray tube is the curve relating screen brightness (candle power per square centimeter) to the control-grid voltage. Thus far we have studied the relationship between screen brightness and anode voltage and between screen brightness and beam



current per unit area (beam current density). The remaining relationship to be examined is that between grid-signal voltage and beam current. This relationship can be most easily measured by noting the second-anode current (equal to the beam current plus leakage currents) as a function of the control voltage. A typical curve of this type is shown in Fig. 204. These curves

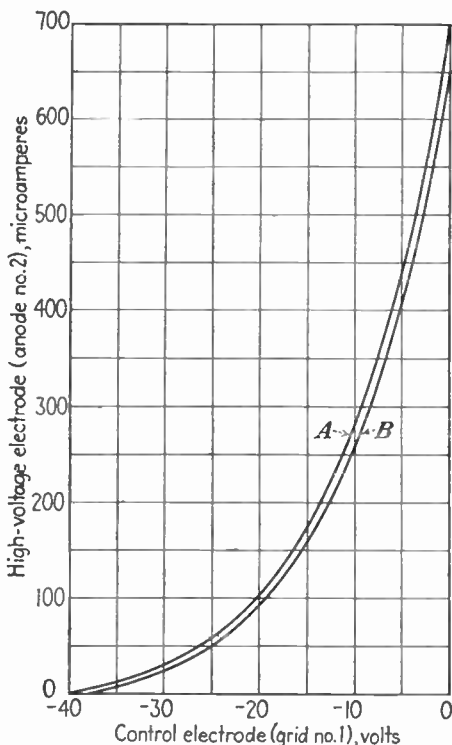

FIG. 204.—Beam current vs. control electrode voltage for electron gun in type 12AP4 picture tube: A, second-anode voltage 7000 volts; B, 6000 volts.

approximate the  $\frac{3}{2}$ -power law (the current increases proportionately to the voltage raised to the  $\frac{3}{2}$  power). The values of current depend also, of course, on the value of the second-anode voltage, so in general a family of curves is required to represent the full relationship, as shown in the figure.

To transfer from the curve of current vs. control-grid voltage to the desired curve of light output vs. control-grid voltage, we make use of the curves shown in Fig. 203, showing candle power

per unit area against beam current per unit area. On this assumption, the curve shown in Fig. 205 has been prepared. In practice, for the reasons given in Chap. IV, the diameter of the beam changes owing to the defocusing action of the control grid, and the current density changes.

The fact that these curves are not linear has important implications in the rendition of the tonal values of the reproduced image. The changes in brightness at the higher values (more

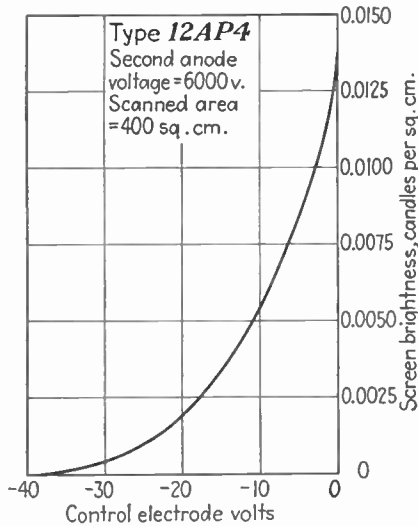

FIG. 205.—Transfer characteristic of 12AP4 tube, plotted from Figs. 203 and 204, on the assumption of a scanned area of 400 sq. cm. (7- by 9.3-in. picture) and second-anode voltage of 6000 volts. Note that the screen brightness is not a linear function of the control electron, *i.e.*, the picture tube is a high-gamma device.

positive values) of grid voltage are emphasized relative to the changes produced by equal changes of grid voltage in the more negative regions of the control-grid characteristic, corresponding to high gamma and high apparent contrast. This is fortunate, since the rest of the system tends to degrade the contrast of the image, especially if masking voltages are prominent.

Other effects of importance in determining the contrast of the image are saturation of the phosphor with increasing beam-current density, halation, and internal reflections of light from the walls of the tube. The saturation effect is indicated in the

curves shown in Fig. 203. Halation<sup>1</sup> arises from the total internal reflection of the light radiated from the phosphor at angles nearly 90° from the normal. The mechanism of the effect is shown in Fig. 206. By means of these reflections, the light from the spot is spread faintly over a region of the screen covering as much as 2 or 3 sq. in. This light, persisting in the eye of the observer, reduces the contrast between all picture elements reproduced within this area. A similar loss of contrast results from the reflection of light from the walls of the tube.

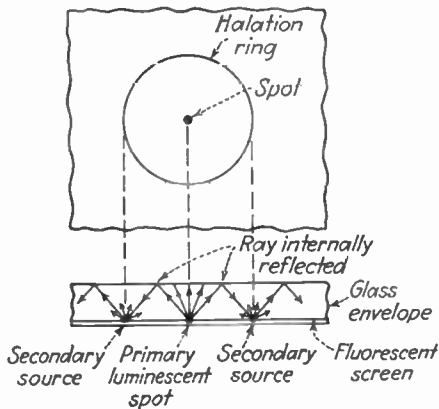

Fig. 206.—Halation due to total internal reflection in the glass face of the picture tube.

**54. Auxiliary Circuits for Cathode-ray Tubes.**<sup>2</sup>—There are four auxiliary circuits used in operating a cathode-ray tube for television-image reproduction: (1) the basic power supply for operating the electron gun so as to form a beam of electrons; (2) the picture-signal circuit which modulates the beam current and thereby varies the intensity of the fluorescent light produced by it; (3) the scanning generators which deflect the beam vertically and horizontally; and (4) the synchronizing signal circuits which control the scanning generators. These devices are discussed in order in the following paragraphs.

*a. High-voltage Power Supply.*—The basic power supply that operates the electron gun in the cathode-ray tube consists of two sources. The first is a source of alternating voltage to heat the

<sup>1</sup> LAW, R. R., Contrast in Kinescopes, *Proc. I. R. E.*, **27**, 406 (July, 1939).

<sup>2</sup> MALOFF and EPSTEIN, "Electron Optics in Television," Chap. XIII, McGraw-Hill Book Company, Inc., New York, 1938.

thermionic emitter (cathode) from which the electrons are obtained. This voltage is supplied by a transformer having the proper voltage and current ratings (usually 2.5 volts, r-m-s, at about 2 amp.). The other circuit is a source of direct voltage that applies the necessary potential differences between the cathode and control grid, the screen grid, the first anode, and the second anode. Usually but one source of voltage is used for all these electrodes; the different voltage levels are obtained from it through a voltage-divider (bleeder) resistor. If separate sources of voltage are used for the first- and second-anode voltages, both supplies are designed in terms of the same principles.

The high-voltage power supply consists of a high-voltage transformer, a rectifier tube or tubes, a heater-current transformer for the rectifier, a filter capacitor or capacitors (with which may be associated resistance or inductance, or both, to improve the filter action), and the voltage-divider resistor. These components perform the same function as those employed in similar power-supply circuits used in radio receivers, but the voltages and currents involved are of different magnitudes. The maximum d-c voltage required varies from 1500 volts for small tubes to 7000 volts or more for large tubes. The currents consumed by the electrodes are small, less than half a milliamper total, under usual conditions. The d-c power consumed from the supply is thus of the order of 2 or 3 watts. The bleeder resistor (voltage divider) usually consumes much more power than the tube electrodes, say 10 to 15 watts. The input power to the supply, exclusive of heater power, is usually not more than 30 watts.

The simplest rectifier circuit, the half-wave type, is shown in Fig. 207A. Only one rectifier tube is used, and the high-voltage transformer secondary has no center tap. The voltage-doubler circuit shown in Fig. 207B has the advantage that the total d-c voltage developed is divided equally between two rectifier tubes, and the high-voltage transformer secondary need supply only half the voltage required in the simple half-wave circuit. For obtaining high voltages, the voltage-doubler circuit has attained some popularity, but the fact that two rectifier tubes and separately insulated filament heater transformers are required has limited its application where cost must be considered. A third type of rectifier, used very little for cathode-ray tube pur-

poses, is the full-wave rectifier, shown in Fig. 207C. This circuit requires two high-voltage secondary windings (or a center-tapped winding which is expensive to construct for high-voltage service) and two rectifier tubes. The only advantage of the circuit is the ease with which its output may be filtered, since the ripple frequency of the output is 120 c.p.s. rather than 60 c.p.s. (for 60-c.p.s. supply). The fact that 60-c.p.s. ripple may be filtered by comparatively simple filter structures makes this advantage a dubious one, and consequently full-wave rectification is rarely used in television cathode-ray tube applications.

The rectifier tubes must be capable of delivering the bleeder resistor current plus the electrode currents (1 or 2 ma., average

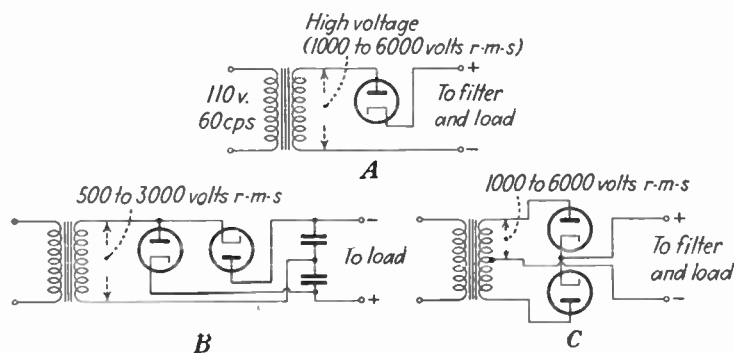

FIG. 207.—High-voltage rectifier circuits: A, half-wave; B, voltage-doubler; C, full-wave.

value), without overheating or loss of life, and of withstanding an inverse voltage at least equal to the peak value of the applied a-c voltage. Preferably the tube should be capable of withstanding peak voltages at least 50 per cent greater than the applied peak value. The voltage drop through the tube while conducting depends upon the design of the tube, but usually it is not more than 500 volts at rated current and may be as low as 50 volts.

*Filtering of High-voltage Supply.*—The filter employed to smooth the rectified output of the supply may be a very expensive piece of equipment, since the filter capacitors used increase in cost approximately as the cube of the operating voltage. Consequently effort has been expended to obtain adequate filtering with low-capacitance circuits.

The early filter circuits employed a single filter capacitor (Fig. 208A), usually 1  $\mu$ f or higher, and a total bleeder resistor of

about 2 megohms. A later development (Fig. 208C) employs two capacitors, of about  $0.05 \mu\text{f}$  each, a 1500-henry inductor (in the low-potential lead), and a bleeder resistor of roughly 6 megohms. A simpler arrangement (Fig. 208B) uses merely a 100,000- to 500,000-ohm resistor between two capacitors of about

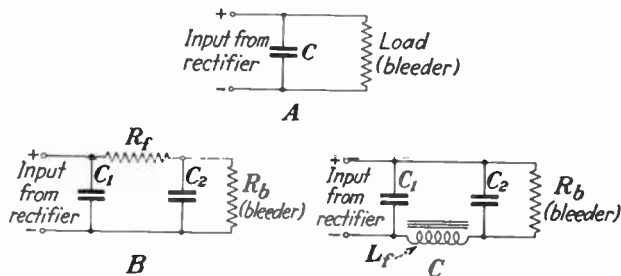

FIG. 208.—High-voltage filter circuits: A, single capacitance; B, double section RC type; C, tuned L-C filter.

$0.03\text{-}\mu\text{f}$  capacitance each and a bleeder resistor of roughly 5 to 6 megohms. This latter circuit seems to represent a good compromise between cost and performance.

The theory of the capacitance-resistance filter may be briefly stated. Consider first the circuit shown in Fig. 209A, in which

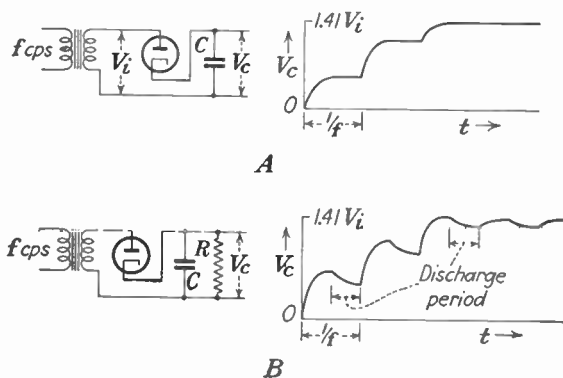

FIG. 209.—Effect of resistance load on ripple in high-voltage supply: A, voltage build-up across capacitor alone (no leakage); B, discharge through load resistor.

the rectifier charges a capacitance, across which there is no bleeder resistor. In this case, the rectifier charges the capacitance to a voltage equal to the peak value of the voltage applied to the rectifier (1.41 times the r-m-s value, sine wave input to rectifier being assumed). The time required to achieve the full charge

depends upon the internal impedance of the rectifier circuit (transformer impedance and tube resistance), but in any event it is a matter of a small fraction of a second for capacitances less than 1  $\mu$ f. Once the capacitor voltage has assumed its peak value, the rectifier then ceases to pass current, except that current needed to replace charge lost through leakage, which we may assume is negligibly small when compared with the bleeder resistance.

When the bleeder resistor is connected across the capacitor, it tends to discharge the capacitor at a rate depending upon the product of the resistance and capacitance values. The discharge

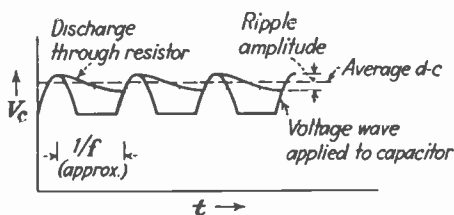

FIG. 210.—Ripple percentage based on height of discharge curve.

curve, plotted against time, is exponential in shape and is expressed by the relation

$$E_C = E_P(\epsilon^{-t/RC}) \quad (253)$$

where  $E_C$  is the voltage in volts across the capacitor at time  $t$  sec. after the discharge begins,  $E_P$  is the peak voltage in volts (achieved at the peak of the charging voltage cycle),  $R$  is the discharge resistance in ohms (the bleeder resistance in the case considered),  $C$  is the capacitance, and  $\epsilon$  is the number 2.718. To avoid exceeding a given percentage ripple in the voltage taken from the bleeder resistor, the discharge must not exceed that given percentage, relative to the peak value, during the time between successive charging peaks. In other words, by substituting from Eq. (253), the percentage ripple may be approximately stated as

$$\text{Percentage ripple} = \frac{E_P - E_C}{E_P} = 1 - \epsilon^{-t/RC} \quad (254)$$

The situation may be represented graphically as shown in Fig. 210. The time between successive charging peaks for half-wave

rectification is  $1/f$  where  $f$  is the frequency of the supply voltage. For 60-c.p.s. systems, this value of time is 0.0166 sec. Suppose the ripple voltage is restricted to 1 per cent. Then substituting this value and  $t = 0.0166$  in Eq. (241), we obtain for the  $RC$  product the value 1.66. The resistance value is determined by the amount of bleeder current permissible. Suppose that a bleeder current of 1.2 ma. is desired at 6000 volts. Then the resistance value is 5 megohms. The capacitance value  $C$  must be

$$C = \frac{1.66}{5,000,000} = 0.33 \mu\text{f}$$

If a larger bleeder current is desired (to minimize voltage changes arising from the varying beam current), the  $R$  value is proportionately less and the  $C$  value proportionately greater. Capacitors of  $0.5 \mu\text{f}$  or greater, designed for working at direct voltage above 5000 volts, are very expensive. Consequently low bleeder currents are used, as low as the regulation of the supply will allow, so that  $R$  value may be high and the  $C$  value low.

The double-section filter, shown in Fig. 208B, cannot be analyzed so simply. An elementary and approximate explanation of the action of the circuit is as follows: The capacitor nearest the rectifier is charged nearly to peak value, as in the single-section case, and is discharged through the two resistors  $R_f$  and  $R_b$ . The bleeder  $R_b$  is very much larger (perhaps 10 times as great) than the filter resistor  $R_f$ , consequently most of the discharge voltage and the accompanying ripple develops across  $R_b$  and is thereby applied to the second capacitor  $C_2$ . This capacitor is charged to the peak value of the discharge voltage, which in itself is partly filtered. The discharge of  $C_2$  can take place through either  $R_f$  or  $R_b$ , but the polarity of the voltage across  $C_1$  limits the discharge through it. Accordingly the principal discharge occurs through  $R_b$ , and the effective time constant in this part of the circuit is  $R_b C_2$ . Typical values are  $0.03 \mu\text{f}$  for  $C_1$  and  $C_2$ , 450,000 ohms for  $R_f$ , and 5,000,000 ohms for  $R_b$ .

One effect of the ripple voltage is to change the screen brightness from top to bottom of the picture, if the power-supply frequency and the vertical sync-signal frequency are synchronous. If they are not synchronous, the change in screen brightness will move upward or downward over the screen. Another effect is a variation in horizontal scanning amplitude from top to bottom of



the picture, the variation being in direct proportion to the change in second-anode voltage. If the ripple voltage is kept to less than 2 per cent, neither of these effects seriously interferes with the quality of the picture.

*The Bleeder Circuit.*—A typical arrangement of the bleeder circuit is shown in Fig. 211. In television applications, it is usual to ground the control grid or the cathode, thus putting the second anode at a high potential above ground. The reason is that the signal circuit (which is at or near ground potential) may then be connected directly to the grid without a high-voltage blocking capacitor intervening. In typical cases, the ground potential is established at the most negative end of the resistor, and the cathode of the electron gun is connected to a tap some 25 to 50 volts higher. The control-grid voltage is obtained from

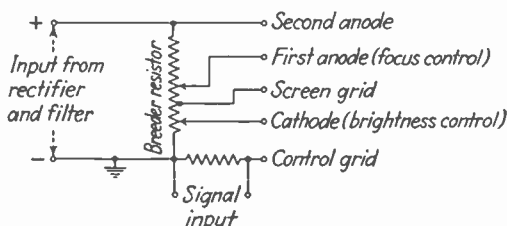

FIG. 211.—Typical bleeder circuit for an electron gun employing a screen grid.

a variable voltage divider between the cathode and the negative end of the bleeder. This voltage divider acts as the brightness control since it sets the bias voltage applied to the grid. The signal circuit, including d-c as well as a-c components of the picture signal, is inserted in series with the control-grid and the bias source, as shown in the figure.

The positive voltages for screen grid, first anode, and second anode are obtained from the bleeder resistor at points higher in potential than the cathode tap. The screen grid has a fixed potential of roughly 5 per cent of the second-anode voltage (in small tubes, the screen grid is usually omitted from the electron gun). The first-anode voltage is roughly 30 per cent of the second-anode voltage and is obtained from the bleeder from a variable tap, which permits adjustment of the first-anode potential relative to the second-anode potential. This tap constitutes the focus control. Its setting depends primarily on the construction of the electron gun and to some extent on the absolute

value of the second-anode voltage. The control may also be adjusted to compensate for changes in focus brought about by changes in average brightness. Since the focus control controls the size of the fluorescent spot and hence the size of the reproduced picture elements, it has an important bearing on the picture quality. For this reason, the focus control may be looked upon as a desirable control for operation by the consumer, although in practice the focus control is sometimes made available only from the rear of the cabinet, where it may be adjusted upon installation of the receiver and when the cathode-ray tube is replaced.

In some cases, the cathode of the electron gun is connected to the most negative (grounded) end of the bleeder resistor, and a separate supply of control-grid-bias voltage is provided elsewhere in the receiver system.

Throughout the high-voltage supply, care must be taken to avoid the difficulties peculiar to high-tension circuits. Sharp bends in the wiring and sharp projections from the high-voltage terminals are apt to give rise to corona discharges. Care should be taken to allow the full extent of the insulation to intervene between ground and the high-potential points. Care must also be taken to protect the operator from coming in contact with the high voltage. If a high-capacitance filter is used, the danger is especially great, since the stored energy in the capacitor is then correspondingly large. One advantage of the low-capacitance double-section filter (in addition to low cost) is the fact that the stored energy is low and the discharge current limited to comparatively small values. In any event, complete enclosure of the power supply and provision of interlocking switches to prevent its operation when the enclosure is opened are considered mandatory in all equipment designed for use by the public.

*Safety Considerations in High-voltage Power Supplies.*<sup>1</sup>—The effect of bodily contact with a high-voltage supply depends principally on the amount of current that passes through the body and on the portion of the body through which the current flows. When direct current is encountered, currents through the body in excess of 150 ma. may produce effects dangerous to

<sup>1</sup> Data supplied by Mr. G. W. Fyler.

See also: BARBER, A. W., Safety in Television Receivers, *Communications*, **14** (3), 26 (March, 1939).

life, whereas currents as small as 20 ma. are capable of producing an uncomfortable shock. However, if the current is limited to 10 ma. or less, the resulting shock, although distinctly felt, is usually not sufficient to cause severe muscular contraction and hence may be considered safe. Since the bleeder currents consumed from high-voltage power supplies are seldom in excess of 2 or 3 ma., it is quite possible to limit the output current from the supply to values not greater than 20 ma. simply by including a series resistance (of say 50,000 to 100,000 ohms) in series with the high-voltage power transformer. This will protect the user against contact with the cathode of the rectifier tube. At high-voltage points more remote from the rectifier cathode, the filter resistor intervenes and limits the output current to a much smaller (and hence safe) value.

TABLE V.—SAFETY LIMITS IN HIGH-VOLTAGE POWER SUPPLIES

Voltage (d-c or r-m-s a-c), volts	Resistance in series with rectifier anode* (a-c protection against contact with anode), ohms	Resistance in series with rectifier cathode* (d-c protection against contact with d-c system), ohms	Capacitance corre- sponding to a charge of 1 joule, $\mu$ f
1000	11,000	6,000	2
2000	21,000	13,000	0.5
3000	34,000	20,000	0.23
4000	47,000	26,500	0.13
5000	61,000	33,000	0.08
6000	75,000	38,500	0.056
7000	89,000	45,500	0.04
8000	103,000	52,000	0.03
9000	116,000	60,000	0.025
10,000	130,000	67,000	0.02

\* These are the minimum values of regulating resistance. Values two to ten times as great should be used for additional safety, if design factors permit.

When the 60-c.p.s. a-c supply is encountered, a current of 100 ma. r-m-s is considered the danger limit and 10 ma. or less the limit above which uncomfortable shocks may occur. The principal danger point in this case is the anode of the rectifier tube, and in this case a series resistor between high-voltage

transformer and rectifier anode may be used to limit the current to a safe value.

Another safety factor to be considered is the effect of the discharge of a filter capacitor through the body, such as might occur with the power disconnected if the body came in direct contact with the capacitor terminal and ground before the capacitor was discharged through the bleeder. An uncomfortable shock arises from this cause if the stored charge exceeds 1 joule, that is, if the capacitance in farads exceeds  $2/V^2$  where  $V$  is the voltage to which the capacitor is charged. The use of low values of capacitance is indicated as a precautionary measure (as well as in the interests of economy). A  $0.03\text{-}\mu\text{f}$  capacitor charged to 7000 volts lies within the 1-joule limit, but a  $0.06\text{-}\mu\text{f}$  capacitor charged to the same voltage lies somewhat above it.

In any event, the precautions of including series current-limiting resistors and employing low values of capacitance should be observed. In no case should such precautions supplant the use of proper interlocking arrangements and adequate mechanical and electrical insulation to protect the user at all times.

*b. The Video-signal Circuit.*—The signal circuit that applies the video signal to the control grid is, in the usual case, the output circuit of a video amplifier. The amplifier output contains all components of the composite video signal (*i.e.*, camera signal, blanking signals, and sync impulses). The amplifier itself must be properly compensated to pass both high and low frequencies without amplitude or phase discrimination. The only effect of the cathode-ray tube in this compensation problem is the capacitance its grid presents to the amplifier output impedance. Ordinarily the input capacitance of the control grid of the electron is appreciable, usually from 10 to 20  $\mu\mu\text{f}$ , and this value must be taken into account in designing load resistor and the compensating inductor for the last stage.

The output video amplifier must meet definite requirements in relation to the control grid of the cathode-ray tube. One is the polarity of the signal. Another is the peak-to-peak voltage value of the signal, which establishes the brightness contrast of the picture. Finally there is the d-c component present in the amplifier output, which combines with the bias voltage applied to the control grid of the tube to establish the average level of brightness produced on the tube screen.

The polarity of the signal is an important consideration since it determines the sense of the tonal values in the reproduced image. If the wrong polarity is used, a "negative" image is produced. The standard polarity of transmission in this country is negative, that is, the greater the amplitude of the modulation envelope, the lower the illumination in the original scene. Accordingly, decreased illumination of the cathode-ray tube must be produced by increased carrier amplitude. Decreased

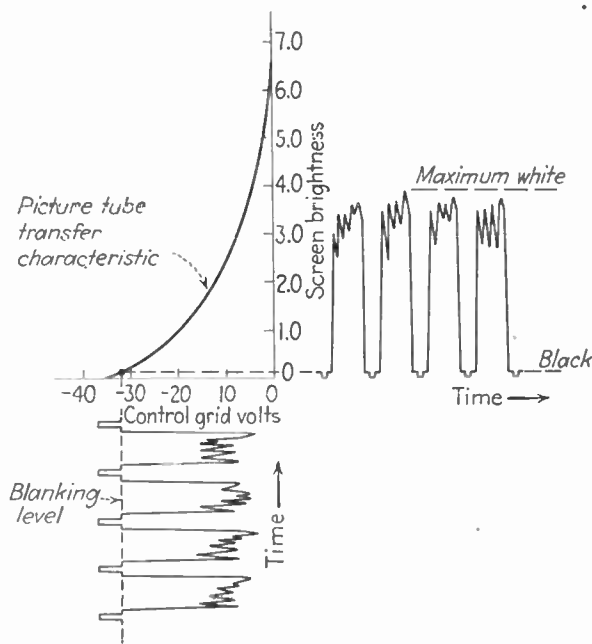

FIG. 212.—Signal-to-light relationship in a typical picture tube. The bias of the tube should be set so that the blanking level of the signal just coincides with the zero-light level of the output scale.

illumination in the cathode-ray tube is produced as the control voltage, relative to the cathode, becomes more negative. Since the control grid is ordinarily connected to the high-potential end of the last video amplifier load resistor, the voltage at this end of the load resistor relative to ground must decrease as the carrier amplitude increases. This condition may be fulfilled in either of two ways. If a cathode-above-ground detector is used, one stage of video amplification (or any odd number of stages) suffices to give the proper polarity. If an anode-above-ground detector

is used, an even number (two, usually) of video amplifier stages is required.

Related to the polarity of the picture are the blanking and sync pulses that are present in the amplifier output (see Fig. 212). The sync pulses are imposed on the signal in the infra-black region, and the level of the blanking impulse corresponds to the voltage level at which no light is produced. When the proper polarity is used, the sync impulses drive the grid more negative and hence are not visible in the picture. Furthermore, if the blanking-signal level corresponds to the grid-voltage level producing no screen illumination, the screen cannot be illuminated during the horizontal- and vertical-retrace intervals. In other words, the only portions of the composite signal then capable of producing light in the picture are the camera-signal variations themselves. This is predicated, however, on the supposition that the blanking level in the signal actually corresponds to the illumination cutoff bias voltage. If the d-c bias voltage applied to the tube is shifted in the positive direction, either by the use of the brightness control or by improper operation of the transmitter, then the black level in the signal no longer corresponds to the black level in the reproduction. In this case since the blanking action is not complete, the retrace lines can be seen. The optimum adjustment of the brightness control is one that just makes the retrace lines invisible. Any further reduction in brightness removes the detail of the shadow portions of the picture.

The peak-to-peak signal level required at the control grid for optimum contrast (best balance between signal amplitude and saturation effects) varies slightly with the value of second-anode voltage. At second-anode voltages of 2500 volts or lower, 10 to 15 volts, peak-to-peak value, is sufficient. At 6000 and 7000 volts, 25 volts is required. By assuming that the detector output is of the order of 2 volts or greater, it follows that the video amplifier need supply a gain of twelve times, or less, to produce the required signal for an image of optimum contrast. A single stage of video amplification employing a tube the mutual conductance of which is 5000 micromhos or more can supply this degree of gain with adequate high-frequency response.

*Gain in the Signal Circuit.*—The amplitude of the control signal applied to the control grid of the tube depends upon the strength

of the signal received and on the gain of the receiver. The gain must be considered in two categories: that applicable to the alternating structure of the picture signal (a-c gain) and that applicable to the average of the picture signal (d-c gain). In the r-f and i-f portions of the receiver up to and including the output of the second detector, the a-c and the d-c gains are identical, since both r-f and i-f stages are concerned simply with the carrier

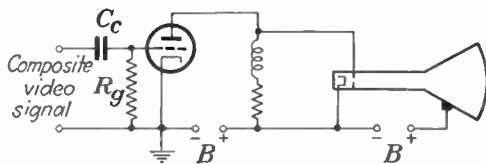

FIG. 213.—Simple d-c reinsertion circuit operating on the grid-current characteristic of the video amplifier, which operates without cathode bias. The circuit has two inherent drawbacks: the video tube draws heavy plate current in the absence of signal, and the control grid of the picture tube assumes cathode potential if the plate current of the video amplifier fails.

envelope. However, after detection the a-c gain is not identical with the d-c gain unless conductive coupling is used between the second detector and the control grid of the picture tube. In some cases, conductive coupling may be used, but in general, capacitive coupling is necessary. Whenever capacitive coupling is used, the d-c level of the signal is lost and replaced by an arbitrary level depending upon the waveform of the signal and

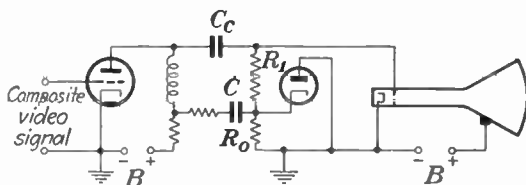

FIG. 214.—Use of a separate diode rectifier for d-c reinsertion. This circuit, while requiring an extra tube, has neither of the drawbacks of that shown in Fig. 213.

the tube bias voltage. When the d-c level is lost, it must be reinserted at the control grid of the cathode-ray tube or at the grid of a tube conductively coupled to this grid. The reinsertion of the d-c level is accomplished by rectifying the picture signal and thus establishing and fixing the blanking level of the signal. This d-c voltage, developed by the rectifier, is used either directly or after directly coupled amplification to set the bias level of the

control grid of the cathode-ray tube. Typical circuits for accomplishing this reinsertion of the d-c component are shown in Figs. 213 and 214.

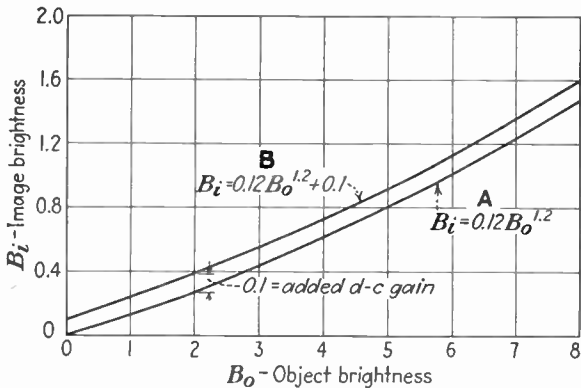

FIG. 215A.—Effect of added d-c gain on the over-all brightness-transfer characteristic: A, original curve in which zero object brightness coincides with zero image brightness; B, same with 0.1 added d-c component.

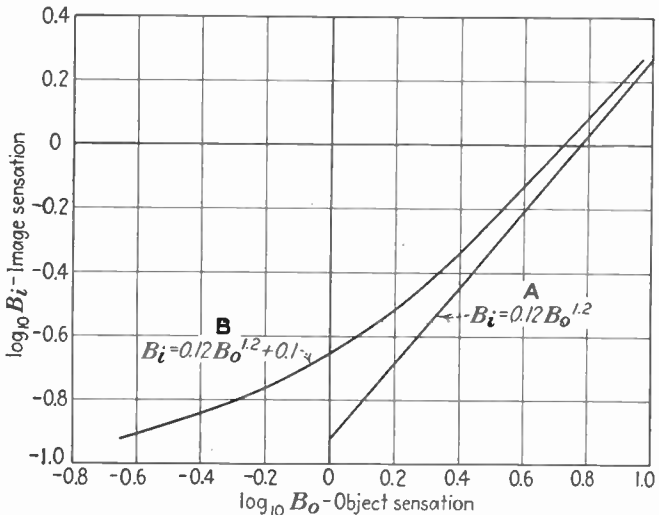

FIG. 215B.—Transfer characteristics of Fig. 215A, plotted in logarithmic coordinates. The original curve A shows a constant slope, whereas the curve B with added d-c gain gives more contrast in the high lights than in the shadows.

Since the d-c component is transmitted separately, the d-c gain may be varied without varying the a-c gain, and vice versa. It is worth while considering the effect of such independent gain



variations on the appearance of the reproduced image. To do so, we make use of the over-all brightness-transfer characteristic of the television system (page 331), *i.e.*, the curve that relates the brightness of the objects in the studio to the brightness of the corresponding objects in the reproduced image. Suppose that the over-all transfer characteristic of the system is represented by the curved line in Fig. 197. Suppose then that the d-c gain of the receiver is varied (for example, by adjusting the brightness control) while the a-c gain remains fixed. Then the transfer characteristic is shifted upward or downward, as shown by the two lines in Fig. 215A. Suppose then that the a-c gain of the receiver is varied without changing the d-c gain (by varying the bias voltage on a capacitively coupled video stage, for example.) The transfer characteristic is thereby revolved about a point corresponding to the d-c bias, as shown by the two lines in Fig. 216A. Now suppose that the a-c and d-c gain are both varied together by the same degree. Then the transfer characteristic is both displaced and rotated, as shown in Fig. 216A.

To evaluate the effects of these changes on the eye, we must make the usual assumption regarding the changes in the sensation in the eye produced by changes in brightness of the objects it views. With the reservations previously noted (page 335), we may use the Weber-Fechner law which states that the sensation varies in proportion to the logarithm of the brightness. The transfer characteristics are plotted in terms of the logarithms of brightness in Figs. 215B and 216B. It will be noted that changing the d-c gain alone changes the eye sensation more in regions of high brightness than in low, whereas varying the a-c gain alone has the reverse effect. By varying both a-c and d-c gains together, both high and low regions are increased or decreased by the same amount. The first case corresponds to an augmentation of the high-light detail, the second to an augmentation of shadow detail, and the third to a simple change in brightness. All three effects are of interest and of use in obtaining the best reproduction of given subjects. But ordinarily the contrast control should not favor either high lights or shadows, that is, it should effect a-c as well as d-c gain by the same amount. In practice, this condition is obtained by varying the gain in the stages of the receiver prior to the d-c restoring circuit. The brightness control should be used simply to set the black level

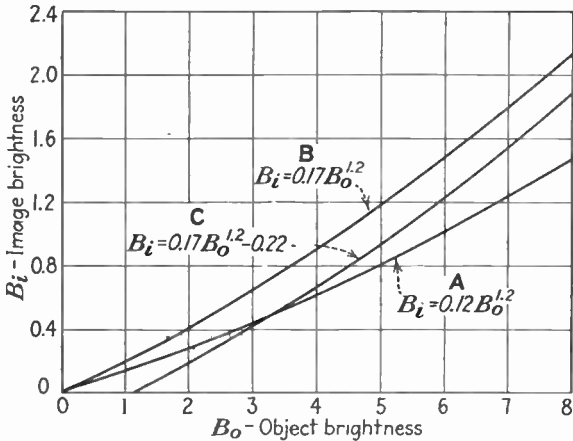

FIG. 216A.—Effect of added a-c gain on over-all brightness-transfer characteristic: A, original curve; B, curve with a-c and d-c gain equal (zero object brightness still coincides with zero image brightness); C, curve with a-c gain only, revolved about the point (3.3, 0.5). The latter curve shift produces the same effect as a reduction in d-c gain.

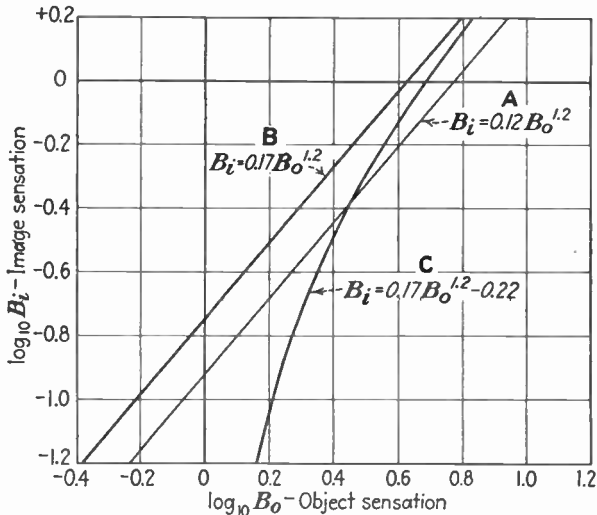

FIG. 216B.—Logarithmic plots of the curves in Fig. 216A. The curve B, representing a change in a-c and d-c gain, is simply displaced from the original curve, producing a brighter picture of the same uniform contrast. The curve C, with excess a-c gain, produces higher contrast in the shadows than in the high lights, just the reverse of the effect shown in Fig. 215B.

of the reproduction and should be set at the point where the retrace lines are just obliterated by the blanking signals.

*c. Scanning and Synchronization Circuits.*—Thus far our consideration of image reproduction has had to do with the electro-optical transfer processes only. We have defined the over-all brightness-transfer characteristic and interpreted it in terms of a sensation logarithmically related to the image brightness. The variations in brightness have been assumed to occur with sufficient rapidity to reproduce each picture element individually and to do so without a minimum of the distortion that arises from improper phase and amplitude responses vs. frequency. The remaining requirement in image reproduction is the geometrical one: it is necessary that the picture elements take their proper positions in the reproduced image. This positioning problem, the subject of the present section, is the concern of the scanning circuits and their synchronizing auxiliaries. Attention has already been paid to scanning and synchronization in Chap. IV, which is specifically devoted to electron scanning beams and their control. Since all the information in that chapter applies directly to the case of the scanning beam in the cathode-ray tube, the reader may wish to review Secs. 25, 26, and 27 (pages 129 to 164) before proceeding with the following paragraphs.

It may be fairly stated that the production of linear scanning motions of adequate amplitude is the simplest part of the scanning process, since circuits are available that can be depended upon to generate the necessary saw-tooth waves of current or voltage with a reliability at least equal to that of any other part of the television receiver. But the synchronization of the scanning generators at the transmitter and the receiver is, on the other hand, one of the most difficult. The difficulty arises from the high degree of precision with which the two scanning motions must be synchronized if displaced picture elements and paired interlaced fields are to be avoided. Since this synchronizing performance may be called the central feature of the geometrical aspect of image reproduction, it is worth while to review some of the defects common to sync circuits and to describe some of the separator circuits that remove the timing impulses from the composite video signal and apply them, properly separated, to the vertical and horizontal scanning generators.

In Fig. 217 is shown a portion of the composite video signal, plotted against time, as it appears at the output of demodulator tube. The polarity chosen is such that portions of the signal corresponding to the higher amplitude levels (black and infra-black) are plotted correspondingly high in the positive region

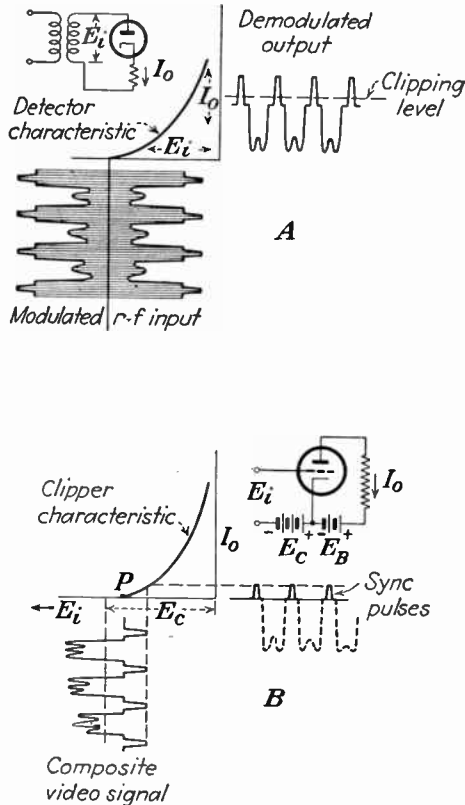

FIG. 217.—Separation of picture signal and sync pulses. The demodulated carrier signal is obtained by the method shown in A. This signal is then passed through a clipper stage which responds only to the positive peaks of the signal, which are the sync pulses, as shown in B.

of the scale. From this composite signal is to be obtained a combined sync signal which contains the vertical and horizontal timing impulses together. This portion of the signal, which exists in the infra-black region, must be sharply separated from the picture-signal portions, which lie below the blanking level.

This separation function (called variously by the names "clipping," "removing the super-sync," or "amplitude separation") is performed by applying the composite signal to a tube (diode, triode, or pentode) which is so biased that no current can flow through it except when the infra-black regions of the signal are reached. Ordinarily a tube so biased is biased in the negative direction, and the blanking level of the applied signal corresponds to the plate current cutoff point. The composite video signal is then applied in the positive polarity shown in Fig. 217. The parts of the signal more positive than the cutoff point cause plate current to flow. The camera signal (more negative than

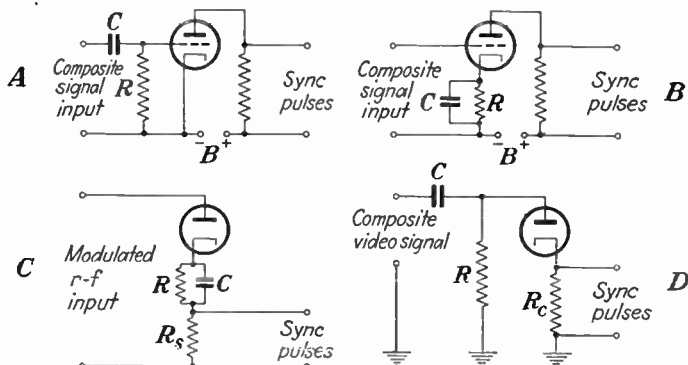

FIG. 218.—Sync clipping circuits: *A*, grid leak and condenser; *B*, cathode bias; *C*, diode with cathode bias and series load; *D*, diode with anode  $RC$  circuit and excess cathode bias.

the blanking level) cannot cause plate current to flow. Consequently the plate current consists only of sync pulses that are completely free of any interference from the picture content itself.

The problem of the initial separation of the combined sync pulses is thus resolved to one of obtaining a bias value approximately equal to the blanking level in the signal. The simplest way of deriving this bias voltage is to obtain it directly by rectification of the signal itself, using a load circuit the time constant of which is suitable for developing a rectified average voltage equal to the cutoff value of the tube concerned. Four alternative means of obtaining the bias from the signal are shown in Fig. 218. The first (Fig. 218.A) is a grid-leak scheme, using the grid and cathode of a triode or pentode tube as the diode ele-

ments that rectify the signal. The rectified d-c average current flows through the grid-leak resistor  $R$  and establishes the bias. The composite signal is applied to the input terminals in such a polarity that the sync signals drive the grid more positive. Consequently the plate circuit of the tube develops an amplified voltage waveform corresponding to the sync signals only. The difficulty is that a very large bias value is required if only the sync pulses are to cause plate current, and the resistor  $R$  must have a high value, above 1 megohm. The presence of gas-current in the tube will make for erratic operation with this large value of grid leak, but otherwise the circuit is simple and quite reliable.

The second bias-developing scheme (Fig. 218B) uses a bias filter in series with the cathode of the separator tube. The resistor  $R$  is considerably larger than would be required for ordinary cathode-bias purposes. The required bias is obtained by the presence of the amplified sync pulses in the plate current. The resistor must have a value such that the averaged plate current above the cutoff level, multiplied by the resistance value, will equal the required cutoff bias voltage. Values in the neighborhood of 10,000 ohms prove satisfactory when high  $g_m$  tubes are employed. The capacitance must perform a compromise function. It must maintain the bias level constant throughout the vertical blanking period and yet allow the bias level to change as the d-c component of the camera signal changes, so that the cutoff bias level always corresponds to the blanking level.

The third biasing method (Fig. 218C) consists of a simple diode containing two load circuits, across one of which the bias voltage is developed and across the other of which the sync signals appear. The bias voltage is developed across the  $RC$  combination, in which  $R$  is a comparatively high resistance (of the order of megohms) and  $C$  is a comparatively high capacitance (0.5  $\mu\text{f}$ ). The sync signals appear in the resistor  $R_s$ , since the capacitance is large enough to constitute a short circuit for the frequency of the sync pulses and their harmonics. The d-c component of the current resulting from the sync pulses biases the tube to the black (pedestal) level. This type of separator is less sensitive than the other two arrangements and works best when a fairly large signal (2 volts or more) is applied to the input terminals.

*Separation of Vertical from Horizontal Pulses.*—When the sync pulses have been removed from the composite signal by one of

the methods outlined above, it then becomes necessary to separate the high-frequency horizontal sync pulses from the low-frequency vertical sync pulses. The discussion in Chap. IV, page 161, has revealed that the standard method of vertical-from-horizontal separation depends upon differences in waveform. These differences are used to actuate separator circuits of the differ-

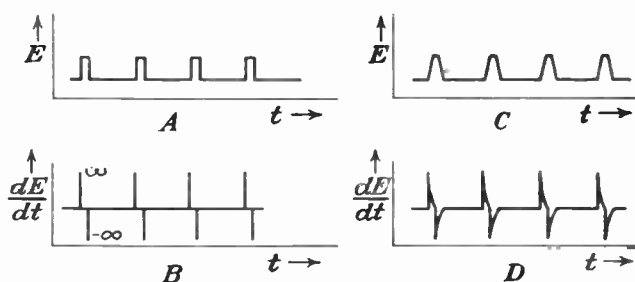

FIG. 219.—Differentiation of sync pulses. Ideal rectangular pulses (A) when differentiated produce sharp pulses of infinite amplitude (B), whereas nonideal trapezoidal pulses (C) produce pulses of finite height followed by sloping discharges (D).

tiator or integrator types. In the case of the horizontal sync pulses (see Fig. 219), the leading or trailing edge of the pulse is used as the timing reference, and a differentiating circuit is used for developing the horizontal pulses independently of the vertical pulses. The serrated vertical sync signals, on the other hand, extend over a considerable period of time, and their effect is

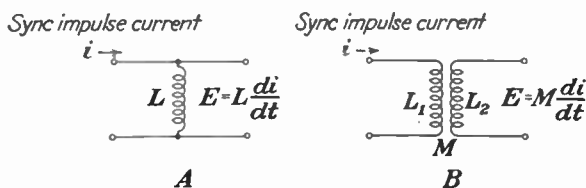

FIG. 220.—Differentiating by inductive means, using impulse current (self-inductance, A; mutual inductance, B).

developed independently of the horizontal pulses by an integrator circuit.

One simple type of differentiating circuit is an inductance in series with the plate circuit of the tube containing the sync pulses, as shown in Fig. 220. The sync-pulse current has a waveform consisting of steep slopes, corresponding to rapid changes of current. The voltage appearing across the inductance

is proportional to  $di/dt$ , the rate of change of current. Consequently at the leading and trailing edges of every pulse in the sync current, a high voltage is produced across the inductance. These voltage pulses occur at the edges of every pulse, whether of the simple line sync pulse type, equalizing pulse, or serrated pulses during the frame blanking period. All these pulses are properly timed to control the horizontal sync generator, except the equalizing pulses, which occur midway between the properly spaced timing pulses. The equalizing pulses have no effect on the timing of the horizontal generator, because they occur at a time when the generator is not in a position to respond to synchronization from external sources. The net result is that the voltage developed across the inductance may be applied directly

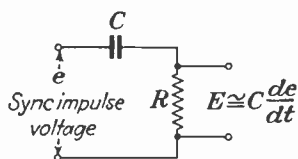

FIG. 221.—RC differentiating circuit.

to the sync terminals of the horizontal generator, so long as it is of the proper polarity and of sufficient amplitude. The scanning generators are synchronized by pulses positive with respect to ground. The simple circuit arrangement shown in Fig. 220A develops negative pulses, but a phase reversal

may be obtained in a single amplifier stage. If sufficient power is available, the required phase reversal together with an increase in voltage level may be obtained in a two-winding transformer, the primary of which is the inductance  $L$  and the secondary of which is connected directly to the horizontal sync generator.

Another form of differentiator circuit, mentioned briefly in Chap. IV, is a series resistance and capacitance, shown in Fig. 221. The separated sync pulses are applied across the combination, and the output is developed across the resistor. The explanation of the circuit action follows from the fact that the current in the capacitance is proportional to the rate of change  $de/dt$  in the voltage applied across it. The sync signal current is largely by-passed by the capacitor, so the voltage waveform developed across the resistor is similar to the current waveform. Further, when the rate of change of voltage  $de/dt$  across the resistance is rapid, the condenser charging current is greater, and a correspondingly high voltage drop appears across the resistance. The result is that sharp voltage peaks appear across the resistance for every sharp change in the sync waveform, that



is, for every horizontal pulse and equalizing pulse and serration. These pulses may then be used, in the proper polarity, to drive the horizontal scanning generator (the equalizing pulse timing is such that these pulses have no effect on the scanning generator).

The integration action necessary to develop the vertical sync pulse energy independently of the horizontal pulse energy is the reverse of the differentiation.

The integrator circuit, Fig. 222, is a series resistance and capacitance, with the output taken across the capacitance. The time constant of the  $RC$  combination is about equal to the duration of the horizontal pulses, conse-

quently the charge accumulated by the capacitance from each horizontal pulse is small and decays rapidly. When the sustained high current levels of the vertical sync pulse are impressed on the combination, the charge accumulated by the capacitor is correspondingly large and builds up rapidly. The shape of the voltage pulses developed during the vertical pulse is shown in

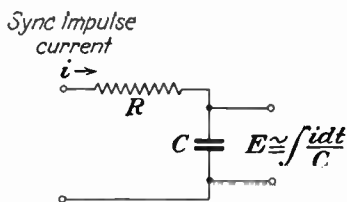

FIG. 222.— $RC$  integrating circuit.

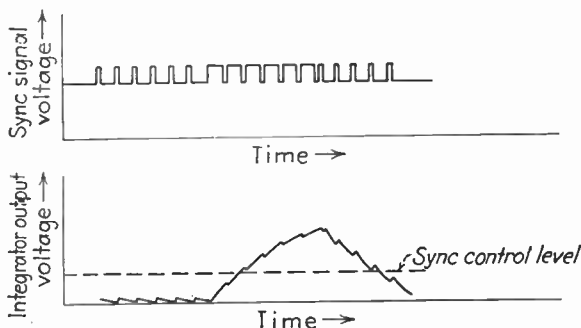

FIG. 223.—Integration of serrated vertical sync pulse and equalizing pulses. The instant of synchronization occurs when the integrated pulse passes through the sync control level. Very slight changes in waveform cause irregular synchronization, hence the need for equalizing pulses (cf. Fig. 97).

Fig. 223. The synchronizing action occurs during the leading edge of the pulse, and it is necessary (to avoid pairing of the lines) that the shape of the slope of this leading edge be precisely the same for each succeeding vertical pulse. The function of the equalizing pulse in maintaining equivalent charging current

during even and odd interlace fields has been discussed in Chap. IV.

The functions of differentiation and integration may be conveniently combined in the plate or grid circuit of a single tube (or in both plate and grid circuits of the tube). A typical example of such a combined circuit is shown in Fig. 224.

*Automatic-gain-control Circuits.*—The necessity for the automatic control of the r-f and i-f amplifier gain of television receivers is not so urgent as in ordinary radio receivers since the ultra-high frequencies display virtually none of the fading characteristics common in lower frequencies. However, the presence of several transmitting stations within range of a receiver and presenting widely varying different signal strengths makes automatic gain control desirable in switching from one station to

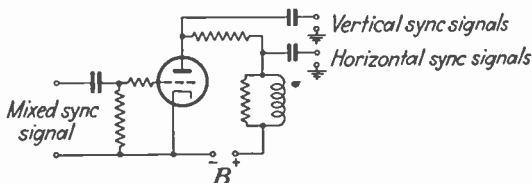

FIG. 224.—Combined waveform separator circuit in plate circuit of sync amplifier. The inductance differentiates the high-frequency pulses, while the resistor develops the low-frequency signals for integration.

another. Still another argument in favor of automatic gain control is the fact that changes in gain arising from slowly varying supply voltage produce very appreciable changes in the contrast of the picture. The eye is very critical of such changes, even when they occur slowly. Hence the automatic gain control serves the function of maintaining the contrast level constant regardless of any cause affecting the signal level up to the detector that develops the gain-control voltage.

The design of a-g-c circuits for television systems is complicated by the fact that the average voltage of the detector output is continually varying as the background level of illumination varies in the transmitted scene. These changes in average voltage have no relation to the required gain in the receiver. Consequently a-g-c systems for television must operate on a portion of the detector output voltage waveform which remains fixed, that is, either the blanking level or the tips of the sync pulses. Any change in this level, at the detector output, indi-

icates a change in signal strength or in gain, and consequently such changes may be used to correct the gain of the amplifier. The circuits shown in Fig. 218 are capable of developing an output voltage directly dependent on the blanking level, and consequently the voltage output of any of these circuits may be used, after direct-coupled amplification if necessary, for the controlling gain of the i-f and r-f amplifiers. For this purpose, it is desirable, as in conventional radio receivers, to use tubes of the remote cutoff type, which will display a minimum of cross-modulation with changes in control-grid bias. Tubes especially designed for this service are available but, in general, do not have as high  $g_m$  values as the tubes that have sharper cutoff character-

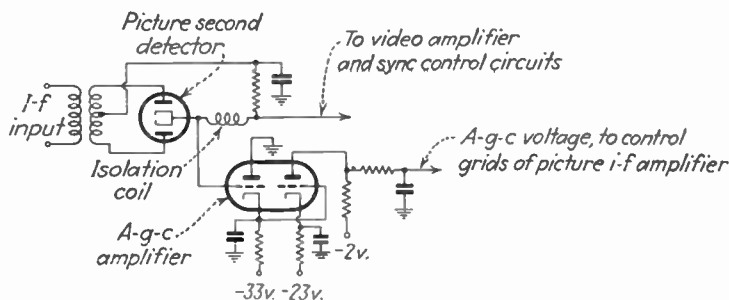

FIG. 225.—Typical automatic-gain-control circuit employing two stages of direct-coupled amplification.

istics. In the latter (high-gain) tubes, the effect of remote cutoff may be obtained by employing a properly by-passed resistance in series with the screen grid of the tube. The details of these arrangements are described in Chap. X. A typical a-g-c circuit is shown schematically in Fig. 225.

**55. Defects in Image Reproduction.**<sup>1</sup>—In Chap. II, several defects of image analysis, displacement of the picture elements, nonlinearity of scanning and aperture distortion were pointed out. These defects originate in the image-analysis process, that is, in the camera. Other defects arise in the transmission process, as we have seen. The principal faults are changes in waveform

<sup>1</sup> Image defects encountered in television-receiver installations are shown in Figs. 226 to 238. From "Practical Television," a service pamphlet compiled by the RCA Manufacturing Company, Camden, N. J., 1939.

WEST, S., Television Picture Faults and Their Remedies, *Television*, **11**, 342 (December, 1938); **12**, 14 (January); **11**, 87 (February); **11**, 148 (March); **212** (April); **11**, 278 (May) (1939).

due to inadequate amplitude and phase response vs. frequency and to amplitude nonlinearities that are introduced by the subsidiary transfer characteristics. Finally the process of image reproduction gives rise to defects of its own: the displacement of

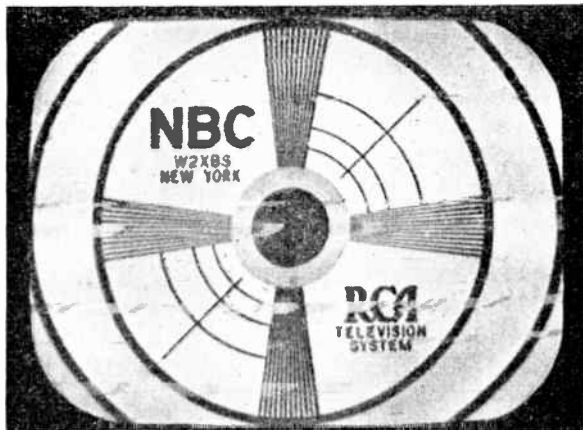

FIG. 226.—Tearing of lines due to loss of horizontal synchronization during excessive interference from an automobile ignition system.

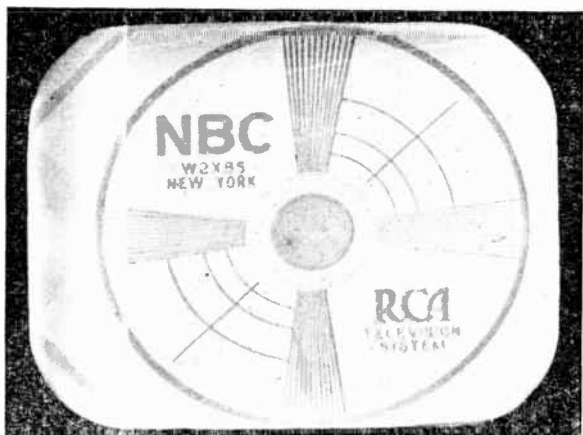

FIG. 227.—Nonlinearity of horizontal scanning due to failure of the damping rectifier circuit (*cf.* Fig. 86).

picture elements, nonlinearity of scanning, improper distribution of light in the scanning spot (including improper focus), improper average brightness level, and inadequate peak-to-peak signal amplitude. All these defects, whether they arise in the camera,

the transmission system, or the reproduction system, make their presence known in the reproduced image. When the image

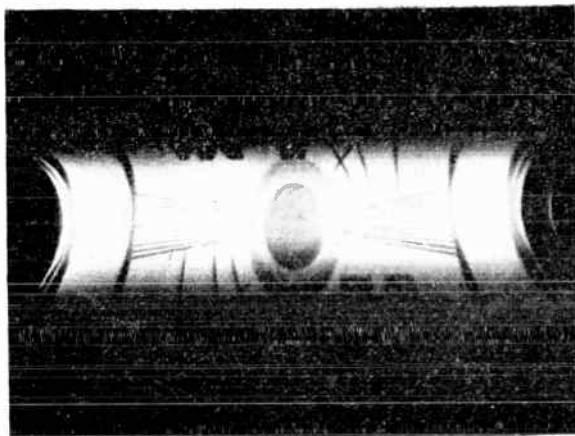

FIG. 228.—Variation in horizontal scanning amplitude and change in brightness from top to bottom of picture due to excessive ripple in the second-anode voltage, such as would occur when the filter capacitors fail. This pattern remains stationary only if the 60-c.p.s. power systems at transmitter and receiver are synchronized.



FIG. 229.—Tearing, phase distortion, and tone reversals resulting from excessive signal strength and too high a setting of the contrast control.

shows signs of these defects, the immediate problem is to locate their source, and this is not an easy assignment in most cases.

In the first place, one of the standard forms of test chart is highly desirable, since its content permits a quantitative estimate

of such items as the vertical and horizontal resolution of the picture. Without some such stationary test pattern as a foundation, it is virtually impossible to track down any but the most obvious faults in the image.



FIG. 230.—60-c.p.s. hum in the video signal circuit.

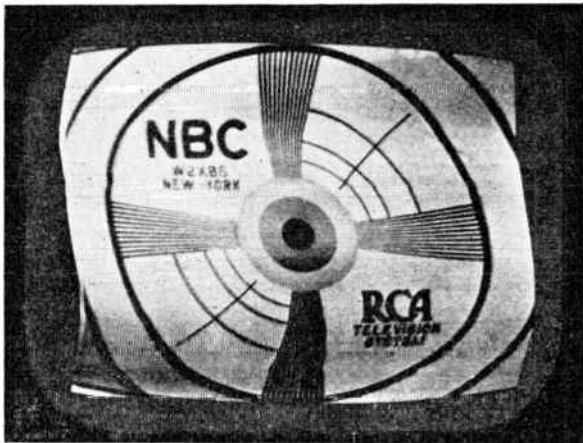

FIG. 231.—Hum (60-c.p.s.) in the horizontal deflection circuit or horizontal synchronizing circuit, or both.

Assuming that a standard tes -pattern transmission is available, it must further be assumed that the signal from the transmitter represents an image of known quality. If the scanning, blanking, synchronization, or shading in the camera circuit is

faulty, the defects thereby produced will appear in the reproduced image and may be indistinguishable from similar faults that may arise in the receiving system. Accordingly the trans-

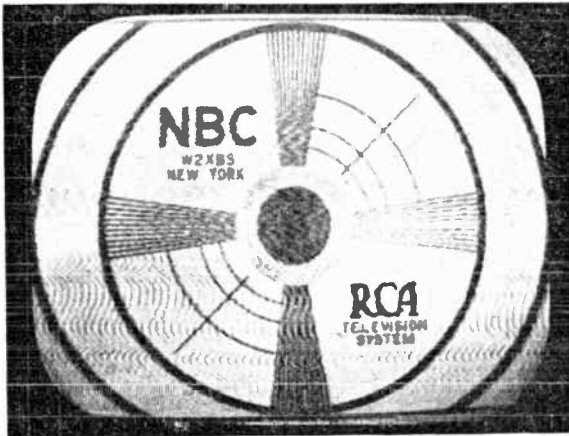

FIG. 232.—Stippled effect due to excessive interference from diathermy apparatus. The herringbone pattern results from frequency modulation of the diathermy interference.

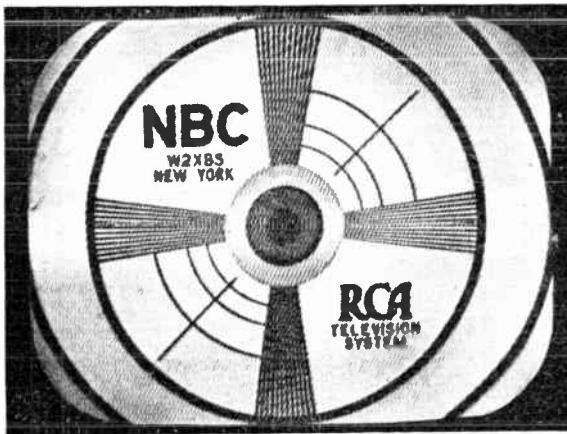

FIG. 233.—Regular interference pattern resulting from beat notes with a stable r-f or i-f carrier signal. Modulation of the interfering signal by audio frequencies shows up as a series of rapidly shifting horizontal dark bands.

mitted signal must be carefully monitored, and the quality of the transmitted image should be made known to the operator of the receiver before he can be sure that the observed defects actually arise in the receiver.



On the assumption of a transmitted signal the quality of which, both geometrically and photographically, is known to be adequate, it is possible to examine the defects in the reproduced

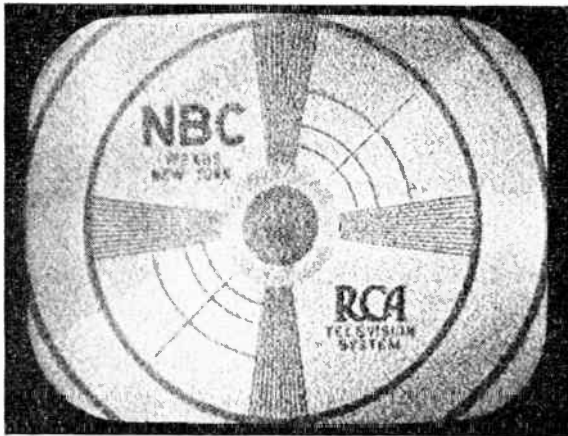

FIG. 234.—Interference caused by tube and circuit masking voltages (thermal agitation and shot-effect noise) usually associated with a weak signal and most clearly visible in the absence of other interferences.



FIG. 235.—Interference from audio frequencies in the signal circuit. May arise from cross-talk anywhere in transmission or reception system, but usually from inadequate trapping of sound intermediate frequencies at 8.25 or 14.25 Mc.

image and to trace their origin to parts of the wave-propagation and receiving systems, which operate subsequent to the transmitter output. The most obvious defects arise in the scanning



system. Several typical examples are shown in Figs. 226 to 231. Figure 226 shows "tearing" or displacement of individual lines in the image, due to faulty synchronization of the line-scanning generator. This example is occasioned by the presence

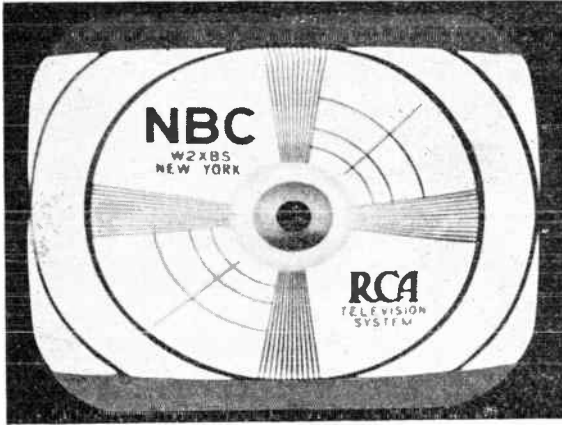

FIG. 236.—Incorrect aspect ratio resulting from insufficient vertical scanning amplitude.

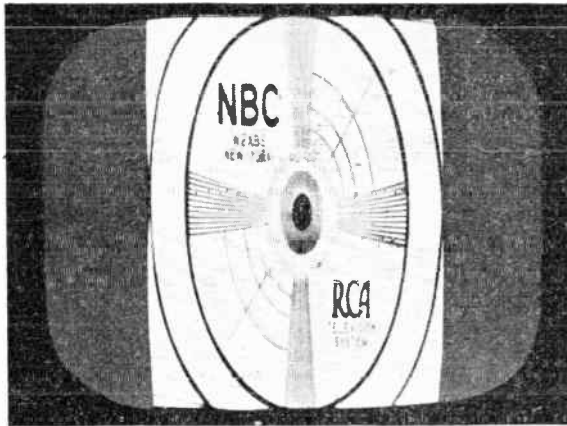

FIG. 237.—Incorrect aspect ratio resulting from insufficient horizontal scanning amplitude.

of interference from auto ignition systems. Nonlinearity of the horizontal scanning velocity occasioned by failure of the damping tube is shown in Fig. 227. Variations in horizontal scanning amplitude due to abnormally high ripple voltage in the

second-anode voltage supply is shown in Fig. 228. The effect of too high a contrast control setting, with consequent streaking and tearing of the lines is shown in Fig. 229. Figure 230 shows the presence of a 60-c.p.s. hum voltage in the control-grid circuit.

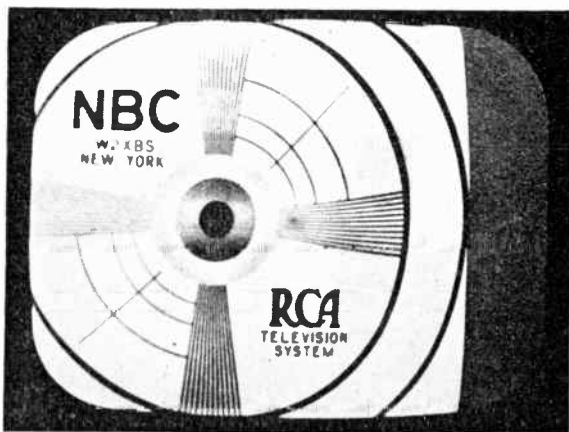

FIG. 238A.—Incorrect positioning due to excessive d-e component in horizontal scanning system.



FIG. 238B.—Incorrect positioning due to excessive d-e component in vertical scanning circuit.

Figure 231 shows a case of 60-c.p.s. ripple in the horizontal deflection circuit.

Problems arising from interfering signals are illustrated in Figs. 232 to 235. The first (Fig. 232) shows excessive diathermy

interference. Figure 233 shows beat frequency interference, arising from the beating of an interfering carrier with the picture carrier. The effect of noise is shown in Fig. 234, which shows plainly the reason for calling noise by the term "masking voltage." Sound modulation in the picture circuit is shown in Fig. 235. Figures 236 and 237 show incorrect aspect ratios, and Fig. 238 shows improper centering.

## CHAPTER IX

### TELEVISION BROADCASTING PRACTICE

The plant equipment of a television-broadcast station consists of a great many elements. The program usually originates in a studio designed either for the televising directly of people and objects or for the projection of motion-picture film. The studio contains one or more cameras, which are the first items of technical equipment in the communication chain. The camera contains some sort of image-perceiving and translating tube. Associated with the camera tube are the video signal preamplifier and the deflecting circuits. The video signal, on leaving the camera, is passed through specialized amplifiers that introduce the blanking level and sync pulses. The video signal is then viewed on a "monitor" image-reproducing tube, and the auxiliary circuits are adjusted until a satisfactory image is obtained. The video signal then travels through line amplifiers and coaxial transmission circuits (or through a radio-relaying system) to the transmitter proper. Here the voltage and power level of the video signal are raised to values high enough to modulate the output of the carrier-generating source. The modulated carrier wave is then imposed on a radiator, and the signal energy enters the surrounding space. At this point, the broadcasting process ceases, and the natural process of wave propagation takes charge, to be followed by the various receiving functions at the receiving set.

**56. Studio Facilities for Television Broadcasting.**<sup>1</sup>—Studios designed for public television service are as yet restricted in number. In this country, one of the representative plants is

<sup>1</sup> Published articles on studio facilities and practice include the following:

BEAL, R. R., Equipment Used in the Current RCA Television Field Tests, *RCA Rev.*, 1 (3), 36 (January, 1937).

EDDY, W. C., Television Studio Considerations, *Communication and Broadcast Eng.*, 4 (4), 12 (April); 5, 14 (May); 6, 20 (June); 7, 17 (July) (1937).

HANSON, O. B., Experimental Studio Facilities for Television, *RCA Rev.*, 1

that of the National Broadcasting Company. The following description is based on that installation:

The main studio, for "live-talent" presentations, is remodeled from a studio originally intended for sound broadcasting. It occupies a space of 50 by 30 ft. with a ceiling about 18 ft. high. The ceiling is fitted with adjustable lighting units which are controlled by rope-and-pulley mechanisms.<sup>1</sup> A powerful air-conditioning system is used to remove the heat radiated by the lighting system. Total lighting is provided to a level of about 75 kilowatts, including "flat" and "spot" lighting. This studio is fitted with three complete and independent camera circuits or "camera chains" with individual monitor and switching circuits.

A second studio is used solely for the televising of motion-picture film and lantern-slide images. Complete duplicate equipments for 35-mm. film are available. There are two cameras and associated circuits, which are so arranged that they can be moved from one projector to another on a track that accurately aligns each camera with the projected image. A third studio is available for televising "special effects" such as miniature sets, titles, and various close-ups that cannot be accommodated conveniently in the main studio.

All the cameras are of the iconoscope variety. A typical camera chain, of which there are six in the studio system, is shown in Fig. 239. The iconoscope tube itself feeds directly in the preamplifier which amplifies the camera output to a level of about 0.1 volt peak to peak, at which level it can be transmitted over coaxial circuits to the equipment outside the studio. The preamplifier is contained within the case of the camera proper. Also in this case is an amplifier that applies blanking impulses to the control grid of the electron gun in the iconoscope. These

---

(4), 3 (April, 1937).

LUBCKE, H. R., An Introduction to Television Production, *Jour. Soc. Motion Picture Eng.*, **33**, 54 (July, 1939).

MORRIS and SHELBY, Television Studio Design, *RCA Rev.*, **2** (1), 14 (July, 1937).

PROTZMAN, A. W., Television Studio Technic, *Jour. Soc. Motion Picture Eng.*, **33**, 26 (July, 1939).

<sup>1</sup> For a discussion of methods and practice in studio lighting see: EDDY, W. C., Television Lighting, *Jour. Soc. Motion Picture Eng.*, **33**, 41 (July, 1939).

impulses cut off the scanning beam during the vertical retrace intervals. The gun is deflected by a magnetic scanning yoke, which is fed from scanning current generators located in the equipment outside the studio. The deflecting currents are led to the camera over wires included in the signal cable.

The signal cable carries the output signal (0.1 volt peak-to-peak) to a room immediately adjoining the studio. This room, the control booth, is so placed that it commands a view of the entire

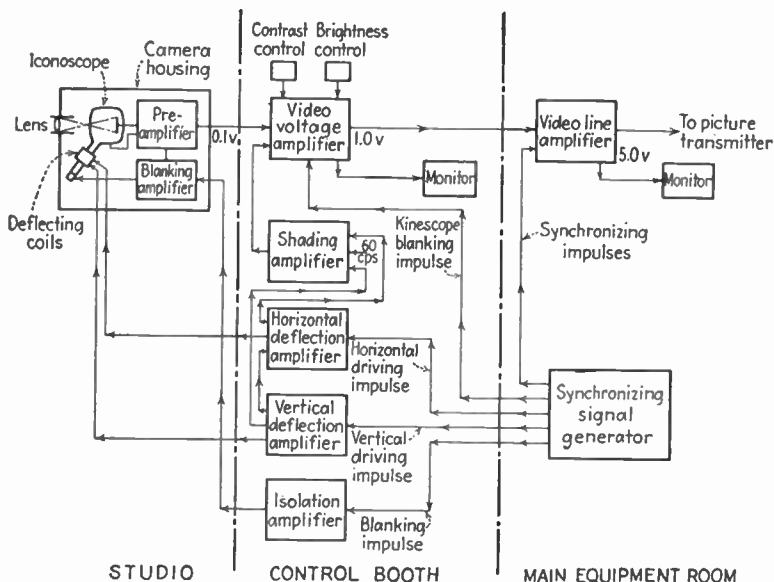

FIG. 239.—Equipment for a single camera chain in the NBC New York City studios. Six chains are provided, each similar to the above, except that the synchronizing signal generator is common to all.

studio. The equipment in the control room is essential not only to supply the scanning currents mentioned above, but also to mix the signal output of the camera with blanking signal as well as with the vertical and horizontal sync impulses. The main item of equipment, as shown in the diagram, is the video control amplifier, which has five functions: to increase the voltage level of the signal from 0.1 to 1.0 volt peak-to-peak, to introduce properly timed shading-correction signals, to fix the average brightness of the reproduced image, to fix the over-all contrast of the image with respect to the background level. The sync pulses are added

in the line amplifier. These functions, as explained more fully in Sec. 57, are carried out by applying two sets of impulses to separate amplifiers feeding a common load impedance.

The output of the video control amplifier feeds two outgoing circuits. One goes directly to an image-reproducing tube, the "monitor," on which the image appears. Any defects of shading, contrast, over-all brightness, or synchronizing appear at once in this image. To aid in the analysis of image faults, a cathode-ray oscilloscope is employed to trace the output voltage of the control amplifier against time. The controls of this oscilloscope permit the examination of from one single line to a complete frame and checking of the blanking and sync performance throughout the entire frame interval. The screen of the oscilloscope is mounted to one side of the image-reproducing tube associated with it. Three complete sets of monitoring equipment (monitor tube and oscilloscope, etc.) are provided, any of which can be connected to any of the three camera chains.

The outputs of the cameras and their associated amplifiers are arranged so that they may be switched to the outgoing line from the monitor booth. This outgoing line travels to the "main equipment room" located several floors below the main-studio section. Here the composite video signal is amplified by a line amplifier which raises its peak-to-peak level to 5.0 volts, at which level it may be transmitted over coaxial cable several thousand feet to the transmitter proper. A monitor reproducing tube and oscilloscope are provided at the output of this line video amplifier to examine the image after amplification and to detect any impairment of the picture quality or sync performance.

Also located in the main equipment room is a most essential piece of equipment, the synchronization generator. This device is the fundamental timing source of the system. The generator consists, in part, of an oscillator tuned to 31,500 c.p.s. and maintained accurately in synchronism with 60-c.p.s. power-supply frequency of the station, by means of a circuit similar to the automatic frequency control circuit. Then by employing frequency-dividing circuits (multivibrators) the 31,500 c.p.s. is divided in frequency divisions of 7, 5, 5, and 3, successively. The product of  $7 \times 5 \times 5 \times 3$  is 525, hence the final frequency is

$$\frac{31,500}{525} = 60 \text{ c.p.s.}$$

This signal acts as the timing impulse for field-scanning synchronizing and is maintained in synchronism with the 60-c.p.s. supply frequency. The horizontal sync timing is accomplished directly from the 15,750-c.p.s. oscillator. The net result is that two frequencies, 60 c.p.s. for the field-repetition frequency and 15,750 c.p.s. for the line-scanning frequency, are obtained in synchronized relation.

The timing generator is used to control the formation of the several different forms of square-wave sync pulses, which are specified in the standard N.T.S.C. standard form of the composite video signal. The pulses (shown in Figs. 99 and 100, pages 170 and 171) are formed from sine waves of the 15,750-c.p.s. frequency generated in the timing generator. The sine wave is passed through a succession of shaping tubes, which cut off the upper portions of pulses (the process called clipping) and which steepen the sides of the remaining pulse by a series of differentiating actions, using resistance and capacitance combinations. The details of these functions are given in Sec. 58. The result is that properly shaped and accurately timed pulses are available from the synchronization generator. These pulses are conveyed by coaxial cable to the control amplifier and to a separate iconoscope blanking amplifier (Fig. 239).

The synchronizing timing generator and impulse sharper employ about 70 vacuum tubes. The generator is kept in operation continuously, night and day, to avoid variations in the output waveform that would be occasioned by the warming-up process if the equipment is turned on before each broadcast.

**57. Camera and Preamplifier.**—A close-up view of a typical iconoscope camera is shown in Fig. 240. The camera is mounted on a standard which permits its being moved vertically upward and downward or being swung through angles in the horizontal and vertical planes. By virtue of the universal mounting, the camera may be aimed in any direction and may be moved about at the will of the camera operator. The whole standard of the most active camera is mounted on a perambulator or "dolly," which permits its being moved rapidly and silently over the floor of the studio.

On the front face of the camera enclosure are fixed two green lamps. The lamps indicate that the camera is in action and is "on the air." They are used to indicate to the performer when



his cue has arrived and to warn him when the camera takes over the televising of a scene and when it is released. The lamps are controlled by switches operated by the video-control engineer in the monitor booth. This engineer is in telephonic communication with the camera operator.

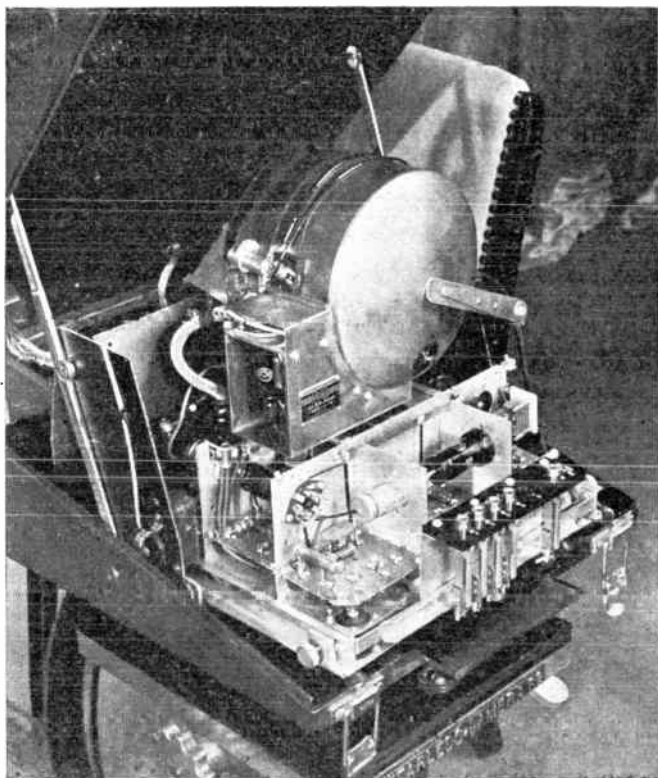

FIG. 240.—Interior view of a typical iconoscope camera in the NBC studios. Note bias-lighting fixtures at edge of shield, first amplifier stage (center), and remaining preamplifier stages (foreground).

The camera is fitted with two identical lenses. The first forms an image on a viewing screen which serves to indicate to the operator the composition, sharpness of focus, and depth of focus of the image. The other lens, which is adjusted simultaneously with the indicator lens, serves to throw the image of the studio scene on the mosaic plate of the iconoscope. This lens must necessarily be of sufficiently long focal length to encompass the

glass enclosure of the iconoscope itself. For ordinary studio work, the lens is an  $f/4.5$  lens of 6.5 in. focal length, suitably corrected against spherical and chromatic aberrations. The angle of view of the camera, using a lens of this type, is of the order of  $37^\circ$ , measured on a horizontal plane which bisects the field of view. Another camera, used for obtaining "close-up" shots at a distance from the performers, uses a similar lens of 14 in. focal length and takes in a field of view, similarly measured, of  $13^\circ$ .

The iconoscope tube itself has already been described in detail in Chap. III, and hence no detailed description is needed here. The electrical equipment associated with the iconoscope within the camera, on the other hand, is worthy of special mention. The principal item of equipment included within the camera housing is the preamplifier, the initial amplifier of the camera signal. This amplifier must be very carefully designed since it determines, with the iconoscope itself, the quality of the signal that is thereafter available to the rest of the system.

*Iconoscope-preamplifier Design.*<sup>1</sup>—The principal problem of design in the camera preamplifier is that of obtaining a high signal-to-mask ratio. It is necessary to use circuit arrangements that give a maximum of useful signal voltage, relative to the mask voltages generated in the coupling resistor at the input to the first amplifier stage as well as to those generated by shot effect in the space current of the first amplifier tube. These requirements are met by using a high value of coupling resistor and by designing the first amplifier stage to have high gain. Both of these arrangements tend to impair the high-frequency response of the amplification, so it is necessary to apply high-frequency compensation in a succeeding stage. Finally it is necessary to develop a signal of 0.1 volt peak-to-peak before the signal is imposed on the coaxial line running to the monitor booth, and this signal must be applied across a coaxial line having a low value of surge impedance, approximately 75 ohms. This means that the output stage of the preamplifier must be of the low-impedance variety. In practice, a cathode-coupled stage ("cathode-follower") is used to obtain the low output impedance.

<sup>1</sup> BARCO, A. A., Iconoscope Preamplifier. Report LB-448 of the RCA License Laboratory. Information made available by special permission. See also: *RCA Rev.*, 4 (1), 89 (July, 1939).

The following description is patterned after an iconoscope preamplifier developed by the RCA License Laboratory staff and described by Allen A. Barco. The information is reprinted by permission.

The amplifier, shown in block diagram in Fig. 241, contains a total of five tubes all of which are type 1851 (high-transconductance low-plate-current type). The first tube accepts the signal from the iconoscope across the coupling circuit. The problem here is to keep the shunt capacitance and the masking voltages low. Careful design in wiring, etc., and the use of a shield surrounding the iconoscope envelope aid in keeping the capacitance low. The thermal noise ratio is kept low by making use of the fact that the mask voltage increases with the square root of the coupling resistance value, whereas the signal varies with the first power of that resistance. It is consequently desirable to

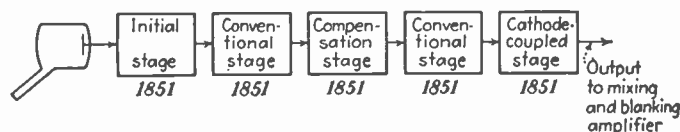

FIG. 241.—Block diagram of iconoscope preamplifier, designed for maximum signal-to-mask ratio and compensated for high-frequency response.

use as high a value of coupling resistance as possible consistent with frequency-response considerations. The effective value of the coupling resistance used in this case is 300,000 ohms, with an effective shunt capacitance of 8  $\mu\text{mf}$ . These values produce a poor high-frequency response characteristic, but this defect is compensated in the third stage. The diagram is in Fig. 242.

To reduce the effective input capacitance, the first amplifier is used with an unbypassed cathode-bias resistor. The mosaic plate is maintained slightly positive with respect to the collector ring by connecting the ring to the cathode and filtering with the capacitance to ground. The bias for the amplifier tube is taken from a tap on the cathode-bias resistor. The iconoscope capacitance-reducing shield is connected to the amplifier cathode. Finally, two resistors are connected between the mosaic plate and ground (of 5 megohms and 7500 ohms) and a tap is taken off between them, leading to the shading-correction generator which supplies synchronized voltages to compensate for the spurious signal generated in the iconoscope (see Sec. 19, page 101).

The stage following the initial amplifier is simply a high-quality video amplifier designed for proper phase and amplitude responses up to 5,000,000 c.p.s. Its purpose is to raise the level of the signal to a point where masking voltages are no longer a factor.

The next stage introduces compensation for the inadequate high-frequency response of the first stage. The method of compensation employs a bifilar winding of two inductors in the plate circuit. The mutual inductance of this winding is so

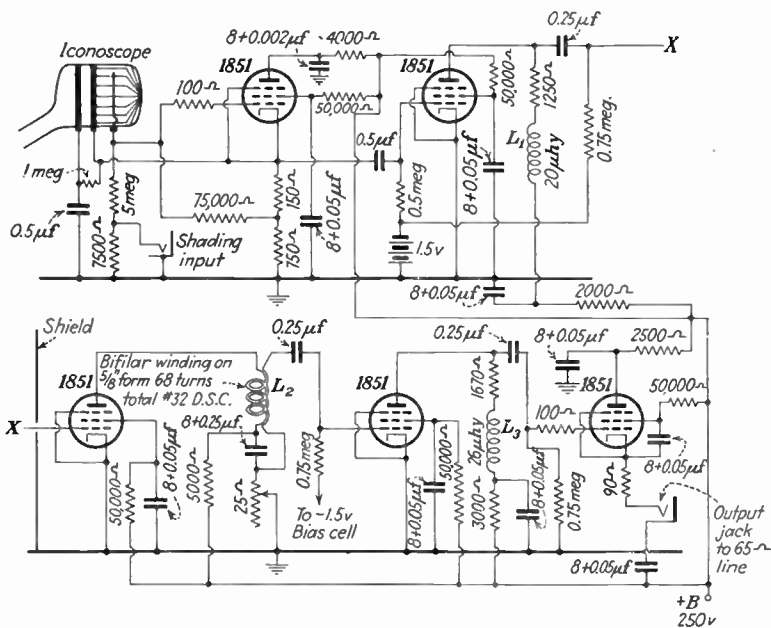

FIG. 242.—Complete diagram of iconoscope preamplifier.

placed in the circuit that the impedance of the power supply is effectively eliminated. Since this is the case, a very small value of load impedance  $R_o$  may be used in this stage (actually less than 25 ohms). By adjusting the value of this load impedance, a wide variation of compensation (up to 50 to 1) of the upper frequencies may be obtained. Actually the compensation is determined by making the inductance-to-resistance ratio of the load impedance in this stage equal to the resistance-capacitance product of the initial coupling connection. The values of 300,000 ohms and 8  $\mu\text{f}$  in this the coupling connection may accordingly

be compensated by values of  $L = 15$  microhenries and  $R = 6.25$  ohms in the plate load of the third stage, provided that  $R$  actually has this low value. The low value can be realized if the power-supply impedance is neutralized by the mutual impedance, as shown.

The fourth stage is like the second, that is, it is a simple video amplifier having good phase and amplitude-frequency characteristics up to and including the 5,000,000-c.p.s. limit. The final output stage is a typical cathode-coupled stage for feeding a 75-ohm line. A cathode resistor of 90 ohms is used, as shown in Fig. 242. The far end of the line is terminated in 65 ohms, which adds to the 90 ohms in determining the value of cathode-bias voltage actually applied to the fifth stage. The power supply is carefully regulated to provide d-c and a-c heater voltages at their rated values within a few per cent.

It should be noted that the capacitive coupling connection employed between the mosaic and the signal plate removes the d-c component and an arbitrary bias value is substituted in its place. The d-c component must be determined and reinserted at a later stage. The manner in which this is done, either manually or automatically, is described in connection with the control amplifier in the following section.

**58. Control Amplifier (Mixing and Blanking Amplifier).**<sup>1</sup>—The video signal supplied by the output of the camera preamplifier is only one part of the composite video signal. As shown in Sec. 28 (page 167), the composite signal must contain, in addition, blanking components, which erase the scanning spot during the retrace intervals, and also vertical and horizontal synchronization pulses, which control the scanning generators. The blanking and sync-impulse portions of the composite signal are added to the camera signal impulses in an amplifier specially designed for this purpose and known either as a *control amplifier* or a *blanking and mixing amplifier*. The present section describes a typical control amplifier based on the design of Allen Barco of the RCA License Laboratory.

The amplifier, shown diagrammatically in Fig. 243, has three input terminals: (1) for video (camera signal, output of preamplifier), (2) for blanking, and (3) for sync signals. The latter

<sup>1</sup> BARCO, A. A., A Video Mixing Amplifier. Report LB-453 of the RCA License Laboratory. Information made available by permission.

two components are supplied by the timing and synchronized impulse generator, described in the next section. The output of the amplifier is the composite video signal, having the standard dimensions of the R.M.A. Standard T-111, described in Sec. 28.

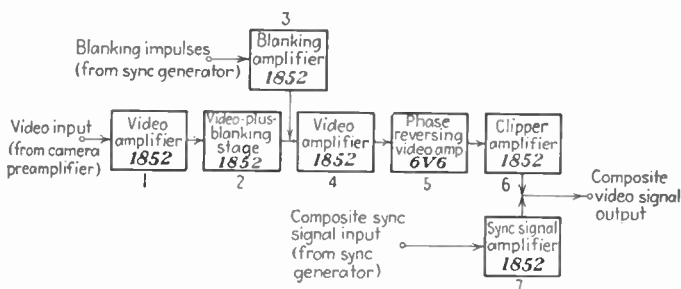

FIG. 243.—Block diagram of control amplifier (blanking and mixing amplifier) which produces the composite video signal from its camera, blanking, and synchronization components.

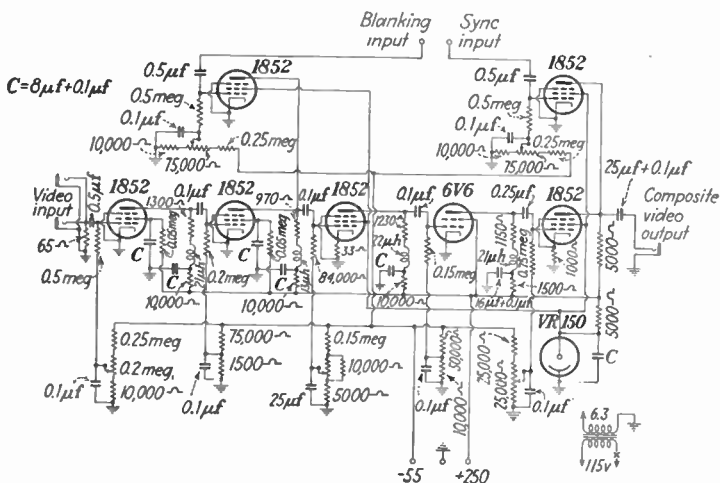

FIG. 244.—Complete circuit diagram of video control amplifier. The video input is derived from the circuit in Fig. 242, whereas the blanking and sync signals are derived from the circuits in Figs. 254 and 255.

With reference to Fig. 244, it will be seen that the first amplifier in the chain is a conventional video amplifier that passes the camera signal to the next tube. The plate of the second amplifier tube is joined to the plate of another tube (the blanking amplifier tube). These two tubes (numbered 2 and 3 in the diagram)

have a common load impedance the value of which is about one-half as great as would be used with a single tube. Tube 3 receives the blanking impulses from the sync generator. In the common load impedance, therefore, the picture-scanning impulses and the blanking signals are mixed together. The mixed signal, which is passed on to the next stage (tube 4), has the shape shown in Fig. 245. The blanking level actually shown is that which persists during the horizontal retrace interval, but the effect is the same during the vertical retrace. During the horizontal retrace shown, the camera tube actually delivers a signal, owing to the transient voltages developed during the retrace and also to the action of the shading correction signals. The camera output during the blanking period is of course an

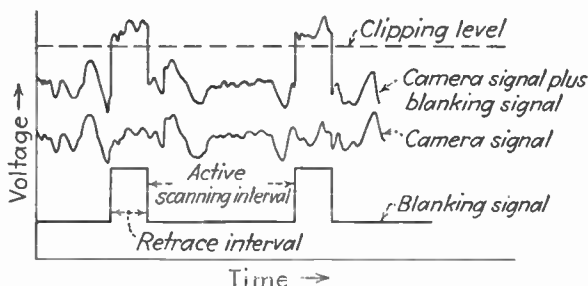

FIG. 245.—Combination of blanking signal (bottom) and camera signal (middle) to form a semicomposite signal which can be clipped at the blanking level.

undesired signal, and it must be removed. Figure 245 shows how the removal is accomplished. The blanking level, imposed during the retrace time, raises the undesired camera output signal to a higher level, well above the level of the desired (active) camera impulses. The signal shown in Fig. 245 is then passed through a tube that refuses to pass any signal above the level shown by the dashed line. This level is sometimes known as the *pedestal*, since it is the level on which the sync impulses are later imposed. The tube that performs this limiting function is known as a “clipper” amplifier. It consists of a tube operated with a large negative grid-bias voltage and arranged with the proper polarity to cut off the plate current when the signal level goes more negative than the pedestal level. The action of the clipper is improved by using a high value of cathode resistor, unbypassed. In the amplifier shown in Fig. 244, two video



amplifier stages are interposed between the first mixing tube (tube 2, for combining blanking and picture) and the clipper tube.

The clipper tube also acts as one of a pair of tubes in a mixing combination, since its load impedance acts in common with the sync amplifier tube (number 7). In the grid circuit of the latter

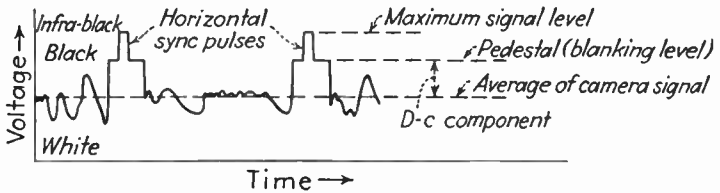

FIG. 246.—Addition of sync signals to the semicomposite signal (Fig. 245) produces the complete composite video signal.

tube, the sync signals from the sync generator are imposed and hence are imposed on the pedestal level, which is determined by the clipping action of tube 6. Across this load impedance appears the final composite video signal. The assumption of the composite form from the three components (picture, blanking, and sync) is shown graphically in Figs. 245 and 246.

The control amplifier contains several controls for varying the gain of several stages. The level of the blanking signal is con-

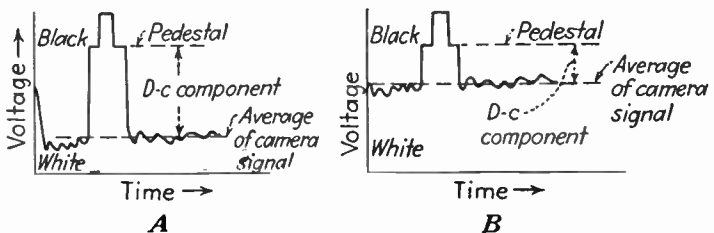

FIG. 247.—Control of the average picture brightness by variation of the pedestal height. By increasing the pedestal height in the control amplifier, the picture may be made brighter, provided the pedestal height remains constant in the rest of the transmission system.

trolled by a voltage divider in the grid circuit of tube 3. The video gain (which controls one aspect of the picture contrast, namely, its a-c component) is controlled by varying the grid-bias voltage of tube 1. The level of the semicomposite signal (picture and blanking, but without sync signals) is controlled similarly by grid-bias voltage variation.



The level at which the clipping action of tube 6 occurs is controlled by the value of grid-bias voltage applied to the clipper tube grid. This control is of great importance in the operation of the entire television system, since it determines the pedestal height, which is used as the "black" reference level throughout the rest of the system. The function of the pedestal height is illustrated in Fig. 247. The average level of the camera signal for one line is shown by the dashed line. The black level is determined by the pedestal level, and the difference between the pedestal and the camera signal average corresponds to the average light content of the reproduced picture. If the scene is a bright one, the average brightness is high and the difference between picture average and pedestal must be large. On the other hand, if the average brightness is low, the difference between picture average and pedestal is correspondingly small. The difference between picture average and pedestal level is, in other words, the d-c component of the picture signal, and if the reproduction is to be accurate, the d-c picture component must correspond with the average brightness which actually exists in the studio or which it may be desired to portray. The d-c level of the picture, as picked up by a storage type of camera tube, is eliminated by the capacitive connection between mosaic and signal circuit. In the nonstorage type of camera, the d-c level may be delivered to the signal circuit if conductive coupling is used, but if capacitive coupling is used between the video stages before the pedestal level is inserted, the d-c component is lost. Consequently, in general, it is necessary to insert the proper d-c level by properly adjusting the pedestal height.

The insertion of the d-c level consists simply of setting the pedestal level at the required value and then seeing to it that this level is used as the black reference level for the entire system. The pedestal height may be controlled automatically or manually, depending on the needs of the subject to be transmitted.

Automatic control of the pedestal level is obtained, with storage-type cameras, by employing a phototube which views the scene or film to be broadcast and which develops an average photoelectric current that is directly proportional to the average brightness, which is inserted directly as the control bias of the clipper amplifier tube. This method of control is used at present primarily in connection with motion-picture film. In

this type of film, the changes in brightness level may be extremely rapid and wide in range, and consequently difficult to follow with a manual control. In studio work, and for live-talent broadcasts generally, the lighting conditions are more or less under control, and sudden changes in level occur less often than in films. In consequence, it is usually possible for an operator to reinsert the d-c level by a manual pedestal-height control. There are other reasons for having the d-c restoring control directly under the control of the operator. One is the effect of changing high-light detail, relative to shadow detail, which results from varying the d-c component relative to the a-c component (see Sec. 54, page 368). Also, the independent control of average brightness vs. brightness range has its uses in correcting the limitations of the television camera tube.

The output of the control amplifier (Figs. 246 and 247) is usually delivered at a level of about 1.0 volt, peak to peak. This signal is then fed by coaxial cable to the video line amplifiers. Here, and in all succeeding amplifiers, the waveform consists not only of the camera-signal impulses but also of the blanking level and sync signals that form a part of the composite signal. It will be noted that all the input and output circuits of the various amplifiers are terminated in resistors of approximately 75 ohms, which match these circuits to the surge impedance of the coaxial lines used.

**59. Synchronization Signal Generator.**<sup>1</sup>—The timing center of the television system is the synchronization signal generator, which produces the blanking signals, the horizontal sync signals, and the vertical sync signals, all properly timed to produce an accurately interlaced scanning pattern of 525 lines and 30 frames per second.

In the following description, which is based on the design of Harmon B. Deal of the RCA License Laboratory, detailed theoretical considerations are omitted in favor of a point-by-point discussion of circuit functions.

The generator is divided into two sections, a *timing unit* and a *wave-shaping* unit. The timing unit establishes the basic periodicity of the system and relates it to the frequency of the

<sup>1</sup> DEAL, H. B., Television Signal and Blanking Signal Generator, Report LB-452 of the RCA License Laboratory. Information made available by permission.

power-supply system. The pulses generated by it are used in turn to control the wave-shaping unit which produces impulses having the shape required by the RMA standard signal, that is, having the prescribed duration and steepness of waveform. The wave-shaping unit also delivers blanking signals of the proper duration which, together with the sync signals themselves, are applied to the control amplifier previously described.

**Timing Unit.**—A block diagram of the timing unit is shown in Fig. 248. The first tube (6A8) is a pentagrid converter tube, the oscillator section of which is connected as a Colpitts oscillator tuned to the basic line-scanning frequency of 13,230 c.p.s. The mixing section accepts the output of the triode section and

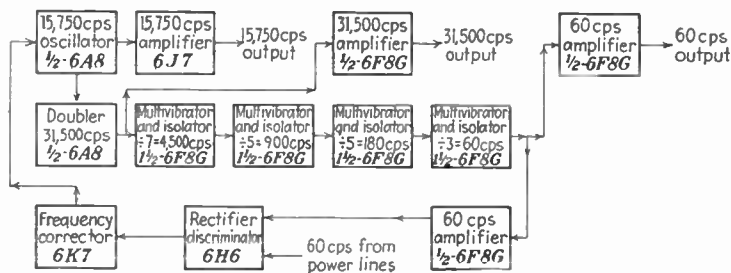

FIG. 248.—Block diagram of the timing unit of the synchronization signal generator, which produces 60-c.p.s. and 15,750-c.p.s. timing impulses and coordinates them with the power supply.

doubles the frequency, to 31,500 c.p.s. This frequency-doubling action is necessary to obtain a basic frequency from which can be produced the 60-c.p.s. field-scanning signal solely with the use of frequency-dividing circuits that operate on odd sub-harmonics. This requirement is necessitated by the odd-line method of interlacing. Following the frequency-doubling stage, an amplifier is used to remove completely any remaining traces of the 15,750-c.p.s. frequency, leaving only the 31,500-c.p.s. second harmonic. This frequency is then divided in a series of four multivibrators, set to give the following divisions: seven times (to 4500 c.p.s.); five times (to 900 c.p.s.); five times (to 180 c.p.s.); and finally three times (to 60 c.p.s.). Between each of these multivibrators is used a simple isolating amplifier stage. From the original oscillator to the final 60-c.p.s. output, there are then a total of 10 tubes, *i.e.*, 4 multivibrators, 5 buffer amplifiers, and the pentagrid oscillator doubler. The multi-

vibrators and buffer amplifiers can be built conveniently with double-triode tubes. A typical multivibrator and buffer stage (that for the first seven-fold division) is shown in detail in Fig. 249. This array of tubes, although cumbersome, is stable in operation and not subject to change due to aging of the tubes.

The final 60-c.p.s. signal derived from the multivibrator chain is then compared with the 60-c.p.s. frequency of the power supply. It is desirable, of course, to tie these two frequencies together, since the whole transmission system is thereby stabilized with respect to variations arising in the power-supply frequency. If the receiver is fed from the same power-supply system as the

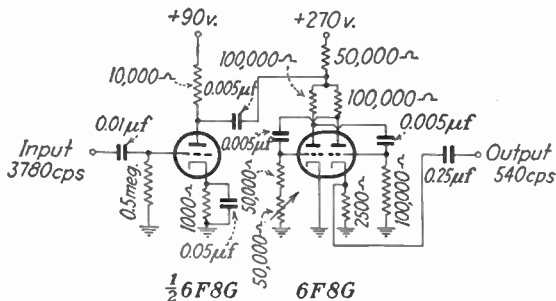

FIG. 249.—Typical multivibrator stage in the timing unit, used to obtain a division of 7 times. The first tube is the isolation amplifier, the second (double triode) the multivibrator proper.

transmitter (as is often the case, since the transmitter's service radius is restricted), the same advantage applies to the receiver as well. If the receiver is on a separate power system, adequate filtering of the power supply in the receiver is necessary to avoid instability of interlace and similar faults arising from the lack of synchronism between the power-supply frequencies.

The manner of tying in the power frequency with the frequency derived by frequency division is shown in Fig. 250. The 60-c.p.s. output from the frequency-divider system is first passed through an amplifier and then to the center tap of the secondary winding of a 60-c.p.s. transformer, the primary of which is connected to the a-c power supply. The locally generated 60 c.p.s. (obtained by frequency division) is applied to a double-diode tube. The power-system 60 c.p.s. is applied to the diodes also, but in two opposed phases. The diode rectifier converts the power-system 60 c.p.s. into full-wave

rectified direct current. If the locally generated and power-system frequencies are in phase, the rectified d-c voltage is derived principally from one diode, since the voltages on the other are opposed. On the other hand, if the local 60 c.p.s. tends to drift out of phase with the power-supply frequency, the a-c voltages fed to the two diode cathodes then become more or less equal depending on whether the phase advances or retards. In consequence, the rectified voltage rises if the phase displacement occurs in one direction and falls if it occurs in the other.

The rectified output of the diodes is then filtered in a highly effective filter (necessary to prohibit any a-c frequency modulation of the controlled oscillation). The filtered direct current

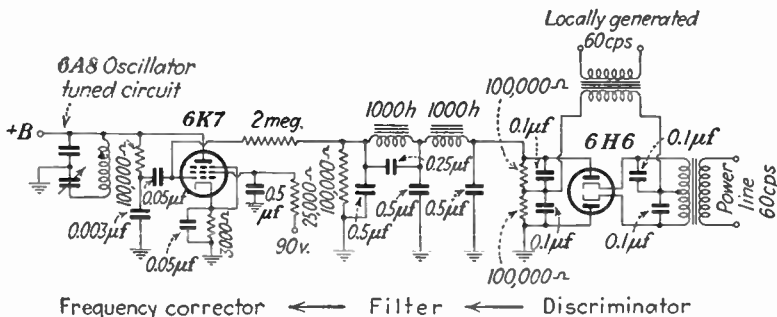

FIG. 250.—Frequency-correction circuit of the timing unit, which controls the frequency of the 15,750-c.p.s. oscillator when a difference develops between the 60-c.p.s. timing signal and the 60-c.p.s. power-supply frequency.

is then applied to the grid of a pentode control tube, the output capacitance of which varies with the applied grid voltage. This output capacitance is used as part of the tuned circuit that develops the 15,750 c.p.s. from which the locally generated 60 c.p.s. is originally derived. The polarity of the voltage that produces the tube-capacitance changes is such that the frequency of the 15,750-c.p.s. oscillator is changed to restore the synchronism between the two 60-c.p.s. sources. In consequence, perfect synchronism is maintained continuously and automatically, provided that the system is protected from sudden surges. To avoid the latter contingency, carefully regulated power supply is a prime necessity. The timing of the system is thus established at two frequencies, 15,750 c.p.s. for the line scanning and 60 c.p.s. for the field scanning. The two frequencies are derived from the same source without the use of



even subharmonics in the frequency divisions, and the whole is synchronized with the power frequency.

To obtain the two timing pulses, separate output amplifiers are employed. In the 15,750-c.p.s. case, two stages are used, both tuned to eliminate any trace of the 31,500-c.p.s. second harmonic. In the 60-c.p.s. case, a single resistance-capacitance coupled stage is used. Jacks are provided for examining (on an oscilloscope) the wave shapes produced by the various multivibrator circuits, and an output terminal is also provided for inspecting the phase of the 60-c.p.s. output with respect to the power-supply frequency.

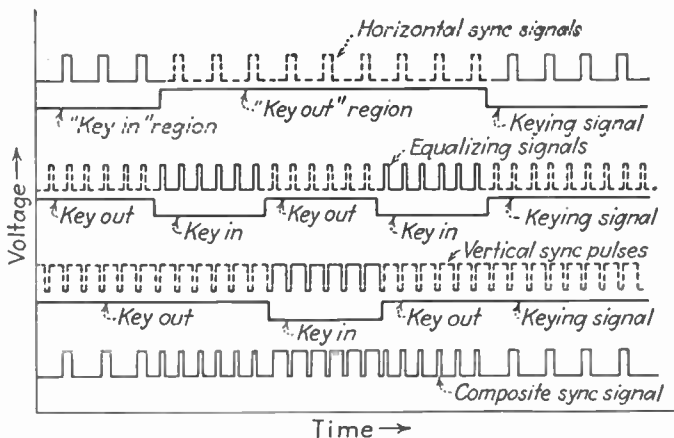

FIG. 252.—Synthesis of the composite sync signal (bottom) from regular periodic impulses which are keyed in and out at the proper times.

*The Shaping Unit.*—The shaping unit is considerably more complicated than the timing unit, largely because its functions are much more complex. To understand fully what is required of the shaping unit, we should refer to the N.T.S.C. Standard Composite Video Signal, described in Sec. 28. This signal consists of the camera impulses during the active scanning time. Between each line, however, a *line-retrace blanking signal* is required, and superimposed upon it is the *line (horizontal) synchronization signal*. When the last active line in the image is scanned, the *frame-retrace blanking signal* begins, and superimposed upon it are the *horizontal sync signals*, the *equalization pulses*, and the *vertical sync pulse*. The detail of these signals is shown in Fig. 252 (see also Figs. 98, 99, and 100, page 171).



The principal difficulty associated with these various signals is the fact that they do not occur with simple regularity. Only the horizontal sync pulses occur more or less regularly, and even then there is an exception during the vertical-sync-pulse interval, when the pulses have an inverted shape. The equalization pulses occur only twelve times during the frame interval, immediately preceding and following the vertical sync pulse. The blanking levels are maintained for durations within narrowly specified limits. Finally, the vertical sync pulse occurs at a specified point within the field-blanking interval and endures for a specified length of time. It is obvious that these irregularly placed signals of various shapes, all of which must be accurate to within a fraction of a microsecond, must be formed by equipment at once flexible and stable. This accounts for the fact that a great many tubes (2 diodes, 41 triodes, and 5 pentodes, which are combined within 28 separate tube envelopes) are required in the shaping unit.

To produce such irregularly spaced pulses from tube pulse generators that operate regularly, it is necessary to employ what are known as "keying" circuits. A keying circuit employs a tube that allows signals to pass through at specified intervals and for specified lengths of time. A typical keying tube consists of a pentode or tetrode the control grid of which receives the signals to be passed or blocked ("keyed in" or "keyed out," respectively), whereas the keying signal itself is applied to the screen grid of the tube. Such tubes are used for removing the horizontal sync pulses during the vertical sync pulse, for inserting the equalization pulses immediately before and after the vertical sync pulse, and for inserting the vertical sync pulses. All these operations occur once every field, that is, sixty times per second. Consequently the keying signals applied to the screen grids of the keying tubes are derived from the 60-c.p.s. unit in the form of flat-top voltage waves of the required lengths to include or omit exactly the right number of pulses (equalizing, vertical, or omission of horizontal) required.

In addition to this keying system which includes (or omits) the various types of pulses in the proper sequence, it is necessary to provide circuits for obtaining the proper shape of pulse. Three operations are necessary for this function: clipping, narrowing, and delay (integrating) circuits.



The clipping operation has previously been described (Fig. 245). It consists of passing a signal through a tube that has a sharp plate-current cutoff characteristic with respect to grid voltage. The input signal is given such polarity that the region of the signal to be clipped extends into the negative grid-voltage region beyond the cutoff point. The wave of current resulting in the plate circuit of the tube is thus given a flat top. If this flattened signal is passed through another clipping stage, the phase-inversion characteristic of each stage will result in clipping the peak of the wave passed by the previous stage. It is thus possible to flatten both positive and negative peaks of a wave by passing it through two clipping stages.

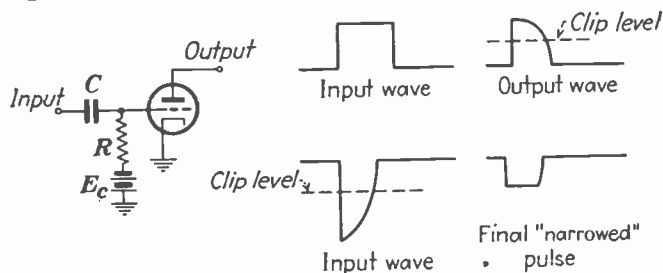

FIG. 253A.—The narrowing function in wave-shaping circuits. The initial square wave is passed through the differentiating circuit ( $RC$  circuit, left) and clipped (upper right). Then the portion above the clip level is amplified and clipped again. The final pulse is thus narrowed but not delayed.

The opposite of clipping action is the narrowing action of the circuit shown in Fig. 253A. This is the familiar differentiating circuit consisting of a series capacitance and shunt resistance. This circuit tends to pass high frequencies, while discriminating against the low. When a wave of approximately square shape is passed through this circuit, the high-frequency components associated with the steep sides of the wave are passed, while the lower frequencies associated with the flat top are attenuated. The result is that the wave becomes narrow and steep after passing through the differentiating circuit.

An integrating action (Fig. 253B) is obtained from a circuit having series resistance and shunt capacitance. The principal use of this action is to delay a pulse by some specified amount, to obtain accuracy in the line-up of the composite signal. When a square wave is impressed on an integrating circuit, the high frequencies associated with the steep sides of the pulse are attenu-

ated, while the low-frequency flat top is passed. The result, as shown in the figure, is that the forward front of the wave is curved in a shape similar to the charge curve of a capacitor, and the trailing edge of the wave is curved like the discharge curve. If such a distorted wave is passed through a clipping stage, which cuts off at the level indicated by the dotted line, then the pulse has been delayed by the amount indicated by the arrows. A

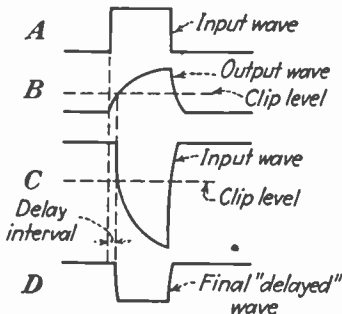
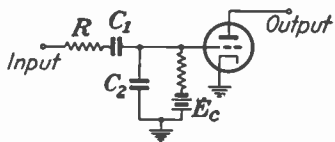

FIG. 253B.—The delay function in wave-shaping circuits. The delay circuit (top) produces a curved wave (B) from the initial square wave (A). The curved wave is clipped and the portion above the clip level is amplified, and then clipped again, resulting in a square wave delayed by the amount shown.

contains half waves of the sine-wave input, at 15,750 c.p.s. One of these half-wave outputs is used directly, after suitable clipping and shaping, to form the horizontal sync pulses. Actually this function is accomplished in a pentode clipping tube, following a buffer amplifier, followed by a narrowing stage. The horizontal sync pulses then have the required periodicity and duration. Thereafter these pulses are passed first through a delay circuit, for adjustment of their phase with respect to the rest of the signal. Next they pass to a keying tube which allows them to pass

subsequent narrowing stage can then be used to square up the clipped wave, and the end result is a square wave similar to the original square wave but delayed by a known and controllable part of the cycle. The control of the delay is obtained by adjusting the constants in the integrating circuits.

#### Horizontal Shaping Action.—

The horizontal shaping circuit of a typical shaping unit is shown in Fig. 254. The timing control is derived from the 15,750-c.p.s. output of the timing unit. This output is approximately sine wave in shape and is applied first to an input transformer that feeds the 15,750-c.p.s. wave in two "in-phase" sections to the two cathodes of a double-diode tube. The plate current of each diode then

only when the vertical sync pulse is not being formed. The output of this tube is a series of horizontal sync pulses interrupted every field for a length of time equal to the full duration of the equalizing pulses and the vertical sync pulses. The output of this tube is then combined with the output of keying tubes that develop the equalizing and vertical sync pulses as required.

The full-wave rectified output of the double diode (Fig. 254) is shaped to form pulses of 31,500-c.p.s. frequency. These pulses are then used to form the equalization pulses, by employing a combination of narrowing and delaying circuits which give the pulses substantially the same shape as the horizontal sync pulses, but twice the frequency (see Fig. 252). The vertical sync pulses are likewise obtained from the 31,500-c.p.s. full-wave rectified output, but in this case no narrowing action is necessary since the vertical sync pulses are broad topped. These 31,500-c.p.s. pulses (equalization and vertical sync) are passed to keying tubes one of which permits the equalization pulses to pass only before and after the vertical sync pulses, the other permitting the vertical sync pulses to appear midway between the two sets of equalizing pulses. The outputs of these two keying tubes are combined with the output of the keying tube that allows the horizontal sync pulses to pass in the proper sequence. The combined output of these three keying tubes contains all the signals that occur higher in amplitude than the blanking level and is consequently sometimes called the "supersync" signal output.

It should be noted that all the supersync components are derived fundamentally from the original 15,750-c.p.s. output of the timing unit, but their division into groups in the field-blanking intervals is derived by signals taken from the 60-c.p.s. output of the timing unit.

The one remaining task of the 15,750-c.p.s. section of the wave-shaping unit so far as forming the standard composite signal is concerned is the development of blanking signals during the line-retrace intervals. The blanking function is taken care of by two amplifiers following one of the clipping stages, which supplies a 15,750-c.p.s. flat wave. This signal is passed through a delay circuit and an output amplifier that combines the horizontal blanking with the vertical blanking pulses, as outlined below.

*Vertical Blanking and Keying Action.*—The vertical (60-c.p.s.) section of the shaping unit is shown in Fig. 255. The 60-c.p.s.

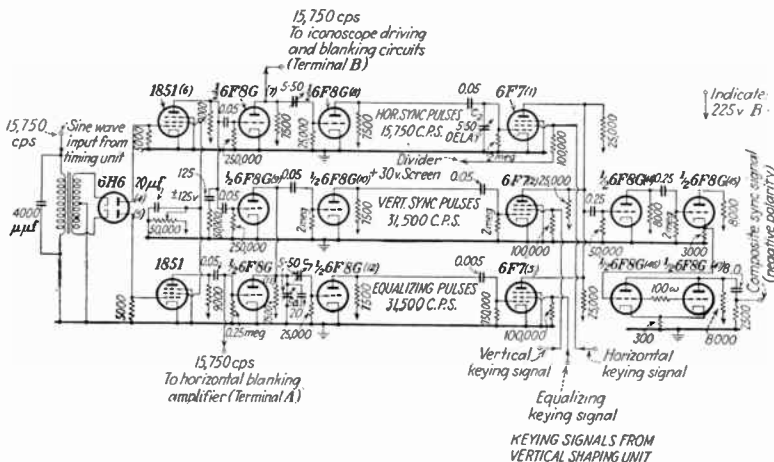

FIG. 254.—Horizontal shaping units of the sync signal generator. This unit accepts 15,750-c.p.s. timing pulses from the timing unit (Fig. 251), and 60-c.p.s. keying signals from the vertical shaping unit (Fig. 255), and derives from them the composite sync signal with horizontal, equalizing, and serrated-vertical pulses. It produces also 15,750-c.p.s. blanking signals for the iconoscope and picture tube.

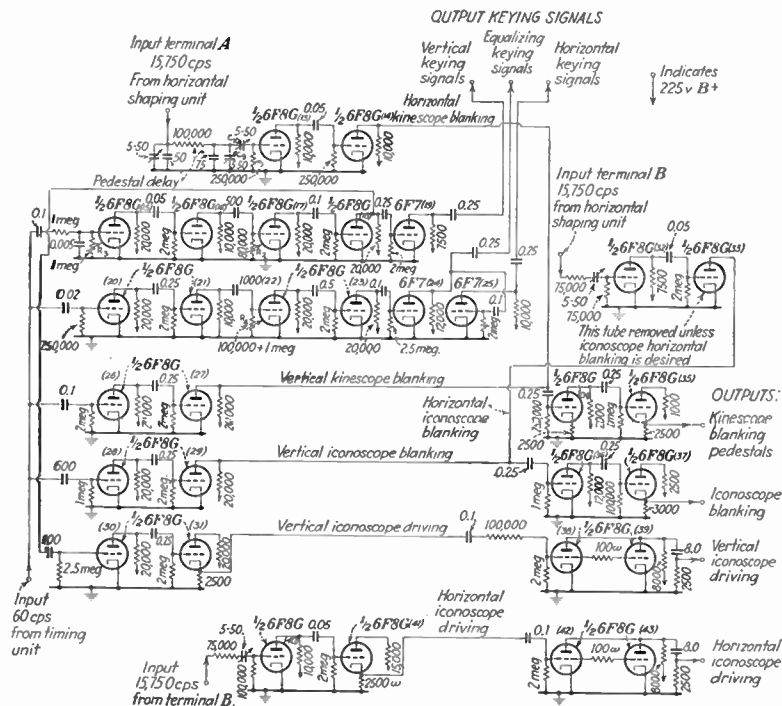

FIG. 255.—Vertical shaping unit of the sync signal generator. The 60-c.p.s. timing impulses from the timing unit are shaped to provide the keying signals used in the horizontal shaping unit (Fig. 254). Combined blanking signals (for the control amplifier, Fig. 244) are derived, as well as impulses for driving the iconoscope deflecting circuits and blanking the iconoscope scanning beam during retrace.

output of the timing unit that has a square shape is applied to four input tubes at once. One of these forms the vertical blanking pulse, which is passed through an amplifier, in the output of which the vertical blanking pulses are combined with the horizontal blanking. The combined output is then passed through an amplifier to a cathode-coupled stage, from which the blanking output is obtained. This output is then connected directly to the blanking terminal of the control amplifier, shown in Fig. 244.

The other two channels in the vertical section are used for developing the signals used by the keying tubes in the horizontal section. One chain develops the signal for keying out the vertical impulses. The sequence of action includes delaying, clipping, narrowing, further clipping, and finally inverting. This pulse has the proper level, polarity, and duration to open conduction through its associated keying tube, which allows the vertical impulses to pass to the output of the unit.

The second chain takes the same input and narrows it, without delay, then clips it, inverts and clips again. The signal is used for keying the equalizing signals in and the horizontal sync signals out, hence two outputs are required, one negative for keying out, the other positive for keying in. A final inverting stage is used to give the positive form. The duration of the keying pulse in each case is determined by the constants in the narrowing or delaying circuits.

*Auxiliary Functions for Iconoscope Control.*—The synchronizing signal generator has been described thus far solely with reference to its function in producing components of the composite video signal. The generator has also important functions in connection with the control of the camera tube. The iconoscope scanning circuits are controlled from the same source as the composite video signal. In consequence, the synchronizing-signal generator is provided with outputs specifically intended for camera-tube control. The diagram (Figs. 254 and 255) shows several terminals that control iconoscope blanking and driving circuits. Ordinarily these latter circuits are included in the same assembly with the main shaping unit but for convenience may be mounted separately.

There are four camera-tube functions under the control of the generator: horizontal blanking, vertical blanking, horizontal

driving (sync pulses), and vertical driving (sync pulses). The horizontal-blanking function is often not employed, since the transient signals developed during the horizontal retrace are removed in the control amplifier. If it is desired to use this blanking function, it is obtained simply by tapping the 15,750-c.p.s. pulses at terminal *B* in Fig. 254 and following with a narrowing and clipping amplifier that produces a blanking pulse of somewhat shorter duration than the blanking pulse imposed on the composite video signal. The shorter duration is used to ensure that the camera-signal impulses will contain a maximum of information, which the image reproduction can approach but not exceed.

The same general approach is taken in forming the vertical camera-tube blanking signals. A narrowing action, with the necessary clipping, ensures that the camera-blanking interval will be somewhat shorter than the image-reproduction blanking interval. The horizontal camera-blanking signal (if employed) is combined with the vertical camera blanking and delivered to the control grid of the electron gun in the camera tube, via a cathode-coupled stage.

The driving (sync) signals for the camera tube are derived from the 15,750- and 60-c.p.s. sources in the generator, as shown in Figs. 254 and 255. These driving signals initiate the scanning-generator action in the camera. The pulses must have very steep sides, to ensure accuracy of scanning timing, and should have durations somewhat less than the corresponding camera-blanking signals. The duration is controlled, in the usual manner, by varying the constants of the narrowing stages, with appropriate clipping action thereafter. Several details of the camera-tube control circuits are shown in Fig. 255.

**60. Shading Correction Generator.**—The remaining item of equipment necessary to produce a composite video signal of adequate quality is the shading correction generator required with camera tubes of the iconoscope (storage-mosaic) type. As stated in Chap. III (page 101), the camera output results partly from the scanning of parts of the mosaic that have received a heterogeneous group of electrons not directly related to the optical image and arising directly from secondary electrons produced by the scanning of the mosaic. The effect of this unwanted distribution of electrons is to produce an uneven

shading of the background in the reproduced picture. To compensate for this defect, it is necessary to superimpose, on the picture impulses, additional signal voltages of the proper shape and polarity to cancel the unwanted component. This is a large order, since in general the unwanted component may have almost any position in the scanning sequence and may have a variety of shapes. Fortunately, however, quite adequate shading correction may be obtained from comparatively simple wave shapes, several of which are shown in Fig. 257. They appear as saw-tooth waves, sine waves, or double-frequency sine waves occupying either a full line or a full frame. The manner of generating these waves is illustrated in the basic circuits shown in Fig. 256. The amplitude and duration as well as the phase of the several shapes are under the control of the operator. The output of the amplifier is imposed on the camera preamplifier as shown in Figs. 241 and 242.

The shading correction generator shown in Fig. 256 derives its fundamental signals from the horizontal saw-tooth generator of the system, from the vertical saw-tooth generators, and from the 60-c.p.s. power line. From these sources are derived saw-tooth and sine waves synchronized with the scanning motion, which may be switched from one polarity to another and shifted in phase. From the horizontal saw-tooth generator (top of Fig. 256), the resistor  $R_1$  derives a simple saw-tooth voltage of 15,750-c.p.s. frequency, which is applied to the shading amplifier tubes  $T_2$  and  $T_3$  through the switch  $S_1$ . This switch can connect the saw-tooth voltage either to the input of  $T_2$ , which transmits it in one polarity, or to the grid of  $T_3$ , which transmits it in opposite polarity. The gain of tube  $T_2$  is made unity, since the only function of this tube is the reversal of phase. Similarly, the other switches  $S_2$  to  $S_6$  perform a similar alternative connection of the other waveforms to these two stages, so that the phase of each signal may be reversed at will.

The circuit containing  $R_2$  and  $R_3$  is used to develop a sine wave from the saw-tooth input. Two circuits tuned to the fundamental frequency of the saw-tooth wave (15,750 c.p.s.) are employed to attenuate the higher order harmonics. The resistor  $R_2$  is used to shift the phase of this sine wave, and the resistor  $R_3$  regulates the amplitude of the sine-wave signal applied to the shading amplifiers  $T_2$  or  $T_3$ . Resistors  $R_4$  and  $R_5$



perform similar functions in a circuit tuned to the second harmonic of the saw-tooth wave, thus developing a double frequency-correction signal, the phase of which may be altered as well as its amplitude. The switch  $S_3$  selects the polarity for this signal.

Three similar signals are derived from 60-c.p.s. sources in the lower circuits in the diagram.  $R_6$  presents a 60-c.p.s. saw tooth to the amplifiers and adjusts its amplitude. The sine wave at 60 c.p.s. is developed directly from a transformer connected to the 60-c.p.s. line (with which the 60-c.p.s. saw tooth is syn-

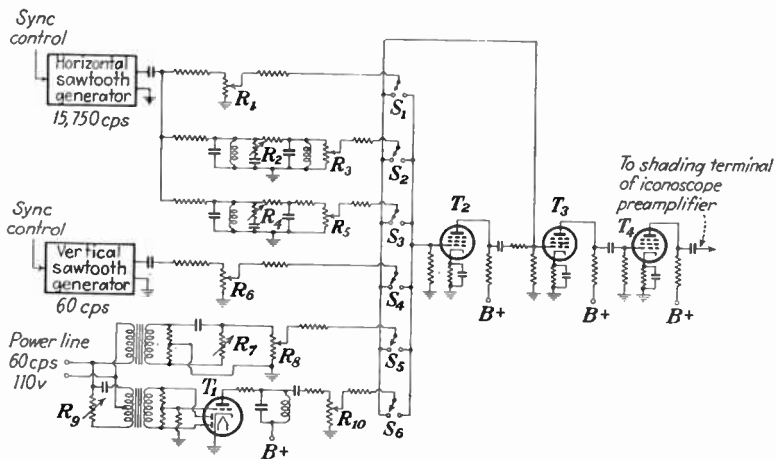

FIG. 256.—Shading correction generator which produces synchronized wave shapes for application to the iconoscope preamplifier (Fig. 242) to correct irregularities in shading due to secondary electron redistribution.

chronized by the sync-signal generator).  $R_7$  adjusts the phase of this sine wave, and  $R_8$  fixes its amplitude. The double frequency (120 c.p.s.) is developed by full-wave rectification from a center-tapped transformer connected to the power line. The rectified signal is amplified and applied to a circuit tuned to 120 c.p.s. The phase of this signal is controlled in the primary of the transformer by resistor  $R_9$ .  $R_{10}$  controls its amplitude.

It will be noted that in series with all the tuned circuits and control voltage-dividers there are resistors which perform the function of isolating the separate circuits. Thus, changing the phase of the 60-c.p.s. sine wave has a negligible effect on the phase of the 120-c.p.s. sine wave, and the same is true of the other circuits.



The circuit shown in Fig. 256 is a simple form of shading correction generator. In the generators used in commercial broadcasting, parabolic wave shapes are also developed (by passing a sine wave through a distorting amplifier or clipper). The circuit shown has 10 controls and 6 switches, whereas commercial forms of the equipment have as many as 10 knobs, several of which perform two functions simultaneously. It is apparent, therefore, that considerable skill is required to operate

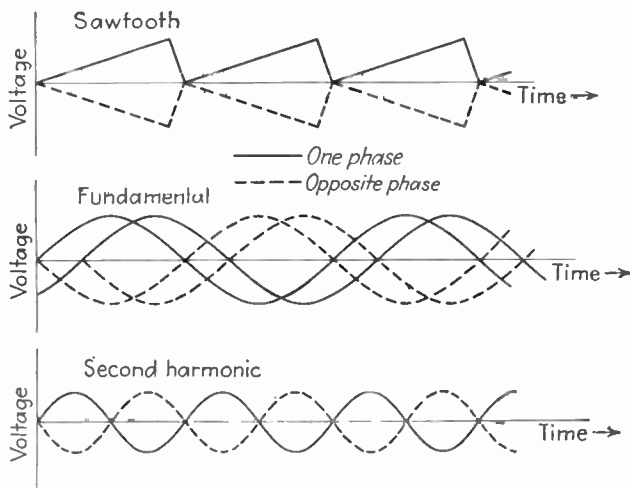

FIG. 257.—Wave shapes produced by the shading correction generator (Fig. 256). The saw-tooth, sine wave and double-frequency sine wave are available at vertical and horizontal scanning rates, with controllable amplitude, phase, and polarity.

the shading correction equipment, even after familiarity with its operation has been acquired.

It is necessary, of course, that the shading correction signals be imposed on the picture impulses in exact synchronism with the defects they are intended to correct. Consequently, the initiation of each pulse generated in the correction unit is under the control of the camera-driving impulses used to control the camera-scanning generators. The input terminals for the synchronizing signals are shown in the figure.

As the program proceeds, it is necessary that an operator maintain more or less continuous watch for improper shading and that he correct it at once by manipulating the controls

of the generator. Since the shading performance of any one camera tube is reproducible under given lighting conditions, it is possible to determine the imperfections of shading during rehearsal of the program, which are then repeated as the "on-the-air" performance proceeds. Even with these elaborate precautions, shading difficulties are seldom completely avoidable. The present research into the manufacture and design of camera tubes, which have the sensitivity of the storage type but not the attendant shading difficulties, shows promise of removing the difficulty at its source (see page 111, on the orthicon camera tube).

**61. Television Transmission of Motion-picture Film.**—A fundamental difference between pictorial representations by television and by motion-picture film lies in the different rates at which the frames are presented. In motion pictures, the standard frame-repetition rate is 24 per second. In television, for the reasons outlined in detail elsewhere, transmissions occur at a frame-repetition rate of 30 per second. The fundamental disparity between the 24 per second rate of the motion-picture film and the 30 per second rate of the television film must be taken into account, therefore, whenever standard motion-picture film is to be televised.

It might be thought at first that standard motion-picture film might be run at 30 frames per second and televised directly. Such a rate, being 25 per cent faster than the rate for which the film was made, would have two effects: increasing the rate of motion of objects in the performance to a degree that would appear unnatural and increasing the pitch of the sound reproduction associated with the film track. It is difficult to say which of these effects is the more annoying, but there is general agreement that neither of them can be tolerated in a broadcast of a film intended to have entertainment value. Consequently it has been necessary to devise mechanical or optical methods which present the film to the television camera at the standard rate of 24 complete pictures per second but which allow scanning of these 24 pictures in 30 separate groups of scanning patterns. The pitch of sound reproduction as well as the speed of action is thereby maintained at the values originally intended.

Two methods are available for transposing 24 to 30 frames per second. The first, applicable to either storage or nonstorage

type cameras, involves an optical system of rotating lenses that move with the film as it passes through the projector. In this case, the film is moved continuously, rather than intermittently, through the projector. The second method, applicable only to the storage type of camera tube, involves a more or less standard intermittent projector with a specially modified mechanism which presents successive frames to the projector lens for unequal lengths of time and which relies on the storage properties of the iconoscope mosaic to retain the image after the projector shutter closes.

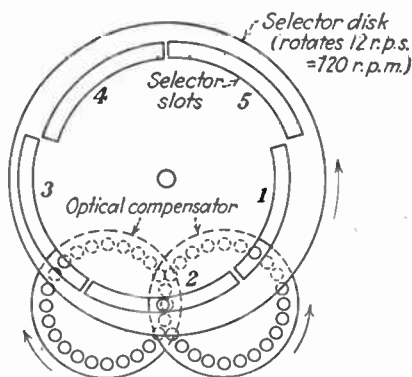

FIG. 258.—Selector disk and lenses used in continuous scanning of motion-picture film. (After Bamford.)

*Continuous-projection Method.*<sup>1</sup>—A typical system of continuous-projection scanning for nonstorage- or storage-type tubes is shown in Fig. 258, patterned after the design of Bamford. The film runs smoothly and continuously through the film gate at a rate of 90 ft. per minute, equal to 24 frames per second. In front of the film, two sets of lenses revolve at a speed synchronous with the film motion, that is, one pair of overlapping lenses moves downward in front of each frame. The motion of the lenses ensures that the image of the frame projected will remain stationary on the photosensitive surface of the camera tube.

<sup>1</sup> BAMFORD, H. S., A Non-intermittent Projector for Television Film Transmission, *Jour. Soc. Motion Picture Eng.*, **31**, 453 (November, 1938). Also see: A New Television Film Projector, *Electronics*, **11**, (7), 25 (July, 1938).

GOLDMARK, P. C., A Continuous type Television Film Scanner, *Jour. Soc. Motion Picture Eng.*, **33**, 18 (July, 1939).

Hence the motion of the film is counteracted by the similarly continuous motion of the lenses. A selector disk ensures that only one pair of lenses is active at a time, hence only one frame is projected at a time. The selector disk operates, furthermore, to divide the projection of each frame into periods of equal length. The slots on the disk marked 1, 2, and 3 follow one set of lenses and cut up the frame there projected into three periods. The opaque portions between slots separate the pictures during the vertical retrace. The next frame projected is divided, by slots numbered 4 and 5, into two projection periods each of the same length as the preceding three periods. The second frame is thereby scanned twice, whereas the first was scanned three times. The successive frames are thus presented to the camera for unequal lengths of time, but this does not interfere with the apparent continuity of motion depicted by the film.

The purpose of dividing the selector disk into five sections is to obtain five scannings of the film for every two frames. Since each frame endures for  $\frac{1}{24}$  sec., the two frames in one complete rotation of the selector disk are present  $\frac{1}{12}$  sec. of scanning time. During this time, the camera scans the two images a total of five times, thereby allowing  $\frac{1}{60}$  sec. for each scanning. This time coincides with the field-scanning rate of the television system. The transfer from 24 frames per second to 60 fields per second is thereby accomplished. The mechanism is expensive, since the lens system must be of the highest quality both optically and mechanically, but the continuous nature of the film motion is an advantage in that it avoids the strain on the film stock inherent in intermittent mechanisms.

It is necessary that the divisions in the selector disk be synchronized with the vertical retrace intervals in the scanning process. This is accomplished by using a synchronous motor in the selector-disk drive, together with a phase-shifting mechanism (framing device) that permits alignment of the disk with the blanking signals in the scanning sequence.

*Intermittent Storage System of Film Scanning.*<sup>1</sup>—The other method of film scanning employs an intermittent mechanism that pulls the film down before the projecting lens, frame by

<sup>1</sup> ENGSTROM, BEERS, and BEDFORD, Application of Motion Picture Film to Television, *Jour. Soc. Motion Picture Eng.*, **33**, 3 (July, 1939). See also *RCA Rev.*, **4** (1), 48 (July, 1939).

frame, in a manner similar to that employed in conventional motion-picture projection. The intermittent mechanism operates so that the length of time between "pull-downs" alternates between  $\frac{1}{20}$  and  $\frac{1}{30}$  sec. The average of these two fractions is  $\frac{1}{24}$  sec., or the time demanded by the standard 24-frame-per-second projection rate. The frame that remains  $\frac{1}{20}$  sec. is scanned by three  $\frac{1}{60}$ -sec. fields. That which remains  $\frac{1}{30}$  sec. is scanned by two such fields. The net result is the same as the

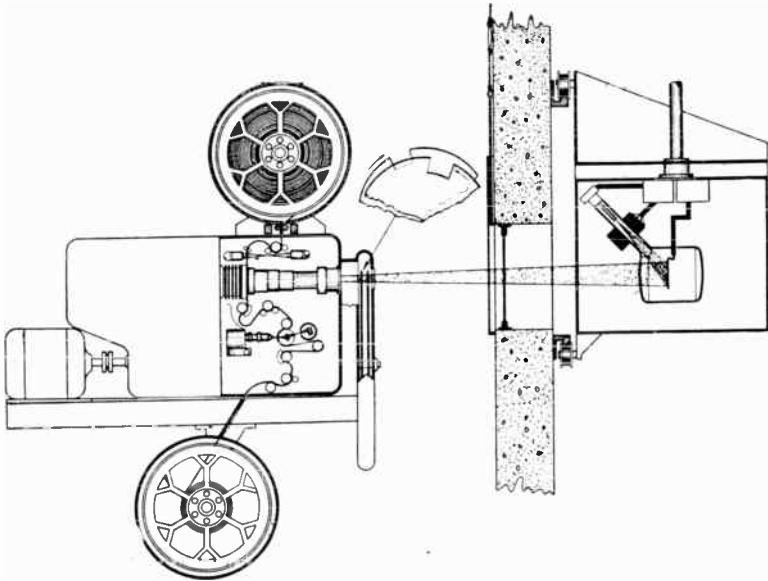

FIG. 259.—Projection system used with storage-type camera tubes for intermittent projection of motion-picture film. (From Lohr, "Television Broadcasting.")

continuous-motion projection, that is, one frame is scanned for three fields, the next for two, the next for three, and so on.

One advantage of the intermittent type of projector is its comparatively low cost, when compared with that of the delicate and exact optical system required in the continuous system. On the other hand, the intermittent system suffers from the fact that the time between frames is limited to the available time for vertical retrace, which is not more than 10 per cent of the frame interval. Ordinary intermittents are not intended for any such rapid "pulling-down" of the film. In the projec-

tion system here described, however, this difficulty is avoided by making use of the storage characteristics of the camera tube, and this fact limits the system to use with that type of camera. An intense projecting light source is employed, and a shutter allows light to enter the camera from the projection lens only during the retrace interval. During scanning, the light is wholly cut off by the shutter, but the charge image is stored on the mosaic and remains there until removed by the scanning beam.

**62. Modulation Methods and Practice.**<sup>1</sup>—Some of the theoretical considerations underlying the modulation of television transmitters have already been given in Chap. VII, page 282. The theory is not markedly different from that of telephonic modulation, but practical considerations give rise to considerable contrast between the two types of transmission. The major differences arise from the fact that in video modulation a very wide band of frequencies must be transmitted, that the d-c component of the modulating signal must be preserved, that one of the sidebands resulting from modulation must be partly removed, and that amplitude linearity, in contrast in telephonic broadcasting, is not a matter of primary importance.

Essentially the practical problem in modulating a television transmitter lies simply in obtaining a very high level of signal voltage without impairing the amplitude or phase responses over the video range of frequencies. The video band is ordinarily taken as between 4,000,000 and 4,500,000 c.p.s. in width. What is required, then, is a video amplifier covering this band, the output voltage of which, peak to peak, is in the hundreds of volts for a low-power transmitter or in the thousands of volts for high-level modulation in a high-powered transmitter.

This in itself would not be a particularly difficult problem were it not for the fact that the higher the voltage (and current) ratings of an amplifier system, the larger must be the amplifier tubes and associated circuit elements. The large size brings with it large capacitances to ground. These large values of capacitance require correspondingly low values of plate-load resistance. The low values of plate resistance can produce high values of output voltage only with large values of plate current, which in turn means large tubes and circuit elements.

<sup>1</sup> Television Transmitters, *Electronics*, 12 (3), 26 (March, 1939).

The whole is a vicious circle that can be broken only by the development of tubes the capacitances of which, both to ground and between input and output electrodes, are small in relation to the power-handling ability of the structure.

A concrete idea of the problem may be derived from an examination of the capacitances associated with the type 891 tube, which was until 1939 used as a video modulator tube for high-level modulation in transmitters rated at 10,000-kw. peak power. This tube is a water-cooled triode tube, with typical anode ratings for modulator service of 8000 volts, 0.9 amp. The output capacitance, including circuit capacitance to ground, is of the order of 100  $\mu\text{mf}$ . To obtain substantially constant responses to 4.5 Mc. which such a tube requires, by Eq. (142), page 222, a load resistance of

$$R = \frac{1}{2\pi 4.5 \times 10^6 \times 100 \times 10^{-12}} \\ = 350 \text{ ohms}$$

The d-c drop through the load impedance with 0.9-amp. plate current is then 315 volts, and the maximum peak-to-peak output voltage, for class A operation, is accordingly 630 volts. This signal output compares very unfavorably with the 8000 volts applied to the anode of the tube.

This situation has been somewhat improved by the advent of tubes having smaller output capacitance, within very recent months (July, 1939), but it is still very difficult to develop much more than 1500 volts, peak to peak, with any existing tube structures, over a band extending as high as 4,500,000 c.p.s. Since the available modulating power is restricted by the necessity of maintaining uniform phase and amplitude responses up

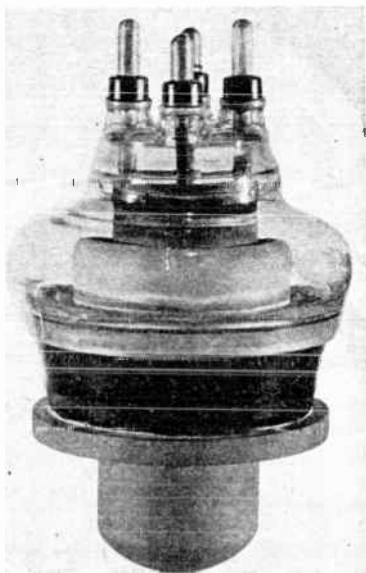

FIG. 260A.—Type GL-880 triode tube with re-entrant anode which allows adequate cooling without excessive electrode length. Used in amplifiers in the General Station at Albany (Fig. 272).

to 4,500,000 c.p.s., the size of the r-f amplifier is correspondingly limited if full modulation of the carrier is to be achieved.

One result of this situation is the advisability, already noted, of using grid-circuit modulation. With 1000 volts peak to peak of modulating voltage, applied to the grid circuit of an r-f power amplifier, it is not difficult to obtain a fully modulated carrier output of 5 kw. carrier power, corresponding to 20 kw. on the peak of the modulation (tips of the sync pulses). But to go

beyond this, using high-level modulation, seems at present to be a very difficult task.

It would appear, therefore, that low-level modulation is indicated for high-powered transmitters. When the modulating is done in a low-powered stage, smaller tube structures and circuit elements may be used, and wider band widths are obtainable for a given voltage output. In one transmitter design, the modulation occurs in the intermediate r-f power amplifier, one stage before the final r-f amplifier. In another case, sufficient output voltage and power was obtained by using 10 tubes in parallel in the modulating amplifier (type 813, 2000 volts, 80-ma. anode rating, output total

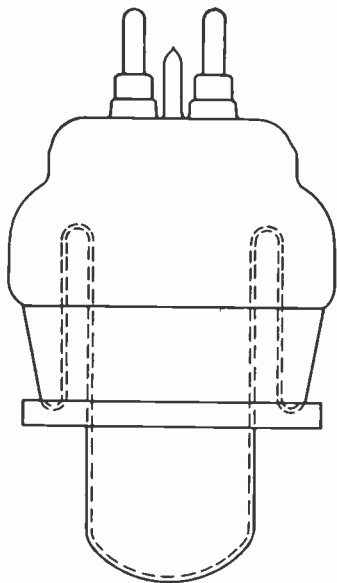

FIG. 260B.—Internal arrangement of anode in type GL-880 tube.

load capacitance of about  $25\mu\text{mf}$ ).

Modulation at a still lower level is indicated for higher powers than this. In the 10-kw. (carrier-level) transmitter at Albany, N. Y., modulation occurs in the 25th stage prior to the final amplifier, and the undesired sideband is attenuated at once. The succeeding 24 r-f amplifiers pass a total sideband width of approximately 5.5 Mc. (rather than to 8 or 9 Mc. which would be required if the sideband were not attenuated). The principal technical difficulty in this arrangement, and the principal reason why it has not been developed earlier in the art, is the fact that the r-f amplifiers following the sideband-attenuating filter must



display a very high degree of amplitude linearity. Otherwise the attenuated sideband will be reinserted as a modulation product, and must then be removed again, before radiation from the antenna.

*Reinserting and Preserving the D-c Component in Video Modulation.*—Previously in this chapter it has been pointed out that the black level of the picture is established by the amplitude of the blanking signal (pedestal) and that the average of the picture-signal impulses, with respect to the blanking level, is made to correspond with the intended average brightness in the reproduced image. The relationship between average brightness

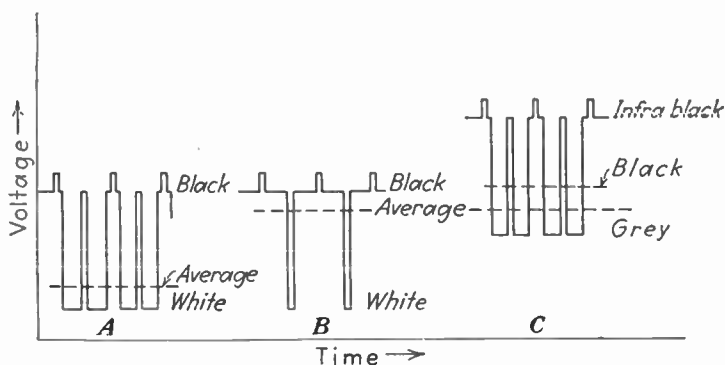

FIG. 261.—Variation of the average of the video signal: A, white image with narrow black bar; B, black image with narrow white bar, with blanking level held same as in A; C, white image with narrow black bar, as in A, but with average coinciding with average in B. Most of the signal in C is lost above the black level, due to the upward displacement of the average.

and the blanking level, once established in the control amplifier, is carried through all succeeding amplifier stages to the input of the modulating stage. Here it is necessary that the d-c component be reestablished at a definite level or, in other words, that the blanking level be made to correspond to a definite value of voltage regardless of the changes in the content of the picture signal. The picture may change from one nearly completely white (Fig. 261A) or nearly completely black (Fig. 261B) through all the intermediate stages, but the blanking level must remain fixed. If it remains fixed at this point and thereafter, then at the receiver the blanking level can be made to occur at the black level of the image-reproducing tube control-grid

characteristic, and the changes in background will be correctly reproduced.

To produce and hold fixed the blanking level at the input to the modulating amplifier, the circuit shown in Fig. 262 may be employed. It consists of a diode rectifier, connected with cathode to the grid of the modulating amplifier and shunted by its own plate-cathode capacitance and a load resistor of 5000 ohms. The diode rectifies the video signal impressed upon it and develops across the load resistance a direct-voltage component that is equal, or very nearly equal, to the peak value of the video signal. The video signal is so poled that the peak value is the tips of the sync pulses. Hence the actual value of direct voltage developed across the diode lies between the

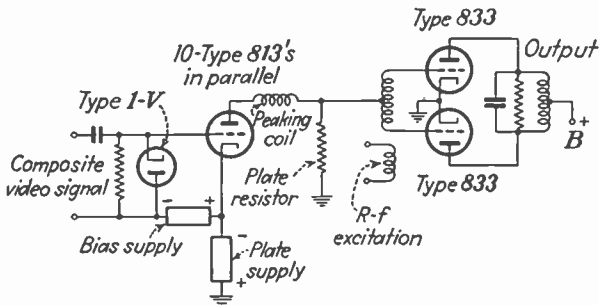

FIG. 262.—D-c reinsertion system employed in RCA transmitter (cf. Fig. 269). The blanking level is held constant at the grids of the type 813 tubes which are direct coupled to the next stage. Hence the corresponding carrier level is maintained constant.

tips of the sync pulses and the blanking level, as shown in Fig. 263. Since the amplitude of the sync pulses remains fixed, the voltage developed remains constant with respect to the blanking level, as is required.

The voltage developed across the diode is added to the bias voltage and applied to the grid of the modulating stage. Since the cathode of the diode connects to the grid, its contribution is added to the bias source. The net bias voltage (bias source plus diode output) is adjusted by adjusting the bias source until the bias point on the modulating characteristic is on the point *P*, in Fig. 263. The variations in the video signal then extend farther into the positive modulating region, and the brightest portions of the picture signal then produce a correspondingly heavy modulating current. In the output of the

modulating stage, the polarity is reversed (by the phase-reversal process inherent in all amplifier stages), and the brightest portions of the picture correspond to the lowest values of video voltage, whereas the blanking level and the sync pulses correspond to high values of voltage. This is the required polarity for the negative type of transmission (page 167) which has been standardized in this country. The output voltage is thus used

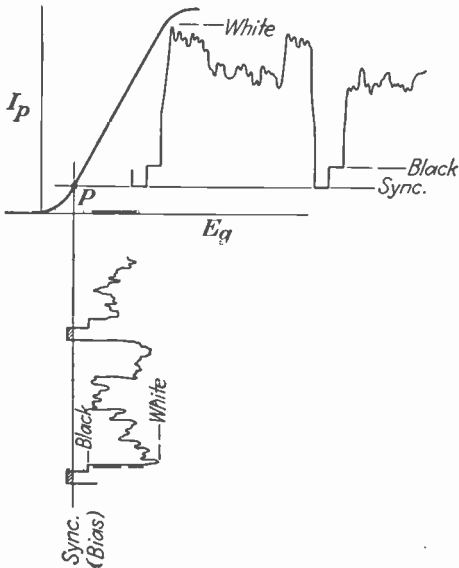

FIG. 263.—Dynamic characteristic of modulating video amplifier showing position of bias level fixed by the d-c restorer tube. The bias point is fixed at the base of the characteristic to allow full swing of the signal into the maximum plate-current region of the tube. The polarity in the plate circuit of this amplifier is reversed from that shown, so the fixed bias level corresponds to the peak of the carrier envelope.

directly to control the amplitude of the output of the modulated r-f stage.

The virtue of selecting the bias point at the base of the modulating characteristic is apparent from Fig. 263. When the point is so chosen, the major portion of the modulating characteristic is available for the variations in the signal voltage. If a bias point higher on the characteristic were chosen, the range available for signal variations would be correspondingly restricted.

By the methods outlined above, the video signal in correct polarity, with the blanking level stabilized at a fixed voltage

level, is made to appear in the output of the modulating stage. It is then necessary to apply this voltage to the r-f modulated amplifier, without losing the relative positions of the d-c levels. This requirement is satisfied by direct coupling between video modulating amplifier and r-f modulated amplifier. Figure 262 shows a typical arrangement for direct coupling. The modulator plate is connected directly to the r-f amplifier grid, and the d-c component acts directly as part of the bias of the r-f stage.

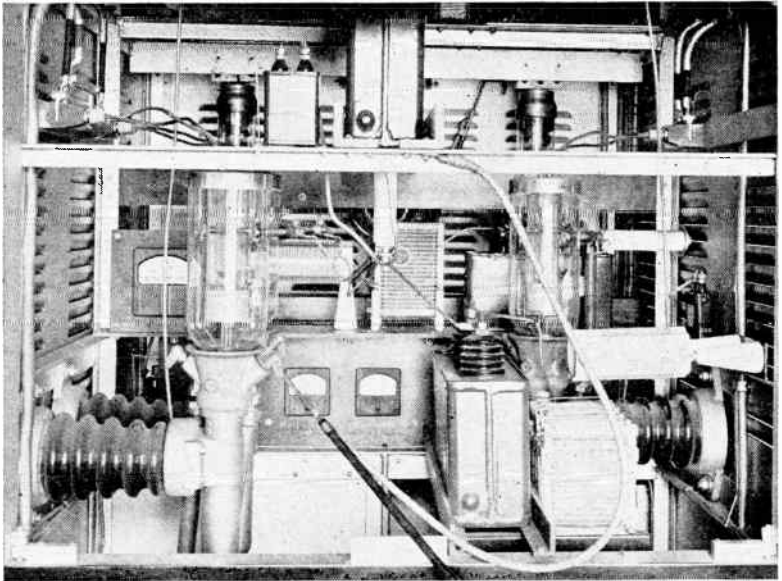

FIG. 264.—Modulating video stages of station W2XBS, New York. Note peaking coils and load resistors (lower right corner and center).

One consequence of this connection is the fact that the net bias on the r-f amplifier may be controlled by varying the bias source of the modulating stage. The bias-source control then becomes an r-f output amplitude control and is in fact useful for setting the average level of the transmitter r-f output.

The particular arrangement shown in Fig. 262, with modulator plate connected directly to the r-f amplifier grid, requires that the modulator plate be operated at the r-f amplifier grid-bias potential. To obtain the necessary difference in potential between modulator cathode and anode, the high-voltage source is connected between ground and cathode, as shown in the

diagram. This arrangement necessitates a separate power supply for the modulator stage, but in any event this is a necessary consequence of the direct-coupled connection to the r-f stage.

The r-f amplifier, being grid-modulated, operates over the characteristic shown in Fig. 161. It may be easiest to visualize the operation of the modulated r-f amplifier by considering it

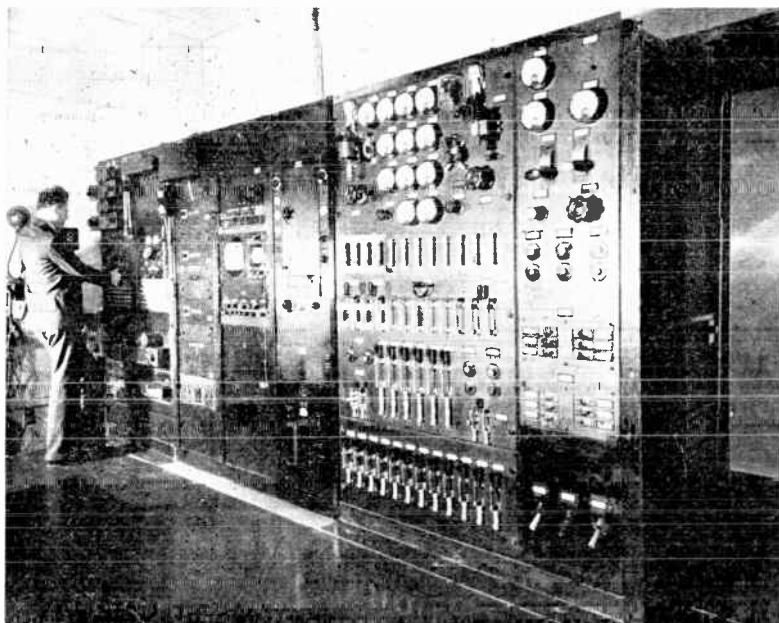

Fig. 265.—Input racks of station W2XBS (left) showing monitor picture tube and oscilloscope.

to be a class C “telegraph” modulated amplifier, normally operating at peak output. When no picture is present, the transmitter maintains the blanking (pedestal) level of carrier amplitude. This condition corresponds to about 75 to 80 per cent of the peak carrier amplitude. The sync signals bring this value up to peak, but they exist for no more than 10 to 12 per cent of the total frame interval; so the normal unmodulated (no picture) condition of the transmitter corresponds roughly to about 90 per cent of peak output. When the picture modulation occurs, it acts to reduce the average carrier level below this 90 per cent level. Consequently when the picture appears, the

transmitter output is reduced, and when the picture is completely white, the transmitter output is at its minimum. The R.M.A. standards state that this minimum shall be no more than 25 per cent of the maximum carrier amplitude. Adequate engineering design demands that the transmitter be capable of continuous operation at 90 per cent of peak output without circuit failure and with as high an efficiency as possible (usually 50 per cent efficiency can be achieved with peak output, although the time average efficiency under picture modulation may fall as low as 30 per cent or lower).

In the plate circuit of the modulated amplifier, and in all succeeding power amplifiers, there appear the carrier frequency and sideband frequencies. The modulator produces two identical sets of sidebands, extending equally above and below the carrier. If the undesired sideband is removed at once, the double-sideband condition applies only to the plate circuit of the modulated r-f amplifier. Otherwise it applies to all succeeding amplifiers until the sideband elimination occurs.

To produce uniform response over the full band width occupied by the sidebands, it is necessary to employ properly damped tuned circuits in the r-f amplifiers, and furthermore it is usually customary to employ some form of critical coupling (either capacitive or inductive) to obtain a flat response over the required band width. Usually the coupling circuits are developed according to more or less conventional filter theory, the principal problem being to obtain the desired flatness of response over the required band width with the highest possible value of effective impedance in the coupling circuit over that band. Unfortunately, the impedance values actually obtainable in practice are low. With a carrier frequency of 50 Mc., sidebands of 4.5 Mc., and an inductance value of 50 microhenries, by Eq. (220), the loading resistor of a single tuned circuit would be 500 ohms. At this low level, it is difficult to get appreciable voltage gains per stage unless tubes of very low internal plate resistance are used. The power gain per stage may nevertheless be adequate if high emission current is available.

*Removal of the Undesired Sideband.*—According to the R.M.A. Standard No. T-115, the lower frequency sideband is radiated in partial form. The standard form of the radiated amplitude characteristic is shown in Fig. 162. The carrier is near the

lower edge of the channel, at a position 1.25 Mc. from the channel edge. Between the carrier and this edge of the channel, room is available for transmitting a vestige of the undesired sideband. Frequencies in the region within 0.75 Mc. of the carrier are transmitted without attenuation. Frequencies in the region between 0.75 and 1.25 Mc. from the carrier are attenuated as rapidly as possible, and at the lower edge of the channel negligible sideband energy is radiated.

The desired sideband extends to its full width higher in frequency than the carrier occupying a total channel width of approximately 4.0 Mc. At 4.5 Mc. from the picture carrier, the sound carrier is located, and at this point no energy is to be radiated by the picture transmitter. The region between 4.0 and 4.5 Mc. higher than the carrier is reserved for rapid attenuation of the outer edge of the desired picture sideband.

The sound carrier, at 4.5 Mc. from the picture carrier, lies within 0.25 Mc. of the upper limit of the channel and contains sidebands that occupy a total width of no more than 0.03 Mc. (corresponding to a double-sideband sound transmission with 15,000-c.p.s. maximum modulating frequency). The 0.25-Mc. region between the audio carrier and the edge of the adjacent television channel is utilized as a "guard band" to avoid interference between the picture of one transmitter and the sound of the transmitter on the channel next higher in frequency.

The problem of sideband elimination (see page 287) is simply stated but difficult of accomplishment. The modulated r-f amplifier develops the carrier and two equal sidebands. Thereafter, either immediately or after subsequent amplification, a filter must be applied to remove the undesired sideband energy in accordance with the diagram shown in Fig. 162. Since filter structures can be built to fill this requirement, as indicated in the basic filter theory, the problem would not be difficult if it were not for the fact that the filter action must be substantially perfect at both edges of the television channel and at all frequencies more remote, as well as in the immediate neighborhood of the sound carrier within the channel. This requirement of non-interference with the adjacent channel and with the sound carrier has made the filter structures rather involved.

The type of filter employed depends on the place in the transmitting circuit at which it is placed. To date, the only trans-



mitters in operation have employed the filter structure in the antenna circuit, following the output of the final amplifier. The reason for choosing this position lies in the fact that it produces definite results, with no possibility of reinsertion of the undesired sideband, and partly in the fact that the transmitters

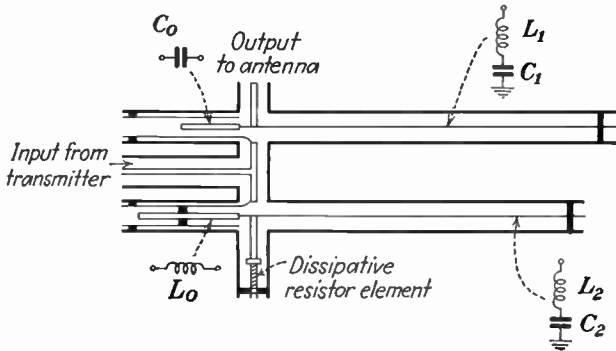

FIG. 266A.—Structure of coaxial vestigial sideband filter used at station W2XBS. The lumped constants shown refer to the corresponding symbols in Fig. 163. (After G. H. Brown.)

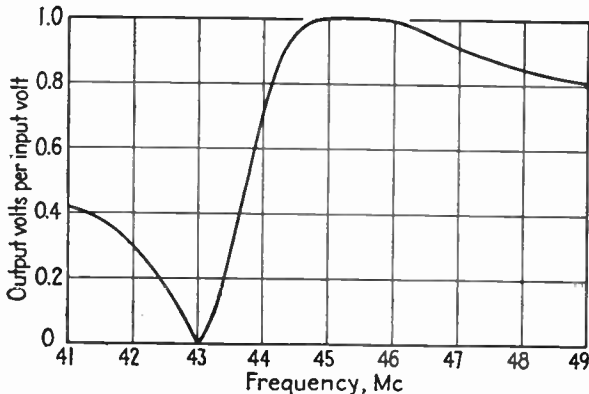

FIG. 266B.—Response characteristic of the filter structure shown in Fig. 266A.

are of the high-level modulation type, modulating either in the final stage or in the next-to-final stage.

When the filter must operate at the high levels encountered in the antenna circuit, its mechanical construction must include provision for resisting rather high voltage peaks. For this and other reasons, it is customary to employ sections of coaxial transmission line as the filter elements. A simple type of filter



making use of this principle is shown in Fig. 266 (see also Fig. 163). In Fig. 163, the filter is shown in conventional lumped-constant form. The output of the transmitter is applied to the junction between a capacitance  $C_0$  and the inductance  $L_0$ . The lower frequencies in the sideband to be attenuated (see Fig. 162) are passed by the inductance to the resistor  $R$ , where the energy is absorbed. The higher frequencies in the desired sideband are passed by the capacitance to the antenna for radiation.

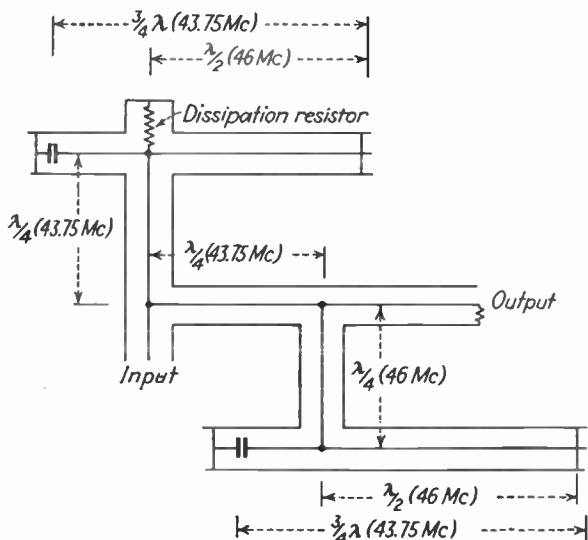

FIG. 267A.—“Notching” filter used to supply additional attenuation at the carrier frequency of the adjacent sound channel. Three structures similar to the above are used in station W2XBS. (After G. H. Brown.)

The coaxial filter that performs these functions is shown in Fig. 266A. Lengths of line shorter than one-quarter wavelength are used to present a capacitive reactance, and lines somewhat longer than a quarter wave produce an inductive reactance. Two such sections used to replace the capacitance  $C_0$  and inductance  $L_0$  are shown. It will be noted that both these reactances are above ground potential and must therefore either be insulated or in some other manner supported. A convenient type of support is shown in the figure. It consists of a coaxial segment, short-circuited and grounded at one end, the length of which is some multiple of a quarter wavelength.

Such segments display theoretically infinite impedance at the open end, and consequently this end can be used for supporting the coaxial elements above ground in the manner shown (the "insulated" inner-conductor segment forming the outer conductor of the reactive element within). The other segments attached to the antenna and to the dissipating resistor replace the tuned elements  $L_1C_1$  and  $L_2C_2$ , respectively.

In addition to the preceding functions, it is necessary to employ a separate filter section, called a "notching" filter, to remove the transmitted energy at the picture-carrier frequency of the

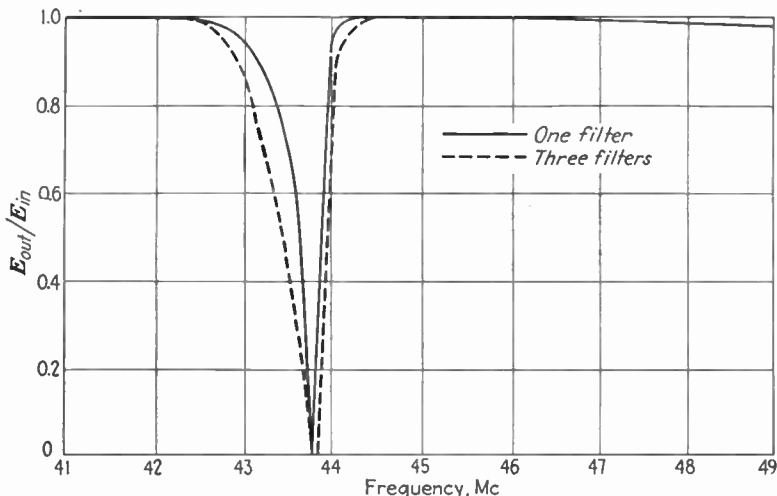

FIG. 267B.—Response characteristic of the filter structure shown in Fig. 267A.

adjacent channel at the lower frequency side. The function and design of a typical notching unit are shown in Fig. 267.

**63. Carrier Generation and Radiation.**<sup>1</sup>—Some of the considerations underlying the generation of the carrier frequency for a television transmitter have already been treated in Chap. VII. The practical aspects of the subject are best illustrated in

<sup>1</sup> BLUMLEIN, BROWNE, DAVIS, and GREEN, Marconi-E. M. I. Television System, *Jour. Inst. Elec. Eng.*, **83**, 758 (December, 1938).

CONKLIN and GHIRING, Television Transmitters Operating at High Powers and Ultra-high Frequencies, *RCA Rev.*, **2** (1), 30 (July, 1937).

GOLDMARK, P. C., Television Station W2XAX, *Communications*, **18** (11), 7 (November, 1938); and **19** (2), 27 (February, 1939).

MACNAMARA and BIRKENSHAW, London Television Service, *Jour. Inst.*

terms of actual installations. A transmitter of 50 watts power is illustrated in Fig. 268. Crystal control is employed with three frequency-multiplying stages. The final stage is grid

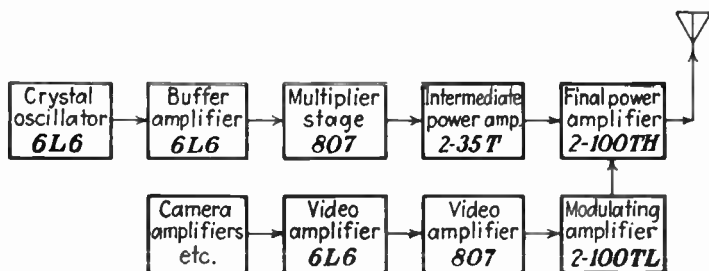

FIG. 268.—Tube line-up of a typical 50-watt picture transmitter, station W2XVT, Passaic, N. J.

modulated. The over-all efficiency is about 30 per cent, and the plate circuit efficiency of the final stage at peak output is 50 per cent. The modulating chain accepts the video signal at 1.0 volt peak to peak and builds it up to 350 volts peak to peak for modulation of the final r-f amplifier. All the tubes in the

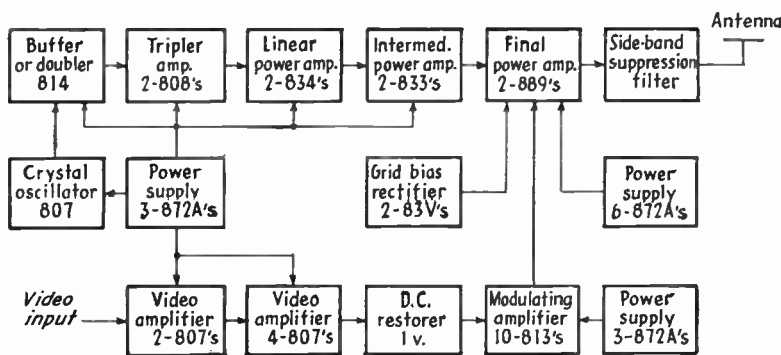

FIG. 269.—Tube line-up of a typical 1000-watt picture transmitter manufactured by the RCA Manufacturing Co.

modulator chain, except the modulators themselves, are beam-power tetrode tubes.

*Elec. Eng.*, 83, 729 (December, 1938).

Television Transmitters, *Electronics*, 12 (3), 26 (March, 1939).

TREVOR and Dow, Television Radio Relay, *RCA Rev.*, 1 (2), 35 (October, 1936).

The 1000-watt carrier transmitter previously referred to is shown in the circuit diagram on Fig. 269. The diagram is self-explanatory, if compared with the descriptions of the modulating methods on page 426. A point of interest is the division of the power-supply facilities among the video chain, the r-f carrier generation chain, and the modulating stage. The frequency

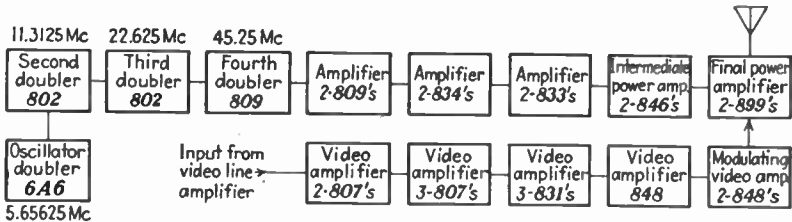

FIG. 270.—Tube line-up of station W2XBS in New York, nominal carrier power 7.5 kw.

control operates at the eighth or ninth subharmonic of the carrier frequency, depending on whether the carrier frequency is below or above 60 Mc., respectively.

A block diagram for a typical 30-kw. peak transmitter, that of the National Broadcasting Company in the Empire State Building, New York City, is shown in Fig. 270. It may be

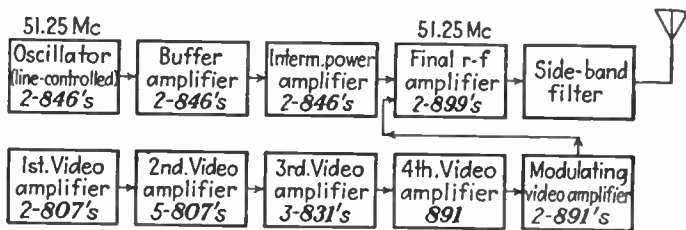

FIG. 271.—Tube line-up of station W2XAX, New York, nominal carrier output 7.5 kw. This transmitter is frequency-controlled by a coaxial-transmission-line circuit.

compared with a similar transmitter, operated by the Columbia Broadcasting System in the Chrysler Building, New York City. The transmitters are very similar, so far as the output stages are concerned, but the CBS equipment operates with a high-powered line-controlled, rather than crystal-controlled, oscillator. A feature of interest in the NBC unit is the large number of class

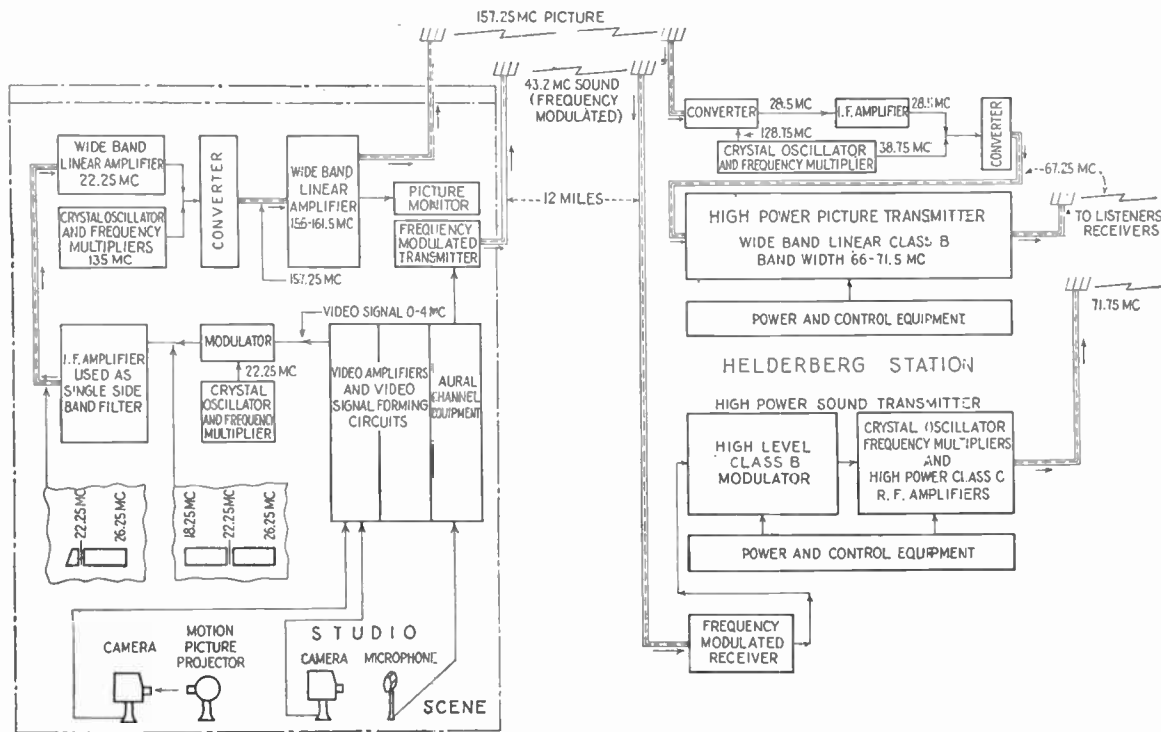

Fig. 272A.—Studio, relay, and main transmitting equipment of station W2XB, Albany, N. Y. (studio in Scheneotady). All picture transmissions are handled by carrier after the initial modulator (center, left).

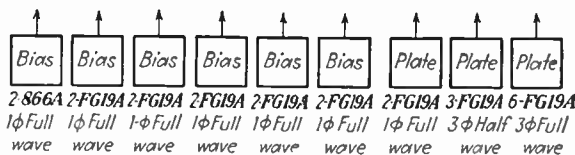
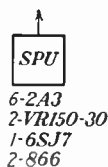
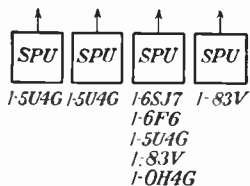
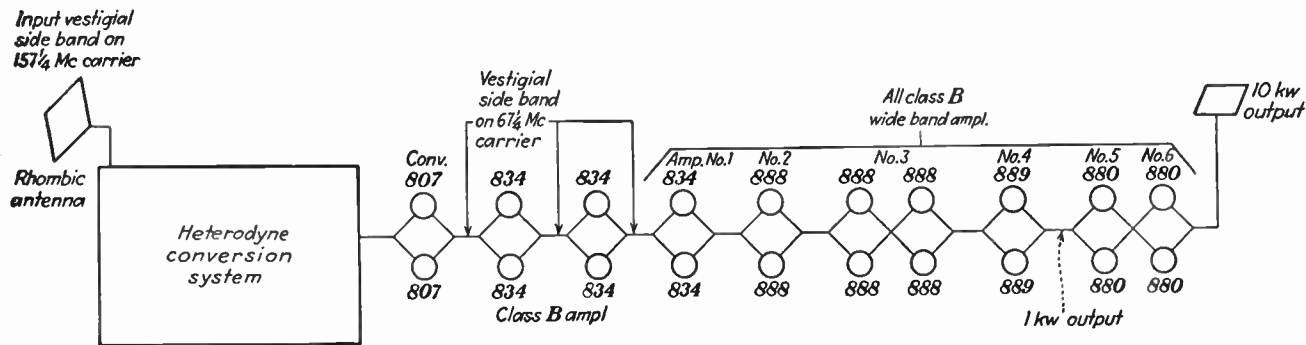

FIG. 272B.—Main transmitter of station W2XB, Helderberg Mountains near Albany, N. Y., nominal carrier power, 10 kw. An elaborate conversion system is necessary to convert the modulated carrier received on the relay frequency of 157.25 Mc., to the broadcast frequency of 67.25 Mc., without incurring beat notes within the sideband range.

C stages employed after the carrier frequency is reached in the carrier-generation chain. This large degree of amplification at the carrier value serves to eliminate all the subharmonics present in the frequency-multiplying process but requires careful shielding to avoid feed-back oscillations.

The low-level-modulated transmitter installed and operated by the General Electric Company in the Helderberg Mountains, near Albany, N. Y., is shown in Fig. 272. The linearity of the stages following the sideband filter does not

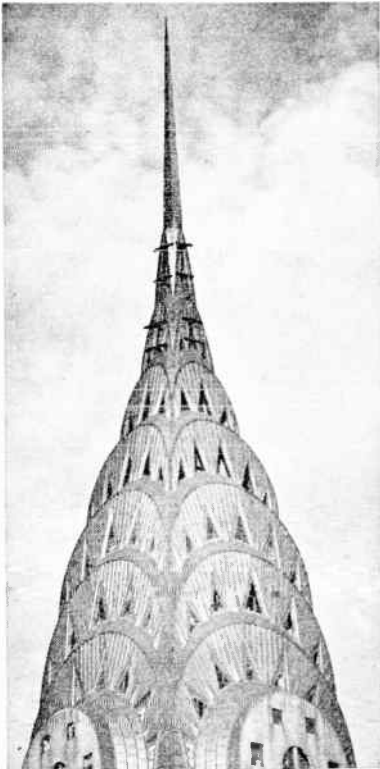

FIG. 273.—Antenna system (crossed dipoles) for sight and sound at station W2XAX, Chrysler Building Tower, New York (cf. Fig. 168).

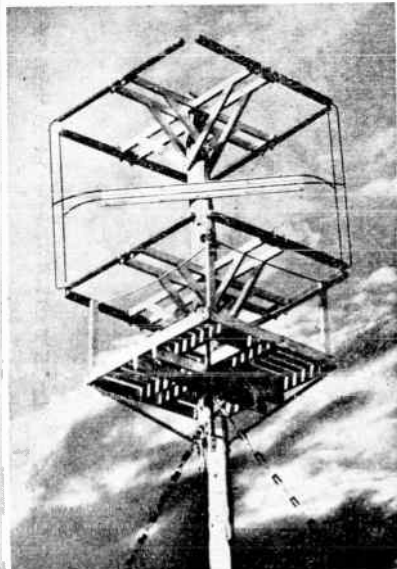

FIG. 274.—Cubic antenna for picture transmissions at station W2XB, near Albany, N. Y.

show in the block diagram but is sufficiently good to make unnecessary any filtering subsequent to the filter following the modulated stage.

Three typical examples of radiating structures are shown in Figs. 169, 273, and 274. They are, respectively, those of the NBC Empire State installation, the CBS Chrysler Building

installation and the General Electric Albany installation. The NBC radiator has already been noted (page 296). The cross-dipole arrangement of the CBS antenna gives it a power gain, distributed in all directions, of about four times over that of a



FIG. 275.—Mobile transmitting equipment of the National Broadcasting Company. The pickup equipment (cameras, microphone, and video signal circuits) is in the forward bus, the relay transmitter in the bus at the rear.

single horizontal dipole. The elements of the General Electric radiator form the sides of a cube and have desirable directional properties both with respect to angles below the horizon and with respect to the direction of greatest population density.



## CHAPTER X

### TELEVISION-RECEIVER PRACTICE

The problems of television-receiver design fall generally into two classes: those related to the signal circuit and those associated with the cathode-ray tube and its auxiliary circuits. The signal circuit includes the r-f, converter, and i-f circuits, as well as the second detector and video amplifier. The cathode-ray tube auxiliaries include the high-voltage power supply and the scanning generators and their synchronizing-control circuits.

Each of the factors involved in these separate circuits must be coordinated to produce a receiver of integrated design. For example, it is useless to employ a picture channel width of 4 Mc. unless the size of the luminescent spot produced on the cathode-ray tube is equal to, or smaller than, the ultimate detail corresponding to the 4-Mc. signal. For this reason, most receivers employing current cathode-ray tubes of 5 in. and smaller diameter are designed for a band width between 2 and 3 Mc.

#### 64. General Factors Relating to Choice of Tube and Circuits.<sup>1</sup>

Before undertaking the design of a television receiver, it is necessary to know the characteristics of available tubes and other specialized components. Tables VI, VII, VIII, and IX list the cathode-ray tubes, video amplifier tubes, high-voltage rectifiers, converters, and oscillators available at the time of writing

<sup>1</sup> Articles on the design and construction of television receivers include the following:

ENGSTROM and HOLMES: Television Receivers, a series of six articles:

Part I. Antenna and R-f Circuits, *Electronics*, 11 (4), 28 (April, 1938).

Part II. Television I-f Amplifiers, *ibid.*, 11 (6), 20 (June, 1938).

Part III. Television V-f Circuits, *ibid.*, 11 (8), 18 (August, 1938).

Part IV. Television Synchronization, *ibid.*, 11 (11), 18 (November, 1938).

Part V. Television Deflection Circuits, *ibid.*, 12 (1), 19 (January, 1939).

Part VI. Power for Television Receivers, *ibid.*, 12 (4), 22 (April, 1939).

FINK, D. G., A Laboratory Television Receiver (in six parts) *Electronics*, Part I, *ibid.*, 11 (7), 16 (July, 1938) Part II, *ibid.*, 11 (8), 26 (August, 1938). Part III, *ibid.*, 11 (9), 22 (September, 1938). Part IV, *ibid.*, 11 (10), 16

(December, 1939). It should be remembered that this list has been compiled in the first year of commercial-receiver production in the United States and that consequently the list is not representative of tube types that further experience is expected to produce.

TABLE VI.—TELEVISION CATHODE-RAY TUBES

Type No.*	Over-all length, inches	Screen diameter, inches	Heater volts, amperes	2d anode max. volts	1st anode max. volts	Control grid range, volts	Deflection system sensitivity at maximum anode rating	Type electron gun
906-P1, P4 } 3AP1E } 3AP4E }	11 $\frac{3}{8}$	3	2.5, 2.1	1500	1000	35	0.22 mm per volt	E.
1800	21 $\frac{3}{8}$	9	2.5, 2.1	7000	2000	40	Magnetic	E.
1801	16 $\frac{3}{8}$	5	2.5, 2.1	3000	1000	25	Magnetic	E.
1802-P1, P4 } 5BP4E }	17 $\frac{3}{8}$	5	6.3, 0.6	2000	1000	47	0.33 mm. per volt	E.
1803-P4 } 12AP4M }	25 $\frac{3}{8}$	12	2.5, 2.1	7000	1900	40	Magnetic	E.
1804-P4 } 9AP4M }	21 $\frac{3}{8}$	9	2.5, 2.1	7000	1900	40	Magnetic	E.
1805-P4 } 5AP4E }	13 $\frac{3}{8}$	5	6.3, 0.6	2000	700	35	0.2 mm. per volt	E.
7AP4M	13 $\frac{1}{2}$	7	2.5, 2.1	3500	675	25	Magnetic	E.
54-11-T	16 $\frac{3}{4}$	5	6.3, 0.6	2000	.....	.....	.....	E.
94-11-T	21	9	6.3, 0.6	5000	2000	40	0.2 mm. per volt	E.
144-11-T	21 $\frac{1}{4}$	13 $\frac{1}{2}$	2.5, 2.1	6000	1800	35	0.15 mm. per volt	E.
34-7-T	11 $\frac{1}{2}$	3	2.5, 2.1	1500	.....	.....	.....	E.

\* Types designated "P4" have a white phosphor material; those "P1" have a green phosphor. All others except 1800 and 1801 have white phosphors. 1800 and 1801 have a yellow-green phosphor.

Table VI lists the cathode-ray tubes. It will be noticed that the range of screen diameters includes 3, 5, 7, 9, 12 and 14 inch. The majority of receivers are designed for the 5-,

(October, 1938). Part V, *ibid.*, 11 (11), 26 (November, 1938). Part VI, *ibid.*, 11 (12), 16 (December, 1938).

FINK, D. G., A Television Receiver for the Home, *Electronics*, 12 (9), 16 (September, 1939).

Television Receiver Practice, Reprints from *Electronics* (includes two series listed above) McGraw-Hill Publishing Company, Inc., 1939.

WILDER, M. P., A series of articles in *QST*: December, 1937, to May, 1938.

9-, and 12-in. types. The types of fluorescent phosphors are various, but the predominant type is the "black-and-white" screen material consisting of either zinc sulphide or cadmium tungstate with zinc silicate. The green-yellow screen composed of zinc-beryllium silicate seems to have second choice. This latter screen produces a greater apparent contrast range for a given signal voltage, owing to the fact that the eye is more sensitive to green light than to any other color or combination

TABLE VII.—CHARACTERISTICS OF AMPLIFIER TUBES IN WIDE-BAND SERVICE

Type No.	Heater volts, amp.	Max. anode, volts	Grid bias, volts	Grid-plate trans-conductance, $\mu$ hos	Amplification factor, $\mu$	Figure of merit ( $g_m/C_{tube}$ )
Triodes						
6C5	6.3, 0.3	250	- 8	2000	20	77
6J5	6.3, 0.3	250	- 8	2600	20	108
6F8G (twin triode)	6.3, 0.6	250	- 8	2600	20	95
955	6.3, 0.15	180	- 5	2000	25	230
Beam-power Tetrodes						
6I6	6.3, 0.9	375	-17.5	6000	135	231
6V6	6.3, 0.45	250	-12.5	4100	218	178
6Y6G	6.3, 1.25	200	-13.5	7000	125	250
25L6	25, 0.3	110	- 7.5	8200	82	315
807	6.3, 0.9	600	-30	6000	135	315
6AG7	6.3, 0.65	300	-10.5	7700	770	320
Pentodes						
6AB7/1853	6.3, 0.45	300	- 3.0	5000	3500	380
6AC7/1852	6.3, 0.45	300	- 1.5	9000	6750	550
1851	6.3, 0.45	300	- 1.5	9000	6750	540
1231	6.3,	300	- 2.5	5500	3850	400
1232	6.3,	300	- 2.0	4000	3000	350
954	6.3, 0.15	250	- 3	1400	2000+	234
956	6.3, 0.15	250	- 3	1800	1440	290

of colors. The green screens also have the advantage of somewhat greater stability and longer length of life. The life expectancy of the phosphors is based on 500 hr., but with care (by avoiding excess brilliance and consequent burning of the screen) the life may be extended to 2000 hr. or more.

TABLE VIII.—HIGH-VOLTAGE RECTIFIER TUBES

Type No.	Filament volts, amp.	Maximum anode current, ma.		Maximum forward anode voltage, r-m-s, a-c	Maximum inverse anode, volts
		Peak	Average		
2V3G	2.5, 5	12	2	5500	16,500
2Y2	2.5, 1.75	75	5	4400	12,000
878	2.5, 5.0	20	5	7100	20,000
2X2/879	2.5, 1.75	100	7.5	2650	7,500

TABLE IX.—OSCILLATOR AND CONVERTER TUBES  
Oscillators

Type No.	Transconductance, $\mu\text{mhos}$	$C_{pk} + C_{pk}$ , $\mu\mu\text{f}$	Figure of merit
6J5	2600	7	372
6F8G	2600	4.8 (one unit)	550
6K8 (triode section)	2400	9.2	261
955	2000	1.6	1250

Converter Tubes

Type No.	Conversion conductance, $\mu\text{mhos}$	$C_{pk} + C_{pk}$ , $\mu\mu\text{f}$	Figure of merit
6K8	350	10.1	35
6AC7/1852	3300	16	206
1231	1830	15	122
956	738	6.2	119

In the smaller tubes, electric deflection is the rule. Since the accelerating voltage is low, usually not more than 2000 volts,

comparatively small values of deflecting voltage suffice to scan the screen. For tubes of 9 in. diameter and larger, magnetic deflection is the rule. This choice is dictated by the excessive values of deflecting voltage that would be required in conjunction with the high accelerating voltages used (up to 7000 volts).

The type of focusing in nearly all American tubes is of the electrostatic variety, but some European tubes used in American receivers make use of magnetic focusing. In the latter case, the combination of magnetic focusing and magnetic deflection avoids the ion spot that appears when magnetic deflection is combined with electrostatic focusing.

The physical outlines of several important tube types are shown in Fig. 276. The so-called "short" tubes require a wide angle of deflection, which in turn requires greater amplitude of scanning current or voltage and makes more difficult the obtaining of an even focus and flat field of illumination. However the utility of short-length tubes in small cabinet sizes has given them considerable popularity.

#### *Wide-band Amplifier Tubes.*<sup>1</sup>

The tubes listed in Table VII are intended for wide-band amplifier service, either in r-f, i-f, or video frequency service. Four tube types (1231, 1851, 6AC7/1852, and 6AB7/1853) have been developed specifically for television service and serve well as general-purpose tubes for all types of wide-band service. All these tubes, except the 1853, are sharp-cutoff pentode tubes.

<sup>1</sup> KAUFMANN, A. P., *New Television Amplifier Receiving Tubes*, RCA Rev., 3 (3), 271 (January, 1939).

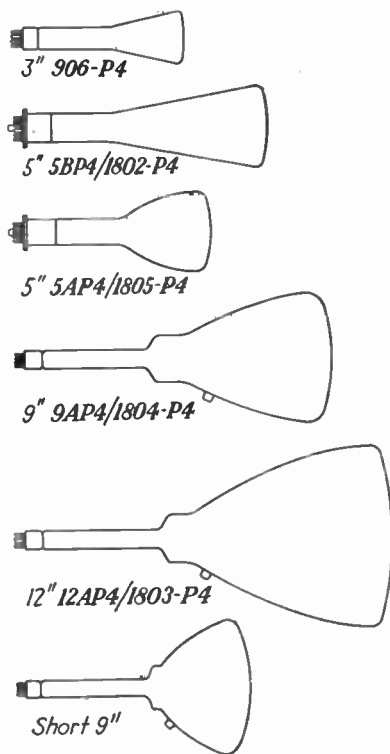

FIG. 276.—Outlines of typical picture tubes, drawn to scale.

The 1853 is a pentode with remote cutoff and is intended for stages using grid-bias gain control. The 6AG7 is a beam-power tetrode especially designed for video-amplifier output stages.

Other tubes not specifically intended for television service, but suited to it by virtue of their special characteristics, are the "acorn" tubes of the 950 series. These tubes are expensive and are not generally used except for experimental purposes, such as in the r-f stages of receivers intended for reception on channels above 100 Mc.

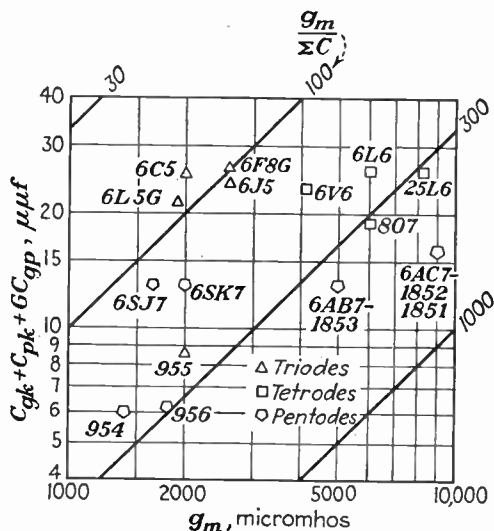

FIG. 277.—Characteristics of typical wide-band amplifier tubes, classed according to transconductance, capacitance sum, and figure of merit. Tubes with high figure of merit have positions toward the lower right-hand corner of the diagram.

For the output stages of video amplifiers, the tubes in the "beam-power" classification are useful. The use of these tubes is predicated on their high values of grid-plate transconductance, their high values of plate current, and on the fact that they can handle high values of plate-voltage swing without undue distortion.

Many other tubes used in general radio-engineering practice have also found their way into television circuits. Notable is the double triode 6F8G, which finds use because of the economy of the double-tube arrangement. In comparing the tubes listed,

the general figure of merit relating transconductance to input and output capacitances is the best index. The values of this figure are given in the table.

*High-voltage Rectifier Tubes.*—Rectifier tubes suitable for power-supply service at high voltage are listed in Table VIII. A tube universally used for the smaller cathode-ray tubes (5 in. diameter and smaller) is the type 2X2/879, a coated-cathode half-wave rectifier the maximum inverse voltage rating of which is 2750 volts r-m-s. This rectifier may also serve for high voltages (up to 5000 volts d-c output) if the anode current is limited to not more than 1 ma.

Tubes especially designed for high-voltage service are the 878 (which is not widely used because of its expense), the 2V3G, and the 2Y2. The former tubes are tungsten-filament tubes of very high inverse-voltage rating. The 2Y2 is a coated-cathode tube of 6000 volts peak rating. The tungsten tubes consume heavy heating current to obtain the necessary emission but are stable and trouble free. The coated-cathode tubes have higher emission efficiency but are more easily injured by abuse.

*Converters and Oscillators.*—The tubes shown in Table IX are used in the conversion system of superheterodyne receivers. The tubes are compared by figures of merit suggested by Lyman. An apparently unanimous choice of the oscillator tubes, up to the present, is the 6J5 tube which combines high amplification constant with high transconductance. The 955 tube is also an excellent oscillator but is considerably more expensive. In the converters, the 1852 tube shows good properties and has been used most widely in current designs. The 6K8, a combined oscillator-converter, has also been used to some extent. One unusual converter-oscillator combination is the 6F8G, a double triode, one section of which acts as the oscillator, the other as the mixer.

A consideration of importance in converter tubes is the relation of the conversion gain to the masking voltages present in typical operating conditions. The figure of merit that takes this ratio into account is stated in the table.

*Video Detectors.*—Virtually the only detector for video demodulation in wide use in America is the 6H6 double diode. Special detectors having lower values of dynamic resistance (and hence

permit high detected output voltage) are sometimes used experimentally but have not proved feasible for commercial designs.

**65. Choice of Circuit Constants and Frequencies.**—The basic factors in the circuit design of a television receiver are the required sensitivity, selectivity, and width of frequency response. Although these items are subject to wide variations, depending on the cost factors and the personal preferences of the designer, common agreement has been reached on many of them.

The sensitivity is limited ultimately by the masking voltage present in the input circuits of the receiver and by the tolerable signal-to-mask ratio. The latter value has been set at 20 to 1 by the most conservative, but values of 5 to 1 are occasionally used as the basis of designs. The minimum necessary signal sensitivity, based on a 5 to 1 ratio and on a mask voltage of 50 microvolts, is 250 microvolts. Despite this fact, some receivers marketed offer sensitivities as low as 100 microvolts. At the other end of the scale in cheaper receivers, in which the gain is limited by cost, the sensitivity is set at 1000 microvolts or even in extreme cases 5000 microvolts.

There is at present no general agreement on the method of measuring sensitivity of a receiver. One method is to base the sensitivity on the r-m-s value of a sine-wave-modulated r-f voltage at the input terminals of the receiver that will produce maximum contrast from the cathode-ray tube. The maximum contrast is somewhat difficult to evaluate inasmuch as apparent contrast varies with ambient illumination, with the size of the pattern elements, and with the d-c average of illumination on the screen. Since 25 volts is ordinarily taken as the peak-to-peak value required for optimum contrast on the cathode-ray tube, it has been suggested that the sensitivity be based on the r-m-s input voltage required to produce 25 volts peak to peak at the control grid of the cathode-ray tube. This is an easily measured factor which states accurately the gain of the electrical circuit but does not evaluate the important end result, namely, the contrast in the reproduced image. Further experience will be required before a definite sensitivity-measuring standard may be defined.

The selectivity problem is intimately related to the band width assumed in the communication channel, since if the channel is narrow, the selectivity against adjacent signals is inherently



better than if the channel has its maximum width. The necessary selectivity in any event may be specified by reference to experience. It has been found that the principal signals to be discriminated against are the two audio carriers adjacent to the video carrier. The sound channel nearest the picture channel is, as shown in Fig. 178, that of the adjacent television station, and this signal accordingly must be sharply attenuated. An attenuation value of 60 db (1000 to 1 in voltage) is recommended. The other sound channel, that which accompanies the picture in the same channel, is more remote from the picture carrier, and consequently 40 db (100 to 1 in voltage) is usually considered sufficient attenuation.

The selectivity problem is not completely answered with the attenuation of the adjacent sound channels, since there are also adjacent picture signals to be considered. Ordinarily, however, the pass band of the i-f amplifier is sufficiently narrow to overcome the effects of adjacent picture components.

The band-width problem is a compromise between desired detail in the image, on one hand, and cost on the other. If the full band width of 4 Mc. is approached, the selectivity problem becomes more acute and this fact entails more complex filter or trap structures to attenuate the adjacent signals. Furthermore, the wider the band width, the lower the gain per stage throughout the receiver, and the more tubes required for a given sensitivity. The masking-voltage problem also increases, the wider the band width, but this problem cannot be mitigated by more costly design—it requires rather that a stronger signal be available to overcome the masking effects.

These considerations have resulted in two basic designs. For the less expensive receivers, employing 5-in. cathode-ray tubes, the band width is purposely limited to a value not greater than 3 Mc. and often lower than 2.5 Mc. There are two good reasons for this decision. One is the fact that at the present state of the art the small cathode-ray tube can hardly reproduce the detail that a wider band width would offer to it. The picture width in the 5-in. tubes is roughly 4 in. The spot size is limited, by gun design as well as by defocusing difficulties, to  $\frac{1}{75}$  in. or greater. It follows that  $4 \times 75 = 300$  picture elements can be accommodated in the picture width. The band width corresponding to this picture detail is roughly 2 Mc. (see Fig. 304).

It is of course of some advantage to have a band width somewhat wider than 2 Mc. in this case, to aid in the building up of sharp edges of more extended details, but the practical limit even for this purpose is reached at about 2.75 or 3.0 Mc. In consequence, purposely restricting the band width has become the general rule with 5-in. and smaller cathode-ray tubes. In the event that the spot size of such tubes is reduced, in the future, to  $\frac{1}{100}$  in. or smaller, then the need for a wider band width in small tubes may appear.

For tubes of 9 in. and larger diameter, there is no advantage in restricting the band width from any consideration of spot size, since the spot size ( $\frac{1}{75}$  in. as before) allows roughly 600 picture elements in each line, and this detail entails a band width greater than 3.5 Mc. In consequence, receivers for these larger tubes are usually designed for band widths from 3.75 to 4 Mc. The more expensive design, necessary in order to obtain sufficient gain for the desired signal and sufficient attenuation of adjacent signals, is justified by the larger picture size and is in line with the greater cost of the cathode-ray tube.

Another general problem in circuit design concerns the number of separate channels to be made available. Of the nineteen television channels definitely set aside in the F.C.C. allocation, only seven are considered immediately useful, and at present not all seven of these channels are provided for in commercial receiver designs. There seems to be no great difficulty in providing circuits to receive the five channels lowest in frequency (from 44-to-50 to 88-to-94 Mc.). But above 95 Mc. there seems to be a dividing line beyond which present tubes and circuits cannot be utilized with economy. In consequence, even the most expensive receivers, at the time of writing, are equipped for five channels only. The less expensive receivers, employing 5-in. and smaller tubes, are equipped for as few as two channels and up to five. The smaller number of channels reflects the fact that at present no more than two or three stations are in operation at any one locality, even in the most populated areas, and that many receivers will be called to receive but one station in any event.

**66. Typical Receiver Design for a 5-in. Cathode-ray Tube.**<sup>1</sup>—To illustrate representative design in the smaller, less expensive.

<sup>1</sup> Design of models TT-5 and TRK-5 RCA Manufacturing Company, data supplied through courtesy of K. A. Chittiek.

receivers, it is convenient to take a particular model and outline its arrangements step by step. The block diagram in Fig. 278 shows such a typical receiver. The tube types will be recognized in Tables VI to IX, and the general circuit limitations follow the reasons given in the preceding section.

The input circuit leads directly to the converter. The omission of the r-f stage is common practice to save the expense of the tube and tuned circuits. Some sacrifice in signal-to-mask ratio is thereby incurred, and the gain of the stage is lost, but these factors do not outweigh the cost consideration. The converter is an 1852, the oscillator a 6J5. There follow three i-f

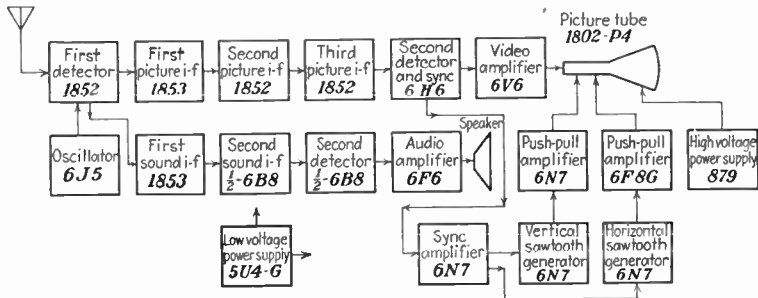

FIG. 278.—Block diagram of typical television receiver with 5-in. picture tube.

stages, band width purposely limited to 2.5 Mc., employing an 1853 pentode followed by two 1852 pentodes. The gain of the first i-f tube is controlled by a manually operated contrast control, but no automatic gain control is provided.

The cathode-ray tube auxiliaries include an 879 full-wave rectifier, supplying 2000 volts direct current to the second anode of the cathode-ray tube. Low voltage power is supplied by a 5U4G full-wave rectifier, the output drain of which is 175 ma. The scanning and sync-control auxiliaries make use, first, of the second section of the 6H6 diode detector, which is used as a clipper rectifier to provide the sync pulses separated from the picture impulses. The output of the clipper rectifier leads to a double triode, type 6N7, which acts to separate the vertical sync pulses from the horizontal. A blocking oscillator and discharge tube combined (Type 6N7) is then used to develop sawtooth waves of voltage, under the control of the vertical impulses. The output of the discharge tube controls the vertical-output scanning amplifier, which is of the push-pull variety to

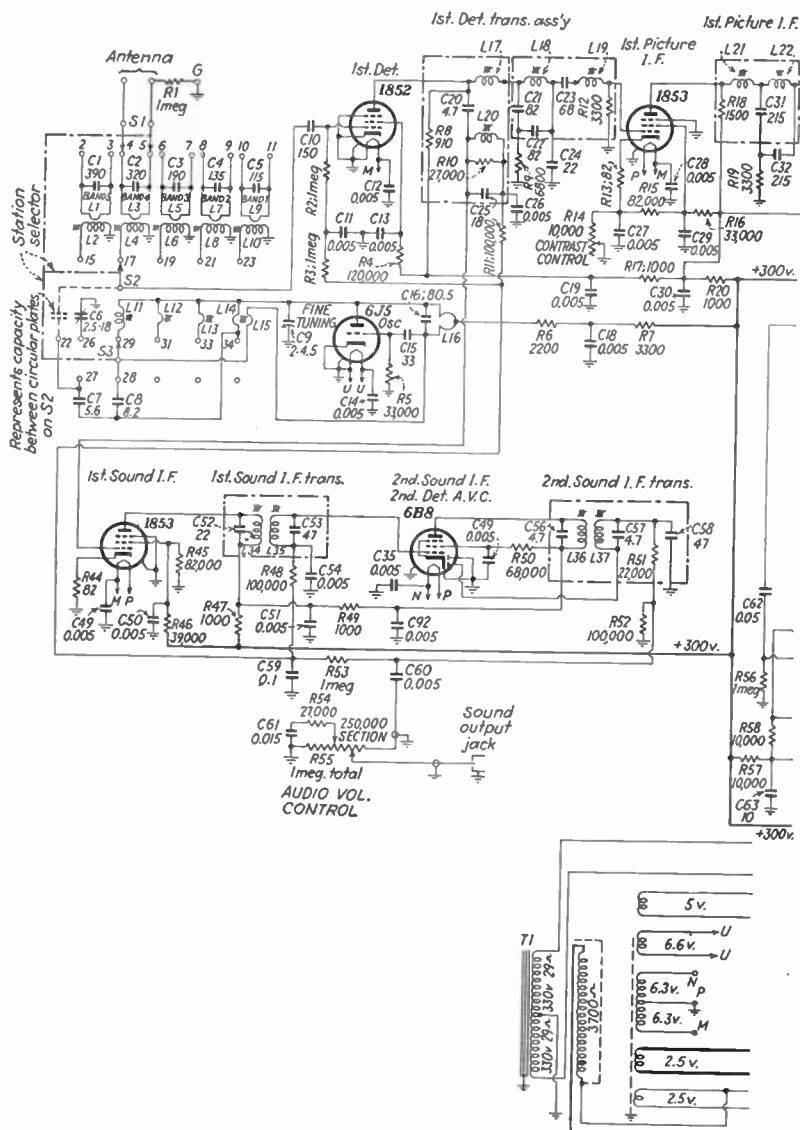
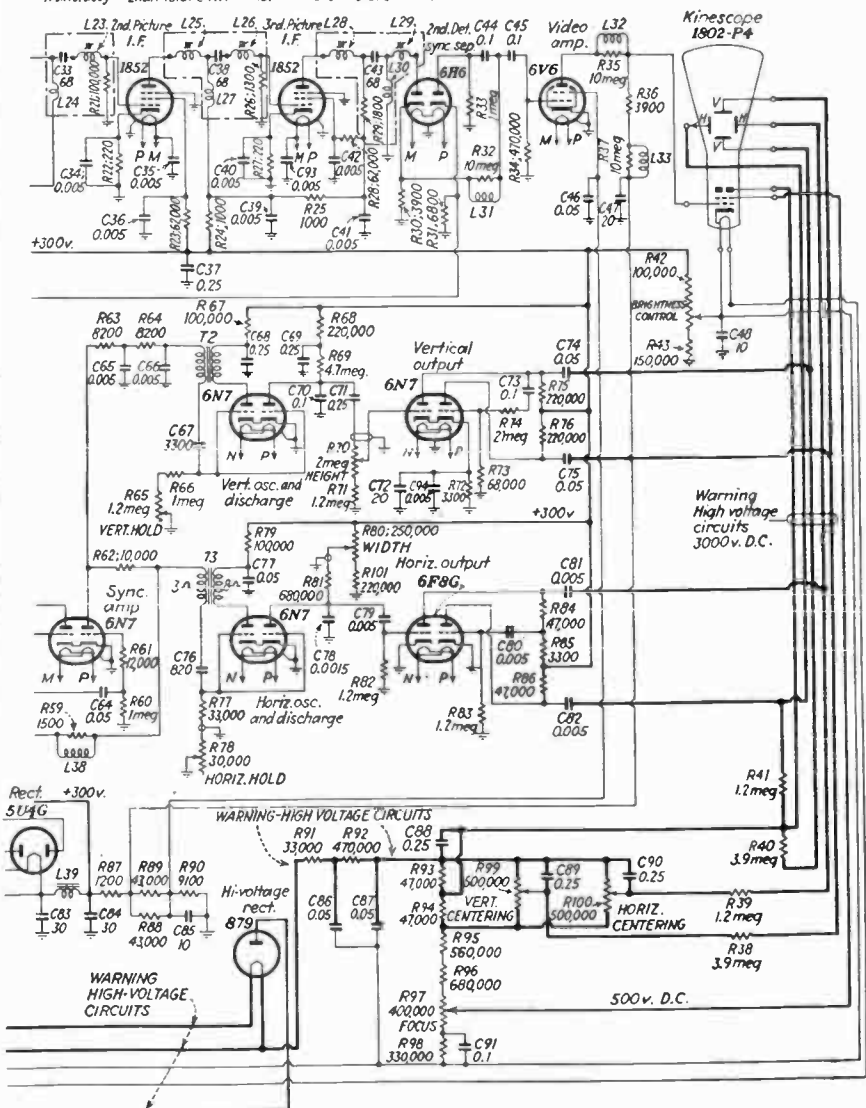

Fig. 279.—Complete circuit diagram of the

trans.assy 2nd Picture I.F.trans. 3rd Picture I.F.trans.



5-in. picture-tube receiver shown in Fig. 278.

avoid defocusing of the scanning spot. A similar series of tubes (blocking oscillator, discharge tube, and push-pull amplifier) is used to develop the scanning voltage for the horizontal direction.

The sound part of the receiver employs two i-f stages (1853, 6B8 tubes) following the 1852 converter, followed by a 6B8 detector and a-f amplifier, with a 6F6 output amplifier tube. The entire receiver contains 18 tubes, including the cathode-ray tube. The detailed circuit arrangements of this receiver are shown in Fig. 279, and the response curves are shown in Figs. 280, 281, and 282.

With reference to the signal circuit shown in Fig. 279 and beginning with the antenna: Separate antenna coupling coils are provided for each of the five channels (44 to 50, 50 to 56, 66 to 72, 78 to 84, and 84 to 90 Mc). The primary of each coupling coil is a metal strap, stamped from sheet, and consisting of but one turn, intended to match the impedance of a 75-ohm transmission line. The values of capacitance shown tune the circuit to the midpoint of each channel, and the loading of the transmission line provides the necessary broadness of the response. The secondary in each coupling unit is tuned with powdered iron cores, which fit within coils wound on polystyrene forms. The gain of the transformer arrangement is roughly 1.5 to 1. The input signal is fed to the grid of the converter, which displays a conversion gain of roughly 2 to 1.

The oscillator arrangement, shown also in Fig. 279, is as follows: The highest frequency to be produced is that for the 84 to 90 Mc. channel, for which a frequency of 98 Mc. is required (the input picture carrier of 85.25 Mc. plus the picture i-f frequency of 12.75 Mc.). To obtain a frequency as high as this, with stability, special precautions must be taken. The basic oscillator coil (shown to the right of the 6J5 tube) is a single turn of strap conductor, about  $1\frac{1}{2}$  in. in diameter, with its ends soldered directly to the tube-socket terminals. The tuning capacitor is a cylindrical, sprayed-silver unit with negative temperature coefficient, likewise soldered directly to the socket terminals. A trimmer ( $C_9$ , 2-4.5  $\mu\mu f$ ) is used to adjust the frequency when necessary.

For the low-frequency channels, the switch is used to add either inductance, or capacitance, or both, to the basic tuned circuit.

For the high-frequency channels, additional lengths of strap are added, tuned by iron-core plugs. For the lowest channel (44 to 50 Mc., oscillator frequency 58 Mc.), a lumped capacitance is added in the form of an adjustable trimmer. The heater voltage for the 6J5 is purposely put slightly above normal (6.6 volts as against 6.3 for the other tubes) to ensure maximum  $g_m$ ,

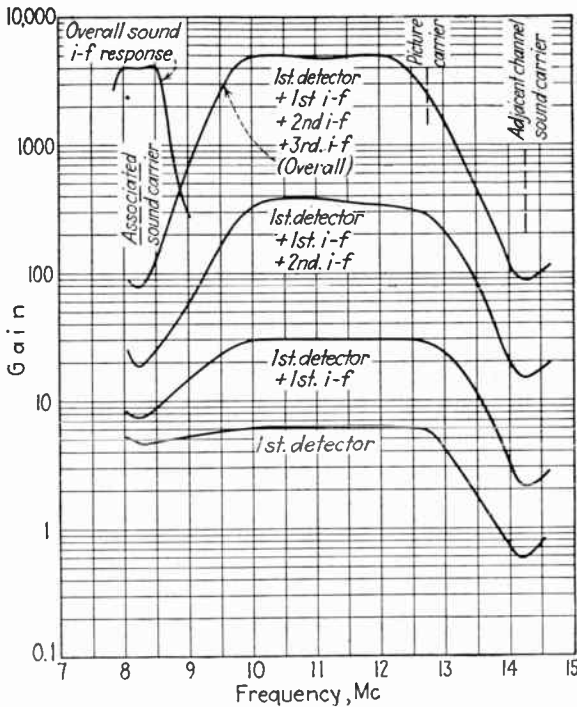

FIG. 280.—Cumulative response curves of the receiver shown in Fig. 279, at output of first detector and successive i-f stages. Note improvement in sound channel attenuation as the number of coupling circuits increases.

on which the oscillator output depends. Experience with this oscillator circuit shows that the drift of the oscillator is negligible, with respect to the pass band of the sound channel (see Fig. 282). The use of the trimmer capacitance  $C_9$  is restricted simply to centering the i-f carrier sound frequencies directly on the points of maximum rejection in the rejector circuits. This use is sufficient, however, to justify bringing the trimmer control out to a knob on the front of the cabinet.



The oscillator voltage is mixed with the input signal at the converter grid. In the output of the converter, the picture and sound intermediate frequencies appear. These are passed on to the first i-f coupling system, in which three functions are performed: (1) the picture intermediate frequency is passed on with proper band width to the first picture i-f amplifier tube. (2) The sound i-f is passed on to the first sound i-f tube. (3) The undesired sound in the adjacent channel (which appears in the i-f system at 14.25 Mc.) is partly removed from the picture channel, and the associated sound channel on 8.25 Mc. is also removed from the picture channel. These various functions are taken care of by a series of tuned circuits shown within dotted lines.

First, consider the picture i-f coupling unit. This consists of two coils (marked  $L_{17}$  and  $L_{18}$ ) with a capacitor  $C_{21}$  as the mutual coupling agent. The coils are permeability tuned and are adjusted by the iron-core plugs for proper band-pass response. Within the coupling unit (but not, strictly speaking, a part of it) is the rejection circuit consisting of the coil marked  $L_{17}$  and the capacitors  $C_{20}$  and  $C_{21}$ . This rejector circuit is tuned, by varying the position of the iron core within the coil, to 14.25 Mc., the frequency of the carrier of the undesired sound channel. Only one rejector circuit of this type is used, since the narrow band width makes possible high attenuation at the upper frequency edge of the picture i-f band-pass region.

Another rejector circuit is that of  $C_{25}$  in shunt with the coil marked  $L_{20}$ . This circuit is tuned, by permeability variation, to 8.25 Mc., the frequency of the desired sound i-f carrier. The circuit serves two purposes: it develops the desired sound i-f carrier and delivers it to the first sound i-f amplifier tube and it removes, partially, the sound carrier and sidebands from the picture channel. It is in this latter function that the circuit acts as a rejector.

To return to the picture i-f system, the first i-f tube passes the picture i-f carrier and sideband to a second coupling unit. This unit, like the first, performs functions of passing on the picture signal and rejecting the sound signals. The rejector circuit ( $C_{31}$ ,  $C_{32}$  and coil marked  $L_{21}$ ) is tuned to 8.25 Mc. to remove the vestiges of the associated sound i-f carrier. No further rejection of the 14.25-Mc. carrier is provided, for the



reasons given above. The portions of the coupling unit for band-pass purposes consists of three coils, marked  $L_{22}$ ,  $L_{23}$ , and  $L_{24}$ . Two permeability tuned "series" units are coupled by the mutual coil ( $L_{24}$ ). Inductive coupling is used in this case in contrast to the capacitive mutual coupling in the preceding stage. It should be noted that in each coupling unit there is a blocking capacitor ( $C_{23}$ ,  $C_{33}$ ,  $C_{38}$ , and  $C_{43}$ ) to avoid placing the anode potential of one stage on the grid of the following stage.

Between the second and third picture i-f tubes is a coupling unit that acts simply as a band-pass circuit (*i.e.*, includes no rejector circuit). Inductive coupling is used. The coupling unit between the third i-f stage and the second detector is essentially the same.

The second detector is the left-hand section of the 6H6 diode. This diode has an internal dynamic impedance of 3900 ohms. The load impedance  $R_{30}$  is 3900 ohms also. Consequently, one-half the demodulated voltage is delivered across the load impedance. From here, a single series peaking coil is employed to convey the signal to the video stage. From the video stage grid, the signal is applied to the right-hand diode section which acts as the sync "clipper" separator.

The d-c reinsertion system of this receiver is simple. In the grid circuit of the output video amplifier (6V6), a resistor of 470,000 ohms and a capacitor of 0.1  $\mu$ f ( $R_{34}$  and  $C_{45}$ ) act as the load circuit for the diode composed of the grid of the tube and the cathode. The tube is operated without cathode bias, consequently grid current is drawn when the video signal is first applied. This current develops a negative bias voltage across the grid resistor approximately equal to the peak value of the video signal. The picture-signal portions of the video signal are more negative than the blanking level at this point (since a cathode-above-ground detector is used). In the plate circuit of the video stage, therefore, the voltage level corresponding to the blanking level is fixed and remains so. The d-c component of the bias on the picture-tube grid is adjusted until no light appears during the blanked portions of the signal. Thereafter the light appearing on the screen depends on the camera components (alternating as well as direct current) of the video signal. Both a-c and d-c components are applied to the picture-tube grid since this grid is conductively coupled to the plate of the

video output tube. The cathode of the picture tube is not grounded but is connected to the 300-volt supply through a voltage divider. The anode voltage of the video output tube is less than 300 volts, hence it is possible to make the cathode of the picture tube more positive than its grid, which is of course the necessary operating condition.

This description includes all the picture and video frequency functions except the two controls for brightness and contrast. The contrast control is the 10,000-ohm resistor  $R_{14}$  in series with the cathode of the first picture i-f tube (type 1853). This tube

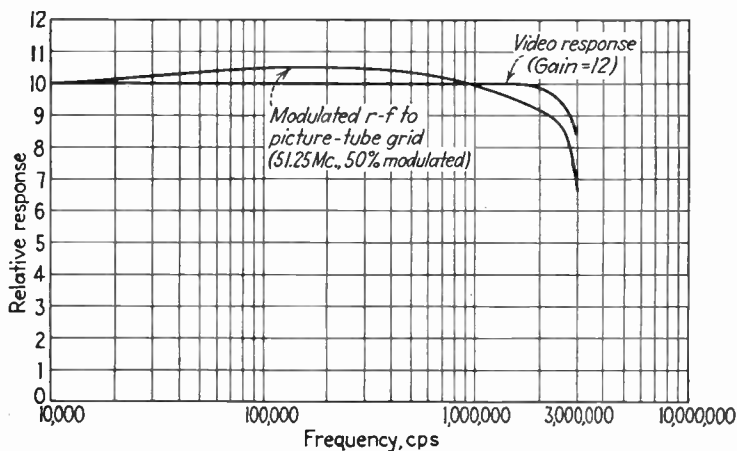

FIG. 281.—Video response curves for the receiver shown in Fig. 279. Note that the modulated carrier characteristic is slightly poorer than the video amplifier characteristic, but no avoidable loss in high-frequency response has been incurred thereby.

is of the remote cutoff type and is adapted to cathode-bias gain control. No control is applied to the last two picture i-f stages, which are high-gain type 1852 tubes. The brightness control is  $R_{42}$  in the cathode circuit of the cathode-ray tube.

The response curves of each of the signal circuits are shown in Fig. 280. From bottom to top these curves show, respectively, the cumulative responses of the converter, first picture i-f, second picture i-f, third picture i-f, and the over-all picture response to the input of the second detector. The gains of these stages are shown on the diagrams. The over-all picture gain is 5000. Consequently with a 500-microvolt signal (the value used as the basis of the receiver sensitivity), the input to the detector is 2.5 volts.

The basis of measurement in this case is a signal modulated 50 per cent which is representative of the average modulation actually present in the video signal. The output of the detector would accordingly be 1.25 volts if the detector output were 100 per cent, but the load resistor equals the detector internal resistor, hence the output is 0.625 volt. The gain of the video stage is 12, hence the output to the cathode-ray tube grid is  $12 \times 0.625 = 7.5$  volts, r-m-s. The peak-to-peak voltage is 2.8 times as great, or 21.0 volts. This is sufficient to swing the grid of the cathode-ray tube, provided that the brightness is not too high. For a bright picture, a signal of perhaps 30 volts peak to peak would be required. This video signal is available when a 0.75-millivolt signal is applied to the antenna terminals.

A comparison of the video amplifier-response curve and the modulated r-f curve is shown in Fig. 281. It will be noted that the video response is somewhat superior to the band-pass response but that the difference is very slight. This indicates a well-integrated design, since if the video amplifier were much better than the band-pass response, it would indicate an avoidable loss of gain in the video stage.

The sound system of the receiver operates as follows: From the converter plate circuit and the rejector ( $C_{25}$ ,  $L_{20}$ ), the sound i-f signal travels to an 1853 first sound i-f amplifier. The gain of this amplifier is a-v-c controlled. The coupling unit following this stage is a conventional permeability tuned unit of high gain (the over-all sound gain is 4000 times). The pentode section of the following 6B8 tube acts as the second i-f stage which is coupled similarly to the second detector and automatic volume control, which is applied to the i-f tubes. The audio output of the second detector is then applied to a compensated volume control. In one form of this receiver, the output of the sound channel is terminated at this volume control, the intention being to connect these terminals to the output a-f tube of any sound receiver. In another form of the receiver, the output tube is as shown in Fig. 278.

The remaining parts of the receiver are the cathode-ray tube and its auxiliaries, shown in Fig. 279. First consider the power supply for low and high voltage. All power-supply windings are wound on a single core, including high voltage (1900 volts r-m-s) 6.3 volts for the cathode-ray tube heater, 2.5 volts for

the high-voltage rectifier (879) filament, two 6.3-volt heater windings for other tubes, a 6.6-volt winding for the oscillator heater, a 660-volt center-tapped B-supply winding, and a 5-volt rectifier heater winding.

The B supply is tapped at three points, 75 volts, 260 volts, and 300 volts. The 75-volt tap goes to the screen grid of the video output stage, which limits the output plate current (which would otherwise be high in the absence of picture signal). The plate of this tube is held at 260 volts. All other B-supply requirements are taken from the 300-volt tap.

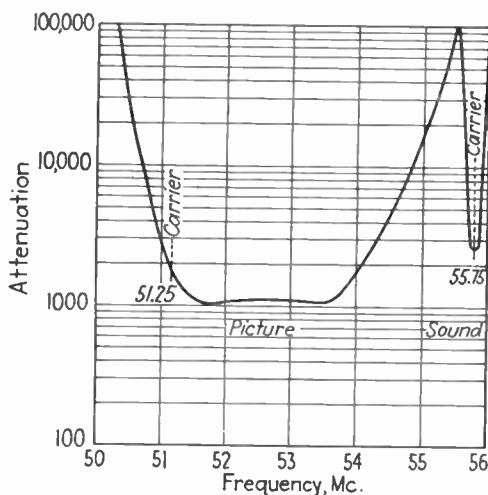

FIG. 282.—R-f sensitivity characteristic of the receiver shown in Fig. 279, for channel number 2 (50–56 Mc.).

The high-voltage supply makes use of the double-section filter shown, consisting of two 3000-volt shunt capacitors and series resistors. The high-voltage bleeder is arranged in four sections: the lowest section is a filter, to remove any signal from the focus control circuit, immediately above. The second-anode tap is taken at 2000 volts, and portions of the bleeder extending above and below this point provide 60 volts in either direction. This 120-volt range is applied to two 500,000-ohm potentiometers which act as centering controls. The center tap of each of these controls connects, through a high resistance, to one set of the deflecting plates of the cathode-ray tube.

The synchronizing circuit begins at the grid of the video amplifier tube. This grid is connected to the anode of a diode tube (the right-hand section of the 6H6) in such polarity that only the sync pulses (more positive than the blanking level) are passed. The diode thus acts as a clipper. The output of this diode is a 6800-ohm load resistor across which the supersync pulses develop. They are led to one section of a 6N7 double triode. This section acts simply as an amplifier, reversing the phase of the signal. The second section of this tube acts to smooth out whatever irregularities exist in the blanking level (including such components of the picture signal as leak across the interelectrode capacitance of the double-diode detector and separator). The 12,000-ohm resistor in series with the grid of the lower 6N7 section is of aid in this latter function. In the plate circuit of this tube, a peaking coil is used to develop a high impedance for the high-frequency (horizontal sync) component, and the low-frequency component is taken directly from the plate. A double-section filter is used in this latter circuit ( $R_{63}$ ,  $C_{65}$ ,  $R_{64}$ ,  $C_{66}$ ) to remove all traces of the high-frequency component.

The scanning generators are of the blocking-oscillator and discharge-tube variety, which are fully described on pages 155 and 474. The discharge tube causes a saw tooth of voltage to appear across the capacitor  $C_{70}$  in the low-frequency circuit and across  $C_{73}$  in the high-frequency circuit. The amplitude of the saw-tooth waves is controlled by a voltage divider in the vertical case and by a charging-current control in the horizontal case.

The output of the saw-tooth generators is amplified in push-pull amplifiers. In the vertical case, the amplifier is a 6N7 double triode. Push-pull action is obtained by a feed-back arrangement (through the  $RC$  combination  $C_{73}R_{74}$ ) from the plate of one section to the grid of the other. The result is two waves of voltage in push-pull relationship across the load resistor  $R_{75}$  and  $R_{76}$ . The total amplitude across this combination is about 500 volts peak to peak, which is sufficient to deflect the scanning spot with 2000 volts as applied to the second anode.

The horizontal output amplifier tube (a double triode 6F8G) is connected in the same fashion, except that the capacitances are kept to a minimum to avoid losing the high frequencies in the saw-tooth wave. No provision is made, in either the vertical

or horizontal circuits, for correcting improper wave shape in the scanning output, but this factor is taken care of in the design of the circuits.

### 67. Typical Receiver Design for a 12-in. Cathode-ray Tube.<sup>1</sup>—

In Fig. 283 is shown the block diagram of a receiver designed for a 12-in. cathode-ray tube. The design is considerably more elaborate than that of the 5-in. tube receiver just described, and the costs of production are proportionately greater, but the receiver has been designed with cost factors in mind. The design is intended to make full use of the standard R.M.A. picture

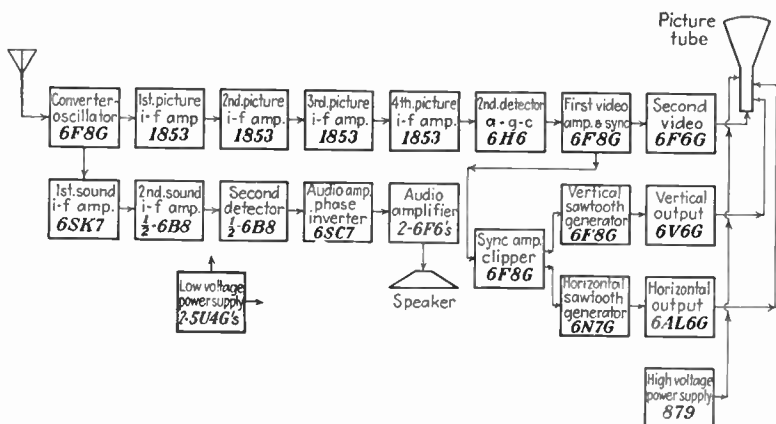

FIG. 283.—Block diagram of typical television receiver for a 12-in. picture tube. In later models, the first and last picture i-f tubes are type 1852.

signal as well as the full picture-reproducing capabilities of the 12-in. picture tube, but no unnecessary expense has been incurred.

The receiver employs 22 tubes, including the picture tube, for all functions. Ordinarily the receiver is mounted in the same cabinet with a seven-tube all-wave sound receiver. The total power consumption for the combination television all-wave receiver is 300 watts. The television chassis has six controls available from the front of the cabinet: volume, brightness, contrast, focus, tone, and vernier tuning. Seven controls are brought out to the rear of the receiver: horizontal size, linearity, and hold (frequency); vertical size, linearity, and hold; and horizontal peaking control. The centering of the image is

<sup>1</sup> Data for model HM-226 of the General Electric Company. Data supplied through courtesy of I. J. Kaar and G. W. Fyler.

controlled mechanically by adjusting the position of the magnetic focusing coil.

The picture receiver is equipped for five channels, with push-button selection, on 44 to 50, 50 to 66, 66 to 72, 78 to 84, and 84 to 90 Mc. On the low-frequency channels, the picture-signal sensitivity is 100 microvolts, 50 per cent modulated, for a 10-volt peak-to-peak signal at the picture-tube grid. The same signal on the sound channel will provide  $\frac{1}{2}$  watt electrical output at the loudspeaker terminals. The band width of the picture channel is approximately 3.5 Mc., corresponding to a picture definition of 350 to 400 lines. The attenuation in the picture channel is 50 db against the associated sound channel and 60 db against the adjacent sound channel. The picture i-f channel employs a delayed a-v-c system.

An unusual aspect of the design, when compared with other American receivers of the same period, is the use of a magnetically focused cathode-ray tube. This method of focusing, in conjunction with the magnetic type of deflection, eliminates the formation of the ion spot on the luminescent screen. The screen material is of the sulphide type, which gives high-light output with relatively low second-anode voltage. In this receiver, the second-anode voltage is 4000 volts.

Magnetic focus is obtained by passing a current of about 100 ma. at 25 volts through a focusing coil. This current is obtained from the low-voltage power supply of the receiver by passing the full load current of the chassis through the focusing coil, at a loss of 25 volts in available voltage from the power supply. The cathode-ray tube is of the "short" variety and is installed in the cabinet with the screen face forward, for direct viewing of the image. The short tube requires a corresponding large angle of deflection, and the horizontal output deflection amplifier is designed for high output current.

With reference to the complete circuit diagram, Fig. 284, it will be noted that no r-f stage is employed. The antenna-input system is of special design to ensure constant band width regardless of the operating frequency. The gain of this circuit, so far as the picture signal is concerned, is about 2 to 1, but the loss in the converter circuit is 1 to 2, and so the converter system, over-all, offers no gain. There follow four picture i-f stages, each having a gain of approximately 8. For a 1-volt r-m-s

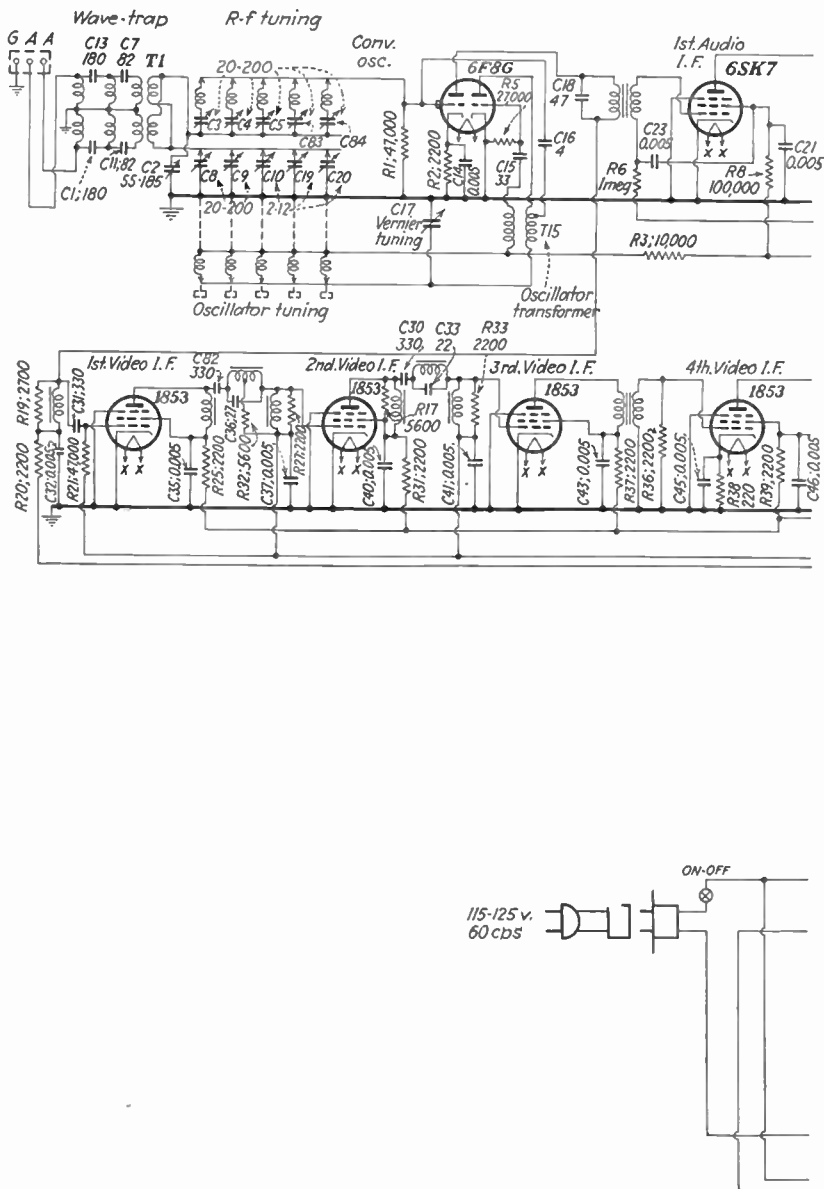
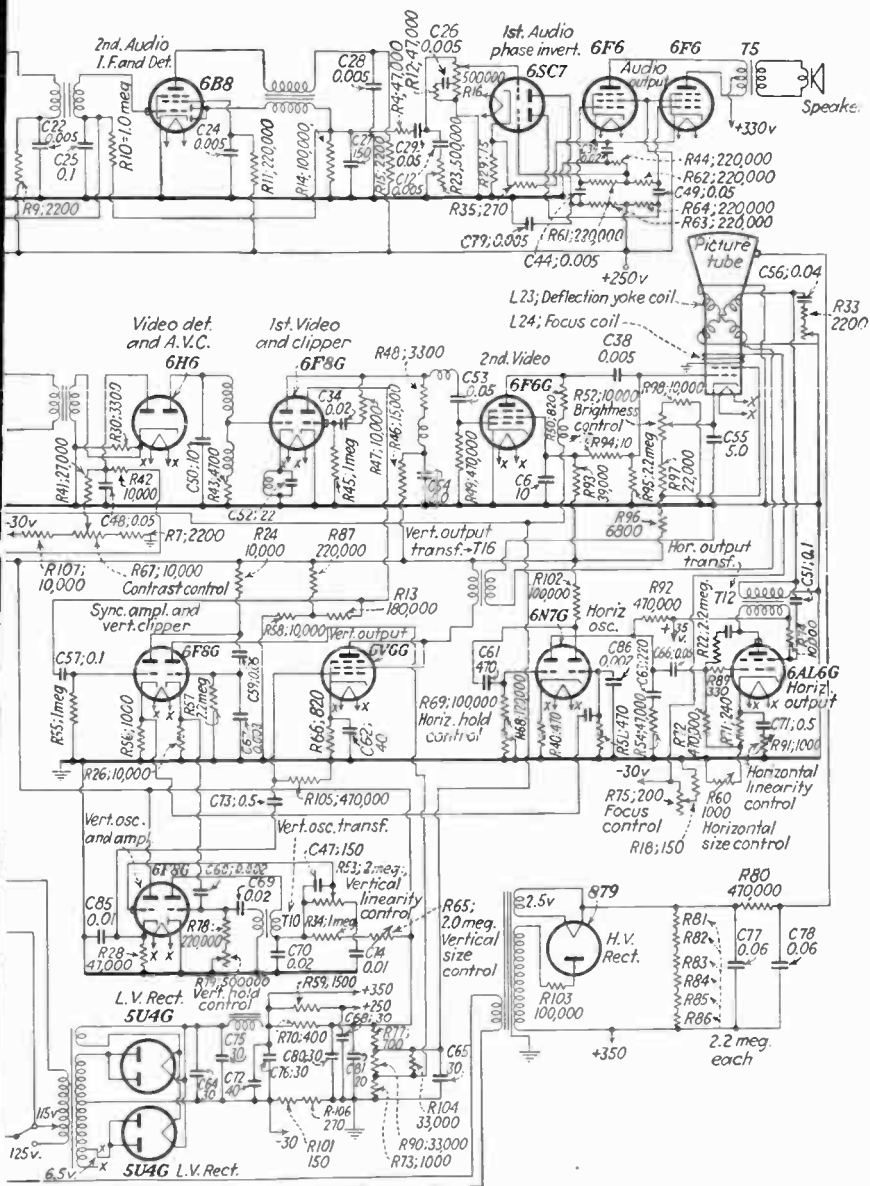

FIG. 284.—Complete circuit diagram of 12-in.





picture-tube receiver shown in Fig. 283.

signal applied to the grid of the first video amplifier stage, a signal of 800 microvolts, 50 per cent modulated, is required at the antenna terminals. The gain of the two video amplifiers is about 5 and 6, or 30 over all. The 1-volt signal on the grid will produce, therefore, a 30-volt r-m-s signal (84 volts peak to peak) on the picture-tube grid. A 10-volt peak-to-peak signal is accordingly produced by a 100-microvolt signal 50 per cent modulated, as previously stated.

The synchronizing auxiliaries include a clipper (one section of the 6F8G tube) which accepts the output of the first video amplifier stage and separates the sync-level signal amplitudes from the picture-signal amplitudes. The output of this first clipper is fed to a synchronizing signal amplifier stage. From the cathode of this stage, the horizontal sync signals are derived and fed to a multivibrator type of saw-tooth generator. A 6AL6G beam output tube amplifies the horizontal scanning current and applies it to the horizontal deflecting coils. No damping rectifier is necessary, inasmuch as the required wave-shape correction is accomplished in the amplifier circuits.

The vertical sync pulses are clipped in the second section of the 6F8G sync amplifier and then fed to a blocking-oscillator type of saw-tooth generator, which applies the vertical scanning current to a 6V6G output tube which in turn applies the deflection current to the scanning yoke. The focusing coil is connected to the most negative end of the low-voltage bleeder (-25 volts below ground). A variable shunt resistor serves to vary the current carried by this coil and hence to permit focusing of the beam.

The power supplies include two 5U4G tubes in parallel to supply all low-voltage requirements and a single type 879 rectifier tube for the 4000 volt d-c supply. The sound receiver includes two i-f stages, second detector, first audio and phase inverter, with push-pull audio output tubes.

In the picture-signal circuit, the first circuit arrangement of interest is the series tuning of the converter grid tuned circuits. The transformer  $T_1$  converts the circuit from a balanced-to-ground form to the single-ended form. The ground side of the single-ended output is conducted to ground through a series of adjustable capacitors, one for each switch position. The high end of the transformer output is connected to the converter

grid through a series of adjustable series inductor-capacitor combinations, one for each switch position. By proportioning the adjustments of the capacitors, it is possible to obtain nearly the same gain and constant band width on each of the five channels. The converter tube itself is one section of a 6F8G double triode. This is an unusual arrangement but one that works very satisfactorily in wide-band service. The other section of the

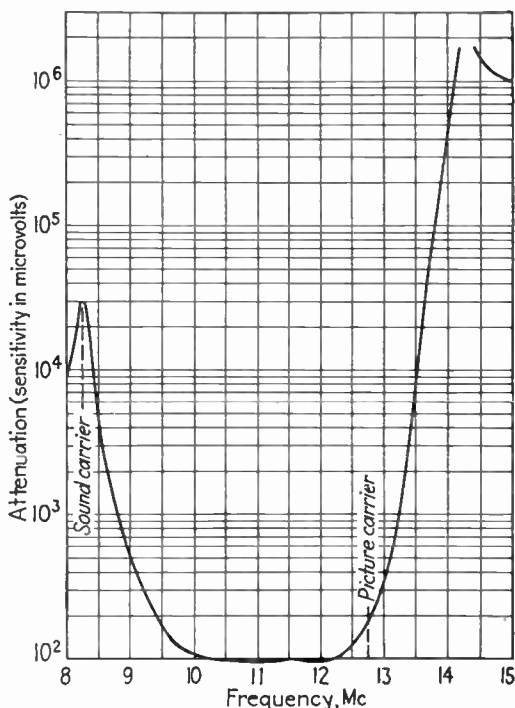

FIG. 285.—Over-all i-f sensitivity characteristic of receiver shown in Fig. 284.

6F8G is used as the oscillator, which is a modified Hartley circuit tuned by series inductances switched in between the grid and plate coils. The capacitor  $C_{17}$  serves as a vernier tuning control and provides a total variation of about 1 Mc.

From the plate of the converter tube, the picture signal is conducted next to the four picture i-f stages. The over-all i-f response curve of the picture i-f amplifier is shown in Fig. 285. The band width at two times down is about 3.3 Mc. in the particular receiver for which the curve was measured. The

attenuation against the associated and adjacent sound channels is shown. Note also that the position of the picture i-f carrier, at 12.75 Mc., is located at the two times down (50 per cent response) level as is required for restoration of the 100 per cent modulation in the i-f carrier. The video amplifier characteristic is plotted in Fig. 286. The band width at two times down is 3.5 Mc., or just slightly better than the i-f response, as is desirable. A remarkable feature of the video amplifier is that it is just 3 db down at 6 c.p.s., which is the result of compensation for phase response at the low frequencies. The sound characteristics, at intermediate frequency, are shown in Fig. 287.

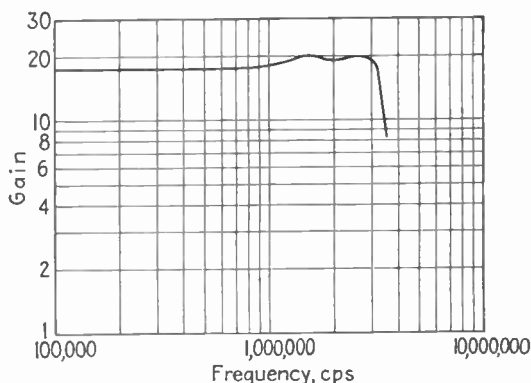

Fig. 286.—Video amplifier response curve of receiver shown in Fig. 284.

The i-f band width at two times down is 160 kc. The a-f characteristic is compensated at 55 c.p.s. and extends flat (when account of the transmitter predistortion<sup>1</sup> is taken) to 10,000 c.p.s.

The controls of the receiver are located on the circuit diagram as follows: The push buttons for station selection are in the

<sup>1</sup> It should be noted here that the sound channel of a television receiver must be designed to introduce attenuation of the high audio frequencies, since these frequencies are emphasized at the transmitter for the purposes of obtaining a better signal-to-noise ratio and higher fidelity of transmission. The R.M.A. Standard on this point (see page 520) states that the upper frequency range of the transmitter should be preemphasized according to the impedance-frequency characteristic of a series inductance-resistance network having a time constant of 100 microseconds. The inverse characteristic (obtainable from a series resistance-capacitance network of the same time constant, say a 100,000-ohm resistor in series with a 0.001  $\mu$ f capacitor) should be inserted in the receiver to avoid excessive high-frequency response.

converter grid circuit and oscillator circuits. The vernier tuning is  $C_{17}$  in the oscillator circuit. The contrast control is  $R_{67}$  associated with the diode-a-g-c system which controls the gain of the first three picture i-f stages. The brightness control is  $R_{52}$  in the cathode circuit of the picture tube. Direct-current reinsertion is obtained from the variations in screen current in the final video amplifier, through the resistor  $R_{94}$ . The focus control is  $R_{75}$  in shunt with the focus coil. The horizontal hold control is  $R_{69}$  in the grid of the left-hand section of the 6N7G multivibrator. The linear control for the horizontal direction is  $R_{91}$  in the cathode of the horizontal output tube. The horizontal size control is  $R_{69}$  which returns the output tube cathode circuit to ground. The vertical hold control is  $R_{79}$  in the primary of the blocking oscillator transformer. The vertical linearity control is  $R_{53}$  in the plate of the oscillator tube, while  $R_{65}$ , the vertical size control, is in the same circuit.

A brief description of the operation of the multivibrator saw-tooth oscillator used for horizontal deflection is in order (the blocking oscillator used in the vertical system is essentially similar to those described in the next section). The multivibrator consists of two triode sections, with a common cathode resistor and with the grid of one section connected through a capacitor to the plate of the other. Initially one triode draws current while the other is cut off. The sync pulse (negative) applied to the first triode decreases its plate current, raising its plate potential and the grid potential of the second triode. The action is cumulative, resulting in virtual cut-off of the first triode and heavy current in the second. The charge on the plate capacitor of the second triode is thereby exhausted, which brings

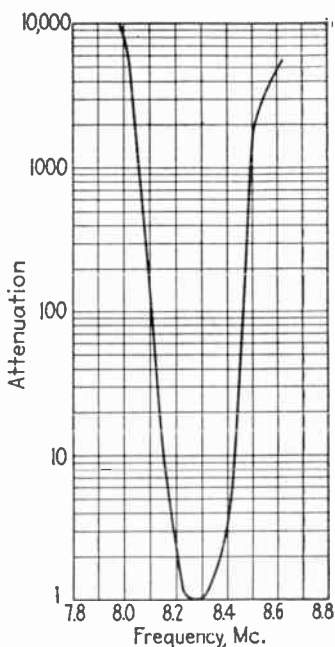

FIG. 287.—I-f sensitivity curve of sound channel of receiver shown in Fig. 284.

the discharge to a sudden stop. The bias across the cathode resistor thus decreases, and the potentials on the several electrodes revert to their initial values, ready for the next sync pulse. In this reversion, the restoration of plate current in the first triode puts a large negative bias on the second triode grid. The rapid changes in current in the second-triode section are conveyed to waveform-correction circuits which produce a corrected sawtooth wave of the proper shape to drive a sawtooth wave of current through the horizontal-deflection circuits.

**68. A Scanning and High-voltage Chassis.**<sup>1</sup>—When the radio engineer is confronted with the design of a television receiver, the principal difficulties lie in the most unfamiliar circuits, which are those associated with the cathode-ray tube. The signal channel is unfamiliar to the extent that a very wide band of frequencies must be handled, but the difference is simply one of degree. In the synchronizing and scanning circuits, however, radically different circuit functions are used. For this reason, it is of value to consider in detail a chassis designed specifically to perform these unfamiliar functions. This chassis has been made available in commercial form for inclusion in complete receivers.

The complete circuit diagram of this scanning and synchronizing chassis is shown in Fig. 288. We consider first the high-voltage power supply, which is intended to supply 7000 volts of adequately filtered direct voltage for the accelerating electrodes of a 9- or 12-in. cathode-ray tube. The power transformer includes but two secondary windings, one 2.5-volt winding insulated to 10,000 volts for the rectifier cathode-heating current, the other of 5500 volts r-m-s for the high-voltage supply. The rectifier, a 2V3G tungsten-filament tube, is mounted on a socket insulated for 7000 volts. The rectifier tube feeds directly the filter structure, which is of the double-section *RC* type, employing two 0.03- $\mu$ f 7000-volt capacitors and a 470,000-ohm dropping resistor. The direct high voltage appears across the terminals of the second capacitor, where it is fed directly to a voltage divider or "bleeder" consisting of 11 carbon-resistor units in series. All but one of these units is fixed, the remaining one

<sup>1</sup>Television Receivers in Production, *Electronics*, 12 (3), 22 (March, 1939).

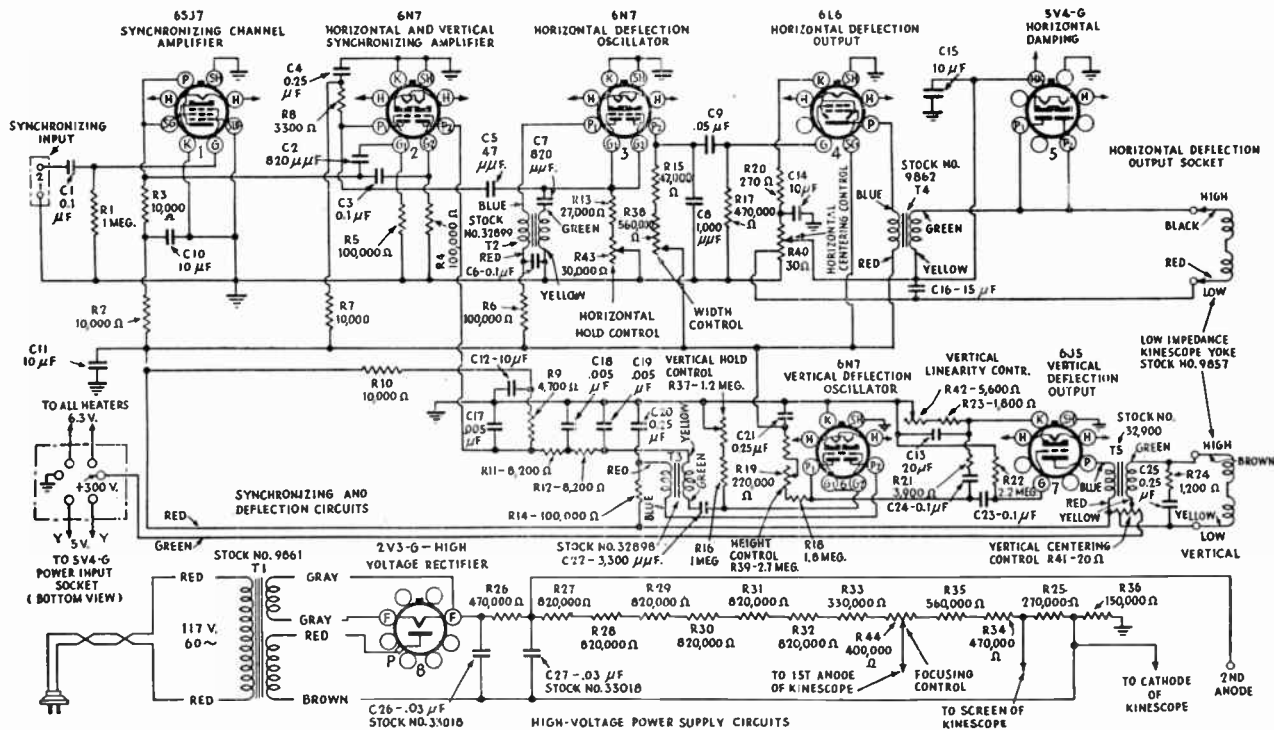

FIG. 288.—Circuit diagram of scanning and synchronizing system with 7000 volt d-c supply, capable of performing all functions exclusive of the signal circuit. (RCA Mfg. Co.)



being a conventional volume control of 400,000 ohms resistance. From the bleeder, four connections are taken to the cathode-ray tube. The high-voltage terminal (7000 volts) leads directly to the second anode of the cathode-ray tube. The center arm of the variable control (the focusing control) leads to the first anode. The shaft of this control must be insulated for at least 2500 volts, and the whole unit must be mounted on insulators for the same voltage. The third connection, taken near the negative end of the bleeder leads to the screen grid of the electron gun. The negative end of the bleeder leads directly to the cathode of the gun. Finally, the negative end of the bleeder is grounded through a 150,000-ohm resistor, which permits the signal source to be grounded at its negative terminal if desired (useful in d-c restoring circuits).

The low-voltage power supply (not shown in the diagram since it is not included in the chassis proper) is conventional in every respect. It must be capable of supplying 6.3 volts alternating current for the tube heaters, 5 volts alternating current for the heater of the damping tube, and 300 volts direct current at 100 ma. for the various plate and screen circuits.

We begin the sync- and scanning-circuit analysis at the synchronizing input terminals, shown to the left of the diagram. Here a voltage of at least 0.1 volt, peak to peak, is required to control the following circuits. This input voltage must contain the sync pulses only, that is, a clipper tube that removes the camera impulses must precede the signal input. The first tube is a sharp-cutoff "synchronizing channel amplifier" employing a 6SJ7 pentode tube. This tube, connected as a triode, serves simply to amplify the sync impulses to a level suitable for separation. The plate circuit of this tube contains the sync pulses in negative polarity and feeds them to the next tube, a double triode, type 6N7. The amplified sync pulses, still in composite form, are fed to the two grids of the 6N7 through capacitors of widely varying capacitance. One tube receives the pulses through a small capacitance (820  $\mu\text{mf}$ ), and this tube accordingly responds principally to the high-frequency (horizontal) sync pulses. The other section of the tube accepts the composite sync signal through a 0.1- $\mu\text{f}$  capacitor and accordingly responds to all frequency components.



The output of the horizontal section (left-hand section in the diagram) contains a simple load circuit which connects directly to the horizontal deflection oscillator tube through another low capacitance ( $47 \mu\text{mf}$ ).

The output of the vertical section, on the other hand, connects to its oscillator tube through an involved coupling network of  $R$  and  $C$  units. The resistance values are 8200 ohms and the shunt capacitances  $0.005 \mu\text{f}$ , producing a time constant of 41 microseconds. This combination effectively blocks any high-frequency components (whose period is  $1/15,750$  sec., or 75 microseconds), although allowing the vertical impulses (period  $\frac{1}{60}$  sec., or 16,666 microsec.) to pass. This sharp separation of the vertical from the horizontal pulses at this point is essential if the interlace performance is to be stable and fool-proof. In fact the slightest degree of cross talk between the circuits (that is, any 15,750-c.p.s. signal in the 60-c.p.s. circuit) will interfere with the interlacing.

The operation of the blocking-oscillator circuits has already been briefly described in Chap. IV. Consider first the horizontal blocking oscillator (left-hand section of the upper 6N7 tube). The transformer  $T_2$  acts to couple the plate and grid circuits of this tube, and hence induces oscillations. These oscillations, by virtue of the low values of inductance and capacitance associated with the transformer, occur at a rate many times greater (usually about 50 times greater) than the desired 15,750-c.p.s. oscillation. In consequence, each period of the oscillation occupies a comparatively small length of time. The grid of this section of the tube is connected to the feed-back transformer through an  $820\text{-}\mu\text{mf}$  capacitor. The amplitude of the oscillations, which start when the power is applied, is so great that the grid of the tube is driven sharply positive on the positive peaks. As a result, the grid draws considerable grid current and becomes negatively charged. The capacitor prevents the escape of this charge, so the negative grid quickly cuts off the plate current of the tube. The result is that a very few oscillations occur, followed immediately by blocking of the tube. This sequence of operations gives rise to the name "blocking oscillator." Immediately after the tube assumes its blocked condition, the charge trapped on the grid begins to leak off through the resistors

$R_{13}$  and  $R_{43}$ . When the charge has leaked off sufficiently, the tube is ready to begin its oscillation once more, followed again by blocking. The rate at which the oscillation and blocking repeat themselves thus depends on the discharge resistor. The variable portion  $R_{43}$  can be adjusted to produce a repetition at a rate of approximately 15,750 c.p.s. Then the sync pulses applied to the tube (from the left-hand section of the preceding 6N7) ensure that the rate of repetition is exactly 15,750 c.p.s. This is the basic synchronizing action. For it to occur, it is necessary that the sync pulses have a polarity that makes the

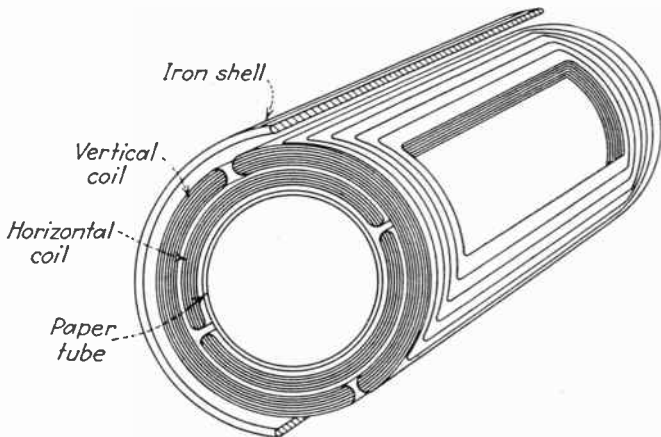

FIG. 289.—Internal construction of a typical magnetic deflection yoke. The axes of the two coils are at right angles to each other and to the axis of the picture tube.

grid positive (thus adding to the initial positive oscillation and producing the subsequent blocking at the required time). The voltage level required of the synchronizing signal is about 20 volts, peak, positive above ground.

The blocking oscillator thus serves to develop sharp positive impulses across the grid, followed by periods of relaxation, the whole occurring in synchronism with the sync signals. The positive peaks on this grid are conducted directly to the grid of the right-hand section of the 6N7 section, which acts as the discharge tube.

The discharge tube has connected in its plate circuit the capacitor  $C_8$  (1000  $\mu\mu\text{f}$ ) which is charged from the B supply through the resistors  $R_{15}$  and  $R_{38}$ . The amount of charge

accumulated thus depends on this value of these resistors, the variable member of which acts to control the width of the horizontal scanning. The condenser charges along the usual exponential charging curve, but the time constant is so long when compared with the 1/15,750-sec. period that only the initial portion of the charge curve is actually covered. This initial portion approximates a straight line. Consequently, the voltage developed across  $C_8$  has the required wave shape of the upward slope of a saw-tooth wave.

The capacitor  $C_8$  is suddenly discharged by the appearance of the sharp positive pulses on the grid of the right-hand section of the 6N7. The sharp pulses make the right-hand section suddenly conduct current, whereby the capacitor is discharged. This discharge constitutes the steep slope of the saw-tooth wave. Across the capacitor  $C_8$ , then, a saw-tooth wave of voltage appears, the period of which is 15,750 c.p.s., in synchronism with the horizontal sync pulses.

The exact form of the saw-tooth wave demanded by the circuit depends on the type of scanning employed. In this case, magnetic scanning is used and a saw-tooth of current, rather than of voltage, is required. To produce a saw-tooth of current in the inductive windings of the scanning yoke, sharp voltage pulses are required. The values of the  $R$  and  $C$  elements are chosen to produce a saw-tooth wave the whole duration of which is a very small fraction of the horizontal scanning period. The result is that the waveform actually appearing across the capacitor  $C_8$  is as shown in Fig. 86. This voltage waveform is amplified in the horizontal amplifier, a 6L6 beam-power tube, to which the waveform source is capacitively coupled. The output of the 6L6 amplifier is coupled to an output transformer of special design, capable of preserving all harmonics up to and including the tenth (157,500 c.p.s.) and handling the high-power output required. The waveform appearing at the output of this transformer has the form shown in Fig. 86. At the left, the 5V4G damping tube has been removed, and in consequence a large residual oscillation occurs at the base of each pulse. This residual oscillation results from the inductance of the scanning coils, in conjunction with the transformer windings acting in conjunction with their distributed capacitances. When the 5V4G rectifier is inserted in its socket, it conducts during the

halves of the undesired oscillation that make its anode positive. As a result, the oscillations are damped to a negligible degree, as shown at the right. Centering of the scanning current about a d-c axis corresponding to the center of the pattern is accomplished by feeding some direct current through the yoke, from the centering control  $R_{40}$ .

The vertical blocking oscillator, discharge tube, and amplifier (the 6N7 and 6J5 tubes in the central portion of the diagram) act in substantially the same manner as the horizontal deflecting system just described, except that the rate of repetition is 60 c.p.s. rather than 15,750 c.p.s. Because of this frequency difference, the  $R$  and  $C$  values are larger, and the transformers employed need not pass harmonics higher than 600 to 1200 c.p.s. The current required to drive the vertical scanning coil is lower, in view of the smaller impedances involved at 60 c.p.s., so the 6J5 output tube has a power output of less than 1 watt. Also, at the lower frequencies, it is comparatively easy to minimize the effect of the inductance in producing unwanted residual oscillations; hence no damping tube is required. However, one additional control is necessary in the cathode lead of the vertical output amplifier. This controls the effective value of grid-bias voltage operating in the output tube and hence controls the portion of the tube characteristic over which this tube operates. By selecting a portion of the characteristic, the curvature of which is the inverse of the curvature in the saw-tooth signal, it is possible to correct nonlinearity of scanning. The frequency, amplitude, and centering controls operate on the same principle as in the horizontal channel.

The scanning yoke used in this case is of the "low-impedance" variety, that is, both horizontal and vertical deflecting windings are of low-impedance construction. Earlier yokes, used in experimental receivers, had a high impedance in the vertical coil, and hence required a different coupling transformer between the 6J5 amplifier and the yoke coils. The internal construction of the yoke is shown in Fig. 289.

It will be noticed that no provision for the control grid of the cathode-ray tube is made in the circuit. It is necessary, of course, that the control grid operate at a voltage more negative than the cathode, and this requirement must be satisfied in the signal circuit. It is possible to obtain the control-grid negative

bias from the high-voltage bleeder circuit by connecting the electron-gun cathode to a tap on the bleeder and selecting the control-grid bias from a voltage divider included between the cathode and the negative end of the bleeder.

**69. Testing High-voltage Power-supply Systems.**—The two important quantities to be measured in connection with a high-voltage power supply are the values of the direct voltage and of the ripple voltage superimposed upon it. We consider first the measurement of the high direct voltage.

An electrostatic voltmeter is perhaps the ideal device for measuring high direct voltages, since it consumes no current from the source, and since its indications are equally reliable on a-c (when the form factor of the alternating current is known) and d-c systems. In television practice, however, it is more customary to use the conventional D'Arsonval-type meter with a series multiplying resistor. The current consumed should be kept at a small fraction of a milliampere to avoid loading the circuits under test. A 0- to 50- $\mu$ a meter is perhaps the highest rating suitable for the purpose, and a 0- to 10- $\mu$ a meter has advantages in measuring voltages across high-resistance bleeder circuits. Assume that a 0- to 10- $\mu$ a meter is used. Then the bleeder resistor for a maximum voltage reading of 10,000 volts must be  $10,000/10^{-5} = 10^9$  ohms, or 1000 megohms. Resistors as large as this are available on special order. It is possible also to build the resistor from fifty 20-megohm units of the ordinary carbon variety. The voltage drop across each resistor is then only 200 volts, at which the given resistance value can usually be depended upon. However it is desirable to measure each resistor separately in a bridge. The sum of the resistance values is then taken as the value of the total resistor.

When such a meter is used to measure 5000 volts, the total meter current is 5  $\mu$ a, or about 0.2 per cent of the bleeder current usually encountered. Care must be taken to keep the multiplier resistor dry and free from dirt, otherwise its resistance value may change with age. Suitable high-voltage terminals, well insulated, must also be provided.

Measuring the ripple voltage in the output of a high-voltage supply is conveniently carried out with the aid of an oscilloscope the vertical deflection plates of which are connected directly to the supply and the deflection sensitivity of which is known

(or if unknown, measured by comparison with a conventional voltmeter). The oscilloscope has the advantage of drawing no current from the bleeder and hence makes possible the measurement of ripple voltage under actual conditions of use. In addition, the oscilloscope gives the waveform of the ripple, which is often valuable in tracing the causes of the ripple voltage.

A section of the high-voltage bleeder near the grounded end is connected to the oscilloscope deflecting plates. The total voltage across this section should be 500 volts, and a 500-volt 1.0- $\mu$ f paper capacitor should be inserted in one test lead to isolate the high voltage. The ripple voltage (assumed 60 c.p.s.) encounters an impedance of 2660 ohms in the capacitor, and the impedance across the deflection plates is many megohms. Therefore, substantially the full ripple voltage is applied to the deflection plates. The peak-to-peak amplitude of the ripple voltage may then be computed by multiplying the deflection sensitivity by the observed deflection. A 1 per cent ripple voltage may be detected in this manner (5 volts in 500). The total ripple voltage across the high-voltage supply is of course obtained by multiplying the observed value by the number of times 500 volts is contained in the whole output voltage (*e.g.*, by ten times if the total output voltage is 5000 volts).

Smaller values of ripple voltage than 1 per cent may be observed if larger portions of the whole output voltage are applied to the deflection plates. The blocking capacitor must have a correspondingly high rating in this case.

For some purposes, it is desirable to measure high alternating voltages especially in determining the regulation of the high-voltage supply transformer. The method outlined above for d-c measurements may be used on alternating current if a calibrated meter rectifier (oxide type) is inserted in series with the microammeter.

**70. Nonimage Methods of Testing.**<sup>1</sup>—There are two general methods of testing television receivers: those involving an image which appears on the screen (image-testing methods), and those which evaluate performance by indirect means (non-

<sup>1</sup> Bibliography on television testing equipment includes the following:

BARCO, A. A., Measurement of Phase Shift in Television Amplifiers, *RCA Rev.*, 3 (4), 441 (April, 1939).

BRUMBAUGH, J. M., Probable Test Equipment Requirements for Design

image testing). The image tests require some sort of image-generating apparatus (either a television camera or a static-image tube and associated equipment). If the image is a pattern of the proper shape, it is possible to evaluate the performance of the entire system readily. However, much simpler means may be taken for testing, using equipment to be found in almost every laboratory. The latter so-called "nonimage" methods of testing are described first.

*a. Nonimage Methods of Testing Scanning Performance.*—It is possible to test the amplitude and linearity of scanning in both vertical and horizontal directions with the aid of a variable-

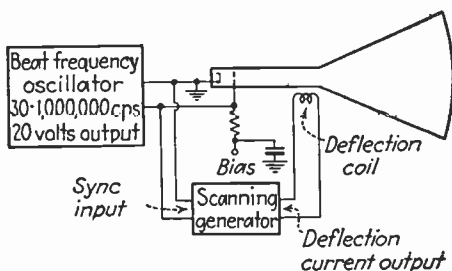

FIG. 290.—Nonimage method of testing linearity and amplitude of scanning motions.

frequency beat oscillator the output of which (either direct or by subsequent amplification) is at least 20 volts, peak to peak, and variable in frequency from below 60 to above 15,750 c.p.s. The method is shown in Fig. 290. The output of the beat-frequency oscillator is connected between the grid and cathode of the electron gun of the tube and also to the input of the scanning circuit to be tested. In testing the vertical circuit, the beat oscillator is set at 60 cycles, whereas for testing the horizontal circuit, the frequency is 15,750 c.p.s.

To illustrate the procedure, consider first the vertical scanning circuit. The 60-c.p.s. output of the beat oscillator is applied to the scanning circuit and the frequency control adjusted until the circuit locks in synchronism with the applied voltage wave.

and Tests of Domestic Television Receivers, *R. M. A. Eng.*, 2 (2), (May, 1938).

STOCKER, A. C., An Oscillograph for Television Development, *Proc. I.R.E.*, 25, 1012 (August, 1937).

FINK, D. G., "A Laboratory Television Receiver," see reference, p. 441.



At the same time, the electron beam in the cathode-ray tube is modulated at 60 c.p.s. Consequently the scanning motion and variation in brightness occur synchronously, and the result is a stationary pair of horizontal bars, one bright, the other dark. The scanning circuit is then operating at standard frequency. The scanning amplitude is indicated by the total height of the scanning pattern when synchronized. If the amplitude is insufficient, means may be taken to increase the amplitude of the scanning current or voltage (depending on whether magnetic or electric scanning is used, respectively). In magnetic scanning, the scanning amplitude depends upon the frequency, so it is necessary to adjust for proper scanning amplitude at rated frequency.

When satisfactory vertical scanning amplitude has been obtained, it is then possible to determine the linearity of scanning by increasing the frequency of the beat oscillator successively in steps to the values 120, 240, 480, 960, 1920, 3840, and 7680 c.p.s. Since these frequencies are multiples of the 60-c.p.s. scanning frequency, the scanning circuit will synchronize on every second wave for 120 c.p.s., every fourth wave on 240 c.p.s., and so on. At the frequency 7680 c.p.s., the scanning circuit synchronizes every 128th cycle (since  $7680/60 = 128$ ), but the scanning frequency remains at 60 c.p.s. Consequently, the pattern on the screen will be broken up into roughly 128 horizontal bars (actually less than 128 since some of these bars will be formed during the vertical retrace interval). If the vertical scanning motion is linear, these bars will be equally spaced; otherwise they will display a spread-out or compressed appearance. By adjusting the linearity controls in the vertical scanning generator, it is usually possible to obtain substantially equal separation between all bars, indicating satisfactory scanning linearity in the vertical direction.

This system does not test the interlacing performance of the vertical oscillator (for which a standard interlaced sync pulse is necessary), but otherwise it serves to determine all the necessary information about the vertical scanning generator.

A very similar procedure is followed for testing the performance of the horizontal scanning generator. The same connections (Fig. 290) are used. The beat-frequency oscillator is set to 15,750 c.p.s. (or as near this value as the accuracy of calibration permits). The frequency control of the scanning generator is



then adjusted, until it falls into synchronism with the applied 15,750 c.p.s. The scanning pattern will then exhibit two vertical bars, one bright, the other dark. As in the vertical case, the half wave of applied voltage that makes the grid positive produces the bright bar, that which makes the grid negative the

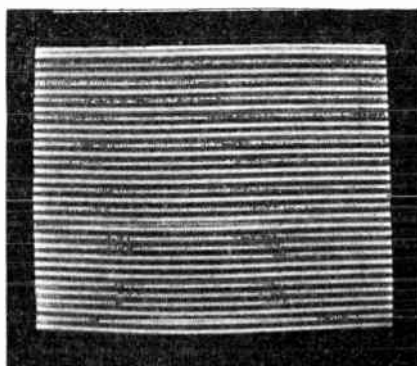

FIG. 291.—Line pattern obtained with testing method shown in Fig. 290, with 2400-c.p.s. signal applied to control grid and vertical sync circuits. The curvature at the bottom is due to a stray magnetic field.

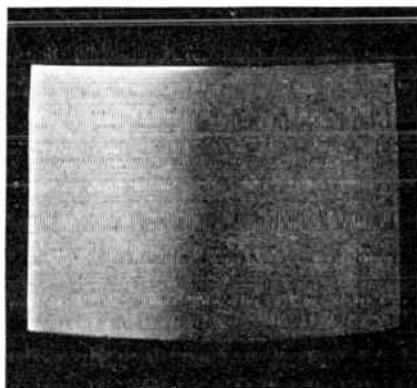

FIG. 292.—Horizontal scanning amplitude test at 15,750 c.p.s., obtained by method shown in Fig. 290.

dark bar. When the synchronized frequency is obtained, the scanning amplitude is adjusted, as before, until it has the proper value (which is roughly four-thirds that of the vertical scanning amplitude).

To test the linearity of the horizontal scanning motion, the beat-frequency oscillator must have its frequency increased to

settings of 31,500, 63,000, 126,000, 252,000, 504,000, and 1,008,000 c.p.s. These frequencies are multiples of the horizontal scanning frequency (15,750 c.p.s.), and in consequence, the generator synchronizes on every second pulse at 31,500 c.p.s. every fourth pulse at 63,000 c.p.s., and on up to every sixty-fourth pulse at 1,008,000 c.p.s. The pattern, in the latter case, displays roughly 64 vertical bars (64 less the number formed during the horizontal retrace interval), and the linearity is revealed by the spacing between bars. If the spacing is not even, then the circuit must be adjusted to produce more linear scanning motion.

It is possible to determine the ratio of the forward scanning velocity to the retrace scanning velocity by noting the number of bars produced during the forward trace and comparing this number with the number produced during the retrace. For example, if a signal of  $f$  c.p.s. is applied and the scanning frequency is at its proper value of 15,750, then the total number of dark bars formed is  $f/15,750$ . If  $N$  bars are visible during the forward scanning motion, then  $(f/15,750) - N$  is the number formed during the retrace. The ratio of retrace scanning speed to forward scanning speed  $k_h$  is then

$$k_h = \frac{N}{f/(15,750) - N} \quad (255)$$

The vertical retrace ratio  $k_v$  may be found in the same manner, using  $N$  as the number of horizontal dark bars visible in the active trace and  $f$  as the applied signal frequency and replacing 15,750 with the number 60.

Most beat-frequency oscillators do not have the wide range in the upper frequencies (that is, frequencies up to 800,000 c.p.s.) necessary to test linearity in the horizontal scanning circuit. It is relatively simple to build a single-tube oscillator for a frequency of say 900,000 c.p.s. with 20-volt output. This single frequency is sufficient to determine the linearity and retrace ratio, by the methods just outlined. Note that a frequency which is an exact multiple of 15,750 c.p.s. is not necessary, since the scanning oscillation frequency can be adjusted to synchronize at any submultiple frequency of the applied signal.

*b. Methods of Testing Video Amplifier Amplitude-frequency Response.*—The beat-frequency oscillator may be used, in con-

junction with a vacuum-tube voltmeter, to determine the amplitude-frequency response curve of a video amplifier. The connections are shown in Fig. 141. The vacuum-tube voltmeter is arranged so that it can be connected across the oscillator output or across the amplifier output by switching, and it is assumed that the range of the voltmeter covers the voltage levels present at the input as well as the output of the amplifier. A direct comparison of the voltages appearing at input and output of the amplifier is obtained at different frequencies within the range of the beat oscillator. A standard r-f signal generator may be

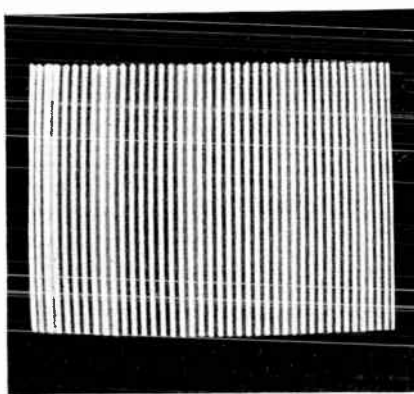

FIG. 293—Line pattern obtained with 660,000 c.p.s. signal applied to control grid and horizontal sync circuits. Note the wide bands in the background, formed during the horizontal retrace. The value of  $k_A$  indicated is about 10 times.

used, in place of the beat-frequency oscillator, to make measurements up into the megacycles. This method of measurement is essentially the same as that described in Chap. VI, page 253. The phase response of the amplifier may be measured, using an oscilloscope, by the method shown in Fig. 142, page 255.

For measuring responses at frequencies lower than 100 c.p.s., it is highly desirable to use a rectangular-wave generator at the input to the amplifier and an oscilloscope to view the waveform at the output. Figure 294 shows several typical distorted waveforms observed at the amplifier-output terminals, together with the causes of the various aberrations. Two simple square generators suitable for this type of testing are shown in Fig. 295.

*c. Methods of Testing Picture I-f and Detector Characteristics.*—In practice, the methods of testing the receiver system at inter-

mediate frequencies are most easily applied with the use of specialized equipment, that is, with a sweep generator and oscilloscope. The sweep oscillator, shown in Fig. 296, is a signal generator capable of covering, continuously and repeatedly, the range from about 7.5 to about 15 Mc. (thus including both video and carrier i-f carrier frequencies and sidebands, as well as the positions of the adjacent carriers). It is common practice to

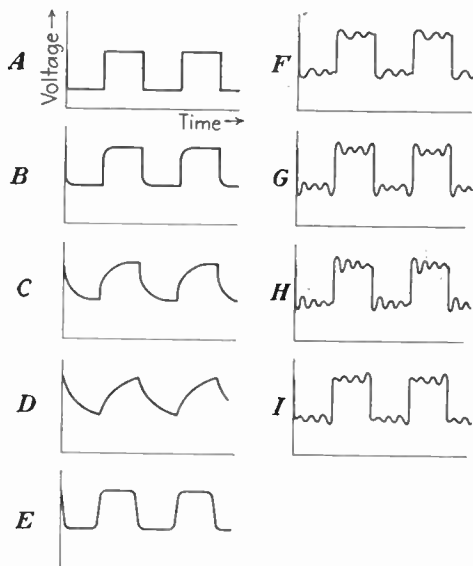

FIG. 294.—Applied square wave (*A*) and distorted reproductions: *B*, small amplitude attenuation at high frequencies, excess delay of high frequencies; *C*, same as *B* but higher amplitude attenuation; *D*, further high-frequency attenuation; *E*, attenuation at high frequencies, no relative time delay; *F*, excess gain at high frequencies, slight underdamping; *G*, sharp cutoff at high frequencies, no relative time delay; *H*, excess high-frequency gain, highly underdamped; *I*, excess gain at high frequencies, positive feedback. (After Gilbert Swift.)

employ a tuned circuit using a motor-driven capacitor, which rotates through the desired capacitance range at a rate of roughly ten to twenty times per second. The output voltage of the signal generator must be nearly the same at all frequencies within the test range. The condenser should be dynamically balanced to prevent excessive vibration and noise. The output of the oscillator should be variable from roughly 10 microvolts to 5 volts, r-m-s, for maximum flexibility, although a more restricted range can be used in many cases. The output imped-

ance should be 25 ohms or less, *i.e.*, much smaller than the impedance of the circuits under test.

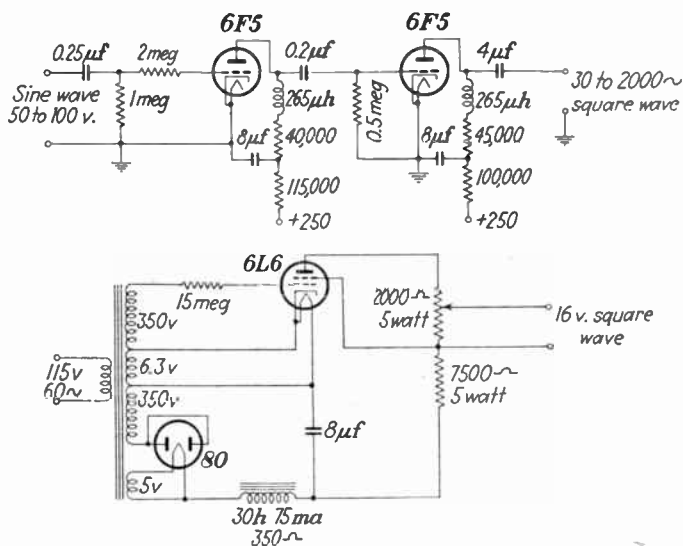

FIG. 295.—Square-wave generators; above, for frequencies from 30 to 2000 c.p.s., with high-voltage sine wave input; below, for 60-c.p.s. square waves, self-generated. (Courtesy RCA Institutes, Inc.)

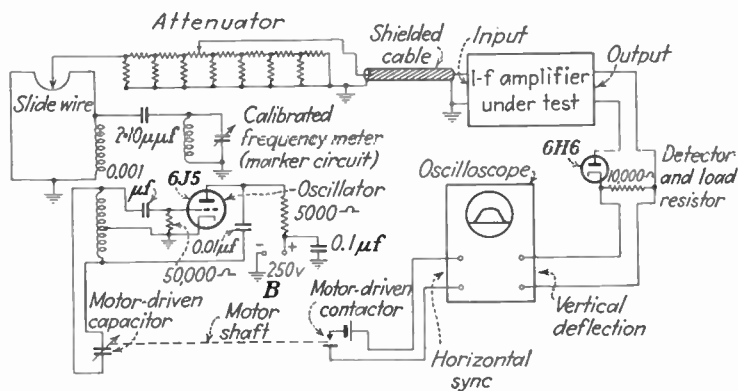

FIG. 296.—Simple mechanically driven sweep oscillator. The sizes of the inductor and capacitor in the tuned circuit depend on the frequency range and sweep range desired.

The connection of the sweep oscillator to the circuit under test is shown in Fig. 297. The sweep-oscillator output is first connected in shunt with the grid of the last i-f stage, and the

output of load resistor of the detector is connected across the vertical-deflection system of the oscilloscope. The horizontal-deflection voltage is obtained, directly or indirectly, from the motor drive of the tuning condenser. In most cases, it is sufficient to connect a commutator segment (driven from the capacitor shaft) in series with a voltage source and the synchronizing terminals of the oscilloscope. Some experimenters derive the entire horizontal-deflection voltage from a variable voltage divider connected to the motor drive.

The operation of the sweep oscillator is as follows. At any instant, the detector output contains a direct voltage proportional to the amplitude of the i-f voltage applied to it. Consequently the vertical deflection of the oscilloscope beam is a

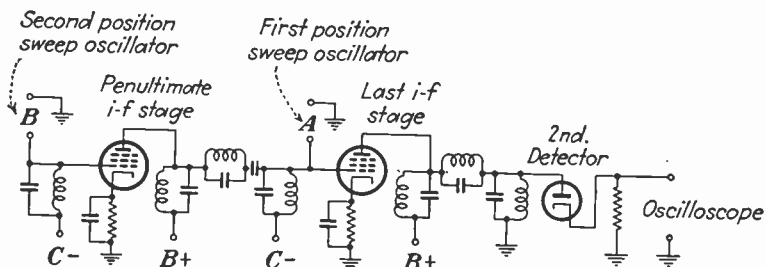

FIG. 297.—Connection points for sweep oscillator and oscilloscope in picture i-f circuit alignment.

measure of the *detector response* at all frequencies impressed. The frequency is changed rapidly throughout the desired test range, and the horizontal deflection is made proportional to the *test frequency*. In this way, the amplitude response of the system is plotted on the oscilloscope screen in terms of voltage against frequency. A typical pattern of this type is shown in Fig. 298.

It is highly necessary to be able to calibrate the oscilloscope curve in terms of megacycles, not only to give the scale, but also to indicate the positions of the various carrier frequencies (desired as well as adjacent). A very simple marking circuit, shown in Fig. 296, consists simply of a tuned circuit connected across the sweep-oscillator output. When the output frequency coincides with the frequency of this tuned circuit, the output drops sharply, and the result is a dip at this frequency in the observed output voltage curve. By tuning the marker circuit, it is possible to mark the curve with this dip at any point on the

output-frequency scale. The "marker" tuned circuit itself must be calibrated against a standard signal generator. It is possible to insert several marker circuits of this type for use in marking as many positions on the curve as may seem desirable. Usually two or three are sufficient, two to mark the limits of the desired channel, and the third to mark the position of an adjacent signal to be attenuated. An oscillator may also be used for marking purposes.

In using the sweep oscillator, the connections shown in Fig. 297 are set up and the pattern observed on the oscilloscope. Then adjustments are made on the i-f coupling circuit between the last i-f tube and the detector. When sufficient flatness of response is obtained within the desired channel limits, and when as much selectivity as possible outside these limits is obtained, the sweep oscillator is connected with reduced output in shunt with the grid of the next-to-last i-f tube and the coupling circuit adjusted between the last and next-to-last i-f tubes. The amount by which the sweep-oscillator output voltage must be reduced, in order to obtain a given vertical deflection on the oscilloscope screen, is a direct measure of the gain of the next-to-last i-f stage.

When adjusting the circuit in this case, sharper selectivity at the channel edges can usually be obtained, but at the same time there is a tendency to restrict the flat-topped portion of the curve within the desired channel region.

In this manner, the sweep oscillator is connected successively in shunt with the grid of each i-f tube, working backward stage by stage until the converter tube is reached. The final test with the sweep oscillator should be with connections in shunt with the converter-tube grid (although in operation no i-f frequency appears at this point) in order to align the circuit immediately following the converter tube.

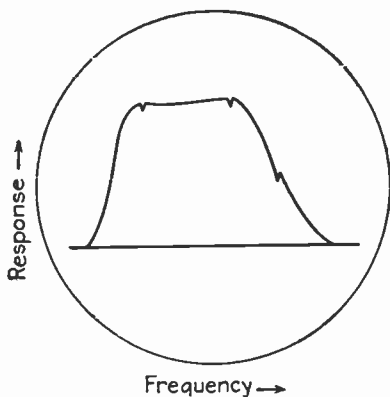

FIG. 298.—Typical oscillogram produced with circuit of Fig. 296. The notches are produced by the absorption in the marker circuits.

No general rules for circuit alignment, other than the above, can be given since the procedure depends almost entirely on the design of the i-f coupling circuits and the manner in which selectivity against the adjacent signals is obtained. A typical procedure for a particular set of coils designed for 3.8-Mc. flat-top response and a gain of 4000 in three stages is given to illustrate the problem in a particular case.<sup>1</sup> Figure 299 shows the arrangement of the i-f system. The converter tube feeds

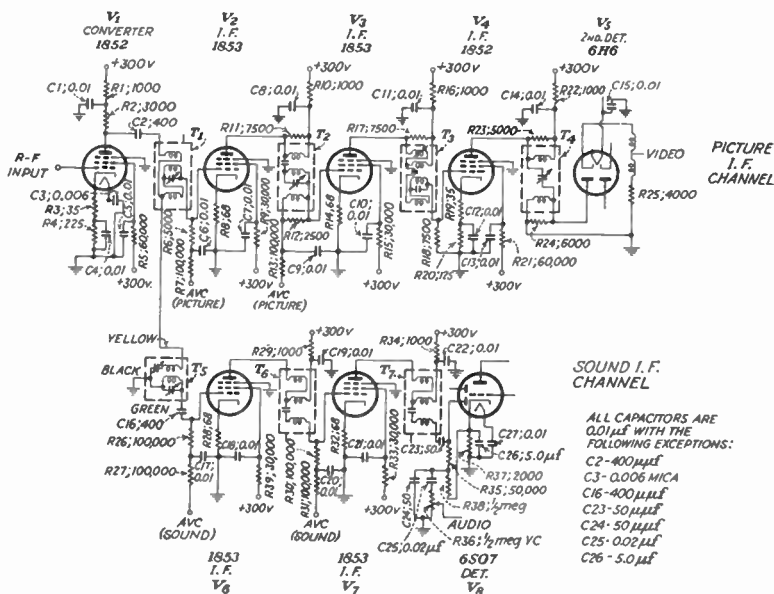

FIG. 299.—Typical i-f system (picture and sound) using commercially available i-f coupling units.

three stages for the picture intermediate frequency and two stages for the sound intermediate frequency.

The alignment of the sound channel is conventional. The coupling units  $T_6$  and  $T_7$  are of the permeability tuned variety. A 400-c.p.s. modulated signal at 8.25 Mc. is applied to the grid of the last stage ( $V_7$ ) and an output meter or oscilloscope and amplifier connected to the detector-load circuit. The two permeability trimmers in  $T_7$  are then adjusted for maximum response in the detector output. The i-f signal generator is

<sup>1</sup> Data and alignment procedure, courtesy H. J. Benner, F. W. Sickles Company.



then connected to the grid of tube  $V_6$  and the same adjustments for maximum output made to the two permeability trimmers of coupling unit  $T_6$ .

The coupling unit  $T_5$  contains two wave traps, both of which are capacitance tuned. The series-tuned circuit is adjusted to the sound i-f frequency of 8.25 Mc. to present a minimum impedance at this frequency and thereby to avoid the transmission of the sound signal into the picture channel. This adjustment

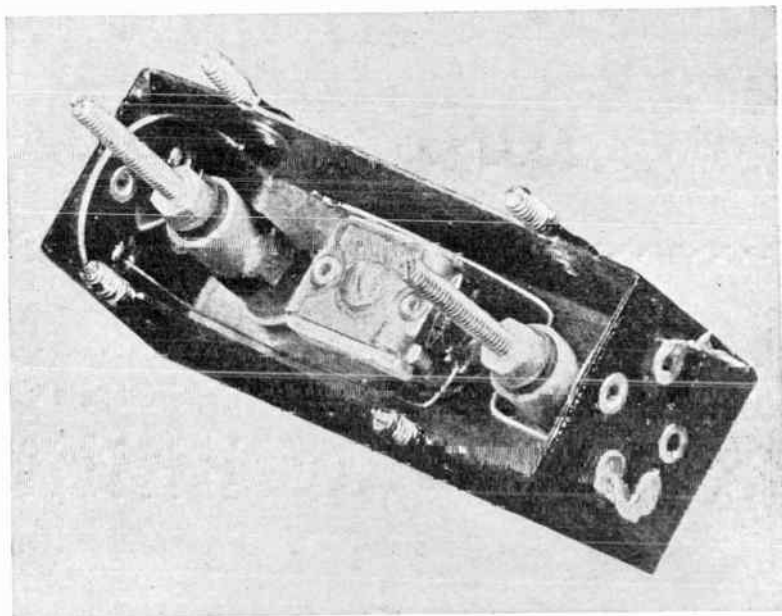

FIG. 300A.—Internal construction of i-f coupling units of circuit in Fig. 299. These units are intended for subchassis mounting to ensure the shortest possible leads to single-ended amplifier tubes.

is made by viewing the output of the video detector in an oscilloscope with the sound i-f frequency applied to the grid of the converter tube. The trimmer of the series-tuned circuit is then adjusted for minimum response in the video detector.

The parallel-tuned circuit within  $T_5$  is used to prevent the sound signals of the adjacent channel from entering the sound system. To adjust this trap, a 400-c.p.s. modulated signal of 14.25 Mc. is applied to the grid of the converter tube and the trap adjusted for minimum response in the sound-detector

output. This completes the adjustment of the sound i-f channel.

In aligning the picture i-f system, a sweep-signal generator is used, with its frequency swing covering the range from 8 to 15 Mc. First the sweep-oscillator output is connected to the grid of tube  $V_4$  and the output observed on synchronized oscilloscope. First the two permeability trimmers in  $T_4$  are adjusted to produce a maximum peak slightly higher in frequency than the desired high-frequency edge of the band. Then the coupling capacitor in  $T_4$  (which was previously set near minimum capaci-

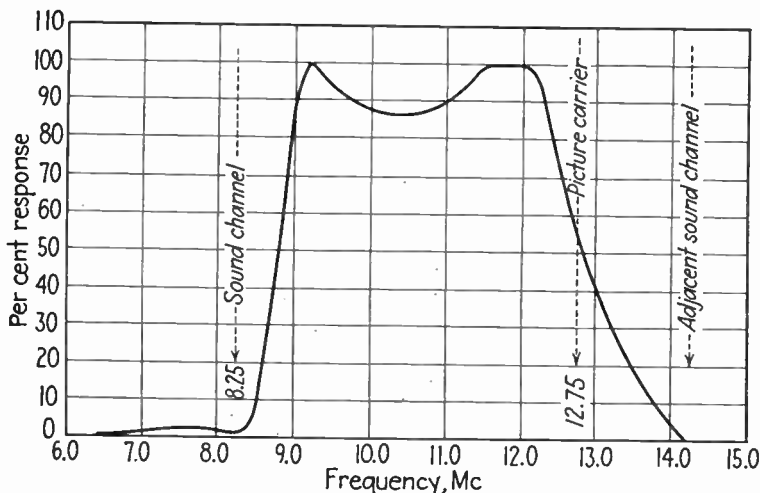

FIG. 300B.—Measured response characteristic of picture i-f system shown in Fig. 299.

tance) is adjusted to produce a flat-top response, which will be noted by the spreading apart of the two peaks in the oscilloscope curve.

The sweep generator (with somewhat reduced output) is then applied to the grid of tube  $V_3$  and the two permeability trimmers of  $T_3$  adjusted to preserve the flat-top response. Then a signal of 400-c.p.s. modulated 14.25 Mc. is applied to the grid of  $V_3$  and the wave trap (capacitance trimmer) adjusted for minimum response. This ensures removal of the adjacent channel sound signal from the picture signal. Resetting of the permeability trimmers may then be necessary, followed by a final adjustment of the wave trap.

The sweep oscillator is then advanced to the grid of  $V_2$  and the permeability trimmers of  $T_2$  adjusted to give suitable band-pass response. The wave trap (capacitance trimmer) is then set to the frequency of the sound signal in the desired channel (with the generator tuned to 8.25 Mc., with 400-c.p.s. modulation). This removes the accompanying sound signal from the picture signal. Readjustment of all trimmers will be necessary in order to obtain simultaneously minimum sound signal response and a flat-top picture response.

Finally the sweep oscillator is connected to the grid of the converter tube ( $V_1$ ) and  $T_1$  is adjusted for picture band-pass response and to eliminate the adjacent channel sound carrier, following the procedure given for  $T_3$ . This completes the alignment of the picture i-f system.

It will be noted that two traps are provided to reject the adjacent sound signal (at 14.25 Mc.) and one against the accompanying sound signal (8.25 Mc.). In the coupling unit  $T_5$ , another trap against the accompanying sound signal is provided in the form of a series-tuned circuit. As already mentioned, the capacitance of this circuit is adjusted for minimum response in the video output, with an 8.25-Mc. 400-c.p.s. signal connected in series with the converter grid.

One of the most important aspects of receiver testing in the i-f circuits is the positioning of the picture carrier at the 50 per cent response point on the i-f band-pass curve.<sup>1</sup> The procedure is as follows: using a sweep i-f oscillator, the over-all response curve of the i-f system is observed and adjusted so that the standard picture intermediate frequency of 12.75 Mc. occurs half-way down the high-frequency edge of the pass band. This point may be established definitely by the frequency marker "dip" in the response curve, when the frequency marker dial is set to 12.75 Mc.

It is of course entirely possible to test the i-f amplitude-frequency response on a point-by-point basis, that is, with the use of a standard signal generator that is adjusted step by step to

<sup>1</sup> For a discussion of the effect of partial suppression of one sideband, see: POCH and EPSTEIN, Partial Suppression of One Sideband in Television Reception, *RCA Rev.*, 1 (3), 19 (January, 1937).

BENHAM, W. E., Asymmetric Sideband Phase Distortion, *Wireless Eng.*, 15, 616 (November, 1938).

various frequencies within the desired test range. This process is extremely tedious and apt to be confusing unless the operation of the coupling circuits is very well understood. Thus, for example, suppose that at a frequency of 11.5 Mc. an excessive amplitude is noted, indicating an undesired resonance at or near this frequency. The excessive amplitude may be reduced by adjusting the i-f circuits, but when this adjustment is made, an effect on the circuit response is produced at other frequencies. This effect is not revealed by the measuring instruments and can be noted only at a later time. For this reason, it is sometimes necessary to go over the test frequency range as many as six times before the optimum adjustment is found for all frequencies. When the sweep oscillator is used, on the other hand, the effect of a given adjustment on the circuit response is revealed for all test frequencies at once. Thus it is possible to line up a circuit by the sweep method in minutes, where hours would be necessary by the point-by-point method. In the commercial production of receivers, the sweep method is, of course, essential.

*d. R-f and Oscillator Testing.*—When the i-f system of the receiver has been adjusted for satisfactory band pass and selectivity, the r-f stages are tested. A sweep oscillator is of value here, but not so essential as in i-f testing. As a matter of fact, the band-pass characteristics of the r-f system are usually determined quite simply by the character of the loading employed, and the main problem becomes simply one of obtaining the desired tuning settings for the stations. In this country, automatic switching of stations (either by push buttons or by rotary switch) is a universal practice. In lining up the circuits for each switch position, it is usually necessary only to apply three test frequencies, one at the picture carrier, one at the upper frequency edge of the channel, and the other at the lower edge of the attenuated sideband. If substantially equal response is obtained at the detector output from each of these three positions, the design of the i-f circuit will usually take care of selectivity beyond these limits and the equality of response within them. On the other hand if the design of the r-f tuning system is under development, a point-by-point analysis may be desirable.

Oscillator performance is a difficult aspect to test. Grid current and r-f output voltage may be observed by using conventional meters, a microammeter for grid current, and a properly

calibrated vacuum-tube voltmeter for output voltage. The most important characteristic of all, the stability of frequency, may be tested by heterodyning the output against a standard frequency source (crystal controlled) and noting the changes in the tone of the resulting beat note. This same method may be used to adjust the frequency of the oscillator at the desired setting for each switch position.

It should be noted that all the preceding tests for i-f and r-f responses are concerned only with the amplitude-vs.-frequency response, and not with the phase-vs.-frequency response. Mention has already been made (page 255) of the methods whereby phase-response tests of these circuits may be performed by using an oscilloscope the vertical plates of which are connected to the amplified output of the oscillator, whereas the output of the circuit under test is connected to the horizontal plates. This method is restricted to point-by-point analysis and cannot be employed simply in conjunction with a sweep generator. For this reason, the discovery of poor phase response is seldom attempted in nonimage testing equipment. Instead, reliance is placed on symmetry of design and adjustment of the coupling circuits, since at i-f and r-f frequencies, proper phase response is associated with symmetry, more than with any other characteristic. The actual phase performance of the system is best found by employing a modulated carrier wave, obtained either from an image-signal generator or more simply from a square-wave generator modulating the input. By adjusting the frequency of such a square-wave generator through a portion of the video frequency range (say 60 to 1,000,000 c.p.s.) and by noting the character of the reproduced bars on the image-reproducing tube pattern, very definite information on the phase response may be obtained. Such a test includes, of course, the phase response of the video amplifiers as well as that of any i-f or r-f stages included in the circuit.

**71. A Simple Image-signal Generator.**—The nonimage methods of testing television circuits described in the preceding section are highly useful in determining circuit performance, but they do not reveal the ability of a receiver to reproduce a picture. It is customary, therefore, to subject receivers to a test with an image-signal generator that imposes on the circuit a signal capable of producing a test pattern on the screen of the image-

reproducing tube. The image-signal generator provides the necessary picture impulses, as well as the sync and blanking pulses, in the video frequency range. The output, suitably amplified, is thus useful for testing cathode-ray tube characteristics and video amplifier performance. The image-signal generator may be used also to modulate either an i-f carrier for testing i-f circuit performance, or an r-f carrier for testing the whole performance of the receiver. In the present section,



FIG. 301A.—Type 1899 monoscope, a static-image signal generator tube widely used for image testing.

we discuss a simple image-signal generator suitable for these functions.

The generator is based on a static-image tube (see page 116), variously known as a monoscope, monotron, or phasmajector, depending on the manufacturer. The particular tube considered is the type 1899 monoscope, shown in Fig. 301A. The signal plate on this tube is printed with an image of the test pattern shown in Fig. 301B. The generator is so arranged that any part or all of this test pattern may be reproduced on the cathode-ray tube of the receiver under test.

The pattern combines several of the features of other standard test patterns (page 58). The large circle has a radius three-

fourths the pattern width, so that the standard aspect ratio of 4 to 3 is maintained. The circle also shows the geometrical symmetry of the scanning motion and reveals nonlinearity in the vertical or horizontal scanning directions. The four circles in the corners have the same purpose and are situated in the four regions of the pattern where geometrical distortions, as well as defocusing of the scanning beam, are most likely to occur. The whole pattern is crossed by a grid of fine lines which reveal any orthogonal distortion at any part of the image.

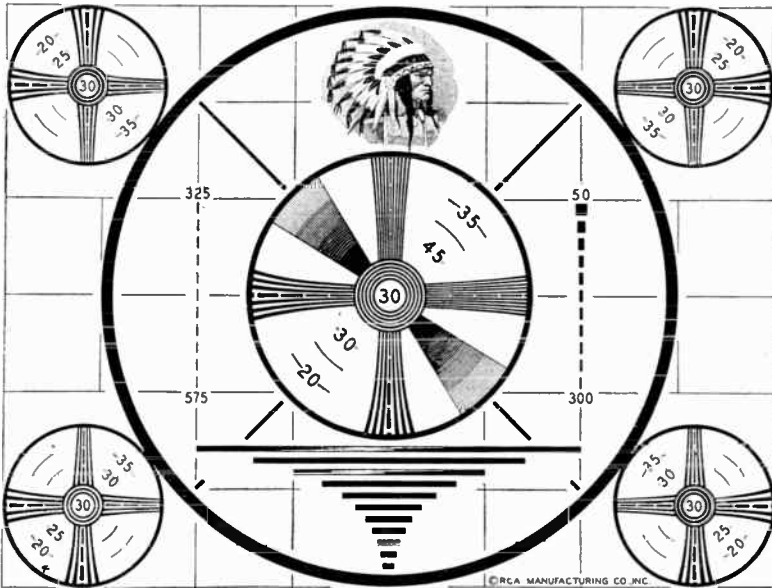

FIG. 301B.—Test chart printed on signal plate of type 1899 monoscope.

Five sets of resolution wedges are included. The main wedges within the central circle are calibrated by the numbers 20, 30, 45, and 35 which stand, respectively, for 200, 300, 450 and 350 line resolution. Open spaces in the centermost line of each wedge indicate the position of the calibration within each wedge. The central concentric circles have 300-line resolution, indicated by the number 30. In each case, the word "line" refers to the number of lines that can be accommodated in the vertical height of the pattern. The four sets of resolution wedges at the corners have similar calibration markings.



The two oblique wedges within the center circle are tonal values, having different degrees of shading. By taking the innermost (black) section of each wedge as 100 per cent, the degrees of shading of the other sections, reading outward, are 75, 50, and 25 per cent, respectively. These shading areas indicate the nonlinear amplitude distortion in the system.

The horizontal black lines below the central circle have lengths that are logarithmically related (the length of each line is 71 per cent of the length of the line above it). These lines are useful in observing defective low-frequency responses in the video range.

To aid in testing the ability of the system to reproduce isolated details, two sets of rectangular areas are provided, arranged in

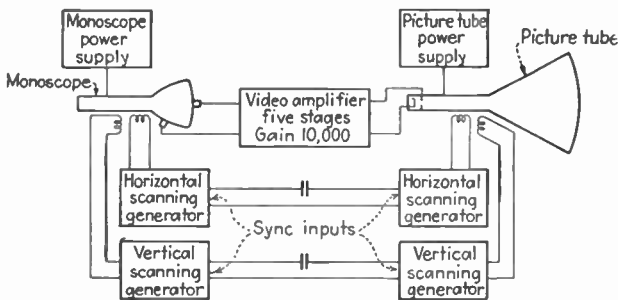

FIG. 302.—Basic connections of simple image-signal generator, which operates without generation of standard sync signals and hence does not produce an interlaced pattern, but which serves for many test purposes.

two vertical columns on either side of the central circle. The numbers indicate the width of the nearest rectangle, the width being stated in the number of lines (*i.e.*, number of times the width could be accommodated in the height of the pattern). Finally, the Indian head above the central circle is useful for judging over-all performance, especially with respect to contrast and average brightness which are most easily judged on a pictorial subject. The ends of the diagonal lines mark the edges of a pattern having half the width of the over-all pattern. Such a half-sized pattern is useful in determining the performance on reduced scanning, as outlined below.

The monoscope contains an electron gun which focuses, under proper applied voltages, to a spot the width of which is roughly  $\frac{1}{500}$ th of the pattern height. In other words, the resolution



limit imposed by scanning spot size is 500 lines. This is a very fine spot (about 0.01 in. in diameter) when compared with those usual in cathode-ray image-reproducing tubes. It is obtained with comparatively low accelerating voltages.

The connection of the monoscope, so far as electrode voltages are concerned, is shown in Fig. 303. The second anode and

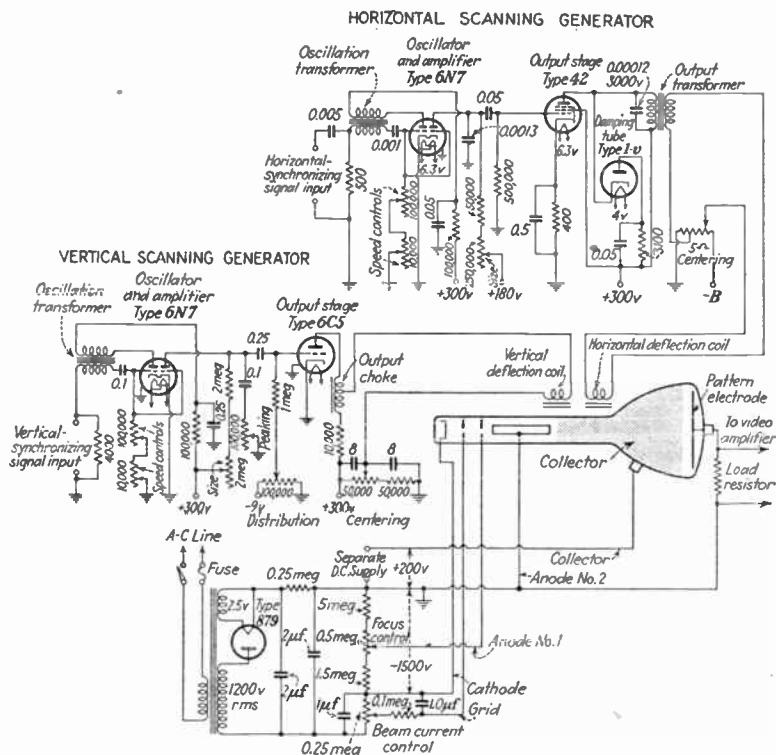

FIG. 303.—Complete circuit diagram of image-signal generator. May be synchronized either from the receiver under test, or from a source of standard synchronizing signals.

pattern electrode are grounded, and the cathode is operated at a voltage roughly 1500 volts negative "below" ground potential. This places the heater and cathode at high potential and requires properly insulated sockets and heater-transformer winding, but it is desirable for safety reasons and because the pattern electrode can be connected directly to the grid of the following video amplifier without a high-voltage blocking condenser

intervening. The collector is operated at 200 volts more positive than the signal plate and serves to collect the secondary electrons and beam electrons that do not enter the signal plate.

Fairly elaborate filtering of the high-voltage power supply is necessary since the ripple voltage must be kept considerably smaller than the video signal generated. Since a video signal of 100 millivolts is about the maximum obtainable under usual operating conditions, the ripple voltage should be no more than 5 millivolts and should preferably be no more than 1 millivolt. The circuit shown in Fig. 303 accomplishes the required filtering. The first-anode voltage tap on the high-voltage bleeder controls the beam focus, and the grid tap controls the beam current, which in turn determines the amplitude of the video output signal.

The scanning system of the monoscope is of the magnetic-deflection type. The scanning-yoke and scanning-current generators shown in Fig. 288 are suitable, except that the scanning amplitude required for the monoscope is small when compared with that of the image-reproducing tube. The insertion of a resistance-voltage divider at the input terminals of each winding in the scanning yoke is a simple method of reducing the scanning amplitude to small values. As shown later, much smaller than usual scanning amplitude is useful in resolution tests.

The signal output is amplified in conventional wide-band video amplifiers, as shown in the figure. An odd number of stages is required between the monoscope output and the control grid of the image-reproducing tube to produce a positive image (negative polarity in the output of the monoscope was chosen to make the monoscope interchangeable with the iconoscope, which inherently produces a negative image when connected in the usual manner). Three stages of video amplification are sufficient to produce roughly 40 volts, peak to peak, over a video range up to 4 Mc. which is sufficient for all test purposes. The video stages are fitted with a bias-type gain control to permit obtaining lower output voltages for testing video amplifier stages.

The synchronization arrangements of the generator in question are extremely simple. They consist simply in connecting the synchronization input of the blocking oscillators in the generator to the inputs of the blocking oscillators in the receiver under test, through a 0.1- $\mu$ f capacitor in the vertical scanning circuit

and a 0.001- $\mu$ f capacitor in the horizontal circuit. The sharp pulses generated in the blocking oscillators of the receiver under test are sufficient to synchronize the scanning system of the signal generator. To ensure synchronism with the 60-c.p.s. supply, it is convenient to connect the grid of the vertical blocking oscillator to one side of the 110-volt line through a 100,000-ohm resistor. The result is a stable and synchronized image on the receiver screen.

This exceedingly simple arrangement can be used to test every aspect of receiver performance, except blanking, interlace, and sync separation. The video output of the generator may be connected directly to any part of the video system of the receiver under test, or it may be used to modulate an r-f signal generator for testing the signal circuits preceding the video system. It should be noted, however, that the system operates under these conditions without interlace and that the vertical resolution indicated by the test pattern will accordingly be about one-half the number of lines that could be reproduced by the system when properly interlaced. So long as the horizontal scanning rate is maintained at 15,750 c.p.s., however, the horizontal resolution is the same as that obtained with the standard composite television signal.

For commercial-receiver development and production, no such simple image-signal generator can suffice. Instead a complete composite signal generator must be used. Such a generator is in most respects similar to the equipment used with an iconoscope, with the exceptions that keystone-correction and shading-correction generators need not be employed. The sync-signal generator described in Chap. IX, (including timing and shaping units to produce the blanking pulses, horizontal sync pulses, and vertical sync pulses) must be used, and the supersync part of the signal must be mixed with the video output in a control amplifier. This equipment has been described in detail in the preceding chapter. Commercial testing equipments have been built to permit the use of an iconoscope and are used for routine testing with a monoscope inserted in the iconoscope socket, with keystone-correction and shading-correction generators disconnected.

*Procedure in Using the Image-signal Generator.*—In using the image-signal generator, it must be remembered that defects in

the pattern may arise either in the generator or in the receiver. It is essential therefore that the defects be removed from the generator before measurements are made with it.

To assure proper geometrical properties in the image signal, the image must be viewed on a receiver the scanning motions of which are known to be linear and of proper amplitude and frequency. The nonimage test methods given in the preceding section are the simplest means of ensuring these conditions. The signal generator is then connected to the receiver and the resulting image viewed. If the pattern shows geometrical distortions, the generator scanning controls are adjusted until the distortions are removed. The image signal is then known to have proper geometrical form, and the generator scanning circuits should not be adjusted thereafter.

The horizontal resolution of the reproduced pattern, like its geometry, can be limited in either the generator or receiver. Actually there are four important places where horizontal resolution can be limited: the scanning spot size in the monoscope, the frequency response of the generator amplifiers, the frequency response of the receiver circuit, and the spot size in the image-reproducing tube. Fortunately there are fairly simple methods of isolating each of these possibilities. The amplifier responses in each case may be tested by the nonimage methods previously described, and the degree of horizontal resolution to be expected can be estimated directly from the upper frequency limit of the measured response curve. Figure 304 shows the expected resolution for band widths extending from 1.0 to 6.0 Mc.

The spot-size limitation may be examined by varying the scanning widths in the following manner: To test the spot size of the monoscope, reduce the scanning amplitude of the generator scanning circuits, in the horizontal direction, until only a small width of the pattern plate is scanned. The result will be a much enlarged image on the receiver screen (since the receiver scanning amplitude remains unchanged). This enlargement of the image removes the limitation of receiver spot size and amplifier response, but does not affect the size of the generator scanning spot. If the finest horizontal detail in the pattern can be resolved in this manner, this is evidence that the scanning spot in the generator is smaller than the finest detail to be transmitted, *i.e.*, that the generator spot size is not limiting resolution.

The proper setting of the focusing control on the generator (which determines the generator spot size) can be found very readily by this method.

Care should be taken, with reduced generator scanning amplitude, to avoid scanning too small an area on the plate with too intense a beam of electrons, else the signal plate may be "burned" by the electron bombardment. By reducing the beam current (making the electron-gun control grid more negative), the intensity of the beam may be reduced at the expense of signal

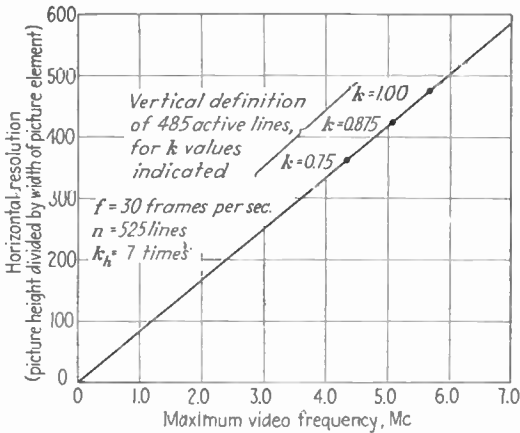

FIG. 304.—Relationship between maximum video frequency and horizontal definition, useful in determining frequency limits in terms of resolution observed in test charts.

output. Full output may be used over small scanning areas, provided that the test periods are limited in duration.

When the generator scanning spot and amplifiers have been eliminated as causes of resolution limiting, the receiver scanning spot-size limitation may be examined by setting the generator horizontal scanning amplitude at normal and causing the horizontal scanning amplitude at the receiver to exceed normal. This increases the size of the reproduced pattern without changing the signal in any way. If more detail is visible in the enlarged pattern than in the pattern of normal width, the inference is that the receiver scanning spot is limiting resolution. This effect can be readily observed on 5-in. tubes in which the ultimate resolution is usually limited by the spot size to not more than 250 lines.

With enlarged receiver scanning amplitude, if no improvement in detail results, the scanning spot is not the limiting factor. Then, if the expected degree of detail is not achieved, it is evident that the amplifiers between monoscope and image tube (either in the generator or in the receiver) are limiting the resolution.

It should be noted that the monoscope tube is a useful source of square waves at controllable frequency. Thus, if no scanning is used in the vertical direction (with greatly reduced beam current in the monoscope), the horizontal scanning motion can be made to pass in a single line over one of the vertical resolution wedges and in so doing produce a rectangular signal wave. The frequency of the square wave depends on the portion of wedge selected (being lower in frequency for the coarser portions of the wedge), on the scanning frequency, and on the scanning ampli-

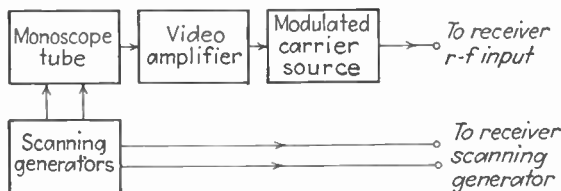

FIG. 305.—Method of testing receiver r-f system with simple image-signal generator.

tude. The frequency of the square waves produced by the horizontal scanning can be adjusted from roughly 50,000 to 5,000,000 c.p.s. by changing the afore-mentioned adjustments. For lower frequency waves, the vertical scanning direction may be used, with the horizontal scanning disconnected. Waves of 300- to 10,000-c.p.s. frequency can thereby be produced.

Square-wave generators of simple design may also be employed to test image resolution without the aid of monoscope-generating equipment. Two such generators are shown in Fig. 295. If the output of a square-wave generator is applied to the signal circuit of a receiver and to the synchronizing terminals of one of the scanning generators, a pattern of alternate bright and dark bars will appear on the screen, the direction of the bars being at right angles to the motion of the scanning generator in question. The advantage of the square wave as a testing device has already been commented on (page 483) for testing low-frequency response. Accordingly square waves of 20 to 10,000

c.p.s. are especially useful. Square waves of higher frequency than 15,750 c.p.s. are also useful in testing high-frequency response, since the sharp edges of each square pulse contain high frequencies that may be limited by the amplifiers or by the scanning spot. In observing distortion of the square wave, a cathode-ray oscilloscope gives more accurate information than observation of the reproduced scanning pattern, but the use of the square wave with the image-reproducing tube is neverthe-

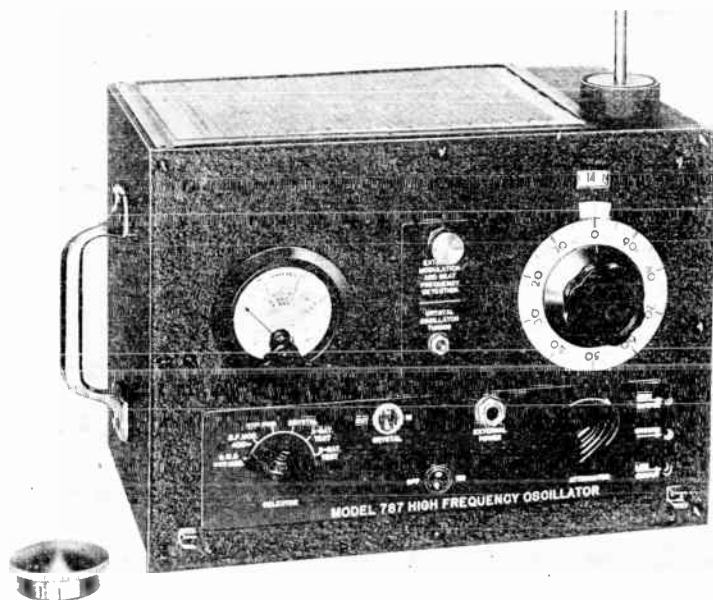

FIG. 306A.—External appearance of u-h-f signal generator, suitable use in method shown in Fig. 305.

less of value in determining the performance of the picture tube and its associated circuits.

*Applying the Image-signal Generator to Carrier Testing.*—For testing the i-f and r-f circuits of a receiver by the image method, it is necessary that the signal output of the image-signal generator modulate a carrier generator of the desired frequency. Conventional carrier generators of the standard-signal variety are not intended to accept modulating frequencies higher than, say, 20,000 c.p.s., hence it is usually necessary to employ a specially constructed generator.

One such generator, shown in Fig. 306, employs a single-tube oscillator, with provision for crystal control at any\* desired frequency within the tuning range. The tuning system is of the variable-inductance type, which provides a frequency range of 22 to 150 Mc. in a single-coil system. The generator contains a self-contained 400-c.p.s. sine-wave modulator and a modulation meter. The modulating voltage is applied to the plate circuit of the oscillator. The device is battery operated but is equipped to take an external source of power for high output. The output voltage is variable from 10 microvolts to 1 volt.

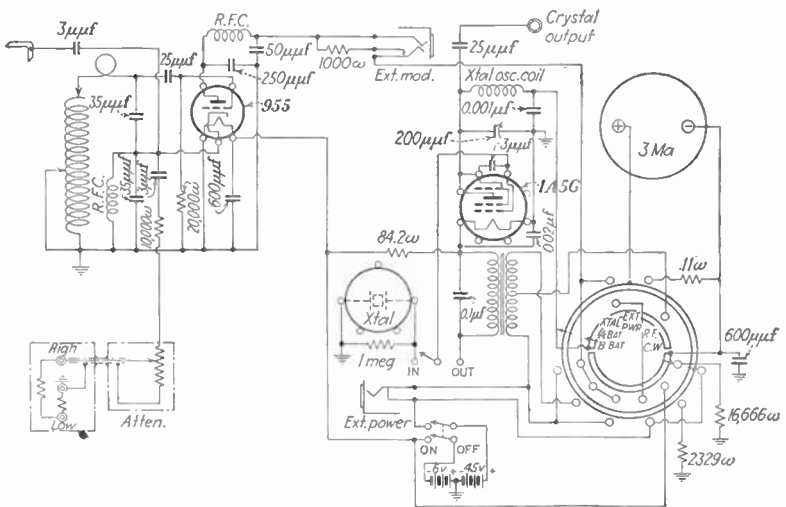

FIG. 306B.—Complete circuit diagram of u-h-f signal generator shown in Fig. 306A. (Weston Electrical Instrument Co.)

The tuning range of the oscillator permits testing on all television channels in the range from 44 to 50 Mc. to 102 to 108 Mc. For testing in the i-f frequency range, it is simplest to beat the modulated output of the generator against a local oscillator 12.75 Mc. higher in frequency, in a 1852 converter tube in the output of which appears the difference frequency of 12.75 Mc. The removal of the undesired sideband in r-f and i-f testing is most easily accomplished by a filter in the output circuit.

The over-all sensitivity of the receiver is most easily checked by means of a vacuum-tube voltmeter compensated or calibrated for use not only in the r-f range but also in the video range.



The modulated input signal to the receiver is measured by using the vacuum-tube voltmeter in conjunction with a calibrated attenuator. The output voltage across the image-tube grid is likewise measured. The input signal required for 10 volts r-m-s at the picture-tube grid may be taken as the sensitivity rating.

**72. Projection of Fluorescent Television Images.**<sup>1</sup>—One of the important limitations in the reproduction of television images by cathode-ray tubes is the fact that the picture size is definitely limited by the area of the fluorescent screen. Commercial tubes are at present limited to 14 in. in diameter, producing a picture less than a foot in width. Monitoring tubes of 20 in. diameter are used, and a tube 3 ft. in diameter has been built experimentally. But the cost and structural complexity of these larger tubes make them unsuited to use in the home.

The necessity of larger pictures is generally admitted for purposes outside the home, and even for home entertainment it seems likely that a picture 24 in. wide would be preferred to the restricted picture sizes now available. For the showing of television images to large gatherings, for example in theaters, images 6 ft. in width or larger are required.

The problem of producing larger pictures has engaged the attention of researchers for nearly as long as the cathode-ray tube itself. Zworykin was successful in projecting low-definition fluorescent images while he was at work on the iconoscope. But the application of projection technique to high-definition images has been impeded by many difficulties.

The general outline of the projection method is as follows: A fluorescent image is formed on the screen of a cathode-ray tube in the conventional manner. The beam current in the scanning beam and the accelerating voltage employed are much higher than those commonly used in nonprojection tubes, and as a result the brilliance of the image is greatly enhanced (although deleterious effects on the cathode of the electron gun, on the fluorescent screen, and in the formation of the ion spot are thereby incurred). The fluorescent screen is purposely made small, not

<sup>1</sup> ZWORYKIN and PAINTER, Development of the Projection Kinescope, *Proc. I.R.E.*, **25**, 937 (August, 1937).

LAW, R. R., High Current Electron Gun for Projection Kinescopes, *Proc. I.R.E.*, **25**, 954 (August, 1937).

larger than 4 in. in diameter, so that the light emanating from it may be collected by a projection lens of practical diameter. The projecting lens throws the light from the fluorescent screen on a reflecting surface, or screen, and the image is brought to focus by adjusting the position of the lens relative to the fluorescent screen and the reflecting screen. The light available from the fluorescent image is lessened in the first place by the imperfect transmission of the lens and in the second by the fact that the light which passes through the lens is attenuated, because it is spread over a larger area. The projected image is therefore dim unless the fluorescent image is very bright.

The principal problem is the production of sufficient light in the fluorescent image. The optical problem is similar to that encountered in the nonstorage types of television camera. In the case of projecting the reproduced image, the light on the screen at any instant is that present in the scanning spot. By the integrating effect of the eye, this small amount of light is spread over the area of the screen, and the illumination is correspondingly lowered. Furthermore, the higher the number of picture elements and the larger the screen area, the lower the apparent illumination for a given amount of luminous flux contained in the scanning spot. The only practical method, thus far, of obtaining bright projected pictures is to crowd a large amount of luminous flux into the scanning spot. The possibility of applying light storage to the projection problem has been investigated, and von Ardenne<sup>1</sup> has suggested a scheme, but as yet it has not been put to practical use.

The conditions to be met in projected pictures can be investigated by reference to the similar problem associated with motion-picture projection. Here there seems to be no general agreement on the illumination level required on the screen.

The unit commonly used to measure the brightness of projected images is the foot-lambert. The levels commonly present in motion-picture projection range from 1 to 10 foot-lamberts. The latter value is generally considered to be necessary to avoid eyestrain, but the Society of Motion Picture Engineers has suggested a compromise standard of 3.7 foot-lamberts. All these values of illumination refer to the screen brightness produced when there is no film in the projector, but they are

<sup>1</sup> See reference, page 339.

commonly considered to represent the brightness of the brightest parts (high lights) of the picture.

The brightness of conventional fluorescent television images, as viewed directly from the screen of a normally operated 12-in. cathode-ray tube, has been determined by Zworykin and Painter on the basis of measured screen brightness to have a value of roughly 15 to 20 foot-lamberts, which is considerably brighter than the values used in motion pictures.

For projection purposes, it is necessary to produce a fluorescent image the brightness of which is considerably greater than that customarily used in nonprojected images. The required degree of brightness depends on the aperture of the projecting lens and its transmission efficiency, the desired size of the projected

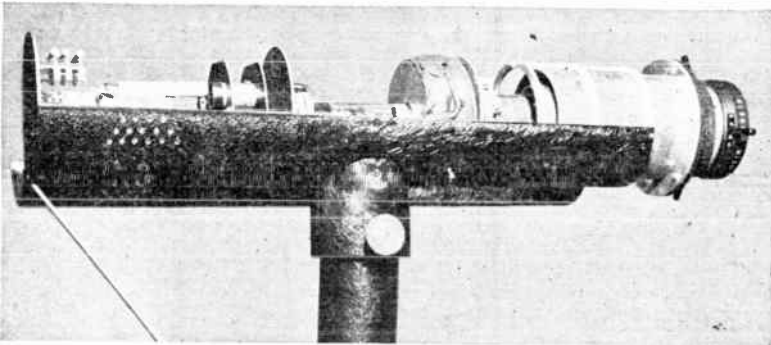

FIG. 307.—Picture-tube assembly for projecting images from a fluorescent screen.

picture, and the type of viewing screen to be employed. In the latter question, it is possible to employ "directional" reflecting screens, which confine most of the reflected light to angles near the perpendicular, that is, in the direction of the audience. The figures given here are based on the work of Zworykin and Painter who employed a transmission (rather than reflection) screen having a light output 4.8 times as great as that from a perfectly diffusing screen. On the assumption of 50 per cent transmission through the projecting lens, an image size of 18 by 24 in., a lens aperture of  $f/1.5$ , and a lens diameter of 3 in., the light output required from the fluorescent screen would be about 70 candle power. This light is that present in the scanning spot when at maximum (high-light) brilliance.

To obtain this much light from the fluorescent area of a single picture element, it is necessary to employ extraordinary tech-

niques. In the first place, means must be taken to produce a very intense beam of electrons. By assuming a luminous efficiency of 1.5 candles per watt, the electrical power for 70 candles must be  $70/1.5 = 46$  watts. This figure compares with a beam power of about 1 watt in the high lights of a conventional 12-in. diameter nonprojection image-reproducing tube. The 50 to 1 ratio in beam power may be divided between the beam current and the accelerating voltage. However, it is impractical to employ accelerating voltages much higher than 50,000 volts, and most work on projected images has been carried out at 10,000 or 25,000 volts. The reason for the voltage limitation rests primarily in insulation difficulties both in the tube itself and in associated circuits, together with the great scanning power required to deflect a high-velocity beam. If 15,000 volts is employed, the advantage gain over nonprojected tubes (which operate at 5000 to 7000 volts) is only 2 to 1 or 3 to 1. The conclusion is that the beam current must be about fifteen to twenty times as great as that employed in nonprojected tubes. The latter current is usually not more than  $\frac{1}{4}$  ma. so that the necessary beam current for projection tubes is roughly 5 ma. No ordinary electron gun can produce such a heavy current, and the difficulty of avoiding aberrations in guns specially designed for the purpose still remains. However, it has been possible to construct high-current electron guns having a beam current of 2 ma. at 10,000 volts (higher currents are possible but only at the expense of defocusing aberrations). The diameter of the scanning spot produced by this gun is exceedingly small (0.25 mm.). This spot is small enough to allow 400-line picture definition within the small picture area (1.66 by 2.22 in.) on the fluorescent end of the tube.

Using this type of gun, a projection cathode-ray tube was constructed in the form shown in Fig. 308. A specially shaped magnetic-focusing coil was used to aid in bringing the beam to a fine focus on the screen. The screen itself was formed from yellow willemite (zinc beryllium orthosilicate). By using an  $f/1.4$  lens, a high-light brilliance of 2.5 foot-lamberts was produced in a picture size of 18 by 24 in. This apparatus was demonstrated before the Institute of Radio Engineers in 1937. Projected images as large as 8 by 11 ft. were produced with it, but the brilliance was so low that severe eyestrain would result

from following the details of the performance over any extended length of time.

In early projection tubes, short life of the fluorescent material was a very severe limitation. Zworykin and Painter report, however, that the yellow willemite screen used for the projection kinescope withstood 1200 hours' use at  $200 \mu\text{a}$  and 10,000 volts with only 27 per cent loss in luminous efficiency. Improvements in the composition and application of fluorescent materials since that time have made possible projection tubes the useful life of which under severe service (average beam currents above 1 ma.) is in excess of 500 hr. This length of life is entirely within

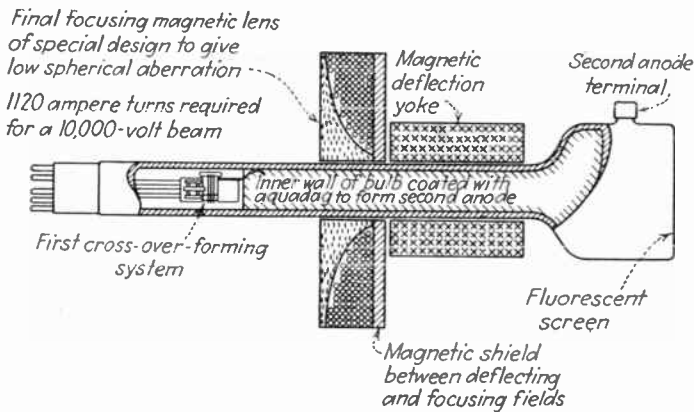

FIG. 308.—Internal arrangement of projection picture-tube system shown in Fig. 307.

reason for use in the theater projection, but is somewhat short for home use, considering the cost of renewing the tube.

A more serious restriction in the life of the tube is the deterioration of the cathode in the electron gun. The emission current is obtained from a very small part of the cathode coating (less than  $10^{-4}$  sq. in.). Furthermore, the high values of accelerating voltage subject the cathode surface to severe bombardment by positive ions. This limitation may be removed by very careful outgassing of the gun structure to avoid the liberation of gas, and by thorough exhausting of the tube. One approach to the problem, reported by Law, consists in using a cathode surface of cuplike shape, which permits using a larger cathode surface without impairing the fineness of focus.

The projection of fluorescent images has been limited in the United States, thus far, to experimental work and isolated demonstrations. In England, several manufacturers have produced projection receivers for use in the home, and one has made available practical projection instruments for use in

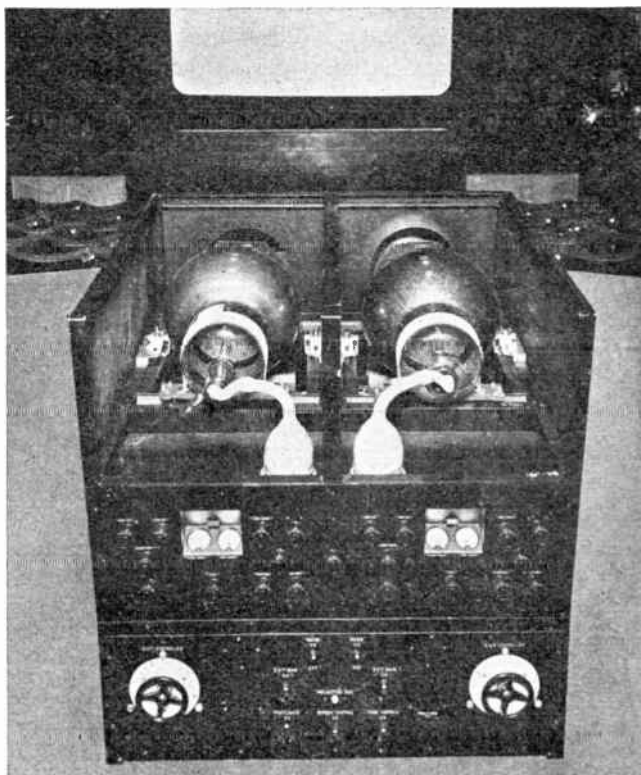

FIG. 309.—British type of projection picture-tube equipment. An accelerating voltage of 50,000 volts is used to obtain pictures about 9 by 12 feet in size.

theaters. The latter equipment produces a picture 8 by 10 ft. of sufficient brilliance to entertain groups of 500 to 700 people seated in motion-picture houses.

**73. The Scopphony System of Projecting Television Images.**<sup>1</sup>—From time to time, various attempts have been made to repro-

<sup>1</sup> Scopphony Television, *Electronics*, 9 (3), 30 (March, 1936).

OKOLICSANYI, F., The Wave-slot—An Optical Television Scanner, *Wire-*

duce high-definition television images (400 lines or more) by the use of mechanical scanning using a fixed source of light and a light valve. The difficulties have been the great speeds of scanning required and the very rapid rate at which the light valve must operate. Stability in the synchronizing of the mechanical scanner has also proved a difficult problem. These obstacles have been overcome to a considerable extent in the Scophony system, which makes use of a light-storage phenomenon in the light valve and which displays great ingenuity in the optical and mechanical methods used in scanning. The success of the Scophony system in producing large bright images, from standard transmissions intended for cathode-ray reception, has been demonstrated in several theater installations in England.

The heart of the Scophony system is the so-called "supersonic light valve." In 1932, Debye and Sears demonstrated that internal stresses may be set up in a body of liquid in such a way that the liquid acts much like a diffraction grating. The liquid (carbon tetrachloride, for example) is placed in a container, at one end of which is a flexible quartz crystal similar to the quartz crystals used for frequency control in radio transmitters. The quartz crystal is excited at a high frequency. The frequency employed, in the neighborhood of 10,000,000 c.p.s., is such that a large number of compressive waves are set up in the liquid within the length of the container. At the end of the container opposite the quartz crystal, a layer of cork, or other absorbing material, is used to absorb the waves, so they are not reflected back to the crystal. The result is a continuous procession of waves traveling across the liquid from the crystal. The rate of wave propagation

---

*less Eng.*, **16**, 167 (April, 1939).

LEE, H. W., The Scophony Television Receiver, *Nature*, **142**, 49 (1938).

ROBINSON, D. M., The Supersonic Light Control and Its Application to Television with Special Reference to the Scophony Television Receiver, *Proc. I.R.E.*, **27**, 483 (August, 1939).

SEIGER, J., The Design and Development of Television Receivers Using the Scophony Optical Scanning System, *Proc. I.R.E.*, **27**, 487 (August, 1939).

WIKKENHAUSER, G., Synchronization of Scophony Television Receivers, *Proc. I.R.E.*, **27**, 492 (August, 1939).

LEE, H. W., Some Factors Involved in the Optical Design of a Modern Television Receiver Using Moving Scanners, *Proc. I.R.E.*, **27**, 496 (August, 1939).



through the liquid is such that several hundred waves are produced within the confines of the container.

The container is set up as shown in Fig. 310 between condensing lenses, with a steady source of light on one side and the projection screen on the other. The condensing lenses bring the image of the light source to a focus at a point some distance in front of the screen. An opaque obstacle at this point intercepts the focused image so that it cannot reach the screen. Another lens serves to focus any light *from within* the cell on the projection screen, as shown in the figure. The liquid, with supersonic

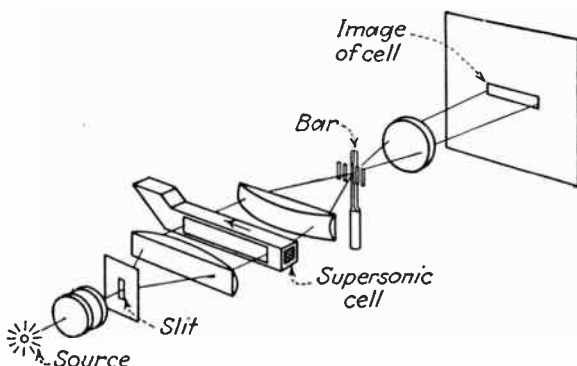

FIG. 310.—Basic light modulation method of the Scophony system of projection television. Light storage is employed to obtain an increase in optical efficiency of over 100 times.

waves imposed upon it, acts like a diffraction grating, and as a result a series of fine illuminated lines are produced on the screen. The width and separation of the lines are dependent on the width of the supersonic waves.

Now if the supersonic frequency (10,000,000 c.p.s.) that controls the quartz crystal is modulated with video frequencies (from 30 to 3 million c.p.s.), the intensity of the supersonic waves may be varied in accordance with the modulation, and the position of the light and dark lines on the projection screen may be changed accordingly. The effect of the modulation is to produce a bright spot where a high light is called for, a dark spot where no light is called for, and intermediate degrees of light for the intermediate half tones. In this way, the light on the screen is broken up into picture elements. Furthermore, as the waves progress through the liquid, they maintain their



shape and it is thus possible to shine light through many waves at once. In this way, several hundred picture elements are projected simultaneously (in practice, as many as 200 elements are involved). The light on the screen at any one time is, in other words, not that present in one element, but that present in several hundred elements, and as a result the apparent screen brilliance is multiplied by the same factor. This supersonic device is a light-storage device, and as such serves much the same purpose (though by a very different mechanism) as the storage elements in the iconoscope mosaic. A comparatively

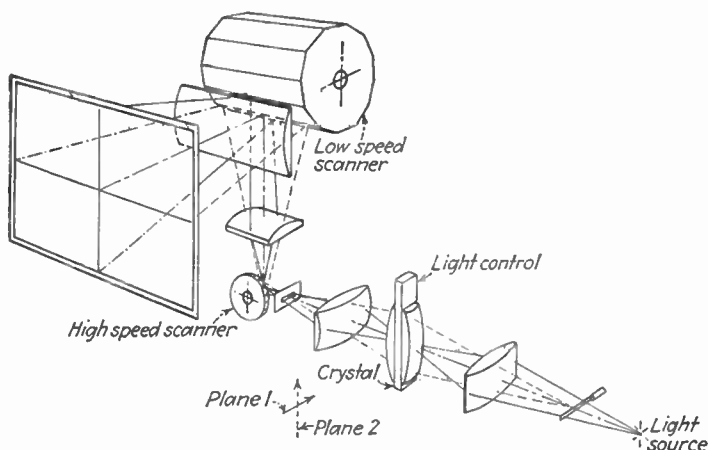

FIG. 311.—High- and low-frequency scanning means in the Seophony projection system.

small light source thus suffices to produce a bright picture. In practice, a high-pressure enclosed mercury-arc lamp of 300 watts power consumption is used for projecting pictures 2 ft. wide, whereas for 4 by 6-ft. pictures, a more powerful (about 1000 watt) open arc may be used.

The optical and mechanical arrangements of the scanning system are shown in Fig. 311. The light source sends light through a slit to a cylindrical lens that brings the light into a line focus which coincides with the plane of the compressive waves in the liquid of the light valve. The light, on emerging from the valve, consists of a group of some 200 picture elements, which extend through the length of the light-valve cell. These picture elements are brought to a fine focus by a second lens

(spherical in shape), which causes them to pass through a slit onto a rotating polygon of mirrors, known as the "high-speed scanner." This scanner is made of highly polished stainless steel. It rotates at a very high speed, 30,375 r.p.m. for the British standard of 405 lines, 25 frames (for the corresponding American standard of 525 lines, 30 frames, the speed would be about 40,000 r.p.m., but this figure depends on the number of sides in the polygon).

From the high-speed scanner (which produces the line-scanning motion), the light passes through a half-cylindrical lens to a second mirror polygon, the low-speed scanner. This scanner rotates at 250 r.p.m. (for 25 frames, 300 r.p.m. for 30 frames) and produces the frame-scanning motion. Finally the light passes through another half-cylindrical lens to the projection screen, which in the case shown is of the transmission type.

Synchronism is accomplished by driving the two mirror polygons from synchronous a-c motors the power of which is derived directly from the sync signals of the standard signal. This system necessitates powerful amplifying stages to produce the necessary driving power. Furthermore it demands the highest stability on the part of the sync signals. Casual drifting of the sync pulses is apt to occur in the transmitter, owing to power-supply phase changes, power surges, etc. Such casual changes are followed instantaneously in the cathode-ray system, since the scanning circuits and the scanning beam itself have very little inertia. In the mechanical system, however, a very considerable inertia is present, and the system cannot follow changes in the synchronizing rate unless they occur very slowly. This fact presented a very difficult problem when the system was first installed. However, when the British Broadcasting Corporation installed a mechanical sync pulse timer, and thereby imposed the same inertial restraint on the variations of sync timing, the Scophony equipment operated satisfactorily.

The most critical mechanical element in the system is the high-speed motor that drives the line-scanning polygon. This motor must be extremely well balanced to avoid making excessive noise and to maintain accurate alignment of the optical system. Its life is at present limited to several thousand hours of operation, even when serviced regularly, but it is easily replaceable. The motor consists of two parts, one of which is synchronous (for

bringing the motor up to the speed) and the other of which locks in with the synchronizing impulses.

A complete Scophony receiver for home use contains 39 tubes. Similar equipment for projection use in theaters contains essentially the same electrical, mechanical, and optical elements, except that the light source is considerably more powerful.

It is difficult to predict whether the mechanical system or the electronic system will eventually prove more effective in projecting large pictures. On the one hand, the electronic system seems to be limited primarily by fluorescent material characteristics, and it is reasonable to expect that chemical and physical research into the properties of these materials will produce much higher luminous efficiencies and stability under powerful electronic bombardment. If this proves to be true, it seems likely that the inertialess character of the electron-beam method of scanning must inevitably prove superior to mechanical methods, especially if larger numbers of lines and high scanning speeds come into prominence. On the other hand, the principle of light storage employed in the Scophony system is a fundamental advance which up to the present has not been copied successfully in electronic systems. It seems likely that both systems must undergo extensive trials in the field before the superiority of either can be conclusively demonstrated.



## APPENDIX

### TRANSMISSION STANDARDS, RECOMMENDED PRACTICES, DEFINITIONS, AND NAMES OF CONTROLS

ADOPTED BY THE RADIO MANUFACTURERS ASSOCIATION

The following list contains accepted standards and terminology as adopted by the R.M.A. Committee on Television and approved by the membership of that body. These standards have been superseded by the N.T.S.C.-F.C.C. standards. The most important change is in T-107, in which the number of lines per frame has been increased from 441 to 525.

#### TELEVISION-TRANSMISSION STANDARDS

##### **T-101 Television Channel Width**

The standard television channel shall not be less than 6 Me. in width.

##### **T-102 Television and Sound Carrier Spacing**

It shall be standard to separate the sound and picture carriers by approximately 4.5 Me.

##### **T-103 Sound Carrier and Television Carrier Relation**

It shall be standard in a television channel to place the sound carrier at a higher frequency than the television carrier.

##### **T-104 Position of Sound Carrier**

It shall be standard to locate the sound carrier for a television channel 0.25 Me. lower than the upper frequency limit of the channel.

##### **T-105 Polarity of Transmission**

It shall be standard for a decrease in initial light intensity to cause an increase in the radiated power.

##### **T-106 Frame Frequency**

It shall be standard to use a frame frequency of 30 per second and a field frequency of 60 per second, interlaced.

##### **T-107 Number of Lines per Frame**

It shall be standard to use 441 lines per frame.

##### **T-108 Aspect Ratio**

The standard picture aspect ratio shall be 4:3.

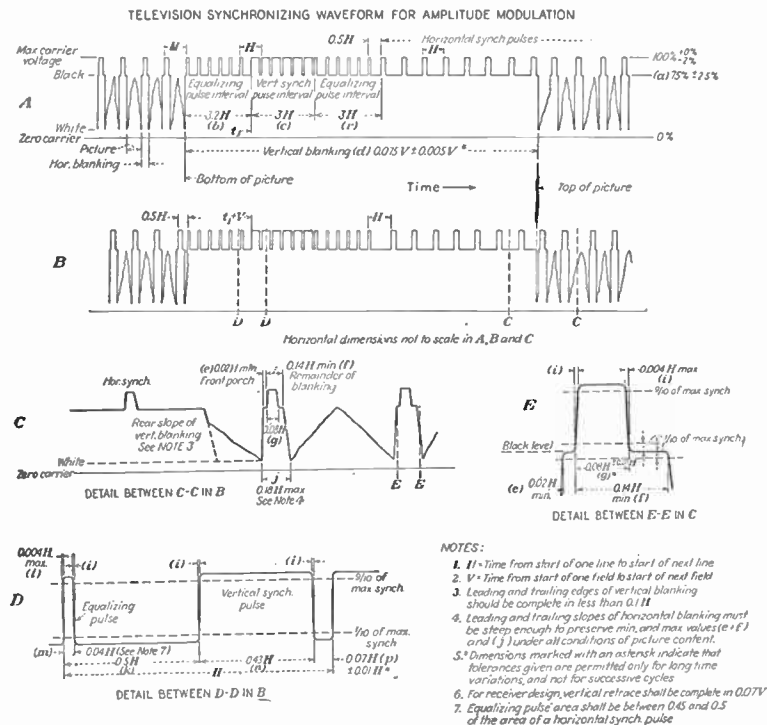

Fig. 312.—N.T.S.C. standard television signal.

### T-109 Percentage of Television Signal Devoted to Synchronization

If the peak amplitude of the radio frequency television signal is taken as 100 per cent, it shall be standard to use not less than 20 per cent nor more than 25 per cent of the total amplitude for synchronizing pulses.

### T-110 Method of Transmission

It shall be standard in television transmission that black shall be represented by a definite carrier level independent of light and shade in the picture.

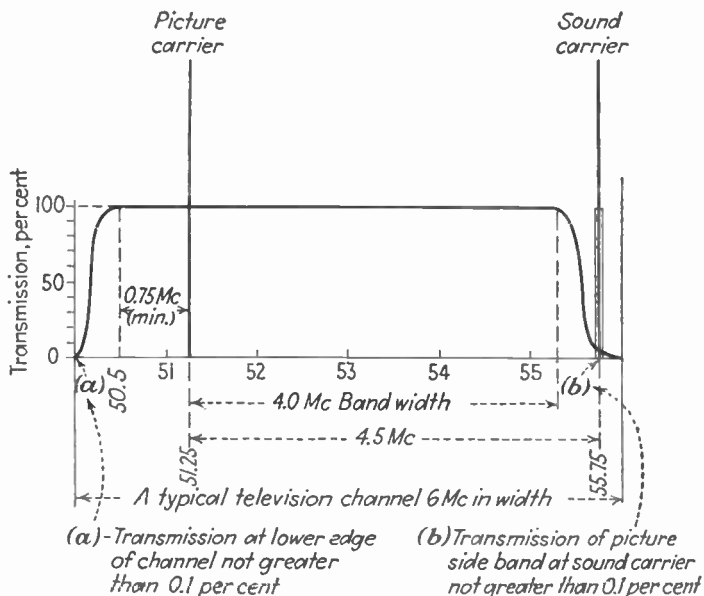

FIG. 313.—Reprint of R.M.A. Standard T-115, Transmitter Amplitude Characteristic, as defined by the R.M.A. Television Committee.

### T-111 Synchronizing

The standard synchronizing signals shall be as shown on Drawing T-111.

### T-112 Transmitter Modulation Capability

If the peak amplitude of the radio frequency television signal is taken as 100 per cent, it shall be standard for the signal amplitude to drop to 25 per cent or less of peak amplitude for maximum white.

### T-113 Transmitter Output Rating

It shall be standard, in order to correspond as nearly as possible to equivalent rating of sound transmitters, that the power of television picture transmitters be nominally rated at the output terminals in peak power divided by four.

**T-114 Relative Radiated Power for Picture and for Sound**

It shall be standard to have the radiated power for the picture approximately the same as for sound.

**T-115 Transmitter Amplitude Characteristic**

It shall be standard to use the transmitter amplitude characteristic shown in Drawing T-115.

**T-116 Scanning**

It shall be standard to scan at uniform velocity in horizontal lines from left to right, progressing from top to bottom when viewing the subject from the camera position.

**T-117 Sound Transmitter Amplitude Characteristic**

It shall be standard in television sound transmission to pre-emphasize the modulation at the higher frequencies according to the impedance-frequency characteristic of a series inductance-resistance network having a time constant of 10  $\mu$ seconds.

## RECOMMENDED PRACTICES

**Polarization of Radiated Wave**

It shall be recommended practice in television transmission that the radiated wave shall be horizontally polarized.

**Intermediate Frequencies for Television Receivers**

It shall be recommended practice in Television Receivers to place the sound modulated intermediate frequency carrier at 8.25 Me. and the picture modulated intermediate frequency carrier at 12.75 Me.

## DEFINITIONS

**Receiver Definitions**

It shall be standard to define at least three classes of receivers as follows:

1. Picture receiver. A receiver for picture only, with no facilities for receiving the associated sound.
2. Picture receiver with sound converter. The same as a picture receiver, with the addition of an incomplete sound channel, requiring the use of a suitable auxiliary sound receiver.
3. Television receiver. A receiver having complete channels for receiving the television picture and its associated sound.

**Transmitter Definitions**

Television transmitter. A transmitter which transmits both picture and sound shall be called a Television Transmitter.

Picture transmitter. A transmitter which transmits the television picture only shall be called a Picture Transmitter.

Sound transmitter. A transmitter which transmits the television sound only shall be called a Sound Transmitter.



## NAMES OF CONTROLS OF TELEVISION RECEIVERS

The following list of controls and their functions shall be standard for Television Receivers:

<i>Name of Control</i>	<i>Function of the Control</i>
Focus.....	Adjustment of spot definition
Contrast.....	Adjustment of video frequency signal amplitude
Brightness.....	Adjustment of average light intensity
Tone.....	Same as in sound receiver practice
Volume.....	Same as in sound receiver practice
Station selector.....	Same as in sound receiver practice
Horizontal hold.....	Adjustment of the free-running period of the horizontal oscillator
Vertical hold.....	Adjustment of the free-running period of the vertical oscillator
Width.....	Adjustment of the picture size in the horizontal direction
Height.....	Adjustment of picture size in the vertical direction
Horizontal centering.....	Adjustment of the picture position in the horizontal direction
Vertical centering.....	Adjustment of the picture position in the vertical direction
Fine tuning.....	Vernier tuning control
Linearity control.....	Adjustment of scanning wave shapes May be qualified by the adjectives "top," "bottom," "right," "left"



## NAME INDEX

### A

Ashbridge, N., 24

### B

Barber, A. W., 219, 362  
 Barco, A. A., 255, 397, 478  
 Barden, W. S., 297, 310, 320, 394  
 Beal, R. R., 24, 388  
 Bedford, A. V., 24, 40, 51, 156, 245,  
 250  
 Beers, G. L., 24  
 Benham, W. E., 301, 491  
 Beverage, H. H., 267  
 Bingley, F. J., 156  
 Birkenshaw, D. C., 434  
 Blumlein, A. D., 434  
 Brolly, A. H., 24  
 Brown, G. H., 432-433  
 Browne, C. O., 434  
 Brumbaugh, J. M., 478  
 Builder, G., 220  
 Burnap, R. S., 340  
 Burnett, C. E., 116, 340  
 Burrill, C. M., 261  
 Burrows, C. R., 267-268, 276

### C

Campbell-Swinton, A. A., 94  
 Carlson, W. L., 24, 146, 153  
 Carnahan, C. W., 245  
 Carter, P. S., 267-268, 274, 297  
 Coeking, W. T., 310  
 Colwell, R. C., 267  
 Conklin, E. H., 268  
 Conklin, J. W., 277, 434  
 Cork and Pawsey, 297

### D

Davis, N. E., 434  
 Deal, H. B., 402

Decino, A., 367  
 DuBridg, L. A., 74  
 Du Mont, A. B., 159

### E

Eddy, W. C., 388-389  
 Einstein, A., 75  
 Engstrom, E. W., 24, 28, 37, 261,  
 441  
 Epstein, D. W., 120, 165, 287, 340,  
 345, 355, 491  
 Everest, E. A., 220

### F

Farnsworth, P. T., 91, 117  
 Ferrell, E. B., 268, 276  
 Fink, D. G., 441-442, 479  
 Finke, H. A., 117  
 Flory, L. E., 94  
 Fogg and Jarvis, 250  
 Fredenhall, G. L., 245, 250  
 Freeman, R. L., 220  
 Friend, A. W., 207  
 Fyler, G. W., 302, 462

### G

Gannett and Green, 24  
 Gardner, B. C., 91  
 George, R. W., 268  
 Gihring, H. E., 277, 434  
 Goddard, D. R., 268  
 Goldman, S., 267  
 Goldmark, P. C., 277, 434  
 Goldsmith, A. N., 24  
 Goldsmith, T. T., 159  
 Gray, F. G., 24, 40  
 Green, E., 434  
 Green and Gannett, 24

- H
- Hallwachs, W., 75  
 Handel, P. von, 268, 277  
 Hanson, O. B., 388  
 Hardy, A. C., 23  
 Helmholtz, H. von, 23  
 Herold, E. W., 220  
 Hertz, H. R., 75  
 Hickok, W. H., 117  
 Hollywood, J. M., 267, 287  
 Holmes, R. S., 24, 146, 153, 268,  
 441  
 Horton, J. W., 24  
 Hughes, A. L., 74  
 Hull, A. W., 153  
 Hull, Ross, 277  
 Hunt, L. E., 267
- I
- Iams, H., 108, 111, 117, 165  
 Ives, H. E., 24, 250
- J
- Janes, R. B., 117  
 Jarvis and Fogg, 250  
 Jenkins, C. F., 24  
 Jesty and Winch, 28  
 Johnson, J. B., 165  
 Jones, L. F., 268
- K
- Kaar, I. J., 282, 462  
 Kauzmann, A. P., 445  
 Keall, O. E., 220, 232  
 Kell, R. D., 24, 40, 51, 156  
 Kimball, C. N., 207, 220, 236, 250,  
 253  
 Koller, L. R., 75
- L
- Lanc, H. M., 246  
 Langmuir, D. B., 165  
 Larson, C. C., 91  
 Law, R. R., 355, 505  
 Lee, H. W., 511  
 Leverenz, H. W., 344, 351  
 Levin, N., 338  
 Levy and West, 344-345  
 Lewis, H. M., 25  
 Lindenblad, N., 295  
 Loughren, A. V., 28  
 Lubcke, H. R., 389  
 Lubszynski and McGee, 340  
 Lyman, H. T., 302-304, 309
- M
- McGee and Lubszynski, 340  
 McIlwain, K., 117  
 McLachlan, H. W., 246  
 MacNamara, T. C., 434  
 Maloff, I. G., 24, 117, 120, 165, 204,  
 329, 340, 345, 355  
 Mathes, R. E., 24  
 Mertz, P., 40  
 Monk, G. S., 24  
 Moon, P., 24, 63  
 Morris, R. M., 389  
 Morton, G. A., 24, 94, 108  
 Mountjoy, G., 302  
 Murray, A. F., 25, 167
- N
- Nagy, P., 220  
 Nelson, E. L., 24  
 Nergaard, L. S., 267  
 Nottingham, W. B., 345, 348
- O
- Oakey, C. W., 220  
 Okolicsanyi, F., 510
- P
- Painter, W. H., 505  
 Parker, W. N., 284  
 Parsons, Sir J. H., 24  
 Pawsey and Cork, 297  
 Perrin, F. H., 23

Peterson, H. O., 268  
 Pfister, W., 268, 277  
 Phillips, H., 178  
 Poch, W. J., 287, 491  
 Pollack, D., 238  
 Preisman, A., 220  
 Protzman, A. W., 369  
 Puckle, O. S., 246

## R

Robinson, D. M., 511  
 Robinson, G. D., 220  
 Roder, Hans, 284  
 Rodwin, G., 24, 26  
 Rose, A., 111, 117  
 Rosing, B., 91

## S

Schantz, J. D., 220  
 Schelkunoff, S. H., 250  
 Schelleng, J. C., 268, 276  
 Schmidling, G. T., 345  
 Seeley, S. W., 207, 220, 236, 250,  
 253, 297, 310  
 Seitz and Leverenz, 344  
 Shelby, R. E., 389  
 Shiffenbauer, R. G., 199  
 Sieger, J., 511  
 Smith, T. A., 24, 26  
 Sokolnikoff, E. S., 178  
 Sokolnikoff, I. S., 178  
 Somers, F. J., 40, 194  
 Stocker, A. C., 479

Stoller and Morton, 24  
 Strieby, M. E., 24, 250  
 Strutt, M. J. O., 302  
 Swift, G., 255

## T

Terman, F. E., 207  
 Thomson, Sir J. J., 75  
 Tolson, W. A., 24, 146, 153  
 Trainer, M. A., 24, 40, 51, 156  
 Trevor, B., 268, 274  
 Turner, A. H., 268

## V

Von Ardenne, M., 194, 339

## W

Waller, L. C., 340  
 Weinberger, J., 24, 26  
 West, S., 344-345, 379  
 Wheeler, H. A., 28, 199, 220  
 Wickizer, G. S., 267  
 Wikkenhauser, G., 511  
 Wildor, M. P., 442  
 Wilson, J. C., 24, 40, 75, 83, 165,  
 220, 338  
 Winch and Jesty, 28

## Z

Zworykin, V. K., 24, 75, 94, 108,  
 165, 505



## SUBJECT INDEX

### A

- A-c component, of camera signal, 176
  - requirement for perfect transmission of, 177
- A-c gain vs. d-c gain, 368
- Acuity of the eye, 31
- Added phase shift  $\phi_a$ , 209
- Amplification, of modulated carrier, 259
  - picture i-f, 310
  - of signal, 81
  - video, 207
- Amplification factor  $\mu$ , 208
- Amplifier, clipper, 400
  - control, 397
  - equivalent circuit of, 209
  - gain, methods of measuring, 253
  - gain  $G$ , 208
  - grid-bias filter, 234
  - high-voltage output, 239
  - logarithmic response, 244
  - low-noise, 243
  - low-output impedance, 240
  - multistage, compensation in, 236
  - response to Heaviside unit voltage, 248
  - single stage, fundamental analysis of, 207
    - high-frequency compensation, 219
    - low-frequency compensation in, 228
  - tube, figure of merit, 311
  - tubes, wide-band, 445
  - uncompensated, phase-response characteristic of, 215
- Amplitude vs. frequency response, 177, 183, 231, 253
- Amplitude characteristic, picture transmitter, 520
  - sound transmitter, 520
- Amplitude-frequency characteristic of multistage amplifier, 236
- Amplitude-frequency response characteristic, ideal, 183
- Amplitude response, low-frequency, 231
  - methods of testing video amplifier, 182
- Amplitude separation of sync pulses, 160, 373
- Analysis, image, 25
- Angular phase, relationship with equivalent time delay, 181
- Anode-above-ground connection, 325
- Antenna, crossed dipoles, 439
  - cubic, 439
  - height, geometrical relationship of, 272
    - and horizon distance, relation between, 270
  - rhombic, 300
  - structure, independent of frequency, 295
  - television receiving, 297
  - termination of, at receiver, 301
- Antenna conductor, velocity of propagation in, 299
- Aperture distortion, 54
- Aspect ratio, 40, 42, 62, 517
  - horizontal, incorrect, 385
  - vertical, incorrect, 385
- Assignments for television stations, 263
- Attenuation of coaxial cable, 252
  - measurement of, 260
- Audio, definition, 166
- Audio carriers, discrimination against, 449

Audio frequencies in the signal circuit, interference from, 384

Automatic gain control, 322, 378

Auxiliary circuits, cathode-ray tube, 343  
for image reproduction, 328

**B**

Background information, 174

Band-pass circuit, capacitively coupled, 315  
inductively coupled, 313  
response curve, 314  
with series trap, 315

Band-pass filter, 312

Beam, defocusing of, 137

Beam current vs. control electrode voltage, 353

Beat note interference, 383

Bias lighting, 107, 393

Blacker-than-black region, 169

Blanking amplifier, 169

Blanking signal, combination with camera signal, 399  
as a fixed reference, 176

Bleeder resistor, 359, 361

Blocking oscillator, 153, 155, 461, 473

Blooming, 72

Brightness, average, control of, 400, 521  
vs. beam current, 350  
calculation, 67  
contrast, 72  
image, 331  
logarithm of, 205, 336  
object, 329  
relationship to accelerating voltage, 349  
surface, 65  
transfer in image reproduction, general theory of, 328  
transfer characteristic, over-all, 331, 334

Broadcasting practice, television, 388

**C**

Cadmium tungstate, 345

Camera, lenses, 393  
plate, illumination of, 69  
preamplifier, 392  
signal, a-c component of, 176  
analysis of, 173  
combination of blanking signal and, 399  
d-c component of, 174  
transfer characteristic, 330

Camera action, fundamentals of, 63

Camera chain, single, equipment for, 390

Camera tube, 15, 18  
low-gamma characteristics of, 206

Candle power, 63

Capacitance to ground  $C_s$ , 215

Carrier frequencies employed in television transmission, 261  
generation of, 277, 434

Carrier radiation, 434

Carrier relation, television and sound, 517

Carrier signal, modulated, 282

Carrier spacing, television and sound, 517

Carrier transmission of video signals, 261

Cathode, 120

Cathode-above-ground connection, 325

Cathode-bias filter, effect of, on low-frequency response, 234

Cathode-coupled stage, 241

Cathode-follower stage, 241

Cathode-ray image-reproducing tube, 340, 442  
auxiliary circuits, 343, 355  
projection, 508

Channels, number of, 450  
television, 22  
width, 517

Charts for testing image characteristics, 58

Chassis, scanning, 470

Checkerboard image, 192



- Circuit analysis, by square-wave generator, 258
- Circuit constants, choice of, 448
- Circuit frequencies, choice of, 448
- Circuit response, value of  $R$  required to broaden, 290
- Clipping, 373, 409
- Clipping circuits, 373, 400, 408
- Coaxial cable, 23  
attenuation in, 252  
measurement of, 260  
measurement of constants of, 259  
parameters, 250  
time delay in, 252
- Color chart, Agfa, 98  
televised reproduction, 99
- Color composition, 63  
nonstandard, 80
- Compensated amplifier, low-frequency, phase-frequency response, 232  
phase-frequency response characteristics of, 224  
series peaking, 226  
shunt peaking, 219
- Compensation, improper, cumulative effect of, 237  
in multistage amplifiers, 236
- Compensation filter, low-frequency, ( $RFCF$ ), 229
- Compensation inductance  $L_c$ , 222
- Compensation methods, high-frequency, comparison of, 228
- Composite sync signal, synthesis of, 407
- Composite video signal, 166
- Contrast, brightness, 72  
control, 521
- Control amplifier, 397  
block diagram of, 398  
complete circuit diagram of, 398
- Control grid, 120, 124
- Control room, 390
- Controlled line oscillator, of station W2XAB, New York, 281
- Controls of television receivers, names of, 521
- Converters, 447
- Converters, circuits, types of, 307  
tubes, 444  
figure of merit, 308
- Coupled circuits, gain of, 304
- Coupling circuit, detector, 320
- Critical viewing distance, 34
- Crossover region, 121
- Crystal control, 278
- Current, available from picture element, 103
- D
- D-c component, 175  
of camera signal, 174  
establishing, in modulation, 285  
picture signal, 286  
reinserting in video modulation, 425  
reinsertion, 175  
circuit, 367  
use of separate diode rectifier, 367  
reinsertion system, 457  
in RCA transmitter, 426  
transmission of, 519
- D-c gain vs. a-c gain, 368
- Definitions, Radio Manufacturers Association, 517  
receiver, 520  
transmitter, 520
- Deflecting force, dynamic action of, 130  
electric, 131  
magnetic, 134
- Deflecting structure, 342  
plates, inclined, 134
- Deflection, electric, 340  
electric and magnetic, defects of, 137  
magnetic, 340  
yoke, magnetic, typical, 474
- Deflection coefficient, 134
- Defocusing, due to nonuniformity, 137  
geometrical cause of, 138  
of low-velocity beam, 112
- Delay circuits, 408, 410

- Demodulation of picture signals, 319
- Detail, along horizontal line, 29  
along vertical line, 26
- Detail information, 174
- Detection, automatic-circuit functions, 326  
diode, 322  
grid-leak, 324  
plate-circuit, 325  
video, 322
- Detector, characteristics, methods of testing, 483  
circuit, loading of i-f circuit, 323  
coupling circuit, 320  
efficiency, 323  
polarity, influence on succeeding circuits, 325
- Diathermy apparatus, interference from, 383
- Differentiating by inductive means, 375
- Differentiation circuit, 162
- Diffraction, signal strength, 276  
of waves, 268
- Diffuse reflection, 66
- Diode detection, 322
- Dipole, directivity, 299  
frequency range, 299  
receiving antenna, 298
- Discharge, three-element vacuum tube, 146
- Distance, to horizon over flat earth, 269  
line-of-sight, maximum unobstructed, 270
- Double sideband television channel, 265
- Doubtlet, double, 301
- Dynamic plate resistance  $r_p$ , 208
- Dynatron, 153
- E
- Electric deflection, 131, 340
- Electron, apparent change in mass, 131  
axial, 125, 128  
centrifugal force of, 135
- Electron, low-velocity, 112  
multiplication, 92
- Electron beams, deflection of, 129  
formation and focusing of, 120  
magnetic focusing, 126
- Electron crossover, 122
- Electron gun, 342  
electrostatic, 120  
control characteristics of, 125  
emission current, 509  
high-current, 508
- Electron image, 109
- Electron lens, immersion, 121  
second, 123  
focusing action of, 122
- Electronic scanning, employing a cathode-ray tube, 90  
instantaneous, 89  
storage, 94
- Electrons, paraxial, 125, 128  
secondary, 100  
velocity, 130
- Engraving, half-tone dots of, 6
- Equalizing pulses, 161, 172  
dimensions of, 173
- Equivalent time delay, 181
- Even function, 190
- Exponent governing field strength, 276
- Extended objects, reproduction of, 188
- Eye, human, 3  
acuity of, 31  
logarithmic response, 73  
visibility curve of, 78
- F
- F.C.C. assignments for television stations, 263
- Field, scanning, 47
- Field repetition rate, 47
- Field strength, against distance and antenna height, 273  
empirical values of, 275  
exponent governing, 276  
of half-wave dipole, 271  
required for 20 to 1 signal-to-mask ratio, 305

- Figure of merit, amplifier tube, 238, 311  
 converter tube, 308
- Film scanning, continuous projection method, 419  
 intermittent storage system of, 420
- Filter, band-pass, 312  
 capacitance-resistance, 358  
 double-section, 300  
 notching, 289, 433  
 vestigial sideband, 288
- Filter circuits, high-voltage, 358
- Filter coupling, 225
- Fine tuning control, 521
- First anode, 121
- Flicker, 8, 13
- Fluorescence, applied to image reproduction, 344  
 theory of, 347
- Flying-spot scanning, 86
- Focus, effect of control grid on, 123  
 magnetic, 463
- Focus control, 521
- Foot-candles, 65
- Fourier analysis of waveforms, 178
- Fourier coefficient, 182
- Fourier integral, 197, 246
- Fourier series, 179  
 fundamental frequency of, 191
- Frame, 42  
 frequency, 517  
 number of lines per, 517  
 repetition, 47, 186
- Free frequency, 157
- Frequency, synchronizing, 157
- Frequency allocations, 264
- Frequency-correction circuit of timing unit, 405
- Full-wave rectifier, 357
- G
- Gain  $G$ , 208  
 band-pass circuit, capacitively coupled, 315  
 coupled circuits, 304
- Gamma, exponent, 206, 329  
 over-all, desirable values of, 335  
 unity, 335
- Generator, image-signal, 493  
 shading correction, 414  
 square wave, 485  
 synchronization, 391, 402  
 timing, 392
- Globules, 96
- Grid-circuit modulation, 283
- Grid-plate capacitance  $C_{gp}$ , 215
- Grid-plate transconductance  $g_m$ , 208
- Ground wave effects, 268
- H
- Halation, 35, 355
- Heaviside unit voltage, 245, 248
- Height control, 521
- High-frequency response, inadequate, compensation for, 396  
 in video amplifier, 211
- High-light detail, 402  
 vs. shadow detail, 369
- High-voltage filter circuits, 358
- High-voltage power supply, 355  
 filtering of, 357  
 ripple, 358  
 safety considerations in, 362  
 safety limits in, 364  
 testing, 477
- Horizon, effect of, 23
- Horizon distance, and antenna height, relation between, 270  
 over flat earth, 269  
 signal strength beyond, 275
- Horizontal centering control, 521
- Horizontal deflection circuit, hum in, 382
- Horizontal hold control, 521
- Horizontal polarization, 294
- Horizontal pulses, separation of, from vertical, 374
- Horizontal resolution, 39, 60
- Horizontal retrace ratio  $k_h$ , 186
- Horizontal scanning, amplitude, variations in, 381  
 nonlinearity of, 380

- Horizontal synchronization signals,  
 14, 169  
 dimensions of, 170  
 tearing due to loss of, 380
- Hum, in horizontal deflection circuit, 382  
 in video circuit, 382
- I
- I-f amplification, picture, components of, 311  
 phase response of, 317  
 response curve of, 310  
 typical phase-response curve, 319
- I-f circuits, positioning of picture carrier in, 491
- I-f detection frequency discrimination, 321
- I-f stages, number required, 311
- I-f system, picture, measured response characteristic of, 490  
 typical, picture and sound, 488
- Iconoscope, 15, 18, 94  
 camera, interior view, 393  
 control, auxiliary functions for, 413  
 curves relating signal to illumination, 101  
 electrical action of, 98  
 electrical connections of, 99  
 factors reducing efficiency of, 107  
 output current of, 103  
 over-all sensitivity, 105  
 preamplifier, block diagram of, 395  
   complete diagram of, 396  
   design, 394  
 transient response, 106
- Iconotron, 108
- Ideal saw-tooth waveform, 192
- Illumination, calculation, 67  
 of camera plate, 69  
 least perceptible difference in, 74  
 theory, elements of, 63
- Image analysis, 25  
 checkerboard, 185  
 defects of, 54  
 standards of, 25
- Image brightness, 331  
 relationship to object brightness, 204
- Image characteristics, charts for testing, 58
- Image dissector, 91, 175
- Image iconoscope, 108
- Image repetition, 5
- Image-reproducing tube, cathode-ray, 340
- Image reproduction, defects in, 379  
 electronic vs. mechanical methods of, 338  
 fluorescence applied to, 344  
 general theory of brightness transfer in, 328  
 picture tubes and auxiliary circuits for, 328
- Image sensation, 336
- Image-signal generator, 493  
 carrier testing, 503  
 complete circuit diagram, 497  
 procedure in using, 499  
 simple, basic connections of, 496  
 testing receiver r-f system with, 502
- Images, fluorescent, projection of, 505  
   Scophony system of projecting, 510
- Impulse generator, 153
- Infra-black region, 169
- Input capacitance  $C_{gk}$ , 215
- Input circuit, typical, 309
- Input signal  $e_i$ , 207
- Integration of serrated vertical sync pulse, 377
- Integration circuit, 162
- Interference, from audio frequencies in signal circuit, 384  
 beat note, 383  
 caused by masking voltages, 384  
 from diathermy apparatus, 383  
 man-made, 306
- Interlaced fields, pairing of, 57
- Interlaced scanning, 14
- Interlaced patterns, geometry of, 46  
 odd-line, fundamental relationships, 49, 50  
 pairing in, 62

- Interlacing, even-line, 48  
 Intermediate frequency, picture, 306  
   for television receivers, 520  
 Ion spot, 139, 340  
 Ion trap, 342
- K
- $k$ , utilization ratio, 40  
 $k_h$ , retrace ratio, 43  
   indicated value of, 483  
 $k_v$ , retrace ratio, 43  
 Kerr-cell, 338  
 Keying circuits, 408  
   action, 411  
 Keystone effect, 142  
 Kinescope, 340
- L
- $L/C$  ratio, 292, 303  
 Lenses, 68  
   camera, 393  
 Light, least perceptible change in,  
   74  
 Light flux, 64  
   in a picture element, 71  
 Light source, "nonstandard," 79  
 Light storage, in projection televi-  
   sion, 512  
   (See also Iconoscope)  
 Light valve, super-sonic, 511  
 Line-controlled oscillator, 281  
 Line-of-sight distance, maximum  
   unobstructed, 270  
 Lincal displacement, 54  
 Linearity control, 521  
 Lines, active, number of, 50  
   per frame, number of, 517  
   reason for number "441," 38  
   in scanning pattern, factors influ-  
   encing number of, 26  
 Lissajous figures, 182, 256, 318  
   for determining phase-frequency  
   characteristic, 255  
 Logarithmic response video ampli-  
   fiers, 239, 244
- Low-frequency amplitude response,  
   231  
 Low-frequency compensation filter,  
   ( $R_{FCF}$ ), 229  
 Low-frequency response, effect of  
   cathode-bias filter on, 234  
   tests, 257  
 Low-impedance video amplifiers, 239  
 Low-noise amplifiers, 243  
 Low signal-to-noise ratio video am-  
   plifiers, 239  
 Lumen, 64  
   per square foot, 65  
 Luminous efficiency of phosphor, 348  
 Luminous sensitivity, 76, 103
- M
- $m$ , resolution factor, 40  
 Magnetic deflection, 134, 340  
   with damping rectifier, 152  
   ion spot in, 139  
   yoke, typical, 474  
 Magnetic focus, 127, 463  
   long coil, 127  
   short coil, 127  
 Marking circuit, sweep oscillator,  
   486  
 Masking voltages, 85, 105  
   interference caused by, 384  
   shot-effect, 202  
   thermal-agitation, 200  
 Maximum frequency in video range,  
   184, 186  
   for different scanning patterns,  
   189  
 Measurement of constants of coaxial  
   lines, 259  
 Measurement of phase-frequency  
   response, 255  
 Measurement of video-frequency  
   characteristics, 253  
 Mid-band response, compensation  
   of, 316, 317  
 Mobile transmitting equipment, 440  
 Modulated carrier, amplification of,  
   289  
   radiation of, 294

- Modulating amplifier, conductive coupling, 283  
 dynamic characteristic of, 427
- Modulation, absorption-, 284  
 capability, transmitter, 519  
 envelope, 282  
 establishing d-c levels, 285  
 grid-circuit, 283, 424  
 low-level, 424  
 plate-circuit, 283  
 practice, 422
- Monitor, 391
- Monoscope, 116, 494
- Monotron, 116
- Mosaic, 94  
 structure of, 95
- Mosaic multiplier, 110
- Motion-picture film, 7  
 continuous scanning of, 419  
 television transmission of, 418
- Motion-picture transmission, 93
- Multiplication, electron, 92
- Multistage amplifier, 236
- Multivibrator, 153, 403, 404  
 circuit, 154  
 saw-tooth oscillator, 469
- N
- Names of controls, Radio Manufacturers Association, 517
- Narrowing circuits, 408-409
- Negative transmission, 167
- Noise, 85
- Nonideal characteristics, distortions due to, 196
- Nonideal saw-tooth wave, 194
- Nonimage testing, 478  
 scanning performance, 479
- Nonlinearity of scanning, 54-55
- Notching filter, 289, 433
- O
- Object brightness, 329  
 related to image brightness, 204
- Object sensation, 336
- Odd function, 190
- Odd-line interlacing, 49-50
- Orthicon, 111
- Orthiconoscope, 111
- Oscillator circuits, 306, 308, 447
- Oscillator frequency in superheterodyne, 307
- Oscillator tubes, 444
- Oscillight, 340
- Output capacitance  $C_{pk}$ , 215
- Output impedance  $Z_o$ , 208  
 form of, in uncompensated amplifier, 210  
 low, amplifiers for, 240
- Output rating, transmitter, 519
- Output voltage  $e_o$ , 208
- P
- Paired-echo method of analyzing phase distortion, 199
- Pairing of interlaced fields, 57, 62
- Parallel transmission, 8
- Path, direct and reflected, difference in, 272
- Pattern, scanning defects, 56
- Peaking coil, 225
- Peaking resistor, 148
- Pedestal, 399, 401  
 automatic control of, 401
- Persistence of vision, 9
- Phase, in Fourier analysis, 180
- Phase characteristic, ideal, 181, 184  
 of compensated amplifier, 224  
 of uncompensated amplifier, 215
- Phase delay, 181
- Phase distortion, paired-echo method of analyzing, 199
- Phase-frequency response, of low-frequency compensated amplifier, 232  
 measurement of, 255  
 of picture i-f amplifier, 317  
 of r-f or i-f amplifiers, method of investigating, 318
- Phase shift, additional,  $\phi_a$ , 208, 213
- Phasmajector, 116
- Phosphor, luminous efficiency of, 348  
 persistence characteristic, 350

- Phosphor, preparation and application of, 351  
properties of, 345  
saturation, 354  
spectral distribution of radiation from, 340
- Photocathode, 91, 109
- Photoelectric current, collection and utilization of, 81
- Photoelectric effect, 75
- Photoelectric surfaces, 74  
output current from, 78
- Photograph, grain structure, 5
- Phototube, 81  
amplifier circuit, 82  
electron-multiplier type, 87
- Picture, black-and-white, 5  
relative radiated power for, and sound, 520
- Picture area, proportions of, 40
- Picture detail, 21
- Picture elements, 5, 6  
area of, 118  
bunching and spreading of, 56  
current from one, 79  
instantaneous current available from, 103  
light flux contained in, 71  
number of, per line, 52  
rate of transmission, 52  
straddling of, 27  
total number in pattern, 39
- Picture height, ratio to viewing distance, 34-35
- Picture i-f amplification, 310  
components for, 311  
phase response of, 317
- Picture i-f detector characteristics, methods of testing, 483
- Picture repetition, 8  
in progressive scanning, 46  
rate, 12, 51  
factors influencing, 51
- Picture signal, 166  
d-c component, 286  
demodulation of, 319  
separation from sync pulses, 372
- Picture transmitter, 7.5-kw., 436  
10-kw., 438  
tube line-up of typical 50-watt, 435  
tube line-up of typical 1000-watt, 435
- Picture tube, 19, 340  
assembly for projecting images, 507  
flat screen, 342  
for image reproduction, 328  
outlines of, 445  
projection, internal arrangement of, 509  
signal-to-light relationship, 365  
typical magnetically deflected, 151
- Plate-circuit modulation, 283
- Point source, 64
- Polarity, blanking and sync, 366  
detector, influence on succeeding circuits, 325  
of transmission, 517
- Polarization, horizontal, 271, 294  
of radiated wave, 520  
vertical, 271, 294
- Positioning, horizontal, incorrect, 386  
vertical, incorrect, 386
- Positive polarity transmission, 167
- Power, relative radiated, for picture and sound, 520
- Power amplifiers, modulated, efficiency of, 281
- Power density, effect of control grid on, 123
- Power supply, high-voltage, 355  
testing, 477
- Preamplifier camera, 392
- Preamplifier design, 394
- Predistortion, sound transmitter, 468
- Projection of fluorescent television images, 505  
picture-tube assembly for, 507  
Scophony system of, 510
- Propagation characteristics, 268

## Q

- Quantum, 75
- Quarter-wave section transmission line, 279
- Quasi-single-sideband operation, 267

## R

- RC* differentiating circuit, 376
- RC* integrating circuit, 377
- R-f amplifier, calculation of gain of, 302
  - employing transmission-line segments, 279
  - final stage, 278
  - grid-modulated, 429
    - characteristic of, 287
    - response of, 303
    - signal-to-mask ratio of, 304
- R.M.A. standard signal dimensions, 170
  - in television receivers, 392
- Radiation of modulated carrier, 294
- Radiator, concentration of radiated energy, 294
  - impedance of, 294
  - of station W2XAB, 295
  - of station W2XBS, 296
- Receivers, cumulative response curves of, 455
  - definitions, 520
  - design for 5-in. cathode-ray tube, 450
  - design for 12-in. cathode-ray tube, 462
  - 5-in., picture tube, complete circuit diagram, 452-453
  - intermediate frequencies for, 520
  - names of controls of, 521
  - over-all i-f sensitivity characteristic of, 467
  - r-f sensitivity characteristic of, 460
  - sound channel, i-f sensitivity curve of, 469
  - television, 441
  - 12-in., picture tube, complete circuit diagram of, 464-465
- Receivers, video response curves for, 458, 468
- Receiving antenna dipole, 298
- Receiving antennas, television, 297
- Recommended practices, Radio Manufacturers Association, 517
- Rectifier, full-wave, 357
- Rectifier circuit, half-wave, 356
- Rectifier tubes, high-voltage, 444
- Reference frequency  $f_0$ , 212
  - in terms  $C_i$  and  $R_i$ , 213
- Reflected and direct rays, combination of, 270
- Reflected signal, 297
- Reflection, diffuse, 66
  - specular, 66
- Reflectors, 68
- Refraction, signal strength due to, 276
  - of waves, 268
- Reinsertion of d-c component, 175
- Rejector circuit, 456
- Repeater stations, 23
- Resolution, effect of motion on, 35
  - horizontal, 29, 39, 60
  - ratio, 186
  - vertical, 26, 39, 61
  - vertical and horizontal, relationship between, 30
- Resolution factor  $m$ , 40
- Response to unit pulse, 198
- Retina, 3
- Retrace ratio  $k_h$ , 43
- Retrace ratio  $k_v$ , 43
- Rhombic antenna, 300
- Ripple, excessive, in second anode voltage, 381
- Ripple percentage, 359
- Ripple voltage, effect of, 360
- Rods and cones, 3
- Rotating-disk scanning, 83

## S

- Safety considerations, high-voltage power, 362
- Saw-tooth current, 141
- Saw-tooth generating circuit, simple discharge, 145



- Saw-tooth oscillator, multivibrator, 469
- Saw-tooth voltage, 141  
rise in voltage across capacitor, 144
- Saw-tooth voltage discharge, 145
- Saw-tooth wave, Fourier analysis, 189  
nonideal, 194
- Saw-tooth waveform, 140
- Saw-tooth waves, of current, method of producing, 146  
in resistive-inductive circuit, 147  
voltage, methods of producing, 143
- Scanning, 8, 10  
amplitude test, 481  
apertures, 84  
circuits, 371  
coils, capacitance, associated, 152  
by cycloidal motion, 114  
chassis, 470  
defects, 56  
disk, rotating, 338  
electronic, instantaneous, 89  
storage, 94  
high- and low-frequency, in Scophony projection system, 513  
interlaced, 14  
light-source (flying-spot), 86  
nonlinearity of, 54, 55, 141  
performance, nonimage methods of testing, 479  
rotating-disk, 83  
sequence of, 520  
spot velocity, 297  
system, circuit diagram of, 471  
technique, application to phototubes, 83  
unequal amplitudes of, 141  
velocity, horizontal, 44, 50  
vertical, 44, 47, 50  
waveform, resonance oscillations, 152  
yoke, 151
- Scanning beams, basic requirements of, 118  
diameter, 119  
distribution of brightness in, 126  
distribution of energy in cross section, 125  
formation, deflection, synchronization of, 118  
power density of, 119
- Scanning generators, 142  
blocking oscillator, 461  
horizontal, 371  
synchronization of, 156  
vertical, 371
- Scanning lines, 36  
active, number of, 45  
relationship of reviewing conditions to number of, 38  
resolution of, 36  
thickness of, 45, 50
- Scanning pattern, application of acuity angle, 33  
factors influencing number of lines in, 26  
geometry of, 40  
progressive, detailed analysis of, 43  
noninterlaced, 41  
standards relating to, 26  
trapezoidal distortion of, 142
- Scene, definition, 4
- Scophony system, 339, 510
- Second anode, 121
- Secondary electrons, 100
- Selectivity of a receiver, 448
- Sensitivity, luminous, 76  
of a receiver, 448
- Separation, amplitude, of sync pulses, 160  
waveform, 161, 374
- Series and shunt peaking, combination of, 227
- Series peaking, 225  
compensation by, 220
- Serrated pulses, 172, 375  
dimensions of, 173  
integration of, 377

- Shading, improper background due to spurious signal, 102
- Shading correction generator, 414, 415  
 wave shapes produced by, 415
- Shadow detail, 402  
 vs. high-light detail, 369
- Shaping unit, 407  
 horizontal, 410
- Shot-effect noise, 305
- Shunt and series peaking, combination of, 227
- Shunt-peaking, 219
- Sideband filter, response characteristic of, 432  
 structure, 432
- Sideband suppression in television modulation, 287, 430, 431
- Signal, least perceptible change in, 74  
 reflected, 297  
 video, 166
- Signal dimensions, R.M.A. Standard, 170
- Signal-generating tubes, static image, 116
- Signal generator, u-h-f, complete circuit diagram of, 504
- Signal level, peak-to-peak, required at control grid, 366
- Signal plate, 97
- Signal strength, attenuation due to obstructions, 274  
 effect of band width on, 277  
 beyond horizon distance, 275  
 tearing from excessive, 381
- Signal-to-light relationship, 352, 365
- Signal-to-mask ratio of input circuit, 304
- Silver sensitizing, 97, 113
- Sky-wave effects, 268
- Sound, relative radiated power for picture and, 520
- Sound carrier, position of, 517
- Sound i-f, standardized, 306
- Sound transmitter predistortion, 468
- Spectral distribution of standard lamp, 77
- Spectral response, 77
- Specular reflection, 66
- Spurious signal, 100, 107, 112, 115
- Square wave, 186  
 distorted reproductions of, 484  
 Fourier analysis, 189  
 generator, 257, 485  
 circuit analysis, 258  
 testing, 254
- Standard candle, 64
- Standards, of image analysis, 14, 25  
 relating to scanning pattern, 26
- Station selector control, 521
- Storage efficiency, photoelectric, 112
- Storage sensitivity, 95
- Straddling of picture elements, 27
- Studio circuits, 187
- Studio facilities for television broadcasting, 388-389
- "Successive" transmission, 9
- Supersonic light valve, 511
- Surface brightness, 65
- Surge impedance, 250
- Sweep oscillator, marking circuit, 486  
 operation of, 486  
 simple mechanically driven, 485
- Sync pulse, amplitude separation of, 160  
 composite, 160  
 differentiation of, 375  
 horizontal, 14, 160, 169  
 narrow vertical, 160  
 separation of, and picture signal, 372  
 serrated, vertical, 161  
 vertical, 14, 171
- Synchronization circuits, 371  
 frequency, 157  
 percentage of television signal devoted to, 519  
 between sync impulses and generator, 157  
 generator, 391, 402  
 horizontal shaping unit of, 412  
 timing unit, blocking diagram, 403  
 vertical shaping unit of, 412

- Synchronizing impulses, form of, 158
- T
- Television antennas, commercial, elementary forms of, 301
- Television broadcasting practice, 388  
studio facilities for, 388
- Television camera, fundamentals of, 63
- Television carrier signal, modulated, 282
- Television cathode-ray tubes, 442
- Television channel, 22  
double sideband, 265  
vestigial sideband, 266
- Television modulation, sideband suppression in, 287
- Television receivers, radio-frequency circuits in, 302  
typical, block diagram with 5-in. picture tube, 451  
block diagram for 12-in. picture tube, 462
- Television signal, 166  
percentage devoted to synchronization, 519  
R. M. A. standard T-111, 518
- Television system, rate of operation, 21  
technical and economic limitations of, 21  
transfer characteristics of, 332  
typical, 15
- Television transmitters, 277  
carrier frequencies employed in, 261  
essential elements of, 279  
modulation of, 282  
reliable range of, 21
- Test Chart, station W2XBS, 58  
"12-square," 61
- Test pattern, monoscope, 495
- Testing, nonimage methods of, 478  
oscillator, 492  
r-f, 492
- Thermal noise, 305
- Time delay, 181  
characteristic of multistage amplifier, 236  
of coaxial cable, 252  
vs. frequency response, 177
- Timing generator, 392, 403  
complete circuit diagram of, 406  
frequency-correction circuit of, 405
- Tonal range, 72
- Tone control, 521
- Total lines  $n$ , 186
- Transfer characteristic, brightness, over-all, 331-334  
camera, 330  
television system, 332  
12AP4 tube, 354
- Transient analysis, of multistage amplifiers, 249  
of single-stage amplifier, 249
- Transient response, by Fourier series, 247  
by operational calculus, 246  
of video amplifiers, 245
- Transient signal, generalized, 245
- Transmission, of d-c component, 519  
of motion-picture film, 418  
standards in the United States, 14, 517
- Transmission line, attenuation, 299  
as frequency-determining source, 280  
quarter-wave section, 279  
receiving antenna, parallel-wire, coaxial, twisted pair, 298
- Transmitter characteristic, R.M.A. standard T-115, 519
- Transmitters, definitions, 520  
equipment, mobile, 440  
output rating, 519  
power required for 1-millivolt signal, 282  
television, 277, 388
- Tube, camera, 15, 18
- Tubes, characteristics of available, 441  
converter, 444

- Tubes, oscillator, 444  
 rectifier, high-voltage, 444, 447  
 re-entrant anode, 423  
 three-element vacuum, discharge, 146  
 video amplifier, figure of merit for, 238  
 wide-band service, characteristics of, 443, 446
- Tuned circuits, closely coupled, 292  
 coefficient of coupling, 304  
 compensation with overcoupled stage, 293  
 coupled, 313  
 general impedance-frequency curves of, 292  
 phase angle vs. frequency, 293  
 with shunt loading, 289  
 characteristic of, 290
- U
- Ultra-high-frequency waves, characteristics of, 267
- Uncompensated amplifier, high-frequency response of, 213  
 effect of increasing  $R_i$ , 215  
 low-frequency response of, 216, 218  
 phase-frequency characteristic of, 219
- Unit pulse, response to, 198
- Utilization ratio  $k$ , 28, 33, 40, 52
- V
- Velocity, electron, 130  
 scanning spot, 297
- Vertical blanking action, 411
- Vertical centering control, 521
- Vertical hold control, 521
- Vertical polarization, 294
- Vertical resolution, 39, 61
- Vertical retrace ratio  $k_r$ , 186
- Vertical synchronization signals, 14, 171  
 separation of, from horizontal, 374  
 serrated, 375  
 equalization signals, 164
- Vestigial sideband, attenuation characteristic required, 288
- Vestigial sideband filter, 288  
 structure of, 432
- Vestigial sideband operation, 267
- Vestigial sideband television channel, 266
- Video, definition, 166
- Video amplification, 207
- Video amplifier, amplitude response, methods of testing, 482  
 cathode-coupled, 241  
 complete circuit, 233  
 designed for special output conditions, 239  
 employing pentode tubes, 209  
 with high-frequency and low-frequency compensation, 233  
 high-frequency response in, 211  
 transient response of, 245  
 tubes, figure of merit for, 238
- Video circuit, 60-c.p.s. hum in, 382
- Video detection, 322, 447  
 actual and equivalent circuits, 323  
 circuit, typical, 320  
 filter coupling in, 321  
 polarities, 325
- Video-frequency characteristics, measurement of, 253
- Video measurements for design purposes, 259
- Video range, maximum frequency in, 184, 186, 189, 501
- Video response curves for receiver, 458
- Video signal, 166  
 carrier transmission of, 261  
 circuit, 363  
 composite, 166  
 d-c component of, 175  
 distortions of, 196  
 during frame retrace, 171  
 general description, 167  
 influence of masking voltages on, 200  
 intentional distortions of, 204  
 R.M.A. standard, 168  
 during vertical blanking, 171

Viewing distance, critical, 34  
desirable, 31  
ratio of, to picture height, 34-35  
Visibility curve of the eye, 78  
Vision, direct, basic factors in, 2  
persistence of, 9  
Visual representation, methods of, 5  
Voltage-doubler circuit, 356  
Voltage waveform combination,  
peaking circuit used in, 148  
Volume control, 521

## W

Wave polarization, 520  
Waveform, complex, analysis of, 180  
degradation, 177  
distorted asymmetrically, 197  
distorted symmetrically, 197  
Fourier analysis of, 178  
of ideal saw-tooth, 192

Waveform, for magnetic deflection,  
amplification of, 150  
preservation of, 177  
produced by shading-correction  
generator, 415  
saw-tooth, 140  
separation, 161  
separator circuit, 163  
combined, 378  
voltage, amplification of, 149  
Waves, ultra-high-frequency, char-  
acteristics of, 267  
Weber-Fechner law, 204, 335  
Wide-band amplifier tubes, char-  
acteristics of, 443  
Width control, 521

## Z

Zinc-beryllium orthosilicate, 345  
Zinc silicate, 345  
Zinc sulphide, 345

