

RADIO CIRCUITS

3/6
NET

By W. MILLER B.A. (Cantab.) M. Brit. I.R.E.

★ FOR RADIO SERVICE ENGINEERS,
STUDENTS IN TECHNICAL COLLEGES,
RADIO TRAINEES FOR THE SERVICES

STEP-BY-STEP
SURVEY OF
SUPERHET
RECEIVERS

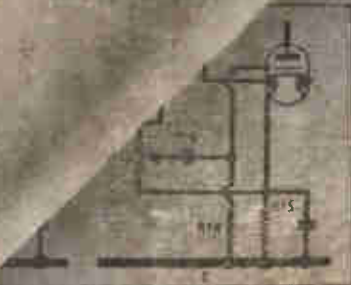

Resistive coupling following a...

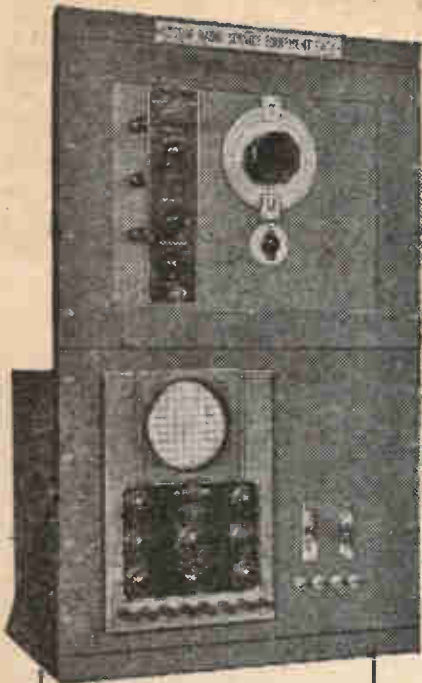

The
COSSOR

*Rack-Mounted
Double-Beam*
OSCILLOGRAPH
RADIO SERVICE
EQUIPMENT

*The
Complete Solution
of the Service Problem*

1. STATIC

by "Signal-Tracing"
For Fixed and Intermittent Fault
Location, HF, IF, LF, AC and DC.

2. DYNAMIC

by "Functional Adjustment"
For Alignment, Tracking, AFC,
etc. Improving Quality and
Selectivity, Reducing Noise, etc.

The Company's wide experience in radio manufacture—and therefore knowledge of the true requirements of Radio Service, together with the well-known pioneer development of Cathode Ray Tubes and Electronic apparatus have been combined in the production of this indispensable equipment.

● The equipment illustrated comprises Double-Beam Oscillograph Model 339 and Ganging Oscillator Model 343, mounted on Model 411 AB Rack

A. C. COSSOR LTD.

COSSOR HOUSE, Highbury Grove, London, N.8

Phone: Canonbury 1234 (30 lines)

Grams: "Amplifiers, Phone, London"

MANUFACTURERS OF

VALVES RECEIVERS RADIOGRAMS
CATHODE RAY TUBES AND EQUIPMENT

H. G. Abel

**NEW ROUND
HALF-PINT TIN 5!**

Actually pre-war price
but a much larger tin.



SERVISOL

Explodes all oxidation
it touches.

- An active polishing abrasive gives that "satisfying bite of newness" to all electrical contacts.
- And here's the secret—ETHIUM is then liberated and seals all the cleaned contacts. The job stays done.

**THERE IS NO SUBSTITUTE
FOR SERVISOL**

READ THIS: Ordnance Factories, Government Precision Instrument Works, B.B.C., etc., have been taking YOUR Servisol because there is no substitute. Please remember this.

SERVISOL LTD.
64, MYRTLE ST., LIVERPOOL 7.

Mullard Valves have enjoyed the confidence of the Industry from its earliest days. They are still the first choice of wireless engineers for consistency, reliability and technical leadership.

Mullard

THE-MASTER-VALVE

A Valve for Every Purpose

RADIO CIRCUITS

A Step-by-Step Survey of
Superhet Receivers

By

W. E. MILLER

B.A.(Cantab.), M.Brit.I.R.E.

Technical Editor of "The Wireless & Electrical Trader"

Published by

The WIRELESS & ELECTRICAL
TRADER

Dorset House, Stamford Street, London, S.E.1

Telephone : WATERloo 3333 (35 lines)

FOREWORD

The subject matter of this book was originally published as a series of articles written for "The Wireless & Electrical Trader," but requests for reprints have been so numerous as to warrant the issue of the series in book form.

At the same time it is felt that the information contained in it will be of use not only to recruits to radio service work (for whom the articles were originally written) but also to students of radio engineering at technical colleges and to the many young men who are now studying for radio work in the Services.

In view of the fact that the superheterodyne receiver circuit has largely displaced other types, it is to the superheterodyne that the book is mainly devoted, although much of the information is equally applicable to the "straight" TRF type of circuit. The subject matter is essentially practical, and there has been no attempt to delve deeply into purely theoretical details. Typical component values have been included wherever possible.

The author has placed himself in the position of a beginner who is confronted by a complete superheterodyne circuit, and who cannot distinguish one end from the other. The circuit has been split up piece by piece, each being treated, as far as possible, as a separate section. Having learned how to identify and isolate the various parts which go to make up the whole, it is believed that the beginner will then be in a position to tackle any normal superheterodyne circuit with confidence.

Second Edition

The large demand for the book has necessitated bringing out a second edition, and the opportunity has been taken to alter the title by the removal of the description "ABC." The reason for this is that it has been felt in some quarters that the original title did not fairly describe the contents, which take the reader well beyond the elementary stage. It has not been necessary to modify the contents of the book in any way, since no circuit changes in commercial receivers have occurred in the past six months.

W. E. M.

*First Edition, First Impression—August, 1941
First Edition, Second Impression—October, 1941
Second Edition, First Impression—February, 1942
Second Edition, Second Impression—July, 1942
Second Edition, Third Impression—May, 1943*

P. G. Abel
14, Wykeham Green
Bagenham
Essex

Radio Circuits

SUPERHET PRINCIPLES

RADIO receiver circuits can be divided broadly into two classes, those which employ what is known as a "straight" TRF (tuned radio frequency) circuit, and those which utilise the superheterodyne (superhet) type of circuit.

In recent years the superheterodyne receiver has become increasingly popular, and in this book it will be dealt with exclusively. It should be pointed out that anyone with a good knowledge of superhet circuits will be able to understand the simpler "straight" type of receiver, and many sections of the book, though written with the superhet type of circuit in mind, are equally applicable to the "straight" receiver. For instance, aerial circuits, RF couplings, AF and output circuits and power supply arrangements are virtually the same in both types of receiver.

The principles of the superheterodyne, though more difficult to understand than those of the TRF receiver, are easy to understand once the circuit is split up into its various sections, and each section is studied separately.

The reason for the popularity of the superhet is that it enables stable and controllable amplification to be carried out with very little difficulty, and it does this by converting the incoming signal from the high frequency at which it is transmitted to a lower frequency (known as the intermediate frequency, or IF). To secure a high degree of amplification of a radio frequency signal without encountering instability is a difficult matter; at the lower frequency to which the signal is converted amplification is relatively simple.

There is another reason for the use of

the superhet, however. In order to secure adequate selectivity in a receiver, we must have a number of tuned circuits. In a "straight" receiver, where all the amplification (except in the AF stages) is carried out at the signal frequency, each stage must obviously be tunable over the whole frequency range covered by the set. In order to permit tuning with a single control, a ganged tuning condenser with as many sections as there are tuned circuits would be necessary, and each stage would also have to have its own complete set of coils, with their associated wavechange switches. In mass production, the difficulties of ganging and stabilising all the tuned circuits would be considerable.

In the superhet, the incoming signal, *whatever its frequency*, is converted to the *fixed* intermediate frequency, at which the major part of the amplification is carried out. The advantages of this are easy to see. In the first place, the tuning of the intermediate frequency amplifying stages is fixed. It is accurately adjusted at the works, and need only be touched when complete re-alignment of the set becomes necessary. The variable tuning of the set is carried out in the stages prior to that at which the signal is converted to the intermediate frequency. This stage is known as the frequency-changing stage.

Many receivers have no amplification prior to the frequency-changing stage, so that the variable tuning is simplified down to one aerial tuning circuit, and an additional one in the frequency-changer section, the latter being the oscillator tuning (which will be dealt with later). In this simple superhet circuit, therefore, a two-gang variable

Radio Circuits

condenser is all that is required, the additional selectivity being obtained from the fixed-tuned IF stage.

The usual IF stage consists of a single amplifier valve, a transformer being used to couple the frequency-changer to the grid circuit of the IF valve, and another similar transformer coupling the anode circuit of the IF valve to the following stage, which is the detector, or demodulator. The two transformers, each with a tuned primary and a tuned secondary winding, provide four tuned circuits which, with the single-tuned aerial circuit (the oscillator does not count), gives five tuned circuits in all. These can be made to give adequate selectivity for all normal requirements.

Where additional selectivity is needed, the manufacturer usually provides a stage of RF amplification between the aerial and the frequency-changer stage, which is known as the pre-amplifier or pre-selector stage. This stage, by virtue of a tuned coupling between it and the frequency-changer, gives an extra tuned circuit, besides handing on an amplified signal. If this additional valve is not used, two tuned circuits between the aerial and the frequency-changer, arranged to give band-pass characteristics, are sometimes used. In both these cases a three-gang tuning condenser (two for signal and one for oscillator tuning) will be employed.

Fig. 1 is a block diagram showing the stages of a simple superhet receiver, in which the pre-selector stage is dotted to indicate that it is not always used.

The frequency-changer is split into two units, the mixer and the oscillator. In order to produce the required intermediate frequency, the incoming signal and a locally generated oscillation are caused to heterodyne each other, that is, they are mixed together, and produce new frequencies, one equal to the sum of the oscillator and signal frequencies and the other equal to the difference between them. It is the latter which is selected for amplification in the IF stages, the sum frequency (and the original signal and oscillator frequencies) being filtered out.

Although the two sections of the frequency-changer are shown separately in the block diagram, the receiver does not necessarily use two separate valves, although in some sets separate valves are in fact employed. More usually a single frequency-changer valve is used which combines the two functions.

It is clear that since the intermediate frequency signal obtained from the frequency-changer has to be fixed in frequency, and since the incoming signal may vary over a wide range of frequencies according to the station being received, the oscillator stage must also be tuned so that its frequency always differs from that of the incoming signal by a constant amount, the difference naturally being the value of the intermediate frequency.

Consequently, with a single tuning control, and the signal and oscillator tuning ganged, special arrangements

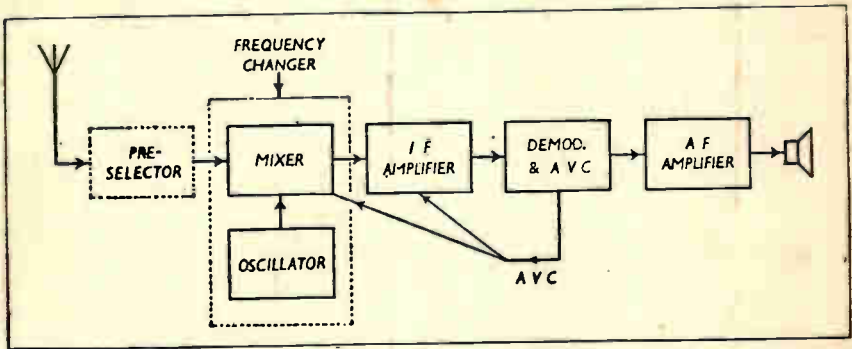

Fig. 1—Block diagram of a simple superhet circuit, showing the separate stages which are described in the text. The two sections of the frequency-changer may be embodied in a single valve.

Stages in a Superhet Receiver

(known as tracking or padding) have to be made so that this constant frequency difference is accurately maintained over the whole signal frequency range covered by the set.

As has already been mentioned, the output from the frequency-changer is passed to the IF stage for amplification, but, as in the case of a modulated RF signal (with which it is identical, except for being of a lower frequency), it must be "detected" or demodulated before it can be passed to the audio frequency stages for further amplification. The stage which performs the demodulation is often known as the second detector, the reason being that in early superhets the frequency-changer was known as the first detector. Although this term has been largely abandoned, the demodulator is still widely known as the second detector.

Whereas in a "straight" receiver the valve used for demodulation is usually a triode, tetrode or pentode, in the modern superhet it is almost invariably a diode, because in this type of set there is an adequate signal voltage to load a diode properly, which results in comparative freedom from distortion.

Usually a double diode is used, one section being used for demodulation and the other, also fed from the IF stage, being used to provide a DC voltage for automatic volume control purposes. This voltage varies in accordance with the strength of the incoming signal, and is fed back to the frequency-changer and IF stages as negative grid bias. With a weak incoming signal only a small bias is applied to these valves, which therefore operate at full amplification and tend to compensate for the weak signal. With a strong incoming signal a large negative bias is applied, with the result that the amplification of the early stages is reduced.

After leaving the demodulator stage the AF modulation of the signal is amplified by one or two AF stages. Sometimes the first stage AF valve forms part of the demodulator and AVC valve, which may be, for instance, a double diode triode type. Where a high gain output pentode is used, the output from the demodulator may be resistance-coupled direct to the output valve, with no intermediate AF stage. A double

diode output pentode is then often employed.

This, then, is a very brief sketch of a simple modern superhet receiver, and it will now be necessary to examine the circuit stage by stage.

AERIAL INPUT CIRCUITS

IN considering the superheterodyne circuit in detail, it is proposed to follow the passage of the signal through the receiver from the point of entry, that is, from the aerial-earth circuit. This is the most convenient method to adopt from the point of view of understanding the circuit, but it should be pointed out that it is not the best way to work in tracing faults in the set. For the latter purpose it is usually best to work from the loudspeaker backwards to the aerial circuit.

The first circuit in the receiver is that to which the aerial and earth of the set are connected, and its purpose is to transfer the signal to the tuned circuit which follows it. The aerial circuit of a modern receiver is rarely, if ever, variably tuned, except in a frame aerial set, which is a special case.

In all open aerial types of receivers the signal is merely handed on from the aerial circuit to the first tuned circuit, and the method by which this is done varies quite considerably. Although the aerial circuit is not tuned, it is often arranged to resonate at some part of the band to which the receiver normally tunes, to increase the efficiency of transfer of the signal at this part of the tuning range. This is arranged by the designer of the set who may wish to increase the sensitivity over a certain frequency band, to compensate for a deficiency elsewhere in the circuit.

If all aerial and earth systems likely to be used with the set were identical in constants, that is, if they had the same capacity, inductance and RF resistance, it would be easy to design a very efficient aerial circuit. Unfortunately, aeri-als vary from a few feet of wire trailing behind the set on to the floor, to a super outdoor type some forty feet high and a hundred feet long.

What the designer has to do is to arrange matters so that whatever aerial is used there will be no appreciable differ-

Radio Circuits

ence in effect on the first tuned circuit of the receiver. It will be appreciated that this circuit, in a modern set, is ganged with the other tuned circuits, and its constants must not vary, whatever the conditions of use of the set.

Consequently, the coupling between the aerial circuit and the first tuned circuit must be small enough to prevent the aerial system from appreciably affecting the tuned circuit, while at the same time

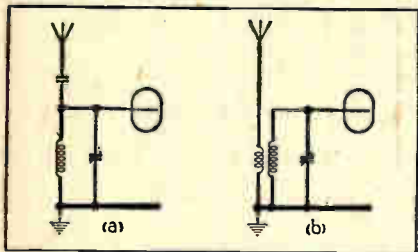

Fig. 2a and 2b, showing two simple forms of aerial coupling.

being adequate to pass on the signal voltage efficiently at all frequencies to which the set may be tuned.

In order to reduce the loading of the aerial system on the first tuned circuit we can adopt either one of two alternatives, or a combination of the two. The first method is to use a small fixed condenser in series with the aerial, which, in the usual manner of condensers in series, lowers the apparent capacity of the aerial, and reduces its effect on the first tuned circuit (Fig. 2a). At the same time, because of the impedance it inserts in the circuit, it also reduces the signal voltage handed on.

Furthermore, the lower the frequency of the signal the higher the impedance of the series condenser, and the smaller the proportion of the signal which reaches the set. Another disadvantage of the series condenser alone is that unless it is very low in capacity (resulting in very small aerial coupling) the aerial will still have an appreciable effect on the first tuned circuit, damping it and rendering the receiver unselective.

The second method of aerial coupling is to use an inductance coil connected between aerial and earth, and coupled to the coil of the first tuned circuit (Fig.

2b). The signal voltage in the aerial system is built up across the coupling coil, and induced into the tuned circuit. The coupling depends on the number of turns of wire and on the proximity of the coupling coil to the tuned coil. If only a few turns of wire are used in the coupling coil, they will generally be wound over or close to the tuned coil. Sometimes, however, the designer uses a comparatively large number of turns in his coupling coil, but spaces it well away from the tuned coil.

Where coupling to several tuned circuits (for different wavebands) is necessary, a single coupling coil is sometimes used and is designed to give the best possible compromise on all bands. While a single coupling coil is often used in a 2-band (MW and LW) receiver (Fig. 3a), it is generally found that in a 3-band (SW, MW and LW) set a separate coupling coil is used for the SW band, with suitable switching (Fig. 3b). Sometimes the aerial is inductively coupled on the MW and LW bands, and capacitatively coupled on the SW band (Fig. 3c).

One of the most common arrangements in a 3-band set makes use of three separate coupling coils, with switching, for each waveband (Fig. 3d). This not only makes for the greatest efficiency on each band, but also permits the use of separate coil units for each band, the coils being wound in pairs on separate formers. The bands can then be made quite independent of each other.

Although aerial coupling coils are often shown in circuit diagrams as having less turns than the tuned coils to which they are coupled, it should be clear from what has already been said that in practice they may consist of a greater number of turns than the tuned coil. In any case, the DC resistance of the coupling coil is generally higher than that of the tuned coil, and sometimes even ten times as great. Occasionally the coupling coil will be wound of resistance wire to produce a flat resonance peak, and in this case its resistance will naturally be quite high, though it may be small in physical dimensions.

The coupling arrangements described are the simplest ones, and though largely used, they by no means embrace all the possible arrangements. Some sets have extremely elaborate aerial circuits, with

Aerial Input Arrangements

capacitive potential dividers, fixed condensers associated with the coupling coils, and other arrangements introduced by the designer to keep the sensitivity as constant as possible on all wavebands.

Sometimes a resistance is used as a shunt across the aerial-earth circuit. It may be that this is to flatten the tuning by damping the aerial circuit, or, possibly, it is an afterthought put in to reduce the sensitivity of the set owing to overload of the first valve by powerful local stations.

Again, a series tuned circuit is sometimes found across the aerial-earth circuit. This is usually intended for use as an IF filter. It is tuned to the intermediate frequency of the set, and bypasses signals of that frequency, thus preventing interference in the IF stages of the set. Sometimes a parallel-tuned circuit is inserted in series with the aerial connection to the circuit, and when this is tuned to the value of the IF it acts as a rejector, blocking the entry of signals of this frequency from the aerial into the set.

Occasionally other tuned filters or rejectors are to be found in the aerial circuit of a receiver, usually intended to reduce the effect of some powerful near-by station.

The case of frame aerial receivers is rather different. Here the frame aeri- als themselves are used as the first tuned circuits. If provision is made for the

use of an external aerial, coupling is generally arranged either by means of a small series condenser, or by a turn or two of wire coupled to the frame winding.

TUNED INPUT STAGE

THE first tuned circuit is always connected, as far as radio frequency signals are concerned, from the control grid of the first valve to chassis. The cathode of the first valve is also connected, either directly or via a bias resistance, to chassis, so that the tuned circuit is connected effectively from control grid to cathode of the valve.

The fundamental arrangement is shown in Fig. 4a. This shows the aerial coupled to a parallel-tuned circuit using a fixed coil and a variable condenser. The top of this circuit is connected to the control grid of the first valve, and the bottom is connected to a chassis. Since the cathode of the valve is also connected to chassis, the tuned circuit is thus connected across the grid/cathode circuit of the valve.

A more practical circuit is shown in Fig. 4b, which has provision for the application of the bias voltage of the automatic volume control circuit to the grid of the valve, and also for the application of fixed grid bias to the valve. The AVC line, carrying the voltage obtained from a later part of the circuit, is shown beneath the chassis, which is

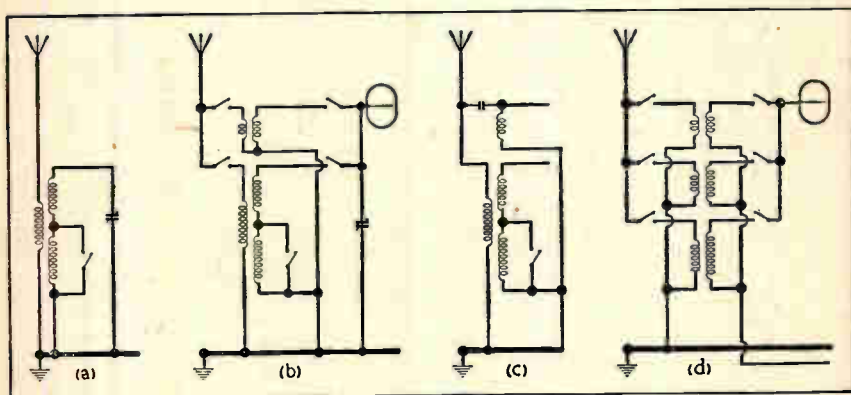

Fig. 3a to 3d—Four more examples of aerial coupling arrangements which are referred to opposite.

Radio Circuits

the convention usually adopted in circuit diagrams. The bottom end of the tuning coil, instead of going to chassis, is connected to the AVC line, and the voltage is therefore impressed on the grid of the valve via the coil. This is known as a series-fed circuit.

The lower side of the tuning condenser goes to chassis, as before, merely because this is convenient in manufacture. The frame of the condenser forms one of its connections, and, by bolting the condenser to chassis to fix it, the desired

end of R1. Since the grid of the valve, via the tuning coil, AVC line and resistors at the far end of the line, is connected to chassis (and in this case the high value of the resistance in series with it and chassis is of no importance, since no DC current should flow in the grid circuit and there will therefore be no voltage drop), the DC potential of the chassis relative to the cathode of the valve is transferred to the grid, so that the grid is biased negatively relative to cathode by an amount depending on the

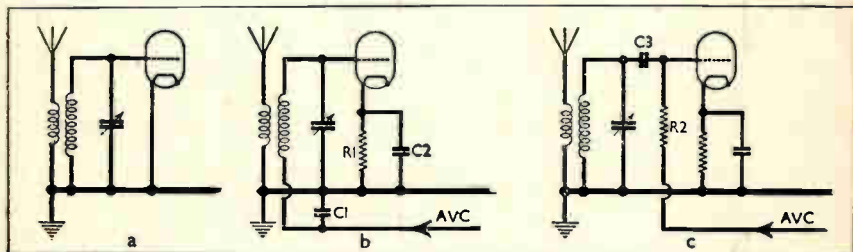

Fig. 4, a to c. a—The fundamental tuned circuit. b—Arrangement including series-fed AVC voltage. c—Alternative arrangement with parallel-fed AVC voltage.

connection is automatically made. As the bottom of the coil is connected to the AVC line (which only connects to chassis at the far end via high value resistances), the coil is not connected properly across the tuning condenser, and the circuit as described is therefore not efficiently tuned.

It will be noted, however, that there is a fixed condenser (C1) between the AVC line and chassis. This usually has a value of the order of 0.01 to 0.05 μF , and as far as radio frequencies are concerned, it is virtually a short circuit, so that from the tuning point of view it can be considered as connecting the bottom of the tuning coil to chassis, and thus completing the tuned circuit.

The principle of the bias arrangement in Fig. 4b must now be considered. Resistance R1, in series between the cathode of the valve and chassis, has the total cathode current of the valve flowing through it, that is, the sum of all the currents taken by any other electrodes in the valve. This produces a certain voltage drop across R1, in such a direction as to make the chassis end of R1 negative by a certain amount, relative to the cathode

value of R1 and the total cathode current of the valve.

In the case of the first valve of the set, which is either an RF amplifier or a frequency changer, R1 will have a low value of about 300 ohms. Nevertheless, it offers an impedance to RF, and in order to get rid of this, R1 is shunted by C2 (0.05 to 0.1 μF), which effectively connects the cathode of the valve to chassis, as far as RF is concerned. Thus, by the use of the by-pass condensers C1 and C2, the tuning circuit of Fig. 4b is made identical with that of Fig. 4a.

It was mentioned a little earlier that Fig. 4b showed a series-fed AVC circuit, the control voltage being applied in series through the tuning coil to the grid. Fig. 4c shows another method of feeding the AVC voltage to the grid. It resembles the old grid leak and condenser circuit. The AVC voltage is fed via the resistance R2 direct to the grid, while the tuned circuit is isolated from the grid by C3. If C3 were not present, the low DC resistance of the tuning coil would have the effect of shorting the grid to chassis and preventing the AVC from working.

C3, of course, is no barrier to the

Automatic Volume Control Details

transfer of RF voltages developed across the tuned circuit to the grid of the valve. Common values for R2 and C3 of Fig. 4c are 1 megohm and 0.005 μ F. Note that when this arrangement is used the tuned circuit is connected as in Fig. 4a.

The DC connection for the application of the fixed bias to the grid is again obtained by virtue of the fact that the far end of the AVC line is connected via a high resistance to chassis. It may not be out of place here to mention that if at any time it is desired, when testing or aligning a set, to put the AVC circuit out of action, the proper method is to connect the AVC line to chassis. If the line is merely broken the bias connection is removed, and the grid of the valve is left "floating," or, as some engineers describe it, "up in the air."

A typical arrangement for the first tuned circuit of a 3-waveband receiver is shown in Fig. 5. Here separately switched tuned circuits are used for each waveband. C4 is the tuning condenser, and C8 is the fixed condenser corresponding to C1 in Fig. 4b. Although on casual inspection they seem to be in different positions in their respective circuits, in actual fact their positions are electrically identical.

It will be noted that small variable condensers are shown connected across the tuning coil of each waveband. These are for alignment purposes, and in actual practice the condensers C5, C6 and C7 are of the pre-set or trimmer type. They are adjusted initially at the factory when the set is made, and subsequently when realignment of the receiver is found to be necessary.

Sometimes the pre-set condensers are replaced by fixed condensers of the requisite capacity, while on one of the bands (usually MW) the trimmer may be associated with the tuning condenser, and will therefore not be shown directly across the coil. Occasionally a trimmer may be omitted altogether from one of the bands.

The single-tuned circuit preceding the first valve has now been covered in adequate detail, but it should be pointed out that variations of the arrangements described are often encountered.

BAND-PASS COUPLING

IN some receivers, particularly those which do not use an RF stage prior to the frequency changer, a double-tuned input circuit may be used to give an extra degree of selectivity. Such circuits are generally of the band-pass type and may take various forms. For instance, to get the correct band-pass effect the two tuned circuits may be inductively coupled, capacitatively coupled, or, using a combination of both methods, "mixed" coupled.

The double-tuned circuit is, of course, designed so that its two sections are ganged together (and with the oscillator stage) for tuning purposes. It therefore needs two sections of a ganged tuning condenser, and as the oscillator needs one, the tuning condenser will be of the 3-gang type. If an RF stage with single-tuned circuits is used, the tuning condenser will also have three sections, but if there is no RF stage, and only the single-tuned input circuit, only a 2-gang condenser is necessary.

In a double-tuned circuit, there is always some form of coupling between the two tuned circuits to enable the signal voltage built up across the first to be transferred to the second, and on the type and degree of coupling depends

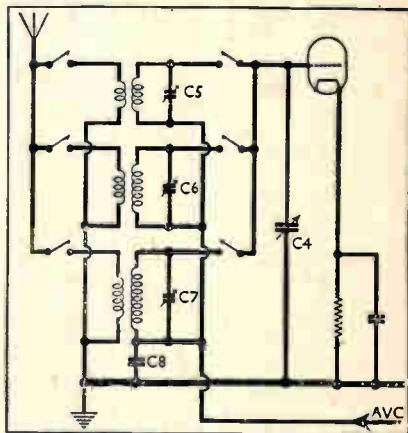

Fig. 5—Typical arrangement of a 3-band circuit, showing AVC feed, and waveband switching.

Radio Circuits

the response of the complete circuit. With a weak coupling, the circuit will give good selectivity but poor sensitivity; with strong coupling, the reverse is the case.

By suitable coupling arrangements a band-pass effect is obtainable, which means that over a certain band of frequencies on either side of the frequency to which the circuits are tuned the re-

as RF is concerned. The coupling between the two circuits is not obtained by the inductive effect of the physical proximity of the two coils, but by the reactance of condenser C5, which is common to both the tuned circuits. The degree of coupling depends on the capacity of C5, and this is carefully chosen by the designer. It may be anything between 0.01 μF and 0.2 μF .

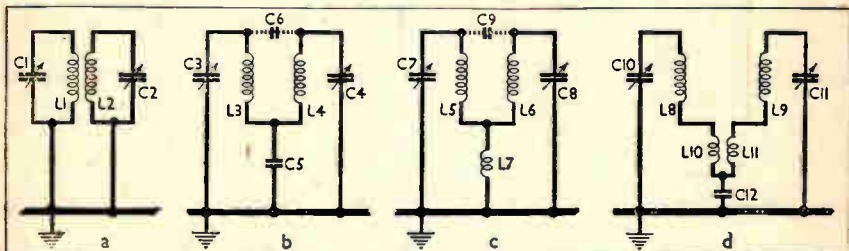

Fig. 6, a to d. a—Simplest form of double-tuned circuit using inductive coupling. b—Circuit of capacitive coupling, showing bottom coupling by C5 and (dotted) top coupling by C6. c—Inductive coupling by means of the common coil L7. d—Special form of coupling used by certain manufacturers.

sponse is at a maximum, while outside this band, on either side, the response falls off rapidly. The ideal curve has a flat top and steeply sloping sides. The effect of a band-pass characteristic of the tuning circuit is that a high degree of selectivity is obtained with no sacrifice in quality of reproduction.

Double-tuned circuits can be coupled in several ways, and the methods used in modern receivers will now be considered. The most common method is simple inductive coupling between the two tuned coils, which really form the primary and secondary of a double-tuned RF transformer. The circuit is shown in Fig. 6a, where L1, C1 and L2, C2 are the two tuned circuits, coupled by the mutual inductance between L1 and L2. The coils are usually identical in shape and characteristics, and are wound and mounted so that a certain definite degree of coupling between them is secured.

The next most common type of coupling is capacitive, as shown in Fig. 6b. Here L3, C3 and L4, C4 are the tuned circuits, each being completed by the fixed condenser C5, which connects the bottom end of each coil to chassis as far

as the "bottom coupling" condenser, owing to its position in the conventional type of circuit. C6 in Fig. 6b, which is shown dotted, is a small capacity (often only a few μF) which is sometimes used in a band-pass circuit, and is referred to as the "top coupling" condenser.

If L3 and L4 are inductively coupled, and C5 (and/or C6) is used as well, we have a form of "mixed coupled" circuit. The only difference between it and the capacitively-coupled circuit is in the disposition of the coils.

Some designers prefer to use the form of inductive coupling shown in Fig. 6c. This is similar to Fig. 6b, except that the inductance coil L7 takes the place of the coupling condenser C5. Coupling is due to the impedance of L7, being common to both the tuned circuits L5, C7, and L6, C8. L7 is usually a fairly small inductance, and, of course, L5 and L6 need not themselves be inductively coupled. Sometimes they are coupled to a certain degree, however, and this obviously modifies the effect of L7.

In Fig. 6c, C9 is shown dotted, and indicates the possibility of mixed coupling

Practical Band-Pass Circuit

by using a small "top coupling" condenser. Another point about Fig. 6c is that sometimes a fixed condenser is interposed between the bottom of L7 and chassis, which also gives a form of mixed coupling. Its main use, however, is to isolate the coils from chassis as far as DC is concerned, so that a bias voltage can be fed through L6 to the grid of the following valve by connecting its feeder to the junction of the bottom of L7 and the extra condenser.

In Fig. 6d is shown a special form of coupled circuit used by certain manufacturers. The main parts of the tuned circuits are L8, C10, and L9, C11, and L8 and L9 are not directly coupled. Instead, coupling is achieved by the two small coils L10 and L11, which are wound in close physical proximity to each other on a small tubular former. C12 is used to modify the coupling by introducing a capacitive effect, and it also serves to isolate the lower ends of the tuned circuits from chassis as far as DC is concerned.

The examples considered cover the main types of double-tuned input circuits normally encountered in modern receivers, although slight variations are often found. For instance, in Fig 6d,

L11 may be omitted, and L10 coupled directly to L9.

It should be pointed out that the diagrams given are the basic ones and for a single waveband only. With two wavebands, switching, trimming condensers, and often separate bottom coupling condensers for each band, the circuit often seems quite elaborate, though it can usually be broken down to one of the forms in Fig. 6.

Fig. 7 shows a practical form of Fig. 6d as used in a 3-band receiver. Here it will be noticed that double-tuned circuits are used on MW and LW only. On the SW band the aerial is coupled by L8 to the single-tuned circuit L9, C38. C5 is the SW fixed trimmer.

On MW and LW the aerial is coupled by L2 and L3 (and the small coupling condenser C2) to the first tuned circuits L4, C36 (MW) and L4, L5, C36 (LW). L6 and L7 are the small coils (corresponding to L10 and L11 in Fig. 6d), and C3, C4 are bottom coupling condensers.

On MW, switches S4, S5 are closed, so that coupling between L4, C36 and L10, C38 is by L6 (with L5 and C3 in parallel) and L7 (with L11 and C3 in parallel), together with C4.

On LW, S4 and S5 are open, so that

Fig. 7—A complete practical 3-band arrangement; incorporating a double-tuned input circuit using the coupling method of Fig. 6d on MW, and capacitive coupling on LW. On SW only a single tuned input circuit is used, and this is quite common in many sets.

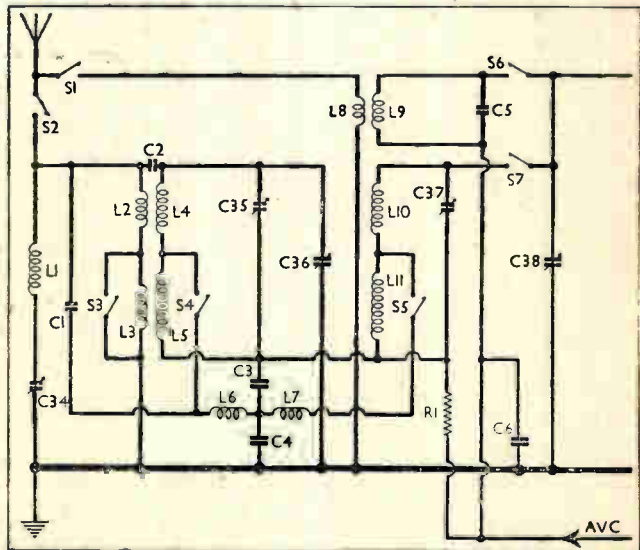

Radio Circuits

one end of L6 and of L7 is disconnected from the tuned circuits, and band-pass coupling is capacitive only, by C3 and C4 in series.

Other points of interest in the circuit shown are the IF filter L1, C34 (already mentioned when dealing with aerial circuits) and the AVC feed circuit. On the SW band the feed is through coil L9, C6 connecting the bottom of the coil to chassis as far as RF is concerned. On MW and LW a separate feed is taken via R1 and then through L11 and L10, with C3 and C4 closing the RF circuit to chassis.

RF AMPLIFIER STAGE

HAVING dealt with the tuned input circuits of a modern superhet one reaches the first valve of the receiver. In the majority of cases this will be the frequency-changer valve, but since many receivers employ a stage of RF amplification in front of the frequency-changer, this will be considered first.

The type of valve used for RF amplification is usually an RF pentode or tetrode having a variable-mu characteristic, which means that its gain can be adjusted by altering the bias applied to the control grid of the valve. In circuit diagrams the variable-mu type of valve is indicated by an inclined arrow drawn through the valve diagram. Fig. 8 shows the standard diagrams used for RF pentodes and tetrodes of the indirectly heated and directly heated (battery) types.

The gain of the RF valve is almost invariably controlled by the AVC voltage mentioned in an earlier section, and that is why a variable-mu valve is essential in this position. The bias voltage derived from the AVC circuits is fed to the control

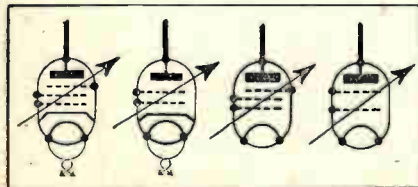

Fig. 8—Conventional diagrams for variable-mu RF valves. Left to right: IH pentode, IH tetrode, DH pentode, DH tetrode.

grid of the valve as explained when dealing with tuned input circuits.

In addition, a small fixed negative automatic bias may be used, so that however weak the signal (and therefore however low the negative AVC voltage) the valve always has a certain fixed minimum bias. This bias is obtained by means of a fixed resistor in the lead from the cathode of the valve to chassis in the case of indirectly heated valves, or from a potentiometer network in the case of a battery receiver.

The other power supplies for the valve

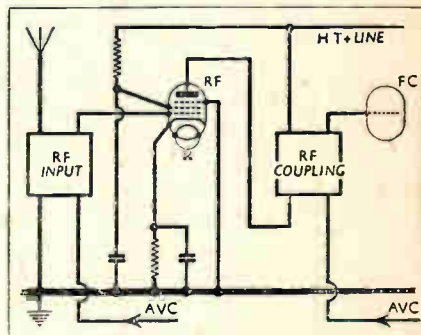

Fig. 9—A complete RF stage, with the couplings indicated by square blocks.

(apart from the filament or heater current) are a positive anode voltage and a positive screen voltage (usually, but not always, lower than the anode voltage). The control grid is the innermost grid (next to the cathode), while the screen grid is next to the control grid. In a tetrode the only remaining electrode is the anode, but in a pentode there is a third grid, between the screen grid and anode. This is the suppressor, and is usually connected direct to chassis, or to the cathode of the valve.

The screen grid obtains its voltage from the HT supply, usually via a decoupling resistor which may have a value up to 50,000 ohms or more. A common value is 25,000 ohms. Alternatively, the screen voltage may be obtained from a potentiometer consisting of two resistors in series across the HT supply from HT positive to chassis. The screen voltage will then be tapped off from the junction between the two resistances.

Radio Frequency Amplifier Couplings

In whatever way the screen obtains its supply, there will almost invariably be a fixed condenser, for RF by-pass purposes, connected from screen to chassis. This condenser will usually have a value of about $0.1 \mu\text{F}$.

So much for the DC supplies of the RF valve. The RF signal voltage, as we have already seen, is fed via the tuned input circuit (which may be of any of the types already described) to the control grid circuit of the valve, and the amplified signal appears in the anode circuit. From this point the signal must be passed on to the next stage in the receiver, namely, the frequency-changer. For this purpose some form of coupling between the anode circuit of the RF valve and the grid circuit of the frequency-changer valve must be used. The diagram in Fig. 9 shows a complete RF stage with skeleton couplings.

It would, of course, be possible to employ an untuned form of coupling of the resistance-capacity or choke-capacity type, but, in order to secure maximum amplification over the whole band, and an extra degree of selectivity, the interval coupling is invariably tuned.

Three common forms of coupling are used in modern sets, namely, tuned-secondary transformer coupling, tuned anode coupling, and choke-fed tuned grid coupling. The three are listed in their order of popularity, and nine sets out of ten employ the first-mentioned form.

In Fig. 10 are shown the three types of coupling in their simplest form. Fig. 10a indicates tuned-secondary transformer coupling. The primary of the trans-

former (L1) is in series with the anode circuit of the RF valve, and is coupled to the secondary (L2), which is tuned by C1. The signal across the tuned circuit is then applied between the grid of the next valve and chassis. It will be observed that this arrangement is very similar to that of the tuned input circuit of the receiver, with the primary of the transformer taking the place of the aerial coupling coil. Similar arrangements are made for applying the AVC voltage via the tuned circuit to those described in the section on the tuned input stage.

Fig. 10b shows the tuned-anode type of coupling, in which the tuned coil L3 is in series with the anode circuit. Sometimes the HT line is connected to a tapping on L3 to minimise damping of the tuned circuit. It will be noted that the tuning condenser C2 is not directly across the coil, although, as far as RF is concerned, it is in parallel with it, by virtue of the condenser C3, connected from the coil to chassis. C4 is a grid condenser isolating the anode voltage of the RF valve from the grid of the following valve, but not preventing the RF voltage from reaching the grid. R1 is a resistance permitting bias to be applied to the grid. Since in this circuit almost the full HT voltage is applied across the tuning condenser, a $0.1 \mu\text{F}$ blocking condenser will sometimes be found between the top of L3 and the top of C2.

Fig. 10c shows the third form of coupling, but this is not very common. L4 is an untuned RF choke in the anode circuit of the RF valve. C5 is the coupling

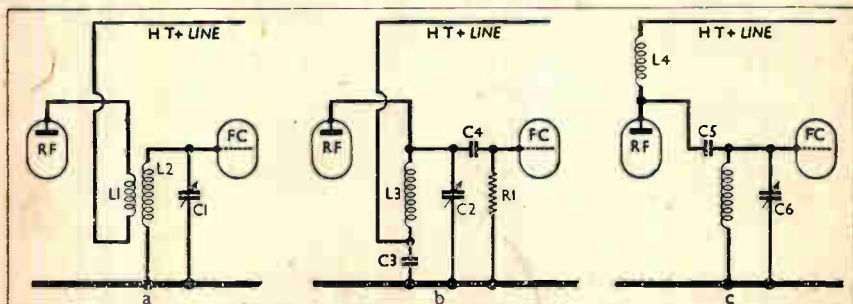

Fig. 10, a to c. a—Tuned secondary transformer coupling. b—Tuned anode coupling. c—Choke-fed tuned grid coupling. Only a single waveband is indicated in each case.

Radio Circuits

condenser from the RF anode to the frequency-changer grid. C6 and the coil across it form the tuned grid circuit.

As has already been mentioned, the tuned-secondary transformer coupling is the most popular of the three, but any of them may be encountered.

In their complete practical forms the couplings will, of course, incorporate waveband switching and trimmer condensers somewhat on the lines of these arrangements in the tuned input circuit (Fig. 7).

FREQUENCY CHANGING

HAVING now followed the superhet circuit up to the signal grid of the frequency-changer stage (and so far there has been practically no difference in the circuit from that of a "straight" receiver, except that AVC is rarely used in the latter), it is now necessary to look into the principles of frequency-changing, on which the whole structure of the superhet circuit depends.

In the frequency-changer stage the incoming signal is mixed with the output of a local oscillator to produce the required fixed intermediate frequency. Thus there are two sections to be considered in the frequency-changer stage—the mixer and the oscillator. Usually the two functions are combined in a single valve, which may have a single cathode stream, as in the heptode (or pentagrid) or two separate cathode streams (obtained from a single cathode), as in the triode-hexode. In the latter case we have virtually two separate valves in a single envelope. It is quite possible to use two entirely separate valves in the frequency-changer stage, and this is actually done in certain receivers. In this case a triode is used as the oscillator and a pentode, hexode or heptode as the mixer.

The output of the frequency-changer, at intermediate frequency, appears in the anode circuit of the mixer section, whence it is fed to the next stage of the receiver, the intermediate frequency amplifier, which will be dealt with later.

Let us now consider in a little more detail what happens in the frequency-changer. We have seen that the incoming signal is fed from the aerial circuit to a tuned input circuit, and thence either direct, or via a pre-selector stage of RF

amplification to the frequency-changer. The actual electrode to which it is fed is known as the signal grid and its position in the valve depends on the type of valve which is used. In any case, the signal modulates the cathode stream of the valve.

At the same time, the output from the oscillator section of the frequency-changer stage is also injected into the mixer section of the stage, and also modulates the cathode stream of the mixer. The effect of this (which in some respects is similar to the production of "beats" in audio-frequency engineering) is to produce in the anode circuit of the mixer signals of various frequencies.

The main frequencies so produced are one equal to the difference between the signal and oscillator frequencies; one equal to the sum of the signal and oscillator frequencies; the original signal frequency and the original oscillator frequency.

In addition, other frequencies will be present, produced as a result of the combination of the fundamentals and harmonics of the signal frequency and the oscillator frequency.

Out of all these frequencies one only is required, and that is the difference between the signal and oscillator frequencies. All the others are undesired and are fortunately sufficiently different from the desired frequency to be blocked or filtered out by the IF amplifier, which will have fairly sharply tuned circuits.

To take a concrete numerical example, we can assume a signal frequency of 1,000 KC/S (300 metres), and an oscillator frequency of 1,450 KC/S. The four main frequencies present in the anode circuit of the mixer will be: Difference, 450 KC/S; sum, 2,450 KC/S; original signal, 1,000 KC/S; oscillator, 1,450 KC/S.

Of these, the 450 KC/S signal is the desired intermediate frequency, and it will be appreciated that if the four frequencies are passed to the IF amplifier, which will be tuned to 450 KC/S, the unwanted signals of 1,000, 1,450 and 2,450 KC/S will not get through.

There is another point to be noticed, however. In the example chosen the oscillator frequency is higher by 450 KC/S than the incoming signal frequency. But suppose a signal of 1,900 KC/S reaches the grid of the mixer when the oscillator is producing a signal of 1,450 KC/S. A

Principles of the Frequency Changer

difference frequency of 450 KC/S will again be produced, and this will also be amplified in the IF stage.

This is known as an "image" signal, and produces interference in the receiver if the wanted signal of 1,000 KC/S and the signal of 1,900 KC/S are of anything like comparable strength. With a well-designed receiver image interference is negligible. If the input circuits are sharply tuned, and particularly if a pre-selector stage is incorporated, the 1,900 KC/S signal will be automatically removed when the input circuits are tuned to 1,000 KC/S, and thus prevented from reaching the frequency-changer.

In view of the fact that the frequency which produces an image differs from the wanted signal frequency by twice the intermediate frequency (1,900 — 1,000 = 2×450), it will be appreciated that with a low value of intermediate frequency there is more chance of image interference. For instance, with an IF of 110 KC/S the signal producing an image is only 220 KC/S away from the wanted signal, whereas, as has been seen, with an IF of 450 KC/S it is 900 KC/S away.

That is largely the reason why a high value of intermediate frequency is chosen for modern receivers, particularly in cases where there is only one tuned circuit in front of the frequency-changer.

It will be noted that in the numerical example quoted earlier the oscillator frequency was assumed to be higher than the signal frequency. As a matter of fact, it practically always is, but for a definite reason.

It will be obvious that, with a signal frequency of 1,000 KC/S an oscillator frequency of 550 KC/S would produce the required intermediate frequency of 450 KC/S and it might be thought immaterial whether the oscillator frequency were made higher or lower than the signal frequency. Actually, the higher oscillator frequency is necessary for reasons connected with the tuning of the circuit.

Suppose the wavelength range of the set on the MW band is 200-500 metres. This is equal to 1,500 to 600 KC/S, a frequency range of 2.5 to 1, which can be covered satisfactorily in a single band with a standard tuning condenser.

If the oscillator frequency is always higher than the signal frequency, and

assuming an intermediate frequency of 450 KC/S, the oscillator will have to tune from 1,950 to 1,050 KC/S, a frequency ratio of about 1.9 to 1, which is also easily covered in a single band.

If, however, the oscillator frequency is always below the signal frequency, the oscillator will have to tune from 1,050 to 150 KC/S, a frequency ratio of 7 to 1. To cover this wide frequency range in a single band is impossible by any normal tuning method, and for this reason it is necessary to arrange for the oscillator frequency to be higher than the signal frequency. Incidentally, this explains why, when aligning the oscillator circuit of a receiver, in cases where two "peaks" or tuning points are noticed, that having the higher frequency is usually the correct one.

The other one corresponds to the oscillator frequency being lower than the signal frequency, and the frequency separation between the two is twice the value of the intermediate frequency of the receiver.

The actual circuit arrangements of typical frequency-changer stages must next be considered.

OSCILLATOR ARRANGEMENTS

ALTHOUGH there are many types of frequency-changer circuits, we have already seen that they have a number of features in common. In all cases they consist of an oscillator and a mixer section, both the output of the oscillator and the signal input being fed into the mixer, where they produce the required intermediate frequency signal.

In considering the oscillator section first of all, it may be pointed out that in practically all cases a triode oscillator circuit is employed, in which the valve used may be actually a triode, as in a triode-pentode or triode-hexode. Alternatively, the oscillator triode may be formed of the cathode and two adjacent grids of the frequency-changer valve, as in a heptode or octode. In this case the grid adjacent to the cathode is the oscillator control grid, and the next grid to it acts as the oscillator anode.

The circuit used for the oscillator usually consists of the familiar tuned coil to which is inductively coupled a "reaction" coil. The coupling is fixed, and

Radio Circuits.

the size of the coil and the degree of coupling is arranged by the designer to secure self-oscillation of the circuit over the whole of the waveband. Occasionally other oscillator arrangements will be found, but that described is the most common.

The tuned coil may be in either the grid or the anode circuit of the oscillator, while the oscillator anode HT feed may be by one of two different methods. Typical skeleton circuits on the lines mentioned are shown in Fig. 11a, b and c.

the correct degree of oscillation over the whole waveband. If the HT voltage on the anode were too low, dead spots might be produced due to the oscillator ceasing to function on certain parts of the band; on the other hand, with too high an anode voltage, there is the possibility of harmonics being produced in the oscillator circuit, which will be productive of whistles in the receiver, and must be avoided.

The circuit of Fig. 11b is very similar to that of Fig. 11a, but in this case it is

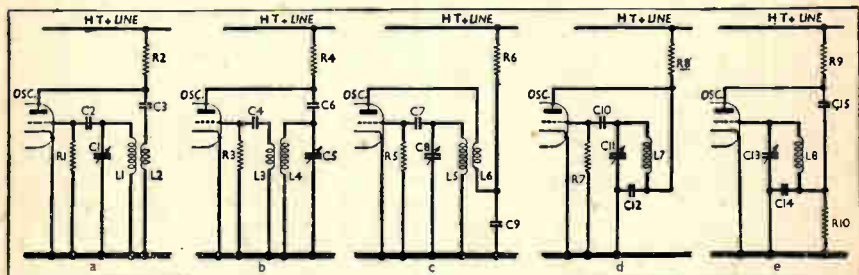

Fig. 11, a to e. Five simplified examples of oscillator circuits. a—Tuned grid, with parallel-fed anode circuit. b—Tuned anode, with parallel-fed anode circuit. c—Tuned grid, with series-fed anode circuit. d and e—Two examples of tuned grid circuits with capacitively-coupled anode reaction.

Taking Fig. 11a first, this shows the tuned grid oscillator circuit with a parallel-fed anode circuit. It will be noticed that the grid is returned to chassis via the grid resistance R1. In practice, where there is a bias resistance in series with the cathode lead of the valve to chassis, R1 will be returned to the cathode of the valve, and not to chassis. This applies to all the circuits shown.

C2 is the grid condenser, which is always present when R1 is used. Typical values for R1 and C2 are 50,000 ohms and 0.0001 μ F. L1, C1 form the tuned circuit, only a single waveband being shown in this, and the other diagrams. L2 is the oscillator reaction coil, coupled inductively to L1, and capacitively by C3 to the oscillator anode. The anode is fed with DC from the HT line via R2, which is almost invariably present, and breaks down the full HT voltage to a suitable lower value for the oscillator anode.

Actually R2 has to be chosen to suit the valve and circuit, in order to secure

the anode circuit L4, C5 which is tuned, reaction being applied in the grid circuit by L3. As before, the anode circuit is parallel-fed.

Fig. 11c shows the other form of tuned grid oscillator circuit, in which a series-fed arrangement for the HT circuit is employed. L5, C8 is the tuned circuit, and L6 is the anode reaction coil. The HT supply is now fed via R6, through L6 to the oscillator anode, so that the anode current of the valve actually flows through the anode coil. C9 (in conjunction with R6) provides decoupling for the oscillator anode circuit.

Occasionally it will be found that from the junction of R6 and C9 a lead will be taken for the HT supply to the screen of the mixer, or the screen of the following IF valve, or both.

Although the three oscillator circuits shown in Fig. 11, a to c, are by far the most common ones in use in modern sets, they are not the only ones which may be encountered. Some designers dispense

Details of Typical Oscillator Circuits

with a separate reaction coil, and use in its place capacitive coupling produced by a condenser which is common to both the grid and the anode circuit of the oscillator.

One example of this is shown in Fig. 11d. R7 and C10 are the grid leak and grid condenser respectively, while L7, C11 are the tuning coil and condenser respectively. The extra condenser C12 (which is shown fixed, but may be pre-set) will be noticed. This is primarily employed as a tracker (or in American, a padder) to keep the oscillator circuit out of step with the signal circuit by a constant amount (equal to the intermediate frequency).

The problem of the tracker will be considered later, but meanwhile it is clear that C12 is common to the grid and the anode circuit of the oscillator. The grid circuit is via C10, L7, and C12 to chassis; the anode circuit is via C12 to chassis. C12 is, therefore, common to both, and the two circuits are thus coupled.

The value of C12 is fixed by considerations of its use as a tracker, but it usually has a sufficiently large value, in conjunction with a suitable oscillator anode voltage, to produce the requisite degree of oscillation over the whole waveband. Occasionally, however, a combination of reaction coil and common capacity will be found on some wavebands in a receiver.

Since R8 and the oscillator anode are isolated (as far as DC is concerned) from chassis, there is no need for a blocking condenser between the bottom of R8 and the bottom of L7, though sometimes this may be found.

Fig. 11e shows another variation of the single coil oscillator circuit, in which it is to be noted that the usual grid leak and condenser are omitted. L8, C13 is the tuned circuit, with C14 as tracker and common capacity in grid and anode circuit. R10 is used in place of the normal grid leak, while C15 prevents leakage of the HT supply to chassis, and also blocks the anode voltage from getting to the oscillator grid via L8.

Another arrangement for the oscillator circuit is to use a single tapped coil for tuning and reaction, the reaction section being a continuation of the section which is tuned.

It will sometimes be found that the reaction circuit contains a resistor in series or parallel with the reaction coil on

one or more wavebands. This is done to modify the reaction effect in certain respects, for instance, to even out the strength of the oscillations over the whole waveband.

The circuits in Fig. 11 show only one waveband, but for multi-waveband receivers the principles are the same, though extended to use extra coils, trimmers and trackers, with switches to select the correct coils and associated components for each waveband.

EARLY FC CIRCUITS

HAVING followed the incoming signal up to the point where it is applied to the frequency-changer, and having also considered the circuit arrangements of the oscillator section of the frequency changer, it is now necessary to see how the signal voltages and the oscillator voltages are applied to the various types of frequency-changer valves in order to produce the required intermediate frequency voltage.

In very early superhets in this country a screened RF tetrode or screened RF pentode was used as the frequency-changer, and it was often termed the "first detector," since it made use of its square-law detector characteristic to effect a combination of the two frequencies applied to it and thus to produce the required intermediate frequency.

It is not proposed to go into the theory of the operation of this type of frequency-changer here, because it is quite complicated. In any case, the student will not come into contact with many receivers incorporating this style of circuit, which had lost its popularity by 1934, owing to the introduction of specialised valves for frequency-changing, which gave far superior results in many respects.

However, for the sake of completeness, a typical schematic circuit using a screened tetrode is given in Fig. 12. Here it will be seen that the signal input goes to the control grid of the valve, while the oscillator section consists of a parallel-fed tuned anode coil inductively coupled to a reaction coil, in the cathode circuit of the valve, so that the oscillator voltages produced in it appear on the cathode of the valve, and thus modulate the cathode stream. The required intermediate fre-

Radio Circuits

frequency signal appears in the anode circuit of the valve, whence it is fed to later stages of the receiver.

In the case of battery receivers, coupling coils were introduced in series with the filament circuit of the first detector, and there was usually one coil in each filament lead. Obviously, in this case the coils had to be of fairly heavy gauge wire in order to keep their resistance low so that it had a negligible effect on the voltage reaching the filament.

Sometimes, in cases where a screened RF pentode was employed, the oscillator coupling coil was in series with the screen

as usual from a resistance, while the suppressor (third grid) is connected externally to the cathode of the valve.

The oscillator section has a parallel-fed tuned anode coil, coupled to another coil in the *cathode* circuit of the valve, and cathode injection of the oscillator signal is thus used. The oscillator grid (grid of the triode) is connected via the grid resistance R1 and the parallel grid condenser C1 to the bottom of the cathode coil, this point being connected via the bias resistance R2 and by-pass condenser C2 to chassis. The IF signal appears in the anode circuit of the pentode mixer section.

The circuit of the later type of triode-pentode is shown in Fig. 13b for comparison. The battery version is shown because it was in this form that the valve was most used. It will be observed that (apart from the difference between the heater/cathode and filament circuit) there is an important difference between the two valves, namely, that in the later type there is an internal connection between the two sections, the oscillator grid being connected to the pentode suppressor. The coupling between the two sections is thus performed internally, and the system is said to operate by suppressor injection.

Since no external coupling is necessary, the oscillator circuit naturally differs from that of Fig. 13a. It will be seen that as shown the oscillator has a tuned-grid circuit, with parallel-fed reaction coupling, but almost any of the circuits described in the preceding section on oscillator arrangements could be used.

Before proceeding to later developments in the type of frequency-changer which uses what are virtually two separate valves in the same envelope, there is one important type which does not come under this heading, and which was extremely popular for a number of years, and is still used in some sets. This is the heptode, or pentagrid.

As its name suggests, it has seven electrodes (counting the filament or heater/cathode assembly as one), of which five are grids. The valve of course, employs a single electron stream, which distinguishes it from the type of frequency-changer which has two separate electrode systems and two electron streams.

Coupling between the incoming signal and the local oscillator occurs in the

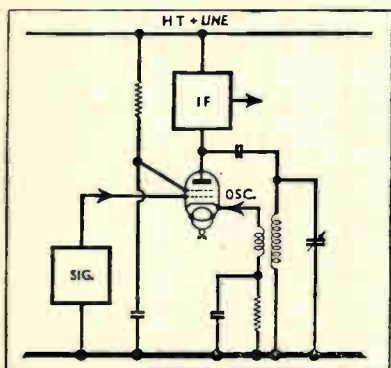

Fig. 12—Early frequency-changer circuit using a screened tetrode.

circuit or the suppressor circuit, thus giving screen or suppressor injection of the oscillator frequency. Such circuits were not very common, however.

One of the first multiple valves to be used for frequency-changing was the original type of triode-pentode. This consisted virtually of two entirely separate valves in a single glass bulb, the only part common to both sections being the heater/cathode system. A similar performance could be, and sometimes was, achieved by using two separate valves, a triode acting as oscillator and a screened pentode as mixer.

The schematic circuit of the original type of triode-pentode is shown in Fig. 13a. It will be seen that the two sections of the valve are quite separate except for the heater and cathode. The signal voltage is fed to the control (first) grid of the pentode. The screen (second grid) is fed

Principles of the Heptode Frequency Changer

electron stream of the valve, and therefore the valve is said to employ electron coupling, instead of the electrode injection system used in most of the dual types of frequency-changer valves. A diagram of the valve, showing the various electrodes, is in Fig. 14.

Of the various grids in the heptode frequency-changer, the first (nearest the cathode) is the oscillator control grid, while the second acts as the oscillator anode, so that the oscillator section is really of the triode type. In addition, however, the oscillator anode acts as the modulating electrode for the electron stream. Grids 3 and 5 are connected together inside the valve and form screens, the third grid screening the oscillator section of the valve from the mixer section.

The fourth grid is the mixer control grid, to which the incoming signal is applied; next comes the fifth (screen) grid already mentioned, then finally the mixer anode, in whose circuit the IF signal appears. It will be noted that the mixer section has no actual cathode, but utilises the electron "cloud" which forms between grids 3 and 4 as a virtual cathode.

This cloud is due to a proportion of the electrons which escape through grid 2 (the oscillator anode) in pulses determined by the frequency of the oscillator. They are attracted through the screen grid 3, and supply the operating power for the mixer section of the valve.

Since the electrons arrive in pulses from the oscillator section with a frequency

determined by the oscillator circuit, the virtual cathode of the mixer is similarly varying, and so modulates the mixer

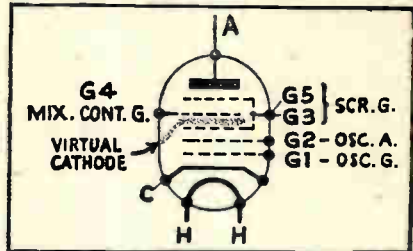

Fig. 14—Diagram of the electrode system of a heptode frequency-changer.

section of the valve at the oscillator frequency to produce the required intermediate frequency. It should be noted that there is no external coupling between the oscillator and mixer sections of this type of valve.

The external circuit of this type of valve does not differ greatly from that of the triode-pentode circuit of Fig. 13b. It is shown in Fig. 15, with the tuned-grid type of oscillator circuit, although any of the arrangements already described may be employed. The signal voltage is fed to the fourth grid. The oscillator anode (grid 2) receives its anode voltage from the HT line via a dropping resistance; the screens are similarly fed from another

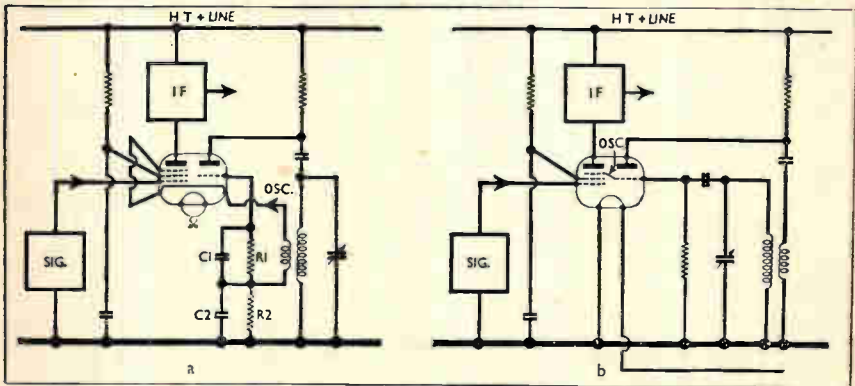

Fig. 13, a and b. a—Circuit using the original type of triode-pentode. b—The later type of battery triode-pentode, with internal coupling.

Radio Circuits

resistance, which is provided with a decoupling condenser to chassis. Occasionally the oscillator anode and the screens are fed from the same resistor, but this is not usual.

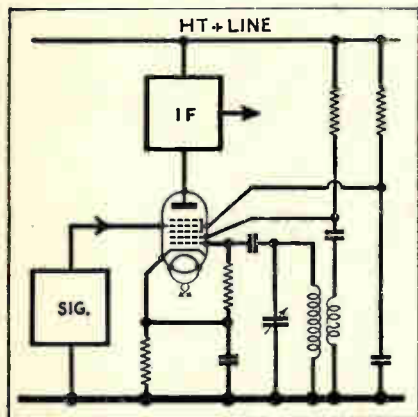

Fig. 15—Circuit arrangement employed with a heptode frequency-changer.

The heptode frequency-changer attained wide popularity, and so did another valve, similar in principles. This is the octode, which has one additional grid, between the fifth grid of the heptode and the mixer anode. This grid is used as a suppressor, and modifies the characteristics of the valve. It is connected internally to the cathode of the valve, and therefore does not produce any complication in the circuit. At a in Fig. 16 is shown the symbol for a mains heptode, while at b the octode is shown to enable the electrode systems in the two to be compared.

MODERN FC VALVES

TURNING now to later types of frequency-changers with double electrode systems and two electron streams, we come to the triode-hexode, which logically follows the later type of triode-pentode mentioned in the last section. The electrode arrangement of the triode-hexode is shown in Fig. 16c. It will be seen that the hexode mixer section has the

input signal applied to the first grid. Grids 2 and 4 are internally connected, and form screens. Grid 3 is the injection electrode, and is internally connected to the grid of the triode section of the valve (oscillator grid).

Apart from the differences inside the valve, the circuit of a triode-hexode frequency-changer is similar to the triode-pentode circuit shown in Fig. 13b.

It is quite possible to use a separate triode oscillator and an RF hexode mixer as a 2-valve frequency changer. This is occasionally done in the case of battery operated superhets. The circuit arrangement is the same as when a dual valve is used, except that a connection from the grid circuit of the triode to the third grid of the hexode serves to inject the oscillator voltage into the mixer. The second and fourth grids of the hexode are connected together externally and are used as screens, as in the dual valve.

Another dual valve is the triode-heptode, of which the electrode arrangement is shown in Fig. 16d. The only difference to be noted is the extra suppressor grid, connected internally to the cathode of the valve.

The triode-heptode circuit can also be employed with separate valves, a triode oscillator and a heptode mixer. A mains heptode (the 6L7G) was produced in America especially for this purpose. Its electrode arrangement is shown in Fig. 16e, and the valve must not be confused with the ordinary heptode frequency-changer (c.f. Fig. 14 and Fig. 16a). It will be observed that it is identical with the heptode section of Fig. 16d. One way of using the heptode mixer is to couple the anode circuit of the triode oscillator to the injector grid (grid 3) of the heptode via a condenser.

Finally, to complete this review of frequency-changers, mention must be made of a new type of triode-hexode, the 6K8. This has a cathode, entirely surrounded by a grid, and two anodes, one on each side of the cathode. The grid surrounding the cathode acts as the oscillator grid on the side nearest the oscillator anode, and as a modulating grid on the opposite side of the cathode, where it forms the first grid of the mixer. Next comes a screen entirely surrounding the signal grid (being thus equivalent to two ordinary screens connected

Maintaining Constant Frequency Difference

together), and finally the mixer anode. It is not easy to show this form of construction correctly in an ordinary valve diagram, but that shown in Fig. 16f is as clear as any.

The point to be noticed with regard to all these types of frequency changers is that from the operational point of view the external circuit does not vary to any considerable extent, the differences lying mainly in the connections to the particular valve employed. The only exceptions to this are the very early types of valve where external coupling coils were necessary. Of course, the constants of the circuits vary from valve to valve, but this is a matter for the designer rather than the student or service engineer.

OSCILLATOR TRACKING

It was pointed out in the section dealing with the principles of frequency-changing that in order to produce the desired intermediate frequency signal in a super-het receiver the oscillator circuit must be tuned to a frequency differing from the signal frequency by a constant amount equal to the value of the intermediate frequency of the receiver, and that usually the oscillator frequency will be higher than the signal frequency.

Consequently, as one tunes over each waveband with the signal-frequency tuning condenser, the oscillator tuning must be varied at the same time, so that the constant difference in frequency is maintained. Naturally, in a modern receiver where one-knob tuning is essential, the signal-frequency and oscillator tuning condensers must be ganged so that they rotate together.

At first sight it might seem a simple matter to ensure a constant frequency

difference between the two circuits over the whole waveband, but actually it is quite a difficult problem. Using two variable condensers of the "straight-line-capacity" type, and arranging for the moving vanes of one to be displaced relative to those of the other by a certain amount gives a constant capacity difference over the whole tuning range, and by suitably adjusting the displacement the desired frequency difference between the two tuned circuits can be secured *at one point on the scale*, and at this one point only.

This is because the frequency of a tuned circuit is, for a given coil inductance, inversely proportional to the square root of the capacity of the tuning condenser. In other words, a capacity difference which produces a certain frequency difference at one setting of the ganged condensers does not produce the same frequency difference at any other setting.

One way of getting over this difficulty is to use a special gang condenser with plates shaped in such a way that the frequency difference between the two tuned circuits is the same at every setting of the gang. This is a solution which is sometimes employed, and the fact can be verified by anyone who cares to compare the oscillator section of the ganged tuning condenser with the other section or sections.

It will often be found that the oscillator section is somewhat smaller, and has vanes shaped differently from those of the section(s) tuning the signal-frequency portion of the set. Sometimes the moving vanes are altered in shape, while in other cases the fixed vanes are altered.

However, specially shaped plates are not a complete solution of the problem. For one thing, a certain shape will only

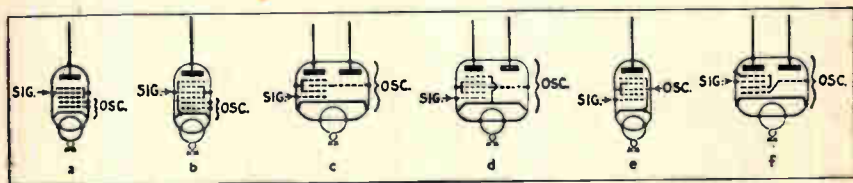

Fig. 16, a to f.—Six examples of valves used for frequency-changing. a—heptode; b—octode; c—triode-hexode; d—triode-heptode; e—6L7 heptode mixer; f—6K8 triode-hexode.

Radio Circuits

give the constant frequency difference on one waveband; it fixes the frequency difference (and hence the intermediate frequency of the receiver); it is only applicable to a certain value of oscillator tuning coil inductance; and it will be upset by changes in stray capacities and inductances in the circuit.

None of these disadvantages, except the first, is serious in a commercial mass-produced receiver, which can be designed round the condenser, and will not vary in its constants to any appreciable degree. The fact that the condenser will only operate correctly on one waveband is a serious matter, however, and to get over this difficulty a technique is adopted which is equally applicable to normal condensers, and to all wavebands.

This technique is known variously as tracking or padding. Both words in this connection mean the same thing, namely, the adjustment of one tuned circuit relative to another to give a constant difference of frequency between the two.

Where a gang condenser with specially shaped plates is used, the shaping is usually designed to give correct tracking on the medium waveband. For other bands, additional corrective condensers have to be employed, in a manner now to be described.

The second and more flexible (and therefore more commonly used) method of getting one tuned circuit to "track" with another to give a constant frequency difference is to use a gang condenser in which all the sections are identical, and to adjust the tuning characteristics of the oscillator section by suitable additional condensers.

As was seen in an earlier section, the ratio between the minimum and maximum frequency of the oscillator on each waveband is less than that of the signal frequency circuits, which means that the ratio between the minimum and maximum capacity of the oscillator tuning condenser must be lower than that of the other tuning condensers.

Using a gang condenser with identical sections, the capacity ratio of the section used for oscillator tuning can be decreased either by increasing the minimum capacity of the section, or by decreasing the maximum capacity.

The minimum can be slightly increased by connecting a small condenser in

parallel with the oscillator section of the gang, since capacities in parallel are additive; the maximum can be slightly decreased by connecting a large condenser in series with the oscillator section of the gang, since the capacity of two condensers in series is always less than that of either of the individual condensers.

In practice a combination of the two methods is used. The adjustment of the small parallel condenser at the higher frequency end of the scale (minimum capacity) permits us to get the oscillator

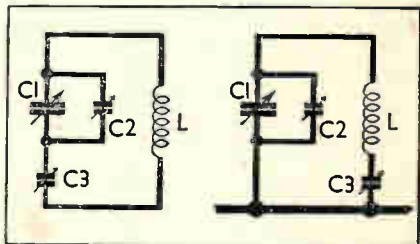

Fig. 17.—Left, the basic oscillator tracking circuit. Right, a practical arrangement.

circuit tuning correct at this point, without seriously affecting the other end of the scale. At the lower frequency (maximum capacity) end of the scale, the adjustment of the large series condenser allows the oscillator circuit tuning to be corrected here, without appreciably affecting the higher frequency end of the scale.

Thus we now have two points on the scale, one at the top and one at the bottom, at which the signal frequency and oscillator circuits are correctly "tracked" relative to each other. The accuracy with which the circuits track over the rest of the scale now depends on careful choice of the value of the inductance of the tuning coil, the value of the parallel condenser and the value of the series condenser.

The method whereby the optimum values can be calculated will not be gone into here, but it may be said that by careful choice of the values, correct tracking may be secured at three points, with only very slight deviation, negligible in practice, at points between them.

So far only a single waveband has

Oscillator Tracking Details

been considered. When two or more wavebands are covered by the receiver, it is quite impossible to choose values of parallel and series condensers such that tracking will be correct on all wavebands.

If the condensers are correct on the MW band, then on the LW band it will be necessary to use a larger parallel condenser and a smaller series condenser.

The basic oscillator tuning circuit is shown on the left of Fig. 17. Here L is the oscillator tuning coil, C1 is the oscillator tuning condenser (a section of the gang condenser), C2 is the oscillator parallel trimmer, and C3 the oscillator series tracker. One possible practical arrangement is shown on the right of Fig. 17, where the components are similarly lettered; it is electrically identical with the basic circuit, and in each case C3 is effectively in series between C1 and L.

It is customary to refer to the parallel condenser as the "oscillator trimmer," while the series condenser is referred to as the "oscillator tracker," enabling the two to be distinguished. Sometimes fixed trackers or trimmers are used, either alone, or in conjunction with variable ones for adjustment purposes.

Naturally, in a multi-band receiver switching has to be introduced to bring the appropriate trimmers and trackers into circuit on the various wavebands.

In modern receivers using iron-dust cored coils, it is often found that, whereas a parallel trimmer condenser is used for adjustment at the higher-frequency end of the scale, tracking at the lower-frequency end of the scale is carried out by adjusting the coil core, and hence the inductance of the coil. In this case there is usually a fixed series condenser in place of the usual variable one.

Short-wave oscillator coils often have provision for tracking at the low-frequency end of the scale by adjustment of a loop of wire or by displacement of the end turn of the coil winding to vary the inductance of the coil.

As has already been explained, adjustment of the oscillator parallel trimmer is always carried out at the high-frequency (low-wavelength) end of the scale, usually at 1,400 KC/S (214 m) on MW, and 300 KC/S (1,000 m) on LW. The series tracking (or inductance adjustment) is carried out at the low-frequency

(high-wavelength) end of the scale, usually at 600 KC/S (500 m) on MW, and 150 KC/S (2,000 m) on LW.

IF AMPLIFIERS

THE last section completed our consideration of the frequency-changer stage of a superhet, and we have arrived at the point where we have the intermediate frequency signal present in the anode circuit of the frequency-changer. As has already been seen, this signal must be amplified in the next stage of the set, namely, the IF amplifier.

It was pointed out earlier that this stage in most simple superhets provides the bulk of the amplification, and also controls the selectivity of the receiver to a large degree. Furthermore, it is one of the stages to which the AVC voltage of the receiver is applied.

The IF stage is tuned to the fixed intermediate frequency of the receiver, and its tuning is therefore not normally altered, except when re-alignment of the receiver is called for.

In most modern superhets the IF amplifier consists of a single stage using an RF pentode or tetrode valve of the variable- μ type. In a few cases two IF valves are employed, which arrangement has the advantage of providing extra amplification, besides permitting more satisfactory response curves to be obtained.

With a single stage, high gain is essential in order to secure the maximum overall amplification, and unless care is taken in the design a very slight fault may produce incipient or actual instability, with distortion and other troubles.

In the IF stage it is necessary to couple the anode circuit of the preceding frequency changer to the grid circuit of the IF valve, and the anode circuit of the IF valve to the following stage, which is the second detector or demodulator. In practically all cases the coupling is by means of IF transformers having tuned primary and tuned secondary windings.

Fig. 18 shows the basic IF stage using a single valve and two tuned-primary, tuned-secondary air-cored transformers. Screen supply, bias arrangements and AVC feed are omitted. The anode circuit of the frequency-changer valve is coupled by the first transformer C1, L1,

Radio Circuits

L2, C2 to the grid circuit of the IF valve, while the anode circuit of this valve is coupled via the second transformer C3, L3, L4, C4 to the second detector stage of the receiver.

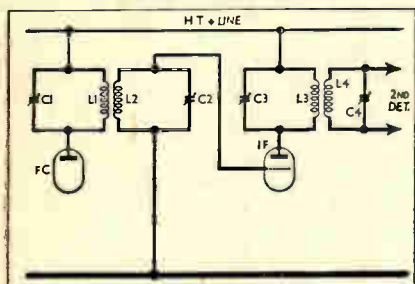

Fig. 18—Skeleton IF circuit showing the transformer couplings.

The circuit in more practical form is shown in Fig. 19. Here the valves and couplings are the same as in Fig. 18, but the additional components which go to make up the complete circuit have been added. R1 is the screen feed resistance, and C6 the screen decoupling condenser. The suppressor is connected externally to the cathode of the valve, and the cathode is returned to chassis via R2 which forms a bias resistor for the IF valve. This fixes the minimum bias which the valve receives when the signal is so weak that the AVC voltage is negligible.

If R2 were not present it would be possible for the bias under no signal conditions to fall to zero, which might cause instability in the stage. Usually the value of R2 is between 100 and 600 ohms, and the resistance is shunted by the condenser C7, which generally has a value of about 0.1 μ F.

The AVC bias in the case under consideration is series fed from the AVC line, via R3 and the secondary of the first IF transformer, to the control grid of the IF valve. C5 is a decoupling condenser (about 0.1 μ F) which places the bottom of the secondary of the first IF transformer at chassis (earth) potential as far as intermediate frequency voltages and currents are concerned. It is in place of the direct connection shown in Fig. 18. R3 is a decoupling resistance which may have a resistance between 250,000 ohms and 2 megohms, a value of 500,000 ohms

being common. Sometimes, however this resistance is omitted.

Turning now to the IF transformers themselves, these are designed in such a way that the desired response curve is obtained when they are correctly adjusted. In their simplest form they consist of the two coils mounted on a former and spaced so that the desired degree of coupling between them is obtained. Each winding is tuned by a pre-set variable condenser, adjustable by means of a screw or nut. The complete assembly is mounted in a screening can with holes in it giving it access to the trimmer condensers.

Occasionally the tuning is carried out by fixed condensers having very small variable types connected in parallel with them. In a few cases the IF transformers are tuned at the works with fixed condensers only, and they are therefore not intended to be subsequently adjusted.

So far we have considered only air-cored IF transformers. The modern tendency, however, is to use iron dust cored coils for greater efficiency and compactness. In this case the coils may have fixed cores, and are tuned with pre-set condensers or, more commonly, they

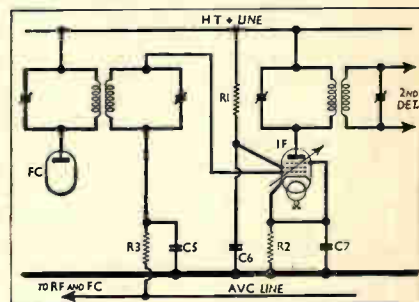

Fig. 19—Completed transformer-coupled IF stage.

may have adjustable cores. The movement of the iron-dust core in or out of the coil by a screw adjustment gives a fine and smooth adjustment of the inductance of the coil. By shunting the coil with a fixed condenser to form the tuned circuit, the adjustment of tuning may be carried out by means of the coil cores.

This type of transformer usually has a

IF Transformer Types

high degree of stability of tuning, which is important in the case of fixed tuned circuits as employed in the IF stage of a receiver. The three types of transformer described are shown in diagrammatic form in Fig. 20.

The first and second IF transformers in a receiver are not necessarily identical, and, in fact, for optimum results their design must be slightly different. It may be found that the two are wound with different types of wire to give different inductances and "goodness" factors. If the inductances are different, the capacity of the tuning condensers will also have to be different, since the frequency of the tuned circuit must remain the same.

In some cases one or more of the windings may be of resistance wire to provide the degree of damping required by the designer. In other cases fixed resistors are shunted across one or more of the windings to modify the response to the desired degree.

Again, it is quite common for a tapped secondary to be used to reduce the loading of the next part of the circuit on the secondary, or to prevent overloading of the next stage. In most cases, however, the IF transformers will be found to be simple 1 to 1 ratio components.

Although straightforward tuned transformers with fixed critical coupling between primary and secondary windings are the IF couplings used in the majority of receivers, the service engineer or student will occasionally come across variants. For instance, an untuned choke coupling has been used in certain simple receivers.

Sometimes extra (capacitive) coupling between the two windings of a transformer is introduced in order to modify the

response curve. This, if used, consists of a small fixed condenser (a few microfarads) connected from one side of the primary to one side of the secondary.

Occasionally the desired response of the IF coupling is secured by using a triple-tuned transformer, consisting of a tuned primary coupled to a tuned secondary, to which is coupled the third tuned winding, the tertiary. In this case the secondary has no external connection, except that one side of it is sometimes earthed. The arrangement is shown in Fig. 21.

The IF stages of a receiver are adjusted,

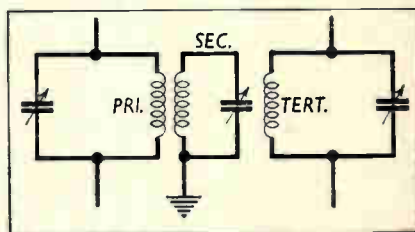

Fig. 21—Triple-tuned IF coupling.

as mentioned earlier, to the intermediate frequency of the receiver. In most cases, each winding will be tuned so that it peaks, that is, gives the maximum output at the intermediate frequency.

This does not apply in all cases, however, for some manufacturers arrange for each winding to be adjusted slightly differently. Thus, in the case of an intermediate frequency of 125 KC/S, the primary may be tuned to 123 KC/S and the secondary to 127 KC/S.

The effect of this, which is known as "staggered" tuning, is to provide a

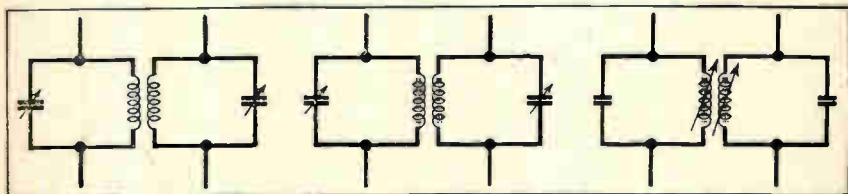

Fig. 20—Three types of IF transformer in diagrammatic form. Left, with air-cored coils and variable trimmer condensers. Centre, with iron-dust cored coils and variable trimmer condensers. Right, with coils having adjustable iron-dust cores, and fixed trimmer condensers.

Radio Circuits

broader overall response in the coupling, so that a wider band of frequencies is amplified and passed on, thus improving the quality of the reproduction, while necessarily reducing the selectivity.

VARIABLE SELECTIVITY

OTHER variants of the simple IF transformer couplings are to be found in receivers which incorporate arrangements

method of indicating variable coupling of the mechanical type is shown in Fig. 22a.

This mechanical method of securing variable selectivity enables a continuously variable adjustment to be made, so that any required combination of selectivity and fidelity can be achieved. In practice, however, such fine adjustments are rarely necessary.

The second method of securing variable selectivity is by altering the degree of

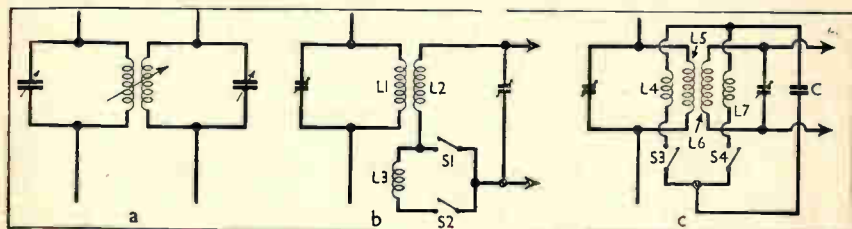

Fig. 22, a to c—Three examples of variable selectivity couplings.

for securing variable selectivity. Since the IF circuits largely control the selectivity of a superhet receiver, it is by adjustment of these circuits that variable selectivity can most readily be achieved. By altering the coupling between primary and secondary windings the response can be varied at will. A weak coupling gives a narrow response curve, and, therefore, high selectivity; a tight coupling broadens the response and gives high fidelity.

The methods of altering the IF transformer coupling in order to vary the response differ from set to set, but in principle they come under two broad classifications.

First of all, there is the fairly obvious method of mechanically altering the relative positions of the primary and secondary coils. The closer they are together on the same axis, the tighter will be the inductive coupling. Consequently, if we arrange for one coil to be capable of movement along a guide towards the other, we shall obtain variable selectivity. This movement can be achieved by an arrangement of levers, pulleys or a Bowden flexible wire, and usually a rotary knob control is fitted. Another mechanical arrangement is to rotate one of the coils relative to the other, which is another way of varying the coupling between them. The usual

coupling electrically, and usually this is done by switching. It is therefore not continuously variable; usually two or three selectivity positions are provided, which are chosen to give a useful compromise.

One example of this method is shown in Fig. 22b. Here L1 is the primary coil, L2 the secondary, while L3 is a small additional coupling coil for varying the selectivity, and S1, S2 are the switches. When S1 is closed, S2 is open, and the transformer is of the normal type. When S1 opens, however, S2 closes, and L3 is in series with L2, and provides the change in selectivity. Depending on the sense of the winding of L3, the selectivity may be increased or diminished when L3 is in circuit. Sometimes a resistance is also included in series with L3.

Another form of circuit for varying the coupling is shown in Fig. 22c. Here L5 and L6 are the normal primary and secondary windings, tuned in the usual way. L4 and L7 are two small extra coils coupled to L5 and L6 respectively, and switched by S3 and S4. When S3 is closed, S4 is open, and L4 (with condenser C across it) is coupled to the primary. When S3 is open, S4 is closed, and L7 (with C across it) is coupled to the secondary. Here again two alternative selectivity positions are provided.

Early Demodulation Circuits

Other variable selectivity circuits are sometimes used, and are all designed so that when changing from one position to the other there is no appreciable change in the frequency to which the IF transformer is tuned, which is naturally very desirable.

In most cases the variable selectivity arrangements are applied to one transformer only, usually the first; the second transformer is then of the normal type. It might be thought at first that, in passing a wide band signal from the first transformer to the more sharply tuned second one, the advantages of the first transformer would be lost, but this is not so, because the overall selectivity of the set depends on the characteristics of both transformers taken together, and a broadly tuned coupling in combination with one which is sharply tuned will always give a broader resultant signal than will two sharply tuned couplings.

When aligning a variable selectivity receiver it is usual to adjust the IF transformers when the set is switched for maximum selectivity.

DEMODULATION CIRCUITS

WE have now arrived at the point where the IF signal, amplified to the requisite degree, is present at the secondary of the final IF transformer.

It should be clear that this signal is in form very similar to the incoming signal picked up by the aerial, the main differences being that it is considerably greater in strength, and, due to the frequency-changing process, its carrier is at

a lower frequency, equal to the intermediate frequency of the receiver.

In form, however, it still consists of a carrier signal modulated by the original audio frequencies which were impressed on the signal at the transmitter. Although the original signal has already undergone several changes in the early stages of the set, the audio frequency modulation remains as it was, except for amplification and for any slight changes, such as a reduction of the very high modulation frequencies, caused by sharp tuning in the stages it has passed through.

When it leaves the IF stages of the receiver, therefore, the signal has to be demodulated, rectified or "detected," just in the same way as the amplified signal in a "straight" receiver must be rectified before the AF content can be used.

The most common method of demodulation in a modern superheterodyne receiver is by the use of a diode valve, but early models used triodes, tetrodes, or pentodes for this purpose, while a metal rectifier has also been employed.

Skeleton circuits of early superheterodyne demodulators are shown in Fig. 23. At a is the cumulative grid detector, using a triode valve, although a tetrode or pentode was sometimes employed. This arrangement has the usual grid condenser (about 0.0001 μ F) and grid resistor (about 1 megohm). The cathode of the valve is generally returned to chassis, although in some cases a small bias is applied to the valve. The AF modulation appears across a load in the anode circuit of the valve (shown by a square), from which it is taken to the next stage.

At Fig. 23b is shown an RF pentode,

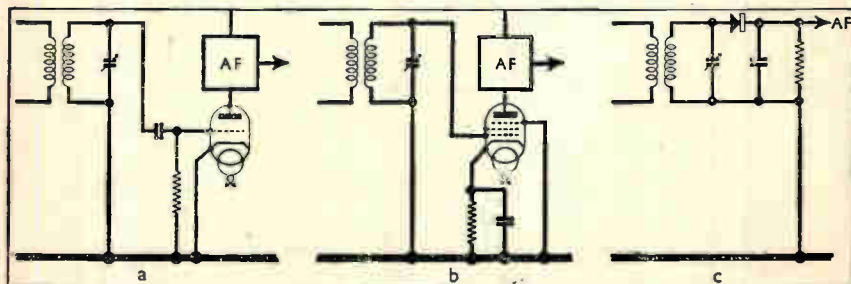

Fig. 23, a to c—Three examples of demodulator (second detector) circuits used in early commercial superheterodynes.

Radio Circuits

used as an anode bend type of detector, the valve being suitably biased by means of a cathode resistor (with by-pass condenser). The screen-grid supply is omitted for clarity. Again the AF signal is available in the anode circuit of the valve. This type of detector is uncommon, and will rarely be encountered, except in a few very old models.

The Westector metal rectifier circuit, shown in skeleton form in Fig. 23c, while not at all common, is actually a very close approach to the diode circuit which is now almost universal. This is understandable, for the Westector is actually a diode valve, though not of the thermionic type. The circuit, it will be seen, is quite simple.

The Westector is connected, in series with a resistor, across the last IF transformer secondary. The resistance forms the load across which the AF voltage is developed. Across it is a small fixed IF by-pass condenser which shunts any residual IF signals to chassis. The value of the resistor is usually about 500,000 ohms, and that of the condenser about 0.0001 μ F. From the high potential side of the load resistance the AF output can be taken and passed on to the next stage of the receiver.

It is now necessary to consider what may be termed the standard super-heterodyne demodulator arrangement, using a thermionic diode. It should be pointed out that the rectifier diode is rarely found as a separate valve on its own. It usually forms part of a multiple valve, such as a double diode, a double diode triode or a double diode pentode.

As we are only concerned at the moment with the signal diode section, the remainder of the multiple valve will be neglected for the present.

At a in Fig. 24 is shown the simplest diode demodulator circuit. One side of the final IF transformer secondary is connected to the diode anode, the diode cathode is returned to chassis, and the other side of the IF secondary goes, via the load resistance R1, to chassis. Across R1 is the by-pass condenser C1. Reference to Fig. 23c will show the resemblance between the Westector and the diode circuit.

R1 and C1 usually have values of 500,000 ohms and 0.0001 μ F respectively, and the AF voltage is available across R1, being taken off from the junction of R1, C1 and the IF secondary.

Fig. 24b shows an arrangement in which the load resistance R2 is in the form of a potentiometer, from the slider of which the AF feed is taken. It is clear that with the slider at the top of R2 the circuit is the same as that of Fig. 24a, but as the slider is moved down towards chassis the voltage tapped off from R2 progressively decreases, until with the slider at the bottom of R2 the voltage is zero. Thus the potentiometer acts not only as the load resistance, but also as a manual AF volume control. C2 is the usual IF by-pass condenser.

Fig. 24b also shows a series resistance R3 in the AF feed, which is sometimes employed as an IF stopper, to prevent any residual IF signal from reaching the AF section of the receiver. R3 usually has a value of about 100,000 ohms. C3

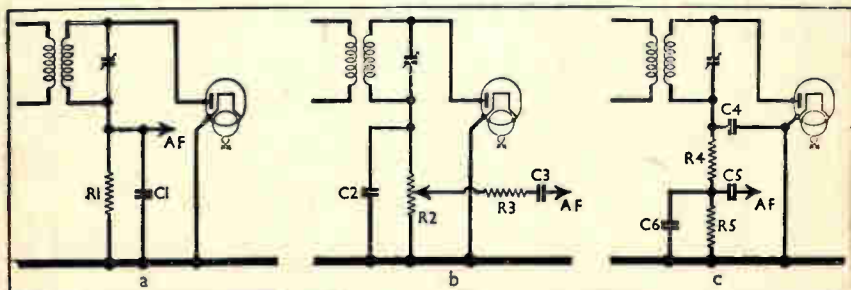

Fig. 24, a to c—Variations of the modern diode demodulator circuit. The diode usually forms part of a multiple valve.

Operation of Automatic Volume Control

is the AF coupling condenser, which was not shown in Fig. 24a, but is nevertheless necessary. The reason is that, in addition to the AF voltage present across the load resistance, there is also a DC voltage, produced by rectification of the IF carrier, which must be blocked and thereby prevented from reaching the AF stages. The value of C3 is usually between 0.005 μ F and 0.02 μ F.

Incidentally, the rectified DC voltage mentioned above is sometimes used for automatic volume control purposes where a separate AVC rectifier is not employed.

Finally, in Fig. 24c is shown a slightly more elaborate signal rectifier circuit. Here R5 is the load resistance with its IF by-pass condenser C6. R4 and C4 are an IF stopper and an extra by-pass condenser respectively. C5 is the AF coupling (and DC blocking) condenser. Typical values are C4, C6, 0.0001 μ F; C5, 0.01 μ F; R4, 100,000 ohms; R5, 500,000 ohms.

The diagrams shown do not exhaust the possible signal rectifier arrangements, but they show the principle of the circuit. Alternative circuits usually have those of Fig. 24 as a basis, but sometimes more elaborate IF filter circuits are used, and slightly different connections may be employed. From the service engineer's and student's points of view, the main thing is to locate the load resistance and AF coupling condenser, which are the key components.

In most cases, automatic volume control will be employed, and as this is often interlinked with the demodulator circuit, it will be considered in the next section.

AVC PRINCIPLES

THE automatic volume control circuit is employed in one form or another in practically every modern superhet, and is often associated with the demodulator. It seems opportune at the moment, therefore, to leave the continuation of the main circuit for a time, and to consider the automatic volume control arrangement, which really forms a branch circuit.

Automatic volume control was introduced originally to minimise the effects of a fading input signal which previously involved more or less continuous operation of the manual volume control in

order to keep the output volume fairly constant.

The automatic control achieves this by variation of the gain of one or more of the stages preceding the second detector, for which reason it is argued that the system is more accurately described as "automatic gain control." However, in popular parlance it will always be known as automatic volume control, or, abbreviated, AVC.

The principle of operation of a simple AVC circuit is not difficult to understand. It depends on the fact that the amplification of a variable- μ valve (and hence the gain of the stage in which the valve is used) is controlled by the value of its grid bias.

As the negative bias of the valve is increased, the amplification factor falls in a smooth and regular manner.

Consequently, if it can be arranged that an increase in negative grid bias is produced by an increase in input signal strength, not only can matters be adjusted so that the gain of the stage is reduced to keep the signal output roughly constant, but at the same time the stage is made capable of handling the increased input without overloading.

The method consists in feeding a suitable negative control bias to the early stages of the receiver, and now we have to consider how the control voltage is derived.

In order to provide effective control a negative voltage of up to 20V or more may be necessary and, of course, since it has to be used for bias purposes, it must be a DC voltage. In order to obtain this voltage, it is usual to make use of the IF output of the receiver, rectify it, and feed back the rectified voltage to the grid circuits of the valves which are to be controlled.

The AVC rectifier is invariably a diode, which may be the same one as is used for the signal rectification, or, more often, a separate AVC diode, which forms part of a double diode valve, a double diode triode or a double diode pentode.

The simplest possible AVC circuit is shown in Fig. 25. A diode valve is used as the rectifier, and R1 is the diode load resistance. The signal is applied to the diode circuit from the secondary of the last IF transformer, and is rectified.

The rectified current, which consists of

Radio Circuits

DC due to the carrier, on which are superimposed AF currents due to the modulation, flows through R1, and therefore produces a voltage across it. At the point A the voltage will be negative relative to the cathode of the diode, which is at earth potential.

This is because in the conducting state

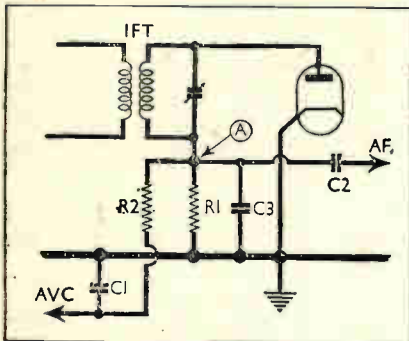

Fig. 25—The simplest AVC circuit, using a single diode for signal and AVC rectification.

of the diode negative electrons flow from cathode to anode, and leak away via the secondary of the IF transformer and R1 to earth.

Consequently, at point A we have a DC voltage proportional to the mean value of the signal carrier, together with AF voltages due to the modulation. If we apply this DC voltage as bias to the grid circuits of the valves to be controlled, it is clear that as the signal through the receiver increases, the negative bias will increase, and this will reduce the amplification of the variable- μ valves, and hence the sensitivity of the stages in which they are situated.

This, in turn, will lower the signal at the diode, and the control bias will be reduced until a balance occurs. In theory, therefore, whatever the value of the input signal, the output will remain constant. In practice, this is not perfectly true, and there are several difficulties to be overcome, as will be seen later.

It will be noted at this point that Fig. 25 is the same as Fig. 24a, but with the addition of R2 in series with the AVC line and C1 from the AVC line to chassis. These components are used to block and

by-pass RF and IF voltages to earth, and to a certain extent to smooth out the irregularities caused by the AF variations on the DC control voltage. If R2 and C1 were not present, RF and IF voltages might be fed back to the early stages and cause instability.

At the point A, of course, the AF modulation is also present, and is taken to the AF stages of the receiver, condenser C2 being used to block the passage of DC from point A which would otherwise affect the AF stages. In this circuit, therefore, the single diode acts as a demodulator and AVC rectifier.

Fig. 26 shows another simple AVC circuit in which a double diode valve is used. Here diode D1 is used solely for signal rectification, the diode load resistance R1 also acting as AF volume control. C1 is a by-pass condenser (of low value) and C2 the usual coupling condenser to the AF stages. C3, usually of a low value (about $0.00005 \mu\text{F}$) feeds a part of the signal at the secondary of the last IF transformer to the second diode (D2), which is provided with the load resistance R2.

As before, a negative voltage with respect to earth is present at A as soon as a signal reaches D2, and is tapped off and passed via the filter resistance R3 to the grid circuits of the valves to be controlled. C4 is a by-pass condenser, removing any residual RF and IF signals, and it can have a large value (say $0.1 \mu\text{F}$)

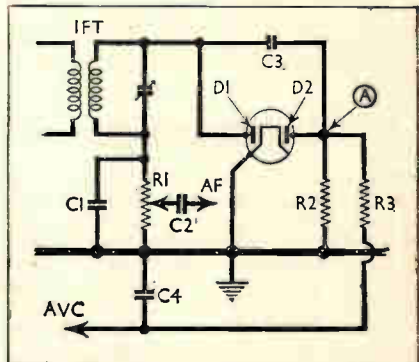

Fig. 26—A simple circuit using one diode for signal rectification and another for providing the AVC control voltage.

Methods of Obtaining Delay Voltage

in order to smooth the DC voltage (on which, of course, the AF modulation is impressed).

DELAYED AVC

THE foregoing circuits, although workable, are not often used in practice, because simple AVC as described has certain disadvantages. However, examples of them will be found in certain all-dry battery superhets using a single diode triode valve in this stage of the receiver.

The main difficulty with the simple circuits is that any signal, however small, will necessarily produce a control voltage, and will therefore be further reduced. It is obvious that a receiver which reduces the strength of signals which initially are too small to load the output valve will not be satisfactory. What is needed is some arrangement whereby all signals below a certain strength are not affected by the AVC circuits, but that above some predetermined signal strength the AVC comes into action.

This is achieved by what is known as "delayed" AVC, and this type of circuit is the one most commonly used.

Delayed AVC is very similar to the simple AVC already described, but with the addition of a means of rendering the action inoperative below a certain signal voltage.

Suppose we need a voltage of, say, 4V peak at the second detector before the output stage is reasonably loaded. Then, obviously, signals which do not reach this peak value need the full amplification available in the early stages, while more powerful signals need AVC.

It is therefore necessary to arrange that for peak voltages below 4V which reach the second detector the AVC diode must be prevented from rectifying and so producing a negative control voltage.

One way of doing this would be to apply a negative voltage of 4V to the AVC diode anode by means of a suitable bias battery. When this is done, any signal below 4V peak will not make the diode anode positive enough even on its positive half-cycles, and consequently no diode current will flow, and there will therefore be no voltage drop across the load resistance, and no control voltage produced.

Above 4V, however, the signal will

overcome the applied delay voltage on its positive half-cycles, and an AVC voltage will be produced—but naturally a lower one than if the delay voltage had not been present. By suitable choice of circuits and valves, this fact need not be a disadvantage.

Instead of applying a negative delay voltage to the diode anode of the AVC rectifier, we can achieve the same results by applying a similar positive voltage (relative to earth) to the cathode of the diode. Fig. 27 shows a double diode circuit in which this has been done, and it should be compared with Fig. 26.

It will be seen that to obtain in a con-

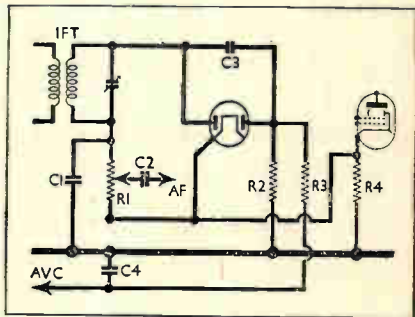

Fig. 27—Delayed AVC using the cathode voltage of the following valve as delay voltage.

venient way a positive voltage on the cathode of the double diode, relative to earth, the cathode is taken to the cathode of the following valve, which is positive to earth by virtue of its cathode bias resistance R4.

In this case the delay voltage is the same as the bias voltage of the succeeding valve, and this is often satisfactory.

If a lower voltage is needed, however, R4 can consist of two resistors in series, with the diode cathode taken to their junction. By suitable choice of values, any delay voltage up to the total bias voltage of the succeeding valve can be obtained.

It will be noted that the AVC diode load remains connected to the earth line, so that this diode anode is negative relative to its cathode by the delay voltage. As we do not wish the signal diode to be

Radio Circuits

delayed, its load resistance $R1$ must be returned to the cathode of the double diode and not to earth, as in Fig. 26.

Fig. 28 shows the delayed AVC circuit of the popular double diode triode. Here the triode section of the valve is used as the first AF amplifier of the receiver. Most of the components are as in Fig. 27. The AF voltage is passed to the triode

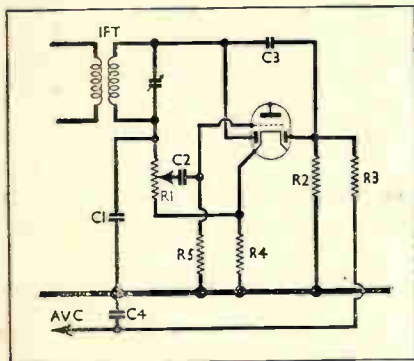

Fig. 28—Delayed AVC with a double-diode triode, using the triode bias resistor to provide delay voltage.

grid via $C2$, and $R5$ is the usual grid leak. $R4$ is the bias resistance for the triode section of the valve, and provides the requisite delay voltage for the AVC diode, the load resistance $R2$ being returned to the earth line.

The load resistance of the signal diode ($R1$) is, however, returned to the cathode of the valve to avoid placing a delay on this diode.

These are only a few of the possible arrangements, some of which are exceedingly complex. Sometimes the AVC diode load resistance is tapped, so that only a part of the available voltage is used for control purposes; sometimes the full control is applied to the frequency-changer, and only a part to the IF valve.

Much depends on the characteristics of the valves used, and the available gain in the early part of the receiver, and no hard and fast rules can be laid down.

It is a fairly common practice to feed the AVC diode, not from the secondary of the final IF transformer, but from the anode of the IF valve, via the usual small

coupling condenser. This has certain advantages, including the removal of part of the damping from the secondary of the transformer. The various filter and by-pass arrangements used also differ widely; some sets use the minimum of components for this purpose; others employ elaborate arrangements.

Care has to be taken in the design of AVC circuits to avoid the introduction of distortion which may arise if the various circuits are not correctly proportioned.

Amplified AVC has a number of advantages, but its complication is seldom worth while in the average receiver, as it often involves the use of an extra valve.

Quiet AVC was introduced to avoid the heavy background noise which occurs as one tunes between two stations and the gain of the set rises to maximum. It functions by rendering the signal diode inoperative until a signal of acceptable strength is applied, so that between stations the set is silent.

Turning to the controlled valves, the arrangements here have already been touched upon on pages 8-9, but will be repeated here for convenience. Fig. 29 shows two arrangements for applying the control voltage. In each case L is part of the tuned circuit preceding the valve, and $R1$ is a fixed bias resistance which assures the valve receiving its correct minimum bias, even when no negative control voltage is present.

In each case also the control voltage is fed to the grid via $R2$, either through the coil L , or, if there is no DC connection from L to the grid, $R2$ is connected to the grid. $C1$, in the left-hand diagram, places the bottom of L at chassis potential as far as RF is concerned; in the right-hand diagram $C1$ is the existing grid condenser, and the bottom of L is connected directly to chassis. $C2$ is then used as an RF and IF by-pass. $R2$ also provides a certain amount of decoupling in the grid circuit, assisted by $C1$ (left diagram only).

AVC CIRCUIT VARIATIONS

THE last section, dealing with the most common forms of delayed automatic volume control, gave sufficient information to enable this part of the

Application of AVC Voltages

circuit to be understood and traced out in a complete circuit diagram.

It will be gathered from a study of a number of complete circuit diagrams that although the principles already described are almost universally followed, slight variations are introduced by certain designers. One of these variations is in the particular valves which are controlled, and another is in the amount of control applied to each.

In practically all cases the full available control voltage is applied to the frequency-changer valve, the mixer section of which is, of course, of the variable- μ type. The only exception to this is that in many cases no AVC is applied to this valve on the short-wave band or bands. Certain types of frequency-changer operate best on short waves with fixed bias, and in this case an examination of the circuit will show that the grid return (usually the bottom of the tuned input circuit) on the SW band is connected not to the AVC line, but to chassis. On the MW and LW bands, however, AVC is applied as usual.

Where an RF stage is used prior to the frequency-changer, AVC will be applied to the RF stage and the frequency-changer. In this case it is often preferable to operate the IF stage with fixed bias, for the efficiency of the AVC action is not seriously reduced, and the possibility of the IF stage introducing harmonic distortion is reduced.

Alternatively, the IF valve can be supplied with a fraction of the total available control voltage, and this is often found also in receivers which have no RF stage. This arrangement is achieved by replacing the single AVC diode load resistance by two resistances in series, forming a potentiometer. The total resistance of the potentiometer will be the same or similar to that of the single resistor normally used.

The total control voltage available is taken from the diode end of the load potentiometer as usual. The lower voltage is taken from the junction of the two resistors forming the potentiometer. Obviously, any fraction of the total voltage available can be obtained from this point by suitably choosing the relative values of the two resistances. Very often they are equal, giving half the total voltage at the tapping, but the ratio may

be as high as five to one in certain receivers.

Occasionally three resistors in series are used as the AVC diode load to provide the total AVC voltage and two lower values. For instance, the RF stage may receive the maximum AVC voltage, the frequency-changer three-quarters of the maximum and the IF stage half the maximum.

Each additional tapping increases the number of components necessary, for each feed circuit usually needs a series filter resistor and a by-pass condenser.

When two IF stages are used in the receiver it is usually, but not invariably, the practice to operate the second IF valve at fixed bias.

The time constant of the feed circuit, that is, the time taken for the condensers in the circuit to charge up to a certain fraction of the feed voltage (or to discharge to a certain fraction of the initial voltage), is a point which has to be borne in mind by the designer of the circuit if unpleasant effects are to be avoided. The time constant controls the speed at which changes in the AVC potential act on the controlled valves. If this speed is too great, distortion or reduction in the bass response of the set may occur; too slow a time constant will not allow the AVC

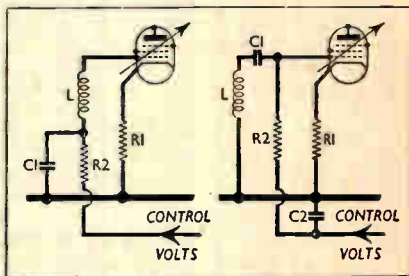

Fig. 29—Two methods of applying the control voltage to the grid circuit of a controlled valve.

circuit to follow rapid changes in input signal, such as fast fades on the short waves.

The charging time constant in the case of a simple circuit is proportional to the product of the value of the series feed resistance and by-pass condenser, but for circuits with several feeds and filters it is much more complicated.

Radio Circuits

Obviously, however, increasing the value of either the filter resistances or condensers will increase the time constant, and vice-versa.

There is always a temptation when repairing a receiver to replace a component which is apparently unimportant by one of a different value if the correct one is not immediately available. In the case of AVC filter components serious changes in value should not be made on account of the change in time constant which they will introduce.

It will also be readily understood that any major changes in value of these components (which is particularly likely in the case of resistors) which occur in use may give rise to faults which would normally be difficult to trace to their origin.

Whereas in the case of indirectly heated valves the delay voltage for the AVC rectifier is usually obtained by making the cathode of the diode valve positive relative to chassis by the required amount (as described in the last section), in the case of directly heated battery valves this method cannot be used. It is customary in this case to take the bottom of the AVC diode load resistance to some point which is *negative* relative to chassis, and thus the diode anode is made negative to chassis, which, as was seen in the last section, is the same as making the cathode positive to chassis.

The necessary negative delay voltage (together with other bias voltages needed in the receiver) can be obtained in two ways. One is by the use of a grid bias battery, one cell of which is used to give 1.5 V delay by connecting the AVC load resistance to this point.

In other cases part of the grid bias battery has connected across it a number of resistors in series, in the form of a potentiometer, the resistors being chosen to provide the desired delay voltage (and other bias voltages) at the tapping points.

A more common method is to employ automatic bias, which eliminates the need for a grid bias battery. In this case, instead of connecting the negative end of the HT battery to LT negative (and chassis), it is connected to one end of a chain of resistors in series, the other end of this chain going to LT negative. Since the total HT current of the receiver flows through the resistors, a voltage is de-

veloped across them, and the tappings at the junctions of the resistors provide fractions of the total available across the whole potentiometer. Often only two resistors are used, the AVC load resistance being taken to their junction.

Examples of this arrangement are seen in many battery superhet circuits. Often an electrolytic by-pass condenser is shunted across the potentiometer from HT negative to LT negative, in which case it should be noted that the *positive* connection of this condenser goes to LT negative (and chassis).

Certain battery receivers employ a special indirectly-heated double-diode battery valve for demodulation and AVC. In this case some manufacturers return the AVC load resistance to a negative point relative to chassis, others return this resistance to chassis, and connect the cathode of the valve to a point positive relative to chassis, while others use a combination of the two methods, the voltages so obtained being additive.

AF AMPLIFICATION

FOLLOWING the demodulator stage (and returning once more to the main circuit of the receiver), we come to the section which provides audio frequency amplification, but before considering the AF amplifier stage or stages in detail, it is important to realise what the amplifier has to do. To return to the demodulator (second detector) stage for a moment, it will be remembered that the function of this stage is to remove and make available for further amplification the AF modulation of the amplified IF signal. At the demodulator we have the AF voltage developed across a load in the anode circuit of the valve, or, in modern sets, across the signal diode load resistor, and, as was shown in the diagrams in Figs. 23 and 24, this voltage is tapped off and passed to the AF stages of the receiver.

It must be pointed out here that the AF output obtainable from the demodulator is quite inadequate to operate a loudspeaker. For this purpose the power required is considerably greater than could be drawn from the receiver at this stage. Voltage in itself is useless for this purpose, and in the AF stages of the receiver, although the voltage

Basic Form of Resistance Coupling

obtained from the demodulator may be amplified, one of the main functions of the stages is to provide AF power. At the demodulator, the power available is of the order of a milliwatt or less, whilst the loudspeaker requires anything from 100 mW to 5 W or more. Consequently, the AF amplifier must provide a high degree of power amplification.

This may be obtained in several ways, depending on the types of valves used. For instance, there may first be one stage of voltage amplification, followed by a stage of power amplification in which one or more output valves are used; at the other end of the scale, using a modern high-efficiency output pentode or tetrode, the output from the demodulator may be fed, via a suitable coupling, direct to the output valve, without any intermediate stage of amplification.

Whatever arrangement is used, the first step is to feed the AF signal from the demodulator to the grid of the following valve, whether this is a voltage amplifier or the output power valve. For this purpose it is necessary that some form of AF coupling be used, and the two usual basic forms are resistance-capacity and transformer coupling. These basic forms are sometimes modified, as will be seen later. Fig. 30a shows the basic form of resistance-capacity coupling, which is almost invariably used for coupling the demodulator to the next stage.

R1 represents the demodulator load resistance (which will be in the anode circuit of a triode, tetrode or pentode used in early superhets, or will be the signal diode load resistance in sets using diode demodulation). Between the high AF potential end of R1 (the anode end

in the case of triodes, etc., and the end remote from chassis in the case of diodes) and the grid of the following valve is the fixed condenser C1 which permits the AF voltages to pass, but isolates the succeeding part of the circuit as far as DC is concerned.

R2 is the grid resistor of the succeeding valve across which the AF input voltage to this valve is developed, and via which grid bias is applied to the valve. R3 is the usual cathode bias resistor, by-passed by the condenser C3.

This resistor, of course, makes the cathode of the valve positive to chassis, and since the grid is returned to chassis via R2, the cathode is equally positive to grid, or, in other words, the grid is negative to cathode, which is the correct condition.

The values of R1, C1, R2, and R3, while not critical, have to be carefully chosen by the designer, and should not be subsequently varied to any appreciable extent. The value of R1 may vary between wide limits according to the circuit in which it is used. C1 may vary between $0.001\mu\text{F}$ and $0.1\mu\text{F}$, but is not usually greater than $0.01\mu\text{F}$ where it is used to couple the demodulator circuit to the next stage. R2 usually has a value of from 250,000 Ω to 5 MO, the higher values being used when C1 is of low value. The value of R3 depends on the valve in use, while C3 usually has a value of 25 μF or 50 μF , and is, of course, of the low voltage electrolytic type.

Turning now to the transformer-coupled AF stage, this is represented basically in Fig. 30b. Here T1 is an iron-cored AF transformer, with a step-up voltage ratio of about 1 to 3 between primary and secondary winding. The

Fig. 30, a and b. a—Basic resistance-coupled AF stage. b—Basic transformer-coupled stage.

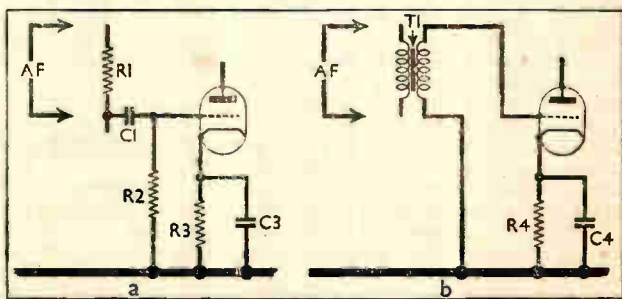

Radio Circuits

primary acts as the load impedance across which the AF voltage to be amplified is developed. A higher voltage is developed across the secondary of transformer T1 and applied between the grid of the following valve and chassis. This valve has the bias resistance R4 in its cathode circuit, by-passed by C4.

Bias is applied to the grid of the valve via the secondary winding of the transformer, and since there is no DC connection between primary and secondary,

of the core and consequent distortion; in fact, the transformer can be designed to give an excellent response at considerably less cost than would be the case in a normal transformer-coupled stage. Another advantage is that the step-up of voltage introduced by a transformer is retained.

Another variation of straightforward transformer coupling is shown in Fig. 31b. This is known as auto-transformer coupling, T3 being an auto-transformer,

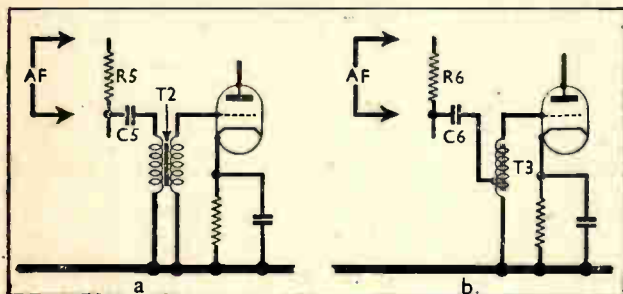

Fig. 31, a and b: a — Basic circuit of parallel-fed transformer coupling. b — Auto-transformer circuit.

the input and output circuits are isolated as far as DC is concerned.

Various considerations of design make it impossible to use transformer coupling as described in certain parts of the circuit, e.g., between a diode demodulator and the succeeding stage, but it is often used to couple one AF stage to the next, particularly in cases where the step-up of voltage between primary and secondary (not obtained with resistance coupling) can be utilised to advantage.

In place of pure transformer coupling, it is quite common to use parallel-fed transformer coupling. This is shown in Fig. 31a, where the primary of the transformer T2 is fed from the high AF potential end of a load resistance R5 via the coupling condenser C5. The secondary of T2 is connected between the grid of the following valve and chassis as before. Comparison of this circuit with those of Figs. 30a and 30b shows that parallel-fed transformer coupling is really a combination of resistance and transformer coupling. One advantage of it is that the transformer primary carries no DC, as it does in Fig. 30b, where its primary is usually in series with the preceding valve anode circuit.

There is therefore no risk of saturation

with a single winding which is tapped to give a step-up ratio between input and output. Actually, although called a transformer, T3 is really a tapped iron-cored choke. It is parallel-fed by R6 and C6, the "primary" being the section of T3 between the tapping and chassis, and the "secondary" the whole winding, connected in the grid circuit of the following valve.

A modification of resistance-capacity coupling is sometimes encountered in which the load resistance R1 in Fig. 30a is replaced by an iron-cored choke. This is known as choke-capacity coupling, and is not very common in ordinary receivers.

So much for the basic outline of resistance-capacity and transformer coupled stages and their simple variations; let us now consider a few practical applications.

PRACTICAL AF CIRCUITS

TAKING first of all the stage following the demodulator, it can be said that in the case of old superhets where the demodulator was a triode, tetrode or pentode, the circuit of Fig. 30a is correct if R1 is placed in series with the anode

Introducing Volume Control

circuit of the demodulator valve.

In the case of superhets with diode demodulators, a typical circuit is in Fig. 32a. Here the first valve is the diode demodulator and the second the first AF amplifier, which is a separate triode. IF stopper resistors and by-pass condensers are not shown for reasons of clarity, while the AVC arrangements are also omitted. R7 is the signal diode load resistance, and C7, taken from the high AF potential end of R7, is the AF coupling condenser.

At this point it is customary for volume control arrangements to be introduced in practically all modern superhets which have only one AF stage. This is usually achieved by means of a variable potentiometer connected so as to pass anything from zero to the full available AF voltage to the grid of the AF valve. In Fig. 32a, R8 is the volume control potentiometer, with one end connected to chassis. The other end is connected to C7, so that across R8 the whole of the AF voltage passed on from the demodulator stage is developed. The variable contact, or slider, of R8 is connected to the grid of the AF valve.

It will be seen that the portion of R8 included between the slider and chassis becomes the grid resistor of the AF valve, and provides the necessary grid return to chassis, enabling the bias voltage developed across R9 to be applied to the valve.

The minimum volume will be obtained with the slider of R8 near the chassis end of this component, the maximum being obtained when the slider is moved

to the end of R8 which is connected to C7.

Since in an AF voltage amplifier which is correctly operated there will be no grid current flowing, R8 does not have to carry any appreciable direct current, and the speech current flowing through it is very small, so that its power dissipation is negligible. Consequently types employing carbon tracks can be employed with success, and wire-wound types are not necessary. This is all the more important because the resistance value of R8 in the position shown may be 1 or 2 megohms. The connection between the two cathodes is necessary to provide AVC delay voltage, as was explained in the section dealing with delayed AVC.

Fig. 32b shows how the circuit of Fig. 32a is altered when a double diode triode valve is used in place of the separate diode and triode types. A comparison will show that, apart from the omission of the connection between the two cathodes in Fig. 32a (which is virtually present because the single cathode of the double diode triode serves both the diode and the triode sections), there is no electrical difference between the two circuits. R10 corresponds to R7, R11 to R8, R12 to R9 and C8 to C7, and their values are the same in each case, providing that the multiple valve has the same characteristics as those of the two separate valves.

Fig. 32c shows a circuit somewhat similar to Fig. 32b, except that a rearrangement has been made. It will be noted that the potentiometer volume control R13 now acts as the signal diode

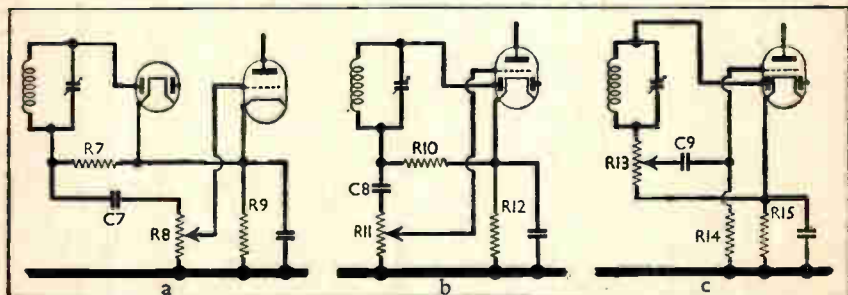

Fig. 32, a to c—Three examples of AF resistance coupling following a diode demodulator.

Radio Circuits

load resistance, the ends of the element being connected between the bottom of the secondary of the last IF transformer and the cathode of the valve. The slider of R13 is taken via the usual AF coupling condenser C9 to the grid of the triode section, while R14 is the grid resistor. R15 is the usual bias resistor.

The difference between Fig. 32b and Fig. 32c, therefore, is that R13 and R14

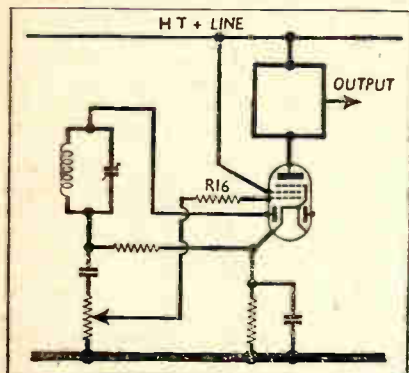

Fig. 33—Diode demodulator resistance-coupled directly to the output stage.

are interchanged, relative to R10 and R11. Both circuits are commonly encountered. It should be pointed out that the value of the grid resistor in an AF amplifier is usually several times that of the preceding load resistor. Consequently, R11 has a higher value than R10, and R14 has a higher value than R13. Thus R11 may be 2 megohms and R10 500,000 ohms, whilst R14 may be 2 megohms and R13 500,000 ohms.

It was mentioned earlier that in certain cases where a high efficiency output valve is employed one can couple the output from the demodulator stage directly to the grid of the output stage, and so obviate the need for an intermediate stage of AF voltage amplification. A typical circuit, omitting minor details, is in Fig. 33, where the valve is a double diode-output pentode.

As will be seen, except for the valve the circuit is almost identical to that of Fig. 32b. In the anode circuit of the valve is the load impedance in which the AF power is developed. This load is

usually the output transformer coupling the valve to the loudspeaker.

The only component worthy of special note is R16, a resistor connected in series with the grid circuit, close to the grid of the valve. This is known as the grid stopper resistor, and prevents any residual RF or IF voltages from reaching the grid of the valve where, in the case of a high efficiency type such as is being discussed, they might cause incipient or actual instability.

R16 may be anything from 5,000 to 100,000 ohms and is often situated in or close to the top cap connector of the valve, in cases where this has its control grid brought out to the top cap.

SECOND AF STAGES

IN the previous section the various forms which the coupling between the demodulator and the first AF valve may take were described and illustrated.

We now come to the next AF stage, which in most cases leads to the output valve or valves. The circuit in which the demodulator is coupled directly to a high-efficiency output pentode or tetrode (described at the end of the last section) is popular in many of the smaller receivers, but the more general practice is to have the demodulator coupled to a first AF valve, which in turn is coupled to the output valve.

In this case, as was seen in the last section, the first AF valve is usually a triode, either on its own, or in the same envelope as the double diode demodulator and AVC rectifier.

At this juncture it will be best to deal with mains receivers first, since battery models sometimes use different couplings which will be covered later. Undoubtedly the most popular arrangement for coupling the first AF valve to the second AF or output valve is the resistance-capacity arrangement which, as was seen in the last section, is also more or less the standard form for the previous AF coupling.

Fig. 34a shows the simplest form of resistance-capacity coupling between the first AF valve (the triode section of a double diode triode) and the output valve (in this case a pentode). R1 is the triode anode load resistance, usually from

Elaboration of the Simple RC Circuit

50,000 to 250,000 ohms except in special cases; C1 is the AF coupling condenser (0.01 to 0.1 μF); R2 the grid resistor of the output valve (250,000 to 500,000 ohms); R3 is the automatic bias resistance to suit the output valve, with C2, its by-pass condenser (usually 25 or 50 μF). C3 is a fixed tone correcting condenser for the output pentode, which is quite distinct from any tone control device which may be fitted. Its value is usually between 0.001 μF and 0.01 μF .

Basically this circuit is the same as the elementary resistance-capacity circuit shown in a previous section. An elaboration of it is shown in Fig. 34b. Here R5 corresponds to R1 of Fig. 34a; C6 to C1; R6 to R2; R8 to R3; C7 to C2; and C8 to C3. This leaves us with the additional components R4, C4, C5, R7 and R9.

R4 and C4 form a "decoupling" arrangement, which, incidentally, is often used in other anode and screen circuits in the receiver in a similar form. R4 tends to prevent AF currents from getting into the HT supply circuit, whence they might be fed to the anode circuits of other valves and give rise to instability. C4 completes the circuit to chassis for AF currents to return to chassis via C4 than via R4 and the HT supply circuit, and accordingly they take the line of least resistance and do not enter the HT

circuit to any appreciable extent. The efficiency of the decoupling depends on the product of C4 and R4, and both should be as large as convenient. In practice, the value of R4 depends on how much DC voltage drop from the HT line to the top of R5 can be allowed, and is usually of the order of 5,000 to 20,000 ohms. For C4 a value of 2 to 8 μF is common, the condenser being of the electrolytic type. Incidentally, it will sometimes be found that C4 and R4 are omitted in certain models.

C5, which is a by-pass condenser for any residual IF currents which may have got as far as the anode of the first AF valve, will have a value of 0.0001 to 0.0005 μF .

R7 is a grid stopper for the output valve, having a value of from 5,000 to 100,000 ohms. Its use was described on page 38. R9 is an anode stopper, sometimes used with high efficiency valves to assist in obtaining complete stability. It will usually have a low value, of the order of 50 ohms.

It will be noted that the output valve shown in Fig. 34b is not a pentode, but a beam tetrode. The two are more or less interchangeable, and in place of the suppressor in the pentode, connected internally to the cathode of the valve, the beam tetrode has its special beam-forming shields connected internally to cathode. Either valve can be used in either circuit.

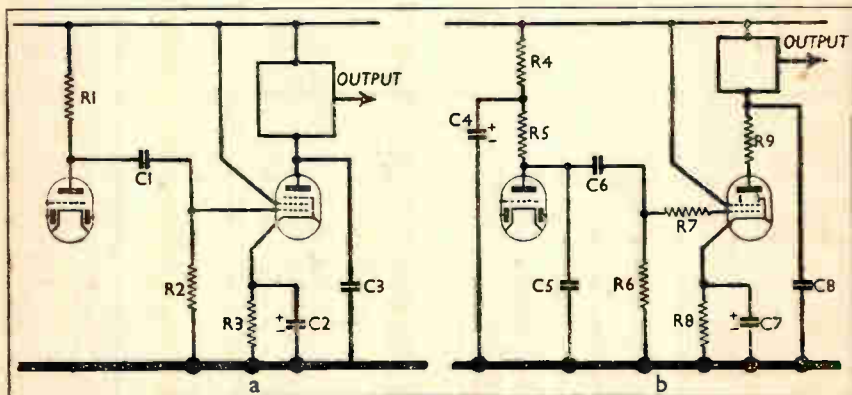

Fig. 34, a and b. a—Simplest form of resistance-capacity AF coupling between two stages. b—An elaboration of the simple circuit, showing decoupling, by-passes and stoppers.

Radio Circuits

Before leaving Fig. 34b, it should be pointed out that some of the additional components shown may be omitted in certain sets—in fact, very few will have all those shown.

Where a large power output is re-

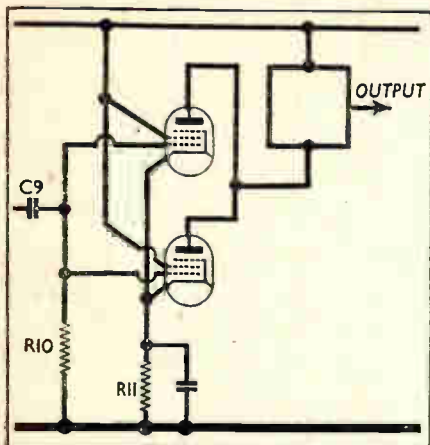

Fig. 35—Basic arrangement of two output valves in parallel.

quired, one can either use a single output valve which gives the requisite power, or one can employ two or more lower-powered valves. If two valves are used (and it is very uncommon in domestic receivers to find more than two valves in the output stage) these valves

can be connected in one of two ways—in parallel or in push-pull.

Paralleled output valves are not often encountered in modern receivers, but for the sake of completeness the arrangement is shown in Fig. 35. This shows two identical output pentodes connected in parallel, and it will be noted that the two cathodes, the two control grids, the two screens and the two anodes are each connected together.

C9 is the usual coupling condenser, and R10 is the grid resistance common in both grid circuits. The screens are connected to the HT supply, and R11 is the common cathode bias resistance. Since the cathode current will be twice that of a single valve, the value of R11 will be half that which would be used for a single valve, so that the same voltage drop across R11, and, therefore, the same bias voltage, is obtained. The load impedance (shown by a square in series with the anode circuit) will also be half the value required by a single valve.

PUSH-PULL RC STAGES

The use of two valves in push-pull in the output stage is more common than the parallel arrangement. The push-pull circuit is quite easily arranged where transformer AF coupling is used, but as we are considering resistance-coupling at the moment, this arrangement must be examined first. In the push-pull circuit, the valves must work 180 degrees out of phase with each other. Signals of equal

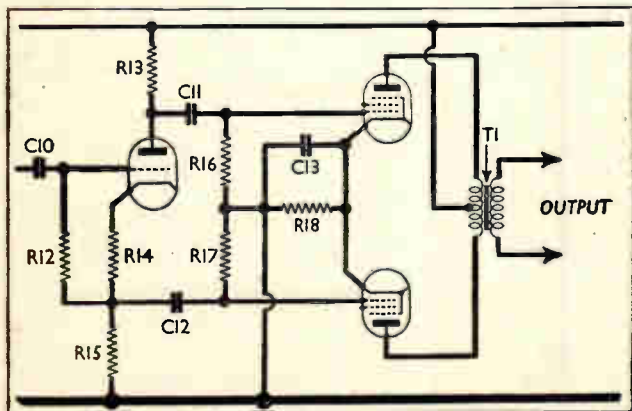

Fig. 36—Push-pull RC coupling, with a phase-splitting valve.

Phase-Splitting Arrangements

voltage but opposite phase are fed to the respective control grids of the two valves, and the resulting separate anode currents, which are also in opposite phase, must be re-combined in such a way that they do not cancel each other out, but assist each other.

The difficulty with resistance coupling preceding the push-pull valves is to split up the input in the correct manner. In fact, a separate phase-splitting valve has to be used for this purpose. One circuit

of the phase-splitter and at the junction of R14, R15 are approximately equal in value, and in opposite phase, which is the requisite state of affairs for feeding the two output valves.

The anodes of the output valves are connected to the opposite ends of the primary winding of the output transformer T1, and the HT supply is fed into a centre-tapping. In this way both valves receive their DC anode supply, and the out-of-phase anode currents are

*Fig. 37 —
Another
method of
arranging the
phase-splitter.*

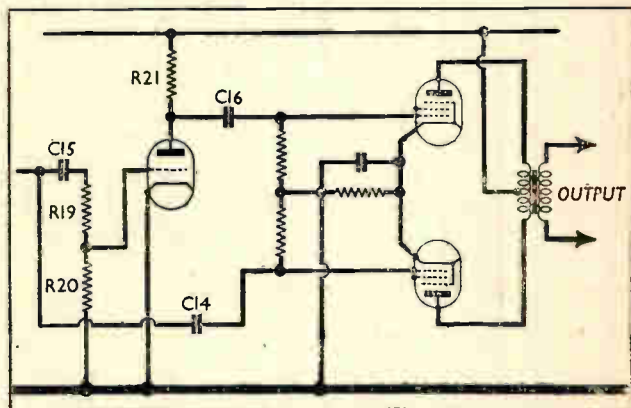

used for this purpose is shown in Fig. 36. Here the output from the first AF amplifying valve is fed to the phase-splitting valve (usually a triode) via the coupling condenser C10. R12 is the usual grid resistor, returned to the bottom of the bias resistor R14. Between this and chassis is another cathode resistor, R15, which is equal in value to the anode load resistor R13.

The anode of the phase-splitter is coupled via C11 to the grid of one of the push-pull output valves, and the junction of R14, R15 is coupled via C12 to the grid of the other output valve. R16 and R17 are the grid resistors of the two output valves, and R18, shunted by C13, is the common bias resistor for the two output valves. The junction of R16 R17, R18 and C13 is returned to chassis.

The result of this arrangement is that, owing to a degenerative effect, the phase-splitting valve has a very low gain, in fact it does very little amplification at all. However, the signals at the anode

re-combined in phase.

The diagram of Fig. 36 is a basic one and does not include decoupling, stopper or tone compensation arrangements, which will be similar to those shown in Fig. 34b. The screen HT feeds are also omitted.

Another arrangement for phase-splitting is shown in Fig. 37. Here the input from the preceding stage is fed via C14 direct to one of the output valves. It is also fed, via C15, to a potentiometer R19, R20, and the grid of the triode phase-splitter valve is taken to the junction of R19, R20. The values of R19 and R20 are so chosen that the input voltage to the phase-splitter is stepped down to an extent which just balances the amplification obtained in the valve. In this way the AF signal voltage at the anode of the phase-splitter can be made equal to that fed to C14 and C15, but owing to the phase reversal introduced by the valve, it will be in opposite phase. It is fed via C16 to the other output valve, and the

Radio Circuits

rest of the circuit is the same as that in Fig. 36.

In a typical case where the amplification factor of the phase-splitting valve is about 15, R19 is made 500,000 ohms, and R20 is 35,000 ohms, so that the

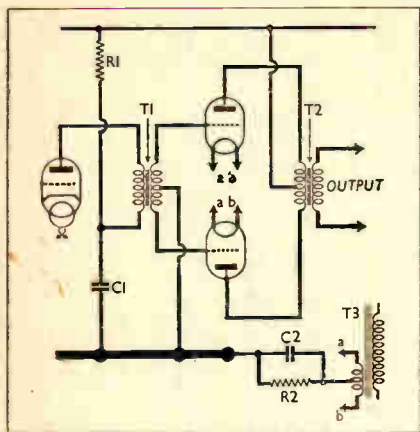

Fig. 38—A push-pull transformer-coupled output stage using two directly-heated mains valves. Note the method of obtaining grid bias in this case.

signal at the grid of the phase-splitter is about one-fifteenth that which is applied to C14 and C15. Thus the signals applied to C14 and C16 will be roughly equal, and in opposite phase.

TRANSFORMER COUPLING

LEAVING the subject of resistance-capacity AF coupling, we come to transformer coupling. Basic transformer circuits were illustrated in Fig. 30b and Fig. 31a and b. A complete diagram is hardly necessary, since except for the insertion of the primary of T1 (Fig. 30b); resistance R5 (Fig. 31a), or resistance R6 (Fig. 31b) in series with the anode circuit of the preceding valve, the circuits are virtually complete. Decoupling of the anode circuit is often employed, together with the by-pass, stopper and tone compensation arrangements covered on page 39. The output valve is usually a pentode or tetrode, of course.

For increasing the output beyond that given by a single valve, push-pull trans-

former coupling is often employed. An example of this applied to a mains receiver, and using two triode power valves in the output stage, is given in Fig. 38.

It will be seen that the inter-valve transformer T1 has its primary in the anode circuit of the first valve, R1 and C1 being the anode decoupling resistance and condenser respectively. The ends of the secondary of T1 go to the control grids of the two triode output valves, while its centre-tap goes to chassis. In this way the AF voltages applied to the grids are made equal in value, but opposite in phase, which, as was seen in the last section, is a necessary condition for push-pull operation.

The output transformer T2 has its primary winding centre-tapped. The ends go to the anodes of the two output valves, while the centre-tap goes to the HT positive line. It thus feeds the anodes with their HT supplies, while the AF outputs from the two valves are recombined in-phase and fed to the loud-speaker from the secondary of T2.

A point to note about Fig. 38 is that the output valves in this case are of the directly-heated type. This is not a necessary condition, but it so happens that many large triode power valves are directly-heated. This affects the method of obtaining bias. With indirectly-heated valves, the two cathodes would be connected together and a common bias resistance inserted in the lead from cathodes to chassis.

The method of obtaining bias in the circuit of Fig. 38 is different. The filaments of the valves are wired in parallel and are fed from a winding on the mains transformer T3, which is quite separate and distinct from that used to supply the other valves in the set. This winding is centre-tapped, and between the centre-tap and chassis is connected a resistance R2 which acts in the same way as a cathode bias resistance used with indirectly-heated valves. The HT current of the two valves flows through R2, and causes a voltage drop across it which is positive relative to chassis. As the grid circuit of the output stage is returned to chassis via the centre tap of the secondary of T1, the grids are made *negative* to the filaments by the amount of the voltage dropped across R2. C2 is a by-pass condenser across R2.

Quiescent Push-Pull Principles

QPP AF COUPLING

LEAVING the AF stages of mains receivers, we come to battery models. Ordinary resistance coupling and "straight" transformer coupling, as well as the parallel-fed and auto-transformer versions of this are largely used, but in addition there are two special forms of push-pull which are often encountered in battery models. Both are designed to provide a large output with the minimum HT current consumption, low HT consumption being an important feature for the designer to achieve.

The actual circuit arrangements of these two special forms of push-pull are almost identical with each other and with that of normal ("Class A") push-pull. The difference lies in the valves, and the manner in which they are operated.

The first arrangement is known as "quiescent push-pull," usually abbreviated to QPP. This depends for its special properties on the over-biasing of the push-pull output valves. If a single valve were employed with negative bias above normal, distortion would result, but by using two valves in push-pull the type of distortion produced by over-biasing is cancelled out. The effect of the excess bias is to reduce the "standing" or quiescent anode current of the output stage, when no signal is arriving, to a very small value. When an AF signal is fed into the stage, the grid of one of the output valves is made more positive

(less negative) at the same time as the grid of the other valve is made more negative, and vice-versa. Each valve only amplifies when its grid becomes less negative, its anode current rising with increase in the signal voltage.

With large signals, the average anode current and the power output of the stage is the same as in a normal push-pull stage, but with small signals the average current is low. Thus during a musical programme, where the full output of the stage is only required for momentary peaks or crescendos, the average anode current over a period will show a distinct saving compared with an ordinary push-pull stage.

A QPP stage requires twice the input voltage which a normal push-pull stage needs for a given power output, consequently pentodes are usually employed on account of their superior sensitivity over triodes. Special double-pentode QPP output valves are popular for use in this type of circuit, an example of which is in Fig. 39.

Here the primary of the QPP intervalve transformer T4 is parallel-fed by resistance R3 and condenser C3.

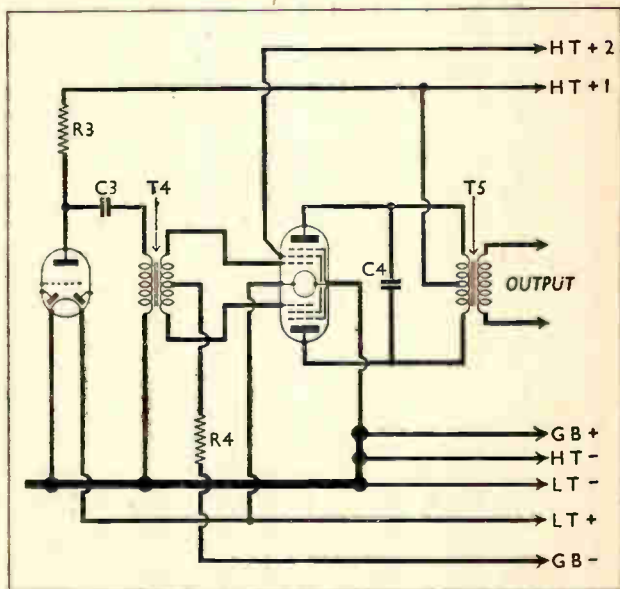

Fig. 39—Arrangement of a battery receiver output stage using quiescent push-pull in conjunction with a special double-pentode valve.

Radio Circuits

output valve is a special double-pentode in which the two suppressor grids are connected internally to one side of the double filament, while the two screens are also connected internally and brought out to a single pin, fed from the HT+2 tapping. The two control grids are quite separate and are fed from the ends of the secondary of T4, the centre tap of which goes, via resistance R4, to a grid bias tapping. R4 is a stabilising resistance of 100,000 to 250,000 ohms, which is usually fitted.

The anodes of the output valve go, to the two ends of the primary of the output transformer T5, of which the centre tap goes to HT+1. The secondary, of course, feeds the loudspeaker. C4 is a tone compensation condenser across the primary of T5.

It will be observed that, except for the use of the special valve, the circuit does not differ from that of an ordinary push-pull stage. The difference lies in the design of the input and output transformers and the fact that the grid bias used is greater than would be the case in ordinary push-pull. It is usually between $7\frac{1}{2}$ and $10\frac{1}{2}$ volts, whereas half these values, or less, would be used for ordinary push-pull.

There is no reason why two pentodes of similar characteristics could not be employed in place of the special valve, but the latter is more convenient in use.

CLASS B AF COUPLING

THE second special form of push-pull coupling largely used in domestic battery receivers is known as "Class B" coupling. This also takes a small anode current under "quiescent" conditions, but differs in that the valves used are generally triodes with a high impedance, which operate with a very low value of bias and only take a small current by virtue of their high impedance.

When a signal is applied to such a stage, the grids of the valves are alternately made more negative and more positive. Under more negative conditions, the valve concerned does not amplify, since the anode current is practically cut off, but with the grid under "more positive" conditions, the valve does amplify, and with the push-pull

arrangement the distortion which would arise is cancelled out.

When the grid of one of the valves is made positive, however, another effect takes place, which does not occur in QPP coupling. Grid current flows in the grid circuit, which, in any ordinary AF stage, must not be allowed to occur. With Class B coupling, arrangements are made whereby grid current can be handled. The flow of grid current necessarily involves a consumption of AF power in the grid circuit of the output stage, and this power must come from the preceding stage. Therefore, with Class B coupling, the preceding valve must be arranged to supply power to drive the grid circuit of the output stage without overloading. It is usual to call this preceding stage the "driver" stage, and it consists of a "driver" valve (usually a lower-power triode) coupled by a Class B "driver" transformer to the output stage. The driver transformer is specially designed for the job, and its windings have a low resistance and are capable of handling power, not only in the primary, but in the secondary as well. The ratio of the driver transformer is usually low.

The complete circuit is shown in Fig. 40. Once again a special valve is used in the output stage, this time consisting of two high-impedance triodes in the same envelope. Two separate valves of similar characteristics could be used.

The first valve is the driver, coupled by the driver transformer T6 to the double output valve. The centre tap of its secondary goes to a low value of grid bias, and in some sets may even be found to go to chassis, thus operating without external bias. T7 is the output transformer arranged in the usual way, with a tone compensation condenser across its primary winding. Note that there is no resistance in the grid bias lead in this case.

A point about both QPP and Class B stages which does not emerge from a study of the circuit diagrams is that the HT supply, owing to the fluctuating demands upon it which are characteristic of both these stages, must be of good "regulation." This means that the HT voltage must not vary appreciably with the working load. If it does vary, distortion is likely to be introduced. An HT battery in good condition fills the

Moving-Coil Loudspeaker Details

requirements, but a partially discharged one, or one which has developed a high internal resistance, will not be satisfactory. If an HT battery eliminator is used with a set of this type, trouble is often encountered unless the eliminator has been specially designed for QPP or Class B supply.

LOUDSPEAKER ARRANGEMENTS

As was seen in the preceding sections, the final stage of AF amplification feeds the output valve or valves, and the AF power in the anode circuit of the output stage is passed on, via a suitable transformer, to the loudspeaker. This transformer may be mounted on the chassis of the receiver or on the frame of the loudspeaker, but its use is the same in each case.

All modern receivers employ a moving-coil type of loudspeaker, with the winding of the speech-coil of low impedance. The anode circuit of the output stage is of high impedance, and since for maximum transference of power the impedance of the load should equal the impedance of the source, the output transformer is used for matching the loudspeaker speech coil to the output stage. For instance, a beam tetrode output valve may have a

recommended matching impedance of 2,000 ohms, while the loudspeaker used with it may have a coil impedance of 5 ohms. In order to arrive at the correct ratio for a suitable matching transformer, 2,000 is divided by 5, and the square root of the result gives the correct ratio. In this case it works out at 20, so that the transformer has a 20 to 1 step-down ratio.

Moving-coil loudspeakers may be of the permanent-magnet type, or they may have an electro-magnet energised from the HT supply of the receiver. Fig. 41a shows the output circuit with a permanent-magnet loudspeaker. Here T1 is the output transformer with its primary in the output valve anode circuit (with push-pull circuits the primary will be centre-tapped; see previous sections) and its secondary connected to the loudspeaker speech coil L1. A connection is shown from the speaker frame (on the extreme right) to chassis. This is not always present, but when it is it serves to earth the frame. In AC/DC sets, when it is used, this connection will be taken to true earth, and not to chassis. The dotted connection shown earths the secondary of T1 and the speech coil, and again it may or may not be present.

The electro-magnetic type of moving-coil loudspeaker (usually referred to as the "energised" type) is a little more complicated. It has a speech coil fed

Fig. 40—A Class B output stage in a battery model, using a special double-triode valve.

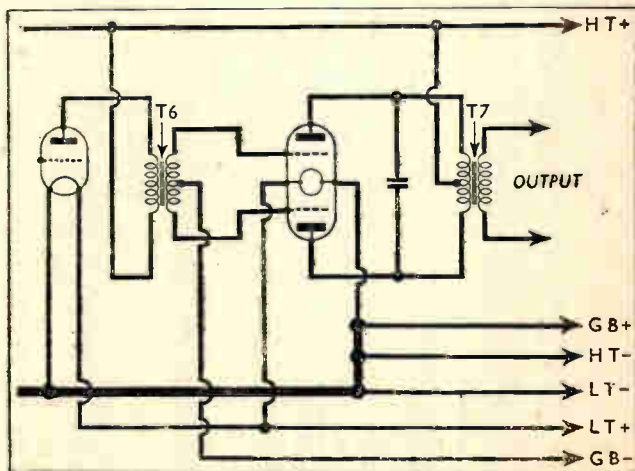

Radio Circuits

from a matching transformer as before, but in addition the energising or "field" coil is connected in circuit. In modern loudspeakers there is usually a third coil, known as the hum neutralising or hum "bucking" coil, which is associated with the speech coil circuit. Fig. 41b shows a typical energised moving-coil speaker circuit. T2 is the output transformer with its secondary connected with one side to L2, the other side to L3, L2 and L3 being

a receiver will be found in which the field coil is not used for smoothing purposes in series with the HT supply, but is connected directly across the HT supply for energising purposes, from the HT positive line to chassis, as shown in Fig. 41d. In this case the resistance of the winding will be higher, usually between 6,000 and 8,000 ohms. This connection is often found in AC/DC midget receivers originally intended for

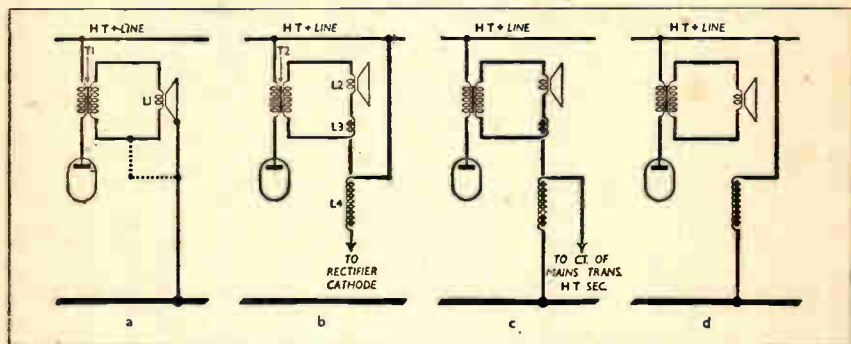

Fig. 41, a to d. a—Connections of a PM loudspeaker with the field in the positive HT lead. b—An energised loudspeaker with the field in the positive HT lead. c—The same with the field in the negative HT lead. d—The same with the field across the HT supply.

connected in series. L2, of course, is the loudspeaker speech coil, while L3 is the hum neutralising coil.

L4, the loudspeaker field or energising coil, is in this case connected from the cathode of the HT rectifier to the HT positive line. When we examine the power supply circuits in a later section it will be seen that in this position the field coil is in series with the HT positive supply lead to the set, and acts as a smoothing choke, at the same time becoming energised by the HT current which flows through it.

In certain receivers L4 may be connected in series with the *negative* HT supply lead to the set, in which case one end will be connected to chassis and the other to the centre-tap of the mains transformer HT secondary winding, as shown in Fig 41c.

In both these arrangements the resistance of the field winding will be between 500 and 2,500 ohms, common values being 1,000 or 1,200 ohms. Occasionally

use on 110 V mains, where the series connection of the field would cause a drop in HT voltage which would reduce the voltage on the HT line too much. The parallel connection avoids this. In such cases the hum neutralising coil is usually omitted.

Referring again to Fig. 41b, it will be seen that the hum coil L3 is represented as being iron-cored and wound on the same core as the field. This is so, for the coil usually consists of a few turns of wire wound either at the side of the field winding in pancake formation or as a single layer winding over the field coil.

When the field coil L4 is energised by unsmoothed HT current there is a tendency for hum voltages to be induced into the speech coil L2, which will produce a loud hum in the loudspeaker. With the coil L3 wound so that it is coupled to the field coil, hum voltages are introduced into it also, and by connecting L3 in series with L2 in the sense such that its hum voltage is in opposite

Provision for External Loudspeakers

phase to that of L2, the resultant hum in the speech-coil circuit is largely cancelled out. It is not reduced entirely to zero, however.

The hum coil, being more tightly coupled to the field coil than is L2, can consist of fewer turns of thick wire. Consequently, its impedance is low (its DC resistance is usually only about 0.1 ohm) and the AF power lost in it is very slight. It is important to remember that the connections of L3 must not be reversed relative to L2, otherwise the hum voltages will be additive, and a loud hum will be produced.

In most sets provision is made for the connection of an external loudspeaker, by means of sockets or terminals. Fig. 42 shows some alternative arrangements. At a, the sockets are placed so that the external speaker is connected across the primary winding of the output transformer. In this case a high impedance external speaker (or an ordinary moving-coil type fitted with its own input transformer) must be used.

The switch S1 is sometimes fitted to permit the internal speaker to be muted, but it should be noted that S1 must not be opened until after the external speaker is connected, otherwise the HT supply to the anode of the output valve will be interrupted. Another arrangement for using a high impedance external speaker is shown at b in Fig. 42. The speaker is fed from the anode of the output valve

via the DC blocking condenser C1, the other side of the speaker being connected to chassis. In this case no DC flows through the windings of the speaker or its transformer. A muting switch connected as in Fig. 42a must not be used with this arrangement.

A more usual arrangement in modern sets is for the external loudspeaker sockets to be arranged as in Fig. 42c. They are connected across the secondary of the output transformer, and this involves the use of a low impedance external loudspeaker (a moving-coil type without a transformer of its own). Switch S2 is often provided to disconnect the speech coil of the internal speaker, thus muting it. Occasionally a resistance R1 of a few ohms is permanently connected across the secondary of the output transformer to act as an artificial load in case S2 is opened before the external speaker is connected up. Alternatively, S2 is sometimes in the form of a jack switch, arranged to be operated only when an external speaker is plugged in.

AC POWER SUPPLIES

IN the previous sections we have covered the various circuit arrangements of typical superheterodyne receivers from the aerial input to the loudspeaker output. For the most part, the main receiving circuit has been dealt with, to

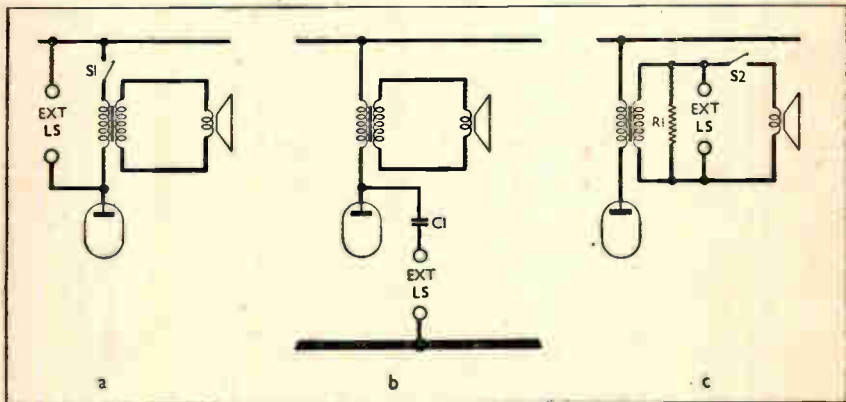

Fig. 42.—Three alternative arrangements of external loudspeaker sockets.

Radio Circuits

the exclusion of subsidiary circuits which, however, must be included before any review of the complete circuit arrangement can be considered complete.

The power supply circuits of mains receivers are, of course, of paramount importance, and will be described next. In the case of battery receivers, operating from LT, HT and GB batteries, the power supply needs very little comment. The principle of obtaining grid bias voltages automatically, thus disposing of

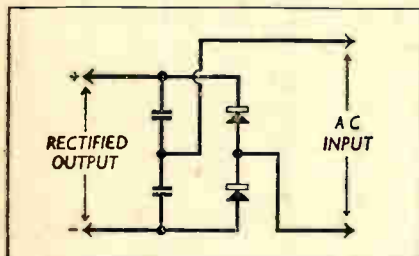

Fig. 43—Basic circuit for metal rectification on the voltage-doubler system.

the need for a grid bias battery, is used in many modern battery sets, the usual technique being to utilise the voltage drop across a resistor or resistors connected in series with the negative HT lead.

In a mains receiver we have to obtain low tension, high tension and grid bias supplies entirely from the mains, and the method of accomplishing this has been more or less standardised in modern receivers.

Taking the case of receivers for use exclusively on alternating current mains first of all, it is hardly necessary to say that power is obtained from a mains transformer and that for the low tension supply for the valve heaters "raw" AC is used. This is obtained from a low voltage secondary winding on the mains transformer. The winding usually has a centre tapping, connected to chassis, although sometimes one side of the secondary goes to chassis.

In most AC receivers the heaters of the valves will all have the same voltage rating, and will be connected in parallel to the heater secondary. In cases where a different voltage is required by one or more of the valves, a separate secondary, or a tapping or extension on the existing

secondary, will be used. The rectifier valve normally employed for the HT supply always has its own heater secondary, as it must be isolated from the other valves.

In order to obtain the necessary DC HT supply from AC mains it is necessary to step the mains voltage up to the amount required, rectify it and smooth it. In the past various types of rectifier have been employed, including the valve and the "metal" (dry-contact) rectifier. Certain early receivers employed the latter, operating on what is known as the "voltage-doubler" system. The circuit of a metal rectifier connected in this system is shown in Fig. 43. No smoothing circuit is shown, and it should be pointed out that the two condensers (usually about $4 \mu\text{F}$ each) form an important part of the actual rectifying circuit, and their value is fairly critical. Of course, there is no reason why half-wave or full-wave metal rectification should not be employed in radio receivers, but this type of circuit is not often encountered.

Turning to valve rectification, which is used by practically every modern mains receiver, it is quite possible for half-wave or full-wave circuits to be found. In AC receivers full-wave rectification is more or less standard, so this will be dealt with first. Half-wave circuits are used mainly in AC/DC receivers.

The basic circuit of a full-wave valve rectifier is shown in Fig. 44a. The mains supply is fed into the primary of the mains transformer, and is stepped up the required voltage by a suitable secondary winding, having a centre-tap. The total voltage across the secondary in full-wave rectification is usually about twice the DC voltage output required.

The full-wave rectifier valve has two anodes, each one of which is connected to one end of the HT secondary winding of the transformer. The heater of the valve (which may be of the directly- or indirectly-heated cathode type) is fed from a separate low-voltage secondary winding on the mains transformer (not shown in Fig. 44a). The rectified output is obtained from the centre-tap of the HT secondary (negative) and the cathode (or one side of the heater) of the valve (positive).

The rectified current, as obtained from the circuit of Fig. 44a, is unidirectional,

Practical AC Power Supply Circuit

but pulsating (at a frequency twice that of the mains supply). It is, therefore, not suitable for the HT supply to a receiver until it has been smoothed. The simplest circuit for this purpose is shown in Fig. 44b, where an iron-cored choke L1 is used in series with the positive supply lead, and two large capacity condensers (usually of the electrolytic type) are connected across the supply, one on either side of the choke. This is called a condenser input smoothing filter. C1 is the "reservoir" condenser and C2 the smoothing condenser.

The choke may be replaced by the field winding of an energised moving coil loudspeaker, as was mentioned in the previous section, and it may be in series with the negative supply lead in some sets. This permits grid bias to be derived from the voltage drop across the field (p. 50). Occasionally an extra section may be added to the smoothing filter in elaborate sets, consisting of an additional choke in series with the supply and a further condenser in parallel. In a few receivers the smoothing choke may be replaced by a resistance in conjunction with condensers, but this resistance-capacity smoothing arrangement is not common.

A practical power supply circuit for an AC receiver is shown in Fig. 45. Here T1 is the mains transformer, with a primary winding tapped for different mains voltages, and a switch S1 for on-off switching. Note that the core of the transformer is earthed to the chassis of the receiver. Sometimes a screen, also earthed, is incorporated in the trans-

former between primary and secondary to reduce the possibility of mains-borne disturbances entering the receiver circuits.

The transformer has three secondaries. The lowest in the diagram supplies the LT requirement of the receiving valves (and scale lamps, if used). It is centre-tapped, with the tapping earthed. The valve rectifier heater is supplied by a separate LT winding, one side of which forms the positive connection to the smoothing circuit. The third secondary winding is for the HT supply to the rectifier valve, its ends going to the anodes of the rectifier. The centre-tap forms the negative HT connection, and goes to chassis (earth). The smoothing circuit consists of the choke (or loudspeaker field), L2, and the electrolytic condensers C3, C4. Note their polarity and the fact that since each negative connection goes to chassis, it is possible to use a double condenser unit, having a common negative lead, but two separate positives.

Fig. 45 also shows some additional components, some or all of which may be employed in certain receivers. They are refinements, however, and are not essential to the operation of the circuit. R1 and R2 are low-value (50 to 100 ohm) resistors inserted in series with each anode circuit of the rectifier for HT current surge-limiting purposes. They also act to some extent as RF stoppers. C5 and C6 bypass to earth any parasitic RF currents which may be introduced into the rectifier circuit. Their value is usually of the order of 0.01 μ F.

C7 and C8 are mains RF by-passes,

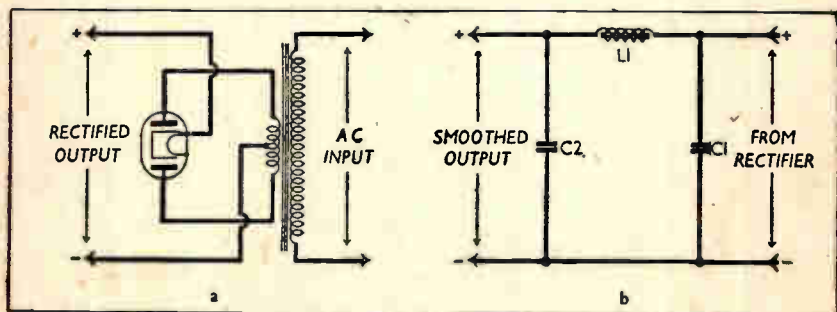

Fig. 44, a and b. a—Basic full-wave valve rectifier circuit. b—The conventional condenser input smoothing filter.

Radio Circuits

and form a filter which to a certain extent suppresses mains-borne interference. It will be seen that their common connection is earthed. Occasionally a single condenser, connected between one side of the mains input and chassis, is employed. Values of $0.01 \mu\text{F}$ are common for these condensers.

It has been mentioned that in certain cases the smoothing choke (or speaker

too high for normal bias requirements, in which case suitable tapings are sometimes provided, but more usually a potentiometer is connected across the choke with one or more tapings as required. This is shown in Fig. 46b, where L4 is the choke and R3, R4 form the potentiometer. The total resistance of a potentiometer connected in this way will be fairly high, of the order of several hundred thousand

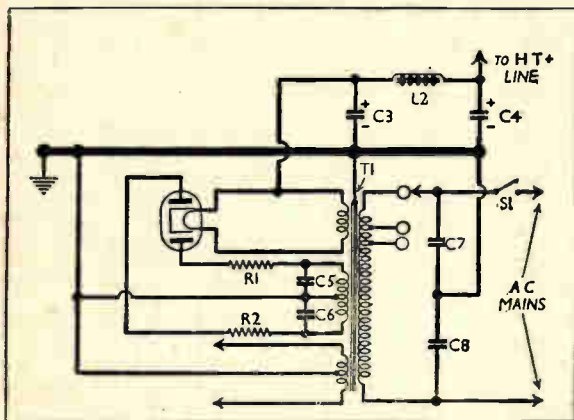

Fig. 45—A complete practical circuit of the power supply section of an AC receiver, using a full-wave rectifier. The smoothing choke is in the positive HT lead. Several refinements are shown which are not always present in commercial receivers.

field) may be inserted in series with the negative HT lead. Fig. 46a shows part of the circuit of Fig. 45 re-drawn with the choke L3 in the negative lead, from the centre-tap of the HT secondary of the transformer to chassis. The rectifier cathode then goes direct to the HT positive line. Note the new positions of the smoothing and reservoir condensers C9 and C10, which are still one each side of the choke. In this case, however, they have a common positive connection to the HT positive line, and two separate negative connections.

With the choke connected as shown, the DC voltage drop across it, due to the total HT current of the receiver flowing through it, may be used, if desired, for automatic grid bias purposes. The lower end of the choke is negative, relative to chassis, by the amount of the voltage drop, so that any valve in the set may be given this value of bias by connecting the cathode of the valve to chassis, and the grid return circuit to the bottom of the choke.

In most cases the total voltage drop across the choke (or speaker field) will be

ohms, in order to prevent any appreciable HT current from by-passing the smoothing choke.

In cases where the choke or speaker field is in the positive HT lead, bias can still be obtained by utilising the voltage drop across resistors inserted in the negative HT lead, as shown in Fig. 46c. R5 is the bias resistor through which the total HT current of the receiver passes. A chain of several resistors could be used to provide more than one value of bias voltage. The resistors used will in this case have low values, of the order of 20 to 100 ohms, depending on the bias required and the HT current drawn by the receiver.

Sometimes a by-pass condenser (C11) is connected across the bias resistor or potentiometer. This will have a capacity of the order of $50 \mu\text{F}$, and it should be noted that its positive lead will be connected to chassis.

The methods of obtaining bias described above merely supplement the usual method of using a suitable resistor in series with the cathode lead of each individual valve, returning the grid circuit in each case to

Heater Supply in AC/DC Receivers

chassis. This was fully explained in an earlier section.

AC/DC POWER SUPPLIES

THE problem of power supplies for receivers which operate from DC or AC mains at will is a somewhat different one from that of purely AC mains receivers. As has been seen, the advantages of an AC supply is that it can readily be transformed up or down, as necessary, in order to provide power at the correct voltage for low-tension and high-tension requirements. This is not readily possible in the case of DC supplies, for although a reduced voltage can be obtained by the use of series resistors, an increased voltage in the case of DC involves the use of a rotary transformer or a complicated conversion to pulsating current, static transformation, rectification and subsequent smoothing.

The disadvantage of a series resistance to cut down the mains voltage to the lower

with parallel heater connections, the heaters must all operate at the same voltage, but the current consumption can vary from valve to valve. In an AC/DC receiver, with series heater connections, all the heaters must operate at the same current, but their voltages may be different.

With a view to reducing the value of the series resistor necessary in the heater circuit of an AC/DC receiver, it is customary to use valves with higher heater voltages than usual; 13-, 20-, 25-, 30-, 35-, 40-, 45-, 50- and 70-volt heaters are common, while the heater currents have been more or less standardised at the present time at one of three different values—0.3, 0.2 and 0.15 amperes.

It is the latter range of valves which usually has the higher heater voltages, and it is common to find American receivers designed for use on 110 V mains, whose total heater voltage adds up almost to the full mains voltage, so that only a small series resistance is needed in the heater circuit.

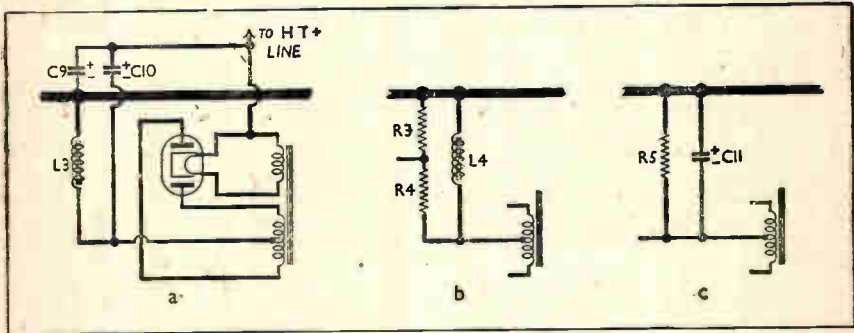

Fig. 46, a to c. a—Part of the circuit of Fig. 45, but with the choke in the negative HT lead. b—Using a potentiometer across the choke for automatic bias supply. c—Automatic bias obtained by a series resistance in the negative HT lead.

value required for the heater supply of normal valves is that considerable power is lost in the resistor, and the arrangement is not economical. Apart from this, there is no reason why this method cannot be employed.

In order to economise in power as far as possible, it is customary to wire the heaters of the valves in an AC/DC receiver in series with each other, the only proviso here being that the heaters must all be rated to consume the same current. It is important to notice that in an AC receiver,

It is customary to arrange the heater circuit of an AC/DC receiver in a definite order, since one end of the heater chain will be at a fairly high potential relative to earth, and there is always a tendency for hum voltages to be introduced into the valve under these conditions. A typical arrangement of the heater chain of a simple superhet is shown in Fig. 47. The low potential end of the heater circuit goes to chassis, which is also connected to one side of the mains via the switch S1. The chassis should, however, be isolated

Radio Circuits

from direct connection to earth by means of the blocking condenser C1 of about $0.1 \mu\text{F}$ capacity, the reason for which will be seen later.

The first valve, starting from the low potential end of the chain will be the demodulator, usually a double diode triode, because hum is more prone to be introduced into this valve than any other. Next comes the frequency-changer, whose

resistance incorporated in the mains lead, or even a plug-in resistance "tube," resembling a valve in external appearance.

Another alternative is a barretter lamp, which is a special form of resistance device (often of iron wire in a bulb filled with hydrogen gas) which has the property of keeping the current flowing through it sensibly constant over a wide range of

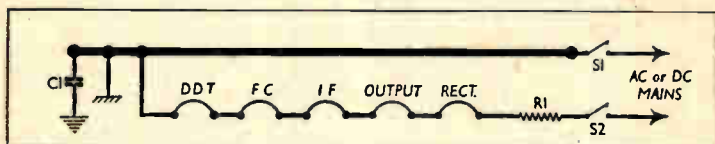

Fig. 47—Diagram showing the principle of connecting the valve heaters in series, together with a ballast resistance. The chassis is isolated from earth by C1.

output, being considerably amplified, must be kept as free from hum as possible. Next in the chain is the IF valve, and following this is the output valve. Any hum introduced here is only very slightly amplified. Finally, there is the HT rectifier valve, in which hum is unimportant. The series resistance R1 completes the chain, and is connected, usually via a second switch S2 (which is ganged with S1) to the other side of the mains.

If a combined demodulator and output valve is used (such as a double diode pentode), this valve will usually become the first in the chain from the low potential end, on account of its demodulator section.

The resistance R1 may be a wire-wound component, tapped for different mains voltages, or it may be a "line cord"

applied voltages. Very often ordinary ballast resistors are described as barretters, but actually the term should only be applied to the self-regulating type of ballast.

If scale or indicator lamps are needed in an AC/DC set they are usually wired in series with the heater chain. It should be noted that they must be rated at the same current as the valve heaters, and should one fail, the heater circuit will be interrupted and the set will stop working. Sometimes they are shunted by a by-pass resistor to avoid this, but in any case they should be replaced as soon as possible.

We now come to the HT supply of an AC/DC receiver, and the point to note here is that the HT voltage is limited by the mains voltage, since one cannot transform DC to a higher voltage very readily.

Early sets which operated on DC only merely used a smoothing filter for their HT supply from the mains, but the later type of AC/DC set obviously needs a rectifier when the set is used on AC. Fortunately, the insertion of a rectifier in a set does not introduce any complication when the mains happen to be DC, for the rectifier valve under these conditions merely acts as a resistance of low value.

The usual rectifier arrangement in an AC/DC set is shown in Fig. 48, where a half-wave rectifier is used. The end of the heater chain with the rectifier heater and ballast resistance R2 is shown. From the same side of the mains a connection goes

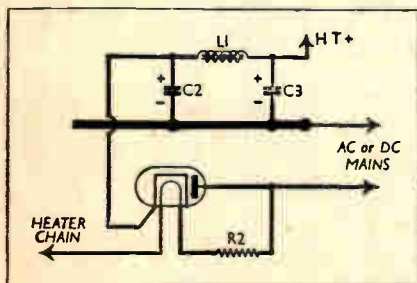

Fig. 48—A half-wave rectifier used to obtain the HT supply in an AC/DC set.

Practical Details of AC/DC Power Supplies

(usually direct) to the rectifier anode; from its cathode is taken the unsmoothed positive HT supply, which is subsequently smoothed by the usual filter L1, C2, C3.

The negative HT connection is the other side of the mains, which, of course, goes to chassis. The need for a condenser (C1 in Fig. 47) to isolate the chassis from direct connection to earth can be seen when one realises that one side of the mains supply is always earthed at the power station. If this side happens to be the same side as is connected to chassis in the receiver, then the chassis could safely be directly earthed. Without testing, however, one cannot be sure of this, and it may prove that one side of the mains is earthed at the power station, and the other side at the receiver. This will place a dead short on the mains supply, blowing the house fuses.

The use of a condenser between true earth and the chassis obviates this, while still placing the chassis at earth potential as far as RF, IF and AF currents are concerned. Incidentally, it will be realised that in an AC/DC receiver the chassis, and any metal parts connected to it, will very likely be at the full mains potential relative to earth, and care should be taken when handling a receiver under these conditions.

As in the case of AC receivers, AC/DC models often include certain refinements in their power supply circuits. A complete circuit, showing various refinements, is in Fig. 49. Some or all of the extra components shown may be present in actual receivers.

F1 and F2 are fuses in series with each mains lead, while S3 and S4 form the double-pole mains switch. L3 and L4 are low-resistance air-cored RF chokes which, combined with the by-pass condenser C7 (of about 0.1 μ F), form a filter which prevents mains-borne RF interference from entering the receiver. R3 is the ballast resistor, tapped for mains of different voltages. If a regulating barretter is used, no mains adjustment is necessary.

The heater chain is as in Fig. 47, except that a scale lamp, shunted by a resistor R4, is interposed in the chain between the demodulator and the frequency-changer valve heaters. In some sets the scale lamp position will be different. R4 will be a low resistance of from 20 to 50 ohms, and must be capable of carrying the full heater current in the event of failure of the scale lamp.

R5, in series with the rectifier anode, is a surge limiting resistance of about 50 ohms. The iron-cored choke L2 and the electrolytic condensers C5, C6, form the HT smoothing filter. C4 is the chassis isolating condenser.

Grid bias in an AC/DC receiver is obtained by the usual method of inserting a bias resistor in series with the cathode lead of each individual valve to chassis.

Owing to the fact that there is usually little, if any, anode voltage to spare in an AC/DC receiver, it is common practice to employ a permanent magnet loudspeaker, and to use a low-resistance smoothing choke for L2. In this way the voltage lost

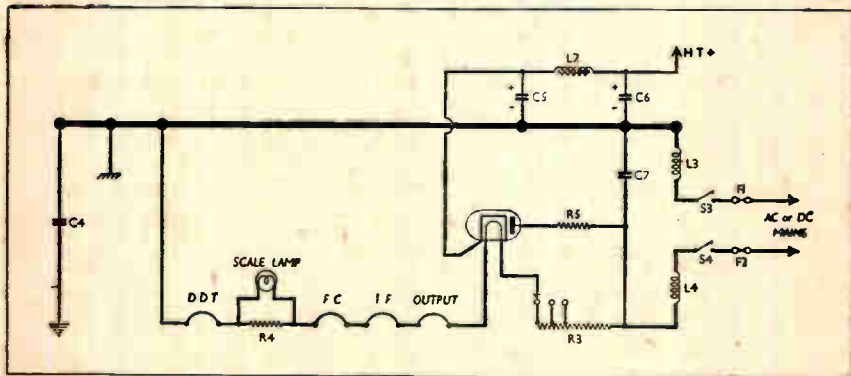

Fig. 49—Complete AC/DC circuit for heater and HT supply, showing various refinements, some or all of which may be present in actual receivers.

Radio Circuits

in the smoothing circuit is minimised. If an energised loudspeaker is used, this will have a fairly low resistance field, of the order of 500 ohms.

Occasionally an energised speaker will be used with its field connected straight across the smoothed HT supply for energising purposes. In this case, as was mentioned when dealing with loudspeakers, the resistance of the field will be high (6,000 to 8,000 ohms), and a low

TONE CONTROL CIRCUITS

WITH the last section we reached the end of the step-by-step dissection of a simple superheterodyne receiver, at any rate as far as the main circuits are concerned. There are, however, a number of subsidiary parts of the main circuit, or additions to it, which must be included in a complete review. The tone control arrangements form one of these additions

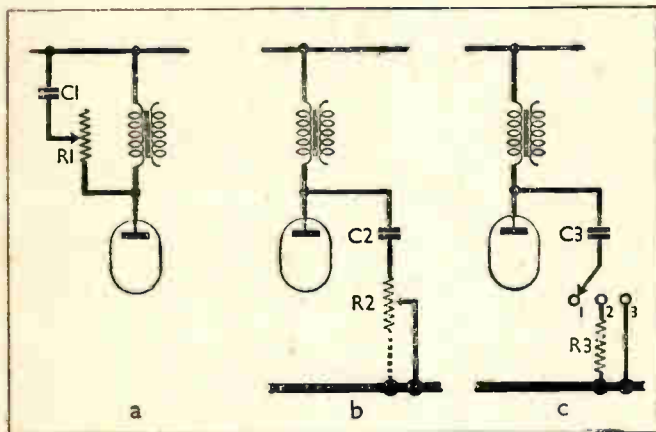

Fig. 50, a to c—
Three examples
of simple variable
tone control in
the anode circuit
of the output
valve.

resistance choke will be needed for HT smoothing purposes.

It will sometimes be found that in place of a standard half-wave rectifier valve, a full-wave or voltage-doubler type will be used in an AC/DC receiver. In this case they will be connected so as to operate as half-wave types, and will usually have their two anodes (and their two cathodes, in the case of voltage-doublers) connected together. Valves used in this way will be capable of handling twice the rectified current which would be obtained from an ordinary half-wave rectifier with similar characteristics to those of each half of the double valve.

Another, but not very common, type of rectifier (American) is one with a tapping on its heater brought out to a separate pin on the base. With this valve, it is intended that a suitable scale lamp shall be connected across one section of the rectifier heater, and the lamp is, therefore, not included in the series heater chain in the usual way.

which will now be considered in detail.

In the majority of simple receivers, the tone control is arranged merely to reduce the response of the receiver to the higher frequencies, thus attenuating interference whistles, background noises and general "mush." At the same time, the tendency is to make the tone "mellow," and to reduce the intelligibility of speech, and the fidelity of reproduction of certain instruments, such as the violin, which rely largely on high harmonics for their characteristic tone. Such controls must therefore be applied with discretion.

This type of tone control can be simply achieved by placing a condenser in some part of the circuit where it will by-pass a certain proportion of the higher AF signals. It will be appreciated that for a given capacity, the higher the frequency, the more readily will it be by-passed through the condenser. Taking a condenser of 0.01 μ F capacity, this behaves to an audio frequency of 5,000 C/S as a resistance of 3,000 ohms. To a

Condenser and Resistance Filters

50 C/S frequency, however, it acts as a resistance of 300,000 ohms. Thus the condenser is 100 times more effective in by-passing a 5,000 C/S current than one of 50 C/S.

In general, receiver designers use the combination of a fixed condenser in series with a variable resistance as a tone control, so that at the maximum setting of the resistance the condenser is least effective as a tone control, while at the minimum setting the condenser is most effective, and the maximum degree of attenuation of the higher frequencies is obtained.

The most usual arrangements of a tone control circuit are shown in Fig. 50, where it will be seen that the control is associated with the anode circuit of the output stage. At a the condenser C1 and variable resistance R1 are connected in series across the primary of the output transformer, while at b C2 and R2 are connected from anode to chassis. The effect is the same in each case, and the values of the components are similar. The condenser usually has a capacity of 0.01 to 0.05 μF , while the variable resistance usually has a maximum value of 50,000 ohms. Sometimes the free end of the resistance in Fig. 50b is connected to chassis.

Both arrangements shown in Fig. 50a

and b provide continuously variable tone control, but in Fig. 50c 3-point control is used, either with a 3-position switch, or a plug and three sockets. C3 is the usual condenser, and R3 is a fixed resistor of, say, 10,000 or 20,000 ohms. With the switch or plug in position 1, the tone control is not in use, and the tone is "brilliant." In position 2, C3 and R3 are in series from anode to chassis, and the upper register is attenuated to a certain degree. In position 3, C3 is connected direct from anode to chassis, and a higher degree of attenuation of the upper register is secured.

In some cases the tone control arrangements will be found in the anode circuit of the first AF valve, the connections being similar to those in Fig. 50b. It is then unusual for C2 to exceed 0.01 μF , while R2 may be as high as 500,000 ohms maximum.

Tone control which merely involves the reduction of the higher frequencies can also be secured by the use of a resistance-capacity filter in the grid circuit of the output or first AF valve. An example of this is shown in Fig. 51a. Here C4 (0.002 μF to 0.005 μF) and R4 (500,000 ohms to 2,000,000 ohms) form the tone control. C5 is the usual AF coupling condenser, and R5 is the volume control.

Many receivers employ a simple form

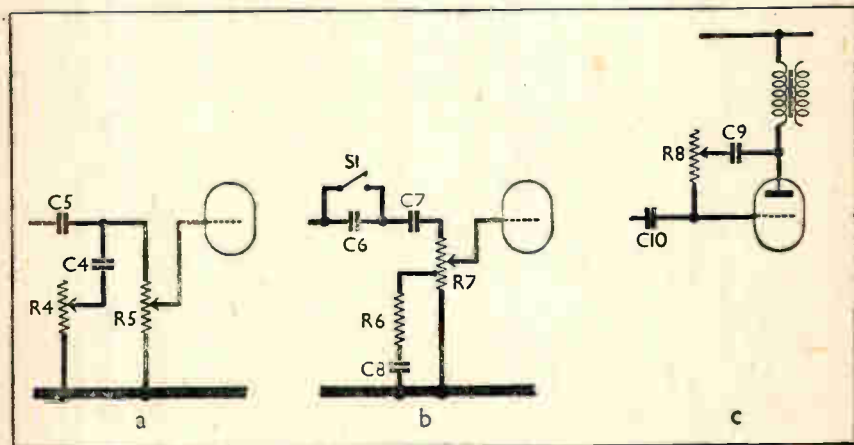

Fig. 51, a to c—Examples of tone control and tone compensation in the grid or anode/grid circuits of the first AF or output valve.

Radio Circuits

of tone compensation which is designed to reduce the upper register progressively as the volume control is turned down. The effect of this is to give an apparent increase in bass response at low volume levels and thus to compensate for the falling off in the bass which always appears to occur under these conditions. The circuit for this is shown in Fig. 51b, where it will be seen that the volume control R7 is tapped near its lower end. From the tapping are connected R6 and C8 in series to chassis, and typical values are 50,000 ohms for R6 and 0.01 μF for C8. The tapping on R7 is usually at between one-quarter and one-half of the resistance from the chassis end. With the slider at the top (maximum volume) the compensation is at its minimum, because the whole of the resistance of the volume control down to the tapping is between the filter circuit and the grid of the valve. As the slider is moved down to reduce the volume, R6 and C8 become more effective in cutting the upper register. When the slider is opposite the tapping, the tone compensation is at its maximum. Below this it becomes reduced again, but one does not usually work with the volume control as low as this. It is not possible to make the tapping too close to the bottom of R7, since the low resistance between the tapping and chassis would practically short-circuit R6 and C8.

Fig. 51b also shows another form of tone control. C7 is the normal AF coupling condenser, while C6, in series with it, can be short-circuited by the switch S1. With S1 closed, C7 only is in circuit, and the tone is normal. With S1 open, C6 and C7 in series produce a low-value coupling capacity, which results in a reduction in the bass response. This, then, is the opposite of the more usual "top cut" tone control, and by a combination of the two methods top cut, bass cut, or both can be secured.

Yet another form of tone control is shown in Fig. 51c. Here the filter C9, R8 is connected between anode and grid of the output valve. C9 being about 0.005 μF and R8 2,000,000 ohms maximum. With R8 at maximum, the feedback between anode and grid is slight, and the tone is "brilliant." As R8 is reduced, feedback increases, and the tone becomes lower-pitched. R8 and C9 can

be replaced by a variable condenser having a maximum capacity of 0.0005 μF .

The tone control circuits described are, of course, the simple ones to be found in the average domestic receiver. Specialised receivers or amplifiers may have much more elaborate arrangements which hardly concern us here. It should be noted that in a sense variable selectivity arrangements in the IF amplifier also provide tone control, since in the least selective positions a wide response is secured, while in the position of maximum selectivity there is a narrow pass band, with a reduction in high frequencies.

NEGATIVE FEEDBACK

NEGATIVE feedback is an arrangement used in the AF section of the receiver which can also be pressed into use for tone compensation or control. Normally it is employed to improve the frequency response of the AF section of a receiver, and to reduce harmonic distortion. At the same time, the stability of the circuit is increased.

The principle used is to feed back from the output to the input a portion of the signal, arranged so as to be in opposite phase to the incoming signal, thus reducing the value of the latter. Now if the AF section of the receiver normally amplifies the very low and very high frequencies less than the middle register (as is usually the case), the feedback at these frequencies will be less than that at frequencies in the middle register, so that the incoming signal will be less reduced at the extreme high and low frequency end, and this will compensate for the deficiencies in the amplifier.

Equally, any pronounced "peak" at a certain frequency in the amplifier will produce a strong feed-back signal at that frequency, and this will reduce the input at the frequency concerned, and so level up the response. This also tends to reduce instability due to high amplification of signals of certain frequencies. Further, unwanted harmonics, when fed back from the output, tend to be cancelled out in the amplifier.

The advantages of negative feedback are to some extent offset by the fact that the overall gain of the amplifier is reduced by the feedback. This, however,

Typical Feedback Circuits

can be easily countered by making arrangements for extra amplification if necessary; often the gain of the AF section of the receiver is sufficient to enable negative feedback to be used without increasing the number of stages of amplification. The main usefulness of negative feedback is in receivers using single tetrode or pentode output valves.

The feedback voltage is usually taken from the anode circuit of the output stage to the grid or cathode circuit of this stage or the preceding one, by means of feed resistors and condensers whose values have to be worked out to give the desired amount of feedback, in the correct phase.

Fig. 52a shows one typical feed-back circuit. From one side of the output transformer secondary to chassis are connected R9 and C11 in series to chassis. R9 may be about 200 ohms, and C11 4 μ F. The voltage developed across C11 is tapped off and taken to the junction of R10 and R11 in the cathode circuit of the first AF valve. R10 is the usual bias resistor, with its by-pass condenser C12. R11 is a low value resistor, of about 25 ohms.

Another feedback circuit is shown in Fig. 52b. It provides in addition tone compensation by being taken to a tapping on the volume control (cf. Fig. 51b). R12, R13 form a potentiometer across the secondary of the output transformer, and a connection is taken from their junction

to the tapping on the volume control R41 via the condenser C13. The feedback effect then varies with the position of the volume control slider.

Sometimes frequency discriminating networks are included in the feedback circuit to modify its effect at different frequencies. Thus a parallel choke and resistance in series with the feed will reduce the high note feedback, and will, therefore, increase the amplification of the upper register. It is also possible to decrease the bass feedback, and so boost the lower register. These extra circuits are often cut in or out of action by means of switches, which thus act as tone controls.

Finally, it may be said that a measure of negative feedback can be secured by omitting the by-pass condenser from the cathode of the output valve to chassis. The cathode bias resistor is then common to both input and output circuits, and a proportion of the total AF voltage in the anode-cathode circuit is thus introduced into the cathode/grid circuit, and provides degeneration.

TUNING INDICATORS

THE need for fairly accurate tuning of a superheterodyne receiver, owing to its high degree of selectivity, has resulted in the adoption of some means of visual indication of correct tuning in a large number of cases.

The earliest types of tuning indicator

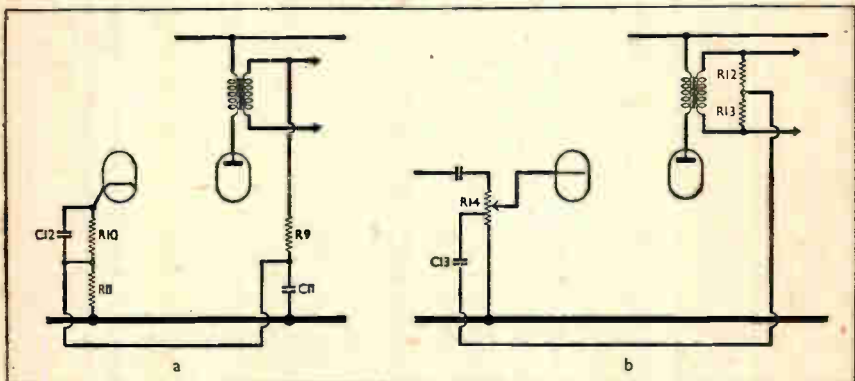

Fig. 52, a and b. a—An example of simple negative feedback explained in the text. b—Negative feedback which also provides tone compensation at low volume levels.

Radio Circuits

made use of the change in anode current of one of the valves controlled by the automatic volume control system (usually the IF valve) when a station was tuned in. It has been seen that on receipt of a strong signal the AVC system supplies an increased negative bias to the controlled valves, thus reducing their gain.

The effect of the increase in bias is also to reduce the anode current of the controlled valve, and when a station is accurately tuned this current will be at its minimum. Any form of current indicator

valve. L1 and L2 are two chokes (or, more accurately, reactors) wound on the same iron core. L1 (by-passed by C2) is in series with the IF valve anode circuit, while L2, in series with an indicator lamp is connected to a suitable source of AC which serves to light the lamp. The heater secondary of the mains transformer can be used for this, or a separate secondary winding may be provided.

When the set is not tuned to a station the AVC bias will be low and the anode current of the IF valve will be at maximum.

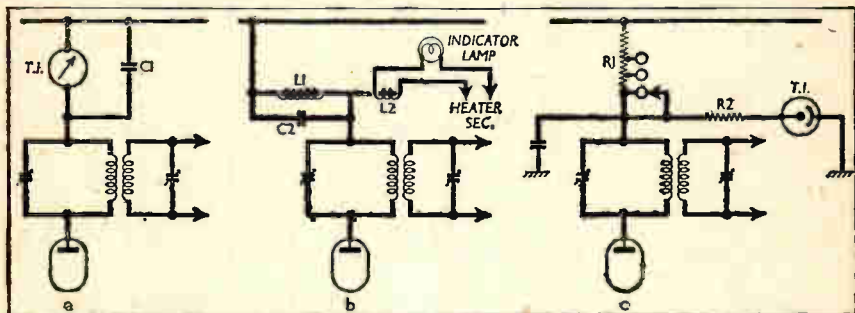

Fig. 53, a to c. a—Simple meter type of tuning indicator. b—Arrangement of the "dimming lamp" indicator circuit. c—Button type of neon indicator.

will therefore serve as a tuning indicator.

A pointer type of milliammeter is an obvious choice and has been used by a number of receiver manufacturers. Its connections are shown in Fig. 53a, where it will be seen that the instrument is shunted by a by-pass condenser. Most of the indicators used are simple devices, consisting merely of a coil of wire in the field of which is an iron armature to which the indicating pointer is attached. The DC resistance of the indicator winding is usually of the order of 2,000 ohms, but its impedance is, of course, high, and the RF and IF by-pass condenser C1 is therefore necessary.

Another form of tuning indicator which obtained a measure of popularity was the "dimming lamp" type, so called because the effect of tuning in a station was to cause a pilot lamp to become less bright, the position of minimum brightness being the correct tuning position.

The arrangement of this type of indicator is shown in Fig. 53b, and it is connected in the anode circuit of the IF

The current flows through L1 and magnetises the common core of L1, L2. The effect of this is to reduce the impedance of L2, and under these conditions matters are arranged so that the lamp glows brightly.

When a station is tuned in, the AVC bias increases, the anode current of the IF valve is reduced, L1 magnetises the common core to a smaller extent, so that the impedance of L2 increases, and, being in series with the lamp circuit, it causes the lamp to dim. At the correct tuning point the lamp is at its minimum brilliance.

A third form of tuning indicator, shown at Fig. 53c, is of the neon bulb variety. This is a simple form known as the "button" type, which is dim when no signal is being received, but glows brightly when a station is tuned in. It operates from the anode voltage of one of the AVC-controlled valves via a feed resistance R2. The cathode of the indicator is connected to chassis. Tappings are usually arranged on R1, the anode

The Cathode Ray Tuning Indicator

decoupling resistance of the controlled valve, for adjusting the neon indicator to its optimum setting.

A more elaborate type of neon indicator, shown at Fig. 54a, is of the tubular type, in which a column of light is produced, the length of the column varying with the applied voltage. As before, the anode voltage of one of the AVC-controlled valves is used to operate the device. The cathode is a rod running the length of the tube, and is connected to chassis. The anode is fed via resistance R4, and R3 can be adjusted for optimum operation of the tube. A third electrode, known as the priming electrode, is fitted, and this is fed from the HT line via a high resistance R5.

Occasionally it will be found that different connections for the priming electrode and the cathode are used. Thus the cathode may be fed with about 100 volts positive, while the priming electrode is taken to chassis via a resistance.

Finally, we come to the cathode-ray type of tuning indicator, sometimes known as the "magic eye." This is by far the most popular type at the present time, since it can be made to have a high sensitivity, enabling it to indicate the tuning points of weak stations, as well as strong ones. The usual circuit for this type of indicator is shown in Fig. 54b. The indicator actually consists of a triode amplifier and a miniature cathode-ray device in the same envelope, the screen of the CR section being visible through the end of the tube. It has the usual heater/cathode assembly. Elec-

trons from the cathode strike the target anode (T), which is maintained at the full anode voltage of the receiver. This produces the usual glow on the target.

Between the cathode and the target, however, is a ray control electrode (RCE), which is connected internally to the anode of the triode amplifier (A), and therefore takes the same voltage as the anode. This ray control electrode produces a shadow on the target, the angle of the shadow depending on the voltage of the electrode. With a low voltage a wide shadow is produced and vice versa. The shadow is sharply defined and is very sensitive to voltage changes.

In use the control grid of the triode section is connected to a point in the receiver where the negative voltage varies according to the signal. For instance, the AVC line can be used for this purpose, or the signal diode circuit can be employed. Assuming the AVC line is used, no signal means that there is zero voltage on the AVC line, and therefore no bias on the control grid of the indicator. This means a high anode current, which, since the anode is fed via a high resistance R6 (about 1 megohm), produces a low anode voltage, which, applied to the ray control electrode, produces a wide shadow angle.

As a station is tuned in, the control grid becomes negatively biased, reducing the anode current, increasing the anode voltage and the ray control voltage, and reducing the shadow angle. On a strong signal the shadow may disappear altogether, and overlapping of the edges of

Fig. 54, a and b.
a—Variable column type of neon indicator.
b—Circuit of a cathode ray tuning indicator, with the electrodes lettered in accordance with the text.

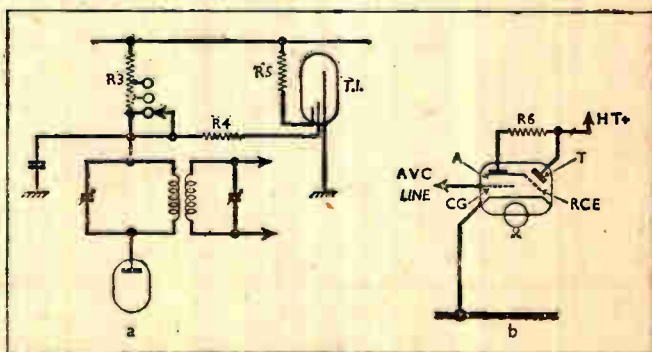

Radio Circuits

the glow may occur, but this is usually avoided in the design as far as possible.

A dual type of indicator is now available, with one section sensitive, for weak signals, and the other less sensitive, for strong signals. It should be pointed out that the cathode-ray type of tuning indicator could be used on any set, whether provided with AVC or not, since it merely needs the signal to produce a certain change in voltage in some part of the receiver. An anode bend detector, for instance, fulfils the requirements in its anode or cathode circuit.

GRAMOPHONE REPRODUCTION

MANY modern receivers include provision for the use of a gramophone pick-up when desired. The output from the pick-up, of course, merely needs AF amplification in the radio receiver.

The most usual arrangement is to feed the pick-up voltages into the first AF stage of the receiver, and to use the radio volume control also for controlling the pick-up output. It is desirable, though not essential, to arrange to switch the pick-up out of circuit when radio reception is desired, and vice-versa. The usual circuit is shown in Fig. 55a. C1 is the AF coupling condenser from the signal diode load, which is connected as usual (but via switch S1) to the top of the volume control R1.

Two terminals are provided for the

pick-up connection, one of which goes to chassis, and the other to the top of the volume control via switch S2. When S2 is closed, the pick-up is connected in circuit, and at the same time S1 opens, disconnecting C1 and thus muting radio signals. When the set is switched to "radio," S2 opens and S1 closes, enabling radio reception to be obtained in the usual way.

This arrangement is perfectly satisfactory providing that the output from the pick-up is large enough to load the AF amplifier sufficiently for the output requirements.

In receivers in which the diode demodulator is directly coupled to a high efficiency output pentode or tetrode, the average pick-up will not always have an adequate output for use in this circuit. In this case the extra amplification must be obtained by making some other valve in the receiver act as an AF amplifier.

There are various ways in which this can be done, one being to cause the IF amplifier valve to act as an AF amplifier when the receiver is switched to "gram." In Fig. 55b, the pick-up is included in the grid circuit of the IF valve, via switch S3. S4 is inserted in the lead to the bottom of the first IF transformer secondary to mute radio on gram. R2, in series with the anode circuit of the IF valve, is used as the load resistance when the IF valve is acting as an AF amplifier, but is short-circuited by S5 on radio. From the bottom of R2 a lead goes, via S6, to C2, which is

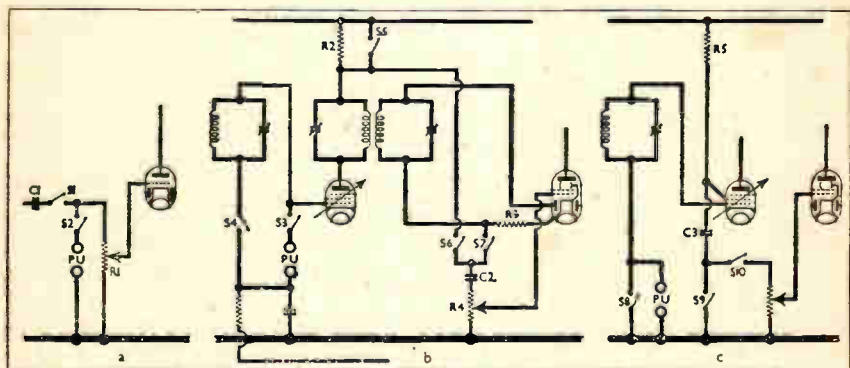

Fig. 55 a to c. a—Simplest gramophone pick-up circuit. b and c—Methods of using the IF valve as an AF amplifier for gramophone reproduction.

Gramophone Pick-up Circuits

the normal AF coupling condenser. The radio connection to C2, from the signal diode load resistance R3, goes via S7. R4 is the normal volume control.

On radio, S3 is open, S4 closed, S5 closed, S6 open and S7 closed, and the circuit is normal. On gram, S3 is closed, bringing the pick-up into circuit; S4 is open, muting radio; S5 is open, bringing the load resistance R2 into circuit; S6 is closed, passing the amplified AF voltages via C2 to R4.

Another arrangement is shown in Fig 55c. Here the screen of the IF valve is used as an anode on gram, the valve working as a triode amplifier. The pick-up is connected between the secondary of the first IF transformer and chassis, and is short-circuited by S8 when the set is switched to radio. R5 and C3 are the usual screen feed resistance and decoupling condenser on radio, S9 being closed. On gram, however, S8 opens, putting the pick-up into the grid circuit of the valve, S9 opens and S10 closes, when R5 acts as the "anode" load resistance of the valve, and C3 becomes the coupling condenser to the volume control.

Finally, the triode oscillator section of a frequency-changer can be used as an AF amplifier, as shown in Fig. 56. Here we have a parallel-fed tuned anode oscillator circuit (c.f. Fig. 11b). The pick-up is connected into the grid circuit of the triode via switch S11, which closes on gram, while S12 opens, muting radio. The anode feed resistance R6 now becomes the load resistance for AF amplification, while the anode coupling condenser C4 becomes the AF coupling condenser. The amplified AF voltages are picked up at the bottom of C4 and taken via switch S13 to the top of the volume control. The normal coupling condenser for radio (C5) is disconnected by switch S14. On radio, S11 opens, S12 closes, S13 opens and S14 closes, giving the normal radio circuit. The tuned anode coil circuit will also be opened on gram by one of the normal wavechange switches, thus isolating the bottom of C4 from chassis.

The arrangements described are sometimes altered in detail, but similar principles are usually employed.

In the case of AC/DC receivers a complication arises in that one side of the pick-up, in the circuits shown, is in direct or indirect electrical contact with the

chassis of the receiver. The usual plan to avoid this is to isolate the pick-up by means of a double-wound AF transformer, or by fixed condensers inserted in series with each pick-up lead. These condensers must, of course, be capable of withstand-

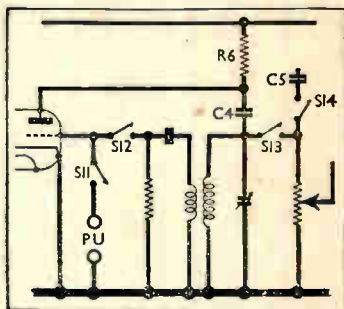

Fig. 56—Using the triode section of the frequency-changer as an AF amplifier.

ing the full mains voltage, since the chassis of the set may be at this potential relative to earth potential.

CONCLUSION

THE scope of this book has now been fulfilled. Superheterodyne circuit arrangements which have not been covered come into a more advanced class.

It is suggested that the student should now obtain a number of complete circuits of commercial superhet receivers, and should study them carefully, attempting to split them up into their various sections on the lines which have been indicated. With practice, and by reference to various sections of the book, this will soon be found to be a reasonably simple matter.

Once it is found possible to take a complete circuit, no matter how complicated, and resolve it into its component sections, the student will be well on the way to a complete understanding of its operation, and of fault location and repair.

If this book has given the reader confidence to tackle what at first sight may seem an incomprehensible jumble of components and wiring, it will have achieved its object.

Radio Circuits

INDEX

- Aerial coupling**, 6, 7
 — input circuits, 5-7
Amplification, AF, 5, 34-45
 —, IF, 3-5, 23-27
 —, RF, 4, 12-14
Automatic grid bias, 34, 35, 42, 48, 50, 53
 — volume control, 5, 24, 29-34
 —, delayed, 31-34
- Ballast resistance**, 51-53
Band-pass tuning, 4, 9-11
Barretter, 52
Beam tetrode, 39
- Choke**, smoothing, 49, 50, 53, 54
Circuit, gramophone pick-up, 60, 61
 —, parallel-fed, 8, 9
 —, series-fed, 8
Circuits, demodulation (*see Demodulation*)
Class B coupling, 44, 45
Coils, coupling, 6, 7
Condenser, earth isolating, 53
 —, smoothing, 49
 —, trimmer, 9, 23
Coupling, aerial, 6, 7
 —, AF, 35-44
 —, auto-transformer, 36
 —, Class B, 44, 45
 —, push-pull RC, 40-42
 —, QPP, 43, 44
 —, resistance capacity, 35-42
 —, transformer, 35, 36, 42-44
 —, transformer push-pull, 42
 —, IF, 23-27
 —, RF, 13, 14
- Decoupling**, 39
Detection (*see Demodulation*)
Delay voltage, 31-34
Demodulation, 5, 27-29, 34
Diode, 28-30
Double diode, 29, 30
 — pentode, 29, 38, 52
 — triode, 29, 32, 37-39
Driver stage, 44
- Extension speaker** (*see Loudspeaker, external*)
- Field coil**, 46, 47, 49, 50
Frequency-changers, early, 17-19
 — modern, 20, 21
 — 2-valve, 20
Frequency-changing, 3, 4, 14, 15
- Grid stopper**, 38, 39
- Heater circuit**, AC/DC, 51-53
Heptode, 18, 19
Heptode-mixer, 20
Hum coil, 46, 47
- IF filter and rejector**, 7, 12
IF valve as AF amplifier, 60, 61
Image signal, 15
Intermediate frequency, 14, 15
 —, staggered, 25, 26
- Loudspeaker circuits**, 45-47
Loudspeaker, external, 47
 —, moving coil, 45-47
- Magic eye**, 59, 60
Metal rectifier, 48
Mixer, 4, 14, 15
- Negative feed-back**, 56, 57
- Octode**, 20
Oscillator, 4, 14-17
 — tracking, 21-23
 — valve as AF amplifier, 61
Output stage, paralleled, 40
 —, push-pull, 40-44
- Padder** (*see Tracker*)
Pentagrid (*see Heptode*)
Pentode, output, 35
 —, RF, 12, 17, 23, 27, 28
Phase-splitting, 41, 42
Pick-up, gramophone, 60, 61
Power supplies, AC, 47-50
 —, AC/DC, 51-54
- Quiescent push-pull**, 43, 44
- Receiver**, TRF, 3, 5
Rectifier valve, full-wave, 48, 54
 —, half-wave, 48, 52-54
- Selectivity**, variable, 26, 27
Smoothing circuit, 49, 53, 54
Speech coil, 45-47
 "Straight" receiver (*see Receiver TRF*)
Superhet principles, 3-5
- Tetrode**, output, 35
 —, RF, 12, 17, 23, 27
Time constant, 33, 34
Tone compensation, 56, 57
 — control, 54-56
 — correction, 39
Tracker, 17, 21-23
Transformer, AF, 35, 36, 42-44
 —, driver, 44
 —, IF, 23-27
 —, iron dust cored, 24, 25
 —, triple-tuned, 25
 —, mains, 48, 49
 —, output, 41, 42, 44-47
Trimmers (*see Condenser, trimmer*)
Triode, AF amplifier, 37
 —, demodulator, 27
Triode-heptode, 20
Triode-hexode, 20, 21
Triode-pentode, 18
Tuned input circuits, 7-9
Tuning indicators, 57-60
Tuning indicator, cathode ray, 59, 60
 —, "dimming lamp," 58
 —, meter, 58
 —, neon, 58, 59
- Valve**, RF, 12
 —, variable-mu, 12, 29
Volume control, 30, 37, 38
- Westector**, 28

*Value proved
by long service*

**Osram
Valves**

MADE IN ENGLAND

Ever since the advent of radio, Osram Valves have been closely connected with all the progressive stages of development in radio science. Intensive research still goes on by improvements in design and technique to keep pace with the advancing times, and which will ultimately be of benefit to all.

THE GENERAL ELECTRIC CO. LTD.
Magnet House, Kingsway, London, W.C.2



PARTRIDGE TRANSFORMERS

FOR LABORATORY USE & EXPERIMENTAL WORK

Specially wound to customers' requirements. Prompt Delivery. Economical Prices.

AS SUPPLIED TO

National Physical Laboratory, British Electrical and Allied Industries Research Association, Medical Research Council, Radium Beam Therapy Research, Government Research Establishments, etc., etc., and to the experimental and development departments of the leading industrial houses,

and

THE AUTHOR OF

'The Radio Laboratory Handbook'

N. PARTRIDGE, *Transformer Specialist*,
King's Buildings, Dean Stanley Street, London, S.W.1

The

CATHODE RAY OSCILLOSCOPE

A practical explanation of the use and working of the Cathode Ray Oscilloscope. Covers such subjects as : cathode ray tube supplies, voltage measurement, tracing of phase diagrams, frequency comparison, time-base and amplifier requirements, the tracing of hum and distortion, receiver alignment, band-width checking and the testing of television receivers. Written by a practical technician for the practical technician. By W. E. Miller, B.A.(Cantab.), M.Brit.I.R.E., Technical Editor of "The Wireless & Electrical Trader."

Price, post free **2/8**

Send cash with order to the publishers

THE WIRELESS & ELECTRICAL TRADER

DORSET HOUSE, STAMFORD STREET, LONDON, S.E.1

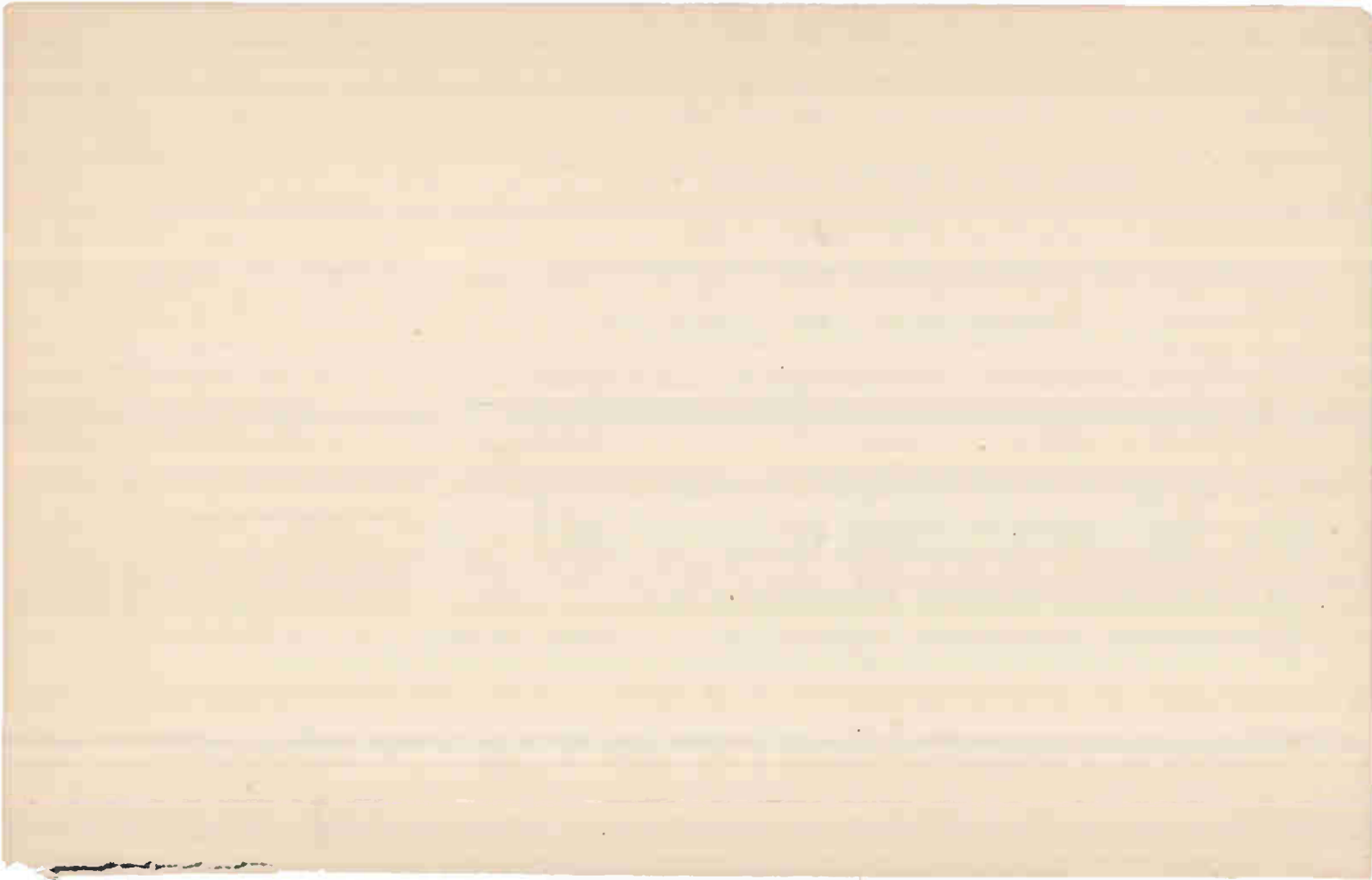

HT →

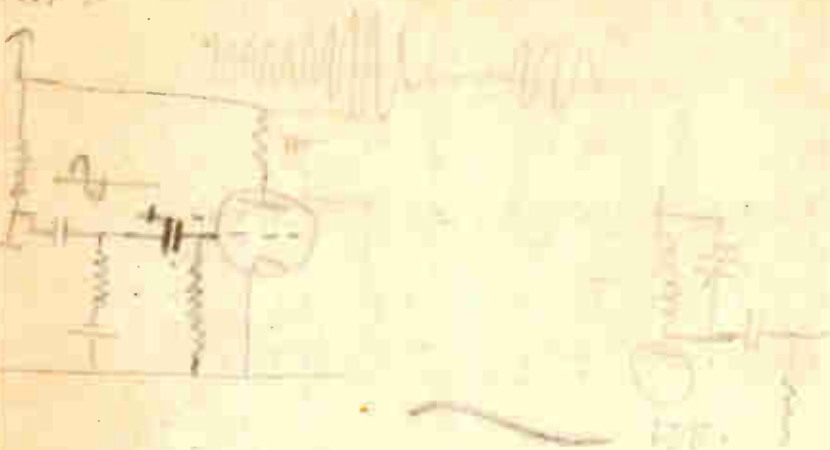

+ 5V -5V
||



PRINTED IN LONDON
 BY SANDERS PHILLIPS
 AND COMPANY, LIMITED
 CHRYSSELI. RD., S.W.9

1400 kc/s 200 kc/s

500 110 kc/s I.F.

5000 450 kc/s I.F. on 500

1000 kc/s

GRAMPIAN

**ALL
EQUIPMENT
for
P.A**

KEW GARDENS · SURREY

CONDENSER COMPONENTS

For Modern Radio Technique



- 1 CERAMIC PEARL TYPE CONDENSERS
- 2 CERAMIC TRIMMER CONDENSERS
- 3 SILVERED CERAMIC FIXED CONDENSERS
- 4 CERAMIC COIL FORMERS
- 5 SILVERED MICA CONDENSERS

Details on Request.

UNITED INSULATOR CO LTD
The Pioneers of Low Loss Ceramics
12-20 LAYSTALL STREET
LONDON. E.C.1

Grams: CAEANEL SMITH; LONDON