

# **Radio Receivers**

---

DEPARTMENT OF THE AIR FORCE

### FOREWORD

This Manual is published to serve as a training text and guide for repairmen and technicians. It covers the field of radio receivers, in sufficient detail, to enable the student to understand the operation, repair, and adjustment of basic communications receivers. The information contained in the Manual also gives the student an adequate background for studying specific Air Force receivers.

There is a general discussion of the fundamentals of radio reception followed by explanations of tuned-radio-frequency and superheterodyne receivers. Descriptions of ordinary communications receivers, and very-high-frequency and ultra-high-frequency receivers are discussed in detail. The latest techniques in receiver design, such as the use of subminiature tubes and plug-in units, are incorporated in the next chapters, followed by explanations of frequency modulation and special purpose receivers. The Manual ends with discussions of performance tests and troubleshooting techniques.

We invite you to send recommendations and or comments for the improvement of this Manual to the Director of Personnel Procurement and Training, Headquarters USAF, Washington 25, D. C.

BY ORDER OF THE SECRETARY OF THE AIR FORCE:

N. F. TWINING  
Chief of Staff, United States Air Force



OFFICIAL:

E. E. TORO  
Colonel, USAF  
Air Adjutant General

### DISTRIBUTION:

Zone of Interior and Overseas	
Headquarters USAF .....	300
Major Air Commands .....	5
Except:	
Air Training Command (for training purposes) .....	3,140
Subordinate Air Commands .....	3
Wings .....	2
Bases .....	1
Groups .....	2
Special**	

\*This Manual supersedes Air Training Command Manual 52-9, December 1953.

\*\*Commanders may requisition additional copies for issue to individuals possessing primary AFSC's in the 30- career fields whose duties require knowledge of receiver principles and circuits.

# *introduction*

A radio receiver is the other half of a communications network—the first half, so to speak, is the radio transmitter. The two halves are linked by radio waves that are radiated from the transmitting antenna and intercepted by the receiving antenna.

Like transmitters, receivers are usually classified and taught as a part of either airborne or ground equipment. In the airborne field, you will become either an Electronic Communications Equipment Repairman or an Electronic Navigation Equipment Repairman. In ground equipment maintenance, you will become either a Radio Repairman or a Radio Technician.

This manual is designed to serve as a basic text in both fields, since basic receiver theory applies equally well to both airborne and ground receivers.

Once you have mastered the operation of the basic receiver circuits presented in this manual, you will have little difficulty understanding the operation of any receiver that you will be required to maintain and service. Actually the only differences between receivers are frequency range, arrangement of stages, types of tubes used in the various stages, and the physical location of the various controls.

# **contents**

CHAPTER

**1**

**Fundamentals of Radio Reception . . Page 1**

**2**

**TRF Receiver . . . . . 7**

**3**

**Superheterodyne Receiver . . . . . 29**

**4**

**Communications Receiver . . . . . 41**

**5**

**VHF and UHF Receivers . . . . . 85**

**6**

**Frequency Modulation . . . . . 105**

**7**

**Special Purpose Receivers . . . . . 129**

**8**

**Performance Tests and  
Troubleshooting Techniques . . . . . 157**

**Index . . . . . 174**

## FUNDAMENTALS OF RADIO RECEPTION

The receiver has the job of completing the communications cycle started by the transmitter. It must intercept some of the RF (radio frequency) energy radiated by the transmitter — separate the intelligence from the RF — and reproduce the intelligence as energy in some meaningful form, such as sound, light, or mechanical energy. What a receiver is, and how it performs its communication job, is discussed in the following pages.

### GENERAL REQUIREMENTS OF RECEIVERS

#### Frequency Coverage

The frequency coverage of a receiver is the range of RF which it can handle.

Consider frequency range from the point of view of a receiver. Radiated frequencies may range anywhere from 10 kc to above 30,000 mc. However, no practical receiver has yet been constructed that will handle this entire range successfully. This range constitutes too big a chunk of frequencies. Even talking about it clearly requires that it be divided

up a bit, as shown in the frequency spectrum chart below.

Another kind of division is shown in the frequency allocation chart on page 2. This is based on the purpose for which the frequencies are used. A receiver might handle a complete band or only part of a band. At most, it will handle only two or three bands. Thus, the broadcast receiver has a frequency coverage of 550 kc to 1600 kc, a complete band, while some receivers used in Air Force communications have a frequency coverage of 225 mc to 399.9 mc, only part of a band.

#### Sensitivity

The *sensitivity* of a receiver is the measure of its ability to intercept weak signals and extract intelligence from them.

A receiver intercepts many radiations. These radiations may originate from transmitters operating anywhere within the radio frequency spectrum. They may originate from transmitters located anywhere in the world. They may also originate from transmitters of wide-

RADIO FREQUENCY SPECTRUM			
Frequency Band		Designation	Abbreviation
KC	MC		
10-30		Very Low	VLF
30-300		Low	LF
300-3000		Medium	MF
3000-30000	3-30	High	HF
30000-300000	30-300	Very High	VHF
300000-3000000	300-3000	Ultra High	UHF
3000000-30000000	3000-30000	Super High	SHF

FREQUENCY ALLOCATION		
Frequency Band	Wavelength (in meters)	Uses
400 mc	0.75	Experimental
400 mc 106 mc	2.83	Government, Aircraft, Police, Television
108 mc 88 mc	3.41	Frequency Modulation
88 mc 50 mc	6.82	Television
50 mc 1600 kc	187.5	Ship-to-Shore, Aircraft, Police, Foreign, Government, Point-to-point, Experimental
1600 kc 550 kc	545.45	Commercial broadcast
550 kc 20 kc	15,000	Government, Commercial, Maritime, Ship-to-Shore, Aircraft, Point-to-Point, High Power Government, Transoceanic

ly varying power output. Thus, the RF radiations intercepted by a receiver are of widely varying signal strength. A highly sensitive receiver does a good job of completing communication, whether signals are weak or strong.

### Selectivity

*Selectivity* is the measure of a receiver's ability to intercept a desired signal and extract its intelligence to the exclusion of others. From the point of view of a receiver, the RF radiation that comes along is composed of a hodgepodge of various frequencies and various signal strengths. A highly selective receiver must be able to concentrate on one signal and reject all others, even those whose frequencies are close to the frequency of the desired signal.

### Fidelity

While sensitivity and selectivity are the measure of radio receivers' ability to intercept a weak signal and to extract the intelligence from that signal to the exclusion of all others, *fidelity* is the measure of receivers' ability to reproduce the intelligence of the

signal. A receiver designed primarily for entertainment requires a high degree of fidelity. It must reproduce faithfully the sounds and sights on which entertainment depends — for example, the music of a symphony orchestra, or the fine details of a television picture. The fidelity requirements for simple communication are not so high. Still, reproduction must be faithful enough to make the message intelligible. This means reproduction without undue distortion. Voice reproduction must be understandable. The reproduction of CW and MCW must be readable.

### Physical Requirements

The components of a receiver are usually smaller and more compact than those of a transmitter. This is due chiefly to the fact that the power requirements of a receiver are less. As a result, power supply components are usually included right in the receiver unit. The actual size, weight, and cost of a receiver vary greatly, depending on the type and quality of operation the receiver is to perform. Communications receivers are usually of rugged construction. Receivers designed for mobile use are shock mounted.

## BASIC REQUIREMENTS FOR RADIO RECEPTION

A simple practical receiver performs three essential operations — selection, detection, and reproduction. By selection, one RF signal is extracted from a multitude of RF signals. By detection, the intelligence is separated from the RF. By reproduction, the intelligence is turned into some type of energy which reproduces the intelligence. Each of these operations, with the exception of selection, is shown in the diagram, Simple Receiver.

### Antenna

Actually an antenna in itself is a tuned circuit. It provides some selectivity. The Antenna Equivalent Circuit shows how an antenna can be a resonant circuit.  $L_a$  represents the distributed inductance of the antenna.  $C_a$  represents the distributed capacitance of the antenna.  $R_a$  represents the resistance of the antenna. The resonant frequency of an antenna

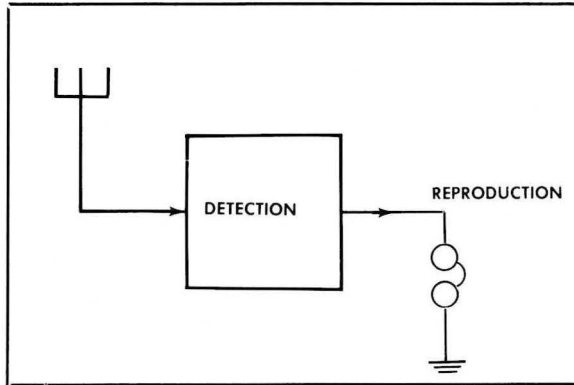

Simple Receiver

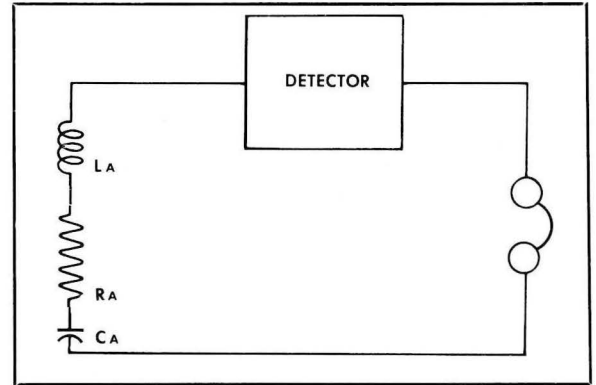

Antenna Equivalent Circuit

can be determined by the formula,

$$F (mc) = \frac{159}{\sqrt{LC}}$$

where  $L$  is in microhenries and  $C$  is in micro-microfarads. Substituting typical values ( $L_a = 50\mu h$  and  $C_a = 200$  mmf) in the formula,

$$\begin{aligned} F (mc) &= \frac{159}{\sqrt{(50)(200)}} \\ &= 1.59 mc \end{aligned}$$

Note that frequency may be changed by varying  $L$  or  $C$  or both. When the antenna is a wire or a mast,  $L$  and  $C$  vary directly with antenna length. The longer the antenna, the lower the resonant frequency.

The resistance of the antenna will affect the sharpness of response of the tuned circuit. This is illustrated by the chart at the right, showing relative values of antenna current for varying values of resistance, with  $L$  and  $C$  remaining constant. Note that the smaller the resistance, the greater the response and the greater the selectivity of the antenna.

An antenna can be tuned in construction by making its length correspond to a quarter or half wavelength or a multiple of a quarter wavelength of a desired frequency. An antenna may also be provided with a means of varying its length for operational purposes.

At high frequencies, the selectivity provided by antenna tuning can be very critical and very important. At those frequencies antennas are short, and their resistance is kept as small as possible. A slightly detuned antenna may make a receiver inoperative.

At low frequencies, antennas are long, and reduction of internal resistance is less practical. Here, antenna tuning is usually much less critical. The gain provided in a receiver by amplifier stages far surpasses the gain obtained by antenna tuning. Antenna length has little importance in broadcast receivers.

However, in simple receivers such as the one under consideration, there are no amplifier stages to provide signal amplification. Here, antenna length is important both for the sensitivity and the selectivity of the receiver.

The receiver antenna intercepts the signal by being in the path of the radiated RF. When

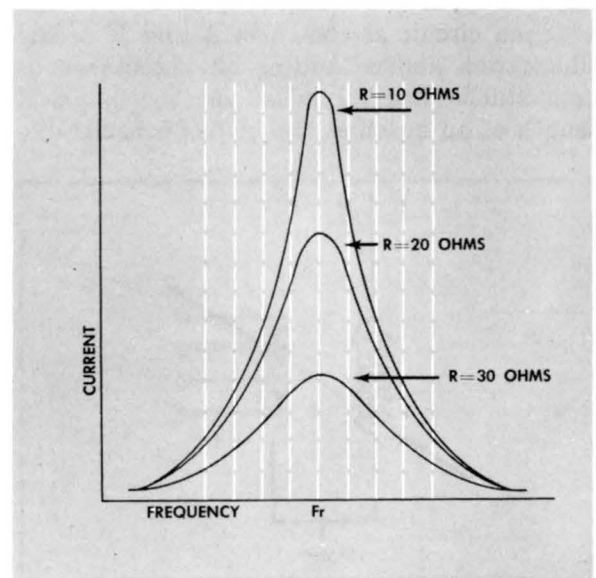

Effect of Resistance on Selectivity

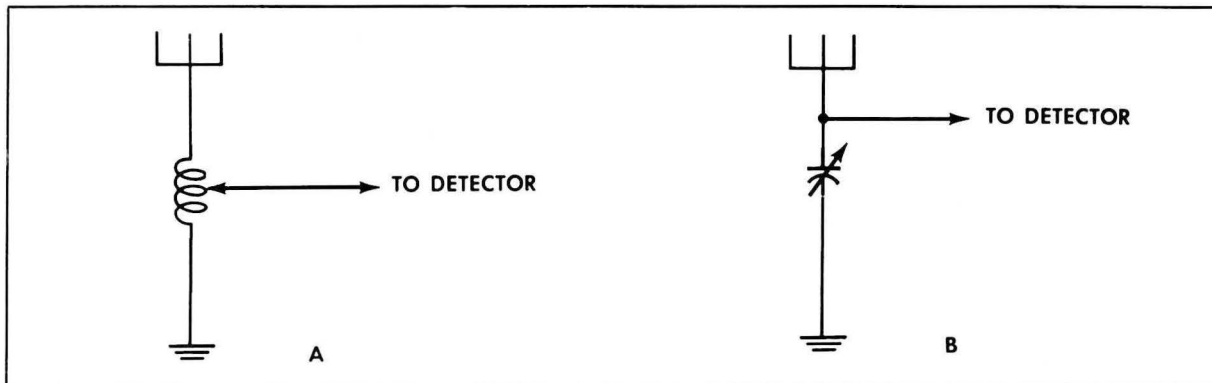

Variable Antenna Circuits

magnetic lines of force cut a conductor (the antenna) an emf is induced in the conductor. This induced voltage reproduces both the RF and any frequency or amplitude variations of the inducing voltage. The induced voltage is greatest when the antenna is tuned to the frequency of the inducing voltage. The induced voltage represents the intercepted energy needed for the first steps in the receiving process — interception and selection.

**Tuning for Selectivity**

As stated before, the resonant frequency of an antenna can be changed by varying antenna inductance, antenna capacitance, or both. This can be done by placing a variable inductance or a variable capacitance in the antenna circuit as shown in A and B of the illustration above. Adding an inductance or capacitance has no effect on the physical length of an antenna, but it has considerable

effect on the electrical length. It is the electrical length which determines the resonant frequency of the antenna. When the added inductance or capacitance is variable, the electrical length of the antenna can be changed to achieve exact tuning for a desired signal.

The variometer, shown below, provides another means of changing antenna resonance by varying inductance. The taps on the secondary can be used to increase the tuning range.

Finally, higher selectivity can be obtained by coupling the received signal into a separate tuned circuit, as shown at the right. With such a selector circuit added, selection may be regarded as a separate step, distinct from antenna tuning. The antenna may then be regarded as being primarily for interception.

The use of a transformer improves both sensitivity and selectivity. The transformer steps up the voltage and isolates the tuned circuit from the resistance of the antenna. For tuning, either the capacitor or the coil could be made variable.

**Detection**

The process of separating the intelligence from the modulated RF signal is called *detection*. In the simple receiver shown, detection is accomplished with the help of a crystal detector. Detection is the opposite of modulation, and is sometimes called demodulation. In the receiver, here, detection separates the amplitude modulation from the carrier. The process of separating frequency modulation

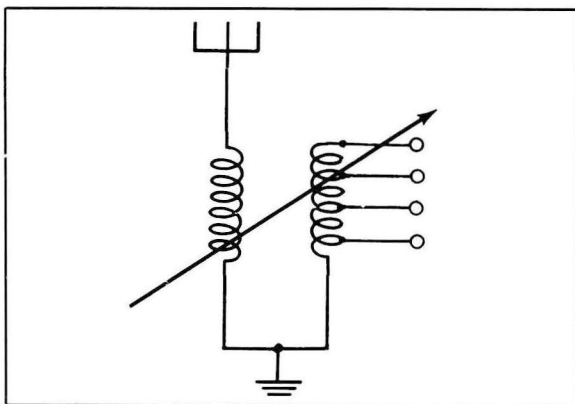

Variometer Tuning



from the carrier is somewhat different. It is discussed in chapter 6.

All detectors are essentially rectifiers. The crystal detector, shown in the illustration, conducts effectively only in one direction. Thus, when it is connected across the selector tank circuit, the crystal acts as a rectifier. Its output is a pulsating direct current, pulsing at the RF rate but at the AF (modulation) amplitude.

This is the first step in detection. The process is completed by filtering the pulsating DC. In the simple circuit shown here, the coils in the headset form part of the filter. They offer little impedance to AF but high impedance to RF. A capacitor across the headset completes the filter. It offers little impedance to RF but high impedance to AF. Thus the capacitor bypasses the RF around the headset while the AF signal goes through the headset.

### Reproduction

The current flowing through the coils of the headset varies at an audio rate. If the current can cause vibrations in the air at the same rate, the vibrations will constitute sound. For the reproduction of sound, the energy of the magnetic field which surrounds the coils is used. The strength of the magnetic field varies as the current varies. In turn, it causes a metal diaphragm to move back and forth at the same rate. This sets up vibrations in the air and produces corresponding sound waves.

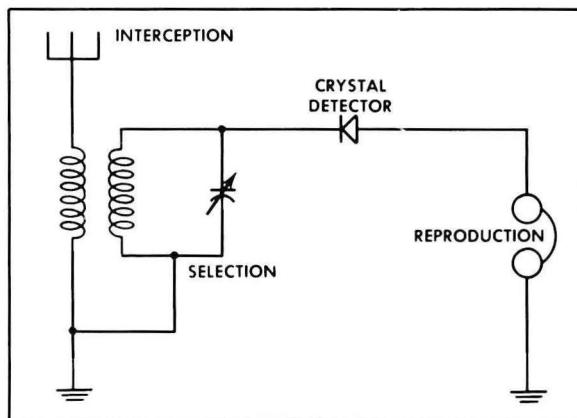

Simple Tunable Receiver

### OPERATIONAL ANALYSIS OF A SIMPLE RADIO RECEIVER

To analyze the simple radio receiver, study the schematic diagram shown on page 6. In this schematic, are gathered together all the steps just discussed. The points to be considered in the analysis are — What are the essential components? — What are the functions of each component? — What are the changes made in the radio waves as they pass through the receiver?

The illustration shows the conventional connections of the components. It also gives a graphic representation of the wave as it passes through the receiver. When the radio wave passes or cuts across the antenna, RF voltage is induced across the antenna, and consequently across the primary of T1. The current flow in the primary of T1 (L1) induces current flow in the secondary. The antenna transformer usually has an air core and a step-up ratio. This allows a small amount of signal gain.

The secondary of T1 is a part of a series tuned circuit, made up of L2 and C1. Maximum circulating current flows through a series tuned circuit when the resonant frequency is applied. In addition, since maximum current flows at resonance, maximum reactive voltage is developed across each component. For maximum output from the headset, maximum voltage must be applied to the rectifier and the parallel combination of C2 and the headset. This results in a maximum

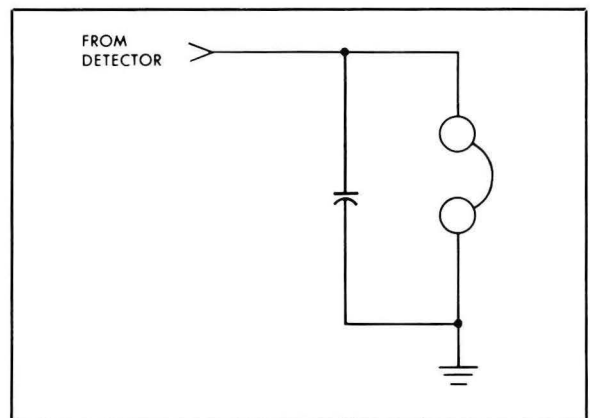

Detector Output Filtering

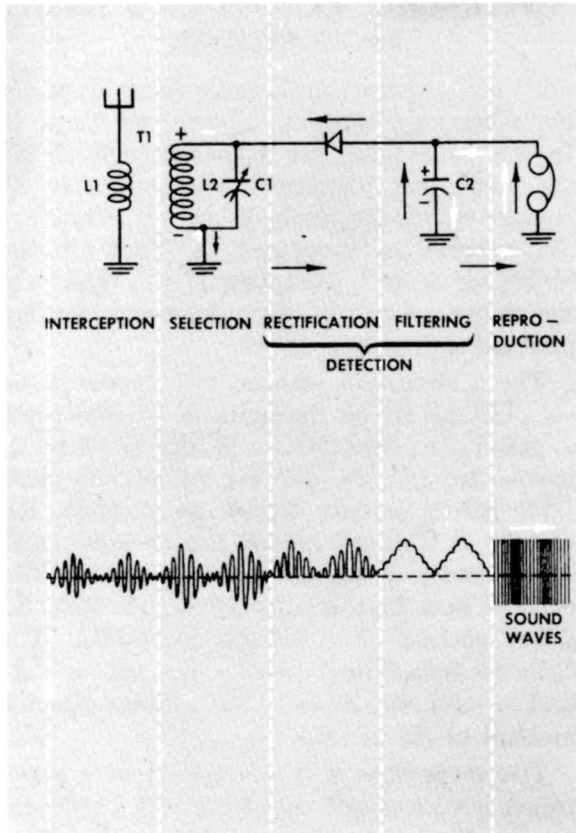

*Simple Tunable Receiver Analysis*

amount of current through the headset, and since the headset is a current device, there will be a maximum audio output. Actually, the tuned circuit (L2-C1) appears as a parallel circuit to the rectifier and the parallel-connected capacitor and headset, and one characteristic of a parallel circuit at resonance is that maximum voltage is developed across it.

The polarity at the extremities of the transformer changes with changes in the incoming signal. When the top of the tank circuit is positive, current flows through the circuit as indicated by the solid black arrows. When the top of the tank is negative, the crystal does not conduct, and the capacitor discharges as shown by the white arrows. Thus, the waveform is rectified, and the signal is changed to a pulsating DC. Note that the pulses still bear the imprint of the modulation after filtering, but this does not affect the intelligence.

Part of the filter is C2, a small capacitor, usually about 250 mmf. It filters the RF component of the pulsating DC. The capacitor charges during the half cycles that the crystal conducts and discharges partially when the crystal is not conducting. In its charging and discharging, it absorbs almost all the swing of the RF pulses and follows the pattern of the modulation envelope, as the waveform shows.

A headset changes current pulses to sound waves by application of the electromagnetic principle. Each receiver contains two coils, a U-shaped permanent magnet which serves as the core of the coils, and a flexible diaphragm. As current travels through the coils, a changing magnetic field is developed. The strength of this field determines how much the diaphragm is attracted. When the field strength decreases, the diaphragm pulls away. The mechanical vibrations of the diaphragm cause the sound which is the intelligence.

### LIMITATIONS OF A SIMPLE RADIO RECEIVER

The simple receiver just described has its limitations. There is only one tuned circuit to improve the selectivity of the antenna. The slight step-up of the antenna transformer does little to improve the sensitivity of the receiver. This limits the effectiveness of the receiver to strong signals from nearby stations. On other signals, the output of the detector is not strong enough to develop magnetic fields around the headset coils to produce diaphragm vibrations.

An effective receiver needs more than the basic requirements. It must include circuits and stages to improve performance in terms of selectivity and sensitivity. It needs additional tuned circuits for selectivity. It needs RF amplifier stages to improve sensitivity. It needs AF amplifiers to increase audio output so that a speaker can be used to reproduce the intelligence. Such a receiver is shown in the block diagram of a tuned radio frequency receiver (TRF) on page 7. Typical stages of a TRF are discussed in chapter 2.

## TRF RECEIVER

The simple receiver studied in the previous chapter is classified as a single stage receiver, since neither the antenna nor the headset can be called a stage. The TRF receiver, on the other hand, is a multistage receiver. As shown in the block diagram, the detector of the TRF is the equivalent of the single stage of the simple receiver. The TRF is the more useful receiver because it has two RF amplifier stages, an AF (audio frequency) voltage amplifier stage, and an AF power amplifier stage.

In performance, the TRF far surpasses the simple receiver. The use of electron tubes makes the big difference. With the help of tubes, the number of steps which the receiver performs is expanded. The steps now are interception, selection, RF amplification, detection, AF amplification, and reproduction.

Amplification, both of RF and AF, is the great advantage gained by using tubes.

## ANTENNA CIRCUITS

The antenna coupling circuits used in connection with the TRF receiver are similar to those you studied in connection with the simple receiver. Usually, though, they are more elaborate. The RF energy which the antenna intercepts is applied to the grid of the first RF amplifier stage. In most cases, transformer coupling is used. This method offers the advantages of signal gain through the step-up action of the transformer.

Sometimes wavetraps are used with transformer coupling. A wavetraps is a device for preventing undesired signals from nearby transmitters or from extra powerful transmitters from drowning out desired signals

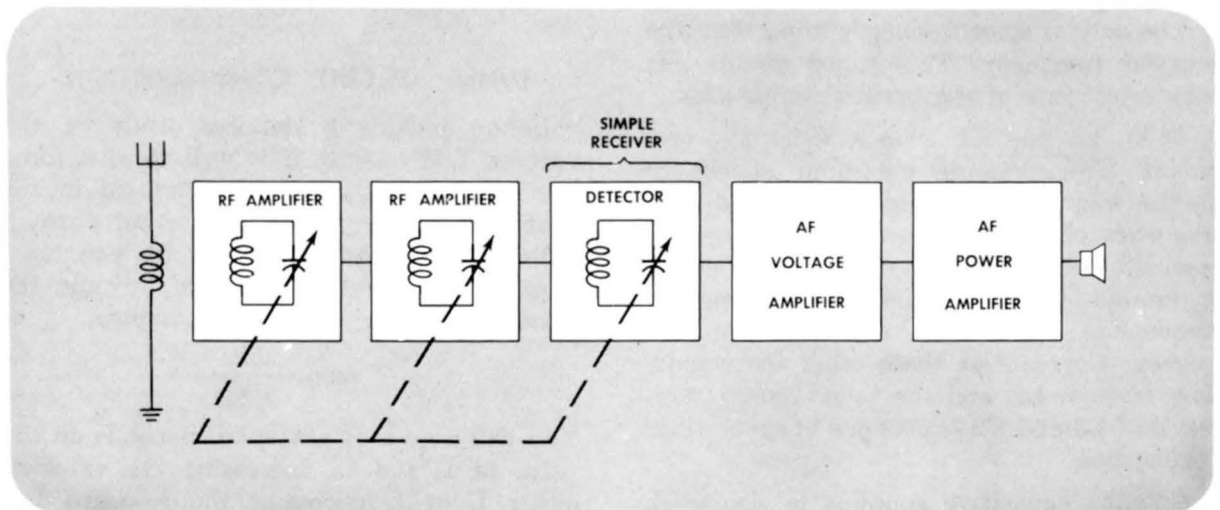

TRF Receiver

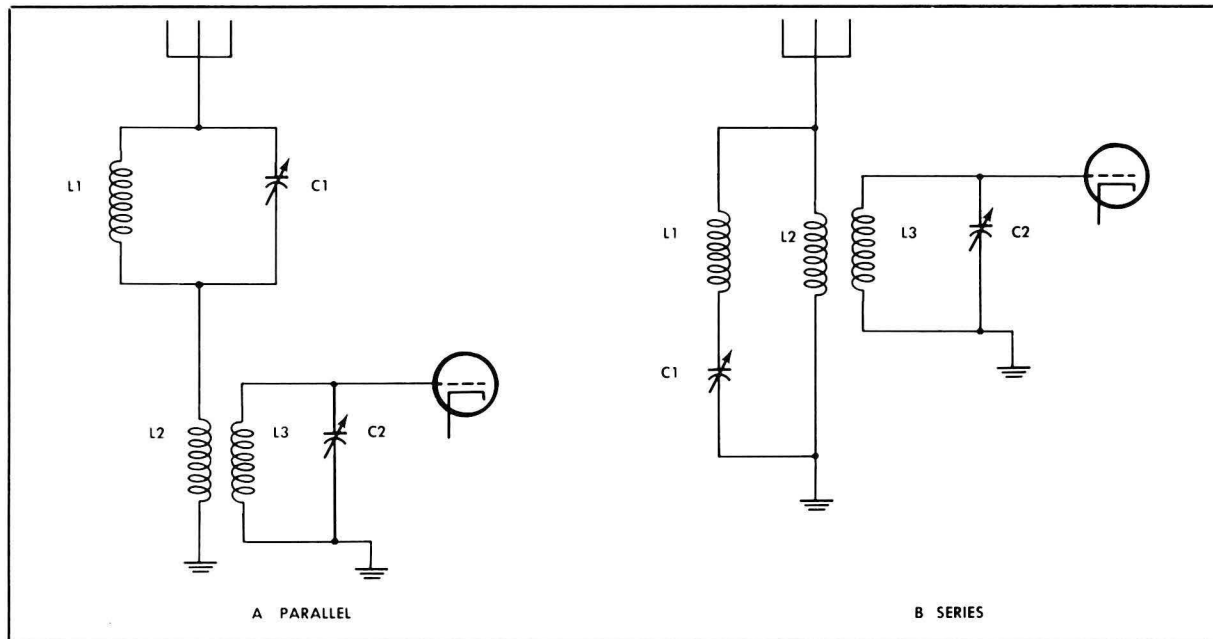

Wavetraps in Antenna Circuits

from weaker or more distant transmitters. As shown above, these wavetraps may be parallel or series resonant circuits. Their use increases selectivity.

At A in the illustration, notice that L1 and C1 form a tunable parallel resonant circuit which presents maximum impedance to the frequency to which it is tuned—the frequency of the undesired signal. Thus, it rejects the unwanted signal. The current through L2 and the voltage across the tuned circuit, L3-C2, can be only at some frequency other than the rejected frequency. This tuned circuit can then select one of the desired frequencies.

At B, L1 and C1 form a series resonant circuit. This presents minimum impedance to the frequency to which it is tuned—the frequency of the undesired signal. This series resonant circuit bypasses the undesired signal to ground, but presents high impedance to frequencies other than the undesired frequency. Currents at these other frequencies flow through L2, and the tuned circuit composed of L3 and C2 selects one of these other frequencies.

Antenna capacitive coupling is also used, especially with a variable coupling capacitor.

In the capacitive coupling illustration on page 9, the capacitor couples the antenna to the tuned circuit. This variable capacitor makes it possible to match antenna impedance to the impedance of the grid circuit to obtain maximum signal input.

In many modern broadcast receivers, a loop antenna is used. The loop circuit is a tuned circuit, for the inductance of the loop combines with the capacitance of the variable capacitor to form a tuned circuit.

**TUNED CIRCUIT CONSIDERATIONS**

Before making a detailed study of the various TRF stages, it is well to give some attention to the tuned circuits used in the TRF. Essentially, these tuned circuits are no different from the tuned circuits you have already studied. Recalling the formula for resonant frequency in the last chapter,

$$F (mc) = \frac{159}{\sqrt{LC}}$$

You will note that resonance depends on the value of L and C. Increasing the value of either L or C decreases the resonant frequency. Decreasing the value of either L or

C increases the resonant frequency. Changing the value of both may change the resonant frequency—or it may not. It depends on whether the *product* of L and C is changed. If L and C are changed so that their product remains the same, the frequency will remain the same. Thus, for the same frequency, L may be high and C low, or L may be low and C high.

You remember, though, that the L C ratio is important to the Q of a tuned circuit. Since

$$Q = \frac{Z}{R},$$

the ratio of impedance to resistance

affects the Q. If the resistance remains the same, raising L and lowering C gives a higher ratio of impedance to resistance and a higher Q. Lowering L and raising C gives a lower ratio of impedance to resistance and a lower Q. A high Q has the advantage of providing sharp tuning and high gain, thus improving selectivity and sensitivity. If the Q is too high, though, tuning is so sharp that it eliminates part of the sidebands and introduces distortion.

This all means that the makeup of the tuned circuit, in terms of L, C, and R, is of considerable importance.

The tuned circuits in the TRF are tunable, usually by means of variable capacitors. The capacitors are ganged so that they may be varied simultaneously by one control. The fact that the capacitors can be varied permits exact tuning for a desired frequency. The fact that the capacitors can be tuned over a range of frequencies provides the receiver with its frequency coverage.

Another way of tuning is by use of variable inductances. They can be ganged in the same way as the variable capacitors.

The tuned circuits used for the TRF receiver are essentially the same as the tuned circuits you have studied. Their individual parts, though, are modified to adapt them to the TRF.

### RF Coils

An RF coil, such as the one shown on page 10, is designed for minimum loss. It uses a multistrand wire called "Litz" wire. This wire is made by weaving together a large number of fine insulated wires. Its AC resistance is low, and therefore the Q of the coil is high.

Very light cardboard is used for the coil form. The form is varnished both before and after winding, to prevent absorption of moisture. The physical size of coil and form is kept as small as possible. The width of the mass of wound wire is usually about equal to its depth, as shown. The form contains both primary and secondary windings. The primary may be wound near the secondary or directly over the secondary.

A shield covers the coil and shields it from electric and/or magnetic fields which might induce unwanted voltages. The shield must be a good conductor to shield against electric fields. Aluminum is usually used because it is light, cheap, and a good conductor. Shielding of coils results in some reduction of efficiency, due to eddy currents induced in the shield by the magnetic field of the coil. These eddy currents produce a magnetic field of their own

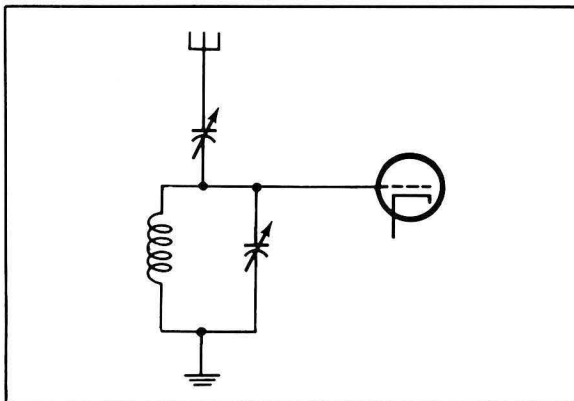

Capacitive Coupling From Antenna

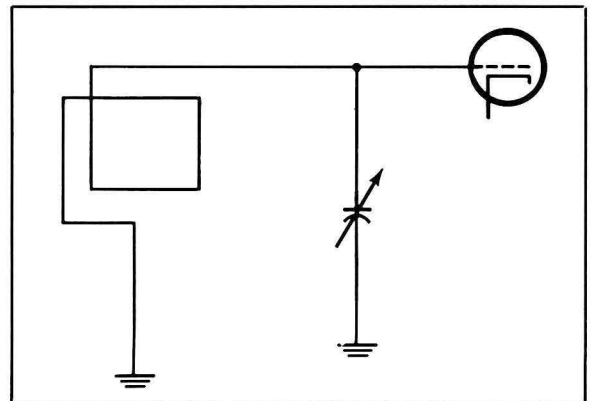

Loop Antenna

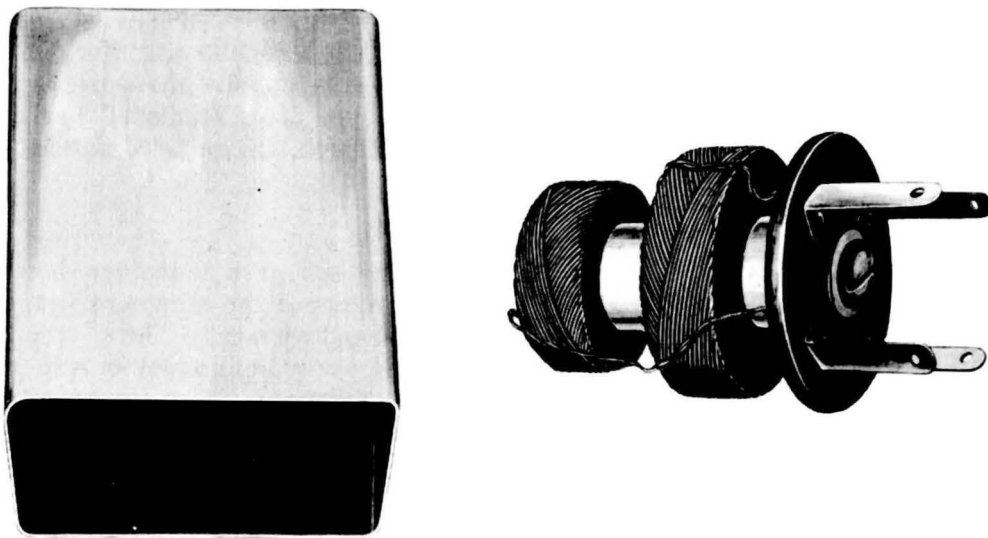

Typical RF Coil with Shield

which opposes the field of the coil. The loss of efficiency due to eddy currents is limited to approximately 15% by using a shield with a diameter twice the diameter of the coil. The shield should be well grounded.

RF coils usually have air cores. A few designed for low and medium frequencies have powdered iron cores. The cores are sometimes adjustable. As the iron core moves into the coil, inductance increases and the frequency of the tuned circuit decreases. A brass core can be used for the opposite effect. As the brass core is moved into the coil, inductance decreases and frequency increases. In either case, the circuit can be tuned by moving the core. This is called *permeability tuning*.

#### Variable Capacitors

Variable capacitors for RF tuned circuits are somewhat bulky. The plates, both rotor and stator, are usually aluminum, but better receivers sometimes use silver-plated brass capacitors for improved RF conductivity.

The calibration pattern of a variable capacitor depends on the shape of its rotor, as shown on page 11. For calibration, capacitors fall into three classifications — straight line capacity, straight line wavelength, and straight line frequency.

With the straight line capacity type, capacity increases directly with the amount of rotation. Since frequency does not increase directly with the decrease in capacitance, calibration puts the upper half of a frequency band in about one-eighth of the dial rotation.

With the straight line wavelength type, wavelength increases directly with the amount of rotation. In this type, the upper half of the band appears on one-third of the dial rotation.

With the straight line frequency type, frequency varies directly with the amount of rotation. This permits linear dial calibration. With this type variable capacitor, a tuned circuit has the same sharpness of tuning over its whole band.

The TRF can use any number of RF amplifier stages, but usually it has no more than three. In each TRF there is one more tuned circuit than there are RF amplifier stages. The extra RF tuned circuit, of course, is in the detector stage. When these tuned circuits are controlled by variable capacitors, it is advantageous to have the capacitors tunable by a single control. This can be done by ganging the capacitors, as shown at the right. This means that the capacitors are mounted in line with their rotors attached to a common shaft. Grounded partitions act as shields. They

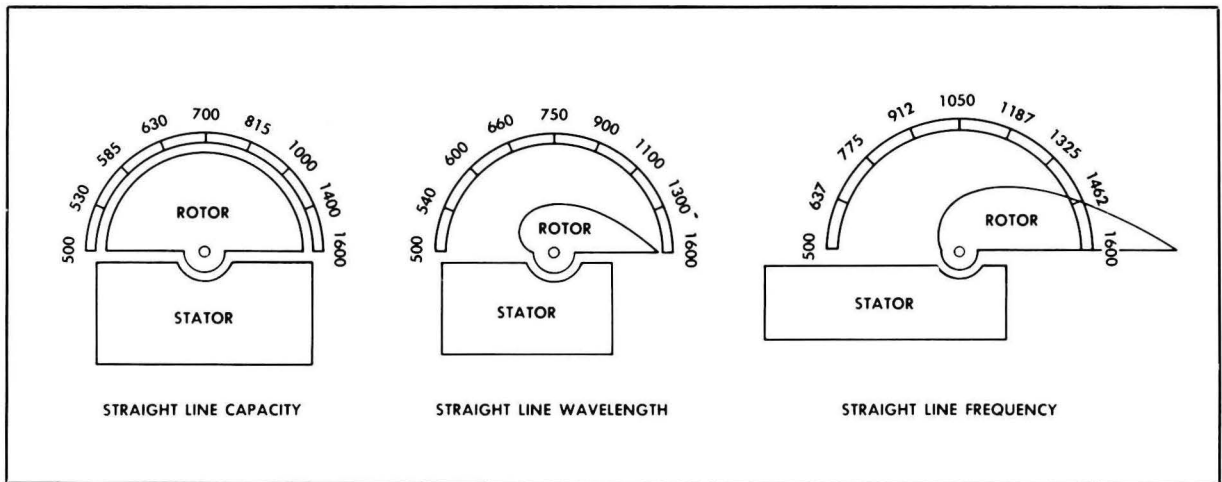

### Variable Capacitors

provide electrical separation between the stator sections of the ganged capacitors.

It is almost impossible to manufacture a set of ganged capacitors of exactly the same capacitance. Similarly, it is difficult to keep each one of a set of ganged capacitors at the same capacitance. Even a slight bending of a single plate of a capacitor will change its value. Still, it is necessary for capacitors to "track"—that is, to maintain equal capacitances at each setting of the rotor. To com-

pensate for differences, therefore, each of the ganged capacitors is provided with a small additional capacitor. It is screwdriver adjustable, and is called a *trimmer*. It is connected in parallel with the main tuning capacitor section. (See illustration on top of page 12.)

To make further adjustment possible, the outer rotor plates on each section are usually slotted, as shown in the illustration of a slotted plate on page 12. The slots make it easy to bend part of a plate and slightly change the capacitance of one section.

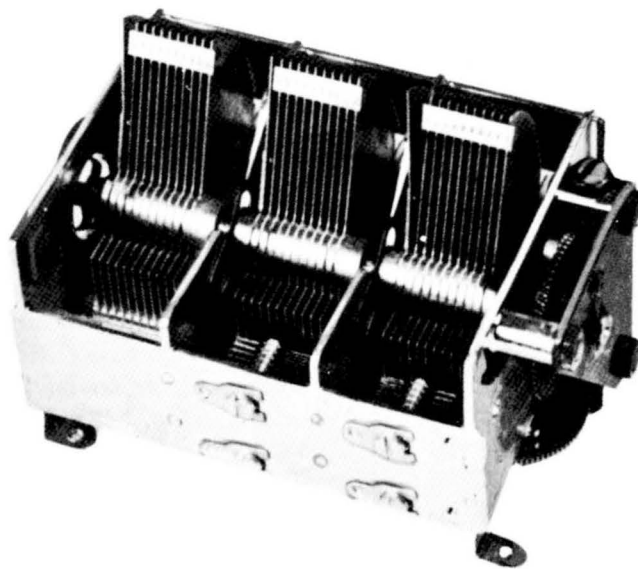

Ganged Tuning Capacitor

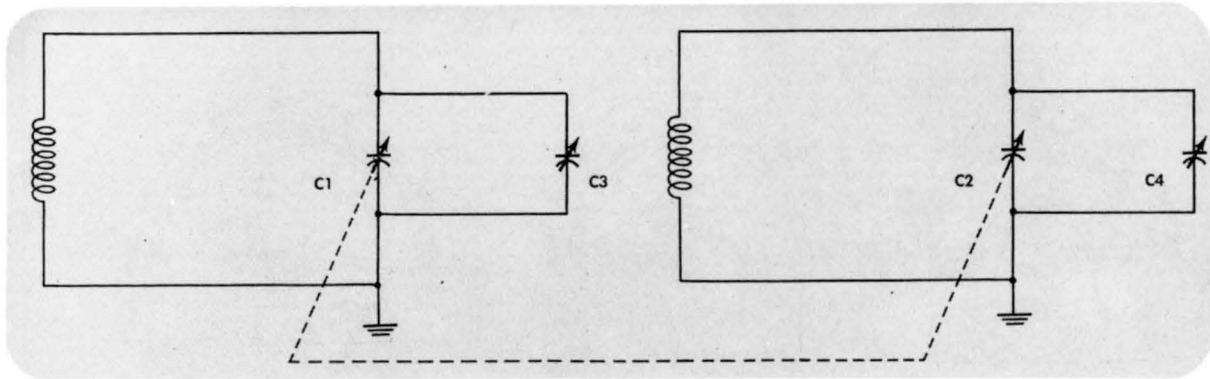

Trimmers Used for Tracking

**Band Switching**

TRF receivers frequently operate over several bands. Switching from one band to another requires switching from one set of tuned circuits to another. Usually the new set of circuits is formed partially out of the old set by substituting different components for either L or C. Since variable capacitors are bulky, it is practical to use as few as possible. Generally, therefore, it is the coils that are changed to form the tuned circuits for the new band. This can be done by use of a series of plug-in type coils, or by use of a switching arrangement. Where a switching arrangement is used, a single coil form may include windings for one, two, or three bands. A rotary wafer switch, such as the one on page 13, is used to switch in the desired set of coils. The switch connects the proper coils to the capacitor section, and, at the same time, grounds all unused coils. As you see, the switch shown has

three wafers. When the shaft is turned, metal contacts fastened to the inner portion move from one contact point to another along the outside portion. Each setting of the switch makes a combination of connections for one band.

You can see the electrical equivalent of two switching arrangements at the right. A shows an arrangement for placing different coils into the circuit with one variable capacitor. B shows an arrangement for switching different capacitors in series with one variable capacitor.

**Bandspreading**

In a multiband receiver, each band has a different bandwidth. Still it is desirable for each band to occupy the entire range of the tuning dial. For example, the broadcast band extends from 550 kc to 1600 kc, a frequency ratio of about 3 to 1 and a frequency coverage across 1050 kc of tuning range. When a dial for this band rotates 180°, it covers about 5 kc for each degree of rotation. Shifting to a new band may bring about a situation where the tuning range occupies only a portion of the dial range and where many kilocycles of frequency are covered for each degree of rotation. This concentration of frequencies in each degree of rotation makes dial reading difficult. To correct this, the band is spread until it more closely approximates the full dial rotation.

Bandspreading can be accomplished by mechanical means. The mechanical arrange-

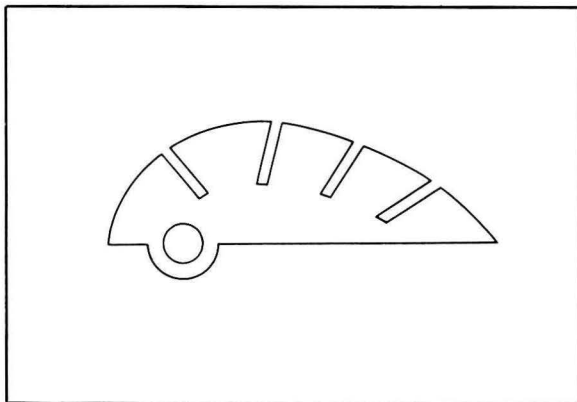

Slotted Rotor Plate



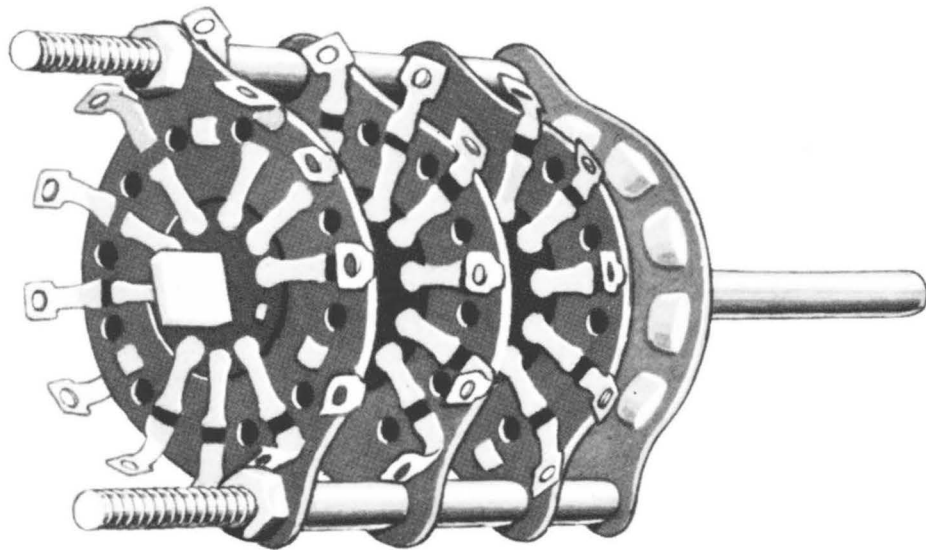

Rotary Switch for Band Switching

ment uses gears which coordinate the rotation of the dial with the rotation of the variable capacitor. But this method is expensive and is used only with precision equipment.

Bandspreading can also be accomplished electrically by using trimmer and padder capacitors, as shown on page 14. These capaci-

tors can affect the minimum to maximum capacitance of a circuit. To increase the bandspread, a variable trimmer, C2, is connected in parallel with the main tuning capacitor. To decrease the maximum capacitance without changing the minimum value appreciably, a padder or series capacitor, C3, is used.

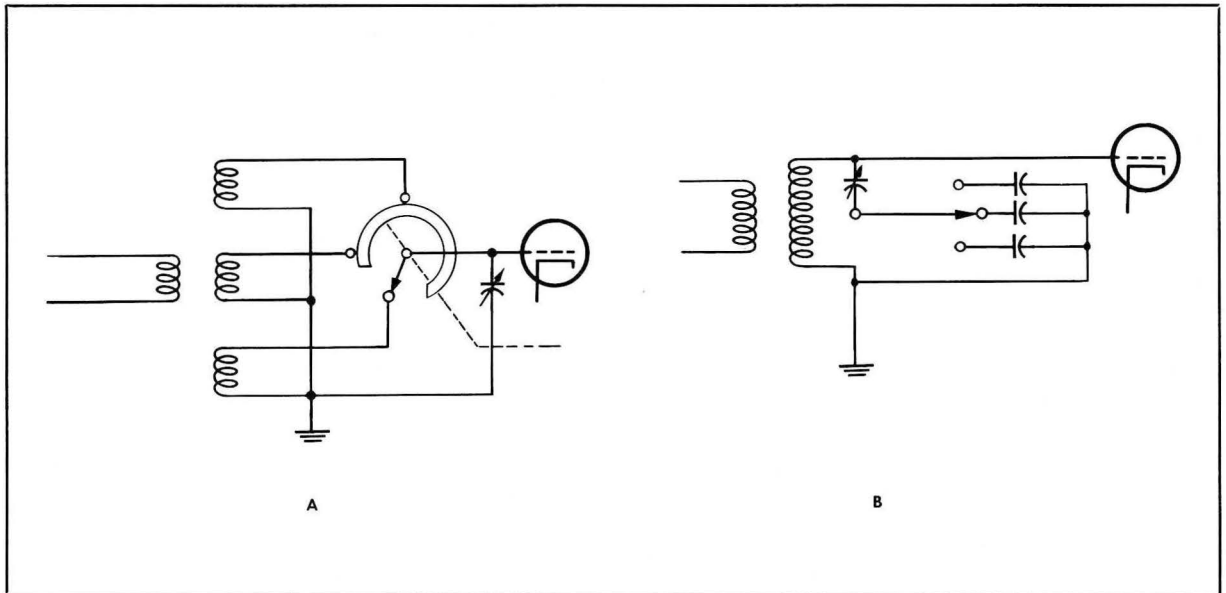

Band Change Circuits

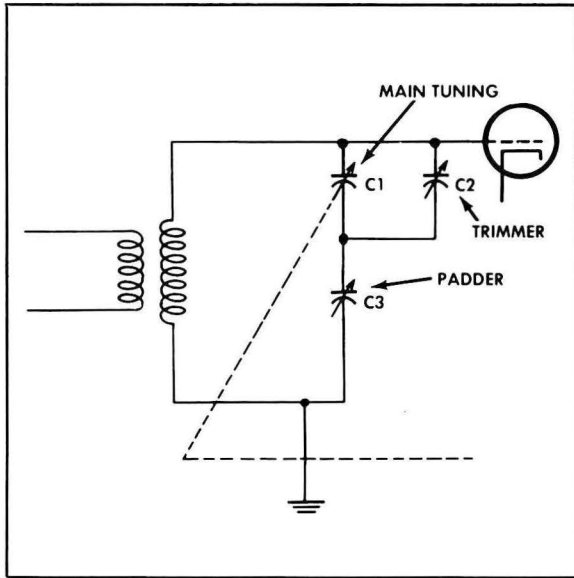

Bandspread Circuit

**THE TUNED CIRCUIT AT VHF AND UHF**

The use of the ordinary tuned circuit for VHF and UHF is impractical. At such frequencies, both L and C become so small that the connecting leads of the coil may have more inductance than the coil itself, and the distributed capacitance of the coil may exceed the capacitance of the variable capacitor. Under such conditions, successful tuning is impractical. Thus, it is common practice to use resonant sections of transmission lines for tuning frequencies above 100 mc. A quarter wavelength resonant line has capacitance and inductance. It is a tuned circuit. This type of tuned circuit will be discussed further in the chapter on VHF and UHF receivers.

**AMPLIFIER TUBE CONSIDERATIONS**

Triodes, tetrodes, or pentodes may be used in TRF receivers. The use of pentodes is most common, for pentodes provide much greater amplification, with little danger of oscillation.

Remote cutoff (variable-mu) or sharp cutoff tubes may be used. Notice the difference in response of these two types as shown above.

The remote cutoff tube is used in circuits with adjustable bias for controlling the gain of a stage without impairing linearity of amplification. With a remote cutoff tube,

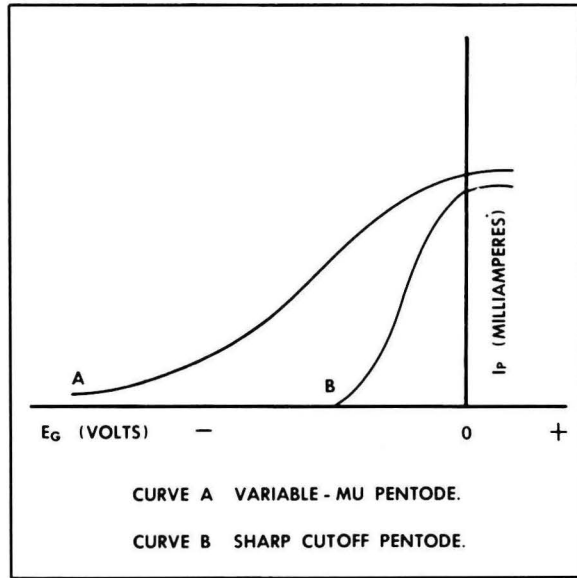

Pentode Response Curves

signal strength may vary considerably without danger of distortion. Some useful remote cutoff tubes are the 6K7, 6SK7, 6SG7, 6BE6, 6AV6, and 6AB7. These tubes cut off at bias voltages of -15 to -45 volts. Class A operation is possible up to the cutoff point.

The sharp cutoff tubes, such as the 6SJ7, 6SH7, or 7V7, have higher transconductances than remote cutoff tubes. They can be used where signal strength is low and high gain is desired, as in the first amplifier stage. They can also be used where signal strength is relatively constant.

**TRF AMPLIFIER TUBES AT VHF AND UHF**

In the VHF and UHF ranges, specially constructed tubes are used. Input impedance must be high, or gain is limited and tuning is broadened. At 60 mc, a normal RF amplifier tube may have an input impedance of 2500 ohms, while a specially constructed tube may have an input impedance of 54,000 ohms.

The specially constructed tube is very small physically, with closely spaced electrodes and no base. To reduce interelectrode capacitance and lead inductance, tube connections are brought out to short wire pins sealed in the glass envelope. The close electrode spacing keeps transit time down to the point necessary for UHF operation. The reduced electrode area

means reduced interelectrode capacitance. These tubes can be used for frequencies as high as 600 mc. Some examples are acorn tubes 954 and 956.

### TRF AMPLIFIER CIRCUIT

Examine the typical RF amplifier stage shown below. The tube is a remote cutoff pentode. The antenna is transformer coupled through a tuned circuit to the grid of the pentode. Cathode bias is provided. The variable resistor in the cathode circuit permits adjustment of the operating bias. The output of the stage is transformer coupled to the next stage.

The RF signal is passed through several such TRF amplifier stages before it is applied to the detector stage. As the signal goes through the three or four tuned circuits, selectivity is greatly improved because each tuned circuit passes the resonant frequency and attenuates the other frequencies. The sensitivity is greatly increased because each tube amplifies the signal.

### DETECTOR CIRCUITS

Detection involves rectification and filtering, as explained before in the simple receiver

analysis. In most modern receivers, the detector uses an electron tube for rectification. Six types of tube circuits are used: diode detector, plate detector, infinite impedance detector, grid leak detector, regenerative detector, and superregenerative detector. The diode detector is the most common.

### Diode Detector

Examine the diode detector circuit shown on page 16. Note that no DC plate voltage is used. The RF voltage across the tuned circuit, L2-C1, is applied across the diode. Since current flows only when the plate is positive in respect to the cathode, the RF voltage is rectified. When the plate is positive, the diode conducts and the capacitor in the filter circuit, C2, charges. When the plate is negative, no current flows in the tube, and C2 partially discharges through R1, the load resistor. However, the value of R1 is so high that the capacitor discharges only slightly before the tube again conducts. This means that the charge on the capacitor follows the positive peaks of the RF voltage. Since the shape of the modulation envelope can be traced in the variations of the RF peaks, the charge on the capacitor reproduces the AF modulation voltages.

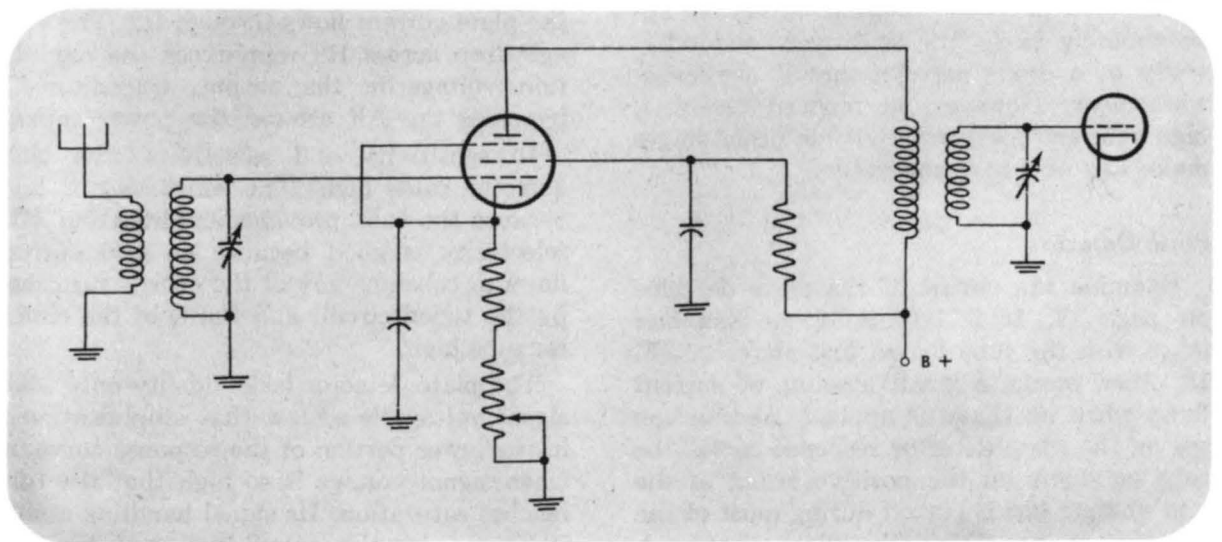

RF Amplifier

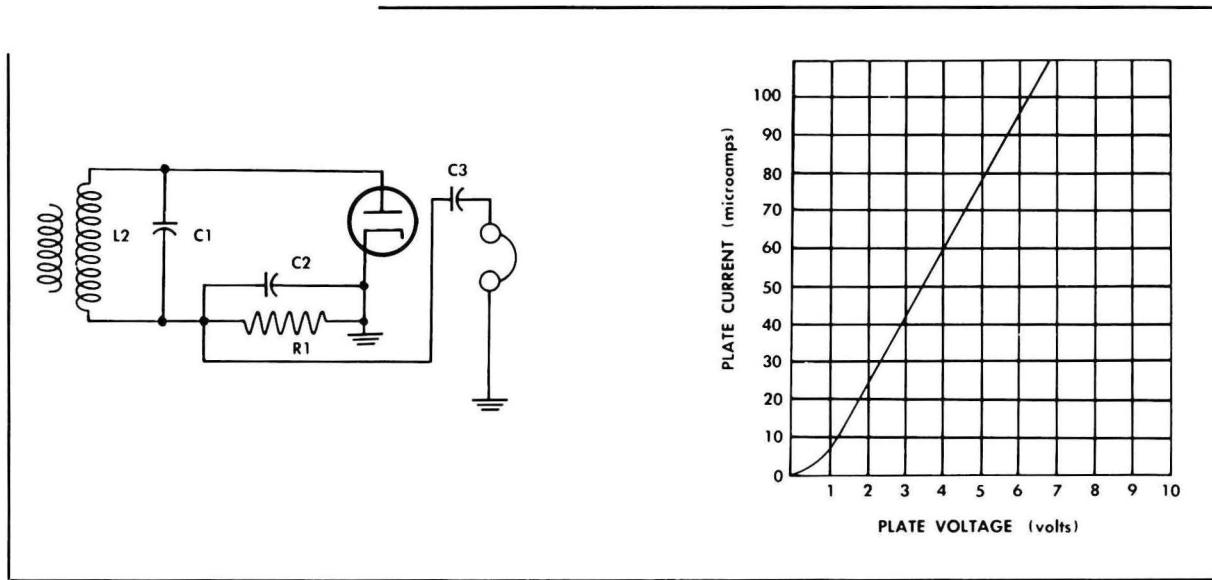

*Diode Detector and Response Curve*

As you can see from the graph in B, the voltage-current response of a diode is linear except when plate voltage is very low. This means that with any reasonable signal strength, diode response is always linear, up to the point of plate saturation. Fidelity is high, even for signals that approach 100% modulation. The signal handling ability of a diode is very high. It can handle signals of almost any amplitude. The efficiency of a diode, in a properly designed circuit, is approximately 90%. The sensitivity and selectivity of a diode detector circuit are somewhat poor. However, in modern receivers, high gain and good selectivity in other stages make this of minor importance.

### Plate Detector

Examine the circuit of the plate detector on page 17. It is essentially an amplifier stage with the tube biased just above cutoff. In other words, a small amount of current flows when no signal is applied. As you can see on the plate detector response curve, the tube conducts on the positive swing of the grid voltage but is cut off during most of the negative swing. Thus, the plate current is DC, pulsating at an RF rate. The amplitude of these pulses follows the amplitude of the

modulation (AF) voltage.

Cathode bias for the tube is provided by R1 and C2. C3 and L3 form a filter circuit. C3 presents high impedance to the AF component of the plate current, and low impedance to the RF. L3 presents low impedance to AF and high impedance to RF. Thus, the filter bypasses RF around the load resistor but passes AF to the output circuit.

R2 is the load resistor. The AF portion of the plate current flows through R2. The voltage drop across R2 reproduces the modulation voltage in the output. Capacitor C4 bypasses the AF around the power supply.

In sensitivity and selectivity, the plate detector rates high. The sensitivity is high because the tube provides amplification. The selectivity is good because no grid current flows to consume any of the energy furnished by the tuned circuit and the Q of the circuit remains high.

The plate detector lacks fidelity only when signal voltage is so low that amplification is in the lower portion of the response curve, or when signal voltage is so high that the tube reaches saturation. Its signal handling ability is limited by the cutoff bias, and by tube saturation. For most tubes, though, the signal handling ability may be considered good.

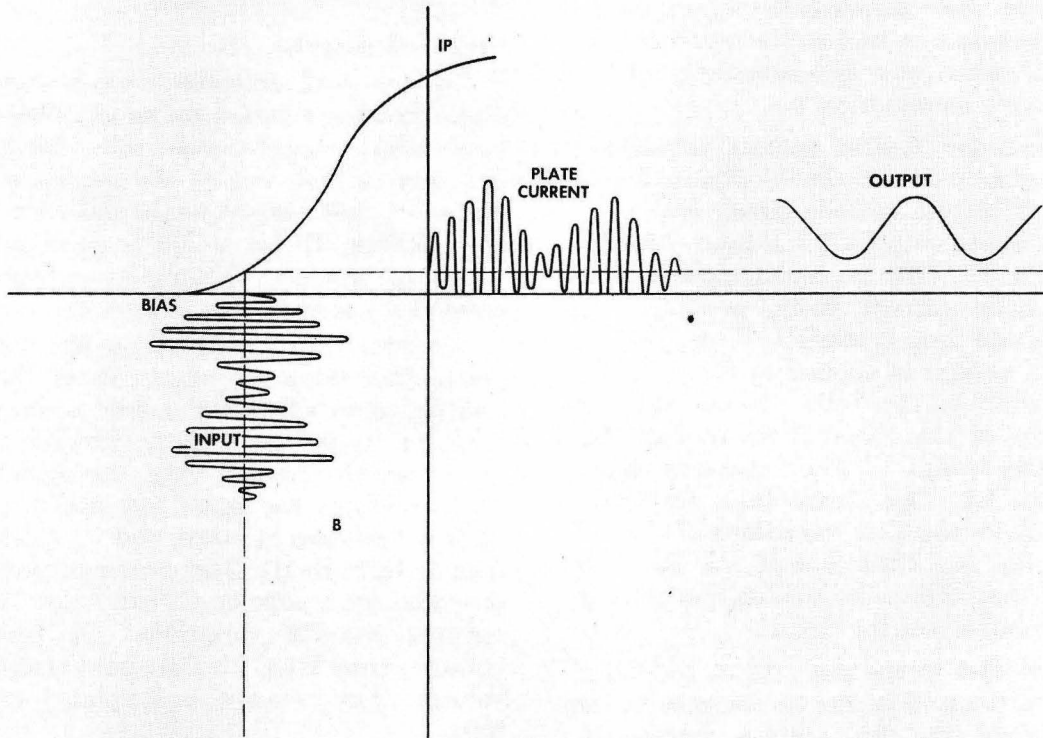
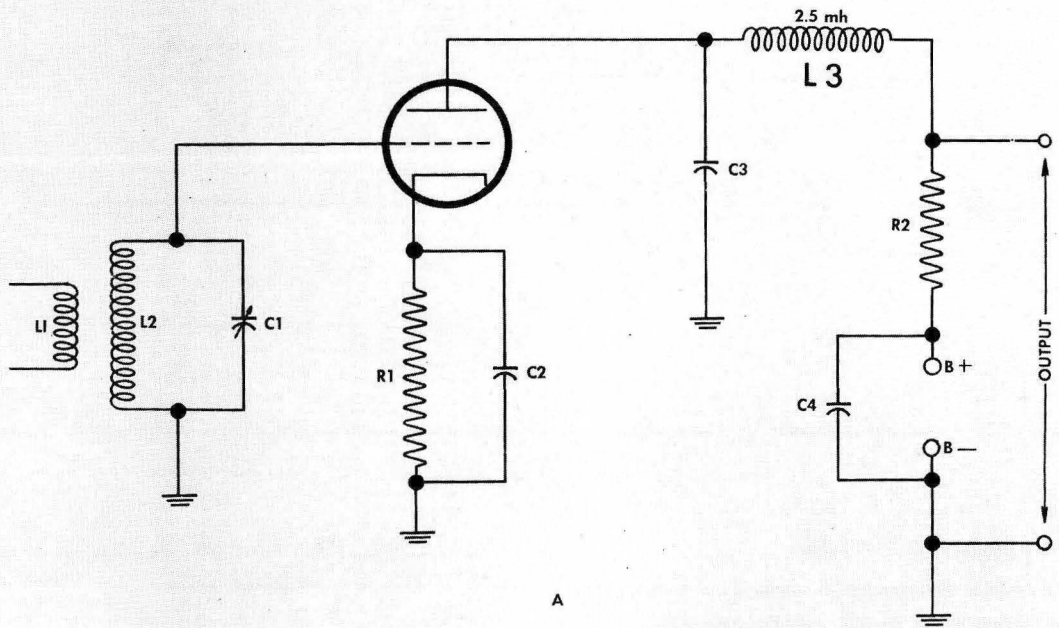
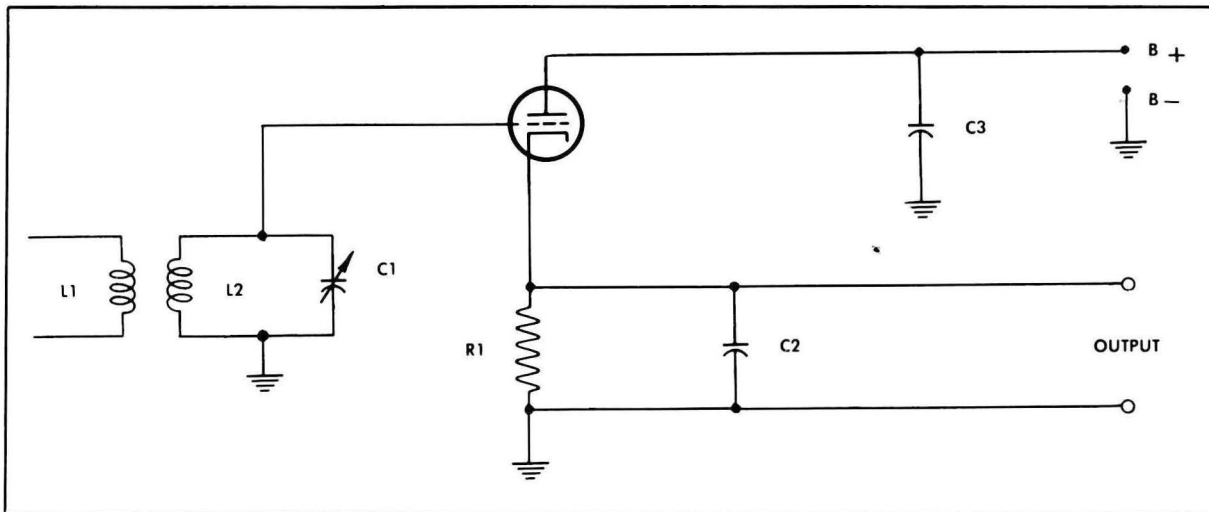

Plate Detector and Response Curve



*Infinite Impedance Detector*

### Infinite Impedance Detector

The infinite impedance detector combines the advantages of diode detection and plate detection. Like the diode, it has very good signal handling capability. Like the plate detector, it never draws grid current so the tube never acts as a load on the tuned circuit. Thus, the sensitivity and selectivity of the tuned circuit remain high.

Examine the typical infinite impedance detector circuit shown above. The action of R1 and C2 in the cathode circuit biases the tube just above cutoff. C2 is a bypass for RF but not for AF. With no signal applied to the grid, a little current flows, producing an initial voltage drop across R1. When positive excitation voltage is applied to the grid, the current through the tube due to the RF component of the signal flows through C2. On negative swings, C2 discharges only slightly through R1. This means that the charge on C2 follows the slow variations of the AF but not the fast variations of the RF. The result is that the audio modulation voltage is reproduced across the circuit.

Any increase in the strength of the signal applied to the grid causes an increase in the amplitude of the AF voltage across R1. Thus, as the grid voltage rises, the cathode voltage also rises. Consequently, the cathode voltage follows the grid voltage, and the grid can never become positive with respect to

the cathode. In other words, the grid always offers infinite impedance to the flow of grid current. As a result, the grid never draws current, and the tube never acts as a load on the tuned circuit. The Q of the tuned circuit therefore remains high.

### Grid Leak Detector

The grid leak detector is equivalent to a diode detector followed by an amplifier, with both circuits centered in one tube. The control grid and cathode act as the electrodes of a diode, yet they also act as the input circuit of an amplifier. Either a triode or a pentode tube may be used. The grid leak circuit diagram at A illustrates use of a triode.

The grid draws current on the positive grid signal. Since the reactance of the grid leak capacitor C2 to RF pulses is much less than the resistance of R1 to the RF pulses, the capacitor charges when the signal goes positive. When the signal goes negative, grid current decreases or stops, and C2 discharges slightly through R1. The discharge time is so slow that the charge on C2 can follow the AF but not the RF variations. The resultant voltage across R1-C2 is the audio modulation voltage. This voltage is amplified by the tube.

In the amplifier section of the tube, it is primarily the AF signal which is amplified. C3 bypasses the RF currents. The output is taken across the plate load resistor R2. When

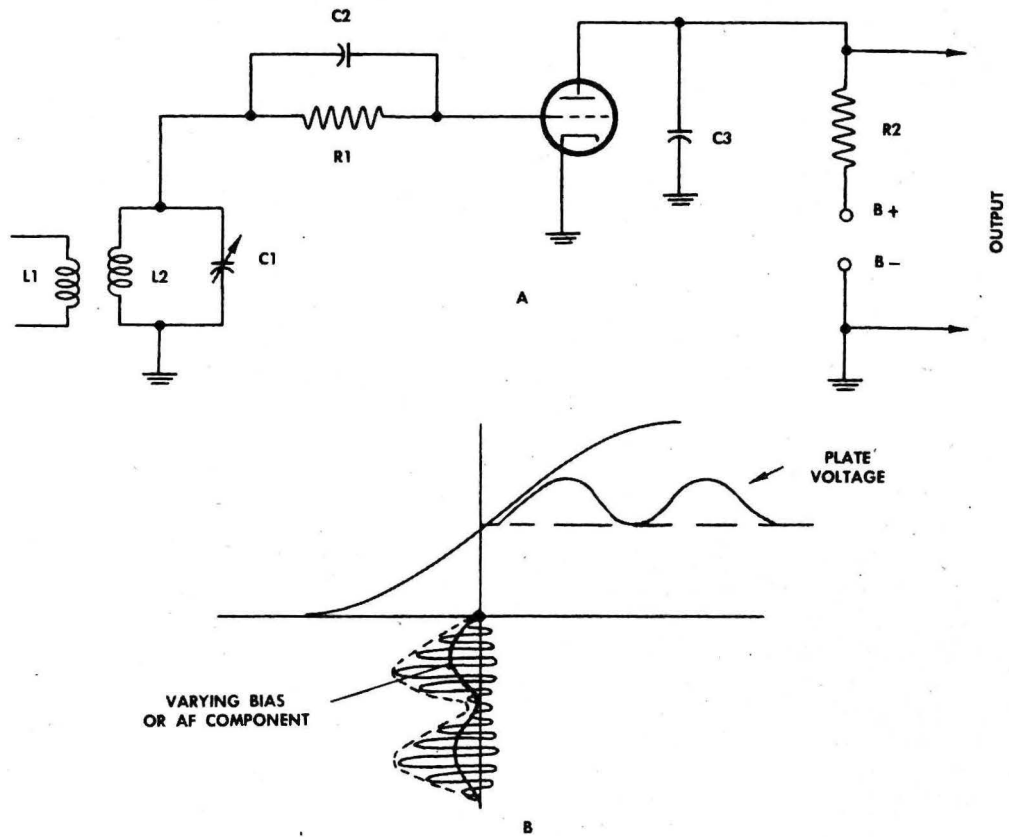

Grid Leak Detector and Response Curves

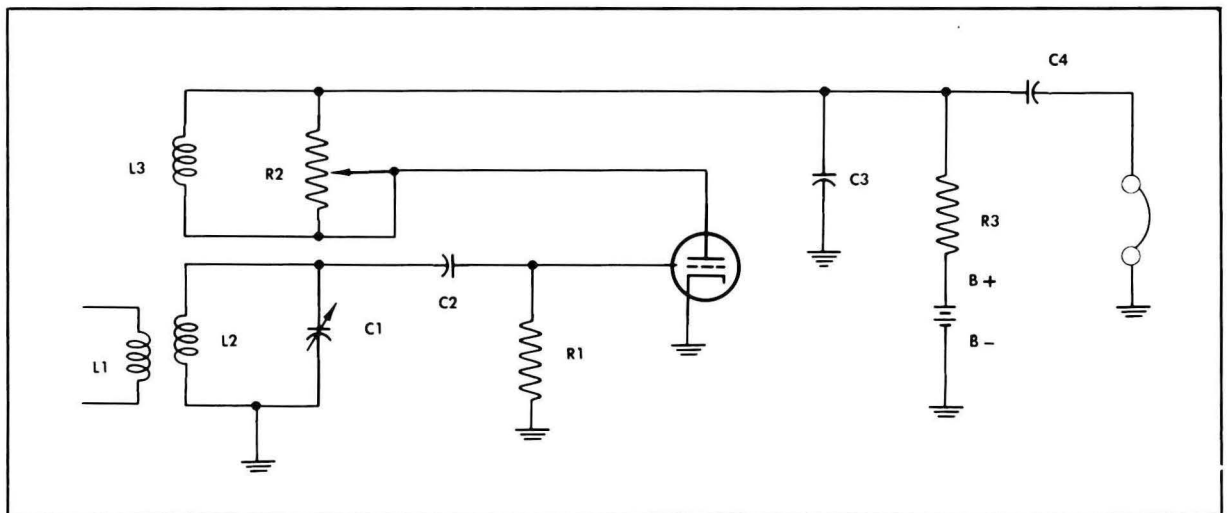

Regenerative Detector

a triode is used, an audio output transformer may serve as the plate load. When a pentode is used, the high plate resistance of the tube makes it necessary to use a resistor as the plate load.

Usually the grid leak circuit is designed to operate with strong grid signals. As shown at B, the detector operates on the linear portion of the curve. This detector has good sensitivity, since the tube amplifies the input signal. Selectivity is only fair, since the grid draws current to load the tuned circuit. Linearity is fair. Signal handling ability is very good.

**Regenerative Detector**

Regenerative detectors are special types of grid leak detectors. The plate circuit of the regenerative detector (page 19) contains a feedback coil (L3) that inductively couples energy back to the tuned circuit. This coil provides feedback to reinforce the incoming signal. Thus the tube not only amplifies the signal, but it also reinforces and increases the signal on the grid. This increased signal is also amplified — and again fed back to the grid. Thus the sensitivity of this circuit is

far greater than the sensitivity of the detectors already studied. However, this circuit is difficult to handle. Circuit adjustments are very critical. If feedback voltage is too great, the stage responds as an oscillator, producing squeals in the sound output of the receiver, and producing interference in other receivers.

This tendency to oscillate can be used to advantage, however, in obtaining intelligence from CW transmissions. For CW reception, variable resistor R2 is adjusted so that the circuit starts to oscillate. The frequency of oscillation is slightly different from the signal frequency (to which L2-C1 is tuned) and this produces an audible beat frequency in the headset. This beat frequency can be varied by adjusting R2.

**Superregenerative Detector**

The operation of this type of receiver is somewhat like that of a regenerative detector receiving a CW signal. When the detector oscillates, the amplitude of oscillation is controlled by the amplitude of the RF input signals. The time that the detector oscillates is controlled by the quench oscillator, which operates at about 20 kc and applies an addi-

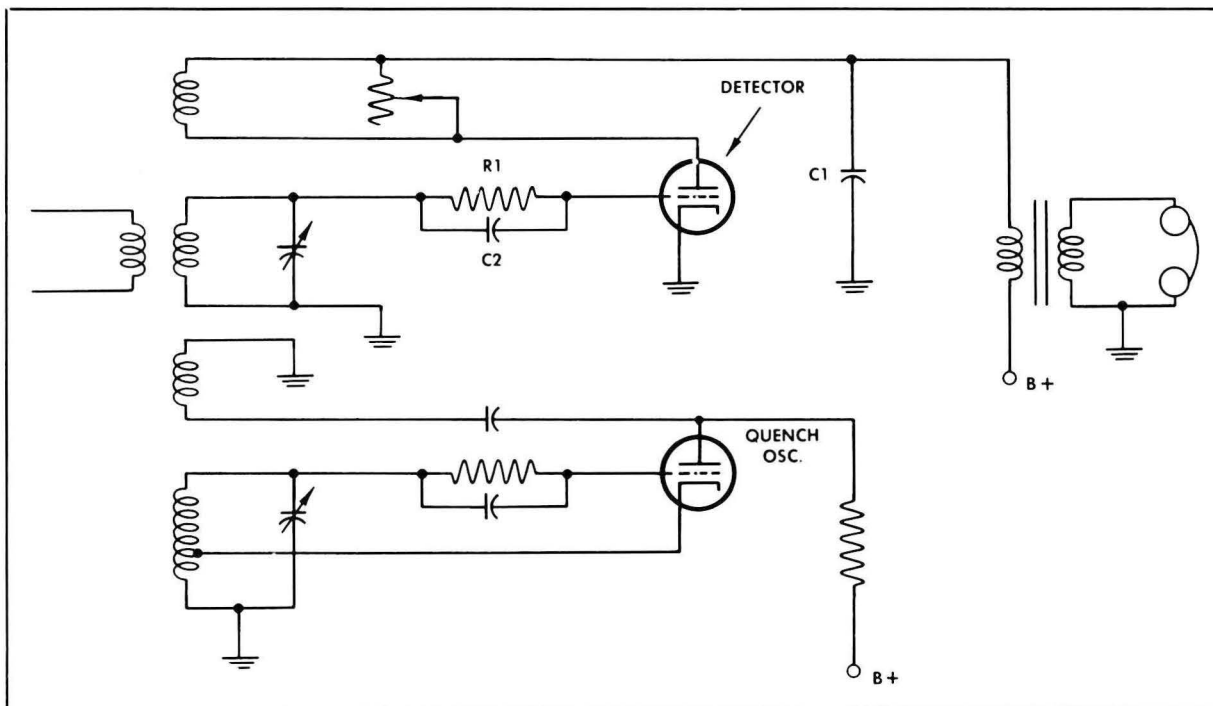

Superregenerative Detector



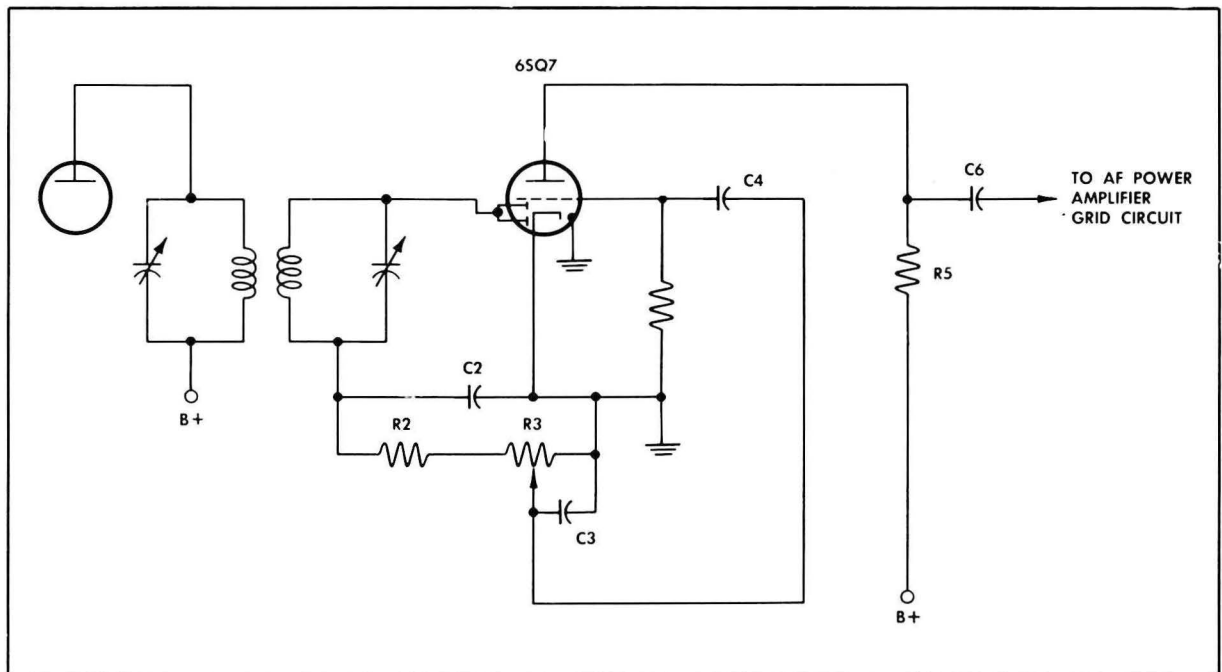

Detector-Amplifier

tional signal to the detector grid. When this signal is positive, the detector oscillates. When this signal is negative, the detector is cut off.

Each time the detector oscillates, a voltage pulse is developed in the plate circuit of the detector. The amplitude of this pulse is controlled by the amplitude of the incoming RF signal during the time of the pulse. Successive pulses, therefore, vary in amplitude according to the modulation envelope. These pulses are filtered by C1 so that only the audio voltage is applied to the primary of the output transformer.

The quench oscillator frequency must be above the audio range to prevent the quench frequency from being heard in the output. Also, the ratio of the RF input signal frequency to the quench frequency must be at least 100 to 1, to prevent a large amount of noise from developing. This means that the minimum RF frequency at which this type of receiver will operate satisfactorily is 2,000 kc. This type of circuit is especially adaptable to the VHF band, and is used in some VHF police equipment.

Superregenerative receivers are compact, light in weight, and low in cost. They consume

little power, and have surprising gain for the number of tubes used. Superregenerative detectors have high sensitivity, but poor linearity. They are poor in selectivity because the grid current loads the tuned circuit. Their signal handling ability is very good.

#### Multielement Tube Detectors

One of the multielement special purpose tubes is the twin diode triode. Its use is shown in the detector-amplifier circuit diagram. This single tube serves simultaneously as a detector and audio amplifier. It contains a cathode, control grid, triode plate, and two diode plates. In this circuit, the diode plates are joined together and, with the cathode, they form the diode section of the tube. When the tuned circuit connected between the diode plates and cathode drives the diode plates positive with respect to the cathode, the diode section conducts.

R2 and R3 in series form the plate load resistor of the diode section. They are bypassed for RF by C2. R3 is a potentiometer which taps the AF voltage across part of the plate load and applies it to the grid of the triode amplifier section through coupling

capacitor C4. This amplifier operates as a high- $\mu$  voltage amplifier, supplying excitation voltage to the power amplifier grid. R5 is the plate load resistance for the triode section.

### THE AUDIO SECTION

Two types of amplifier stages are used — voltage amplifiers and power amplifiers. When intelligence is to be reproduced by a headset, the audio section usually has one or two voltage amplifiers. When intelligence is to be reproduced by a speaker or a number of headsets in parallel, one voltage amplifier and one power amplifier are usually used.

The AF voltage amplifier is used to build up the signal enough to excite the grid of the power amplifier or to energize the headset. Either a triode or pentode tube can be used as the voltage amplifier. In most cases, a medium- $\mu$  tube is used, especially when preceding RF amplifier stages provide sufficient gain. Resistance-capacitance coupling of the voltage amplifier to the power amplifier is conventional. The voltage gain for a medium- $\mu$  triode operating at frequencies around 1000 cps runs from 10 to 70. The load resistance of the voltage amplifier should be several times the plate resistance.

A power amplifier must efficiently convert DC power to AC power. If a triode is used, it should have low internal resistance. Maximum power transfer takes place when the load impedance equals the internal resistance.

However, in practice, the load impedance is kept smaller than the plate resistance to prevent distortion. Power amplifiers generally use tetrodes or pentodes. These have higher power efficiency than triodes. Some tetrodes deliver nearly twice the output of a triode, even when the grid voltage of the tetrode is one-fourth that of the triode. For tetrodes and pentodes, a load impedance of about one-tenth of the plate resistance is used.

Study the voltage and power amplifier shown in the circuit diagram. The generator in the grid circuit of V1, the voltage amplifier, represents the detector stage as a source of driving energy. The voltage output of V1 is capacitively coupled to V2, the power amplifier. The output of the power amplifier is transformer coupled to the speaker so that the high impedance of the power amplifier plate circuit can be matched to the low impedance of the speaker voice coil.

### VOLUME CONTROL METHODS

Since the signals intercepted by an antenna may be of widely differing strengths, the receiver should be able to handle both weak and strong signals. It is advantageous to bring both the very weak signal and the very strong signal to approximately the same level of strength for the final reproduction of the intelligence. The process of matching signal strength to desired audio output involves the use of volume controls. Three methods are in common usage — manual control of audio

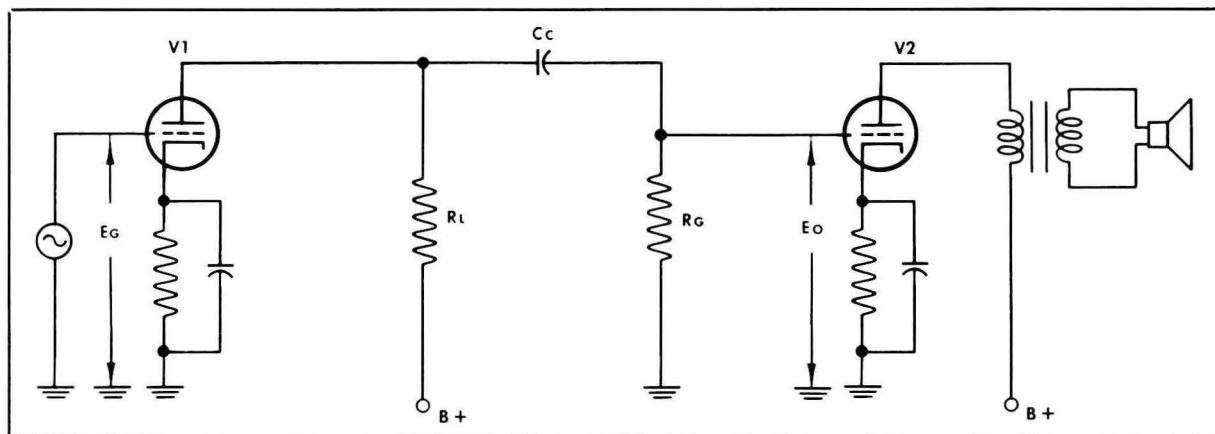

Audio Amplifier Section of TRF

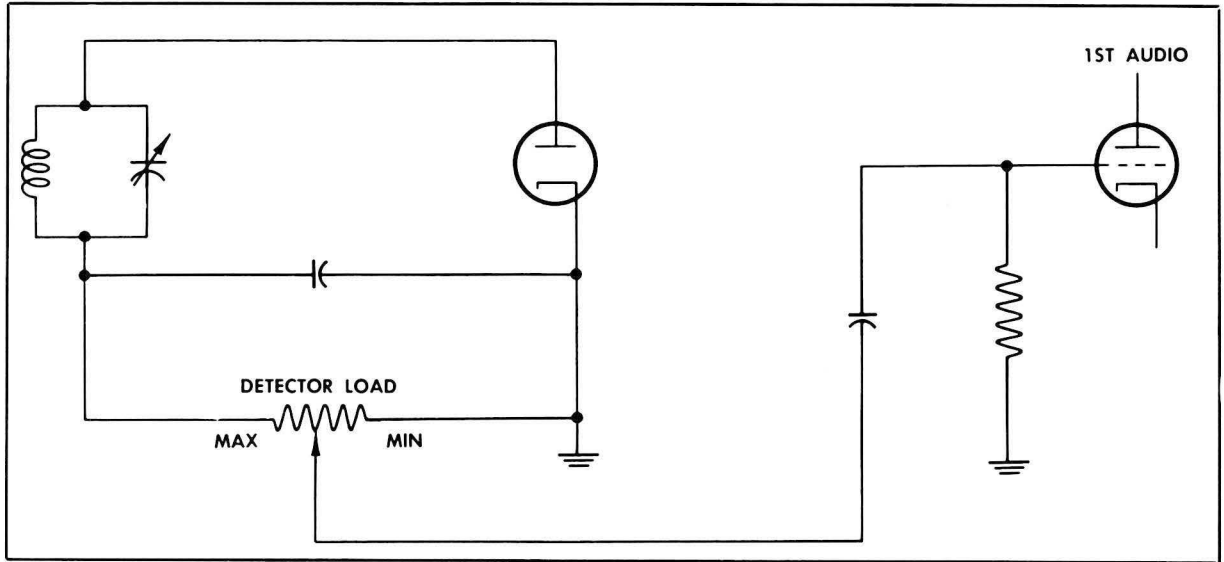

Manual Volume Control

signal, manual control of RF signal, and automatic control of RF signal.

**Manual Audio Control**

The control of signal strength in the AF section of a receiver is called manual volume control (MVC). As shown in the circuit diagram above, this type of control is accomplished by using a potentiometer as the detector load resistor. The strength of the audio signal applied to the grid of the first audio amplifier can be regulated by this means. Maximum and minimum points of volume are indicated on the circuit diagram.

For other kinds of coupling, the potentiometer arrangements are made as shown below.

At A, the output is capacitively coupled to a potentiometer. The movable tap on the potentiometer is connected directly to the first audio amplifier grid. Here, the potentiometer is the grid resistor of the audio amplifier. The tap selects a portion of the voltage across the resistor.

At B, the detector stage is transformer coupled to the AF amplifier. The potentiometer is across the secondary winding. The movable tap is connected directly to the grid. Here, the potentiometer is in series with the secondary of the transformer. The tap selects a portion of the voltage across the potentiometer and applies it to the grid.

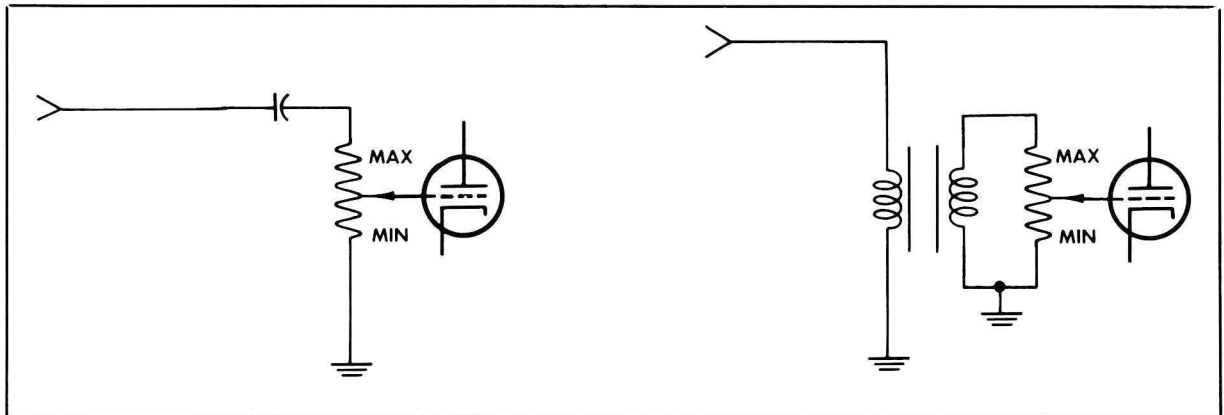

Variations of MVC

**Manual RF Control**

As shown in the illustration at the left, the RF signal amplitude can be controlled in the antenna circuit. At A, the antenna is connected to the movable tap of the potentiometer. At B the movable tap is connected to ground while the antenna is connected to one end of the potentiometer. At C, the movable tap is connected to the grid of the first RF amplifier while a tuned circuit is connected between the grid and ground. In each case, regulation of the potentiometer controls the amount of signal applied to the grid.

RF signal amplitude can also be controlled in the RF amplifier stages by regulating the amount of amplification of the stage. This is known as manual gain control (MGC). As shown on page 25, the variable resistor is in the cathode circuit of the RF amplifier. It is in series with a fixed resistor which provides a minimum amount of cathode bias. Adjusting the potentiometer changes the bias and thus the amount of amplification. This type of regulation is used with variable-mu pentode tubes, since these tubes permit considerable variation of bias without distortion. In actual use, the potentiometer would be in the cathode circuit of several stages. Thus, it would control the gain of several RF stages simultaneously.

Antenna volume control and manual gain control can be accomplished simultaneously by use of a single potentiometer, as shown below. The potentiometer controls both the resistance across the primary of the input transformer and the cathode resistance of the first amplifier.

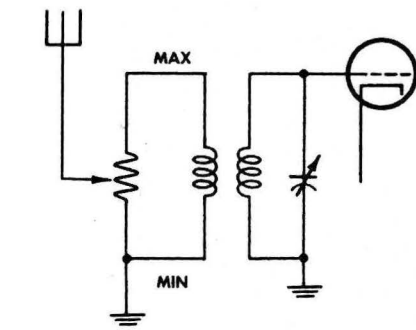

A

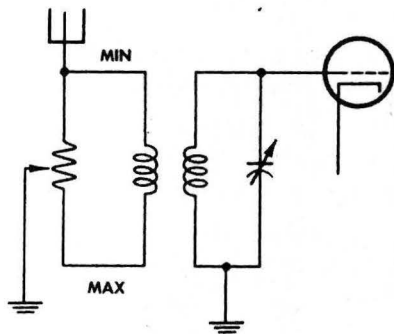

B

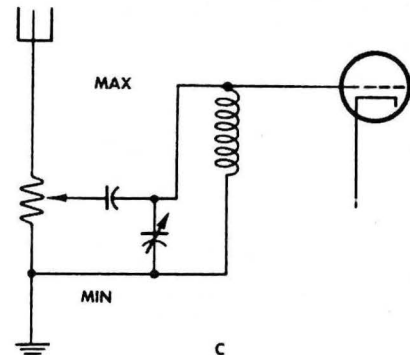

C

Antenna Volume Control Circuits

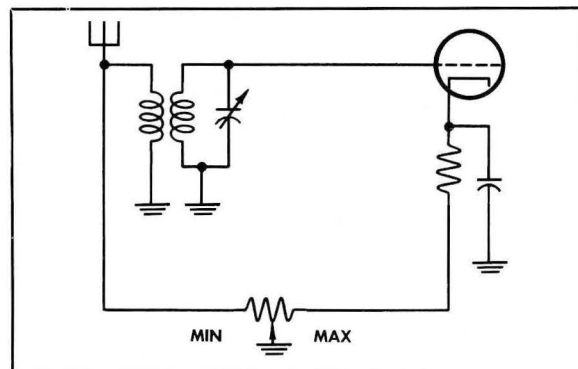

Dual Antenna and Gain Control

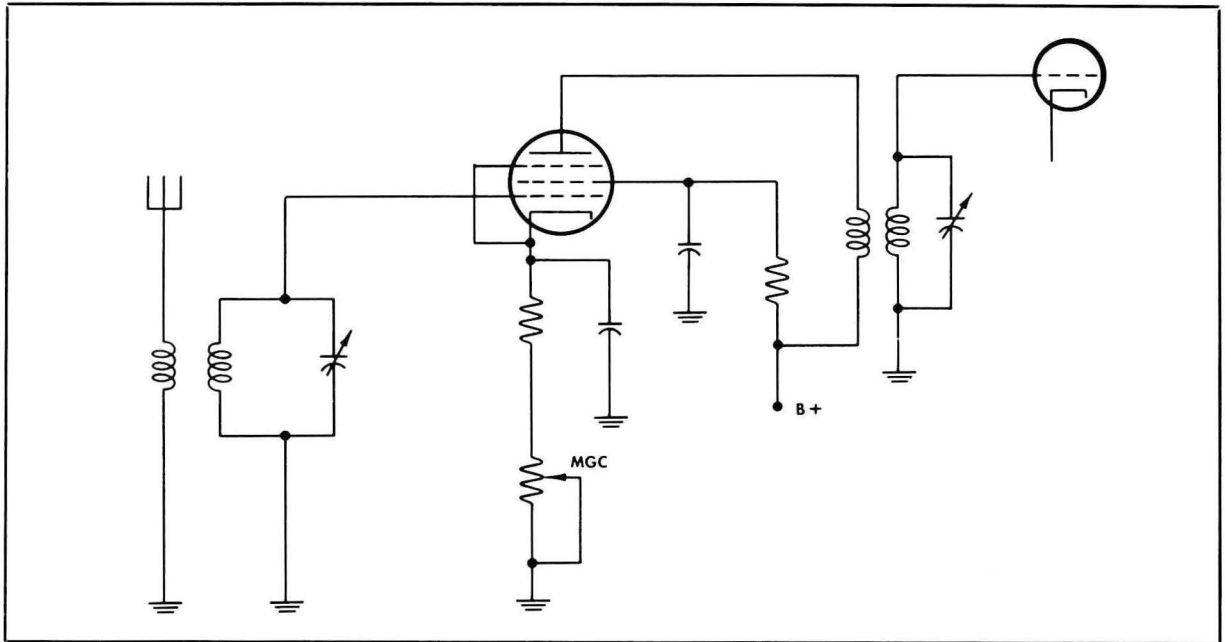

Manual Gain Control

**Automatic Volume Control**

A volume control permits the level of output to be kept approximately the same for both a weak signal and a strong one. However, fading causes such variations in signal strength that no single setting of the volume control

gives uniform output. Automatic volume control (AVC) corrects this situation and permits uniform output for a signal of varying strength.

In general, AVC controls the gain in several amplifier stages preceding the detector. Such an arrangement is shown below. The parts

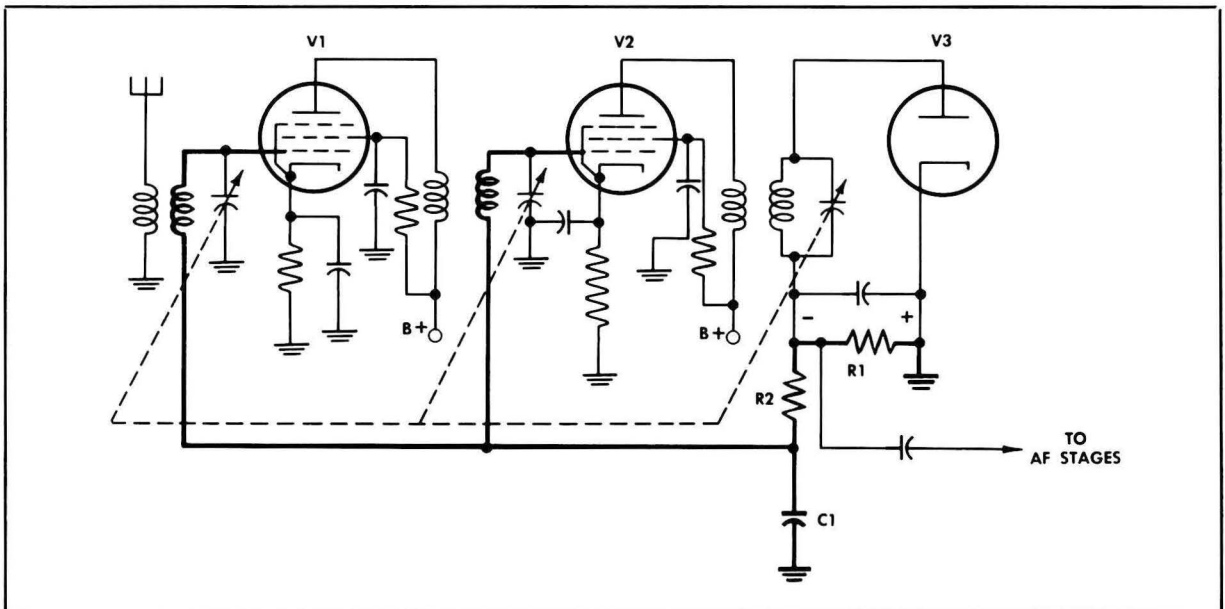

Basic AVC Circuit

of the circuit involved in AVC are drawn in heavy lines. When using AVC, these tubes are usually variable- $\mu$  tubes.

V1 and V2 are RF amplifiers. V3 is the detector. The AVC process starts with the detector and works back to the RF amplifiers. R1 is the load resistor of the detector. The voltage across R1 depends on the strength of the signal being detected by the diode. When the signal is strong, the voltage across R1 is large. Note that the voltage drop across R1 is negative in respect to ground. Note also that this negative voltage drop is applied through R2 to the grids of V1 and V2. This means a reduction in the gain of each amplifier stage. The amount of reduction depends on the size of the voltage drop across R1. If the signal is weak and the voltage across R1 is small, then the gain of the amplifier stages is reduced only a small amount. If the signal is strong and the voltage drop across R1 is large, then the reduction in gain is large. This means that AVC reduces the gain in both tubes. However, since the amount of reduction is proportional to signal strength, the output is kept fairly uniform. The general loss of gain caused by the use of AVC is small compared to the amount of gain provided by the amplifiers.

Of course, the voltage drop across R1 is DC, pulsating at an audio rate. To apply these audio variations to the RF amplifier grids would produce distortion. Therefore, the DC voltage fed back to the grids is filtered to remove the audio component by the filter made up of R2 and C1. The time constant of C1 and R2 is such that the AF pulses are filtered out, and a pure DC voltage is fed back to the amplifier grids.

### TYPICAL TRF RECEIVER

You have now studied, circuit by circuit, all the parts of the TRF. You have studied various methods of detection used in the TRF, and in other receivers. You have studied various methods of volume control used in the TRF, and in other receivers. It is time now to bring the various circuits together to form one typical TRF circuit diagram. To help you understand the circuit diagram, the table on page 28 gives a description of each of the circuit components.

The antenna circuit includes a tunable parallel wavetrap for undesirable signal rejection. The antenna is inductively coupled to the input of the first RF amplifier.

There are three RF amplifier stages, followed by a detector stage. Four tuned RF circuits control the inputs to these stages. These tuned circuits are ganged—their variable capacitors, C2, C3, C4, and C5 can be adjusted by a single control. Capacitors C6, C7, C8, and C9 are trimmers. They are separately adjustable and can be used for tracking the four tuned circuits. These stages, the three RF amplifiers and the detector, are transformer coupled.

The three RF amplifier stages use variable- $\mu$  pentode tubes. The detector stage provides diode detection by using a triode tube with plate and control grid connected for diode action.

The output of the detector is capacitively coupled to the audio amplifier, a pentode tube. The output of the audio amplifier is transformer coupled to the headset.

All the amplifiers use cathode bias. A single potentiometer (R4) forms part of the cathode resistance of the first two RF amplifiers. It also forms part of the antenna circuit. Adjustment of this potentiometer provides manual gain control when ganged switch SW2 is in the MGC position. In this position, one contact of the switch grounds the potentiometer so that it can be used. Another contact grounds the AVC circuit so that it can't feed voltage to the grids of the RF amplifiers. A third contact applies the entire voltage drop across the diode load resistor to the AF amplifier. This makes the adjustable part of the manual volume control inoperative.

When switch SW2 is in the MVC-AVC position, one contact grounds the top of potentiometer R4, removing it from the cathode circuit of the first two RF amplifiers, leaving all of R4 across the primary of T1. Another contact removes the ground connection which prevented AVC voltage from being fed to the amplifier grids. A third contact connects the variable arm of potentiometer R15 (the detector load resistor) to the input of the audio amplifier. Thus, the output of the

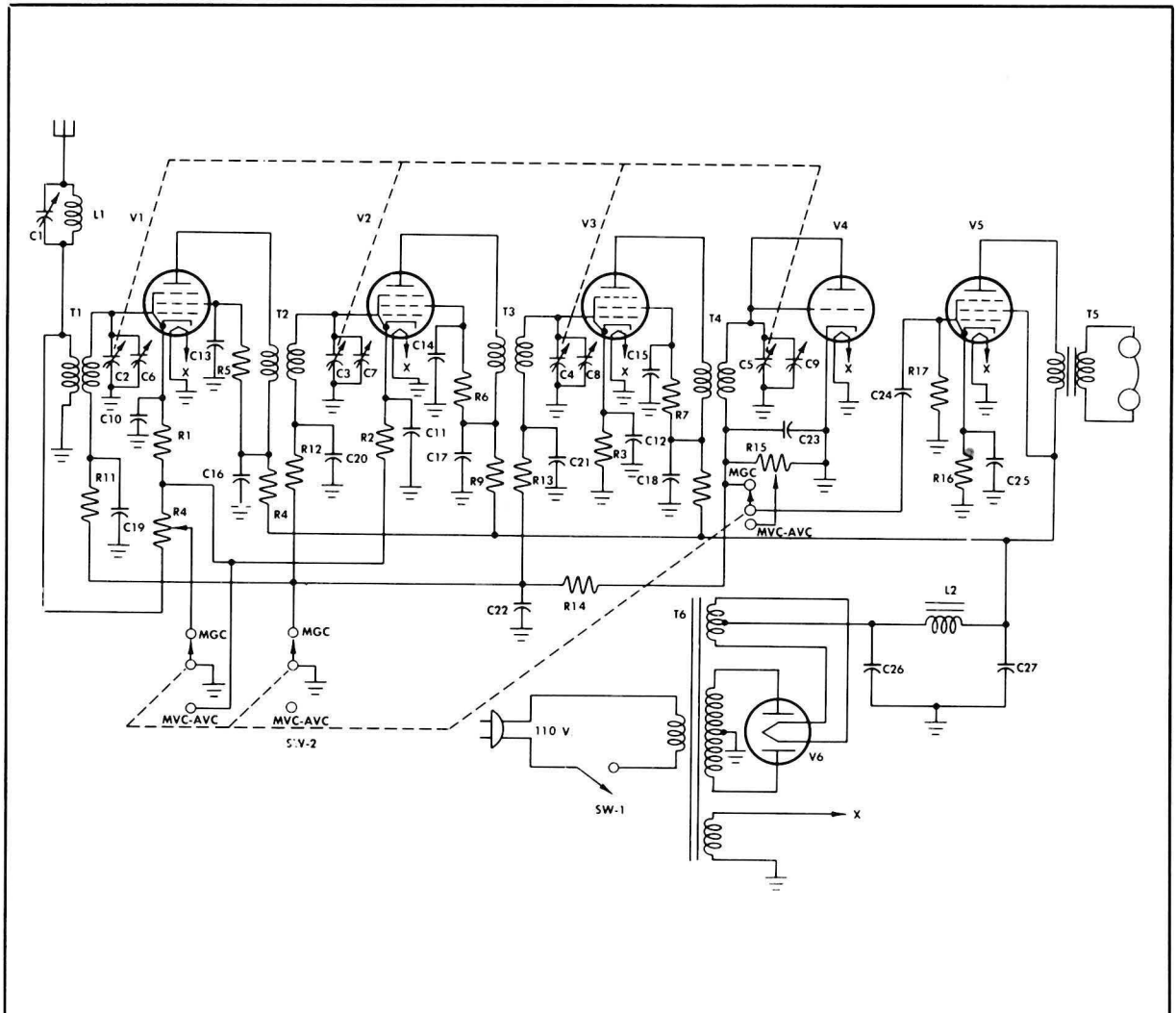

Typical TRF

detector can be regulated manually, and the automatic volume control circuit is in operation.

Altogether, then, three methods of volume control are used: manual gain control on one position of the switch, and both manual volume control and automatic volume control on the other.

The power supply uses a full wave high vacuum rectifier tube, with a capacitor input pi-type filter. This type of filter develops a high DC voltage output (about 0.9 of the peak AC voltage), but has poor voltage regulation. However, the load current taken by the receiver circuits is fairly constant. Thus, the power supply functions very efficiently. This

is the type of power supply used in the majority of AC receivers.

TRF receivers have been widely replaced by superheterodyne receivers. The selectivity and response of the TRF are not uniform over the tuning range. Also, it is difficult to design TRF receivers for satisfactory operation at extremely high frequencies. However, the TRF continues to be useful, particularly in military communications, because it has one advantage over the superheterodyne—it does not use an oscillator in its circuit, while the superheterodyne does. Thus, the superheterodyne cannot be used where the enemy has direction finding equipment to detect a receiver's location.

**TRF COMPONENTS**

SECTION	REFERENCE NUMBER	FUNCTION	SIZE OF PART	
RF AMPLIFIER	C1	CAPACITOR FOR WAVETRAP	35 - 365 MMF (broadcast band)	
	C2, 3, 4, 5	4-GANG VARIABLE TUNING		
	C6, 7, 8, 9	TRIMMERS		
	C10, 11, 12	CATHODE BIAS BYPASS	.1 MFD	
	C13, 14, 15	SCREEN GRID BYPASS	.05 MFD	
	C16, 17, 18	PLATE DECOUPLING FILTER	.05 MFD	
	C19, 20, 21	GRID DECOUPLING FILTER	.05 MFD	
	C22	AVC FILTER	.05 MFD	
	L1	COIL FOR WAVETRAP		
	R1, 2	MINIMUM CATHODE BIAS	400 OHMS	
	R3	CATHODE BIAS	400 OHMS	
	R4	MANUAL GAIN CONTROL	10 K	
	R5, 6, 7	SCREEN VOLTAGE DROPPING	90 K	
	R8, 9, 10	PLATE DECOUPLING FILTER	1.5 K	
	R11, 12, 13	GRID DECOUPLING FILTER	100 K	
	R14	AVC FILTER	1 MEG	
	SW2	DETERMINE FORM OF VOLUME CONTROL		
	DETECTOR	T1	ANTENNA TRANSFORMER	
		T2, 3, 4	INTERSTAGE COUPLING; TUNING	
		V1, V2, V3	RF AMPLIFICATION	6K7 OR 6SK7
C23		RF FILTER	250 MMF	
C24		AF COUPLING	.02 MFD	
AF AMPLIFIER	R15	LOAD RESISTOR; MANUAL VOLUME CONTROL	500 K	
	V4	TRIODE CONNECTED AS A DIODE: DETECTOR	6J5	
	C25	CATHODE BYPASS	25 MFD	
	R16	CATHODE BIAS	200 OHMS	
POWER SUPPLY	R17	GRID RETURN	500 K	
	T5	OUTPUT TRANSFORMER		
	V5	AUDIO AMPLIFIER	6F6	
POWER SUPPLY	C26, 27	FILTER CAPACITORS	8 TO 16 MFD	
	L2	AUDIO FILTER CHOKE	20 HENRIES	
	SW1	ON/OFF		
	T6	POWER TRANSFORMER		
	V6	FULL WAVE RECTIFIER	5Y4-G	



## SUPERHETERODYNE RECEIVER

The superheterodyne receiver is the type of receiver in most common use today. Almost all broadcast and communications receivers are now superheterodynes. Most receivers designed for high frequencies are superheterodynes.

This chapter discusses the basic principles of superheterodyne operation and the types of circuits used.

### PRINCIPLES OF SUPERHETERODYNE OPERATION

The superheterodyne receiver takes advantage of two important facts of radio operation. First, amplification of a radio signal at a low frequency can be more successful than amplification at a high frequency. Second, amplification of a signal by fixed tuned circuits is more successful than amplification by variable tuned circuits.

The superheterodyne converts all input frequencies to a single, fixed, lower frequency which is amplified by fixed tuned circuits. This process distinguishes the superheterodyne from other receivers in performance, for it provides outstanding sensitivity and selectivity over the whole tuning range. The superheterodyne is distinguished from other receivers in construction, as shown on page 30.

Note the IF (intermediate frequency) amplifier stage. It is this stage which employs the fixed tuned circuits. The fixed frequency which it amplifies is called the intermediate frequency, because it is lower than any input frequency within the receiver's tuning range, but higher than audio frequencies. The receiver shown in the block diagram is a broadcast receiver with an IF of 455 kc. This fre-

quency is substantially lower than the lower limit of the broadcast band which is 550 kc.

Note the local oscillator stage. The output frequency of this stage is combined with the output frequency of the RF amplifier stage to produce a new frequency — the intermediate frequency. This process is called heterodyning. The frequencies on the block diagram show the frequencies at which various stages operate when the receiver is tuned to receive a signal of 800 kc. Note that the oscillator frequency is given in the block diagram as 1255 kc, and the RF amplifier frequency as 800 kc. This means that the oscillator operates at a frequency 455 kc above the RF amplifier frequency.

The difference frequency, equal to the IF, appears in the output of the mixer. The oscillator frequency is heterodyned against the RF amplifier frequency in the mixer stage. The output of the mixer contains the oscillator frequency, the RF amplifier frequency, the sum of these two frequencies, and the difference between these two frequencies. The fixed tuned circuits of the IF amplifier are tuned to 455 kc. Therefore, they accept the difference frequency but reject the others.

The heterodyning process is illustrated by the waveforms shown in the block diagram. The RF modulated wave intercepted by the antenna is shown at A. At B, the waveform shows the same modulated carrier after it has been amplified by the RF amplifier stage. At C, the waveform shows the output of the local oscillator. It is unmodulated. Its amplitude is considerably higher than the amplitude of the waveform put out by the RF amplifier. At D, the waveform represents the amplified

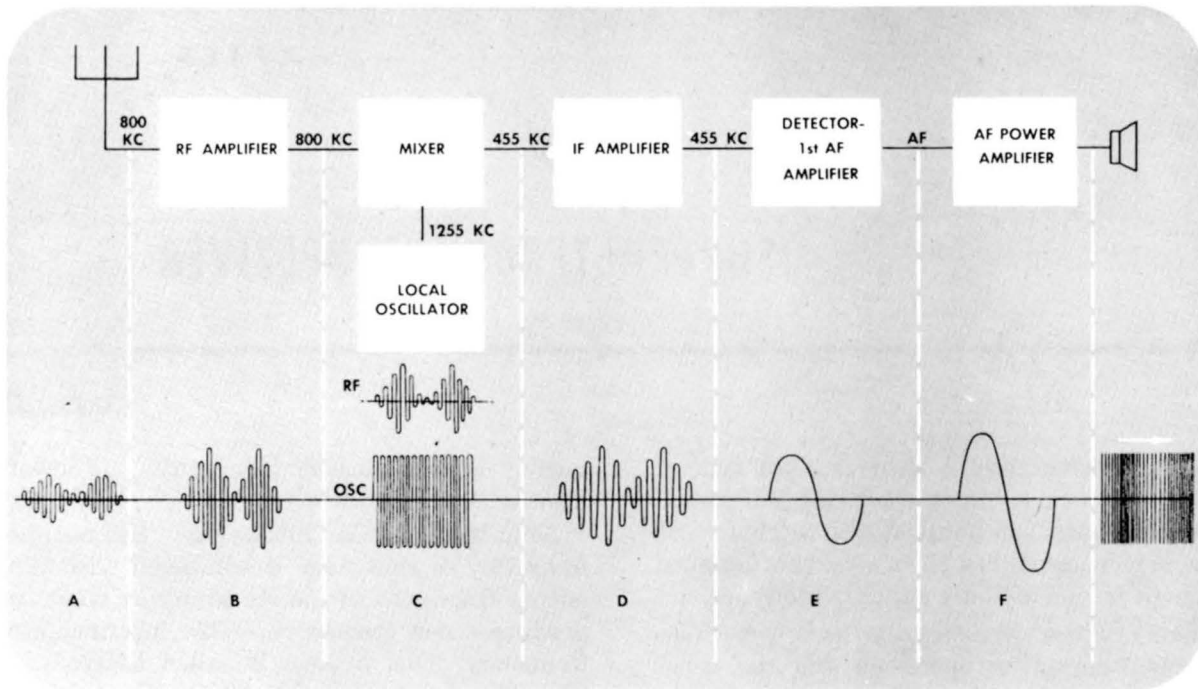

Typical Superheterodyne

difference frequency. Note that it bears the same modulation pattern as the RF carrier. At E, the waveform represents the detected audio frequency. At F, the waveform represents the amplified audio frequency.

Of course, the superheterodyne receiver is not confined to an input frequency of 800 kc. The RF amplifier tuned circuit is variable and can select any frequency in the broadcast band. The tuned circuit of the oscillator is also variable. It is ganged with the RF amplifier tuned circuit so that it is always 455 kc above the frequency to which the RF amplifier is tuned. Thus, the difference frequency between oscillator frequency and the RF input frequency is always 455 kc. This arrangement for keeping frequencies separated by a fixed amount is called *tracking*. It means that the frequency presented to the IF amplifier is always the same, no matter what the RF input frequency may be.

For low, broadcast, and medium frequencies, the oscillator usually tracks above the signal. For VHF and UHF, the oscillator usually tracks below the signal.

There is one major disadvantage to super-

heterodyne operation. If a local oscillator frequency of 1255 kc can mix with an input frequency of 800 kc to produce a difference frequency of 455 kc, this same local oscillator frequency of 1255 kc can also mix with an input frequency of 1710 kc to produce a difference frequency of 455 kc. Thus, the mixer section might present to the IF amplifier the signal from two different stations at the same time, both converted to the same IF. The IF amplifier would accept and amplify both at the same time. The demodulator would detect the signal of both at the same time. The intelligence of both would be present in the speaker at the same time. Such a mixture of signals would be confusing, if not unintelligible.

The second signal which might interfere with the desired signal is called the *image frequency*. Image frequencies can best be prevented by selective tuning of the RF amplifier section. Highly selective RF amplifier tuned circuits, when tuned 455 kc below the oscillator frequency, will reject a frequency 455 kc above the oscillator frequency. In other words, the RF stage tuned to a frequency of 800 kc rejects the image frequency of 1710 kc.

## SUPERHETERODYNE CAPABILITIES

The superheterodyne receiver has more uniform selectivity and sensitivity over its tuning range than the TRF, because most of its gain is obtained in fixed-tuned circuits. These low frequency fixed-tuned amplifiers are more easily designed for high gain and selectivity. While the selectivity of the IF stages determines the overall adjacent channel selectivity of the superheterodyne receiver, an RF preselector having sufficient selectivity to reject image frequencies must be added. Even so, the superheterodyne receiver requires fewer sections of a ganged capacitor, thereby reducing the tracking problem. For these reasons the superheterodyne receiver has largely replaced the TRF.

## SUPERHETERODYNE PRESELECTOR

The RF amplifier section of the superheterodyne receiver is called the *preselector*. The RF circuits of the preselector are essentially the same as the RF circuits of the TRF receiver. In the superheterodyne, however, the selectivity of the RF amplifier stages is more important than the gain. It is the selectivity which prevents the appearance of image frequencies.

One, two, or three RF amplifier stages may be used for the preselector section. Two is the usual number in a communications receiver. The selectivity graph shows the amount of selectivity afforded by a preselector section containing one and two RF amplifier stages. The vertical axis shows the relative input voltage required for a constant output. The horizontal axis shows the number of kilocycles off resonance. Notice that, with one RF amplifier, a signal 30 kc off resonance must have about nine times the voltage of a signal at resonance, to give the same response. With two RF stages, a signal 30 kc off resonance must be about eighty times as strong as a signal at resonance, to give the same response.

## FREQUENCY CONVERSION

The heterodyning process that takes place in the superheterodyne receiver is called *frequency conversion*. The actual stage in which

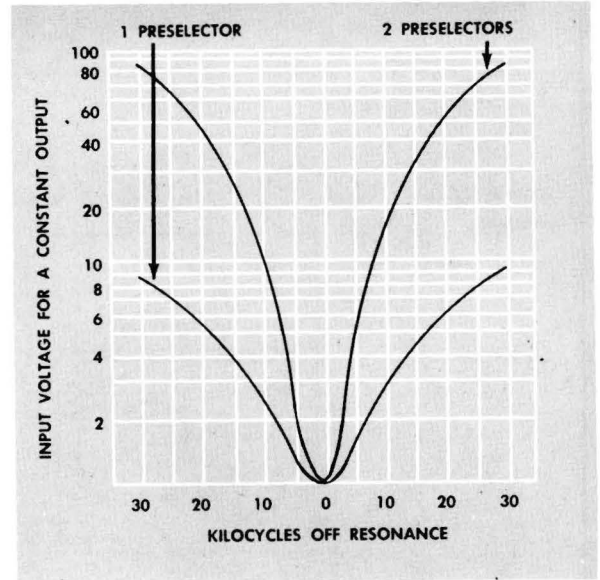

Superheterodyne Selectivity Graph

this takes place is called the mixer or converter, depending upon the arrangement of the circuit. When one multielement tube is used as an oscillator and frequency converter, the stage is called a *converter*. When one tube is used as the oscillator and the oscillator and signal frequencies are applied to another tube, the latter tube is called a *mixer*.

Converters and mixers are also known as first detectors. The reason for this is that either a converter or a mixer tube must be nonlinear before its output will contain the difference or intermediate frequency. In other words, the tube must conduct more during the positive portions of the applied frequencies than during the negative portions—otherwise, the intermediate frequency would not be produced.

## Local Oscillator

The local oscillator must meet exacting requirements in frequency coverage, frequency stability, constant output, and correct tracking. The local oscillator may use any of the fundamental oscillator circuits. The modified Hartley and the tuned grid are commonly used. Most VHF and UHF receivers use crystal-controlled local oscillators. To maintain frequency stability, the plate voltage of the oscillator is often regulated.

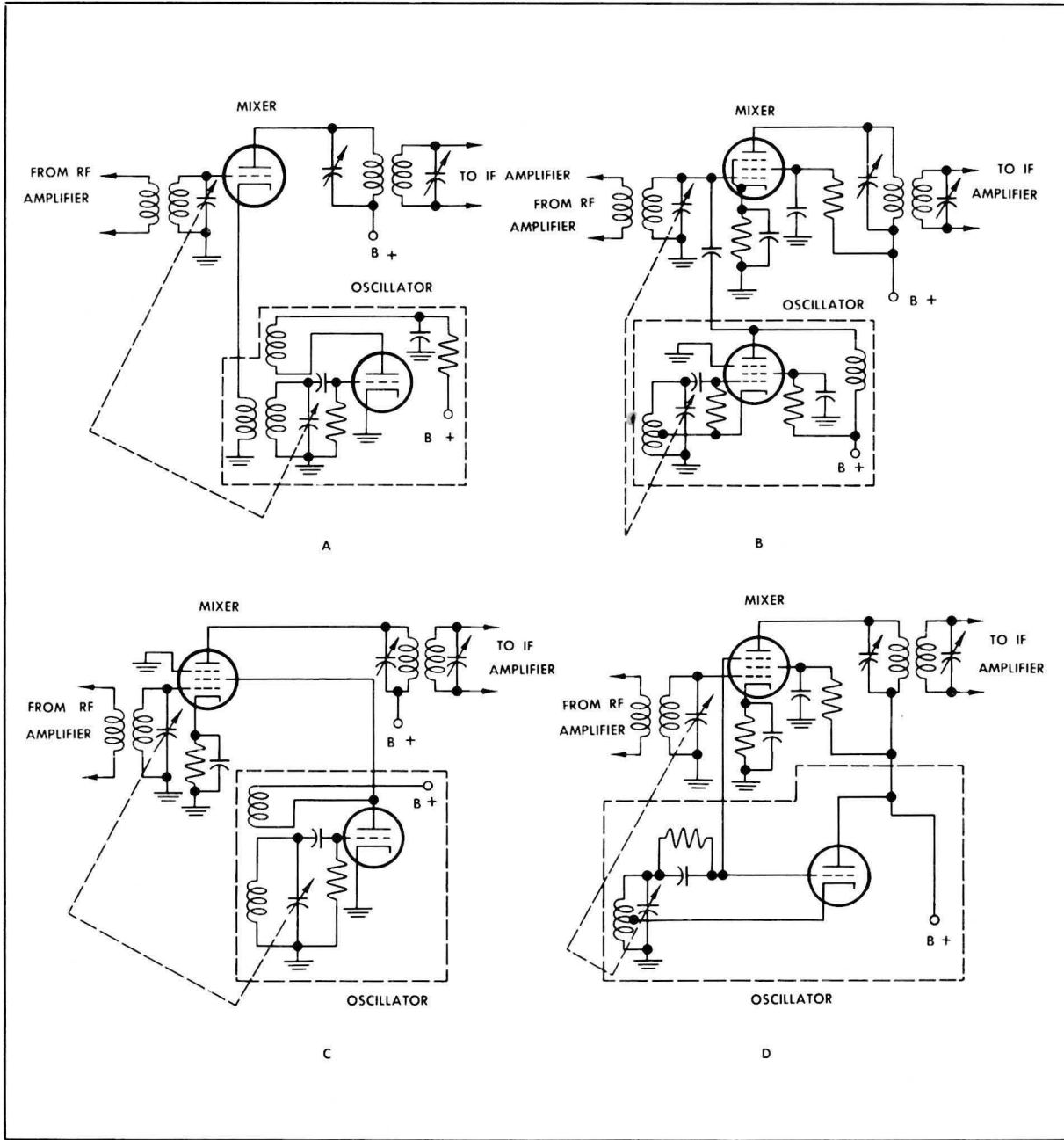

Methods of Mixer Injection

Another problem of stability is the effect that the other radio frequencies present have on the local oscillator. The oscillator tends to synchronize its oscillation with the other radio frequencies. The stronger these other RF signals are and the closer their frequency is to the oscillator frequency, the greater is the tendency for the oscillator to synchronize

with these RF signals. A change in oscillator frequency caused by these RF signals is called *oscillator pulling*. Oscillator pulling may be reduced by isolating the oscillator as completely as possible from the other radio frequencies. This isolation is accomplished not only by proper shielding of oscillator components, but also by using appropriate means

for coupling the oscillator signal to the 1st detector. Oscillator voltage may be introduced into the 1st detector by inductive, capacitive, or electron coupling. It may be injected at the cathode, control grid, screen grid, or suppressor grid. Other types of injection make use of pentagrid tubes, discussed later in this chapter. These special purpose tubes are designed to isolate the oscillator circuit more effectively from the RF signal frequencies. For that reason they are helpful in reducing oscillator pulling.

### Mixer

Notice the various mixers and various methods of injection shown in the illustration on page 32. Both pentodes and triodes can be used as mixer tubes.

At A, the output of a tuned grid oscillator is inductively coupled to the cathode circuit of the mixer. At B, a modified electron coupled Hartley oscillator is capacitively coupled to the control grid of the mixer. The oscillator uses a pentode instead of a triode because with the pentode there is less likelihood of pulling. At C, a tuned grid oscillator

is conductively coupled to the screen grid of the mixer. At D, the output of the oscillator is taken from the oscillator control grid and connected directly to the suppressor grid of the mixer.

An advantage of suppressor grid injection is that the screen grid acts as a shield between the oscillator signal and the RF input signal (applied to the mixer control grid). This reduces pulling. However, with suppressor grid injection, the suppressor grid of the mixer is at the potential of the oscillator control grid. This puts negative voltage on the suppressor grid and lowers the gain of the mixer tube.

### Pentagrid Mixer

A multielement tube called the pentagrid may be used as a mixer or as a converter. The five grids of the pentagrid tube are shown in the pentagrid mixer diagram below. Counting up, the first and third grids are the first and second control grids. The second and fourth grids, joined within the tube, are the inner and outer screen grids. The fifth grid, joined to the cathode within the tube, is the suppressor grid. The oscillator voltage is injected at the second

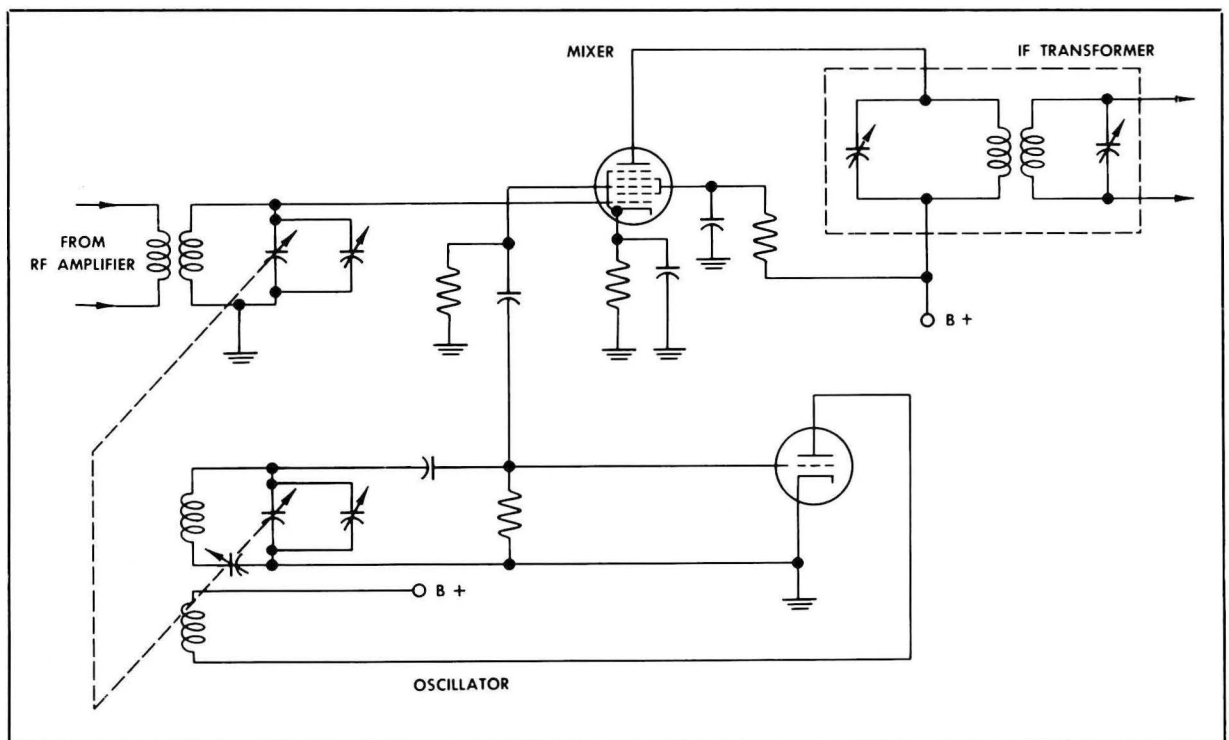

Typical Pentagrid Mixer

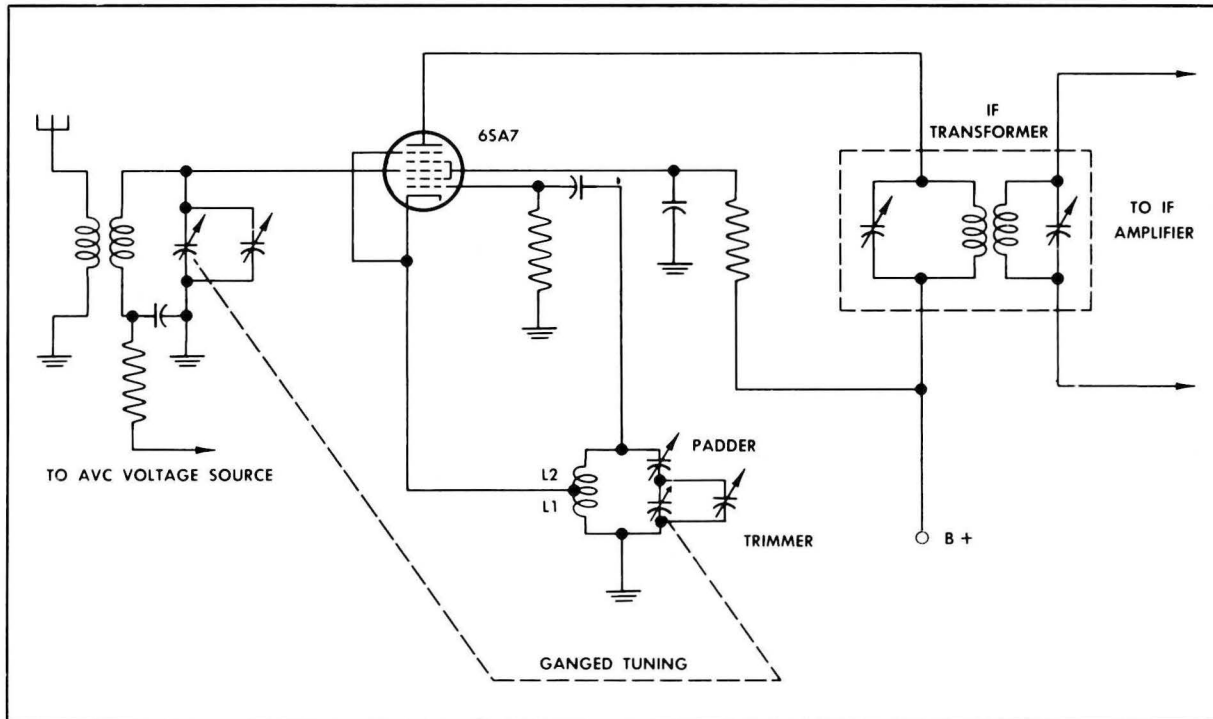

Pentagrid Converter

control grid, which is isolated from the first control grid and from the plate by screens. Thus, pulling on the oscillator is kept to a minimum. The RF signal voltage is introduced at the first control grid. Both control grids affect the flow of current from cathode to plate so that the signals of both grids are reproduced in the mixer output.

**Pentagrid Converter**

For low frequencies, where electrode interaction is relatively less important, the pentagrid can be used as a converter. In this use, it combines mixer and oscillator functions in a single tube, as shown in the diagram above. The oscillator section of the tube is composed of cathode, first control grid, and the combined screen grids (as the anode). Feedback to maintain oscillation is provided by the autotransformer action of tapped coil L1-L2. Current flowing to the cathode through L1 induces the feedback in L2. The oscillator voltage appearing on the first control grid affects the flow of current through the tube. The RF signal voltage is applied to the second control grid.

**Conversion Gain**

The efficiency of a conversion stage is calculated in terms of the ratio of IF output in the plate circuit of the mixer to the RF signal voltage input on the grid of the mixer. The conversion gain is usually about 0.3 of the normal gain of the tube when used as an IF amplifier.

**Oscillator-Mixer Tracking**

Notice that in all the frequency conversion circuit diagrams shown before the variable capacitor of the oscillator tuned circuit is ganged with a variable capacitor of an RF tuned circuit. This makes the oscillator tuned circuit track with the RF tuned circuit. The difference frequency is the IF. In addition to the ganged variable capacitors, the pentagrid converter circuit has small variable *padder* and *trimmer* capacitors. These can be adjusted to assure that the ganged circuits maintain the correct difference frequency throughout the tuning range. The trimmer, a parallel capacitor, has its greatest effect at the high end of the band. The padder, a series capacitor, has its greatest effect at the low frequency end of the band.

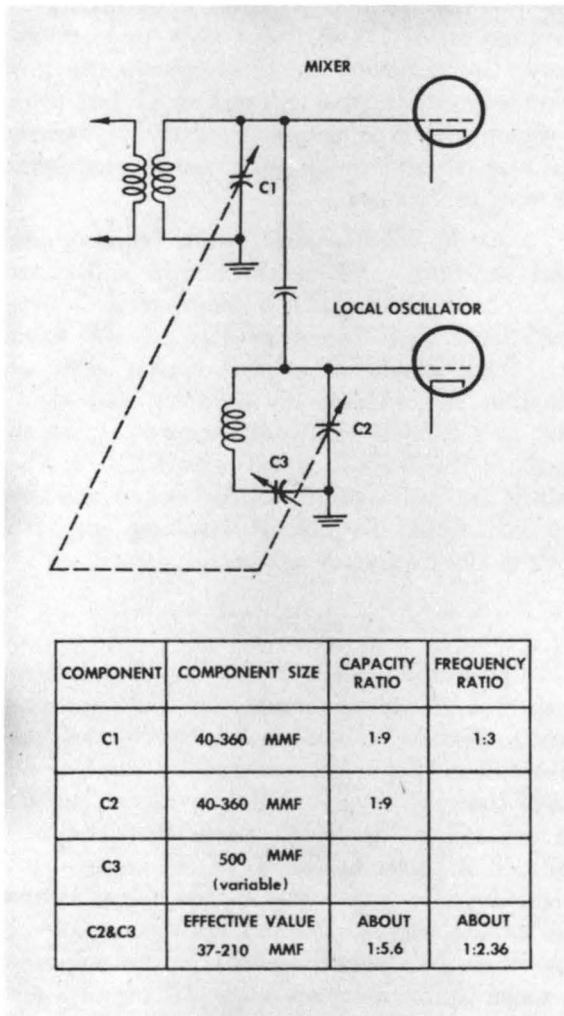

*Padder in Oscillator Tracking*

You can see how the padder capacitor is important from the above circuit diagram and the accompanying chart. C1 and C2 are the ganged capacitors. Each has the same range of capacitance (40-360 mmf). However, each does not tune across the same range of frequencies. The oscillator circuit tracks higher than the RF circuit by a frequency difference equal to the IF. Therefore, if the frequency coverage of the receiver is 1 to 3 mc and the IF is 465 kc, then the oscillator covers from 1.465 mc to 3.465 mc. The tuning ratio of the RF circuit, low to high frequency, is 1:3. The tuning ratio of the oscillator is 1:2.36. The capacity ratio of both ganged capacitors is the

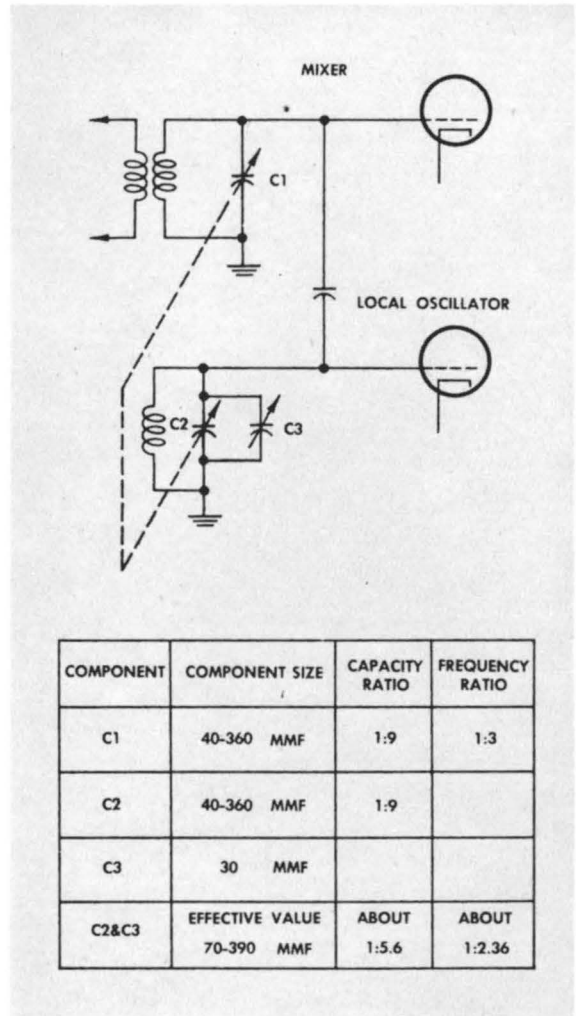

*Trimmer in Oscillator Tracking*

same - 1:9.

Since frequency is inversely proportional to the square root of the capacitance  $f = \left( \frac{1}{2\pi \sqrt{LC}} \right)$ ,

there is a match between a tuning ratio of 1:3 and a capacity ratio of 1:9 for capacitor C1. However, for capacitor C2, the tuning ratio of 1:2.36 does not match the capacity ratio of 1:9. Therefore C3 is added as a padder. The addition of capacitor C3, 500 mmf (variable), makes the range of C2 and C3 together vary between 37-210 mmf. This is a capacity ratio of 1:5.6. The combination is a good match for the tuning ratio of the oscillator of 1:2.36.

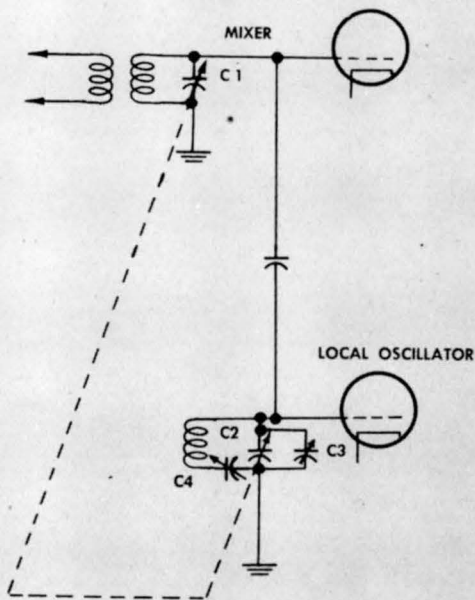

COMPONENT	COMPONENT SIZE	CAPACITY RATIO	FREQUENCY RATIO
C1	40-360 MMF	1:9	1:3
C2	40-360 MMF	1:9	
C3	3 MMF (variable)		
C4	500 MMF (variable)		
C2, C3, C4	EFFECTIVE VALUE 40-210 MMF	ABOUT 1:5.2	ABOUT 1:2.3

*Padder and Trimmer in Oscillator Tracking*

Note that adding the padder affects the high frequency end of the band (the low capacity end) very little. It merely changes the capacity from 40 mmf to 37 mmf. At the low frequency (high capacity) end, however, it affects the capacity considerably. It changes the capacity from 360 mmf to 210 mmf.

Now examine the circuit diagram and chart showing the use of a trimmer. C1 and C2 are the same capacitors shown in the padder circuit. C3 is the trimmer in parallel with C2. Its value is 30 mmf. The parallel combination of C2 and C3 has the effective range of 70-390

mmf. Thus the capacity ratio is 1:5.6, which matches the frequency ratio of the oscillator tank circuit of 1:2.36. Note that, proportionately, the trimmer capacitor affects the low frequency (high capacity) end much less than it affects the high frequency end. It changes the high frequency (low capacity) end from 40 mmf to 70 mmf.

To see how both padder and trimmer are used together, examine the circuit and chart at the left. Adding C3, a trimmer of 3 mmf (variable), and C4, a padder of 500 mmf (variable), produces a combination with an effective range from 40 mmf to 210 mmf. This is a capacity ratio of about 1:5.2 which matches the frequency ratio of 1:2.3 for the oscillator tuned circuit. Trimmers and padders are adjustable to permit tracking at both ends of the frequency range.

**IF AMPLIFIER**

An IF amplifier is basically an RF amplifier with a fixed tuned input and output. The tuned circuits act as bandpass filters, accepting the IF but rejecting other frequencies. Since they are fixed tuned, the tuned circuits have constant Q. With variable tuned circuits, like those in the TRF, Q varies with frequency. Response may be too sharp at one end of the frequency band and too broad at the other. In a superheterodyne, the response is more uniform because the IF circuits are fixed tuned. In addition, these fixed tuned circuits provide high selectivity and sensitivity.

Most IF transformers are double tuned with both a tuned primary and a tuned secondary. When less selectivity is desired, the primary is untuned. For greater selectivity, a third tuned circuit is sometimes inserted between primary and secondary.

The IF transformers used in any particular set may all be identical or they may vary from stage to stage depending on the design of the set. In one stage, for example, a higher or lower L C ratio may be required in order to match impedances. Coils are shielded to prevent stray coupling.

The tuned circuits are fixed tuned by screwdriver adjustment. The adjustable component



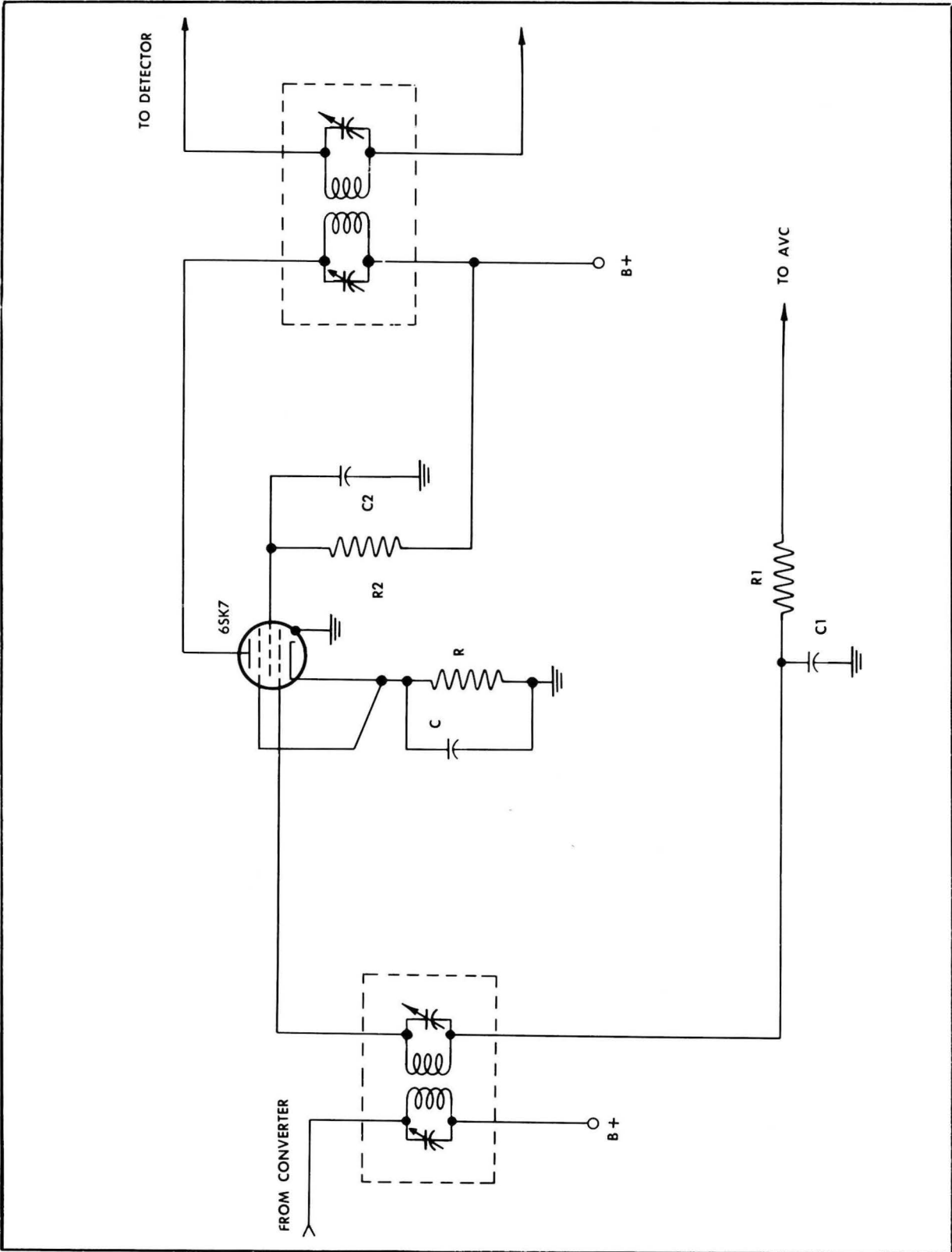

IF Amplifier Stage

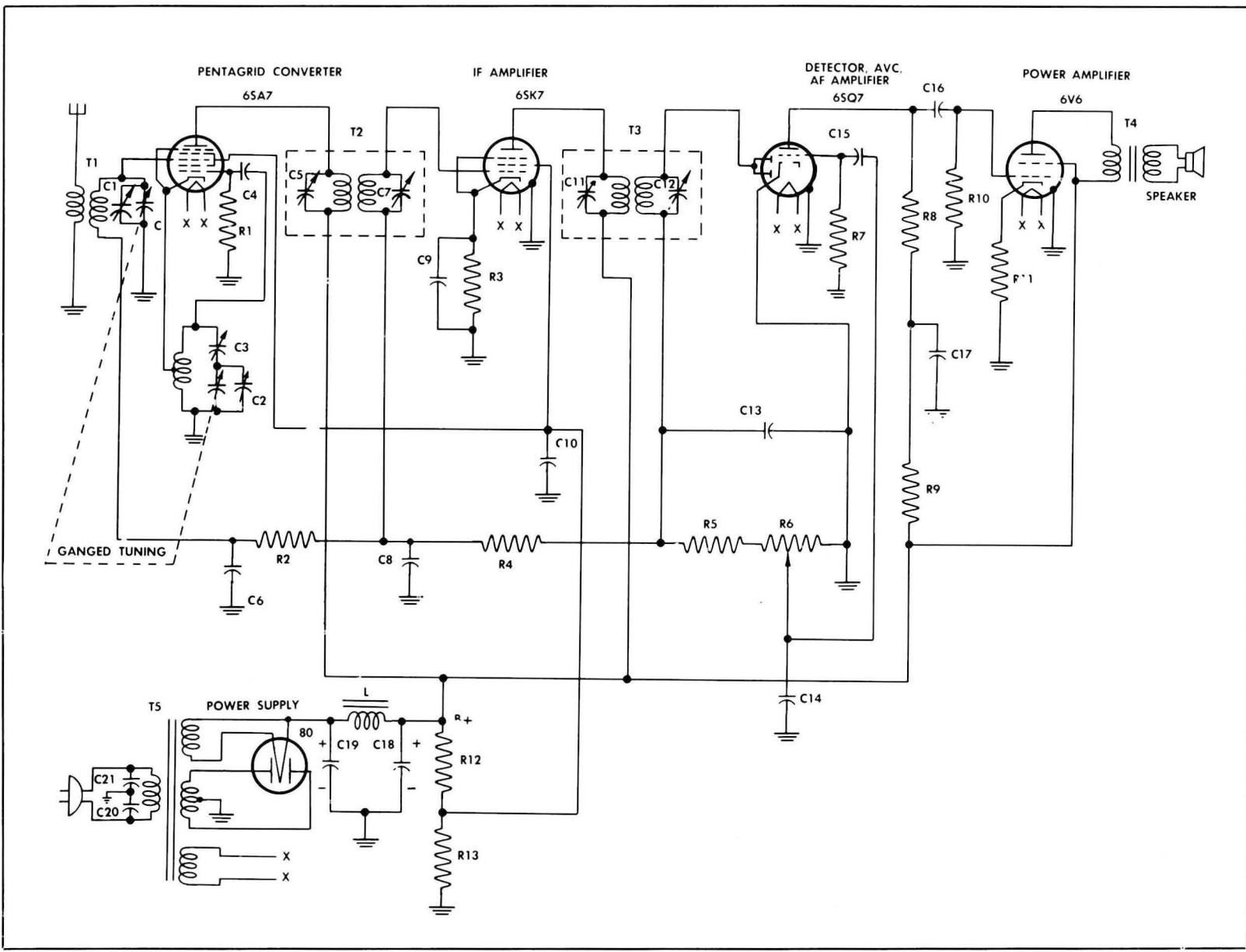

Typical Superheterodyne Receiver

may be a capacitor or a coil. Most receivers designed for military use have an adjustable core in the coil. This type of tuning is called permeability tuning. With this type of tuning, the components are more compact, and there are no open capacitor plates to vibrate, corrode, or gather moisture.

The amplifier tube is usually a variable-mu pentode. It is necessary that it be variable-mu to provide for AVC action.

Study the circuit diagram showing a typical IF amplifier stage. A constant DC cathode bias is developed across R and C. C bypasses the AC component of the current. R2 is a dropping resistor for the screen voltage. Both screen and suppressor are grounded for RF. The screen is grounded through C2, and the suppressor is grounded through C of the cathode circuit. Thus, both grids act as a shield between plate and control grid. R1 and C1 form a filter circuit to smooth out the AVC voltage so that audio modulation is not fed to the control grid along with the AVC.

The number of such stages used in a superheterodyne receiver depends on operating frequency and on the amount of gain desired. At higher frequencies, sensitivity and selectivity decrease and more stages are required. Receivers for the UHF and VHF ranges may have many IF stages.

### ANALYSIS OF THE SUPERHETERODYNE

To get an overall view of a typical superheterodyne receiver, examine the complete schematic diagram on page 38. Two special purpose tubes are used. The pentagrid converter functions as local oscillator and mixer. The variable tuned circuits are ganged for oscillator tracking. Trimmer capacitors C1 and C2 and padding capacitor C3 are included to help in tracking. They are screwdriver

adjustable. R1 provides about 3 volts grid leak bias for the local oscillator. IF transformer T2 selects the IF frequency and applies it to the grid of the IF amplifier.

The second special purpose tube, a 6SQ7, serves as a detector, an AF voltage amplifier, and an AVC rectifier.

The detector filter is formed by load resistors R5 and R6 and RF bypass capacitors C13 and C14. C15 and R7 make up the RC circuit that supplies the audio voltage to the grid of the first AF amplifier.

The volume control system includes MVC and AVC. MVC is made possible by potentiometer R6.

Filters formed by C6-R2 and C8-R4 eliminate modulation from the AVC voltage fed back to the grids of the converter and IF amplifier.

The power supply uses a full wave rectifier tube, with a capacitor input filter composed of L, C19, and C18, an arrangement used in most AC operated receivers. R12 and R13 form a voltage divider and bleeder circuit. Screen voltages for the converter and IF amplifier are taken from this divider. Capacitor C10 keeps the screens of both tubes at RF ground potential. Note the plate and screen voltages applied to the power amplifier. B+ is applied directly to the screen but has to go through transformer T4 to reach the plate. Because of the voltage drop across the plate transformer, the screen voltage is slightly higher than the plate voltage.

The AF output of the 1st AF amplifier is capacitively coupled to the power amplifier. The value of the coupling capacitor C16 and resistor R10 are such that they pass the lowest desired audio frequency. R11 provides bias for the power amplifier. Note that R11 is not bypassed by a capacitor. Thus there is degenerative feedback, providing greater fidelity.

## PARTS LIST, TYPICAL SUPERHETERODYNE RECEIVER

REFERENCE NUMBER	CAPACITORS VALUE (mfd unless otherwise stated)	DESCRIPTION
C1	10 to 30 MMF	ANTENNA TRIMMER
C2	10 to 30 MMF	OSCILLATOR TRIMMER
C3	500 (max) MMF	OSCILLATOR PADDER
C4	500 MMF	OSCILLATOR COUPLING
C5, 7, 11, 12	10 to 30 MMF	IF TRIMMERS
C6	0.05	RF BYPASS
C8	0.1	AVC FILTER
C9	0.05	CATHODE BYPASS
C10	0.05	SCREEN GRID BYPASS
C13	0.00025	DIODE LOAD RF FILTER
C14	0.05	RF BYPASS
C15	0.005	AF COUPLING
C16	0.01	AF COUPLING
C17	0.1	AF BYPASS
C18, 19	8-8, 450V	DUAL ELECTROLYTIC FILTER
C20, 21	0.05	LINE NOISE FILTERS
C	350 MMF	GANGED TUNING
C <sub>o</sub>	350 MMF	GANGED TUNING
<b>RESISTORS</b>		
REFERENCE NUMBER	VALUE (ohms) K=1000	DESCRIPTION
R1	20K, 1/2 W (watt)	OSC GRID LEAK
R2, 4	2 MEG, 1/2 W	DECOUPLING
R3	250, 1/2 W	CATHODE BIAS
R11	250, 1 W	CATHODE BIAS
R5	250K, 1/2 W	DIODE LOAD
R6	250K	DIODE LOAD AND VOLUME CONTROL
R7	10 MEG, 1/2 W	1st AF AMP GRID LOAD (OR LEAK)
R8	250K, 1/2 W	1st AF AMP PLATE LOAD
R9	50K, 1/2 W	DECOUPLING
R10	500K, 1/2 W	2d AF AMP GRID LOAD
R12	10K, 10 W	SCREEN SERIES DROPPING AND BLEEDER
R13	15K, 10 W	BLEEDER
<b>TRANSFORMERS AND CHOKES</b>		
REFERENCE NUMBER	COIL DC RESISTANCE (ohms)	DESCRIPTION
T1	PRI—22 SEC— 5	ANTENNA
T2	PRI—20 SEC—20	455 KC INPUT IF
T3	PRI—20 SEC—20	455 KC OUTPUT IF
T4	PRI—400 (Z 5K) SEC— 4	OUTPUT AF
T5	PRI—110V, 2 OHMS SEC—350-0-350V, 400 OHMS 5.0V FILAMENT, 1 OHM 6.3V FILAMENT, 1.5 OHMS	POWER TRANSFORMER
L	50 OHMS (10 HENRIES)	POWER SUPPLY FILTER

## COMMUNICATIONS RECEIVER

The communications classification covers a multitude of receivers. Though communications receivers may be less numerous than broadcast receivers, they show much greater variety in design and purpose. Communications receivers may be TRFs or superheterodynes. They may have switching and tuning arrangements for operation on several bands, or they may be fixed tuned for operation at a single frequency. Communications receivers may incorporate manual tuning or automatic tuning and may receive AM, FM, or pulse transmissions. Communications receivers may receive CW, tone, or voice modulation. They may be used for navigation, direction finding, or for aircraft instrument landings.

In spite of this great diversity, a superheterodyne receiver, basically very much like the one just studied, can serve as a typical communications receiver. Most communications receivers are superheterodynes. Many operate in the frequency range between 2.0 and 25 mc, although the use of VHF and UHF for communications is becoming more and more important. The greater number are commercial receivers, though many are manufactured expressly for military use. Most have provision for CW reception, as well as tone and voice.

Examine the block diagram of a typical communications receiver. Most of it should look familiar. Note, though, that two oscillator stages are represented. The heterodyne oscillator is called the *high frequency oscillator* (HFO). The other oscillator is called the *beat frequency oscillator* (BFO). The output of the BFO beats against the IF signal to produce

a difference frequency in the audio range. Note, too, the crystal filter. It provides IF selectivity and is part of the fixed tuning arrangement of the IF section. The noise limiter and squelch stages are used to combat noise and increase the effective sensitivity of the receiver. The tuning indicator is included to provide simpler, more accurate tuning.

All these special circuits, as well as others not shown in the block diagram, are important. Each of them deserves a detailed explanation. Two specific receivers used by the Air Force are discussed at the end of the chapter.

### CRYSTAL FILTER

The crystal filter acts as a selective coupling between the converter and the first IF amplifier. A crystal can be used as a filter, because it acts as a series-tuned resonant circuit. Because of its very high Q, the crystal filter passes a much narrower band of frequencies than the best conventional tuned circuits. It may pass a band as narrow as 1,000 cycles or less while the narrowest band passed by IF tuned circuits is about 5 kc. Therefore, it is used effectively for CW reception.

The crystal filter is usually controlled by a switch so that its use can be optional. Because of its high selectivity, the filter rejects signals close to the desired signal. Also, because of its selectivity it reduces the amount of noise in the receiver output. Since the crystal filter acts as a high Q series resonant circuit tuned to the intermediate frequency, it permits high current flow at the resonant frequency and sharply attenuates other frequencies.

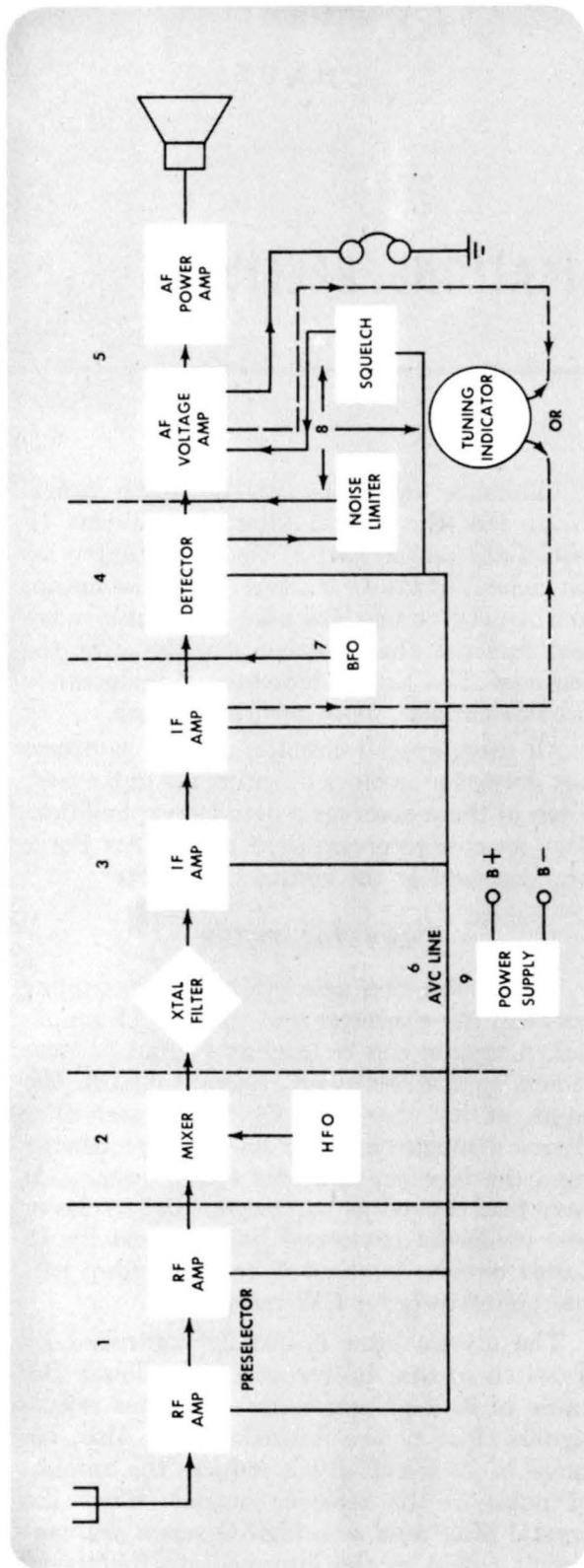

Typical Communications Receiver

### Equivalent Circuit

Examine the equivalent circuit of the crystal and crystal holder. The components L, C1, and R represent the crystal series resonant circuit. C2 represents the parallel capacitance of the crystal holder. Thus, the crystal at series resonance offers a short circuit path to the desired frequency and a high impedance path to other frequencies. However, the crystal holder capacitance, C2, shunts the crystal and offers a path to undesired frequencies. In a practical crystal filter circuit some means must be provided to counteract the shunting effect of the crystal holder. To see how this is done, look at the actual circuit diagram of the crystal filter circuit at B.

Variable capacitor C5, called the *phasing capacitor*, counteracts the holder capacitance (C2 in the diagram at A). C5 can be adjusted so that its capacitance equals the capacitance of C2. Then both C2 and C5 pass undesired frequencies equally well. The voltages across them due to undesired frequencies are equal and 180° out of phase since the secondary of the input transformer is centertapped. Therefore, undesirable voltages cancel, and undesired signals are not applied to the grid of the IF amplifier.

Actually, there is only one frequency in the filter's pass band at which total cancellation takes place. This occurs at the frequency at which C5's capacitive reactance equals that of the effective capacitance of the holder-crystal combination. Since the crystal's impedance varies with frequency, the effective capacitance of the holder-crystal combination also varies. However, C5 can be adjusted to cause exact cancellation at any frequency within the pass band except for frequencies

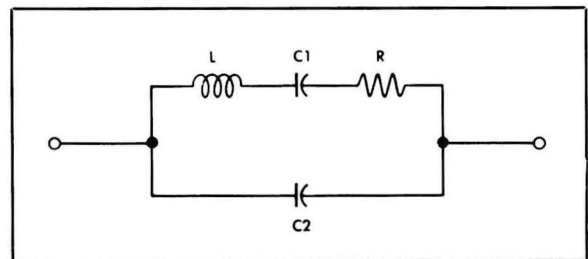

Mounted Crystal Equivalent Circuit

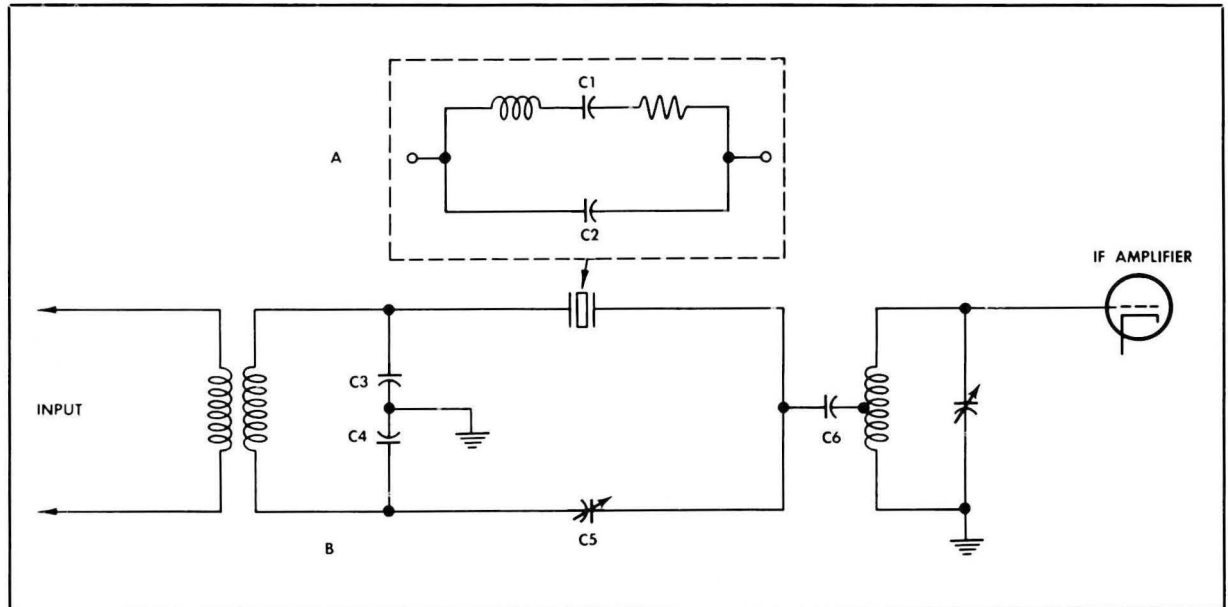

Crystal Filter Circuit

very close to the crystal's resonant frequency. This cancellation effect is called the *rejection notch*.

To understand why the rejection notch may be positioned as desired by varying C5, the effective impedance of the holder-crystal combination must be considered. At the crystal's series resonant frequency, its capacitive and inductive reactances are equal and effectively cancel. As the frequency is increased, the inductive reactance increases while the capacitive reactance decreases so that the crystal's impedance becomes inductive. At some frequency slightly higher than the crystal's series resonant frequency, this net inductive reactance of the crystal equals the capacitive reactance of C2. This is the parallel resonant frequency of the holder-crystal combination. At still higher frequencies, the net inductive reactance of the crystal exceeds the capacitive reactance of C2 so that the impedance of the holder-crystal combination becomes capacitive. C5 can be adjusted to be equal to this effective capacitance. Thus, the rejection notch can be positioned at frequencies above the holder crystal combination's parallel resonant frequency.

At frequencies below series resonance, the crystal's capacitive reactance exceeds its in-

ductive reactance and the net crystal impedance is capacitive. This capacitance, paralleled with C2, causes the holder-crystal combination's impedance to be capacitive.

Thus, the effective impedance of the holder-crystal combination is capacitive at frequencies below the crystal's series resonant frequency and at frequencies above the holder-crystal combination's parallel resonant frequencies. C5 can be adjusted, then, to equal the effective capacitance of the holder-crystal combination and to position the rejection notch at the desired point.

### Response Graph

Now look at the response graph for the crystal filter on page 44. The crystal is series resonant to 465 kc, the IF. At that frequency, the relative gain is 1000. At 461 kc, and at 469 kc, the relative gain is only 1. The decibel loss is 60, as compared to the response at 465 kc.

The rejection notch is positioned at 463 kc. Thus the relative gain of the crystal filter to 463 kc is also 1, and the relative loss in decibels is 60.

The rejection notch can be used to good advantage, since it will aid in making the receiver's response very selective. For example, the BFO can be set at a frequency of

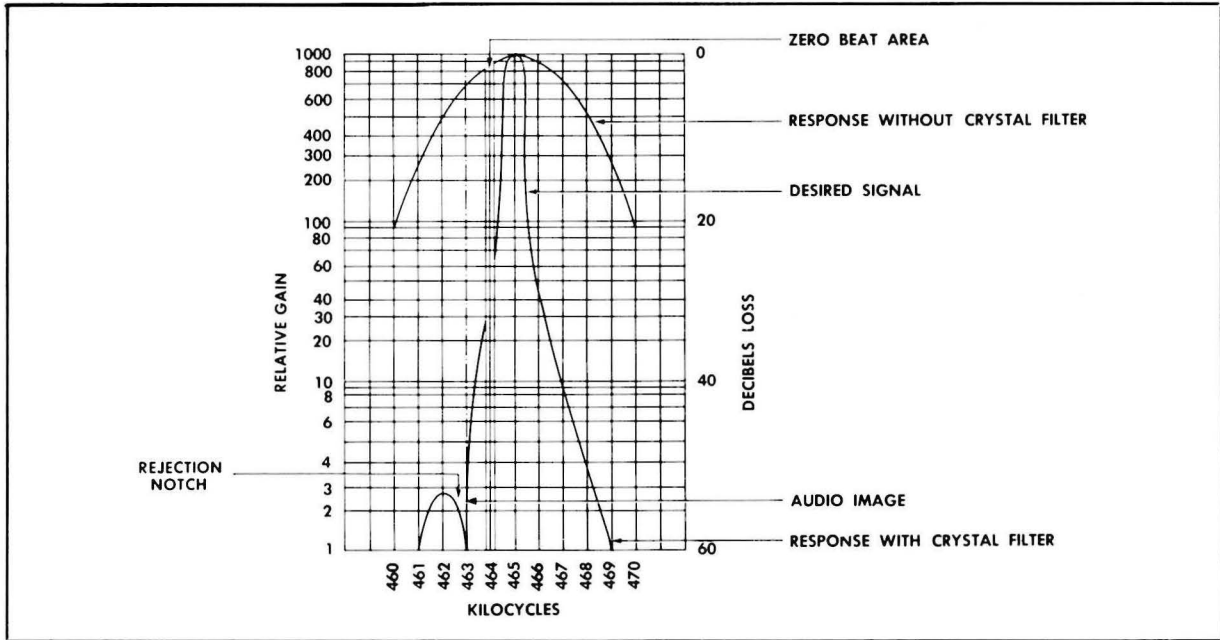

Crystal Filter Response Graph

464 kc. Then for CW reception, the BFO output combines with the IF output of 465 kc to produce a 1-kilocycle audio tone. However, if there were no rejection notch, the BFO output could also combine with a frequency of 463 kc to produce a 1-kilocycle audio tone. With the rejection notch in the crystal filter's response curve, a frequency of 463 kc is blocked. Thus, while the narrow band-pass of the crystal filter circuit makes the receiver's response highly selective, in addition, the rejection notch can be used to attenuate a strong undesired signal that falls within the pass band.

### Q of Crystal Circuit

The Q of a crystal is naturally very high. This means that while the impedance it presents to its series resonant frequency is low, the impedance presented to other frequencies is comparatively very high. Thus, at the desired frequency, the crystal could be represented by a small impedance, and at other frequencies, by a large impedance. However, the ratio of these crystal impedances to the impedance across which the output of the crystal circuit is developed must be carefully selected if the filter is to operate efficiently. For example, if the series resonant impedance

could be presented by 100 ohms, and its impedance to an undesired frequency by 10,000 ohms, then the impedance across which its output is developed should be closer to 100 ohms than 10,000 ohms. If the impedance across the output were 10,000 ohms, then one-half of the voltage at the undesired frequency would be dropped across the crystal and one-half across the output. At the desired frequency, 1/100 of the total voltage would be dropped across the crystal and 99/100 would be dropped across the output. Since the undesired signal is cut to only one-half of its value, the filter is not functioning very effectively. If, however, the impedance across which the crystal's output is developed were 100 ohms, then 99/100 of the undesired signal voltage would be dropped across the crystal and only 1/100 would be present in the output. This would be efficient filtering action.

Obviously, the impedance across the output of the filter circuit must be carefully chosen, since it helps to determine the band of frequencies which will be passed by the crystal filter circuit. At B in the circuit diagram of the crystal filter circuit shown previously, note that the crystal output is tapped down



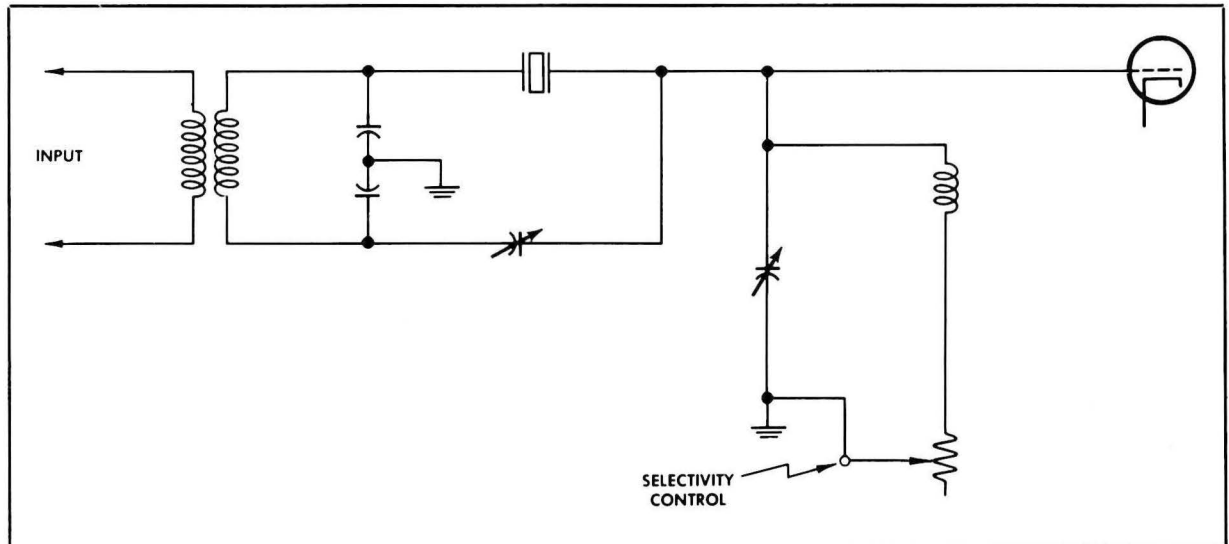

Crystal Filter with Variable Selectivity

on the coil of the tank circuit. By tapping down on the tank circuit, a suitable output impedance can be selected.

By varying the output impedance, the effectiveness of the filter can be varied. This offers a means of controlling the bandpass of the filter circuit. In the circuit shown above, the setting of the selectivity control determines the effective  $Q$  of the tuned circuit across which the crystal filter's output is developed. By varying the  $Q$ , the total impedance of the parallel resonant circuit is varied. This controls the effectiveness (and thus bandwidth) of the filter and provides positive selectivity control.

### COMMUNICATIONS RECEIVER AVC CIRCUITS

Communications receivers use manual gain control (MGC), manual volume control (MVC), and automatic volume control (AVC). The circuits you studied before in connection with TRF receivers are generally applicable. Communications receivers also use a type of volume control called *delayed automatic volume control* (DAVC), and a type called *delayed and amplified* automatic volume control.

#### Delayed AVC

The AVC voltage normally is in direct proportion to the strength of the detected signal.

Even the weakest signal produces a slight negative voltage. With AVC, this results in a slight loss in amplification. Such reduction in the amplification of weak signals is undesirable, because such signals are difficult to read at best.

To correct this situation, delayed volume control is used. Delayed volume control is a method which exempts weak signals from automatic volume control and allows them full amplification. DAVC goes into action only when signals exceed a set minimum signal strength.

Look at the typical DAVC circuit shown on page 46. Operation of DAVC requires a diode. In the circuit diagram, the diode of a multipurpose tube is used. In the one envelope is included a diode section for detection and a diode section for DAVC. The detector section uses plate D1 as its diode plate. The DAVC section uses plate D2.

In the diagram, the parts of the circuit important to DAVC action are shown in heavy outline. The IF signal is applied to both diode plates simultaneously. Plate D1 conducts immediately when the IF voltage swings positive. As a result, an AF voltage is developed across R1 as the current flow returns to the cathode. Plate D2, however, does not begin to conduct at the same time as D1. Plate D2 does not conduct until the voltage applied to it is high

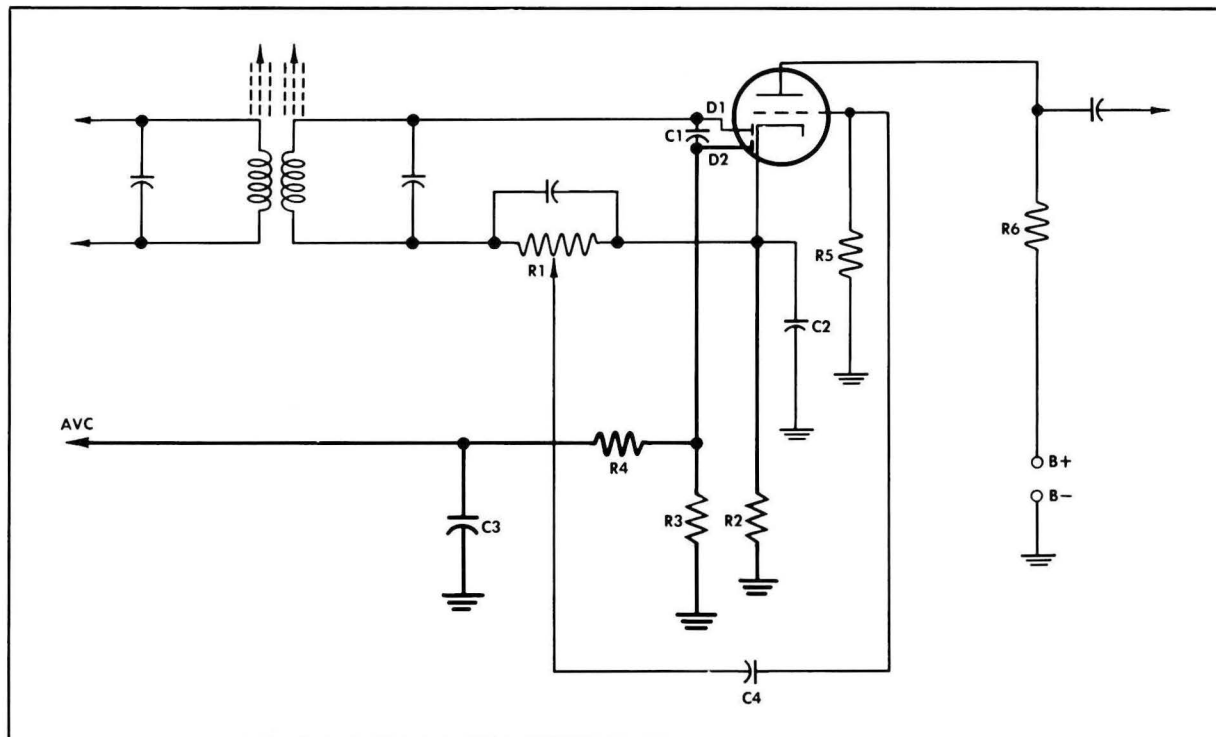

Delayed AVC

enough to offset the voltage drop across R2.

When D2 does draw current, C1 charges on the positive swing (becomes negative at the bottom in respect to the top). On the negative swing, C1 discharges down through R3. This action is repeated for each cycle of the IF. The voltage drop across R3 is used for the AVC voltage. It is fed back to the grid circuits of the amplifier stages to reduce gain. R4 and C3

form a filter to remove RF and AF components. Since D2 does not conduct until the voltage is high enough to overcome the bias on R2, there is no AVC in operation until the signal strength is greater than the voltage drop across R2. Above that value, normal AVC voltage is developed. This means that AVC action takes place only for strong signals. The voltage applied to the first audio amplifier (the triode section of the twin diode-triode) is taken from across R1, the detector load.

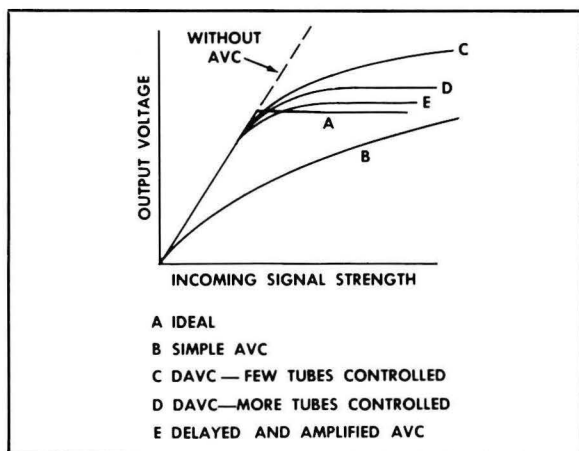

AVC Response Curves

### Delayed and Amplified AVC

An ideal DAVC should operate so that weak signals get full amplification while strong signals are held to a satisfactory, uniform level. Such an ideal AVC response is shown at A of the graph at the left. B shows the response of simple AVC. C shows the response of DAVC when only a few stages are controlled. D shows DAVC with more tubes controlled. E shows the response of a special kind of DAVC called *delayed and amplified AVC*. Its response comes quite close to the ideal. To see how this is achieved, study the circuit for delayed and amplified AVC.

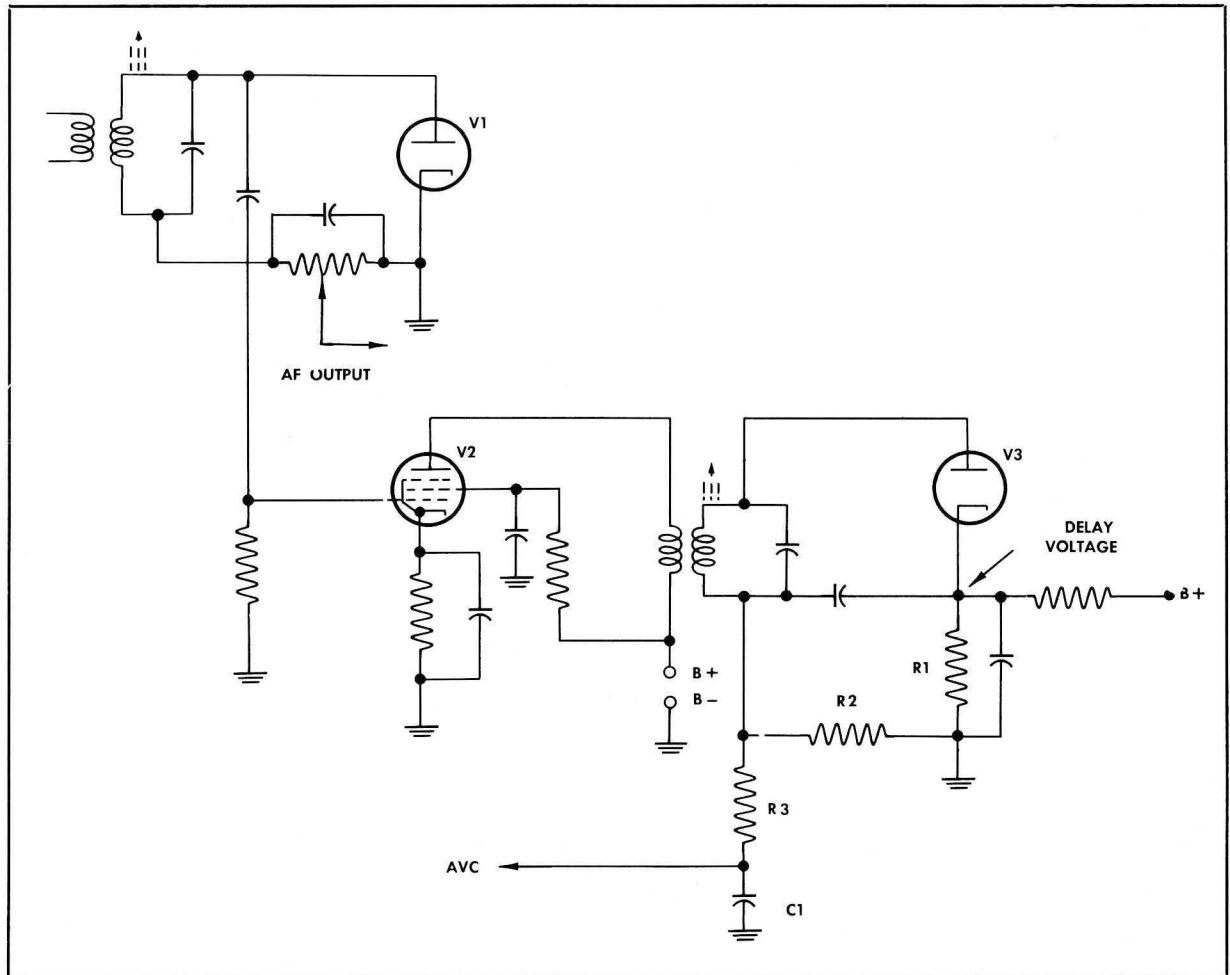

*Delayed and Amplified AVC*

V1 is the detector. V3 is a separate DAVC tube. The IF signal is applied to V1 for detection. It is also applied to V2, an IF amplifier used to provide a separate channel for the DAVC circuit. The output of this amplifier is applied to the DAVC diode. Because of the separate channel IF amplifier, the IF signal applied to the DAVC diode is stronger than the signal applied to the detector diode. As a result, the AVC voltage taken across R2 increases more rapidly than the signal strength applied to the detector. Thus, with proper gain in V2, the response to strong signals is almost constant.

#### **Use of AVC for CW Reception**

Special precautions to maintain high sensitivity must be taken when AVC is used for

reception of CW signals. The BFO, which makes CW reception possible, produces a strong signal which plays its part in forming the AVC voltage. Thus, the BFO helps to reduce gain. This reduction in gain becomes excessive unless special measures are taken. The CW switch shown in the circuit diagram on page 48 permits two precautionary measures.

The switch has three positions. In the A position, B+ is connected to the BFO and the AVC is grounded. In this position, the switch permits CW operation without AVC. In the B position, the switch connects B+ to the plate of the BFO and adds a capacitor to the AVC circuit. This 0.25-mfd capacitor increases the time constant of the decoupling filter so that the AVC voltage does not follow the make-break characteristic (the interrupted

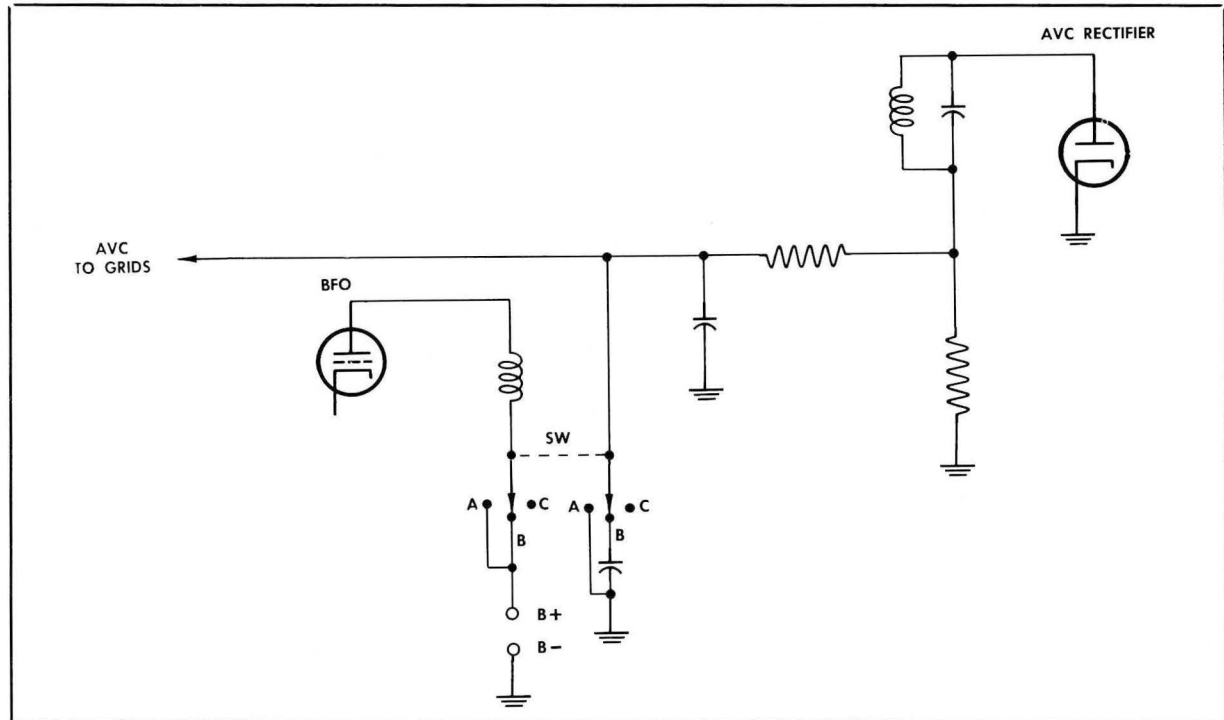

AVC with CW Reception

carrier) of the CW signal. In position C of the switch, no B+ is applied to the BFO so that it is inoperative, while the AVC remains normally operative.

Some communications receivers achieve satisfactory CW reception while AVC is operating by taking the IF signal for the AVC detector before the point where the BFO oscillations are introduced. Thus, the BFO cannot affect the amplitude of the AVC voltage. Such an arrangement is called a *separate AVC channel*.

### BEAT FREQUENCY OSCILLATOR

To enable a superheterodyne receiver to obtain intelligence from a CW transmission, a beat frequency oscillator is used. The output of the BFO heterodynes with the IF and produces a difference frequency which is audible. A BFO, set at 466 kc, can heterodyne with a 465-kc IF to produce an audio frequency of 1000 cps.

Notice the typical BFO circuits at the right. The circuit at A, a modified Hartley, is widely used. The circuit at B, an Armstrong, is used in some Air Force equipment. At C is an

electron coupled Hartley, an oscillator of good stability.

These oscillators are heterodyned against the IF through the various kinds of coupling. At A, coupling is through a small capacitor, 1 or 2 mmf, to the plate circuit of the final IF amplifier. At B, a few turns of insulated wire around the lead to the plate of the detector provide capacitive coupling without a capacitor. The capacity between the coupling wire and the wire of the plate lead accounts for the transfer of the signal. With this type of coupling, the output of the BFO must be kept low to prevent blocking of the detector. At C, there is capacitive coupling to the grid of the final IF amplifier.

The stability of the BFO is important. Therefore, a voltage regulator is frequently used for the plate supply voltage. In addition, the BFO is well shielded to prevent coupling of harmonics to the preceding IF and RF stages of the receiver. In some cases, for stability and shielding, the BFO is enclosed in an insulated, temperature-controlled compartment.

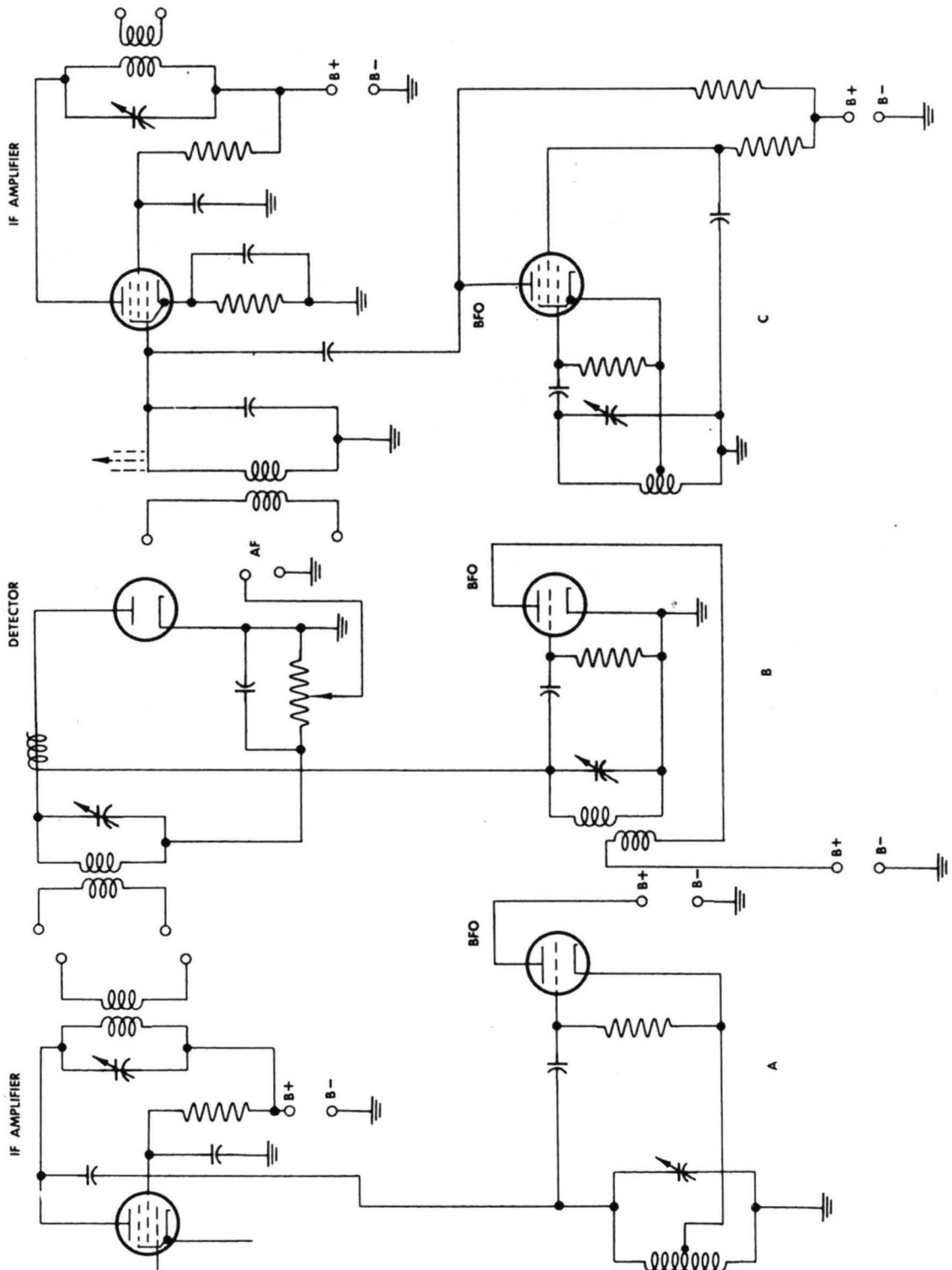

Beat Frequency Oscillators

### NOISE CONTROL CIRCUITS

Whenever there is an electric current, whether in nature or in man-made equipment, there is some radiation of electrical energy. Whenever electricity breaks down the insulation of air, whether in the form of a bolt of lightning or a discharge across the points of a sparkplug, there is RF radiation from what is effectively a spark gap transmitter. The air is always filled with such radiations, usually without fixed frequency. When these radiations get into a communications receiver, they are classed as noise. At the receiver antenna, these radiations compete with the radiations of regular transmitters. When the antenna intercepts a signal, it also intercepts some noise. If the signal is weak, the noise may make it unreadable.

Battles have been won and lost in terms of signal-to-noise ratio. Battles have been saved by the skill and persistence of resourceful operators who managed to read intelligence under almost impossible conditions. In fact, the signal-to-noise ratio can be so important that radio engineers have developed special jamming equipment designed solely to make noise to prevent successful communication by an enemy.

The signal-to-noise problem affects all re-

ceivers, but it is the communications receiver that must meet the problem head on. With a communications receiver, you can't just turn to another station to get a program just as good. The communications receiver is usually assigned to definite channels and stations. It must do the best it can with the signals it receives.

Of course, the receiver itself uses electricity, and the receiver itself generates some of the noise which appears in its output. For one thing, energy may be coupled improperly from one circuit to another to produce noise. For another, the movement of electrons in a tube can produce noise.

Some of the noise in a receiver output may originate in the power supply system of the receiver. Improper filtering and shielding may allow generator or dynamotor frequencies to penetrate to the receiver audio output.

Some of the noise in a receiver output may originate in the transmitter. It may be brought to the receiver as modulation impressed on the RF carrier.

Many effective measures to combat noise are incorporated in radio components and transmitter and receiver units. Some of the most effective of these measures involve the use of circuits specially designed to reduce noise.

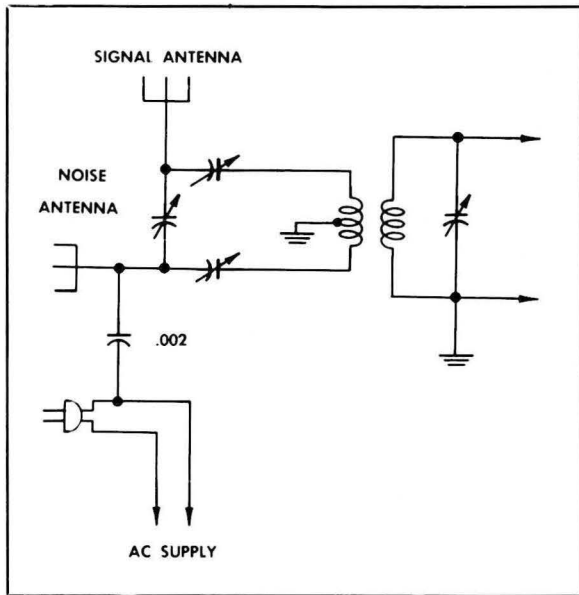

Noise-Balancing Antenna

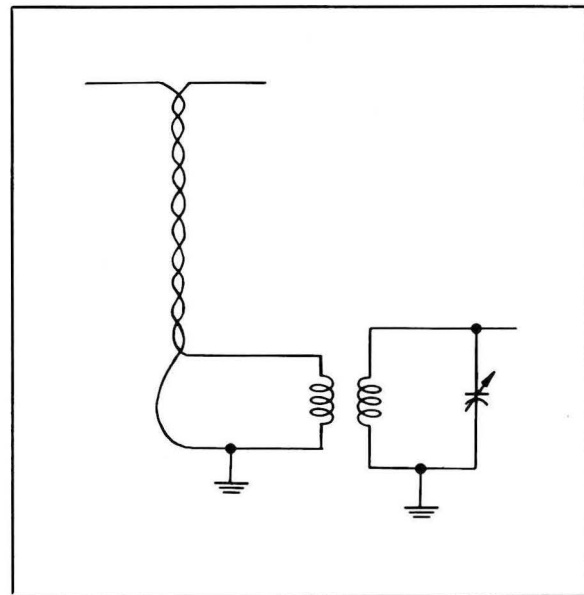

Twisted Pair for Noise Reduction

**Noise-Balancing Antenna Circuits**

Power line interference can be reduced by the special arrangement on page 50. Here a noise antenna introduces noise to the input circuit in such a way as to cancel the same noise introduced by the signal antenna. Cancellation takes place across the two halves of the grounded primary of the transformer. For best results, the noise interception of each antenna must be about equal. There must be considerable experiment and adjustment before noise interception is equalized. Consequently, the arrangement works best for a fixed station where the source of noise is also fixed. Of course, this arrangement could cause cancellation of the signal, too. However, the tuning and location of the signal antenna enable it to intercept signal energy much more effectively than the noise antenna. Thus, only part of the signal is cancelled. Furthermore, although the signal is weaker, it is more readable because the noise is eliminated.

Now examine the noise-balancing circuit which uses a twisted pair to cancel noise. In this circuit, the antenna is far enough away from the noise source that it does not itself pick up the noise. However, the leadin does pick up noise. Therefore a twisted pair is used as the leadin. The noise field of one conductor is cancelled by the noise field of the other, and the noise input to the receiver is minimized.

**Series Noise Limiter**

Much receiver noise consists of high voltage pulses of very short duration. The amplitude of the noise pulses is much higher than the usual signal voltage amplitude. Therefore, the limiter circuit can use the high amplitude of the noise pulse to block the receiver. Since the noise pulse is of very short duration, the receiver is blocked for such a short time that it cannot be noticed by the ear.

The limiter is arranged to block the receiver

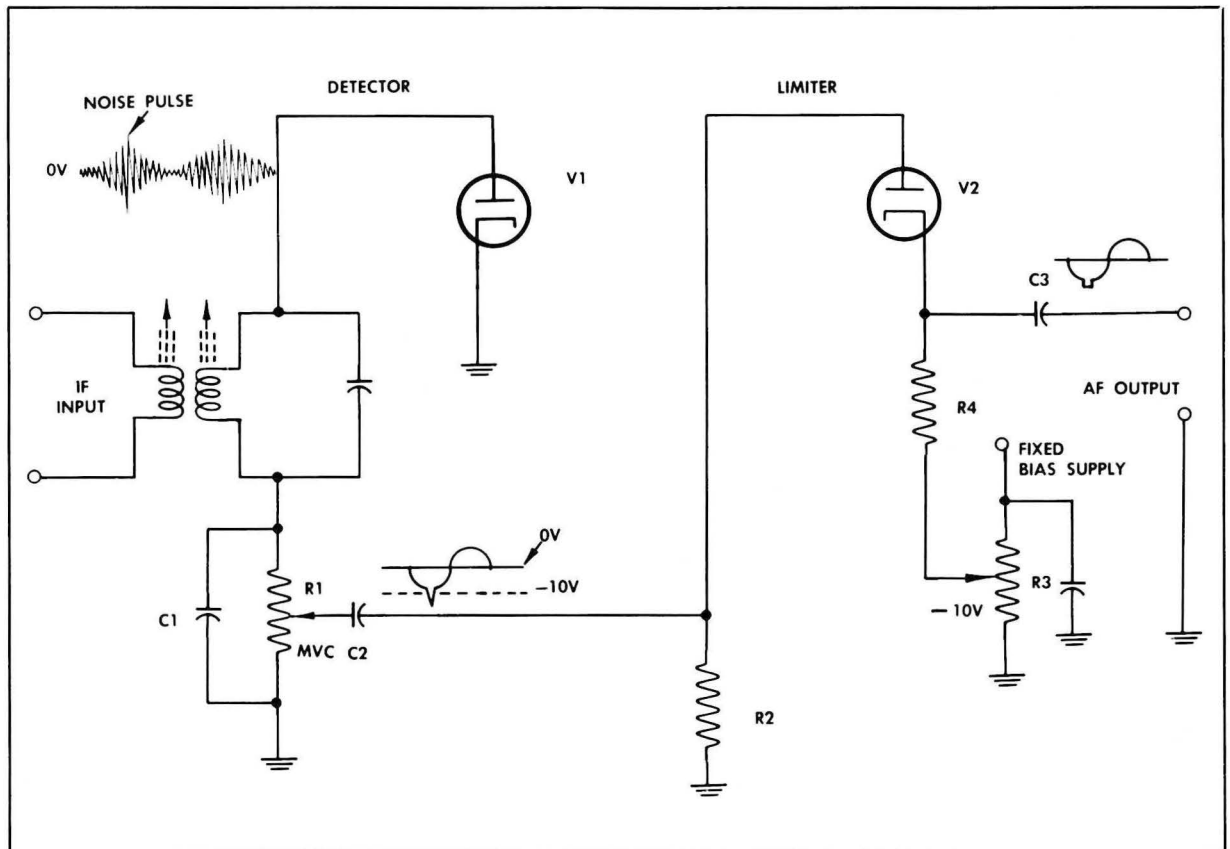

Series Noise Limiter

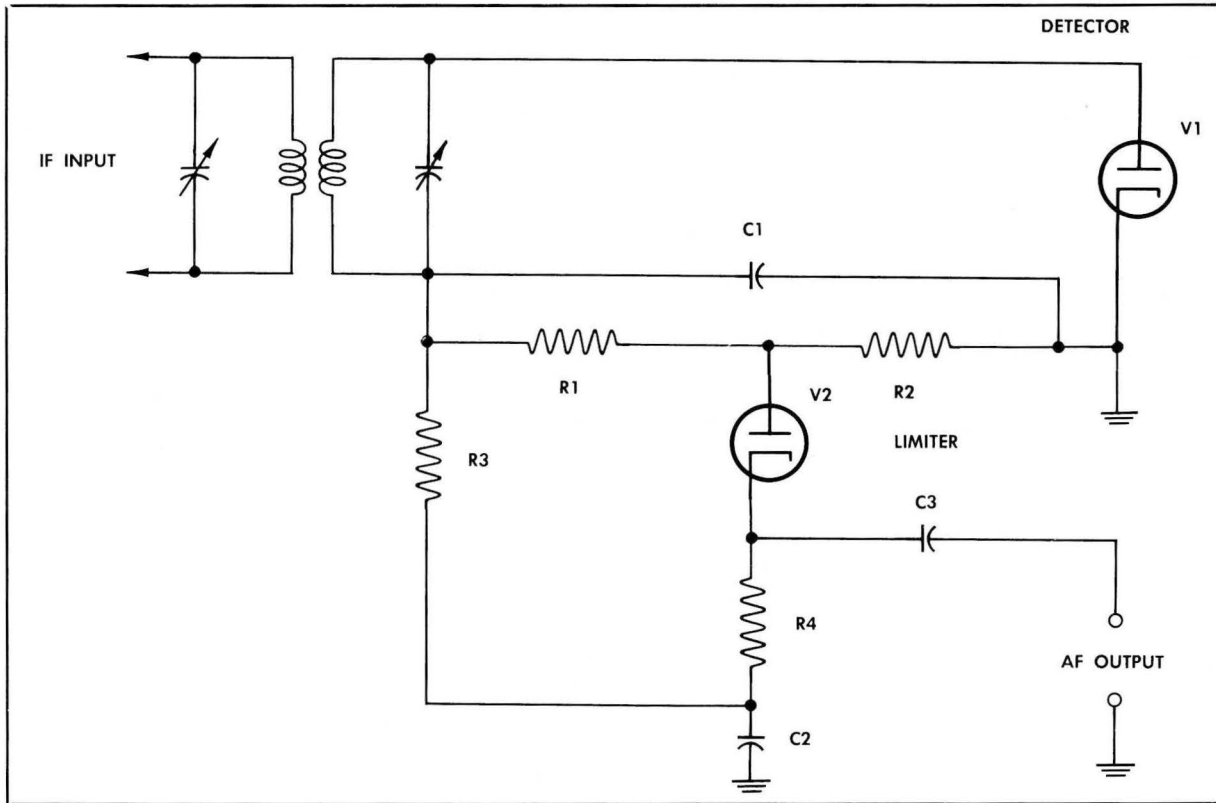

*Self-Adjusting Series Noise Limiter*

whenever the noise voltage exceeds a certain level, a level higher than the usual signal voltage. Thus, the receiver is silent during noise pulses. The noise does not get through, but the signal does.

The limiter uses the diode following the detector stage. In the series limiter circuit diagram on page 51, the limiter is V2. Note the noise pulse shown in the waveform applied to the diode plate.

The output of the diode detector, V1, is present across R1, a potentiometer used for MVC. This output is a pulsating DC, negative in respect to ground. Coupling capacitor C2 blocks the DC from the limiter plate but passes the AF component. The AF component containing a noise pulse is illustrated by the waveform. The limiter has a variable cathode voltage usually set at approximately  $-10$  volts. Thus, all voltages applied to the plate which do not drive the plate 10 volts negative are passed through the diode limiter. All voltages which go more than 10 volts negative (the

noise voltages) cut off the tube and are not passed.

The limiter is normally conducting so that the audio voltage appears across R4 and is applied to the following amplifier. When the noise pulse, which is more negative than  $-10$  volts, is applied, the limiter momentarily stops conducting and no voltage appears across R4. The waveform with the noise pulse clipped off illustrates the AF coupled through C3 to the output.

### **Self-Adjusting Series Noise Limiter**

The cathode voltage of the limiter tube can be made self adjusting, as shown in the circuit diagram above. The detector (V1) is conventional except that its load resistance is divided between two resistors, R1 and R2. The plate of the limiter is connected between R1 and R2. Thus, part of the voltage drop across the two resistors is applied to the limiter plate. At the same time, the full



voltage drop across the two is applied to the limiter cathode. This means that the DC plate-to-cathode voltage of the limiter equals the voltage drop across R1. This voltage drop, of course, varies with the detector output. Thus, with a strong signal the voltage drop increases and so does the DC plate-to-cathode voltage. With a weak signal, these voltages decrease.

You might think then, that the limiter could never be cut off, since DC plate-to-cathode voltage adjusts to signal strength. However, the time constant of R3 and C2 is such that the cathode voltage does not immediately follow a sudden decrease in plate voltage as during a noise pulse. On the noise pulse, the plate voltage decreases instantaneously, but the cathode voltage decreases slowly. Thus, the tube is cut off, and for a fraction of a second there is an open circuit. When there is a less sudden decrease in plate voltage, as when there is a slow change in signal strength, cathode voltage can follow it closely. Thus, the diode acts as a short circuit at all times except during noise pulses. As a short circuit, it passes the AF signal.

This circuit is widely used in Air Force equipment.

### Shunt Noise Limiter

In a shunt limiter circuit, the limiter diode acts as a short circuit for noise voltages. This is the opposite of the series limiter which acts as an open circuit for noise voltages.

In shunt limiter circuit, the cutoff level is also self-adjusting. As you can see in the diagram above, part of the voltage drop across the two load resistors R1 and R2 of the detector V1 is applied to the cathode of V2. The complete voltage drop is applied to the plate. Since the voltage drop is negative in respect to ground, the plate is more negative than the cathode, and the tube is cut off. The time constant of R3 and C2 is such that plate and cathode change together for signal voltages, and the limiter diode remains cut off. However, the time constant is such that, on sudden noise peaks, the plate voltage does not follow the cathode voltage. On noise peaks, the cathode is driven negative instantaneously

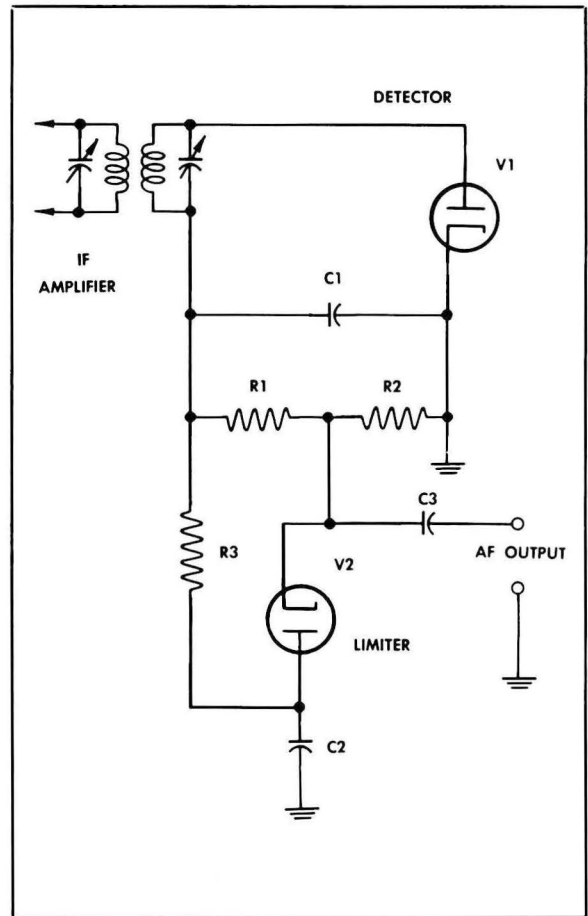

Shunt Noise Limiter

until it is more negative than the plate. The tube then conducts, shorting the noise voltage to ground through C2.

Note that the cathode voltage is coupled to the AF output. The cathode voltage represents the voltage drop across R2. When V2 conducts, it short circuits R2 as far as AF is concerned. Thus, for the duration of the noise voltage, there is no AF output.

### Separate Channel Noise Limiter

In some communications receivers, a separate channel noise limiter system is used. This prevents the strength of the BFO signal from affecting the noise limiter.

As shown in the circuit diagram on page 54, the separate channel consists of a noise amplifier and twin diode noise rectifier. The IF signal is applied partly to the first IF amplifier, and partly to the noise amplifier. The part

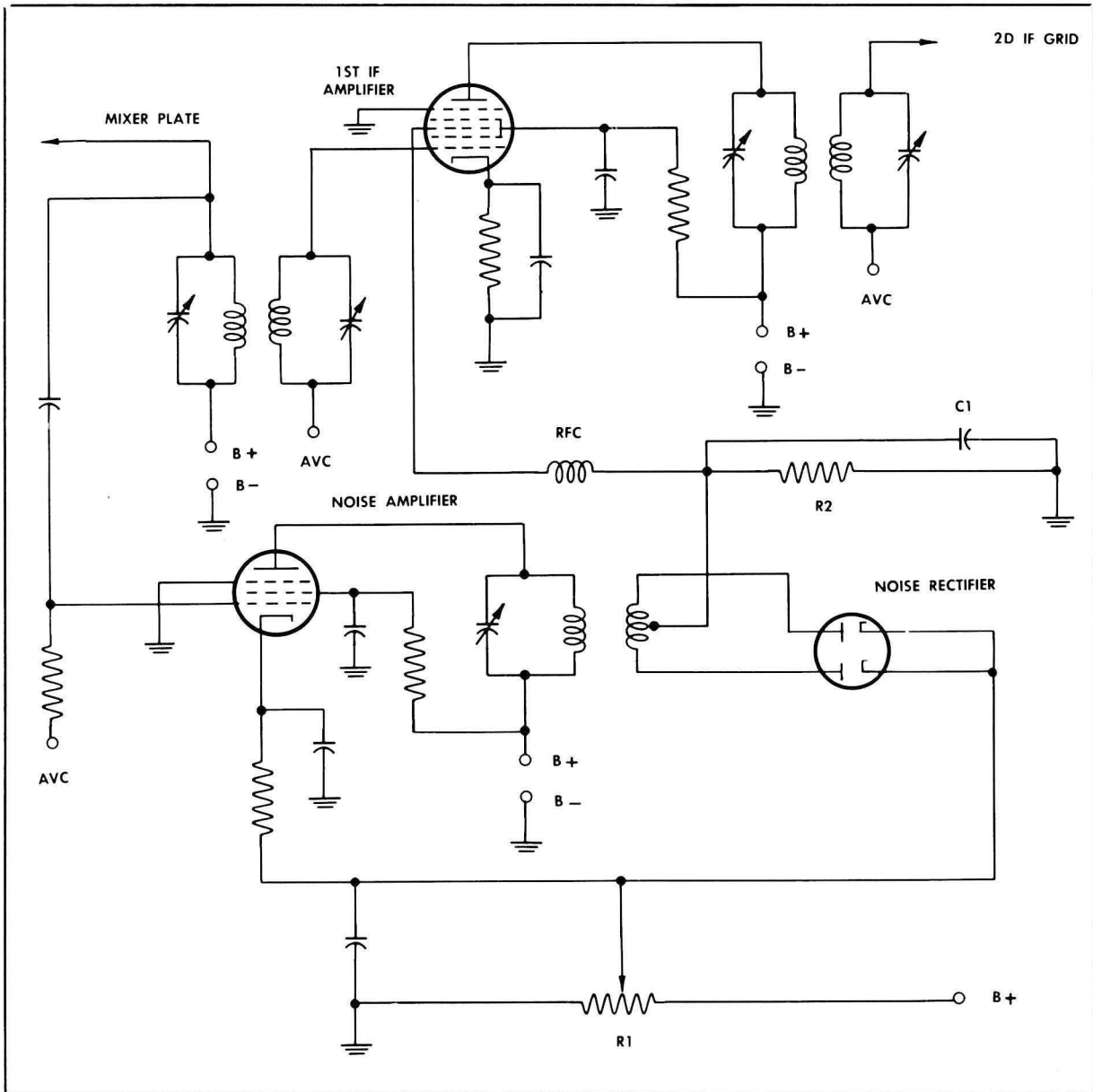

Separate Channel Noise Limiter

applied to the noise amplifier is amplified and then applied to the plates of the diode limiter (noise rectifier). The bias of both the noise amplifier and rectifier is controlled by the threshold control R1. Adjustment of the threshold control is critical. If it is set too low, the circuit will cause a reduction in the signal to the second IF amplifier. If it is set too high, some noise will not be removed. The voltage on the noise rectifier is adjusted below cutoff, so that the normal IF signal applied to

it is not sufficient to bring it out of cutoff. When there is noise, however, the voltage becomes high enough to bring the noise rectifier out of cutoff. When the noise rectifier is brought out of cutoff and conducts, current flows through R2 and develops a negative voltage which is applied to the second control grid of the 1st IF amplifier. This cuts off the IF amplifier for the duration of the noise pulse. To prevent the IF signal itself from being applied to the second control grid of the first IF

amplifier, an RF choke is used. This choke, between the noise rectifier and the second control grid of the first IF amplifier, blocks the IF.

Because of the short duration of a noise pulse, the momentary blocking of the IF signal is unnoticeable. The elimination of noise takes place before the BFO output is mixed with the IF signal. Normal AVC is applied to the first control grid of the first IF amplifier through the IF transformer.

### Basic Squelch Circuit

While communications receivers are in a standby position, or being tuned between stations, they are far from quiet. With no signal, the receiver is in its most sensitive condition, as no AVC is developed. Noise reaches its highest volume. Good communications receivers eliminate this no-signal noise by a muting system, sometimes called *quiet AVC (QAVC)*. Sometimes, it is called *interchannel noise suppression*, sometimes *squelching*, and sometimes *tuning silencing*. A basic

squelch circuit is shown in the illustration below.

The triode section of V1 serves as a squelch tube. When no signal is being received, there is no rectification, and neither diode section of V1 conducts. Consequently, there is no voltage drop across R3. There is no voltage applied to the grid of the triode section of V1, and it conducts. Neither is there any voltage applied to the grid of V2 through C6. However, since the triode section of V1 conducts, there is a voltage drop across R6. This is applied to the grid of V2 and is sufficient to cut off the tube. Thus, with no signal, neither diode section of V1 conducts, and V2 is cut off. There is no AF output from V2, and the receiver is quiet.

When a signal appears, there is rectification. Current flows through R3. A fixed part of the voltage drop across R3 is applied to the grid of the triode section. A variable part of the voltage is also applied to the grid of V2. The variation is by MVC.

The voltage applied to the grid of the triode

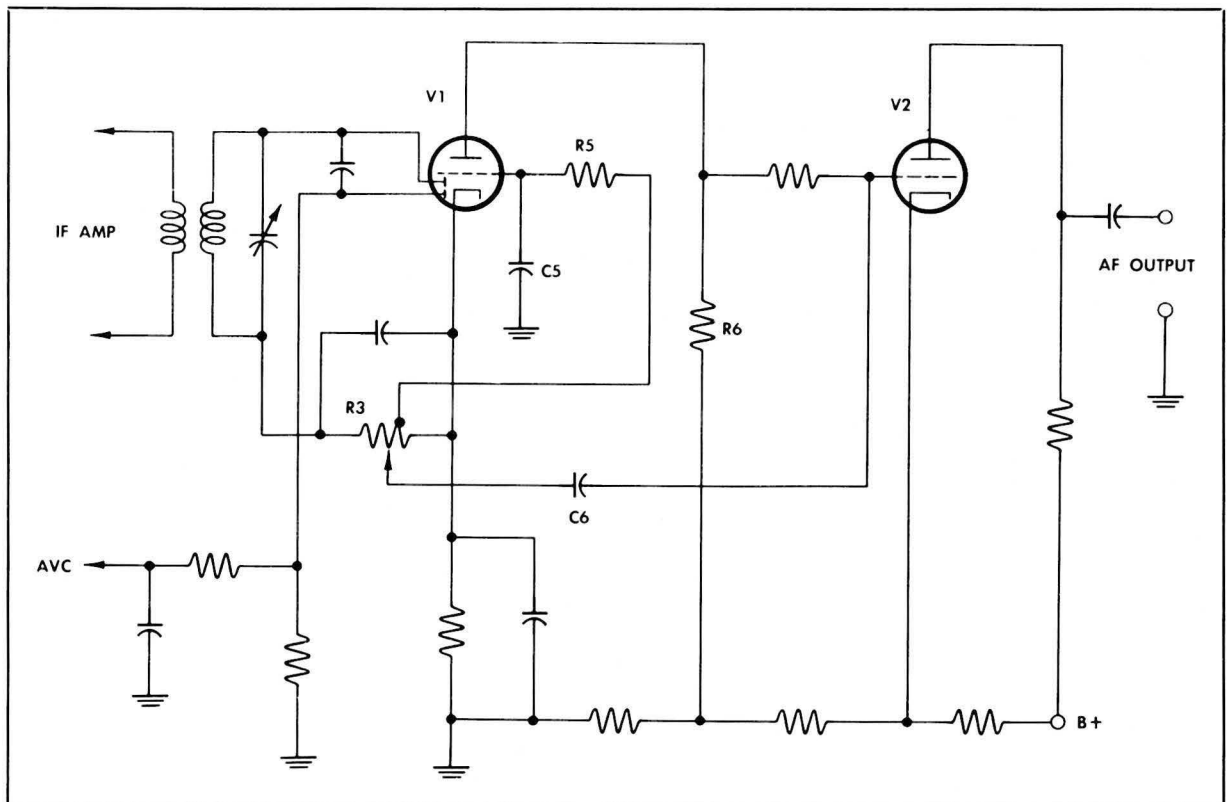

Basic Squelch Circuit

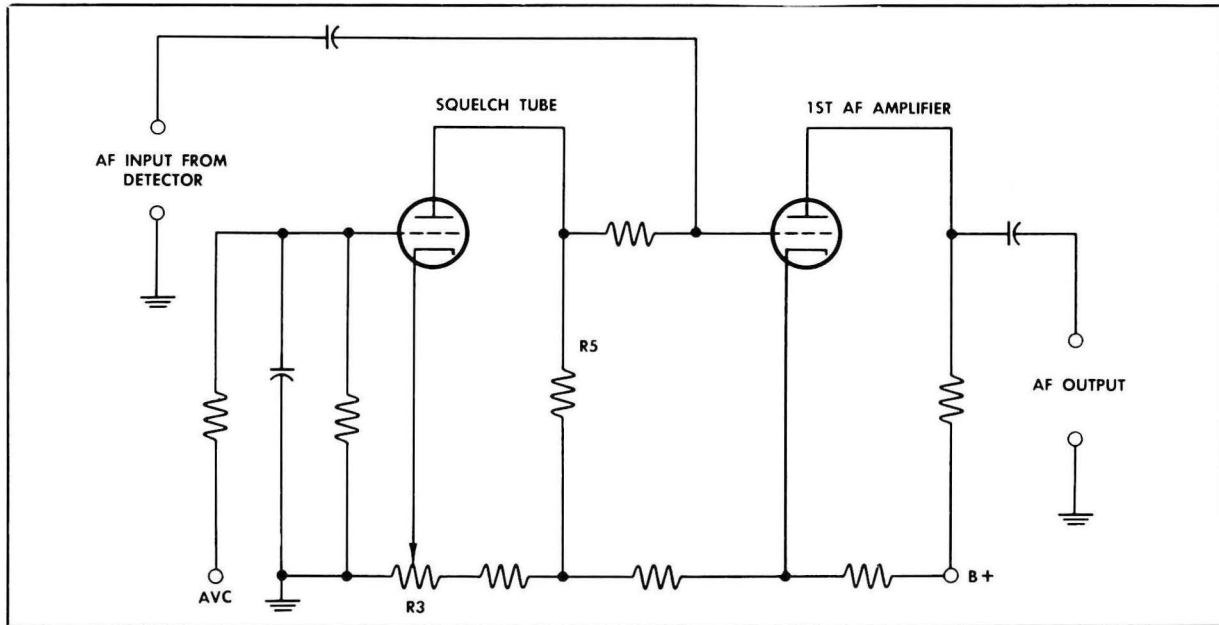

Squelch Circuit Controlled by AVC

section of V1 biases it practically to cutoff. C5 and R5 form a filter for this bias voltage. C5 bypasses the audio component of the bias voltage to ground. Thus, the bias on the triode section is a DC bias set at about cutoff. Plate current almost ceases. This means that the voltage drop across R6 which is applied to the grid of V2 almost disappears. The bias voltage on V2 thus becomes much more positive. This brings V2 out of cutoff, and it can now amplify the rectified AF signal coupled to its grid through C6. Thus, the signal is passed on to the AF output.

Note that the AVC circuit uses one diode section of V1 and is independent of the squelch circuit.

### Squelch Circuit Controlled by AVC

Now examine the squelch circuit above. This circuit is controlled by the presence or absence of AVC. With no signal, no AVC voltage is applied to the grid of the tube, and the squelch tube conducts. The only bias on the tube is cathode bias obtained from variable resistor R3. The plate current of the tube flows through R5. The voltage drop across R5, applied to the grid of the AF amplifier, cuts off that tube, and there is no AF output.

When a signal appears, an AVC voltage is developed. Part of this voltage is applied to the grid of the squelch tube. This increases the bias on the tube and reduces plate current. As a result, the voltage drop across R5 decreases. This raises the grid voltage of the first AF amplifier, and it conducts. It then amplifies the AF signal coupled to it from the detector.

### TUNING AND SIGNAL STRENGTH INDICATORS

An indicator to show relative signal strength can be very helpful in the operation or alignment of a communications receiver. Two types of indicators are in use. One, the signal strength meter (S-meter), is calibrated to show the strength of any signal. It can be used for tuning since it shows when a signal is strongest. The other, the tuning indicator, is not calibrated but it shows when any signal is at its strongest. Hence it indicates correct tuning.

#### S-Meter Circuits

The S-meter is essentially a milliammeter designed to indicate signal level. Usually the dial is calibrated from 0 to 9, with each suc-

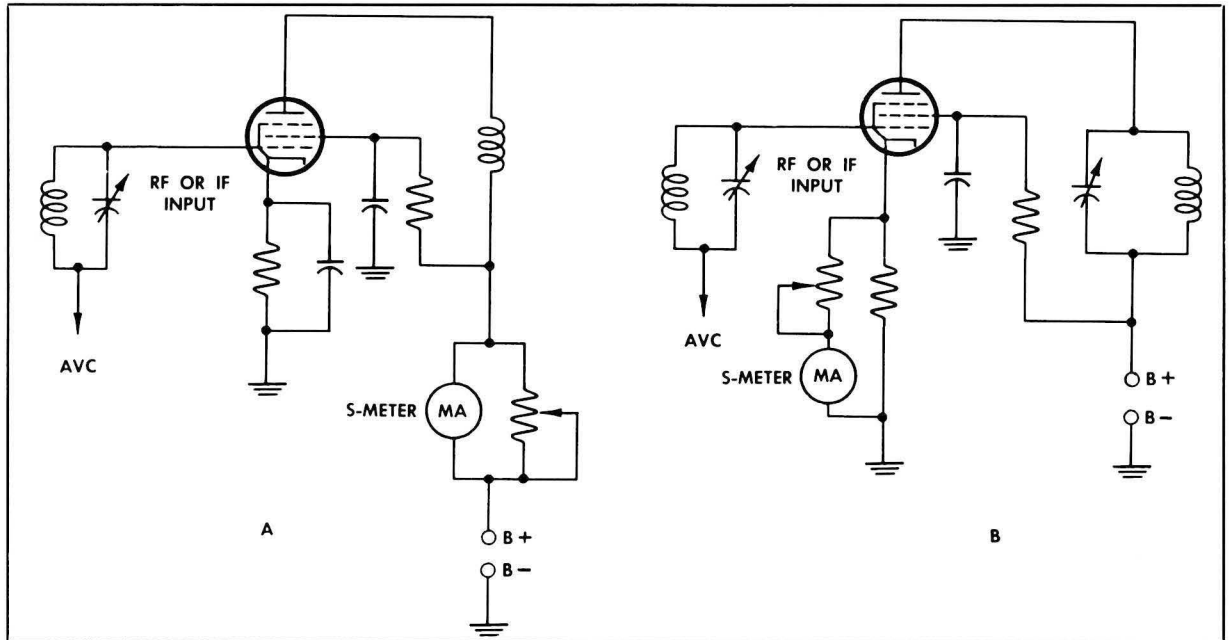

Signal Strength Meter

ceeding point indicating a doubling of signal level.

Notice the two common methods of S-meter placement. At A above, the meter is placed in the plate circuit of a variable-mu tube. A movement of 0-200 microamperes is used, and a variable shunt resistor makes possible zero adjustment for no signal response. At B, the S-meter is located between cathode and ground. It uses a movement of 0-1 milli-

ampere in series with a variable resistor. It is in parallel with the cathode bias resistor.

In both cases, the tube operates class A. Therefore, the only time there is a change in plate current is when AVC is applied to the grid. With a large signal, the AVC voltage becomes greater and increases the bias on the tube. This reduces the plate current and causes the proper reading on the S-meter. Consequently, the meter must be arranged to show

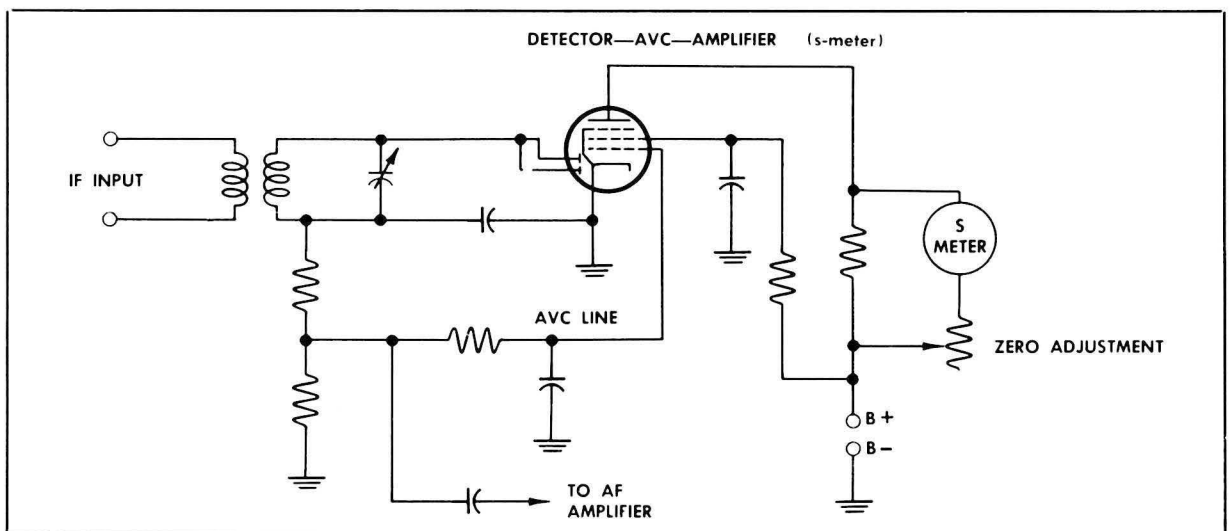

S-Meter With Separate Amplifier

minimum signal strength when current is maximum (no signal and no AVC), and maximum signal when current is minimum (maximum signal and maximum AVC). The meter movement is the reverse of that in the usual milliammeter. To read left to right on increasing signal strength, the meter deflects from right to left when current is increased. Such a meter is called a right-zero meter.

Sometimes the S-meter is used with a separate amplifier circuit. Notice in the diagram at the bottom of page 57 that a multielement tube is used. The AVC voltage is applied to the control grid of the pentode section of the tube. Since the AVC voltage is negative, an increase in signal strength causes a decrease in plate current.

Only a small part of the current, probably about one tenth of the total tube current, flows through the meter. The meter response is not perfectly linear, but the meter dial is calibrated according to the characteristics of the tube used in the amplifier circuit.

The S-meter can also be located in the AVC rectifier, as shown below. A portion of the diode current flows through the meter. Here, signal strength is in proportion to current flow, and the meter is calibrated for left-to-right deflection.

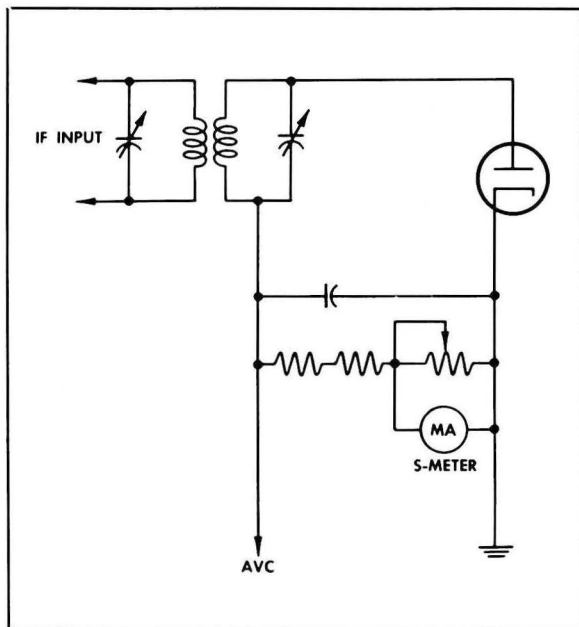

S-Meter in AVC Circuit

### Tuning Indication with Electron Ray Tube

Though not as common as S-meters, electron ray tubes are used in some communications equipment. The electron ray tube is not intended as an accurate signal strength indicator. It is a tuning indicator that shows when a signal is tuned to maximum strength. As shown in the circuit diagram below, the indicator responds to the AVC voltage applied to the grid of the triode section.

The triode amplifies the AVC signal. But the plate of the triode section serves also as control grid of the indicator section. (Notice the connection between the plate of the triode section and the grid of the indicator section.) The indication on the fluorescent target is controlled by the difference in potential between the deflecting probe (the control grid of the indicator section) and the fluorescent target (the plate of the indicator section).

If the probe and target are at the same potential, the electrons flowing from the cathode to the target are not deflected. Consequently, the electron shadow of the deflecting probe appears only as a dark line on the target. This is the condition that exists when a large AVC voltage prevents the triode section from conducting.

With little or no AVC (little or no signal)

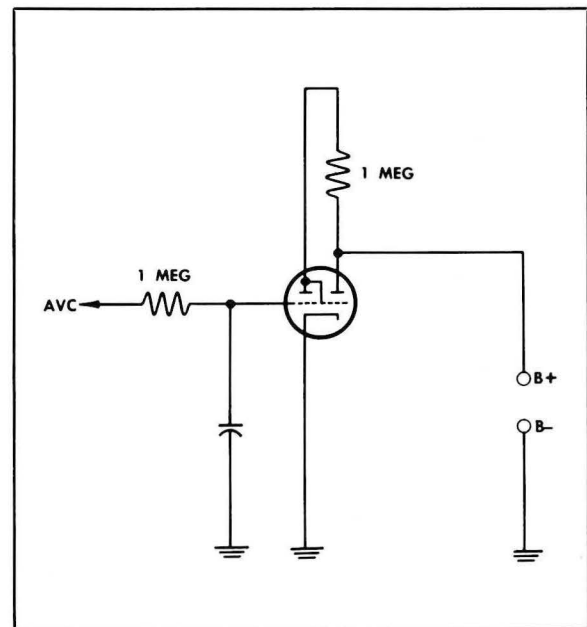

Electron Ray Tube Circuit

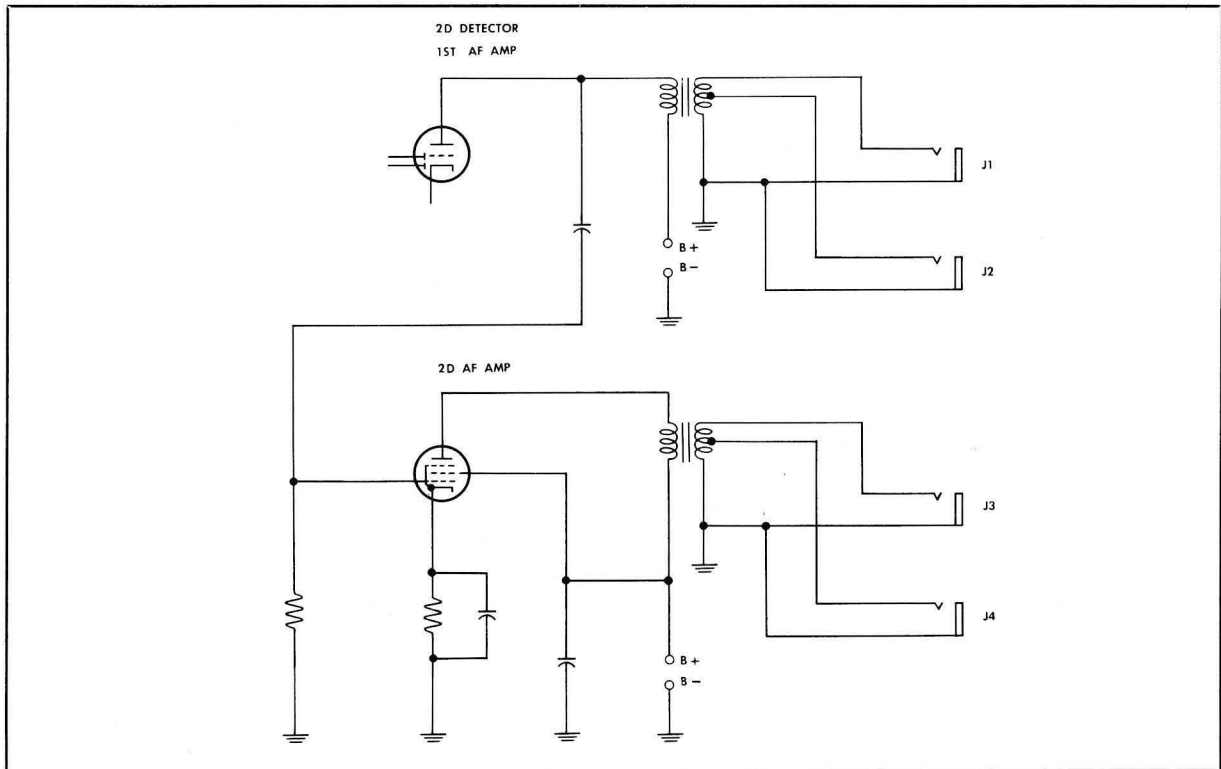

Provision for Headset Reception

getting through), the triode section conducts and there is voltage drop across the 1-megohm resistor. The voltage drop puts the two plates at different potentials. Since the deflecting probe is connected to the triode plate, its voltage is below that of the target plate. It therefore acts as a grid between the cathode and the target plate and causes a wide deflection of the electron beam and a wide pie-shaped shadow on the target. This indicates that the receiver is not exactly tuned to the station.

### CIRCUITS FOR AUDIO REPRODUCTION

Communications receivers have various arrangements for reproduction of intelligence. These arrangements are sometimes quite complicated. The receiver may serve a number of headsets. It may serve loudspeakers. It may serve a combination of headsets and speakers. The audio section of the receiver may also serve as part of an intercommunications system between different receiving sites, or receiving and transmitting sites.

### Headset Circuits

Examine the above diagram showing four headset jacks. Provision is made for using any of four different types of headsets. The output of the 1st audio amplifier is obviously less than the output of the second. However, the output of the first amplifier may be sufficient to drive high sensitivity headsets. If the high sensitivity headset is a high impedance type, J1 should be used. If the high sensitivity headset is of the low impedance type, J2 would be used. The output of the 2d audio amplifier would be used to drive headsets of lower sensitivity. J3 is for headsets having high impedance and low sensitivity, while J4 is for use with headsets which have both low sensitivity and low impedance.

Headsets are coupled to the communications receiver by an iron-core transformer. Such transformers provide for impedance matching. They also isolate DC from the headsets.

Communications receivers used for military operations have enough power to provide output at one or more remote positions.

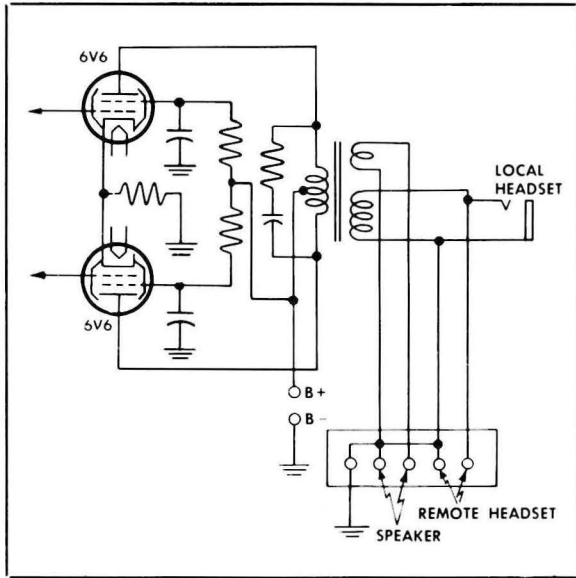

AF Output Circuit

**Speaker Circuits**

Most speakers used with Air Force equipment are mounted in a separate case. The output transformer is mounted in the receiver, and the receiver is rated according to the output impedance of the output transformer. This permits selection of the proper speaker to be used with it. The output impedance must be low, for the impedance of the voice coil of a speaker is very low—4 to 15 ohms.

The voice coil is wound around the permanent magnet, but does not touch it. The voice coil is attached to the cone of the speaker so that it causes the cone to vibrate as the AF current flow in the voice coil sets up magnetic fields which alternately oppose and reinforce the magnetic field of the permanent magnet. Under such conditions, the voice coil must be small and thus of low resistance. When the impedance of the voice coil is not known, an approximate impedance of 1.25 times the DC resistance can be used.

Impedance matching is achieved in the output transformer of the receiver. To see how it is worked out, follow the example below. Suppose a receiver with a 6V6 power amplifier is to be coupled with a 6-ohm voice coil. The recommended load impedance of a 6V6 (from a tube manual) is 5,000 ohms. The necessary turns ratio of the transformer can be determined by the formula,

$$\frac{N_p}{N_s} = \sqrt{\frac{Z_p}{Z_s}}$$

Substituting the figures,

$$\frac{N_p}{N_s} = \sqrt{\frac{5,000}{6}} = 28.8$$

For a 6V6 to be coupled to a 6-ohm voice coil, the output transformer should have a practical turns ratio of 29 1.

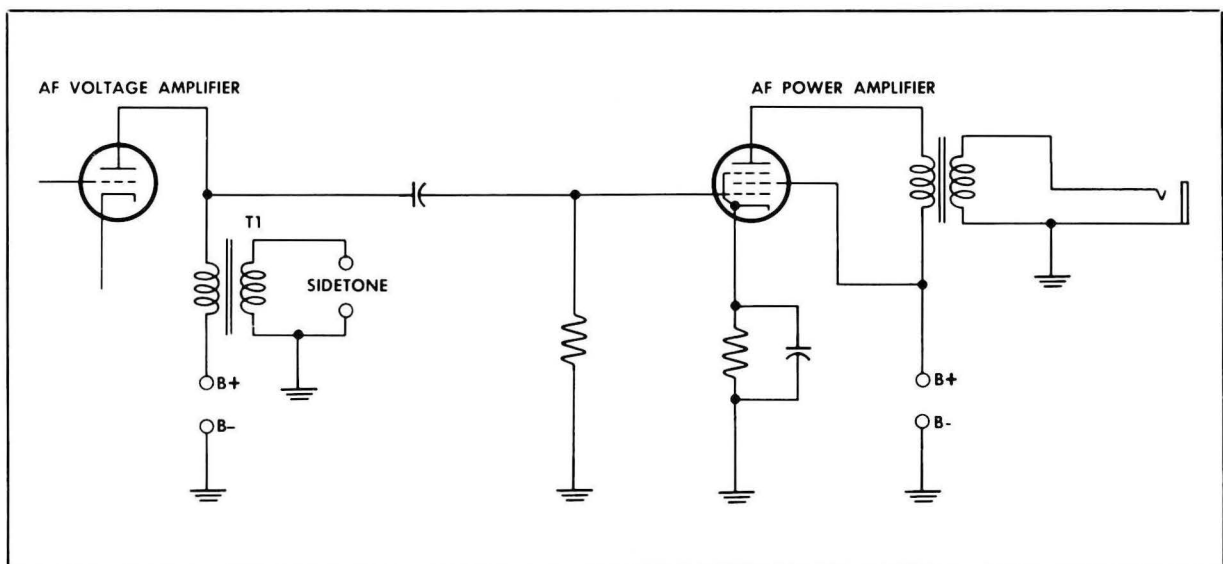

Coupling Sidetone to Receiver



To see how an arrangement can be worked out for using a speaker as well as headsets, look at the diagram AF Output Circuit. Notice that the secondary winding used for the speaker has few turns. The speaker winding leads are brought out to a terminal board. A separate, secondary winding of more turns provides for the use of local headsets and remote headsets as well.

An output transformer also helps increase the signal-to-noise ratio. Noise tends to be at the higher audio frequencies, and the impedance of the coils increases with frequency. However, this situation is often modified in order to establish a more constant load impedance over the entire AF range. This is done by placing a capacitor of about 0.003 mfd in parallel with the primary. Then, as the impedance of the coil rises with frequency, the impedance of the capacitor decreases. In the circuit diagram, a resistor is in series with the capacitor. The resistor decreases the  $Q$  of the circuit and flattens the response for more even handling of a broad band of audio signals.

#### Circuits for Auxiliary Use of Audio Section

Some communications receiver circuits are arranged to provide audio amplifier action

for accompanying equipment. For example, a transmitter's sidetone may be coupled to a receiver so that the operator can monitor his own transmissions. The receiver amplifies the sidetone and reproduces it in headsets or a speaker.

Notice the receiver circuit on page 60 for coupling a transmitter sidetone to headsets. The sidetone is coupled through transformer T1 to the plate circuit of the first AF amplifier. Then, depending on the position of the receive-send switch, the headsets will provide either transmitter monitoring or receiver reception.

Auxiliary equipment can be used with the receiver through a switching arrangement. As an example, see the below diagram of the phono jack at which an AF signal may be injected. When auxiliary equipment is connected to the receiver at the phono jack, the AF amplifier is disconnected from the detector. MVC then controls the signal strength of the auxiliary equipment.

#### COMMUNICATIONS RECEIVER POWER SUPPLIES

Communications receivers usually take advantage of an AC source of power whenever it is available. A power supply unit, often

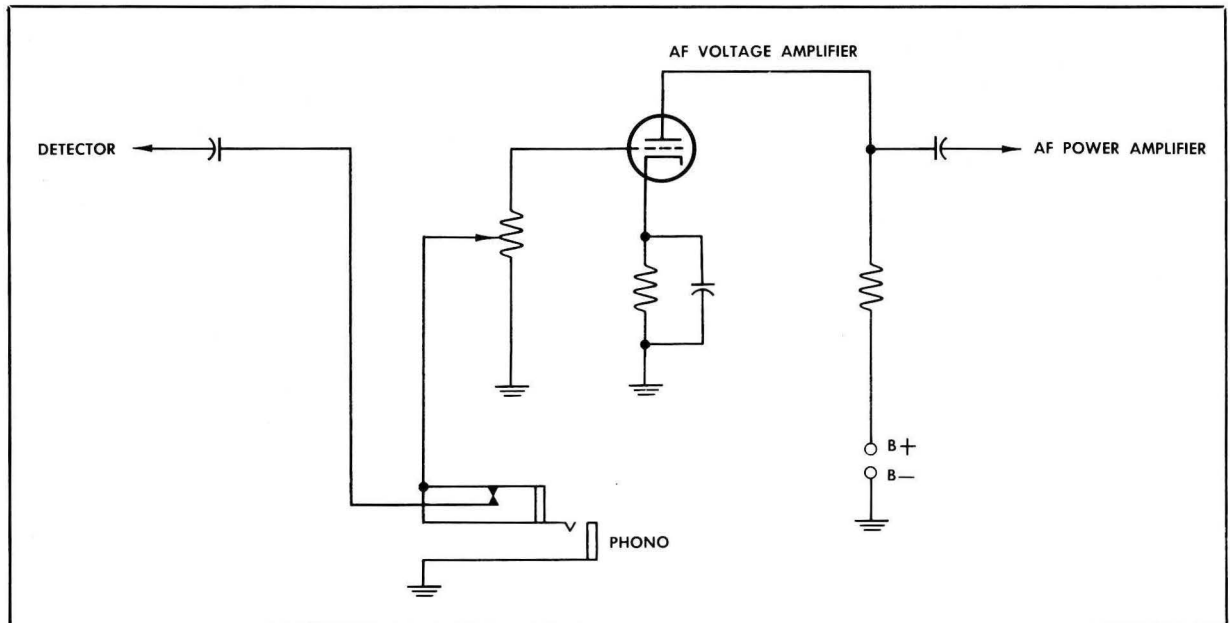

Using Receiver As Audio Amplifier

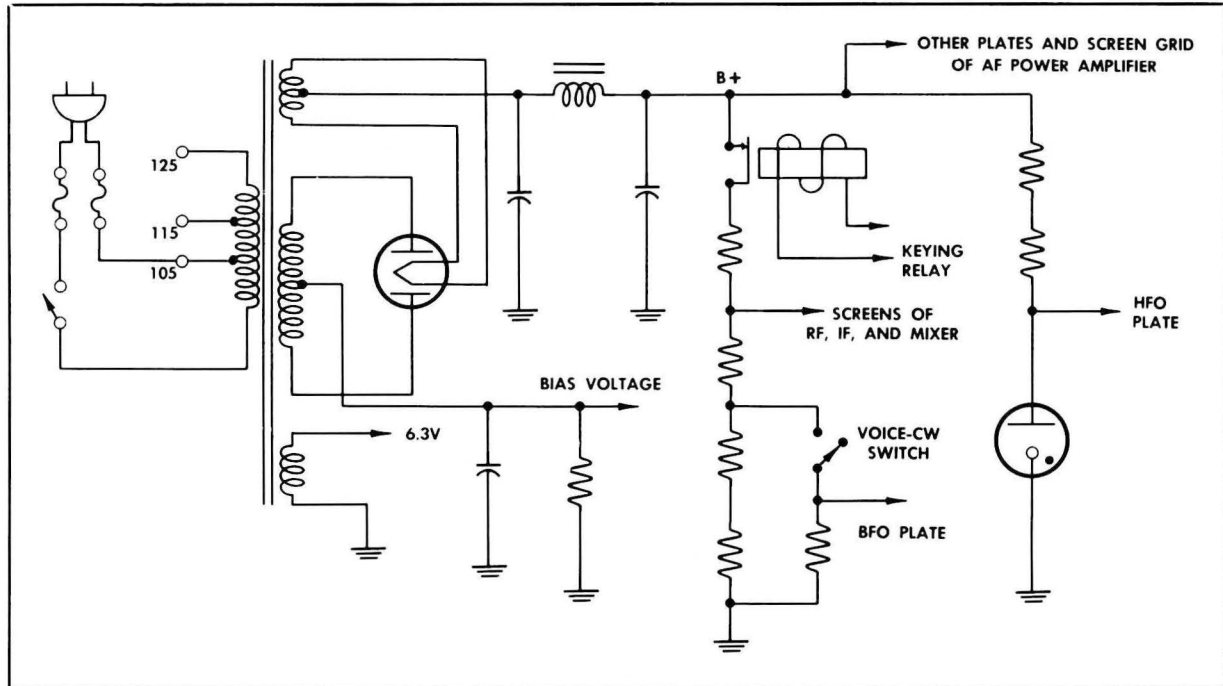

Typical Receiver AC Power Supply

a separate unit in communications receivers, applies the DC to the receiver. It steps the AC voltage up or down by transformer action when necessary, rectifies it, and filters it to provide correct DC potentials. However, for many communications receivers, particularly those used by the Air Force, an AC source is not available. Then, a DC source of power is used. Sometimes batteries alone are used. More often a battery-generator DC source is used. Dynamotors and vibrators are also employed to convert low voltage DC to high voltage DC.

Communications receivers operated where no commercial source of AC is available may be supplied with AC by gasoline-driven generator units. These units are started by batteries which, in turn, are charged by the generator while it is in action.

### AC Power Supplies

Examine the power supply circuit shown above. It has a relatively complex DC voltage distribution. It contains the typical full wave rectifier circuit, filter circuit, and voltage divider circuit. It also contains a voltage regulator circuit to provide stable plate volt-

age for the HFO. The voltage divider provides screen voltages for the RF, IF, and mixer tubes. The keying circuit opens the voltage divider circuit to remove these voltages when the transmitter is keyed.

### DC Power Supplies

**BATTERIES.** Portable receiver equipment operates directly from batteries. A heavier receiver may operate from batteries on an emergency basis. To see how the connections are made for a receiver that can be battery operated in an emergency, look at the diagram on page 63. The receiver has a terminal strip to which the battery cable can be connected. One 45-volt battery supplies bias voltage. Five 45-volt batteries in series provide a 225-volt supply. A lead taken from two of the batteries in series provides a 90-volt B+ supply. A 6-volt battery supplies filament voltage. Terminals 2 and 8 of the receiver terminal strip are connected so that the application of filament voltage as well as bias voltage can be controlled by the switch. Since the tubes draw no current until filament voltage has been applied, the application of B+ is not controlled by the switch.

**GENERATORS.** In aircraft, DC power is supplied mainly by engine-driven generators. By gear reduction, the high rpm of the engine is matched to the speed of the generator. Provision is made to supplement battery and generator with either outside or auxiliary sources of power during periods of radio operation or adjustment when the engines are not in operation. A battery cart is an example of an outside source.

When no outside source is available, it is necessary to use the auxiliary power unit consisting of a gasoline-driven DC generator. You can see the interrelation of battery, generator, auxiliary, and outside power units in the circuit diagram on page 64. The battery is of the lead-acid type, rated at 24V, 34 amp. The battery, or an outside power source, or an auxiliary source, can be used to operate the radio equipment or the starter. When the engines have started, the generator operates the radio equipment. It also charges

the battery. In large aircraft, more batteries are used. They are connected in parallel so that the voltage is the same, but the current capacity is the total of that of the individual batteries.

Notice the switches for such an arrangement in the diagram on page 65. There are three battery switches—a master battery switch and two other battery switches. There are also two battery relays. After the master battery switch has been thrown, either or both batteries may be used. Auxiliary and outside power sources may also be used. All buses are connected to the positive leads of the power sources. The negative leads of all power sources are grounded to the metallic framework of the aircraft, which serves as the negative return of all circuits. All electrically operated equipment is grounded, and all metallic parts of the aircraft are bonded together.

The generator unit, as shown in the dia-

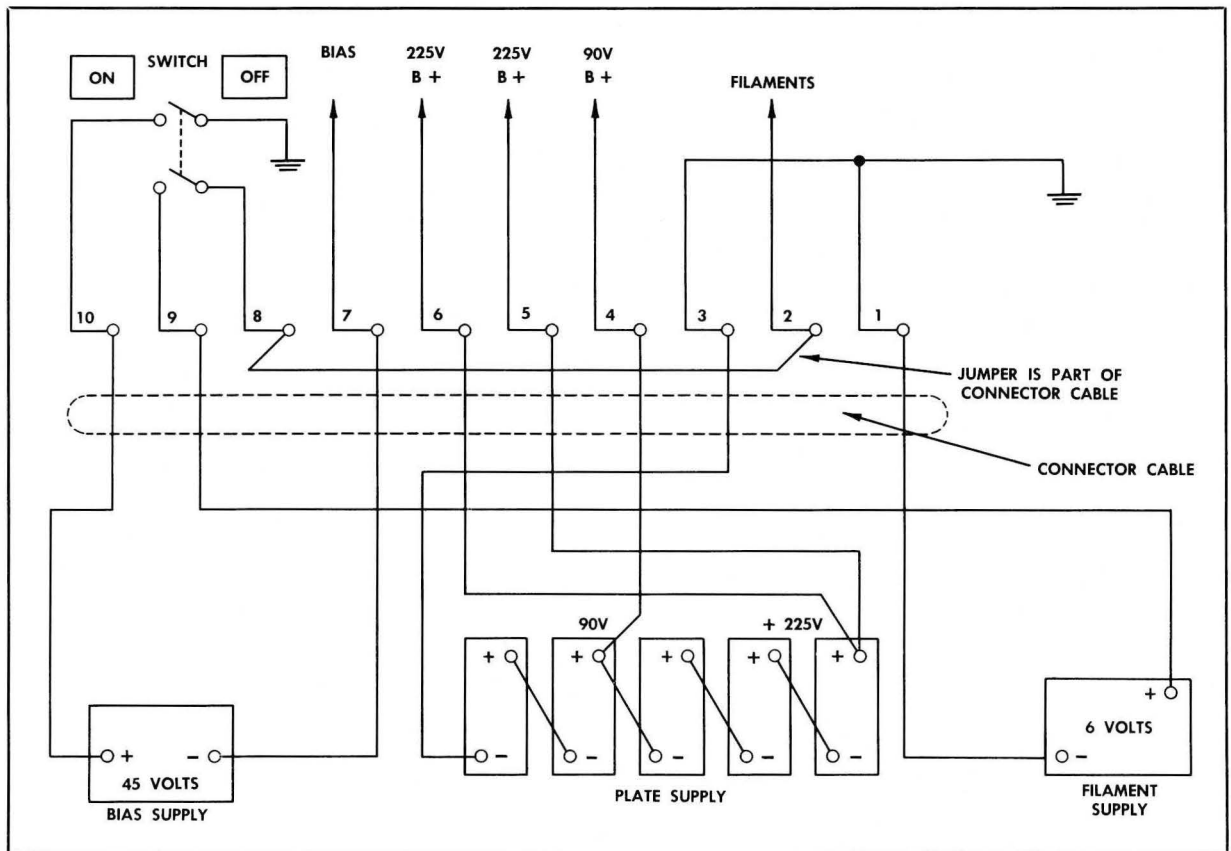

*Emergency Operation of a Receiver on Batteries*

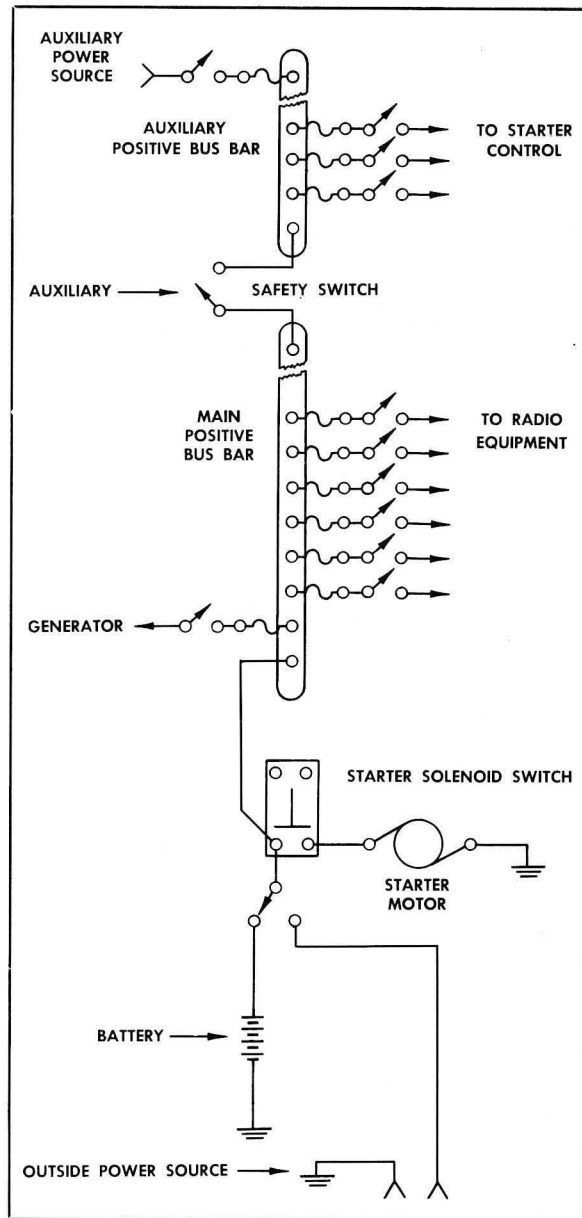

Aircraft Power Distribution System

gram on page 66, is governed by three electrical systems of control. There is a voltage regulator, a current limiter, and a reverse current cutout.

**Voltage Regulator.** Since most of the electrical circuits are designed to operate within a definite range of voltages, the voltage regulator is necessary to maintain a voltage within these limits. When the generator is not operating or when its voltage is quite

low, the springs, S1 and S2, hold the contact points, P1 and P2, closed. These closed contacts put the armature and the field directly in parallel with each other.

As the voltage of the generator rises, the current through winding V increases and its iron core becomes more strongly magnetized. When the voltage reaches a value greater than desired, the magnetic attraction for the movable arm becomes strong enough to overcome the spring tension with the result that contact points P1 are separated. When this happens, the field current must flow through the reverse winding W and resistor R1. Because of the resistance which this adds to the field circuit, the current in the field decreases. The magnetic field of the generator is therefore weakened and the generator output voltage decreases.

The reverse winding W, which is connected in series with the field current resistor R1, is wound on the core in the reverse of the direction of the main voltage winding V. The purpose of the reverse winding is to speed up the operation of the contact points P1. When the generated voltage becomes sufficiently high to cause coil V to open the contact points, the current which then flows through W and R1 tends to demagnetize the core. Therefore, the contact points close much more quickly than they would if coil W were not used. The increased frequency of vibration (chatter) of the points results in a steadier terminal voltage. The difference between the peak and minimum values of voltage during each cycle of contact vibration is considerably reduced. The normal voltage output from the generator is 28 volts.

**Current Limiter.** The current limiter shown in the circuit diagram is also of the vibrator type. The current limiter is designed so that it automatically keeps the current drain from the generator within safe operating limits. If the generator were not protected in this way, the current drain might become so heavy that the generator would burn out.

Nearly all current which flows in the generator circuit flows through coil X. Spring S2 normally holds contact points P2 together. However, when the current through coil X

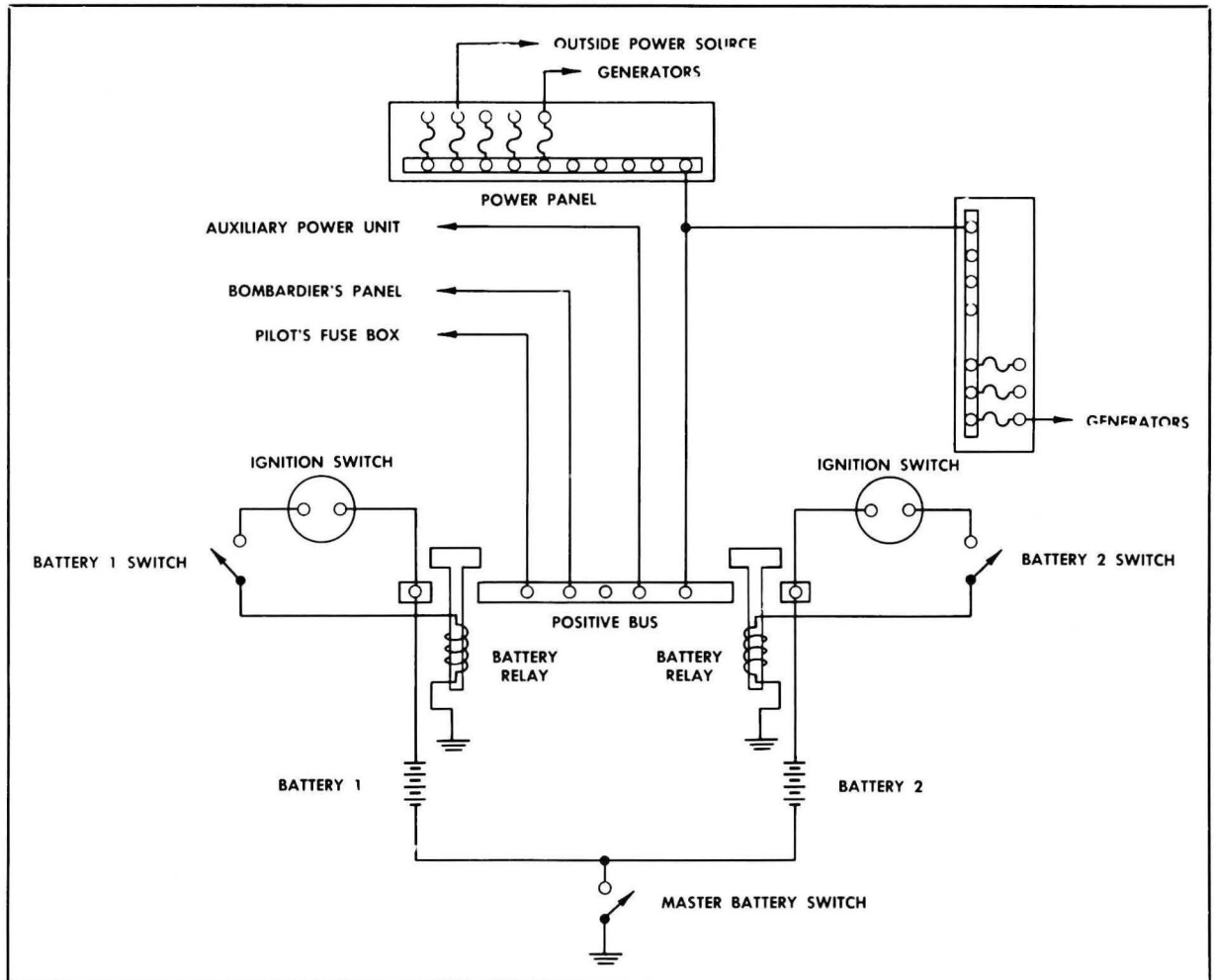

Connection of Batteries to Power Distribution System

becomes excessive, its iron core magnetizes to the extent that its magnetic pull on the movable arm overcomes the tension of the spring and opens contact points P2. This inserts the resistor R2 into the field circuit of the generator. This, in turn, decreases the field current and the strength of the magnetic field, and causes the generated voltage to drop. This will normally bring the generator current down to a safe value, and S2 will cause points P2 to close again. Thus, when the generator circuit is delivering large amounts of current, the current limiter will chatter in order to protect the generator.

*Reverse Current Cutout.* The purpose of the reverse current cutout relay is to connect the generator system to the aircraft elec-

trical system whenever the generator voltage is greater than the voltage of the aircraft battery and to disconnect the generator from the aircraft battery when generator voltage is less than the battery voltage. This is necessary in order to prevent current flow from the battery into the generator system. When the generator is not operating, or when its voltage output is below normal battery voltage, spring S3 holds contacts P3 open. As generator voltage increases, current through winding Z builds up a magnetic field which causes contacts P3 to close. Then generator current may flow through the aircraft electrical system, P3, and coil Y. The generator current flowing through Y develops a magnetic field which

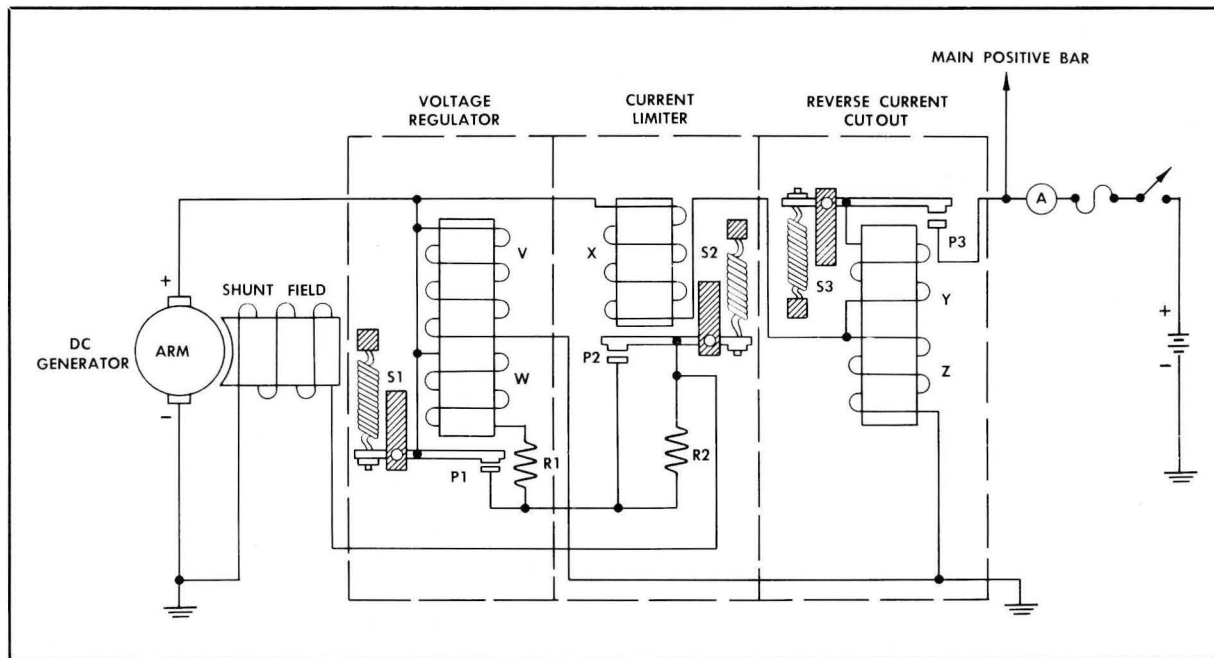

Typical Aircraft Generator Control System

aids the field created by current through winding Z. Therefore, contacts P3 are held firmly closed so long as current through Y continues in this direction. However, if the generator voltage were to decrease below battery voltage, the current flowing through Y would reverse its direction so that the magnetic fields developed in coils Y and Z would oppose and cancel each other. As a result, the armature holding one of the contacts, P3, would be released, spring S3 would open the contacts, and battery current would no longer flow through the generator system. The contacts would remain open until generator voltage again reached the voltage necessary to build up a magnetic field which would overcome the spring tension of S3. This spring tension is adjusted so that it will not be overcome by the pull of the magnetic field until the voltage across coil Z exceeds a certain value—usually a value slightly higher than the normal voltage of the battery.

During flight, the aircraft battery-generator system provides the airborne radio equipment with a 28-volt DC supply. Some equipment may operate directly from this supply, using tubes which require slightly less than 28 volts for B+.

However, most airborne equipment needs voltages in excess of 28 volts. A dynamotor provides one means of using the 28 volts provided by the generator to produce higher DC voltages. Some voltage outputs for typical dynamotors are 220 volts, 400 volts, and 750 volts. The efficiency of a dynamotor is low, frequently less than 40%.

A vibrator power supply can also be used to step up generator-battery voltage. Look at the two vibrator circuit diagrams shown on page 67. At A, the circuit is that of a non-synchronous vibrator. When the battery switch is closed, current flows through the magnet coil L1 and up through the lower half of the primary coil. The magnetic pull draws the reed down until it reaches the lower contact. When it touches the lower contact, the reed shorts electromagnet L1 which then loses its attraction. The reed then swings up to the upper contact, causing the current to flow down through the upper portion of the primary. But now, with L1 no longer shorted out, current again flows through L1 and up through the lower portion of the primary. Again the reed is attracted down to the lower contact. With the reed no longer in contact with the upper contact

point, current ceases to flow in upper portion of the primary. The process is repeated over and over again, and the reed vibrates continuously as long as battery voltage is applied.

Transformer action takes place as the secondary is cut by expanding and collapsing magnetic fields developed by the primary. The collapsing and expanding primary field induces an AC voltage in the secondary. Capacitor C2 across the secondary (called a buffer) absorbs the voltage surges caused by the very sudden collapsing and expanding of the primary field. Thus C2 smoothes out the secondary response. This resultant AC voltage is rectified by an electron tube rectifier.

The circuit at B illustrates a synchronous vibrator. It has a double set of upper and lower contact points. One pair of contacts is connected to the secondary and rectifies the secondary voltage. Thus, an electron tube rectifier is not needed. As the reed vibrates, first the top and then the bottom of the

secondary is grounded. This means that the secondary current flows to the centertap of the secondary to ground, first up through the upper section of the secondary, then through the lower section. This action is synchronized with the collapse and expansion of the primary field. Here again, capacitor C2 acts as a buffer. L2 and C1, and L3 and C3, in their respective circuits, form RF filters to eliminate high frequency interference caused by sparking of the reed with the contact points.

### OPERATION AND ANALYSIS OF TYPICAL COMMUNICATIONS RECEIVERS

Now that you've covered the special circuits of communications receivers, it is time for an overall look at complete circuits. For this purpose, the circuits of two actual Air Force receivers have been chosen. Naturally they will probably become outmoded. Still, the basic principles involved will undoubtedly be carried over in the receivers that replace them.

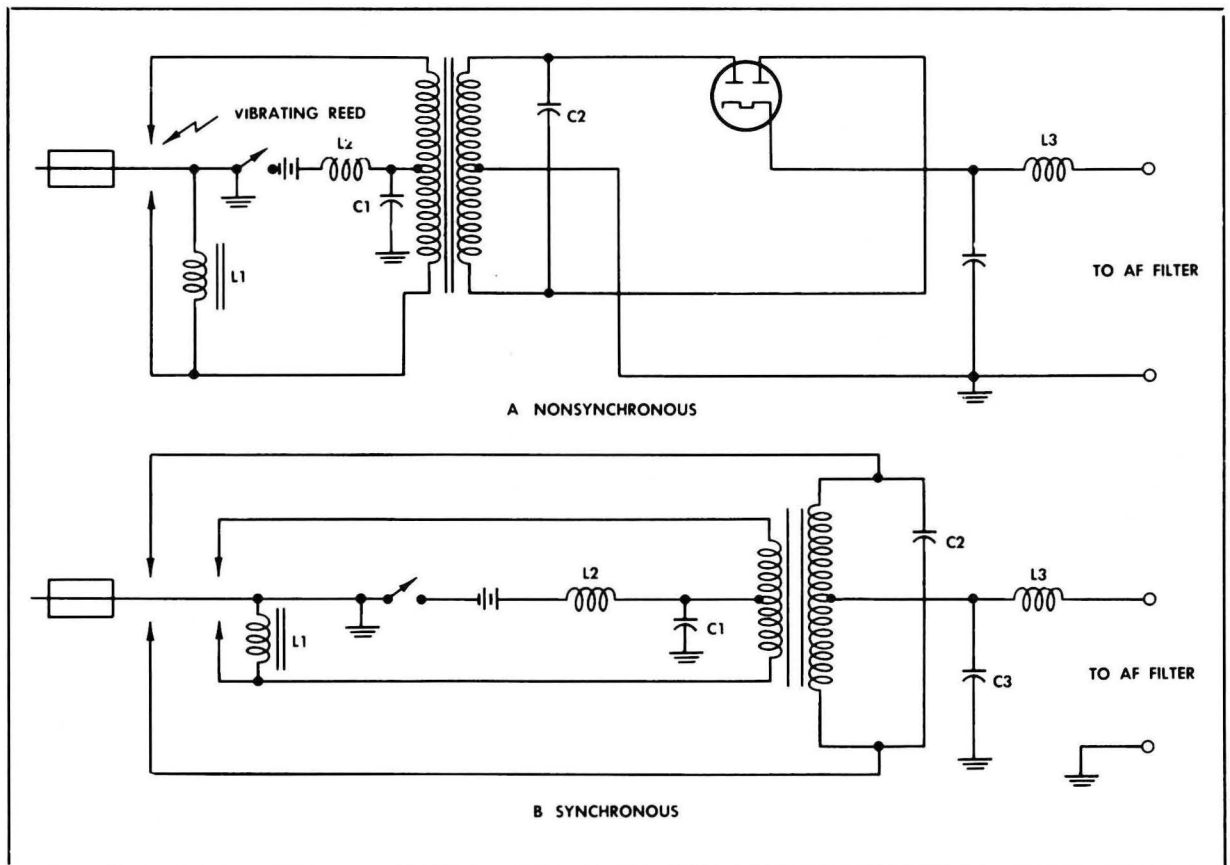

Vibrator Circuits

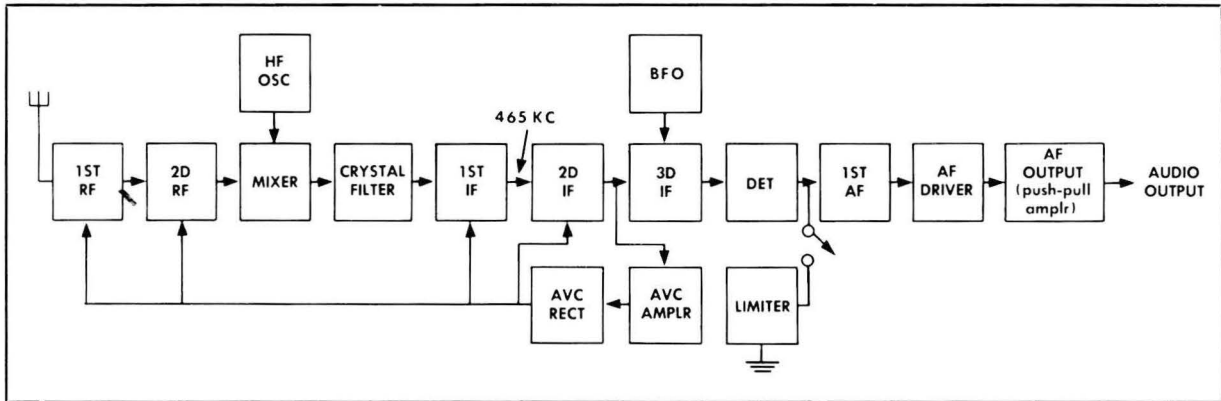

Receiver BC-779, Block Diagram

**Air Force Receiver BC-779**

The first of these receivers is a commercial unit. The Air Force designation is BC-779. The receiver is for ground installations.

Notice in the block diagram of the receiver above that it has two RF stages, three IF stages, and three AF stages. It has a separate channel AVC system. It uses a

limiter stage but no squelch circuit. A separate power supply unit is necessary. The receiver is available in different frequency ranges, but all models use the same basic circuit.

Looking at the control panel below, notice first the five-position bandswitch. This permits selection of any one of five different frequency ranges. The switch also operates

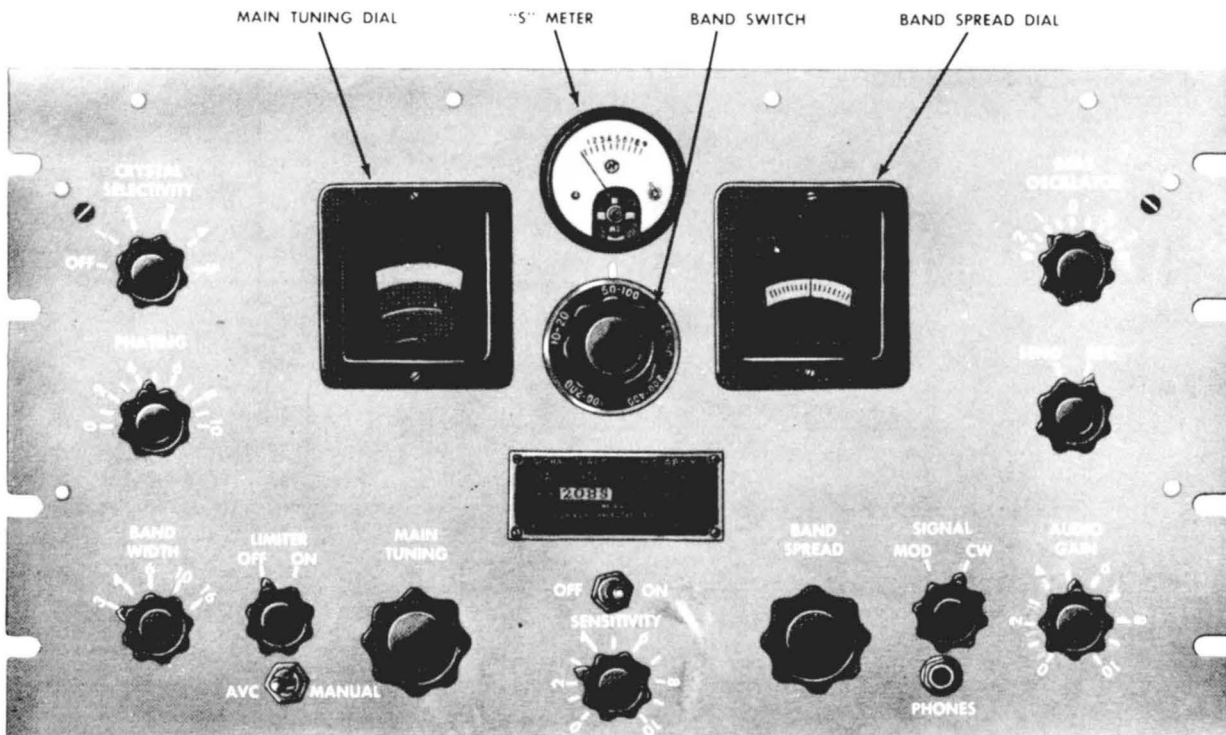

Receiver BC-779, Front View



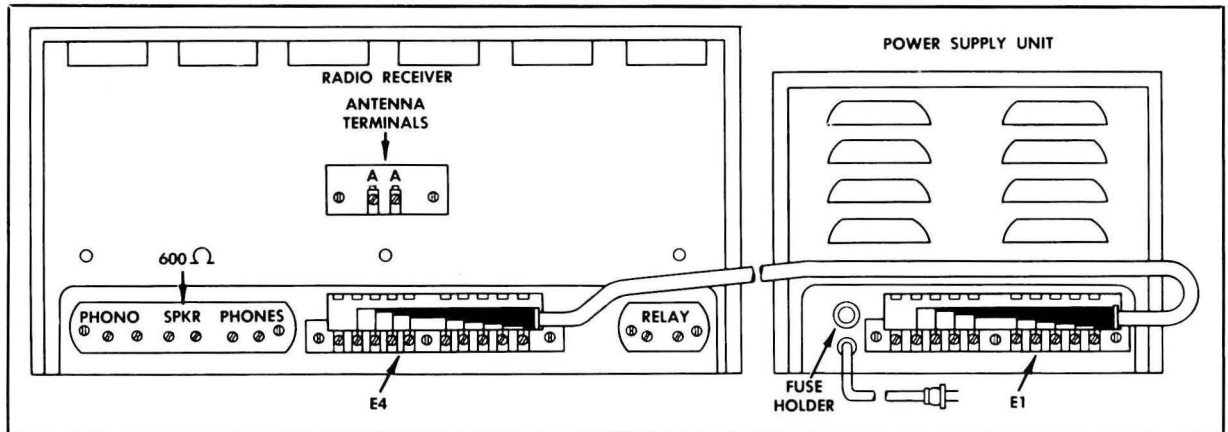

Receiver BC-779 and Power Unit RA-94, Rear View

a masking plate over the main tuning dial in order to expose only the calibration scale of the particular band selected.

The main tuning dial turns with the control beneath it. It is used to tune the receiver within the range of the band selected. The dial is illuminated from the rear.

The bandspread dial and the control beneath it are operated in conjunction with the tuning dial. The bandspread dial has a scale reading from 0 to 100. It is used to get fine tuning over a narrow band of frequencies.

The S-meter may be used when the receiver is operating on AVC. It can be used to log the strength of a received signal or to tune in a signal. It shows the greatest deflection when a signal is correctly tuned. The meter circuit is adjusted at the factory so that a change of one number on the calibration indicates a change in signal strength of approximately two to one.

The CRYSTAL SELECTIVITY control provides five degrees of crystal selectivity by varying the Q of the crystal filter circuit.

The PHASING control is used in conjunction with the crystal filter. With this control, the rejection notch in the crystal filter response can be moved in order to eliminate reception of image frequencies.

The BANDWIDTH control adjusts the bandwidth of the IF by changing the coupling of the IF transformers. Minimum bandwidth occurs at position 3, and clockwise rotation increases the bandwidth.

The LIMITER switch is an on-off switch which permits use of the limiter as desired. When the noise level is low, the limiter can be shut off.

The AVC-MANUAL switch permits disconnection of the AVC. Then manual gain control is available through the sensitivity control. In either position, the audio gain control can be used to vary the audio output.

The SIGNAL control permits a choice between modulated or CW reception. The BFO is turned on when the control is in CW position.

The BEAT OSCILLATOR control adjusts the frequency of the beat oscillator by varying a capacitor in the oscillator tuned circuit. Adjusting the oscillator varies the pitch of the audio tone signal.

The SEND-REC control can be operated when the receiver is used with an associated transmitter. In the SEND position, the receiver is silenced, though ready for instant use when the control is moved to the REC position.

The phone jack provides for connection of a headset to the receiver output. This jack is in parallel with the phone lugs on the terminal strip at the rear of the receiver.

Now look at the drawing of the rear of the receiver and power supply above. On the same terminal strip as the phone connections are the speaker connections and the phono connections. The phono terminals provide a means of using the audio section of the

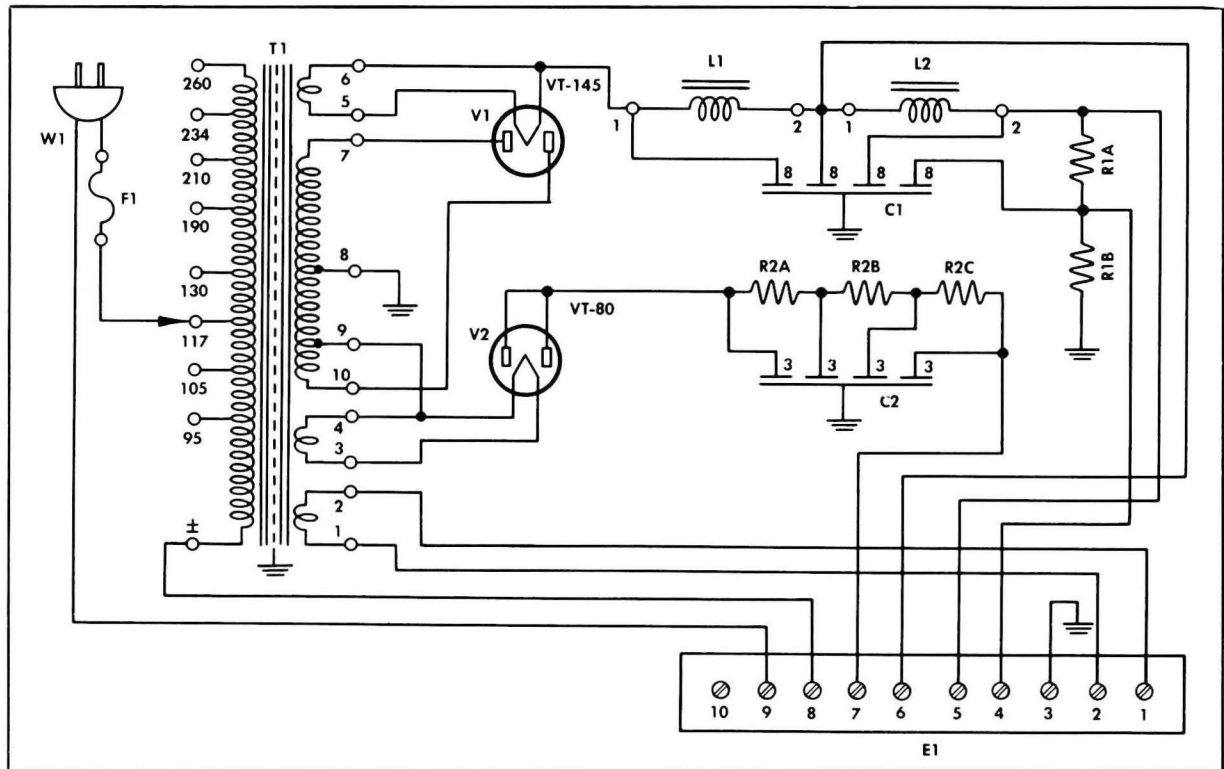

Power Unit RA-94C

receiver as an audio amplifier. Other terminal strips provide connections for the power cable, the antenna, and a relay to disconnect the receiver automatically during transmissions.

The overall schematic diagram shows the complete receiver circuit. The circuits for band switching are shown at the lower left. There are five sets of ganged input and output tuned circuits for the three RF amplifier stages and the high frequency oscillator. Each set of tuned circuits provides for one frequency band. The selection of the proper band is controlled by ganged switches, SW1A to SW1E.

Conversion is accomplished through a pentagrid mixer and separate oscillator.

A crystal filter is used between the mixer and the first IF amplifier. C32 is the variable phasing capacitor which counteracts the capacitance of the crystal holder. It can be varied to move the rejection notch in the crystal filter response curve. Crystal selectivity is controlled by SW7, a ganged switch which provides five degrees of selectivity.

In the OFF position, the crystal is shorted. On position 1 the crystal filter is placed in the circuit. On each of the other four positions additional resistance is introduced into the crystal filter output parallel tuned circuit. Thus, in each position more and more resistance is placed in series with the filter (the parallel tuned circuit is purely resistive), and the  $Q$  of the filter decreases. The selectivity of the crystal filter circuit increases.

The bandwidth of the IF bandpass is controlled by ganged regulation of the amount of coupling in T2 and T3, the IF transformers.

The AVC has its own amplifier, operating with part of the output of the second IF amplifier. Plate current of the AVC rectifier flows through the S-meter when the AVC-MANUAL switch is in the AVC position.

The output of the BFO, a beat frequency, is injected into the plate circuit of the third IF amplifier. This means that the AVC voltage has already been coupled to an AVC amplifier and cannot be affected by the BFO. To insure that there is no stray coupling between os-

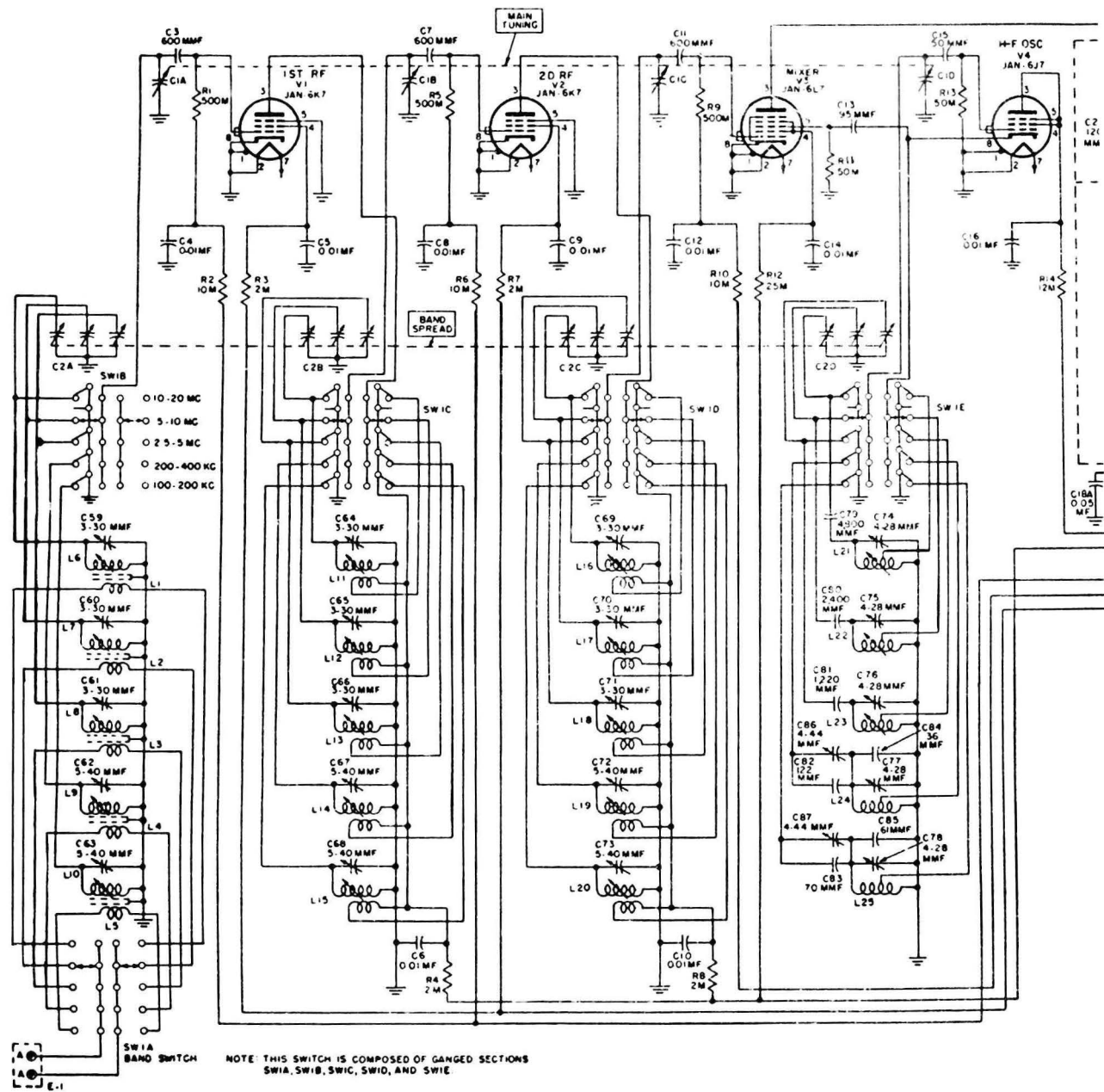

Schematic Diagram, Receiver BC-779-A, B

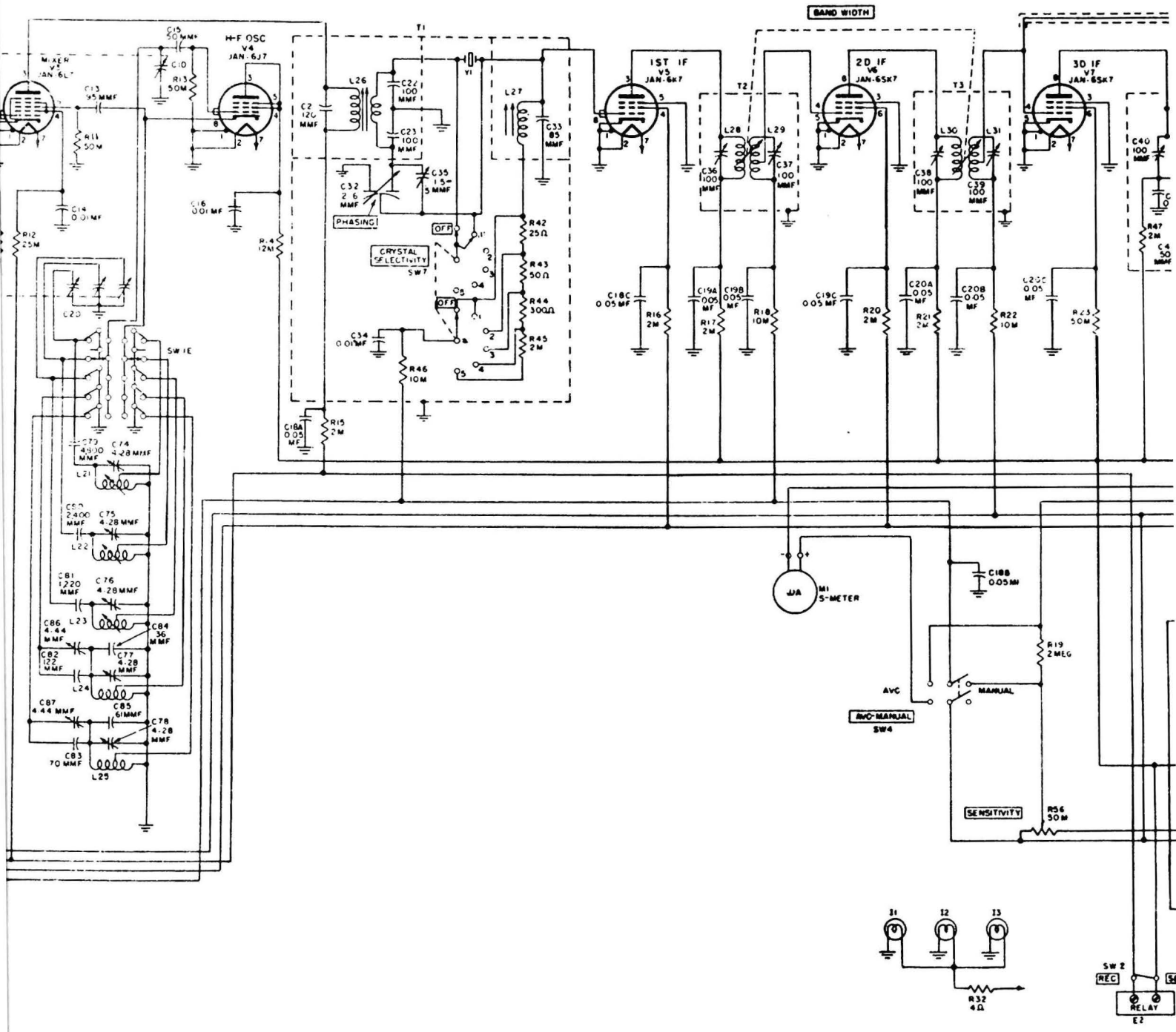

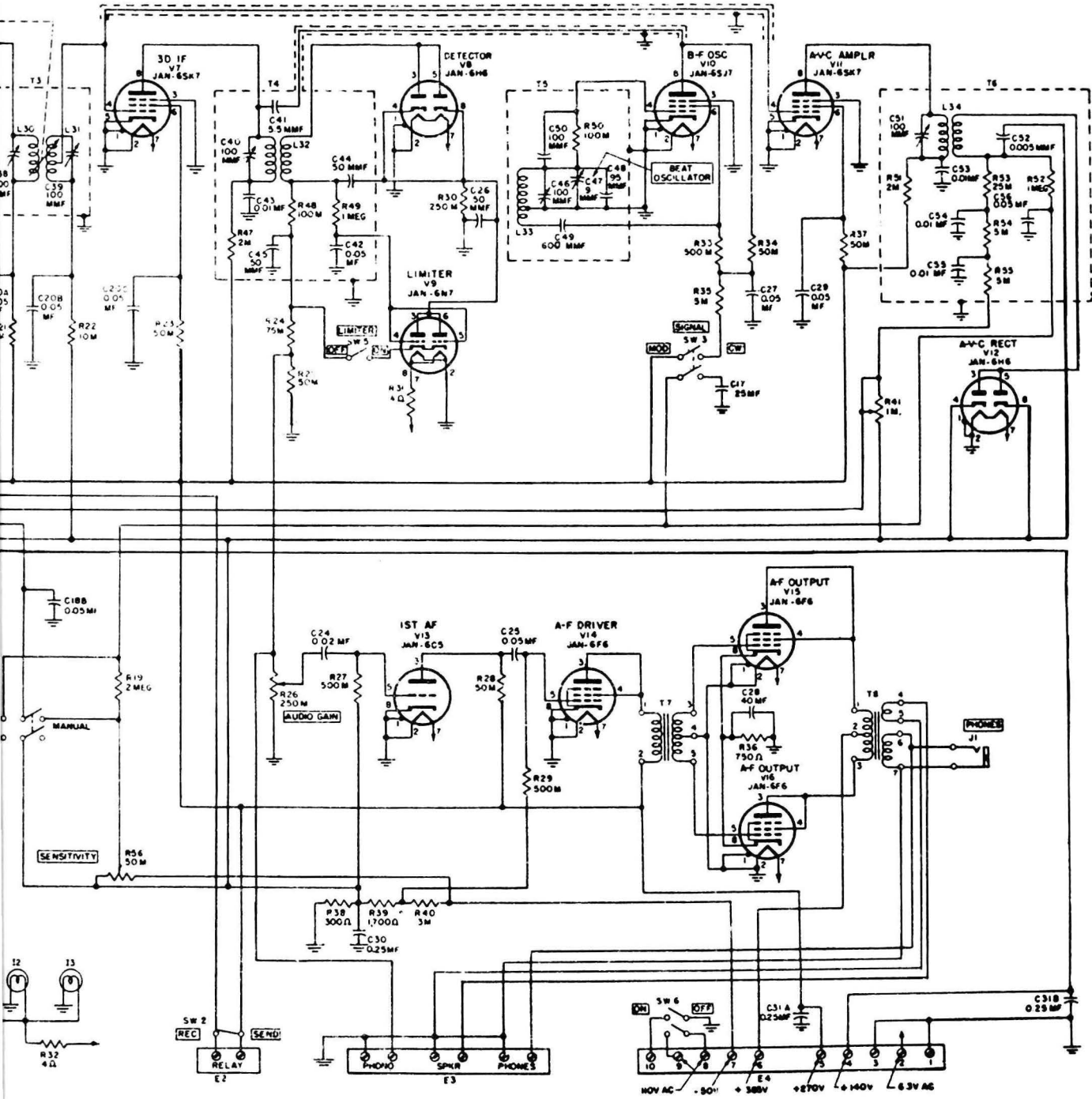

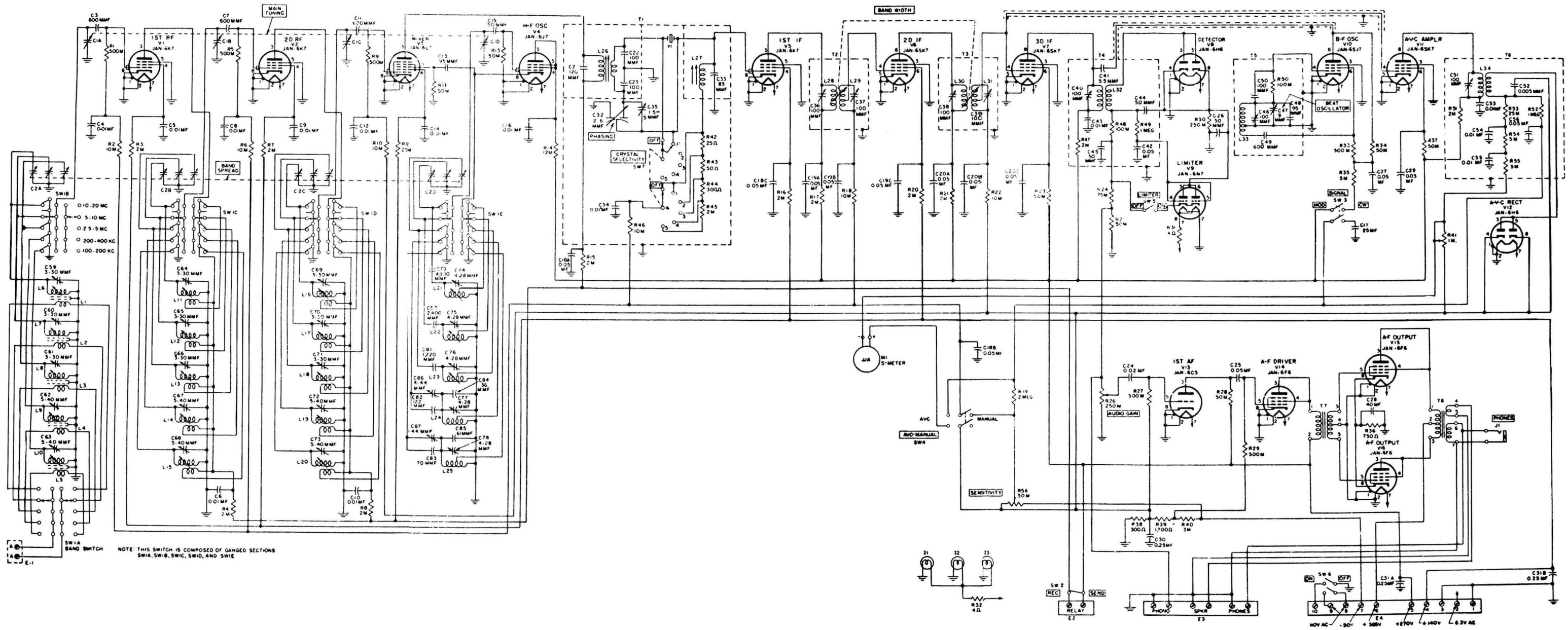

Schematic Diagram, Receiver BC-779-A, B

cillator and AVC, the output lead of the BFO and the input lead of the AVC amplifier are shielded.

When the limiter on-off switch is ON, the limiter operates on the detector output. The limiter tube is a twin triode operated as a single triode. Grid and cathode voltages are taken from the negative voltage divider system of the detector output. Bias is self-adjusting, and, with a normal signal, the limiter is cut off. However, the time constants of grid and cathode circuits are such that a sudden negative voltage of high amplitude (noise) drives the cathode negative faster than the grid. The limiter conducts for the duration of the noise pulse. Since its cathode is connected to the detector output voltage divider, the limiter shorts the signal when it conducts.

The audio section uses two voltage amplifiers. The output of the second AF amplifier (the driver) is transformer-coupled to a push-pull power amplifier stage. The power amplifier, in turn, is transformer-coupled to headsets and speaker. The secondary of this transformer consists of a high impedance winding for headsets and a low impedance winding for the speaker.

The power supply unit used with this receiver bears the designation RA-94-C. It is usually mounted under the receiver. Look at its circuit diagram on page 76. It consists of a full wave rectifier (VT-145) with an output filter and voltage divider to supply plate and screen voltages; a half wave rectifier (VT-80) with a resistance-capacitance filter to supply negative bias voltage, and a secondary winding to supply AC heater voltage.

#### Air Force Receiver BC-348(\*)

This receiver has the usual stages of a communications receiver, as you can see in the diagram at the right. The BFO is combined with the second IF in a single stage with a single tube for both circuits. Another single tube combines the third IF, detector, and AVC circuits.

Notice the bench installation of the receiver on page 78. Here, the receiver is associated with an autotune transmitter shown at the

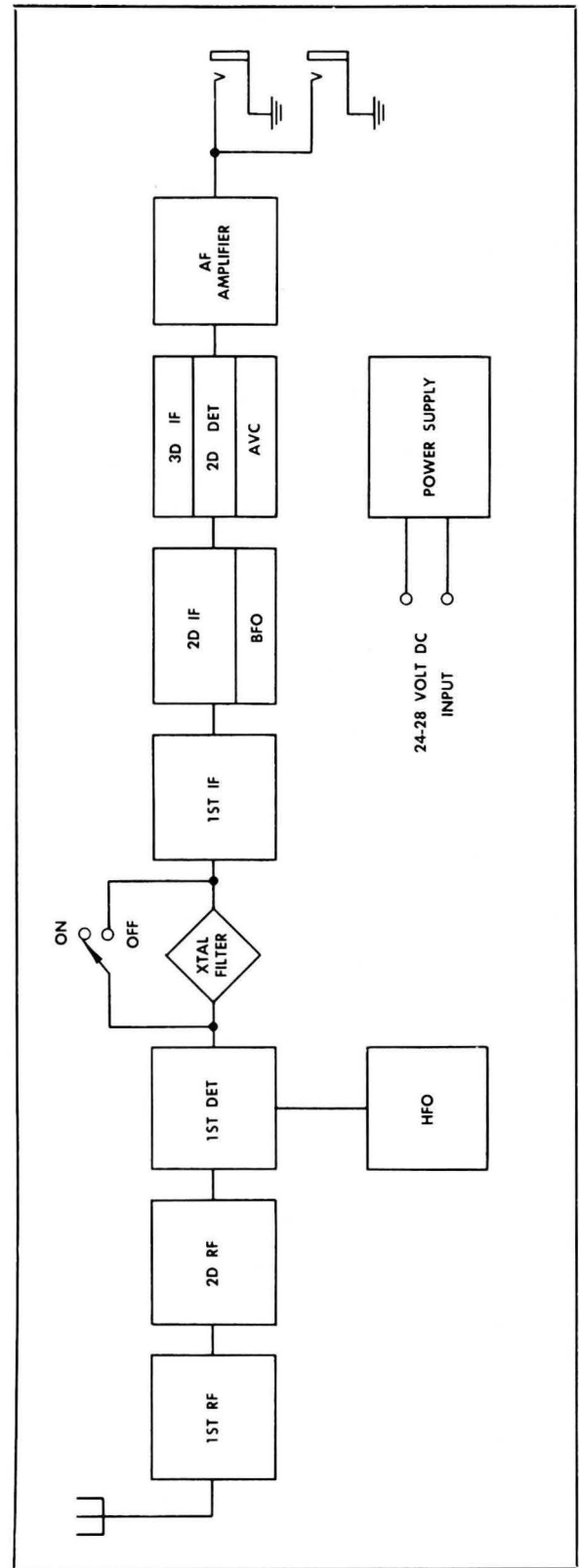

Receiver BC-348(\*)

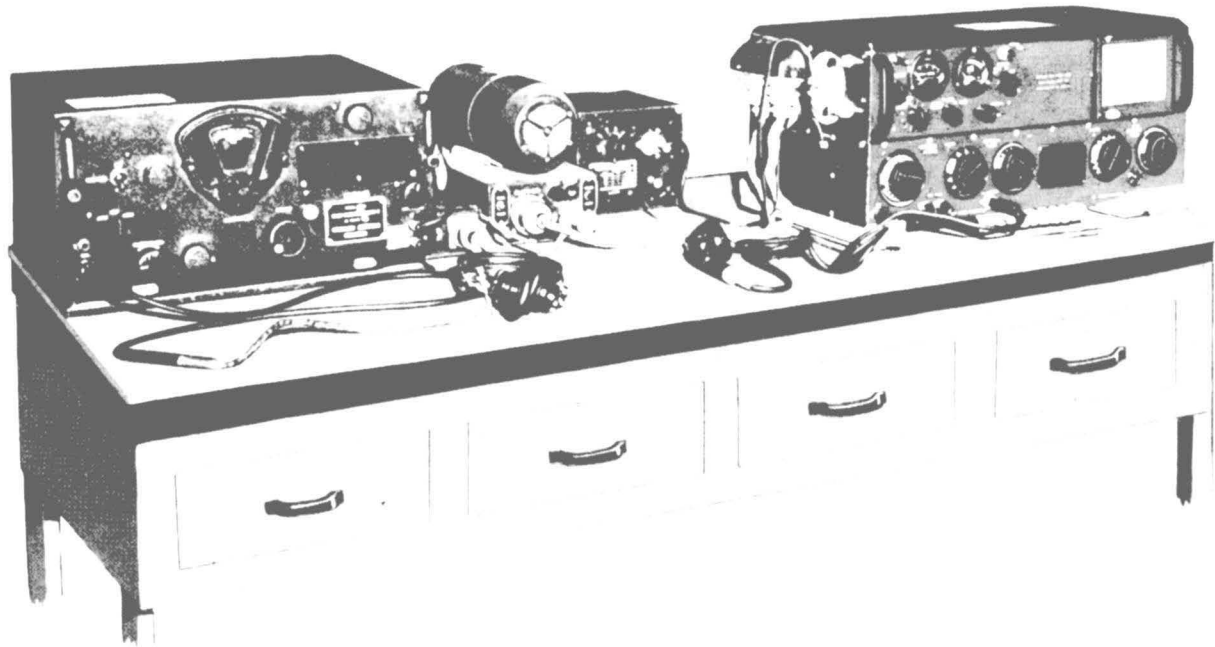

*Bench Installation of Receiver BC-348*

right. The main tuning dial is at the upper center of the central panel. The bandswitch control is at the bottom of the dial mounting, and the control is below and to the right. The dial lights control, at the top right, regulates the intensity of the light behind the dial. It is provided with an off position. At the lower right are the antenna and ground terminals, marked A and G. The control directly above is for alignment of the receiver input circuit with the antenna.

At the left hand side of the control panel is a toggle switch to provide use of the BFO. Beside it is the crystal control, used for connecting the crystal filter for CW selectivity. Below the toggle switch is a three-position switch which turns the receiver on by selecting either AVC or MVC. Beside this three-position switch is the volume control. On either AVC or MVC, it can be adjusted to regulate the output. On AVC, the volume control provides manual volume control to regulate the output level. On MVC, the volume control provides manual gain control. At the side of the volume control is the BFO control used to regulate the frequency of the beat oscillator. Two head-

set jacks marked TEL, provide for connection of two headsets.

The dynamotor in the center of the photo provides power for the transmitter. The receiver dynamotor is housed in the receiver unit, as shown in the illustration of the receiver on page 79. In the upper right hand corner are three shielded compartments each containing six RF tuning coils for the six tuning bands. The fourth compartment houses the HFO and its tuning coils. In the lower left hand corner are the shielded IF transformers. The gear arrangement for the band change mechanism can be seen in the center. Behind the gears is a shielded compartment containing the audio output transformer and the audio choke for the power supply filter.

The overall circuit diagram shows the tube sequence from left to right in the top row and from right to left in the bottom row. The band change switch is represented by the components marked 130, 131, 132, 133B, 133A, 134, 135B, 135A, 136, 137, 138, and 139. In the diagram, the switch is in the lowest frequency band position. The ganged tuning



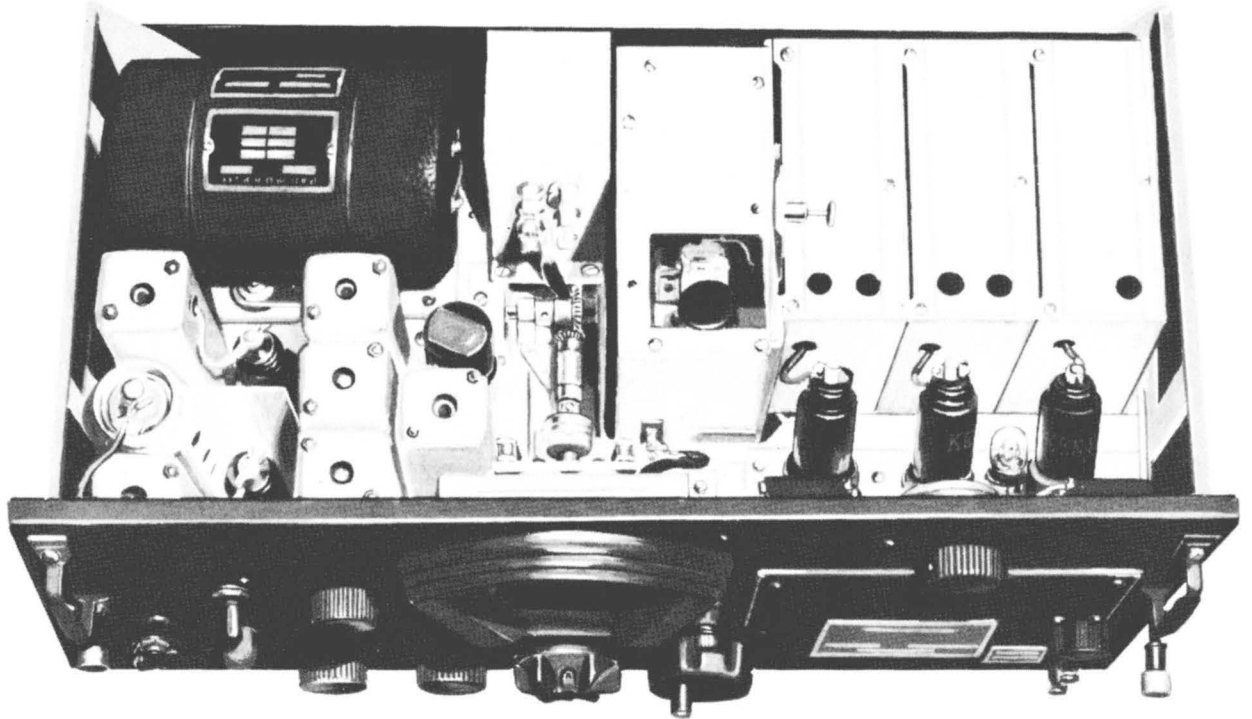

*Receiver BC-348 Top View, Removed from Cabinet*

capacitors are numbered 1-A, 1-B, 1-C, and 1-D. The voltage regulator circuit, at the right end of the second row of tubes, regulates the high voltage supply of all the tubes. The second IF amplifier uses a multielement tube which also serves as the BFO tube. Another multielement tube serves as both the third IF amplifier and the detector-AVC tube. Thus,

the number of tubes is held to the minimum necessary for effective operation. This is in line with a general policy of keeping airborne equipment as light and as compact as is practicable. Note that there is no noise limiter or squelch circuit. Note, too, that the delayed AVC circuit follows the point where the BFO voltage is introduced.

Some of the symbols in the schematic diagram on page 81 are obsolete. However, they will still be found in some technical orders. The symbols that do not correspond with symbols elsewhere in this manual include those for tubes, fixed and variable capacitors, and permeability-tuned coils.

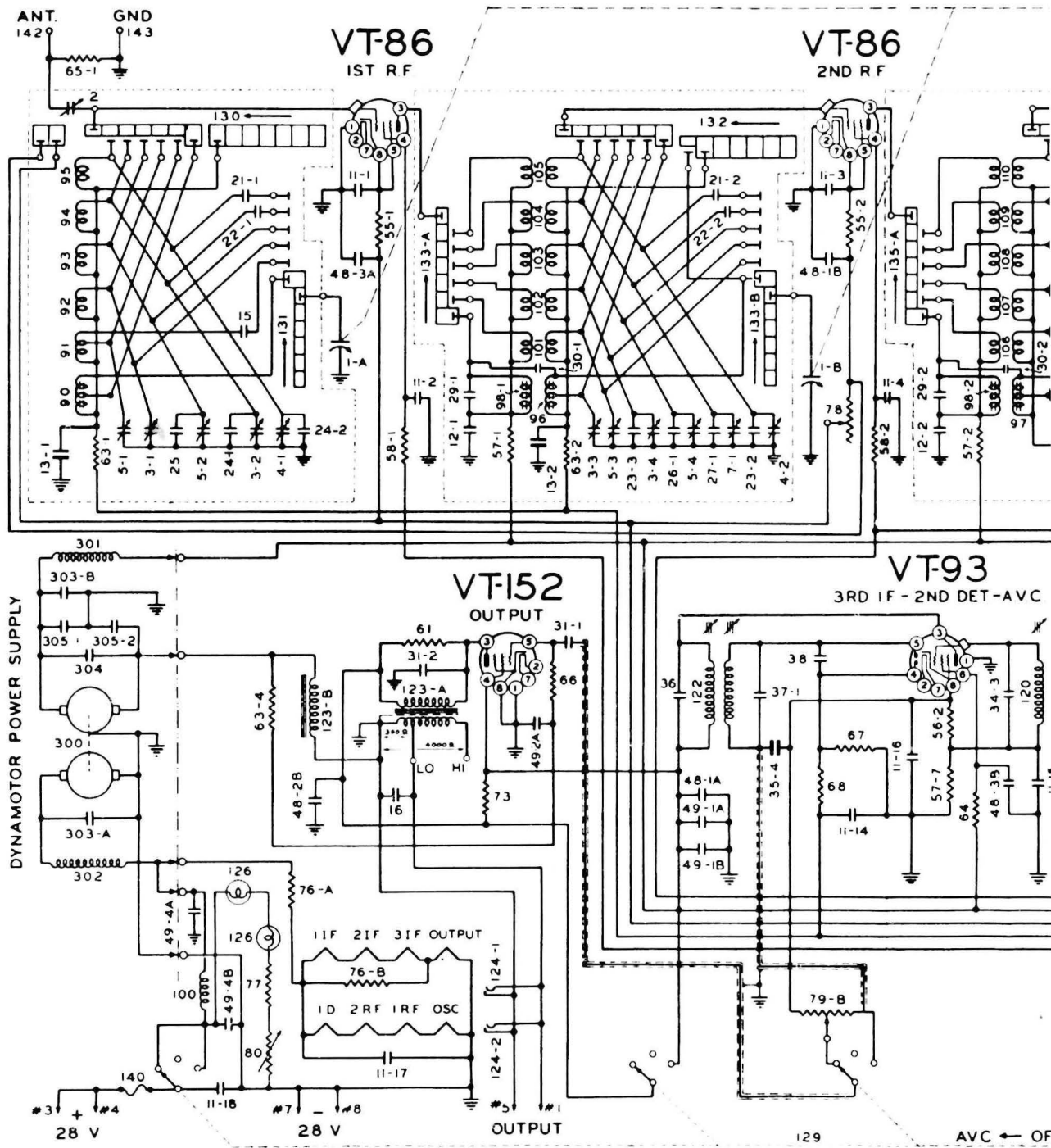

Schematic Diagram, Receiver BC-348 AL

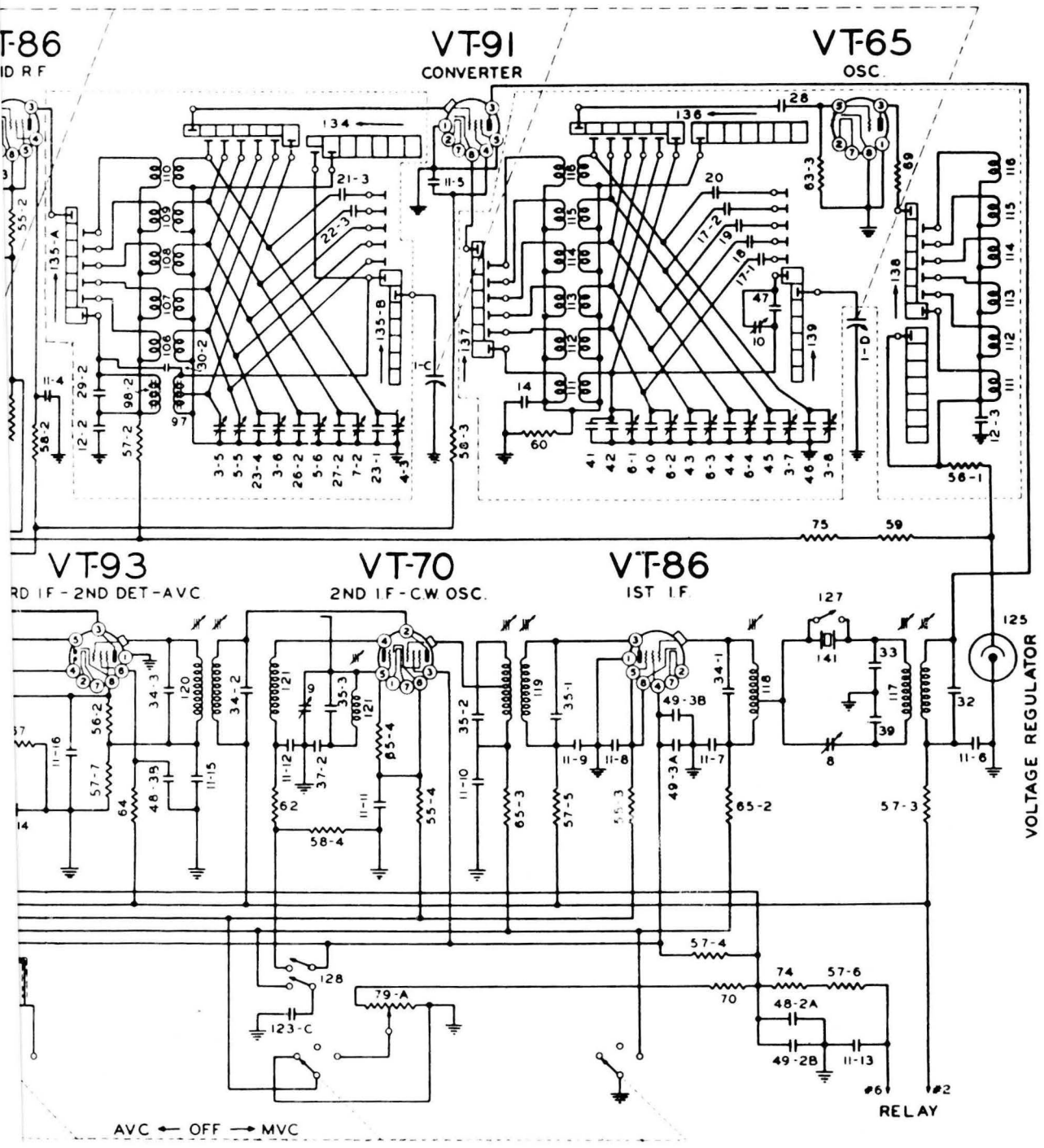

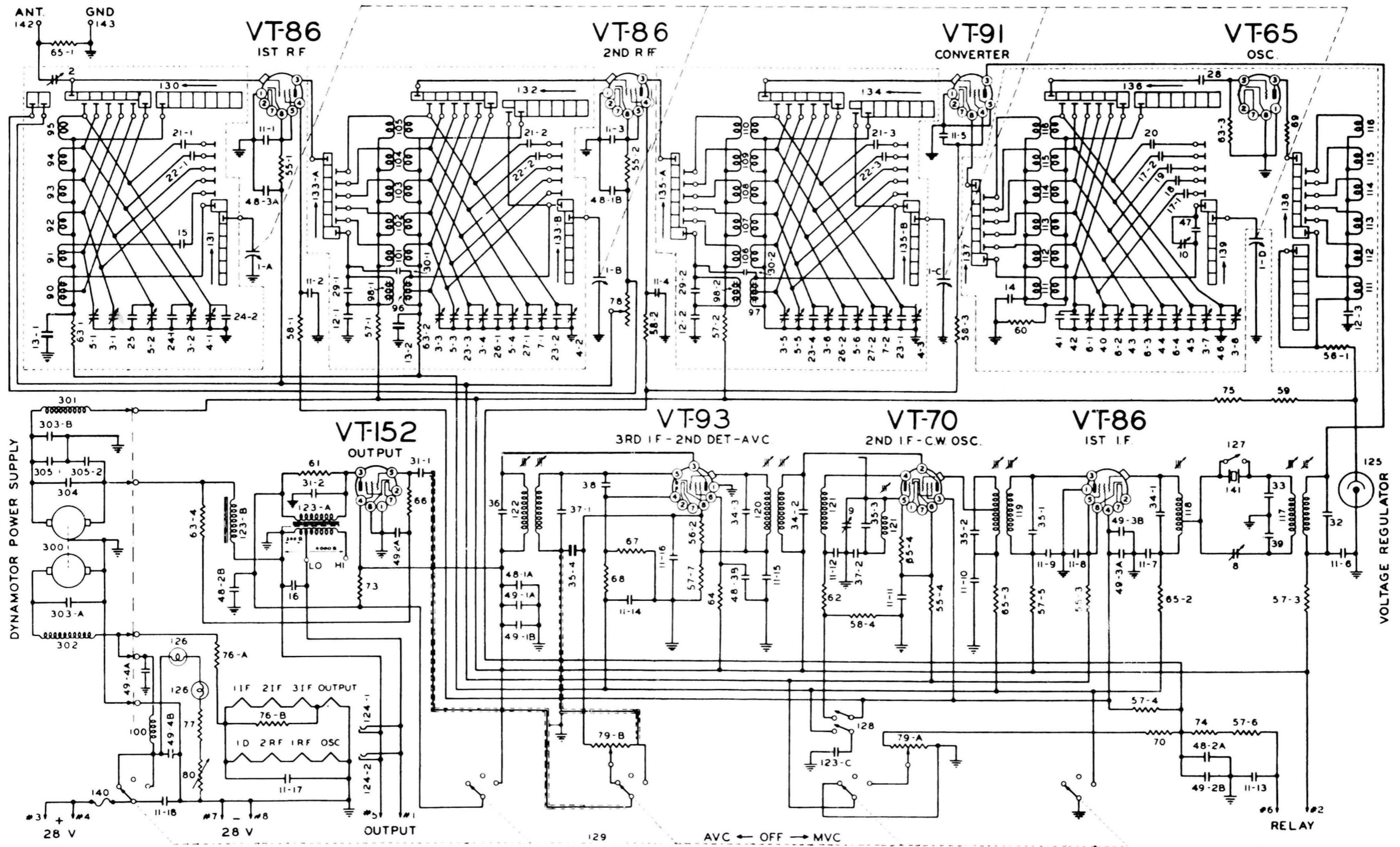

Schematic Diagram, Receiver BC-348 AL

## VHF AND UHF RECEIVERS

VHF and UHF receiver circuits can be represented by the same symbols used for the circuits of other receivers. The basic principles of circuit theory apply to VHF and UHF receivers. Yet, VHF and UHF receivers are actually different enough from other receivers to warrant separate discussion.

This chapter deals with the characteristics and principles of VHF and UHF operation and special considerations that must be given to tuned circuits, electron tubes, and physical layout and wiring of VHF and UHF receivers. Typical VHF and UHF receivers are discussed at the end of the chapter.

### PRINCIPLES OF VHF AND UHF OPERATION

To handle VHF and UHF successfully, a receiver usually has specially designed components and circuits, particularly in the RF section. The block diagram shows a communications receiver for operation in the VHF range. As shown in block diagram below,

the receiver is not unusual except that it uses *double conversion*. The input frequency is converted twice, once to a high IF and again to a low IF. Double conversion is accomplished by means of two heterodyne oscillators. In this receiver circuit, the high IF is 10 mc and the low IF is 455 kc. Double conversion is very common in VHF and UHF receivers, though superheterodynes with single conversion are also used. Sometimes, in UHF, triple conversion is used. With double conversion, the heterodyne oscillator can operate at a frequency sufficiently different from the carrier frequency to prevent oscillator pulling.

The section marked "converter" in the block diagram, is often a separate unit. It contains the components and circuits which are specially designed for VHF and UHF. As a separate unit, its output can be fed to a low frequency superheterodyne. In that case, the section of the low frequency receiver which usually serves as the RF section is used as the high IF section of the VHF or UHF

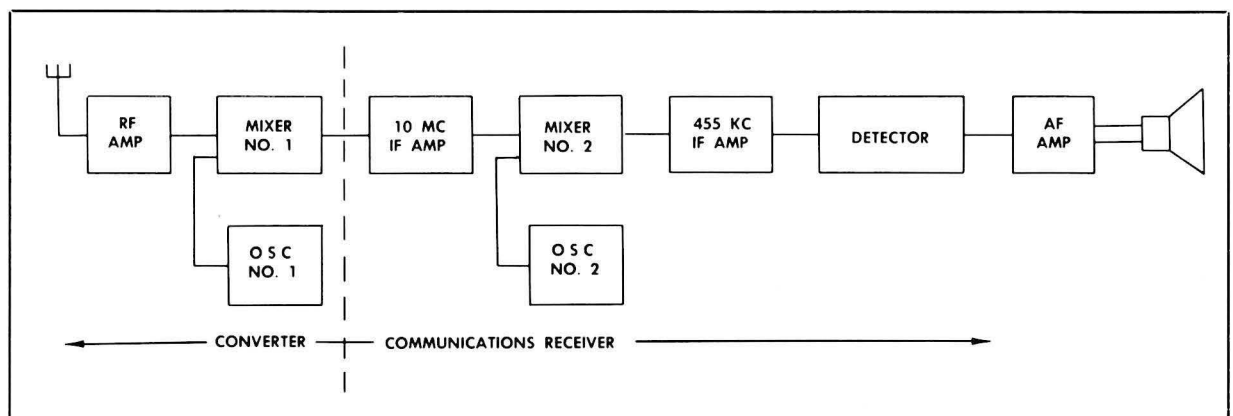

Typical VHF Receiver

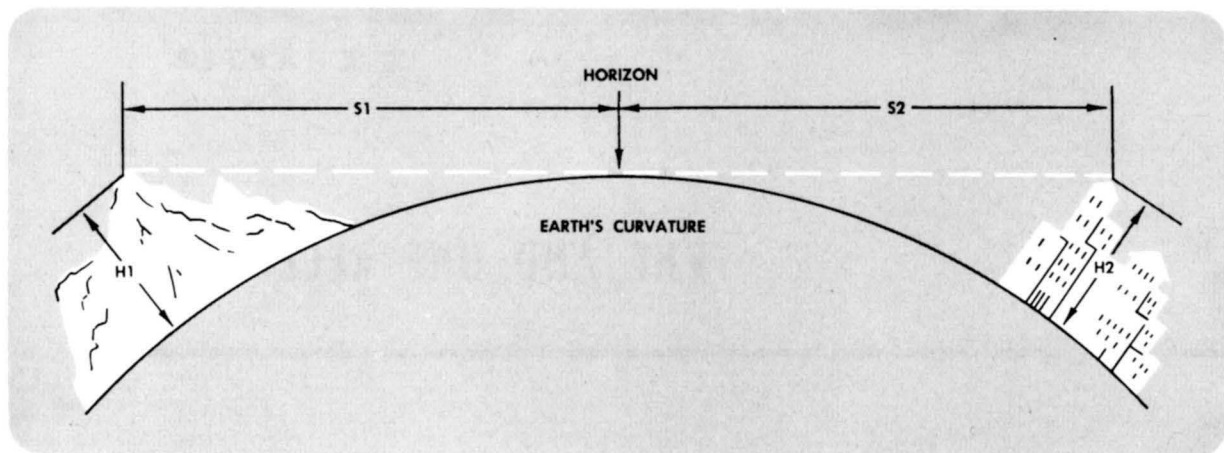

Total Line-of-Sight Distance

combination. Then the IF section of the low frequency receiver serves as the low IF section.

### CHARACTERISTICS OF VHF AND UHF WAVES

Since the effective transmission distance of a ground wave decreases as frequency increases, the effective transmission distance of VHF and UHF ground waves may sometimes be measured in units as small as yards. At VHF and UHF, therefore, the ground wave has little usefulness. Since the ability of the ionosphere to refract skywaves enough to send them back to earth decreases as frequency increases, there is little or no skywave at VHF and UHF. This means that VHF and UHF communication must depend almost entirely on the direct wave or line-of-sight transmission.

In calculating VHF and UHF ranges, the curvature of the earth as well as the intervening terrain must be taken into account. The height of the transmitting and receiving antennas determines how far apart antennas may be located and still provide communication. The VHF and UHF horizon distances can be calculated by a simple formula. This formula is completely accurate only over water or when the intervening ground is almost level. Yet it serves as a useful guide in less ideal conditions. When the height of a transmitting antenna above ground level is known, the distance to the horizon can be

found by the formula,

$$S \text{ (horizon distance)} = 1.42 \sqrt{H}$$

In this formula,  $S$  (distance) is in miles and  $H$  (height of antenna) is in feet. When the receiving antenna is also elevated, the total communication path is the sum of the two horizon distances from each antenna. The formula then becomes,

$$S1 + S2 = 1.42\sqrt{H1} + 1.42\sqrt{H2}$$

The distance between transmitter and receiver is seldom over 30 miles for point-to-point communications. Because of favorable elevation, airborne equipment is often capable of useful work at several times this distance.

Obviously, the range of VHF and UHF communications is limited. However, this can be an advantage. In military operation, the short range of VHF and UHF makes it difficult for an enemy to intercept and monitor communications transmissions.

There are other advantages in the use of VHF and UHF. For example, very little static is observed at frequencies too high to be reflected from the ionosphere. This is partially due to the very limited range of such high frequencies. It is also due to the fact that there is very little noise energy generated at such high frequencies. When circuits are properly shielded against machine made noise, and when the tubes are chosen for low internal noise characteristics, VHF and UHF communication can be as noise-free as a good telephone connection.

## TUNED CIRCUIT CONSIDERATIONS

The circuits used at VHF and UHF are similar to those used at the lower communication frequencies, but the construction features change progressively as the frequency becomes higher. With ordinary coils and capacitors in the tuned circuits, it becomes increasingly more difficult to obtain a satisfactory amount of selectivity. As the frequency goes up, the reactance of any shunt capacitance across the input circuit of an amplifier tube goes down  $\left(X_c = \frac{.159}{FC}\right)$ . This means that the ordinary capacitor will shunt the higher frequencies. Then the voltage on the grid of the tube will be small. The tuned circuit impedance will be low in proportion to resistance. Therefore, the tuned circuit will have low Q and poor selectivity.

As the frequency increases, the capacitance and inductance needed to tune the circuits become smaller and smaller  $\left(F = \sqrt{\frac{.159}{LC}}\right)$ .

A single, short wire will have enough distributed inductance and capacitance to be resonant at a very high frequency. Thus, the distributed inductance and capacitance of the leads are important factors. This makes the size and relative location of every part in the receiver of great importance at the higher frequencies. Skin effect also increases with frequencies. This means that current flow is confined to an increasingly narrow path. This serves to increase the effective resistance of the conductor. To reduce resistance to high frequency currents, conductors with large surface areas are used. Solid leads of small gauge wire are replaced with comparatively large copper tubes.

At VHF and UHF, quarter wavelength sections of parallel conductors or concentric transmission lines have the size and electrical characteristics which make them very desirable as tuned circuits. The physical length of such conductors is comparable to the wavelength of the radio waves. For example, at 300 mc a wavelength is about 1 meter or 39.37 inches, and a quarter wavelength line is about 10 inches long. Such sections may serve as high

Q tuned circuits. The operation of quarter-wave sections as tuned circuits is explained in AFM 52-19, Antenna Systems.

## ELECTRON TUBE CONSIDERATIONS

At VHF and at lower communications frequencies, the transit time of electrons (the time it takes them to travel from cathode to plate in the tube) is negligible. Above 400 mc, however, this time is equal to a considerable part of a cycle. Therefore, plate current lags the input grid signal. Thus, the transit time of the electrons produces an effect like an inductive lag in an ordinary circuit. This sets a high frequency limit on a tube's ability to act as an oscillator.

Transit time can be reduced by increasing plate voltage to speed up the movement of electrons from cathode to plate. However, heat dissipating ability is a limiting factor, for an increased voltage requires greater heat dissipating ability. Transit time can also be reduced by building miniature tubes with smaller, more closely spaced electrodes. Such tubes are called acorn, doorknob, button-base, and lighthouse tubes.

The miniature tube provides a solution to another frequency limitation of the ordinary tube—interelectrode capacitance. As frequency increases, the signal shunting effect of interelectrode capacitance also increases. It finally reaches the point where the tube cannot provide adequate amplification. The smaller electrodes of the miniature tube decreases the interelectrode capacitance and raises this frequency limit.

The design of miniature tubes helps in overcoming still another frequency limitation of the ordinary tube. The interelectrode capacitance and lead inductance of a tube form part of the capacitance and inductance of any tuned circuit with which the tube might be used. Miniature tubes not only have minimum interelectrode capacitance, but they have minimum lead inductance as well. The low lead inductance is due to the fact that the leads to the tube elements are not brought out through the base but straight through the glass envelope. This keeps leads at the shortest practical length.



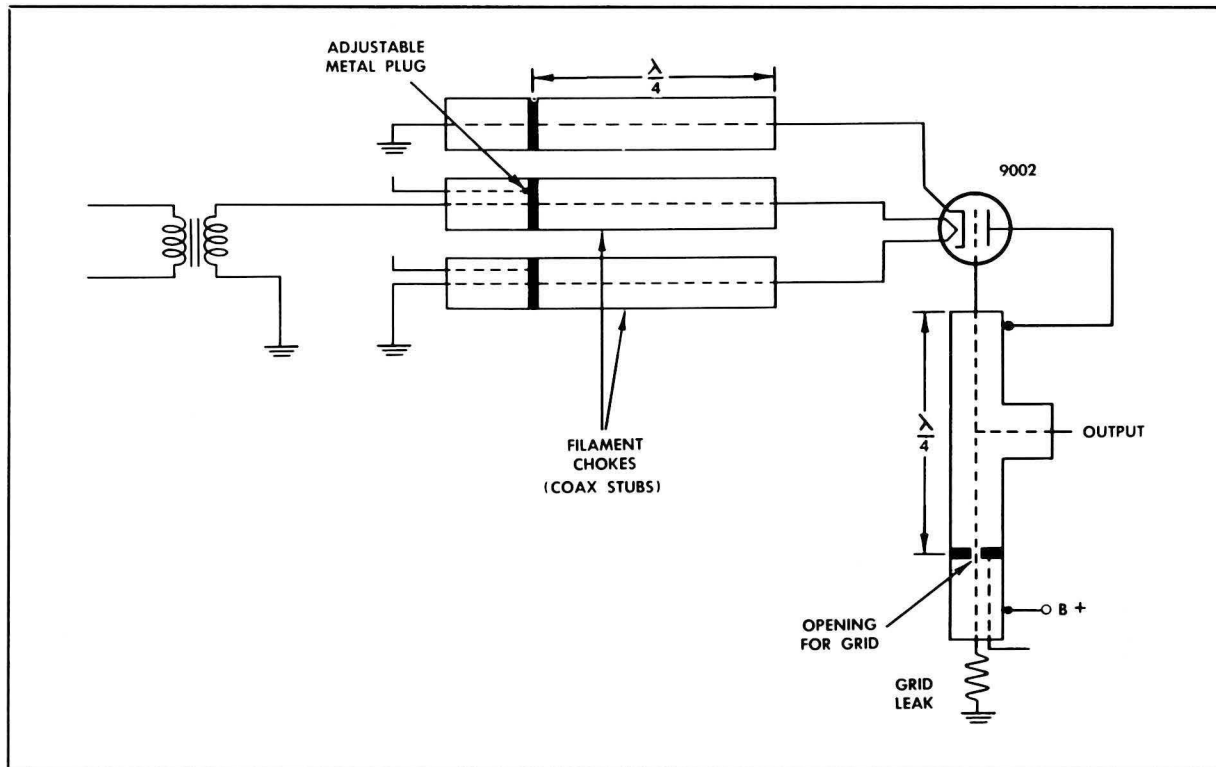

UHF Oscillator

The frequency limits at which some typical miniature tubes may operate are:

- 6J4 button-base triode—500 mc
- 6F4 acorn triode—1200 mc
- 1A3 button-base diode—1000 mc
- 9005 acorn diode—1500 mc
- 2C40 lighthouse triode—3500 mc (as an oscillator)

### Use of Miniature Tubes

An oscillator circuit using a miniature tube is shown in the diagram above. This tube is a 9002. The effect of transit time is negligible in this tube because the elements are very closely spaced. The interelectrode capacitances are small due to the fact that the elements are small. Short internal leads minimize lead inductance. This circuit, with this type of tube, operates very satisfactorily at 600 megacycles. It can be used in numerous UHF applications, including its use as a high frequency oscillator in the UHF television band.

The resonant circuit that determines the

output frequency is formed by a short length of hollow coaxial cable. The center conductor is the grid lead and the plate is connected to the outer conductor. The circuit is tuned to a definite frequency by adjusting the length of the grid-plate stub. The stub is a quarter wavelength long at its resonant frequency. The length of the stub, for example, is about 4.5 inches at 640 megacycles.

The tuned stubs in the cathode and filament leads are similar to the grid-plate stub. However, their only purpose is to keep the cathode and filament at a high RF potential. Conventional wire wound chokes are not practical in this circuit because they are self-resonant at a much lower frequency and therefore interfere with the proper operation of the oscillator.

### Positive Grid Oscillators

The positive grid oscillator uses a conventional tube as a high frequency oscillator by employing an entirely different principle of tube operation. The positive grid oscillator

resembles a special group of high frequency oscillators called *transit time tubes*. This group includes the magnetron and the klystron.

In the transit time tube, electrons are caused to oscillate in the vacuum of the tube without reaching the plate. In this way the distance between plate and cathode no longer forms a transit time limit. Since the plate draws little or no current, the problems of plate voltage and heat dissipation can be more easily solved. Electrons can be made to oscillate at such extremely short wavelengths that the resulting waves are called *microwaves*.

In the positive grid oscillator the grid is positive in respect to cathode, as shown by the power supply polarity of the circuit diagram. The plate operates at the cathode potential. When the grid attracts electrons from the cathode, some of the electrons strike the grid and flow as grid current toward the power supply. However, most of the electrons pass through the grid wires and travel on toward the plate. The plate has no attraction for these electrons, though, and they turn again toward the grid. Most pass through again, going toward the cathode. The cathode has no attraction, and again they turn toward the grid. This means that electrons pulled from the cathode oscillate back and forth through the grid wires and are carried past the grid each time by inertia. They move a shorter distance on each trip past the grid until they hit the grid and are absorbed as grid current.

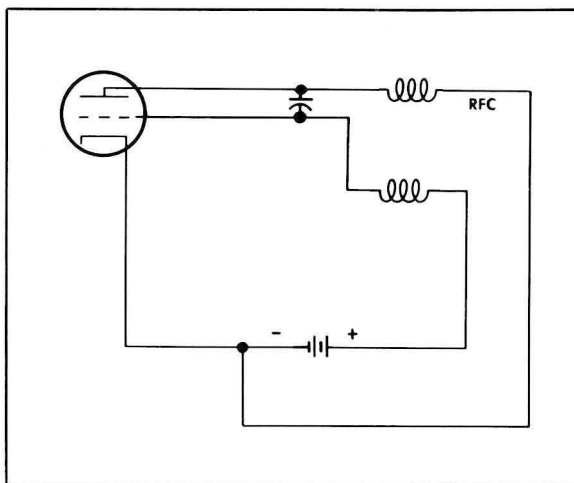

Positive Grid Oscillator

If the grid circuit were not a tuned circuit, there would be no special pattern to this electron movement. However, the grid circuit is tuned by interelectrode capacitance and lead inductance. The movement of electrons excites the tuned circuit, and the grid alternates more and less positive at its resonant frequency. This alternation causes the electrons to be formed into bunches. If the transit time of a complete electron cycle (determined by plate, grid, and cathode voltages) is of the proper value, the extra electrons that the grid pulls from the cathode on its more positive swing will combine with a bunch of electrons which have already made one trip through the grid wires toward the plate and back through the grid wires toward the cathode. This means that a large mass of electrons move toward the plate when the grid becomes more positive and moves back toward the cathode when the grid becomes less positive. This movement, in phase with the frequency of the grid tuned circuit, maintains oscillations. The transit time of the electrons moving within the vacuum of the tube conforms to the resonant frequency. The output is coupled capacitively from the grid.

### Magnetron

The magnetron, shown in the simplified illustration below, uses the transit time principle to achieve ultra high frequencies, surprising efficiency, and very high output. Illustrated are the plate circuit, the cathode

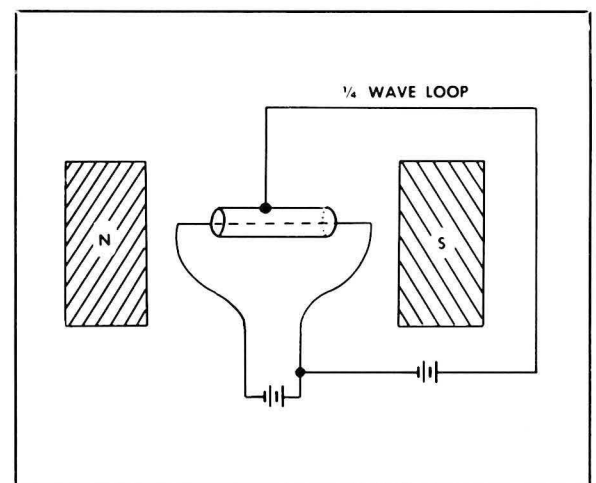

Magnetron Simplified Circuit

circuit, and the magnets which give the tube its name. The plate, tube-shaped, encircles the cathode. There is no grid. The magnetic field set up by the magnets may be thought of as acting as a grid. The cathode emits electrons which are attracted to the plate. The force resulting from the magnetic field is at right angles to the plate attraction. The combined forces cause the electrons to follow a curved path. If the magnetic field is strong enough or the plate voltage is weak enough, this path may miss the plate entirely. When the electrons miss the plate, they follow a heart-shaped path and return to the cathode. If plate voltage and magnetic field strength are properly adjusted, electrons can be made to just touch the plate without being absorbed by the plate. In that case, the electrons continue on their heart-shaped path back to the cathode. They will, however, transfer energy to the plate and cause its tuned circuit to oscillate.

Modern magnetrons, of course, are much more complicated. The plate may be so large that it makes up most of the outer surface of the tube, with only small areas of glass through which tube connections are made. The tube then resembles a resonant cavity. However, the plate metal may be so thick that it may contain actual resonant cavities hollowed out of the plate's inner surface. These built-in resonant cavities are excited into oscillation in the same manner that the plate tuned circuit in the simplified diagram is excited.

## Klystron

The klystron tube, called a velocity-modulated tube, uses an electron beam. In the klystron tube, the cathode and plate are separated by a relatively great distance. Two grids connected to a generator are inserted into the stream of electrons between cathode and plate. The alternating voltage of the generator retards some electrons and accelerates others, as shown below. By this process the electrons are formed into bunches. The grids are called bunchers.

The bunches of electrons then pass another set of grids called *catchers*. These catcher grids are connected to a tuned circuit which normally is a resonant cavity. The bunches of electrons excite the cavity resonator into oscillation if the rate of recurrence of bunches conforms to the resonant frequency of the cavity. This means that the RF generator connected to the bunchers and the resonant cavity connected to the catchers must be at the same frequency.

In actual practice another resonant cavity replaces the RF generator shown in the circuit diagram. Then energy from the catcher resonant cavity is coupled, in proper phase, back to the bunchers resonant cavity. This coupled energy excites and maintains oscillations in the buncher resonant cavity. The output of the oscillator is usually coupled by a small loop placed inside the catcher resonant cavity.

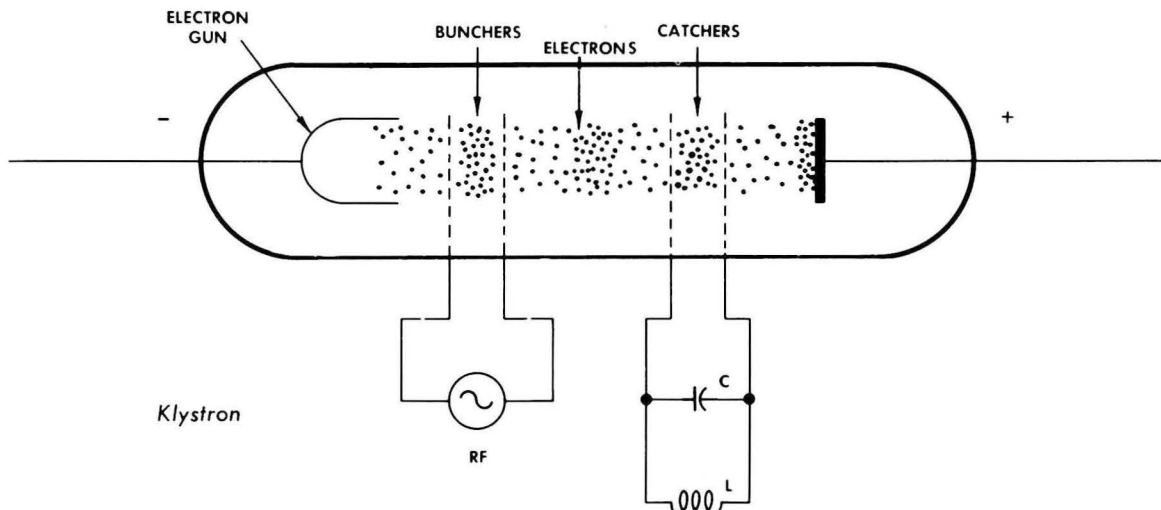

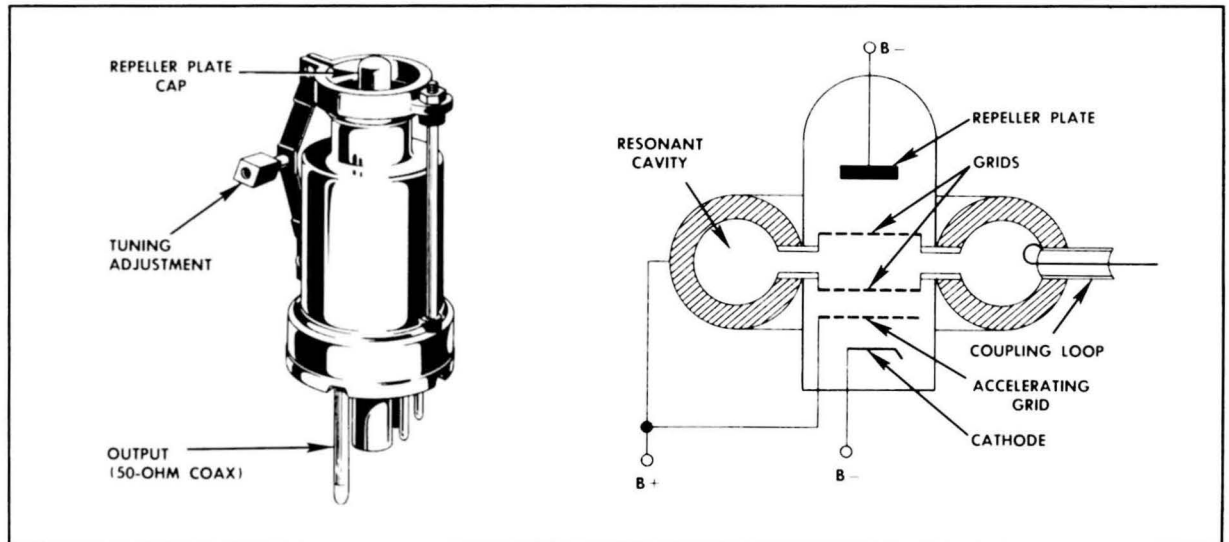

*Reflex Klystron and Its Schematic Diagram*

The klystron tube is very critical to adjust, therefore a similar tube called a reflex klystron is used for oscillator applications. This tube, illustrated above, has only one pair of grids. They perform both the bunching and catching functions. A negative voltage is applied to the repeller plate to cause the electrons to retrace their path through the grids.

#### PHYSICAL LAYOUT AND WIRING PROBLEMS

As you have seen, the inductance, capacitance, and resistance requirements in VHF and UHF circuits are critical. In studying the broadcast receiver, you were concerned with the lumped constants associated with coils, capacitors, and resistors. In studying VHF and UHF receivers, you are concerned with the distributed inductance and capacitances of segments of transmission lines or of resonant cavities used as tuned circuits. In addition, you must consider all stray inductances and capacitances, since they may affect the frequency or the  $Q$  of the tuned circuit. Even shielding, so important at VHF and UHF, contributes to the overall capacitance and to the RF losses. Skin effect is also important. As the frequency increases, skin effect becomes more pronounced and conductors may have to be silver plated to reduce their resistance to the high frequency currents. A 3-inch length of wire that, in a broadcast receiver,

merely connects the grid to a coil and capacitor, in a UHF receiver operating at 1000 megacycles, may act as a tuned circuit and impair the operation of the set. On the other hand, the distributed  $L$  and  $C$  of a grid lead may be used to advantage as the tuned input circuit of a miniature tube. Since the overall  $L$  and  $C$  required to resonate a VHF or UHF circuit is small, a slight change in the circuit constants will render a circuit inoperative or detune it, lowering its sensitivity and selectivity.

Therefore, a technician replacing a defective component must restore the circuit to its original condition. This is hard to do, so the circuit must usually be realigned or retuned. The new component should be identical with the original component. It should occupy the same position with respect to other components. Leads must be of the same length and in the same position. Yet even the greatest care will not guarantee a successful replacement. Even with the finest tolerance, no two parts are exactly alike. Furthermore, the process of soldering may change the  $L$  and/or  $C$  characteristic of a lead.

As a consequence, the importance of correct soldering technique cannot be overemphasized. It is necessary to apply sufficient heat and solder to a joint to make a good clean bond. But too much or too little of either heat or solder will generally result in failure.

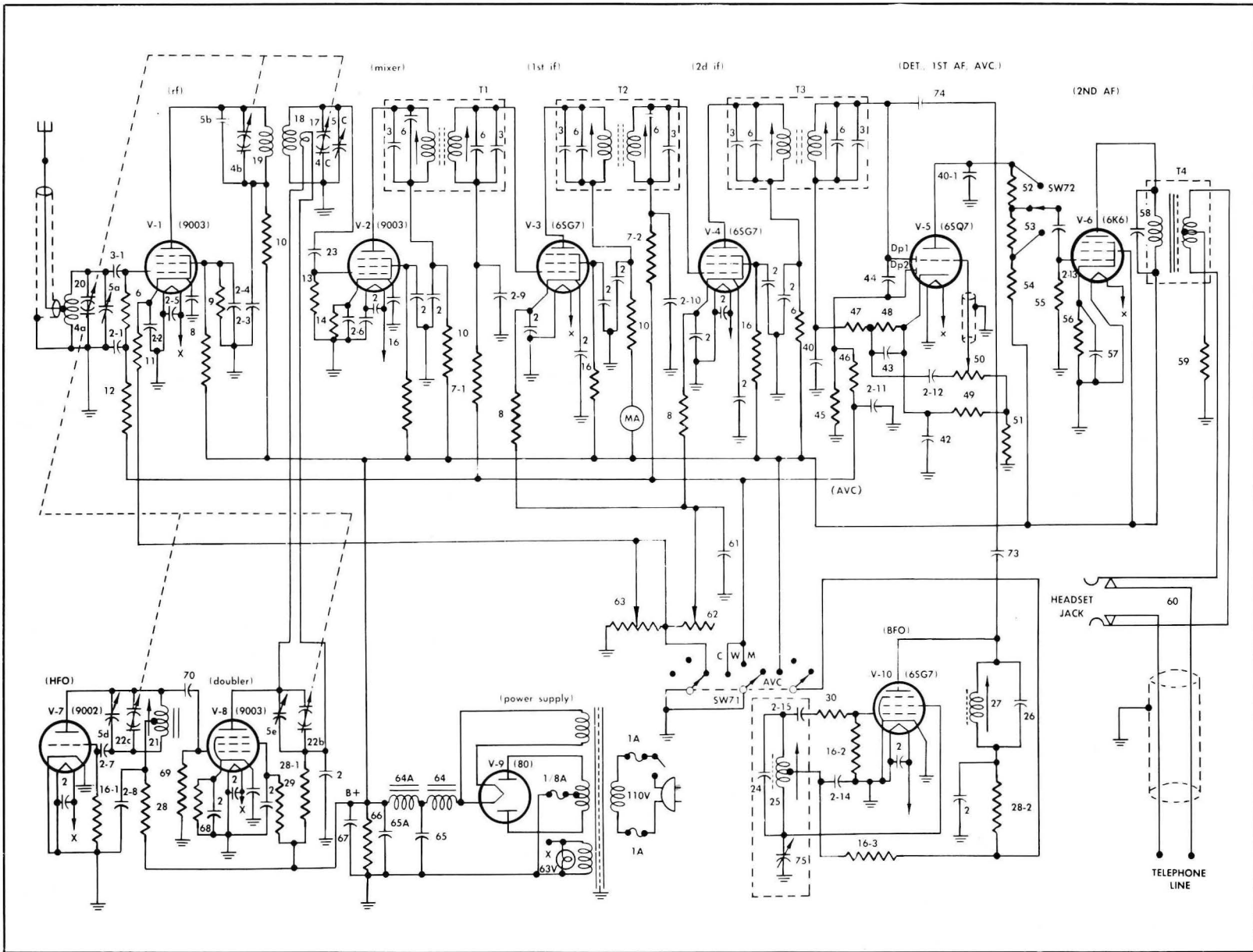

VHF Receiver

Great care must also be taken in replacing parts which are not soldered. In replacing a defective tube, for example, several identical new tubes may have to be tried before satisfactory operation is obtained. Some electrical adjustments may also be necessary.

The tendency today, therefore, is to build the receiver as a combination of replaceable units. Each unit plugs in or requires a minimum of soldered connections to complete the receiver. If the defective unit requires more than a change of tubes, it is replaced with a new unit. The defective unit is then repaired and tested by specialists at depots or factories.

### VHF RECEIVER ANALYSIS

The typical VHF receiver is a superheterodyne using a double conversion system. However, the VHF receiver analyzed here uses only single conversion. Its range is from 100 to 156 mc. In the circuit diagram shown at the left, all circuit components of identical value have the same reference number. A dash followed by a second number is added to distinguish components having the same value but different usages. The separate capacitors of a gang have the same reference number. This number, in each case, is followed by a different letter in order to distinguish one capacitor from the others in the gang.

#### RF Stage

The antenna shown at the left of the diagram is a half-wave antenna coupled by a coaxial cable to the tuned grid circuit. The cable has a characteristic impedance of 70 ohms. It connects to 70-ohm impedance points on both the antenna and tuned grid circuit. The tuned grid circuit acts as a series resonant circuit to the induced RF signal.

The grid coil (20) consists of two turns with about  $\frac{3}{16}$  of an inch spacing. The diameter of the coil is  $\frac{5}{16}$  of an inch. The coil is tuned by a split-stator capacitor whose rotor is ungrounded. The tuning mechanism has a large step-down gear ratio to permit very fine tuning. Trimmer capacitor (5a) is adjusted only when aligning the receiver. The RF coils are also adjusted only when aligning. Then

they are adjusted by spreading or compressing the individual coil turns. The signal is capacity-coupled by 3-1, 15 mmf, to the grid circuit. The main purpose of 3-1, however, is to prevent the AVC voltage from grounding through the low resistance grid coil. Capacitor 2-1 (680 mmf) and resistor 12 (100 K) form a decoupling filter which tends to prevent any interaction between the RF amplifier and the IF stages connected to the common AVC line. Resistor 6 (560 K) is part of the grid return circuit. With 12 it completes the DC path back to cathode through ground. Through these same two resistors the AVC voltage is applied to the grid. Since 6 is effectively in parallel with the tuned grid circuit it affects the overall input impedance to the grid and therefore the signal voltage amplitude, since it serves to broaden the response curve of the tuned circuit. Resistor 11 (330  $\Omega$ ) is the cathode bias resistor and 2-2 the cathode bypass capacitor which bypasses RF to keep the cathode bias constant. Capacitor 2-5 is an RF bypass across the heater. All the RF tube heaters are shunted with such bypass capacitors to prevent oscillations due to feedback between stages. The 9003 and 6SG7 tubes actually have two cathode leads. Both leads are provided with RF bypasses to ground. This is especially important if the cathode leads are an appreciable fraction of a wavelength long. The leads must serve as conductors, not resonant lines. That is why much more RF bypassing is necessary in VHF (and UHF) circuits.

The V1 screen grid is grounded for RF by 2-3 which makes the screen grid act as an effective shield between the control grid and the plate. It is tapped between resistor 8 (39K) and 9 (120 K) which act as a voltage divider. Capacitor 2-4 and resistor 10 (1000  $\Omega$ ) form the plate circuit decoupling filter to keep RF out of the power supply. The plate parallel resonant tank circuit consists of 4b (the variable tuning capacitor) 5b (the trimmer) and 19 (a 2-turn coil of No. 14 wire inductively coupled to the mixer grid coil 18). Corresponding components in both the tuned plate circuit of V1 and the tuned grid circuit of the mixer V2 are physically identical.

Tuning is accomplished by a single tuning

control which drives a gear reduction train. The train drives 5 tuning capacitors for a complete coverage of the frequency band.

High frequency miniature pentode tubes are used for the RF, mixer, and doubler stages because of their small interelectrode capacitances.

### Mixer Stage

The circuit components of the *mixer stage* are practically identical to those in the RF stage except that the plate tank is tuned to the IF of 12 mc. Bias for the tube is developed across the cathode bias resistor, 14 (1000  $\Omega$ ), which is bypassed by 2-6. Resistor 13 is a 1.8-megohm grid return resistor, and 23 is a 47-mmF silver-mica coupling capacitor. The second harmonic of the local oscillator is inductively coupled from the doubler plate circuit into the mixer grid circuit through a single turn of silvered copper wire, coil 17. The doubler plate circuit is tuned to twice the oscillator frequency by 17, 22b, and 5e. The coupling of coil 17 to coils 18 and 19 is not very critical. Thus, small changes in its position can be tolerated. But the coupling between coils 18 and 19 is very critical. It can be varied by changing the spacing between the coils.

The high frequency oscillator (V-7) is a series fed Hartley. The tank circuit is common to the plate and grid circuits. The tapped coil (21) acts as an autotransformer. The voltage developed below the center tap is used for feedback, while the voltage developed from the center tap to the top of the coil is the signal voltage applied to the doubler grid circuit through the 27-mmF coupling capacitor, 70. Capacitor 2-8 and 28 (4700  $\Omega$ ) form the plate decoupling filter. Resistor 16-1 (47 K) and 2-7 form the grid leak bias circuit.

The doubler stage is a conventional VHF frequency multiplier. Its plate circuit is tuned to twice the oscillator frequency. Bias is developed across the 560-ohm cathode resistor (68) and across the 27,000-ohm grid leak resistor (69). The doubler also acts as a buffer to isolate the oscillator from the mixer grid circuit, thereby giving better oscillator stability. Use of the doubler permits the oscillator to operate at a lower frequency. This provides

greater efficiency and stability. Use of the doubler also provides added amplification of the oscillator output to achieve higher conversion gain.

The use of multipliers to obtain the heterodyning frequency is common in VHF receivers. With crystal controlled oscillators, multipliers are generally used. The inherent stability of the crystal makes it the most desirable type of oscillator. Its disadvantages of fragility and weak output are overcome by grinding the crystal for a low resonant frequency. Then its frequency and amplitude are built up by multipliers and amplifiers. In this receiver, the doubler plate circuit tracks 12 mc below the RF signal. Thus, while the signal frequency circuits tune from 100 to 156 mc, the doubler tunes from 88 to 144 mc and the high frequency oscillator at half the doubler frequency tunes from 44 to 72 mc.

### IF and AF Stages

So far as the rest of the stages are concerned, you can analyze them yourself, for the IF and AF sections are substantially the same as those of the receivers you have already studied. In fact, the RF, HFO, and mixer stages are also substantially the same as those of receivers already studied. They differ primarily in their physical appearance. One difference, for example, is that concentric lines are used to couple the antenna to the RF amplifier. Another is that the tubes are miniatures, chosen for short transit time and low internal noise. Coils and conductors are formed of heavy, metal wires, often silver coated.

Other VHF receivers may use double conversion and crystal-controlled HF oscillators. Such receivers, of course, use a system of crystal switching for reception on fixed frequencies, because crystal controlled oscillators are not continuously variable. Other VHF receivers use segments of parallel transmission lines and concentric lines as resonant circuits.

## UHF EQUIPMENT

The modern trend in UHF communications equipment is to use some circuits that are common to both the receiver and transmitter.

It is therefore no longer possible to study the theory of operation of the receiver separately and then learn about the transmitter. To some extent, both must be studied in conjunction with each other.

The reason that equipment is being designed in this manner hinges on the fact that so many channels are made available. For example, the AN ARC-27 has 1,750 crystal-controlled channels, of which any 10 channels can be set up on the equipment for a given mission. The equipment operates between 225.0 and 399.9 mc. It was found that the simplest way to automatically tune both transmitter and receiver circuits to the same frequency, with so many possible channels available, was to make some of the circuits part of both the transmitter and receiver.

Radio set AN ARC-34 is used as an example, in the following pages, of an equipment in which some of the circuits are common to both the receiver and transmitter. This set is illustrated on page 102.

A simplified block diagram of the ARC-34 is shown below. The heart of this set is

the master oscillator, shown at the left. The RF signal generated by the master oscillator goes to two separate parts of the equipment. One part of the output is fed to the frequency selector subassembly, as shown. This subassembly consists of a number of crystal oscillators, mixers, and a phase discriminator. The output of this subassembly is a DC voltage whose value depends upon how much the master oscillator is off from its exact frequency. This DC voltage is applied to the reactance tube and to the control monitor. When the set is tuning, this voltage causes the control monitor to turn the tuning capacitor in the master oscillator to the position that will produce the approximate output frequency desired. The DC voltage applied to the reactance tube causes it to control the master oscillator to the exact frequency desired.

The output of the master oscillator is also applied to two doubler circuits. The output of these doubler circuits is also applied to two different places. First, it is applied to tripler and power amplifiers. The modulator applies audio voltage to the power amplifiers, modu-

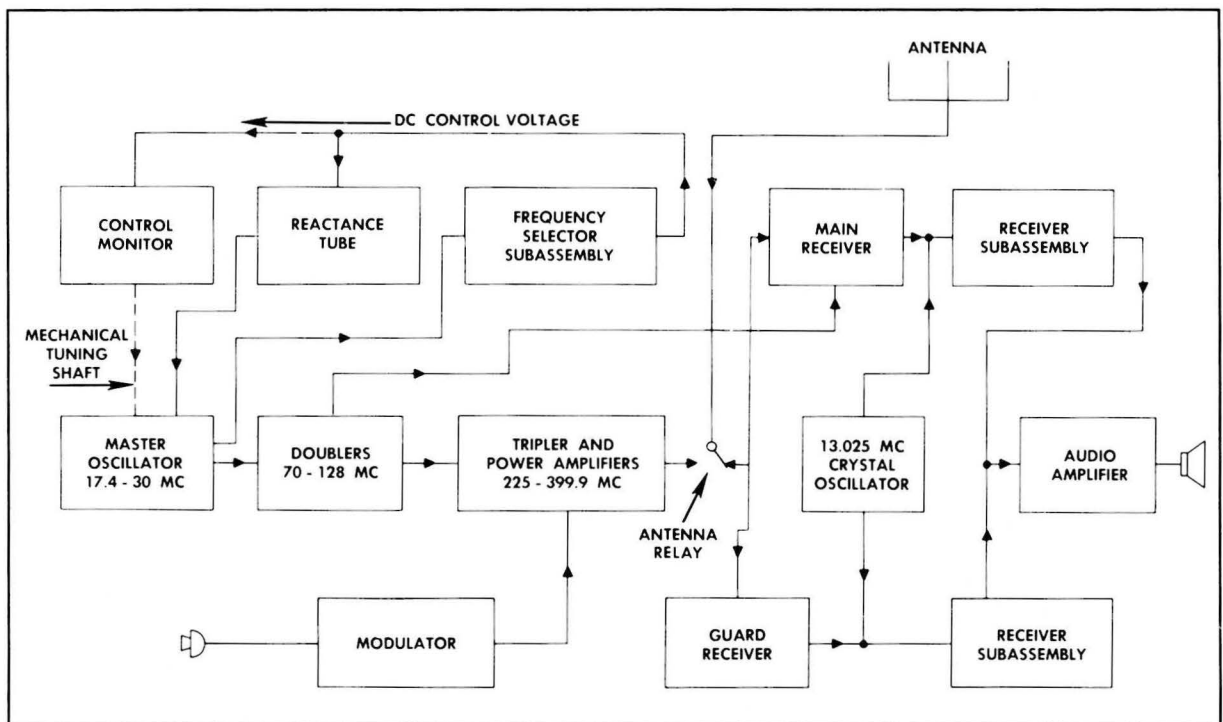

Simplified Block Diagram AN/ARC 34



lating the RF carrier before it is applied to the antenna through the antenna relay. Second, the output of the doublers is applied to a part of the main receiver. Here, the doubler frequency is tripled and used as the high frequency oscillator signal to be applied to the first mixer.

The guard receiver is a small unit that fits into the same chassis as the main receiver and transmitter. The purpose of the guard receiver, is to furnish an additional channel that can be monitored regardless of the frequency to which the main receiver is tuned. It has its own high frequency oscillator circuits that supply an RF signal to its first mixer.

A second conversion is made in both the main receiver and the guard receiver. The RF signal generated for this second conversion comes from the 13.025-mc crystal oscillator.

Two separate IF strips amplify the outputs of the main and guard receivers before the detected audio signals from each is applied to a common audio amplifier circuit. Since both IF signals are fed to the same AF amplifier, the pilot can listen to both channels at the same time.

### UHF Converter

The converter section of the ARC-34 main receiver is shown in the illustration on page 97. This section consists of the first and second RF amplifiers, frequency multiplier (tripler), mixer, and first IF amplifier.

The RF signal is introduced into the first RF amplifier input cavity at J667, at the extreme left of the diagram. This amplifier is a grounded-grid amplifier, with the signal being applied to the tube through the cathode. The grid is connected to the AGC (automatic gain control) line, but is at RF ground potential due to the low impedance of grid capacitor C654.

The operation of the input cavity is similar to the operation of the resonant cavity discussed under Additional UHF Developments, on page 102. Inductive loop L651 induces a magnetic field in the cavity and since the dimensions of the cavity are correct for this frequency band, the cavity resonates, giving all the characteristics of an ordinary parallel-

tuned circuit. The cavity is tuned to a particular frequency in the band of 225 to 399.9mc by tuning capacitors C651A and C651B. These two capacitors effectively change the dimensions of the cavity to resonate at a particular frequency. C652 is a 5-8 mmf trimmer capacitor for aligning this amplifier with the second RF amplifier and the mixer. L652 is a small adjustable vane that makes it possible to vary the inductance of the cavity by a small amount when aligning.

The magnetic field in the cavity induces a voltage into cathode loop L653 and this causes the input signal to be applied to the cathode of the tube. C653 and R652 are conventional cathode bias components.

The output of the tube is applied to the common plate-grid cavity Z651B through C655, a 47-mmF capacitor. This signal sets up an electric field in this cavity. Tuning is accomplished in this cavity in the same manner that it was accomplished in the input cavity. The cathode loop L655 has the signal induced into it and thus the signal is applied to the cathode of the second RF amplifier. This is also a grounded grid amplifier stage, with the DC grid path connected to the AGC line. The output of this second RF amplifier is similar to that of the first.

The signal input to the mixer is applied by means of inductive loop L657 and C666 to the grid. The bottom end of grid resistor R664 is connected to receiver test jack so that the mixer grid current can be measured for alignment and troubleshooting purposes.

The HFO signal for the mixer originates at the master oscillator in the transmitter, as explained earlier. From there it is applied to two doublers before it is applied to the frequency multiplier (tripler) shown here. The range of this signal is from 70 to 128 mc, over the 225-399.9-mc range of the equipment. The plate circuit of the tripler and the cathode injection circuit of the mixer are the same. This cavity is tunable the same as the RF cavities.

Since the incoming signal is applied to the mixer grid and the HFO signal is applied to the cathode, there is a mixing action taking place in the mixer tube. The plate of the mixer tube is connected to ground through a parallel

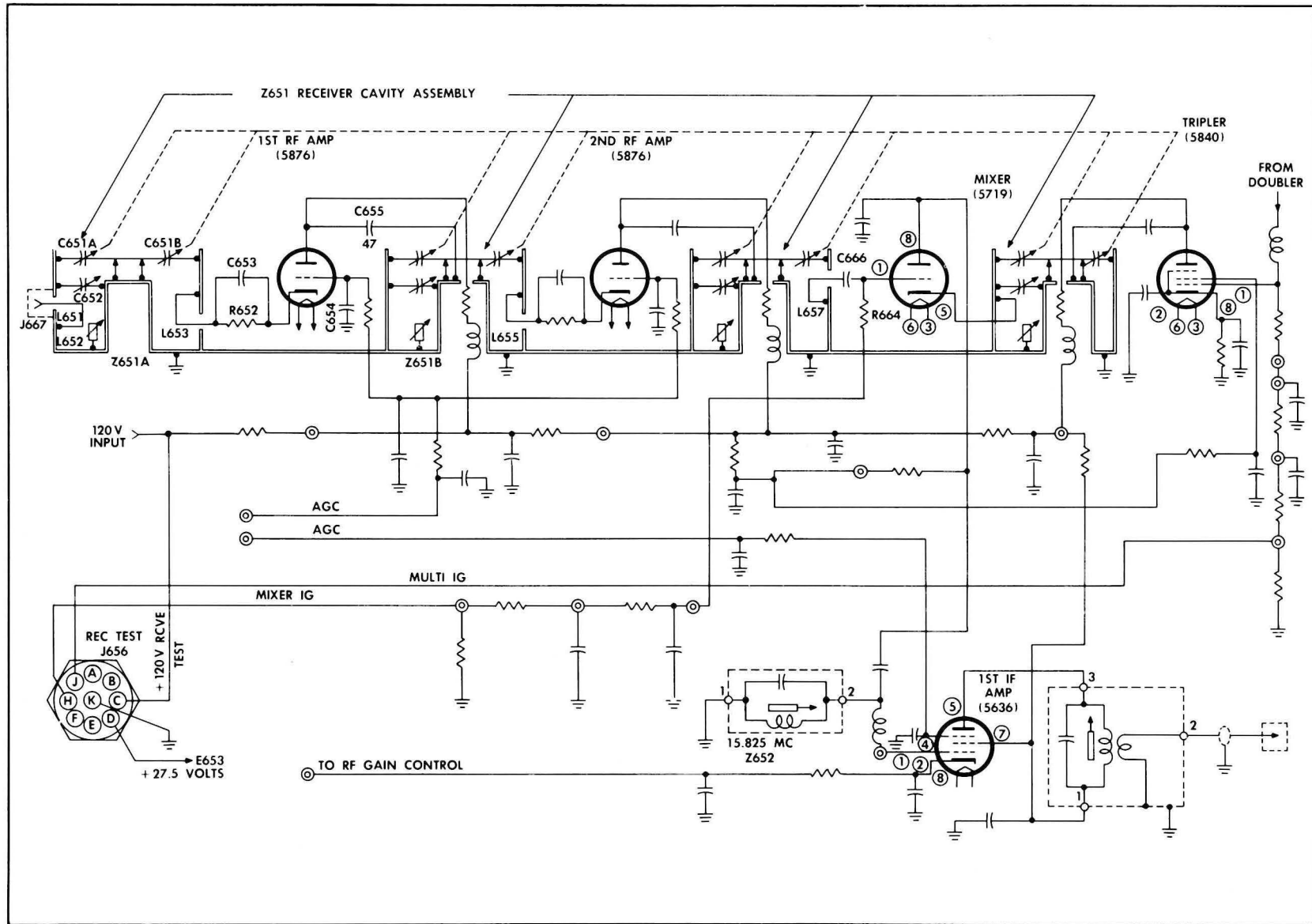

UHF Converter

resonant circuit tuned to 15.825 mc. This is the first intermediate frequency of the receiving equipment. From this stage on, the receiver is similar to the VHF receiver discussed earlier in the chapter.

### MINIATURIZATION

In the past few years there has been a move toward making airborne electronic equipment smaller, lighter, and more compact. This has become necessary with the advent of jet aircraft. Our modern jets carry more electronic equipment than the older fighters and therefore this equipment must be squeezed together so that it will not occupy too much space. In addition, the weight of the equipment had to be minimized so as not to cut down appreciably on the aircraft's speed.

As a result of this miniaturization program, various parts and components have been designed so that they are much smaller than similar parts were a few years ago. Some of these smaller parts are illustrated and discussed in the following pages.

#### Subminiature Tubes

Most of the modern UHF command sets contain a number of subminiature tubes similar to the one illustrated below. This is a

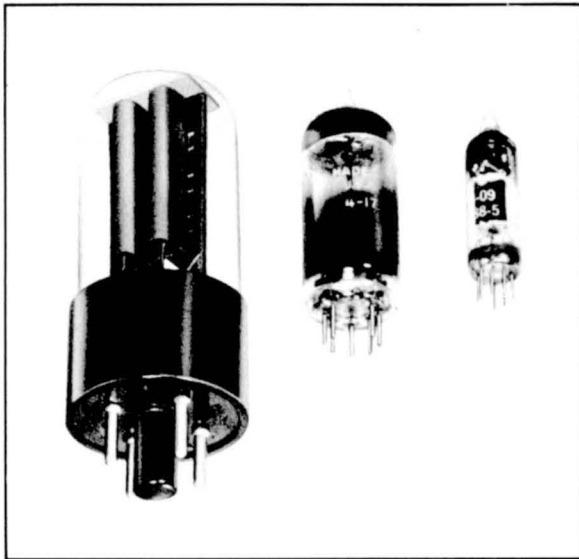

*Subminiature Tube Compared with Standard Tube*

5718 triode. Compare its size with that of the standard size 5Y3-GT and the standard size miniature 5651. The 5718 has long flexible leads that can be soldered directly to the proper points in the circuit. However, these leads can also be cut off leaving short pins, so that the tube can be plugged into a subminiature tube socket. The leads are left long and are soldered in place when the tube is used in a small unit that can be replaced when the tube filament burns out or when the tube becomes bad in some other respect.

#### Tantalum Capacitor

The small capacitor shown below is the relatively new tantalum filter capacitor. The one illustrated is rated at 25 mfd and 80 volts, DC working voltage. The ordinary electrolytic capacitor shown with it for size comparison is a dual 25 mfd, rated at 50 volts DC working voltage. You can see that the tantalum capacitor is less than one-fifth the size of the ordinary filter capacitor.

As the name implies, the electrode for this new type capacitor is made of the metal, tantalum, rather than aluminum as in the older type. The operating temperature range of the tantalum capacitor is from minus 55° C to 85° C. At minus 55° C, the aluminum electrolytic capacitor has lost almost all of



*Tantalum Capacitor*

its capacitance while the tantalum capacitor still has about 80% of its rated capacitance.

Another advantage of the tantalum capacitor, in addition to its small size and wide useful temperature range, is its long life when not in use. Ordinary aluminum electrolytics lose their capacitance when they are stored for a long period of time and must then be rejuvenated by applying the rated working voltage to them until their leakage current drops to normal. This is not necessary with the tantalum capacitor.

### Miniature Potentiometers

A new type miniature potentiometer is shown in the illustration at the right. Physically, this potentiometer is about one-half the size of the conventional potentiometer. In addition to this advantage, the method of applying the resistive material to the insulated disc is superior to the method used in conventional potentiometers. The view at the right shows the parts of the component. Notice the triangular-shaped piece of carbon. This fits into the triangular-shaped indentation in the bakelite frame and the straight-wire spring insures sufficient pressure between this triangular contact and the circular resistive element.

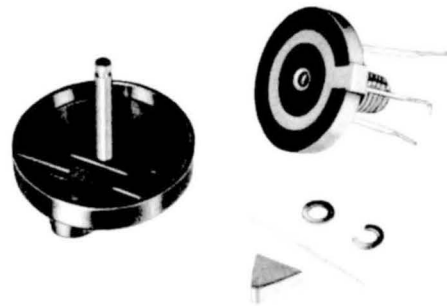

Miniature Potentiometer

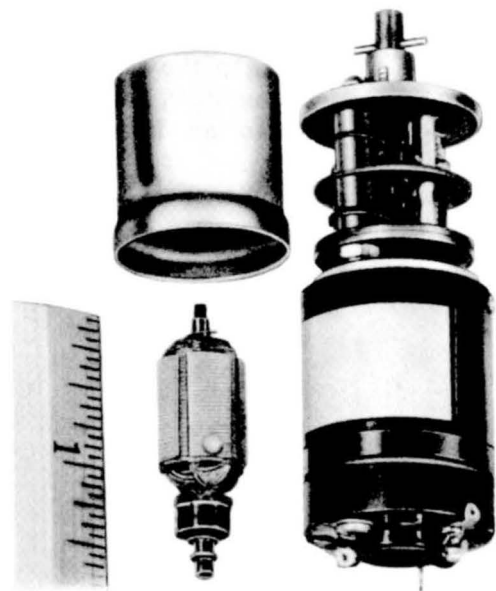

Drive Motor

### Drive Motors

Most automatically-tuned communications equipment uses some type of motor to drive the tuning elements around to a point of resonance. The drive motor and gear assembly at the right shows how small these units are in modern equipment. The armature of this 28-volt DC motor is not much more than an inch long. Yet, this is a conventional DC motor that is electrically similar to a much larger unit.

### Relays

The relay shown at the right is a hermetically-sealed single-pole double-throw relay used in the AN/ARC-34 command set. This relay is less than one-half the size of similar relays used in the older equipment such as the AN/ARC-3.

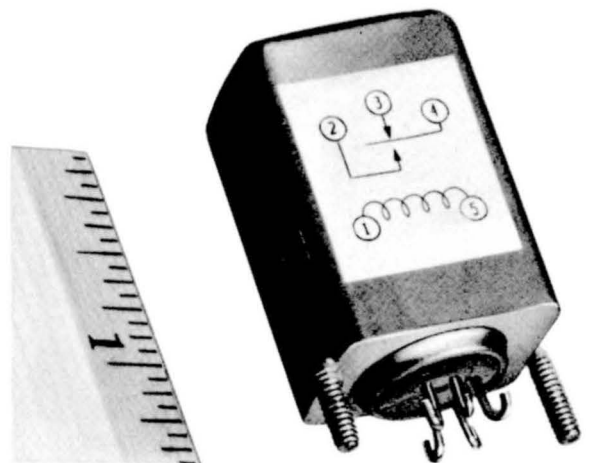

Miniature Relay

### Etched Circuits

A relatively new technique in the electronics field is the etched circuit. One of these is shown in the illustration below. Both sides of the unit are shown and you can compare the size of the whole unit with the markings on the ruler. This particular circuit is an oscillator, using the subminiature tube discussed earlier. Notice the long tube leads and the absence of a tube socket. The crystal, which is a plug-in unit, is the only part of the circuit not included on the insulated mounting. The frequency of this oscillator is 13.025 mc.

An etched circuit is similar in some respects to the printed circuit. In the printed circuit, various conductive, resistive, and insulating paints are applied to an insulated sheet.

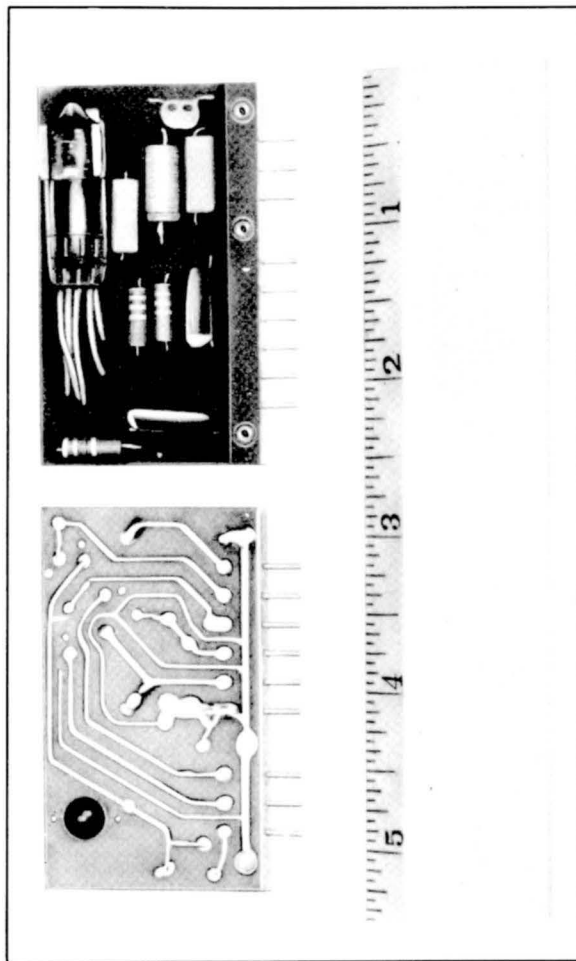

*Etched Circuit*

These may take the place of wires, resistors, coils, capacitors, and insulators. In the etched circuit, an acid is used to etch or eat away the parts not wanted, leaving the conductors shown in the illustration imbedded in the insulated sheet. These conductors form the current paths between the small parts mounted on the other side of the board.

### PLUG-IN UNITS

Another new technique that has been adopted in airborne equipment is the plug-in unit. The main advantage of these units is that they greatly simplify troubleshooting and maintenance.

#### IF Stage

Look at the illustration below. This is a complete IF stage in an airborne command set, with the shield can removed. If trouble is suspected in this unit, it can be easily and quickly replaced with a new one. If the new unit eliminates the trouble, the old one can be discarded.

This plug-in IF unit also fits into the miniaturization program. Compare the size of the unit with the conventional miniature tube that became popular at the end of World War II. The miniature IF unit includes the amplifier tube, IF coils, resistors, and capacitors. The schematic diagram of the unit is shown at the top of the next page.

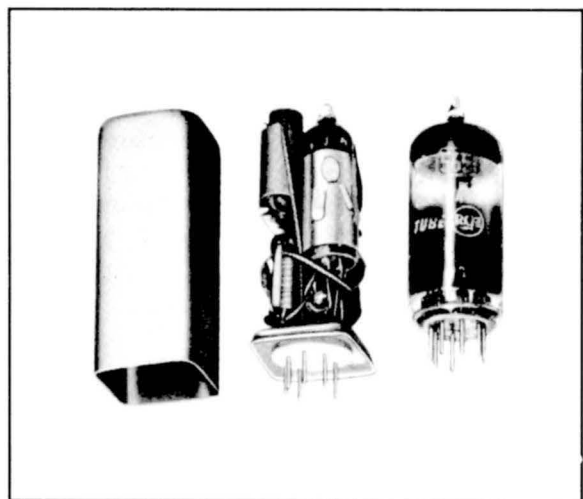

*Plug-in IF Unit*

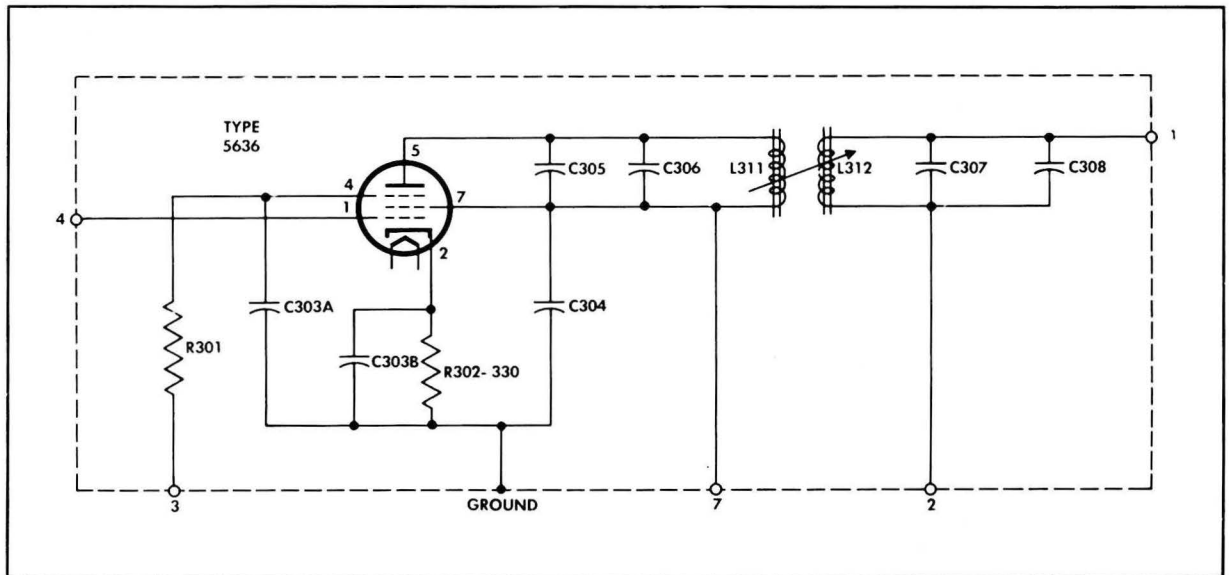

*Diagram of Miniature IF Unit*

### **Oscillator Panel and Its Subassembly**

The etched-circuit oscillator discussed previously plugs into the ARC-34 receiver subassembly as shown below. If trouble is suspected in this plug-in oscillator, it can be removed and a new plug-in unit can be inserted. This saves time in both troubleshooting and maintenance of this oscillator circuit.

### **Receiver Subassembly and the Chassis**

The whole subassembly which the oscillator plugs into also is a plug-in unit. It plugs into the chassis as shown in the illustration on page 102. Here again, troubleshooting is greatly simplified. If the repairman suspects trouble in this receiver subassembly, he can remove it and insert a new subassembly. If this was the trouble, he leaves the new unit

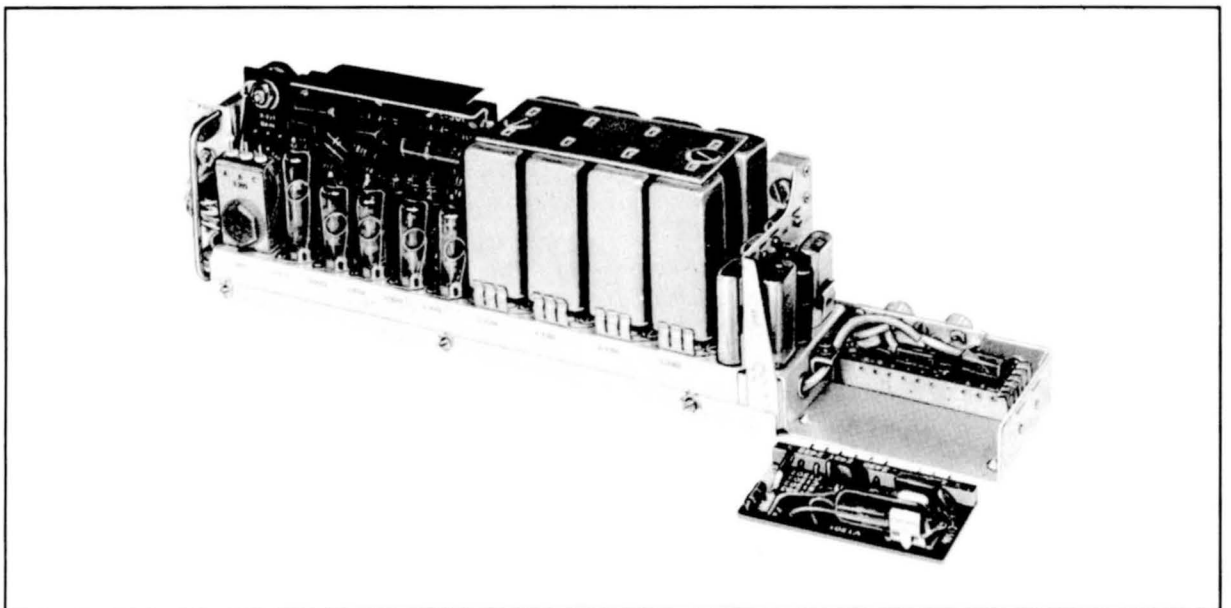

*Plug-in Oscillator and Its Subassembly*

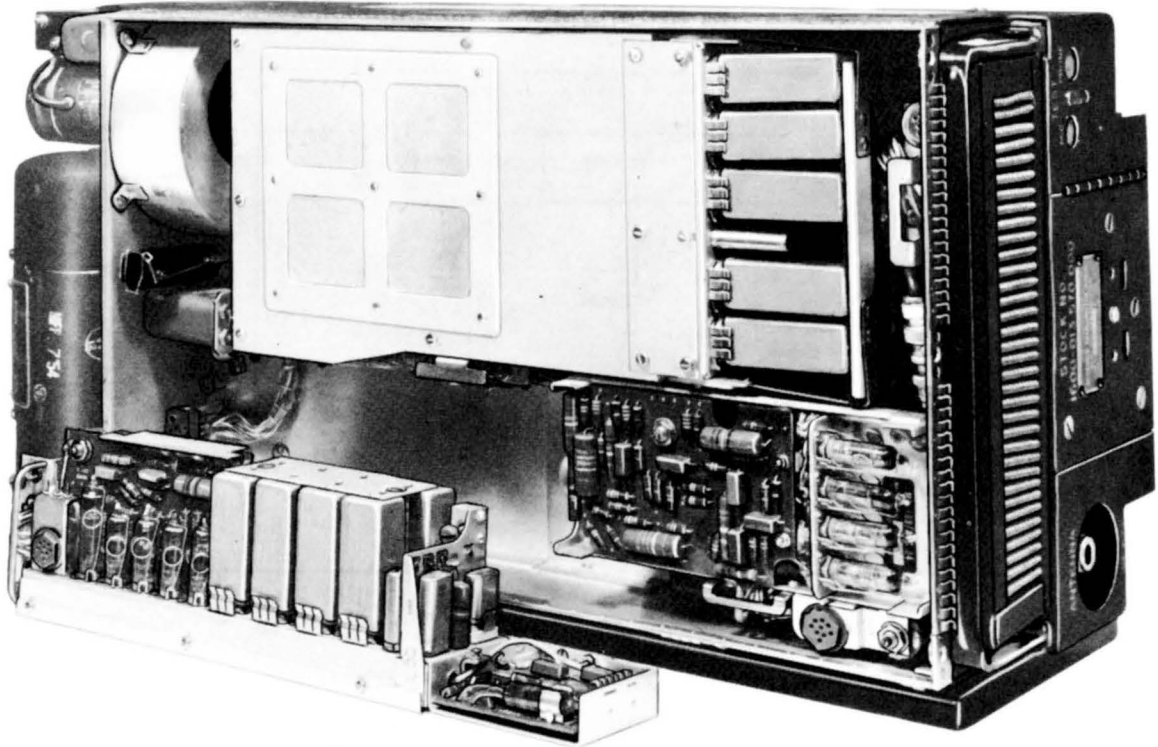

*Receiver Subassembly and the Chassis*

in place and sends the defective subassembly back to the depot for maintenance.

### **ADDITIONAL UHF DEVELOPMENTS**

#### **Tuned Cavities and Pencil Tubes**

Conventional tuned circuits, made up of a coil and a variable capacitor, are not possible in the frequency range covered by UHF equipment. Instead, receiver RF amplifiers, oscillators, and mixers are designed around *resonant cavities*.

In order for you to understand what a resonant cavity is and how it operates as a tuned circuit, look at the diagram on page 103. In A, a U-shaped piece of wire is compared to a conventional tuned circuit. The wire itself can be compared to a half of one turn in a conventional coil. Even this half turn has some inductance. Capacitance exists between the two open ends of the U-shaped wire, making up the required capacitance for a tuned circuit. You now have both inductance and capacitance, which is all that is required for a resonant circuit. In a circuit of the type, the physical dimensions of the U-shaped

piece of wire determines its resonant frequency. The resonant frequency is the frequency at which the length of the U is a quarter of one wavelength. As a tuned circuit, the closed end of the U has practically no impedance and the open end has almost infinite impedance.

Since the open end of a U-shaped piece of wire has infinite impedance, a number of similar U's can be fastened together as shown in B to form a complete cylinder. The resonant frequency of the cylinder is still the same as the resonant frequency of the single U. This cylinder is called a resonant cavity. When used as an oscillator, the oscillations take place within this cavity and therefore there is a minimum loss of energy. To start the cavity oscillating, an inductive loop can be inserted in the cavity at the proper point, shown in C. It sets up a magnetic field within the cavity. Another inductive loop can be placed in the cavity to take some of the energy out to be applied to another circuit.

In a UHF receiver, resonant cavities are used for the RF amplifier, oscillator, and

mixer. The output frequency of the mixer, being a much lower frequency, is applied to a conventional IF circuit.

Special tubes have been designed to function with the resonant cavity. One tube of this type is the pencil triode.

The tube is inserted in the center of the cavity so that the grid flange makes electrical connection with one side of the cavity and the plate flange makes electrical connection with the other side of the cavity. This is shown in D in the illustration at the right.

### Mechanical Filter

Some modern command sets use a mechanical filter between two IF stages to limit the frequencies passed from one stage to the next to a certain band. A filter of this type is illustrated below.

This filter operates on the principle of magnetostriction. Briefly, this principle is explained as follows. When nickel is subjected to a magnetic field, it contracts. When the field is removed, the metal returns to its normal size.

The inner portion of the filter, consisting of couplers and resonators fastened together, is shown in the illustration. This unit fits inside of the hollow tube. At each end of the tube there is a coil of wire. When the intermediate frequency is applied to the coil at one end, the resonators between the couplers contract and expand at the intermediate frequency. This motion is transferred to the other end of the unit. The last coupler is caused to move back and forth in the metal tube changing a flux through the coil at the other end, inducing a voltage in that coil at the intermediate frequency.

The physical dimensions of the coupler and resonators that make up the inner element determine the resonant frequency of the mechanical filter. Small magnets are fastened to both ends, near the coils, to dampen the movement of the inner element so that the output frequency is not doubled.

The mechanical filter has a nearly perfect *shape factor*. That is, the bandpass characteristic allows almost equal passing of a de-

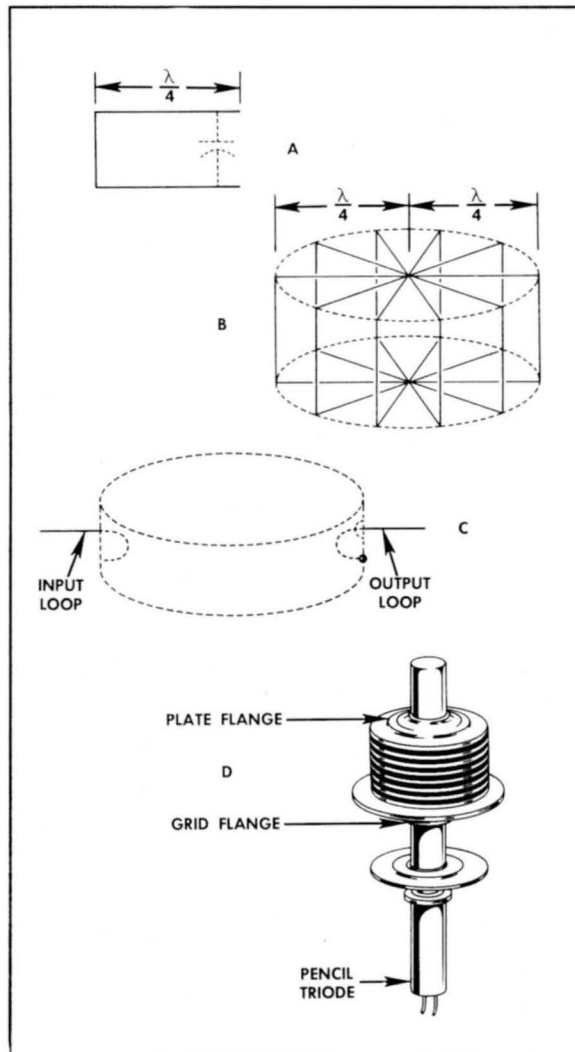

Resonant Cavity

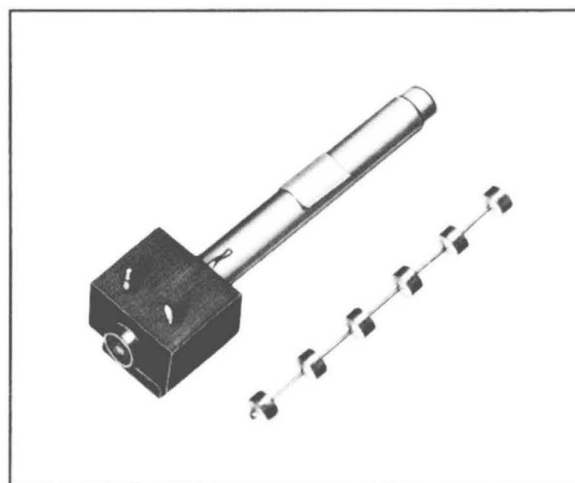

Mechanical Filter



sired band of frequencies and almost complete attenuation of the undesired frequencies.

### Test Points

Since UHF components are so small and the subassemblies are so compact, it would be very difficult to take voltage readings in some parts of a subassembly. To simplify troubleshooting, test points are built into the subassemblies. Such a test point is shown in the subassembly on page 101. The test equipment that was designed for use with this equipment has an 8-pin plug that fits into this receptacle. The plug is wired directly to a special test meter and a multiple switch selects the circuit to be tested.

In the test point shown, there are nine connections, as follows: A connects to the 120-volt line in the guard receiver. B connects to the 120-volt source from the power supply. C connects to the 120-volt line in the main receiver. D connects to the series-parallel filament circuit. E connects to a resistor in the oscillator grid circuit so that you can see if the oscillator is working. F, H, and J are blank in this particular test receptacle, and K is connected to a common ground.

### BUTLER OSCILLATOR

The Butler oscillator, used in the ARC-27 receiver, deserves a separate study. The oscillator is formed by combining a grounded-grid amplifier circuit with a cathode follower circuit and a crystal. Looking at the circuit diagram, assume that both tubes are conducting. Assume, also, that a random positive pulse appears on the cathode of V1. Since the grid of V1 is grounded, the cathode becomes more positive in respect to the grid, and plate current decreases. This means that the plate voltage of V1 increases. The plate of V1 is coupled to the grid of V2. Thus, an increase in the plate voltage of V1 means an increase in the grid voltage of V2. Plate current in V2, therefore, increases. As a result, the voltage drop across the cathode

resistor of V2 increases and the voltage at point X becomes more positive. However, point X is coupled to the cathode of V1 through the crystal. This provides a feedback path. Now note that C and L form a tank in the grid circuit of V2. The pulse of positive voltage triggers oscillations in the tank circuit. Therefore, the grid voltage of V2 varies with the oscillations of the tank, and current through V2 rises and falls at the tank frequency.

At the same time, the voltage at X rises and falls with the tank frequency. Therefore, the crystal, series resonant at the same frequency, couples the signal pulses to the cathode of V1 which are in phase with the tank oscillations. Thus V1 continues to supply feedback to the tank circuit in order to keep it in oscillation.

The Butler oscillator, as used in this receiver, uses 18 different crystals and 18 different tank coils to cover (with the help of multipliers) a range from 180 to 350 mc in 10-mc increments.

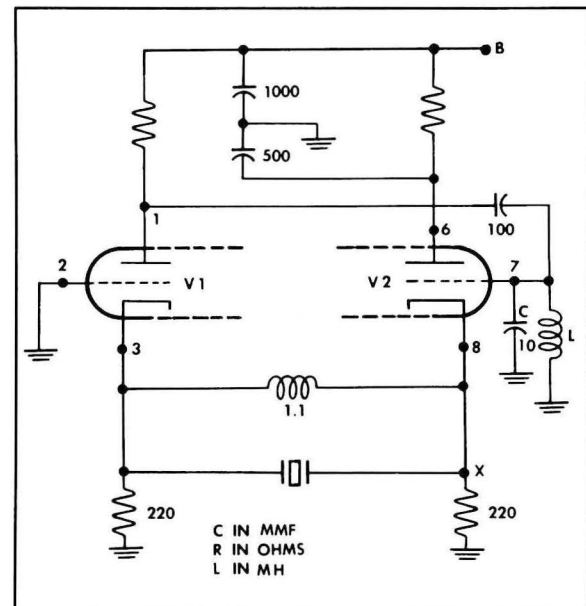

Basic Butler Oscillator

## FREQUENCY MODULATION

Frequency modulation (FM) is achieved by varying the *frequency* of a carrier wave by the use of an audio signal. The frequency variations constitute the intelligence carried by the transmitted wave.

This chapter is devoted to the theory of FM and the analysis of a typical FM receiver used in the Air Force.

### FM IN COMMUNICATIONS WORK

FM is one of several types of special radio transmission which are used as radio links in communications systems when wire links are impracticable. An FM link, as part of the overall communications system, handles the regular traffic of the system, whether that traffic be telephone, telegraph, or teletypewriter communication.

FM transmission is especially valuable as a radio link because its naturally wide audio bandpass permits multichannel operation over a single RF channel. The wide audio bandpass can be divided at various frequency levels to provide a number of separate communication channels. For example, a bandpass of 12,000 cycles can be divided into four separate channels, each approximately 3,000 cycles wide. A channel of 3,000 cycles is very satisfactory for voice communication. Thus, each of the four channels, one below 3,000 cycles, one between 3,000 and 6,000 cycles, one between 6,000 and 9,000 cycles, and one between 9,000 and 12,000 cycles, might carry a separate voice message. All messages would be impressed simultaneously on a single carrier as a complex pattern of audio modulation.

The division of audio frequencies into separate channels usually is not accomplished in either the FM transmitter or receiver. Rather, it is accomplished somewhere in the communications network before the messages are delivered to the transmitter for modulation. As modulation, the frequencies of only one channel, the lowest frequency channel, are at normal voice frequencies. Only the lowest channel, if heard alone, would be intelligible. If all four channels were heard together, they would be completely unintelligible. The separation of the channels into separate intelligible messages takes place somewhere in the communications network after the receiver has passed along its audio output to the rest of the system.

The modulation for each audio channel begins at a separate microphone and is composed of the normal voice frequencies. The modulation for each audio channel is then passed through a filter which cuts off all frequencies above 3,000 cps. The modulation for the lowest audio channel is then delivered without further change to the transmitter. The modulation for each of the other audio channels is stepped up to a higher level by the use of a beat oscillator and several bandpass filters. For example, the modulation for a 3,000- to 6,000-cycle audio channel can be heterodyned against a 3,000-cycle beat oscillator. The result would be the sum of the modulation (below 3,000 cycles) and the beat oscillator. This would constitute a band between 3,000 and 6,000 cycles. To insure delivery of only the sum frequencies to the

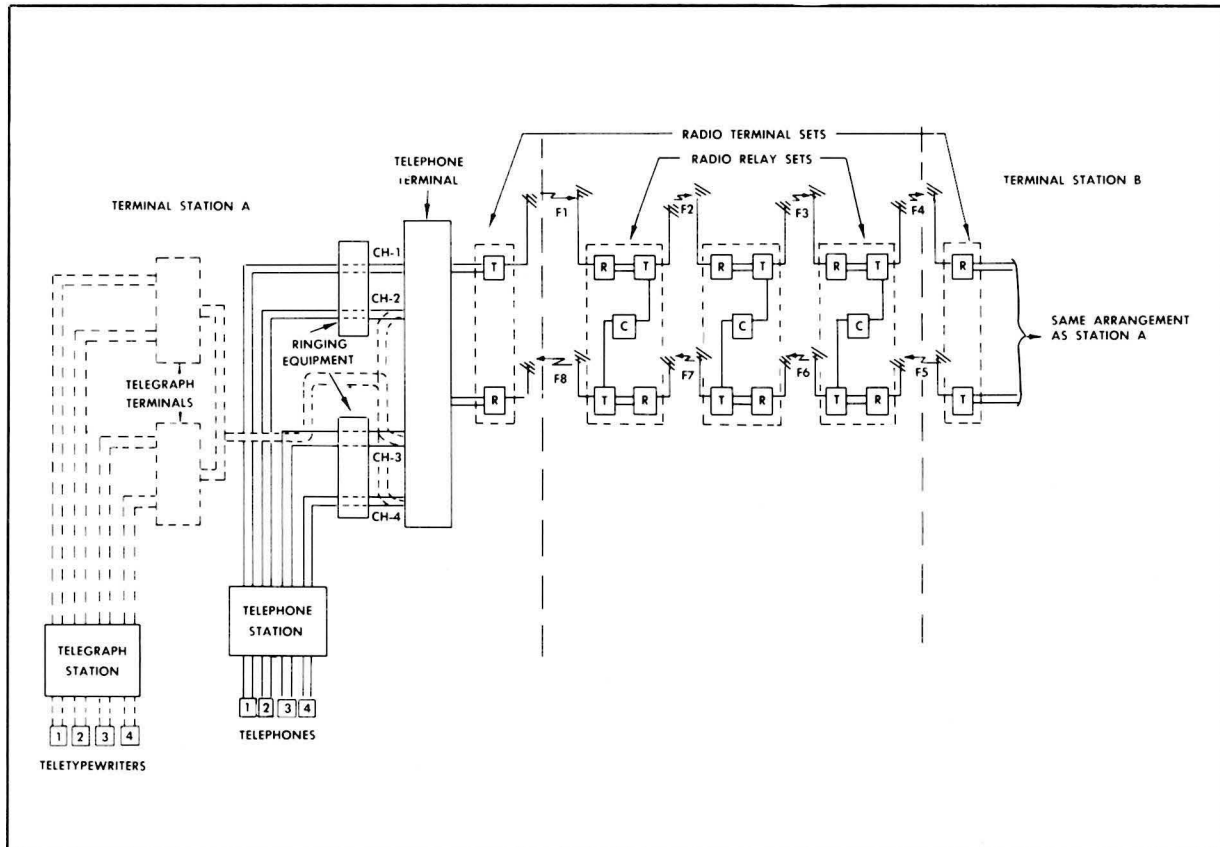

Communications System Using an FM Radio Link

transmitter, a filter is used. This band passes through the FM transmitter and receiver. Then, before it reaches the terminal headsets or speaker, it is restored to the original audio frequencies (below 3,000 cycles) by use of another beat oscillator and at least two more filters.

While passing through the FM transmitter and receiver, each audio channel is separated from the other audio channels only by a difference in frequency. A speaker reproducing the audio output of a multichannel FM receiver would reproduce all channels simultaneously, and the result would be unintelligible. Therefore, an FM receiver designed for communications work has a filter in its own speaker circuit which passes only the frequencies of the lowest audio channel. Thus, one channel can always be heard at the receiver site. This channel is usually reserved for monitoring transmissions and for communications between the receiver site and

other positions in the system.

While an audio channel 3,000 cycles wide is adequate for voice communication, it is more than adequate for telegraph communication. A 3,000-cycle band can handle as many as four simultaneous telegraph messages. To provide four telegraph channels for each voice channel, another arrangement of beat oscillators and filters is used. Thus, a multichannel communications system with four voice channels might be divided into as many as sixteen telegraph channels and all could be transmitted as modulation on one FM carrier wave.

Notice the block diagram of a multichannel communications system using an FM radio link above. There is a single transmitter and receiver at each end of the radio link. However, since relay stations are used, there are two transmitters and two receivers at each relay station. The variety of frequencies used in the system (F1, F2, F3, etc.) is

due to the necessity for preventing interference between transmitters and receivers at the terminals, and, especially, at the relay stations. The block diagram shows, at terminal A, how telegraph and telephone circuits are connected into the transmitter receiver radio link.

**PRINCIPLES OF FM OPERATION**

Now study the block diagram below of a typical FM communications receiver designed to serve as a radio link in a communications system. This receiver is a superheterodyne, employing double conversion. Though it is capable of covering a frequency range 70-100 mc, it provides only single channel operation. Changing from one operating frequency to another is essentially a bench job. The crystal of the heterodyne oscillator

must be replaced, and the RF, mixer, and high IF stages must be aligned to a new signal and high intermediate frequency.

Receivers for FM, whether commercial receivers or communications receivers, are invariably superheterodynes. Single or multiple conversion systems can be used. Notice the oscillator-mixer arrangement indicated on the block diagram. It is a crystal controlled heterodyne oscillator that provides single channel operation, and serves as oscillator for both the high IF and the low IF. It is used only in communications receivers. A typical commercial FM receiver uses an oscillator with tuning controls continuously variable over its tuning range and ganged with the tuning controls of the RF and mixer stages.

One oscillator can provide the beat fre-

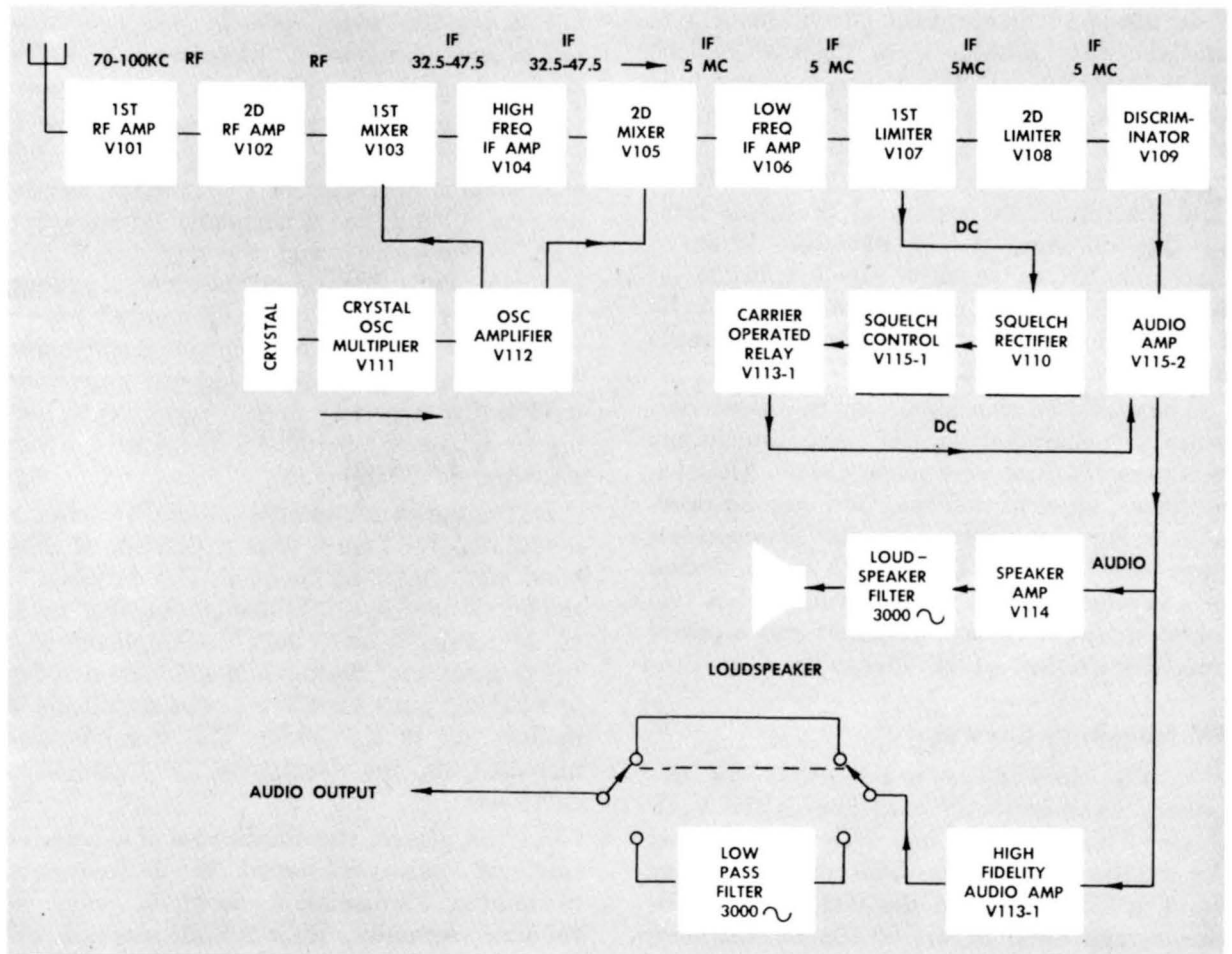

FM Communications Receiver

quency to produce both the 1st IF and the 2d IF by operating at a frequency slightly higher than half the RF signal to be received. In the receiver shown, the oscillator frequency is 2.5 mc higher than half that of the desired RF signal. Thus, if the desired RF signal frequency were 80 mc, then the oscillator would supply a 42.5 mc signal to the first mixer. This would produce a difference frequency of 37.5 to serve as the high IF. The same oscillator frequency when applied to the second mixer would produce a difference frequency of 42.5 mc minus 37.5 mc, or 5 mc. No matter what the desired radio frequency might be, if the heterodyne oscillator is tuned to a frequency 2.5 mc higher than half the RF signal, the 2d IF is always 5 mc. Thus, the tuning of the 2d IF does not have to be changed when a new operating frequency is selected.

In the block diagram the two limiter stages and the discriminator stage together replace the detector stage of the AM superheterodyne receiver. An arrangement of one or two limiters and a discriminator is common in both commercial and communications FM receivers. The discriminator, explained in detail later in this chapter, is the detector. When a discriminator is sensitive to amplitude as well as frequency modulation it must be preceded by one or two limiters to eliminate amplitude variations.

The audio section shown in the block diagram is characteristic of communications receivers. It has a squelch circuit (squelch rectifier, squelch control, and carrier-operated relay) and filter circuits (loudspeaker filter and low pass filter). The audio section of a commercial FM receiver usually has two audio stages, a voltage amplifier and a power amplifier driving a high fidelity speaker.

### FM Frequency Coverage

In the block diagram note that the frequency band is 70-100 mc. This is the VHF range. This band is one of two bands used for military operation. The other military band is 230-250 mc in the UHF range. The commercial band covers 88-108 mc. Because FM operates at such high frequencies, only line-of-sight transmission is possible. There-

fore, relay stations have to be used when FM serves as a radio link. The high frequencies also account for the common use of multiple conversion in the superheterodyne FM receivers.

Such high frequencies are the result of a need to accommodate very wide channels in the FM operating band. For commercial operation a channel is 200 kc wide. This means that the commercial band, 88-108 mc, with its coverage of 20 mc, can accommodate 100 channels. For military operation, a channel is 100 kc wide. This means that the low military band, 70-100 mc, covering 30 mc, can accommodate 300 channels, while the high military band, 230-250, covering 20 mc can accommodate 200 channels.

### Sidebands

Any modulated radio signal, whether AM or FM, contains many radio frequencies. These frequencies consist of the carrier plus the sidebands. Normally sidebands occur in pairs.

In amplitude modulation, when a carrier is modulated by a pure tone, a single pair of sidebands is formed. One sideband, called the upper sideband, has a frequency equal to the sum of the carrier and the modulation frequencies. The other, called the lower sideband, has a frequency equal to the difference between the carrier and the modulation frequencies. Thus, an audio tone of 3,000 cps amplitude modulating a carrier of 100 mc produces an upper sideband of 100.003 mc and a lower sideband of 99.997 mc.

In frequency modulation, when a carrier is modulated by a pure tone a number of sideband pairs may be formed. The number of sidebands which result from frequency modulation depends upon both the amplitude and the frequency of the modulation. The number of sideband pairs increases as the amplitude of modulation is increased. The number also increases as the frequency of modulation decreases.

At first glance, the amplitudes of successive sideband pairs contained in a frequency modulated transmission seem to vary at random. Actually, their amplitudes are explained by higher mathematics involving Bessel functions. While the amplitude of many

sidebands close to the carrier may be less than that of side bands farther from the carrier, at a point sufficiently distant from the carrier the amplitude of sidebands diminishes and effectively disappears. The edge of the bandwidth is marked by the last sideband pair the amplitude of which exceeds one percent of the amplitude of the unmodulated carrier.

### Frequency Deviation

In AM operation, the frequency of a transmitter is maintained at maximum stability to keep it within the limits of its assigned channel. If an AM transmitter is stable, it can operate with complete satisfaction within a narrow channel. In FM operation, the stability of the transmitter presents an entirely different problem. Since the FM carrier wave is modulated by varying its frequency, its frequency must vary in response to audio voltages. When the modulation frequency goes positive, the transmitter frequency increases. When the modulation voltage goes negative, the transmitter frequency decreases. The *rate of change* back and forth, above and below the unmodulated frequency is determined by the audio modulation frequency. The *amount of change* (the difference between the unmodulated frequency and the highest or lowest frequency) is determined by the audio modulation amplitude. The amount of change is called the *deviation*. The unmodulated frequency is called the *resting frequency*. Thus, deviation is determined by the amplitude of the audio modulation.

### Modulation Index

Modulation in FM is usually expressed in terms of the *modulation index*. The modulation index is the ratio of the frequency deviation to the modulation frequency. Thus, if the deviation is 10 kc when modulated by a 5-kc signal, the modulation index is 10/5 or 2. To see how the modulation index is related to the number of effective sidebands, look at the chart at the right.

Note that the number of effective sideband pairs increases as the modulation index increases. Since the modulation index is the ratio of deviation to modulation frequency, it can be increased either by increasing the

SIDE BAND PAIRS VERSUS MODULATION INDEX	
MODULATION INDEX	NUMBER OF EFFECTIVE SIDE BAND PAIRS
0.5	2
1	3
2	4
3	6
4	7
5	8
6	9
7	11
8	12
9	13
10	14
11	15
12	16
13	17
14	18
15	19
16	20
17	21
18	23
19	24
20	25

deviation or by decreasing the modulation frequency. If the deviation is increased, the bandwidth increases as shown at A in the illustration on page 111, and the number of effective sideband pairs increases as shown in the chart. If the modulation frequency is decreased, the bandwidth decreases as shown at B in the illustration on page 111, while the number of effective sideband pairs increases as shown in the chart. Since the governing body limits the amount of deviation and sets a maximum modulation frequency, there is always a corresponding maximum value of the modulation index for the maximum modulation frequency. This is called the *deviation ratio*. For example, in civilian operation, the maximum deviation of 75 kc divided by the maximum modulation frequency of 15 kc results in a corresponding modulation index (deviation ratio) of 5. However, a lower amplitude of a 15-kc modulation signal will produce a deviation less than 75 kc and a correspondingly smaller modulation index while a 75-kc deviation produced by a modula-

tion whose frequency is less than 15 kc results in a correspondingly larger modulation index.

Successful reproduction of a number of sidebands requires that the receiver pass a wide channel of radio frequencies, and, after detection, a wide band of audio frequencies. FM receivers usually are designed to handle audio frequencies up to 15 kc. Thus, the tuned circuits of FM receivers usually have low Q and low selectivity. They are specially designed for level response over a wide range of frequencies.

Except for their low selectivity, the RF and IF circuits in an FM receiver are very much like those you studied in VHF and UHF receivers. FM antennas are usually broadly tuned directive arrays arranged for line-of-sight transmission. The RF tubes are special high frequency types. Segments of resonant transmission line are frequently used as tuned circuits. Leads are kept short and are formed of heavy wire or hollow tubing. Concentric line is usually used as transmission line. Considerable shielding and RF bypassing are employed.

### **Bandwidth**

The width of the section of the radio frequency spectrum (bandwidth) occupied by a frequency modulated transmission depends primarily upon the amount of deviation. This bandwidth can never be less than twice the deviation. The relationship between bandwidth and deviation with the modulation frequency fixed at 15 kc is shown at A, on page 111. Note that as the deviation is increased, the bandwidth also increases rapidly. For this reason, the maximum allowable deviation is set by the FCC (Federal Communications Commission) for civilian sets and by the JCEC (Joint Communications-Electronics Committee) for military sets. The maximum deviation assigned by the governing body is defined as "100 percent modulation." There is no natural limit in FM as there is in AM, to determine the value of 100 percent modulation. In AM, 100 percent modulation is reached when the amplitude of the modulation is sufficient to drive the carrier amplitude periodically to zero. Modulation beyond that point causes distur-

tion in the transmitted signal. In FM, however, modulation beyond 100 percent causes no distortion in the transmitted signal. Therefore, in FM, the maximum deviation set by the governing body is defined as "100 percent modulation" since this deviation is produced by the maximum allowable amplitude of modulation just as 100 percent modulation in AM is produced by the maximum desirable amplitude of modulation.

For one military set (the AN/TRC-1) the maximum deviation has been set at 30 kc or a total frequency swing of 60 kc. This results in a minimum bandwidth of 60 kc when maximum deviation is used. The actual bandwidth for maximum deviation is usually larger than this since the bandwidth also depends upon the frequency of modulation.

For civilian operation, the maximum deviation has been set at 75 kc, or a total frequency swing of 150 kc. Therefore, the minimum bandwidth is 150 kc when maximum deviation is used. Again, the actual bandwidth for a 75-kc deviation is usually more than this depending upon the modulation frequency. Of course, the maximum deviation (30 kc or 75 kc) occurs only when the amplitude of the modulating voltage is maximum. Since the average modulation level is usually less than maximum, the average deviation, and thus the band of frequencies occupied by the transmission, is usually somewhat less than the maximum allowable value.

Bandwidth also depends upon the modulation frequency. The relationship between bandwidth and modulation frequency with deviation fixed at 75 kc is shown at B on page 111. Note that as the modulation frequency is increased, the bandwidth also increases slightly. Thus the band of frequencies occupied by an FM transmission depends primarily upon the deviation and to a lesser extent upon the modulation frequency. For commercial operation, the assigned channel width is 200 kc, the maximum deviation is 150 kc, and the maximum modulation frequency (if interference is a problem) is 15 kc. Thus the RF and IF amplifiers in commercial transmitters and receivers must have sufficient bandwidth to pass a very wide band of frequencies.

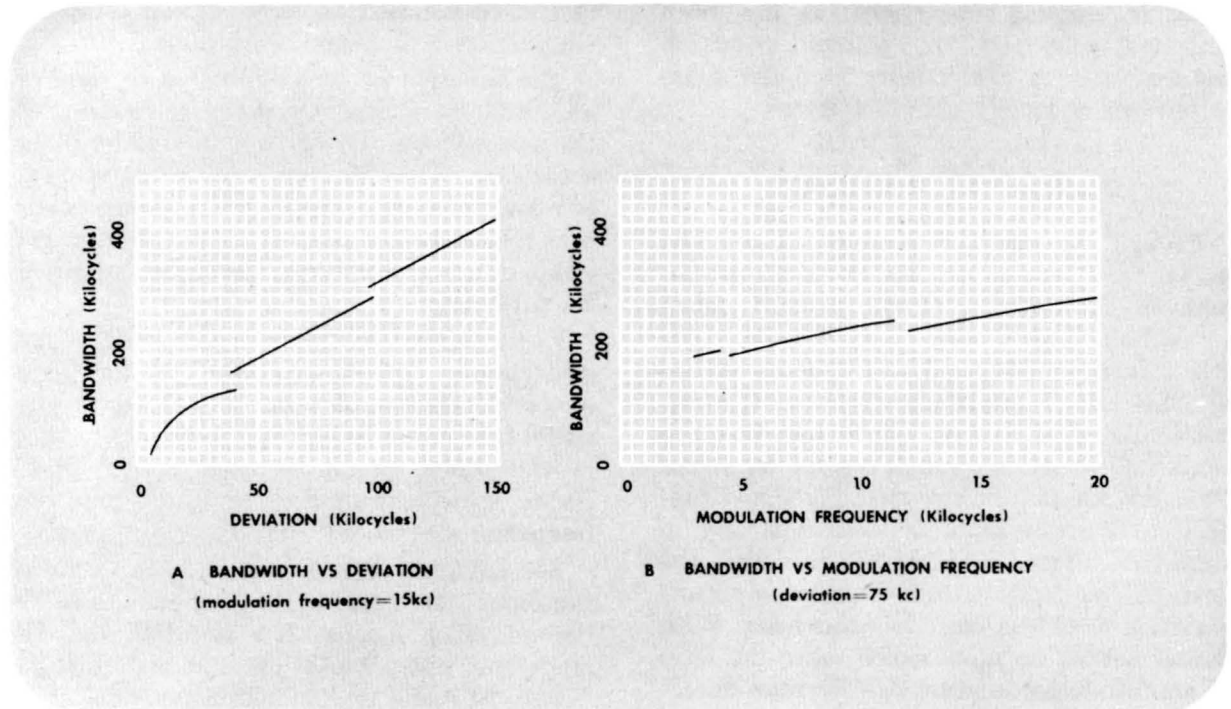

*Bandwidth of FM Transmissions*

The bandwidth of RF circuits in military sets is engineered to suit the purpose of the set. The AN VRC-19 vehicular communications set has a maximum deviation of 15 kc, and a maximum modulation frequency of about 3,500 cps while the bandwidth of the receiver's RF circuits is approximately 20 kc. This set uses narrow band frequency modulation (NBFM). This is possible since a wide band of audio frequencies is not necessary for adequate voice or code communications. When NBFM is used, interchannel interference is reduced, more stations can be accommodated in a given frequency spectrum, and the transmitter and receiver equipment can be of simplified design and thus more easily adapted for mobile operation. On the other hand, the AN TRC-1 radio relay multichannel equipment has a maximum deviation of 30 kc, and a maximum modulation frequency of 12 kc. The minimum acceptable bandwidth of its RF tuned circuits is 80 kc. Also, the AN TRC-8 radio relay multichannel equipment has a maximum deviation of 100 kc, a maximum modulating frequency of 12 kc, and the bandwidth of its RF tuned

circuits is approximately 300 kc. These two sets can be used for multichannel operation in which the audio band is divided into four channels of approximately 3000 cps bandwidth each so that the same RF carrier supports four audio channels simultaneously.

### **Fidelity**

Fidelity is a measure of the ability of the receiver to reproduce the modulation existing on the RF carrier. Actual sounds, whether voice, or music, are rich in harmonics. Harmonics give sounds a richness and depth which the human ear treats as natural. Thus, to reproduce sounds that seem natural, a radio receiver must reproduce the harmonics as well as the fundamentals. This requires that it be able to pass a wide band of audio frequencies. In AM broadcast practice, the maximum allowable audio frequency (where interference is a problem) is set at 5 kc by the FCC. In commercial FM broadcast practice, the maximum allowable audio frequency (where interference is a problem) is set at 15 kc. Obviously, under these conditions, FM systems have greater fidelity than AM sys-



tems. In military operations, as has been indicated, voice and CW communications do not require such high fidelity, and the audio bandwidth is usually about 3000 cps.

### DISCRIMINATOR CIRCUITS

Though RF and IF sections of an FM receiver are very much like those of an AM receiver, the detector circuit (usually called a discriminator) is very much different. The discriminator must react to frequency deviation and not to amplitude variation. If a discriminator is of a type which does react to amplitude variations, one or two limiter stages must precede it to insure that the signal supplied to the discriminator does not vary in amplitude. Since intelligence is carried in the form of frequency variation, any amplitude variation would be reproduced as noise. With limiter action, no noise which takes the form of amplitude modulation can be reproduced. Consequently, since noise gets into a receiver in the form of amplitude pulses, FM reproduction is relatively noiseless.

#### Limiters

A two-stage limiter, like that in the receiver block diagram shown on page 107, is in common use. Two stages are used where one stage

cannot be counted on to provide a complete elimination of amplitude variations.

The function of each limiter is to remove amplitude variations. On the positive swing of the grid voltage, the signal is limited by plate saturation. This limiting level is maintained at a low value by operating plates and screens at a relatively low potential. On the negative swing of the grid voltage, the signal is limited by tube cutoff.

Rectification takes place in each limiter tube grid circuit. The signal appears in the plate circuit as pulses of plate current. However, the signal is restored to AC by the flywheel effect of the tuned circuit in each limiter plate circuit. Since the limiters faithfully pass the frequency deviations, no distortion results.

For complete limiter action, each cycle of the input signal must be strong enough to be limited. This means that the RF and IF amplifiers must build up the signal sufficiently to make limiter action possible.

#### Slope Detector

One type of circuit which reacts to differences in frequency is a tuned circuit. Thus, discriminator circuits are essentially special applications of tuned circuits. The slope detector shown below is a simple discriminator.

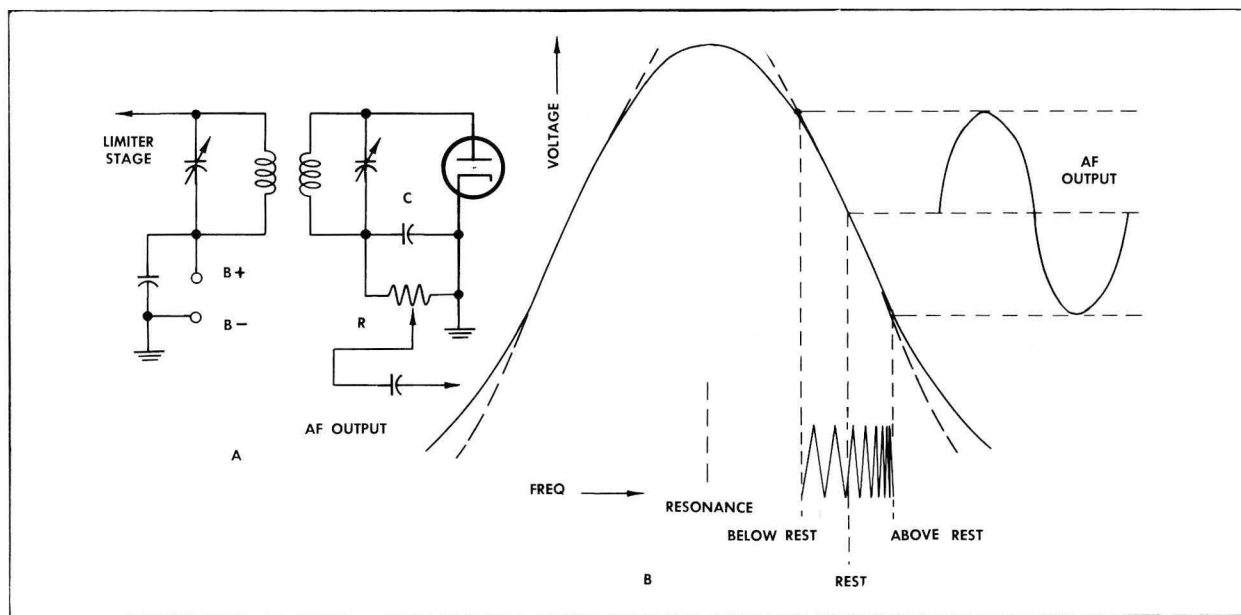

Slope Detector

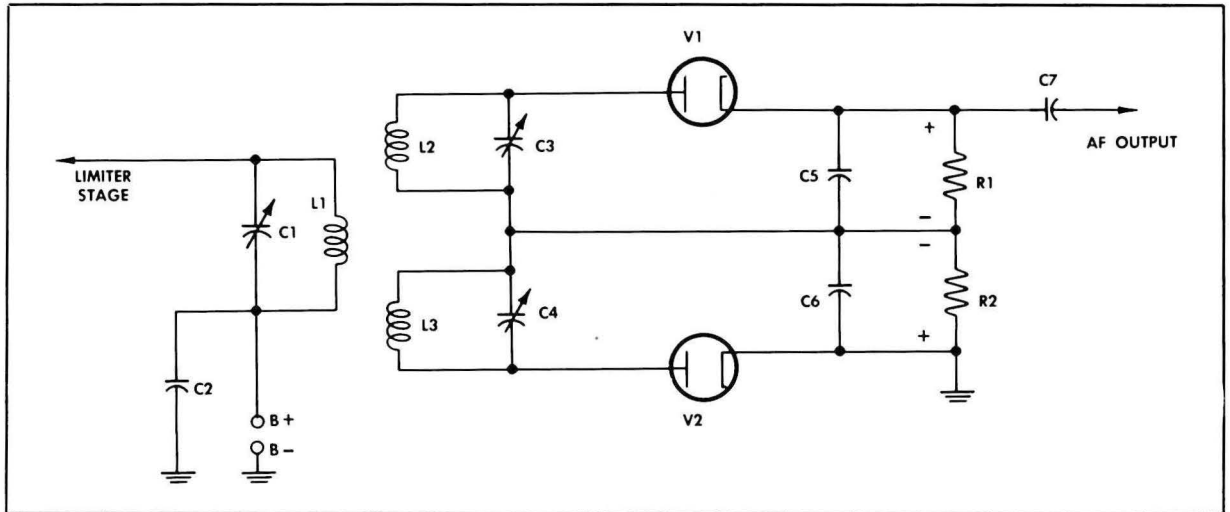

Double-Tuned Detector

The detector, a diode, is connected across the output of a transformer which couples the signal from the limiter. The resonant circuits of both primary and secondary are tuned to a frequency other than the resting frequency of the signals. This means that the tuned circuits do not give maximum response to the resting frequency. They give maximum response to the frequency to which they are tuned. This frequency is close enough to the resting frequency to allow the resonant frequency to fall along the linear portion of the response as shown in B of the diagram.

The response curve of the tuned circuits has two linear portions, one on the rising slope and one on the following slope. Either linear portion could be used, depending on whether the tuned circuits are resonant at a frequency above or below the resting frequency. In the circuit shown here, the tuned circuits are resonant below the resting frequency. Thus, as the signal frequency deviates below the resting frequency, the response of the tuned circuits increases linearly. As the signal frequency deviates above the resting frequency, the response decreases linearly.

The diode rectifies the signal and the time constant of the RC circuit (composed of the diode load resistor and the capacitor across it) is set to follow the variations in tuned circuit response. Thus, the AF output varies in amplitude as the modulated carrier varies

in frequency. The original from of the intelligence has been restored.

The slope detector, though simple in design, is seldom used. It cannot handle large signals because the linear portion of the response curve is too short for large signal operation. Any signals beyond the linear portion of the curve are distorted.

#### Double-Tuned Detector

Another type of discriminator, shown in the illustration above, is called a *double-tuned detector*, or *Travis discriminator*. The signal is coupled to the push-pull tuned circuits through a primary which is tuned to the signal resting frequency. In the secondary, one tuned circuit (L2-C3) is tuned to a frequency above the signal resting frequency, while the other (L3-C4) is tuned to a frequency an equal amount below the resting frequency. Thus, each secondary tuned circuit responds equally to the resting frequency, and each diode conducts an equal amount.

When the signal frequency deviates above the resting frequency, the response of L2-C3 increases while the response of L3-C4 decreases. V1 then conducts more than V2. When the signal frequency deviates below the resting frequency, the response of L2-C3 decreases, while the response of L3-C4 increases. V2 then conducts more than V1.

The load resistor of V1 is R1, and the

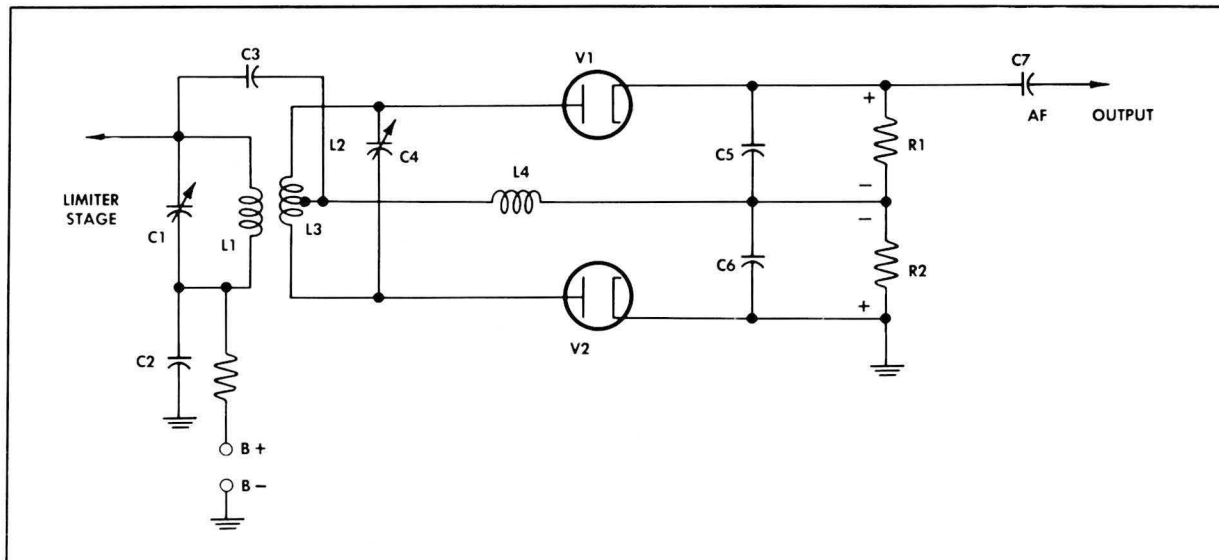

Foster-Seeley Discriminator

voltage drop across R1 reflects the amount that the tube conducts. The load resistor of V2 is R2, and the voltage drop across R2 reflects the amount that V2 conducts. The voltage drops across R1 and R2 are of opposite polarity since current flows through the resistors in opposite directions.

This means that the total voltage drop across the resistors when the tubes conduct an equal amount (at the resting frequency) is zero, because the voltage drops cancel. When V1 conducts more than V2 (above the resting frequency), the total voltage drop is positive. When V2 conducts more (below resting frequency), the total voltage drop is negative. The total voltage drop follows the frequency deviation. Thus, the total voltage drop reproduces the intelligence as an AF voltage.

### Foster-Seeley Discriminator

**GENERAL DISCUSSION.** Now look at the diagram of a *Foster-Seeley* discriminator above, sometimes called a *phase discriminator*. This type is in common use. The output of the limiter is transformer-coupled to the discriminator. The primary and secondary of the transformer are parts of resonant circuits, tuned to the IF signal resting frequency. The output of the limiter is also capacitively coupled to the discriminator. Thus, the output of the limiter is applied to the discriminator

by two coupling methods. This is necessary in order to obtain discriminator action.

C2 and C3 are effectively short circuits at the intermediate frequencies. Thus, the bottom of the transformer primary is effectively grounded. C3 also acts as a short circuit at these frequencies. Therefore, the signal appearing across the transformer primary also appears across L4. This voltage is applied to both diodes since one end of L4 is connected to the diode cathodes and the other end is connected to the diode plates through the transformer secondary. Thus, the total voltage applied to the upper diode, V1, is the sum of the voltage across L4 and the voltage across the upper half of the transformer secondary, L2. The total voltage applied to the lower diode, V2, is the sum of the voltage across L4 and the voltage across the lower half of the transformer secondary, L3.

At first glance, it would appear that the total voltage applied to one diode is equal to that applied to the other. However, the total voltage applied to either diode is the vector sum of two voltages. Note, also, that when the voltage across the upper half of the transformer secondary, L2, causes V1's plate to be positive, the voltage across the lower half of the transformer secondary, L3, causes V2's plate to be negative. Thus, these two voltages effectively are 180° out-of-phase with each

other. This means that the total voltage applied to V1 is not necessarily equal to the total voltage applied to V2. For example, if the voltage across L2 is in phase with the voltage across L4, the total voltage applied to V1 will be large, being the sum of two in-phase voltages, while the total voltage applied to V2 will be small, being the sum of two out-of-phase voltages.

Actually, the phase relationship between the transformer secondary voltages and the voltage across L4 varies in step with the input frequency variations. At the IF resting frequency, the voltage across L2 leads the voltage across L4 by  $90^\circ$  while the voltage across L3 lags the voltage across L4 by  $90^\circ$ . Therefore, with rest frequency input, the total voltages applied to V1 and V2 are equal and the diodes conduct equally. Note that V1's current is upward through R1 tending to cause the top of resistance network, R1 and R2, to be positive with respect to ground, while V2's current is downward through R2 tending to cause the top of the network to be negative with respect to ground. Thus, with rest frequency input, voltages across R1 and R2 are equal and of opposite polarity so that the top of R1 is at ground or zero potential.

At frequencies above the IF resting frequency, the voltage across L2 tends to be more nearly in phase with the voltage across L4 while the voltage across L3 tends to be more out of phase with the voltage across L4. This causes the total voltage applied to V1 to

exceed that applied to V2. The voltage drop across R1 is then greater than the voltage drop across R2 and thus the top of R1 is positive with respect to ground.

By a similar process of reasoning it can be determined that at frequencies below the IF resting frequency, the top of R1 is negative with respect to ground.

Since the input frequency is varying above and below the resting frequency at the modulation rate, the top of R1 varies above and below ground potential at the modulation rate. This audio voltage is coupled by C7 to the following AF stages. Capacitors C5 and C6 act as filters to prevent any IF in the discriminator output. Their action is similar to the action of the filter capacitor across a regular diode detector load resistor.

**DETAILED DISCUSSION.** To understand exactly what goes on in the circuit, it is necessary to know how the tuned, centertapped, secondary circuit operates. Refer to the illustration below. First, as in any transformer, the primary ( $E_p$ ) and secondary voltage ( $E_s$ ) are  $180^\circ$  out of phase. The current that is induced in the secondary ( $I_s$ ) flows up and down through the secondary coil (L2-L3). Consider just the coil part of the secondary. You know that a coil has inductance. This inductance causes the voltage across the secondary coil to be  $90^\circ$  out of phase with the current through it. This voltage is called the *reactive voltage* and is different from the voltage across the tuned secondary. Also, since the

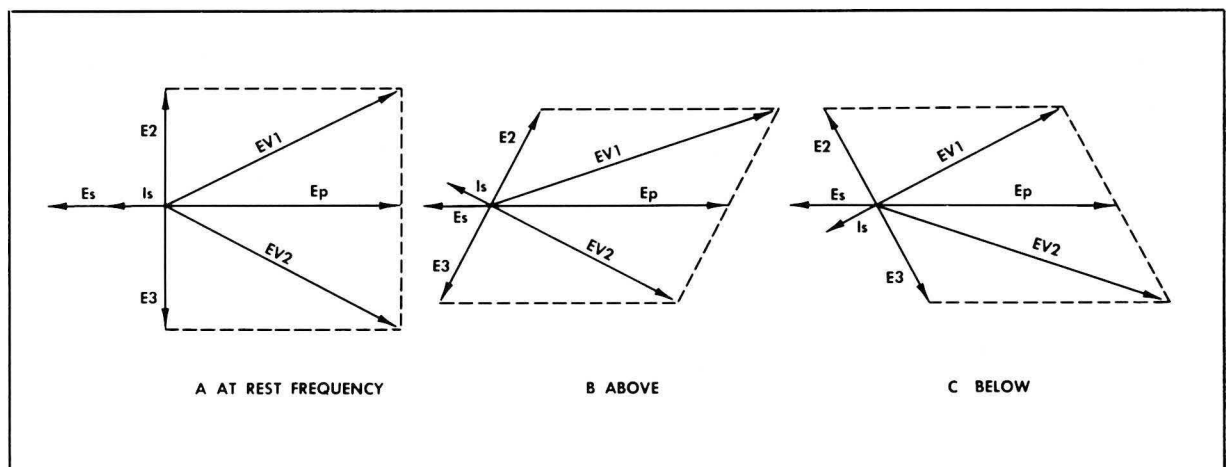

Discriminator Operation

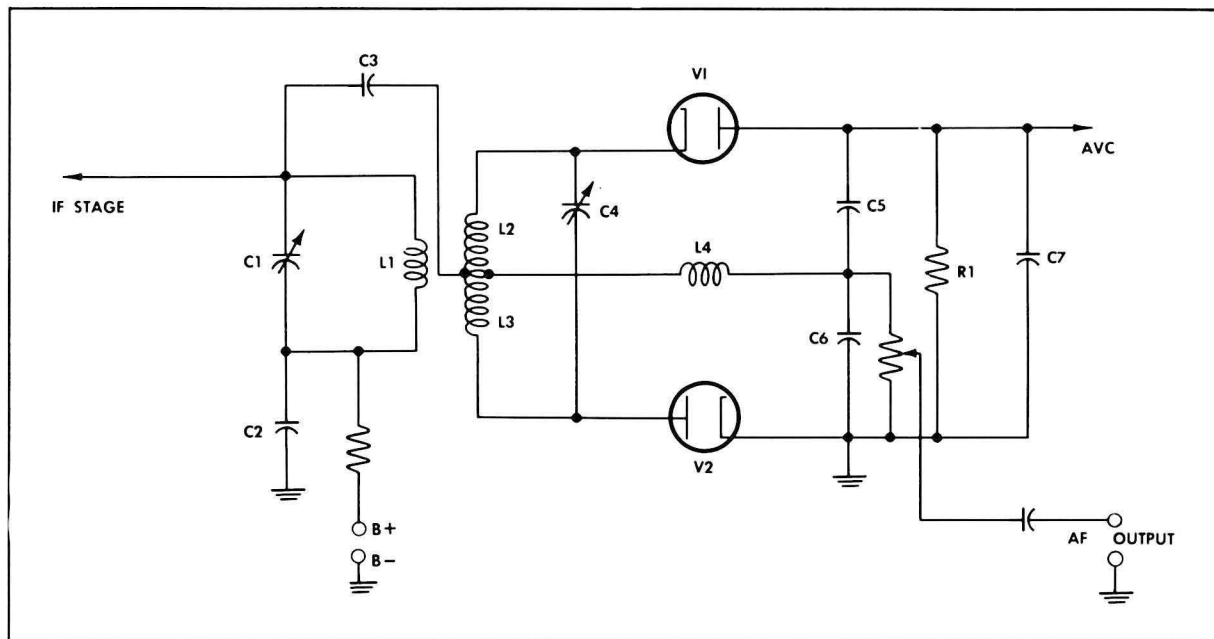

Ratio Detector

secondary is centertapped, the voltage across the upper half of the secondary coil is  $180^\circ$  out of phase with the voltage across the lower half. At A, in the diagram on page 115, the reactive voltage across L2 is called E2 and the reactive voltage across L3 is called E3. The primary voltage ( $E_p$ ), coupled through C3 and developed across L4, is used as a reference and is therefore drawn at  $0^\circ$ . The total voltage applied to V1 is the vector sum of the reactive voltage across L2 (E2) and  $E_p$ . The total voltage applied to V2 is the vector sum of the reactive voltage across L3 (E3) and  $E_p$ . The voltages applied to the two diodes are therefore equal as shown. This causes both diodes to conduct a like amount and the resultant voltage across the cathode resistors is zero. This is the condition that exists when the signal is passing through the resting frequency.

When the frequency applied to the secondary is above the resting frequency, at B, the whole secondary is no longer a resonant circuit but is a series inductive circuit in itself. This causes the current through the secondary coil ( $I_s$ ) to lag the voltage across the secondary circuit. ( $E_s$  and  $E_p$  are still  $180^\circ$  out of phase.) This causes the reactive voltages to shift as shown in B, because one still leads  $I_s$  by  $90^\circ$  and the other still lags  $I_s$  by  $90^\circ$ . The resultant

voltage applied to V1 is now greater than the resultant voltage applied to V2. Therefore, V1 conducts the most and the resultant output voltage is positive.

When the applied frequency goes below the resting frequency (at C), the secondary becomes a capacitive series circuit within itself and  $I_s$  leads the secondary voltage. The net result of this is that V2 conducts the most and the output is negative.

Summarizing the operation of the discriminator, deviation above the resting frequency reproduces the positive portions of the audio voltage and deviation below the resting frequency reproduces the negative portions of the audio voltage. The IF variations are filtered out by C5 and C6.

**SINE WAVE EXPLANATION.** The discriminator shown at the right is used in the AN/ARN-14 receiver. The operation of this circuit is almost identical to the one on page 114, but the following explanation will deal with sine wave voltages instead of vectors to give you a different slant on discriminator operation.

Due to the construction of transformer T, the voltage appearing between terminals 1 and 2 also appears across coil C which is

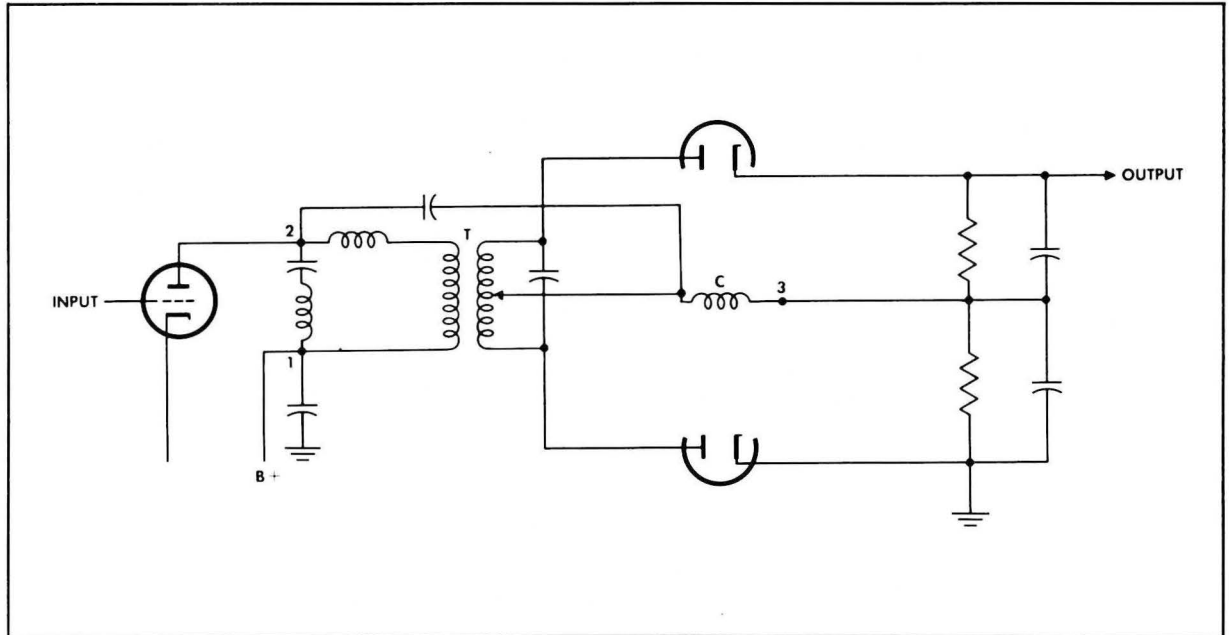

Discriminator, AN/ARN 14 Receiver

connected between terminals 2 and 3. Regardless of the input frequency, this voltage is applied in phase to both diodes. However, the action of the entire circuit does depend upon the change in frequency of the input signal because the tuned secondary (9960 cps) causes a varying phase difference in the induced voltages applied to the two diode plates.

The action of this transformer is illustrated on page 118. Waveform A shows the sinusoidal voltage across the primary of the transformer. Since the primary winding of the transformer is almost purely inductive, the current through it lags this voltage by approximately  $90^\circ$ . This lag is illustrated by waveform B. Note that the negative current peak of waveform B occurs just  $90^\circ$  later (in time) than the negative voltage peak in waveform A.

The current through the primary of the transformer creates a flux about it which is directly proportional to the amount of current through it. Therefore, waveform B can also represent the magnitude and direction of the expanding and collapsing field surrounding the primary winding. This field ceases to expand in a positive direction at  $0^\circ$  and  $360^\circ$ , and momentarily halts at these points be-

fore beginning to collapse. The field is changing most rapidly as it passes through zero. Since the amount of voltage induced into the secondary depends upon the speed with which the magnetic field cuts the secondary, it is evident that the greatest amount of voltage is induced into the secondary winding at the instant that the magnetic field around the primary passes through zero. The resultant voltage induced into the secondary is shown in waveform C.

The capacitor placed across the secondary of the transformer is of such a value as to resonate the secondary circuit to 9960 cps. At resonance, the induced voltage across the secondary appears across a resistive impedance, and the resulting current flow is in phase with the induced voltage. This current flow is represented by waveform D. Since the voltage across any capacitor lags the current through it by  $90^\circ$ , the voltage across this capacitor lags the current through it as shown by waveform E. Note that this voltage is just  $90^\circ$  out of phase with the primary voltage shown in waveform A. These voltages are the two signals applied to each diode. They are  $90^\circ$  out of phase and form an equal resultant voltage for both diodes. This causes equal currents to flow

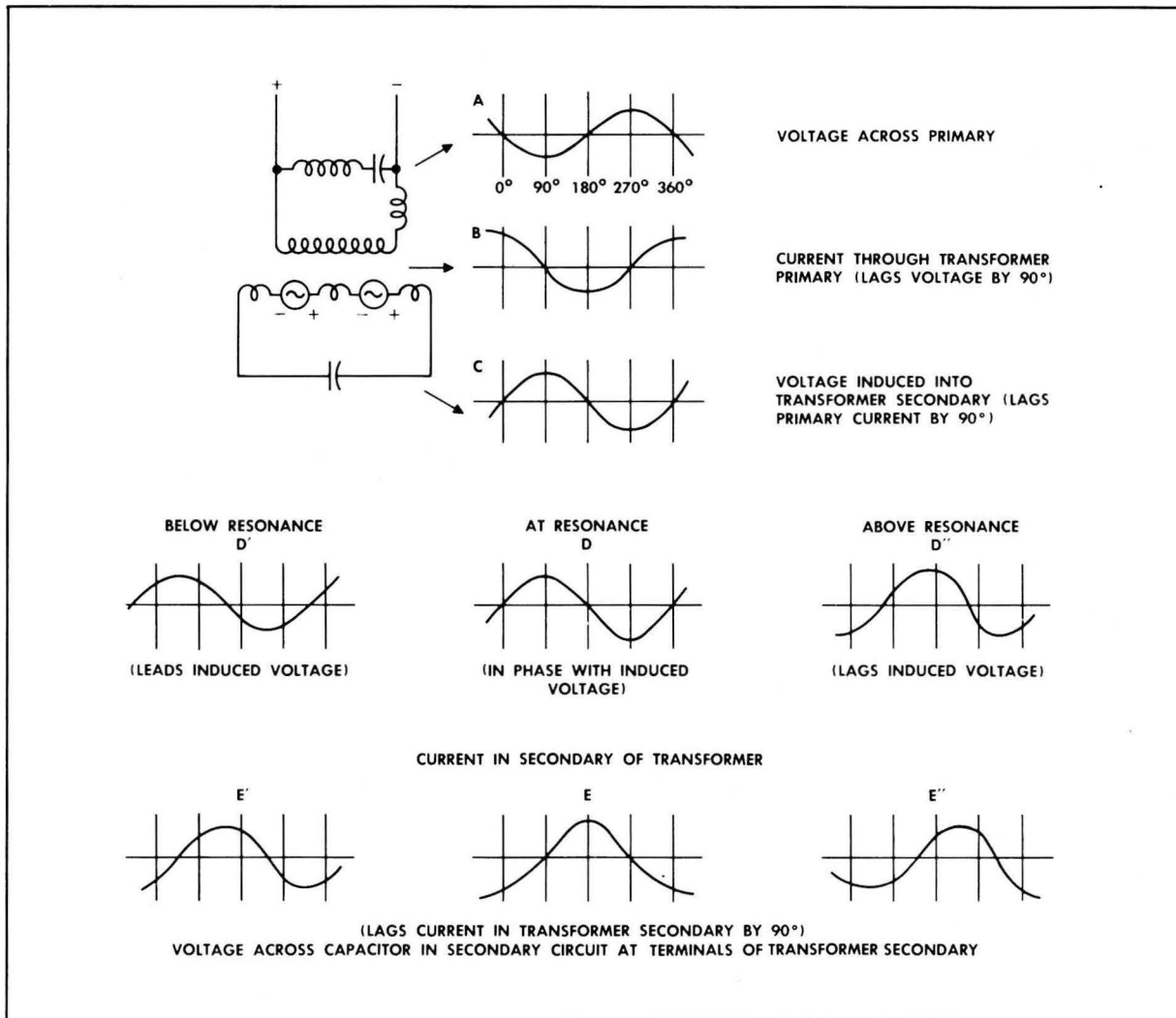

Discriminator Currents and Voltages

through the two cathode resistors. As the equal voltages appearing across these resistors are of opposite polarity they cancel, leaving zero audio output.

At a frequency above resonance, the inductive reactance of the secondary winding is greater than the reactance of the capacitor. The voltage induced into the secondary thus meets an inductive impedance, and the secondary current therefore lags the induced voltage as shown in waveform D". The voltage across the capacitor lags this current by 90° as shown in waveform E". Consequently, the resultants of these two signals, applied to the diodes (waveforms A and E"), are more nearly in phase and cause the output of the dis-

criminator to be positive.

Waveforms D and E illustrate why the output of the discriminator will be negative if the input frequency is below resonance.

**Ratio Detector**

Now study the diagram on 116 of the type of discriminator called the *ratio detector*. Though somewhat similar to the Foster-Seeley discriminator, it does not require a limiter in its input. Unlike the discriminators already studied, it does not respond to amplitude variations. The total voltages applied to V1 and V2 are equal at the resting frequency but become unequal with frequency deviation, just as in the Foster-Seeley dis-

criminator. However, one diode has been reversed. A major portion of the current through both diodes flows through R1 and the voltage across R1 remains constant due to the filtering action of C7 (about 8 mfd). A long time constant for the RC network composed of R1, C7, C5, and C6, is long enough to keep the voltage across R1 from varying even with the audio amplitude modulation. Thus, the RC network provides limiter action. The total charge across capacitors C5 and C6 in series is the full value of the voltage drop across R1. However, the charge across C5 reflects the value of the total voltage applied to V1 while the charge across C6 reflects the value of the total voltage applied to V2. This means that while the total voltage across C5 and C6 always equals the voltage drop across R1, the voltage across each capacitor varies as the ratio of the total voltages applied to V1 and V2. Since the ratio of these voltages varies as the signal frequency varies, the voltage across either C5 or C6 varies with frequency variations. Thus, voltage taken across C6 provides

the audio output.

### Locked-in Oscillator

The *locked-in oscillator* is another type of discriminator that does not react to amplitude modulation and needs no limiter preceding it. Note the three tank circuits in the diagram below. These tank circuits—L1-C1, L2-C2, and L3-C3—are all tuned to resonance at the signal resting frequency. However, they are not sharply tuned circuits. They are tuned broadly enough so that each locks with the intermediate frequency and follows its deviations. Both the signal input tank circuit, connected to the third grid, and the oscillator tank circuit, connected to the first grid, use grid leak bias. With an increase in signal amplitude, both grids draw current. Thus, there is little change in plate current with a change in amplitude. However, the average plate current does increase with a change in signal frequency. This change in plate current appears across R2 as a change in voltage drop. The time constant of R2 and C4 is

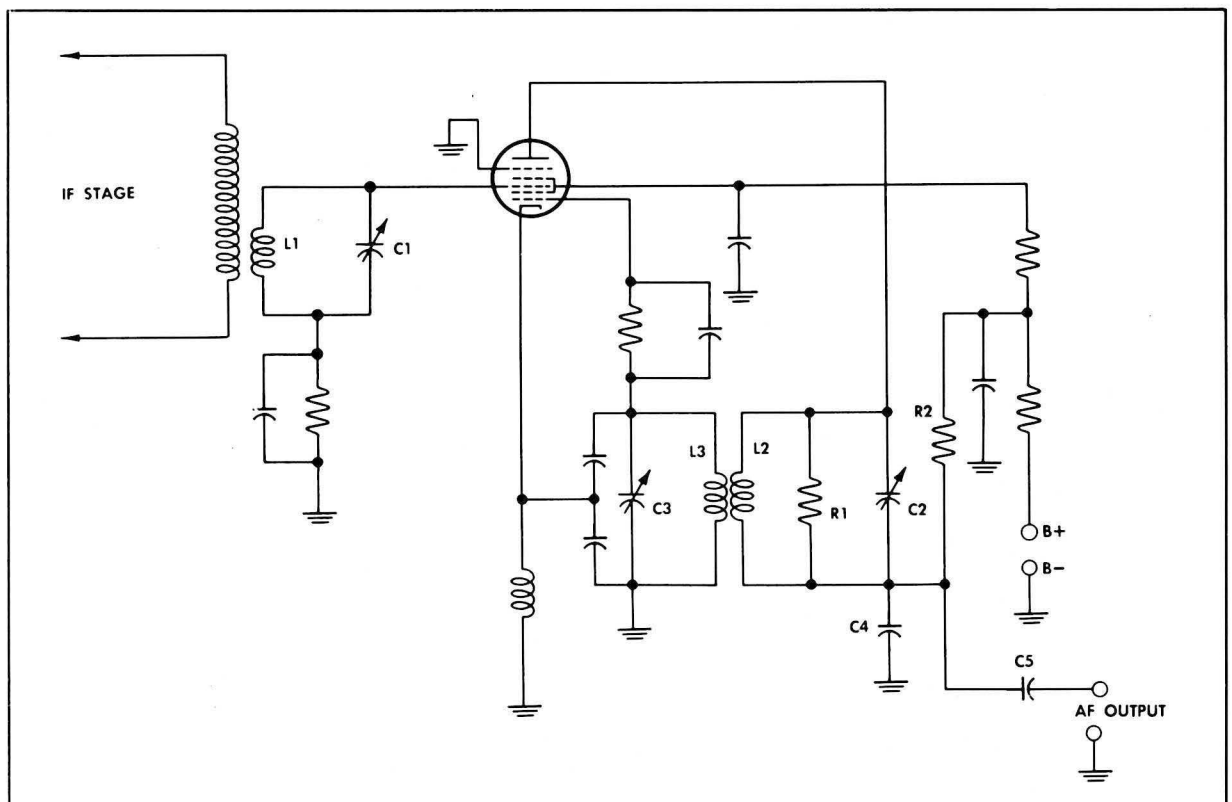

Locked-in Oscillator



such that the voltage across C4 varies at the audio rate but not at the RF rate. This audio voltage is coupled through C5 as the audio output.

### **CIRCUIT ANALYSIS OF AN FM COMMUNICATIONS RECEIVER**

To analyze the complete circuit of an actual FM communications receiver, study the circuit diagram of the R-19/TRC1 on page 121. The RF and IF circuits are conventional, except that the tube cathodes are operated at ground potential. Such operation provides maximum gain, but poor amplitude linearity. Amplitude linearity is not important in FM, for the intelligence is carried by frequency modulation, and the signal is limited in amplitude before it is applied to the discriminator.

A double conversion system using a single crystal-controlled HFO provides for both a high IF and a low IF. The oscillator is followed by an amplifier stage with tuned circuits to provide for frequency multiplication. The amount of multiplication depends on the operating frequency and on the frequency of the crystal used in the oscillator.

Detection is accomplished by a Foster-Seeley discriminator. Since the discriminator is sensitive to amplitude variations, it is preceded by two limiter stages designed to supply a signal of constant amplitude. The discriminator output is developed as the sum of the voltage drops across R127 and R128, the load resistors of the two diode sections of the discriminator tube. The output voltage appears across capacitors C140 and C141. Three series resistors in parallel with the two capacitors provide a voltage divider from which the output voltage is tapped and capacitively coupled to the grid of the 1st AF amplifier.

#### **Squelch Circuit**

The 1st AF amplifier is the first triode section of V115. The second triode section of V115 serves as a squelch tube to silence the receiver when no signal is being received. In fact, the second triode section controls a switch which opens or closes the circuit of the first triode section.

Note that the grid of the first AF amplifier

can be shorted to ground through relay RL101. The relay, as shown, is in the no-signal condition and is shorting the grid of the first audio amplifier to ground. Note, too, that the current through the winding of the relay is the plate current of the first triode section of the audio and relay amplifier tube V113. The grid of this triode section is connected directly to the plate of the squelch triode section of V115. In turn, the grid of the squelch triode is connected through the squelch rectifier circuit to the grid circuit of the 1st limiter tube.

With no signal, the grid of the first limiter draws no current and develops no bias. Consequently the squelch triode is not biased. This allows the squelch triode to conduct. Current flow through the plate load resistors R148 and R149 causes the plate voltage of the squelch triode to drop. This plate voltage is applied to the grid of the relay triode section of V113. In the relay triode section the grid voltage is now below the cathode voltage. This is due to the fact that the cathode has high bias because of its connection between R163 and R141 which are part of a B+ bleeder circuit. The relay triode section does not conduct and the relay is de-energized.

However, when a signal is received, the first limiter develops bias, which is applied to the squelch triode section of V115. The plate current of the squelch triode section is now reduced. As a result, plate voltage rises enough to raise the grid voltage of the relay section of V113 above the cathode voltage. The relay section conducts and energizes the relay. This removes the ground from the grid of the 1st AF amplifier and allows the signal to pass through the audio amplifier stages.

The amount of grid current in the first limiter grid depends to a large extent on the overall gain of the preceding stages. This overall gain can be controlled for proper squelch operation by screwdriver adjustment of the potentiometer in the screen circuit of the high frequency IF amplifier. This potentiometer control is effective only when the squelch switch of the control panel is ON.

When the carrier operated relay, RL101 is energized, it lights a lamp on the front panel to indicate the presence of a carrier in the receiver circuits.

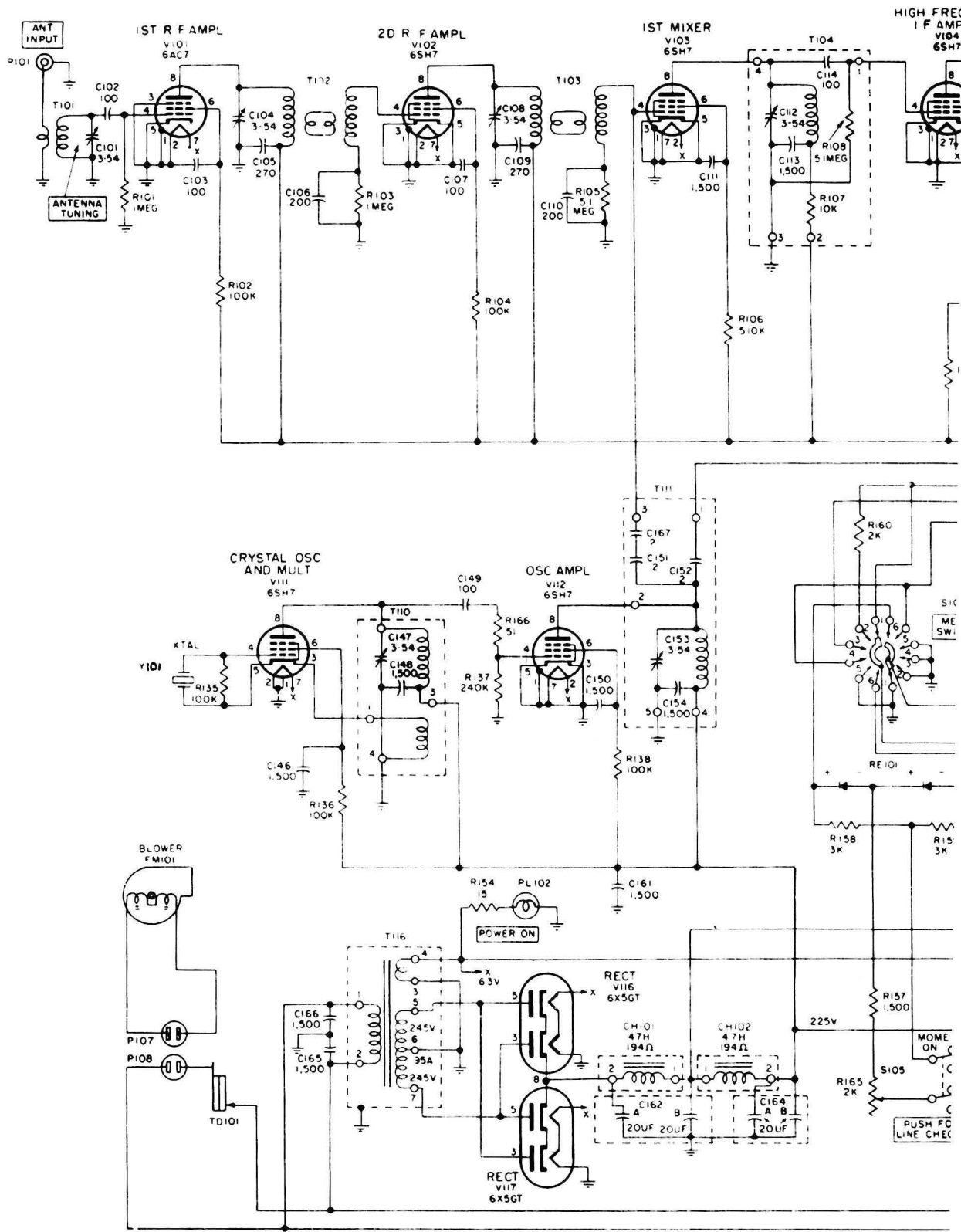

Complete Circuit Diagram, Receiver R-19/TRC1

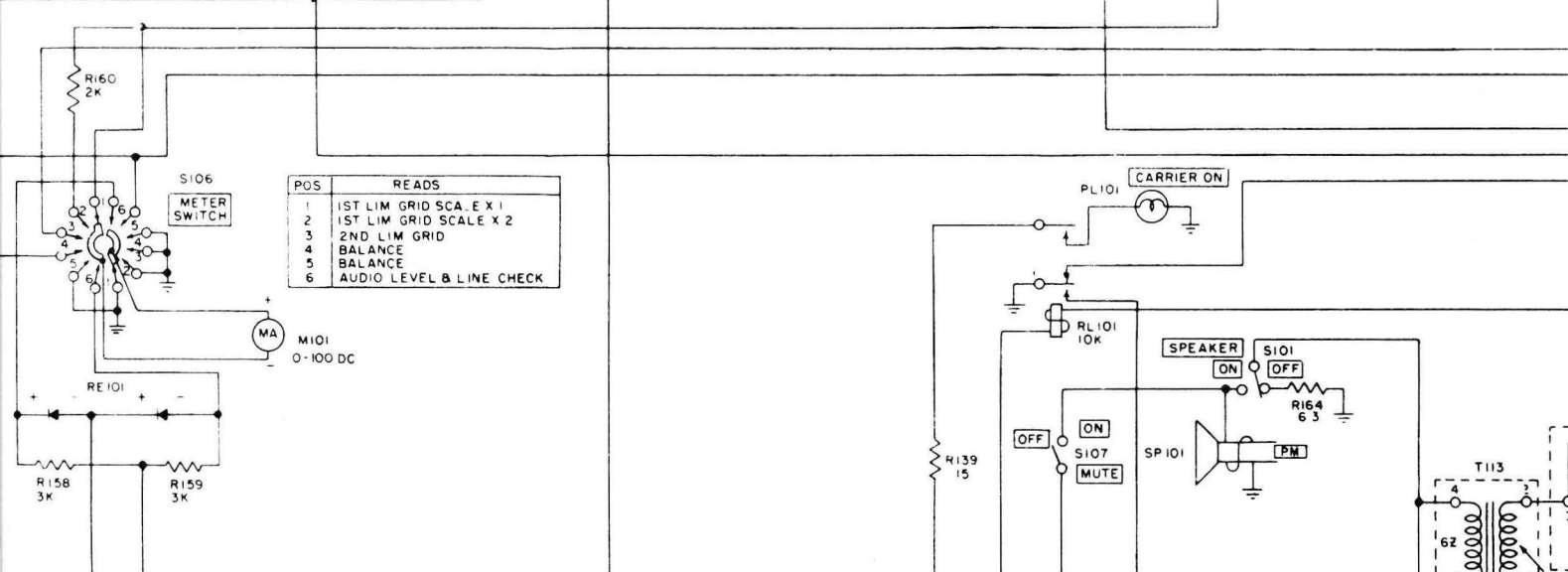
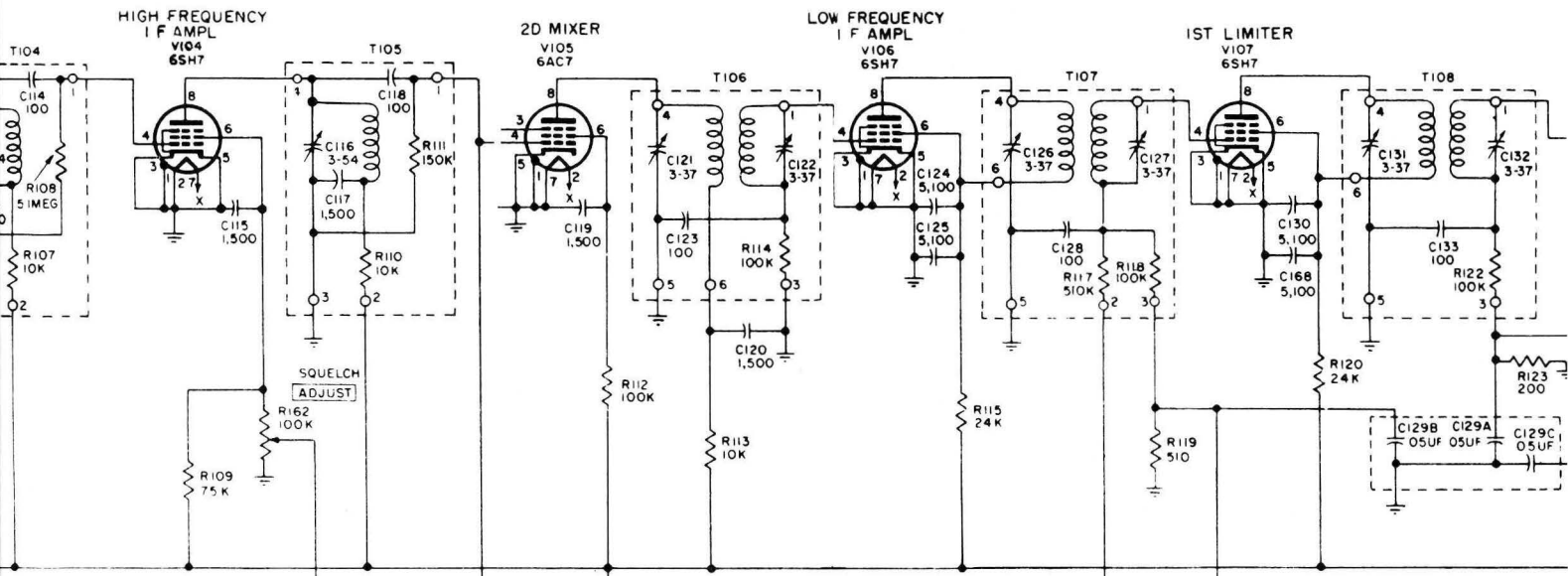

POS	READS
1	1ST LIM GRID SCALE X 1
2	1ST LIM GRID SCALE X 2
3	2ND LIM GRID
4	BALANCE
5	BALANCE
6	AUDIO LEVEL & LINE CHECK

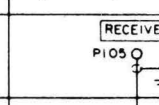
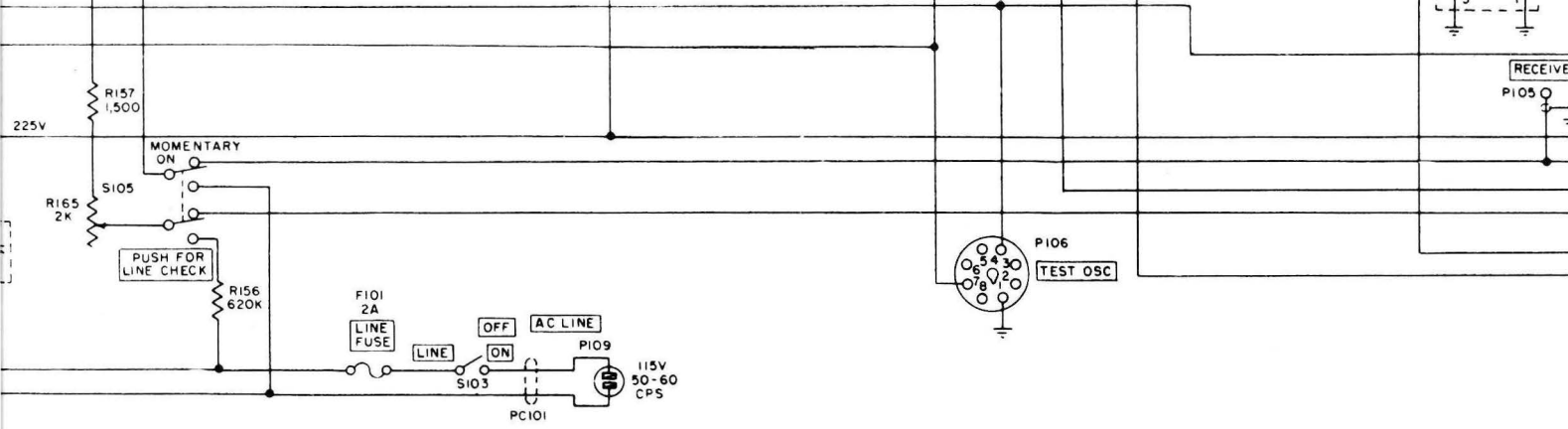

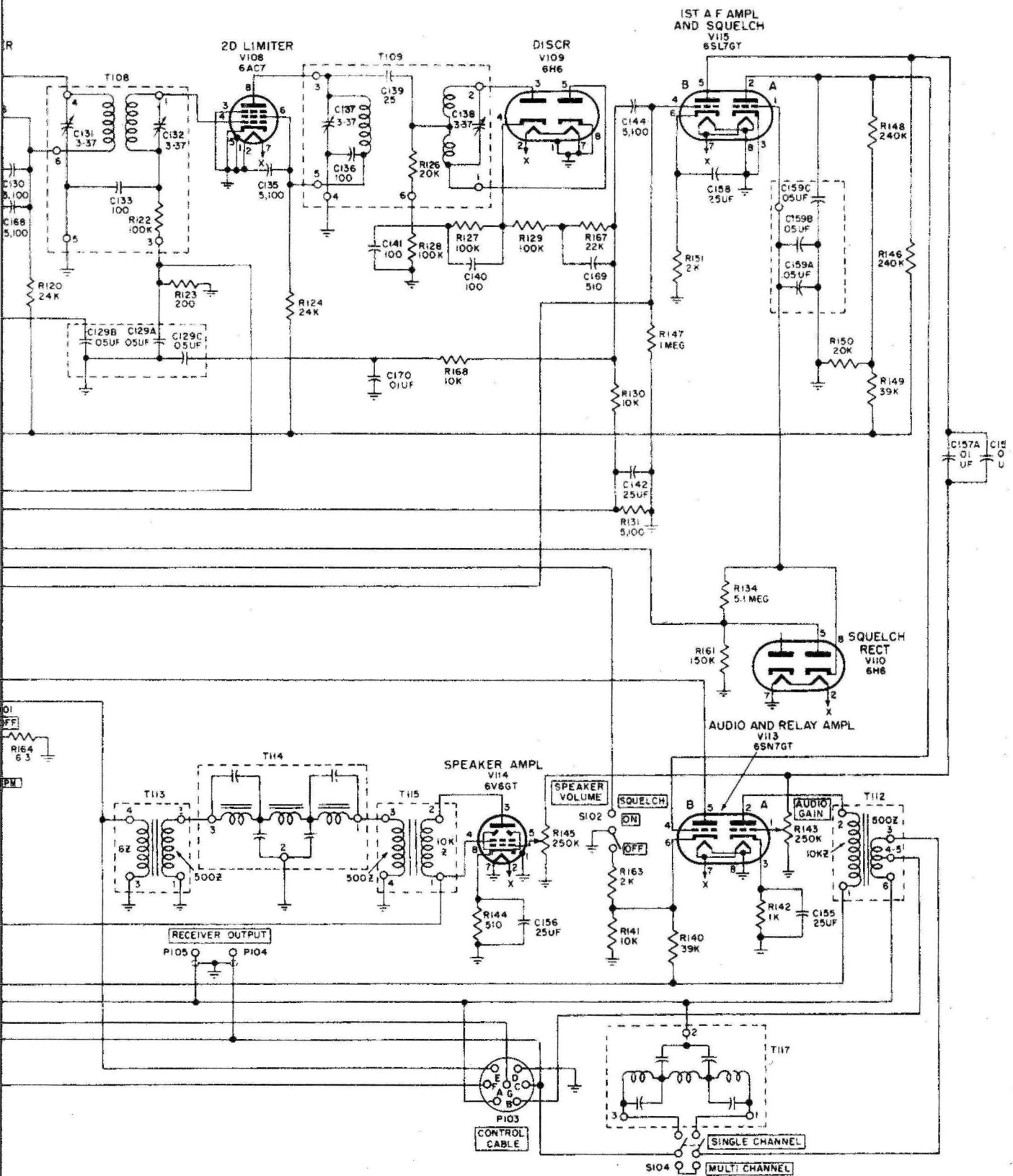

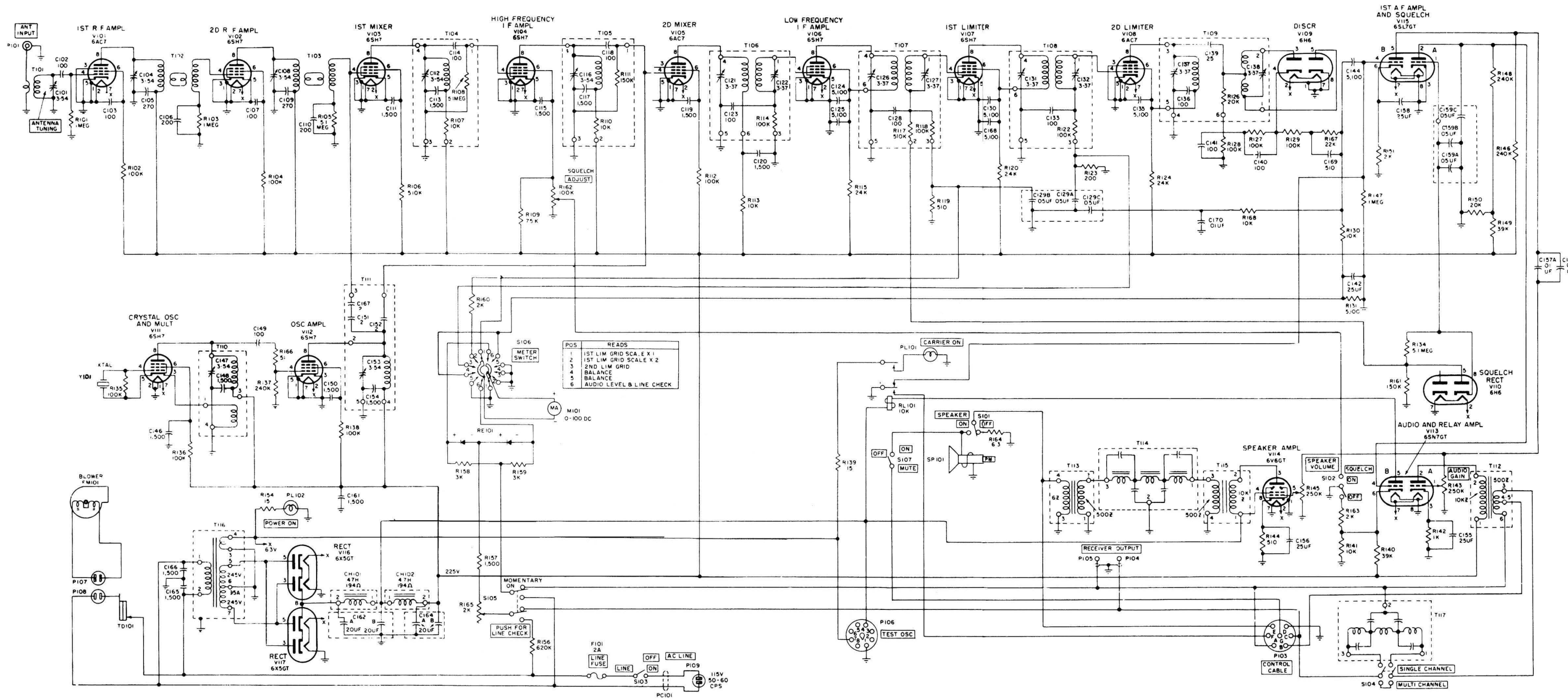

Complete Circuit Diagram, Receiver R-19/TRC1

### Audio Circuits

When the presence of a carrier has opened up the 1st AF amplifier to the audio signal, the output is passed along to two different final audio amplifiers. One is the high fidelity amplifier which is the second triode section of V113. The other is the power amplifier V114.

Audio is applied to the grid of the high fidelity amplifier through a potentiometer, variable for audio gain control. The output of the high fidelity amplifier is transformer coupled, for impedance matching, to two outlets. One is in the control cable connector, and the other is in the receiver output terminals on the front panel of the receiver. This output represents the complete audio bandpass. However, a low pass filter can be connected across this output by placing the single channel-multichannel switch in the single channel position. This cuts off all but the lowest AF channel.

The control cable connects the high fidelity output to the associated transmitter if the receiver is located at a relay station. Otherwise, it connects the output to the communications terminal unit for transmission through the wire system. The receiver output terminals on the front panel permit the use of a headset or a separate speaker at the receiver site to monitor the high fidelity output.

The speaker incorporated in the receiver is normally driven by the power amplifier V114. It cannot be used for monitoring the complete high fidelity output. The speaker is fed through a permanently connected low pass filter which cuts off all but the lowest AF channel. The audio is coupled to the speaker through two transformers used for impedance matching between the speaker input and the power amplifier output. The grid of the power amplifier is driven by audio coupled from the 1st AF amplifier through a potentiometer made variable to provide volume control. A switch in the speaker circuit is used to disconnect the speaker. However, whether the speaker is disconnected or not, part of the audio output of the power amplifier is connected to the control cable. It is fed to the associated relay transmitter or to the terminal unit. This low audio channel provided through

the power amplifier is normally used for point-to-point communication within the communications system.

### Metering Circuits

The meter (left of center) draws current from various receiver circuits to provide readings helpful in operation and adjustment.

It is controlled by a six-position switch. The first two positions of the switch provide for measuring the grid current of the first limiter. The first position is used for weak signals. When the signal is strong enough to drive the meter off scale, the second position is used. This connects an additional resistor into the meter circuit.

The third position provides for measuring the grid current of the second limiter and aids in the alignment of the second limiter. The fourth and fifth positions provide for measuring the off-balance current in the discriminator circuit. Two positions are used for this indication so that the meter polarity may be reversed to give an upscale reading no matter which way the discriminator is unbalanced.

Position six, using a crystal rectifier, provides for measuring either the line voltage or the audio output of the high fidelity circuit. Potentiometer R165 in the crystal rectifier circuit is used to compensate for changes in the response of the rectifier (due to aging, etc.).

### OPERATIONAL ANALYSIS OF RECEIVER R-19/TRC1

Notice the front view of receiver R-19 TRC1 which illustrates the controls on the front panel. At the upper left corner are the receiver output terminals used in four-wire radio remote control to connect the high fidelity output to a remote control unit. Most of the other controls at the left of the control panel concern the AC power circuit.

The AC line brings power into the receiver. The PUSH FOR LINE CHECK switch can be used when the meter switch, at lower center of the panel, is on position 6. The AC line voltage is then indicated by the meter, above the meter switch. The LINE ON-OFF switch is the main power switch. The lamp beside the line switch lights when power is applied.

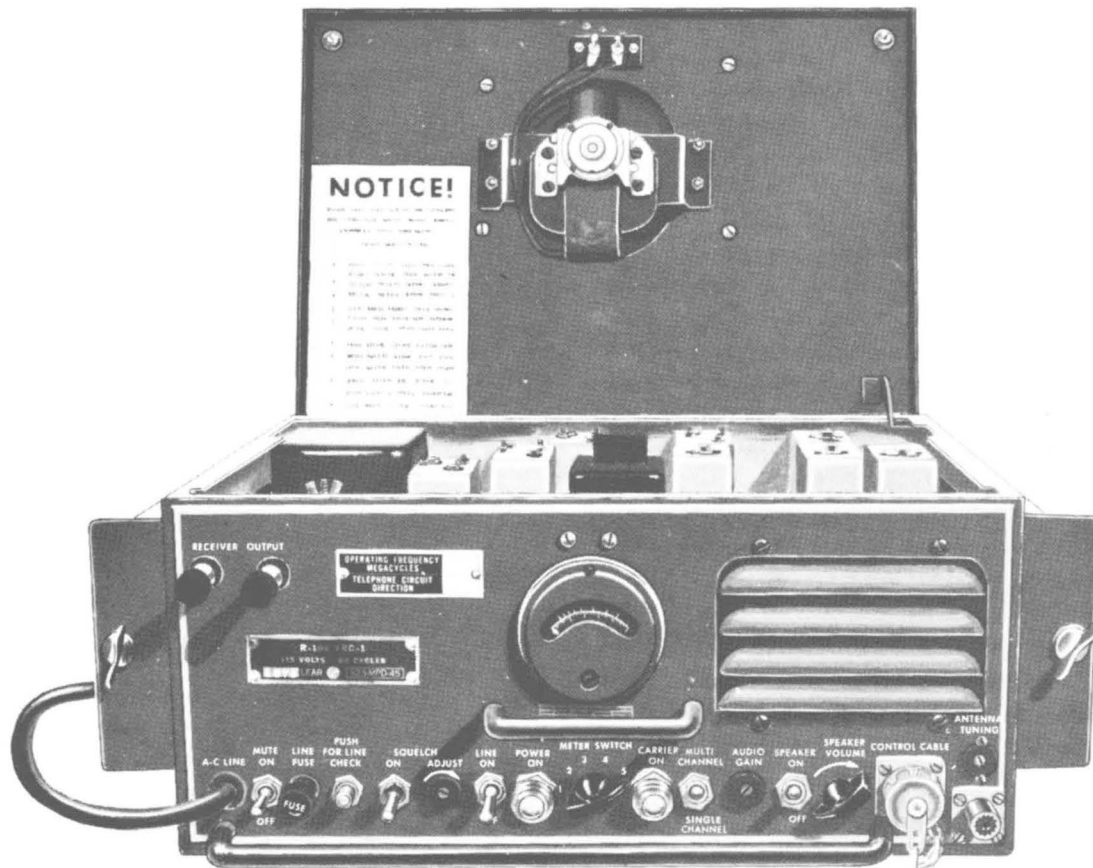

*Radio Receiver RI9/TRC-1, Front View*

The other controls provide for control of the receiver speaker and the squelch circuit. The MUTE switch, in the ON position, permits the handset at the transmitter to short out the receiver speaker when the transmitter is being modulated through the handset. This facilitates point-to-point communication within the system. The SQUELCH ON-OFF switch permits use of the squelch circuit as desired. The SQUELCH ADJUST provides screwdriver adjustment of the gain of the RF and IF stages for proper squelch action.

There is no tuning control on the panel. The set is tuned by inserting the proper crystal into the HFO and tuning the RF and high IF tuned circuits, with the help of the meter readings.

The presence of a carrier signal is indicated by the meter, or by the lamp to the right of the

meter switch. Multichannel or single channel operation of the high fidelity circuit can be selected by the next switch to the right. The audio gain of the high fidelity circuit can be screwdriver adjusted by the AUDIO GAIN control. A switch for disconnecting the receiver speaker, with its low audio channel, is next to the right. The speaker volume control permits the regulation of the amplitude of the low audio channel carried by the receiver speaker. The control cable connector provides for connection of the receiver output to the transmitter terminal unit. At the far lower right corner is the ANT. INPUT connector for connecting a concentric transmission line between receiver and antenna. A screwdriver adjustment directly above the antenna connector permits the tuning of the antenna to adjust it to the various frequencies in the receiver's range.

Editors note: Readers who are not familiar with modern single-sideband radio technology may wish to skip this section, which describes early SSB systems of the 1950's, and uses terminology of that time.

## SPECIAL PURPOSE RECEIVERS

The special purpose equipment covered in this chapter includes single sideband receivers, teletypewriters, pulse receivers, television receivers, and direction finders.

### SINGLE SIDEBAND RECEIVERS

In a basic single sideband (SSB) system, the RF carrier frequency is amplitude modulated with an audio signal the same as in the ordinary amplitude modulation (AM) system. However, the original carrier frequency is removed by a balanced modulator and one of the sidebands is removed by a filter network. The only radiation from the transmitting antenna is one sideband.

This basic system is being used in some cases but it has one big disadvantage. In receiving this type of signal, the carrier must be reinserted by the receiver so that there will be a resulting beat frequency that will produce the original audio frequencies when the signal is detected or demodulated. It has been found that this reinserted carrier frequency must be accurate to within 20 cycles before the resulting audio is intelligible. It is difficult to control a generated frequency in a receiver this accurately and therefore this system is not widely used.

A more common system of SSB is to transmit one of the sidebands and a carrier that has been reduced in amplitude. This carrier must only be strong enough to operate an automatic frequency control circuit in the receiver that will hold the local oscillator within 20 cycles of the original carrier frequency. This system is called a suppressed carrier SSB system.

For military use, the upper sideband of one modulating signal, the lower sideband of another modulating signal, and a suppressed carrier are transmitted. In this system, two audio signals can be transmitted in the bandwidth normally occupied by a single amplitude-modulated system. This is called a twin SSB system.

There are a number of advantages of SSB. As stated above, two audio signals can be transmitted in the place of one in the AM system, or, when only one sideband is transmitted, the channel required is only half as wide, making it possible to have many more transmitters operating in a certain communications band. Another advantage is that there is about a 9 db improvement in signal-to-noise ratio. This is possible since a much narrower band is used in handling the same audio frequencies and the energy required by the full carrier in the AM system is used by the sideband carrying the intelligence. A third advantage that may be possible in conjunction with a teletype system is a reduction in the effect of selective fading. In selective fading, some of the audio frequencies fade as the radiated signal is passing through space. In conjunction with radio teletype, two tones may be used for the same purpose so that if selective fading reduces the amplitude of one tone, the other tone will probably be received with full strength. Still another advantage in teletype, when a twin sideband is used, is that six channels of radio teletype can be transmitted on one sideband and a full voice channel can be transmitted on the other sideband. After the signal has been demodulated or detected by the receiver,



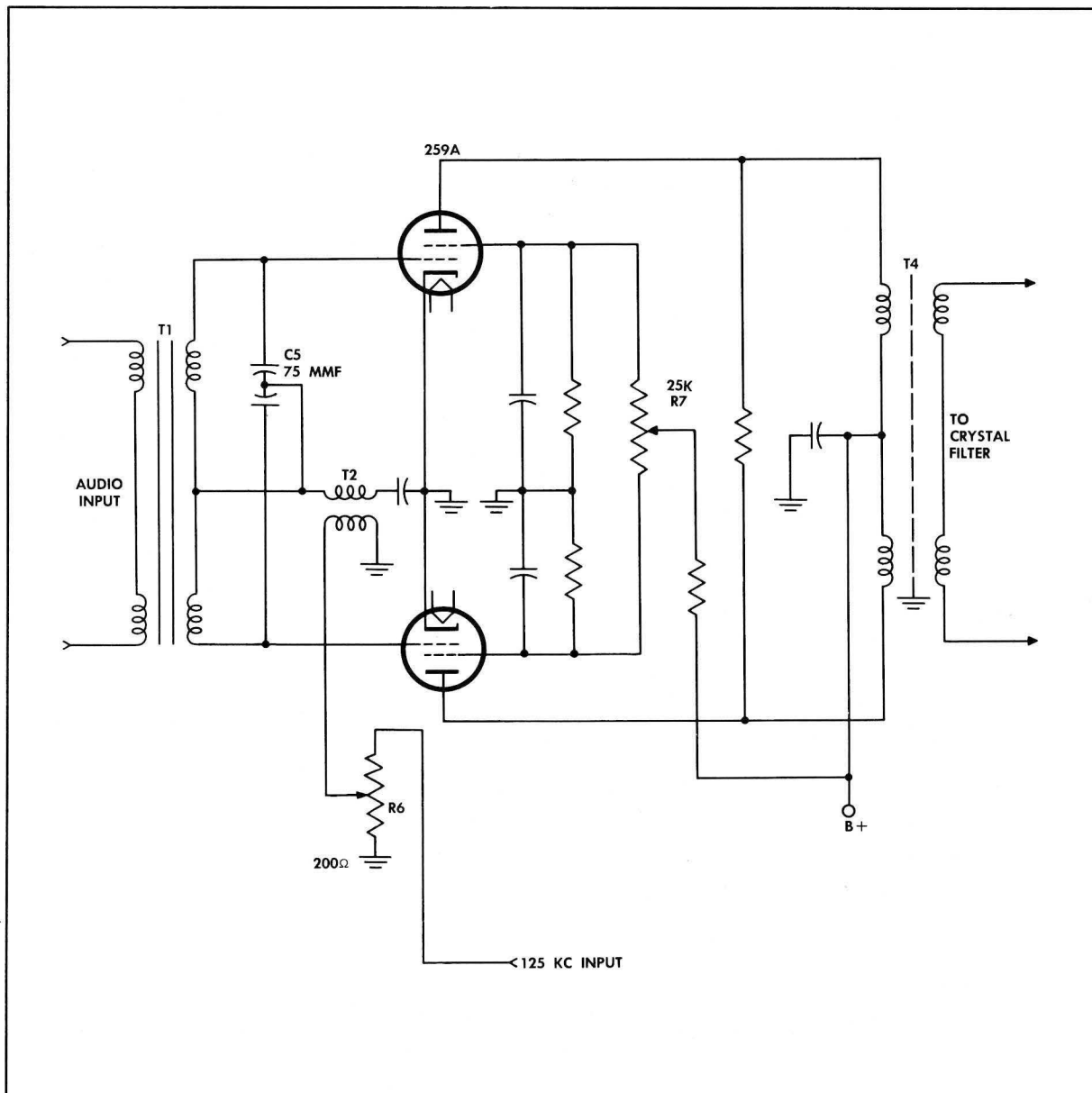

*Typical Balanced Modulator*

it is applied to a series of filters that separate it into its original teletype and voice channel components.

The main disadvantage of the SSB system is that both the transmitting and receiving equipment are more complicated than those in the AM system.

### **Balanced Modulator**

A typical balanced modulator circuit is shown above. A 125-kc RF carrier signal is

applied to each grid in phase through T2. That is, the RF signal drives both grids positive and negative at the same time. Therefore, the plate current components of the RF carrier signal cancel out in the primary of T4 since their magnetic fields are opposing.

The audio voltage is applied to the two grids through transformer T1. Since the audio voltage and the RF carrier voltage are both applied to the grids, there is a modulation action in the grid circuit, producing both the

upper and lower sidebands. However, since one grid is connected to one end of audio transformer T1 and the other grid is connected to the other end, one grid goes positive while the other goes negative. This also causes the upper and lower sideband components to be out of phase in the plate circuits and therefore they are not cancelled. Transformer T4 does not present a load to the audio voltage, therefore it is not passed on to the filter circuit. However, both sidebands are passed to the filter circuit and the lower sideband is removed because the filter has a pass band of from 125.1 to 131 kc. In other words, only the upper sideband is passed from this balanced modulator. The RF carrier is balanced out, the audio signal is not passed through RF transformer T4, and the lower sideband is filtered out by the crystal filter.

### SSB in Communications Systems

Though SSB can be used at any of the AM frequencies, it is most commonly used as a radio link in the high frequency range (2-26 mc) for long distance communication.

The antennas are directive and are aimed for communication with particular distant stations. The transmission system is essentially a one-bounce system. The radio wave is returned from the ionosphere at an angle calculated to bring it to earth in the area of the target station. HF is ideal for this type of transmission because its frequencies can be refracted to the greatest one-bounce distance. VHF cannot be used in this manner because the frequency is too high to be refracted back to earth.

In calculating the angle of refraction for HF operation, two factors are important—the operating frequency and the effective height of the ionosphere. Since the effective height of the ionosphere changes between day and night, and between winter and summer, a long distance HF system must be organized to shift operating frequency to compensate for ionospheric changes.

To see the interrelationship of the various

channels, study the frequency spectrum of a typical SSB system shown on page 132.

Because the suppressed carrier is unmodulated, it can occupy a very narrow portion of the spectrum. It is separated from the upper sideband by only 425 cycles, and from the lower sideband by only 100 cycles.

**SIDE BANDS.** The upper and lower sidebands in the frequency spectrum do not constitute a sideband pair. They do not contain identical intelligence. They are merely two independent single sidebands which are transmitted at the same time. To obtain a single sideband such as the upper sideband, a lower sideband has to be eliminated. This leaves a vacant space, both in terms of the RF channel width and of the AF bandpass. This vacant space can be made useful by substituting for the eliminated sideband another single sideband which is independently formed and independently modulated. Thus, the amount of useful intelligence which can be transmitted over one RF channel is increased. In this spectrum, the independent lower sideband is used as a voice channel.

Note that the frequencies of the upper sideband are divided into two sets of six teletypewriter channels. One set is called *normal*, the other is called *diversity*. There are also two CW channels, one called *normal* and the other called *diversity*. In the normal group each channel carries a different message. In the diversity group each channel also carries a different message. However, identical channels in each group carry the same message. Thus, the teletypewriter channels marked "2" in each group carry identical intelligence. A diversity channel carries the same message as a corresponding normal channel, but on a different frequency.

**DIVERSITY OPERATION.** Diversity operation is a means of combatting the fading which occurs in long distance radio transmission. Two types of diversity operation are commonly used — *frequency diversity* and *space diversity*. The diversity illustrated by the frequency spectrum is frequency diversity. The principle of frequency diversity is this: two RF signals are transmitted at slightly different frequen-

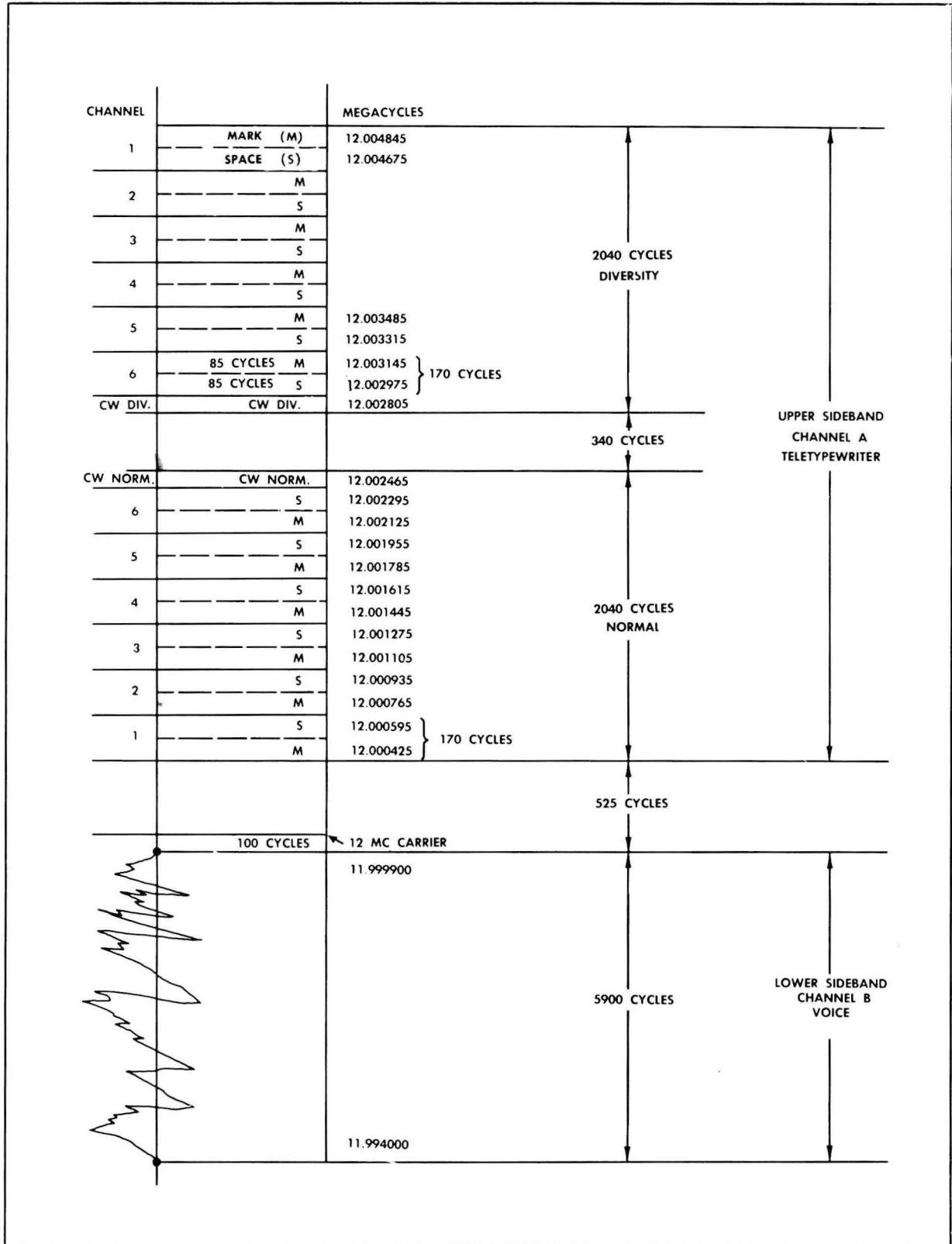

Frequency Spectrum of Twin Channel Single Sideband Klystron Communication System

cies, but with the same modulation. They are received simultaneously by a single receiver. However, since they do not fade simultaneously, they provide a fairly level signal strength at all times.

Space diversity operation consists of using two or more receiving or transmitting antennas spaced several wavelengths apart. In this case, the signals have the same frequency and the same intelligence. The principle of space diversity is this: identical RF signals transmitted simultaneously from two different places or received simultaneously at two different places will not fade simultaneously. Space diversity is used most commonly in connection with receivers. Two antennas may be used with one receiver, or with two receivers having a common audio section.

**TELETYPEWRITER CODE.** Note in the illustrated spectrum that two frequencies are assigned to each normal teletypewriter channel and each diversity teletypewriter channel. These two frequencies are used alternately to form the special code employed in teletypewriter operation.

Each symbol of the code is made up of a combination of five selecting intervals called spaces and marks. A space uses one frequency and a mark uses the other. Since each selecting interval has the same duration, each symbol of the code has the same duration. Each is made up of five selecting intervals. The possible combinations for forming symbols are  $2^5$ , or 32 combinations.

To see a specific example, look at the diagram of the teletypewriter symbol for the letter R. The combination is space-mark-space-mark-space — a total of five selecting intervals. In addition to the selecting intervals, two other intervals are used. A mark of longer duration is used as a stop symbol, and a space equal in duration to a selecting interval is used as a start symbol.

**FREQUENCY FORMATION.** In the spectrum being studied, the frequency difference between spaces and marks is 170 cycles. In other teletype systems, the frequency difference may vary between 170 and 850 cycles. This frequency difference may represent a difference between two audio frequencies carried as

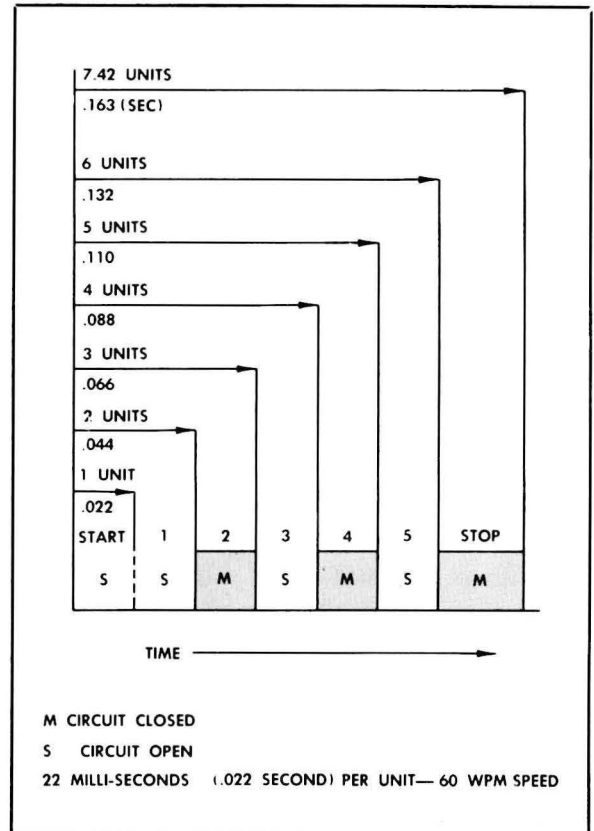

Teletypewriter Symbol for Letter R

modulation by a carrier, or it may represent variation in the carrier itself.

In channel 1 of the normal section on page 132, the marking and spacing frequencies are 425 and 595 cycles, respectively. They are heterodyned against a 12-mc carrier to form sideband frequencies of 12.000425 and 12.000595 mc. To form the diversity channel 1, the same marking and spacing frequencies are first heterodyned against an audio oscillator set at 5270 cycles. This produces beat frequencies of 4845 cycles for marking, and 4675 cycles for spacing. These are then heterodyned against the 12-mc carrier to form sideband frequencies of 12.004845 mc and 12.004675 mc. This process of forming the diversity channel is called *inversion*. All the diversity frequencies in the spectrum shown here are formed in the same way — by heterodyning the normal audio frequencies against the 5270-cycle beat oscillator, then impressing them on the 12-mc carrier to form the diversity sideband frequencies.

In transmission, a normal channel and its inverted diversity channel carry the same message. Yet, since the messages are carried at different RF levels, they do not fade at the same time. At the receiver, both the normal channel and its inverted channel are passed through the RF and IF sections and their audio components are detected. Then the diversity audio frequencies are heterodyned against another audio oscillator and restored to the normal frequency range. At this point, they are combined with the detected output of the normal channel. Since restored audio does not fade at the same time as the normal audio, this combination provides a fairly level audio output.

The formation of the diversity channels takes place in a unit called a *diversity shifter*. It precedes the transmitter. Reconversion of the diversity channels to the normal channel frequency range takes place in a unit called a *restorer* unit. It follows the receiver.

### Functional Analysis of a Typical SSB Receiver

To see the relationship of the parts in an SSB communications receiver, look at the block diagram on page 135. Basically, the receiver is a double conversion superheterodyne. It has an RF, a high IF, a low IF, and an audio section. However, to permit satisfactory SSB operation, a number of stages are added to the basic superheterodyne stages.

**RF SECTION.** The alternate channels in the RF section are simply for convenience and accuracy of tuning. The frequency coverage, 4-22 mc, is too broad for efficient single band tuning. Consequently, the frequency band is divided into two segments — one, 4-10 mc; and the other 10-22 mc. This reduction in tuning range also permits more accurate operation of the high frequency oscillator, B01. With two channels, the oscillator can track below the 10-22 mc band and above the 4-10 mc band. Thus, it covers 18 mc of receiver tuning range with only 12 mc of oscillator tuning range. The conversion output of the 1st detector is 2900 kc, which is fed to the 1st IF filter. The filter passes only a narrow band of frequencies, between 2892 and 2907 kc.

**IF SECTION.** The second high frequency

oscillator, B02, supplies a 3000-kc signal. This heterodynes against the high IF of 2900 kc to produce a difference frequency of 100 kc for the low IF. The output of the balanced 2d detector is supplied to three different low IF channels (counting channel branch B, shown in dotted outline). Each low IF channel contains a filter stage which permits it to pass a different component of the low IF frequencies. The carrier branch, with a crystal filter, passes the low IF carrier frequency of 100 kc through a bandwidth only 40 cycles wide. The channel A branch passes the frequencies of the lower sideband (voice channel) through a bandwidth of 94-99.9 kc. The channel B branch passes the frequencies of the upper sideband through a bandwidth of 100.1-106 kc.

Thus, the low IF component frequencies are separated before they are applied to the 3d detectors. There are several reasons for doing this instead of separating them on the audio level *after* passing the 3d detector. The suppressed carrier is separated because it requires more amplification than either the upper or lower sideband. It requires the extra amplification because it is used to supply AVC voltage and because its use is essential in the automatic frequency control circuits. The two sidebands are separated so that the voice channel, channel 1A, can be used for communication from the receiver site. The channel B branch contains CW and teletypewriter frequencies in both normal and diversity form. It is separated into CW and teletypewriter channels in restorer circuits located beyond the receiver. These are not shown in the block diagram.

**AVC CIRCUITS.** Part of the carrier branch output is used to develop AVC in the AVC rectifier stage. Three kinds of AVC are developed. Fast time constant AVC is applied only to the second amplifier stage of the carrier branch. Slow time constant AVC is applied to the first amplifier stage of the carrier branch, to the first and second amplifier stages of both channel branches, to the amplifier stage in the high IF section, and to the first amplifier stage in both channels of the RF section. Finally, compensating AVC is applied to the final amplifier stages in the

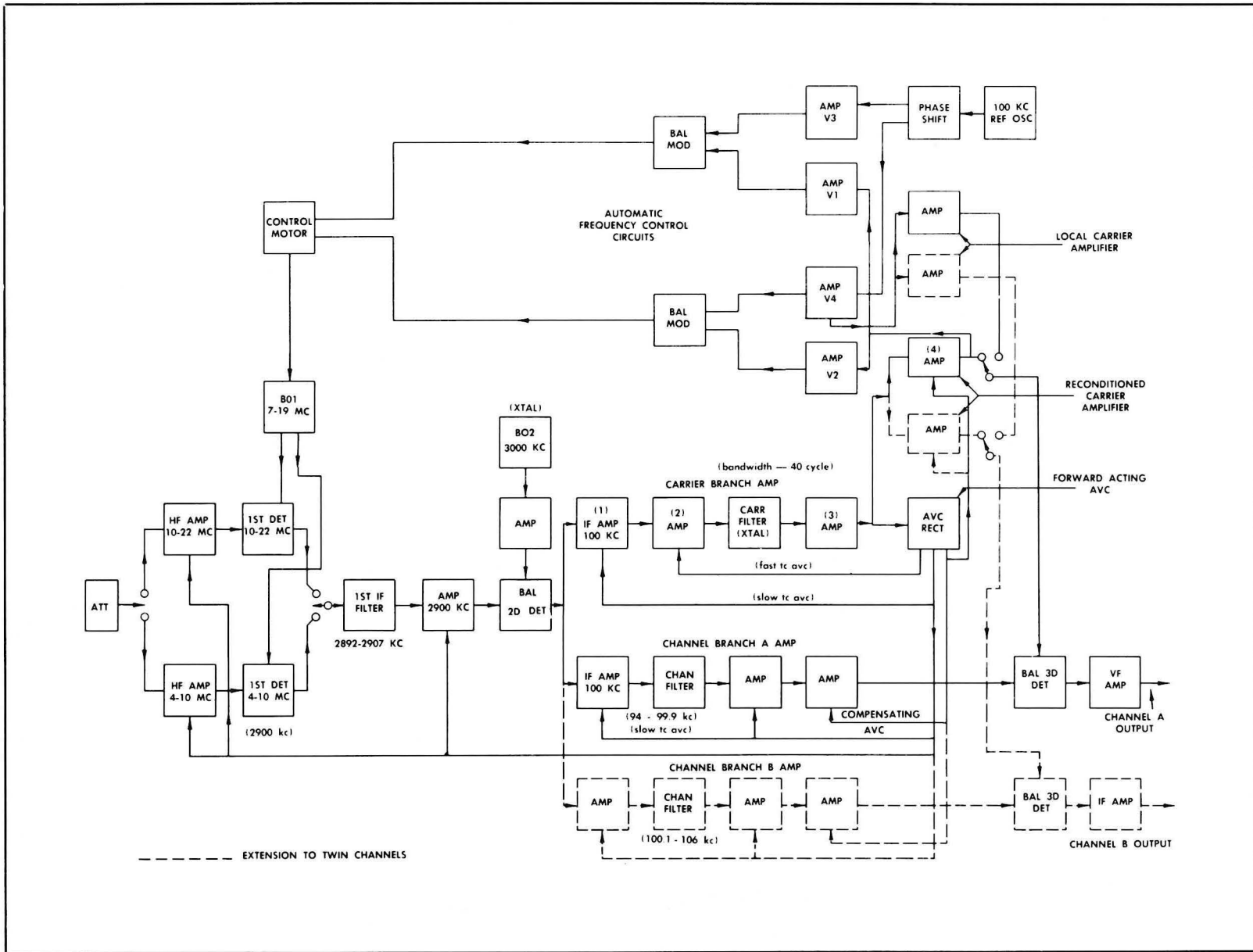

carrier branch and in both channel branches.

The fast time constant AVC actually operates with five time constants, ranging between 0.1 and 2.0 seconds. Any one of these can be selected to meet carrier fading conditions. The reason why the AVC can be so fast is that it is derived from the suppressed carrier. A time constant in an AVC system developed by an unmodulated carrier can be much faster than a time constant developed by a normal modulated carrier. In normal AVC, the time constant must be slow enough to keep the AVC from following the audio signal variations. The advantage of the fast time constant is that it permits adjustment to fading conditions which occur at a fast rate.

The slow time constant AVC and the compensating AVC have a time constant of 8.0 seconds. Since this AVC is applied to audio-modulated signals, it has the normal AVC time constant.

**DETECTION.** After the suppressed carrier passes through the final carrier branch amplifier, it is available for the 3d detector. The presence of the carrier in the detector permits separation of the audio component of the sidebands from the higher frequencies. However, the receiver does not depend entirely on the suppressed carrier. As an alternative, it can supply a locally generated carrier. This is supplied by the reference oscillator shown in the upper right hand corner. The output of this oscillator also can make possible successful detection. A switch permits use of either the local carrier or the suppressed carrier. Note also that there are two amplifiers and two 3d detectors. The extra ones, in dashed lines, are for channel B.

**AFC CIRCUITS.** The local carrier generated by the reference oscillator has very high stability. It is used along with the suppressed carrier for the automatic frequency control (AFC) circuits. The reference oscillator is controlled by AFC to keep exactly on frequency.

To see how this is done, look at the block diagram of the AFC circuits. Note that the reference oscillator signal is passed through a phase shift circuit which produces two signals 90° out of phase. One of the phased signals is

applied through an amplifier to one balanced modulator while the other phased signal is applied through another amplifier to the other balanced modulator. In addition, the suppressed carrier signal from the carrier branch amplifier is applied to both balanced modulators.

When the reference oscillator signal and the suppressed carrier signal are at exactly the same frequency, the outputs of the balanced modulators are equal, and the tuning motor remains stationary. When the reference oscillator frequency goes above the suppressed carrier frequency, the output of one balanced modulator increases and the output of the other balanced modulator decreases. This makes the motor turn and adjusts the tuning capacitor that controls the frequency of the high frequency heterodyning oscillator. This adjustment continues until the reference oscillator signal again matches the frequency of the suppressed carrier signal. At that time, the modulator outputs are equal, and the motor stops. When the reference oscillator signal goes below the frequency of the suppressed carrier, the balance of the modulators is oppositely affected, and the motor turns in the opposite direction. It turns until the reference oscillator is back at the correct frequency.

The AFC circuits are very important to the successful operation of the SSB receiver. Without accurate tuning, the filter circuits incorporated in the carrier and channel branches of the low IF section would not pass the signal. These filters have narrow band-passes with very sharp cutoff. The carrier branch filter is especially sharp, passing a bandwidth only 40 cycles wide. Therefore, the signals presented to these filters must be exactly on frequency or they will not pass through the filters.

## TELETYPEWRITER SYSTEMS

Teletypewriter systems provide common examples of device-actuating receiver operation. In this type of operation, intelligence is reproduced mechanically rather than orally or visually.

Teletypewriter systems are usually designed

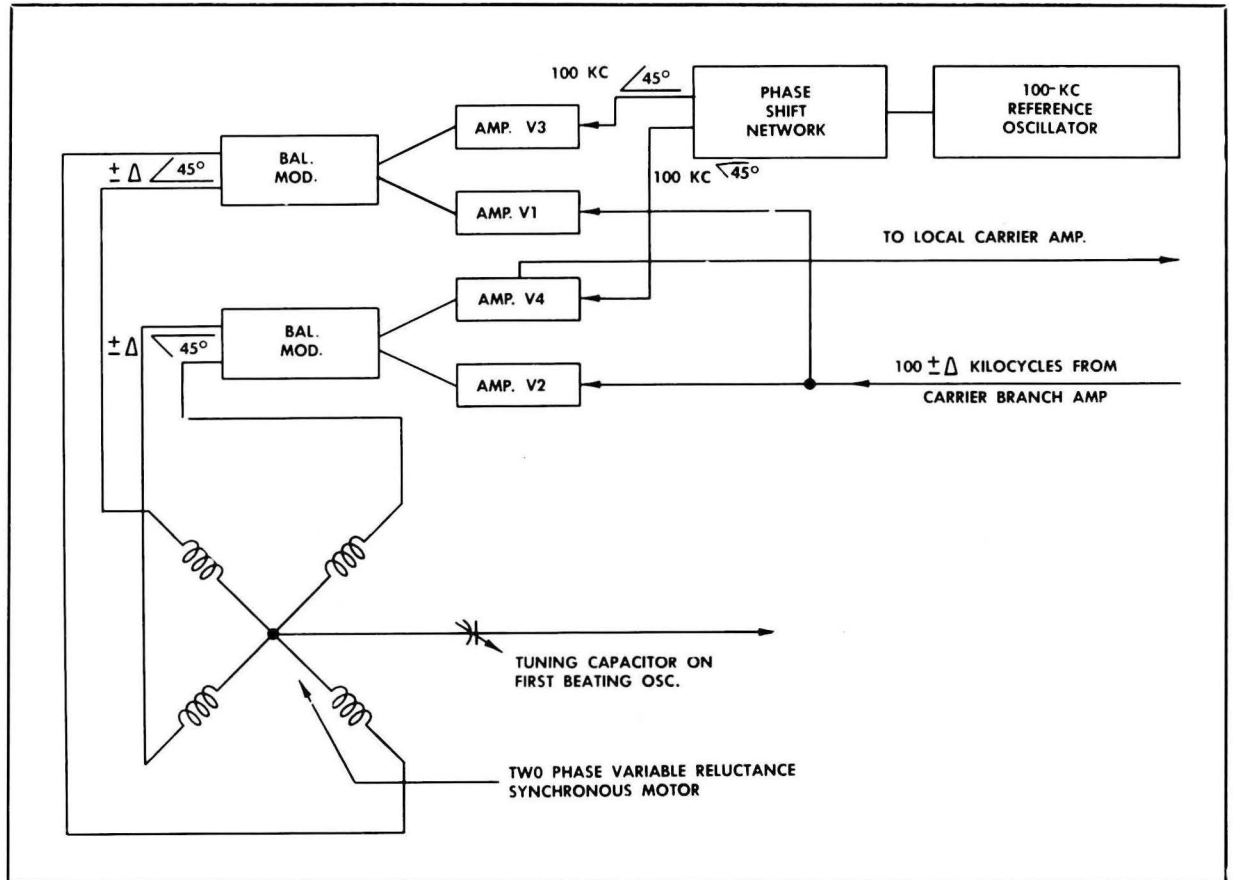

Automatic Frequency Control Circuit

to use various types of receivers and transmitters as radio links. The receivers and transmitters do not have to be specifically designed for teletypewriter work. They could be used just as well for voice communications. However, the terminal units which connect the receiving and sending teletypewriters to the receivers and transmitters can be used only for teletypewriter work. The terminal units are concerned primarily with shaping the sending teletypewriter intelligence for presentation to the transmitter, and with converting the output intelligence of the receiver into the proper form for actuating the receiving teletypewriter.

Look at the block diagram showing the equipment for a teletypewriter system on page 138. The terminal units are in solid outline and the transmitter and receiver units are in broken outline. The teletypewriter system shown here provides simultaneous single chan-

nel operation in both directions. The operating frequencies are in the HF range. Twin receivers are provided at each terminal for space diversity reception.

The main sections of the terminal unit are the following: the frequency shift exciter, which supplies proper modulation for the transmitter; the dual diversity converter, which handles the output of the twin receivers; and the control unit, which binds together the various sections of the terminal.

### Frequency Shift Exciter

As you can see from the block diagram on page 139, the frequency shift exciter consists of a shift diode, an oscillator, and a buffer amplifier. Through the control unit the shift diode is supplied by the teletypewriter circuits with polar DC signals in the form of the teletypewriter code. The diode conducts during spacing signals and cuts off during marking



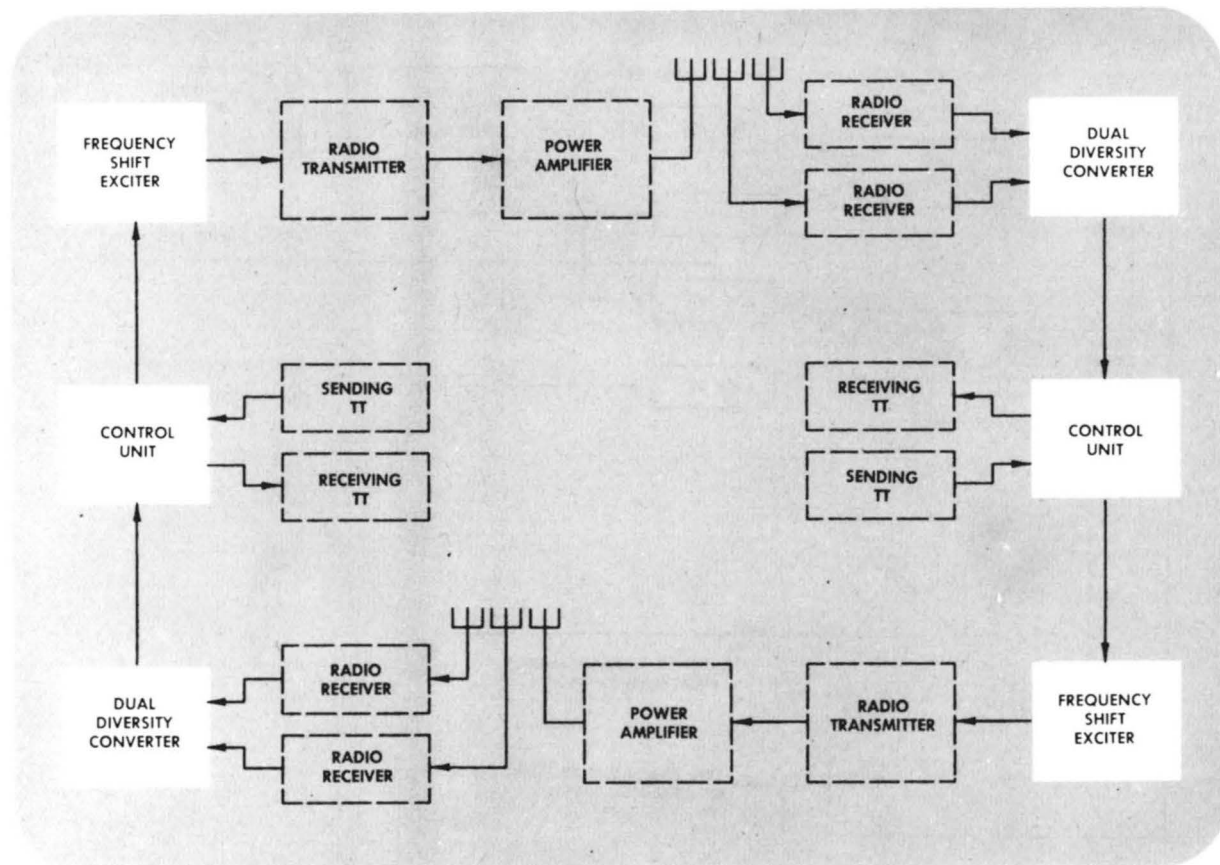

*Two Radio Terminals Arranged for Duplex Teletypewriter Operation*

signals. When the diode conducts, it shorts out part of the inductance in the tank circuit of the Hartley oscillator. With part of the tank circuit inductance shorted, the oscillator frequency drops. Thus, the oscillator operates at two frequencies — a higher frequency for marking and a lower frequency for spacing. The buffer amplifier passes these two oscillator frequencies along to the transmitter.

The difference in frequency between marking and spacing usually ranges between 170 and 850 cycles. The actual marking and spacing frequencies may be anywhere from the audio range to the UHF range, depending on the type of transmitter to be supplied. When the transmitter operates with AM, the marking and spacing signals are usually in the audio range and are transmitted as modulation on the carrier. When the transmitter operates with FM, as in the system shown, the marking and spacing frequencies are usually in the

lower part of the HF range. Here, the oscillator in the frequency shift exciter establishes the basic mark and spacing frequencies. Then they are passed on to the transmitter which is used without its own oscillator. The transmitter merely builds up the signals to the desired power output. Often, though, multipliers are used in the transmitter to multiply the frequencies generated in the shift exciter.

### Dual Diversity Converter

Now look at the block diagram of the dual diversity converter on page 139. This converter handles the output (the IF) of two receivers arranged for space diversity. The diversity arrangement is continued in the converter through the detectors. Thus, the two sets of mark and space signals are combined only in the converter output. However, a limiter, common to both diversity channels, can be used, since the limiter is both preceded and followed by stages containing filters.

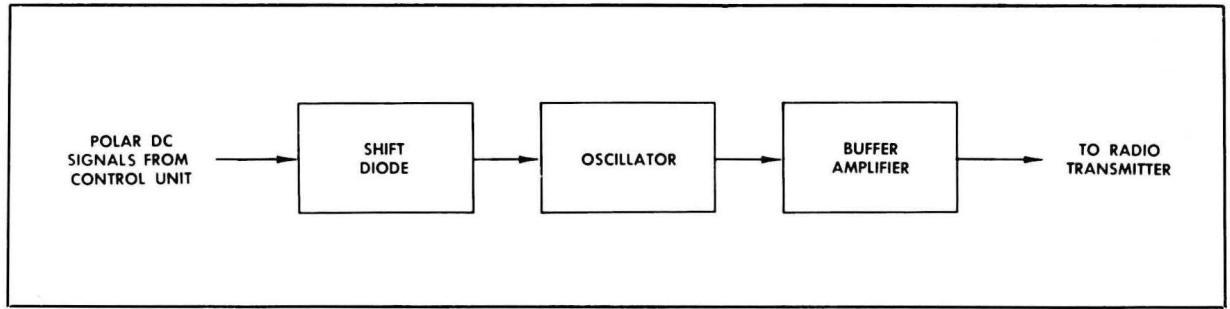

*Frequency Shift Exciter*

The inputs of both diversity channels are tunable to an input frequency between 400 and 470 kc (depending on the normal IF of the preceding receivers). The receiver IF is converted in each channel to a lower frequency. The conversion output for channel A is 50 kc. The conversion output for channel B is 29.3 kc.

Since marking and spacing intelligence is carried in the form of frequency variation, a limiter is used to remove amplitude variations. Both the 50-kc signal and the 29.3-kc signal pass through the same limiter. The removal of amplitude variations prevents noise impulses which might interfere with the mark and space output and cause incorrect operation of the teletypewriter.

Filter circuits in the rectifier stages separate the two channel frequencies before the final detection. Discriminators are used for detection. They convert the FM signals to DC amplitude pulses.

The driver stage and the DC output stage contain amplifier stages to build up the mark and space pulses. This gives them enough

power to operate the teletypewriters. The DC output circuit contains two separate channels — one to change the mark and space signals to polar DC signals which operate the receiving teletypewriter, and the other to change the same mark and space signals to neutral signals which operate a monitoring teletypewriter.

### Teletype Control Unit

The main function of the control unit is to coordinate the functioning of the various units of terminal equipment. The control unit itself divides into separate sections — a sending section, connecting it to the frequency shift exciter and thence to the receiver, and an extension section, connecting it to the teletypewriters. The control unit contains amplifier stages to maintain and control the voltages of the marking and spacing signals.

### PULSE RECEIVERS

Pulse systems are used as radio links in communications systems. They provide for the transmission of a comparatively high number of audio channels on one RF carrier.

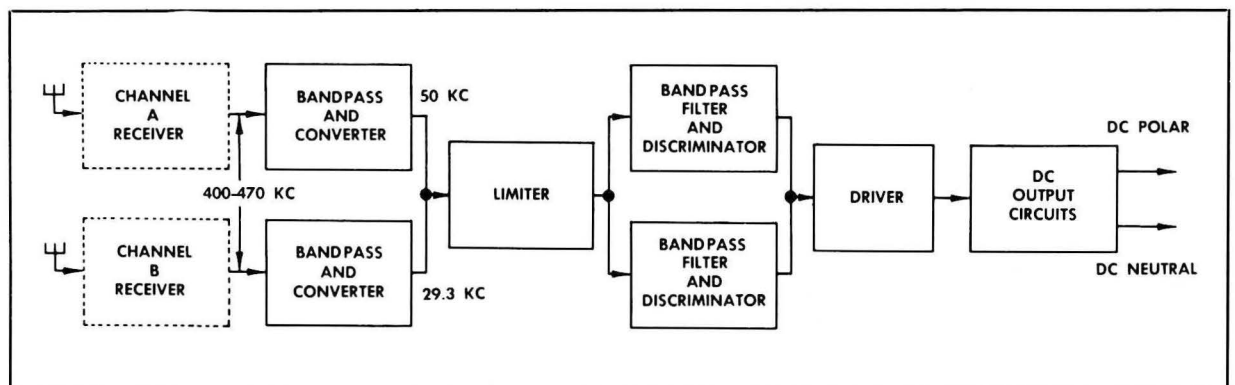

*Dual Diversity Converter*

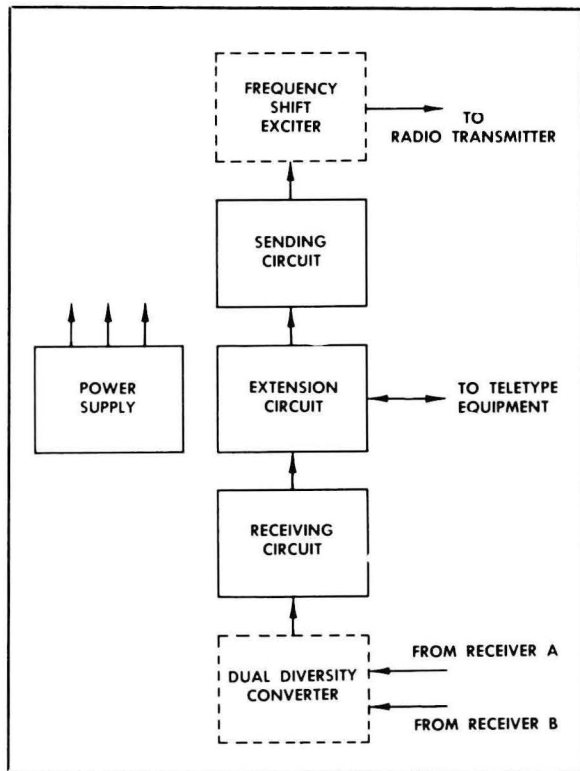

Control Unit

Where the FM and SSB systems allow three or four full audio channels, pulse systems often provide as many as 8 or 10 full audio channels. The extra channels are possible because the principle by which channels are formed in pulse systems is entirely different from that in FM and SSB systems. FM and SSB channels are formed by dividing the AF modulation bandpass at various frequency levels. Pulse

system channels are formed by dividing transmission time into various channels.

**Principles of Pulse Operation**

In pulse systems, the transmission time is divided among the channels. Thus, for 8-channel operation, about 1/8 of the total transmission time is devoted to each channel in sequence in such a way that all 8 channels are in operation simultaneously. The total transmission time is divided into segments called *sync periods*. You can see such a sync period shown graphically in the illustration below. Note that each sync period lasts for 100 microseconds. It's a very short period and is repeated 10,000 times every second. Yet this sync period itself is subdivided into nine subdivisions — eight channel pulses and a sync (synchronizing) pulse. This division into pulses and intervals between pulses insures adequate separation between pulses, and, therefore, between channels.

As shown, the sync pulse lasts for 2 microseconds while each channel pulse lasts only 0.4 microsecond. A 10.533-microsecond interval separates each pulse from the next. The waveform shown represents an unmodulated carrier.

Various systems of modulation can be used. The common methods of modulation include *amplitude modulation* (by which the amplitude of pulses is varied), *pulse duration modulation* (by which the width of the pulse is varied), and *pulse position modulation* (by which the position of the pulse with respect to the sync pulse is varied). When modulated, each chan-

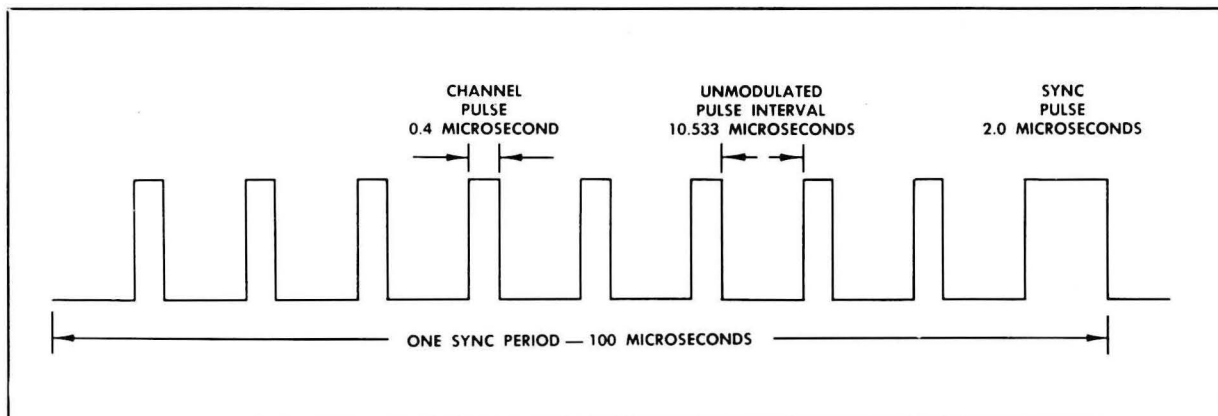

Typical Pulse System Waveform, Unmodulated

nel pulse in a sync period may be considered as being connected to a separate microphone at the transmitter. At the receiver, each channel pulse may be considered as being connected to a separate audio reproducer. Thus, there are eight distinct communications channels, beginning at eight different microphones, passing to eight different channel pulses on the common carrier, and ending at eight different reproducers.

The modulation at the microphone has the natural continuity of the human voice. However, the modulation carried by the RF carrier occurs for only 0.4 microsecond out of each 100 microseconds. Likewise, the modulation reproduced by the reproducer occurs for only about 0.4 microsecond out of each 100 microseconds. Thus, the modulation at the reproduction end of each circuit falls far short of the natural continuity of the human voice. Remember, however, that each channel pulse occurs once in each sync period and is repeated 10,000 times in every second. To the human ear, the reproduction sounds perfectly natural. Thus, pulse systems take advantage of the inability of the human ear to distinguish between naturally continuous and rapidly interrupted sounds, just as the reproduction of television pictures takes advantage of the inability of the human eye to distinguish between naturally continuous and rapidly interrupted light.

The key to pulse systems operation is to have each microphone connected to the transmitter only while its corresponding channel pulse is being transmitted, and to have each reproducer connected to the receiver output only while its corresponding channel pulse is being received. This requires an extremely rapid and precise switching arrangement. However, such switching can be managed quite easily with proper electronic circuits.

Each pulse is composed of RF, usually in the UHF range. The usual transmitter uses a magnetron oscillator. This means line-of-sight transmission and directive antenna arrays. The receiver is usually a superheterodyne. Both transmitter and receiver are usually regular UHF communication units, and little or no modification is required to adapt them for pulse operation. Like the multichannel

FM and SSB systems already studied, the circuits which provide pulse multichannel operation are housed in separate units. In signal sequence, they precede the transmitter and follow the receiver. These units are called transmitting and receiving multiplexes.

### **Functional Analysis of a Receiving Multiplex**

Look at the functional block diagram of a receiving multiplex on page 142. It consists of one common unit, shown at the top of the diagram, and a number of channel units, one for each channel. Since the channel units are all essentially the same in structure and function, only one is shown.

Notice the waveforms included in the block diagram. Together with the sync pulse, they control the timing and switching functions which make multichannel operation possible. The stepped waveform put out by the common unit is applied to all the channel units. It causes each channel unit to pass only its own proper channel pulse. The production of the stepped waveform is controlled by the sync pulse.

Note that the waveform supplied by the receiver to both the common unit and the channel units is composed of the sync pulse and eight channel pulses.

**COMMON UNIT.** In the common unit, the waveform from the receiver is passed through a limiter to a sync separator. The sync separator reacts to the sync pulse but not to the channel pulses. Thus, the output of the sync separator contains only the sync pulse. This is fed to the discharge pulse generator where the pulse is shaped to the proper amplitude and duration. Part of the output of the discharge pulse generator is fed to three discharge tubes, and part is fed to the phasing trigger. Here the pulse is retarded by 10 microseconds.

The retarded pulse is then applied to the exciter which contains an oscillator tuned to 90 kc. The retarded pulse sets the oscillator into action. The 90-kc output of the exciter then passes through a limiter. Now, remember that the retarded pulse fed to the exciter is 10 microseconds behind the pulse fed to the discharge tubes. This means that the retarded

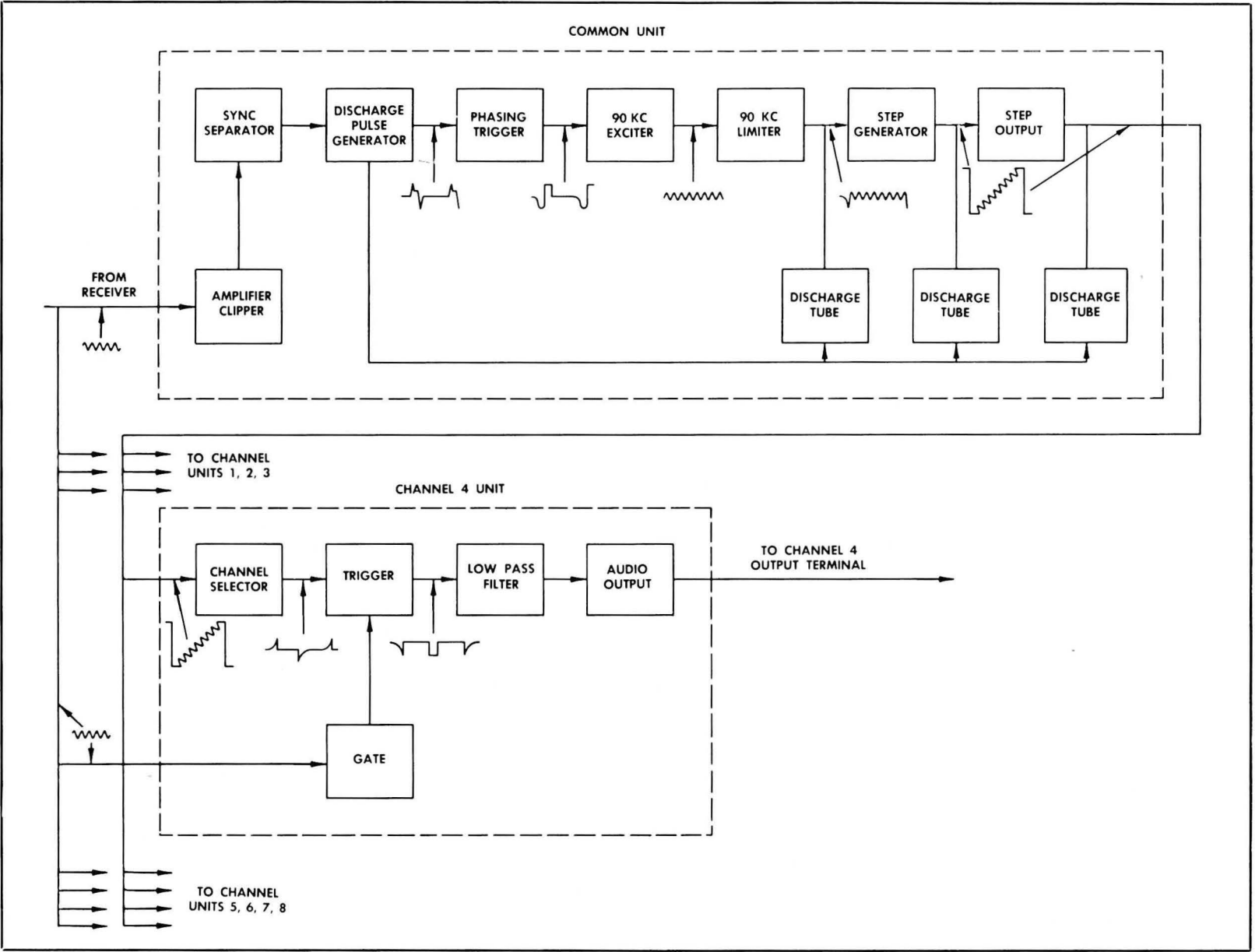

Pulse-Receiving Multiplex

pulse is 90 microseconds ahead of the next discharge pulse. It starts the exciter, and a 90-kc signal is put out through the limiter for 90 microseconds. Then a discharge pulse comes along. The discharge pulse cuts off the 90-kc signal, as the waveform shows. After 10 microseconds a retarded pulse again excites the oscillator. This means that the limiter output consists of 90 microseconds of oscillation and 10 microseconds of cutoff. Thus, the 90-kc output is divided into segments which correspond to the 100-microsecond sync period. The sync pulse is separated from the sync period and it is used both to excite the oscillator and to cut off its output waveform. The other two discharge tubes simply reinforce the cutoff.

The waveform output of the 90-kc limiter consists of eight full cycles and the cutoff. These cycles last as long as the time devoted to each channel in the sync period. These cycles are fed to a step generator which is essentially an RC circuit with a long time constant. The charge on the RC circuit builds up on part of one cycle, and then remains steady during the rest of the cycle. The charge increases during part of the next cycle and then remains steady during the rest of the cycle. Thus, the voltage builds up cycle by

cycle, step by step, until the discharge pulse discharges the RC circuit. The output consists of the stepped waveform which is applied to the individual channel units.

**CHANNEL UNIT.** The channel selector of each channel unit is set to operate on only one particular step of the waveform. When the selector operates, it sends a pulse to the trigger stage and sets off a new pulse in that stage. This opens the gate tube circuit to the receiver output pulse, which corresponds to the step on which the particular channel operates. This means that the proper pulse in the receiver output is applied back through the gate tube to the trigger. The receiver output pulse cuts off the pulse which was begun in the trigger by the pulse from the channel selector. Thus voltage from the channel selector begins a trigger pulse while voltage from the gate tube ends it. Voltage from the trigger always recurs at 100-microsecond intervals since it is governed by the sync pulse. Voltage from the gate tube varies since that voltage is governed by the channel pulse which is variable. In the multiple system shown it varies in time (that is, in its position relative to the sync pulse) as determined by the modulating voltage. Thus, the duration of each trigger pulse varies with the

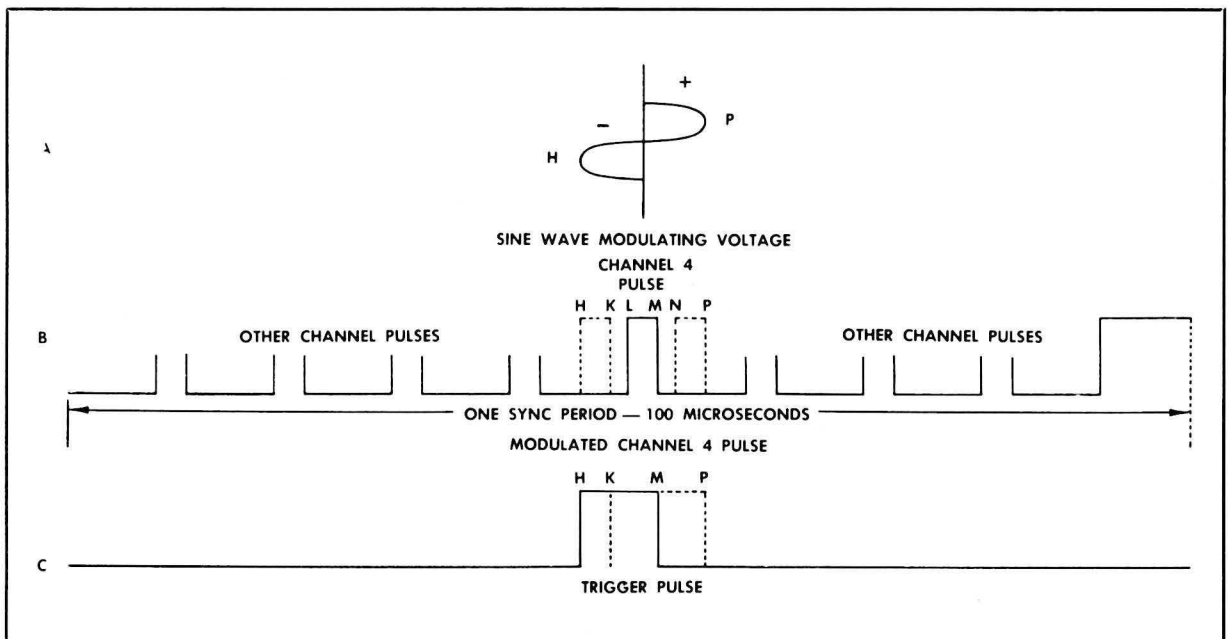

Channel Pulse Modulation Patterns for Forming Trigger Pulses

position of the channel pulse. Likewise, the duration of each trigger pulse varies with the modulation. A detector which is responsive to the varying duration of the trigger pulse extracts the modulation and makes it available to drive the reproducer.

To see how the channel pulse varies with modulation and how this variation affects the duration of the trigger pulse, examine the waveforms on page 143. The channel pulse for channel 4 is shown at B. The pulse in solid outline represents the unmodulated pulse. The pulse in broken outline HK represents the position of the same pulse when it is at the greatest distance from the sync pulse. The pulse in broken outline NP represents the pulse at its shortest distance from the sync pulse. The various positions of the channel pulse are determined by the modulating voltage. In this case, the modulating voltage is the sine wave voltage shown at A. During the positive swing of the modulating voltage, the channel pulse moves toward the sync pulse. When the positive swing drops back to zero the pulse moves back to its resting (unmodulated) position. During the negative swing of the modulating voltage, the channel pulse leaves its resting position and moves away from the sync pulse. When the negative swing drops back to zero the pulse again returns to its resting position.

Now look at the waveform of the trigger pulse at C. The position of point H of the trigger pulse is determined by the fourth step of the stepped voltage. This, in turn, is determined by the sync pulse. Therefore, point H, like the sync pulse, does not change its position. However, point H marks only the beginning of the trigger pulse. The end of the trigger pulse is determined by the position of the channel pulse. Thus, point M of the trigger pulse marks the end of that pulse when the channel pulse is in its rest position. Point P marks the end of the trigger pulse when the channel pulse is closest to the sync pulse. Point K of the trigger pulse marks the end of the trigger pulse when the channel pulse is in its position farthest from the sync pulse. Thus, the trigger pulse varies in duration as the channel pulse varies in position with the modulation. Other channels work in the same

way. While they are being modulated, their pulses vary their position with respect to the sync pulse. Since each of the other channel pulses is varied independently, the movement of each is independent of the movement of the channel 4 pulse. The only requirement is that the pulses of each of the channels be kept separate, that no channel pulse moves into the area of movement of another channel pulse.

Because pulse systems have a high number of effective audio channels, they are frequently used in well-established commercial telephone systems, as well as in military systems. Pulse systems can carry the full communications load of commercial systems, and frequently include dialing and ringing circuits.

## TELEVISION RECEIVERS

There is already some use of television (TV) in military operations, and it is probable that the use of TV, especially by the Air Force, will greatly increase in the future. TV makes possible instantaneous observation and reconnaissance by many observers at a distance. It even makes possible observation and reconnaissance from positions completely inaccessible to human observers.

### Principles of TV Operation

Commercial television broadcasting has been assigned three bands—54-88 mc, 174-216 mc, and 470-890 mc. The first two are in the VHF range and the last is in the UHF range. Consequently, most of the special considerations of VHF and UHF operation (line-of-sight transmission, directive antenna, special tubes, special tuned circuit, etc.) apply to TV.

The picture signal for TV is carried by an amplitude modulated single sideband RF wave. (One full sideband, the carrier, and part of the other sideband are transmitted.) Consequently, many of the special considerations of SSB operation apply also to TV.

The sound signal is carried by a frequency modulated RF wave. Consequently many of the special considerations of FM operation apply also to TV.

There are even some resemblances between TV operation and pulse operation. The pic-

ture signal is transmitted as amplitude modulation but the time interval between picture pulses is utilized for the transmission of timing or synchronizing pulses.

**RECEIVER PICTURE TUBE.** Even the feature which sets TV receivers apart from all the receivers already studied in this manual—the reproduction of pictures—is not completely unfamiliar. The picture tube of a TV receiver is essentially a cathode ray tube. The TV picture is formed by a stream of electrons striking the fluorescent coating on the face of the tube. The electron beam is governed by a control grid and pairs of horizontal and vertical deflection plates or coils. Thus, the TV picture is simply a more complicated oscilloscope pattern. There is, however, this important difference: whereas the control grid voltage of the oscilloscope is only manually varied to control the brightness of the oscilloscope pattern, the picture control grid voltage responds automatically to the picture signal voltage. These variations in the picture signal create the whites and blacks—the lights and shadows of the TV picture.

The oscilloscope pattern can fill the whole face of the tube. There is no area on the tube face to which the vertical and horizontal plate voltages cannot drive the trace. Likewise, the TV picture is created by causing the trace to cover, systematically and point by point, the whole face of the tube. The face of the tube is scanned in 525 lines, moving from left to right and downwards. During the time that the trace moves back (from right to left) to start

a new line, a voltage, called a *blanking signal*, is applied to the picture tube grid to cut off the electron beam.

The trace covers the entire face of the picture tube 30 times in each second. An entire coverage, the whole 525 lines, is called a *frame*. The entire coverage is made in two parts. During the first part the odd lines are scanned, and during the second part the even lines are scanned. Each part is called a *field*. Each of the two fields of a frame is capable of reproducing a picture. The pictures reproduced by the two fields of a frame interlace and reinforce each other. Having the trace scan alternate lines produces two pictures for each frame and helps to reduce flicker. Fields are produced 60 times a second. This corresponds to the normal AC power frequency. The frame repetition rate of 30 is even higher than the repetition rate of motion pictures—24 frames a second.

The TV picture is formed because a varying RF signal received by the receiver is applied to the control grid of the picture tube. This means that electrical energy is turned into a picture. At the transmitter the process is the reverse. A picture is turned into a varying RF signal.

**TRANSMITTER PICTURE TUBE.** To turn a picture into a varying electrical signal, a tube which might be regarded as a cathode ray tube in reverse is used. Several types of such tube are in common use. The *image orthicon tube*, shown below, may be regarded as typical. It is a long cylindrical tube with an opening at

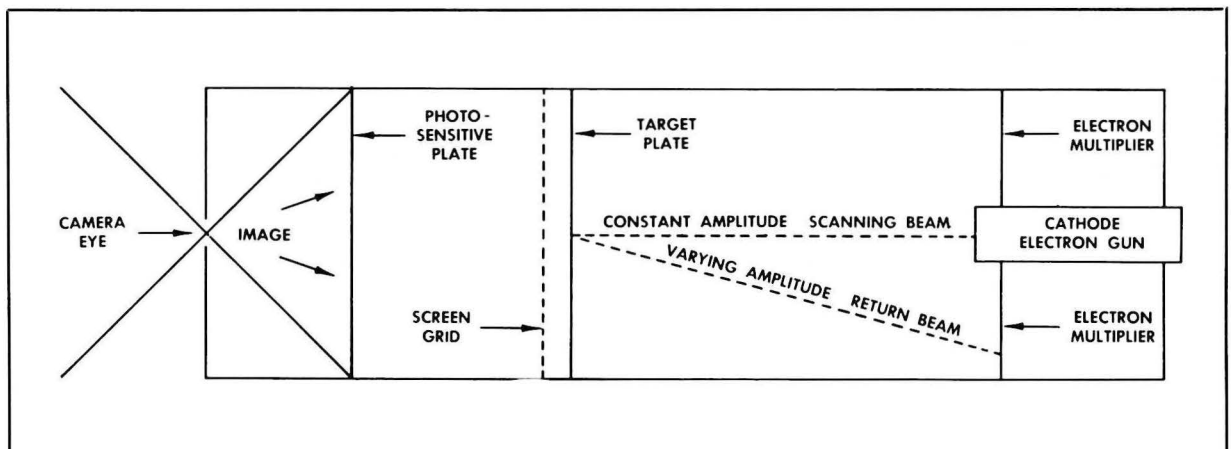

Scanner Functional Drawing, Image Orthicon Tube



one end like the lens of a camera. This opening focuses light, a reproduction of whatever scene faces the opening, on a plate within the tube. This plate is coated with a material which might be regarded as the reverse of the fluorescent material on the face of the picture tube. Instead of giving off light when struck by electrons, it gives off electrons when struck by light. It is photosensitive. It gives off electrons in proportion to the amount of light striking it.

These electrons are attracted farther into the tube where they strike another plate, called the target plate. At first, this plate is of neutral potential. Then, as electrons strike the target plate, they dislodge electrons from the plate in a process similar to secondary emission.

Between the photosensitive plate and the target plate there is a grid similar to a screen grid. This grid absorbs the electrons dislodged from the target plate. Thus, there is a charge on the target plate proportional to the number of electrons dislodged. At any particular point on the target plate, the charge is proportional to the light striking the photosensitive plate at the corresponding point. This means that the light pattern on the photosensitive plate is reproduced on the target plate in terms of electrical charge. Where the light on the photosensitive plate is brightest, the charge on the target plate is greatest. Where the light on the photosensitive plate is dimmest, the charge on the target plate is weakest.

From the farther end of the image orthicon tube a beam of electrons is directed toward the target plate. This beam is controlled by vertical and horizontal deflection plates or coils similar to the deflection plates or coils of the picture tube in the receiver. This beam scans the target plate in a frame of 525 lines in two fields, one for the odd lines and another for the even. The rate is 30 frames and 60 fields each second. In other words, the target plate is scanned exactly like the screen of the picture tube.

The electron stream, produced at a steady rate, is directed toward the target plate. Just as the stream approaches the target plate it is drawn back to another plate, called an *electron*

*multiplier*. However, some of the electrons do not return to the multiplier. These are the electrons absorbed by the target plate to neutralize the charge created by the action of the electrons from the photosensitive plate. The electrons absorbed at the target plate subtract from the number of electrons returning to the electron multiplier. This means that when the electron stream reaches the electron multiplier, it varies in the same way as the charge on the target plate. This, in turn, means that the electron stream at the electron multiplier varies in the same way as the light on the photosensitive plate. Thus, the picture is transformed into a varying electrical signal. This signal is applied to the transmitter carrier as picture intelligence.

**SYNCHRONIZATION.** For a clear picture, it is essential that the movement of the electron stream in the image orthicon tube be coordinated with the movement of the electron stream in the picture tube. This is accomplished by translating the voltages on the vertical and horizontal deflection plates of the image orthicon tube into voltage pulses. These pulses are used as synchronizing pulses and are transmitted in the intervals between the picture lines. At the picture tube, the synchronizing pulses control the timing of the voltages applied to the vertical and horizontal plates. The trace of the picture tube therefore moves in exact coordination with the scanner.

**MODULATION.** The intelligence transmitted in television is like the intelligence transmitted in any AM system. It consists of a varying voltage applied as modulation to a high frequency carrier. However, the intelligence transmitted in television is different from the intelligence transmitted in other AM systems in that the varying modulation voltage occurs at frequencies far higher than the audio range. Before the transmission of pictures became common, the terms *modulation* and *audio* meant just about the same thing. Practically all modulation was at audio frequencies. Since the development of television, the frequencies used for television modulation have been termed *video* to distinguish them from the *audio*.

The frequencies used for video depend on

the number of picture elements scanned in order to reproduce a picture. A system that scans 525 horizontal lines of a picture divides the picture into 525 horizontal strips. In order to show equal vertical differentiation in a square picture, each line ought to be divided into 525 different segments. This division is accomplished in terms of frequency. From point to point, the scanner must be able to vary its voltage response to light intensity fast enough to show as much as 525 differences along the line. This means that a square picture is divided into 525 vertical and 525 horizontal segments. That makes a total of  $525^2$ , or 275,625 segments. These segments are called picture elements.

Actually the picture is rectangular rather than square and wider than it is high. If the width is to the height as 4:3, then the picture elements are  $4/3$  times those in a square picture. Thus, the total picture elements are  $275,625 \times 4/3$ , or 367,500 for each frame. Each frame, however, is repeated 30 times each second. Thus, the total picture elements per second are  $367,500 \times 30$ , or about 11,000,000. To differentiate that many picture elements, the scanner must be capable of a frequency of half of 11,000,000 or 5.5 mc. The reason why the frequency of the scanner is only half the number of picture elements is that the scanner voltage can go either up or down. Thus, in moving across three picture elements, the voltage may vary upward for the change from the first to the second element, but downward again for the third element. This means that the maximum frequency need be only one half the number of picture elements. The modulation frequencies used for the reproduction of a

television picture therefore need to be only 5.5 mc.

Note that a frequency of 5.5 mc falls well inside the HF range. A carrier frequency capable of carrying a 5.5-mc signal as modulation must be substantially higher. This accounts for the use of VHF and UHF for TV.

Note, too, that in modulating a higher frequency carrier, a 5.5-mc signal forms a pair of sidebands—one, 5.5 mc above the carrier, and one 5.5 mc below the carrier. This would require a receiver bandpass of 11 mc. A bandpass of 11 mc would occupy a large chunk of the spectrum, even at VHF and UHF. That is why single sideband operation is used for television. Experiment has shown that the most effective operation is obtained when one full sideband, the carrier, and only part of the second sideband is transmitted. In addition, this type of operation permits more television channels than would be possible with double sideband operation. The channel assigned to commercial TV stations is 6 mc wide and the actual maximum video modulating frequency is 4.5 mc.

**WAVEFORM.** The general principles of television operation can best be summed up by a representation of a typical video signal. Look at the diagram below showing the waveform for the last two lines in a field. The video intelligence portions represent the varying voltages supplied by the scanner. The high amplitude pulses represent the intervals being scanned. These pulses have two levels. The lower level provides a voltage which is used to blank the electron beam of both the scanner and the picture tube between the end of one line and the beginning of the next line. The

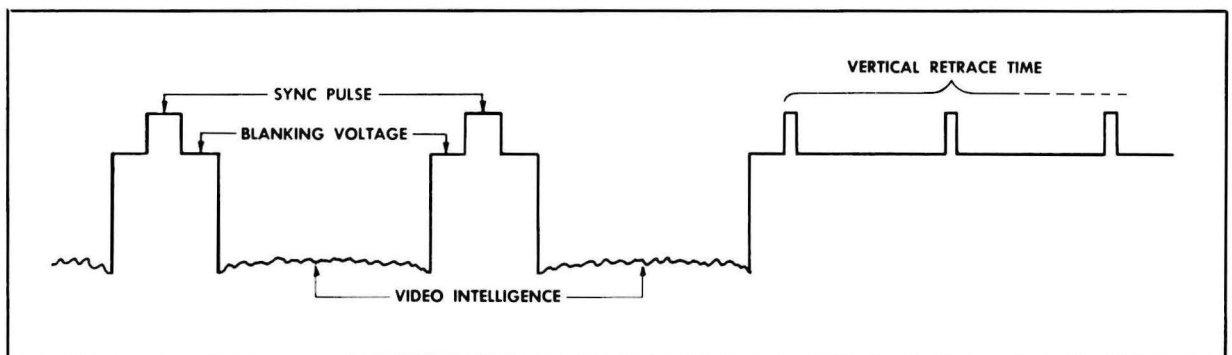

Television Modulation Pattern

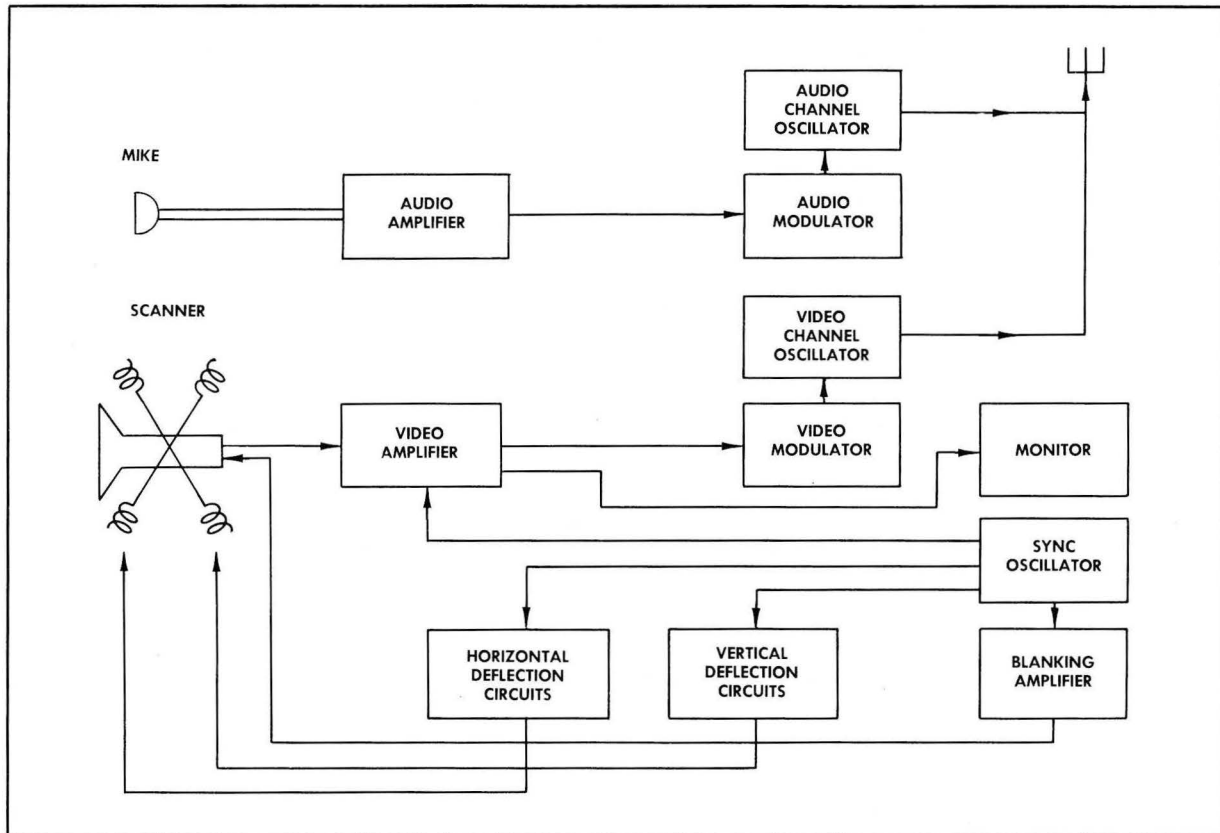

Television Transmitter

upper level of the pulses provides the voltage used to synchronize the movement of the electron stream in the scanner with that of the electron stream in the receiver picture tube. The upper level of the pulses is supplied by the voltage applied to the deflection plates in the scanner. In the picture tubes, these upper level pulses govern the timing of the voltages applied to the deflection plates. The pulses at the right occur at the end of each field. They provide blanking voltage (lower level) and synchronizing voltage (upper level) to move the trace back to the upper left corner of the picture to start a new field.

### Functional Analysis of A Typical TV System

Look at the simplified block diagram of the television transmitter shown above. It actually consists of two transmitters — one supplying an FM signal with audio modulation, and the other supplying an AM signal

with video intelligence. The two transmitters utilize a common power supply and a common antenna.

The circuits of the transmitter for audio intelligence begin with a microphone, proceed through an audio amplifier, a modulator, and a high frequency FM oscillator, to the antenna.

The circuits of the transmitter for video intelligence begin with a scanner and proceed through a video amplifier, a modulator, and an oscillator to the antenna. The transmitter for video intelligence also contains a second oscillator called a *sync oscillator*. This controls the blanking and synchronizing voltages. Part of the sync oscillator output is fed to the horizontal and vertical deflection circuits which control the movement of the electron beam in the scanner. Another part of the sync oscillator output is fed to the blanking amplifier. This supplies blanking voltage to the control grid of the scanner to cut off the electron beam during retraces. The rest of the

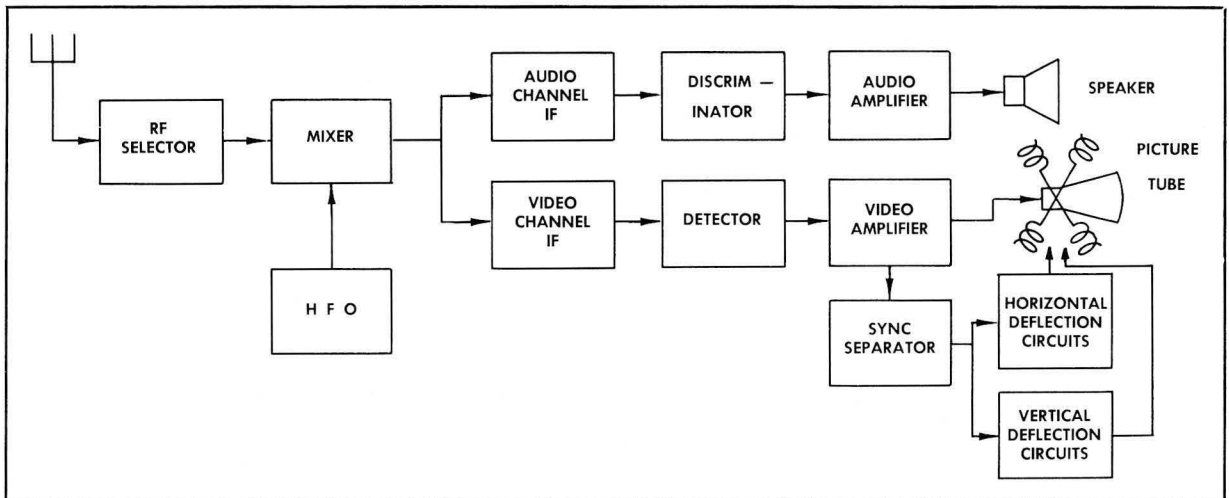

Television Receiver

output of the sync oscillator is fed to the video amplifier as pulses occurring during the intervals between the lines. These pulses are transmitted as modulation on the carrier. At the receiver, these pulses synchronize the deflection and blanking voltages of the picture tube with the deflection and blanking voltages of the scanner.

Now look at the simplified block diagram of the TV receiver above. It handles both an FM signal for the audio and an AM signal for the video. Both signals are received over a single antenna, tuned in and amplified by a single RF section, and heterodyned against a single high frequency oscillator. The heterodyned signals are then sent through different IF sections, one for the audio channel and the other for the video channel. The audio signal is demodulated by a discriminator, amplified by an audio amplifier section, and applied to the speaker. The video signal is demodulated by a detector and amplified by an amplifier section. Part of the output of the amplifier goes directly to the picture tube, alternately applying the video signal and the blanking voltage. The other part of the amplifier output goes to the sync selector circuit. Here the sync pulses are extracted and are used to control the timing of the horizontal and vertical deflection voltages applied to the picture tube. This keeps the trace in the picture tube moving in synchronization with the trace in the scanner.

## RADIO DIRECTION FINDERS

Radio direction finders determine the direction of arrival of radio waves. This information is vital in navigation, for it makes possible the positioning, controlling, and homing of ground, sea, and air forces. It is especially vital in air-sea rescue work, because manually operated portable transmitters are standard equipment in survival gear. Directional information is also a very important aid to military intelligence. Locating enemy transmitters makes it possible to monitor them, to jam them, to home on them, to transmit on their frequencies, or to destroy them.

The composition of radio direction finders depends on the job they are designed to do. Those used as navigation aids are relatively simple, since they are designed for operation on one or two predetermined frequency bands. Those used as aids to military intelligence are

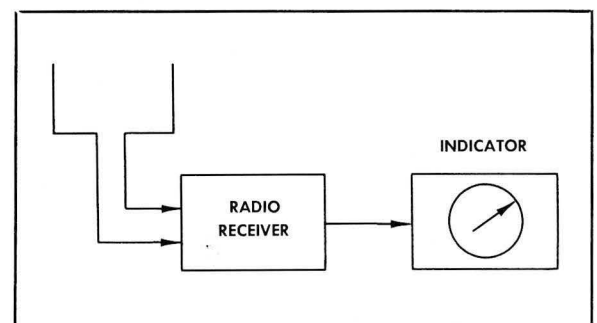

Basic Direction Finder

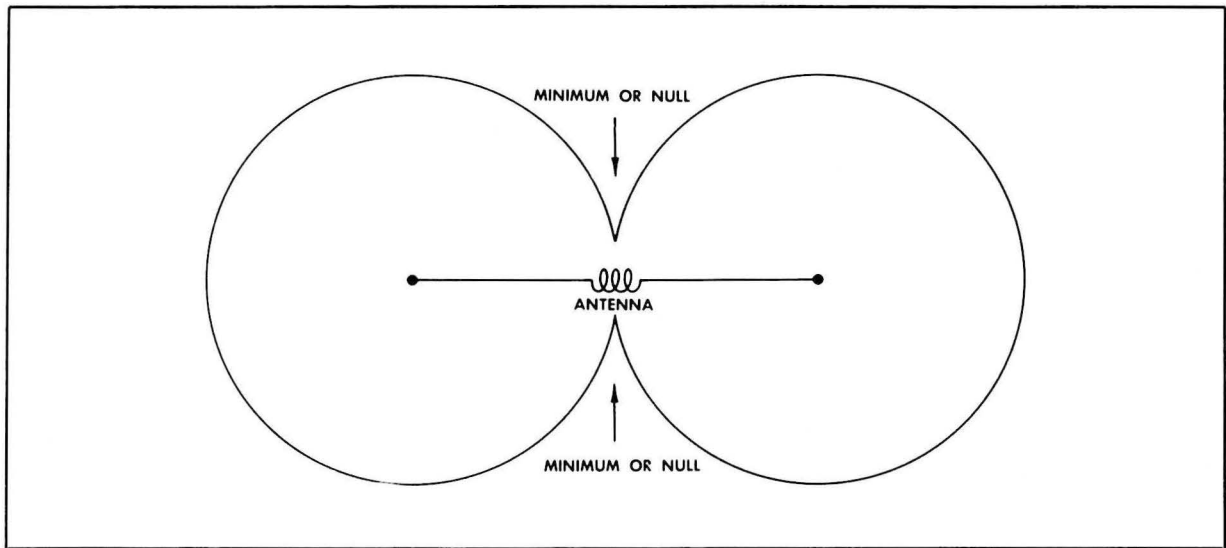

*Loop or U-Antenna Response Pattern*

usually quite complicated since the operating frequencies of the enemy are unknown, and the entire frequency spectrum must be monitored.

**Principles of Direction Finder Operation**

As you can see in the block diagram of a simple direction finder, the three basic units of a direction finder are a directional antenna, a radio receiver, and an indicator.

**ANTENNAS.** Two simple antennas which qualify as directional antennas are the loop antenna and the U-antenna. Such antennas have a directional response pattern which takes the form of a figure 8, as you can see in the illustration above.

When a radio wave arrives at right angles to the plane of the two vertical arms of the directional antenna, it reaches each arm at the same moment. The voltages induced in

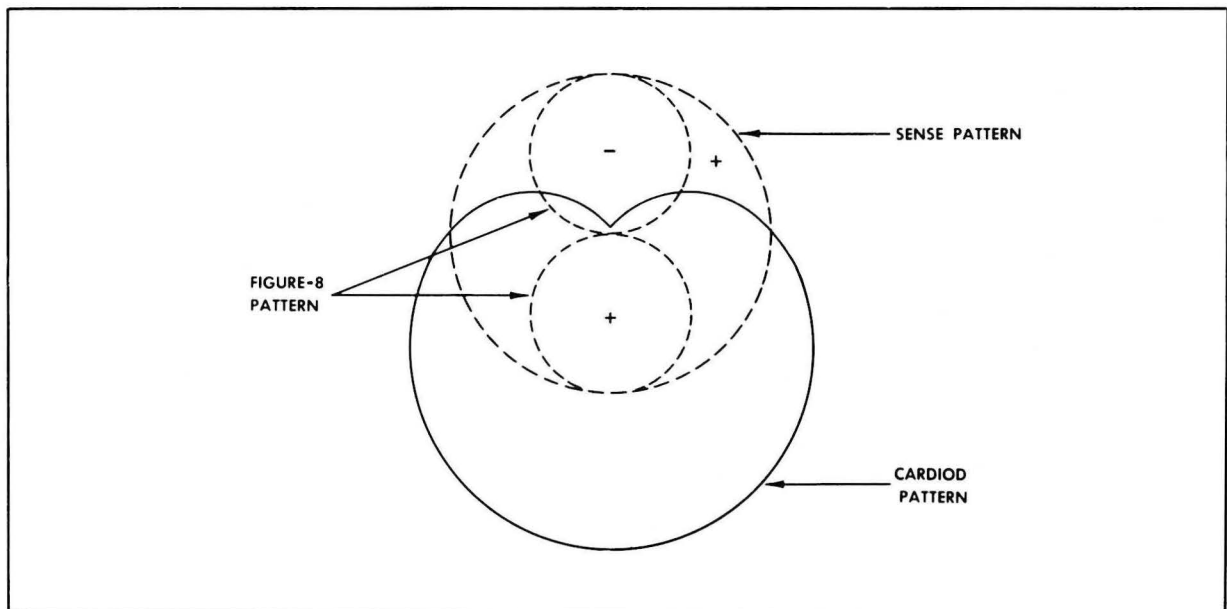

*Sense Response Pattern*

the two arms are equal, but opposite in phase. They cancel.

When a wave arrives in the same plane as the vertical arms, the voltage induced in the closer arm is out of phase with the voltage induced in the farther arm. Only partial cancellation takes place, and the total voltage is maximum. However, as the figure 8 shows, there can be nulls (complete cancellation) in two directions, and maximums (the least amount of cancellation) in two directions. Thus, the response of a single loop or U-antenna, shows the line of movement of a radio wave but does not distinguish between two possible directions of arrival. A null indicates only that a transmitter lies in either of two opposite directions. To get a response which will show true direction, the response of a directional antenna must be combined with the response of a nondirectional (sense) antenna. A monopole vertical antenna meets the requirements for a nondirectional antenna. You can see the combined response pattern in the accompanying illustration on page 150. It is the figure in solid outline. Its shape is cardioid (heart shaped), and it represents the resultant of the directional and nondirectional responses shown in broken outline.

The two lobes of the directional response (the figure 8) are of opposite polarity. However, the nondirectional response has the same polarity in all directions. This means that, in combination, the nondirectional response cancels one lobe of the figure 8 and increases the amplitude of the other. The resulting cardioid pattern has only one null. Thus, the null of the cardioid pattern can indicate only one direction. In direction finding, the null is used instead of the maximum, for it permits more accurate bearings than the maximum.

Note that the null of the cardioid pattern is  $90^\circ$  removed in direction from the two nulls of the figure-8 pattern. This  $90^\circ$  difference must be taken into account in calibrating the indicator. Operation to provide a cardioid pattern showing true direction is called *sense operation*. Operation to provide a figure-8 pattern showing the plane of movement of a radio wave is called *bearing operation*.

**RECEIVER.** The receiver used in a direction finder amplifies and detects the varying response of the antenna system and makes it available for the indicator. The direction finder receiver is usually a highly selective superheterodyne.

**INDICATORS.** The response supplied by the receiver can be used for either visual or aural

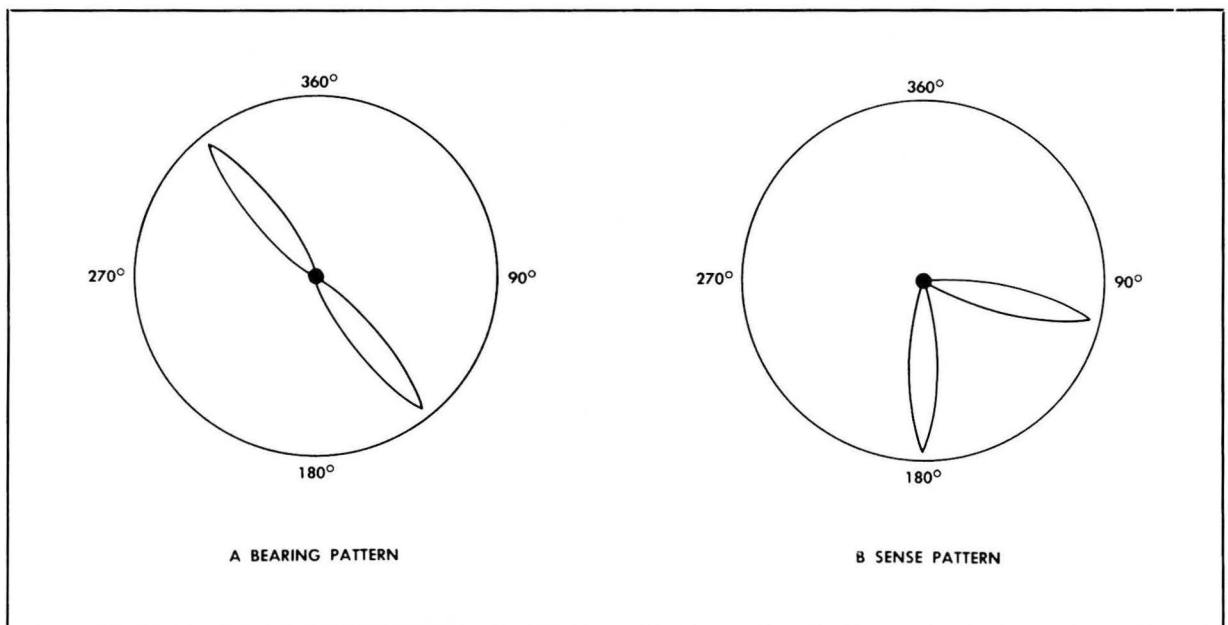

Cathode Ray Tube Patterns

indication. For visual indication a pointer is usually used against a scale calibrated in degrees. On the scale, north (either magnetic or true) is the reference point. For aural indication the receiver supplies a heterodyned audio tone signal, with zero beat indicating aural null (minimum or no sound).

The most satisfactory visual indicator makes use of a cathode ray tube. The face of the tube is calibrated in degrees with reference to north. Notice the two examples of cathode ray indicator patterns on page 151. The indicator pattern at A is propeller shaped, with the propeller tips indicating bearing. Since the tips point in opposite directions, the pattern does not indicate true bearing. For true bearing the pattern at B is used. This pattern is the cathode ray equivalent of the cardioid pattern used to show true bearing.

### Functional Analysis of a Typical Direction Finder

Examine the block diagram of a typical direction finder used for intelligence on page 153. It has, of course, the three basic units—antenna, receiver, and indicator. In addition, it has a modulating voltage generator and an azimuth indicator. These two units are not used at the same time. One is a substitute for the other. When the modulating voltage generator unit is used, instantaneous electrical indication is provided by the cathode ray tube indicator. When the azimuth indicator unit is used, indication is by means of an aural null associated with a manually operated indicator.

**ANTENNA ARRAY.** The usual antenna array for a typical direction finder consists of four monopole vertical antennas arranged in the form of a square with the antennas oriented to north, south, east, and west. The total output of the four antennas is developed across a combining impedance and represents the vectorial sum of the outputs of the individual antennas. The phase of the output voltages of the individual antennas depends on the direction of the RF wave. The total output developed across the combining impedance contains directional information.

In a direction finder used for intelligence work there is usually an arrangement by which

the length of the monopole antennas can be varied to conform to the various wavelengths at which a transmitter may be operating. Such an array of monopole antennas cannot be used in place of a loop antenna in most navigational work. The array is too big and cumbersome to be rotatable. However, the effect of rotation can be achieved by use of a device called a *goniometer*.

A goniometer is a special kind of transformer. The primary consists of two coils arranged at right angles to each other. Each coil develops the output of two monopole antennas of opposite phase. The secondary consists of a single rotatable coil. When the secondary coil is rotated within the fields of the two primary coils, the response is the same as if the antenna array were rotated.

**MODULATING VOLTAGE GENERATOR.** The modulating voltage generator unit contains an oscillator which supplies a 147-cps signal. This audio signal is used to synchronize the response of the cathode ray tube indicator with the response of the antenna circuits. The signal also modulates locally any RF wave picked up by the antennas. Thus, the direction finder receiver can detect a response even though the RF wave may be unmodulated. It can also detect a response if the RF wave represents FM, SSB, or pulse transmission.

The 147-cps signal passes through a phase splitter circuit and two phase inverter circuits before it is applied to the balanced modulators of the antennas. The 90° phase splitter produces two versions of the original 147-cps signal, one 90° out of phase with the other. Each of these two signals is passed through a phase inverter. Each inverter produces two signals 180° out of phase. This means that the two inverters put out a total of four signals. As the waveforms on the block diagram show, these signals are 0°, 90°, 180°, and 270° out of phase with the original 147-cps signal.

The four phased signals are fed to the four balanced modulators. There is one balanced modulator at the base of each of the four monopole antennas. In each balanced modulator, the phased 147-cps signal is mixed with the output of the antenna. Thus, the output of each balanced modulator consists

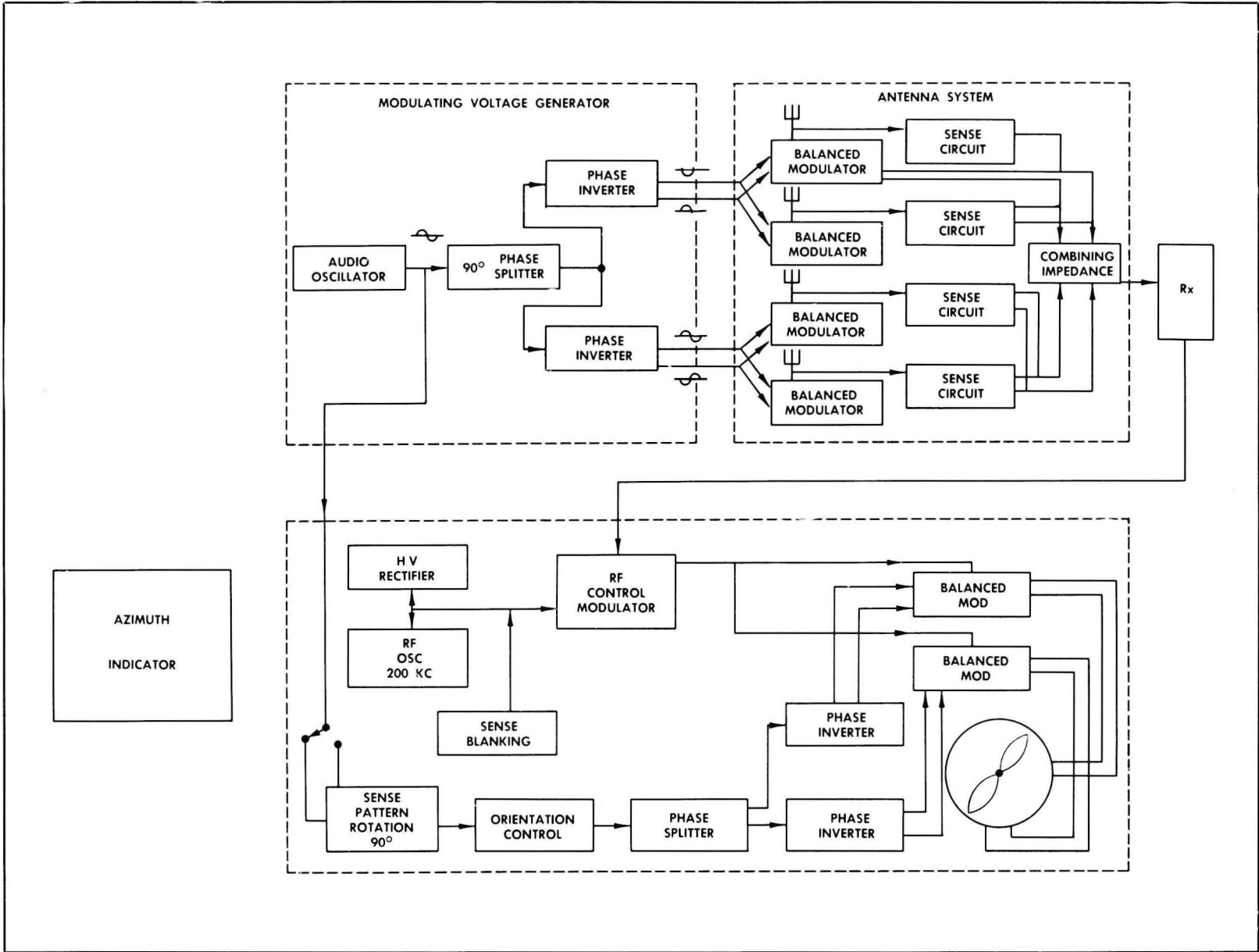



of an RF signal modulated by a phased 147-cps signal. The phase of the RF signal is determined by the direction of its arrival at the antenna. The modulation is the phased 147-cps audio signal. The output of the combining impedance consists of the vectorial sum of the four RF signals modulated by the vectorial sum of the 147-cps signals. The vectorial sum of the RF signals depends on the bearing and direction of the RF while the vectorial sum of the 147-cps signals shows time. This means that the directional response of the antennas occurs at a definite point in the  $360^\circ$  of one cycle of the 147 cps.

**BEARING INDICATOR UNIT.** Note that the original 147-cps signal is also fed into the bearing indicator unit. Here it passes through a phase splitter and two phase inverters. This produces four 147-cps signals, out of phase  $0^\circ$ ,  $90^\circ$ ,  $180^\circ$  and  $270^\circ$  with the original signal. These four phased signals are passed through balanced modulators and applied to the vertical and horizontal plates of the cathode ray tube. There, they cause the trace of the tube to rotate  $360^\circ$  for each cycle of the 147-cps signal. The face of the tube is calibrated in degrees. Since the circular movement of the trace is controlled by the 147-cps signal, the directional response of the antenna is applied to the scope at the same point in the  $360^\circ$  of the 147-cps signal as the point at which it occurs in the indicator unit.

Note that the bearing indicator unit contains a 200-kc oscillator. This 200-kc signal is eventually applied to the cathode ray tube. There it provides the voltages that cause the trace to move from one side of the tube to the other, with one complete movement back and forth for each cycle. The 147-cps phased signal is also applied to the cathode ray tube to cause the trace to move in a circular direction through  $360^\circ$  around the face of the tube. The trace moves through  $360^\circ$  of rotation for each full cycle of the 147-cps signal. Thus, the circular movement of the trace is coordinated with the antenna response, since both are governed by the 147-cps signal.

For the indicator response pattern, the voltages of the antenna response add to or subtract from the voltages of the 200-kc signal. This means that in some directions the

trace moves clear to the edge of the scope, but in other directions, the trace does not move from the center of the scope. Thus, the bearing pattern which results is a propeller-shaped pattern. The tips of the propeller-shaped pattern indicate the null points in the antenna's response pattern and thus the line of direction.

**SENSE OPERATION.** Since there are two propeller-shaped tips to the pattern, the indication is ambiguous as to direction of arrival. Sense operation to resolve this ambiguity is necessary. A single switch puts sense circuits into operation.

Note that sense operation in this system does not require a separate nondirectional antenna. The sense signals are taken from the same antennas that supply the balanced modulators. This is made possible by the balanced modulators. The output of a balanced modulator is an RF signal modulated by the 147-cps signal. However, because of the action of the modulators, the direction of the RF bearing signal reverses itself. Through the first  $180^\circ$  of the 147-cps signal it has the opposite phase of what it has through the other  $180^\circ$  of the 147-cps signal. The RF sense signal, on the other hand, does not reverse itself.

Thus, for a half cycle of the 147-cps signal, the bearing RF and the sense RF are in phase. For the other half cycle, they are  $180^\circ$  out of phase. When the RF signals are in phase they add; when they are out of phase they cancel. The resultant response is the characteristic cardioid pattern. There is only one null and it shows direction. The resultant pattern of all four antennas developed across the combining impedance is a cardioid pattern showing the true direction of arrival of the RF wave.

The cardioid sense pattern has its null displaced  $90^\circ$  from the two nulls of the bearing pattern. To keep the indicator from being  $90^\circ$  in error, therefore, the 147-cps synchronizing signal applied to the indicator is passed through the sense pattern rotation circuit in the indicator unit.

The same unit has a sense blanking circuit to cut off the 200-kc signal for one half of each of its cycles. The purpose of this is to prevent ambiguity. Here's why: the 200-kc signal pro-

vides the sweep voltage for the indicator tube. It provides a complete sweep for each half cycle. This means that the propeller-shaped pattern, formed with no blanking, is really a double pattern, one pattern superimposed on the other. The two patterns are opposite in polarity. Yet, since each pattern is composed of two identically shaped lobes, this difference in polarity does not matter in bearing operation. However, for sense operation, which requires a pattern of only one lobe, this difference in polarity would produce ambiguous results. The two patterns produced by a double sweep would not be superimposed. They would be produced in opposite directions, and no sense indication could be obtained. This difficulty is overcome by using a single sweep for sense operation. Blanking one half of each 200-kc cycle provides the single sweep.

**AZIMUTH INDICATOR.** The azimuth indicator provides an alternate means of getting bearing and sense indications. For azimuth indicator operation, the azimuth indicator unit is switched in to replace both the modulating voltage generator unit and the bearing indicator unit.

To replace the modulating voltage generator, the azimuth indicator unit uses a sinusoidal potentiometer. The sinusoidal potentiometer is a variable resistance across which a DC voltage is applied. The potentiometer has four output arms coupled to a common, rotatable shaft. An azimuth scale is affixed to this shaft and serves as indicator.

As the shaft is rotated through 360°, the DC potential at the end of one of the potentiometer arms rises from zero to a maximum positive voltage. As rotation continues, the potential falls back to zero. With further rotation, it goes to a maximum negative; then, it rises again to zero. Thus, during a complete cycle, voltages at the end of one arm correspond to the voltages produced at an AC source.

If the shaft were rotated at a rate of 147 cps, the output of one arm would be identical with the oscillator output of the modulating voltage generator. The output of each of the other potentiometer arms would be similar. However, the four arms point in four different

directions. Therefore, the four voltages at the ends of the arms at any one instant are 90° apart in phase. If one represents 0°, the others represent 90°, 180°, and 270°.

This means that if the shaft were rotated at a rate of 147 cps, the signal presented to the balanced modulators would be identical with that presented to the balanced modulators by the 147-cps oscillator and the phasing circuits. If the shaft were rotated at 147 cps, the sinusoidal potentiometer would do exactly the same job as the modulating voltage generator. However, for azimuth operation, it is not necessary to rotate the shaft that fast. The phased voltages presented by the potentiometer arms are DC voltages. They are present even when rotation is stopped. These phased DC voltages are supplied to the modulators and react with the signals of the four antennas to give a response pattern which shows bearing. When the sense circuits of the antenna system are connected, a sense response results.

Thus, operating the azimuth unit for bearing indication produces the characteristic response pattern with two nulls. Operating the azimuth unit for sense indication produces the characteristic response pattern with a single null. The nulls are detected aurally in the receiver output by rotating the shaft of the sinusoidal potentiometer. An azimuth scale and a pointer are mounted on the shaft and are calibrated for bearing and sense operation. Consequently, the calibrated position of the shaft when aural null is reached can be used to indicate either bearing or sense.

The azimuth dial consists of two scales (red and white). These are calibrated in degrees (0 to 360) and displaced 180° from each other. In operation, the azimuth dial is rotated to either of the two null positions. Then the sense switch is thrown to either the red or white position. In the vicinity of the null, the aural signal will be louder in one position than in the other. The position that gives the louder response indicates the direct or true azimuth. The exact indication is therefore on the azimuth scale that has the same color as the sense switch position which produces the louder signal.

The general system just described is basically the system of all homing and direction-

finding equipment. Airborne homing equipment usually has a rotatable directional antenna (the loop) and an indicator coordinated either electrically or mechanically with the position of the antenna. For homing opera-

tion, the RF signals (from the radio beacons) are usually coded to identify each station. These coded signals can appear visually on a cathode ray tube indicator, or can be heard aurally in a headset.

## PERFORMANCE TESTS AND TROUBLESHOOTING TECHNIQUES

---

Under normal conditions the repairman or technician has a fine collection of tools to help him do his job. He has a stock of spare components with which to replace defective components. He has a collection of test units to help him in locating defective components, in discovering incorrect voltages and currents, and in setting the receiver's variable components properly. He has, also, his knowledge of radio principles and his experience. Knowledge and experience are of major importance. A technician without an understanding of radio principles but with a tube tester, can detect a defective tube—by testing all the tubes. A technician with an understanding of radio principles and a tube tester, can locate a defective tube by testing only one or two tubes. His knowledge and experience enable him to isolate the trouble mentally.

The repairman or technician can make use of the knowledge and experience of others. Full information concerning any equipment he may use is available in the form of technical orders (TO's). The technician can also make good use of the knowledge and experience of others concerning each individual radio unit which he services. The trouble reports and the operating record of a unit can be most helpful for fast and efficient repair work.

The first part of this chapter deals with test equipment. A number of types are discussed briefly as to capabilities and uses. This is followed by discussions of technical publications that help in troubleshooting and maintenance. The last part of the chapter deals with general maintenance problems.

### TEST EQUIPMENT

Test equipment is often supplied in the form of a test set such as the I-56 on page 158. It includes two multimeters and a tube tester, all contained in a single carrying case.

#### Multimeter

A multimeter, as the name implies, incorporates several different meters in the same case, all using the same meter movement. Selector switches provide for selecting the particular meter and range that are desired. Notice the multimeters on pages 152 and 153, which are part of test equipment I-56. They are multimeter I-166 and multimeter I-176. They provide measurements of resistance, current, and voltage. These measurements help to locate defective components, bad connections, improper voltages and currents, and incorrectly set variable elements. Multimeter I-166 contains an output meter, an AC voltmeter, a DC voltmeter, and an ohmmeter. Multimeter I-176 contains an AC voltmeter, a DC voltmeter, an AC ammeter, a DC ammeter, and an ohmmeter. In general, similar meters of the I-176 and the I-166 complement rather than duplicate each other since their ranges and sensitivities are different.

#### Vacuum Tube Voltmeter

Now look at the vacuum tube voltmeter, TS-375A U, on page 159. The vacuum tube voltmeter is one of the most useful single unit instruments. In this unit, the voltage to be measured is applied to the control grid of an electron tube. Measurements and calibration



*Test Set I-56*

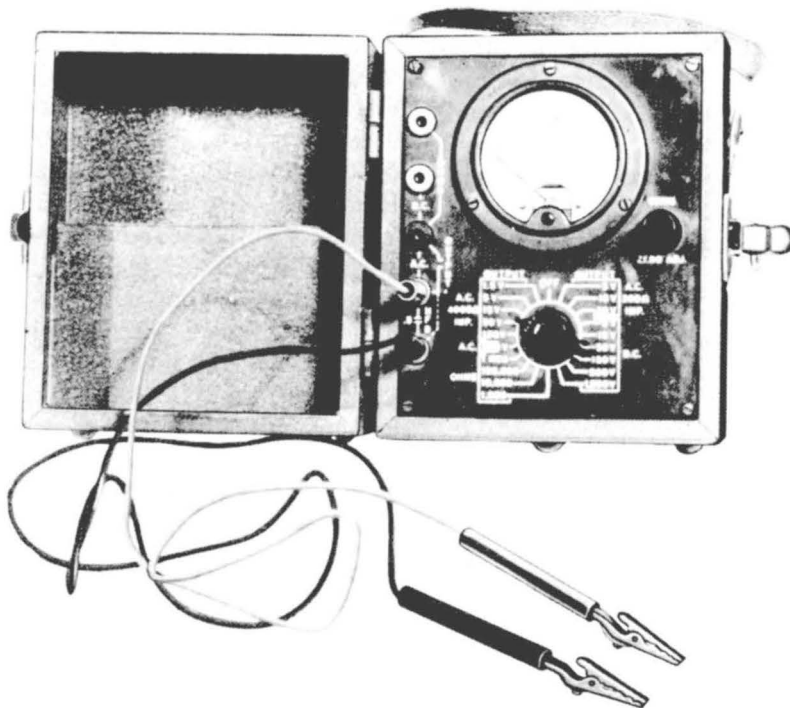

*Multimeter I-166*

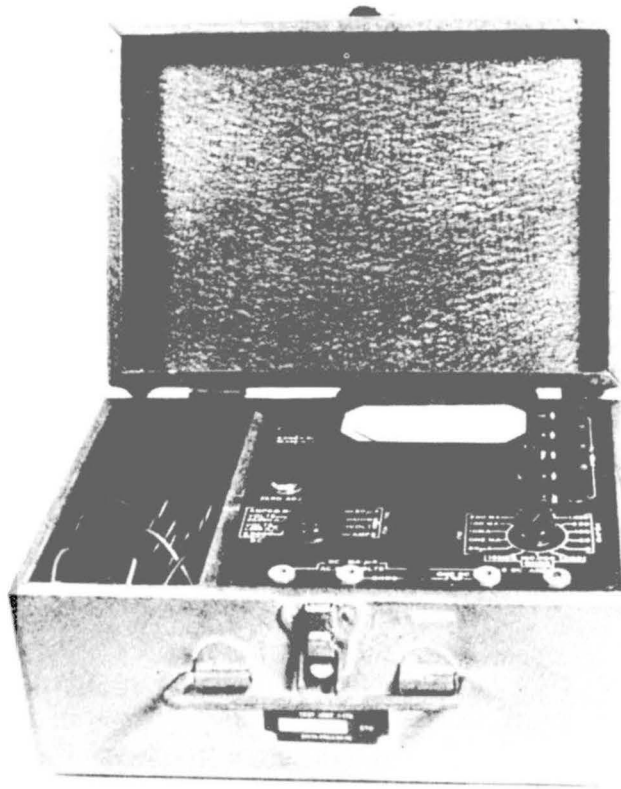

*Multimeter I-176*

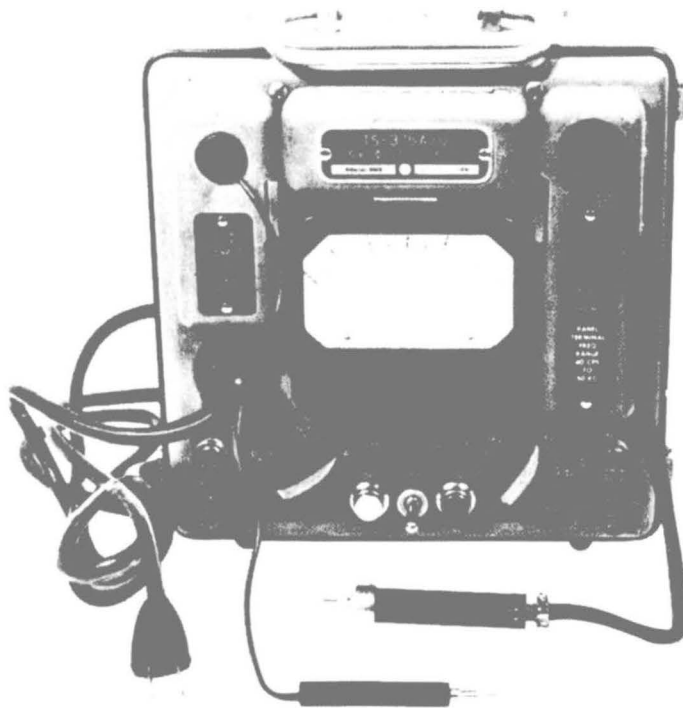

*Vacuum Tube Voltmeter TS-375A/U*

are made in terms of the plate current of the tube. Thus, this meter draws less current from the circuit being measured than does an ordinary voltmeter. Therefore, measurements made with a vacuum tube voltmeter more nearly indicate actual circuit conditions, since the meter does not load the circuit being tested.

The vacuum tube voltmeter has other advantages also. It may operate at high frequencies, while the ordinary voltmeter is limited to frequencies below a few kc. The use of an electron tube also protects the meter from overloading, and makes it an almost foolproof voltmeter. However, because of the tube, the voltmeter must have a source of power for its operation. It may be operated from AC line voltage or from self-contained batteries.

### **Output Meters**

The output meter is used for measuring the output power of a radio receiver. The meter scales are calibrated in volts, decibels or both. Ordinarily, an output meter consists of a load impedance (resistive) and an associated rectifier type AC voltmeter. In the output meter of the I-166, provision is made for selecting either a load impedance of 4000 ohms or 300 ohms. The load impedance should be the impedance into which the receiver normally works. An AC voltmeter may be used as an output meter if the correct load impedance is placed in parallel with the meter.

Since the output of a receiver is an indication of its operating conditions, the output meter can be helpful in both alignment and troubleshooting. The visual indication on an output meter is an accurate means of obtaining a maximum output when aligning.

### **Signal Generator**

For an output meter to be helpful there must, of course, be an output. If a receiver is operating normally, the signal travels from the antenna to the output. If the receiver does not operate properly, however, the pathway may be blocked somewhere along the line. There may be no output. That's where the signal generator is important. It provides a substitute signal which can be introduced at any point along the pathway, in order to make an output possible.

Signal generators are available for every frequency range. The usual signal generator unit contains an RF oscillator to cover the RF range, and an AF oscillator to cover the audio range. Thus, the unit can provide an RF signal, an AF signal, or RF signal modulated by an AF signal. This means that a unit can provide a substitute signal for introduction to a receiver's AF, IF, or RF sections. A signal generator unit may have several oscillator circuits which can be switched in to permit operation over a number of frequency ranges. Thus, one unit may cover all frequencies up to VHF. Another may cover the VHF and UHF ranges.

As an example of a signal generator, notice the unit on page 161. Signal generator TS-413A/U is a unit for the lower frequencies. Other signal generators are made for the higher frequencies. Such units may introduce their signal at the receiver input through a dummy antenna, or they may introduce the signal, by means of probes, into any stage of the receiver.

### **Wobbulator or Sweep Generator**

A wobbulator or sweep generator is a special type of signal generator. It provides the signals simultaneously. One signal is a frequency modulated RF output. The other signal is a duplicate of or is synchronized by the audio voltage which is used to frequency modulate the RF signal. This audio output may be either a sinusoidal or a sawtooth voltage. In practice, the audio voltage is applied to the horizontal deflection system of an oscilloscope while the frequency modulated RF output is applied to the input of an IF or RF amplifier. The rectified output of the amplifier is then applied to the vertical deflection system of the oscilloscope. The resulting oscilloscope pattern shows the frequency response of the amplifier and provides the best possible indication for aligning the amplifier's tuned circuits.

### **Marker Generator**

The marker generator is also a special type of signal generator. It is essentially a highly accurate, calibrated RF signal generator. It is used with a sweep generator and an oscillo-

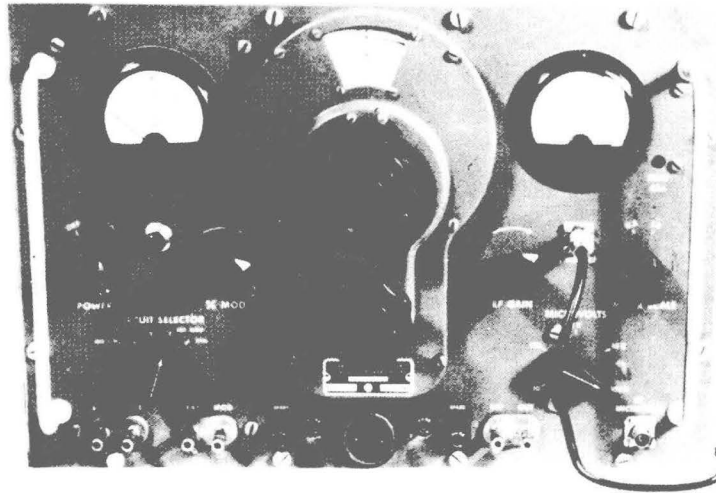

Signal Generator TS-413A/U

scope to produce a marker pip on the frequency response pattern. The pip on the scope pattern establishes a reference point. It marks the frequency of the marker generator on the response curve.

Look at the markers shown in the illustrations of receiver marker response patterns. The pattern at A shows a single marker. It indicates that the marker frequency is approximately at the center of the receiver bandpass. The pattern at B shows two markers. Each is supplied by a separate marker generator. The markers indicate the frequency at each end of the bandpass. Thus, the marker generator helps in adjusting a bandpass to the desired bandwidth and frequency.

### Signal Tracer

Any device which provides the means for detecting the presence of signal at appropriate points throughout the signal path in the receiver can be used as a signal tracer. Signal tracers vary in complexity, usefulness, and frequency ranges. The signal tracer TS-303 A C shown on page 162, is one of the most versatile. Like a signal generator, it permits stage-by-stage analysis of a receiver. However,

where the signal generator provides a substitute signal to be applied to the various receiver stages, the signal tracer provides substitute circuits which, stage by stage, can take the place of the receiver circuits.

A chanalyst has an RF IF section, an oscillator section, an audio section, and a separate cathode ray tuning indicator for each section. Thus, a signal can be taken from any section of the receiver by probes, applied to the corresponding section of the chanalyst, and evaluated by the chanalyst indicator. Since there are a number of probes and indicators, it is possible to observe conditions

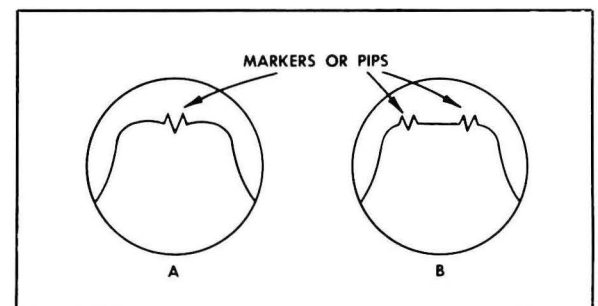

Oscilloscope Patterns of Markers



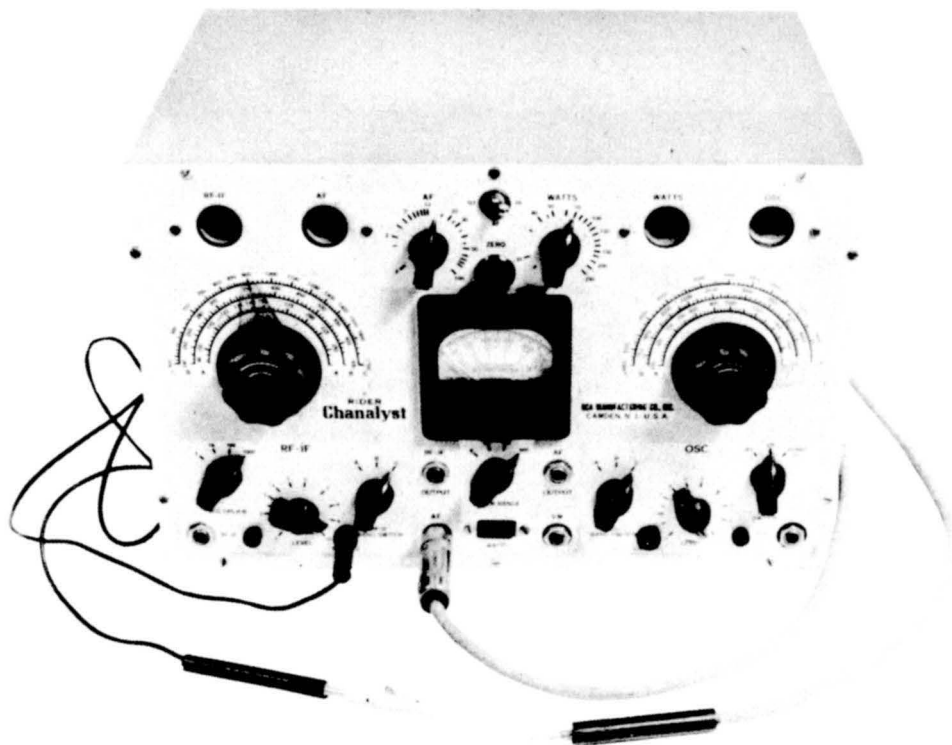

Signal Tracer TS-303A/C

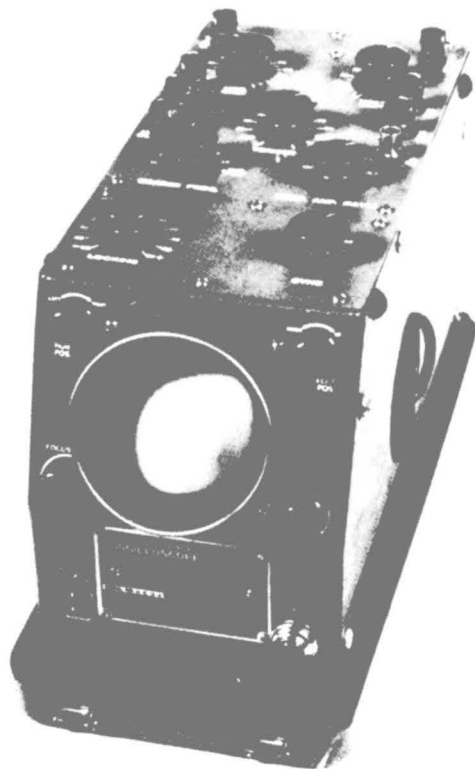

Oscilloscope OS-8/U



*Tube Tester I-177*

simultaneously at a number of points in the receiver. The signal tracer is most useful in localizing the trouble in a receiver.

### **Oscilloscope**

The use of the oscilloscope as an aid in adjusting the receiver bandpass has already been mentioned. In addition, the oscilloscope can be very useful in most types of receiver servicing. Because the oscilloscope can show voltage waveforms, it has advantages that cannot be duplicated by other indicating devices. It can follow a signal through the entire receiver and, by showing the waveform, show the existence of distortion. It can be used as an indicator in alignment processes. In some very complicated circuits as in television, where the waveform shape is critical, no other indicator can do the job.

### **Tube Tester**

Tube testers are designed to test the operating fitness of electron tubes. There are two types of testers—emission testers and dynamic

mutual conductance testers. The emission testers are rapidly becoming obsolete. They check the tube for filament emission, for open circuit, and for interelectrode short circuits. Dynamic mutual conductance testers, such as the Tube Tester I-177 shown here, check emission, mutual conductance, and interelectrode shorts. This tube tester is often included in part of a test set.

### **Capacity Checker**

The capacity checker is used to detect such defects in capacitors as opens, shorts, and intermittent operation. It shows leakage and power factors for electrolytic capacitors. It measures capacitance of all types of capacitors. An example of a capacitor checker is the TS-415 shown on page 164.

### **Other Test Equipment**

Other test equipment often includes frequency meters, Wheatstone bridges, impedance bridges, capacitance or resistance decades, and distortion meters.



Capacitor Analyzer TS-415

### PRINTED AIDS TO ALIGNMENT AND TROUBLESHOOTING

Full information concerning all Air Force electronic equipment is available in printed form. Each unit, whether it be a test unit or an operational unit, has its complete writeup. This writeup contains data for the assembly, operation, maintenance, alignment, and troubleshooting of the equipment. The writeup includes performance standards, voltages, and the values of all components. Such information is essential to good radio work.

#### Technical Orders

Publications concerning Air Force equipment are classified as technical orders (TO's), and are given an Air Force numerical-alphabetical designation. Such publications may originate with the Air Force, with other branches of the service, especially the Signal Corps of the Army, or with the manufacturer.

Publications originating outside the Air Force may have a different classification. Signal Corps publications may be designated both as technical orders and technical manuals (TM's) and may have an Army number. They are also assigned an Air Force number, which stands as the equivalent of the original designation. For instance, the publication designated by the Army as TM 11-850 is equivalent to the Air Force designation 16-40BC312-6.

#### Publication Indexes

With publications covering all equipment, the technical library of the Air Force is very large. To provide help in locating any publication, there is an index volume entitled, Numerical Index of Technical Publications. This divides publications into categories. Category 16, for example, deals with electronics equipment. The index for this category is published as TO 00-1-16. It lists the publica-

vides the sweep voltage for the indicator tube. It provides a complete sweep for each half cycle. This means that the propeller-shaped pattern, formed with no blanking, is really a double pattern, one pattern superimposed on the other. The two patterns are opposite in polarity. Yet, since each pattern is composed of two identically shaped lobes, this difference in polarity does not matter in bearing operation. However, for sense operation, which requires a pattern of only one lobe, this difference in polarity would produce ambiguous results. The two patterns produced by a double sweep would not be superimposed. They would be produced in opposite directions, and no sense indication could be obtained. This difficulty is overcome by using a single sweep for sense operation. Blanking one half of each 200-kc cycle provides the single sweep.

**AZIMUTH INDICATOR.** The azimuth indicator provides an alternate means of getting bearing and sense indications. For azimuth indicator operation, the azimuth indicator unit is switched in to replace both the modulating voltage generator unit and the bearing indicator unit.

To replace the modulating voltage generator, the azimuth indicator unit uses a sinusoidal potentiometer. The sinusoidal potentiometer is a variable resistance across which a DC voltage is applied. The potentiometer has four output arms coupled to a common, rotatable shaft. An azimuth scale is affixed to this shaft and serves as indicator.

As the shaft is rotated through 360°, the DC potential at the end of one of the potentiometer arms rises from zero to a maximum positive voltage. As rotation continues, the potential falls back to zero. With further rotation, it goes to a maximum negative; then, it rises again to zero. Thus, during a complete cycle, voltages at the end of one arm correspond to the voltages produced at an AC source.

If the shaft were rotated at a rate of 147 cps, the output of one arm would be identical with the oscillator output of the modulating voltage generator. The output of each of the other potentiometer arms would be similar. However, the four arms point in four different

directions. Therefore, the four voltages at the ends of the arms at any one instant are 90° apart in phase. If one represents 0°, the others represent 90°, 180°, and 270°.

This means that if the shaft were rotated at a rate of 147 cps, the signal presented to the balanced modulators would be identical with that presented to the balanced modulators by the 147-cps oscillator and the phasing circuits. If the shaft were rotated at 147 cps, the sinusoidal potentiometer would do exactly the same job as the modulating voltage generator. However, for azimuth operation, it is not necessary to rotate the shaft that fast. The phased voltages presented by the potentiometer arms are DC voltages. They are present even when rotation is stopped. These phased DC voltages are supplied to the modulators and react with the signals of the four antennas to give a response pattern which shows bearing. When the sense circuits of the antenna system are connected, a sense response results.

Thus, operating the azimuth unit for bearing indication produces the characteristic response pattern with two nulls. Operating the azimuth unit for sense indication produces the characteristic response pattern with a single null. The nulls are detected aurally in the receiver output by rotating the shaft of the sinusoidal potentiometer. An azimuth scale and a pointer are mounted on the shaft and are calibrated for bearing and sense operation. Consequently, the calibrated position of the shaft when aural null is reached can be used to indicate either bearing or sense.

The azimuth dial consists of two scales (red and white). These are calibrated in degrees (0 to 360) and displaced 180° from each other. In operation, the azimuth dial is rotated to either of the two null positions. Then the sense switch is thrown to either the red or white position. In the vicinity of the null, the aural signal will be louder in one position than in the other. The position that gives the louder response indicates the direct or true azimuth. The exact indication is therefore on the azimuth scale that has the same color as the sense switch position which produces the louder signal.

The general system just described is basically the system of all homing and direction-

finding equipment. Airborne homing equipment usually has a rotatable directional antenna (the loop) and an indicator coordinated either electrically or mechanically with the position of the antenna. For homing opera-

tion, the RF signals (from the radio beacons) are usually coded to identify each station. These coded signals can appear visually on a cathode ray tube indicator, or can be heard aurally in a headset.

## PERFORMANCE TESTS AND TROUBLESHOOTING TECHNIQUES

---

Under normal conditions the repairman or technician has a fine collection of tools to help him do his job. He has a stock of spare components with which to replace defective components. He has a collection of test units to help him in locating defective components, in discovering incorrect voltages and currents, and in setting the receiver's variable components properly. He has, also, his knowledge of radio principles and his experience. Knowledge and experience are of major importance. A technician without an understanding of radio principles but with a tube tester, can detect a defective tube—by testing all the tubes. A technician with an understanding of radio principles and a tube tester, can locate a defective tube by testing only one or two tubes. His knowledge and experience enable him to isolate the trouble mentally.

The repairman or technician can make use of the knowledge and experience of others. Full information concerning any equipment he may use is available in the form of technical orders (TO's). The technician can also make good use of the knowledge and experience of others concerning each individual radio unit which he services. The trouble reports and the operating record of a unit can be most helpful for fast and efficient repair work.

The first part of this chapter deals with test equipment. A number of types are discussed briefly as to capabilities and uses. This is followed by discussions of technical publications that help in troubleshooting and maintenance. The last part of the chapter deals with general maintenance problems.

### TEST EQUIPMENT

Test equipment is often supplied in the form of a test set such as the I-56 on page 158. It includes two multimeters and a tube tester, all contained in a single carrying case.

#### Multimeter

A multimeter, as the name implies, incorporates several different meters in the same case, all using the same meter movement. Selector switches provide for selecting the particular meter and range that are desired. Notice the multimeters on pages 152 and 153, which are part of test equipment I-56. They are multimeter I-166 and multimeter I-176. They provide measurements of resistance, current, and voltage. These measurements help to locate defective components, bad connections, improper voltages and currents, and incorrectly set variable elements. Multimeter I-166 contains an output meter, an AC voltmeter, a DC voltmeter, and an ohmmeter. Multimeter I-176 contains an AC voltmeter, a DC voltmeter, an AC ammeter, a DC ammeter, and an ohmmeter. In general, similar meters of the I-176 and the I-166 complement rather than duplicate each other since their ranges and sensitivities are different.

#### Vacuum Tube Voltmeter

Now look at the vacuum tube voltmeter, TS-375A U, on page 159. The vacuum tube voltmeter is one of the most useful single unit instruments. In this unit, the voltage to be measured is applied to the control grid of an electron tube. Measurements and calibration



*Test Set I-56*

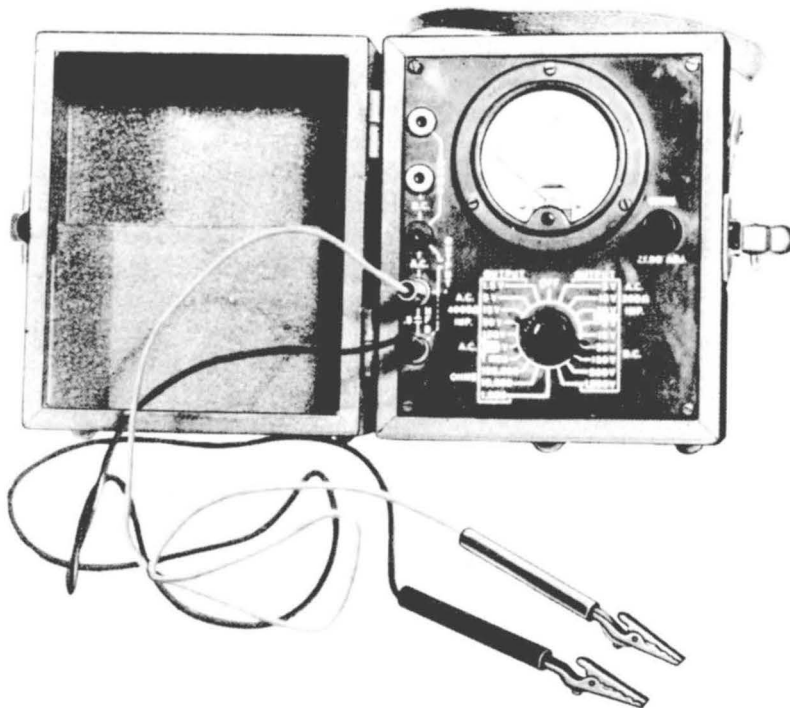

*Multimeter I-166*

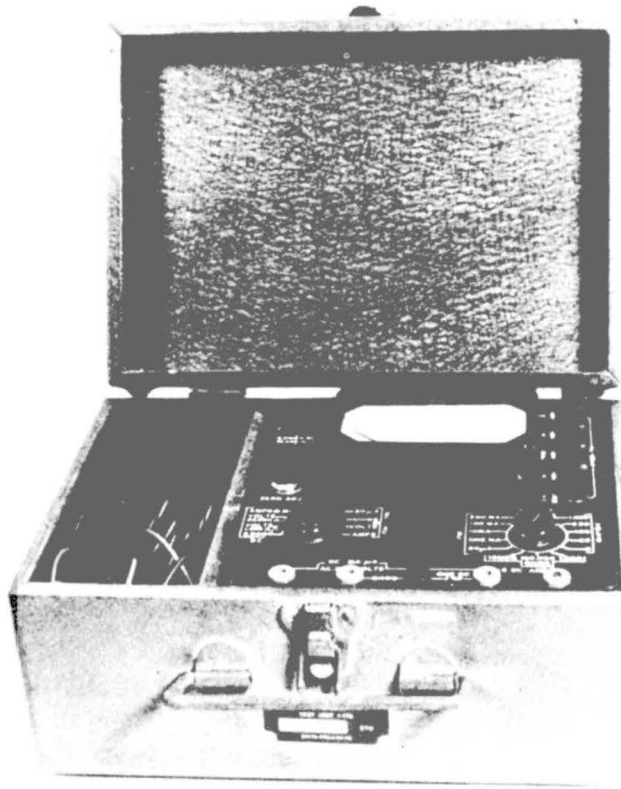

*Multimeter I-176*

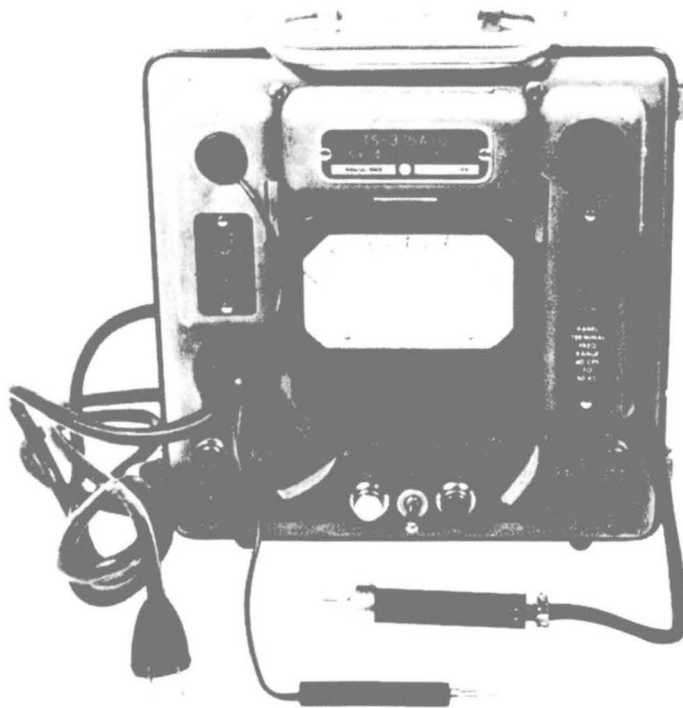

*Vacuum Tube Voltmeter TS-375A/U*



are made in terms of the plate current of the tube. Thus, this meter draws less current from the circuit being measured than does an ordinary voltmeter. Therefore, measurements made with a vacuum tube voltmeter more nearly indicate actual circuit conditions, since the meter does not load the circuit being tested.

The vacuum tube voltmeter has other advantages also. It may operate at high frequencies, while the ordinary voltmeter is limited to frequencies below a few kc. The use of an electron tube also protects the meter from overloading, and makes it an almost foolproof voltmeter. However, because of the tube, the voltmeter must have a source of power for its operation. It may be operated from AC line voltage or from self-contained batteries.

### **Output Meters**

The output meter is used for measuring the output power of a radio receiver. The meter scales are calibrated in volts, decibels or both. Ordinarily, an output meter consists of a load impedance (resistive) and an associated rectifier type AC voltmeter. In the output meter of the I-166, provision is made for selecting either a load impedance of 4000 ohms or 300 ohms. The load impedance should be the impedance into which the receiver normally works. An AC voltmeter may be used as an output meter if the correct load impedance is placed in parallel with the meter.

Since the output of a receiver is an indication of its operating conditions, the output meter can be helpful in both alignment and troubleshooting. The visual indication on an output meter is an accurate means of obtaining a maximum output when aligning.

### **Signal Generator**

For an output meter to be helpful there must, of course, be an output. If a receiver is operating normally, the signal travels from the antenna to the output. If the receiver does not operate properly, however, the pathway may be blocked somewhere along the line. There may be no output. That's where the signal generator is important. It provides a substitute signal which can be introduced at any point along the pathway, in order to make an output possible.

Signal generators are available for every frequency range. The usual signal generator unit contains an RF oscillator to cover the RF range, and an AF oscillator to cover the audio range. Thus, the unit can provide an RF signal, an AF signal, or RF signal modulated by an AF signal. This means that a unit can provide a substitute signal for introduction to a receiver's AF, IF, or RF sections. A signal generator unit may have several oscillator circuits which can be switched in to permit operation over a number of frequency ranges. Thus, one unit may cover all frequencies up to VHF. Another may cover the VHF and UHF ranges.

As an example of a signal generator, notice the unit on page 161. Signal generator TS-413A/U is a unit for the lower frequencies. Other signal generators are made for the higher frequencies. Such units may introduce their signal at the receiver input through a dummy antenna, or they may introduce the signal, by means of probes, into any stage of the receiver.

### **Wobbulator or Sweep Generator**

A wobbulator or sweep generator is a special type of signal generator. It provides the signals simultaneously. One signal is a frequency modulated RF output. The other signal is a duplicate of or is synchronized by the audio voltage which is used to frequency modulate the RF signal. This audio output may be either a sinusoidal or a sawtooth voltage. In practice, the audio voltage is applied to the horizontal deflection system of an oscilloscope while the frequency modulated RF output is applied to the input of an IF or RF amplifier. The rectified output of the amplifier is then applied to the vertical deflection system of the oscilloscope. The resulting oscilloscope pattern shows the frequency response of the amplifier and provides the best possible indication for aligning the amplifier's tuned circuits.

### **Marker Generator**

The marker generator is also a special type of signal generator. It is essentially a highly accurate, calibrated RF signal generator. It is used with a sweep generator and an oscillo-

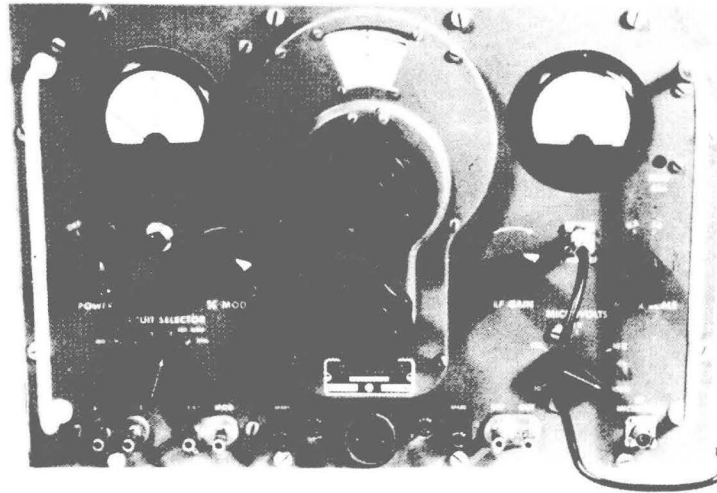

Signal Generator TS-413A/U

scope to produce a marker pip on the frequency response pattern. The pip on the scope pattern establishes a reference point. It marks the frequency of the marker generator on the response curve.

Look at the markers shown in the illustrations of receiver marker response patterns. The pattern at A shows a single marker. It indicates that the marker frequency is approximately at the center of the receiver bandpass. The pattern at B shows two markers. Each is supplied by a separate marker generator. The markers indicate the frequency at each end of the bandpass. Thus, the marker generator helps in adjusting a bandpass to the desired bandwidth and frequency.

### Signal Tracer

Any device which provides the means for detecting the presence of signal at appropriate points throughout the signal path in the receiver can be used as a signal tracer. Signal tracers vary in complexity, usefulness, and frequency ranges. The signal tracer TS-303 A C shown on page 162, is one of the most versatile. Like a signal generator, it permits stage-by-stage analysis of a receiver. However,

where the signal generator provides a substitute signal to be applied to the various receiver stages, the signal tracer provides substitute circuits which, stage by stage, can take the place of the receiver circuits.

A chanalyst has an RF IF section, an oscillator section, an audio section, and a separate cathode ray tuning indicator for each section. Thus, a signal can be taken from any section of the receiver by probes, applied to the corresponding section of the chanalyst, and evaluated by the chanalyst indicator. Since there are a number of probes and indicators, it is possible to observe conditions

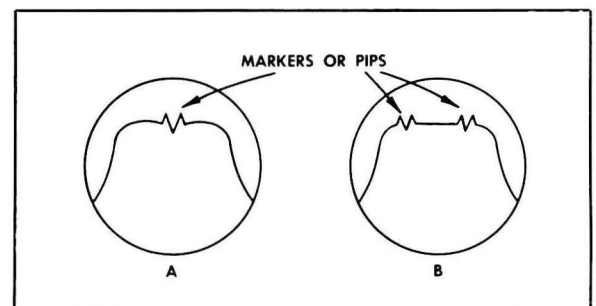

Oscilloscope Patterns of Markers

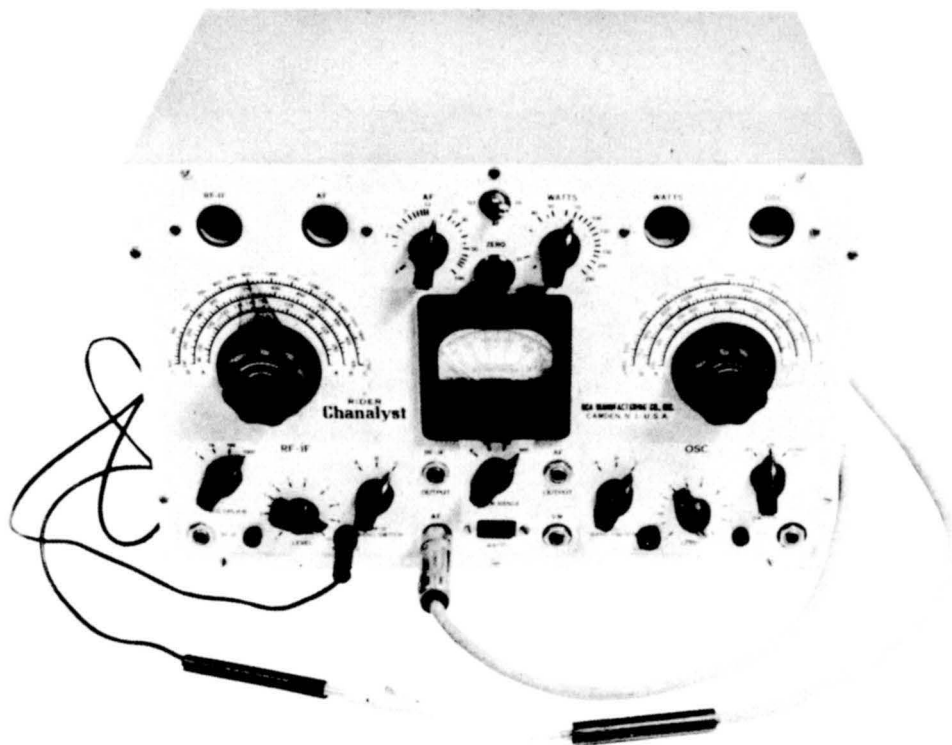

Signal Tracer TS-303A/C

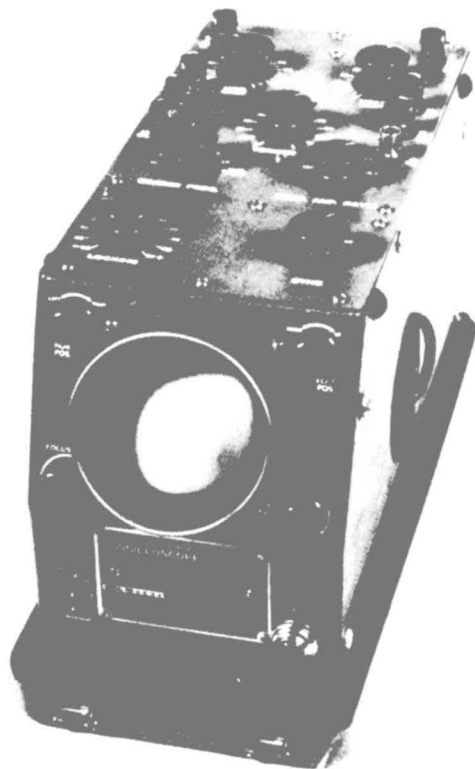

Oscilloscope OS-8/U



*Tube Tester I-177*

simultaneously at a number of points in the receiver. The signal tracer is most useful in localizing the trouble in a receiver.

### **Oscilloscope**

The use of the oscilloscope as an aid in adjusting the receiver bandpass has already been mentioned. In addition, the oscilloscope can be very useful in most types of receiver servicing. Because the oscilloscope can show voltage waveforms, it has advantages that cannot be duplicated by other indicating devices. It can follow a signal through the entire receiver and, by showing the waveform, show the existence of distortion. It can be used as an indicator in alignment processes. In some very complicated circuits as in television, where the waveform shape is critical, no other indicator can do the job.

### **Tube Tester**

Tube testers are designed to test the operating fitness of electron tubes. There are two types of testers—emission testers and dynamic

mutual conductance testers. The emission testers are rapidly becoming obsolete. They check the tube for filament emission, for open circuit, and for interelectrode short circuits. Dynamic mutual conductance testers, such as the Tube Tester I-177 shown here, check emission, mutual conductance, and interelectrode shorts. This tube tester is often included in part of a test set.

### **Capacity Checker**

The capacity checker is used to detect such defects in capacitors as opens, shorts, and intermittent operation. It shows leakage and power factors for electrolytic capacitors. It measures capacitance of all types of capacitors. An example of a capacitor checker is the TS-415 shown on page 164.

### **Other Test Equipment**

Other test equipment often includes frequency meters, Wheatstone bridges, impedance bridges, capacitance or resistance decades, and distortion meters.



Capacitor Analyzer TS-415

### PRINTED AIDS TO ALIGNMENT AND TROUBLESHOOTING

Full information concerning all Air Force electronic equipment is available in printed form. Each unit, whether it be a test unit or an operational unit, has its complete writeup. This writeup contains data for the assembly, operation, maintenance, alignment, and troubleshooting of the equipment. The writeup includes performance standards, voltages, and the values of all components. Such information is essential to good radio work.

#### Technical Orders

Publications concerning Air Force equipment are classified as technical orders (TO's), and are given an Air Force numerical-alphabetical designation. Such publications may originate with the Air Force, with other branches of the service, especially the Signal Corps of the Army, or with the manufacturer.

Publications originating outside the Air Force may have a different classification. Signal Corps publications may be designated both as technical orders and technical manuals (TM's) and may have an Army number. They are also assigned an Air Force number, which stands as the equivalent of the original designation. For instance, the publication designated by the Army as TM 11-850 is equivalent to the Air Force designation 16-40BC312-6.

#### Publication Indexes

With publications covering all equipment, the technical library of the Air Force is very large. To provide help in locating any publication, there is an index volume entitled, Numerical Index of Technical Publications. This divides publications into categories. Category 16, for example, deals with electronics equipment. The index for this category is published as TO 00-1-16. It lists the publica-

tion numbers for all equipment in which you, as a radio repairman or technician, may be interested. It includes four sections: Part I, Active Technical Publications; Part II, Rescinded and Reclassified Technical Publications; Part III, Cross Reference of Department of Army (DA) to Department of the Air Force (AF) Publication Numbers; Part IV, Ruled Pages for Entry of New Publications.

With the help of this index, you can find the TO number for any piece of electronic equipment. Knowing the number, you can readily locate the TO in the file. By use of the index, you can also see whether a publication you already have is up-to-date.

### MAINTENANCE PROCEDURES

The organized procedures which you will be expected to carry out with radio equipment can be divided into three classifications: troubleshooting, alignment, and performance testing. The three procedures overlap considerably, since troubleshooting may reveal a need for alignment, and some troubles may not be discovered until performance testing has been tried.

Usually you will find no set procedure for troubleshooting in a TO for a particular receiver. However, you will find many helpful hints. In addition, the TO usually will contain procedures for alignment and performance testing which you should follow whenever possible. For useful general information, study the procedures on the following pages of this chapter. Though each receiver has its own performance standards and its own test requirements, this information will help you in maintenance.

#### Troubleshooting

As a radio repairman or technician, your real worth lies in your ability to analyze and isolate troubles. With extensive and complicated radio circuits, such ability helps you save considerable time and effort. Usually, if you can locate the trouble, the actual repair is merely a mechanical operation—replacing a tube or a capacitor, or making a new connection.

If you draw on your experience and your understanding of radio principles, each trouble suggests its own cause and its means of correction. This amounts to a preliminary analysis. Then you troubleshoot — that is, you check this analysis. If the analysis is correct, repairs can then be made.

One means of proving out an analysis is tube testing. Other methods include checking voltage values, resistance values, or capacitance values. Still other methods are: checking from stage to stage, antenna to speaker, by using a signal tracer; and checking from stage to stage, speaker to antenna, by using a signal generator-output meter combination. The tests you use and the order in which you use them depend on the nature of the trouble.

In general, the stage-by-stage treatment is the most thorough and accurate procedure. It is best in all cases where a preliminary analysis is impossible or incorrect. However, for some troubles, a stage by stage procedure with a signal tracer, or a signal generator-output meter combination is impossible. When the receiver is electrically dead, or is blowing fuses, you must begin your troubleshooting with a tube tester or an ohmmeter.

**PRECAUTIONARY MEASURES.** Most receivers contain voltage potentials which are dangerous to personnel and to test equipment. When working on an energized circuit, make sure that all access to the circuit is made only with properly insulated probes and tools, and that contact is made only to the points intended. Make the actual repairs only with the receiver turned off and with capacitors discharged. Test equipment is usually as delicate as it is sensitive; use it only for its proper measurements and within the range of its rated performance.

In addition, there are tactical precautions that you must take at times. For example, a local oscillator in a receiver or a signal generator provides a signal, which could be picked up by enemy direction finders. This problem may make testing and repair work in forward areas a much different proposition from testing and repair in rear areas.

**HELPFUL SOURCES OF INFORMATION.** Trouble reports and operational reports can be most helpful in indicating what is wrong with a re-

ceiver. Seek and welcome such reports. Treat them with great respect, because a receiver is of no value unless it works under operating conditions. Remember that a receiver that works perfectly on the bench by every usual test may not work at all in an aircraft. A receiver that works perfectly on the ground may not work at all at 20,000 feet. A receiver that works perfectly during 2 hours of operation, may not work at all after 4 hours of operation.

The TO also contains helpful information for troubleshooting. Though a TO usually doesn't give a set procedure for troubleshooting, it frequently surveys most of the common troubles which can happen to a receiver. In the TO, you will find the possible causes for most troubles and the means of correction.

If you need information concerning any unit commonly serviced on the bench, you can take it from the TO and keep it at the bench in the form of notes.

**TROUBLESHOOTING PROCEDURE.** The following is a general troubleshooting procedure to meet actual conditions.

1. Get a trouble report or an operational report and evaluate it.
2. Inspect the receiver and its circuits visually for trouble indications such as breakage, disconnected leads, signs of overheating.
3. Operate the receiver, allowing at least 15 minutes for a warmup, then study the trouble.
4. Check the tubes, if such a check seems necessary. (Before checking, turn off the receiver.)
5. Check the voltages under operating conditions.
6. Make a stage by stage analysis.

If you find the trouble at any time during this entire procedure, immediately set about verifying and correcting it. After you complete the repairs, make an operational check. If necessary, align the receiver and check its operation again.

**TROUBLESHOOTING FOR VHF AND UHF.** Just as VHF and UHF present special problems in the construction and arrangement of RF components, so do they present special problems in testing and repair. Special test and

repair equipment must be used. Special precautions must be used in working on the circuits, since values of inductance are extremely critical. A conductor bent slightly from its usual place may change the frequency of a tuned circuit. A piece of extra solder left in making a connection may detune a high frequency oscillator.

Repairs to high frequency circuits may cause changes in circuit constants. For this reason, VHF and UHF receivers are usually manufactured in replaceable sections. To troubleshoot, you localize the trouble in a particular section, and then replace the section. You then return the faulty section to the factory where it can be repaired under laboratory conditions.

**EMERGENCY TROUBLESHOOTING AND REPAIR.** Sometimes, you may be called on to troubleshoot under emergency conditions, with few tools and little or no test equipment. If you are resourceful you can do good work.

You can test tubes by substituting them, one by one, in a satisfactorily operating receiver, or by substituting good tubes, one by one, for the tubes in a bad receiver.

You can troubleshoot using an RF signal from a source other than a signal generator, and your ears, and the speaker output in place of an output meter. Often you can do a stage by stage analysis by touching the grid of each stage with an insulated screwdriver and noting whether the noise is carried to the speaker.

Many amplifier stages can be bypassed, one stage at a time, by connecting the grid of one stage to the grid of the following stage. This procedure will disclose an inoperative stage, which can be further tested by substitution of tubes, resistors, capacitors, and coils. You can also connect the grids of a bad receiver, one by one, to the corresponding grids of a satisfactorily operating receiver, thus using the good receiver as a signal tracer. You can also connect the grids of a good receiver to the grids of a bad receiver, thus using the good receiver as a signal generator.

If you have simple test equipment—a voltmeter or ohmmeter—but no technical order covering the bad receiver, you can use one or two satisfactorily operating receivers as a basis of comparison.

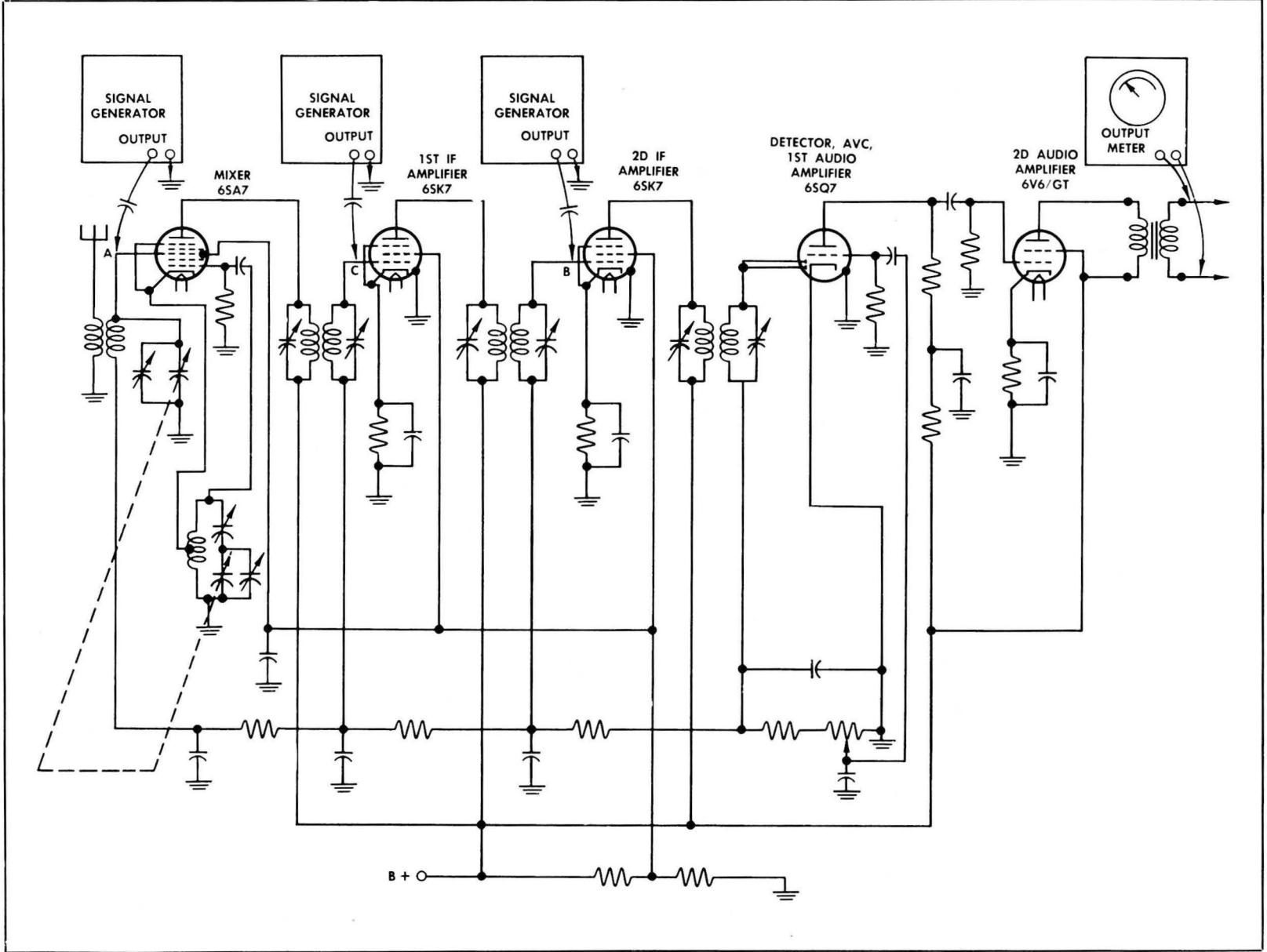

Alignment — Use of Signal Generator



## Alignment

Some of the components that make up the receiver are variable. Of these, some are used for tuning and volume adjustment and are variable at the will of the operator. Other components can be varied only with the help of special tools and special test equipment. The variable components of the IF tuned circuits belong to the latter classification. Their adjustment to satisfactory working conditions is called alignment. Alignment also includes setting the ganged-tuned circuits of both the HFO and the RF stages so that they track always at the correct frequency difference required for the IF tuned circuits.

Alignment is difficult and time consuming. Undertake it only when necessary—usually after major repairs, or when troubleshooting or performance testing indicates a need for alignment.

The actual procedure of alignment differs from receiver to receiver. Follow the TO procedure whenever possible. However, you can adapt the procedure described in the following paragraphs to most receivers if a more specific procedure is not available.

**ALIGNMENT SETUP.** You can see the setup for an alignment procedure in the schematic diagram on page 167 for a superheterodyne receiver. Note that the tuning indicator is an output meter connected across the secondary of the output transformer. A signal generator (shown in three different positions) provides a test signal which, in turn, provides an output indication. Each stage is tuned for a maximum indication on the output meter.

The position of the signal generator depends on how difficult it is to get the test signal through to the output meter. If the receiver alignment is not too far below standard, the signal generator may precede all the stages to be tuned. If the alignment is very bad, it may be necessary to connect the signal generator directly before the stage to be aligned to make sure that the test signal can get through the stage.

Alignment begins with the tunable stage closest to the output meter, and then moves stage by stage in the direction of the antenna until alignment is completed. The signal gen-

erator also moves stage-by-stage in the direction of the antenna. The signal generator supplies a test signal at the IF frequency when it is connected to the grid of one of the IF amplifier tubes. When it is connected to the grid of an RF amplifier, the signal generator supplies an RF signal within the tuning range of the receiver. When the stages have been tuned in order, each stage is given a touchup retuning for greater accuracy.

**HANDLING THE AVC IN ALIGNMENT.** The AVC of a communications receiver makes tuning more difficult, because it cuts down and broadens the response of the tuning indicator. To overcome this disadvantage, perform the alignment with as weak a test signal as possible, or disconnect the AVC circuit.

The AVC has least effect when the signal is weak. To take advantage of a weak signal, set the receiver volume control at maximum. Then regulate the signal generator so that the response is about half scale on the most sensitive range of the output meter. As tuning progresses and the response increases in amplitude, keep reducing the signal generator output so that the response continues to read about half scale on the output meter.

The other solution is to disconnect the AVC. Many receivers have a switch for disconnecting the AVC. Otherwise, you can disable the AVC circuit by disconnecting the AVC lead at the diode detector load resistor. Often, when the AVC is disconnected, you must supply a fixed bias. The bias voltage can be introduced through the disconnected AVC lead.

**OUTPUT INDICATOR POSITIONS.** In alignment, the output indicator can be connected across the secondary of the output transformer between the plate of the second audio amplifier and ground, or across the plate load resistors of the diode detector. Since such connections put a DC potential on the output indicator, make the connection through a coupling capacitor. Of course, if the indicator has such a capacitor in its circuit, the connection may be direct.

**ALIGNMENT OF RECEIVERS CONTAINING A CRYSTAL FILTER.** Many communications receivers have a crystal filter which can be switched into the IF circuit as desired. In

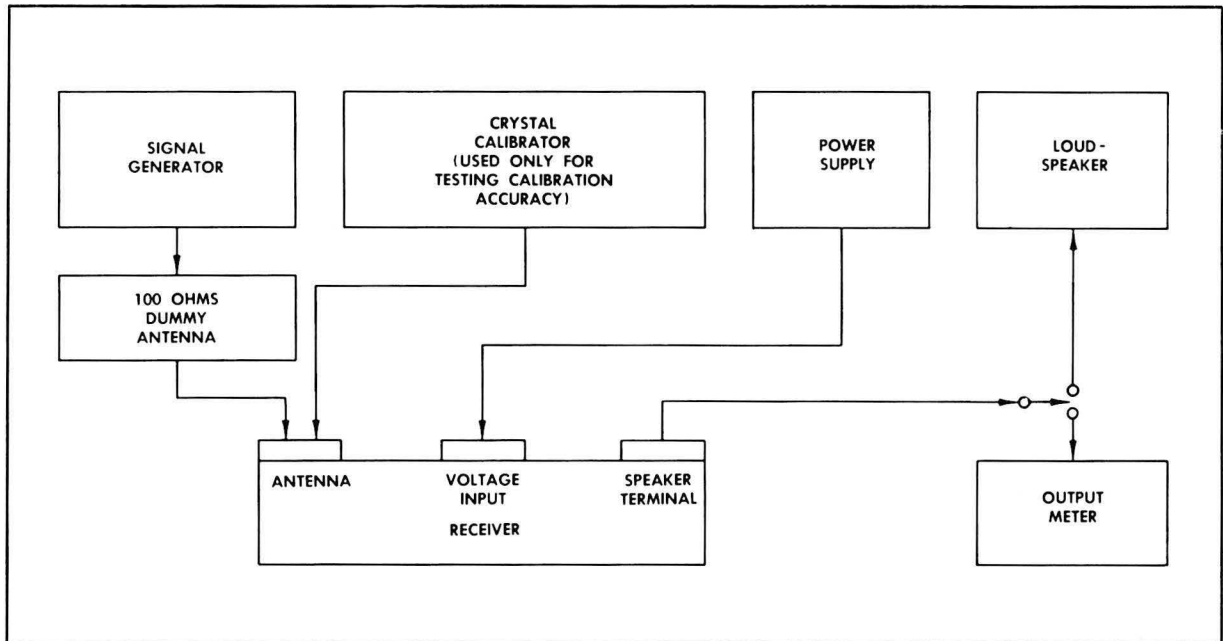

Test Setup

aligning such a receiver, first tune the circuits with the crystal switched out of the circuit. Then, touch up the tuning with the crystal switched into the circuit and the signal generator supplying a test signal at the exact frequency of the crystal.

**ALIGNMENT OF WIDE BAND RECEIVERS.** FM, SSB, and television receivers require special treatment because they have special circuit arrangements to provide a wide IF bandpass. On these receivers it is usually necessary to tune each stage in the IF section to a different test frequency. You will find the frequency to be used at each stage in the proper TO.

**OUTPUT INDICATORS FOR ALIGNMENT.** Many receivers contain meters or metering circuits which can be used in alignment. With those that do not, you can use a voltmeter, a vacuum tube voltmeter, or an oscilloscope as an output indicator. When you use an oscilloscope as an output indicator, connect the receiver output to the vertical deflection plates.

### Performance Test

The purpose of performance testing is to determine whether the radio receiver is functioning properly for its tactical use and meets its minimum performance standards. Perform-

ance testing of a radio receiver may include checking the general overall performance, alignment, calibration accuracy, sensitivity, selectivity, signal-plus-noise to noise ratio, image rejection ratio, IF rejection ratio, AVC characteristic, power output characteristics and final operation. The exact procedures and performance values of different radio receivers vary and therefore the technical order on the specific receiver should be followed. The performance test is made on the bench, usually in a specially prepared test setup designed for the particular unit.

**SENSITIVITY CHECK.** The sensitivity check is usually made only in performance testing. It is made with test signals supplied by a signal generator. Generally, three frequencies are used—a high, a low, and a medium—for each receiver band. You can see the test setup for this and other checks in the above block diagram.

The test signals are applied to the antenna input through a shielded dummy antenna. The receiver output signal amplitude is measured by an output meter connected across the receiver output. The output signal amplitude is measured in terms of both signal and noise (usually at a 10:1 signal-plus-noise to noise ratio). This means that the modulated signal

supplied by the signal generator must produce a 10-milliwatt output on the output meter, and the unmodulated signal must produce a 1-milliwatt output.

**SIGNAL-PLUS-NOISE TO NOISE RATIO CHECK.** Using the same test setup, supply a test signal to the receiver in both a modulated and an unmodulated condition, at a single setting of the signal generator output control. Compare the output reading for the modulated signal with the output reading for the unmodulated signal. The ratio of the two readings is the signal-plus-noise to noise ratio.

**IMAGE REJECTION CHECK.** With the same test setup, supply the receiver with a signal within its tuning range. Note the output reading. Then supply a signal at the image frequency and again note the output reading. The two readings provide the image rejection ratio. If the oscillator tracks above the signal, the image frequency is the signal frequency plus twice the IF. If the oscillator tracks below the signal, the image frequency is the signal frequency minus twice the IF.

**AUDIO POWER OUTPUT CHECK.** With the same test setup, set the receiver volume control to maximum gain. Supply the receiver with a signal at the low end of its tuning range. Then note the strength of the generator signal necessary to produce normal output and the strength necessary to produce maximum output, as specified in the TO for the particular receiver. Compare these readings with the standards set forth in the TO. The power output is usually checked in terms of both a modulated and unmodulated signal delivering power to the speaker. The check can also be made in terms of the power delivered to the phone jack. The ratings for each check are found in the TO.

**BANDWIDTH CHECK.** The following procedure for determining bandwidth is used with Guard Receiver, RT-178 ARC-27. However, the general procedure applies to all receivers.

First of all, tune the IF stages to 3.45 mc. Connect the signal generator output to the mixer grid. Then adjust the signal generator to the center frequency as shown by point A in the illustration at the right. The output

of the signal generator is adjusted to produce 1 volt of AVC voltage. Record this setting of the signal generator output attenuator. This reading will be referred to as the *reference level signal*. Now adjust the output attenuator until the output voltage of the signal generator is doubled. A quick check of the chart in the illustration on page 173 will show this to represent a change in signal strength of 6 db.

Rotate the tuning control of the signal generator above and below the center frequency and note the two frequencies where the AVC voltage is again 1 volt. These points are shown at B and C in the illustration at the right. The generator signal at reference level produced 1 volt of AVC voltage at the center frequency. In order to produce 1 volt of AVC voltage at frequencies represented by points B and C, the reference level signal must be increased by 6 db.

The difference in frequency between these two points, B and C, is the 6 db bandwidth. If this bandwidth is very much less than 100 kc, this section of the receiver is too selective.

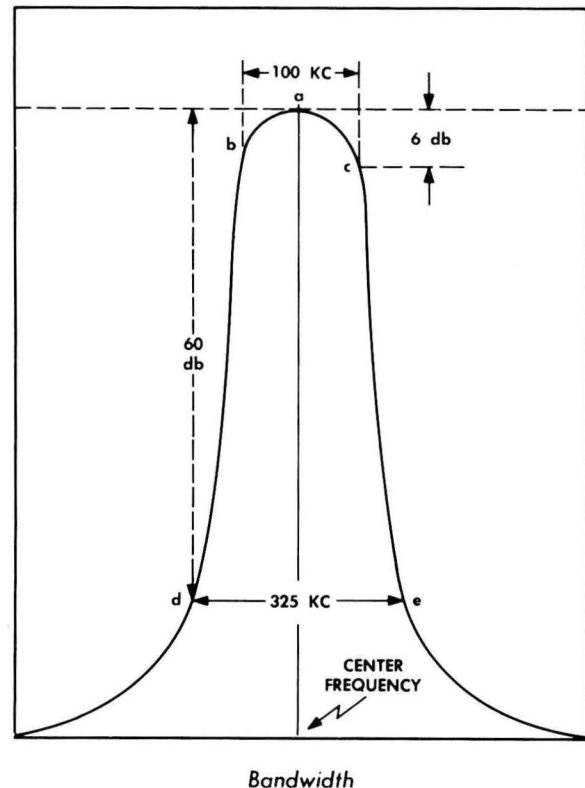

If this bandwidth is greater than 100 kc, the frequency response is too broad. In either case, the alignment should be rechecked. Weak or bad tubes can also account for improper bandwidth.

The difference in frequency between points D and E is the 60 db bandwidth. The method for finding these points is the same as for finding the 6 db points except that the reference level output is increased 1,000 times.

When the receiver contains a crystal filter, make this check twice, once with the filter out of the circuit and once with it in the circuit.

**BFO CHECK.** Apply an unmodulated signal to the dummy antenna of the receiver. Note the speaker output. Zero beat should occur at the zero setting of the BFO. Then slowly rotate the BFO control to both sides of the zero point to see whether the tone occurs at equal distances on both sides of zero. If the calibration is off, recenter the control knob and pointer on the control shaft. If you find no zero beat indication, there is trouble in the IF or BFO circuits.

**DIAL CALIBRATION ACCURACY CHECK.** Connect a suitable calibrator (a fixed frequency generator of high accuracy) to the dummy an-

TYPICAL MINIMUM REQUIREMENTS, IMAGE REJECTION RATIO	
Test frequency in kilocycles	Rejection ratio
200	100,000:1
400	100,000:1
1,160	100,000:1
2,500	9,000:1
5,000	3,000:1
10,000	800:1
20,000	200:1
40,000	30:1

tenna. Obtain an audible tone by use of the BFO control. Then check the dial calibration with the frequency of the calibrator. Make three such checks for each frequency band—one at the high end, one at the low end, and one in between. The dial calibration should be within 1.5 percent. If the calibration is uniformly off scale, reset the dial. If the calibration varies for the high, low, and medium settings, check the alignment of the RF setting and adjust the padders and trimmers.

**USE OF TO'S IN PERFORMANCE TESTING.** The procedures just described are general. Each might have to be modified for a particular receiver. Always consult the TO for the actual procedure for each check. As an example of the kind of help offered by the TO, look at the chart of the control settings of a typical receiver at the left. The chart represents the settings for a test setup which would be used for some of the checks described before.

As a further example of the kind of help given in the TO, look at the chart showing the standards for an image rejection check on the same typical receiver. The chart shows what the rejection ratio should be for various frequencies under the test setup. Failure of the receiver to come up to the standards would be an indication of trouble.

TYPICAL CONTROL SETTINGS AS GIVEN IN T. O.	
Control	Setting
Crystal selectivity	Off
Phasing	On arrow
Band Width	3
Limiters	Off
AVC-Manual	AVC
Sensitivity	10
Band Spread	100
Mod-CW	Mod
Audio gain	6
Send-receive	Receive
Beat frequency oscillator	0
Off-On	On
Main tuning dial	As desired
Signal strength meter	Maximum indication

<b>TYPICAL SOURCES OF TROUBLE REVEALED BY PERFORMANCE TESTS</b>	
Test	Possible trouble cause
Beat Frequency oscillator	Does not oscillate at the IF frequency on the zero setting.
Calibration accuracy	Signal generator used in aligning not correctly calibrated. Alignment off.
Sensitivity	Low emission of tubes or alignment off.
Signal-plus-noise to noise ratio.	Microphonic tubes. Ungrounded shields.
Selectivity	IF alignment off.
Image and IF rejection	Interstage coupling leads too long. Leads not properly spaced.
AVC characteristic	Alignment off.
Power Output	Low emission of tubes. Alignment off.

As an example of the troubleshooting help to be found in the TO, read the chart above listing the checks which are carried through in a performance test on the same typical receiver. The chart also lists the possible causes of trouble when the receiver fails to meet standards for the particular check.

**FINAL OPERATIONAL TEST.** During the process of performance testing, a receiver may reveal troubles (including a need for alignment) which have to be corrected. A satisfactory performance test should mean that the receiver is in excellent operating condition. Therefore, as the final step, make an operational test, using the receiver's own power supply. The operational test is a listening test on signals received from a radio transmitter. It should consist of several hours of operation, and should be made under usual operating conditions of temperature, vibration, humidity, and atmospheric pressure.

### VOLTAGE RATIO AND DECIBELS

Decibels (db) are used to express a ratio between two electrical quantities. Technical order standards for alignment and performance of a receiver are stated in decibels. You must be able to use decibels in order to

understand the graphs that are used in technical orders to show when a receiver is properly aligned.

The use of decibels in receiver alignment and maintenance, and in sound systems, is made necessary and is convenient because the response of the human ear is not linear. To explain this, let us examine three cases:

- a. If the output of an audio amplifier is increased from 6 watts to 12 watts, it will sound louder, but not twice as loud.
- b. If another amplifier, delivering an output of 20 watts, has its output increased by 6 watts, the change would scarcely be noticed.
- c. An additional increase of 6 watts from 26 to 32 watts, could not be detected by the human ear.

In each of the above cases, the power increase was 6 watts, but the amount of change detectable by the ear differed considerably. In other words, a mere statement of the amount of increase in power is meaningless unless the original level is known. Since a change in level of 1 db is barely noticeable, let us restate the amplifier power output changes in db. In the first case (a), a 6-watt increase would result in a 3-db gain. In the second case (b), the same increase in output

would be a gain of 1.1 db. In the third case (c), the gain would be only .9 db.

So far, we have been discussing power changes and decibels. Db changes also refer to voltage changes. Since current and voltage are functions of power, voltage changes can be converted to db. When impedances remain the same,

$$db = 20 \log \frac{E_1}{E_2}$$

When the input and output voltages are known, substitute them in the formula and solve for db. This method requires the use of a table of logarithms. However, the chart on this page can also be used.

To use this chart, first divide the smaller voltage into the larger and find this voltage ratio along the bottom of the chart. Follow the vertical line upward from this value to the diagonal line. Where the vertical line crosses the diagonal line, follow the horizontal line to the left and read the number off of the left side of the chart. If the input voltage is greater, you have a db loss; if smaller, you have a gain.

If you know the db value, you can read to the right to the diagonal line and then down, to find the voltage ratio. You use the horizontal and vertical row nearest the chart when converting from voltage ratio to db.

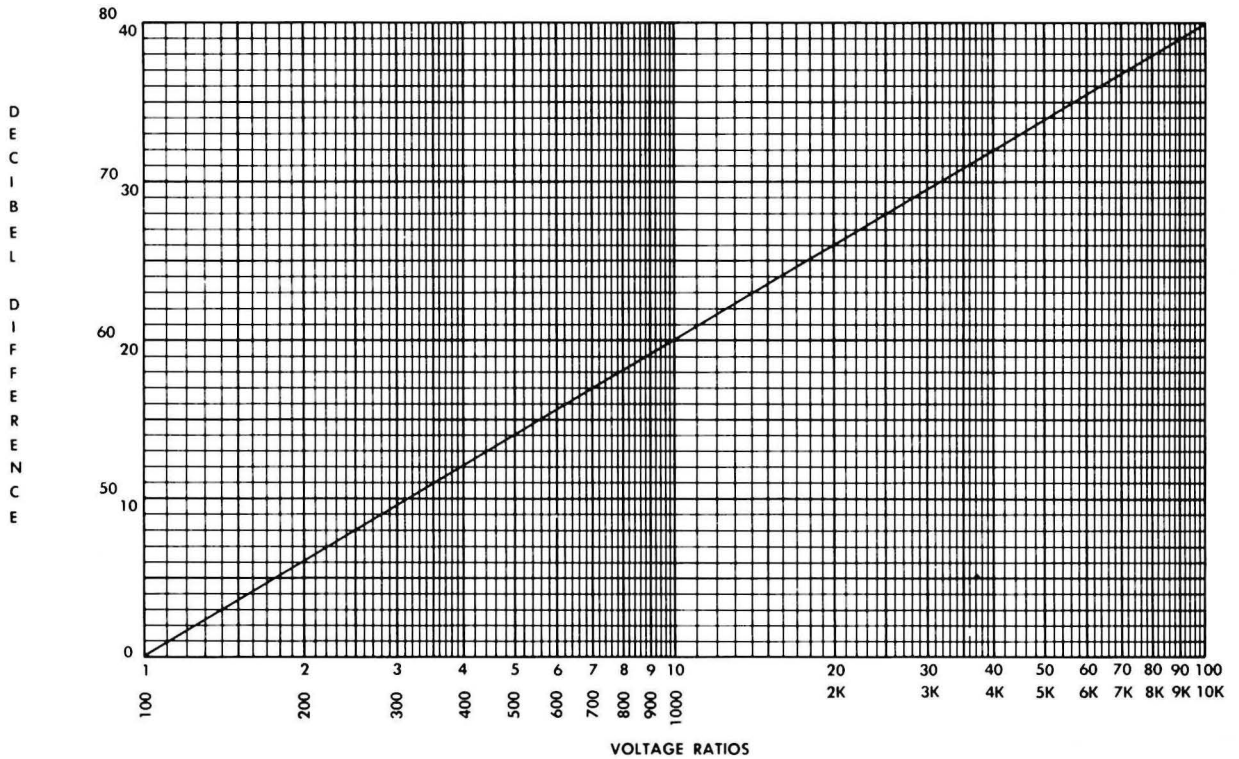

# INDEX

<b>A</b>	
Alignment	168
AN /ARC-34 VHF receiver	95
Audio power output check	170
Automatic volume control (AVC)	25, 45
<b>B</b>	
Balanced modulator	130
Bandspreading	12
Band switching	12
Bandwidth	110
BC-348	77
BC-779	68
Beat frequency oscillator	48, 171
Butler oscillator	104
<b>C</b>	
Capacity checker	163
Conversion	31
Conversion gain	34
Converter	31, 96
Crystal filter	41
<b>D</b>	
Delayed and amplified AVC	46
Delayed AVC	45
Detection	4, 15
Detector:	
Diode	15
Double-tuned	113
Grid leak	18
Infinite impedance	18
Plate	16
Ratio	118
Slope	112
Superregenerative	20
Deviation	109
Diode detector	15
Direction finders	149
Discriminator	112
Double conversion	85
Double-tuned detector	113
Dual diversity converter	138
<b>E</b>	
Electron ray tube	58
Etched circuits	100
<b>F</b>	
Fidelity	2, 111
Foster-Seeley discriminator	114
Frequency conversion	31
Frequency modulation	105
<b>G</b>	
Grid leak detector	18
<b>H</b>	
Headset circuits	59
<b>I</b>	
IF amplifier	36, 94
Image frequency	30
Infinite impedance detector	18
<b>K</b>	
Klystron	90
<b>L</b>	
Limiters	112
Local oscillator	31
Locked-in oscillator	119

<b>M</b>		Series noise limiter . . . . .	51
Manual volume control (MVC) . . . . .	23	Shunt noise limiter . . . . .	53
Marker generator . . . . .	160	Signal generator . . . . .	160
Mechanical filter . . . . .	103	Signal-plus-noise to noise ratio . . . . .	170
Miniaturization . . . . .	98	Signal tracer . . . . .	161
Mixer . . . . .	33, 94	Single sideband receiver . . . . .	129
Modulation index . . . . .	109	Slope detector . . . . .	112
Multimeter . . . . .	157	S-meter circuits . . . . .	56
<b>N</b>		Speaker circuits . . . . .	60
Noise control circuits . . . . .	50	Squelch circuit . . . . .	55, 120
<b>O</b>		Subminiature tubes . . . . .	98
Oscillator pulling . . . . .	32	Superheterodyne receiver . . . . .	29
Oscilloscope . . . . .	163	Superregenerative detector . . . . .	20
Output meters . . . . .	160	Sweep generator . . . . .	160
<b>P</b>		<b>T</b>	
Padder . . . . .	34	Tantalum capacitor . . . . .	98
Pencil tubes . . . . .	102	Technical orders . . . . .	164, 171
Pentagrid converter . . . . .	34	Teletypewriter systems . . . . .	136
Pentagrid mixer . . . . .	33	Television receivers . . . . .	144
Performance test . . . . .	169	Test equipment . . . . .	157
Permeability tuning . . . . .	10	Test points . . . . .	104
Plate detector . . . . .	16	Tracking . . . . .	30, 34
Plug-in units . . . . .	100	TRF receiver . . . . .	7, 26
Power supplies . . . . .	61	Trimmer . . . . .	34
Preselector . . . . .	31	Troubleshooting . . . . .	165
Printed circuits . . . . .	100	Tubes:	
Publication indexes . . . . .	164	Electron ray . . . . .	58
Pulling . . . . .	32	Miniature . . . . .	88
Pulse receivers . . . . .	139	Tube tester . . . . .	157
<b>R</b>		Tuned cavities . . . . .	102
R-19/TRC1 . . . . .	127	<b>U</b>	
R-278/GR . . . . .	96	UHF equipment . . . . .	94
Ratio detector . . . . .	118	<b>V</b>	
Resonant cavities . . . . .	102	Vacuum tube voltmeter . . . . .	157
RF coils . . . . .	9	VHF receiver . . . . .	93
Regenerative detector . . . . .	20	Voltage ratio and decibels . . . . .	172
Rejection notch . . . . .	43	Volume control methods . . . . .	22
<b>S</b>		<b>W</b>	
Selectivity . . . . .	2	Wavetraps . . . . .	7
Sensitivity . . . . .	1	Wobbulator . . . . .	160