

# Radio Transmitters

By

HARRY F. DART, E.E.

RADIO ENGINEER

AND

E. V. AMY, E.E.

RADIO ENGINEER

CODES AND CODE PRACTICE

By HARRY F. DART, E.E.

RADIO-TELEGRAPH TRANSMITTERS

RADIO-TELEPHONE TRANSMITTERS

By E. V. AMY, E.E.

553

Published by

INTERNATIONAL TEXTBOOK COMPANY

SCRANTON, PA.



Codes and Code Practice: Copyright, 1931, 1921, by INTERNATIONAL TEXTBOOK COMPANY.

Radio-Telegraph Transmitters: Copyright, 1929, 1925, by INTERNATIONAL TEXTBOOK COMPANY.

Radio-Telephone Transmitters: Copyright, 1930, by INTERNATIONAL TEXTBOOK COMPANY.

---

Copyright in Great Britain

---

All rights reserved

---

Printed in U. S. A.

# CONTENTS

NOTE.—This book is made up of separate parts, or sections, as indicated by their titles, and the page numbers of each usually begin with 1. In this list of contents the titles of the parts are given in the order in which they appear in the book, and under each title is a full synopsis of the subjects treated.

## CODES AND CODE PRACTICE

	<i>Pages</i>
Introduction .....	1- 3
Definition of Telegraphy and Telephony.....	1
Codes .....	2- 3
Morse code; International Morse code.	
Code-Practice Apparatus .....	4-16
Keys .....	4-10
General uses; One type of telegraph key; Small-capacity radio key; Large-capacity radio key; Relay key; Troubles of keys.	
Signal-Receiving Apparatus .....	11-16
Wire-telegraph sounders; Buzzers; Principle of operation; Applications of buzzers.	
Operating Hints .....	17-35
Learning to Send.....	17-27
Method of holding key; Adjustment of key spring; Code charts; Length of dot, dash, and space; Special International Morse code signals; Practice with the key; Dash characters; Dot characters; Dash-and-dot characters; Dot-and-dash characters; Spaced characters; Results of improperly made characters; Accuracy more desirable than speed.	
Learning to Receive.....	28-29
Automatic Sending and Receiving Apparatus.....	30
Codes of Abbreviations.....	31-34
Ciphér A B C code; Toll charges.	
United States Government Publications.....	35

## RADIO-TELEGRAPH TRANSMITTERS

	<i>Pages</i>
Damped-Wave Commercial Transmitters.....	1-10
Rotary and Quenched Gaps.....	1- 4
Damped-Wave Transmitters for Ship Use.....	5-10
Circuits of dampened-wave transmitter; Wave-length limitations and ranges of transmitters for ship use; Typical 2-kilowatt ship spark transmitter.	
Undamped-Wave Transmitters .....	11-66
Advantages of Undamped-Wave Transmission.....	11-14
Selectivity; Range and efficiency; Heterodyne reception; Antenna voltage decreased; Adjustment of signal note.	
Alexanderson High-Frequency Alternator.....	15-19
Principle of construction; Magnetic amplifier.	
Commercial Arc Transmitters.....	20-22
Fundamental Vacuum-Tube Circuits.....	23-33
Meissner circuit; Tickler-coil circuits; Reversed feed-back circuits; Hartley circuit.	
Vacuum-Tube Transmitters .....	34-54
Tube-Attachment Set .....	34-37
Model ET-3628 ACW Tube Transmitter.....	38-40
Description; Battery-charging panel; Motor-generator circuits; Type I switch; High-frequency circuits; Receiving circuit.	
Master-Oscillator Circuit .....	40-43
200-Watt Model ET-3655 Short-Wave Transmitter...	44-50
General features; Radio unit; Motor-generator set; Radio-frequency oscillating circuit; Antenna; Keying; Meters; Operation.	
Model ET-3626A Telegraph Transmitter.....	51-54
Description of Short-Wave Amateur Station.....	55-58
Radio Direction Finder.....	59-65
Short-Wave Radio-Transmission Data.....	66
Allocation of Wavelength Bands.....	66

## RADIO-TELEPHONE TRANSMITTERS

	<i>Pages</i>
Principles of Radio Telephony.....	1-15
Telephone Service in Radio Communication.....	1
Radio telephone and radio telegraph; Radio telephone and wire telephone.	
Radio-Telephone Apparatus and Basic Circuits.....	2-15
Elementary circuits; Microphone; Effect of microphone on radio-frequency currents; Harmonics; Modulating systems; Methods employed; Variation of resistance; Variation of grid voltage of oscillator tube; Variation of plate supply.	
Broadcasting and Commercial Transmitters.....	16-63
Broadcasting Transmitters .....	16-48
Layout of Broadcasting Station.....	17-22
Power plant; Control room and studio; Microphones; Microphone transmitter type 387-W; Condenser microphone.	
One-Kilowatt Broadcast Transmitter.....	22-29
Apparatus used; Studio control; Speech-input equipment; Transmitting units; Advantages of crystal-controlled oscillator; Station speech-input equipment; Power equipment and water-cooling system; SOS receiver.	
Five-Kilowatt Western-Electric Broadcast Transmitter	30-35
Description of No. 105-C transmitter; A.-C. Power-panel unit; Rectifier unit; Oscillator unit; Amplifier unit; Tuning unit; Accessory equipment.	
Five - Kilowatt R. C. A. Broadcasting Transmitter, Model 5-A .....	35-48
General features; Power supply for model 5-A transmitter; Vacuum tubes; Frequency range; Component units; Special features of model 5-A transmitter; Maintenance of crystal-controlled amplifier unit; Maintenance of miscellaneous equipment; Notes on operation of screen-grid transmitting tube UV-861. Notes on operation of radio tube UV-848.	
Data on Tube Layout for Composite Broadcast Stations	49
Ten-Watt Aircraft Transmitter .....	49-58
Frequency range; method of signalling, power rating; Antenna characteristics; Vacuum tubes; Power supply; Construction of equipment; Installation; Theory of operation; Adjustment of transmitter; General maintenance of equipment.	
Transatlantic Radio Telephony.....	59-63

# CODES AND CODE PRACTICE

Serial 2014

Edition 1

---

## INTRODUCTION

---

### DEFINITION OF TELEGRAPHY AND TELEPHONY

**1.** Electric telegraphy and telephony are branches of the art, science, or process of transmitting intelligible signals or information between distant points by means of electric impulses moving between those points. Messages may be transmitted in this manner to produce audible signals. The essential parts of these systems are the transmitting and receiving devices, and the mediums which carry the electric impulses.

**2.** In the common wire telegraph and telephone systems the impulses are carried from one party to the other by means of wires, or at least, one wire and ground return. There is thus a complete electric circuit between the two stations, which circuit is a part of the necessary apparatus in this method of communication.

**3.** In radio practice, no wires are used between the distant stations, the signals being carried by a medium called *ether* which is supposed to fill all space and which allows of the transmission of waves of energy. Special apparatus produces and sends out electric impulses which are readily carried by the ether. These impulses, by means of special receiving devices, are made to produce audible signals, by means of which the electric impulses become intelligible. As no wires are used between the communicating stations, this system is sometimes

called *wireless*. The name wireless, however, may be applied to other systems of transmitting signals not employing electricity, as, for example, one using beams of light that are interrupted at intervals so as to produce long and short flashes.

4. In both wire and radio telephony, special sets of signals are not necessary and consequently not used. Communication on these systems is by word of mouth and the messages are received by the human ear. Communication by telephony is, therefore, much more rapid and convenient than by radio telegraphy and accounts for the rapid development of this branch of the radio art.

---

## CODES

---

### MORSE CODE

5. **Telegraph codes** consist of *characters* formed by combinations of dots, dashes, and spaces, which represent letters, numerals, and punctuation marks. These characters are sent by one operator to the other by means of electric impulses. With the aid of suitable apparatus, the receiving operator hears the incoming signals and is then able to reproduce the original message. The characters representing letters, figures, and punctuation marks for the International Morse code, the Morse code, and the Phillips punctuation code, which is used as a part of the Morse code, are to be found in the latter portion of this Section under the heading Operating Hints.

6. The **Morse code** of characters came into general use in wire telegraphy shortly after the establishment of that means of communication. In this system, which is also called the *American Morse code*, some of the characters are made with so-called *spaces* which are a part of the group signal, and are essential in distinguishing those characters. The use of spaced letters in this system quite frequently leads to errors in the transmission of messages, as the parts of those letters are apt to be divided into two letters, or two letters composed of a small



number of signals may be combined unintentionally to form a single letter. This does not imply that no mistakes are made when other codes are used, but rather that they are apt to be more common in the Morse for the reason given. It is usually somewhat more difficult to learn a code with spaced letters than one which does not have any spaces as part of the letter characters. The *Phillips punctuation code* has superseded the punctuation characters of the Morse code as it is much more complete and systematic.

---

#### INTERNATIONAL MORSE CODE

7. The **International Morse code** is a modified form of the Morse code in which no spaced characters are used, except in the character for the period. This alphabet is also commonly called the *Continental*, and the *Universal code*, and has come into extensive use in some fields.

The International Morse code is used all over the world for radio and submarine telegraphy, and for wire telegraphy in almost every country except the United States, Canada, and parts of Australia. It is superior for signaling through long submarine cables, as some of the recording devices used in that work do not give accurate signals when used with spaced letters.

The Morse code, owing to the fact that there are fewer dashes in its characters, is about 5 per cent. more rapid than the International Morse code. The latter is, however, preferable for several reasons and would doubtless have been adopted in the United States if the Morse alphabet had not already obtained such extensive use among operators.

The only codes that are in general use are the Morse and the International Morse. Either of these codes may be used in wire or radio telegraphy, yet each has been adopted in certain particular fields. In some fields, such as railroad work where both wire and radio systems are employed and the Morse code is used in the wire system, it is sometimes convenient to use the Morse code also for the radio system.

## CODE-PRACTICE APPARATUS

---

### KEYS

---

#### GENERAL USES

8. The signals transmitted in telegraph systems consist of proper groups of current impulses. A **key** is the device used in telegraphy to open and close the electric circuit and thus form the current impulses which are transmitted through the line. The current impulses acting on the receiving device produce the signals or dots and dashes of the various codes. The receiving operator translates the signal combinations into the proper characters, or they may be recorded on some type of *automatic recorder* and later transcribed into message form.

9. Keys such as are used in wire telegraphy are satisfactory in radio work where the current to be broken is not too large. The current used in wire telegraphy is very small, and the *contact points* which actually make and break the circuit are correspondingly small. The interrupted current in radio practice is often many times greater than that used in wire telegraphy, hence larger contact points are necessary.

10. The downward stroke of the key is often called the *make*, and the upward stroke, the *break*, referring, of course, to the making and breaking of the circuit. The contacts on most good keys were formerly made of platinum, because of the ability of that metal to resist better than most other metals the corroding and fusing action of the electric arc that is always formed at the break. The scarcity of platinum and consequent advance in price has been instrumental in causing the adoption of silver as the metal from which the contact points are made. Silver contacts must be larger than those of platinum for the

same current capacity, as the former do not stand up quite as well as the latter. When the silver contact points are properly designed and of ample size, they have been found to give good service. Various other metals are used for contacts in the many different types of keys, and are listed under numerous trade names.

#### ONE TYPE OF TELEGRAPH KEY

11. A type of key extensively used, particularly in wire telegraphy, is shown in Fig. 1. It consists of a steel lever *l* and trunnion, all in one piece, and pivoted in trunnion screws *c*, which are mounted in standards projecting upwards from the brass plate *m*. Locknuts *c'* bind the trunnion screws in any

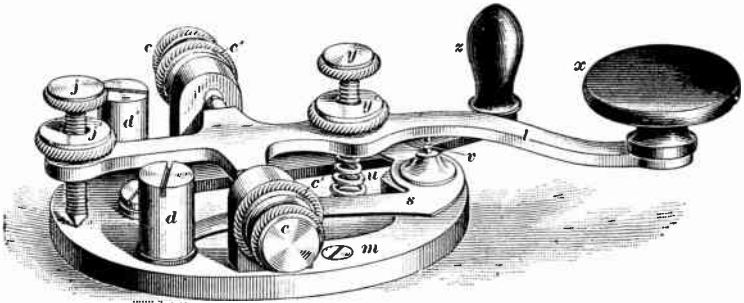

FIG. 1

position to which they have been adjusted. A coiled spring *u*, which may be adjusted by the screw *y* and secured by the locknut *y'*, presses the forward end of the lever upwards. The upward movement of the forward end of the lever is limited by the screw *j*, and the latter is held securely in position by the locknut *j'*. As the handle, or button, *x*, made of insulating material, is pressed down, a contact point carried on the under side of the lever, makes contact with a point *v* carried on, but insulated from, the base *m*. This lower contact point, or anvil, is in metallic connection, by means of a flat strip of metal *s*, with the binding post *d*, which is also insulated from the base plate *m*. The other binding post *d'* is connected directly to the base plate. These binding posts *d* and *d'* form the terminals of the key.

12. The path through the instrument may be traced as follows: From the binding post *d*-strip *s*-lower contact point *v*; then, when the key is depressed, to the upper contact point-the trunnion-trunnion screws and spring *u*-base plate *m*-binding post *d'*. The switch handle *z* is connected with a metallic arm called the *circuit closer*, pivoted directly on the base *m*, and, when pressed toward the key lever *l*, makes contact with an extension of the strip *s*, thus short-circuiting the key. The circuit closer in wire telegraphy is used to close the current through the home key when the key at another station is sending impulses over the line. When this key is used in radio work, the circuit closer should be left open at all times or it may be detached from the base.

#### SMALL-CAPACITY RADIO KEY

13. A type of key suitable for use in small-power radio stations is shown in Fig. 2. The essential parts of this key are not radically different from those of the key which has been described. It will be noted that the key as a whole is of rather rugged construction, so it may stand up well under rough usage. The lever *a* carries a comparatively large contact point at *b* which closes the circuit through a stationary contact point just below *b*. The base *c* is made of bakelite dilecto, which material has been found entirely satisfactory for that purpose and considerably cheaper than brass. The lower stationary contact is connected directly to one of the binding posts by a conductor underneath the base. The circuit from the upper contact at *b* is through the lever, thence through a flexible copper braid *d* and a connection under the base to the other binding post. The reason for using the copper braid is that a low-resistance connection is assured between the lever and the binding post. With fairly large currents it is not con-

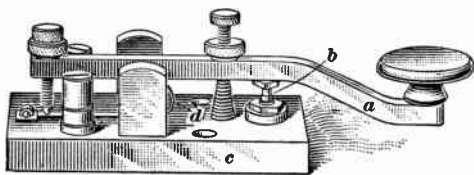

FIG. 2

atively large contact point at *b* which closes the circuit through a stationary contact point just below *b*. The base *c* is made of bakelite dilecto, which material has been found entirely satisfactory for that purpose and considerably cheaper than brass. The lower stationary contact is connected directly to one of the binding posts by a conductor underneath the base. The circuit from the upper contact at *b* is through the lever, thence through a flexible copper braid *d* and a connection under the base to the other binding post. The reason for using the copper braid is that a low-resistance connection is assured between the lever and the binding post. With fairly large currents it is not con-

sidered good practice to rely on the path through the trunnion and trunnion mounting to carry the current, as that path is liable to introduce a high resistance.

#### LARGE-CAPACITY RADIO KEY

14. A key of somewhat similar design is shown in Fig. 3. The lever *a* carries a very large contact *b*, indicating that this key is designed for interrupting quite large currents. The base *c* is made of bakelite dilecto, with countersunk screw holes to hold screws for fastening the base to a table. A heavy copper braid *d* is provided to carry current from or to the lever arm. The length of the air gap between the contacts may be adjusted by screw *e*. The rapidity with which the lever opens the circuit

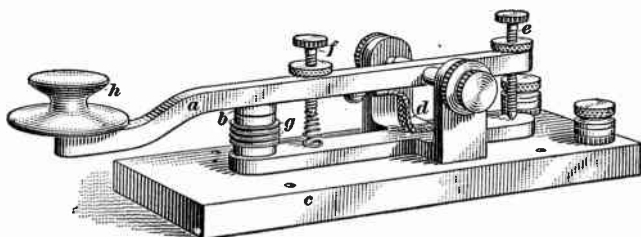

FIG. 3

depends largely upon the setting of screw *f*, acted upon by the spring immediately below it. The gap must be opened far enough to break the circuit completely, and the more rapidly this is done the better.

15. The contact points are apt to become heated to a considerable extent when the key is used to carry and interrupt large currents. Making these points of large dimensions assists materially in the dissipation of the heat produced. In this key auxiliary cooling flanges *g* are provided which offer a large cooling surface and are, therefore, instrumental in radiating a large part of the heat. Keeping the contact points at a fairly low temperature has been found helpful in breaking the arc quickly. The handle *h* of the key is fitted with a safety disk to prevent the operator's hand from accidentally touching the metal lever.

## RELAY KEY

16. A relay key is an electromagnet so arranged that movements of its armature open and close an electric circuit. This circuit may or may not be separate electrically from the circuit that supplies current to the winding of the relay. The electromagnet is usually so constructed that it operates with a very low current and a hand-operated control key can be used with safety to control the low-voltage, low-current exciting circuit. The armature of the relay is capable of controlling a circuit of such voltage and current as to make it undesirable to use a hand-operated key. In many cases it is desirable to control the main circuit by a control key placed some distance

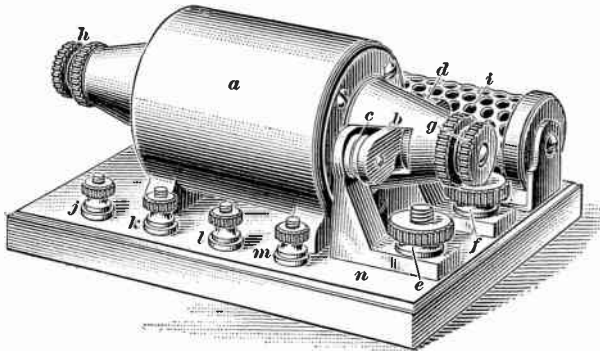

FIG. 4

from the relay key, thus making it unnecessary to extend the main-circuit wiring to the point of control.

The circuit including the operating key and relay winding is called a *local*, or *auxiliary*, circuit, to distinguish it from the main circuit, which is controlled by the armature of the relay.

17. A relay key such as used in radio telegraphy is shown in Fig. 4. Fig. 5 shows a wiring diagram of this relay key connected to the operating key of the local circuit. Corresponding parts of the device are lettered in a similar manner in both figures. In Fig. 4 the relative positions of the parts of the device are shown, and in Fig. 5 the wiring within the protecting shells is indicated. The electromagnet is shown at *a*

and the iron plunger at *b*. When the coil *a* is excited, the plunger *b* is drawn into the coil and the contact points at *c* and *d* are closed. These main contact points are connected to binding posts *e* and *f* which serve as terminals for the heavy-current circuit from point *e* through *c*, *b*, and *d* to terminal *f*. It should be noted that there are two points at which the circuit is opened and closed. This arrangement insures a more rapid break and also reduces sparking and heating by dividing the arc. Thus, a larger current may be interrupted than would be possible if a single contact were used.

18. A spring connected to the adjusting and locking nuts at *g* is placed under tension when the plunger is drawn up to

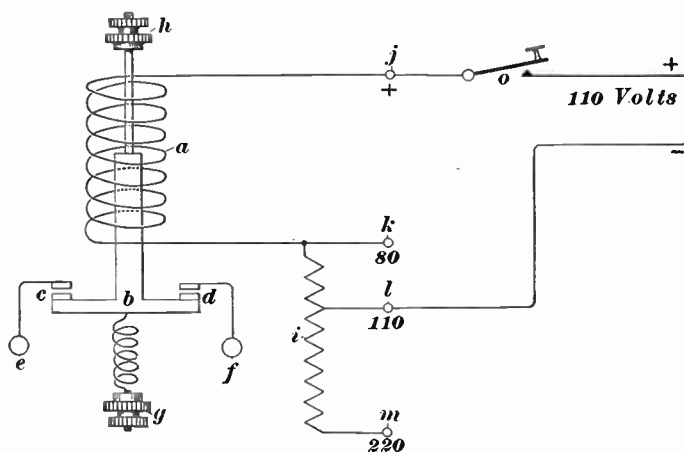

FIG. 5

close the circuit, and promptly withdraws the plunger when the coil *a* is deenergized. The distance to which the plunger is *withdrawn* depends upon the adjustment of the nuts at *h* which screw on an extension of the plunger core. The air gaps at *c* and *d* need only open far enough to insure that the arc will be suppressed with every opening of the contact points. Also the tension of the spring should not be such that the plunger does not have time to close the main contacts before coil *a* is demagnetized during rapid sending.

A resistance coil  $i$  permits the use of this relay key on several different operating voltages. The positive side of the control circuit is connected to terminal  $j$ , and the negative side to the proper one of the terminals  $k$ ,  $l$ , and  $m$ . The coil itself may be operated satisfactorily on 80 volts, but for higher voltages it is necessary to use all or part of resistance  $i$ . No special internal connections are necessary for operation at the higher voltages; it is merely necessary to connect the line to the terminals marked for that particular voltage. The device is mounted on an insulating base  $n$  and makes a very compact unit, as shown in Fig. 4. Fig. 5 shows how a small key  $o$  is connected in series with coil  $a$ , the whole being connected for operation from a 110-volt, direct-current supply circuit. Closing key  $o$  excites coil  $a$  which attracts plunger  $b$ , thereby closing the circuit between terminals  $e$  and  $f$ .

---

#### TROUBLES OF KEYS

19. When a key, on rising, does not break the circuit, it is said to *stick*. This sticking may be due to any one of several causes. The principal cause is the fusing action of the electric spark at the contact points, but it may be caused by metallic dust collected on and bridging over the contact points, or by an improper adjustment that causes the points to come together improperly and bind. The contact points, therefore, should be kept clean by drawing between them a piece of hard, clean paper or fine emery cloth, or they may be rubbed very gently with a very fine file and then wiped clean. Frequent use of the file or emery paper, however, should be avoided.

Pivot, or trunnion, screws often become loose and cause trouble; to prevent this they should be kept as tight as is consistent with a free and easy movement of the key. Loose connections are frequently the cause of poor and irregular signals, but with frequent inspections little trouble should be experienced from this source.



## SIGNAL-RECEIVING APPARATUS

### WIRE-TELEGRAPH SOUNDERS

20. Signals in wire telegraphy consist of impulses of current sent over the line whose circuit includes a suitable electromagnet. The operation of the key causes the interruptions in the line current. One type of signal-receiving apparatus consists of a special form of electromagnet with its auxiliary devices and is called a **sounder**, because of its ability to produce audible signals when energized by a flow of electricity through its windings.

21. One type of sounder, which is shown in Fig. 6, represents the main features common to this apparatus. The wind-

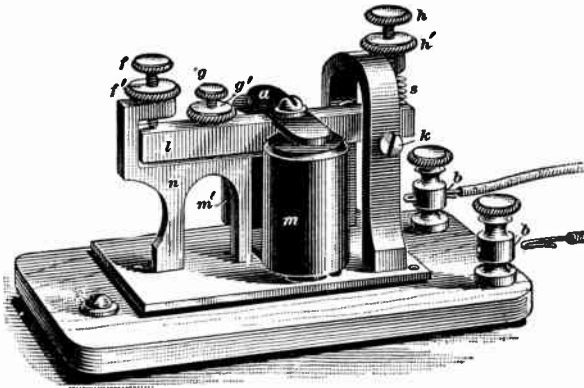

FIG. 6

ings of the two magnets are mounted on iron cores and protected by hard-rubber casings *m* and *m'*. An armature *a* of soft iron is mounted on a brass or aluminum lever *l* which is pivoted between the trunnion screws *k*. The armature is normally held in its upper position by means of the compression spring *s*, which bears down on the short end of the lever *l*, the compression of the spring being regulated by the thumbscrew *h* and locked, after adjustment, by the locknut *h'*. The downward

stroke of the lever is limited by the lower end of the screw  $g$  striking against the anvil  $n$ ; and the upward stroke is limited by the lever striking against the lower end of the screw  $f$ . The play of the armature can therefore be adjusted by means of the screws  $f$  and  $g$ , and, after the proper adjustment is obtained, it can be made permanent by the locknuts  $f'$  and  $g'$ . The binding posts  $b$  form the terminals of the circuit through the coils, the current passing through them in series so as to make the upper pole of one iron core have north polarity and the upper pole of the other core have south polarity. The sounds given out by the sounder may be augmented by mounting the instrument on a sounding board. The metal base plate and the wooden base are usually constructed with this idea in view, and, for this reason, are slightly separated.

**22.** Direct current is used in wire telegraphy; hence the armature strikes the anvil when the current is established, and strikes a second blow on its back stop when the circuit is broken. The interval between the successive strokes enables the operator to determine the length of the signal. For example, a dot would be represented by a downward stroke immediately followed by an upward stroke of the armature. A longer interval of time between the two strokes indicates a dash.

Alternating current of a rather high frequency is generally used in radio work. When alternating-current impulses are received, the signals give a buzzing or humming tone; the relative duration of the sound indicating the length of the transmitted signal or impulse. The sounder, with its rather heavy armature, does not readily respond to these rapid pulsations of current. The main factor that prevents the use of sounders in this field, is that the received current is so weak that it cannot produce the required magnetic strength, and an entirely different system of rendering the current impulses audible has been developed.

**BUZZERS**

**23.** A **buzzer** is an electromagnetic device which emits a buzzing sound when current is established through it. The tone is similar to that produced in a telephone receiver by radio signals and it is, therefore, common practice to use a buzzer in learning the International code. There is a considerable difference between the sound of the buzzer and that of a sounder, but a professional telegraph operator can usually receive radio signals after a short period of practice. The ordinary buzzer resembles the sounder in that an electromagnet, when excited, attracts an armature of rather light weight. The buzzer, however, is provided with a circuit-breaking device which breaks up the received current into still smaller impulses, thereby causing a rapid vibration of the armature.

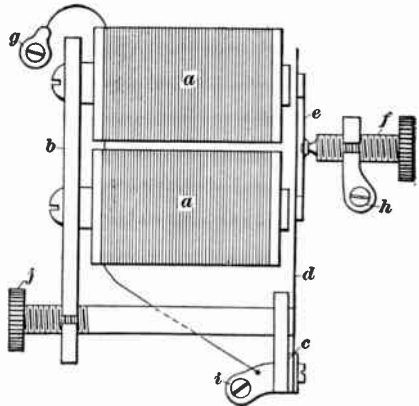

FIG. 7

The ordinary buzzer resembles the sounder in that an electromagnet, when excited, attracts an armature of rather light weight. The buzzer, however, is provided with a circuit-breaking device which breaks up the received current into still smaller impulses, thereby causing a rapid vibration of the armature.

**24. Principle of Operation.**—Fig. 7 shows the arrangement and connections of the parts of a buzzer. Fig. 8 shows

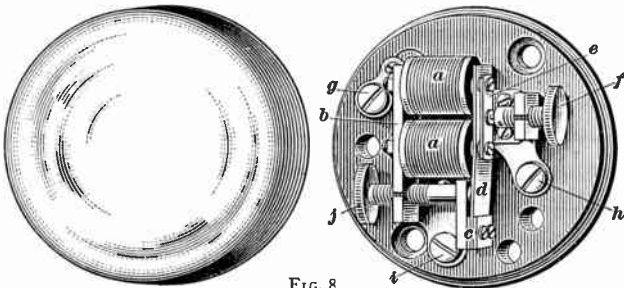

FIG. 8

an assembled view. Similar reference letters apply to both figures. The magnet windings are shown at *a* and their iron

cores are supported rigidly by the iron yoke *b*. A support *c* holds firmly one end of the vibrator spring, or armature, *d*. The armature near its free end carries a small spring *e* at the center of which a contact point is mounted. When the buzzer magnets are deenergized, this contact is pressed against the contact mounted at the end of screw *f*. The main terminals of the buzzer are shown at *g* and *h* and an auxiliary terminal at *i*.

Adjustment of screw *j*, which presses against the armature *d* near its fixed end, changes the tone of the buzzer. Adjustment of screw *f* serves to make up for the gradual burning of the contacts and to a certain extent changes the frequency of the vibrations of the armature. The holes in the supports for screws *f* and *j* are made slightly small; slots are cut to the holes and when the screws are inserted, a tight fit is assured which is relied upon to hold the screws in adjustment without the use of locknuts.

25. The operation of the buzzer is independent of the direction of the current through its windings. The current enters, say at *g*, and passes through the device by way of the magnet windings *a*—mounting *c*—the spring *d*—spring *e*—contact point on spring *e*—point and body of screw *f*—through mounting of screw *f*, and out at terminal *h*. As soon as current is established through coils *a*, the armature *d* is drawn toward the magnets. This movement of the armature causes the contact points to separate and open the circuit between *e* and *f*. The opening of the circuit cuts off the current and the armature is released. The springiness of armature *d* causes its free end to fly back and the circuit is reestablished through the contact points. This cycle of events is rapidly repeated and the vibration of the armature gives rise to the audible buzzing sound. Due to the light weight of the vibrating parts, the tone of the buzzer is quite high, and closely resembles that given out by a radio receiving set.

A terminal *i* may be used in connection with terminal *h* in case it is desired to connect only the circuit-breaking part of the buzzer in another circuit for special testing or other pur-

poses. It is, however, necessary to energize the magnets *a* through terminals *g* and *h*. The various parts of the buzzer are mounted on an insulating base shown in Fig. 8. Suitable holes are provided for mounting screws and for the entrance of connecting wires to the buzzer terminals when the cover is in place. A metal cover, Fig. 8, serves to provide mechanical protection to the device and also adds to its appearance.

26. There is, apparently, considerable variation between the types of buzzers made by the various companies, but the difference is chiefly one of design and in the arrangement of parts. The fundamental principle of operation remains the same in all of them despite the particular advantages of certain types. Numerous devices are in common use, by means of which the emitted tone of the buzzer may be varied until it gives out a clear high-frequency signal.

27. **Applications of Buzzers.**—The combination of a buzzer *a* and a key *b* properly connected to a primary cell *c* is

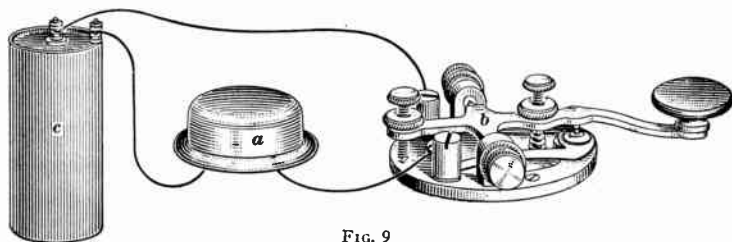

FIG. 9

shown in Fig. 9. This outfit is particularly suitable for learning the radio code. The judgment of the sender should not be relied upon, however, as to the accuracy of his signals. He may to his own satisfaction be sending perfect code, but it may be impossible for any one to read it.

Instruction in code practice is usually given by an experienced operator who sends the code characters. The student listens to the signals and endeavors to write the letters and figures corresponding to the characters sent by the operator. In order to give better practice it is desirable that the persons be located in different rooms or even in separate houses, and that

all communication between them should be by means of the code signals. This may easily be accomplished by connecting two keys, two buzzers, and a battery in series in a circuit connecting the two stations. It is necessary in this case to use keys with short-circuiting switches, such as regular wire-telegraph keys. This short-circuiting switch must be closed at one station when the other is sending, otherwise the circuit would be open at two places, and no signals could be transmitted. In case a key with a short-circuiting switch is not available, a good expedient is to short-circuit the terminals of the key which is not used by a short length of wire. When operating properly both buzzers respond to current impulses caused by the closing of one key. This arrangement of two outfits is somewhat inconvenient because no means of signaling are provided by which the operator who has left his short-circuiting switch open may be called.

**28.** When two or more instruments in the same house are to be connected, insulated copper wire, called annunciator, or office, wire may be used. A No. 18 Brown & Sharpe gauge copper wire will be about the right size. Insulated wire may be fastened in place by small staples, or double-pointed tacks, care being taken not to injure the insulation in any way. When joining the wire to a binding post, the end of the wire should first be made clean and bright, then placed in the hole in the binding post, and firmly fastened there by the screw. Do not allow the bare end of a wire to touch anything except the binding post or another wire to which it is intentionally joined. By wrapping 8 or 10 inches at the end of a wire in a close helix around a lead pencil, and then sliding out the pencil, a neat springy coil can be made, by means of which no slack need be left in the wiring, and it will give a finished appearance to the connections.

**29.** Because of their great convenience, dry cells are in quite common use with beginners' sets as a source of electro-motive force. Some types of wet cells are used in large installations where the item of cost is an important one. It must always be remembered, when connecting cells in series, that

they should be so connected that their voltages add or assist each other. This is particularly important where two or more batteries are located at different points in the same circuit, as one reversed battery will not only be of no value in that circuit, but will oppose part or all of the electromotive force established by the other batteries.

**30.** The use of telephone receivers for the reception of radio signals is quite common. In order to give practice in this method of receiving, it is customary to use telephone receivers for a portion of the training period, if not exclusively. They also help to exclude outside sounds by being held against the ears, which enables the person receiving to concentrate on the incoming signals. The principles of operation of telephone receivers will be covered in a succeeding Section.

---

## OPERATING HINTS

---

### LEARNING TO SEND

---

#### METHOD OF HOLDING KEY

**31.** The first step in learning to send telegraph characters is to develop complete control of the hand. The key should be located on the table in such a position that when the hand is placed on the key, the arm will assume the normal writing position. This arrangement will be much less tiring than if the hand and arm were placed in an unnatural position. A good position for holding the key is shown in Fig. 10; it is the one adopted by many of the most speedy and perfect operators. Rest the first finger on the top, near the edge, of the key button, with the thumb and the second finger against the opposite edges, as shown. Curve the first and the second finger so as to form the quarter section of a circle. Avoid straightness or rigidity of these fingers and the thumb. Partly close the third and the fourth fingers.

**32.** Many operators prefer to rest both the first and second fingers upon the key handle or button, with the thumb and third finger pressing lightly upon opposite sides of the button. This method is perhaps preferable, especially in the operation of large keys. The thumb and fingers should always remain in contact with the handle, but still must be kept flexible enough to form a sort of spring action between the rigid key and the hand. The elbow should rest easily on the table at all times, and the wrist should be elevated from the table and perfectly

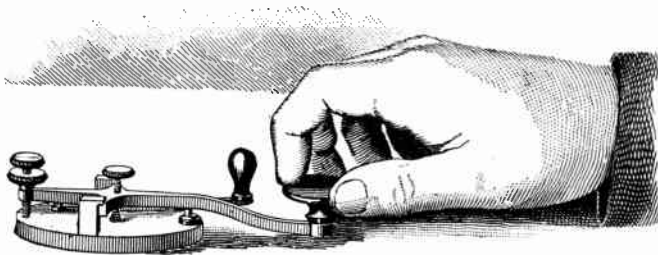

FIG. 10

flexible. The key is operated by a free and easy motion of the whole forearm rather than by motion of the wrist alone. The motion should be directly up and down, avoiding all side pressure. When the proper swing is acquired, the forearm moves freely in conjunction with the wrist and fingers. The grasp on the button should be moderately firm, but not rigid. Grasping the knob tightly will quickly tire the hand and destroy control of the key, causing what is termed telegraphers' cramp.

#### ADJUSTMENT OF KEY SPRING

**33.** In the matter of adjusting the spring of the key, there is considerable difference of opinion. It is a good rule to avoid too much force or too light a touch, and to strive for a medium firm closing of the key. It is not the heavy pressure on the key, but the evenness of the stroke that constitutes good sending. A few of the very fastest senders use very stiff springs, while many other fast senders use springs that are barely strong enough to keep the weight of the key from closing



the contacts. Some operators even use a spring which will not of itself open the key, in which case the thumb must be used to raise the key. A moderate amount of play and a medium pressure of the spring should be used by the beginner unless he has good reason to believe another adjustment more suitable.

---

#### CODE CHARTS

34. Code charts are introduced at this point in the text so that reference may be easily made to them in connection with the suggestions for sending the characters. The first code chart includes the characters for letters and figures for the International Morse and the Morse codes. The second code chart includes the characters for punctuation marks for the International Morse code, the Phillips code, and special International Morse code signals.

---

#### LENGTH OF DOT, DASH, AND SPACE

35. In all codes, the dot is taken as the unit by which the lengths of the dashes and spaces are measured. The generally accepted relative lengths of the different dashes and spaces, some of which are used only in the Morse code, are as follows:

	SIGNAL	DURATION OF SIGNAL
Dot . . . . .	$\frac{1}{\quad}$	1 unit
The dash . . . . .	$\frac{3}{\quad}$	3 units
The long dash ( <i>l</i> ) . . . . .	$\frac{6}{\quad}$	6 units
The extra-long dash (naught) . . . . .	$\frac{9}{\quad}$	9 units
Space between parts of a character	$\frac{1}{\quad}$	1 unit
Space in spaced characters . . . . .	$\frac{2}{\quad}$	2 units
Space between characters . . . . .	$\frac{3}{\quad}$	3 units
Space between words . . . . .	$\frac{5}{\quad}$	5 units

36. The dot, which also represents the character *e*, is made by a single instantaneous downward stroke of the key followed immediately by an upward stroke. The actual time required in making the dot will vary with the speed of signaling, but it

## ALPHABETS

LETTERS	INTERNATIONAL MORSE	MORSE
A	- - -	- - -
B	- - - - -	- - - - -
C	- - - - - - -	- - - - -
D	- - - - -	- - - - -
E	-	-
F	- - - - -	- - - - -
G	- - - - -	- - - - -
H	- - - - -	- - - - -
I	- -	- -
J	- - - - - - -	- - - - - - -
K	- - - - -	- - - - -
L	- - - - -	- - - - -
M	- - - - -	- - - - -
N	- - -	- - -
O	- - - - -	- - - - -
P	- - - - - - -	- - - - - - -
Q	- - - - - - -	- - - - - - -
R	- - - - -	- - - - -
S	- - - - -	- - - - -
T	- - -	- - -
U	- - - - -	- - - - -
V	- - - - - - -	- - - - - - -
W	- - - - - - -	- - - - - - -
X	- - - - - - -	- - - - - - -
Y	- - - - - - -	- - - - - - -
Z	- - - - - - -	- - - - - - -
&	- - - - -	- - - - -

## NUMERALS

FIGURES	INTERNATIONAL MORSE	MORSE
1	- - - - - - -	- - - - - - -
2	- - - - - - -	- - - - - - -
3	- - - - - - -	- - - - - - -
4	- - - - - - -	- - - - - - -
5	- - - - -	- - - - -
6	- - - - - - -	- - - - - - -
7	- - - - - - -	- - - - - - -
8	- - - - - - -	- - - - - - -
9	- - - - - - -	- - - - - - -
0	- - - - - - -	- - - - - - -

## PUNCTUATION MARKS, ETC.

CHARACTERS	INTERNATIONAL MORSE	PHILLIPS PUNCTUATION USED WITH MORSE CODE
. Period	- - - - -	- - - - -
: Colon	- - - - -	K O - - - - -
; Semicolon	- - - - -	S I - - - - -
, Comma	- - - - -	- - - - -
? Interrogation	- - - - -	- - - - -
! Exclamation	- - - - -	- - - - -
- / } Fraction line	- - - - -	{ E - U T - - - - -
- Dash	- - - - -	D X - - - - -
- Hyphen	- - - - -	H X - - - - -
' Apostrophe	- - - - -	Q X - - - - -
Underline	- - - - -	U X - - - - -
End	- - - - -	U J - - - - -
( Parenthesis	- - - - -	P N - - - - -
) End	- - - - -	P Y - - - - -
" Quotation	- - - - -	Q N - - - - -
" End	- - - - -	Q J - - - - -
= Double Dash	- - - - -	B K - - - - -

### SPECIAL INTERNATIONAL MORSE CODE SIGNALS

#### CONVENTIONAL SIGNALS

Attention call, to precede every transmission	- - - - -
General inquiry call	- - - - -
From (de)	- - - - -
Invitation to transmit (go ahead)	- - - - -
Warning (high power)	- - - - -
Wait	- - - - -
Understand	- - - - -
Error (series of dots)	- - - - -
Received (O. K.)	- - - - -
Transmission finished (end of work)	- - - - -
Distress call	- - - - -

#### SPECIAL LETTERS

Ä (German)	- - - - -
Á or À (Spanish-Scandinavian)	- - - - -
CH (German-Spanish)	- - - - -
Ê (French)	- - - - -
Ñ (Spanish)	- - - - -
Ö (German)	- - - - -
Û (German)	- - - - -

is important that the relative lengths of the dots, dashes, and spaces should remain constant. There are four lengths of spaces and three of dashes, or, including the dot, four.

A dash, or the letter *t*, is made by holding the key down as long as it takes to make 3 dots. This should be timed so that the duration of the signal transmitted is actually 3 times as long as that sent as a dot. The space or interval of time between characters should equal 3 units. It will then be exactly like the dash in length of time. The space between words or groups of characters should be made equal to 5 units. This spacing is very distinct and enables the operator to separate the letter and number groups of characters very readily even when receiving code words such as are used for secret communications.

**37.** Some characters which are used only in the Morse code have special lengths of dashes and spaces. A long dash is used to represent the letter *l*, and is made 6 units long. An extra long dash, normally 9 units in length, designates the figure 0 (naught). However, in practice, the *l* and the 0 are often made 5 and 7 units long, respectively. In many cases the *l* and the 0 (naught) are made the same; occurring alone, the long dash would be read as *l*, but when found among figures it would be translated as 0 (naught). Reducing the length of all dashes allows a little greater speed in transmission, but is not desirable where recording instruments are used.

The space in the *spaced letters* of the Morse code, *C, O, R, Y, Z, &*, is 2 units long, or just double that ordinarily used between the elements of a letter. In case the receiving is rather poor, it is sometimes difficult to distinguish the 2- and 3-unit spaces because of the relatively small difference between them.

---

#### PRACTICE WITH THE KEY

**38.** Begin the use of the key by making dashes in succession, first at the rate of about one a second, and then gradually increasing to two or three. Care should be taken to make the break between the dashes quite short, for there is always a

tendency to make too large a space between dashes, and this should be guarded against.

The dots should be made as regularly as possible, and at the rate of about five a second, and the speed increased with practice; but, no matter how fast the dots are made, they should be regular, definite, and uniform.

Sending is not merely making the dots and dashes as arranged on the code chart. It involves the accurate timing of the dot and dash signals, and of the spaces and intervals between individual elements of the characters. In accordance with these views, it is desirable to practice on the following exercises in the order given. In each exercise, after learning to make each character correctly without hesitating, write them in succession, both forwards and backwards, until able to do so without having to repeat a single character before proceeding to the next. The characters in the following examples relate to the International Morse Code.

—————

**DASH CHARACTERS**

<i>t</i>	<i>m</i>	<i>o</i>	<i>0</i>
—	— — —	— — — —	— — — — —

39. The tendency to prolong the final dash or dot can be overcome by making it with a movement apparently a little quicker than that used for the preceding dash or dot. In making characters containing a succession of dashes, care must be taken to have them follow one another as closely as possible; too much space is apt to be put between dashes.

—————

**DOT CHARACTERS**

<i>e</i>	<i>i</i>	<i>s</i>	<i>h</i>	<i>5</i>
·	· ·	· · ·	· · · ·	· · · · ·

40. Practice each one of these characters until the right number of dots can be made for each one almost unconsciously, being careful at the same time to make all dots of equal duration and not to prolong the last dot into a dash.

**DASH-AND-DOT CHARACTERS**

*n*            *d*            *b*            *o*

-----

41. There is a great tendency to make the break between the dash and the dot too long; should this be done, for instance, in making the letter *n*, *te* is made instead of *n*.

**DOT-AND-DASH CHARACTERS**

*a*            *w*            *j*            *l*

-----

42. When making each of these characters, let the dash signals follow the preceding dot closely, and avoid making the dashes improperly.

**MISCELLANEOUS CHARACTERS**

*g*            *z*            *7*

-----

*u*            *v*            *4*

-----

*k*            *c*            *y*

-----

*f*            *r*            *l*

-----

*x*            *p*            *q*

-----

*2*            *3*            *8*            *9*

-----

## SPACED CHARACTER

. (Period)

- - - - -

43. When making the period, the space between each pair of dots should be just double that allowed between the elements of each pair. Avoid making this space too long, as there is more likelihood that it will be made too long, rather than too short.

## RESULTS OF IMPROPERLY MADE CHARACTERS

44. In the following lines, the first two characters, improperly connected by too short an interval, will make the third character. Thus, if *a* and *t* are connected by too short an interval, *w* will be made; and if *e* and *d* are made with too short an interval between them, an *l* will be made, and so on.

<i>a</i>	<i>t</i>	<i>w</i>	<i>e</i>	<i>d</i>	<i>l</i>
- - - - -		- - - - -	- - - - -		- - - - -
<i>u</i>	<i>e</i>	<i>f</i>	<i>d</i>	<i>e</i>	<i>b</i>
- - - - -		- - - - -	- - - - -		- - - - -
<i>i</i>	<i>t</i>	<i>u</i>	<i>m</i>	<i>a</i>	<i>q</i>
- - - - -		- - - - -	- - - - -		- - - - -

45. The following exercise shows that if the last dot in the characters given is carelessly prolonged into a dash, the character following it will be made instead of the one intended. Other examples could have been used to show a similar effect.

<i>i</i>	<i>a</i>	<i>s</i>	<i>u</i>	<i>h</i>	<i>v</i>
- - - - -		- - - - -	- - - - -	- - - - -	- - - - -
5	4	<i>n</i>	<i>m</i>	<i>r</i>	<i>w</i>
- - - - -		- - - - -	- - - - -	- - - - -	- - - - -

46. If the final dash in *k* is made too short, *d* will be formed, and if too much space is made before the final dash, *nt* will be formed. Similarly, too much space before the second dash in *c* (— — — —) will transform it into *nn* (— — — —). Many other examples of common errors in sending could be

mentioned, but those given will serve to illustrate the necessity for accuracy in the transmission of code signals. In many cases the receiving operator can tell from the meaning of the word or message what the missing or incorrect character should be, but this does not excuse the inaccuracy of the sender.

47. The following words may be used when learning the code. It is well to make up additional groups of words for practice, starting with words represented by a few simple or short signals, and advancing through longer words as progress continues.

*And*

*Humane*

*Judgment*

*Limited*

*Maintain*

*Barn*

*Chair*

*Desire*

*Exchange*

*Family*

*Terminate*

*Umbrage*

*Vacant*

*Warrant*



The following also are good words on which to practice: *Let, little, take, train, jaw, knoll, knot, need, nod, ice, rice, person, poison, Mississippi*. Be careful to make *an, c, h, i, k, s,* and *th* correctly, in order to avoid their being taken for other characters, as previously indicated.

48. Each word of these groups should be repeated until each character in them can be made at will. The beginner should be careful to form each character correctly, because this will lead to a perfect style in sending. Operators have almost as many styles of sending as there are styles of penmanship. When these groups have been mastered, the transmission of short sentences may next be taken up. Care must always be taken to write one sentence correctly before another is attempted.

49. In some cases, the code is taught by starting with characters represented by the least number of dots or dashes. Progress then is continued through the code, starting with the simpler combinations and advancing through the more complex characters until finally all can be made with equal ease. The beginner should start by making the letters *e, t, i,* and *m* correctly, after which the slightly more difficult combinations, as *n, a, s, h, o,* and *r,* should be taken up and mastered. Practice in sending words made up of groups of these letters would help to fix the groups in mind. The practice with the simpler characters helps to some extent to master the more complex ones. The student can easily assemble the letters made up of simple dot and dash combinations into short words. Practice with short word groups, such as *at, me, bat, dot, eat, him, date, met, tie, moose,* and *home,* followed by the more advanced word groups, will be the plan to follow in this method.

50. **Accuracy More Desirable Than Speed.**—A firm, even, smooth style of sending should be cultivated. At first, accuracy rather than speed is desirable. The practice of timing in order to ascertain the speed of sending should be very sparingly indulged in by the beginner, for this practice is conducive to careless habits. The speed of sending should be graduated to suit the capacity of the receiver; the latter should never be

crowded. Strictly first-class work will not be required in the first position obtained by the operator, but he must be reliable. It is well to remember that an operator is no judge of his own Morse, and therefore should not try to see how fast he can send until he has had considerable experience. Fast sending is seldom indulged in by strictly first-class operators, but fast time is made by them on account of their steady, even gait, their perfect characters, and few repetitions or mistakes. The average receiver's opinion in regard to sending should be accepted before a person decides for himself that his sending is all right, for the poorest operators often believe that their sending is good. If the receiver complains that the operator does not space properly, or calls attention to some particular fault, he should not get angry. On the other hand, he should take the hint, and try to remedy all weak points.

51. In code practice, when slow sending is necessary, the elements of the characters should not be drawn out. They should preferably be sent at a moderately fast rate, the different sending speeds being obtained only by varying the interval between characters and their groups. If the elements of a character are changed by lengthening the resulting group signal sounds different than if the same characters were properly sent.

---

#### LEARNING TO RECEIVE

52. To learn to receive, it is necessary to have another person manipulate the key, or an automatic sending device to produce the characters, for one cannot read by sound from his own sending. It is very desirable that the sender should be able to make the signals distinctly and correctly, otherwise it will be very difficult, if not impossible, for the learner to understand the signals. However, two beginners can get good practice by taking turns at sending and receiving, each correcting the faults of the other.

53. There is considerable variation in the tone of different stations, depending largely on the type of transmitting apparatus. This is found to give very little trouble in actual

practice. In fact this feature is in many cases desirable as it enables an operator to distinguish between separate stations which may be operating at the same time. The sounds produced by the buzzer depend upon the length of the signal and the length of the spaces, or intervals between signals. The sounder used in wire telegraphy is different, in that the letter or character is determined solely by the time or times the lever strikes the bottom and top stops, and the duration of time between these clicks. No sound is emitted excepting at the beginning and end of the dot or dash. The buzzer, on the other hand, operates throughout the length of the dot or dash, and, for that reason, is in many cases, easier to read.

54. A learner should begin to read by sound by receiving letters and copying them. He should continue this exercise until each letter is instantly recognized. It is not well for a beginner to wait for whole words; each letter should be written down as soon as it is received, for if he waits for the whole word he is apt to become confused and fail to get the word, thus causing him to guess at it. He should learn to listen and write at the same time, and after he is proficient in receiving and writing letters he should practice on words and sentences. The speed of receiving and copying should be gradually increased until both can be done rapidly.

The beginner should thoroughly study the International Morse alphabet and memorize it perfectly before making an attempt to copy from a sounder or an automatic transmitting device. Many learners require a longer time than necessary to become fair operators on account of failure to understand and memorize the proper signal combinations representing the telegraph characters. In some cases, it may assist the beginner to copy every other word of the message from a fast sender. This will give very good practice, and the number of letters received may be increased until all are copied correctly.

55. An operator should learn to copy that which is sent him as far behind transmission as possible. Although this will be hard to do, especially at the beginning, because it divides the attention and requires the exercise of memory, it must be

accomplished before one can become a good receiver of rapid sending. The beginner will find it difficult at first to keep one or two words behind, but improvement will come by practice.

---

### AUTOMATIC SENDING AND RECEIVING APPARATUS

**56.** Several types of automatic sending and receiving devices are in successful operation. Some of these are built primarily for the instruction of the beginner, while others are designed for operation in the transmission and reception of commercial messages. A device which will record signals sent is of benefit to a beginner as he can check over the message to see that the elements of the characters were properly made. An automatic sending device is also an advantage, even though it is mechanically operated, as the signals it makes must be accurately spaced.

**57.** In one method by which commercial messages are sent automatically, a special typewriter which makes perforations in a paper tape is used. The arrangement of the perforations will represent the characters of the telegraph code. The perforated tape is fed at high speed through a circuit-closing device which sends out signals at a higher rate than could be accomplished by manual sending. A special receiving apparatus records the incoming high-speed signals on another paper tape by making corresponding perforations thereon. This tape may then be run through a signaling device which will produce audible signals at a convenient speed for the operator to receive and copy.

**58.** Many other methods of sending and recording signals automatically are in use. A description of the principles of operation of any special type of apparatus is usually furnished with that device. A careful study of the instructions will reveal the proper method of operation. The chief advantage of these devices is that they permit the transmission and reception of a larger number of messages during a given time, with a

limited amount of apparatus. The additional care required and practicability of such devices should always be investigated when considering the adoption of such complex apparatus.

---

### CODES OF ABBREVIATIONS

**59.** A telegraph code of abbreviations is a system of abbreviations, or a sort of shorthand applied to a means of communication. It usually consists of single letters and a combination of two or more letters, which arbitrarily represent figures, words, and phrases. Words and phrases in very common use are represented by single letters or short combinations of letters. In some cases, the communication companies, to save time, and for their own convenience transfer the message into code form. Because of the difficulty in memorizing a long list of abbreviations, the code message is usually recorded just as it is sent, no effort being made to copy the matter in full wording as it comes in. The message is later transcribed from the record and put out in regular message form.

These codes have come into very extensive use in wire telegraphy, especially in newspaper reporting. Such codes enable a person to send a rather long message in a few word groups, thereby reducing the cost considerably, as charges can be collected only on the amount of material sent. If desired, the message can be made relatively secret.

**60.** Several code systems have come into use, and by employing one of them it is possible to send a message very economically and with a fair degree of secrecy. One extensive and complete system arranged for the use of the public, is called the A B C code. By its use, a long message can be transmitted in a few words, and the cost of a message, which might otherwise be very expensive, can be made quite reasonable. It is published in book form, and both the sender and receiver must have a copy of the same code book, for the various communication companies will not form or translate the message. Each page in the book is divided into three columns. In the first column are figures from 1 to 99,999,

inclusive; in the second column are words or combinations of letters arranged alphabetically; and in the third column are placed the words, phrases, or sentences that the numbers or words in the first or second column represent. For example, suppose the body of a message to be cabled is as follows: *Tugs now assisting; we write you full particulars*, in which the important words are *tugs* and *write*. Looking these up in the code book, the lines containing them will be found to be:

14,643	<i>Turtle</i>	<i>Tug (s) now assisting</i>
15,419	<i>Worthily</i>	<i>I (we) write you full particulars</i>

The body of the message may then be written *Turtle Worthily*. The person receiving this message would then look up in his code book the meaning of the two words *turtle* and *worthily* and thus learn the meaning of the message. In this way, instead of eight words, only two have to be transmitted and paid for.

**61. Cipher A B C Code.**—Any one by using this code, can arrange a *secret and private cipher*. To do this, he should take ten letters, or, preferably, a ten-letter word in which the same letter does not occur more than once; such as the word *Cumberland*, and number each letter as follows:

<i>c</i>	<i>u</i>	<i>m</i>	<i>b</i>	<i>e</i>	<i>r</i>	<i>l</i>	<i>a</i>	<i>n</i>	<i>d</i>
1	2	3	4	5	6	7	8	9	0

In the first column of the code book, opposite the two phrases “*Tug (s) now assisting*” and “*I (we) write you full particulars*,” are the two numbers 14,643 and 15,419, respectively. In the word “*Cumberland*,” *c* represents the numeral 1, *u* the numeral 2, *m* the numeral 3, and so on. Thus, the number 14,643 is represented by the group of letters *cbrbm*, and the number 15,419 by *cebcn*. On the message blank, the sender using this cipher code would write, as the body of the message, the two following combinations of letters, for they are not apt to be words: *cbrbm* and *cebcn*.

These letters would be transmitted by the operator, in groups exactly as written, and the person to whom the message was addressed would first translate it into the two numbers 14,643 and 15,419 by means of the private code word "Cumberland" and the numerals corresponding to each letter in this word. Then, by looking up these numbers in the code book, the correct meaning would be obtained. Only the parties knowing what numeral corresponds to each letter in the code word can interpret the message.

**62.** If the code runs up to 99,999, that is, five figures, each combination of letters transmitted should contain five letters, and, therefore, if the number contains less than five figures, ciphers must be prefixed to make five figures. This is necessary, to avoid the risk of a wrong grouping of the letters by either the sending or receiving operator. For instance, suppose the word *best* were to be sent. In the code book would be found:

1,734	<i>Becalming</i>	<i>Best</i>
-------	------------------	-------------

Now, 1,734 has only four figures in it, but five must be used. This is accomplished by prefixing a cipher to the set, which would give 01,734, and the corresponding combination of letters to be sent would be *dclmb*.

**63. Toll Charges.**—The company operating any station usually has certain rules concerning the counting of characters and words in determining the charge for the service. The operator accepting the message must determine the number of words or groups of characters on which the charge is based. In many cases a fee is charged for part or all of the address and signature as well as for the main part of the message. It is especially important that each letter, figure, and punctuation mark be transmitted exactly as it is written by the sender.

**TABLE I—INTERNATIONAL RADIOTELEGRAPHIC LIST OF ABBREVIATIONS USED IN RADIO COMMUNICATION**

Abbreviation	Question	Answer or Notice
PRB	Do you wish to communicate by means of the International Signal Code?	I wish to communicate by means of the International Signal Code.
QRA	What ship or coast station is that? . . . . .	This is . . . . .
QRB	What is your distance? . . . . .	My distance is . . . . .
QRC	What is your true bearing? . . . . .	My true bearing is . . . . . degrees.
QRD	Where are you bound for? . . . . .	I am bound for . . . . .
QRF	Where are you bound from? . . . . .	I am bound from . . . . .
QRG	What line do you belong to? . . . . .	I belong to the . . . . . Line.
QRH	What is your wave length in meters? . . . . .	My wave length is . . . . . meters.
QRJ	How many words have you to send? . . . . .	I have . . . . . words to send.
QRK	How do you receive me? . . . . .	I am receiving well.
QRL	Are you receiving badly? Shall I send the signal ( — — — — — ) 20 times for adjustment? . . . . .	I am receiving badly. Please send the signal ( — — — — — ) 20 times for adjustment.
QRM	Are you being interfered with? . . . . .	I am being interfered with.
QRN	Are the atmospheric strong? . . . . .	Atmospherics are very strong.
QRO	Shall I increase power? . . . . .	Increase power.
QRP	Shall I decrease power? . . . . .	Decrease power.
QRO	Shall I send faster? . . . . .	Send faster.
QRS	Shall I send slower? . . . . .	Send slower.
QRT	Shall I stop sending? . . . . .	Stop sending.
QRU	Have you anything for me? . . . . .	I have nothing for you.
QRV	Are you ready? . . . . .	I am ready. All right now.
QRW	Are you busy? . . . . .	I am busy (or: I am busy with . . . . .) Please do not interfere.
QRX	Shall I stand by? . . . . .	Stand by. I will call you when required.
QRY	When will be my turn? . . . . .	Your turn will be No. . . . . .
QRZ	Are my signals weak? . . . . .	Your signals are weak.
QSA	Are my signals strong? . . . . .	Your signals are strong.
QSB	{ Is my tone bad? . . . . . { Is my spark bad? . . . . .	The tone is bad. The spark is bad.
QSC	Is my spacing bad? . . . . .	Your spacing is bad.
QSD	What is your time? . . . . .	My time is . . . . .
QSF	Is transmission to be in alternate order or in series? . . . . .	Transmission will be in alternate order.
QSG	. . . . .	Transmission will be in series of 5 messages.
QSH	. . . . .	Transmission will be in series of 10 messages.
QSI	What rate shall I collect for? . . . . .	Collect . . . . .
QSK	Is the last radiogram canceled? . . . . .	The last radiogram is canceled.
QSL	Did you get my receipt? . . . . .	Please acknowledge.
QSM	What is your true course? . . . . .	My true course is . . . . . degrees.
QSN	Are you in communication with land? . . . . .	I am not in communication with land.
QSO	Are you in communication with any ship or station (or: with . . . . .)? . . . . .	I am in communication with . . . . . (through . . . . .).
QSP	Shall I inform . . . . . that you are calling him? . . . . .	Inform . . . . . that I am calling him.
QSQ	Is . . . . . calling me? . . . . .	You are being called by . . . . .
QSR	Will you forward the radiogram? . . . . .	I will forward the radiogram.
QST	Have you received the general call? . . . . .	General call to all stations.
QSU	Please call me when you have finished (or: at . . . . . o'clock)? . . . . .	Will call when I have finished
*QSV	Is public correspondence being handled? . . . . .	Public correspondence is being handled. Please do not interfere.
QSW	Shall I increase my spark frequency? . . . . .	Increase your spark frequency.
QSX	Shall I decrease my spark frequency? . . . . .	Decrease your spark frequency.
QSY	Shall I send on a wave length of . . . . . meters? . . . . .	Let us change to the wave length of . . . . . meters.
QSZ	. . . . .	Send each word twice. I have difficulty in receiving you.
QTA	. . . . .	Repeat the last radiogram.
QTE	What is my true bearing? . . . . .	Your true bearing is . . . . . degrees from: . . . . .
QTF	What is my position? . . . . .	Your position is . . . . . latitude . . . . . longitude.

\*Public correspondence is any radio work, official or private, handled on commercial wave lengths.  
When an abbreviation is followed by a mark of interrogation, it refers to the question indicated for that abbreviation.



### UNITED STATES GOVERNMENT PUBLICATIONS

64. The United States Government has entered into an agreement with other large governments of the world in adopting a certain list of abbreviations to be used in International Radio Communication. This list is printed in Table I. Slight revisions and additions are made from time to time to meet the requirements arising from change of conditions.

The distinct advantage of such a list of abbreviations is that it permits the exchange of ideas and information among persons who speak different languages. The well-known radio signal, *SOS*, used as a ship distress call, is, perhaps, the best illustration of the convenience of such a code. These abbreviations are in common use at nearly all radio stations.

This list, as well as much other information pertaining to radio communication, is contained in the pamphlet *Radio Communication Laws of the United States*. The book may be obtained from the Department of Commerce at Washington, D. C., at a nominal cost, and is of real value to one interested in radio communication. The pamphlet also contains regulations governing radio operators and the use of radio apparatus on ships and on land, a knowledge of which is necessary for any one who wishes to obtain a government license. Other authoritative information relative to the radio art may be obtained from the Government Printing Office.

# RADIO-TELEGRAPH TRANSMITTERS

Serial 2489

Edition 1

---

## DAMPED-WAVE COMMERCIAL TRANSMITTERS

---

### ROTARY AND QUENCHED GAPS

---

#### ROTARY GAP

**1. Introduction.**—The early types of spark transmitting systems have been greatly improved and simplified with the result that now may be found only two general systems which are used to any great extent commercially for damped-wave, or spark, radio-telegraph communication purposes. These are commonly termed the *rotary-gap type*, and the *quenched-gap type*.

**2. Synchronous Gap.**—The disk discharger, or rotary gap, has many advantages over the early spark transmitters of the open-gap type; namely, it provides regular sparking without missing, thus giving a pure musical note; it eliminates danger of arcing if the voltage rises too high; it gives automatic prevention of the return of energy from the aerial circuit to the primary circuit, allowing closer coupling than with an ordinary spark set; this means more energy delivered to the aerial and a more efficient transmitter.

Rotary gaps of the size used with the average 2-kilowatt, or 2,000-watt, ship spark sets are enclosed in an iron casing *a*, Fig. 1, which acts as a silencer to the spark. This casing is

fitted with an inspection door and glass window and is provided with a fan arrangement that circulates the air inside the casing, driving off the nitrous gases through outlets in the casing fitted with sound-proof material. If the rotary gap is so arranged that two of the rotary studs on the disk *b* are opposite the two fixed studs *c* and *d* at the instant of maximum voltage across the condenser so that a maximum of oscillating energy may discharge across the gap, the gap is then termed the *synchronous rotary gap*. This implies that there is one spark for each half cycle of generator voltage, so that the sparking rate

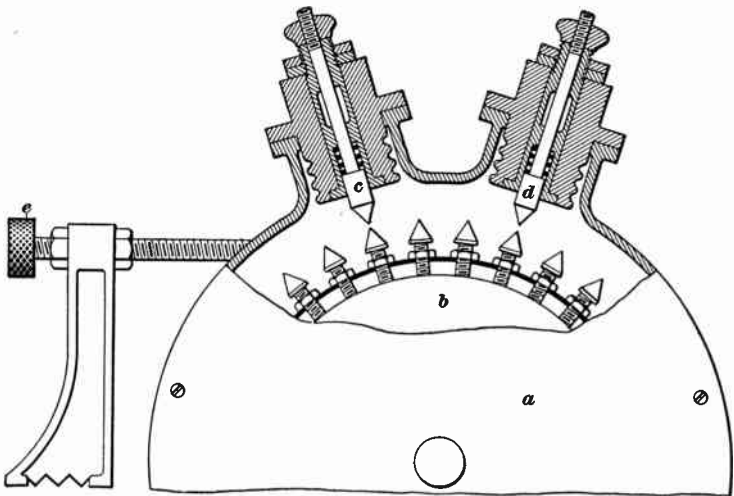

FIG. 1

equals twice the generator frequency. The rotary disk has as many studs as there are poles on the generator and is driven at the same speed as the generator.

The wedge-shaped studs on the disk *b* move past the stationary electrodes *c* and *d*. The clearance between the studs and the electrodes usually does not exceed .01 inch. Two of the studs on the disk *b* should be opposite the stationary electrodes when the voltage across the latter is maximum. If this condition does not obtain, the casing with the stationary electrodes may be shifted slightly by means of the adjusting screw *e*

until a position is found where the discharge takes place at the proper time.

**3. Non-Synchronous Gap.**—Now, if there are more studs on the rotary disk than poles on the generator, a discharge can be obtained before the half cycle is complete; the condenser will charge up again during the completion of the cycle and a second discharge may be obtained during the half cycle. This is the principle of the *non-synchronous* or *asynchronous rotary-gap* system. The condenser in this system never charges up to the maximum voltage and therefore the oscillating energy at each discharge will be less than with the synchronous method and the gap will have to be smaller. Although there is less energy at each discharge, there are more discharges per second and the ultimate oscillating energy per second may be the same with the added advantage of a higher spark note. The sparking note is given by the following expression:

$$\frac{\text{revolutions per minute of disk} \times \text{number of studs}}{60}$$

As there is not necessarily the same amount of energy in each discharge some of the movable studs may regularly get the heavier sparks and wear away faster than the others. This is obviated in practice by putting the fixed electrodes on the supporting ring at a different distance apart from that of the fixed electrodes arranged for synchronous sparking, thus insuring that every stud will get a heavy and a light discharge alternately and the wear on the studs will be equal.

---

#### QUENCHED GAP

**4.** With the quenched-spark system it was found possible to increase the transmitting range nearly three times over that previously possible with the older systems using the same amount of power input to the set. The spark thus produced has a musical pitch of about 500 cycles ordinarily and is very effective in being distinguished above the usual static noise and interference of other stations. The important feature in the quenched-spark system is in the spark gap, which is of

novel design. It is a well-known fact that in order to radiate the most energy from any spark set coupled to an antenna, it is essential that the primary circuit remain active long enough to build up the secondary oscillations to a maximum, and then if the gap can be made to lose its conductivity the energy in the secondary will not be lost in setting up oscillations again in the primary circuit, but will be sent into the antenna. This desirable property of promptly damping or quenching out the primary oscillations is possessed by both the rotary gap and the quenched gap.

One type of quenched gap is shown in Fig. 2. In view (a) is shown the complete device consisting of a number of outer

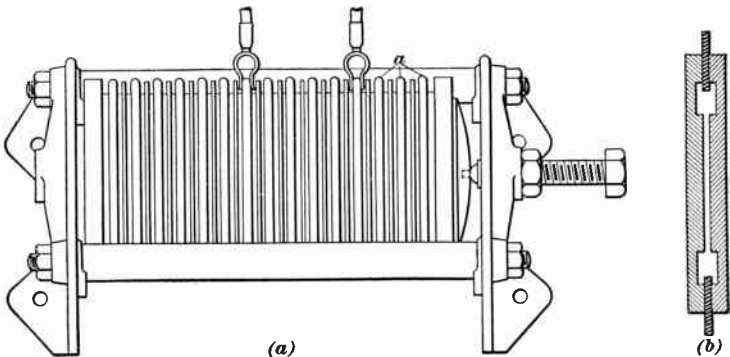

FIG. 2

cooling disks *a* of bronze that hold inner disks across which the sparks pass. Contact may be made by clips to the ridges on the periphery of the outer disks. A series of cooling disks are compressed between clamps so as to make the inner sparking spaces air-tight. In view (b) are shown the copper inner disks that are mounted within the cooling disks. Adjacent inner disks are separated by mica rings, and the sparking surfaces, which are covered by silver, are about .01 inch apart.

**5.** It is customary to allow about 1,200 volts to each gap and as many gaps are placed in series as are necessary for the operating voltage. In the standard sets the gap is composed of a number of copper disks clamped together in a special

framework. A metal spring piece is inserted between the contact ridges on the outer disks if the spark gap is to be cut out or short-circuited.

If a nearby station is to be called, the operator is required to lower the voltage of his generator, and to short-circuit a number of gaps, leaving only a few. In this way signals are reduced to such a point as to reach the nearby desired station without disturbing the other stations within the full-power range.

It is customary, in the larger sets, for the copper disks to be single faced, the raised portion being on only one side, while the other side of the disk is perfectly flat. The disk is then placed into the countersunk portion of a large bronze disk, which serves as a cooling surface. These extra cooling surfaces are very necessary, since the sparks can be quenched more efficiently when the gap is reasonably cool.

---

#### DAMPED-WAVE TRANSMITTERS FOR SHIP USE

**6. Circuits of Damped-Wave Transmitter.**—In general, the function of the ship transmitter is to convert an ordinary low-voltage 110-volt direct current into high-frequency oscillations to be radiated from the antenna at a correspondingly high voltage, such as 50,000 volts. The spark transmitter consists essentially of three circuits: 1, Low-frequency, or alternating-current, circuit; 2, closed, or high-frequency circuit; and 3, antenna, or radiating circuit.

The purpose of the low-frequency circuit is to convert the 110- or 120-volt direct current supplied by the ship's generator to the radio room into an alternating current of low frequency and low voltage, for use in the closed circuit. The direct current is made to rotate a motor, which is directly connected to the shaft of an alternating-current generator, which supplies, usually 500 cycles alternating current at 220 volts, for the low-frequency circuit. This is called the motor-generator unit. For the usual 2-kilowatt spark set, this consists of a 220-volt, 2-kilowatt, 500-cycle, single-phase generator, driven by a 120-volt, direct-current, 5-horsepower, four-pole motor at a speed

of about 1,600 revolutions per minute. It is generally a two-bearing machine of the oil-ring type. Terminal boxes are secured to the frame of the machine to provide connections to the machine. This alternating current is then supplied to the primary winding of a step-up transformer, having the proper turn ratio to deliver to the closed high-frequency circuit a 500-cycle current at 10,000 to 30,000 volts. The sending key is located in series with this low-frequency circuit, and is used to open or close the circuit, thus making the dots or dashes as sent out by the transmitter. In addition to the sending key, motor-generator, and transformers, the switchboard instruments are considered part of the low-frequency circuit equipment. These consist of an ammeter and voltmeter and a frequency

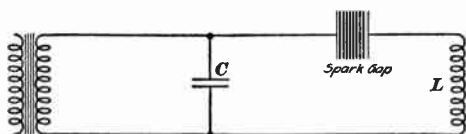

FIG. 3

meter. A switchboard is provided for mounting these instruments, also for mounting the circuit-breaker and instruments for the current from the ship's mains.

7. The function of the closed circuit, shown in Fig. 3, is to convert the 500-cycle, high-voltage, alternating-current supplied from the secondary of the step-up transformer into a high-frequency current of, say, 500,000 cycles (600 meters), at a still higher voltage. In its fundamental form the closed oscillating circuit consists of: Capacity  $C$ , represented by the condenser, Fig. 3; inductance  $L$ , represented by the inductance coil  $L$ , consisting of spirals of copper strip; and a spark gap either of the rotary or quenched type. These three devices are all in series as shown in Fig. 3.

The values of the capacity and of the inductance in electrical units determine the wave-length to which the closed circuit is adjusted. The larger the capacity and the inductance, the longer the wave-length, and vice versa. When the lowest wave-length to be used by any particular set is determined,

the capacity is fixed definitely and arrangements made to vary, conveniently, the number of turns of the inductance, thus permitting variation of the transmitting wave-length. Fixed mica condensers each having a capacity of about .002 microfarad and variable inductances are therefore used in the closed circuit. The condensers may be single, two or more in parallel, or two or more in series.

The function of the spark gap in the closed circuit is to allow the condenser to charge to the required potential, then to break down and permit the charge to surge back and forth until its energy is dissipated. The ideal spark gap would be one which would insulate perfectly while the condenser was charging and conduct perfectly on discharging. The quenched-type gap is the nearest practical solution of the problem that has been found.

**8.** The purpose of the radiating or antenna circuit is to provide the means for transferring the high-frequency oscillations from the closed circuit to the ether. This is accomplished by induction from the helix in the closed circuit to the helix or coupler in the antenna circuit. The separation between the two coils is adjustable in order to provide a loose or tight coupling, as desired. Loose inductive coupling is commonly used. The number of turns in each helix is variable in order to vary the wave-length of each circuit. The antenna circuit consists of the antenna, lightning switch, coupling helix, ground connection, hot-wire ammeter, and wave-change coils.

**9. Wave-Length Limitations and Ranges of Transmitters for Ship Use.**—All ship sets are required by law to be in adjustment for transmission and reception on 300 and 600 meters. Spark sets on shipboard are usually operative between 300 and 3,000 meters. The majority of merchant-marine ships, however, are only adjusted for 300, 600, and 800 meters. The 700-meter wave is coming into use as a working wave-length in place of the shorter ones, which are close to the wave-lengths used by the modern broadcasting stations. The 600-meter wave is authorized for calling purposes or for *S O S* distress calling. The 800-meter wave is used for compass-bearing work.



The sizes of spark transmitters on merchant ships vary from  $\frac{1}{2}$  to 2 kilowatts. Small cargo vessels are equipped with  $\frac{1}{2}$ -kilowatt sets; and ships above 6,000 tons with 2-kilowatt sets. The reliable ranges for this type of damped-wave equipment vary widely according to height of antenna, wave-length, weather conditions, season, and time of day. The following is an estimate of the average range of spark-type equipment for vessels:  $\frac{1}{2}$ -kilowatt set = 100 miles by day, 150 miles at night; 1-kilowatt set = 150 miles by day, 300 miles at night; 2-kilowatt set = 200 miles by day, and 400 miles at night; and 5-kilowatt set = 300 miles by day, 600 miles at night. On cold nights the above figures are often doubled.

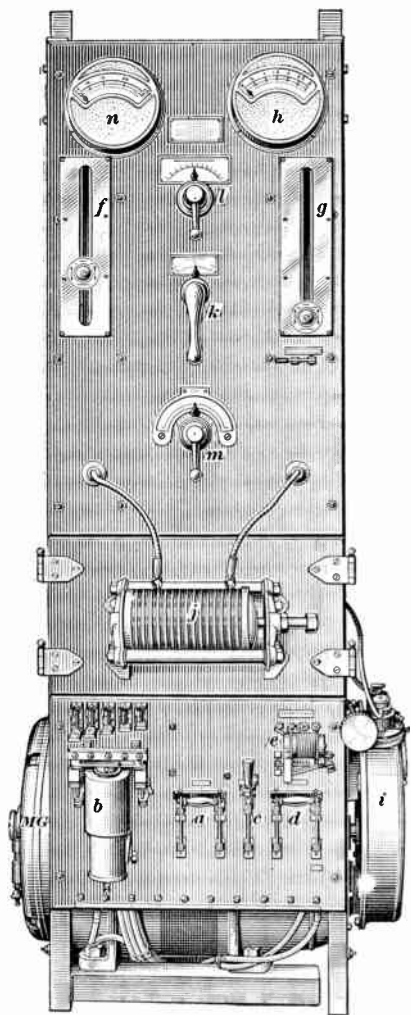

FIG. 4

Figs. 4 and 5, when closed, extends the direct-current circuit from the ship's mains to the automatic motor starter *b*. The switch *c* is in the field circuit of the generator, and the switch *d*

#### 10. Typical 2-Kilowatt Ship Spark Transmitter.

The 2-kilowatt spark-transmitter panel shown in Fig. 4 is fairly typical of the sets used on ships. The circuit arrangement is shown in Fig. 5, the reference letters having the same meaning in both figures. The switch *a*,

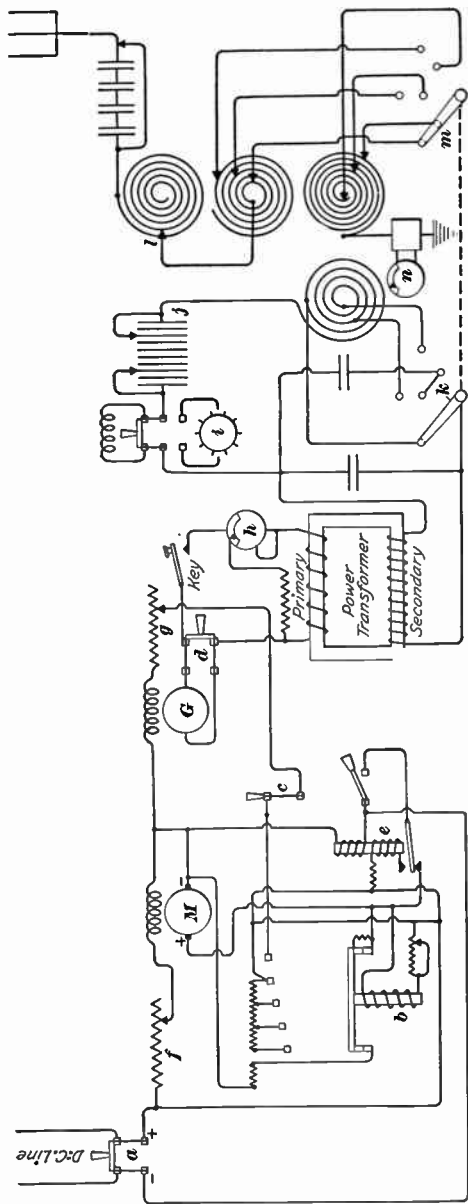

FIG. 5

in the output circuit of the 500-cycle generator. The overload relay is shown at *e*. The current in the field of the motor may be varied by means of the rheostat *f*; the result is a variation of speed with a resultant variation in the frequency of the current in the generator circuit. The generator voltage may be varied by means of the rheostat *g*. The power circuit also includes the wattmeter *h* and the transmitting key. The manner in which these devices operate has been explained in a preceding Section.

From the secondary of the power transformer, Fig. 5, the high-voltage low-frequency alternating current is changed into a high-frequency current in the closed oscillating circuit. Either the rotary gap *i*, Figs. 4 and 5, or the quenched gap *j* may be switched in the circuit. When the rotary

gap is used, the clips on the quenched gap are fastened to the same disk, thus short-circuiting the quenched gap. A small inductance coil is in series with the quenched gap when it is in use, to compensate for the inductance of the leads to the rotary-spark gap.

**11.** The transmitting set, Figs. 4 and 5, is so arranged that the wave-length may be instantly changed from 300 to 600 or 800 meters by means of the wave-change switch *k*. The switch *k* controls two other switches, which, when the switch *k* is moved, cut in the proper amount of inductance and capacity into the closed and open oscillating circuits. Fine adjustments of inductance in the antenna circuit may be made with the switch *l*. The coupling between the open and closed circuits may be varied by means of the lever *m*. The antenna circuit also includes an ammeter *n* for reading the current in the antenna circuit.

**12. Factors Limiting Future Use of Damped-Wave Transmitters.**—The general tendency of development is toward the use of continuous- or undamped-wave equipment, due to the fact that the interference is greatly reduced, by using undamped waves. More pairs of communication can be carried on at the same time on closely separated wave-lengths when undamped waves are used than when damped waves are used, owing to the sharper tuning of the undamped-wave transmitter. There are many other advantages of the undamped-wave type of transmitter which will be explained later. Many of the ships of the merchant marine are equipped with damped-wave transmitters; but the larger passenger ships and warships have both types.

## UNDAMPED-WAVE TRANSMITTERS

---

### ADVANTAGES OF UNDAMPED-WAVE TRANSMISSION

**13. Selectivity.**—Radio transmission becomes more efficient and more selective the less the antenna oscillations are damped. It has been shown that during the time that the key of an ordinary spark transmitter is closed there are comparatively long periods of inactivity, or time intervals between the trains of wave energy sent out into the ether, even when quenched or rotary spark gaps are employed. A system in which these intervals do not exist, and in which the energy is radiated all the time that the key is closed would obviously be more efficient, since it would radiate more energy in a given time, and, therefore, greater ranges would be possible for the same amount of primary power to the transmitter. It follows that an ideal system would be one in which the waves are not damped at all.

Some of the more important advantages of continuous-wave transmission (cw.), or of undamped-wave transmission, over damped-wave transmission are as follows: Transmission becomes more selective. This advantage is due primarily to the fact that energy radiated by a spark transmitter is sent out in damped wave-trains. When these wave-trains pass through the receiving antenna they induce a voltage. This voltage causes a current to pass in the primary circuit of the receiver. This current sets up a field which cuts the secondary winding of the receiving circuit inducing therein a voltage, which in turn causes current to pass in this circuit. If these circuits are tuned to the incoming wave, maximum current and signal strength is obtained. However, even if these circuits are somewhat detuned, the damped wave-train will excite them to a considerable extent, causing them to oscillate at their own frequency as well as at the frequency of the signal wave. Thus,

the selectivity of reception of a spark signal is fixed, not only by the decrement of the receiving circuit, but by the decrement of the wave-train itself, which, of course, is that of the transmitting station; therefore, more or less interference always exists between spark stations, if the wave-lengths are close to one another.

In the case of a transmitter that is sending out continuous waves, the effect at the receiving station will be somewhat different. When these waves pass through the receiving antenna they cause the circuit to oscillate at the signal frequency alone, because they have no decrement. Therefore, if the receiving circuit is not tuned to resonance with the incoming signal the current set up in the circuit will be very small and the signal strength extremely weak, and this will be true for all conditions of adjustment other than that for resonance. Thus, the selectivity is very good and the station will receive no messages except those for which it is tuned.

**14. Range and Efficiency.**—The energy radiated from a spark transmitter is spread out over a comparatively large wave-band; that radiated from a continuous-wave transmitter is concentrated into essentially one wave-length. Thus, it follows that the greater the amount of energy that can be concentrated into one wave-length, the greater will be the distance to which this energy will penetrate, and stations may be reached at much greater distances from the sending station than with the spark transmitter; hence the transmission efficiency is greatly improved.

**15. Heterodyne Reception.**—If the transmitted signal is by continuous wave, heterodyne reception is possible, thus permitting greater amplification than can be obtained in the reception of spark signals. Take for instance, the regenerative type of receiver. When a spark signal is being received, it is possible to carry the regeneration only to a certain limited point where the signal becomes mixed up and is not understandable. On the other hand, if the incoming signal is by continuous wave it is possible to carry the regeneration to a maximum.

When a continuous-wave transmitter is used, it is possible to send and receive on the same antenna at the same time if the proper circuit is inserted in the receiving circuit and if there is a slight difference between the transmitted and received wave-lengths. This would be absolutely impossible with the spark type of transmitter.

The tube transmitter may be adapted to continuous wave, interrupted continuous wave, and phone transmission, and the change may be effected by the operation of a gang switch in the transmitter assembly.

**16. Antenna Voltage Decreased.**—Since, with the continuous-wave transmitter, the energy is radiated in a continuous stream when a signal is being sent, and not in groups as with the spark transmitter, it follows that for a given amount of energy in the antenna, the amplitude of the oscillations need not be so great. In a damped wave-train the shape of the successive waves is such that the ratio of any maximum to the next one following is a constant. The rate of decrease of the amplitudes in a wave-train is also indicated by the *logarithmic decrement*, which is defined to be the natural logarithm of the ratio of two successive maxima in the same direction. As an example, consider the case of a spark transmitter operating on a wave-length of 300 meters with a decrement of .1, the spark gap breaking down 1,000 times per second. The number of complete oscillations in a circuit when the amplitude of the last oscillation has been reduced to 1 per cent. of the initial oscillation, is equal to the sum of the constant 4.605 plus the decrement divided by the decrement, or

$$\text{Number of oscillations per spark} = \frac{4.605 + .1}{.1} = 47.05$$

Therefore, for every spark there will be 47.05 oscillations and for 1,000 sparks there will be 47,050 oscillations. The frequency will be equal to the constant 300,000,000 divided by the wave-length, which in this case is 300.

$$\text{Frequency} = \frac{300,000,000}{300} = 1,000,000 \text{ cycles per second;}$$

thus, the frequency will be 1,000,000 cycles per second and the time per second during which energy is radiated is equal to the total number of oscillations divided by the frequency, or

$$\frac{1,000 \times \frac{4.6 + .1}{.1}}{1,000,000} = .047 \text{ second}$$

It is found that energy is radiated for only .047 second and this is 4.7 per cent. of the total time. Comparison of this with the case of the continuous-wave transmitter shows quite a difference, since with the latter the time per second during which energy is radiated is 100 per cent.

It follows, therefore, that if much power is to be radiated by the spark type of transmitter, comparatively high-oscillation amplitudes must be used, which means that relatively high voltages must be employed, since energy is radiated only during a small fraction of the time, whereas, with the continuous-wave transmitter, much lower voltages could be used, with subsequently lower oscillation amplitudes, to obtain the same power output. Thus, for a given power output, in using the spark transmitter, the antenna system would be under a much greater voltage strain than in the case of the tube transmitter giving the same output. Moreover, a given antenna system will have a greater possible energy radiation on continuous waves, thus decreasing the construction difficulties encountered in extremely high-voltage apparatus.

**17. Adjustment of Signal Note.**—With spark reception the signal note is determined by the transmitter-group frequency, while the note received from a continuous-wave transmitter may be varied between wide limits and the operator at the receiving station may adjust the latter to that pitch which is the easiest for him to copy and to distinguish from strays or static. This feature of being able to adjust the note also helps very much in the reading of any one signal through interference, since the desired signal may be tuned to a note that will be slightly different from that of any of the signals that are giving interference and this difference in pitch is usually

enough to enable the experienced operator to get the message that he is after through the signals that are causing him interference.

---

### MODERN COMMERCIAL SYSTEMS

**18.** Modern transmitting systems employing the undamped, or continuous, wave, are classified as follows: (a) High-frequency alternator; (b) Arc transmitter; (c) Vacuum tube. The fundamental principle of operation of each of these systems has been treated elsewhere. Many additions and refinements have been made in the commercial adoption of these systems. A brief description of each of these systems with their auxiliary apparatus will therefore be of interest.

---

### ALEXANDERSON HIGH-FREQUENCY ALTERNATOR

**19. Principle of Construction.**—In the diagram, Fig. 6, is shown the principle of construction of the 200-kilowatt Alexander-son high-frequency alternator as installed with its connection to the antenna system and to the magnetic amplifier. The general principle on which it operates is that of an inductor alternator with a large number of poles. The only moving part is the rotor disk shown in the center of the diagram. This consists of a solid steel disk with several hundred slots milled radially into its two faces adjacent to the outer edges. These slots are filled with strips of non-magnetic material to minimize air friction.

The rotor disk revolves between the two faces *a* and *b* of the field yoke. The field flux which is in a counter-clockwise direction passes between the field-yoke faces and through the rotor disk. The armature windings are placed in slots cut in the faces of the field and, in the diagram, are shown tipped away from the rotor. As will be noted, there is but one wire in each slot. Two of these slots, making a complete loop, comprise a pole in the armature winding and there is one slot in the rotor disk for each loop. The armature winding is divided into sections and the terminals of each section are carried out to the air-core



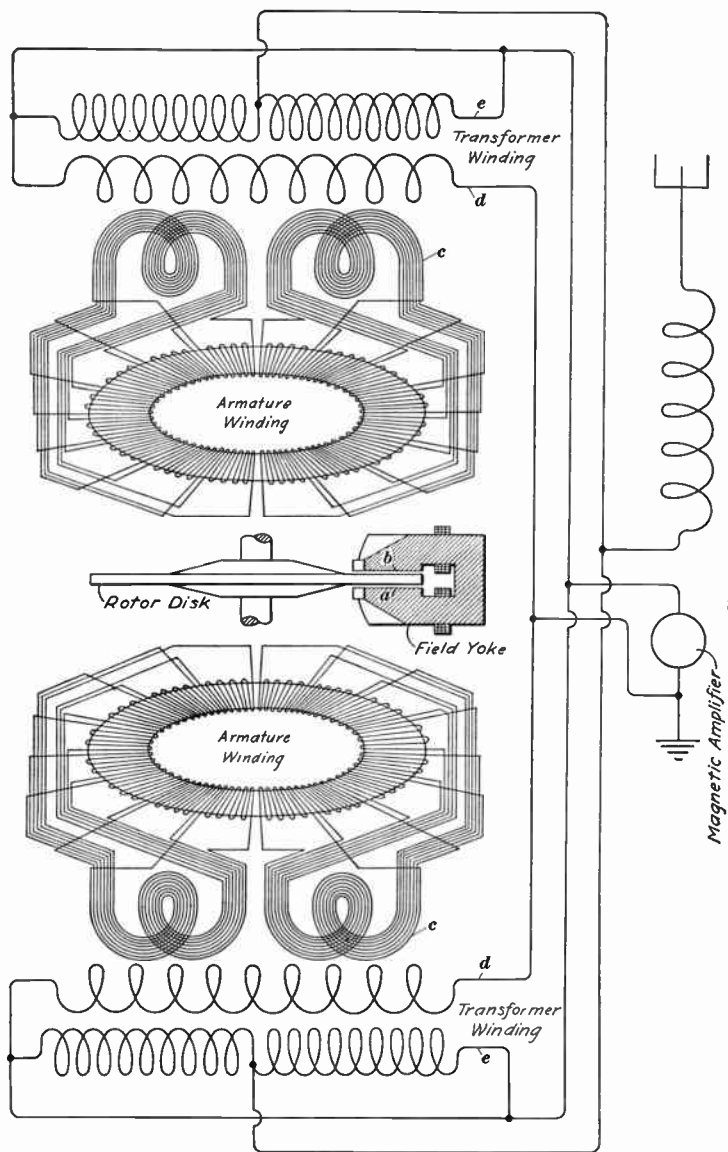

FIG. 6

transformer, which is considered a part of the alternator. There are thirty-two of these sections on each of the two field-yoke faces. Also, there are what are equivalent to four transformers, two on each side of the machine and the pairs placed end to end.

Each transformer consists of three sets of windings, wound on concentric paper-board drums. The primary windings  $c$  are wound on the inner drum and consist of three turns of sixteen wires in parallel. Each one of these wires is connected to an individual section of armature winding. In this way, no two armature sections are conductively connected but are all inductively coupled to each other and to the transformer secondary. By the use of this method the potential on the armature windings is kept at a very low value. Also, should a ground or an open circuit develop on the armature winding, the section affected can be disconnected and the alternator output only very slightly decreased. The direction of the current in adjacent transformer primaries is such that the magnetic fields are adding.

On the second drum is wound what is termed the magnetic amplifier winding and consists of six turns of eight wires in parallel on each transformer, the sections on adjacent transformers being connected in series as shown in the diagram at  $d$ . The secondary windings  $c$  consist of 75 turns on each transformer and are so wound that the high potential ends of adjacent transformers are at the center. The diagram shows the relative connection of these transformers, with the four sections of the magnetic-amplifier transformer windings connected in multiple-series in series with the secondary windings all in parallel. The low-potential sides of the magnetic-amplifier windings are connected to the ground and the high-potential side of the secondary windings to the antenna loading inductance. This combination gives an open-circuit voltage of from 2,000 to 2,500 volts, depending on the alternator speed. As shown, the magnetic amplifier is shunted across the magnetic-amplifier winding only, thus affecting the remainder of the transformer by induction only.

**20. Magnetic Amplifier.**—A schematic diagram of the Alexanderson alternator connected to an antenna system is

shown in Fig. 7. The armature coils of the alternator *a* are each connected to separate windings in the primary *b* of the oscillation transformer. The secondary winding *c* is connected directly in the antenna circuit.

The antenna *d* is of the multiple-tuned type, where a number of down leads are employed, each connected to an independent outdoor tuning coil *e* and common ground system. The antenna efficiency is thereby greatly increased and a greater antenna current is obtained with the same power input than would be otherwise possible. The alternator equipment is fully protected

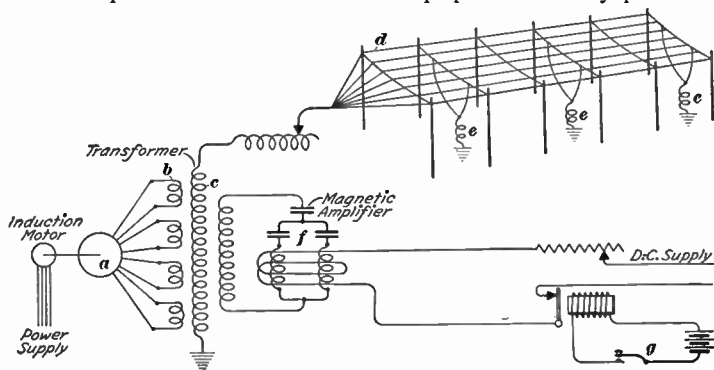

FIG. 7

and has automatic alarms that shut down the machine in case of failure of proper supply of oil and water to the various cooling systems.

Keying is effected through a magnetic amplifier. The magnetic amplifier is a device that is physically of the nature of an oil-cooled transformer. The iron core, which is made of thin laminations, is designed in such a way that the magnetic permeability of the iron core can be varied by magnetic saturation. By a special combination of tuned circuits as shown, it has become possible to separate the controlling current from the radio-frequency current so that a comparatively weak current of a few amperes controls many hundreds of amperes in the antenna. The effect of the amplifier is that of a variable impedance shunt across the alternator, the impedance depending on the degree of saturation of the iron core linked

by its windings. The degree of saturation in turn is dependent on the amount of current in the control windings. When the impedance of the amplifier is low, it acts as a short circuit on the alternator, reducing its effective voltage to a very low value and also reducing its inductance and thus detuning the antenna. The combined result is such that in normal operation the current in the antenna with the sending key up is less than 10 per cent. of that when it is down. A telegraph key *g*, controlling through a relay the direct-current supply to this magnetic amplifier, therefore causes the high-frequency current in the antenna to be switched on and off correspondingly, and telegraphic signaling is secured.

21. A more detailed drawing of the magnetic amplifier is shown in Fig. 8. It consists essentially of two windings *a* and *b*,

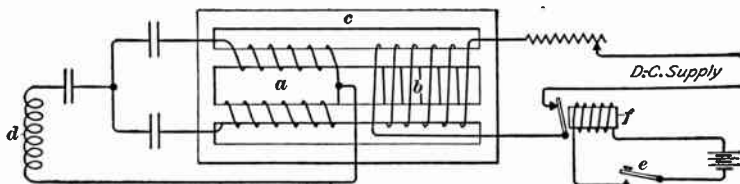

FIG. 8

wound on a specially formed magnetic core *c*. The winding *a* is made up of two separate coils connected in parallel and across the coil *d*. The coil *d* is coupled to the antenna circuit. The winding *b* is wound on both legs of the magnetic core in such a manner that the flux produced by the winding *a* strikes the coil *b* in opposite directions and no voltages can be induced in it by the current circulating in the coils *a*. The radio-frequency currents that may circulate in the coils *a* cannot therefore, have any effect on the coil *b*.

With the transmitting key *e* open, the circuit of the winding *b* is closed, through the back stop of the relay *f*. When in this condition, the core *c* of the magnetic amplifier is saturated, and hence an increase of current in the winding *a* will not increase the number of lines of force, except for the number of lines of force that would be set up even if no iron core were present. The inductance of the circuit including the coils *a* and *d* is

thereby reduced, which also affects the antenna coil and reduces its inductance. This further detunes the antenna circuit, so that it is out of resonance with the alternator; and the energy now set up in the antenna is just 9 per cent. of that when resonance obtains.

When the key *e* is closed, the relay *f* becomes energized and draws its armature away from the back contact. This results in the opening of the circuit through the winding *b*; the core *c* is then no longer saturated. The inductance of the path through the coils *a* and *d* is increased, which in turn affects the antenna coil to which coil *d* is coupled. The circuits are so arranged that with the key *e* closed the core *c* is not saturated, resonance obtains between the generator and the antenna circuits, and maximum energy is sent out into the ether.

---

## COMMERCIAL ARC TRANSMITTERS

---

### USE OF ARC TRANSMITTERS

**22.** Arc transmitters are used for both low-power and high-power radio-telegraph communication. From 50 per cent. to 100 per cent. greater ranges are obtained with the arc transmitters than with the spark-type transmitters. For wavelengths below 1,000 meters, the arc sets are very unstable and inefficient and for this reason the commercial application of the arc is limited to the longer wavelengths.

The wavelengths for high-power transmitting stations vary between 5,000 and 25,000 meters. Reliable communication throughout the year is now possible across the Atlantic Ocean, over distances of 3,000 to 4,000 miles, by use of high-power arc and alternator equipment. A great advantage has been obtained by the use of undamped waves for transmission over long distances, where the daylight absorption is great and a long wave is found more desirable. Daylight absorption is less on the long wavelength than on the shorter waves below about 3,000 meters.

## FEDERAL 2-KILOWATT ARC TRANSMITTER

**23. Circuit Diagram and Operation of Set.**—Radio transmitters are designed and constructed with a view to their ultimate power output. In the case of arc sets, the power output is usually reflected in the construction of the arc cham-

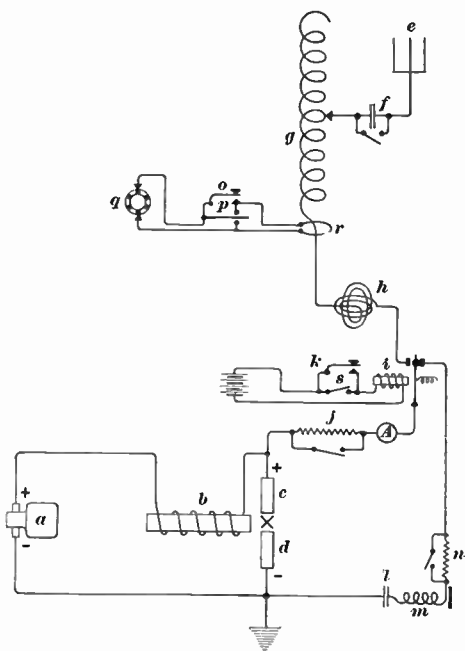

FIG. 9

ber and its auxiliary apparatus. The same principle of operation, however, holds true for both the low-power and the high-power arc transmitters. To explain the construction and operation of a commercial arc transmitter, the Federal 2-kilowatt set will be used.

The operation of an arc transmitter is dependent on the formation of an arc between two electrodes. In the transmitter represented in Fig. 9, the energy required by the arc is supplied by the direct-current generator *a*. The current passes from the positive terminal of the generator, through the electromagnet *b*,

copper electrode  $c$ , carbon electrode  $d$ , to the negative terminal of the generator. The antenna or radiating circuit includes the antenna  $e$ , series condenser  $f$ , loading inductor  $g$ , variometer  $h$ , front contact and armature of the key relay  $i$ , ammeter, resistance  $j$ , electrodes  $c$  and  $d$ , and ground. When the transmitting key  $k$  is closed, the relay  $i$  draws up its armature and completes the antenna circuit. Undamped oscillations are set up in the antenna circuit and continue as long as the transmitting key  $k$  is closed.

When the key  $k$  is opened the generation of oscillations is not stopped, but rather shifted to the back-shunt, or dummy-antenna, circuit. This circuit resembles the antenna circuit in that it possesses capacity represented by the condenser  $l$ , inductance represented by the coil  $m$ , and resistance represented by the resistor  $n$ . By operating the key  $k$  the generation of oscillations is shifted alternately from the antenna to the dummy-antenna circuit as required for transmitting a message. The arc is therefore active throughout the entire time that the set is in operation.

**24.** The method of signaling with the key  $k$ , Fig. 9, just described, is known as the back-shunt method. The energy in the antenna circuit may also be modified by means of the auxiliary key  $o$ . This key is provided with a single-pole double-throw switch  $p$ , which, when in contact with its upper stop, short-circuits the chopper  $q$ ; when the switch  $p$  is in its intermediate position in contact with neither stop, the key  $o$ , the chopper  $q$ , and the single turn  $r$  coupled to coil  $g$  are all connected in series.

To transmit signals with the key  $o$ , the antenna circuit must be closed through the front contact of the relay  $i$ . This may be done either by closing the short-circuiting switch  $s$  of the key  $k$  and holding the armature of relay  $i$  magnetically against its front stop, or by placing an insulating wedge between the armature and its back stop and thus mechanically holding it in contact with the front stop.

In order to transmit undamped or continuous waves (cw.) the switch  $p$  is brought in contact with the lower stop. This short-circuits the chopper  $q$  and places the loop  $r$  in series with

the key  $o$  only. If under this condition the key  $o$  is closed, the inductance of coil  $g$  will be changed and the transmitted wave will be on a different wavelength. The antenna inductor  $g$  must then be so arranged that it transmits on the proper wavelength when the key  $o$  is closed.

**25.** For interrupted continuous-wave (icw.) transmission, the switch  $p$  is in its intermediate position. The inductance of the antenna coil  $g$  is then modified not only by the operation of the key  $o$ , but also by the chopper  $q$ . Each dot and dash will be sent out as a series of audio-frequency pulsations. The chopper  $q$  may also be used in connection with the key  $k$ . The switch  $p$  is brought in contact with its upper stop so as to short-circuit the key  $o$ . The dots and dashes formed by the key  $k$  will then be modulated or broken up by the action of the chopper  $q$ .

The resistances  $j$  and  $n$  are provided with short-circuiting switches, which are closed when greater power is required. The antenna condenser  $f$  is also provided with a short-circuiting switch, which is closed when transmission takes place on the longer wavelengths. Wavelength adjustments are made on the antenna coil  $g$ , while the final or vernier adjustment is made with the variometer  $h$ . The ammeter in the antenna circuit shows the value of current in that circuit. Other current and voltage measuring instruments are provided, but these are not shown in the illustration.

---

## FUNDAMENTAL VACUUM-TUBE CIRCUITS

---

### MEISSNER CIRCUIT

**26.** The Meissner circuit, which is named after Dr. A. Meissner of the Telefunken Company of Berlin, is shown in Fig. 10. The direct-current plate supply passes through the inductance  $a$ . The frequency of the oscillations generated by the tube is determined by the constants of the plate circuit; namely, the inductance of coil  $a$  and the capacity of condenser  $b$ .

The grid condenser and grid biasing resistance are shown at  $c$  and  $d$ , respectively. The former is of sufficiently high capac-



ity to offer a low resistance to the passage of the radio-frequency currents that are generated by the tube and is therefore a by-pass for these currents. It also blocks off all direct current in the grid circuit at such a point that it is necessary for this direct current to pass through the biasing resistance, or grid lead  $d$ . There is a direct current in the grid circuit due to the passage of electrons from the filament to the grid just as there is direct

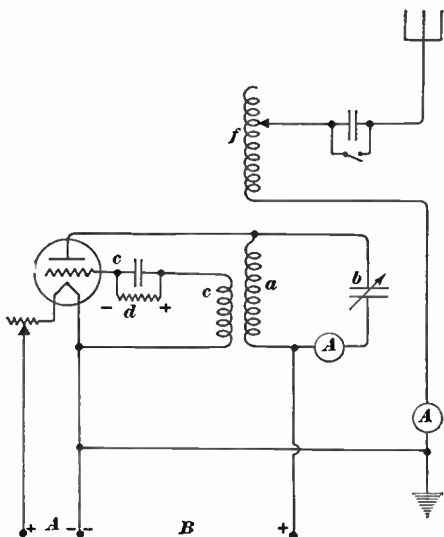

FIG. 10

current in the plate circuit due to the flow of electrons from the filament to the plate. Of course, the grid current is much smaller than the plate current. This grid current passes through the resistance  $d$  toward the grid. There is a drop in voltage across this resistance and the end near the grid is negative and the other end positive. Since the positive end of the biasing resistance is connected to the negative filament lead, the grid has a negative bias, the amount of which depends on the value of the biasing resistance and the grid current passing in the circuit. When a 250-watt tube, type UV-204 is used, the grid resistance might be 10,000 ohms and the grid current about 30 milliamperes; thus, there would be a drop of 300 volts across

the biasing resistance and the grid would be thrown 300 volts negative.

**27.** The grid coil  $e$ , Fig. 10, is inductively coupled to the plate coil  $a$  and it is by this means that energy is fed back to the grid for its excitation. Care must be taken to have the proper phase relation in obtaining this feed-back for the grid excitation or the feed-back action may tend to block oscillations rather than maintain them. If either the grid coil or the plate coil is reversed from the position it should be in, the alternating-current feed-back to the grid will be in direct opposition, or 180 degrees out of phase with the pulsations in the plate circuit, and there will be a bucking action rather than a boosting action; thus, oscillations will not be maintained. The grid circuit as shown is simply an untuned pick-up circuit but may be tuned to the frequency of the plate circuit by shunting a capacity of the proper value across the grid coil  $e$ . The antenna coil  $f$  is inductively coupled to the plate circuit and is tuned to the frequency of that circuit. This circuit is very flexible, and by means of the coupling between the plate circuit and the antenna circuit the transfer of power from any tube to the antenna circuit can be taken care of. The adjustment of the feed-back is also conveniently made and does not depend on the voltage drop across a reactance in the load circuit as in the case of the Hartley and Colpitts circuits, which are described later.

---

#### TICKLER-COIL CIRCUITS

**28. Inductive Plate Coupling.**—The tickler-coil circuit with inductive plate coupling is shown in Fig. 11. The antenna circuit consists of the antenna  $a$ , the series condenser  $b$ , the inductance  $c$ , the ammeter  $d$ , and the ground. The plate is connected to the positive side of the high-voltage plate supply through the inductance  $e$ . The grid radio-frequency circuit is coupled to the antenna circuit through the condenser  $f$ . The grid-leak circuit is composed of the radio-frequency choke coil  $g$  and the grid biasing resistance  $h$ . The choke coil  $g$  keeps the radio-frequency currents out of the grid-leak circuit. Without this

choke coil there is a loss of 20 watts in a 5,000-ohm grid leak when a 250-watt tube is used, which is 8 per cent. of the normal power. This loss is due to the passage of radio-frequency currents through this biasing resistance. When the choke coil  $g$  is used, the loss is decreased to .5 watt, which is .2 per cent. of 250 volts. The amount of grid excitation is determined by the capacity of the condenser  $f$  and the point at which the grid is tapped on the coil  $c$ . The coupling between plate and grid due

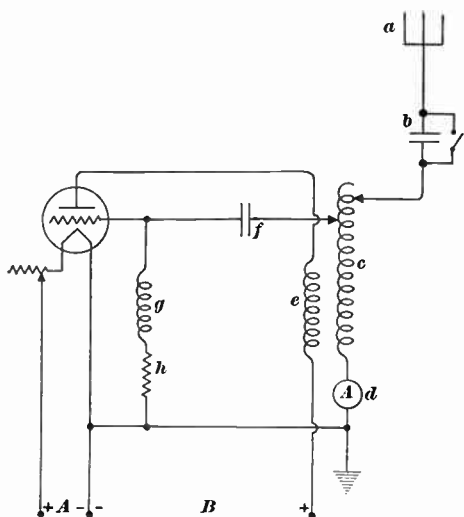

FIG. 11

to the coil  $c$ , maintains the oscillatory condition. The constants of the antenna circuit determine the frequency of the oscillations generated by the tube.

**29. Inductive Grid Coupling.**—The tickler-coil circuit with inductive grid coupling is shown in Fig. 12. The antenna circuit shown here is the same as in the previous case and determines the frequency of the oscillations. The plate potential is supplied through the radio-frequency choke coil  $a$ . The purpose of this coil is to isolate the radio-frequency current in the plate circuit from the high-potential current of the plate supply. The plate is connected to the antenna coil  $b$  through the blocking

condenser *c*. The purpose of this condenser is to keep the inductance coil *b* from short-circuiting the direct-current plate source. The grid biasing resistance and grid condenser are shown at *d* and *e* respectively, and function as previously described. The grid excitation is derived by means of the grid

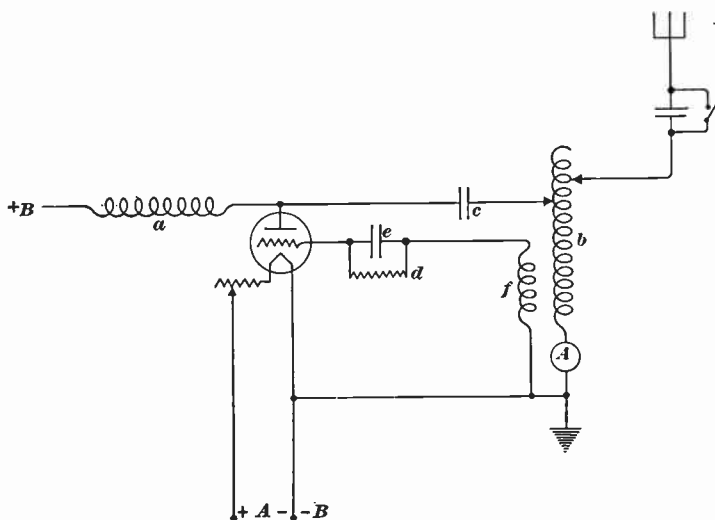

FIG. 12

coupling coil *f*. The grid circuit, as shown in the figure, is an untuned pick-up circuit but may be tuned to the frequency of the antenna by shunting a capacity across the coil *f*. The last two circuits described are not so flexible as the Meissner circuit.

#### REVERSED FEED-BACK CIRCUIT

**30.** The tuned-plate or reversed feed-back circuit is shown fundamentally in Fig. 13. In this circuit the oscillatory condition, which is due to the feed-back from the plate circuit to the grid circuit, is obtained by means of the small-capacity coupling between the plate and the grid within the tube *a* itself. This small capacity is formed by the grid and plate electrodes. It is important to note that the plate and grid coils *b* and *c* are not inductively related but may be widely separated from each

other. The only coupling between the plate and grid is the capacity coupling within the tube. The feed-back effect increases as the wavelength is shortened, and also depends on the value of the grid-plate capacity; so the action may often be improved and controlled by connecting a variable condenser of small capacity (.0001 microfarad) between the plate and the grid. Thus, the principle of this circuit is different from any yet described. Oscillations occur when the plate circuit is in tune with the grid circuit and the frequency of these oscillations depends mainly on the constants of the grid circuit, but the constants of the plate circuit do have some effect on the generated oscillations. This is an important point, because, by con-

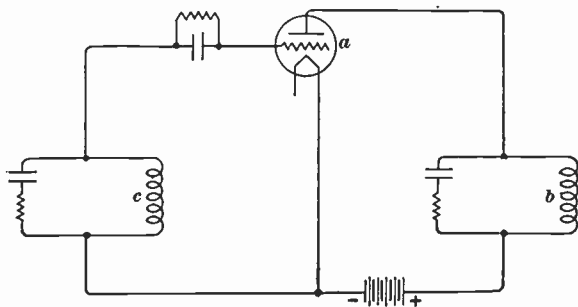

FIG. 13

necting the antenna to the plate circuit as shown in Fig. 13, the change in the antenna capacity due to swinging of the aerial will have a smaller effect on the frequency of the generated oscillations than in those circuits where the antenna circuit has a greater influence on the circuit whose constants determine the frequency of the oscillations generated. Thus, the constant-frequency advantage of the master-oscillator system is embodied to some extent in this circuit.

**31.** In Fig. 14 is shown the method of connections for transferring energy, generated by a tube in a circuit of the reversed feed-back type, to an antenna. The tuned plate circuit shown in Fig. 13 is replaced in Fig. 14 by its equivalent, an antenna circuit of inductance  $a$ , series capacity  $b$ , and resistance. This circuit is tuned to the frequency of the grid circuit.

The radio-frequency choke coil  $c$  functions as usual to prevent the shorter-circuiting of the output circuit by the plate source, and the blocking condenser  $d$  functions, conversely, to prevent the short-circuiting of the plate source by the output circuit.

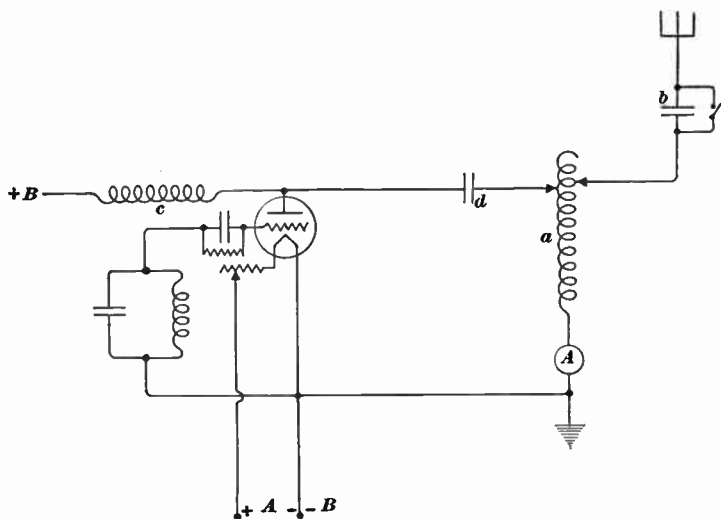

FIG. 14

and the blocking condenser  $d$  functions, conversely, to prevent the short-circuiting of the plate source by the output circuit.

### COLPITTS CIRCUIT

**32.** The Colpitts circuit, which is named after its inventor, is shown fundamentally in Fig. 15. The frequency of the

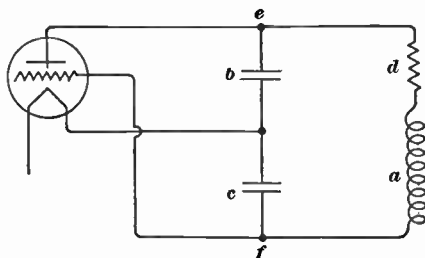

FIG. 15

generated oscillations depends on the inductance  $a$  and the two capacities  $b$  and  $c$  in series. These elements together with the

resistance  $d$  constitute the load circuit. The grid excitation is determined by the voltage drop across the condenser  $c$ , and therefore the smaller the condenser, the greater the voltage drop and the greater the grid excitation. The grid excitation varies with the power capacity of different tubes. If a 1-kilowatt tube were used in this circuit the values of inductance and capacity should be so chosen that, with 1 kilowatt dissipated in the circuit, the total reactive voltage (that between the points  $e$  and  $f$ ) would be 7,500 volts. The proper grid excitation for this tube is 1,000 volts, so the proper values for the condensers  $b$  and  $c$  are deter-

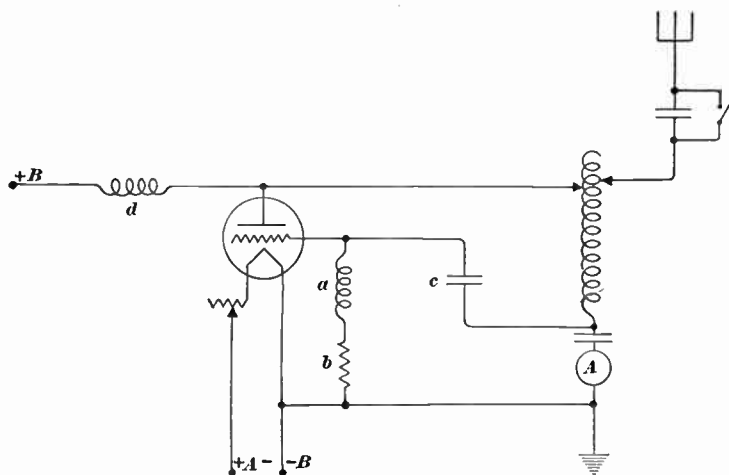

FIG. 16

mined by the relation  $c \div b$  equals  $6,500 \div 1,000$ ; then  $c$  equals  $6.5 b$ . Thus when the grid condenser  $c$  is 6.5 times as large as the plate condenser  $b$ , the voltage drop across the grid condenser  $c$  is  $1 \div 6.5$  of the voltage drop across the plate condenser  $b$ , giving 1,000 volts across the grid condenser and 6,500 volts across the plate condenser and 7,500 volts across the two.

**33.** In Fig. 16 is shown the application of the Colpitts circuit to an antenna, with the addition of grid choke  $a$ , grid leak  $b$ , grid blocking condenser  $c$ , and plate choke  $d$ , which function as previously described. This circuit is the same as the fundamental circuit shown in Fig. 15 with the exception that the plate capacity  $b$ , Fig. 15, has been replaced by the antenna, Fig. 16,

which functions as a capacity. No plate blocking condenser is shown in this circuit, since, owing to the load-circuit arrangement, there is no possibility that the plate supply will be short-circuited by the output circuit.

#### HARTLEY CIRCUIT

**34. General Description.**—The Hartley circuit, which is named after its inventor, is shown in Fig. 17. The frequency of the oscillations generated depends on the constants of the load circuit. The grid excitation is obtained by means of the voltage drop between the points *a* and *b*. As is the case in the Colpitts circuit, the grid excitation depends on the voltage drop

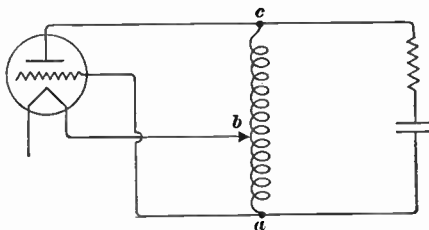

FIG. 17

across a reactance in the load circuit, but in this case the reactive drop is across a coil, whereas in the Colpitts circuit the reactive drop is across a condenser. The greater the number of turns between the points *a* and *b* the greater the grid excitation. As in the previous case, if a 1-kilowatt tube, type UX-206, were used in this circuit, the total drop from the point *a* to the point *c* should be 7,500 volts and the drop from *a* to *b* 1,000 volts, thus leaving 6,500 volts from *b* to *c*.

**35. Simplified Hartley Oscillator.**—Before discussing the more complicated circuits used in modern high-power tube transmitters, it is necessary to have a clear understanding of how and why a vacuum tube can be made self-oscillating.

A schematic diagram of a standard Hartley oscillator is shown, in simplified form, in Fig. 18. When the circuit is not oscillating, but the circuits are closed, a steady current



will flow through the inductance  $L_p$  from plate to filament. The magnitude of this current  $I_p$  will depend on the grid voltage. When the flow of electrons from the filament to the plate is cut off by a highly negative grid potential, the plate current becomes zero, but it cannot be made to reverse. Current can also flow from the grid to the filament in the tube, returning from the filament to the grid in the external coil  $L_g$ . This latter current is only appreciable when the grid is positive with reference to the filament, and its magnitude depends on the grid potential.

When the tube is oscillating, these currents will not be steady, but pulsating. They are pulsating and not alternating on account of the unidirectional conductivity between the filament-plate and the filament-grid paths in the tube.

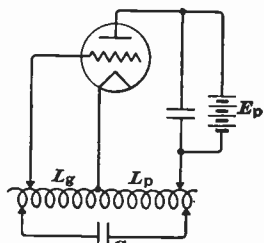

FIG. 18

The circuit  $C-L_g-L_p$  is resonant to these pulsating currents, and an oscillatory current is generated which circulates around this branched circuit, flowing through the capacity  $C$  and the inductances  $L_g$  and  $L_p$ . This current will be called the *circulating tank* current and may be many times greater in amplitude than either the pulsating grid or pulsating plate current.

The pulsations in the steady current, which flows during the stable condition from the filament to the plate, are caused by periodic variations in the potential of the grid with respect to the filament, and these variations in grid potentials are induced in the grid coil  $L_g$  by the circulating tank current. There is a similar potential induced by the current across the plate coil  $L_p$ .

**36.** It is true of this circuit, Fig. 18, and typical of any oscillating tube circuit, that, during the portion of the cycle of the output current when the grid is positive due to the potential difference across the grid coil  $L_g$ , the voltage drop between the plate and the filament is such as to oppose the d.-c. plate-supply voltage and hence to reduce the potential between the filament and the plate inside the tube. During the other half of the cycle, when the grid is negative to the filament, the potential

acting between the plate and the filament is increased above that of the stable potential of the plate-supply voltage. Further, as the grid becomes positive there is a resultant increase in the flow between the filament and the plate of the tube, even though the plate potential on the tube is being reduced. This increase in plate current is limited, when the tube has reached the stable oscillation condition by the saturation effect, which, owing to the loss of electrons captured by the grid, may occur at lower values of plate current than that corresponding to the total filament emission.

The plate-current wave form is distorted at the extreme part of the cycle; that is, when the grid is negative as a result of rectification effects. Moreover, the grid current is always pulsating, and is zero for a considerable part of the cycle, when the grid is negative. Consequently, the wave forms of the current supplied to the circuit between the filament and plate and the filament and grid are each composed of three constituents; namely, (1) a direct or average component; (2) a fundamental corresponding in frequency to that of the output circuit; and (3) a number of higher frequency or harmonic components.

**37.** The useful oscillating output current depends neither on the direct nor average values of the plate and grid currents, nor on the harmonic frequency components; but is determined solely by fundamental constituents of these currents, to which the same considerations regarding phase relations apply as were stated with regard to distorted current waves.

Thus, to speak only in terms of useful current constituents, a sine-wave alternating current flows in the grid circuit in phase with the alternating electromotive force across the inductance  $L_g$ , Fig. 18, and therefore represents a withdrawal of power from the output circuit, which power is expended within the tube. On the other hand, a sine-wave alternating constituent of the plate current flows in opposition to the electromotive force across the inductance  $L_p$ ; this means that power is being supplied to the output circuit from the plate circuit of the tube. As is apparent, the impedance of the output circuit to all frequencies that are harmonic multiples of the fundamental

is very high. Hence no appreciable multiple frequencies are constituents of the current circulating in the output circuit, and the alternating electromotive forces across the inductances  $L_p$  and  $L_g$  are in all cases practically of sine-wave form. Consequently, the useful power supplied by the tube can be determined in terms of the alternating electromotive force across the coil  $L_p$  and the fundamental constituent of the plate current; and if the grid current be neglected, this would be the power available for dissipation in the resistances in the circuit. As the output current increases, the amplitudes of the alternating electromotive forces across the plate and grid inductances increase proportionally. The alternating grid current increases more and more rapidly as the amplitude of the plate electromotive force becomes larger. On this account, the power loss to the grid increases.

The power supplied by the plate increases with increasing plate potential; but, as the grid potential increases, the effective saturation current is reached when the grid is positive, and the plate current becomes zero for an appreciable part of the cycle, when the grid is negative. Consequently, a continued increase in the amplitude of the output current results chiefly in an increase in the harmonic constituents of the plate current without greatly increasing the fundamental. Obviously, then, a condition of stability ensues when the power supplied by the fundamental of the plate current minus the power dissipated by the fundamentals of grid current is just equal to the power dissipated by the output current in the resistance of the plate and grid circuits.

---

## VACUUM-TUBE TRANSMITTERS

---

### TUBE-ATTACHMENT SET

**38.** The first step in the change-over from spark to tube transmitters for ship use is found in the application of the tube-attachment set. This transmitter is shown schematically in Fig. 19 and is designed to be operated from the same source of power as the 2-kilowatt type of quenched-spark transmitter.

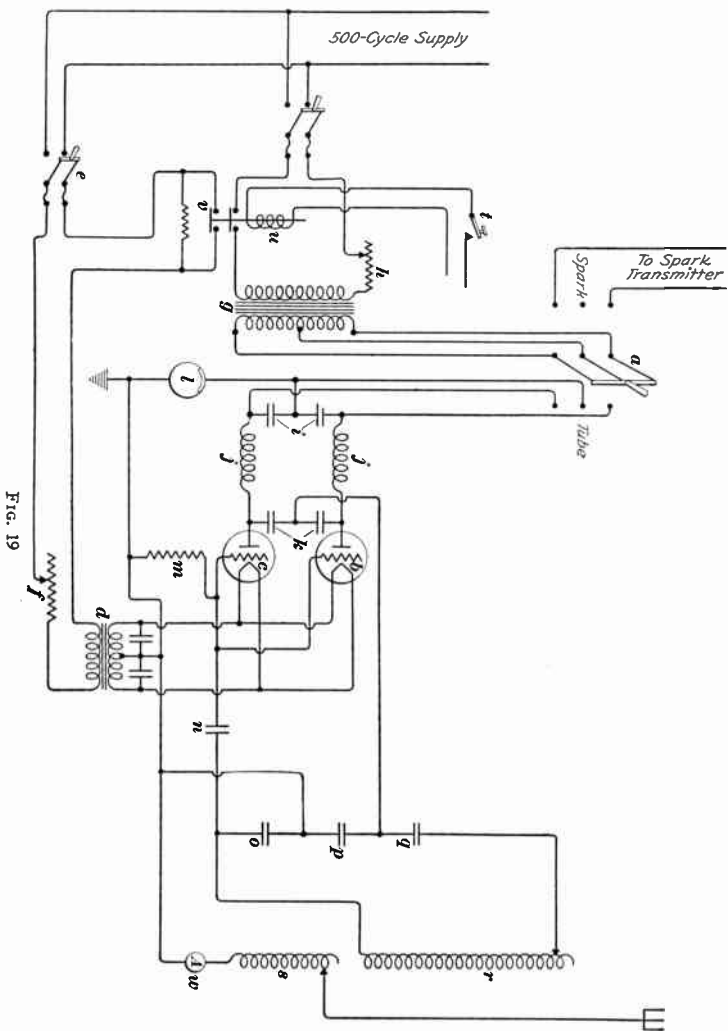

which employs the same motor-generator set. It is so arranged that by means of a change-over switch *a* the operator may throw on either the spark set or the tube set. This is a means of gradually educating the operator to the use of the tube set and generally results in the use of the tube set the majority of the time as soon as the operator becomes familiar with its operation.

The tubes *b* and *c* used in this circuit are of the 250-watt type. The filaments of these tubes are heated from the alternating-current supply by means of the step-down filament transformer *d*, which supplies 3.75 amperes to each filament at 11 volts. When the filament switch *e* is closed, the amount of current supplied to the tubes is regulated by means of the filament rheostat *f* in the primary side of the circuit. It is advantageous to have the control rheostat in the primary side, as in this case its current-carrying capacity may be much smaller than if it were placed in the secondary side, as the current in the secondary is approximately ten times as great as in the primary. The same high-voltage transformer *g* that is used in connection with the 2-kilowatt spark set is also used with the tube set. This transformer gives 12,500 volts on the secondary side when 110 volts is applied to the primary through a switch connecting to the 110-volt 500-cycle supply circuit. A resistance *h* is inserted in series with the primary winding so that the secondary voltage may be controlled. The plate of each tube is connected to an end of the transformer. The normal direct-current plate voltage of these tubes is rated at 2,000 volts, but this value may be increased 100 per cent. for alternating current without damaging the tube. This would mean, since the mid-point of the secondary winding is at ground potential, that if 4,000 volts were supplied to each plate, there would be 8,000 volts across the secondary. Owing to the drop in the secondary voltage with normal load on it, it is only necessary to insert a small amount of resistance by means of the plate rheostat to get the desired voltage on the plate.

The two .004-microfarad condensers *i* connected in series directly across the secondary of the plate transformer are for the purpose of raising the natural frequency of the circuit from one side of the secondary through the 30-millihenry choke coil *j*

and from plate to filament of one tube back to the mid-point of the secondary, so that it will not be in resonance with the applied frequency. Without these condensers there would be a case of audio-frequency resonance and the voltages in this circuit would reach abnormal values with subsequent breaking down of the circuit, probably in the bushings where the secondary leads come out of the transformer. The 30-millihenry coils are for the purpose of keeping any radio-frequency current from getting back into the part of the circuit ahead of these chokes. The two .004-microfarad condensers  $k$  connected directly across the two plates serve to isolate the oscillating circuit from the high-voltage source, and to enable the plates to be connected (from a radio-frequency viewpoint) in parallel, without short-circuiting the source. The milliammeter  $l$  in the plate-return circuit shows the amount of plate current taken by the two tubes and should be around 125 milliamperes.

39. The grid-leak resistance  $m$ , Fig. 19, is connected from the two grids, in parallel, to the ground and should be about 10,000 ohms. The grid lead is connected to the oscillating circuit as shown, and the .004-microfarad condenser  $n$  in series with this lead serves to block any direct current from passing in this circuit and, therefore, causes the direct current to pass through the grid-leak resistance to the ground, thus putting the necessary operating bias on the grids of the tubes. The grid excitation voltage is that across the grid condenser  $o$ , which has a capacity of .078 microfarad. The plate condenser  $p$  has a capacity of .008 microfarad. The .02-microfarad condenser  $q$  is for the purpose of giving an autotransformer effect and thus stepping up the voltage across the inductance in the oscillating circuit to get the necessary amount of current in this circuit. The energy from the closed oscillating circuit, or tank circuit, is passed into the antenna circuit by means of the inductive coupling between the tank inductance  $r$  and the antenna inductance  $s$ . The antenna current obtainable when this circuit is properly adjusted is in the neighborhood of 10 amperes when the antenna resistance is 4 ohms and the antenna capacity is .002 microfarad.

The telegraph key  $t$  is in the primary side of the plate transformer. When the key is pressed it operates a relay  $u$ , whose contacts make and break the circuit through the primary winding of the plate transformer  $g$ . There is also an auxiliary set of contacts on this relay which are isolated from those just mentioned, and when these contacts are closed they short out the compensating resistance  $v$  in the filament circuit. If this means of compensation or some other means were not employed and the filaments were adjusted to proper brilliancy with the key open, owing to the drop in primary voltage when the key was pressed the filaments would correspondingly drop below normal and would not be operating at the proper point. Therefore, the filaments are adjusted with the key down and the compensating resistance cut out, and then the key is opened and the resistance adjusted to that value which allows normal current to pass through the filaments of the tubes. Thus there is no change in the filament current, whether the key is closed or open. An ammeter  $w$  in the antenna circuit provides a means for determining the value of the current in the antenna circuit.

This type of circuit is very good for ship use, as it allows very little reaction on the tank, or closed oscillating, circuit owing to changes in the antenna circuit. For instance, as the ship antenna swings from the motion of the ship and the wind, there will be a change in the antenna capacity, which, if allowed to react on the oscillating circuit, would cause the frequency to change, thus giving a note of varying frequency, which might vary so much as to be unreadable at the receiving station. It might go completely out and then come in again. This circuit also eliminates harmonics to a great extent.

---

#### MODEL ET-3628 ACW TUBE TRANSMITTER

**40. Description.**—Model ET-3628 ACW tube transmitter consists of a modified 2-kilowatt, P-4 or P-8 spark transmitter, like that shown in Fig. 4, converted for tube operation, using two 250-watt 204- $\Lambda$  radiotrons in a self-rectifying Colpitts circuit. The schematic circuit diagram is the same as that used for the tube-attachment set, the only difference being that





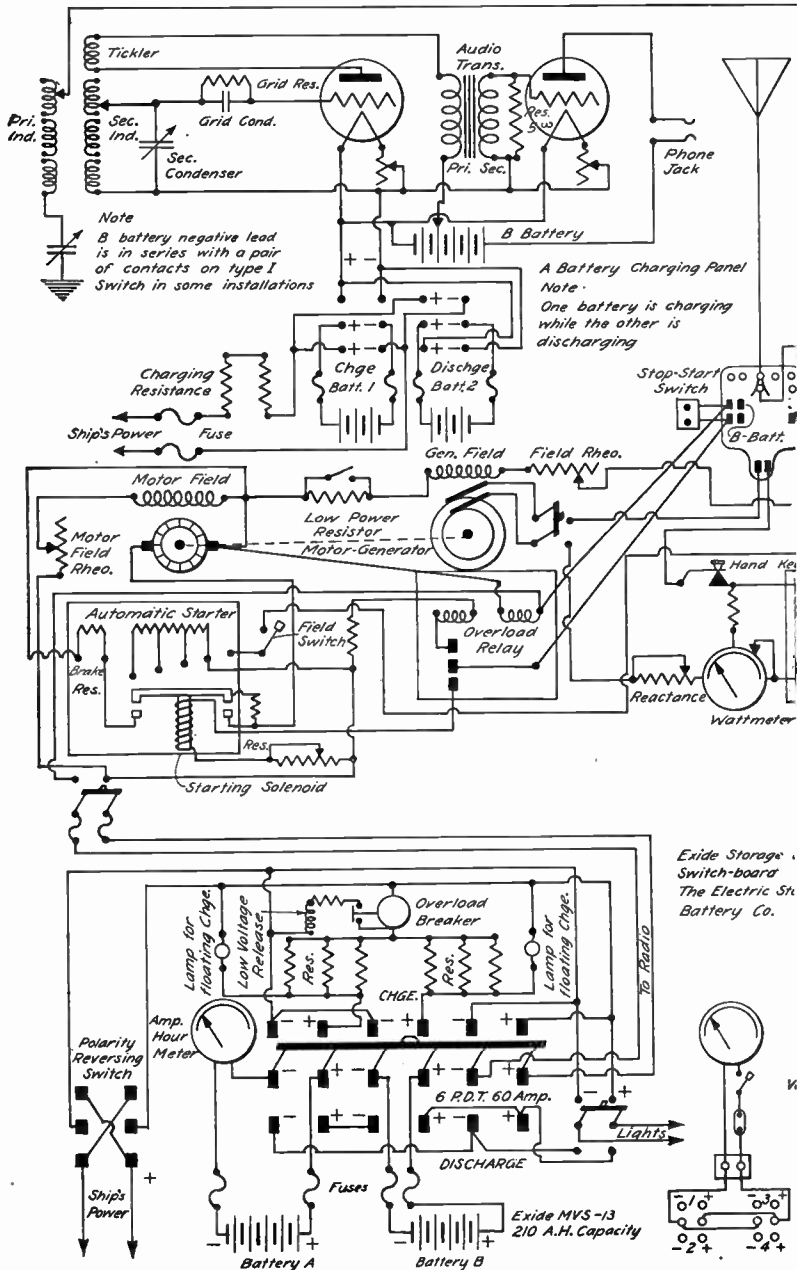

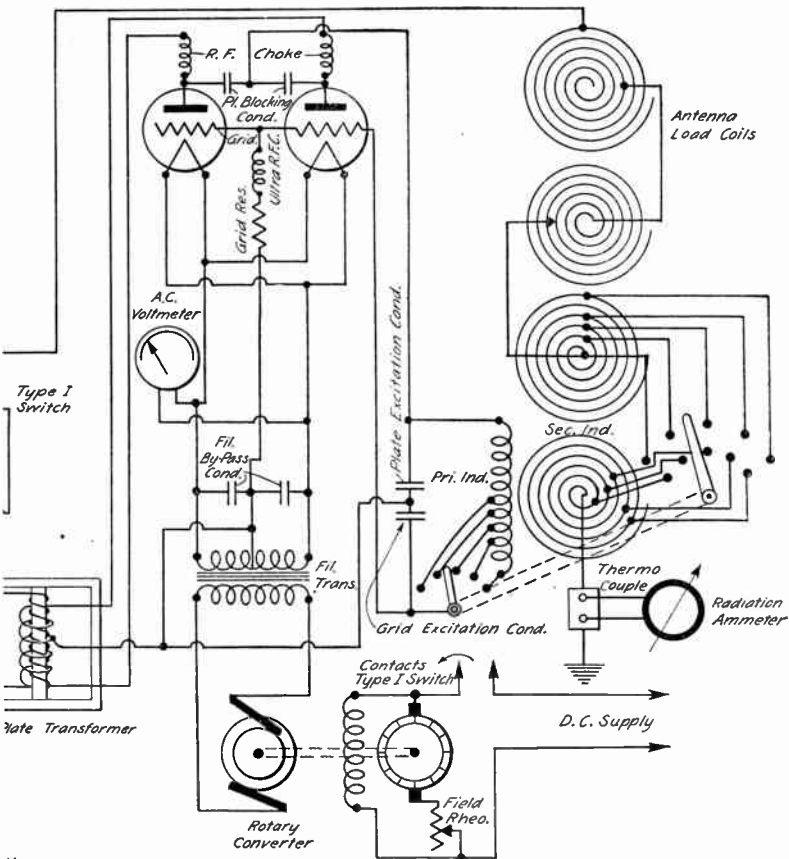

meter Connections  
 int 1 Battery Disc.  
 int 2 Bus  
 int 3 Battery A  
 int 4 Battery B



all the associated tube apparatus is located within the reconditioned P-4 or P-8 spark-set unit, rather than in a separate unit as in the tube-attachment set.

**41. Battery-Charging Panel.**—The circuit diagram of a complete installation is shown in Fig. 20. In the lower left-hand corner is shown the battery charging panel through which passes all the electric energy required for the operation of the transmitter. The six-pole double-throw switch (6 P.D.T. 60 Amp.) connects the batteries *A* and *B* to the charging source when thrown upwards (to the left in actual installation), and connects the batteries to the radio set when closed downwards (to the right in installations). The charging current is obtained from the ship's power supply. As it is possible that the voltage-supply circuit may become reversed, a polarity reversing switch is included in the supply circuit to permit of changing the polarity when necessary.

The charging circuit is provided with an overload breaker and a low-voltage release for opening the circuit when the charging current becomes either too high or too low. An ampere-hour meter is provided for determining the state of charge of the battery. When the battery is on charge, the hand of the meter moves toward zero. When the charge is completed, the hand reaches zero and opens the charging circuit. When the battery is on discharge, the hand of the ampere-hour meter moves away from zero, and when the indication corresponds to the rating of the battery, it should be connected again to the charging circuit.

The battery may be placed on a floating charge by opening the overload breaker and closing the six-pole double-throw switch in its charging position. The charging current will then flow through the lamps and not through the charging resistance. This is the normal condition of operation, with the radio set connected directly to the bus bars.

**42. Motor-Generator Circuits.**—The motor-generator circuit, Fig. 20, consists essentially of a direct-current motor and an alternating-current generator. The motor is operated by current received from the battery panel. The operation of

the starter, switches, etc., is exactly like that explained in connection with Fig. 5.

**43. Type I Switch.**—The type I aerial change-over switch performs numerous circuit changes. When switched to the transmitting position it closes the field circuit of the generator, the primary circuit of the plate transformer, and the supply circuit to the rotary converter; it connects the antenna to the transmitting set and opens the negative lead of the B battery in the receiving set.

When this switch is in the receiving position it connects the antenna to the receiver, closes the B-battery circuit in the receiving set, and opens the transmitter-supply circuits.

**44. High-Frequency Circuits.**—The high-frequency apparatus consists of the following: Two plate radio-frequency choke coils, two plate blocking condensers, plate excitation condenser, grid excitation condenser, tank, or primary, oscillations inductance, coupling, or secondary inductance, three fixed antenna-loading inductances, spirals, variable antenna inductance, grid leak, grid-leak choke coil, two filament bypass condensers, and two UV-204-A radiotrons.

The complete diagram shown in Fig. 20 should be known and drawn by applicants taking the Government Examination for Commercial First or Second Class Operators' License.

**45. Receiving Circuit.**—The receiving set consists of a regenerative detector circuit with one stage of audio-frequency amplification. The filament current for the receiving tubes is supplied by one of two storage batteries, the remaining battery being on charge. The charging current is obtained from the ship's supply and is applied to the battery through a suitable charging resistance.

---

#### MASTER-OSCILLATOR CIRCUIT

**46.** All of the foregoing types of oscillatory circuits have been of the self-excited type; that is, they were of the type that supplied their own grid excitation. The master-oscillator system is a separately excited type of circuit. From an elec-

trical viewpoint this type of circuit is superior to any of the self-excited type. It is far more flexible than the self-excited type and is also less susceptible to frequency changes. This latter feature is of special importance. The fundamental circuit shown in Fig. 21 is composed of two tubes. One is the master-oscillator tube *a* and the other the power-amplifier tube *b*. The constants of the master-oscillator circuit determine the frequency of the energy to be radiated from the antenna. The master-oscillator tube *a* simply has to be of sufficient size to supply the losses in its own oscillatory circuit and the losses in the grid circuit of the power amplifier tube *b*. The losses in the grid circuit of the power-tube *b* would probably be between 2 per cent. and 10 per cent. of the total capacity of the tube, hardly ever over 10 per cent. The oscillatory circuit for the master-oscillator tube *a* is of the Colpitts type, which has already been described. The grid circuit of the power-amplifier tube *b*, instead of being coupled to its own output circuit, as in the case of the self-excited types, is inductively coupled to the master-oscillator oscillatory-circuit inductance *c* through the grid coil *d*. The grid of the power amplifier tube *b* is supplied with the proper amount of grid excitation by varying the coupling between the coils *c* and *d*. The grid-blocking condenser *e*, grid choke *f*, and biasing resistance *g*, function as previously described. The plate circuit of the power-amplifier tube is tuned by means of the inductance *h* and the condenser *i* to the frequency of the oscillations generated by the master-oscillator circuit. The antenna circuit is inductively coupled to the plate circuit of the power-amplifier tube *b* by means of the coupling coil *j*.

**47.** The adjustment of this system is simple. The master-oscillator circuit is first set at the frequency desired. The power-amplifier plate circuit is then tuned to resonance with the frequency of the master-oscillator circuit. The grid excitation of the power-amplifier tube *b*, Fig. 21, is adjusted for maximum efficiency. The antenna circuit is then tuned to the same frequency and its coupling to the power-amplifier circuit is varied until maximum efficiency is obtained.

On ships at sea during heavy storms the ship rolls and the antenna swings from side to side and is constantly changing in capacity. If a type of circuit were used in which the antenna circuit was directly associated with that part of the circuit whose constants determined the frequency of the radiated energy, the frequency would change owing to the change in antenna capacity, and the frequency of the radiated signals would vary in synchronism with the swinging of the antenna. This condition is unfavorable because signals of this type are difficult to understand at the receiving station. They would

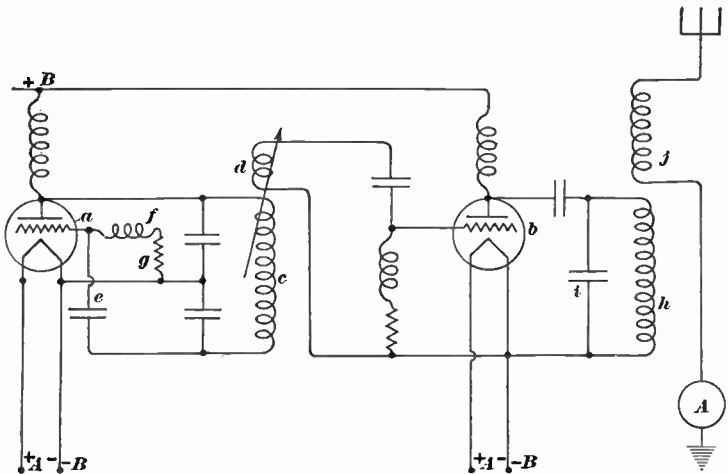

FIG. 21

be strong one minute and the next minute would be weak because of the change in wave-length and it would be impossible to vary the tuning of the receiver in synchronism with the variations in the frequency of the incoming signals. This condition is not only true of ship antennas but might also be true of shore-station antennas that are subjected to a strong wind. The master-oscillator system eliminates this condition. The frequency is fixed by the constants of the master-oscillator circuit, and there is no reaction from the antenna. Therefore, the only thing that changes as the antenna capacity changes is the efficiency. As the antenna swings out of tune the current in that circuit will decrease.

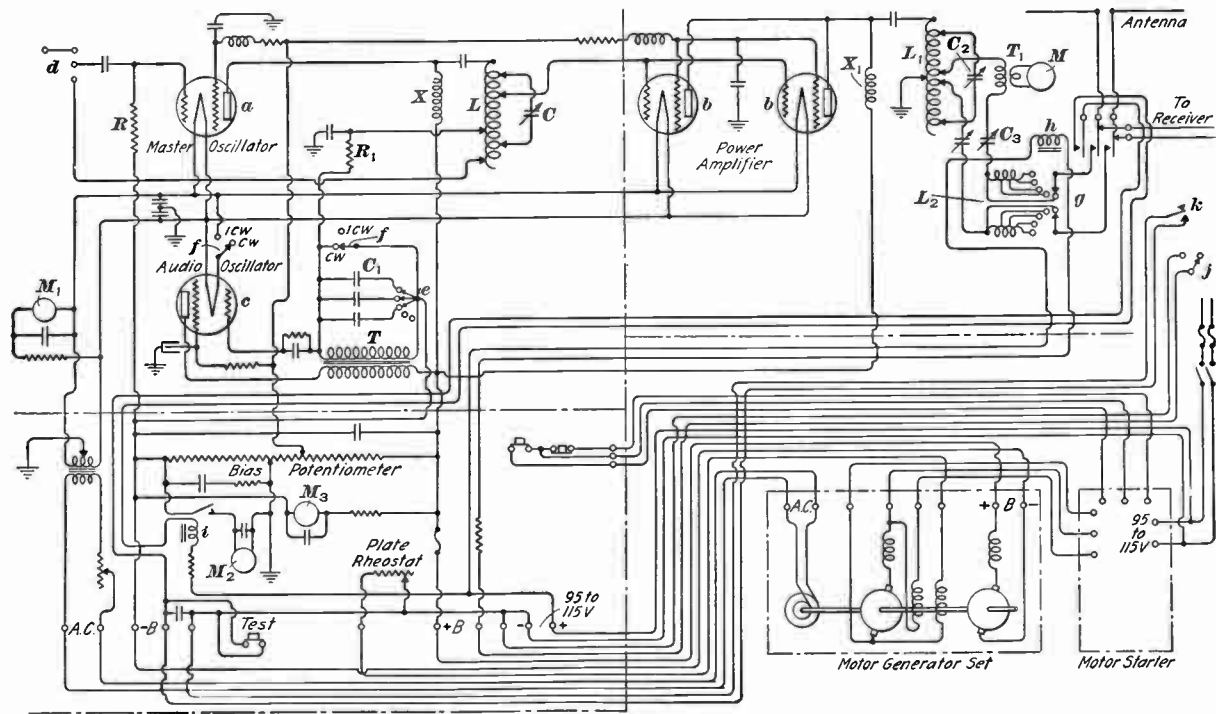

FIG. 23



## 200-WATT MODEL ET-3655 SHORT-WAVE TRANSMITTER

**48. General Features.** — The 200-watt Model ET-3655 short-wave transmitter, the circuit diagram of which is shown in Fig. 22, is intended primarily for marine service, and consequently special attention has been paid to the design in order to provide maximum frequency stability under widely varying conditions. The circuit used is of the master-oscillator power-signaling type with the power amplifier feeding into a Hertzian antenna. Icw. signaling is obtained by an audio-frequency vacuum-tube generator, which modulates the carrier-frequency of the transmitter.

The tubes required are: One UX-860, master oscillator *a*; two UX-860, power amplifiers *b*; one UX-860, audio oscillator *c*.

The transmitter operates on four wave bands, covering the entire range from 26 to 150 meters. These bands are as follows: 26 to 36 meters; 36 to 50 meters; 50 to 90 meters; and 90 to 150 meters.

The apparatus can be divided roughly into three parts as follows: (*a*) The radio unit; (*b*) the motor-generator set; (*c*) the antenna system.

**49. Radio Unit.**—The radio unit of the short-wave transmitter, shown in Fig. 22, contains everything necessary for taking power from the high-voltage direct-current generator and delivering 200 watts of radio-frequency energy to the radio antenna. The equipment necessary to do this is housed in a unit 45 inches high, 21 inches wide, and 22 inches deep.

The frame is made of  $\frac{3}{16}$ -inch brass angles with corners reinforced with gusset plates and brazed. The unit is divided vertically from front to rear by a brass panel extending from top to bottom. It is also divided by horizontal brass partitions into five compartments. These partitions add greatly to the frequency stability of the unit besides shielding the various circuits from each other and from outside inductive effects. The sides are solid and of non-magnetic material. A spring supporting structure, upon which the base rests, pro-

vides resiliency to shock and vibration and permits rigid mounting of the tubes in the frame proper. It also does away with any spring or cushion mounting for the tubes. The connections between the electrical components are rigid, thus eliminating the possibility of frequency shift due to flexible leads. The front of the unit is a solid brass sheet, except the doors, which give access to the tubes. These are perforated to permit observation of all tubes during operation of the set. The front panel is finished in black lacquer and has the appearance of leather. All meters and tuning and power controls are mounted on this panel.

**50. Motor-Generator Set.**—The motor generator, Fig. 22, furnished with the short-wave transmitter, is a direct-current power set made up of a 2-horsepower 110-volt direct-current motor, driving a 1-kilowatt 2,000-volt direct-current generator operated at 1,750 revolutions per minute. The motor is supplied with slip rings from which 200-watt alternating-current power is obtained for the tube filaments.

**51. Radio-Frequency Oscillating Circuit.**—The master-oscillator circuit is the conventional Hartley with parallel feed. It consists essentially of the tube *a*, Fig. 22, and the tuned circuit *LC*. The oscillator tube *a* is a four-element tube, known as type UX-860, and has a rated plate voltage of 2,000. Since the plate-to-grid capacity is almost negligible, frequency instability due to variation in tube capacity has been practically eliminated.

The plate voltage is applied through the plate choke *X*. The oscillator generates its own bias by passing the rectified current to ground through the resistor *R*. The screen-grid is by-passed to ground through a condenser, and any radio-frequency coupling due to the common screen-grid leads is prevented by the combination of choke and resistance in the screen-grid lead. The filament of this tube as well as those of the other tubes is also by-passed to ground by means of condensers. The tuning condenser *C* is operated by a control knob mounted on the front of the panel and geared to the condenser by means of a 5 to 1 gear ratio.

A three-binding-post terminal board  $d$  is provided so that the master oscillator can be conveniently converted to a radio-frequency amplifier or frequency multiplier, should it be desirable to incorporate crystal control. Crystal control can be supplied with this equipment. This will necessitate an extra unit consisting of a crystal-control master oscillator and a radio-frequency amplifier.

**52. Audio-Frequency Oscillator.** — The audio-frequency oscillator, Fig. 22, is composed of the transformer  $T$  and the condenser  $C_1$  working in conjunction with the tube  $c$ . The grid is coupled through a grid condenser, and its bias is self-generated across the grid leak. The screen-grid is by-passed to ground through a condenser; the screen-grid voltage is applied through a resistance.

The various audio frequencies are obtained by varying the capacities  $C$  of the audio oscillator. This is accomplished by the three-position tone-selector switch  $e$ . The frequencies normally obtained on the three different settings of the selector switch are 500, 700, and 1,000 cycles. The audio-frequency oscillator modulates the output of the radio-frequency oscillator and by this means icw. transmission is obtained. For icw. transmission the switches  $f$  are thrown to the icw. position. For cw. transmission these switches are obviously thrown to the cw. position. In this position the filament circuit of the audio-oscillator tube  $c$  is opened and the condensers  $C_1$  are shorted. The audio-oscillator tube is put on the same shelf as the master-oscillator tube for convenience in replacement. It is of the UX-860 type.

**53. Power-Amplifier Circuit.**—The power-amplifier circuit, Fig. 22, is composed of the inductance  $L_1$  and condenser  $C_2$  working in conjunction with the two power-amplifier tubes  $b$ , in parallel. Plate power is supplied through the choke coil  $X_1$ , which prevents the radio-frequency voltage from going to ground through the generator. The amplifier screen grids are by-passed to ground through a condenser. Grid bias is obtained by passing the rectified grid current through the resistance  $R_1$ .

The power-amplifier tubes operate on the fundamental frequency of the master oscillator. The plate-to-grid capacity

of these tubes is very small and neutralization of the power amplifier is unnecessary. Any coupling due to common connections of the master oscillator and power-amplifier screened grids has been eliminated by a combination of impedance and resistance in series with these elements. The power-amplifier equipment is housed in a shielded compartment so as to remove it from external electrical influences.

**54. Antenna.**—The power amplifier, Fig. 22, works into a Hertzian antenna of the type in which the transmission line determines the constants of the antenna system to a degree comparable with that part of the antenna that actually radiates. In essence the arrangement is similar to two quarter-wave antennas, either flared or disposed horizontally in opposite directions at their ends, but placed together for the remainder of the length running to the transmitter to form the transmission-line portion.

The antenna is coupled conductively by means of clips spaced symmetrically on either side of the ground point on the power-amplifier plate inductance  $L_1$ . Tuning the antenna is accomplished by means of the capacities  $C_3$  and the divided and tapped inductance coil  $L_2$ . The inductance of each section of the coil  $L_2$  is varied by the tap switches  $g$  operated simultaneously by a knob on the front of the panel. The two sections are closely coupled to reduce the effect of unbalance.

To facilitate accuracy in resonance adjustments and to reduce unbalance of the transmission line due to length of the leads to the antenna ammeter  $M$ , a current transformer  $T_1$  has been provided, which is so placed as to reduce unbalance to a minimum and designed so as to give a variable transformation ratio. The steps on the transformer are arranged to give approximately 100 per cent., 75 per cent., and 50 per cent. of the actual measured antenna current.

**55.** For purposes of description, the antenna may be likened to two inverted L-type antennas with the vertical portions back to back, and the horizontal portions extending in opposite directions from the vertical portion. The vertical portion, known as the transmission line, is transposed through-

out its entire length to insure minimum radiation in this part of the antenna.

Since the transmission-line portions of the two antennas have currents in them 180 degrees out of phase and are placed close together and transposed, there is no material radiation from this part of the antenna system. To obtain a reasonable radiating length, the proportion of the horizontal, or radiating, part to the length of the transmission line, or non-radiating part, should be so chosen that the overall dimension of the horizontal part of the antenna corresponds to half the shortest wavelength at which the transmitter operates. Such a design infers harmonic operation, and since the arrangement is essentially two quarter-wave antennas, the lowest order of harmonic operation is the third.

From the foregoing it is apparent that the physical disposition of the antenna must necessarily be confined to limited dimensions. An example of the procedure necessary in determining the dimensions of the antenna for use on a known wavelength band is as follows: The fundamental wavelength of the antenna is chosen so that it falls approximately in the middle of the known wavelength band; that is, its length is an average of the longest and the shortest wavelength of the band. The antenna series condensers  $C_3$ , Fig. 22, will reduce the natural period to that of the lower end of the wave band. The antenna loading coils  $L_2$  will increase the natural period to that of the top of the band. The theoretical length of one-half of the antenna is then determined by taking three-quarters, or .75, of the selected natural wavelength.

Owing to the capacity of the antenna to adjacent objects, such as masts, stays, bulkheads, etc., the theoretical length will be greater than that actually necessary, and experience indicates that the ratio of the actual natural wavelength to the theoretical natural wavelength is in the order of 1.25; therefore, the actual length of one-half the antenna will be the theoretical value divided by the factor 1.25 or multiplied by .8. One-half of the horizontal portion of the antenna will have 25 per cent. of the wavelength at the lower end of the band. This dimension automatically determines all dimensions of the antenna.

**56.** The method of calculating an antenna for operation in the 26.3 to 36.6 wave band is as follows: The average wavelength is  $\frac{26.3+36.6}{2} = 31.45$  meters. The theoretical length of the antenna is  $.75 \times 31.45 = 23.6$  meters. The approximate actual length is  $23.6 \times .8 = 18.9$  meters, or  $18.9 \times 3.28 = 62$  feet. The length of one-half of the flat top is  $\frac{1}{4} \times 26.3 = 6.575$  meters, or 21.6 feet, which is also the length of one section of the flat top. Therefore, an antenna whose lead-in is  $62 - 21.6 = 40.4$  feet long, and whose overall flat top has a length of 43.2 feet will be satisfactory for operation in the 26.3—36.6 meter band. The two lead-in wires should be spaced about 3 inches apart and transposed every 2.5 feet.

**57. Keying.**—Two magnetically operated relays  $h$  and  $i$ , Fig. 22, are provided in the transmitter. The relay  $h$ , which is under the control of switch  $j$ , changes the antenna from the transmitter to the receiver, whereas the relay  $i$ , which is operated by the transmitting key  $k$ , closes the keying contacts. These relays are so interconnected that the keying relay circuit can only be completed when the antenna relay is in the transmitting position. The antenna relay  $h$  is placed in the left-hand top part of the frame near the antenna-tuning components, whereas the keying relay  $i$  is mounted on the front panel, where it is convenient for inspection.

The keying is accomplished through the keying relay  $i$  on the front of the panel. When the key  $k$  and the relay  $i$  are in the open position, a sufficiently high bias is applied to block off constantly the grids on both the master oscillator and the power amplifier. This relay is provided with the necessary contacts to give break-in operation, by connecting the receiving set to the antenna when the key is up, and short-circuiting the receiver when the key is down. A separate receiving antenna may be used if desired.

**58. Meters.**—The transmitter, Fig. 22, is provided with several meters for determining rapidly and accurately the voltage and current values. Since the transmitter is designed

to operate over a very wide range of frequencies, the antenna resistances will vary greatly, and hence the antenna current will also vary to an extent that would make it impractical to use one antenna ammeter  $M$ . To obviate the necessity of putting in different antenna ammeters for different wavelength bands, the transmitter has integral in its assembly a radio-frequency variable-ratio current transformer  $T_1$ . The ammeter  $M$  is calibrated uniformly from zero to 100 and serves merely as an indication of maximum antenna current.

An 0 to 15 volt alternating-current voltmeter  $M_1$  is placed across the filament leads. It is shunted by a condenser and a resistance.

A 2-ampere direct-current ammeter  $M_2$  is included in the keying circuit. This meter indicates the value of the grid current when the keying contacts are closed.

A 2,500-volt direct-current voltmeter  $M_3$  is connected across the high-voltage plate supply.

**59. Operation.**—All preliminary tuning of the transmitter, Fig. 22, is done with reduced plate voltage. The voltage should not exceed 1,000 volts for the original adjustments on the transmitter.

The master oscillator is adjusted to the desired frequency by setting the master-oscillator variable condenser  $C$  until an indication of the current frequency is shown on whatever type of frequency meter is used. Then, with the antenna disconnected, the power-amplifier circuit is tuned to the frequency of the master-oscillator circuit by adjusting the power-amplifier tuning control  $C_2$  until the plate current is a minimum. The antenna is next tuned by first connecting the antenna and then adjusting the antenna inductance  $L_2$  and the antenna series condensers  $C_3$  until the antenna current is a maximum.

The adjustment for the maximum efficiency should next be made. This requires an adjustment of the coupling. The coupling is controlled by the position of two clips on the power-amplifier plate-circuit inductance  $L_1$ . The closer the clips are to ground, the less will be the effective coupling. The coupling should first be reduced, and if a decrease in plate current results

without a decrease in antenna current, the coupling should be further reduced until the antenna current drops off with the plate current. If this condition happens on the first adjustment, the coupling should be increased until further increase of coupling will not give an increase in antenna current proportional to the increase in the plate current.

The audio oscillator may be adjusted to the desired operating tone frequency by means of a switch *c* that governs the amount of capacity in the oscillator tank circuit. This switch is located in the lower left-hand compartment and is marked 500, 750, 1000, these figures being approximately the frequency of oscillation of the audio oscillator when the pointer is set to one of them. The audio oscillator modulates the power-amplifier circuit by increasing an alternating voltage on the grid circuit of the power amplifier.

Keying is accomplished by removing a high negative bias from the grids of all tubes. The antenna change-over relay has an interlock in the keying circuit, so that the transmitter cannot be keyed while the relay is thrown in the receiving position.

After all adjustments for maximum efficiency and resonance have been made the plate voltage can be increased to 2,000 volts. Then the meter readings should not exceed the proper limits.

#### MODEL ET-3626A TELEGRAPH TRANSMITTER

**60.** The Model ET-3626A telegraph transmitter is rated at 500 to 750 watts in the antenna for continuous-wave transmission. It is designed for installation on vessels requiring reliable telegraph service at ranges up to 1,000 miles. The dimensions are such that it may easily be installed in the average radio room on board ship. A special *break-in system* has been built in this set so that it is not necessary to use a manually operated antenna switch. The front view of the set is shown in Fig. 23.

The wavelength range is from 600 to 2,500 meters when the apparatus is used with an antenna having the following electrical characteristics: Capacity, .001 to .0015 microfarads; resistance, 2 to 10 ohms; natural period, 300 to 450 meters. The transmitter is designed for either continuous-wave (cw.) or interrupted continuous wave (icw.) telegraph signaling. The inter-



rupted continuous wave is obtained by means of a motor-driven chopper in the grid-bias lead of the power amplifier.

The following vacuum tubes are used in the set: two UV-211 radiotrons as master oscillator; six UV-211 radiotrons as power amplifiers.

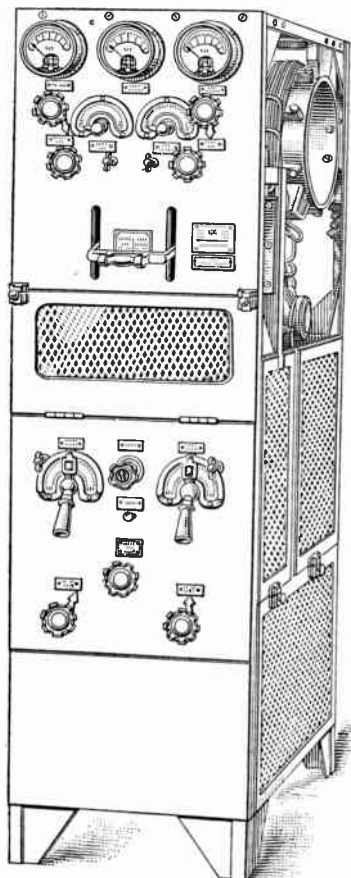

FIG. 23

for the master oscillator consists of the coil *f* and the condenser *g*. The grid terminal of the master oscillator is connected to the oscillatory-circuit inductance through the parasitic choke *h* and the grid blocking condenser *i*. The direct current

**61.** A schematic wiring diagram of Model ET-3626A tube transmitter is shown in Fig. 24. The tube *a* is a master oscillator, the tube *b* is a bias rectifier tube, and the other six *c* are power-amplifier tubes. The master oscillator has the Hartley type of oscillatory circuit where the grid and plate terminals of the oscillator tube *a* are connected to the extremities of a coil; and the ground, or filament lead, is brought to a point between them. The grid excitation is a function of the number of turns between the point on the coil where the grid is tapped on and the point that is grounded.

The high-voltage d.-c. plate supply is fed to the master-oscillator plate through a radio-frequency choke coil *d*. The .004-microfarad blocking condenser *e* keeps the high voltage direct current out of the oscillatory circuit. The oscillatory circuit

passes down through the grid biasing resistance  $j$ . The choke coil  $k$  keeps the radio-frequency currents out of the biasing circuit, thus preventing losses of this nature.

The grid excitation for the power-amplifier tubes is obtained by tapping on the coil  $f$  at the desired potential above ground and bringing this lead to the grids of the amplifier tubes through

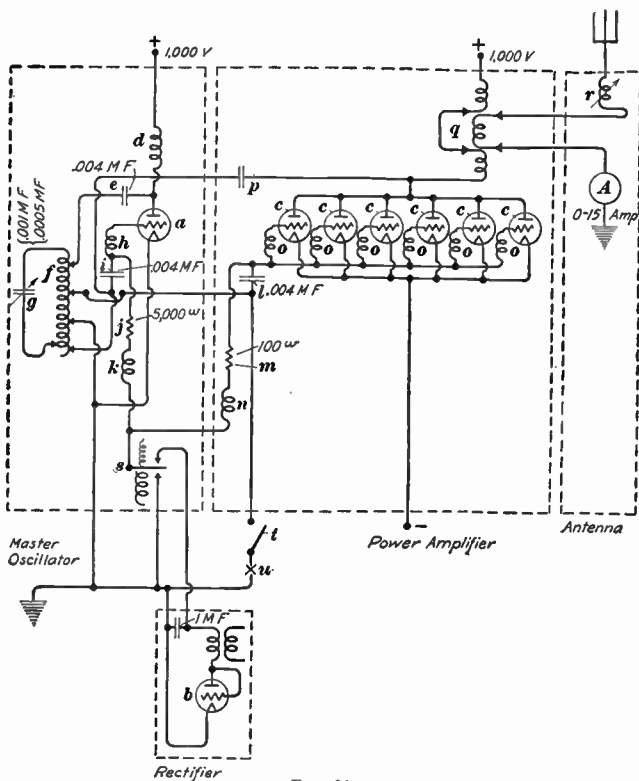

FIG. 24

the blocking condenser  $l$ . The condenser  $l$  prevents the direct current from the grids of the power-amplifier tubes from getting back into the master-oscillator circuit and incidentally makes it go through the power-amplifier grid biasing resistance  $m$  and the radio-frequency choke coil  $n$ . The six power-amplifier grids are connected to the common grid lead through six separate

parasitic choke coils  $o$ . These small choke coils prevent oscillations of very high frequency from existing locally between the elements of the tubes.

The blocking, or neutralizing, condenser  $p$  prevents reaction of the amplifier on the master oscillator due to the internal capacity of the power-amplifier tubes. Plate current from the 1,000-volt supply is fed to the plates of the power-amplifier tubes, which are all connected in parallel, through the primary winding of the radio-frequency transformer  $q$ . The secondary of this transformer is connected in series with the antenna circuit and it is by this means that the radio-frequency energy generated by the master oscillator and amplified by the six power-amplifier tubes is induced into the antenna circuit. The variable loading coil  $r$  is used for tuning the antenna system and the ammeter is used to indicate the value of radio-frequency current flowing in the antenna circuit.

**62.** Keying is accomplished by means of the keying relay  $s$ , Fig. 24, which is operated by the hand key at the operator's desk. When the operator's key is pressed down, the tongue of the keying relay engages the contact that is connected to ground. Since the leads from the master-oscillator and power-amplifier grid-bias circuits are connected to the tongue of the relay, they are grounded when the operator's key is pressed down. This means that the proper operating bias is applied to the grids of the tubes in question and a cw. signal is sent out from the antenna.

When the operator's key is opened, the tongue of the relay  $s$  engages the contact that is connected to the negative terminal of the bias rectifier tube  $b$ , the positive terminal of the bias rectifier tube being connected to ground; thus, in this position of the keying relay, there is a negative potential of 250 volts (the potential of the rectified output from the rectifier) applied to the grids of the master-oscillator and power-amplifier tubes.

For cw. transmission the signal switch  $t$  is closed. This connects the chopper  $u$  into the circuit. The chopper motor is started and the amplifier feed is grounded intermittently, the number of times per second that it is ground being a function

of the speed of the chopper motor and the number of metallic segments in the chopper disk. When the circuit is closed through the chopper contacts, the grid excitation to the amplifier tubes is grounded and there is no radio-frequency energy radiated from the antenna; thus, in the course of icw. transmission, when the key is closed, wave trains of continuous amplitude are sent out into the ether and the wave-train frequency is usually between 500 and 1,000 cycles per second.

### DESCRIPTION OF SHORT-WAVE AMATEUR STATION

**63.** The schematic wiring diagram of a crystal-controlled, 500-watt, 80-meter transmitter is shown in Fig. 25. Seven transmitting tubes are employed as follows: one 7.5 watt radio-tran, UX-210, is used as a crystal amplifier tube; two more of these tubes are used in the first intermediate push-pull amplifier; then, still greater amplification is effected through the medium of two 50-watt tubes, UV-203-A, in a second intermediate push-pull amplifier stage. The final stage of amplification employs two 250-watt tubes, UV-204-A, in a push-pull amplifier circuit.

On the diagram, *A* denotes ammeter; *C*, condenser; *L*, inductance; *RFC*, radio-frequency choke; *T*, transformer. The individual devices are indicated by the number given with the letter, as  $C_{10}$ ,  $L_2$ , etc. The constants for the various devices are given in the accompanying list.

#### CONSTANTS FOR SCHEMATIC DIAGRAM, FIG. 25

- $RFC_1$  150 turns No. 24 d.c.c.,  $\frac{3}{4}$ " diameter.
- $RFC_2$  150 turns No. 24 d.c.c.,  $\frac{3}{4}$ " diameter.
- $T_1$  Acme modulation transformer.
- $L_1$  7 turns No. 8 bare copper, spaced wire width, 3" diameter.
- $L_2$  8 turns No. 24 d.c.c., spaced wire width, 2" diameter, center tap.
- $L_3$  8 turns No. 16 bare copper, space wound, 3" diameter, mid-tap.
- $L_4$  5 turns No. 24 d.c.c., bunch wound, 2" diameter.
- $L_5$  5 turns No. 24 d.c.c., bunch wound, 2" diameter.
- $L_6$  10 turns No. 16 bare copper, space wound, 5" diameter, mid-tap.
- $L_7$  8 turns No. 18 d.c.c., bunch wound, 5" diameter, mid-tap.
- $L_8$  8 turns  $\frac{1}{2}$  inch copper strip, edgewise wound,  $\frac{1}{4}$ " pitch, 6" diameter.
- $L_9$  8 turns  $\frac{1}{2}$  inch copper strip, edgewise wound,  $\frac{1}{4}$ " pitch, 6" diameter.

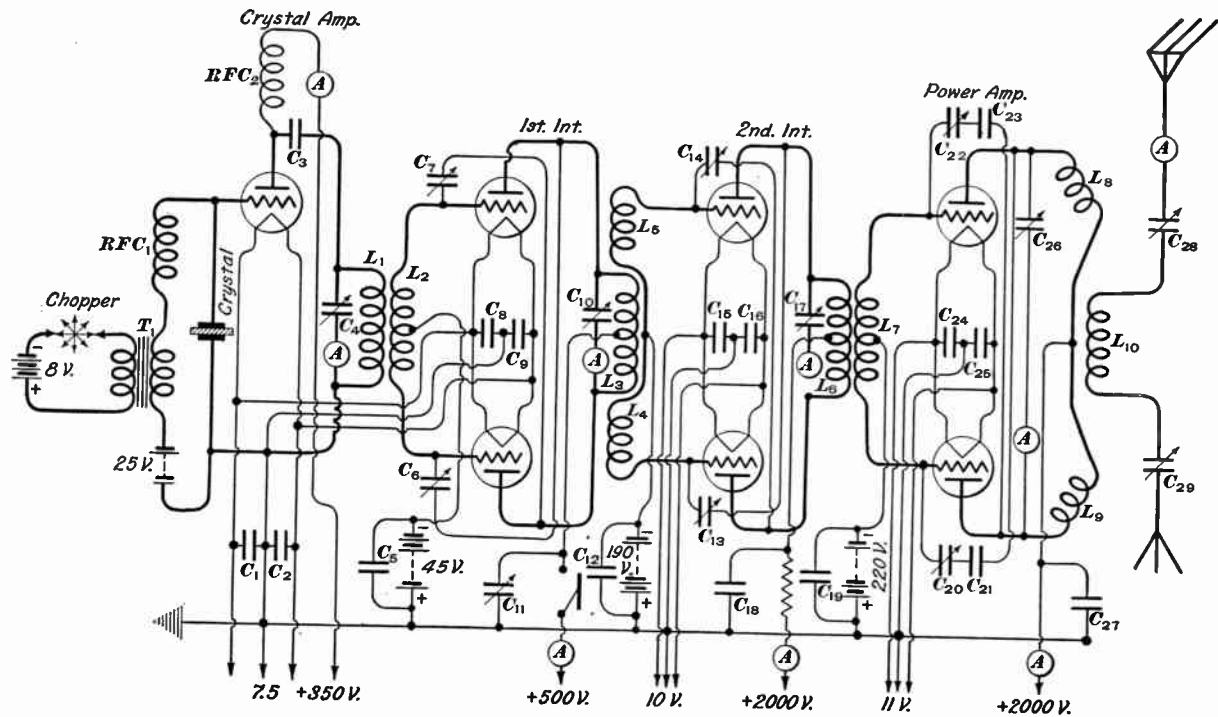

FIG. 25

- L<sub>10</sub> 10 turns  $\frac{1}{2}$  inch copper strip, edgewise wound,  $\frac{1}{4}$ " pitch, 8" diameter.
- C<sub>1</sub> .002-microfarad fixed condenser.
- C<sub>2</sub> .002-microfarad fixed condenser.
- C<sub>3</sub> .002-microfarad fixed condenser.
- C<sub>4</sub> .0005-microfarad variable condenser.
- C<sub>5</sub> .002-microfarad fixed condenser.
- C<sub>6</sub> .00002-microfarad midget 5-plate neutralizing condenser.
- C<sub>7</sub> .00002-microfarad midget 5-plate neutralizing condenser.
- C<sub>8</sub> .002-microfarad fixed condenser.
- C<sub>9</sub> .002-microfarad fixed condenser.
- C<sub>10</sub> .0005-microfarad variable condenser.
- C<sub>11</sub> 1-microfarad variable condenser.
- C<sub>12</sub> .002-microfarad fixed condenser.
- C<sub>13</sub> .0005-microfarad variable condenser, double spaced.
- C<sub>14</sub> .0005-microfarad variable condenser, double spaced.
- C<sub>15</sub> .002-microfarad fixed condenser.
- C<sub>16</sub> .002-microfarad fixed condenser.
- C<sub>17</sub> Two Cardwell transmitting condensers in series.
- C<sub>18</sub> .002-microfarad fixed condenser.
- C<sub>19</sub> .002-microfarad fixed condenser.
- C<sub>20</sub> .0005-microfarad variable condenser, double spaced.
- C<sub>21</sub> .002-microfarad fixed condenser.
- C<sub>22</sub> .0005-microfarad variable condenser, double spaced.
- C<sub>23</sub> .002-microfarad fixed condenser.
- C<sub>24</sub> .002-microfarad fixed condenser.
- C<sub>25</sub> .002-microfarad fixed condenser.
- C<sub>26</sub> Cardwell transmitting condenser.
- C<sub>27</sub> .002-microfarad fixed condenser.
- C<sub>28</sub> Cardwell transmitting condenser.
- C<sub>29</sub> Cardwell transmitting condenser.

**64.** The output of this powerful amateur short-wave transmitter is radiated from an antenna system which is suspended from the top of a 112-foot mast. A counterpoise is used to increase the efficiency of the station. The antenna and the counterpoise system are shown in Fig. 26, view (a) being an elevation, and view (b) a plan of the counterpoise. Push-pull amplification is used throughout this transmitter with the exception of the first stage, the crystal amplifier stage. Each stage of push-pull amplification is carefully neutralized to prevent parasitic oscillations and to effect maximum amplification.

The fundamental frequency of the crystal used in this transmitter is 3,665 kilocycles or 81.9 meters. Since that is the fre-

quency of the radiated signals, no frequency multipliers are used in this transmitting system. Often in the course of short-wave transmission, it has been found to be easier to use a crystal having a frequency of the order of, say 1,000 kilocycles, and then, through successive frequency multiplier stages, to step this frequency up to something in the order of 3,000 kilocycles. However, it is far more difficult to use a crystal having a fundamental

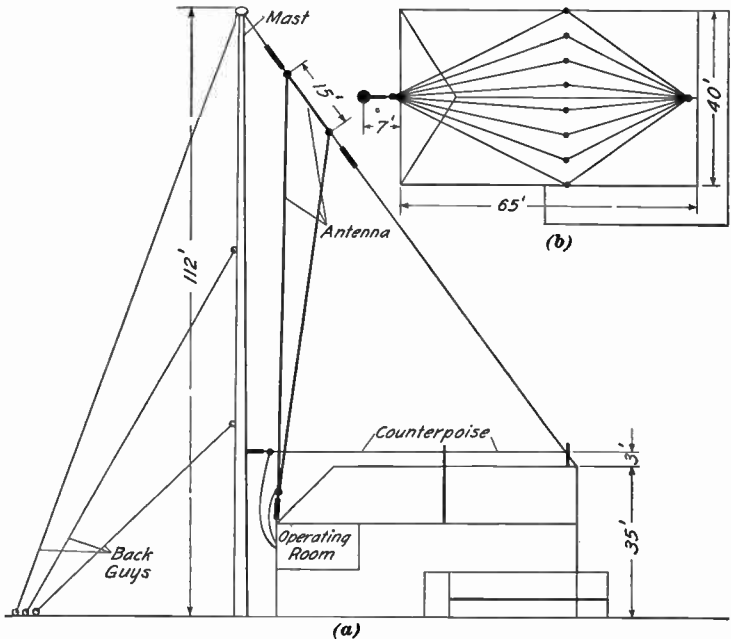

FIG. 26

frequency of the order of 3,000 kilocycles, because the higher the fundamental frequency of a crystal, the more delicate it is mechanically. Thus, in this transmitting system, straight amplification is employed.

**65.** Another novel feature of the transmitter shown in Fig. 25 is its flexibility as regards the sharpness of the transmitted wave. If the operator wishes to broaden out his signals he can actually accomplish that effect, through the medium of a chopper which

allows direct current to pass through the primary winding of a modulation transformer at an audio-frequency rate (the rate at which the chopper contacts are made and broken). The secondary winding of this modulation transformer is connected in series with a radio-frequency choke coil, and a bias battery is connected across the terminals of the crystal oscillator. The terminals of the crystal are also connected to the grid and filament terminals of the 7.5-watt crystal amplifier tube.

Every time that there is a direct-current pulse through the primary winding of the modulation transformer, there is a voltage "kick" across the secondary winding of this transformer, this kick being transferred to the terminals of the crystal oscillator, and subsequently to the grid of the first amplifier tube. The effect of each one of these kicks is to change the frequency, right at the source, hence the frequency of the transmitted signals is also changed. The degree of this change, as near as the ear can tell, is between 500 and 1,000 cycles. Thus, by this novel method of modulation, the frequency of the transmitted signals is changed through a band of 500 to 1,000 cycles wide, at an audio-frequency rate.

---

### RADIO DIRECTION FINDER

**66.** The terms *radio direction finder* and *radio compass* are synonymous, and either term may be used to designate the instrument here described. A general view of a direction finder installed on the deck of a passenger ship is shown in Fig. 27. All direction finders operate on the principle that a radio signal of maximum intensity will be received through a loop aerial when it is so placed that its plane is pointing at the station that is transmitting. If, on the other hand, the plane of the loop aerial is at right angles to the direction of the transmitting station, no energy is picked up and nothing can be heard in the telephones connected to the receiver. This position of the loop at which the signal drops out, known as the *zero point*, is well defined and is used to determine the direction of the transmitting station.

By means of a direction finder, a ship may obtain its bearing in relation to another ship and thus avoid collision in foggy



weather. Bearings taken on a vessel in distress will enable a rescue ship to steer directly to her. A ship in distress may, with a direction finder, determine the bearings of rescuing ships and

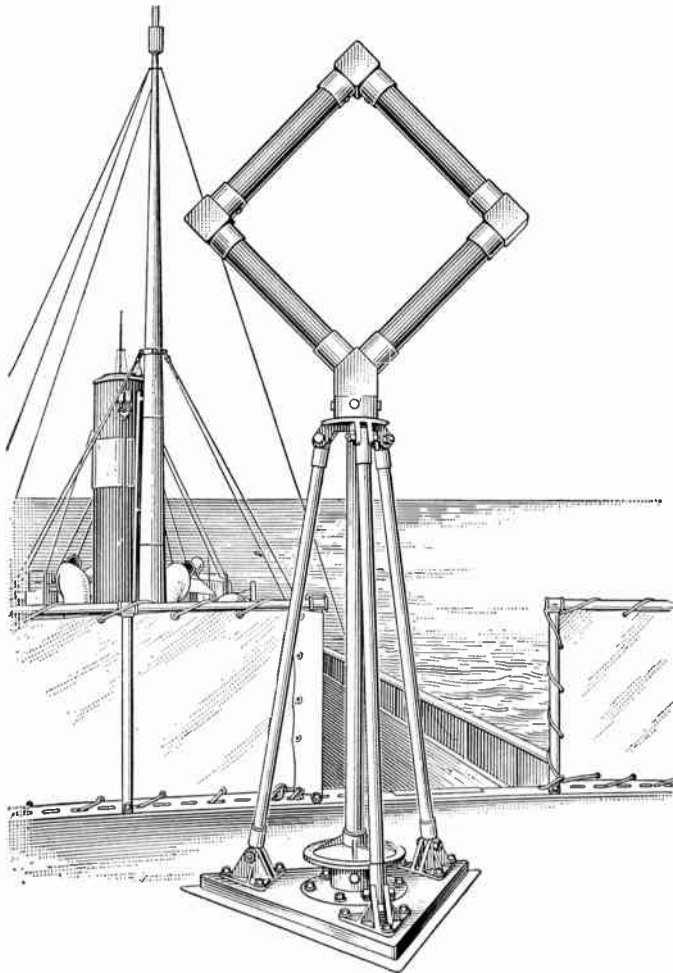

FIG. 27

guide them to her by the most direct route and no time will be lost in searching for a ship whose exact position may not be known.

67. In Fig. 28 is shown a map on which are indicated the locations of three radio fog beacon stations in the vicinity of New York Harbor. By taking cross bearings on two or more of these stations the position of a ship may be accurately determined. Or the radio signal from a lightship or a coast light station may be used as a leading mark for a ship to approach to

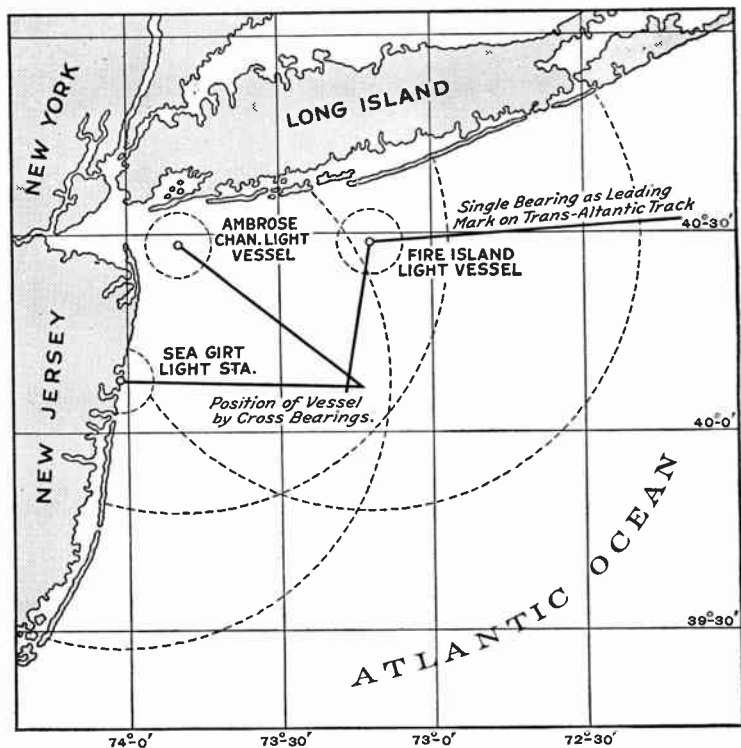

FIG. 28

New York harbor. The distinctive characteristics of the signals from the three stations, Fire Island, Ambrose Channel, and Sea Girt, are indicated by dots on the circles around each station. The larger circles represent the approximate useful range of these signals. Radio beacon stations are located on important lighthouses, and lightships along the coast are arranged with apparatus for sending radio signals of easily recognized charac-

ters during foggy weather by means of which any navigator of a ship equipped with a direction finder may take definite bearings to guide or locate his ship, although no object or sight of the sending station is visible.

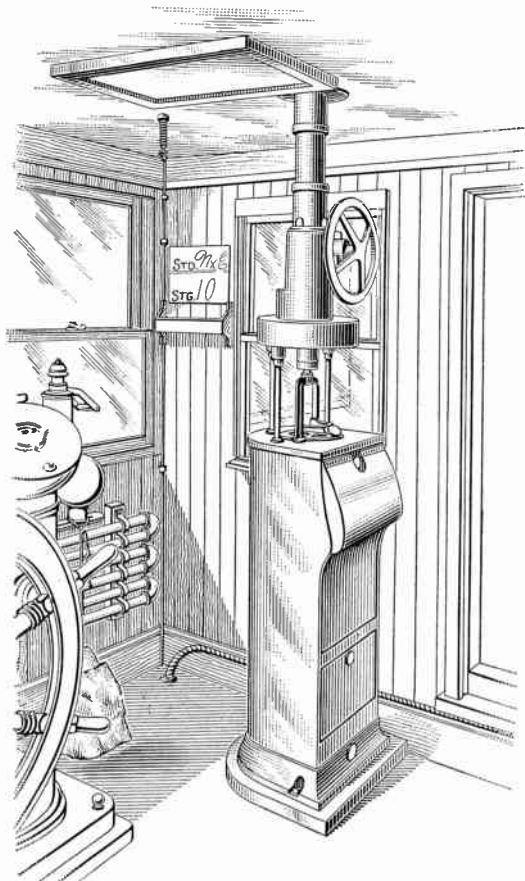
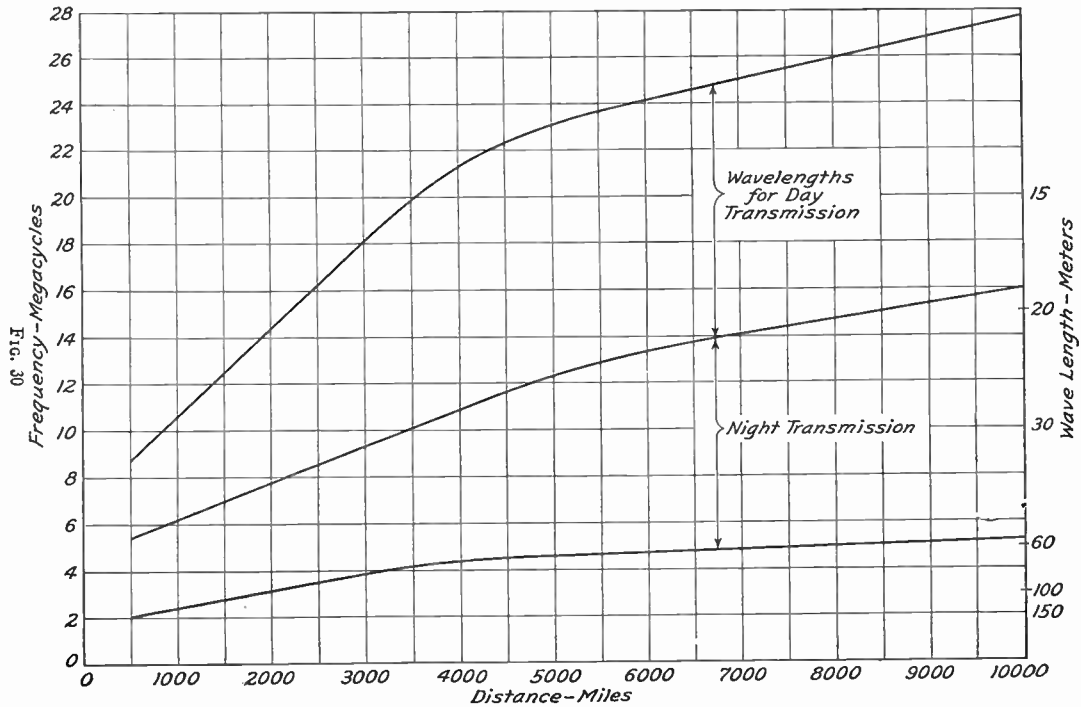

FIG. 29

**68.** The direction finder shown in Fig. 27 consists of a rotatable loop aerial arranged for outside mounting above the chart room or pilot house, and connected by a shaft passing through the deck to an indicator with a compass or a gyro repeater. Between the loop and the indicator is a special



mechanical compensator to provide the necessary connection to offset errors introduced by metal objects such as steel halyards etc. aboard the ship. The wires from the loop aerial pass to an eight-tube superheterodyne receiver mounted in the base with

### ALLOCATION OF WAVEBANDS

*Agreed on at the International Radiotelegraph Conference at Washington, 1927*

<i>Meters</i>	<i>kC.</i>	
3,000-30,000	(100-10)	Fixed stations; point-to-point services.
2,725-3,000	(110-100)	Point-to-point and mobile services.
2,400-2,725	(125-110)	Mobile services.
2,000-2,400	(150-125)	Maritime services. Public correspondence only.
1,875-2,000	(160-150)	Mobile services.
1,550-1,875	(194-160)	(a) Broadcasting; (b) Point to point; (c) Mobile; subject to agreement with regard to broadcasting stations already working on wavelengths above 1,000 meters. Regional agreements will respect the rights of one another in this band.
1,050-1,550	(285-194)	(a) Mobile; (b) Point to point; (c) Broadcasting, subject to regional modification as follows: <i>Europe.</i> (a) and (b) for aircraft services only; (c) 1,050-1,200 meters (285-250 kC.), point to point, not for general public correspondence. 1,340-1,550 meters (224-194 kC.), broadcasting. <i>Other Regions.</i> (a) Mobile, except commercial ships; (b) point to point; aircraft only. (c) Point to point, not for general public correspondence.
950-1,050	(315-285)	Radio beacons.
850-950	(350-315)	Aircraft service only, 900 meters being the International aircraft wavelength for calling and listening.
830-850	(360-350)	Mobile. Not for general public correspondence.
770-830	(390-360)	(a) Direction Finding; (b) Mobile where it does not interfere with D.F.
650-770	(460-390)	Mobile stations.
620-650	(485-460)	Mobile, except damped waves and radio telephony.
580-620	(515-485)	Mobile, 600 meters is the wavelength for International ship traffic and distress signals. May be used for other purposes when it will not interfere with calling.
545-580	(550-515)	Mobile, except damped waves and radio-telephony (not for general public correspondence).
230-545	(1,300-550)	<i>Broadcasting.</i> Mobile services may use this waveband provided that they do not interfere with the broadcasting service.
200-230	(1,500-1,300)	(a) <i>Broadcasting.</i> (b) Mobile, on 200 meters (1,364 kC.) only.

easily operated tuning controls. The receiver uses UX-199 tubes and has a wavelength range of 550 to 1,050 meters. All batteries or battery eliminators, if used, are contained in the bottom of the pedestal, the entire direction finder being a single unit.

---

<i>Meters</i>	<i>kC.</i>	
175-200	(1,715-1,500)	Mobile services.
150-175	(2,000-1,715)	Mobile, fixed and amateurs.
133-150	(2,250-2,000)	Mobile and fixed stations.
109-133	(2,750-2,250)	Mobile stations.
105-109	(2,850-2,750)	Fixed stations.
85-105	(3,500-2,850)	Mobile and fixed stations.
75-85	(4,000-3,500)	Mobile, fixed and amateurs.
54-75	(5,500-4,000)	Mobile and fixed stations.
52.7-54	(5,700-5,500)	Mobile stations.
50-52.7	(6,000-5,700)	Fixed stations.
48.8-50	(6,150-6,000)	<i>Broadcasting.</i>
45-48.8	(6,675-6,150)	Mobile stations.
42.8-45	(7,000-6,675)	Fixed stations.
41-42.8	(7,300-7,000)	<i>Amateurs.</i>
36.6-41	(8,200-7,300)	Fixed stations.
35.1-36.6	(8,550-8,200)	Mobile stations.
33.7-35.1	(8,900-8,550)	Mobile and fixed stations.
31.6-33.7	(9,500-8,900)	Fixed stations.
31.2-31.6	(9,600-9,500)	<i>Broadcasting.</i>
27.3-31.2	(11,000-9,600)	Fixed stations.
26.3-27.3	(11,400-11,000)	Mobile stations.
25.6-26.3	(11,700-11,400)	Fixed stations.
25.2-25.6	(11,900-11,700)	<i>Broadcasting.</i>
24.4-25.2	(12,300-11,900)	Fixed stations.
23.4-24.4	(12,825-12,300)	Mobile stations.
22.4-23.4	(12,350-12,825)	Mobile and fixed stations.
21.4-22.4	(14,000-12,350)	Fixed stations.
20.8-21.4	(14,400-14,000)	<i>Amateurs.</i>
19.85-20.8	(15,100-14,400)	Fixed stations.
19.55-19.85	(15,350-15,100)	<i>Broadcasting.</i>
18.3-19.55	(16,400-15,350)	Fixed stations.
17.5-18.3	(17,100-16,400)	Mobile stations.
16.9-17.5	(17,750-17,100)	Mobile and fixed stations.
16.85-16.9	(17,800-17,750)	<i>Broadcasting.</i>
14.0-16.85	(21,450-17,800)	Fixed stations.
13.9-14.0	(21,550-21,450)	<i>Broadcasting.</i>
13.45-13.9	(22,300-21,550)	Mobile stations.
13.11-3.45	(23,000-22,300)	Mobile and fixed stations.
10.7-13.1	(28,000-23,000)	Not reserved.
10.0-10.7	(30,000-28,000)	<i>Amateurs and experimenters.</i>
5.35-10.0	(56,000-30,000)	Not reserved.
5.0-5.35	(60,000-56,000)	<i>Amateurs and experimenters.</i>
Under 5.0	(over 60,000)	Not reserved.

---

In order to avoid shielding effect and false readings, with the direction finder, the ship's main radio telegraph antenna must be open when bearings are taken; therefore a signal light is used to notify the radio operator when the direction finder is being used so that he will keep the antenna switch open. Fig. 29 shows the unit installed in the chart room or pilot house of a large vessel, and Fig. 27 the loop structure above the deck.

---

#### SHORT-WAVE RADIO-TRANSMISSION DATA

**69.** In Fig. 30 is shown a graphical representation of the short-wave radio-transmission data collected by the author which has been found to be very useful in determining the best wavelength or frequency for any short-wave transmitter of 1 kilowatt or more to reach any desired distance. For example, to transmit over a distance of approximately 3,500 miles during daylight hours at the transmitter, wavelengths between 15 to 30 meters, or about 20 meters, could be used with the best results. During darkness over the path from the transmitter to receiver longer wavelengths of from 30 to 75 meters would be more reliable.

---

#### ALLOCATION OF WAVELENGTH BANDS

**70.** The allocation of wavebands in terms of frequency assignments as agreed on at the Washington conference and used in the limited states today is given on pages 64 and 65.

# RADIO-TELEPHONE TRANSMITTERS

Serial 2490

Edition 1

## PRINCIPLES OF RADIO TELEPHONY

### TELEPHONE SERVICE IN RADIO COMMUNICATION

1. **Radio Telephone and Radio Telegraph.**—The radio telephone supplements the radio telegraph in the same manner that the wire telephone supplements the wire telegraph. The advantages of the radio telephone over the radio telegraph are numerous. The radio telegraph requires an experienced operator who is familiar with the code, whereas the radio telephone does not. In the case of the radio telephone, therefore, the conversation can be carried on directly between the interested parties. Thus, the same factors that favor the wire telephone over the wire telegraph, operate in favor of the radio telephone over the radio telegraph.

2. **Radio Telephone and Wire Telephone.**—The radio telephone and the wire telephone bear the same relation to each other as the radio telegraph and the wire telegraph. Each has a definite and a distinct field of use. There is no antagonism; one aids the other. Thus, the radio telephone's accepted field of use is from ship to shore, from ship to ship, from airship to shore, and from airship to airship; also, between points on land that are separated by water or desert country, where it would be either impossible or extremely uneconomical to use wires.

Again, the radio telephone is found far more economical than the wire telephone between points that are separated by deserts



and undeveloped country. The foregoing does not by any means imply that the radio telephone and the wire telephone are antagonistic, because the converse is true. They cooperate absolutely in their functioning, and go hand in hand in the development of the transmission of speech from one person to another. Take, for instance, the case where telephone conversations are carried on between persons in New York City and other persons on a ship hundreds of miles at sea, en route to Europe. The speech is transmitted via land line to the central radio station, where it is sent out by radio to the ship. Another instance of this close relationship between radio telephone and wire telephone, although their fields of use are distinctly different, is in the accomplishment of the transmission of speech from a person on land to another in an airship many miles distant. Here again the speech is carried by a land line to the central radio station and from there to the airship via radio.

The preceding discussion has only considered radio telephony from a standpoint of two-way conversation and therefore has not mentioned the most popular application of the radio telephone transmitter; namely, broadcasting.

## RADIO-TELEPHONE APPARATUS AND BASIC CIRCUITS

### ELEMENTARY RADIO-TELEPHONE TRANSMITTER

3. **Elementary Circuit.**—To transmit speech by radio it is necessary to have a source of radio-frequency energy and a means of varying this energy in accordance with the variations in speech frequency. Controlling the radio-frequency energy in this manner is known as *modulation*.

A simple telephone transmitter is shown in Fig. 1. It consists essentially of an antenna *a*, a variable capacity *b*, an inductance coil *c*, a source of radio-frequency energy *d*, a microphone *e*, and the ground *f*. The microphone *e* may be of the ordinary carbon-granule type and since a clear understanding of its functioning is necessary in order to understand better the facts that are to follow, a description of the construction and functioning of this piece of apparatus will be considered at this point, in detail.

4. **Microphone.**—In Fig. 2 is shown a cross-sectional view of the carbon-granule type of microphone. This diagram gives a good idea of the construction of the microphone when stripped of details. The elastic diaphragm *a* is mounted in the rubber ring support *b*, which in turn is held against the metal frame of the microphone case *c*. The diaphragm is mechanically connected to a carbon block *d*, which is placed opposite a similar carbon block *e*. The chamber between the carbon blocks is filled with small carbon granules *f*. This chamber is sealed by means



FIG. 1

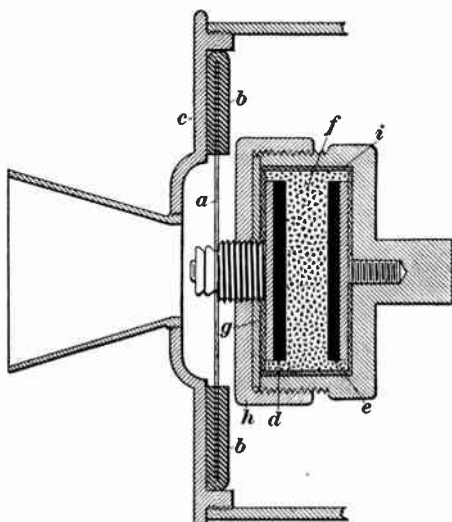

FIG. 2

of the mica washer *g* and the insulating nut *h*. The wall of the chamber containing the carbon granules is covered with a strip of paper *i*. The two carbon blocks *d* and *e* are the electrical terminals of the microphone.

If an electromotive force is applied to the two terminals of the microphone a current will pass through the carbon granules. If the source is of constant polarity (direct current) the current will be unidirectional. If the source is of constantly changing polarity (alternating current) the current will be first in one direction and then in another. The value of the current depends

on the potential applied and the resistance of the carbon granules. As long as the diaphragm remains in one position and the potential is constant the current will be constant, but it is a property of these carbon granules in the microphone to vary in resistance as the mechanical pressure exerted on them is varied. As the pressure is increased (an inward movement of the diaphragm) the resistance is decreased and as the pressure is decreased (an outward movement of the diaphragm), the resistance is increased. Hence, the current through the microphone is increased or decreased.

5. When some one is speaking into the microphone illustrated in Fig. 2, the diaphragm *a* vibrates in synchronism with the frequency of the sound waves produced by the voice. Thus, the resistance varies in synchronism with the voice frequencies and it follows that the current passing through the carbon granules within the microphone, varies in a similar manner. The type of microphone just described is very sensitive to changes of pressure on the diaphragm. The current-carrying capacity of such a device is very small owing to the fact that a limit is soon reached where arcing occurs between granules, the contact points of which become red-hot, and the microphone becomes useless. The average resistance of a unit of this type is between 50 and 100 ohms. The current-carrying capacity is about .1 ampere. Thus the power capacity is a maximum of  $.1^2 \times 100$ , or 1 watt. There are some special low-resistance microphones (10 to 20 ohms) that have a current-carrying capacity of .5 ampere and a maximum power capacity of  $.5^2 \times 20$ , or 5 watts.

6. **Effect of Microphone on Radio-Frequency Currents.** When the microphone *c*, Fig. 1, is not being spoken into, the diaphragm remains stationary and exerts a constant pressure on the carbon granules, the resistance of which, therefore, remains constant and the radio-frequency current in the antenna circuit is of constant amplitude as shown in Fig. 3. If the diaphragm of the microphone is depressed inwards, as indicated in view (*a*), the pressure on the carbon granules increases, the resistance decreases, and the amplitude of the antenna current, view (*b*), increases and remains constant at this value as long as the dia-

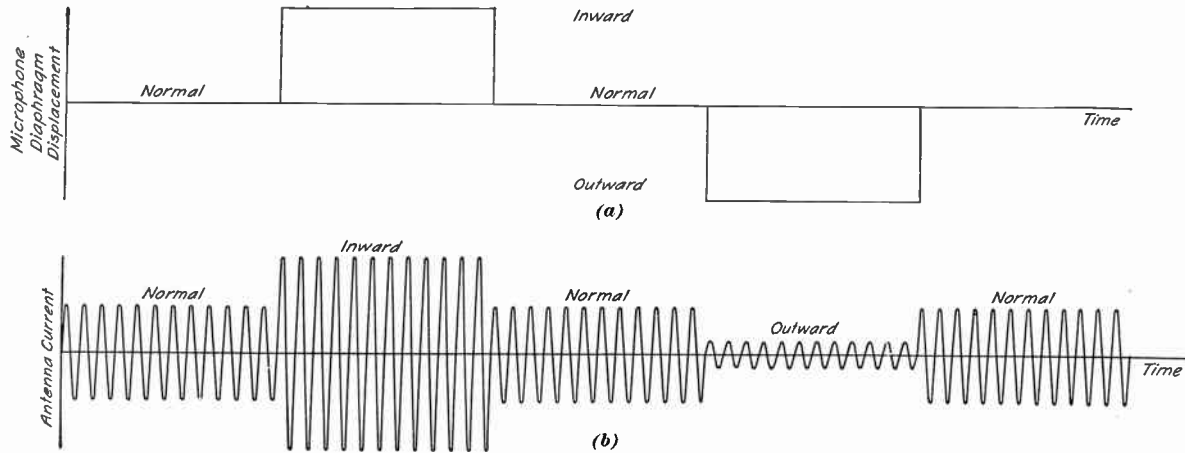

FIG. 3

phragm is maintained in that position. When the diaphragm is released the resistance returns to normal and the antenna current also returns to its normal value. Again, if the diaphragm is pulled outwards, the pressure decreases, the resistance of the carbon granules increases and the antenna current subsequently decreases and remains at this lower value as long as the diaphragm is held in the outward position. Then, of course, when the diaphragm is released, the resistance returns to normal and the antenna current again reaches its normal value.

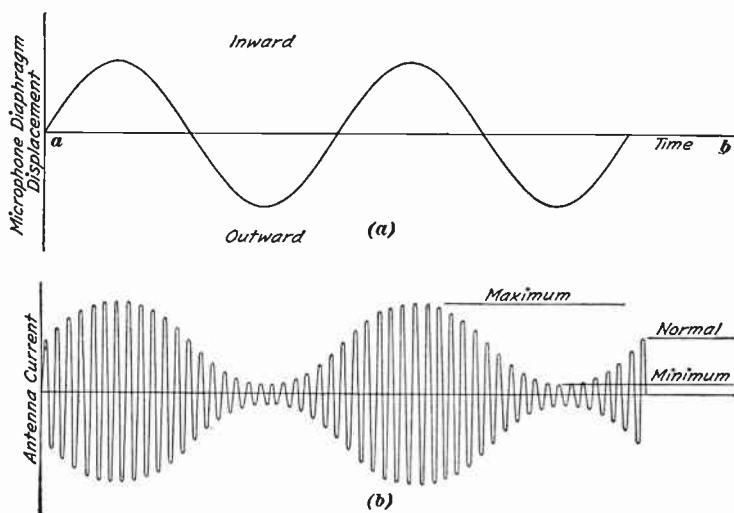

FIG. 4

7. Let it be assumed that a 1,000-cycle tuning fork is set vibrating and placed in front of the microphone. Owing to the sound waves from the tuning fork, the diaphragm of the microphone vibrates at a frequency of 1,000 cycles. In Fig. 4, if the line *ab*, view (a), represents the normal position of the microphone diaphragm when idle, then the sine curve superimposed on the straight line represents the action of the diaphragm when the tuning fork is placed in front of the mouthpiece. Thus, the diaphragm attains its maximum inward and outward positions 1,000 times per second and the resistance of the carbon granules varies accordingly. The antenna current, as indicated in

view (*b*), changes from maximum to minimum and back to maximum again 1,000 times per second and the radiated energy varies accordingly.

The radio frequency is the *carrier frequency*. The radio-frequency current is the *carrier current*. The frequency of the microphone diaphragm, which in this case is 1,000 cycles per second, is the *modulating frequency*.

From the foregoing it follows that it is possible to modulate the carrier current by the voice and thus transmit speech. Instead of placing the tuning fork in front of the microphone one may talk into the mouth piece, which will vibrate in accordance with the complex air vibrations produced by speaking.

**8. Harmonics.**—The diaphragm of a telephone transmitter should respond faithfully to all the different frequencies impressed on it. Suppose that instead of one tuning fork three of them are brought near the transmitter, each differing in pitch, or frequency, and loudness. The curve *a*, Fig. 5, represents the pitch and loudness of one tuning fork; the curve *b* represents the sound produced by another tuning fork, which, as may be seen, is of a lower frequency but of a higher amplitude than curve *a*; the curve *c* represents the sound produced by still another tuning fork, this sound differing from the preceding two in both pitch and loudness. Three different forces are acting on the transmitter and each one of them has an effect on the diaphragm. Of course the loudest tone *c* has the greatest effect, but the other two are not neglected. For example, at the instant represented by the dotted line, the curves *a* and *b* show a decided tendency to move the diaphragm inwards; the curve *c*, on the other hand, shows a much stronger tendency to move the dia-

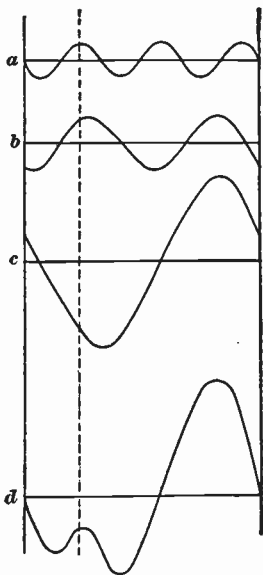

FIG. 5

phragm in the opposite direction, or outwards. The effect on the diaphragm is represented in the curve *d*. At the instant represented by the dotted line when the curves *a* and *b* act in opposition to curve *c*, the influence on the diaphragm, curve *d*, may be readily seen. The diaphragm, curve *d*, is bent outwards, by the curve *c*, but the loop in the curve *d* at this point indicates the effect of the curves *a* and *b*. The curve *d* is, as may be seen, the resultant of the component curves *a*, *b*, and *c*. If the diaphragm of the microphone vibrates in the fashion shown in curve *d*, it satisfies each of the tuning forks and the sound heard at some distant receiver will be the same as that imposed on the transmitter.

9. In a complex wave such as that represented at *d*, Fig. 5, the predominating tone *c* is called the *fundamental tone*, and the other two, *a* and *b*, are the *overtones*, or *harmonics*. A harmonic may be two, three, or more times the frequency of the fundamental tone, and hence it is called a second harmonic, a third harmonic, etc.

When two waves of the same frequency similar to that at *c* pass through their maximum, zero, and minimum values at the same time they are considered as being *in phase*. When their corresponding maximum and minimum values do not occur at the same time even though both waves may be of the same frequency, the waves are considered as being *out of phase*. The difference in phase is usually expressed in degrees. One complete set of values from normal or zero to maximum in one direction, zero, maximum in the opposite direction back to zero, is given a value of 360 degrees.

10. All the complex vibrations of the microphone due to speech may be resolved into an infinite number of harmonic components of different frequencies and different amplitudes bearing certain phase relations to one another. Theoretically the number of these components is infinite, but practically, only those having a frequency of between 300 and 2,000 cycles per second have an amplitude great enough to be considered. The amplitude of the others is so small that they are negligible.

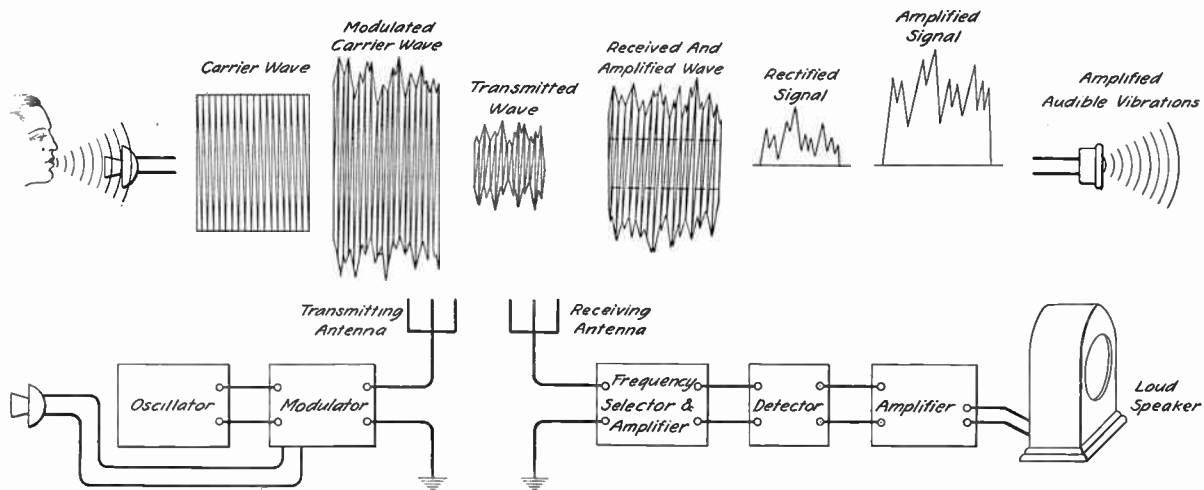

FIG. 6



The following is a principle that is of very great importance in radio telephony as well as in wire telephony: As long as the amplitude of the harmonic components of the transmitting microphone diaphragm vibrations are reproduced in the receiving microphone diaphragm vibrations, bearing the same ratio to one another that they had at the start, without any reference whatever to phase relations, the speech that caused the vibrations of the transmitting microphone diaphragm will be faithfully reproduced in the receiver without any distortion.

### 11. Graphic Representation of Radio-Telephone System.

The various transformations of energy in a radio-telephone system are shown graphically in Fig. 6. On the left is represented the transmitter and on the right the receiving system. Sound waves striking the microphone modulate the carrier wave, which appears in the transmitting antenna circuit as a modulated carrier wave. This energy reaches the receiving antenna in reduced form, and is amplified by the radio amplifier, rectified by the detector, amplified by the audio amplifier, and changed into sound by the loud speaker. The performance at the receiving station is exactly the reverse of that at the transmitting station.

## MODULATING SYSTEMS

12. **Methods Employed.**—The function of the modulating system is to vary the radio-frequency output current in accordance with the low-frequency variations of the sounds to be transmitted. The different schemes of modulation operate principally by three fundamental methods; namely, variation of the resistance of the antenna circuit, of the grid voltage of the oscillator tube, and of the plate supply to the oscillator tube.

13. **Variation of Resistance.**—The first of these methods has already been touched on and is illustrated in Fig. 1. This method shows very clearly the fundamental operation of a radio-telephone transmitter, but as far as its practical application is concerned, it is obsolete where any power over 5 watts is used. Fair results can be obtained with it when the output of the transmitter is 5 watts or less, but the method is inherently a poor one.

14. **Variation of Grid Voltage of Oscillator Tube.**—The second method listed depends on the variation of the average grid voltage (biasing voltage) of the oscillator tube. In Fig. 7 is shown the application of this method of modulation when the Meissner type of oscillatory circuit is used. The functioning of this type of oscillatory circuit has already been described, so only the method of modulation will be considered. The microphone circuit is composed of the microphone *a*, a 6-volt storage

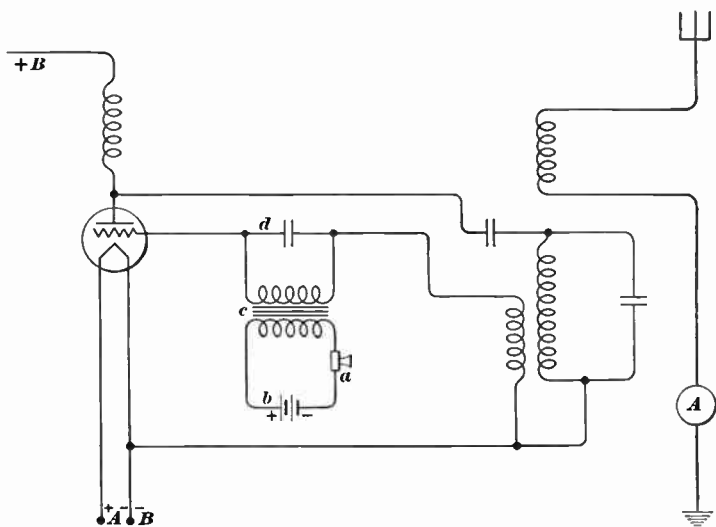

FIG. 7

battery *b* or any 6-volt battery capable of supplying 200 or 300 milliamperes, and the primary of the microphone transformer *c*. The secondary of the microphone transformer takes the place of the grid biasing resistance and is connected across the grid condenser *d*. When the microphone *a* is spoken into, the resultant action is the varying of the grid biasing voltage in accordance with the variation in the microphone displacement. As mentioned before, the result desired is to have the amplitude of the antenna current vary exactly in accordance with the microphone displacement. This result is not entirely obtained with this system of modulation owing to the following facts: The relation

between the grid biasing voltage and the antenna current is not linear (and it should be for good modulation); that is, a certain percentage variation in grid biasing voltage does not produce a relative percentage variation in antenna current. In fact, if a circuit condition has been obtained at which point the oscillations are stable, the antenna current is only slightly affected throughout a relatively wide range of variation in the grid biasing voltage. Therefore, these conditions are not favorable for good modulation, and by good modulation is meant the faithful reproduction of speech vibrations in the varying of the amplitude of the output radio-frequency current. By very careful adjustment, however, fairly satisfactory operation is possible.

**15. Variation of Plate Supply.**—The third method of modulation, which depends on the variation of the plate supply to the oscillator tube, is far more efficient than either of the other two methods. By variation in plate supply is meant the variation of the plate voltage, the plate current, or the plate power.

This method excels the resistance method because there is no waste in the oscillatory power as there is in the variation of resistance, which might logically be called the *absorption method*. It excels the second method because the relation between plate supply and antenna current is fairly linear over a wide range. In this method a voice voltage (one that varies in accordance with the frequency and amplitude of the sound waves due to speech which actuate the microphone diaphragm) is superposed on the direct-current voltage in the plate circuit of the oscillator tube, thus causing the plate current, and subsequently the plate power, to vary at speech frequencies.

A complete variation from zero current to double the normal current of the oscillator tube entails an amount approximately equal to that supplied to the oscillator during normal operation. By normal operation is meant the functioning of the oscillator tube as a generator of radio-frequency currents with a constant plate supply, hence with no superposed variations due to speech. Thus, the modulating device must be capable of supplying this power to the oscillator tube or of controlling its supply from the plate source. The microphone, because of its low current-

carrying capacity rating (100 milliamperes), is incapable of controlling the plate supply to the oscillator tube directly, but must effect its control indirectly; and it does this through the medium of an auxiliary tube called the modulator tube.

16. The practical application of the plate modulation system, which is called the Heising method of modulation after Mr. A. R. Heising of the Western Electric Company, is shown in Fig. 8. The oscillatory circuit shown here is of the Colpitts type. When the microphone *a* is idle, there is a constant plate supply, both to the modulator tube *b* and the oscillator tube *c*. It follows, then, that the radio-frequency currents in the antenna circuit are of constant amplitude (c.w.) and the output is unmodulated. When the microphone is spoken into, its diaphragm follows the speech-frequency variations and subsequently its resistance varies accordingly. Thus, the direct current in the microphone circuit goes through similar variations and there is a pulsating direct current in this circuit. Alternating voltages are set up in the secondary winding of the microphone transformer *d*, owing to the pulsating currents in the primary winding, and are applied to the grid of the modulator tube. This causes the plate current of this tube to vary accordingly. In the common plate supply to the modulator and oscillator tubes *b* and *c* there is an iron-core choke coil *e* of very high inductance. It is the inherent property of an inductance to oppose any change in the current passing through it, therefore the choke coil in the plate circuit tends to keep the value of the current passing through it constant.

If at any instant the grid of the modulator tube *b* goes positive, the plate current of this tube increases, and since the choke coil *e* tends to keep the total current to both tubes constant, the modulator tube *b* draws current away from the oscillator tube *c* and the current to the oscillator tube decreases. Conversely, when the modulator grid goes negative, the modulator plate current decreases and the oscillator plate current increases because the total supply of current to both tubes is maintained constant by the choke coil. Thus, the average plate current to the oscillator tube, as well as the radio-frequency antenna current, is varied at an audio-frequency rate, or speech frequency.

Fig. 8

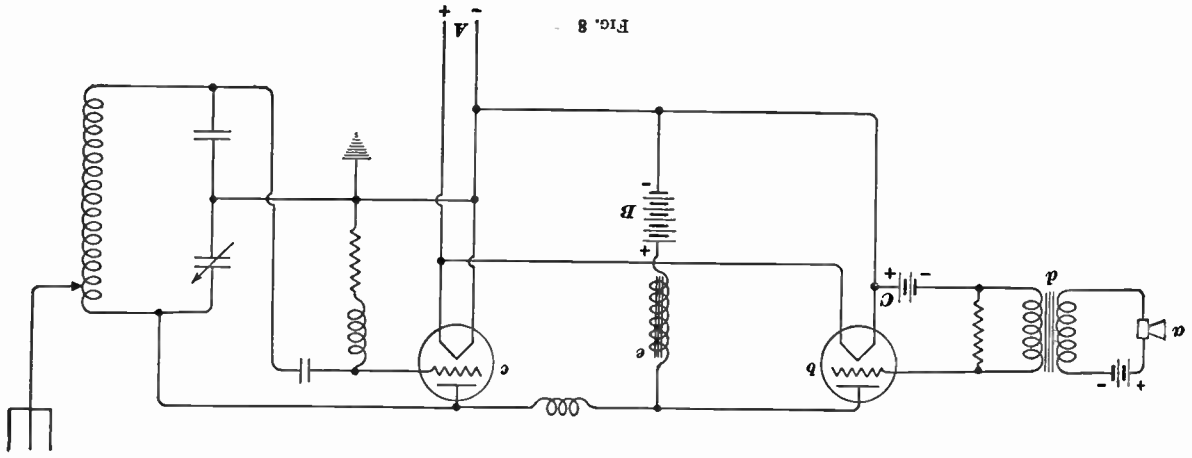

17. With the aid of Fig. 9 this action can be made clearer. Here the modulator plate-filament circuit has been represented as a variable resistance  $a$  because its average grid voltage varies at a speech-frequency rate. The oscillator-tube plate-filament circuit has been represented as a constant resistance  $b$ , since its average grid voltage remains constant. The plate source is shown at  $B$  and the iron-core choke coil at  $c$ .

Let it be assumed that a 1,000-cycle tuning fork is set vibrating in front of the microphone. The modulator grid voltage and, consequently, plate current, will go through similar variations of the same frequency as the tuning fork. This will make the plate circuit of the modulator tube function as a variable resistance connected across the plate supply. If it is assumed that the modulator plate current changes from zero to twice its normal value, and by normal value is meant the value of the plate current passing when the microphone is idle, then it follows that the oscillator plate current must increase and decrease about its normal value to the same extent.

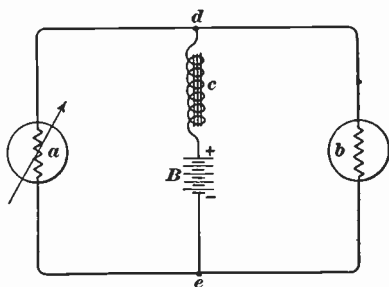

FIG. 9

If the value of the oscillator plate current is varied at the rate of 1,000 cycles per second, the amplitude of the radio-frequency antenna current is varied at the same rate. Since the resistance of the oscillator plate-filament circuit is considered constant and since the current through this resistance is changing from zero to twice the normal value, the power expended in this resistance must change from zero to four times the normal value, since power is equal to the square of the current times the resistance. The power is also equal to the voltage across the resistance times the current through it, and since the power changes to four times the normal power, the current only changing to twice normal current, it follows that the voltage across the oscillator resistance and hence the voltage across the points  $d$  and  $e$  in Fig. 9 must change to twice its normal value.

## BROADCASTING AND COMMERCIAL TRANSMITTERS

### BROADCASTING TRANSMITTERS

#### DIFFERENCE BETWEEN BROADCASTING AND COMMERCIAL TRANSMITTERS

18. There is a marked difference between the commercial type of radio-telephone transmitter and the type of transmitter used for broadcasting. The limits for both the mechanical and electrical designs of the former are definitely fixed by economic and operating conditions. On the other hand, the economics of the broadcasting station are indefinite and the method of operation is determined by factors far removed from those governing commercial traffic.

The commercial radio-telephone transmitter is designed in such a manner that it can be used for either telegraph or telephone communication. On the commercial type of transmitter it is possible, by means of a wave-change switch, to change to any one of half a dozen wavelengths to which the set is tuned and, by means of a separate gang switch, to select any one of the following methods of transmission: continuous-wave telegraphy (cw.), interrupted continuous-wave telegraphy (icw.), and telephone. The broadcasting transmitter, however, is limited to one particular wavelength. The oscillatory circuits are tuned to that one wavelength and all the associated apparatus is adjusted for maximum efficiency at that particular wavelength. In general, the commercial transmitter is required to transmit only the band of frequencies necessary to handle commercial telephony, whereas the broadcast transmitter must be capable of transmitting frequencies from the deepest tone of the organ or orchestral instruments to the highest note of the piccolo or flute.

19. The broadcast transmitter has been subjected to numerous refinements that, owing to both economic and operating con-

ditions, could not be incorporated in the commercial type of transmitter. All apparatus in a broadcasting station is in duplicate to insure continuity of service. The general requirements of the broadcasting station are as follows:

The station must be ready to operate at all times so that the director may at any time handle a special program; continuity of service is absolutely necessary—the equipment must be so designed and operated that there will be no interruptions during the program; the quality must be of the highest order; the transmitter frequency must remain constant under all operating conditions.

#### LAYOUT OF BROADCASTING STATION

20. **Power Plant.**—In Fig. 10 is shown the plan view of the layout for a modern broadcasting station. In this case the power-

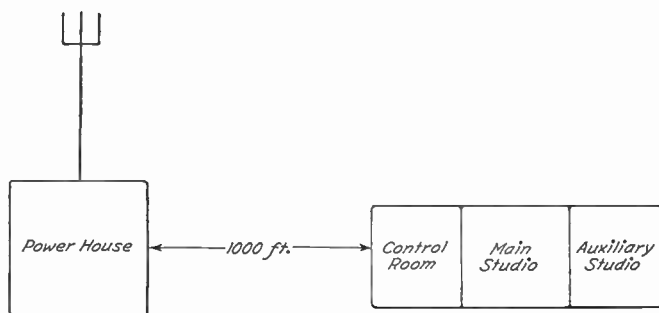

FIG. 10

house is situated 1,000 feet from the studio, but this is not a necessity, and in many instances the powerhouse is located adjacent to the control room.

The powerplant contains all equipment necessary for the generation, modulation, and radiation of radio-frequency power. This apparatus is located in what is called the powerhouse, and consists of the following equipment supplied in duplicate to insure continuity of service; Kenotron rectifier unit or motor-generator set to supply high-voltage direct current; radio-frequency generator utilizing high-power vacuum tubes as oscillators; modulator unit, utilizing high-power vacuum tubes as modulators, and the antenna and ground system.



21. **Control Room and Studio.**—The control room, Fig. 10, contains all amplifying and switching equipment. The main studio consists of the usual room prepared and furnished espe-

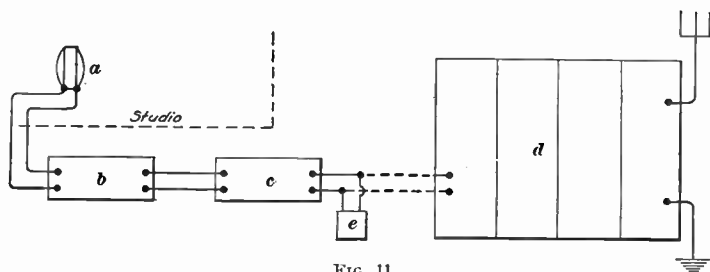

FIG. 11

cially for broadcasting service. The walls and ceiling are covered with draperies to prevent excessive reflection of the sound waves. All microphone and control circuits are carried in lead-covered cables laid behind the wall draperies. Connection boxes are usually located along the baseboard near the floor for the microphone outlets. The auxiliary studio is similar to the main studio but is generally much smaller, and is used principally for readings and lectures.

In Fig. 11 is shown the arrangement of apparatus for local broadcasting from a studio. The output of the microphone *a* at the studio goes to the amplifiers *b* and *c* and finally to the transmitter *d*. A modulation indicator *e* follows the second

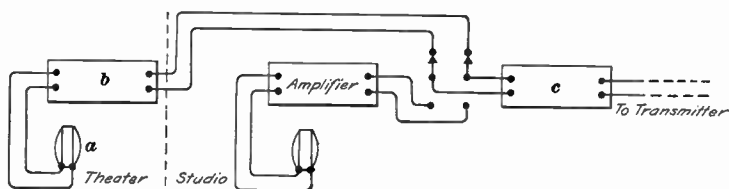

FIG. 12

amplifier *c* to enable the attendant to check the degree of modulation. The arrangement for broadcasting from a distant point such as from a theater or concert hall is shown in Fig. 12. A microphone *a* and an amplifier *b* are placed in the theater and connect by a line and change-over switch to the second ampli-

fier *c*. The output of the second amplifier is delivered to the station transmitter.

22. **Microphones.**—Several types of microphones, or pick-ups, are used in broadcasting stations. The ordinary carbon-granule transmitter is the one that is most frequently used. Other types such as the magnetic, condenser, etc., may be found at the various broadcasting stations. The magnetic transmitter

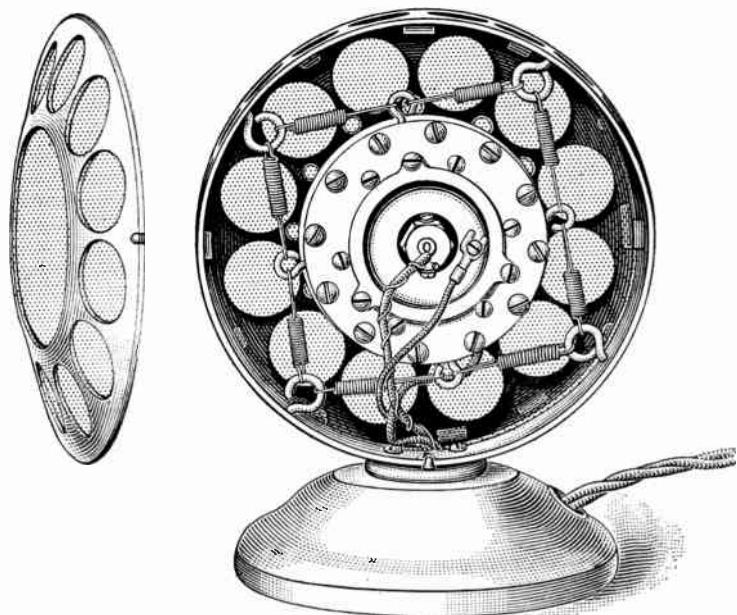

FIG. 13

is similar to the magnetic amplifier used in large commercial telegraph stations. In this connection a microphone takes the place of the telegraph key. The condenser microphone, as the name implies, utilizes the condenser principle for its operation. One of the plates of such a condenser is made rigid, the other movable. Sound waves striking the movable plate cause it to vibrate, thereby varying the capacity of the condenser so formed.

23. **Microphone Transmitter Type 387-W.**—The 387-W microphone transmitter encased in a 1-B mounting is shown in

Fig. 13. This microphone is of the push-pull type and consists of two heavy metal rings supporting a thin stretched metallic diaphragm, which acts on two carbon buttons mounted one on each side of the diaphragm. The manner in which this transmitter is connected to the first amplifier tube is shown in Fig. 14, where the microphone is shown at *a*. The resistance of each button is about 100 ohms and, as the two are in reality in series for the voice currents, the output impedance of the transmitter is approximately 200 ohms.

The transmitter should be mounted in No. 1-B transmitter mounting, as shown in Fig. 13, or in a program microphone stand. It should always be properly mounted in a vertical position before current is allowed to pass through it.

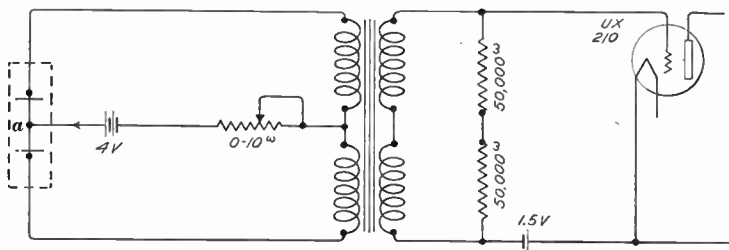

FIG. 14

24. The operating current in each side of the transmitter circuit, Fig. 14, should not exceed 35 milliamperes. In the 387-W transmitter, the difference between the values of the current in the two sides of the circuit should not exceed 5 milliamperes. The normal operating current for this transmitter is 30 milliamperes per button. This gives as good results as a higher value and the life of the transmitter is correspondingly increased.

If the current in either side of the transmitter circuit exceeds 35 milliamperes or if the difference between the current in the two sides of the circuit exceeds 5 milliamperes, it indicates that the transmitter has become packed or permanently aged. *Packing* consists of a coherence of the carbon granules and is accompanied by a drop in the resistance of the transmitter and a loss of sensitivity. A transmitter that has become packed may be

brought back practically to normal by disconnecting it and gently rotating or tapping it so as to shake up the carbon granules. If this does not remedy the packing a new transmitter should be used. Current readings should be taken after the current has been flowing through the transmitter for a few minutes.

25. Although the 387-W transmitter is of rather rugged construction, it has a very thin diaphragm, and unless the transmitter is handled carefully, the diaphragm may be damaged or put out of adjustment. It is not wise to attempt to repair a defective transmitter; it should be returned to the factory when repairs are necessary. The mounting, Fig. 13, is a drum-shaped metal case mounted on a circular base and equipped with coil springs for suspending the transmitter. It has a three-conductor cord by means of which the transmitter is connected to the circuit with which it is used.

The transmitter and the 1-B transmitter mounting are assembled by removing the side of the case marked *back* and suspending the transmitter by the coil springs as shown in the figure. The back of the transmitter should always face the side of the transmitter mounting marked *back* and the mounting should always be placed so that this side is away from the source of sound.

If the cord becomes defective and replacement is necessary, the transmitter should be removed from the transmitter mounting and the cord disconnected. The bottom is then removed from the base by taking out the screw in the center. A new cord is then inserted through the hole in

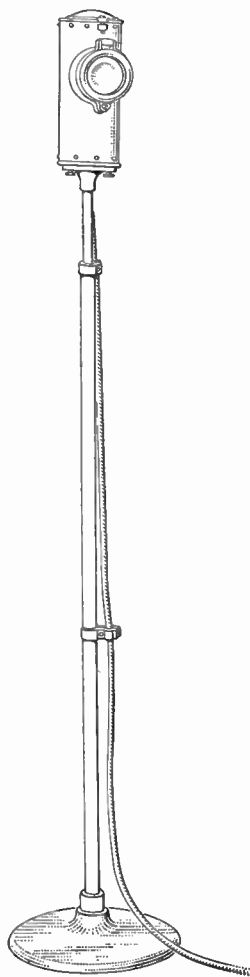

FIG. 15

the side of the base and run up into the case, sufficient length of cable being left for connection to the transmitter. The bottom of the base is then replaced and the transmitter is connected. The transmitter may be mounted in a program microphone stand in the same manner that it is mounted in the 1-B mounting, except that there is no protective covering around it.

**26. Condenser Microphone.**—A condenser microphone combined with a two-stage amplifier and mounted on a stand is shown in Fig. 15, and a schematic circuit diagram of the com-

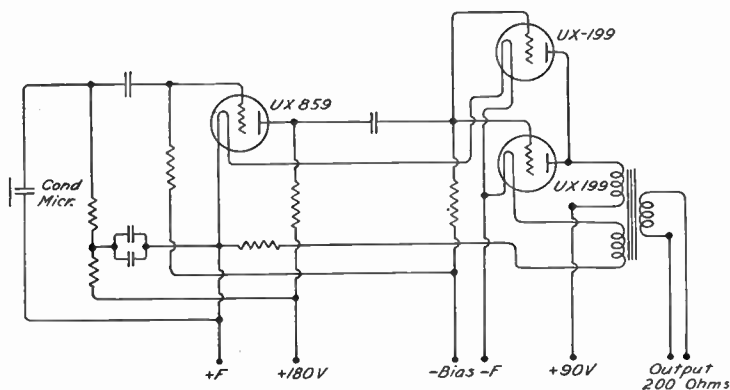

FIG. 16

plete unit is shown in Fig. 16. The secondary winding on the output transformer is of low impedance (200 ohms) so that the microphone cable may be run for a considerable distance without picking up interfering current.

#### ONE-KILOWATT BROADCAST TRANSMITTER

**27. Apparatus Used.**—A complete radio broadcasting transmitter, having a radio-frequency power output of 1 kw. will now be considered. The complete installation consists of (a) a studio, and (b) the radio transmitting station. The studio includes the studio control and speech equipment as well as the necessary power supply. The radio transmitting station contains the speech input panel, the radio transmitting unit, the power control and rectifier unit, the filament motor-generator

set, and the water circulating and cooling system. All this apparatus is designed for continuous service, 24 hours a day, if necessary. Except for the renewal of rectifier and amplifier tubes and the adjustment of the microphone, the equipment will last indefinitely.

28. **Studio Control.**—The studio includes all the equipment necessary for high-quality conversion of sound into electrical energy suitable to send over a telephone line to the radio transmitter. For the studio itself are provided one carbon microphone and one condenser microphone for program pick-up. One

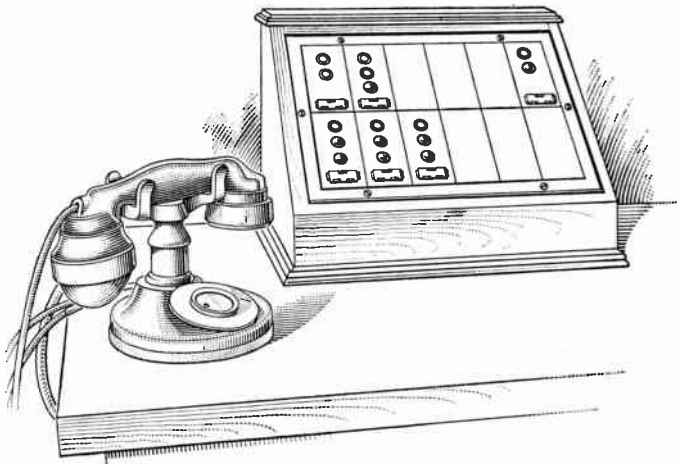

FIG. 17

additional carbon microphone is provided for the announcer. A small control unit, Fig. 17, having key switches, signal lights, and intercommunicating telephone to the control room enables the announcer to switch on or off the different microphones and keep the control and radio-station operators advised of the progress of the program.

29. **Speech-Input Equipment.**—The speech-input equipment consists of an assembly of apparatus mounted on relay racks and located in the control room at the studio location. The use of relay racks saves floor space, provides easy access to the apparatus, and permits of addition of more apparatus when

desired. This equipment includes the necessary relays for the studio signal lights, microphone control and mixing panel, line compensating panel, jacks for telephone lines, amplifier for use between the microphone and telephone line, volume indicator and monitoring amplifier for loud-speaker operation. The amplifiers are designed with sufficient amplification to give the maximum voltage allowed by telephone companies on their lines, and with proper impedance for connecting to them. Unless the lines are very poor, the amplifier will deliver ample audio voltage to the radio station over circuits up to 15 miles in length.

30. In addition to the amplifiers and the associated miscellaneous equipment, the relay-rack assembly contains a rectifier and associated filter circuits for providing plate voltage for all the amplifiers as well as the necessary voltage for the condenser transmitters. Each equipment also includes heavy-duty glass-jar storage batteries in duplicate with charging equipment for supplying filament current to the amplifiers, current for operating the relays and signal lights of the control system, and current for carbon transmitters if these are used.

The tubes used in the studio control-room equipment are: Three UX-210 in the line amplifier; one UX-210 in the volume indicator; one A-548 in the condenser microphone; two UX-201A in the monitoring receiver; and one UX-210 in the monitoring amplifier.

31. **Transmitting Units.**—The 1-kilowatt Western-Electric broadcast transmitter is shown in Fig. 18. It consists of two units. The unit shown on the left is the oscillator in which three 50-watt tubes are located. One of the tubes is a crystal-controlled oscillator and two of the tubes are radio-frequency amplifiers. Modulation takes place in the second radio-frequency amplifier tube of this unit, which may be seen in the schematic diagram, Fig. 19. Thus modulation occurs with considerable advantage at an early stage.

The crystal-control facilities maintain adherence within 100 cycles of the assigned frequency. This is accomplished by means of a small quartz plate, the faces of which are accurately paralleled. The plate is kept at a constant temperature in an insu-

lated, electrically heated, and thermostatically controlled container.

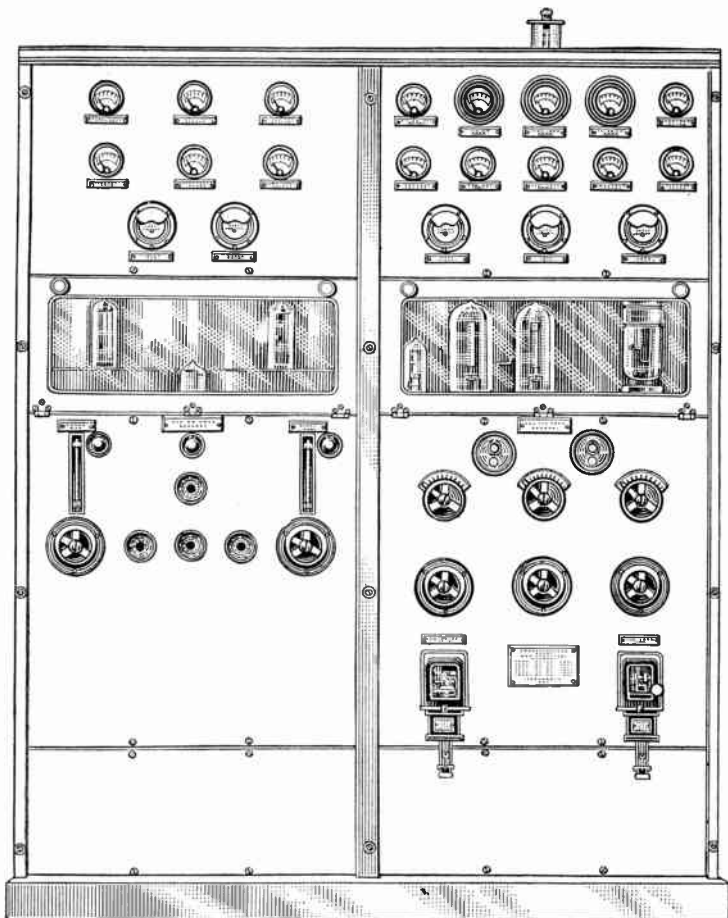

FIG. 18

32. The unit on the right, Fig. 18, is the amplifier, in which one 50-watt, two 250-watt, and one water-cooled tube are located. The 50-watt tube and the first 250-watt tube (audio input and audio power amplifiers, Fig. 19) operate as speech amplifiers. The output of the 250-watt speech amplifier is used



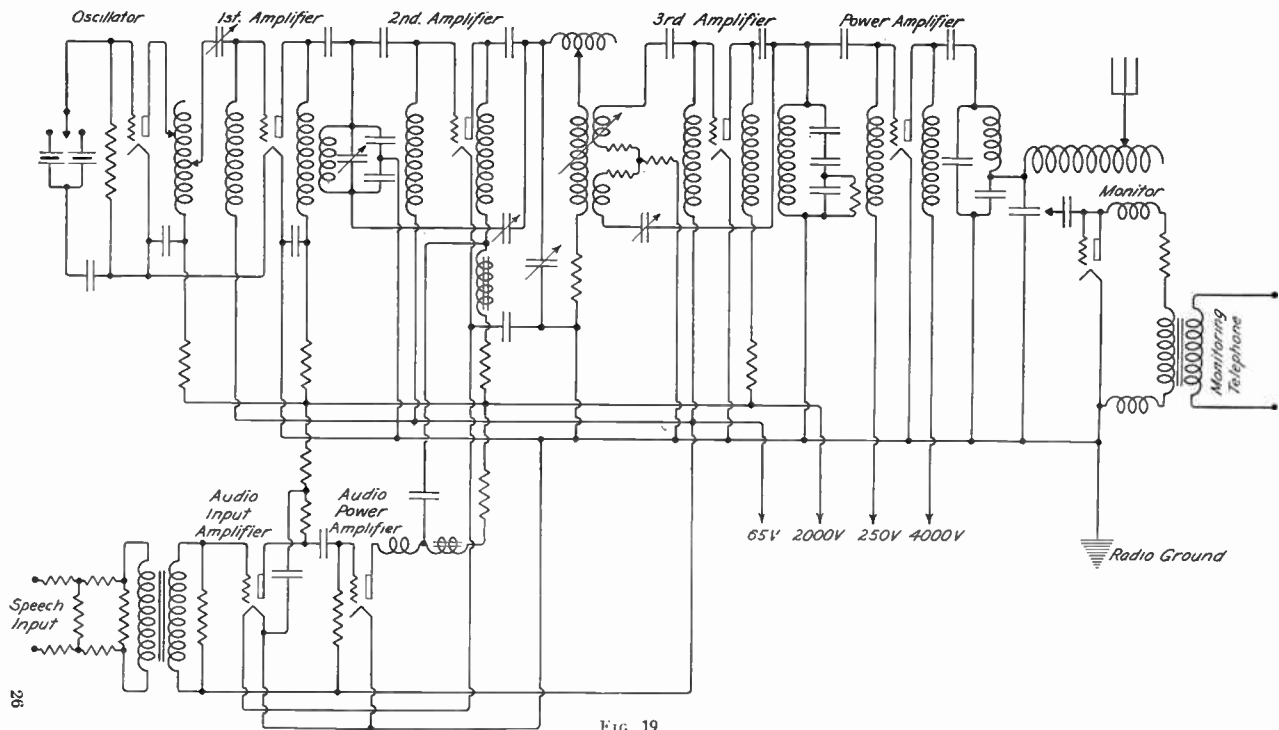

FIG. 19

to modulate the radio-frequency output of the last amplifier (second amplifier, Fig. 19) of the oscillator unit, while the second 250-watt tube (third amplifier, Fig. 19), and the water-cooled tube (power amplifier, Fig. 19) amplify the modulated radio-frequency output of the oscillator unit. The output of the water-cooled tube is delivered to the antenna by means of a capacity-coupled circuit.

In addition to these two units, power supply, cooling system, and speech-unit equipment are included. The system also includes monitoring equipment to judge the output, and receiving equipment to catch distress signals on ship wavelengths.

**33. Advantages of Crystal-Controlled Oscillator.**—It has been mentioned that the frequency of the transmitter under consideration is maintained well within 100 cycles of the assigned frequency. This unusual precision is accomplished by the crystal-controlled oscillator. A piezo crystal consisting of a small quartz plate about 1 inch square is used. Its faces are accurately paralleled and ground to a thickness dependent on the operating frequency of the station. To assure the utmost degree of reliability a second crystal, complete with container, thermostat control, and heater is provided for emergencies. It is possible to switch from one crystal to the other while the transmitter is in operation.

**34.** The crystal control guarantees closer adherence to the frequency for which the oscillator is adjusted than is possible under the most favorable conditions of manual control. Another advantage of the crystal control is that in combination with the isolating stage between the oscillator and the modulating amplifier, it prevents frequency modulation and its attending distortion in transmission.

**35. Station Speech-Input Equipment.**—If the studio and the station are remotely located from each other, then the use of two speech-input equipments is necessary; one at the studio and one at the station. The station equipment includes jacks for terminating the necessary program and order-wire circuits, a line amplifier, monitoring features, and an emergency announc-

ing microphone. A rectifier furnishes the plate voltages; and storage batteries, in duplicate, with charging equipment furnish the filament voltages.

**36. Power Equipment and Water-Cooling System.**—Motor generators, shown in Fig. 20, provide the power supply for the transmitter. One set consists of a 24-volt generator for filament supply and a 250-volt generator for grid voltage supply and excitation of the high-voltage machines. Both generators are

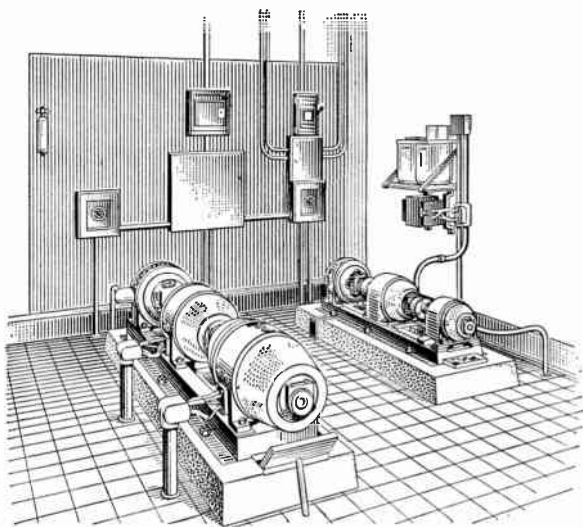

FIG. 20

mounted on the same base with a 4-horsepower driving motor. The other motor-generator set consists of two 2,000-volt generators driven by an 8-horsepower motor. One of these generators furnishes the plate voltage to the radiation-cooled tubes. The water-cooled tube required 4,000 volts plate potential, and this is obtained with the two 2,000-volt generators connected in series.

**37.** The motors are started by means of automatic motor starters, which operate on the impulses on the starting and stopping push buttons. The automatic starters together with a

safety-type line switch and fuses for the driving motors are designed to mount on the wall contiguous to the motor-generator sets. The starters, safety switch, and fuses are enclosed in black steel cabinets as shown in Fig. 20.

38. The water-cooling system for the power amplifier tube consists of a large radiator, an expansion tank, and a motor-driven rotary impeller pump. The water is pumped from the radiator, which is usually placed near a window or other source of outside air, passes through the pump to the tube jacket, where

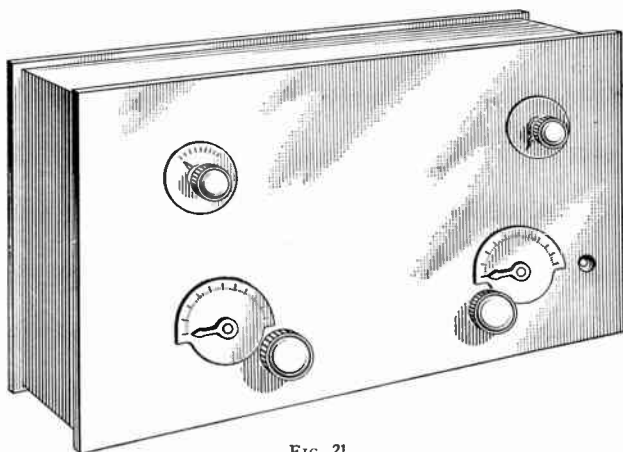

FIG. 21

it performs its cooling function and then is dispatched through a rubber and metal tube into the radiator, where the heat is dissipated.

Some of the salient advantages of the use of water-cooled instead of radiation-cooled tubes are: larger capacity tubes are possible; lower tube temperature is maintained, which results in better operating conditions and longer life of tubes; tube overhead is reduced; less heat is radiated from the tubes into the operating room. Should the water-cooling system for any reason fail, a water-flow operated relay automatically shuts down the set.

39. **S O S Receiver.**—An S O S receiver, like that shown in Fig. 21, is furnished with the transmitter whenever the trans-

mitter is to be located near the seaboard where its programs may interfere with the reception of distress signals. The receiver is of the superheterodyne type utilizing eight dry-cell radio tubes. Included with the receiver is a wavetrap tuned to the transmitter wavelength to overcome any receiving difficulties that may arise from proximity to the transmitting antenna. The receiver and wavetrap are mounted in and completely shielded by an aluminum case finished in cracked crystalline lacquer.

#### FIVE KILOWATT WESTERN-ELECTRIC BROADCAST TRANSMITTER

**40. Description of No. 105-C Transmitter.**—The Western-Electric No. 105-C transmitter incorporates certain advanced principles of engineering which add to the stability, range, and economy of operation. Like the 1-kilowatt No. 106-B transmitter, it uses a crystal-controlled oscillator, which adds considerably to maintenance of the assigned frequency standards. Modulation also takes place at a low level, which permits of substantially complete modulation. Doubling the amount of modulation, quadruples the effectiveness of the equipment. When modulation takes place at a high level, a considerable number of large and expensive tubes are required to obtain comparable results. Low-level modulation is, therefore, not only a better engineering solution but is a noteworthy contribution toward decreased cost of operation.

The complete transmitter is shown in Fig. 22, where the panels from left to right are as follows: A.-c. power-panel unit, rectifier unit, oscillator unit, amplifier unit, power-amplifier unit, and tuning unit. A schematic circuit diagram of the transmitter is shown in Fig. 23.

**41. A.-C. Power-Panel Unit.**—The a.-c. power-panel unit, Fig. 22, is served by a 220-volt, 3-phase, 60-cycle power supply. It imparts the necessary electric energy to the motor-generator sets, rectifier transformers, pump and blowers for the cooling system, the heater circuit for the crystal enclosing chambers and to other components requiring power from this source. Suitable overload protection and control for associated apparatus is provided in this unit.

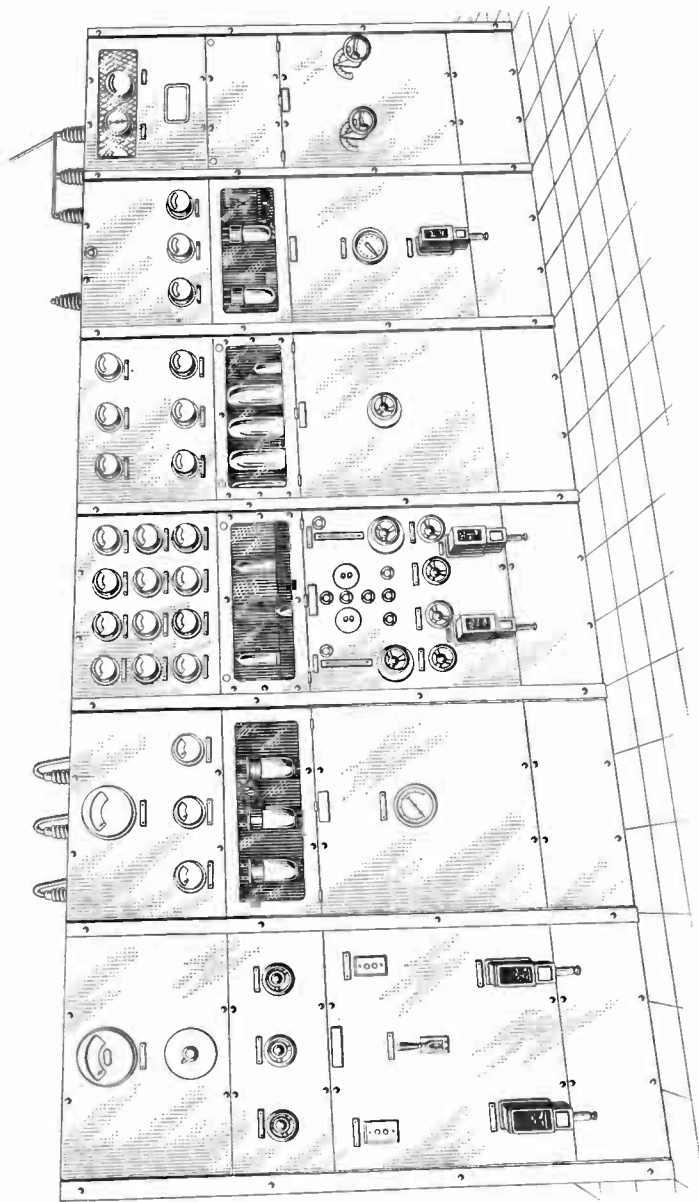

FIG. 22

**42. Rectifier Unit.**—The second unit, Fig. 22, contains the rectifier elements. This unit supplies 10,000 volts for the water-cooled tubes in the power-amplifier unit. From the schematic diagram of the transmitter, Fig. 23, it will be seen that the rectifier is of the 3-phase type and employs three two-element tubes as rectifying elements. The tubes are of the water-cooled type. Their filaments are heated by alternating current at a potential of 21 volts, which is obtained by stepping down the 220-volt supply by means of three single-phase transformers. The transformers also provide suitable insulation between the filaments of the rectifier tubes and the power-supply system.

The 3-phase transformer steps up the 220-volt 3-phase supply to a voltage of approximately 10,000 to neutral. The rectified 10,000-volt direct current is filtered by means of a retardation coil and condenser to smooth out the ripples.

**43. Oscillator Unit.**—The third unit, Fig. 22, is the one in which the oscillating crystals and their amplifier are located. The circuit connections of the oscillator and its amplifier may be seen in Fig. 23. In this transmitter, modulation is effected at an early stage. The first and second amplifiers, which are 50-watt vacuum tubes, are mounted in the oscillator unit. The first amplifier is tuned and feeds the grid of the second amplifier. The tuned plate circuit of the second amplifier is connected by a modification of the Heising modulation system to the plate circuit of the audio power-amplifier tube, which in this case acts as a modulator and is mounted in the amplifier unit. Coupling between the modulating or second amplifier and the third amplifier is made by means of a movable coupling coil operated from the panel, permitting a continuously variable adjustment of the power output.

The oscillator unit also contains the direct-current power-control apparatus, and the system for obtaining from a 250-volt generator the several negative grid voltages required in operating the set.

The same form of frequency control is used as in the 1-kilowatt transmitter. Crystals are supplied in duplicate, complete with containers and thermostatic control.

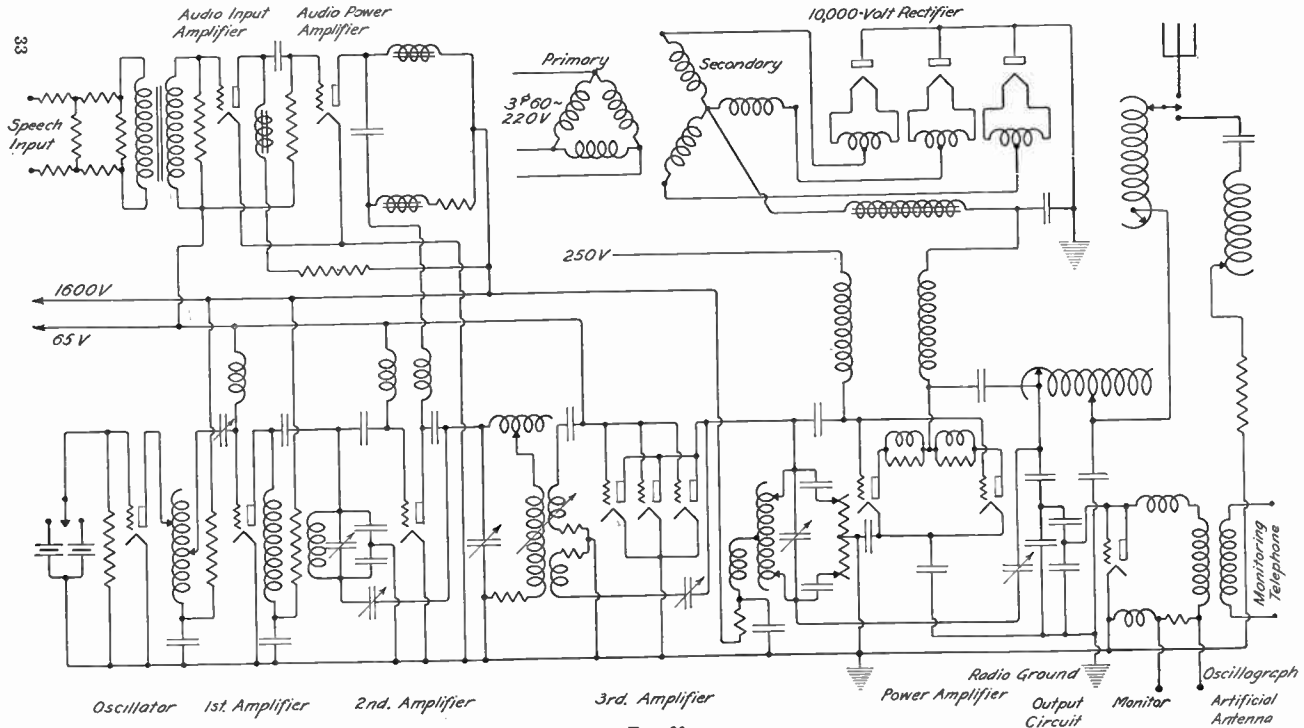

FIG. 23



**44. Amplifier Unit.**—The amplifier unit is housed behind the fourth panel, Fig. 22, and its circuit connections are indicated in Fig. 23. There are four 250-watt tubes included in this unit, three of which are used in parallel to make up the third radio-frequency amplifier. The other 250-watt tube is the audio power amplifier, which is used as the modulator, having its plate circuit connected to the plate circuit of the second radio-frequency amplifier in the oscillator unit by means of the special arrangement of the Heising modulation system mentioned in describing the oscillator unit.

**45. Power Amplifier Unit.**—The power amplifier unit is the last step of amplification. This unit is housed behind the fourth panel, Fig. 22, and its circuits are shown in Fig. 23. The output of the amplifier unit is received by this unit and amplified to the 5-kilowatt level by two tungsten-filament water-cooled tubes operated in parallel. Plate potential for these tubes is supplied by the rectifier unit at 10,000 volts. Water for cooling these tubes is conducted to the tube jacket by means of a rubber hose. A pressure gauge in the center of the panel shows at a glance whether the water-circulating system is operating properly.

**46. Tuning Unit.**—The tuning unit, which is housed behind the last panel, Fig. 22, contains a closed tuned circuit and a coupling condenser of large capacity. It provides the means by which the output of the power-amplifier unit is transmitted to the antenna. The coupling circuits, shown in Fig. 23, constitute a filter that minimizes the radiation of all radio-frequency harmonics. The tuning coil is shielded. The arrangement of tuning and coupling condensers makes it possible to operate the transmitter in connection with antennas whose resistances fall within the range of 15 to 600 ohms. Three meters behind the plate-glass window in this unit assure very precise adjustment of the output circuits, especially in connection with tuning high-impedance antennas.

The tuning unit contains also monitoring equipment so that the operators may compare the quality of the output of the transmitter with its input. Sound conversion is accomplished by means of speakers, like that shown in Fig. 24. These speakers

operate from an amplifier in the speech-input equipment. One in this way the operating staff is constantly aware of the effectiveness of the programs as broadcast.

**47. Accessory Equipment.**—The 105-C transmitter is provided with speech-input equipment both for studio and for station. This equipment is practically the same as that described in connection with the 1-kilowatt transmitter.

The power equipment requires for its operation 3-phase, 220-volt, 60-cycle power. To supply the 16 volts for the filaments and 1,600 volts for the plates of the air-cooled tubes used in the oscillator and amplifier units, a three-unit motor-generator set is used. For energizing the tube filaments in the power amplifier unit, a 22-volt motor-generator is employed. A 250-volt motor-generator set supplies all grid voltages. The transformer-rectifier system mentioned in describing the rectifier panel supplies the 10,000 volts necessary for the plates of the water-cooled tubes.



FIG. 24

**48.** The water cooling and circulating system is similar to that used in the 1-kilowatt system.

Floor-type or table-model condenser or carbon microphones are provided. The condenser transmitter is generally supplied with its associated amplifier.

The studio-control system, radio-receiving equipment, tuning unit, and filter complete the transmitter equipment.

#### **FIVE-KILOWATT R. C. A. BROADCASTING TRANSMITTER, MODEL 5-A**

**49. General Features.**—The radio circuit utilized in this transmitter is of the crystal-controlled master-oscillator, intermediate power-amplifier, main power-amplifier type. This circuit is used to maintain a high degree of frequency stability, a

feature necessary in modern broadcasting. The frequency of the transmitter wave is not affected by normal variations in antenna constants, or in power-supply voltage. The master oscillator is accurately maintained on its frequency by either one of the four quartz crystals supplied. Modulation of the radio-frequency output is obtained by the constant-current system of plate modulation, which provides positive modulation. High quality is maintained with modulation percentages to the order of 60 to 70 per cent., with one modulator tube. This transmitter

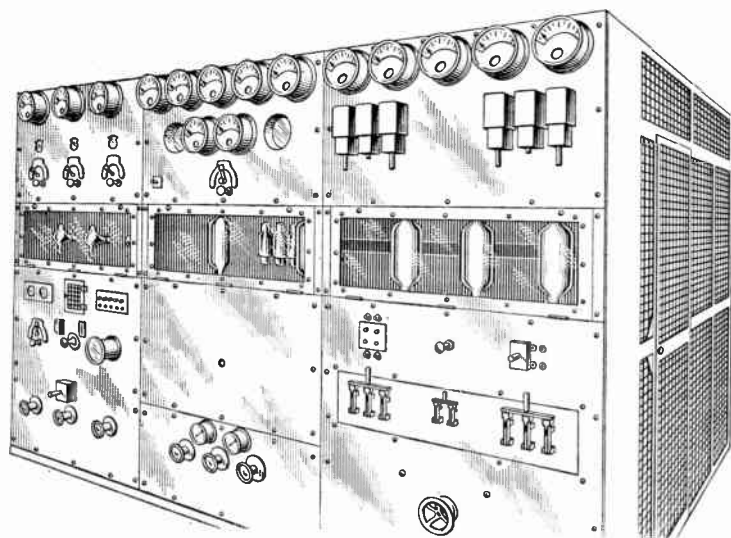

FIG. 25

is rated at 5 kilowatts in the antenna. The radio-frequency power amplifier is designed to deliver 5 kilowatts of unmodulated power to the antenna. A front view of the transmitter is shown in Fig. 25.

**50. Power Supply for Model 5-A Transmitter.**—All the power for the transmitter is obtained from motor-generator sets and a high-voltage rectifier. All power equipment operates from a 220-volt 3-phase, 60-cycle power supply.

The filament supply for the UV-203-A tubes of the high-power audio amplifier is obtained from storage batteries. The

motor-generator is shown in Fig. 26. The motor is rated at 6 horsepower and operates at 1,800 revolutions per minute. The plate generator is rated at 3 kilowatts and is capable of supplying 1 ampere at 3,000 volts. The bias generator is rated at .53 kilowatt and 125 volts.

**51. Vacuum Tubes.**—The complete equipment at the transmitter utilizes a total of seventeen active power tubes as follows:

Two UV-203-A as audio amplifier;

One UV-849;

One UX-210 as crystal-controlled master oscillator;

Two UX-860 as intermediate power amplifier;

One UV-861 as intermediate power amplifier;

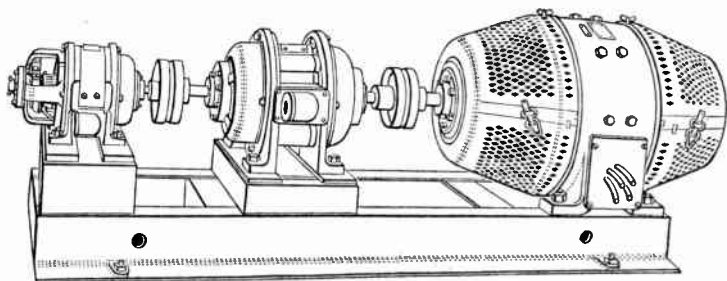

FIG. 26

One UV-848 as main power amplifier;

One UV-848 as modulator;

Four UV-217-C as bias rectifier;

One UV-217-C as monitoring rectifier;

Three UV-219 as kenotron rectifier—high voltage.

**52. Frequency Range.**—The model 5-A transmitter is designed to operate at any frequency in the band from 500 to 1,500 kilocycles (545-200 meters), when the corresponding quartz crystals are supplied. The antenna system is fed by a transmission line having a surge impedance of approximately 600 ohms. The transmitter is designed so as to reduce all harmonics to a minimum.

**53. Component Units.**—The complete equipment is divided into a number of major units as follows:

- (a) High-power audio amplifying equipment ;
- (b) Crystal-controlled amplifier equipment ;
- (c) Main power-amplifier and modulator ;
- (d) Antenna coupling and tuning equipment ;
- (e) Rectifier equipment and control panel ;
- (f) Motor-generator and battery-charging equipment ;
- (g) Miscellaneous equipment.

**54. Special Features of Model 5-A Transmitter.**—The following is a summary of some of the special features of Model 5-A transmitter :

1. The frequency characteristic of the transmitter is substantially flat from 30 cycles to 10,000 cycles with a slight drop at the high-frequency end. By substantially flat is meant a variation not greater than plus or minus 10 per cent. from the average value.

2. Each UV-848 power tube of the transmitter has its own mounting and water-jacket. Each tube is removable from the front of the panel and is provided with the following controls and meters: (a) plate ammeter (direct-current); (b) grid ammeter (direct-current); (c) grid-bias voltmeter; (d) overload indicating drop; (e) filament and plate disconnect switches; (f) a relay in the grid circuit of the power amplifier tube so that the plate voltage cannot be applied to the tube unless the grid is excited.

3. The modulation system used with this transmitter is commonly known as the constant-current system of plate modulation. Amplitude modulation of the power amplifier is accomplished by increasing and decreasing the plate voltage on the power-amplifier tubes, in contrast to increasing the grid swing on these tubes, as is done in grid-modulated systems. Inherently, all things being equal, the undistorted maximum output of a tube becomes much higher from an increase of plate voltage than from an increase of grid swing. In general, it is possible to obtain higher percentages of undistorted modulation with the constant-current system than with the grid-modulation system, each case using the same total number of tubes of equal power rating.

4. This transmitter is quartz-crystal controlled and is more than capable of meeting General Order No. 7 of the Federal Radio Commission, which states that the "Federal Radio Commission hereby fixes a maximum of one-half kilocycle (500 cycles) as the extreme deviation from its authorized frequency, which will be permitted to any broadcast station operating under permit or license issued under the terms of the Radio Act of 1927." The four quartz crystals supplied are mounted in an asbestos-lined container and are held at a constant temperature of 45° C. by means of a thermostat. Because of this feature, the frequency of these quartz crystals will not change.

5. Each UV-848 plate circuit is provided with an indicating drop-out, which displays a white target when the tube has been overloaded. This feature enables the operator to locate any trouble with a minimum of lost time.

6. The UV-848 water-cooled tubes used in this transmitter are rated at 15,000 volts; but in this case they are being used at only 10,000 volts, which means that they are being conservatively operated in such a manner as to give long tube life.

7. This transmitter will supply 5 kilowatts of unmodulated radio-frequency power to the antenna and when modulated will deliver more than 5 kilowatts of energy, because of its system of plate modulation. Modulation percentages in the order of 60 to 70 per cent. may be obtained without distortion.

8. The transmitter is fully protected from overloads and other causes that might damage the apparatus. Some of these protections may be listed as follows:

(a) A water-flow interlock for each of the water-cooled tubes rings a warning signal should the water flow become slightly restricted, and immediately shuts down the transmitter should the water flow be stopped.

(b) Two instantaneous relays are provided in the input circuit and one instantaneous relay *kickout* under extremely heavy surges either in the input or output circuit of the rectifier. The time-delay relay opens, should the overload extend over a short period of time. After the relays have operated, it is necessary to depress the rectifier start-stop push-button switch in order to apply plate voltage again to the transmitter.

(c) The audio-amplifier and crystal-controlled amplifier units are totally enclosed and have their doors provided with interlocks, which remove excitation from the high-voltage generator when the doors open. The ordinary procedure for removing voltages from these units is to open the field on the 3,000-volt motor-generator set. The door interlocks are supplied so that the operator cannot accidentally come in contact with any of the live parts should he neglect to open the plate field switch. The doors on the front of the power amplifier and rectifier panels are also interlocked. The interlocks on the door of the power-amplifier control the power-amplifier and modulator-bias rectifiers and also the high-voltage rectifier. The interlock on the door of the rectifier controls the high-voltage rectifier.

9. This transmitter is designed to feed the antenna system through a transmission line. Some of the outstanding advantages of transmission-line coupling over a direct-coupled antenna may be listed as follows:

(a) The antenna may be erected at a distance from the transmitter building, thus eliminating losses resulting from metallic structures in the field of the antenna.

(b) Transmission-line coupling also tends to reduce the radiation of harmonics, since the antenna condenser used at the antenna end of the transmission line provides a low-impedance path for these harmonics and thus prevents them from being radiated.

10. The water cooling system used for this transmitter is known as a *closed system* and uses distilled water. The advantages of a closed circulated system may be listed as follows:

(a) Distilled water may be used, thus eliminating the formation of scale on the anodes of the tubes. This scale is produced by mineral salts in the cooling water and when distilled water is used, obviously, these salts are not present.

(b) Very little make-up water is required, since the only loss that can occur will be from leaks in the piping system or carelessness in removing a tube from the socket.

(c) The cooling system is very compact, being complete with radiator, pump, fan, etc., and capable of being mounted in the basement of the transmitter building. The radiator may be pro-

vided with a shutter to prevent freezing, if climatic conditions warrant this feature.

11. The motor-generator sets supplied with this equipment are run conservatively under normal operation so as to reduce the chances of failure.

**55. General Maintenance of Model 5-A Broadcasting Transmitter.**—Very little special care is necessary in the ordinary maintenance of this transmitter, other than would be given any piece of power apparatus. A few points covering the care of the set are included here. The high-power audio amplifying equipment of the transmitter has no moving parts except the volume control. The volume control should be inspected at least once a week to insure that the slider is making good contact. At least once a month all tubes should be removed from their sockets and their contact-making surfaces should be cleaned. All apparatus should be dusted at least once a week. The voltage of the bias batteries should be checked at least once a week, and if found low the bias battery should be changed. The slider and contact points of the rheostats should be inspected once a week, and the contacts cleaned if necessary.

**56. Maintenance of Crystal-Controlled Amplifier Unit.** The moving parts of the crystal-controlled amplifier unit consist of the variable condensers and variometers. The bearings of the variometers and variable condensers should be oiled occasionally. A little vaseline applied every few months to the jaws and hinges of the push-button and interlock switches will keep them in a smooth working condition.

At least once a month all tubes should be removed from their sockets and all tube contact-making surfaces should be cleaned. All apparatus should be dusted at least once a week.

Clipped contacts on the tank coil should be inspected weekly and cleaned when necessary with fine sandpaper. The slider and contact points of the rheostats should be inspected once a week and the contacts cleaned if necessary. The plate motor-generator set overload relay should be checked daily.

The contacts on the thermostat on the crystal compartment should be checked daily. These contacts should be cleaned with



fine sandpaper whenever they are found dirty or pitted. Care should be taken to insure that the thermostat shall control the temperature inside the crystal compartment so that it remains constant at 45° C.

#### **57. Maintenance of Power-Amplifier and Modulator Unit.**

The moving parts on the power-amplifier and modulator unit consist of a variometer and a variable neutralizing condenser, the bearings on these should be oiled occasionally. The mercury in the water-flow interlocks should be drained and cleaned once a month. A mercury filter is recommended for cleaning the mercury. The electrode tips of the water-flow interlocks should be cleaned with fine sandpaper as required.

The following daily routine is recommended: Dust and dirt should be carefully removed from all radio-frequency and high-voltage terminals, tank-coil conductors, tank-coil clips, tank condenser, insulator supports, filter-condenser terminal insulators, etc. Contact clips to the tank coil should be inspected and cleaned, if necessary, with fine sandpaper.

The following weekly routine is recommended: Water-cooled tubes should be removed from their sockets and all scale or foreign material should be removed from the anode by use of fine sandpaper. Filament jaws and filament tips should be cleaned carefully to insure good contact and avoid overheating. The slider and contact points of the rheostats should be inspected once a week and the contact points cleaned if necessary.

#### **58. Maintenance of Rectifier and Control Panel.**—The moving parts on the rectifier and control panel consist of relays and contactors. The contactor bearings should be lightly oiled occasionally. A little vaseline applied every few months to the jaws and hinges of the knife and disconnect switches will keep them in smooth working condition.

The leather bellows of the time-limit relays should be rubbed with neatsfoot oil at least once in 3 months to keep the leather soft and pliable and so prevent it from cracking.

The following daily routine is recommended: All dust and foreign material must be removed from all insulators and bare

conductors, especially in the high-voltage circuits. All relays should be checked.

The following weekly routine is recommended: Contacts of all rheostats, contactors, and switches should be cleaned thoroughly and their proper operation assured by trial.

**59. Maintenance of Antenna Coupling and Tuning Equipment.**—The only moving part in this unit is the motor-driven variable air condenser in the antenna tuning house. The commutator of the driving motor should be cleaned at monthly intervals and tested to insure proper operation. All radio-frequency circuits should be kept clear of dust and any foreign material, and all contact clips should be kept clean and bright by the use of fine sandpaper.

**60. Maintenance of Motor-Generator and Battery-Charging Equipment.**—Oiling of moving parts should be done systematically and carefully. The oil wells of the battery-charging motor-generator set should be kept full but not overflowing, as oil may then be drawn into the machine, damage the insulation, and cause dust to collect. All other motor-generator sets have ball bearings, and are described in detail in their respective instruction books. The commutators of all generators should be kept polished and free from sparking. A great deal of attention should be given the commutator of the filament generator to insure quiet transmission. It should be cleaned and lightly lubricated with a clean cloth and a mixture of kerosene and dynamo oil, about once an hour, during operation. The brush tension should be carefully adjusted so that the brushes make good contact but do not cut the commutator.

**61. Maintenance of Miscellaneous Equipment.**—The impregnated wooden strips used as supports for power-amplifier tank condenser, resistors, etc., should be painted once a year with linseed oil. This insures keeping the wood free from moisture.

The appearance of the panel will be improved if the panel is rubbed occasionally with a rag moistened with a medium-body oil.

The iron work, such as frame and fittings, should be kept painted to prevent rusting.

The appearance of the copper tube connections can be best preserved by cleaning with sandpaper immediately after installation and then giving them a coat of shellac. This will keep the copper clean and bright and it should never be necessary to repeat the treatment.

The rubber hose insulating the tube jackets will need replacement approximately every 6 months. This is due to a gradual hardening and disintegration caused by the high frequency and high voltages across the hose. This action is hastened considerably by moisture on the outside of the hose, and for this reason the outside of the hose should be kept dry.

The hose nipples on the water-jackets will need replacement occasionally, possibly once a year, owing to a gradual disintegration of the tips of the nipples caused by electrolysis. This electrolytic action increases with decreasing water resistance, and also with the age of the hose as a result of formation of a deposit on the inside of the hose.

The water pump should be inspected and oiled frequently. Provisions should be made to keep the water radiator from freezing in cold weather.

**62. Notes on Operation of Screen-Grid Transmitting Tube UV-861.**—The UV-861 is a four-element tube of the screen-grid type designed for use as a power amplifier in transmitting circuits. It may also be used as an oscillator, although under this condition it usually has no advantage over a three-element tube. It has a nominal output rating of 750 watts and is especially adapted for use on the shorter wavelengths.

The rating of type UV-861 screen-grid transmitting tube is: filament, 11 volts 10 amperes; plate potential, 3,000 volts d-c.; maximum safe plate dissipation, 400 watts; maximum safe screen-grid dissipation, 35 watts; rated output, 750 watts.

The general design is similar to that of the three-element short-wave transmitting tubes. The filament, grid, and plate are supported on separate stems with the leads brought out at separate seals, thus insuring high insulation and low electrostatic

capacities between elements. The filament is thoriated tungsten in the shape of a double helix supported from a center rod and requiring no tension springs. The grid and plate are cylindrical; and the plate has six wings for dissipation of heat. The plate and grid lead wires are large and each element is supplied with two in parallel to carry relatively high circulating currents.

The screen grid, which is the fourth element, consists of a close mesh placed between the control grid and the plate and extending the full height of the tube. It is supported by collars on the filament and grid stems. Its lead is brought to the grid pin of the base on the filament arm. The function of this second grid is to provide an electrostatic shield between the plate and the control grid. The potential of the screen grid is held constant, and variations in potential of the plate have practically no effect on the control-grid potential or on the electrostatic field at the filament. Therefore, there can be practically no feedback through the tube from the plate circuit; in radio-frequency amplifier circuits this eliminates the necessity for any neutralization to prevent feedback and oscillation.

63. The filament of type UV-861 tube should be operated at constant voltage rather than constant current and always at the rated voltage. Less than this voltage will in time result in loss of emission, due to too low a rate of diffusion of the active material to the surface of the filament. More than rated voltage will shorten the life by the rapid evaporation of the active material from the surface.

In adjusting circuits, it should be remembered that the tube loss—that is, the difference between output and input—should always be limited to the safe value of 400 watts. Because of the difficulty in measuring outputs at short wavelengths, the practical method of judging tube loss is by plate temperature. A cherry-red color is roughly equivalent to 400 watts dissipation. The normal plate voltage for the tube is 3,000 volts. In the case of a non-modulated oscillator only, this may be increased to 4,000 volts, provided the plate dissipation is 400 watts or less, although considerably greater care is required in adjusting the circuit at the higher voltage.

The screen-grid transmitting tube should never be operated with over 2,000 volts on the plate without adequate grid bias, from either a battery or a grid leak. Circuit adjustment should always be made at reduced voltage, as otherwise the tube can easily be overloaded. The shorter the wavelength at which the tube is used, the greater the care necessary in making adjustments.

In case of severe overload resulting in overheating of the tube, the electron emission may decrease. Unless the overload has liberated a large amount of gas, the activity of the filament may be restored by operating at rated filament voltage for 10 minutes or longer with the plate voltage off. This reactivation may be accelerated by raising the filament voltage to 13 volts, but no higher.

In order to prevent possible overheating of the grid and plate leads from improper circuit adjustments or overloading, a fuse blowing at 10 amperes should be placed directly in series with the plate leads. No fuse should be used in the control grid leads, for its opening would leave the tubes without grid bias.

The screen voltage may be obtained from a separate source or from the plate supply by means of a potentiometer. In any case the impedance between the screen grid and the filament must be kept as low as possible by the use of by-pass condensers.

The screen grid does not need to dissipate much energy for proper functioning. The voltage should therefore be kept as low as possible. The dissipation on this grid should never exceed 35 watts. The screen voltage is usually approximately one-quarter of the plate voltage.

**64. Notes on Operation of Radio Tube UV-848.**—Radio tube, model UV-848, is used as an oscillator, a power amplifier, or a modulator. The following ratings apply only when it is used as an oscillator or power amplifier for cw. telegraph service: output 20 kw.; filament, 22 volts 52 amperes; plate potential, 15,000 volts; plate current (oscillating), 2 amperes; maximum safe plate dissipation, 10 kw.; voltage amplification constant, 8; plate impedance (at 15,000 volts plate potential), 2,400 ohms.

When the UV-848 radio tube is used as an oscillator or a power amplifier for broadcast service where the tubes are plate modulated, the direct-current plate-voltage rating must necessarily be reduced to between 10,000 and 12,000 volts, depending on the percentage of modulation used.

The plate-voltage rating for modulator service is reduced to 10,000 or 12,000 volts. The plate current, when the tube is used as a modulator at 12,000 volts direct-current, will be approximately .45 ampere and when used at 10,000 volts direct-current, will be approximately .40 ampere. The dissipation rating of the tube, that is, the product of plate voltage and plate current (d.-c.) when used as a modulator is 7.5 kilowatts.

65. The filament temperature of radio tube UV-848 should be brought up slowly by means of resistance in the primary of the filament transformer. The filament should be allowed to reach normal operation temperature before the plate voltage is applied. Care must be taken to make the filament connectors very tight so as to prevent overheating.

Before the tube is put into use, care should be taken to note whether any foreign matter has fallen into the stem opening and lodged between the glass and the filament leads. The filament leads operate at a fairly high temperature so that any shavings, paper or excelsior that might have fallen into the stem would become charred and possibly cause a puncture at this point. A blast of air will remove any light material.

Considerable care must be taken in fastening the grid to avoid causing the lead to become too tight. The tube should be securely fastened in the water-jacket and the fastening devices that fit over the anode flange should be tightened before any adjustment of the grid lead is made. The water-jacket should never be moved nor should the lightening devices on the anode flange be readjusted while the grid is connected to the set, as undue strain may very easily be put on the grid seal at such times. The lead itself should never be so tight that any vibration or shock will cause tension on the lead, and it is especially desirable to avoid any tension in the plane at right angles to the grid lead where this lead leaves the glass seal.

Holes have been provided along the grid lead for use in short-wave installations where it is important to have short leads. Since the lead is made of soft annealed copper, it is easily mutilated and the connections should be made carefully.

TABLE I

RECOMMENDED TUBE LAYOUT FOR COMPOSITE BROADCAST STATIONS

Output Watts	Speech Amplifier	Modulator	Oscillator	Approximate Modulation Factors	Rectifier Tubes
50	1-210	1-211	1-211	45	2-217A
	1-842	2-211		58	
	or	1-845		62	
	1-250	2-845		66	
100	1-210	2-211	2-211	45	2-217A
	1-842	4-211		58	4-217A
	or	2-845		62	2-217A
	1-250	4-845		66	4-217A
250	1-211	1-849	1-204A	47	2-1651
	1-211	2-849		59	or
	1-211	1-851		56	2-856
	1-211	2-851		67	
500	1-211	1-851	2-204A	43	6-1651
	1-211	2-851		or	56
	1-211	3-851	1-851	62	6-856
	1-211	4-851		67	
750	1-211	1-851	1-851	36	6-1651 or
	1-211	2-851		49	6-856
	1-211	3-851		56	12-1651 or
	1-211	4-851		60	12-856
1,000	1-211	2-851	2-851	43	12-1651
	1-211	3-851		51	or
	1-211	4-851		56	12-856

In making connections, care must be taken that the wires are not so tight as to put a strain between the glass and anode, and that the wires do not lay on or close to the surface of the glass.

Otherwise, serious trouble may arise from corona, and almost certain puncture.

At any time during the handling of the tube, care must be taken that the filament leads do not swing so as to strike the glass.

#### DATA ON TUBE LAYOUT FOR COMPOSITE BROADCAST STATIONS

66. In Table I is given the recommended tube layout for various composite broadcast transmitting circuits ranging in power from 50 to 1,000 watts output. In each case the tube to be used is designated by its number, preceded by a figure showing how many of that style are used. The modulation factors given are for plate modulation on the last stage, which is the method used by nearly all composite broadcast stations. The column for rectifier tubes is given for general information as in many cases motor-generator sets are used in place of rectifiers. These figures are based on 50 per cent. oscillator efficiency and not more than 5 per cent. second harmonic on modulator output.

#### TEN-WATT AIRCRAFT TRANSMITTER

67. **Equipment.**—The 10-watt radio telegraph and telephone transmitter, type RT-22-A, and associated equipment was designed for aircraft use where a small, light-weight, and compact transmitter is required. The principal parts of this equipment are shown in Figs. 27 and 28. The parts in Fig. 27 represent the transmitter equipment and those in Fig. 28 the receiver.

The transmitter equipment consists of the following units: Transmitter *a*; control unit *b*; filter unit *c*; antenna reel *d*, consisting of a reel and 300 feet of antenna wire, with a fairlead *e* and weight; transmitting key *f*; terminal box *g*; a wind-driven double-current generator *h*, shuntwound, supplying 5 amperes at 9 volts and .16 amperes at 425 volts.

In Fig. 28 may be seen the receiver unit *a*, aircraft antinoise microphone *b*, and telephone headset *c*.

68. **Frequency Range, Method of Signalling, Power Rating.**—The equipment was designed to provide either phone or cw. operation on any frequency between the limits 2,250 and



2,750 kilocycles. When operating into the specified antenna on any frequency in its band, the rated cw. output of the transmitter is 10 watts.

**69. Antenna Characteristics.**—The transmitter is designed to operate into a trailing wire antenna, the length of which is

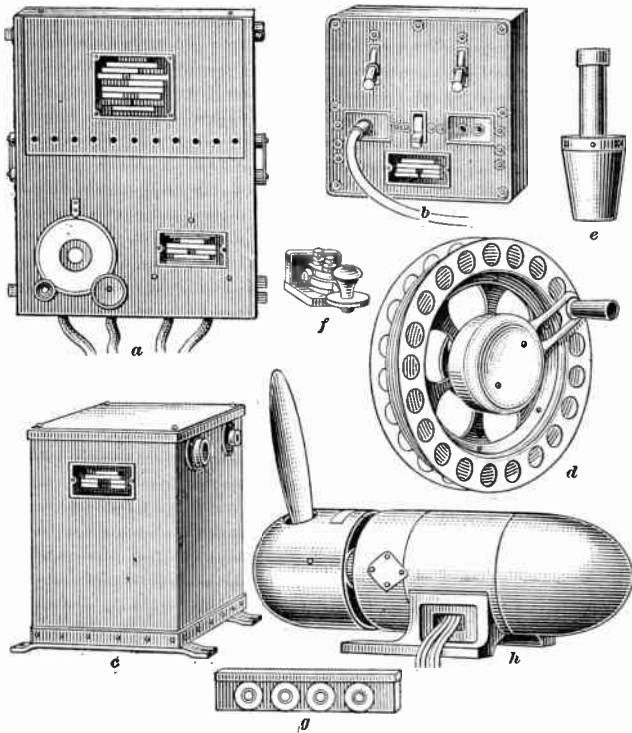

FIG. 27

adjusted so that the resonant frequency of the antenna is equal to that of the transmitter. In other words, the antenna acts as an unloaded quarter-wave system in which the body of the aircraft is used as the ground connection.

In order to facilitate tuning of the antenna, a special type of antenna reel *d*, Fig. 27, is provided. This reel is normally locked in position no matter how much of the wire has been unreeled.

In order to reel in the antenna wire, the crank connected to the reel is turned in a clockwise direction by the operator. Upon releasing the crank, the reel again locks in position. In order to pay out antenna wire, the crank is pressed in a counterclockwise direction. A friction brake, connecting the reel and the crank, is thus disengaged and the wire is unreeled by the action of the weight on its end independently of the crank. This operation may be stopped at any point by simply releasing the pressure on the crank.

The length of antenna for frequencies between 2,250 and 2,750 kilocycles will vary between 90 and 130 feet, approximately. Under these conditions, the antenna resistances will be from 20 to 30 ohms.

**70. Vacuum Tubes.**—Three UX-210 vacuum tubes are used in the transmitter as follows: one as a master oscillator, one as a radio power amplifier, one as a modulator. The UX-210 tube is rated at a safe plate dissipation of 15 watts. The filament of this tube requires 1.25 amperes at 7.5 volts, and the normal direct-current plate potential is 425 volts.

**71. Power Supply.**—Power for the equipment is supplied from a double-current wind-driven generator. The filaments are supplied from the 9-volt commutator, and plates from the 425-volt commutator. The receiver filament supply is filtered, and a reduced plate voltage for the receiver is obtained from a potentiometer connected across the 425-volt commutator. The wind-driven generator is supplied with a DesLauriers self-regulating fan, which maintains a very constant speed of the generator.

**72. Construction of Equipment.**—General construction of the equipment may be understood by reference to Figs. 27 and 28. The transmitter *a*, Fig. 27, consists of a duralumin box that is separated into four compartments containing, respectively, the master oscillator, power amplifier, audio-frequency circuits, and vacuum tubes. The tube compartment is made accessible from the front and top of the transmitter by means of a hinged door. The only control on the transmitter unit, that of the mas-

ter-oscillator variometer, is located at the lower left-hand corner of the front of the transmitter box *a*. This control is provided with friction drive and locking device. The transmitter is

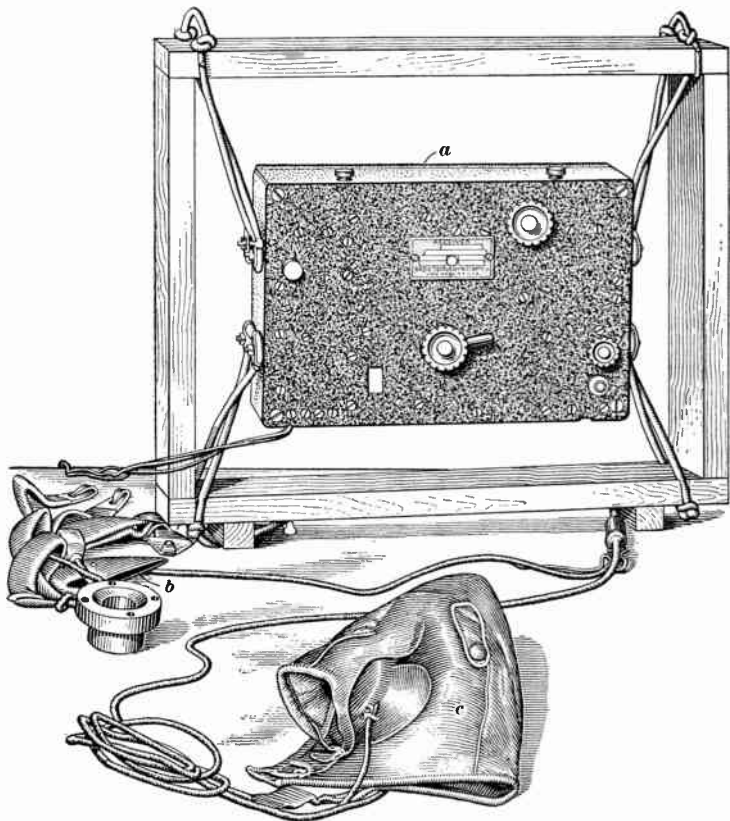
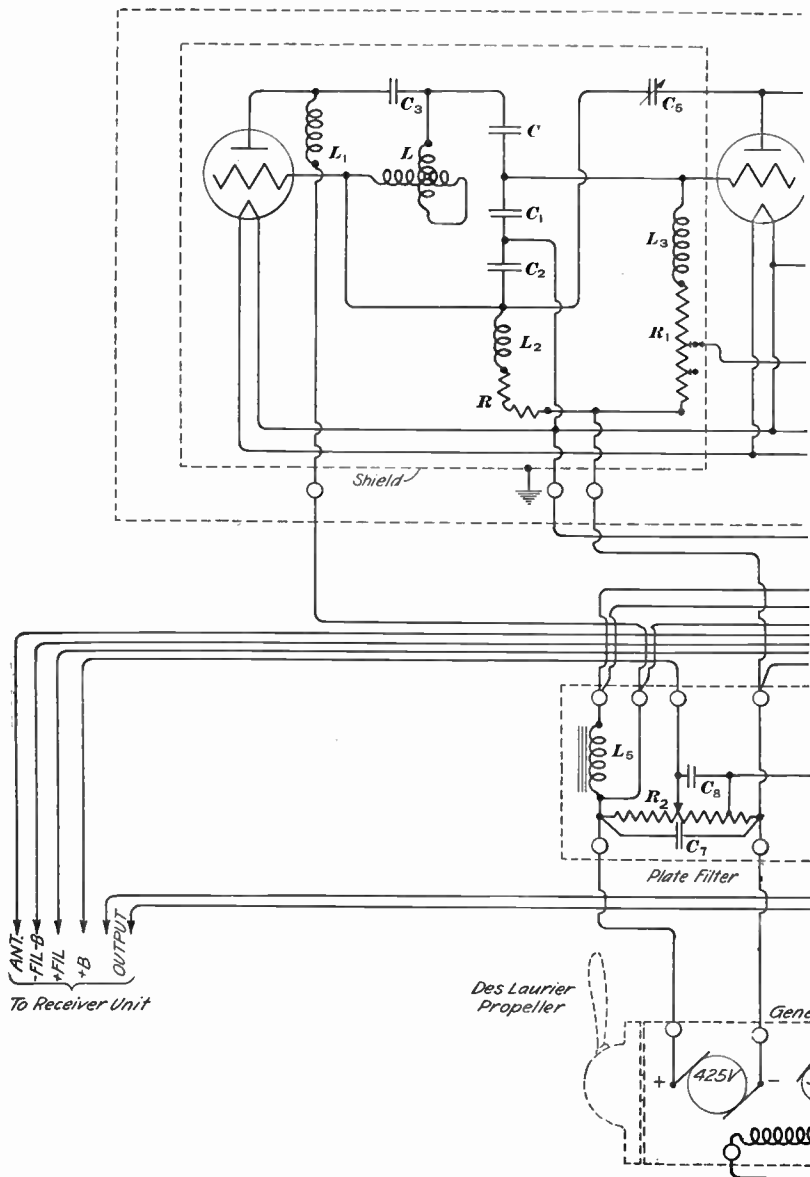

FIG. 28

arranged for shock-proof mounting. This is accomplished by passing rubber shock-absorber cords through the guides on the sides of the transmitter. These cords are then fastened to the aircraft frame-work in such a way that the transmitter unit is completely suspended. This method of suspension is similar to that shown on the receiver unit *a*, Fig. 28.

All incoming power and control leads to the transmitter unit are cabled. These cables terminate in a small terminal box *g*.





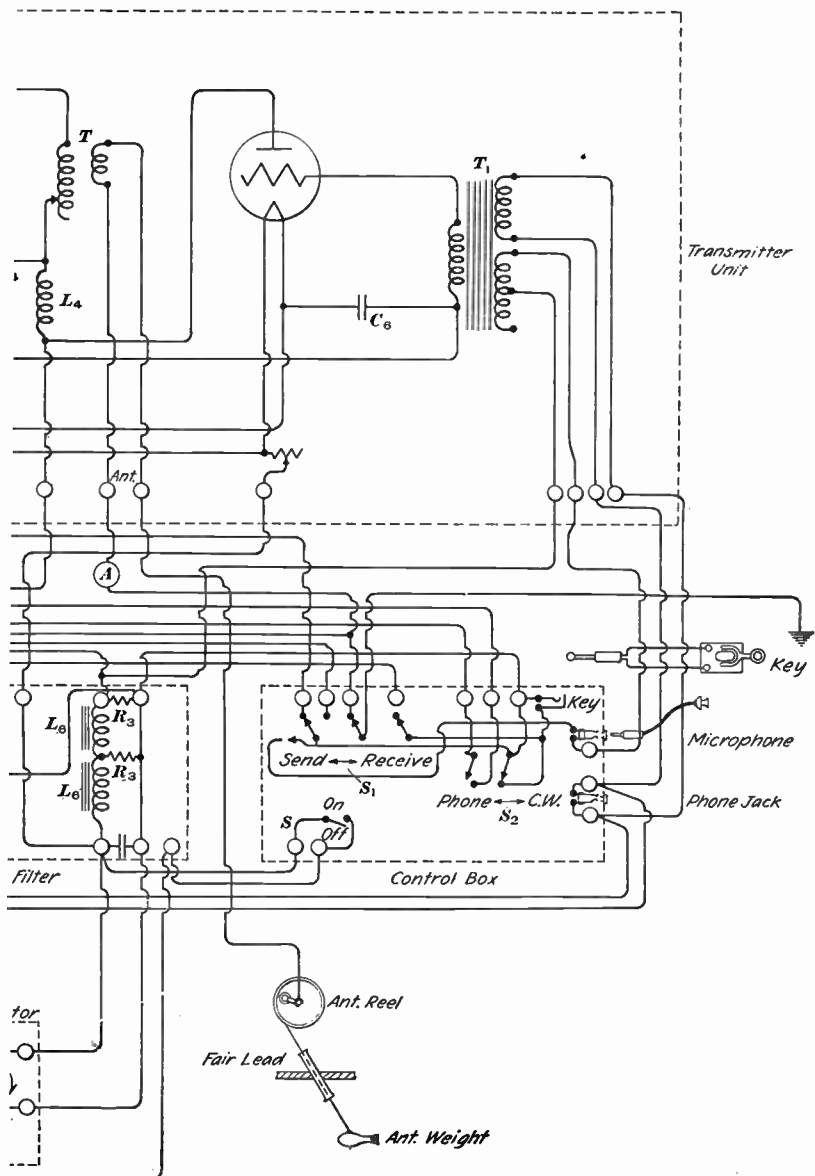



Fig. 27, external to the transmitter, and to this box all external connections are made.

The filter unit *c* is a duralumin box in which are placed plate and filament supply filters. Access to the terminal board of the filter box is had by removing the cover from the filter unit. Connections to the terminal board are brought through outlets on the sides of the filter box.

The control unit *b* consists of a metal panel carrying the various control switches, the jacks for the telephone headset, the microphone, and the transmitting key. This panel is set into a duralumin box for protection of the component parts. Access to the terminal board may be had by removing the panel from its box. Outlets are provided in the box for bringing out connections to the terminal box *g*.

**73. Installation.**—A complete schematic wiring diagram showing all external connections of the transmitter and associated equipments is shown in Fig. 29. This drawing shows the proper method of cabling the external wiring.

The transmitter unit does not necessarily have to be installed so as to be completely accessible to the operator, since its one control may be set before starting the flight. This feature makes it possible to place a transmitter in an otherwise unoccupied part of the aircraft.

The control unit, receiver, antenna reel, and antenna ammeter should all be mounted so as to be completely accessible to the operator during flight. The antenna reel should be so mounted that the operator may turn it with a minimum of effort and the antenna ammeter should be so placed as to be visible to the operator while he is operating the antenna reel.

The filter unit, since it contains no controls, may be mounted in any convenient place on the aircraft, and it does not have to be accessible except for servicing purposes. All units except the transmitter, which is arranged for shockproof mounting, should be rigidly mounted to framework.

It is essential that antenna and ground leads be made as short and direct as possible, and antenna leads should not be cabled with other wiring.



**74. Theory of Operation.**—Before considering in detail the procedure for adjusting the transmitter to any desired frequency within its range, it is well to understand the theory of operation of the various circuits involved. Reference will be made to the schematic circuit diagram, Fig. 29.

The circuit used in the transmitter consists of the conventional master-oscillator, power-amplifier type arranged for plate modulation. The master oscillator makes use of one UX-210 tube operating in a capacity-coupled circuit. As shown in Fig. 29 the condensers  $C$ ,  $C_1$ , and  $C_2$  in parallel with variometer  $L$  constitute the tuned circuit of the oscillator. The ground or filament tap of this oscillating circuit is connected to the common terminal of the condensers  $C_1$  and  $C_2$ . The voltage drop across the condenser  $C_2$  is used for grid excitation of the master oscillator. Since the condensers  $C$ ,  $C_1$ , and  $C_2$  are all equal in capacity, the voltage built up across the condenser  $C_2$  is one-half that built up across capacitors  $C$  and  $C_1$  in series. The ratio 1 to 2 of grid excitation to plate voltage thus obtained is correct for stable oscillator operation.

The condenser  $C_3$  is the master-oscillator plate-blocking condenser, which keeps the d.-c. plate voltage at the tube out of the oscillating circuit. The coil  $L_1$  serves as plate radio-frequency choke and it prevents radio-frequency voltage existing at the plate of the tube from entering the supply wiring. The coil  $L_2$  and resistor  $R$  serve as master-oscillator grid chokes and master-oscillator grid leak, respectively. It is the purpose of coil  $L_2$  to prevent radio-frequency voltage existing at the grid of the master-oscillator tube from entering the grid-circuit wiring. One-half of the radio-frequency plate voltage of the master oscillator, obtained by connection to the common terminal of condensers  $C$  and  $C_1$ , is applied as excitation to the grid of the power-amplifier tube. This value of exciting voltage is then exactly equal to the voltage which is applied to the grid of the master oscillator tube, except that it is 180 degrees out of phase with the master-oscillator excitation voltage. The coil  $L_3$  and resistor  $R_1$  serve as power-amplifier grid choke and grid lead, respectively, and it is through these that the proper bias is applied to the grid of the tube.

75. In the plate circuit of the power-amplifier tube is the antenna transformer  $T$  by which power is transferred to the antenna circuit. The condenser  $C_4$  serves to maintain one end of the primary of the antenna transformer at a very low radio-frequency potential with respect to ground, and the coil  $L_4$  still further serves to prevent any radio-frequency voltage existing at the low end of the antenna transformer primary from entering the plate-supply wiring. If some system of balancing of the power amplifier were not used, radio-frequency voltage existing on the plate of the power-amplifier tube could feed into the grid circuit through the power-amplifier tube plate-to-grid capacity. The energy fed over in this way would tend to augment the exciting voltage until the amplifier was in the state of self-oscillation. In order to prevent this, a voltage is applied at the plate of the power-amplifier tube which is equal to, and 180 degrees out of phase with, the voltage which would exist at the plate due to excitation on the power amplifier. The voltage across the condenser  $C_2$ , which is equal to, and 180 degrees out of phase with, the excitation voltage, is applied to the plate of the power amplifier to variable condenser  $C_5$ , which is adjusted to be equal to the power-amplifier tube grid-to-plate capacity. A balanced-capacity bridge is thus formed, and the power amplifier may be operated over its entire band without any tendency to self-oscillation.

76. Then the transmitter, Fig. 29, is set for phone operation, and a reactor, or choke coil,  $L_5$ , is connected in series with the plate supply to the modulator and the power-amplifier tubes. The master oscillator still obtains its plate supply from the original source and not through the reactor. The procedure of modulation is as follows: When the microphone is spoken into, an audio-frequency voltage is applied to the grid of the modulator tube by means of the microphone transformer  $T_1$ . The plate current of the modulator tube tends to vary according to the voltage impressed on its grid. Because of the fact that the modulation reactor has a high resistance to audio frequency, the plate current is held practically constant, and an amplified reproduction of the grid audio-frequency voltage is built up across

the reactor. Since the modulator tube is connected in parallel with the power amplifier, this voltage is also impressed on the plate of the power amplifier. Antenna current is directly proportional to power-amplifier plate voltage, and as a result the antenna current has its amplitude varied according to the audio frequency impressed by the microphone. Bias for the modulator tubes is obtained from the power-amplifier grid leak  $R_1$ , and the condenser  $C_6$  serves to filter this bias voltage.

77. Keying of the transmitter, Fig. 29, is accomplished by inserting a high resistance in the path of the negative high-voltage tube filament, and also by placing a high negative bias on the tubes, still further insuring that they will cut off. The resistor  $R_2$  in the plate filter unit serves the purpose of a keying resistor, and also as a potentiometer from which receiver plate supply is obtained. The resistor is connected across the 425-volt supply from the generator and has a small current flowing through it whenever the generator field switch  $S$  is on. The plate-return, or filament connection, is taken at the first tap on the right of the resistor  $R_2$ . When the transmitting key is up, a negative high voltage is developed across the biasing section of the resistance  $R_2$  and there is assurance that the plate current will be very small. The negative high-voltage and grid-leak returns are connected to the negative terminal of the resistor  $R_2$ . Since the filament tap is toward the point of higher voltage, that is, the positive terminal, the filaments are at a higher potential than the grids. In other words, the grids are biased negatively with respect to the filaments. The value of the voltage drop across the biasing section of resistor  $R_2$  is adjusted to such a point that the tubes are biased beyond cut-off, and they cannot draw plate current. To key the transmitter, all that is necessary is to short-circuit the biasing section. This removes the high bias from the grids of the tubes, and makes the path of high voltage to the filaments of low resistance, thus allowing plate current to flow.

78. The filter unit, in addition to containing the modulation reactor  $L_5$ , Fig. 29, the key, and potentiometer resistor  $R_2$ , contains also filter condensers  $C_7$  and  $C_8$  for transmitter and receiver

plate supply, and chokes  $L_6$  and resistors  $R_3$  for receiver filament supply.

The switch  $S_1$  of the control unit is the send-receive switch, and it is manually operated. This switch in *send* position transfers the antenna circuit and the filament voltage from the receiver to the transmitter and makes the transmitter ready for operation. The switch  $S_2$  is the signal switch. In *phone* position, this switch short-circuits the transmitting key and places the modulation reactor  $L_5$  in the circuit.

The switch  $S$  is the power switch, and it is connected in the field circuit of the wind-driven generator. When this switch is in the *off* position, all power is cut off from the equipment.

Jacks are provided for microphone, headset, and transmitting key, and they are so arranged that it is impossible to cause any damage to equipments by plugging the wrong equipment in any jack.

The head-phones are connected across the side-tone winding of the microphone transformer and across the receiver output, so that the phone transmission may be monitored and radio signals received without any change of head-phone connections.

**79. Adjustment of Transmitter.**—The antenna transformer  $T$ , Fig. 29, is designed to cover the frequency band of 2,250 to 2,750 kilocycles with a maximum of four adjustments. The primary of this transformer is tapped in four places, so that adjustment for variation of antenna resistance and frequency is possible. Each tap is used to cover approximately one-fourth of the total frequency band of the transmitter. The frequency bands covered by the various taps are as follows: Tap 1, 2,250—2,375 kilocycles; tap 2, 2,375—2,500 kilocycles; tap 3, 2,500—2,625 kilocycles; tap 4, 2,625—2,750 kilocycles.

The following procedure is recommended for tuning the transmitter to any frequency in its band. Assume that it is desired to transmit on 2,500 kilocycles, with *phone* operation.

1. From a calibration of the master oscillator, set the scale to correspond to the desired frequency.

2. Select either tap 2 or tap 3 on the antenna transformer. Since 2,500 kilocycles is one of the overlap points on the antenna

transformer, it makes but little difference whether the tap is set on 2 or 3. Access to the antenna transformer may be had by removing the back of the transmitter box.

3. Plug the head-phones, the microphone, and the transmitting key into their respective jacks.

4. Throw the power switch  $s$  in the control unit to the *on* position. Field is now applied to the generator and the radio receiver may be operator, provided that the *send-receive* switch is in *receive* position.

5. Place the signal switch in the *phone* position.

6. Place the *send-receive* switch  $S_1$  in *send* position and slowly unreel the antenna wire by means of the antenna reel. Antenna resonance is indicated by a maximum reading of the antenna ammeter  $A$ . It may be necessary to reel and unreel small amounts of antenna wire in order to make sure that the antenna is in perfect resonance with the transmitting frequency.

The transmitter is now adjusted and should be putting from 10 to 15 watts of radio-frequency energy into the antenna. The operator may now speak into the microphone, and the antenna current will be modulated according to the voice frequency impressed by the microphone.

In order to change to cw. operation, the signal switch  $S_2$  should be placed in the cw. position, and the transmitting key should then be operated. The normal antenna current will be from .5 to 1 ampere.

**80. General Maintenance of Equipment.**—The equipment should be inspected periodically to make sure that all parts are operating in a satisfactory manner. The various cables and terminal-board connections should be kept tight, in order to insure maximum reliability of the equipment at all times. The bearings of the antenna reel should be slightly lubricated, and the connection between antenna wire and the antenna weight should be inspected for any strain due to spinning of the antenna weight.

## TRANSATLANTIC RADIO TELEPHONY

81. **Theory of Side Bands and Carrier.**—The first time that the human voice was ever transmitted across the Atlantic ocean was in 1915. It was accomplished by the American Telephone and Telegraph Co. by means of radio. Speech was transmitted from the navy station at Arlington, Va., to the Eiffel Tower, in Paris, but it was only received at occasional intervals, when transmitting conditions were exceptionally favorable.

In March, 1926, commercial two-way radio-telephone conversation was carried on between the United States and England and the type of transmitter used is the subject of the discussion at this point. It is termed a *single side-band eliminated-carrier transmitter*.

When the continuous waves generated by a tube transmitter are modulated, the radiated power is distributed over a frequency range that may be considered in three parts. First, energy at the carrier frequency; second, energy distributed throughout a frequency band, extending from the carrier upwards and covering a band equal to the band of audio-frequencies with which the carrier is modulated (this is termed the upper side band); third, energy distributed throughout a frequency band, extending from the carrier downwards, covering a band of width equal to the width of the frequency band used for modulation (this is termed the lower side band).

Another way of stating the fundamentals involved in the preceding paragraph, is as follows:

When a constant amplitude wave of frequency  $C$  is modulated by a constant amplitude wave of frequency  $S$ , the resultant modulated wave can be considered to be made up of three waves of constant amplitude, of frequencies,  $C+S$ ,  $C$ , and  $C-S$ .

82. The energy radiated from the standard type of broadcasting station is composed of the carrier frequency and the two side bands. The power at the carrier frequency itself makes up somewhat more than  $\frac{2}{3}$  of the total power, even when modulation is as complete as possible, and this energy can in itself convey no message; therefore, in the transmitter about to be described the carrier is eliminated.

Each of the two side bands transmits power representing the complete message and it is therefore unnecessary to transmit both, so one of them is eliminated in the single side-band transmitter; thus, only half the normal frequency band is utilized.

All the important speech frequencies are included in the frequency band between 300 and 3,000 cycles per second; so, if all of this frequency band can be transmitted and received, the speech issuing from the receiver output will be of good quality.

**83. Description of Transmitter.**—In Fig. 30 is shown a schematic wiring diagram of the 200-kw. single side-band carrier-eliminated transmitter that was designed and built by the American Telephone and Telegraph Co., at the Rocky Point Radio Station of the Radio Corporation of America. The voice input to this transmitter covers a band of frequencies that lie between 300 and 3,000 cycles. These audio frequencies are passed into the first balanced modulator, where they modulate a carrier current having a frequency of 33,000 cycles per second. The inherent function of a balanced modulator is to suppress the carrier frequency and pass the two side bands, thus the 33,000-cycle carrier frequency does not appear in the output circuit of modulator No. 1, only the two side bands, which are the upper side band (33,300 to 36,000) and the lower side band (32,700 down to 30,000).

These two side bands are passed on to a band filter, which selects the lower side band, passing it on to balanced modulator No. 2. In this second modulator, the carrier frequency is 88,500 cycles, and the two side bands that appear in the output circuit of this unit are the upper, 118,500 to 121,200, and the lower, 58,500 down to 55,800. These two side bands are passed on to the second filter, where the lower band is selected, namely, 55,800 to 58,500.

**84.** One of the thoughts involved in the use of the second modulator is to produce two side bands that are widely separated, thus facilitating the efficient exclusion of one side band and the selection of the other. Thus, the frequency band between 55,800 and 58,500 cycles per second is the one to be radiated, and, by dividing 300,000,000 by the two frequency values given, the

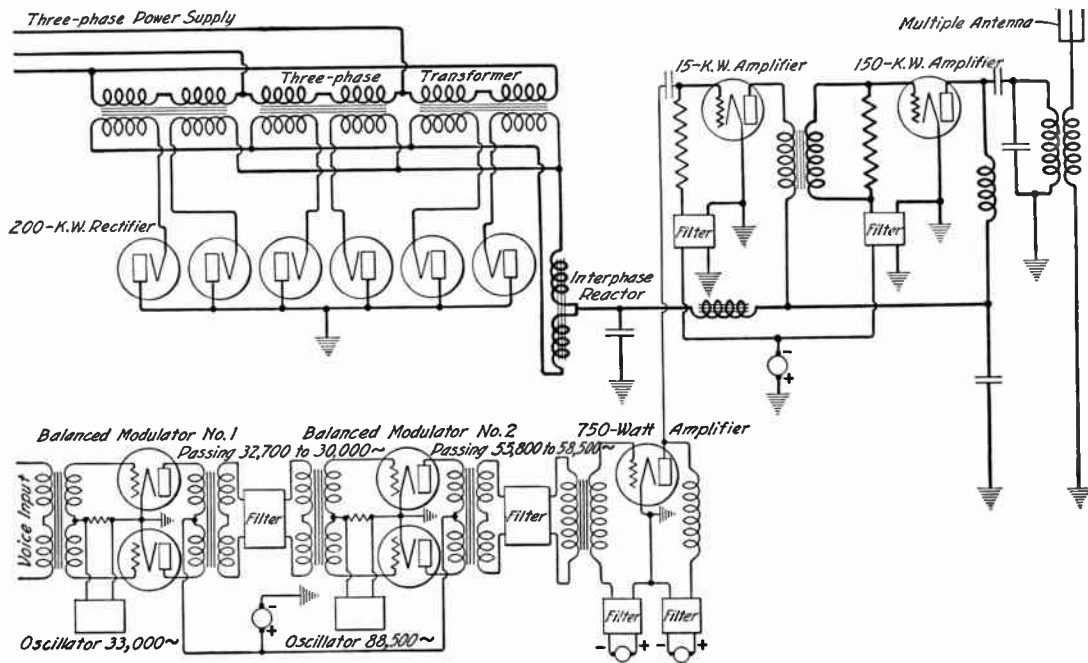

FIG. 30



wavelength limits of the transmitted signal are obtained. Both values are slightly over 5,000 meters.

In Fig. 31 is shown a graphical representation of the changes in frequency that occur in the preparation of the side-band currents at low power for transmission. Now will be considered the stages of amplification that are necessary to produce 150 kilowatts of radio-frequency energy in the antenna. The schematic wiring diagram shown in Fig. 30 only includes the basic fundamentals of the transmitter and this diagram is shown, rather than a complete detailed diagram, to facilitate the comprehension of the functioning of the circuit in question.

The output of the second filter passes into a 5-watt stage of amplification, then through a 50-watt stage, and finally into a 750-watt stage consisting of three 250-watt tubes operating at a plate potential of 1,500-volts. This means that the output of this stage of amplification is 750 watts and, although there are several tubes in this amplifier, only one is shown for the sake of simplicity in the appearance of the diagram.

The output of the 750-watt amplifier is applied to the input circuit of a 15-kw. amplifier. This stage of amplification employs two water-cooled tubes in parallel operating at 10,000-volts plate potential. This stage of amplification produces enough power to supply grid excitation to the grids of the tubes in the 150-kw. amplifier which constitutes the next stage of amplification. This

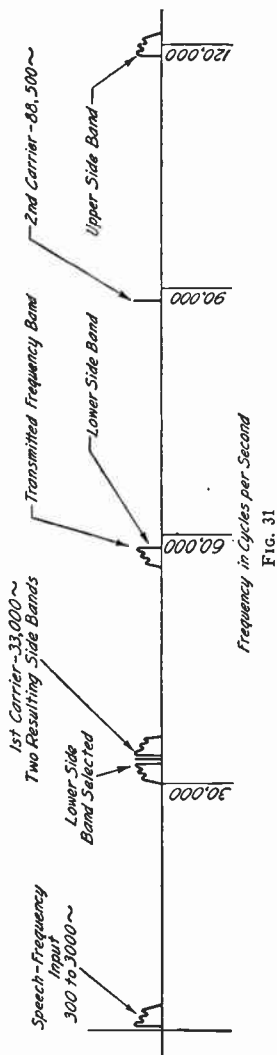

FIG. 31

150-kw. amplifier consists of 20 water-cooled tubes (two banks of 10 each), which operate at a plate potential of 10,000 volts. The output of this last stage is supplied to the antenna system.

85. The high voltage for the plates of the power amplifier tubes is supplied from a 200-kw. rectifier consisting of 12 water-cooled tubes. Full-wave rectification is effected from a 3-phase 60-cycle supply. The two sets of rectified waves from each full-wave rectifier (two tubes) are combined by means of the interphase reactor, Fig. 30, which serves to smooth out the resultant current, and, by distributing the load between tubes of adjacent phases, increase the effective load capacity of the rectifier unit. The ripple is further reduced by means of the filtering retardation coil and the condensers.

This transmitter is one of the latest developments in modern radio telephony and the following are outstanding advantages that are inherent in this type of transmitting unit.

1. Conservation of frequency range, due to using only one side band.
2. Conservation of power due to the fact that all the radiated energy in this system is useful; whereas, in the type of transmitter that radiates the carrier and two side bands, only  $\frac{1}{3}$  of the radiated energy is useful in carrying the message.

7