

STEREO F.M. RADIO HANDBOOK

P. HARVEY

B.Sc., C.Eng., M.I.E.E., A.F.I.M.A.

Senior Lecturer in Mathematics
Lincoln College of Technology

and

K. J. BOHLMAN

T.Eng., F.S.E.R.T., A.M.Inst.E.

Lecturer in Radio and Television
Lincoln College of Technology

This book presents a survey of the complete stereo system from transmitter to listener. It contains the latest information available on equipment design, servicing and operation and it deals with aërials, encoding, decoding, acoustics and speaker positioning, receiver adjusting, circuit analysis and stereo recording.

The book will be of use to students, technicians, enthusiastic amateurs and hi-fi equipment owners.

LONDON: NORMAN PRICE (PUBLISHERS) LTD

£2.50 net

STEREO F.M. RADIO HANDBOOK

P. HARVEY

B.Sc., C.Eng., M.I.E.E., A.F.I.M.A.

Senior Lecturer in Mathematics
Lincoln College of Technology

and

K. J. BOHLMAN

T.Eng., F.S.E.R.T., A.M.Inst.E.

Lecturer in Radio and Television
Lincoln College of Technology

LONDON
NORMAN PRICE (PUBLISHERS) LTD

NORMAN PRICE (PUBLISHERS) LTD
17 TOTTENHAM COURT ROAD, LONDON, W1P 9DP

© NORMAN PRICE (PUBLISHERS) LTD., 1974

ACCESSION No.		
140344		
CLASS No.		
0		
26 JUN 1979		
G/S	N	CATEGORY

Printed in Great Britain by
A. BROWN & SONS LTD., Hull

AUTHORS' PREFACE

The desire to improve the quality of sound in recorded music led to the introduction of stereophony. This first became available on gramophone records and was so successful that it was later extended to pre-recorded stereo tapes and finally to BBC radio transmissions.

Stereo receivers are now common items of domestic equipment and the BBC plan to extend their stereo service in the near future.

Whilst details of the basic theory are available in separate articles, it was thought desirable to prepare a book containing a survey of the complete stereo system from transmitter to listener. This inevitably has meant the inclusion of such items as frequency-changers, i.f. amplifiers and f.m. detectors which are common to both monophonic and stereophonic radio.

The book includes the latest information available on equipment design, servicing and operation. It deals with aerials, stereo decoding, transmission and reception, stereo decoding, acoustics and speaker positioning, receiver adjusting and circuit analysis. Designs incorporating integrated circuits, ceramic filters and electronic push-button tuning are fully described.

Whilst most of the book is descriptive, mathematical analysis has been included where required. It is hoped that it will be of use to students, technicians, enthusiastic amateurs and hi-fi equipment owners, and that it will remove some of the difficulties in understanding stereophonic techniques.

The authors have shared equally in the task of writing (although one did not take the Left channel and the other the Right) and any mistakes found will naturally be the fault of the other.

Our thanks are due to the many organizations who have assisted us by providing circuits and details of their products and giving permission to publish them. Our families, who also deserve our thanks, will now be able to revert back to listening to the speaker outputs instead of looking at an oscilloscope trace.

P. HARVEY

K. J. BOHLMAN

CONTENTS

1	Stereophonic Sound: Basic Ideas	<i>page</i> 1
2	Transmitter, Encoding and Modulation	9
3	The Receiver; Tuning and Demodulating	39
4	Decoding the Multiplex Signal	62
5	Typical Receiving and Decoding Circuits	80
6	Decoder Adjustments	129
7	V.H.F. Waves and Aerials	142
8	The Reproduction of Stereo Sound	164

Appendices

<i>A</i>	INTENSITY STEREOPHONY	<i>page</i> 185
<i>B</i>	THE SIDE-FREQUENCIES AND BAND- WIDTH OF AN F.M. WAVE	188
<i>C</i>	SWITCHED DECODING AND CROSSTALK	196
<i>D</i>	TABLE OF ANGLE AND DISTANCE ERRORS	199

Bibliography	200
Index	201

I

STEREOPHONIC SOUND: BASIC IDEAS

ONE of the main aims in the reproduction of sound for entertainment purposes, whether pre-recorded or radio transmitted, is that of **fidelity**. This means the reproduction of sound in a form as near to that of the original as possible. The problem of reproducing the frequency range has to a large extent been overcome, but the dimensional or 'spacial' properties of the sound source must also be reproduced before anything approaching realism is attained.

If we view a three-dimensional scene with only one eye, or listen to a sound with only one ear, we do obtain some idea of distance or position but only as a result of our previous experience. We associate loud sounds with near sources and faint sounds with distant sources. This alone is insufficient as it gives no indication as to the **direction** or angular position of the sound source. A much greater defect is that in a microphone-amplifier-loudspeaker system the amplitude may be varied by a volume control which gives the impression of varying the distance from the source.

Just as we require two eyes to judge the distance of an object, we require two ears to locate the origin of a sound source. In a monophonic system, Fig.1.1, the listener uses two ears, but his sound source may be a single loudspeaker.

The speaker represents a point-source of sound whereas the original sound source may be quite extensive, as in the case of a full orchestra or stage production. The listener has no conception of the **sound stage width**, the directional properties of his two ears only locate the position of the loudspeaker.

Early attempts to improve this situation consisted of using more than one loudspeaker, the speakers being placed some distance apart in order to simulate a wide 'sound stage'. Each speaker was fed with the same signal which, although it overcame the effect of listening to a point-source, gave no impression as to where the individual sounds were coming from. For a listener placed midway between the speakers the uncanny feeling of being completely surrounded by sound is obtained. The instruments of an orchestra, for example, appear to be evenly distributed along the sound stage rather than being localized to the right or left of the centre.

This difficulty is overcome by using more than one microphone. Indeed, the use of multiple microphones is often necessary to achieve correct tonal balance even if only one loudspeaker is used. We now have a rudimentary 'stereophonic' system consisting of separate 'left' and 'right' channels, Fig.1.2. By increasing the number of channels used the effect of realism is enhanced. In commercial sound film projection three to six channels may be used to surround the audience with sound.

Fig.1.2 indicates the possible sound paths from the extremities of the sound stage. It will be noticed that **crossed channel** signals are present (*i.e.*, the left ear hears sound from the right speaker and *vice versa*) which complicates the

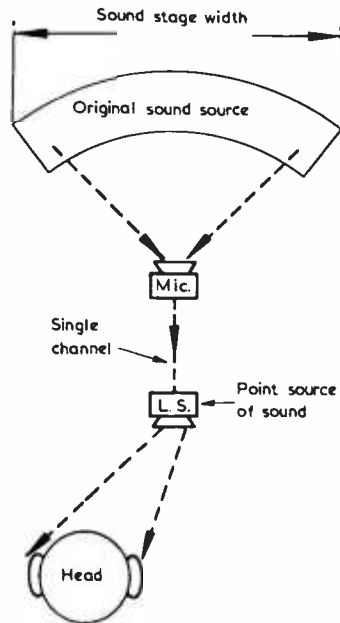

FIG. 1.1. A MONOPHONIC SYSTEM

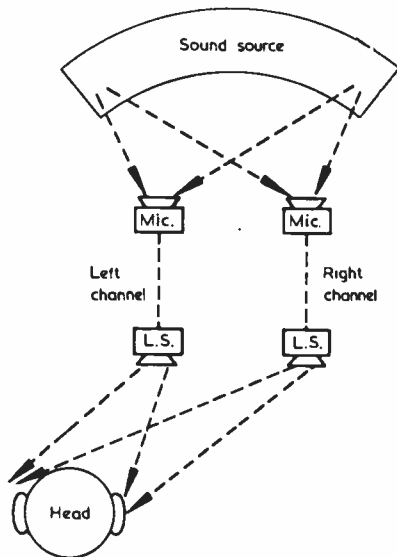

FIG. 1.2. A SIMPLE TWO-CHANNEL SYSTEM

behaviour of the system. In order to determine the required directional properties of the microphones, the microphone separation and speaker separation, it is necessary to discuss the way in which the hearer locates a sound source.

Fig.1.3 shows a listener and a point-source of sound. There are two main differences in the sound heard by the left and right ears.

- (1) **Intensity difference.** The right ear will hear the louder sound due to its closer proximity to the source and the fact that the left ear is partially shielded by the head. The intensity or amplitude difference will be referred to as $A_R - A_L$.
- (2) **Time difference.** As the path to the left ear, SL , is longer than that to the right ear, SR , there will be a time difference or **phase lag** of T_d .

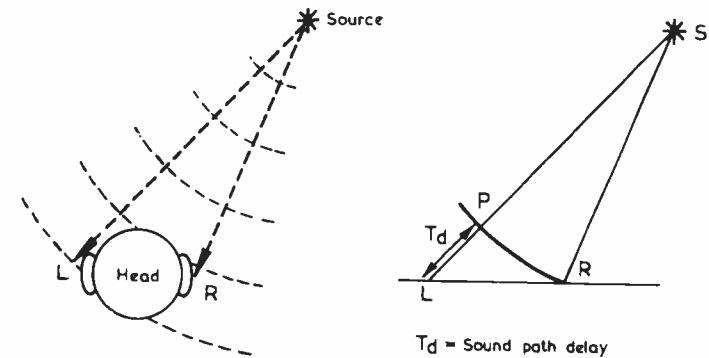

FIG. 1.3. THE DELAY BETWEEN LEFT AND RIGHT SOUND PATHS

Although the way in which the brain interprets these left and right differences is not fully understood, it is reasonable to assume that BOTH effects play an important part in 'sound positioning' by a listener. For the lower frequency sounds both intensity and phase difference could impart directional information, Fig.1.4.

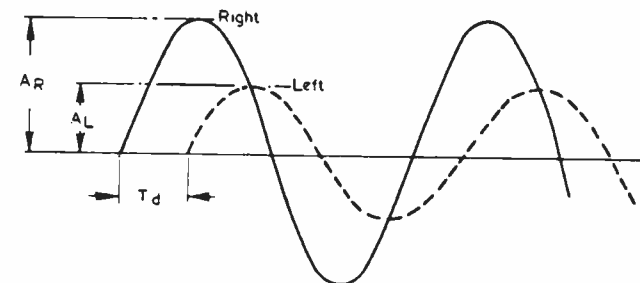

FIG. 1.4. DIFFERENCES BETWEEN LEFT AND RIGHT SOUND SIGNALS

As the frequency from the sound source increases, the time T_d becomes comparable with half a wavelength of the sound waves, Fig.1.5. The left and right signals are now in antiphase and it is impossible to determine whether

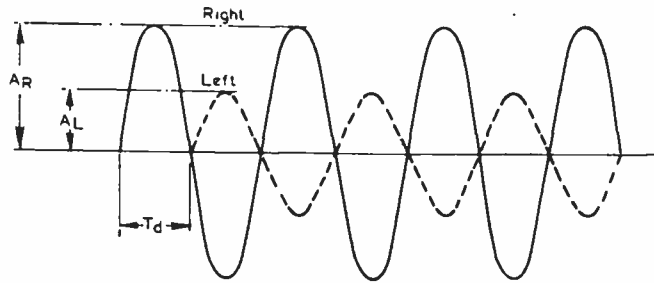

FIG. 1.5. THE EFFECT OF INCREASED FREQUENCY, T_d REMAINING THE SAME

A_R or A_L is leading in phase. This could imply a signal from the extreme right or the extreme left of the listener, and an ambiguous situation is reached. This effect normally occurs at about 1200 Hz (see Chapter 8).

However, the average listener can accurately determine the source position of a pure tone at frequencies above this. This suggests that the ambiguity is resolved by additional information due to intensity difference, supported by the fact that the head becomes a more effective baffle between the ears at high frequencies. Above 1200 Hz we assume that the intensity difference alone determines the source position.

We must now attempt to simulate the sound waves by means of a two-channel system. The positioning of the microphones is very important and the performance of three possible arrangements will be discussed.

(1) WIDE SPACED MICROPHONE METHOD

This method employs two omni-directional microphones spaced about 3 metres apart. The signal paths a , b , c and d , are shown for two extreme sound sources in Fig.1.6. Unfortunately, it will be seen that the signals b and c are reversed to b' and c' on reproduction and appear to come from the opposite side of the sound stage. The effect of this arrangement is to produce a 'hole' in the centre of the image sound stage as the extreme left and right sounds are over emphasized. This may be avoided by increasing the number of sound channels to three or more. In radio-stereophony only two channels are economically feasible and other microphone configurations are used to remove the 'hole' in the sound stage.

(2) FOUR MICROPHONE SYSTEM

This system uses two pairs of directional microphones. In Fig.1.7 it will be seen that the signal paths b and c have been restored to their correct sides of origin in the reproduction. There is still an error in the phase of b and c due to the additional distance from source to microphone compared with a and d .

(3) CLOSE SPACED DIRECTIONAL MICROPHONE PAIR

Two directional microphones are located as close together as possible with their directions of maximum sensitivity at right angles, Fig.1.8.

This system is sometimes called 'Intensity Stereophony'. The polar response curves are cardioid or figure of eight, and a sound source at S will produce

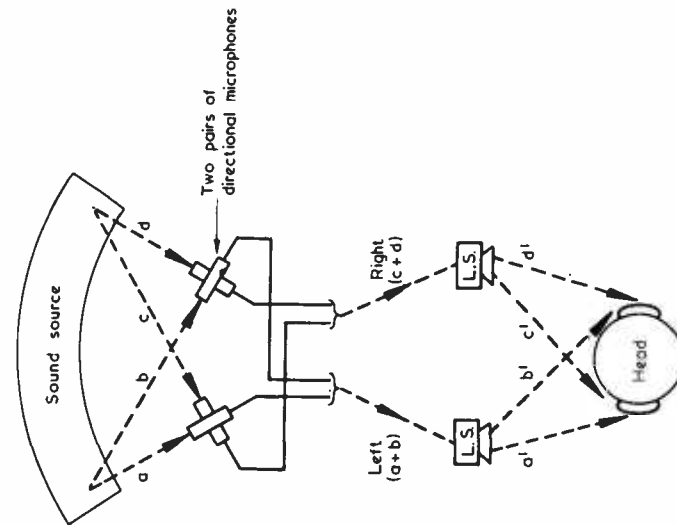

FIG. 1.7. FOUR-DIRECTIONAL MICROPHONE SYSTEM

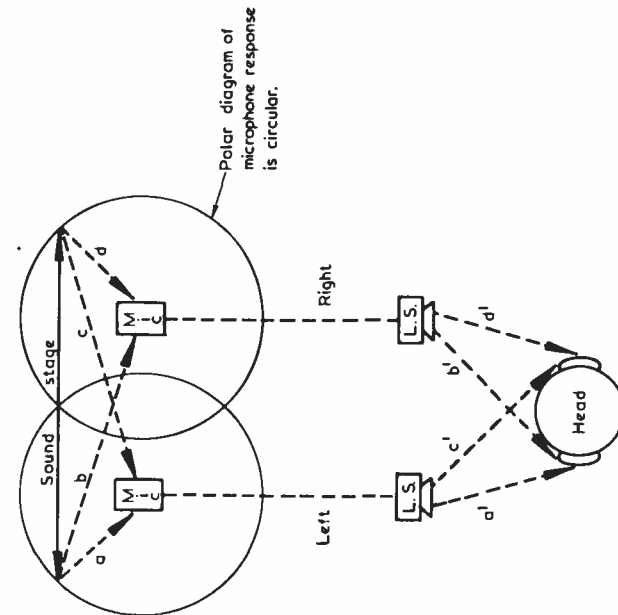

FIG. 1.6. WIDE-SPACED MICROPHONE SYSTEM

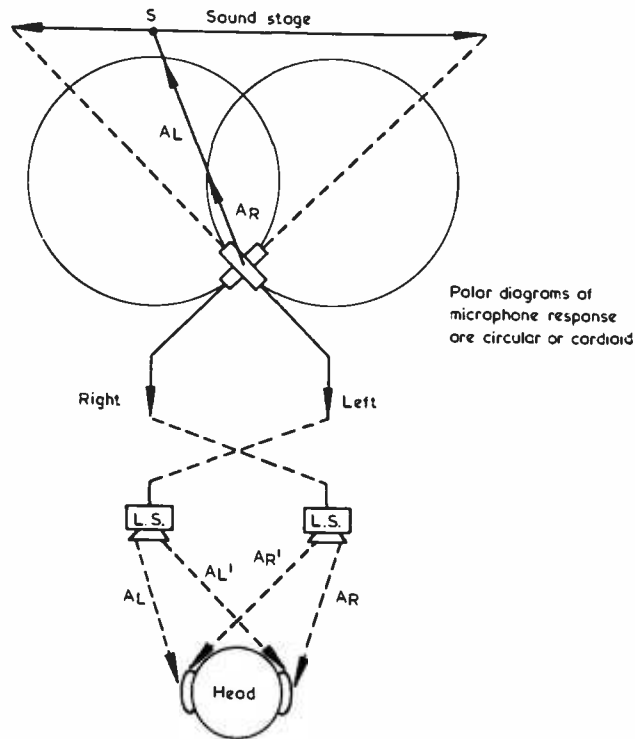

FIG. 1.8. DIRECTIONAL PAIR MICROPHONE SYSTEM. (INTENSITY STEREOPHONY)

signals of relative amplitudes A_L and A_R in the respective microphones. The arrangement obviously introduces an intensity difference in the two channels, but there is no phase difference between the electrical signals as the source to microphone distance is the same for each channel. The phase difference is introduced when the sound is reproduced by a pair of spaced loudspeakers. This may be seen in the waveform of Fig. 1.9. (See also Appendix A, page 185.)

The left ear receives A_L at maximum intensity and in the shortest time. It also hears A'_R which is A_R reduced in intensity due to the longer sound path and the directional properties of the human ear, with time lag of T_d . Similarly, the right ear receives $A_R + A'_L$.

The resultant left waveform, $A_L + A'_R$, leads the right waveform, $A_R + A'_L$, by $(\beta - \alpha)$ as in Fig. 1.9. This shows in fact that the time difference between the reproduced sound signals may be effected by an intensity difference *only* in the electrical channels. It would seem that the time and intensity differences between sound channels are really interrelated (see Appendix A). It may also be shown that if an inter-channel time difference is introduced, the sound source appears to move towards the leading channel.*

* Leakey, D. M., *Wireless World*, April, 1960, pp 154-160, May, 1960, pp 238-240.

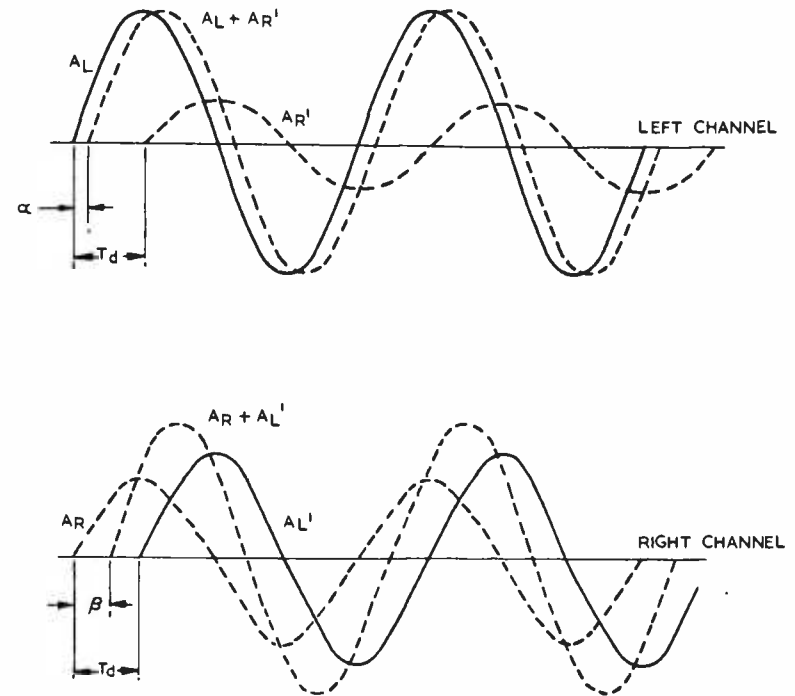

FIG. 1.9. THE INTRODUCTION OF PHASE SHIFT $\beta - \alpha$ BETWEEN THE REPRODUCED SOUND SIGNALS $A_L + A'_R$ AND $A_R + A'_L$

Summarizing these methods, we see that the close-spaced directional microphone pair (or intensity stereophony) is theoretically superior to the others. In practice too it has advantages over the wide-spaced microphones, but these may be used to over-emphasize the stereo effect where required.

THE TRANSMISSION OF STEREO INFORMATION

Stereo recording is usually associated with music, both classical and popular, but with the advent of stereo broadcasting the advantages to be gained by using stereo speech are being appreciated. In the monophonic production of, say, Shakespearian or Restoration drama the editor or arranger has to insert the names of characters in the script to ensure that the listener knows who is being addressed and by whom. The visual information which would obviously make this clear is missing, and the sounds produced by two actors with very similar voice characteristics lead to ambiguity. Stereo drama transmission goes some way to overcome this as the actors can be placed to the right, left or centre by the listener. The movement of the characters can also be simulated by suitable left and right channel mixing.

Stereo information is required just as much for solo instrumentalists as for a full orchestra, as the echoes and reverberations from a single sound source in a room or studio are necessary for tonal balance and 'realism'.

With disc or tape recording, a two-channel stereophonic system is easily obtained by recording the left and right information on the sides of the disc groove or on two parallel tape tracks. The information may be reproduced monophonically by simply replaying on monophonic equipment, provided that the tape recorder is arranged to scan the two tracks simultaneously. This property is known as **compatibility**.

For economy and frequency allocation restrictions it is necessary that a stereo radio transmission be capable of adequate reception by both mono and stereo receivers when tuned to the same frequency. The transmitted signals must be compatible to both types of receiver. The reception of only one of the two channels by a mono receiver is unsatisfactory. This makes it unacceptable to transmit left and right information separately. To overcome this one channel transmits 'left plus right' information for reception by both mono and stereo equipment, the other channel carrying 'left minus right' information for use with stereo receivers. This arrangement of channels is produced in the **encoder** before transmission. On reception the two channels are then combined in the stereo **decoder** to produce the separate left and right signals, Fig.1.10.

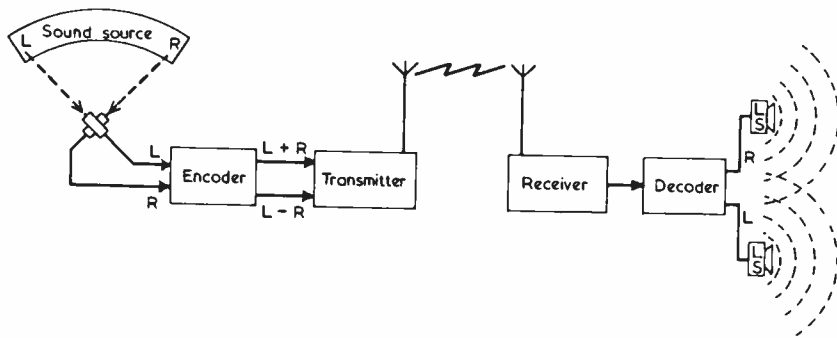

FIG. 1.10. STEREO TRANSMISSION SYSTEM

TRANSMITTER, ENCODING AND MODULATION

SINCE 1967 the BBC has radiated stereophonic signals from a number of v.h.f. stations using the ZENITH-G.E. STEREOGRAPHIC BROADCAST SYSTEM, developed originally in America through the combined efforts of the Zenith and General Electric Corporations. This system was adopted for use in the U.S.A. in 1961 and later by Canada, Japan and some European countries.

It would be helpful before looking into the operation of a particular system to outline the main features that are desirable in a stereo broadcast arrangement adopted for national use. The important requirements may be summarized as follows:

(a) The stereo signal information should be transmitted *via* a single radio-frequency channel without causing a significant increase in bandwidth over mono transmissions (a bandwidth of 240 kHz is required for v.h.f./f.m. mono transmissions).

(b) The area of satisfactory reception should not be reduced for mono listeners and any reduction for the stereo listener should be kept as small as possible.

(c) The system must be **compatible**, *i.e.* existing mono receivers should be able to tune in to the stereo transmission and extract the information necessary to give satisfactory mono reproduction.

(d) The stereo reproduction should be comparable with other acceptable forms of stereo (*e.g.* stereo disc recordings) without resorting to complicated and expensive receiving equipment.

Over the years (tests were carried out as early as 1926) a number of stereo broadcast systems have been proposed which more or less meet the requirements mentioned. In Europe the interest centred around systems designed to operate at v.h.f., an extensive network of mono stations having already been established operating on these frequencies. Also, at v.h.f., there was sufficient bandwidth available for hi-fi quality. After intensive investigations into a number of systems the European Broadcasting Union accepted the Zenith-G.E. system in modified form as the method for Europe, thereby meeting the desirability of international standardization for stereo broadcasting. This system will now be described.

ZENITH-G.E. SYSTEM (PILOT-TONE MULTIPLEX)

(i) L+R and L-R signals

The first step in the system is the production of L+R and L-R signals. The process is carried out in a device called a **matrix**. This is a circuit where the signals are combined or mixed in a special way. In electronic terms the matrixing network can be quite simple.

Inputs to the matrix are the left and right channel signals originating from the studio microphones as illustrated in Fig.2.1. These signals will lie in the audio frequency range of 30 Hz to 15 kHz. The matrix has two outputs.

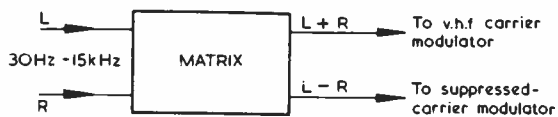

FIG. 2.1. MATRIXING THE L AND R SIGNALS

One is the sum of the input signals ($L+R$) and the other is the difference between the two inputs ($L-R$). In Chapter 1 it was stated that the sum of the signals from the two channels, *i.e.* $L+R$, would serve as a monophonic version of a stereo programme and would provide satisfactory mono reproduction. Thus the $L+R$ signal at the matrix output corresponds to the ordinary mono signal and requires no further processing. It may, therefore, be fed to the v.h.f. carrier modulator which will be discussed later.

The provision of a $L+R$ signal thereby meets one of the desirable features mentioned—namely, compatibility. It will be seen later that an ordinary mono receiver will be able to extract the $L+R$ signal from the transmitted information (due to its position in the frequency spectrum of the composite signal) and provide the listener with a mono version of the stereo broadcast.

By some means or other it is necessary to induce into the two audio channels of a stereo receiver the original left and right microphone signals. This is the reason for the provision of an $L-R$ signal. If a stereo receiver is presented with $L+R$ and $L-R$ signals it can easily recombine them to reconstitute the original L and R components of a stereo programme. Thus the $L+R$ and $L-R$ signals convey the stereo content of a stereo broadcast.

Fig.2.2 illustrates two possible methods of combining or matrixing the L and R signals. In diagram (a) the transformers T_1 and T_2 are used for the matrixing. The left-hand microphone signals are fed to the primary of T_1 and the right-hand signals are supplied to T_2 primary. To provide the $L+R$ output, the L signal across W_2 is added to the R signal across W_3 , the winding directions being arranged to give inphase operation. The $L-R$ output is

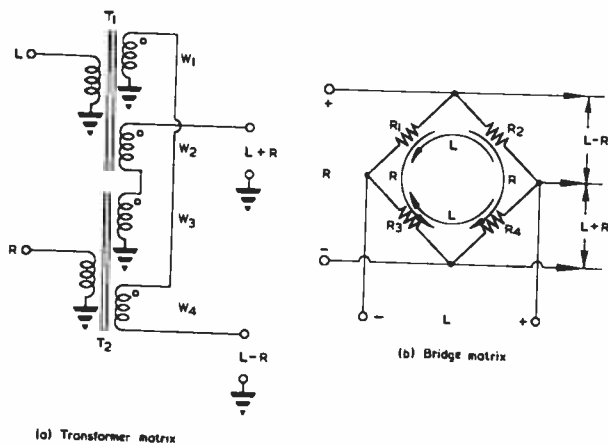

FIG. 2.2. METHODS OF MATRIXING

obtained by combining the voltages across windings W_1 and W_4 which are wound in phase opposition. An alternative arrangement at (b) employs a bridge circuit with equal value resistors in each arm. When the L and R input terminals are phased as indicated, the left and right audio currents will be in the direction shown during one half-cycle. In R_4 (and R_1) the L and R currents will be flowing in the same direction thereby producing voltage drops which are additive, *i.e.* $L+R$. The L and R currents in R_2 (and R_3) flow in opposite directions thus the voltage drops will oppose each other, *i.e.* a difference ($L-R$) voltage will appear across the resistor.

Examples of possible waveshapes for the sum and difference signals are given in Fig.2.3. Diagram (a) shows a 3 kHz sine wave from the left channel and (b) a 1 kHz sine wave from the right channel; for simplicity they are

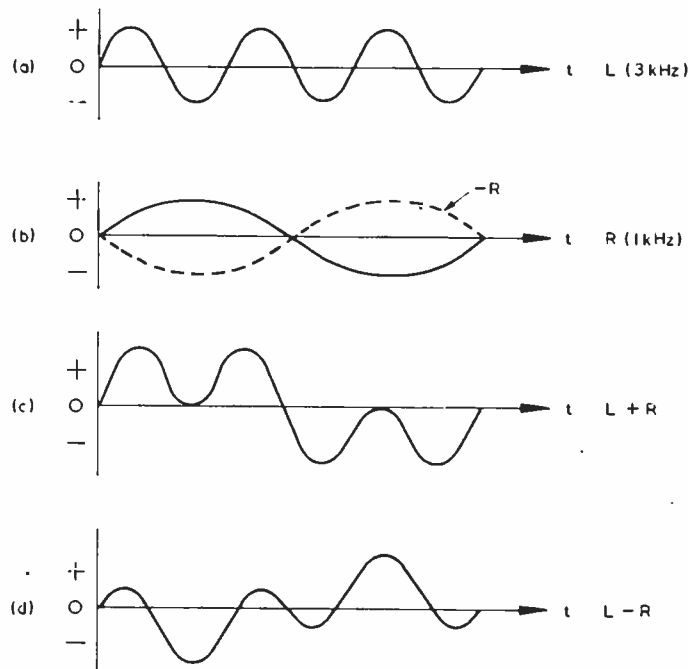
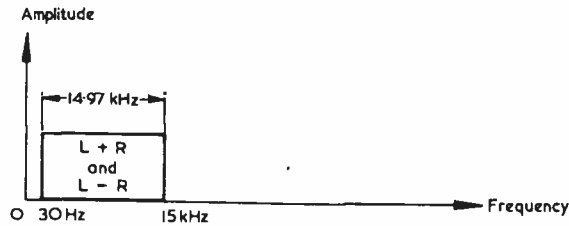

FIG. 2.3. EXAMPLE OF $L+R$ AND $L-R$ WAVEFORMS

assumed to be of equal amplitude. The $L+R$ waveshape of diagram (c) may be obtained graphically by adding waveforms (a) and (b) at various instants in time. To obtain the $L-R$ waveshape, the R signal is drawn with its phase inverted to give $-R$ as shown in diagram (b). If the L and $-R$ waveshapes are now added graphically, waveform (d) will result. This is precisely what occurs in the transformer matrix of Fig.2.2, *i.e.* the right-hand signal is inverted in phase in W_4 and added to the left-hand signal in W_1 giving $L+(-R) = L-R$.

As the $L-R$ and $L+R$ signals are formed by combining the L and R signals, the matrix outputs must contain components at 1 kHz and 3 kHz.

In general, since the L and R channels may carry signals in the audio frequency range of 30 Hz—15 kHz, the L+R and L-R outputs will likewise contain sinusoidal components that lie within this frequency range. At the matrix output, therefore, the L+R and L-R share the same frequency band as illustrated in Fig.2.4(a).



(a) L+R and L-R signals sharing some frequency band at matrix output.

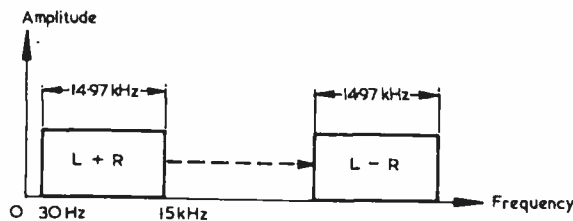

(b) L-R signal shifted in frequency to occupy a higher frequency band

FIG. 2.4. SEPARATING THE L+R AND L-R SIGNALS ON A FREQUENCY BASIS

The sharing of the same frequency band by the sum and difference signals is undesirable from the point of view of signal recognition at the receiver. So they must be separated from one another on a frequency basis. This is achieved by translating the L-R signal to a higher band of frequencies as in Fig.2.4(b). To obtain the result illustrated, the L-R signal is fed to a modulator where it amplitude modulates a supersonic subcarrier.

(ii) Suppressed Carrier Modulator

The process of 'shifting' the frequency band of a signal is called **frequency translation**. It may be accomplished using an ordinary non-suppressed carrier modulator. In the Zenith-G.E. system, however, a **suppressed-carrier** or **balanced modulator** is employed. The use of a balanced modulator helps to improve the signal-to-noise ratio of the system.

At this point it would be useful to explain some important differences between suppressed-carrier and non-suppressed-carrier working. In an ordinary non-suppressed-carrier modulator when the modulating signal is zero there is a carrier of constant amplitude appearing in the output as shown in Fig.2.5(c). With the modulating signal applied, the amplitude of the carrier varies in sympathy with the modulating voltage. On positive half-cycles of the modulating signal the carrier amplitude increases and on negative half-cycles it decreases. This action may be brought about using a circuit similar

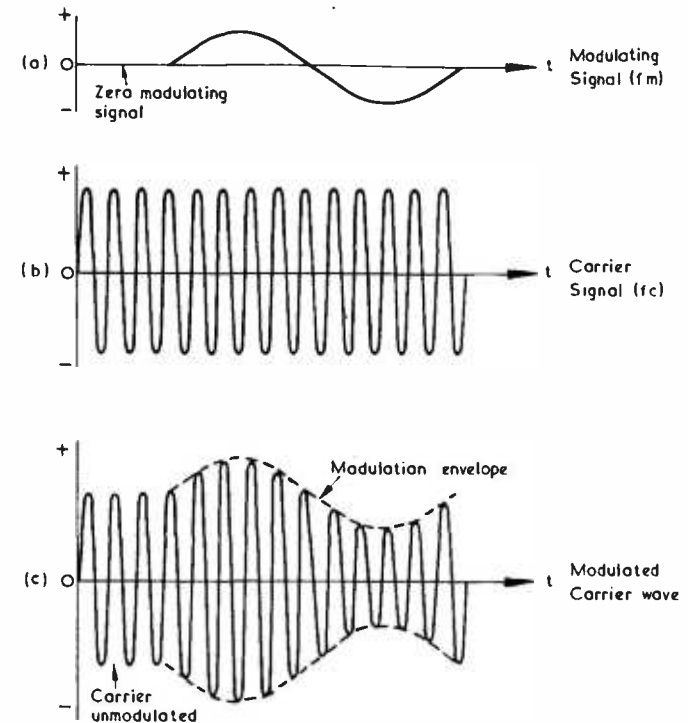

FIG. 2.5. ORDINARY AMPLITUDE MODULATION

to that shown in Fig.2.6.

When the modulating signal is zero there is a steady bias applied to g_2 at a level which will permit anode current to flow. The r.f. applied to g_1 is amplified by the valve and developed across the tuned circuit L_1/C_1 which is tuned to the r.f. carrier. Thus the stage operates like an ordinary r.f. amplifier with a constant amplitude carrier wave appearing at the output. If a modulating signal is now applied, the bias on the suppressor grid is alternately raised and lowered in sympathy with the modulating signal. This causes the anode current (which already bears the r.f. variations of the control grid) to rise and fall as the amplitude of the modulating signal changes. Thus the magnitude of the voltage across L_1/C_1 will vary.

On inspection of the modulated output waveform [Fig.2.5(c)] it would appear that the modulated carrier consisted simply of a voltage of one frequency (the carrier frequency) with amplitude variations. However, this is not so: mathematically and experimentally it can be shown that there are three frequencies present in the output and they are:

- f_c : the carrier frequency
- $f_c + f_m$: the upper side-frequency
- $f_c - f_m$: the lower side-frequency.

Due to the bandwidth of the anode tuned circuit in Fig.2.6, the side-frequency

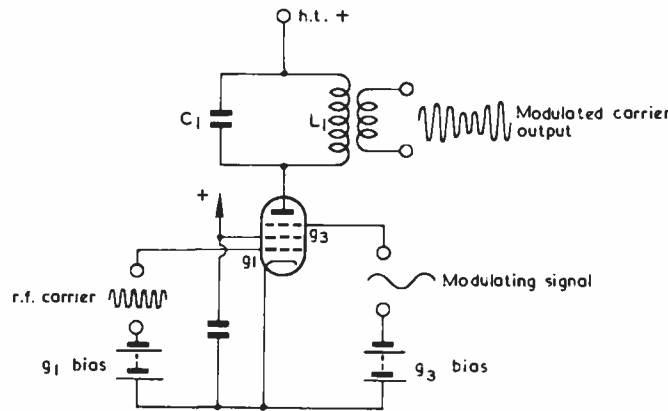

FIG. 2.6. BASIC CIRCUIT FOR AMPLITUDE MODULATION

components will be passed to the output. The carrier and its side-frequencies may be represented by an amplitude/frequency diagram as in Fig.2.7(a). Here we have assumed a carrier frequency of 38 kHz (as this is pertinent to stereo broadcasting) and a modulating tone of 1 kHz. Thus the side-frequencies will lie at 39 kHz ($f_c + f_m$) and 37 kHz ($f_c - f_m$) as indicated. For 100 per cent modulation, the side-frequency components will be a half of the amplitude of the carrier.

Of course, in sound broadcasting of good quality the modulating signals will lie in the frequency range of 30 Hz—15 kHz and not be of a single modulating tone. For EACH modulating frequency within this range a PAIR of side-frequencies will appear in the modulator output, i.e. there will be side-frequencies at $f_c \pm 30$ Hz up to $f_c \pm 15$ kHz. The side-frequency components now broaden into bands (sidebands) on either side of the carrier as illustrated in Fig.2.7(b). Therefore, the original audio band of 30 Hz to 15 kHz has been frequency translated to higher supersonic frequency bands on either side of the carrier.

It is important to note that each sideband fully contains the information of

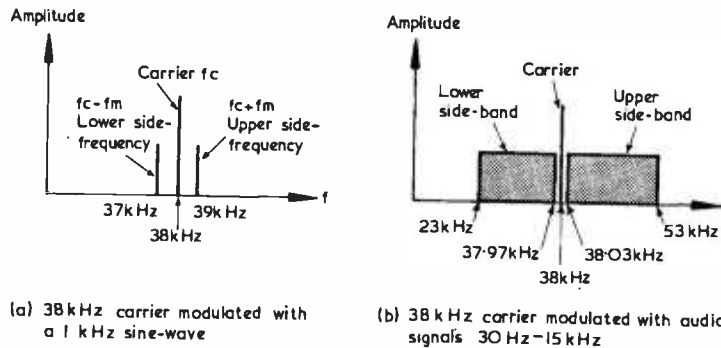

FIG. 2.7. THE CARRIER AND ITS SIDE-FREQUENCIES

the modulating signal. Also, that the carrier does not contribute directly to the magnitude of the information signal; its only purpose is to enable the detector at the receiver to function properly. Provided a signal (of correct frequency and adequate amplitude) to take the place of the carrier can be made available at the receiver, THE CARRIER NEED NOT BE TRANSMITTED.

Of particular interest is the fact that with non-suppressed carrier working the modulated carrier does not change its phase position, i.e. the waveform of Fig.2.5(c) when displayed on a c.r.o. appears as a continuous sine wave free from sudden changes in phase.

We will now consider the operation of a suppressed-carrier modulator using the circuit diagram of Fig.2.8 and the waveforms of Fig.2.9. The circuit shows a balanced modulator consisting of two identical modulated pentode amplifiers. Carrier voltage is applied in push-pull via T_1 to the control grids

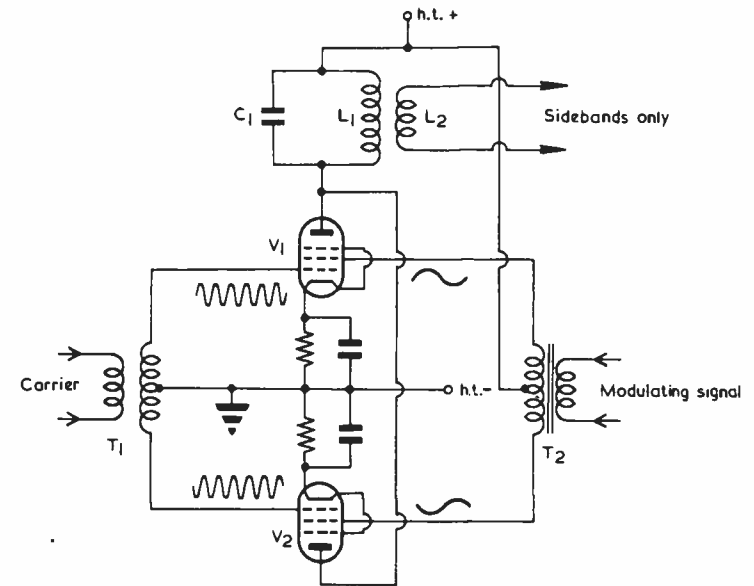

FIG. 2.8. SUPPRESSED-CARRIER MODULATOR

of the two valves, whilst the modulating signal is supplied to the screen grids from T_2 which also provides push-pull drive. The outputs from the anodes feed a common anode load (L_1, C_1). It may be considered that each valve is a separate modulator with the outputs combining in the tuned anode load.

First, we will discuss the circuit action when the modulating signal is absent (the screen grids will then receive a steady voltage). The carrier applied to the control grids will modulate the electron streams of the two valves causing the anode currents of each to vary in sympathy. As V_1 anode current is (say) rising, V_2 anode current will be falling since the carrier drives the control grids in antiphase. Similarly, when $V_2 I_a$ is rising, $V_1 I_a$ will be falling. Thus the anode currents will take the form as shown in (ii) and (iii) of Fig.2.9(a). Provided the modulator is symmetrical and balanced in all

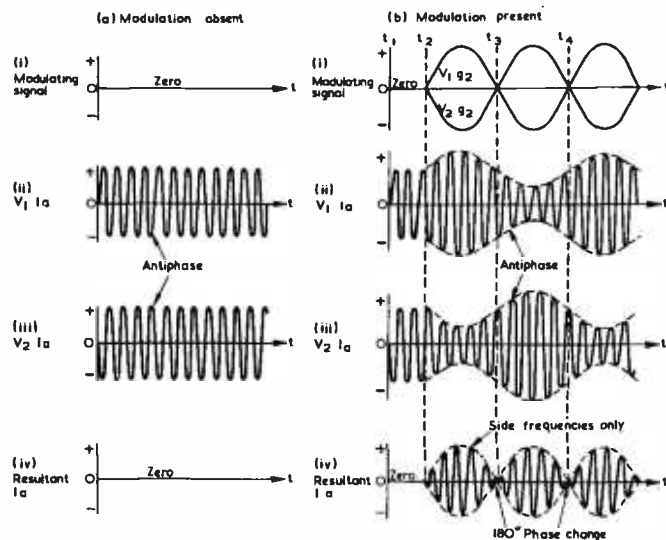

FIG. 2.9. WAVEFORMS EXPLAINING ACTION OF SUPPRESSED-CARRIER MODULATOR

respects, the anode currents will be of the same amplitude and form. Quite clearly, because the anode currents are in antiphase and feed a common load, the resultant carrier current in L_1/C_1 will be zero. Thus there will be no output from the modulator, *i.e.* the carrier is suppressed.

When the modulation is present, the screen grids will be 'swinging' in sympathy with the modulation. Therefore, in addition to the carrier variations of V_1 and V_2 electron streams, the anode currents of each will be further modulated by the push-pull signals at the screen grids. The anode currents of the two valves will thus take the form of an amplitude modulated wave. This is shown in Fig. 2.9(b) where a sine wave modulating signal (i) is used as an example. Note that when the modulating signal at V_1 screen grid is going (say) positive causing V_1 output to increase in amplitude, the modulating signal at V_2 screen grid will be going negative thus causing V_2 output to decrease (t_2-t_3). Conversely, when V_1 screen grid is swinging negatively and V_1 output is decreasing, V_2 screen grid will be swinging positively causing V_2 output to increase in amplitude (t_3-t_4). The anode current variations will then be as shown in (ii) and (iii). Note that the cyclic variations of the two waveforms are in antiphase with one another.

The resultant anode current flowing in L_1/C_1 may be arrived at graphically by adding waveforms (ii) and (iii) at various instants in time. During the period t_2-t_3 the cycles of V_1 anode current are increasing in amplitude but those of V_2 are decreasing. From t_3-t_4 the reverse is true. The resultant I_a will be as shown in waveform (iv) during these periods. Between t_2 and t_3 the resultant current takes on the phase of $V_1 I_a$ variations, since these are always greater in amplitude than those of V_2 . From t_3-t_4 , however, the resultant I_a bears the phase of $V_2 I_a$ variations since these are greater than

those of V_1 . The phase of waveform (iv) during t_3-t_4 will therefore be opposite to the phase during t_2-t_3 . A 180° phase change occurs every time the modulating signal changes polarity.

As the resultant I_a is supplied to L_1/C_1 a voltage wave shape will appear across the tuned circuit similar to waveform (iv). This will be passed to the output via L_2 . Note that the output is composed of side-frequencies only and that the modulation envelope varies at twice the modulating frequency. Clearly, if the output were rectified using an ordinary envelope detector, the demodulated output would be a much distorted version of the original modulation, owing, of course, to the absence of the carrier.

Another way of generating sidebands without the carrier appearing in the output is to employ a ring modulator which is a balanced bridge circuit incorporating four diodes (Fig. 2.10). The modulating signal is applied to the diode bridge in push-pull from T_1 . The carrier input across AB of T_2 is at a level substantially greater than that of the modulating signal.

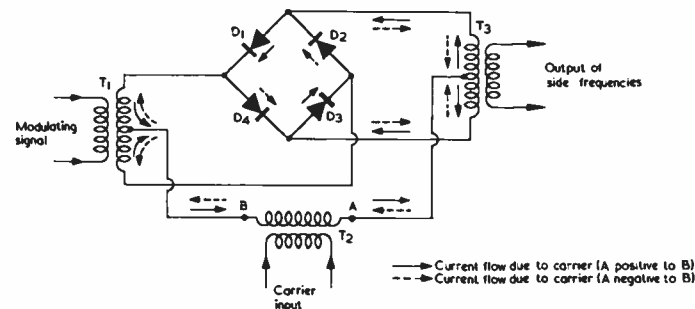

FIG. 2.10. BASIC ARRANGEMENT OF RING MODULATOR

Fig. 2.10 gives the direction of current flow around the circuit when the carrier voltage is applied to T_2 . If A is positive with respect to B , the influence of the carrier voltage is to make the diodes D_1 and D_3 conduct but to reverse bias D_2 and D_4 . When A is negative to B , the carrier causes D_2 and D_4 to conduct but cuts off D_1 and D_3 . Thus the effect of T_2 input on the circuit is to switch the pairs of diodes on and off in accordance with the polarity of the carrier voltage. This action takes place continuously and is independent of the modulating signal since the carrier is of much greater amplitude. Note that the current splits in T_3 primary and flows in opposite directions in the two halves of the winding. These currents will give rise to e.m.f.s acting in opposite directions in T_3 secondary. Provided that the primary currents are balanced (potentiometers may be included in the circuit to correct for asymmetrical operation) the opposing e.m.f.s in T_3 secondary will cancel each other thereby suppressing the carrier at the output.

We will now consider the effect of the modulating signal on the operation of the circuit with the aid of Figs. 2.11 and 2.12. Assume that the modulating signal is just commencing a positive half-cycle and that D_1 and D_3 are conducting. The effective circuit is then as shown in diagram (i) of Fig. 2.11. Due to the modulating voltage, current will flow in the direction indicated with a magnitude varying in accordance with the modulating signal. This

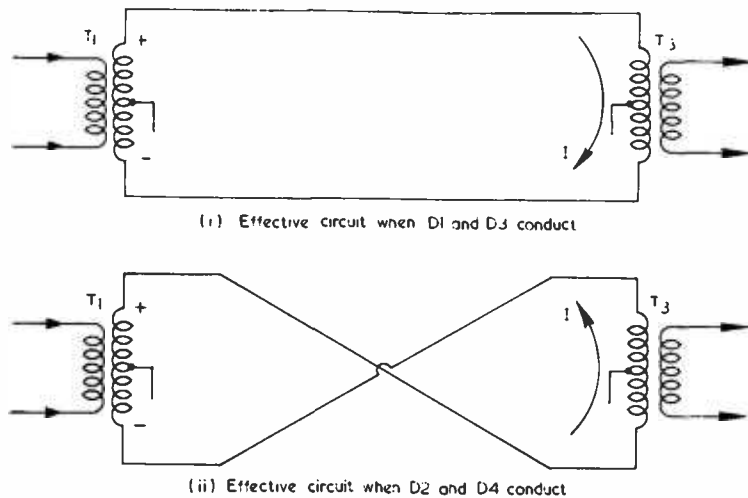

FIG. 2.11. CURRENT (I) DUE TO MODULATING SIGNAL

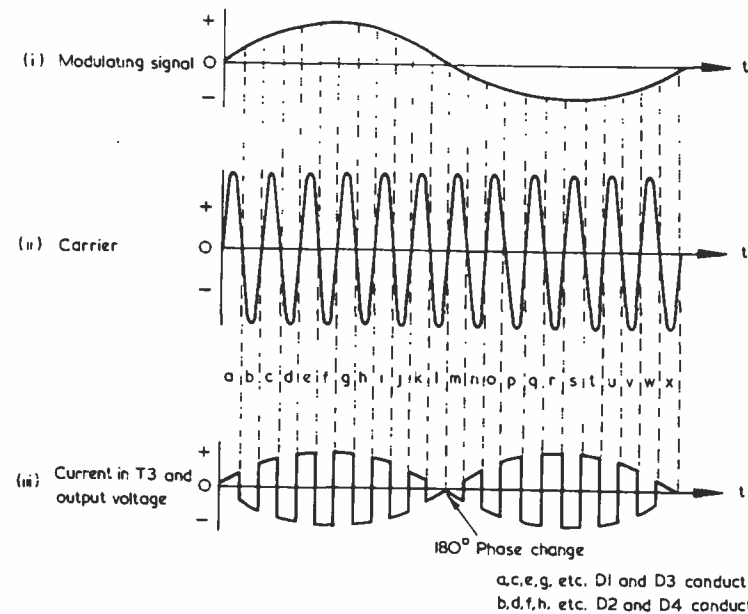

FIG. 2.12. WAVEFORMS OF RING MODULATOR

corresponds to period *a* of Fig.2.12. During this time the modulating signal amplitude is increasing thus causing the current in T_3 to rise in sympathy with it. When the polarity of the carrier voltage changes, D_2 and D_4 conduct and the effective circuit is then as given in (ii) of Fig.2.11. If the polarity of the

modulating signal is unchanged, current flows around the circuit in the opposite direction to that in diagram (i). Again, the magnitude of the circulating current varies in accordance with the modulating signal. This corresponds to period *b* of Fig.2.12. As the switching action continues the current reverses direction each half-cycle of the carrier input as indicated in (iii) of Fig.2.12. At the commencement of period *m*, not only does the carrier polarity change but also the polarity of the modulating signal. This accounts for the 180° phase change in the current waveform.

The output from T_3 secondary contains both the upper and lower side frequencies. There is no component at the carrier frequency, but there are certain (unwanted) higher frequencies generated by the switching action. These unwanted components may be removed by a filter which follows the modulator output. Thus at the filter output only the side-frequencies remain.

Fig.2.13 shows the effective output of a balanced modulator, such as that described, when modulated with an L-R signal whilst receiving a carrier input

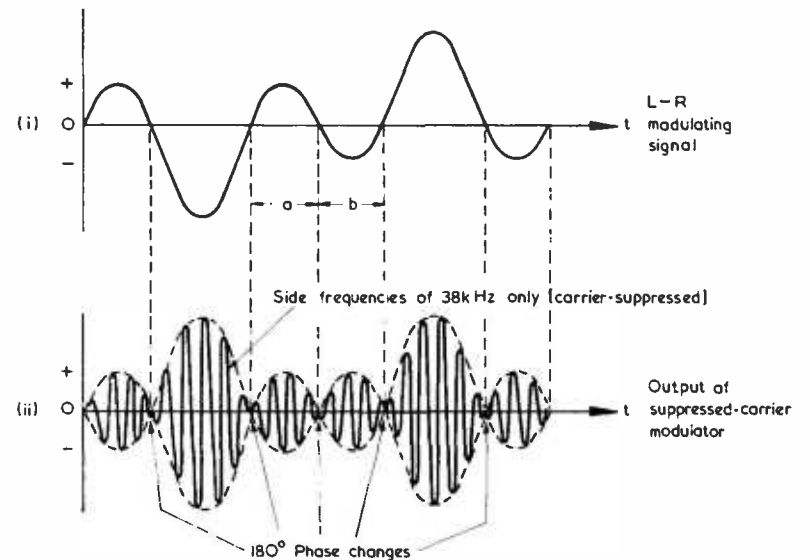

FIG. 2.13. MODULATOR OUTPUT WHEN L-R MODULATING SIGNAL AND 38 kHz CARRIER ARE APPLIED

of 38 kHz. The output waveform has an amplitude directly proportional to the L-R modulation and is composed solely of side-frequencies on either side of the 38 kHz suppressed carrier. Note that during the periods *a* and *b* of the modulating signal the amplitude variations of the output are identical. How then is the information that the modulating signal has changed polarity conveyed by the outgoing signal of the modulator? The answer lies in the 180° phase change which occurs whenever the modulating signal alters its polarity.

Now that the operation of the suppressed-carrier modulator has been discussed in some detail, we may now continue with the description of the Zenith-G.E. system which uses this type of modulator. Fig.2.14 illustrates the essential processes where a balanced modulator is used to effect the frequency

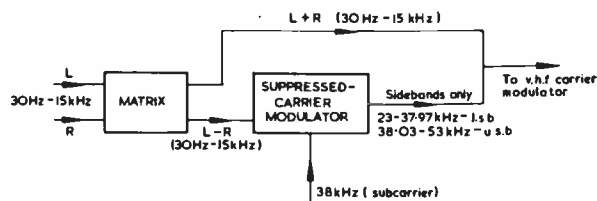

FIG. 2.14. BLOCK DIAGRAM OF PROCESSES SO FAR DESCRIBED

translation of the L-R signal. The carrier input to the modulator is at the supersonic frequency of 38 kHz. The 38 kHz input is referred to as the **sub-carrier** rather than just the 'carrier' to distinguish it from the higher v.h.f. carrier used to carry the information radiated from the transmitting aerial. The subcarrier is suppressed at the output to less than 1 per cent by the action of the balanced modulator. At the output, the side-frequencies produced lie within the range of 38 kHz—15 kHz to 38 kHz—30 Hz and 38 kHz+30 Hz to 38 kHz+15 kHz with an L-R modulating signal of 30 Hz to 15 kHz. Thus the l.s.b. extends from 23 kHz to 37.97 kHz and the u.s.b. from 38.03 kHz to 53 kHz. Both sidebands are then combined with the L+R signal. Fig.2.15 shows the frequency spectrum of the combined signals. There is now a

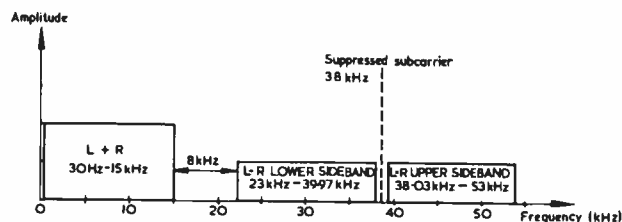

FIG. 2.15. FREQUENCY SPECTRUM OF L+R AND TRANSLATED L-R SIGNALS

frequency space (8 kHz wide) between the highest L+R signal component of 15 kHz and the lowest translated L-R signal component of 23 kHz. This frequency gap is wide enough to allow efficient separation of the signals at the receiver. The amplitude of the L-R sideband components is one half that of the L+R signal. This is to compensate for the presence of both sidebands of the translated L-R signal, which become additive at the output of the receiver detector.

(iii) The Pilot Tone

The subcarrier signal input to the balanced modulator is not obtained directly from an oscillator working at a frequency of 38 kHz, but indirectly from a stable 19 kHz oscillator *via* a **frequency-doubler** as shown in Fig.2.16. As 'frequency-doubling' is employed at the receiver as well, it would be helpful at this point to say something about this technique.

When an amplifier is operated in class-C or class-B, the anode or collector current pulses have an appreciable harmonic content. To extract a harmonic it is merely necessary to tune the output circuit to the desired harmonic of the

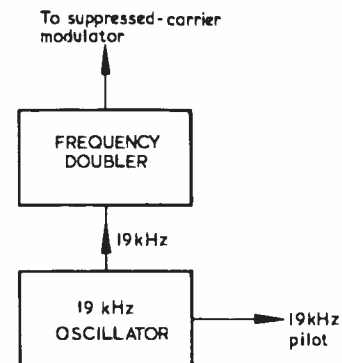

FIG. 2.16. GENERATING THE SUBCARRIER

drive signal and to adjust the angle of current flow so that an appreciable component of the harmonic frequency involved is contained in the current pulses. If the output circuit is tuned to the second harmonic, the stage is a frequency-doubler. With the load tuned to the third harmonic, the stage becomes a frequency-tripler. It is possible to extract in this way higher order harmonics but the amplitude becomes smaller as the order of harmonic increases. Usually, the frequency multiplication obtained with a single stage is restricted to doubling and tripling. If a high multiplication factor is required, several doublers and/or triplers are arranged in cascade.

Fig.2.17 shows a basic circuit employing an n-p-n transistor which may be used as a frequency-doubler. Class-B operation is employed, *i.e.* the collector current only flows on positive half-cycles of the input signal. The angle of flow is therefore 180° which produces collector current pulses very rich in second harmonic content. L_1, C_1 , in the collector is tuned to the second harmonic of the input signal frequency, thus this particular harmonic is developed across the tuned circuit. The impedance of L_1, C_1 , to the fundamental frequency is very small hence there is no appreciable voltage at this frequency across the tuned-circuit. The peak-to-peak amplitude of the second harmonic between

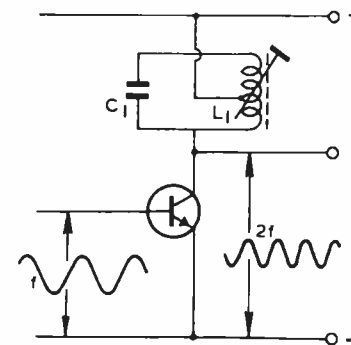

FIG. 2.17. BASIC CIRCUIT OF A FREQUENCY MULTIPLIER

the collector and the tap on the coil is limited to approximately twice the line supply voltage. Tapping the coil prevents undue damping of the tuned circuit by the output resistance of the transistor thereby maintaining a high Q. Waveforms illustrating the circuit action are given in Fig.2.18.

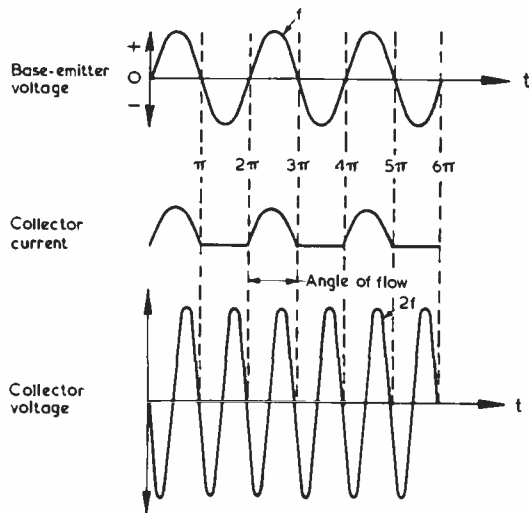

FIG. 2.18. WAVEFORMS ILLUSTRATING FREQUENCY DOUBLING

One may well ask at this stage why the subcarrier is generated in this way: why not use a 38 kHz oscillator and eliminate the need for a frequency-doubler? The reason lies in the need to re-introduce at the receiver a 38 kHz subcarrier of the correct phase and amplitude so that the L-R information may be successfully demodulated. Clearly, some sort of synchronizing signal must be transmitted so that the receiver can reconstitute the 38 kHz subcarrier in the correct phase. The original subcarrier is suppressed at the transmitter to allow a greater deviation of the f.m. carrier by the L+R and L-R sidebands (this is why a balanced modulator is used). One way of providing a synchronizing signal without reducing the deviation available to the programme information would be to radiate the original subcarrier at a low level (as a pilot signal). However, this would create a formidable problem at the receiver: the circuit designer would be faced with the task of filtering out a synchronizing signal from a mass of sideband components spaced as little as 30 Hz in frequency and of considerably greater amplitude.

The method used is to transmit a pilot signal, referred to as the **pilot tone**, at a frequency one half that of the original subcarrier, *i.e.* at 19 kHz. Fig.2.15 on page 20 shows that there is a 8 kHz frequency gap between the L+R signal and the translated L-R lower sideband into which the pilot tone may be accommodated. Here the 19 kHz pilot has sufficient room to permit simple tuned circuits at the receiver to provide the necessary filtering. If the filtered pilot is then applied to a frequency-doubler, the required 38 kHz signal may be reconstituted. The reason for using a 19 kHz oscillator in the signal encoder now becomes clearer, since the oscillator provides a reference

between the transmitted 19 kHz pilot tone and the 38 kHz subcarrier feed to the balanced modulator. Correct phasing between the pilot tone and the suppressed subcarrier is necessary to avoid any ambiguity as to the parent channel of the transmitted L and R hand signals. The two signals are phased so that the zero-crossing points of the 19 kHz pilot are coincident with those of alternate cycles of the 38 kHz suppressed subcarrier. This happens in such a way that at each of the coincident crossings the subcarrier is crossing the zero axis in a positive direction, as shown in Fig.2.19. The frequency of the pilot tone oscillator is $19\text{ kHz} \pm 2\text{ Hz}$ and its phase is maintained within $\pm 3^\circ$ of the nominal value.

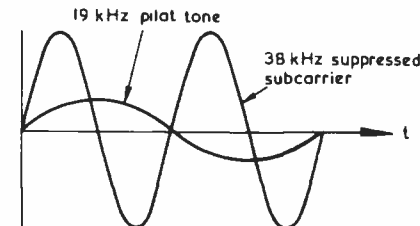

FIG. 2.19. PHASE RELATIONSHIP OF PILOT TONE AND SUBCARRIER

(iv) The Multiplex Signal

The block schematic diagram giving the essentials of the complete stereo encoder is shown in Fig.2.20. Operation of the individual blocks is as pre-

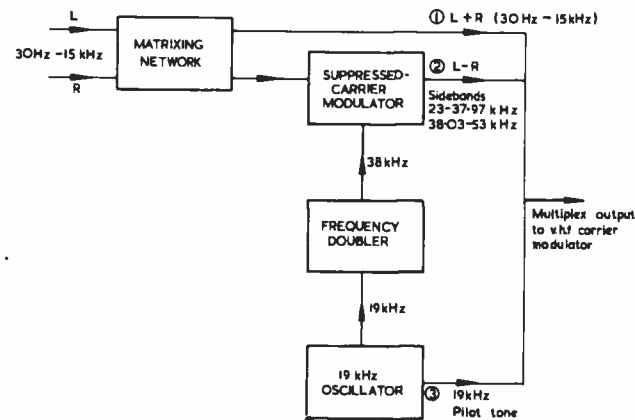

FIG. 2.20. THE STEREO ENCODER

viously described with the outputs ①, ②, and ③ combining to form the **multiplex** or combination signal. The modulating signal applied to the v.h.f. carrier modulator thus consists of three separate components:

① The L+R mono information as a normal audio signal with a frequency range of 30 Hz—15 kHz.

② The sidebands of the frequency translated L-R signal extending from 23 kHz to 53 kHz and existing on either side of a 38 kHz subcarrier suppressed

to less than 1 per cent. This information together with ① provides the stereo signal.

③ A pilot tone at an amplitude of 9 per cent of signal modulation for the purpose of reconstituting the 38 kHz subcarrier at the receiver.

Fig.2.21 shows the frequency spectrum of the multiplex signal input to the v.h.f. carrier frequency modulator. Precisely the same frequency rela-

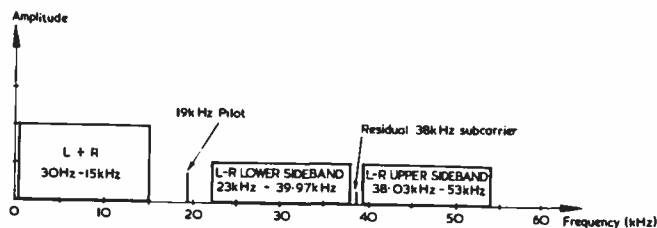

FIG. 2.21. FREQUENCY SPECTRUM OF MULTIPLEX SIGNAL

tionships between the three components of the multiplex signal will apply at the output of the receiver f.m. detector. The amplitudes shown for the L+R and L-R signal components should not be regarded as being static. For example, if a single sound source were placed at the centre of the sound stage the left and right channel signals would be equal in which case $L-R = 0$. Thus the L-R sidebands would disappear and only L+R transmitted. As the sound source moves across the sound stage, the magnitude of the L and R channel signals will vary thus altering the amplitudes of the L+R and L-R components.

An example showing the build-up of the multiplex waveform is given in Fig.2.22. At (a) and (b) are the left and right channel signals with the left signal assumed to be three times the frequency of the right. The matrix output signals are given in (c) and (d). Waveform (e) shows the output from the balanced modulator when modulated with the L-R signal of (d) and when receiving a subcarrier input of 38 kHz. Diagram (f) shows the effect of adding the L+R signal of (c) to the output of the balanced modulator. Waveform (g) is the constant but small amplitude pilot signal of 19 kHz. When this is added to waveform (f), the complete multiplex waveform (h) results. The effect of adding the pilot tone is to raise and lower the peaks of waveform (f).

(v) Modulation of the v.h.f. Transmitter

After the original left and right channel signals have been encoded, the resulting multiplex waveform is fed to the modulator of the v.h.f. transmitter. Band II (87.5 MHz to 100 MHz) is reserved for v.h.f. broadcasting. Most v.h.f. receivers, however, have a coverage extending to 108 MHz which includes the mobile services (police, ambulances, etc.). Frequency modulation of the v.h.f. carrier is used for transmitting both mono and stereo information; this is essential for compatibility. In this section we shall discuss some of the basic ideas of frequency modulation. Detailed circuit diagrams of the transmitter will not be considered because various circuits can be used.

In frequency modulation, the instantaneous frequency of the carrier wave is varied in accordance with the modulating signal but the amplitude of the carrier wave is kept constant. The character of a frequency modulated wave

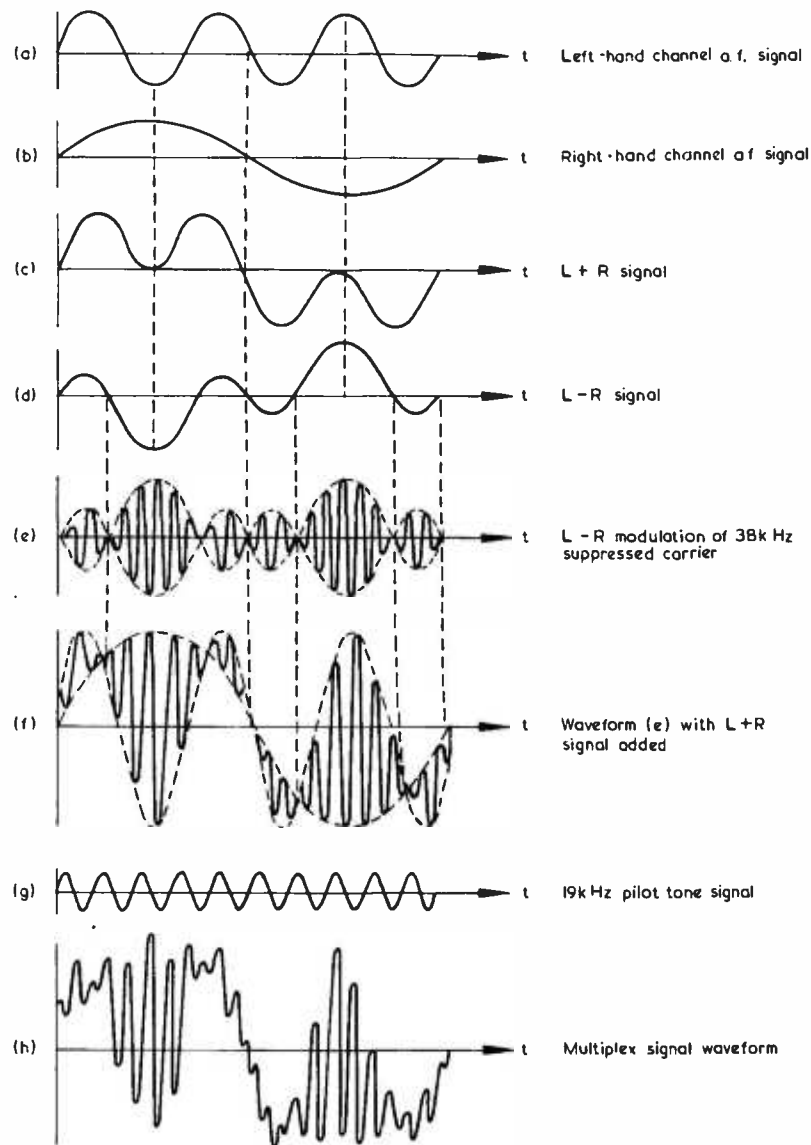

FIG. 2.22. BUILD-UP OF MULTIPLEX WAVEFORM

is illustrated in Fig.2.24. Between A and B the modulating signal is zero and the carrier is maintained at its unmodulated or average frequency. When the modulating signal increases in the positive direction (B to C) the frequency of the carrier increases in direct proportion. From C to D the carrier frequency decreases (also in direct proportion to the modulating signal) so that at D it

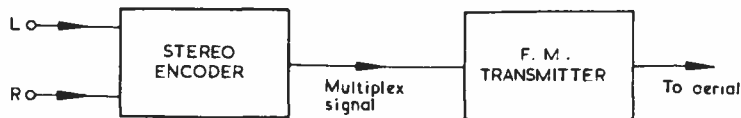

FIG. 2.23. MODULATION OF THE V.H.F. CARRIER

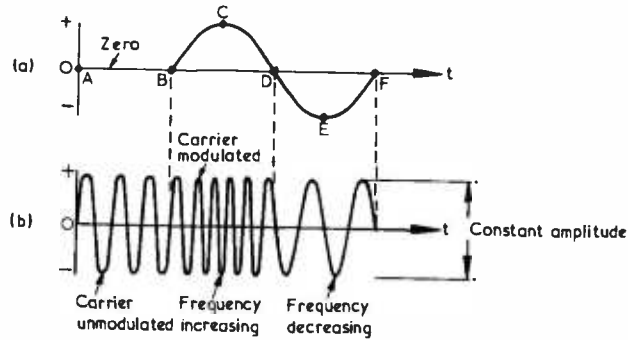

FIG. 2.24. FREQUENCY MODULATION

returns to its average frequency. Between *D* and *E*, after the modulating signal has changed polarity, the carrier frequency decreases. During *E* to *F* the carrier frequency decreases and at *F* it again assumes its average frequency. This frequency variation of the carrier is called **frequency deviation**. Within certain limits, the amount of deviation is determined by the **amplitude** of the modulating signal. For Band II v.h.f. broadcast transmissions the deviation limits are ± 75 kHz of the carrier frequency. This figure corresponds to the largest amplitude or volume of the modulating signal.

Fig. 2.25 shows the effect on carrier deviation when the modulating signal amplitude is varied. For a signal of low volume, the deviation may be ± 10 kHz as in diagram (a), or less. With a large volume signal the deviation increases, reaching ± 50 kHz [diagram (b)] or more up to a maximum of ± 75 kHz.

The **frequency** of the modulating signal determines the rate at which the carrier is caused to deviate. For example, a carrier of (say) 100 MHz when modulated with a signal of 1000 Hz at maximum volume, will increase in frequency to 100.075 MHz, return to 100 MHz, decrease to 99.925 MHz and finally return to 100 MHz in 0.001 second. If the modulating signal frequency is increased to 2000 Hz but the amplitude is kept the same, the carrier will be taken through a cycle of deviation in half this time, i.e. 0.0005 second. The **tone** or timbre of the modulating sound determines the manner in which the above cycle is carried out.

SIDE-FREQUENCIES

At first sight it may appear that if the frequency deviation is ± 75 kHz, the bandwidth would be 2×75 kHz = 150 kHz. However, in fact, it may be much greater because of side-frequencies generated by the modulation process.

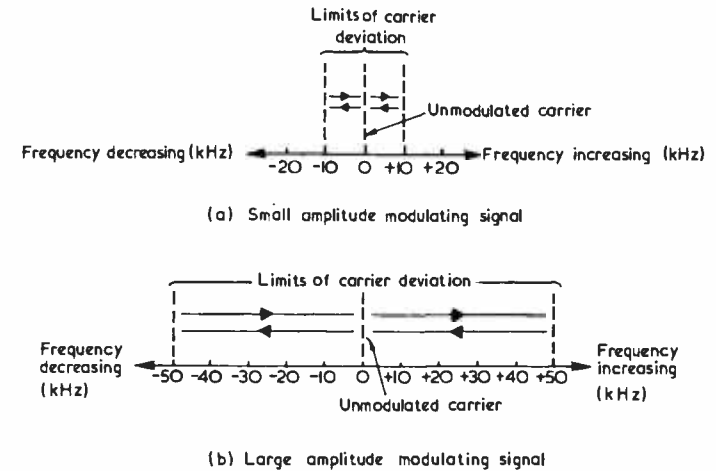

FIG. 2.25. SHOWING HOW THE FREQUENCY DEVIATION OF THE CARRIER VARIES WITH THE AMPLITUDE OF A MODULATING SIGNAL OF CONSTANT FREQUENCY

Amplitude modulation of a carrier by a single tone causes the production of a pair of side-frequencies, the upper and lower on either side of the carrier. With frequency modulation a large number of side-frequencies are generated whose frequencies differ from the carrier frequency by multiples of the modulating signal frequency. For example, when a carrier of frequency f_c is frequency modulated by a sinusoidal f_m , the side-frequencies produced are

$$f_c \pm f_m, f_c \pm 2f_m, f_c \pm 3f_m, f_c \pm 4f_m, f_c \pm 5f_m \dots \text{etc.}$$

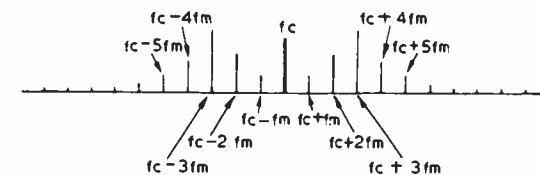

FIG. 2.26. EXAMPLE OF SIDE-FREQUENCIES PRODUCED BY FREQUENCY MODULATION

This is illustrated in Fig. 2.26. The reason for the appearance of multiple side-frequencies is that when the carrier is modulated, the variations of instantaneous frequency do not allow the individual cycles of the carrier to be exactly sinusoidal. As Fig. 2.27 indicates, the time required to complete consecutive quarter-cycles steadily decreases. Thus the actual carrier is a distorted sine wave oscillation.

Theoretically, there is an infinite number of side-frequencies present but most are of negligible amplitude. For practical purposes the significant number

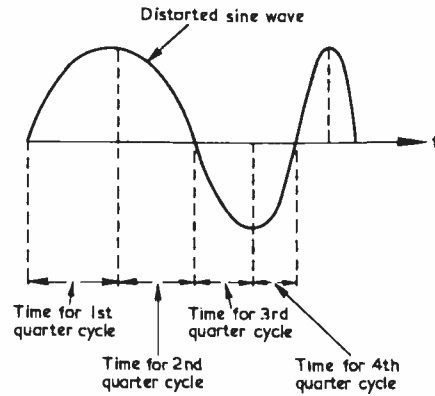

FIG. 2.27. FREQUENCY OF F.M. CARRIER INCREASING. CARRIER IS NO LONGER SINUSOIDAL

of side-frequencies involved is determined by the **modulation index**. This is defined as

$$\frac{\text{Carrier Frequency Deviation}}{\text{Modulating Signal Frequency}}$$

The actual amplitudes of the carrier and side-frequencies relative to the unmodulated carrier amplitude are dependent upon the modulation index, but they are not proportional to it. The greater the magnitude of the modulation index, the larger the number of significant side-frequencies involved. Calculation of the amplitudes is rather involved (see Appendix B, page 188) and the solution requires taking **Bessel functions** of the modulation index. The Bessel functions for various modulation indices are obtained from tables.

To give some idea of the method of solution, consider a modulating signal of 15 kHz at maximum amplitude causing a carrier deviation of ± 75 kHz. The modulation index is therefore $75/15 = 5$. By taking Bessel functions of the modulation index (5), the relative amplitudes of the carrier and side-frequencies to the unmodulated carrier amplitude (assumed to be unity) may be obtained. The actual amplitudes (from tables) are tabulated in Fig.2.28(a). As the order of the side-frequency increases the amplitude tends to diminish although there are several fluctuations. Above the 8th order pair of side-frequencies the amplitudes are less than 1 per cent and for practical purposes can be excluded. As there are eight pairs of side-frequencies with amplitudes greater than 1 per cent, the total bandwidth of the transmission would be 16 times the frequency separation of adjacent side-frequencies, *i.e.* 240 kHz. Reducing the amplitude of the modulating signal but keeping its frequency constant has the effect of decreasing the bandwidth. This is shown in Fig.2.28(b) where the amplitude of the 15 kHz modulating signal has been reduced to provide a frequency deviation of ± 30 kHz. The modulation index for this condition is $30/15 = 2$. The table gives the amplitude of the side-frequencies

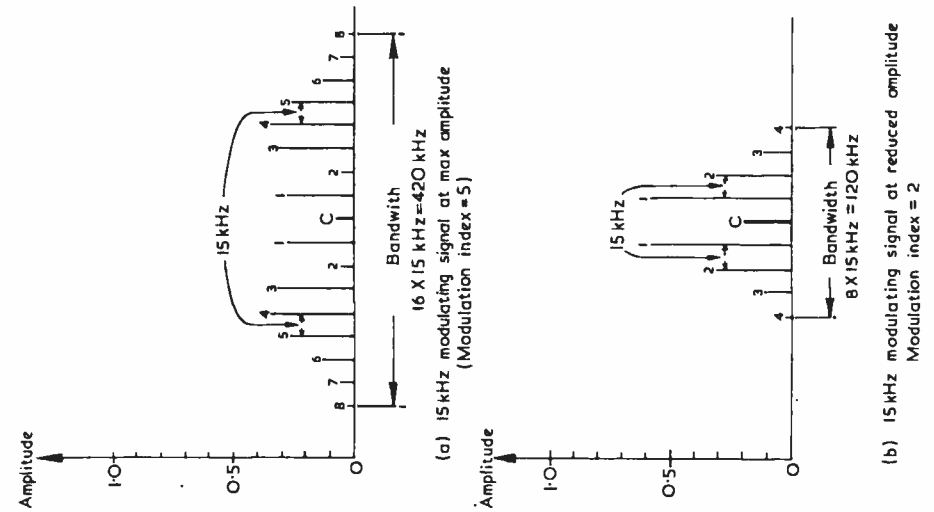

FIG. 2.28. TABLES AND FREQUENCY SPECTRUMS OF CARRIER AND ITS SIDE-FREQUENCIES SHOWING RELATIVE AMPLITUDES

MOD. INDEX = 5

COMPONENT	AMPLITUDE
Carrier	0.18
1st order side-frequencies	0.33
2nd	0.05
3rd	0.36
4th	0.39
5th	0.26
6th	0.13
7th	0.05
8th	0.02
9th	0.0035
10th	0.0014

MOD. INDEX = 2

COMPONENT	AMPLITUDE
Carrier	0.22
1st order side-frequencies	0.58
2nd	0.35
3rd	0.13
4th	0.03
5th	0.007
6th	0.001

involved [from tables listing the Bessel functions of the modulation index (2)]. This time only those frequencies up to the 4th order pair have a magnitude greater than 1 per cent, thus for practical purposes the bandwidth may be assumed to be eight times the frequency separation, *i.e.* 120 kHz.

If the amplitude of the modulating signal is kept constant but its frequency lowered, the modulation index increases and a greater number of significant side-frequencies are involved. Fig.2.29 shows the case for a modulating tone of 7.5 kHz at maximum amplitude. The modulating index for this set of circumstances is $75/7.5 = 10$. As the table shows, side-frequencies up to the 14th order are 1 per cent or greater thus the bandwidth becomes 210 kHz which is slightly less than with a 15 kHz modulating tone at maximum amplitude.

Of course, during a musical programme the modulating signal is continually altering in amplitude and frequency. Thus the modulation index and hence the transmission bandwidth will be varying from instant to instant. The maximum bandwidth is dependent on the higher modulating signal frequencies and the maximum frequency deviation. As previously shown a 15 kHz signal at maximum amplitude yields a total transmission bandwidth of 240 kHz which is that required for mono transmission.

It is interesting to note that with frequency modulation the amplitude of the carrier varies with the modulation index. Indeed, for some values of modulation index the carrier disappears and all of the transmitted power is carried by the sidebands.

DEVIATION DUE TO THE MULTIPLEX SIGNAL

The **PEAK** deviation of the transmitter carrier frequency caused by the multiplex signal is ± 75 kHz as for mono v.h.f. transmissions.

Mathematically, the instantaneous deviation of the main carrier may be expressed as

$$0.9 \left(\frac{L+R}{2} + \frac{L-R}{2} \sin 2 \omega t + 0.1 \sin \omega t \right) \times 75 \text{ kHz}$$

\uparrow \uparrow \uparrow
 1st term 2nd term 3rd term

The 1st term represents the compatible mono signal, the 2nd term the frequency translated difference signal and the 3rd term the pilot tone where

$$\frac{\omega}{2 \pi} = 19 \text{ kHz.}$$

The expression reveals that only 90 per cent of the peak deviation is available for the sum and difference signals whilst the remaining 10 per cent is taken up by the pilot tone (9 per cent) and the residual 38 kHz subcarrier.

One of the features of the Zenith-G.E. system is that if the original L and R signals are restricted to a maximum value which either alone just causes the maximum carrier deviation of 90 per cent, then the total deviation of the

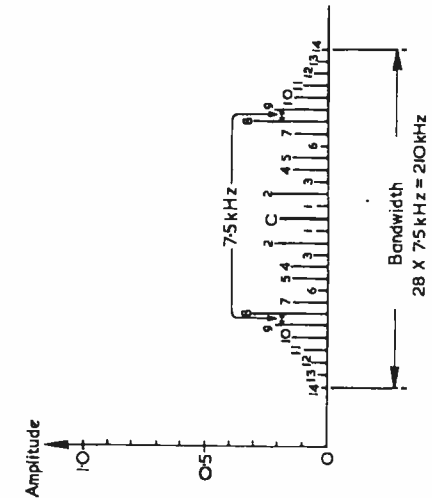

MOD. INDEX = 10	AMPLITUDE
Carrier	0.25
1st order side-frequencies	0.04
2nd	0.25
3rd	0.06
4th	0.22
5th	0.23
6th	0.01
7th	0.22
8th	0.32
9th	0.29
10th	0.21
11th	0.12
12th	0.06
13th	0.02
14th	0.01
15th	0.0045
16th	0.0015

FIG. 2.29. EFFECT OF REDUCING MODULATING FREQUENCY BUT KEEPING THE AMPLITUDE CONSTANT

carrier by the sum and difference signals cannot exceed this permitted maximum. Two extreme cases are listed in columns A and B of the table given in Fig.2.30. Column A shows the results when equal maximum amplitude signals of the same phase are fed into the left and right channels (maximum amplitude is represented by unity). Quite clearly, $L+R$ and $L-R$ become 2 and 0 respectively. The $(L+R)/2$ and $(L-R)/2$ values are 1 and 0 (a reduction by a factor of 2 is used to restrict the numerical values to the range of ± 1). The unity value of the $(L+R)/2$ signal corresponds to the maximum permitted deviation of 90 per cent (67.5 kHz). Since the $(L-R)/2$ signal is zero, there can be no deviation due to the difference-signal. This is shown in Fig.2.31(a) and represents a pure mono transmission. The other extreme occurs when equal maximum amplitude signals are fed into the left and right channels but the phase of one signal is opposite to the other (column B). In this case 90 per cent of the peak deviation will be available to the $(L-R)/2$ signal and 9 per cent to the pilot tone. Fig.2.31(b) illustrates this condition where it will be noted that each sideband of the translated $L-R$ signal contributes one half of the available 90 per cent. It may be thought that both sidebands should be shown at the 90 per cent level, but it must be appreciated that carrier modulation by the $L-R$ signal is due to the combined effects of the upper and lower side-frequencies which at various instants will have an amplitude twice that of a single side-frequency.

Columns C and D together with Fig. 2.31(c) give the results for intermediate conditions when the signal in one channel is missing and the signal in the other channel is at maximum amplitude. Then the available deviation is shared between the $L+R$ signal and the $L-R$ sidebands. Column E and diagram (d) illustrate the case when both channels are carrying signals at reduced amplitude. Here the total deviation of 54 per cent is divided between the $L+R$ signal and $L-R$ sidebands but not equally. If the amplitudes of the left and right channel signals are kept at these values (but a phase difference introduced between the signals) the relative contribution of $L+R$ and $L-R$ towards the total modulation will alter (also the total modulation itself).

EFFECT OF REDUCED DEVIATION

It is now opportune to say something about the performance of the system and in particular what effect the Zenith-G.E. system has on the signal-to-noise ratio compared with ordinary mono transmissions.

Fig.2.31 shows that the maximum carrier deviation for the $L+R$ signal is limited to 90 per cent of 75 kHz which is 67.5 kHz. It is this signal, of course, that the mono listener receives when tuned to a stereo broadcast. A reduction in carrier deviation means that a smaller signal is available at the output of the receiver demodulator and consequently the signal-to-noise ratio is lowered. If the $L+R$ signal were allowed to command the whole of the available deviation of ± 67.5 kHz, the reduction in the signal-to-noise ratio would be about 1 dB as compared with normal mono transmissions. This only holds good when the L and R channel signals are identical in amplitude and phase in which case $L-R$ will be zero. In a typical stereo programme, however, it has been found that the average deviation due to the $L+R$ signal is reduced a further 3 dB. Thus the mono listener suffers about a 4 dB reduction in

	A	B	C	D	E
	L = 1 R = 1	L = 1 R = -1	L = 1 R = 0	L = 0 R = 1	L = 0.5 R = 0.3
$L+R$	2	0	1	1	0.8
$L-R$	0	2	1	-1	0.2
$\frac{L+R}{2}$	1	0	0.5	0.5	0.4
$\frac{L-R}{2}$	0	1	0.5	-0.5	0.1
Percentage of deviation available to MONO SIGNAL $\left(\frac{L+R}{2}\right)$ (± 67.5 kHz)	90%	0%	45%	45%	36%
Percentage of deviation available to STEREO SIGNAL $\left(\frac{L-R}{2}\right)$ (± 67.5 kHz)	0%	90%	45%	45%	9%
Percentage of deviation available to MONO plus STEREO SIGNALS	90%	90%	90%	90%	45%
Percentage of deviation available to PILOT TONE* (± 6.75 kHz)	9%	9%	9%	9%	9%
Total Deviation (100% = ± 75 kHz)	99%	99%	99%	99%	54%

* Varies between 8% and 10% of maximum deviation.

FIG. 2.30. TABLE SHOWING THE PROPORTIONS OF THE PEAK DEVIATION AVAILABLE FOR THE SUM, DIFFERENCE AND PILOT TONE SIGNALS

(a) TRANSMITTER MODULATION WHEN $L=1$ and $R=1$ (b) TRANSMITTER MODULATION WHEN $L=1, R=-1$ or $L=-1, R=1$.(c) TRANSMITTER MODULATION WHEN $L=1, R=0$ or $L=0, R=1$ (d) TRANSMITTER MODULATION WHEN $L=0.5, R=0.3$

FIG. 2.31. DIAGRAMS SHOWING PERCENTAGE MODULATION CAUSED BY L+R, L-R AND PILOT TONE WHEN SIGNALS OF VARIOUS AMPLITUDES AND PHASES ARE FED INTO THE LEFT AND RIGHT CHANNELS

signal-to-noise ratio as compared with ordinary mono transmissions. Except for fringe reception this should not be very noticeable.

As far as the stereo listener is concerned the position is more complicated. It has been demonstrated that the signal-to-noise ratio in respect of random circuit hiss is reduced by up to 22 dB, whereas the audible effects of impulsive electrical interference is increased up to about 15 dB. This, of course, is a more serious reduction and is the price to be paid for transmitting the additional stereo information. Listeners in the areas of fringe and middle reception areas for ordinary mono transmissions will find that more efficient aerials and improved receivers are desirable.

MAXIMUM BANDWIDTH OF STEREO TRANSMISSION

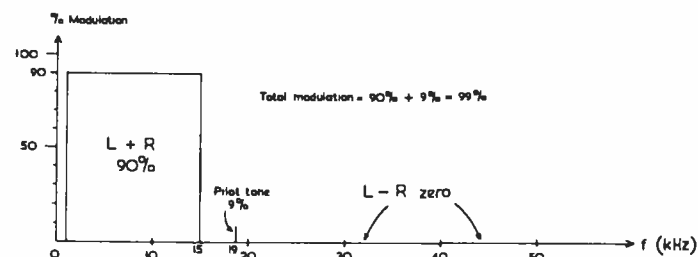
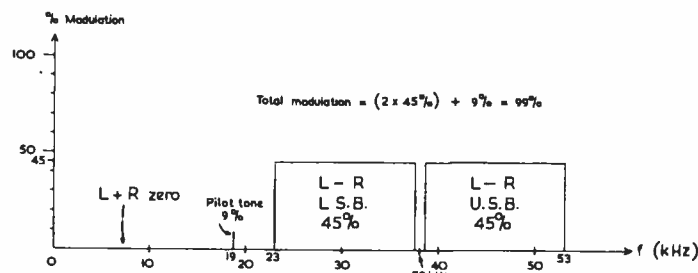
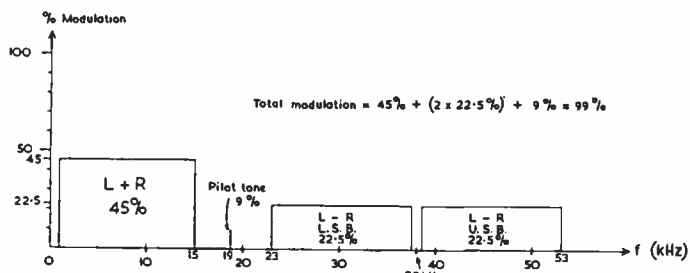
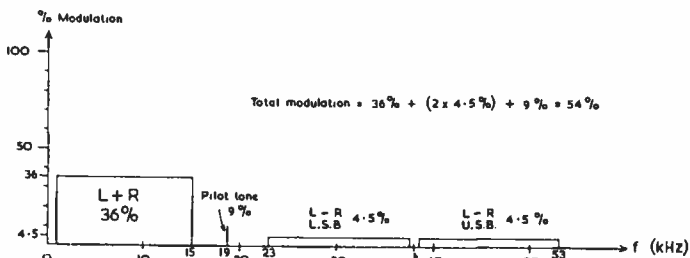
It has been shown that the maximum deviation available for the L-R signal is 90 per cent of ± 75 kHz = ± 67 kHz. This peak deviation, however, is due to the combined effects of the lower and upper side-frequencies of the L-R signal. The deviation caused by any SINGLE side-frequency of the translated L-R information (in the extreme case of $L=1, R=-1$ or $L=-1, R=1$) will be 45 per cent of ± 75 kHz = ± 33.75 kHz. In determining the maximum bandwidth required for the L-R signal it is this deviation value that must be used.

For reasons set out in Appendix B it is wrong to consider only the maximum modulating frequency of 53 kHz. This signal produces a modulation index of

$$\frac{33.75}{53} \approx 0.64$$

giving two pairs of side-frequencies with amplitudes greater than the arbitrary level of 1 per cent. Hence, the bandwidth required to pass the L-R signal would APPEAR TO BE 4×53 kHz = 212 kHz. This is insufficient: a greater bandwidth is necessary at the lower modulating frequency of 42 kHz. For a modulating signal of 42 kHz the modulation index is

$$\frac{33.75}{42} \approx 0.8$$

giving three pairs of significant side-frequencies and a bandwidth of 6×42 kHz = 252 kHz as shown in Fig.2.32. The reason for the higher modulating frequency of 53 kHz resulting in a smaller bandwidth is given in Appendix B. If one chooses an arbitrary level of 0.5 per cent for the significant side-frequencies a bandwidth approaching 300 kHz is indicated.

For stereo reception, receiver i.f. bandwidths are generally found to be in the range of 200—300 kHz as opposed to 150—250 kHz for mono reception.

PRE-EMPHASIS

When noise is superimposed on a frequency modulated carrier whose amplitude is greater than the noise, the resultant wave is modulated both in amplitude and phase. The idea is illustrated in Fig.2.33 where the phasor V_c represents the carrier voltage and V_n a single noise voltage having a frequency greater than that of the carrier. As the noise frequency is higher, V_n rotates anticlockwise relative to the carrier voltage. V_r is the resultant of the two voltages and has an amplitude which varies between the limits of $V_c + V_n$

Mod Index = 0.8	
Component	Amplitude
Carrier	0.85
1st order side-frequencies	0.37
2nd " "	0.08
3rd " "	0.01
4th " "	

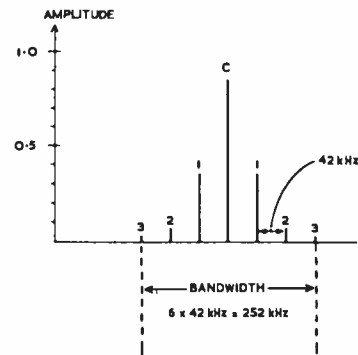

FIG. 2.32. MAXIMUM BANDWIDTH OF STEREO TRANSMISSION

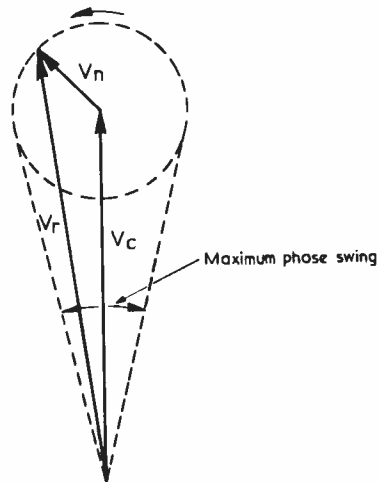

FIG. 2.33. VECTOR DIAGRAM SHOWING HOW NOISE SUPERIMPOSED ON AN F.M. CARRIER CAUSES AMPLITUDE AND PHASE MODULATION OF THE RESULTANT

and $V_c - V_n$ for each cycle completed by V_n . In addition to the amplitude variation, the phase of V_r oscillates about the phase position of the carrier. Therefore, the resultant of the two voltages is modulated both in amplitude and phase at the difference frequency of the two voltages.

An f.m. receiver can be made insensitive to the amplitude variations of the resultant by incorporating effective a.m. limiting in the design. The phase modulation, however, involves a frequency swing to which the f.m. demodulator will respond and so some of the original noise signal is passed to the output. It is a characteristic of phase modulation that the amount of frequency swing introduced is proportional not only to the amplitude of the modulating signal but also to its frequency. Thus for Fig. 2.33 the higher the frequency of V_n relative to the carrier, the greater will be the degree of frequency variation

introduced into the resultant signal and hence the larger the noise output of a responding receiver.

As Fig. 2.34(a) indicates, the noise in the output of an f.m. receiver increases with the frequency difference (f) between the carrier and the noise voltage.

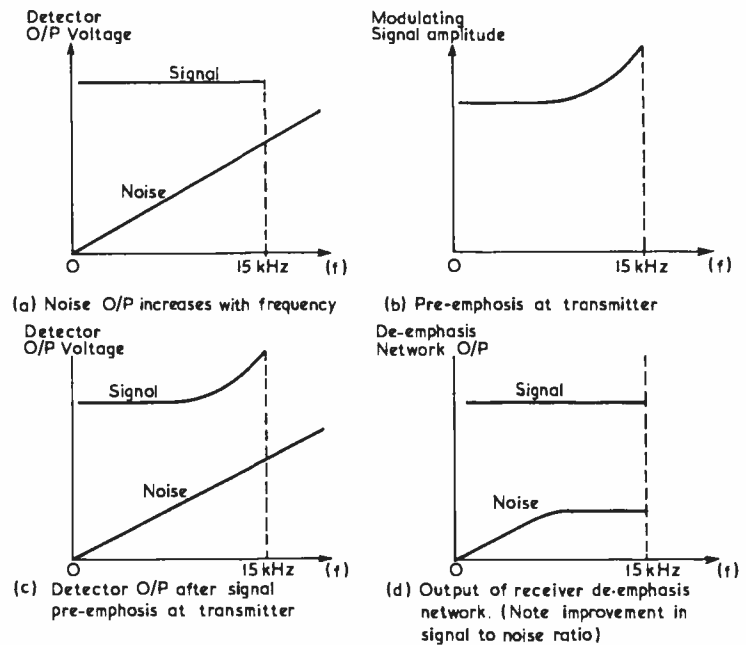

FIG. 2.34. DIAGRAMS ILLUSTRATING PRE-EMPHASIS AND DE-EMPHASIS

In this diagram the origin 0 refers to the carrier signal since we are now considering the detected output. Of course, a limit is set to the audible effects of the noise which is assumed to be 15 kHz. Quite clearly, the signal-to-noise ratio is at its worst for the higher frequency modulating signals which occupy the same frequency position as the larger amplitude noise voltages. The noise can be made less annoying by including after the detector a CR network which attenuates the high frequencies relative to the middle and lower frequencies. The network would, however, operate also on the programme signal and affect the tonal balance. To compensate for this, high frequency boost or **pre-emphasis** is given to the audio signals at the transmitter [diagram (b)]. At the receiver detector output [diagram (c)] an improvement in the signal-to-noise ratio at the higher modulating frequencies is already evident but the tonal response of the programme signal needs correcting. This is the purpose of the attenuator or **de-emphasis network** of the receiver which restores the tonal balance of the programme and simultaneously attenuates the noise voltages [diagram (d)].

Pre-emphasis may be achieved by including a simple LR network like that shown in Fig. 2.35(a) in the audio signal path at the transmitter. For example, the LR combination may be used to form the load of an a.f. amplifier

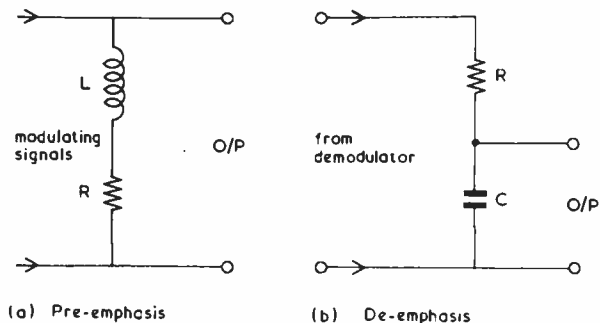

FIG. 2.35. PRE-EMPHASIS AND DE-EMPHASIS NETWORKS

in which case the gain of the stage would rise with increasing frequency. Provided suitable values were used for L and R the desired degree of boost would be obtained. The de-emphasis network usually takes the form of diagram (b) connected to the detector output. As the final output is taken from across C it will fall with rising frequency.

The actual values used in the pre-emphasis and de-emphasis networks will vary from circuit to circuit but the degree of boost or attenuation is dependent upon the time-constant of the filter. Rather than specifying component values it is more usual to quote the time-constant. In Great Britain this is $50 \mu\text{s}$ for f.m. broadcast transmitters. For stereo broadcasting the same time-constant is used in contrast to the $75 \mu\text{s}$ time-constant used in the U.S.A. Pre-emphasis networks may be included in the L and R channel signal paths as illustrated in Fig.2.36. The outputs of these networks are limited to a maximum amplitude of ± 1 so that the permitted deviation of 90 per cent is never exceeded.

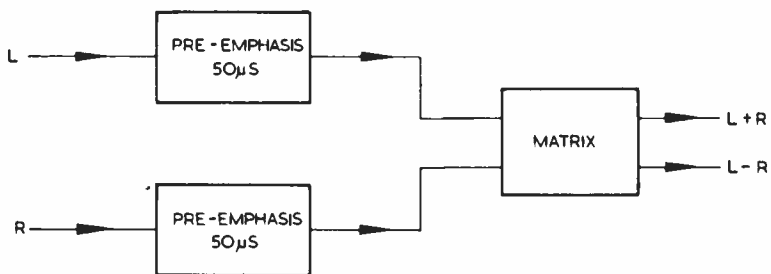

FIG. 2.36. PRE-EMPHASIS OF L AND R CHANNEL SIGNALS

In a stereo receiver or a mono receiver with added decoder, the de-emphasis filter will not appear immediately following the f.m. detector as is normal mono practice. The reason for this is the need to preserve the detected pilot and $L-R$ modulating signals prior to the re-forming of the original L and R channel information.

REFERENCE

Phillips, G. J. and Spencer, J. G., "The Zenith-G.E. Stereophonic Broadcasting System", *Wireless World*, January 1963.

3

THE RECEIVER; TUNING AND DEMODULATING

THE stereo f.m. receiver must select the required incoming signal, amplify it, remove the carrier, and reassemble the left and right audio frequencies prior to amplification and reproduction. It must, in fact, reverse the processes of encoding and modulating described in Chapter 2. Fig.3.1 shows the general layout and indicates the complex nature of the receiver. This

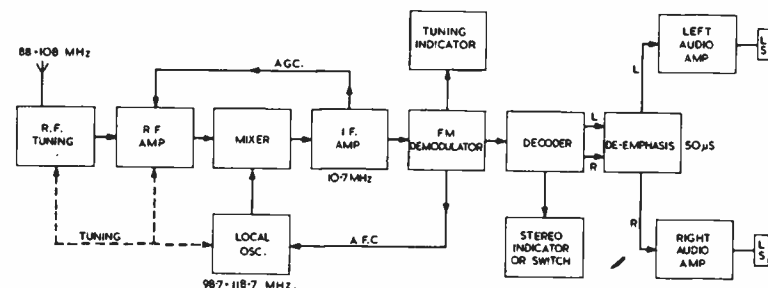

FIG. 3.1. F.M. STEREOPHONIC RECEIVER

resembles a conventional f.m. mono receiver with the addition of a decoder and an extra audio amplifier, but it must be remembered that the bandwidth of the i.f. amplifier must be at least 200 kHz and that extra care must be taken to reduce noise. It is therefore inadvisable to convert a standard mono receiver with an i.f. bandwidth of 150 kHz to stereo by adding a decoder; the sensitivity and bandwidth are usually unsatisfactory.

Referring to Fig.3.1 we see that the incoming modulated carrier is amplified and then mixed with a local oscillator signal to produce a difference-frequency of 10.7 MHz. After amplification, the carrier is removed from this intermediate frequency signal by **demodulation** leaving the multiplex signal as shown in Fig.2.21. This is **decoded** to produce the left and right audio signals. These are de-emphasized to reduce the amplitude of the higher frequencies (enhanced in transmission to improve the signal-to-noise ratio: see Chapter 2), amplified and fed into the loudspeaker system.

In a monophonic receiver the de-emphasis takes place immediately after the demodulation, but this **MUST** come after the decoder in a stereo system as otherwise the de-emphasis removes the pilot tone and the $L-R$ sidebands. Remember that the $L-R$ information was frequency translated upwards to a subcarrier of 38 kHz and any de-emphasis network that attenuates the higher audio frequencies will have a drastic effect on these supersonic frequencies.

This is made use of when a mono receiver is picking up stereo transmitted signals, for the $L-R$ information and pilot tone are effectively filtered out by the de-emphasis network, leaving only the required $L+R$ signal.

THE R.F. TUNER AND AMPLIFIER

Commercial receivers are usually tunable over the range 88 to 108 MHz, a frequency ratio of only 1.23 : 1. With this narrow band it is possible to pre-tune the r.f. stage to 98 MHz and use a damped tuned circuit having a bandwidth of 20 MHz at 3 dB down. The r.f. tuning in Fig.3.1 is then unadjusted by the user when selecting the required station. This arrangement, however, is only used on the cheaper circuits as it offers no 'image rejection'.

To explain this, consider a receiver tuned to 100 MHz. In order to provide an i.f. of 10.7 MHz the local oscillator will be tuned to 110.7 MHz (the local oscillator is usually tuned ABOVE the signal frequency although some manufacturers use the lower oscillator frequency—89.3 MHz in this case). Now, if an unwanted signal of 121.4 MHz is received in the aerial circuit it also produces a difference of 10.7 MHz with the local oscillator and will be selected and amplified by the i.f. circuit, Fig.3.2.

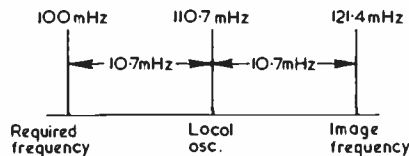

FIG. 3.2. IMAGE FREQUENCY

The unwanted frequency and the image frequency will be separated by twice the intermediate frequency, 21.4 MHz. This is one reason for using an i.f. as high as 10.7 MHz to separate the signal and its image. The ability of a receiver to suppress this image frequency is known as 'image rejection'.

A fixed or pre-tuned r.f. input offers little or no image rejection for, as shown in Fig.3.3, at the lower end of the tuning range the local oscillator frequency of 98.7 MHz tunes in the 88 MHz AND the image of 109.1 MHz,

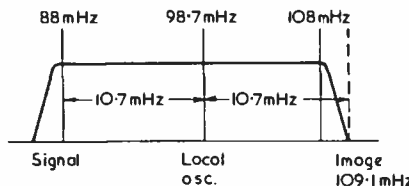

FIG. 3.3. R.F. PASS-BAND FOR IMAGE REJECTION

which is only 1.1 MHz above the top frequency of the tuning range. This difference is usually too small to be filtered out by the pass-band of the tuning circuit without attenuating the reception at the top end of the tuning range.

It is therefore desirable to provide variable tuning of the r.f. input as well as of the r.f. amplifier and local oscillator. As this requires a three-gang tuning capacitor, with additional tracking and lining-up problems, it is usually found only in the more expensive receivers. When r.f. tuning is used an image rejection figure of 50 dB is typical.

As the mixer introduces noise it is desirable to amplify the r.f. signal before mixing in order to improve the signal-to-noise ratio of the receiver. The r.f. amplifier also prevents direct coupling between the local oscillator and the

THE RECEIVER; TUNING & DEMODULATING 41

aerial, and suppresses unwanted radiation. This radiation would cause annoying interference between f.m. and television receivers operating in close proximity. The r.f. amplifier also prevents de-tuning of the local oscillator caused by variable aerial loading.

It will be shown later that in order to suppress any unwanted a.m. component of the incoming f.m. signal, a limiter circuit may be used. To be effective this limiter circuit must be kept saturated and the r.f. amplifier provides the receiver sensitivity for this to occur. Whilst it is possible to incorporate a very high gain r.f. amplifier for high sensitivity, this introduces noise and the gain must be limited to a usable level. The amplification is limited by an automatic gain control (a.g.c.) signal fed back from the i.f. amplifier, Fig.3.1. Receiver sensitivity must be quoted together with the corresponding noise figure; a typical figure for a good circuit is $2 \mu\text{V}$ for 30 dB quieting. This means that at least $2 \mu\text{V}$ input is required if the signal-to-noise ratio is to be greater than 30 dB. In poor reception areas any further increase in signal must be obtained by improved aerial design and installation if the noise level is to be kept down.

An example of a pre-tuned r.f. circuit and amplifier is shown in Fig.3.4. L_1C_1 form an acceptor circuit tuned to 98 MHz; this determines the centre

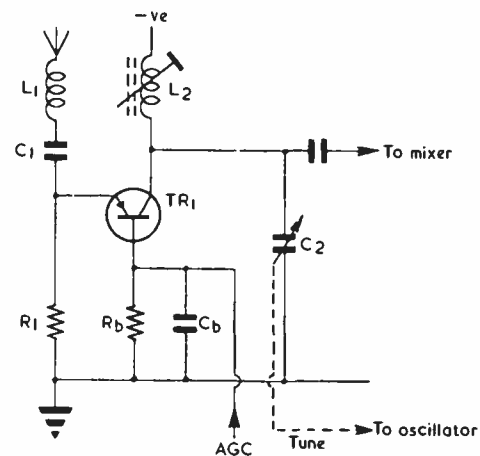

FIG. 3.4. PRE-TUNED R.F. AMPLIFIER

frequency of the incoming pass-band (see Fig.3.3.). No aerial transformer is used here as the input impedance is typically 75Ω to 100Ω which matches the average aerial.

TR_1 is connected in common-base mode as this provides positive feedback; there is an output-to-input feedback at the frequencies used and the gain obtained is higher than for common-emitter mode. The gain of TR_1 is set by varying the bias, which is determined by R_b , C_b and the a.g.c. signal from the i.f. amplifier output. Tuning is by L_2C_2 after amplification.

Fig.3.5 shows another r.f. arrangement using an aerial transformer. The pre-tuned circuit here is of the rejector type and contains a d.c. blocking capacitor, C_1 , to ensure correct bias conditions for the transistor. The damping

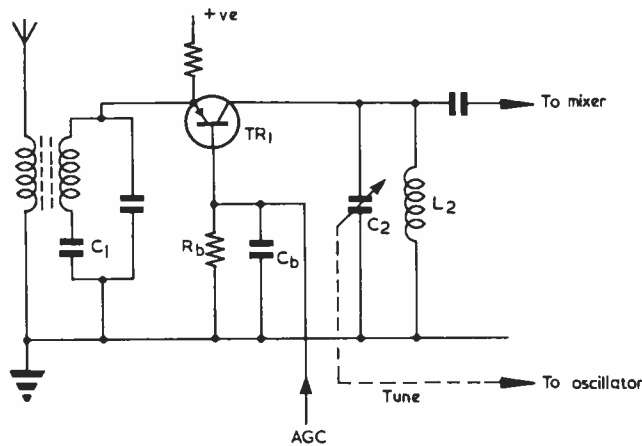

FIG. 3.5. PRE-TUNED R.F. AMPLIFIER

provided by the input impedance of the transistor ensures adequate bandwidth. Tuning is by means of L_2C_2 .

As stated earlier, for adequate image rejection variable input tuning is required. Fig.3.6 shows a circuit incorporating this in conjunction with a balanced input. L_1C_1 form the first tuned circuit followed by L_2C_2 after amplification.

Field effect transistors (f.e.t.s) are now commonly used for the first stages of f.m. receivers and Fig.3.7 shows a typical circuit. They have the advantages of low noise and a relatively high input impedance.

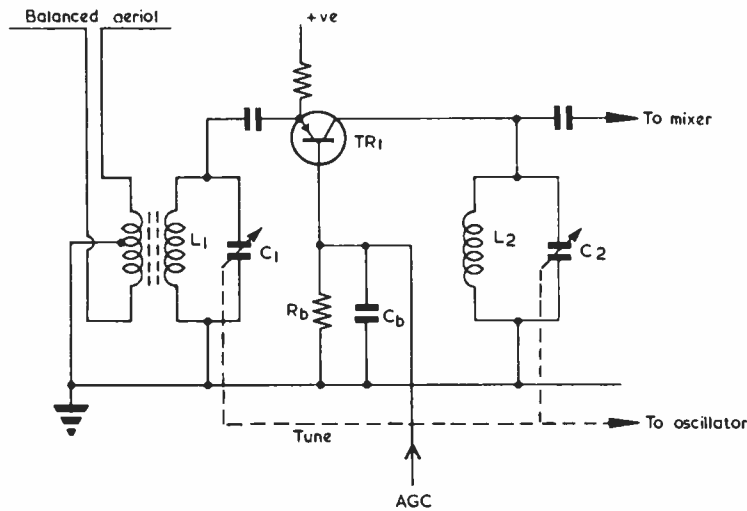

FIG. 3.6. R.F. TUNABLE AMPLIFIER WITH BALANCED INPUT

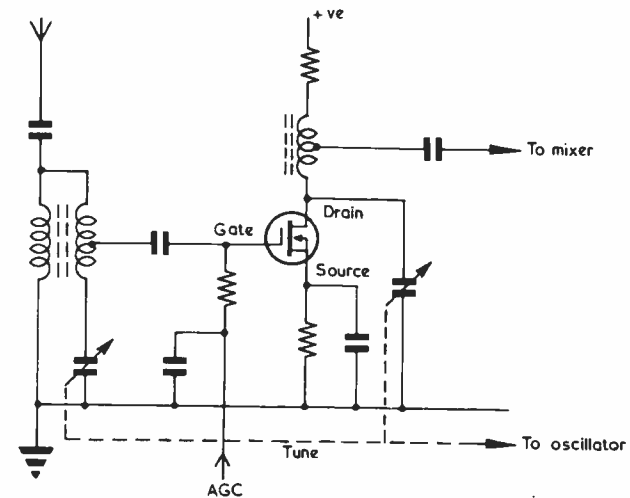

FIG. 3.7. R.F. TUNABLE AMPLIFIER USING F.E.T.

A comparison of the circuits in this chapter with actual receiver designs will show that manufacturers use tapped transformers and inductances, as in Fig.3.7. These have been omitted here in circuits intended to illustrate the basic principles. The tapings are chosen to limit the damping of the tuned circuits by the transistor impedances (or to ensure correct load matching).

THE FREQUENCY-CHANGER (MIXER)

In this part of the receiver the amplified r.f. carrier of frequency f_1 is combined with the local oscillator signal of frequency f_0 to produce an output of frequency $f_0 - f_1$, the intermediate frequency.

The simple addition of a carrier e_1 to the oscillator voltage e_0 will produce a waveform as shown in Fig.3.8(c), the amplitude of which varies with a frequency of $f_0 - f_1$. The average value of this waveform is zero, and to extract the i.f. component $e_1 + e_0$ is detected or rectified to produce the waveform (d). This is fed into a circuit tuned to the intermediate frequency $f_0 - f_1$. Fig.3.9 shows the basic mixer circuit, the voltage sum being detected by the diode D , sometimes called the first detector, and the i.f. component extracted by the tuned LC circuit.

The tuned circuit is necessary as the waveform (d) will have a large component at a frequency of $f_0 + f_1$, together with others of higher frequency but smaller amplitude, which must be rejected.

In practice, a transistor is used for mixing and detecting, the rectifying action of the base-emitter junction detecting the added voltages, the transistor amplifying the weaker carrier signals, Fig.3.10.

Alternatively, the two signals to be mixed may be fed together into the base of the transistor and the tuned circuit arranged to have one side grounded, Fig.3.11.

The local oscillator is usually of the type shown in Fig.3.12, in which oscillation is maintained by capacitor feedback, via C_f , from collector to

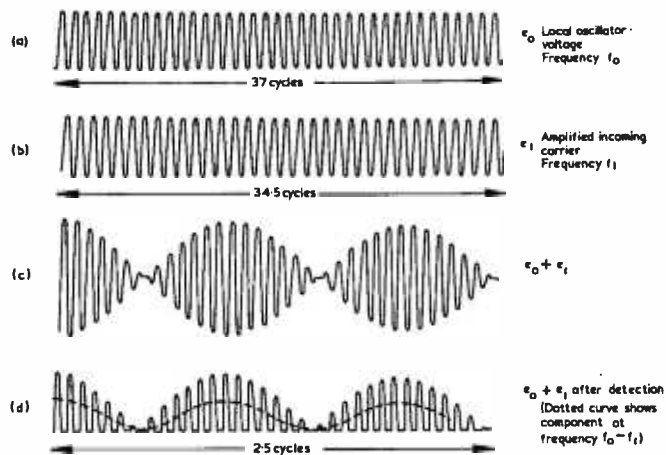

FIG. 3.8. THE ADDITION OF TWO VOLTAGES OF DIFFERENT FREQUENCY

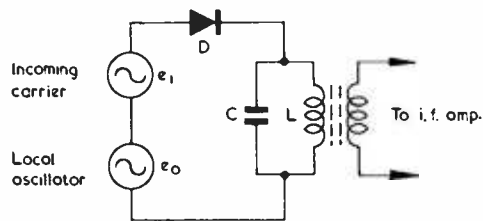

FIG. 3.9. BASIC ADDITIVE MIXER CIRCUIT

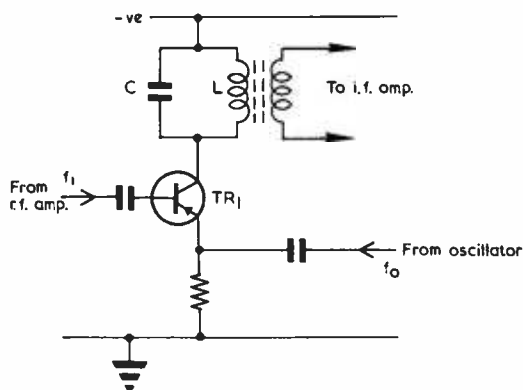

FIG. 3.10. A TRANSISTOR MIXER

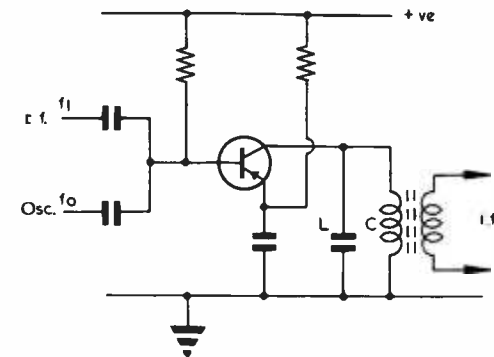

FIG. 3.11. ALTERNATIVE TRANSISTOR MIXER

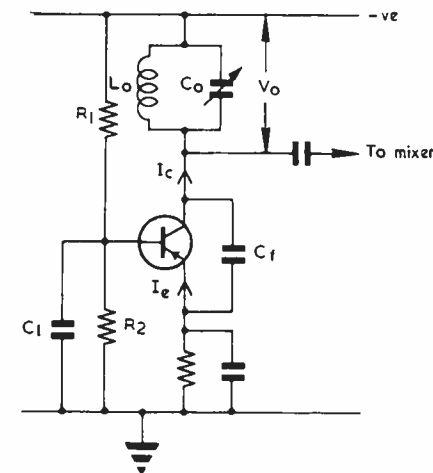

FIG. 3.12. TRANSISTOR OSCILLATOR

emitter, the frequency being determined by a tuned collector circuit. The output required is of the order of 400 mV.

The oscillator transistor operates in common base mode—the base being grounded to a.c. by C_1 . The oscillating voltage V_o drives a current through C_f , chosen so that the current I_e flowing into the emitter leads V_o by approximately 90° . Because of the transit time of the transistor there is an internal 90° phase lag from emitter to collector. Hence the collector current, I_c , is in phase with V_o and the oscillation is maintained, Fig. 3.13. With some transistors the transit time may be negligible, and in this case C_f is adjusted to give the appropriate phase angle.

The circuit of Fig. 3.12 has the disadvantage that the tuning capacitor is not at earth potential at either end. To overcome this the oscillator is usually

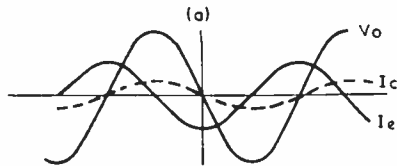

FIG. 3.13. OSCILLATOR WAVEFORMS

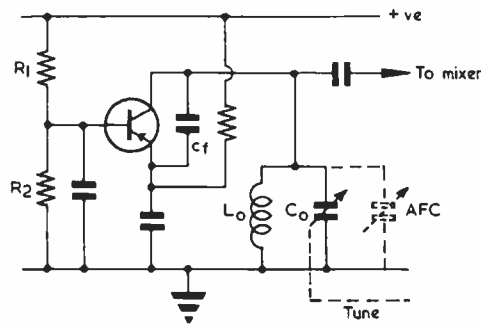

FIG. 3.14. OSCILLATOR WITH GROUNDING TUNING CAPACITOR

rearranged as in Fig.3.14.

Difficulty is often experienced in identifying the type of oscillator circuit from the circuit diagram, as by redrawing the circuit as in Fig.3.15 the transistor appears to be operating in common-base mode. It will be seen in fact that the two circuits are identical.

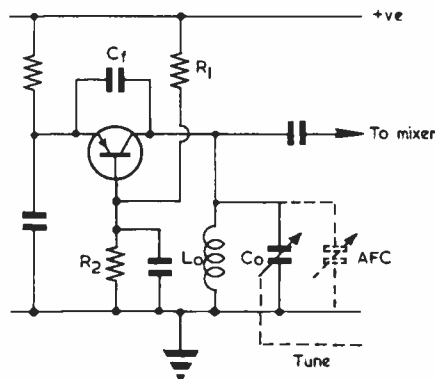

FIG. 3.15. THE OSCILLATOR OF FIG. 3.14 REDRAWN

A.F.C. AND AUTOMATIC TUNING

The outline drawing of Fig.3.1 shows automatic frequency control (a.f.c.) fed back from the demodulator stage. This takes the form of a d.c. voltage.

To adjust the oscillator frequency by applying this d.c. feedback a voltage-sensitive variable capacitor is used, shown dotted in Figs.3.14 and 3.15. Now, a semiconductor junction diode has a capacitance which decreases with applied reverse voltage and may be used for this purpose.

Fig.3.16 shows typical characteristics for a silicon junction diode. For the oscillator frequencies used (approximately 100 MHz) a trimming capacitor, C, is necessary as in Fig.3.17. This also blocks the d.c. path through L_o to earth.

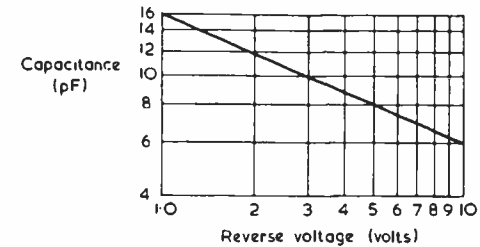

FIG. 3.16. THE CAPACITANCE OF A SEMICONDUCTOR p-n JUNCTION (TYPICAL)

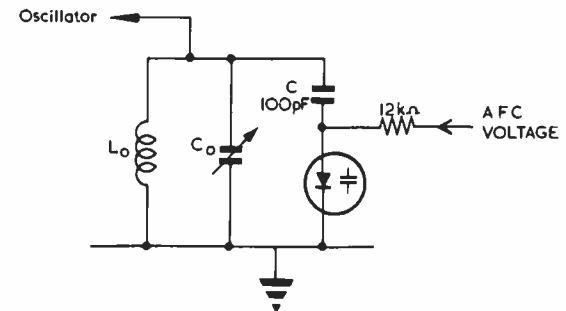

FIG. 3.17. AUTOMATIC FREQUENCY CONTROL CIRCUIT

The variable capacitance diodes may also be used to tune the r.f. stages and the oscillator; this eliminates the mechanical variable capacitors enabling push-button switches to tune the receiver by applying preset voltages to the capacitor-diodes, Fig.3.18. This technique allows the r.f. circuits to be placed in the best position for screening, as they are now independent of any mechanical connection to the tuning dial and associated mechanism.

In many receivers the functions of oscillation and mixing are performed by the same transistor, called a **self-oscillating mixer**. Fig.3.19 shows a possible circuit in which the collector circuit is tuned to the i.f. and the L_o C_o circuit tuned to the required oscillator frequency. The collector supply is taken through the primary of the i.f. transformer and a capacitor C_b is introduced to block the d.c. path to earth via L_o.

One further refinement is included before the frequency-changer—namely, an **i.f. trap**. This is a simple acceptor circuit tuned to the i.f. and connected across the input to the mixer stage, Fig. 3.20. It effectively shorts any incoming signal of 10.7 MHz which may have passed through the r.f. stage and which would be passed through to the i.f. amplifier as an unwanted signal.

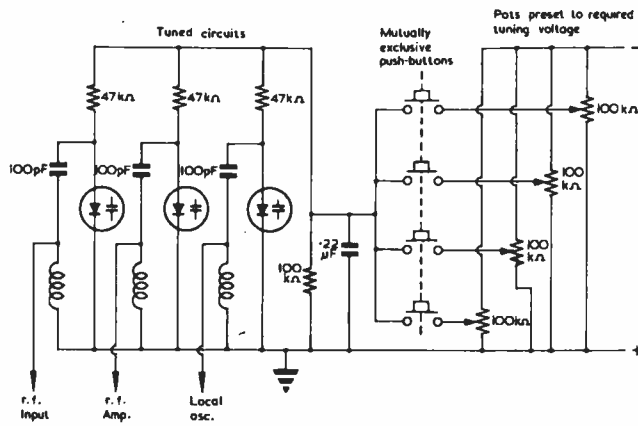

FIG. 3.18. ELECTRICAL PUSH-BUTTON TUNING

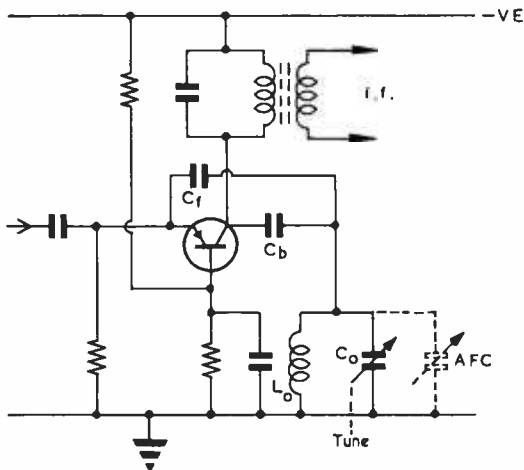

FIG. 3.19. SELF-OSCILLATING MIXER

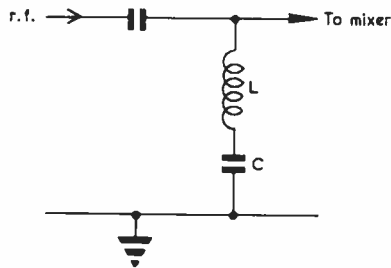

FIG. 3.20. AN I.F. TRAP

MODULATION

In the previous description of frequency changing, Fig.3.8, no modulation of the incoming carrier was considered. The effects of both amplitude and frequency modulations on the i.f. waveform are shown in Fig.3.21.

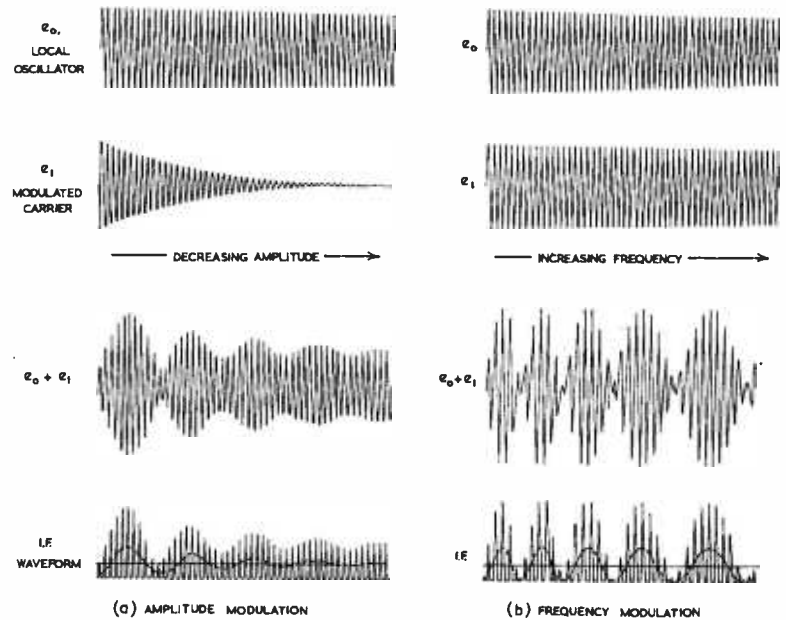

FIG. 3.21. THE EFFECTS OF AMPLITUDE AND FREQUENCY MODULATIONS ON THE I.F. WAVEFORM

As an example the carrier in Fig.3.21(a) is modulated by a fall in amplitude. When the carrier, e_1 , is added to the local oscillator voltage, e_0 (of constant amplitude and frequency), the sum $e_0 + e_1$ is produced. This is then detected and the i.f. component, shown dotted, is extracted by the i.f. amplifier. Notice that the i.f. waveform is itself now amplitude modulated in the same way as the carrier showing that the information contained in the carrier is still preserved in the i.f. signal.

In Fig.3.21(b) the carrier is modulated by an increase in frequency, the result of which is a corresponding DECREASE in intermediate frequency. (This is because the local oscillator is tuned to a frequency above that of the carrier, any increase in carrier frequency tending to bring the frequencies closer together and hence giving a lower beat frequency. For local oscillator frequencies below the carrier, an increase in carrier frequency gives a corresponding increase in intermediate frequency). Again, the information in the carrier is passed to the i.f. signal in the same form, i.e. as a frequency modulation.

It is interesting to see that the two forms of modulation remain quite distinct after frequency changing, the amplitude modulated i.f. having no change in frequency, and the frequency modulated i.f. having no change in peak amplitude. In considering the reception of stereo information we are

only interested in the frequency modulated i.f.; any a.m. component, including impulsive interference, can be suppressed without any loss of the desired signal.

Reference to Fig.3.1 (page 39) shows that after mixing, the signal is now passed to the i.f. amplifier.

THE I.F. AMPLIFIER

The i.f. amplifier provides the selectivity and most of the gain of the receiver. The superhet principle ensures that we are only concerned with a fixed frequency amplifier, which greatly simplifies the design problems. However, we have seen that the bandwidth of an i.f. amplifier for stereo reception must be at least 200 kHz. This relatively wide bandwidth may be obtained by flattening the tuning of the i.f. transformers, Fig. 3.22, but this reduces the stage gain and necessitates the use of three or four stages. Alter-

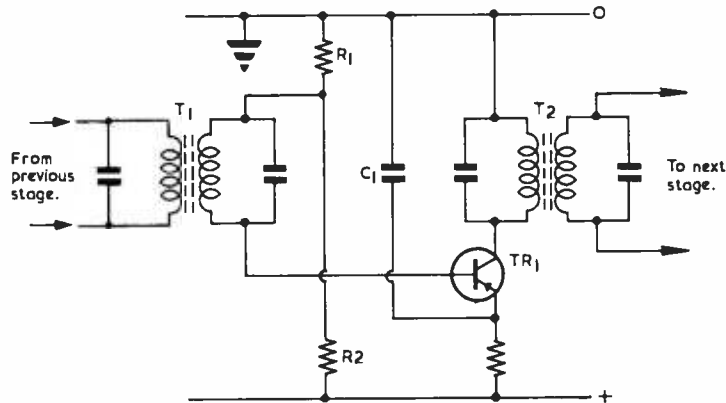

FIG. 3.22. A 10.7 MHz I.F. AMPLIFIER STAGE
(T_1 and T_2 are the tuned i.f. transformers)

natively, the coupling transformers may be tuned to slightly different frequencies to widen the bandwidth by **stagger tuning**. As explained in Chapter 2, any reduction in bandwidth will result in poor channel separation.

Note that in Fig.3.22 the earth is at the TOP of the diagram and hence the decoupling capacitor, C_1 , is taken to this line. Resistors R_1 and R_2 provide the base bias for TR_1 .

The ideal response of the i.f. amplifier, having a centre frequency of 10.7 MHz and a 300 kHz bandwidth, is shown as the solid line in Fig.3.23.

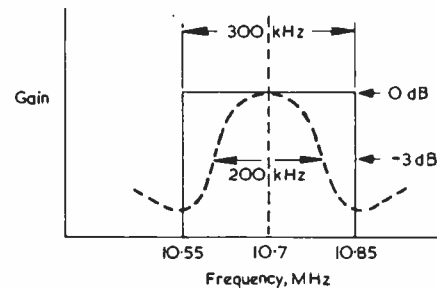

FIG. 3.23. SELECTIVITY OF AN I.F. AMPLIFIER

The sharp cut-off at 10.55 and 10.85 MHz would ensure adequate selectivity between broadcast signals but in practice tuned transformer coupling gives a response similar to the dotted curve of Fig.3.23. It is therefore necessary to specify the performance of a receiver in terms of the frequency pass-band at a given attenuation (in dB). For example, the bandwidth shown is 200 kHz at 3 dB down.

We have said that several i.f. stages will be required as the overall gain is reduced by stagger tuning, or flattened tuning, and the gain of the transistors at 10.7 MHz may not be high.

Fig.3.24 (overleaf) shows a complete four-stage i.f. amplifier using h.f. alloy-diffused transistors. At the intermediate frequency there is some capacitive feedback from collector to base which may cause oscillation; this can be effectively prevented by the stopper resistors connected directly to the collector terminals, neutralization not normally being required. A d.c. voltage, proportional to the signal at the collector of TR_3 , is fed back to the r.f. amplifier to provide the automatic gain control described earlier. This will limit the input to the i.f. amplifier and prevent overloading.

Recent developments have lead to the use of integrated circuits and ceramic resonators or filters to provide the required bandwidth characteristics. The use of filters does introduce some 'insertion loss' between stages, as a passive filter cannot introduce any voltage or current gain, but it removes the difficulties of stagger tuning or 'lining up' of the amplifier.

To explain the behaviour of the band-pass filter we must first examine the characteristics of a single crystal element. Fig.3.25 shows the attenuation produced by the series insertion of a crystal into a circuit operating at a variable frequency.

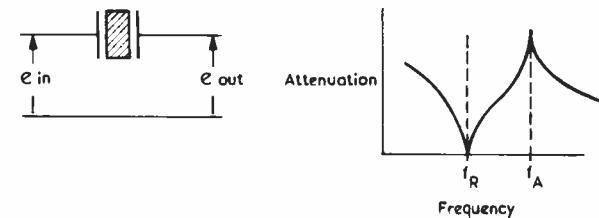

FIG. 3.25. SINGLE-CRYSTAL FILTER

At the **resonant frequency**, f_r , the attenuation is a minimum, and at the **anti-resonant frequency**, f_a , the attenuation peaks at a maximum. Band-pass characteristics may be obtained by connecting three crystals in the form of a T, Fig.3.26(a). If the crystals are manufactured so that CR_1 and CR_3 have a resonant frequency f_r , equal to the anti-resonant frequency of CR_2 , say f_a , the bandwidth is approximately 0.8 of $f_a - f_2$ as shown in Fig.3.26(b). (f_2 is the resonant frequency of CR_2).

The three crystal elements may be replaced by one, as in Fig.3.27, and if ceramic is used in place of quartz the device is known as a **ceramic resonator**.

In an i.f. amplifier several filters may be used in cascade if separated by the amplifier stages; the filters cannot be coupled together directly or capacitively.

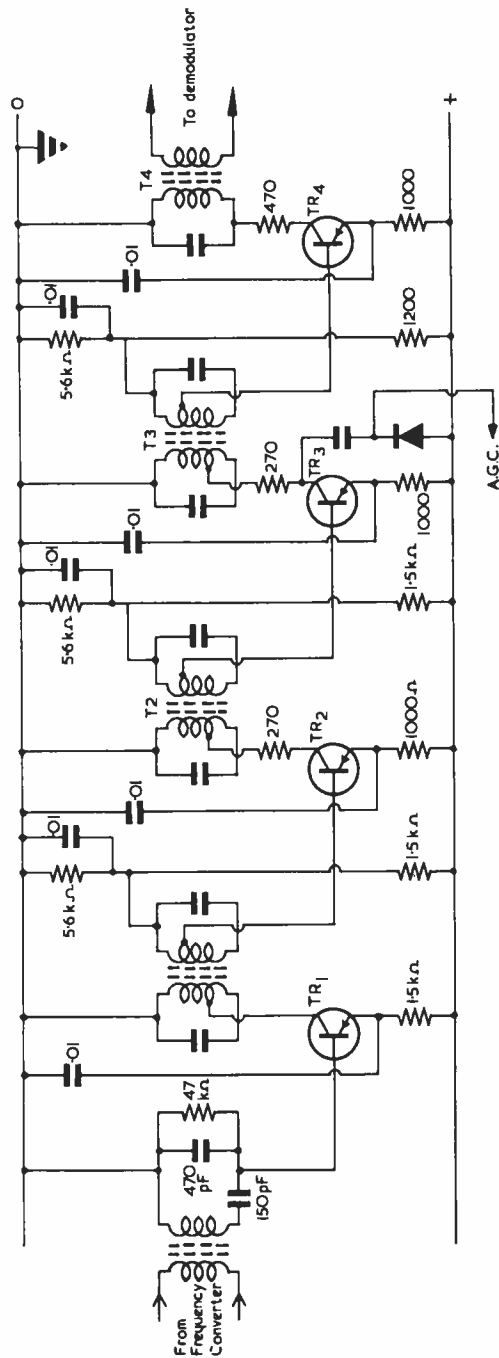

FIG. 3.24. COMPLETE FOUR-STAGE I.F. AMPLIFIER

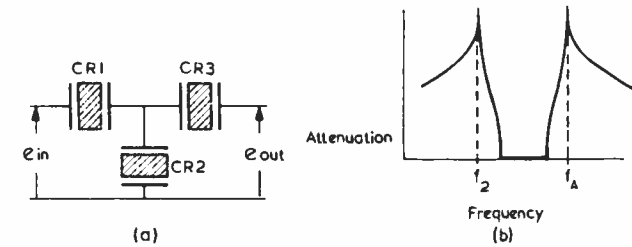

FIG. 3.26. A T-CRYSTAL FILTER

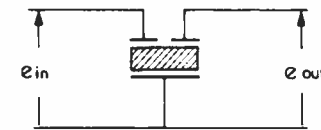

FIG. 3.27. CERAMIC FILTER

Correct impedance matching (approximately 330 Ω) must be provided to give satisfactory operation and Fig.3.28 shows a typical double filter arrangement using integrated circuit amplifiers.

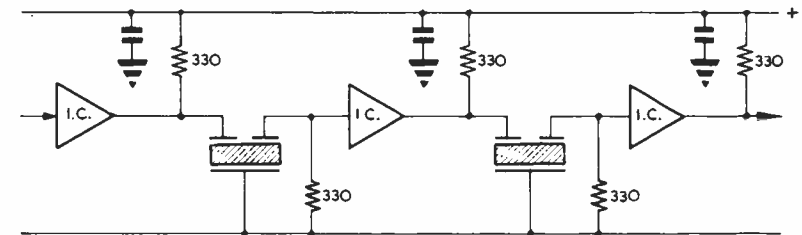

FIG. 3.28. I.F. AMPLIFIER USING CERAMIC FILTERS AND INTEGRATED CIRCUITS

The insertion loss characteristics of one and two cascaded filters are shown in Fig.3.29. When more than one filter is used it is important that they are all tuned to the same centre frequency. The units themselves are not tunable and are graded by the manufacturer into frequency groups and colour coded. The filters used in any i.f. amplifier must all be from the same frequency group. Typical frequency gradings for the Vemtron FM4 ceramic filter are:

COLOUR	ORANGE	YELLOW	GREEN	BLUE	VIOLET
Centre Frequency MHz	10.625	10.6625	10.700	10.7375	10.775

The fact that some i.f. amplifiers will be working at a centre frequency slightly

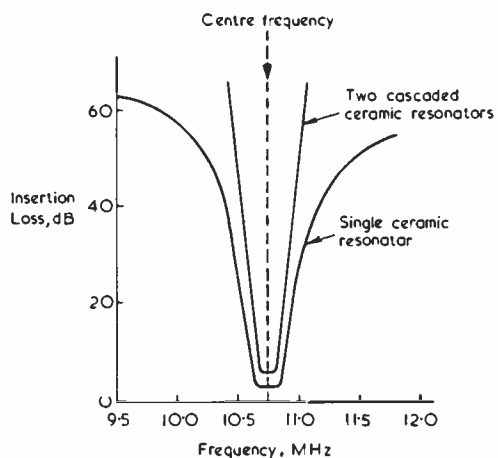

FIG. 3.29. INSERTION LOSS OF CERAMIC FILTERS

different from 10.7 MHz is of no consequence as this figure is, to a certain extent, arbitrary.

The electrical performance of the FM4 ceramic filter is summarized in the following table:

	SINGLE FILTER	TWO CASCADED FILTERS
3 dB bandwidth	200 to 280 kHz	180 kHz min. 230 kHz typ.
6 dB bandwidth	900 kHz max.	
40 dB bandwidth	900 kHz max.	800 kHz typ. 900 kHz max.
80 dB bandwidth	5 dB max.	
Insertion loss	330 $\Omega \pm 20\%$	10 dB max.
Impedance		

It should be noted that in matching the filters to 330 Ω account must be taken of the input and output impedances of the integrated circuits; these may be ignored if they exceed 3000 Ω .

An integrated circuit contains the transistors, diodes and resistors of the amplifier fabricated on a single silicon crystal. The external connections are used for the input, output, power supplies and decoupling capacitors. Fig. 3.30 shows a diagram of the basic external connections to a CA 3011 or CA 3012 integrated circuit used as an i.f. stage.

The basis of the integrated circuit (I.C.) is the differential amplifier, Fig. 3.31.

With no signal applied to the input the current through each transistor is approximately the same. For a positive input, V_A , the collector current of TR_1 increases causing a volt drop across R , reducing $V_{B'}$ and hence the current in TR_2 . In this way the total current through both transistors remains approximately constant.

The effect is reversed for a negative input. As the input signal increases, limiting takes place at about 0.6 V and is the same for both positive and negative

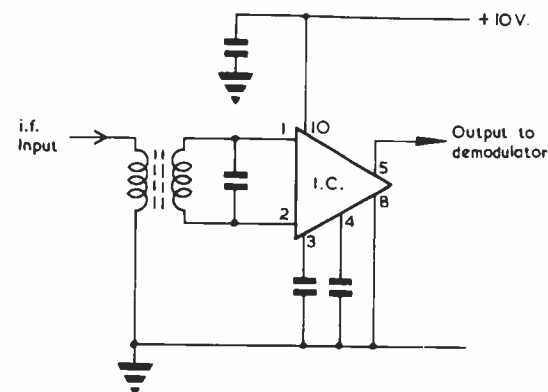

FIG. 3.30. INTEGRATED CIRCUIT I.F. STAGE

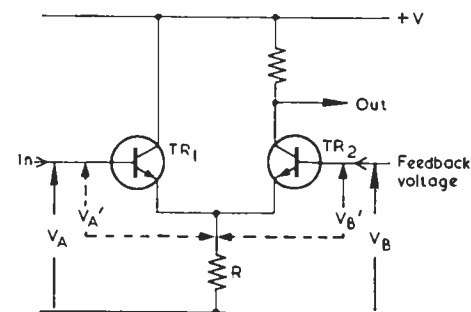

FIG. 3.31. DIFFERENTIAL AMPLIFIER

signals due to the symmetrical design of the circuit. This amplitude limiting gives a certain amount of a.m. and interference rejection which is desirable.

The complete internal circuit of a CA 3012 I.C. is shown in Fig. 3.32. A typical gain for 4 μ V input is 65 dB, more than adequate for driving ceramic filters with an insertion loss of 5 dB.

We can now incorporate the I.C.s and ceramic filters into a final circuit based on the outline given in Fig. 3.28. Two typical circuits are given, one for a positive supply (Fig. 3.33) and one for a negative supply (Fig. 3.34).

DEMODULATION

The next stage (see Fig. 3.1, page 39) is the f.m. demodulator; this converts the frequency deviations (carrying the information) into voltage variations. A frequency-sensitive circuit must be used having a response similar to that shown in Fig. 3.35. As maximum modulation corresponds to a frequency deviation of ± 75 kHz the response should be linear over this range. The centre frequency will correspond to the nominal intermediate frequency, and the demodulator output will be zero for an unmodulated carrier with the

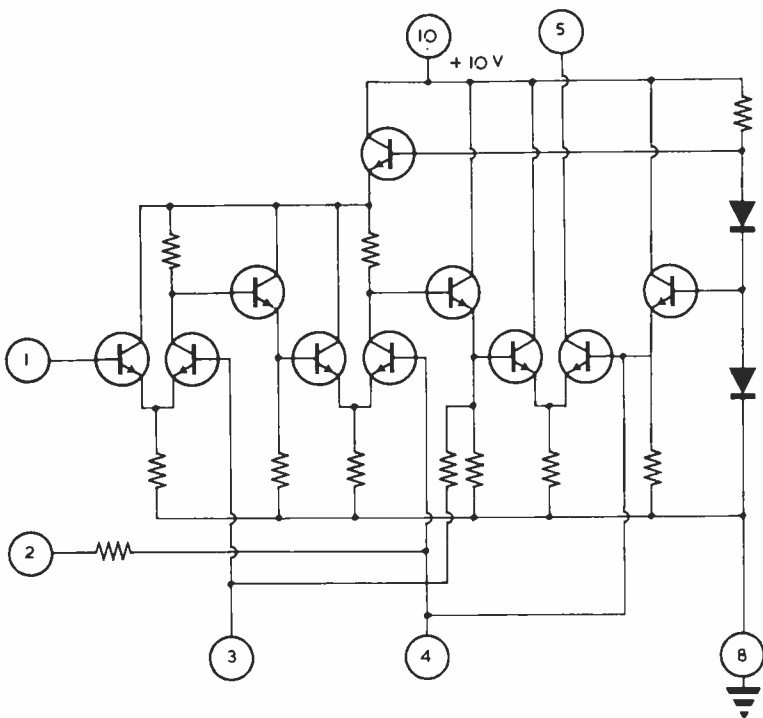

FIG. 3.32. INTEGRATED CIRCUIT AMPLIFIER, CA3012

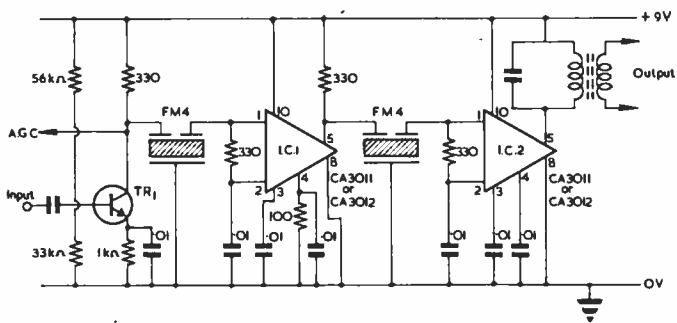

FIG. 3.33. INTEGRATED CIRCUIT I.F. AMPLIFIER (POSITIVE SUPPLY)

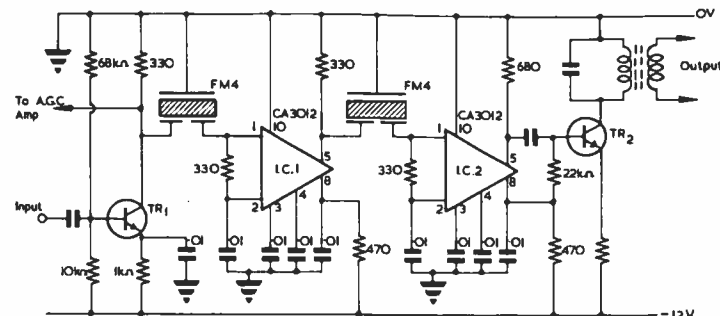

FIG. 3.34. INTEGRATED CIRCUIT I.F. AMPLIFIER (NEGATIVE SUPPLY)

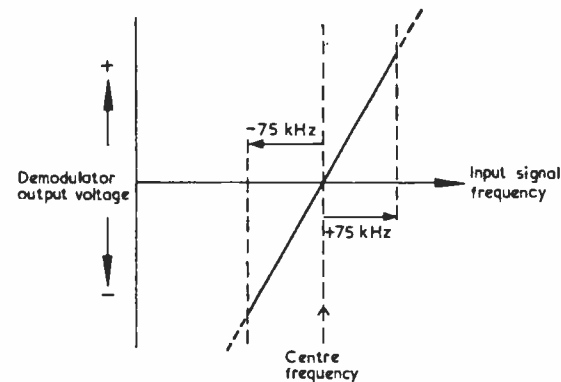

FIG. 3.35. IDEAL DEMODULATOR RESPONSE

receiver exactly on tune. This property can be made use of for automatic frequency control (a.f.c.).

A simple tuned circuit could be used for f.m. demodulation but is unsatisfactory for high-fidelity work as it affords no amplitude modulation rejection and introduces harmonic distortion due to the non-linear tuned circuit response curve. The most common frequency sensitive circuits are the Foster-Seeley phase discriminator and the ratio detector, both based on tuned transformers. Of these two circuits the ratio detector is invariably used as it offers automatic a.m. rejection whereas the Foster-Seeley discriminator is sensitive to the level of the input signal and must be preceded by a limiter stage.

In order to describe the behaviour of these demodulators we must first consider a tuned transformer and its vector (phasor) diagrams. Fig.3.36 shows an untuned transformer with a primary voltage V_P applied. If the



FIG. 3.36.

secondary is unloaded the primary behaves as a simple inductor in which the current, i_p , and flux, ϕ , lag the voltage by approximately 90° .

Tuning the primary by a capacitor, C_p , affects only the primary impedance loading, Fig.3.37, and as the total primary circuit now appears resistive (dynamic impedance at resonance) i_T is in phase with V_p .

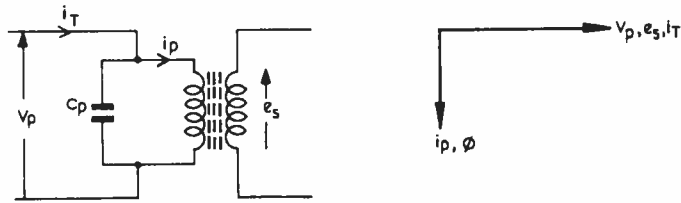

FIG. 3.37.

When the secondary is tuned by C_s , Fig.3.38, the voltage output, V_s , will not be the same as the secondary induced e.m.f., e_s , due to the voltage drop in the secondary leakage reactance X_s (the secondary is now loaded by the capacitor).

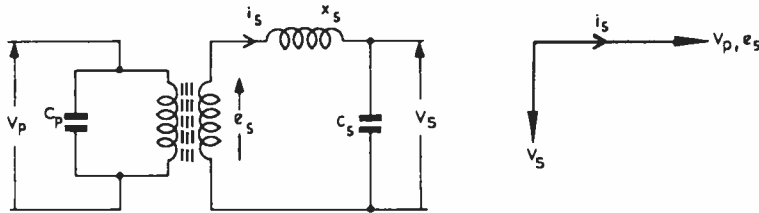

FIG. 3.38.

As the secondary is tuned to resonance, i_s will be in phase with e_s . The output voltage V_s will lag i_s and also e_s by 90° . We see that V_s lags V_p by 90° when the circuit is on tune.

When the applied frequency is BELOW resonance the secondary circuit becomes predominantly capacitive and i_s leads e_s , Fig.3.39. V_s still lags i_s by 90° , however, and we see that V_s is ADVANCED in phase.

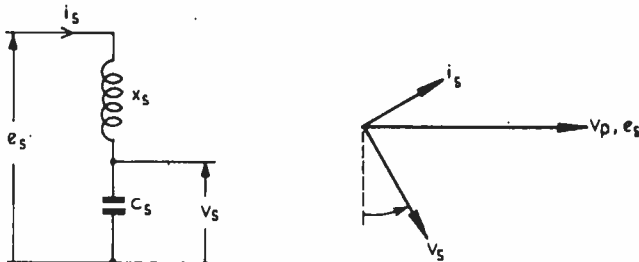

FIG. 3.39. FREQUENCY BELOW RESONANCE

When the applied frequency is ABOVE resonance the secondary circuit becomes predominantly inductive and i_s lags e_s , Fig.3.40, and hence V_s is RETARDED in phase.

The next step is to convert these phase displacements of V_s , which are proportional to the frequency deviations we are trying to detect, into voltages.

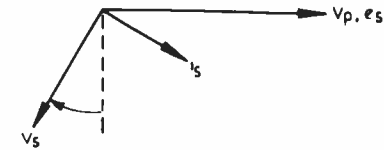

FIG. 3.40. FREQUENCY ABOVE RESONANCE

The secondary is centre-tapped giving voltages $+V_s/2$ and $-V_s/2$ with respect to the centre-tap. These voltages are added to V_p to give V_A and V_B , Fig.3.41. The changes in V_A and V_B for frequencies below, above and at resonance are indicated in Fig.3.42.

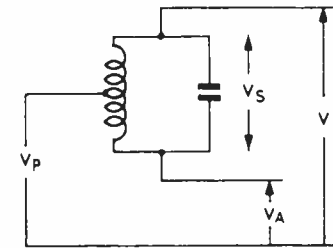

FIG. 3.41.

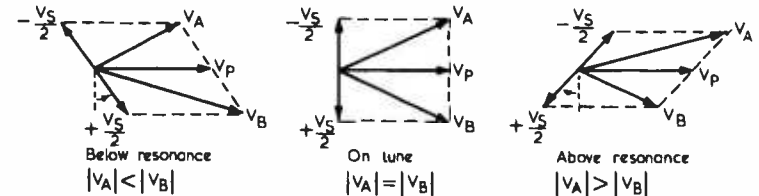

FIG. 3.42.

In the Foster-Seeley discriminator V_A and V_B are detected or rectified and the resultant voltages summed to give the output, Fig.3.43. On-tune, $V_A = V_B$ and the output is zero, but at other frequencies the output is proportional to the frequency deviation.

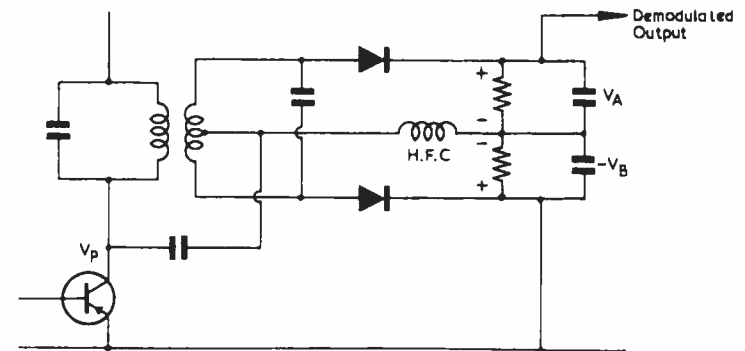

FIG. 3.43. FOSTER-SEELEY DISCRIMINATOR

Unfortunately, the Foster-Seeley discriminator responds to changes in input amplitude as well as frequency and a limiter is always required as a preceding stage to suppress the a.m. component in the i.f. signal.

The ratio detector, which is a modification of the previous circuit, has far superior a.m. rejection characteristics. In this circuit V_A and V_B are detected by diode capacitor circuits as before, but one of the diodes is reversed, Fig. 3.44.

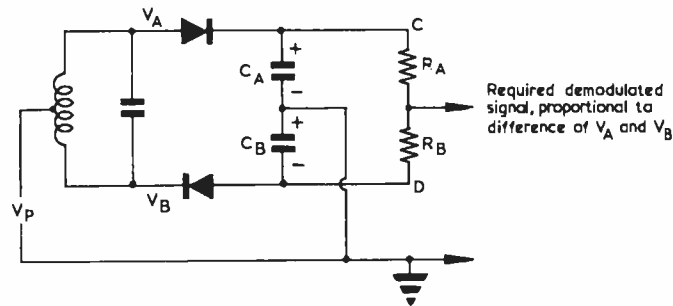

FIG. 3.44. RATIO DETECTOR

V_A and V_B now appear across C_A and C_B , connected to two equal resistors at C and D . The potential at the centre-point of these resistors will be proportional to the DIFFERENCE between the voltages V_A and V_B . Up to this point the behaviour is similar to the Foster-Seeley discriminator, but as the voltage between C and D is $V_A + V_B$ it remains CONSTANT with changes of input frequency, provided that no change in input amplitude occurs. If this voltage can be held constant we have a means of suppressing any a.m. component present in the input. A capacitor connected across $C D$ will hold the voltage constant provided that the time-constant is large compared with the frequency of any a.m. component. In practice, a capacitor of the order of $10 \mu\text{F}$ is used, giving a time-constant between 0.1 and 0.2 second.

As it is inconvenient to add V_P to the centre-tap directly, due to the d.c. level of the preceding stage, a tertiary winding is used to provide a voltage of the same phase. Unbalance in the detector circuits can cause an output to appear even when the frequency deviation is zero, therefore balancing resistors are used in series with the diodes. One resistor is usually variable to enable the output to be set to zero for the on-tune condition. The complete circuit for a typical balanced ratio detector is given in Fig. 3.45.

The multiplex signal, as in Fig. 2.22 and Fig. 2.23, appears at the output of the demodulator. Considering the tuner, i.f. amplifier and demodulator, typical voltages are 0.5 V multiplex output for a $5 \mu\text{V}$ f.m. input.

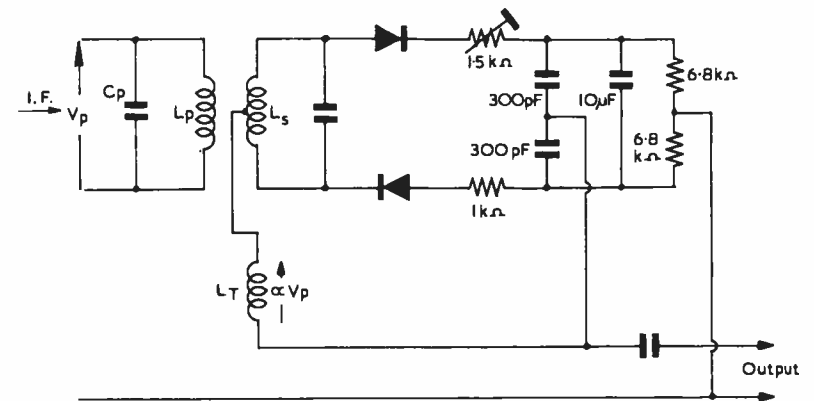

FIG. 3.45. BALANCED RATIO DETECTOR CIRCUIT

DECODING THE MULTIPLEX SIGNAL

THE purpose of the decoder is to extract and separate the left and right signals from the multiplex waveform. There are several ways of doing this, but in all cases the aim is to reduce to a minimum the crosstalk between channels and the signal distortion. We must remember that the multiplex signal is of the form

$$0.9 \left[\left(\frac{L+R}{2} \right) + \left(\frac{L-R}{2} \right) \sin 2 \omega t \right] + 0.09 \sin \omega t$$

and contains four necessary components:

- the left signal, L;
- the right signal, R;
- the 19 kHz pilot tone, $\sin \omega t$;
- the 38 kHz modulation, $\sin 2 \omega t$.

Reference to Fig.2.22 (page 25) will show how these components are assembled in the transmitter. In decoding, the 19 kHz pilot tone is first filtered out and doubled to produce a 38 kHz signal exactly in synchronism with the transmitter subcarrier.

Consider the simplified waveforms of Fig.4.1. Diagram (f) shows the multiplex signal WITHOUT the 19 kHz pilot tone which we shall assume has been filtered out. This waveform is sometimes referred to as the 'composite audio signal' but it must be remembered that it contains 38 kHz modulation components well above the normal audio range.

Some methods of combining this waveform with the reconstituted 38 kHz subcarrier to produce channel separation will now be described.

THE ENVELOPE DECODER AND SWITCHED DETECTOR

If a relatively large 38 kHz signal is simply ADDED to the audio signal, the envelopes of the peaks of the positive and negative half-cycles have the same shapes as the left and right channel signals. Fig.4.2 shows this (using the waveforms of Fig.4.1).

The explanation of this is that the positive and negative half-cycles of the 38 kHz signal alternately 'push up' the left components and 'lower' the right components of the composite signal. The 38 kHz signal literally 'separates' the alternate half-cycles of the multiplex or audio waveform. The left and right channel signals can now be recovered by using two detector circuits, one sensitive to positive voltage and the other to negative voltage. This is called **switched detection**.

Fig.4.3 shows a block diagram of such a decoder.

The 38 kHz signal may be derived in one of two ways, either by synchronizing a local 38 kHz oscillator with the 19 kHz pilot tone or by doubling

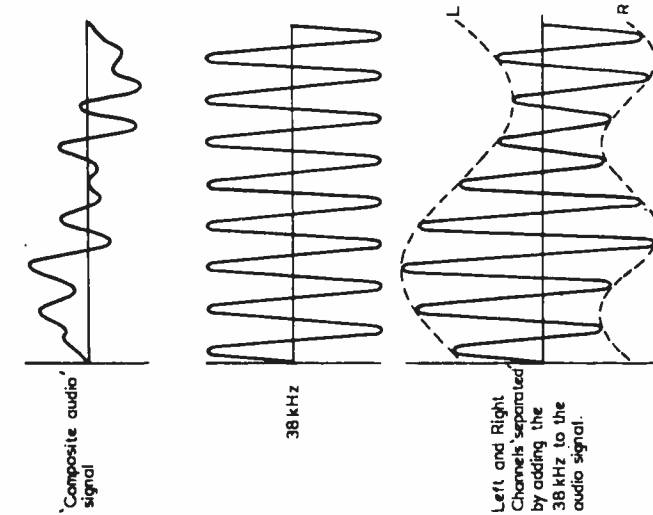

FIG. 4.2. 'ENVELOPE' DECODING BY ADDING A 38 kHz SIGNAL

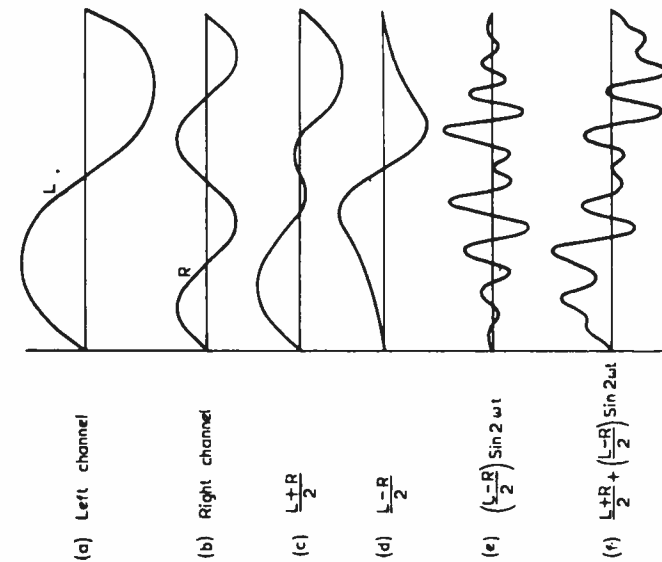

FIG. 4.1. THE COMPONENTS OF THE DETECTED 'AUDIO' SIGNAL. (19 kHz PILOT TONE NOT INCLUDED)

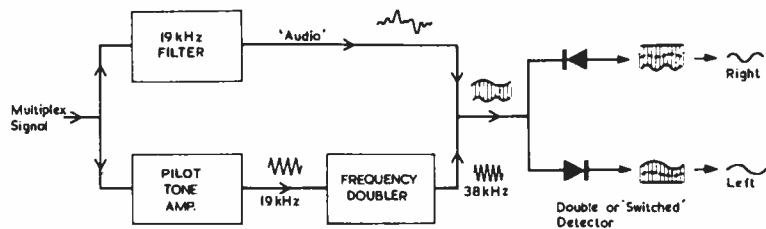

FIG. 4.3. 'ENVELOPE' DECODER

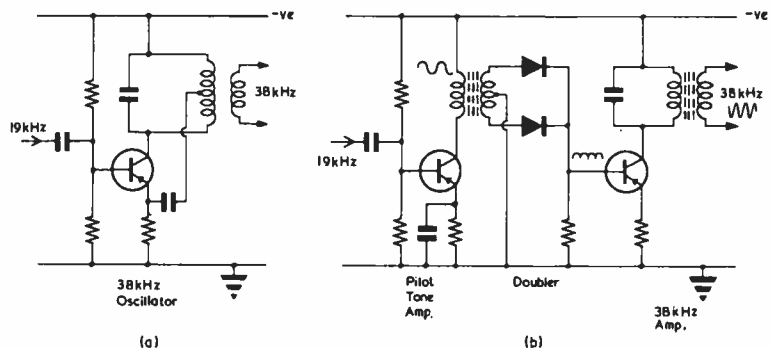

FIG. 4.4. TWO METHODS OF PRODUCING THE SYNCHRONIZED 38 kHz SIGNAL
(a) Triggering a local oscillator by the pilot tone
(b) Doubling the pilot tone frequency

the 19 kHz tone directly, Fig.4.4.

From Fig.4.2 it is obvious that not only must the reinserted 38 kHz sub-carrier be in synchronism with the transmitter subcarrier, but must also be EXACTLY IN PHASE WITH IT. Any error in the phase of the subcarrier will lead to a lack of channel separation (crosstalk) as shown in Fig.4.5.

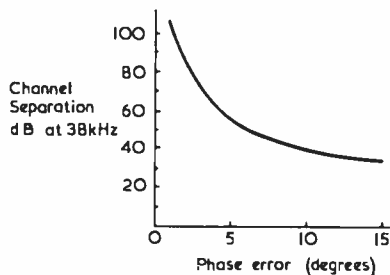

FIG. 4.5. EFFECT OF PHASE ERROR ON CHANNEL SEPARATION

The phase of the 38 kHz signal may be corrected by a phase shift of 45° in the pilot tone prior to doubling, Fig.4.6. This may be effected by detuning the 19 kHz tuning coil. In many receivers the phase control is made variable

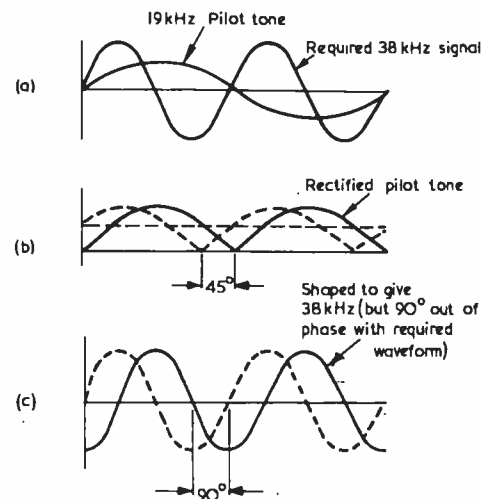

FIG. 4.6. PHASE ERROR OF SWITCHING SIGNAL DUE TO DOUBLING. (DOTTED CURVE SHOWS CORRECTED WAVEFORM)

or preset to facilitate optimum channel separation. This is equally important if the 38 kHz signal is derived from a triggered local oscillator, Fig.4.4(a).

The local oscillator signal may be automatically held in phase with the transmitted pilot tone by applying feedback forming a phase-locked loop.* The system consists of a voltage-controlled oscillator generating a 76 kHz sine wave. This is divided by 2 to obtain both a normal and an inverted 38 kHz square wave, Fig. 4.7(a). The normal signal is again divided by 2 to give a 19 kHz quadrature signal for feeding back along the phase-lock loop. A quadrature signal is used as one input to the phase-sensitive detector to ensure a zero average output when the oscillator is exactly in phase. Changes in phase then give either a positive or negative error signal which pulls the voltage-controlled oscillator back into phase, according to whether it is leading or lagging the input pilot tone.

The inverted 38 kHz signal is also divided by 2 to give a 19 kHz square wave in phase with the incoming pilot tone. When 'phase-lock' is achieved the in-phase detector registers this by providing a d.c. output. This output is filtered and amplified to operate both the STEREO/MONO switch (enabling the 38 kHz signal to reach the decoder) and the stereo indicator lamp.

The filters are necessary to limit the bandwidth of the feedback loops; too high a bandwidth causes 'phase jitter' which reduces channel separation, and too low a bandwidth will require a long 'locking-in' time.

Owing to the complexity of the phase-locked loop (see footnote) discrete components are now usually replaced by an integrated circuit. A typical arrangement is shown in Fig.4.7(b) using an MC 1310P integrated circuit (Motorola).

A channel separation of 40 dB over the whole audio range is obtainable

* Portus, R. T., Haywood, A. J., "Phase-Locked Stereo Decoder." *Wireless World*, Sept., 1970.

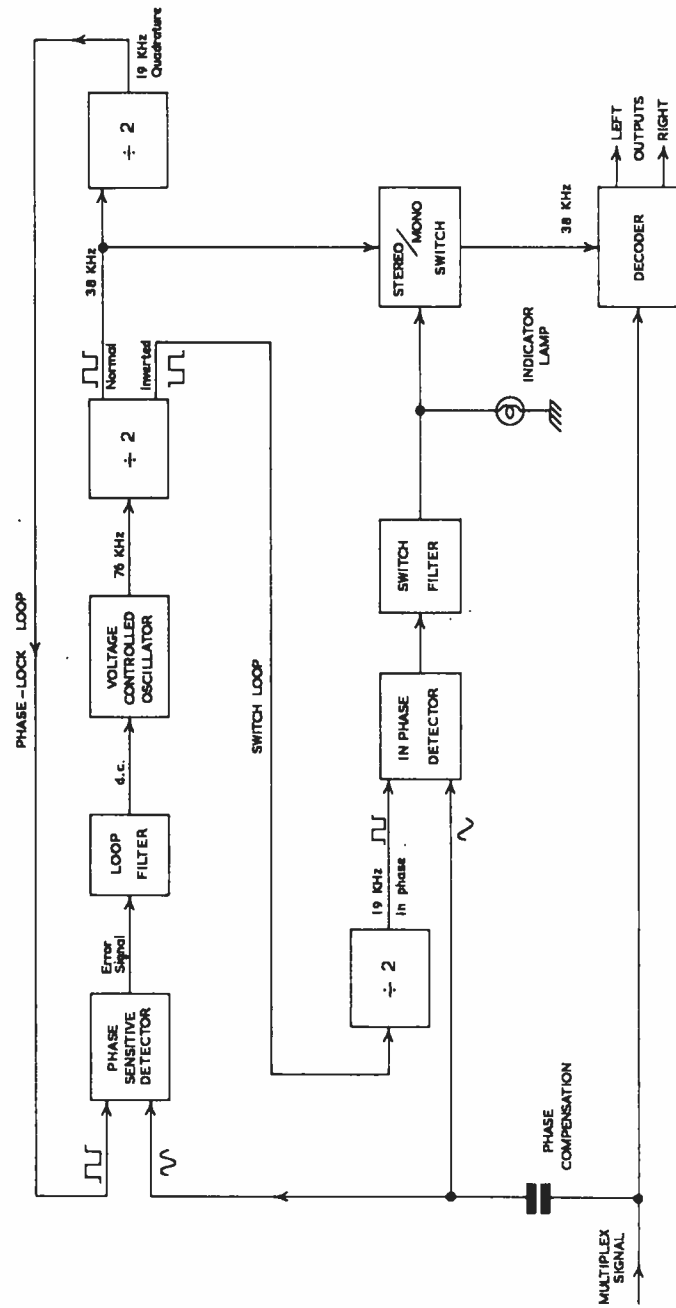

FIG. 4.7 (a) PHASE-LOCKED LOOP DECODER SYSTEM

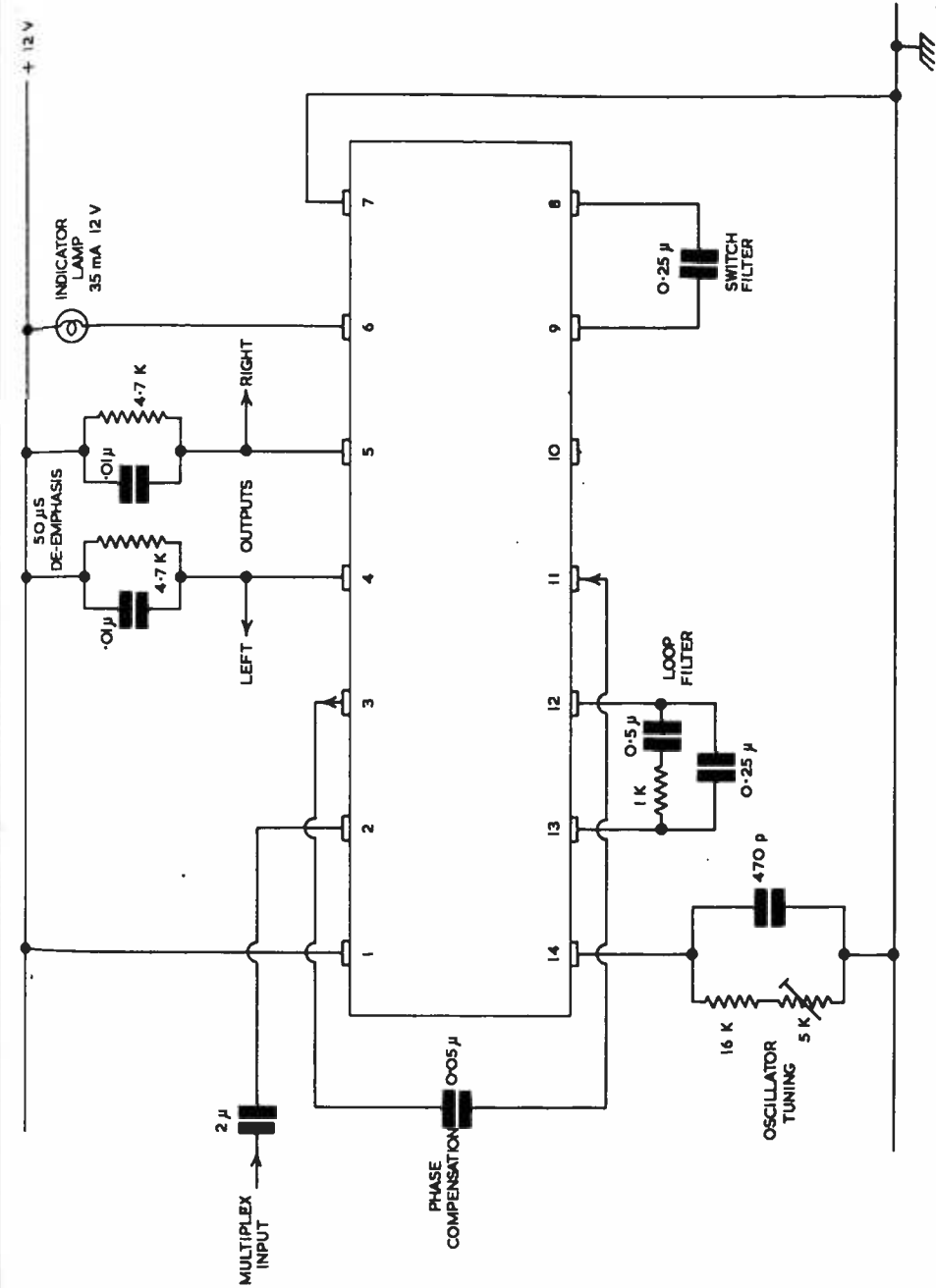
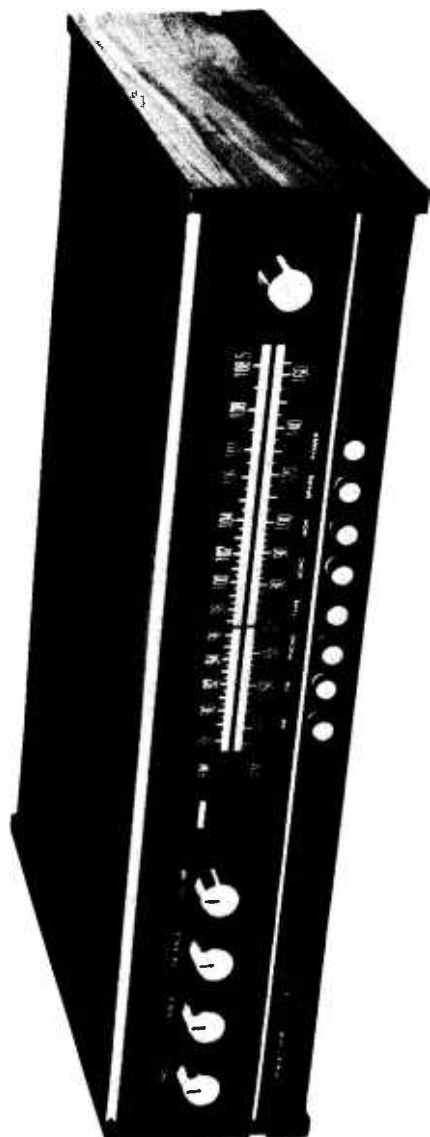

FIG. 4.7 (b) PRACTICAL INTEGRATED CIRCUIT PHASE-LOCKED LOOP DECODER



[Courtesy Heath (Gloucester) Ltd.]

HEATHKIT ARJ214 AM-FM STEREO RECEIVER. FEATURES INCLUDE INTEGRATED CIRCUIT I.F. AMPLIFIER WITH CERAMIC FILTERS, INTEGRATED CIRCUIT QUADRATURE DETECTOR AND INTEGRATED CIRCUIT PHASE-LOCK MULTIPLEX DECODER

with this circuit. With a 16 mV input of 19 kHz the stereo switches ON and decoding takes place. However, due to hysteresis this input may have to fall to 10 mV before the switch turns OFF and the circuit reverts to 'mono' operation. The audio output is about 500 mV r.m.s.. The oscillator must work within ± 3 per cent of the nominal frequency; 0.5 per cent for temperature variations, which leaves 2.5 per cent for detuning due to drift of component values.

The circuit may be switched to MONO operation by earthing terminal 8 through an external MONO/STEREO switch. This is useful in poor signal-to-noise conditions where the pilot tone is still large enough to switch into 'stereo' mode.

Some receivers are designed to accept both a.m. and f.m. When receiving a.m. it is desirable to stop the 76 kHz oscillator by an AM/FM switch which earths terminal 14.

The separation of the left and right channels by the 38 kHz signal is sometimes described as **switched detection** or **synchronous detection**. The subcarrier can be considered as 'steering' the left and right components into the appropriate channel detector, Fig.4.8 Whilst this is sometimes referred to as an alternative method of decoding it can be seen that it is really an alternative explanation of envelope decoding.

The electronic 'switch' may consist of diodes or transistors.

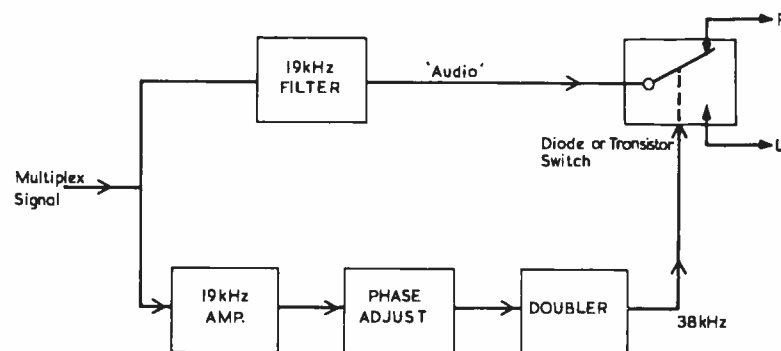

FIG. 4.8. DECODING CONSIDERED AS 'SWITCHED DETECTION'

Fig.4.9 shows a simple diode switch in which the diodes are alternately switched on and off by a large 38 kHz signal. In a circuit such as this it will be obvious that a large 38 kHz component will be present in the audio output. Although de-emphasis will be applied it will not be sufficient to remove this, and if it did the higher audio frequencies would also be reduced giving a poorer audio performance. The presence of this 38 kHz component is undesirable as it may cause distortion in the audio amplifiers which follow and beat frequencies to be produced with tape recorder oscillators. A balanced detector, as in Fig.4.10, eliminates most of this trouble as the potentials at R and L (depending on which pair of diodes are conducting) will be the same as that of point X. But this is the mid-point of the transformer winding, i.e. the zero voltage point of the 38 kHz source.

In some designs the point X may be grounded and the composite audio signal applied to point Y; this does not affect the circuit operation.

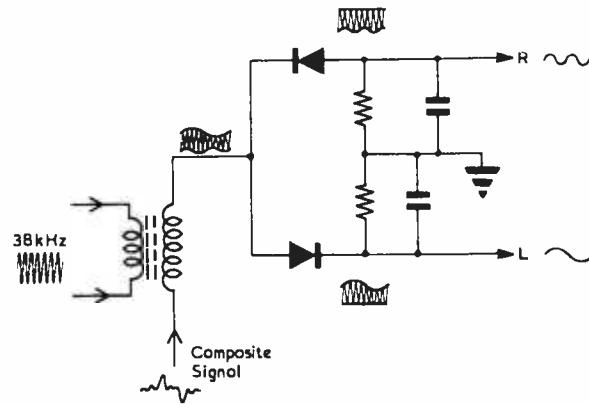

FIG. 4.9. DIODE 'SWITCHED' DETECTOR

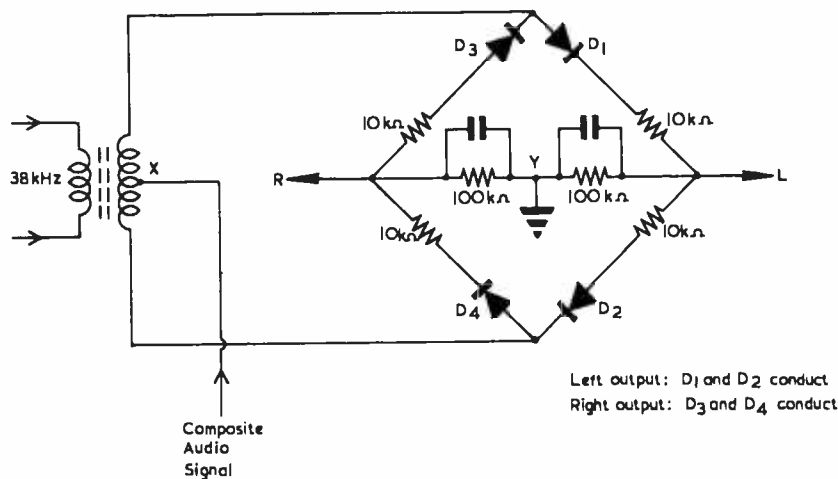

FIG. 4.10. BALANCED DETECTOR TO REDUCE THE 38 kHz COMPONENT IN THE AUDIO OUTPUT

If possible the receiver must be compatible and detect both mono and stereo transmissions. If the diodes are biased into a forward conducting state when no pilot tone is present (on mono transmissions) the audio signal is applied equally to left and right outputs, Fig.4.11. This does not affect the stereo operation as the 38 kHz switching signal is large compared with the d.c. bias.

In transistor switched detectors the audio signal is usually applied to the bases of a pair of transistors. The transistors are alternately turned on and off by raising and lowering their emitter potentials by the 38 kHz signal, Fig.4.12.

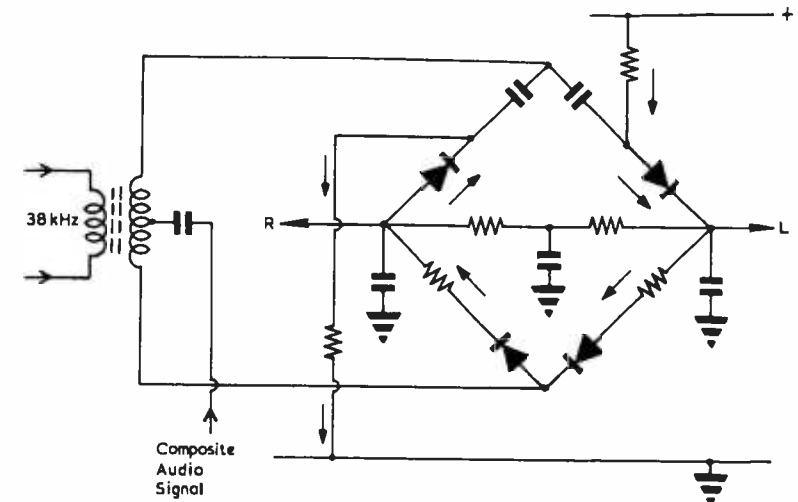

FIG. 4.11. BIASED DIODES FOR MONO-STEREO COMPATIBILITY. CAPACITORS ARE USED TO BLOCK THE D.C. PATH THROUGH THE TRANSFORMER

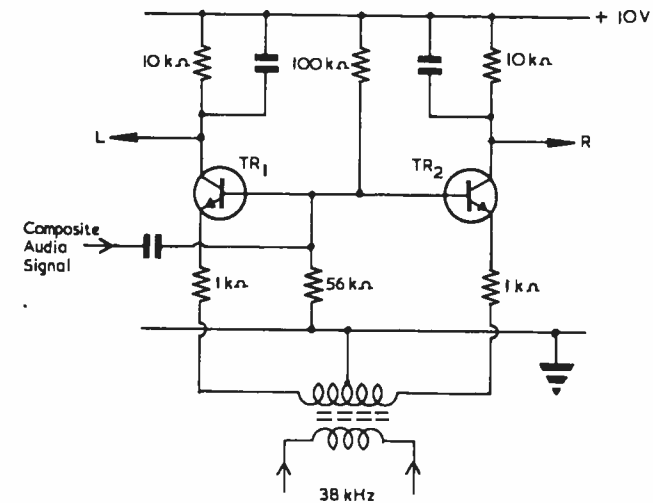

FIG. 4.12. A SWITCHED TRANSISTOR DETECTOR

If the emitter of TR_1 is positive, TR_1 cuts off and no output appears at the collector; at the same time the emitter of TR_2 will be negative, the transistor will amplify the base signal producing an output at the collector of TR_2 . When the 38 kHz signal reverses at the next half-cycle the operation is reversed.

This transistor circuit will not suppress the 38 kHz switching signal and a large component will be present in the output. This can be removed by a

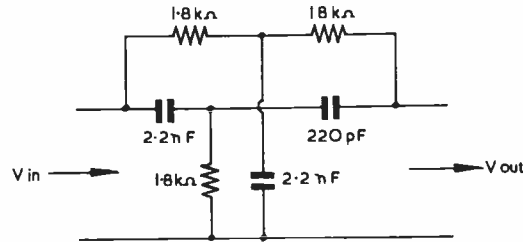

FIG. 4.13. 38 kHz PARALLEL T FILTER

parallel T filter, Fig. 4.13, in each channel output.

In the absence of the 38 kHz signal in the circuit of Fig. 4.12 the bias enables the two transistors to amplify the base signal equally and identical outputs appear at both the left and right collectors. Hence automatic mono-stereo compatibility is achieved.

Another decoder circuit, which forms the basis of integrated-circuit designs, is shown in Fig. 4.14.

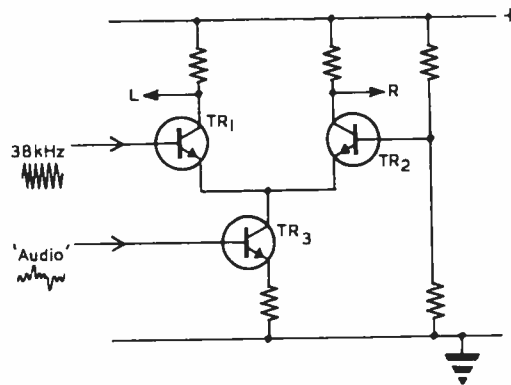

FIG. 4.14. PRINCIPLE OF THE INTEGRATED CIRCUIT SWITCHED DECODER

The operation is as follows:

- (a) When the 38 kHz signal is in its **negative** half-cycle, TR_1 is turned OFF, and TR_2 is turned ON by the positive base potential applied. The audio signal at the collector of TR_3 appears at the collector of TR_2 as the RIGHT output.
- (b) When the 38 kHz signal is **positive**, TR_1 is turned ON and the emitters of TR_1 and TR_2 go more positive. This turns OFF TR_2 and the audio output from TR_3 appears at the collector of TR_1 as the LEFT output.

Again, no 38 kHz suppression takes place and the outputs must include suitable filter circuits.

THE MATRIX DECODER

This is similar to the matrix encoder described in Chapter 2, Fig. 2.2(b), page 10, but in this case it is used to produce the L and R signals from L+R and L-R. Fig. 4.15 shows a possible circuit, although it suffers from the disadvantage that the L+R and L-R must be isolated and have no common ground connection.

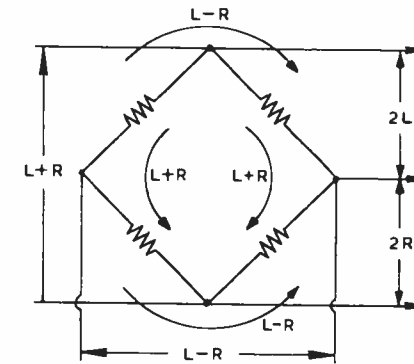

FIG. 4.15. DECODING MATRIX

It must be remembered that the L-R signals have been frequency translated by the 38 kHz subcarrier, and must be restored to their original 0 to 15 kHz range before matrixing.

A practical arrangement is to extract the L+R, $(L-R) \sin 2\omega t$ and the pilot tone signal from the composite audio signal by means of filters and recombine them in a matrix to produce L and R, Fig. 4.16. As this circuit offers no advantages over the switched detector it is not widely used.

CHANNEL SEPARATION AND CROSSTALK

Unfortunately, none of the systems and circuits so far described gives complete channel separation. Some of the LEFT signal appears at the RIGHT output, and some of the RIGHT at the LEFT. The reason for this in the switched or envelope detector is that although the receiver treats the incoming signal as a switched or 'time-division-multiplex' waveform, it was never assembled as such in the transmitter. Even if it had been, the fast rising and falling sides of the square switching waveform would be decidedly rounded off after transmission due to the system bandwidth.

The effect is shown in Fig. 4.17, where for simplicity the right signal is assumed to be zero. The signals are combined to give $(L-R)/2$ and $(L+R)/2$ (which in this case will be identical as R is zero). The difference signal, $(L-R)/2$, is frequency translated by modulating a 38 kHz subcarrier producing

$$\left(\frac{L-R}{2}\right) \sin 2\omega t.$$

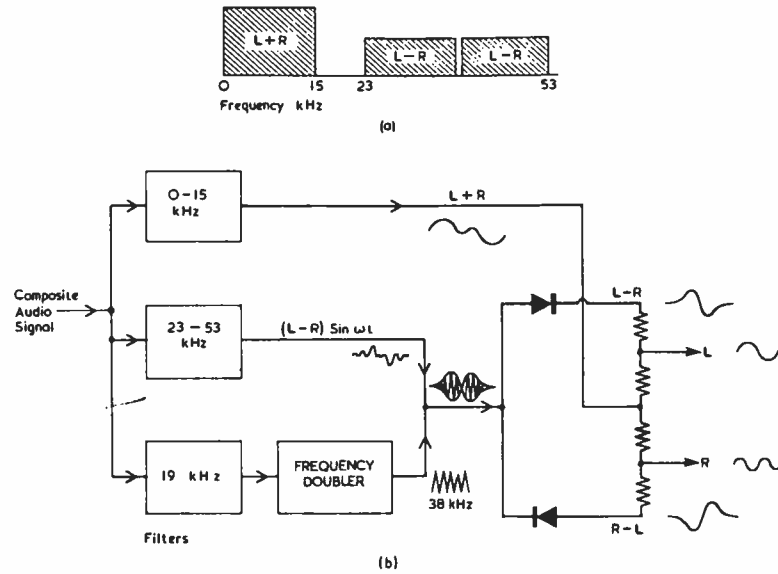

FIG. 4.16. MATRIX DECODER
 (a) Bandwidth of composite signal
 (b) Block diagram of decoder
 (Waveforms refer to Fig. 4.1)

To encode the information the sum and difference components are now added giving

$$\left(\frac{L+R}{2}\right) + \left(\frac{L-R}{2}\right) \sin 2\omega t.$$

In the receiver the decoder chops this waveform by its switching action and it can be seen that some of the left signal appears in the time intervals allocated to the right channel and a proportion of the left signal appears at the right output.

The mathematical theory of crosstalk is given in Appendix C (page 196).

One method of correcting this defect is to feed a neutralizing signal to the two channels in opposition to the crosstalk. A phase-inverted (L+R) signal is added to the L and R outputs and adjusted to the amplitude required for maximum channel separation. As well as cancelling the crosstalk this does slightly reduce the main channel amplitudes, but is of little importance.

Fig.4.18 shows how a simple diode switched detector (as in Fig.4.9) is modified for crosstalk compensation.

A complete decoder circuit is shown in Fig.4.19 incorporating an input signal amplifier, TR₁, which is also used to provide a compensating waveform proportional to -(L+R). This stage is followed by a 19 kHz amplifier, TR₂, feeding a doubler circuit and 38 kHz amplifier TR₃. The composite signal from the emitter of TR₁ is mixed with the restored 38 kHz signal

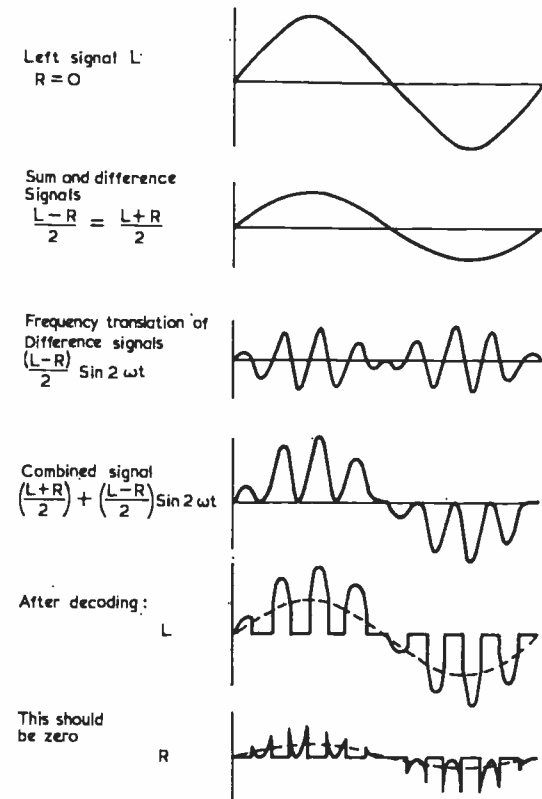

FIG. 4.17. CROSSTALK IN 'SWITCHED' DECODERS. RIGHT SIGNAL, R, SHOULD BE ZERO; BUT A FRACTION OF THE LEFT SIGNAL, L, APPEARS AT THE RIGHT OUTPUT

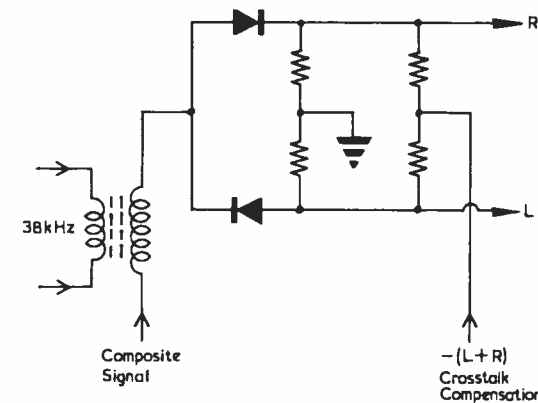

FIG. 4.18. CROSSTALK COMPENSATION IN A SWITCHED DIODE DETECTOR

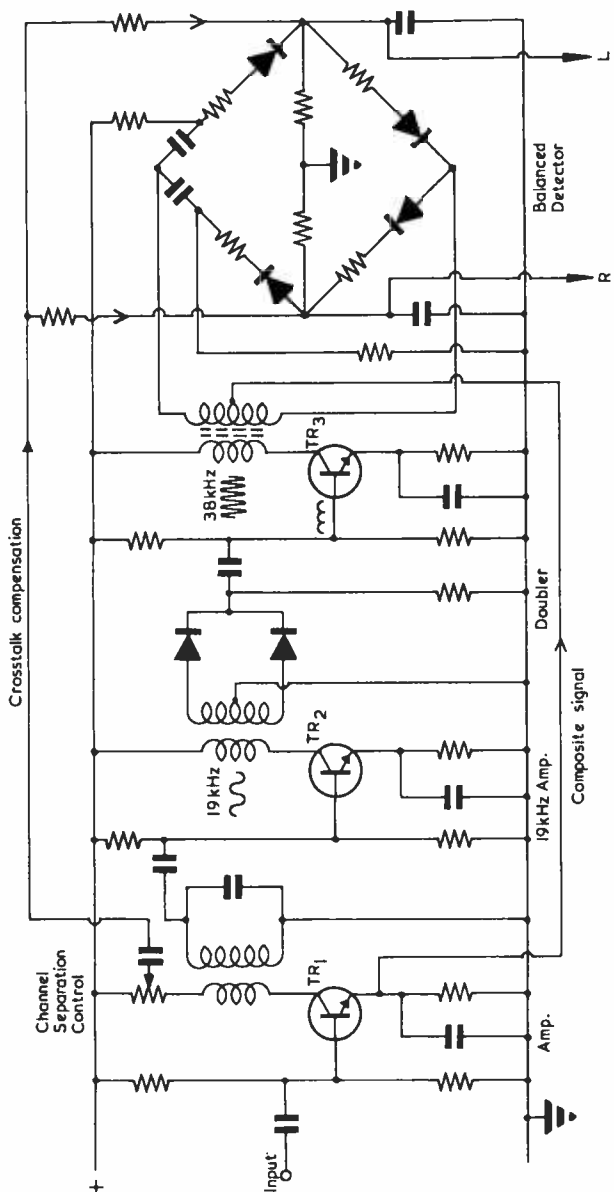

FIG. 4.19. COMPLETE STEREO DECODER CIRCUIT

and fed into a balanced detector (as in Fig.4.10). The crosstalk compensation signal is then added to the outputs.

With the integrated circuit decoder (Fig.4.14) the crosstalk compensation is achieved by duplicating the circuit as in Fig.4.20.

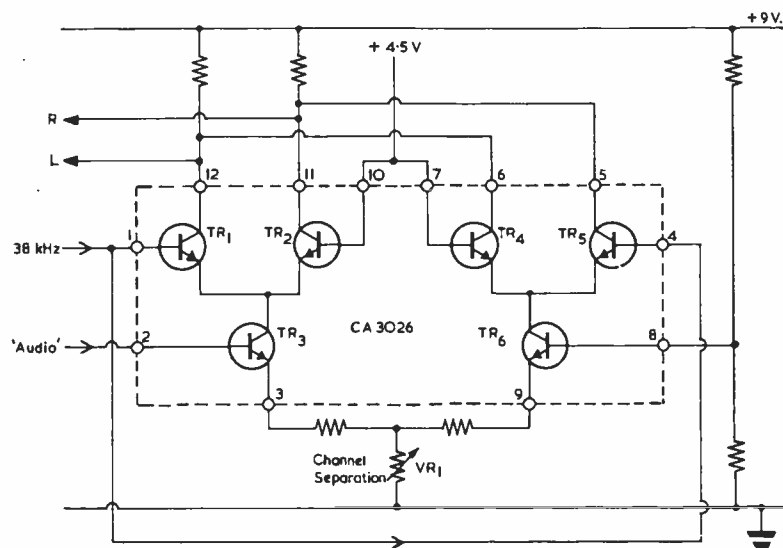

FIG. 4.20. CROSSTALK COMPENSATION ON A CA3026 INTEGRATED CIRCUIT DECODER

TR₁, TR₂ and TR₃ behave exactly as described earlier with reference to Fig.4.14. TR₄, TR₅ and TR₆ behave in a similar manner except that their base inputs are 'cross connected', the left signal being applied to the right output and *vice versa*. This gives the crosstalk compensation. The audio signal driving TR₆ is obtained by emitter coupling with TR₃ which is set by the coupling resistor VR₁ to give the correct amount of compensation for maximum channel separation.

Crosstalk is also present in matrix decoders, but the cause of the trouble is different from that discussed above. The (L+R) and (L-R) signals (see Fig.4.16) are derived from different circuits and travel *via* different paths. The result of this is that a certain amount of phase and amplitude distortion is inevitable, giving rise to crosstalk. The correction circuits, however, are the same as for the switched decoder.

THE SAMPLING DECODER*

Fig.4.17 shows that the crosstalk introduced in switched decoding is due to the breakthrough of one channel on to the other immediately before and after switching takes place. Midway between switching operations the breakthrough is seen to be virtually zero. If the left and right signals are reconstituted

* Waddington, D. F. O'N. "Stereo Decoder Using Sampling." *Wireless World*, Feb. 1971.

from voltage levels at these mid-points, it is obvious that the crosstalk will be reduced to a negligible level, Fig.4.21. The composite audio waveform is sampled for about 1 per cent of the 38 kHz cycle time at these mid-points,

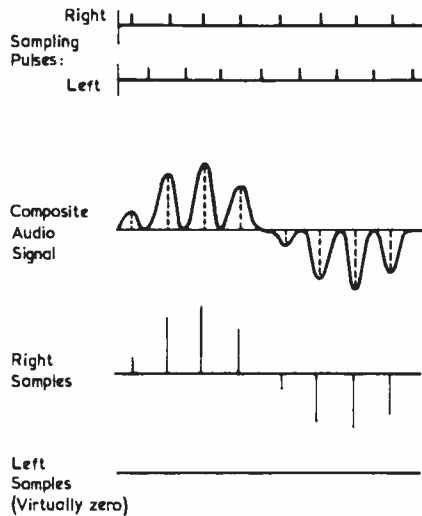

FIG. 4.21. SAMPLING THE COMPOSITE WAVEFORM AT MID-SWITCHING POINTS

and the sampled voltage held until the next sampling pulse is applied, Fig.4.22.

The composite signal is fed to a transistor in series with a small capacitor. The sampling pulse momentarily turns on the transistor allowing the capacitor

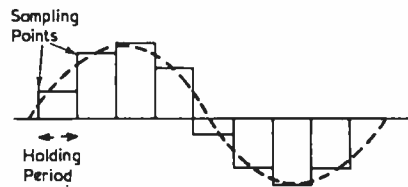

FIG. 4.22. THE RECONSTITUTED RIGHT CHANNEL WAVEFORM

to charge up to the audio voltage at the time of sampling. The capacitor holds the voltage at this level (with a small exponential decay) until the next sampling pulse occurs.

The sampling pulses themselves are derived from a pulse generator driven by the 38 kHz signal. Fig.4.23 shows a block outline of the arrangement. The 38 kHz component in the output is small and up to 40 dB separation between channels is obtainable. The sampling decoder circuit is described on page 117.

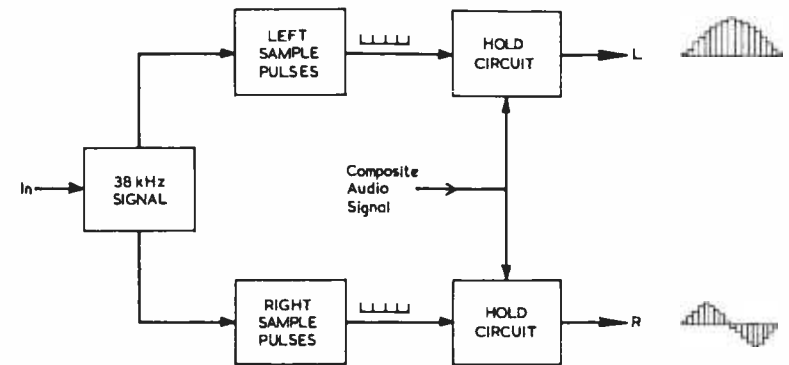

FIG. 4.23. BLOCK OUTLINE OF SAMPLING DECODER SYSTEM

DE-EMPHASIS

After the separation of the left and right signals, a 50 μs de-emphasis is applied to the collector outputs of the decoder, Fig.4.24.

Typical values for the resistors and capacitors are

12 kΩ and 4.7 nF; or

4.7 kΩ and 0.01 μF.

The 38 kHz filters which follow the decoding in an unbalanced circuit affect the de-emphasis and care must be taken to see that the performance is not reduced to an unacceptable level.

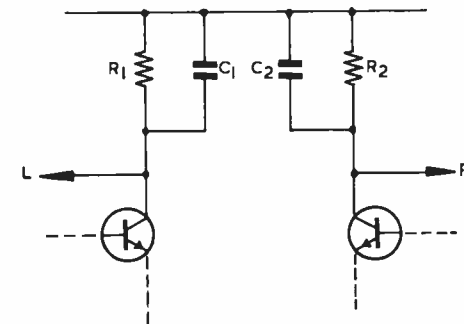

FIG. 4.24. DE-EMPHASIS APPLIED AFTER CHANNEL SEPARATION

Typical values for 50 μs :

R₁, R₂: 12 kΩ R₁, R₂: 4.7 kΩ

C₁, C₂: 4.7 nF or C₁, C₂: 0.01 μF

5

TYPICAL RECEIVING AND DECODING CIRCUITS

IN this chapter we shall consider the important circuit arrangements and interesting features of the radiogram and tuner-amplifier with decoding facilities. Radiograms are now usually equipped to decode and reproduce stereo transmissions at the time of purchase, or provision is made to easily fit a decoding unit at a later date. If the reproducing equipment of a unit audio system is to be linked to f.m. reception, the tuner-amplifier may serve as the main unit of the system. Some tuner-amplifier designs, in addition to incorporating an f.m. tuner, decoding unit and high-power stereo amplifier, include a.m. tuning for the reception of LW, MW and SW stations. The compactness of the tuner amplifier has been made possible by the use of circuit modules employing solid-state electronics. In a number of designs this has been achieved without detracting from the high quality normally associated with separate tuner and amplifier systems.

POWER SUPPLIES

As transistors are used almost exclusively in receiving equipment, a low voltage d.c. supply 10—40 V (say) is needed. Thus the first requirement is to step down the mains supply to a lower voltage. A double-wound transformer is normally used as it has the advantage of isolating the equipment from mains potentials. Full-wave rectification is preferred to half-wave because the former provides better regulation and the ripple voltage is less. The rectifiers may be arranged in a conventional full-wave circuit using a centre-tapped transformer with two rectifiers or form a bridge circuit. The bridge arrangement makes more efficient use of the available secondary voltage but requires four rectifiers. Thus the choice is a question of economics.

With some equipment a single line supply of positive or negative polarity will be required, whereas in others lines of both polarities may be necessary, Fig.5.1. This diagram shows the power supplies for a Bush SOUND SYSTEM which includes an am/fm stereophonic radio tuner and a high quality stereo amplifier. A full-wave bridge circuit is used incorporating four silicon diodes (D_1 — D_4) and a centre-tapped secondary winding. The tapped secondary is used to provide a stable d.c. output, split to form two lines of opposing polarities with respect to the chassis. Large values are chosen for the reservoir capacitors C_1 and C_2 as the ripple voltage is approximately inversely proportional to the value of the reservoir capacitor. The a.f. push-pull stages require a 33 V supply which is taken directly from C_1 and C_2 (between the +16.5 V and -16.5 V lines).

R_2, C_4 and R_4, C_6 in the negative line supply form two RC filter sections to give a smoothed d.c. supply to the f.m. tuner, a.m. mixer and i.f. amplifiers. Similarly, in the positive line R_1, C_3 and R_3, C_5 reduce the residual ripple to an acceptable level for feeding the remaining stages which include the decoder

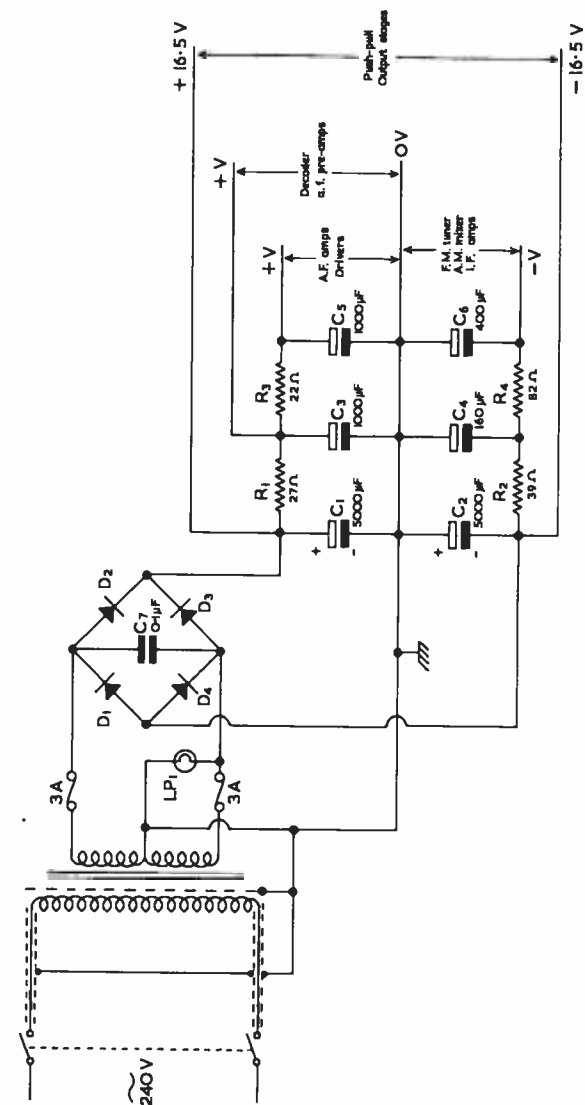

FIG. 5.1. D.C. SUPPLIES USED IN A BUSH SOUND SYSTEM

section. Additional line filters are included in some sections but have not been shown.

The d.c. resistance of the secondary winding protects the rectifiers from damage by the large current pulses which flow due to the initial charging of C_1 and C_2 at switch-on. C_1 is an r.f. by-pass to keep impulsive interference entering *via* the mains out of the d.c. supplies. LP_1 is a warning lamp which is illuminated when the power supply is switched on.

VOLTAGE STABILIZATION

A number of designs are now incorporating a stabilizer circuit to help maintain a constant d.c. output voltage. The main causes of output voltage variation are (a) fluctuations in the mains supply; and (b) changes in the current drawn by the load.

The basic principle of voltage stabilization is shown in Fig.5.2. Essentially, three separate devices are necessary. One is a sampling device to detect varia-

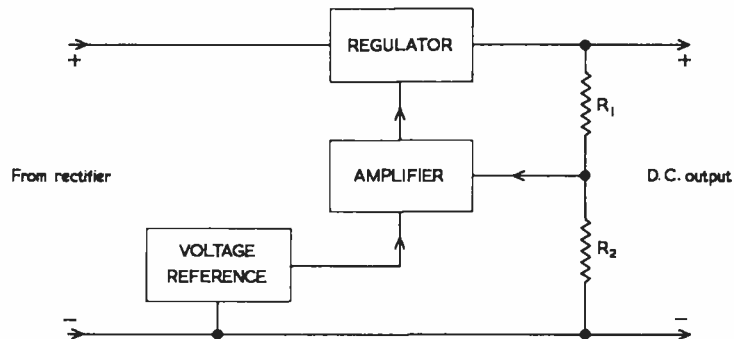

FIG. 5.2. BASIC PRINCIPLE OF STABILIZER

tions in the voltage fed to the load. This is the purpose of the potential divider R_1, R_2 connected across the output. Secondly, a stable voltage reference is required with which the sampled voltage may be compared so that an 'error voltage' is available. Thirdly, a device which we will call a regulator, is needed which responds to the error voltage and restores the output voltage to the correct level.

Suppose that the voltage across R_1, R_2 rises due to an increase in mains voltage. The voltage across R_2 will rise and this is fed to the amplifier where it is compared with the stable voltage reference. The error voltage is detected, amplified and applied to the series regulator. This causes the resistance of the regulator to increase thereby increasing its voltage drop and restoring the output to the correct level. The regulator may be connected in series or in shunt with the load as indeed may be the measuring device but the principle of operation remains the same. An amplifier is not essential but its use improves the regulation of the stabilizer circuit.

Fig.5.3 shows a typical circuit employing the principle described. The zener diode D_1 which is supplied with a suitable current *via* R_1 provides the stable voltage reference, this being applied to the emitter of TR_1 . Suppose, for example, that the d.c. supplied to the load falls due to a reduction in the

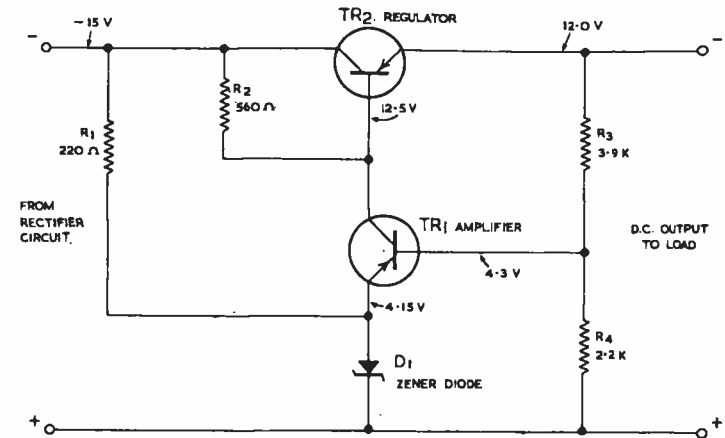

FIG. 5.3. TYPICAL BASE CIRCUIT ILLUSTRATING PRINCIPLE OF FIG. 5.2

mains voltage. The voltage across R_4 will fall thereby reducing the forward bias of TR_1 . As a result, TR_1 current will decrease and the volts dropped across TR_1 collector load resistor (R_2) will be less. This will cause the base of TR_2 to go more negative. Now, TR_2 is connected as an emitter-follower, thus the emitter of TR_2 will go more negative causing the output voltage to rise. In this manner the output is restored to its former correct value. One disadvantage of the circuit shown is that variations in TR_1 current, which flow in D_1 , alter the reference voltage.

The stabilizer circuit used in the Leak Stereofetic F.M. Tuner power supply, Fig.5.4, is different to the one just described but the principle is essentially the same. The tuner requires +9 V at about 90 mA and -5 V at about 5 mA. Separate full-wave bridge circuits are employed to provide two lines of opposing polarities, with C_1 and C_2 forming the reservoir capacitors. Any variation in voltage level of the d.c. output lines will cause mistuning of the local oscillator in the tuner front end and may cause limiting of the output audio signal. Thus each rectifier circuit is complemented by a stabilizer. Since the same circuit configuration is used in the positive and negative lines, we need only consider one circuit (say the upper one in the diagram) to understand the operation. This will now be described.

Consider first Fig.5.5 which illustrates the basic idea of the Leak stabilizer. A zener diode D_1 is fed with a suitable current from the d.c. input *via* R_1 . The reference voltage across the zener diode is supplied to the base of the series regulating transistor TR_1 , connected as an emitter-follower. Thus the voltage supplied to the load will be approximately the voltage applied to the base, *i.e.* the reference voltage. More precisely, the output voltage is the reference voltage less the base-emitter voltage drop of TR_1 . Provided the reference voltage is constant the output voltage must remain steady. To a first approximation, the voltage across D_1 will remain constant in spite of variations in the level of the input to the circuit, any variations being felt across R_1 rather than across D_1 . Unfortunately, the current in D_1 is not constant when the input level changes and due to the finite slope resistance of the zener diode

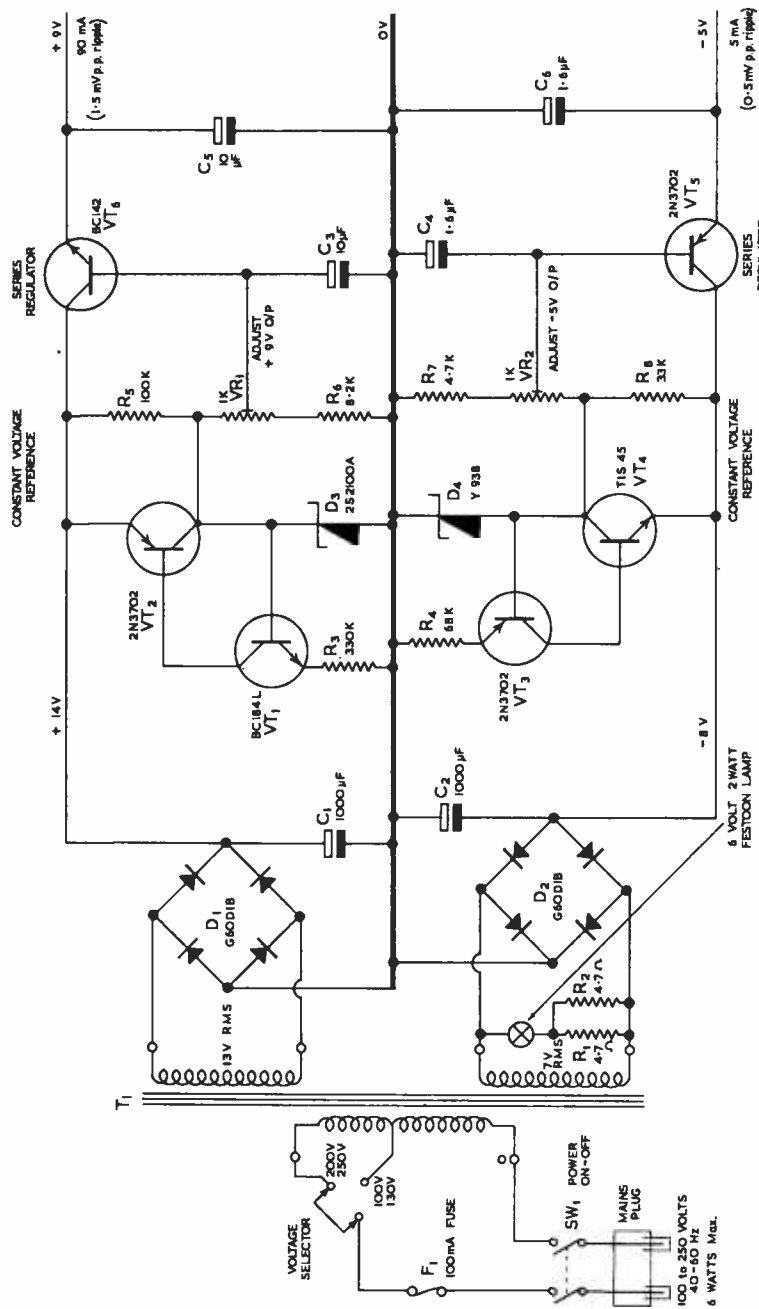

FIG. 5.4. STABILIZED SUPPLY USED IN THE LEAK STEREOFETIC F.M. TUNER.

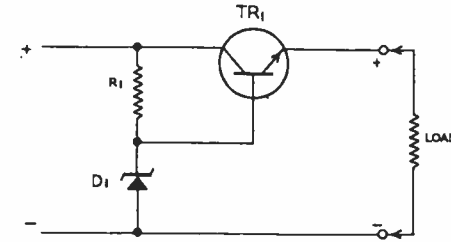

FIG. 5.5. BASIC IDEA OF EMITTER-FOLLOWER CIRCUIT USED IN FIG. 5.4

changes in zener voltage occur. Thus the regulation of this circuit is not perfect. To improve the voltage regulation a constant current circuit may be used to supply the zener diode. This technique is employed in Fig.5.4 to which we now refer.

The zener diode D_3 supplies a reference voltage to the base of the series regulator VT_6 . The voltage is not fed directly but *via* the potential divider VR_1 and R_6 connected in shunt with D_3 . The output of the regulator can be varied by about ± 0.5 V by means of VR_1 . R_5 acts as a 'starter' resistor for D_3 which subsequently is fed by VT_2 . The zener diode controls its own current by means of a constant current transistor (VT_1) feeding base current back into its own transistor feeder (VT_2). That is, VT_1 is a constant source feeding base current to VT_2 . VT_2 feeds a constant current to D_3 which in turn sets up a constant current in VT_1 . Should (say) the +14 V line rise as the result of an increase in mains voltage, the emitter-collector voltage drop of VT_2 will be greater. However, since it is fed with constant base current from VT_1 , the collector current of VT_2 will remain constant. Hence the current in D_3 will be steady and so will be the output voltage from VT_6 emitter.

The collector-emitter resistance of VT_6 together with C_5 form an RC filter to reduce the ripple voltage at the regulator output. C_1 decouples the ripple at VT_6 base.

R.F. AMPLIFIER AND MIXER STAGES

A typical front end using bipolar transistors is given in Fig.5.6. VT_1 is the r.f. amplifier operating in the common base mode. Signals from the 75 Ω external aerial are coupled *via* C_1 and C_2 to the primary of the aerial input transformer T_{1a} . A step-up ratio is used to match the aerial to the impedance of the fixed tuned input circuit formed by T_{1a} , secondary, C_4 and C_5 . The f.m. aerial socket is coupled to the ferrite rod aerial used on the a.m. bands. Thus, when using an external f.m. aerial, additional a.m. pick up is transferred to the ferrite rod *via* C_3 . This helps to offset possible null points when the ferrite rod is of a fixed orientation.

Signals from the input circuit are transferred to the emitter of VT_1 *via* the capacitive divider formed by C_4 and C_5 . This arrangement prevents undue damping of the tuned circuit by the low input resistance of VT_1 . C_7 grounds the base to signal and R_1 provides a suitable forward bias current. As VT_1 is a silicon transistor, the base-emitter voltage drop is larger (0.5 V in this case) than with germanium types. A.G.C. is applied to VT_1 base *via* R_2 . Amplified signals are developed across L_5 , CV_1 in the collector circuit of VT_1 . CV_1

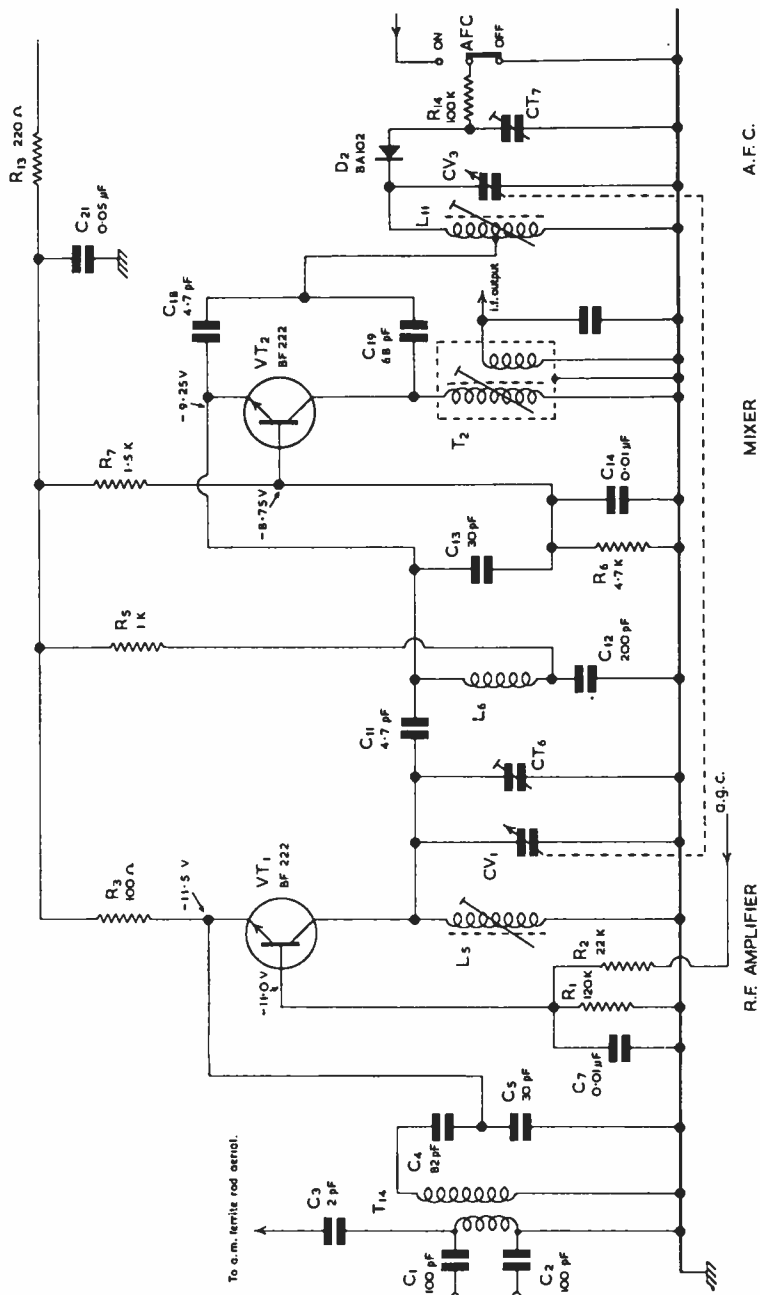

FIG. 5.6. BUSH A747 TUNER

provides variable tuning over the range of 88 MHz to 108 MHz. L_5 and CT_6 are adjusted during r.f. alignment for optimum gain at opposite ends of the band. The output of the r.f. amplifier is capacitively coupled to the emitter of the mixer transistor via C_{11} . L_6 , C_{12} form a series resonant 10.7 MHz trap to prevent i.f. breakthrough. Also, the trap isolates the i.f. stages from the aerial to prevent radiation at 10.7 MHz.

VT_2 is the mixer transistor of the self-oscillating variety. R_5 provides the d.c. return for the emitter circuit and R_6 , R_7 are used for base biasing. The transistor is operated in common base, the base being grounded to signals by C_{14} . The oscillator tank circuit is formed by L_{11} , CV_3 , CT_7 and D_2 (vari-cap diode). A tap on L_{11} is used to couple the tank circuit to the transistor. Oscillatory energy from L_{11} tap is applied to the emitter of VT_2 via C_{18} . Amplified, in-phase energy is returned to the tank circuit from the collector of the mixer via C_{19} . The principle of operation of this type of v.h.f. oscillator has been discussed in Chapter 3, page 45. In this receiver, the oscillator is tuned on the low side with respect to the signal frequency. The difference frequency of 10.7 MHz is extracted by the tuned i.f. transformer T_2 in the collector circuit of the mixer.

When the a.f.c. switch is in the ON position, a control voltage derived from the f.m. detector is used to bias D_2 . The change in capacitance which results brings the oscillator into step should there be a tuning error. The hold range of the a.f.c. is not less than 1.8 MHz with a signal input of 1 mV at 95 MHz. An important design feature is that the amplitude of the oscillatory voltage across D_2 must not be such that it brings the diode into forward conduction, otherwise uncontrollable changes in oscillator frequency may occur. In the a.f.c. OFF position the d.c. control voltage is removed and the receiver may be tuned manually. It should be noted that manual tuning should not be carried out with the a.f.c. switched ON as the a.f.c. will tend to correct for tuning variations. It is possible to finish up apparently correctly tuned in but with the a.f.c. at the end of its hold range and unable to cope with any subsequent drift.

F.E.T. FRONT END

Some designs are now making use of the advantages to be gained by incorporating f.e.t.s in the front end, in particular the dual-gate metal oxide semiconductor field effect transistor (m.o.s.f.e.t.). Before looking at a typical circuit it may be useful to briefly consider the operation of the f.e.t.

An f.e.t. has a resistive channel of a semiconductor material whose resistance can be varied by an electric field cutting into the channel and altering its cross-sectional area. Fig.5.7 shows the basic construction. A resistive channel of n-type silicon is shown with non-rectifying connections at either end. One connection is called the source and the other the drain. On either side of the channel are formed regions of p-type silicon which are connected together and a connection is brought out from these areas called the gate. This forms an n-channel device but p-channel f.e.t.s are available with a resistive p-channel and n-gate areas.

The f.e.t. is a unipolar device, i.e. it conducts by majority carriers only, whereas the ordinary bipolar transistor conducts by majority and minority carriers. Thus if the drain connection of Fig.5.7 is made positive with respect to the source connection, conduction will take place by electrons from source to drain. To vary the conduction of the channel a voltage is applied between

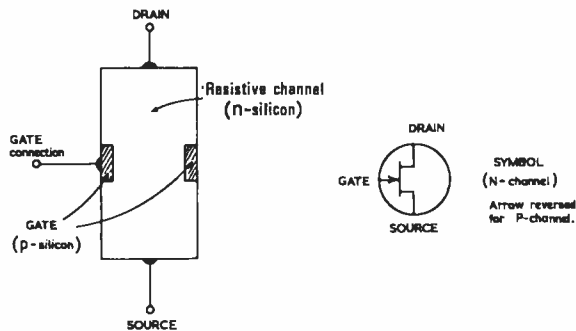

FIG. 5.7. BASIC CONSTRUCTION OF JUNCTION F.E.T.

gate and source (gate negative with respect to the source for an n-channel f.e.t.). The effect of varying the gate-to-source voltage is shown in Fig.5.8. As V_{gs} is increased, the potential field (shown shaded) extends further into the resistive

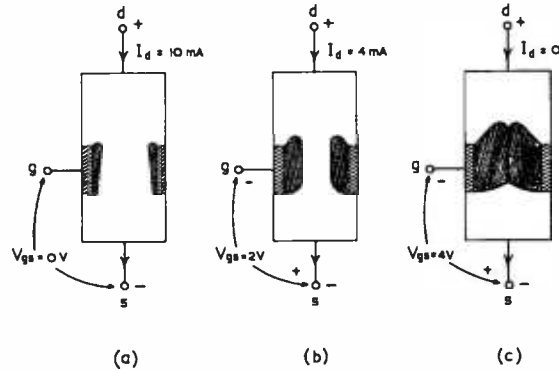

FIG. 5.8. EFFECT OF GATE-TO-SOURCE VOLTAGE ON DRAIN CURRENT

channel reducing the effective cross-sectional area. This causes the channel resistance to increase and reduces the current flow from source to drain (I_d). Thus the effect of increasing V_{gs} is to 'pinch-off' the current. The voltage corresponding to zero I_d is called the **pinch-off voltage**. Fig.5.9 shows typical characteristics. The relationship between drain current and gate-to-source voltage is $I_d \propto V_{gs}^2$ which is confirmed by the parabolic form of the $I_d - V_{gs}$ curve of diagram (a).

The current flowing in the gate lead is very small indeed (a fraction of a microampere) since the gate-channel junction is essentially a reversed biased diode. A high input resistance results, of the order of $10^7 \Omega$ at d.c. Thus the f.e.t. is a voltage-operated device like the thermionic valve but unlike the bipolar transistor which is current operated. In some respects the f.e.t. is similar to the pentode valve (compare the curves of Fig.5.9 with the $I_a - V_g$ and $I_a - V_a$ characteristics for a pentode). The mode of operation outlined is called the **depletion mode** since the drain current is reduced when V_{gs} is increased. An f.e.t. offers the following advantages: (a) a high input resistance—typically $10^7 \Omega$ at d.c.; (b) low noise performance—better than valves and

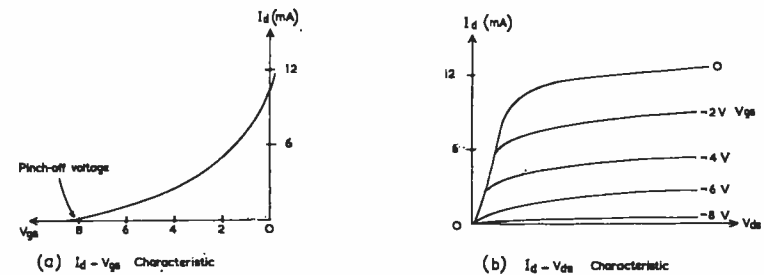

FIG. 5.9. CHARACTERISTICS OF F.E.T.

bipolar transistors; and (c) good signal handling characteristic resulting in a reduction of cross-modulation and intermodulation products. This means that the f.e.t. is well suited to r.f. and mixer applications.

An a.f. amplifier using a junction-gate f.e.t. is shown in Fig.5.10. The input signal is applied between gate and source. R_3 provides a suitable bias

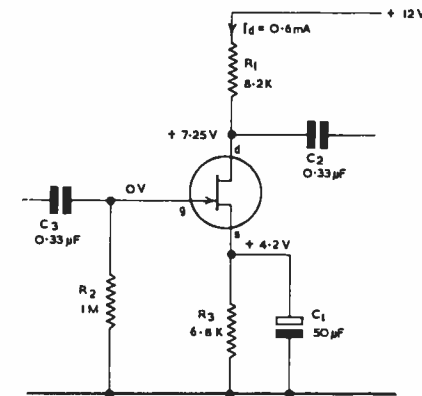

FIG. 5.10. JUNCTION-GATE F.E.T. AMPLIFIER

for the gate, obtained in the same way as cathode bias for a valve. C_1 decouples R_3 to prevent a.c. negative feedback. R_2 provides the d.c. return for the gate to the negative line. The amplified signal is developed across the drain load R_1 . In this circuit a standing current of 0.6 mA is obtained with a V_{ds} of 3.05 V (7.25 V - 4.2 V) and a gate voltage of -4.2 V.

The f.e.t. just described is called the junction-gate f.e.t. or JGFET. There is another type known as the insulated gate f.e.t. (IGFET) or metal oxide semiconductor f.e.t. (MOSFET). These may be of the depletion mode or enhancement mode variety. Fig.5.11 illustrates the basic construction of an n-channel enhancement mode MOSFET. The source and drain are heavily doped n+ regions which are diffused close together on to a p-type section called the substrate. Between the source and drain and extending to the edges of the substrate is a thin layer of silicon dioxide. This layer acts as an insulating zone between the substrate and the aluminium gate electrode.

With the drain made positive with respect to the source (V_g zero) very little current flows since the two p.n. junctions formed are connected in series

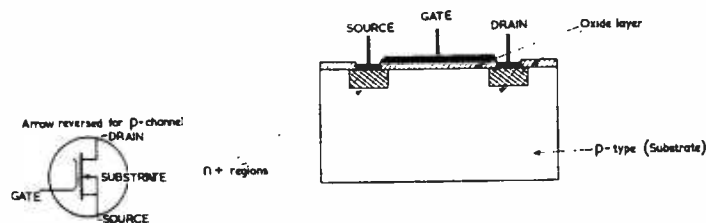

FIG. 5.11. CONSTRUCTION OF MOSFET (IGFET) N-CHANNEL ENHANCEMENT

opposition. If the gate is made positive the electric field set up across the silicon dioxide layer attracts electrons out of the substrate. This creates an n-type surface channel between the source and drain through which conduction may take place. Hence, this type of MOSFET has to be forward biased like the bipolar transistor, but of course is voltage operated.

When the gate voltage is increased, the width of the surface enhancement channel increases, Fig.5.12, and its resistance decreases. Thus, the current between source and drain will rise. Typical characteristics are given in Fig.5.13.

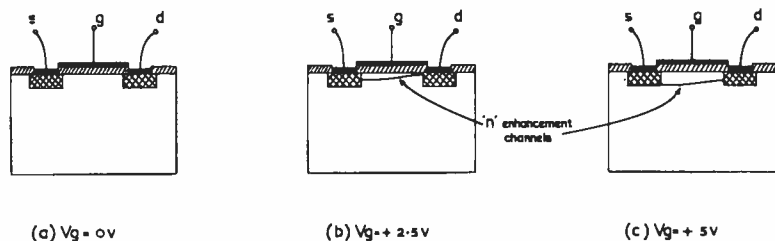

FIG. 5.12. EFFECT OF FORWARD BIASING THE GATE

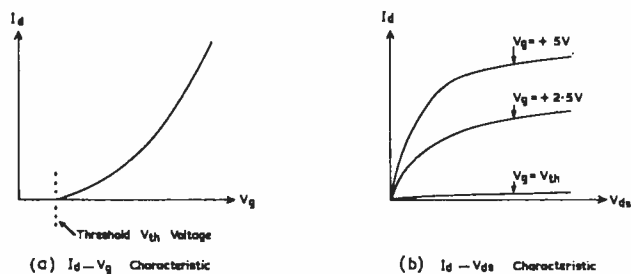

FIG. 5.13. ENHANCEMENT MODE MOSFET CHARACTERISTICS

Drain current does not flow until the gate voltage is a few volts positive; the gate voltage at which current commences to flow is called the **threshold voltage**.

Owing to the presence of the dioxide layer the input resistance is higher than that of the JGFET ($10^{12} \Omega$). Because of this high resistance an electric charge

might easily be built up on the gate electrode which may cause the oxide layer to break down. Thus the gate should be connected to the source until the transistor has been wired into the circuit.

We have been considering an n-channel transistor, but a p-channel may be formed by using an n-type substrate and highly doped p-areas. The channel width and hence I_d increase when the gate is made negative in this case. Enhancement mode MOSFETs are the most common but depletion mode types are available. The principle of operation of the depletion mode MOSFET is illustrated in Fig.5.14. A small channel having n-type conductivity is diffused between the source and drain n+ areas. This channel has a higher resistivity

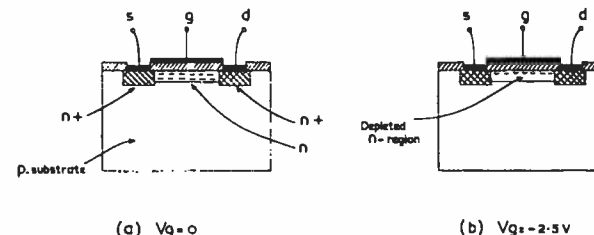

FIG. 5.14. PRINCIPLE OF DEPLETION MODE MOSFET

than the n+ sections. When a voltage is applied between drain and source ($V_g = 0$) a current will flow. If the gate is made negative, the electric field across the dioxide layer attracts holes from the substrate into the channel. This depletes the channel of electrons and increases its resistivity, thereby reducing current flow.

A relatively new class of MOSFET is one having two independent insulated gates: see Fig.5.15. The device includes three diffused regions connected by two channels each of which can be controlled by its own independent gate.

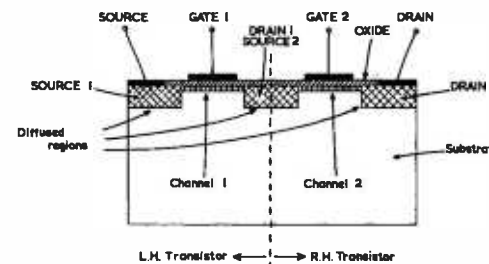

FIG. 5.15. SCHEMATIC OF A DUAL-GATE MOSFET

This dual-gate device may be considered as comprising two transistor units with the central diffused region acting as the drain for the left-hand transistor and the source for the right-hand transistor.

The current flowing between the source and drain connections may be controlled by the voltage applied to either of the two series gates. By making either of the gates sufficiently negative the current may be cut off. One may consider that the right-hand transistor acts as a drain load for the left-hand

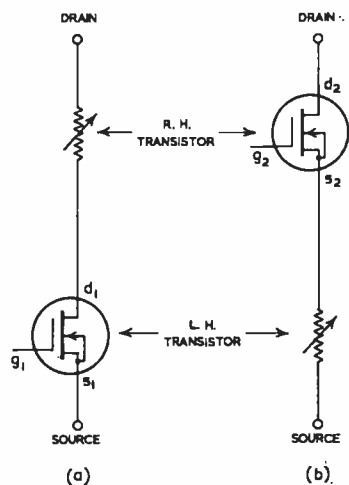

FIG. 5.16. EQUIVALENT CIRCUIT REPRESENTING THE DUAL-GATE MOSFET

transistor, Fig.5.16(a), or, alternatively, the left-hand transistor acts as a source load for the right-hand transistor, Fig.5.16(b). If one gate is biased to cut-off, a variation in voltage on the other gate is equivalent to a change in the value of a resistor in series with a cut-off transistor.

Two uses of the dual-gate f.e.t. are illustrated in Fig.5.17. In (a) it is arranged as a cascode amplifier with the signal applied to g_1 and g_2 grounded to signal by C_1 . With this method of connection the feedback capacitance from the drain connection to g_1 is very small (about 0.02 pF). Gain control may be

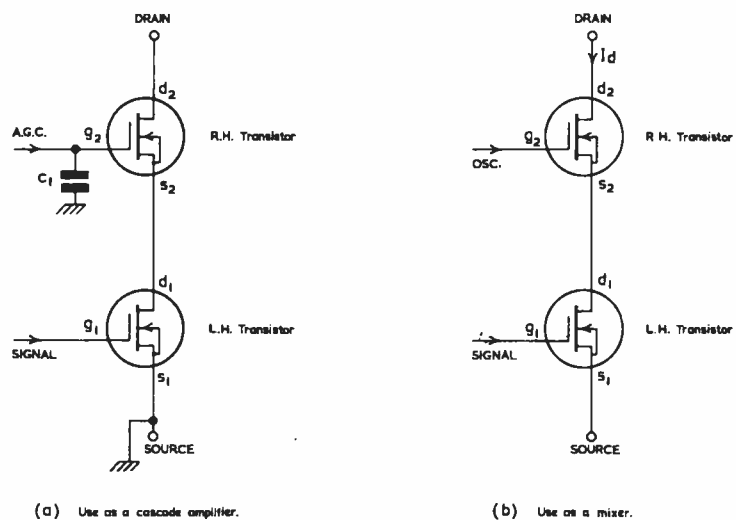

FIG. 5.17. USES FOR THE DUAL-GATE MOSFET

effected by varying g_2 voltage. The dual-gate f.e.t. may also be used in mixer applications, Fig.5.17(b). With devices having a single input electrode, mixing occurs due to the non-linearity of the device (additive mixing). When a dual-gate device is used, the signal is applied to one gate and the oscillator injection signal to the other. Since the drain current is a function of both gate voltages, product mixing takes place.

The dual-gate transistor has the same advantages as the single-gate f.e.t.—namely, low noise, high input impedance at d.c. and good signal handling. Its low feedback capacitance will allow such a device to give a power gain of up to 28 dB at 100 MHz without the need for neutralizing, making it suitable for r.f. applications in f.m. tuners. Some dual-gate f.e.t.s (like the RCA 40673) have built-in zener diodes connected between each gate and the source-substrate connection. These diodes protect the gates from over-voltage which would otherwise break down the oxide layer.

A circuit of an r.f. amplifier incorporating a dual-gate f.e.t. is given in Fig.5.18. The circuit is designed around an RCA 40603 which is an n-channel depletion mode type. The drain is held positive with respect to the source, the drain being returned to the positive line via L_3 . Bias for g_1 is provided by the voltage drop across the source resistor R_2 making g_1 negative with respect to the source. R_1 provides the d.c. return to the negative line for g_1 . The source resistor is decoupled to signals by C_3 . This capacitor is returned to the chassis rather than the negative line in the interests of stability. The second gate, g_2 , is held positive with respect to the source, the d.c. potential being supplied from an a.g.c. rectifier located in the i.f. strip. As regards the polarity of d.c. potentials there is a certain similarity here with g_1 and g_2 of a tetrode valve.

The f.e.t. operates as a cascode r.f. amplifier since g_2 is grounded as regards signals via C_3 . This capacitor is a feed-through type having a low self-inductance which is an important property of an r.f. decoupler. Signals from the aerial are applied to the input tuned circuit comprising L_2, C_1, C_2 and C_3 via a step-up transformer L_1, L_2 . The turns-ratio chosen provides a match between the low impedance aerial and the tuned circuit. C_4 together with the input capacitance of the transistor tap L_2 at a suitable point. This prevents excessive damping of the tuned circuit by the input resistance of the transistor which is only about 3.5kΩ at 100 MHz. After amplification the signals are developed across L_3 and C_5 in the drain circuit. The preset components L_3, C_7 and L_2, C_2 are adjusted to give accurate tracking over the f.m. band. A match to the mixer transistor is obtained by tapping down L_3 .

With increasing signal strengths the voltage applied to g_2 from the a.g.c. rectifier is made less positive with respect to the source. This depletes the second channel of carriers thereby reducing the drain current. As the drain current falls so does the gain (see Fig.5.19).

A complete f.e.t. front end circuit diagram is given in Fig.5.20. This employs a single-gate f.e.t. for the r.f. amplifier and a dual-gate device for the mixer. An ordinary bipolar transistor serves as the local oscillator.

Signals from the 75 Ω aerial are fed via C_7 and C_8 and developed across some of the lower turns of L_1 . This coil, together with C_2 , form a variable tuned input circuit. C_7 and C_8 stop any chassis currents which might otherwise cause noise or interference. The aerial tap on L_1 is suitably placed to give correct matching between the low impedance aerial and the tuned circuit.

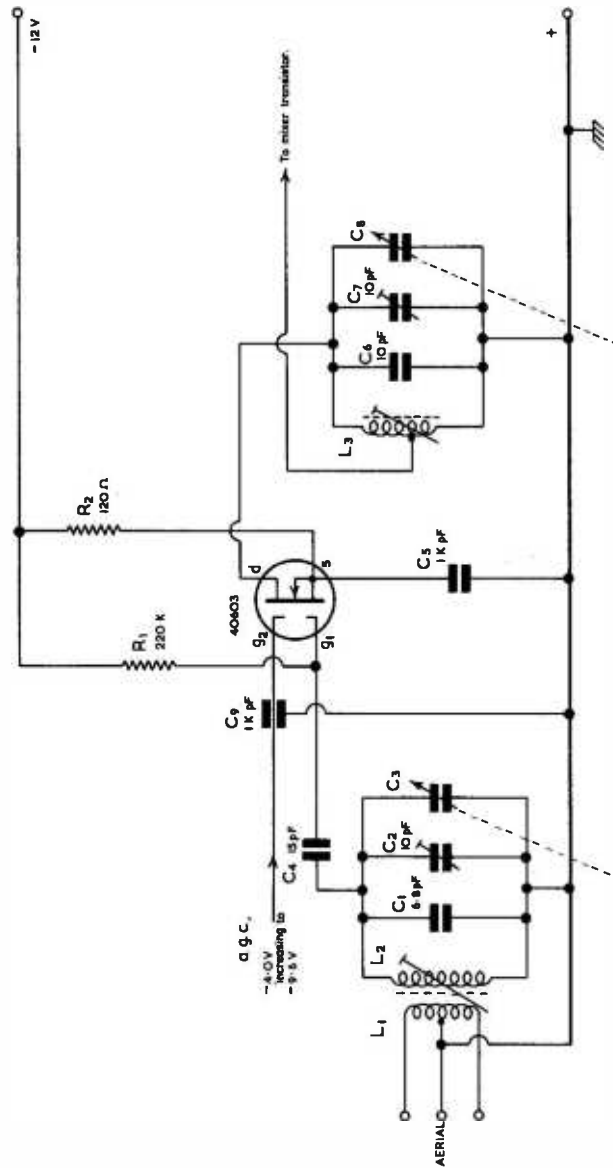

FIG. 5.18. R.F. AMPLIFIER USING A DUAL-GATE F.E.T. (WHARFEDALE F.M. TUNER)

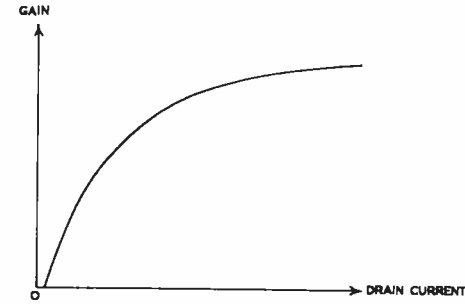

FIG. 5.19. THE RELATIONSHIP BETWEEN DRAIN CURRENT AND GAIN FOR A MOSFET

The gate of the r.f. amplifier VT_7 , is tapped into L_1 via C_{10} which also serves as a d.c. block for the gate potential. The gate tap on L_1 allows correct matching between the input resistance of VT_7 and the tuned circuit, also variations in the input capacitance of VT_7 , arising from changing a.g.c. bias have less effect on L_1 tuning. Bias for the gate is provided by the voltage drop across the source resistor R_{11} . Additionally, an a.g.c. voltage is applied to the gate via R_9 . The source resistor is effectively decoupled to signal frequencies by C_{13} and i.f. frequencies by C_{14} . After amplification by VT_7 , the signals are developed across L_2, VC_4 in the drain circuit. Supply voltage to the drain is fed via the line decoupling network R_{10}, C_{12} . Note that C_{12} grounds the upper end of L_2 to signals, thus VC_4 is effectively in shunt with L_2 .

The output of the r.f. amplifier is coupled to g_1 of the mixer via C_{16} from a tap on L_2 which is placed to give correct matching to the input resistance of VT_8 (a few kilohms at 100 MHz). Gate 1 is biased by R_{17} , which is suitably decoupled by C_{22} . R_{22} is the d.c. return resistor for g_1 . The oscillator injection voltage is applied to g_2 via C_{19} from the oscillator coil L_4 . Gate 2 receives a positive voltage from the potential divider R_{13}, R_{14} thus making g_2 0.6 V positive with respect to the source. R_{12}, C_{17} filters the supply to g_2 . A series resonant trap tuned to 10.7 MHz and formed by L_3, C_{18} grounds g_2 to i.f. frequencies. This is to reduce capacitive feedback between the drain and g_2 which would otherwise cause a reduction in output impedance and gain. Multiplicative mixing takes place in VT_8 and the i.f. is developed across the primary of the band-pass transformer T_2 . The secondary of the transformer feeds the i.f. strip from the capacitive divider C_{26}, C_{27} (used for matching).

The local oscillator section has been redrawn and is given in Fig.5.20(a). A Hartley oscillator is used in the grounded-collector mode (C_{25} grounds the collector). Starting bias is provided by the bias network R_{19}, R_{20} . The main tank circuit components are formed by L_4 and VC_5 , the lower end of L_4 being grounded by C_{21} . Oscillatory energy is applied to the base of VT_9 via C_{28} . In-phase energy is returned to a tap on L_4 from the emitter of the transistor. The oscillator is tuned on the high side with respect to the signal and feeds out about 500 mV r.m.s. at 100 MHz to the mixer. This decreases to around 400 mV at 120 MHz.

Automatic frequency control is applied to the oscillator via the variable capacitance diode D_3 . The series combination of D_3 and C_{29} is effectively in shunt with L_4 (C_{34} and C_{21} are of comparatively large value and can be

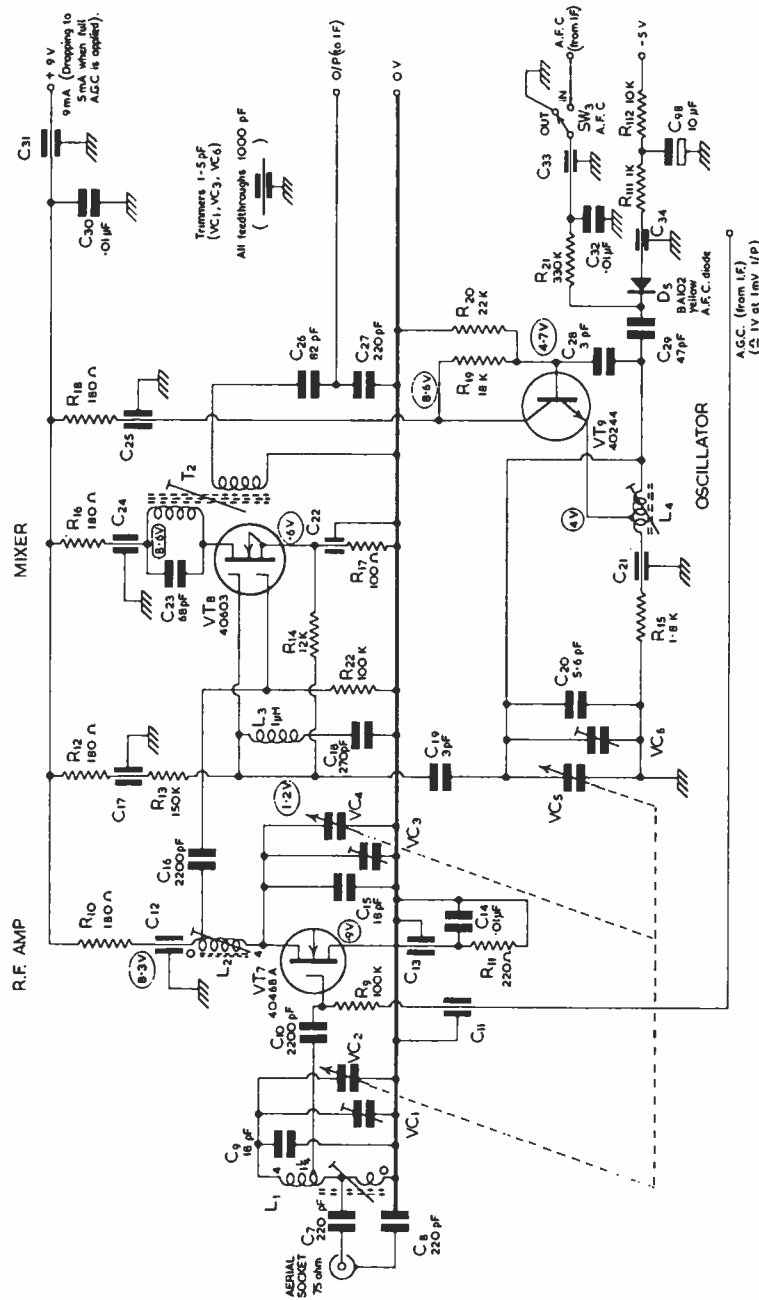

FIG. 5.20. F.E.T. FRONT END (LEAK)

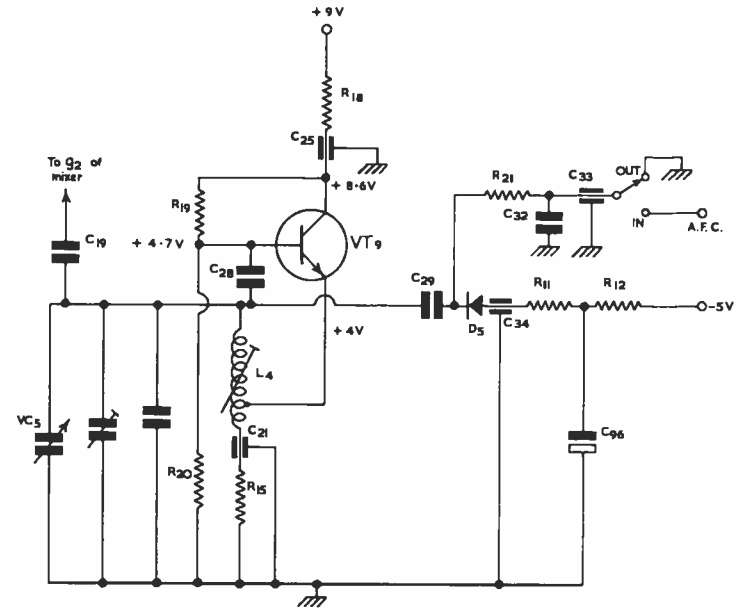

FIG. 5.20(a). LOCAL OSCILLATOR OF FIG. 5.20 REDRAWN

neglected). When the a.f.c. is switched out, D_5 receives a constant reference voltage from the -5 V line. The diode is in consequence reverse biased and presents a steady capacitance to the oscillator tank circuit. With the a.f.c. switched in, the a.f.c. voltage derived from the detector changes the reverse bias of D_5 in the correct direction to compensate for any oscillator drift. An increase in oscillator frequency will result in an increase in the intermediate frequency. This will cause a reduction in the reverse voltage across D_5 , and an increase in the capacitance of the diode. As a result the oscillator frequency will be lowered thus correcting the drift. The filter formed by R_{21} and C_{32} keeps oscillatory energy out of the control line from which radiation could take place. The change in correction voltage fed to D_5 is 2.7 mV for a 1 kHz change in the intermediate frequency, i.e. the a.f.c. rate is 2.7 mV/kHz.

Electronic tuning of the signal and oscillator sections is a feature of the Beomaster 1600 tuner, Fig.5.21. TR_1 and TR_2 are connected as a cascode r.f. stage with the input signal applied to the gate of the lower transistor and a.g.c. applied to the gate of the upper transistor. Variations in a.g.c. bias do not therefore affect the tuning of L_1 . After amplification in this stage the signal is fed to the gate of the mixer TR_4 via the band-pass transformer T_1 . The oscillator injection voltage is supplied to the source from a separate oscillator TR_3 via the inductive coupling L_5-L_4 . Additive mixing takes place in TR_4 and the i.f. is extracted by a tertiary winding on the i.f. transformer T_2 .

Four variable capacitance diodes D_1-D_4 and a potentiometer P_1 are used instead of a ganged tuning capacitor. D_1 tunes L_1 , D_2 tunes L_2 , D_3 tunes L_3 and D_4 tunes the oscillator coil L_5 . With the push-button switches (S_1-S_4) in the positions shown, a d.c. tuning voltage is supplied to the four diodes from P_1 .

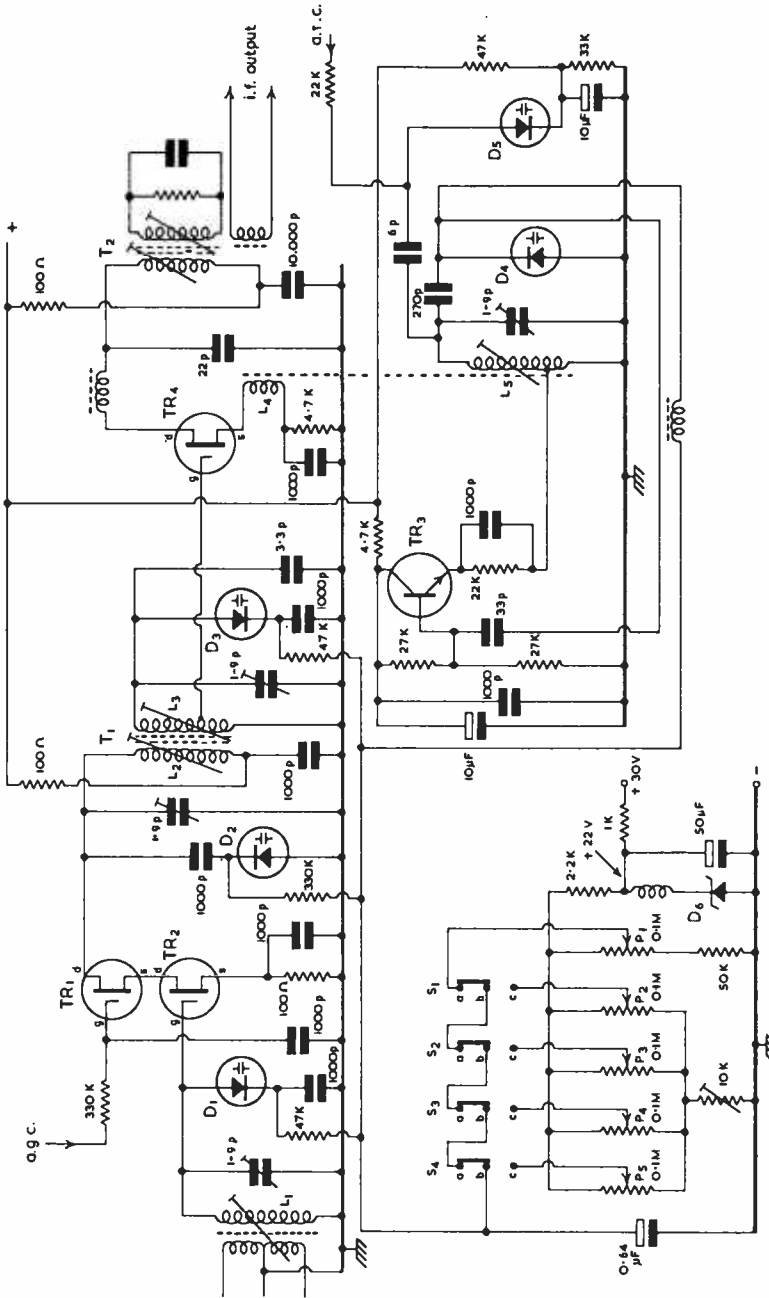

FIG. 5.21. F.E.T. FRONT END WITH ELECTRONIC TUNING (BEOMASTER 1600)

This potentiometer is used for tuning over the entire f.m. band. Four other potentiometers are provided (P_2-P_3) for selecting a fixed tuned station. Each of these potentiometers can be switched into circuit by its own push-button and can be set to receive any signal within the entire f.m. band. Operating any push-button removes the d.c. feed from P_1 , the tuning voltage for the diodes then coming from the selected potentiometer. All five potentiometers receive a 22 V stabilized supply from the zener diode D_6 . The diode D_5 is used for a.f.c. and is controlled from the f.m. detector.

I.F. STAGES AND DETECTOR

The i.f. stages of the Beomaster 1000 (Fig.5.22) follow conventional lines based on tuned transformers. Four stages of i.f. amplification are used to provide the gain, each incorporating a band-pass transformer to give the required selectivity.

Signals from the mixer are coupled to the base of TR_1 via L_3, L_1 and L_2 . L_1, C_1 form a parallel-tuned circuit resonant to the receiver i.f. of 10.7 MHz. The step-up ratio of L_2 and L_3 to L_1 prevents excessive damping of the tuned circuit. Amplified signals from TR_1 are developed across L_4, C_2 , the primary of the band-pass transformer T_1 . After transfer to the secondary circuit comprising L_5, C_3 , the signals are coupled to the base of TR_2 from L_6 . A step-down ratio is used from L_5 to L_6 to match to the low input impedance of TR_2 . Feedback from collector to base within TR_1 is cancelled by external feedback through R_1 and C_4 from L_7 . The winding direction of L_7 is such that signals at the lower end of this coil are in antiphase with the signals at the lower end of L_4 . In this way the stage is unilateralized. Exactly the same technique is used in TR_2, TR_3 and TR_4 stages.

TR_1 receives forward bias from a common-base potential divider R_2, R_3 , connected across the line supply. The d.c. to TR_1 base is fed via the decoupling network R_2, C_5 . Additionally, C_5 grounds the lower end of L_2 so that signals across it are effectively applied between base and emitter (C_5 completes the path to the emitter). Stabilization of the working point is given by R_4 , being suitably decoupled by C_6 . R_6 in the collector circuit of TR_1 is to prevent instability should the stage bottom on the receipt of strong signals. The collector supply feed for TR_1 is decoupled by R_7 , and C_8 ; this capacitor is returned to the emitter rather than chassis as the collector has to be 'tied' well back to the emitter circuit for stability.

The signal transferred to TR_2 base receives further amplification in TR_2, TR_3 and TR_4 stages which are similar in operation and circuitry to TR_1 and therefore will not be discussed in detail. A.G.C. is taken out from TR_2 stage, however, and this can be now mentioned. D_3 is the a.g.c. rectifier fed with i.f. signals via C_{10} . The diode is permanently biased on a little through R_9 and R_{10} . This helps to preserve a constant loading on TR_2 . Signals fed to the diode cause it to conduct harder on positive half-cycles making the junction of R_9, R_{10} more negative, hence the a.g.c. line goes more negative. This change is in the correct sense for controlling the r.f. amplifier.

The output of the final i.f. amplifier feeds the demodulator which is a balanced ratio detector.

Normally, in a ratio detector of the balanced type, the centre-point of the load is earthed and the output signal is taken from the tertiary winding as in

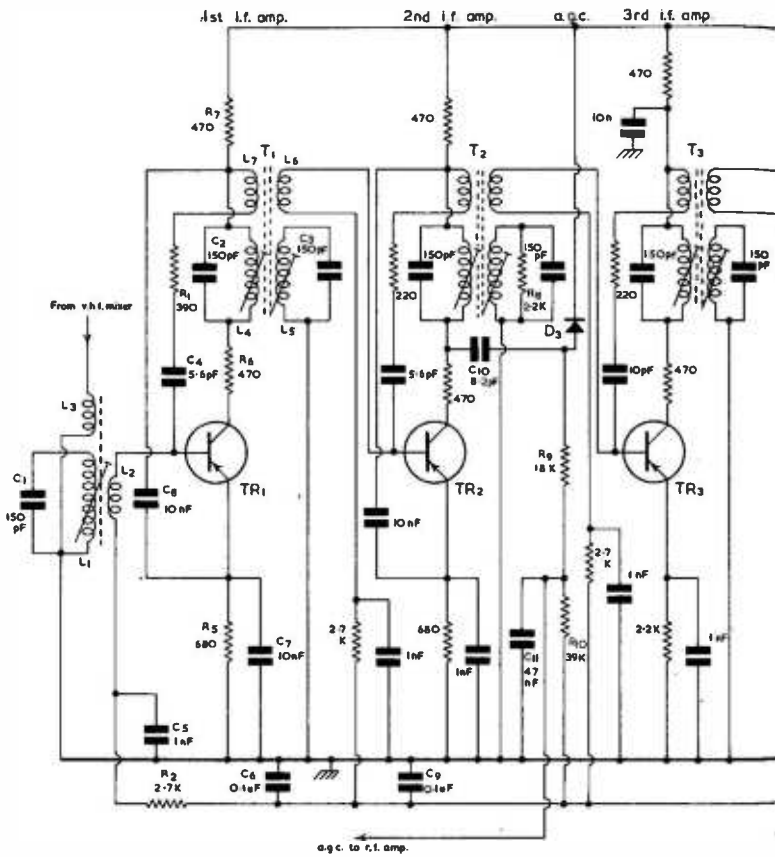
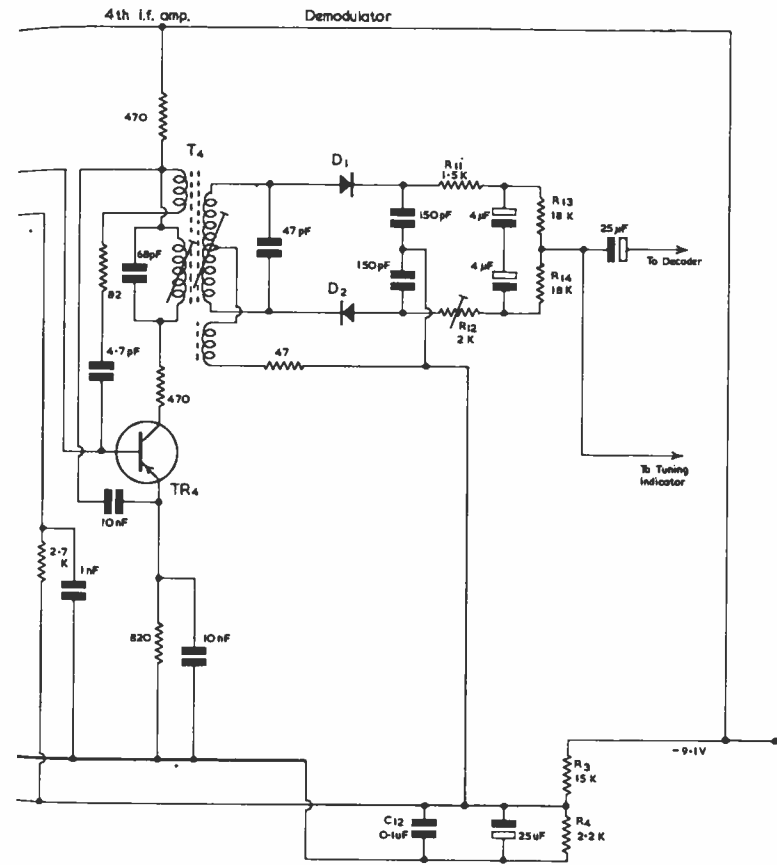

FIG. 5.22. I.F. AND DEMODULATOR STAGES



BEOMASTER 1000 (BANG AND OLUFSEN)

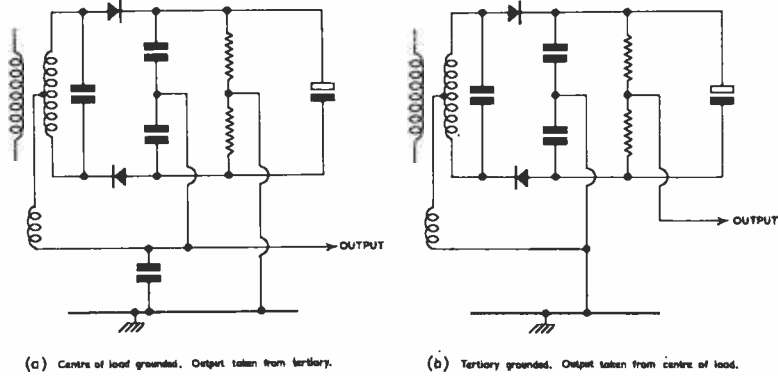

FIG. 5.23. ALTERNATIVE METHODS OF TAKING THE OUTPUT FROM A RATIO DETECTOR

Fig.5.23(a). This output consists of the audio signal and a d.c. voltage proportional to the degree of mistuning which may be used for a.f.c. Also present is the i.f. and harmonics of the i.f. which can be radiated to the early stages of the receiver and cause interference and instability.

If the circuit is rearranged with the tertiary winding earthed and the output taken from the centre-point of the load as in Fig.5.23(b), the operation of the circuit is unaffected. However, the amounts of i.f. and odd harmonics of the i.f. present with the output signal are much reduced provided the detector is properly balanced. The dangers of interference at $9 \times 10.7 \text{ MHz} = 96.3 \text{ MHz}$ are therefore reduced (note that 96.3 MHz is close to the wavelengths of Radio 3 or 4 in some regions).

In the Beomaster 1000 circuit, the tertiary winding is grounded by C_{12} . The audio signal is taken out from the centre-point of the load resistors R_{13} and R_{14} . To compensate for variations in the forward resistances of the diodes, balancing resistors R_{11} and R_{12} are included. R_{12} is adjusted for minimum a.m. in the output.

USE OF INTEGRATED CIRCUITS AND CERAMIC FILTERS

A more recent technique using ceramic filters and integrated circuits is shown in Fig.5.24. Two ceramic filters provide the required band-pass characteristics and two integrated circuits give the necessary gain.

Signals from the front end are applied to VT_{10} base via C_{35} . This transistor gives a gain of +10 dB and acts as an impedance match from the front end to the first ceramic filter X_1 . Both filters require 300Ω matching at input and output. Note that X_1 is fed from across a 330Ω resistor in the collector of VT_{10} and terminated at its output by a 330Ω resistor, R_{28} . The insertion loss of the filter is about 10 dB which is compensated for by VT_{10} gain. The first i.c. is fed from across R_{28} into connections 1 and 2 and the amplified i.f. output taken from connection 5 (the other connections are used for decoupling components and d.c. supply).

IC_1 feeds the second ceramic filter X_2 which is matched at input and output by R_{37} and R_{42} . It should be noted that such filters are factory tuned

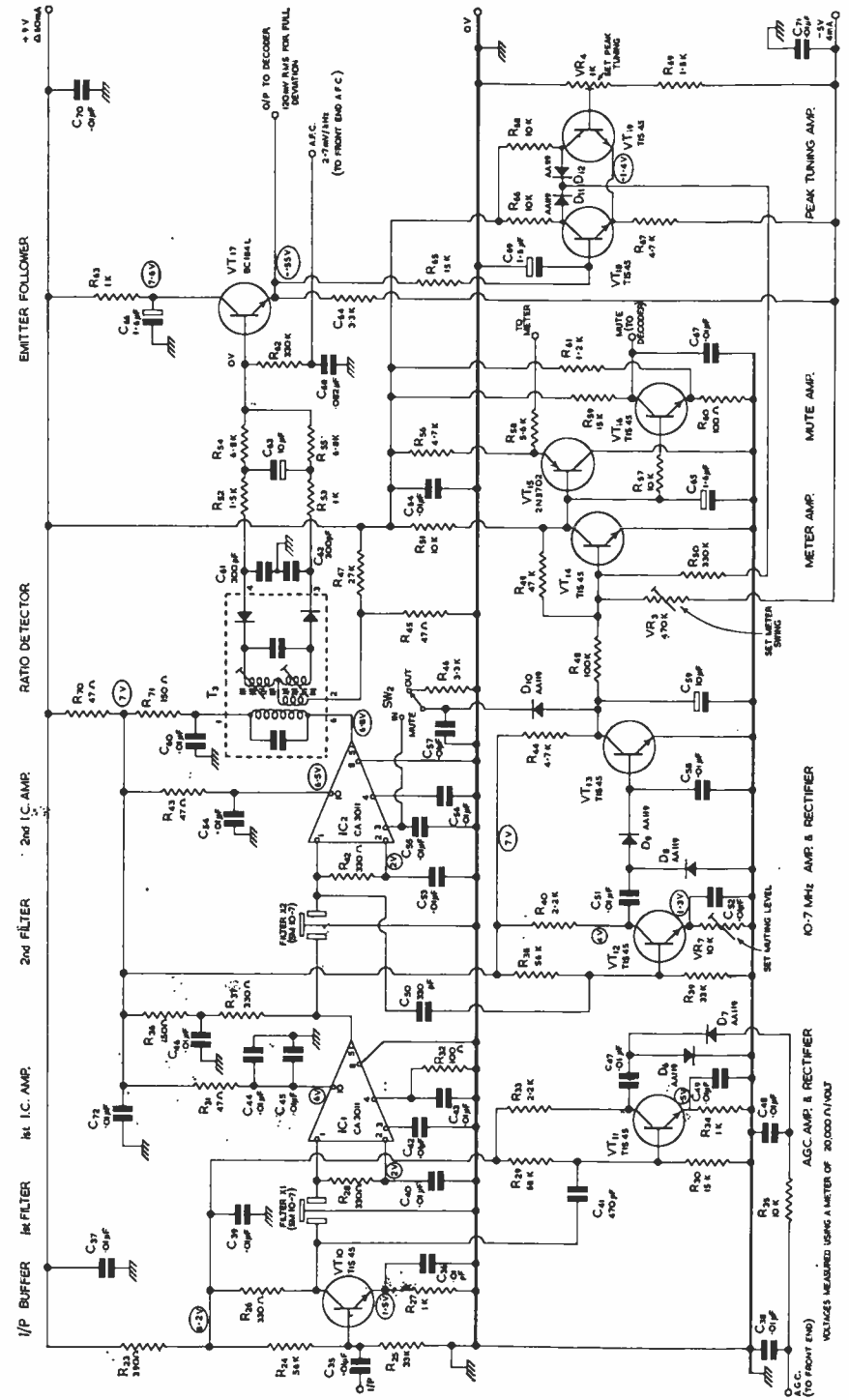

FIG. 5.24. LEAK TUNER I.F. STAGES

and are non-adjustable. The precise centre-frequency (probably not exactly 10.7 MHz) usually indicated by a coloured dot on the top of each filter. If a replacement is necessary, the new filter must have the same coloured dot so that its centre-frequency matches the remaining filter (see Chapter 3). The i.f. signal receives further amplification in $I.C._2$ which feeds the primary of the ratio detector transformer T_3 . A balanced ratio detector is used with the output taken from the centre-point of the load resistors R_{34} and R_{35} , the tertiary winding being grounded *via* R_{45} . This alternative method of taking the output from a ratio detector is discussed on page 100.

An a.f.c. voltage to the tuner (see Fig.5.20) is fed out from the detector through the filter R_{62}, C_{68} which removes the a.f. component. The audio signal is fed to the decoder *via* an emitter follower VT_{17} . With a fully modulated i.f. signal of $4 \mu\text{V}$ supplied to VT_{10} base an audio output of about 120 mV will be obtained at VT_{17} emitter having a signal-noise ratio better than 30 dB. This represents an overall voltage gain of about +90 dB.

MUTING, TUNING INDICATOR AND A.G.C.

An interesting feature of the Leak tuner is the muting system used to eliminate noise between stations when tuning and to reduce the edge-of-station 'plop'. Also, if hi-fi listening is desired, the i.f. strip is inhibited unless a pre-determined signal strength is reached; in this way weak stations are muted. The muting system is in two parts. One inhibit signal is fed to the i.f. strip and another to an audio amplifier in the decoder. The i.f. muting operates at a slightly different level to the audio muting. The system is arranged so that the audio mute is activated before the i.f. mute and this staggering of the two muting levels reduces the edge-of-station 'plop'.

The i.f. inhibit signal is derived from the 10.7 MHz output of the second ceramic filter X_2 which is fed to the base of VT_{12} *via* C_{50} . After amplification in VT_{12} , the i.f. is rectified by D_8 and D_9 . Together with C_{51} and C_{58} these diodes form a voltage doubler circuit, the d.c. output of which is fed to VT_{13} base. If the signal presented to the i.f. strip is below about $40 \mu\text{V}$, the d.c. applied to VT_{13} base is insufficient to cause the transistor to conduct. In these circumstances the collector potential of VT_{13} is high, D_{10} conducts and feeds a current into pin 3 of $I.C._2$ which mutes the i.f. strip. When the i.f. input exceeds $40 \mu\text{V}$, the rectified voltage at VT_{13} base will cause this transistor to conduct. As a result its collector potential will drop and D_{10} will cease to conduct. This allows $I.C._2$ to operate. The actual level at which VT_{13} switches ON can be controlled by VR_7 which adjusts the gain of VT_{12} .

The audio inhibit signal is derived from the d.c. output of the ratio detector which is fed to VT_{18} from the emitter follower VT_{17} . Only the d.c. component of VT_{17} output arrives at VT_{18} base, the audio component being attenuated by R_{65}, C_{69} . VT_{18} and VT_{19} form a differential pair arranged to give a unidirectional output from the junction of D_{11}, D_{12} . When the receiver is accurately tuned, there is no d.c. output from the ratio detector and the differential pair is in the balanced condition (VR_4 balances the offset due to the V_{be} of VT_{17}). In these circumstances the voltages at VT_{18} and VT_{19} collectors are equal at about 5.75 V. This voltage is fed to VT_{14} base *via* R_{50} from D_{11} and D_{12} which are both conducting. In VT_{14} base circuit the d.c. output of the differential pair is summed with the d.c. output of VT_{13} . When on tune the voltage at VT_{14} base is about 0.59 V. VT_{14} is d.c. coupled to VT_{16} and the

effect of the 0.59 V at VT_{14} base is to cause VT_{16} collector to take up a potential of 0.8 V. In this condition the audio amplifier in the decoder is active and passing signals.

As the receiver tuning is altered when tuning out-of-station, the d.c. output of the ratio detector swings either positive or negative with respect to zero. This unbalances the differential pair causing one transistor to conduct harder than the other. Assume that VT_{18} is conducting harder. Its collector potential will be lowered to (say) +3 V and VT_{19} collector potential will be raised to (say) +8 V. In this case D_{11} will be cut off and the +8 V at VT_{19} collector will be fed out to VT_{14} base *via* D_{12} (conducting) and R_{50} . If VT_{19} conducts harder by the same amount the voltage levels at the collectors are reversed. In these circumstances D_{12} will be cut off and +8 V will be fed out from VT_{18} collector *via* D_{11} which will be conducting. Thus, either side of centre-tuning, the bi-directional change in the d.c. output of the ratio detector results in a unidirectional change in the d.c. output of the differential pair. The effect of unbalancing the differential pair is to cause VT_{14} collector current to increase which results in a rise of voltage at VT_{16} collector. At the edge of the station, VT_{16} collector rises to +8 V and this level inhibits the audio amplifier in the decoder. The point at which the mute is removed is dependent upon the output from VT_{16} and the ratio between the two inhibit signal levels. This is set by R_{60}, R_{61} and R_{48}, R_{50} . To ensure that the 'plop' is kept to a low value, at the same time keeping a reasonably wide tuning range, the voltage at VT_{16} collector drops to +5.5 V at the edge of the band and down to +3.5 V before the audio circuits can pass signals.

The indicator system is fed directly from VT_{15} *via* R_{58} . It gives a peak reading when the receiver is exactly tuned, *i.e.* zero d.c. output from the ratio detector. This coincides with the minimum distortion point. Away from centre tuning VT_{14} conducts harder and its collector voltage falls (as explained in connection with the audio muting). In consequence VT_{15} emitter voltage falls and the meter reading is reduced.

VT_{11} is the a.g.c. amplifier fed with i.f. signals from the output of VT_{10} . After amplification in VT_{11} , the i.f. signals are applied to a voltage doubler and rectifier circuit comprising C_{47}, D_6 and D_7, C_{48} . After smoothing by R_{35}, C_{38} the negative d.c. component is fed to the front end as a.g.c. bias.

DECODER

The majority of commercial designs in current use are based on the 'switched' or 'envelope' decoder principle. A schematic of this type of decoder is shown in Fig.4.7, page 65. The actual circuits used vary in complexity due to individual designer's preference and the performance/cost factor. To begin with we will consider a simpler arrangement using switched transistors, Fig.5.25. This circuit was designed by Mullards for construction by enthusiasts and experimenters.

The multiplex input from the receiver detector is fed *via* C_1 and R_1 to the parallel resonant circuit comprising L_1, C_2 . This tuned circuit is resonant to the pilot tone frequency and in consequence will be of high impedance at 19 kHz. Thus the pilot tone will be passed on to TR_1 base *via* C_3 . At other frequencies the impedance of L_1, C_2 will be low and these frequencies will be shunted from TR_1 base. In this way, the pilot tone is extracted from the composite signal input. The tap on L_1 is to ensure a high Q for the tuned

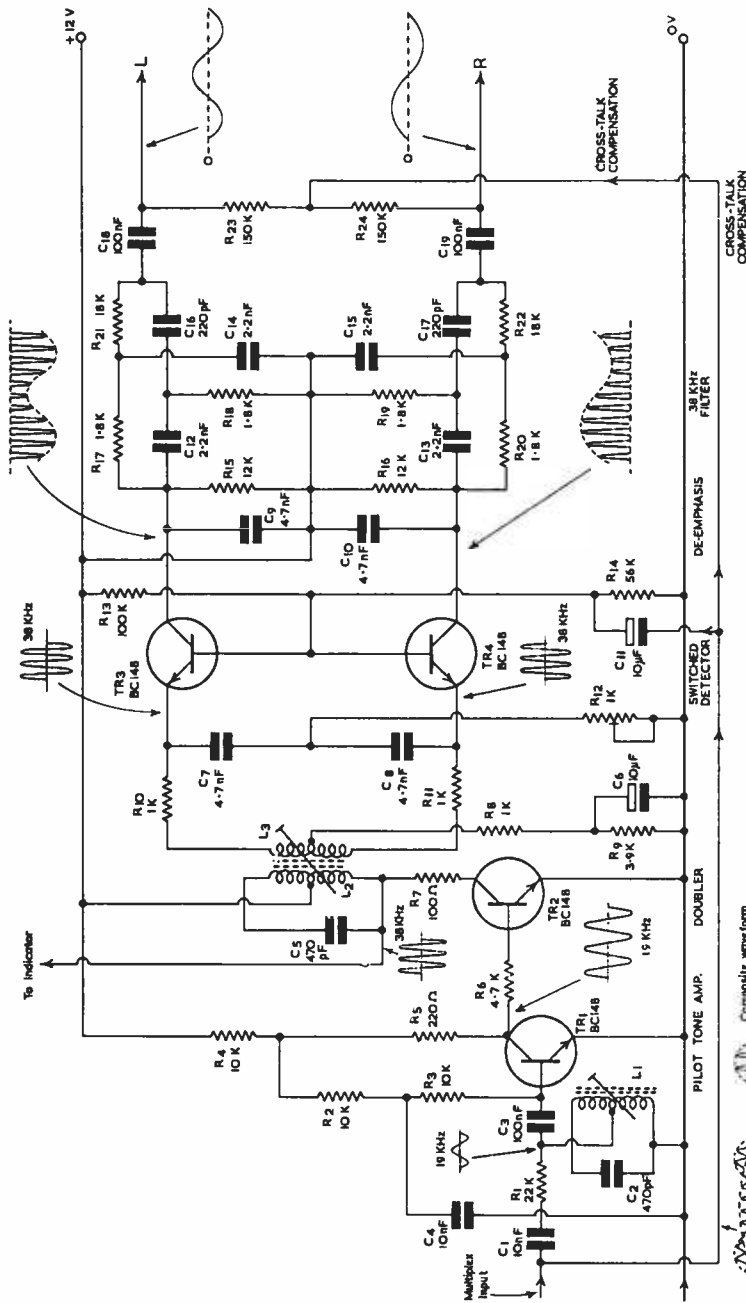

FIG. 5.25. MULLARD SWITCHED DECODER
(Published originally in *Mullard Outlook*, September 1968)

circuit. R_1 acts as a stand-off resistor to prevent L_1, C_2 from shunting the input terminals away from resonance. TR_1 amplifies the pilot tone and the 19 kHz signal is developed across the collector load R_4 . Forward bias is provided by R_2, R_3 which also gives a measure of d.c. stabilization. C_4 prevents a.c. feedback from collector to base.

D.C. coupling is used between TR_1 and TR_2 with the d.c. applied to TR_2 base arranged to give class-B operation for TR_2 . Thus, only the positive half-cycles of the pilot tone will be amplified by TR_2 . The distorted waveform resulting from class-B operation is very rich in second harmonic content and this harmonic (38 kHz) is developed across the tuned circuit L_2, C_3 in the collector. The peak-to-peak signal between the collector end of L_2 and the tap is approximately twice the line supply voltage; hence its amplitude is constant regardless of the level of the input once a certain value has been reached. The tapped coil L_3 provides antiphase 38 kHz switching signals to the emitters of the switched transistors TR_3 and TR_4 . These transistors also have the composite waveform applied to their bases via C_{11} . Forward bias is provided by the potential divider R_{13}, R_{14} and R_8, R_9 are the common-emitter resistors. The effect of the large amplitude switching signal applied to the base is to cut off TR_3 and TR_4 alternately on each half-cycle. Thus 'switched' detection takes place with the separated left and right channel signals appearing at the collectors. R_{10}, C_7 and R_{11}, C_8 form phase-shift networks to the 38 kHz signal. Some control over the degree of shift is provided by R_{12} which is adjusted during the initial setting up of the decoder.

The output signals from TR_3 and TR_4 are developed across the collector loads R_{15} and R_{16} . The load resistors are shunted with capacitors C_9 and C_{10} . These CR combinations provide conventional de-emphasis (time-constant $\approx 56 \mu\text{s}$). Insufficient attenuation of the 38 kHz component is given by the de-emphasis networks so these are followed by parallel-T filters comprising $C_{12}, C_{14}, C_{16}, R_{17}, R_{18}$ and R_{21} in the L output and $C_{13}, C_{15}, C_{17}, R_{19}, R_{20}$ and R_{22} in the R output.

With switched detection, crosstalk compensation is needed (see Chapter 4 and Appendix C). This is obtained by feeding a controlled amount of the composite signal into the L and R outputs via R_{23} and R_{24} . This correction is in antiphase with the inherent crosstalk due to the phase inversion received by the detected components of the composite signal in TR_3 and TR_4 .

In the absence of the switching signal, i.e. on mono transmissions, the switching transistors operate in class-A; thus any signal applied to their bases is reproduced at their collectors. Therefore the circuit is compatible and requires no switching between mono and stereo operation.

The stereo indicator circuit for the Mullard decoder is given in Fig.5.26. The 38 kHz signal obtained from the frequency-doubler is applied via a limiting resistor (R_{25}) and C_{20} to a shunt rectifier (D_1). On negative half-cycles of the input signal D_1 conducts, causing C_{20} to charge with polarity as indicated. This d.c. is used to provide forward bias for TR_3 , which therefore conducts causing the lamp in the collector circuit to glow. The lamp is illuminated when a stereo broadcast is in progress, but is extinguished during mono transmissions when the 38 kHz input signal is absent.

The Bush A747 circuit, Fig.5.27, is also a 'switching' type decoder using several interesting and original features. The composite signal is fed via C_{26} to the base of an emitter-follower VT_4 . This stage provides a low impedance

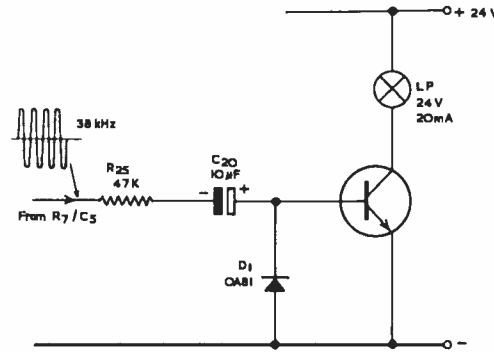

FIG. 5.26. THE INDICATOR CIRCUIT

drive to the ring demodulator and a feed to the 19 kHz series resonant circuit L_8, C_{33} . The resonant circuit extracts the pilot tone from the composite signal for amplification in VT_6 stage. In the collector of this transistor L_9, C_{34} and L_{10}, C_{36} form a band-pass circuit using top capacitance coupling (C_{35}). The pilot tone is rectified by the full-wave arrangement comprising D_3, D_4 and L_{10} to give a pulsating output at twice the pilot tone frequency. VT_7 amplifies the output of the doubler and feeds T_9 tuned secondary with the 38 kHz component of the rectified pilot signal. The 38 kHz drive signal from T_9 secondary is applied to a balanced or ring demodulator incorporating the switching diodes D_5-D_8 . When point A is positive D_8 and D_3 conduct, and with point B positive D_7 and D_6 conduct. As the composite signal is fed to the tap on T_9 secondary, switched detection takes place and the separated left-hand and right-hand signals are available from points C and D . The diodes are forward biased by $300 \mu A$ via R_{42}, R_{43} (for D_5 and D_6) and R_{46}, R_{40} (for D_7 and D_8) to provide compatibility and a low distortion level on stereo.

The left-hand and right-hand signals from C and D are fed via C_{53}, C_{64} to the audio output amplifiers VT_{11} and VT_{12} . In these stages crosstalk compensation is applied via C_{65} and RV_3 connected between the emitters. Note that this method provides an antiphase correcting signal (set by RV_3) to neutralize the breakthrough signal. For example, the right-hand breakthrough at VT_{11} base is cancelled by the portion of the right-hand correcting signal fed from VT_{12} emitter to VT_{11} emitter. Since the breakthrough and correcting signals are in phase, but one applied to the base and the other applied to the emitter, the resulting right-hand signal acting between VT_{11} base and emitter is considerably reduced.

In designing this decoder, the manufacturer aimed at a considerably better-than-average performance as regards distortion, especially intermodulation distortion. The main cause of this distortion in a decoder is the presence of the 19 kHz component in the 38 kHz feed to the detector and modulation of it by noise or audio signals at subharmonics of 19 kHz. This manifests itself as poor quality and noise in the sound. This problem was dealt with in several ways.

The first 19 kHz tuned circuit, L_8, C_{33} , is series-tuned and the output taken from across the capacitor. This gives maximum rejection of higher frequency

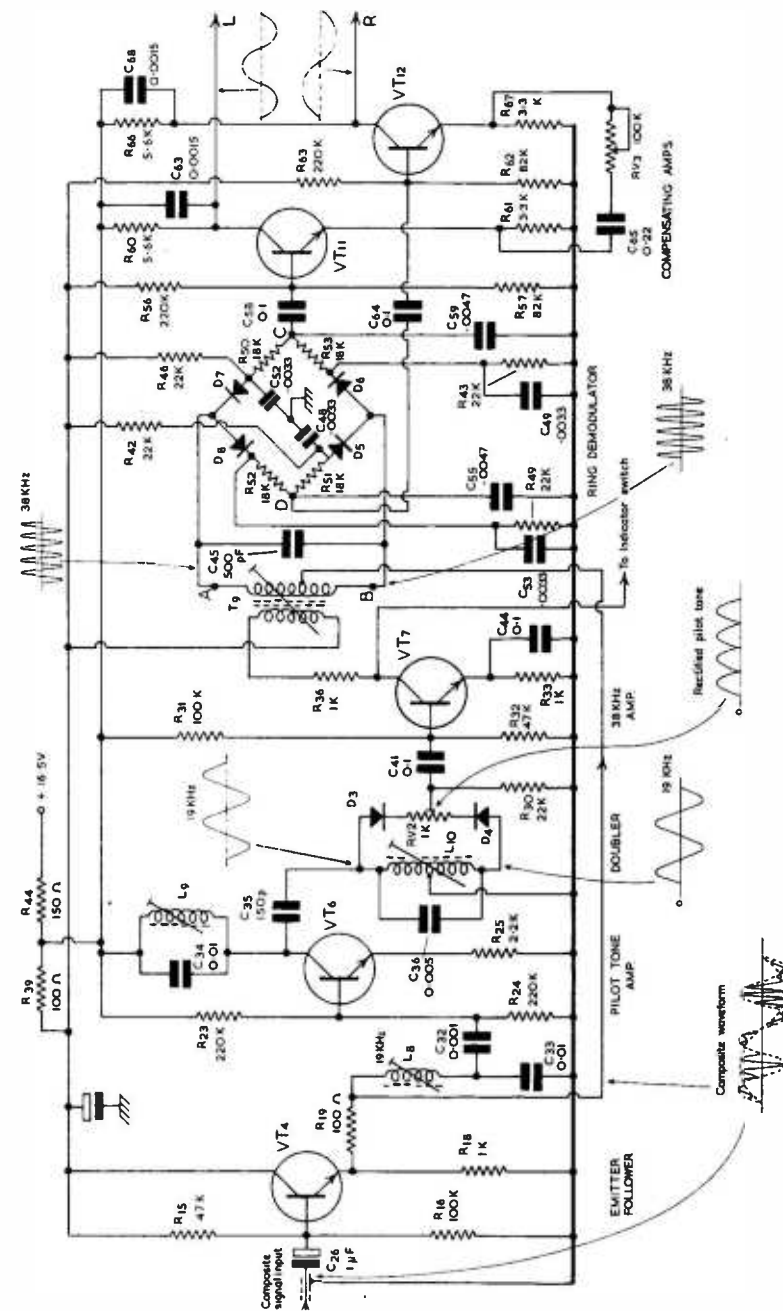

FIG. 5.27. BUSH A747 DECODER USING COMPATIBLE RING DEMODULATOR

noise components. The base of VT_s is then fed via C_{11} which, together with the input resistance of the transistor, form a high-pass filter to providing further rejection of audio signals. The band-pass circuit used in VT_s collector was found to be more satisfactory than coils of high Q which were too critical and liable to drift out tune. To remove any residual 19 kHz component the frequency doubling diodes D_7 and D_8 were connected via a balance control RV_2 . These measures made a very large improvement in intermodulation distortion which is typically 0.25 per cent.

The low level of third harmonic distortion (0.3 per cent) achieved with this design was obtained in part by the choice of the forward bias current for the demodulator diodes. Another factor which assisted was the choice of the capacitors C_{11} , C_{12} and C_{13} . The values chosen give the diodes an angle of flow optimized for distortion rather than channel separation which at the demodulator output is 22 dB. However, the crosstalk compensation improves this to 40 dB at the output.

Another problem which received a good deal of attention was that of spurious outputs at 38 kHz and harmonics. This is important when using a tape recorder or working into a wide-band amplifier. To reduce the spurious output to an acceptable level, a series of APLT time-constants were used to provide the signal de-emphasis. These consist of (for one channel) D_9, C_{14} ; R_{10}, C_{15} ; R_{10}, C_{15} , giving a very steep roll-off above the audio spectrum.

The requirement of the stereo beacon (LP_1) of Fig. 5.28 is for it to switch on very positively without any flickering or hesitation in an intermediate

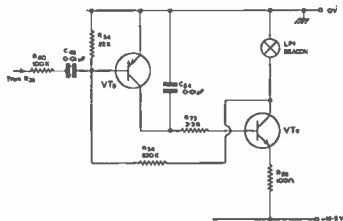
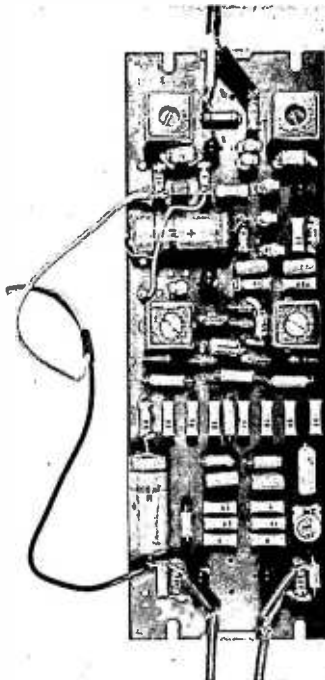

FIG. 5.28. FLIP-FLOP STEREO INDICATOR (BUSH)

condition. The method adopted by Bush was to operate the lamp from a bistable flip-flop VT_s and VT_c . During mono transmissions the lamp is extinguished as VT_s and VT_c are non-conducting. On receipt of a stereo signal, the 38 kHz component from VT_s collector is fed via R_{10} and C_{10} to VT_c base. C_{10} charges on negative half-cycles of the 39 kHz input providing forward bias for VT_c . Thus, this transistor turns on and feeds current into VT_s base. In consequence VT_s conducts and the current in LP_1 causes its filament resistance to increase. The increasing voltage drop across LP_1 is



(Courtesy Bush Radio)

BUSH A43 DECODER PANEL INCORPORATING SWITCHING DETECTOR USING DISCRETE COMPONENTS

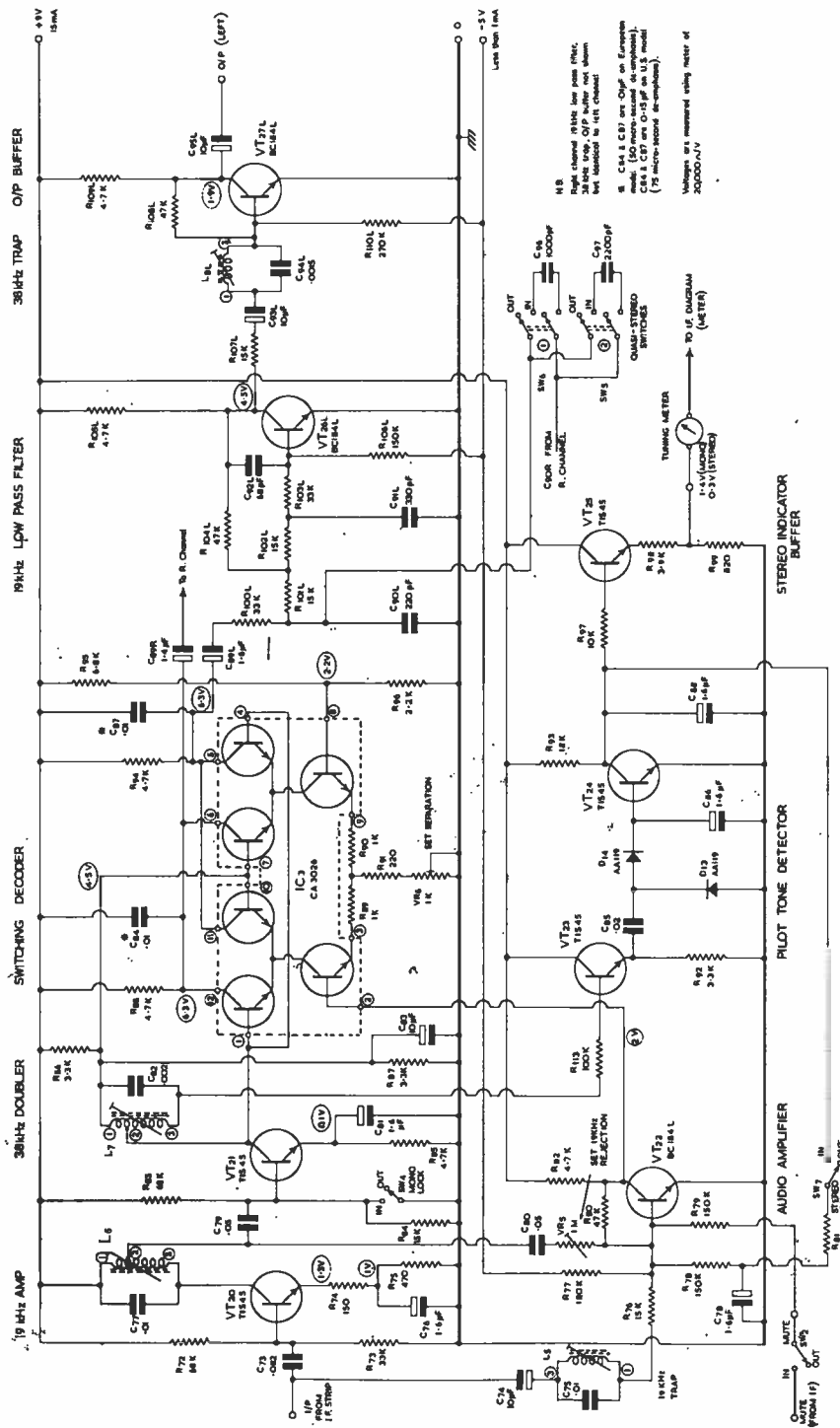

FIG. 5.29. LEAK DECODER (I.C. DETECTOR)

applied as feedback via R_{54} to VT_8 base causing VT_8 to come harder on and feeds a larger current into VT_9 base. Cumulative action follows resulting in both VT_8 and VT_9 coming into full conduction very rapidly and the lamp to turn on quickly.

A further example of a switching type decoder is given in Fig.5.29. Here the detector is of the integrated circuit variety (I.C.) using six transistors formed on a single chip. There are two other features of interest in this decoder: the audio muting and the Quasi-Stereo facility.

The signal input from the i.f. strip is applied via C_{73} to VT_{20} base. When there is a pilot tone at the input, it is amplified by VT_{20} and developed across the parallel tuned circuit L_6, C_{77} which is resonant at 19 kHz. The amplified pilot tone is then fed to VT_{21} which forms a frequency-doubler stage together with L_7, C_{82} tuned to 38 kHz in the collector circuit. The resulting 38 kHz signal at VT_{21} collector is applied to the bases (pins 1 and 4) of the two differential pairs so that the output collectors are switched synchronously with the multiplex audio signal applied to the base of the lower left-hand transistor. Two differential pairs are used to effect crosstalk compensation as explained in Chapter 4, page 77. The cross-coupling of the outputs, i.e. pin 6 to pin 12 and pin 11 to pin 5 ensures maximum channel separation, set by VR_6 . In the absence of the switching signal, i.e. on mono transmissions, I.C., acts as two pairs of differential amplifiers producing in-phase audio signals across the collector load resistors R_{88}, R_{94} . These audio voltages are de-emphasized by R_{88}, C_{34} and R_{94}, C_{87} .

After de-emphasis the audio signals are fed through a 19 kHz low-pass filter. This comprises a 6 dB per octave RC network (R_{100}, C_{90}) followed by a simple second order filter giving an overall 3 dB point of 19 kHz. These provide a flat response up to 17 kHz and an attenuation rate of 18 dB per octave above 21 kHz. The low-pass filter is followed by a 38 kHz trap (L_8, C_{94}) to remove any residual 38 kHz component. VT_{27} is the terminating amplifier providing a gain of 3 with a low output impedance of about 200 Ω . The overall decoder gain lies between 18 to 20 dB.

The stereo beacon signal is derived from the output of the 38 kHz doubler. This is supplied to the base of VT_{23} which acts as a buffer stage. VT_{23} emitter output signal is rectified by the voltage doubler circuit $C_{85}, D_{13}, D_{14}, C_{86}$ and the resulting d.c. produced across C_{86} is used to bias VT_{24} on. As a result VT_{24} collector voltage falls which reduces the current in VT_{25} . This causes a fall in VT_{25} emitter voltage which is fed to one side of the tuning meter. Now the meter serves as a tuning indicator as explained on page 105 and as a stereo beacon. On mono the meter pointer remains in the dotted region of the indicator as in Fig.5.30(a), due to the holding bias of 1.4 V applied to one side of the meter from the junction of R_{98} and R_{99} . When stereo signals



(a) Mono signals received (b) Stereo signals received

FIG. 5.30. TUNING INDICATOR (LEAK)

are received, the fall in VT_{25} emitter voltage to 0.3 V allows the pointer to read in the stereo (shaded) region of the indicator as illustrated in diagram (b). Thus the movement of the pointer from the dotted to the shaded region of the indicator serves as a stereo beacon.

It is now opportune to say something about the muting amplifier VT_{22} . This stage is fed with the composite signal via C_{74} and the trap L_{53}, C_{73} which helps to suppress the pilot tone. If the stage is not muted in any way, VT_{22} amplifies the audio signal which is then fed into one side of the switching detector (I.C.₃). Now VT_{22} may be muted in two ways. The stage may be inhibited by depressing the MUTE button (see Fig. 5.31) which operates SW_2 and allows an inhibit signal to be applied to VT_{22} base cutting the stage off. This particular muting signal is used to reduce the edge-of-station plop. The stage may also be inhibited by operating the STEREO ONLY button which actuates SW_7 . When this switch is set to the IN position, the d.c. applied to VT_{22} base from VT_{24} collector keeps VT_{22} OFF unless a stereo signal is being received. This facility allows the user to set the tuner ready to receive stereo only broadcasts or for use as a 'stereo search' aid. The variable resistor VR_5 feeds an out-of-phase 19 kHz signal into VT_{22} which helps to reduce the pilot tone breakthrough of the system.

The decoder switches automatically from mono to stereo unless the MONO LOCK button is depressed which operates SW_4 . If SW_4 is set to the IN position the 38 kHz doubler is locked off. Thus, stereo signals are locked out (even if the STEREO ONLY button is also pressed in). This facility is used to reduce stereo transmission noise by totally eliminating the stereo effect. Note that in these circumstances only the L+R component of received stereo signals will appear in the duplicated output amplifier VT_{27} , the L-R modulation being lost in the low-pass filters.

QUASI-STEREO

This is a new design philosophy used to reduce the background noise on distant stereo programmes without losing the stereo effect. The principle used is based on the fact that the noise signal present on weak stereo transmissions is coherent between channels, i.e. the noise is a mono signal. The decoder action ensures that the noise signal, or at least its high frequency components, are separated into antiphase signals by the decoder. If crosstalk is deliberately introduced at high frequencies, the noise signal tends to cancel out at the expense of reduced channel separation at high frequencies.

The quasi-stereo switches SW_6 and SW_5 cross couple the left and right audio channels via frequency selective networks C_{96} and C_{97} , in conjunction with R_{100L} and R_{100R} . Thus at high frequencies the left and right channels mix whilst at lower frequencies they remain quite separate, the actual change-over frequencies depending upon the values of C_{96} and C_{97} . The switches are operated by the QUASI-STEREO buttons (see Fig. 5.31). These buttons progressively reduce the noise when used in the order 1,2 then 1+2.

There seems little doubt that future designs will take advantage of the various integrated circuits now becoming available. These have the great advantage of providing a large number of junctions the cost of which would be prohibitive if discrete devices were used. The compactness and reliability of I.C.s also makes them very attractive for decoder functions. They are available to perform part circuit function as in the Leak design or complete

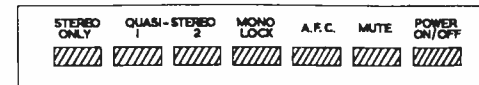

FIG. 5.31. PUSH-BUTTON FACILITIES (LEAK)

decoder operation.

A schematic of a complete I.C. decoder is shown in Fig. 5.32 using a Sprague ULN-2122A. A certain amount of external circuitry is required for those

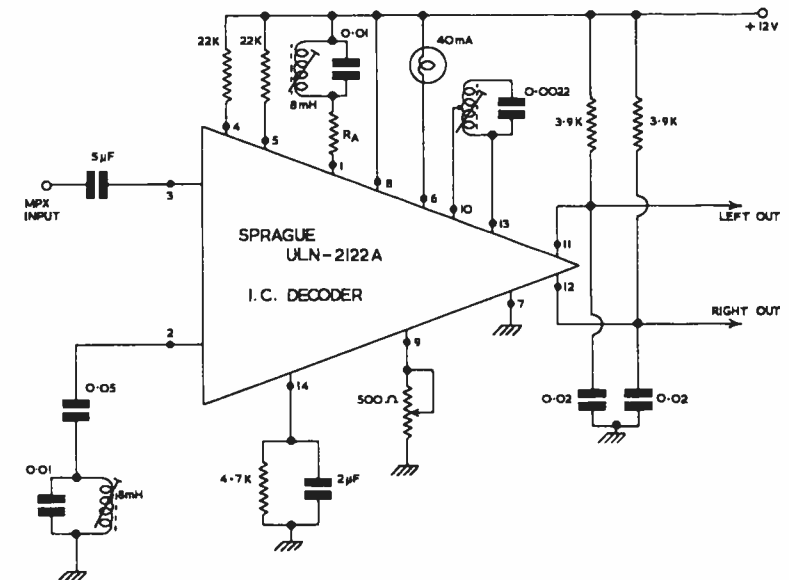

FIG. 5.32. SPRAGUE INTEGRATED CIRCUIT DECODER WITH EXTERNAL CIRCUITRY

components which cannot be formed in solid state, i.e. tuning coils, large value capacitors, etc. Faced with the internal circuit of the I.C. and the external circuitry one would find it difficult to follow. For this reason, the circuit of the I.C. and the external circuitry have been rearranged to give a complete diagram (Fig. 5.33) on the lines of an ordinary circuit diagram.

The first point to note is that there are 37 transistors and 11 diodes incorporated in the I.C. but not all of these are used for signal handling. Starting on the left of the diagram, Q_1, Q_2, Q_3, Q_6, Q_5 and Q_7 , together with the diodes D_1-D_6 are simply a voltage-dividing network whose sole function is to provide a number of stabilized voltage points for the rest of the circuit. These points have been numbered +1 V to +5 V but the connections to which they feed have been omitted to avoid a lot of confusing lines on the circuit diagram.

The first signal-handling transistor is Q_4 , connected as an emitter-follower and fed with the composite signal input through C_1 . One output from Q_4 emitter is routed to Q_8 , in the base circuit of which is a tuned circuit L_1, C_2 .

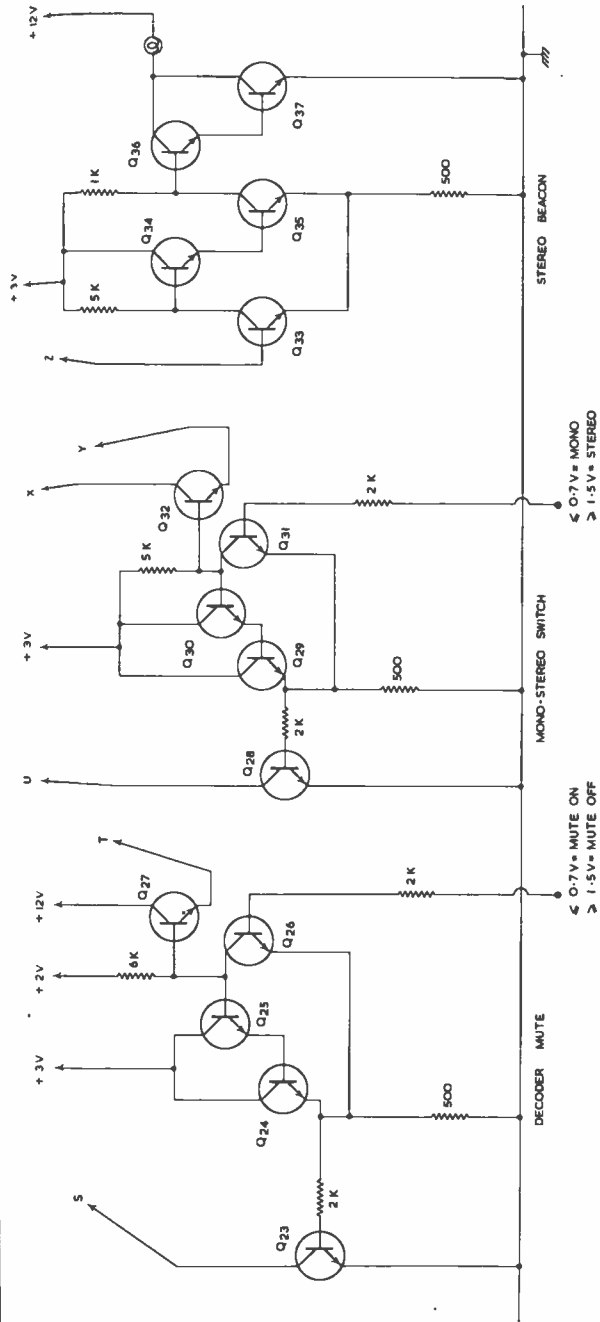
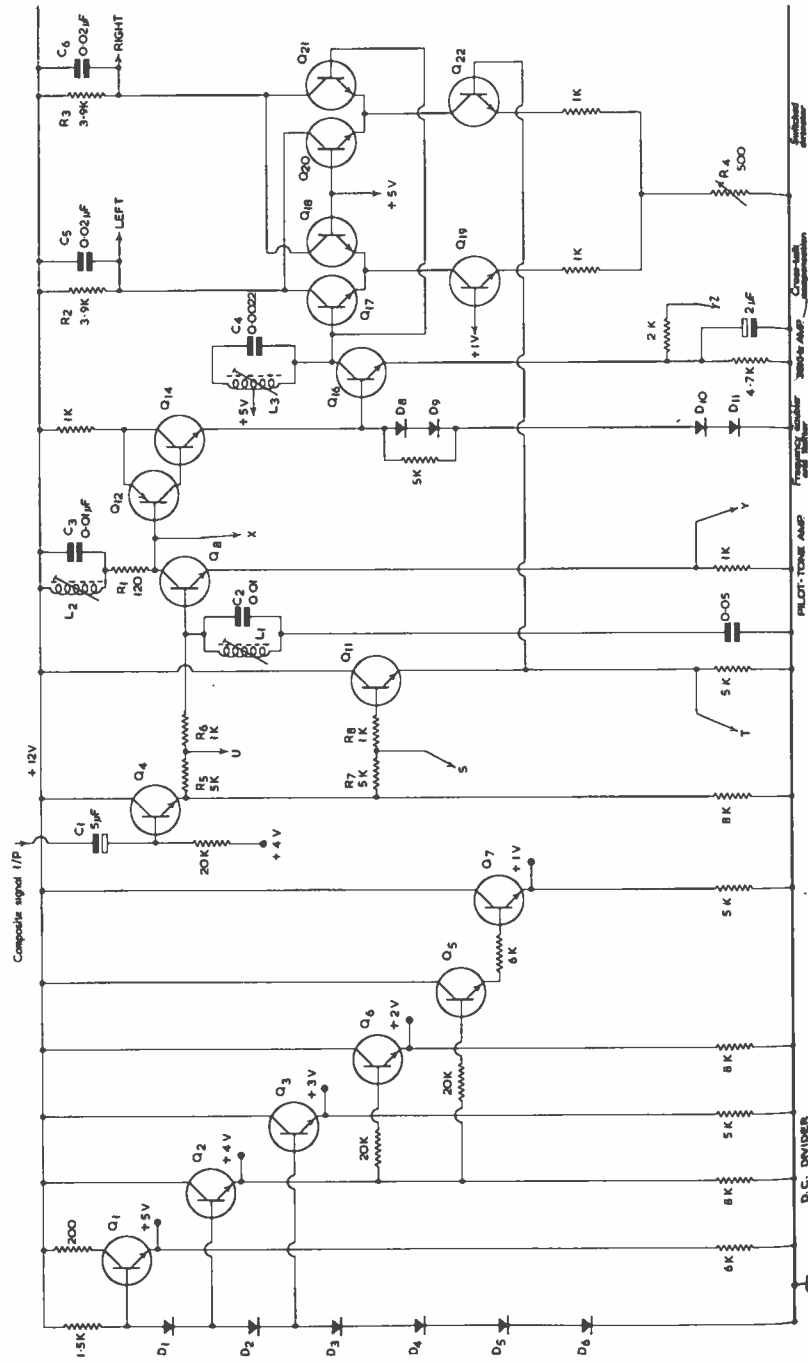

FIG. 5.33. SPRAGUE I.C. DECODER INCLUDING EXTERNAL CIRCUITRY

This is tuned to 19 kHz and extracts the pilot tone which is then amplified in Q_8 and developed across L_2, C_3 (also tuned to 19 kHz) in the collector circuit. Q_8 is directly coupled to a conjugate pair Q_{12} and Q_{14} with R_1 providing the forward bias for Q_{12} . The conjugate pair operate in a non-linear condition causing frequency doubling of the pilot tone. As a result a 38 kHz signal is available at Q_{14} emitter, the amplitude of which is set by the diodes D_8-D_{11} . This limiting action removes any noise or audio modulation. In Q_{16} the 38 kHz signal is amplified and developed across L_3, C_4 resonant to 38 kHz in the collector circuit.

The 38 kHz signal from Q_{16} collector is applied to the two differential pairs Q_{17}, Q_{18} and Q_{20}, Q_{21} with Q_{19} and Q_{22} acting as common emitter loads for the respective pairs. These differential amplifiers perform the function of switched detection with the 38 kHz signal acting as the switching signal. The composite 'audio' signal is supplied to the base of Q_{22} from an emitter-follower Q_{11} which is coupled to the input transistor Q_4 . This detector functions as already explained, thus separated left and right channel signals will be available from the commoned collector outputs. R_2, C_5 and R_3, C_6 provide signal de-emphasis in the usual way, as well as aiding the attenuation of the 38 kHz component.

We have seen that with switched detection channel separation is not perfect but that by duplicating the differential amplifiers crosstalk compensation may be achieved. Note that Q_{22} has a variable resistor R_4 in its emitter circuit and that this resistor is common to Q_{19} . Thus, Q_{19} and Q_{20} act as a differential pair in a manner exactly similar to the switched pairs Q_{17}, Q_{18} and Q_{20}, Q_{21} . However, the signal current in Q_{19} will be less than the signal current in Q_{22} since part only of the emitter circuit is common. By adjusting R_4 to the correct value, the signal current in Q_{19} can be made any desired fraction of the current in Q_{22} . Assuming that the fraction is 10 per cent (see Appendix C) then the multiplex signal input to the common emitter connection of Q_{11} and Q_{18} will be 1/10th of the signal input to Q_{20}, Q_{21} common emitter connection and in antiphase with it. Now, supposing that the inherent crosstalk is 10 per cent, i.e. 10 per cent of the right signal appears in the output of Q_{20} and 10 per cent of the left signal appears in the output of Q_{21} . We can therefore say that Q_{20} output is

$$L + \frac{R}{10} \text{ and that } Q_{21} \text{ output is } R + \frac{L}{10}$$

Neglecting for the moment the inherent crosstalk in Q_{17} and Q_{18} , the output from Q_{17} will be $-R/10$ and from Q_{18} it will be $-L/10$ (the minus sign indicates the composite signal at Q_{19} collector is in phase opposition to the signal at Q_{22} collector whilst the reduction by a factor of 10 is due to the smaller signal current in Q_{19}).

Now Q_{17} and Q_{20} collectors are commoned, thus the combined output for the left channel is

$$L + \frac{R}{10} - \frac{R}{10} = L$$

Similarly, since Q_{18} and Q_{21} collectors are commoned, the combined output for the right channel is

$$R + \frac{L}{10} - \frac{L}{10} = R$$

Thus crosstalk between channels is completely eliminated. This neglects the effect of crosstalk in Q_{17} and Q_{18} outputs which will result in a small reduction in the separated channel signal amplitudes which is of little consequence. In this type of detector therefore the setting of R_4 is arranged to out-of-balance the signal currents in Q_{19} and Q_{22} by an amount depending upon the degree of crosstalk introduced. It is important to note that the unbalancing of the signal currents in Q_{19} and Q_{22} is essential in order to obtain a mono output from this type of detector.

The remaining transistors $Q_{23}-Q_{37}$ are arranged in three groups of five with each group operating in a very similar way based on the Schmitt-trigger or level-sensitive principle.

Taking the middle group ($Q_{28}-Q_{32}$) first, if a d.c. voltage of less than 0.7 V is applied to Q_{31} base, Q_{28} and Q_{32} will be hard on. If the d.c. input is greater than 1.5 V, Q_{28} and Q_{32} will be fully off. Now, the collector of Q_{28} is connected to the junction of R_5, R_6 which lies in the signal path between Q_4 and Q_8 . If point U is grounded by the conducting transistor Q_{28} the signal path is broken and it is obvious that there can be no switching action at the detector which thus becomes disabled and operates as a simple monophonic amplifier. To ensure that the differential pairs operate correctly (note that d.c. coupling is used throughout from Q_8 to the detector) the correct d.c. conditions must be maintained. This is achieved by connecting Q_{32} across Q_8 . If this is not done the transistors Q_8, Q_{12}, Q_{14} and Q_{16} will cut off when the base of Q_8 is grounded by Q_{28} , causing the d.c. conditions at the differential amplifiers to be upset. Thus it will be seen that $Q_{28}-Q_{32}$ act as a MONO-STEREO switch actuated by an externally applied d.c. voltage, which may be under the control of the user.

The left-hand group $Q_{23}-Q_{27}$ operates in exactly the same way but in this case the junction of R_7, R_8 is grounded by Q_{23} when the d.c. input to Q_{26} base is less than 0.7 V. This completely interrupts the path taken by the composite 'audio' signal to the detector. If the d.c. applied to Q_{26} base is taken from the ratio detector of the f.m. receiver the decoder could be made to mute automatically when tuning from one station to another. This would suppress inter-station noise.

The third group consists of $Q_{33}-Q_{37}$. The base of Q_{33} is connected to point Z , the emitter of Q_{16} . At this point there is a change in d.c. potential whenever a pilot tone is being received due to the d.c. variation at Q_{14} emitter which is passed on to Q_{16} . This change of d.c. potential operates the Schmitt-trigger causing Q_{36} and Q_{37} to conduct which switch on the stereo beacon lamp.

In Chapter 4 the basic principle of a sampling decoder was outlined. With this arrangement the composite audio signal voltage is sampled at the mid-points by a train of short pulses and the sampled voltage level is held between pulses. Using this sample-and-hold technique, good channel separation, low distortion and low subcarrier breakthrough may be realized. The operation

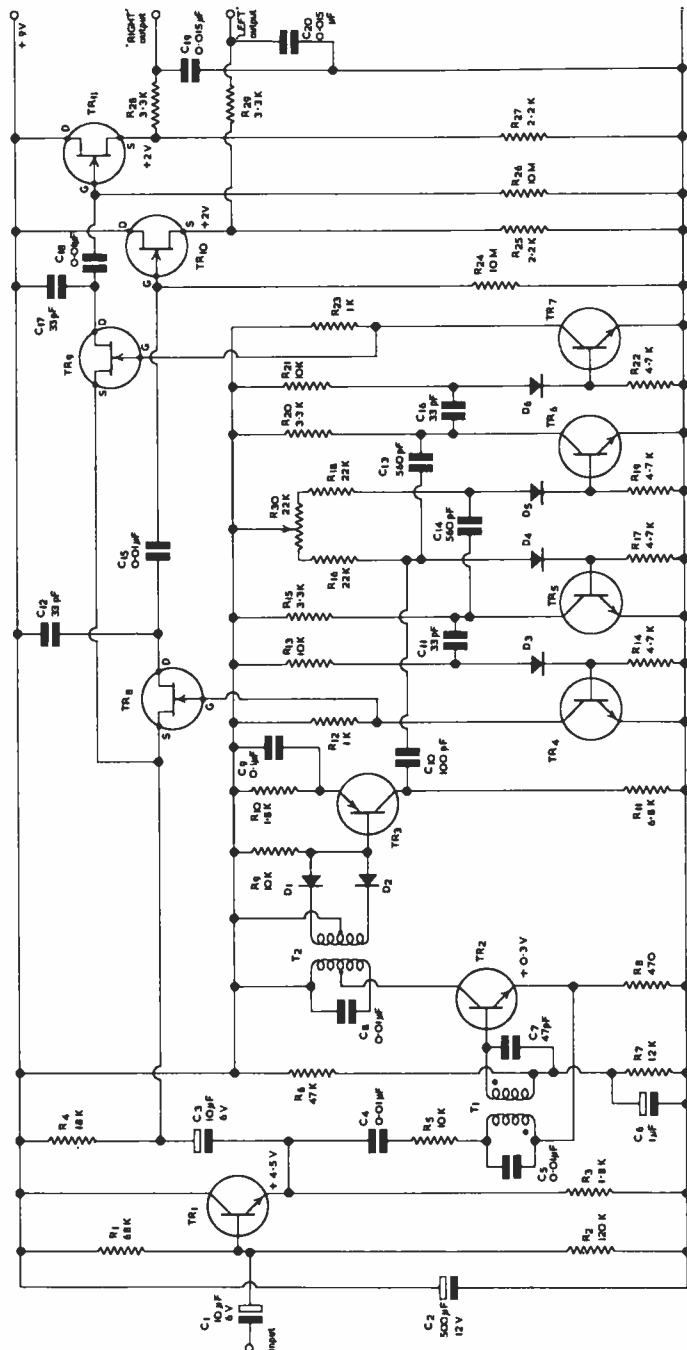

FIG. 5.34. DECODER USING SAMPLE-AND-HOLD TECHNIQUE (Waddington, D.F.O'N, "Stereo Decoder Using Sampling", *Wireless World*, Feb. 1971)

of a decoder circuit using the sampling principle is shown in Fig.5.34.

The composite audio signal from the f.m. detector is fed via C_1 to the base of an emitter-follower TR_1 which has two outputs. One output, routed via C_2 , is used for eventually producing the sampling pulses and will be considered first. Only the high frequency components of the composite signal are fed to T_1 , the primary of the transformer being peaked to 19 kHz. TR_2 amplifies the signal input from T_1 and the output of this stage is fed to the primary of the tuned transformer T_2 which is also peaked to 19 kHz. At the secondary of the transformer, the pilot tone is full-wave rectified and applied to the base of TR_3 . This stage has a high gain and limits the output to produce a rectangular waveform at its collector as illustrated in Fig.5.35. The limited output is differentiated as it is applied through C_{10} so that it may be utilized to lock the free-running multivibrator TR_5 and TR_6 .

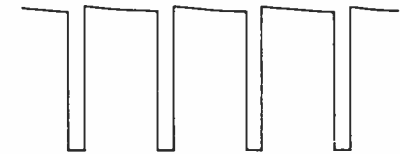

FIG. 5.35. OUTPUT AT TR_3 COLLECTOR

Pulses of about 250 ns duration, which is equivalent to approximately 1 per cent of the period of a cycle of the subcarrier, are used for the sampling. These pulses are generated in the stages TR_4 (for the left channel) and TR_7 (for the right channel). The method of generating the sampling pulses is as follows. TR_5 and TR_6 produce square waves at their collectors due to normal multivibrator action. These waveforms have a 1 : 1 mark-to-space ratio set by R_{30} . Consider now the effect that TR_5 output has on TR_4 . Just prior to the generation of a sampling pulse, instant t_1 of Fig.5.36, TR_5 is in the off condition, TR_4 is bottomed and C_{11} is charged to the supply voltage. When TR_5 turns

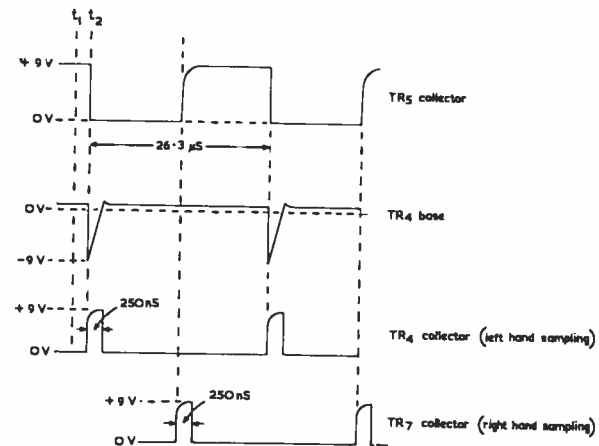

FIG. 5.36. WAVEFORMS SHOWING THE GENERATION OF THE SAMPLING PULSES

on (instant t_2) due to normal multivibrator action, the fall in voltage at its collector is transferred to TR_4 base via C_{11} , thus switching TR_4 off. The voltage at the collector of this transistor then rises towards the positive line. C_{11} now discharges through R_{13} , and when TR_4 base voltage is sufficiently positive, TR_4 turns on and its collector voltage falls. As a result a repetitive positive-going pulse is generated at TR_4 collector and is used for sampling the left-hand signal. The duration of this pulse is approximately $0.7 \times$ time-constant of C_{11}, R_{13} . Sampling pulses for the right-hand signals are generated in precisely the same manner by the action of TR_6 with TR_7 . The pulse output of TR_7 will, of course, be displaced in time from TR_4 output since when TR_4 is bottomed, TR_6 is cut off.

We may now return to the input and consider the other composite audio output from TR_1 emitter. This output is routed via C_3 to the sources of the f.e.t. stages TR_8 and TR_9 , which are referred to the positive line via R_4 . Prior to the arrival of the sampling pulses, these transistors are in the off condition as their gates are returned to the bottomed transistors TR_4 and TR_7 . When a sampling pulse arrives at (say) TR_8 gate, the f.e.t. is switched to the low-impedance condition thus allowing C_{12} to charge to the voltage at the source of the transistor. As the resistance between drain and source in the on state will be less than 500Ω , the charging CR will be less than 16.5 ns , i.e. it will be less than 10 per cent of the sampling pulse width. Thus the voltage across C_{12} at the end of the sampling period will closely equal that at the source of TR_8 . On the trailing edge of the sampling pulse TR_8 switches off and C_{12} commences to discharge through R_{24} . The discharge time-constant will be $330 \mu\text{s}$ hence C_{12} will discharge by a small amount only before the next sampling pulse arrives—this is 'holding'. Thus the output consists of a series of steps as shown in Fig. 5.37. In the right channel, C_{17} performs a similar function charging via TR_9 and discharging through R_{26} . So as not to load the

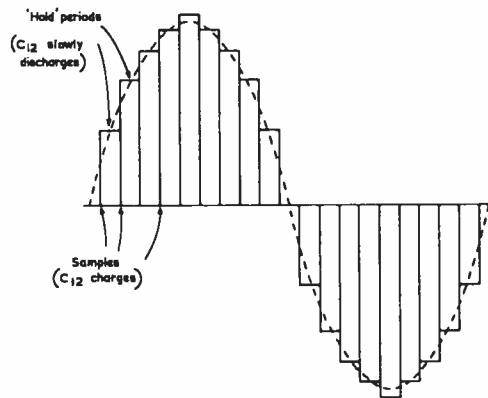

FIG. 5.37. STEP-OUTPUT FROM ONE CHANNEL (LEFT)

high-value resistors R_{24} and R_{26} the outputs are taken via the source-followers TR_{10} and TR_{11} . In the source-circuits of these transistors R_{29}, C_{20} and R_{28}, C_{19} provide de-emphasis in the usual way and also remove any residual 38 kHz

component. On mono, the sampling pulse generators will be free-running thus TR_8 and TR_9 will pass the mono signal to both outputs.

None of the decoder circuits described will give good results if the receiver is of poor design or is badly adjusted. The receiver must have adequate bandwidth for stereo reception. Lack of bandwidth in the front end or i.f. stages will attenuate the maximum modulation frequencies, i.e. the L-R signal and crosstalk between L and R will occur resulting in reduced separation. The phase-frequency response must be linear and any departure from this will also reduce the channel separation.

AUDIO STAGES

The audio stages to which the L and R outputs of the decoder are fed will normally be designed to accept stereo signals from other sources (e.g. disc and tape) and must faithfully reproduce all these inputs without degrading the crosstalk performance. Each audio channel of the stereo amplifier is a duplicate of the other from component specification to layout which aids the equalization of the parameters for the two channels.

The power stages of the amplifier may have a capability of (say) 3 W up to 15 W or more per channel and may often be used with a choice of loud-speaker impedances. The tone controls, which correct for room acoustics and listener's preferences are usually located in the preamplifier stages. They may form a passive circuit or more usually an active one so that boost at either end of the audio frequency spectrum may be realized. Separate volume controls are included in each channel and like the tone adjusters are ganged to ensure balance of gain and tonal response throughout the range of the controls.

A balance control will be necessary to compensate for small variations in gain of the separate channels and for any discrepancy in the balance in the amplifier inputs, reproducing system or acoustics of the listening-room. This acts as a differential control, i.e. it increases the gain in one channel whilst decreasing the gain in the other or vice versa. The balance control may consist of two ganged potentiometers, one in each channel as shown in Fig. 5.39. Here RV_1 and RV_2 control the magnitude of the signal fed from

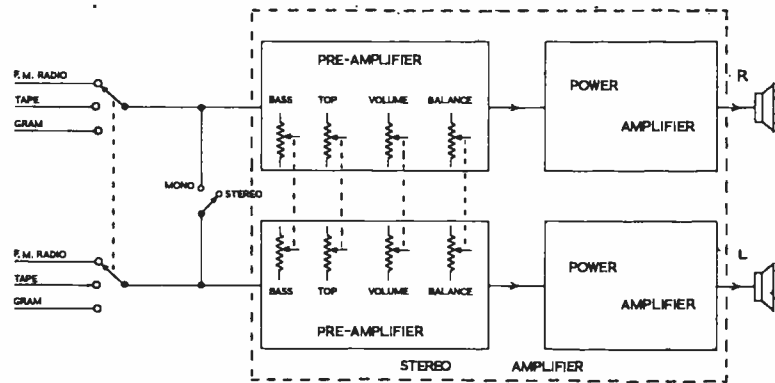

FIG. 5.38. BASICS OF A STEREO AMPLIFIER

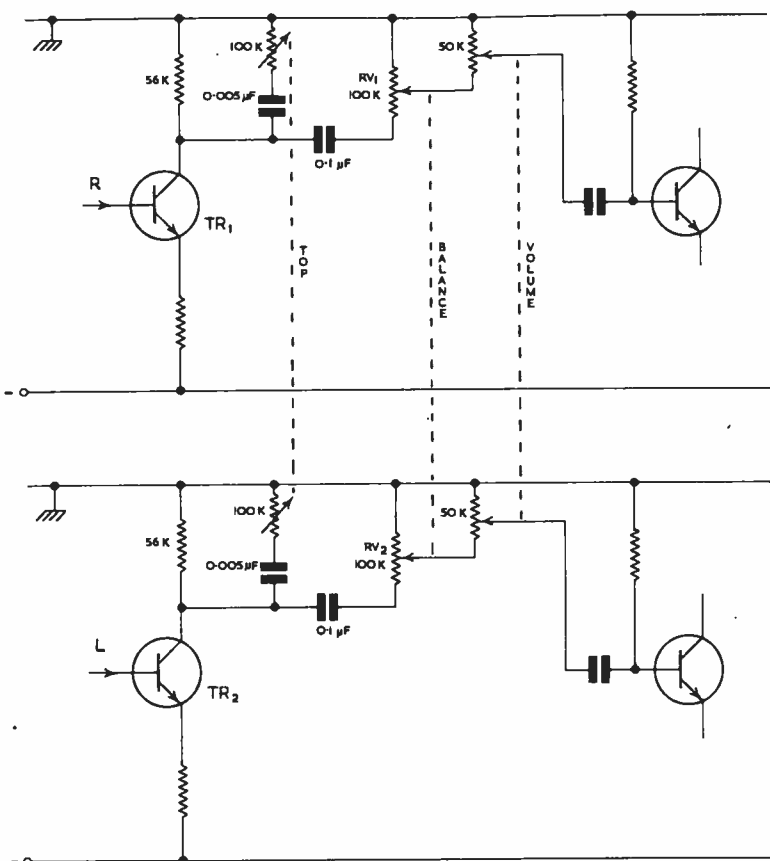

FIG. 5.39. GANGED BALANCE POTENTIOMETERS

TR₁ and TR₂ collector circuits to the following stages in the respective channel preamplifiers. More often the balance control is a single variable resistor and so connected that it acts differentially in a negative feedback circuit of each channel: see Fig.5.40.

Additionally, the preamplifier may contain a scratch filter to help minimize noise emanating from poor recordings or reception. Also, a rumble filter may be included with a sharp roll-off below about 40 Hz to reduce turn-table rumble.

A complete circuit for a single channel of a stereo amplifier is shown in Fig.5.41. This design is of a high quality incorporating 17 transistors and providing a simultaneous output power, on both channels, of 15 watts (Music Power Rating) or 11 watts (with sine wave input). The amplifier may be used with TAPE, RADIO or GRAM inputs of various source impedances, selected by the input switching (not shown).

Tone variation is achieved by independent BASS and TREBLE controls (RV₂ and RV₃) acting in conjunction with a bass compensated volume control RV₁.

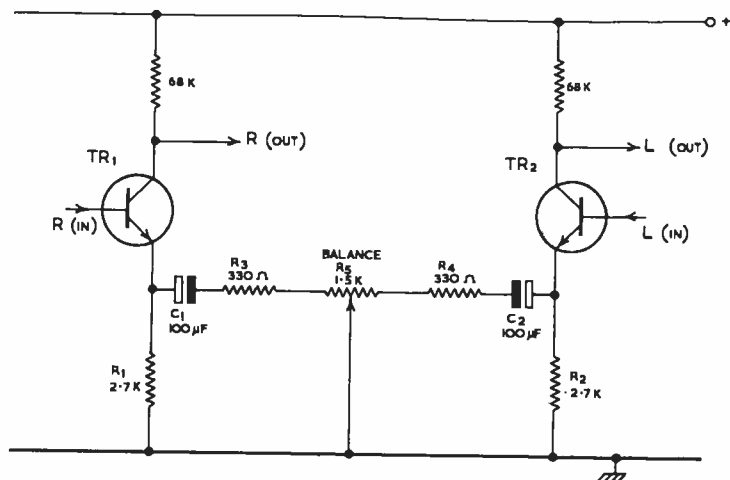

FIG. 5.40. BALANCE CONTROL AFFECTING DEGREE OF NEGATIVE FEEDBACK

This combination allows independent control of bass boost or cut and treble boost or cut (see Fig.5.42).

The tonal response may also be varied by means of a three-position PRESENCE switch. In position 1, the response is flat with the tone controls set to their mid-settings. In positions 2 or 3, frequencies in the mid-range between about 3000 Hz and 5000 Hz are given prominence. In position 2 the mid-range boost is accompanied by a degree of bass boost. The amount of bass boost is at a maximum at low settings of the volume control and decreases as the volume setting is advanced. Fig.5.43 shows the effect on the frequency response for positions 2 and 3.

This switch is used to create an impression of presence to soloists whilst at the same time may be used to compensate for the inherent insensitivity of the ear in the lower audio range which gives an apparent lack of bass response when operating the amplifier at low volume settings. Also, the control is useful in improving reproduction in listening-rooms where the acoustics are poor.

As d.c. coupling is employed between VT₂ and VT₃ stages, also between VT₄, VT₅ and VT₆, d.c. feedback is provided by R₂₁, R₂₀ from VT₃ to VT₂ and R₃₄, R₃₂ from VT₆ to VT₄, to assist in stabilizing the working conditions. Additional feedback to both d.c. and a.c. is included from the junction of R₄₂, R₄₃ to VT₄ emitter. The preset control RV₄ is to facilitate correct setting of the d.c. conditions to avoid asymmetrical clipping of the output signal.

The output pair VT₇ and VT₈ are connected in series as regards d.c. but are effectively in parallel to signal driving a common loudspeaker load. Push-pull drive to the output pair is provided by the secondary windings of the driver transformer T₁. A loudspeaker or combination of loudspeakers may be used having a total impedance between 4 Ω and 16 Ω per channel. Maximum power output is obtained when the total impedance is 4 Ω.

An alternative circuit arrangement for the audio power stages which is common to a large number of stereo and mono amplifiers is shown in Fig.5.44. This features the well-established technique of using complementary n-p-n and

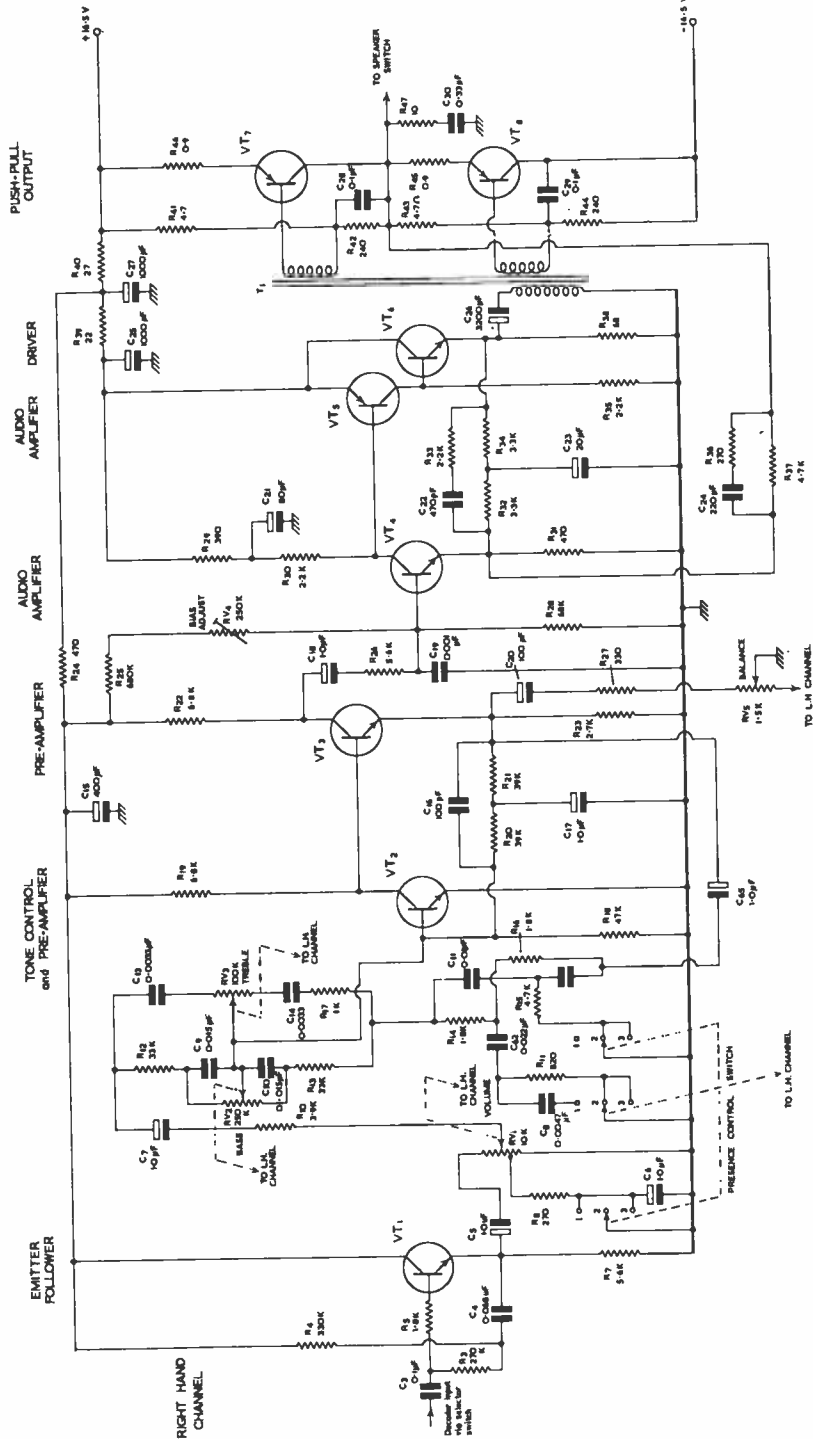

FIG. 5.41. BUSH A746 STEREO AMPLIFIER (ONLY ONE CHANNEL SHOWN)

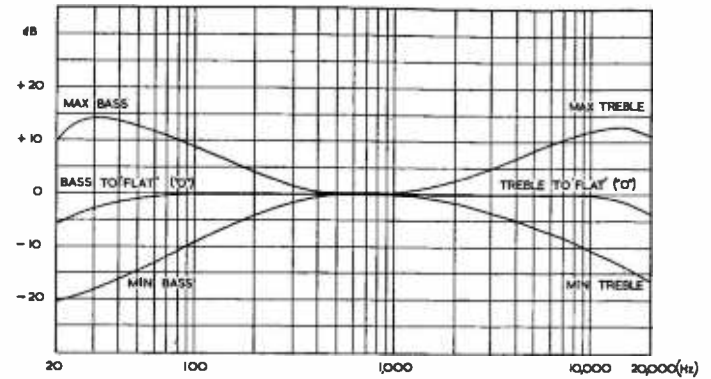

FIG. 5.42. CURVES SHOWING EFFECT ON FREQUENCY RESPONSE WHEN R_{V1} AND R_{V3} OF FIG. 5.39 ARE VARIED

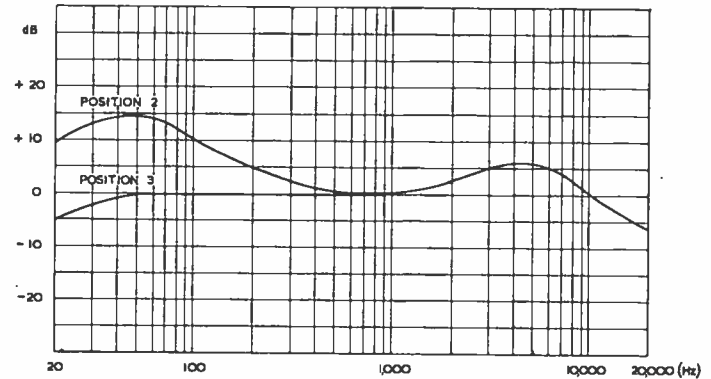

FIG. 5.43. CURVES SHOWING PROMINENCE GIVEN TO MID-RANGE AND BASS FREQUENCIES BY THE PRESENCE CONTROL

p-n-p transistors (TR_3 and TR_4) in a transformerless output stage. Here an audio output of 7 W per channel may be obtained supplied to two 8 Ω loudspeakers.

TR_3 and TR_4 , connected as emitter-followers, are biased on from the potential divider consisting of R_{11} , R_{10} , R_8/R_9 and TR_2 . The driver transistor TR_2 provides a common phase signal drive to the bases of the output pair but since they have complementary characteristics, the operation is in effect push-pull. R_{12} and R_{13} provide a measure of d.c. stabilization against ambient temperature variations, assisted by the thermistor R_9 . Audio signals are fed to the loudspeakers via C_3 which is of large value to ensure that adequate bass is

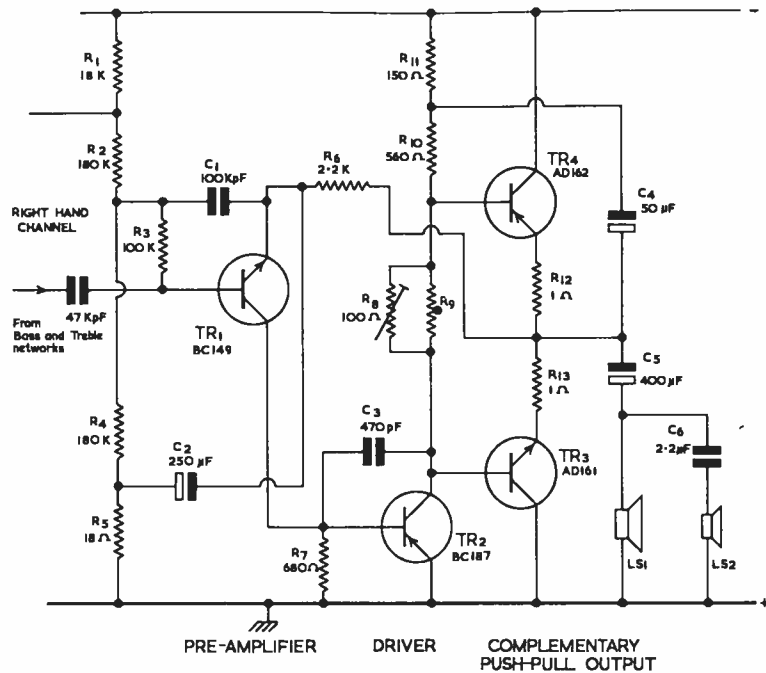

FIG. 5.44. COMPLEMENTARY SYMMETRY OUTPUT STAGE (ONE CHANNEL FEATURED IN G.E.C. G991 AM/FM STEREO-RADIOGRAM)

supplied to LS_1 . The top end of the audio spectrum is fed to LS_2 via C_6 . C_4 is included so that the drive signal is effectively applied between base and emitter of both output transistors.

The driver is supplied with signals from R_7 , the collector load of the pre-amplifier transistor TR_1 . D.C. coupling is used throughout from TR_1 to the output pair with d.c. feedback from the junction of R_{12} , R_{13} to the emitter of TR_1 .

6

DECODER ADJUSTMENTS

To align a stereo decoder, it is necessary to have an injection signal which has characteristics as regards frequency, phase and modulation similar to the stereo programme signal. The injection signal used may be (a) a stereo programme; (b) a BBC test transmission; or (c) originate from a stereo signal generator. Sources (a) and (b) are frequently utilized for aligning home-constructed kits where only a limited amount of test equipment is available. For the alignment of commercial units, manufacturers invariably specify the use of a stereo signal generator. All three methods of alignment will be discussed.

The components to be adjusted during complete decoder alignments are shown in Fig. 6.1 (not all of the adjustments shown will necessarily be found in a particular decoder). Usually there will be one or more 19 kHz tuning coils and one 38 kHz tuning coil. The 19 kHz circuits (1) and (2) are tuned to obtain maximum amplitude of the pilot tone arriving at the frequency-doubler. The 38 kHz tuned circuit (3) is usually peaked so as to extract the largest possible 38 kHz component from the doubler to drive the switching detector. Not only must the tuning of these coils be set to ensure maximum amplitude of the reconstituted subcarrier but also that its **phase** is correct. Some control over the phase of the subcarrier may be provided in some designs by a control marked **PHASE** which is often mounted so that it can be adjusted by the user. If the phase of the reconstituted subcarrier is not exactly correct, separation of the two channels will not be complete. For example, if the phase of the subcarrier input to the detector is shifted by 180° from its correct phase position the left and right channel signals will be reversed. With a 90° error there will be no separation, i.e. equal amounts of L and R will appear in both channels.

In Chapter 4 it was shown that the frequency-doubler introduced a 90° phase error into the subcarrier and that this error could be corrected by providing a 45° phase shift prior to doubling by means of an R-C network. Correction of the subcarrier phase may also be obtained by detuning the pilot tone tuned circuits—indeed in some designs there is no obvious phase-shift network so it may be assumed that correction is achieved by detuning. It is therefore important to note that whether or not an R-C network is featured in the design, the setting of the tuned circuits (19 kHz and 39 kHz) will play an important part in determining the phase of the subcarrier when it finally arrives at the detector.

With correct subcarrier phase there will still be crosstalk between channels when switched detection is employed (see Chapter 4 and Appendix C). This, of course, is a defect in the detection process and is normally compensated for by cross-coupling in the output amplifiers or in the detector. Some adjustment over the degree of cross-coupling may be provided by a preset control (5) labelled **SEPARATION** which also may be under the control of the user. Note that although channel separation is affected by both subcarrier phase and the degree of cross-coupling used, the cause of crosstalk is different for the two.

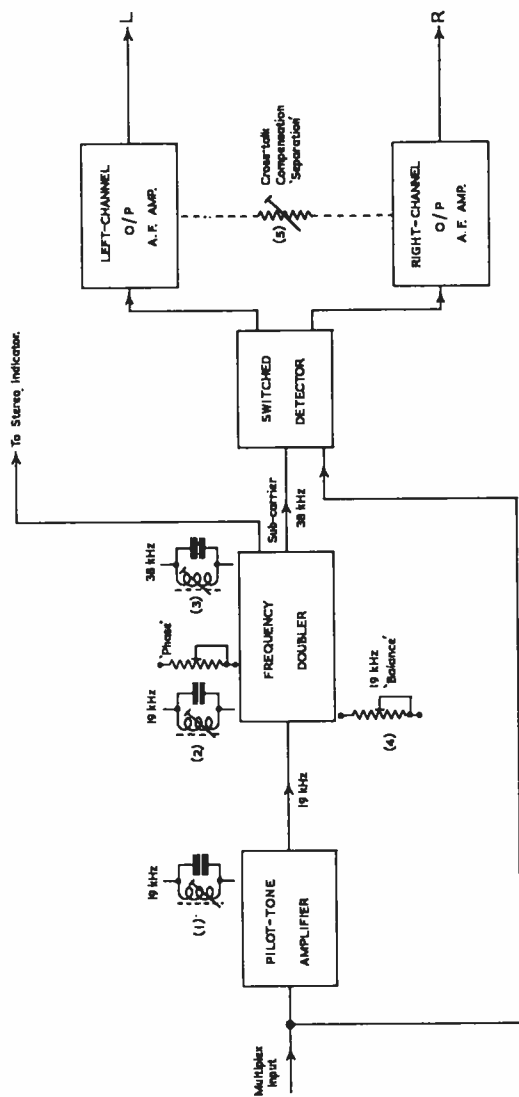

FIG. 6.1. BLOCK DIAGRAM SHOWING LOCATION OF ADJUSTABLE CIRCUIT ELEMENTS FOR USE IN DECODER ALIGNMENT

In some designs a form of 19 kHz 'balance' may be included (as in the Bush A747 circuit on page 84) to reduce the amount of residual 19 kHz component reaching the detector and output; this assists in minimizing noise at the output of the decoder. The various methods of alignment will now be considered.

ALIGNMENT

(a) Using the Stereo Programme Signal

This method will be discussed using the Heathkit decoder as an example. The essentials of the circuit are shown in Fig.6.2 based on the switched detector principle. TR_1 amplifies the composite input signal which is then passed on to TR_2 base. In TR_2 stage the pilot tone is extracted from the composite signal by the tuned circuit L_1, C_1 in the collector. There are two outputs from L_1, C_1 ; one feeds the stereo indicator amplifier which operates the beacon lamp; and the other is applied to TR_3 base to synchronize a 38 kHz oscillator. The oscillator circuit is formed by T_1 primary winding and C_2 tuned to 38 kHz with feedback to TR_3 emitter via C_3 . The pilot tone applied to TR_3 base positively locks the oscillator as regards frequency and phase (when correctly adjusted) to the suppressed subcarrier. TR_4 and TR_5 are the switched detectors with the switching waveform applied to the bases from T_1 secondary and the composite signal applied to their emitters from TR_2 emitter via C_4 and S_1 (when listening to stereo or mono signals S_1 is set to NORMAL). Separated left and right channel signals appear at TR_4 and TR_5 collectors to be subsequently de-emphasized and filtered. On mono, TR_4 and TR_5 act as a.f. amplifiers, the transistors being biased on by R_2 . The oscillator transistor is rendered inoperative by S_2 to avoid 'beating' effects with the mono signal.

To allow adjustment over the phase of the regenerated subcarrier, the variable resistor, VR_1 , is included. As R_1 and C_6 are connected across two antiphase points on L_1 , the phase of the pilot tone fed to TR_3 base can be varied over a range of almost 180°. When S_1 is opened (the ADJUST position) L_2 and C_5 are brought into circuit. These components form a tuned filter centred on 38 kHz, permitting only the L-R modulation components through to the detector. This facility allows the phasing adjustment to be carried out on a stereo programme.

After checking the receiver alignment the sequence of decoder adjustments is as follows:

(1) The receiver is tuned to a station known to be broadcasting a stereo programme. S_1 is set to the ADJUST position and R_1 is set to minimum resistance.

(2) L_1 is adjusted for maximum brightness of the stereo indicator lamp, the objective at this point being to extract the largest possible pilot tone signal. Now, L_2, C_5 allow only the L-R modulation components through to the detector. If the frequency of the 38 kHz input to TR_4 and TR_5 is correct, the L-R modulating signal will appear in both channel outputs (with opposing phase). At this stage of the procedure, however, the switching waveform may have a frequency differing from 38 kHz because T_1 has not been tuned, in which case the output may sound distorted. Therefore, after adjusting L_1 the sound may be of poor quality.

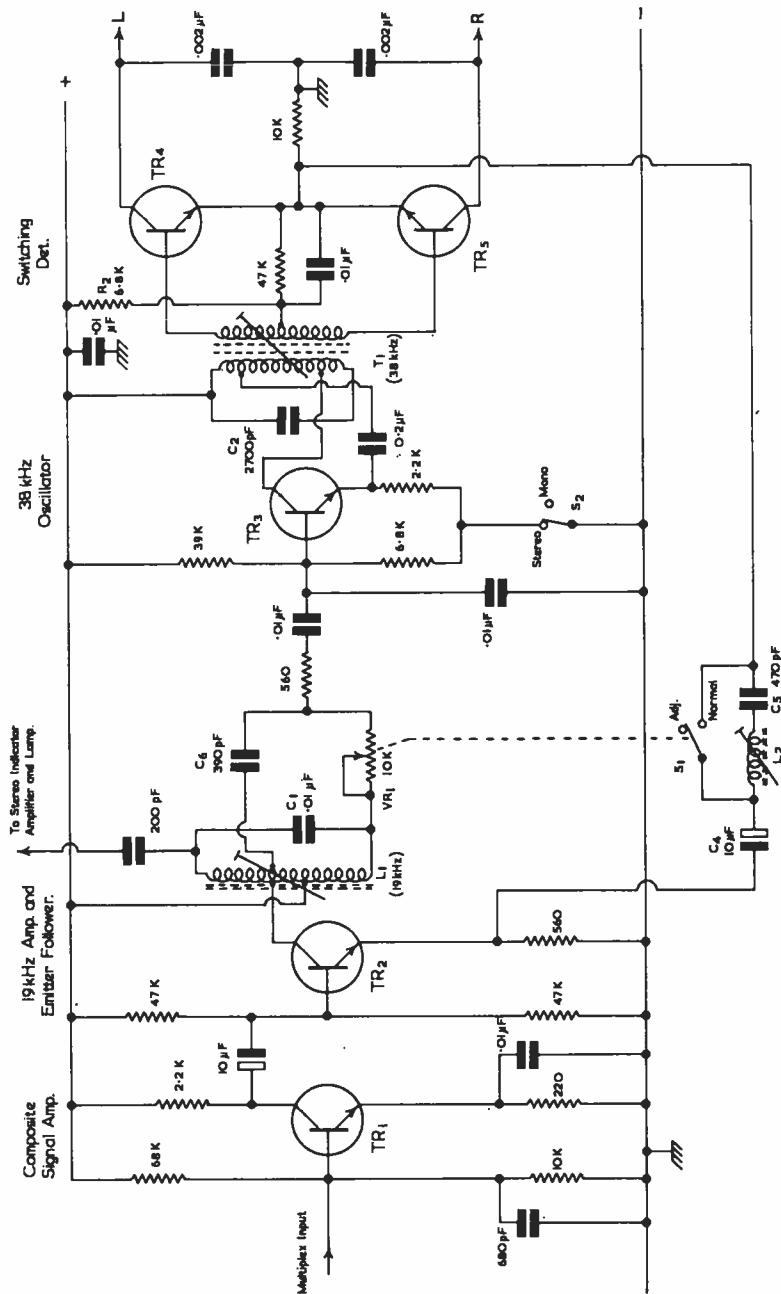

FIG. 6.2. HEATHKIT (DAYSTROM LTD) STEREO DECODER

(3) T_1 core is now adjusted until the sound output is clear. The frequency of the switching input to the detector is now correct but its phase will be in error (a phase error has the effect of reducing the level of the sound output).

(4) It now remains to set the phase of the regenerated subcarrier. L_1 is readjusted until a null or minimum sound output is obtained.* Altering the tuning of L_1 will result in a change in the phase of the pilot tone applied to TR_3 and in consequence a change in the subcarrier phase. Minimum sound will occur when the subcarrier phase is 90° from its correct phase position (see Fig.6.3). R_1 is now turned until the point of maximum sound is obtained; this should occur when the slider is near the centre of its track. The adjustment

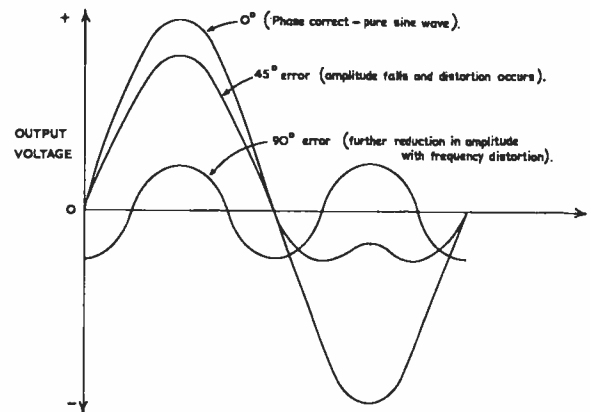

FIG. 6.3. EFFECT ON DETECTOR OUTPUT WHEN PHASE OF REGENERATED SUBCARRIER IS ALTERED, ASSUMING THE L-R MODULATING SIGNAL TO BE A PURE SINE WAVE

of R_1 is best carried out during periods of music rather than speech as announcements from the centre of the sound stage will result in L-R assuming a very low amplitude (theoretically zero). This completes the decoder adjustments which are now optimized for minimum distortion and maximum channel separation. S_1 may then be set to the NORMAL position.

With other types of decoder, initially it is usual to adjust the 19 kHz tuned circuits and often the 38 kHz tuning to obtain maximum brightness of the stereo beacon lamp or maximum deflection of the tuning meter (when fitted). It may be necessary with certain decoders to attenuate the aerial signal to obtain an accurate setting for these adjustments. Unless the circuit incorporates an L-R modulation component filter like the Heathkit circuit, it is not possible to set the PHASE of the subcarrier on a stereo programme. This particular adjustment may, however, be carried out using Test 2 during the BBC Test Tone transmissions which will now be described.

* The reason for detuning L_1 prior to adjusting R_1 is to ensure that the correct subcarrier phase position occurs near the centre of R_1 track and not at one end. The correct setting of L_1 should be close to the point of maximum brightness from the stereo beacon lamp. Two nulls may be obtained and the null closer to the top of the coil should be used. This is important because if the wrong null is selected the channels may be reversed on adjusting R_1 for maximum sound output.

(b) BBC Test Transmissions

Test tone transmissions are radiated by the BBC on Wednesdays and Saturdays to facilitate decoder adjustment and testing. These tests are set out in TABLE 6.1 which are taken from the BBC Information Sheet 1605(5), June 1970. This schedule is subject to variation or cancellation in accordance with programme requirements and essential transmission tests. On other days, a 250 Hz tone is transmitted on the LEFT CHANNEL ONLY from about four minutes after the end of the last programme on Radio 3 until 23.55, but may be interrupted from time to time. This test tone may be used for channel identification and adjustment of crosstalk.

The purpose of the tests, and how they may be used in the setting and checking of decoder adjustments, are as follows:

Test 1

The purpose of this test is to enable identification of the left and right channels. One can identify the channels by simply listening for a 250 Hz tone in the left-hand speaker and for a 440 Hz tone in the right-hand speaker. If the tones are reversed, it may be that the L and R output leads from the decoder to the audio amplifier require interchanging or that the loudspeakers are connected to the wrong audio channel outputs, which would cause a reversal when the audio channel inputs originate from other stereo sources, e.g. disc or tape. It is useful to have an oscilloscope monitoring the decoder outputs during this test and the others.

Test 2

Tones of the same frequency (900 Hz) and amplitude but with opposing phase are used for this test. This will result in the L+R signal assuming zero amplitude but cause the L-R signal to take on an amplitude twice that of the signal in one channel. Consequently the transmitted signal will lie wholly in the L-R channel (sometimes called the S channel), i.e. the input to the decoder will consist of L-R modulation components only together with the pilot tone signal. This test can therefore be used for adjusting and checking the phase of the reconstituted subcarrier. The PHASE control is adjusted for maximum output at 900 Hz from either channel by assessing the loudness of the tone from the loudspeaker or by measuring (say) the decoder output with a signal-level meter. As the outputs of some decoders include a significant level of the 19 kHz pilot tone and its harmonics, it will be necessary to provide filters with adequate attenuation at these frequencies to ensure that readings are not affected when signal meters are used.

This test may also be used to check for distortion of the signal as it passes through the L-R channel path.

Test 3

The 900 Hz tones used are of the same amplitude and phase. Thus the L-R signal will be zero and the L+R signal will have an amplitude twice that of the signal in one channel. This time, therefore, the transmitted signal will lie wholly in the L+R channel, i.e. it is a mono signal. The purpose of this test is to permit a check on the distortion of the signal when it lies in the L+R channel path. Amplitude distortion of the test tone may be checked

TABLE 6.1

TEST	TIME	LEFT CHANNEL (L)	RIGHT CHANNEL (R)
1	23.42	250 Hz at zero level*	440 Hz at zero level
2	23.44	900 Hz at +7 dB	900 Hz at +7 dB (antiphase to left channel)
3	23.48	900 Hz at +7 dB	900 Hz at +7 dB (in phase with left channel)
4	23.49	900 Hz at +7 dB	Zero modulation
5	23.50	Zero modulation	900 Hz at +7 dB
6	23.51.20	Tone sequence at -4 dB 60 Hz 900 Hz 5 kHz 10 kHz Sequence repeated	Zero modulation
7	23.52.20	Zero modulation	Tone sequence at -4 dB 60 Hz 900 Hz 5 kHz 10 kHz Sequence repeated
8	23.53.20	Zero modulation	Zero modulation
23.55		Reversion to monophonic transmission	

* The zero level reference corresponds to 40% of the maximum modulation level applied to either channel before pre-emphasis. All tests are transmitted with pre-emphasis.

BBC TEST TONE TRANSMISSIONS
(Wednesday and Saturday)

with a c.r.o. connected across the L and R outputs of the decoder. A distortion analyser should be used if an accurate assessment is required.

Tests 4 and 5

These are for checking crosstalk between the left and right channels. In Test 4 the 900 Hz tone is present in the left-hand channel only whereas in Test 5 it lies solely in the right-hand channel. Thus in (say) Test 4 if the test tone appears at the right-hand channel output crosstalk is occurring. This may be corrected by adjusting the SEPARATION or CROSSTALK control for minimum breakthrough of the signal in the unwanted channel. To measure the channel separation after adjustments have been made, signal-level meters may be used connected at the channel outputs. Filters may be required when using instruments as mentioned in Test 2, but in any event the meters should be connected across points of the circuit following normal de-emphasis and decoder filtering.

For decoders having separate controls for the adjustment of subcarrier phase and crosstalk, the correct order of alignment is to adjust the subcarrier PHASE control for **maximum** output from the left or right channels during Test 2 and then to adjust the SEPARATION or CROSSTALK control for minimum crosstalk between channels during Tests 4 and 5. With those decoders in which the only control over crosstalk is by adjustment of the subcarrier phase, the adjustment should be made on Tests 4 and 5.

Tests 6 and 7

The purpose of these is to check the frequency response of the left and right channels and to assess the crosstalk performance at high and low frequencies. A sequence of four tones is used, transmitted solely in the left channel during Test 6, and then only in the right channel during Test 7. The frequency response may be checked by connecting signal-level instruments at the channel outputs; they may also be used for assessing the crosstalk at the test tone frequencies. One usually finds that channel separation is worst at the higher frequencies, but in a good design it may be -24 dB or better at 10 kHz improving to about -60 dB at 60 Hz.

Test 8

This permits the noise level of the receiver to be checked during the presence of the pilot tone. Using an audio output meter during Test 1 one can set a reference level (0 dB) for the test tone at either channel output. With the reference level established, a reading may be taken for the noise present at both channel outputs during this test. A signal-to-noise ratio of about 50 dB or better would be expected from receivers of good design with adequate signal delivered from the aerial system.

Adjustment of the stereo amplifier 'balance' control to produce equal loudness from the left and right speakers is best carried out when listening to announcements during a stereo programme, which are always made from the centre of the sound stage. If adjustment is attempted during the test tone transmissions the results may be confusing because of standing-wave patterns set up in the listening-room.

The Mullard circuit illustrated in Fig.5.25 on page 104 may be aligned using the BBC test tones and the recommended method is as follows:

(1) For the initial alignment any stereo broadcast can be used. A potentiometer with a value of at least 50 k Ω is connected across the f.m. demodulator output and the decoder input is connected to the potentiometer slider. With the potentiometer set for maximum output, the receiver is tuned in to a stereo broadcast.

(2) The cores of the 19 kHz and 38 kHz tuning coils L_1 and L_2 are adjusted to give maximum brightness of the stereo indicator bulb. The input potentiometer setting should then be reduced until the indicator lamp just glows and the cores of L_1 and L_2 readjusted to give maximum brightness once more. This procedure should be repeated until adjusting the cores in either direction results in the indicator lamp getting dimmer. The two coils are now aligned and the potentiometer may be disconnected.

(3) R_{12} is now adjusted to its mid-position whereupon the decoder should give a reasonable degree of channel separation. However, further adjustment is necessary using the test tone transmission.

(4) Connect the decoder outputs to a stereo amplifier and using Test Tone 1 identify the left and right channels. Disconnect the left-hand amplifier input and when the left channel signal only is being transmitted during Test Tone 4, turn the core of L_2 anticlockwise until minimum sound is heard in the right-hand loudspeaker (adjusting L_2 from optimum will alter the phase of the reconstituted subcarrier). Reconnect the left-hand amplifier input.

(5) Disconnect the right-hand amplifier input and when the right-hand channel signal only is being transmitted during Test Tone 5, R_{12} is adjusted from its mid position setting to give minimum output from the left-hand loudspeaker. Reconnect the right-hand amplifier. The decoder is now correctly aligned.

(c) Stereo Signal Generator Alignment

The Test Tone Transmissions have to be transmitted outside normal broadcast hours which is inconvenient to radio technicians. To meet the requirements of manufacturing concerns and the servicing technician, stereo multiplex generators are available. A block schematic of one generator is shown in Fig.6.4.

This particular instrument can be used for aligning and testing two kinds of stereo equipment: integrated f.m. multiplex tuners; and separate multiplex adaptors. The basic tests that can be performed are: channel separation; phase alignment of the subcarrier part of the receiver; electrical fidelity; and distortion.

The stereo generator contains two RC oscillators (400 and 1000 Hz) which can be connected to the preamplifiers. These amplifiers both have a 50 and a 75 μ s pre-emphasis network. The preamplifiers may be switched to the input terminals for the selection of external left and right channel audio signals. Each preamplifier has a gain of 20 dB and is followed by a low-pass filter with a rejection frequency of 19 kHz. After passing through the filters, the left and right signals are applied to driver amplifiers which have a gain of 6 dB.

The outputs of the driver stages, together with a feed from the 38 kHz subcarrier oscillator, are fed into the ring modulator of the modulator stage in which the L+R (M) and L-R (S) signals are produced, the latter being modulated on the subcarrier. The subcarrier is suppressed in this balanced modulator. The 19 kHz pilot tone is obtained from the 19 kHz generator which is locked to a 38 kHz signal derived from the modulator stage. The

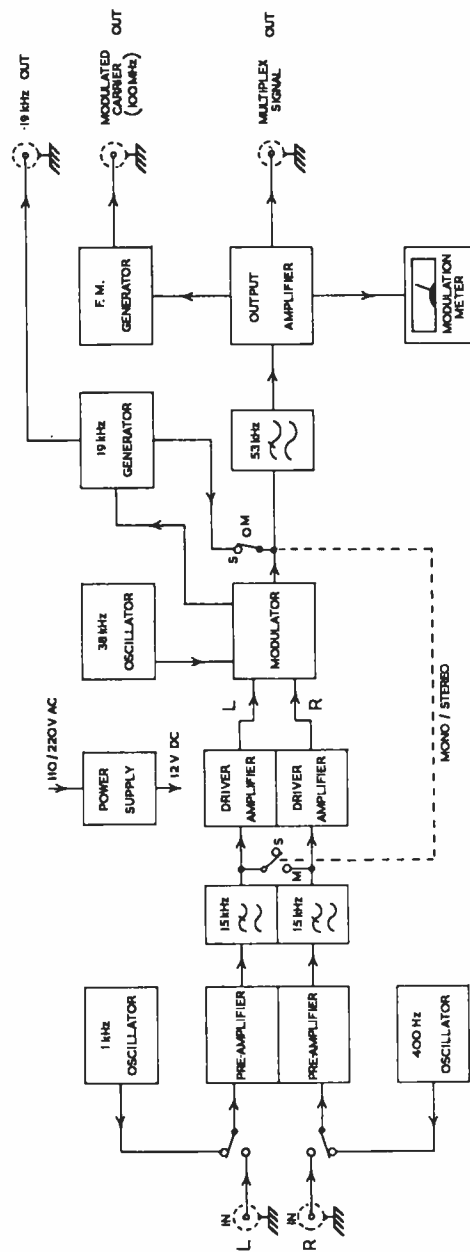

FIG. 6.4. BLOCK SCHEMATIC OF PHILIPS F.M. STEREO MULTIPLEX GENERATOR, TYPE PM6450

composite signal consisting of the L+R signal, suppressed 38 kHz carrier modulated with L-R and the 19 kHz pilot tone are fed *via* a 53 kHz low-pass filter into a wide band output amplifier which has a gain of 15 dB.

In the f.m. generator stage this multiplex signal frequency modulates an r.f. oscillator operating at 100 MHz. With 100 per cent modulation (monitored by the modulation meter) the carrier is deviated by ± 75 kHz. The output of the f.m. generator can be continuously adjusted by means of a logarithmic attenuator having a constant output impedance of 75 Ω . The pilot tone carrier can be adjusted from 0-18 per cent in seven steps.

In the MONO position of the function selector, the left and right channel signals are connected in parallel and the pilot tone signal is removed. This results in L+R only appearing at the input to the output amplifier and f.m. generator.

The instrument is of high precision, generating a pilot tone carrier with a phase accuracy of $\pm 1.5^\circ$ and r.f. signals of high stability and low distortion. It may be used for design work, production testing and servicing f.m. multiplex receivers and adaptors.

Alignment using a stereo signal generator is essentially no different from using the BBC test tones but, of course, the duration and type of test signal is entirely under the control of the user which is advantageous. As an example, the alignment of the Bush A747 (Fig. 5.27 on page 107) will be considered. The equipment required is: (a) a stereo signal generator; (b) an oscilloscope; and (c) an audio amplifier (Bush A746) connected *via* suitable leads to the decoder output. The receiver tuning is set to 94 MHz (a.f.c. OFF) and the amplifier volume control set to minimum. Decoder adjustments are as follows:

- (1) Connect the oscilloscope between the centre tap and point B of T_1 , taking care to isolate the low potential input terminal of the c.r.o. from earth (an isolation transformer may be used to supply the c.r.o. with mains voltage).
- (2) Connect the output from the stereo generator between V_{T_4} base *via* C_{26} and chassis. Inject a 19 kHz pilot signal at a level of 20 mV and adjust the cores of L_8 , L_9 , L_{10} and T_1 for maximum output as indicated on the oscilloscope.
- (3) Now connect the c.r.o. across R_{30} and adjust RV_2 until the alternate peaks of the displayed rectified pilot tone are exactly equal in amplitude, then disconnect the c.r.o.
- (4) Set RV_3 fully counterclockwise then set the stereo generator for 90 per cent modulation at 1 kHz on the left-hand channel with 10 per cent pilot tone and 0 per cent modulation on the right-hand channel. With a signal input level of 2 V peak-to-peak, connect the c.r.o. between $V_{T_{12}}$ collector and chassis. Adjust L_{10} and RV_3 in that order for minimum output (crosstalk) on the c.r.o. This completes the decoder adjustments, but the following checks recommended by the manufacturer should be carried out.

Crosstalk Check

- (1) Set the stereo generator for 90 per cent modulation at 1 kHz on the left-hand channel, with 10 per cent pilot tone and 0 per cent modulation on the right-hand channel. Inject a signal at a level of 2 V peak-to-peak between C_{26} and chassis, then connect the c.r.o. between $V_{T_{11}}$ collector and chassis. Note the output level as indicated by the oscilloscope.

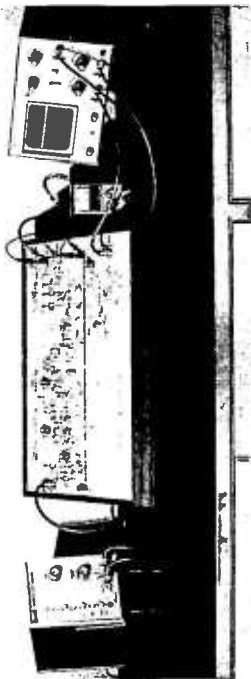

© General Pty. (Australia) Ltd.

PHILIPS PARAMS STEREO GENERATOR USED IN ALIGNMENT OF DEMONSTRATION RECORDER WITH DOUBLE GUN C.R.O. AS OUTPUT MONITOR.

(2) Now switch the stereo generator to the right-hand channel using the same depth of modulation and signal level as before. Note that the output level on the c.r.o. display is at least 30 times down (about 29 dB) on that noted in (1) above.

(3) Steps (1) and (2) may be repeated but with the modulation at 90 per cent on the right-hand channel at first and later the left-hand channel only but with the c.r.o. connected between VT_{11} collector and chassis. Again, the second reading of the signal level on the c.r.o. should be at least 30 times down on the first reading.

Audio Sensitivity

Inject an audio signal of 1 kHz to the base of VT_1 via C_{11} at a level of 100 mV. Connect the oscilloscope in turn between VT_{11} and chassis and VT_{12} and chassis and check that the output is at least 100 mV.

Stereo Beacon Check

Check that the stereo beacon is illuminated when a 94 MHz stereo signal is injected at the v.h.f. aerial socket with a level of 200 μ V.

The foregoing shows that there is no typical alignment procedure although many of the adjustments are common to a large number of decoders. If available, the manufacturer's procedure should be followed for best results and to meet the specifications that may be claimed for the unit. However, with an understanding of the principles behind the adjustments and with a knowledge of test instruments it is possible to achieve satisfactory results by sensibly applying the principles when instructions are not available.

V.H.F. WAVES AND AERIALS

THE reception of a stereo transmission like any other type of radio signal is only possible because of the fact that energy is radiated from a conductor carrying ALTERNATING currents. This energy is in the form of an electromagnetic wave which consists of an electric field and a magnetic field acting at right angles to one another (Fig.7.1). The level of radiation of electromagnetic waves increases as the frequency of the alternating current is increased.

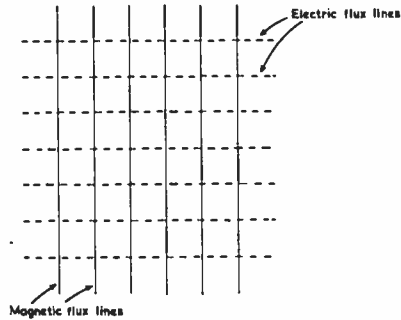

FIG. 7.1. THE COMPONENTS OF AN ELECTROMAGNETIC WAVE

At d.c. there is no radiation whilst below about 10 kHz the radiation is negligible. Now a radio wave is identical in character to a light wave since both are electromagnetic radiations. The radio wave travels at the same speed of 300,000,000 metres per second and it obeys the same laws, *i.e.* it can be reflected and refracted. However, in one respect the radio wave is different as its wavelength is longer than that of a light wave. The fact that radio and light waves are of the same form is of great assistance in studying the behaviour of aerial systems and radio wave propagation.

HORIZONTAL AND VERTICAL POLARIZATION

To intercept a radio wave and extract as much energy as possible from it, a receiving aerial must be suitably orientated with respect to the magnetic and electric components of the wave. These components may be represented by vectors as in Fig.7.2 The plane contained by the electric component and the direction of propagation or wave travel is called the **plane of polarization**. In this case the wave is said to be **HORIZONTALLY POLARIZED** since the **ELECTRIC** field is **HORIZONTALLY ORIENTATED**. If the electric field acts in the **VERTICAL** direction, the wave is said to be **VERTICALLY POLARIZED**.

When a transmitting aerial is fed with a high frequency current, magnetic and electric fields are set up close to the aerial as illustrated in Fig.7.3. These fields are shown for a dipole aerial which, as will be seen later, is a suitable form of radiator. In (a) the aerial is mounted vertically and a vertical electric field is produced. This field will cause a vertically polarized wave to be propagated.

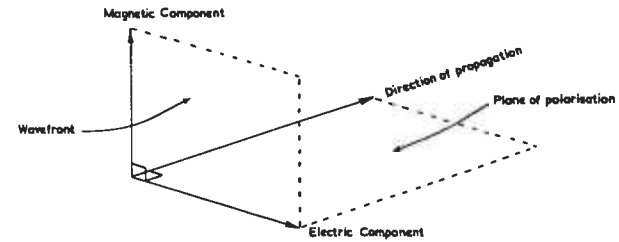

FIG. 7.2. PLANE OF POLARISATION FOR A RADIO WAVE

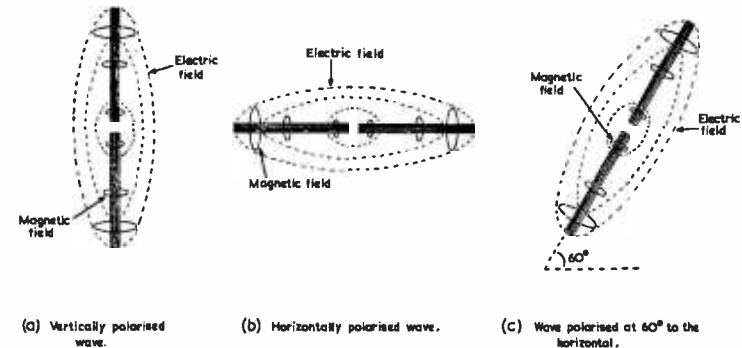

FIG. 7.3. THE EFFECT OF POLARISATION WHEN AERIAL ORIENTATION IS ALTERED

As the wave travels away from the aerial it spreads out so that at some remote point only a small part of the wave is intercepted by a receiving aerial. If the aerial is rotated through 90° to take up a position as in diagram (b), the electric field will be horizontal and a horizontally polarized wave will be sent out. Diagram (c) shows the aerial rod lying at 60° to the horizontal. As its electric field also lies at this angle, the propagated wave will be polarized at 60° to the horizontal. To intercept the radio wave and extract maximum energy from it the receiving aerial must lie parallel to the radiated electric field so that the largest possible p.d. is set up in the aerial rod. Alternatively, one may say that the receiving aerial should be mounted at right angles to magnetic component of the wave thereby ensuring that maximum flux 'cuts' the aerial rod. Both statements, of course, imply that the receiving aerial must lie in the same plane as the electric field of the arriving wave. Thus, under ideal propagation conditions, the transmitting and receiving aerials will be mounted with the same orientation (Fig.7.4).

TYPES OF PROPAGATED WAVES

Sky-wave

The energy radiated from a transmitting aerial T may take any of three main paths. The wave may be directed upwards towards the ionosphere which consists of a number of layers of ionized gas located some 50-500 km above the earth's surface. This wave is commonly known as the **sky-wave** and may

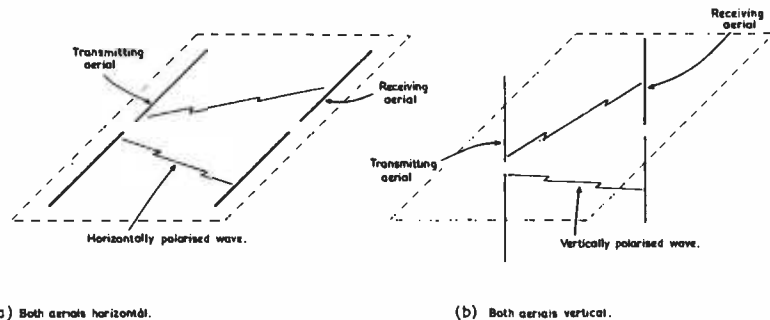

(a) Both aeriels horizontal. (b) Both aeriels vertical.
 FIG. 7.4. TRANSMITTING AND RECEIVING AERIALS MOUNTED WITH SAME ORIENTATION FOR BEST TRANSFER OF WAVE ENERGY

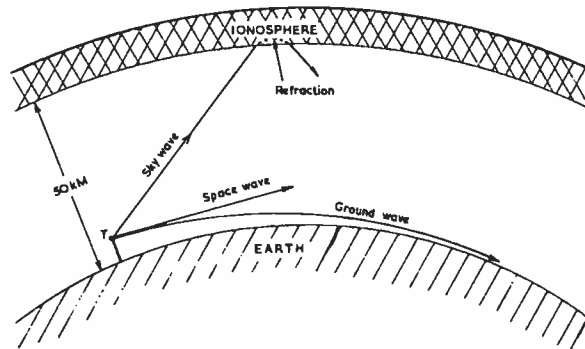

FIG. 7.5. TYPES OF PROPAGATED WAVES

be refracted back towards the earth by the layers of ionized gas. Refraction of the radio wave occurs due to the effects of the varying density of the gas layers in which the wave is travelling. The mechanism of refraction is similar to that of light waves when they travel in a medium of varying density. The amount of bending or refraction decreases as the frequency of the wave increases. Thus, reception of the refracted sky-wave is important at low frequencies. Waves of frequency above 30 MHz are seldom refracted back from the ionosphere. If the angle of the sky-wave is too steep the wave will not be refracted back to the earth. By alternate refraction by the ionosphere and reflection at the earth's surface the sky-wave may take a series of hops round the earth thus enabling a transmission to be received in any part of the world. Since the ionization of the gas layers constituting the ionosphere is affected by radiant energy from the sun, the density of the ionosphere is continually changing. This results in the reception of the sky-wave varying, particularly from day to night and from season to season, but in a predictable manner.

Ground-wave

If the transmitting and receiving aeriels are situated close to the earth's surface a ground-wave can exist provided the wave is vertically polarized.

As the wave travels over the surface of the earth, the electric field induces charges into the earth which travel with the wave. The part of the wave travelling in the earth moves with less velocity than the wave above the surface. As a result, the wave-front is tilted downwards so that the direction of motion is inclined towards the earth. This characteristic of the ground-wave is partly responsible for reception beyond line of sight, i.e. the ground-wave tends to follow the curvature of the earth for some distance. As the wave travels forward it is attenuated by the ground. This varies with the material of the earth's surface, e.g. dry sand: large loss; over sea: small loss. In general, the higher the frequency of the wave the greater is the loss. At frequencies below 100 kHz the ground-wave attenuation is low and a satisfactory signal can be obtained up to distances of 10,000 miles. Above about 20 MHz, the ground-wave attenuation is so large that this form of communication is not practicable.

Space-wave

The space-wave represents energy that travels in the space close to the earth. This type of propagation is principally used by systems operating at high frequencies, e.g. television, radar and f.m. radio. The range of the space-wave is chiefly determined by the height of the transmitting and receiving aeriels. As Fig.7.6 shows, a receiving aerial R_1 will lie in the line-of-sight path of the transmitting aerial T and in consequence will receive its radiations. A



FIG. 7.6. SPACE WAVE RANGE LIMITED TO LINE OF SIGHT

receiving aerial R_2 at the same height as R_1 and located farther round the earth's circumference cannot 'see' the transmitting aerial and therefore does not pick up the line-of-sight signal.

At v.h.f., reflections from the ground or some other object becomes more important. Consider Fig.7.7 which shows a wave P_2 reflected from the ground arriving at the receiving aerial R_1 in addition to the direct wave P_1 . This

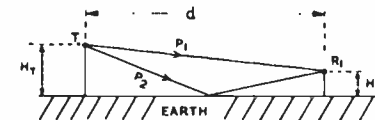

FIG. 7.7. DIRECT WAVE P_1 AND GROUND-REFLECTED WAVE P_2

may seem to be advantageous but when P_2 is reflected from the ground the phase of the wave changes by 180° ; thus P_1 and P_2 tend to cancel at the receiving aerial. If the path lengths of the two signals were identical, P_1 and P_2 would exactly cancel and no signal voltage would arrive at the receiver. In these circumstances the only reason why a signal is fed to the receiver is because the path of P_2 will always be longer than that of P_1 .

The field strength of the wave arriving at R_1 of Fig.7.7 may be found from

$$E = \frac{88\sqrt{W} H_T H_R}{d^2 \lambda} \text{ volts/metre}$$

- where W = Transmitter power (watts)
- H_T = Transmitting aerial height (metres)
- H_R = Receiving aerial height (metres)
- d = Distance between transmitting and receiving aerials (metres)
- λ = Wavelength of wave (metres).

The expression shows that the receiving aerial height is an important factor. By raising the height, the signal arriving at the receiver may be increased. As the aerial height is increased, the path length of P_2 is increased which increases the phase difference between P_1 and P_2 , thus providing a larger signal. If the aerial height is increased until the difference in path lengths corresponds to half a wavelength, the signal arriving at the receiver will rise to a maximum. Raising the aerial height beyond this point will result in a fall in the signal strength as the difference in path lengths approach one wavelength. When the difference in path lengths is exactly one wavelength the signal will be zero.

Fig.7.8 shows the result of calculations based on this effect assuming a transmitting aerial height of 320 metres (which is fairly typical) and for a

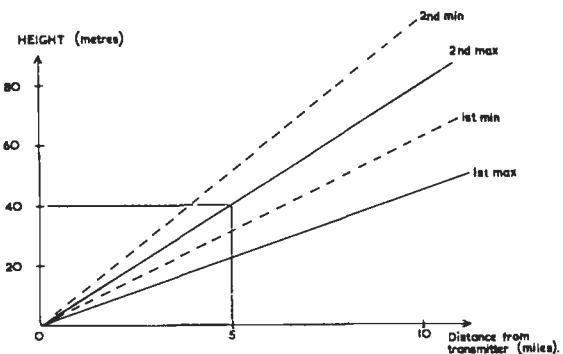

FIG. 7.8. FIELD MAXIMAS AND MINIMAS AT CLOSE RANGES CALCULATED FOR A SIGNAL OF 100 MHz AND A TRANSMITTER HEIGHT OF 320 METRES

transmitted wave of frequency 100 MHz. At five miles from the transmitter, the first signal maximum is reached at about 19 metres falling off to a minimum at 28 metres and then rising to a second maximum at 38 metres and so on. Farther away from the transmitter the first maximum is reached at much greater heights. Assuming a receiving aerial height of (say) 9 metres (about chimney height for a two-storey building), the first signal maximum will normally be out of reach for most domestic installations. A rule of thumb may be applied for band II: MOUNT THE RECEIVING AERIAL AS HIGH AS POSSIBLE aiming for the first signal maximum. The results set out in Fig.7.8 should not be relied on for any accuracy as they are based on transmission over a flat surface and in practice there may be several reflected signals arriving at the

receiving aerial. However, the results do give some indication as to what may be happening at medium ranges from the transmitter.

MULTIPATH RECEPTION

Reflected waves may also arrive at a receiving aerial as a result of reflection from large buildings or metallic masses such as cranes, gas-holders, aircraft, etc. In Fig.7.9 three waves are arriving at a receiving aerial R . The direct (wanted) signal is arriving along the path P_1 and reflected (unwanted) signals *via* the

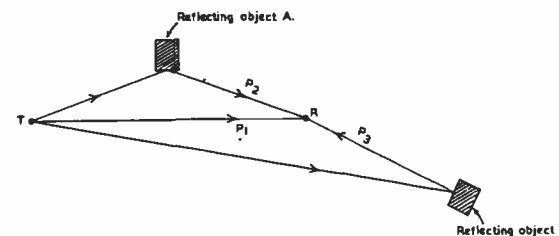

FIG. 7.9. MULTIPATH RECEPTION

reflection paths P_2 and P_3 . With fixed path lengths the phase difference between the signals would be constant if the transmission consisted of a SINGLE FREQUENCY. However, with frequency modulation of the transmitter many different frequencies (side-frequencies) are involved. Thus the phase difference between the three signals will vary. This constitutes a phase modulation of the signal delivered to the receiver. Unfortunately, an f.m. receiver will respond to this phase modulation and demodulate it, producing an a.f. noise which causes an unpleasant buzz in the loudspeaker. The effect is called **multipath distortion** and applies to mono as well as stereo receivers.

In a stereo receiver there is a more serious effect. We have seen that the phase of the reconstituted 38 KHz subcarrier must be held constant with respect to the L-R components for channel separation. Under multipath reception conditions, the phase of the pilot tone (and hence the reconstituted subcarrier) with respect to the L-R components will change and lead to crosstalk between channels.

To deal with this problem a highly directive aerial should be used which is discussed on page 157.

EXTENDED RANGE

As reception of the direct signal is limited to line of sight, a shadow zone (Fig.7.10) is created beyond the horizon in which reception of the direct wave becomes impossible. However, the useful range of a v.h.f. transmitter may be



FIG. 7.10. SHADOW ZONE

more than indicated by Fig.7.10 as a result of **tropospheric refraction or scattering**.

The troposphere is the region of changing weather and clouds extending from sea-level to an altitude of about 10 miles. Refraction of v.h.f. waves by this part of the earth's atmosphere is affected by the pressure, temperature and water vapour content of the region. Because of the presence of water vapour in particular, the permittivity of the air in the troposphere is greater than unity. Since the density of the air and moisture content vary with height so does the permittivity. In general the permittivity of the air decreases with increasing altitude. The change in permittivity and hence refractive index causes bending towards the earth as a wave travels through the atmosphere. The v.h.f. wave thus travels for some distance around the curvature of the earth into the shadow zone of the direct wave (Fig.7.11).

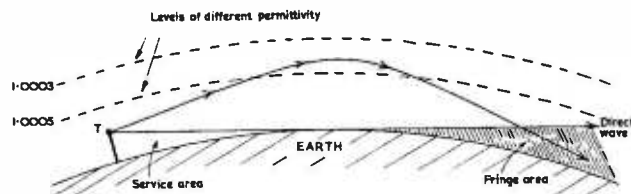

FIG. 7.11. EFFECTIVE RANGE OF TRANSMITTER INCREASED DUE TO REFRACTION BY THE TROPOSPHERE

Refraction by the troposphere is the usual mode of propagation to the fringe area of a v.h.f. transmitter. Unfortunately, tropospheric refraction is greatly influenced by weather conditions. Thus reception in the fringe area is variable. During settled weather, reception may be reliable up to 30 miles or more beyond the normal service area. With unstable conditions, reception may be inconsistent and subject to fading. In calm weather following a hot day freak reception is often possible over several hundreds of miles.

WAVE OBSTRUCTIONS

It is well known that when a medium or long wave signal meets an object such as a building or hill, the wave appears to pass through or over it without any apparent difficulty. When an opaque object lies in the path of a light beam a shadow is cast. How can such different behaviour be accounted for when the radio and light waves are identical forms of radiation? The answer is to be found in the wavelength of the radiation and the relative dimensions of the obstruction.

Suppose that the object in the path of the arriving wave of Fig.7.12 is 10 metres high and 10 metres across and that the wavelength of the arriving

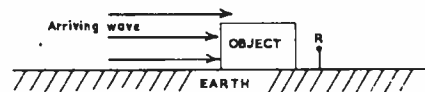

FIG. 7.12. OBSTRUCTION IN PATH OF WAVE signal is 1500 metres (L.W.—200 kHz). The obstruction will thus appear very small indeed to the advancing wavefront which will not 'see' it, i.e. the

object will be transparent to the wave. A receiving aerial located behind the object will therefore intercept the wave. On the other hand if the arriving wavefront has a wavelength of 1 metre (300 MHz), the object will appear large by comparison and the wave will be severely attenuated by an amount depending on the nature of the object. Thus, practically no signal will arrive at the receiving aerial R.

In some areas Radio 2 is transmitted on 90 MHz which corresponds to a wavelength of approximately 3.3 metres. Therefore obstructions of moderate size lying in the path of a v.h.f. wave will attenuate the signal. Consider a hill in the path of a v.h.f. wave (Fig.7.13) whose dimensions are large compared with the wavelength. When the advancing wave meets the hill, powerful

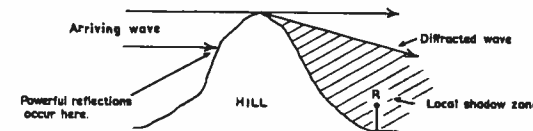
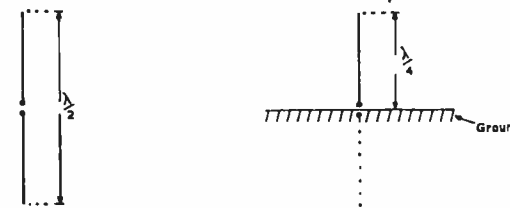

FIG. 7.13. LOCAL SHADOW ZONE CREATED BY LARGE HILL

reflections will occur and a local shadow zone will be produced. A receiving aerial R lying low down in the shadow region will be starved of signal. When the wave strikes the top of the hill some of the energy will be bent downwards into the shadow cast by the hill due to **diffraction**. Thus the receiving aerial may pick up the diffracted signal depending upon its height and distance from the hill. Obviously, raising the height of the aerial or moving it to the right may prove beneficial.

V.H.F. AERIALS

Aerials for use at v.h.f., irrespective of design, are based on either the **Hertz dipole** or **Marconi quarter-wave**, Fig.7.14. Roof and loft mounted aerials designed for f.m. reception are invariably based on the Hertz dipole. This



(a) HERTZ DIPOLE (b) MARCONI

FIG. 7.14. BASIC AERIAL FORMS

is a resonant type of aerial, i.e. its rods are cut to an optimum length so that it is resonant to the frequency of the energizing signal. In connection with the resonant properties of the aerial we must first consider a few basic facts about transmission lines.

When the length of a pair of conductors such as those in Fig.7.15(a) becomes comparable with the wavelength there may be appreciable phase difference between the voltage or current at one point and another along the line. This

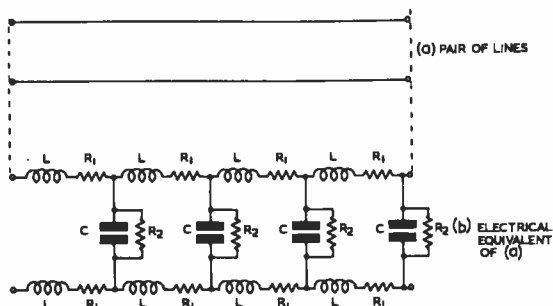

FIG. 7.15. TRANSMISSION LINES

arises from the fact that a line pair possess distributed inductance (L) along their length and distributed capacitance (C) between the conductors. Also present are the resistance of the wires (R_1) and the leakage resistance between the conductors (R_2). When a voltage is supplied to one end of the line, voltage and current travel down the line with a progressive phase lag due to the distributive reactive elements present. For a loss-less line the phase lag is equal to $W\sqrt{LC}$ radians/unit length. It should be noted that the path for the current wave is completed *via* the capacitance increments (C). If we were to measure the voltage and current at intervals along an infinite length of such a line we would discover that the ratio of voltage to current was constant. This ratio is called the **characteristic impedance** Z_0 . For a finite line with no losses the characteristic impedance is given by

$$\sqrt{\frac{L}{C}}$$

where L and C are the inductance (henrys) and capacitance (farads) per unit length. Frequency does not come into the expression, *i.e.* Z_0 is the same for all frequencies. When the voltage and current waves arrive at the end of the line they are either absorbed or reflected depending upon the termination, Fig.7.16.

With a termination of impedance equal to the Z_0 of the line, Fig.7.16(a), all the power arriving at the end of the line will be absorbed by the termination. This is the 'matched' condition for the line. If there are no losses, voltage and current at every point along the line will be of the same magnitude. Losses are always present in practice causing voltage and current to decay exponentially along the line as shown at (a).

If the termination is not equal to the Z_0 of the line, the line is said to be 'mismatched' and reflection occurs at the termination. An *o/c* or *s/c* termination [(b) and (c)] will cause all of the arriving energy to be reflected back towards the sending end. As the wave travels back down the line it is retarded in phase and attenuated in precisely the same manner as when travelling in the forward direction. The forward and reflected waves travelling in the line give rise to a standing-wave pattern. At some points the forward and reflected waves cancel to produce current and voltage minima, whereas at other points along the line addition occurs creating maxima. The maxima and minima repeat themselves regularly at $\lambda/2$ intervals. In (b) the current must be zero

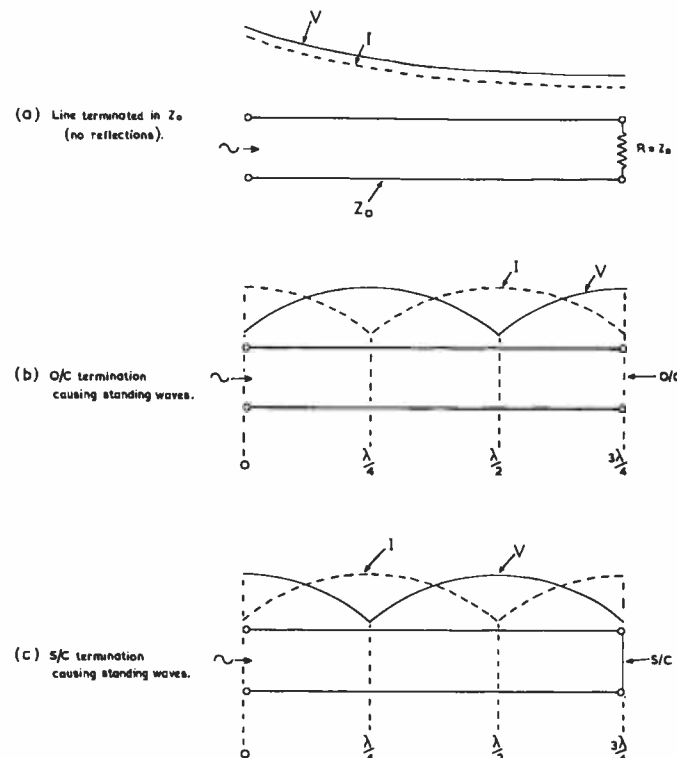

FIG. 7.16. EFFECT OF DIFFERENT TERMINATIONS

at the termination since it is *o/c* whereas in (c) the voltage is zero at the termination which is a *s/c*. Both situations represent gross mismatch of the line.

The reason that reflection occurs at the termination when it is mismatched to the line is that the wave does not 'know' what the termination is until it arrives there. A parallel situation occurs when a sound wave is directed at a wall. If the wall is of an acoustically absorbent material the sound wave energy will be absorbed; this is the matched condition. If the wall is made of brick, reflection will occur and the sound wave will travel back towards the source.

When a line is correctly terminated, the impedance everywhere is equal to the characteristic impedance (Z_0). Under mismatch conditions the impedance is alternately higher and lower than the Z_0 . This is illustrated for an *o/c* line in Fig.7.17(b). At the end of the line the impedance is high but a $\lambda/4$ back from the termination it is low. The point of interest here is that when the impedance is high or low corresponding to a voltage maximum or minimum, the phase angle is zero. Low impedance at zero phase angle meets the requirements of a series resonant circuit, whereas high impedance at zero phase angle corresponds to the conditions in a parallel resonant circuit. Trans-

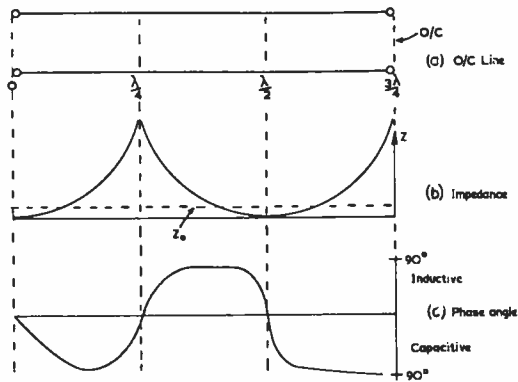

FIG. 7.17. SHOWING HOW THE IMPEDANCE AND PHASE ANGLE VARIES ALONG A LINE WITH AN O/C TERMINATION

mission lines, therefore, can be used as tuned circuit elements. An o/c line has the property of series resonance when the applied signal makes its length equal to a $\lambda/4$ of the energizing signal. If the frequency of the energizing signal makes the line length equal to a $\lambda/2$, the line behaves as a parallel resonant circuit.

There is a certain resemblance between the o/c $\lambda/4$ line and the dipole aerial which may be explained with the aid of Fig.7.18. If the lines of (a) are opened out as shown at (b), the capacitance between the lines decreases and the inductance increases, i.e. the L/C ratio increases. However, the LC product remains approximately constant, thus the voltage and current distribution are unaltered (c).

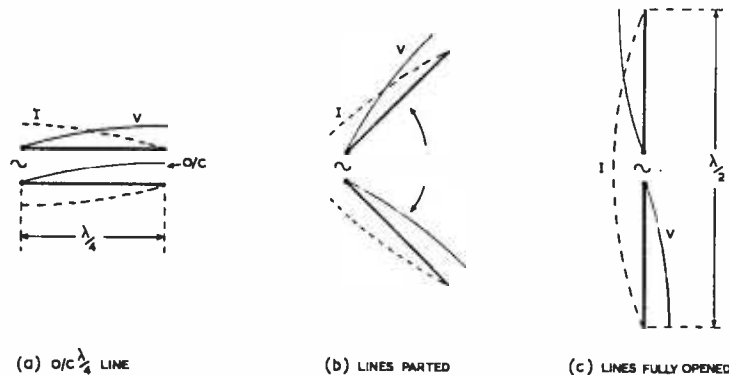

FIG. 7.18. DERIVATION OF DIPOLE FROM O/C QUARTER-WAVE LINE

Connection to the dipole is usually made at the centre where its impedance is about 75Ω . This permits a suitable match to be made to standard coaxial feeder with a Z_0 of between $70-80 \Omega$. The actual length of the dipole is made slightly less (about 5 per cent) of the value calculated from

$$\lambda = \frac{v}{f}$$

(λ = wavelength in metres, v = velocity of radio waves at 3.10^8 metres/sec and f = frequency in Hz). This is because of fringing of the electric field at the ends of the aerial rods which makes its effective length slightly greater than its physical length. A dipole tuned to the centre of the f.m. band should have an overall length of about 1.54 metres.

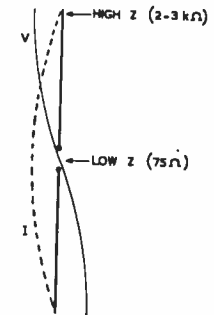

FIG. 7.19. IMPEDANCE (Z) OF DIPOLE VARIES ALONG LENGTH

The suitability of a half-wave aerial to act as a radiator may be understood by reference to Fig.7.20. Consider an instant t_1 when terminal A is (say)

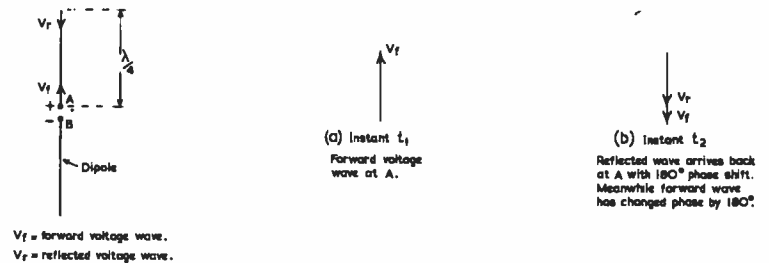

FIG. 7.20. SUITABILITY OF DIPOLE TO ACT AS A RESONANT RADIATOR

positive with respect to terminal B. The wave generated at this particular instant may be represented by the vector V_f of diagram (a). This wave will travel along the aerial rod and on reaching the end will be reflected back towards the source. In travelling to the end of the rod and returning back to A (a distance of $\lambda/2$) the wave will have received a phase lag of 180° . At instant t_2 when the reflected wave (V_r) arrives back at A, the terminals A and B will have changed polarity and the forward wave will be IN PHASE with the reflected

wave. Thus in a $\lambda/2$ aerial the reflected wave in the rods assists in the radiation of energy from the aerial which is the condition for maximum efficiency. An aerial of length equal to one wavelength would give rise to similar conditions but its physical dimensions would be unnecessarily large.

POLAR DIAGRAM

The directional performance of an aerial may be indicated by a polar diagram in which the distance from the origin to the curve represents the relative strength of the received or radiated signal in that direction.

For a vertically mounted dipole, the polar diagrams are as indicated in Fig.7.21. Diagram (a) shows a plan view looking down on the vertically mounted aerial. In this case the distance from the origin *D* to the curve is the same no matter what direction is considered. Thus the aerial is completely

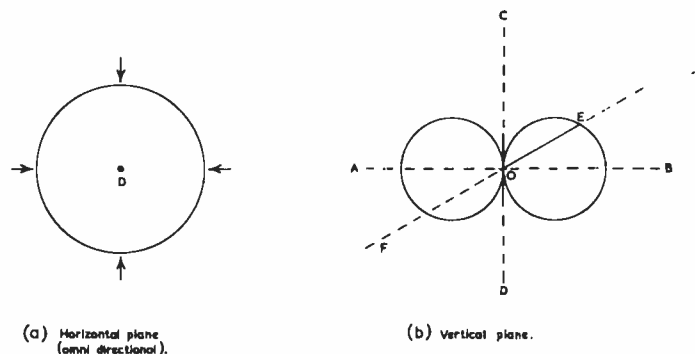

FIG. 7.21. POLAR DIAGRAMS OF VERTICAL DIPOLE AERIAL

non-directional or omnidirectional in the horizontal plane. This is not so in the vertical plane, diagram (b). Here the aerial has a maximum response to waves arriving along the direction *A—B* but zero response to waves arriving along the path *C—D*. A wave, however, arriving from *E* along a path *E—F* would have a relative strength as indicated by the solid line *OE*. For a horizontal aerial, as used in f.m. transmissions, diagram (a) represents the polar diagram in the vertical plane and (b) in the horizontal plane. To extract the maximum possible signal, therefore, the f.m. dipole should be orientated so that it faces the transmitted signal path, i.e. as at (b) if the transmitted signal path is along *A—B*.

In its basic form the dipole may be used in areas of high signal strength where reflected signals are of little importance.

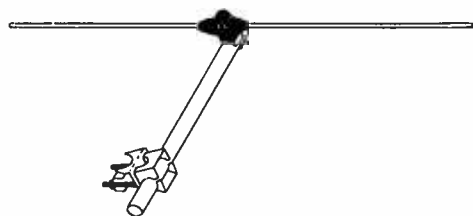

FIG. 7.22. DIPOLE AERIAL FOR STRONG SIGNAL AREAS (AERIALITE)

AERIAL ARRAYS

The directional characteristics of the basic dipole may be considerably improved by positioning additional elements close to it to form an array. The simplest array consists of a dipole and a reflector arranged in H form. A reflector is a conductor having a length slightly greater than the dipole and is placed about a $\lambda/4$ from it as shown in Fig.7.23. The reflector is not broken at the centre like the dipole but is a continuous conductor. By making the

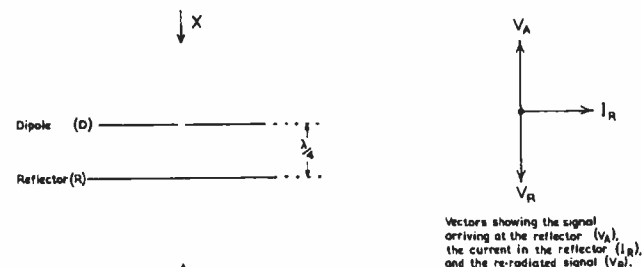

FIG. 7.23. DIPOLE PLUS REFLECTOR

reflector longer than the dipole it will have an inductive reactance at the frequency to which the dipole is tuned.

The addition of a reflector modifies the polar diagram to that shown in Fig.7.24. We will now briefly consider the reason for this. Suppose that a transmission is being received from the direction *X*. The arriving wave will

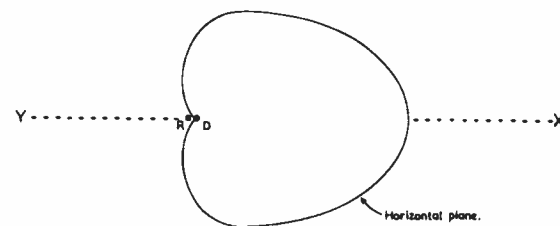

FIG. 7.24. POLAR DIAGRAM OF DIPOLE PLUS REFLECTOR (VERTICALLY MOUNTED)

be intercepted by both the dipole AND the reflector. However, the signal arriving at the reflector (*V_a*) will be lagging on the signal arriving at the dipole by 90° due to the extra $\lambda/4$ the signal must travel to reach the reflector, Fig.7.23. The signal voltage induced in the reflector will set up a current in it (*I_r*) lagging behind *V_a* by approximately 90°, since the reflector is inductive. The reflector reradiates a signal (*V_r*) lagging by 90° on the reflector current, i.e. lagging 180° behind *V_a*. This reradiated signal is picked up by the dipole but lagging *V_r* by a further 90° because of the $\lambda/4$ spacing. Thus the wave arriving at the dipole from the reflector will be out of phase by 360° or in phase with the direct signal arriving at the dipole. In consequence the two signals augment one another.

When a wave is arriving from the *Y* direction, the signal arriving at the reflector (*V_a*) gives rise to a reradiated signal (*V_r*) as before and 180° out of

phase with V_a . The direct signal arriving at the dipole will lag V_a by 90° due to $\lambda/4$ spacing. The reradiated signal arriving at the dipole will lag V_r by 90° which will cancel the 90° lag of the direct signal. Thus the two signals arriving at the dipole will be 180° out of phase with one another and therefore cancel. By applying similar reasoning for other directions of approach to the array, the polar diagram of the H aerial may be deduced.

The polar diagram now favours the desired signal approaching from X and removes the effects of unwanted interfering signals, particularly from the Y direction. Thus a very large improvement in signal/noise ratio is obtainable with the H aerial over the basic dipole. This factor is usually referred to as the **front-to-back ratio** which for the dipole is 0 dB and for the H aerial theoretically infinite.

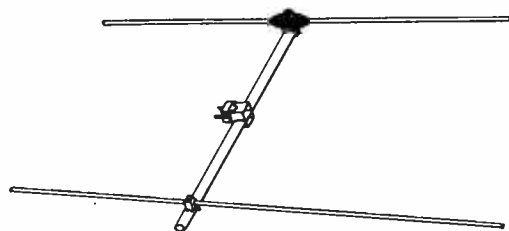

FIG. 7.25. H AERIAL (AERIALITE)

The addition of the reflector element increases the gain over the dipole by about 3 dB in the forward direction. Aerial gain is an important factor on f.m. if the high signal/noise ratio obtainable with an f.m. receiver is to be realized. The a.m. limiter included in the receiver requires a large input signal to function efficiently. If the aerial is incapable of delivering a large signal to the receiver the noise in the output will be excessively high. Also, the receiver a.g.c. needs to be driven hard so that it can assist in optimum noise reduction. On stereo, as explained in Chapter 2, the signal/noise ratio may be as much as 20 dB down on mono reception: thus aerial gain becomes even more an important factor. Whilst it is true that reception of a local transmission can often be obtained on an elementary form of aerial (the odd length of wire at times) and may sound quite good, it will be much better if a correctly designed aerial is used on account of the reduction in the noise level at the output. This is particularly noticeable on stereo.

ADDING DIRECTORS

To improve directivity additional elements may be added to the H aerial to form a **Yagi array**, named after a Japanese engineer who developed the

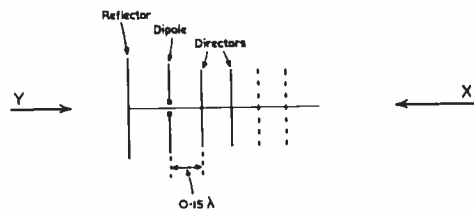

FIG. 7.26. THE YAGI ARRAY

idea about 40 years ago. The Yagi array, Fig. 7.26, forms the basis for nearly all v.h.f. and u.h.f. aerials intended for domestic use.

The additional elements, called **directors**, are slightly shorter than the dipole and are placed on the opposite side to the reflector with a spacing of about 0.12λ . One or more directors may be used in the array and, like the reflector, they are continuous conductors. The length and spacing of the directors are adjusted so that the reradiated signals from them assist the signal arriving at the dipole when the transmitted signal approach is from the direction X.

The effect on the polar diagram of adding directors is to increase the forward gain and reduce the beam width as shown in Fig. 7.27. Any number of director elements may be added to provide further increase in gain. The

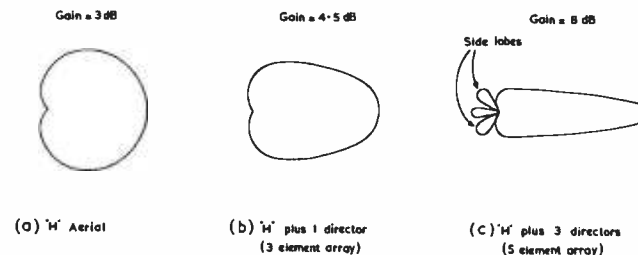

FIG. 7.27. EFFECT ON POLAR DIAGRAM OF ADDING DIRECTORS (VERTICALLY MOUNTED—HORIZONTAL PLANE)

extra yield in gain is about 1.5 dB per element up to five directors but falls off as more directors are added. Unfortunately, as more directors are added the polar diagram is more difficult to control and side-lobes sometimes appear. However, the greatly improved directional properties of a multielement array will be of considerable use in controlling multipath distortion which was discussed on page 147. The extra yield in forward gain that may be obtained with an array incorporating several directors like the J-Beam FM6S of Fig. 7.28 may be used to improve the signal/noise ratio of stereo reception outside the service area where reception is liable to vary. Also, in suitable locations, the reception of continental stereo programmes may be made possible.

In general, the design of an aerial array is a compromise between the following features: (a) Gain; (b) Beamwidth; (c) Front/Back Ratio; (d) Side-Lobe production; (e) Bandwidth; and (f) Impedance. So far nothing has been said about aerial bandwidth which is important. The European Broadcast Band extends from 87.5 MHz to 100 MHz and the aerial should be capable of efficient operation over the band. To cover the three local stations in any one area a bandwidth of about 5 MHz is needed (the spacing between stations being 2.2 MHz in most areas). It has been shown that a dipole aerial is a resonant system and so will favour certain frequencies at the expense of others. To achieve a broadband characteristic it is necessary to reduce the resonant effects, *i.e.* to reduce the Q of the aerial. If the diameter of the aerial rods is made large, the effective Q is substantially reduced and the bandwidth increased. This arises from the fact that a thick aerial conductor has a larger capacitance and a smaller inductance than a thin conductor hence the 'stored' electric and magnetic energy will be less (for a given aerial current). The dia-

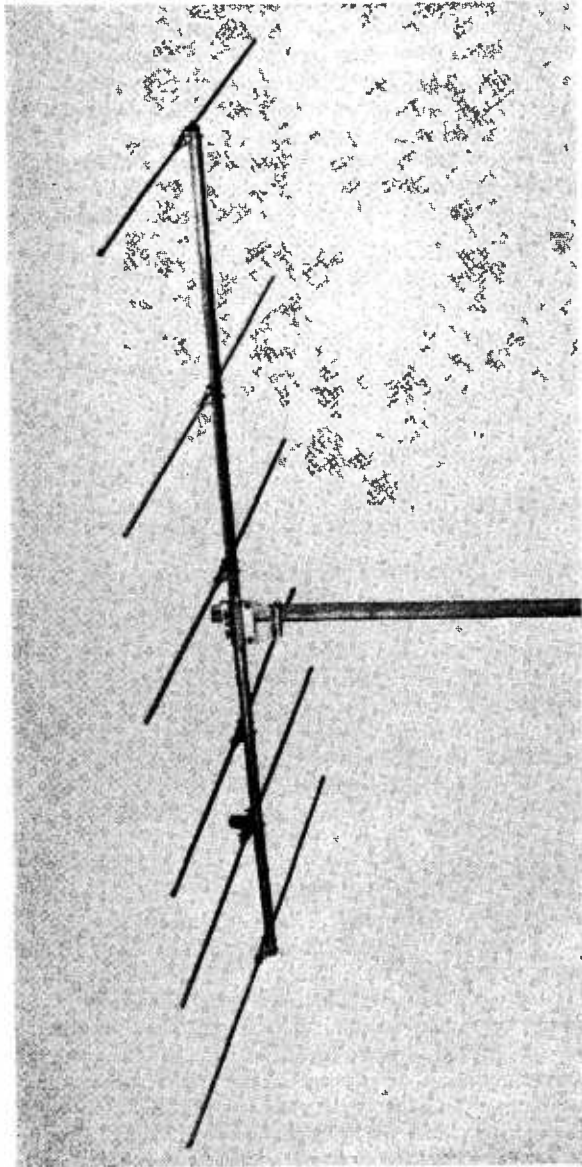

FIG. 7.28. YAGI WITH FOUR DIRECTORS (1 BEAM FM6S)

FIG. 7.29. FM6S POLAR DIAGRAM H PLANE ($f = 92$ MHz
(Manufacturer's Figures))

FIG. 7.30. FM6S GAIN VERSUS FREQUENCY

meter of the rods for an f.m. aerial should be at least 10 mm. The odd length of thin wire is equivalent to a fairly high Q system and therefore has a relatively narrow bandwidth: it is therefore no substitute for a real aerial.

Fig. 7.30 shows the gain-frequency curve for the J-Beam FM6S aerial shown in Fig. 7.28. This aerial has a response which is 'flat' to within 1 dB over the frequency range of 81—98 MHz making the aerial suitable for wide band operation. A maximum forward gain of 8 dB is obtainable, this being relative to a $\lambda/2$ dipole. Sometimes aerial gain is referenced to an 'isotropic' aerial which is an element that will receive a signal with equal efficiency from ANY direction. An isotropic aerial is purely a theoretical idea with no practical counterpart. The half-wave dipole has a gain of about 2 dB over the isotropic element, thus gain figures of aerial arrays referenced to the isotropic aerial can be made to look better by 2 dB.

Another important factor is impedance. A plain dipole has a centre impedance of about 75 Ω . However, when the dipole is incorporated into a Yagi array, the presence of the reflector and directors lowers the impedance to about 20 Ω . For this reason a folded dipole (Fig. 7.31) is often used as the

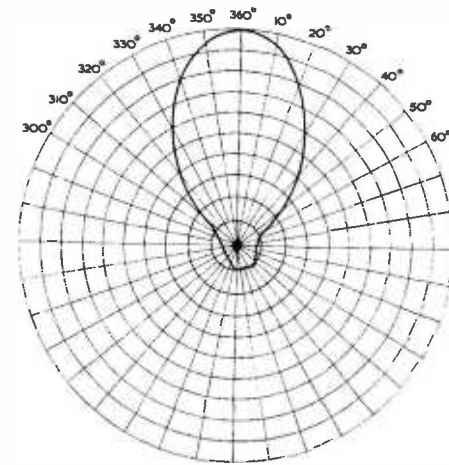
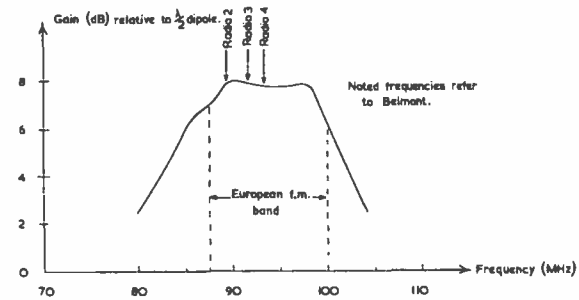
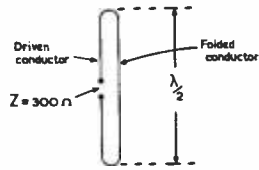

FIG. 7.31. FOLDED DIPOLE

main element in an array. Like the ordinary dipole, the folded dipole has an overall length of $\lambda/2$ less about 5 per cent to allow for the 'end' effect. The aerial consists of two conductors in parallel sometimes called the **folded** and **driven** parts. If the diameters of the two conductors are the same the current in each will be the same and half of that in a plain dipole. Because the available signal current is divided, the centre impedance is raised by a factor of four to 300Ω . When a folded dipole is featured in a Yagi array the centre impedance is lowered to about 75Ω thus enabling a good match to be made to standard 75Ω cable. By making the diameters of the two conductors unequal the centre impedance of the folded dipole can be made larger or smaller than 300Ω . Advantage is taken of this in the design of arrays having many directors.

An array using a folded dipole for the main element and the reflector is shown in Fig. 7.32. This array has an overall gain of 7 dB reference to a half-wave dipole and is specially designed to give the minimum response to unwanted signals to overcome the effects of multipath reception. Spacing between the first and second directors is 0.25λ , second director and dipole 0.1λ , and between dipole and reflector 0.22λ . The conductors forming the folded reflector carry equal currents, their total aperture approximating a sheet of metal $0.5 \times 0.75 \lambda$. This permits a good front-to-back ratio to be obtained without off-tuning the directors, the design objective being a clean polar diagram free from side-lobes.

Some improvement in forward gain may be achieved by stacking Yagi arrays one above the other. This technique requires special matching and phasing of the aerials and will not be considered here. Often the extra yield in gain achieved by stacking is disappointing.

FIELD STRENGTH

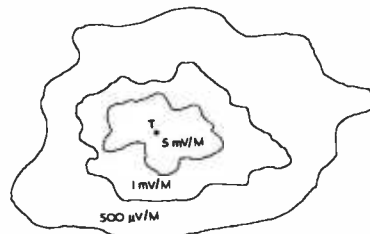

FIG. 7.33. FIELD STRENGTH CONTOURS

Field strength is usually expressed in mV/metre or μV /metre and the figures are noted on field strength contour maps published at the opening of a new transmitter. These maps give some idea of the expected signal strength in the area served by the transmitter. Precisely what do such figures mean in terms of the signal voltage picked up by the receiving aerial and the signal level developed at the receiver input?

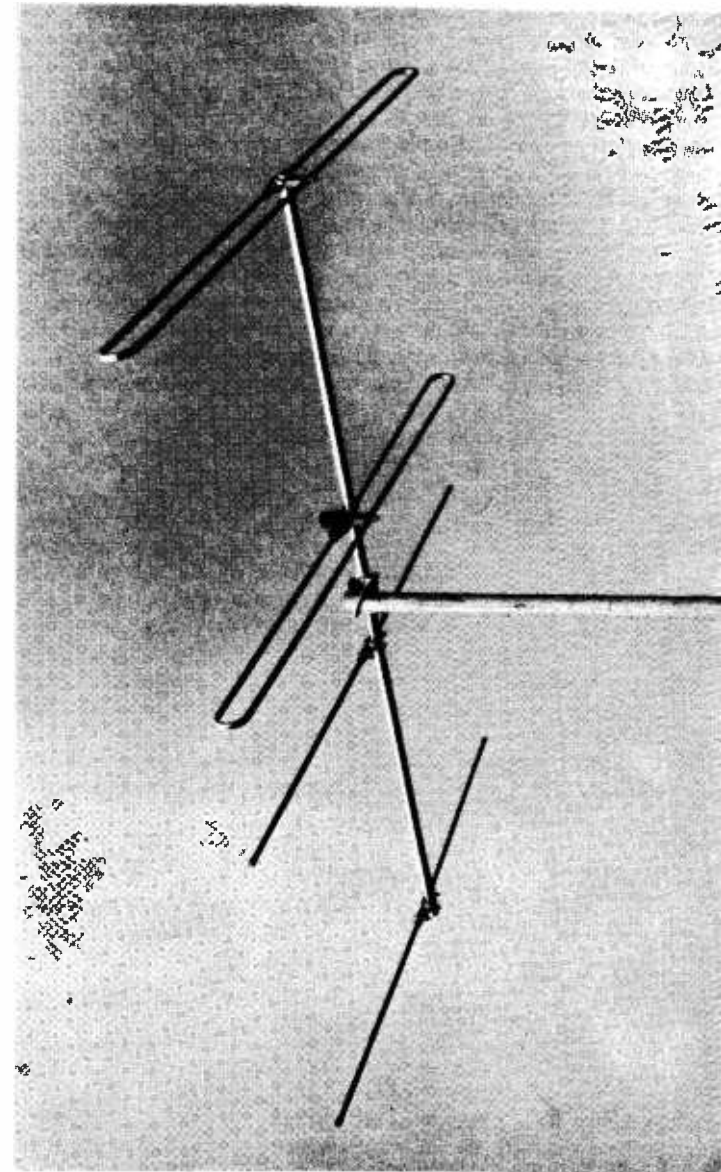

FIG. 7.32. YAGI WITH FOLDED DIPOLE AND FOLDED REFLECTOR (J BEAM FM'S)

The strength of the field radiated by a transmitter can be expressed as the p.d. set up between any two points 1 metre apart and lying in the electric field of the wave. For example, if the field strength is 5 mV/m and the two points are 1 metre apart there would be a p.d. of 5 mV between them. With a 4 metre spacing the p.d. would be 20 mV. Assuming equal field strengths it is clear that a $\lambda/2$ aerial designed for operation on 100 MHz will have a larger signal voltage developed in it than a $\lambda/2$ aerial operating on 500 MHz since the former aerial will be longer.

Consider now a practical example where a plain dipole is suitably orientated in the field of an advancing wave transmitted on a frequency of 100 MHz and the aerial is lying in a field of strength 2 mV/m. A dipole tuned to 100 MHz will have a length of approximately 1.5 metres. Thus the p.d. between its ends when lying in a 2 mV/m field will be 3 mV. The actual value will be about 2/3rds of this because not every part of a dipole is a useful interceptor of the advancing wave. The current distribution of the dipole provides a measure of the effectiveness of different parts of the aerial as a wave interceptor (Fig. 7.34). At the ends of the aerial where the current is zero it is of no value but at the centre where the current is high it is most useful. Thus

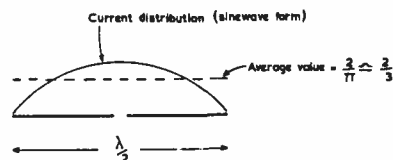

FIG. 7.34. CURRENT DISTRIBUTION OF DIPOLE SHOWS EFFECTIVENESS OF AERIAL AS WAVE INTERCEPTOR

the actual signal voltage in the aerial will be $3 \text{ mV} \times \frac{2}{3}$ (approximately the average value of the current distribution) = 2 mV. Does all of this voltage arrive at the receiver?

With a correctly matched system (Fig. 7.35) the impedances will be the same throughout. The receiver input impedance must correctly terminate

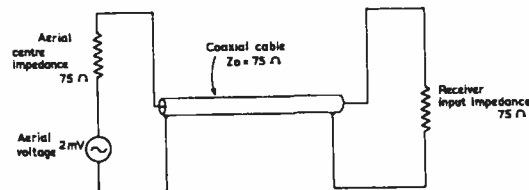

FIG. 7.35. CORRECTLY MATCHED CONDITIONS—RECEIVER SIGNAL INPUT EQUALS ONE HALF OF AVAILABLE AERIAL VOLTAGE

the coaxial cable to avoid reflections and be equal to the aerial impedance for maximum power transfer. In these circumstances (assuming no cable loss) only a half of the available aerial voltage will appear at the receiver input terminals i.e. 1 mV. If a Yagi array were used with a 9 dB gain over the plain dipole, the signal voltage delivered to the receiver would be $1 \times 2.8 = 2.8 \text{ mV}$.

Summarizing, it may be said that an aerial for receiving f.m. stereo signals should meet the following requirements:

(1) It must have sufficient gain to give a signal that will result in optimum noise suppression at the receiver. In areas of high signal strength a roof-mounted plain dipole will normally be adequate and will provide some discrimination against interfering signals arriving at right angles to the wanted signal. (If the aerial has to be mounted in the loft a three-element array is worth the extra expense on account of its higher gain and directivity). At more distant ranges a roof-mounted H or simple Yagi will be necessary and in the fringe area a multielement array will be required to pull in sufficient signal. For long-distance (DX) reception an aerial amplifier and/or aerial rotator are useful accessories to a high gain aerial in extracting the largest possible signal to drive the receiver into full amplitude limiting.

(2) The aerial must have sufficient bandwidth to receive at least Radio 2, 3 and 4 with no large 'dips' in the response, thereby ensuring that these programmes are received equally well.

(3) To overcome multipath distortion the aerial should possess sufficient directivity, achieved by a clean polar diagram as free as possible from side-lobes.

In addition, the aerial should be mounted as high as possible in a clear site. Metallic objects in the vicinity of the aerial may alter its polar diagram impairing its gain and directivity. This is a particular problem with loft-mounted aerials since the loft space often contains a water tank with associated plumbing, electric wiring and gas-pipe runs. In these circumstances the effect on the polar diagram is difficult to predict and considerable patience is required in locating an optimum position for the aerial. Finally, the impedance of the aerial, feeder and receiver should be the same throughout to ensure freedom from line reflections and to provide maximum transfer of the aerial signal to the receiver.

8

THE REPRODUCTION OF
STEREO SOUND

THE relative placing of loudspeakers and listeners determines the effective sound stage width. This cannot be too closely specified as it is subjective; what may constitute an adequate stereo sound system for one person may be totally unacceptable to another. The size of the room and its furnishing also plays an important part and each case must be considered individually. The usual procedure is to base the system design on theory as far as possible and then to move the speakers and furniture about until a satisfactory result is obtained.

There are obvious types of transmitted programme in which a wide sound stage is directly desirable, as in drama, opera and similar productions where an indication of the position and movement of the characters is important.

Another advantage to be gained by the use of stereo is that of selective listening. It becomes possible for a listener to concentrate on one particular instrument in the orchestra, or on one speaker out of a group of speakers, by mentally concentrating on the desired sound. An attempt to record a public meeting or a party using a mono tape recorder will show how important this effect can be. What appears to be a normal conversation on recording produces an unintelligible jumble of sound on playback. Stereo improves the selectivity, enabling extraneous sound sources and noise to be filtered out by the brain.

Sound position location by the ears and brain is dependent upon the sound intensity. There is a minimum level below which the stereo effect is lost. If a stereo receiver is used to provide background music it may as well be switched to mono. Presumably the brain sacrifices location information for sensitivity when attempting to hear weak signals. Unless a reasonably high sound level is used the feeling of 'presence' at an orchestral concert is entirely lost.

The qualities of a stereo system may be summarized as follows:

- (1) Reproduction of the reverberant characteristics of the original studio or concert hall.
- (2) Location of the sound sources and their movement.
- (3) Improved selective listening.
- (4) A wide sound stage.

REVERBERATION

One of the paradoxes of stereo sound reproduction, as far as orchestral music is concerned, is that the players are concentrated reasonably close together in the concert hall or studio in order to REDUCE the audio stage in both depth and lateral spread. Consider the undesirable effect that would be produced if the orchestra were arranged in a single line across the stage. But

the aim in stereo reproduction is to SEPARATE the sound to give a large audio stage width.

At first it may be thought that the reproduction of narrative or the sound of a solo instrument would benefit little by the use of stereo as the sound is virtually originating from a point-source. In practice, considerable improvement in realism is obtained by the reproduction of reflected sounds from the walls, floor and ceiling of the studio or hall. This is known as **reverberation** and the reproduction of these reflected sounds makes the use of a wide sound stage desirable. However closely packed the orchestra may be the reflections from the boundaries of the room produce a distinctive rich tone which requires a wide sound stage to give 'realism' or a sense of 'presence'.

Reverberation and echoes are both produced by reflected sound waves. If the reflected sound is more than about 0.1 second delayed it is heard separately from the incident sound wave and the effect is that of an echo. For time-delays less than this the incident and reflected sounds merge together and produce reverberation. As sound travels approximately 34 metres in 0.1 second the listener has to be at least 17 metres from the nearest wall to hear any appreciable echo. With the average size lounge we can obviously discount echoes produced at the receiving end. But echoes may be present in the transmitted information due to the characteristics of the concert hall or studio in which the performance is taking place.

Whilst the size of a room determines the DELAY of the reflected sound, the furnishings and floor, wall and ceiling materials determine the DECAY of the sound with time. In general this decay is the more important factor as it affects the quality of sound and intelligibility of speech.

To illustrate this consider the quality of sound in a cathedral. The building is large and the delay of the reflected sounds long, but the echoes produced are of low intensity as they decay away reasonably quickly. Compare this with the sound characteristics of an indoor swimming pool. Here the building is smaller and the sound delays reduced, but as there is almost a complete absence of absorbent material the decay time is very long and sound may rebound from wall to wall for several seconds. The effect of this is often to make speech unintelligible and the average noise level uncomfortably high.

For this reason the acoustic characteristic of a room is measured in terms of **reverberation time**, which is the time taken for the average sound energy density to fall by 60 dB after the sound source is switched off. A very approximate indication of this can be obtained by giving a loud hand-clap in a room and noting the time for the sound to disappear.

Some typical reverberation times are:

Lecture halls: $\frac{3}{4}$ to 1 second.

Cathedrals: 6 to 12 seconds.

Concert halls: $1\frac{1}{2}$ to 2 seconds.

With lack of reverberation a room feels acoustically 'dead'; it is difficult for a speaker or singer to project the sound into the room as there is no re-

inforcement by reverberant power. With too much reverberation there is a build-up of sound which leads to confusion and unintelligibility.

The reverberation time may be calculated using Eyring's formula:

$$t = \frac{0.05V}{-S \ln(1-\alpha)} \text{ seconds}$$

where V = volume of the room (cubic feet)

S = surface area (square feet)

α = absorption coefficient (0.4 typical for a small furnished room).

[\ln is the natural logarithm to a base of 'e' (2.718)]

This gives an approximate reverberation time of 0.2 second for a well-furnished lounge with a fitted carpet.

It may appear that it is impossible to reproduce the sounds of a full orchestra with any degree of accuracy in a small lounge as the reverberation time of the listening-room is too small. This is not entirely true as the reverberant sounds of the concert hall are reproduced in the listening-room by using stereo.

In practice the reverberation and delay times of the average lounge can be ignored compared with those of the original recording conditions. A stereo recording of organ music in a cathedral illustrates this very well. The organist may finish with a loud chord which echoes round the room for several seconds before decaying away, just as in the cathedral; but the room itself would not be big enough to sustain this sound even if the organ were actually present in it. The characteristics of the cathedral are 'transferred' to the lounge by the stereo system, sometimes called **artificial reverberation**.

Resonant modes in a room can be troublesome as certain frequencies are increased in amplitude by natural resonance. These frequencies are determined by the actual dimensions of the room and cavities within it, but the effect can usually be minimized by distributing the furniture evenly to break up or diffuse the sound, and particularly by not leaving the centre of the room empty. The location of the loudspeakers also determines which modes are 'excited'. When the source of sound is in one corner of the room there is a tendency to produce low-frequency peaks and it is often preferable to site the loudspeakers on the longer sides of the room, Fig.8.1.

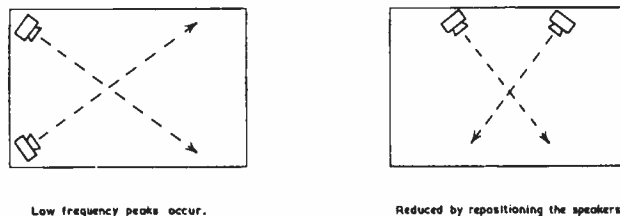

Low frequency peaks occur.

Reduced by repositioning the speakers

FIG. 8.1. REDUCTION OF LOW FREQUENCY RESONANCE BY SPEAKER POSITIONING

THE LOCATION OF SOUND SOURCES

The two possible errors in locating the position of a sound source are:

- (a) angular position error; and
- (b) distance or range error.

The relative positions of the loudspeakers with respect to the listener should be chosen so as to minimize these errors over as much of the sound stage as possible.

(a) Angular position error

Consider the interaural time-difference, T_d , actually heard by a listener to the original sound source, S , at a true angle, θ_i , to the centre line.

Although the actual spacing between the ears is about 0.16 m it is found that the 'effective' spacing is 0.2 m due to the curved path round the head that the sound has to travel to reach the more distant ear.

In Fig.8.2

angle $ABO \simeq \theta_i$

$\therefore OA = 0.2 \sin \theta_i$ m

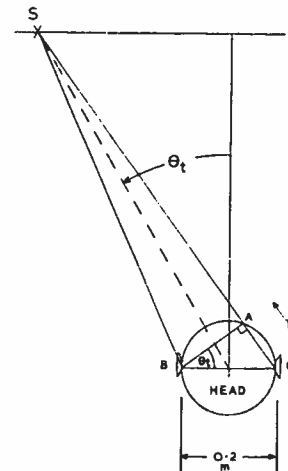

FIG. 8.2. THE TIME-DIFFERENCE HEARD, T_d , FROM A SOUND SOURCE AT S

Taking the speed of sound to be 335 m/s, the delay time, T_d , is given by

$$T_d = \frac{OA}{0.335} \text{ ms}$$

$$\therefore T_d = \frac{0.2 \sin \theta_i}{0.335} \simeq 0.6 \sin \theta_i \text{ ms} \dots \dots \dots (1)$$

This formula agrees well with experimental results obtained by Dr. Leakey using six different listeners.* The corresponding phase difference ($\beta - \alpha$) between the signals arriving at the left and right ears is ωT_d , where ω is the angular velocity of the sound wave.

Hence, $\beta - \alpha = 6 \times 10^{-4} \omega \sin \theta_i$ radians.....(2)

We may now assume that position sensing is either by intensity difference

* Leakey, D. M., "Stereophonic Sound Systems" *Wireless World*, April, 1960, pp 154-160.

OR interchannel time difference. The relation between the two is derived in Appendix A.

Equation (2) gives the phase difference from a source at a true angle θ_t . We must find the left and right ear signals produced in the microphones from a source at the same position. Consider a CIRCULAR sound stage, i.e. the sound is at the same intensity whatever the angle θ_t .

From a source, S, the left and right microphones pick up signals proportional to OA and OB respectively, Fig.8.3.

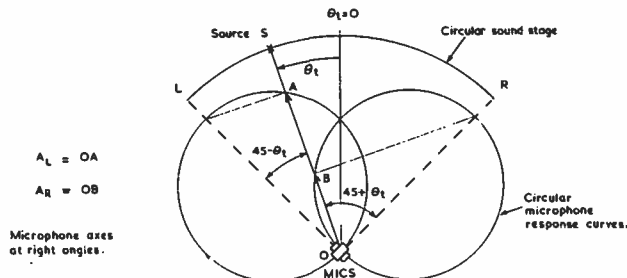

FIG. 8.3. DETERMINATION OF MICROPHONE SIGNALS A_R AND A_L FROM A SOURCE S

Let the peak microphone response (diameter of the polar circle) be $\sqrt{2}$ by a suitable choice of sound units, then

$$\left. \begin{aligned} OA &= \sqrt{2} \cos (45 - \theta_t) = \cos \theta_t + \sin \theta_t = A_L \\ OB &= \sqrt{2} \cos (45 + \theta_t) = \cos \theta_t - \sin \theta_t = A_R \end{aligned} \right\} \dots\dots\dots(3)$$

The signals A_L and A_R are coded, transmitted, decoded and fed to two loudspeakers. Appendix A shows that the effective phase angle heard by the listener ($\beta - \alpha$), will be given by

$$\tan (\beta - \alpha) = \frac{(A_L^2 - A_R^2) \sin \omega T_d}{2 A_L A_R + (A_L^2 + A_R^2) \cos \omega T_d}$$

where T_d is the interchannel time difference introduced by the positioning of the left and right speakers, and ω is the angular velocity of the audio signal.

Consider the effect at low frequencies, ω is small. Then the phase angle ($\beta - \alpha$) will also be small.

$$\begin{aligned} \text{Hence } \tan (\beta - \alpha) &\simeq (\beta - \alpha) \\ \cos \omega T_d &\simeq 1 \\ \text{and } \sin \omega T_d &\simeq \omega T_d \end{aligned}$$

Then

$$(\beta - \alpha) = \frac{A_L - A_R}{A_L + A_R} \omega T_d$$

Substituting for A_L and A_R from equation (3) gives

$$(\beta - \alpha) = \tan \theta_t (\omega T_d) \dots\dots\dots(4)$$

If the speakers are placed at an angle ψ from the centre position, Fig.8.4, the time delay, T_d , is fixed at

$$6 \times 10^{-4} \sin \psi \text{ by equation (1).}$$

The phase angle ($\beta - \alpha$) gives the *apparent* source position angle θ_a ,

$$\text{where } (\beta - \alpha) = 6 \times 10^{-4} \omega \sin \theta_a \text{ from equation (2).}$$

Substituting for ($\beta - \alpha$) and T_d in (4) gives the relationship between the true angle θ_t and the apparent angle θ_a as

$$\sin \theta_a = \tan \theta_t \sin \psi \dots\dots\dots(5)$$

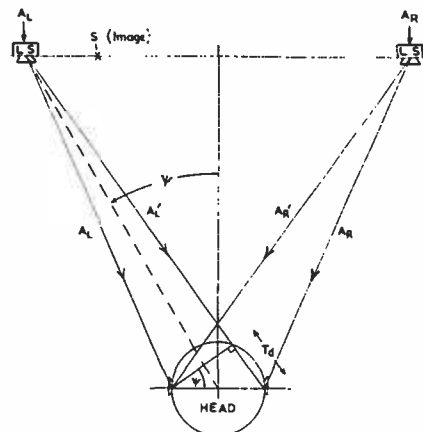

FIG. 8.4. SPEAKERS PLACED AT ANGLE ψ FROM CENTRE TIME DELAY $T_d = 0.6 \sin \psi$ ms

Equation (5) may now be used to calculate the angular position error. With the microphones at right angles, each at 45° to the centre of the sound stage, Fig.8.3, we have a convenient reference point. A signal from a source 45° from centre will provide an output from ONE speaker only. Therefore, if the speaker angle ψ is made 45° the listener locates the sound position EXACTLY, as he is simply locating the position of a loudspeaker in a room. The sound location is then exact at three points: 45° to the left, the centre of the sound stage, and 45° to the right. At this listener position, which we may call the microphone 'image' position, the listener hears the sound just as if he were standing where the microphone is placed.

Substituting $\psi = 45^\circ$ in equation (5) will give the angular position error for this situation. Values are tabulated in Appendix C. Fig.8.5 shows a graph of apparent angle θ_a plotted against the true angle θ_t .

In this calculation the frequency of the sound signal was assumed to be low, say below 600 Hz. We must now consider the behaviour of the system at frequencies above this, remembering that the sound will not normally be a 'pure tone' but a very complex waveform of different frequency components.

Ambiguity occurs at the 'inversion' frequency where T_d corresponds to half a wavelength of the sound wave. The left and right signals are then in antiphase and theoretically it is impossible to locate the sound source.

At $\theta_t = 45^\circ$, $T_d = 0.424$ ms from equation (1).

This corresponds to half a wavelength of frequency

$$\text{where } f = \frac{1}{2 T_d} = \frac{10^3}{0.848} = 1180 \text{ Hz.}$$

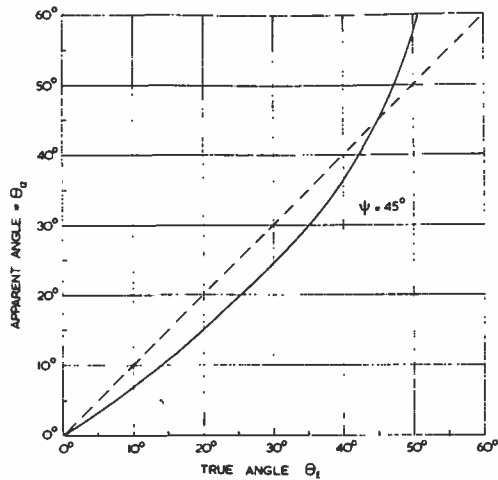

FIG. 8.5. ANGULAR POSITION ERROR, $\psi = 45^\circ$

This is the inversion frequency and is usually taken as 1200 Hz.

At angular positions with θ_t less than 45° this frequency will be higher and so the 'outer' positions of the sound stage should be the first to exhibit this inversion effect.

It is found that between 1200 and 2000 Hz it is difficult to locate a sound source exactly. (Incidentally, this is the range of frequencies used by many animals for danger signals). Note that there is not necessarily an error introduced into the position location, just a falling off in resolution or sensitivity.

Above this 'blind spot' range we find that it becomes possible to locate sound sources with increasing accuracy. This indicates that there must be some alternative mechanism by which the brain converts the incoming signals to angular position, as the previous 'pure tone' theory has broken down. It appears that the brain is triggered by the initial wave front of a high frequency sound wave and measures the time-difference between the impulse reaching first one ear and then the other, Fig. 8.6(a).

When the sound impulse is picked up by the microphones, two electrical signals A_L and A_R are produced that differ in amplitude but are exactly in phase, Fig. 8.6(b). These signals are applied to the two loudspeakers, situated at say ψ° to the centre, which produce sound signals in the ears as shown in Fig. 8.6(c). Note that the time interval T_d is now CONSTANT and is determined by the speaker spacing only.

We assume that the brain combines or synthesizes the pairs of pulses received at each ear to form a single equivalent pulse of amplitude $A_L + A_R$. The effective time at which these equivalent pulses occur will lie somewhere between the two original signals A_L and A_R and depends upon their relative amplitudes, Fig. 8.7.

Combining A_L and A_R by moments we see that

$$(A_L + A_R) x = A_R T_d$$

and by symmetry the apparent time interval between the left and right pulses is

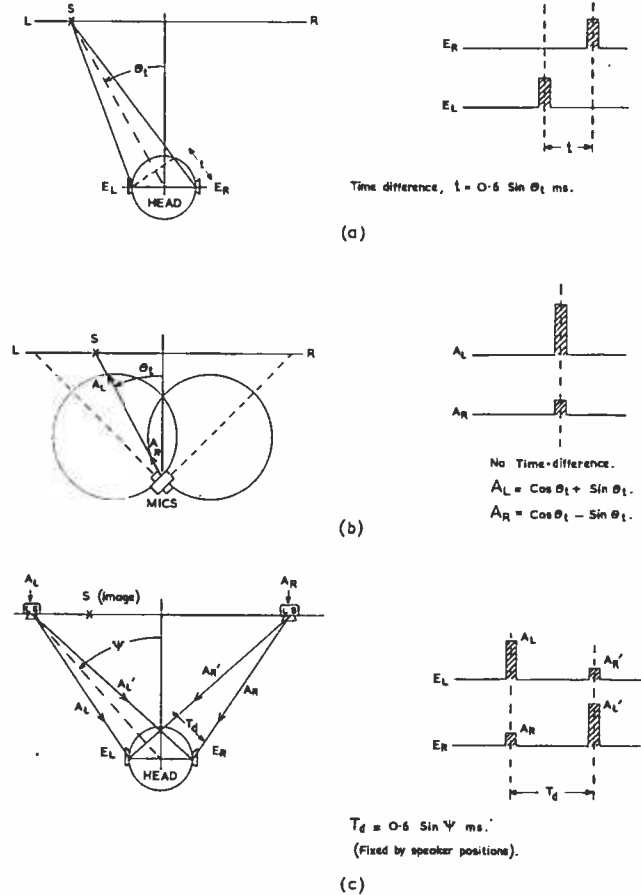

FIG. 8.6. THE EFFECT OF A SOUND IMPULSE

- (a) On the cars
- (b) On the microphones
- (c) From the speakers to the ears

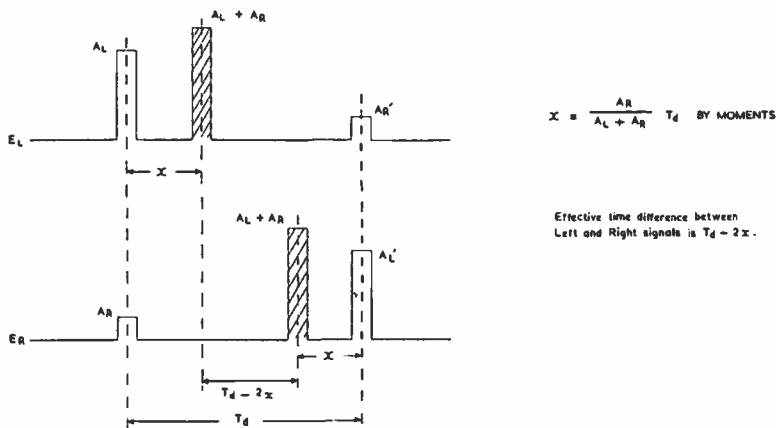

FIG. 8.7. THE SYNTHESIS OF THE SOUND IMPULSES BY THE BRAIN TO FORM SINGLE LEFT AND RIGHT SIGNALS

$$t_{app} = T_d - 2x$$

$$= T_d \left[\frac{A_L - A_R}{A_L + A_R} \right]$$

from equation (3) $\frac{A_L - A_R}{A_L + A_R} = \tan \theta_t$

from equation (1) $T_d = 0.6 \sin \psi$ ms
for a speaker angle ψ , and the sound appears to come from a position angle θ_a

where $t_{app} = 0.6 \sin \theta_t$.
Hence $0.6 \sin \theta_a = 0.6 \sin \psi \tan \theta_t$
giving the same equation as before

$$\sin \theta_a = \tan \theta_t \sin \psi \dots \dots \dots (5)$$

The apparent position of a sound as located by the brain is not known to be frequency dependent, so whilst we are not sure how the brain actually deals with these sound signals, the above approach would seem reasonable as it produces the same apparent angle for frequencies both above and below the inversion frequency.

Increasing the Speaker Angle ψ

Whilst Fig.8.5 shows the angular position error for a speaker angle of 45° , we must see if the situation can be improved by choosing other values of ψ . Increasing the speaker separation increases ψ which has the same effect as the listener moving towards the sound stage, Fig.8.8.

If ψ is increased from 45° to 60° the listener appears to move from 0 to $0'$, as sound sources A and B, initially at 45° , now appear to be at 60° .

By applying the sine formula to triangles OBO' and OSO' we find that

$$\cot \theta'_t = \frac{\cos \theta_t - 0.3}{\sin \theta_t} \dots \dots \dots (6)$$

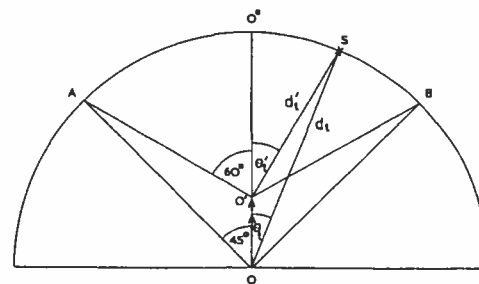

FIG. 8.8. CIRCULAR SOUND STAGE CORRECTION FOR $\psi = 60^\circ$

For practical purposes this gives a linear relationship between θ_t and θ'_t for θ_t from 0° to 50° .

Using equations (5) and (6) an angular position error curve, Fig.8.9, can be constructed.

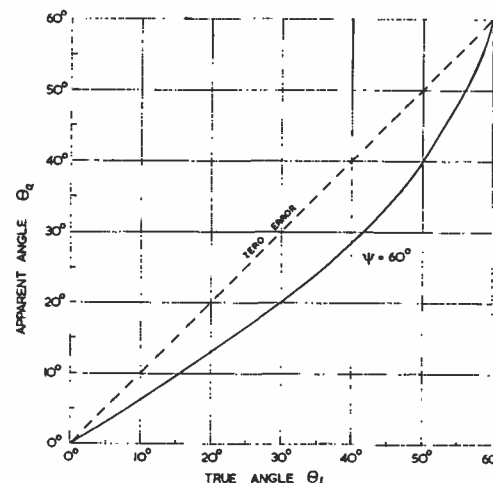

FIG. 8.9. ANGULAR POSITION ERROR $\psi = 60^\circ$

The effect of increased speaker separation may be seen by comparing Figs.8.10 and 8.11 which show the apparent angles heard with $\psi = 45^\circ$ and 60° respectively.

In the first case there is a slight bunching of the sound stage towards the centre, correct location at 45° , and a rapid fanning out of the apparent angles above this. Sound sources above 55° from centre appear to come from the extreme right or left. In the second case, $\psi = 60^\circ$, the bunching towards the centre is rather more pronounced, the angles slowly increasing to give correct location at 60° . The advantage gained is a wider sound stage, sources from -65° to $+65^\circ$ being heard as if spreading from the extreme right to the extreme left. There is a tendency to be 'sitting in the orchestra' as the sound images move towards the listener, Fig.8.8, but this effect is preferred by some listeners.

Before deciding which is the better speaker angle, distance or range errors must be considered.

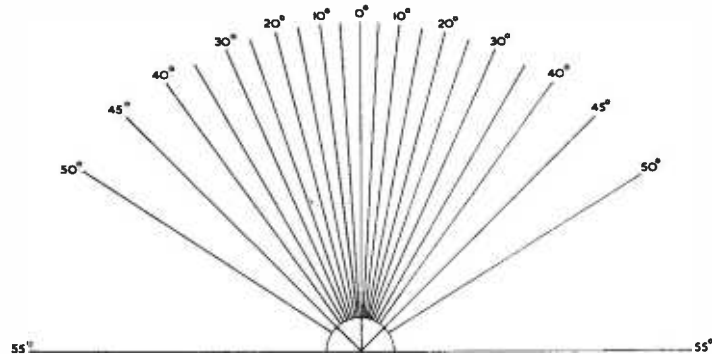

FIG. 8.10. ANGULAR POSITION DISTORTION, $\psi = 45^\circ$. PLOTTED AT 5° INTERVALS

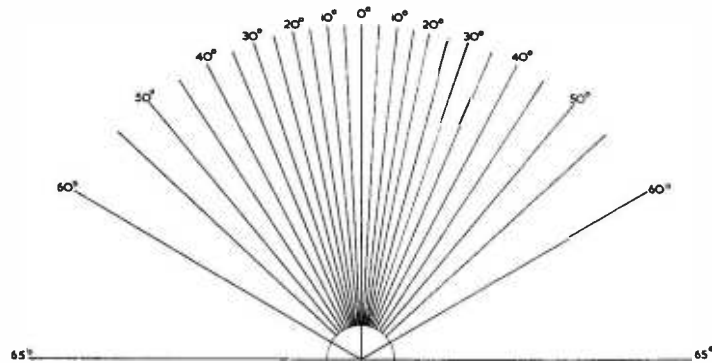

FIG. 8.11. ANGULAR POSITION DISTORTION, $\psi = 60^\circ$. PLOTTED AT 5° INTERVALS

(b) Distance or Range Error

Not only may the image sound appear to come from the wrong angle, it may appear too close to the listener or too far away. This cannot be corrected by simply controlling the overall volume because the RELATIVE levels over the sound stage must be in correct proportion.

There are two cases to consider:

- (1) If a source of sound is moving in a circle with the microphones at its centre, the deviation of the image from a similar circle round the listener is **circular stage distortion**;
- (2) If a source of sound is moving in a straight line past the microphones, the deviation of the image from a straight line is **linear stage distortion**.

The apparent path of an express train passing the microphones is often given as an example of the second case; it usually appears too close to the listener in the centre of the stage.

Fig.8.12(a) shows a sound source moving round a circular stage. The distance, d , is constant and we should expect a constant sound level on repro-

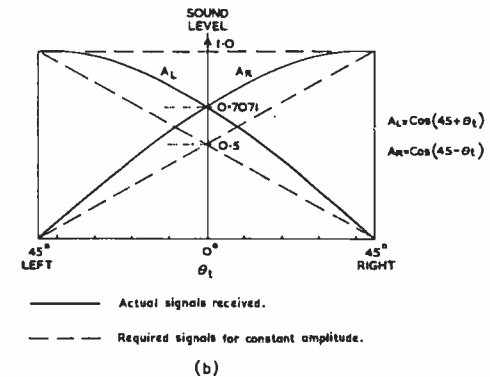
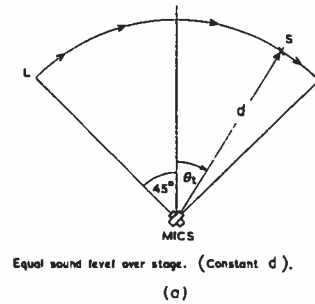

FIG. 8.12. SIGNAL INTENSITY FROM A CIRCULAR SOUND STAGE

duction. But equation (3) shows that the total sound level picked up by the microphones, $A_L + A_R$, is

$$\cos(45 + \theta_i) + \cos(45 - \theta_i),$$

$$\text{which gives } |A_R + A_L| = \sqrt{2} \cos \theta_i \dots\dots\dots(7)$$

Fig.8.12(b) shows the actual signal levels from each microphone and shows clearly that the intensity is too large in the centre of the stage.

The sound intensity along the axis of a typical loudspeaker* for 1 watt acoustical power is shown in Fig.8.13, and indicates that the intensity I is related to the distance d by

$$I : \frac{1}{d^2}$$

the inverse square law.

$$\text{Now } I = \sqrt{2} \cos \theta_i \text{ from the microphones}$$

$$\text{and } d = \sqrt{\frac{1}{I}} \text{ by a suitable choice of sound units,}$$

* Langford-Smith, "Radio Designers Handbook". Iliffe.

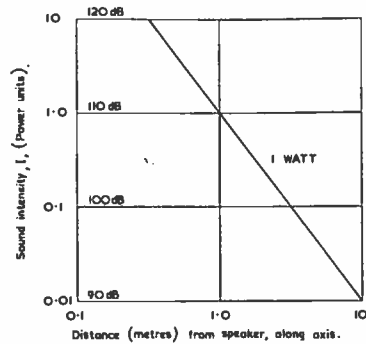

FIG. 8.13. FALL IN SOUND INTENSITY ALONG AXIS OF LOUDSPEAKER

therefore the apparent distance of the sound source, d_a , is

$$d_a = \sqrt{\frac{1}{\sqrt{2} \cos \theta_t}} \dots \dots \dots (8)$$

The image sound stage for $\psi = 45^\circ$ can be plotted as a polar diagram, Fig.8.14, using equation (8) to find the apparent distance and equation (5) to find the

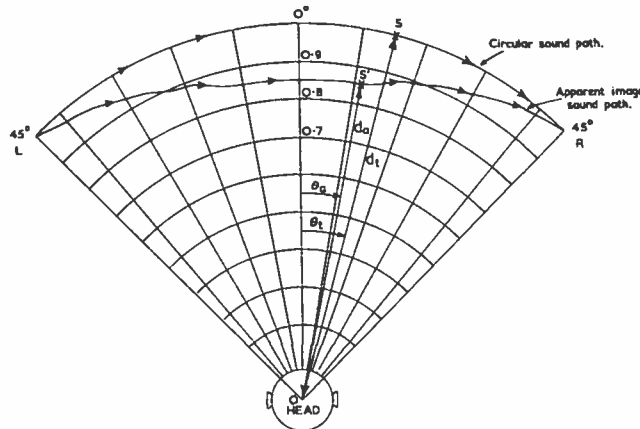

FIG. 8.14. THE IMAGE PRODUCED FROM A CIRCULAR SOUND STAGE SHOWING BOTH DISTANCE AND ANGULAR ERRORS, $\psi = 45^\circ$

apparent angle, for of course both forms of distortion will be present at the same time. It is convenient to assume the sound level correct at 45° from the centre as we then have both angle and distance correct at these points. The 'image' sound stage is seen to be nearly linear.

The effect produced by increasing ψ to 60° in order to widen the sound stage is more complicated. Referring to Fig.8.8 we see that the true distance is changed from d_t to d'_t . Again, it is as if the listener has walked forward from 0 to $0'$ to make the angle subtended at A and B equal to 60° .

Fig.8.15 shows the polar diagram of the image sound stage for $\psi = 60^\circ$.

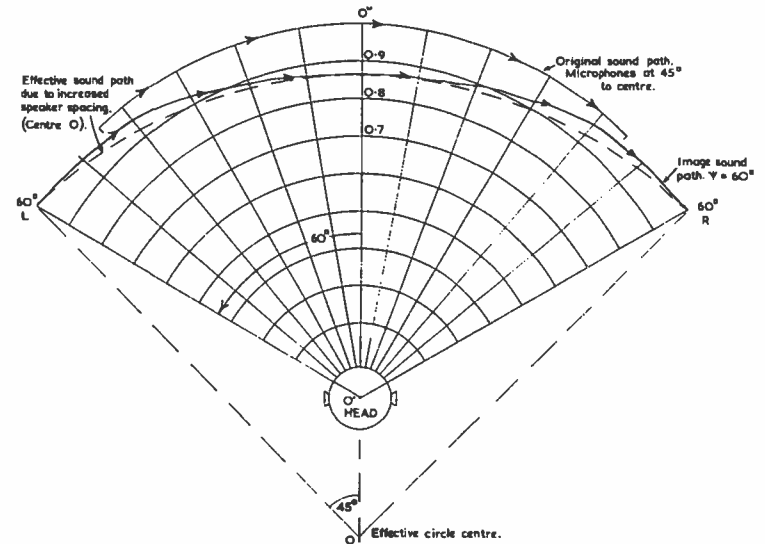

FIG. 8.15. CIRCULAR STAGE ERROR, $\psi = 60^\circ$

The response is more nearly circular and bearing in mind the fact that the listener has effectively moved towards the stage it coincides closely with the original radius. Increasing ψ from 45° to 60° has improved the circular sound stage image considerably.

Now consider a linear sound stage, Fig.8.16.

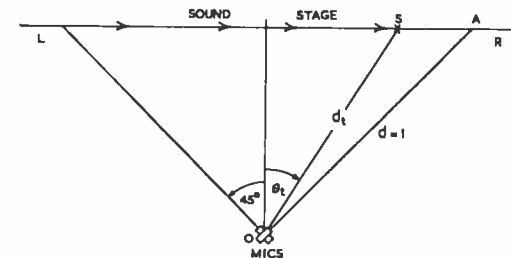

FIG. 8.16. THE CHANGE IN DISTANCE, d_t , WITH A LINEAR SOUND STAGE

The distance d_t will be $\frac{1}{\sqrt{2} \cos \theta_t}$ if the distance OA is taken as unity.

The sound intensity at the microphones will be I_m ,

$$\text{where } I_m = \frac{1}{d^2} \text{ and } d_t = \frac{1}{\sqrt{2} \cos \theta_t} \text{ i.e. } I_m = 2 \cos^2 \theta_t.$$

But the polar response of the microphones, equation (7), gives a total signal intensity proportional to $\sqrt{2} \cos \theta$. The signal output produced from a source moving across the front of the microphones in a straight line will therefore be

$$I = (2 \cos^2 \theta_t) (\sqrt{2} \cos \theta_t) = 2 \sqrt{2} \cos^3 \theta_t$$

Assuming $I = 1$ at $\theta_t = 45^\circ$.

On reception, the apparent distance of the sound is again given by the inverse square law

$$d_a = \sqrt{\frac{1}{I}}$$

$$\therefore d_a = \sqrt{\frac{1}{2\sqrt{2} \cos^3 \theta_i}} \dots \dots \dots (9)$$

Fig.8.17 shows a polar plot of equation (9) for $\psi = 45^\circ$, including the angular errors of Fig.8.5.

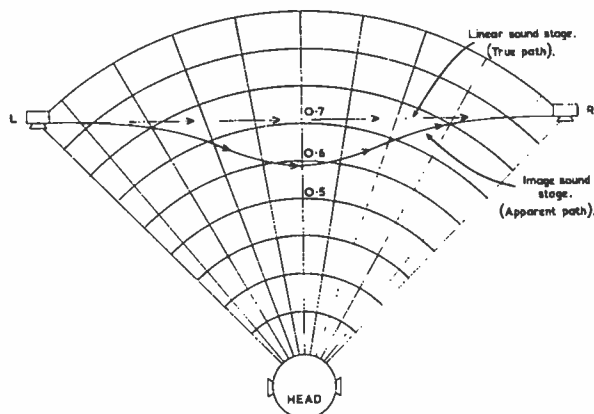

FIG. 8.17. IMAGE PRODUCED FROM A LINEAR SOUND STAGE, $\psi = 45^\circ$

Finally, when the speaker angle ψ is made 60° the image sound stage is as shown in Fig.8.18. Here the sound appears to recede from the listener, whereas in the previous case it tended to come towards the listener at the centre of the stage. It can be deduced from this that the best speaker angle is somewhere between 45° and 60° as far as linear distortion is concerned.

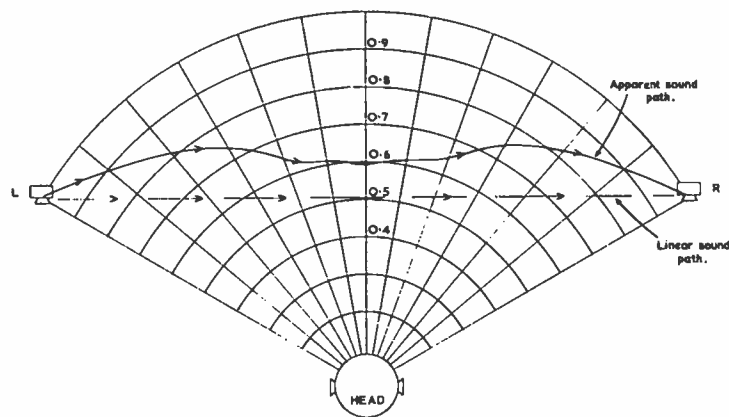

FIG. 8.18. IMAGE PATH PRODUCED FROM A LINEAR SOUND STAGE, $\psi = 60^\circ$

THE OPTIMUM SPEAKER POSITION

To obtain a wide sound stage image the speaker angle should be large; we have seen that to limit the angular and distance distortion the angle should be about 60° . In an average room this may be difficult, as even if the speakers are placed in the corners of the room (which may excite low-frequency modes) the listening positions may be very limited, Fig.8.19.

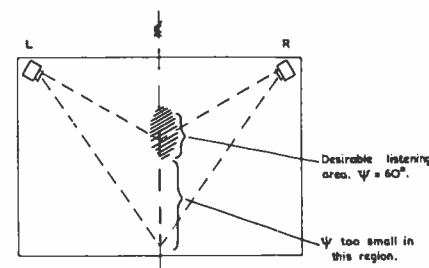

FIG. 8.19. THE SPEAKER ANGLE $\psi = 60^\circ$ LIMITS THE POSSIBLE LISTENING POSITIONS ON THE CENTRE LINE

This may be overcome by positioning the speakers near the middle of one of the longer walls but FACING OUTWARDS as in Fig.8.20.

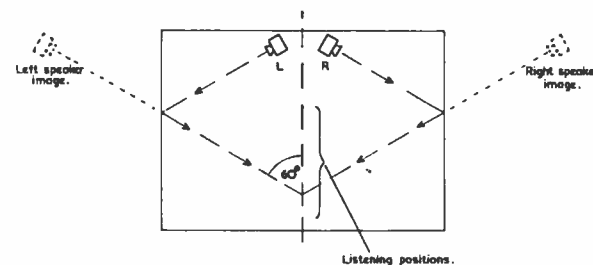

FIG. 8.20. INCREASE OF LISTENING AREA BY USING REFLECTED SOUNDS

It is not practicable to sit all the listeners exactly midway between the loudspeakers, and the stereo sound must be made acceptable to people sitting either side of centre. Use may be made here of the directional properties of the speakers, and if the axes of the image speakers are made to cross in front of the centre listening position, point X in Fig.8.21, a listener moving from position 1 to position 2 moves nearer the axis of the right speaker and further

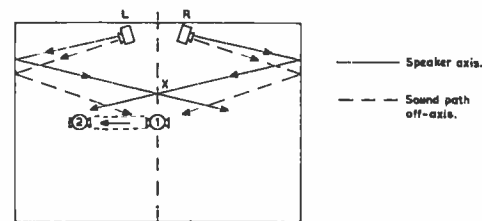

FIG. 8.21. SPEAKER AXES CROSSING IN FRONT OF THE LISTENER TO COMPENSATE FOR OFF-CENTRE POSITION

away from the axis of the left speaker. The corresponding increase in right sound intensity (and decrease in left sound intensity) can be made to compensate for the difference in sound path lengths.

So pronounced is this effect that it is possible to over-compensate. Moving to the left appears to increase the output from the right channel and *vice versa*.

One further advantage is observed by this speaker positioning. When listening to a performance in a concert hall the reverberation and a large proportion of the sound appears as reflections from the walls either side of the sound source. With the speakers positioned as shown in Fig.8.21 the realism is enhanced by the simulation of these reflected sounds. The one major disadvantage of this method, compared with the direct-facing speakers of Fig.8.19, is the loss in high frequency response unless the reflecting walls are very hard. Glass, polished wood and plaster make good reflecting surfaces, but curtains and some porous types of wallpaper will absorb a large part of the high-frequency components.

STEREO RECORDING

Stereo tape recording presents no special problems. Two or four-track recorders enable the left and right channels to be recorded on separate tracks giving almost complete absence of crosstalk, unlike disc recording and playback. The channel separation is so good that two tracks of completely different music may be replayed, with the speakers situated in different parts of the building of course. This is very convenient for social functions where background music is required in one room and high intensity music for dancing in another. Separate left and right volume controls are necessary for this mode of operation.

With a four-track recorder, tracks 1 and 2 are used for the two channels in one tape direction, and tracks 3 and 4 for the reverse travel obtained by turning over the reels.

Many mono tape recorders have facility for stereo playback only, for use with pre-recorded tapes. Such equipment may be modified to record stereo radio transmissions by utilizing the amplifiers in the stereo receiver to feed the recording heads directly. The h.f. bias must be obtained from the existing tape recorder oscillator, as beat frequency whistles will be produced if a separate oscillator is used.

Fig.8.22 shows the additional wiring necessary on a typical domestic tape recorder. The additional components are two resistors and two capacitors, and the values should be chosen to match the existing components in the tape recorder. The stereo input can be obtained conveniently from the speaker or head-phone socket on the receiver. It should be noted that the additional tape channel so obtained is NOT erased automatically on recording and a clean, erased tape must be used.

For stereo playback, a separate preamplifier is available from some manufacturers to feed the second channel into the main stereo amplifier, Fig.8.23.

COPYRIGHT

The law regarding the tape recording of broadcast transmissions is complicated, and the following remarks are only intended as a brief guide.*

* Further details may be obtained from the Mechanical Copyright Protection Society Ltd., 380 Streatham High Road, London, S.W.16.

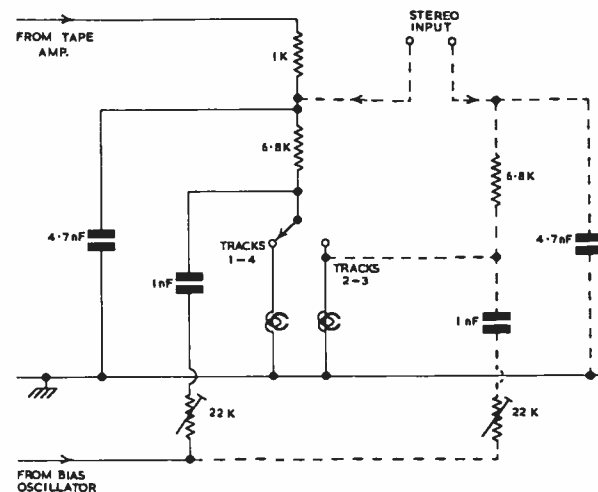

FIG. 8.22. MODIFICATION TO THE WIRING OF A FOUR-TRACK MONO TAPE RECORDER FOR STEREO USE. ADDITIONAL WIRING IS SHOWN DOTTED

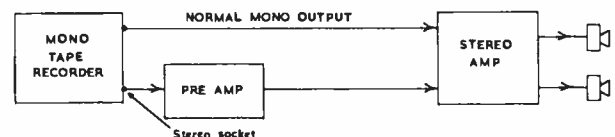

FIG. 8.23. THE SEPARATE CHANNEL PRE-AMP FOR STEREO PLAYBACK

The BBC holds copyright in all its broadcasts and prior permission should be obtained before making a recording of a stereo broadcast otherwise than for private purposes. The permission of the BBC is NOT needed when a recording is made for private purposes.

Prior permission of the owners of the copyright in musical and literary material used in any BBC broadcast should be obtained before such material is recorded, unless the recording can be described as 'fair dealing' for the purposes of research or private study. Permission is needed if it is replayed in public whether the audience pays or not.

A separate copyright exists for a gramophone record distinct from the copyright on the material contained on the record. This right is usually controlled by the company issuing the record. No unauthorized rerecording of a gramophone record either directly or from a broadcast is allowed by copyright.

The permission of performers taking part in a broadcast must be obtained before recording their performances, unless the recording is to be used only for private and domestic purposes by the person making it.

It is in order to record copyright work if it is replayed in the course of instruction, at a school or elsewhere, if the recording is made by a teacher or pupil. This does not apply to commercial gramophone records or performers whose position is separately covered. This would make the use of tape recorders

almost impossible in education had not the BBC made arrangements with certain associations allowing the recording of educational broadcasts to be made by a teacher or pupil, provided that the recordings are used for instructional purposes and destroyed within one year of being made.

The relevant acts are

1. The Copyright Act 1956.
2. Performers' Protection Act 1958.
3. Performers' Protection Act 1963.

APPENDICES

APPENDIX A

Intensity Stereophony.

It is required to show a relationship between the time or phase difference, and the intensity difference between the left and right sound channels.

Fig. A.1. represents the sound source and the directional-microphone pair with figure of eight polar characteristics. From the source, S , the left and right microphones pick up signals A_L and A_R respectively.

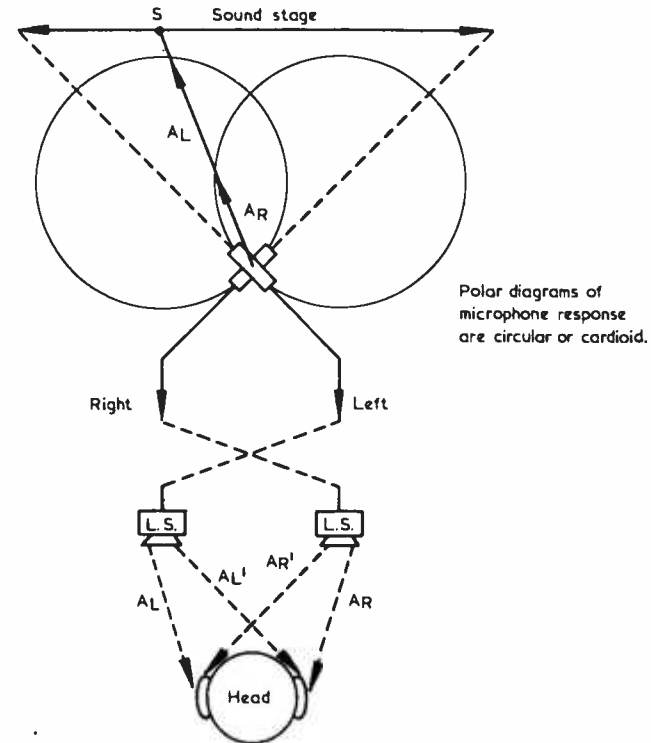

FIG. A.1. INTENSITY STEREOPHONE SYSTEM

A_L and A_R , are received and fed to the two loudspeakers. If the signal frequency has an angular velocity ω rads per second, these signals will be of the form

$$A_L \sin \omega t \text{ and } A_R \sin \omega t$$

with no phase difference as the microphones are situated close together.

The sound heard in the left ear will be

$$\begin{aligned} A_L + A'_R &= A_L \sin \omega t + A_R \sin (\omega t - \omega T_d) \\ &= [A_L + A_R \cos \omega t] \sin \omega t - [A_R \sin \omega T_d] \cos \omega t \end{aligned}$$

From this the phase angle of the left signal, α , is given by

$$\tan \alpha = \frac{A_R \sin \omega T_d}{A_L + A_R \cos \omega T_d}$$

Similarly, the sound heard in the right ear will be

$$A_R + A'_L = A_R \sin \omega t + A_L \sin (\omega t - \omega T_d)$$

and the phase angle of the right signal will be β , where

$$\tan \beta = \frac{A_L \sin \omega T_d}{A_R + A_L \cos \omega T_d}$$

The phase difference, $\beta - \alpha$, is given by

$$\begin{aligned} \tan (\beta - \alpha) &= \frac{\tan \beta - \tan \alpha}{1 + \tan \beta \tan \alpha} \\ &= \frac{(A_L^2 - A_R^2) \sin \omega T_d}{2 A_L A_R + (A_L^2 + A_R^2) \cos \omega T_d} \end{aligned}$$

This shows the relation between the phase difference, $\beta - \alpha$, and the intensity difference between A_L and A_R , Fig. A.2.

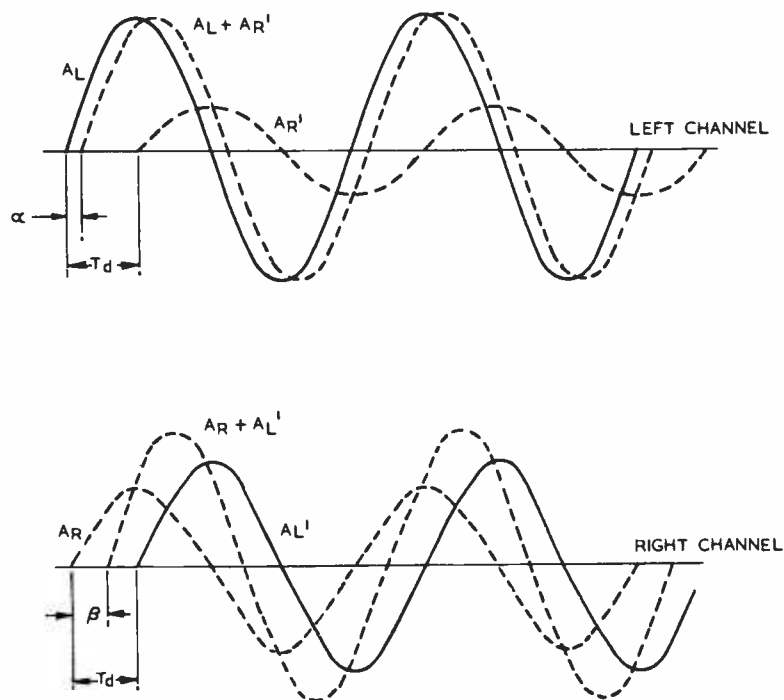

FIG. A.2. THE PHASE SHIFT, $\beta - \alpha$, BETWEEN THE SOUND SIGNALS $A_L + A'_R$ AND $A_R + A'_L$

Note that if earphones are used instead of speakers, the cross channel signals are not present and there is no phase difference in the information supplied to the ears. The intensity difference alone must then be decoded by the brain to indicate the source position. This is possible because of the time-intensity

'trading effect' of the ear by which a loud sound is heard to be shifted forward in time*.

*Lynn, P.A. "Signal Coding by the Human Ear", *Jour. I.E.E.*, July 1971.

APPENDIX B

The Side Frequencies and Bandwidth of an f.m. Wave.

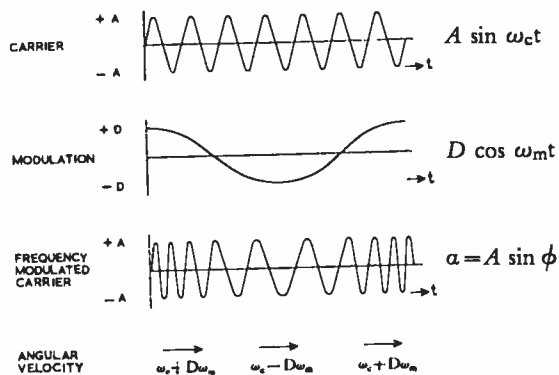

FIG. B.1. FREQUENCY MODULATED WAVEFORM

Fig. B.1 shows the carrier, modulating signal and the frequency modulated wave in an f.m. system. The modulated wave will be of the form

$$a = A \sin \phi$$

where A is the carrier amplitude and ϕ a function of time, t . The angular velocity will not be constant but will vary from $\omega_c + D\omega_m$ to $\omega_c - D\omega_m$, where D is the deviation (proportional to the modulation). ω_c is the carrier angular velocity and ω_m is the modulation signal angular velocity.

At any instant the angular velocity of the modulated wave will be

$$\omega_i = \omega_c + D \cos \omega_m t, \text{ Fig. B.2.}$$

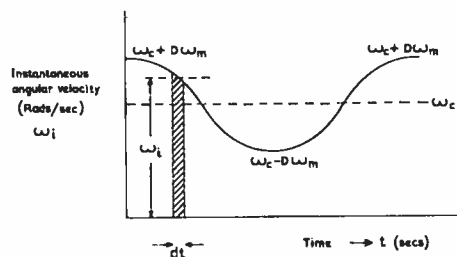

FIG. B.2. THE VARIATION IN INSTANTANEOUS ANGULAR VELOCITY, ω_i . THE AREA UNDER THIS CURVE IS PROPORTIONAL TO THE ELECTRICAL ANGLE IN RADIAN

The area under this curve represents

$$\begin{aligned} &\text{angular velocity (rads/sec)} \times \text{time (secs)} \\ &= \text{the electrical angle (rads).} \end{aligned}$$

In any small interval of time, dt ,

$$\text{electrical angle} = \omega_i dt$$

Therefore, the total angle covered from 0 to t seconds is the sum of the areas of the small strips, such as that shown shaded in Fig. B.2,

$$\begin{aligned} \text{Area} &= \int_0^t \omega_i dt \text{ radians} \\ &= \int_0^t (\omega_c + D \cos \omega_m t) dt \\ &= \omega_c t + \frac{D}{\omega_m} \sin \omega_m t = \phi \text{ rads.} \end{aligned}$$

The resulting f.m. waveform is

$$\begin{aligned} a &= A \sin \phi \\ &= A \sin \left(\omega_c t + \frac{D}{\omega_m} \sin \omega_m t \right) \end{aligned}$$

The ratio $\frac{D}{\omega_m} = M$, the modulation index,

$$= \frac{\text{Frequency deviation, Hz}}{\text{Modulation frequency, Hz}}$$

The modulated waveform is therefore

$$\begin{aligned} a &= A \sin (\omega_c t + M \sin \omega_m t) \\ &= A \sin (2 \pi f_c t + M \sin 2 \pi f_m t) \dots \dots \dots (1) \end{aligned}$$

Now $A \sin (\alpha + \beta) = A(\sin \alpha \cos \beta + \cos \alpha \sin \beta)$

$$\therefore a = A [\sin 2 \pi f_c t \cdot \cos (M \sin 2 \pi f_m t) + \cos 2 \pi f_c t \cdot \sin (M \sin 2 \pi f_m t)]$$

This expression can be expanded as a Fourier series giving

$$\begin{aligned} a &= A \left\{ J_0(M) \sin 2 \pi f_c t + J_1(M) [\sin 2 \pi (f_c + f_m) t - \sin 2 \pi (f_c - f_m) t] \right. \\ &\quad + J_2(M) [\sin 2 \pi (f_c + 2 f_m) t + \sin 2 \pi (f_c - 2 f_m) t] \\ &\quad + J_3(M) [\sin 2 \pi (f_c + 3 f_m) t - \sin 2 \pi (f_c - 3 f_m) t] \\ &\quad \left. + \dots \dots \dots \text{etc.} \dots \dots \dots \right\} \end{aligned}$$

OR

$$\begin{aligned} a &= A J_0(M) \sin 2 \pi f_c t + \\ &+ A \sum_{n=1}^{\infty} J_n(M) [\sin 2 \pi (f_c + n f_m) t + (-1)^n \sin 2 \pi (f_c - n f_m) t]. \end{aligned}$$

The terms $J_n(M)$ are the Bessel* functions of M , of order n , and may be found from tables (see Table B.1 page 190). These functions are the amplitudes of the side-frequencies, relative to the unmodulated carrier, and are shown graphically in Fig. B.3 as far as the 3rd pair.

Theoretically, the pairs of side-frequencies are infinite in number, but practically the number that are significant depends upon the quality required and is usually in the range $M+1$ to $M+4$.

Finding the Bandwidth

In a high-quality receiver we require all those frequency components whose amplitudes are greater than 1 per cent or even 0.5 per cent of the unmodulated carrier. Unfortunately, the usual tables and curves of Bessel functions are not convenient for determining the numbers of pairs of significant side-frequencies

*See note on Bessel's Integral, page 193

TABLE B.1

TABLE B.1

MODULATION INDEX, M

	0	1	2	3	4	5	6	7	8	9	10	11	12	13	14	15	
$J_0(M)$	1.00	0.77	0.22	-0.26	-0.40	-0.18	0.15	0.30	0.17	-0.09	-0.25	-0.17	0.05	0.21	0.17	-0.01	$J_0(M)$
$J_1(M)$	0	0.44	0.58	0.34	-0.07	-0.33	-0.28	0.00	0.23	0.25	0.04	-0.18	-0.22	-0.07	0.13	0.21	$J_1(M)$
$J_2(M)$	0	0.11	0.35	0.49	0.36	0.05	-0.24	-0.30	-0.11	0.14	0.25	0.14	-0.08	-0.22	-0.15	0.04	$J_2(M)$
$J_3(M)$	0	0.02	0.13	0.31	0.43	0.36	0.11	-0.17	-0.29	-0.18	0.06	0.23	0.20	0.00	-0.18	-0.19	$J_3(M)$
$J_4(M)$	0	0	0.03	0.13	0.28	0.39	0.36	0.16	-0.11	-0.27	-0.22	-0.02	0.18	0.22	0.08	-0.12	$J_4(M)$
$J_5(M)$	0	0	0.01	0.04	0.13	0.26	0.36	0.35	0.19	-0.06	-0.23	-0.24	-0.07	0.13	0.22	0.13	$J_5(M)$
$J_6(M)$	0	0	0	0.01	0.05	0.13	0.25	0.34	0.34	0.20	-0.01	-0.20	-0.24	-0.12	0.08	0.21	$J_6(M)$
$J_7(M)$	0	0	0	0	0.02	0.05	0.13	0.23	0.32	0.33	0.22	0.02	-0.17	-0.24	-0.15	0.03	$J_7(M)$
$J_8(M)$	0	0	0	0	0	0.02	0.06	0.13	0.22	0.31	0.32	0.22	0.05	-0.14	-0.23	-0.17	$J_8(M)$
$J_9(M)$	0	0	0	0	0	0.01	0.02	0.06	0.13	0.21	0.29	0.31	0.23	0.07	-0.11	-0.22	$J_9(M)$
$J_{10}(M)$	0	0	0	0	0	0	0.01	0.02	0.06	0.12	0.21	0.28	0.30	0.23	0.09	-0.09	$J_{10}(M)$
$J_{11}(M)$	0	0	0	0	0	0	0	0.01	0.03	0.06	0.12	0.20	0.27	0.29	0.24	0.10	$J_{11}(M)$
$J_{12}(M)$	0	0	0	0	0	0	0	0	0.01	0.03	0.06	0.12	0.19	0.26	0.29	0.24	$J_{12}(M)$
$J_{13}(M)$	0	0	0	0	0	0	0	0	0	0.01	0.03	0.06	0.12	0.19	0.25	0.28	$J_{13}(M)$
$J_{14}(M)$	0	0	0	0	0	0	0	0	0	0	0.01	0.03	0.07	0.12	0.19	0.25	$J_{14}(M)$
$J_{15}(M)$	0	0	0	0	0	0	0	0	0	0	0	0.01	0.03	0.07	0.12	0.18	$J_{15}(M)$
$J_{16}(M)$	0	0	0	0	0	0	0	0	0	0	0	0	0.01	0.03	0.07	0.12	$J_{16}(M)$
$J_{17}(M)$	0	0	0	0	0	0	0	0	0	0	0	0	0	0.01	0.03	0.07	$J_{17}(M)$
$J_{18}(M)$	0	0	0	0	0	0	0	0	0	0	0	0	0	0	0.02	0.03	$J_{18}(M)$

THE RELATIVE AMPLITUDES OF THE SIDE-FREQUENCIES (BESSEL FUNCTIONS) ROUNDED TO 2 DECIMAL PLACES

VALUES LESS THAN 0.01 (1%) ARE ENTERED AS ZERO.

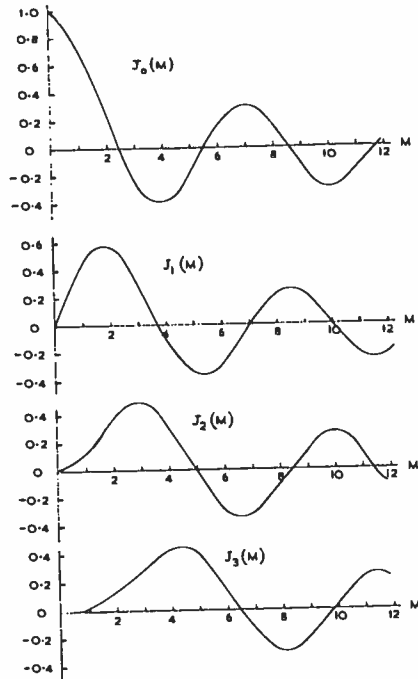

FIG. B.3. THE BESSEL FUNCTIONS $J_n(M)$, SHOWING THE RELATIVE AMPLITUDES OF THE CARRIER, $J_0(M)$, AND THE FIRST OF THREE PAIRS OF SIDE-FREQUENCIES

with any accuracy. We are not interested in the complete amplitude values (as in Fig. B.3) but only in the rise of the functions when their values are at a very low level, i.e. 1 per cent or 0.5 per cent.

Fig. B.4 shows the Bessel functions over the range 0 to 0.1, enabling the significant side-frequencies to be determined for a 0 to 10 per cent level. Care must be taken in calculating the bandwidth after fixing an arbitrary level for the significance of the side-frequencies; it is easy to obtain the wrong answer by starting with the modulating frequency. The bandwidth must be calculated for frequencies at which a pair of side-frequencies just become significant. A curve of bandwidth against modulating frequency would not be smooth but have 'jumps' or discontinuities in it every time a pair of side-frequencies reached the significance level (see the dotted curve in Fig. B.6).

As an example consider an f.m. stereo system whose maximum frequency deviation is 75 kHz. If all the components less than 1 per cent (relative to the unmodulated carrier) are to be ignored, Fig. B.4 shows that the third pair of side-frequencies just reach 0.01 when $M = 0.8$ ($n = 3, J_n(M) = 0.01$). However, the maximum frequency deviation due to the L-R signal will not be 75 kHz but $0.45 \times 75 = 33.75$ kHz as the amplitude is only 45 per cent of the maximum (see Fig. 2.30, page 33).

Therefore $0.8 = \frac{33.75}{f_m}$

and hence $f_m = 42$ kHz at this point.

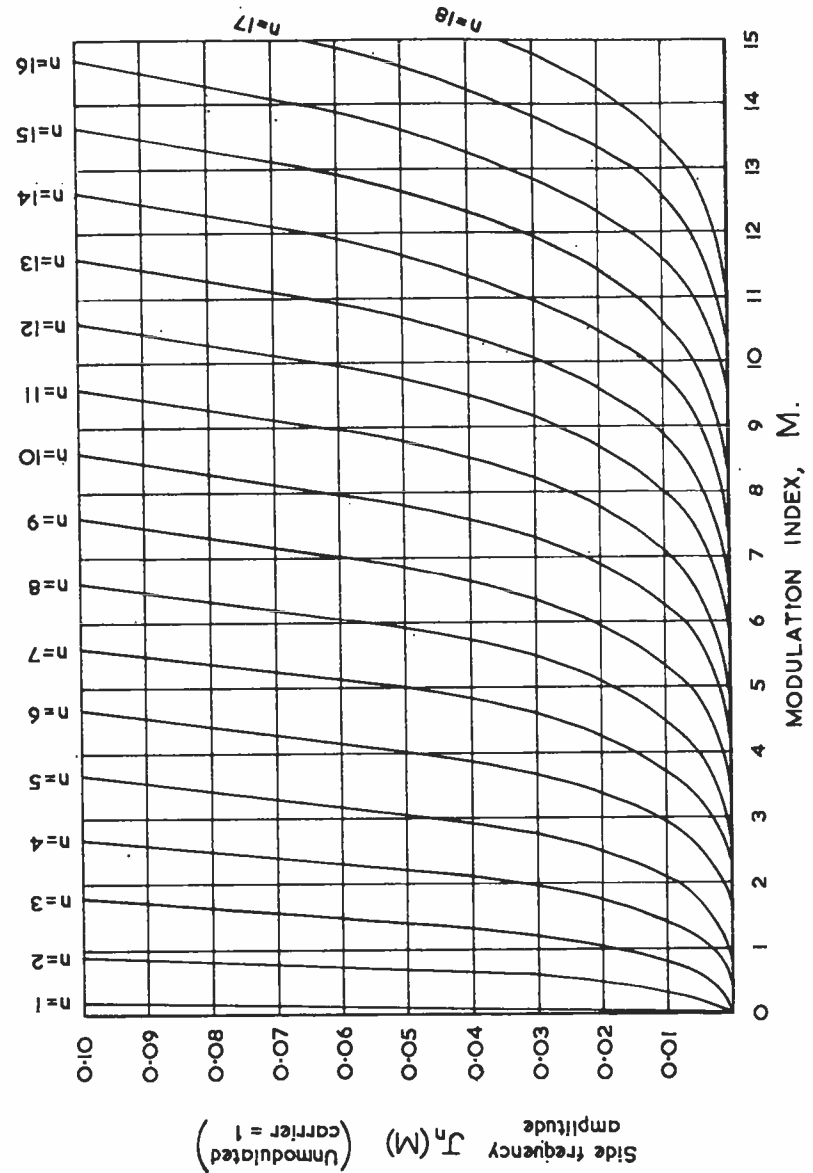

FIG. B.4. THE AMPLITUDES OF THE FIRST 18 PAIRS OF SIDE-FREQUENCIES, $J_n(M)$, RELATIVE TO THE UNMODULATED CARRIER. $J_n(M)$ IS THE BESSEL FUNCTION OF THE FIRST KIND, OF ORDER n , OF THE MODULATION INDEX, M .

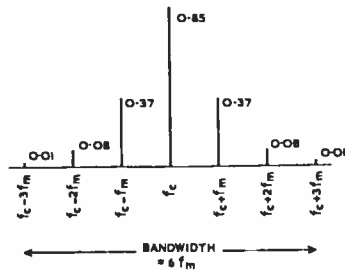

FIG. B.5. THE SIDE-FREQUENCIES FOR A DEVIATION OF 33.75 kHz AND A MODULATING FREQUENCY OF 42 kHz. (BANDWIDTH = 6 × 42 = 252 kHz)

Fig. B.5 shows the side-frequencies given by

$$\begin{aligned}
 J_0(0.8) &= 0.85 & f_c \text{ carrier} \\
 J_1(0.8) &= 0.37 & f_c \pm f_m \\
 J_2(0.8) &= 0.08 & f_c \pm 2f_m \\
 J_3(0.8) &= 0.01 & f_c \pm 3f_m
 \end{aligned}$$

From this the bandwidth required is seen to be

$$6 f_m = 6 \times 42 = 252 \text{ kHz.}$$

By calculating the bandwidth at similar significant points in the frequency modulation range, curves such as Fig. B.6 are obtained. These show the bandwidth required for the L + R and the L - R modulating signals for both the 1 per cent and 0.5 per cent levels. The indication is that a 300 kHz bandwidth is desirable for a good quality stereo system.

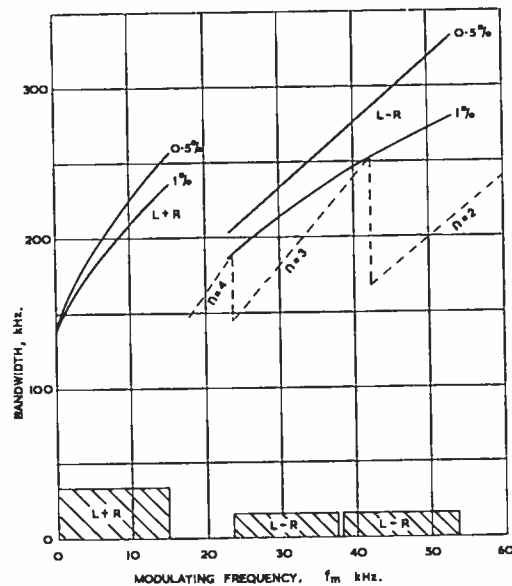

FIG. B.6. BANDWIDTH REQUIRED FOR 0.5% AND 1% COMPONENTS OF THE SIDE-FREQUENCIES. (DOTTED CURVE SHOWS THE INTRODUCTION OF THE PAIRS OF SIDE-FREQUENCIES AT THE 1% LEVEL)

It is quite wrong to consider only the maximum modulating frequency (as often stated) for in a stereo system we have a maximum modulation of 53 kHz giving a modulation index of

$$\frac{33.75}{53} \approx 0.64$$

The side-frequency relative amplitudes will be

$$\begin{aligned}
 J_0(0.64) &= 0.90 & f_c \text{ carrier} \\
 J_1(0.64) &= 0.30 & f_c \pm f_m \\
 J_2(0.64) &= 0.05 & f_c \pm 2f_m \\
 J_3(0.64) &= 0.006 & f_c \pm 3f_m
 \end{aligned}$$

Ignoring the term less than 0.01 we are left with the carrier and two pairs of side-frequencies giving a bandwidth of

$$4 \times 53 = 212 \text{ kHz.}$$

This is obviously insufficient as we need at least 252 kHz at the lower frequency of 42 kHz as already calculated. The error is due to the fact that 53 kHz is not a critical frequency at which a pair of side-frequencies becomes significant; we are in fact calculating a point on the dotted curve of Fig. B.6 instead of on the solid line.

BESSEL'S INTEGRAL

In 1824 F.W. Bessel was investigating the eccentricity of the elliptical orbits of planets. He found it necessary to introduce the function

$$J_n(M) = \frac{1}{\pi} \int_0^\pi \cos(n\theta - M \sin\theta) d\theta$$

known as **Bessel's Integral**. By observing the form of the integral on the right-hand side, the occurrence of Bessel Functions in the analysis of frequency modulation is no longer surprising — it is almost the same as our equation (1).

The function, as in Table B.1, may be computed from the series

$$J_n(M) = \sum_{r=0}^{\infty} (-1)^r \frac{\left(\frac{M}{2}\right)^{n+2r}}{r!(n+r)!}$$

After finding $J_n(M)$ and $J_1(M)$ the recurrence relation

$$J_{n+1}(M) = \frac{2n}{M} J_n(M) - J_{n-1}(M)$$

is used to find $J_2(M), J_3(M) \dots$ etc.

e.g.

$$J_0(1) = 1 - \left(\frac{1}{2}\right)^2 + \frac{\left(\frac{1}{2}\right)^4}{2!2!} - \dots = 1 - 0.25 + 0.15625 - \dots = 0.76562$$

$$J_1(1) = \frac{1}{2} - \frac{\left(\frac{1}{2}\right)^3}{2!} + \frac{\left(\frac{1}{2}\right)^5}{2!3!} - \dots = 0.5 - 0.0625 + 0.0026 - \dots = 0.4401$$

$$\text{Hence } J_2(1) = \frac{2}{1} (0.4401) - 0.76562 = 0.11458 \approx 0.11$$

$$J_3(1) = \frac{4}{1} (0.11458) - 0.4401 = 0.01822 \approx 0.02$$

.....etc.

N.B. Errors tend to increase as n becomes greater than M .

APPENDIX C

Switched Decoding and Crosstalk.

After detection the stereo multiplex signal is of the form

$$0.9 \left[\frac{L + R}{2} + \frac{L - R}{2} \sin 2\omega t + 0.1 \sin \omega t \right]$$

The 19 kHz component is extracted from the signal leaving

$$\left(\frac{L + R}{2} \right) + \left(\frac{L - R}{2} \right) \sin 2\omega t$$

as the composite waveform. $\sin 2\omega t$ is the 38 kHz frequency translation of the

difference component $\frac{L - R}{2}$.

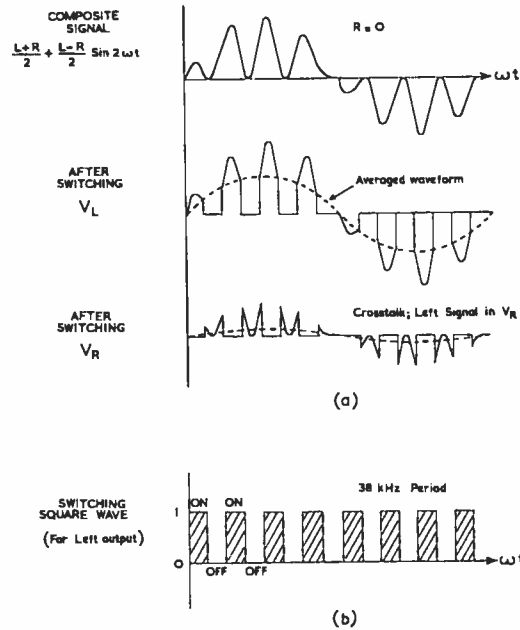

FIG. C.1. (a) COMPOSITE SIGNAL BEFORE AND AFTER SWITCHING
(b) 38 kHz SWITCHING WAVEFORM

Fig. C.1(a) shows this waveform for the case where the right component R is zero. The switching decoder chops this waveform at a rate of 38 kHz to separate the left and right signals. In effect, this is the same as multiplying the signal by a square wave of unity amplitude, Fig. C.1(b)..

The square wave may be represented by the Fourier series

$$\frac{1}{2} + \frac{2}{\pi} \sin 2\omega t + \frac{2}{3\pi} \sin 6\omega t + \dots$$

Multiplying the composite signal by the square wave gives

$$V_L = \left[\frac{L + R}{2} + \frac{L - R}{2} \sin 2\omega t \right] \left[\frac{1}{2} + \frac{2}{\pi} \sin 2\omega t + \frac{2}{3\pi} \sin 6\omega t + \dots \right]$$

$$= (L + R) \left[\frac{1}{4} + \frac{1}{\pi} \sin 2\omega t + \frac{1}{3\pi} \sin 6\omega t + \dots \right] +$$

$$+ (L - R) \left[\frac{1}{4} \sin 2\omega t + \frac{1}{\pi} \sin^2 2\omega t + \frac{1}{3\pi} \sin 2\omega t \sin 6\omega t + \dots \right] \dots (I)$$

After switching, this waveform is averaged out and components of 38 kHz and higher removed. The averaging period, determined by the R.C. circuit at the output of the decoder, must be long compared with the switching period but short compared with the highest audio signal required. If equation (I) is integrated between 0 and π radians and divided by π , we obtain the average value for components of 19 kHz and below, Fig. C.2.

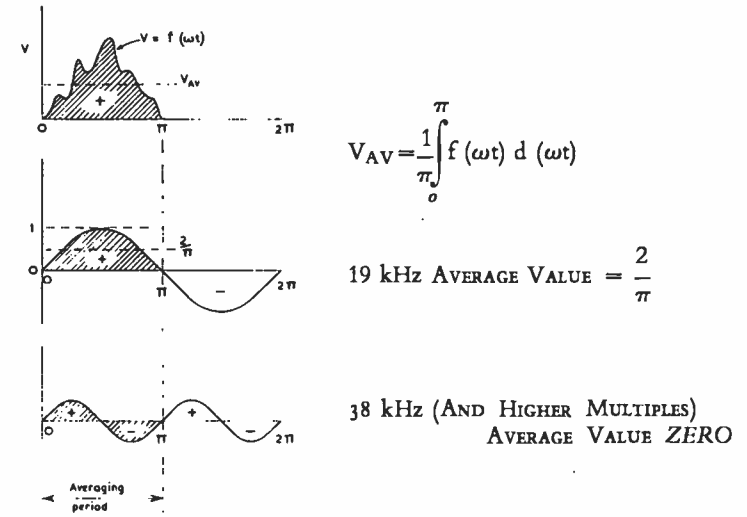

FIG. C.2. AVERAGING OVER 0 TO π RADIANS TO REMOVE 38 kHz COMPONENTS AND ABOVE

The 38 kHz frequencies, and even multiples of them, will average to zero over this period. In practice, the averaging is not quite as severe as this (which would attenuate the higher audio frequencies) but it leads to a simpler mathematical analysis.

Averaging equation (I)

$$V_L = \frac{(L + R)}{\pi} \int_0^\pi \left(\frac{1}{4} + \frac{1}{\pi} \sin 2\omega t + \frac{1}{3\pi} \sin 6\omega t + \dots \right) d(\omega t) +$$

$$+ \frac{(L - R)}{\pi} \int_0^\pi \left(\frac{1}{4} \sin 2\omega t + \frac{1}{\pi} \sin^2 2\omega t + \frac{1}{3\pi} \sin 2\omega t \sin 6\omega t + \dots \right) d(\omega t)$$

Now $\frac{1}{\pi} \int_0^{\pi} \sin^2 n\omega t d(\omega t) = \frac{1}{2}$ For $n = 1, 2, 3, \dots$ etc.

and $\frac{1}{\pi} \int_0^{\pi} \sin m\omega t \sin n\omega t d(\omega t) = 0$ For $m, n = 1, 2, 3, \dots$ etc.

$$\therefore V_L = (L + R) \left(\frac{1}{4}\right) + (L - R) \left(\frac{1}{2\pi}\right)$$

$$= \left(\frac{\pi + 2}{4\pi}\right)L + \left(\frac{\pi - 2}{4\pi}\right)R \dots \dots \dots (2)$$

showing a proportion of the Right signal in the Left output voltage. Similarly, for the Right channel output,

$$V_R = \left(\frac{\pi - 2}{4\pi}\right)L + \left(\frac{\pi + 2}{4\pi}\right)R \dots \dots \dots (3)$$

showing a Left component in the Right output.

To eliminate this crosstalk, $-\left(\frac{\pi - 2}{4\pi}\right)(L + R)$ is added to each output, V_L and V_R , giving

$$V'_L = \frac{L}{\pi} \text{ and } V'_R = \frac{R}{\pi}$$

and we have complete channel separation.

Numerically, from (2) and (3)

$$V_L \cong 0.41L + 0.09R$$

$$V_R \cong 0.09L + 0.41R$$

Adding $-0.09(L + R)$ to each gives

$$V'_L = 0.32L$$

$$V'_R = 0.32R$$

showing a reduction in amplitude but complete separation. Additional crosstalk compensation may be necessary to allow for phase error in the 38 kHz switching signal. As crosstalk depends upon phase error and the averaging after decoding, both difficult to assess, the $-a(L + R)$ control is usually a preset potentiometer. In some decoders there is no $-a(L + R)$ control and compensation is achieved by cross coupling in the left and right channel audio amplifiers.

APPENDIX D

TABLE OF ANGLE AND DISTANCE ERRORS

$\psi = 45^\circ$		$\psi = 60^\circ$		APPARENT DISTANCE, d_a	
θ_t	θ_a	θ'_t	θ_a	CIRCULAR SOUND STAGE	LINEAR SOUND STAGE
0°	0°	0°	0°	0.841	0.595
5°	3° 33'	7° 08'	4° 11'	0.842	0.598
10°	7° 10'	14° 14'	8° 47'	0.847	0.608
15°	10° 55'	21° 15'	13° 31'	0.850	0.626
20°	14° 55'	28° 08'	18° 23'	0.867	0.635
25°	19° 15'	34° 53'	23° 49'	0.883	0.689
30°	24° 06'	41° 27'	30° 00'	0.904	0.738
35°	29° 41'	47° 51'	37° 20'	0.925	0.802
40°	36° 24'	54° 04'	46° 37'	0.961	0.887
45°	45° 00'	60° 00'	60° 00'	1.000	1.000
50°	57° 26'	64° 54'	$\cong 90^\circ$	1.049	1.154
55°	$\cong 90^\circ$	71° 34'	—	1.110	1.369

- ψ , Semi Speaker-Angle.
- θ_t , True Angle of Source from centre position.
- θ_a , Apparent Angle.
- θ'_t , True Angle, corrected for apparent shift of microphones when $\psi = 60^\circ$.
- d_a , Apparent distance from source.
(Unit distance at $\theta_t = 45^\circ$)

BIBLIOGRAPHY

- (1) Clark, H. A. M., Dutton, G. F. and Vanderlyn, P. B. "The Stereosonic Recording and Reproducing System", *Proc. I. E. E.*, Sept. 1957 pp 417-432.
- (2) "Decoder for f.m. Stereo Transmissions", *Mullard Outlook*, Sept. 1968.
- (3) "F. M. Tuners", *Wireless World*, Sept. 1970, pp 465-468.
- (4) Haydn Jones, E. "Audio Frequency Engineering", Chatto & Windus, London, 1961.
- (5) Jordan, E. J. "Loudspeaker Stereo Techniques", *Wireless World*, Feb. 1971, pp 67-70.
- (6) Keller, P. R. "V.H.F. Radio Manual", Newnes, London, 1957.
- (7) Langford-Smith, F. "Radio Designer's Handbook", Iliffe, London.
- (8) Leakey, D. M. "Stereophonic Sound Systems", *Wireless World*, April, 1960, pp 154-160, May, 1960, pp 238-240.
- (9) Lynn, P. A. "Signal Coding by the Human Ear", *Jour. I.E.E.*, July, 1971, pp 269-272.
- (10) Nelson-Jones, L. "F.M. Stereo Tuner", *Wireless World*, April, 1971, pp 175-180, May, 1971, pp 245-249.
- (11) Phillips, G. J., and Spencer, J. G. "The Zenith-G.E. Stereophonic Broadcasting System", *Wireless World*, Jan. 1963, pp 39-44.
- (12) Portus, R. T. and Haywood, A. J. "Phase-Locked Stereo Decoder", *Wireless World*, Sept., 1970, pp 418-422.
- (13) "Receiving Stereo Broadcasts", *Wireless World*, Sept., 1966, pp 445-448.
- (14) Waddington, D. E. O'N. "Stereo Decoder Using Sampling", *Wireless World*, Feb. 1971, pp 71-75.
- (15) Waddington, D. E. O'N. "A Stereo Decoder", *Wireless World*, Jan. 1967.
- (16) Waddington, D. E. O'N. "Stereo Signal Simulator", *Wireless World*, Oct. 1967.
- (17) Danielson, G. L. and Walker, R. S. "Radio and Line Transmission", Vols. 2 and 3, Iliffe, London.

INDEX

- AERIAL ARRAYS, 155, 156
 Aerial height, 146
 Aerial impedance, 153, 159, 160
 Aerial marching, 85, 93, 162
 Aerial rotator, 163
 Alignment, decoder, 131-133, 137-141
 Amplifier, r.f., 40-43, 85, 87, 93
 Amplitude distortion, decoder, 134
 Amplitude modulation, 13
 A.M. rejection, 57, 60
 Angle of flow, demodulator diodes, 110
 Angular position error, 167-174, 199
 Apparent sound path, 174, 176
 Apparent source position, 169
 Artificial reverberation, 166
 Audio stages, 123-128
 Automatic frequency control, 46, 47, 87, 95, 97
 Automatic gain control, 85, 92, 93, 95, 104
 Automatic tuning, 46
- BANDPASS TRANSFORMERS, 99
 Bandwidth, aerial, 157, 159, 163
 Bandwidth, f.m. signal, 188-195
 Bandwidth, receiver i.f., 35
 Balance control, 123, 124, 136
 Balance control, 19 kHz, 110, 131
 Balanced detector, 70
 Balanced modulator, 12, 15, 16, 137
 Balanced ratio detector, 61
 Balancing resistors, ratio detector, 102
 BBC test transmissions, 134-137
 Bessel functions, 189-195
 Bridge matrix, 10
- CASCADE AMPLIFIER, 93
 Ceramic resonator, crystal filter, ceramic filter, 51, 53, 54, 102
 Channels, reversed, 133, 134
 Channel separation, 73-77, 110, 136
 Channel separation, effect of phase error, 64
 Circular sound stage, 168, 173
 Circular sound stage distortion, 174, 176
 Colour code, ceramic filters, 53
 Compatibility, 8-10, 70, 71, 107
 Complementary symmetry, 125, 127, 128
 Conjugate pair, 118
 Copyright, 180-182
 Crossed channel signals, 1, 123, 129, 136
 Crosstalk compensation, 74-77, 107, 108, 113, 118, 196-198
- DECAY, SOUND, 165
 Decoder, 8, 39, 105
 Decoder, balanced, 70
 Decoder, envelope, 62-64
 Decoder, matrix, 73, 74
 Decoder, phase-frequency response, 123
 Decoder, sampling, 77, 78, 119, 121, 122
 Decoder, switched, 69-72, 105, 107, 108, 113, 196
 De-emphasis, 37, 38, 79, 107, 110
 Delay, sound, 165
- Demodulation, 39, 55
 Demodulator, ring, 108
 Deviation, 26, 27, 30
 Differential amplifier, 54, 55, 104, 113, 118
 Diffraction, 149
 Dipole aerial, 142, 149, 152, 153, 154, 159, 160
 Dipole impedance, 153
 Director, aerial, 155, 157
 Distance or range error, 174-178, 199
 Distortion, decoder, 108
 Dual gate, mosfet, 92
- ECHO, SOUND, 165, 166
 Electromagnetic wave, 142
 Electronic tuning, 47, 97, 99
 Encoder, 8
 Envelope detector, 62-64
 Eyring's formula, 166
- FIELD STRENGTH, 146, 160, 162
 Field effect transistor, f.e.t., 42, 87-92
 Filters, 38 kHz, 72
 Filters, ceramic, 51, 53, 54, 102
 Folded dipole, 160
 Foster-Seeley discriminator, 57, 59
 Frequency-changers, 43-45
 Frequency deviation, 22, 26, 27, 30
 Frequency doubler, 21, 22, 64, 107
 Frequency modulation, 26-28
 Frequency modulation detectors, 59, 60, 99, 102
 Frequency multiplier, 21
 Frequency spectrum, 20, 24
 Frequency translation, 12, 23
 Fringing, 153
 Front end, 87
 Front-to-back ratio, 156
- GAIN, AERIAL, 159
 Gain, mosfet, 95
 Ground wave, 144, 145
- HERTZ DIPOLE, 149
 Hold range, a.f.c., 87
- I.F. AMPLIFIER, 50-56, 99-102
 I.F. harmonics, 102
 I.F. trap, 47
 I.F. waveform, 49
 Image frequency, rejection, 40
 Impedance, aerial, 153, 159, 160
 Impulsive sound, 107-172
 Indicator, flip-flop, 110
 Indicator lamp, 107
 Indicator meter, 113
 Input resistance, f.e.t., 88
 Insertion loss, ceramic filter, 53, 54
 Integrated circuit, i.f. amp., 53-55, 102
 Integrated circuit, crosstalk compensation, 77

Integrated circuit, decoder, 115
 Integrated circuit, phase-locked loop, 65
 Integrated circuit, switched detector, 72, 113
 Intensity difference, 3, 186
 Intensity stereophony, 4, 185-186
 Inversion frequency, 3, 4, 169, 170, 172
 Ionosphere, 144
 Isotropic aerial, 159

J-BEAM AERIAL, 157-159
 Jgft, 90

LINEAR SOUND STAGE, 174, 177
 Linear sound stage distortion, 178
 Local oscillator radiation, 41
 Local oscillators, 45, 46, 87, 95, 97
 Local oscillators, de-tuning of, 41
 Location of sound wave, 166-178
 Loudspeaker, position of, 166
 Low frequency peaks, speaker siting, 166

MARCONI QUARTER-WAVE AERIAL, 149
 Matrix decoder, 74
 Matrix, L and R signals, 9, 10, 73
 Microphone, systems of, 4, 5, 6, 7
 Mixer, 44, 45
 Mixer, multiplicative, 95
 Mixer, self-oscillating, 47, 87
 Modulation, 49
 Modulation, amplitude, 13
 Modulation, frequency, 24
 Modulation index, 28, 30, 189, 193, 194
 Modulator, balanced, 12, 15, 16, 137
 Modulator, ring, 17, 18
 Modulator, suppressed carrier, 12, 15, 16, 137
 Monophonic, transmission bandwidth, 9
 MOSFET, 90, 91, 92
 M signal, 137
 Multipath distortion, 147, 157, 163
 Multipath reception, 147
 Multiplex signal, 23, 24
 Multiplex waveform, 25
 Muting, 104, 105, 114

NEGATIVE FEEDBACK, BALANCE, 125
 Noise, effect on f.m. carrier, 36

OBSTRUCTION, OF WAVE, 148, 163
 Off-centre compensation, 179
 Oscillator, local, 45, 46, 87, 95
 Oscillator, 19 kHz, 21, 22
 Oscillator, 38 kHz, triggering of, 64

PARALLEL-T FILTER, 72, 107
 Phase control, 129, 134
 Phase difference, sound, 186
 Phase error, 64, 198
 Phased-locked loop, 65
 Phase modulation, v.h.f. carrier of, 36

Pilot tone, 20, 21, 22, 24, 105
 Pilot tone breakthrough, 114
 Pilot tone, phase of, 23, 129
 Pinch-off voltage, 88
 Plop, edge of station, 104, 105
 Polar diagram, aerial, 154, 155, 157
 Polar diagram, microphone, 4, 5, 6
 Polarization, radio waves, 142, 143
 Position error, angular, 167-174
 Position error, distance, 174-178
 Power supplies, 80-85
 Pre-emphasis, 35, 36, 37, 38
 Presence, 165
 Presence switch, 125, 127
 Propagation, radio waves, 143-147
 Push-button controls, 115
 Push-button tuning, 47, 97, 99

QUASI-STEREO, 114
 Quieting, 41

RANGE OF TRANSMISSION, 148
 Range or distance error, 174-178, 199
 Ratio detector, 5, 7, 60
 Ratio detector, balanced, 61
 Recording, stereo, 180
 Reduced deviation, 32
 Reflected sound, 165, 179, 180
 Reflection, radio waves, 144, 148
 Reflector, aerial, 155
 Refraction, radio waves, 144, 148
 Resonant modes, rooms, 166
 Reverberation, 7, 164, 165, 166
 Reverberation, artificial, 166
 Reverberation time, 165
 R.F. amplifiers, 40, 41, 42, 43
 R.F. amplifiers, cascode, 93
 R.F. amplifiers, f.e.t., 87
 R.F. amplifiers, transistor, 85, 87
 Ring modulator, 17, 18

SAMPLING DECODER, 77, 78, 119, 121, 122
 S Channel, 134
 Schmitt trigger, 119
 Selective listening, 164
 Sensitivity, audio, 141
 Separation control, 129
 Side-frequencies, amplitude modulation, 13, 14
 Side-frequencies, frequency modulation, 26-28, 188-195
 Side lobes, aerial, 157
 Signal generator alignment, 137-141
 Signals, L + R and L - R, 9, 10, 11, 12, 19, 30, 32
 Signal-to-noise ratio, 32, 35, 157
 Sky wave, 143
 Sound intensity difference, 3, 4, 6
 Sound, location of, 164, 166-178
 Sound, monophonic system, 1, 2
 Sound source, 1, 3, 24

Sound stage, circular, 173
 Sound stage, linear, 174
 Sound stage width, 1, 164
 Sound, stereophonic, 1
 Sound time-difference, 3, 6, 167
 Space wave, 145-147
 Speaker angle, 168, 169, 172
 Speaker position, 179
 Stabilizers, power supply, 82-85
 Stagger tuning, 50
 Stereo beacon, 141
 Stereo search aid, 114
 Stereo signal generator, 137
 Stereophonic receiver, 39-60
 Stereophonic recording, 180
 Stereophony, intensity, 4
 Subcarrier, 20, 21
 Subcarrier, phase of, 23, 64, 129
 Suppressed carrier modulation, 12, 15
 Switched decoder (detector), 69-72, 105, 107, 108, 113, 196
 Synthesis, sound, 170, 171, 172

TAPE RECORDERS, 180, 181
 Terminations, transmission lines, 151, 152, 162
 Test signals, 129

Test transmissions, BBC., 134-137
 Threshold voltage, 90
 Time-difference, 3, 167
 Tone control, 125, 127
 Transmission lines, 149-152
 Trap, 38 kHz, 113
 Troposphere, 148
 Tropospheric refraction, 148
 Tuner, r.f., 40, 85, 86, 87
 Tuning, electrical (electronic), 47, 97, 99
 Tuning indicator, 104, 105, 113

UNILATERALIZATION, 99
 Unipolar, transistor, 87

VARIABLE CAPACITANCE, SEMICONDUCTOR, 47
 Vector diagrams, f.m. demodulator, 57-59
 V.H.F. aerials, 149
 V.H.F. transmitter, modulation of, 24, 26
 V.H.F. waves, 142, 145, 146

YAGI AERIAL, 156-160

ZENER DIODE STABILIZER, 83
 Zenith-G.E. system, 9