

T **BE YOUR OWN** **TELEVISION** **REPAIRMAN**

K 1
.84c

NEW EDITION!
LATEST MODELS!
LATEST PORTABLES!

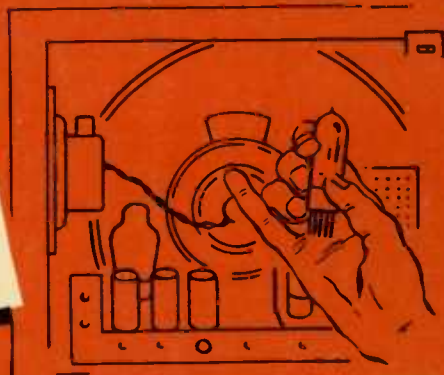

plus NEW MONEY-SAVING FEATURES!



How to repair your own
TRANSISTOR
PORTABLES

BERNARD GUTH

ONLY
\$ 1

BE YOUR OWN TELEVISION REPAIRMAN

Bernard Guth



THIS BOOK HAS BEEN PREPARED
WITH THE INTENTION OF SAVING
YOU MONEY AND AGGRAVATION—



STATISTICS COMPUTED FROM
MANUFACTURERS AND SERVICE
ORGANIZATIONS SHOW THAT
75% OF ALL TV TROUBLES ARE
CAUSED BY DEFECTIVE TUBES
OR FAULTY AERIALS.

CHILTON BOOK COMPANY

Philadelphia New York London

Copyright © 1965 by Bernard Guth. Published in Philadelphia by Chilton Book Company, and simultaneously in Ontario, Canada, by Thomas Nelson & Sons, Ltd. All rights reserved. Manufactured in the United States of America. *Fifth Printing, April 1969*

HOW TO BE YOUR OWN TELEVISION REPAIRMAN

CONTENTS

Index to Tube Layouts	1
How to Repair Your Transistor Portable Radio	10-11
Common Faults to Correct	12
Things to Do Before Looking for Bad Tubes	13
How to Take the Back off Your Set	14-15
Guide to Use of Layouts; TV Troubles	16-17

IMPORTANT: Check model list closely. If there are 2 layout numbers next to a model name, the same model had 2 different chassis. Compare the diagrams to your set to see which is yours. IF YOUR SET'S MODEL NUMBER IS NOT LISTED, don't give up. Many manufacturers use the same chassis under different model numbers. Compare all the tube layouts listed under name of your TV set with your tube layout, usually found inside cabinet or on rear of the set. You should be able to find your model.

TUBE LAYOUTS FOR TV MODELS

MODEL	LAY OUT	MODEL	LAY OUT	MODEL	LAY OUT	MODEL	LAY OUT
ADMIRAL							
Models May have suffix letter M, A or C.							
PS17F13		26X76	5	37F35	6	321K65	6
Chassis 15B2	1	29X15	5	37F36	6	321K66	6
P17E34-32		29X16	5	37K15	6	321K67	6
Chassis 15C1	2	29X17	5	37K16	6	21M1	6
Chassis 19R3U	3	29X26	5	37K28	6	21M1	6
Chassis P59204	3	29X27	5	37K35	6	18A2 Series	6
Chassis P59211	3	36X36	5	37K36	6	Chassis 17X32	6
Chassis P59219	3	36X37	5	39K26	6	Chassis 17X53	6
Chassis P59014	3	39X16	5	39X17	6	TS-T 1801	6
C24M121, M122	4	39X17	5	39X25	6	TS-T 1802	6
C24M123	4	39X25	5	39X26	6	TS-T 1806	6
C24M131, 132, 133	4	39X36	5	39X35	6	TS-T 1807	6
C24M142	4	T22M11	5	39X36	6	P910	7
C24M149	4	C24M22	5	221K16	6	P911	7
C24M171, 172	4	16R11	6	221K26	6	P915	7
C24M189	4	16R12	6	221K28	6	P918	7
C524M131, 132, 133	4	17K11	6	221K35	6	901	7
C524M142	4	17K12	6	221K36	6	909	7
C524M149	4	17K16	6	221K71	6	908	7
L24M151, 152, 153	4	17R12	6	221K72	6	711	7
L24M161, 162	4	26R35	6	321F15	6	All 17" Models	
L24M169	4	26R36	6	321F16	6	24X15	8
LS24M152	4	26R37	6	321F18	6	20X1	8
LS24M159	4	26R25A	6	321F27	6	20X11	8
LS24M161	4	26R26A	6	321F35	6	20X12	8
LS24M169	4	26R35A	6	321F36	6	20X122	8
STA24M120, 121	4	26R36A	6	321F46	6	20X136	8
STA24M122, 123	4	26R37A	6	321F47	6	24A125AM	8
STA24M132	4	26X55	6	321F49	6	20Z1	8
STA24M139	4	26X56	6	321K15	6	24X17	8
STA24M141	4	26X57	6	321K16	6	20X145	8
STA24M149	4	26X65	6	321K18	6	20X147	8
STA24M151, 152, 153	4	26X66	6	321K27	6	32X35	8
STA24M162	4	26X67	6	321K28	6	32X36	8
STA24M169	4	26X75	6	321K35	6	32X37	8
STA24M171	4	26X76	6	321K36	6	12X11	8
STA24M179	4	26X77	6	321K46	6	12X12	8
T24M110, 111	4	26X85A	6	321K47	6	22X12	8
T24M112, 113	4	26X56A	6	21B1	6	22X26	8
T524M120	4	26X57A	6	21F1	6	22X27	8
T524M122	4	26X65A	6	21D1	6	32X15	8
T524M123	4	26X66A	6	21P1	6	32X16	8
24D1	5	27K12	6	21W1	6	32X26	8
24E1	5	27K15	6	21C1	6	32X27	8
24F1	5	27K16	6	21E1	6	1172	8
24G1	5	27K25	6	21G1	6	14D11	9
24H1	5	27K26	6	21Q1	6	14D12	9
26R35	5	27K27	6	21J1	6	14D13	9
26R36	5	27K35	6	21K1	6	14D14	9
26R37	5	27K36	6	21L1	6	16M1	9
26X36	5	27K46	6	17K21	6		
26X37	5	29X25	6	17K22	6	T23A1	10
26X45	5	29X26	6	17K27	6	T23A2	10
26X35	5	36R37	6	27K87	6	T23A3	10
26X46	5	36R45	6	27K85	6	T23A6	10
26X56	5	36R46	6	37K55	6	T23A7	10
26X57	5	36X36	6	37K56	6	T23A11	10
26X55	5	36X36S	6	37K67	6	T23A12	10
26X65	5	36X36 AS	6	121K15	6	T23A13	10
26X67	5	37F15	6	121K16	6	T23A26	10
26X66	5	37F16	6	221K45	6	T23A27	10
26X66	5	37F27	6	221K46	6	Chassis 1723D	10
26X75	5	37F28	6	221K47	6		

Refer to UNLISTED TROUBLE-SHOOTING Section if your set is not listed.

MODEL	LAY OUT	MODEL	LAY OUT	MODEL	LAY OUT	MODEL	LAY OUT
ADMIRAL (Cont.)		ADMIRAL (Cont.)		ADMIRAL (Cont.)		C. B. S. COLUMBIA (Cont.)	
Chassis 1723DC	10	Chassis C2526N	17	F25B6, 7	26	23TC004	34
Chassis 1723DT	10	Chassis 18A6CB, T8	18	Chassis 20Y4L	26	22TX2	34
		Chassis 18B6CB, T, B	18	Model T23B1.2, 6, 7	26	23TK001	34
16AB1.C	11	Model 621G12	18	T23B26	26	23CS013	34
16AD1.C	11	17DX10	19	T23B27	26	23T5005	34
16AE1.C	11	17DX11	19			23K002	34
16AG1.C	11	17DX12	19	AIRLINE		23CS014	34
16AL1.C	11	H2217Z	19	21E2 C, CA	27	24C11	35
16B1.C	11	121DX12A	19	21E3	27	27C31	35
16D1.C	11	121DX16, A, L	19	21E6	27	Chassis 1027-1	35
16E1.C	11	121DX17, A, L	19	21E7	27	2001-Model-6T301	36
16G1.C	11	221DX17, A, L	19	21E12	27	6T363	36
16J1.C	11	221DX26, A, L	19	21E13	27	6T304	36
16K1.C	11	221DX3B, A	19	21E14	27	6K321	36
16L1.C	11	222DX15	19	21E16	27	6K322	36
16U1C	12	T23A1	20	21E17	27	2002-Model-6T301U	36
16W1C	12	T23A2	20	21E22	27	6T303U	36
16AV1C	12	T23A3	20	21E23	27	6T304U	36
16AW1C	12	T23A6	20	21E24	27	6K321U	36
		T23A7	20	T21UG12		6K322U	36
Chassis 1824ES, A	13	T23A11	20	Chassis 18UB6T	28	6K327U	36
Chassis 1824FS, A	13	T23A12	20			6K328U	36
Chassis 1824LSA	13	T23A13	20	C. B. S. COLUMBIA		2003-Model-6T305	36
Chassis 1824PSA	13	T23A26	20	17C18	31	6TR306	36
T23012, 2N	14	T23A27	20	17M06	31	6KR323	36
T23022, 2N	14	Chassis 1723D	20	17M10	31	6KR324	36
T2326Z, 2N	14	Chassis 1773DC	20	17T18	31	6KR327	36
T2327Z, 2N	14	Chassis 1723DT	20	18C18	31	6KR328	36
TS2301Z, 2N	14			18L18	31	Model 22C05	37
TS2302Z, 2N	14	Chassis 18Y4B	21	18M08	31	23C092	37
TS2326Z, 2N	14			18M18	31	22C07	37
TS2327	14			18M28	31	Chassis 921	37
Chassis		Chassis		18M38	31	93	37
18BX413Z, E2, F2, G2	14	20X5, A, B, C2, E2, G2	22	18T18	31	94	37
18X04, BZ	14	20AX5-A, B, D, E2, F	22	20M18	31	Chassis 1611	38
18X4C2, E2, F2, G2	14	20XPSA	22	20M28	31	Model 3T602	38
C2566F/2N	14	Model C2256	22	20T18	31	3T615	38
T2318Z	15	Z306B2, Z	22	22C06	31	3T616	38
TA2318Z	15	Z307BZ, Z	22	22C08	31	3T621	38
T2319Z	15	K2366Z	22	22C18	31	3T622	38
T2311Z	15	K2367Z	22	22C28	31	3T623	38
TA2311Z	15	KA2256	22	22C48	31	3T624	38
T2312Z	15	KA2257	22	22C49	31	3C628	38
TA2312Z	15	KA2267Z	22	22C58	31	3C629	38
T2316Z	15	KA2366Z	22	22C68	31	3C631	38
TA2316Z	15	T1812B	22	22C78	31	3C632	38
T2317Z	15	T1813	22	22C88	31	3C633	38
TA2317Z	15	T1832	22	22L18	31	3C634	38
C2316Z	15	T1842	22	22M08	31	3C635	38
CA2316Z	15	T2212B	22	22M18	31	3C636	38
C2317Z	15	T2242BZ	22	22M28	31	23CK012	38
CA2317Z	15	TA1831	22	22M38	31	Chassis 1621	39
C2319Z	15	TA1832	22	22T18	31	Model 5C603	39
C2326Z	15	TA1842	22	22T28	31	5C604	39
CA2326Z	15	T2303DR	23	22T38	31	23C39, B, M	40
C2327Z	15	T2301DR	23	17C18	32	49, L, LB, S, SB, SM	40
CA2327Z	15	Chassis 18Y4LS	23	17M06	32	23T19, B	40
C2826Z	15	L23B6	24	17M18	32		
C2827Z	15	L23B7	24	17T18	32	DUMONT	
C2827	15	LS23B6	24	18C18	32	Chassis RA166	47
F2326Z	15	LS23B7	24	18L18	32	Chassis RA167	47
FA2326Z	15	Chassis 20Y4H	24	18T18	32	Chassis RA168	47
FA2327Z	15	Chassis 20SY4H	24	18T28	32	Chassis RA169	47
FA2328Z	15	C2216Z	25	20T18	32	Chassis RA170	47
F2328Z	15	C2236A	25	20C18	32	Chassis RA171	47
L2326Z	15	F2226	25	18M118	32	RA350/351	48
LA2326Z	15	T2217A	25	18M08	32	RA352	48
L2329Z	15	K2216A	25	20M18	32	RA306	48
LA2327Z	15	K2217A	25	20M28	32	RA307	49
		Chassis 20Y4E	26	22C06	32	Chatham	50
Chassis 16J1.C	16	Model C23B1.2, 3	26	22C08	32	Ridgewood	50
Chassis 16K1.C	16	C23B16	26	22C18	32	Wakefield	50
Chassis 16B1.C	16	C23B17	26	22C28	32	Essex	50
Chassis 16D1	16	C23B18	26	22L18	32	Oxford	50
Chassis 16E1	16	C23B26	26	22M08	32	Lynwood	50
Chassis 16G1.C, L1	16	C23B27	26	22C05	33	Somerset	50
Chassis 16AB1.C	16	F23B6	26	22C07, M, B	33	Newbury	50
Chassis 16AD1	16	F23B7	26	22T1K301	34	Hanover	50
Chassis 16AE1.C	16	Chassis 20Y4F	26	23T55007	34	21T366-367-350	50
Chassis 16AG1.C	16	Model T25B6	26	23T1K003	34	21T327-329	50
Chassis 16AL1.C	16	T25B27	26	22T3C21	34	21T339-376	50
Chassis 1962	17	G25B6, 7, 8	26	23T5008	34	21T378	50

Refer to UNLISTED TROUBLE-SHOOTING Section if your set is not listed.

MODEL	LAY OUT	MODEL	LAY OUT	MODEL	LAY OUT	MODEL	LAY OUT
DUMONT (Cont.)		EMERSON (Cont.)		EMERSON (Cont.)		EMERSON (Cont.)	
RA356	50	1414	44	1265	63	686	67
RA357	50	1415	44	741F	64	699	67
RA104	51	1432	44	757D	64	666	67
RA110A	51	1433	44	758F	64	697	67
Westwood	51	1434	44	759C	64	700B	67
RA313	51	1435	44	760M	64	1418	67
RA312	51	1438	44	766D	64	Chassis 395S	67
RA112	52	1439	44	767A	64	Chassis 397R	67
RA113	52	1440	44	781A, B, E	64	T1860	68
117	52	1441	44	784M	64	T1840	68
Reverse	52	1254	45	785K	64	1060F	69
Tarrytown 120	52	1255	45	792D	64	1062F	69
Sunster	52	1258	45	793E	64	1058D	69
RA360	52	1259	45	1000G	64	1062H	69
RA387A	52	1264	45	1001E, G	64	1060D	69
RA380/381	54	1265	45	1002E	64	1104D	69
RA341/341	55	1268	45	1003E, G	64	1062D	69
RA342/343	55	1269	45	1004C	64	1106D	69
RA164	56	2064	45	1005E, F, G	64	1064D	69
RA165	56	2065	45	1006C	64	1106F	69
RA400	57	1146	46	1007E, G	64	1030D	70
RA160/162	58	1047D	46	1008E	64	1032D	70
RA356/357	59	1060H	46	1009E, G	64	661B	71
RA370/371	59	1062J	46	1010C	64	667B	71
RA321/372	60	1102H	46	1011C, G	64	668B	71
		1103	46	1012D	64	674B	71
		1104	46	1013C	64	677B	71
EMERSON		1105	46	1014D	64	678B	71
7P1701	41	1106	46	1015C	64	684B	71
1484	41	1114	46	1018C, D	64	689B	71
1402	41	1115	46	1022C, D	64	698B	71
1403	41	1118	46	1023E	64	1628P	71
1452	41	1119	46	1024C	64	1012H	72
1453	41	1128	46	1025E	64	1002H	72
1454	41	1130	46	1026C	64	1040H	72
1455	41	1132	46	1027E	64	1048D	72
1472	41	1142	46	1028C	64	1050D	72
1473	41	1143	46	1029E	64	1066D	72
1482	41	1146	46	1040F	64	1004H	72
1484	41	1148	46	1041F	64	1042H	72
1485	41	1149	46			1054D	72
1488	41	1166	46	1109D, F	65 & 66	1098D	72
1489	41	1168	46	1110D	65 & 66	1068B	72
1416	42	1170	46	1111D	65 & 66	1066H	72
1417	42	1172	46	1112D	65 & 66	1074D	72
1422	42	1184	46	1113D	65 & 66	1056D	72
1423	42	1196	46	1116D	65 & 66	1070D	72
1436	42	1198	46	1117D	65 & 66	1008H	72
1437	42	1199	46	1120D	65 & 66	1084D	72
1442	42	1234	46	1121D	65 & 66	1086D	72
1443	42	1236	46	1122D, F	65 & 66	1072D	72
1447	42	1237	46	1023D	65 & 66	1018H	72
1446	42	1238	46	1024D, F	65 & 66	1100D	72
1477	42	1246	46	1125D	65 & 66	1088D	72
1457	42	2008 A, C	46	1126D, F	65 & 66	1012J	72
1458	42	2020A	46	1129D	65 & 66	1020H	72
1460A	42	2034S	61	1138D	65 & 66	1044D	72
1466	42	2038S	61	1139D	65 & 66	1090D	72
1467	42	2040S	61	1140D	65 & 66	1014J	72
1468	42	2042S	61	1141D	65 & 66	1036H	72
1469	42	2056	61	1144D	65 & 66	1046H	72
1470	42	2057	61	1145D	65 & 66	1092D	72
1471	42	2058	61	1150D	65 & 66	571B-D	73
1476	42	2059	61	1151D	65 & 66	606B-D	73
1477	42	2060	61	1152D	65 & 66	611B-D	73
1478	42	2061	61	1153D	65 & 66	621B-D	73
1479	42	2062	61	1154D, F	65 & 66	619B-D	73
1480	42	2063	61	1155D	65 & 66	624B-D	73
1486	42	1214	62	1156D	65 & 66	627B-D	73
1490	42	1215	62	1157D	65 & 66	638B-D	73
1492	42	1216	62	1158A	65 & 66	661B	73
1493	42	1217	62	1160D	65 & 66	667B	73
1494	42	1218	62	1161D	65 & 66	668B	73
1496	42	1219	62	1162D, F	65 & 66	674B	73
1497	42	1224	62	1163D	65 & 66	677B	73
1498	42	1225	62	1164D	65 & 66	678B	73
1620	42	1226	62	1165D	65 & 66	684B	73
1621	42	1227	62	1124	65 & 66	689B	73
1800	43	1248	62	1174	65 & 66	698B	73
1806	43	1254	63	1175	65 & 66	620E	74
1805	43	1255	63			660E	74
1818	43	1264	63	700 Series	67	664	74
1628	43						

Refer to UNLISTED TROUBLE-SHOOTING Section if your set is not listed.

MODEL	LAY DUT	MODEL	LAY OUT	MODEL	LAY DUT	MODEL	LAY DUT
EMERSON (Cont.)		EMERSON (Cont.)		EMERSON (Cont.)		GENERAL ELECTRIC (Cont.)	
673	74	1255 UHF Sets	82	6948	91	M750, M751 Series	94
614A, B	75	1265 UHF Sets	82	6978	91	M782, M783 Series	94
637	75	1258	82	1420	92	M430VBN	94
660	75	1268	82	1424	92	M431VBN	94
644	75	1259	82	1426	92	M432VMD, VDA	94
647	75	1269	82	1428	92	M433VMD, VDA	94
648	75	711B	83			M434VMD, VMD	94
614	75	712B	83			M870, M871 Series	94
571	75	720B	83	GENERAL ELECTRIC		R750 Series	94
631	76	732D	83	21C2535	53	R306 Series	94
629	76	721-D	84	21C2536	53	R310 Series	94
632	76	728-D	84	21C2550	53	R420 Series	94
629C	76	736-B	84	21C2551	53	R432 Series	94
651C	76	740-D	84	21C2558	53	R738 Series	94
658B	76	743-A	84	21C2559	53	R740, R741 Series	94
6628	78	750-D	84	21C2560	53	M202, M203 Series	95
663B	78	764-F	84	21C2561	53	M204, M205 Series	95
698B	78	765-D	84	21C2574	53	17T20	96
676B	79	769-F	84	21C2575	53	21C103	96
676D	79	780-A	84	21C2576	53	21C105	96
680B	79	782-D	84	21C2577	53	21T22	96
680D	79	1452	85	21C2578	53	21T24	96
681B	79	711-F	86	21L2555	53	21T25	96
681D	79	712-F	86	21L2556	53	17C110	97
686B	79	720-D	86	21T2580	53	17C111	97
686D	79	720-F	86	21T2581	53	21C3478	97
687B	79	732-B	86	17T2405	53	17T3320	97
687D	79	734-B	86	17T2410	53	21C3445	97
696B	79	742-B	86	17T2411	53	21T3432	97
741F	80	767-C	86	17T2412	53	21T3419	97
757D	80	771-C	86	21C2437	53	21C137	98
758F	80	748-B	86	21C2438	53	21C138	98
759C	80	787-A	86	21C2440	53	21C143	98
760M	80	748-C	86	21C2445	53	21C159	98
766D	80	787-B	86	21C2446	53	21C160	98
767A	80	796-C	86	21C2470	53	21C161	98
781A, B, E	80	732-G	86	21C2419	53	21C162	98
784M	80	762-F	86	21C2420	53	21C172	98
785K	80	776-A	86	21C2421	53	21T050	98
792D	80	742-B, E	86	21C2425	53	21T054	98
793E	80	768-A-C	86	21C2426	53	21T055	98
1000C	80	784-A-E	86	17T2405	77	21T056	98
1001E, G	80	752A	86	17T2410	77	21T057	98
1002C	80	770G	86	17T2411	77	21T060	98
1003E, G	80	785C	86	17T2412	77	21T061	98
1004C	80	733-D-F	86	21C2437	77	24C182	98
1005E, F, G	80	771-A-D	86	21C2438	77	24C183	98
1006C	80	791-D	86	21C2440	77		
1007E, G	80	760-D-H	86	21C2445	77	21T21	99
1008E	80	761-C	86	21C2446	77	21T32	99
1009E, G	80	762-D	86	21C2419	77	21T33	99
1016C	80	772-A	86	21C2420	77	21T35	99
1011C, G	80	773-A	86	21C2421	77	21T36	99
1012D	80	774-A	86	21C2425	77	21T37	99
1013C	80	776-A	86	21C2426	77	21C106	99
1014D	80	794-A	86	17T-21	93	21C107	99
1015C	80	795-C	86	17T-22	93	21C108	99
1018C, D	80			21T-32	93	21C109	99
1022C, D	80	650 B	87	21T-35	93		
1023E	80	654 B	87	21T-36	93	21C3567	100
1024C	80	1200	88	21T-37	93	21C3568	100
1025E	80	1202	88	21C-106	93	21C3569	100
1026C	80	1204	88	21C-107	93	21C3570	100
1027E	80	1206	88	21C-108	93	21C3571	100
1028C	80	1208	88	21C-109	93	21C3573	100
1029E	80	1210	88	21C-151	93	21C3575	100
1040F	80	1201	88	21C-152	93	21C3576	100
1041F	80	1203	88	21C-156	93	21C3580	100
1176	81	1205	88	21C-157	93	21C3581	100
1178	81	1207	88	M304V6R	94	21C3585	100
1180	81	1209	88	M307VMD	94	21C3586	100
1186	81	1211	88	M308V8G	94		
1188	81	1500	89	M310VEB, VVY	94	21C40	101
1190	81	1502	89	M311VYV	94	21C128	101
1192	81	1504	89	M736, M737 Series	94	21C129	101
2030	81	1506	89	M738, M739 Series	94	21C130	101
1177	81	1182	90	M420VBZ, VEB, VMD, VDR	94	21C131	101
1179	81	669B	91	M421VEB, VMD	94	21C151	101
1181	81	675B	91	M424VMD	94	21C152	101
1189	81	690B	91	M426VL, VMD	94	21C156	101
1254	82	692B	91	M427VMD	94	21C157	101
1264	82	693B	91	M740, M741 Series	94	21T029	101

Refer to UNLISTED TROUBLE-SHOOTING Section if your set is not listed.

MODEL	LAY OUT	MODEL	LAY OUT	MODEL	LAY OUT	MODEL	LAY OUT
GENERAL ELECTRIC (Cont.)		GENERAL ELECTRIC (Cont.)		GENERAL ELECTRIC (Cont.)		MAGNAVOX (Cont.)	
21T030	101	14T011	107	21T3	114	V21-04AA	120
21T33	101	14T012	107	21T6	114	V21-05AA	120
21T32	101	14T014	107			V21-06AA	120
		21C238	108				
21T038	102			HOTPOINT		CT262	121
TD39	102	21C1536	109	17S302	95	CT263	121
T041	102	21C1537	109	14S20-Series 107	95	CT264	121
T042	102	21C1545	109	21S401	102	CT265	121
T043	102	21C1547	109			CT283	121
T045	102	21C1548	109			CT284	121
21C110	102	21C1549	109	MAGNAVOX		CT267	121
21C111	102	21C1550	109	17" Port	116	CT285	121
21C112	102	21C1551	109	57-58	116	CT286	121
21C113	102	21C1552	109			CT268	121
21C123	102	21C1553	109	Series-107		CT287	121
21C124	102	21C1554	109	CT-358AA, AB, BA, BB, CB, DC	117	CT288	121
21C125	102	21C1555	109	CT-359AA, AB, BA, BB, CB, DC	117	CT269	121
21C126	102	21C1556	109	CT-385AA, AB, BA, BB, CB, DC	117	CT289	121
21C127	102	21C1557	109	CT-386AA, AB, BA, BB, CB, DC	117	CT290	121
24T070	102	21C1558	109			CT291	121
24T071	102	21C1559	109	Series-650		CT292	121
24C180	102	21C1560	109	CMUA, 465AA, BB	118	CT293	121
24C181	102	21C1562	109	CMUA, 466AA, BB	118	CT294	121
21C133	102	21C1563	109	CMUA, 469AA, BB	116	CT297	121
21C134	102	21C1564	109	CMUA, 473AA, BB	118	CT299	121
21C135	102	21C1566	109	CMUA, 474AA, BB	118	CT316	121
21C136	102	21C1567	109	CMUA, 478BB	118	29 Series	121
21C137	102	21C1570	109	CMUA, 482BB	118	U29-01-00	121
21C141	102	21C1572	109	CMUA, 483BB	118	U29-02-00	121
21C142	102	21C1573	109	CMUA, 485BB	118	U29-03-00	121
9T001	103	21C1574	109	CMUB, 470AA, BB	118	U29-06-00	121
		21T1539	109	CMUD, 471AA, BB	118	U29-07-00	121
21T4	104	21T1540	109	CMUD, 456BB	118	U29-08-00	121
21T5	104	21T1542	109	CMUE, 472AA, BB	118	V29-01-00	121
		21T1543	109	CTA, 465AA, BB	118	V29-02-00	121
21E10	105	24C1660	109	CTA, 466AA, BB	118	V29-03-00	121
21C114	105	24C1661	109	CTA, 469AA, BB	118	V29-04-00	121
21C115	105	24C1670	109	CTA, 473BB	118	V29-04-00	121
21C116	105	24C1671	109	CTA, 474BB	118	V29-06-00	121
21C117	105			CTA, 478BB	118	V29-07-00	121
21C119	105	21T1439	110	CTA, 482BB	118	V29-08-00	121
21C120	105	21C1449	110	CTA, 483BB	118	V29-09-00	121
21C121	105	21C1450	110	CTA, 485BB	118		
21T10	105	17P1328	110	CTB, 470AA, BB	118	102 Series	122
21T11	105	17P1329	110	CTB, 471AA, BB	118	CT270	122
21T13	105	17P1330	110	CTD, 486BB	118	CT271	122
21T14	105	17P1331	110	CTE, 472AA, BB	118	CT272	122
21T15	105	17P1333	110	CTE, 484BB	118	CT273	122
21T19	105	17P1334	110			CT274	122
17C127	105	17P1335	110	CTA465AA, BB	119	CT275	122
17C15	105			CTA466AA, BB	119	CT276	122
17C17	105	21T18	111	CTA469AA, BB	119	CT277	122
		21T18 UHF	111	CTA473BB	119	CT278	122
*21C133	106			CTA474BB	119	CT279	122
*21C134	106	21C223	112	CTA482BB	119	CT280	122
*21C135	106	21C226	112	CTA483BB	119	CT281	122
*21C140	106	21C227	112	CTA485BB	119	CT282	122
*21C141	106	21C228	112	CTB470AA, BB	119	CT298	122
*21C142	106	21C229	112	CTD471AA, BB	119	MU33J1	122
*21C110	106	21C230	112	CTD486BB	119	MU33F1	122
*21C111	106	21C231	112	CTE472AA, BB	119	MU32C1	122
*21C112	106	21C232	112	CTE484BB	119	MU26C3	122
*21C113	106	21C233	112	CMUA465AA, BB	119	MU41V1	122
21C123	106	21T20	112	CMUA466AA, BB	119	MV21J	122
21C124	106	21T21	112	CMUA469AA, BB	119	MV72F3	122
21C125	106			CMUA473AA, BB	119	MV72J	122
21C126	106	21C140	113	CMUA474AA, BB	119		
21C127	106	21C141	113	CMUA478BB	119	35 Series	
21T039	106	21C142	113	CMUA482BB	119	Chassis C35-01-00	115
21T039	106	21C133	113	CMUA483BB	119	Chassis C35-02-00	115
21T041	106	21C134	113	CMUA485BB	119	Chassis C35-03-00	115
21T042	106	21C135	113	CMUB470AA, BB	119	Chassis C35-04-00	115
21T043	106	21C136	113	CMUD471AA, BB	119	Chassis C35-07-00	115
21T045	106			CMUD486BB, B	119	Chassis C35-07-11	115
21T048	106	21C201	114	CMUE472AA, BB	119	Chassis U35-01-00	115
24C180	106	21C202	114	CMUE483BB	119	Chassis U35-02-00	115
24C181	106	21C204	114			Chassis U35-03-00	115
24T070	106	21C206	114	MV324R1	120	Chassis U35-04-00	115
24T071	106	21C208	114	T249-21	120	Chassis U35-07-00	115
		21C210	114	V21-01AA	120	Chassis U35-07-11	115
14T007	107	21C214	114	V21-02AA	120	Chassis V35-01-00	115
14T009	107	21T1	114	V21-03AA	120	Chassis V35-02-00	115

Refer to UNLISTED TROUBLE-SHOOTING Section if your set is not listed.

MODEL	LAY OUT	MODEL	LAY OUT	MODEL	LAY OUT	MODEL	LAY OUT
MAGNAVOX (Cont.)		MOTOROLA (Cont.)		OLYMPIC (Cont.)		PHILCO (Cont.)	
Chassis V35-03-00	115	17K8, B, BA	129	AK Chassis		4212	138
Chassis V35-04-00	115	17K9, A, BA	129	24CJ68BK	135	4622	138
Chassis V35-07-00	115	17K10	129	24CJ68MK	135	6206	138
Chassis V35-07-11	115	17K11A, BA	129	24CK77	135	6620	138
		1775A, C	129	AB Chassis		4632	138
		1776, B, F	129	21CB35	135	4634	138
		1776, F	129	21CB41	135	4636	138
				21UB71	135		
MOTOROLA		21T37	130	21KB26	135	TV440-Chassis	139
19T38B	123	21T39	130	21KB36	135	TV444-Chassis	139
19T38E	123	21T43	130	21KB76	135	4148	139
19T38F	123	21T49	130	21TB34	135	4162	139
19T38Z	123	21K70	130	21TB40	135	4163	139
19T39	123	21K72	130	220B Series	135	6126	139
19T40	123	21K74	130	AC Chassis		6320	139
		21K79	130	21CC55	135	4110	139
		TS542	130	21CC70	135	6002	139
				21DC71	135	200	139
21K37B etc.	124	17F12A, B, BA	131	21K044	135	90	139
21K39B etc.	124	17K12A, B, BA, W, WA	131	21K0C6	135	3002	139
21K40B etc.	124	1777A	131	21K0C4	135	4010	139
21K48 etc.	124	1777A	131	21K0C5	135	4014	139
21T26B etc.	124	1778, A, B, BA	131	21K0C4	135	4001	139
21T27B, MA, PK	124	21F1B	131	21K0C5	135	4002	139
21T28B	124	21K1B	131	22C Series	135	4003	139
24K9B	124	21K2B	131	CA135U	136	4005	139
24T3BR	124	21T1B	131	CB136U	136	4006	139
		21T2B	131	CB137U	136	4007	139
Y14P10	125	1777A	131	CF410U	136	4009	139
Y14P11	125	177A, B	131	CF411U	136	4105	139
		21P1	131	KA145U	136	4107	139
17K17	126	21T2	131	KA55U	136	4112	139
21K16	126	TS325	131	KB156U	136	4406	139
21T14	126	TS326	131	B131	136	4405	139
19T16	126	TS351	131	KD148U	136	4404	139
21C2	126	17P3-1-2	132	KD149U	136	4402	139
21K12	126			KD193U	136	4400	139
21K13	126	21K30B	133	KM416U	136	6300	139
21K14	126	21K46B	133	KM417U	136	4304	139
21K15	126	21K50B	133	TAY199	136	4302	139
21K27	126	21T25CH, PT, TN	133			6104	139
21K18	126	21T30BH, M, MH	133				
21T8	126			PHILCO		E-3034, B, SA, SS	140
21T10	126			6604	137	F-3035, B, SA, SS	140
21T11	126			Chassis-7L40U	137	UE-30321, R	140
21T13	126			Chassis-7L41	137	UE-3034B, SA, SS	140
21T16	126			Chassis-7241U	137		
				Chassis-7145U	137	Chassis-8241	141
Y21F8B, BA, W, WA	127	16K2	134	Chassis-7P50U	137	Chassis-42	141
21K7B, BA, M, MA	127	12K3	134	4600	137	Chassis-43	141
21K75B, BA, CW, CWA, M, MA	127	12T3	134	4601	137	Chassis-8L410	141
21K76B, BA, CW, CWA, M, MA	127	14T3	134	4602	137	Chassis-420	141
21K77B, M	127	16F1	134	4603	137	Chassis-430	141
21K80C, W, CWA	127	16T1	134	4606	137	Chassis-8P510	141
21T40BG, BGA, MG, MGA	127	16F2	134	4610	137	Chassis-8L41	141
21T42B, BA, M, MA	127	17K3	134	4612	137	Chassis-8L41U	141
21V1W, WA	127	17F1	134	4614	137	Chassis-8L42	141
		17F2W	134	4700	137	Chassis-8L42U	141
		17K1E	134	4802	137	Chassis-8L43	141
14K18H, H	128	17T3G	134	4804	137	Chassis-8L43U	141
14T3	128	17T4C-E	134	6200	137	Chassis-8051	141
16F18H, H	128	17T2	134	6204	137	Chassis-8051A	141
16K28H, H	128	17T1	134	6602	137	Chassis-8P51U	141
16T18H, H	128	17K1	134	6604	137		
17F1A, B, BA	128	17K4	134	4202	137	18C3010E, L, M	142
17F2W, WA	128	17F5	134	4203	137	22C4006	142
17F3B, BA	128	17F4	134	4204	137	22C4011X, XL, XW	142
17F4A	128	17F3	134	4205	137	22C4014L, X	142
17F5A, B, BA	128	17F6B-C	134	4206	137	22C4015	142
17F6B, BC, C	128	17F7B-C	134	4207	137	22C4018	142
17F8	128	17F8	134	4630	138	22C4113	142
17K1A, BA, BE, S	128	17F9B-C	134	4628	138	22C4117	142
17K2, B, E	128	17K1	134	4624	138	22C4119, X	142
17K3, A, B, BA	128	17K6E	134	4625	138	22C4120, L, X	142
17K4, A, E	128	17K7C-B	134	4620	138	22C4123	142
17K5, C	128	17K2B-E	134	4621	138	22C4124, L, S	142
17K6, C	128			4618	138	22C4125, H, M	142
17K7D, BC, C	128	OLYMPIC		4214	138	22C4127	142
17K10A	128	AA Chassis		4212	138	22C4130, L	142
17T1, A, B, BA	128	17C20	135	4628	138	22C4310, L	142
17T2, A, B, BA	128	17T19	135	4210	138	22C4311	142
17T3, A	128	17T52	135				
17T4, C	128	17T33	135				
		A.J. Chassis					
17F11	129	24CJ68	135				

Refer to UNLISTED TROUBLE-SHOOTING Section if your set is not listed.

MODEL	LAY OUT	MODEL	LAY OUT	MODEL	LAY OUT	MODEL	LAY OUT
PHILCO (Cont.)		PHILCO (Cont.)		RCA VICTOR (Cont.)		RCA VICTOR (Cont.)	
24C4006	142	2133	147	231DE667	153	21T6255.U	163
24C6005	142	2170	147	231DE675	153	21T6256.U	163
24C6105M	142	2176	147	231DE676	153	21T6257.U	163
24C6108	142	2244	147	231DE677	153		
		2245	147	231DE722	153	21S358K.KU	164
403N	143	2275	147	231DE742	153	21S348K.KU	164
4041	143			231DE746	153	21S357K.KU	164
4145	143	51T1602	148	231DE755	153	21S362K.KU	164
4184	143			231DE756	153	21S367K.KU	164
4151	143	P3043	149	231DR655	153	21S369K.KU	164
4152	143	P3044	149	231DR656	153		
4156	143			231DR657	153	21D905	165
4157	143	RCA VICTOR		231DR665	153	21D917	165
4160	143	21T8225U	150	231DR666	153	21D926	165
4161	143	21T8245U	150	231DR695	153	21D927	165
4165	143	21T8247U	150	231DR716	153	21D928	165
4324	143	21T8477U	150	231DR719	153	21D929	165
4326	143	21T8246U	150	231HR776	153	21D930	165
6120	143	21T8475U	150	231HR788	153	21D958	165
6122	143	21T8478U	150	231HR789	153	21D968	165
		21T8478U	150	231HR797	153	21D976	165
22C4016	144	94A064MV	151	231HR799	153	21D977	165
22C4124	144	94A08MV	151			21D978	165
22C4126	144	94A010MV	151	Chassis	154	21D979	165
22C4129	144	94A102MV	151			21D980	165
22C4312	144	94A109MV	151	KCS133 Series	154		
22C4410	144			191A192	154	21D8585U	166
		21D305	152	191AE202	154	21D8527U	166
2228	145	21D317	152	191AE208	154	21D8545U	166
2233	145	21D326	152			21D8547U	166
2234	145	21D327	152	21D641	155	21D8566U	166
2268	145	21D328	152	21D645	155	21D8588U	166
2269	145	21D329	152	21D647	155	21D8607U	166
2270	145	21D330	152	21D648	155	21D8526U	166
2271	145	21D358	152	21D648	155	21D8528U	166
2273	145	21D368	152	21D652	155	21D8546U	166
2280	145	21D376	152	21D667	155	21D8565U	166
2281	145	21D377	152	21D670	155	21D8567U	166
2285	145	21D378	152	21T6125	155	21D8560U	166
2287	145	21D379	152	21T6127	155		
2289	145	21D380	152	21T6135	155		
2292	145			24T6142	156	21D7425	167
2294	145	231D66C4	153	24T6285	156	21D7445	167
2127	145	231D66N4	153	24T6287	156	21D7447	167
2750	145	231D626	153			21D7485	167
		231D627	153	21S354	157	21D7488	167
1814	146	231D635	153	21S362	157	21D7506	167
1816	146	231D636	153	240K495	157	21D7429	167
1817	146	231D637	153			21D7446	167
1824	146	231D645	153	21S6052	158	21D7479	167
1825	146	231D646	153	21S6053	158	21D7487	167
1826	146	231D647	153	21S6055	158	21D7505	167
1852	146	231D655	153	21S6057	158	21D7507	167
1854	146	231D656	153	21S632	158	21T7385	167
1856	146	231D657	153			21T7386	167
1858	146	231D659	153	21T323	159	21T7387	167
2124	146	231D665	153	21T322	159	21T7415	167
2125	146	231D666	153	21T324	159	21T7416	167
2126	146	231D667	153	21T303	159	21T7417	167
2152	146	231D669	153	21T313	159		
2183	146	231D694	153	21T314	159	21R78202	168
2226	146	231D695	153	21T315	159	21R78425	168
2227	146	231D696	153	21T316	159	21T820	168
2230	146	231D716	153	21D411	159	21T826	168
2232	146	231D719	153	21D410	159	21T837	168
2255	146	231D730	153	21D4K59	159	21T939	168
2235	146	231D734	153			21T840	168
2260	146	231B612	153	231D730	160	21T842	168
2262	146	231B615	153			21T844	168
2264	146	231B616	153	630 Chassis	161	21T846	168
2272	146	231B617	153			21T848	168
2274	146	231B625	153	21T176	162		
2277	146	231B626	153	21T177	162	17P09062	169
2288	146	231B627	153	21T178	162	17P09064	169
2290	146	231BER625	153	21T179	162	17P09070	169
1883	146	231BER626	153			17P09072	169
1884	146	231BER627	153	21T6082.U	163	17P09074	169
1886	146	231BR615	153	21T6083.U	163	17P09078	169
1887	146	231BR616	153	21T6087.U	163	17P09079	169
1888	146	231BR617	153	21T6114.U	163	17P19041	169
		231DE665	153	21T6115.U	163	17P19042	169
2142L	147	231DE666	153	21T6117.U	163	17PT9050	169

Refer to UNLISTED TROUBLE-SHOOTING Section if your set is not listed.

MODEL	LAY OUT	MODEL	LAY OUT	MODEL	LAY OUT	MODEL	LAY OUT
WESTINGHOUSE (Cont.)		ZENITH (Cont.)		ZENITH (Cont.)		ZENITH (Cont.)	
21KU186, A, B	200	B1410 L, L2	193	D2458	206	L2259E, EU, R, RU	211
21KU187, A, B	200	B1411 P, P2	193	D2460	206	L2260R, RU	211
21KU194, A, B	200	B1412 G, G2	193	D2462	206	L2261E, EU, H, HU	211
21KUR188, A, C, D	200	B1413 G, G2	193	D2464	206	L2266R, RU	211
21KUR189, A, C, D	200	B1715L	193	D3010	206	L2267E, EU, H, HU	211
21KUR190, A	200	B1716 C	193	D3011	206	L2270U	211
21KUR191, A, D	200	B1717 J	193	D3012	206	L2287R, RU	211
21T107, A, B	200	B1718 B	193	D3013	206	A2221R-L	212
21T108, A, B	200	B1720 C	193	D3014	206	A2223E, EU, Y	212
21T180, A, B, L, M	200	Chassis 205J1	194	D3015	206	A2245E, R	212
21T185, B	200	2322-Z	202	T1985C4, J4	207	A2246E, R	212
21TR181, A, C, D, E	200	2340R-2	202	T1986F	207	A2252R	212
21TR182, A, B, C, D, E	200	2346R	202	T1992C, L	207	A2253E, R	212
21TR183, A, B, C, D, E	200	2356R	202	T1994F, L	207	A2673E, R	212
21TR184, A, C, D, E	200	2353	202	T1995W	207	A3000E, R	212
21TR188, C	200	23G22	202	T1997R, W	207	A3001E, R	212
21TR189, C	200	23G24	202	T1998W	207	A3006E, H, R	212
21TRU181, A	200	2350R2	202	Chassis 14L30	207	A3007R	212
21TRU182, A	200	23Z72	202	Chassis 14L36	207	A3008E, R	212
21TRU183, A	200	2355	202	L2008L, R, W	207	A3009E, H	212
21TRU184, A	200	2957R	202	T1980C4, G4	207	I11006, I, U	213
11TU101, A	200	2958R	202	T1981G, L	207	A1411, P, PU	213
21TU107, A, B	200	3157RZ	202	T2203J	207	A1412G, GU	213
21TU108, A, B	200	3158RZ	202	L2005C, F	207	A1716, L, LU	213
21TU180, A, B	200	3173RZ	202	L2009C, L	207	A1717, G, GU	213
21TU185, A	200	3062	202	L2012F	207	A1718, G, GU	213
24K126, B, E, G	200	2441R	202	L2014L, R, W	207	A1719, J, JU	213
24K127, B	200	2442	202	L2210J	207	A2001L	213
24K128, B	200	2446	202	L2240J, L	207	Chassis-24H20	214
24RR126, A, F	200	2448	202	SA2020R, W	208	Chassis-24H21	214
24RR127, A, F	200	16025Q	202	SA2054W	208	H-2437	214
24KRU127, B, A	200	E2015L	202	SA3040E, R, W	208	H-2438	214
24KRU128, B, A	200	E1801	202	SA3042E, M, R, W	208	H-2439	214
24KRU126, A	200	E1810	202	SA3042ED, HD, RD, WD	208	H-2443	214
24KRU126, F	200	E2010C	202	SA3078E, R, W	208	H-2445	214
MP332 Chassis	201	Chassis 18E20	203	SA3078ED, RD, WD	208	H-2447	214
3324	201	E2755	203	SA3080E, D, R, W	208	H-2449	214
3325	201	E2764	203	SA3080ED, RD	208	H-2455	214
3326	201	E3354	203	L2705R, Y	208	H-3267	214
3333	201	E3356	203	L2708G, R, W	208	H-3465	214
3331	201	E3360	203	L2735G, L, R, W	208	H-3469	214
3332	201	F2735	204	L2736E, M, R, W	208	H-3475	214
3170	201	F2301	204	L2737E, R, W	208	H-3477	214
3171	201	F2304	204	L2738E, R, W	208	A-2329-J, JU	215
3173	201	F2340	204	L3308R, W, Y, RD	208	A-2330-E, EU, H, HU, R, RU	215
3174	201	F2341	204	L3340R, W, RD, WD	208	A-2358-E, EU, R, RJ	215
3320	201	F2342	204	L3341H, R, M, W	208	A-2359-E, EU, H, HU, R, RU	215
3321	201	F2710	204	L3341H, MD, RD, WD	208	A-2362-M, MU, R, RU	215
3322	201	F2712	204	L3342H, M, R, W	208	A-3010-E, M, R	215
3323	201	F2735	204	L3342H, MD, RD, WD	208	A-3011-E, Y	215
3176	201	F2737	204	ML2785M, R, W	208	A-3012-M, R	215
ZENITH		F2738	204	ML2786L, R, W	208	A-3013H	215
C2221Y	190	F2739	204	RL2785M, R, W	208	A-3014H	215
C2223E, R, Y	190	F2740	204	T2028W	208	A-4007-E, R	215
C2225E, R, W	190	F2751	204	T2029H, R	208	A-2241, E, EU, M, MU, R, RU	216
C2245E, R, W	190	F2752	204	T2030M	208	Z-2223, EZ, CZU, E2, G2U,	
C2246E, R, W	190	F2755	204	T2040E4, R4, W4	208	RZ, RZU, Y2, Y2U	216
C2247E, R, W	190	F2756	204	T2042E, M, R, W	208	2243-EZ, EZU, RZ, RZU	216
C2249E, R, W	190	F2786	204	T2045W, W	208	2244-EZ, EZU, RZ, RZU	216
C2254E, H, R, W	190	F3006	204	T2055H, M, R, W	208	2249-EZ, EZU, RZ, RZU	216
C3001E, R, W	190	F3310	204	T2080E4, R4, W4	208	2251-EZ, EZU, RZ, RZU	216
C3006E, R, W	190	F3311	204	T2081E, R, W	208	2282-EZ, EZU, RZ, RZU	216
C3007E, R, W	190	F3342	204	L2717E, R, W	208	3000-EZ, EZU, RZ, RZU	216
C3008 R	190	F3348	204	L2742H, M, R, W	208	3001-EZ, EZU, RZ, RZU	216
C3009E, W, Y	190	F3350	204	L2746H	208	3004-EZ, EZU, RZ, RZU	216
D3002 R	190	F3353	204	L2748M, M, R, W	208	3008-EZ, EZU, RZ, RZU	216
Chassis 16C21	190	F3354	204	L2756L, R, W, Y	208	L1615L	217
Chassis 16C24	190	F3359	204	L2786W	208	L1620B, L, Y	217
Chassis 16C21Q	190	F3388	204	L3311R, W, Y	208	L2150L, Y	217
D2464	191	H2739	191	L3350L, R, W, Y	208	L2155B, J, L, Y	217
Chassis 17D20	191	R1800E-R	205	L3355H	208	T1966L	217
C1415L	192	R1812E-R	205	L3358W, Y	208	Chassis 14K20	217
C1416B	192	R2229E-R	205	Chassis 15L32.33	208	M2003U	218
C1417L	192	R2230E-R	205	14L36	209	M2002	218
C1715L	192	R2249E-R	205	L2108G, L	210	M2000	218
C1716C	192	R2258E-R	205	L2109F, L	210	M2109	218
C1717J	192	R2250E-R	205	L2110R, W	210	M2001	218
C1719P	192	R2253M	205	L2127B, W	210	M2150	218
C1720C	192	R2257E-R	205	L2213L, LD	210	M2155	218
Chassis 16C20	192	F2111L	205	L2214L	210	M2110	218
D1803	192	Chassis 17D20	206	L2231L, R, W	210	M2127	218
		D2430	206	Chassis 15L37	210	Chassis 14M28	218

Refer to UNLISTED TROUBLE-SHOOTING Section if your set is not listed.

HOW TO REPAIR YOUR TRANSISTOR PORTABLE RADIO.

The average transistor portable is relatively a simple mechanism and under most circumstances may be repaired easily. Our instructions cover the basic means for checking and correcting most troubles. The defective-part factors such as coils, condensers or transistors will have to be left to your local repair man. However, the following procedures in most cases will enable you to repair your own portable.

- 1—Make sure battery is fresh.
- 2—Check battery connections. Wires sometimes become disengaged from clips. Fig. A.
- 3—Antenna leads should be followed and checked. Fig. B. Antennas are located in different positions in various models and can be easily recognized. Fig. B-1. Antenna leads are very thin and a break could make your portable inoperative.
- 4—If antenna checks out, the next step is the loudspeaker. Remove screws holding printed board in place and gently raise slightly from case. Care should be taken so that no connecting wires are pulled out. Check wires leading to speaker. Fig. C. If intact, look at connections from transistors, coils and condensers. Fig. D. A sharp pointed pencil will be excellent to use in probing for loose connections.

Because everything is in miniature just a drop of solder will suffice.

Assuming all connections are unbroken, proceed to the next step. Replace circuit board, connect battery, turn set on and check all printed connections on board.

- 5—Using a thin screwdriver, slowly run along all connections up and down, side to side, pressing slightly on circuit board. Fig. E.

A break in the circuit board can easily be overlooked by the eye. Therefore, this is the most important procedure and should be done painstakingly. If a signal is heard while doing this, stop at the point of contact. Ascertain where the break is located and resolder. Fig. F.

A pencil-type soldering iron should be used and only a small amount of solder should be dropped on the broken connection. Be extremely careful for too much solder on the break will cause a short and will have to be removed.

It is also important to check earphone jack. This sometimes becomes jammed and automatically cuts off speaker. A small screwdriver can be used to close prongs.

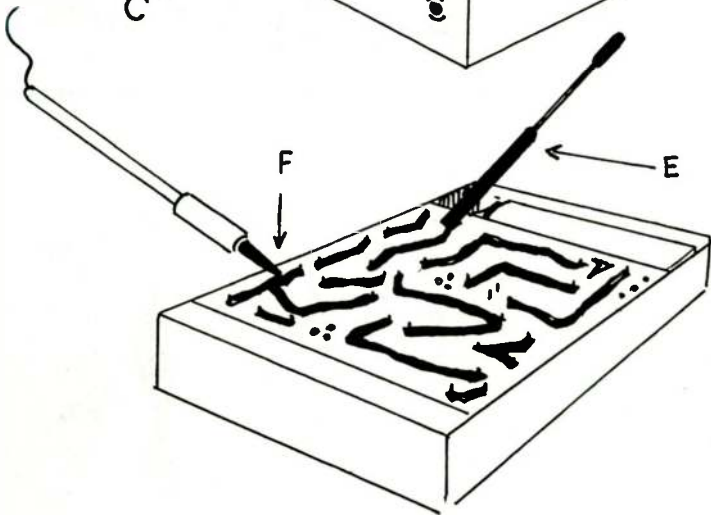
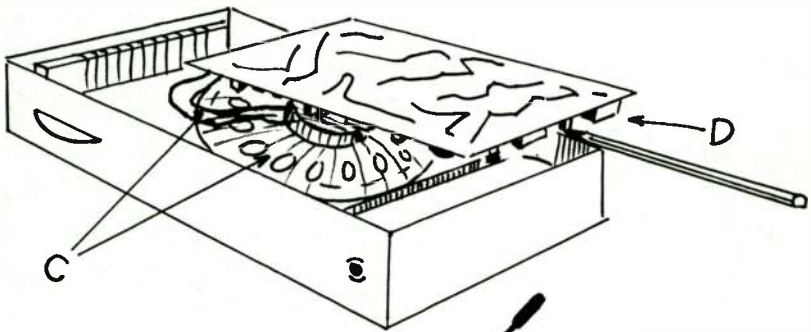
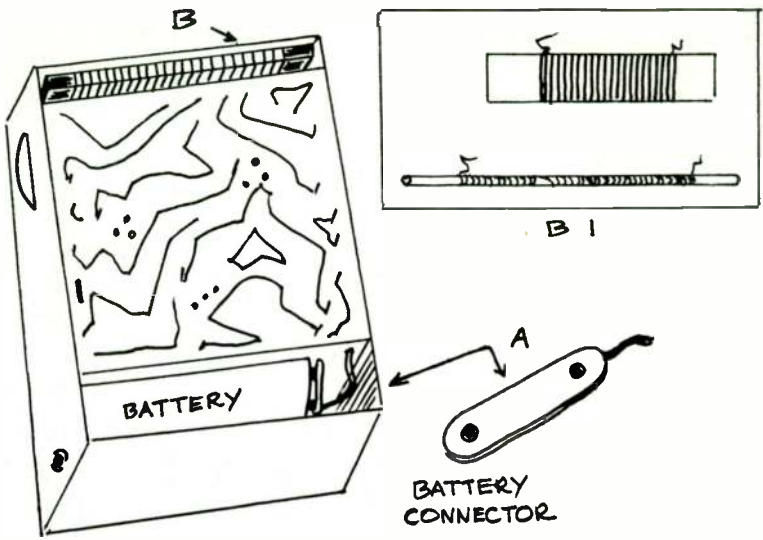

CORRECT THESE FAULTS

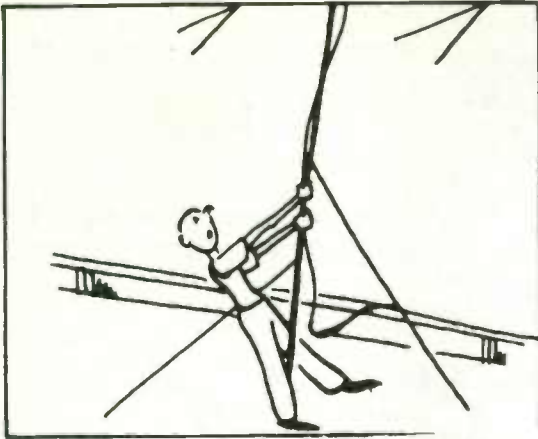

MAKE SURE ANTENNA CONNECTIONS ARE TIGHT.

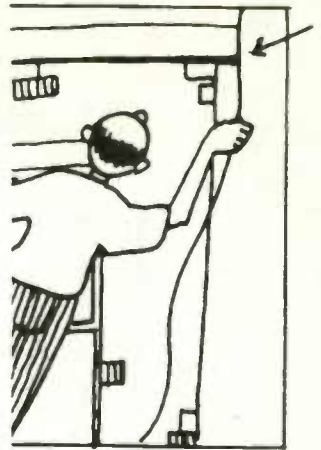

IF AERIAL LEAD WIRE TOUCHES ANY PART OF ROOF OR BUILDING MAKE SURE IT IS NOT RUBBING ON ROUGH SURFACE - THIS WILL WEAR THE WIRE.

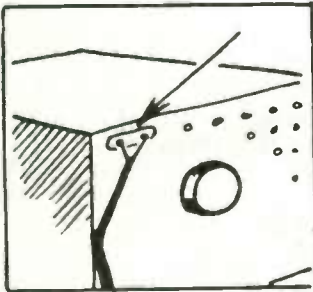

ALL CONNECTIONS ON SET SHOULD BE TIGHT - NO STRANDS OF WIRE SHOULD OVERLAP

-Wind sometimes changes position of antenna causing ghosts or double image. To correct this, turn your set on the channel that is giving you this trouble. Have someone turn the antenna mast on the roof slowly until an improvement is noticed. Check all channels this way to notice whether the change in position has affected them, if so, it will be necessary to adjust the antenna for each station to get the maximum reception.

-Interference from outside causes such as, automobile ignition, diathermy or any electrical apparatus in the immediate vicinity may cause lines and intermittent flashes across the screen of your set. A simple way of getting rid of some of this interference is by twisting the lead-in from your antenna, one twist per foot down to the set. Illustrated Fig. K.

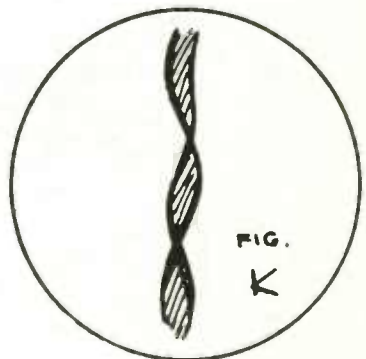

BEFORE YOU
START LOOKING
FOR BAD TUBES
READ THIS...

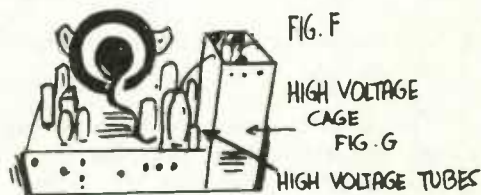
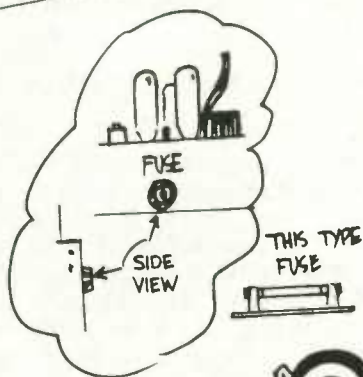
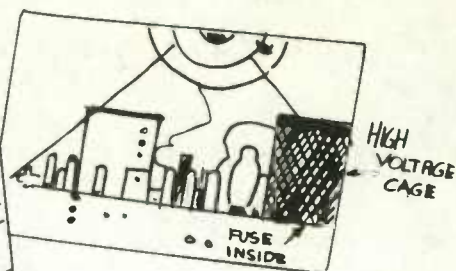
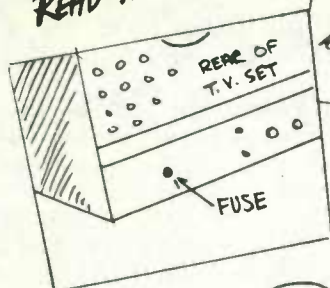

BEFORE YOU ATTEMPT TO FIND THE TUBE THAT IS DEFECTIVE, THERE ARE A FEW PRELIMINARIES TO ATTEND TO.

1—Quite a number of sets are equipped with fuses—some of these are located in the back of the chassis—usually a black knob so marked. By turning this knob the fuse comes out. Other sets sometimes have the fuse mounted in the High Voltage Cage which you will find illustrated in the book. If, when you turn the set on and there is no light in the picture tube and no sound, look in the rear of the set and try to see if any of the tubes are lit. No light in the tubes, no sound and no picture sometimes means a fuse has blown. If it is necessary to take the back of your set off to locate the fuse, refer to page 14 for instructions.

HOW TO TAKE THE BACK OFF YOUR TV SET
THERE IS NO DANGER OF ANY SHOCK IF THE
DIRECTIONS ARE FOLLOWED.

- 1—SHUT OFF THE SET AND PULL OUT THE PLUG FROM THE A.C. WALL OUTLET. WAIT A FEW MINUTES AFTER THE SET HAS BEEN TURNED OFF.
- 2—After the required time has elapsed, remove the back of the set. Fig. 1. Most sets have the electrical connection mounted on the lower corner or the top of the back. You will notice when the back is removed the A.C. line will automatically be disconnected from the set. Fig. 2. **THEREFORE, IT IS IMPOSSIBLE FOR CURRENT TO PASS THROUGH THE SET WHILE YOU ARE CHANGING TUBES.** When you are finished and the back is to be replaced, make sure the plug fits securely in its socket—just as it was when you took it off.
- 3—If the tube to be replaced is located in the High Voltage section follow these directions.
 - A—Any tube which has a grid cap on it, Fig. F, is a high voltage tube. As a rule this tube is sometimes located in the High Voltage Cage, Fig. G. Either the top, front or the whole cage can be removed by taking out the screws or bolts holding it. In some cases this cage contains two or three other type tubes which might have to be changed if your trouble is due to these. In some sets the High Voltage cage has been eliminated, therefore, all your tubes are exposed to view. Even with the current off grid cap tubes sometimes retain a little voltage which if touched by the hand might give a mild shock — not dangerous.
 - B—Dissipate current in high-voltage tubes, if desired. Get a screwdriver with a wood or plastic handle. Holding handle, place screwdriver on grid cap of tube and simultaneously place metal shaft of screwdriver against the High Voltage Cage. If there is no cage, place shaft of screwdriver against any metal part of chassis.
 - C—At no time is it necessary to move or adjust the picture tube. This should be left to an experienced service man.
- 4—When removing the tiny tubes from their respective sockets you will notice pins on the bottom of the tubes. There is a wide space between two of the pins. Fig. H. Try to remember which way the wide space faced in respect to the socket so that you can put the new tube back the same way. In putting the new tube back it is not necessary to force it in—just push gently. If you get it in the wrong way and bend the pins, simply straighten them out by hand.
- 5—The other larger tubes have a bakelite projection in the middle of the base. Fig. I. This fits into a slot in the middle of the socket. The tube will only go in one way. Therefore, it is impossible to make a mistake.

6—If you find, when you remove the defective tube from your set, that it is marked differently than our layout, do not become confused. Some manufacturers make changes in the tube complement on later models of the same set by using a new number to improve performance. This tube was not listed in the diagram at the time of printing. Therefore, replace the tube if it is defective with a duplicate—disregard the tube number on our layout.

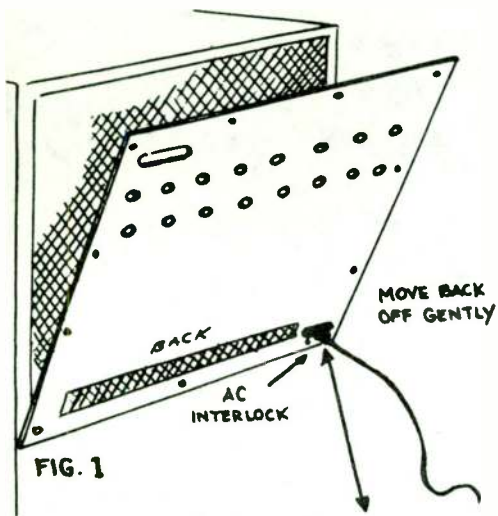
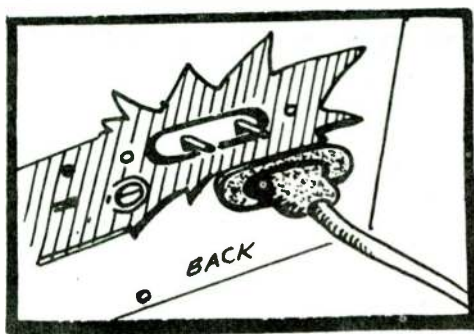
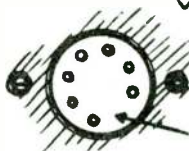

FIG. 2



VIEW OF TINY TUBE SOCKET LOOKING DOWN.



NOTICE SPACE BETWEEN TWO OF THE HOLES



THESE TROUBLE NUMBERS WILL BE FOUND WITH EACH LAYOUT

Every tube in your television set performs a function necessary for sound and picture, therefore, by consulting the Table of Contents for the layout which applies to your particular television receiver, we will show you how simple it is to replace the tubes which are the cause of your troubles.

Listed below the tube layout of your set are the most common troubles—and what to do—per example:

TROUBLE	LOCATION
1—No brightness on tube and no sound	A4 A7 A9
2—No vertical height. White line across screen. Fig. 2.....	A3 A5 A20 A11
3—No horizontal height. White line running up and down. Fig. 3.....	A15 A6 A1
4—Small picture in center of tube. Picture does not fill up entire screen. Fig. 4.....	A12 A17 A13
5—Picture out of shape. Fig. 5. If picture is distorted in the reverse, at the bottom instead of the top—follow same procedure.....	A19 A22 A5 A18 A8
6—Picture out of shape and proportion as in Fig. 5 but from side to side instead of from top to bottom	A16 A14 A10
7—Picture, but no sound.....	A23 A6 A3
8—Picture rolls. Fig. 8.....	A26 A28 A29
9—Picture tears. Fig. 9. Figures on screen wave back and forth.....	A15 A14 A9 A2
10—Sound, brightness, no picture.....	A9 A4 A2 A17
11—Brightness, no picture, no sound..	A6 A3 A5

The black arrows outside the layout point to the tubes which usually are responsible for this trouble. It is not necessary to replace all the tubes, but we suggest you have them tested to find the defective ones.

We realize there are technical adjustments and repairs on a television set which can only be made by a qualified service man if one has to be called in due to troubles which are not caused by defective tubes or a faulty antenna.



1

1—No brightness on tube



2

2—No vertical height. White line across screen, Fig. 2



3

3—No horizontal height. White line running up and down, Fig. 3



4

4—Small picture in center of tube. Picture does not fill up entire screen, Fig. 4

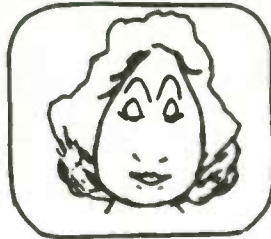

5

5—Picture out of shape, Fig. 5. If picture is distorted in the reverse, at the bottom instead of the top—follow same procedure



6

6—Picture out of shape and proportion as in Fig. 5 but from side instead of from top to bottom

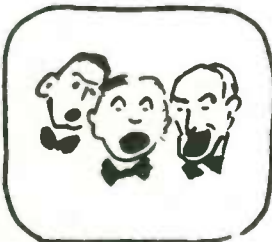

7

7—Picture, but no sound

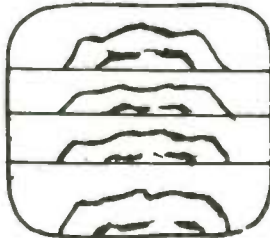

8

8—Picture rolls.



9

9—Picture tears, Fig. 9. Figures on screen wave back and forth



10

10—Sound, brightness, no picture

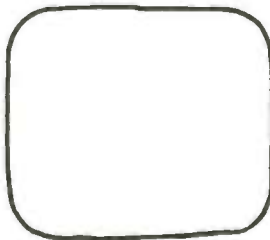

11

11—Brightness, no picture, no sound.

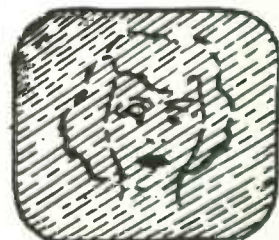

12

SNOW IN THE PICTURE
(Sometimes caused in poor signal areas)

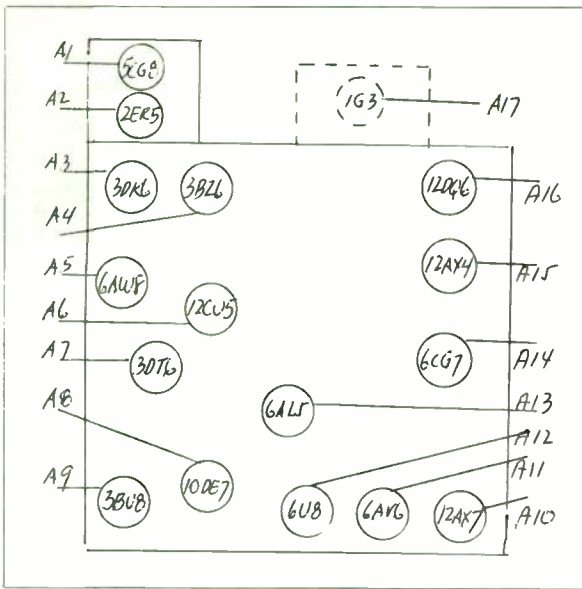

ADMIRAL-LAYOUT NO. 1

TROUBLE	LOCATION
1-No brightness on tube.	A14 - A15 - A16 - A17 *
2-No vertical height. White line across screen Fig. 2	A8
3-No horizontal width. White line running up and down. Fig. 3	A14 - A15 - A16 *
4-Small picture in center of tube. Picture does not fill up entire screen. Fig. 4	A14 - A15 - A16 *
5-Picture out of proportion vertically. (top to bottom) Fig. 5	A8
6-Picture out of proportion horizontally. (side to side) Fig. 6	A14 - A15 - A16
7-Picture present, but no sound.	A10 - A11 - A12 - A13 - A7
8-Picture rolls. (Vertical movement up and down). Fig. 8	A8 - A9
9-Picture tears. Figures on screen wave from side to side. Fig. 9	A9 - A14 - A15 - A16
10-Sound, brightness but no picture.	A3 - A4 - A5 - A9
11-Brightness, but no picture or sound.	A1 - A2 - A3 - A4 - A5 - A9 * Selenium Rectifier

ADMIRAL - LAYOUT NO. 2

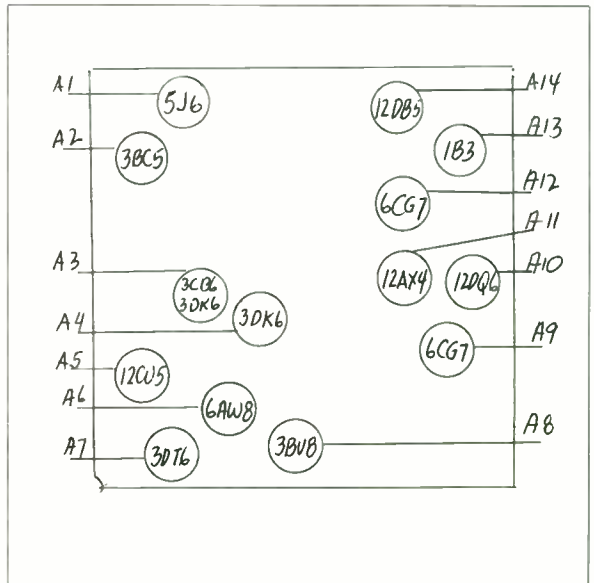

TROUBLE	LOCATION
1-No brightness on tube.	A9 - A10 - A11 - A13
2-No vertical height. White line across screen Fig. 2	A12 - A14
3-No horizontal width. White line running up and down. Fig. 3	A9 - A10 - A11 *
4-Small picture in center of tube. Picture does not fill up entire screen. Fig. 4	A9 - A10 - A11 *
5-Picture out of proportion vertically. (top to bottom) Fig. 5	A12 - A14
6-Picture out of proportion horizontally. (side to side) Fig. 6	A9 - A10 - A11
7-Picture present, but no sound.	A5 - A6 - A7
8-Picture rolls. (Vertical movement up and down). Fig. 8	A8 - A12 - A14
9-Picture tears. Figures on screen wave from side to side. Fig. 9	A8 - A9 - A10 - A11 - A12
10-Sound, brightness but no picture.	A3 - A4 - A6 - A8
11-Brightness, but no picture or sound.	A1 - A2 - A3 - A4 - A6 - A8 *Selenium Rectifiers

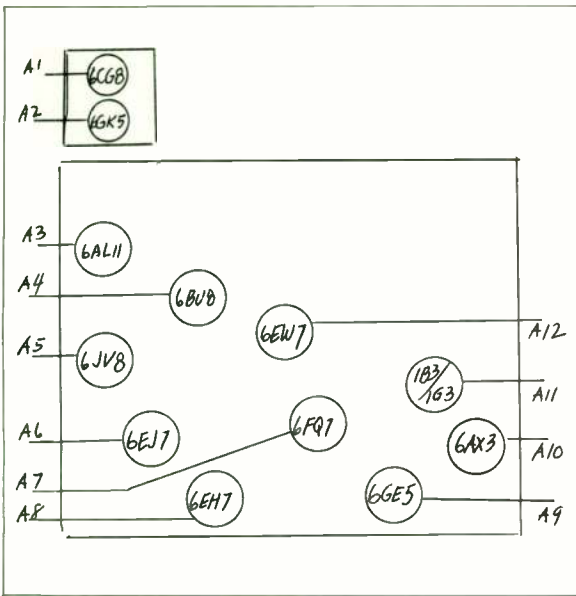

TROUBLE	LOCATION
1-No brightness on tube.	A7 - A9 - A10 - A11
2-No vertical height. White line across screen Fig. 2	A12
3-No horizontal width. White line running up and down. Fig. 3	A7 - A9 - A10
4-Small picture in center of tube. Picture does not fill up entire screen. Fig. 4	A7 - A9 - A10
5-Picture out of proportion vertically. (top to bottom) Fig. 5	A12
6-Picture out of proportion horizontally. (side to side) Fig. 6	A7 - A9 - A10
7-Picture present, but no sound.	A3 - A5
8-Picture rolls. (Vertical movement up and down). Fig. 8	A4 - A12
9-Picture tears. Figures on screen wave from side to side. Fig. 9	A4 - A7 - A9 - A10
10-Sound, brightness but no picture.	A4 - A5 - A6 - A8
11-Brightness, but no picture or sound.	A1 - A2 - A4 - A5 - A6 - A8

ADMIRAL-LAYOUT NO.3

TROUBLE

- 1-No brightness on tube.
- 2-No vertical height. White line across screen Fig. 2
- 3-No horizontal width. White line running up and down. Fig. 3
- 4-Small picture in center of tube. Picture does not fill up entire screen. Fig. 4
- 5-Picture out of proportion vertically. (top to bottom) Fig. 5
- 6-Picture out of proportion horizontally. (side to side) Fig. 6
- 7-Picture present, but no sound.
- 8-Picture rolls. (Vertical movement up and down). Fig. 8
- 9-Picture tears. Figures on screen wave from side to side. Fig. 9
- 10-Sound, brightness but no picture.
- 11-Brightness, but no picture or sound.

LOCATION

- A12 - A13 - A14 - A15 - A16
- A7 - A8
- A12 - A14 - A15 - A16
- A15
- A7 - A8
- A12 - A14 - A16
- A5 - A10 - A11 - A17
- A3 - A7 - A8
- A3 - A8 - A12 - A14 - A16
- A3 - A4 - A5 - A6 - A9
- A1 - A2 - A3 - A4 - A5 - A6 - A9

ADMIRAL-LAYOUT NO.4

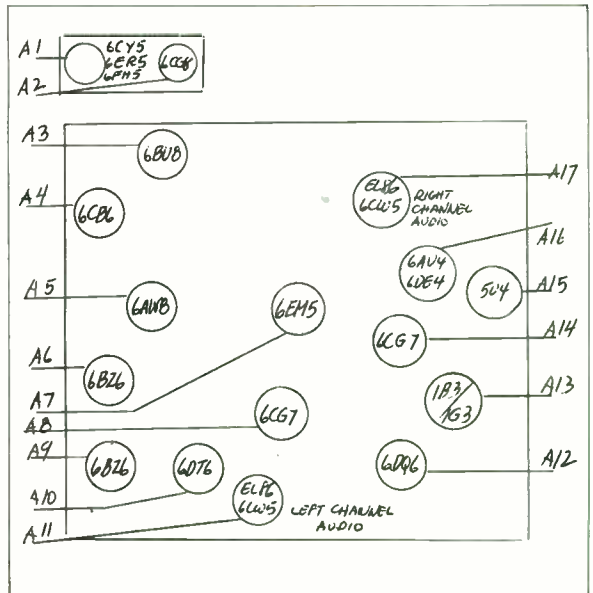

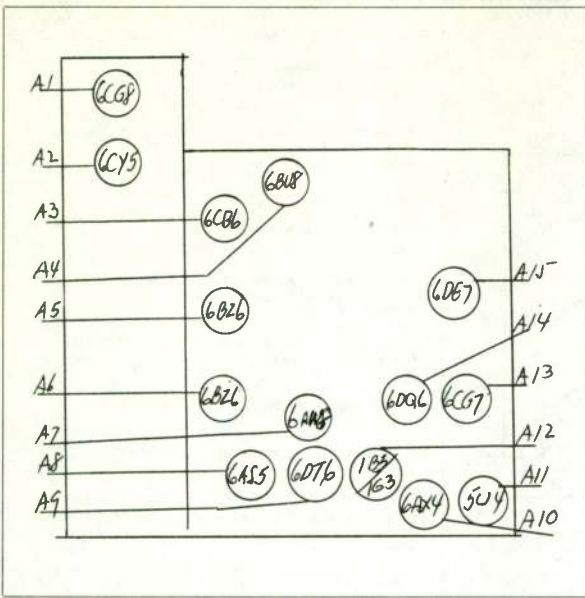

ADMIRAL - LAYOUT NO. 5

TROUBLE	LOCATION
1-No brightness on tube.	A10 - A11 - A12 - A13 - A14
2-No vertical height. White line across screen Fig. 2	A15
3-No horizontal width. White line running up and down. Fig. 3	A10 - A11 - A13 - A14
4-Small picture in center of tube. Picture does not fill up entire screen. Fig. 4	A11
5-Picture out of proportion vertically. (top to bottom) Fig. 5	A15
6-Picture out of proportion horizontally. (side to side) Fig. 6	A10 - A13 - A14
7-Picture present, but no sound.	A7 - A8 - A9
8-Picture rolls. (Vertical movement up and down). Fig. 8	A4 - A15
9-Picture tears. Figures on screen wave from side to side. Fig. 9	A4 - A10 - A13 - A14
10-Sound, brightness but no picture.	A3 - A5 - A6 - A7
11-Brightness, but no picture or sound.	A1 - A2 - A3 - A5 - A6 - A7

TROUBLE

LOCATION

1-No brightness on tube.	A1 - A2 - A3 - A15*
2-No vertical height. White line across screen Fig. 2	A14 - A16
3-No horizontal width. White line running up and down. Fig. 3	A2 - A3 - A15*
4-Small picture in center of tube. Picture does not fill up entire screen. Fig. 4	A2 - A3 - A15*
5-Picture out of proportion vertically. (top to bottom) Fig. 5	A4 - A16
6-Picture out of proportion horizontally. (side to side) Fig. 6	A2 - A3 - A15
7-Picture present, but no sound.	A5 - A6 - A12
8-Picture rolls. (Vertical movement up and down). Fig. 8	A4 - A14 - A16
9-Picture tears. Figures on screen wave from side to side. Fig. 9	A2 - A3 - A4 - A13 - A15
10-Sound, brightness but no picture.	A4 - A7 - A10 - A11
11-Brightness, but no picture or sound.	A7 - A8 - A9 - A10 - A11

*Selenium Rectifiers.

ADMIRAL - LAYOUT NO. 6

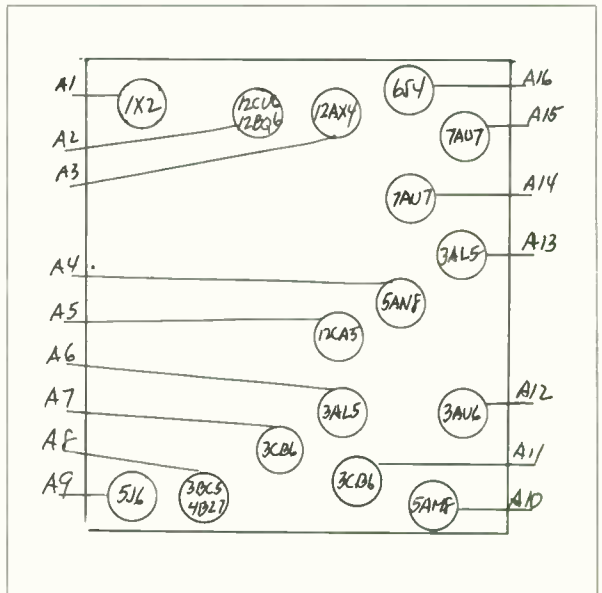

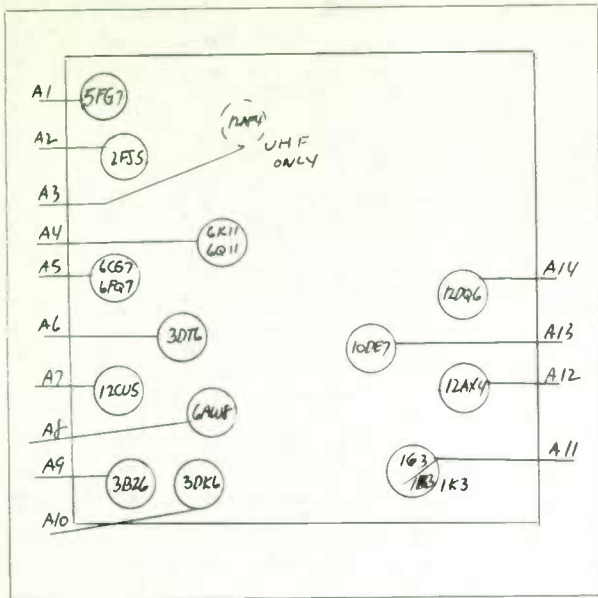

TROUBLE	LOCATION
1-No brightness on tube.	A5 - A11 - A12 - A14
2-No vertical height. White line across screen Fig. 2	A13
3-No horizontal width. White line running up and down. Fig. 3	A5 - A12 - A14
4-Small picture in center of tube. Picture does not fill up entire screen. Fig. 4	A5 - A12 - A14
5-Picture out of proportion vertically. (top to bottom) Fig. 5	A13
6-Picture out of proportion horizontally. (side to side) Fig. 6	A5 - A12 - A14
7-Picture present, but no sound.	A6- A7- A8
8-Picture rolls. (Vertical movement up and down). Fig. 8	A4- A13
9-Picture tears. Figures on screen wave from side to side. Fig. 9	A4 - A5 - A12 - A14
10-Sound, brightness but no picture.	A8 - A9 - A10
11-Brightness, but no picture or sound.	A1 - A2 - A8 - A9 - A10 A3 - UHF only.

ADMIRAL - LAYOUT NO. 7

TROUBLE	LOCATION
1-No brightness on tube.	A4 - A5 - A6 - A13*
2-No vertical height. White line across screen Fig. 2	A7
3-No horizontal width. White line running up and down. Fig. 3	A4 - A5 - A13*
4-Small picture in center of tube. Picture does not fill up entire screen. Fig. 4	A4 - A5 - A13*
5-Picture out of proportion vertically. (top to bottom) Fig. 5	A7
6-Picture out of proportion horizontally. (side to side) Fig. 6	A4 - A5 - A13
7-Picture present, but no sound.	A3 - A8 - A9
8-Picture rolls. (Vertical movement up and down). Fig. 8	A7 - A9 - A10
9-Picture tears. Figures on screen wave from side to side. Fig. 9	A4 - A5 - A9 - A10 - A13
10-Sound, brightness but no picture.	A10 - A11 - A12
11-Brightness, but no picture or sound.	A1 - A2 - A10 - A11 - A12

ADMIRAL - LAYOUT NO. 8

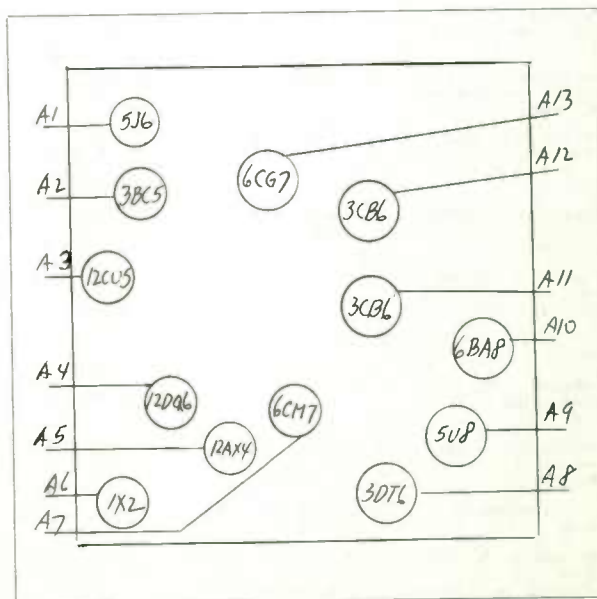

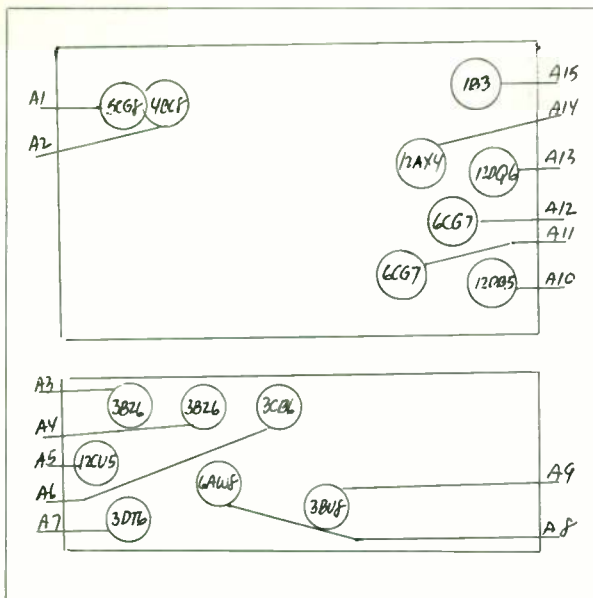

ADMIRAL - LAYOUT NO.9

TROUBLE

LOCATION

- | | |
|---|------------------------------|
| 1-No brightness on tube. | A12 - A13 - A14 - A15 |
| 2-No vertical height. White line across screen Fig. 2 | A10 - A11 |
| 3-No horizontal width. White line running up and down. Fig. 3 | A12 - A13 - A14 |
| 4-Small picture in center of tube. Picture does not fill up entire screen. Fig. 4 | A12 - A13 - A14 |
| 5-Picture out of proportion vertically. (top to bottom) Fig. 5 | A10 - A11 |
| 6-Picture out of proportion horizontally. (side to side) Fig. 6 | A12 - A13 - A14 |
| 7-Picture present, but no sound. | A5 - A7 - A8 |
| 8-Picture rolls. (Vertical movement up and down). Fig. 8 | A9 - A10 - A11 |
| 9-Picture tears. Figures on screen wave from side to side. Fig. 9 | A9 - A12 - A13 - A14 |
| 10-Sound, brightness but no picture. | A3 - A4 - A6 - A8 |
| 11-Brightness, but no picture or sound. | A1 - A2 - A3 - A4 - A6
A8 |

TROUBLE

LOCATION

- | | |
|---|-----------------------------|
| 1-No brightness on tube. | A11 - A13 - A14 - A15 |
| 2-No vertical height. White line across screen Fig. 2 | A10 - A12 |
| 3-No horizontal width. White line running up and down. Fig. 3 | A11 - A14 - A15 |
| 4-Small picture in center of tube. Picture does not fill up entire screen. Fig. 4 | A11 - A14 - A15 |
| 5-Picture out of proportion vertically. (top to bottom) Fig. 5 | A10 - A12 |
| 6-Picture out of proportion horizontally. (side to side) Fig. 6 | A11 - A14 - A15 |
| 7-Picture present, but no sound. | A6 - A7 - A9 |
| 8-Picture rolls. (Vertical movement up and down). Fig. 8 | A8 - A10 - A12 |
| 9-Picture tears. Figures on screen wave from side to side. Fig. 9 | A8 - A10 - A11 - A14 - A15 |
| 10-Sound, brightness but no picture. | A2 - A4 - A5 - A8 |
| 11-Brightness, but no picture or sound. | A1 - A2 - A3 - A4 - A5 - A8 |

NOTE * Due to chassis changes, tubes #A1 - A3 - A4 may differ. Replace, if needed, by same tube as in set.

ADMIRAL - LAYOUT NO.10

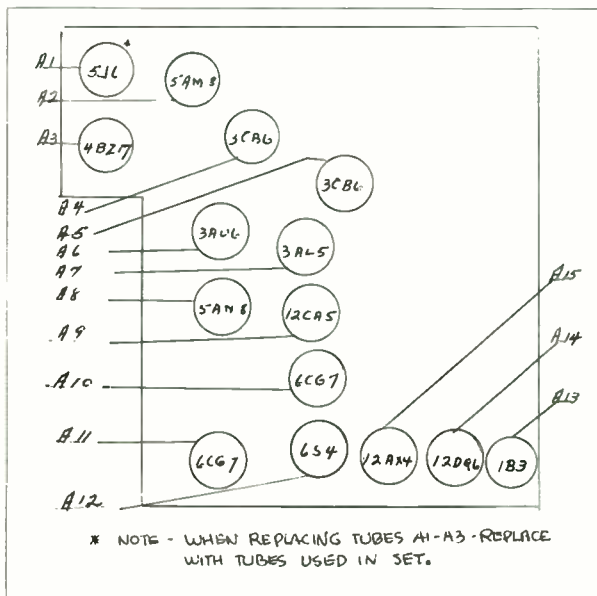

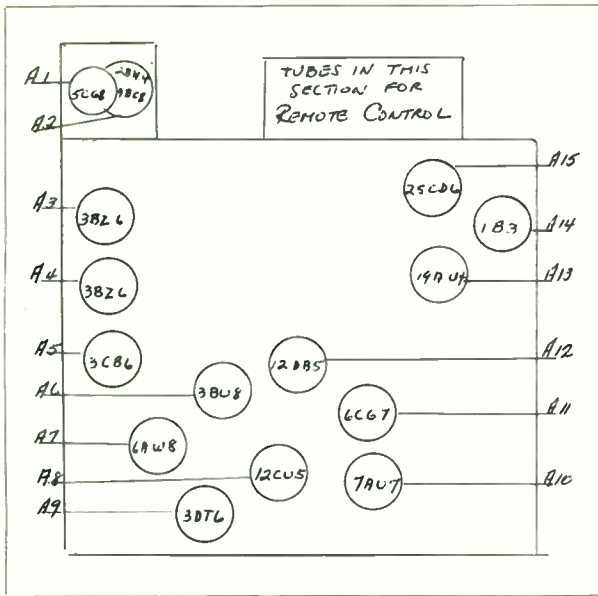

ADMIRAL-LAYOUT NO. 11

TROUBLE	LOCATION
1-No brightness on tube.	A11 - A13 - A14 - A15 *
2-No vertical height. White line across screen Fig. 2	A10 - A12
3-No horizontal width. White line running up and down. Fig. 3	A11 - A13 - A15 *
4-Small picture in center of tube. Picture does not fill up entire screen. Fig. 4	A11 - A13 - A15 *
5-Picture out of proportion vertically. (top to bottom) Fig. 5	A10 - A12
6-Picture out of proportion horizontally. (side to side) Fig. 6	A11 - A13 - A15
7-Picture present, but no sound.	A7 - A8 - A9
8-Picture rolls. (Vertical movement up and down). Fig. 8	A6 - A10 - A12
9-Picture tears. Figures on screen wave from side to side. Fig. 9	A6 - A10 - A11 - A13 - A15
10-Sound, brightness but no picture.	A3 - A4 - A5 - A6 - A7
11-Brightness, but no picture or sound.	A1 - A2 - A3 - A4 - A5 - A6 - A7

* Selenium Rectifiers.

TROUBLE

LOCATION

1-No brightness on tube.	A11 - A13 - A14 - A15 *
2-No vertical height. White line across screen Fig. 2	A10 - A12
3-No horizontal width. White line running up and down. Fig. 3	A11 - A13 - A14 *
4-Small picture in center of tube. Picture does not fill up entire screen. Fig. 4	A11 - A13 - A14 *
5-Picture out of proportion vertically. (top to bottom) Fig. 5	A10 - A12
6-Picture out of proportion horizontally. (side to side) Fig. 6	A11 - A13 - A14
7-Picture present, but no sound.	A9 - A16 - A17 - A18
8-Picture rolls. (Vertical movement up and down). Fig. 8	A7 - A10 - A12
9-Picture tears. Figures on screen wave from side to side. Fig. 9	A7 - A10 - A11 - A13 - A14
10-Sound, brightness but no picture.	A4 - A5 - A6 - A7 - A8
11-Brightness, but no picture or sound.	A2 - A3 - A4 - A5 - A6 - A7 - A8 (A1 - UHF only)

* Selenium Rectifiers.

ADMIRAL-LAYOUT NO. 12

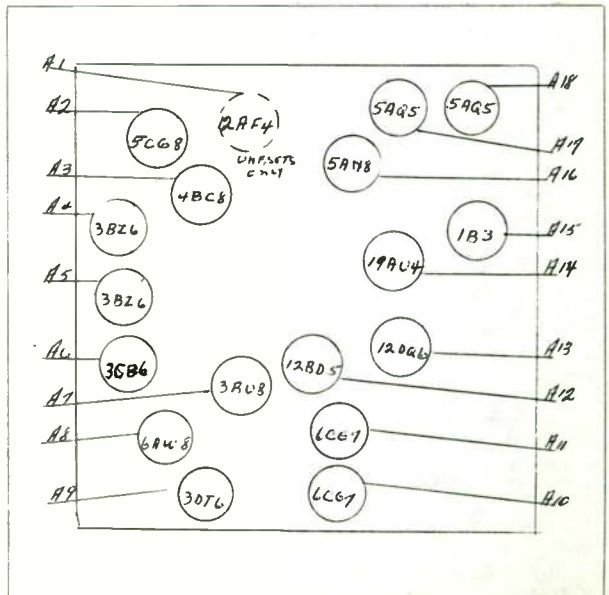

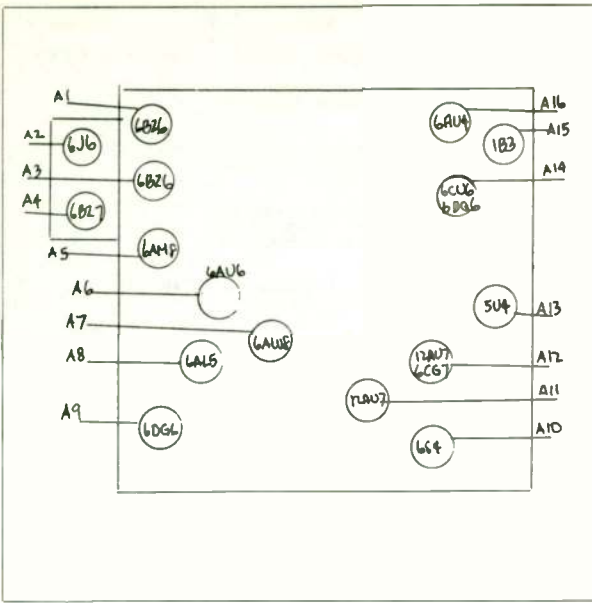

TROUBLE	LOCATION
1-No brightness on tube.	A12 - A13 - A14 - A15 - A16
2-No vertical height. White line across screen Fig. 2	A10 - A11
3-No horizontal width. White line running up and down. Fig. 3	A12 - A13 - A14 - A16
4-Small picture in center of tube. Picture does not fill up entire screen. Fig. 4	A13
5-Picture out of proportion vertically. (top to bottom) Fig. 5	A10 - A11
6-Picture out of proportion horizontally. (side to side) Fig. 6	A12 - A14 - A16
7-Picture present, but no sound.	A6 - A8 - A9
8-Picture rolls. (Vertical movement up and down). Fig. 8	A7 - A10 - A11
9-Picture tears. Figures on screen wave from side to side. Fig. 9	A7 - A11 - A12 - A14 - A16
10-Sound, brightness but no picture.	A1 - A3 - A5 - A7
11-Brightness, but no picture or sound.	A1 - A2 - A3 - A4 - A5 - A7

ADMIRAL - LAYOUT NO.13

ADMIRAL - LAYOUT NO.14

TROUBLE	LOCATION
1-No brightness on tube.	A10 - A11 - A13 - A14 - A15
2-No vertical height. White line across screen Fig. 2	A16 - A17
3-No horizontal width. White line running up and down. Fig. 3	A10 - A13 - A14 - A15
4-Small picture in center of tube. Picture does not fill up entire screen. Fig. 4	A10
5-Picture out of proportion vertically. (top to bottom) Fig. 5	A16 - A17
6-Picture out of proportion horizontally. (side to side) Fig. 6	A13 - A14 - A15
7-Picture present, but no sound.	A1 - A2 - A4
8-Picture rolls. (Vertical movement up and down). Fig. 8	A3 - A16 - A17
9-Picture tears. Figures on screen wave from side to side. Fig. 9	A3 - A12 - A13 - A14 - A15 - A16
10-Sound, brightness but no picture.	A3 - A5 - A6 - A7
11-Brightness, but no picture or sound.	A5 - A6 - A7 - A8 - A9

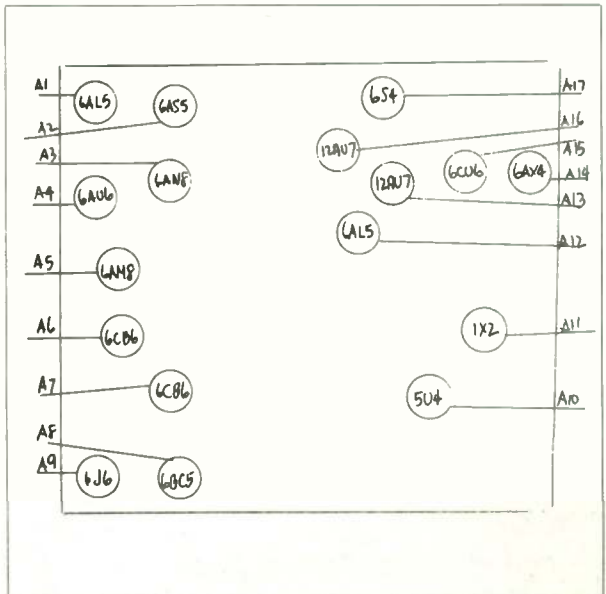

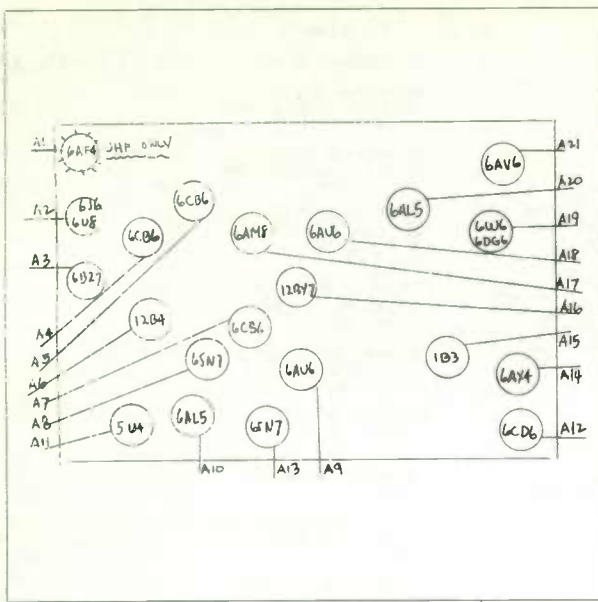

ADMIRAL - LAYOUT NO. 15

TROUBLE	LOCATION
1-No brightness on tube.	A11 - A12 - A13 - A14 - A15
2-No vertical height. White line across screen Fig. 2	A6 - A8
3-No horizontal width. White line running up and down. Fig. 3	A11 - A12 - A13 - A14
4-Small picture in center of tube. Picture does not fill up entire screen. Fig. 4	A11
5-Picture out of proportion vertically. (top to bottom) Fig. 5	A6 - A8
6-Picture out of proportion horizontally. (side to side) Fig. 6	A12 - A13 - A14
7-Picture present, but no sound.	A18 - A19 - A20 - A21
8-Picture rolls. (Vertical movement up and down). Fig. 8	A6 - A7 - A8
9-Picture tears. Figures on screen wave from side to side. Fig. 9	A7 - A10 - A12 - A13 - A14
10-Sound, brightness but no picture.	A4 - A5 - A9 - A16 - A17
11-Brightness, but no picture or sound.	A2 - A3 - A4 - A5 - A9 - A17 (A1 - UHF only)

TROUBLE	LOCATION
1-No brightness on tube.	A11 - A13 - A14 - A15 *
2-No vertical height. White line across screen Fig. 2	A9 - A12
3-No horizontal width. White line running up and down. Fig. 3	A11 - A13 - A15 *
4-Small picture in center of tube. Picture does not fill up entire screen. Fig. 4	A11 - A13 - A15 *
5-Picture out of proportion vertically. (top to bottom) Fig. 5	A9 - A12
6-Picture out of proportion horizontally. (side to side) Fig. 6	A11 - A13 - A15
7-Picture present, but no sound.	A7 - A8 - A10
8-Picture rolls. (Vertical movement up and down). Fig. 8	A9 - A12
9-Picture tears. Figures on screen wave from side to side. Fig. 9	A11 - A12 - A13 - A15
10-Sound, brightness but no picture.	A3 - A4 - A5 - A6 - A7
11-Brightness, but no picture or sound.	A1 - A2 - A3 - A4 - A5 - A6 - A7 (A16 - UHF only)

* Selenium Rectifiers.

ADMIRAL - LAYOUT NO. 16

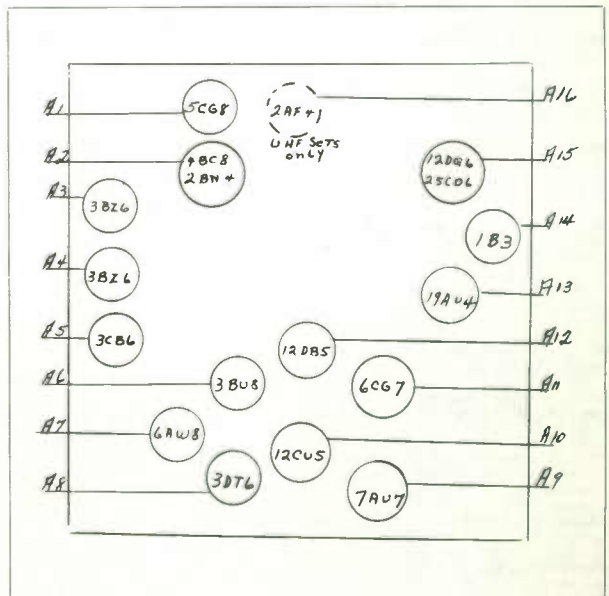

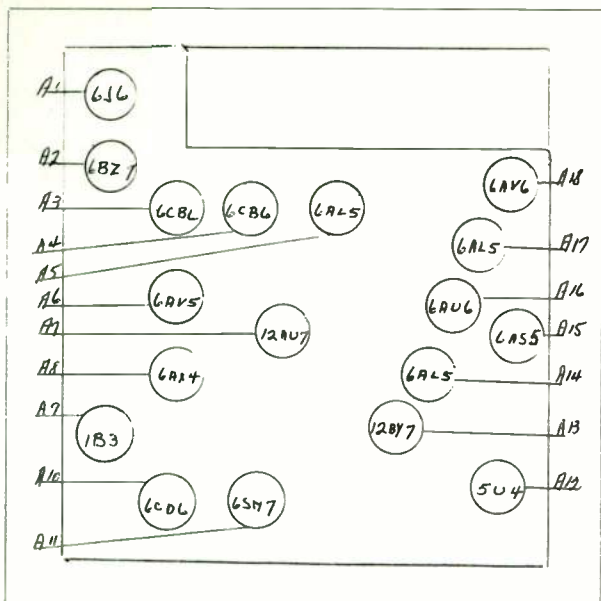

TROUBLE	LOCATION
1-No brightness on tube.	A8 - A9 - A10 - A11 - A12
2-No vertical height. White line across screen Fig. 2	A6 - A7
3-No horizontal width. White line running up and down. Fig. 3	A8 - A10 - A11 - A12
4-Small picture in center of tube. Picture does not fill up entire screen. Fig. 4	A12
5-Picture out of proportion vertically. (top to bottom) Fig. 5	A6 - A7
6-Picture out of proportion horizontally. (side to side) Fig. 6	A8 - A10 - A11
7-Picture present, but no sound.	A15 - A16 - A17 - A18
8-Picture rolls. (Vertical movement up and down). Fig. 8	A6 - A7
9-Picture tears. Figures on screen wave from side to side. Fig. 9	A7 - A8 - A10 - A11 - A14
10-Sound, brightness but no picture.	A3 - A4 - A5 - A13
11-Brightness, but no picture or sound.	A1 - A2 - A3 - A4 - A5 - A13

ADMIRAL - LAYOUT NO. 17

TROUBLE	LOCATION
1-No brightness on tube.	A5 - A11 - A12 - A13 - A14
2-No vertical height. White line across screen Fig. 2	A15 - A16
3-No horizontal width. White line running up and down. Fig. 3	A5 - A11 - A12 - A14
4-Small picture in center of tube. Picture does not fill up entire screen. Fig. 4	A5
5-Picture out of proportion vertically. (top to bottom) Fig. 5	A15 - A16
6-Picture out of proportion horizontally. (side to side) Fig. 6	A11 - A12 - A14
7-Picture present, but no sound.	A7 - A8 - A9
8-Picture rolls. (Vertical movement up and down). Fig. 8	A10 - A15 - A16
9-Picture tears. Figures on screen wave from side to side. Fig. 9	A10 - A11 - A12 - A14 - A15
10-Sound, brightness but no picture.	A3 - A4 - A6 - A8 - A10
11-Brightness, but no picture or sound.	A1 - A2 - A3 - A4 - A6 - A8 - A10

ADMIRAL - LAYOUT NO. 18

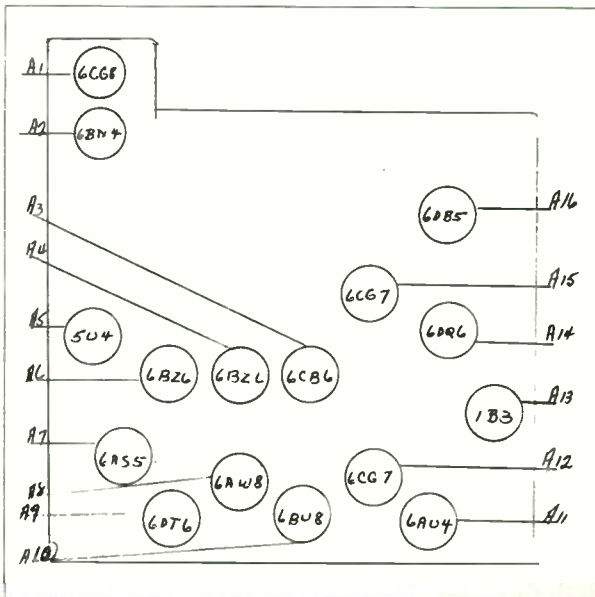

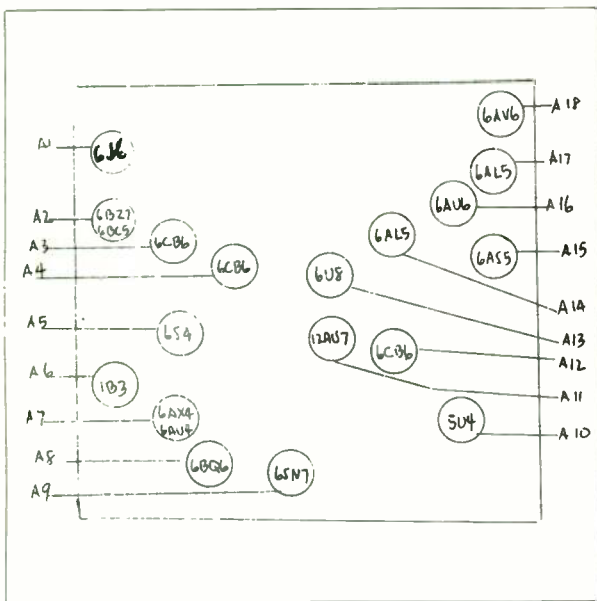

TROUBLE	LOCATION
1-No brightness on tube.	A6 - A7 - A8 - A9 - A10
2-No vertical height. White line across screen Fig. 2	A5 - A11
3-No horizontal width. White line running up and down. Fig. 3	A7 - A8 - A9 - A10
4-Small picture in center of tube. Picture does not fill up entire screen. Fig. 4	A10
5-Picture out of proportion vertically. (top to bottom) Fig. 5	A5 - A11
6-Picture out of proportion horizontally. (side to side) Fig. 6	A7 - A8 - A9
7-Picture present, but no sound.	A15 - A16 - A17 - A18
8-Picture rolls. (Vertical movement up and down). Fig. 8	A5 - A11
9-Picture tears. Figures on screen wave from side to side. Fig. 9	A7 - A8 - A9 - A11
10-Sound, brightness but no picture.	A3 - A4 - A12 - A13 - A14
11-Brightness, but no picture or sound.	A1 - A2 - A3 - A4 - A13 - A14

ADMIRAL - LAYOUT NO. 19

TROUBLE	LOCATION
1-No brightness on tube.	A11 - A13 - A14 - A15
2-No vertical height. White line across screen Fig. 2	A10 - A12
3-No horizontal width. White line running up and down. Fig. 3	A11 - A14 - A15
4-Small picture in center of tube. Picture does not fill up entire screen. Fig. 4	A11 - A14 - A15
5-Picture out of proportion vertically. (top to bottom) Fig. 5	A10 - A12
6-Picture out of proportion horizontally. (side to side) Fig. 6	A11 - A14 - A15
7-Picture present, but no sound.	A6 - A7 - A9
8-Picture rolls. (Vertical movement up and down). Fig. 8	A8 - A10 - A12
9-Picture tears. Figures on screen wave from side to side. Fig. 9	A8 - A10 - A11 - A14 - A15
10-Sound, brightness but no picture.	A2 - A4 - A5 - A8
11-Brightness, but no picture or sound.	A1 - A2 - A3 - A4 - A5 - A8

ADMIRAL - LAYOUT NO. 20

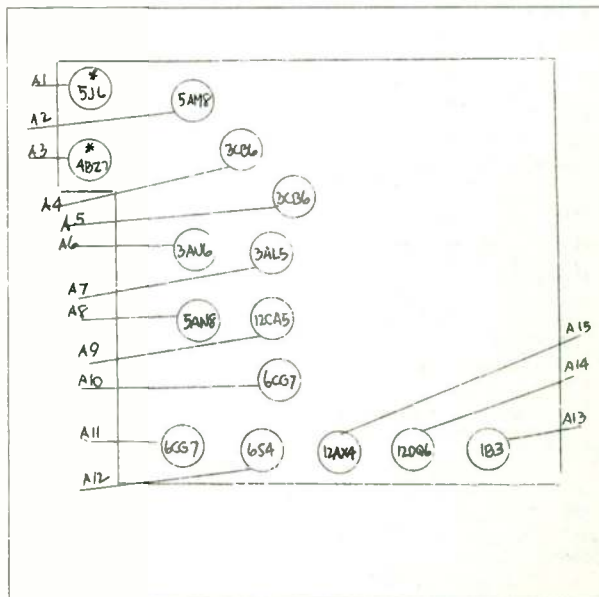

* NOTE: Due to chassis changes tubes A1 - A3 may differ. Replace when needed by same number as now being used.

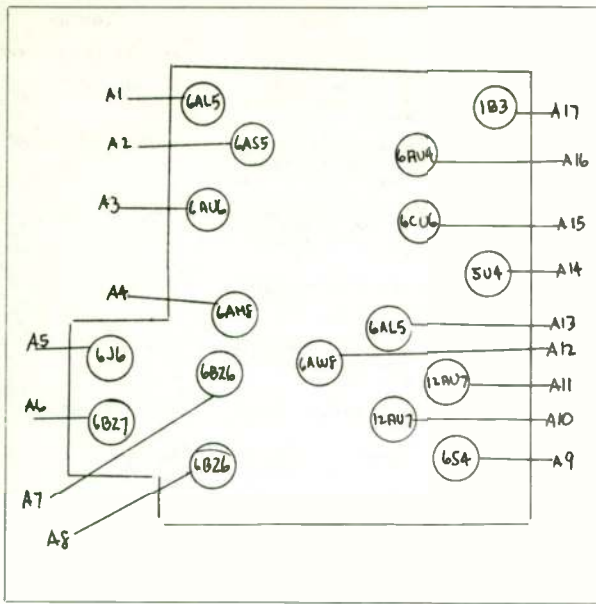

ADMIRAL - LAYOUT NO. 21

TROUBLE	LOCATION
1-No brightness on tube.	A11 - A14 - A15 - A16 - A17
2-No vertical height. White line across screen Fig. 2	A9 - A10
3-No horizontal width. White line running up and down. Fig. 3	A11 - A14 - A15 - A16
4-Small picture in center of tube. Picture does not fill up entire screen. Fig. 4	A14
5-Picture out of proportion vertically. (top to bottom) Fig. 5	A9 - A10
6-Picture out of proportion horizontally. (side to side) Fig. 6	A11 - A15 - A16
7-Picture present, but no sound.	A1 - A2 - A3
8-Picture rolls. (Vertical movement up and down). Fig. 8	A9 - A10 - A12
9-Picture tears. Figures on screen wave from side to side. Fig. 9	A10 - A11 - A12 - A15 - A16 - A13
10-Sound, brightness but no picture.	A4 - A7 - A8 - A12
11-Brightness, but no picture or sound.	A4 - A5 - A6 - A7 - A8 - A12

TROUBLE

LOCATION

1-No brightness on tube.	A7 - A8 - A9 - A10 - A13
2-No vertical height. White line across screen Fig. 2	A6 - A12
3-No horizontal width. White line running up and down. Fig. 3	A8 - A9 - A10 - A13
4-Small picture in center of tube. Picture does not fill up entire screen. Fig. 4	A13
5-Picture out of proportion vertically. (top to bottom) Fig. 5	A6 - A12
6-Picture out of proportion horizontally. (side to side) Fig. 6	A8 - A9 - A10
7-Picture present, but no sound.	A15 - A17 - A18 - A19
8-Picture rolls. (Vertical movement up and down). Fig. 8	A6 - A12
9-Picture tears. Figures on screen wave from side to side. Fig. 9	A8 - A9 - A10 - A11 - A12
10-Sound, brightness but no picture.	A1 - A3 - A5 - A14 - A16
11-Brightness, but no picture or sound.	A1 - A2 - A3 - A4 - A5 - A16

ADMIRAL - LAYOUT NO. 22

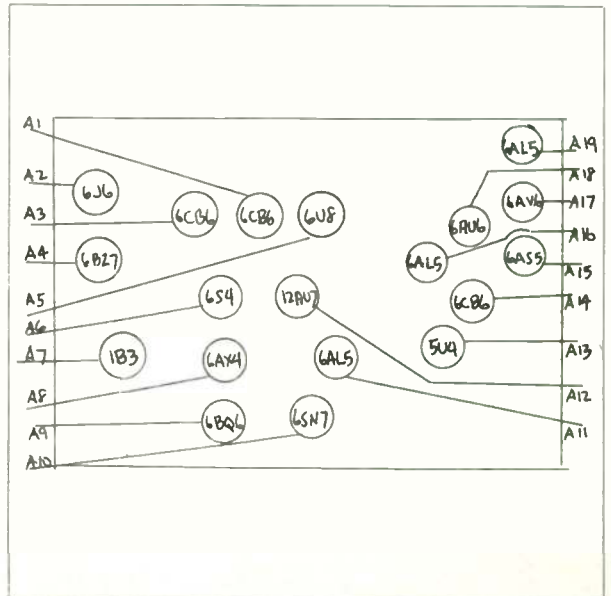

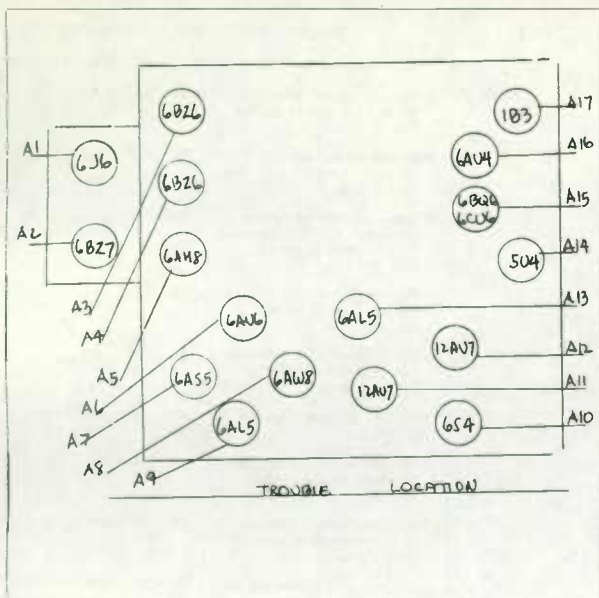

ADMIRAL-LAYOUT NO. 23

TROUBLE	LOCATION
1-No brightness on tube.	A12 - A14 - A15 - A16 - A17
2-No vertical height. White line across screen Fig. 2	A10 - A11
3-No horizontal width. White line running up and down. Fig. 3	A12 - A14 - A15 - A16
4-Small picture in center of tube. Picture does not fill up entire screen. Fig. 4	A14
5-Picture out of proportion vertically. (top to bottom) Fig. 5	A10 - A11
6-Picture out of proportion horizontally. (side to side) Fig. 6	A12 - A15 - A16
7-Picture present, but no sound.	A6 - A7 - A9
8-Picture rolls. (Vertical movement up and down). Fig. 8	A8 - A10 - A11
9-Picture tears. Figures on screen wave from side to side. Fig. 9	A8 - A11 - A12 - A13 - A15 - A16
10-Sound, brightness but no picture.	A3 - A4 - A5 - A8
11-Brightness, but no picture or sound.	A1 - A2 - A3 - A4 - A5

TROUBLE

LOCATION

1-No brightness on tube.	A14 - A16 - A17 - A18 - A19
2-No vertical height. White line across screen Fig. 2	A11 - A12
3-No horizontal width. White line running up and down. Fig. 3	A14 - A16 - A17 - A18
4-Small picture in center of tube. Picture does not fill up entire screen. Fig. 4	A16
5-Picture out of proportion vertically. (top to bottom) Fig. 5	A11 - A12
6-Picture out of proportion horizontally. (side to side) Fig. 6	A14 - A17 - A18
7-Picture present, but no sound.	A6 - A7 - A8 - A9
8-Picture rolls. (Vertical movement up and down). Fig. 8	A11 - A12 - A13
9-Picture tears. Figures on screen wave from side to side. Fig. 9	A13 - A14 - A15 - A17 - A18
10-Sound, brightness but no picture.	A3 - A4 - A5 - A10
11-Brightness, but no picture or sound.	A1 - A2 - A3 - A4 - A5

ADMIRAL-LAYOUT NO. 24

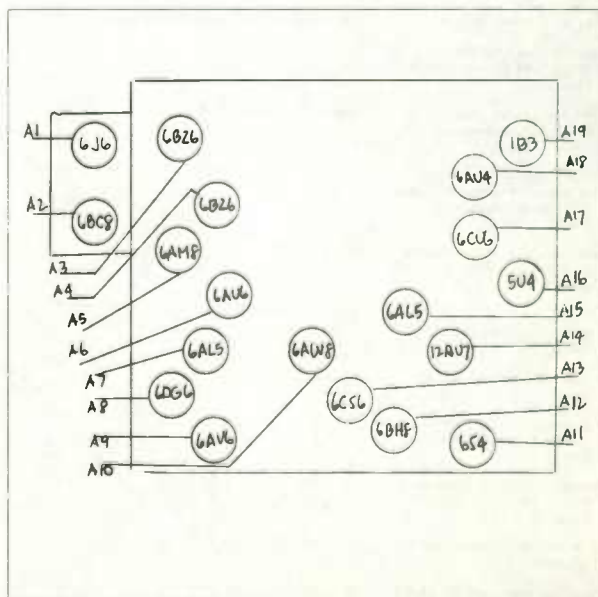

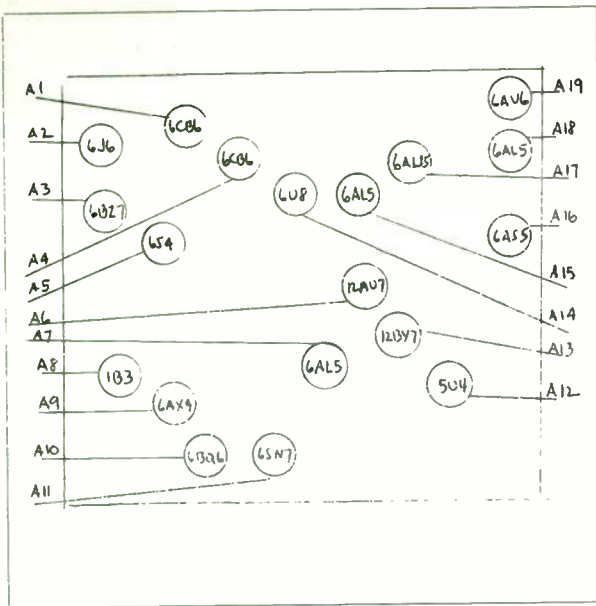

TROUBLE	LOCATION
1-No brightness on tube.	A8 - A9 - A10 - A11 - A12
2-No vertical height. White line across screen Fig. 2	A5 - A6
3-No horizontal width. White line running up and down. Fig. 3	A9 - A10 - A11 - A12
4-Small picture in center of tube. Picture does not fill up entire screen. Fig. 4	A12
5-Picture out of proportion vertically. (top to bottom) Fig. 5	A5 - A6
6-Picture out of proportion horizontally. (side to side) Fig. 6	A9 - A10 - A11
7-Picture present, but no sound.	A16 - A17 - A18 - A19
8-Picture rolls. (Vertical movement up and down). Fig. 8	A5 - A6 - A14
9-Picture tears. Figures on screen wave from side to side. Fig. 9	A6 - A9 - A10 - A11 - A14 - A7
10-Sound, brightness but no picture.	A1 - A4 - A13 - A15 - A14
11-Brightness, but no picture or sound.	A1 - A2 - A3 - A4 - A14 - A15

ADMIRAL - LAYOUT NO. 25

ADMIRAL - LAYOUT NO. 26

TROUBLE	LOCATION
1-No brightness on tube.	A14 - A16 - A17 - A18 - A19
2-No vertical height. White line across screen Fig. 2	A11 - A12
3-No horizontal width. White line running up and down. Fig. 3	A14 - A16 - A17 - A18
4-Small picture in center of tube. Picture does not fill up entire screen. Fig. 4	A16
5-Picture out of proportion vertically. (top to bottom) Fig. 5	A11 - A12
6-Picture out of proportion horizontally. (side to side) Fig. 6	A14 - A17 - A18
7-Picture present, but no sound.	A6 - A7 - A8 - A10
8-Picture rolls. (Vertical movement up and down). Fig. 8	A9 - A11 - A12 - A13
9-Picture tears. Figures on screen wave from side to side. Fig. 9	A9 - A13 - A14 - A15 - A17 - A18
10-Sound, brightness but no picture.	A1 - A4 - A5 - A9
11-Brightness, but no picture or sound.	A1 - A2 - A3 - A4 - A5

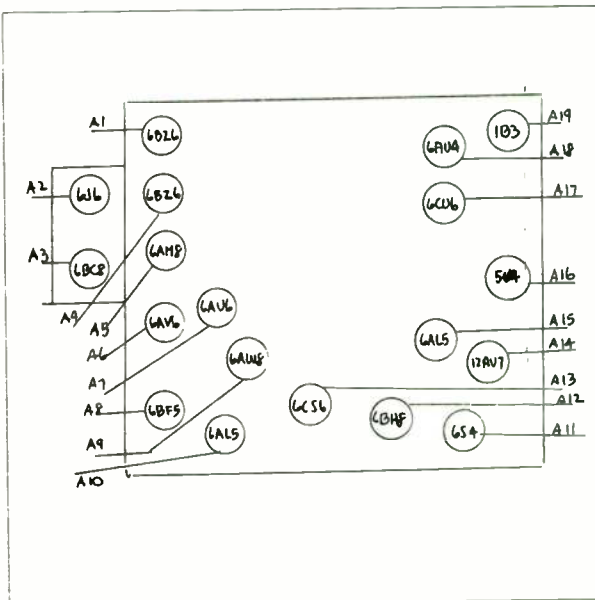

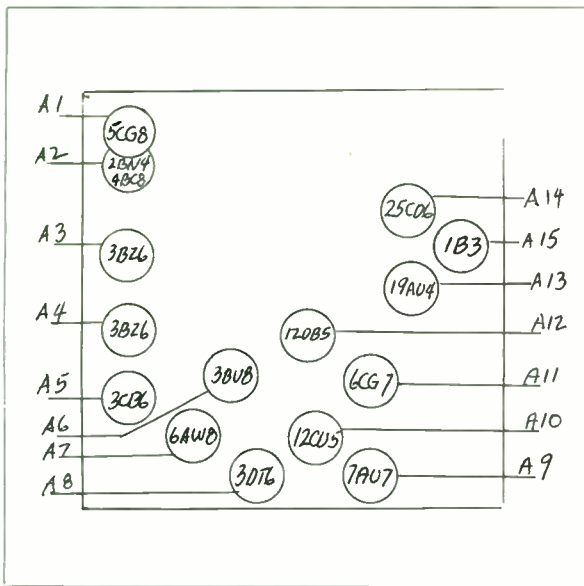

ADMIRAL-LAYOUT NO. 27

TROUBLE	LOCATION
1-No brightness on tube.	A11 - A13 - A14 - A15 - *
2-No vertical height. White line across screen Fig. 2	A12 - A9
3-No horizontal width. White line running up and down. Fig. 3	A11 - A13 - A14 - *
4-Small picture in center of tube. Picture does not fill up entire screen. Fig. 4	A11 - A13 - A14 - *
5-Picture out of proportion vertically. (top to bottom) Fig. 5	A12 - A9
6-Picture out of proportion horizontally. (side to side) Fig. 6	A11 - A13 - A14
7-Picture present, but no sound.	A7 - A8 - A10
8-Picture rolls. (Vertical movement up and down). Fig. 8	A6 - A9 - A12
9-Picture tears. Figures on screen wave from side to side. Fig. 9	A6 - A9 - A11 - A13 - A14
10-Sound, brightness but no picture.	A3 - A4 - A5 - A6 - A7
11-Brightness, but no picture or sound.	A1 - A2 - A3 - A4 - A5 - A6 - A7 *Selenium Rectifiers

TROUBLE

LOCATION

1-No brightness on tube.	A1 - A8 - A10 - A11 - A12
2-No vertical height. White line across screen Fig. 2	A13 - A14
3-No horizontal width. White line running up and down. Fig. 3	A1 - A8 - A11 - A12
4-Small picture in center of tube. Picture does not fill up entire screen. Fig. 4	A1
5-Picture out of proportion vertically. (top to bottom) Fig. 5	A13 - A14
6-Picture out of proportion horizontally. (side to side) Fig. 6	A8 - A11 - A12
7-Picture present, but no sound.	A6 - A6 - A7
8-Picture rolls. (Vertical movement up and down). Fig. 8	A9 - A13 - A14
9-Picture tears. Figures on screen wave from side to side. Fig. 9	A8 - A9 - A11 - A12 - A13
10-Sound, brightness but no picture.	A2 - A3 - A4 - A6 - A9
11-Brightness, but no picture or sound.	A2 - A3 - A4 - A6 - A15 - A16

ADMIRAL-LAYOUT NO. 28

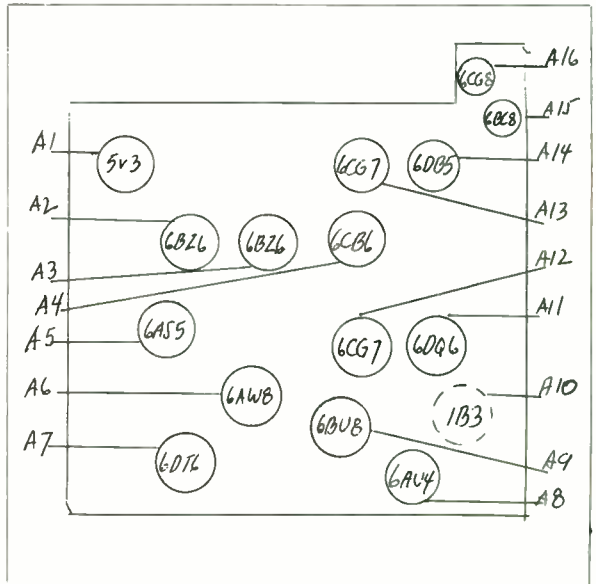

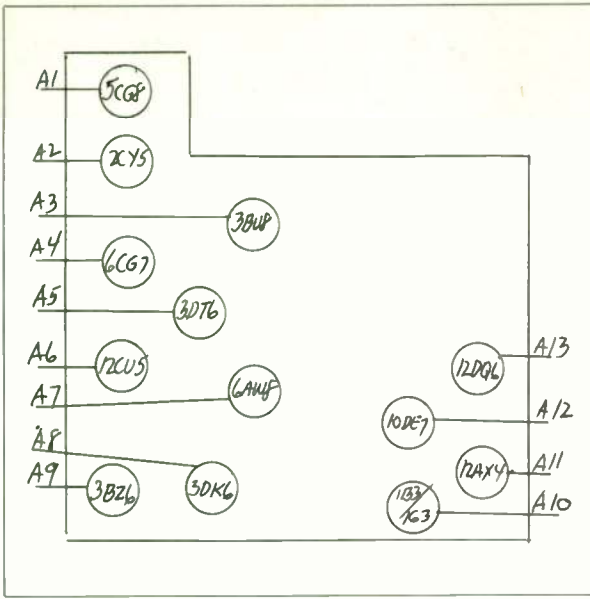

ADMIRAL - LAYOUT NO. 29

TROUBLE	LOCATION
1-No brightness on tube.	A4 - A10 - A11 - A13*
2-No vertical height. White line across screen Fig. 2	A12
3-No horizontal width. White line running up and down. Fig. 3	A4 - A11 - A13*
4-Small picture in center of tube. Picture does not fill up entire screen. Fig. 4	A4 - A11 - A13*
5-Picture out of proportion vertically. (top to bottom) Fig. 5	A12
6-Picture out of proportion horizontally. (side to side) Fig. 6	A4 - A11 - A13
7-Picture present, but no sound.	A5 - A6
8-Picture rolls. (Vertical movement up and down). Fig. 8	A3 - A12
9-Picture tears. Figures on screen wave from side to side. Fig. 9	A3 - A4 - A11 - A13
10-Sound, brightness but no picture.	A7 - A8 - A9
11-Brightness, but no picture or sound.	A1 - A2 - A7 - A8 - A9

* Selenium Rectifiers.

ADMIRAL - LAYOUT NO. 30

TROUBLE	LOCATION
1-No brightness on tube.	A4 - A5 - A12 - A13 - A14 - A15 - A17 - A19
2-No vertical height. White line across screen Fig. 2	A4 - A5 - A12 - A13 - A14
3-No horizontal width. White line running up and down. Fig. 3	A4 - A5
4-Small picture in center of tube. Picture does not fill up entire screen. Fig. 4	A17 - A19
5-Picture out of proportion vertically. (top to bottom) Fig. 5	A12 - A13 - A14
6-Picture out of proportion horizontally. (side to side) Fig. 6	A8 - A9 - A10 - A11
7-Picture present, but no sound.	A16 - A17 - A19
8-Picture rolls. (Vertical movement up and down). Fig. 8	A12 - A13 - A14 - A16 - A17
9-Picture tears. Figures on screen wave from side to side. Fig. 9	A6 - A7 - A9 - A18
10-Sound, brightness but no picture.	A1 - A2 - A6 - A7 - A9 - A18 (A3 UHF only)
11-Brightness, but no picture or sound.	

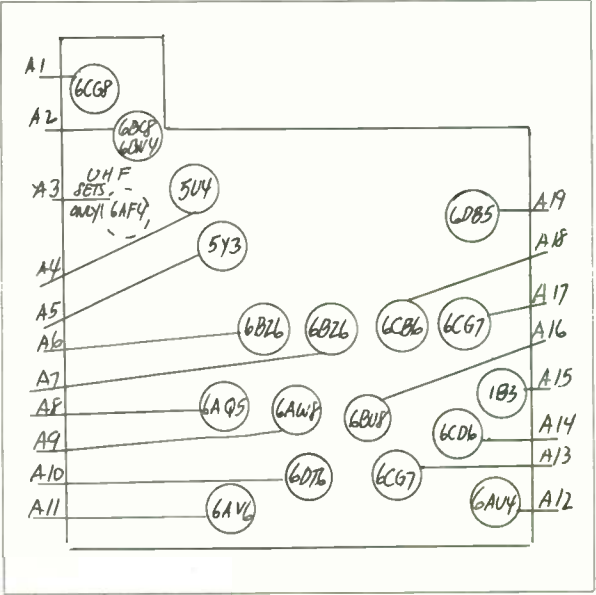

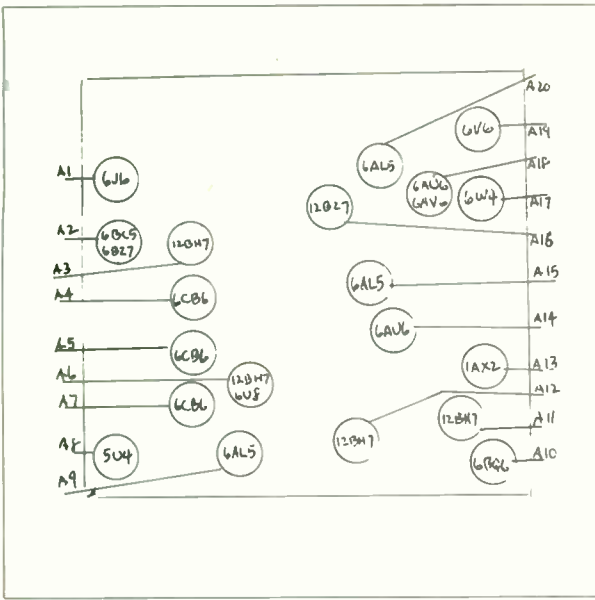

TROUBLE	LOCATION
1-No brightness on tube.	A8 - A10 - A11 - A13 - A17
2-No vertical height. White line across screen Fig. 2	A3
3-No horizontal width. White line running up and down. Fig. 3	A8 - A10 - A11 - A17
4-Small picture in center of tube. Picture does not fill up entire screen. Fig. 4	A8
5-Picture out of proportion vertically. (top to bottom) Fig. 5	A3
6-Picture out of proportion horizontally. (side to side) Fig. 6	A10 - A11 - A17
7-Picture present, but no sound.	A14 - A18 - A19 - A20
8-Picture rolls. (Vertical movement up and down). Fig. 8	A3 - A16
9-Picture tears. Figures on screen wave from side to side. Fig. 9	A6 - A10 - A11 - A15 - A16
10-Sound, brightness but no picture.	A4 - A5 - A7 - A6 - A9 - A12
11-Brightness, but no picture or sound.	A1 - A2 - A4 - A5 - A6 - A7 - A9

C.B.S. COLUMBIA - LAYOUT NO. 31

C.B.S. COLUMBIA - LAYOUT NO. 32

TROUBLE	LOCATION
1-No brightness on tube.	A12 - A13 - A15 - A18
2-No vertical height. White line across screen Fig. 2	A4
3-No horizontal width. White line running up and down. Fig. 3	A12 - A13 - A18
4-Small picture in center of tube. Picture does not fill up entire screen. Fig. 4	A8
5-Picture out of proportion vertically. (top to bottom) Fig. 5	A4
6-Picture out of proportion horizontally. (side to side) Fig. 6	A12 - A13 - A18
7-Picture present, but no sound.	A16 - A17 - A19 - A20
8-Picture rolls. (Vertical movement up and down). Fig. 8	A1 - A4
9-Picture tears. Figures on screen wave from side to side. Fig. 9	A1 - A6 - A12 - A14
10-Sound, brightness but no picture.	A10 - A11
11-Brightness, but no picture or sound.	A2 - A3 - A5 - A7 - A9 - A10

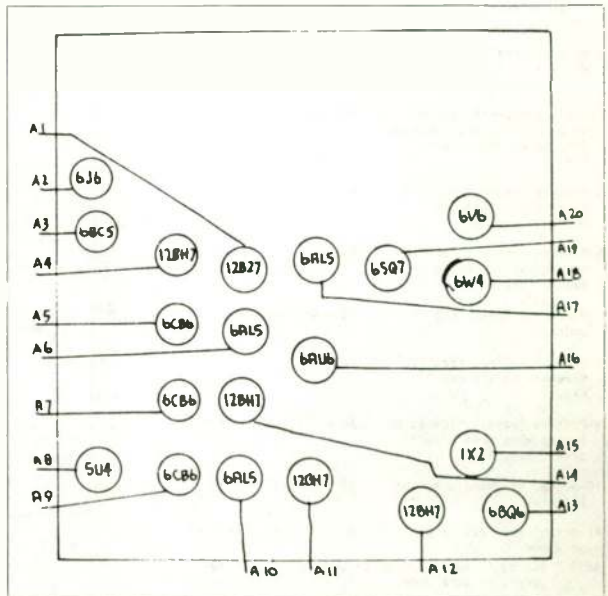

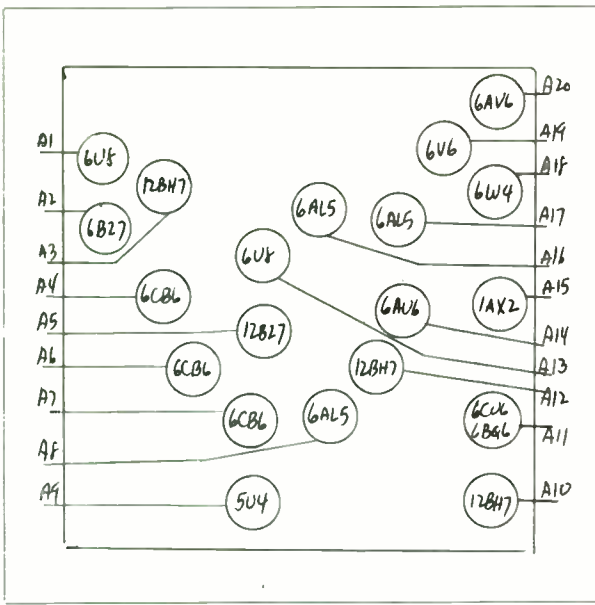

TROUBLE	LOCATION
1-No brightness on tube.	A9 - A10 - A11 - A15 - A18
2-No vertical height. White line across screen Fig. 2	A3
3-No horizontal width. White line running up and down. Fig. 3	A9 - A10 - A11 - A18
4-Small picture in center of tube. Picture does not fill up entire screen. Fig. 4	A9
5-Picture out of proportion vertically. (top to bottom) Fig. 5	A3
6-Picture out of proportion horizontally. (side to side) Fig. 6	A10 - A11 - A18
7-Picture present, but no sound.	A14 - A17 - A19 - A20
8-Picture rolls. (Vertical movement up and down), Fig. 8	A3 - A5 - A13
9-Picture tears. Figures on screen wave from side to side. Fig. 9	A5 - A10 - A11 - A13 - A16 - A18
10-Sound, brightness but no picture.	A4 - A6 - A7 - A8 - A12
11-Brightness, but no picture or sound.	A1 - A2 - A4 - A6 - A7 - A8

C.B.S. COLUMBIA - LAYOUT NO. 33

TROUBLE	LOCATION
1-No brightness on tube.	A12 - A13 - A14 - A15
2-No vertical height. White line across screen Fig. 2	A3
3-No horizontal width. White line running up and down. Fig. 3	A12 - A13 - A14
4-Small picture in center of tube. Picture does not fill up entire screen. Fig. 4	A12 - A13 - A14
5-Picture out of proportion vertically. (top to bottom) Fig. 5	A3
6-Picture out of proportion horizontally. (side to side) Fig. 6	A12 - A13 - A14
7-Picture present, but no sound.	A8 - A9 - A10
8-Picture rolls. (Vertical movement up and down). Fig. 8	A3 - A4
9-Picture tears. Figures on screen wave from side to side. Fig. 9	A4 - A12 - A13 - A14
10-Sound, brightness but no picture.	A5 - A6 - A7 - A11
11-Brightness, but no picture or sound.	A1 - A2 - A5 - A6 - A7

C.B.S. COLUMBIA - LAYOUT NO. 34

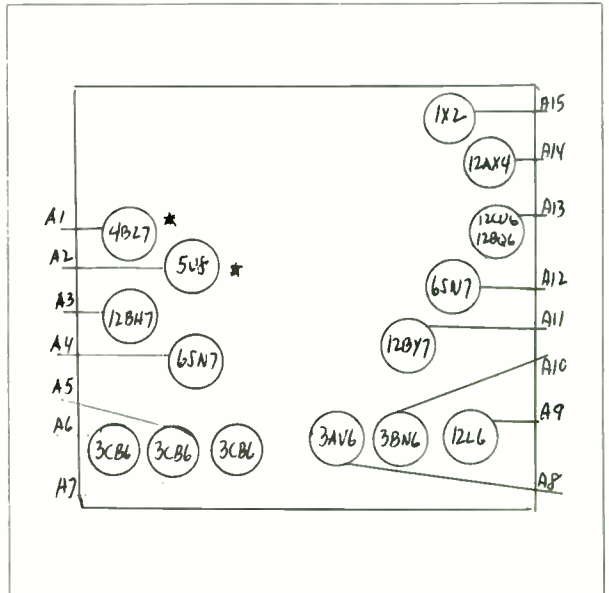

NOTE * Due to factory changes these tube numbers may vary with each model. Replace only with same numbers as set now uses.

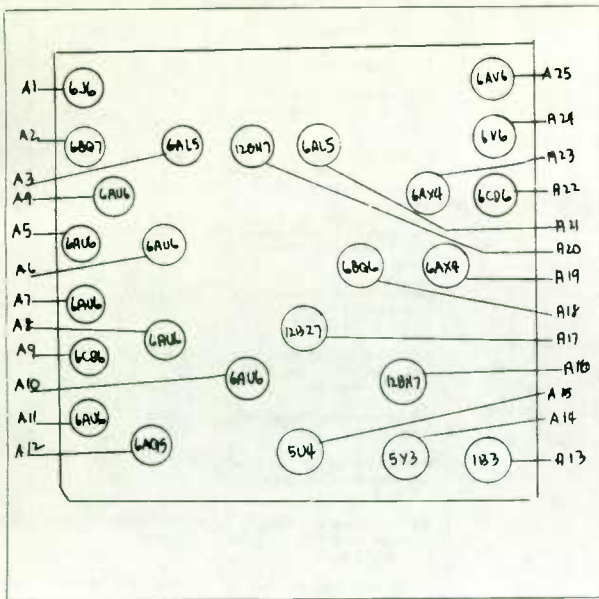

TROUBLE	LOCATION
1-No brightness on tube.	A13 - A14 - A15 - A16 - A19 - A22 - A23
2-No vertical height. White line across screen Fig. 2	A18 - A20
3-No horizontal width. White line running up and down. Fig. 3	A14 - A15 - A16 - A19 - A22 - A23
4-Small picture in center of tube. Picture does not fill up entire screen. Fig. 4	A14 - A15
5-Picture out of proportion vertically. (top to bottom) Fig. 5	A18 - A20
6-Picture out of proportion horizontally. (side to side) Fig. 6	A16 - A19 - A22 - A23
7-Picture present, but no sound.	A3 - A6 - A8 - A24 - A25
8-Picture rolls. (Vertical movement up and down). Fig. 8	A17 - A18 - A20
9-Picture tears. Figures on screen wave from side to side. Fig. 9	A16 - A17 - A19 - A20 - A21 - A22 - A23
10-Sound, brightness but no picture.	A4 - A5 - A7 - A9 - A10 - A11 - A12
11-Brightness, but no picture or sound.	A1 - A2 - A4 - A5 - A7 - A9 - A11

C.B.S. COLUMBIA - LAYOUT NO. 35

TROUBLE	LOCATION
1-No brightness on tube.	A9 - A10 - A11 - A12 *
2-No vertical height. White line across screen Fig. 2	A6 - A7
3-No horizontal width. White line running up and down. Fig. 3	A9 - A10 - A12
4-Small picture in center of tube. Picture does not fill up entire screen. Fig. 4	A9 - A10 - A12 *
5-Picture out of proportion vertically. (top to bottom) Fig. 5	A6 - A7
6-Picture out of proportion horizontally. (side to side) Fig. 6	A9 - A10 - A12
7-Picture present, but no sound.	A14 - A13 - A16
8-Picture rolls. (Vertical movement up and down). Fig. 8	A6 - A7 - A13
9-Picture tears. Figures on screen wave from side to side. Fig. 9	A6 - A9 - A10 - A12 - A13
10-Sound, brightness but no picture.	A1 - A3 - A5 - A13
11-Brightness, but no picture or sound.	A1 - A2 - A3 - A4 - A5 (A8 - UHF only)

C.B.S. COLUMBIA - LAYOUT NO. 36

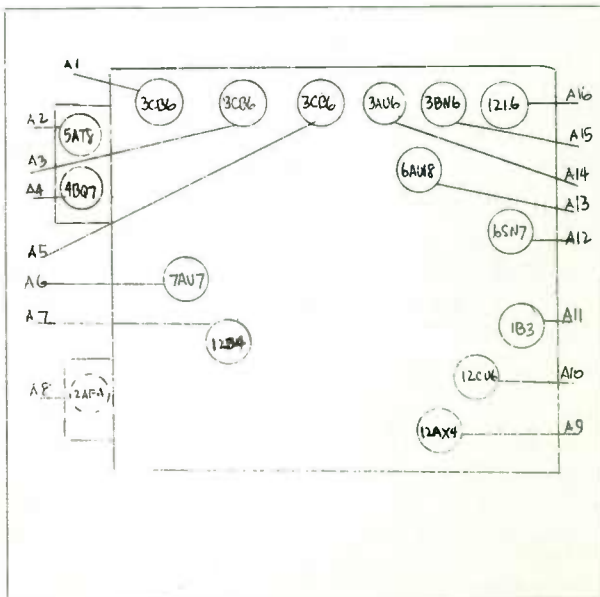

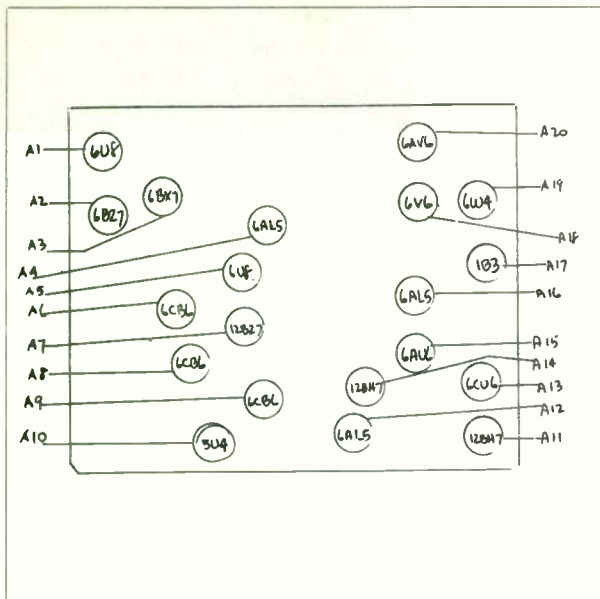

TROUBLE	LOCATION
1-No brightness on tube.	A10 - A11 - A13 - A17 - A19
2-No vertical height. White line across screen Fig. 2	A3
3-No horizontal width. White line running up and down. Fig. 3	A10 - A11 - A13 - A19
4-Small picture in center of tube. Picture does not fill up entire screen. Fig. 4	A10
5-Picture out of proportion vertically. (top to bottom) Fig. 5	A3
6-Picture out of proportion horizontally. (side to side) Fig. 6	A11 - A13 - A19
7-Picture present, but no sound.	A15 - A16 - A18 - A20
8-Picture rolls. (Vertical movement up and down). Fig. 8	A3 - A5 - A7
9-Picture tears. Figures on screen wave from side to side. Fig. 9	A4 - A5 - A7 - A11 - A13 - A19
10-Sound, brightness but no picture.	A6 - A8 - A9 - A12 - A14
11-Brightness, but no picture or sound.	A1 - A2 - A6 - A8 - A9 - A12

C.B.S. COLUMBIA - LAYOUT NO. 37

C.B.S. COLUMBIA - LAYOUT NO. 38

TROUBLE	LOCATION
1-No brightness on tube.	A8 - A9 - A10 - A11
2-No vertical height. White line across screen Fig. 2	A6
3-No horizontal width. White line running up and down. Fig. 3	A9 - A10 - A11
4-Small picture in center of tube. Picture does not fill up entire screen. Fig. 4	A9 - A10 - A11
5-Picture out of proportion vertically. (top to bottom) Fig. 5	A6
6-Picture out of proportion horizontally. (side to side) Fig. 6	A9 - A10 - A11
7-Picture present, but no sound.	A13 - A14 - A15
8-Picture rolls. (Vertical movement up and down). Fig. 8	A6 - A7
9-Picture tears. Figures on screen wave from side to side. Fig. 9	A7 - A9 - A10 - A11
10-Sound, brightness but no picture.	A1 - A2 - A5 - A12
11-Brightness, but no picture or sound.	A1 - A2 - A3 - A4 - A5

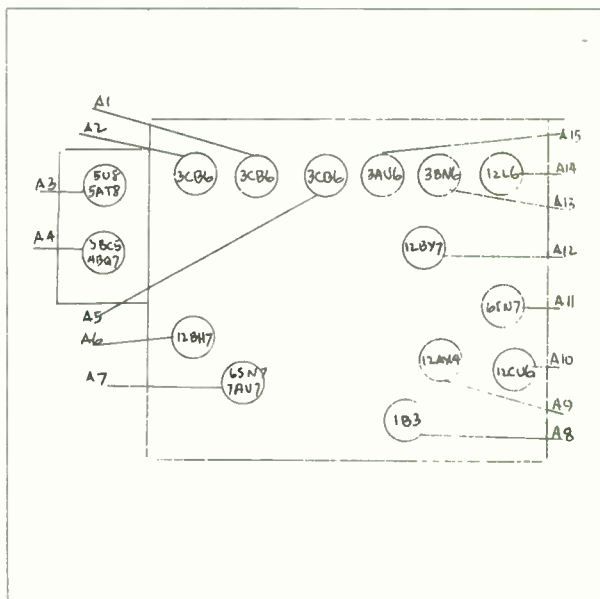

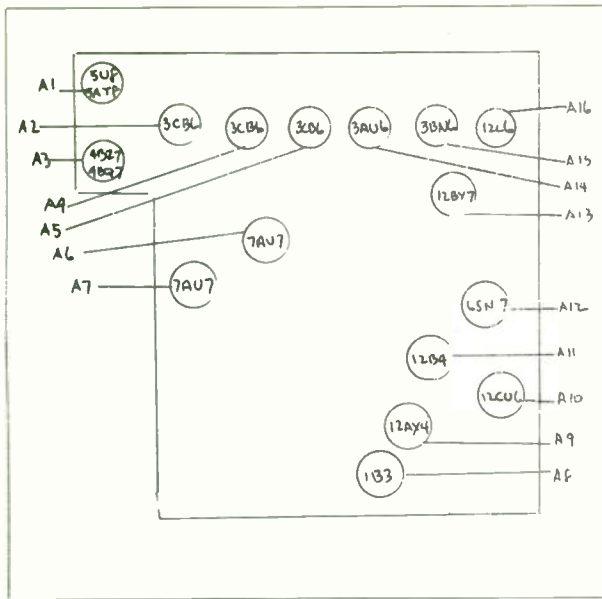

C.B.S. COLUMBIA - LAYOUT NO. 39

TROUBLE	LOCATION
1-No brightness on tube.	A8 - A9 - A10 - A12
2-No vertical height. White line across screen Fig. 2	A7 - A11
3-No horizontal width. White line running up and down. Fig. 3	A9 - A10 - A12
4-Small picture in center of tube. Picture does not fill up entire screen. Fig. 4	A9 - A10 - A12
5-Picture out of proportion vertically. (top to bottom) Fig. 5	A7 - A11
6-Picture out of proportion horizontally. (side to side) Fig. 6	A9 - A10 - A12
7-Picture present, but no sound.	A14 - A15 - A16
8-Picture rolls. (Vertical movement up and down). Fig. 8	A6 - A7 - A11
9-Picture tears. Figures on screen wave from side to side. Fig. 9	A6 - A9 - A10 - A12
10-Sound, brightness but no picture.	A2 - A4 - A5 - A13
11-Brightness, but no picture or sound.	A1 - A2 - A3 - A4 - A5

TROUBLE

LOCATION

1-No brightness on tube.	A9 - A10 - A11 - A17 - A19
2-No vertical height. White line across screen Fig. 2	A3
3-No horizontal width. White line running up and down. Fig. 3	A9 - A10 - A11 - A19
4-Small picture in center of tube. Picture does not fill up entire screen. Fig. 4	A9
5-Picture out of proportion vertically. (top to bottom) Fig. 5	A3
6-Picture out of proportion horizontally. (side to side) Fig. 6	A10 - A11 - A19
7-Picture present, but no sound.	A13 - A16 - A18 - A20
8-Picture rolls. (Vertical movement up and down). Fig. 8	A3 - A5 - A14
9-Picture tears. Figures on screen wave from side to side. Fig. 9	A5 - A10 - A11 - A14 - A15 - A19
10-Sound, brightness but no picture.	A4 - A6 - A7 - A8 - A12
11-Brightness, but no picture or sound.	A1 - A2 - A4 - A6 - A7 - A8 - A12

C.B.S. COLUMBIA - LAYOUT NO. 40

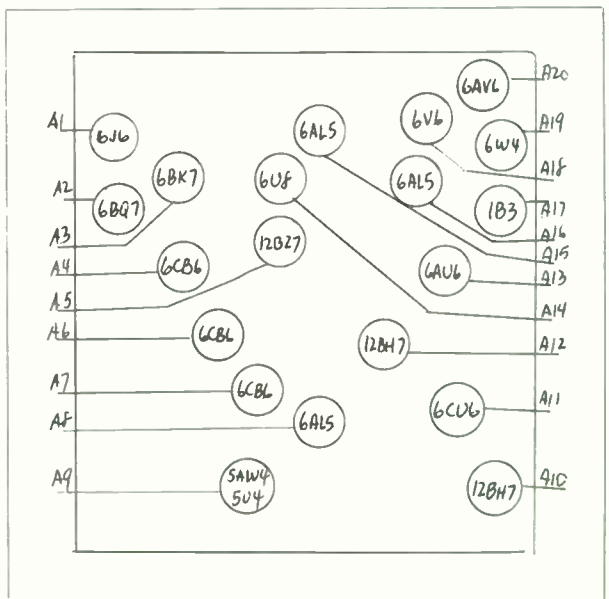

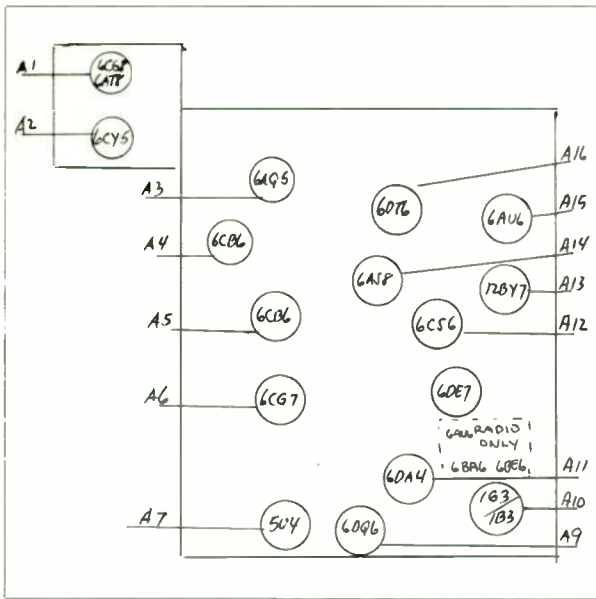

TROUBLE	LOCATION
1-No brightness on tube.	A6 - A7 - A8 - A9 - A10
2-No vertical height. White line across screen Fig. 2	A11
3-No horizontal width. White line running up and down. Fig. 3	A6 - A7 - A8 - A10
4-Small picture in center of tube. Picture does not fill up entire screen. Fig. 4	A7
5-Picture out of proportion vertically. (top to bottom) Fig. 5	A11
6-Picture out of proportion horizontally. (side to side) Fig. 6	A6 - A8 - A10
7-Picture present, but no sound.	A3 - A15 - A16
8-Picture rolls. (Vertical movement up and down). Fig. 8	A11 - A12
9-Picture tears. Figures on screen wave from side to side. Fig. 9	A6 - A8 - A10 - A12
10-Sound, brightness but no picture.	A4 - A5 - A13 - A14
11-Brightness, but no picture or sound.	A1 - A2 - A4 - A5 - A13 A14

EMERSON-LAYOUT NO. 41

TROUBLE

LOCATION

1-No brightness on tube.	A8 - A9 - A10 - A11 - A13
2-No vertical height. White line across screen Fig. 2	A15
3-No horizontal width. White line running up and down. Fig. 3	A8 - A9 - A11 - A13
4-Small picture in center of tube. Picture does not fill up entire screen. Fig. 4	A8
5-Picture out of proportion vertically. (top to bottom) Fig. 5	A15
6-Picture out of proportion horizontally. (side to side) Fig. 6	A9 - A11 - A13
7-Picture present, but no sound.	A3 - A4 - A6
8-Picture rolls. (Vertical movement up and down). Fig. 8	A14 - A15
9-Picture tears. Figures on screen wave from side to side. Fig. 9	A9 - A11 - A13 - A14
10-Sound, brightness but no picture.	A7 - A12 - A5 - A16
11-Brightness, but no picture or sound.	A1 - A2 - A5 - A7 - A12 A16

EMERSON-LAYOUT NO. 42

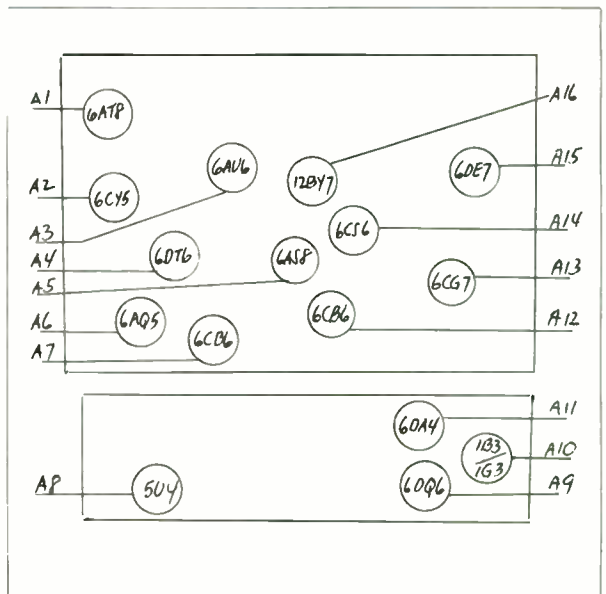

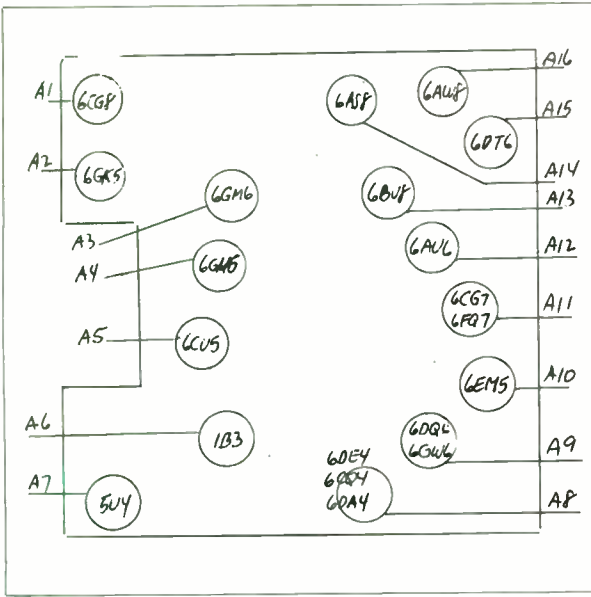

TROUBLE	LOCATION
1-No brightness on tube.	A6 - A7 - A8 - A9 - A11
2-No vertical height. White line across screen Fig. 2	A10 - A16
3-No horizontal width. White line running up and down. Fig. 3	A7 - A8 - A9 - A11
4-Small picture in center of tube. Picture does not fill up entire screen. Fig. 4	A7
5-Picture out of proportion vertically. (top to bottom) Fig. 5	A10 - A16
6-Picture out of proportion horizontally. (side to side) Fig. 6	A6 - A9 - A11
7-Picture present, but no sound.	A5 - A12 - A15
8-Picture rolls. (Vertical movement up and down). Fig. 8	A10 - A13 - A16
9-Picture tears. Figures on screen wave from side to side. Fig. 9	A8 - A9 - A11 - A12
10-Sound, brightness but no picture.	A3 - A4 - A14 - A16
11-Brightness, but no picture or sound.	A1 - A2 - A3 - A4 - A14 - A16

EMERSON - LAYOUT NO. 43

TROUBLE	LOCATION
1-No brightness on tube.	A6 - A7 - A8 - A9 - A10
2-No vertical height. White line across screen Fig. 2	A11 - A12
3-No horizontal width. White line running up and down. Fig. 3	A7 - A8 - A9 - A10
4-Small picture in center of tube. Picture does not fill up entire screen. Fig. 4	A10
5-Picture out of proportion vertically. (top to bottom) Fig. 5	A11 - A12
6-Picture out of proportion horizontally. (side to side) Fig. 6	A7 - A8 - A9
7-Picture present, but no sound.	A15 - A16 - A17
8-Picture rolls. (Vertical movement up and down). Fig. 8	A11 - A12 - A13
9-Picture tears. Figures on screen wave from side to side. Fig. 9	A7 - A8 - A9 - A11 - A13
10-Sound, brightness but no picture.	A3 - A4 - A5 - A14
11-Brightness, but no picture or sound.	A1 - A2 - A3 - A4 - A5 - A14

EMERSON- LAYOUT NO. 44

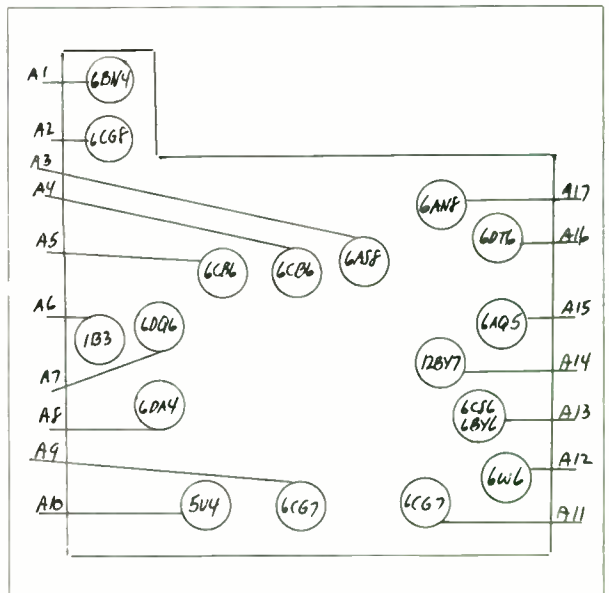

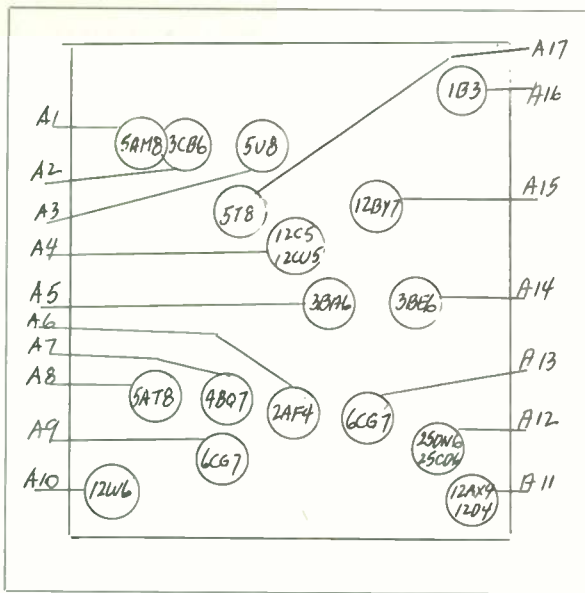

EMERSON - LAYOUT NO. 45

TROUBLE	LOCATION
1-No brightness on tube.	A11 - A12 - A13 - A16 -
2-No vertical height. White line across screen Fig. 2	A9 - A10
3-No horizontal width. White line running up and down. Fig. 3	A11 - A12 - A13 - *
4-Small picture in center of tube. Picture does not fill up entire screen. Fig. 4	A11 - A12 - A13 - *
5-Picture out of proportion vertically. (top to bottom) Fig. 5	A9 - A10
6-Picture out of proportion horizontally. (side to side) Fig. 6	A11 - A12 - A13
7-Picture present, but no sound.	A1 - A3 - A4 - A5 - A14 - A17
8-Picture rolls. (Vertical movement up and down). Fig. 8	A3 - A9 - A10
9-Picture tears. Figures on screen wave from side to side. Fig. 9	A3 - A9 - A11 - A12 - A13
10-Sound, brightness but no picture.	A1 - A2 - A15
11-Brightness, but no picture or sound.	A1 - A2 - A7 - A8 - A15 - (A6 UHF) *Selenium Rectifiers

TROUBLE

LOCATION

EMERSON - LAYOUT NO. 46

1-No brightness on tube.	A11 - A13 - A14 - A15 - *
2-No vertical height. White line across screen Fig. 2	A10 - A12
3-No horizontal width. White line running up and down. Fig. 3	A11 - A13 - A14 - *
4-Small picture in center of tube. Picture does not fill up entire screen. Fig. 4	A11 - A13 - A14 - *
5-Picture out of proportion vertically. (top to bottom) Fig. 5	A10 - A12
6-Picture out of proportion horizontally. (side to side) Fig. 6	A11 - A13 - A14
7-Picture present, but no sound.	A7 - A8 - A9
8-Picture rolls. (Vertical movement up and down). Fig. 8	A8 - A10 - A12
9-Picture tears. Figures on screen wave from side to side. Fig. 9	A8 - A12 - A11 - A13 - A14
10-Sound, brightness but no picture.	A3 - A4 - A5 - A6
11-Brightness, but no picture or sound.	A1 - A2 - A3 - A4 - A5 - A6 *Selenium Rectifiers

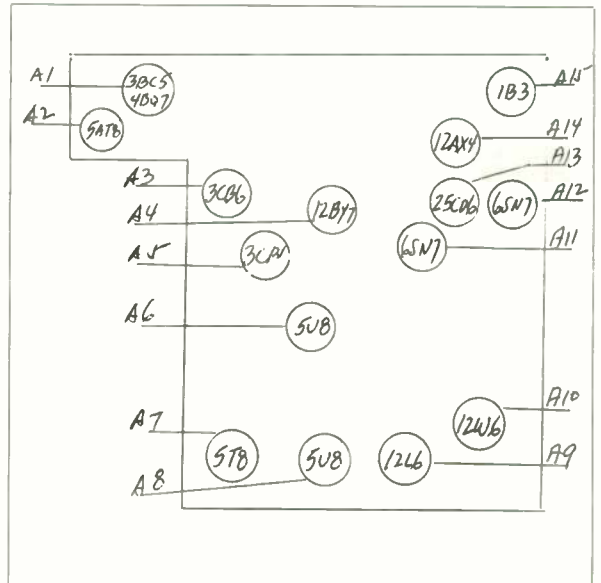

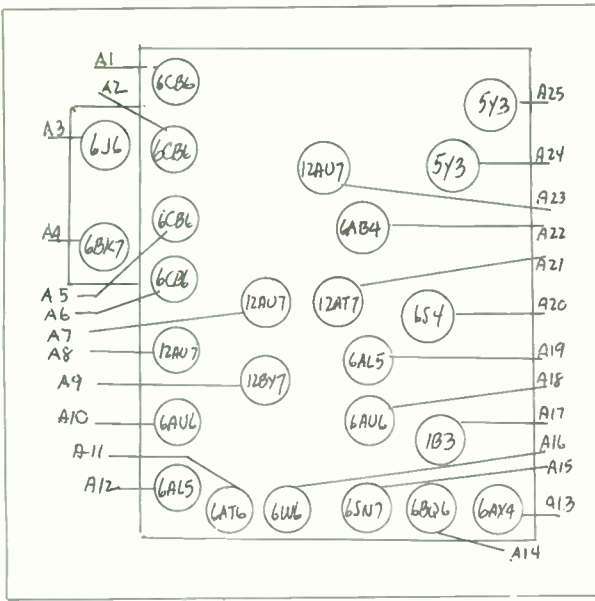

TROUBLE	LOCATION
1-No brightness on tube.	A13 - A14 - A15 - A17 - A23 - A24 - A25
2-No vertical height. White line across screen Fig. 2	A20 - A22
3-No horizontal width. White line running up and down. Fig. 3	A13 - A14 - A15 - A23 - A24 - A25
4-Small picture in center of tube. Picture does not fill up entire screen. Fig. 4	A23 - A24 - A25
5-Picture out of proportion vertically. (top to bottom) Fig. 5	A20 - A22
6-Picture out of proportion horizontally. (side to side) Fig. 6	A13 - A14 - A15 - A23
7-Picture present, but no sound.	A8 - A10 - A11 - A12 - A16
8-Picture rolls. (Vertical movement up and down). Fig. 8	A7 - A20 - A21 - A22
9-Picture tears. Figures on screen wave from side to side. Fig. 9	A7 - A13 - A14 - A15 - A19 - A21 - A23 - A18
10-Sound, brightness but no picture.	A1 - A2 - A5 - A6 - A8 - A9
11-Brightness, but no picture or sound.	A1 - A2 - A3 - A4 - A5 - A6 - A8

DUMONT - LAYOUT NO. 47

TROUBLE

LOCATION

1-No brightness on tube.	A8 - A9 - A10 - A11 - A12 - A13
2-No vertical height. White line across screen Fig. 2	A5
3-No horizontal width. White line running up and down. Fig. 3	A8 - A9 - A10 - A11 - A13
4-Small picture in center of tube. Picture does not fill up entire screen. Fig. 4	A8 - A9
5-Picture out of proportion vertically. (top to bottom) Fig. 5	A5
6-Picture out of proportion horizontally. (side to side) Fig. 6	A10 - A11 - A13
7-Picture present, but no sound.	A17 - A18 - A19
8-Picture rolls. (Vertical movement up and down). Fig. 8	A5 - A14 - A15
9-Picture tears. Figures on screen wave from side to side. Fig. 9	A7 - A10 - A11 - A13 - A14 - A15
10-Sound, brightness but no picture.	A3 - A4 - A6 - A7 - A16
11-Brightness, but no picture or sound.	A1 - A2 - A3 - A4 - A6 - A7

DUMONT - LAYOUT NO. 48

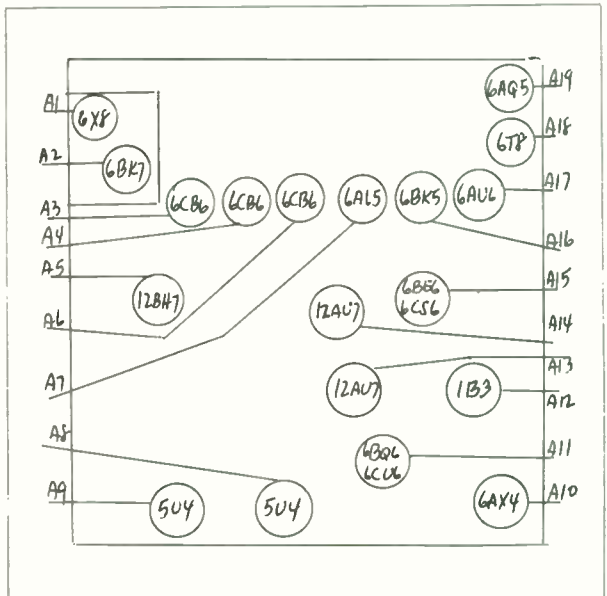

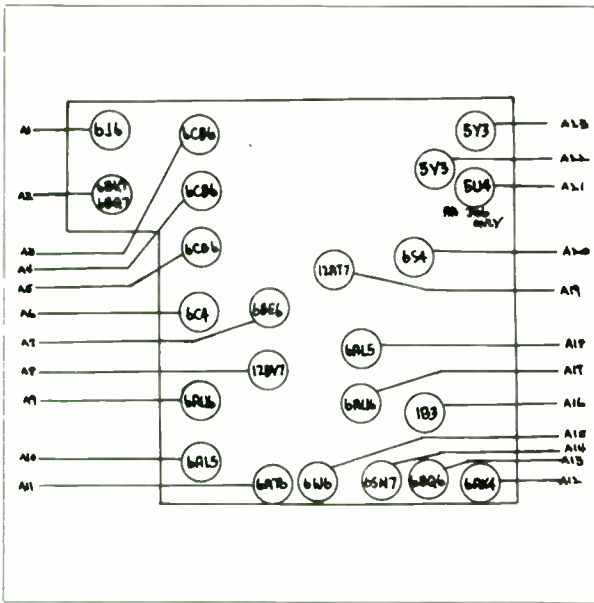

DUMONT - LAYOUT NO. 49

TROUBLE	LOCATION
1-No brightness on tube.	A12 - A13 - A14 - A16 - A21 - A22 - A23
2-No vertical height. White line across screen Fig. 2	A19 - A20
3-No horizontal width. White line running up and down. Fig. 3	A12 - A13 - A14 - A21 - A22 - A23
4-Small picture in center of tube. Picture does not fill up entire screen. Fig. 4	A21 - A22 - A23
5-Picture out of proportion vertically. (top to bottom) Fig. 5	A19 - A20
6-Picture out of proportion horizontally. (side to side) Fig. 6	A12 - A13 - A14 - A21 - A23
7-Picture present, but no sound.	A9 - A10 - A11 - A18
8-Picture rolls. (Vertical movement up and down). Fig. 8	A7 - A19 - A20
9-Picture tears. Figures on screen wave from side to side. Fig. 9	A12 - A13 - A14 - A18 - A21 - A22 - A23
10-Sound, brightness but no picture.	A3 - A4 - A5 - A6 - A8 - A17
11-Brightness, but no picture or sound.	A1 - A2 - A3 - A4 - A5 - A6 - A8 - A17

DUMONT - LAYOUT NO. 50

TROUBLE	LOCATION
1-No brightness on tube.	A9 - A10 - A11 - A12 - A13
2-No vertical height. White line across screen Fig. 2	A8
3-No horizontal width. White line running up and down. Fig. 3	A9 - A10 - A11 - A12
4-Small picture in center of tube. Picture does not fill up entire screen. Fig. 4	A10
5-Picture out of proportion vertically. (top to bottom) Fig. 5	A8
6-Picture out of proportion horizontally. (side to side) Fig. 6	A9 - A11 - A12
7-Picture present, but no sound.	A16 - A17 - A18
8-Picture rolls. (Vertical movement up and down). Fig. 8	A6 - A8 - A14
9-Picture tears. Figures on screen wave from side to side. Fig. 9	A6 - A14 - A16 - A17 - A18
10-Sound, brightness but no picture.	A3 - A4 - A5 - A7 - A15
11-Brightness, but no picture or sound.	A1 - A2 - A3 - A4 - A5 - A7 - A15

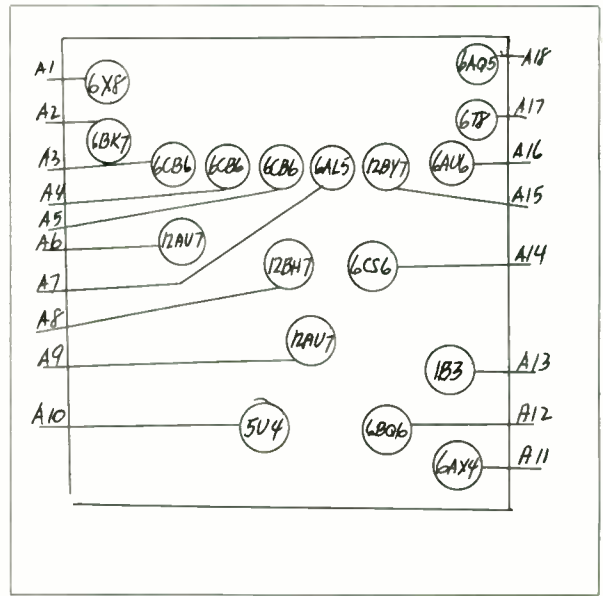

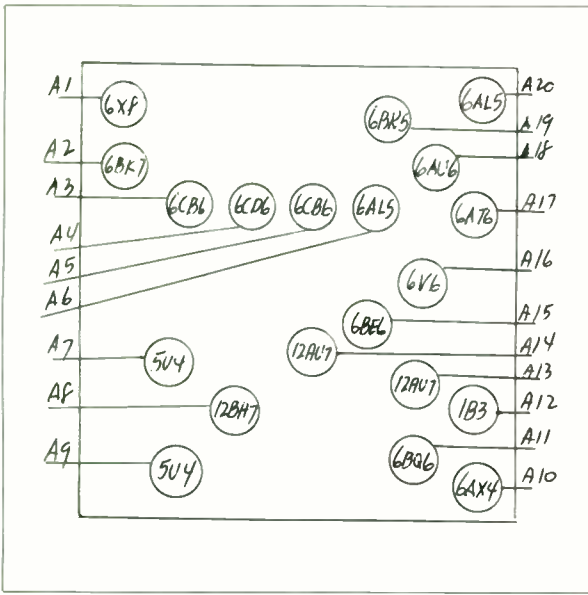

DUMONT - LAYOUT NO. 51

TROUBLE	LOCATION
1-No brightness on tube.	A7 - A9 - A10 - A11 - A12 - A13
2-No vertical height. White line across screen Fig. 2	A8
3-No horizontal width. White line running up and down. Fig. 3	A7 - A9 - A10 - A11 - A13
4-Small picture in center of tube. Picture does not fill up entire screen. Fig. 4	A7 - A9
5-Picture out of proportion vertically. (top to bottom) Fig. 5	A8
6-Picture out of proportion horizontally. (side to side) Fig. 6	A10 - A11 - A13
7-Picture present, but no sound.	A16 - A17 - A18 - A19 - A20
8-Picture rolls. (Vertical movement up and down). Fig. 8	A8 - A14 - A15
9-Picture tears. Figures on screen wave from side to side. Fig. 9	A10 - A11 - A13 - A14 - A15
10-Sound, brightness but no picture.	A3 - A4 - A5 - A6 - A19
11-Brightness, but no picture or sound.	A1 - A2 - A3 - A4 - A5 - A6 - A19

DUMONT - LAYOUT NO. 52

TROUBLE	LOCATION
1-No brightness on tube.	A7 - A8 - A9 - A10- A11
2-No vertical height. White line across screen Fig. 2	A2 - A13
3-No horizontal width. White line running up and down. Fig. 3	A7 - A9 - A10 - A11
4-Small picture in center of tube. Picture does not fill up entire screen. Fig. 4	A11
5-Picture out of proportion vertically. (top to bottom) Fig. 5	A2 - A13
6-Picture out of proportion horizontally. (side to side) Fig. 6	A7 - A9 - A10
7-Picture present, but no sound.	A3 - A4 - A5
8-Picture rolls. (Vertical movement up and down). Fig. 8	A2 - A6 - A13
9-Picture tears. Figures on screen wave from side to side. Fig. 9	A6 - A7 - A9 - A10 - A12
10-Sound, brightness but no picture.	A1 - A2 - A3 - A14
11-Brightness, but no picture or sound.	A1 - A2 - A3 - A14 - A15 - A16

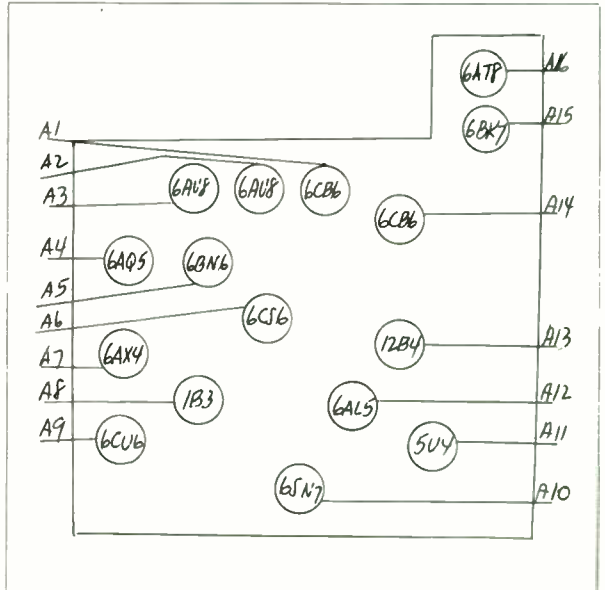

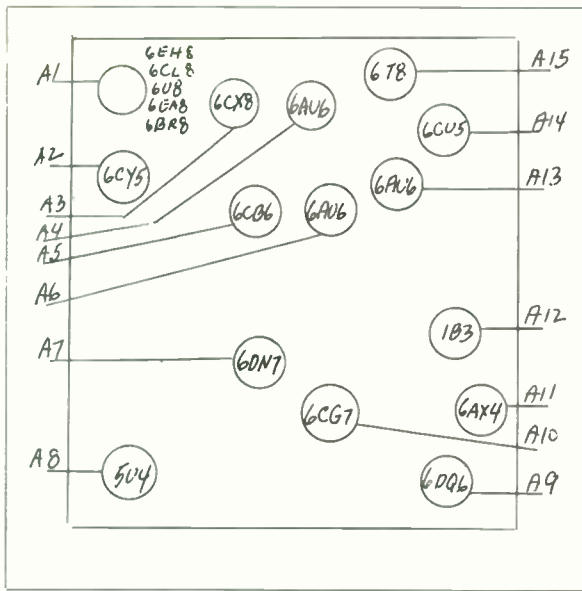

TROUBLE	LOCATION
1-No brightness on tube.	A6 - A8 - A10 - A11 - A12
2-No vertical height. White line across screen Fig. 2	A7
3-No horizontal width. White line running up and down. Fig. 3	A6 - A8 - A10 - A11
4-Small picture in center of tube. Picture does not fill up entire screen. Fig. 4	A8
5-Picture out of proportion vertically. (top to bottom) Fig. 5	A7
6-Picture out of proportion horizontally. (side to side) Fig. 6	A8 - A10 - A11
7-Picture present, but no sound.	A4 - A14 - A15
8-Picture rolls. (Vertical movement up and down). Fig. 8	A3 - A7
9-Picture tears. Figures on screen wave from side to side. Fig. 9	A3 - A8 - A10 - A11
10-Sound, brightness but no picture.	A3 - A5 - A6 - A13
11-Brightness, but no picture or sound.	A1 - A2 - A3 - A5 - A6 - A13

GENERAL ELECTRIC-LAYOUT NO. 53

DUMONT - LAYOUT NO. 54

TROUBLE	LOCATION
1-No brightness on tube.	A11 - A12 - A13 - A14 - A17
2-No vertical height. White line across screen Fig. 2	A6 - A16
3-No horizontal width. White line running up and down. Fig. 3	A11 - A12 - A14 - A17
4-Small picture in center of tube. Picture does not fill up entire screen. Fig. 4	A17
5-Picture out of proportion vertically. (top to bottom) Fig. 5	A6 - A16
6-Picture out of proportion horizontally. (side to side) Fig. 6	A11 - A12 - A14
7-Picture present, but no sound.	A8 - A9 - A10
8-Picture rolls. (Vertical movement up and down). Fig. 8	A6 - A7 - A16
9-Picture tears. Figures on screen wave from side to side. Fig. 9	A7 - A11 - A12 - A14 - A15
10-Sound, brightness but no picture.	A4 - A5 - A6 - A8
11-Brightness, but no picture or sound.	A2 - A3 - A4 - A5 - A6 - A8 (A1 - RA381 only)

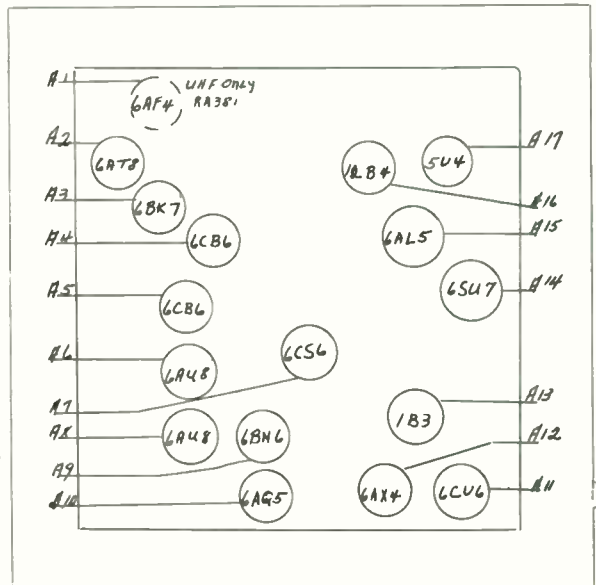

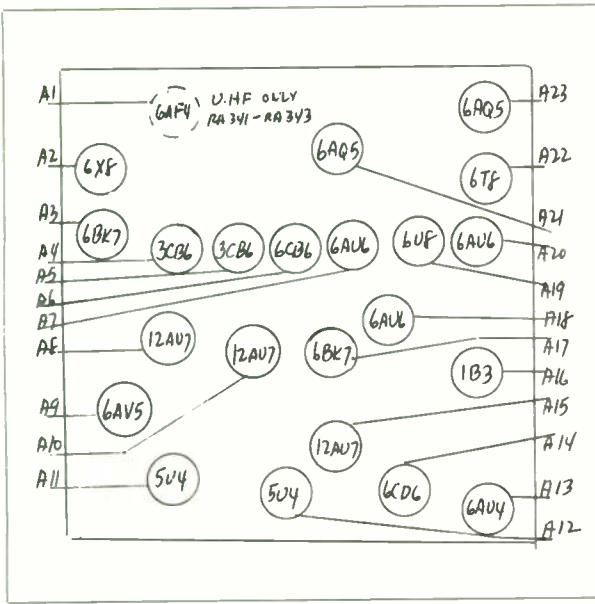

TROUBLE	LOCATION
1-No brightness on tube.	A11 - A12 - A13 - A14 - A15 - A16
2-No vertical height. White line across screen Fig. 2	A8 - A9
3-No horizontal width. White line running up and down. Fig. 3	A11 - A12 - A13 - A14 - A15
4-Small picture in center of tube. Picture does not fill up entire screen. Fig. 4	A11 - A12
5-Picture out of proportion vertically. (top to bottom) Fig. 5	A8 - A9
6-Picture out of proportion horizontally. (side to side) Fig. 6	A13 - A14 - A15
7-Picture present, but no sound.	A7 - A20 - A22 - A23 - A19
8-Picture rolls. (Vertical movement up and down). Fig. 8	A8 - A9 - A10 - A17
9-Picture tears. Figures on screen wave from side to side. Fig. 9	A8 - A10 - A13 - A14 - A15 - A17
10-Sound, brightness but no picture.	A4 - A5 - A6 - A18 - A19 - A21 - A22
11-Brightness, but no picture or sound.	A2 - A3 - A4 - A5 - A6 - A18 - A22 (A1 - UHF only)

DUMONT - LAYOUT NO. 55

TROUBLE	LOCATION
1-No brightness on tube.	A11 - A12 - A13 - A15 - A20
2-No vertical height. White line across screen Fig. 2	A18 - A19
3-No horizontal width. White line running up and down. Fig. 3	A11 - A12 - A13 - A20
4-Small picture in center of tube. Picture does not fill up entire screen. Fig. 4	A20
5-Picture out of proportion vertically. (top to bottom) Fig. 5	A18 - A19
6-Picture out of proportion horizontally. (side to side) Fig. 6	A11 - A12 - A13
7-Picture present, but no sound.	A7 - A9 - A10 - A14
8-Picture rolls. (Vertical movement up and down). Fig. 8	A6 - A18 - A19
9-Picture tears. Figures on screen wave from side to side. Fig. 9	A6 - A11 - A12 - A13 - A18 - A17
10-Sound, brightness but no picture.	A3 - A4 - A5 - A18 - A16
11-Brightness, but no picture or sound.	A1 - A2 - A3 - A4 - A5 - A16

DUMONT - LAYOUT NO. 56

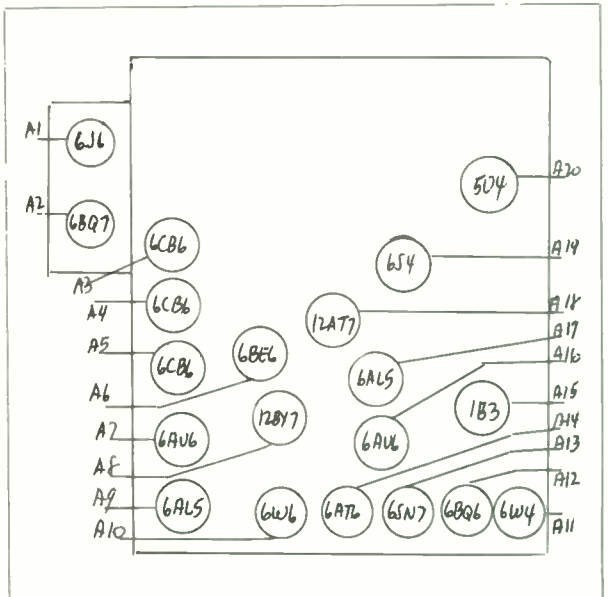

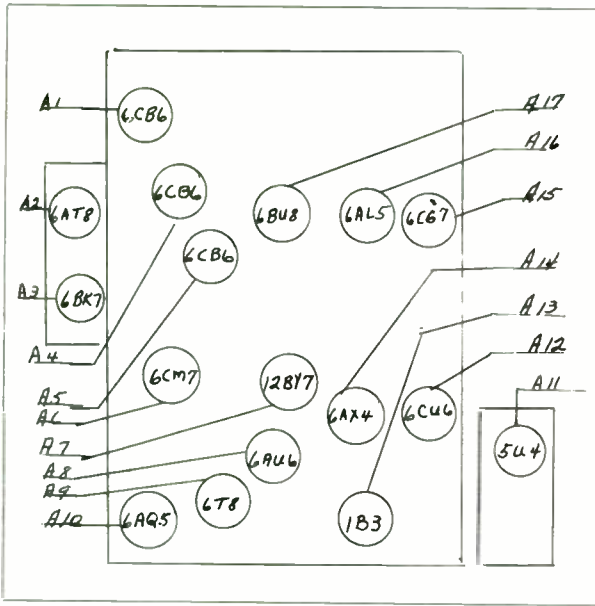

DUMONT - LAYOUT NO. 57

TROUBLE	LOCATION
1-No brightness on Tube.	A11 - A12 - A13 - A14 - A15
2-No vertical height. White line across screen Fig. 2	A6
3-No horizontal width. White line running up and down. Fig. 3	A11 - A12 - A14 - A15
4-Small picture in center of tube. Picture does not fill up entire screen. Fig. 4	A11
5-Picture out of proportion vertically. (top to bottom) Fig. 5	A6
6-Picture out of proportion horizontally. (side to side) Fig. 6	A12 - A14 - A15
7-Picture present, but no sound.	A8 - A9 - A10
8-Picture rolls. (Vertical movement up and down). Fig. 8	A6 - A17
9-Picture tears. Figures on screen wave from side to side. Fig. 9	A12 - A14 - A15 - A16 - A17
10-Sound, brightness but no picture.	A1 - A4 - A5 - A7
11-Brightness, but no picture or sound.	A1 - A2 - A3 - A4 - A5 - A7

DUMONT - LAYOUT NO. 58

TROUBLE	LOCATION
1-No brightness on tube.	A10 - A11 - A13 - A14 - A15 - A16 - A17
2-No vertical height. White line across screen Fig. 2	A12
3-No horizontal width. White line running up and down. Fig. 3	A10 - A11 - A13 - A16 - A17
4-Small picture in center of tube. Picture does not fill up entire screen. Fig. 4	A10 - A11
5-Picture out of proportion vertically. (top to bottom) Fig. 5	A12
6-Picture out of proportion horizontally. (side to side) Fig. 6	A13 - A16 - A17
7-Picture present, but no sound.	A3 - A4 - A8 - A9 - A21
8-Picture rolls. (Vertical movement up and down). Fig. 8	A6 - A7 - A12
9-Picture tears. Figures on screen wave from side to side. Fig. 9	A5 - A7 - A13 - A16 - A17
10-Sound, brightness but no picture.	A18 - A19 - A20 - A22 - A23 - A24 - A25
11-Brightness, but no picture or sound.	A1 - A2 - A22 - A23 - A24 - A25

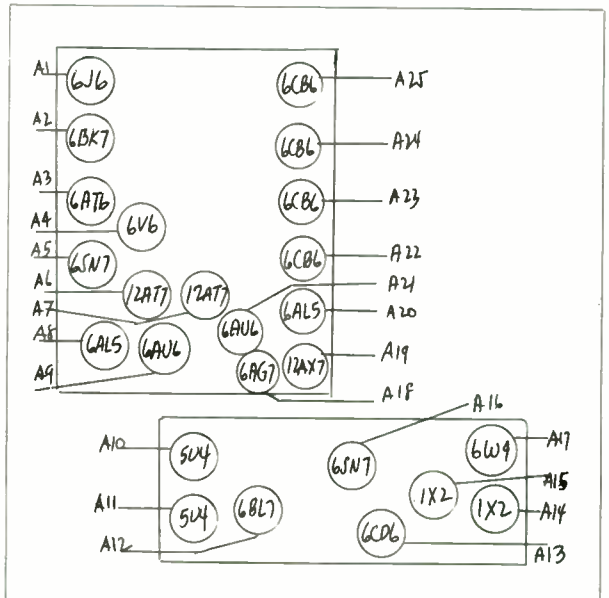

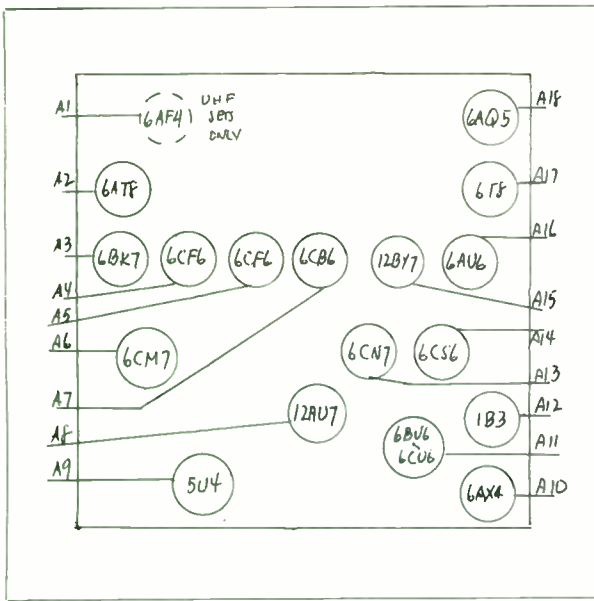

TROUBLE	LOCATION
1-No brightness on tube.	A8 - A9 - A10 - A11 - A12
2-No vertical height. White line across screen Fig. 2	A6
3-No horizontal width. White line running up and down. Fig. 3	A8 - A9 - A10 - A11
4-Small picture in center of tube. Picture does not fill up entire screen. Fig. 4	A9
5-Picture out of proportion vertically. (top to bottom) Fig. 5	A6
6-Picture out of proportion horizontally. (side to side) Fig. 6	A8 - A10 - A11
7-Picture present, but no sound.	A16 - A17 - A18
8-Picture rolls. (Vertical movement up and down). Fig. 8	A6 - A13 - A14
9-Picture tears. Figures on screen wave from side to side. Fig. 9	A8 - A10 - A11 - A13 - A14
10-Sound, brightness but no picture.	A4 - A5 - A7 - A15
11-Brightness, but no picture or sound.	A2 - A3 - A4 - A5 - A7 (A1 - UHF only)

DUMONT-LAYOUT NO. 59

DUMONT - LAYOUT NO.60

TROUBLE	LOCATION
1-No brightness on tube.	A10 - A11 - A12 - A13 - A14 - A15
2-No vertical height. White line across screen Fig. 2	A7 - A9
3-No horizontal width. White line running up and down. Fig. 3	A10 - A11 - A12 - A13 - A14
4-Small picture in center of tube. Picture does not fill up entire screen. Fig. 4	A11 - A12
5-Picture out of proportion vertically. (top to bottom) Fig. 5	A7 - A9
6-Picture out of proportion horizontally. (side to side) Fig. 6	A10 - A13 - A14
7-Picture present, but no sound.	A6 - A19 - A20 - A22
8-Picture rolls. (Vertical movement up and down). Fig. 8	A7 - A8 - A9 - A16
9-Picture tears. Figures on screen wave from side to side. Fig. 9	A7 - A8 - A10 - A13 - A14 - A16
10-Sound, brightness but no picture.	A3 - A4 - A5 - A17 - A18 - A21
11-Brightness, but no picture or sound.	A1 - A2 - A3 - A4 - A5 - A17 - A18

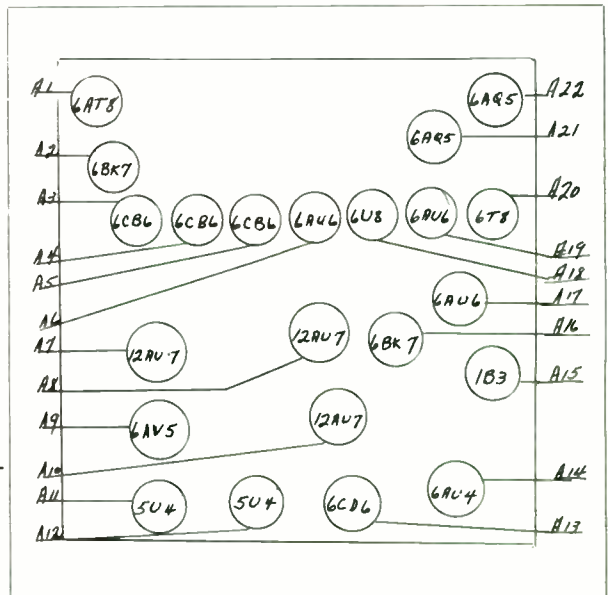

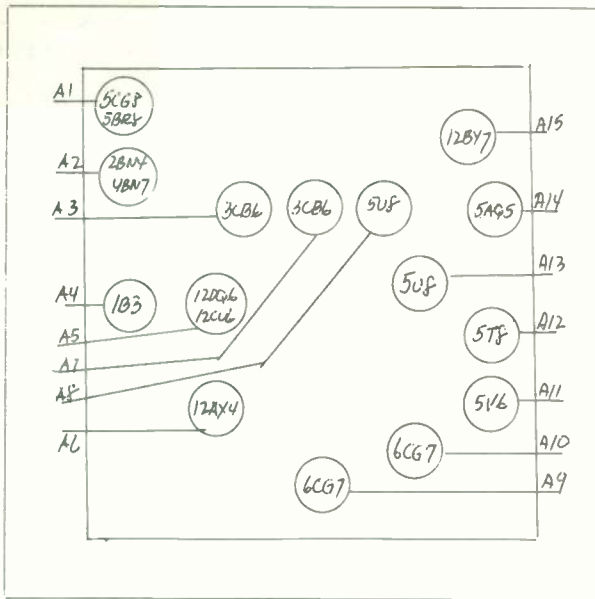

EMERSON - LAYOUT NO. 61

TROUBLE	LOCATION
1-No brightness on tube.	A4 - A5 - A6 - A9 *
2-No vertical height. White line across screen Fig. 2	A10 - A11
3-No horizontal width. White line running up and down. Fig. 3	A5 - A6 - A9 *
4-Small picture in center of tube. Picture does not fill up entire screen. Fig. 4	A5 - A6 - A9 *
5-Picture out of proportion vertically. (top to bottom) Fig. 5	A10 - A11
6-Picture out of proportion horizontally. (side to side) Fig. 6	A5 - A6 - A9
7-Picture present, but no sound.	A12 - A13 - A14
8-Picture rolls. (Vertical movement up and down). Fig. 8	A10 - A11 - A13
9-Picture tears. Figures on screen wave from side to side. Fig. 9	A5 - A6 - A9 - A10 - A13
10-Sound, brightness but no picture.	A3 - A7 - A8 - A15
11-Brightness, but no picture or sound.	A1 - A2 - A3 - A7 - A8 - A15

* Selenium Rectifiers.

TROUBLE

LOCATION

1-No brightness on tube.	A6 - A7 - A8 - A9 - A11
2-No vertical height. White line across screen Fig. 2	A10 - A12
3-No horizontal width. White line running up and down. Fig. 3	A6 - A7 - A8 - A11
4-Small picture in center of tube. Picture does not fill up entire screen. Fig. 4	A6
5-Picture out of proportion vertically. (top to bottom) Fig. 5	A10 - A12
6-Picture out of proportion horizontally. (side to side) Fig. 6	A7 - A8 - A11
7-Picture present, but no sound.	A16 - A17 - A19
8-Picture rolls. (Vertical movement up and down). Fig. 8	A10 - A12 - A15 - A17
9-Picture tears. Figures on screen wave from side to side. Fig. 9	A7 - A8 - A11 - A12 - A13 - A15 - A17
10-Sound, brightness but no picture.	A1 - A2 - A3 - A14 - A18
11-Brightness, but no picture or sound.	A1 - A2 - A3 - A4 - A5 - A14 - A18

Series Circuit - Open Filament makes set inop.

EMERSON - LAYOUT NO. 62

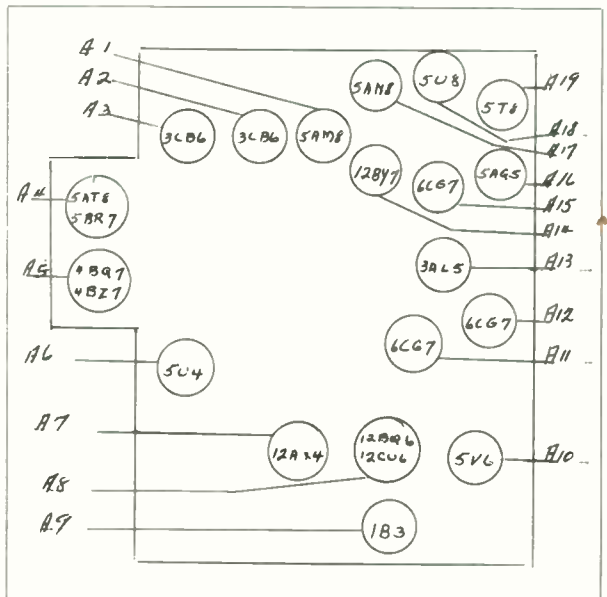

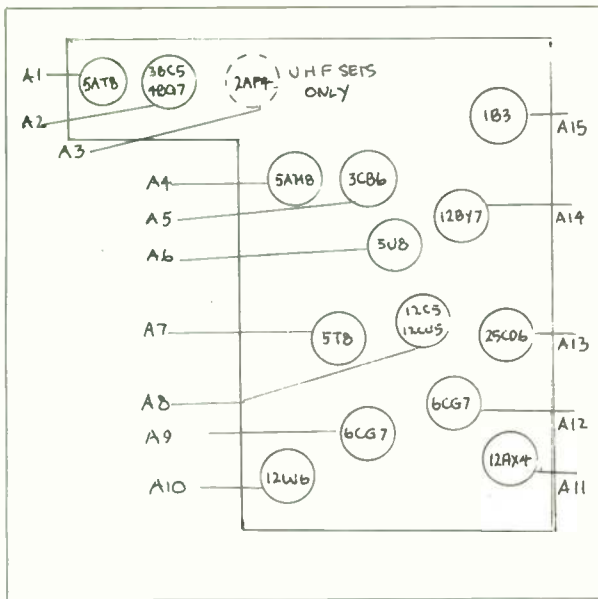

EMERSON - LAYOUT NO. 63

TROUBLE	LOCATION
1-No brightness on tube.	A11 - A12 - A13 - A15 *
2-No vertical height. White line across screen Fig. 2	A9 - A10
3-No horizontal width. White line running up and down. Fig. 3	A11 - A12 - A13
4-Small picture in center of tube. Picture does not fill up entire screen. Fig. 4	A11 - A12 - A13 *
5-Picture out of proportion vertically. (top to bottom) Fig. 5	A9 - A10
6-Picture out of proportion horizontally. (side to side) Fig. 6	A11 - A12 - A13
7-Picture present, but no sound.	A6 - A7 - A8
8-Picture rolls. (Vertical movement up and down). Fig. 8	A9 - A10
9-Picture tears. Figures on screen wave from side to side. Fig. 9	A6 - A9 - A11 - A12 - A13
10-Sound, brightness but no picture.	A4 - A5 - A14
11-Brightness, but no picture or sound.	A1 - A2 - A3 - A4 - A5 - A14

NOTE * Selenium Rectifiers.

TROUBLE

LOCATION

1-No brightness on tube.	A7 - A8 - A9 - A10 - A11 - A12
2-No vertical height. White line across screen Fig. 2	A13 - A14
3-No horizontal width. White line running up and down. Fig. 3	A7 - A8 - A9 - A11 - A12
4-Small picture in center of tube. Picture does not fill up entire screen. Fig. 4	A7 - A8
5-Picture out of proportion vertically. (top to bottom) Fig. 5	A13 - A14
6-Picture out of proportion horizontally. (side to side) Fig. 6	A9 - A11 - A12
7-Picture present, but no sound.	A16 - A17 - A18 - A19
8-Picture rolls. (Vertical movement up and down). Fig. 8	A13 - A14 - A16
9-Picture tears. Figures on screen wave from side to side. Fig. 9	A9 - A11 - A12 - A14 - A16
10-Sound, brightness but no picture.	A3 - A4 - A5 - A6 - A15
11-Brightness, but no picture or sound.	A1 - A2 - A3 - A4 - A5 - A6

EMERSON - LAYOUT NO. 64

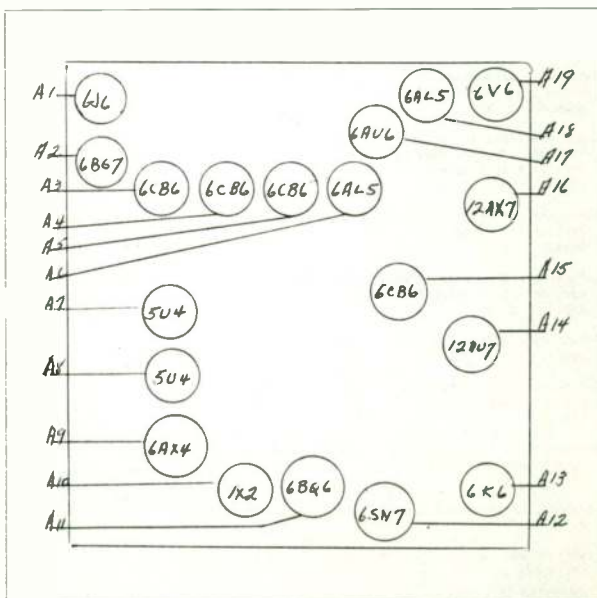

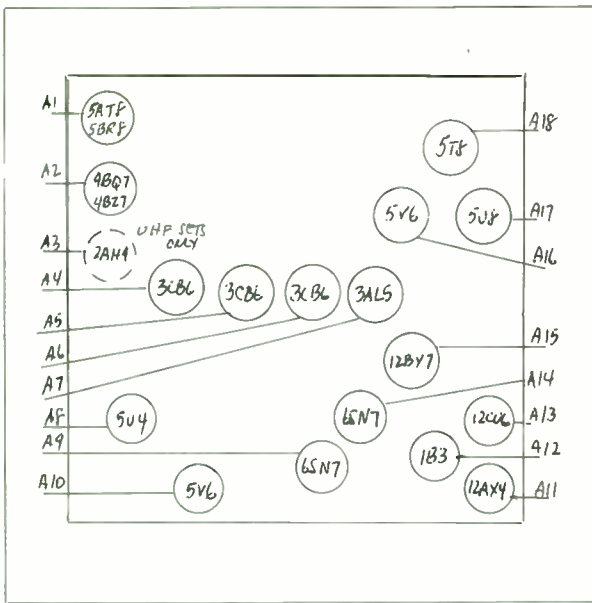

TROUBLE	LOCATION
1-No brightness on tube.	A8 - A9 - A11 - A12 - A13
2-No vertical height. White line across screen Fig. 2	A10 - A14
3-No horizontal width. White line running up and down. Fig. 3	A8 - A9 - A11 - A13
4-Small picture in center of tube. Picture does not fill up entire screen. Fig. 4	A8
5-Picture out of proportion vertically. (top to bottom) Fig. 5	A10 - A14
6-Picture out of proportion horizontally. (side to side) Fig. 6	A9 - A11 - A13
7-Picture present, but no sound.	A16 - A17 - A18
8-Picture rolls. (Vertical movement up and down). Fig. 8	A10 - A14 - A17
9-Picture tears. Figures on screen wave from side to side. Fig. 9	A9 - A11 - A13 - A14 - A17
10-Sound, brightness but no picture.	A4 - A5 - A6 - A7 - A15
11-Brightness, but no picture or sound.	A1 - A2 - A4 - A5 - A6 - A7

EMERSON - LAYOUT NO. 65

EMERSON - LAYOUT NO. 66

TROUBLE	LOCATION
1-No brightness on tube.	A8 - A9 - A10 - A11 *
2-No vertical height. White line across screen Fig. 2	A7 - A12
3-No horizontal width. White line running up and down. Fig. 3	A8 - A9 - A11
4-Small picture in center of tube. Picture does not fill up entire screen. Fig. 4	A8 - A9 - A11 *
5-Picture out of proportion vertically. (top to bottom) Fig. 5	A7 - A12
6-Picture out of proportion horizontally. (side to side) Fig. 6	A8 - A9 - A11
7-Picture present, but no sound.	A14 - A15 - A16
8-Picture rolls. (Vertical movement up and down). Fig. 8	A6 - A7 - A12 - A14
9-Picture tears. Figures on screen wave from side to side. Fig. 9	A8 - A9 - A11 - A12 - A14
10-Sound, brightness but no picture.	A3 - A4 - A5 - A6 - A13
11-Brightness, but no picture or sound.	A1 - A2 - A3 - A4 - A5 - A6 - A13

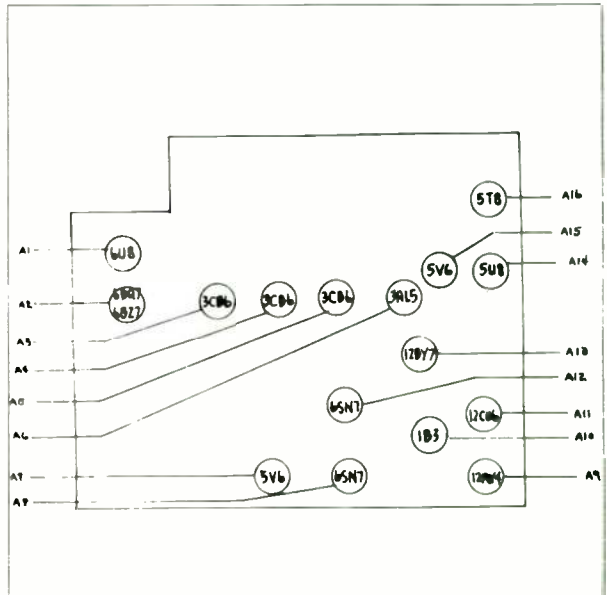

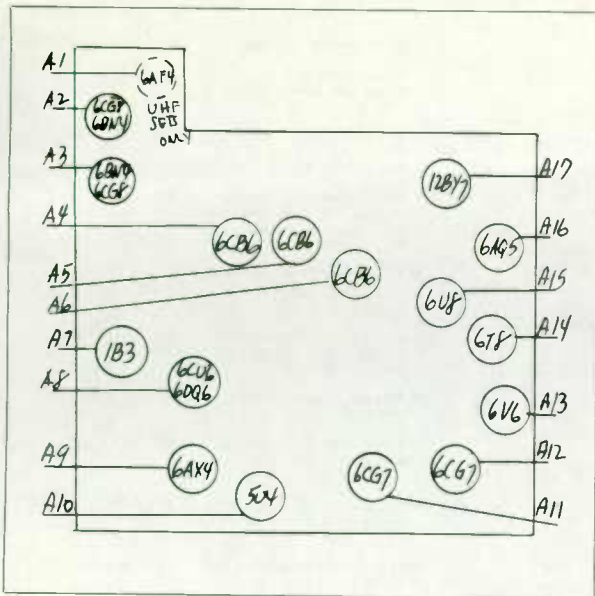

TROUBLE	LOCATION
1-No brightness on tube.	A7 - A8 - A9 - A10 - A11
2-No vertical height. White line across screen Fig. 2	A12 - A15
3-No horizontal width. White line running up and down. Fig. 3	A8 - A9 - A10 - A11
4-Small picture in center of tube. Picture does not fill up entire screen. Fig. 4	A10
5-Picture out of proportion vertically. (top to bottom) Fig. 5	A12 - A15
6-Picture out of proportion horizontally. (side to side) Fig. 6	A8 - A9 - A11
7-Picture present, but no sound.	A13 - A14 - A16
8-Picture rolls. (Vertical movement up and down). Fig. 8	A12 - A15
9-Picture tears. Figures on screen wave from side to side. Fig. 9	A8 - A9 - A11 - A15
10-Sound, brightness but no picture.	A4 - A5 - A6 - A17
11-Brightness, but no picture or sound.	A2 - A3 - A4 - A5 - A6 - (A1 UHF only)

EMERSON - LAYOUT NO. 67

TROUBLE	LOCATION
1-No brightness on tube.	A6 - A11 - A12 - A13
2-No vertical height. White line across screen Fig. 2	A7 - A10
3-No horizontal width. White line running up and down. Fig. 3	A6 - A12 - A13
4-Small picture in center of tube. Picture does not fill up entire screen. Fig. 4	A6 - A12 - A13
5-Picture out of proportion vertically. (top to bottom) Fig. 5	A7 - A10
6-Picture out of proportion horizontally. (side to side) Fig. 6	A6 - A12 - A13
7-Picture present, but no sound.	A6 - A8 - A9
8-Picture rolls. (Vertical movement up and down). Fig. 8	A3 - A7 - A10
9-Picture tears. Figures on screen wave from side to side. Fig. 9	A3 - A6 - A12 - A13
10-Sound, brightness but no picture.	A3 - A4 - A5 - A7
11-Brightness, but no picture or sound.	A1 - A2 - A3 - A4 - A5 A7 - (A14 UHF ONLY)

EMERSON - LAYOUT NO. 68

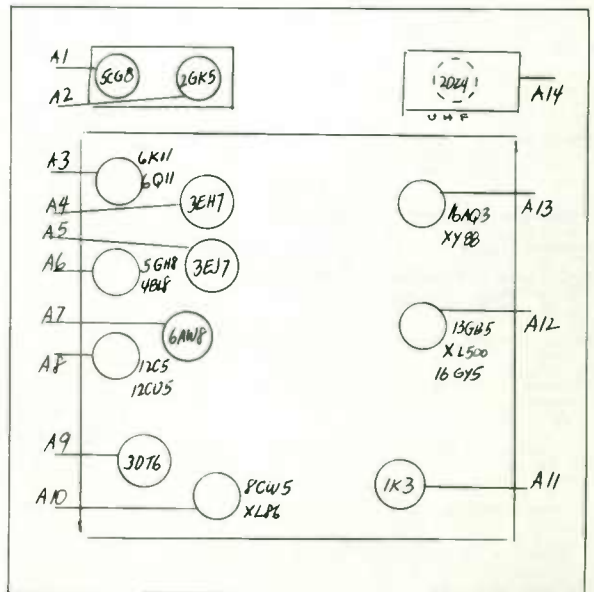

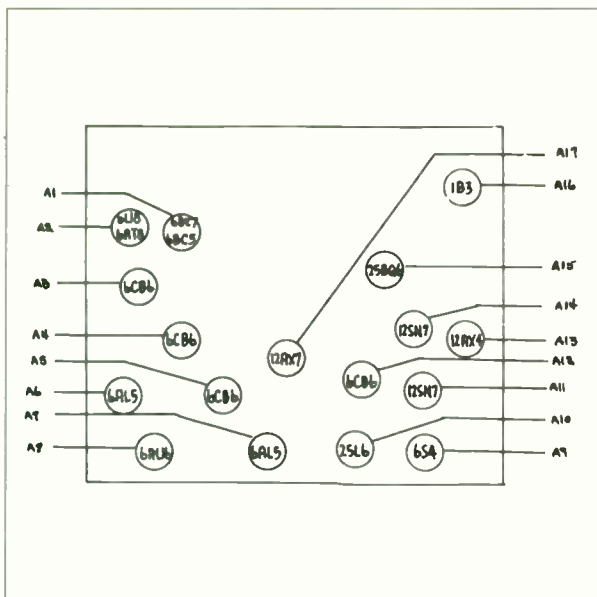

EMERSON - LAYOUT NO. 69

TROUBLE	LOCATION
1-No brightness on tube.	A13 - A14 - A15 - A16 *
2-No vertical height. White line across screen Fig. 2	A9 - A11
3-No horizontal width. White line running up and down. Fig. 3	A13 - A14 - A15
4-Small picture in center of tube. Picture does not fill up entire screen. Fig. 4	A13 - A14 - A15 *
5-Picture out of proportion vertically. (top to bottom) Fig. 5	A9 - A11
6-Picture out of proportion horizontally. (side to side) Fig. 6	A13 - A14 - A15
7-Picture present, but no sound.	A4 - A6 - A8 - A10 - A17
8-Picture rolls. (Vertical movement up and down). Fig. 8	A9 - A11 - A17
9-Picture tears. Figures on screen wave from side to side. Fig. 9	A13 - A14 - A15 - A17
10-Sound, brightness but no picture.	A3 - A4 - A5 - A7 - A12
11-Brightness, but no picture or sound.	A1 - A2 - A3 - A4 - A5 - A7 - A12

* Selenium Rectifiers.

TROUBLE

LOCATION

1-No brightness on tube.	A13 - A14 - A16 - A17 *
2-No vertical height. White line across screen Fig. 2	A9 - A11
3-No horizontal width. White line running up and down. Fig. 3	A13 - A14 - A16
4-Small picture in center of tube. Picture does not fill up entire screen. Fig. 4	A13 - A14 - A16 *
5-Picture out of proportion vertically. (top to bottom) Fig. 5	A9 - A11
6-Picture out of proportion horizontally. (side to side) Fig. 6	A13 - A14 - A16
7-Picture present, but no sound.	A4 - A6 - A8 - A10 - A15
8-Picture rolls. (Vertical movement up and down). Fig. 8	A9 - A11 - A15
9-Picture tears. Figures on screen wave from side to side. Fig. 9	A13 - A14 - A15 - A16
10-Sound, brightness but no picture.	A3 - A4 - A5 - A7 - A12
11-Brightness, but no picture or sound.	A1 - A2 - A3 - A4 - A5 - A7 - A12

* Selenium Rectifiers.

EMERSON - LAYOUT NO. 70

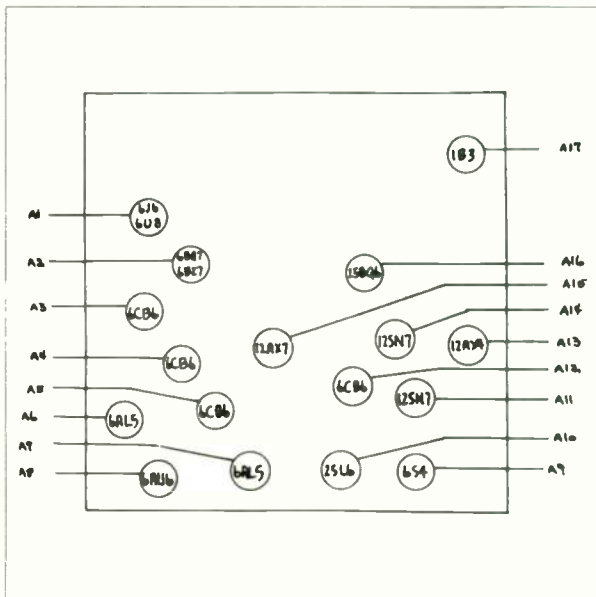

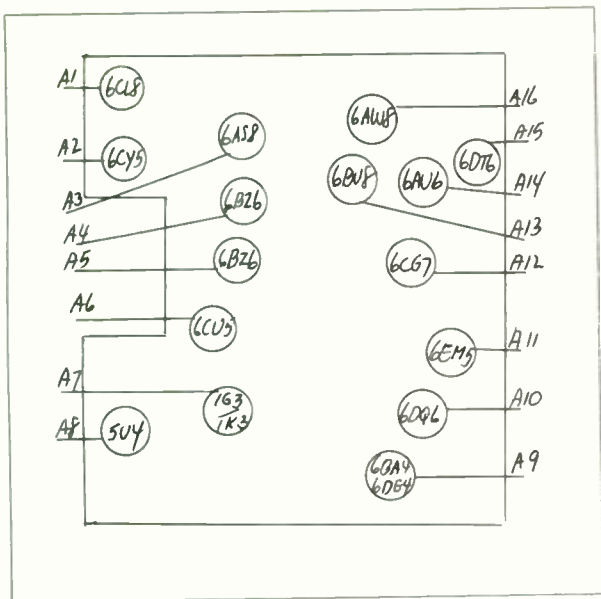

EMERSON - LAYOUT NO. 71

TROUBLE	LOCATION
1-No brightness on tube.	A7 - A8 - A9 - A10 - A12
2-No vertical height. White line across screen Fig. 2	A11 - A16
3-No horizontal width. White line running up and down. Fig. 3	A8 - A9 - A10 - A12
4-Small picture in center of tube. Picture does not fill up entire screen. Fig. 4	A8
5-Picture out of proportion vertically. (top to bottom) Fig. 5	A11 - A16
6-Picture out of proportion horizontally. (side to side) Fig. 6	A9 - A10 - A12
7-Picture present, but no sound.	A6 - A14 - A15
8-Picture rolls. (Vertical movement up and down). Fig. 8	A11 - A13 - A16
9-Picture tears. Figures on screen wave from side to side. Fig. 9	A9 - A10 - A12 - A13
10-Sound, brightness but no picture.	A3 - A4 - A5 - A16
11-Brightness, but no picture or sound.	A1 - A2 - A3 - A4 - A5 - A16

TROUBLE

LOCATION

1-No brightness on tube.	A4 - A6 - A9 - A10 - A11 - A12
2-No vertical height. White line across screen Fig. 2	A7 - A8
3-No horizontal width. White line running up and down. Fig. 3	A4 - A6 - A9 - A10 - A11
4-Small picture in center of tube. Picture does not fill up entire screen. Fig. 4	A4 - A6
5-Picture out of proportion vertically. (top to bottom) Fig. 5	A7 - A8
6-Picture out of proportion horizontally. (side to side) Fig. 6	A4 - A6 - A9 - A10 - A11
7-Picture present, but no sound.	A16 - A17 - A18 - A19
8-Picture rolls. (Vertical movement up and down). Fig. 8	A7 - A8 - A16
9-Picture tears. Figures on screen wave from side to side. Fig. 9	A4 - A6 - A9 - A10 - A11 - A16
10-Sound, brightness but no picture.	A3 - A5 - A13 - A14 - A15
11-Brightness, but no picture or sound.	A1 - A2 - A3 - A5 - A13 - A14 - A15

EMERSON - LAYOUT NO. 72

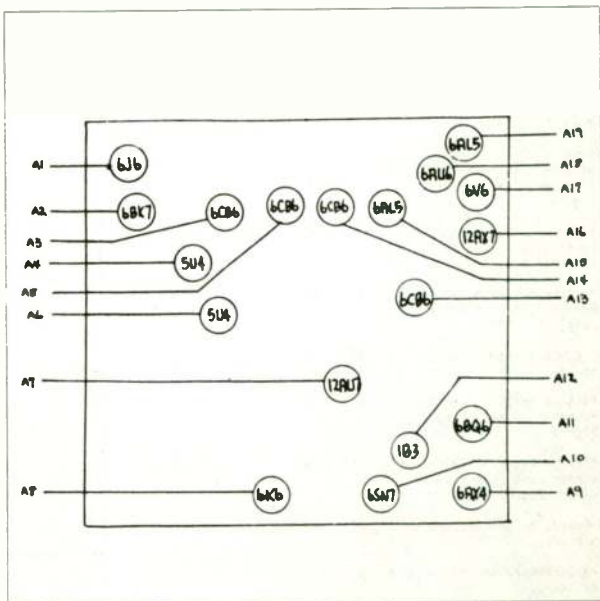

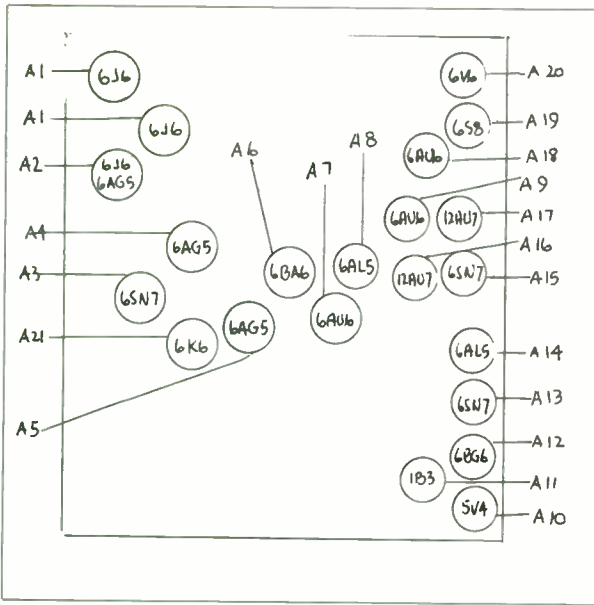

TROUBLE	LOCATION
1-No brightness on tube.	A10 - A11 - A12
2-No vertical height. White line across screen Fig. 2	A21 - A3
3-No horizontal width. White line running up and down. Fig. 3	A13 - A14
4-Small picture in center of tube. Picture does not fill up entire screen. Fig. 4	A10 - A12
5-Picture out of proportion vertically. (top to bottom) Fig. 5	A3 - A21
6-Picture out of proportion horizontally. (side to side) Fig. 6	A13 - A14
7-Picture present, but no sound.	A6 - A18 - A19 - A20
8-Picture rolls. (Vertical movement up and down). Fig. 8	A3 - A21 - A16
9-Picture tears. Figures on screen wave from side to side. Fig. 9	A14 - A13 - A15 - A17
10-Sound, brightness but no picture.	A4 - A5 - A7 - A8 - A9
11-Brightness, but no picture or sound.	A1 - A1a - A2

EMERSON - LAYOUT NO. 73

TROUBLE LOCATION

1-No brightness on tube.	A16 - A14 - A15
2-No vertical height. White line across screen Fig. 2	A13
3-No horizontal width. White line running up and down. Fig. 3	A10
4-Small picture in center of tube. Picture does not fill up entire screen. Fig. 4	A14
5-Picture out of proportion vertically. (top to bottom) Fig. 5	A13 - A8
6-Picture out of proportion horizontally. (side to side) Fig. 6	A10 - A9
7-Picture present, but no sound.	A4 - A5 - A6 - A7
8-Picture rolls. (Vertical movement up and down). Fig. 8	A13 - A8
9-Picture tears. Figures on screen wave from side to side. Fig. 9	A10 - A9
10-Sound, brightness but no picture.	A3 - A12 - A11 - A9 - A8
11-Brightness, but no picture or sound.	A1 - A2

EMERSON - LAYOUT NO. 74

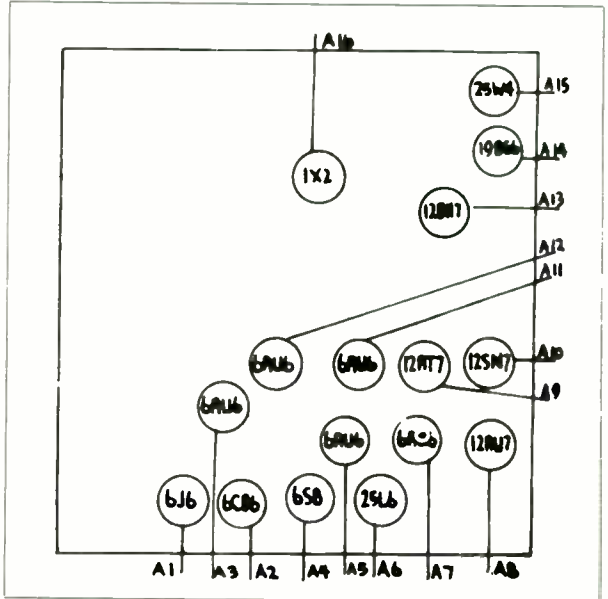

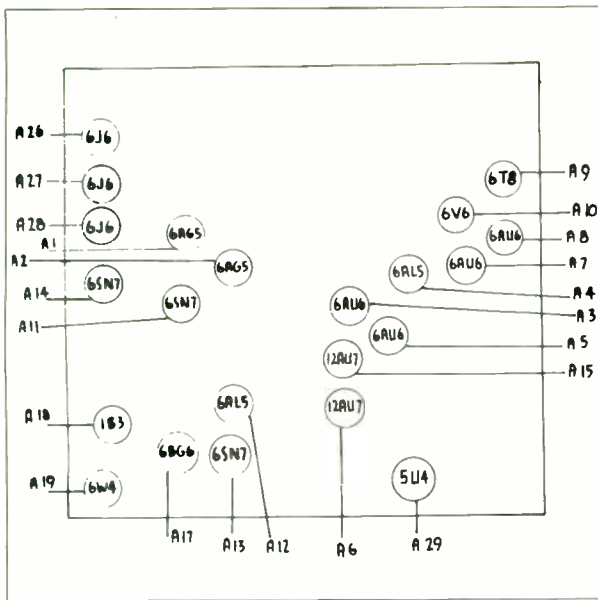

EMERSON - LAYOUT NO. 75

TROUBLE	LOCATION
1-No brightness on tube.	A17 - A18 - A19 - A13
2-No vertical height. White line across screen Fig. 2	A16 - A14
3-No horizontal width. White line running up and down. Fig. 3	A13 - A17 - A19
4-Small picture in center of tube. Picture does not fill up entire screen. Fig. 4	A29
5-Picture out of proportion vertically. (top to bottom) Fig. 5	A14 - A11
6-Picture out of proportion horizontally. (side to side) Fig. 6	A17 - A18 - A13
7-Picture present, but no sound.	A7 - A8 - A9 - A10
8-Picture rolls. (Vertical movement up and down). Fig. 8	A14
9-Picture tears. Figures on screen wave from side to side. Fig. 9	A12
10-Sound, brightness but no picture.	A1 - A2 - A3 - A4 - A5 - A6
11-Brightness, but no picture or sound.	A26 - A27 - A28

EMERSON - LAYOUT NO. 76

TROUBLE	LOCATION
1-No brightness on tube.	A28 - A20 - A19 - A18 - A17
2-No vertical height. White line across screen Fig. 2	A15 - A16
3-No horizontal width. White line running up and down. Fig. 3	A17 - A19 - A20
4-Small picture in center of tube. Picture does not fill up entire screen. Fig. 4	A23 - A19
5-Picture out of proportion vertically. (top to bottom) Fig. 5	A15 - A16
6-Picture out of proportion horizontally. (side to side) Fig. 6	A21 - A20
7-Picture present, but no sound.	A6 - A7 - A8 - A9
8-Picture rolls. (Vertical movement up and down). Fig. 8	A15 - A16
9-Picture tears. Figures on screen wave from side to side. Fig. 9	A19 - A21
10-Sound, brightness but no picture.	A1 - A2 - A3 - A4 - A5 - A6 - A12
11-Brightness, but no picture or sound.	A25 - A26 - A27

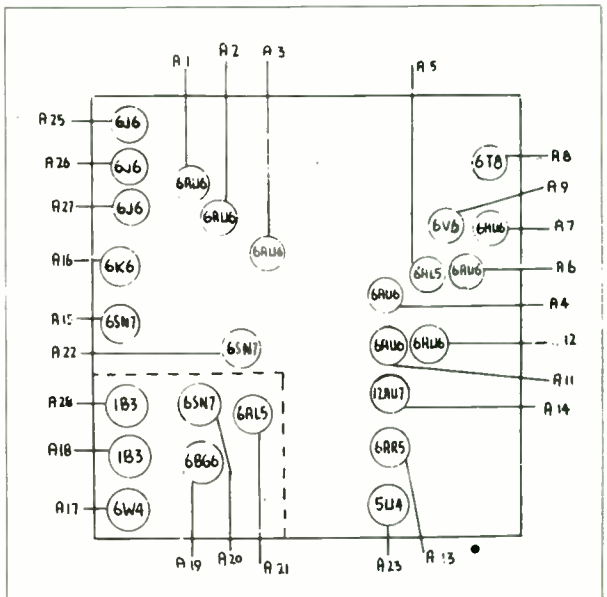

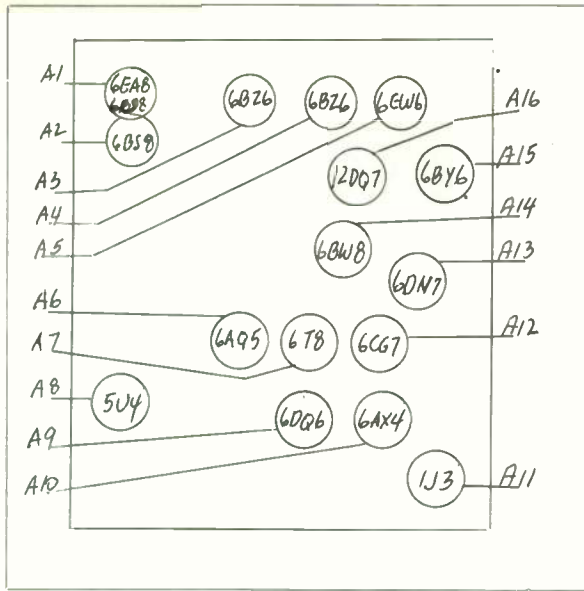

TROUBLE	LOCATION
1-No brightness on tube.	A8 - A9 - A10 - A11 - A12
2-No vertical height. White line across screen Fig. 2	A13
3-No horizontal width. White line running up and down. Fig. 3	A8 - A9 - A10 - A12
4-Small picture in center of tube. Picture does not fill up entire screen. Fig. 4	A8
5-Picture out of proportion vertically. (top to bottom). Fig. 5	A13
6-Picture out of proportion horizontally. (side to side) Fig. 6	A9 - A10 - A12
7-Picture present, but no sound.	A6 - A7 - A14
8-Picture rolls. (Vertical movement up and down). Fig. 8	A13 - A15
9-Picture tears. Figures on screen wave from side to side. Fig. 9	A9 - A10 - A12 - A14 - A15
10-Sound, brightness but no picture.	A3 - A4 - A5 - A16
11-Brightness, but no picture or sound.	A1 - A2 - A3 - A4 - A5 - A16

GENERAL ELECTRIC - LAYOUT NO. 77

EMERSON - LAYOUT NO. 78

TROUBLE	LOCATION
1-No brightness on tube.	A13 - A14 - A15 - A16 - A18
2-No vertical height. White line across screen Fig. 2	A19 - A20
3-No horizontal width. White line running up and down. Fig. 3	A13 - A14 - A15 - A16
4-Small picture in center of tube. Picture does not fill up entire screen. Fig. 4	A13
5-Picture out of proportion vertically. (top to bottom) Fig. 5	A19 - A20
6-Picture out of proportion horizontally. (side to side) Fig. 6	A14 - A15 - A16
7-Picture present, but no sound.	A10 - A11 - A12 - A17
8-Picture rolls. (Vertical movement up and down). Fig. 8	A6 - A7 - A19 - A20
9-Picture tears. Figures on screen wave from side to side. Fig. 9	A6 - A14 - A15 - A16 - A20
10-Sound, brightness but no picture.	A3 - A4 - A5 - A8 - A9
11-Brightness, but no picture or sound.	A1 - A2 - A3 - A4 - A5 - A8

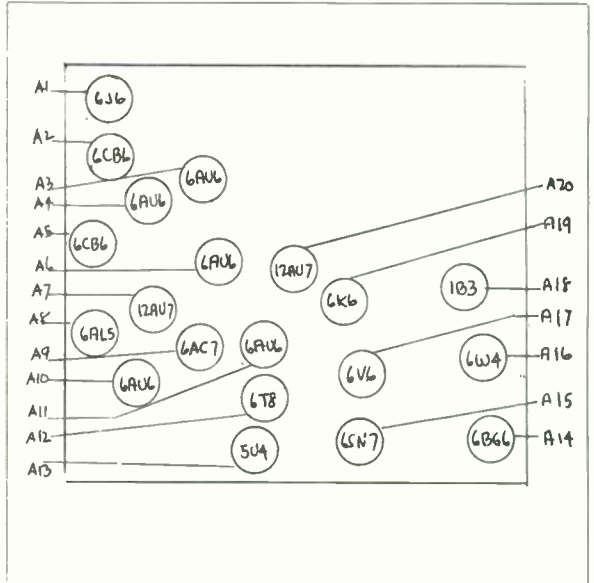

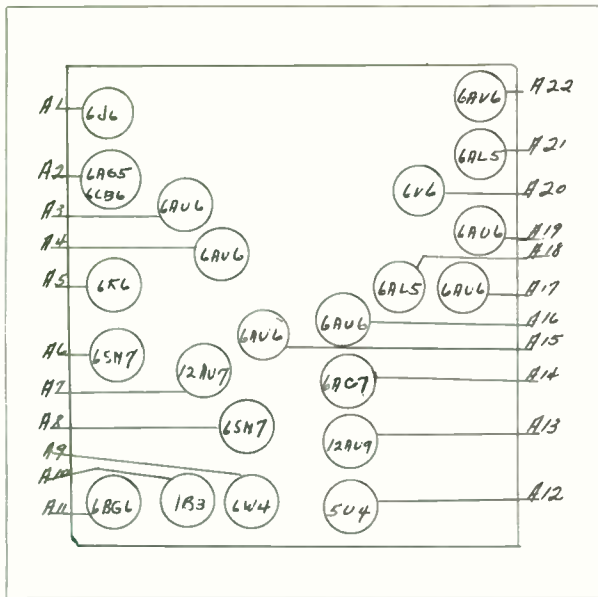

TROUBLE	LOCATION
1-No brightness on tube.	A8 - A9 - A10 - A11 - A12
2-No vertical height. White line across screen Fig. 2	A5 - A6
3-No horizontal width. White line running up and down. Fig. 3	A8 - A9 - A11 - A12
4-Small picture in center of tube. Picture does not fill up entire screen. Fig. 4	A12
5-Picture out of proportion vertically. (top to bottom) Fig. 5	A5 - A6
6-Picture out of proportion horizontally. (side to side) Fig. 6	A8 - A9 - A11
7-Picture present, but no sound.	A17 - A19 - A20 - A21 - A22
8-Picture rolls. (Vertical movement up and down). Fig. 8	A5 - A6 - A7 - A13
9-Picture tears. Figures on screen wave from side to side. Fig. 9	A5 - A8 - A9 - A11 - A13
10-Sound, brightness but no picture.	A3 - A4 - A14 - A15 - A16 - A18
11-Brightness, but no picture or sound.	A1 - A2 - A3 - A4 - A15 - A16 - A18

EMERSON - LAYOUT NO. 79

EMERSON - LAYOUT NO. 80

TROUBLE	LOCATION
1-No brightness on tube.	A7 - A8 - A9 - A10 - A11 - A12
2-No vertical height. White line across screen Fig. 2	A13 - A14
3-No horizontal width. White line running up and down. Fig. 3	A7 - A8 - A9 - A11 - A12
4-Small picture in center of tube. Picture does not fill up entire screen. Fig. 4	A7 - A8
5-Picture out of proportion vertically. (top to bottom) Fig. 5	A13 - A14
6-Picture out of proportion horizontally. (side to side) Fig. 6	A9 - A11 - A12
7-Picture present, but no sound.	A16 - A17 - A18 - A19
8-Picture rolls. (Vertical movement up and down). Fig. 8	A13 - A14 - A16
9-Picture tears. Figures on screen wave from side to side. Fig. 9	A9 - A11 - A12 - A14 - A16
10-Sound, brightness but no picture.	A3 - A4 - A5 - A6 - A15
11-Brightness, but no picture or sound.	A1 - A2 - A3 - A4 - A5 - A6

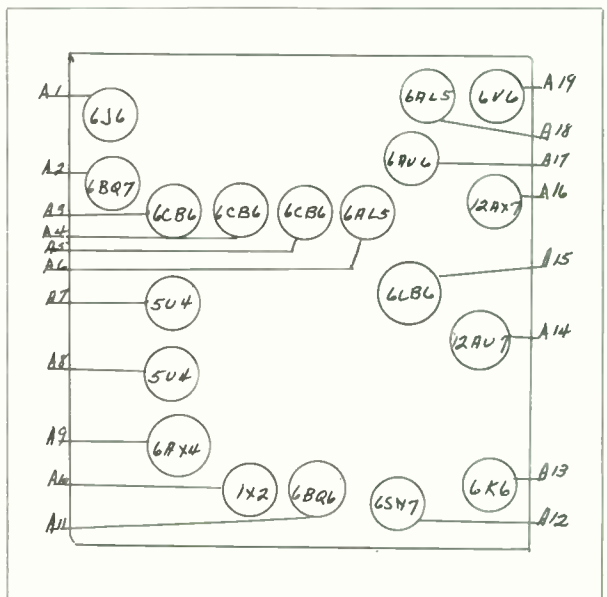

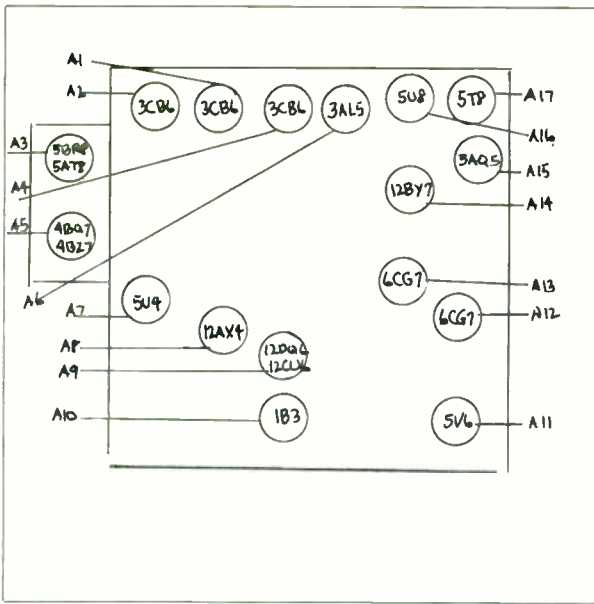

TROUBLE	LOCATION
1-No brightness on tube.	A7 - A8 - A8 - A10 - A13
2-No vertical height. White line across screen Fig. 2	A11 - A12
3-No horizontal width. White line running up and down. Fig. 3	A7 - A8 - A8 - A13
4-Small picture in center of tube. Picture does not fill up entire screen. Fig. 4	A7
5-Picture out of proportion vertically. (top to bottom) Fig. 5	A11 - A12
6-Picture out of proportion horizontally. (side to side) Fig. 6	A8 - A9 - A10
7-Picture present, but no sound.	A15 - A16 - A17
8-Picture rolls. (Vertical movement up and down). Fig. 8	A11 - A12 - A16
9-Picture tears. Figures on screen wave from side to side. Fig. 9	A8 - A9 - A12 - A13 - A16
10-Sound, brightness but no picture.	A1 - A2 - A4 - A6 - A14
11-Brightness, but no picture or sound.	A1 - A2 - A3 - A4 - A5 - A6

EMERSON - LAYOUT NO. 81

TROUBLE	LOCATION
1-No brightness on tube.	A11 - A12 - A13 - A15 *
2-No vertical height. White line across screen Fig. 2	A9 - A10
3-No horizontal width. White line running up and down. Fig. 3	A11 - A12 - A13
4-Small picture in center of tube. Picture does not fill up entire screen. Fig. 4	A11 - A12 - A13 *
5-Picture out of proportion vertically. (top to bottom) Fig. 5	A9 - A10
6-Picture out of proportion horizontally. (side to side) Fig. 6	A11 - A12 - A13
7-Picture present, but no sound.	A6 - A7 - A8
8-Picture rolls. (Vertical movement up and down). Fig. 8	A9 - A10
9-Picture tears. Figures on screen wave from side to side. Fig. 9	A6 - A9 - A11 - A12 - A13
10-Sound, brightness but no picture.	A4 - A5 - A14
11-Brightness, but no picture or sound.	A1 - A2 - A3 - A4 - A5 - A14

* Selenium Rectifiers.

EMERSON - LAYOUT NO. 82

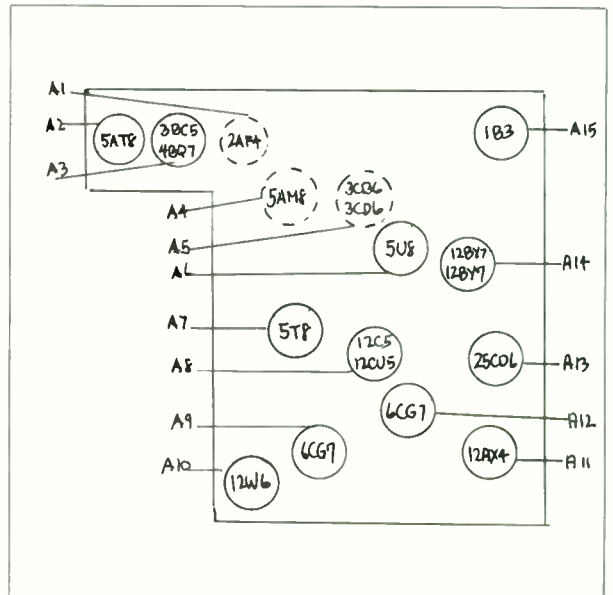

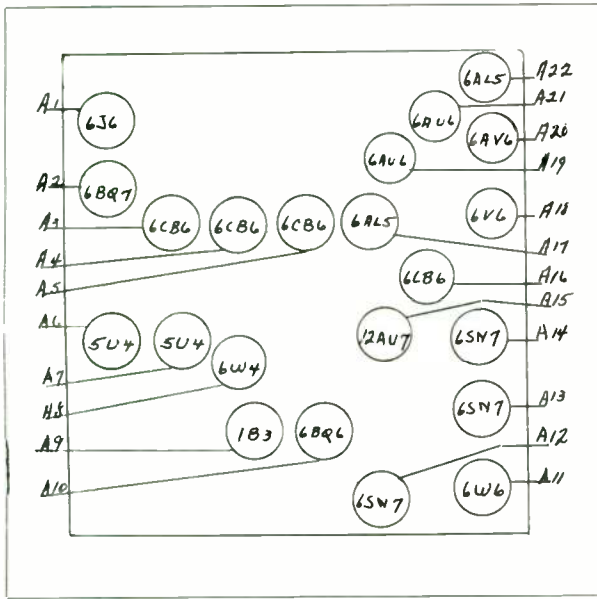

EMERSON - LAYOUT NO. 83

TROUBLE	LOCATION
1-No brightness on tube.	A6 - A7 - A8 - A9 - A10 - A12
2-No vertical height. White line across screen Fig. 2	A11 - A13
3-No horizontal width. White line running up and down. Fig. 3	A6 - A7 - A8 - A10 - A12
4-Small picture in center of tube. Picture does not fill up entire screen. Fig. 4	A6 - A7
5-Picture out of proportion vertically. (top to bottom) Fig. 5	A11 - A13
6-Picture out of proportion horizontally. (side to side) Fig. 6	A8 - A10 - A12
7-Picture present, but no sound.	A18 - A19 - A20 - A21 - A22
8-Picture rolls. (Vertical movement up and down). Fig. 8	A11 - A13 - A14 - A15
9-Picture tears. Figures on screen wave from side to side. Fig. 9	A8 - A10 - A12 - A14 - A15
10-Sound, brightness but no picture.	A3 - A4 - A5 - A16 - A17
11-Brightness, but no picture or sound.	A1 - A2 - A3 - A4 - A5 - A16 - A17

TROUBLE

LOCATION

1-No brightness on tube.	A10 - A12 - A13 - A14 - A15 - A17
2-No vertical height. White line across screen Fig. 2	A16 - A19
3-No horizontal width. White line running up and down. Fig. 3	A10 - A12 - A13 - A14 - A17
4-Small picture in center of tube. Picture does not fill up entire screen. Fig. 4	A10 - A12
5-Picture out of proportion vertically. (top to bottom) Fig. 5	A18 - A19
6-Picture out of proportion horizontally. (side to side) Fig. 6	A13 - A14 - A17
7-Picture present, but no sound.	A3 - A20 - A21 - A22 - A23
8-Picture rolls. (Vertical movement up and down). Fig. 8	A9 - A16 - A18 - A19
9-Picture tears. Figures on screen wave from side to side. Fig. 9	A8 - A9 - A13 - A14 - A17
10-Sound, brightness but no picture.	A4 - A5 - A6 - A7 - A11
11-Brightness, but no picture or sound.	A1 - A2 - A4 - A5 - A6 - A7

EMERSON - LAYOUT NO. 84

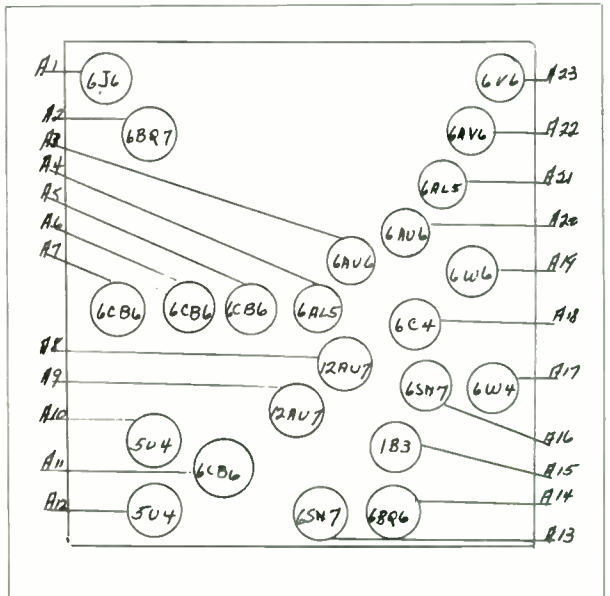

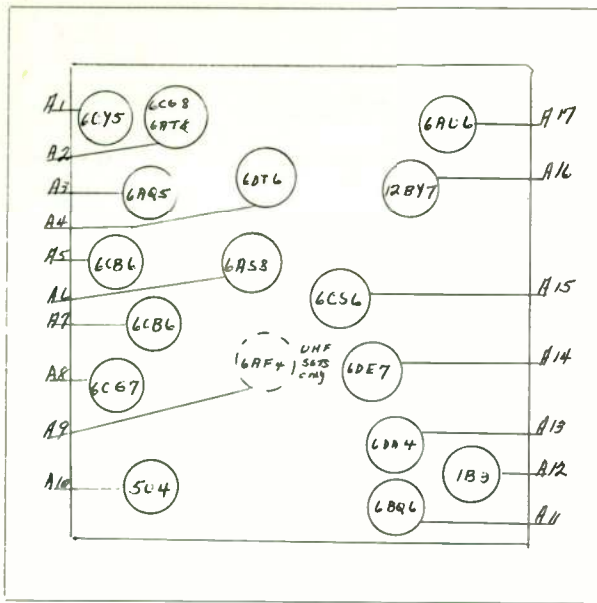

EMERSON - LAYOUT NO. 85

TROUBLE	LOCATION
1-No brightness on tube.	A8 - A10 - A11 - A12 - A13
2-No vertical height. White line across screen Fig. 2	A14
3-No horizontal width. White line running up and down. Fig. 3	A8 - A10 - A11 - A13
4-Small picture in center of tube. Picture does not fill up entire screen. Fig. 4	A10
5-Fixture out of proportion vertically. (top to bottom) Fig. 5	A14
6-Picture out of proportion horizontally. (side to side) Fig. 6	A8 - A11 - A13
7-Picture present, but no sound.	A3 - A4 - A17
8-Picture rolls. (Vertical movement up and down). Fig. 8	A14 - A15
9-Picture tears. Figures on screen wave from side to side. Fig. 9	A8 - A11 - A13 - A15
10-Sound, brightness but no picture.	A5 - A6 - A7 - A16
11-Brightness, but no picture or sound.	A1 - A2 - A5 - A6 - A7 - A17 (A9-UHF only)

TROUBLE

LOCATION

EMERSON - LAYOUT NO. 86

1-No brightness on tube.	A5 - A7 - A9 - A10 - A11 - A13
2-No vertical height. White line across screen Fig. 2	A12 - A14
3-No horizontal width. White line running up and down. Fig. 3	A5 - A7 - A9 - A11 - A13
4-Small picture in center of tube. Picture does not fill up entire screen. Fig. 4	A5 - A7
5-Picture out of proportion vertically. (top to bottom) Fig. 5	A12 - A14
6-Picture out of proportion horizontally. (side to side) Fig. 6	A9 - A11 - A13
7-Picture present, but no sound.	A19 - A20 - A21 - A22 - A23
8-Picture rolls. (Vertical movement up and down). Fig. 8	A12 - A14 - A16 - A17
9-Picture tears. Figures on screen wave from side to side. Fig. 9	A9 - A11 - A13 - A16 - A17
10-Sound, brightness but no picture.	A3 - A4 - A6 - A8 - A18
11-Brightness, but no picture or sound.	A1 - A2 - A3 - A4 - A6 - A8

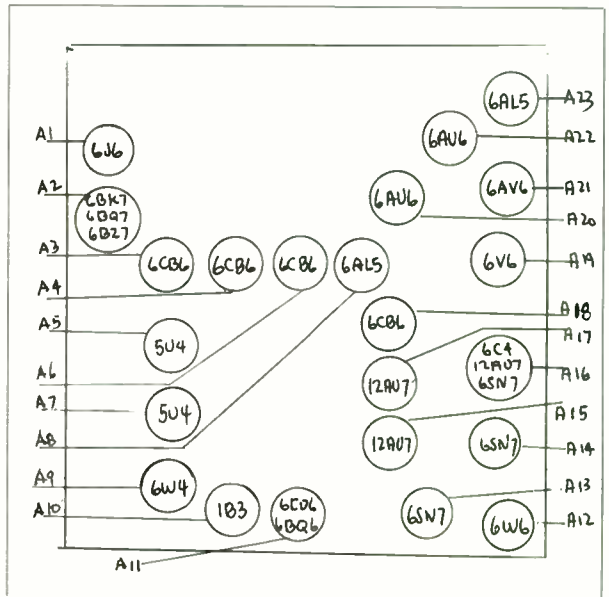

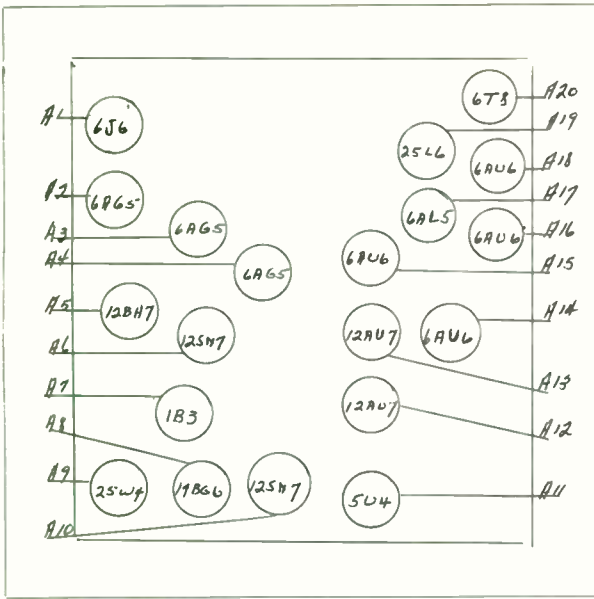

TROUBLE	LOCATION
1-No brightness on tube.	A7 - A8 - A9 - A10 - A11
2-No vertical height. White line across screen Fig. 2	A5
3-No horizontal width. White line running up and down. Fig. 3	A8 - A9 - A10 - A11
4-Small picture in center of tube. Picture does not fill up entire screen. Fig. 4	A11
5-Picture out of proportion vertically. (top to bottom) Fig. 5	A5
6-Picture out of proportion horizontally. (side to side) Fig. 6	A8 - A9 - A10
7-Picture present, but no sound.	A16 - A18 - A19 - A20
8-Picture rolls. (Vertical movement up and down). Fig. 8	A5 - A6 - A12 - A13
9-Picture tears. Figures on screen wave from side to side. Fig. 9	A6 - A8 - A9 - A10 - A12 - A13
10-Sound, brightness but no picture.	A3 - A4 - A12 - A14 - A15 - A17
11-Brightness, but no picture or sound.	A1 - A2 - A3 - A4 - A12 - A14 - A15

EMERSON - LAYOUT NO. 87

TROUBLE	LOCATION
1-No brightness on tube.	A7 - A8 - A9 - A10 *
2-No vertical height. White line across screen Fig. 2	A11 - A12
3-No horizontal width. White line running up and down. Fig. 3	A7 - A9 - A10 *
4-Small picture in center of tube. Picture does not fill up entire screen. Fig. 4	A7 - A9 - A10 *
5-Picture out of proportion vertically. (top to bottom) Fig. 5	A11 - A12
6-Picture out of proportion horizontally. (side to side) Fig. 6	A7 - A9 - A10
7-Picture present, but no sound.	A13 - A14 - A15
8-Picture rolls. (Vertical movement up and down). Fig. 8	A11 - A12 - A14
9-Picture tears. Figures on screen wave from side to side. Fig. 9	A7 - A9 - A10 - A11 - A14
10-Sound, brightness but no picture.	A1 - A2 - A6 - A16
11-Brightness, but no picture or sound.	A1 - A2 - A4 - A5 - A6 - A16 (A3 - UHF only)

* Selenium Rectifiers.

EMERSON - LAYOUT NO. 88

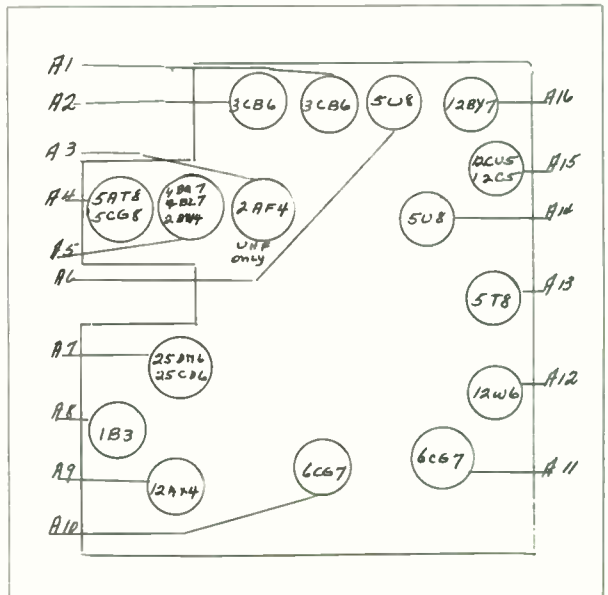

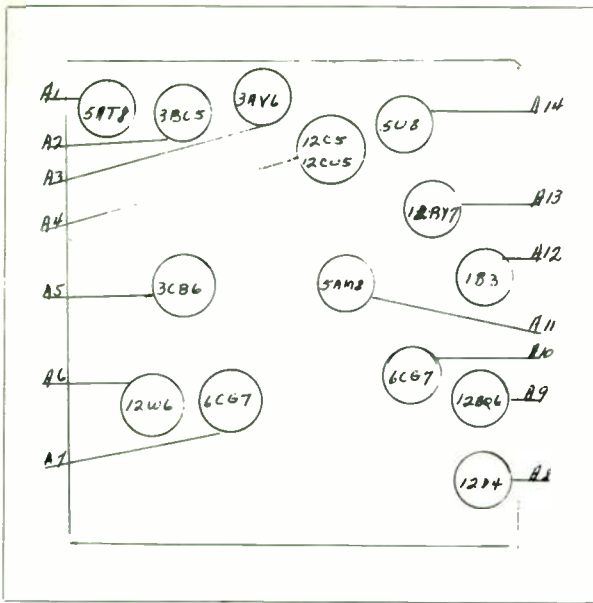

TROUBLE	LOCATION
1-No brightness on tube.	A8 - A9 - A10 - A12
2-No vertical height. White line across screen Fig. 2	A6 - A7
3-No horizontal width. White line running up and down. Fig. 3	A8 - A9 - A10
4-Small picture in center of tube. Picture does not fill up entire screen. Fig. 4	A8 - A9 - A10
5-Picture out of proportion vertically. (top to bottom) Fig. 5	A6 - A7
8-Picture out of proportion horizontally. (side to side) Fig. 8	A8 - A9 - A10
7-Picture present, but no sound.	A3 - A4 - A14
6-Picture rolls. (Vertical movement up and down). Fig. 8	A6 - A7 - A14
9-Picture tears. Figures on screen wave from side to side. Fig. 9	A7 - A8 - A9 - A10 - A14
10-Sound, brightness but no picture.	A5 - A11 - A13
11-Brightness, but no picture or sound.	A1 - A2 - A5 - A11 - A13

EMERSON - LAYOUT NO. 89

EMERSON - LAYOUT NO. 90

TROUBLE	LOCATION
1-No brightness on tube.	A10 - A13 - A14 - A15
2-No vertical height. White line across screen Fig. 2	A9 - A12
3-No horizontal width. White line running up and down. Fig. 3	A10 - A13 - A14
4-Small picture in center of tube. Picture does not fill up entire screen. Fig. 4	A10 - A13 - A14
5-Picture out of proportion vertically. (top to bottom) Fig. 5	A9 - A12
6-Picture out of proportion horizontally. (side to side) Fig. 8	A10 - A13 - A14
7-Picture present, but no sound.	A6 - A7 - A8
8-Picture rolls. (Vertical movement up and down). Fig. 8	A7 - A9 - A12
9-Picture tears. Figures on screen wave from side to side. Fig. 9	A7 - A10 - A12 - A13 - A14
10-Sound, brightness but no picture.	A3 - A4 - A5 - A11
11-Brightness, but no picture or sound.	A1 - A2 - A3 - A4 - A5

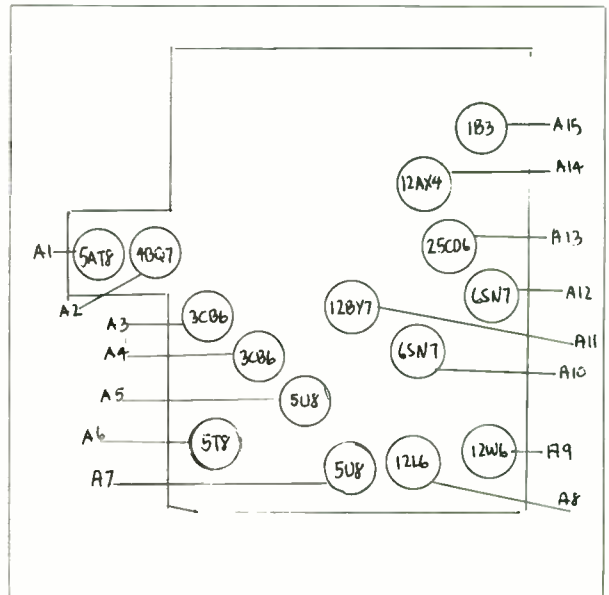

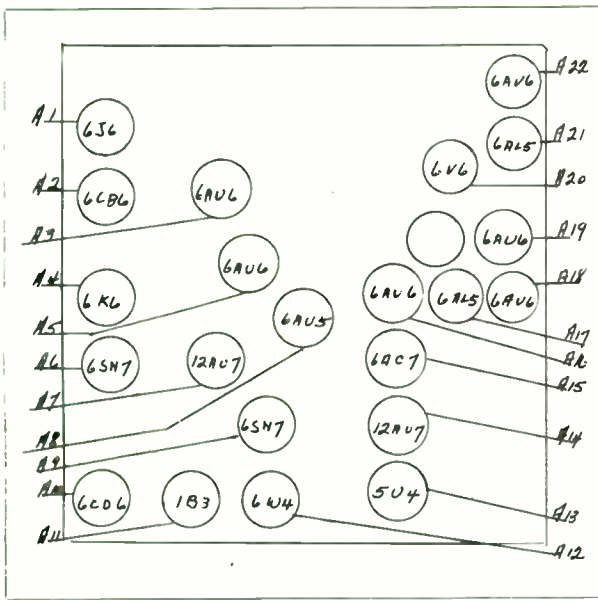

TROUBLE	LOCATION
1-No brightness on tube.	A9 - A10 - A11 - A12 - A13
2-No vertical height. White line across screen Fig. 2	A4 - A6
3-No horizontal width. White line running up and down. Fig. 3	A9 - A10 - A12 - A13
4-Small picture in center of tube. Picture does not fill up entire screen. Fig. 4	A13
5-Picture out of proportion vertically. (top to bottom) Fig. 5	A4 - A6
6-Picture out of proportion horizontally. (side to side) Fig. 6	A9 - A10 - A12
7-Picture present, but no sound.	A18 - A19 - A20 - A21 - A22
8-Picture rolls. (Vertical movement up and down). Fig. 8	A4 - A6 - A7 - A14
9-Picture tears. Figures on screen wave from side to side. Fig. 9	A7 - A9 - A10 - A12 - A14
10-Sound, brightness but no picture.	A3 - A5 - A8 - A15 - A16 - A17
11-Brightness, but no picture or sound.	A1 - A2 - A3 - A5 - A8 - A16 - A17

EMERSON - LAYOUT NO. 91

TROUBLE

LOCATION

1-No brightness on tube.	A1 - A2 - A5 - A6 - A7
2-No vertical height. White line across screen Fig. 2	A8 - A9
3-No horizontal width. White line running up and down. Fig. 3	A2 - A5 - A6 - A7
4-Small picture in center of tube. Picture does not fill up entire screen. Fig. 4	A6
5-Picture out of proportion vertically. (top to bottom) Fig. 5	A8 - A9
6-Picture out of proportion horizontally. (side to side) Fig. 6	A2 - A5 - A7
7-Picture present, but no sound.	A14 - A16 - A17
8-Picture rolls. (Vertical movement up and down). Fig. 8	A8 - A9 - A10
9-Picture tears. Figures on screen wave from side to side. Fig. 9	A2 - A5 - A7 - A10
10-Sound, brightness but no picture.	A11 - A12 - A13 - A15
11-Brightness, but no picture or sound.	A3 - A4 - A11 - A12 - A13 A15

EMERSON - LAYOUT NO. 92

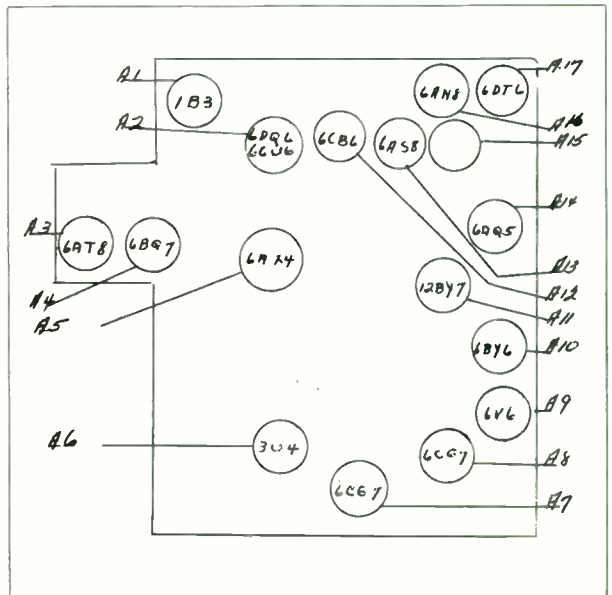

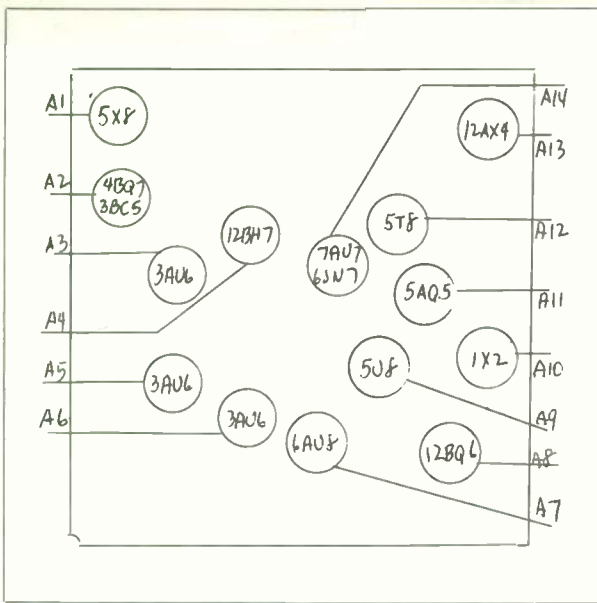

GENERAL ELECTRIC - LAYOUT NO. 93

TROUBLE	LOCATION
1-No brightness on tube.	A8 - A10 - A13 - A14 *
2-No vertical height. White line across screen Fig. 2	A4
3-No horizontal width. White line running up and down. Fig. 3	A8 - A13 - A14
4-Small picture in center of tube. Picture does not fill up entire screen. Fig. 4	A8 - A13 - A14 *
5-Picture out of proportion vertically. (top to bottom) Fig. 5	A4
6-Picture out of proportion horizontally. (side to side) Fig. 6	A8 - A13 - A14
7-Picture present, but no sound.	A9 - A11 - A12
8-Picture rolls. (Vertical movement up and down). Fig. 8	A4
9-Picture tears. Figures on screen wave from side to side. Fig. 9	A8 - A13 - A14
10-Sound, brightness but no picture.	A3 - A5 - A6 - A7
11-Brightness, but no picture or sound.	A1 - A2 - A3 - A5 - A6

* Selenium Rectifiers.

TROUBLE

LOCATION

1-No brightness on tube.	A12 - A13 - A15 - A16
2-No vertical height. White line across screen Fig. 2	A14
3-No horizontal width. White line running up and down. Fig. 3	A12 - A15 - A16
4-Small picture in center of tube. Picture does not fill up entire screen. Fig. 4	A12 - A15 - A16
5-Picture out of proportion vertically. (top to bottom) Fig. 5	A14
6-Picture out of proportion horizontally. (side to side) Fig. 6	A12 - A15 - A16
7-Picture present, but no sound.	A3 - A4 - A7
8-Picture rolls. (Vertical movement up and down). Fig. 8	A11 - A14
9-Picture tears. Figures on screen wave from side to side. Fig. 9	A11 - A12 - A15 - A16
10-Sound, brightness but no picture.	A5 - A6 - A8 - A9 - A10
11-Brightness, but no picture or sound.	A1 - A2 - A5 - A6 - A8 - A9 - A10

GENERAL ELECTRIC - LAYOUT NO. 94

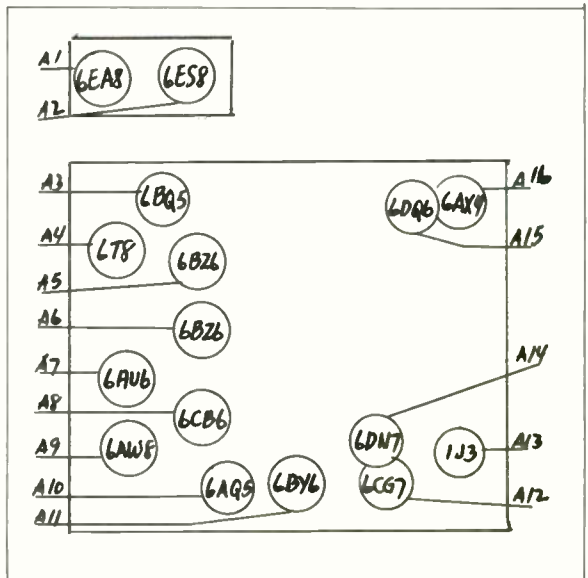

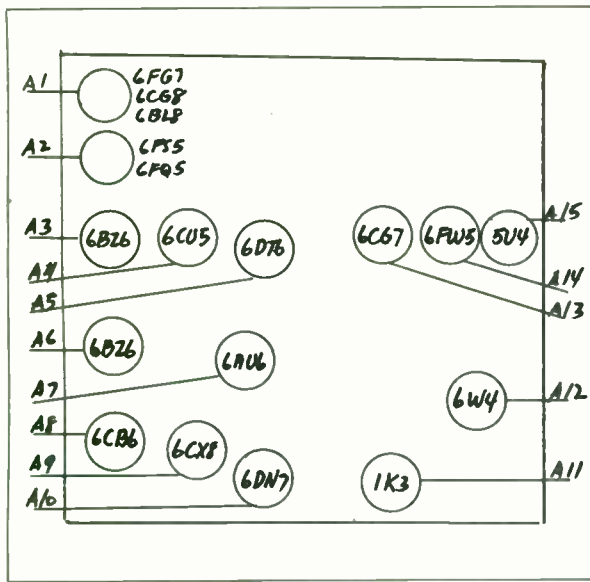

TROUBLE	LOCATION
1-No brightness on tube.	A11 - A12 - A13 - A14 - A15
2-No vertical height. White line across screen Fig. 2	A10
3-No horizontal width. White line running up and down. Fig. 3	A12 - A13 - A14 - A15
4-Small picture in center of tube. Picture does not fill up entire screen. Fig. 4	A15
5-Picture out of proportion vertically. (top to bottom) Fig. 5	A10
6-Picture out of proportion horizontally. (side to side) Fig. 6	A12 - A13 - A14
7-Picture present, but no sound.	A4 - A5 - A7
8-Picture rolls. (Vertical movement up and down). Fig. 8	A9 - A10
9-Picture tears. Figures on screen wave from side to side. Fig. 9	A9 - A12 - A13 - A14
10-Sound, brightness but no picture.	A3 - A6 - A8 - A9
11-Brightness, but no picture or sound.	A1 - A2 - A3 - A6 - A8 - A9

HOTPOINT-G.E. - LAYOUT NO. 95

TROUBLE

LOCATION

1-No brightness on tube.	A9 - A10 - A11 - A13
2-No vertical height. White line across screen Fig. 2	A15
3-No horizontal width. White line running up and down. Fig. 3	A9 - A10 - A11
4-Small picture in center of tube. Picture does not fill up entire screen. Fig. 4	A8
5-Picture out of proportion vertically. (top to bottom) Fig. 5	A15
6-Picture out of proportion horizontally. (side to side) Fig. 6	A9 - A10 - A11
7-Picture present, but no sound.	A14 - A16 - A17 - A18
8-Picture rolls. (Vertical movement up and down). Fig. 8	A12 - A15
9-Picture tears. Figures on screen wave from side to side. Fig. 9	A6 - A11 - A12
10-Sound, brightness but no picture.	A7
11-Brightness, but no picture or sound.	A1 - A2 - A3 - A4 - A5 - A7

GENERAL ELECTRIC - LAYOUT NO. 96

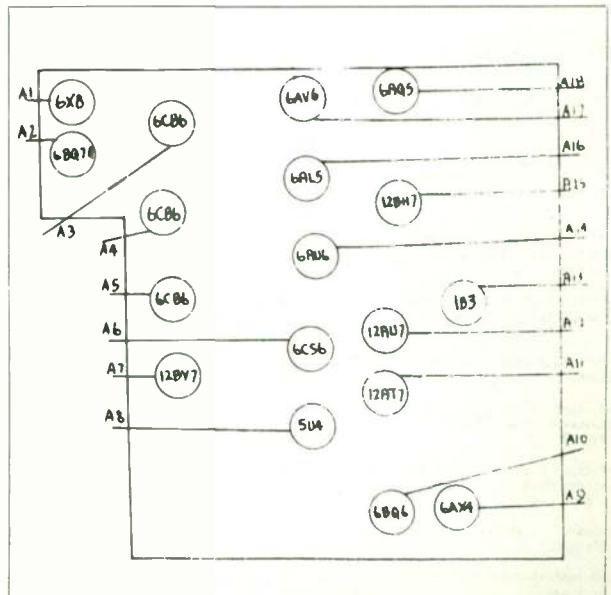

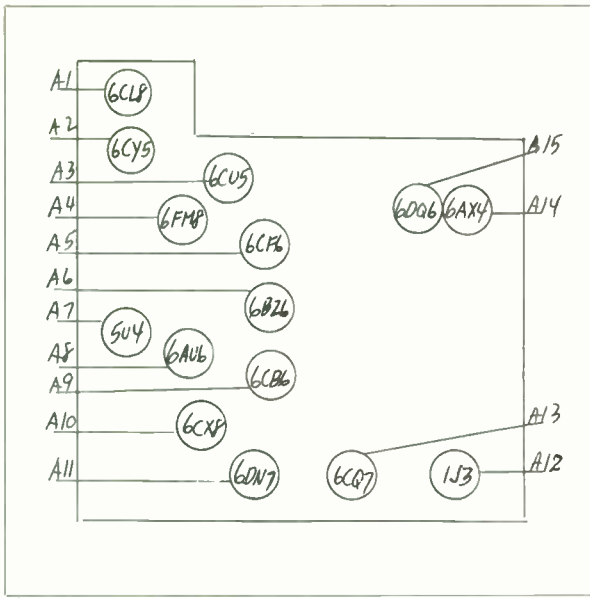

GENERAL ELECTRIC - LAYOUT NO.97

TROUBLE	LOCATION
1-No brightness on tube.	A7 - A12 - A13 - A14 - A15
2-No vertical height. White line across screen Fig. 2	A11
3-No horizontal width. White line running up and down. Fig. 3	A7 - A13 - A14 - A15
4-Small picture in center of tube. Picture does not fill up entire screen. Fig. 4	A7
5-Picture out of proportion vertically. (top to bottom) Fig. 5	A11
6-Picture out of proportion horizontally. (side to side) Fig. 6	A13 - A14 - A15
7-Picture present, but no sound.	A3 - A4 - A8
8-Picture rolls. (Vertical movement up and down). Fig. 8	A10 - A11
9-Picture tears. Figures on screen wave from side to side. Fig. 9	A10 - A13 - A14 - A15
10-Sound, brightness but no picture.	A5 - A6 - A9 - A10
11-Brightness, but no picture or sound.	A1 - A2 - A5 - A6 - A9 - A10

TROUBLE

LOCATION

1-No brightness on tube.	A10 - A11 - A12 - A13 - A14
2-No vertical height. White line across screen Fig. 2	A16
3-No horizontal width. White line running up and down. Fig. 3	A10 - A11 - A12 - A13
4-Small picture in center of tube. Picture does not fill up entire screen. Fig. 4	A10
5-Picture out of proportion vertically. (top to bottom) Fig. 5	A16
6-Picture out of proportion horizontally. (side to side) Fig. 6	A11 - A12 - A13
7-Picture present, but no sound.	A1 - A2 - A17
8-Picture rolls. (Vertical movement up and down). Fig. 8	A8 - A16
9-Picture tears. Figures on screen wave from side to side. Fig. 9	A11 - A12 - A13 - A16
10-Sound, brightness but no picture.	A6 - A7 - A9 - A15
11-Brightness, but no picture or sound.	A3 - A5 - A6 - A7 - A9 - A15 (A4 - UHF only)

GENERAL ELECTRIC - LAYOUT NO.98

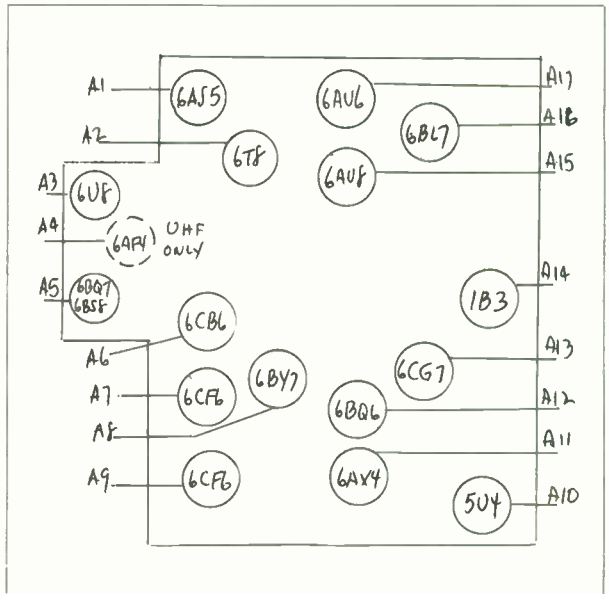

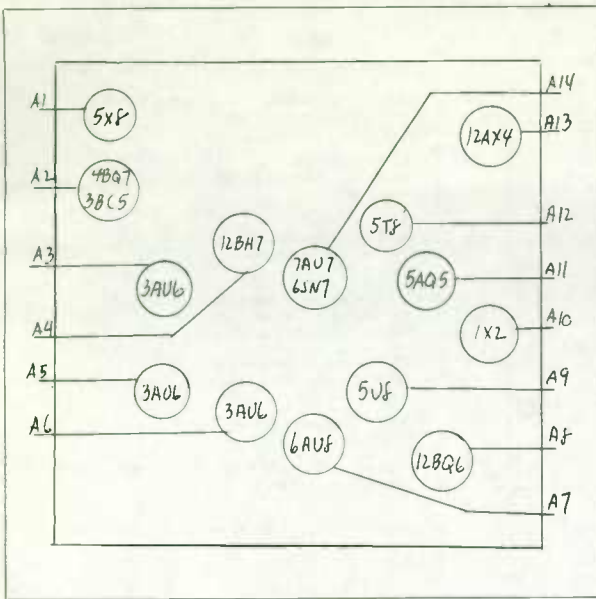

GENERAL ELECTRIC - LAYOUT NO. 99

TROUBLE	LOCATION
1-No brightness on tube.	A8 - A10 - A13 - A14 *
2-No vertical height. White line across screen Fig. 2	A4
3-No horizontal width. White line running up and down. Fig. 3	A8 - A13 - A14
4-Small picture in center of tube. Picture does not fill up entire screen. Fig. 4	A8 - A13 - A14 *
5-Picture out of proportion vertically. (top to bottom) Fig. 5	A4
6-Picture out of proportion horizontally. (side to side) Fig. 6	A8 - A13 - A14
7-Picture present, but no sound.	A9 - A11 - A12
8-Picture rolls. (Vertical movement up and down). Fig. 8	A4
9-Picture tears. Figures on screen wave from side to side. Fig. 9	A8 - A13 - A14
10-Sound, brightness but no picture.	A3 - A5 - A6 - A7
11-Brightness, but no picture or sound.	A1 - A2 - A3 - A5 - A6

NOTE * Selenium Rectifiers.

TROUBLE

LOCATION

1-No brightness on tube.	A12 - A13 - A15 - A16
2-No vertical height. White line across screen Fig. 2	A14
3-No horizontal width. White line running up and down. Fig. 3	A12 - A15 - A16
4-Small picture in center of tube. Picture does not fill up entire screen. Fig. 4	A12 - A15 - A16
5-Picture out of proportion vertically. (top to bottom) Fig. 5	A14
6-Picture out of proportion horizontally. (side to side) Fig. 6	A12 - A15 - A16
7-Picture present, but no sound.	A3 - A4 - A7
8-Picture rolls. (Vertical movement up and down). Fig. 8	A11 - A14
9-Picture tears. Figures on screen wave from side to side. Fig. 9	A11 - A12 - A15 - A16
10-Sound, brightness but no picture.	A5 - A6 - A8 - A9 - A10
11-Brightness, but no picture or sound.	A1 - A2 - A5 - A6 - A8 - A9 - A10

GENERAL ELECTRIC - LAYOUT NO. 100

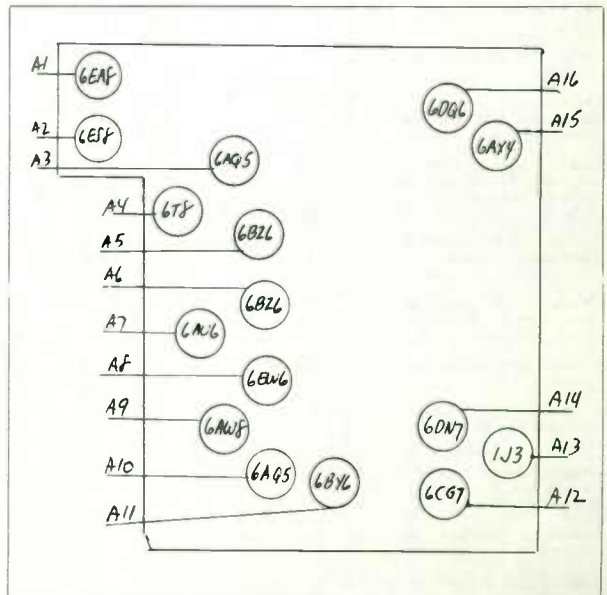

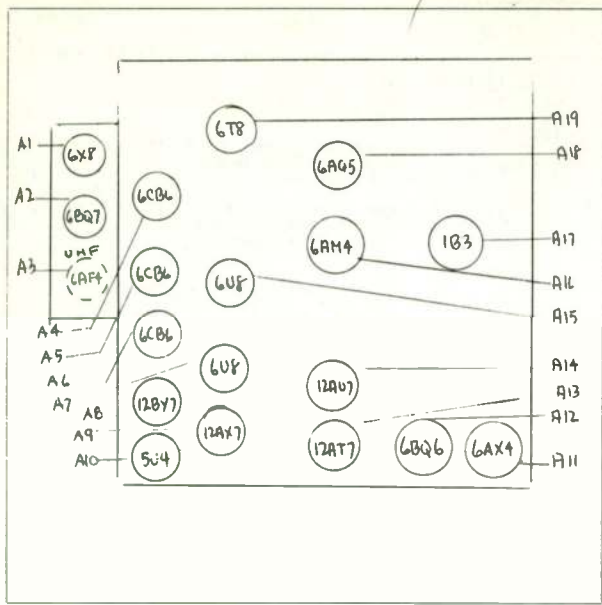

TROUBLE	LOCATION
1-No brightness on tube.	A10 - A11 - A12 - A13 - A17
2-No vertical height. White line across screen Fig. 2	A15 - A16
3-No horizontal width. White line running up and down. Fig. 3	A10 - A11 - A12 - A13
4-Small picture in center of tube. Picture does not fill up entire screen. Fig. 4	A10
5-Picture out of proportion vertically. (top to bottom) Fig. 5	A15 - A16
6-Picture out of proportion horizontally. (side to side) Fig. 6	A11 - A12 - A13
7-Picture present, but no sound.	A7 - A15 - A18 - A19
8-Picture rolls. (Vertical movement up and down). Fig. 8	A9 - A15 - A16
9-Picture tears. Figures on screen wave from side to side. Fig. 9	A9 - A11 - A12 - A13 - A14
10-Sound, brightness but no picture.	A4 - A5 - A6 - A7 - A8
11-Brightness, but no picture or sound.	A1 - A2 - A4 - A5 - A6 - A7 (A3 - UHF only)

GENERAL ELECTRIC - LAYOUT NO. 101

GENERAL ELECTRIC - LAYOUT NO. 102

TROUBLE	LOCATION
1-No brightness on tube.	A4 - A12 - A13 - A14 - A17
2-No vertical height. White line across screen Fig. 2	A5
3-No horizontal width. White line running up and down. Fig. 3	A4 - A12 - A13 - A17
4-Small picture in center of tube. Picture does not fill up entire screen. Fig. 4	A4
5-Picture out of proportion vertically. (top to bottom) Fig. 5	A5
6-Picture out of proportion horizontally. (side to side) Fig. 6	A12 - A13 - A17
7-Picture present, but no sound.	A11 - A15 - A16
8-Picture rolls. (Vertical movement up and down). Fig. 8	A5 - A7
9-Picture tears. Figures on screen wave from side to side. Fig. 9	A7 - A12 - A13 - A17
10-Sound, brightness but no picture.	A6 - A7 - A8 - A9 - A10
11-Brightness, but no picture or sound.	A2 - A3 - A6 - A7 - A8 - A9 (A1 - UHF only)

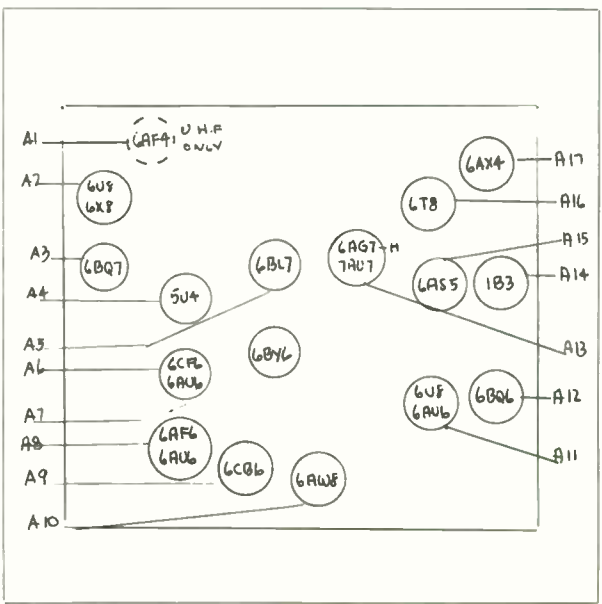

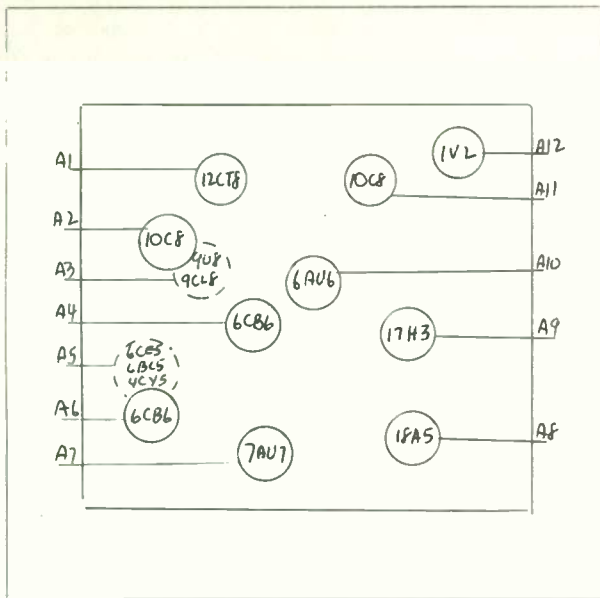

TROUBLE	LOCATION
1-No brightness on tube.	A7 - A8 - A9 - A12 *
2-No vertical height. White line across screen Fig. 2	A2
3-No horizontal width. White line running up and down. Fig. 3	A7 - A8 - A9 *
4-Small picture in center of tube. Picture does not fill up entire screen. Fig. 4	A7 - A8 - A9 *
5-Picture out of proportion vertically. (top to bottom) Fig. 5	A2
6-Picture out of proportion horizontally. (side to side) Fig. 6	A7 - A8 - A9
7-Picture present, but no sound.	A10 - A11
8-Picture rolls. (Vertical movement up and down). Fig. 8	A1 - A2
9-Picture tears. Figures on screen wave from side to side. Fig. 9	A1 - A7 - A8 - A9
10-Sound, brightness but no picture.	A1 - A4 - A6
11-Brightness, but no picture or sound.	A1 - A3 - A5 - A6

* Selenium Rectifiers.

GENERAL ELECTRIC-LAYOUT NO. 103

TROUBLE	LOCATION
1-No brightness on tube.	A8 - A9 - A10 - A12 *
2-No vertical height. White line across screen Fig. 2	A2 - A4
3-No horizontal width. White line running up and down. Fig. 3	A8 - A9 - A12 *
4-Small picture in center of tube. Picture does not fill up entire screen. Fig. 4	A8 - A9 - A12 *
5-Picture out of proportion vertically. (top to bottom) Fig. 5	A2 - A4
6-Picture out of proportion horizontally. (side to side) Fig. 6	A8 - A9 - A12
7-Picture present, but no sound.	A7 - A11 - A15 - A16 - A17
8-Picture rolls. (Vertical movement up and down). Fig. 8	A2 - A4 - A14
9-Picture tears. Figures on screen wave from side to side. Fig. 9	A5 - A8 - A9 - A12 - A14
10-Sound, brightness but no picture.	A1 - A3 - A6 - A13
11-Brightness, but no picture or sound.	A1 - A3 - A6 - A18 - A19 - A20

* Selenium Rectifiers.

GENERAL ELECTRIC-LAYOUT NO. 104

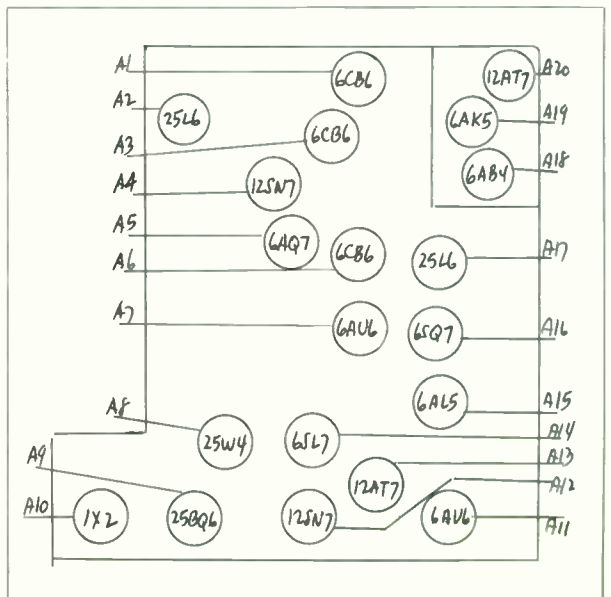

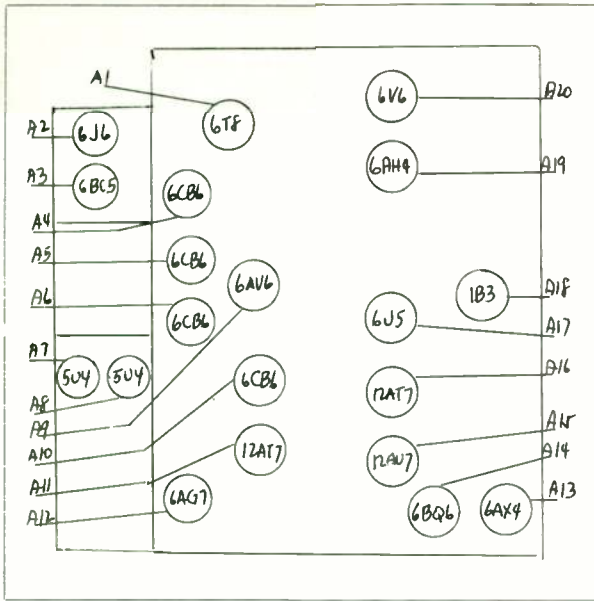

GENERAL ELECTRIC - LAYOUT NO. 105

TROUBLE	LOCATION
1-No brightness on tube.	A7 - A8 - A13 - A14 - A15 - A18
2-No vertical height. White line across screen Fig. 2	A17 - A19
3-No horizontal width. White line running up and down. Fig. 3	A7 - A8 - A13 - A14 - A15
4-Small picture in center of tube. Picture does not fill up entire screen. Fig. 4	A7 - A8
5-Picture out of proportion vertically. (top to bottom) Fig. 5	A17 - A19
6-Picture out of proportion horizontally. (side to side) Fig. 6	A13 - A14 - A15
7-Picture present, but no sound.	A1 - A9 - A10 - A11 - A20
8-Picture rolls. (Vertical movement up and down). Fig. 8	A11 - A16 - A17 - A19
9-Picture tears. Figures on screen wave from side to side. Fig. 9	A11 - A13 - A14 - A15 - A16
10-Sound, brightness but no picture.	A4 - A5 - A6 - A12
11-Brightness, but no picture or sound.	A2 - A3 - A4 - A5 - A6

TROUBLE

LOCATION

1-No brightness on tube.	A3 - A9 - A13 - A15 - A16
2-No vertical height. White line across screen Fig. 2	A4
3-No horizontal width. White line running up and down. Fig. 3	A3 - A9 - A15 - A16
4-Small picture in center of tube. Picture does not fill up entire screen. Fig. 4	A3
5-Picture out of proportion vertically. (top to bottom) Fig. 5	A4
6-Picture out of proportion horizontally. (side to side) Fig. 6	A9 - A15 - A16
7-Picture present, but no sound.	A11 - A12 - A14
8-Picture rolls. (Vertical movement up and down). Fig. 8	A4 - A6
9-Picture tears. Figures on screen wave from side to side. Fig. 9	A6 - A9 - A11 - A15 - A16
10-Sound, brightness but no picture.	A5 - A7 - A8 - A10
11-Brightness, but no picture or sound.	A1 - A2 - A5 - A7 - A8 - A10

GENERAL ELECTRIC - LAYOUT NO. 106

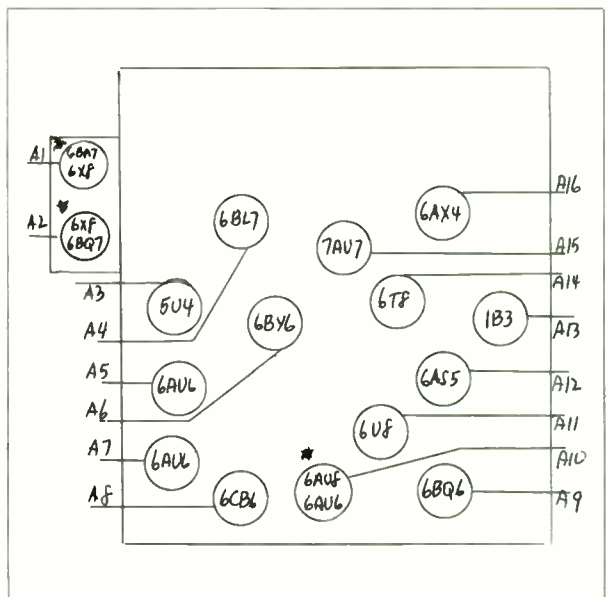

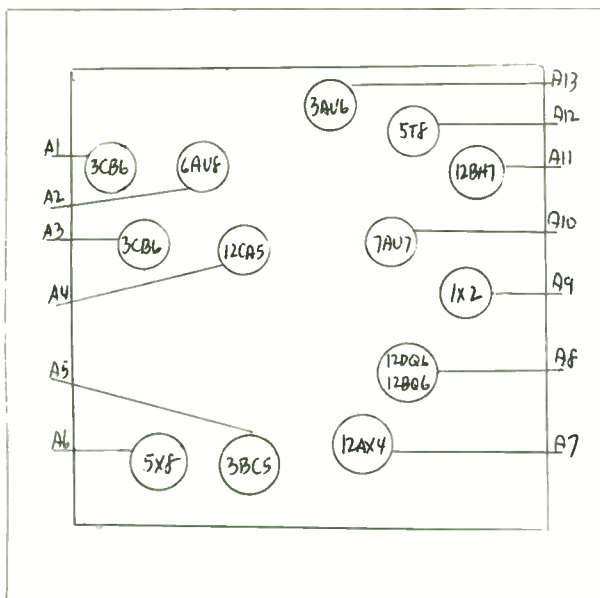

TROUBLE	LOCATION
1-No brightness on tube.	A7 - A8 - A9 - A10 *
2-No vertical height. White line across screen Fig. 2	A11
3-No horizontal width. White line running up and down. Fig. 3	A7 - A8 - A10 *
4-Small picture in center of tube. Picture does not fill up entire screen. Fig. 4	A7 - A8 - A10 *
5-Picture out of proportion vertically. (top to bottom) Fig. 5	A11
6-Picture out of proportion horizontally. (side to side) Fig. 6	A7 - A8 - A10
7-Picture present, but no sound.	A4 - A12 - A13
8-Picture rolls. (Vertical movement up and down). Fig. 8	A11
9-Picture tears. Figures on screen wave from side to side. Fig. 9	A1 - A2 - A3 - A7 - A8 - A10
10-Sound, brightness but no picture.	A1 - A2 - A3
11-Brightness, but no picture or sound.	A1 - A2 - A3 - A5 - A6

NOTE: Since this receiver employs tubes used in series-parallel filament network, an open filament in any tube may cause the set to be inoperative.

GENERAL ELECTRIC-LAYOUT NO. 107

TROUBLE	LOCATION
1-No brightness on tube.	A10 - A11 - A12 - A13 - A16
2-No vertical height. White line across screen Fig. 2	A15
3-No horizontal width. White line running up and down. Fig. 3	A10 - A11 - A12 - A13
4-Small picture in center of tube. Picture does not fill up entire screen. Fig. 4	A10
5-Picture out of proportion vertically. (top to bottom) Fig. 5	A15
6-Picture out of proportion horizontally. (side to side) Fig. 6	A11 - A12 - A13
7-Picture present, but no sound.	A5 - A7 - A9 - A17
8-Picture rolls. (Vertical movement up and down). Fig. 8	A14 - A15
9-Picture tears. Figures on screen wave from side to side. Fig. 9	A11 - A12 - A13 - A14
10-Sound, brightness but no picture.	A3 - A4 - A5 - A6 - A8
11-Brightness, but no picture or sound.	A1 - A2 - A3 - A4 - A5 - A6

GENERAL ELECTRIC-LAYOUT NO. 108

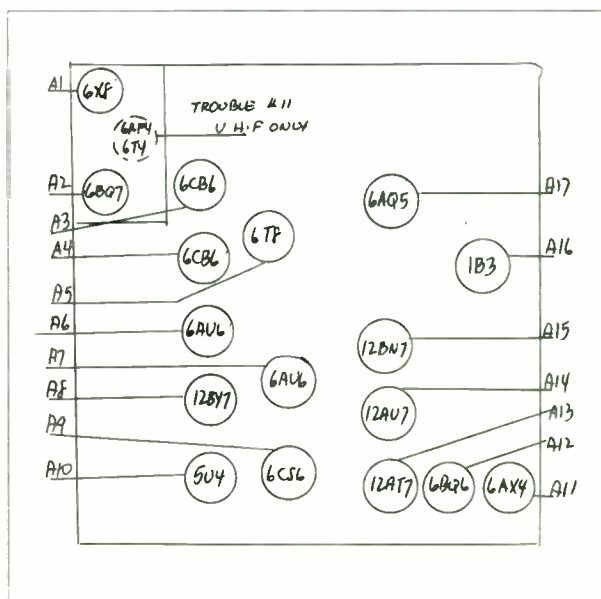

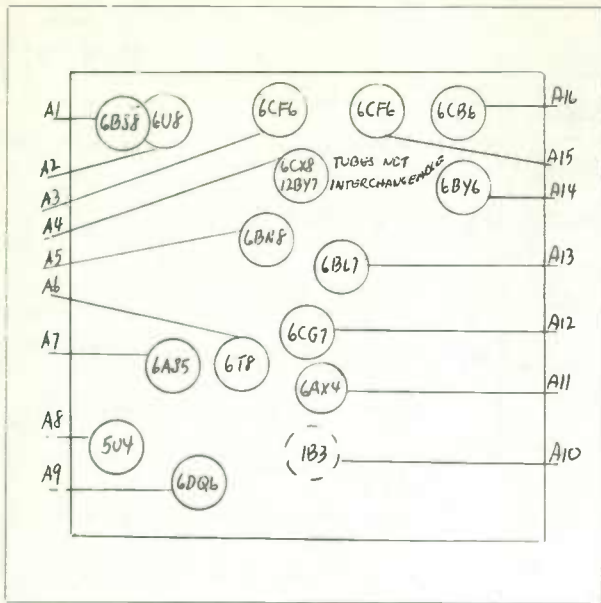

GENERAL ELECTRIC-LAYOUT NO. 109

TROUBLE	LOCATION
1-No brightness on tube.	A8 - A9 - A10 - A11 - A12
2-No vertical height. White line across screen Fig. 2	A13
3-No horizontal width. White line running up and down. Fig. 3	A8 - A9 - A11 - A12
4-Small picture in center of tube. Picture does not fill up entire screen. Fig. 4	A8
5-Picture out of proportion vertically. (top to bottom) Fig. 5	A13
6-Picture out of proportion horizontally. (side to side) Fig. 6	A9 - A11 - A12
7-Picture present, but no sound.	A5 - A6 - A7
8-Picture rolls. (Vertical movement up and down). Fig. 8	A13 - A14
9-Picture tears. Figures on screen wave from side to side. Fig. 9	A5 - A9 - A11 - A12 - A14
10-Sound, brightness but no picture.	A3 - A4 - A15 - A16
11-Brightness, but no picture or sound.	A1 - A2 - A3 - A4 - A15 - A16

TROUBLE	LOCATION
1-No brightness on tube.	A14 - A13 - A12 - A11
2-No vertical height. White line across screen Fig. 2	A5
3-No horizontal width. White line running up and down. Fig. 3	A12 - A11 - A13
4-Small picture in center of tube. Picture does not fill up entire screen. Fig. 4	A14 - A12 - A11
5-Picture out of proportion vertically. (top to bottom) Fig. 5	A10
6-Picture out of proportion horizontally. (side to side) Fig. 6	A12 - A11
7-Picture present, but no sound.	A3 - A2 - A9
8-Picture rolls. (Vertical movement up and down). Fig. 8	A2 - A10 - A11
9-Picture tears. Figures on screen wave from side to side. Fig. 9	A5 - A6
10-Sound, brightness but no picture.	A2 - A8
11-Brightness, but no picture or sound.	A6 - A4 - A1 - A7

GENERAL ELECTRIC-LAYOUT NO. 110

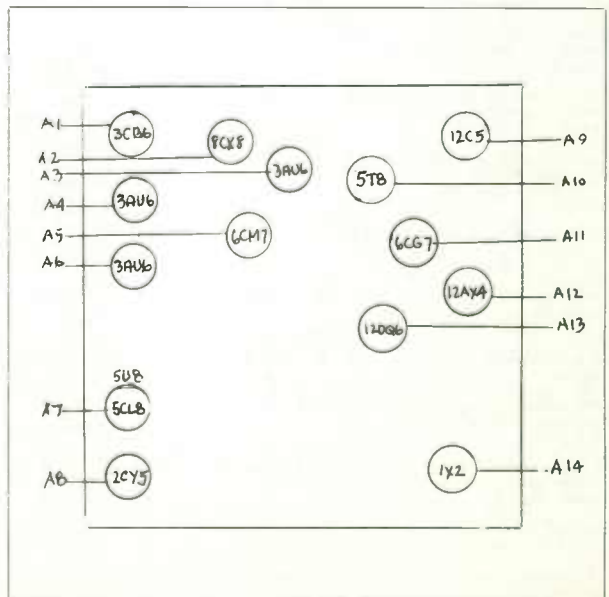

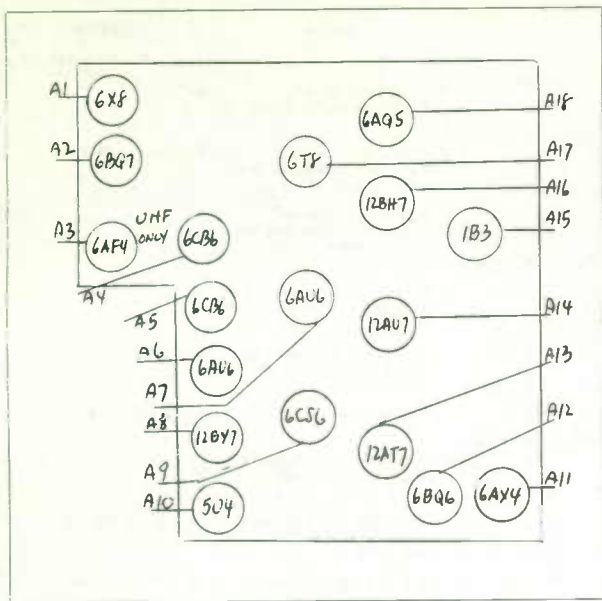

TROUBLE	LOCATION
1-No brightness on tube.	A10 - A11 - A12 - A13 - A15
2-No vertical height. White line across screen Fig. 2	A16
3-No horizontal width. White line running up and down. Fig. 3	A10 - A11 - A12 - A13
4-Small picture in center of tube. Picture does not fill up entire screen. Fig. 4	A10
5-Picture out of proportion vertically. (top to bottom) Fig. 5	A16
6-Picture out of proportion horizontally. (side to side) Fig. 6	A11 - A12 - A13
7-Picture present, but no sound.	A7 - A17 - A18
8-Picture rolls. (Vertical movement up and down). Fig. 8	A9 - A16
9-Picture tears. Figures on screen wave from side to side. Fig. 9	A9 - A11 - A12 - A13 - A14
10-Sound, brightness but no picture.	A4 - A5 - A6 - A8
11-Brightness, but no picture or sound.	A1 - A2 - A4 - A5 - A6 (A3 - UHF only)

GENERAL ELECTRIC-LAYOUT NO.111

GENERAL ELECTRIC-LAYOUT NO.112

TROUBLE	LOCATION
1-No brightness on tube.	A7 - A8 - A12 - A13 - A14 - A18 - A19
2-No vertical height. White line across screen Fig. 2	A20 - A22
3-No horizontal width. White line running up and down. Fig. 3	A7 - A8 - A12 - A13 - A14 - A19
4-Small picture in center of tube. Picture does not fill up entire screen. Fig. 4	A7 - A8
5-Picture out of proportion vertically. (top to bottom) Fig. 5	A20 - A22
6-Picture out of proportion horizontally. (side to side) Fig. 6	A12 - A13 - A14 - A19
7-Picture present, but no sound.	A17 - A21 - A23 - A24
8-Picture rolls. (Vertical movement up and down). Fig. 8	A14 - A20 - A22
9-Picture tears. Figures on screen wave from side to side. Fig. 9	A12 - A13 - A14 - A15 - A16 - A19 - A20
10-Sound, brightness but no picture.	A4 - A5 - A6 - A9 - A10 - A11
11-Brightness, but no picture or sound.	A1 - A2 - A3 - A4 - A5 - A6 - A9 - A10

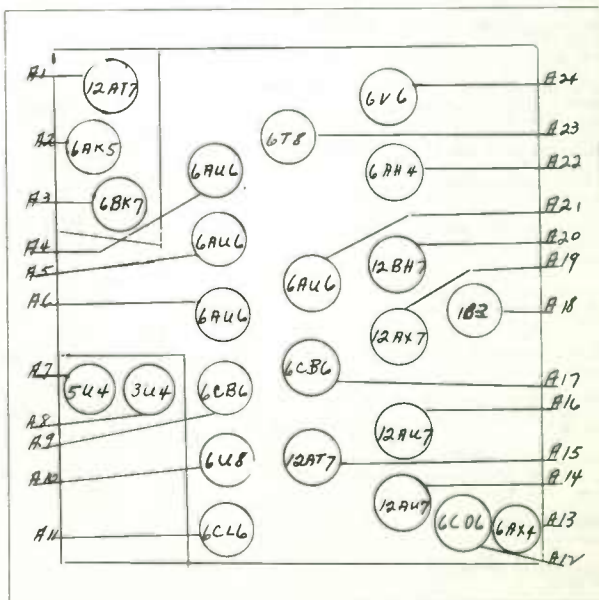

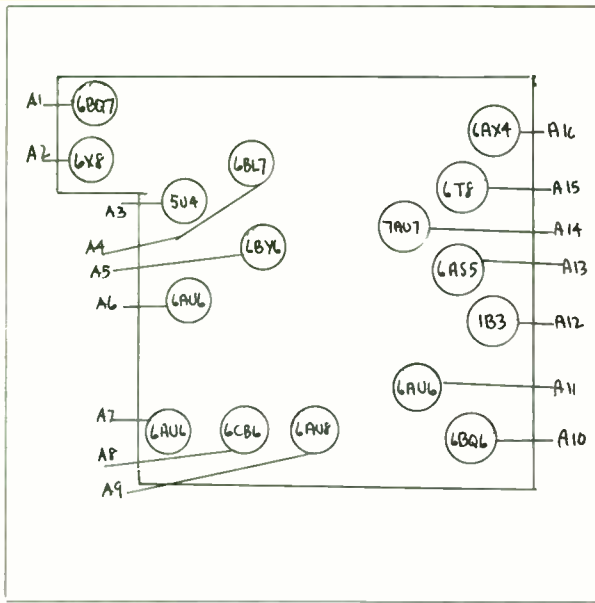

GENERAL ELECTRIC-LAYOUT NO. 113

TROUBLE	LOCATION
1-No brightness on tube.	A3 - A10 - A12 - A14 - A16
2-No vertical height. White line across screen Fig. 2	A4
3-No horizontal width. White line running up and down. Fig. 3	A3 - A10 - A14 - A16
4-Small picture in center of tube. Picture does not fill up entire screen. Fig. 4	A3
5-Picture out of proportion vertically. (top to bottom) Fig. 5	A4
6-Picture out of proportion horizontally. (side to side) Fig. 6	A10 - A14 - A16
7-Picture present, but no sound.	A11 - A13 - A15
8-Picture rolls. (Vertical movement up and down). Fig. 8	A4 - A5
9-Picture tears. Figures on screen wave from side to side. Fig. 9	A5 - A11 - A13 - A15
10-Sound, brightness but no picture.	A6 - A7 - A8 - A9
11-Brightness, but no picture or sound.	A1 - A2 - A6 - A7 - A8 - A9

TROUBLE

LOCATION

1-No brightness on tube.	A13 - A14 - A15 - A18 - A19 - A20 - A21 *
2-No vertical height. White line across screen Fig. 2	A12 - A16
3-No horizontal width. White line running up and down. Fig. 3	A18 - A19 - A20 - A21 *
4-Small picture in center of tube. Picture does not fill up entire screen. Fig. 4	A18 - A19 - A20 - A21 *
5-Picture out of proportion vertically. (top to bottom) Fig. 5	A12 - A16
6-Picture out of proportion horizontally. (side to side) Fig. 6	A18 - A19 - A20 - A21
7-Picture present, but no sound.	A7 - A9 - A11 - A22
8-Picture rolls. (Vertical movement up and down). Fig. 8	A10 - A12 - A16
9-Picture tears. Figures on screen wave from side to side. Fig. 9	A10 - A17 - A18 - A19 - A20 - A21
10-Sound, brightness but no picture.	A4 - A5 - A6 - A8
11-Brightness, but no picture or sound.	A1 - A2 - A3 - A4 - A5 - A6 - A8

* Selenium Rectifiers.

GENERAL ELECTRIC-LAYOUT NO. 114

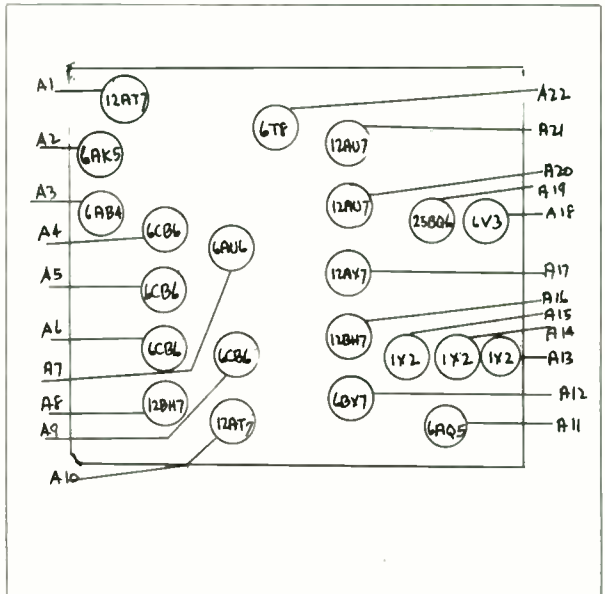

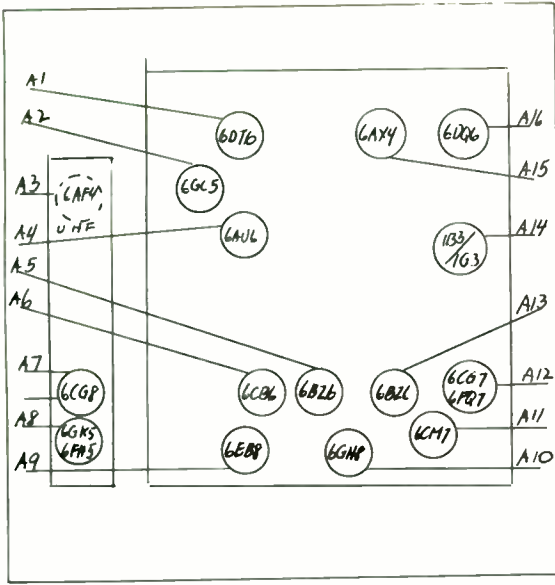

MAGNAVOX - LAYOUT NO. 115

TROUBLE	LOCATION
1-No brightness on tube.	A12 - A14 - A15 - A16
2-No vertical height. White line across screen Fig. 2	A11
3-No horizontal width. White line running up and down. Fig. 3	A12 - A15 - A16
4-Small picture in center of tube. Picture does not fill up entire screen. Fig. 4	A12 - A15 - A16
5-Picture out of proportion vertically. (top to bottom) Fig. 5	A11
6-Picture out of proportion horizontally. (side to side) Fig. 6	A12 - A15 - A16
7-Picture present, but no sound.	A1 - A2 - A4
8-Picture rolls. (Vertical movement up and down). Fig. 8	A9 - A10 - A11
9-Picture tears. Figures on screen wave from side to side. Fig. 9	A9 - A10 - A12 - A15 - A16
10-Sound, brightness but no picture.	A5 - A6 - A9 - A10 - A13
11-Brightness, but no picture or sound.	A5 - A6 - A7 - A8 - A9 - A10 - A13 (A3 UHF only)

MAGNAVOX - LAYOUT NO. 116

TROUBLE	LOCATION
1-No brightness on tube.	A10 - A11 - A12 - A14*
2-No vertical height. White line across screen Fig. 2	A7 - A9
3-No horizontal width. White line running up and down. Fig. 3	A10 - A12 - A14*
4-Small picture in center of tube. Picture does not fill up entire screen. Fig. 4	A10 - A12 - A14*
5-Picture out of proportion vertically. (top to bottom) Fig. 5	A7 - A9
6-Picture out of proportion horizontally. (side to side) Fig. 6	A10 - A12 - A14
7-Picture present, but no sound.	A3 - A5 - A7
8-Picture rolls. (Vertical movement up and down). Fig. 8	A7 - A9 - A13
9-Picture tears. Figures on screen wave from side to side. Fig. 9	A10 - A12 - A13 - A14
10-Sound, brightness but no picture.	A4 - A6 - A8
11-Brightness, but no picture or sound.	A1 - A2 - A4 - A6 - A8 (A15-UHF only)

* Selenium Rectifiers.

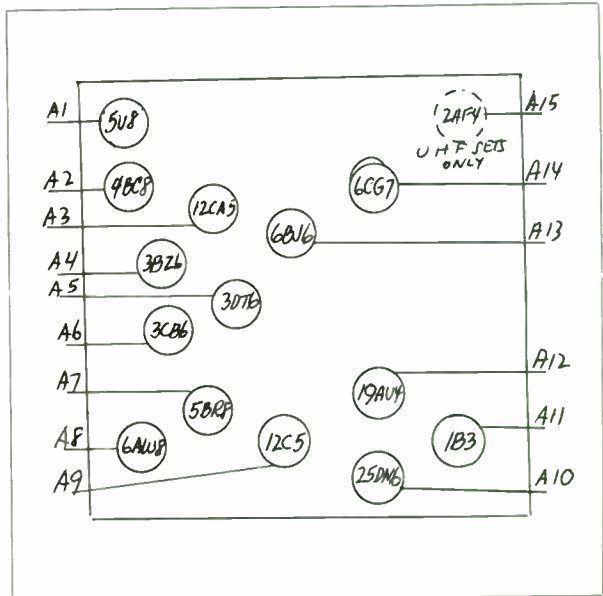

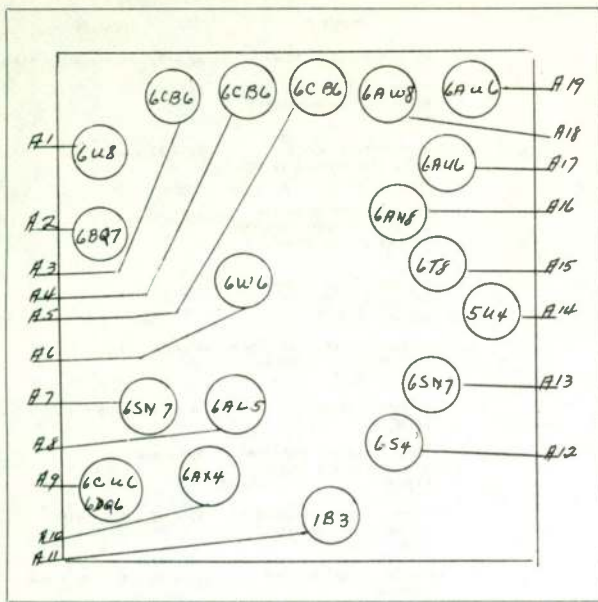

MAGNAVOX - LAYOUT NO. 119

TROUBLE	LOCATION
1-No brightness on tube.	A7 - A9 - A10 - A11 - A14
2-No vertical height. White line across screen Fig. 2	A12 - A13
3-No horizontal width. White line running up and down. Fig. 3	A7 - A9 - A10 - A14
4-Small picture in center of tube. Picture does not fill up entire screen. Fig. 4	A14
5-Picture out of proportion vertically. (top to bottom) Fig. 5	A12 - A13
6-Picture out of proportion horizontally. (side to side) Fig. 6	A7 - A9 - A10
7-Picture present, but no sound.	A6 - A15 - A17 - A19
8-Picture rolls. (Vertical movement up and down). Fig. 8	A12 - A13 - A16 - A18
9-Picture tears. Figures on screen wave from side to side. Fig. 9	A6 - A7 - A8 - A9 - A10 - A16 - A18
10-Sound, brightness but no picture.	A3 - A4 - A5 - A16 - A18
11-Brightness, but no picture or sound.	A1 - A2 - A3 - A4 - A5 - A16 - A18

* Omitted in some chassis.

MAGNAVOX - LAYOUT NO. 120

TROUBLE	LOCATION
1-No brightness on tube.	A7 - A8 - A9 - A11 - A13
2-No vertical height. White line across screen Fig. 2	A12
3-No horizontal width. White line running up and down. Fig. 3	A7 - A8 - A9 - A13
4-Small picture in center of tube. Picture does not fill up entire screen. Fig. 4	A13
5-Picture out of proportion vertically. (top to bottom) Fig. 5	A12
6-Picture out of proportion horizontally. (side to side) Fig. 6	A7 - A8 - A9
7-Picture present, but no sound.	A6 - A14 - A16
8-Picture rolls. (Vertical movement up and down). Fig. 8	A12 - A15
9-Picture tears. Figures on screen wave from side to side. Fig. 9	A7 - A8 - A9 - A10 - A15
10-Sound, brightness but no picture.	A1 - A2 - A3 - A15 - A17
11-Brightness, but no picture or sound.	A1 - A2 - A3 - A4 - A5 - A15 - A17

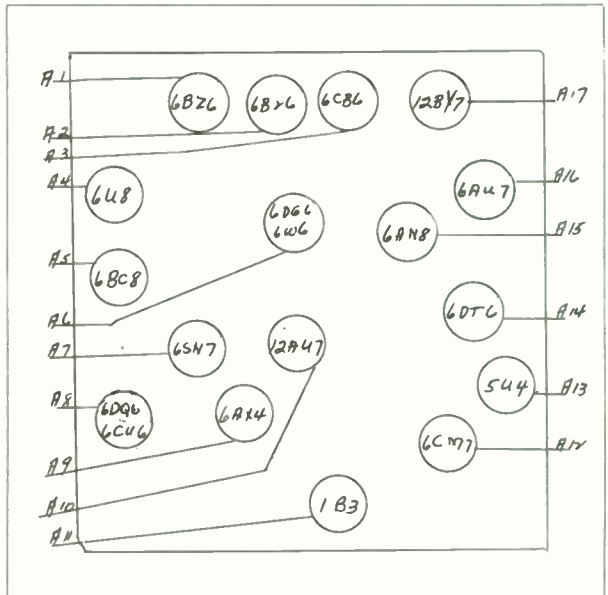

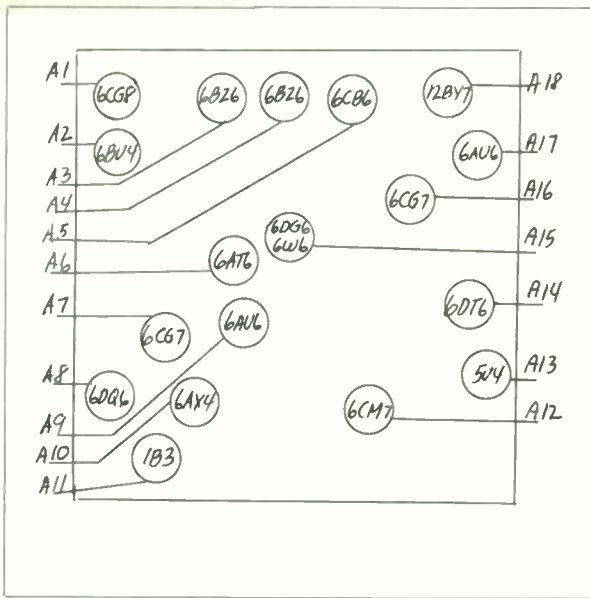

TROUBLE	LOCATION
1-No brightness on tube.	A7 - A8 - A10 - A11 - A13
2-No vertical height. White line across screen Fig. 2	A12
3-No horizontal width. White line running up and down. Fig. 3	A7 - A8 - A10 - A13
4-Small picture in center of tube. Picture does not fill up entire screen. Fig. 4	A13
5-Picture out of proportion vertically. (top to bottom) Fig. 5	A12
6-Picture out of proportion horizontally. (side to side) Fig. 6	A7 - A8 - A10
7-Picture present, but no sound.	A6 - A14 - A15 - A17
8-Picture rolls. (Vertical movement up and down). Fig. 8	A12 - A16
9-Picture tears. Figures on screen wave from side to side. Fig. 9	A7 - A8 - A10 - A16
10-Sound, brightness but no picture.	A3 - A4 - A5 - A8 - A18
11-Brightness, but no picture or sound.	A1 - A2 - A3 - A4 - A5 - A18

MAGNAVOX - LAYOUT NO. 121

MAGNAVOX - LAYOUT NO. 122

TROUBLE	LOCATION
1-No brightness on tube.	A12 - A13 - A15
2-No vertical height. White line across screen Fig. 2	A6 - A18
3-No horizontal width. White line running up and down. Fig. 3	A14
4-Small picture in center of tube. Picture does not fill up entire screen. Fig. 4	A10 - A13
5-Picture out of proportion vertically. (top to bottom) Fig. 5	A6 - A18
6-Picture out of proportion horizontally. (side to side) Fig. 6	A14
7-Picture present, but no sound.	A11 - A16 - A17 - A19
8-Picture rolls. (Vertical movement up and down). Fig. 8	A7 - A14
9-Picture tears. Figures on screen wave from side to side. Fig. 9	A6 - A16 - A18
10-Sound, brightness but no picture.	A3 - A4 - A5 - A8 - A9
11-Brightness, but no picture or sound.	A1 - A2

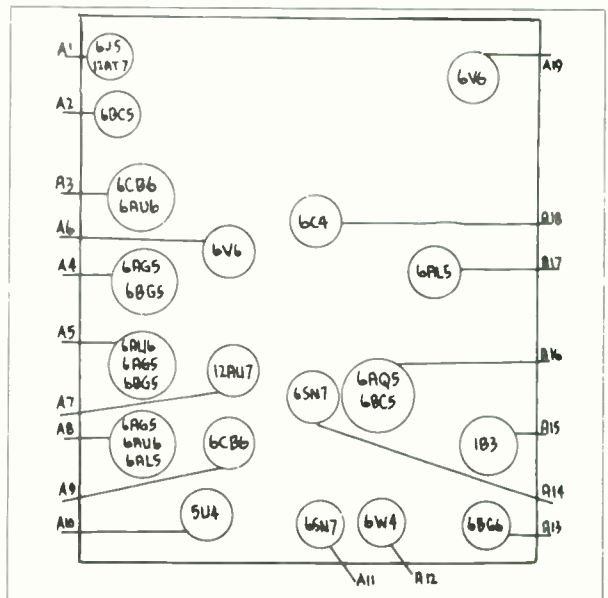

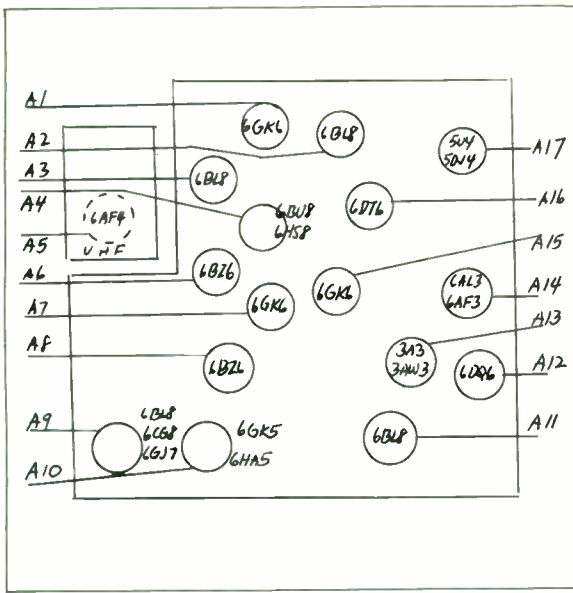

TROUBLE	LOCATION
1-No brightness on tube.	A11 - A12 - A13 - A14 - A17
2-No vertical height. White line across screen Fig. 2	A2 - A15
3-No horizontal width. White line running up and down. Fig. 3	A11 - A12 - A14 - A17
4-Small picture in center of tube. Picture does not fill up entire screen. Fig. 4	A17
5-Picture out of proportion vertically. (top to bottom) Fig. 5	A2 - A15
6-Picture out of proportion horizontally. (side to side) Fig. 6	A11 - A12 - A14
7-Picture present, but no sound.	A2 - A7 - A16
8-Picture rolls. (Vertical movement up and down). Fig. 8	A2 - A4 - A15
9-Picture tears. Figures on screen wave from side to side. Fig. 9	A4 - A11 - A12 - A14
10-Sound, brightness but no picture.	A1 - A3 - A4 - A6 - A8
11-Brightness, but no picture or sound.	A1 - A3 - A4 - A6 - A8 - A9 - A10 (A5 UHF only)

MOTOROLA - LAYOUT NO. 123

**Selenium Rectifiers.
*Open Filament in any Tube makes set inoperative.

TROUBLE	LOCATION
1-No brightness on tube.	A6 - A7 - A8 - A9 - *
2-No vertical height. White line across screen Fig. 2	A11
3-No horizontal width. White line running up and down. Fig. 3	A7 - A8 - A7 - *
4-Small picture in center of tube. Picture does not fill up entire screen. Fig. 4	A7 - A8 - A7 - *
5-Picture out of proportion vertically. (top to bottom) Fig. 5	A11
6-Picture out of proportion horizontally. (side to side) Fig. 6	A7 - A8 - A9
7-Picture present, but no sound.	A10 - A13 - A17 - A18
8-Picture rolls. (Vertical movement up and down). Fig. 8	A5 - A11
9-Picture tears. Figures on screen wave from side to side. Fig. 9	A5 - A7 - A8 - A7 - A12
10-Sound, brightness but no picture.	A3 - A4 - A13 - A14 - A16
11-Brightness, but no picture or sound.	A1 - A2 - A3 - A4 - A13 - A16

MOTOROLA - LAYOUT NO. 124

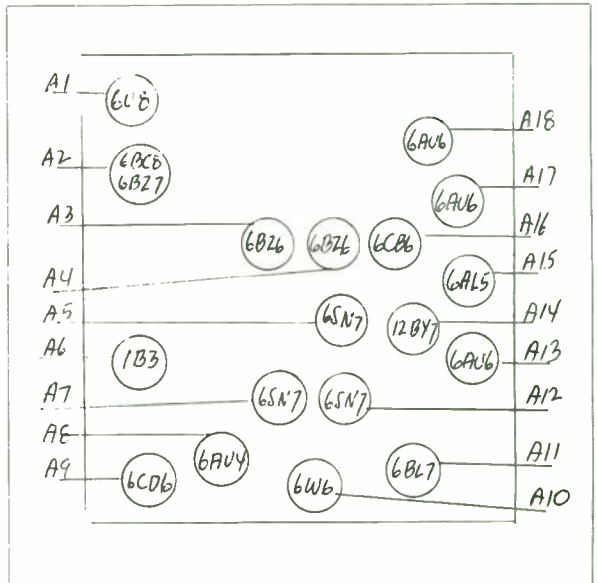

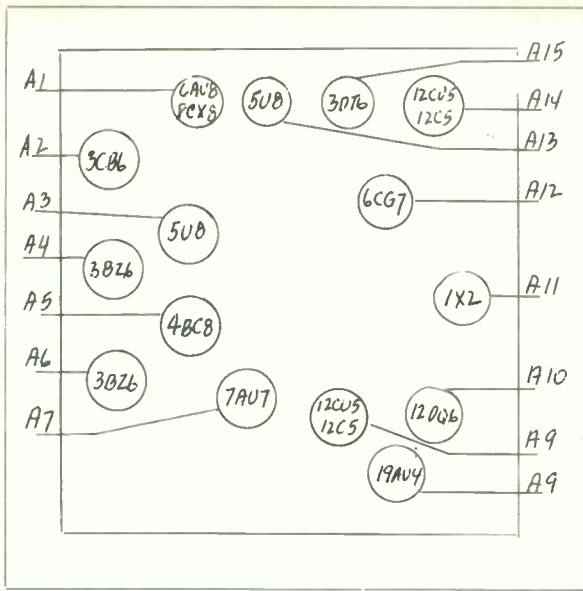

TROUBLE	LOCATION
1-No brightness on tube.	A8 - A10 - A11 - A12 - *
2-No vertical height. White line across screen Fig. 2	A13 - A14
3-No horizontal width. White line running up and down. Fig. 3	A8 - A10 - A12 - *
4-Small picture in center of tube. Picture does not fill up entire screen. Fig. 4	A8 - A10 - A12 - *
5-Picture out of proportion vertically. (top to bottom) Fig. 5	A13 - A14
6-Picture out of proportion horizontally. (side to side) Fig. 6	A8 - A10 - A12
7-Picture present, but no sound.	A9 - A13 - A15
8-Picture rolls. (Vertical movement up and down). Fig. 8	A1 - A7 - A13 - A14
9-Picture tears. Figures on screen wave from side to side. Fig. 9	A1 - A7 - A8 - A10 - A12
10-Sound, brightness but no picture.	A1 - A2 - A4 - A6 - A7
11-Brightness, but no picture or sound. *Selenium Rectifiers	A1 - A2 - A3 - A4 - A5 - A6 - A7

MOTOROLA-LAYOUT NO. 125

MOTOROLA-LAYOUT NO. 126

TROUBLE	LOCATION
1-No brightness on tube.	A14 - A15 - A16 - A17 *
2-No vertical height. White line across screen Fig. 2	A18
3-No horizontal width. White line running up and down. Fig. 3	A14 - A16 - A17
4-Small picture in center of tube. Picture does not fill up entire screen. Fig. 4	A14 - A16 - A17 *
5-Picture out of proportion vertically. (top to bottom) Fig. 5	A18
6-Picture out of proportion horizontally. (side to side) Fig. 6	A14 - A16 - A17
7-Picture present, but no sound.	A5 - A7 - A9 - A12 - A13
8-Picture rolls. (Vertical movement up and down). Fig. 8	A11 - A18
9-Picture tears. Figures on screen wave from side to side. Fig. 9	A11 - A13 - A14 - A16 - A17
10-Sound, brightness but no picture.	A4 - A6 - A8 - A10
11-Brightness, but no picture or sound. * Selenium Rectifiers.	A1 - A2 - A3 - A4 - A6 - A8

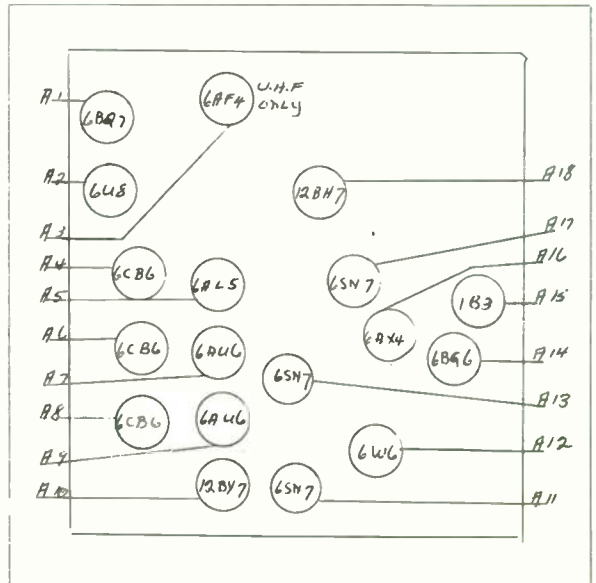

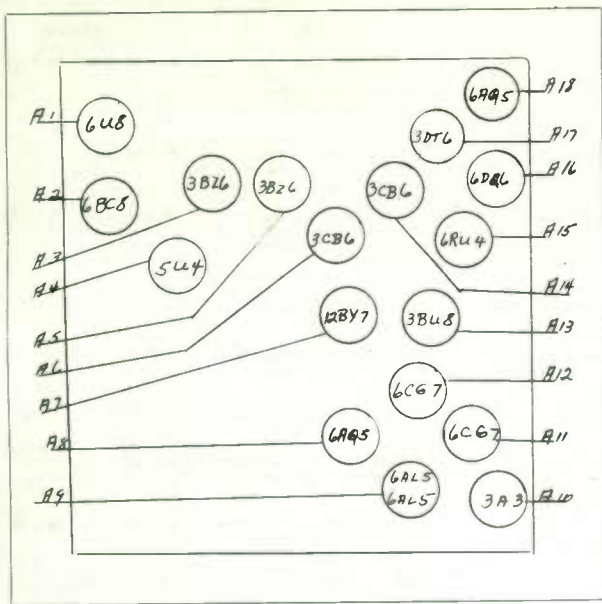

MOTOROLA - LAYOUT NO. 127

TROUBLE	LOCATION
1-No brightness on tube.	A4 - A10 - A11 - A15 - A16
2-No vertical height. White line across screen Fig. 2	A8 - A12
3-No horizontal width. White line running up and down. Fig. 3	A4 - A11 - A15 - A16
4-Small picture in center of tube. Picture does not fill up entire screen. Fig. 4	A4
5-Picture out of proportion vertically. (top to bottom) Fig. 5	A8 - A12
6-Picture out of proportion horizontally. (side to side) Fig. 6	A11 - A15 - A16
7-Picture present, but no sound.	A14 - A17 - A18
8-Picture rolls. (Vertical movement up and down). Fig. 8	A8 - A12 - A13
9-Picture tears. Figures on screen wave from side to side. Fig. 9	A9 - A11 - A12 - A13 - A15 - A16
10-Sound, brightness but no picture.	A3 - A5 - A6 - A7 - A13
11-Brightness, but no picture or sound.	A1 - A2 - A3 - A5 - A6 - A7 - A13

TROUBLE

LOCATION

1-No brightness on tube.	A8 - A10 - A11 - A12 - A14
2-No vertical height. White line across screen Fig. 2	A16 - A17
3-No horizontal width. White line running up and down. Fig. 3	A8 - A10 - A11 - A14
4-Small picture in center of tube. Picture does not fill up entire screen. Fig. 4	A11
5-Picture out of proportion vertically. (top to bottom) Fig. 5	A16 - A17
6-Picture out of proportion horizontally. (side to side) Fig. 6	A8 - A10 - A14
7-Picture present, but no sound.	A13 - A15 - A18 - A19
8-Picture rolls. (Vertical movement up and down). Fig. 8	A6 - A16 - A17
9-Picture tears. Figures on screen wave from side to side. Fig. 9	A6 - A8 - A9 - A10 - A14
10-Sound, brightness but no picture.	A3 - A4 - A5 - A7
11-Brightness, but no picture or sound.	A1 - A2 - A3 - A4 - A5

MOTOROLA - LAYOUT NO. 128

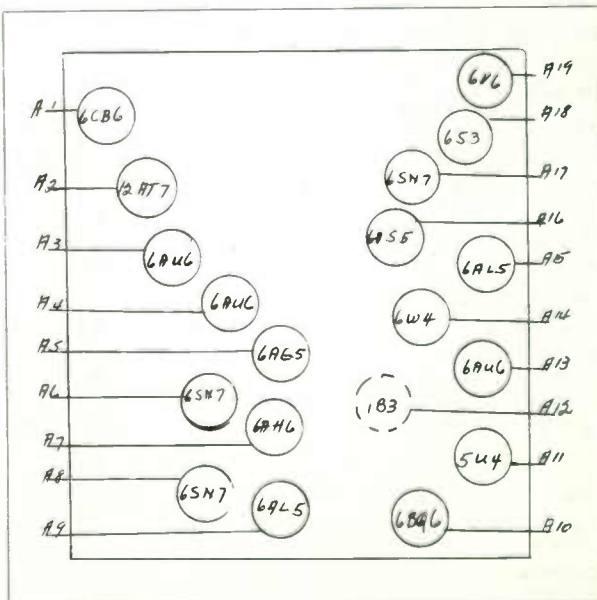

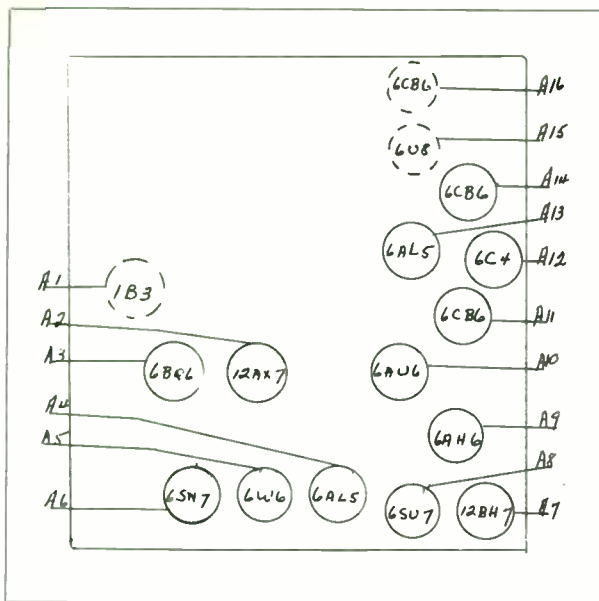

MOTOROLA - LAYOUT NO. 129

TROUBLE	LOCATION
1-No brightness on tube.	A1 - A2 - A3 - A6 *
2-No vertical height. White line across screen Fig. 2	A7
3-No horizontal width. White line running up and down. Fig. 3	A2 - A3 - A6 *
4-Small picture in center of tube. Picture does not fill up entire screen. Fig. 4	A2 - A3 - A6 *
5-Picture out of proportion vertically. (top to bottom) Fig. 5	A7
6-Picture out of proportion horizontally. (side to side) Fig. 6	A2 - A3 - A6
7-Picture present, but no sound.	A5 - A1D - A12 - A13
8-Picture rolls. (Vertical movement up and down). Fig. 8	A7 - A8
9-Picture tears. Figures on screen wave from side to side. Fig. 9	A2 - A3 - A4 - A6 - A8
1D-Sound, brightness but no picture.	A9 - A11 - A14
11-Brightness, but no picture or sound.	A9 - A11 - A14 - A15 - A16

* Selenium Rectifiers.

TROUBLE	LOCATION
1-No brightness on tube.	A11 - A12 - A14 - A15 *
2-No vertical height. White line across screen Fig. 2	A8 - A9
3-No horizontal width. White line running up and down. Fig. 3	A12 - A14 - A15
4-Small picture in center of tube. Picture does not fill up entire screen. Fig. 4	A12 - A14 - A15 *
5-Picture out of proportion vertically. (top to bottom) Fig. 5	A8 - A9
6-Picture out of proportion horizontally. (side to side) Fig. 6	A12 - A14 - A15
7-Picture present, but no sound.	A16 - A17 - A18
8-Picture rolls. (Vertical movement up and down). Fig. 8	A8 - A9 - A13
9-Picture tears. Figures on screen wave from side to side. Fig. 9	A8 - A12 - A13 - A14 - A15
1D-Sound, brightness but no picture.	A4 - A5 - A6 - A7 - A13
11-Brightness, but no picture or sound.	A1 - A2 - A4 - A5 - A6 - A7 - A13 (A3 - UHF only)

MOTOROLA-LAYOUT NO. 130

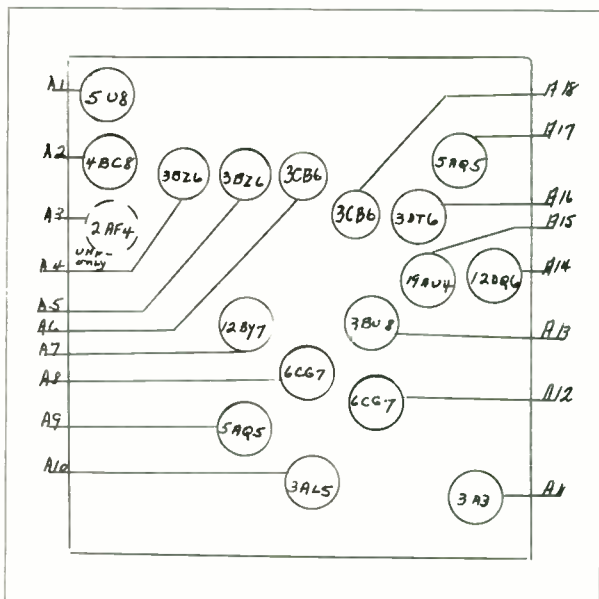

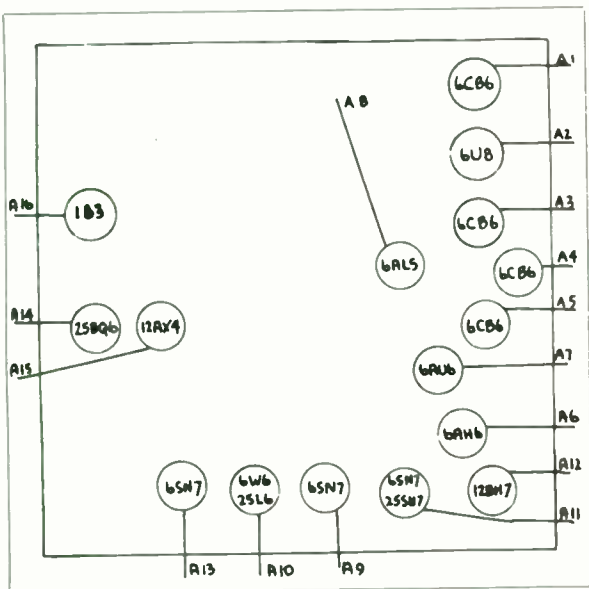

TROUBLE	LOCATION
1-No brightness on tube.	A14 - A15 - A16
2-No vertical height. White line across screen Fig. 2	A12
3-No horizontal width. White line running up and down. Fig. 3	A13 - A14
4-Small picture in center of tube. Picture does not fill up entire screen. Fig. 4	A14 - A16
5-Picture out of proportion vertically. (top to bottom) Fig. 5	A12
6-Picture out of proportion horizontally. (side to side) Fig. 6	A13 - A14
7-Picture present, but no sound.	A7 - A8 - A9 - A10
8-Picture rolls. (Vertical movement up and down). Fig. 8	A11 - A12
9-Picture tears. Figures on screen wave from side to side. Fig. 9	A13 - A14
10-Sound, brightness but no picture.	A3 - A4 - A5 - A6
11-Brightness, but no picture or sound.	A1 - A2

MOTOROLA-LAYOUT NO. 131

TROUBLE

LOCATION

1-No brightness on tube.	A9 - A10 - A11 - A12 - "
2-No vertical height. White line across screen Fig. 2	A13 - A15
3-No horizontal width. White line running up and down. Fig. 3	A9 - A10 - A12 - "
4-Small picture in center of tube. Picture does not fill up entire screen. Fig. 4	A9 - A10 - A12 - "
5-Picture out of proportion vertically. (top to bottom) Fig. 5	A13 - A15
6-Picture out of proportion horizontally. (side to side) Fig. 6	A9 - A10 - A12
7-Picture present, but no sound.	A8 - A13 - A14
8-Picture rolls. (Vertical movement up and down). Fig. 8	A1 - A7 - A13 - A15
9-Picture tears. Figures on screen wave from side to side. Fig. 9	A1 - A7 - A9 - A10 - A12
10-Sound, brightness but no picture.	A1 - A2 - A4 - A6
11-Brightness, but no picture or sound.	A1 - A2 - A3 - A4 - A5 - A6 *Selenium Rectifiers

MOTOROLA-LAYOUT NO. 132

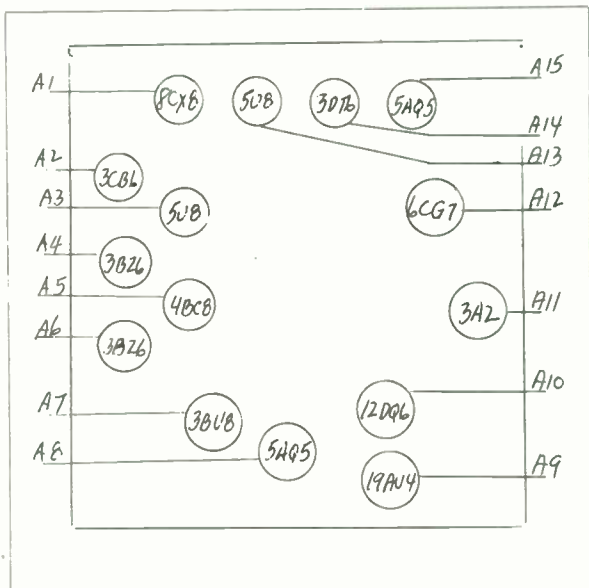

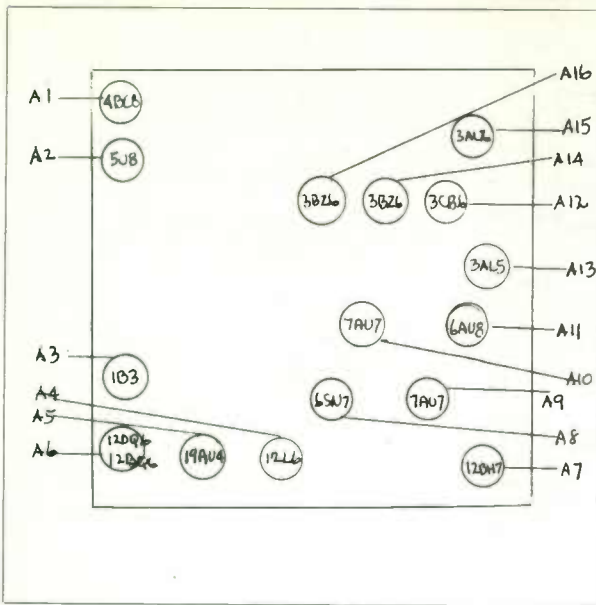

TROUBLE	LOCATION
1-No brightness on tube.	A3 - A5 - A6 - A8 *
2-No vertical height. White line across screen Fig. 2	A7
3-No horizontal width. White line running up and down. Fig. 3	A5 - A6 - A8
4-Small picture in center of tube. Picture does not fill up entire screen. Fig. 4	A5 - A6 - A8 *
5-Picture out of proportion vertically. (top to bottom) Fig. 5	A7
6-Picture out of proportion horizontally. (side to side) Fig. 6	A5 - A6 - A8
7-Picture present, but no sound.	A4 - A13 - A15
8-Picture rolls. (Vertical movement up and down). Fig. 8	A7 - A10
9-Picture tears. Figures on screen wave from side to side. Fig. 9	A5 - A6 - A8 - A9 - A10
10-Sound, brightness but no picture.	A11 - A12 - A14 - A16
11-Brightness, but no picture or sound.	A1 - A2 - A11 - A12 - A14 - A16

MOTOROLA - LAYOUT NO.133

MOTOROLA - LAYOUT NO. 134

TROUBLE	LOCATION
1-No brightness on tube.	A16 - A17 - A18 - A19
2-No vertical height. White line across screen Fig. 2	A13 - A14
3-No horizontal width. White line running up and down. Fig. 3	A16
4-Small picture in center of tube. Picture does not fill up entire screen. Fig. 4	A21 - A18
5-Picture out of proportion vertically. (top to bottom) Fig. 5	A13
6-Picture out of proportion horizontally. (side to side) Fig. 6	A16 - A15
7-Picture present, but no sound.	A3 - A4 - A5 - A8 - A10 - A11
8-Picture rolls. (Vertical movement up and down). Fig. 8	A13 - A14
9-Picture tears. Figures on screen wave from side to side. Fig. 9	A16 - A12
10-Sound, brightness but no picture.	A6 - A7 - A8 - A9
11-Brightness, but no picture or sound.	A1 - A2

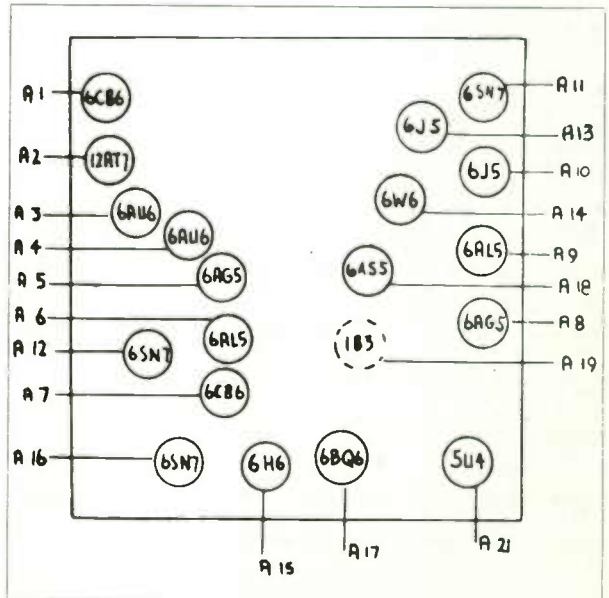

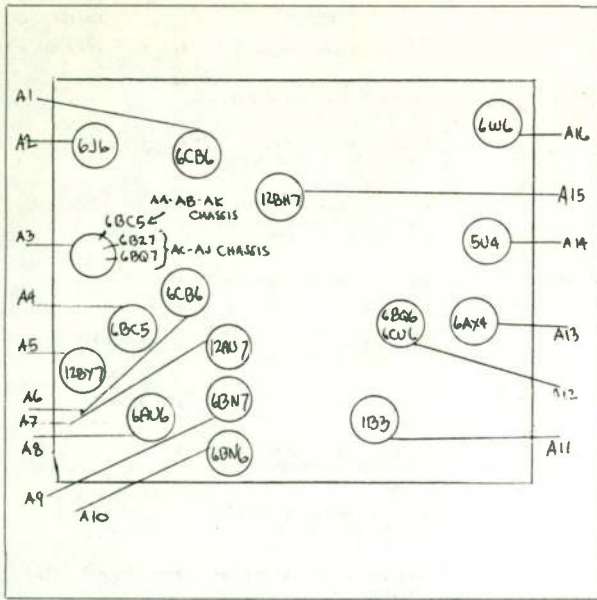

TROUBLE	LOCATION
1-No brightness on tube.	A9 - A11 - A12 - A13 - A14
2-No vertical height. White line across screen Fig. 2	A15
3-No horizontal width. White line running up and down. Fig. 3	A9 - A12 - A13 - A14
4-Small picture in center of tube. Picture does not fill up entire screen. Fig. 4	A14
5-Picture out of proportion vertically. (top to bottom) Fig. 5	A15
6-Picture out of proportion horizontally. (side to side) Fig. 6	A9 - A12 - A13
7-Picture present, but no sound.	A8 - A10 - A16
8-Picture rolls. (Vertical movement up and down). Fig. 8	A7 - A15
9-Picture tears. Figures on screen wave from side to side. Fig. 9	A7 - A9 - A12 - A13
10-Sound, brightness but no picture.	A1 - A4 - A5 - A6
11-Brightness, but no picture or sound.	A1 - A2 - A3 - A4 - A6

OLYMPIC - LAYOUT NO. 135

TROUBLE	LOCATION
1-No brightness on tube.	A7 - A8 - A9 - A10 - A11
2-No vertical height. White line across screen Fig. 2	A12
3-No horizontal width. White line running up and down. Fig. 3	A7 - A8 - A9 - A11
4-Small picture in center of tube. Picture does not fill up entire screen. Fig. 4	A8
5-Picture out of proportion vertically. (top to bottom) Fig. 5	A12
6-Picture out of proportion horizontally. (side to side) Fig. 6	A7 - A9 - A11
7-Picture present, but no sound.	A3 - A6 - A14
8-Picture rolls. (Vertical movement up and down). Fig. 8	A12 - A13
9-Picture tears. Figures on screen wave from side to side. Fig. 9	A7 - A9 - A11 - A13
10-Sound, brightness but no picture.	A4 - A5 - A14
11-Brightness, but no picture or sound.	A1 - A2 - A4 - A5 - A14

OLYMPIC - LAYOUT NO. 136

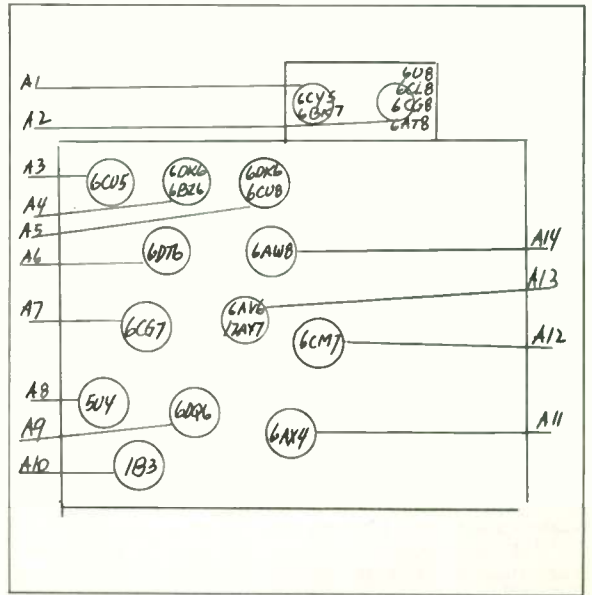

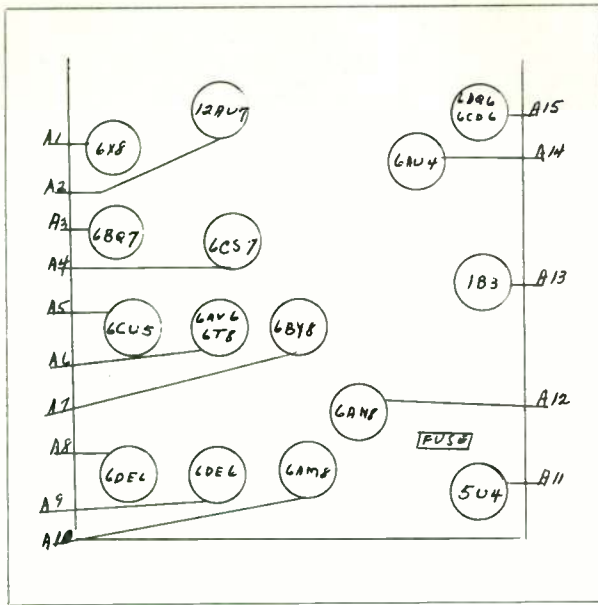

TROUBLE	LOCATION
1-No brightness on tube.	A2 - A11 - A13 - A14 - A15
2-No vertical height. White line across screen Fig. 2	A4
3-No horizontal width. White line running up and down. Fig. 3	A2 - A11 - A14 - A15
4-Small picture in center of tube. Picture does not fill up entire screen. Fig. 4	A11
5-Picture out of proportion vertically. (top to bottom) Fig. 5	A4
6-Picture out of proportion horizontally. (side to side) Fig. 6	A2 - A14 - A15
7-Picture present, but no sound.	A5 - A6 - A7
8-Picture rolls. (Vertical movement up and down). Fig. 8	A4
9-Picture tears. Figures on screen wave from side to side. Fig. 9	A2 - A14 - A15
10-Sound, brightness but no picture.	A8 - A9 - A10 - A12
11-Brightness, but no picture or sound.	A1 - A3 - A8 - A9 - A10 - A12

PHILCO - LAYOUT NO. 137

PHILCO - LAYOUT NO. 138

TROUBLE	LOCATION
1-No brightness on tube.	A5 - A4 - A3 - A1 - A2
2-No vertical height. White line across screen Fig. 2	A12 - A6
3-No horizontal width. White line running up and down. Fig. 3	A12 - A13 - A8 - A15
4-Small picture in center of tube. Picture does not fill up entire screen. Fig. 4	A13 - A8 - A5
5-Picture out of proportion vertically. (top to bottom) Fig. 5	A15 - A13 - A14
6-Picture out of proportion horizontally. (side to side) Fig. 6	A6 - A7
7-Picture present, but no sound.	A7 - A14 - A9
8-Picture rolls. (Vertical movement up and down). Fig. 8	A15 - A13 - A8
9-Picture tears. Figures on screen wave from side to side. Fig. 9	A12 - A13 - A8
10-Sound, brightness but no picture.	A11 - A15 - A9
11-Brightness, but no picture or sound.	A3 - A4 - A11 - A12 - A9

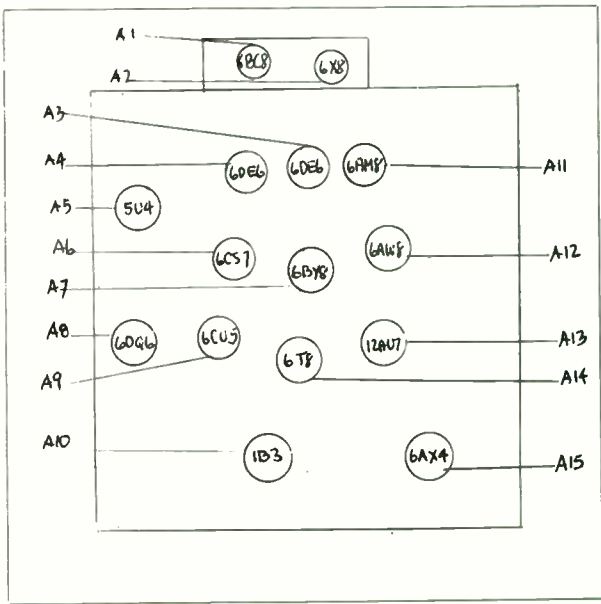

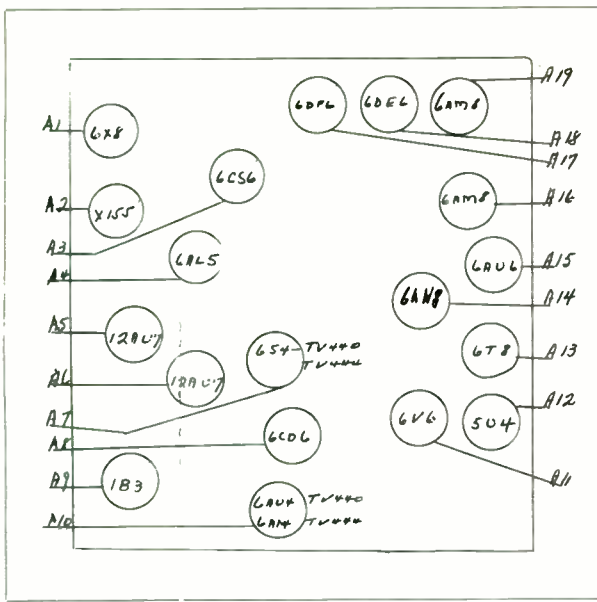

TROUBLE	LOCATION
1-No brightness on tube.	A6 - A8 - A9 - A10 - A12
2-No vertical height. White line across screen Fig. 2	A5 - A7
3-No horizontal width. White line running up and down. Fig. 3	A6 - A8 - A10 - A12
4-Small picture in center of tube. Picture does not fill up entire screen. Fig. 4	A12
5-Picture out of proportion vertically. (top to bottom) Fig. 5	A5 - A7
6-Picture out of proportion horizontally. (side to side) Fig. 6	A6 - A8 - A10
7-Picture present, but no sound.	A11 - A13 - A15
8-Picture rolls. (Vertical movement up and down). Fig. 8	A3 - A5 - A7 - A16
9-Picture tears. Figures on screen wave from side to side. Fig. 9	A3 - A4 - A6 - A8 - A10 - A16
10-Sound, brightness but no picture.	A14 - A17 - A18 - A19
11-Brightness, but no picture or sound.	A1 - A2 - A17 - A18 - A19

PHILCO - LAYOUT NO. 139

TROUBLE LOCATION

1-No brightness on tube.	A3 - A5 - A6 - A7 *
2-No vertical height. White line across screen Fig. 2	A4
3-No horizontal width. White line running up and down. Fig. 3	A3 - A6 - A7 *
4-Small picture in center of tube. Picture does not fill up entire screen. Fig. 4	A3 - A6 - A7 *
5-Picture out of proportion vertically. (top to bottom) Fig. 5	A4
6-Picture out of proportion horizontally. (side to side) Fig. 6	A3 - A6 - A7
7-Picture present, but no sound.	A8 - A9 - A10
8-Picture rolls. (Vertical movement up and down). Fig. 8	A4 - A11
9-Picture tears. Figures on screen wave from side to side. Fig. 9	A3 - A6 - A7 - A11
10-Sound, brightness but no picture.	A11 - A12 - A13 - A14
11-Brightness, but no picture or sound.	A1 - A2 - A11 - A12 - A13 - A14

* Selenium Rectifiers.

PHILCO - LAYOUT NO. 140

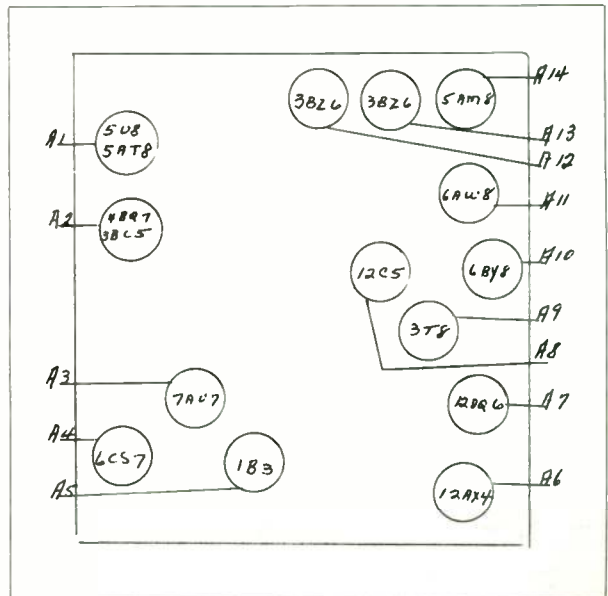

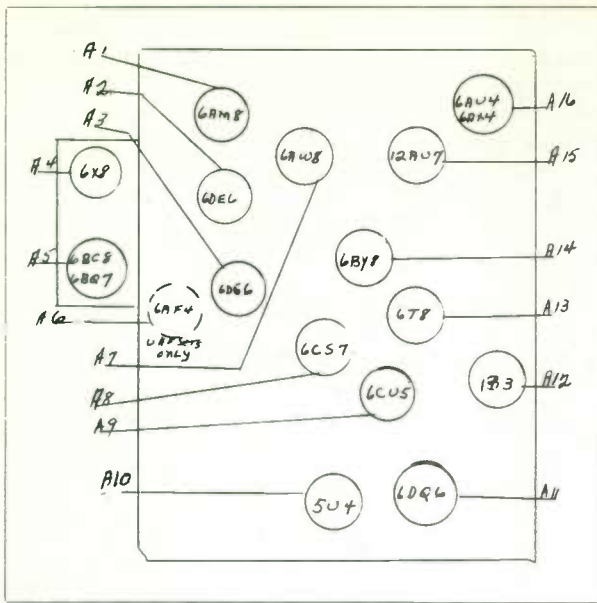

TROUBLE	LOCATION
1-No brightness on tube.	A10 - A11 - A12 - A15 - A16
2-No vertical height. White line across screen Fig. 2	A8
3-No horizontal width. White line running up and down. Fig. 3	A10 - A11 - A15 - A16
4-Small picture in center of tube. Picture does not fill up entire screen. Fig. 4	A10
5-Picture out of proportion vertically. (top to bottom) Fig. 5	A8
6-Picture out of proportion horizontally. (side to side) Fig. 6	A11 - A15 - A16
7-Picture present, but no sound.	A9 - A13 - A14
8-Picture rolls. (Vertical movement up and down). Fig. 8	A7 - A8
9-Picture tears. Figures on screen wave from side to side. Fig. 9	A7 - A11 - A15 - A16
10-Sound, brightness but no picture.	A1 - A2 - A3 - A7
11-Brightness, but no picture or sound.	A1 - A2 - A3 - A4 - A5 - A7 (A6 - UHF only)

PHILCO - LAYOUT NO. 141

PHILCO - LAYOUT NO. 142

TROUBLE	LOCATION
1-No brightness on tube.	A7 - A8 - A9 - A10 - A11
2-No vertical height. White line across screen Fig. 2	A5
3-No horizontal width. White line running up and down. Fig. 3	A7 - A9 - A10 - A11
4-Small picture in center of tube. Picture does not fill up entire screen. Fig. 4	A7
5-Picture out of proportion vertically. (top to bottom) Fig. 5	A5
6-Picture out of proportion horizontally. (side to side) Fig. 6	A9 - A10 - A11
7-Picture present, but no sound.	A12 - A13 - A14
8-Picture rolls. (Vertical movement up and down). Fig. 8	A5 - A16
9-Picture tears. Figures on screen wave from side to side. Fig. 9	A9 - A10 - A11 - A16
10-Sound, brightness but no picture.	A3 - A4 - A6 - A15
11-Brightness, but no picture or sound.	A1 - A2 - A3 - A4 - A6

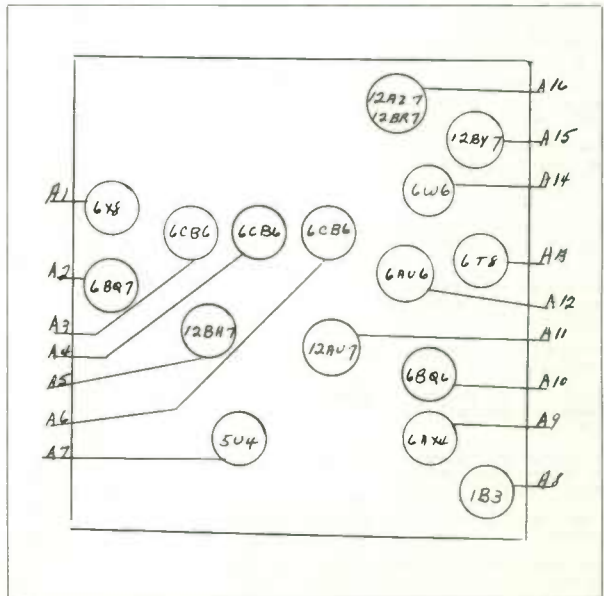

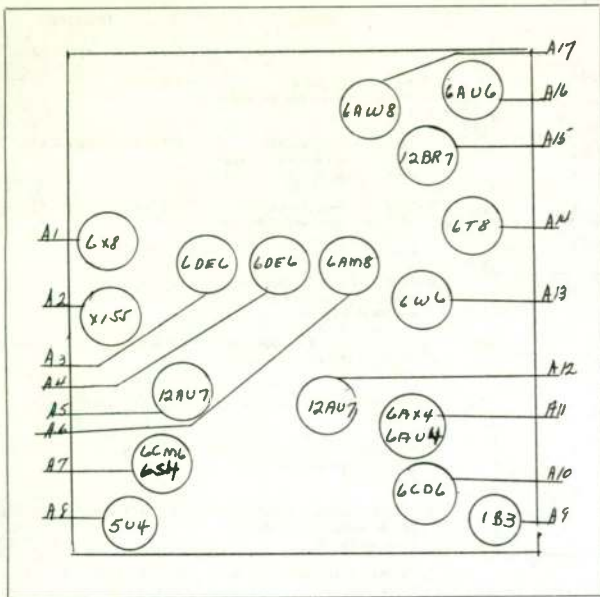

TROUBLE	LOCATION
1-No brightness on tube.	A8 - A9 - A10 - A11 - A12
2-No vertical height. White line across screen Fig. 2	A5 - A7
3-No horizontal width. White line running up and down. Fig. 3	A8 - A10 - A11 - A12
4-Small picture in center of tube. Picture does not fill up entire screen. Fig. 4	A8
5-Picture out of proportion vertically. (top to bottom) Fig. 5	A5 - A7
6-Picture out of proportion horizontally. (side to side) Fig. 6	A10 - A11 - A12
7-Picture present, but no sound.	A13 - A14 - A16
8-Picture rolls. (Vertical movement up and down). Fig. 8	A5 - A7 - A15
9-Picture tears. Figures on screen wave from side to side. Fig. 9	A10 - A11 - A12 - A15 - A17
10-Sound, brightness but no picture.	A3 - A4 - A6 - A17
11-Brightness, but no picture or sound.	A1 - A2 - A3 - A4 - A6

PHILCO - LAYOUT NO. 143

PHILCO - LAYOUT NO. 144

TROUBLE	LOCATION
1-No brightness on tube.	A6 - A8 - A9 - A10 - A19
2-No vertical height. White line across screen Fig. 2	A4 - A11
3-No horizontal width. White line running up and down. Fig. 3	A6 - A9 - A10 - A19
4-Small picture in center of tube. Picture does not fill up entire screen. Fig. 4	A6
5-Picture out of proportion vertically. (top to bottom) Fig. 5	A4 - A11
6-Picture out of proportion horizontally. (side to side) Fig. 6	A9 - A10 - A19
7-Picture present, but no sound.	A7 - A12 - A13 - A15
8-Picture rolls. (Vertical movement up and down). Fig. 8	A4 - A11 - A17
9-Picture tears. Figures on screen wave from side to side. Fig. 9	A5 - A9 - A10 - A17 - A19
10-Sound, brightness but no picture.	A3 - A13 - A14 - A16 - A18
11-Brightness, but no picture or sound.	A1 - A2 - A3 - A13 - A14 - A16

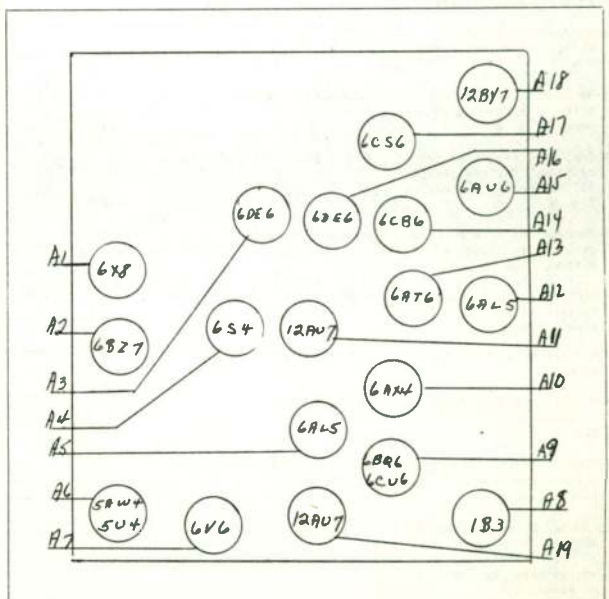

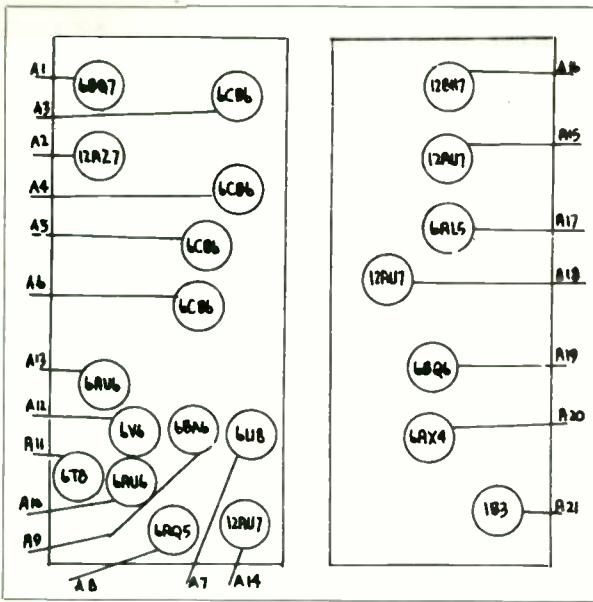

TROUBLE	LOCATION
1-No brightness on tube.	A18 - A19 - A20 - A21
2-No vertical height. White line across screen Fig. 2	A15 - A16 - A17
3-No horizontal width. White line running up and down. Fig. 3	A18 - A19 - A20 - A21
4-Small picture in center of tube. Picture does not fill up entire screen. Fig. 4	A18 - A19 - A20 - A21
5-Picture out of proportion vertically. (top to bottom) Fig. 5	A7 - A15 - A16
6-Picture out of proportion horizontally. (side to side) Fig. 6	A7 - A17 - A18 - A19 - A20
7-Picture present, but no sound.	A9 - A10 - A11 - A12
8-Picture rolls. (Vertical movement up and down). Fig. 8	A7 - A15 - A16
9-Picture tears. Figures on screen wave from side to side. Fig. 9	A7 - A13 - A17 - A18 - A20
10-Sound, brightness but no picture.	A3 - A4 - A5 - A6 - A7 - A8 - A13 - A14
11-Brightness, but no picture or sound.	A1 - A2

PHILCO - LAYOUT NO. 145

PHILCO - LAYOUT NO. 146

TROUBLE	LOCATION
1-No brightness on tube.	A14 - A15 - A16 - A17
2-No vertical height. White line across screen Fig. 2	A12
3-No horizontal width. White line running up and down. Fig. 3	A14 - A15 - A16
4-Small picture in center of tube. Picture does not fill up entire screen. Fig. 4	A14 - A15 - A16 - A17
5-Picture out of proportion vertically. (top to bottom) Fig. 5	A10 - A11 - A12
6-Picture out of proportion horizontally. (side to side) Fig. 6	A10 - A11 - A13 - A14 - A15 - A16
7-Picture present, but no sound.	A7 - A8 - A9
8-Picture rolls. (Vertical movement up and down). Fig. 8	A10 - A11 - A12
9-Picture tears. Figures on screen wave from side to side. Fig. 9	A10 - A11 - A13 - A14 - A15 - A16
10-Sound, brightness but no picture.	A3 - A4 - A5 - A6 - A11
11-Brightness, but no picture or sound.	A1 - A2

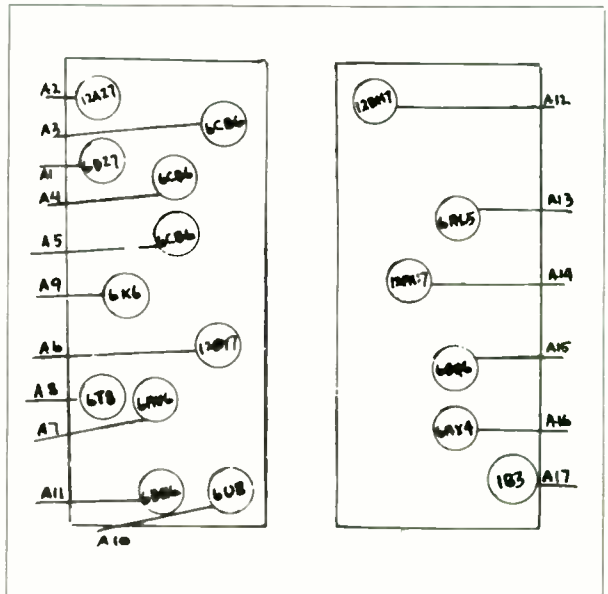

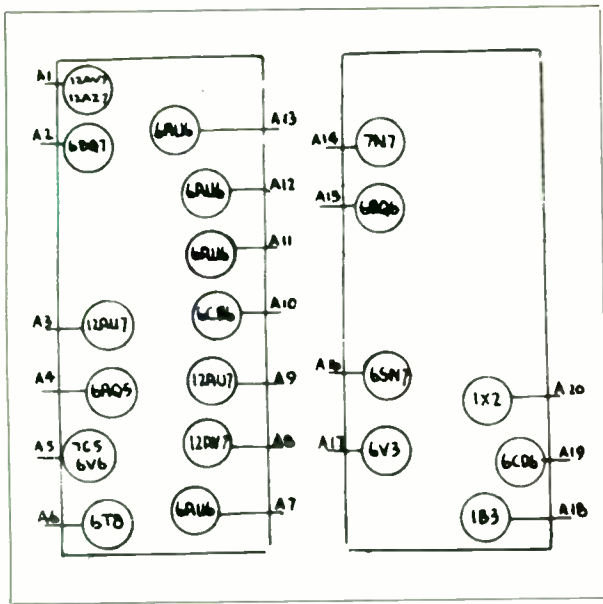

PHILCO - LAYOUT NO. 147

TROUBLE	LOCATION
1-No brightness on tube.	A20 - A18 - A17 - A19
2-No vertical height. White line across screen Fig. 2	A15
3-No horizontal width. White line running up and down. Fig. 3	A16
4-Small picture in center of tube. Picture does not fill up entire screen. Fig. 4	A18
5-Picture out of proportion vertically. (top to bottom) Fig. 5	A15
6-Picture out of proportion horizontally. (side to side) Fig. 6	A16
7-Picture present, but no sound.	A7 - A6 - A5 - A9
8-Picture rolls. (Vertical movement up and down). Fig. 8	A15 - A3 - A14
9-Picture tears. Figures on screen wave from side to side. Fig. 9	A16 - A8
10-Sound, brightness but no picture.	A13 - A12 - A11 - A1D - A9 - A8 - A4
11-Brightness, but no picture or sound.	A1 - A2

TROUBLE

LOCATION

1-No brightness on tube.	A19 - A18 - A17 - A16 - A15
2-No vertical height. White line across screen Fig. 2	A21 - A22
3-No horizontal width. White line running up and down. Fig. 3	A19 - A18
4-Small picture in center of tube. Picture does not fill up entire screen. Fig. 4	A14 - A2D - A19
5-Picture out of proportion vertically. (top to bottom) Fig. 5	A22 - A21
6-Picture out of proportion horizontally. (side to side) Fig. 6	A18 - A15
7-Picture present, but no sound.	A6 - A11 - A12 - A10
8-Picture rolls. (Vertical movement up and down). Fig. 8	A13 - A21 - A22
9-Picture tears. Figures on screen wave from side to side. Fig. 9	A18 - A13 - A22
10-Sound, brightness but no picture.	A13 - A8 - A9
11-Brightness, but no picture or sound.	A1 - A2 - A3 - A4 - A5 - A7 - A8

PHILCO - LAYOUT NO. 148

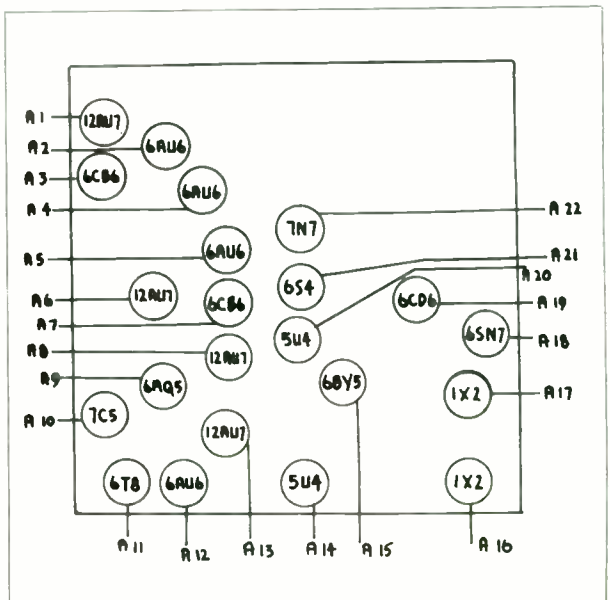

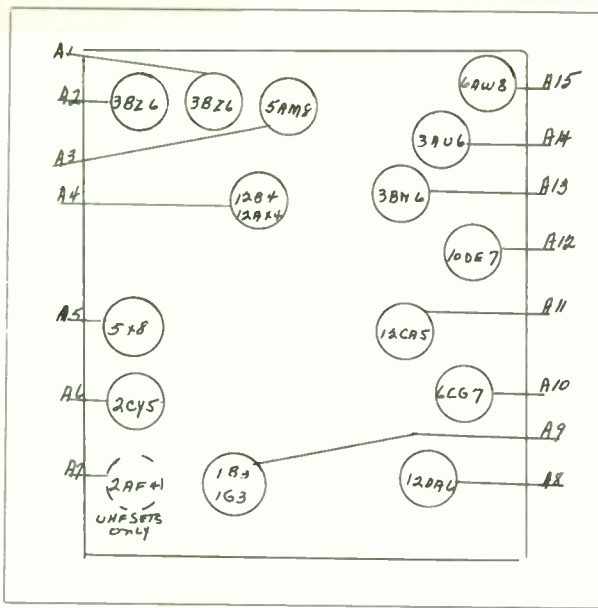

TROUBLE	LOCATION
1-No brightness on tube.	A8 - A9 - A10 - A14 * Fuse
2-No vertical height. White line across screen Fig. 2	A12
3-No horizontal width. White line running up and down. Fig. 3	A4 - A8 - A10 *
4-Small picture in center of tube. Picture does not fill up entire screen. Fig. 4	A4 - A8 - A10 *
5-Picture out of proportion vertically. (top to bottom) Fig. 5	A12
6-Picture out of proportion horizontally. (side to side) Fig. 6	A4 - A8 - A10
7-Picture present, but no sound.	A11 - A13 - A14
8-Picture rolls. (Vertical movement up and down). Fig. 8	A12
9-Picture tears. Figures on screen wave from side to side. Fig. 9	A4 - A8 - A10
10-Sound, brightness but no picture.	A1 - A2 - A3 - A15
11-Brightness, but no picture or sound.	A1 - A2 - A3 - A5 - A6 - A15 (A7 - UHF only)

* Selenium Rectifiers.

PHILCO - LAYOUT NO. 149

TROUBLE	LOCATION
1-No brightness on tube.	A4 - A5 - A6 - A7 *
2-No vertical height. White line across screen Fig. 2	A8 - A9
3-No horizontal width. White line running up and down. Fig. 3	A4 - A5 - A6 *
4-Small picture in center of tube. Picture does not fill up entire screen. Fig. 4	A4 - A5 - A6 *
5-Picture out of proportion vertically. (top to bottom) Fig. 5	A8 - A9
6-Picture out of proportion horizontally. (side to side) Fig. 6	A4 - A5 - A6
7-Picture present, but no sound.	A10 - A11 - A12
8-Picture rolls. (Vertical movement up and down). Fig. 8	A8 - A9 - A13
9-Picture tears. Figures on screen wave from side to side. Fig. 9	A4 - A5 - A6 - A9 - A13
10-Sound, brightness but no picture.	A13 - A14 - A15 - A16
11-Brightness, but no picture or sound.	A1 - A2 - A3 - A14 - A15 - A16 (A3 - UHF only)

* Selenium Rectifiers.

R.C.A. - LAYOUT NO. 150

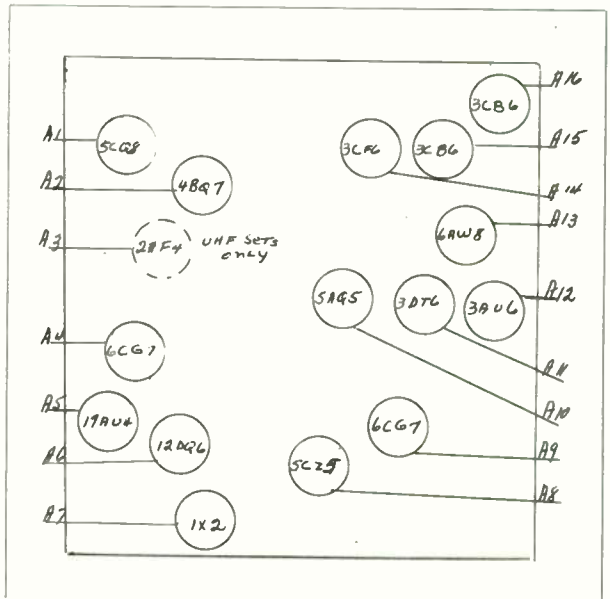

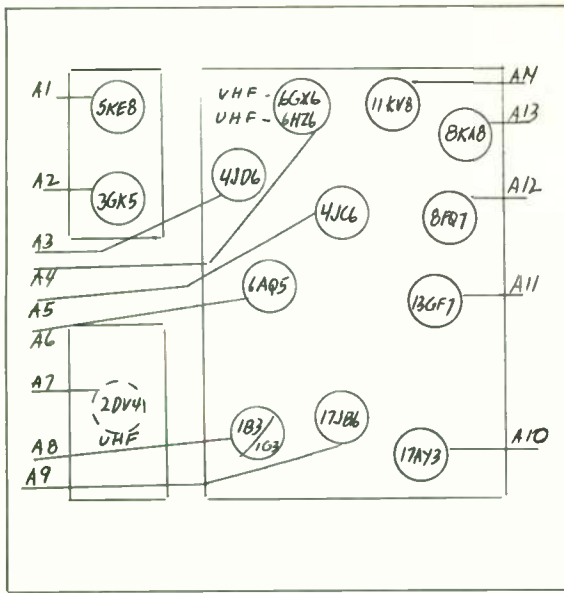

R.C.A. - LAYOUT NO. 151

TROUBLE	LOCATION
1-No brightness on tube.	A8 - A9 - A10 - A12
2-No vertical height. White line across screen Fig. 2	A11
3-No horizontal width. White line running up and down. Fig. 3	A9 - A10 - A12
4-Small picture in center of tube. Picture does not fill up entire screen. Fig. 4	A9 - A10 - A12
5-Picture out of proportion vertically. (top to bottom) Fig. 5	A11
6-Picture out of proportion horizontally. (side to side) Fig. 6	A9 - A10 - A12
7-Picture present, but no sound.	A6 - A14
8-Picture rolls. (Vertical movement up and down). Fig. 8	A11 - A13
9-Picture tears. Figures on screen wave from side to side. Fig. 9	A9 - A10 - A12 - A13
10-Sound, brightness but no picture.	A3 - A4 - A5 - A13 - A14
11-Brightness, but no picture or sound.	A1 - A2 - A3 - A4 - A5 - A13 - A14 (A7 UHF only)

R.C.A. - LAYOUT NO. 152

TROUBLE	LOCATION
1-No brightness on tube.	A12 - A13 - A14 - A15 - A16 - A18 - A19
2-No vertical height. White line across screen Fig. 2	A3 - A21
3-No horizontal width. White line running up and down. Fig. 3	A12 - A14 - A15 - A16 - A18 - A19
4-Small picture in center of tube. Picture does not fill up entire screen. Fig. 4	A18 - A19
5-Picture out of proportion vertically. (top to bottom) Fig. 5	A3 - A21
6-Picture out of proportion horizontally. (side to side) Fig. 6	A12 - A14 - A15 - A16
7-Picture present, but no sound.	A8 - A10 - A11 - A22 - A23
8-Picture rolls. (Vertical movement up and down). Fig. 8	A3 - A9 - A21
9-Picture tears. Figures on screen wave from side to side. Fig. 9	A12 - A14 - A15 - A16 - A17
10-Sound, brightness but no picture.	A4 - A5 - A6 - A7 - A20
11-Brightness, but no picture or sound.	A1 - A2 - A4 - A5 - A7 - A20

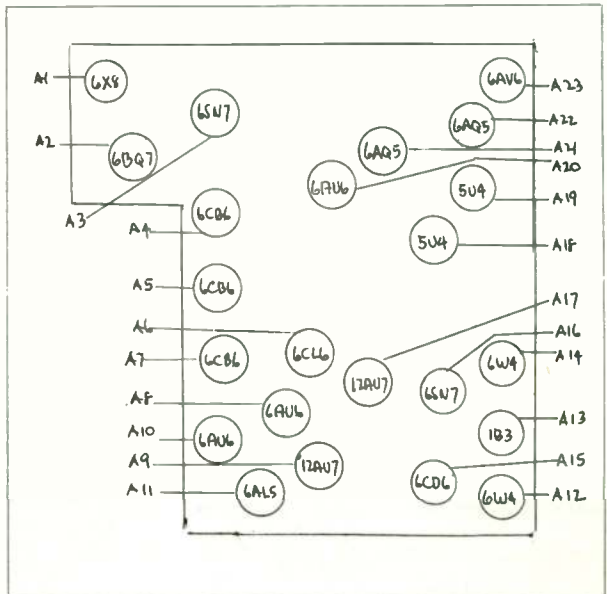

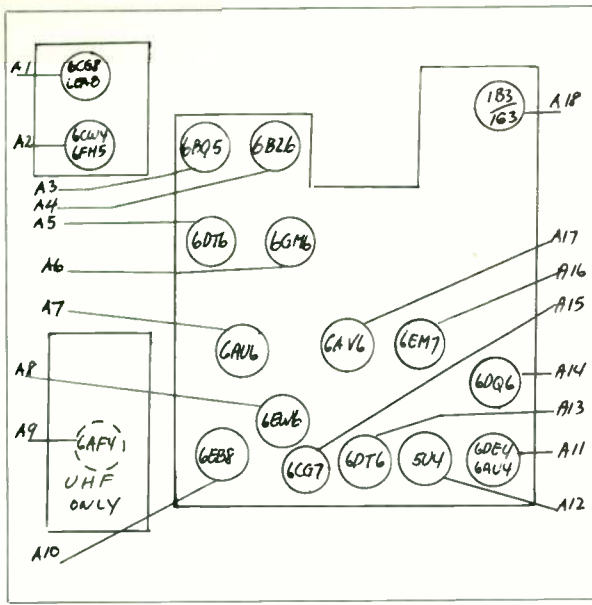

TROUBLE	LOCATION
1-No brightness on tube.	A11 - A12 - A14 - A15 - A18
2-No vertical height. White line across screen Fig. 2	A16
3-No horizontal width. White line running up and down. Fig. 3	A11 - A12 - A14 - A15
4-Small picture in center of tube. Picture does not fill up entire screen. Fig. 4	A12
5-Picture out of proportion vertically. (top to bottom) Fig. 5	A16
6-Picture out of proportion horizontally. (side to side) Fig. 6	A11 - A14 - A15
7-Picture present, but no sound.	A3- A5 - A7
8-Picture rolls. (Vertical movement up and down). Fig. 8	A16 - A17
9-Picture tears. Figures on screen wave from side to side. Fig. 9	A11 - A14 - A15 - A17
10-Sound, brightness but no picture.	A4 - A6 - A8 - A10- A13
11-Brightness, but no picture or sound.	A1 - A2 - A4 - A6 - A8 - A10 (A9 UHF only)

R.C.A. - LAYOUT NO. 153

TROUBLE	LOCATION
1-No brightness on tube.	A14 - A15 - A16 - A17
2-No vertical height. White line across screen Fig. 2	A10
3-No horizontal width. White line running up and down. Fig. 3	A14 - A15 - A16
4-Small picture in center of tube. Picture does not fill up entire screen. Fig. 4	A14 - A15 - A16
5-Picture out of proportion vertically. (top to bottom) Fig. 5	A10
6-Picture out of proportion horizontally. (side to side) Fig. 6	A14 - A15 - A16
7-Picture present, but no sound.	A1- A3 - A7
8-Picture rolls. (Vertical movement up and down). Fig. 8	A10 - A13
9-Picture tears. Figures on screen wave from side to side. Fig. 9	A13 - A14 - A15 - A16
10-Sound, brightness but no picture.	A2 - A6 - A8 - A9 - A12
11-Brightness, but no picture or sound.	A2 - A4 - A5 - A6 - A8 - A9 A12 (A11 UHF)

R.C.A. - LAYOUT NO. 154

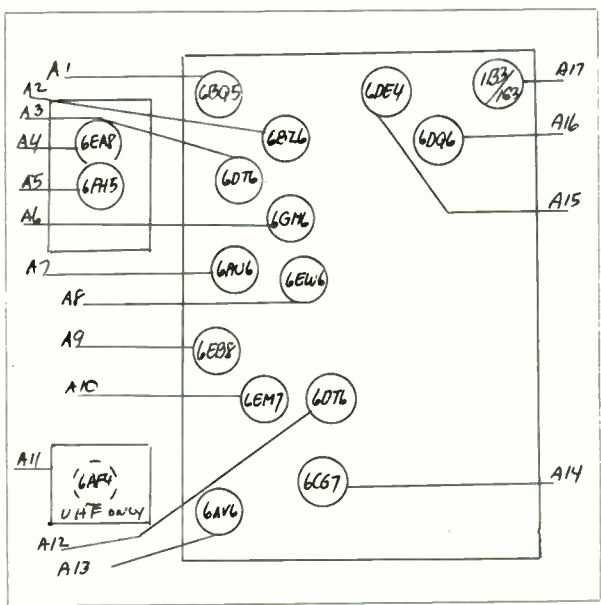

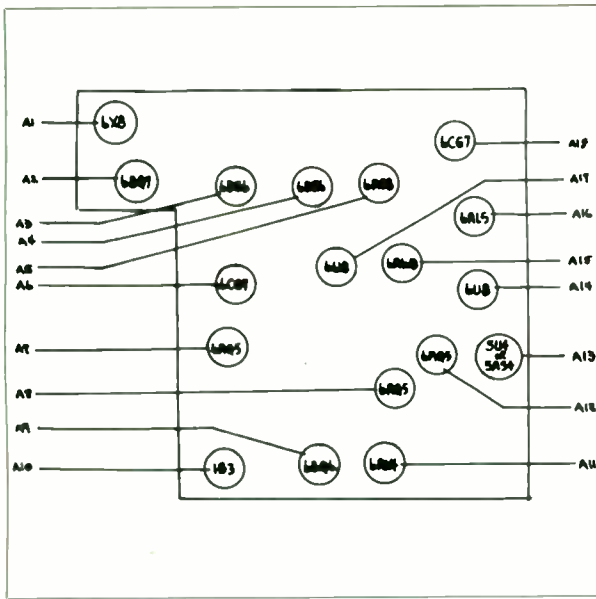

R.C.A. - LAYOUT NO. 155

TROUBLE	LOCATION
1-No brightness on tube.	A9 - A10 - A11 - A13 - A18
2-No vertical height. White line across screen Fig. 2	A6 - A7
3-No horizontal width. White line running up and down. Fig. 3	A9 - A11 - A13 - A18
4-Small picture in center of tube. Picture does not fill up entire screen. Fig. 4	A13
5-Picture out of proportion vertically. (top to bottom) Fig. 5	A6 - A7
6-Picture out of proportion horizontally. (side to side) Fig. 6	A9 - A11 - A13 - A18
7-Picture present, but no sound.	A12 - A14 - A16
8-Picture rolls. (Vertical movement up and down). Fig. 8	A6 - A7
9-Picture tears. Figures on screen wave from side to side. Fig. 9	A9 - A11 - A13 - A18
10-Sound, brightness but no picture.	A3 - A4 - A5 - A8 - A15 - A17
11-Brightness, but no picture or sound.	A1 - A2 - A3 - A4 - A5 - A8 - A15 - A17

TROUBLE

LOCATION

1-No brightness on tube.	A10 - A11 - A12 - A13 - A18
2-No vertical height. White line across screen Fig. 2	A6 - A8
3-No horizontal width. White line running up and down. Fig. 3	A10 - A11 - A13 - A18
4-Small picture in center of tube. Picture does not fill up entire screen. Fig. 4	A13
5-Picture out of proportion vertically. (top to bottom) Fig. 5	A6 - A8
6-Picture out of proportion horizontally. (side to side) Fig. 6	A10 - A11 - A13 - A18
7-Picture present, but no sound.	A14 - A15 - A17
8-Picture rolls. (Vertical movement up and down). Fig. 8	A6 - A8
9-Picture tears. Figures on screen wave from side to side. Fig. 9	A10 - A11 - A13 - A18
10-Sound, brightness but no picture.	A3 - A4 - A5 - A7 - A8 - A16
11-Brightness, but no picture or sound.	A1 - A2 - A3 - A4 - A5 - A8 - A16

R.C.A. - LAYOUT NO. 156

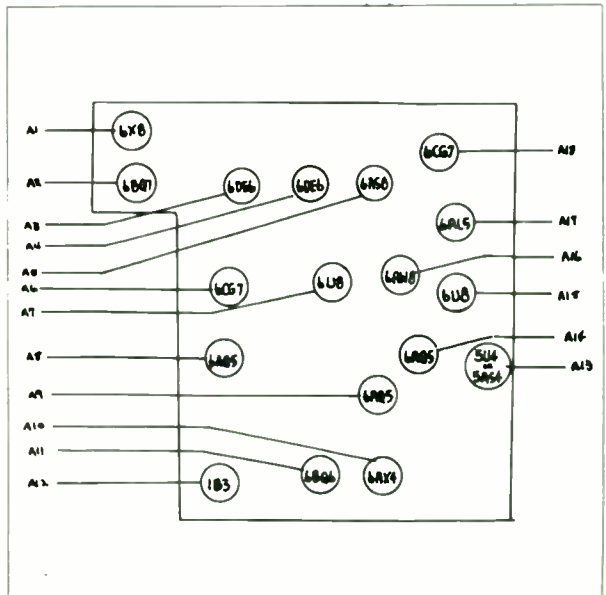

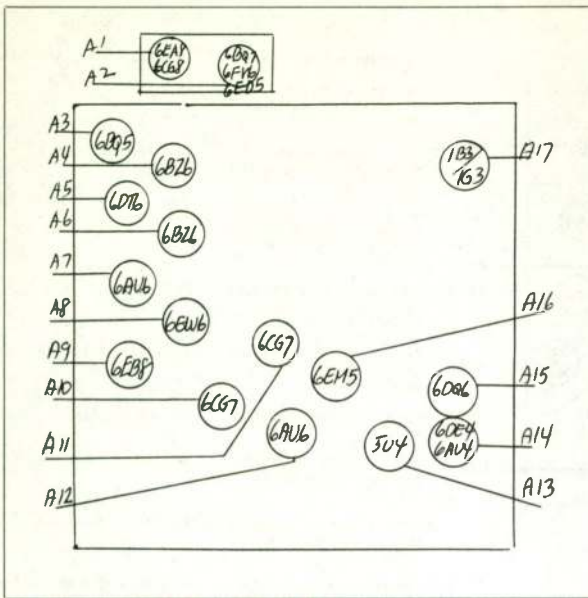

R.C.A. - LAYOUT NO. 157

TROUBLE	LOCATION
1-No brightness on tube.	A10 - A13 - A14 - A15 - A17
2-No vertical height. White line across screen Fig. 2	A11 - A16
3-No horizontal width. White line running up and down. Fig. 3	A10 - A13 - A14 - A15
4-Small picture in center of tube. Picture does not fill up entire screen. Fig. 4	A13
5-Picture out of proportion vertically. (top to bottom) Fig. 5	A11 - A16
6-Picture out of proportion horizontally. (side to side) Fig. 6	A10 - A14 - A15
7-Picture present, but no sound.	A3 - A5 - A7
8-Picture rolls. (Vertical movement up and down). Fig. 8	A9 - A11 - A16
9-Picture tears. Figures on screen wave from side to side. Fig. 9	A9 - A10 - A11 - A14 - A15
10-Sound, brightness but no picture.	A4 - A6 - A8 - A9 - A12
11-Brightness, but no picture or sound.	A1 - A2 - A4 - A6 - A8 - A9 - A12

R.C.A. - LAYOUT NO. 158

TROUBLE	LOCATION
1-No brightness on tube.	A3 - A7 - A8 - A9 *
2-No vertical height. White line across screen Fig. 2	A10 - A11
3-No horizontal width. White line running up and down. Fig. 3	A3 - A7 - A8
4-Small picture in center of tube. Picture does not fill up entire screen. Fig. 4	A3 - A7 - A8 *
5-Picture out of proportion vertically. (top to bottom) Fig. 5	A10 - A11
6-Picture out of proportion horizontally. (side to side) Fig. 6	A3 - A7 - A8
7-Picture present, but no sound.	A12 - A14 - A15
8-Picture rolls. (Vertical movement up and down). Fig. 8	A10 - A11
9-Picture tears. Figures on screen wave from side to side. Fig. 9	A3 - A7 - A8
10-Sound, brightness but no picture.	A4 - A5 - A6 - A13
11-Brightness, but no picture or sound.	A1 - A2 - A4 - A5 - A6 - A13

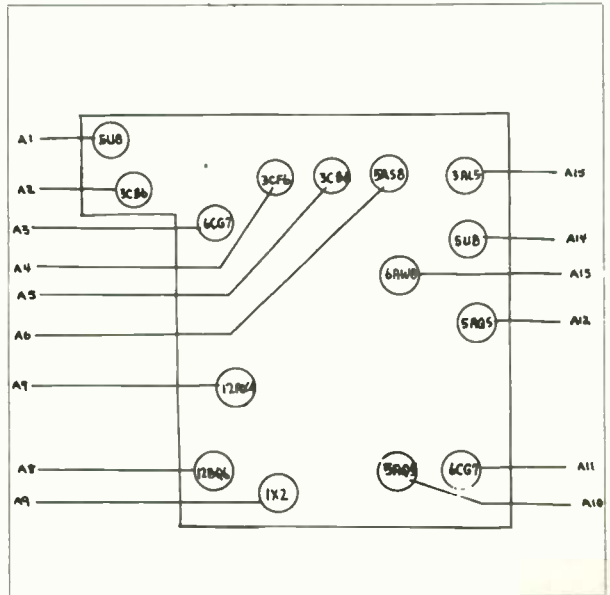

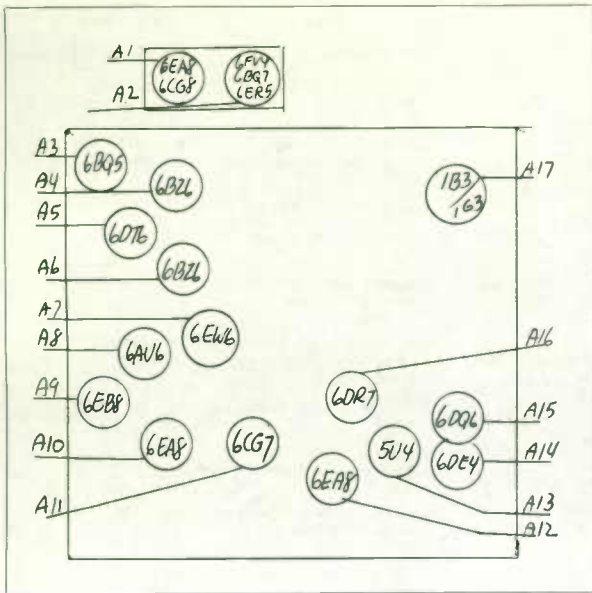

R.C.A. - LAYOUT NO. 159

TROUBLE	LOCATION
1-No brightness on tube.	A11 - A13 - A14 - A15 - A17
2-No vertical height. White line across screen Fig. 2	A16
3-No horizontal width. White line running up and down. Fig. 3	A11 - A13 - A14 - A15
4-Small picture in center of tube. Picture does not fill up entire screen. Fig. 4	A13
5-Picture out of proportion vertically. (top to bottom) Fig. 5	A16
6-Picture out of proportion horizontally. (side to side) Fig. 6	A11 - A14 - A15
7-Picture present, but no sound.	A3 - A5 - A8
8-Picture rolls. (Vertical movement up and down). Fig. 8	A10 - A12 - A16
9-Picture tears. Figures on screen wave from side to side. Fig. 9	A10 - A11 - A12 - A14 - A15
10-Sound, brightness but no picture.	A4 - A6 - A7 - A9
11-Brightness, but no picture or sound.	A1 - A2 - A4 - A6 - A7 - A9

R.C.A. - LAYOUT NO. 160

TROUBLE	LOCATION
1-No brightness on tube.	A7 - A12 - A13 - A15 - A17
2-No vertical height. White line across screen Fig. 2	A14 - A16
3-No horizontal width. White line running up and down. Fig. 3	A7 - A12 - A13 - A15
4-Small picture in center of tube. Picture does not fill up entire screen. Fig. 4	A12
5-Picture out of proportion vertically. (top to bottom) Fig. 5	A14 - A16
6-Picture out of proportion horizontally. (side to side) Fig. 6	A7 - A13 - A15
7-Picture present, but no sound.	A3 - A5 - A8 - A9
8-Picture rolls. (Vertical movement up and down). Fig. 8	A14 - A16
9-Picture tears. Figures on screen wave from side to side. Fig. 9	A7 - A13 - A15 - A16
10-Sound, brightness but no picture.	A4 - A6 - A10 - A11
11-Brightness, but no picture or sound.	A1 - A2 - A4 - A6 - A10 - A11

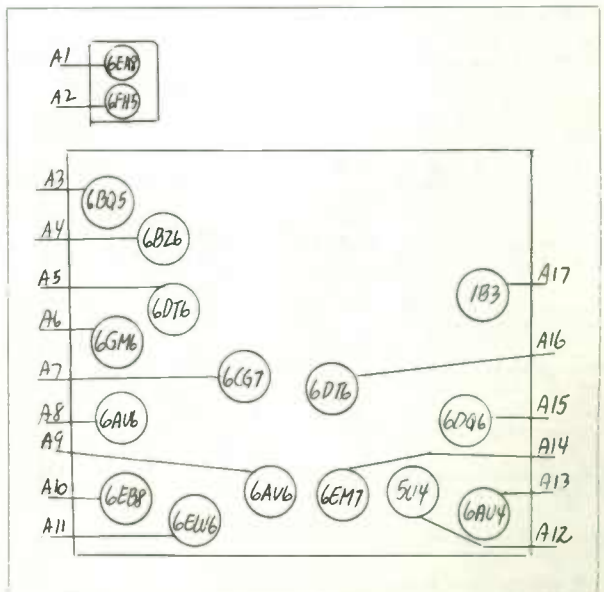

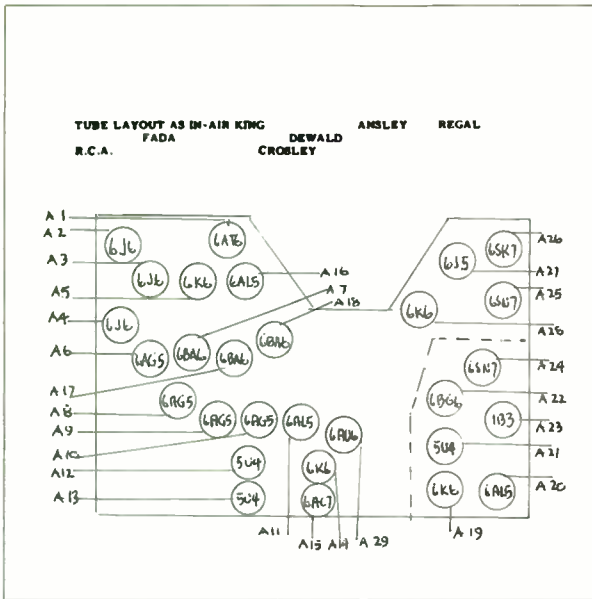

TROUBLE	LOCATION
1-No brightness on tube.	A22 - A19 - A21 - A23 - A24
2-No vertical height. White line across screen Fig. 2	A27 - A28
3-No horizontal width. White line running up and down. Fig. 3	A12 - A13 - A22 - A21 - A19 - A24
4-Small picture in center of tube. Picture does not fill up entire screen. Fig. 4	A12 - A13
5-Picture out of proportion vertically. (top to bottom) Fig. 5	A25 - A26 - A28
6-Picture out of proportion horizontally. (side to side) Fig. 6	A21 - A22
7-Picture present, but no sound.	A7 - A17 - A16 - A18 - A1 - A5
8-Picture rolls. (Vertical movement up and down). Fig. 8	A27
9-Picture tears. Figures on screen wave from side to side. Fig. 9	A15 - A20
10-Sound, brightness but no picture.	A6 - A8 - A9 - A10 - A11 - A14 - A29
11-Brightness, but no picture or sound.	A2 - A3 - A4

R.C.A. - LAYOUT NO. 161

R.C.A. - LAYOUT NO. 162

TROUBLE	LOCATION
1-No brightness on tube.	A10 - A11 - A12 - A13
2-No vertical height. White line across screen Fig. 2	A17 - A19
3-No horizontal width. White line running up and down. Fig. 3	A10 - A12
4-Small picture in center of tube. Picture does not fill up entire screen. Fig. 4	A16
5-Picture out of proportion vertically. (top to bottom) Fig. 5	A17 - A19
6-Picture out of proportion horizontally. (side to side) Fig. 6	A10 - A12
7-Picture present, but no sound.	A6 - A7 - A8 - A20 - A21
8-Picture rolls. (Vertical movement up and down). Fig. 8	A17
9-Picture tears. Figures on screen wave from side to side. Fig. 9	A9 - A14 - A15
10-Sound, brightness but no picture.	A2 - A6 - A7 - A8 - A18
11-Brightness, but no picture or sound.	A1 - A3 - A4 - A5

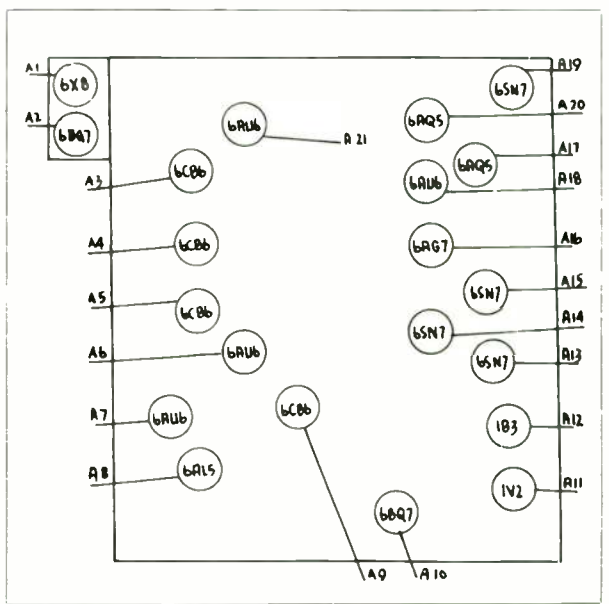

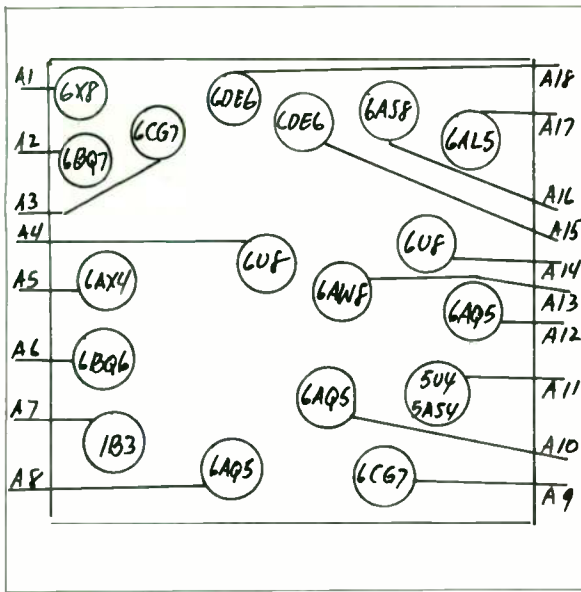

TROUBLE	LOCATION
1-No brightness on tube.	A11 - A12 - A13 - A14 *
2-No vertical height. White line across screen Fig. 2	A7
3-No horizontal width. White line running up and down. Fig. 3	A11 - A12 - A14 *
4-Small picture in center of tube. Picture does not fill up entire screen. Fig. 4	A11 - A12 - A14 *
5-Picture out of proportion vertically. (top to bottom) Fig. 5	A7
6-Picture out of proportion horizontally. (side to side) Fig. 6	A11 - A12 - A14
7-Picture present, but no sound.	A5 - A6 - A15
8-Picture rolls. (Vertical movement up and down). Fig. 8	A7 - A9
9-Picture tears. Figures on screen wave from side to side. Fig. 9	A9 - A10 - A11 - A12 - A14
10-Sound, brightness but no picture.	A3 - A4 - A5 - A8 - A10
11-Brightness, but no picture or sound.	A1 - A2 - A3 - A4 - A5 - A8 - A10

* Selenium Rectifiers

R.C.A. - LAYOUT NO. 163

R.C.A. - LAYOUT NO. 164

TROUBLE	LOCATION
1-No brightness on tube.	A8 - A9 - A10 - A11 - A15
2-No vertical height. White line across screen Fig. 2	A1 - A2
3-No horizontal width. White line running up and down. Fig. 3	A8 - A9 - A10 - A15
4-Small picture in center of tube. Picture does not fill up entire screen. Fig. 4	A8
5-Picture out of proportion vertically. (top to bottom) Fig. 5	A1 - A2
6-Picture out of proportion horizontally. (side to side) Fig. 6	A9 - A10 - A15
7-Picture present, but no sound.	A16 - A17 - A18 - A19
8-Picture rolls. (Vertical movement up and down). Fig. 8	A1 - A2 - A14
9-Picture tears. Figures on screen wave from side to side. Fig. 9	A2 - A9 - A10 - A14 - A15
10-Sound, brightness but no picture.	A4 - A6 - A12 - A13 - A14
11-Brightness, but no picture or sound.	A3 - A4 - A5 - A6 - A12 - A13 - A14 (A7 - UHF only)

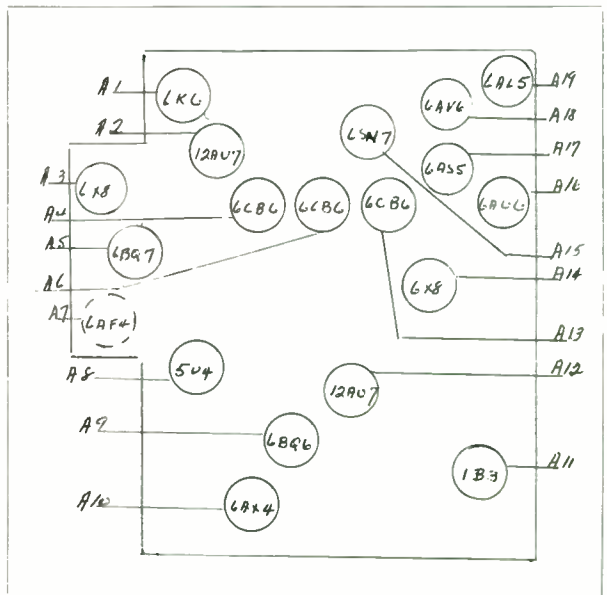

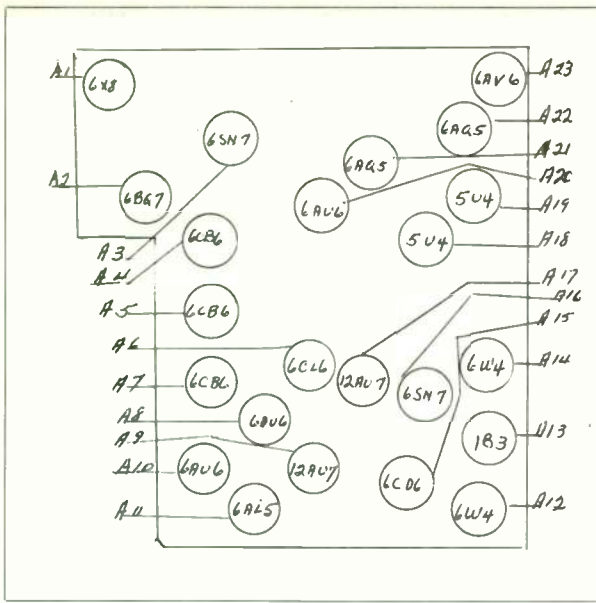

TROUBLE	LOCATION
1-No brightness on tube.	A12 - A13 - A14 - A15 - A16 A18 - A19
2-No vertical height. White line across screen Fig. 2	A3 - A21
3-No horizontal width. White line running up and down. Fig. 3	A12 - A14 - A15 - A16 - A18 A19
4-Small picture in center of tube. Picture does not fill up entire screen. Fig. 4	A18 - A19
5-Picture out of proportion vertically. (top to bottom) Fig. 5	A3 - A21
6-Picture out of proportion horizontally. (side to side) Fig. 6	A12 - A14 - A15 - A16
7-Picture present, but no sound.	A8 - A10 - A11 - A22 - A23
8-Picture rolls. (Vertical movement up and down). Fig. 8	A3 - A9 - A21
9-Picture tears. Figures on screen wave from side to side. Fig. 9	A12 - A14 - A15 - A16 - A17
10-Sound, brightness but no picture.	A4 - A5 - A6 - A7 - A20
11-Brightness, but no picture or sound.	A1 - A2 - A4 - A5 - A7 - A20

R.C.A. - LAYOUT NO. 165

TROUBLE	LOCATION
1-No brightness on tube.	A4 - A8 - A9 - A10 - A13
2-No vertical height. White line across screen Fig. 2	A11 - A12
3-No horizontal width. White line running up and down. Fig. 3	A4 - A8 - A9 - A13
4-Small picture in center of tube. Picture does not fill up entire screen. Fig. 4	A13
5-Picture out of proportion vertically. (top to bottom) Fig. 5	A11 - A12
6-Picture out of proportion horizontally. (side to side) Fig. 6	A4 - A8 - A9
7-Picture present, but no sound.	A15 - A17 - A19
8-Picture rolls. (Vertical movement up and down). Fig. 8	A11 - A12 - A18
9-Picture tears. Figures on screen wave from side to side. Fig. 9	A4 - A8 - A9 - A12 - A18
10-Sound, brightness but no picture.	A5 - A6 - A7 - A14 - A16 - A18
11-Brightness, but no picture or sound.	A1 - A2 - A5 - A6 - A7 - A14 - A16 - A18 (A3 - UHF only)

R.C.A. - LAYOUT NO. 166

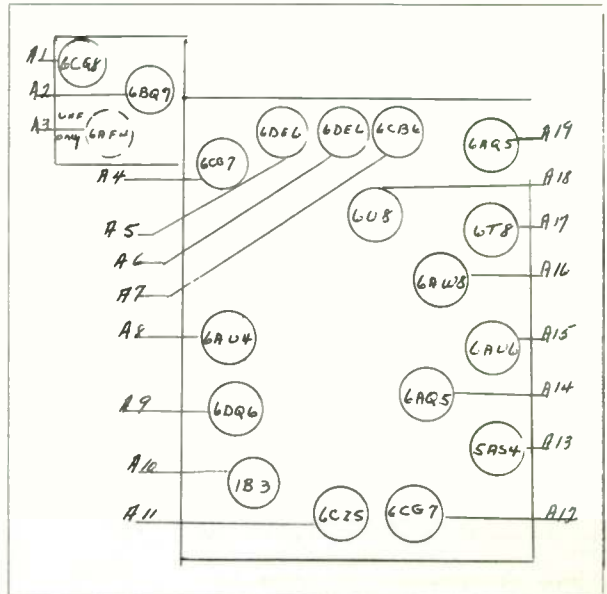

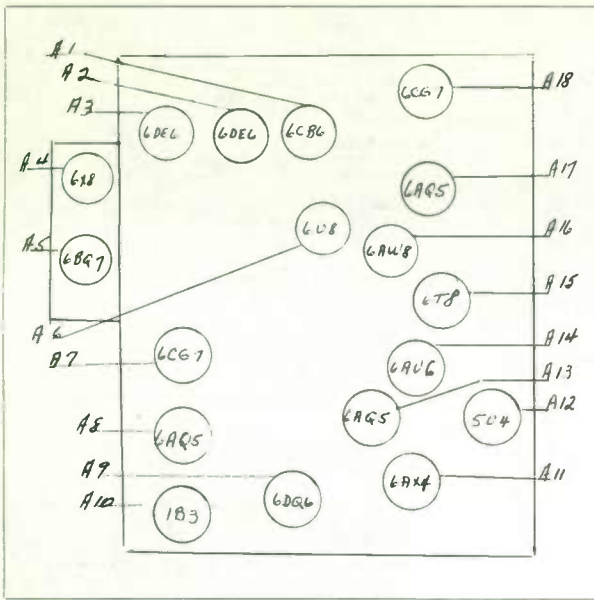

R.C.A. - LAYOUT NO. 167

TROUBLE	LOCATION
1-No brightness on tube.	A9 - A10 - A11 - A12 - A18
2-No vertical height. White line across screen Fig. 2	A7 - A8
3-No horizontal width. White line running up and down. Fig. 3	A9 - A11 - A12 - A18
4-Small picture in center of tube. Picture does not fill up entire screen. Fig. 4	A12
5-Picture out of proportion vertically. (top to bottom) Fig. 5	A7 - A8
6-Picture out of proportion horizontally. (side to side) Fig. 6	A9 - A11 - A18
7-Picture present, but no sound.	A14 - A15 - A17
8-Picture rolls. (Vertical movement up and down). Fig. 8	A6 - A7 - A8
9-Picture tears. Figures on screen wave from side to side. Fig. 9	A6 - A7 - A9 - A11 - A18
10-Sound, brightness but no picture.	A1 - A2 - A3 - A6 - A13 - A16
11-Brightness, but no picture or sound.	A1 - A2 - A3 - A4 - A5 - A6 - A13 - A16

TROUBLE

LOCATION

R.C.A. - LAYOUT NO. 168

1-No brightness on tube.	A5 - A8 - A9 - A10 - A12
2-No vertical height. White line across screen Fig. 2	A11 - A13
3-No horizontal width. White line running up and down. Fig. 3	A5 - A8 - A10 - A12
4-Small picture in center of tube. Picture does not fill up entire screen. Fig. 4	A12
5-Picture out of proportion vertically. (top to bottom) Fig. 5	A11 - A13
6-Picture out of proportion horizontally. (side to side) Fig. 6	A5 - A8 - A10
7-Picture present, but no sound.	A14 - A16 - A17
8-Picture rolls. (Vertical movement up and down). Fig. 8	A11 - A13 - A15
9-Picture tears. Figures on screen wave from side to side. Fig. 9	A5 - A8 - A10 - A13 - A15
10-Sound, brightness but no picture.	A4 - A6 - A7 - A15
11-Brightness, but no picture or sound.	A1 - A2 - A4 - A6 - A7 - A15 (A3-UMF only)

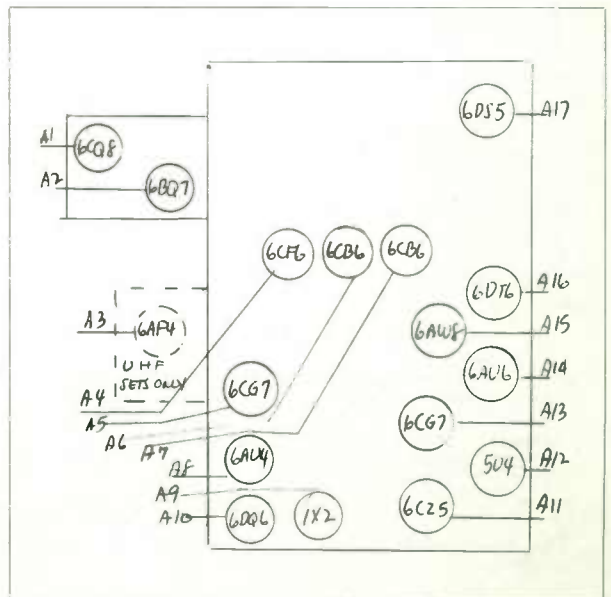

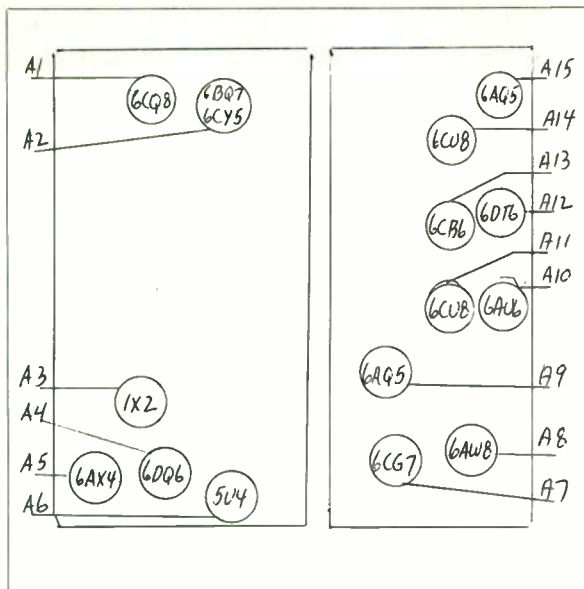

TROUBLE	LOCATION
1-No brightness on tube.	A3 - A4 - A5 - A6 - A7
2-No vertical height. White line across screen Fig. 2	A9 - A14
3-No horizontal width. White line running up and down. Fig. 3	A4 - A5 - A6 - A7
4-Small picture in center of tube. Picture does not fill up entire screen. Fig. 4	A6
5-Picture out of proportion vertically. (top to bottom) Fig. 5	A9 - A14
6-Picture out of proportion horizontally. (side to side) Fig. 6	A4 - A5 - A7
7-Picture present, but no sound.	A10 - A12 - A15
8-Picture rolls. (Vertical movement up and down). Fig. 8	A8 - A9 - A11 - A14
9-Picture tears. Figures on screen wave from side to side. Fig. 9	A4 - A5 - A7 - A8 - A11
10-Sound, brightness but no picture.	A8 - A11 - A13 - A14
11-Brightness, but no picture or sound.	A1 - A2 - A8 - A11 - A13 - A14

R. C. A. VICTOR - LAYOUT NO. 169

TROUBLE	LOCATION
1-No brightness on tube.	A3 - A4 - A5 - A6 - A9
2-No vertical height. White line across screen Fig. 2	A7 - A8
3-No horizontal width. White line running up and down. Fig. 3	A3 - A4 - A5 - A9
4-Small picture in center of tube. Picture does not fill up entire screen. Fig. 4	A9
5-Picture out of proportion vertically. (top to bottom) Fig. 5	A7 - A8.
6-Picture out of proportion horizontally. (side to side) Fig. 6	A3 - A4 - A5
7-Picture present, but no sound.	A11 - A12 - A14
8-Picture rolls. (Vertical movement up and down). Fig. 8	A7 - A8 - A13
9-Picture tears. Figures on screen wave from side to side. Fig. 9	A3 - A4 - A5 - A13
10-Sound, brightness but no picture.	A10 - A13 - A15 - A16 - A17 - A18
11-Brightness, but no picture or sound.	A1 - A2 - A13 - A15 - A16 - A17 - A18

R. C. A. VICTOR - LAYOUT NO. 170

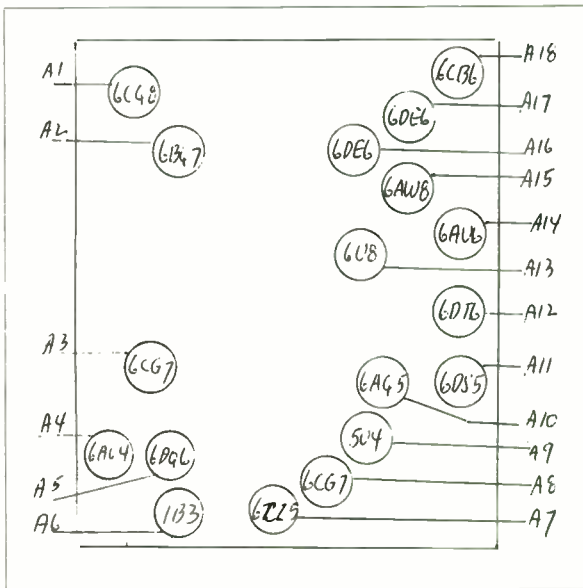

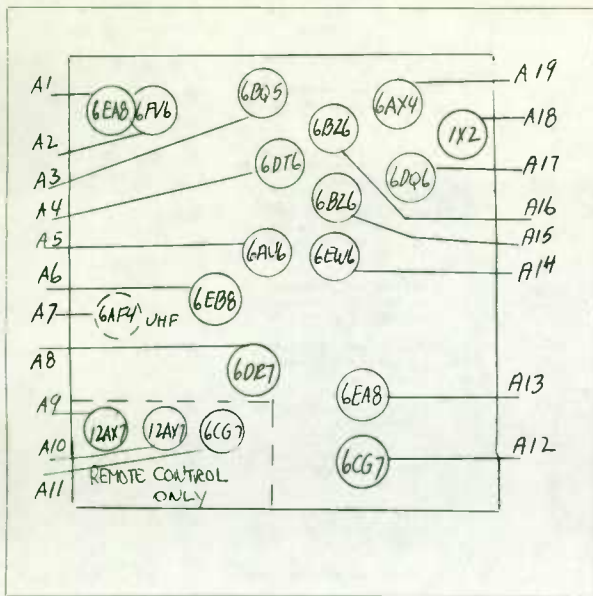

TROUBLE	LOCATION
1-No brightness on tube.	A12 - A17 - A18 - A19
2-No vertical height. White line across screen Fig. 2	A8
3-No horizontal width. White line running up and down. Fig. 3	A12 - A17 - A19
4-Small picture in center of tube. Picture does not fill up entire screen. Fig. 4	A12 - A17 - A19
5-Picture out of proportion vertically. (top to bottom) Fig. 5	A8
6-Picture out of proportion horizontally. (side to side) Fig. 6	A12 - A17 - A19
7-Picture present, but no sound.	A3 - A4 - A5
8-Picture rolls. (Vertical movement up and down). Fig. 8	A6 - A8 - A13
9-Picture tears. Figures on screen wave from side to side. Fig. 9	A6 - A12 - A13 - A17 - A19
10-Sound, brightness but no picture.	A6 - A14 - A15 - A16
11-Brightness, but no picture or sound.	A1 - A2 - A6 - A14 - A15 - A16 - (A7 - UHF)

RCA VICTOR - LAYOUT NO. 171

TROUBLE	LOCATION
No brightness on tube.	A8 - A9 - A10 - A13
No vertical height. White line across screen Fig. 2	A12
No horizontal width. White line running up and down. Fig. 3	A9 - A10 - A13
Small picture in center of tube. Picture does not fill up entire screen. Fig. 4	A9 - A10 - A13
Picture out of proportion vertically. (top to bottom) Fig. 5	A12
Picture out of proportion horizontally. (side to side) Fig. 6	A9 - A10 - A13
Picture present, but no sound.	A3 - A5 - A6
Picture rolls. (Vertical movement up and down). Fig. 8	A3 - A4 - A12
Picture tears. Figures on screen wave from side to side. Fig. 9	A3 - A4 - A9 - A10 - A13
-Sound, brightness but no picture.	A4 - A7 - A11
-Brightness, but no picture or sound.	A1 - A2 - A4 - A7 - A11

SILVERTONE-LAYOUT NO. 172

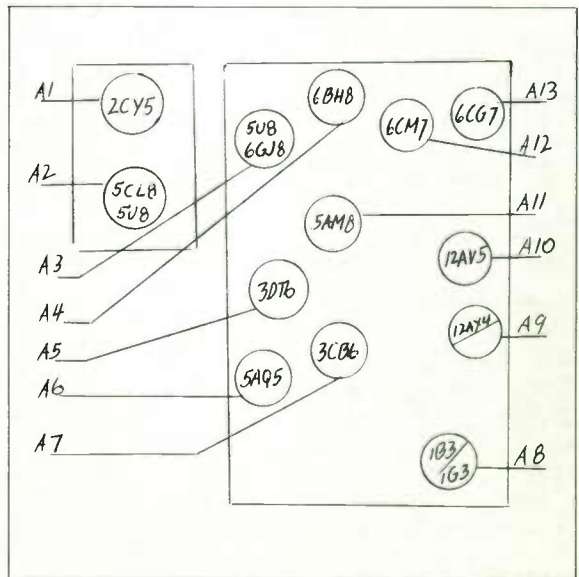

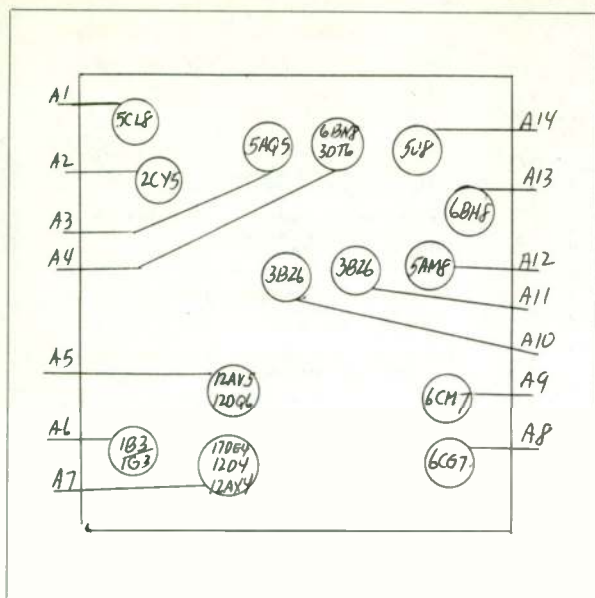

SILVERTONE-LAYOUT NO. 173

TROUBLE	LOCATION
1-No brightness on tube.	A5 - A6 - A7 - A8*
2-No vertical height. White line across screen Fig. 2	A9
3-No horizontal width. White line running up and down. Fig. 3	A5 - A7 - A8*
4-Small picture in center of tube. Picture does not fill up entire screen. Fig. 4	A5 - A7 - A8*
5-Picture out of proportion vertically. (top to bottom) Fig. 5	A9
6-Picture out of proportion horizontally. (side to side) Fig. 6	A5 - A7 - A8
7-Picture present, but no sound.	A3 - A4 - A14
8-Picture rolls. (Vertical movement up and down). Fig. 8	A9 - A13 - A14
9-Picture tears. Figures on screen wave from side to side. Fig. 9	A5 - A7 - A8 - A13 - A14
10-Sound, brightness but no picture.	A10 - A11 - A12 - A13
11-Brightness, but no picture or sound.	A1 - A2 - A10 - A11 - A12 - A13

* Selenium Rectifiers.

TROUBLE

LOCATION

1-No brightness on tube.	A9 - A10 - A11 - A13*
2-No vertical height. White line across screen Fig. 2	A12
3-No horizontal width. White line running up and down. Fig. 3	A10 - A11 - A13*
4-Small picture in center of tube. Picture does not fill up entire screen. Fig. 4	A10 - A11 - A13*
5-Picture out of proportion vertically. (top to bottom) Fig. 5	A12
6-Picture out of proportion horizontally. (side to side) Fig. 6	A10 - A11 - A13
7-Picture present, but no sound.	A2 - A4 - A6
8-Picture rolls. (Vertical movement up and down). Fig. 8	A1 - A2 - A12
9-Picture tears. Figures on screen wave from side to side. Fig. 9	A1 - A2 - A10 - A11 - A13
10-Sound, brightness but no picture.	A1 - A3 - A5
11-Brightness, but no picture or sound.	A1 - A3 - A5 - A7 - A8

* Selenium Rectifiers.

SILVERTONE-LAYOUT NO. 174

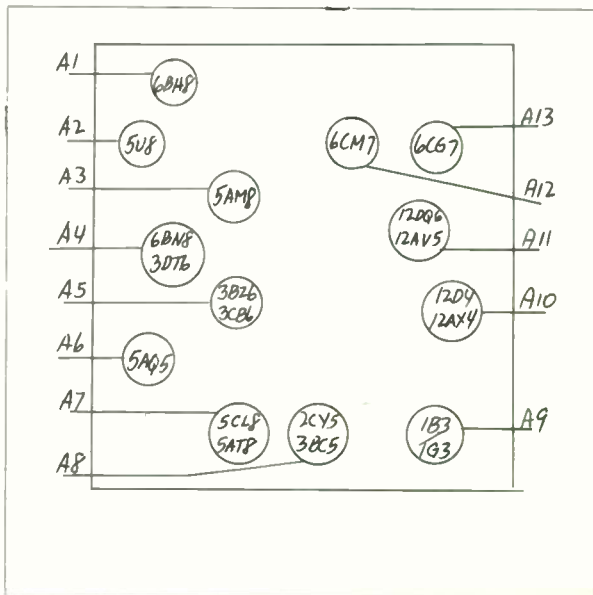

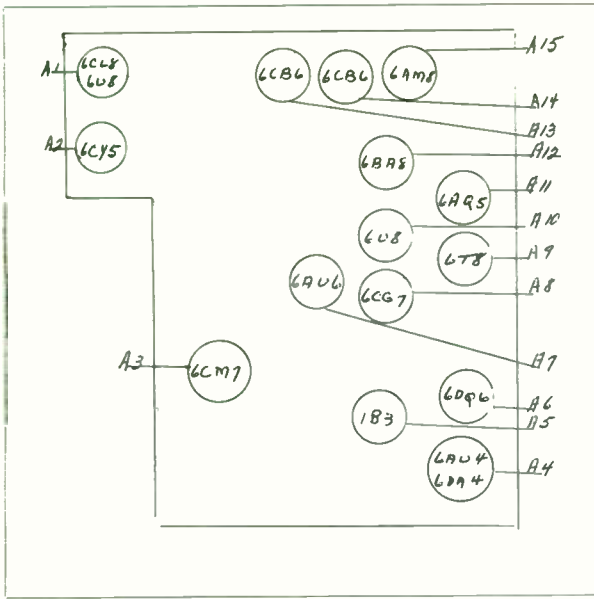

TROUBLE	LOCATION
1-No brightness on tube.	A4 - A5 - A6 - A8 *
2-No vertical height. White line across screen Fig. 2	A3
3-No horizontal width. White line running up and down. Fig. 3	A4 - A6 - A8 *
4-Small picture in center of tube. Picture does not fill up entire screen. Fig. 4	A4 - A6 - A8 *
5-Picture out of proportion vertically. (top to bottom) Fig. 5	A3
6-Picture out of proportion horizontally. (side to side) Fig. 6	A4 - A6 - A8
7-Picture present, but no sound.	A9 - A10 - A11
8-Picture rolls. (Vertical movement up and down). Fig. 8	A3 - A10 - A12
9-Picture tears. Figures on screen wave from side to side. Fig. 9	A4 - A6 - A8 - A10 - A12
10-Sound, brightness but no picture.	A7 - A12 - A13 - A14 - A15
11-Brightness, but no picture or sound.	A1 - A2 - A7 - A12 - A13 - A14 - A15

* Selenium Rectifiers

SILVERTONE NO. 175

SILVERTONE - LAYOUT NO. 176

TROUBLE	LOCATION
1-No brightness on tube.	A6 - A7 - A8 - A9 *
2-No vertical height. White line across screen Fig. 2	A5
3-No horizontal width. White line running up and down. Fig. 3	A6 - A8 - A9 *
4-Small picture in center of tube. Picture does not fill up entire screen. Fig. 4	A6 - A8 - A9 *
5-Picture out of proportion vertically. (top to bottom) Fig. 5	A5
6-Picture out of proportion horizontally. (side to side) Fig. 6	A6 - A8 - A9
7-Picture present, but no sound.	A3 - A4 - A10
8-Picture rolls. (Vertical movement up and down). Fig. 8	A5 - A10 - A11
9-Picture tears. Figures on screen wave from side to side. Fig. 9	A6 - A8 - A9 - A10 - A11
10-Sound, brightness but no picture.	A11 - A12 - A13
11-Brightness, but no picture or sound.	A1 - A2 - A11 - A12 - A13

* Selenium Rectifiers

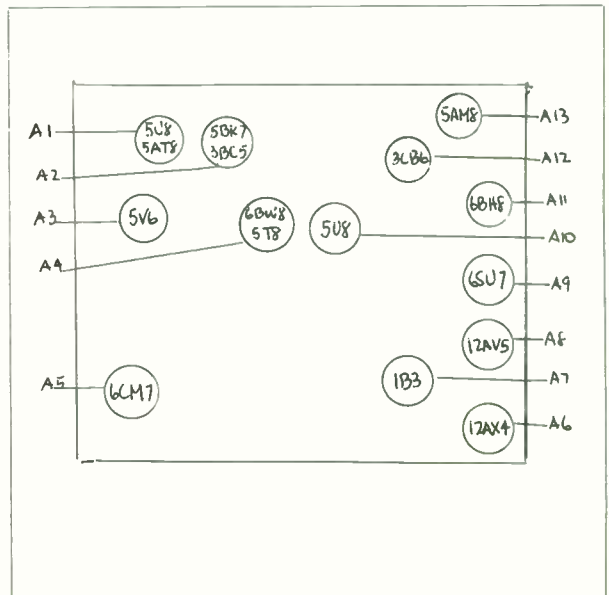

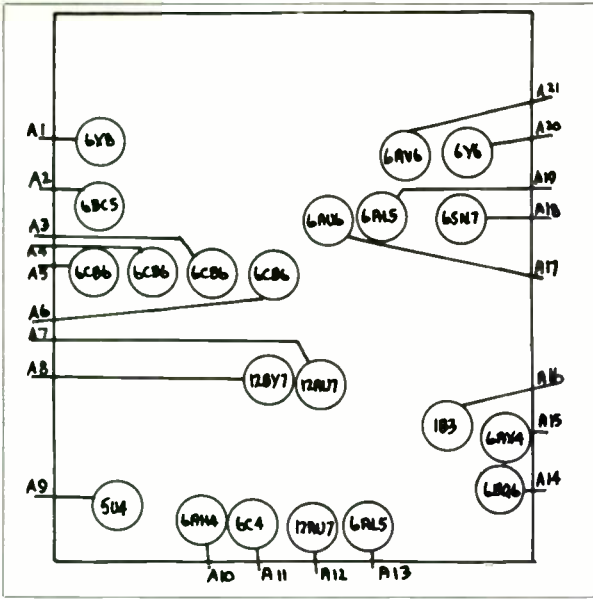

SYLVANIA - LAYOUT NO. 177

TROUBLE	LOCATION
1-No brightness on tube.	A14 - A15 - A16 - A18
2-No vertical height. White line across screen Fig. 2	A10 - A11
3-No horizontal width. White line running up and down. Fig. 3	A14 - A15 - A18
4-Small picture in center of tube. Picture does not fill up entire screen. Fig. 4	A9
5-Picture out of proportion vertically. (top to bottom) Fig. 5	A10 - A11
6-Picture out of proportion horizontally. (side to side) Fig. 6	A14 - A15 - A18
7-Picture present, but no sound.	A17 - A19 - A20 - A21
8-Picture rolls. (Vertical movement up and down). Fig. 8	A11 - A12
9-Picture tears. Figures on screen wave from side to side. Fig. 9	A7 - A12 - A13 - A18
10-Sound, brightness but no picture.	A8
11-Brightness, but no picture or sound.	A1 - A2 - A3 - A4 - A5 - A6

TROUBLE

LOCATION

1-No brightness on tube.	A13 - A15 - A16 - A17 *
2-No vertical height. White line across screen Fig. 2	A1 - A2
3-No horizontal width. White line running up and down. Fig. 3	A13 - A16 - A17
4-Small picture in center of tube. Picture does not fill up entire screen. Fig. 4	A13 - A16 - A17 *
5-Picture out of proportion vertically. (top to bottom) Fig. 5	A1 - A2
6-Picture out of proportion horizontally. (side to side) Fig. 6	A13 - A16 - A17
7-Picture present, but no sound.	A9 - A10 - A11 - A12 - A14
8-Picture rolls. (Vertical movement up and down). Fig. 8	A1 - A2 - A14
9-Picture tears. Figures on screen wave from side to side. Fig. 9	A12 - A13 - A14 - A16 - A17
10-Sound, brightness but no picture.	A6 - A7 - A8 - A14
11-Brightness, but no picture or sound.	A3 - A4 - A6 - A7 - A8 - A14 (A5 UHF only)

* Selenium Rectifiers

SYLVANIA - LAYOUT NO. 178

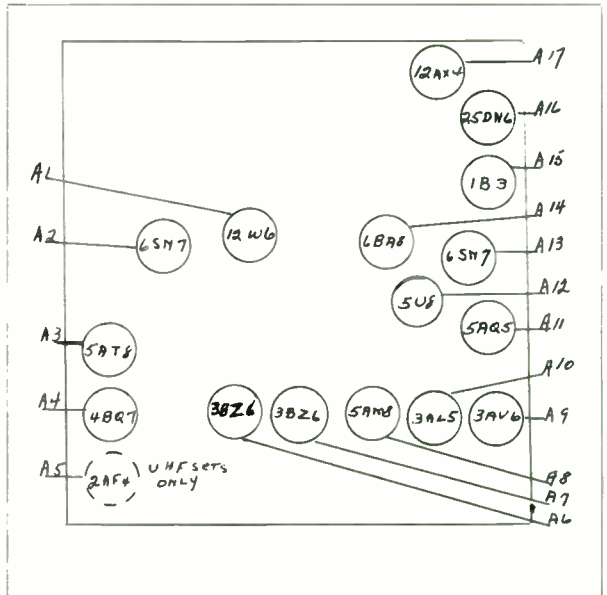

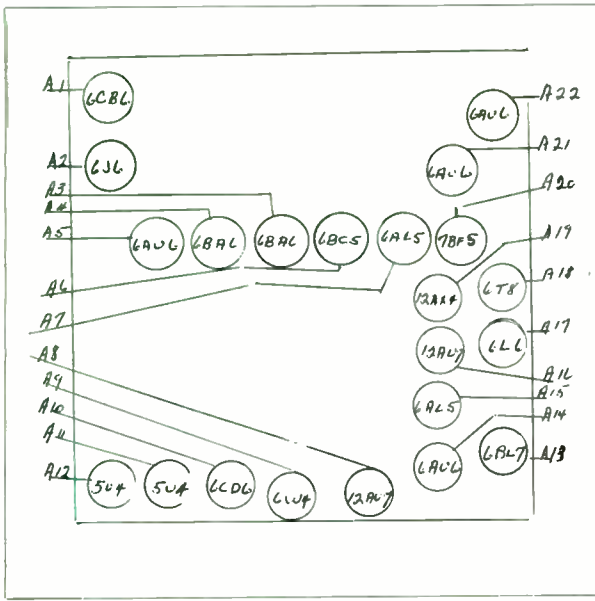

TROUBLE	LOCATION
1-No brightness on tube.	A8 - A9 - A10 - A11 - A12
2-No vertical height. White line across screen Fig. 2	A13
3-No horizontal width. White line running up and down. Fig. 3	A8 - A9 - A10 - A11 - A12
4-Small picture in center of tube. Picture does not fill up entire screen. Fig. 4	A11 - A12
5-Picture out of proportion vertically. (top to bottom) Fig. 5	A13
6-Picture out of proportion horizontally. (side to side) Fig. 6	A8 - A9 - A10
7-Picture present, but no sound.	A17 - A18 - A21 - A22
8-Picture rolls. (Vertical movement up and down). Fig. 8	A13 - A16 - A19
9-Picture tears. Figures on screen wave from side to side. Fig. 9	A8 - A9 - A10 - A14 - A15 - A16 - A19
10-Sound, brightness but no picture.	A3 - A4 - A5 - A6 - A7
11-Brightness, but no picture or sound.	A1 - A2 - A3 - A4 - A5 - A6 - A7

SYLVANIA-LAYOUT NO. 179

TROUBLE

LOCATION

1-No brightness on tube.	A9 - A13 - A14 - A15
2-No vertical height. White line across screen Fig. 2	A11
3-No horizontal width. White line running up and down. Fig. 3	A9 - A13 - A14
4-Small picture in center of tube. Picture does not fill up entire screen. Fig. 4	A9 - A13 - A14
5-Picture out of proportion vertically. (top to bottom) Fig. 5	A11
6-Picture out of proportion horizontally. (side to side) Fig. 6	A9 - A13 - A14
7-Picture present, but no sound.	A6 - A7 - A8
8-Picture rolls. (Vertical movement up and down). Fig. 8	A10 - A11
9-Picture tears. Figures on screen wave from side to side. Fig. 9	A9 - A10 - A12 - A13 - A14
10-Sound, brightness but no picture.	A4 - A5 - A12
11-Brightness, but no picture or sound.	A2 - A3 - A4 - A5 - A12 - (A1 - UHF only)

SYLVANIA - LAYOUT NO. 180

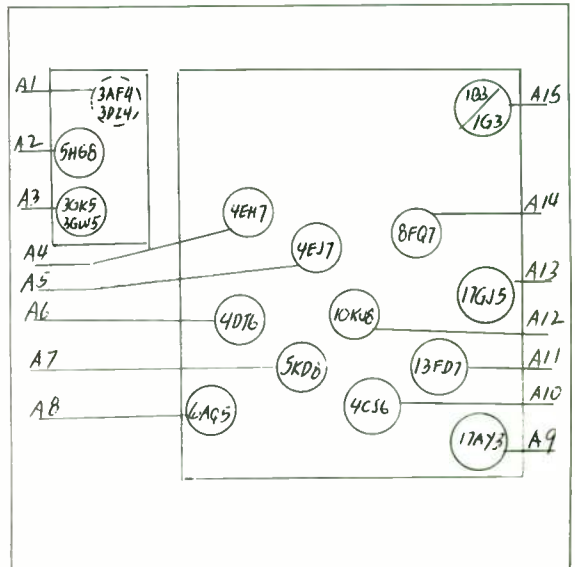

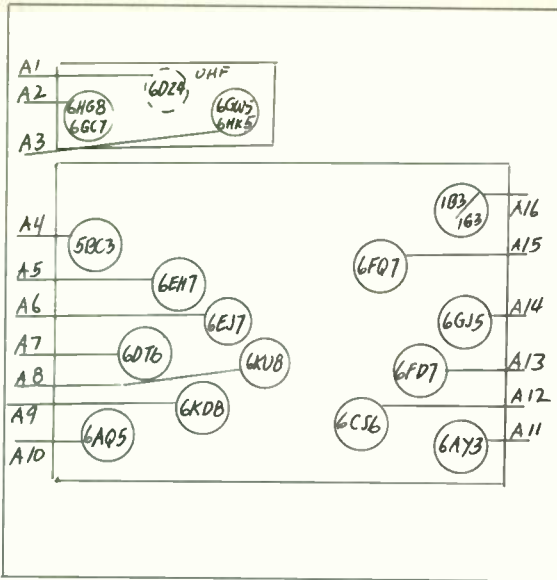

TROUBLE	LOCATION
1-No brightness on tube.	A11 - A14 - A15 - A16 (A4)
2-No vertical height. White line across screen Fig. 2	A13
3-No horizontal width. White line running up and down. Fig. 3	A11 - A14 - A15 (A4)
4-Small picture in center of tube. Picture does not fill up entire screen. Fig. 4	A4
5-Picture out of proportion vertically. (top to bottom) Fig. 5	A13
6-Picture out of proportion horizontally. (side to side) Fig. 6	A11 - A14 - A15
7-Picture present, but no sound.	A7 - A9 - A10
8-Picture rolls. (Vertical movement up and down). Fig. 8	A12 - A13
9-Picture tears. Figures on screen wave from side to side. Fig. 9	A7 - A8 - A9 - A10 - A12
10-Sound, brightness but no picture.	A5 - A6 - A8 - A9
11-Brightness, but no picture or sound.	A2 - A3 - A5 - A6 - A8 - A9 - (A1 UHF only)

SYLVANIA-LAYOUT NO. 181

TROUBLE

LOCATION

1-No brightness on tube.	A8 - A9 - A10 - A12 *
2-No vertical height. White line across screen Fig. 2	A11
3-No horizontal width. White line running up and down. Fig. 3	A8 - A10 - A12 *
4-Small picture in center of tube. Picture does not fill up entire screen. Fig. 4	A8 - A10 - A12 *
5-Picture out of proportion vertically. (top to bottom) Fig. 5	A11
6-Picture out of proportion horizontally. (side to side) Fig. 6	A8 - A10 - A12
7-Picture present, but no sound.	A2 - A5 - A13
8-Picture rolls. (Vertical movement up and down). Fig. 8	A1 - A2 - A11
9-Picture tears. Figures on screen wave from side to side. Fig. 9	A1 - A8 - A10 - A12
10-nd, brightness but no tube.	A1 - A3 - A4
ightness, but no picture sound.	A1 - A3 - A4 - A6 - A7

* Selenium Rectifiers

SYLVANIA-LAYOUT NO. 182

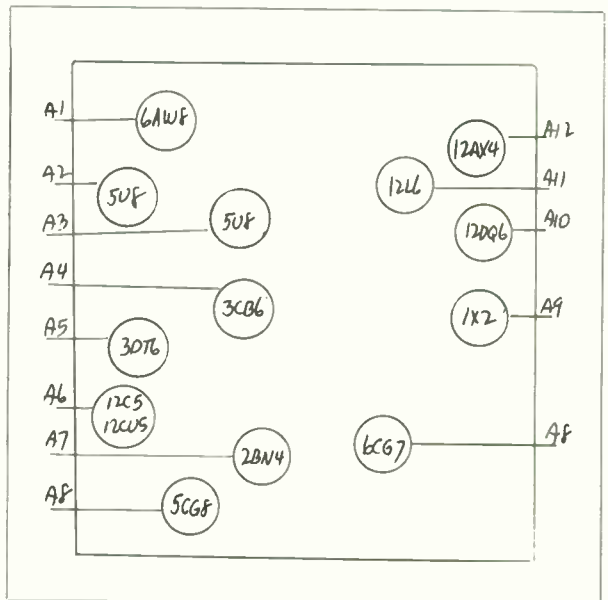

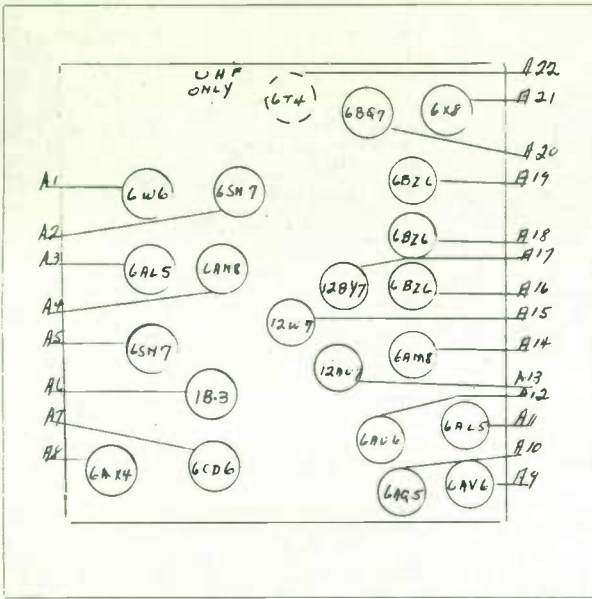

TROUBLE	LOCATION
1-No brightness on tube.	A5 - A6 - A7 - A8 *
2-No vertical height. White line across screen Fig. 2	A1 - A2
3-No horizontal width. White line running up and down. Fig. 3	A5 - A7 - A8
4-Small picture in center of tube. Picture does not fill up entire screen. Fig. 4	A5 - A7 - A8 *
5-Picture out of proportion vertically. (top to bottom) Fig. 5	A1 - A2
6-Picture out of proportion horizontally. (side to side) Fig. 6	A5 - A7 - A8
7-Picture present, but no sound.	A9 - A10 - A11 - A12 - A13
8-Picture rolls. (Vertical movement up and down). Fig. 8	A1 - A2 - A4 - A13
9-Picture tears. Figures on screen wave from side to side. Fig. 9	A3 - A5 - A7 - A8 - A13 - A15
10-Sound, brightness but no picture.	A4 - A14 - A16 - A17 - A18 - A19
11-Brightness, but no picture or sound.	A4 - A14 - A16 - A18 - A19 - A20 - A21 (A22-UHF only)

* Selenium Rectifiers

SYLVANIA-LAYOUT NO. 183

TROUBLE	LOCATION
1-No brightness on tube.	A7 - A12 - A13 - A14 - A19
2-No vertical height. White line across screen Fig. 2	A8 - A9
3-No horizontal width. White line running up and down. Fig. 3	A7 - A12 - A14 - A19
4-Small picture in center of tube. Picture does not fill up entire screen. Fig. 4	A7
5-Picture out of proportion vertically. (top to bottom) Fig. 5	A8 - A9
6-Picture out of proportion horizontally. (side to side) Fig. 6	A12 - A14 - A19
7-Picture present, but no sound.	A17 - A18 - A20 - A21
8-Picture rolls. (Vertical movement up and down). Fig. 8	A8 - A9 - A10
9-Picture tears. Figures on screen wave from side to side. Fig. 9	A10 - A11 - A12 - A14 - A15 - A19
10-Sound, brightness but no picture.	A3 - A4 - A5 - A6 - A16
11-Brightness, but no picture or sound.	A1 - A2 - A3 - A4 - A5 - A6

SYLVANIA-LAYOUT NO. 184

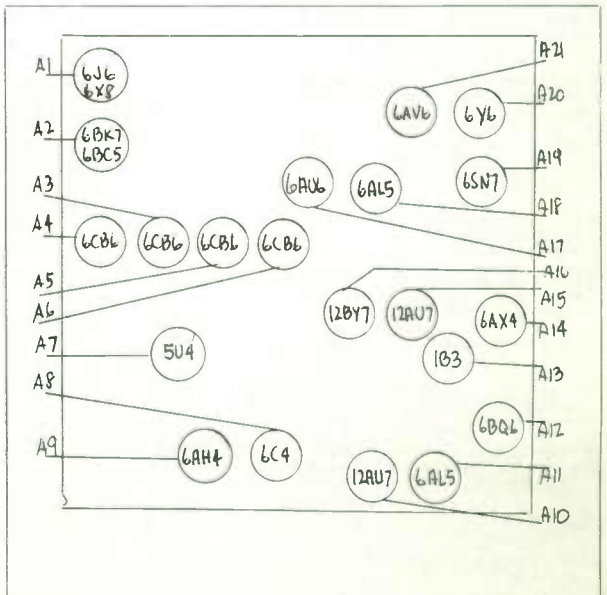

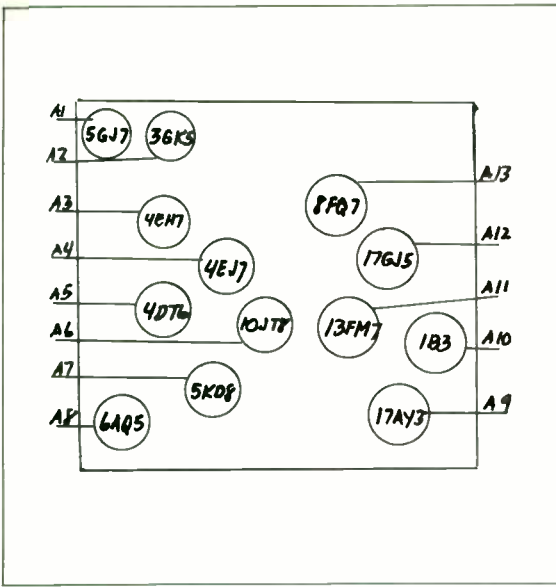

TROUBLE	LOCATION
1-No brightness on tube.	A9 - A10 - A12 - A13
2-No vertical height. White line across screen Fig. 2	A11
3-No horizontal width. White line running up and down. Fig. 3	A9 - A12 - A13
4-Small picture in center of tube. Picture does not fill up entire screen. Fig. 4	A9 - A12 - A13
5-Picture out of proportion vertically. (top to bottom) Fig. 5	A11
6-Picture out of proportion horizontally. (side to side) Fig. 6	A9 - A12 - A13
7-Picture present, but no sound.	A5 - A7 - A8
8-Picture rolls. (Vertical movement up and down). Fig. 8	A6 - A11
9-Picture tears. Figures on screen wave from side to side. Fig. 9	A6 - A9 - A12 - A13
10-Sound, brightness but no picture.	A3 - A4 - A6 - A7
11-Brightness, but no picture or sound.	A1 - A2 - A3 - A4 - A6 - A7

SYLVANIA-LAYOUT NO. 185

TROUBLE

LOCATION

1-No brightness on tube.	A8 - A9 - A12 - A14 - A17 - A18 - A19 - A13
2-No vertical height. White line across screen Fig. 2	A10 - A11
3-No horizontal width. White line running up and down. Fig. 3	A8 - A9 - A12 - A14 - A17 - A19 - A13
4-Small picture in center of tube. Picture does not fill up entire screen. Fig. 4	A8 - A9
5-Picture out of proportion vertically. (top to bottom) Fig. 5	A10 - A11
6-Picture out of proportion horizontally. (side to side) Fig. 6	A12 - A14 - A17 - A19 - A13
7-Picture present, but no sound.	A21 - A22 - A23 - A24 - A25
8-Picture rolls. (Vertical movement up and down). Fig. 8	A10 - A11 - A15 - A16
9-Picture tears. Figures on screen wave from side to side. Fig. 9	A12 - A14 - A15 - A16 - A19 - A20 - A13
10-Sound, brightness but no picture.	A3 - A4 - A5 - A6 - A7
11-Brightness, but no picture or sound.	A1 - A2 - A3 - A4 - A5 - A6

SYLVANIA-LAYOUT NO. 186

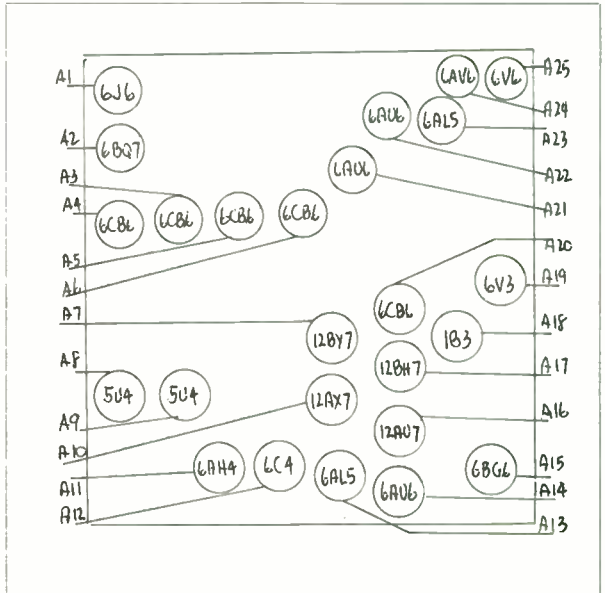

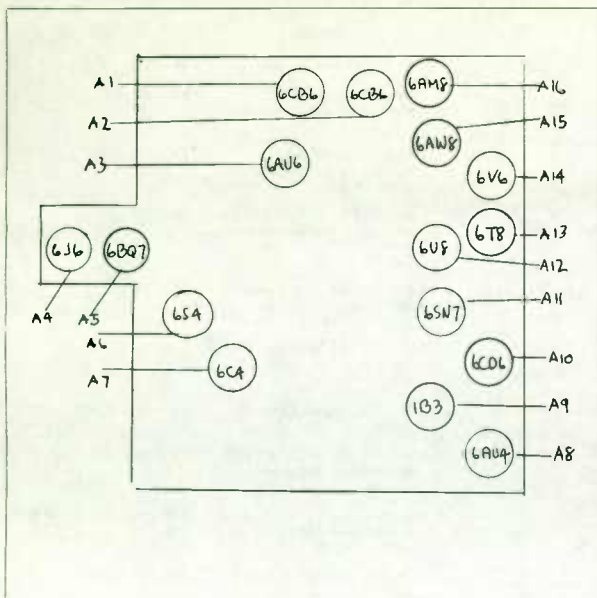

SILVERTONE-LAYOUT NO.187

TROUBLE

LOCATION

- | | |
|---|------------------------------------|
| 1-No brightness on tube. | A8 - A9 - A10 - A11 * |
| 2-No vertical height. White line across screen Fig. 2 | A6 - A7 |
| 3-No horizontal width. White line running up and down. Fig. 3 | A8 - A10 - A11 |
| 4-Small picture in center of tube. Picture does not fill up entire screen. Fig. 4 | A8 - A10 - A11 * |
| 5-Picture out of proportion vertically. (top to bottom) Fig. 5 | A6 - A7 |
| 6-Picture out of proportion horizontally. (side to side) Fig. 6 | A8 - A10 - A11 |
| 7-Picture present, but no sound. | A12 - A13 - A14 |
| 8-Picture rolls. (Vertical movement up and down). Fig. 8 | A6 - A7 - A12 - A15 |
| 9-Picture tears. Figures on screen wave from side to side. Fig. 9 | A8 - A10 - A11 - A12 - A15 |
| 10-Sound, brightness but no picture. | A1 - A2 - A3 - A15 - A16 |
| 11-Brightness, but no picture or sound. | A1 - A2 - A3 - A4 - A5 - A15 - A16 |

* Selenium Rectifiers

TROUBLE

LOCATION

- | | |
|---|-----------------------------------|
| 1-No brightness on tube. | A8 - A9 - A10 - A11 * |
| 2-No vertical height. White line across screen Fig. 2 | A7 |
| 3-No horizontal width. White line running up and down. Fig. 3 | A8 - A10 - A11 * |
| 4-Small picture in center of tube. Picture does not fill up entire screen. Fig. 4 | A8 - A10 - A11 * |
| 5-Picture out of proportion vertically. (top to bottom) Fig. 5 | A7 |
| 6-Picture out of proportion horizontally. (side to side) Fig. 6 | A8 - A10 - A11 |
| 7-Picture present, but no sound. | A12 - A13 - A14 |
| 8-Picture rolls. (Vertical movement up and down). Fig. 8 | A7 - A13 - A15 |
| 9-Picture tears. Figures on screen wave from side to side. Fig. 9 | A8 - A10 - A11 - A13 - A15 |
| 10-Sound, brightness but no picture. | A3 - A4 - A5 - A6 - A15 |
| 11-Brightness, but no picture or sound. | A1 - A2 - A3 - A4 - A5 - A6 - A15 |

* Selenium Rectifiers

SILVERTONE-LAYOUT NO.188

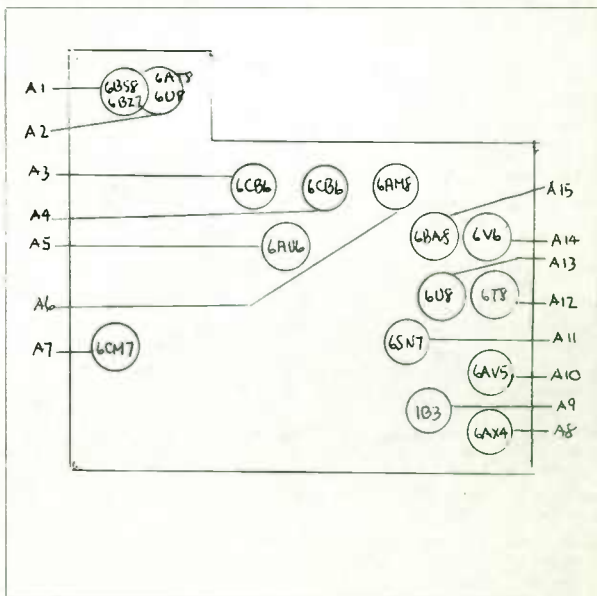

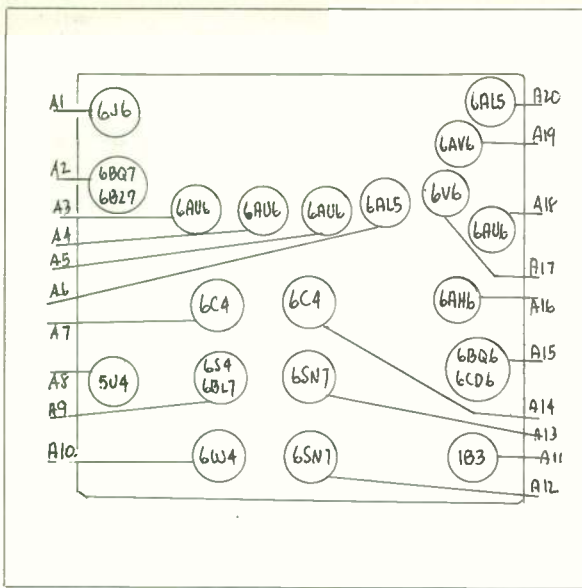

TROUBLE	LOCATION
1-No brightness on tube.	A8 - A10 - A11 - A12 - A15
2-No vertical height. White line across screen Fig. 2	A7 - A9
3-No horizontal width. White line running up and down. Fig. 3	A8 - A10 - A12 - A15
4-Small picture in center of tube. Picture does not fill up entire screen. Fig. 4	A8
5-Picture out of proportion vertically. (top to bottom) Fig. 5	A7 - A9
6-Picture out of proportion horizontally. (side to side) Fig. 6	A10 - A12 - A15
7-Picture present, but no sound.	A17 - A18 - A19 - A20
8-Picture rolls. (Vertical movement up and down). Fig. 8	A7 - A9 - A13 - A14
9-Picture tears. Figures on screen wave from side to side. Fig. 9	A10 - A12 - A13 - A14 - A15
10-Sound, brightness but no picture.	A3 - A4 - A5 - A6 - A16
11-Brightness, but no picture or sound.	A1 - A2 - A3 - A4 - A5 - A6

TRAV-LER - LAYOUT NO. 189

ZENITH - LAYOUT NO. 190

TROUBLE	LOCATION
1-No brightness on tube.	A3 - A12 - A13 - A14 - A15
2-No vertical height. White line across screen Fig. 2	A4
3-No horizontal width. White line running up and down. Fig. 3	A3 - A12 - A14 - A15
4-Small picture in center of tube. Picture does not fill up entire screen. Fig. 4	A3
5-Picture out of proportion vertically. (top to bottom) Fig. 5	A4
6-Picture out of proportion horizontally. (side to side) Fig. 6	A12 - A14 - A15
7-Picture present, but no sound.	A5 - A9 - A10 - A11
8-Picture rolls. (Vertical movement up and down). Fig. 8	A4 - A11
9-Picture tears. Figures on screen wave from side to side. Fig. 9	A11 - A12 - A14 - A15
10-Sound, brightness but no picture.	A5 - A6 - A7 - A8
11-Brightness, but no picture or sound.	A1 - A2 - A5 - A6 - A7 - A8

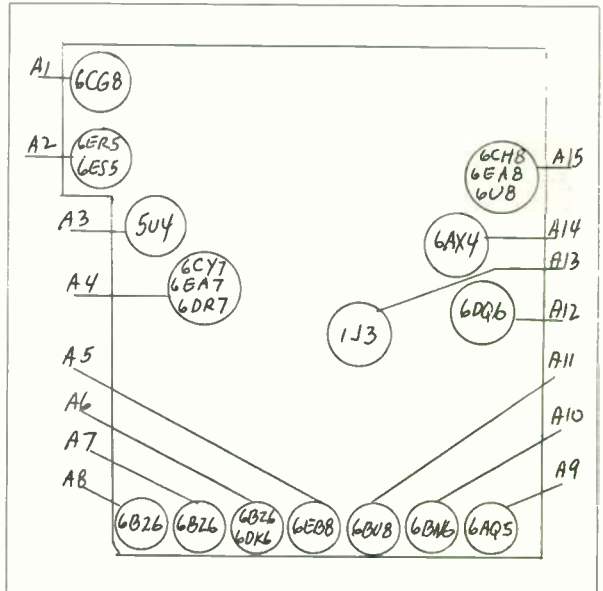

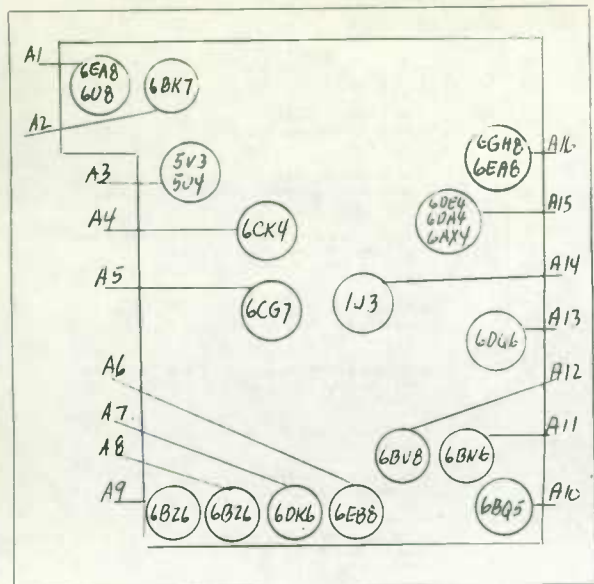

TROUBLE	LOCATION
1-No brightness on tube.	A3 - A13 - A14 - A15 - A16
2-No vertical height. White line across screen Fig. 2	A4 - A5
3-No horizontal width. White line running up and down. Fig. 3	A3 - A13 - A15 - A16
4-Small picture in center of tube. Picture does not fill up entire screen. Fig. 4	A3
5-Picture out of proportion vertically. (top to bottom) Fig. 5	A4 - A5
6-Picture out of proportion horizontally. (side to side) Fig. 6	A13 - A15 - A16
7-Picture present, but no sound.	A6 - A10 - A11
8-Picture rolls. (Vertical movement up and down). Fig. 8	A4 - A5 - A12
9-Picture tears. Figures on screen wave from side to side. Fig. 9	A12 - A13 - A15 - A16
10-Sound, brightness but no picture.	A6 - A7 - A8 - A9
11-Brightness, but no picture or sound.	A1 - A2 - A6 - A7 - A8 - A9

ZENITH-LAYOUT NO. 191

TROUBLE	LOCATION
1-No brightness on tube.	A10 - A11 - A12 - A14 - A15
2-No vertical height. White line across screen Fig. 2	A5
3-No horizontal width. White line running up and down. Fig. 3	A10 - A11 - A12 - A15
4-Small picture in center of tube. Picture does not fill up entire screen. Fig. 4	A10
5-Picture out of proportion vertically. (top to bottom) Fig. 5	A5
6-Picture out of proportion horizontally. (side to side) Fig. 6	A11 - A12 - A15
7-Picture present, but no sound.	A7 - A8 - A9 - A13
8-Picture rolls. (Vertical movement up and down). Fig. 8	A5 - A7
9-Picture tears. Figures on screen wave from side to side. Fig. 9	A7 - A11 - A12 - A15
10-Sound, brightness but no picture.	A3 - A4 - A6 - A7 - A8
11-Brightness, but no picture or sound.	A1 - A2 - A3 - A4 - A6 - A7 - A8

ZENITH-LAYOUT NO. 192

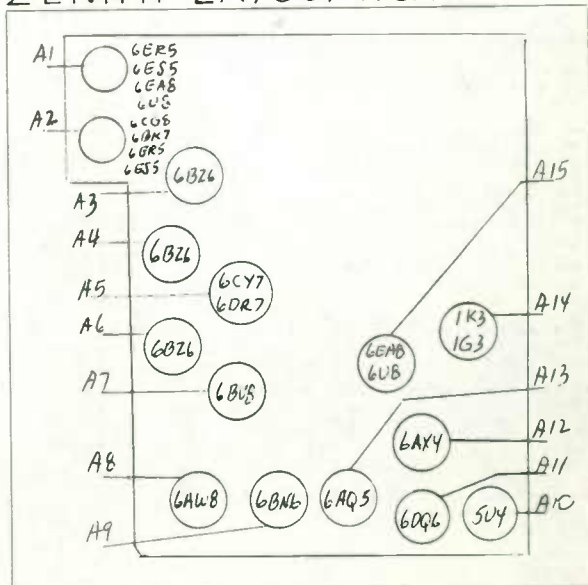

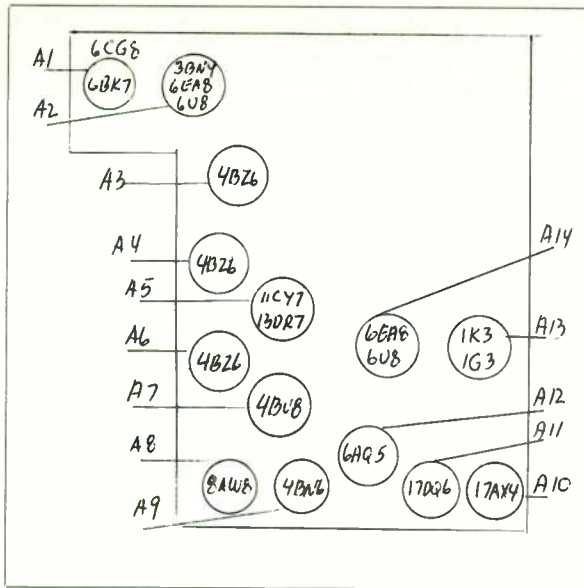

ZENITH-LAYOUT NO. 193

TROUBLE	LOCATION
1-No brightness on tube.	A10 - A11 - A13 - A14
2-No vertical height. White line across screen Fig. 2	A5
3-No horizontal width. White line running up and down. Fig. 3	A10 - A11 - A14
4-Small picture in center of tube. Picture does not fill up entire screen. Fig. 4	A10 - A11 - A14
5-Picture out of proportion vertically. (top to bottom) Fig. 5	A5
6-Picture out of proportion horizontally. (side to side) Fig. 6	A10 - A11 - A14
7-Picture present, but no sound.	A8 - A9 - A12
8-Picture rolls. (Vertical movement up and down). Fig. 8	A5 - A7
9-Picture tears. Figures on screen wave from side to side. Fig. 9	A7 - A10 - A11 - A14
10-Sound, brightness but no picture.	A3 - A4 - A6 - A8
11-Brightness, but no picture or sound.	A1 - A2 - A3 - A4 - A6 - A8

TROUBLE

LOCATION

1-No brightness on tube.	A14 - A15 - A16 - A17 - A11
2-No vertical height. White line across screen Fig. 2	A1
3-No horizontal width. White line running up and down. Fig. 3	A15 - A16 - A17 - A11
4-Small picture in center of tube. Picture does not fill up entire screen. Fig. 4	A11
5-Picture out of proportion vertically. (top to bottom) Fig. 5	A1
6-Picture out of proportion horizontally. (side to side) Fig. 6	A15 - A16 - A17
7-Picture present, but no sound.	A8 - A9 - A12
8-Picture rolls. (Vertical movement up and down). Fig. 8	A1 - A13
9-Picture tears. Figures on screen wave from side to side. Fig. 9	A13 - A15 - A16 - A17 - A18 - A19
10-Sound, brightness but no picture.	A2 - A3 - A4 - A5 - A8
11-Brightness, but no picture or sound.	A6 - A7 - A9

ZENITH-LAYOUT NO. 194

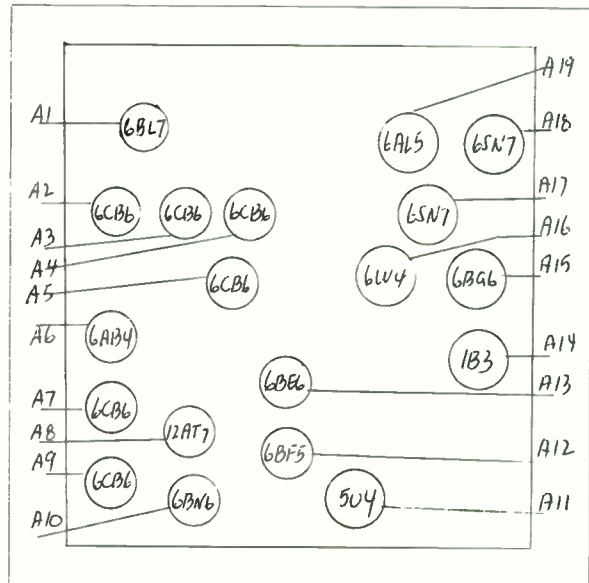

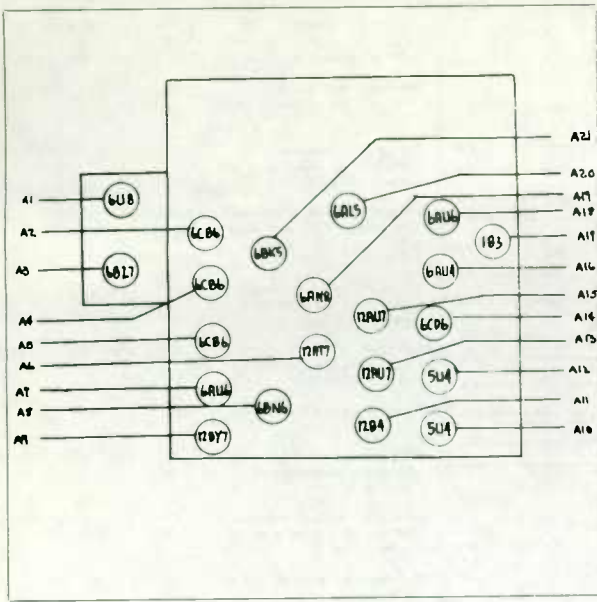

TROUBLE	LOCATION
1-No brightness on tube.	A10 - A12 - A14 - A15 - A16 - A17
2-No vertical height. White line across screen Fig. 2	A11 - A13
3-No horizontal width. White line running up and down. Fig. 3	A10 - A12 - A14 - A15 - A16
4-Small picture in center of tube. Picture does not fill up entire screen. Fig. 4	A10 - A12
5-Picture out of proportion vertically. (top to bottom) Fig. 5	A11 - A13
6-Picture out of proportion horizontally. (side to side) Fig. 6	A10 - A12 - A14 - A15 - A16
7-Picture present, but no sound.	A7 - A8 - A21
8-Picture rolls. (Vertical movement up and down). Fig. 8	A6 - A11 - A13 - A18 - A19
9-Picture tears. Figures on screen wave from side to side. Fig. 9	A6 - A10 - A12 - A14 - A15 - A16 - A19 - A20
10-Sound, brightness but no picture.	A2 - A4 - A5 - A9
11-Brightness, but no picture or sound.	A1 - A2 - A3 - A4 - A5 - A9

WESTINGHOUSE NO. 195

WESTINGHOUSE NO. 196

TROUBLE	LOCATION
1-No brightness on tube.	A11 - A13 - A15 - A16 - A17 - A18
2-No vertical height. White line across screen Fig. 2	A12 - A14
3-No horizontal width. White line running up and down. Fig. 3	A11 - A13 - A15 - A16 - A17
4-Small picture in center of tube. Picture does not fill up entire screen. Fig. 4	A11 - A13
5-Picture out of proportion vertically. (top to bottom) Fig. 5	A12 - A14
6-Picture out of proportion horizontally. (side to side) Fig. 6	A11 - A13 - A15 - A16 - A17
7-Picture present, but no sound.	A5 - A8 - A10
8-Picture rolls. (Vertical movement up and down). Fig. 8	A7 - A12 - A14 - A19
9-Picture tears. Figures on screen wave from side to side. Fig. 9	A7 - A11 - A13 - A15 - A16 - A17 - A20
10-Sound, brightness but no picture.	A3 - A4 - A6 - A9
11-Brightness, but no picture or sound.	A1 - A2 - A3 - A4 - A6 - A9

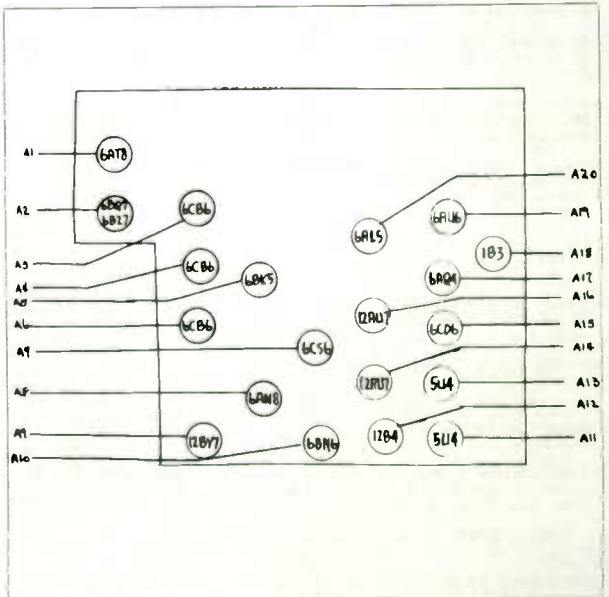

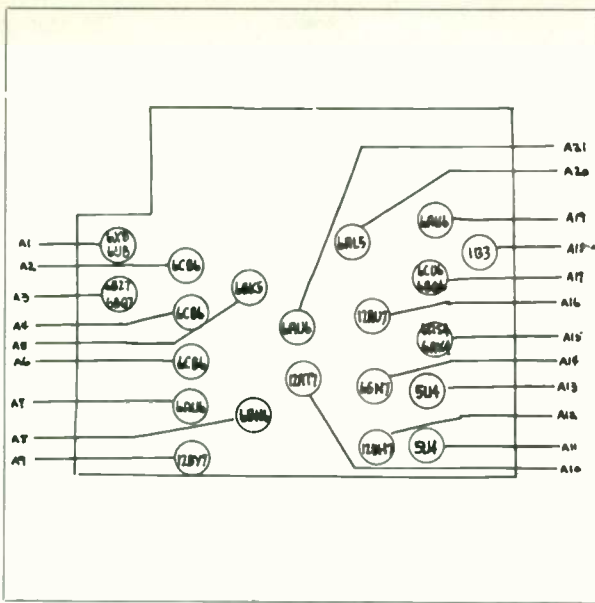

TROUBLE	LOCATION
1-No brightness on tube.	A11 - A13 - A15 - A16 - A17 - A18
2-No vertical height. White line across screen Fig. 2	A12 - A14
3-No horizontal width. White line running up and down. Fig. 3	A11 - A13 - A15 - A16 - A17
4-Small picture in center of tube. Picture does not fill up entire screen. Fig. 4	A11 - A13
5-Picture out of proportion vertically. (top to bottom) Fig. 5	A12 - A14
6-Picture out of proportion horizontally. (side to side) Fig. 8	A11 - A13 - A15 - A16 - A17
7-Picture present, but no sound.	A5 - A7 - A8
8-Picture rolls. (Vertical movement up and down). Fig. 6	A10 - A12 - A14 - A19 - A21
9-Picture tears. Figures on screen wave from side to side. Fig. 9	A10 - A11 - A13 - A15 - A16 - A17 - A20 - A21
10-Sound, brightness but no picture.	A2 - A4 - A6 - A9
11-Brightness, but no picture or sound.	A1 - A2 - A3 - A4 - A6 - A9

WESTINGHOUSE NO. 197

TROUBLE

LOCATION

1-No brightness on tube.	A12 - A14 - A15 - A16 - A17 - A18
2-No vertical height. White line across screen Fig. 2	A11 - A13
3-No horizontal width. White line running up and down. Fig. 3	A12 - A14 - A15 - A16 - A17
4-Small picture in center of tube. Picture does not fill up entire screen. Fig. 4	A12 - A14
5-Picture out of proportion vertically. (top to bottom) Fig. 5	A11 - A13
6-Picture out of proportion horizontally. (side to side) Fig. 6	A12 - A14 - A15 - A16 - A17
7-Picture present, but no sound.	A5 - A8 - A10
8-Picture rolls. (Vertical movement up and down). Fig. 8	A7 - A11 - A13 - A19 - A20
9-Picture tears. Figures on screen wave from side to side. Fig. 9	A7 - A12 - A14 - A15 - A16 - A17 - A20 - A21
nd, brightness but no picture.	A2 - A4 - A6 - A9
ightness, but no picture sound.	A1 - A2 - A3 - A4 - A6 - A9

WESTINGHOUSE NO. 198

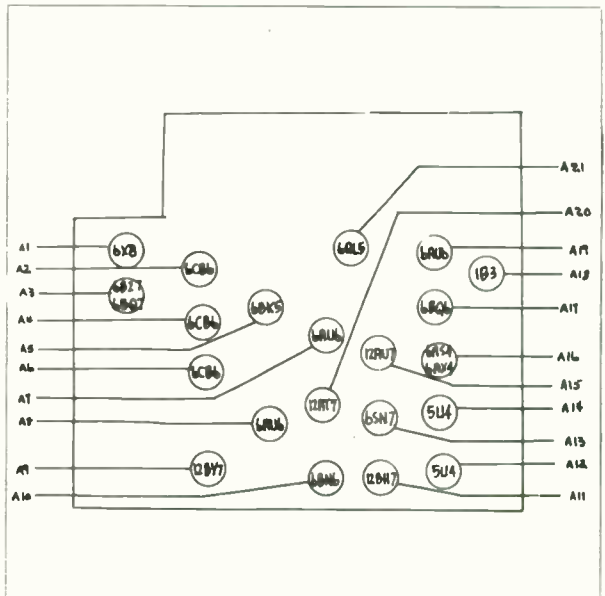

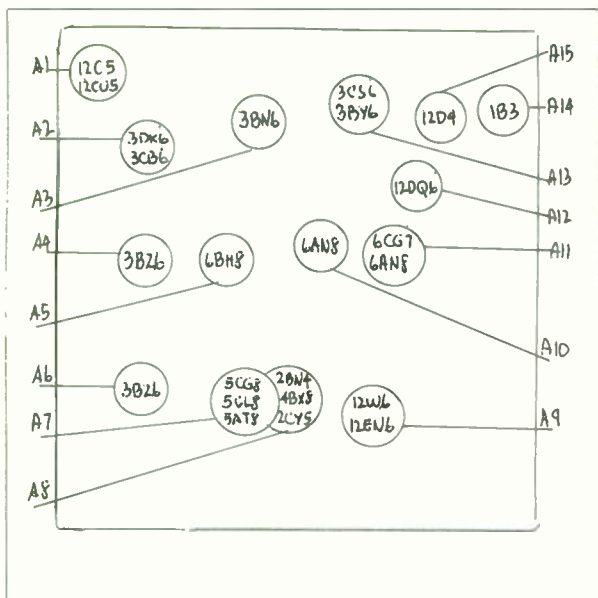

WESTINGHOUSE NO. 199

TROUBLE	LOCATION
1-No brightness on tube.	A11 - A12 - A14 - A15 *
2-No vertical height. White line across screen Fig. 2	A9 - A10
3-No horizontal width. White line running up and down. Fig. 3	A11 - A12 - A15 *
4-Small picture in center of tube. Picture does not fill up entire screen. Fig. 4	A11 - A12 - A15 *
5-Picture out of proportion vertically. (top to bottom) Fig. 5	A9 - A10
6-Picture out of proportion horizontally. (side to side) Fig. 6	A11 - A12 - A15
7-Picture present, but no sound.	A1 - A3 - A10
8-Picture rolls. (Vertical movement up and down). Fig. 8	A9 - A10 - A13
9-Picture tears. Figures on screen wave from side to side. Fig. 9	A11 - A12 - A13 - A15
10-Sound, brightness but no picture.	A2 - A4 - A5 - A6
11-Brightness, but no picture or sound.	A2 - A4 - A5 - A6 - A7 - A8

* Selenium Rectifiers

TROUBLE

LOCATION

1-No brightness on tube.	A11 - A12 - A13 - A14 *
2-No vertical height. White line across screen Fig. 2	A7
3-No horizontal width. White line running up and down. Fig. 3	A11 - A12 - A14 *
4-Small picture in center of tube. Picture does not fill up entire screen. Fig. 4	A11 - A12 - A14 *
5-Picture out of proportion vertically. (top to bottom) Fig. 5	A7
6-Picture out of proportion horizontally. (side to side) Fig. 6	A11 - A12 - A14
7-Picture present, but no sound.	A5 - A6 - A15
8-Picture rolls. (Vertical movement up and down). Fig. 8	A7 - A9
9-Picture tears. Figures on screen wave from side to side. Fig. 9	A9 - A10 - A11 - A12 - A14
10-Sound, brightness but no picture.	A3 - A4 - A5 - A8 - A10
11-Brightness, but no picture or sound.	A1 - A2 - A3 - A4 - A5 - A8 - A10

* Selenium Rectifiers

WESTINGHOUSE NO. 200

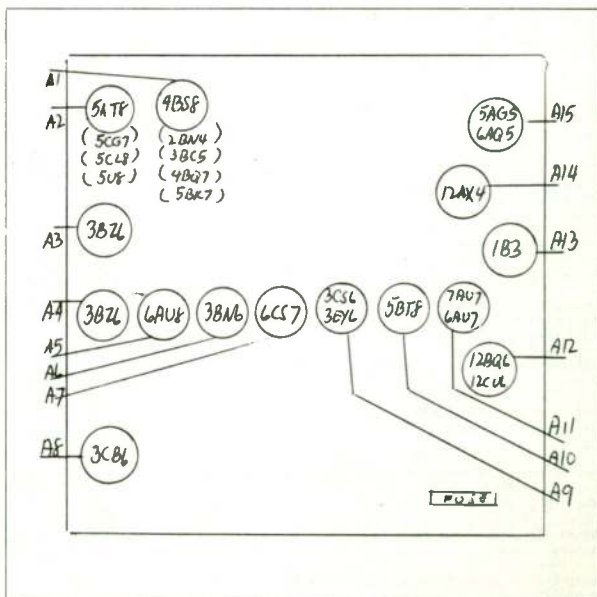

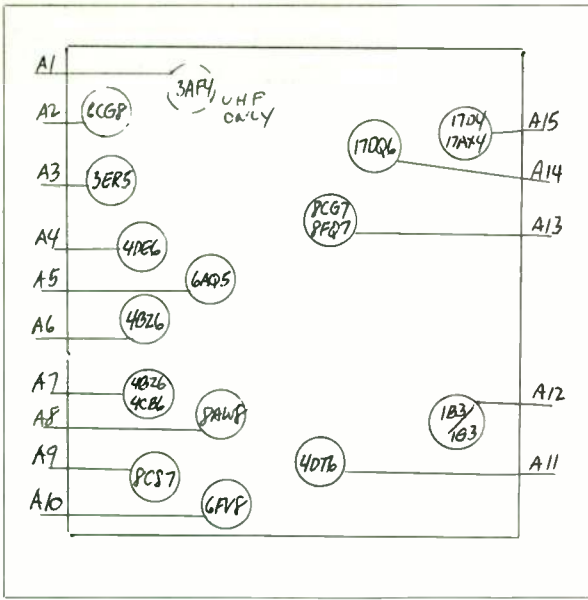

TROUBLE	LOCATION
1-No brightness on tube.	A12 - A13 - A14 - A15
2-No vertical height. White line across screen Fig. 2	A9
3-No horizontal width. White line running up and down. Fig. 3	A13 - A14 - A15
4-Small picture in center of tube. Picture does not fill up entire screen. Fig. 4	A13 - A14 - A15
5-Picture out of proportion vertically. (top to bottom) Fig. 5	A9
6-Picture out of proportion horizontally. (side to side) Fig. 6	A13 - A14 - A15
7-Picture present, but no sound.	A5 - A10 - A11
8-Picture rolls. (Vertical movement up and down). Fig. 8	A8 - A9
9-Picture tears. Figures on screen wave from side to side. Fig. 9	A8 - A13 - A14 - A15
10-Sound, brightness but no picture.	A4 - A6 - A7 - A8
11-Brightness, but no picture or sound.	A2 - A3 - A4 - A6 - A7 - A8 (A1-UHF only)

WESTINGHOUSE - LAYOUT NO. 201

ZENITH-LAYOUT NO. 202

TROUBLE	LOCATION
1-No brightness on tube.	A10 - A11 - A12 - A13 - A14
2-No vertical height. White line across screen Fig. 2	A9
3-No horizontal width. White line running up and down. Fig. 3	A10 - A11 - A13 - A14
4-Small picture in center of tube. Picture does not fill up entire screen. Fig. 4	A14
5-Picture out of proportion vertically. (top to bottom) Fig. 5	A9
6-Picture out of proportion horizontally. (side to side) Fig. 6	A10 - A11 - A13
7-Picture present, but no sound.	A3 - A5 - A15
8-Picture rolls. (Vertical movement up and down). Fig. 8	A7 - A9
9-Picture tears. Figures on screen wave from side to side. Fig. 9	A7 - A10 - A11 - A13
10-Sound, brightness but no picture.	A3 - A4 - A6 - A8
11-Brightness, but no picture or sound.	A1 - A2 - A3 - A4 - A6 - A8

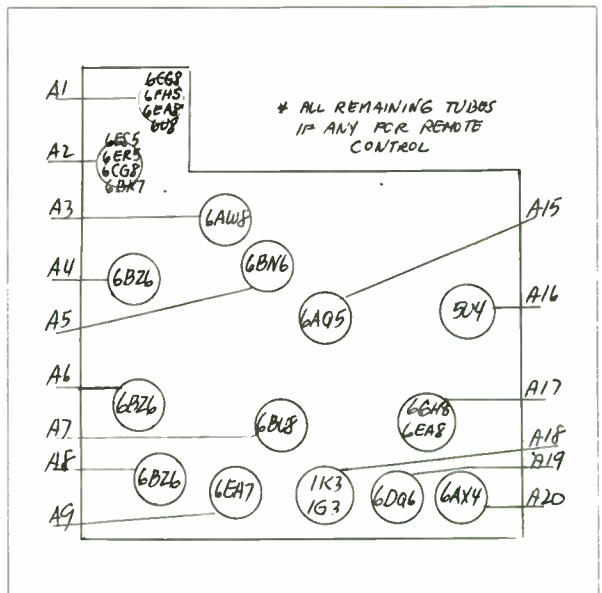

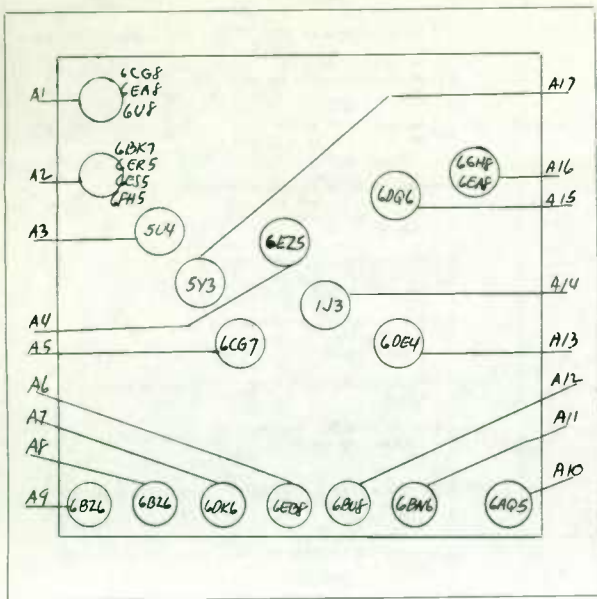

TROUBLE	LOCATION
1-No brightness on tube.	A3 - A13 - A14 - A15 - A16 - A17
2-No vertical height. White line across screen Fig. 2	A4 - A5
3-No horizontal width. White line running up and down. Fig. 3	A3 - A13 - A15 - A16 - A17
4-Small picture in center of tube. Picture does not fill up entire screen. Fig. 4	A3 - A17
5-Picture out of proportion vertically. (top to bottom) Fig. 5	A4 - A5
6-Picture out of proportion horizontally. (side to side) Fig. 6	A13 - A15 - A16
7-Picture present, but no sound.	A6 - A10 - A11
8-Picture rolls. (Vertical movement up and down). Fig. 8	A4 - A5 - A12
9-Picture tears. Figures on screen wave from side to side. Fig. 9	A12 - A13 - A15 - A16
10-Sound, brightness but no picture.	A6 - A7 - A8 - A9
11-Brightness, but no picture or sound.	A1 - A2 - A6 - A7 - A8 - A9

ZENITH-LAYOUT NO. 203

TROUBLE

LOCATION

1-No brightness on tube.	A3 - A12 - A13 - A14 - A15
2-No vertical height. White line across screen Fig. 2	A4
3-No horizontal width. White line running up and down. Fig. 3	A3 - A13 - A14 - A15
4-Small picture in center of tube. Picture does not fill up entire screen. Fig. 4	A3
5-Picture out of proportion vertically. (top to bottom) Fig. 5	A4
6-Picture out of proportion horizontally. (side to side) Fig. 6	A13 - A14 - A15
7-Picture present, but no sound.	A5 - A9 - A10 - A11
8-Picture rolls. (Vertical movement up and down). Fig. 8	A4 - A11
9-Picture tears. Figures on screen wave from side to side. Fig. 9	A11 - A13 - A14 - A15
10-Sound, brightness but no picture.	A5 - A6 - A7 - A8 - A11
11-Brightness, but no picture or sound.	A1 - A2 - A5 - A6 - A7 - A8 - A11

ZENITH-LAYOUT NO. 204

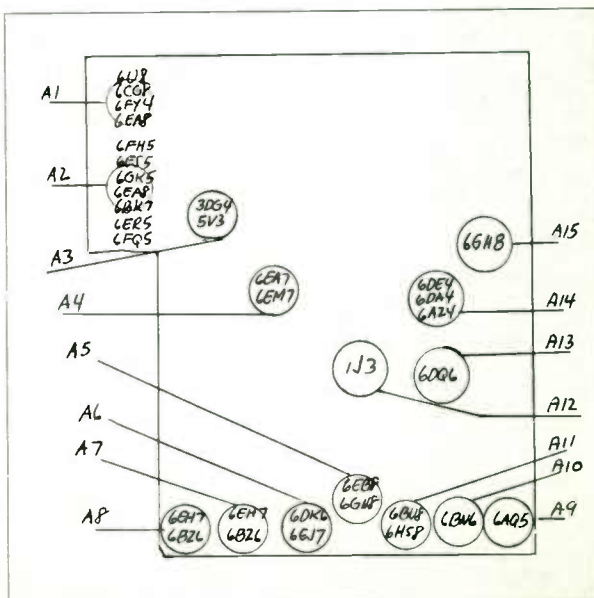

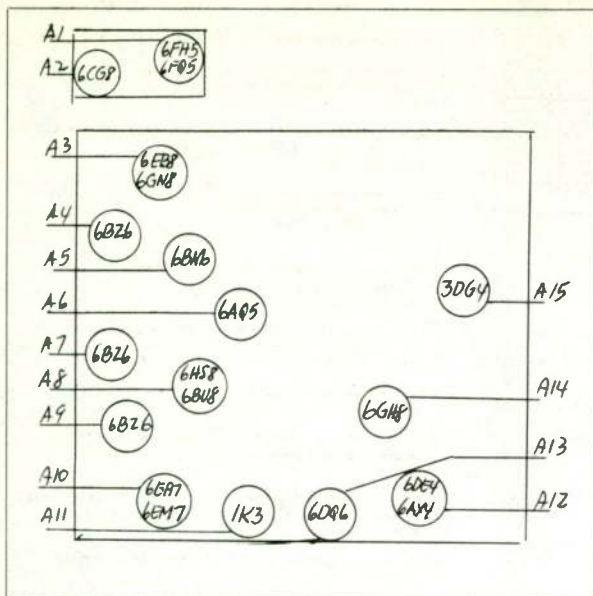

TROUBLE	LOCATION
1-No brightness on tube.	A1 - A2 - A3 - A14 - A15 - A16
2-No vertical height. White line across screen Fig. 2	A10
3-No horizontal width. White line running up and down. Fig. 3	A12 - A13 - A14 - A15
4-Small picture in center of tube. Picture does not fill up entire screen. Fig. 4	A12 - A13 - A14 - A15
5-Picture out of proportion vertically. (top to bottom) Fig. 5	A10
6-Picture out of proportion horizontally. (side to side) Fig. 6	A12 - A13 - A14
7-Picture present, but no sound.	A3 - A5 - A6
8-Picture rolls. (Vertical movement up and down). Fig. 8	A8 - A10
9-Picture tears. Figures on screen wave from side to side. Fig. 9	A8 - A12 - A13 - A14
10-Sound, brightness but no picture.	A3 - A4 - A7 - A9
11-Brightness, but no picture or sound.	A1 - A2 - A3 - A4 - A7 - A9

ZENITH-LAYOUT NO. 205

TROUBLE

LOCATION

1-No brightness on tube.	A3 - A13 - A14 - A15 - A16
2-No vertical height. White line across screen Fig. 2	A4 - A5
3-No horizontal width. White line running up and down. Fig. 3	A3 - A13 - A15 - A16
4-Small picture in center of tube. Picture does not fill up entire screen. Fig. 4	A3
5-Picture out of proportion vertically. (top to bottom) Fig. 5	A4 - A5
6-Picture out of proportion horizontally. (side to side) Fig. 6	A13 - A15 - A16
7-Picture present, but no sound.	A6 - A10 - A11
8-Picture rolls. (Vertical movement up and down). Fig. 8	A4 - A5 - A12
9-Picture tears. Figures on screen wave from side to side. Fig. 9	A12 - A13 - A15 - A16
10-Sound, brightness but no picture.	A6 - A7 - A8 - A9
11-Brightness, but no picture or sound.	A1 - A2 - A6 - A7 - A8 - A9

ZENITH-LAYOUT NO. 206

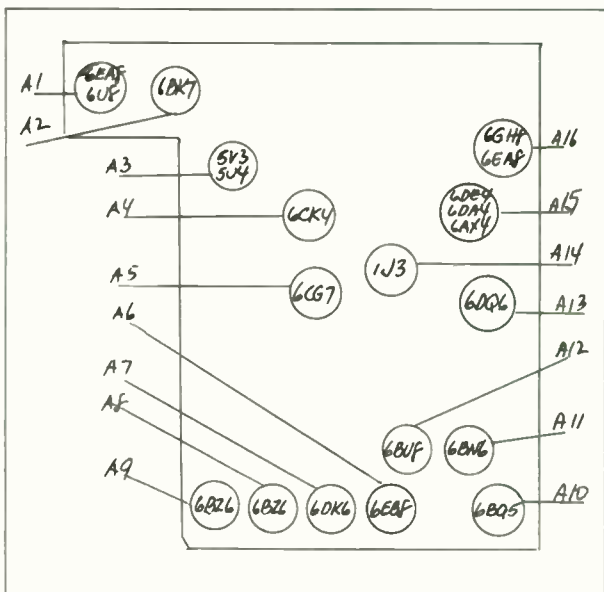

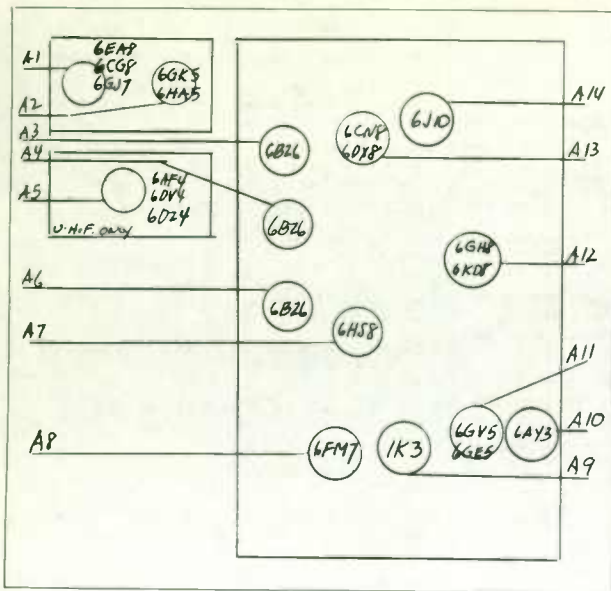

TROUBLE	LOCATION
1-No brightness on tube.	A9 - A10 - A11 - A12
2-No vertical height. White line across screen Fig. 2	A8
3-No horizontal width. White line running up and down. Fig. 3	A10 - A11 - A12
4-Small picture in center of tube. Picture does not fill up entire screen. Fig. 4	A10 - A11 - A12
5-Picture out of proportion vertically. (top to bottom) Fig. 5	A8
6-Picture out of proportion horizontally. (side to side) Fig. 6	A10 - A11 - A12
7-Picture present, but no sound.	A13 - A14
8-Picture rolls. (Vertical movement up and down). Fig. 8	A7 - A8
9-Picture tears. Figures on screen wave from side to side. Fig. 9	A7 - A10 - A11 - A12
10-Sound, brightness but no picture.	A3 - A4 - A6 - A7 - A13
11-Brightness, but no picture or sound.	A1 - A2 - A3 - A4 - A6 A7 - A13 (A3 UHF ONLY)

ZENITH-LAYOUT NO. 207

TROUBLE	LOCATION
1-No brightness on tube.	A12 - A13 - A14 - A15
2-No vertical height. White line across screen Fig. 2	A4
3-No horizontal width. White line running up and down. Fig. 3	A13 - A14 - A15
4-Small picture in center of tube. Picture does not fill up entire screen. Fig. 4	A13 - A14 - A15
5-Picture out of proportion vertically. (top to bottom) Fig. 5	A4
6-Picture out of proportion horizontally. (side to side) Fig. 6	A13 - A14 - A15
7-Picture present, but no sound.	A5 - A9 - A10
8-Picture rolls. (Vertical movement up and down). Fig. 8	A4 - A11
9-Picture tears. Figures on screen wave from side to side. Fig. 9	A11 - A13 - A14 - A15
10-Sound, brightness but no picture.	A5 - A6 - A7 - A8 - A11
11-Brightness, but no picture or sound.	A1 - A2 - A5 - A6 - A7 A8 - A11 (A3 UHF ONLY)

ZENITH-LAYOUT NO. 208

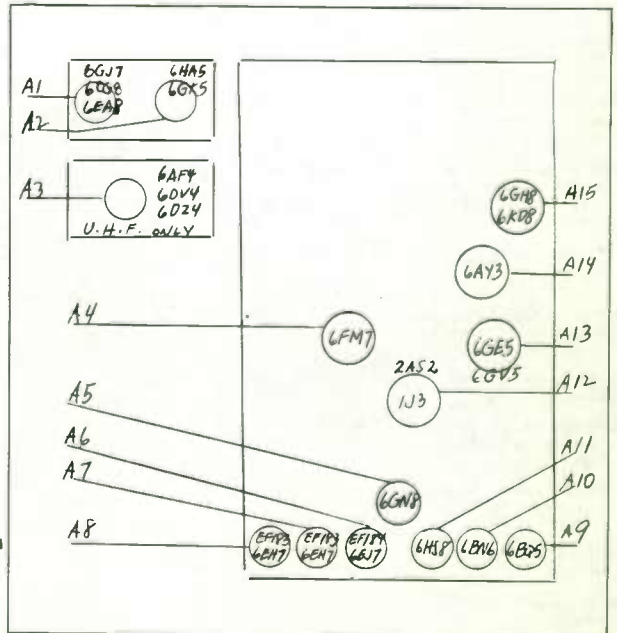

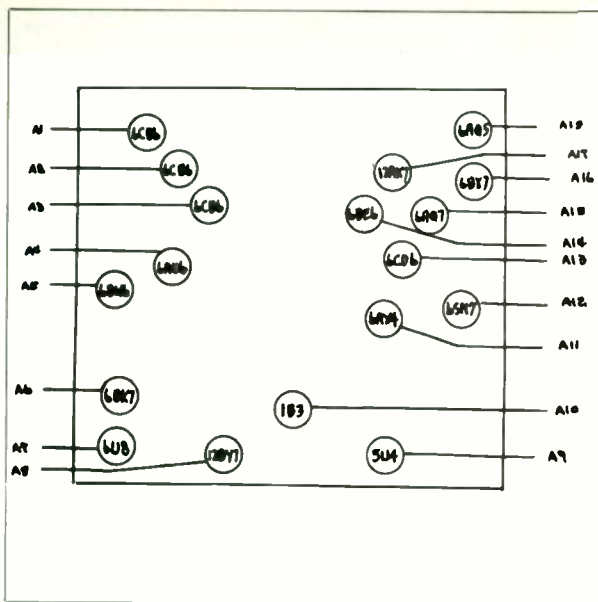

ZENITH-LAYOUT NO. 209

TROUBLE	LOCATION
1-No brightness on tube.	A9 - A10 - A11 - A12 - A13
2-No vertical height. White line across screen Fig. 2	A16 - A17
3-No horizontal width. White line running up and down. Fig. 3	A9 - A11 - A12 - A13
4-Small picture in center of tube. Picture does not fill up entire screen. Fig. 4	A9
5-Picture out of proportion vertically. (top to bottom) Fig. 5	A16 - A17
6-Picture out of proportion horizontally. (side to side) Fig. 6	A9 - A11 - A12 - A13
7-Picture present, but no sound.	A4 - A5 - A18
8-Picture rolls. (Vertical movement up and down). Fig. 8	A14 - A16 - A17
9-Picture tears. Figures on screen wave from side to side. Fig. 9	A9 - A11 - A12 - A13 - A14 - A15
10-Sound, brightness but no picture.	A1 - A2 - A3 - A8 - A17
11-Brightness, but no picture or sound.	A1 - A2 - A3 - A6 - A7 - A8 - A17

TROUBLE

LOCATION

1-No brightness on tube.	A9 - A10 - A11 - A12
2-No vertical height. White line across screen Fig. 2	A7 - A8
3-No horizontal width. White line running up and down. Fig. 3	A10 - A11 - A12
4-Small picture in center of tube. Picture does not fill up entire screen. Fig. 4	A10 - A11 - A12
5-Picture out of proportion vertically. (top to bottom) Fig. 5	A7 - A8
6-Picture out of proportion horizontally. (side to side) Fig. 6	A10 - A11 - A12
7-Pictures present, but no sound.	A13 - A14 - A15
8-Pictures rolls. (Vertical movement up and down). Fig. 8	A7 - A8
9-Picture tears. Figures on screen wave from side to side. Fig. 9	A7 - A10 - A11 - A12
10-Sound, brightness but no picture.	A4 - A5 - A6 - A7 - A14.
11-Brightness, but no picture or sound.	A1 - A2 - A4 - A5 - A6 A7 - A14 (A3 UHF ONLY)

ZENITH-LAYOUT NO. 210

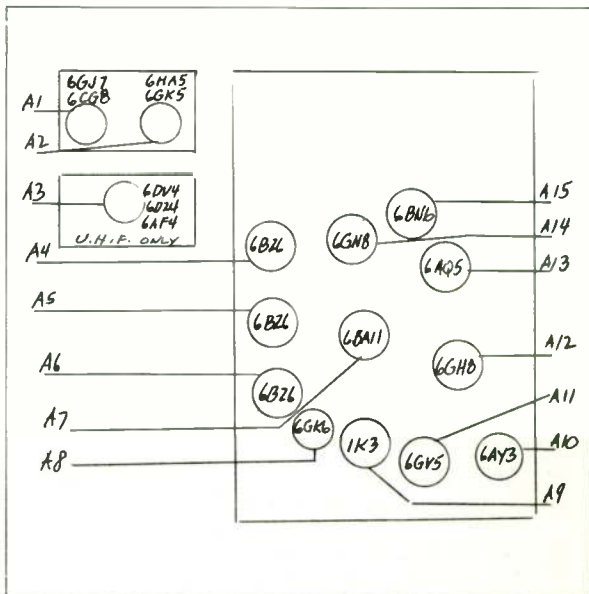

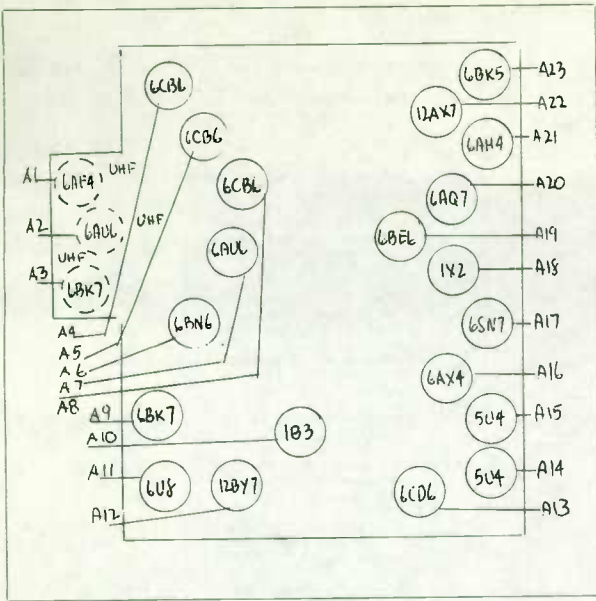

ZENITH-LAYOUT NO.211

TROUBLE

LOCATION

- | | |
|--|--|
| 1-No brightness on tube. | A10 - A13 - A14 - A15 - A16
- A17 - A18 |
| 2-No vertical height.
White line across screen
Fig. 2 | A21 - A22 |
| 3-No horizontal width.
White line running up and
down. Fig. 3 | A13 - A14 - A15 - A16 - A17 |
| 4-Small picture in center
of tube. Picture does not
fill up entire screen.
Fig. 4 | A14 - A15 |
| 5-Picture out of proportion
vertically. (top to
bottom) Fig. 5 | A21 - A22 |
| 6-Picture out of proportion
horizontally. (side to
side) Fig. 6 | A13 - A16 - A17 |
| 7-Picture present, but no
sound. | A6 - A7 - A23 |
| 8-Picture rolls. (Vertical
movement up and down).
Fig. 8 | A19 - A21 - A22 |
| 9-Picture tears. Figures on
screen wave from side to
side. Fig. 9 | A13 - A16 - A17 - A19 - A20 |
| 10-Sound, brightness but no
picture. | A4 - A5 - A8 - A12 - A22 |
| 11-Brightness, but no picture
or sound. | A4 - A5 - A8 - A9 - A11
(A1 - A2 - A3 UHF only) |

ZENITH-LAYOUT NO.212

TROUBLE

LOCATION

- | | |
|--|--------------------------------------|
| 1-No brightness on tube. | A1 - A12 - A13 - A14 - A15 |
| 2-No vertical height.
White line across screen
Fig. 2 | A4 |
| 3-No horizontal width.
White line running up and
down. Fig. 3 | A1 - A13 - A14 - A15 |
| 4-Small picture in center
of tube. Picture does not
fill up entire screen.
Fig. 4 | A1 |
| 5-Picture out of proportion
vertically. (top to
bottom) Fig. 5 | A4 |
| 6-Picture out of proportion
horizontally. (side to
side) Fig. 6 | A13 - A14 - A15 |
| 7-Picture present, but no
sound. | A5 - A9 - A10 |
| 8-Picture rolls. (Vertical
movement up and down).
Fig. 8 | A4 - A11 |
| 9-Picture tears. Figures on
screen wave from side to
side. Fig. 9 | A11 - A13 - A14 - A15 - A16 |
| 10-Sound, brightness but no
picture. | A5 - A6 - A7 - A8 - A11 |
| 11-Brightness, but no picture
or sound. | A2 - A3 - A5 - A6 - A7
- A8 - A11 |

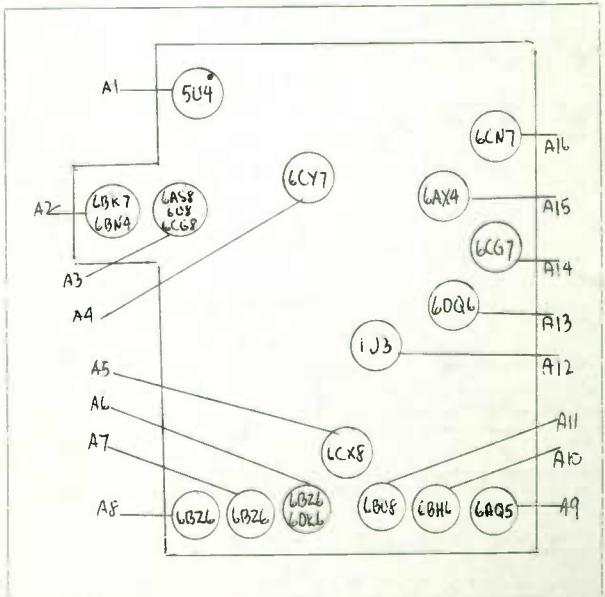

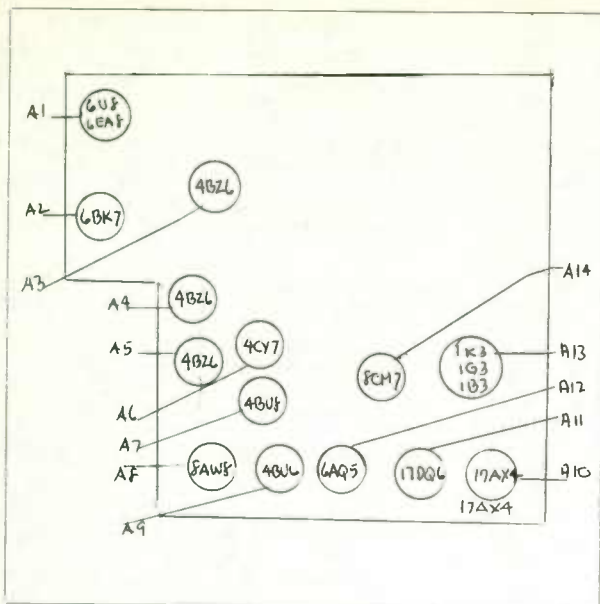

ZENITH-LAYOUT NO. 213

TROUBLE	LOCATION
1-No brightness on tube.	A10 - A11 - A13 - A14 *
2-No vertical height. White line across screen Fig. 2	A6
3-No horizontal width. White line running up and down. Fig. 3	A10 - A11 - A14 *
4-Small picture in center of tube. Picture does not fill up entire screen. Fig. 4	A10 - A11 - A14 *
5-Picture out of proportion vertically. (top to bottom) Fig. 5	A6
6-Picture out of proportion horizontally. (side to side) Fig. 6	A10 - A11 - A14
7-Picture present, but no sound.	A8 - A9 - A12
8-Picture rolls. (Vertical movement up and down). Fig. 8	A6 - A7 - A8
9-Picture tears. Figures on screen wave from side to side. Fig. 9	A7 - A8 - A10 - A11 - A14
10-Sound, brightness but no picture.	A3 - A4 - A5 - A7 - A8
11-Brightness, but no picture or sound.	A1 - A2 - A3 - A4 - A5 - A7 - A8

* Selenium Rectifiers

TROUBLE

LOCATION

1-No brightness on tube.	A13 - A14 - A16 - A17 - A18 - A19 - A21
2-No vertical height. White line across screen Fig. 2	A8 - A10
3-No horizontal width. White line running up and down. Fig. 3	A13 - A14 - A17 - A18 - A19 - A21
4-Small picture in center of tube. Picture does not fill up entire screen. Fig. 4	A13 - A14
5-Picture out of proportion vertically. (top to bottom) Fig. 5	A8 - A10
6-Picture out of proportion horizontally. (side to side) Fig. 6	A17 - A18 - A19 - A20 - A21
7-Picture present, but no sound.	A4 - A6 - A15
8-Picture rolls. (Vertical movement up and down). Fig. 8	A8 - A10 - A20
9-Picture tears. Figures on screen wave from side to side. Fig. 9	A17 - A18 - A19 - A20 - A21 - A22 - A23
10-Sound, brightness but no picture.	A1 - A2 - A3 - A4 - A5 - A12
11-Brightness, but no picture or sound.	A7 - A9 - A11

ZENITH-LAYOUT NO. 214

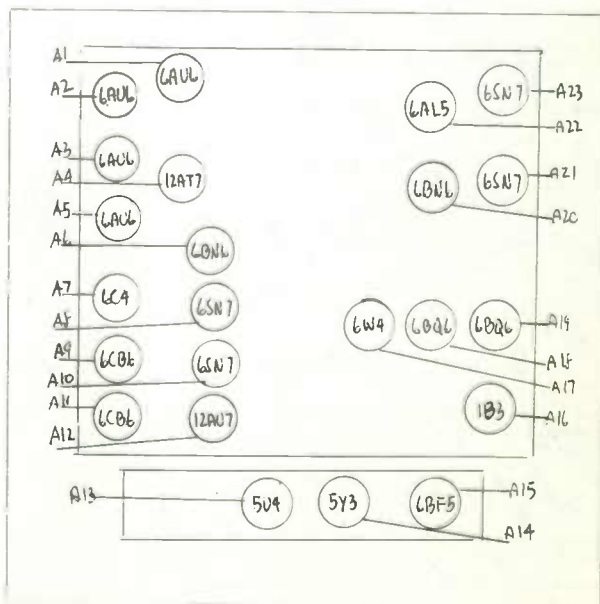

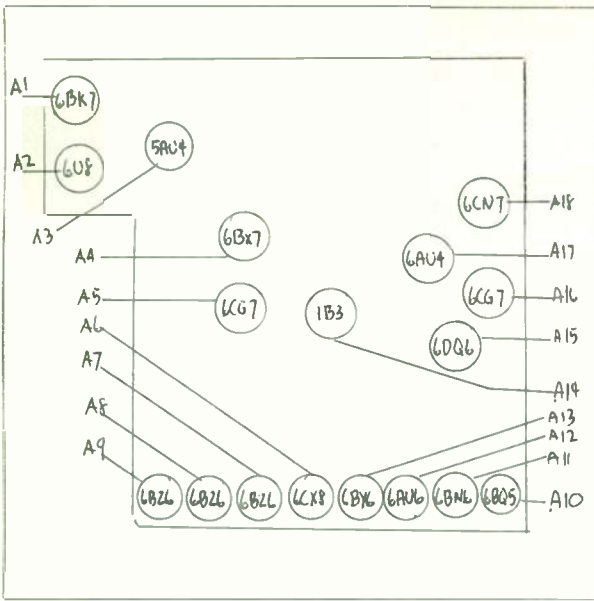

TROUBLE	LOCATION
1-No brightness on tube.	A3 - A14 - A15 - A16 - A17
2-No vertical height. White line across screen Fig. 2	A4 - A5
3-No horizontal width. White line running up and down. Fig. 3	A3 - A15 - A16 - A17
4-Small picture in center of tube. Picture does not fill up entire screen. Fig. 4	A3
5-Picture out of proportion vertically. (top to bottom) Fig. 5	A4 - A5
6-Picture out of proportion horizontally. (side to side) Fig. 6	A15 - A16 - A17
7-Picture present, but no sound.	A10 - A11 - A12
8-Picture rolls. (Vertical movement up and down). Fig. 8	A4 - A5 - A13
9-Picture tears. Figures on screen wave from side to side. Fig. 9	A13 - A15 - A16 - A17 - A18
10-Sound, brightness but no picture.	A6 - A7 - A8 - A9
11-Brightness, but no picture or sound.	A1 - A2 - A6 - A7 - A8 - A9

ZENITH-LAYOUT NO. 215

ZENITH-LAYOUT NO. 216

TROUBLE	LOCATION
1-No brightness on tube.	A8 - A9 - A10 - A11 - A13
2-No vertical height. White line across screen Fig. 2	A14
3-No horizontal width. White line running up and down. Fig. 3	A9 - A10 - A11 - A13
4-Small picture in center of tube. Picture does not fill up entire screen. Fig. 4	A13
5-Picture out of proportion vertically. (top to bottom) Fig. 5	A14
6-Picture out of proportion horizontally. (side to side) Fig. 6	A9 - A10 - A11
7-Picture present, but no sound.	A4 - A5 - A6
8-Picture rolls. (Vertical movement up and down). Fig. 8	A7 - A14
9-Picture tears. Figures on screen wave from side to side. Fig. 9	A7 - A9 - A10 - A11 - A12
10-Sound, brightness but no picture.	A1 - A2 - A3 - A4 - A7
11-Brightness, but no picture or sound.	A1 - A2 - A3 - A4 - A7 - A15 - A16

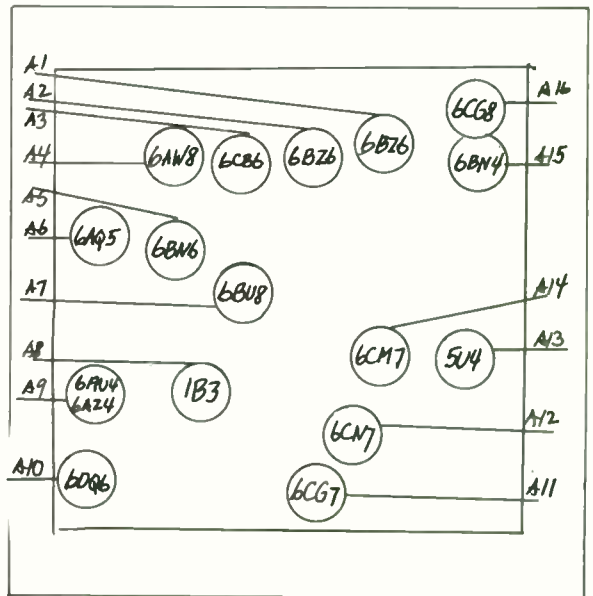

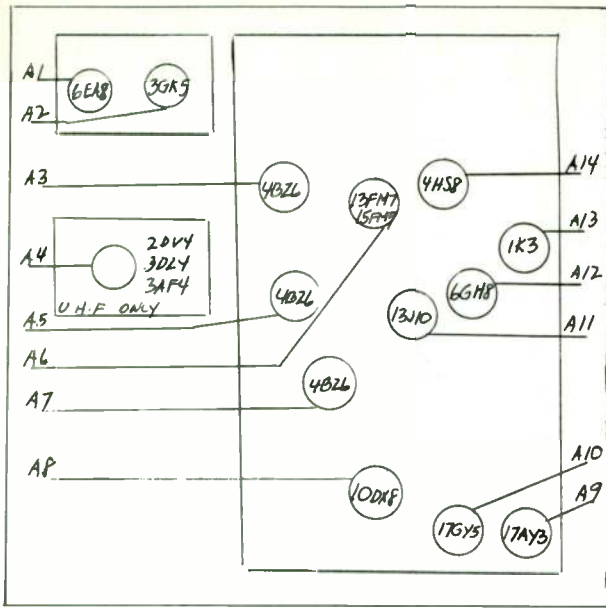

TROUBLE	LOCATION
1-No brightness on tube.	A9 - A10 - A12 - A13
2-No vertical height. White line across screen Fig. 2	A6
3-No horizontal width. White line running up and down. Fig. 3	A9 - A10 - A12
4-Small picture in center of tube. Picture does not fill up entire screen. Fig. 4	A9 - A10 - A12
5-Picture out of proportion vertically. (top to bottom) Fig. 5	A6
6-Picture out of proportion horizontally. (side to side) Fig. 6	A9 - A10 - A12
7-Picture present, but no sound.	A8 - A11
8-Picture rolls. (Vertical movement up and down). Fig. 6	A6 - A14
9-Picture tears. Figures on screen wave from side to side. Fig. 9	A9 - A10 - A12 - A14
10-Sound, brightness but no picture.	A3 - A5 - A7 - A8 - A14
11-Brightness, but no picture or sound.	A1 - A2 - A3 - A5 - A7 A8 - A14 (A4 UHF ONLY)

ZENITH-LAYOUT NO. 217

TROUBLE

LOCATION

1-No brightness on tube.	A10 - A11 - A12 - A13
2-No vertical height. White line across screen Fig. 2	A7 - A9
3-No horizontal width. White line running up and down. Fig. 3	A10 - A12 - A13
4-Small picture in center of tube. Picture does not fill up entire screen. Fig. 4	A10 - A12 - A13
5-Picture out of proportion vertically. (top to bottom) Fig. 5	A7 - A9
6-Picture out of proportion horizontally. (side to side) Fig. 6	A10 - A12 - A13
7-Picture present, but no sound.	A3 - A5
8-Picture rolls. (Vertical movement up and down). Fig. 8	A7 - A9
9-Picture tears. Figures on screen wave from side to side. Fig. 9	A7 - A10 - A12 - A13
10-Sound, brightness but no picture.	A3 - A4 - A6 - A7 - A8
11-Brightness, but no picture or sound.	A1 - A2 - A3 - A4 - A6 - A7 - A8

ZENITH - LAYOUT NO. 218

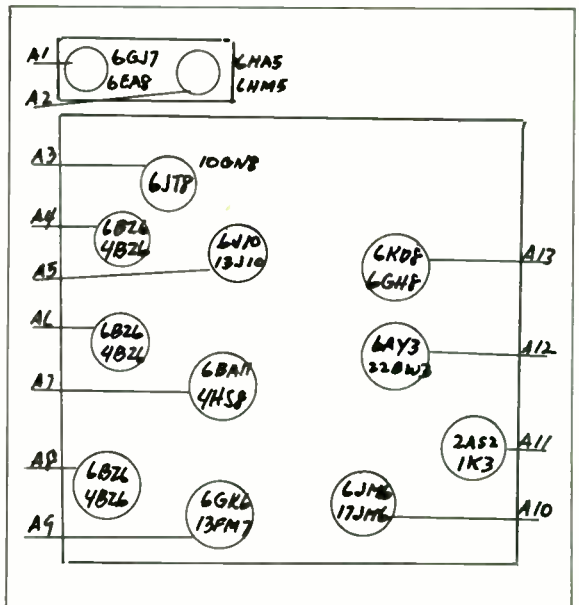

UNLISTED TROUBLE-SHOOTING SECTION

IF YOUR SET IS NOT LISTED USE THIS CHART . . . YOU WILL FIND A TUBE LAYOUT USUALLY INSIDE OR ON THE BACK OF YOUR SET—CHECK IT TO FIND THE TUBES WHICH ARE LISTED BELOW AND REPLACE THE TUBES WHICH ARE CAUSING THE TROUBLE . . .

- | | |
|---|--|
| <p>No. 1 . . . No Brightness
No Picture
No Sound</p> | <p>a. Check Fuse
b. If tubes are lit and the fuse is not blown check the following tubes. Any one can cause the trouble.
5U4-5Y3-5V4-6AX4-6AX5
c. In the event that your set does not use these tubes check the following tubes.
6BG6-6BQ6-6CD6--25BQ6--19BG6--
6AS7-6AU5</p> |
| <p>No. 2 . . . No Brightness
No Picture
Sound Good</p> | <p>a. This is caused by any one of the following defective tubes.
6BG6-1B3-5V4-6SN7-12SN7-1X2-6W4-
25BQ6-19BG6-6CD6-25W4-6AL5-6AU5--
7N7-5U4-6K6-6BQ6-6AS7--12AU7--
6SL7-6AX4--6V3-6AX5</p> |
| <p>No. 3 . . . Brightness
No Picture
No Sound</p> | <p>a. Check any one of the following tubes for this trouble.
6J6-6AG5-12AU7-6BC5-12AT7-6AB4--
6CB6-6AK5-6BQ7-6X8-12AZ7-6BK7--
6U7-6BJ6--7F8</p> |
| <p>No. 4 . . . Brightness
No Picture
Sound Good</p> | <p>a. These are the tubes to check. One of them may be bad.
6AK5-6AU6-6AC7-6AG5-12AU7-6AH6--
6AL5-6BC6-6SN7-6K6-6BC5-12AT7--
7N7-12BY7-6BZ7-6AG7-7B6-7B7</p> |
| <p>No. 5 . . . Vertical
Bright Line
Sound Good</p> | <p>a. This trouble may be caused by any one of the following tubes.
6BG6-1B3-5V4-6SN7--12SN7-1X2-6W4-
25BQ6-19BG6-6CD6-25W4-6AL5-6AU5--
7N7-5U4-6K6-6BQ6-6AS7-12AU7-6SL7--
6AX4-6V3-6AX5</p> |
| <p>No. 6 . . . Horizontal
Bright Line
Sound Good</p> | <p>a. Check for these defective tubes. One of them may be bad.
6S4-6C4-6SN7-6K6-6W6-12AU7-6V6--
12SN7-6BF5-6SL7-6J7-6AQ5-12SK7--
12SH7-12BH7-6AB4-6SH4--12AX7</p> |
| <p>No. 7 . . . Small Picture
In Center of
Tube</p> | <p>a. Space on all sides of picture (picture gradually getting smaller on all sides)
b. First check the following tubes.
5U4-5Y3-5V4-6AX4-6AX5
c. In the event that your set does not use these tubes check the following tubes.
6BG6-6BQ6-6CD6--25BQ6--19BG6--
6AS7-6AU5
d. If your set does not use the above mentioned tubes your set most likely employs a selenium rectifier which may be defective. We suggest a serviceman check on this rectifier.</p> |
| <p>No. 8 . . . Weak or No
Audio (sound)
Picture good</p> | <p>a. The tubes affecting sound are any one of the following
6AU6-6AL5-6V6-6T8-6J6-6BA6-6AT6--
6SQ7-6W6-25L6-6AV6-6Y6-6SN7--6CB6--
12AU7-12AT7-12BH7--12BY7-12SN7--
6BE6-6BA7-6H6-6AK5-6BK5-6U8-6BN6--
12AV7-6AS5-7B4-7B5--7B6--7C5-7C6</p> |
| <p>No. 9 . . . No Vertical
Height
(Picture good
but insufficient
height)
Also Refer to
A1 & A2</p> | <p>a. Check for any one of these defective tubes.
6S4-6C4-6SN7-6K6-6W6-12AU7-6V6--
12SN7-6BF5-6SL7-6J5-6AQ5-12BK7--
12SH7-12BH7-6AB4-6AH4--12AX7
b. If these tubes check perfect, it is possible the Vertical Linearity and/or Vertical Height controls are misadjusted.</p> |

- No. 10... No Horizontal Width**
(Picture good but insufficient width)
Also Refer to A5 & A6
- a. This is caused by any one of the following defective tubes.
6BG6--1B3--5V4--68N7--12SN7--1X2--6W4--
25BQ6--19BG6--6CD6--25W4--6AL5--6AU5--
7N7--5U4--6K6--6BQ6--6AS7--12AU7--6SL7--
6AX4--6V3--6AX5
- b. If these tubes check perfect, it is possible that the Horizontal width, Horizontal Linearity or Horizontal Drive controls are misadjusted.
- No. 11... Rolling Picture (Vertical)**
Continual flop over of picture.
Also Refer to A4
- a. Check for any one of these defective tubes.
6S4--6C4--6SN7--6K6--6W6--12AU7--6V6--
12SN7--6BF5--6SL7--6J5--6AQ5--12SK7--
12SH7--12BY7--6AB4--6AH4--12AX7
- b. If these tubes check perfect, it is possible that the Vertical Hold Control is misadjusted.
- No. 12... Picture Tearing**
Also Refer to A8 & 9
- a. This trouble may be caused by any one of the following tubes:
6BG6--5V4--6SN7--6W4--25BQ6--6CD6--
19BG6--6AC7--25W4--6AL5--5U4--12SN7--
6SL7--7N7--12AU7--6AU5
- b. If these tubes check perfect, it is possible that the Horizontal Hold, Horizontal Locking Range or Horizontal Frequency Controls are misadjusted, also Horizontal Drive.
- No. 13... Distortion (Horizontal)**
Picture out of proportion from side to side.
Also Refer to A5 & A6
- a. Check the following tubes. One may be bad.
6BG6--5V4--6SN7--6W4--25BQ6--6CD6--
19BG6--6AC7--25W4--6AL5--5U4--12SN7--
6SL7--12AU7--6AU5
- b. If these tubes check perfect, it is possible that the Horizontal Linearity or Horizontal Frequency controls are misadjusted.
- No. 14... Distortion (Vertical)**
Picture out of proportion from top to bottom.
Also Refer to A1 & A2
- a. Check for these defective tubes. One may be bad.
6S4--6C4--6SN7--6K6--6W6--12AU7--6V6--
12SN7--6BF5--6SL7--6J5--6AQ5--12SK7--
12SH7--12BH7--6AB4--6AH4--12AX7
- b. If these tubes check perfect, it is possible that the Vertical Linearity and Vertical Height controls are misadjusted.
- No. 15... Snow in the Picture** (sometimes caused in poor signal areas)
Also Refer to A11
- a. Check antenna and lead in wire for corrosion, loose connection, or break in wire.
- b. Also check the following tubes. One may be bad.
6J6--6AG5--12AU7--6BC5--12AT7--6AB4--
6CB6--6AK5--6BQ7--6X8--12AZ7--6BK7--
6U8--6BJ6--7F8--6AU6--6AC7--6AH6--6AL5--
6SN7--6L6--6BC5--7N7--12BY7--6BZ7--6AG7--
7B6--7B7
- No. 16... 1/2 Picture Vertically** (1/2 Picture on top and 1/2 picture on bottom.)
Also Refer to A4
- a. This trouble is sometimes caused by any one of the following tubes.
6S4--6C4--6SN7--6K6--6W6--12AU7--6V6--
12SN7--6BF5--6SL7--6J5--6AQ5--12SK7--
12SH7--12BY7--12BH7--6AB4--6AH4--12AX7
- No. 17... 1/2 Picture Horizontally** (Half pictures, sometimes 3 or 4 running from side to side.)
Also Refer to A9
- a. These tubes may cause this trouble. One may be bad.
6BG6--5V4--6SN7--6W4--25BQ6--6CD6--19BG6--
6AC7--25W4--6AL5--5U4--12SN7--6SL7--7N7--
12AU7--6AU5
- No. 18... Focus Poor** (Picture not clear) (Fuzzy Picture)
Also Refer to A12
- a. Check any one of the following tubes.
6AK5--6AU6--6AC7--6AG5--12AU7--6AH6--
6AL5--6CB6--6SN7--6K6--6BC5--12AT7--
7N7--12BY7--6BZ6--6AG7--7B6--7B7
- No. 19... Black line running up and down on left side picture, running through picture.**
Also Refer to A5
- a. This trouble is sometimes caused from defective tubes as follows. One may be bad.
6BG6--1B3--5V4--68N7--12SN7--1X2--6W4--
12BQ6--19BG6--6CD6--25W4--6AL5--6AU5--
7N7--5U4--6K6--6BQ6--6AS7--6V3--12AU7--
6SL7--6AX4--6AX5
- b. If these tubes check perfect, it is possible that the Horizontal Drive control is misadjusted.

ADJUSTMENTS AND THEIR USES IN TV.

A 1 VERTICAL SIZE (sometimes called) VERTICAL HEIGHT

This control is used to fill the screen (picture) vertically from top to bottom. There should be no blank spaces either on top or bottom of picture. If this control affects the vertical proportion (flat top or bottom) use the Vertical Linearity control to correct this. It is sometimes advisable to use the VERTICAL HEIGHT and VERTICAL LINEARITY controls together.

A 2 VERTICAL LINEARITY (sometimes called) VERTICAL PEAKING

This control is used to adjust the roundness of the picture so that the top or bottom is not squeezed together (flat top or bottom). This control is set correctly when the upper half of picture is equal in length with the lower half. If any blank spaces appear either on top or bottom or both readjust #A1.

A 3 VERTICAL CENTERING (sometimes called) VERTICAL POSITION

This control is used to move entire picture either up or down. It does not affect the size or shape of picture. Not all sets have this control and therefore the centering is accomplished by the maneuvering of the focus coil located on the neck of the picture tube.

A 4 VERTICAL HOLD (sometimes called) VERTICAL LOCK

This control is used when the picture is rolling (slipping) up or down. By properly adjusting this control the picture will stop rolling.

A 5 WIDTH (sometimes called) HORIZONTAL SIZE or HORIZONTAL DRIVE

Set this control so that the picture fills the screen from left to right. If by setting this control the picture tends to lose its roundness, correct this by readjusting control A6.

A 6 HORIZONTAL LINEARITY

This control affects the roundness of picture from left to right. If set has two such controls one is for the left side and the other is for the right side.

A 7 HORIZONTAL CENTERING (sometimes called) HORIZONTAL POSITIONING

This control is used to move entire picture to the left or to the right. It does not affect the size or shape of picture. Not all sets have this control and therefore the centering is accomplished by the maneuvering of the focus coil located on the neck of the picture tube.

A 8 HORIZONTAL HOLD (sometimes called) HORIZONTAL LOCK

This control prevents the picture from slipping from side to side and also the bending and tearing of picture. The control is set correctly when you are able to switch from channel to channel without the picture slipping or tearing.

A 9 AFC (automatic frequency control)

Rotate this control, when picture is split in or near the middle, so that the black bar splitting the picture gradually moves off the screen and a full picture is attained.

A10 SOUND DISCRIMINATOR

This control is used to attain and maintain minimum buzz in speaker.

A11 AGC or Automatic Gain Control

To properly adjust this control turn the contrast control all the way to the right, and then turn the AGC control to the left to a position where the picture does not tear or bend. Use the strongest station for adjusting this control.

A12 FOCUS

Adjust this control so that the thin horizontal lines (scanning lines) are as clear as you possibly can make them with the control. The picture then should be in good focus.

IF YOUR SET IS NOT LISTED

Many TV manufacturers use the same chassis under different model numbers. Compare all the tube layouts listed under name of your TV set with that of tube layout usually found inside cabinet or on rear of your set. This should enable you to identify your model.

*You don't have to be an expert Television Serviceman
to remedy these **COMMON TV TROUBLES—***

No brightness on the picture tube and no sound.

No brightness on the picture tube but sound normal.

Brightness on the picture tube, but no sound and no picture.

Brightness on the picture tube, sound normal but no picture.

**Normal picture on the screen but no sound, sound low, or
sound distorted.**

Picture distorted or out of shape from top to bottom (vertical).

**No vertical height. White line across the screen from side to
side.**

**Picture distorted or out of shape from side to side (horizontal).
White line from top to bottom.**

**Small picture from side to side and top to bottom. Picture does
not fill up the entire screen.**

Picture rolls up or down.

**Picture rips or tears. Figure on the screen moves from side to
side.**

Picture moves up and down and from side to side.

If you own a TV set, why pay big service charges to repairmen when *you can fix it yourself?* Seventy-five percent of the time the only trouble with your set is a faulty tube. All you have to know is which tube is defective and how to replace it. And here is a *brand-new, up-to-date guide* that tells you exactly how to do it.

This book covers almost every known make of set which includes over 3000 models. **BE YOUR OWN TELEVISION REPAIRMAN** has been prepared by an expert for the average man or woman. If your set is faulty and poses one of the above problems, simply take this amazing book and look up your model in the complete manufacturers' index. Then turn to the proper page, where you will find a diagram of the tube locations in your set. Follow the *safe, simple instructions for removing and replacing the faulty tubes* and your troubles are over—and the only cost to you is the price of a new tube.

CHILTON BOOK COMPANY

Philadelphia New York London