

RADIO SERVICING

Vol. 1—Basic Electrotechnology

G. N. PATCHETT

B.Sc. (Eng.), Ph.D., M.Brit.I.R.E., M.I.E.E., M.I.R.E.

Head of Department of Electrical Engineering
Bradford Institute of Technology

This is the first volume of a series, which comprises four volumes, designed to cover the syllabuses of the City and Guilds and R.T.E.B. examinations in radio servicing.

The main purpose of the series is to supply a set of notes on the subject to supplement knowledge already acquired, or to supplement lectures.

Although Volume 1 is on basic electrotechnology it is specially written for the radio and television servicing engineer, stress being laid on those sections of the basic work which are important in radio and television servicing.

The books in the series have been kept small so as to reduce costs, but they still contain the essential information required by the student.

LONDON: NORMAN PRICE (PUBLISHERS) LTD.

Five Shillings net.

RADIO SERVICING

Vol. 1—Basic Electrotechnology

G. N. PATCHETT

B.Sc. (Eng.), Ph.D., M.Brit.I.R.E., M.I.E.E., M.I.R.E.

Head of Department of Electrical Engineering
Bradford Institute of Technology

LONDON
NORMAN PRICE (PUBLISHERS) LTD.

NORMAN PRICE (PUBLISHERS) LTD.
283 CITY ROAD, LONDON, E.C.1

•
First published 1956
Second edition 1957
Reprinted 1958
Reprinted 1959

Printed in Great Britain by
A. BROWN & SONS, LTD., Hull.

AUTHOR'S PREFACE

THIS is the first volume of a series of books designed to cover the syllabus of the City and Guilds and R.T.E.B. examination in radio and television servicing.

The main purpose of the series is to supply a set of notes on the subject to supplement knowledge a reader may already have acquired, or to supplement lectures which the student may be attending. The book saves the student taking notes at the lectures and enables him to pay attention to the lecturer rather than concentrate on a set of notes which he is often unable to understand at a later date.

The books have been kept small so as to reduce the cost, but they still contain the essential information required by the student.

Although Volume 1 is on basic electrotechnology it is specially written for the radio and television servicing engineer, stress being placed on those sections of the basic work which are important in radio and television servicing. The volume is written using the M.K.S. (metre-kilogramme-second) system of units as this system has many advantages and is used in nearly all technical literature on radio and electrical engineering, and in most examinations.

Volumes 1 and 2 are intended to take the student to the Intermediate Radio Servicing Examination; Volume 3 to the Final Radio Servicing Certificate Examination; and Volume 4 covers the practical examination of the Radio Servicing Certificate.

CONTENTS

CHAP.		PAGE
1	Principles of Radio Communications	11
2	Voltage, Current and Resistance	12
3	Conductors and Insulators	17
4	Electric Charge, Power and Energy	21
5	Resistors	25
6	Batteries	31
7	Magnetism	35
8	Measuring Instruments	40
9	Electrostatics and Capacitors	45
10	Electromagnetic Induction	53
11	Alternating Currents and Voltages	56
12	Alternating Current Flow in Electrical Circuits	60
13	Transformers	76
	Index	79

ILLUSTRATIONS

FIG.		PAGE
1.1	Block Diagram of Transmitter and Receiver	12
2.1	Simple Atomic Structure	13
2.2	Measurement of Current in Circuit	16
2.3	Measurement of Voltage in Circuit	16
5.1	Colour Code for Resistors (Older Method)	26
5.2	Colour Code for Resistors	26
5.3	Resistors in Series	28
5.4	Resistors in Parallel	29
6.1	Internal Resistance of Cell	32
6.2	Cells in Series	32
6.3	Cells in Parallel	32
6.4	Leclanche Cell (Dry Type)	33
6.5	Charging of Accumulator	35
7.1	Magnetic Field round a Conductor	35
7.2	Magnetic Field due to Solenoid	36
7.3	Coil on Iron Core	36
7.4	Relationship between Flux Density and Magnetizing Force for Iron and Air	37
7.5	Relationship between Permeability and Magnetizing Force	37
7.6	Force on a Conductor in a Magnetic Field	38
7.7	Motor Principle	39
7.8	Principle of Commutator	39
8.1	Attraction Type Moving Iron Instrument	40
8.2	Repulsion Type Moving Iron Instrument	41
8.3	Moving Coil Instrument	41
8.4	Hot Wire Instrument	42
8.5	Thermo-Couple Instrument	43
8.6	Use of Shunt	43
8.7	Universal Shunt	44
8.8	Use of Voltage Multiplier	44
9.1	Principle of Capacitor	45
9.2	Construction of Air Dielectric Capacitor	47
9.3	Variable Air Dielectric Capacitor	47
9.4	Ceramic Capacitors	48
9.5	Cross Section through Paper Dielectric Capacitor	49
9.6	Paper Dielectric Capacitor with Aluminium Coating for the Plates	49
9.7	Capacitors in Parallel	51
9.8	Capacitors in Series	51
9.9	Charge of a Capacitor through a Resistor	51
9.10	Charge of a Capacitor through a Resistor	51
9.11	Discharge of a Capacitor through a Resistor	52
9.12	Electrostatic Voltmeter	52
10.1	Principle of Generator	53
10.2	Magnetic Field set up by Solenoid	53
10.3	Direct Voltage applied to Inductive Circuit	54
10.4	Rise of Current in Inductive Circuit	54
10.5	Fall of Current in Inductive Circuit	55
10.6	Diagram showing Mutual Inductance	55
11.1	Alternating Voltage or Current	56
11.2	Triangular and Rectangular Waveforms	57

ILLUSTRATIONS

FIG.		PAGE
11.3	Idea of Sinusoidal Waveform	57
11.4	Diagrams showing the Phase Difference between Current and Voltage	58
11.5	Peak or Maximum Value of Alternating Voltage or Current	59
11.6	Average Value of Alternating Voltage or Current	59
11.7	Method of obtaining Mean and r.m.s. values of Alternating Voltage or Current	59
11.8	Relationship between Peak, Mean and r.m.s. Values	60
12.1	Flow of Current in Circuit consisting of Resistance only	60
12.2	Circuit with Inductance only	61
12.3	Flow of Current in Circuit consisting of Inductance only	61
12.4	Circuit with Capacitance only	62
12.5	Flow of Current in Circuit consisting of Capacitance only	62
12.6	Vectors	64
12.7	Addition of Two Alternating Voltages	65
12.8	Vector Diagram corresponding to figure 12.7	65
12.9	Vector Diagram corresponding to figure 12.7	65
12.10	Vector Diagram of Two Voltages with Large Phase Difference	66
12.11	Vector Diagrams	66
12.12	Circuit with Inductance and Resistance	67
12.13	Circuit with Capacitance and Resistance	68
12.14	Series Resonant Circuit	69
12.15	Vector Diagram for Series Resonant Circuit at Resonance	69
12.16	Resonance Curve for Series Circuit	70
12.17	Effect of Resistance on the Resonance Curve of Series Circuit	71
12.18	Parallel Resonant Circuit	71
12.19	Vector Diagram for Parallel Resonant Circuit	71
12.20	Vector Diagram for Parallel Resonant Circuit at Resonance	72
12.21	Resonance Curve for Parallel Resonant Circuit	72
12.22	Effect of Resistance on the Resonance Curve of Parallel Circuit	72
12.23	Power in Circuit where I and V are 90° out of phase	74
12.24	Power in Resistive Circuit	74
12.25	Vector Diagram for Circuit where I and V are not in phase	75
13.1	Basic Principle of Transformer	76
13.2	Idea of Iron Core for Transformer	76
13.3	Use of Laminations for Transformer Core	77
13.4	Construction of Transformer	77

SYMBOLS, UNITS AND ABBREVIATIONS OF UNITS

SYMBOL	TERM	UNIT	ABBREVIATION OF UNIT
V, E	Voltage or potential difference (steady or r.m.s.)	{ volt millivolt microvolt	V mV μV
v, e	Voltage (Instantaneous)		
I	Current (steady or r.m.s.)	{ ampere milliampere microampere	A mA μA
i	Current (Instantaneous)		
R	Resistance	{ ohm kilohm megohm	Ω k Ω M Ω
ρ (<i>rho</i>)	Resistivity		
P	Power	ohm/cm cube or ohm-cm watt and kilowatt joule, watt-hour & kilowatt-hour	W & kW
W	Energy		
θ (<i>theta</i>)	Temperature or temperature rise	degree centigrade	$^{\circ}C$
F	Force	newton	N
ϕ (<i>phi</i>)	Magnetic flux	weber	Wb
B	Magnetic flux density	weber/square metre	Wb/m ²
μ_0 (<i>mu</i>)	Permeability of free space	(Value $4\pi \times 10^{-7}$)	—
μ (<i>mu</i>)	Relative permeability	—	—
H	Magnetizing force	ampere-turn per metre	AT/m
E	Electric force or field strength	volt per metre	V/m
ψ (<i>psi</i>)	Electric flux	coulomb (or lines)	C
ϵ_0 (<i>epsilon</i>)	Permittivity of free space	(Value 8.85×10^{-12} farad/metre)	—
ϵ (<i>epsilon</i>)	Relative permittivity	—	—
D	Electric flux density	Coulomb per square metre	C/m ²
Q	Charge	coulomb	C
C	Capacitance	{ farad microfarad picofarad	F μF pF
L	Inductance (self)		
M	Inductance (mutual)	henry (plural = henrys)	H
X	Reactance	henry	H
Z	Impedance	ohm	—
ϕ (<i>phi</i>)	Phase angle	ohm	—
ω (<i>omega</i>)	Angular frequency ($2\pi f$)	degree	$^{\circ}$
f	Frequency	radian per second	rad/s
N or T	Turns	cycle per second	c/s
l	Length	—	—
A	Cross section	metre	m
α (<i>alpha</i>)	Temperature coefficient	square metre	m ²
t	Time	ohm/ohm/ $^{\circ}C$	—
e.m.f.	Electromotive force	second or hour	sec or h
m.m.f.	Magneto motive force	volt	V
r.m.s.	Root mean square	ampere-turn	AT
p.d.	Potential difference	—	—
θ (<i>theta</i>)	Angle	volt	V
		degree	$^{\circ}$

PRINCIPLES OF RADIO COMMUNICATIONS

THE basic method of communication between two individuals is that of sign language, and that which was used before the introduction of a spoken language. Our general method of communication to-day is by a spoken language; but it is important to note that it is quite useless unless both individuals know the same language. The language may be considered to be a code which must be known by both parties before a message can be communicated. Communication by the unaided voice in this way is limited to short distances, and to be able to communicate over greater distances various devices may be used, such as flag or lamp signalling. In this case another code, such as the Morse code, must be used and, again, must be known by both sender and receiver. These methods, also, are limited to comparatively short distances. The discovery of electricity enabled communication over much greater distances; first by the use of wires and then by radio. The simplest is the use of a code which may be sent over two wires by switching a current on and off at the sending end, and having some device which will detect the flow of current at the receiving end. This is **telegraphy** and is still used extensively to-day. The next stage was the **telephone**. Here we require, firstly, a device which will convert the sound waves, which are produced when we speak, into corresponding electric currents. Such a device is called a **microphone**. Secondly, we require a device which will convert the electric currents back to corresponding sound waves at the receiving end, and this is known as a **telephone receiver** (or, in the case of radio receivers, **headphones** or **loudspeaker**). By connecting the microphone through two wires to the receiver currents flow which correspond to the sound waves picked up by the microphone, and these operate the receiver where they are converted back to sound waves. This system of communication is known as **telephony** and, using either telegraphy or telephony, we are able to communicate between two points several thousand miles apart; but in both cases we need a wire or wires connecting the two points.

The next development was **radio** which enables us to dispense with the wires and transmit the message through space by means of radio waves. We must now have a generator of radio waves at the sending end which we call the **radio transmitter**, and a device which will receive them at the receiving end which we call the **radio receiver**. In radio telegraphy, which is the radio equivalent of telegraphy, we switch the radio waves on and off according to some code (such as the Morse code), and at the receiver we have some device which will indicate when radio waves are being received from the transmitter. Although this system is not used for domestic radio it is used to a large extent for world communications over extremely long distances. Finally, we come to **radio telephony** where we are able to transmit actual speech or music from one point to another. As in telephony we must first convert the sound waves into corresponding electric currents by using a **microphone**. These currents are then used to vary the radio waves in some way, *e.g.* to vary the amplitude according to this current. This process is known as **modulation**. Thus, we must first generate radio frequency currents which are modulated by the output from the microphone and then fed to the transmitter aerials, where they are radiated in the form of radio waves. At the receiver we use a device known as a **demodulator** or **detector** to sort out the variations that we have impressed on the radio waves and convert these variations back to an electric current, which we can finally convert back to sound waves in a **loudspeaker**. As the radio frequency currents picked up by the receiving aerial are very small it is generally necessary to amplify these before we apply them to the demodulator. Similarly, we may have to amplify the output from this

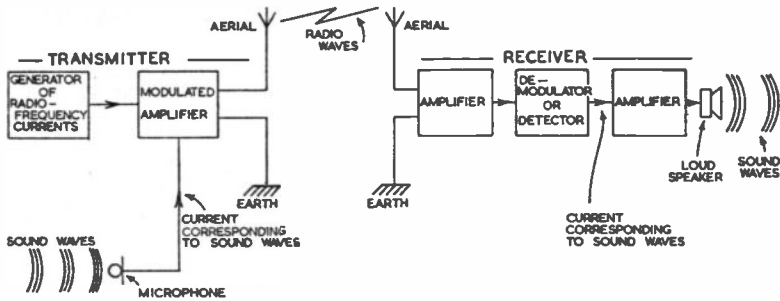

FIG. 1.1. BLOCK DIAGRAM OF TRANSMITTER AND RECEIVER

demodulator before we can feed it to the loudspeaker. Figure 1.1 shows a simple block diagram of a radio transmitter and receiver.

The foregoing gives a very general idea of the operation of radio telephony or wireless but, before we can understand how the transmitter and receiver operate, it is essential to learn something about the elements of electrical engineering, and that is the purpose of this book. Having studied these fundamentals of electricity we can then see how they are used in radio circuits.

CHAPTER 2

VOLTAGE, CURRENT AND RESISTANCE

NATURE OF MATTER

IF we take any known material and divide it into smaller and smaller particles we reach a point where we cannot divide any further without changing the material. The smallest particle of matter that can exist is known as a **molecule**. In general, the molecule is composed of smaller particles known as **atoms**, and it is the combination of different types of atom that make up all known materials or compounds. The materials making up the different types of atom are called **elements**. (There are approximately 90 different elements.) Taking an example, a molecule of water is composed of two atoms of hydrogen and one atom of oxygen.

If we split up the atom we find that it is composed basically of two particles: the **electron**; and the **proton**. (There are other particles involved, but they need not concern us here.) An atom may be considered as comprising a central body called the **nucleus**, composed of protons (and perhaps other particles) around which rotate one or more electrons in circular orbits. Some simple examples are shown in figure 2.1. The electrons are maintained in their orbits by the electrostatic attraction between the positive nucleus and the negative electrons (charges of opposite polarity attract and charges of similar polarity repel each other). The electron is a negative charge of electricity and is the basis of all electrical and electronic work. A flow of electricity in a circuit is produced by a flow of electrons. The proton has a positive charge equal to that on the electron; the total charge on the nucleus is equal to the total charge on all the electrons, so that the whole atom normally has no electric charge. If electrons are removed from the atom then it will have a resultant positive charge. Thus, a negative charge is due to electrons or an excess of electrons, while a positive charge is due to a shortage of electrons.

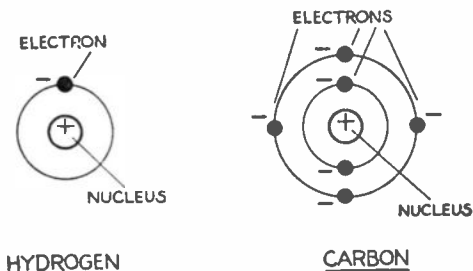

FIG. 2.1. SIMPLE ATOMIC STRUCTURE

Long before electrons were discovered the idea of an electric current was introduced to explain many of the phenomena which occurred. At that time no one knew what actually flowed in the circuit and it was not until later that the idea of the flow of electrons was discovered. It will be shown later that the flow of current is in the opposite direction to the flow of electrons. In ordinary electrical engineering this is not important as we can still use and do use the idea of an electric current; but, when we come to electronic devices such as valves, although we usually refer to an electric current, we must consider the flow of electrons if we are to explain how the devices function.

VOLTAGE AND CURRENT

If we take a source of electricity such as a battery there is a certain force tending to send a current or flow of electrons through an external circuit between the two terminals. This force is called the electromotive force (e.m.f.), or often the voltage of the battery. The force is produced as a result of chemical action in the cell and if we complete the electrical circuit between the two terminals a current will flow. By convention the current is taken as flowing from the positive terminal of the battery to the negative terminal. Earlier it was stated that the electron is a negative particle of electricity, hence the negative terminal of the battery has an excess of electrons while the positive terminal has a shortage. When the circuit is completed the negative electrons flow from the negative terminal to the positive, i.e. in the opposite direction to our conventional current flow.

The unit of electromotive force is the volt (V). For many purposes in radio we are concerned with a small fraction of a volt and so this unit is subdivided into:

$$1 \text{ millivolt (mV)} = 1/1000 \text{ volt (V)} = 10^{-3} \text{ volt} \tag{2.1}$$

$$1 \text{ microvolt } (\mu\text{V}) = \begin{cases} 1/1000 \text{ 000 volt} & = 10^{-6} \text{ volt} \end{cases} \tag{2.2}$$

$$1 \text{ microvolt } (\mu\text{V}) = \begin{cases} 1/1000 \text{ millivolt} & = 10^{-3} \text{ millivolt} \end{cases} \tag{2.3}$$

Sometimes, where large voltages are concerned, we use multiples of the volt as follows:

$$1 \text{ kilovolt (kV)} = 1000 \text{ volts} = 10^3 \text{ volts} \tag{2.4}$$

$$1 \text{ megavolt (MV)} = 1000 \text{ 000 volts} = 10^6 \text{ volts} \tag{2.5}$$

When the electrical circuit between the terminals is completed a current will flow; the unit of current is the ampere (A).* In radio work the ampere is a relatively large current and subdivisions of this are commonly used:

$$1 \text{ milliampere (mA)} = 1/1000 \text{ ampere} = 10^{-3} \text{ ampere} \tag{2.6}$$

$$1 \text{ microampere } (\mu\text{A}) = \begin{cases} 1/1000 \text{ 000 ampere} & = 10^{-6} \text{ ampere} \end{cases} \tag{2.7}$$

$$1 \text{ microampere } (\mu\text{A}) = \begin{cases} 1/1000 \text{ milliampere} & = 10^{-3} \text{ milliampere} \end{cases} \tag{2.8}$$

* This corresponds to the flow of approximately 6×10^{18} electrons/second.

RESISTANCE

For a certain applied voltage the current which will flow in the circuit will depend on the opposition of the circuit to current flowing through it. This opposition is called the **resistance** of the circuit; the unit of resistance is the **ohm** (Ω). For radio purposes the ohm is rather a small unit and multiples are commonly used:

$$1 \text{ kilohm (k}\Omega) = 1000 \text{ ohms} = 10^3 \text{ ohms} \quad (2.9)$$

$$1 \text{ megohm (M}\Omega) = \begin{cases} 1000 \text{ 000 ohms} & = 10^6 \text{ ohms} & (2.10) \\ 1000 \text{ kilohms} & = 10^3 \text{ kilohms} & (2.11) \end{cases}$$

One may consider the voltage as being equivalent to the pressure in a water system: the current as the flow of water, and resistance as the friction of the pipe to the flow of water.

OHM'S LAW

An important law connects the voltage (or e.m.f.), current and resistance of a circuit and this is known as Ohm's law. This states that:

$$\text{Current (amperes)} = \frac{\text{Voltage (volts)}}{\text{Resistance (ohms)}}$$

This means that an e.m.f. of 1 volt will cause a current of 1 ampere to flow through a circuit having resistance of 1 ohm. This law may be conveniently written as:

$$I = V/R \quad (2.12)$$

where I is the current in amperes

V is the voltage in volts

R is the resistance in ohms.

Turning the expression round we get:

$$R = V/I \quad (2.13)$$

$$\text{and } V = I.R \quad (2.14)$$

Thus, the current in a circuit is proportional to the applied voltage and inversely proportional to the resistance.

It should be pointed out here that not all devices obey this law. Most non-electronic devices obey this law fairly accurately but, unfortunately, electronic devices, such as valves, do not, and calculations are then made more difficult. For the present it will be assumed that all the devices do obey Ohm's law.

It will be seen from the above expressions that if any two of the three quantities are known we can always calculate the third. In using these expressions the basic units of amperes, volts and ohms should be used. When experience has been gained it may be found more convenient, when dealing with radio circuits, to use milliamperes, volts and kilohms; but these should not be used in the first place.

Examples

1. A battery of e.m.f. 10 volts is connected to a circuit having a resistance of 20 ohms. What current will flow?

$$I = V/R \quad (\text{see 2.12})$$

Substituting the above values:

$$I = 10/20 = 0.5 \text{ ampere or } 500\text{mA.}$$

2. When a battery of 100 volts is connected to a radio circuit it is found that a current of 20mA flows. Find the resistance of the circuit.

A current of 20mA = 20/1000 ampere or 0.02 ampere (see 2.6)

$$\text{Now } R = V/I \quad (\text{see 2.13})$$

Substituting the above values:

$$R = 100/0.02 = 5000 \text{ ohms or } 5 \text{ kilohms}$$

$$\text{or, } R = \frac{100.1000}{20} = 5000 \text{ ohms.}$$

3. If, in a radio circuit, a current of 20 microamperes is required to flow in a circuit having a resistance of 1 megohm what must be the applied voltage?

20 microamperes = 20/1000 000 ampere or 20×10^{-6} ampere
(see 2.7)

1 megohm = 1000 000 ohms or 10^6 ohms (see 2.10)

$$\text{Now } V = I.R \quad (\text{see 2.14})$$

Substituting the above values:

$$V = \frac{20}{1000 \ 000} \times 1000 \ 000 = 20 \text{ volts}$$

$$\text{or } V = 20 \times 10^{-6} \times 10^6 = 20 \text{ volts.}$$

Further examples

4. When a 47 kilohm resistor is connected across an h.t. battery the current is found to be 2.2 milliamperes. What is the voltage of the battery? (Answer 103.4 volts.)
5. A 12 volt lamp is found to have a resistance of 33 ohms. What current will flow through the lamp when it is operated on 12 volts? (Answer 0.364 ampere.)
6. When constructing a particular radio receiver it is necessary to have a current of 0.3 amperes flowing through the valve heaters when the set is connected to a 230V supply. What must be the resistance of the heated circuit? (Answer 767 ohms.)

METHOD OF MEASURING CURRENT

Suppose that we wish to measure the current flowing in the circuit shown in figure 2.2(a). To do this we use an instrument called an **ammeter** (or, when measuring small currents, a **milliammeter** or **microammeter**), which must be placed in the circuit so that all the current flows through it. This is shown in figure 2.2(b). It is not important where the ammeter is placed in the circuit since the current flowing must be the same in all parts of the circuit. If we are to measure the true current that was originally flowing in the circuit shown at (a) it is important that the connection of the ammeter should not upset the current in the circuit. Ideally, the ammeter should have no resistance, or opposition to current flow, otherwise it will tend to increase the resistance of the circuit and, therefore, reduce the current from the original and correct value. In practice we cannot make the resistance of the meter zero but it is made as small as possible and generally negligible in radio circuits. The actual value depends on the range of the meter (*i.e.* the current required to give full scale reading).

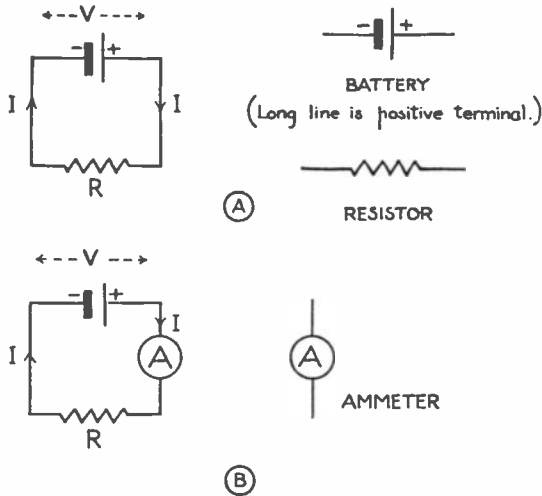

FIG. 2.2. MEASUREMENT OF CURRENT IN CIRCUIT

METHOD OF MEASURING VOLTAGE

Suppose that we wish to measure the voltage of the battery or the voltage across the resistor R shown in figure 2.3. These voltages will be the same if we neglect the resistance of the connecting leads, which is normally the case

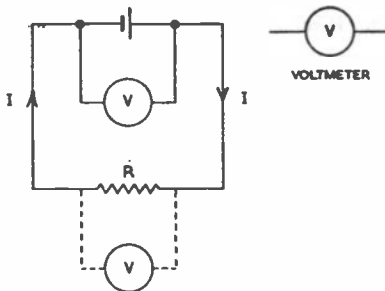

FIG. 2.3. MEASUREMENT OF VOLTAGE IN CIRCUIT

in practice. We now use a **voltmeter** which must be connected to the two points across which we wish to measure the voltage or voltage difference (or potential difference as it is sometimes called). The voltmeter is therefore connected *across* the battery or across the resistor R as shown. Again the connection of the meter to the circuit should not upset the circuit conditions and, ideally, no current should flow through the meter.* In practice a small current normally flows and, unlike the case of the ammeter, the effect is not always negligible in radio circuits where the currents in the circuits are small. This means that it is often necessary to make an allowance for the current taken by the meter, and this will be considered later.

Thus, an ammeter is a very low resistance meter and a voltmeter a high resistance instrument. It is important that an ammeter is *never* connected across a battery or electricity supply (in the same way as a voltmeter) since

* In this circuit the meter current would not upset the circuit conditions if we assume a perfect battery. For further details of the effect of meter current see supplementary the volume *Fault-Finding*.

the low resistance would allow a large current to flow, normally damaging the meter.

It is also important when we are measuring currents and voltages to see that the range of the instrument is sufficiently high for the current and voltage that we are likely to expect in the circuit, otherwise the instrument is likely to be damaged by overloading.

CHAPTER 3

CONDUCTORS AND INSULATORS

MATERIALS which allow an electric current to flow easily are known as **conductors**, while those which prevent the flow of an appreciable current are known as **insulators**. By the use of conductors and insulators we are able to make the current flow where we wish. Practically all materials fall into the above two classes: they are either good conductors or good insulators. There are very few materials which are in between and, until recently, these were not considered to be of any importance. In the last few years those materials which fall between conductors and insulators, known as **semi-conductors**, have become vitally important and are likely to be more so in the future, *e.g.* in rectifiers and transistors.

The best conductor is silver, but for most purposes it is not used owing to its cost. Where we want a good conductor copper is nearly always used; occasionally aluminium may be used, but it has about 60 per cent. greater resistance. In order to control the current flowing in the circuit we often use a material which is a poor conductor compared with copper. These materials, if they are metals, are usually alloys since an alloy is a poorer conductor than the pure metals forming the alloy. The resistance materials commonly used are: **Eureka** (Constantan or Advance) (60 per cent. copper and 40 per cent. nickel); **Manganin** (84 per cent. copper, 4 per cent. nickel and 12 per cent. manganese); and **Nichrome** (80 per cent. nickel and 20 per cent. chromium). Carbon or carbon composition is used for most of the resistors in radio circuits (see later).

Since the resistance of a piece of material depends on its shape, we must use a standard shape and size to compare the conducting properties of different materials. This standard is a cube of 1 cm side and the resistance is measured between opposite sides of this cube. This resistance is called the **resistivity** (ρ)* (or sometimes **specific resistance**) of the material. Some typical values for materials used in radio are given in Table 1.

TABLE 1
RESISTIVITIES OF METALS AND ALLOYS

<i>Material</i>	<i>Resistivity (Ohms/cm cube)</i>
Silver	1.62×10^{-6}
Copper	1.76×10^{-6}
Aluminium	2.83×10^{-6}
Gold	2.4×10^{-6}
Brass	$6-9 \times 10^{-6}$
Iron	9.4×10^{-6}
Nickel	7.24×10^{-6}
Tungsten	5.48×10^{-6}
Eureka (Constantan, Advance)	49×10^{-6}
Manganin	45×10^{-6}
Nichrome	108×10^{-6}
Carbon (non-metal)	$33-185 \times 10^{-6}$

* ρ is the Greek letter *rho*.

The most common conducting material used in radio is, of course, copper, for it is a good conductor and relatively cheap. Generally, it is used in the form of wire which is usually "tinned" for ease of soldering. Silver is used in the form of a thin plating on certain switches where good contact is essential. Aluminium is not normally used in the form of wire owing to the difficulty of soldering, but is often used for screening "cans" around coils and other components. It may also be used for chassis, but it is generally too expensive for commercial sets. Iron, usually cadmium plated to prevent corrosion, is used for chassis in commercial receivers; it is cheaper and stronger than aluminium. Brass is used for terminals, soldering tags and many other small parts in a radio set. Nickel and tungsten are used in valves. Resistance alloys are used for the construction of certain resistors.

The resistance of a piece of material depends on its length and its cross section. If we double the length, since the current has to flow through twice the length of material, its resistance will be doubled; or, expressed in another way, the resistance is proportional to the length. If we double the cross section of the material the path for current flow is made larger and the resistance is halved; or, alternatively, the resistance is inversely proportional to the cross section. Since the resistivity is really the resistance of a block of material 1 cm long and 1 sq cm cross section the resistance of any piece of material of length l cm and uniform cross section A sq cm will be

$$R = \rho.l/A \text{ ohms} \quad (3.1)$$

Thus, if we know the resistivity of the material it is easy to find the resistance of a piece of the material, such as a length of wire. If the wire is circular in section the cross sectional area will be

$$A = \pi d^2/4 \quad (3.2)$$

where d is the diameter.

Alternatively, the resistance per cm of different sizes of wire may be obtained from tables, when they are available.

Examples

1. A 100 metre length of copper wire is used to wind the primary of a transformer and the wire has a cross sectional area of 0.001 sq cm. What will be the resistance of this winding? Resistivity of copper 1.76×10^{-6} ohm/cm cube.

$$\begin{aligned} 100 \text{ metres} &= 100 \times 100 \text{ cm} \\ 1.76 \times 10^{-6} &= 1.76/1000 \text{ 000} \\ R &= \rho.l/A && \text{(see 3.1)} \\ &= \frac{1.76}{1000 \text{ 000}} \times \frac{100 \times 100}{0.001} \text{ ohms} \\ R &= 17.6 \text{ ohms} \end{aligned}$$

2. A length of 1000 cm of resistance wire of diameter 0.01 cm is made into a wirewound resistor and is connected to a supply of 10 volts. What current will flow? The resistivity of the material of the wire is 50 microhm/cm cube.

$$\begin{aligned} A &= \pi d^2/4 && \text{(see 3.2)} \\ &= \frac{\pi 0.01^2}{4} \\ &= \frac{\pi}{4} 0.0001 \text{ sq cm.} \end{aligned}$$

Now, 50 microhm is 50/1000 000 ohm

$$\text{and } R = \rho \cdot l/A \quad (\text{see 3.1})$$

$$= \frac{50}{1000\ 000} \times \frac{1000}{\frac{\pi}{4} \cdot 0\cdot0001}$$

$$= 500 \times \frac{4}{\pi} = 2000/\pi$$

$$= 638 \text{ ohms.}$$

$$\text{By Ohm's law } I = V/R \quad (\text{see 2.12})$$

$$= 10/638 \text{ ampere}$$

$$= 0\cdot0157 \text{ ampere or } 15\cdot7 \text{ milliamperes.}$$

Further examples

3. A coil is composed of 2000 cm of 20 s.w.g. copper wire (dia. 0·0914 cm). What will be the resistance of the coil? Resistivity of copper $1\cdot76 \times 10^{-6}$ ohm/cm cube. (Answer 0·537 ohm.)
4. A wirewound resistor of 100 ohms is required and it is to be wound with Nichrome wire of 30 s.w.g. (dia. 0·0315 cm). What length of wire will be required? Resistivity is 108 microhm/cm cube. (Answer 720 cm.)

In the same way that we measure the resistivity of a conductor so can we measure the resistivity of an insulator; but, in this case, the value obtained is large. (Values for some typical insulating materials are given in Table 2.) In this case, of course, the higher the resistivity the better.

The main insulating materials used in radio are:

Mica: in valves and capacitors; **Ceramics:** in capacitors, certain switches and in the construction and protection of resistors; **Glass:** in valves; **Thermosetting plastics (e.g. Bakelite):** valveholders, coil formers, knobs, plugs and sockets and many small components; **Thermosplastic plastics (e.g. polyvinyl chloride, or P.V.C.):** on cables and wires; **Plastic impregnated paper or cloth (e.g. Paxolin):** in panels supporting components (tag boards) and the insulation of plugs and sockets, switches and small components; **Wax impregnated paper:** in capacitors; **Enamel and certain plastic:** on wires used for coils and transformers; **Cotton, silk and rayon:** on wire used for coils; **Rubber:** on cables and wires.

TABLE 2
RESISTIVITIES OF INSULATING MATERIALS

Material	Resistivity (Ohms/cm cube)
Paraffin wax	10^{17}
Insulating oil	10^{15}
Bakelite	10^{11} approx.
Laminated plastic sheet	10^{11} approx.
Polystyrene	10^{18}
Polythene	10^{17}
Mica	10^{16}
Glass	10^{14} approx.
Ceramics	10^{14} approx.

EFFECT OF TEMPERATURE ON RESISTANCE

When the temperature of a conductor is changed the resistance also changes. For most materials a rise in temperature results in an increase in resistance. The amount of the change is called the temperature coefficient (α)* of resistance and is the change of resistance of 1 ohm at 0° C. of the material when the temperature is raised 1° C. In other words, suppose a length of wire has a resistance of 1 ohm when measured at 0° C. If the temperature is now raised to 1° C. (an increase of 1° C.) and the resistance increases to 1.004 ohms, then the temperature coefficient of the material would be 0.004 ohm/ohm/C°.

Thus, the increase in resistance of a resistor R_0 at 0° C., when raised in temperature by θ ° C, will be $R_0 \cdot \alpha \cdot \theta$ ohms. Thus, its new resistance R_t will be $R_0 + R_0 \cdot \alpha \cdot \theta$ ohms

$$\text{or } R_t = R_0 (1 + \alpha \cdot \theta) \quad (3.3)$$

Thus, the resistance can be found at any temperature. In general we are more concerned with the change in resistance when the temperature is raised from room temperature (not 0° C.) to some other temperature. For normal purposes the above expression is accurate enough if R_0 is replaced by the resistance at room temperature, but this expression must not be used if the initial temperature is high. Some typical values for the temperature coefficient are given in Table 3. The temperature coefficient of pure metals does not vary much, is not large, and is always positive; but it will be seen that the values for resistance alloys are very small. The temperature coefficient of carbon and semiconductors is always negative and, in the case of semiconductors, is much greater in magnitude.

TABLE 3

TEMPERATURE COEFFICIENTS OF RESISTANCE IN OHM/OHM/C°

Material	Temperature Coefficient
Copper	0.00426
Aluminium	0.0043
Brass	0.001
Gold	0.0034
Iron	0.0055
Nickel	0.0059
Tungsten	0.0045
Silver	0.0038
Eureka (Constantin and Advance)	-0.00007 to +0.00004
Manganin	0.000002 to 0.00005
Nichrome	0.0001
Carbon	-0.0006 to -0.0012

Examples

1. The resistance of the winding of a smoothing inductance composed of copper wire is 100 ohms at 0° C. What will be the resistance at 30° C. if the temperature coefficient of copper is 0.004 ohm/ohm/C°?

$$\begin{aligned} \text{Increase in resistance} &= R_0 \cdot \alpha \cdot \theta && \text{(see 3.3)} \\ &= 100 \times 0.004 \times 30 \text{ ohms} \\ &= 12 \text{ ohms} \end{aligned}$$

Therefore, resistance at 30° C. will be $100 + 12 = 112 \text{ ohms}$.

* α is the Greek letter *alpha*.

2. The current taken by the primary winding of a transformer wound with copper wire at 0° C. is 100mA when a voltage 10V d.c. is applied to it. When the winding has increased in temperature due to the current flowing through it the current is 90mA. If the temperature coefficient is 0.004 what is the temperature of the winding? (NOTE: This is often a convenient way of measuring the temperature rise of a transformer or other coil.)

$$\text{Original resistance} = V/I = 20/0.1 = 200 \text{ ohms} \quad (\text{see 2.13})$$

$$\text{New resistance} = V/I = 10/0.09 = 222 \text{ ohms}$$

$$\text{Increase in resistance } 22 \text{ ohms and this equals } R_0 \cdot \alpha \cdot \theta$$

$$\text{Therefore } \theta = 22/R_0 \cdot \alpha = \frac{22}{200 \times 0.004} = 27.5^\circ \text{C.}$$

Further examples

3. A resistor wound with Nichrome wire has a resistance of 50,000 ohms at 0° C. What will be its value at 200° C. if the temperature coefficient of the wire is 0.0001? (Answer 51,000 ohms.)
4. A tungsten filament lamp has a resistance of 100 ohms at room temperature of 20° C. When operated at 230 volts the temperature of the filament is 2020° C. What will be the approximate resistance at this temperature and what current will the lamp take? (Temperature coefficient of tungsten is 0.0045 ohm/ohm/°C.) (Answers 1000 ohms and 0.23 ampere.)

CHAPTER 4

ELECTRIC CHARGE, POWER AND ENERGY

ELECTRIC CHARGE

ELECTRIC charge (Q) or the quantity of electricity is the product of current and time, and may be considered as the number of electrons which have passed through the circuit. The unit of charge is the coulomb* and is the charge corresponding to the flow of 1 ampere for 1 second. It will be seen later that this charge is important when we deal with capacitors. The coulomb may be considered as an ampere-second and when we come to accumulators we use a larger unit of charge called the ampere-hour which is the flow of 1 ampere for 1 hour or 3,600 ampere-seconds or coulombs.

POWER AND ENERGY

When we have a voltage across a circuit and a current flowing through the circuit there is a certain electric power (P) developed in the circuit. The unit of electric power is the watt (W) and is the power in a circuit when the voltage is 1 volt and the current 1 ampere, or

$$\text{Power } P = I \cdot V \text{ watts} \quad (4.1)$$

Since $I = V/R$ (see 2.12) by Ohm's law, substituting in the above for I we get

$$P = V/R \times V = V^2/R \text{ watts} \quad (4.2)$$

and since $V = I \cdot R$ (see 2.14) by Ohm's law, substituting in equation 4.1 we get

$$P = I \times I \cdot R = I^2 \cdot R \quad (4.3)$$

* Corresponding to the flow of approximately 6×10^{18} electrons.

Examples

1. If a 250V h.t. supply is connected to a resistor of 10,000 ohms resistance what power will be lost in the resistor?

$$\begin{aligned} P &= V^2/R && \text{(see 4.2)} \\ &= \frac{250 \cdot 250}{10,000} = 6.25 \text{ watts.} \end{aligned}$$

2. If a valve requires 1.89 watts to heat the cathode, and the heater of the valve is supplied with 6.3 volts, what current will the valve take and what will be the resistance of the heater?

$$\begin{aligned} \text{Power } P &= I \cdot V && \text{(see 4.1)} \\ \text{or } I &= P/V = 1.89/6.3 = 0.3 \text{ ampere} \\ \text{Resistance } R &= V/I && \text{(see 2.13)} \\ &= 6.3/0.3 = 21 \text{ ohms.} \end{aligned}$$

Further examples

3. If an electric kettle is rated at 1000 watts, 230 volts, what current will it take from a supply of 230V and what is the resistance of the heating element? (Answer 4.35 amperes, 52.9 ohms.)
4. If a valve takes an anode current of 10mA at 250 volts what power is being absorbed by the valve? (Answer 2.5 watts.)

The energy (W) used up in the circuit is the product of power and time. The basic unit is the joule which is the energy expended when a power of 1 watt is used in a circuit for a period of 1 second, or

$$\begin{aligned} \text{Energy } W &= P \cdot t \text{ joules} && \text{(4.4)} \\ &\text{where } t \text{ is in seconds.} \end{aligned}$$

Another unit more commonly used is called the watt-hour, which is equal to the energy expended by a circuit when a power of 1 watt is used in the circuit over a period of 1 hour, or

$$\begin{aligned} \text{Energy } W &= P \cdot t \text{ watt-hours} && \text{(4.5)} \\ &\text{where } t \text{ is in hours.} \end{aligned}$$

As this is a fairly small unit a multiple of it, the kilowatt-hour, is generally used and

$$\begin{aligned} 1 \text{ kilowatt-hour (kWh)} &= 1000 \text{ watt-hours (Wh)} && \text{(4.6)} \\ &= 3,600,000 \text{ joules} && \text{(4.7)} \end{aligned}$$

When being charged for electricity it is the kilowatt-hour (often referred to as a "unit") for which we pay.

Examples

1. A radio set is operated from a 230V d.c. supply and takes a current of 0.3 ampere. What is the power consumed by the set? For how many hours can it be operated for a consumption of 1 kWh or "unit"?

$$\begin{aligned} \text{Power} &= I \cdot V && \text{(see 4.1)} \\ &= 0.3 \times 230 = 69 \text{ watts.} \end{aligned}$$

$$\text{Energy } W = P \cdot t \quad \text{(see 4.5)}$$

$$\text{or } t = W/P \text{ where } t \text{ is in hours and } W \text{ is in watt-hours.}$$

$$\text{But } 1 \text{ kWh} = 1000 \text{ watt-hours} \quad \text{(see 4.6)}$$

$$\text{therefore, } t = 1000/69 = 14.5 \text{ hours.}$$

Examples

1. An electric kettle containing 1000 grammes (approx. 2 pints) of water at 20° C. has an element consuming 1000 watts. How long will it take to raise the water to boiling point (100° C.) and how many kilowatt-hours will be consumed?

$$\text{Number of calories} = w.\theta \quad (\text{see 4.8})$$

$$\text{where } \theta = \text{temperature rise} = 100 - 20 = 80^\circ \text{ C.}$$

$$\text{Number of calories} = 1000 \times 80 = 80,000 \text{ calories}$$

$$\begin{aligned} \text{Number of joules} &= 4.2 \times 80,000 \text{ joules} && (\text{see 4.9}) \\ &= 336,000 \text{ joules.} \end{aligned}$$

$$\text{Energy } W = P.t \quad (\text{see 4.4})$$

$$\text{or } t = W/P = \frac{336,000}{1,000} = 336 \text{ seconds}$$

$$= 336/60 = 5.6 \text{ minutes.}$$

$$1 \text{ kWh} = 3,600,000 \text{ joules} \quad (\text{see 4.7})$$

$$\text{Therefore energy} = \frac{336,000}{3,600,000} = 0.0933 \text{ kWh.}$$

2. An electric drill gives a power output of $\frac{1}{4}$ h.p. If the drill is operated from 230V mains, what current will be taken, and how long can the drill be operated for the consumption of 1 kWh? (Assume efficiency of drill to be 70 per cent.)

$$1 \text{ h.p.} = 746 \text{ watts} \quad (\text{see 4.10})$$

$$\text{therefore } \frac{1}{4} \text{ h.p.} = 746/4 = 187 \text{ watts.}$$

$$\text{Allowing for the efficiency, power input} = 187/0.7 = 267 \text{ watts}$$

$$(\text{Efficiency} = \text{output/input and, therefore,}$$

$$\text{input} = \text{output/efficiency})$$

$$\text{Power } P = I.V \quad (\text{see 4.1})$$

$$\text{and, therefore, } I = P/V = 267/230 = 1.62 \text{ amperes}$$

$$\text{Energy } W = P.t \text{ or } t = W/P \quad (\text{see 4.5})$$

$$\text{Now, } 1 \text{ kWh} = 1000 \text{ watt-hours, therefore,}$$

$$t = 1000/267 = 3.75 \text{ hours.}$$

Further examples

3. A 400V d.c. motor gives an output of 2 h.p. at an efficiency of 86 per cent. What current will the motor take? (Answer 4.3 amperes.)
4. An electric generator gives an output of 250 volts at 60mA to supply a radio set, and is driven by a motor operating on 12 volts. If the combined efficiency is 55 per cent. what power will the motor take, and what will be the current from the 12V supply? (Answer 27.3 watts, 2.27 amperes.)

CHAPTER 5

RESISTORS

ONE of the most important components used in radio is the resistor, which controls the flow of current in the circuit. We have seen that electrical power is produced in a resistor and this is equal to I^2R , V^2/R or $V.I$. This electrical power is converted to heat in the resistor and this causes its temperature to rise. It is important that this temperature rise is not excessive or the resistor itself may be damaged by too high a temperature, or it may damage adjacent components. The maximum power that we can put into a resistor without excessive temperature rise is known as the **power rating** of the resistor and is important. Thus, there are two factors about a resistor: its resistance value in ohms; and its power rating in watts.

There are two basic methods of producing resistors for radio using either metallic resistance wire, when it is known as a **wirewound** resistor; or a carbon composition or thin carbon layer when it is known as a **carbon** type resistor.

WIREWOUND RESISTORS

Wirewound resistors are more stable in resistance value and, on the whole, are more reliable than carbon resistors; but they are more expensive and are not generally available in high resistance values (say above 10,000 or 50,000 ohms). Fixed resistors for radio are usually made by winding a single layer of resistance wire on a ceramic tube. The wire is then protected by a paint or, better, by a high temperature resistant material. Many of these resistors are designed to run at high temperatures (*e.g.* 160° C.) and care must be taken not to place other components too close to them. Wirewound resistors of this type are generally used in radio where the power is large (say above about 1 watt). Resistors are made in power ratings of various values from about 1 watt to 50 watts or more. Variable wirewound resistors are not commonly used in radio sets, but when they are they consist of a thin card, wound with suitable resistance wire, which is bent into a circle. An arm rotates and makes contact with the wire at the edge of the card so that the resistance value may be varied.

CARBON RESISTORS

The most common type of resistor used in radio is the carbon resistor. This may be constructed in a number of ways. Some are made from a solid rod of carbon composition with copper connecting wires attached to the ends. Others are made from a carbon deposit on a ceramic tube, again with suitable connections at the ends. A spiral is usually cut round the carbon deposit in order to produce the required resistance value. Some resistors are protected from damage by a layer of paint, but in many cases the resistance element is placed inside a ceramic tube to protect it from mechanical damage and accidental electrical contact with other components. The power rating of carbon resistors is smaller than the wirewound type, and they are made in $\frac{1}{8}$, $\frac{1}{4}$, $\frac{1}{2}$, 1, 2 and 5 watt ratings (the last not being common). It is important that the power rating of a carbon resistor is not exceeded; it is likely to be damaged and may change appreciably in resistance value if overloaded, or it may become open circuited.

Carbon track variable resistors are also used for volume and tone controls in radio sets. These consist of a circular insulated track on which is deposited a layer of carbon. Connections are made to both ends of the track so that it may be used as a potentiometer: a moving arm slides along the carbon

track. This type of resistor is not intended to handle much current or power and is normally only made in high resistance values, above (say) 5000 ohms. The power rating is usually 1 watt, or less, depending on the size.

COLOUR CODE

A colour code is now generally used on carbon resistors to mark the resistance value (but not on wirewound resistors). The colour code is based on the use of ten colours to represent ten numbers as shown below:

Black	0	Green	5
Brown	1	Blue	6
Red	2	Violet	7
Orange	3	Grey	8
Yellow	4	White	9

Two methods of marking are used as follows:

1. The body colour represents the first figure, the tip represents the second figure, and the dot or band the number of 0s. See figure 5.1. For example, a yellow body, violet tip and orange dot denotes a resistance of 47,000 ohms.

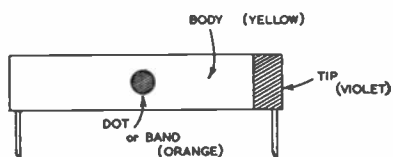

FIG. 5.1. COLOUR CODE FOR RESISTORS (OLDER METHOD)

2. Three rings are now used having the same significance as above, the rings being read from the end of the resistor towards the centre. Thus, a 47,000 ohm resistor would have yellow, violet and orange rings. See figure 5.2.

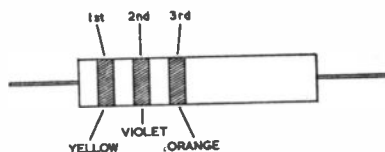

FIG. 5.2. COLOUR CODE FOR RESISTORS

Resistors cannot be economically made to exactly the correct value and a tolerance is therefore allowed. A normal resistor has a tolerance of $\pm 20\%$ i.e. a 47,000 resistor may be anywhere between 80% of 47,000 ohms = 37,600 ohms; and 120% of 47,000 ohms = 56,400 ohms. In most cases this is sufficiently accurate, but where greater accuracy is required resistors are available with $\pm 10\%$ and $\pm 5\%$ tolerances. The $\pm 10\%$ resistor is marked with a silver tip in the first colour code system (the end used being opposite to that which is used for the resistance value); and in the second system a silver ring is added. For $\pm 5\%$ tolerance a gold tip or ring is added. A $\pm 20\%$ resistor has no tolerance markings.

Examples

1. Resistors have the following colour markings. What are the values of the resistors?

RESISTOR	BODY OR FIRST RING	TIP OR SECOND RING	DOT OR THIRD RING
A	Blue	Grey	Orange
B	Black	Orange	Black
C	Green	Blue	Black
D	Brown	Black	Green

Resistor A: First figure 6, second 8 and three 0s, i.e. 68,000 ohms

Resistor B: First figure 0, second figure 3 and no 0s, i.e. 3 ohms

Resistor C: First figure 5, second figure 6 and no 0s, i.e. 56 ohms

Resistor D: First figure 1, second figure 0 and five 0s, i.e. 1,000,000 ohms.

2. If the tolerance on resistor A is 20% what are the maximum and minimum values of the resistors?

$$\text{Minimum} \quad 80\% \times 68,000 = 54,400 \text{ ohms.}$$

$$\text{Maximum} \quad 120\% \times 68,000 = 81,600 \text{ ohms.}$$

Further examples

3. If the colour markings read as follows what will be the resistance values of the resistors?

Resistor A: Red, black and green

Resistor B: Red, red and brown

Resistor C: Red, violet and red

Resistor D: Blue, grey and red

Resistor E: Grey, red and yellow.

(Answers: 2,000,000 ohms, 220 ohms, 2700 ohms,
6800 ohms and 820,000 ohms.)

4. If the tolerances of resistor A are 5%, resistor B 10% and resistor C 20% what will be the minimum and maximum values of these resistors?

(Answers: 1,900,000 to 2,100,000 ohms, 198 to 242 ohms and
2160 to 3240 ohms.)

HIGH STABILITY RESISTORS

A normal carbon resistor is not very stable with temperature, time, humidity, etc., so special carbon resistors are available. These are known as **high stability resistors**, which are more stable and are used in circuits where the resistance value is critical. The stability of these resistors is about $\pm 1\%$. They can be supplied in tolerances of ± 1 , ± 2 , ± 3 , ± 4 , ± 5 and $\pm 10\%$. The ± 1 , ± 2 , ± 3 and $\pm 4\%$ tolerances are marked with a tip or ring in brown, red, orange or yellow respectively; the ± 5 and $\pm 10\%$ tolerance markings being as before.

RESISTORS IN SERIES

When resistors are so connected that the same current flows through all of them they are said to be connected in series. This is shown in figure 5.3.

By Ohm's law (see 2.14) $V_1 = I.R_1$, $V_2 = I.R_2$ and $V_3 = I.R_3$

The total voltage $V = V_1 + V_2 + V_3$ and hence
 $V = I.R_1 + I.R_2 + I.R_3$

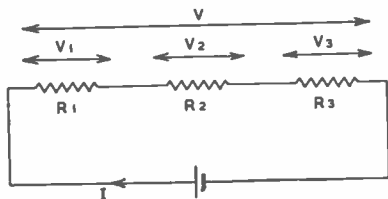

FIG. 5.3. RESISTORS IN SERIES

If the equivalent resistance is R then the total voltage would be

$$I.R$$

and thus $I.R = I.R_1 + I.R_2 + I.R_3$

$$\text{or } R = R_1 + R_2 + R_3 \quad (5.1)$$

i.e. the total resistance is the sum of the resistances of the individual resistors.

Examples

1. Three resistors of 22,000 ohms, 47,000 ohms and 4700 ohms are connected in series to a 250V supply. What current will flow and what will be the voltage across the 47,000 ohm resistor?

$$\begin{aligned} \text{Total resistance } R &= R_1 + R_2 + R_3 && (\text{see 5.1}) \\ &= 22,000 + 47,000 + 4700 \\ &= 73,700 \text{ ohms.} \end{aligned}$$

$$\begin{aligned} \text{Current flowing in the circuit} &= V/R && (\text{see 2.12}) \\ &= 250/73700 \text{ amperes} \\ &= \frac{250.1000}{73700} \text{ milliamperes} \\ &= 3.39 \text{ mA} \end{aligned}$$

$$\begin{aligned} \text{Voltage across 47,000 ohm resistor} &= I.R && (\text{see 2.14}) \\ &= \frac{3.39.47,000}{1000} = 159.5 \text{ volts.} \end{aligned}$$

2. A circuit in a radio set has a resistance of 120,000 ohms and is composed of four resistors in series. Three of these resistors are 27,000, 33,000 and 5,600 ohms. What must be the value of the fourth resistor? If this circuit is connected to a supply of 350 volts what will be the power generated in the 33,000 ohm resistor? What would be the nearest standard rating that could be used?

$$R = R_1 + R_2 + R_3 + R_4 \quad (\text{see 5.1})$$

$$\text{or } 120,000 = 27,000 + 33,000 + 5,600 + R_4$$

$$\text{hence } R_4 = 120,000 - 65,600 = 54,400 \text{ ohms.}$$

$$\begin{aligned} \text{Current in circuit} &= V/R && (\text{see 2.12}) \\ &= \frac{350.1000}{120,000} \text{ milliamperes} \\ &= 2.92 \text{ mA} \end{aligned}$$

$$\text{Power in the 33,000 ohm resistor} = I^2.R \quad (\text{see 4.3})$$

$$= \left(\frac{2.92}{1000} \right)^2 33,000 \text{ watts} = 0.281 \text{ watt.}$$

Since this is more than a $\frac{1}{2}$ watt it would be necessary to use a $\frac{1}{2}$ watt resistor in this position.

Further examples

3. A circuit is composed of three resistors of 1 megohm, 470,000 ohms and 100,000 ohms in series. What is the total resistance? If the 1 megohm resistor has a $\pm 5\%$ tolerance, the 470,000 ohm resistor a $\pm 10\%$ tolerance and the 100,000 ohm resistor a $\pm 20\%$ tolerance what are the maximum and minimum values of the total resistance of the circuit? (Answers: 1,570,000 ohms, 1,687,000 and 1,453,000 ohms.)
4. A circuit consists of two resistors and has to pass a current of 20mA when a voltage of 250V is applied. If one resistor has a value of 5,000 ohms what must be the resistance of the other? (Answer 7,500 ohms.)

RESISTORS IN PARALLEL

When resistors are so connected that the same voltage is applied to all of them they are said to be connected in parallel. This is shown in figure 5.4.

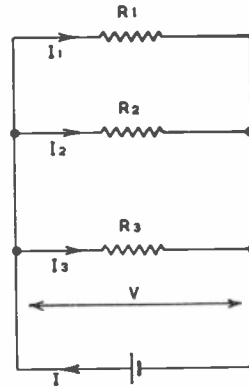

FIG. 5.4. RESISTORS IN PARALLEL

By Ohm's law (see 2.12)

$$\begin{aligned} I_1 &= V/R_1 \\ I_2 &= V/R_2 \\ I_3 &= V/R_3 \end{aligned}$$

The total current $I = I_1 + I_2 + I_3$

If the equivalent resistance is R the total current would be V/R

$$\begin{aligned} \text{Hence } V/R &= V/R_1 + V/R_2 + V/R_3 \\ \text{or } 1/R &= 1/R_1 + 1/R_2 + 1/R_3 \end{aligned} \quad (5.2)$$

Resistors in parallel are therefore added as reciprocals. $1/R$ is known as the **conductance** of the circuit (in mhos). Thus, the total conductance of parallel circuits is the sum of the conductances of the individual circuits.

If two equal resistors are connected in series or in parallel the total wattage rating will be twice that of each resistor. This idea may be used to increase the wattage rating when large wattage resistors are not available. Since the resistors may not be exactly alike, due to the allowable tolerances, it is desirable to keep the total wattage below twice that of each resistor or one resistor may be overloaded.

By connecting resistors in series and parallel it is, of course, possible to obtain a value of resistor which may not be a standard value or which may not be available at the time required.

However complicated a circuit may be it can generally be reduced to a number of parallel and series circuits which can be dealt with in the methods described above.

Examples

1. A resistor of 47,000 ohms is connected in parallel with one of 33,000 ohms. What will be the equivalent resistance, what will be the current in each resistor and the total current if they are connected to a supply of 250 volts?

$$1/R = 1/R_1 + 1/R_2 \quad (\text{see 5.2})$$

$$\begin{aligned} 1/R &= 1/47,000 + 1/33,000 \\ &= \frac{33,000 + 47,000}{47,000 \times 33,000} = \frac{80,000}{47,000 \times 33,000} \end{aligned}$$

$$\text{therefore } R = \frac{47,000 \times 33,000}{80,000} = 19,400 \text{ ohms.}$$

(It is useful to remember when we connect two resistors in parallel that the equivalent resistance is

$$\frac{\text{product of the resistance values}}{\text{sum of the resistance values}}$$

Note that this only applies to two resistors.)

$$\text{Current in 47,000-ohm resistor} = \frac{250.1000}{47,000} \text{ mA} = 5.32 \text{ mA}$$

$$\text{Current in 33,000-ohm resistor} = \frac{250.1000}{33,000} \text{ mA} = 7.58 \text{ mA}$$

$$\text{Total current} = 5.32 + 7.58 = 12.9 \text{ mA.}$$

$$\text{Check: } I = V/R = 250/19,400 \text{ ampere} = 0.0129 \text{ ampere or } 12.9 \text{ mA.}$$

2. The resistance of a circuit is 470 kΩ in value and it is required to reduce it to 330 kΩ by connecting a resistor in parallel. What value of resistor must be used? If the supply voltage is 350 V what must be the rating of the resistor?

$$\begin{aligned} 1/R &= 1/R_1 + 1/R_2 \\ \text{therefore } 1/R_2 &= 1/R - 1/R_1 \\ &= 1/330 - 1/470 \quad (\text{working in kilohms}) \\ &= \frac{470 - 330}{330 \times 470} = \frac{140}{330 \times 470} \end{aligned}$$

$$R = \frac{330 \times 470}{140} = 1108 \text{ kilohms.}$$

Nearest standard value 1 megohm.

$$\begin{aligned} \text{Power} &= V^2/R \\ &= 350^2/1108,000 = 0.111 \text{ watt.} \end{aligned} \quad (\text{see 4.2})$$

Nearest standard wattage $\frac{1}{4}$ watt.

3. What is the equivalent resistance of the following circuit?

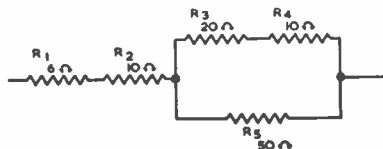

R_3 and R_4 are in series and the equivalent resistance is $R_3 + R_4$
 $= 20 + 10 = 30$ ohms

Resistors R_3 and R_4 together are in parallel with R_5 and the equivalent resistance of these two circuits is given by:

$$\begin{aligned} 1/R &= \frac{1}{R_3 \text{ and } R_4} + \frac{1}{R_5} \\ &= 1/30 + 1/50 \\ &= \frac{50 + 30}{30 \cdot 50} = \frac{80}{1500} \end{aligned}$$

therefore $R = 1500/80 = 18.8$ ohms

R_1 , R_2 and the above resistance are in series

Therefore total equivalent resistance is $R_1 + R_2 + R$
 $= 6 + 10 + 18.8 = 34.8$ ohms.

Further examples

- In a four valve set the valve heaters are connected in parallel. If the resistance values of the heaters are 21 ohms, 14 ohms, 31.5 ohms and 10.5 ohms what will be the total current taken from a 6.3V supply? (Answer 1.55 amperes.)
- A circuit consists of two resistors of 10,000 ohms and 5,600 ohms in parallel. What is the value of the resistor that must be placed in parallel to reduce the total resistance to 2,000 ohms? (Answer 4.53 k Ω .)

CHAPTER 6

BATTERIES

PRIMARY CELLS

A BATTERY is a collection of primary or secondary cells. A primary cell is a device producing electrical energy by chemical changes taking place in it. These chemical changes are not reversible: once the chemical has been used up the battery must be discarded.

ACCUMULATOR OR SECONDARY CELL

An accumulator or secondary cell is a device which produces electrical energy from a chemical change, but by passing a current through it the chemical changes are reversed and the accumulator may be restored to its original condition.

E.M.F. AND INTERNAL RESISTANCE

If we measure the voltage across the terminals of a cell or accumulator with no current flowing this is called the **electro-motive force** (e.m.f.) It is this force which is available to send an electric current round the circuit when the circuit is completed. All this e.m.f. is not available to send current through the external circuit since it requires some e.m.f. or voltage to cause current to flow through the cell itself. The cell is said to have **internal resistance** and it behaves as an ideal cell with an e.m.f., E , together with a

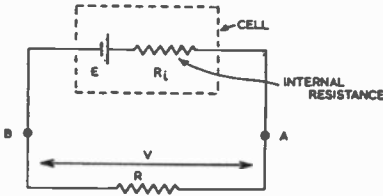

FIG. 6.1.
INTERNAL RESISTANCE OF CELL

resistance equal to the internal resistance R_i , as shown in figure 6.1. When we complete the circuit through the resistor R the current flowing will, by Ohm's law, be equal to

$$\frac{\text{e.m.f.}}{\text{total resistance of circuit}}$$

or

$$\frac{E}{R + R_i}$$

Obviously, the internal resistance tends to reduce the current flowing and causes the voltage across the terminals $A-B$ of the cell to drop when we take current from the battery. The voltage across $A-B$ is the e.m.f., E , less the drop in the internal resistance, which is equal to $I.R_i$, or

$$V = E - I.R_i \quad (6.1)$$

Since we do not normally wish this drop to occur the internal resistance of a battery should be small.

CELLS IN SERIES AND PARALLEL

SERIES

As the voltage of a single cell is limited by the chemicals used, the voltage may be increased by connecting cells in series as shown in figure 6.2. If the

FIG. 6.2. CELLS IN SERIES



cells are similar and have the same e.m.f., E , the total e.m.f. will be $n.E$ where n is the number of cells connected in series. Since the internal resistances are also in series the total internal resistance will be $n.R_i$ where R_i is the internal resistance of a single cell. This connection of cells is very commonly used in radio for high tension batteries.

PARALLEL

Cells are sometimes connected in parallel as shown in figure 6.3. Assuming

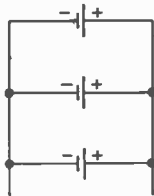

FIG. 6.3. CELLS IN PARALLEL

the cells to be similar the total voltage remains the same, but the internal resistances are in parallel and the total internal resistance is now R_i/n . This

connection is used where large currents are required since it reduces the internal resistance of the battery. It also prevents damage by taking excessive currents from the cells, the current supplied by each cell being I/n where I is the total current.

DRY CELLS

There is only one basic type of dry cell used in radio work: the Leclanche cell. The cell is constructed as shown in figure 6.4. It consists of a carbon

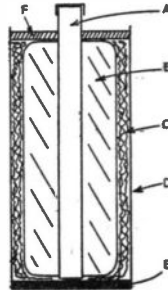

FIG. 6.4.
LECLANCHE CELL (DRY TYPE)

rod *A* which is usually fitted with a brass cap at the top. Around the carbon rod is the depolarizer which is held in place in a muslin or canvas sack. The depolarizer is composed of powdered carbon and manganese dioxide, and its purpose is to remove the hydrogen formed at the carbon rod when the cell is delivering current. If this is not done the cell becomes polarized, the current dropping to a low value due to the hydrogen gas film formed on the carbon rod as a result of the chemical action taking place in the cell. The carbon rod and depolarizer are put inside a zinc container *D* with a suitable insulating material *E* at the bottom to prevent the rod touching the zinc case. The space between the zinc case and the depolarizer is filled with a paste of active chemicals. This consists of a thick fluid paste *C* containing sal ammoniac (ammonium chloride). The cell is then sealed by wax or pitch *F* to prevent the cell drying out as it would then become useless. The carbon rod is the positive terminal and the zinc case the negative. The e.m.f. of the cell is approximately 1.5 volts.

The Leclanche cell will give a moderate current for short intervals with a pause between (*e.g.* ringing bells, flash-lamps, etc.), which gives time for the depolarizer to work. It will also give a small current (say 10mA) for long periods, *e.g.* when it is used for the high tension supply for a receiver. The cells are made in various sizes depending on the current required. When voltages higher than 1.5V are required the cells are connected in series, and when large currents are required they are often connected in parallel. As the battery is operated the active material is used up and the zinc is eaten away; the e.m.f. of the cell drops and the internal resistance rises until the cell is useless and must be replaced.

TESTING A CELL

The main point about testing a dry cell is that this should be done when current is flowing. If the cell has stood for some time with no current being taken and then the e.m.f. is measured it may be nearly normal (*i.e.* 1.5 volts); but as soon as current is taken the voltage drops to a low value due to the cell having a high internal resistance. Accordingly, a cell should always be tested with normal load current flowing.

LEAD ACID ACCUMULATORS

An accumulator consists of several plates in an electrolyte of dilute sulphuric acid. The negative plates, which are all connected together at the top, consist of a lead or lead alloy grid filled with spongy lead. The positive plates, which are interleaved with the negative plates, are similarly joined and constructed, but are filled with lead peroxide. The plates are either placed far enough apart to prevent contact (being held in place by suitable grooves in the container), or are separated by insulating separators, which are usually of wood or plastic. Accumulators used for radio are invariably in glass containers.

The e.m.f. of a fully charged accumulator is slightly over 2 volts, but when supplying current this soon drops to about 2 volts. As the cell is discharged the e.m.f. drops steadily and when it reaches about 1.85 volts the accumulator should be recharged or it may be damaged. On charge the voltage rises fairly rapidly to about 2 volts and then rises more slowly to about 2.2 volts. Further charging then causes the voltage to rise rapidly to about 2.6 volts, when the accumulator is fully charged. Towards the end of the charge the plates begin to give off gas freely (known as "gassing").

The best test for the state of charge of an accumulator is the measurement of the specific gravity of the electrolyte with a hydrometer. The specific gravity should be about 1.250 when fully charged; it drops to about 1.180 at the end of discharge. Since only the water in the accumulator evaporates, it should be topped up to the correct level with distilled water. The advantage an accumulator has over a dry battery is that it can be charged and discharged very many times before it is worn out. Also, it has a much lower internal resistance than a dry cell. Accumulators are not used much in modern radio sets and have largely been replaced by dry batteries, mainly because they are cleaner to handle. But replacement of a dry battery is much more expensive than recharging an accumulator. To keep an accumulator in good condition it should never be left in a discharged state, nor should excessive currents be taken from it. Damage may also result if the accumulator is charged at a current greater than that stated on it by the manufacturer.

The size of an accumulator is quoted in ampere-hours and is really the charge that the accumulator will give out on discharge. Thus, if an accumulator has a capacity of 20 ampere-hours it means it will give a current of 1 ampere for a period of 20 hours. The actual discharge that can be obtained from an accumulator is not constant and depends on the rate of discharge. If the rate of discharge was increased to 5 amperes it would be found that the period would be considerably less than 4 hours.

NICKEL IRON ACCUMULATORS (*Nife*)

These are not normally used in radio and only a brief description will be given. In these cells the negative plates consist of finely divided iron in steel plates. The positive plates are of similar construction but they are filled with nickel oxide. The container is also steel and the electrolyte is potassium hydroxide. The normal e.m.f. is about 1.4 volts. No change occurs in the specific gravity of the electrolyte during charge or discharge. These cells are mechanically strong and do not need the same care as the lead acid type to maintain them in good condition.

CHARGING ACCUMULATORS

Accumulators are charged from a d.c. supply, which is usually obtained from the a.c. supply by means of a rectifier. The accumulator is connected

as shown in figure 6.5. The voltage required is obtained by taking the total e.m.f. of the battery (assuming 2.6 volts per cell) and adding the drop in the internal resistance of the battery and in the resistor R , *i.e.*

$$V = I.R + I.R_i + E$$

The resistor R is necessary to stabilize the current, otherwise a large current will flow when the accumulator is first put on charge owing to the low e.m.f. of the cells. The charging current can also be conveniently altered by variation of the resistor R . Accumulators should be charged at the current given by the manufacturer until the specific gravity has risen to 1.250, and the plates are gassing freely.

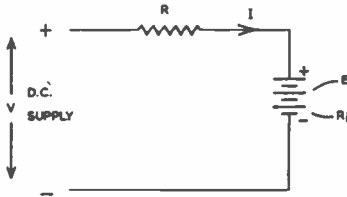

FIG. 6.5.
CHARGING OF ACCUMULATOR

CHAPTER 7

MAGNETISM

WHEN a current flows through a wire a magnetic field is produced, as shown in figure 7.1. The magnetic lines of force consist of circles around the wire in a clockwise direction when the direction of current flow is into the paper. The easy way to remember the direction is to imagine a screw being turned in the direction of the current flow when the direction



FIG. 7.1. MAGNETIC FIELD ROUND A CONDUCTOR

of the magnetic field will be the direction in which the screw is turned. The strength of the magnetic field produced by a single conductor is small, unless the current is very large. When we require a strong magnetic field without a large current we use a number of conductors running side by side, all carrying the same current, in the form of a coil as shown in figure 7.2. The end of the coil from which the lines emerge is known as a North pole and the other end a South pole. If we look at the end of the coil it will be seen that if the direction of current is anti-clockwise, it is a North pole and *vice versa*. If we have two such coils or permanent magnets (see later) and bring similar

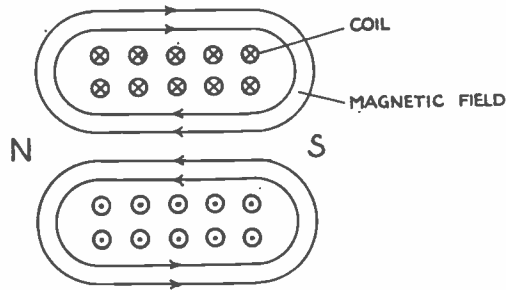

FIG. 7.2. MAGNETIC FIELD DUE TO SOLENOID

poles together (such as two North poles) we find that they repel each other; but if the poles are of opposite types they attract each other.

The action of the current flowing in the coil sets up a force which, in turn, produces the magnetic field or magnetic flux. This force is called the **magneto-motive force (m.m.f.)**. Its magnitude depends on the number of turns on the coil and the current carried by the wire of the coil, or:

$$\text{m.m.f.} = I.N \text{ ampere-turns}$$

where I is the current in amperes

N is the number of turns on the coil.

The m.m.f. has to force the magnetic lines round the magnetic circuit against an opposition which is called the **reluctance of the circuit**. To some extent we may relate the e.m.f., the current and the resistance of an electrical circuit to the m.m.f., flux and reluctance of a magnetic circuit. The reluctance of the magnetic circuit depends (in a way somewhat similar to the resistance of an electrical circuit) on the length of path, the cross sectional area and the material composing the circuit. The reluctance of a magnetic circuit composed of air is high, but is greatly reduced if the air is replaced by iron. In most cases in radio we wish to produce a large magnetic field and, therefore, the magnetic circuit is made largely or completely of iron.

Suppose that we have a magnetic circuit as shown in figure 7.3, on which is wound a coil of N turns carrying a current of I amperes. This coil sets up

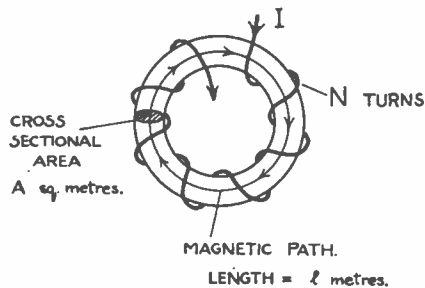

FIG. 7.3. COIL ON IRON CORE

an m.m.f., which we have seen is $I.N$. We often use another term called the **magnetizing force (H)** which is the m.m.f. per unit length of magnetic path. In the diagram the magnetic circuit is uniform, and therefore the m.m.f. is used up equally throughout the circuit. If the length of the magnetic circuit is l metres, the magnetizing force is $I.N/l$ ampere-turns/metre. We are not only concerned with the flux, or number of lines, which pass round the circuit, but also the concentration of these lines, *i.e.* the number of lines per unit

cross section. This is known as the flux density and has some similarity to current density. Thus, if there are ϕ^* lines and the cross sectional area of the path is A square metres, then the flux density (B) is ϕ/A webers/square metre, the unit of flux being the weber and the flux density being the number of webers per square metre.

If the magnetic path is composed of air (or, more accurately, a vacuum) we should get a certain relationship between the magnetizing force H and the corresponding flux density B . The ratio of B/H is known as the permeability (μ_0)[†] of free space (or air for our purpose) and has a value of $4\pi \times 10^{-7}$. If iron is substituted for the air we should find that B would be much greater, and the ratio of the flux density with iron (B_{iron}) to the flux density with air (B_{air}) is known as the relative permeability (μ) of the iron.

$$\text{Thus } B_{\text{iron}} = \mu \cdot B_{\text{air}} = \mu_0 \cdot \mu \cdot H.$$

The value of the permeability depends on the nature or composition of the iron. The permeability of all materials other than iron and iron alloys is practically unity, so only iron and iron alloys are used in magnetic circuits. The value of μ gives an indication of the ease with which magnetic flux can flow through the material, but in the case of iron and iron alloys not only does it depend on the composition, but it also depends greatly on the value of the magnetizing force. If we plot the value of B against H for a typical sample of iron we obtain the curve A shown in figure 7.4. It is seen that B increases rather slowly with increase of H when H is very small (from a to b); but it then increases rapidly from b to c . Beyond c the flux density B increases only slightly as H increases several times. At c the iron is said to be saturated and it is impossible to increase the value of B very much above the value at c . The manner in which the permeability varies is shown in figure 7.5. This rises to a maximum (between b and c of figure 7.4) and then drops off to a low value at large values of H and B . The value of H and B when saturation occurs depends on the type of iron or iron alloy. The corresponding B - H and μ - H characteristics for air are shown in figures 7.4 and 7.5. It is seen that in this case B is always proportional to H , and therefore the permeability is constant.

In many cases (in loudspeakers, electrical machines and instruments) it is not possible to make the magnetic circuit completely of iron, but even in these cases the path in air is made as short as possible.

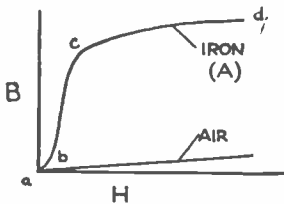

FIG. 7.4. RELATIONSHIP BETWEEN FLUX DENSITY AND MAGNETIZING FORCE FOR IRON AND AIR

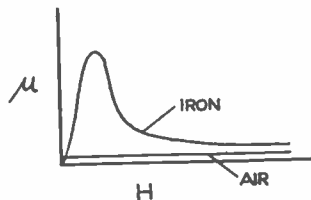

FIG. 7.5. RELATIONSHIP BETWEEN PERMEABILITY AND MAGNETIZING FORCE

PERMANENT MAGNETS

When the ring of figure 7.3 is magnetized by passing a current through the coil and the current is then decreased to zero, it is found that some magnetism remains. This is known as residual magnetism and such a magnet is known as a permanent magnet. The amount of magnetism that remains in this way depends on the material, and special iron alloys are used to make good permanent magnets (e.g. Alnico, Ticonal). Another important factor

* ϕ is the Greek letter phi.

† μ is the Greek letter mu.

in permanent magnet materials is the value of the opposing magnetizing force necessary to reduce the residual magnetism to zero. This is known as the **coercive force** and should be as large as possible, otherwise the magnet will soon become demagnetized. Permanent magnets are used in loudspeakers and many electrical instruments.

MOTOR PRINCIPLE

If a conductor is placed in a magnetic field and a current is passed through the conductor a force acts on it. Suppose that we have a magnetic field as shown in figure 7.6(a) and a conductor carrying current. This conductor will

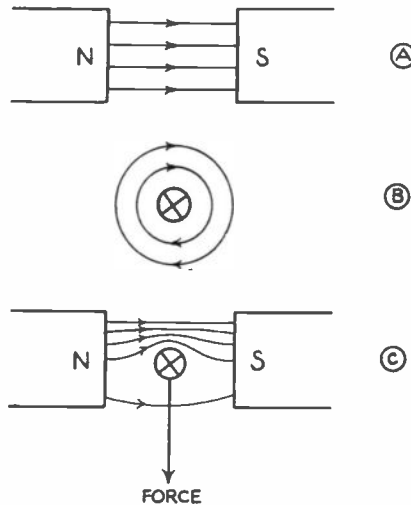

FIG. 7.6. FORCE ON A CONDUCTOR IN A MAGNETIC FIELD

produce a magnetic field as shown at (b). If the conductor is now placed in the magnetic field of (a) the resultant field will be as shown at (c). At the top of the conductor the magnetic lines are in the same direction and reinforce each other; but below the conductor the fields oppose each other and tend to cancel out. The lines tend to repel each other and therefore a downward force is produced on the conductor as shown. This is known as the **motor principle** and is the principle of all electric motors, modern loudspeakers and many instruments. The direction of the force may be obtained by the left hand rule. If the first finger of the left hand is placed along the direction of the field, and the second finger along the direction of current flow, the thumb indicates the direction of the resulting force (the fingers and thumb being at right-angles to each other). The magnitude of the force is:

$$F = B \cdot I \cdot l \text{ newtons}$$

where B = magnetic flux density (webers/square metre)

I = current in amperes

l = length of conductor in magnetic field (metres)

* (1 newton = 0.225 lb).

SIMPLE MOTOR

The basic principle of a motor is shown in figure 7.7. A strong magnetic field is produced by a coil F (or permanent magnet in the case of small

* The newton is the unit of force in M.K.S. units and is the force to give 1 kilogramme an acceleration of 1 metre/second².

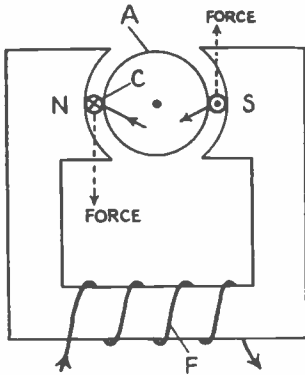

FIG. 7.7. MOTOR PRINCIPLE

machines) which carries a suitable current. A coil *C* is wound on an iron armature *A*. An iron armature is used so that the magnetic flux passes through iron for most of the path in order that a strong magnetic field may be produced for a reasonable current in the coil *F*, known as the field coil. The gap between the armature and the pole pieces *N* and *S* is made as small as possible. If a current is passed through the coil *C*, forces will be produced in the directions shown in the diagram; if the armature is free to rotate then it will move in an anti-clockwise direction. Unfortunately, the movement will stop when it has moved a quarter of a turn as the coil will come out of the magnetic field and, should it tend to turn further, the forces produced are such as to tend to turn it in the opposite direction. To obtain continuous rotation it is necessary to reverse the current in the coil when it reaches the vertical position, and at every following half revolution. This is done by using a split ring or commutator. The coil is connected to the brushes as shown in figure 7.8 and two brushes bear on the ring, the brushes being connected to

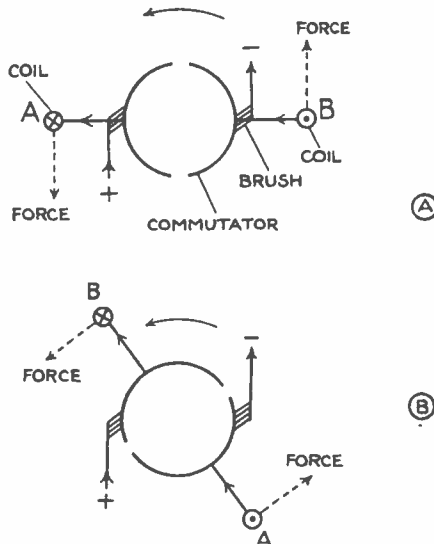

FIG. 7.8. PRINCIPLE OF COMMUTATOR

the supply. At (a) the forces are such as to rotate the coil in an anti-clockwise direction until the coil is vertical. The inertia of the coil will carry it beyond the vertical position to that shown at (b). In this position coil side *A* is connected to the negative supply which is opposite to that at (a). In other words, the coil connections have been reversed and the currents and forces are in the directions shown and the coil will continue to rotate in an anti-clockwise direction. On reaching the vertical position the connections are again reversed, the conditions being as shown at (a). In this way continuous rotation will take place.

In a practical machine many coils are used which are wound in slots in the armature, and the commutator is split into a similar number of segments; but the basic principle remains the same.

CHAPTER 8

MEASURING INSTRUMENTS

MOVING IRON METERS

THE simplest kind of meter is shown in figure 8.1 and is known as the **attraction moving iron type**. It consists of a coil *C* and a piece of iron *I* pivoted at *P*. Attached to the iron is a pointer *P'* moving over a scale *S*. When a current is passed through the coil the iron is attracted towards the

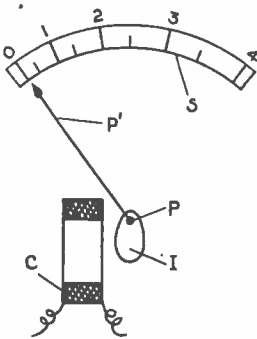

FIG. 8.1. ATTRACTION TYPE MOVING IRON INSTRUMENT

coil and the pointer moved over the scale. The extent of the movement depends on the magnitude of the current. The pointer is returned to the zero mark by the weight of the iron *I*, *i.e.* by gravity and the instrument is, therefore, known as a **gravity controlled instrument**. Although the instrument is simple it is not satisfactory, and a modification known as the **repulsion moving iron type** is now used. This is shown in figure 8.2. It consists of a coil *C* inside of which is an iron rod *I*₂, supported by a spindle pivoted at *P*. The pointer *P'* is attached to the spindle and the pointer is now controlled by a spring *Sp*. This replaces the action of gravity in the first type and is now always used as being more convenient, since a gravity controlled instrument will operate only in a vertical position. Inside the coil is also a fixed rod *I*₁. When current is passed through the coil the rods become magnetized, both in the same direction, with the result that they repel each other (like magnetic poles repel), thus moving the pointer across the scale. The greater the current the greater the repulsive force and the further the pointer moves over the scale, against the action of the control spring *Sp*.

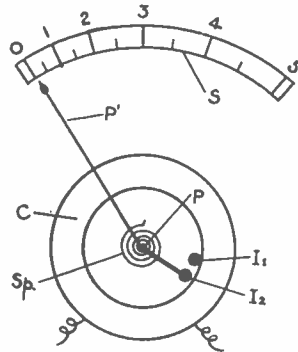

FIG. 8.2. REPULSION TYPE MOVING IRON INSTRUMENT

This type of instrument is not used much in radio, mainly because considerable power is required to obtain full scale deflection (*e.g.* 1 to 2 watts), and the power available in radio circuits is very limited. It also has a non-linear scale, *i.e.* unequal scale divisions, the divisions closing up at low readings, as shown in figure 8.2. Its advantages are that it will operate on both d.c. and a.c. (frequencies up to about 100 c/s) and is inexpensive.

MOVING COIL METER

This is the most important instrument for radio work and the construction is shown in figure 8.3. Its principle of operation is similar to that of the motor. A strong magnetic field is produced by a permanent magnet and this

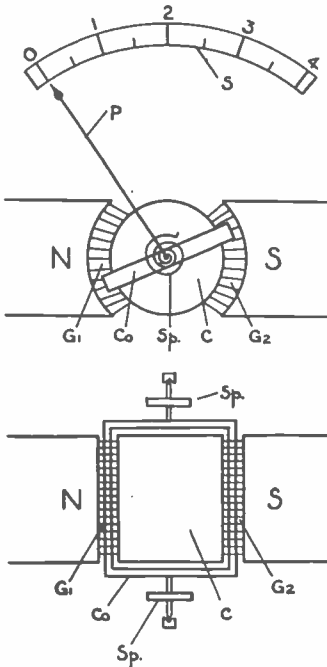

FIG. 8.3. MOVING COIL INSTRUMENT

field passes across the gaps G_1 and G_2 , between the pole pieces N and S , to the fixed cylinder C . Surrounding this cylinder, or core, and free to move in the gap, is the moving coil Co pivoted at the top and bottom. The coil is wound on an aluminium former. Two control springs Sp are used which also serve to feed the current in and out of the moving coil. When a current is passed through the coil a force is produced moving the coil against the control springs and moving the pointer over the scale. The advantages of this instrument are that the power required to give full-scale deflection is very small (e.g. 0.1 milliwatts or 1/10,000 watt) and that it has a linear scale. The disadvantages are that it will only operate directly on d.c. and is more costly to manufacture than a moving iron type. By using a rectifier to convert a.c. to d.c. the instrument may also be used to measure alternating voltages and currents. The moving coil meter is used almost exclusively for servicing radio and television receivers.

HOT WIRE METER

This instrument is quite different to the other types since it operates on the heating effect of an electric current, and not on the magnetic effect. A simple instrument of this type is shown in figure 8.4. It consists of a resistance

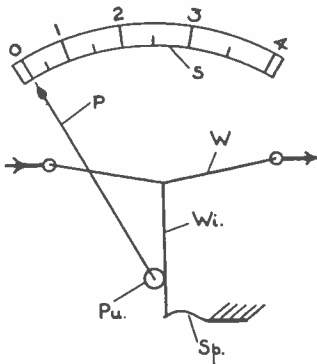

FIG. 8.4. HOT WIRE INSTRUMENT

wire W through which the current passes and which becomes heated as a result of this current. The heating of the wire causes it to expand and to sag more. At the centre is another wire Wi which passes round a pulley Pu to a spring Sp . As the wire W sags, the wire Wi causes the pulley Pu to rotate and move the pointer P across the scale S . The instrument has the advantage that it will operate equally well on d.c. and a.c. (up to radio frequencies); but has the disadvantages of large power consumption, a non-linear scale and being easily burnt out. It is very rarely used to-day.

THERMO-COUPLE METER

This instrument operates on the heating effect of an electric current and the principle is shown in figure 8.5. The current to be measured is passed through a resistance wire W which is heated by this current. Attached to the wire is a thermo-couple T which consists of two wires of different metals welded together. When the joint between the two wires is heated a small voltage is produced and this causes a current to flow through the moving coil meter M . Thus, as the current in the wire W increases, the temperature of the wire increases, so causing a larger voltage to be produced by the thermo-couple and a larger current to flow in the meter M . This instrument has the advantage that it can be used equally well on d.c. and a.c. (up to high radio frequencies). It has the disadvantage that it is easily burnt out

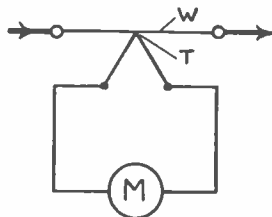

FIG. 8.5. THERMO-COUPLE INSTRUMENT

and has a non-linear scale. The thermo-couple meter is used to measure radio frequency currents, but chiefly in laboratories and not in general radio servicing.

SHUNTS

The current necessary for full scale deflection of an instrument depends on the design of the instrument. It is often convenient to be able to alter this current by an external device known as a **shunt**. This is commonly done with moving coil instruments used in radio. The basic arrangement is shown in figure 8.6. Part of the total current I_t is passed through the shunt R_s , so

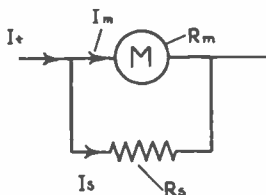

FIG. 8.6. USE OF SHUNT

that only a fraction passes through the meter.

The voltage drop across the meter at full scale = $I_m \cdot R_m$
 and this must equal the voltage drop across the shunt = $I_s \cdot R_s$

But $I_s = I_t - I_m$
 Therefore $I_m \cdot R_m = (I_t - I_m)R_s$ or $R_s = R_m \frac{I_m}{I_t - I_m}$ (8.1)

The resistance of the shunt can therefore be calculated for any required range.

Example

A meter has a full scale deflection of 1mA and a resistance of 100 ohms. What would be the resistance of a shunt to convert this instrument to 500mA full scale deflection?

$$R_s = R_m \frac{I_m}{I_t - I_m} \quad (\text{see 8.1})$$

$$= 100 \frac{0.001}{0.5 - 0.001} = 100 \frac{0.001}{0.499} = 0.205 \text{ ohm}$$

or, drop across instrument = $100 \times 0.001 = 0.1$ volt

Current in shunt = $500 - 1\text{mA} = 499\text{mA}$.

Resistance of shunt = $0.1/0.499 = 0.205 \text{ ohm}$.

A modification called the **universal shunt** (figure 8.7) is generally employed in multirange instruments as used for radio servicing. This is used to avoid the switch contacts being in the circuit between the meter and the shunt, which would cause errors due to the variation of the switch contact resistance. It will be seen that any contact resistance is in the main circuit and does not alter the ratio of R_s/R_m and so upset the accuracy.

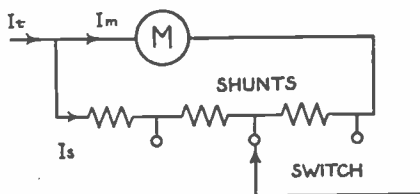
FIG. 8.7.
UNIVERSAL SHUNT

MULTIPLIERS

A normal instrument actually measures current and is converted to a voltmeter by measuring the current flowing through a known resistance. The basic arrangement is shown in figure 8.8. Suppose that the full scale deflection of the instrument is I_m and the voltage to be measured is V .

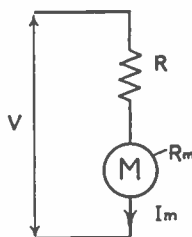

FIG. 8.8. USE OF VOLTAGE MULTIPLIER

Total resistance of circuit is $R + R_m$

$$\text{Therefore } I_m = \frac{V}{R + R_m} \quad \text{or } R + R_m = V/I_m$$

$$\text{or } R = \frac{V}{I_m} - R_m \quad (8.2)$$

Hence the value of R can be calculated. In multirange instruments various values of R are used, a switch connecting them in circuit on the various ranges. For ease of reading the instrument is, of course, scaled in volts.

Example

A meter has a full scale deflection of 1mA and a resistance of 100 ohms. What series resistance will be required to convert it to a voltmeter of 5 volts full scale deflection?

$$\text{Total resistance} = 5/0.001 = 5000 \text{ ohms.}$$

$$\text{Therefore external resistance} = 5000 - 100 = 4900 \text{ ohms.}$$

It has already been mentioned that, ideally, a voltmeter should take no current. In practice it must take some but, particularly in radio, it is important that this current should be small. Instead of stating the current a voltmeter takes it is more usual to quote the resistance of the instrument on a 1 volt range or:

$$\frac{\text{resistance of instrument}}{\text{voltage for full scale deflection}}$$

A common figure for radio work is 1000 ohms/volt. Some newer instruments are as high as 20,000 ohms/volt and have advantages in radio and television circuits. More details of the effect of meter current are given in the supplementary volume, *Fault-Finding*.

Example

If an instrument has a sensitivity of 20,000 ohms/volt what current will flow at half full scale deflection?

$$\begin{aligned} \text{Current for full scale deflection} &= 1/20,000 \text{ ampere} \\ &= 50\mu\text{A} \end{aligned}$$

$$\text{Therefore, current for half full scale deflection} = 25\mu\text{A}.$$

CHAPTER 9

ELECTROSTATICS AND CAPACITORS

ELECTROSTATICS

IN a way rather similar to the way we get magnetic lines of force, or magnetic flux, as a result of a magneto-motive force, we obtain an electric flux as a result of an electromotive force. Suppose that we have two parallel plates as shown in figure 9.1 and we apply a certain voltage or e.m.f. V

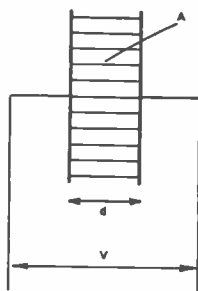

FIG. 9.1. PRINCIPLE OF CAPACITOR

between them. As a result of this a certain stress is produced between the plates, or certain force (similar to the magnetizing force) or field strength is set up tending to result in the production of electric flux. As the path between the plates is uniform the e.m.f. will be used up uniformly and the electric force or field strength is

$$E = V/d \text{ volts/metre} \quad (9.1)$$

If we let the flux between the plates be ψ^* (coulombs or electrostatic lines) then the flux density will be

$$D = \psi/A \quad (9.2)$$

where A is the cross sectional area of the space between the plates or the area of one plate.

In a corresponding way to the magnetic case the ratio of D/E for vacuum between the plates is known as the **permittivity of free space** and is given the symbol ϵ_0 .†

$$\begin{aligned} \text{Thus } D &= \epsilon_0 E \\ \text{where } \epsilon_0 &= 8.85 \times 10^{-12} \text{ farad/metre.} \end{aligned} \quad (9.3)$$

If another material were placed between the plates we should find that a greater value of D would be obtained, and the ratio of D with the new material

* ψ is the Greek letter *psi*. † ϵ is the Greek letter *epsilon*.

to that with vacuum is known as the **relative permittivity** ϵ . Thus for any material

$$D = \epsilon_0 \cdot \epsilon \cdot E \quad (9.4)$$

Some values of ϵ are given in Table 4.

TABLE 4

<i>Material</i>	<i>Relative Permittivity</i>
Air	1.0006
Bakelite	4.5—5.5
Glass	5—10
Rubber	2—3.5
Mica	3—7
Polythene	2.3
Ceramics	6—1000

In order to produce this electric flux we find that electrical energy must be supplied from the source of voltage or e.m.f. V , *i.e.* a current will flow in the circuit for a short time to establish the electric flux. This current represents charge, and the ratio of the charge Q to the voltage V is an important quantity known as the capacitance C .

$$\text{Thus } C = Q/V \quad (9.5)$$

One line of electric flux is supposed to emanate from a positive charge of 1 coulomb and, therefore, if the charge given to the plates is Q the total flux ψ must be numerically equal to Q . The flux density D which is given by ψ/A is now equal to Q/A . If the voltage between the plates is V , then the electric field strength E is V/d (from (9.1)).

$$\text{From (9.4) } D = \epsilon_0 \cdot \epsilon \cdot E$$

Substituting for D and E from the above we get

$$Q/A = \epsilon_0 \cdot \epsilon \cdot V/d$$

$$\text{or } Q/V = \epsilon_0 \cdot \epsilon \cdot A/d$$

and the ratio Q/V is the capacitance (see 9.5)

$$\text{Therefore capacitance } C = \epsilon_0 \cdot \epsilon \cdot A/d \text{ farads} \quad (9.6)$$

Thus, the capacitance is proportional to the area of the plates and inversely proportional to the distance between the plates and also proportional to the relative permittivity ϵ . If the charge Q is measured in coulombs and the voltage V is in volts then the resulting capacitance is in farads. This is a large unit and a submultiple of it is commonly used, called the **microfarad** (μF) and

$$1 \mu\text{F} = 1/1,000,000 \text{ farad or } 10^{-6} \text{ farad} \quad (9.7)$$

A still smaller unit called the **picrofarad** (or micro-microfarad) is used in radio and

$$\begin{aligned} 1 \text{ pF} &= 1 \mu\mu\text{F} = 1/1,000,000 \mu\text{F} = 1/1,000,000,000,000 \text{ farad} \\ &= 10^{-6} \mu\text{F} = 10^{-12} \text{ farad} \end{aligned} \quad (9.8)$$

When we construct a device in this way it is known as a **capacitor** which is a most important item in radio. The material between the plates is known as the **dielectric** and various materials may be used resulting in different types of capacitor.

AIR DIELECTRIC CAPACITORS

Capacitors using air dielectric are used in radio mainly as variable capacitors. It has been seen that the capacitance is proportional to the area, and inversely proportional to the spacing. Even with close spacing the area of plate must be large in order to obtain a capacitance large enough for most purposes. Instead of using two large plates, which would be inconvenient, a number of plates are interleaved as shown in figure 9.2. This is really a

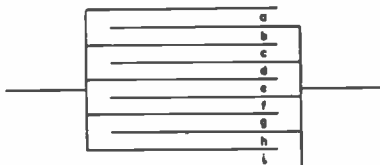

FIG. 9.2. CONSTRUCTION OF AIR DIELECTRIC CAPACITOR

number of capacitors, a, b, c, etc., in parallel, and the total capacitance is proportional to the total area of dielectric between the plates. The capacitance can easily be varied by sliding the plates in and out of mesh since the capacitance is proportional to the cross section of the dielectric *between* the plates connected to opposite terminals.

A practical capacitor is constructed with a set of fixed plates and a set of moving plates which rotate on a spindle, shaped approximately as shown in figure 9.3. As the moving plates are rotated through 180° the meshing, and

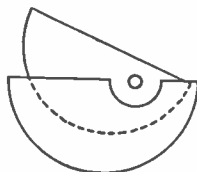

FIG. 9.3. VARIABLE AIR DIELECTRIC CAPACITOR

therefore the capacitance, varies from a maximum to a minimum value. The maximum value of the capacitance is generally about 500pF. It is common practice to use two or three of these capacitors ganged together on a common spindle.

Air spaced fixed capacitors are sometimes used in transmitters and special equipment, but not in radio receivers.

MICA CAPACITORS

In this type of capacitor mica is used in place of air as the dielectric. In the older type the construction is similar to that shown in figure 9.2 but with a thin sheet of mica between each plate (the plates being made of lead or aluminium foil) and the whole then being clamped up tight. To prevent moisture getting in between the plates the whole capacitor is impregnated with wax and then placed in a moulded plastic (*Bakelite*) case for further protection and to further keep out the moisture. This type of capacitor has a high insulation resistance between the plates and is very satisfactory in most ways, but expensive. The cost depends on the number of plates and, therefore, on the capacitance. For this reason it is normally used only in small sizes and is not often used in domestic radio receivers to-day.

A modification of this type known as the *silvered mica* type is in more common use. In place of the foil plates the mica is coated on both sides

with a thin layer of silver and these layers form the plates. As the silver is in intimate contact with the mica, the capacitance is more stable in value and less likely to change with age, etc. This type is usually protected by a layer of lacquer or a coating of wax. It is commonly used where the capacitance value is rather important and is made in values up to about 1000pF.

CERAMIC CAPACITORS

This type of capacitor is now being used to a great extent and makes use of a ceramic material in place of the mica. Various forms of construction are used depending on the capacitance value. The larger values are made in the form as shown in figure 9.4(a) and consist of a ceramic tube with a conducting

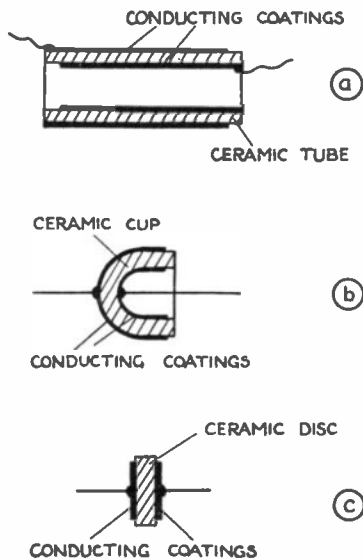

FIG. 9.4. CERAMIC CAPACITORS

coating on the outside and inside. These two coatings form the plates and suitable connecting wires are attached to the coatings. For smaller values a cup construction is used as shown at (b); and for still smaller values the disc construction as shown at (c).

Various types of ceramic may be used so that the capacitors have different properties, an important property being the manner in which the capacitance value changes with temperature. This is known as the **temperature coefficient** of the capacitor. By using different types of ceramic this may be made positive or negative and may be varied over quite large limits (up to 0.25 per cent. per °C).

Certain ceramic materials have a very high permittivity and it is therefore possible to make a capacitor of relatively large value in a small space. This is important in many cases. Ceramic capacitors are generally available from 1pF to about 20,000pF. The use of a high permittivity material for the larger sizes results in the capacitor having a large temperature coefficient, but this is often not important.

PAPER CAPACITORS

The above types are only available with relatively small capacitances (mainly a question of cost and space), and when larger values are required a paper dielectric is used. The plates are formed of lead or aluminium foil and the dielectric is now waxed paper. Instead of using a number of plates as in the mica type it is more convenient and cheaper to use two plates only, about 1 to 2 inches wide and of length corresponding to the capacitance. The two plates and dielectric are now wound in a roll so as to take up as little space as possible. Connections are made to the foils and the capacitor is wax-impregnated. Usually it is placed in a waxed cardboard container, but it may be placed in a special plastic container which is moulded round the capacitor, or in an aluminium tube which is sealed at the ends (where the leads project) by rubber plugs. The use of a plastic or an aluminium case gives better protection for the capacitor from moisture. Originally, connection was made to each foil in one place only, but this is undesirable as the capacitor then has appreciable inductance (see chapter 10). In the non-inductive type (as it is called, although it still has a small inductance) which is in general use to-day the connections to the foil are made throughout the length. Figure 9.5 shows a section through a small portion. One end of each

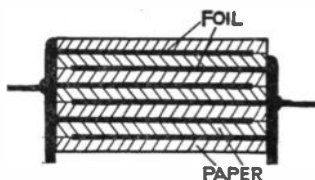

FIG. 9.5. CROSS SECTION THROUGH PAPER DIELECTRIC CAPACITOR

foil projects over the paper, alternately left and right as in the diagram. The projecting foils at each end are then pushed together to form a more or less solid end, to which the lead is soldered. If one side of the capacitor is to be at earth potential it is desirable that this should be the outer foil; the connection going to the outer foil is usually indicated by a ring marked on the outside of the capacitor near the connection.

Another type of paper capacitor is made by coating a length of paper with aluminium as shown in figure 9.6. The aluminium coating is obtained

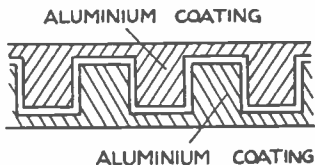

FIG. 9.6. PAPER DIELECTRIC CAPACITOR WITH ALUMINIUM COATING FOR THE PLATES
The pitch of the "steps" varies along the length to allow for the increase in diameter towards the outside of the roll

by evaporating aluminium on to the paper in a vacuum. The paper is then wound in a roll and connection made to the two edges of the aluminium coating with a layer of copper, then suitable connecting wires are soldered to the coating. The capacitor is sealed by moulding a plastic around it.

Paper capacitors are made in various working voltages; in tubular form up to about $1\mu\text{F}$. Above this value they are generally assembled in sheet metal cases and commonly available up to 8 or $16\mu\text{F}$. Larger values are manufactured, but are not used for radio.

ELECTROLYTIC CAPACITORS

Paper capacitors above about $1\mu\text{F}$ are expensive and take up a large space, so are not used in domestic radio receivers. When large capacitors are required electrolytic capacitors are used. Originally these were made in the wet form with two electrodes in an electrolyte (hence the name), but this type has now been replaced by what is termed a dry electrolytic capacitor (although there must be some moisture present). This type of capacitor is made in a way generally similar to a paper capacitor except that (a) aluminium foil is used for the plates; and (b) the material between the plates is of relatively thick absorbent material (often paper) impregnated with a chemical electrolyte.

The operation of this type of capacitor depends on the formation of a thin aluminium oxide layer on the positive plate by electrolytic action, when a suitable d.c. potential is maintained between the plates. This oxide is very thin and, therefore, the capacitance is large for the area of plate (the absorbent paper is a conductor and does not act as the dielectric). The capacitance may be further increased by etching the positive plate which increases its area. Since the formation and retention of this aluminium oxide depends on the d.c. potential between the plates, the capacitor must always be used on d.c., and the d.c. supply must be connected with the correct polarity or the capacitor will be ruined.

Capacitors are made for working voltages from 6 to 500 volts and it is important that the working voltage is not exceeded. This type of capacitor cannot be used on a.c. (except in special cases not connected with radio) and its use is therefore limited, but it does find great use in smoothing circuits in radio sets. It passes a small leakage current in operation, particularly when first switched on, but this is not important in the applications for which it is used. If the capacitor has been out of use for a long period the aluminium oxide layer tends to be lost and a large leakage current will flow when switched on. In these circumstances the capacitor should be "reformed" by connecting it to a low voltage and gradually increasing the voltage to the working value of the capacitor as the leakage current falls.

CAPACITOR TOLERANCES

As for resistors the tolerance on most capacitors is large, which in most circuits is not important. When the value of the capacitor is important a close or small tolerance component must be used. In some cases the maximum value is not important, and therefore a large tolerance of up to 80 per cent. is sometimes allowed, although the tolerance in the other direction is only - 20 per cent.

COLOUR CODE

A colour code similar to that for resistors is often used, the number obtained by the colour code being the capacitance in picofarads. The tolerance may also be marked in a manner similar to resistors.

CAPACITORS IN SERIES AND PARALLEL

When capacitors are connected in parallel, as shown in figure 9.7, the total capacitance C_T is given by:

$$C_T = C_1 + C_2 + C_3 \quad (9.9)$$

This might be expected from the construction of capacitors.

When capacitors are connected in series, as shown in figure 9.8, the total capacitance is given by:

$$1/C_T = 1/C_1 + 1/C_2 + 1/C_3 \quad (9.10)$$

This is similar to resistors in parallel.

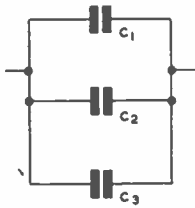

FIG. 9.7. CAPACITORS IN PARALLEL

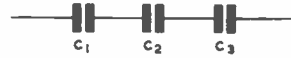

FIG. 9.8. CAPACITORS IN SERIES

If capacitors are required for a high voltage circuit it is not good practice to connect low voltage capacitors in series, since the voltage across each (on d.c.) is not settled by the capacitance but by the leakage resistance. As this will not generally be the same for similar capacitors the total voltage will not be distributed uniformly among the capacitors in series. The difficulty may be overcome by connecting resistors (say 1 megohm) across each capacitor, when the presence of the resistors will not upset the circuit.

CHARGE AND DISCHARGE OF A CAPACITOR

If a capacitor C is connected to a d.c. supply through a resistor R , as shown in figure 9.9, a current will flow through R until the capacitor is charged to the voltage V . As the capacitor charges, the voltage across it will rise as shown in figure 9.10, and it will rise to 63.3 per cent. of its final value V in a time equal to $C.R$ seconds (where C is in farads and R is in ohms). This time is known as the time constant of the circuit. The voltage across R is the difference between the supply voltage and the voltage across the capacitor and, therefore, decreases as the capacitor charges. Thus, the current will also decrease (since it obeys Ohm's law as regards the resistor R) in the manner shown in figure 9.10.

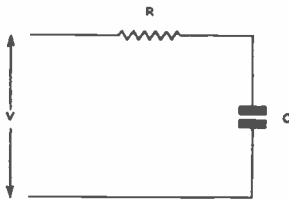

FIG. 9.9. CHARGE OF A CAPACITOR THROUGH A RESISTOR

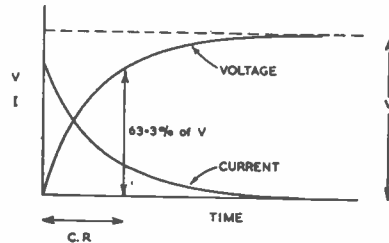

FIG. 9.10. CHARGE OF A CAPACITOR THROUGH A RESISTOR

If the supply is now disconnected the capacitor will remain charged, apart from the small leakage in the capacitor itself. It may remain nearly fully charged for hours or even days if it is a high-class capacitor. A large capacitor (say $8\mu\text{F}$) charged to a high voltage (say 500 volts) stores considerable energy and it is unwise to touch the terminals or a nasty shock will result. If the resistor is connected across the charged capacitor it will discharge by passing a current through R , the value of the current being determined by Ohm's law. The voltage will decrease as shown in figure 9.11. As before it will decrease by 63.3 per cent. in a time equal to the time constant $C.R$. The current will decrease in a similar way to the voltage, but the flow will be in the opposite direction to that when charging the capacitor.

This principle of charge and discharge of a capacitor is important and is made use of in radio and particularly in television.

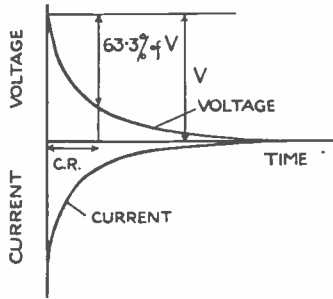

FIG. 9.11. DISCHARGE OF A CAPACITOR THROUGH A RESISTOR

ELECTROSTATIC VOLTMETER

This instrument is the only one that really measures voltage and not the current through a known resistor. The construction is rather like a small variable capacitor and is shown in figure 9.12. A set of moving vanes *M* is

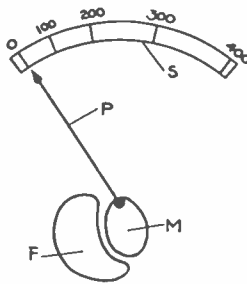

FIG. 9.12. ELECTROSTATIC VOLTMETER

arranged to operate between a set of fixed vanes *F*. Attached to the moving vanes is a pointer *P* which moves over a scale *S*. A spring (not shown) returns the pointer to the zero position. On applying a potential to the vanes a force of attraction is set up and the moving vanes move into the fixed vanes against the force of the control spring.

It is not a common instrument as it is expensive and rather delicate. Further, it cannot be made with a full scale deflection below about 300 volts; but, on the other hand, it has the advantage that it consumes no current (on d.c.) apart from the leakage current which can be made extremely small. It may be used on d.c. or a.c., and even on a.c. the current taken is generally negligible. Its main application is in the measurement of high voltage and it is sometimes used to measure the e.h.t. voltages on cathode ray tubes.

ELECTROMAGNETIC INDUCTION

SUPPOSE that we have a conductor in a magnetic field as shown in figure 10.1, and that the conductor is so moved that it cuts the magnetic lines. When this occurs an e.m.f. is induced in the conductor, and the magnitude of this e.m.f. is proportional to the rate of cutting of the lines. If the wire cuts a

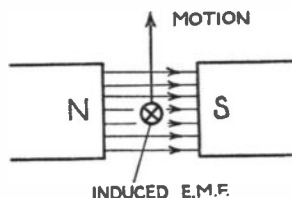

FIG. 10.1. PRINCIPLE OF GENERATOR

magnetic field at the rate of 1 weber per second the induced e.m.f. is one volt. The idea of induced e.m.f. is extremely important and is the principle of the electric generator and the transformer.

The direction of the e.m.f. can be determined by the right-hand rule. If the first finger is placed in the direction of the field and the thumb (at right angles to the finger) in the direction of motion, the second finger gives the direction of the induced e.m.f. If the circuit is complete a current will flow as a result of this e.m.f. It will be seen from figure 7.6 (page 38) that when a current flows in this direction a force is set up opposite to the direction of motion, *i.e.* the force tends to oppose the motion. This is an application of Lenz's law, an important law which states that the force, current or e.m.f. produced is always in such a direction as to oppose that which is causing it. This is a perfectly general result which applies to many devices in electrical and radio engineering. In the above case it is the movement that is causing the current and it therefore flows in such a direction as to try to stop or oppose this motion.

A d.c. generator is constructed in the same way as a motor described in chapter 7 and, in a general way, there is no difference between a motor and a generator; a generator may be operated as a motor and *vice versa*. As the conductors rotate in the magnetic field an alternating voltage will be induced in them, which is converted to d.c. or unidirectional voltage by the commutator.

SELF-INDUCTANCE

In the last section we saw how the e.m.f. is induced in a conductor when it cuts a magnetic field. It is not essential for the conductor to move and an e.m.f. will be induced if the field moves relative to the conductor. If a coil, as shown in figure 10.2, is considered, the magnetic field due to the

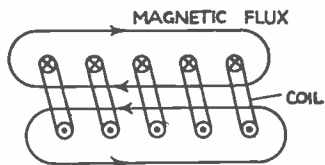
FIG. 10.2.
MAGNETIC FIELD SET UP BY SOLENOID

current in the coil will be as shown. When the current is decreased it is imagined that the lines of force grow smaller and smaller and finally collapse in the centre of the conductors. When this happens the lines cut the

conductors and, therefore, induce an e.m.f. in them. Thus, whenever the current in the coil is increased or decreased, changes in flux occur and an e.m.f. is induced; but no e.m.f. is induced if the current is constant. This property of the coil is known as its **self-inductance** and the unit of inductance is the **henry (H)**. A coil is said to have an inductance of 1 henry if, when the current changes at the rate of 1 ampere per second, the induced e.m.f. is 1 volt. Subdivisions of the henry are often used in radio as follows:

$$1 \text{ millihenry (mH)} = 1/1000 \text{ henry} \quad (10.1)$$

$$1 \text{ microhenry } (\mu\text{H}) = 1/1000 \text{ millihenry} = 1/1000,000 \text{ henry} \\ = 10^{-6} \text{ henry} \quad (10.2)$$

It has been shown in chapter 7 that the flux produced (for a given size of coil) is proportional to the current and turns provided an iron core is not used. Thus, if the turns are doubled the flux is doubled and, therefore, for a given rate of change of current, the e.m.f. per turn is doubled. But, since the number of turns is doubled, the total e.m.f. will be four times as great. Thus, the inductance is proportional to (turns)².

RISE AND FALL OF CURRENT IN AN INDUCTIVE CIRCUIT

Consider the circuit shown in figure 10.3, which consists of an inductance L with a resistance R which may be just the resistance of the coil. If the

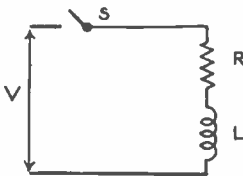

FIG. 10.3.
DIRECT VOLTAGE APPLIED TO INDUCTIVE CIRCUIT

switch is closed a current will start to flow in the circuit but as the current rises in the inductance, an e.m.f. is set up tending to stop the current increasing. This is known as the **back e.m.f.** This e.m.f. slows up the current rise but eventually the current will reach a steady value settled by Ohm's law and the resistance R of the circuit (*i.e.* $I = V/R$).

The way in which the current rises is shown in figure 10.4 which is exactly similar in shape to that of the voltage rise across a capacitor (see chapter 9).

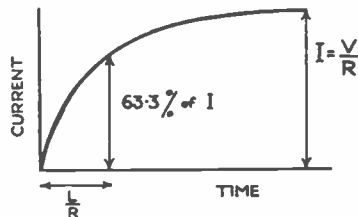

FIG. 10.4.
RISE OF CURRENT IN INDUCTIVE CIRCUIT

It can be shown that the current rises to 63.3 per cent. of its final value in a time equal to L/R seconds (L being in henrys and R in ohms) and known as the **time constant of the circuit**.

If the voltage is suddenly reduced to zero (but the circuit not broken) the current will start to decrease; but an e.m.f. will be induced in L tending to keep the current flowing. The current decreases as shown in figure 10.5

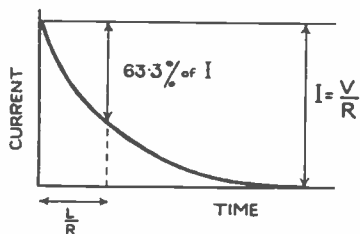

FIG. 10.5. FALL OF CURRENT IN INDUCTIVE CIRCUIT

and will fall by 63.3 per cent. in a time equal to the time constant L/R . Thus, an inductance tends to prevent changes of current through it, and is a property made use of in radio circuits. If we attempt to break an inductive circuit rapidly a high voltage is induced in the inductance (since this is proportional to the rate of current change), which may be dangerous or may damage the insulation between the turns of the inductance. This principle is put to good use in induction coils and ignition coils used in cars.

MUTUAL INDUCTANCE

If there are two coils as shown in figure 10.6 so that the flux set up by the current in coil 1 cuts or links the turns of coil 2, any changes in

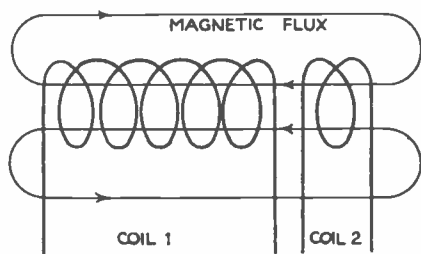

FIG. 10.6. DIAGRAM SHOWING MUTUAL INDUCTANCE

current in coil 1 will not only induce an e.m.f. in coil 1 but also in coil 2. This is known as **mutual inductance**, the unit being the henry as for self-inductance. The henry has the same significance except that the induced e.m.f. is in the second coil (secondary) instead of in the coil carrying the current (primary). The magnitude of the voltage induced in the secondary will depend on: (a) the number of turns on the secondary; and (b) the fraction of the flux passing through the primary which passed through the secondary, *e.g.* it will depend on how near the coils are together.

This property is used in the transformer, a vital component in radio. It should be noted that the e.m.f. is proportional to the rate of change of current and does not depend on the value of the current itself. Thus, if a steady d.c. is passing through the coil no e.m.f. is induced in the coils.

ALTERNATING CURRENTS AND VOLTAGES

So far only direct or unidirectional currents (currents flowing in one direction) and voltages have been considered, and we must now consider alternating currents and voltages. An alternating voltage is one which varies continuously, first in one direction and then in the other. If a graph is plotted of the value of the voltage (or current) against time we should commonly obtain the result shown in figure 11.1. The voltage rises from

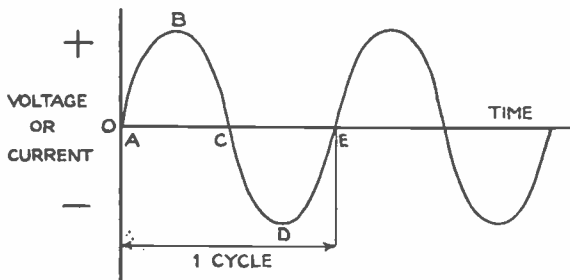

FIG. 11.1. ALTERNATING VOLTAGE OR CURRENT

A to *B*, then decreases to zero at *C*. It then rises to a maximum value at *D* in the opposite direction (usually, but not always, to the same value as at *B*) and then decreases to zero at *E*. After this, the sequence is repeated in exactly the same way. The complete sequence of events from *A* to *E* is known as a **cycle** and the number of cycles which occur in a second is known as the **frequency**, the units being **cycles/second**, abbreviated to **c/s**. Frequencies used in radio may be divided into three regions:

Power Frequencies.—These are the frequencies used for the supply of electrical power and in this country is 50 c/s. (In America it is 60 c/s.) For aircraft work a frequency of 500-2000 c/s is used.

Audio Frequencies.—This is the range of frequencies which are audible when in the form of vibrations in air. The extreme range is 16 c/s to 20,000 c/s but, for general use, we may say that 100 to 10,000 c/s will cover most requirements in radio.

Radio Frequencies.—These are the frequencies used by radio transmitters and are much higher. For domestic radio and television we may say 100,000 c/s to 200,000,000 c/s or 200 Mc/s (1 Mc/s = 1,000,000 c/s). Much higher frequencies are used for radar and for what are termed microwave transmissions.

The way in which the voltage or current varies may not be that shown in figure 11.1, but might be that shown in figure 11.2. At (a) the current rises at a constant rate to the maximum value at *B* and then decreases at the same rate to *C*. It then repeats this in the opposite direction. The way in which the current or voltage varies is known as the **waveform** and that at (a) is usually referred to as a **triangular waveform**. Alternatively, it might rise suddenly from *A* to *B* (as shown at (b)), remain constant to point *C* and then suddenly decrease to zero at *D*. The current then increases suddenly to *E* in the opposite direction, remains constant to *F* and then suddenly decreases to zero at *G*. This waveform is known as a **rectangular or square waveform**. Obviously there is an unlimited number of possible waveforms, but that shown in figure 11.1 is the most common and actually by far the

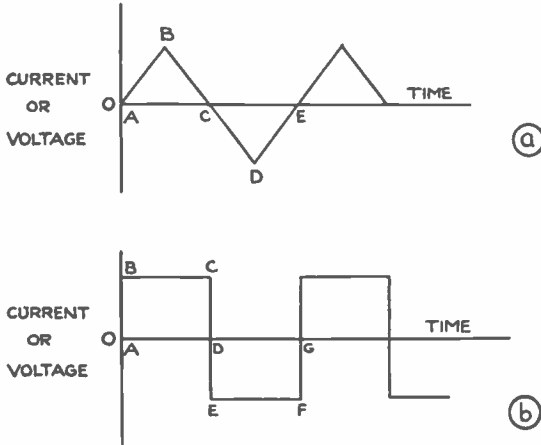

FIG. 11.2. TRIANGULAR AND RECTANGULAR WAVEFORMS

easiest to use and make calculations with. The waveform shown in figure 11.3 is known as a sine waveform because the variation of voltage is proportional to the sine of an angle. This is explained by considering a rod or arm moving round in a circle at constant speed starting at A (figure 11.3). If the distance

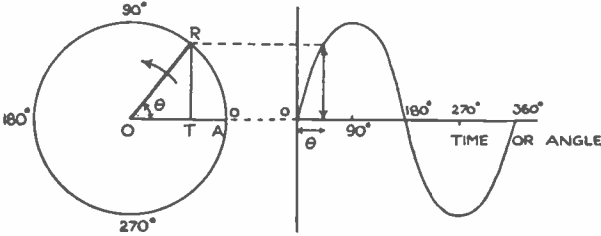

FIG. 11.3. IDEA OF SINUSOIDAL WAVEFORM

of the end R of the rod to the horizontal (*i.e.* RT) is plotted against the angle of the rod from the starting point, a curve is obtained which is the same as that in figure 11.1. The complete cycle occurs in one revolution or 360° .

The waveform of power supplies is always approximately sinusoidal, but in the currents and voltages produced by microphones or fed to loudspeakers (*i.e.* audio or speech frequencies) the waveform may be far from sinusoidal. Actually all waveforms, however complicated, can be shown to be built up of a number of sinusoidal voltages (or currents), one of the fundamental frequency, and others, known as harmonics, which are multiples of the fundamental frequency.

PHASE DIFFERENCE

If we have a voltage and a current in a d.c. circuit they act either in the same direction or in opposite directions; but in a.c. circuits things are more complicated. As shown in figure 11.4(a) the voltage and current may vary together so that the instant of maximum voltage corresponds to the instant of maximum current, or they may vary together but in opposite directions as shown at (b). On the other hand, there is no reason why they must vary together, so they may vary as shown at (c). In this case the current reaches

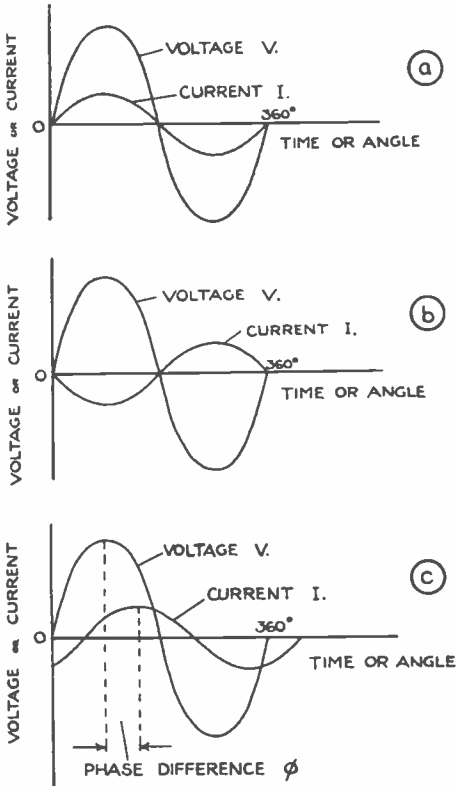

FIG. 11.4.
DIAGRAMS SHOWING THE
PHASE DIFFERENCE BETWEEN
CURRENT AND VOLTAGE

its maximum value sometime later than the voltage and it is said to **lag the voltage**. The difference between *corresponding* points on the waveforms is known as the **phase difference** and is usually expressed as an angle ϕ^* or, in simple cases, as a fraction of a cycle. Thus we say that I lags V by an angle ϕ ; or that V leads I by an angle ϕ . When I and V are out of phase by 90° they are said to be in **quadrature**. It will be seen later that this phase angle is extremely important and is the cause of the many interesting phenomena which occur when alternating currents flow in electrical circuits.

MAGNITUDE

In the case of d.c. the value of the current or voltage is easily defined since it is of constant value; but more difficult in the case of a.c. which is continually varying. There are three methods of quoting the value of an alternating current or voltage.

1. **Peak or maximum value.**—This is the peak or maximum value that the voltage or current reaches in one direction as shown in figure 11.5. This method is useful in radio circuits where the operation of valves is concerned.
2. **Mean or average value.**—This is the average or mean value of the voltage during half a cycle (see figure 11.6). It may be determined by obtaining the voltage at definite intervals during the half cycle and calculating the average value of these instantaneous voltages. For a sine wave the ratio of the peak

* ϕ is the Greek letter *phi*.

FIG. 11.5. PEAK OR MAXIMUM VALUE OF ALTERNATING VOLTAGE OR CURRENT

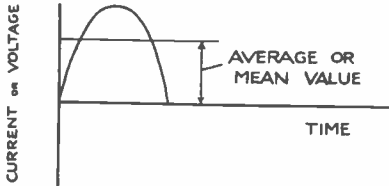
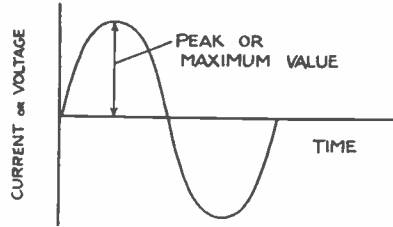

FIG. 11.6. AVERAGE VALUE OF ALTERNATING VOLTAGE OR CURRENT

value to the mean value is 1.57. This mean or average value is not commonly used except in rectifier circuits.

3. **Root-mean-square or r.m.s. value.**—This is the most commonly used value and is the value of a.c. which gives the same heating effect as the same value of d.c. To take a simple case: if we connect a radiator to a 240V d.c. supply it will give out a certain amount of heat; if we connect it to a 240V r.m.s. a.c. supply it will give out exactly the same amount of heat. The instantaneous heating is proportional to i^2 or v^2 , and the r.m.s. value is obtained by dividing the half cycle into strips of equal width, and taking values of voltage or current at the centre of each strip, squaring these, taking the mean value and then taking the square root.

Thus, for the waveform shown in figure 11.7 where the magnitudes are taken as six points in the half cycle, the mean value is

$$\frac{a + b + c + d + e + f}{6}$$

The mean square value is

$$\frac{a^2 + b^2 + c^2 + d^2 + e^2 + f^2}{6}$$

and the root mean square or r.m.s. value is

$$\sqrt{\frac{a^2 + b^2 + c^2 + d^2 + e^2 + f^2}{6}}$$

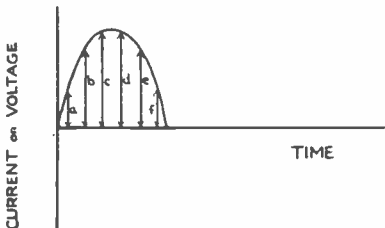

FIG. 11.7. METHOD OF OBTAINING MEAN AND R.M.S. VALUES OF ALTERNATING VOLTAGE OR CURRENT

In normal work the r.m.s. value is always used and when speaking of a 240V supply we are always referring to the r.m.s. value. The ratio of the peak value to the r.m.s. value (known as the peak factor) for a sine waveform is $\sqrt{2}$ or 1.414. The ratio of the r.m.s. value to the mean value for a sine waveform is 1.11 and is known as the form factor. The relationship between the values is shown in figure 11.8.

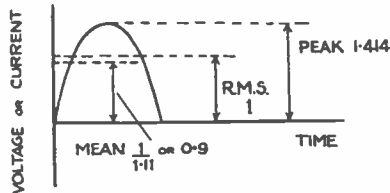

FIG. 11.8. RELATIONSHIP BETWEEN PEAK, MEAN AND R.M.S. VALUES

CHAPTER 12

ALTERNATING CURRENT FLOW IN ELECTRICAL CIRCUITS

WE must now consider the flow of alternating currents in electrical circuits and the associated phenomena. In the case of d.c. we are only concerned with the flow of steady d.c. in a resistor, but in the case of a.c. we are concerned with the flow of current in resistors, inductors and capacitors.

CIRCUIT WITH RESISTANCE ONLY

If a voltage V is applied to the circuit (see figure 12.1) then at any instant when the voltage is v the current is i given by $i = v/R$. Thus the current is proportional to the voltage at any instant, and if the applied voltage is sinusoidal the current will be sinusoidal and will be in phase with the voltage. Since $i = v/R$ at all instants then

$$I = V/R \quad (12.1)$$

where I and V are the r.m.s. values.

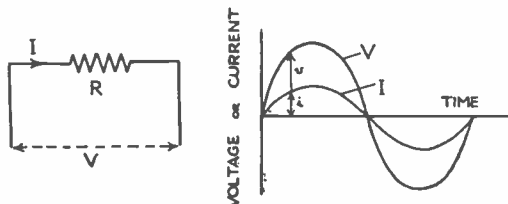

FIG. 12.1 FLOW OF CURRENT IN CIRCUIT CONSISTING OF RESISTANCE ONLY

CIRCUIT WITH INDUCTANCE ONLY

Suppose that we have a circuit (figure 12.2) consisting of an inductance L henrys, and it is assumed that the resistance of the coil is negligible. It has been shown earlier that when the current in an inductance is changed in value an e.m.f. is set up tending to oppose the current change. Suppose now that an alternating current I is passed through the coil L . Since the current is continually changing in value there will be an e.m.f. induced in the coil. At instants A, C and E (figure 12.3) the rate of change of current is greatest

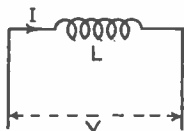

FIG. 12.2. CIRCUIT WITH INDUCTANCE ONLY

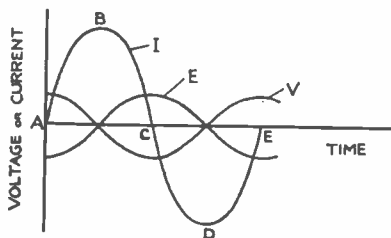

FIG. 12.3. FLOW OF CURRENT IN CIRCUIT; CONSISTING OF INDUCTANCE ONLY

and, therefore, the e.m.f. induced in the coil will be at maximum; but at instants B and D the current is constant and just at this instant there will be no induced voltage. By Lenz's law we saw that the induced e.m.f. is always in such a direction as to oppose the change which is causing the e.m.f. At instant A it is the rise of current that is causing the e.m.f. and, therefore, the e.m.f. will be in such a direction as to oppose the current rise, *i.e.* it will be negative. As we go towards B the rate of rise decreases and hence the e.m.f. becomes less, until at point B the current is steady for a brief instant, and the e.m.f. e is zero. After B the current starts to decrease so that the induced e.m.f. will reverse in direction (*i.e.* become positive) so as to try and maintain the flow of constant current. The rate of decrease reaches to a maximum at C and hence the e.m.f. increases to a maximum. From C to D the rise of current is in the opposite direction and the e.m.f. is positive, opposing the rise of current in a negative direction. Finally, from D to E the current is decreasing and the e.m.f. is in such a direction as to assist the current. It can be shown that if the current is of sine waveform then the waveform of the e.m.f. is the same shape, but, as will be seen, it is displaced from the current by 90° . This is the voltage induced in the coil by the current flowing in it. Thus, if we are to force the current through the coil we must apply a voltage to the coil equal and opposite to this e.m.f., as shown by V in figure 12.3. In practice V must be somewhat greater than E in order to overcome the resistance of the coil, but the effect of this resistance will be considered later.

From figure 12.3 it is seen that the applied voltage leads the current in the inductance by 90° or, looking at it the other way, the current in an inductance always lags the voltage by 90° .

There is a certain ratio between the voltage and current in an inductive circuit (similar to the case of a circuit composed of a resistor only) and this ratio is called the reactance (X) of the circuit. Thus

$$X = V/I \text{ ohms} \tag{12.2}$$

The reactance of an inductor is $2\pi f.L$ or $^*\omega L$ ohms (12.3)

where f is in cycles per second, L is in henrys and $\omega = 2\pi f$.

* Angular frequency. ω is the Greek letter *omega*.

Thus, the reactance or opposition to current flow in the circuit is proportional to:

- (i) the inductance L ; (ii) the frequency f .

Turning the above equation around:

$$I = V/X = V/2\pi f.L. \quad (12.4)$$

Summarizing, the current in an inductance:

- (i) lags the voltage by 90°
 (ii) is proportional to $1/L$ or inversely proportional to L
 (iii) is proportional to $1/f$ or inversely proportional to f .

CIRCUIT WITH CAPACITANCE ONLY

Suppose we consider a circuit with capacitance only as shown in figure 12.4. When d.c. is applied to the circuit we have seen that (apart from an

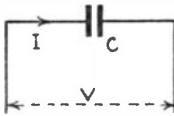

FIG. 12.4. CIRCUIT WITH CAPACITANCE ONLY

initial charging current) no current flows; but with an alternating voltage this is not the case. This is due to the fact that whenever we change the voltage across a capacitor a charge flows in or out of it, and thus a current must flow. With a.c. the voltage is continuously changing, hence a resulting current flows in the circuit. Suppose we apply a sinusoidal voltage V to the capacitor, then the current that flows at any instant depends on the rate of change of voltage. This is a maximum at A , C and E (figure 12.5) and is zero at instants B and D .

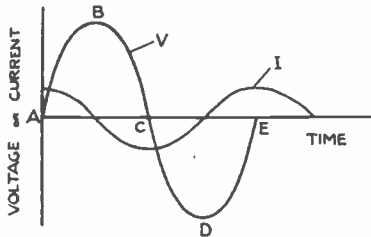

FIG. 12.5.
 FLOW OF CURRENT IN CIRCUIT
 CONSISTING OF CAPACITANCE ONLY

Thus, as the voltage rises rapidly at A a large current will flow into the capacitor to charge it up; but, as the rate of voltage rise decreases towards B , this current decreases until at B , when the voltage is steady for a brief instant, the current has decreased to zero. From B to C the voltage decreases; the capacitor discharges and the current flows in the opposite direction being at maximum at C , where the rate of change of voltage is at maximum. From C to D the capacitor is charged in the opposite direction and the current flows in the same direction as the voltage, but reaches zero at D , where the rate of change of voltage is zero. From D to E the capacitor again discharges. Thus, we may consider that a charge and current just flow in and out of the capacitor every half cycle.

It can be shown that when the applied voltage is sinusoidal the shape of the current curve is the same. It is seen from figure 12.5 that the current leads the voltage by 90° . As in the case of an inductance there is a certain

ALTERNATING CURRENT FLOW IN CIRCUITS 63

ratio between V and I and it is also known as the reactance. The reactance of a capacitor is:

$$1/2\pi f.C \text{ or } 1/\omega.C \text{ ohms} \quad (12.5)$$

where f is in cycles per second, and C is in farads.

Thus, the reactance, or opposition to current flow, in the circuit is

proportional to $1/C$ (inversely proportional to C)
 proportional to $1/f$ (inversely proportional to f)

Turning the above equation around

$$I = V/X = \frac{V}{1/2\pi f.C} = V.2\pi f.C \quad (12.6)$$

Summarizing, the current in a capacitor:

- (i) leads the voltage by 90°
- (ii) is proportional to C
- (iii) is proportional to f .

It will be seen from this that an inductor and capacitor act in exactly opposite ways to the flow of alternating current. This fact is rather important and will be made use of later.

Examples

1. *A radiator has a resistance of 40 ohms and is connected across a 230V, 50 c/s a.c. supply. What current will flow?*

$$I = V/R \quad (\text{see } 12.1)$$

$$I = 230/40 = 5.75 \text{ amperes.}$$

2. *An inductor (smoothing choke) has an inductance of 20 henrys and negligible resistance. What will be its reactance at 50 c/s and what current would flow if it were connected to a 230V, 50 c/s supply?*

$$\begin{aligned} \text{Reactance} &= 2\pi f.L && (\text{see } 12.3) \\ &= 2\pi 50.20 = 2\pi 100 = 6,280 \text{ ohms.} \\ \text{Current} &= V/X && (\text{see } 12.2) \\ &= 230/6280 = 0.0367 \text{ A} = 36.7 \text{ mA.} \end{aligned}$$

3. *A tuning coil (inductor) in a radio receiver has an inductance of $200\mu\text{H}$ and the receiver is operated at a frequency of 0.8Mc/s . What current will flow in the coil if the voltage across it is 20 volts?*

$$I = V/X = V/2\pi f.L \quad (\text{see } 12.4)$$

$$I = \frac{20}{2\pi 0.8 \cdot 10^6 \cdot 200 \cdot 10^{-6}}$$

$$= \frac{20}{2\pi 160} = 0.0199 \text{ A} = 19.9 \text{ mA.}$$

4. *A $4\mu\text{F}$ capacitor is connected across a 50 c/s, 230V supply. What current will flow?*

$$I = V/X = V.2\pi f.C \quad (\text{see } 12.6)$$

$$= 230.2\pi 50.4 \cdot 10^{-6}$$

$$= 0.289 \text{ A} = 289 \text{ mA.}$$

5. If a capacitor of 200pF is placed across the coil of question No. 3 what will be its reactance and what current will flow through the capacitor?

$$\text{Reactance } X = 1 / 2\pi f.C \quad (\text{see 12.5})$$

$$X = \frac{1}{2\pi \cdot 8.10^6 \cdot 200.10^{-12}}$$

$$= \frac{1}{2\pi 160.10^{-6}}$$

$$= \frac{1,000,000}{2\pi \cdot 160} = 995 \text{ ohms.}$$

$$I = V/X = 20/995 = 0.0201 \text{ ampere} = 20.1 \text{ mA.}$$

Further examples

6. A capacitor of 5pF is connected across two points in a radio receiver across which is a voltage of 50 volts at 120Mc/s. What current will flow through the capacitor? (Answer 188.4mA.)

7. A current of 0.5 ampere at 60 c/s flows through a 1.5 henry inductor. What will be the voltage across the inductor? (Answer 282 volts.)

VECTORS

Before continuing with the flow of current in more complex circuits it is necessary to introduce the idea of vectors. When we come to more detailed circuits we require to add voltages together. This cannot be done arithmetically as in d.c. because of the fact that, in general, the waveforms are not in phase and we must make allowance for this fact. The idea of vectors can only be applied to sinusoidal voltages and currents, hence sinusoidal quantities will be assumed in the following working. We have seen that an alternating quantity not only has magnitude (as in d.c.) but (unlike d.c.) it also has phase and cannot be represented by a simple number. The idea of a vector is a convenient way of showing the magnitude and phase of an alternating voltage or current. A vector is simply a line whose length represents the magnitude of the quantity and whose angle (from some reference position) represents phase. The sine wave was introduced earlier by the idea of a rotating rod. This may be considered as a vector. Thus if we have a line OA (figure 12.6)

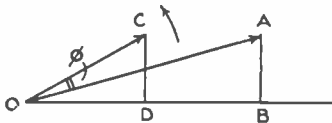

FIG. 12.6. VECTORS

of such a length that it represents the peak or maximum value of the alternating voltage or current, then the value at any instant is given by the vertical from A to the horizontal line, *i.e.* AB . The vector, by convention, is taken as rotating in an anti-clockwise direction, once per cycle. If we have another voltage or current which leads OA then this may be represented by another vector OC , and CD represents the value of this voltage or current at this instant. The voltage OC leads voltage OA because the vector OC will reach the vertical position first, where the instantaneous value represented by CD will be at maximum. The phase angle between the two vectors is the angle ϕ . In the diagram the magnitude of the voltage OC is about half that of voltage OA , *i.e.* $OC = \frac{1}{2} OA$.

Suppose that we have two voltages as shown in figure 12.7. The two voltages V_1 and V_2 differ in phase by angle ϕ . Assume that we wish to find

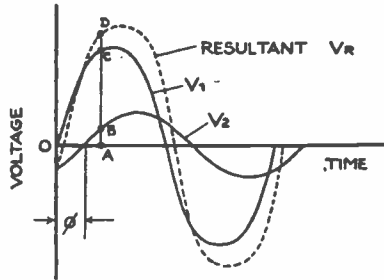

FIG. 12.7. ADDITION OF TWO ALTERNATING VOLTAGES

the resultant of these two voltages when they are connected in series. We could do this by taking an instant such as *A*. At this instant V_1 is AC and V_2 is AB , hence the total voltage is $AC + AB = AD$. By taking a number of instants in this way we could obtain a curve representing the total voltage as shown. It can also be shown that the addition of any two sinusoidal quantities results in a sinusoidal waveform as in figure 12.7. It is fairly obvious from this figure that the resultant voltage will not be the direct sum of the voltage V_1 and V_2 since the peaks of the voltages do not occur at the same instant, and that the resultant will depend on the phase angle ϕ between them. This method of obtaining the resultant is laborious and not used, which is one of the reasons for the introduction of vectors.

The above two voltages may be represented by the two vectors shown in figure 12.8. The length of V_1 and the length of V_2 correspond (to the same

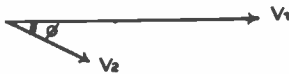

FIG. 12.8. VECTOR DIAGRAM CORRESPONDING TO FIGURE 12.7

scale) to the peak amplitudes of these two voltages. The angle ϕ between the two vectors is the phase angle between the two voltages, and V_2 is lagging V_1 . The position of the vectors corresponds to the instant of start *O*, but they could be drawn corresponding to any instant such as *A* (figure 12.7) as shown in figure 12.9. (In general it is more convenient to arrange for one of the

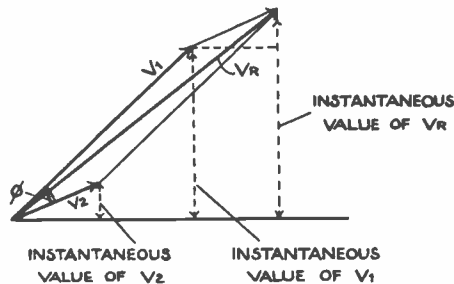

FIG. 12.9. VECTOR DIAGRAM CORRESPONDING TO FIGURE 12.7

voltages to be drawn horizontally.) The resultant voltage V_R may be obtained by completing the parallelogram, when the diagonal shown represents the resultant voltage both in magnitude and phase. From the diagram it is seen that the instantaneous value of V_R is the sum of the instantaneous values of V_1 and V_2 . Since this diagram was drawn at any instant it is equally true at all the instants, and thus V_R does represent the resultant of V_1 and V_2 . To

distinguish this resultant from the arithmetic sum of V_1 and V_2 (which is of no value) it is called the **vector sum** of V_1 and V_2 .

From the vector diagram (figure 12.9) it is seen that V_R will be a maximum when V_1 and V_2 are in phase *i.e.* $\phi = 0$ which is confirmed by considering figure 12.7, when it will be seen that the resultant will be a maximum when the peaks occur at the same instant. As angle ϕ is increased, the resultant V_R will decrease, and when ϕ is large as shown in figure 12.10 V_R may be

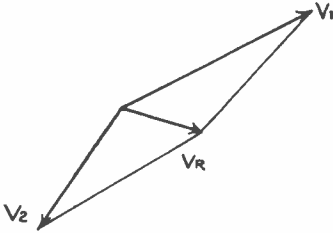
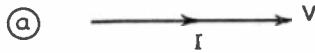

FIG. 12.10.
VECTOR DIAGRAM OF TWO VOLTAGES
WITH LARGE PHASE DIFFERENCE

less than either V_1 or V_2 . Thus, V_R may be many values depending on the phase difference ϕ . This fact is of extreme importance as will be seen later. In many cases where we are only interested in finding the vector sum of two voltages the vectors are drawn of length proportional to the r.m.s. value, so that the resultant is also in r.m.s. value.

If we consider the vector diagram for the three circuits already discussed we have:

- (i) Circuit with resistance only. Current in phase with the voltage as shown in figure 12.11(a).
- (ii) Circuit with inductance only. Current lags the voltage by 90° as shown in figure 12.11(b).
- (iii) Circuit with capacitance only. Current leads the voltage by 90° as shown in figure 12.11(c).



CIRCUIT WITH RESISTANCE ONLY

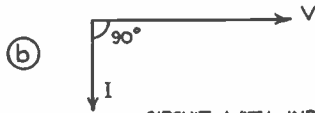

CIRCUIT WITH INDUCTANCE ONLY

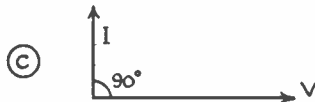

CIRCUIT WITH CAPACITANCE ONLY

FIG. 12.11. VECTOR DIAGRAM

CIRCUIT WITH RESISTANCE AND INDUCTANCE IN SERIES

Since the two components (see figure 12.12(a)) are in series the same current must flow through both. Drawing the vector diagram (see figure

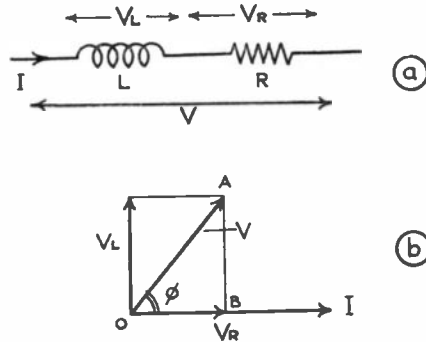

FIG. 12.12. CIRCUIT WITH INDUCTANCE AND RESISTANCE

12.12(b), I represents the current in R and L . Voltage V_R is the voltage across R and is in phase with the current. Voltage V_L is that across L and leads I by 90° . The resultant voltage V is the vector sum which is obtained by completing the rectangle as shown. By Pythagoras' theorem, considering triangle OAB :

$$V^2 = V_R^2 + V_L^2 \tag{12.6}$$

but, using expressions (12.1) and (12.2)

$$\begin{aligned} V_R &= I.R \\ \text{and } V_L &= I.X_L \text{ where } X_L = \omega.L. \\ \text{Thus } V^2 &= I^2R^2 + I^2X_L^2 \\ &= I^2(R^2 + X_L^2) = I^2(R^2 + \omega^2L^2) \\ \text{or } V/I &= \sqrt{R^2 + (\omega L)^2} \end{aligned} \tag{12.7}$$

Now, the ratio V/I is the opposition of this circuit to current flow and is known as the impedance Z of the circuit. Thus

$$Z = \sqrt{R^2 + X_L^2} = \sqrt{R^2 + (\omega.L)^2} \text{ ohms} \tag{12.8}$$

By trigonometry the phase angle ϕ between I and V may be obtained from

$$\cos. \phi = V_R/V = I.R/I.Z = R/Z \tag{12.9}$$

$$\tan. \phi = V_L/V_R = I.X_L/I.R = X_L/R \text{ or } \omega L/R \tag{12.10}$$

Thus, the phase angle increases as ωL is made large compared with R but in all cases the voltage will lead the current. It will be seen that both the magnitude of Z and the phase angle depend on ω and hence on frequency.

CIRCUIT WITH RESISTANCE AND CAPACITANCE IN SERIES

This is similar to the last case except that V_C now lags the current by 90° as shown in figure 12.13(a) and (b).

Now $Z = \sqrt{R^2 + X_C^2}$ but in this case $X_C = 1/\omega C$
and therefore

$$Z = \sqrt{R^2 + (1/\omega C)^2} \tag{12.11}$$

Similarly

$$\cos. \phi = R/Z \tag{12.12}$$

$$\tan. \phi = X_C/R = \frac{1/\omega C}{R} = 1/\omega CR \tag{12.13}$$

Again ϕ depends on the ratio of X_C to R and the value of Z and ϕ depend on frequency.

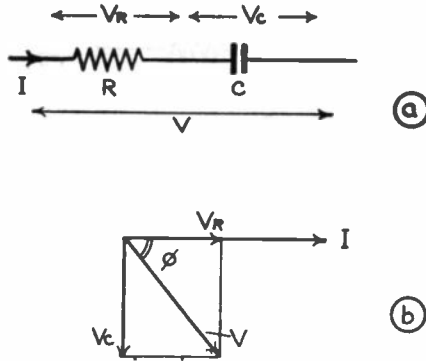

FIG. 12.13. CIRCUIT WITH CAPACITANCE AND RESISTANCE

Examples

1. A smoothing choke having a resistance of 300 ohms and an inductance of 5 henrys is connected across a 50 c/s 230V supply. What current will flow and what will be the phase angle between the voltage and the current?

$$\begin{aligned} \text{Impedance } Z &= \sqrt{R^2 + (\omega L)^2} && \text{(see 12.8)} \\ &= \sqrt{300^2 + (2\pi 50 \times 5)^2} \\ &= \sqrt{300^2 + 1570^2} \\ &= \sqrt{2,560,000} = 1,600 \end{aligned}$$

$$\text{Therefore } I = V/Z = 230/1600 = 0.144 \text{ ampere.}$$

$$\begin{aligned} \cos. \phi &= R/Z && \text{(see 12.9)} \\ &= 300/1600 = 0.188 \end{aligned}$$

$$\text{From tables } \phi = 79^\circ.$$

2. A capacitor is connected in series with a resistor and connected across two points across which is a voltage of 20 volts. The frequency of this voltage is 1000 c/s. What current will flow if the resistor is 1000 ohms and the capacitor is 0.1 μ F?

$$Z = \sqrt{R^2 + (1/\omega C)^2} \quad \text{(see 12.11)}$$

$$\text{Therefore } Z = \sqrt{1000^2 + (10^6/2\pi \cdot 1000 \cdot 0.1)^2}$$

$$= \sqrt{1000^2 + 1600^2} = 1890 \text{ ohms}$$

$$\text{Now } I = V/R = 20/1890 = 0.0106 \text{ ampere.}$$

CIRCUIT WITH RESISTANCE, INDUCTANCE AND CAPACITANCE IN SERIES OR SERIES RESONANT CIRCUIT

This is an important circuit (see figure 12.14(a)) in radio and has some interesting properties. Drawing a vector diagram we obtain the result shown in figure 12.14(b). Adding vectorally the vectors V_L and V_C we obtain $V_{L \& C}$ (which is the arithmetic subtraction of V_C from V_L since they are, in this case, in direct opposition). Adding $V_{L \& C}$ to V_R vectorally we obtain the total voltage V .

V_L and V_C which depend on the values of L , C and the frequency, may be varied and may become equal as shown in figure 12.15. The resultant $V_{L \& C}$ is now zero and the resultant voltage is equal to V_R . Thus the total voltage

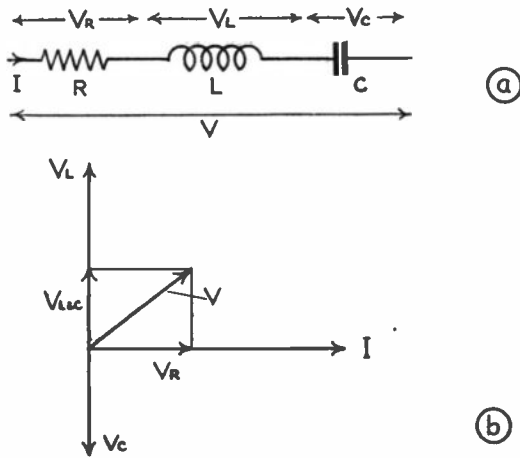

FIG. 12.14. SERIES RESONANT CIRCUIT

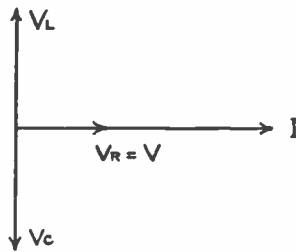

FIG. 12.15. VECTOR DIAGRAM FOR SERIES RESONANT CIRCUIT AT RESONANCE

may be considerably less than the voltage across L or C . Since the voltage is small under these conditions the impedance $Z (= V/I)$ must also be small, and the circuit behaves as if it were composed of R only (since $V = V_R = I.R.$ or $V/I = R$).

Under these conditions the circuit is said to be **resonant** and the condition is that

$$\begin{aligned}
 V_L &= V_C \\
 \text{or } I.X_L &= I.X_C \\
 \text{or } I.\omega L &= I/\omega C \\
 \text{or } \omega^2 &= 1/LC \text{ or } \omega = 1/\sqrt{LC} \\
 \text{or } f &= \frac{1}{2\pi \sqrt{LC}}
 \end{aligned}
 \tag{12.14}$$

Thus, there is one frequency at which this phenomenon occurs. This comes about because L and C are exact opposites: *i.e.* in L the voltage leads 90° and in C it lags 90° ; and the reactance of L increases with frequency while that of C decreases with frequency. Thus, there must be some frequency (as given above) which makes these reactances equal.

It has been shown that at resonance $I = V/R$. Now the voltage across $L = I\omega L$ or, substituting for I , the voltage across L is given by

$$V_L = \frac{V}{R} \cdot \omega L$$

$$\text{and } V_L/V = \frac{\frac{V}{R} \cdot \omega L}{V} = \omega L/R \quad (12.15)$$

This ratio is known as the **magnification factor** (Q) of the circuit since it is the amount the input voltage is stepped up across L . This factor may be quite large (say 100) in radio circuits.

As the circuit departs from resonance the total applied voltage must increase to maintain the same current or, put another way, if the voltage were fixed the current would decrease. If the frequency is varied either side of resonance the current would vary, as shown in figure 12.16.

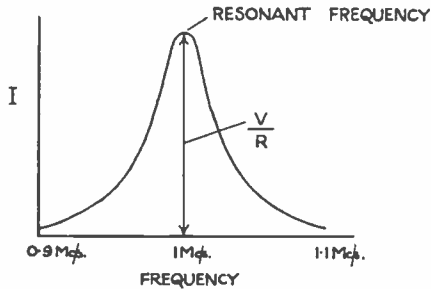

FIG. 12.16. RESONANCE CURVE FOR SERIES CIRCUIT

From the vector diagram of figure 12.14(b)

$$V_{L \& C} = V_L - V_C$$

$$\text{and } V^2 = V_R^2 + V_{L \& C}^2$$

$$V^2 = V_R^2 + (V_L - V_C)^2 \quad (\text{substituting for } V_{L \& C} \text{ from above})$$

$$\text{but } V = IZ$$

$$V_R = I.R$$

$$V_L = I.\omega L$$

$$V_C = I/\omega C$$

Substituting in the above equation:

$$(I.Z)^2 = (I.R)^2 + (I.\omega L - I/\omega C)^2$$

Cancelling I

$$Z^2 = R^2 + (\omega L - 1/\omega C)^2$$

$$Z = \sqrt{R^2 + (\omega L - 1/\omega C)^2} \quad (12.16)$$

At resonance $\omega L = 1/\omega C$ and again $Z = R$. At other frequencies Z is obviously higher. If the resistance of the circuit is increased the current at resonance will be decreased, but the resistance will not have much effect at frequencies removed from resonance as the impedance is high. The effect of resistance on the resonance curve (*i.e.* current against frequency) is shown in figure 12.17.

This resonant property of the circuit enables us to pick out voltages of one frequency when voltages of several frequencies are present

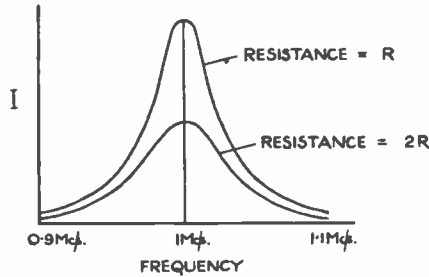

FIG. 12.17. EFFECT OF RESISTANCE ON THE RESONANCE CURVE OF SERIES CIRCUIT

PARALLEL RESONANT CIRCUIT

This circuit (figure 12.18) is composed of an inductor L in parallel with a capacitor C . Since it is impossible to make an inductor without resistance, a resistor R is shown in series with L , but it does not normally exist as a physical component. In this circuit the voltage applied to the two branches is the same. The current in the capacitive circuit will lead the voltage by 90° as shown in figure 12.19. The current I_L in the inductor-resistor arm will

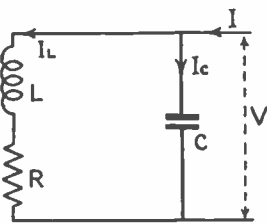

FIG. 12.18. PARALLEL RESONANT CIRCUIT

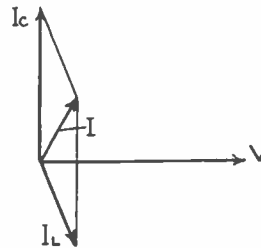

FIG. 12.19. VECTOR DIAGRAM FOR PARALLEL RESONANT CIRCUIT

lag V but not by 90° , owing to the presence of the resistor. The total current I is obtained by taking the vector sum of I_C and I_L . It will be seen that in the case shown I is smaller than I_C or I_L . In a similar way to the series resonant circuit there will be some frequency where $I_L = I_C$ and under these conditions I will be a minimum as shown in figure 12.20, and will be practically in phase with V .

Now $I_C = V/X_C = \frac{V}{1/\omega C} = V \cdot \omega C$ and $I_L = V/Z$ where Z is the impedance

of the inductive arm. This impedance is:

$$Z_L = \sqrt{R^2 + (\omega L)^2}$$

If the resistance is small compared with ωL (a condition normally true in practice) then we may neglect R and say that

$$Z_L = \omega L$$

$$\text{Thus } I_L = V/\omega L$$

Equating, so as to make $I_L = I_C$ so as to give minimum current:

$$V/\omega L = V\omega C \text{ or } \omega^2 = 1/LC$$

$$\text{or } f = \frac{1}{2\pi \sqrt{LC}} \tag{12.17}$$

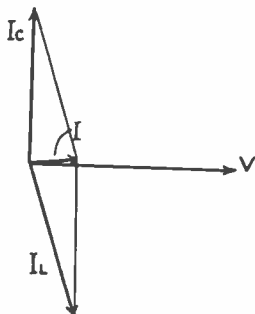

FIG. 12.20.
VECTOR DIAGRAM FOR PARALLEL
RESONANT CIRCUIT AT RESONANCE

This frequency is the same as the resonant frequency of a series resonant circuit.

If the frequency is varied it will be seen that the circuit behaves in the opposite way to the series resonant circuit, *i.e.* I is a minimum at the resonant frequency, as shown in figure 12.21. Since the current is small at resonance

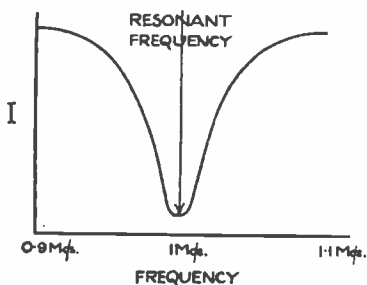

FIG. 12.21.
RESONANCE CURVE FOR
PARALLEL RESONANT CIRCUIT

the impedance will be high and this is called the dynamic resistance (R_D) of the tuned circuit. The circuit behaves as a resistance since, for all practical purposes, V and I are in phase. The value of this dynamic resistance can be shown to be given by:

$$R_D = L/CR = \omega^2 L^2/R \quad (12.18)$$

The effect of increasing the resistance of the coil is shown in figure 12.22, where it will be seen that increasing R tends to flatten the curve, and in practice we keep R as small as possible.

This circuit is used in radio receivers for selecting a voltage of one frequency from voltages of other frequencies.

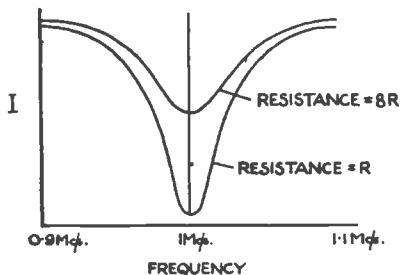

FIG. 12.22.
EFFECT OF RESISTANCE ON
THE RESONANCE CURVE
OF PARALLEL CIRCUIT

Examples

1. *The tuning circuit of a receiver is composed of a capacitor of 500pF and an inductance of 200μH. Calculate the frequency at which the circuit is resonant, i.e. the frequency to which the receiver is tuned.*

$$\begin{aligned}
 f &= \frac{1}{2\pi \sqrt{LC}} && \text{(see 12.14)} \\
 &= \frac{1}{2\pi \sqrt{200.10^{-6} \times 500.10^{-12}}} \\
 &= \frac{1}{2\pi 10^{-7} \sqrt{10}} = 10^7/19.9 = 503,000 \text{ c/s}
 \end{aligned}$$

2. *It is required to tune a receiver to 700kc/s with a capacitor of 200pF capacitance. What value of inductance is required?*

$$\begin{aligned}
 f &= \frac{1}{2\pi \sqrt{LC}} && \text{(see 12.14)} \\
 f^2 &= 1/4\pi^2 LC \\
 \text{or} \\
 L &= 1/4\pi^2 C.f^2 \\
 &= 1/4\pi^2 \times 200 \times 10^{-12} \times (700 \times 10^3)^2 \\
 &= 1/8\pi^2 \times 49 = 0.000259 \text{ henry or } 259\mu\text{H}.
 \end{aligned}$$

3. *A series-tuned or resonant circuit is composed of an inductor of 200μH and a capacitor of 500pF, and is connected to a 2V supply. If the inductor has a resistance of 30 ohms, what current will flow in the circuit at its resonant frequency of 503kc/s? What is the magnification factor of the circuit and the voltage across the inductor?*

At resonance the impedance of the circuit is R only, hence

$$I = V/R = 2/30 = 0.0667 \text{ ampere}$$

$$\begin{aligned}
 \text{Magnification factor } Q &= \omega L/R = 2\pi 503,000 \times 200 \times 10^{-6}/30 && \text{(see 12.15)} \\
 &= 4\pi 50.3/30 = 21.1
 \end{aligned}$$

$$\text{Voltage across } L = V.Q = 21.1 \times 2 = 42.2.$$

4. *If the components of question No. 3 form a parallel resonant circuit what will be the impedance at the resonant frequency (or dynamic resistance)?*

$$\begin{aligned}
 R_D &= L/CR && \text{(12.18)} \\
 &= 200.10^{-6}/500.10^{-12} \times 30 \\
 &= 2.10^6/150 = 13,300 \text{ ohms.}
 \end{aligned}$$

Further examples

5. *A set uses a coil of inductance 100μH and this is tuned by a capacitor which can be varied from 50 to 500pF. What range of frequencies can be covered? (Answer 0.715 to 2.26Mc/s.)*
6. *A coil and capacitor are connected in series across a 20V supply. The coil has an inductance of 100μH and a resistance of 50 ohms and the capacitor has a value of 500pF. Calculate the current at 0.715Mc/s and at 1Mc/s. (Answers 0.4 ampere and 0.0638 ampere.)*

POWER IN A.C. CIRCUITS

Power in a d.c. circuit has been shown to be simply the product of voltage and current, but this is not the case in an a.c. circuit. In an a.c. circuit the power at any instant is $i \times v$, where i and v are the instantaneous current and voltage. Of course, i and v are continuously changing. Consider a voltage and current as shown in figure 12.23. In this figure the voltage and

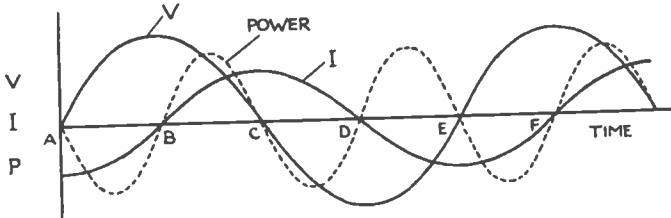

FIG. 12.23. POWER IN CIRCUIT WHERE I AND V ARE 90° OUT OF PHASE

current are 90° out of phase. From A to B , V is positive, but I is negative and, therefore, the power will be negative. From B to C both I and V are positive and the power is, therefore, positive. From C to D , V is negative and I is positive, so the power is negative; while from D to E both I and V are negative and the power is again positive. Thus, over a cycle, there is as much power flowing in one direction as the other, with the result that no power is absorbed by the circuit or given out by the circuit. Thus, a circuit consisting of a perfect inductor or capacitor (where I and V are 90° out of phase) does not consume power.

Where I and V are in phase, as in figure 12.24, the power is always positive; the power consumed by the circuit is $I.V$ where I and V are in r.m.s. values.

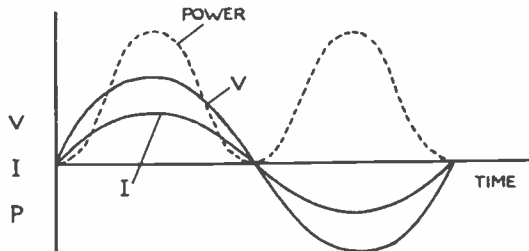

FIG. 12.24. POWER IN RESISTIVE CIRCUIT

The easiest way to calculate the power in any circuit where I and V are not in phase but at an angle ϕ , is as shown in figure 12.25. We split I into two components at right angles so that I_i is in phase with V and I_q is in quadrature* with V . The current I_q , since it is in quadrature with V , does not represent any power, the power component of current being I_i .

Now from the figure $\cos \phi = I_i/I$

$$\text{or } I_i = I \cos \phi \quad (12.19)$$

Thus, the total power in the circuit is

$I_i.V$ and, substituting for I_i

$$\text{Power} = I.V.\cos \phi \quad (12.20)$$

* i.e. 90° out of phase with V .

Thus, the power consumed by a circuit depends on the phase angle ϕ . $\cos \phi$ is known as the **power factor** of the circuit. The product of $V.I$ is now known as the volt-amperes of the circuit.

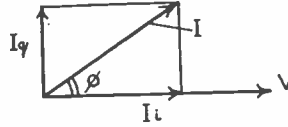

FIG. 12.25. VECTOR DIAGRAM FOR CIRCUIT WHERE I AND V ARE NOT IN PHASE

The power factor is more important when dealing with electric motors than in radio. In general, the nearer the power factor is to unity the better. Since $\text{Power} = I.V. \cos \phi$ the current $I = \text{Power} / V. \cos \phi$. Thus, if the power factor is low, the current taken by the device (for a fixed voltage) is larger for a given power. This is a disadvantage since a larger size of wire is required to supply the apparatus. In the case of large consumers an additional charge may be made by the supply authorities if the power factor is low. For the above reasons capacitors are usually fitted in fluorescent lamps and sometimes in induction motors to bring the power factor (which is always lagging in the case of fluorescent lamps and induction motors) nearer to unity.

Examples

1. A coil of inductance $5H$ and resistance 1000 ohms is connected to a $230V$ 50 c/s supply. What current will flow and what power will be consumed by the circuit?

$$Z = \sqrt{R^2 + (\omega L)^2} \quad (\text{see 12.7})$$

$$= \sqrt{1000^2 + (2\pi \cdot 50 \times 5)^2}$$

$$= 1860 \text{ ohms}$$

$$\text{Current} = V/Z = 230/1860 = 0.124 \text{ ampere}$$

$$\cos \phi = R/Z = 1000/1860 = 0.538$$

$$\text{Power} = I.V. \cos \phi \quad (\text{see 12.20})$$

$$= 0.124 \cdot 230 \cdot 0.538 = 15.3 \text{ watts}$$

$$\text{or power equals } I^2R = 0.124^2 \cdot 1000 = 15.3 \text{ watts.}$$

2. A $230V$ 50 c/s single phase induction motor gives an output of 0.25 h.p. If the efficiency is 70 per cent. and the power factor 0.6 , calculate the current.

$$\text{Power input} = 0.25 \times 746/0.7 \text{ watts}$$

$$= 266 \text{ watts}$$

$$\text{Power input} = V.I. \cos \phi \quad (\text{see 12.20})$$

$$\text{therefore } I = P/V. \cos \phi = 266/230 \times 0.6 = 1.93 \text{ amperes.}$$

TRANSFORMERS

WE saw in chapter 10 that when the current in the primary winding of a mutual inductance is changed there is an induced e.m.f. in the secondary. If we connect the primary (figure 13.1) to a supply of a.c. where the current is continually changing in value, there will be an e.m.f.

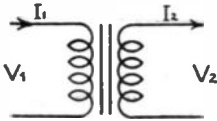

FIG. 13.1.
BASIC PRINCIPLE OF TRANSFORMER

produced continuously in the secondary. This is the principle of the transformer. When we connect the primary to an a.c. supply of voltage V_1 , a current I_1 will flow which will depend on the inductance of the primary ($I_1 = V_1/\omega L$). This current sets up an alternating magnetic field which cuts the turns of the secondary and induces a voltage V_2 in it. In most cases the two coils are wound on an iron core as shown in figure 13.2. This has two

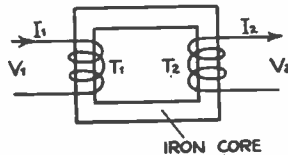

FIG. 13.2.
IDEA OF IRON CORE FOR TRANSFORMER

effects: it increases the inductance of the primary and so reduces the current that flows in the primary; and concentrates the magnetic flux so that most of it passes through the secondary winding.

The alternating flux sets up an e.m.f. in the primary which (neglecting the resistance of the winding) must be equal and opposite to the applied voltage. If the primary has T_1 turns the voltage per turn is V_1/T_1 . Since the same flux cuts the secondary it will induce in it the same voltage per turn. Thus, the secondary voltage will be $T_2 \cdot V_1/T_1$. Thus

$$\frac{\text{Voltage on primary}}{\text{Voltage on secondary}} = \frac{V_1}{\frac{V_1 \cdot T_2}{T_1}} = \frac{T_1}{T_2} \quad (13.1)$$

i.e. the ratio of voltages on the two windings is proportional to the turns ratio.

If the secondary winding is connected to a closed circuit, a current will flow, and as a result of this a magneto-motive force will be set up by the secondary which, by Lenz's law, will oppose the flux. On the other hand if the flux were reduced there would not be sufficient e.m.f. induced in the primary to oppose the applied voltage. Thus, the current in the primary increases just sufficiently to offset the m.m.f. due to the secondary. The m.m.f. of the secondary is $I_2 T_2$ and, therefore, the increase in primary current I_1' will set up an m.m.f. $I_1' T_1$ equal to $I_2 T_2$.

Hence $I_1' T_1 = I_2 T_2$

or

$$\frac{I_1'}{I_2} = \frac{T_2}{T_1} \quad (13.2)$$

i.e. the currents are in the inverse ratio to the turns. In many cases the current

I_1 is small compared with I_1' and can be neglected, so that the above expression is the ratio of primary to secondary currents.

A transformer is a most useful device since it enables us to increase or decrease a voltage as required and, neglecting any small losses in the transformer, the power output equals the power input.

If the core of the transformer were made of solid iron an e.m.f. would be induced in it similar to that induced in the turns of wire, and currents would flow in the iron. These eddy currents, as they are called, would cause the core to get hot, resulting in undesirable losses. To reduce the effect to small proportions, the core must be made of laminations which are lightly insulated from each other so that these currents cannot flow. This is shown in figure 13.3. Currents will flow in the laminations, but these will be small as the flux passing down each lamination is small.

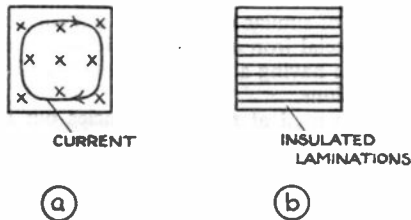

FIG. 13.3. USE OF LAMINATIONS FOR TRANSFORMER CORE

To ensure that all the flux passing through the one coil on the transformer shall pass through the other, the two coils are commonly wound on top of one another, and the core shaped as shown in figure 13.4. The core is usually

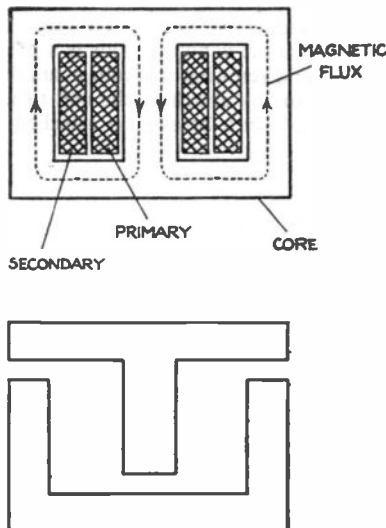

FIG. 13.4. CONSTRUCTION OF TRANSFORMER

built up of T and U laminations as shown. Alternate layers of laminations are placed opposite ways round so that no air gap is produced.

Transformers of various types are used in radio receivers. Mains transformers (operating from the supply mains at 50 c/s) are often used to supply appropriate voltages to valves in the receiver. In this type of transformer, where considerable power output is required, the windings must be of sufficiently thick wire to carry the current without overheating. Hence, the larger the power output the larger the transformer.

Transformers of a similar construction are also used at audio frequencies in a receiver. A transformer of this type is used in all receivers to feed the loudspeaker from the output valve. Since the power associated with this type of transformer is smaller than the mains transformer it is normally smaller, but the wire must be sufficient cross-section to carry the required currents. Audio frequency transformers were at one time used between valves but they are not common to-day. Transformers are sometimes used with microphones and pick-ups. These are of similar construction but smaller as the power involved is very small. Special iron alloy laminations are usually used in this type of transformer, these having a high permeability compared with normal transformer iron laminations.

Transformers are also used at radio frequencies but the construction is generally quite different. Laminated iron cores cannot be used owing to the excessive eddy current loss that would occur. Often no core is used (air cored coils) and the windings are placed one on top of the other or side by side on a suitable insulated former. Special windings are often used so as to reduce the capacitance between the turns of the winding.

In order to reduce the size of the coil dust iron cores are commonly used in modern receivers. These cores are composed of very fine iron or alloy particles bonded together so that the particles are insulated from each other, so reducing the eddy current loss. In most cases the core is just a solid dust iron cylinder fitted inside the two windings.

Inductors are commonly required to operate at radio frequencies to form resonant circuits and the construction of these is similar to the radio frequency transformers just described, except that only one winding is required. When a dust iron core is used the inductance value is conveniently varied by movement of the core in and out of the winding. This is arranged by moulding a screw thread onto the core and screwing this into a suitably threaded former on which the coil is wound or, by attaching the coil to a screwed brass rod which turns in a threaded hole in a brass strip attached to the coil former.

INDEX

ACCUMULATORS	31	FARAD	46
lead acid	34	Field strength	45
nickel-iron	34	Flux density	37
charging	34	Form factor	60
Alternating currents and voltages	56	Frequency	56
flow of	60-68		
Ammeter	15	GENERATOR	53
<i>Ampere</i>	13		
Ampere-hour	21, 34	HENRY	54
Ampere-turn	36	High stability resistor	27
Angular frequency	61	Horse power	23
Atom	12	Hot wire meter	42
Audio frequencies	56		
BATTERIES	31	IMPEDANCE	67
		Inductance, self	53
CALORIE	23	mutual	55
Carbon resistor	25	Induction, electromagnetic	53
Capacitance	46	Inductor, rise and fall of current in	54
Capacitors, charge and discharge	51	Internal resistance	31
in parallel	50	Instruments, measuring	40
in series	50	Insulators	17, 19
types	47-50		
Cells, primary	31	JOULE	22
secondary	31	Joule's equivalent	23
testing	33		
Ceramics	19	KILOWATT-HOUR	22
Charge, electric	21		
Charging accumulators	34	LAMINATIONS	77
Coercive force	38	Left-hand rule	38
Colour code	26, 50	Lenz's law	53
Communication, radio	11	Loudspeaker	11
Commutator	39		
Conductance	29	MAGNETIC, field	36
Conductors	17	flux	36
<i>Coulomb</i>	21	saturation	37
Cycle	56	Magnetism	35
		residual	37
DEMODULATOR	11	Magnetizing force	36
Detector	11	Magneto-motive force	36
Dry cell	33	Magnets, permanent	37
Dynamic Resistance	72	Magnification factor	70
		<i>Manganin</i>	17, 20
EDDY CURRENTS	77	Meters	40-42
Electric, charge	21	Meter, shunts	43
current	12, 13	multipliers	44
energy	21	Mica	19
force	45	capacitors	47
power	21, 74	Microphone	11
Electromotive force	13, 21	Modulation	11
Electron	12	Molecule	12
Electrolytic capacitor	50	Motor, electric	38
Electrostatics	45	Moving coil meter	41
Electrostatic voltmeter	52	Moving iron meter	40
Element	12	Multiplier	44
Energy, electric	21	Mutual inductance	55
heat, light, sound and			
mechanical	23		
<i>Eureka</i>	17, 20		

NEWTON	38	Resonance	68, 71
Nichrome	17, 20	Resonant, circuit	68, 71
Nucleus	12	effect of resist- ance on	70, 72
		frequency	69, 72
OHM	14	Right-hand rule	53
Ohm's law	14	Root-mean-square	59
PAPER CAPACITOR	49		
Parallel, resistors	29	SECONDARY CELL	31
cells	32	Self-inductance	53
capacitors	50	Semi-conductor	17
resonant circuit	71	Series connected capacitors	50
Peak factor	60	cells	32
Permanent magnet	37	resistors	27
Permeability	37	resonant circuit	68
Permittivity	45, 46	Shunts	43
Phase, angle	64	Silvered mica capacitor	47
difference	57	Sine waveform	57
Plastics	19	Specific resistance (see Resistivity)	
Power, electric	21		
in alternating current			
circuits	74	TELEGRAPHY	11
factor	75	radio	11
frequencies	56	Telephony	11
Primary cell	31	radio	11
Proton	12	Temperature coefficient	20, 48
QUADRATURE	58	Thermo-couple meter	42
		Time constant	51, 54
		Tolerance	26, 50
		Transformer	76
		Transmitter, radio	11
RADIO, frequencies	56	VECTORS	64
receiver	11	Vector sum	66
telegraphy	11	Volt	13
telephony	11	Voltmeter	16
transmitter	11	electrostatic	52
Reactance	62		
Receiver, radio	11	WATT	21
Reluctance	36	Watt-hour	22
Residual magnetism	37	Waveform	56
Resistivity	17, 18, 19	Weber	37
Resistance	14	Wirewound resisto	25
effect of temperature on	20		
Resistors, colour code	26		
in parallel	29		
in series	27		
tolerance	26		
types	25, 26		

RADIO SERVICING		
G. N. Patchett, B.Sc., Ph.D., M.Brit.I.R.E., M.I.E.E., M.I.R.E.		
Vol. 1— <i>Basic Electrotechnology</i>		5/-
Vol. 2— <i>Intermediate Radio Theory</i>		5/-
Vol. 4— <i>Fault-Finding</i>		5/-
B. Fozard, B.Sc. (Eng.)		
Vol. 3— <i>Final Year Radio Theory</i>		5/-
TELEVISION SERVICING		
G. N. Patchett, B.Sc., Ph.D., M.Brit.I.R.E., M.I.E.E., M.I.R.E.		
Vol. 1 5/-	Vol. 2 6/-	Vol. 3 5/-
		Vol. 4 7/6
AUDIO HANDBOOK SERIES		
N. H. Crowhurst, A.M.I.E.E., M.I.R.E.		
No. 1 AMPLIFIERS		3/6
No. 2 FEEDBACK		3/6
No. 3 THE USE OF A.F. TRANSFORMERS		3/6
No. 4 PUBLIC ADDRESS		4/6
No. 5 THE QUEST FOR QUALITY		6/-
AN F.M. TUNER: THEORY AND CONSTRUCTION		
E. Adler, B.Sc. (Eng.), A.M.I.E.E.		5/-
RADIO SERVICING INSTRUMENTS		
E. N. Bradley		4/6
ELECTRONIC NOVELTIES FOR THE CONSTRUCTOR		
E. N. Bradley		5/-
RADIO CONTROL OF MODELS		
G. Sommerhoff, M.A.		5/-
SUPPRESSING RADIO AND TELEVISION INTERFERENCE		
B. L. Morley		5/-
TELEVISION SYNCHRONIZING SEPARATORS		
G. N. Patchett, B.Sc., Ph.D., M.Brit.I.R.E., M.I.E.E., M.I.R.E.		5/-
TRANSISTORS AND CRYSTAL DIODES		
B. R. Bettridge		5/-
TRANSISTOR CIRCUITS FOR THE CONSTRUCTOR No. 1		
E. N. Bradley		3/6
TRANSISTOR CIRCUITS FOR THE CONSTRUCTOR No. 2		
E. N. Bradley		3/6
TELEVISION TEST EQUIPMENT	PERSONAL RECEIVERS	
E. N. Bradley 5/-	E. N. Bradley	3/6
TELEVISION CIRCUIT REFINEMENTS		
C. H. Banthorpe		5/-
UNIT CONSTRUCTED TV RECEIVERS		
E. N. Bradley		6/-
THE OSCILLOSCOPE BOOK		
E. N. Bradley		5/-
TELEVISION FAULTS		
N. Stevens		5/-
MAGNETIC RECORDING		
M. L. Quartermaine		4/6
TV PREAMPLIFIERS FOR BANDS I AND III		
B. L. Morley		5/-
TELEVISION TIMEBASE CIRCUITS		
C. H. Banthorpe		5/-
ELECTRONIC GADGETS FOR THE CONSTRUCTOR		
E. N. Bradley		3/6
PRACTICAL TV AERIAL MANUAL FOR BANDS I AND III		
R. Laidlaw		5/-
TV CIRCUITS AND SERVICE DATA No. 1		
		9/6
TV CIRCUITS AND SERVICE DATA No. 2		
		3/6
OSCILLOSCOPE EQUIPMENT		
D. W. Easterling		5/-
HOW TO GET THE BEST OUT OF YOUR TAPE RECORDER		
Percival J. Guy		8/6